

Wireless World

RADIO AND ELECTRONICS



FEB. 1948

1/6

Vol. LIV. No. 2

IN THIS
ISSUE :

ELECTRONICS AND ATOMIC ENERGY

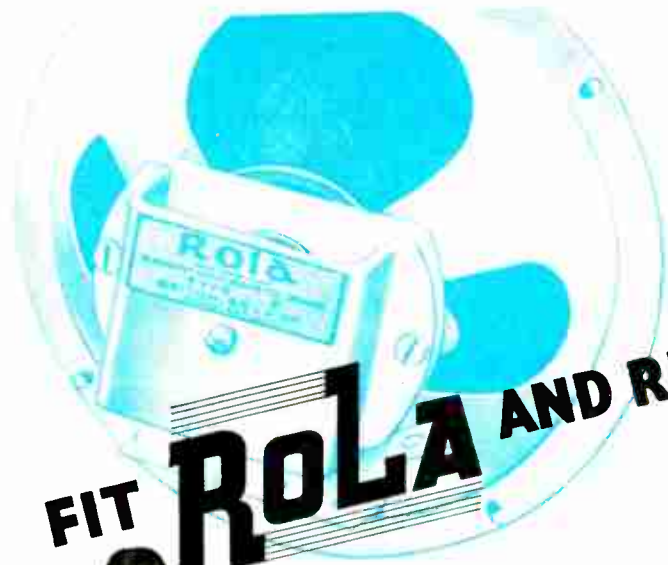

FIT **ROLA** AND RELAX

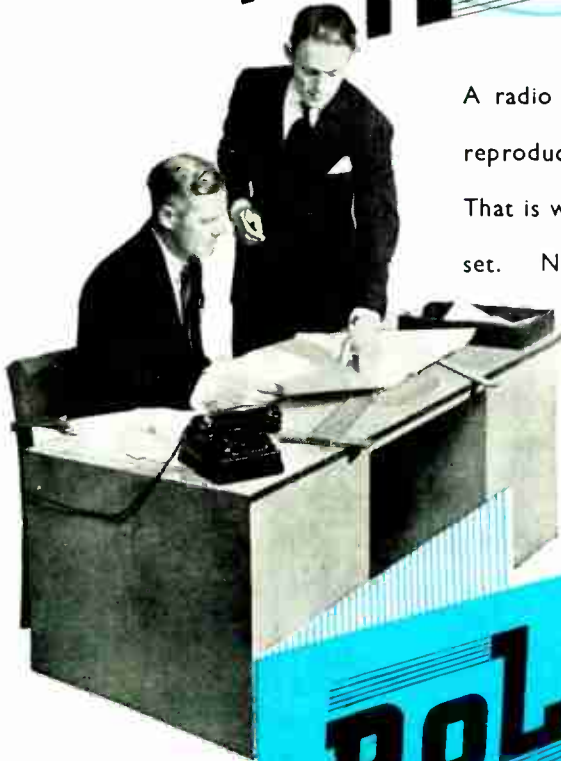

A radio receiver is judged by the quality of its reproduction more than by any other single factor. That is why the speaker is such a vital part of any set. No wonder so many Planning Engineers decide on Rola speakers for all their models. They know they can fit Rola and relax !

ROLA SPEAKERS
THEIR QUALITY SPEAKS FOR ITSELF

BRITISH ROLA LTD • 8 UPPER GROSVENOR STREET • LONDON W.1



At-a-glance
ACCURATE VALVE TESTS!

The "Avo" Valve Tester gives reliable and definite indication of the state and efficiency of some 2,000 English, American and Continental valves under actual working conditions. It is accompanied by a comprehensive Valve Data Book and is a typical example of the high standard of accuracy associated with all "Avo" Electrical Testing Instruments. Fully descriptive literature available on application to the Sole Proprietors and Manufacturers :-



"Avo" Instruments available from stock:
 VALVE TESTER
 TEST BRIDGE
 D.C. AVOMINOR

Electrical Measuring Instruments

THE AUTOMATIC COIL WINDER & ELECTRICAL EQUIPMENT CO., LTD.
 WINDER HOUSE · DOUGLAS STREET · LONDON · S.W.1 TELEPHONE: VICTORIA 3104/9

A



"A PRECEDENT
EMBALMS A
PRINCIPLE" ...
Benjamin Disraeli.

A principle creating a precedent
— Lectrona — Quality —

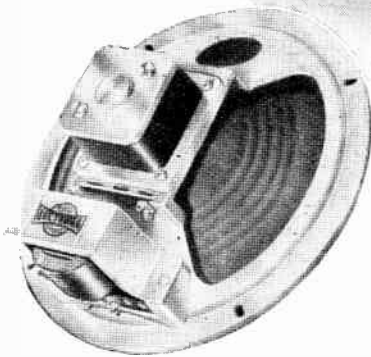

LECTRONA
EDSTONE LTD
7 PRINCES STREET
WESTMINSTER · S.W.1
TELEPHONES · WHITEHALL · 07856

IT CAN SEEM LIKE CHILD'S PLAY



With a good testing instrument you can make fault finding on a defective wireless set seem like child's play. The Weston Model E772 Analyser will meet all your normal radio servicing requirements and will save you time, trouble and money. The instrument is simple to use and is both accurate and reliable. It has a wide range coverage with a sensitivity of 20,000 ohms per volt on all D.C. ranges. Please write for full details.

SYSTEMATIC
SERVICING
STARTS WITH A

WESTON

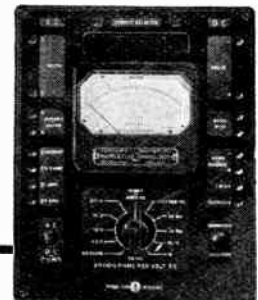

SANGAMO WESTON LTD. ENFIELD, MIDDX. Telephone: Enfield 3434 & 1242.

SOUND DESIGN

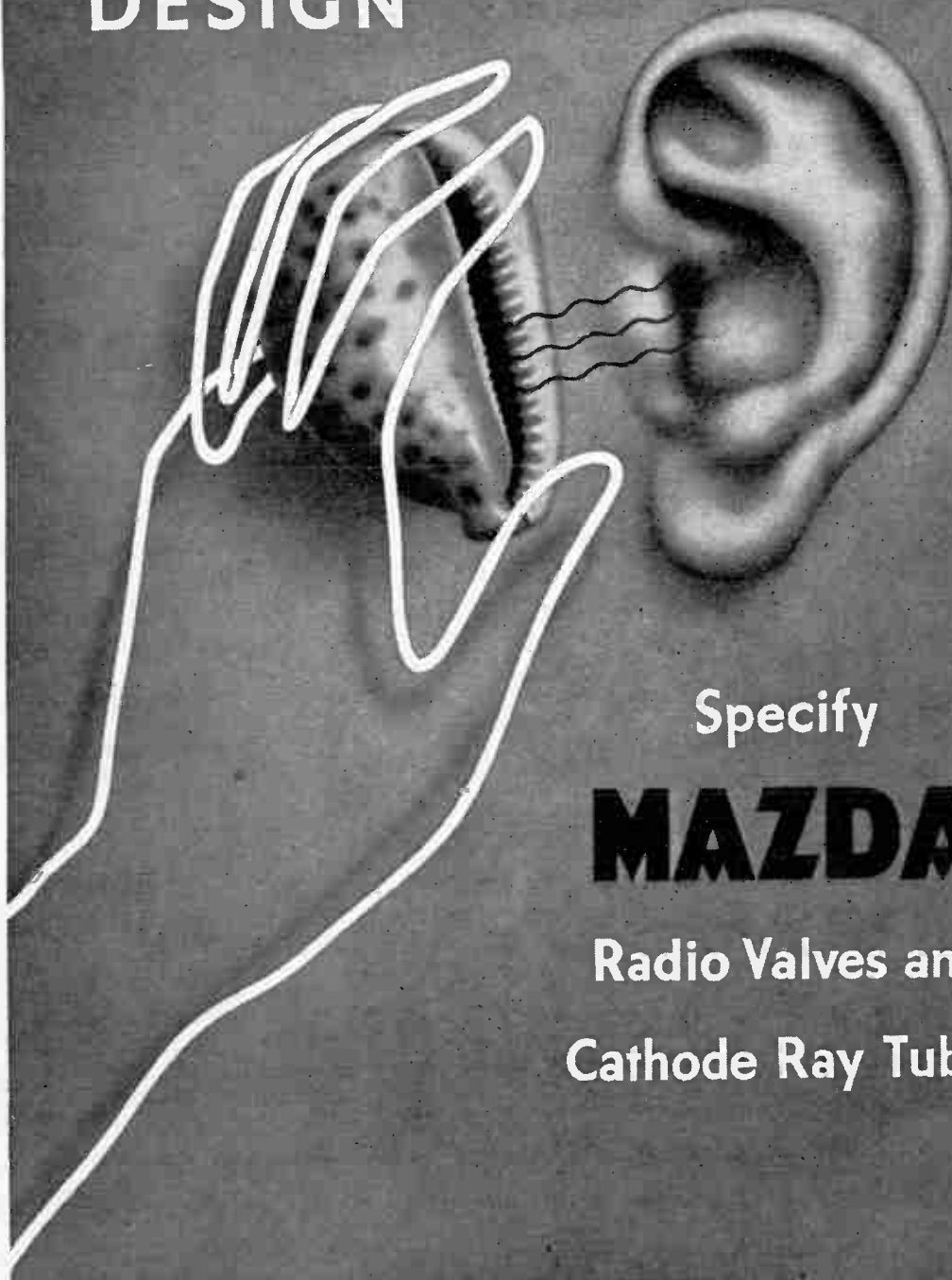

Specify

MAZDA

Radio Valves and
Cathode Ray Tubes

THE EDISON SWAN ELECTRIC CO. LTD., 155 CHARING CROSS ROAD, LONDON, W.C.2

R.M.52

Technically

We believe that the only way to build a receiver is to begin at the beginning with a sound circuit design—a design that's been tested and re-tested—a design that will stand up to the most critical examination. From this design a prototype is constructed in which every component receives the same rigorous testing. We leave the experts to pass judgment on the resulting Sobell receivers. We are confident that for ease of control and absolute fidelity of reproduction these models will be found to have no equals—that, in fact, you will pronounce them to be 'technically outstanding'.

Outstanding

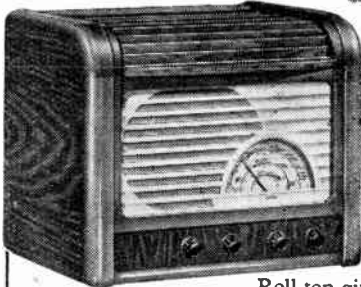

**SOBELL
MODEL 516
T.G. TABLE
RADIOGRAM**

Roll top gives easy access to gramophone turntable. The receiver is a 5-valve super-het. operating from 200/250 volts, 40/100 cycles per second A.C. supply. Wave range: 16-50 metres; 193-577 metres; 800-2, 140 metres.

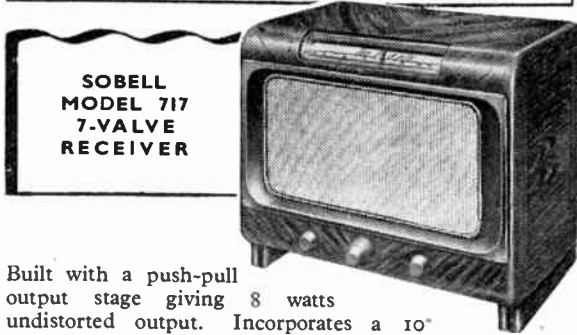

**SOBELL
MODEL 717
7-VALVE
RECEIVER**

Built with a push-pull output stage giving 8 watts undistorted output. Incorporates a 10" loudspeaker. Covers long, medium and two short wave ranges. Voltages as for 516 T.G.

SOBELL RADIO

TWO YEARS' FREE ALL-IN SERVICE IN THE HOME
 Advt. of Sobell Industries Ltd., Langley Park, near Slough, Bucks. 85-9

**SENSITIVITY
10,000 OHMS
PER VOLT**

Designed to meet the demands of Service and Plant Engineers, also Radio Amateurs, 21 Ranges:—Volts: A.C./D.C. 10, 25, 100, 250, 500 and 1,000.

Microamps: A.C./D.C. 0—100.
 Milliamps: D.C. 2.5, 10, 25, 100 and 500.
 Ohms: 0/10,000 and 0/1 Megohm.

All voltage measurements A.C. and D.C. are at 10,000 ohms per volt, to comply with the requirements of modern radio and electronic equipment, where tests have often to be made across high impedance circuits. Price: £10. 10s.

Immediate delivery from wholesale stockists.

PULLIN
 Series 100
MULTI-RANGE TEST SET



MEASURING INSTRUMENTS (PULLIN) LTD
 Address all enquiries to Dept. J, Electric Works,
 Winchester Street, Acton, London, W.3. Telephone: Acorn 4651-4











FORTHCOMING PRODUCTIONS

"Monobolt" speakers, the first of the new TruvoX radio range, are now available from all radio dealers. Quality enthusiasts, and all those who want "the best," will welcome this news. If you require fuller details than are given below—a postcard will bring them.

Model EX 50	5in.	8,500 lines	£1 1 0
Model BX 52	5in.	10,000 lines	£1 4 6
Model EX 60	6½in.	8,500 lines	£1 2 6
Model BX 62	6½in.	10,000 lines	£1 6 0
Model BX 80	8in.	8,000 lines	£1 4 0
Model BX 82	8in.	10,500 lines	£1 10 0
Model BX 100	10in.	8,000 lines	£1 10 0
Model BX 102	10in.	10,500 lines	£1 17 6

 P.A. EQPT	 HIGH FIDELITY PICKUPS
 REFLEX SPEAKERS	 WAFER SPEAKERS
 AUDITORIUM LOUDSPEAKERS	 EXTENSION LOUDSPEAKERS

New products, as illustrated above, are well under way. Full details will be announced as they become available.

TRUVOX

TRUVOX ENGINEERING CO., LTD., EXHIBITION GROUNDS, WEMBLEY, MIDDLESEX.

TWO OUTSTANDING MODELS

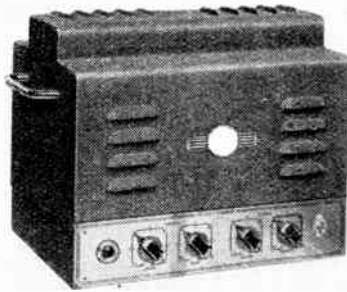

15 Watt Quality Amplifier Special Amplifier designed primarily for the high quality reproduction of Gramophone records. Incorporating a built-in variable scratch filter, bass and treble lift controls and negative feedback. A maximum output of 15 Watts is obtained, but low average listening levels may be run without deterioration in quality. The valve line up is:—2 ECC 32 Twin Triodes, 2 EF 50 Pentodes, 2 EL 37 Pentodes 1 5U4G Rectifier.

Price £29.15.0

FROM THE



RANGE OF QUALITY AMPLIFIERS



The Rad. 20 model illustrated is ideal for Schools, Clubs, Hotels, etc., where high quality reception of the normal broadcasting programmes is required. A Three wave band superhet radio unit of the very latest design is incorporated, and provision is also made for microphone and gramophone inputs. Available for 200 250v. A.C. mains.

Retail Price £44.15.0

WODEN TRANSFORMER CO. LTD.,

MOXLEY ROAD, BILSTON, STAFFS. Phone: Bilston 41959

J.T.L.

M. R. SUPPLIES Ltd.

have the following first-class, brand new **Radio and Laboratory Material** available for immediate delivery from stock. All prices nett.

MICRO-AMPERE METERS (new, ex-A.M.) 0/100 micro-amps, 1st grade m/coil, 2 1/2 in. scale. 3 in. flush mount. Int. res. 175 ohms (average), by prominent maker. 37 6.

INSTRUMENT RECTIFIERS (full-wave) 1 ma. only, 5-.
VARIABLE TRANSFORMERS. Essential for correcting mains fluctuations, maintaining constant voltage (manually operated by knob) Model "A." input 200 240 v. 50 c., output 220 v. 50 c. Loading 1.65 kva., 27 10/-. Model "B." input 200/250 v. 50 c., output 230 v. 50 c., loading 1.01 kva., 26 10/-. Voltages are infinitely variable within limits stated. (Despatch p. train, either 3 6.)

PRECISION VOLTMETERS (suitable for use with variacs) 3 1/2 in. flush panel mount. 0/250 v. A.C., rectified moving coil, 76 6.

E.H.T. VOLTMETERS, m/coil, by best makers. 0/3500 volts D.C., 3 1/2 in. dia. Projection 4 in., with internal series resistance, 47 6.

G.E.C. EXTRACTOR FANS, operation 6/12 v. D.C. or 50 v. A.C., 7 1/2 in. impeller, very well made in die-cast chassis 9 1/2 in. sq. by 6 1/2 in. overall. These can be used either as extractor or cooling fan, 35 -.

L.T. RECTIFIERS, full-wave, bridged, selenium, S.T.C., all for charging up to 12 v. At 1.5 amp., 12 6. At 4-amps., 25 -. At 6 8-amps., 39 6. At 10/12 amps., 49/6. Also for D.C. delivery up to 30 v. 4 amps., 45 6.

STEP-DOWN MAINS TRANSFORMERS to suit above rectifiers. All primaries tapped 200/220/240 v. 50 c. and secs. tapped for 6 and 12 v. charge. For 1.5 a. rect., 23/6. For 4-amp., 38/6. For 6 8-amp., 55 -. For 10/12 amp., 77/6 (des. 2/6). For the 30 v. 4 amp. rect., 57/6 (des. 2/-).

SHORT-WAVE RECEIVERS. Last few of the excellent B2 Mk. II Receivers and Power Packs. Operation any A.C. mains and 6 v. D.C. Range 3.1 to 15.3 mc/s. Superhet with B.F.O. Compact and highly efficient set with all leads, phones, etc., in waterproof steel transit case. 27 17 6 (des. p.t. 5/-). We have the coils for the B.2. Transmitter at 10/6 the set of four.

MASTER CONTACTORS, suitable for process timers, or darkroom work. Spring driven, impulse every half-second with closed circuit. Precision made, in teak transit box, 25/-.

THERMOSTATIC SWITCHES. Capacity 1.5 amp. On at 32 deg. F. and off at 59 deg. F., therefore right for frost protection. Adjustable, 4 6.

GERMANIUM CRYSTAL RECTIFIERS (G.E.C.). Only 13 mm. long. Frequency range 59 c. to 45 mc. Many applications—discriminator and limiting circuits, second detectors, meter rectifiers, A.F. and R.F., in place of diodes, valve voltmeter, etc., 27 6.

LARGE ALARM BELLS. Operation 50, 100, 240 v. A.C. Fitted twin gongs each 5 in. dia. Overall height 12 in., width 12 1/2 in. P.O. type, completely weatherproof, 29 6.

CENTRIFUGAL BLOWERS (G.E.C.). Operation 6/12 v. D.C. or 15 v. A.C. Intake 2 1/2 in. Outlet 1 1/2 in. Height overall 8 1/2 in. Suction and blast greater than average vacuum cleaner, 57 6 (des. 2/-).

H.T. RECTIFIERS (S.T.C. selenium). D.C. delivery up to 350 v. 120 m.a. in half-wave or voltage doubler (two can be bridged for 300 m.a.) Very special offer 7 6.

HEAVY DUTY OUTPUT TRANSFORMERS, improved "W.W." spec. Providing 11 ratios from 12/1 to 75/1 with C.T. for push-pull. Handling up to 25-watts at high fidelity. Weight 7 1/2 lbs., 59 6 (des. 2/-).

HOT-PLIE STRIPPERS (S.T.C.) Operation 200/250 v. A.C. For rapid and clean stripping of V.C. and rubber insulation. With transformer, ready for use, 63 -. Please include sufficient for packing and despatch.

M. R. SUPPLIES Ltd., 68, New Oxford Street, London, W.C.1

Telephone: MUSeum 2953

"You're CERTAIN to get it at ARTHURS!"

★ **VALVES**: We have probably the largest stock of valves in the Country.

Let us know your requirements.

AVOMETERS. NOW IN STOCK.

AVOMETER, Model 7£19 10 0

AVOMETER, Model 40£17 10 0

VALVE TESTER (Complete)£16 10 0

TEST BRIDGE£11 0 0

AVOMINOR, Universal Model £8 10 0

AVOMINOR, D.C. Model £4 4 0

SIGNAL GENERATORS, A.C.£13 0 0

TAYLORS' METERS. COMPLETE RANGE NOW IN STOCK.

All orders sent **STAGE EQUIPMENT** Terms C.O.D.
by return of Post **PROJECTOR LAMPS** or cash with order.

London's Oldest Leading Radio Dealers.

Arthur's

EST.
1919

PROPS: **ARTHUR GRAY, LTD.**

Our Only Address: **Gray House, 150, Charing Cross Rd., London, W.C.2**

TEmple Bar 5833/4.

ELECTRICAL, TELEVISION & RADIO ENGINEERS.



G.E.C.
"Flat End"
CATHODE RAY
TUBE

The G.E.C. 9" diameter cathode ray tube 6501 is intended for high quality television reception, and is magnetically focused and deflected. The screen fluorescence is white.

The tube end is made by a special moulding technique, which produces a screen face nearly flat, and more constant in production than is normally possible with bulbs made by the usual blowing technique. A picture size of approximately 200x160 mms. is obtainable with slight masking of the edges and corners. The bulb is made of high insulating glass giving a minimum of screen charging effects. The electrode gun is designed to give a high picture brightness, with excellent definition for a relatively small voltage drive to the modulator.

Detailed technical data sheet available on request.

Osram
PHOTO CELLS

G.E.C.
CATHODE RAY TUBES

Osram
VALVES

The General Electric Co. Ltd., Magnet House, Kingsway, London, W.C.2.

Presenting the New Model D



The Type 1684 series of Oscilloscopes is already well known. The new Model D retains the desirable features of this series—d.c. shift controls, response flat to video frequencies, d.c. coupled symmetrical amplifiers on both axes, semi-automatic synchronisation of the time base, etc. It incorporates many new features of design, both electrical and mechanical. One such improvement is that the grids of the input stages of both amplifiers are available at Earth potential enabling the instrument to be used more easily for d.c. measurement.

PRINCIPAL FEATURES

- ★ TUBE 3½ in. diam. Blue, green or delay screen.
- ★ AMPLIFIERS. D.C. to 3 Mc/s 18 mV. r.m.s. per cm. or D.C. to 1 Mc, 6 mV per cm. Symmetrical or asymmetrical input. X and Y amplifiers are similar.
- ★ TIME BASE. 0.2 c/s to 150 kc/s. Variable through X amplifier 0.2 to 5 screen diameters.
- ★ ACCESSORIES. Camera, telescopic light shield, ruled graticule.



Fitzhull LABORATORIES LTD

BORHAM WOOD, HERTS
Telephone: ELSTREE 1137

H. P. Radio Services Ltd. offer—

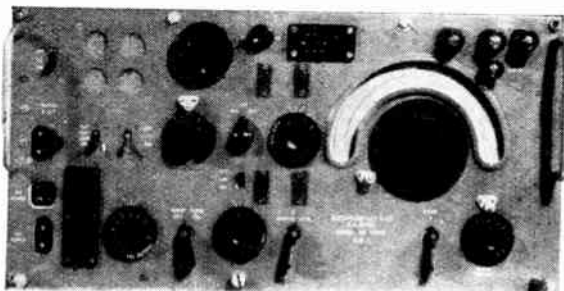

Ex-Army Reception Sets, Type R107. 9 Valve receiver designed for CW and RT signals. Weight 96 lbs. Length 24 ins. Height 13 ins. Depth 17½ ins. Frequency range 17.5-7 mcs., 7.25-2.9 mcs., 3.0-1.2 mcs. Highly Sensitive and Selective. A.C. mains 100-250 volts or 12 volt accum. Mains Consumption 31 watts Circuit RF Amplifier. Oscillator. Frequency Changer. Two IF stages (465kcs) Second detector. AVC. AF amplifier. Output Stage and Heterodyne Oscillator (beat). Three types of valves used—EF39, EBC33, 6X5. 12 volt non sync. vibrator pack fitted. Monitor loudspeaker built in. Amazing value £16 16 0 carr. paid.

All in first-class order and condition.
Terms: Cash only. (No C.O.D. or Hire Purchase)

We are still offering Ex-Govt. Combined Moving Coil Headphones and Moving Coil Hand Microphone. Guaranteed perfect 9 6, post. 8d.

We guarantee satisfaction and safe delivery.

H. P. RADIO SERVICES LTD.

Britain's Leading Radio Mail Order House

55 County Rd., Walton, Liverpool, 4.

Tel.: Aintree 1445

Miniature or Midget

ACTUAL SIZE ACTUAL SIZE

30% 24% 10% 10%

XY 1-4A XW 0-75A

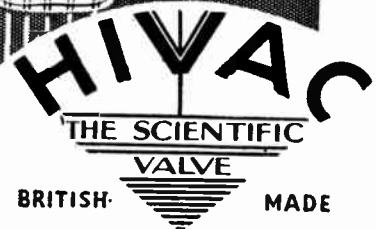

NEW TYPES FOR
MIDGET RECEIVERS
HEARING AIDS
METEOROLOGICAL
INSTRUMENTS
ETC.

HIVAC LIMITED Greenhill Crescent, Phone HARROW
Harrow on the Hill, Middx. 0895

METALLISED CERAMICS

Two additions to the S.P. range
of FREQUENTITE
bushes



R.50650

R.50764

★ R.50844

★ R.50855

TYPE	A mms.	B mms.	C mms.	D mms.	E mms.
R.50650	9.5	9.5	6.4	6.25	2.75
R.50764	9.5	16.7	6.4	6.25	2.75
★ R.50844	9.5	12.7	9.5	6.25	2.75
★ R.50855	12.7	22.2	12.7	9.5	3.9

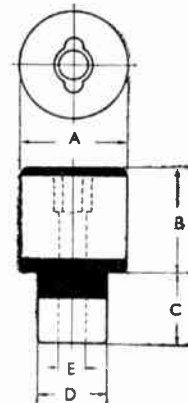

★ Recent additions to the range

For full information and prices please write to :

STEATITE & PORCELAIN PRODUCTS LTD.

STOURPORT-ON-SEVERN, WORCS. Telephone: Stourport III. Telegrams: Steatite, Stourport.



S.P.43

Fault finding Simplified

**The New Taylor
CIRCUIT ANALYSER Model 20A**

The 20A traces the signal through the receiver stage by stage from aerial to loudspeaker. A midget pentode detector is contained in the probe, used for R.F., oscillator and I.F. checks, followed by an amplifier and loudspeaker in the instrument with a "magic eye" to give visual indication of signal strength. The latter is used for D.C. checking on A.V.C. lines or oscillator self-bias. For A.F. checking the input is taken directly to the amplifier which can be switched to feed either the loudspeaker or the magic eye. The selector switch enables the internal speaker to be used separately for test purposes either as low or high impedance. A.C. mains operated, 110 volts and 200/250 volts, 40/100 c.p.s.

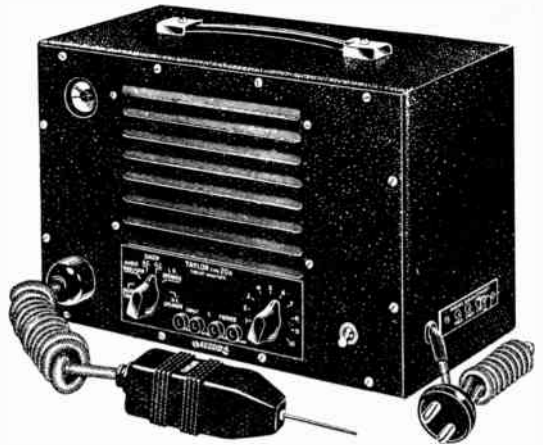

PRICE £15-15-0

HIRE PURCHASE TERMS

£1.10.5 DEPOSIT & 11 MONTHLY PAYMENTS OF £1.10.2

EARLY DELIVERY

TAYLOR PRODUCTS INCLUDE: MULTIRANGE A.C. D.C. TEST METERS ● SIGNAL GENERATORS ● VALVE TESTERS ● A.C. BRIDGES ● CIRCUIT ANALYSERS ● CATHODE RAY OSCILLOGRAPHS ● HIGH AND LOW RANGE OHMMETERS ● OUTPUT METERS ● INSULATION TESTERS ● MOVING COIL INSTRUMENTS



TAYLOR ELECTRICAL INSTRUMENTS LTD
419-424 MONTROSE AVENUE, SLOUGH, BUCKS, ENGLAND

Telephone SLOUGH 21381 (4 lines)
Grams & Cables "TAYLINS" SLOUGH

SPHERE INSTRUMENTS



Introducing the
**ALL WAVE
SIGNAL
GENERATOR** **TYPE 505**

A portable Signal Generator for A.C. Mains operation. Specially developed by SPHERE as a high class instrument, for general Laboratory and Workshop use, it is the ideal instrument for the aligning and testing of radio receivers and amplifiers.

This is a specially designed Generator embodying several new and unique features and improvements, which radio engineers will find invaluable.

All "SPHERE" Test-instruments are entirely British made with highest quality materials and workmanship and carry a SIX Months' guarantee.

- Continuous Frequency coverage from 110 Kilocycles to 56 Megacycles, in six bands.
- Exclusive "SPHERE" "SEE AT A GLANCE" Band and Attenuator indicators.
- Built in ladder attenuator, with fine control, giving 1 Volt maximum, in five steps, in multiples of 10 Microvolts.
- Radio and Audio Frequency Voltages can be switched via single Test-lead.
- Variable control of 400 C.P.S. audio, from 0 to 1 Volt.

**FOR RADIO SERVICE, RADIO ENGINEERING
AND LABORATORY USE.**

Write for List No. 505 S.G.

SPHERE RADIO LIMITED

Radio Instrument Manufacturers

HEATH LANE, WEST BROMWICH

ISOLATION FROM VIBRATION

**NEW
VIBRATION
ELIMINATORS**

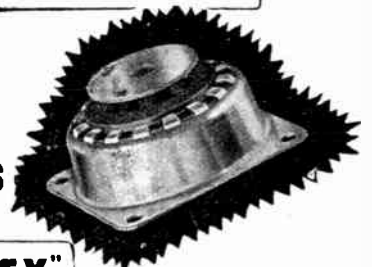

"EQUIFLEX"
MOUNTINGS

AN **AV** PRODUCT

"Equiflex" Mountings are invaluable for the mounting and suspension of machines, equipment, instruments,

electrical apparatus, motors, etc., and wherever elimination of vibration and shock is required.

SPECIAL FEATURES

Flexible in all directions at an equal deflection. Can be loaded on any side, thus eliminating vibration in Vertical, Horizontal and Longitudinal planes employing best quality natural rubber spring elements and complete with snubbing device. Special Fittings made to suit customers' requirements.

Also available as previously advertised, the ALL-METAL construction comprising an ingenious Damped Spring System.

Write for illustrated brochure, and send us details of your requirements.

A. WELLS & CO. LTD. (Dept. W.W.),

STIRLING ROAD, WALTHAMSTOW, LONDON, E.17

Phone: Larkswood 2691

We'd like you to know — NEGATIVE and POSITIVE FEEDBACK on the FERRANTI 347

'Quality' enthusiasts have long regarded the pentode or tetrode output valve with suspicion. Yet the pentode has two advantages which have made it universal in broadcast receivers — it gives high output with economy in H.T. consumption and it requires quite a small input signal. It also has the useful quality of giving a relatively greater amplification of high notes than a triode, which helps to make up the loss due to the selectivity of the I.F. circuits.

The disadvantages of the pentode or tetrode are that the high power levels, which are apt to occur in the lower audio frequencies of a programme, can cause unpleasant distortion; and that it does not damp the 'boom' which arises from the bass resonance of the loudspeaker.

The pentode can be made to behave like a triode by negative feedback; but amplification is lost, which reduces the sensitivity of the receiver and makes the use of a pick-up difficult. The useful 'boost' of high frequencies is also lost. We have, therefore, introduced a system in which negative feedback is used to give the advantages of a triode in handling the low notes and cutting out boom. The loss of gain is made good by the use of positive feedback. The circuit is

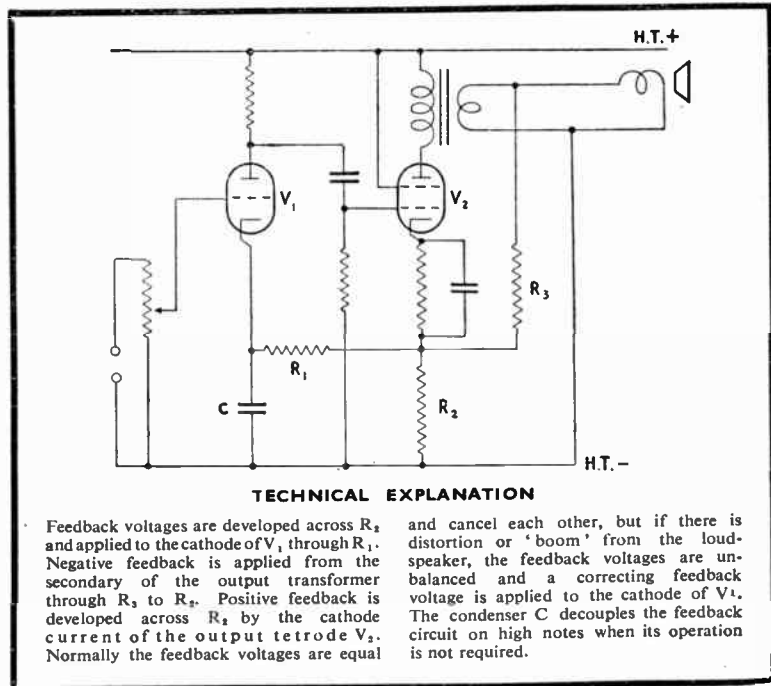

so arranged as not to operate on the high notes, which do not require feedback, and so the increased high note amplification of the pentode is unimpaired.

This system combines the advantages of pentode economy and triode quality. It is used in the Ferranti 347 Console Receiver with a generously designed output transformer and a 10" high flux density P.M. loudspeaker.

Model 347 Console Receiver. 5-valve, 3-waveband A.C. superhet. Pre-set tuning on 2 switch-selected stations. 10" energised permanent magnet speaker. Variable tone control. Figured walnut cabinet. Retail price £46.4.8. (Inc. £11.4.8 tax.)

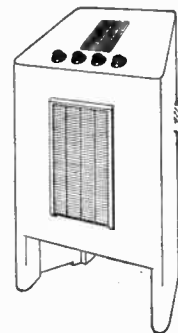

Ferranti Ltd

MOSTON MANCHESTER 10; & 36 KINGSWAY LONDON WC 2

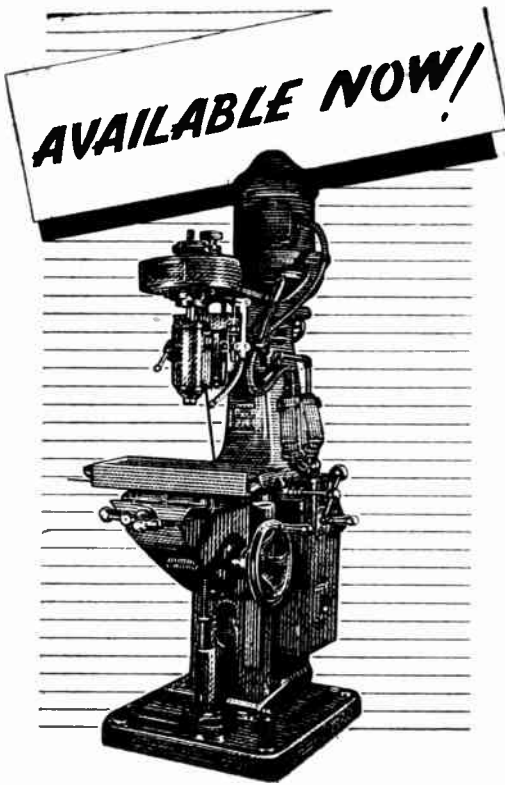

machine tools OF NUMEROUS TYPES

Government Surplus machine tools available NOW at attractive prices. YOUR opportunity to get better equipment and increase production.

DISPOSAL CENTRES, where records of all machines available may be inspected, are open to the public for enquiries from 10 a.m. to 4 p.m. Monday to Friday inclusive :—

BIRMINGHAM C.M.L. Buildings, Great Charles Street

BRISTOL 8/9 Elmdale Road, Bristol 8.

CARDIFF Imperial Buildings, Mount Stuart Square.

GLASGOW 21 Glassford Street.

LEEDS 10 Bank Street, off Boar Lane.

LONDON Room 0088, Ground Floor, Thames House North, Millbank, S.W.1.

MANCHESTER Britannia House, Fountain Street.

ISSUED BY THE MINISTRY OF SUPPLY

K

The ARDENTE LABYRINTH LOUDSPEAKER

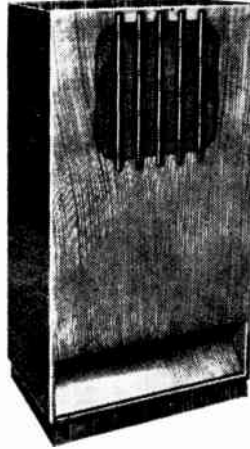

Exceptional frequency response and power handling capacity; 12" heavy duty, permanent magnet, moving-coil unit gives finest possible reproduction of speech and music. Specially designed walnut cabinet brings out sounds from the back of the loud-speaker cone in phase with the frontal waves.

Ideal for theatres, dance halls, ice rinks, etc.

● Details/demonstrations from :
ARDENTE ACOUSTIC LABORATORIES LTD.
COMPTON, GUILDFORD, SURREY
Guildford 3278

London Branch : 309, OXFORD ST.,
W.1. Mayfair 7917.

Makers of all types of speakers for indoor, outdoor and mobile use

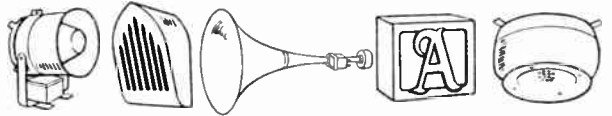

THE "PYROGRIP"

(Patent Applied For)

Every Radio, Electrical, Motor and Model Engineer hates those fiddling small screws in awkward corners! Here's the perfect solution—fits any screwdriver $\frac{3}{8}$ in. dia. approx., holds the screw snug and straight, slips up the shank when not required.

6d. EACH from Hardware Shops Everywhere.



THE ACRU ELECTRIC TOOL MFG. CO. LTD

123, HYDE ROAD, MANCHESTER, 12.

Tel.: ARDwick 4284

P2

LONDON CENTRAL RADIO STORES

Special Offer of Ex-Govt. Receivers, etc.

10-VALVE COMMUNICATION RECEIVER—Type R1155

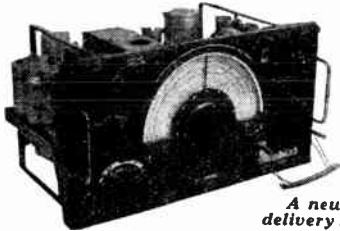

A new delivery!

These sets are equal to new, need only a power pack for immediate use (see "W.W." July, 1946). Freq. range 7.5 mc/s. or 1,500 kc/s., complete with 10 valves, including magic eye. Enclosed in strong metal box. Each receiver is aerial tested.

Complete with Power Pack and Loudspeaker, for A.C. mains 200-250v. **£20**
(Carr. and pkg. 10/8 extra)

Super Quality Heavy Duty TWIN-ELEMENT SLIDING RESISTANCES

5.4 ohm at 20 amp.	47/6
12 ohm at 10 amp.	39/6
70 ohm at 5 amp.	35/-
Single Element 14 ohm at 5 amp.	13/6

TELEPHONE LINE or UNISELECTOR SWITCHES



4-bank	28 6
6-bank	30.-

4- or 6-bank, 26 constants. Have various applications including a automatic tuning, circuit selection, etc. Operates on 25-50v.

ELECTRO MAGNETIC COUNTERS

Ex-G.P.O., every one perfect, electro-magnetic, 500 ohm coil, counting to 9,999, operated from 25 v.-50 v. D.C., many industrial and domestic applications **5/6**

EX-GOVT. TELEPHONE HANDSETS

Self-Energising. Needs no battery or current. **15/-** Less Wall bracket. Each

2-VALVE BATTERY AMPLIFIERS Type A1134



G.P.P. output. Complete with 2-volt valves. In strong wood transit case 10 1/2 x 8 x 7 in. New bargain offer. Carr. and pkg. 2/6 extra. **25/-**

GENALEX A.C. MOTORS

230/250 v. 0.6 amp., 1,350 r.p.m., 50 cycles, single phase. 0.01 b.h.p., 80 watts. 1/2 in. spindle extends 2 1/2 in. Overall dimensions 7 x 5 in. Weight 17 lbs. Carr. **£4 2 6** paid

P.M. M.C. SPEAKERS

2 1/2 in., 2,000 ohms transformer, 3 ohms voice coil **19/6**

5-WAY PUSH-BUTTON CONTROL UNIT

With indicators and knife switch. Complete in case **5/6**

MICROPHONE & HEADPHONE ASSEMBLY.

Ex-58 Mk. 1 Set. 2 mikes, 2 pairs headphones, satchel and dry battery carrying case. Carr paid **25/-**

FRACTIONAL H.P. A.C. MOTORS Converted from ex-Govt. Generators

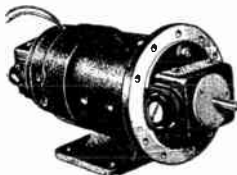

Brush type 220-250 v. 50 cycles approx. 5,000 r.p.m. Overall diam. 10 x 4 in. 1/2 in. spindle extends 1 in. both ends. Post. 2.6 extra. **37/6**

RADAR VIEWING UNITS

Consisting of 6 in. diameter Electrostatic C.R. Tube, 7 valves including four EF50, potentiometers, resistances and other associated components. In metal cabinet 10 x 8 x 7 1/2 in.

Bargain price (plus carr. and pkg. 7/6) **£3.7.6**

Type Demolition Mk. 1. Ex-ARMY TEST SET—NEW

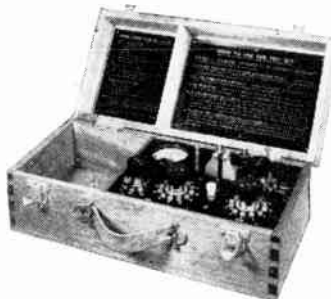

For circuit continuity and general testing. In hardwood carrying case. Carriage paid **£3.10.0**

RUBBER COVERED 5-WAY CABLE

Heavy duty. 7/6 doz. yards.

EX-U.S. ARMY ULTRA LIGHTWEIGHT HEADSETS

Deaf-aid type earpieces 1/2 in. dia. with soft rubber ear fittings. 100 ohms. Brand new and packed .. **23 6**

Type R1147A 7-VALVE U.H.F. RECEIVER Range approx. 200 megacycles (with 4 Acorn valves)



A Real Opportunity!

Beautifully constructed and fitted with micro-condenser drive. Valve types: two EF36, one EBC33, three 954, one 953. In black metal case, 8 x 7 x 6 in. Set **£2.7.6** complete with valves. Carr. paid.

EX-R.A.F. CAMERA MOTORS

Dimensions 3" x 2" x 1 1/2" 12v. and 24v. **8/6**

POLARISED RELAYS

115 ohms + 115 ohms. 6 in. x 3 in. **6/-**

EX-G.P.O. TELEPHONE TRANSMITTERS



On table stand with screened lead and Jack Plug. New. Carr. **13 6** paid.

OSCILLATOR UNITS. Type 217.

These units contain very useful components: two EF50 Valves, three P.O. type Relays, numerous Condensers including two 20 v. 25 mfd. Electrolytics, Resistors, Potentiometers, etc. Bargain price, carr. pd. **19 6**

PULSE MODULATOR AND MIXER W6331

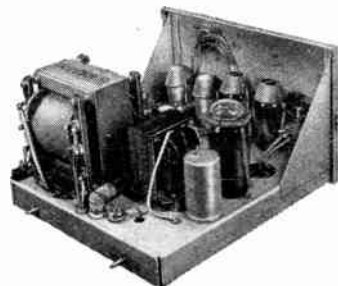

Valves: two 6J5, three VR66, one VR65, one EB34, and Rectifier 5U4. Transformers, resistances, condensers, etc. Carr. and pkg. 5/- extra

40/-

Please Note: All carriage charges relate to the British Isles only • We do not issue lists or catalogues

LONDON CENTRAL RADIO STORES, 23, LISLE ST. (GERrard 2969) LONDON, W.C.2

Closed Thursday 1 p.m. Open all day Saturday and weekdays 9 a.m.—6 p.m.

WESTINGHOUSE WESTALITE

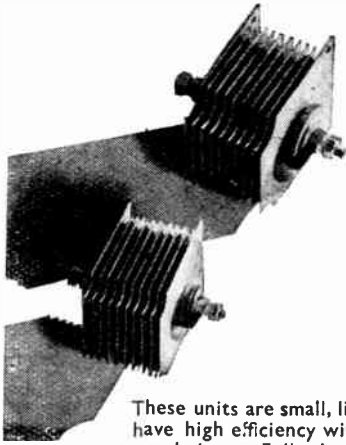

These units are small, light and have high efficiency with good regulation. Full details are given in publication M.R.14 Suppt. 1, a copy of which may be obtained from Dept. W.W.

RECTIFIERS for AC/DC RECEIVERS

Type	Normal Output		Max. Input Volts AC/DC	Reservoir condenser		Circuit	Dimensions			Approx Weight Ozs.
	Volts	mA		mFd.	Wkg. Volts		Ht.	Wdth	Lgth.	
HT.46* 4A79	240	120	250	16	350	Half-wave	2 1/2"	2 1/2"	4 3/8"	8 3/4
HT.47* 14A46	260	60	250	16	350	Half-wave	2 1/2"	2 1/2"	3 5/8"	6 1/2
HT.48* 15B46	260	30	250	8	350	Half-wave	1 1/8"	1 3/4"	3 3/16"	3 3/4

* Units available to bona-fide manufacturers, who should ask for Data Sheet 49.

WESTINGHOUSE BRAKE & SIGNAL CO. LTD., 82, York Way, King's Cross, London, N.1

M. ALLEN (Radio) Ltd

113, CHARING CROSS ROAD, LONDON, W.C.2

SHORT WAVE COILS

FOR BETTER RESULTS
LARGE STOCKS AVAILABLE



"IVALEK" INTERCHANGEABLE COIL SET comprising the following wave ranges:—12-24 Meters, 20-36 Meters, 30-80 Meters. 9/- per set of 3 coils. MEDIUM WAVE COILS 3/6 each. Call and see our exceptionally wide selection of Radio, Television, Electronic and Electrical instruments and components.

M. ALLEN (Radio) Ltd.

113, CHARING CROSS ROAD, LONDON, W.C.2
Tel.: Gerrard 8734

FOR RADIO, TELECOMMUNICATION AND GENERAL ELECTRICAL WORK

Superspeed SPECIAL

ROSIN CORED SOLDER

Outstanding Characteristics of

"SUPERSPEED SPECIAL" ROSIN CORED SOLDER

1. Chemically activated rosin core ensures high degree of "wetting."
2. Increased fluidity accelerates production.
3. Allows more moderate soldering iron bit temperatures, and minimises the risk of physical damage and alteration to the electrical values of small pre-calibrated components such as Capacitors, Resistors, Coil windings, etc.
4. Ensures complete mechanical bonding of joint metals, maintaining perfect electrical conductivity.
5. Reduces to a minimum the solder required per joint and cuts down waste.
6. Residue is non-corrosive, solidifies to a semi-transparent film of high electrical insulation value, is non-hygroscopic and unaffected under tropical conditions.
7. The heating of the activated rosin core does not cause any deleterious fume deposits, or unpleasant odour.

AIR MINISTRY APPROVED

Supplied in a wide range of Gauges and Alloys on 11lb. and 7lb. reels, works coils, or as required. Prices on application.

Sole Manufacturers:—

H. J. Enthoven & Sons Ltd., 230 Thornton Road, West Croydon, Surrey. THOrnton Heath 2462. Enthoven Phone London

AN EVEN HEAT

A high production rate of flaw-free compression mouldings can be assisted by using high frequency equipment to pre-heat the moulding powders. B.I. Callender's High Frequency Pre-Heaters ensure the even and thorough penetration of heat necessary for a uniformly plastic condition of the powder. Less moulding pressure is required, tool wear is reduced and large areas, thick sections or intricate shapes can be moulded with equal certainty. B.I. Callender's high-frequency heaters are available in a range of capacities from 4 ozs. to more than 80 ozs. of wood flour filled phenolic moulding powder. Electrical filters prevent radiation from the supply mains and the equipment is effectively screened in accordance with Post Office requirements. Write for Publication No. 219P on High Frequency Heating Equipment.



B.I.
Callender's

HIGH FREQUENCY HEATERS

BRITISH INSULATED CALLENDER'S CABLES LIMITED

NORFOLK HOUSE, NORFOLK STREET, LONDON W.C.2

THE NEW **KOLECTRIC** HIGH SPEED PRECISION AUTOMATIC COIL WINDING MACHINE

Type A1.1

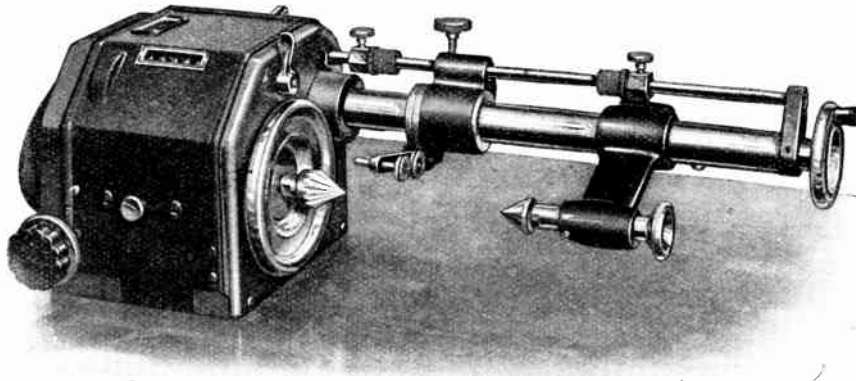

A few features :

Totally enclosed headstock.

Ease of operation and setting.

Winding of 2 coils simultaneously if required.

Infinitely variable micrometer wire gauge adjustment.

Wire gauges 25-50 S.W.G.

Winding Speeds up to 3,000 R.P.M.

Carriage setting handle.

Enclosed drive, with pedal control.

Write us for full information of this NEW DEVELOPMENT IN COIL WINDING.

KOLECTRIC LTD 20, Avonmore Road, LONDON, W.11

RAYTHEON CONTRIBUTIONS to development of Hearing Aids

Little valve outlasts big one...

5 TO 1

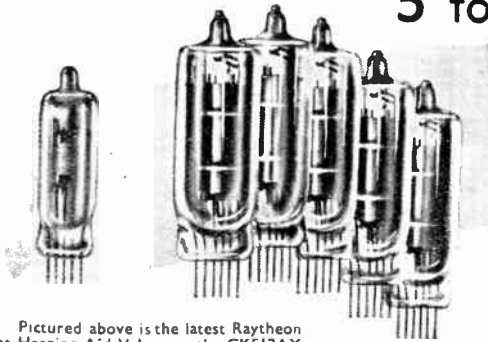

Pictured above is the latest Raytheon Flat Hearing Aid Valve... the CK512AX... and a group of the earliest Raytheon Hearing Aid valves. Apart from the improvement in hearing qualities, just look at the difference in size! Though less in height and of much smaller cross section, the present Raytheon Flat Valve provides five times the life. This is but one of many developments which have made Raytheon the leading Hearing Aid Valve... outnumbering all other makes combined by nine to one!

Ask for complete information. Address your inquiry to Submarine Signal Company (London) Ltd., Artillery House, Artillery Row, London, S.W.1, England, or to:

South African Distributors:

Lynch-Wilde (Africa) (Pty.) Ltd., Jo'burg.

RAYTHEON
INTERNATIONAL DIVISION
60 EAST 42nd STREET
NEW YORK 17, N. Y., U. S. A.
Excellence in Electronics

*Which switch
is the right switch?*

... is it Rotary or Pushbutton or Slider? Is it wanted for circuit selection, band selection, tap switching? Is it for a new design or in quantities for a well proved circuit?

Whatever it is — the answer is always OAK! The basic design of all Oak switches is one of strength and efficient functioning, including such exclusive features as the double-contact clip and the floating rotor, ensuring self-alignment of each section.

OAK SWITCHES

BRITISH N.S.F. CO. LTD., Keighley, Yorkshire
(Sole Licensees of OAK Manufacturing Co., Chicago)

A.B. METAL PRODUCTS LTD., Feltham, Middx.
(Sub-Licensees of N.S.F.)

The only Manufacturers of OAK Switches under Patent Nos. 478391 & 478392



Announcing... SIX ENTIRELY NEW

ELECTRONIC INSTRUMENTS

by CINEMA-TELEVISION LIMITED

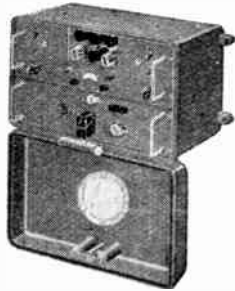

INDUSTRIAL ELECTRONIC METAL DETECTOR

An automatic inspection equipment for the detection of ferrous and non-ferrous metal particles of all kinds in non-metallic substances such as foodstuffs, plastics, textiles, tobacco, timber, pharmaceutical products, etc.

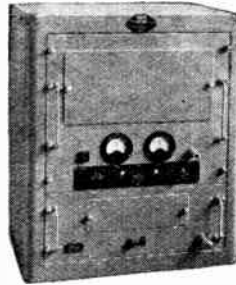

STANDARD ELECTRONIC COUNTER

A high speed electronic counter of particular appeal to the industrialist. Facilities are provided for batching, selective counting etc., the maximum counting-speed for the equipment being 30,000 per minute.



UNIVERSAL OSCILLOSCOPE

A unique instrument meeting fully the requirements of the serious users of oscilloscopes for laboratory and industrial purposes, arranged to permit readily the assembly of suitable units to fulfil every application. Complete range of units is available, e.g. stabilised time base, A.C. and D.C. amplifiers, 5 beam switch unit etc.



LABORATORY OSCILLOSCOPE

A high grade 6" screen oscilloscope expressly designed for laboratory use, incorporating hard valve linear time base, 3 megacycle "Y" amplifier and 1 megacycle "X" amplifier. Cupboard and trolley are available if required.

DEMONSTRATION OSCILLOSCOPE

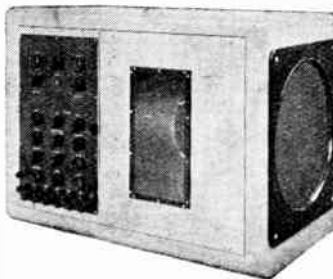

FOR LECTURE PURPOSES

Demonstrator and student alike will acclaim the features of this equipment—15" tube with glare removing filter, 2 beam switch for simultaneous delineation of two recurrent wave forms, or their "addition" to produce a single resultant trace. Provision is made for setting up from rear of instrument.

PROCESS TIMER



A compact instrument, from the "CINTEL" range, providing simple and accurate electrical control for scientific and industrial processes of every kind. The timing range extends from 0.25 to 90 seconds.



CINEMA-TELEVISION LTD.,

INCORPORATING BAIRD TELEVISION LIMITED
WORSLEY BRIDGE RD., LONDON, S.E.26

Telephone: Hither Green 4600

Suppliers to ADMIRALTY, MINISTRY OF AIRCRAFT PRODUCTION, MINISTRY OF SUPPLY, ARMAMENT RESEARCH, etc. Manufacturers of Scientific Instruments and Photo-electric cells



RM

Permeability Tuned I.F. Transformer

TYPE I.F.T. 67.

PRICE 8/9 EACH
Supplied in Cartons

The I.F.T.67 is a new development inasmuch as it is the same size as a standard electrolytic condenser, being 1 3/8" diameter x 2 1/4" high. It is secured to the chassis with the same type clip. With a minimum Q of 90 in can, it is ideal for modern receivers.

Send for full particulars.
R.M. ELECTRIC LTD., TEAM VALLEY, GATESHEAD, 11.



CALLING ALL AMATEURS!

TYPE "A"

5,000 S/W STATIONS

The famous S. G. Brown Type "A" Headphones give highest possible efficiency; this is attained by the Adjustable Reed Movement which replaces the usual flat diaphragm.

Price 60/- per pair FROM YOUR LOCAL DEALER

In a letter recently received by us from Mr. H. R. Lodge, of Worthing, Sussex, he says:—

"With further reference to the S/W list of Stations heard on my ONE Valve Receiver using your TYPR 'A' Headphones, I have pleasure in reporting that I have now listed 5,000 S/W Stations mostly 40 and 20 metres with a few on 10 metres, with 130 Territories represented.

"Among the G Stations recorded were four working on low power. Henley-on-Thames ONE watt, Falmouth 3 watts, Lincs 5 watts and S. Wales 8 watts.

"Am now out for ten thousand! but each additional thousand now is hard work; but, careful listening with these sensitive headphones should eventually secure the target.

"Yours sincerely,
H. R. Lodge."

Phone : ACO rn 5021

S.G. Brown, Ltd.

VICTORIA RD., NORTH ACTON, LONDON, W.3

A WIDE RANGE OF
OKERIN
WAX DI-ELECTRICS

—created in our own laboratories and manufactured in our own works—supplies almost every requirement of Electrical Industry. Grades have been designed for operation under the most severe and varied conditions, and many are resistant to mould and fungus growth.



Special types are evolved as new demands arise, and technical discussion on manufacturers' problems is welcomed.

Telephone Temple Bar 5927

ASTOR BOISSELIER & LAWRENCE LTD.

Sales Dept. : Norfolk House, Norfolk Street, London, W.C.2

Wharfedale

LOUDSPEAKER ACCESSORIES



TRUQUAL

Volume Control

10 Watts, 9/6

20 " 11/6

With Escutcheon

Also COKE V.C. at 27/6, for use with SEPARATOR.

75/-



8" x 5" x 4"

L.S. SEPARATOR

Crossover 1,000 c.p.s., 3 — 15 ohms, 38 Watts, cleaner reproduction. Improved "top."

SPEAKER SWITCH

1. Set Speaker only.
2. Extension Speaker only.
3. Both Speakers.

With Escutcheon and Back Plate for fixing.



9/6

Made and Guaranteed by

WHARFEDALE WIRELESS WORKS

BRADFORD ROAD, IDLE, BRADFORD • Phone : IDLE 416 • Grams : Wharfedel, Idle, Bradford

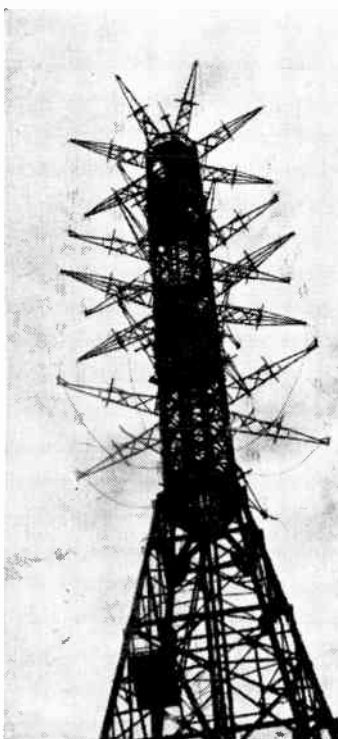

TELCON R.F. CABLES

for all Television and Radio requirements

CABLE CHARACTERISTICS

CODE	Z ₀	CAPACITY	ATTENUATION
A5 72 M	120 140 ohms.	9.5 μμ F per foot.	At 1 Mc/s 0.5 db/100 Ft. " 10 " 1.7 " " " " 100 " 5.0 " " "

DIAMETER :—0.225 inches.

"TELCO" Dielectric

TYPE :—

Flexible. PVC Sheath

Further details of this and other R.F. Cables on application

THE TELEGRAPH CONSTRUCTION & MAINTENANCE CO. LTD.

Founded 1864

Head Office : 22 OLD BROAD ST., LONDON, E.C.2. Tel : LONDON Wall 3141
Enquiries to TELCON WORKS, GREENWICH, S.E.10. Tel : GREENWICH 1040



THE NEW ROTHERMEL CRYSTAL PICK-UP MODEL

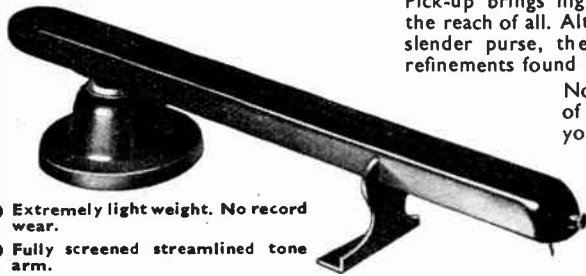

- Extremely light weight. No record wear.
- Fully screened streamlined tone arm.
- New type of torsional crystal element.
- Cartridge specially treated to withstand extreme humidity.
- Tone arm lifts to almost vertical position for easy needle changing.
- Negligible tracking error.
- Finished in attractive brown cellulose.

The introduction of the Model U/48 Crystal Pick-up brings high fidelity reproduction within the reach of all. Although priced to meet the most slender purse, the U/48 possesses many of the refinements found in the more expensive models.

Note the outstanding features of the U/48, which will convince you that it is an instrument of remarkable value and of outstanding merit.

PRICE 25/-
Purchase Tax - - 9/4½



If fitted with a Rothermel Jewel Tipped Needle which gives over 2,000 playings, **PRICE 31/-**. Purchase Tax 11/7½.

Needle Replacement Service.

On and after the date of this announcement, any Rothermel Jewel Tipped Needle when fitted to Pick-up and which fails within 3 months of purchase will be replaced free of charge.

OTHER MODELS IN THE FAMOUS ROTHERMEL RANGE

DE LUXE MODEL	SENIOR MODEL	MODEL S/8 and S/12
Price £4.4.0 Plus purchase Tax.	Price 45/- Plus Purchase Tax.	Price 42/- Plus Purchase Tax.
With Volume Control £4.9.0 ..	With Volume Control 50/- ..	With Volume Control 47/- ..
With Jewel Needle £4.10.0 ..	With Jewel Needle 51/- ..	With Jewel Needle 48/- ..
With Volume Control and Jewel Needle £4.19.0 Plus Purchase Tax.	With Volume Control and Jewel Needle 60/- Plus Purchase Tax.	With Volume Control and Jewel Needle 57/- Plus Purchase Tax.

The Rothermel Jewel Tipped Needle, over 2,000 playings, no record wear. Straight type 9/- Plus Purchase Tax.

★ Note: There is a saving in cost if your pick-up is ordered with jewel tipped needle fitted.

R. A. ROTHERMEL LTD., CANTERBURY ROAD, KILBURN, LONDON, N.W.6 Telephone : MAIDA VALE 6066 (3 lines)

• CONSTANT VOLTAGE • POWER SUPPLY UNITS

THE UNIT ILLUSTRATED PROVIDES AN OUTPUT OF 200-275 VOLTS AT UP TO 250mA., WITH THE FOLLOWING PERFORMANCE SPECIFICATION :

- STABILIZATION RATIO > 100
- OUTPUT IMPEDANCE < 1 OHM.
- OUTPUT RIPPLE < 2mV. R.M.S.

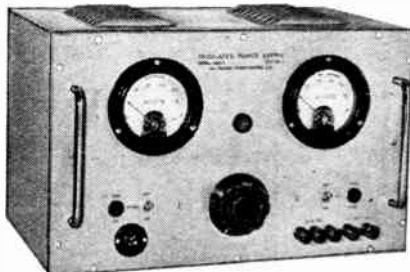

MAY WE QUOTE FOR YOUR REQUIREMENTS ?

ALL-POWER TRANSFORMERS LTD.
8a, GLADSTONE RD., WIMBLEDON, S.W.19
Telephone : LIBerty 3303

Simple Arithmetic



THE GRAMPHIAN 461 RECEIVER AMPLIFIER

This new high-grade reproducer has been specially designed for use in Small Factories, Hotels, Clubs, Swimming Pools, Municipal Buildings, etc., where it is desired to broadcast Radio or Gramophone Records and provide amplification of speech by use of a microphone. Let us send you further details.

A dual wave-band superheterodyne with Power Amplifier having an output of 15 watts. Provision is made for both pick-up and microphone inputs with separate volume controls and high and low impedance outputs. It is of extremely robust construction in an attractively finished metal case.

GRAMPHIAN

LOUDSPEAKERS

GRAMPHIAN REPRODUCERS LTD.
Ampton Road, Hanworth, Middlesex.

Price List £42 0 0
Plus £2 2 0
Purchase Tax
A.C. Mains ONLY

HAVE YOU HAD
DETAILS OF OUR
NEW LINES ?

Phone : Feltham 2657

Scientific G.6A.

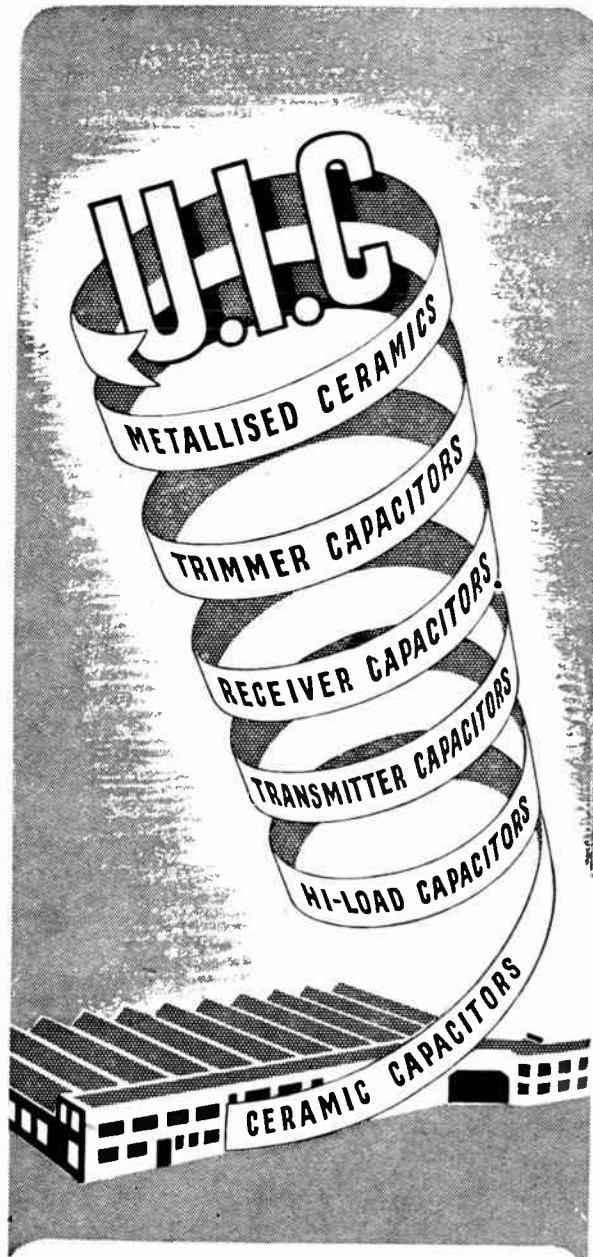

UNITED INSULATOR CO. LTD.

OAKCROFT RD., TOLWORTH, SURBITON, SURREY

Telephone: Elmbridge 5241

Telegrams: Calanel, Surbiton

Unsurpassed
In
Ceramics

Webb's RADIO

Interested in really good reproduction ?

IF SO . . . hear the new loudspeakers in our Demonstration room.

WHARFEDALE "CORNER" CABINET

Triangular cabinet construction in solid mahogany of pleasing finish. (Available in solid oak—any shade to order.) Uses separate speakers for bass and treble, with new cross-over system at 1,000 c/s. Very pleasing balance between bass and treble. All bass resonance above 50 c/s eliminated. Size of cabinet 25½" x 18½" deep x 44" high. PRICE £48.10.0.

ACOUSTICAL "LABYRINTH S.L.15"

Solidly constructed cabinet of ingenious internal design giving equivalent of a five-foot, folded pipe, the anti-resonances of pipe being cancelled by cabinet acoustic resonance. Wide-response bass down to 35 c/s with good middle and top definition. Size 21" x 15" deep x 32" high. (Cabinet is in plain wood, WEBB'S can finish to your requirements.) PRICE £19.10.0.

SOUND SALES "PHASE INVERTER SPEAKER"

Cabinet design gives 180° phase-inversion and general effects are better than results obtained with a 4-foot baffle. Uses Sound-Sales Dual-Suspension Unit that remains centralized during a parallel excursion of ⅜" in the magnetic field. Very good diffusion of sound. Cabinet size 14" x 14" x 29" high. PRICE £14.7.6.

WEBB'S are world known as Short-Wave Specialists—in addition we have for years joined in the quest for that elusive quality—really high-fidelity reproduction. The specialised speakers shown above are all good—we have our own ideas of relative merit but you may not agree—that last elusive "touch" is largely a matter of personal preference (or aural idiosyncrasy!).

. . . hear them playing from:

WILKINS & WRIGHT MOVING COIL PICK-UP

Lexington Moving Coil Pick-up.
Connoisseur Moving Iron Pick-up.
Sound Sales Radio Feeder and Amplifier.
Webb's "Quality" Amplifier.
Acoustical "QA/12/P" Amplifier, etc.

. . . We are also stockists for Broadcast Receivers and Televisors by MURPHY, BUSH, COSSOR, etc.

Write, phone or call!

14 SOHO ST., OXFORD ST., LONDON, W.1

Phone: GERrard 2089. Shop hours: 9 a.m.—5.15 p.m. Sats. 9 a.m.—1 p.m.

synonymous with
PLUGS & SOCKETS

PAINTON & CO LTD KINGSTHORPE NORTHAMPTON

M.G. 1, 2 or 3 GANG CONDENSER

This small size condenser is of rigid construction, and is made in various capacities up to 540mmf. with tropical finish. It can be supplied with trimmers built in if required. The 2 Gang Frame is $2\frac{3}{4}$ " x $1\frac{3}{4}$ " x $2\frac{1}{8}$ " over all.

JACKSON
BROS (LONDON) LIMITED
KINGSWAY · WADDON · SURREY
TELEPHONE: CROYDON 2754-5 TELEGRAMS: WALFILCO, PHONE, LONDON

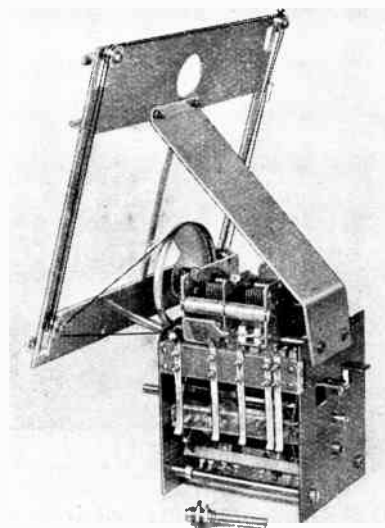

ANOTHER
DENCO
WINNER !

COIL TURRET
CT6.

A unique superhet tuning unit complete with large dial and drive mechanism.

Price complete :
£4. 10. 0

- 5 Bands covering completely 0.15-30 Mcs. (465 L.F.).
- Polystyrene insulation throughout—including coilformers.
- Permeability pre-set coils.
- All padding and trimming condensers included.
- Stable air spaced trimmers for adjusting circuit minimums.

Full particulars of this and other new components in our latest catalogue—from your stockist or direct—9d.

DENCO (CLACTON) LTD., OLD ROAD, CLACTON, ESSEX

*Your best Set's
most important
accessory*

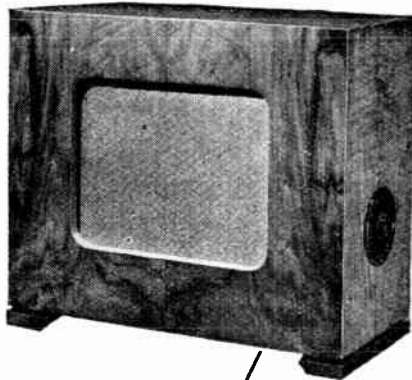

No set is complete without at least one Stentorian speaker to allow you to enjoy the luxury of radio away from the receiver—in the kitchen or bedroom, for instance. And the quality of the most magnificent set will be matched without fault, for each Stentorian provides a high level of output with distortion-free reproduction—and is housed in a handsome wooden cabinet of perfect acoustical construction. Ask your local dealer about them.

PRICES:

"SENIOR" Model:	"JUNIOR" Model:
*Type SC £5. 15. 6	*Type JC £5. 0. 0
Type SX £5. 2. 6	Type JX £4. 10. 6
"CADET" Model:	
*Type CC £4. 10. 0	
Type CX £4. 0. 0	

"BABY" Model:	"MINOR" Model:
*Type BC £2. 19. 6	*Type MC £2. 5. 6
Type BX £2. 13. 6	Type MX £1. 19. 6

*SPECIAL NOTE. Supplied complete with universal transformer making it suitable for use as principal speaker and/or extension unit.



Stentorian

—the finest extra **SPEAKER** for any set

WHITELEY ELECTRICAL RADIO CO. LTD., MANSFIELD, NOTTS

ALL-BRITISH VIBRATORS

- HERMETICALLY SEALED.
- FULLY TROPICALLY TESTED.
- Proof against thermal mis-alignment of contacts.
- Tested for radio-frequency at -40Db at a reference level of 500 mW.

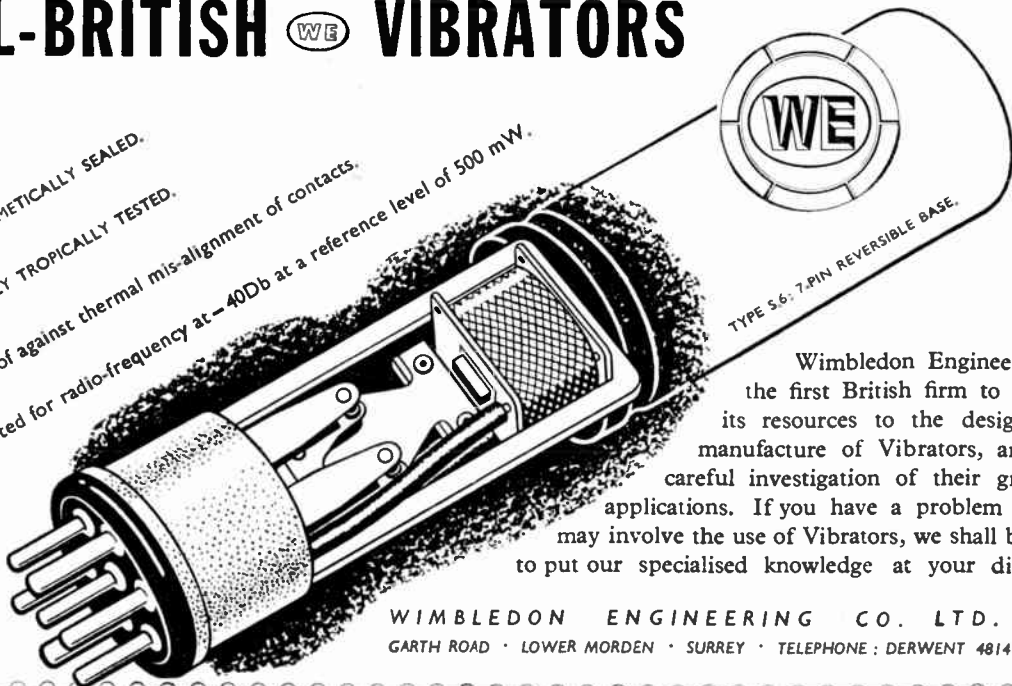

Wimbledon Engineering is the first British firm to devote its resources to the design and manufacture of Vibrators, and the careful investigation of their growing applications. If you have a problem which may involve the use of Vibrators, we shall be glad to put our specialised knowledge at your disposal.

WIMBLEDON ENGINEERING CO. LTD.
GARTH ROAD · LOWER MORDEN · SURREY · TELEPHONE: DERWENT 4814 · 5010.

C.R.C.I



the new "700"

This new reproducer represents an outstanding technical achievement in the design and production of sound reproducers, and reveals great advances in performance. Both permanent magnet and energised types are particularly suitable for television receivers, since there is no external magnetic field. In the permanent magnet types the latest anisotropic magnet steels are employed and owing to the design of the whole magnetic structure, 25% more of the total energy in the magnet is usefully employed in the gap. Our technical staff will be pleased to supply further details and information on request.

R&A

REPRODUCERS

REPRODUCERS & AMPLIFIERS LTD., FREDERICK STREET, WOLVERHAMPTON

Telephone : 22241

Telegrams : Audio-Wolverhampton

Special Offers by "Radiomart"

RESISTORS

10 Watt Vitreous. 250 ohms., 500, 2,000, 4,700, 5,000, 10,000, 20,000, 22,000, 25,000, 2/6 each.
100 Watt Vitreous. 20,000 ohms., 50,000 ohms., 5/6 each.
25 Watt Vitreous. 5,000 ohms., 7,000 ohms., 2/6 each. 5,000 ohms. tapped at 2,000 and 1,500 ohms., 3/6.
75 Watt Vitreous. 12,000 ohms.+2,000 ohms, 4/6.
 Also 1/2 watt Resistors, 4d.; 1 watt, 6d.; 2 watt, 1/-; 3 watt, 1/6 each.

HIGH VOLTAGE OIL-FILLED CONDENSERS

4 mfd., 2,000 v. wkg., 15/-; 1,500 v. wkg., 12/6; 1,000 v. wkg., 10/-; 750 v. wkg., 5/-.
 2 mfd. 1,000 v. wkg., 5/-; 8 mfd. 500 v. wkg., 7/6; 10 mfd. 600 v. wkg., 10/-.

TRANSMITTING BY-PASS AND COUPLING CONDENSERS

.002 mfd. 1,000 v. Sprague screened, .01, .1, 1/- each.
 .1 mfd. 1,000 v. Tubular paper, 1/-; .03 mfd. 2,500 v. Tubular in plastic cases. Tropical. Clip Terminal. Threaded at end for chassis mounting, 3/-.
 .01 ditto but 4,000 v. wkg., 3/-; .1 mfd. 350 v. wkg. (no threaded terminal), 1/6.
 .001 mfd. 5,000 v. Test. High voltage Mica, 2/6; .002 mfd. ditto but 1,250 v. Test, 1/-; .0001 mfd. ditto but 2,200 v. test, 1/6.

RECEIVER AND LOW POWER TRANSMITTING CONDENSERS

.5 mfd. 600 V. Tubular paper, 1/6; .5 mfd. Mansbridge type, 1/-; .5 mfd. 450 V. Tubular paper, 1/-; .5 mfd. 350 V. Tubular Aluminium, 1/-; .25 mfd. 500 V. Tubular Aluminium, 1/-; .1 mfd. 500 V. Mica Block type, 2/6; .1 mfd. 350 V. Tubular paper, 9d.; .02 mfd. 750 V. Tubular Aluminium, 1/-; .002 mfd. 500 V. Mica Ceramic Casing, 2/6; .000255 mfd. 500 V. ditto, 1/6; .00015 mfd. 500 V. Silver Ceramic Tubular, 1/6.
 Various values of Mica Condensers from .00015 to .005, 6d. each.
 25 mfd. 50 Volt Electrolytic, metal cased, 2/6.

SWITCHES

2 pole 6 way single wafer (ideal for meter switching in Tx), 2/6; 3 pole 1 way double wafer, 3/6; 2 pole 3 way triple wafer, 3/6; 2 pole 4 way 1 wafer, 5 pole 4 way 2 wafers (triple wafer), 3/6; 2 pole 2 way and off 3 connections to common rotar and 3 sets stator contacts, 2/-. (All well-known makes.)

Ceramic Switch. 2 pole 4 way double wafer. (The switch for that "Band Switching." Tx and other R.F. applications.) (List price £1.), 5/-.

RADIOMART

CSA (RADIOMART) LTD.

THE ABOVE ARE A SELECTION FROM OUR LIST No. 6 "W.W." SEND S.A.E. FOR A COPY.

48, HOLLOWAY HEAD, BIRMINGHAM, I.

EXCELLENT SELLING LINE

High Fidelity S.H.E.F.I. Moving Coil Pick-ups

Manufactured by licence under Voigt Patent No. 538058

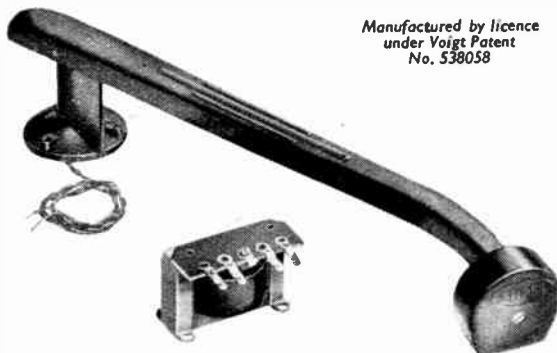

Retail Price, including Transformer, in Walnut and black plastic finish - - - **£2.0.0**
 Plus 10/4s. Par hts. Tax. Generous Trade Discounts.
 Ivory finish £2.3.8. Plus 11/7d. Purchase Tax.

The only Moving Coil Pick-up with high level output. Will operate average receiver. No Pre-amplifier. No Shielded Transformer. No Hum Problem. Genuine High Fidelity reproduction flat to 12,000 c.p.s. with bass boost below 250 c.p.s. to allow for drop in recording level of 6 db. per octave. Needles of approximately 0.3 to 0.4 inches long and 0.036 inches diameter should be used. Available for home trade and export. Immediate delivery in beautiful plastic finish. This is one of many other electrical appliances. Overseas enquiries are invited. Agency arrangements may be made.

BROOKS & BOHM LTD.,
 90, VICTORIA ST., LONDON, S.W.1. VIC. 9550-1441.

INTRICATE PARTS



BULLERS LOW LOSS CERAMICS

but not too
intricate
for

Bullers

Made in Three Principal Materials

FREQUELEX

An insulating material of Low Di-electric Loss, for Coil Formers, Aerial Insulators, Valve Holders, etc.

PERMALEX

A High Permittivity Material. For the construction of Condensers of the smallest possible dimensions.

TEMPLEX

A Condenser material of medium permittivity. For the construction of Condensers having a constant capacity at all temperatures.

BULLERS LTD., 6, Laurence Pountney Hill, London, E.C.4

Telegrams: "Bullers, Cannon, London"

Phone: Mansion House 9971 (3 lines)

Instrument Individuality

The new Universal Bridge exemplifies the principle that individuality in instrument design is without virtue in itself; each innovation must directly contribute to functional efficiency and the evolution of a completely satisfactory measuring unit.

For general purpose use, the Universal Bridge Type TF 868, contains the necessary elements for the measurement of inductance and capacitance at 1000 c/s ($1\mu\text{H}$ — 100H and $1\mu\text{F}$ — $100\mu\text{F}$), and for d.c. resistance measurements (0.1Ω to $10\text{M}\Omega$). Elaborations which would add appreciably to complexity or cost have been intentionally excluded.

By an ingenious mechanical arrangement, a single dial, in combination with a range selector, provides direct reading of L, C & R, without risk of confusion and without recourse to multiplying factors. Full specification and description available on request.



THE UNIVERSAL BRIDGE, TYPE TF 868

MARCONI INSTRUMENTS LTD

ST. ALBANS, HERTS. Telephone: St. Albans 6161/5. Northern Office: 30 ALBION STREET, HULL. Tel.: Hull 16144.
Southern Office: 109 EATON SQUARE, S.W.1. Tel.: Sloane 8615. Western Office: 10 PORTVIEW ROAD, AVONMOUTH. Tel.: Avonmouth 438.



"Cyldon"

MICA DIELECTRIC TRIMMER Capacitors

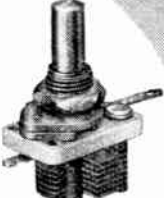
Type No. 184
Type No. 185

SYDNEY S. BIRD & Sons, Ltd.

CAMBRIDGE ARTERIAL ROAD, ENFIELD, MIDDX.
Phone: Enfield 2071-2 Grams: Capacity, Enfield.

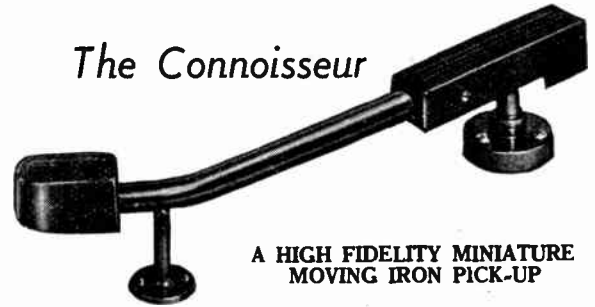

The Connoisseur

A HIGH FIDELITY MINIATURE MOVING IRON PICK-UP

Faithful reproduction of all recordings from 12,000 c.p.s. to 30 c.p.s. will win many new friends for the CONNOISSEUR miniature moving iron Pick-up in 1948.

The CONNOISSEUR reveals a wide range of notes and instruments that has hitherto been hidden by bass and treble resonance. The CONNOISSEUR will reproduce every sound on the record. Try it and prove it.

Note new prices. Pick-up 54'- plus 17'7 P. tax Transformer 13'- nett.

Apply to
Albion Electric Stores, 125, Albion Street, Leeds 1
or to
Lawton Bros. (Sales) Ltd., Henry Square, Ashton-under-Lyne

Made by
A. R. SUGDEN & Co. (Engineers) Ltd., Brighouse, Yorks

Coils

PACKS

6uh to 6MH available as individual coils or built into 3 band or 6 band coil packs with RF stage. Deliveries rapidly improving. Enquiries invited.

LABORATORY



TESTED

H. C. ATKINS Laboratories, 32, Cumberland Road, Kew, Surrey.
Richmond 29:0

AT106

ST

The LOWEST EVER



attenuation and capacitance
Latest additions to the range of
air insulated articulated

CO-AX R.F. CABLES

1. **HIGH POWER FLEXIBLE R.F. CABLE:**
70 ohms. 4.8 KW at 10 Mc/s. Diameter 0.8". Bending radius 5".
2. **VERY LOW CAPACITANCE CABLES:**
Capacitances per foot from 6.3 mmf for 0.36" diam. to 4.2 mmf for 1".
3. **PHOTOCELL CABLE:**
non-microphonic, low loss.

TRANSRADIO LTD. 138A CROMWELL ROAD LONDON S.W.7

SPEAKING OF *Quality...*

The leading radiograms are fitted with Goodmans 12" loudspeakers.

Type No. T2/1205/15

GOODMANS

Loudspeakers
A TRADITION OF EXCELLENCE

GOODMANS INDUSTRIES LTD.
LANCELOT ROAD, WEMBLEY, MIDDX



POINTS OF LOW CONTACT RESISTANCE IN MODERN CIRCUIT DESIGN

CLIX

RADIO & TELEVISION COMPONENTS . . .

. . . ARE USED BY ALL THE LEADING SET MANUFACTURERS

BRITISH MECHANICAL PRODUCTIONS LTD.

21 BRUTON ST., LONDON, W.1

Telephone: MAYfair 5543

Foremost in Valveholder design

CLIX-TYPE B8A VALVEHOLDERS

BVA Standard Dimensions

Easy insertion of valve
Firmly retained
Easy withdrawal

Standard fixing centres $1\frac{1}{8}$ "
Hole diameter $\frac{1}{8}$ "

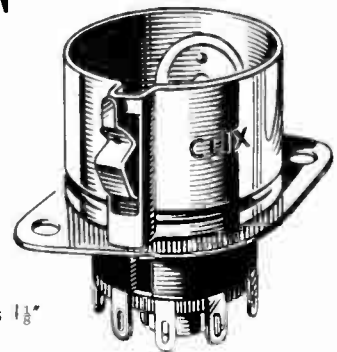

Designed to meet the requirements of the new all-glass type B8A Valves.

Moulded body... Plated saddle... Screen... and Sockets, — ensuring extremely low contact resistance.

A valve-retaining latch specially suitable to these new all-glass valves.

A feature exclusive to Clix B8A Valveholders.

Clix Valveholders are adequately protected by British and Foreign Patents.

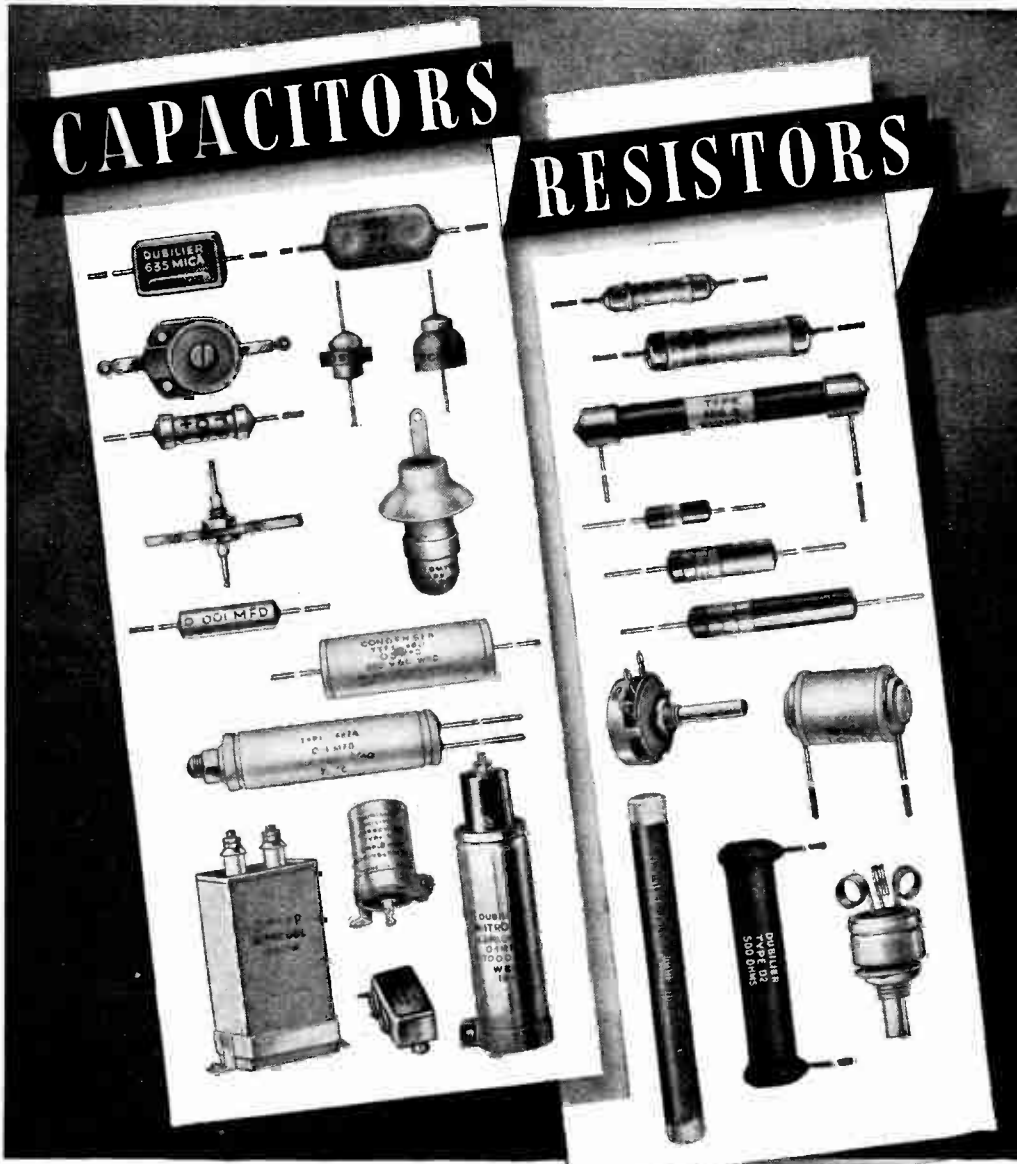

FOR more than 30 years, radio and electrical designers and engineers in all parts of the world have found their most exacting requirements met by the unrivalled Dubilier ranges of capacitors and resistors, renowned for their constancy and complete reliability under the most arduous operating conditions. These capacitors and resistors, so important in Radio, Radar and Television equipment, are being continuously developed and extended in order to provide for every conceivable application.

Dubilier capacitors and resistors owe their unvarying quality, technical excellence and high degree of stability to the close control which is maintained throughout all stages of their manufacture.

Full technical data and prices supplied upon request.

DUBILIER

CONDENSER CO. (1925) LTD.

DUBILIER CONDENSER CO. (1925) LTD., DUCON WORKS, VICTORIA ROAD, NORTH ACTON, W.3
 Telephone : Acorn 2241 (5 lines) Telegrams : Hivoltcon, Phone, London
 Cables : Hivoltcon, London Marconi International Code
 D12A

Wireless World

RADIO AND ELECTRONICS

FEBRUARY

1948

37th YEAR OF PUBLICATION

Proprietors : ILIFFE & SONS LTD

Managing Editor : HUGH S. POCOCK, M.I.E.E.

Editor : H. F. SMITH

Editorial, Advertising and Publishing Offices :

DORSET HOUSE, STAMFORD STREET,
LONDON, S.E.1.

Telephone :
Waterloo 3333
(60 lines).

Telegrams :
"Ethaworld, Sedist
London."

PUBLISHED MONTHLY

Price : 1/6

(Publication date 26th of preceding month)

Subscription Rate : 20/- per annum. Home and
Abroad

Branch Offices :

Birmingham : King Edward House, New Street, 2.

Coventry : 8-10, Corporation Street.

Glasgow : 26B, Renfield Street, C.2.

Manchester : 260, Deansgate, 3.

In this Issue

EDITORIAL COMMENT	39
ELECTRONICS AND ATOMIC ENERGY By E. W. Titterton ..	40
IONOSPHERE REVIEW : 1947 By T. W. Bennington	44
TEST REPORT : RADIOMOBILE MODEL 100	48
CLEANING SWITCH CONTACTS By J. J. Payne	51
SHORT-WAVE CONDITIONS	52
WORLD OF WIRELESS	55
SLOT AERIALS By D. A. Bell	57
COIL-PACK MODIFICATION By L. Miller	59
C.P.S. EMITRON	60
PUSH-PULL INPUT CIRCUITS By W. T. Cocking	62
COMMERCIAL DISC RECORDING	67
"j" By "Cathode Ray"	68
UNBIASED By "Free Grid"	72
LETTERS TO THE EDITOR	73
RANDOM RADIATIONS By "Diallist"	76
RECENT INVENTIONS	78

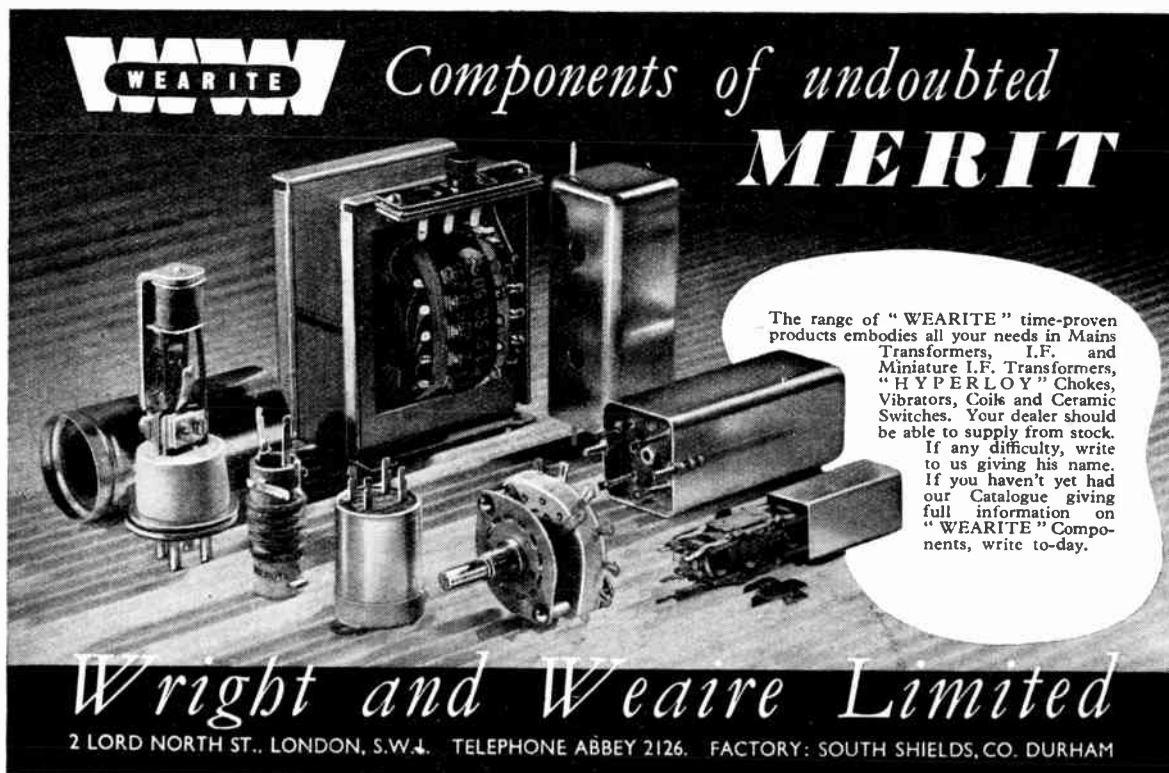

WEARITE Components of undoubted **MERIT**

The range of "WEARITE" time-proven products embodies all your needs in Mains Transformers, I.F. and Miniature I.F. Transformers, "HYPERLOY" Chokes, Vibrators, Coils and Ceramic Switches. Your dealer should be able to supply from stock. If any difficulty, write to us giving his name. If you haven't yet had our Catalogue giving full information on "WEARITE" Components, write to-day.

Wright and Weaire Limited
2 LORD NORTH ST., LONDON, S.W.4. TELEPHONE ABBEY 2126. FACTORY: SOUTH SHIELDS, CO. DURHAM



VALVES AND THEIR APPLICATIONS

By M. G. SCROGGIE, B.Sc., M.I.E.E.

No. 14: Mullard HIGH-SLOPE R.F. PENTODE EF42 (continued)

LAST month's notes were devoted to constructional features of the EF42; here follow some of the electrical data. As a basis for comparison, the EF50, having been used so widely during the last nine years, is probably the best known; while the EF54 is a more recent type in the same class. Typical operating conditions (250V on anode and screen and 10mA anode current at about $-2V$ grid bias) are similar for all three valves.

The slope of the EF42, 9.5mA/V, is about 50% up on the EF50 and 25% better than the EF54, for practically equal heater rating. Input and output capacitances (9.5 and 4.5pF respectively) are together about the same as in the EF50; C_{in} alone is not quite so good as the EF54's 6.2pF, but C_{a-gl} is better — <0.005 compared with 0.02pF. Maximum anode dissipation is slightly less — 2.5W instead of 3W in EF50 and EF54. Equivalent noise resistance of the EF42 (750 Ω) is about the same as in the EF54 and twice as good as in the EF50. Input resistance at 50Mc/s (5000 Ω) is slightly better than the EF50 but only half as good as the EF54.

The upshot of all this is that if the criterion is maximum operating frequency, where $g_m \times$ input resistance is the limiting factor, the EF42 must give way to the EF54, useful up to 250Mc/s. But notwithstanding its miniaturity, at television and f.m. frequencies the EF42 is appreciably better than the EF54 and substantially better than the EF50; enough perhaps to save a whole stage (and, of course, considerable space) in a television r.f. or i.f. amplifier. It is particularly applicable to radar i.f. amplifiers, because they usually work at about 45Mc/s and require an even wider bandwidth.

Though the type specifically for the v.f. stage is the EF55, especially if there is any doubt about sufficiency of output from a smaller valve, in most situations the design can be made to allow the economy of using the EF42 there also.

A demand that is likely to increase is for a valve suitable for r.f. amplification in v.h.f. receivers, especially f.m. The EF42 is eminently suitable for this purpose up to at least 150Mc/s.

Then again, the EF50 has been used in a great variety of special circuits — cathode followers, time base generators, etc. — where its high slope is helpful; and here the EF42 does even better. Its output resistance as a cathode follower is not much more than 100 Ω ; and the fact that all the electrodes — even the outer screen — are brought out separately allows the maximum adaptability.

So altogether the EF42 looks like being an exceptionally versatile and effective valve, a decided improvement on the EF50, and preferable in some respects even to the EF54.



This is the fourteenth of a series written by M. G. Scroggie, B.Sc., M.I.E.E., the well-known Consulting Radio Engineer. Reprints for schools and technical colleges may be obtained free of charge from the address below. Technical Data Sheets on the EF42 and other valves are also available.

**THE MULLARD WIRELESS SERVICE CO. LTD.,
TECHNICAL PUBLICATIONS DEPARTMENT,
CENTURY HOUSE, SHAFTESBURY AVE., W.C.2**

Wireless World

RADIO AND ELECTRONICS

Vol. LIV. No. 2

February 1948

Short-wave Broadcasting Under Fire

A LETTER from a correspondent, printed on another page, draws attention to a vitally important aspect of the use of communication channels. For some years there has been a growing body of opinion, particularly in America, that short-wave international broadcasting has failed; that it is a gross misuse of valuable communication channels to monopolize them for a service which benefits a negligible proportion of the world's listeners. We believe that it was intended strongly to oppose the allocation of channels for such purposes at the Atlantic City Conference, but apparently other views prevailed, and the H.F. broadcasting bands have actually been widened rather than curtailed.

As an alternative to long-distance H.F. broadcasting for direct reception by the listener, it has been suggested that much better results could be obtained, with greater economy of channels, by distribution over line or radio international communication networks, with subsequent rebroadcasting by the national stations of the country of destination. In addition to the saving of channels it is urged that the use of diversity reception and other methods open to big organizations will ensure a better signal than the "direct" listener can ever hope to achieve.

Since our correspondent's letter was written, strong support for his contentions has come from a leading article in the American journal *QST*. Referring to the Atlantic City Conference, the article says "It is difficult to portray adequately the greed, rapacity and general radio-dumbness of the average foreign spokesman for government broadcasting. With exceptions, of course, he is commonly a rather high-powered political character, not a real radio man and not a technical man, caring less than nothing for the communication services and rioting in the plenipotentiary powers given him by his government. Radio means only broadcasting to him and he doesn't care what happens to other services as long as he gets what he wants."

Turning to the large number of channels required for international short-wave broadcasting, *QST* goes on to say "It has been reliably calculated by engineers, that it would take about half of the H.F. spectrum to set up, on sound technical

principles, an idealized system meeting every nation's ambition of being able to propagandize every other nation."

Obviously, some of those who oppose short-wave broadcasting are actuated by motives of self-interest. Some of the arguments against it carry force; others, such as those based on the present short-comings of the service due to chaotic ether conditions and inadequate receivers, do not. These are defects that can be overcome; they are not fundamental to the issue.

Admission of Defeat

To recommend the total or even partial abolition of S.W. broadcasting would, in our view, be a counsel of despair, and an admission of defeat; an admission that mankind lacks the wit to turn to proper uses a medium of such self-evident potentialities for good. Many years ago, *Wireless World*, campaigning against apathy and even active opposition, urged the setting up of an Empire broadcasting service, and many of the arguments then adduced in support still hold good. But it cannot be denied that S.W. broadcasting has been misused, and also that conditions have changed. Many of the factors involved—social, political and cultural—cannot properly be discussed in a technical journal. Undeniably, such services, like all forms of H.F. long-distance communication, make heavy demands on channels, as it is necessary to cater for diurnal and seasonal variations in propagation conditions. In the case of broadcasting the demands on channels become almost unbearably heavy when the nations seek to use a multiplicity of languages other than their own.

The sole concern of this journal is that radio communication channels should be used to the greatest advantage. We are by no means convinced that H.F. long-range broadcasting represents what is inherently a misuse of valuable channels. But it is perhaps overdone; some of it is ineffective and some is put to base uses. Those who are laying claim to channels and those responsible for the conduct of services must regard themselves as being under an obligation to justify themselves, and see that they have a good case to present.

Electronics and Techniques Used in Research and Production

BEFORE we can proceed to discuss the part played by electronic techniques in the field of atomic energy* it is necessary to trace the development of the subject from its early beginnings. To examine so wide a field within the confines of a single, short article will necessitate an abbreviated, and in some details, a not completely rigorous treatment.

It has been known since the closing years of the last century that certain heavy elements like uranium and radium are radioactive. Their atoms disintegrate (or split) of their own accord with the emission of ionizing radiations. Energy is liberated during the process as is evidenced by the fact that a lump of radium stays warm and radiates heat continuously. The process is uncontrolled, no efforts of man can increase or decrease the rate at which the energy is liberated, and the elements providing atomic energy in this form are too scarce in nature for them to be useful sources of power.

The ionizing radiations emitted from radioactive substances are of three types. α -particles, which are the central positively-charged cores (or nuclei) of helium atoms, β -particles which are now known to be electrons similar to those emitted from a hot cathode, and γ -rays which are high-frequency electromagnetic waves similar to X-rays but with greater penetrating power.

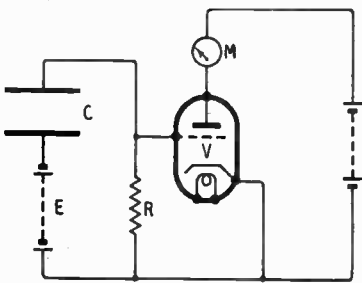

Fig. 1. Schematic diagram of ionization chamber and D.C. amplifier.

* The description "atomic energy," now widely accepted, is somewhat misleading since the term describes energy derived from the nucleus of the atom. A better description might have been "nuclear energy." Atomic energy is released whenever we burn petrol or coal.

Such radiations may be detected and their properties examined by means of an ionization chamber depicted in Fig. 1.

In this case the chamber is a parallel-plate air capacitor C across which a potential E is maintained. α -particles, β -particles or γ -rays passing through the air between the plates produce (+) and (-) ions which migrate under the influence of the electric field and produce a current in the circuit.

Measurement of the change in potential caused by this current flowing through R gives an indication of the strength of the radioactive source. In Fig. 1 the poten-

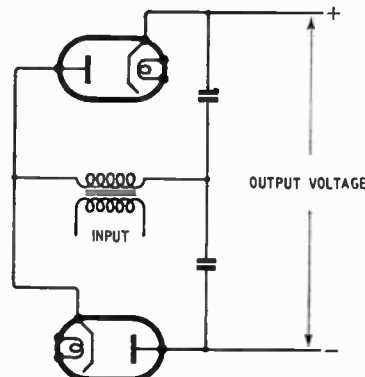

Fig. 2. Greinacher voltage doubler circuit.

tial change across R causes the bias of V and therefore the current through it to change. This is indicated by the meter M. This technique of D.C. amplification forms the basis of a large number of instruments now in use.

The controlled release of atomic energy came as a result of experiments by Lord Rutherford in which, by bombarding the nitrogen atoms in air with the bullet-like α -particles emitted from a mixture of radioactive materials, nitrogen was transformed into a form of oxygen with the emission

of a nuclear particle called the proton (which is the nucleus of a hydrogen atom). Rutherford's experiments opened up the whole field of nuclear physics.

Application of electronics in this

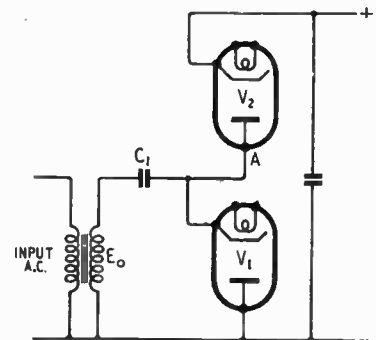
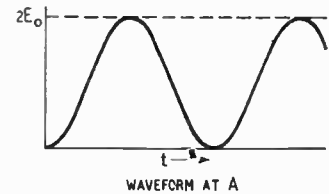

Fig. 3. Cockcroft-Walton voltage doubler circuit.

field came about in two ways. First, it was desired to replace the radioactive source of bombarding particles by a man-controlled source. This led to the development of high voltages for the acceleration of the charged particles to sufficiently high velocities, and therefore energy, to split atoms.

Fig. 2 shows one of the early circuits—the Greinacher voltage doubler. This circuit is well-known to users of metal rectifiers and it will be seen to be two half-wave rectifier circuits connected back-to-back, so that the outputs are in series.

It was little used for particle acceleration because it is only possible to double the voltage obtained from the transformer secondary.

Atomic Energy

By E. W. TITTERTON, Ph.D. (Atomic Energy Research Establishment, Harwell)

Instead a new circuit was developed by Cockcroft and Walton and is shown in Fig. 3. If E_0 is the peak voltage from the transformer secondary the capacitor C_1 charges to E_0 through V_1 dur-

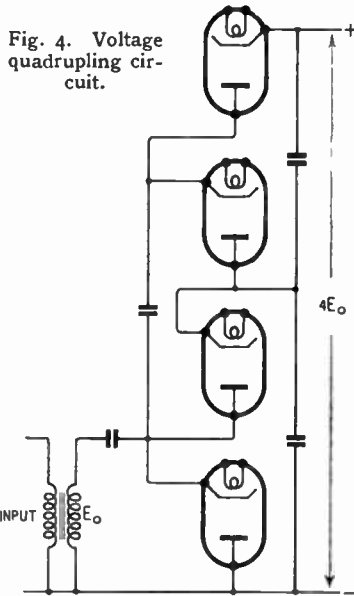

ing the negative half cycle. On the positive half cycle the voltage E_0 across C_1 is in series with that across the transformer secondary and therefore C_2 charges through V_2 to a potential $2E_0$. The voltage waveform at A is sinusoidal, oscillating between earth potential and $2E_0$.

The circuit has the advantage that further diodes and capacitors may be put in cascade to obtain voltages greater than $2E_0$. Thus Fig. 4 shows the circuit modified to provide an output voltage of $4E_0$.

With such equipment as this Cockcroft and Walton, in 1932, accelerated protons by allowing them to fall through a potential difference of 600 kV and produced nuclear reactions by allowing the particles to bombard targets made

of certain elements. This was the first wholly man-controlled atom-splitting.

Although nuclear energy may be released in such reactions the process is very inefficient, since the energy consumed in accelerating the particles is far greater than that which may be released.

The rectifier-transformer type of accelerator has been largely replaced by other forms of equipment, notably the electrostatic generator devised by Van de Graaff and the cyclotron, developed by Lawrence.

Fig. 5 shows the essentials of an electrostatic generator. A series of corona points, A, usually gramophone needles, are held at a potential of 10 to 50 kV and spray

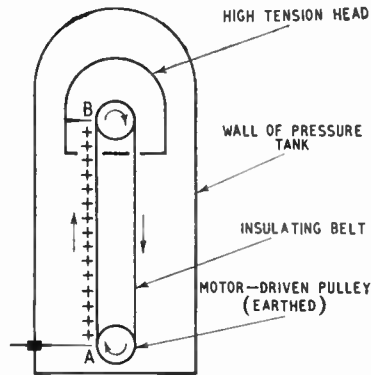

Fig. 5. Simplified diagram of electrostatic high-voltage generator.

positive charge on an insulating, endless belt. The belt, passing over two pulleys, carries the charge up and takes it inside the hollow aluminium spinning which constitutes the high-voltage electrode. Further corona points, B, remove the charge from the belt and transfer it to the high-voltage electrode somewhat like a lightning conductor discharges a thunder cloud. The H.T. head therefore acquires charge and rises in voltage. Equilibrium conditions are attained when the current con-

veyed to the H.T. head by the belt is exactly equal to that drawn by the ion source and leakage along the insulators (not shown).

Generators such as this operate at voltages between 2 and 5 million and are usually enclosed inside a steel pressure tank. Gas, such as nitrogen, at a pressure of 10 to 20 atmospheres, can then be used as a high-voltage insulating medium.

Higher energies still may be achieved by the use of a cyclotron, a schematic diagram of which is given in Fig. 6. D_1 and D_2 are flat, semi-circular boxes open along their straight sides and called "dees" because of their shape. They are like the two halves of a very short cylinder cut along a diameter. They form part of the capacitance of an R.F. oscillator (about 10 Mc/s) and are mounted on insulating supports within an evacuated circular box. This box lies between the poles of an electromagnet so that the magnetic field is perpendicular to the plane of the dees (i.e., the paper in Fig. 6).

Suppose that the ion source, located centrally between the dees, is producing protons. Then at the instant when D_1 is negative with respect to D_2 (the peak voltage between D_1 and D_2 is between 20 and 50 kV) protons are accelerated forwards and into D_1 . Since the dees are metal there is no electric field inside them and, once inside, the proton moves in a circular path under the influence of the magnetic field. If the frequency

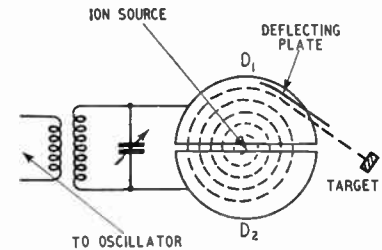

Fig. 6. Schematic diagram of cyclotron showing spiral ion path. In practice the ion path has many more turns than are shown here.

is chosen correctly the proton completes a semi-circle and returns to the accelerating gap between D_1 and D_2 when the field is reversed, i.e., D_2 negative with respect to D_1 . The proton is then accelerated again and proceeds to

Electronics and Atomic Energy—

describe a semi-circle of larger radius inside D_2 returning again for further acceleration in the correct phase. As indicated in Fig. 6 the path is made up of a series of semi-circles of increasing radius until eventually the protons come under the influence of the electric field of the negatively charged deflector plate which pulls them out of the magnetic field and causes them to strike a target.

Cyclotrons giving particles with energies corresponding to 10 million volts are commonplace, and the largest, at Berkeley, California, which has pole-faces 184 in diameter, has produced protons with energy corresponding to an acceleration of 100 million volts.

Professor Oliphant, at Birmingham University, has a special form of accelerator under construction called a proton synchrotron which, it is hoped, will give protons energies corresponding to an acceleration through 1,000 million volts.

The second point at which electronic techniques entered the field was in the detection of the single particles of matter emitted in a nuclear reaction; for example, the protons emitted in Rutherford's original experiment mentioned earlier. A single, energetic, charged particle such as a proton

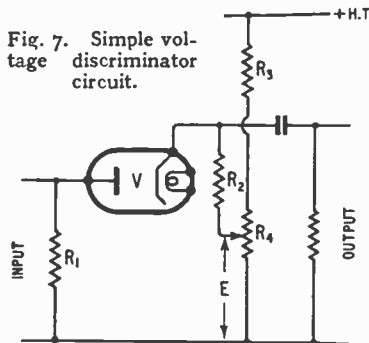

or α -particle entering an ionization chamber (Fig. 1) causes a burst of ionization. If the ions are collected quickly the charge Q collected causes a voltage pulse of amplitude Q/C to be developed across the plates of the chamber whose capacity C may be between 50-100 $\mu\mu\text{F}$. The magnitude of the charge is such that a single nuclear particle gives rise to a pulse of the order of 10^{-4} volt. An A.C. coupled linear amplifier

with a gain of a million will amplify the pulse to 100 volts at which level it can be presented on a cathode-ray oscillograph screen.

The output of the amplifier may contain pulses of a variety of sizes, and it is often necessary to reject pulses less than a chosen size. This can be achieved by employing a voltage-discriminator, an example of which is given in Fig. 7. The anode of V is nor-

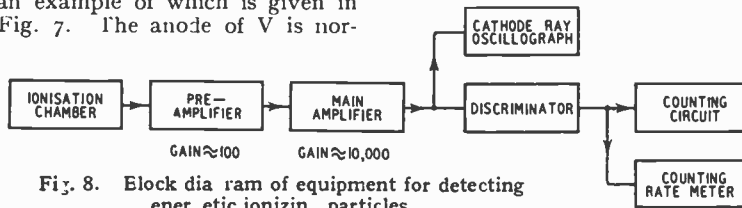

Fig. 8. Block diagram of equipment for detecting energetic ionizing particles.

mally at earth potential while its cathode is held at some positive potential E through the resistance R_2 which connects to the potentiometer chain R_3, R_4 .

The circuit gives no output pulse except when the amplitude of the input pulse applied across R_1 exceeds E volts. The diode V then conducts and a positive output pulse is developed across R_2 .

The rate at which the pulses leave the discriminator can be determined by an integrating counting rate circuit or by an electronic counting circuit, which adds up the pulses it receives and presents the answer as a total on a telephone message register. Originally, counting circuits employed thyratrons in a circuit which would produce only one output pulse for every two input pulses; that is the circuit divided by two. The use of thyratrons imposed a limitation on speed because of the de-ionization time, and to-day hard-valve circuits are preferred. With hard valves, circuits can be designed which will accept pulses at rates up to one or two million per second. The block diagram of the complete equipment for detecting and counting individual nuclear particles is shown in Fig. 8, and is representative of thousands of such pieces of equipment in daily use in laboratories throughout the world.

Two fundamental discoveries led to the large-scale release of atomic energy.

The first, made by an Englishman, Sir James Chadwick, was the discovery of the neutron. The neutron is one of the ultimate units from which atoms are built

and, because it has no electrical charge, it does not ionize gases and can travel through great thicknesses of material.

The second discovery was made by two Germans, Hahn and Strassman, and was that a neutron impinging on the heavy uranium atom can be captured and cause the atom to break up

into two nearly equal parts—smaller atoms—with the release of a large amount of energy and between one and three further neutrons. This process is called nuclear fission. If, for simplicity, we assume that two neutrons are emitted for fission, then if each of these two neutrons is captured by other uranium atoms further fissions can occur and four neutrons result. It will be seen, as depicted pictorially in Fig. 9, that the neutrons multiply in the system and energy is liberated. This process is called a chain reaction.

These ideas were known before the war and the wartime development was concerned with putting them into practice. The first attempts were made employing slow (low velocity) neutrons and the growth of neutrons in the reaction was arranged to proceed slowly enough to enable control to be effected. Such control is achieved by absorbing the neutrons with some material like cadmium which does not undergo fission and generate further neutrons. The machine which results is called a pile because it is a pattern of uranium rods embedded in a pile of graphite blocks. The graphite is used to slow down the neutrons. The number of neutrons present in the system is constant when the number formed by fission per second is equal to the number lost per second by leakage from the machine and by absorption in the cadmium control rods. By moving the control rods in or out of the pile we can decrease or increase the rate of fission and hence the rate of energy production.

The first pile was completed and went into operation in Chicago, U.S.A., late in 1942. The first pile in England was completed in August, 1947, and can be operated at a power level of 100 kW.

The more spectacular development, the extremely rapid release of atomic energy in a bomb, was achieved in July, 1945, in the U.S.A., employing fast neutrons so that the reaction built up extremely rapidly and was completed in a time of the order of a millionth of a second.

To provide energy on a scale large enough for industrial use it will be necessary to build large piles operating at high temperatures and developing many megawatts of output power. Such developments are in progress in the U.S.A., in England, and in France.

To determine the power level at which a pile is operating it is necessary to measure the number of neutrons present. Since neutrons are uncharged and do not ionize, special methods of detection are necessary.

A special boron-coated ionization chamber can be employed. Boron, on capturing a neutron, disintegrates with the emission of an α -particle which ionizes and can be detected electronically as described earlier. The number of α -particles therefore gives an indication of the number of neutrons crossing the ionization chamber and hence the power level at which the pile is working. If the number of neutrons increases, the number of counts increases and this information can be fed through an electromechanical system (e.g., a selsyn) to lower the control rods into the pile to reduce the reactivity of the system, thereby maintaining the power level constant. The process is analogous to the performance of an electronically regulated power supply.

Electronically operated safety circuits are usually employed to drop special safety control rods into the pile and shut the plant down in the event of failure of the cooling system, instrument breakdown, or the power rising too fast.

The materials used in pile construction—uranium and plutonium

—are poisonous and workers fabricating the materials have to be protected. Because both materials emit α -particles it is possible for very minute quantities of material on the hands to be detected by the single particle technique. Automatic equipment for monitoring hands is employed to indicate when the hands are contaminated and need cleansing.

Near an operating pile there is strong neutron and γ -radiation and the strength of these radiations is measured remotely, usually by D.C. amplifier techniques as described earlier.

Within the pile, in addition to a higher intensity of neutrons and γ -rays, the fission products themselves are radioactive. Moreover, slow neutrons are captured and produce artificial radioactivity in

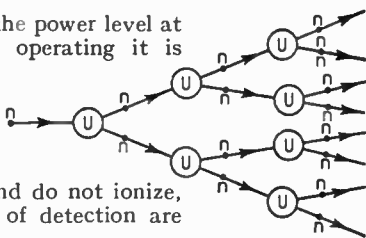

Fig. 9. Diagrammatic representation of a chain reaction illustrating the growth of the neutron n population by the fission of uranium atoms (U) on the assumption that two neutrons are emitted at each fission.

many elements. A pile thus produces large quantities of radioactive materials the radiations from which can be harmful to health. Some of these materials are wanted for medical purposes, such as the treatment of cancer, but the majority have to be disposed of safely from time to time.

The circulating gas, water or other medium used to cool the pile becomes radioactive and it is of importance to ensure that it will cause no harm to human beings, animal or plant life if it is to be discharged into the atmosphere in the case of a gas, or a river or the sea in the case of a liquid.

It will be seen from these remarks that the development of instruments which will detect radioactive materials, through the α , β or γ -radiations which they may emit, is of paramount importance. We have already discussed α -particle detection. Fortunately β -particle and γ -ray detection can be done very easily by means of a device known as a Geiger-Muller counter. In one form this device, which can be regarded as a sensitive form of

ionization chamber, consists of a wire passing axially down a metalized glass tube as shown in Fig. 10. A very high electric field is maintained between the wire and the cylindrical wall. The cylinder is filled with a gas-vapour mixture at a pressure of a few centimetres of mercury. Entry of a β -particle or absorption of a γ -ray within the counter can precipitate a discharge in the gas (somewhat like a thyratron breakdown) which causes current to flow through the high resistance R . The change of potential across R is of the order of 1 volt and can be amplified and used to drive a counting rate meter or counting circuit. The counters used are usually self-quenching and the discharge extinguishes itself after a de-ionization period of about 100 μ sec.

Large numbers of instruments of this type need to be located about the plant, in laboratories, etc., to protect the health of the workers.

A last sombre thought is that, until we can be certain that there will never be another war, we must always consider the possibility that atomic bombs might be used against us. If that ever happened it would be vital that our Armed Forces and Civil Defence Services be equipped with electronic instruments for detecting radioactive contamination.

Sufficient has been said in this brief review of the subject to indicate that we are at the beginning of an era of technical development

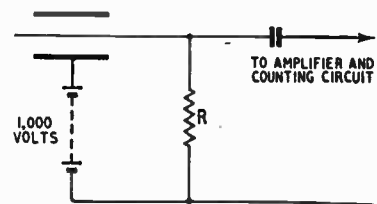

Fig. 10. Schematic representation of a Geiger-Muller counter circuit.

in the field of atomic energy. As we go forward towards industrial applications more and more instrumentation will be required.

The ingenuity of the physicists and electronics engineers has been, and will be, called into play to design the necessary electronic instruments, and increasing numbers of skilled technicians will be required to operate and maintain them.

Ionosphere Review: 1947

FOLLOWING the usual practice of *Wireless World* at the end of each year it is intended here to review the course of the present sunspot cycle, with particular reference to the changes which occurred during 1947, and to examine the effects of these upon short-wave propagation during the year. And after that we may attempt to see how conditions may vary during 1948 and after, though, because of the present impossibility of accurately predicting the changes in solar activity a long way ahead, this attempt must necessarily be some-

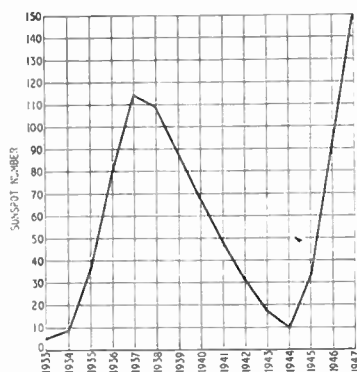

Fig. 1. Annual means of sunspot of relative numbers.

thing in the nature of a conjecture.

1947 was an extremely interesting year so far as radio-wave propagation is concerned—a year during which much information was acquired which will be of value to several branches of physical science, as well as to the radio engineer. Sunspot maximum apparently occurred during the year, and was a maximum of very exceptional magnitude. Consequent on this high sunspot activity the regular ionosphere layers became capable of propagating higher radio frequencies than they ever have since radio first began—thus providing for the first time practical information as to their behaviour under such peak conditions of solar activity.

First, for those new to the subject, a few brief words about the

Short-wave Propagation Survey, with Forecast for 1948

By

T. W. BENNINGTON
(Engineering Division, B.B.C.)

nature of the data to be examined. The ionization of the upper atmosphere, which is responsible for the propagation of short radio waves, is brought about, in the main, by the action of the sun's ultra violet radiations, and, since the sun's activity and hence the strength of its radiations varies over a long period which is the sunspot cycle, the state of the ionosphere and hence the conditions for short-wave propagation also varies over the same period. Among other evidence of the variations in the sun's activity are the sunspots which appear upon it, and these are regularly examined at the various astronomical observatories, and the information they obtain is published in the form of "sunspot relative numbers." The observations made at the different observatories are correlated by that at Zurich, and the final "number" published from there. Continuous records of this index of the solar activity go back to 1749—less comprehensive data exist since 28 B.C.—though the final "numbers" for 1947 are not yet available. For this year we have, therefore, used those obtained by the Royal Observatory at Greenwich alone, and these are provisional only.

Measurements of the atmospheric ionization are regularly made at ionosphere observatories in many parts of the world, though, of course, the records of these only go back for a few years. Nevertheless, as will be seen, the correlation between the two sets of phenomena, solar and ionospheric, has been well established. The ionospheric data is usually published in the form of hourly values of the critical frequency of the various layers, and we have mainly used that obtained by the station of the D.S.I.R. at Slough. The critical frequency, it will be remembered, is the highest frequency returned from a given

layer when the exploring wave is sent vertically upwards. For communication over a distance the corresponding value is the Maximum Usable Frequency, which is dependent on the critical frequency and the angle of incidence made on the layer in order for the wave to cover the particular distance. As a rough guide we could assume that, at present, the M.U.F. for the maximum distance it is possible to cover in one hop would be about 3.3 times the critical frequency in these latitudes.

Course of the Sunspot Cycle.—

In Fig. 1 are plotted the annual means of the sunspot relative numbers for a period covering the whole of the last and present cycles, and from these a rough idea of the characteristics of the present cycle can be gained. It is seen that the solar activity increased exceptionally quickly from the minimum in 1944, reaching, in three years, a far greater value than was reached in the first four years after the preceding minimum in 1933. Sunspot activity during 1947 was thus, generally speaking, at a higher level than at any time in the preceding cycle, and indeed, was higher than it has been during any year since 1778. In fact, during the period of 198 years covered by the continuous records there is only that one year during which the mean sunspot activity was greater than that during 1947—and that 169 years ago. We are thus perhaps fortunate in living at an epoch during which the possibilities for observing the effects of high solar activity upon radio communication—and upon other

terrestrial phenomena—are such as do not occur very frequently.

However, there are indications that the maximum in the present sunspot cycle has now been reached, and that during 1948 the activity will be decreasing. We cannot, however, be at all certain about this, since there is no reliable way of telling exactly what will happen round about a period of maximum activity like the present. As we shall later see, however, the value of sunspot relative number recorded in May, 1947, has not since been reached, and, during the last few months of the year, there was a more or less steady fall in the activity. Altogether, therefore, we should expect 1948 to be the first year in the "decreasing" phase of the present cycle. Sunspot cycle curves are, however, of the "saw-tooth" variety, indicating a longer period for the "decreasing" than for the "increasing" phase, so that we should not, in any case, expect the activity to fall during 1948 to the same extent that it rose during 1947. 1948, then, may be expected to be a year of high solar activity and consequently of high usable frequencies for long-distance radio communication. During the winter 1948-49, however, these frequencies are likely to be somewhat lower than they are at the present time.

Ionospheric Variations. — In Fig. 2 are plotted (top curve) the monthly means of the sunspot relative numbers for each month of the years 1944-47, and (bottom curve) the monthly means of the noon critical frequencies of the F₂ layer for the same period, as measured in England.

The sunspot activity is seen to vary erratically month by month, but to have a generally increasing characteristic towards May, 1947. In May it reached the phenomenally high value of 225 (this is a provisional number, and is, therefore, subject to later correction when the observations of a number of observatories are taken into account). Only twice before within the period covered by continuous records has the monthly mean reached a value exceeding 200, namely, in December, 1836, when it was 206.2, and in May, 1778, when it was 238.9.

The bottom curve of Fig. 2

shows some interesting features, the first of which is the general sweep upwards of the critical frequencies in sympathy with the increasing sunspot activity, due, of course, to the increasing level of ionization of the gases in the F₂ layer under the influence of ionizing solar rays of a gradually increasing intensity. It is seen that, as between the epochs of minimum and of maximum activity the increase in noon critical frequency was of the order of 3.0 Mc/s during the summer and 8.0 Mc/s during the winter, implying increases in the M.U.F. for longest-distance transmission of about 9.0 Mc/s and 29.0 Mc/s respectively.

In this curve there are, of course, the seasonal variations in critical frequency superimposed on those due to the sunspot cycle, and these are interesting in themselves. First, as is always the case with the F₂ layer in the Northern Hemisphere, the lowest daytime values of critical fre-

quency of the year occurring, generally speaking, in November and in February.

Thus, in November, 1947, the mean critical frequency for noon was 14.0 Mc/s, implying a mean M.U.F. for longest-distance working in these latitudes of 46 Mc/s. This high value of noon critical frequency will probably not be exceeded in the present cycle, so we may come to regard November, 1947, as being the month of highest frequency radio conditions for the current sunspot cycle, and indeed for many years years past, and possibly for many yet to come. These high critical frequencies were not, of course, unexpected, as will be evident from a quotation from last year's "Ionosphere Review" (*Wireless World*, March, 1947, p. 120): "From Figs. 2 and 3 we might hazard a guess that the highest daytime critical frequencies of the present cycle will occur about October or November of 1947, and that during the latter month the

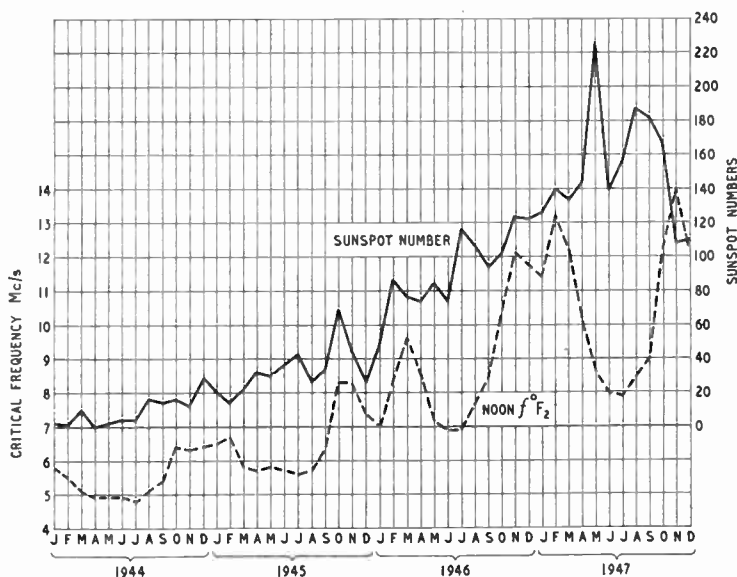

Fig. 2. Monthly means of sunspot relative numbers and noon F₂ critical frequencies for the past four years.

quency occur each year during the midsummer period. Then there is, each year, an increase of critical frequency towards the winter, but with the peculiar "mid-winter effect" causing a small fall in the critical frequency at the extreme mid-winter period. This results in the highest daytime criti-

noon mean is likely to be of the order of 14.0 Mc/s."

Correlating Sunspot and Ionospheric Phenomena.—In Fig. 3 are given (full-line curve) the twelve-month running average value of the sunspot number during the present sunspot cycle, and (dashed line curves) the

Ionosphere Review: 1947—

twelve-month running average of the noon and midnight critical frequencies as obtained in England. The object of presenting the information in this way is to smooth out the month-by-month fluctuations on the sunspot activity and the seasonal fluctuation in the critical frequency variations, and thus render the long-period effects in both quantities more apparent. It is done by taking for the mean for the epoch at the centre of any month the average of the twelve-monthly means having that month as the centre. Both noon and midnight critical frequencies are seen to respond to the changing sunspot activity relatively faithfully. The greatest degree of critical frequency variation over the cycle occurs in the noon curve—for at noon the sun's effect upon the ionosphere is more direct—and we see that the increase in mean critical frequency over the cycle has been about 5.4 Mc/s. Though over most of the cycle the correlation was very good, during the past few months the increase in critical frequency has lagged behind that in the sunspot numbers, as if some sort of saturation effect in the ionization were occurring. The midnight critical frequency, which is, of course, much lower than that at noon, also follows the increasing sunspot activity faithfully, and does not show the "saturation effect" referred to. Here the increase over the cycle is about 2.8 Mc/s.

The good correlation between the twelve-month running averages of sunspot number and critical frequency applies to all layers and all times of day, the magnitude of the critical frequency change varying with the layer and time of day. Thus the response of the whole ionosphere to variations in the activity of its producing agent, the sun, is, over a period of time, remarkably faithful and well defined.

When we consider this close correlation of the measured critical frequency—and thus, implicitly, of the M.U.F.—with the observed sunspot activity, and when we turn back and examine the sunspot activity during past cycles, we are forced to a rather remarkable yet perfectly logical conclusion—that short-wave propa-

gation conditions during 1947 must have been generally better, and particularly so on the higher frequency bands than they have been during any year since 1778. This will be apparent when it is remembered that the ionization of the *absorbing* layers is not increased by the increasing sunspot activity to the same extent as is the ionization of the refracting layers. Thus, with exceptionally high activity the M.U.F. will be exceptionally high, the L.U.H.F. (lowest useful high frequency) will be only moderately so, and

down variation in the ionization of the layers, and hence in the M.U.F.s, from day to day, even under normal conditions, and the most information about long-distance high-frequency propagation will be obtained on frequencies above these regular day-by-day ones. We may briefly examine a few such results to see what they indicate.

We must, of course, confine our attention to propagation over long distances—by way of the regular ionospheric layers. For, as is well known, there frequently oc-

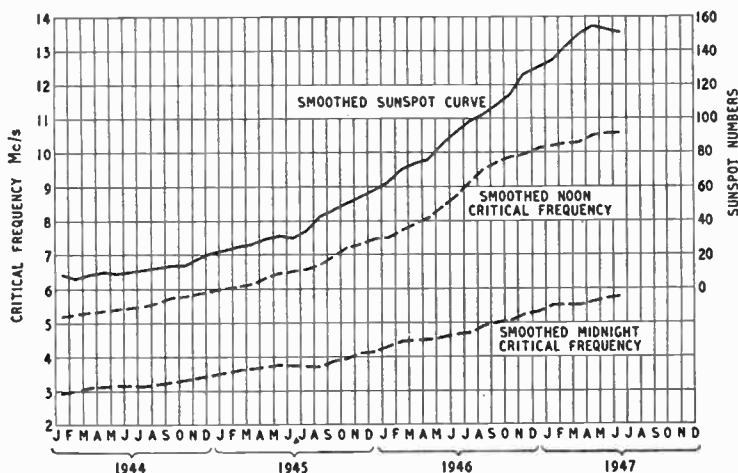

Fig. 3. Twelve-month running averages of sunspot numbers and of noon and midnight F_2 critical frequencies in England.

so the band of usable frequencies will be at its widest.

Practical Results.—The high theoretical values of M.U.F. indicated by the measured critical frequencies during 1947 seem to have been well borne out by the results achieved in actual practice. Higher working frequencies were usable during the autumn and winter in the various communication services than, generally speaking, have ever been regularly usable before. But regular communication services are not usually in a position to experiment in the use of very high frequencies for long-distance work—they have to maintain services on frequencies that are well received on every day, although, of course, it is advantageous to work on the highest frequencies on which this object can, at any particular time, be well achieved. But there is considerable up-and-

cur during the summer months cases of propagation over *medium* distances on frequencies up to 100 Mc/s. Such transmissions however, are effected either by way of Sporadic E ionization or by means of refraction within the troposphere, and, since both these phenomena appear not to be affected by the changing sunspot activity, they have no significance in the present case.

Long Ranges on 50 Mc/s.—At the last sunspot maximum (see Fig. 1) there was no authenticated case of long-distance transmission being effected on the amateur 50-Mc/s frequency. During the winter 1946-47, with the sunspot activity approaching that of the last maximum, one such case was recorded between U.S.A. and this country, and one between Holland and South Africa. Since then the sunspot activity has considerably increased, and during

the later part of 1947—particularly during November—numerous amateur transmissions on this frequency have been effected between the U.S.A. and Europe, and over many other paths as well. The fact that long-distance transmission on 50 Mc/s has become frequently possible, albeit only during the appropriate season of a year of exceptional sunspot activity like 1947, is certainly interesting information as to the highest frequencies which the regular ionosphere layers are ever likely to become capable of propagating. One is tempted to add that, after the winter of 1948-49, it is unlikely that the amateurs will be able to work their 50-Mc/s contacts again for very many years to come.

Turning to the somewhat lower frequency of 45 Mc/s — upon which the vision channel of the London Television Service operates—it was well known by observations made around the last sunspot maximum that long-distance propagation on this frequency could occur, and on such paths as that between the U.S.A. and this country. The observations indicated that such transmissions would be possible—though not by any means a daily occurrence—during the winters of years when the sunspot number was of the order of 100 or greater, whilst the implication was that they would be possible over southerly transmission paths for longer seasonal periods than in the case of transatlantic paths.

This idea seems, in general, to have been well confirmed. Last winter the sound transmissions on 41.5 Mc/s were received in numerous parts of the world, and this autumn and winter the 45-Mc/s signals have also been frequently received. Furthermore, considerable interference has been experienced by viewers in this country from American F.M. stations operating within the vision channel and, in particular, station WEFM in Chicago has frequently been received with such an intensity as to constitute a strong source of interference with the television picture. All these events are of great interest.

Forecast for 1948.—It will be seen from Fig. 3 that the running average sunspot curve has now commenced to fall, and, although

the critical frequency curves have not yet begun to do so the indications are that they will soon follow suit. As has been said, attempts to forecast the variations in solar activity a long way ahead have not hitherto been conspicuously successful. And, at a time like the present, when the activity is only just showing signs of a reversal in its trend, prediction is more than usually difficult. However, we may be justified in assuming that during 1948 the activity will, in general, decrease, and, remembering that it usually decreases at a slower rate than that at which it increases, and also that during the first year after the maximum the decrease is often particularly slow, estimate that the running average of sunspot number for the middle of 1948 will be about 120. This would imply that the running average of the noon critical frequency should have fallen from its maximum value by about 0.8 Mc/s to about 9.8 Mc/s, and that for midnight by about 0.5 Mc/s to about 5.2 Mc/s.

It is of more practical use, however, to know, not what the running average critical frequency may be at a particular epoch, but what value of monthly mean critical frequency is likely to occur during a particular month. It is not possible to deduce from the twelve-month running average what the monthly mean for any one month is likely to be, owing to the erratic nature of the month-by-month variations in solar activity. But it would appear from a study of Figs. 2 and 3 that by November, 1948, the noon mean critical frequency would only have fallen to about 12.6 Mc/s. This implies that the mean noon M.U.F. for longest-distance working in these latitudes should be of the order of 41.6 Mc/s, as compared with 46 Mc/s in 1947, whilst on certain days it should be quite considerably higher than this.

It is not possible in an article like this to say just how these changes will affect the working frequencies for communication services during 1948, for the detailed specification of such frequencies for all directions and distances is a very complex business. Generally speaking, however, it appears that, so far as the

sunspot cycle is concerned, 1948 will be a year of little change. There will, of course, be the alterations in working frequencies necessitated by the seasonal changes, which themselves vary considerably with the geographical location of the transmission paths, but apart from these the alterations made necessary should be of a minor character only. The daytime working frequencies should, it is anticipated, be from 3 to 6 Mc/s lower next November than they are at present, varying according to the different circuits, whilst the decrease in the nighttime working frequencies should be of a lower order than this. And the 50-Mc/s amateur band, which was about 10 per cent above the noon mean monthly M.U.F. during November, 1947, should be about 20 per cent above it next November. Nevertheless, since the sun-spot activity will still be high, radio conditions should, in general, be good, and favour the higher frequencies.

Miniature Portable

DESIGNED in the form of a book, this self-contained battery superhet measures 8½ in × 6 in × 2½ in and weighs 5½ lb with batteries. It covers the medium wave band



Hermes "Radio Tourist" portable. A waterproof carrying case with shoulder sling is available

(200-550 metres) and makes use of a sliding metal panel as an aerial. A socket is provided for an additional outside aerial if required. Mullard 1.4 volt miniature range valves are employed and 120 mW of power is delivered to the 3½-in loudspeaker.

The set is available in a variety of colours and the price is £13 13s exclusive of purchase tax. The makers are Hermes, Brooke and Co., Poynters, Cobham, Surrey.

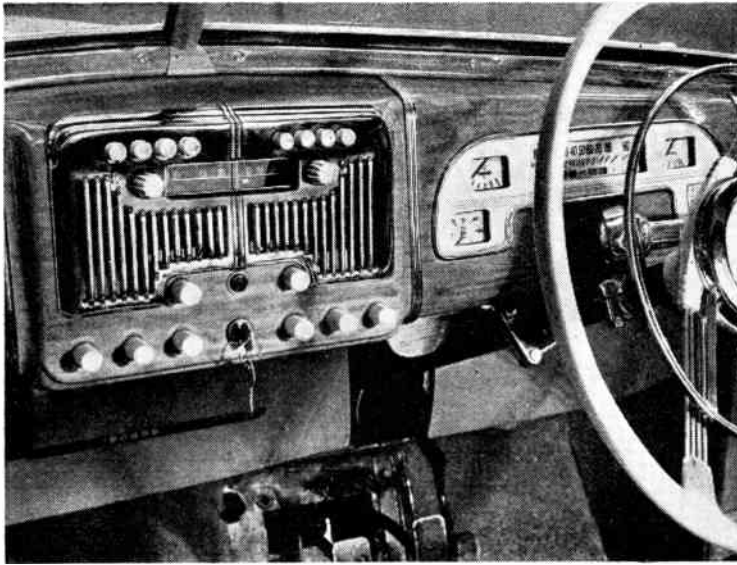

TEST REPORT

Push-button Car Set

the gang condenser and each rotates it a pre-determined amount. The setting-up process is very simple; the desired station is tuned in manually and then one of the push buttons is made to register with this setting of the condenser. This operation is effected by loosening the milled head of the button, allowing the spindle to be drawn in by its spring and register on its conden-

IN this set we see the result of an eminently rational pooling of experience in the diverse fields of radio and car equipment manufacture. The design of the set represents collaboration between the Gramophone Company (H.M.V.) and Smith's Motor Accessories; it is sold, installed and serviced by a subsidiary firm, Radiomobile, Ltd.

The user of a car radio, who is very often the driver, can rarely do more than give the set a cursory glance before switching on, or changing the programme, so that the very simplest form of tuning is most desirable. This fact has been realized by the designers of the Radiomobile set and most of the operations are effected by push buttons. These include programme selection, waveband changing and tone control.

If a passenger wishes to search for a programme not previously set-up on the push buttons he or she can do so merely by pressing in a knob and turning the set in the customary fashion. A wavelength calibrated scale and pointer are included for this purpose.

All the controls of the set are grouped on a small panel measuring $9\frac{1}{2} \times 2\frac{1}{2}$ in mounted slightly forward of the receiver unit proper. It has a detachable moulded escutcheon which is available in a range of colours to harmonize with the car instru-

The Model 100 embodied in the design of the fascia board of a car.

ment panel. The front of the receiver unit has a slight backward tilt and in this inclined face is mounted a 5 in loudspeaker.

As the available space for mounting the receiver in some cars may be limited the receiver and power supply units are separate entities, but normally combined. They can be separated when occasion demands and the power unit could then be stowed either in the engine compartment or anywhere else more convenient.

Considerable use is made of miniature components in order to keep the size as small as possible and the weight low. Miniature type valves of the all-glass pattern are used and as a result the overall dimensions, excluding the power unit, are $9\frac{1}{2}$ in wide, $4\frac{7}{8}$ in high and $9\frac{3}{8}$ in deep. The power unit adds another $2\frac{3}{4}$ in to the depth. The total weight is $17\frac{1}{4}$ lb.

The push buttons for programme selection act directly on

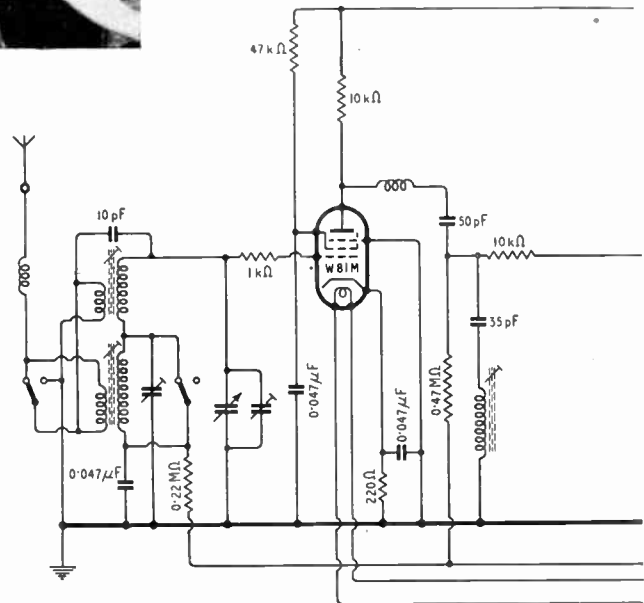

Theoretical circuit of the Model 100 showing the power unit arranged for connection to a 12-volt car installation with a positive earth.

ser stop, then retightening the milled head.

By repeating this procedure, choosing either medium- or long-wave stations, four pre-selected programmes become available by finger-tip control. It is perfectly feasible to make these changes in the selected stations while on the road, the passenger being able to do it while the car is actually in motion as no tools of any kind are required.

The four-programme push buttons are just above and to the right of the scale aperture

Radiomobile Model 100

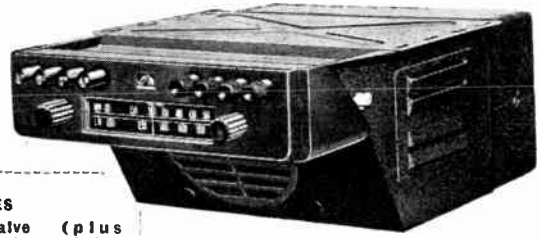

and they are balanced on the left by four more, two for tone and two for waveband switching. Immediately to the right of the scale aperture is the manual tuning control which drives the condenser through bevel gears and arranged so that a spring normally holds the driving bevel out of mesh. This prevents disturbing the tuning by turning the knob accidentally. On the left of

- FEATURES**
- Circuit.** Five-valve (plus rectifier) superhet.
 - Controls.** Push-button or manual tuning. Push-button wave-change. Push-button tone control. Volume combined with on-off switch.
 - Tuning Range.** 195 - 550m; 1,000-2,000m.
 - Output.** 3.5 watts.
 - Input.** 3.25A at 12V (6-V models available).

the input circuit and merely results in certain limits being set for the length of the co-axial cable, and the type that can be used. Included in the aerial circuit is a form of anti-interference filter.

The receiver has an R.F. stage with a tuned input circuit with a wide-band coupling linking its anode circuit to the frequency

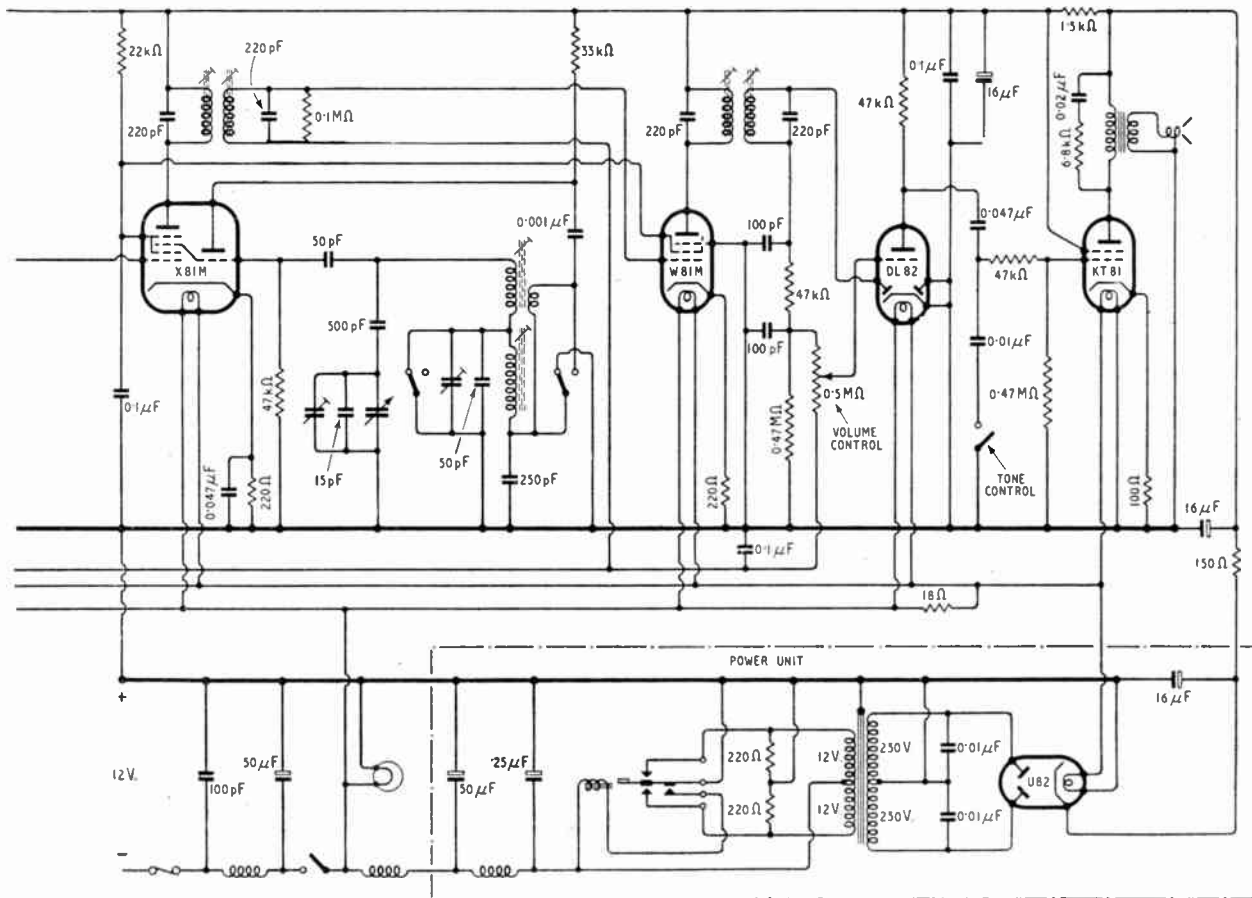

the scale is another rotary control knob. This is the combined volume control and on-off switch.

The superheterodyne circuit is by no means orthodox. The very short aerial that has to be used necessitates a sensitivity

above the average for a broadcast receiver. As the signal pick-up is small, matching the aerial and its screened co-axial cable to the receiver input circuit is of far more importance than usual. But this is embodied in the design of

changer. This covers medium and long waves without switching and obviates the need for a third section in the tuning gang condenser. There is included also a further interference rejection network.

Radiomobile Model 100—

The frequency changer is a triode-hexode of normal design, and it is followed by one I.F. stage working on 465 kc/s and having a band width of 10 kc/s for 6db attenuation at the limits.

Signal detection, A.G.C., and one stage of A.F. amplification, are provided by a double-diode-triode which in turn is resistance-capacity coupled to an A.F. pentode giving about 3.5 watts output.

A.G.C. is applied in full to the R.F., F.C. and I.F. stages, and consequently good control is obtained under all conditions of operation, and they vary very considerably on the road.

High tension at 210 volts and 55 mA is supplied by a vibrator in conjunction with a transformer and valve rectifier. This, and the filaments of the valves, which are 6.3-volt type and arranged in series-parallel, draw 3.25 amps from the car's 12-volt battery. The valves used in the set and in the sequence described here are W81, X81, W81, DL81, KT81 and U82, the last mentioned being the H.T. rectifier.

It is a tribute to the design that with the majority of modern cars only the minimum of engine suppression is needed. Some rearrangement of the plug leads and H.T. wiring may be required, also possibly repositioning of the coil. As for suppressors, one 5-k Ω resistor in the lead from the coil to the distributor and a few 0.5- μ F capacitors across some of the L.T. make and break contacting points will generally suffice.

Radiomobile is building up an installation and servicing organization throughout the country. Likely mechanics drawn mainly from garages are given a week's intensive course at the Radiomobile school at Hayes, Middlesex. Here they are coached in the circuit technique, in fault-finding, in installation and the many other aspects of the subject deemed necessary to inspire confidence in the pupils to tackle any problem arising from the use of this equipment.

A road test was made with a Model 100 fitted in a 1947 family saloon car, the installation having been carried out by the Radiomobile service department in Cricklewood. One suppressor re-

sistor only was fitted in the ignition system and a few changes were made in the run of the leads from the distributor to the plugs. The object of this was to eliminate, so far as possible, loops between the leads and engine casing, thereby minimizing the radiation from these leads. A roof aerial was fitted just above the middle of the windscreen.

With the volume control turned fully up and the set detuned from a station so that maximum sensitivity was obtained, a slight suspicion of ignition noise could be discerned in the background noise of the set. This condition of maximum sensitivity rarely, if ever, is needed for broadcast reception, as in most cases the signal will be strong enough to operate the A.G.C. and so lower the general sensitivity.

As an example of this, the B.B.C. Moorside Edge transmitter was receivable in London at sufficient strength to operate the A.G.C. except in badly

screened localities. Several Continental stations were tuned in with ease and provided a signal of real entertainment value. Indeed, on open ground, such as on Wimbledon Common, these stations were of such strength that the volume control had to be backed off, and this was during daylight.

The only interference of any consequence experienced during the tests emanated from passing lorries, motor buses and trolley buses, the former two producing typical ignition noises and the last mentioned the "scratchy" type of interference associated with electrical contacting equipment. The overhead power wires accentuated this, but at no time were these forms of interference really troublesome, due, no doubt, to the filtering action of the built-in noise suppressors.

The set sold by Radiomobile, Ltd., Cricklewood Works, London, N.W.2, costs £27 6s, plus £10 4s 9d purchase tax.

Wolsey Television Aerial

Use of Synthetic Rubber Waterproof Fittings

SEVERAL improvements have been made in the design of Wolsey television aerials and the latest models are lighter, stronger and more weather-proof than hitherto. The familiar "H" pattern, comprising aerial and reflector,

weighs only 4lb and consists of a light-weight tubular cross arm with welded-on masthead cap and end junction boxes.

Aluminium alloy tubes, fitted with synthetic rubber connectors, screw into waterproof sockets on the junction boxes. The aerial junction box has a removable cover giving access to the centre connections for joining up the feeder. The other has a sealed-in straight-through connector.

Either co-axial or twin wire cable can be used. It is brought out through a hole at the masthead cup so that it can be lashed to and brought down the pole.

The "H" pattern aerial, which is listed as model H/M, is a close-spaced array with the reflector 32in, or $\frac{1}{2}\lambda$ approximately at 45Mc/s behind the aerial. The complete aerial, less pole and securing fittings, costs 67s 6d. Wall brackets, chimney stack lashings and feeder are extra. For example, a double set of chimney stack lashings and 8ft pole costs 60s 6d.

A single dipole without reflector and constructed on the same light-weight and weatherproof lines is also available. It costs 37s 6d.

The makers are Wolsey Television, Ltd., 87, Brixton Hill, London, S.W.2.

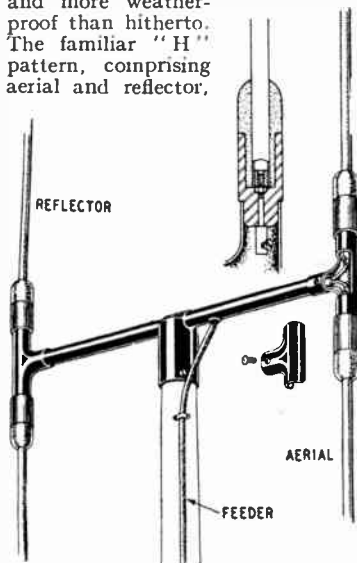

Synthetic rubber waterproof fittings are used at the joints between the aerial rods and junction boxes in the latest Wolsey television aerial.

BRIMAR — still *★* BRIMARIZING!

TYPES 36 and 39/44 were widely used in Philco and other American type receivers dated 1933-1936. Replacement by Brimar types 6J7G and 6K7G respectively, involves a change of sockets and re-alignment of receiver. The substitution of the new valves will give increased gain and it may be necessary to reduce screen voltages or re-arrange wiring to preserve stability.

PUNCH HOLES HERE →

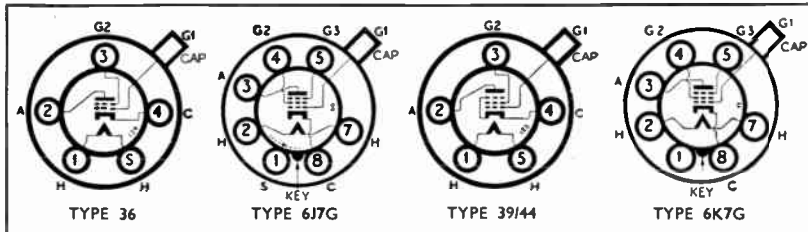

TYPE	CHANGE SOCKET		CHANGE CONNECTIONS		OTHER WORK NECESSARY	PERFORMANCE CHANGE
	FROM	TO	FROM OLD SOCKET	TO NEW SOCKET		
6J7G	U.X. S pin.	OCTAL	Pin No. 1 2 3	Pin No. 2 3 4 8 7	Connect Pins 1 & S to Pin No. 8. Change top cap connector. Re-align receiver. See note.	SLIGHTLY HIGHER GAIN.
6K7G	U.X. S pin.	OCTAL	Pin No. 1 2 3 4 S	Pin No. 2 3 4 8 7	Connect Pin S to Pin 8. Change top cap connector. Re-align receiver.	SLIGHTLY HIGHER GAIN.

Note: A higher value of screen dropping resistor (to Pin 4 of Type 6J7G) may be necessary to ensure that the screen voltage does not exceed 100 volts.

★ BRIMARIZING . . . A scheme devised by BRIMAR for keeping repair lines on the move, a profitable means whereby radio sets may be kept working happily in the home and not waiting on the shelf.

BRIMAR RADIO VALVES

STANDARD TELEPHONES AND CABLES LIMITED, FOOTSCRAY, SIDCUP, KENT.

A SERVICE PLAN FOR PLANNED SERVICE

36
39/44

INSTRUCTIONS: Punch holes where indicated, cut away this portion and file in order of appearance for a quick reference guide.

PREMIER RADIO COMPANY

MORRIS & CO. (RADIO) LTD.

ALL POST ORDERS to 167 LOWER CLAPTON RD., LONDON, E.5. 'Phone: Amherst 4723.
ALL CALLERS to 169 FLEET STREET, LONDON, E.C.4. 'Phone: Central 2833.

Terms of Business: Cash with order or C.O.D. over £1. Send 2½d stamp for latest list.

RADIOGRAM CABINETS

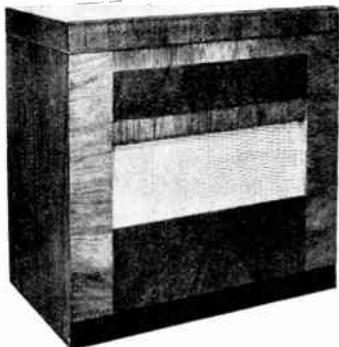

RADIOGRAM CABINETS. Dignified appearance and good workmanship. Size 31½ in. high, 18½ in. deep, 33 in. wide. French polished, veneered walnut. Price £28 7s. 3d. Also available complete with electric motor, auto stop and magnetic pick-up, £37 6s. 2d. Litto with Rothermel Crystal Pick-up, £38 12s. 7d. or with 8 record-mixer changer, £48 18s. 0d.

GOVERNMENT SURPLUS OFFERS

D/C TO A/C CONVERTERS. TYPE 1—Input 18/24 v. D/C. Output 230 v. 50 cycles, 100 watts, £5; TYPE 2—Input 12 v. D/C. Output 230 v. 50 cycles, 75 watts, £2; TYPE 3—Input 100 v. D/C. Output 230 v. 50 cycles, 200 watts, £3.

HIGH VOLTAGE BLOCK CONDENSERS. 1 mf. 2,500 v., working size 5¼ x 3¼ in. x 3¼ in., 5/-; 1 mf. 5,000 v., working size 8 in. x 5 in. x 4¼ in., 5/-; 4 mf. 1,000 v., working size 5¼ x 4 in. x 1¼ in., 5/6; 4 mf. 2,000 v., working size 5¼ x 6 in. x 2¼ in., 12/8; 8 mf. 750 v., working size 4¼ in. x 4 in. x 2¼ in., 7/6.

SHORT WAVE CONDENSERS. High-grade; Ceramic insulation. Super Midget type. Single-gang available in 10, 20, 50, 75, 100 p.f. (75 p.f. has double spindle for ganging). Price 2/6.

2-GANG, in 4.8, 9.6, 27.1, 50, 75 p.f. Price 5/-.
SIGNAL GENERATOR TYPE 33. Consists of a battery-driven generator with two separate units for approximately 1 metre and 7 metre operation, include 2 CV6 (VR135) horned triodes and one EA50 diode, also a large quantity of U.H.F. tuning gear. Contained in a teak case, size 18 in. x 8 in. x 8 in. Price 30/-.

OUTPUT TESTER TYPE 9 consists of a unit incorporating three separate diode detectors and a 3-valve Amplifier, each diode with its separate U.H.F. Tuning System. A retractable 18 in. aerial is fitted and three VR130 (HL125) valves, 3 D.L. Diodes and a large quantity of U.H.F. Tuning Gear is included. Contained in a teak case size 18 x 8 x 8 in. Price 30/-, or minus three HL125 valves, 15/-.

METAL RECTIFIERS.

Output Volts	Current	Type	Price
240	40 m/a.	H.W. or V.D.	5/-
350	75 m/a.	H.W.	5/-
16	1 amp.	Bridge	12/6
48	1½ amp.	Bridge	25/-

TEST UNIT TYPE 73 consists of a special purpose Oscilloscope that requires only rewiring and the addition of a few condensers and resistors to convert into a standard Oscilloscope, input 230 v. 50 c. A 3½ in. C.N. tube and 1 SU220A, 1 EB34, 1 5Z4, 3 SP41, 2 EA50s, are included. Controls are "Brightness," "Velocity," "X Shift," "Y Shift," "Focus Amplifier," "in/out," "Calibrate," "on/off/TX." Price £3 8s. 0d. Carriage and packing 20/-.

TEST UNIT AP53874 consists of a Test Unit for a U.H.F. Tx., incorporates a 230 v. 50 c/s Power Pack, with a smoothed output of 240 v. up to 50 m/a and 6.3 v. 2 a., 2 EF50, 1 EC52, 1 EA50, 1 5Z4G, 1 Y63 Magic Eye, and a large quantity of condensers, resistors and tuning gear. Contained in an attractive steel case. Size 10½ x 9 x 8½ in. Price 45/-, Carriage and packing 5/-.

RELAY UNIT TYPE 9 consists of a 24 v. operated relay unit incorporating 3 KT33C valves, a telephone line (Uniselect) switch with 6 poles, 26 contacts, 5 P.O. type relays, 2 high-speed relays, and a quantity of other material. Contained in an attractive relay rack type metal case 19 x 19 x 9½ in. deep. Price £4 5s., or without valves, 30/-. Carriage and packing 5/-.

R107. ONE OF THE ARMY'S FINEST COMMUNICATIONS RECEIVER. (See "W.W." Aug., 1945.) 9 Valves, R.F. amp. osc. Frequency Changer, 2 IF's, (465 kc.), 2nd Detector, AVC. A.I. amp., AC mains, 100-250 v. or 12 v. accum. Frequency range 17.5 to 7 mc/s., 7.25 mc/s. to 2.9 mc/s., 30 to 1.2 mc/s. Monitor L.S. built in. Complete with output stage. Write for full details. £16 16s. complete.

VARIABLE CONDENSERS. Ceramic insulation. 2-gang .0005, 7/6; 3-gang .0005, 10/-; 4-gang .0005, 10/-; 1-gang .0005, 5/-; 2-gang .00016, 5/-; 3-gang .00016, 10/-; 3-gang .0003, 10/-.

TYPE 103 ROTARY TRANSFORMER. Normal rating is 19 v. D/C input. Output, 300 volts 30 m/a and 6.5 volt 3 a. D/C. By applying between 200 and 250 volts D/C to the H.T. output side, the two low-tension windings may be used to charge accumulators. The 19-volt side will charge a 6-volt accumulator at 2-3 amps. the 6.5 side a 2-volt accumulator at 1-2 a. With a 12-volt input to the 19-volt side, 180 v. at 30 m/a and 4 v. at 3 a. may be obtained. With a 6-volt input to the 6.5 side, 150 v. at 30 m/a may be obtained. By extending the spindle which is flush with the frame and applying 200 to 250 v. D/C mains to the 300 v. side, the unit becomes a powerful high-speed electric motor, suitable for small drilling machines, etc. Similarly, it may be used with 6 or 12 v. input to the 6.5 v. or 19 v. side. It employs a powerful ring magnet and is of substantial construction, costing originally over £5. A fortunate purchase enables us to offer these fine units at 10/-.

DENCO C.T.3 COIL TURRET COVERS. 15 to 42 m/s. in six bands. Consists of completely wired coil pack for communication receiver, including trimmers, padders, scales, knobs. Mechanical lamspreed, I.F. 1.6 mc/s. R.F. stage, iron cores, polystyrene insulation. Circuits available at 1/8. Price £7 0s. 10d.

LOUDSPEAKERS. 5 in. P.M., 15/-, with trans., 20/-, 6 in. P.M., 17/6, with trans., 22/6. 8 in. P.M., 20/-, with trans., 25/-, 10 in. P.M., 15 (2 watt, 47/6. 12 in. P.M. 15 (2 watt, £5. 12 in. P.M. 15 (2 watt twin-core high fidelity, £8 8s. 12 in. P.M. 20 watt, £7, 6 in. 1,140Ω Flea with trans., 27/6. 10 in. 2,100Ω Flea 3 (2 watt, 30/-.

BABY ALARM KIT. Consists of a complete kit of parts for a mains-driven amplifier, microphone and Midget speaker, to enable sound of baby's breathing or crying to be heard in any room. Complete with circuit. 55/-.

CRYSTAL RECEIVER KIT. Complete with phones. The ideal gift for the schoolboy, 10/-.

WEARITE TUNING PACK. A super job. Completely wired with padders and trimmers. Long-medium and short-waves. Iron core coils, 42/-.

2-VALVE SHORT-WAVE BATTERY KIT. A complete kit of parts for a 2-valve receiver, covering 15-300 metres, including valves, coils, drilled chassis, H.T. and L.T. dry batteries to last approximately 6 to 12 months. A pair of double headphones and full instructions. Price £3 18s. 4d.

STANDARD OUTPUT TRANSFORMERS. Match any push-pull pentodes to 3 or 15 ohms. Handles 8 watts, 17/6.

GRAMOPHONE AMPLIFIER KIT. A complete kit of parts to construct a good quality mains-driven 21-watt gramophone amplifier. May be used with any pick-up. Complete with circuit, £3 6s.

SUPER OUTPUT TRANSFORMERS. By means of a series parallel arrangement wherein the maximum winding is used for each ratio extremely high efficiency is obtained. Any valve single or push pull may be matched to any voice Coil (2 to 30ohms) type Mo.15.15 watts, 35/-.

METERS. A huge purchase of military surplus meters allows us to offer the following bargains. Best makes. Bakelite cases, prices are approx. ½ original cost.

Range	Ext.	Basic	Fitting	Type	Price
300 v.	3 1/2"	8 M/A	Flush	M.I.A/C	12/6
500 M/A	3"	—	Proj.	M/C D/C	12/6
2 1/2 A	2"	—	Flush	Thermo	7/6
4 A	2"	—	Port	H. Wire	7/6
20 A	2"	25 M/A	Flush	M/C D/C	7/6
40 A	2"	12 M/A	Flush	M/C D/C	7/6
25 A	3 1/2"	5 M/A	Flush	M/C D/C	7/6
25 A	3 1/2"	25 M/A	Proj.	M/C D/C	7/6
1 M/A	2"	1 M/A	Flush	M/C D/C	7/6
150 M/A	2 1/2"	150 M/A	Flush	M/C D/C	12/6
200 M/A	3 1/2"	200 M/A	Flush	M/C D/C	12/6
1 M/A	3 1/2"	1 M/A	Flush	M/C D/C	20/-
5 M/A	2 1/2"	5 M/A	Flush	M/C D/C	10/-

MIDGET RADIO KITS

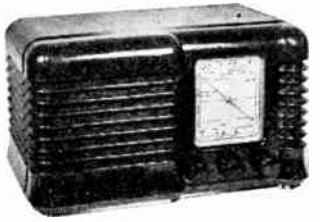

MIDGET RADIO KIT. Build your own midget radio. A complete set of parts, including valves, loudspeaker and instructions. In fact, everything except cabinet necessary to build 4-valve Medium and long Wave T.R.F. radio operating on 200-250 v. mains, A/C or D.C. Wavelengths covered 200-557 and 700-2,000. Size 10 x 6 x 6 in. Completely drilled chassis. Price including tax, £8 0s. 11d.

SUPERHET MIDGET RADIO KIT. A complete kit of parts for a 5-valve superhet. Covers 16-50 and 200-557 metres. AC/DC 200-250 v. Size, 10 x 6 x 6 in. Completely drilled chassis. Price including tax, £9. An attractive brown bakelite cabinet can be supplied for either kit at a cost of 27/4.

ELECTROSTATIC VOLT METERS. 0-5K, 3½ in. scale, flush mounting, 4½ in. dia. 65/- each.

FERRANTI 0-500 MICROAMP METERS. 3½ in. dia. scale 2½ in., res. 75 ohms., flush mounting, 25/-.

AIR-DIELECTRIC TRIMMERS. Super-midget variables ceramic insulation, screw-driver adjustment, 2½, 50 or 100 pF. 1/-.

FERRANTI 1 MILLIAMPER METERS. 3½ in. external diameter, flush mounting, with self-contained Westinghouse bridge rectifier. Scale marked 0-10 volts with fifty divisions, fitted in well-made wooden box 6 x 6 x 6 in. 35/-.

MAINS TRANSFORMERS. Military surplus. All 230 v. 50 cycles input.

Type	Output	Price
3	500-0-500 v. 150 m/a. 4 v. 2½ a. 4 v. 1 a. 4 v. 5 a.	35/-
4	865-0-865 v. 500 m/a. Tapped at 690 v. and 760 v. 4 v. 3 a. 4 v. 4 a.	75/-
5	450-0-450 v. 150 m/a. Tapped 300 v.	30/-
35	300-0-300 v. 250 m/a. 4 v. 3 a. 4 v. 3 a. 6.3 v. 5.7 a. 6.3 v. 1-2 a.	35/-
30	Output 30 v. 4 a.	20/-
31	Output 40 v. 3 a. and 104 v. 1½ a. (auto-wound)	21/-
32	Output 700-700 v. 150 m/a. 1,000 v. 30 m/a. 4 v. 1 a. 4 v. 4 a.	40/-
33	Output 38 v. at 2 a. tapped at 32, 34, 36 v.	15/-

ALL-WAVE SUPERHET KIT. A Kit of Parts to build a 6-valve (plus rectifier) receiver, covering 16-500 metres. Medium and Long-wave bands. Valve line-up 6X5, 6X7, 6U7, 6J7, two 25A6 in pushpull. Metal Rectifiers are incorporated for H.T. supply. Output Impedance is for 3 and 15 ohms. The latest Wearite Coil Pack incorporating Iron Dust Coils is used, making construction and alignment extremely simple. A pick-up position on the waveband switch and pickup terminals is provided. A complete kit including valves but without speaker or cabinet. Chassis size 14 x 6 in. Overall height, 9 in. Price £11 16s. 3d.

Suitable loudspeakers are the GOODMANS 10 in. 6-watt P.M. at 47/6, or for superlative reproduction, the Goodmans 12 in. P.M. at £6 15s.

SUPERHET TUNING PACKS. Completely wired and aligned. 13-40, 40-120, 150-570 metres. R.F. stage, 465 k/c; 9 connections only. Complete with 3-gang condenser, calibrated, engraved Perspex dial, and S/M driver. Litz wound polystyrene insulation, permeability tuned I.F.'s, 7 c. bandwith. Price complete £3 17s. 6d. Write for details.

ELECTRIC GRAMOPHONE MOTORS. A few available. Write for details.

ALUMINIUM CHASSIS. Substantially made of bright aluminium, with four sides.

7 x 3½ x 2½ in.	4/6	9½ x 4½ x 2½ in.	5/6
10 x 8 x 2½ in.	7/6	12 x 9 x 2½ in.	7/6
14 x 9 x 2½ in.	5/3	16 x 8 x 2½ in.	8/6
20 x 8 x 2½ in.	10/6	22 x 10 x 2½ in.	13/6

Cleaning Switch Contacts

Use of Solvents: Effect of Lubrication

By J. J. PAYNE, Grad. I.E.E.
(Admiralty Signal Establishment)

CARBON tetrachloride is generally accepted as a useful agent for removing the cause of defective or noisy switch contacts and it is widely believed that it functions by removing surface films of grease.

The opinion that grease is often the cause of faulty contact is inaccurate, as will be seen later; it can have little or no direct effect on electrical contact. It will, in fact, be shown that a thin layer of grease is an important feature in the operation of a switch, or any form of moving contact. The real cause of noisy contact is thought to be due to particles of solid matter with insulating characteristics which mechanically lift the surfaces of the contacts apart, and are held by the thin layer of grease.

In order to study the process involved let us consider a switch of the wiping contact type. The two mating surfaces appear smooth, but in fact consist of a series of microscopic undulations. Only the high spots of these two surfaces can be in electrical contact, as shown in the figure.

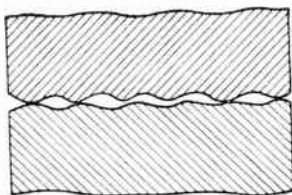

Sketch of contact surfaces.

would appear possible from this figure that the high spots of one contact could enter the valleys of the other. There is little chance of such an occurrence, as it is extremely unlikely that all the scratches will be exactly parallel.

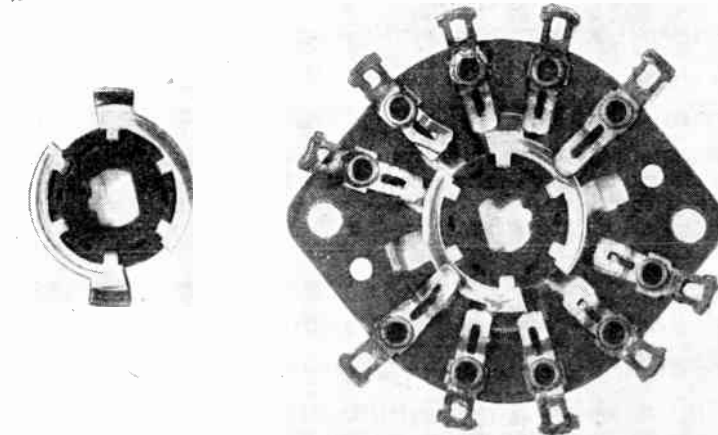

Photograph of typical wafer switch, subjected to mechanical life test after cleaning with carbon tetrachloride.

Thus high spots only will be in contact.

Consider now a layer of grease applied to these surfaces, of thickness less than the depth of the scratches, and the switch operated a few times. Due to the viscous nature of the grease, the contact pressure will force the high spots through this layer. Thus they will still make electrical contact, and the valleys will now be filled with grease. As it is the high spots which are again in contact the presence of the grease has in no way affected the area of contact, and hence the resistance. When this layer has collected sufficient foreign matter to pile up and separate the contacts, the switch will become noisy and erratic in operation. This is due to random building-up and collapsing of the piles of foreign matter during movement of the switch. When the majority of them are forced into the valleys, electrical contact between the high spots is again possible. This random effect will, therefore, result in large changes of contact resistance, even causing a series of complete makes and breaks, accompanied by the usual symptoms known as noise.

Let us now proceed to cure this fault by applying a quantity of carbon tetrachloride to the contact. As this is a solvent for the

grease, the grease will go into solution. Hence the foreign matter is no longer held to the contact faces, and will be washed off, together with the grease. As the cause of the faulty contact has been removed, our switch has now returned to its original noise-free action.

But we are not yet out of the wood. In curing the faulty switch, we have removed the film of grease. As in any mechanical device, the result will be increased friction, and, eventually, excessive wear, even though a switch is not normally operated at high speed.

A series of mechanical life tests were conducted by the author on a batch of new wafer-type switches. Half of this batch were treated with carbon tetrachloride. In every case the untreated switches showed no serious effects, while excessive wear took place on those treated. This in some cases led to the severing of the tongue on the moving contact, and in others the fixed contacts were dragged from their normal position until the moving contact jammed against their edges. The dark patches on the tongue of the switch rotor, illustrated in the accompanying photograph, represent the area denuded of plating, thereby exposing the base metal, which has suffered severely from

Cleaning Switch Contacts—

the effects of wear. One of the upper contacts clearly shows the distortion due to drag. It was known that a film of grease had been applied to the above switches during manufacture. Thus the increased life of the untreated switches can be attributed to the presence of this film. This was further confirmed by tests on treated samples, which had a new film of grease applied in the manner about to be described. The presence of this grease produced no significant change in contact resistance.

It may be concluded that the ideal switch-cleaning fluid is one which will remove any foreign matter, but will leave a film of grease deposited on the contact surfaces. A suitable method of achieving this result is to use a cleaning fluid with lubricant in solution. Such a solution when applied to a faulty switch would wash out any foreign matter in the manner previously described. Furthermore, on evaporation of the solvent a film of grease would be deposited on the surfaces. A suitable solution was found to be 10 per cent lanolin in white spirit or trichlorethylene.

There is a danger of flooding the switch in an attempt to make sure. This must be avoided, as excess fluid will spread over the insulation, and the thickness of film on the contact will not be increased. The effect of flooding the switch would be to deposit grease on the surface of the switch insulation. As this will also tend to collect foreign matter, trouble may eventually occur due to surface tracking.

The continued use of this method of contact cleaning may eventually lead to insulation troubles as mentioned above, although no cases of this nature have been brought to the author's attention. This difficulty may be overcome, however, by periodically cleaning the entire switch with neat solvent and when dry applying a drop of lanolin solution to the contacts. In cases where low insulation losses are of vital importance this latter method may be adopted every time such a switch is cleaned. A method of controlling the application of this solution, by colouring with an aniline dye, has been sug-

gested to the author. This would give visual indication of the area covered by solution, and would also serve as a warning of large

deposits of grease on vital insulators. Conversely the effectiveness of removing this excess grease may be observed.

Short-wave Conditions

December in Retrospect : Forecast for February

By **T. W. BENNINGTON**

(Engineering Division, B.B.C.)

DURING December, maximum usable frequencies for this latitude decreased both by day and night. The daytime decrease—mentioned in this column for December—was due to the "mid-winter effect," while the night-time decrease was the normal one due to the greater length of night in the Northern Hemisphere. Despite the daytime decrease in M.U.F.'s conditions were such that long-distance communication on the higher frequencies was good to most parts of the world, albeit frequencies as high as 50 Mc/s were seldom usable, though they had been during November. Night-time working frequencies, though relatively low, seldom fell below about 9 Mc/s, except over a few high-latitude paths.

There was not much ionosphere disturbance during the month, and those storms which did occur were not of great intensity. The most disturbed period was 4th/13th, and disturbances of a minor kind took place on 15th/16th, 23rd and 29th/31st.

Forecast. — By February the "mid-winter Effect," which, in the Northern Hemisphere, always results in a decrease in the daytime F₂ layer ionization round about the winter solstice, should have come to an end, and the daytime M.U.F.'s should therefore increase considerably. There should also be an appreciable increase in the night-time M.U.F.'s, as compared with those for January.

Daytime working frequencies are thus expected again to be very high—of the same order as those which prevailed last November—and long-distance communication on exceptionally high frequencies should be frequently possible in all directions from this country. The 28-Mc/s amateur band should be regularly usable for long periods over daylight paths, and long-distance communication on 50 Mc/s may become an occasional possibility. In fact, conditions for the use of this latter frequency are not likely again to

be so good during the present sunspot cycle. Night-time working frequencies will be higher than during January, though frequencies as low as 9 Mc/s will still be necessary in order to maintain regular communication in some directions.

Below are given, in terms of the broadcast bands, the working frequencies which should be regularly usable during February for long-distance circuits running in different directions from this country. In addition a figure in brackets is given for the use of those whose primary interest is the exploitation of certain frequency bands, and this indicates the highest frequency likely to be usable for about 25 per cent of the time during the month for communication by way of the regular layers. All time in these reports are in G.M.T.

Montreal :	0000	11 Mc/s	(16 Mc/s)
	0200	9 "	(14 ")
	0900	11 " , or 15 Mc/s	(18 ")
	1100	21 "	(28 ")
	1200	26 "	(40 ")
	2000	21 " , or 17 Mc/s	(34 ")
	2200	15 "	(22 ")
2300	11 "	(18 ")	
Buenos Aires:	0000	15 Mc/s	(20 Mc/s)
	0400	11 "	(19 ")
	0700	15 "	(20 ")
	0800	21 "	(30 ")
	0900	26 "	(41 ")
	1900	21 "	(34 ")
	2100	17 "	(29 ")
2300	15 "	(23 ")	
Cape Town :	0000	15 Mc/s	(20 Mc/s)
	0300	11 "	(18 ")
	0500	15 "	(20 ")
	0600	21 "	(30 ")
	0700	26 "	(42 ")
	1800	21 "	(32 ")
	2000	17 "	(28 ")
2300	15 "	(22 ")	
Chungking :	0000	9 Mc/s	(14 Mc/s)
	0400	11 " , or 15 Mc/s	(16 ")
	0600	21 "	(29 ")
	0700	26 "	(39 ")
	1300	21 "	(29 ")
	1500	17 " , or 15 Mc/s	(21 ")
	1800	11 "	(15 ")
2200	9 "	(14 ")	

February is not usually a particularly bad month for ionosphere storms, though those which do occur are likely to be troublesome over dark transmission paths. At the time of writing it would appear that storms are more likely to occur during the periods 1st/4th, 7th/8th, 15th, 21st/22nd and 25th/29th than on the other days of the month.

WORLD OF WIRELESS

Receiver Production ♦ First Radar Patent? ♦ New Government Radio Post

B.R.E.M.A.

THE third annual report of the British Radio Equipment Manufacturers' Association, one of the four constituent bodies of the R.I.C., was issued last month.

In the section dealing with the production programme for the year June, 1947, to May, 1948, details are given of the £18,200,000 worth of receivers which the pre-war set manufacturers are licensed by the Ministry of Supply to produce during that period. This is said to be the equivalent of 1,300,000 sets. Special arrangements have been made to meet the needs of newcomers to the industry.

An increase of £70,000 a month over the rate of exports during the peak period of 1946 has to be maintained to the end of 1948 to meet the year's target of £12 million which the Government has set the industry.

It is stated that the Ministry of Supply regards car radio "as a pure luxury at this present time" and in consequence the policy of allowing free production would have to be modified.

Under "Television" the report states that the shortage of C.R. tubes is the main limiting factor to greater output of receivers. The root of the difficulty is said to be the scarcity of skilled glass-blowers and it is therefore unlikely that the supply of tubes would meet future demands unless moulded production becomes economically possible. This, in turn, is dependent on large orders for tubes within a limited range of sizes. The question of standardizing tube sizes as a first step towards mass production is, therefore, being considered.

In reviewing the work of the Association's Technical Committee reference is made to its investigations into F.M. It is pointed out that it is likely that a frequency of around 90 Mc/s will be employed by the B.B.C. for the F.M. transmissions, whereas the original investigation into the increased cost of producing receivers for F.M. was based on the use of 45 Mc/s. The further cost of covering the 90 Mc/s band "would undoubtedly be very considerable."

HISTORIC PATENT

WHAT is believed to be Watson-Watt's first radar specification has just been published by the Patent Office. Originally filed on

September 17th, 1935, the complete specification was accepted in May, 1937, but it was withheld from publication until now, when it is issued as No. 593,017.

Watson-Watt's address on the complete specification is given as Bawdsey Research Station, Bawdsey Manor, Woodbridge, Suffolk.

Among the claims enumerated by the patentee is that of "locating the position of aircraft, marine craft or other objects by utilizing re-radiation broadcast from the object when subjected to primary radiation, consisting in radiating from a transmitter pulses of electro-magnetic waves of suitable frequency and polarization separated by intervals of substantially zero radiation, and receiving the electro-magnetic pulses re-radiated from the object in an indicating receiver."

The specification is obtainable from The Patent Office, 25, Southampton Buildings, Chancery Lane, London, W.C.2, price 1s inland or 1s 1d abroad.



OUR COVER. Two processes in the manufacture of C.R. tubes are given on our front cover an' above; showing, respectively, annealing the neck to the bulb an' sealing-in the electrodes. The photographs were taken at the High Wycombe factory of Electronic Tubes Ltd., a Cossor subsidiary.

TELEVISION FRANCAISE

OUR note in the December issue regarding the reception of French television in this country has brought forth enquiries regarding the present transmissions from the Eiffel Tower. We, therefore, give below one or two relevant details.

The transmitter, used during the war, was installed by the Germans and was dismantled by them during the retreat. The equipment now in use was produced by Cie Française de Television.

The vision transmitter works on 46 Mc/s with a peak power of 30 kW. The scanning rate is 455 lines per frame and 25 frames per second. Sound is transmitted on 42 Mc/s with a power of 5 kW.

Transmission times (G.M.T.) are: Daily (except Sat. and Sun.), 1150-1205. Daily (except Sat. and alternate Sun.), 1600-1730. Tuesday and Friday, 2000-2130.

"SPRAYED-ON" SETS FOR INDIA

IT is understood that a contract is about to be signed between Sargrove Electronics, Walton-on-Thames, and an Indian firm for the supply of 100,000 broadcast receivers. These are to be made by the ECME process (*Wireless World*, April, 1947), in which the principle of high-speed "printed circuit" manufacture is carried to extreme lengths by spraying on circuit elements and wiring in the form of metallic and graphite coatings on insulating panels.

The recently imposed ban on the import of completed receivers into India has been temporarily relaxed in favour of these sets, though ECME plant is ultimately to be installed there for local production.

DR. SMITH-ROSE

THE new post of Director of Radio Research in the Department of Scientific and Industrial Research is to be filled by Dr. R. L. Smith-Rose, who has been superintendent of the Radio Division of the National Physical Laboratory since 1939.

In his new position he will be in charge of the radio research work of the D.S.I.R. for which a new station is to be built. The work at present being carried out in the N.P.L. Radio Division and the D.S.I.R. Radio Station at Slough, together with the work being undertaken for the D.S.I.R. at the Ministry of

Handwritten notes:
 2018
 Houghton & Co. Ltd.
 102
 Houghton & Co. Ltd.
 Slough

World of Wireless—

Supply's Telecommunications Research Establishment, Malvern, will be conducted at the new station.

Dr. Smith-Rose, who is 53, and was recently elected a vice-president



Dr. R. L. Smith-Rose, D.Sc., Ph.D., M.I.E.E., D.I.C., A.R.C.S.

of the American Institute of Radio Engineers, joined the staff of the electrical department of the N.P.L. in 1919 and later was a member of the small band of workers who formed the nucleus of the wireless division of that department. He has been associated with the work of the Radio Research Board since its formation in 1920. He became principal scientific officer on the formation of the Radio Division in 1933.

His researches cover radio direction finding, the propagation of radio waves and the investigation of the electrical constants of the soil and sea water and their influence on propagation.

WHAT IS RADAR?

IN the course of recent correspondence with the Post Office on the vexed question of "What is a Broadcasting Station?" we were given *inter alia* a concise definition of radar. It is defined as "a radio-location system where transmission and reception are carried out at the same location and which utilizes the reflecting or retransmitting properties of objects in order to determine their position."

This definition was given during the recent Atlantic City Conference.

PICKUP TRACKING ERRORS

THE practice of setting pickup heads at an angle to the arm to minimize tracking errors was one of the topics discussed in a lecture by W. J. Lloyd, B.Sc., A.M.I.E.E., on "Factors in the Reproduction of Gramophone Records" at the British Sound Recording Association meeting on December 19th. It was pointed out that although angular

tracking errors were reduced by this method, the frictional force at the stylus point did not act on a line passing through the pickup arm pivot as it does in the case of straight arms. There is a resultant force acting on the needle point towards the centre of the record and in some pickup movements the bias due to this force might give rise to more distortion than that due to the tracking error.

NEWS IN MORSE

IT is some months since we last published details of the transmissions of official news bulletins in morse in the London Press Service radiated daily by the Post Office stations. As there have been a number of changes recently we give the revised schedule below. These transmissions are intended for overseas reception.

The transmission times (G.M.T.) and the stations radiating are:—

0130-0315 GBV, GIJ, GAH, GPN, MIJ, MIK, GIH
 0330-0500* MIK, GIH
 0445-0545* GAIH
 0600-0830 GCV
 0845-1045* GCV
 1100-1200* GBV, GIM, GCV, GCF
 1215-1315* GCF, GCV, GIA
 1330-1430* GBV, GIM, GDZ, GCF
 1445-1545* GCF, GCV, GIA, GAG
 1600-1700* GBV, GIH, GBI, GCF
 1715-1815* GBO, GCV, GIA
 1830-1930* GBV, GDI, GAH, GBO, GPN
 1945-2045* GPN, GPF, GAV
 2100-2200* GBV, GDI, GAH, GPN
 2215-2315* GPN, GBI, GIH
 2330-0100* GBV, GIJ, GAH, GPN, MIJ, MIK, GIH
 2330-0030* GBV, GIJ, GAH, GPN, MIJ, MIK, GIH

The frequencies (kc/s) on which these stations operate are:—

GBV, 78; GIJ, 6,985; MIJ, 7,447; GDI, 7,780; GAH, 8,065; GPN, 8,827; MIK, 9,725; GIH, 10,650; GPX, 11,645; GBI, 10,865; GIM, 12,975; GBO, 13,665; GDZ, 13,910; GAV, 14,455; GPF, 16,190; GAG, 17,105; GCF, 19,005; GCV, 19,365 and GIA, 19,640.

* Sundays excluded. † Sundays only.

NEW YEAR HONOURS

J. D. Cockcroft, C.B.E., Ph.D., LL.D., M.Sc., F.R.S., director of the Atomic Energy Research Establishment at Didcot; V. Z. de Ferranti, M.C., chairman and managing director of Ferranti, Ltd., and R. Y. Southwell, F.R.S., rector of the Imperial College of Science and Technology, were created Knights Bachelor in the New Year Honours.

Among those appointed Officers of the Order of the British Empire (O.B.E.) in the New Year Honours were: C. G. Phillips, for services as assistant director of telecommunications at the Ministry of Civil Aviation, and F. J. Toone, managing director of Parmeko, Ltd.

A. E. Adams, chief designer of Scopphony, Ltd.; L. I. Farren, technical assistant in the G.E.C. Research Laboratory, Wembley; S. B. Gwynn, divisional engineer (wireless), Burma, and H. Wolfson, senior research chemist in the Valve Research Laboratory of Standard Telephones and Cables, were appointed M.B.E.s.

H. Widbourne, lately foreman of workshops at T.R.E., has been awarded the British Empire Medal.

PERSONALITIES

Air Cdre. C. P. Brown, C.B., C.B.E., D.F.C., is relinquishing his Air Ministry post of Director of Operational Requirements (E) to become Chief Signals Officer, R.A.F. Mediterranean and Middle East Command. He was Director of Radar at the Air Ministry from 1942 to 1946.

R. G. Clark, M.I.E.E., who has been manager of the engineering department of the Ferguson Radio Corporation since July, 1946, has been appointed a director. He was formerly head of the research and development department of Philips Lamps.

W. H. Date, B.Sc., A.M.I.E.E., has been appointed head of the Electrical Engineering Department of the Polytechnic, Regent Street, London, W.1, on the retirement of Philip Kemp. He was formerly senior assistant in the department.

J. V. Holman, managing director of Philco, has been elected a deputy chairman of the Joint Air Transport Committee of the London Chamber of Commerce.

C. L. G. Fairfield, M.A., A.M.I.E.E., who has joined the Mullard Wireless Service Co., will act as assistant to the directors in a technical capacity. He will be concerned with the applications of Mullard research and development work to industrial problems.

E. S. McCallister has been appointed to the electro-medical department of Philips Electrical, Ltd. He was previously in the instrument section of Mullards.

A. McVie, director of Kolster-Brandes and Standard Telephones and Cables, has retired from the chairmanship of the British Radio Equipment Manufacturers' Association.

O. S. Puckle, formerly chief engineer of Sobell Industries, has joined E.M.I. Developments.



Vincent de Ferranti, M.C., who is created a Knight Bachelor.

Andrew Reid, who handled the Press arrangements for the 1947 National Radio Exhibition at Olympia, has been appointed Press Officer to the Radio Industry Council. He will work from his own office at 11, Garrick

Street, London, W.C.2 (Tel.: Temple Bar 3901/2).

D. Robinson has been appointed sales manager of the Amplifier Department of Philips. He was the first chairman of the Institute of Public Address Engineers and was, before the war, joint managing director of Gramplan Reproducers, Ltd.

WHAT THEY SAY

Pre-eminence of Radio.—"I believe that radio equipment is already more continuously available and serviceable than the celestial bodies which are so readily obscured by haze, mist or cloud and of which the sun alone is conveniently available, if at all, for daylight observation. Consequently I believe that the radio aids as a group are no longer secondary to classical celestial navigation, and that they are now the primary aids, a first eleven with celestial methods relegated to the second and reserve teams."—Sir Robert Watson-Watt broadcasting on "Twentieth-Century Aids to Navigation."

IN BRIEF

A.S.E. now A.S.R.E.—The Admiralty Signal Establishment, which, with branches at Haslemere and Whitley, is the largest of the Admiralty research organizations, has changed its name to the Admiralty Signal and Radar Establishment. The work of the establishment now touches upon all aspects of Naval warfare, including communications, naval aviation and modern weapons of diverse types.

Television Licences.—In the six months ended in November the number of television licences issued in this country had risen by 12,515, which is an increase of 66.8 per cent on the May figure of 18,735. The latest figure is 31,250. The number of broadcast receiving licences (including television) in force in Great Britain and Northern Ireland at the end of November was approximately 10,992,200.

Physical Society's Exhibition.—The 32nd annual exhibition of scientific instruments and apparatus, organized by the Physical Society, will be held in the Physics and Chemistry Departments of Imperial College, South Kensington, London, S.W.7, from April 6th-9th. Admission will be by ticket obtainable from the Society. On the opening day the hours of admission will be from 2.0 to 9.0 and on subsequent days from 10.0 to 1.0 and from 2.0 to 8.0.

Mullard's Educational Service, which is at the disposal of technical colleges, training centres, radio societies, etc., was featured by the company in its exhibit at the Science Masters' Exhibition held recently in Sheffield. The service is especially intended for users of film-strip projectors and includes a series of lectures under the general title "The Radio Valve." The Unicorn Head Film Strip Library, British Industrial Films, Chenil Galleries, 183, King's Road, Chelsea, London, S.W.3, distributes the lectures which, with the film strip of approximately 50 illustrations, cost 10s each.

Empire Radio School.—A liaison team from the R.A.F. Empire Radio School at Debden, Essex, is to visit Australasia in a Lincoln aircraft, "Mercury II," fitted with the latest types of radio equipment for demonstration to units of the Australian and New Zealand Air Forces. Among the gear with which the aircraft is equipped is the G.E.C. radio compass, Rebecca Mk IV—a miniaturized version of Mk II, which is also carried, Gee, Loran, H2S and V.H.F. communication sets TR1143A and TR5043.

Continental Television.—The Dutch secretariat of the Continental Television Society, the object of which is the promotion of television in Belgium, France, Luxembourg and Holland, is appealing for technical literature. The address of the Society is Kerksingel 69, Overschie, Rotterdam, Holland.

German Production.—The manufacture of civilian broadcast receivers has been resumed by a number of old-established firms in Germany. Most of the receivers are of comparatively simple type and vary in price from 235 to 540 marks. Among the well-known pre-war names appearing on the new sets are Telefunken, Loewe, Blue Spot, and Lorenz.

R.S.G.B. Membership.—The annual report of the R.S.G.B. records that during the year 2,997 new members joined the society. Of the total membership of 13,870 at the end of September, 546 corporate members resided overseas.

Television Film.—Special film recording equipment was developed and manufactured by Pamphonic Reproducers for making the B.B.C. film of the Royal Wedding. The film was made by photographing the image on a television screen at Alexandra Palace. The equipment, comprising apparatus for camera control and sound recording with automatic volume compression was developed within three weeks.

Electrical Trades Union.—The Radio Technical Advisory Committee of the E.T.U. has arranged a series of meetings in London for the radio workers it numbers among its members. Details of the first two meetings are given in the meetings section on page 56. The meetings are not confined to members of the Union. The full list of fixtures is obtainable from the Area Office, 324, Gray's Inn Road, London, W.C.1.

French Components Exhibition.—The French Radio Industry Council announces that its annual exhibition of components, accessories and measuring instruments will be held from February 2nd to 7th at the Parc des Expositions de la Porte de Versailles, Paris, 15^e. The full title and address of the French R.I.C. is Syndicat National des Industries Radioélectriques, 25, Rue de la Pépinière, Paris, 8^e.

A Valuable Index.—The annual index to Abstracts and References published in our sister journal *Wireless Engineer* during 1947 will be available after February 9th, from our Publisher. It includes an author index and a classified subject index. As supplies are limited early application for copies is advised. The price is 2s 6d (by post 2s 8d).

INDUSTRIAL NEWS

E.M.I. has purchased from Radio and Television Trust, Ltd., its Perivale factory, which is some three miles from the main factory of the E.M.I. group at Hayes, Middlesex. These two factories, together with that at Treorchy, South Wales, will be operated largely to increase the company's exports.

Philco and Airmec.—The factory referred to above has been disposed of by Radio and Television Trust, Ltd., owing to the need for reducing the company's manufacturing organization on account of the drastic cuts in the quota of receivers for the home market. Airmec, Ltd., is the manufacturing side of the company and produces Philco sets for the home market, which are sold through Philco Radio and Television Corp. of Great Britain, and Airmec sets for export through Airmec International Sales, Ltd.

Philips Electrical Industries, Ltd., is the name of a private company formed to acquire and hold certain shares of the Philips group of companies in this country. This internal reorganization of the company "has no external implications."

Radio Equipment, Ltd., has been formed as a Holding Company to acquire ninety per cent of the shares in the Mullard Wireless Service Co.

Components Exhibition.—The Radio Component Manufacturers' Federation, which is organizing the fifth annual private exhibition of British radio, television and electronic components and test gear, announces that stands have been allotted to 100 exhibitors. The exhibition, which will be held at Grosvenor House, Park Lane, London, W.1, from March 2nd-4th, will be open from 10.0 a.m. to 6.0 p.m. to holders of invitation tickets. It will not be open to the general public.

Belling-Lee.—The twenty-fifth anniversary of the founding of Belling and Lee, Ltd., was celebrated with a dinner in London on December 22nd to which friends and supporters of the company were invited.

R.S. Amplifiers, Ltd., of Reynolds Road, Acton Lane, London, W.4, has been acquired by Henri Selmer and Co., Ltd., of 114-116, Charing Cross Road, London, W.C.2 (Tel.: Temple Bar 0444), to whom all enquiries regarding R.S. equipment should now be sent.

Mullard has opened another "feeder" factory at Hove, Sussex. It is for the assembly of sub-miniature valves, including those used in the Government-sponsored "Medresco" hearing aid.

Rola-Celestion.—The Board of British Rola has been enlarged to include W. H. Page and S. J. Tyrrell, directors of Celestion. At the same time C. R. Nortcliffe, sales director of Rola, joins the Board of Celestion. Mr. Tyrrell will co-ordinate the research and technical development of the two companies.

Marconi's announce that the £300,000 order placed by the Chinese Government twelve months ago is now ready for shipment. The contract included sixteen telegraph/telephone transmit-

World of Wireless—

ters, thirty triple diversity receiving equipments and 150 commercial receivers.

Radio Industries Ball.—The success of the Ball held at the Royal Albert Hall on October 3rd has prompted the Radio Industries Club to decide to make it an annual event.

O. Greenlick, Ltd., of 34, Bancroft Road, Cambridge Heath Road, London, E.1, has moved to 265, Whitechapel Road, E.1.

S. G. Brown, Ltd., of Victoria Road, North Acton, London, W.3, ask us to say that the price of the moving-coil headphones advertised in the December issue was incorrect and should have been £5 5s.

CLUBS

Birmingham.—High-frequency hearing will be discussed and demonstrated at the meeting of the Slade Radio Society on February 6th by W. D. Wilkinson, B.Sc., of the G.E.C. Development Laboratory. Meetings are held at 8.0 on alternate Fridays at the Parochial Hall, Broomfield Road, Slade Road, Erdington. Sec.: C. N. Smart, 110, Woolmore Road, Erdington, Birmingham, 23, Warwick.

Bovingdon.—An Amateur Radio Section of the Bovingdon Airport Club has been formed but is not confined to members of the airport staff. It therefore serves the Bovingdon, Chesham, Hemel Hempstead, and Berkhamstead areas of Hertfordshire. Meetings are held on Wednesdays at 7.30 in Building 161. B. N. MacLarty, deputy engineer-in-chief of Marconi's, who until recently was head of the B.B.C. Design and Installation Dept., will talk on high-powered B.B.C. transmitters at the meeting on February 4th. Sec.: J. D. Lord, Police Station, Bovingdon, Hemel Hempstead, Herts.

Brighton.—Dr. D. G. Tucker will lecture on the Synchrodyne receiver at the meeting of the Brighton and Hove Group of the R.S.G.B. at the Golden Cross Hotel, Western Road, Brighton, at 7.30 on February 23rd.

Ilford.—Demonstrations of the Goodmans' infinite baffle speaker and the G.E.C. tape recorder will be given to members of the Ilford and District Radio Society on January 29th and February 19th respectively. Meetings are held on Thursdays at 8.0 at St. Alban's Church Room, Albert Road, Ilford. Sec.: C. F. Lagen, 44, Trelawney Road, Barkingside, Essex.

Oxford.—The Oxford and District Amateur Radio Society has been reformed and now meets on the first and third Wednesdays of the month at 7.30 at the Club Room, "Magdalen Arms," Iffley Road, Oxford. Sec.: H. Worsfold, 143, Iffley Road, Oxford.

Worthing.—The February meeting of the Worthing and District Group of the R.S.G.B. will be held on the fifth at Oliver's Café, Southfarm Road, Worthing, at 7.30. The Ministry of Supply film "R.D.F. to Radar" and some R.S.G.B. films, including that of the Atlantic City Conference, will be shown. Sec.: G. W. Morton, 42, Southfarm Road, Worthing, Sussex.

MEETINGS**Institution of Electrical Engineers**

Radio Section.—The application of Frequency Modulation to V.H.F. Multi-Channel Radiotelephony," by J. H. H. Merriman, M.Sc., and R. W. White, B.Sc., on February 4th.

"Maintenance of Television Receivers in the Home," discussion, opener G. H. Watson, on February 10th. Both these meetings will be held at Savoy Place, London, W.C.2, at 5.30.

Faraday Lecture.—"Electricity and Everyman," by Dr. P. Dunsheath, C.B.E., M.A., on February 27th, at 6.30, at the Central Hall, Westminster. This is a public meeting.

East Midland Centre.—"Speech Communication under Conditions of Deafness or Loud Noise," by Dr. W. G. Radley, C.B.E., on February 10th, at 6.30, at the Gas Department Lecture Theatre, Nottingham. Sec.: G. Smith, Loughborough College, Loughborough.

Cambridge Radio Group.—"The Cavity Magnetron," by Drs. H. A. H. Boot and J. T. Randall, F.R.S., on February 3rd, at 8.15, at the Cavendish Laboratory.

Mersey and North Wales Centre.—"The Design of High-Fidelity Disc Recording Equipment," by H. Davies, M.Eng., on February 16th, at 6.30, at the Royal Institution, Colquitt Street, Liverpool. Sec.: A. V. Milton, 12, Bevington Hill, Liverpool.

North-Eastern Centre.—Dr. Dunsheath's Faraday Lecture (see above), on February 18th, at 6.15, in the Lecture Theatre, Literary and Philosophical Society, Newcastle-on-Tyne. Sec.: E. C. Rippon, c/o C. A. Parsons and Co., Ltd., Heaton Works, Newcastle-on-Tyne, 6.

North-Eastern Radio Group.—Dr. Radley's paper (see East Midland Centre) on February 16th, at 6.15, at King's College, Newcastle-on-Tyne.

North-Western Radio Group.—"Some Wartime Developments in Electronic Circuit Technique," by Prof. F. C. Williams, O.B.E., D.Sc., D.Phil., on February 25th, at 6.30, at the Engineers' Club, Albert Square, Manchester.

Western Centre.—Dr. Dunsheath's Faraday Lecture (see above) on February 10th, at 6.0, at the Reardon-Smith Lecture Theatre, Cardiff. Sec.: L. Burdes, B.Sc. (Eng.), Electricity Dept., Dorset House, The Promenade, Clifton, Bristol, 8.

Irish Branch.—"Propagation Problems in connection with Short-Wave Broadcasting," by W. Jones, M.Sc., on February 19th, at 6.0, at Trinity College, Dublin. Sec.: R. N. Eaton, 1, Foster Place, Dublin.

Mersey and North Wales Students' Section.—"The Engineering Aspects of Gramophone Record Reproduction," by R. G. Whitehead, B.Sc. (Hons.), H. K. Barker, B.Sc., and H. P. Caldecott, B.Sc., on February 7th, at 2.30 at the Royal Institution, Colquitt Street, Liverpool.

British Institution of Radio Engineers

London Section.—"A Multi-Carrier V.H.F. Police Radio Scheme," by J. R. Brinkley, on February 12th, at 6.0, at the London School of Hygiene and Tropical Medicine, Keppel Street (Gower Street), London, W.C.1.

Midlands Section.—"Some Aspects

of Moderate Precision Temperature Control in Communication Engineering," by M. P. Johnson, B.A.Sc., on January 30th, at 6.30, at the Technical College, The Butts, Coventry. Sec.: C. Stokes, B.Sc., 6, Esterton Close, Coventry, Warwick.

Merseyside Section.—"Link-Coupled I.F. Circuits Applied to Car Radio Receivers," by R. D. Trigg, on February 18th, at 6.45, at the Lecture Room, Liverpool Engineering Society, 9, The Temple, 24, Dale Street, Liverpool, 2. Sec.: J. Gledhill, B.Sc., 123, Portelet Road, Liverpool, 13.

North-Eastern Section.—Questions Evening on February 11th, at 6.0, at Neville Hall, Westgate Road, Newcastle-on-Tyne. Sec.: M. A. Boardman, 20, Princes Avenue, Gosforth.

North-Western Section.—"A New All-Stage Valve," by J. A. Sargrove, on February 12th, at 6.45, at the College of Technology (Reynolds Hall), Sackville Street, Manchester. Sec.: B. E. P. Ritson, 38, Parswood Court, East Didsbury, Manchester, 20.

Scottish Section.—"Supervisory Control," by L. G. Brough, on Feb. 18th, at 6.45, at the Institution of Engineers and Shipbuilders in Scotland, 39, Elmbank Crescent, Glasgow, C.2.

Institution of Electronics

"Electronic Organs," by L. E. A. Bourn, on January 26th at 7.0 in the rooms of the Royal Society of Arts, John Adam Street, London, W.C.2. Sec.: A. H. Hayes, 24, Buckingham Street, London, W.C.2.

North-West Branch.—"The High-Vacuum Technique," by Dr. R. Witty, on February 6th, at 6.30, at the Reynolds Hall, College of Technology, Manchester. Sec.: L. F. Berry, 105, Birch Avenue, Chadderton, Lancs.

British Sound Recording Association

"Recent Developments in Magnetic Recording," by P. T. Hobson, on February 27th at 7.0, at the Royal Society of Arts, John Adam Street, Adelphi, London, W.C.2.

Institution of Mechanical Engineers

"Radio Valve Manufacture," by J. W. Davies, H. W. B. Gardiner, B.Sc. (Eng.), and W. H. C. Gomm, B.Sc. (Eng.), on January 30th at 5.30, at The Institution, Storey's Gate, St. James's Park, London, S.W.1.

British Kinematograph Society

Newcastle-on-Tyne Section.—"The Film in Relation to Television," by Marcus F. Cooper, on February 3rd, at 10.30 a.m., in the Neville Hall, Neville Street, Newcastle. Sec.: Edward Turner, 30, Ettrick Grove, Sunderland, Co. Durham.

Radio Society of Great Britain

"Interference—its Cause, Effects and Cure," by W. Hartley, G8UY, on February 13th at 6.30, at the I.E.E., Savoy Place, London, W.C.2.

Electrical Trades Union

"Definitions and Standards of Skill in the Radio Trade," open discussion on January 26th at 7.0 at the Alliance Hall, Caxton Street, London, S.W.1.

"Pre-detector Amplifying Systems," open discussion on February 24th at 7.0 at the Caxton Hall, Victoria Street, London, S.W.1.

The names and addresses of secretaries are included where they have not been given previously in this volume.

Slot Aerials

By D. A. BELL, M.A., B.Sc.

Vertical Polarization from a Horizontal Radiator

A LOT of the optimistic talk about the benefits to broadcasting and television of radar technique has been unjustified, but the "slot" aerial may prove to be a new line of development which, having started in wave-guide technique for radar, will grow upwards from centimetre wavelength to V.H.F. broadcasting, if not lower. As an example, it is reported that the B.B.C. are considering the use of slot aerials for their 90-Mc/s F.M. transmissions.

At centimetre wavelengths, energy is transmitted more efficiently as bounded electromagnetic waves in a waveguide than as currents in a conductor. When we want to radiate the energy which is being carried by a waveguide, we need not put the energy back into current form and then radiate from an aerial, but instead we can radiate electromagnetic wave energy directly, for example, through a horn.

Now the directivity of any radiator, whether aerial array or horn, is proportional to the dimension (in wavelengths) of the radiator at right angles to the plane in which the directivity is measured. So if we want a beam

which is liable to roll, we must use an aerial such as a one-tier broadside array of radiators (all fed in suitable phase) which is broad but not high.

The connection of a large number of dipoles to a common feeder with correct phasing and impedance matching would be a difficult problem at centimetre wavelengths. But if we punch a row

Fig. 2 Diagram (a) represents a strip dipole; (b) is the corresponding slot in an infinite metal sheet.

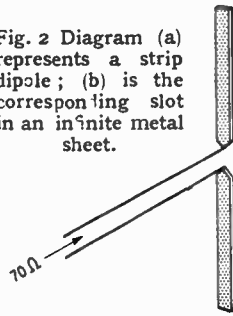

(a)

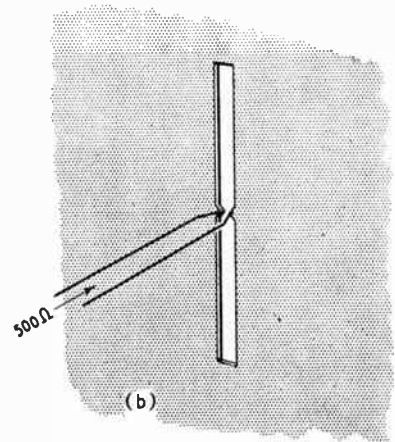

(b)

of spaced holes in the side of a waveguide, each hole will radiate some of the energy passing down the guide; and uniform phasing of the radiation from the holes is effected by spacing them correctly along the length of the guide, remembering that the wavelength

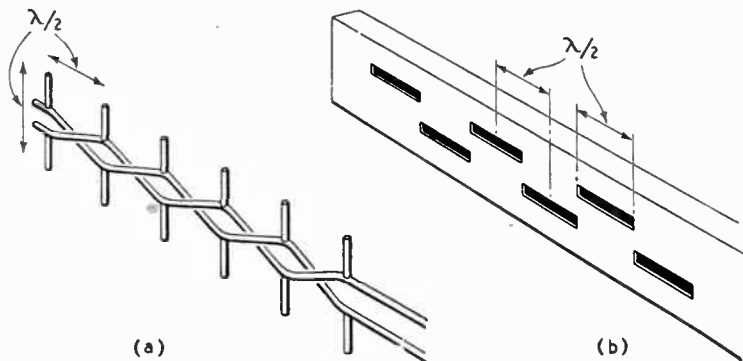

Fig. 1 An array of dipoles (a) becomes difficult to construct and feed at centimetre wavelengths; but a slot waveguide (b) gives an equivalent radiation pattern.

which is narrow in the horizontal plane but covers a wide vertical angle, for example, in a ship

inside the guide will be greater than the wavelength in free space. (Fig. 1.)

Investigation of the optimum type of radiating "hole" in the waveguide led to the use of a slot of length about half a wavelength and of much smaller width, and from here on we find that study of the radiating properties of the resonant slot leads to re-

sults of much wider interest. First of all, a slot in an infinite sheet is closely equivalent to a flat strip dipole in free space if we consider the shapes of conductor and dielectric to be interchanged, (Fig. 2), except that the slot behaves as a "magnetic dipole." The polar diagram of a slot radiator in an infinite sheet is very similar to that of a dipole in free space, but whereas the electric field is parallel to the length of the dipole, it is the magnetic field that is parallel to the length of the slot. In practice, of course, the conductor in which the slot is situated is rarely even an approximation to an infinite sheet, and the resulting edge effects may be regarded as a diffraction phenomenon which can slightly improve the polar diagram in favourable cases. If we enclose one side of the slot, preferably with a chamber at least a quarter-wavelength in diameter, the radiation can emerge from one side only; but unless the sheet is of very large extent, there will

still be some backward radiation due to diffraction round the edges of the sheet.

The feed to a dipole is normally inserted in series with the mid-point, and for the resonant length the input impedance is purely re-

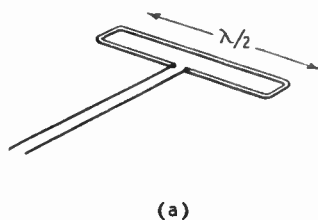

dipole has zero pick-up in the end-on direction, while a single vertical dipole receives uniformly from

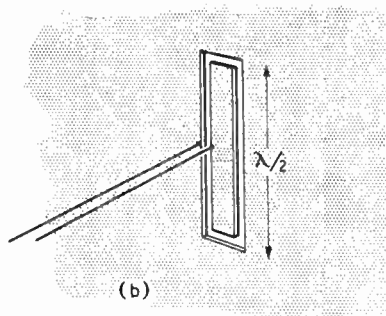

Fig. 3. Folded dipole diagram (a) with the corresponding folded slot (b)

sistive and about 70 ohms in magnitude, for a fairly thin conductor; similarly, the input to a slot is fed across the centre (Fig. 1b) and the input resistance at resonance is about 500 ohms.^{1, 2, 3} Increasing the diameter of the conductors of a dipole reduces the impedance, but increasing the width of a slot reduces the admittance; i.e., increases the impedance. Again, just as the input impedance of a dipole can be multiplied by a factor of the order of 4 by using a folded construction, so the input impedance of a slot can be reduced roughly four-fold by folding it.

The two practical advantages of a slot aerial are, first, that it can be incorporated in a conducting structure and, secondly, that its polarization is at right-angles to that of a dipole. For the first factor, Booker¹ has suggested that slots might be cut in the skin of an aircraft and plugged with dielectric, thus avoiding the use of projecting-rod aerials for the V.H.F. band. Similarly, marker and landing beacons on aerodromes could radiate from horizontal slots let into the surface of the ground, even in the surface of a runway if necessary. The low-frequency limit to this type of application is set by the need for a cavity about a quarter-wave-length deep below the slot.

Although the question of horizontal *versus* vertical polarization for television broadcasting is complicated, there are one or two advantages of horizontal dipoles that are not available with vertical dipoles. One is that a horizontal

dipole has zero pick-up in the end-on direction, while a single vertical dipole receives uniformly from all directions in the horizontal plane. By replacing the vertical dipole by a horizontal slot, we can receive a vertically polarized signal and yet have little response in the end-on directions. (At first sight one might hope to get perfect suppression of back radiation by enclosing one side of the slot; but unless the slot is in a very large sheet, the diffraction round the edges may reduce the front/back ratio to the same order as that of a dipole with reflector or director in the optimum position; it will also cause some end-on pick-up.) In future, perhaps, blocks of flats will have provision for a television slot aerial to be incorporated in the window frames on the side of the building facing the transmitter, thus providing a good built-in aerial for those on the upper floors, without disturbing the clean lines of the building.

Another possibility is the use of a vertical stack of slots as a vertically polarized analogue of a stack of horizontal dipoles. If 6 narrow slots are fed in parallel (Fig. 4) the resultant impedance will be about 80-90 ohms, which will match into the conventional types of feeder cable. The main difficulty is the requirement for the surrounding sheet to be considerably larger than the slot dimensions. The sheet might be of wire mesh, and stretched between two masts.

The technique has now been carried a stage further by eliminating the sheet surrounding the slot and leaving only a narrow loop of conductor corresponding to the edge of the slot.⁴

The examples which have been quoted should be sufficient to show that there are many possibilities of interesting applications.

References

- ¹ "Slot Aerials and Their Relation to Complementary Wire Aerials (Babinet's Principle)," H. G. Booker, *J.I.E.E.*, Vol. 93, Part IIIA, p. 620.
- ² "Slot Feeders and Slot Aerials," C. E. G. Bailey, *ibidem*, p. 615.
- ³ "Resonant Slots," W. H. Watson, *ibidem*, p. 747.
- ⁴ *F.M. and Television*, July, 1947; p. 38.

Appendix

Driving-point Impedance of a Slot.

In reference ¹ above, Booker has shown that if Z_1 is the impedance of a dipole, and Z_2 the impedance of a corresponding slot, then

$$Z_1 Z_2 = \frac{1}{4} Z^2$$

where Z is the "characteristic impedance of free space" and is equal to 120 ohms (377 ohms). Hence if the impedance of any type

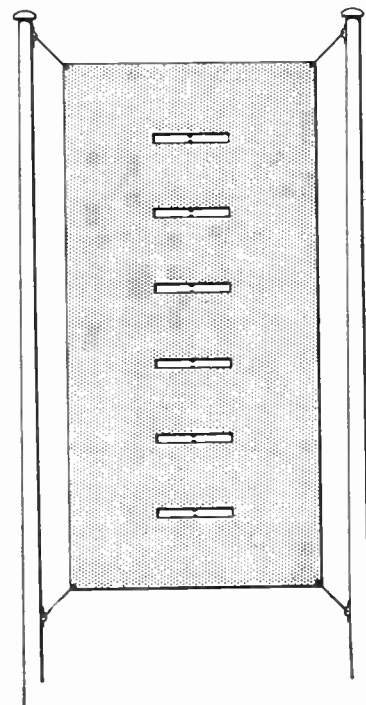

Fig. 4. Suggested stack of slots to give directional gain in the vertical plane with vertically polarized radiation.

of dipole system is already known, the impedance of the corresponding slot system is immediately obtainable from the relation

$$Z_2 = \frac{1}{4} Z^2 / Z_1$$

THE "BELLING-LEE PAGE"

Providing technical information, service and advice in relation to our products and the suppression of electrical interference



Window Mounting Aerials

We have been examining some official statistics showing that of all complaints of interference reported by the public to the Post Office Engineering Department, a very large proportion can be attributed to the set user trying to do without any aerial, or at least a wire round the room.

Readers of this journal know that a good outside aerial is necessary in order to obtain a reasonable signal to noise ratio. They also know that their advice is often ignored owing to expense, trouble and difficulty of erection. All these objections can be met by the recommendation of a "Winrod" *1 window mounting aerial. The cost is low, under a pound and deliveries are ex-stock. We all know it cannot be said to take the place of a normal aerial such as we would like to see erected, but it is an out-door aerial that can be fitted at window-sill level, and as such, the signal to noise ratio must be many times better (very often 20 db.). Its more general use would add greatly to the enjoyment of radio reception and would have the effect of giving new life to an old set.

Where there is really serious interference then a full blooded anti-interference aerial such as the "Eliminoise" *2 and "Skyrod" *3 would have to be considered.

Suppression of Interference

Although regular readers of the "Wireless World" do not require

to be reminded of the fact, the general public should remember that no aerial suppresses interference; it may, if correctly chosen and erected with skill, enable the listener to pick up programmes without interference, but the interference has not been suppressed.

With a "Winrod" or other aerials, mains borne-interference may be present. This can be dealt with by the use of a "Belling-Lee" set lead suppressor L.300/3*4 which is normally fitted at the plug point supplying the receiver, and ensures that the mains lead going to the receiver is free of interference. This is important as at no other time do the mains come so close to the set. An alternative arrangement is to fit a "Belling-Lee" L.1118/CT*5 to the incoming mains of the house, but this may be rendered ineffective in a terraced house or flats by re-radiation through the walls, of interference from neighbouring wiring. It would also be ineffective if the interference is caused by faulty switches or wiring inside the house.

Midland Television Service

At the time of writing it occurs to us that information of the vision and sound frequencies of the Birmingham television station (Sutton Coldfield) may be released before this goes to press. Experience in the London area has shown that there would be a rush by members of the public to have aerials erected, and certainly wide-awake dealers will be anxious to announce to passers-by that they are in fact television minded. We have put ourselves in the position that within a few days of the release of the vital information, Belling & Lee Ltd. will be able to despatch aerials. We have in fact many orders already on our books.

If rumours are to be believed, the service area will be very great and the potential market enormous.

Belling-Lee Service

Most wireless dealers will be glad to give service on Belling-Lee products. To assist both the dealer and the public, we are issuing window cards to dealers so that it is clear to prospective customers that willing and knowledgeable service is available within. Every dealer

cannot know all the answers, but they are supported by an efficient specialist service department who are here to give prompt attention to their queries.

If this comes to the notice of any dealer who has not yet had a card, and who is interested, will he please get in touch with us giving the name of his preferred wholesaler.

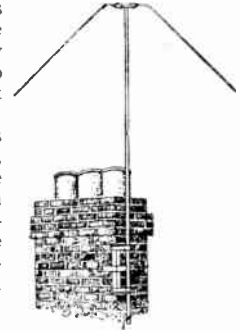

*1 "WINROD" (Regd. trade mark) 8 feet, 3 section, window mounting aerial.

L581 Price each 19s. 6d. Supplied EX-STOCK in cartons each containing 6 "WINRODS."

*2 "ELIMINOISE" (Regd. trade mark) anti-interference transformers for attachment to "Skyrod" vertical aerial or a 60ft. horizontal aerial.

L308 Pair of transformers with receiver connecting lead L621/5. Price £4 10s. 0d.

L308/K Complete kit with L1221 screened downlead, aerial and earth wire, and insulators. For fitting horizontally. Price £6 6s. 0d.

*3 "SKYROD" (Regd. trade mark) vertical aerial in 3 sections for chimney mounting.

L518 Collector only. Price £4 4s. 0d.

L618 Complete kit with "Eliminoise" matching feeder transformers, L1221 Screened feeder, earth wire and insulator. Price £10 0s. 0d.

*4 Set lead suppressor L300/3 Price £2 19s. 6d.

*5 Capacitor suppressor, centre tapped, for fitting at the meter board or at the source.

L1118/CT Price £1 7s. 6d.

BELLING & LEE LTD
CAMBRIDGE ARTERIAL ROAD, ENFIELD, MIDD.X

E.M.I. TRAINING FOR CAREERS IN ELECTRONICS

E.M.I. basic training fits you for entry to Careers in such fields as:—

- SERVICE ENGINEERING
- OPERATING
- DESIGN AND DEVELOPMENT
- TECHNICAL SALESMANSHIP
- TEACHING



The Correspondence and College Courses provided by E.M.I. Institutes which cover recognised diplomas such as the City and Guilds, etc. are written and supervised by E.M.I.* scientists who are specialists in Electronic Science.

Courses are already available in such subjects as Basic Radio, Basic Television, etc., and the prospectus is being constantly extended.

With this basic training you can eventually become a specialist in Television, Radio Communications, Radar, Navigational Aids, Audio Frequency, Medical and various Electronic applications. There are also short courses for Executives, Amateurs, Students, etc.

For full details apply to your local "H.M.V." Radio dealer or direct to:—

The Principal: PROFESSOR H. F. TREWMAN, M.A. (Cantab), M.I.E.E., M.I.Mech.E., M.Brit.I.R.E.

E.M.I. INSTITUTES LTD

Dept. 16, 43, Grove Park Road, Chiswick, London, W.4

* The E.M.I. Group includes "H.M.V.", Marconiphone and other important electronic interests

E.37

FOR FREQUENCY SUB-STANDARDS
TYPE JCF/200. 100 KC/S
Available from stock adjusted to ±0.01%
Higher accuracies supplied to special order
PRICES ON APPLICATION

V WIREMOUNTING
BRITISH PATENT NO 576290

The type JCF/200 unit illustrated above is representative of the wide range of vacuum tube units available for low and medium frequency.

G.E.C.

QUARTZ CRYSTAL UNITS

FOR STABLE FREQUENCY GENERATION

FEATURES:

Low temperature coefficient—less than 2 in 10⁶ per °C.
Patented nodal suspension. Mounted in vacuum;
performance independent of climatic conditions.
Exceptionally high Q value. High stability. Small size,
3in. × ½in. overall excluding pins. Fits standard miniature deaf aid valve socket.

SALFORD ELECTRICAL INSTRUMENTS LTD.
PEEL WORKS SALFORD 3
Phone: BLA. 6688 (6 lines) Grams & Cables "Sparkless, Manchester"

Proprietors, THE GENERAL ELECTRIC CO. LTD. England.

Coil-pack Modification

Two-station Switch Selection with Variable Short-wave Tuning

By L. MILLER

THE need occasionally arises for designing a "compromise" broadcast receiver; that is, a set with switch tuning for the local stations, plus a good normal performance for short-wave reception.

By a simple modification of the present-day widely used "tuning pack," these requirements are easily satisfied, the method used and described here by the writer having the advantage that no additional switching is necessary.

The experiments carried out were on a standard "Weymouth" two-circuit coil pack, and the values given apply specifically to that company's product, but the principle can easily be adapted, with a little experimentation in capacitor values, for other makes of tuning packs.

Modification Details. — The medium-wave band is fixed-

total capacity of some 220 pF, the inductance of the medium-wave

fore, the Home Service is peaked with the trimmer nearly fully screwed home. A further 150-pF fixed capacitor is, of course, wired across the medium-wave oscillator coil trimmer.

The Light Programme is picked up on the long-wave band, and a total capacity of 320 pF is re-

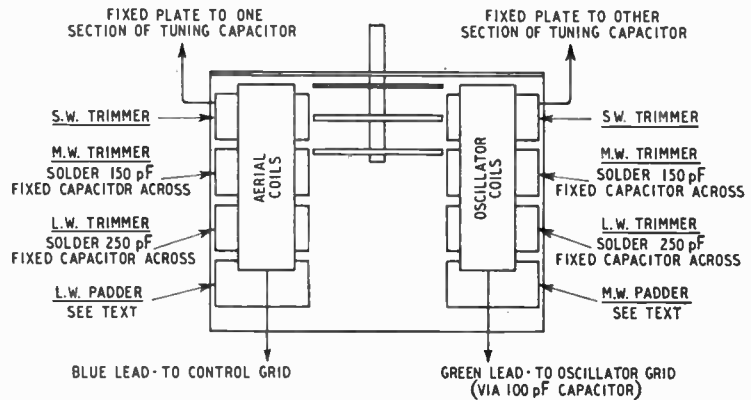

coil being 153 microhenrys. Allowing for 20 pF due to stray capacities, a fixed capacitor of 150 pF is wired across the medium-wave trimmer, which

Fig. 2. Modification of the tuning assembly, as seen from wiring side.

quired to peak the 2,000-microhenry long-wave coil to 200 kc/s.

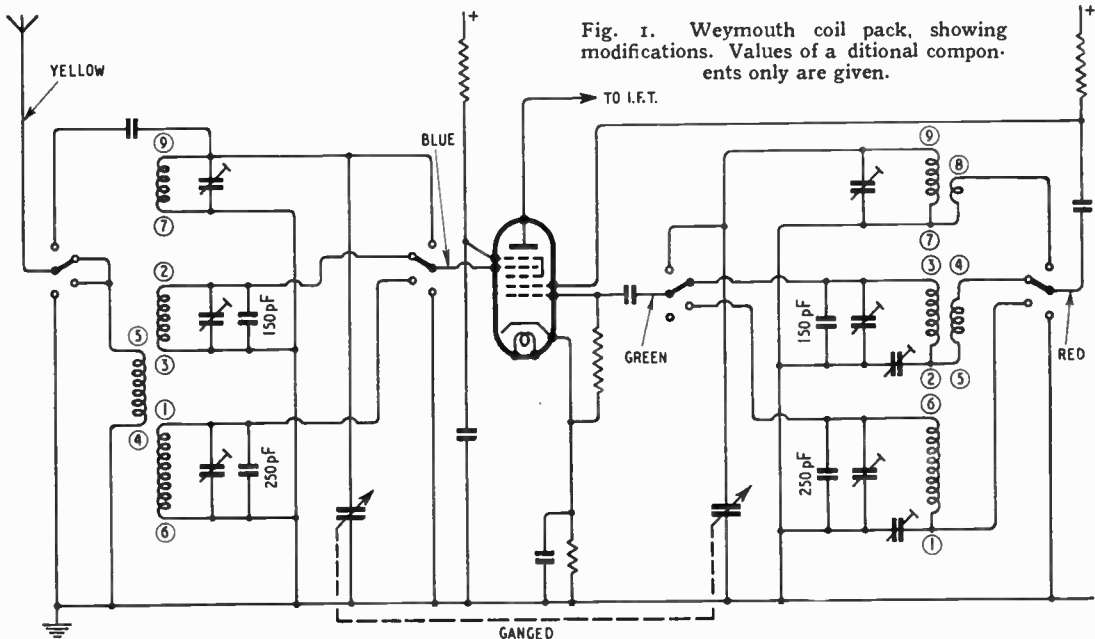

Fig. 1. Weymouth coil pack, showing modifications. Values of additional components only are given.

tuned to the Home Service on 877 kc/s, which, in the case of the Weymouth pack, requires a

tunes from 15 to 65 pF. When the wave-change switch is set at the medium-wave position, there-

Still assuming 20 pF for strays, fixed capacitors of 250 pF are wired across the long-wave

Coil-pack Modification—

trimmers (Ae. and Osc.) and with the aid of approximately 50pF capacity of the trimmers, the Light Programme is peaked.

It will be noticed that no consideration has been given to the fact that the oscillator inductances are different to that of the aerial coils, but it should be apparent that this is of no import, as once the required capacity is ascertained for the aerial coils, the same capacity is required for the oscillator coils, as the padding capacitors provide the difference in the capacity which is actually required.

Variable Short-wave Tuning.—

The fixed plates of the two-gang tuning capacitor are wired *direct* to the high-potential ends of the short-wave coils, and *not* to the leading-out wires as is usual. It is quite possible to make these leads very much shorter, and so improve the short-wave performance.

In the schematic diagram of Fig. 2 these connections are shown to the fixed plates of the short-wave trimmers, but it may be

more convenient to connect to the grid end of the short-wave coil itself, in which case the correct lug is No. 9 on both coils.

The blue lead of the pack still goes to the control grid of the frequency changer, and the green lead to the oscillator grid (*via* the 100-pF capacitor).

Initial Setting-up.—The initial setting of the trimmers is quite straightforward—the L.W. and M.W. padders should be screwed fully home, and then unscrewed half a turn, no further adjustment of these padders being necessary.

Switch the tuning pack to the medium-wave position and adjust the medium-wave oscillator trimmer until the Home Service is received; then adjust the medium-wave aerial trimmer for maximum volume.

Switch the tuning pack to the long-wave position and adjust the long-wave oscillator trimmer until the Light Programme is received, then adjust the long-wave aerial trimmer for maximum volume. The four-position switch now reads "Gram," "Light," "Home" and "Short Wave."

to be transmitted on a mosaic of photo-sensitive elements. The light of the image liberates electrons from these minute particles and as they are lost, positive charges are built up on the mosaic which correspond to the light distribution in the image. The mosaic is then scanned by a high-velocity beam of electrons which discharge these positive charges in succession. As each is discharged, an electrical pulse is imparted to a common electrode known as the signal plate, which passes these pulses on to the amplifier. Unfortunately, besides discharging the mosaic elements, these high-speed electrons also knock out of the mosaic a large number of secondary electrons which spread across the mosaic and reduce the efficiency as well as producing the spurious shading signals referred to above.

In the C.P.S. Emitron the mosaic is stabilized at the potential of the cathode from which the beam electrons come and the scanning beam is itself of relatively low velocity. The electrons, therefore, reach the mosaic at such a low energy level that they cannot knock secondary electrons out of the surface. In this way the undesirable shading signals are eliminated and much higher efficiency attained. The output signal is derived from the current in the lead to the "signal plate," which backs the mosaic, in a similar manner to the Emitron. A further post-war E.M.I. development has enabled the sensitivity of the photo-electric mosaic to be very greatly increased, and the spectral response to be improved.

Intensive work on these methods (all television research was stopped during the war) has culminated in the C.P.S. Emitron. This tube is capable of transmitting satisfactory pictures which are quite free from shading effects, with only normal lighting—such as is required for comfortable working, reading, writing, and considerably less than is normally used on a theatre stage. This is something like fifty times less light than is required by an Emitron and one-tenth that needed by the Super Emitron. Moreover, with quite moderate lighting the aperture of the camera lens can be stopped down

C.P.S. Emitron

New Television Camera

THE C.P.S. Emitron is an electronic television pickup tube which has been developed since the end of the war by the E.M.I. Research Laboratories, and gives promise of extending the scope and quality of the B.B.C. television service. Preliminary trials of this new camera tube have been very encouraging; among recent broadcasts for which it was used are the Royal wedding, an Itma programme, and the relay of Cinderella from an Edmonton theatre.

The Emitron and Super-Emitron, which were developed before the war and are still in use by the B.B.C., give very good-quality television pictures and enable a reasonable variety of programmes to be broadcast. However, they have several limitations. First, it is necessary to have a high level of illumination for the transmission of a

good-quality picture. Studio illumination at Alexandra Palace is uncomfortably intense and the stage illumination for a broadcast direct from a theatre has to be increased to such a degree that it spoils the show for the audience. Outside broadcasts are often of poor quality because the light is inadequate. Secondly, undesirable shading appears in the picture, even when there is sufficient light, and this must be continually corrected by the operating engineers. When the light is poor this shading of the picture ("tilt" and "bend") becomes uncontrollable.

The C.P.S. Emitron overcomes these defects by applying a method known as Cathode Potential Stabilization (hence the initials C.P.S.), which was invented by E.M.I. Research engineers in 1934. As is well known, the Emitron operates as follows: a lens forms an image of the scene



The new camera in use.

to such an extent that great depth of focus can be obtained in

the picture. Since shading signals are entirely absent the camera can be turned from one scene to another without the picture being upset by these troublesome effects, which can be very irritating even when the equipment is under expert control.

The C.P.S. Emitron will enable a great saving in the electric power required to illuminate indoor scenes as well as improving the comfort of the actors, and outdoor broadcasts will be possible until dusk. Indeed, the camera will go on producing a satisfactory picture until failing light stops play in most games.

the price is 24/6 complete with sealing compound and full assembly instructions.

Television Pre-amplifier

AT the limit of the television service area greater amplification than that provided in the average receiver is sometimes needed and is conveniently obtained from a pre-amplifier. The type TAB, produced by Clive Courtenay & Co., of 5, Horsham Road, Dorking, Surrey, has two R.F. stages using SP41 valves. It is designed for 80-Ω input and output impedances and gives a gain of 30 db for a bandwidth of 7Mc/s (41-48 Mc/s) so that it covers both sound and vision channels.

Designed for use with coaxial feeders it is easily connected between the aerial feeder and the receiver. It has its own internal power supply unit and is in a steel case measuring 7½in by 5½in by 2½in. There is a gain control operating by grid bias, compensated for input capacitance changes, on the first R.F. stage. The two valves are coupled by a band-pass filter and there are input and output transformers matching the valves to 80 Ω.

A padder unit designed for use in conjunction with the pre-amplifier is also available. This is a resistance network of 80-Ω input impedance providing three outputs each at 80 Ω. There is a loss of some 16 db between the input and each output, so that with the pre-amplifier the overall gain to each output becomes about 14 db. It measures 1½in by 5½in by 1½in and enables three receivers to be used on a common aerial without interaction.

Manufacturers' Products

Checking Electricity Consumption

AN electronic kilo-volt-ampere meter, designed to give large industrial consumers a warning when the rate of consumption of electricity exceeds a predetermined amount has been introduced by Everett, Edgcumbe & Co., Ltd., Colindale Works, Hendon, London, N.W.9.

It operates on the basis of comparing the time taken to charge a capacitor through a resistance, in one case from a voltage generated by the total factory load and in another by a voltage generated in the instrument and which is the "reference."

The instrument integrates the relative time taken to charge the condensers over periods of about five minutes and if the load circuit exceeds the rate of charge of the reference it actuates a relay which can be wired into a local alarm circuit or repeated to any distant part of the factory.

Aerial Connector

THE Burgoyne aerial connector provides means for making a watertight connection between a coaxial or low-impedance balanced pair, feeder and an aerial of the dipole or other resonant type, for which wire or cage elements are employed.

It consists of a massive aluminium casting, the two halves of which are held together by 16 nuts and bolts and weatherproofed by applying a sealing compound to the joints.

Large eye-bolts fitted with ceramic bushes serve as anchorages for the aerial on the outside and the feeder on the inside, soldering tags being

included to give good electrical connections. Rubber and fibre washers make watertight seatings for these bushes.

With co-axial feeders and the centre conductor and sheath joined direct to the two parts of the aerial an unbalanced system results, but this is often used quite successfully for both transmission and reception on the short waves.

The connector appears a little heavy for the purpose, weighing as it does 14½oz without the feeder. In the case of a 40-metre doublet it would probably be suspended in the centre of a 66-foot stretch of wire. However, there is a ¼in hole in the top rib for an anchorage wire if facilities allow.

The Burgoyne connector is distributed by Mail Order Supply Co., 24, New Road, London, E.1, and

Books issued in conjunction with "Wireless World"

	Net Price	By post
WIRELESS DIRECTION FINDING. By R. Keen, M.B.E., B.Eng. (Hons.), Fourth Edition, XII+1,059 pages	45/-	45/9
TELEVISION RECEIVING EQUIPMENT, by W. T. Cocking, M.I.E.E., Second Edition	12/6	12/11
FOUNDATIONS OF WIRELESS. Fourth revised Edition, by M. G. Scroggie, B.Sc., M.I.E.E.	7/6	7/10
WIRELESS SERVICING MANUAL, by W. T. Cocking, M.I.E.E., Seventh Edition	10/6	10/10
HANDBOOK OF TECHNICAL INSTRUCTION FOR WIRELESS TELEGRAPHISTS, by H. M. Dowsett, M.I.E.E., F.Inst.P., and L. E. Q. Walker, A.R.C.S., Eighth Edition	30/-	30.8
BASIC MATHEMATICS FOR RADIO STUDENTS, by F. M. Colebrook, B.Sc., D.I.C., A.C.G.I.	10/6	10.10
GUIDE TO BROADCASTING STATIONS, Third Edition	1/-	1.1
RADIO WAVES AND THE IONOSPHERE, by T. W. Bennington	6/-	6.3
RADIO DATA CHARTS, by R. T. Beatty, M.A., B.E., D.Sc., Fourth Edition—revised by J. McG. Sowerby B.A., Grad. I.E.E.	7/6	7.11

Obtainable from all leading booksellers or from

ILIFFE & SONS LTD., Dorset House, Stamford Street, London, S.E.1.

Push-pull Input Circuits

Part 2.—Cathode-follower Phase-splitter

By W. T. COCKING, M.I.E.E.

ONE of the most widely used phase-splitters has the form of a cathode-follower, but with a coupling resistance in the anode as well as in the cathode circuit. It is by no means new and it preceded the cathode-follower as such, probably in time, and certainly in popularity. The earliest reference¹ to it which the writer has been able to trace is October 1935.

In basic form the circuit is the same as that of Fig. 7 (Part I), but with the input voltage applied between grid and earth instead of between grid and cathode. It is shown in Fig. 9 in its commonest form. It has the very desirable feature that the input and both output voltages all have one common earth terminal, so that it can readily be used after a circuit which has one of its output terminals earthy. The input voltage is E_{AB} and the outputs are E_3 and E_{12} .

If the bias resistor R_b in Fig. 9 (a) is considered as short-circuited to alternating currents it is obvious that the input voltage E_{AB} must be equal to the sum of the grid-cathode voltage e_{gc} and the cathode output voltage E_3 . With resistive circuit elements it is also obvious that all these voltages are in the same phase. Therefore, E_3 must always be less than the input voltage by the amount of the grid-cathode voltage. The "amplification" $A_c = E_3/E_{AB}$ is thus always less than unity.

With the unearthed input circuit of Fig. 7 an amplification of 10-20 times is possible, but when one input terminal is earthed the amplification drops to less than unity. This is the price which must be paid for the convenience of the earthy input circuit. There is, however, also a considerable gain in linearity, through the negative feedback provided by R_c .

It is obvious that the circuit of Fig. 9 suffers from the same defect as that of Fig. 7 at low frequencies, which is that the

output at the anode tends to increase relative to the output at the cathode because of the rising impedance of C_d , the decoupling capacitor. By analogy with Fig. 7 one would expect to obtain equality of the outputs at other frequencies when $R_a = R_c$ and this is actually the relation usually adopted in practice.

However, strictly speaking, this does not equalize the outputs, for the anode current of the valve is not the only current through R_a and R_c . There is a current through the grid leak R_g which flows through R_c and increases the cathode output. At high frequencies there are also currents through the grid-cathode and grid-anode capacitances C_{gc} and C_{ga} . These currents are not in phase with the anode current and

all have a negligible effect, the equivalent circuit has the form of Fig. 9 (b). The usual expression for the amplification is given by Eqn. (1) in Appendix II and it shows the cathode and anode outputs as being equal when $R_a = R_c$. It is accurate only when the frequency is such that the capacitances exercise a negligible effect and when R_g is infinitely large. This last condition is approached very closely in practice if R_g is returned to a potential divider across the H.T. supply instead of to the cathode circuit. This is shown in Fig. 10 and in using Eqn. (1) for this circuit we write $R_g = 0$, since there is no point in providing a bias resistor when the bias is otherwise obtained.

Although it is the better from this point of view the circuit of Fig. 10 is not often used. It demands more parts than the other and the conditions for correct grid bias are rather more critical.

With cathode bias (Fig. 9) and when $R_a = R_c$, as is usual in practice, Eqn. (2) gives the un-

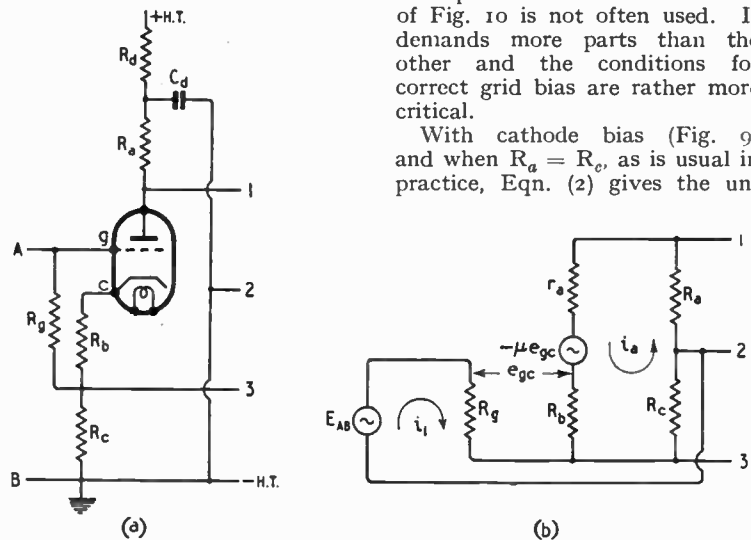

Fig. 9. The usual circuit of a cathode-follower type phase-splitter is shown at (a) and the equivalent circuit for low and medium frequencies at (b).

they have the effect of making the anode and cathode output voltages unequal in amplitude and of giving them a phase difference which is not equal to the ideal 180° .

Over the middle range of frequencies, where the capacitances

balance in the two outputs; that is, the value of this equation is the fraction by which the cathode exceeds the anode output. It is at once obvious that a pentode is likely to be better than a triode, for the numerator will be

smaller owing to the higher A.C. resistance of the valve, and the denominator may well be somewhat larger.

However, the pentode is inconvenient in this circuit because of the screen supply which *must* be decoupled to cathode if the valve is not to become effectively a triode. This introduces further possibilities of error at extremes of frequency. A triode is, therefore, almost invariably used.

It is usual to make R_a and R_c equal and about equal to r_a , while R_b is rarely more than one-tenth of R_a . Under these conditions the unbalance is of the order of

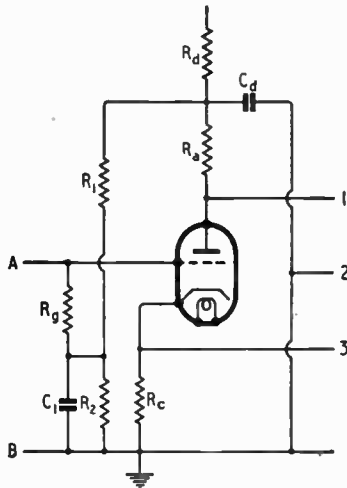

Fig. 10. A modified form of bias circuit is shown here.

$5/g_m R_g$. Now R_g can be as high as $2M\Omega$ in most cases and g_m will rarely be less than 2 mA/V . Under these conditions the unbalance will be 0.125 per cent. In no practical case is the unbalance from this cause likely greatly to exceed this figure, so that it can nearly always be ignored. It is likely to reach practical importance only when R_g is below about $100\text{ k}\Omega$.

At high frequencies the equivalent circuit has the form shown in Fig. 11, ignoring the anode-cathode capacitance of the valve. If the current i_1 through R_g can also be ignored, and it has been indicated above that this usually is permissible, the unbalance is given by Eqn. (4) of Appendix II. The expression is in two parts one with and one without the operator j attached to it. The part without j indicates a differ-

ence of amplitude between the anode and cathode outputs, the voltages so compared being correctly in opposite phase. Such an error can be corrected by a subsequent balance adjustment except in so far as its frequency-dependent term is concerned.

The part prefixed by j indicates the fractional amplitude of a component of one output in phase quadrature with the main output. It cannot readily be corrected in any subsequent circuit.

In a typical practical case we may well have $g_m = 2\text{ mA/V}$, $R_a = R_c = r_a = 20\text{ k}\Omega$, and $R_b = 2\text{ k}\Omega$. If $C_c = 100\text{ pF}$ and it is unlikely to be higher, and $C_{gc} = 5\text{ pF}$, the phase unbalance at 10 kc/s is 0.02 per cent. The inphase unbalance is some 0.2 per cent.

These figures are so small that they are without much practical significance. In spite of the fact that the cathode-follower phase-splitter is inherently unbalanced, the magnitude of the unbalance is so small that for all ordinary purposes in A.F. amplifiers it is quite negligible. Practically speaking, it is necessary only to make R_a and R_c equal, and also the shunt capacitances C_a and C_c , and to keep the grid leak of as high a value as possible. The capacitances C_a and C_c are usually composed mainly of the input capacitances of the two halves of the following push-pull amplifier, and so normally tend to be approximately equal. It is usually unnecessary to equalize them artificially.

As already mentioned the low-frequency unbalance is the same as with an earlier circuit and is given by Eqns. (7) and (8) Part I. It is almost entirely a phase unbalance and can be made negligible by the use of a large enough value for the decoupling capacitance C_d . Under normal conditions it should have a minimum value of $8\text{ }\mu\text{F}$.

The input impedance of the stage is high. It is defined as the ratio of the input voltage E_{AB} to the total current flowing from the input voltage source into the input lead. Referring to Fig.

11, $Z_{in} = E_{AB}/(i_1 + i_2 + i_3)$. At low and medium frequencies i_2 and i_3 are negligibly small, and it has already been shown that $i_1 = e_{gc}/R_g$; therefore, $Z_{in} = R_g E_{AB}/e_{gc} = R_g E_{AB}/(E_{AB} - E_3) = R_g/(1 - A_c)$. By inserting typical values into Eqn. (1) it is found that A_c usually lies

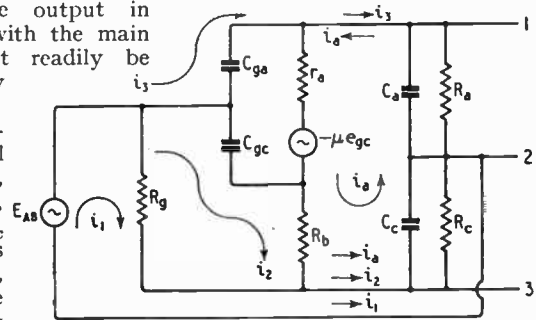

Fig. 11. The circuit equivalent at high frequencies to that of Fig. 9 (a) is given here. The anode-cathode capacitance of the valve can usually be ignored without serious error.

between 0.85 and 0.95. If it is 0.9, $Z_{in} = 10 R_g$, and with the usual $2\text{ M}\Omega$ for R_g , the input impedance becomes $20\text{ M}\Omega$.

A similar effect occurs at high frequencies with C_{gc} as long as E_{AB} and E_3 are nearly in phase. As A_c approaches unity, the cathode-earth voltage approaches the grid-earth voltage in value, and the difference between them, which is the grid-cathode voltage, is small, so that the current is small and the effective input capacitance from the element becomes very small and tends to zero.

The effect of the grid-anode capacitance is increased, however. In the limiting case when $A_a = 1$, if E_{AB} and E_{21} are in phase, the voltage acting to drive the current i_3 through C_{ga} is $E_{AB} + E_{21} = 2E_{AB}$, and then the effective input capacitance is $2C_{ga}$.

With normal values of components and over the audio-frequency range it is sufficiently accurate for most ordinary purposes to take the input impedance as comprising a resistance $10 R_g$ shunted by a capacitance $2C_{ga}$. The inequalities of, and phase errors between, the two outputs are negligible, and the amplification A_c [given by Eqn. (1)] is of the order of 0.9.

No mention has so far been made of the output impedance of the stage. That at the cathode tends

Push-pull Input Circuits—

towards that of a cathode follower whereas that at the anode conforms to the output impedance of a stage with negative current feedback. The cathode output impedance is much lower than r_a whereas the anode output impedance is much higher than r_a . In normal applications of the circuit, however, these facts are without much practical significance.

In choosing circuit values it is generally satisfactory to make R_a and R_c about one to two times the working value of r_a and to make R_g as high as possible without making it so high that reverse grid current in the valve, or surface leakages on components, become troublesome. Because the input resistance is about 10 times R_g , the value of the input coupling capacitance

with a coupling resistor of $2R_a$, the same decoupling resistor R_d and bias resistor R_b , and the same H.T. supply voltage, but the linearity will be better because of the negative feedback provided by R_c . The output referred to above is the total output, $E_{a2} + E_{c1}$.

The exact conditions can readily be calculated by the usual graphical method. The D.C. load line for a resistance $R_a + R_b + R_c + R_d$ is drawn from the H.T. supply voltage on the anode-volts/anode-current valve curves and the desired operating point is selected; the mean anode current I_a and anode-cathode voltage V_{ac} are then known. The A.C. load line for $R_a + R_b + R_c$ is then drawn through the point.

It is convenient to tabulate the anode currents and grid-cathode voltages corresponding

against input voltages and is the actual working characteristic taking feedback into account.

This procedure, while easy, takes some little time to carry out and it is helpful, therefore, to have a quick means of roughly estimating the output. With a triode the anode-cathode voltage cannot usually be swung below $25 + V_c/6$ volts (where V_c is the voltage across C_d) without driving the valve into grid current.

The maximum anode-cathode voltage is usually about the same amount less than the mean voltage across C_d ; i.e., $V_c - 25 - V_c/6$ volts. The total swing is thus $\frac{2}{3} V_c - 50$, and the peak outputs at anode and cathode are each $(\frac{2}{3} V_c - 50)/4$. This is a very rough figure, but is useful for an initial estimation of the possibilities. If $V_c = 200$ V, for instance, an output at anode and cathode of the order of 20 V peak each can be expected. With 300 V the output will be about 37.5 V peak.

The mean anode-cathode voltage is about $V_c/2$ and the mean anode current about $V_c/2 (2R_a + R_b)$. The mean cathode-earth voltage is about $\frac{V_c}{2}$.

$\frac{R_a + R_b}{2R_a + R_b} \approx \frac{V_c}{4}$. This is important, for with many valves there is a maximum permissible heater-cathode voltage and it is usually desirable to earth the heater. In the case of the EF37 valve, for instance, the rating is 100 V. There is also for this valve a maximum figure of 20 kΩ quoted by the makers for the resistance between heater and cathode, so that $R_a + R_b$ must not exceed 20 kΩ.

With such a valve therefore, V_c is limited to about 400 V and the outputs to about 55 V peak, and the mean anode current will be of the order of 5 mA. This is within the maximum rating of 6 mA.

As an example of the determination of operating conditions and to illustrate the degree of accuracy of this rough method, the dynamic characteristic will now be deduced by the accurate method given earlier. We shall take an EF37 valve strapped as a triode. Since $R_b + R_c \leq 20$ kΩ, we shall take $R_a = R_c =$

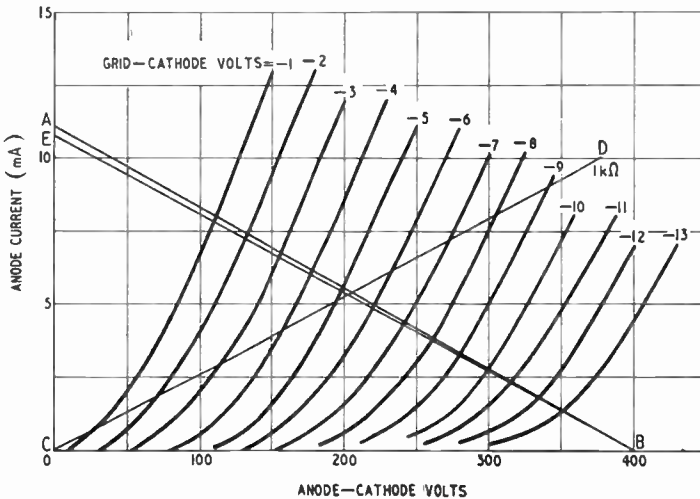

Fig. 12. Characteristics of the EF37 valve as a triode with load lines AB (36kΩ), and EB (37kΩ) and a bias line CD (1kΩ).

can be about one-tenth of that appropriate to the value of R_g alone.

The decoupling resistor R_d should be as high as possible consistent with obtaining the requisite output from the stage, and C_d should be large, say 8-16 μF. The bias resistor R_b must be chosen to suit the valve and its operating conditions, but is usually 1-2 kΩ.

Turning now to the output available, this is of the same order as that given by the same valve working as a normal amplifier

to the intersections of the line with the valve curves and to convert them to changes of current and voltage about the mean values by deducting these mean values from them. The cathode-earth voltage is then the product of the current changes and $R_b + R_c$ while the cathode output voltage is the product with R_c . The sum of the grid-cathode voltage changes and the cathode-earth voltage changes give the grid-earth voltage changes, — the input. The dynamic characteristic is the plot of cathode output

18 kΩ, since this is the nearest preferred value in the 5 per cent and 10 per cent tolerance ranges. The valve data places a limit of

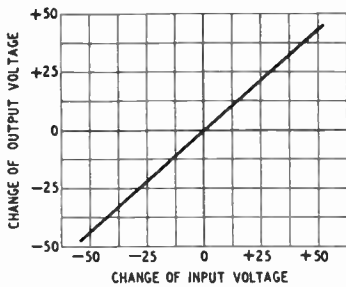

Fig. 13. Dynamic characteristics of the phase-splitter.

3 MΩ on R_g , and we can with confidence settle this at once at the standard value of 2.2 MΩ. We shall take V_c as 400 V.

The valve curves are shown in Fig. 12. As we do not know R_b at this stage we cannot draw the final load line, and we start off by drawing AB for 36 kΩ. It is obvious that the bias should be about -6 V. With an input of 5 V peak, the grid-cathode voltage would swing from -1 V to -11 V and grid current should just be avoided. The anode-cathode voltage would swing from 105 V to 308 V with a mean value of 220 V. The outputs would be -115 V and +88 V so that there is considerable distortion. The cathode-earth voltage would be $(400-220)/2 = 90$ V and the anode current 5 mA, so that the valve would operate within its rating.

A slightly lower bias would be better, but it cannot be much lower without the rating of the valve being exceeded. It is convenient to use a standard resistor for R_b , so let us try 1 kΩ. We draw the bias resistor line² by joining the intersections of the current ordinates with the grid-volts curves corresponding to the product of the current and the resistance. This is the line CD in Fig. 12. The new load line is now for 37 kΩ and is BE, and the no-signal operating point is the intersection of CD and BE at a current of 5.3 mA. The heater-cathode voltage is $5.3 \times 19 = 100$ V. It is just on the rating of the valve and it would be desirable to reduce it some-

what by reducing the H.T. voltage. The grid bias is 5.3 V.

The next step is to tabulate the grid voltages and the corresponding anode currents as in columns 1 and 2 of the table. Then prepare columns 3 and 4 for the changes of voltage and current, by deducting the no-signal values from columns 1 and 2, and produce column 5 by multiplying the figures of column 4 by the total cathode resistance $R_b + R_c = 19$ kΩ; this gives the change of cathode voltage. The sum of columns 3 and 5, in 6, gives the change of input voltage. Finally, column 7 is prepared by multiplying the figures of column 4 by the resistance R_c across which the output voltage is developed, in this case by 18 kΩ. The output at the anode is the same but with the signs reversed.

The relation between input and output voltages is shown by the curve of Fig. 13 and it will be seen that this is a straight line within the limits of accuracy imposed by rather small-scale graphical calculations. The maximum input is set by the onset of grid current, and is at a grid-cathode voltage of -1, corresponding to a grid-earth potential of +51.8 V, the corresponding output being +45 V. The amplification is $45/51.8 = 0.87$ times.

The output of 45 V peak is somewhat below the figure of

giving a preliminary indication of the output. In this case the output is limited by grid current and this indicates that a somewhat higher value of bias resistor would be better. There are, however, signs in Fig. 13 that the curve is starting to bend beyond -50 V input and but little increase in bias resistance would be practicable.

A stage such as this will just feed a pair of push-pull PX4 valves directly but in view of the high value of H.T. supply needed there is nothing to spare for decoupling. Fortunately in this case decoupling is usually unnecessary.

The heater-cathode voltage with no signal is some 100 V, the maker's maximum rating. On full output it rises to 145 V peak. It is not clear from the published figures whether this is permissible or not. Since a large heater-cathode voltage is normally used only with a superimposed signal it has probably been taken into account.

It will be seen from this that the conditions are rather tight when the phase-splitter is called on to feed a triode output stage directly and because of this the writer usually prefers to use an intermediate push-pull stage with an amplification of the order of 10 times. The phase splitter is then called on to provide an output of 4.5 volts or so only,

TABLE

1 Grid-cathode volts	2 Anode current (mA)	3 Change of grid- cathode volts	4 Change of Anode current (mA)	5 Change of cathode volts	6 Change of input voltage	7 Change of output voltage
-1	7.8	+4.3	+2.5	+47.5	+51.8	+45
-2	7.2	+3.3	+1.9	+36.1	+39.4	+34.2
-3	6.6	+2.3	+1.3	+24.7	+27.0	+23.4
-4	5.95	+1.3	+0.65	+12.15	+13.45	+11.65
-5	5.45	+0.3	+0.15	+2.85	+3.15	+2.7
-5.3	5.3	0	0	0	0	0
-6	4.8	-0.7	-0.5	-9.5	-10.2	-9.0
-7	4.3	-1.7	-1.0	-19.0	-20.7	-18.0
-8	3.75	-2.7	-1.55	-29.5	-32.2	-27.9
-9	3.2	-3.7	-2.1	-40.0	-43.7	-37.8
-10	2.65	-4.7	-2.65	-50.4	-55.1	-47.7
-11	2.3	-5.7	-3.0	-57.0	-62.7	-54.0
-12	1.8	-6.7	-3.2	-61.0	-67.7	-57.5

55 V estimated earlier, but the agreement is reasonable since the method of estimation is a very rough one intended only for

and the valve can very easily be operated well within its limits.

In conclusion, it must be pointed out that condition of R_a and R_c

Push-pull Input Circuits—

being equal, which has been assumed in all the foregoing, is one which must be closely observed in practice. It is usually desirable to employ resistors matched within about 2 per cent, but the usual tolerance of ± 20 per cent on actual value is quite satisfactory.

APPENDIX II

Referring to the circuit of Fig. 9(b),

$$U \approx \frac{i_2 + i_3}{i_a} \approx \frac{(\nu_a + R_b + 2Z_c)(1 + Z_{gc}/Z_{ga}) + 2\mu Z_c Z_{gc}/Z_{ga}}{\mu Z_{gc}} \quad \dots \quad (3)$$

under the conditions that the reactance of C_d is negligibly small,

$$U \approx \frac{2\omega C_{gc}}{g_m} \left[1 + \frac{R_b}{\nu_a} + \left(g_m + \frac{2}{\nu_a} \right) \frac{R_c}{1 + \omega^2 C_c^2 R_c^2} \right] + j \frac{2\omega C_{gc}}{g_m} \cdot \frac{\omega C_c R_c}{1 + \omega^2 C_c^2 R_c^2} \left(g_m R_c + \frac{2R_c}{\nu_a} \right) \quad \dots \quad (4)$$

that $R_g = \infty$ and that $R_a = R_o$,

$$A_c = \frac{E_{32}}{E_{AB}} = A_a = - \frac{E_{12}}{E_{AB}} = \frac{g_m R_c}{1 + \frac{R_b + 2R_c}{\nu_a} + g_m(R_b + R_c)} \quad (1)$$

where $g_m = \mu/\nu_a =$ mutual conductance.

When R_o is not infinite and $R_a = R_c$, the unbalance is

$$U = \frac{E_{32} - E_{21}}{E_{21}} = \frac{i_1}{i_a} \approx \frac{1}{1 + \frac{R_b + 2R_c}{\nu_a} + g_m R_b} \quad \dots \quad (2)$$

provided that $i_1 \ll i_a$

At high frequencies the circuit has the form of Fig. 11. Assuming that C_{ac} and R_g have a negligible effect, the unbalance is

When $Z_{g0} = Z_{g\infty} = 1/j\omega C_{gc}$ and $Z_o = Z_c = R_c/(1 + j\omega C_c R_c)$ this becomes:

References

- 1 "Resistance Coupling for Push-Pull Amplification," by Walther Richter, *Electronics*, October 1935, Vol. 8, p. 382.
- 2 "Self-Bias and the Valve Load Diagram," by W. T. Cocking, *Wireless Engineer*, December 1934, Vol. 11, p. 655.

Book Review

Klystron Tubes. By A. E. Harrison. Pp. 271 + x; 155 figures and charts. McGraw-Hill Publishing Company, Aldwych House, Aldwych, London, W.C.2. Price 17s 6d.

THE word "Klystron" is taken from the Greek, and is derived from the "breaking of waves in the sea," as they do whenever the wind and shallow ground force them to move along bodily. The higher portions on the crest of the wave are then moving faster than the lower portions in the troughs, with the result that the higher portions catch up with the lower ones. This produces a progressively steeper slope of the front of the wave, until finally the wave topples over, disintegrating into foam and spray.

A stream of electrons moving along in one particular direction can be made to behave in a fashion not unlike the above described wave if we superimpose a rapidly alternating velocity on the common uniform velocity of the electrons. Then slower moving groups will be immediately followed by faster moving groups, with the result that the faster ones catch up with the slower ones, eventually, and form what is called a "bunch." The rapidly alternating velocity is impressed on

the stream of electrons by an electrode consisting of a pair of grids connected to and surrounded by an external circuit; this is called the "buncher." It will now be clear why a device based on a process as just described has been called a "Klystron." To complete this rough description; when the beam has been "bunched," that is to say, once there is a strong alternating component of current density in the beam, it is passed through an electrode similar to the "buncher" in every respect, but called the "catcher." There the alternating component of beam current gives rise to an alternating voltage across the grids, which can and should be larger than the voltage across the grids of the "buncher," which originally gave rise to the alternating velocity component in the electron beam.

The Klystron tube, or valve, was first described in papers by the brothers Varian and W.W. Hansen working in the Physics Department of Stanford University, California, not long before the outbreak of World War II. Later on development of the Klystron was carried on by the Sperry Gyroscope Company, a firm very much concerned with aids to navigation and blind

flying and blind landing systems. Dr. Harrison, now Assistant Professor of Electrical Engineering at Princeton University, was formerly Klystron Applications Engineer at Sperry's. He is thus very well qualified to write a monograph on the Klystron, to the practical and theoretical progress of which he has himself contributed so much.

This is a book mainly addressed to the user and to the designer of Klystron tubes. By user here is meant somebody who conceives, engineers and develops, for instance, communication systems using Klystrons, or radar systems involving Klystrons—not somebody who merely takes a new Klystron out of a box and plugs it in place when the old one has failed. The book should also be of interest to those who teach modern radio engineering and who wish to have a solid and authoritative account of the principles and the theory of the Klystron on which to base their teaching. The mathematics employed in the book is of a standard implying familiarity with the elements of differential and integral calculus, and is marshalled with great care and with a view to clarity and simplicity. Though Bessel functions are employed, this should not dismay anyone who has realized that they are merely the cylindrical analogue of the familiar circular functions, to which they are indeed asymptotic in most cases.

The Klystron in all its ramifications is treated in great detail and many diagrams are given both of theoretical and practical results. A special chapter on power supplies will be very welcome to users who are new to the field, similarly a chapter on microwave measurement techniques. Design charts, a glossary of terms and symbols and a very comprehensive bibliography round off the book which should form a valuable addition to many technical libraries.

R. K.

Books Received

The World Radio and Television Annual.—Edited by Gale Pedrick. Although primarily concerned with programme matter, this annual contains a number of interesting contributions on the broadcasting organizations of various countries. Pp. 192, with many illustrations. Sampson Low, Marston and Co., 43, Ludgate Hill, London, E.C.4. Price 12s 6d.

These You Can Hear.—By W. Norman Stevens. Most of the pages in this booklet are devoted to descriptions of overseas broadcasting stations. It also includes a wavelength-frequency conversion chart. Pp. 32, illustrated. Amalgamated Short-Wave Press, Ltd., 57, Maida Vale, Paddington, London, W.9. Price 2s.

*Virtually
Distortionless*

MODEL A.D./47 10-VALVE TRIODE CATHODE FOLLOWER AMPLIFIER

This is a 10-valve amplifier for recording and play-back purposes for which we claim an overall distortion of only 0.01 per cent., as measured on a distortion factor meter at middle frequencies for a 10-watt output. The internal noise and amplitude distortion are thus negligible and the response is flat plus or minus nothing from 50 to 20,000 c/s and a maximum of .5 db down at 20 c/s.

A triple-screened input transformer for $7\frac{1}{2}$ to 15 ohms is provided and the amplifier is push-pull throughout, terminating in cathode-follower triodes with additional feedback. The input needed for 15 watts output is only 0.7 millivolt on microphone and 7 millivolts on gramophone. The output transformer can be switched from 15 ohms to 2,000 ohms, for recording purposes, the measured damping factor being 40 times in each case.

Built-in switched record compensation networks are provided for each listening level on the front panel, together with overload indicator switch, scratch compensation control and fuse. All inputs and outputs are at the rear of the chassis.



Send for full details of Amplifier type AD/47

C.P. 20A. 15 WATT AMPLIFIER

for 12 volt battery and A.C. Mains operation. This improved version has switch change-over from A.C. to D.C. and "stand by" positions and only consumes 5½ amperes from 12 volt battery. Fitted mu-metal shielded microphone transformer for 15 ohm microphone, and provision for crystal or moving iron pick-up with tone control for bass and top and outputs for 7.5 and 15 ohms. Complete in steel case with valves.

As illustrated. Price £28 0 0



RECORD REPRODUCER

This is a development of the A.C.20 amplifier with special attention to low noise level, good response (30-18,000 cps.) and low harmonic distortion (1 per cent. at 10 watts). Suitable for any type of pick-up with switch for record compensation, double negative feedback circuit to minimise distortion generated by speaker. Has fitted plug to supply 6.3 v. 3 amp. L.T. and 300 v. 30 m/a H.T. to a mixer or feeder unit.



Complete in metal cabinet and extra microphone stage. As illustrated. Price 25½ Gns. CHASSIS, without extra microphone stage. Price £21.

EXPORT

Enquiries from Overseas will receive prompt attention. **CONTINENTAL BUYERS** are invited to get into touch with our Belgian Agents:

Ms. Constant L. Bisman,
129 Avenue de la Reine,
Bruxelles

Téléph. 16.10.31.

Vortexion
LIMITED

257-261 THE BROADWAY, WIMBLEDON, LONDON, S.W. 19

TELEPHONES: LI Berty 2814 and 6242-3.

TELEGRAMS: "VORTEXION, WIMBLE, LONDON."

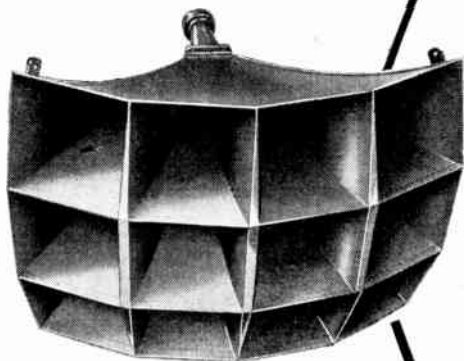

HERE IS THE WAY TO BETTER SOUND DISTRIBUTION

The Multicellular type of horn has been developed to facilitate quality sound reproduction in auditoria by providing satisfactory distribution of the higher audio frequencies essential for intelligibility. Vitavox Multicell horns are available in two types having lower cut-off frequencies of 220 and 550 c.p.s. respectively and in a wide range of cell combinations to suit particular circumstances.

VITAVOX

MULTICELL HORNS

Obtainable from your VITAVOX Dealer but do not hesitate to Consult us in case of difficulty or if you require further details.

Vitavox Limited, Westmoreland Road, London, N.W.9
Telephone: Colindale 8671-3

Yours Faithfully . . .



THIS ADVERTISEMENT FIRST APPEARED DURING MAY, 1946. WE ARE STILL SELLING AMPLIFIERS AS A RESULT ; THIS IS PARTLY DUE TO THE ADVERTISEMENT, BUT MAINLY DUE TO THE FACT THAT ONE AMPLIFIER " SELLS " SEVERAL MORE—SIMPLY A QUESTION OF HEARING IS BELIEVING.

THE FIRST AMPLIFIER BY SOUND SALES LTD. APPEARED IN 1934, AND THE LATEST SERIES INCLUDES THE 6 WATT, 12/14 WATT, 35 WATT AND 50 WATT MODELS, INCORPORATING ALTERNATIVE TYPES OF TRI-CHANNEL ELECTRONICALLY MIXED TONE CONTROL UNITS, TOGETHER WITH V.U. OUTPUT METERS IF REQUIRED.

AGENTS : Barnes & Avis, Reading; Bowers & Wilkins, Worthing; Binns Ltd., Newcastle; Dalton & Sons, Ltd., Derby; Clark & Sons, Isle of Wight; Hickie & Hickie, Ltd., Reading (and branches); Thomas Lynn & Sons, Andover; Merriots Ltd., Bristol; Needham Engineering Ltd., Sheffield; Pank's Radio, Norwich; Sound Ltd., Cardiff; Bernhard Smith, Barnstaple; Sound Services, Jersey, C. I.; Precision Services, Edinburgh; Seals Ltd., Southsea; G. E. Samways, Hazel Grove; Weybridge Radio Electric, Weybridge; West End Radio, Farnham; Vallance & Davison, Ltd., Leeds (and branches).

Sound Sales Ltd.

57, St. Martin's Lane, London, W.C.2

(TEMPLE BAR 4284)

WORKS: Farnham, Surrey. (FARNHAM 6461/2/3)

Commercial Disc Recording

Informal Lecture and Discussion at the I.E.E.

AT a meeting of the Radio Section of The Institution of Electrical Engineers on 9th December, 1947, an informal lecture on "Commercial Disc Recording and Processing" was given by B. E. G. Mittell, M.I.E.E. Mr. Mittell stated that at present commercial conditions appeared to confine the disc record to the speed, diameters and groove spacing which were in common usage.

Commercial records were, perhaps, too tied to their traditional paths, and it was necessary to consider what steps could be taken to adopt improved techniques, consistent with maintaining the continuity requisite to avoid adverse reaction from the buying public. Mr. Mittell then put forward proposals for the standardization of groove and stylus shape and recording characteristics.

Discussion was particularly invited towards a measure of agreement in this country, and an exchange of views elsewhere.

With the aid of lantern slides and exhibits the manufacture of commercial disc records was described, starting with the studio and ending with the finished record.

Demonstrations were given of recorded quality and surface noise successively in the original recording, the metal "mother" and the "pressing." Recording up to 20 kc/s was also demonstrated.

The discussion which followed indicated that there was no fundamental disagreement with the proposals for standardization of groove, stylus and recording characteristics put forward by the opener. It was thought that a preliminary committee on which the principal British record producers were represented would have no difficulty in reaching tentative agreement, and that their findings could then form the basis of a British Standard.

Attention was given mainly to recording at 78 r.p.m. and it was pointed out that the proposed

recording characteristic put forward by the N.A.B. of America was essentially a 33½ r.p.m. standard; it could not be said to have met so far with universal acceptance even in the United States. Most speakers thought that some degree of pre-emphasis of high frequencies was desirable with present recording materials, but that the amount proposed by the N.A.B. was excessive and would lead to tracing distortion at the modulation levels usually recorded on commercial discs. A rise of 3 db from 3,000 c/s to 6,000 c/s and a further 3 db from 6,000 c/s to 12,000 c/s was suggested as a suitable compromise.

There was general agreement that an extended high-frequency response was worth while, provided that distortion components in both record-

preliminary market research in America seemed to indicate that the public did not yet regard the improvement as worth the extra cost. The absence of abrasive meant that more care would have to be taken to ensure a correctly shaped needle point, and specially designed pick-up movements might be needed, owing to the reduced elasticity of the groove wall. It was pointed out that the recording characteristic was intimately bound up with the properties of the record material and that a statement of mechanical impedance limits at the reproducing point should be included in any standardization of frequency characteristic.

Groove wear during playing was discussed and it was stated that sapphire points did not necessarily damage the groove walls. A record which had been played 1,000 times

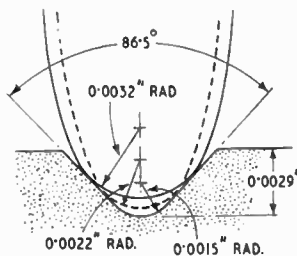

Proposals for standardization of groove, reproducing stylus and recording characteristic put forward by Mr. Mittell.

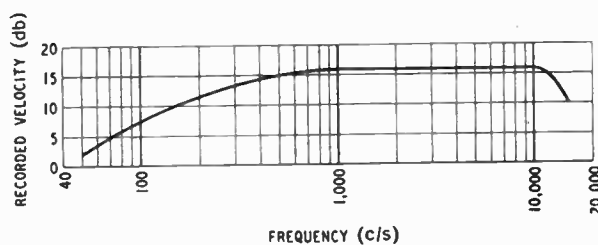

ing and reproducing systems could be reduced to a satisfactory low level. Even when the response of the reproducer, or of the ear of the listener, was restricted, the subtle improvement resulting from the recording of high, even ultrasonic, frequencies could be detected. It was thought that this might be explained on the basis of improved transient response.

The only justification for a rising characteristic, with subsequent correction in the reproducer, was the relative reduction of surface noise. Many speakers thought that the proper approach would be to reduce noise at its source by research into alternative materials for the record.

Vinyl plastics had been given extensive trials as an alternative to standard shellac mixes and had shown considerable promise. They were, however, more expensive, and

by a commercial pick-up with 38-gm vertical weight on the sapphire point was demonstrated by way of proof.

Opinions differed on the expectations of life of sapphire points. Some thought that wear could be detected after 50 playings, others that 2,000 playings could be obtained with a 30-gm pick-up before the width of the flat reached 0.002 in. In the absence of the grinding-in process the shape of sapphire and diamond styli was of paramount importance in controlling surface noise.

The development of lightweight pickups and the demand for automatic record changers meant that "permanent" points were essential. Fears of trouble through breakage were largely unfounded. With a cantilever-sprung mounting, giving vertical compliance, sapphire points could be dropped several inches on to a disc without risk of fracture.



What It Is, and How To Use It

By "CATHODE RAY"

I HAVE been asked to do something to clear up the great mystery of the small *j*—for those to whom it is a mystery. Apart from any mystery that may be considered to attach to mathematics in general, *j* seems to be surrounded by an aura of special mystery, akin to occultism and spooks. The idea is that $j = \sqrt{-1}$, which is obviously incomprehensible, seeing that no number when squared equals -1 . $\sqrt{-1}$ is openly referred to in sober mathematical works as an "imaginary number"; and when the bewildered student seeks light on this it is explained to him that imaginary quantities (i.e., those in which $\sqrt{-1}$ appears as a factor) extend into some other dimension, which does exist but cannot be visualized by the human mind. Here we recall the stories of people who have suddenly and mysteriously disappeared, and the explanation that somehow they have slipped into a fourth dimension which is outside normal human experience or comprehension. At that point the student is tempted to give up.

Well, there is something in all this, but there is no need to let it hinder one from using *j* for solving A.C. calculations. If it worries you, you can ignore all the $\sqrt{-1}$ business. Actually, however, even its unimaginableness may be a help to those, like myself, who are unhappy about any mathematical operations that they cannot visualize.

First let me say that I am not going to attempt a complete treatise on *j*. There is at least one whole book devoted to it, and extensive parts of many other books; and the Editor has better use for his precious paper supply than republishing at length what can be found elsewhere. Anybody who wants to be able to handle A.C. calculations intelligently and effectively ought to get down to it and study *j* until its use is quite natural and familiar. There is no other way. I suggest Colebrook's "Basic Mathematics for Radio

Students"; and there are some concise practical notes (Colebrook-inspired) in Hague's fine book "Alternating Current Bridge Methods." All I hope to do is to show that *j* is worth knowing and can be understood by anybody who can cope with elementary algebra and geometry.

What use is *j*, then? Students of electricity in general, and of radio in particular, start with D.C., and (unless hopelessly dim) soon find their way about D.C. circuits quite confidently. It is when they tackle A.C. that the trouble begins. It is like trying to

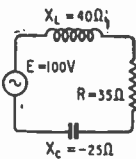

Fig. 1. Simple A.C. circuit to illustrate the meaning of *j*.

see exactly in what order a trotting horse puts down its feet; they never keep still long enough. Even when one has become accustomed to using fixed numbers for reckoning the strength of something that is rapidly varying all the time, and has grasped the idea of two new sorts of circuit element to add to resistance, there is the difficulty that these new sorts (inductive and capacitive reactances), although reckoned in ohms, cannot just be added to resistive ohms in a straightforward sensible manner.

Take an example of the simplest possible circuit that contains all three (Fig. 1). I assume you know all about how to work out the reactances ($X_L = 2\pi fL = \omega L$; $X_C = 1/2\pi fC = 1/\omega C$). What one generally wants to know in this sort of situation is (a) the strength of current that will flow, and (b) the phase of the current relative to the voltage. If one could just add up all the ohms, $40 + 35 + 25 = 100$, apply Ohm's Law, and say the current is 1 amp, everything would be nice and easy, but unfortunately there would be no such thing as radio.

What we are told to do is first to subtract X_C from X_L to get the total reactance (because the two reactances are opposite, whatever that may mean), and then work out the circuit impedance, *Z*, from the formula

$$Z = \sqrt{R^2 + X^2}$$

In this case $X = 15\Omega$, so $Z = 38.1\Omega$ if I have done my arithmetic correctly, and the current is 2.625A. The angle of lag, ϕ —the proportion of a complete 360° cycle by which the current lags behind the generator voltage—can be calculated from

$$\tan \phi = X/R$$

or alternatively (if we have worked out *Z*), $\cos \phi = R/Z$ or $\sin \phi = X/Z$. They all come to the same. Here X/R is 0.4285; so, looking up a table of tangents, $\phi = 23.2^\circ$.

Even in such a very simple example, the $\sqrt{R^2 + X^2}$ sort of thing is rather a nuisance, because one cannot do it all on a slide-rule. The squaring and the square-rooting are all right, but they have to be interrupted in the middle to do the addition. If calculations of this sort have to be done only occasionally, perhaps one can put up with that. But it is very time-wasting when there are strings of them, as there may be in working out experimental results or in designing. And this is only the simplest possible case. When it comes to working out complicated circuits, either for particular values as in Fig. 1, or generally, by means

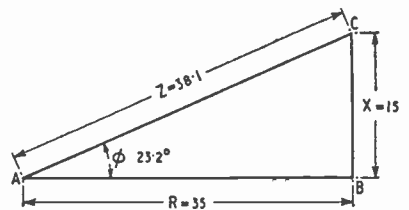

Fig. 2. The graphical method of calculating the impedance of the circuit, Fig. 1.

of algebra, and expressions of the $\sqrt{R^2 + X^2}$ kind have to be multiplied and divided and otherwise

manipulated, it decidedly becomes what the R.A.F. describes as a bind. And anyway, what lies behind this awkward $\sqrt{R^2 + X^2}$?

In the days of our youth I suppose we were all confronted with the celebrated Theorem of Pythagoras, according to which, in a right-angled triangle, the length of the hypotenuse (word the Greeks had for the longest side) is related to the lengths of the other two sides in exactly the same way as the magnitude of the impedance in Fig. 1 is related to the reactances. So an alternative method of arriving at Z and ϕ is to draw a right-angled triangle with the lengths of its shorter sides representing R and X to any convenient scale (Fig. 2). Then the length of the third side to the same scale gives Z ; while ϕ can be measured with a protractor. I usually measure R and X along a

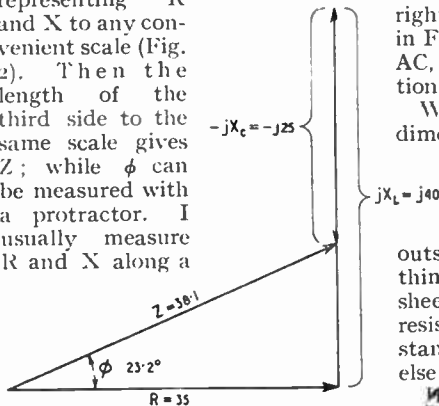

Fig. 3. Fully graphical solution to Fig. 1.

corner of whatever paper I am using (provided I can depend on its having been cut at right angles).

Although that is probably the quickest and most mistake-proof method for approximate results with this simple circuit, it is not quite so convenient for complicated circuits, and breaks down entirely when general forms have to be worked out.

If, then, we are likely to have more to do with A.C. circuits than occasionally computing the simplest forms, it is worth while adopting a better method.

The process of adding a number of things of the same kind (such as resistances in a D.C. circuit) can helpfully be represented by distances moved along a straight line. The usual convention is to measure the distances from left to right along a horizontal line; negative quantities are then represented by movements from right to left. The plus and minus signs

are the instructions to add or subtract (in the graphical representation, to move to right or left), and the number indicates the quantity or distance. The only stipulation is that they must all be the same sort of quantity—all ohms resistance, or all volts, or all potatoes, etc.

Resistance and reactance, although both measured in ohms so that they can both be represented to the same scale in a diagram, just don't add in this way. It is a fact of nature, which can't be changed. They do combine in a certain way to make impedance; and, as we know, that certain way happens to be the same way as that by which two journeys at right angles, such as AB and BC in Fig. 2, are equal to one journey, AC, so far as distance and direction from the start are concerned.

We live in and can visualize three dimensions; but suppose there were single-dimension or D.C. creatures that lived in a straight line and were incapable of going outside or even imagining anything else. To them it would be sheer nonsense to say that 35Ω resistance (which they could understand) added to 15Ω of something else gave 38.1Ω .

If we just said $+ 35 + 15$, the carrying out of this operation would be a total movement of 50 units to the right. So it is necessary to have some other symbol of command, or *operator*, to mean that the 15 units must be in a different direction, i.e., at right angles. A very convenient operative symbol is j . So the instructions for calculating the combined impedance of 35Ω resistance and 15Ω reactance are written very concisely as $35 + j15$. Expressing this generally:—

$$Z = R + jX$$

In Fig. 1 there are two kinds of reactance which are mutually cancelling, so can be expressed as $+$ and $-$. So the more detailed formula is:—

$$Z = R + j(X_L - X_C)$$

and if the whole thing were done in a diagram it would be as in Fig. 3.

You may have noticed that the Z was printed in special type. That is the conventional way of showing that it is not just the ordinary algebraical symbol " Z " representing *how much* there is of

Now available
NEW
TROUBLE TONE
REPRODUCER

Gramophone Cabinet Amplifier TP. 614 (RC)

(as illustrated) incorporates NEW Amplifier T.614, specially designed for High Fidelity reproduction of gramophone records. Variable frequency response. Separate control of bass, treble and middle frequencies. Inputs for mic. and gram. with mixing controls. Alternatively with single record player (TP. 614). Also available, new TWIN TWELVE speaker for use with this model.

Write for illustrated list of full Sound Equipment range, including AC/DC types.



TRIX
Quality
SOUND EQUIPMENT

THE TRIX ELECTRICAL CO. LTD.

1-5 MAPLE PLACE · TOTTENHAM COURT ROAD · LONDON, W.1
TELEPHONE: MUSEUM 5817 · GRAMMOPHONES: TRIXAD, WESDO, LONDON.

"j," What It Is, and How to Use It—a certain quantity (to wit, impedance). It is what is called a vector operator, involving direction as well as magnitude. So when you see " $Z_1 + Z_2 = Z_3$ " it does not mean that if Z_1 and Z_2 were 100Ω and 150Ω respectively, then Z_3 would necessarily be 250Ω. They have to be worked out fully in the $R + jX$ form.

Now as j is simply an instruction to change direction through one right angle anti-clockwise, two such instructions in succession

Fig. 4. Graphical construction illustrating the adding of two impedances, Z_1 and Z_2 , in series.

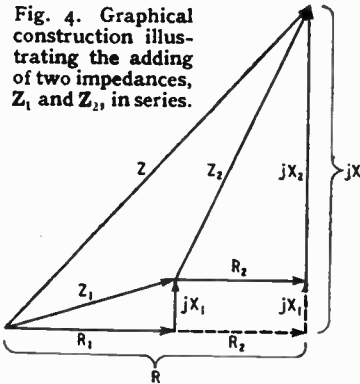

must change it through two right angles, which has precisely the same ultimate result as a minus. The obvious shorthand for jj is j^2 ; so the operator j^2 is equivalent to $-$, and $j^2 1 = -1$; j is not an algebraical quantity like x or y , but the result of treating it as if it were is $\sqrt{j^2} = j = \sqrt{-1}$ is unimaginable, and therefore quite appropriate as a factor to apply to quantities which lie outside the universe of the one-dimensional D.C. people. What is more, treating j as an algebraical quantity does get the sums right. Although quantities with j in them must always be kept strictly separate from those without, the algebra often results in two j quantities being multiplied together, giving a j^2 . When that happens, it is quite allowable—and very convenient—to substitute -1 for j^2 , and so bring the quantity concerned over on to the ordinary rational side of the iron curtain.

I shall give an example of this shortly; but in the meantime it would be as well to be quite clear that all j or up-and-down quantities can be combined together by the usual laws of algebra or

arithmetic (so long as the label " j " is not allowed to come off until it is squared), and of course the same for the non- j quantities. So the impedance of any circuit, however complicated, can be expressed in the general form

$$Z = R + jX$$

in which " R " and " X " stand for more or less elaborate expressions.

The simplest possible case, after Fig. 1, is a circuit in which there are two impedances in series. Call them Z_1 and Z_2 , and their component parts R_1, X_1, R_2 and X_2 . (X_1 and X_2 may of course themselves be combinations of positive and negative reactances.) Then the impedance of the whole lot, Z , is

$$Z = Z_1 + Z_2 = (R_1 + jX_1) + (R_2 + jX_2)$$

Sorting these out,

$$Z = (R_1 + R_2) + j(X_1 + X_2)$$

which can be renamed

$$R + jX$$

where $R = R_1 + R_2$ and $X = X_1 + X_2$

This ought to be almost painfully obvious, but in case it isn't, the whole thing should be quite clear if it is done graphically as in Fig. 4. Here it is all the same whether the whole impedance, Z , is arrived at by adding the two separate impedances Z_1 and Z_2 , either as wholes, or in steps (R_1 to the right, jX_1 up, R_2 to the right, jX_2 up) or after classification (R_1 to the right, R_2 to the right, jX_1 up, jX_2 up).

"So what?" you say. Well, provided that it was obvious to you all along that when adding two—or any number—of impedances in series the resistances and reactances could be separately added to reduce the circuit to only two elements—one omnibus resistance and one omnibus reactance—then the above does not carry you any further, except perhaps to emphasize the basic principle of combining impedances in the j manner. Once you have got the whole impedance into the form

$$Z = R + jX$$

then the magnitude of Z , which is denoted by Z , can be calculated in the usual way from

$$Z = \sqrt{R^2 + X^2}$$

and the phase angle from

$$\tan \phi = X/R$$

Actually, however, one often doesn't bother to do so. To specify

any impedance completely, two things are necessary. They can be the magnitude and phase angle, Z/ϕ ; for example $38.1\Omega/23.2^\circ$ in Fig. 1. But seeing how convenient it is to work with j (if you don't see yet, I hope you soon will), it is often better to adopt the alternative method, $R + jX$, and to say that the impedance in Fig. 1 is $35 + j15$. This is the form in which some types of impedance-measuring instrument read. There are still other forms, such as the sin-and-cos form; but that is another story. The choice is purely a matter of ease and convenience, just as the settling of a debt may take the alternative forms of a bar of gold, a cheque, a shipment of coal, or an entry in a book. Similarly, there are standard methods of converting from one form to another. For impedances, the $R + jX$ form is becoming increasingly popular.

As you are no doubt bursting to point out, using j does nothing to simplify the Fig. 1 calculation if you have to find the impedance in the Z/ϕ form. It only provides an alternative form that cuts out the $\sqrt{R^2 + X^2}$ work. But try a slightly less simple example—Fig. 5. Here there are two impedances in parallel. Now the beauty of the j method is that by substituting Z 's for R 's the ordinary D.C. circuit principles—Ohm's Law and all that—can be used for

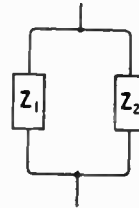

Fig. 5. General case of two impedances in parallel.

A.C. circuits. The rule for resistances in parallel is

$$R = \frac{1}{\frac{1}{R_1} + \frac{1}{R_2}}$$

which easily reduces to

$$R = \frac{R_1 R_2}{R_1 + R_2}$$

In the same way

$$Z = \frac{Z_1 Z_2}{Z_1 + Z_2}$$

To work this out for completely general Z_1 and Z_2 —that is to say, each being any possible combina-

tion of R and X—is admittedly quite a lengthy job by this means, and the final formula is complicated. For the sake of clearness, take the special case of it shown in Fig. 6, where the circuit is supposed to be tuned to series resonance by making $X_1 = -X_2 =$ (say) X. R_2 is zero; so call R_1 just R.

Then $Z_1 = R + jX$
 $Z_2 = -jX$
 So $Z = \frac{Z_1 Z_2}{Z_1 + Z_2}$
 $= \frac{(R + jX)(-jX)}{R + jX - jX}$
 $= \frac{X^2 - jXR}{R}$
 $= \frac{X^2}{R} - jX$

This means that although in the loop circuit, in which all three elements are in series, the two reactances cancel out leaving only R, as a parallel or rejector circuit Z is *not* a pure resistance. It is, in effect, a pure resistance, in magnitude X^2/R , in series with a capacitive reactance which is the same as X_2 . Generally in radio circuits R is very small compared with X, so X_2/R (the so-called dynamic resistance) is very large compared with X, and the $-jX$ can almost be neglected.

Compare the above very easy working with the old $\sqrt{R^2 + X^2}$ way. First it would be necessary to transform X_1 and R_1 into their parallel equivalents; then combine the resultant reactance with

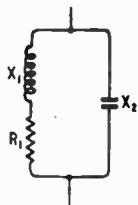

Fig. 6. Special example of impedances in parallel, in which X_1 is made equal to $-X_2$. The j method gives a quick solution.

X_2 ; and then transform the resulting X and R into series equivalents.

That is not to say the j method is always the best. Experience shows which method to choose. But even apart from its usefulness for such calculations as the above, it is worth while as a link between algebraical and graphical work, and generally for making things more intelligible. And I have kept to only one part of j -work—impedances. One really ought to start with currents and voltages, and do the thing properly under the heading of "Vectors." But, as I said, my function is not to duplicate what the books say; only (this time) to try to show that j is useful and not unreasonably hard to understand.

Valve Symbols

THE British Standards Institution (28, Victoria Street, London, S.W.1) has recently issued a pamphlet (B.S.1409:1947) giving standardized letter symbols for reference to electrodes and quantities relating to valves. All symbols for elements or quantities inside a valve are small letters, while those referring to externals are capitals; thus, r_a refers to the internal A.C. resistance while R_a is used for external resistance. Similarly, c_{ag} is the internal anode-grid capacitance but C_{ag} any external capacitance across the same points. Double subscripts are used, as above, to indicate the points between which the element is effective.

The valve electrodes are indicated by small initial letters of their names, as "a" for anode, with the exception of the cathode which is designated by "k." This is Continental usage and is strange to British eyes; it is doubtless necessitated by the use of "c" for capacitance.

The sections of multiple valves are labelled by letter subscripts, as "aa" for diode anode, while the halves of double valves are indicated by single and double "ticks" as, $k', g', a', k'', g'', a''$, for a double triode. The various grids of multi-electrode valves are indicated by number subscripts in order outwards from the cathode. B.S.1409 costs 2s.

"High-quality Amplifier Design"

A Correction

In Fig. 3 of this article in last month's issue, the anode load of V_2 should be 47 kΩ, and not 4.7 kΩ as shown.

The author recommends the addition of a 47-pF capacitor across each of the 0.47-MΩ resistors feeding the grid of V_2 , especially if a screened lead is used to feed this grid. The addition recommended makes for better balancing of the circuit at high frequencies, with slight reduction of distortion and slightly less phase-shift.

How to WIN SALES and Influence people



Lesson number one in selling is to present your product attractively. We are specialists in this field. We design and build cases that not only fit the job but do a job—of hard selling. And we work fast—7 days from rough sketch to finished product, if necessary.

IMPOSSIBLE? BUT IT'S TRUE
 TRY US AND SEE



PRECISION BUILT
 INSTRUMENT CASES

112-116, NEW OXFORD ST.,
 LONDON, W.C.1. MUSeum 5944.

Unbiased

By FREE GRID

Is Spookology Spurious?

I DARE say that some of you may have heard of the famous rectory at Borley, in Suffolk. It is hard by the ancient town of Sudbury where Mr. Pickwick laid down the principles which he deemed it expedient to follow whenever he found himself in the midst of an excited election crowd, as he did when he and his followers were in that famous old borough.

It is not with any desire to adopt his advice of shouting with the crowd that I raise the subject of Borley rectory. If recent reports are to be believed, it is still known as the most haunted house in England, as it was when I recollect it in its heyday some thirty or more years ago; and this, mark you, even though it has since been destroyed by fire and razed to the ground. What surprises me is that although it has been visited by Professor Joad and by sundry B.B.C. officials, nobody seems as yet to have had the gumption to adopt modern scientific research methods, such as radar, to elucidate the mystery:



A paranormal entity.

They have been content to rely for their observations on the human senses to detect the presence or otherwise of what I see are now described as paranormal entities—these being the same things as you and I in our vulgar unscientific way used to call ghosts.

It has already been pointed out in

Wireless World (page 174, May, 1946) that American observers have shown that these so-called paranormal entities are opaque to radio waves of certain length and, therefore, give an indication of their presence on the radar screen. This new application of science is known as radio-psycheuresis, and the specially designed radar apparatus which it employs is called a radio-psycheurlator.

It looks, therefore, as if the duty of being the first to use this new radio aid to ghost detection will devolve on me. Quite frankly I don't intend to go alone, not because I am afraid of paranormal manifestations but simply because my unsupported testimony might be received with incredulity in scientific circles. In any case, I shall want somebody to attend to the diesel-driven generator for supplying power to the radar apparatus. Any reader who is prepared to share my damp and dismal vigil should, therefore, get in touch with the Editor.

Rationalized Radio

IT is astonishing how difficult it is to argue with some men. If you are not very careful they will, when a discussion threatens to go against them, adopt the tactics of a woman or a cross-examining counsel and browbeat and confuse you to such an extent that you will find yourself using your own arguments to contradict yourself. You finally end up by not knowing whether you are for or against the thing you are arguing about. I well recollect this happening to me some years ago when giving expert evidence for the Crown in a well-known murder trial which ended in the jury stopping the case and the acquitted prisoner giving me the inside story of the crime as a token of his gratitude.

The reason that I mention this now is that I have recently had a very heated argument with a man who wants to adopt what I call totalitarian methods in broadcast listening although he terms it the rationalization of radio. He points out, quite rightly, that the function of a radio receiver is fundamentally the same as that of a transmitter.

Both are reproducers, their function being to give out a faithful rendering of what is put into them, be it good, bad or indifferent from a musician's point of view. My friend further states that this goal of perfection is not, and cannot be, attained with our present knowledge. Various deliberate distortions, such as contrast contraction, have to be introduced in the transmitter and



Expert evidence.

these ought to be carefully ironed out and counterbalanced in the receiver.

All this seems obvious, but where I fail to agree with him is in his methods of carrying out his ideal. He suggests stopping the sale of ordinary radio sets and having special receivers issued by the B.B.C. These would be designed by their engineers to meet the characteristics of the corporation's transmitters. The sets would be serviced and controlled by the B.B.C. in much the same manner as our telephones are supplied and looked after by the G.P.O.

This is, of course, sheer radio totalitarianism and, as I pointed out to my idealistic friend, if we submitted to it we might just as well abandon the radio link altogether and get the B.B.C. to supply us with carrier-current programmes over the lighting mains. Instantly he agreed with me and, before I knew where I was, I found myself being congratulated on being a convert to the carrier-current system. It is, of course, this sort of technique in argument which is so dangerous and so strongly akin to political platform methods where both sides speak with such a mixture of sincerity, conviction and low cunning that you end up by not knowing what to believe and caring less.

LETTERS TO THE EDITOR

Is H.F. Broadcasting Worth While? ♦ F.M., A.M., and Interference ♦ Impregnation of Windings ♦ Awkward Components

Short-wave Broadcasting

THOMAS RODDAM'S article, "Short Waves for Pleasure," in your October issue, together with the statement of Brigadier-General Stoner, Chief Communications Engineer, United Nations, that of the 300,000,000 people throughout the world who daily listen to some form of broadcasting less than 3 per cent hear any form of direct short-wave broadcast, prompts me to write about the appalling waste of frequency channels, not to mention public money, that is being expended on short-wave broadcasting throughout the world.

Under present chaotic conditions the reception of a short-wave station is a grimly serious business for which the ordinary broadcast listener with his single (16-50 metres) short-wave band receiver is, to put it mildly, hopelessly ill-equipped, and when a station *has* been tuned in the programme value is nil unless the wanted station happens to be the strongest signal in the band at that geographical point.

Not satisfied with the truly appalling chaos that exists, the broadcasting authorities of nearly every country in the world whose treasury can squeeze the necessary funds from the taxpayers are striving to increase their transmissions in every language and dialect with which mankind is afflicted. Most of the peoples speaking these languages, incidentally, are too poor to eat, let alone afford the doubtful luxury of a radio receiver capable of receiving these transmissions.

Could anything be more insane? The magic of the word "propaganda" has so allured all the ruling powers-that-be in the world that this senseless waste of public money, labour, and communication channels must go on. National prestige would suffer otherwise, forsooth! But so long as the B.B.C., for instance, can produce its odd letter or so of en-

thusiastic appreciation from an eccentric Kaffir on the African veldt, I suppose the end will justify the means.

Surely it is time for a general stocktaking of the whole field of short-wave broadcasting, to assess its value to the community in terms of the enormous expenditure of money, time and valuable technical and other labour. In this it is the duty of radio technicians to take the lead in arousing governments to a sense of responsibility in this matter.

The technical press and the radio engineering profession can discharge its duty to the people at large by ceaselessly "plugging" the present mutually unsatisfactory state of affairs. Some day the truth will penetrate the deep recesses of Portland Place, Whitehall, and (who knows?) even beyond the Oder and the Statue of Liberty.

F. W. T. ATKIN.

London, W.9.

"F.M. and Monopoly"

A LETTER under this heading in your January issue contains the statement: "Only long overdue legislation (already existing in certain European countries) prevents a *selfish minority* from being obliged to keep offending apparatus in good order and fit suppressors—the cost of which would be quite small."

This frequent complaint about "selfish minorities" and the like incites me to ask if your correspondents can tell us, more precisely, what they mean by these expressions. And do they really believe that the fitting of suppressors to a limited range of apparatus—amenable to measurement and control—will, alone, suffice to eliminate the more prevalent types of interference.

As to the existence of legislation in other countries; can anyone name a country in Europe (or elsewhere) where the listener, intent on good reception, has, on

RE-ENTRANT HORN TYPE 42 REH



The new 42REH has advantages of complete weather-proofness, smaller overall length, better weight distribution and consequently greater ease in handling, which make this one of the most popular of the new F.I. loudspeakers. The horn is designed for use with the standard F.I. L.S.7 Unit and allows for this unit to be driven to 12 watts input. A spun aluminium cover over the unit has room for housing a suitable matching transformer.

The construction has been designed so that the whole unit is assembled and held together with ONE LARGE NUT only. This construction enables a number of units to be packed for export in a space which is a fraction of that normally required; assembly is a matter of a few minutes unskilled labour. This unique feature will recommend itself to all export buyers particularly.

The 42REH is not of the "loud-hailer" type of speaker, but is designed to cover a range of frequencies considerably greater than those needed for purely "announcing" purposes: i.e., it is suitable for all normal requirements of high power reproduction of music as well as speech.

Dimensions assembled ...	22in. dia. x 24in.
Bell diameter ...	22in.
Cut-off frequency ...	175
Effective Air Column ...	42in.
Weight Horn only ...	8 lbs.
Shipping space ...	One—23in. x 23in. x 18in. 12—33in. x 33in. x 27in.

F.I. for P.A.
FILM INDUSTRIES LTD.
 CO, PADDINGTON ST., W.1
 Telephone: WELbeck 2385

Letters to the Editor—

average, better opportunities and service than is available in these islands?

Lastly: whilst the fitting of suppressors and the elimination of interference is most desirable, it may be that the cost, if applied to all *potentially* offending apparatus would press too hard on our national economy to be sanctioned at the present time. This, I must add, is personal opinion, and it may be wrong, but, at least, it seems a reasonable assumption, having regard to the many other cuts and restrictions in national expenditure.

Rugby. T. H. KINMAN.

THE focal point of W. H. Cazaly's letter on F.M. appears to be a rash presumption that "the great majority of the listening public do not like, or want, super-high-fidelity reproduction."

As we have never had the chance of hearing such reproduction it is astonishing that Mr. Cazaly can glibly state that we don't like it. If he pauses to think for a moment, he will, no doubt, admit that our receivers invariably employ circuits designed, in the interests of selectivity, to remove most of the high, and all the very high audio frequencies. Many and various attempts have been made, usually by the use of electrical and mechanical resonances, to replace, in the amplifier and speaker, what has been carefully eliminated in the tuned circuits. This does not give fidelity, any more than do gramophone records reproduced through "level" amplifiers.

It is true that there is very little to choose between wide-band A.M. and F.M. so far as the recreation of studio sound is concerned. It is in the matter of interference that F.M. scores so heavily, for, to make A.M. as silent a service, all electrical apparatus, including lighting switches, would have to be fitted with suppressors. This is impracticable. In addition, F.M. can deal effectively with thunderstorms and atmospheric, while A.M. and legislation most certainly can not.

During the last few weeks I have been listening to the B.B.C. experimental F.M. transmissions

from Alexandra Palace on an unpretentious but carefully home-made receiver. The quality is astonishing, and the silent background quite uncanny. Before I am accused of living in Alexandra Park let me say that I am using an indoor dipole 25 miles from the transmitter, which, I believe, achieves a mere half-kilowatt in its aerial.

It is really rather frivolous to suggest that one will be forced to listen to the National F.M. service exclusively. There is no unduly difficult or expensive problem involved in incorporating F.M. in an all-wave receiver, although, to cover foreign listening, an additional short-wave band would probably suffice. Incidentally, it is cheaper to install a F.M. transmitter than to provide an equivalent A.M. coverage.

Obviously, the development of such a service will be delayed by present economic difficulties, but I sincerely hope that this country will proceed, as rapidly as possible, with a system which seems to offer the nearest approach to perfect quality in broadcast reception currently available.

S. C. BARRELL.

Ashstead, Surrey.

Television Standards

IN his references to television in his article "Broadcasting Jubilee," in your December issue, P. P. Eckersley has surely overlooked the fact that television is essentially an entertainment for the home.

Criticism of television by non-technical viewers, is not on account of the definition or the size of screen, but rather on account of the lack of colour. So many items in television broadcasts need colour; ballet, opera, exhibitions of pictures for example. For home reception a 600- or 700-line picture in colour would I think be entirely satisfactory.

The "electronic distribution of films" or cinema television, is an entirely separate subject. Possibly 1,500 lines would be required for this, but the problem is one for the cinema industry.

To lay down standards for home television one must take into account the sort of programmes transmitted and I would say that the B.B.C. has certainly sketched

the general pattern of the television art.

The cinema is not a yardstick for the measurement of the "goodness" of a television picture. Even the Government Committee made this error.

G. H. L. THOMAS.

Herne Bay, Kent.

Impregnated Windings

IN a letter to the Editor of *Plastics* (Dec., 1947, issue), C. R. Pye expressed concern at the attitude of British radio manufacturers towards the impregnation of windings. There are some statements and criticisms in this letter which cannot be allowed to pass unchallenged.

Mr. Pye states, correctly, that few of the transformers and chokes exhibited at Radiolympia were impregnated. He infers, incorrectly, that the same is true of the production models. The omission of impregnation for exhibition purposes improves appearance, and enables the standard of workmanship to be seen more clearly. No other reasons need be sought.

Mr. Pye "made enquiries at a technical level," and was told that "manufacturers were not convinced of the benefits of impregnation." In view of Mr. Pye's remarks on p. 625 of the same journal, this is understandable. Nevertheless, he proceeds to accuse the industry of sabotaging the export drive by this attitude, with many details of the perils which beset "dry" windings.

He is apparently unaware of the policy of designing special export models, speaking of "exportable commodities [which] are unsound technically." He states with more courage than wisdom: "if components can be kept free from permeation of moisture they will function satisfactorily." One would wish this were true. Personal experience of tropical conditions has shown that this is a comparatively minor point. Mr. Pye refrains from stating the effect of impregnation on fungoid growth and insects. He does not mention that there is no impermeable impregnant, thus removing all reason for using the process.

The truth is that impregnation is used by all reputable manufacturers, the main advantage being increased mechanical rigidity. It

is very doubtful if it would ever be used for moisture protection alone. There are many more efficient methods of achieving this, such as immersion in bitumen. Examples of this were shown at Radiolympia, but were not readily recognizable as transformers and chokes by those unfamiliar with such gear. R.F. coils are generally waxed, for similar reasons. The resulting "tropicalization" is of an adequate standard.

Mr. Pye is a varnish chemist. We may therefore forgive electrical inaccuracies. We cannot forgive unjustified criticism based on such inaccuracies. If Mr. Pye can produce an impregnant that will not react with enamel insulation, while retaining a low permeability, its adoption will follow without any encouragement.

D. W. THOMASSON.
Electronic Applications
Research Laboratory, Exeter.

Components for Amateurs

MAY I ventilate in your columns a grievance amateurs hold against manufacturers of certain larger components—notably paper smoothing capacitors, chokes, transformers, etc.—who, with few exceptions, insist on building these units upside-down. The designs, with their fixing flanges at the bottom and terminals perched at the top, are obviously relics of the old "breadboard hookup" days.

Even the not-so-modern amateur uses a metal chassis as the basis of his set and likes to keep his wiring ship-shape underneath. Valve manufacturers realized this many years ago but the fact seems to have escaped designers of other components with a result that wiring keeps popping in and out of the chassis and trailing up and down components like a creeper on a trellis.

Perversely, these unshrouded terminals held magnificently aloft are invariably high potential spots which make running adjustments to pre-sets quite unnecessarily precarious.

With components made the right way up; i.e., with terminals protruding into the chassis at the flanged or fixing end, there is no reason why anything on the upper deck should be dangerously live and the improvement in appear-

ance and efficiency is, surely, obvious.

S. JOHNSON.
Twyford, Berks.

Television and Thunderstorms

IN connection with Mr. Hill's experiences (your Sept. issue) some observations which I made at radar stations in Denmark may be relevant. The frequency mainly used there was 600 Mc/s, and the greatest distance from which echos normally could be received was about 30 miles. Under certain weather conditions this range increased for a short time to 150 miles and more.

The reason for this increase was obviously layers of different temperature in the atmosphere ("inversions of temperature"), which refracted the waves back to the ground, so that they followed the curvature of the earth over a long distance. Similar conditions in the atmosphere may also account for the extremely good reception of television outside the local zone just before a thunderstorm. OTFRID REIGER.
Vienna.

MANUFACTURERS' LITERATURE

ILLUSTRATED leaflet describing complete equipment for visual alignment of R.F. and I.F. circuits from Erskine Laboratories, Scalby, Scarborough, Yorks.

"Mullard Valves for Industry and Communications," Part 1, including valves up to 25 watts dissipation supplied for electronic and telecommunication equipment, from Technical Publications Dept., Mullard Wireless Service Co., Century House, Shaftesbury Avenue, W.C.2. Circulation restricted to professional equipment designers.

Catalogue of photoelectric cells from Radio-Electronics, St. George's Works, Merton Road, Norwood Junction, London, S.E.25

Illustrated leaflet describing Export Model 127 car radio receiver for short, medium, and long waves from Romac Radio Corporation, The Hyde, Hendon, London, N.W.9.

Technical details of transformer turns-ratio bridge (Type 307B) and oscillator detector units (Types 403A and 404A) from Dave Instruments, Harlequin Avenue, Great West Road, Brentford, Middlesex.

"Cossor Gee Mark III," Part 1, General Description, from Cossor Radar, Wren Mill, Chadderton, Lancs. Available to air operating companies, service organizations, etc.

The following figures are the pass figures on final test for Model QA12/P AMPLIFIER



FREQUENCY RANGE
± 0.3 db 20 - 20,000 c.p.s.
SENSITIVITY
1.5 millivolts for full output
(without boosts)
15 millivolts for full output
(with boosts)
BASS CONTROL RANGE
- 12 db to + 16 db at 30 c.p.s.
relative to 600 c.p.s.
TREBLE CONTROL RANGE
- 30 db to + 18 db at 15,000
c.p.s. relative to 600 c.p.s.
DISTORTION CONTENT
(up to 12 watts output)
2nd Harmonic < 0.2%
3rd Harmonic < 0.3%
Higher order < 0.03%
Total < 0.4%
BACKGROUND NOISE
better than - 66 db at full gain
DAMPING FACTOR - 12
INPUT IMPEDANCE
1.5 megohms
SOURCE IMPEDANCE
Up to 50,000 ohms
OUTPUT IMPEDANCE
7 and 15 ohms

2262

 **ACOUSTICAL**
ACOUSTICAL MANUFACTURING
CO., LTD., HUNTINGDON
TEL: 361

RANDOM RADIATIONS

By "DIALLIST"

Interference

ONE comes across some queer faults! Here's one that gave me a spot of bother. For some time it had been noticed that wireless receivers working in the house had occasional fits of noisiness. Neighbours were mentally anathematized for using radiating apparatus; I felt quite sure that nothing in my house could be to blame. One evening a fuse blew. Obviously it "didn't order," for it was a 5-amp fuse and the circuits served by it never carried more than 1 amp; still, fuses do "go" sometimes owing to old age and corrosion and as there was no further trouble when it was replaced nothing more was thought of it. A few evenings later the noisiness of the receivers increased and remained incessant. I decided to investigate next morning, just to make certain that nothing was amiss with lighting or power circuits, all of which, by the way, are of lead-covered cable, with a sheath-to-earth resistance well under the regulation ohm. Fate was kind to me in three different ways when I switched off at the mains. First of all, the old-fashioned distribution box, put in before my time, has separate switches in the phase and neutral legs of the main lighting leads; secondly, I chanced to switch off the neutral first; thirdly the lamp near the box happened to be alight. You can imagine that when it stayed alight with the neutral lead broken I did a bit of quick thinking. Clearly, a dead short from neutral to earth. But where? There are thirty-eight outlets in the house and, as you'll gather, no small length of wiring.

Sluething

It was a fault that might have taken ages to locate but for the fortunate fact that soon after I came into the house I'd reorganized the out-of-date fusing system, arranging matters so that groups of three, four or at the most five lighting outlets were served by separate sub-circuits, each with 5-amp fuses in both legs. By removing these fuses, one pair at a time, with only the phase lead switched on at the mains one should be able either to track it down to an individual sub-circuit, or to exonerate the lighting circuits altogether. Recalling the blown fuse of some days before, the first bridge I removed was that which had held it. The lights on both sides of it went

out. To verify, I replaced it and tried the other fuses pair by pair. Lights on the mains side of all of them remained glowing. The power circuits also gave negative results. The faulty sub-circuit served five outlets. A careful inspection of the visible parts of them disclosed nothing wrong, so with a sigh of resignation I rolled back the carpet, found the required floorboard by the tell-tale marks of the "electricians' chisel" and got it up. With its six pairs of leads, the junction box was quite a little Clapham. Better have a look inside. I pulled off the cover before switching off and as I did so the lights went out.

Cause and Effect

Have you guessed yet what was causing the trouble? Let me tell you before you have your final shot that all the "Scruts" were in place, with their skirts well over the insulation in every case. Switching off, I verified every connection and there were certainly no uncovered bits of the bared ends. I knelt, thinking it over and twiddling the metal cover in my hands. Suddenly I let fly a naughty word and transferred a cut and bleeding finger to my mouth. What had bitten me was the jagged edge of a small hole which someone had for some unknown reason made in the cover—I remembered then that the box was an old one which I had transferred from another place when wiring up those circuits. Careful examination showed a cut that the jag had made into the insulation of a neutral lead. Now, why was it over five years before the insulation was cut right through? That time had passed between the installation of the box and the first signs of the fault. Why, again, was the fault intermittent? It obviously was, for radio sets were only occasionally noisy until the final evening. And not long before that a Megger test had given highly satisfactory readings. I believe the reason is this. The junction box was fixed to a joist, which probably moved slightly not only when people walked over the floor, but also as the wood expanded and contracted under the influence of weather conditions. The little jagged piece eventually sawed its way through the rubber and cotton. When it had done that, movements of the joist sometimes made and sometimes broke the short that had caused the trouble. A neutral-to-

earth short is a fault that may easily occur in a house and remain unsuspected, particularly if the wiring is old. It might not be dangerous, unless a phase-to-neutral fault occurred at the generating station. But it is certainly a most undesirable state of affairs and it may be the cause of mysterious fuse-blowings and of noisy radio reception, if of nothing worse. Hence, should such symptoms occur and other expedients fail, tests on the lines described may be profitable.

□ □ □

The Steel Bars

MANY thanks to the numerous readers who sent in answers to my very easy magnet problem (December issue): how can you produce a pair of steel bars of exactly the same size and appearance, one of which is magnetized and the other not, such that the magnet cannot be detected at once by placing them in T-formation. The solution is, of course, to magnetize one so that there are similar poles at either end and an area of opposite polarity in the middle. There is then marked attraction between the two, no matter which is the cross-piece and which the stalk of the T. Special thanks to one reader who points out an unpardonable piece of loose wording on my part. I wrote that if the bar magnetized so as to have its opposite poles at either end were used as the cross-piece and the non-magnet as the stalk, there would be no attraction between the two. I should, of course, have written "minimum attraction," for it is only at a point that the force is zero, the end of the other bar covers an area.

□ □ □

Teleciné Pictures

REFERRING to my suggestion last month that "Teleciné Review" might include films transported by air from distant places a third correspondent writes: "Why not transmit the images to this country, frame by frame, by ordinary still-picture radio methods, reassemble them into a film and televise that? The time-lag would then be greatly reduced." There may be something in the idea if a means of speeding up still picture transmissions is evolved; but I hardly think it could be worked with present systems. So far as I remember from my last visit to Cable & Wireless, the time needed for transmitting a 5in x 4in picture is eight minutes. Suppose that prints of 12 consecutive ciné pictures are pasted up into a rectangle of about that size, we could send and receive them in eight minutes. The definition

would, of course, be rather poor, since each individual frame would be made up of only 1/12th of the total number of picture points. Still, people might not be over-critical about pictures of distant events, televised a few hours after their occurrence. To make things easy let us suppose that 25 individual pictures could be transmitted and received in 16 minutes. Then the time required for transmitting the 25 x 15 images needed for a 15-second news flash would be 15 x 16 minutes = 4 hours, assuming that there were no delays or interruptions of any kind. As many of the radio picture services are already working at their maximum capacity it might be a matter of some difficulty to secure a 4-hours' run just when you wanted it. It would also be pretty costly.

□ □ □

Television Forges Ahead

FOR some time now television receivers have been selling in the London area (and even in places surprisingly far outside it) just about as fast as manufacturers can turn them out in the factories. The number of television licences has increased by 50 per cent since the end of May and all the signs are that the rate of increase now is governed only by the rate of supply of televisions, the latter being in its turn governed to a great extent by the rate of supply of the right kind of cathode-ray tubes. The man in the street appears to have become reconciled to the 7½ in by 6 in picture, realising that, small though it may seem, it is amply large for the average living-room of to-day. Certainly, the best-sellers amongst television receivers are those using 9-inch tubes. Those who have bought them seem to be perfectly satisfied with the results and I don't often hear people regretting that the picture isn't a bit bigger. With a set that is interlacing as it should and which handles frequencies up to 2.5 Mc/s adequately, the definition is so good that one soon ceases to think about picture size.

Remarkable Achievement

An outstanding achievement in television was the O.B. of the pantomime from the Regal Theatre at Edmonton. It was announced before the programme started that nothing but the ordinary stage lighting would be used. One expected, perhaps, rather muzzy images and was prepared to make allowances. Actually, the broadcast was first-rate—a great credit to the engineers responsible, for even with the newest type of C.P.S. camera there must have been some pretty problems.



Switches

● **OVER 200 TYPES DESIGNED**

Produced by the largest manufacturers of electrical switches, the famous BULGIN range affords you the choice of over 200 different types of high-quality switches, covering all requirements and suitable for a wide range of voltage and current ratings. BULGIN switches, supplied in nickel, Florentine-bronze and gun-metal finishes, are made from the finest materials only, and can be relied upon to give long and trouble-free service. BULGIN switches give the distinctive touch!

“The Choice

BULGIN

of Critics”

REGISTERED TRADE MARK

A. F. BULGIN & CO. LTD. · BYE-PASS RD. · BARKING

Telephone: R1Ppleway 3474 (5 lines)

RECENT INVENTIONS

A Selection of the More Interesting Radio Developments

TRANSMISSION LINE AMPLIFIER

THE control grid of a triode valve V with plane electrodes, designed for use as a coaxial line amplifier of centimetre waves, is formed with and carried by an external copper disc D, which is sealed through the glass of the bulb, and is earthed, so far as radio-frequency currents are concerned, by capacity coupling to the walls of the cathode and anode resonators A, B. Input energy is applied to the cathode resonator A from a coaxial feeder L₁, which can be moved axially to adjust the coupling. The cathode is heated through the centre core of that resonator. The amplified output is drawn off from the resonator B by a coaxial line L₂, which makes a push-fit, so that the usual coupling loop can be rotated.

The earthing of the grid prevents any positive feedback between the anode and grid. In addition, since the anode current also flows through the input impedance, this provides sufficient

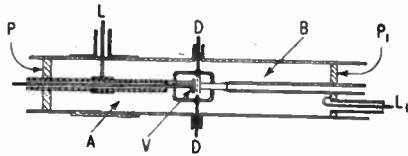

Coaxial line amplifier.

negative feedback to ensure complete stability.

Standard Telephones & Cables, Ltd., and S. G. Tomlin. Application date May 10th, 1941. No. 585447.

TELEVISION RECEIVERS

THE present television service may eventually be replaced by one using up to 600 or 800 scanning lines per frame. The higher definition will naturally increase the cost of the receiver, putting an undue strain on those who have little fault to find with the standard of reproduction now available.

The inventors have devised a relatively inexpensive type of set which is capable of receiving, say, an 800-line transmission and of reproducing a 400-line picture from it.

The received synchronizing impulses are applied, through an integrating circuit, to a gas-filled relay which responds only to every second impulse. The saw-toothed time-base voltage initiated by the first pulse overlaps the

The British abstracts published here are prepared with the permission of the Controller of H.M. Stationery Office, from specifications obtainable at the Patent Office, 25, Southampton Buildings, London, W.C.2, price 1/- each.

succeeding pulse, which is therefore ineffective. This avoids the circuit complications required to follow an ultra-fast "flyback," and so saves cost.

The General Electric Co., Ltd., and D. C. Espley. Application date October 6th, 1943. No. 587772.

NAVIGATIONAL SYSTEMS

TO increase the sharpness of the "off-course" indication given by an approach beacon of the overlapping beam type, the carrier wave is radiated separately from the signal sideband energy. By suitably adjusting the phasing of the currents fed to the aerials, the maximum of the sideband radiation pattern is made to coincide substantially with the minimum of the carrier pattern, though the carrier amplitude is always kept higher than the maximum sideband amplitude. Both patterns are then simultaneously alternated about the desired line of approach.

The aircraft receiver is provided with automatic volume control, so that its gain is always regulated by the prevailing level of carrier wave energy, being greatest when the sideband level is lowest, and vice versa. This provides a clear-cut indicator response of the order of one decibel per degree of deviation.

Standard Telephones & Cables, Ltd. (assignees of W. D. McGuigan). Convention date (U.S.A.) November 15th, 1943. No. 586814.

PHASE INVERTERS

A PUSH-PULL amplifier A is driven from an unbalanced signal source S through the phasing network shown. The bridge is normally balanced with no signal input, the respective anode resistances R₁, R₂ and cathode resistances R₃, R₄ of the two valves V₁, V₂ all being equal. High tension is applied across one diagonal of the bridge, the H.T. source being centred at Z to the zero point of the push-pull amplifier, which is connected across the opposite diagonal.

With this arrangement, an input signal applied to the grid of the valve V₂, across a

Bridge-type phase splitter.

resistance R, unbalances the bridge, and develops output voltages at T and T₁ that are oppositely phased with respect to the point Z. Fluctuations in the supply voltages are automatically balanced out in the bridge, and any difference in the operating characteristics of the valves V₁, V₂ can be offset by adjusting the output

terminals T, T₁ along the resistance arms.

Marconi's Wireless Telegraph Co., Ltd. (assignees of H. W. Berry). Convention date (U.S.A.) July 27th, 1943. No. 584191.

SHORT-WAVE VALVES

THE valve shown is designed to be directly coupled to a coaxial transmission line carrying centimetre waves. The bulb is divided by a metallic disc

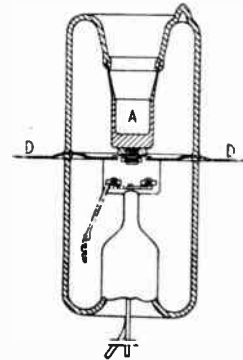

Grounded-grid triode.

1), which is sealed in through the glass and is connected to the control grid, which is located in an aperture at its centre. The cathode is mounted just below the grid, the leads being sealed through the lower pinch. The anode A is thimble-shaped, to take the centre core of a coaxial line, and is sealed to the upper part of the bulb. The inter-electrode spacing is very close.

In operation, the valve is used as an "inverted" or grounded-grid amplifier, the grid disc D being earthed either directly or by close capacity coupling, to the walls of the transmission line. The disc then screens the

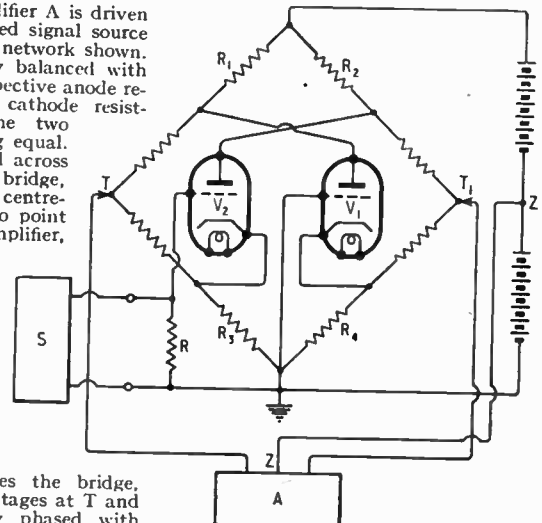

input from the output circuit, and otherwise serves to stabilize the valve and give it a high amplification factor.

Standard Telephones & Cables, Ltd., and J. Foster. Application date, June 13th, 1941. No. 585448.

1992

Quality

**ACKNOWLEDGED
THROUGHOUT
THE WORLD**



ERIE

Radio & Electronic Components

**RESISTORS · CERAMICONS · Hi-K CERAMICONS · POTENTIOMETERS
SUPPRESSORS · VITREOUS ENAMELLED WIRE-WOUND RESISTORS**

Erie Resistor Ltd., The Hyde, London, N.W.9, England

Telephone: COLindale 8011-4.

Cables: RESISTOR, LONDON.

Factories: London & Gt. Yarmouth, England · Toronto, Canada · Erie, Pa., U.S.A.



PIFCO

ALL - IN - ONE RADIOMETER

tests everything electrical, Radio and P.A. Equipments, Household appliances of all kinds, Car Lighting Systems, Bell and Teleprinter Circuits. May be used on AC or DC mains.

25/-

Still in short supply but ask your Local Dealer to put your name down on his waiting list.

The SHERLOCK HOLMES OF RADIO SINCE 1930

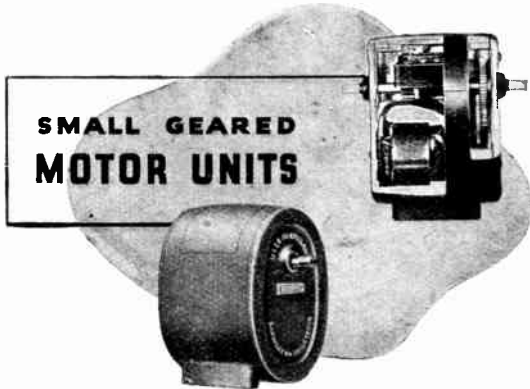

SMALL GEARED MOTOR UNITS

The Drayton "R.Q." is a 25-watt motor unit geared to a final shaft, to which may be fitted eccentrics, arms or cranks, gears, links or pulleys for actuating valves or dampers, movements, switchgear or other devices.

Unidirectional or reversing, with or without self-switching, for 100/110 or 200/250 volts A.C.

Both types are fitted with an auxiliary two-way switch actuated by movement of the final shaft, for operating auxiliary gear such as fan motors, pumps, interlocking devices, etc.

FINAL SHAFT SPEEDS		
Reversing	Max 600 R.P.M.	27 min. per rev.
Unidirectional	Max 280 R.P.M.	60 min. per rev.
TORQUE: Reversing ... 80 lb. lbs. max.		
Unidirectional ... 87 lb. lbs. max.		

Send for List 302-1/N

for

Operating Valves, Dampers or Rheostats, Cinema Projectors, Rotating Screens, Illuminated Signs, Small Working Models, Geneva Movements for Drum-type Switches, Rocking Baths, Work Movement, Soldering and Welding Fixtures, Continuous Turning, Feed of Light Strip Under Process.

Drayton Regulator & Instrument Co., Ltd., West Drayton, Mdx.

SYLMAR RADIO LTD. BARGAINS

All articles are new and guaranteed and are of well-known manufacture.

Two-gang .0005 Condensers	8/6
Mains Transformers:				
280-0-280 v. 6.3 v. 3 amp.	20
60 m/a Chokes, 400 ohms.	5 6
485 Kc. I.F.'s, iron dust cored, permeability tuned, 1 1/2 in. x 1 in. can	15 6
Midget I.F.'s, iron dust cored	15 6
7 mcs I.F.'s	5
GRAMOPHONE AMPLIFIER KITS, 4 watts output, including 2nd detector and A.V.C. components. All parts mounted. Complete with circuit.	A.C.	£3
Gramophone Amplifier Kits as above, AC/DC...	£3

GOVERNMENT SURPLUS OFFERS

.1 mfd. 350 v. Condensers	doz.	4 6
.1 mfd. 1,000 v. Condensers	doz.	6 6
.1 x .1 x .1 Condensers, 250 v.	doz.	9
Octal Valveholders	41d.
Mazda type Valveholders	3d.
12 v. 1 amp. Recifiers	7 6
5in. P.M. Speakers	12 6
6in. P.M. Speakers with trans.	15 6
2 1/2 in. Drums	1-
3-pole 2-way Switches, long spindles	2-
16 x 8 450 v. working Cond.	7 6
8 x 8 450 v. working Cond.	6 6
Clips for above	3d.
Vibrator Pack. 12 v. Input 210 v. 70 m/a output. Special price to clear	25-
3-way .3 amp. Line Cord, 60 ohms per foot.	yd.	1/6

Terms: Cash with Order or C.O.D. Post Orders only, carriage and packing extra.

Retailers' enquiries for above welcomed.

SYLMAR RADIO LTD.

197, Lower Richmond Road, Richmond, Surrey

LAL DATA SHEET N°1

TIME BASE UNIT TYPE 84

Sweep is substantially linear over the frequency range which may be extended downwards to 0.5 cps. by the addition of external capacitors. The time base may be locked to an external impulse, or the signal developed on one of the Y plates, or to the 50 cps. mains supply. Sweep amplitude is controlled without affecting amplitude or synchronizing and the amplifier delivers balanced P.P. voltage to the X plate, eliminating trapezium distortion, etc.

Single stroke operation is available. Amplifier voltage gain is about 25 and the full screen diameter is covered without distortion. A switch arranges the internal connection of X plates to terminals on the front panel with A.C. or D.C. coupling and for single-ended or P.P. input, other positions interconnect amplifier and sweep generator. Self-contained power pack unit may be used independently as a portable time base or with other makes of oscilloscope.



Main features include:

- (i) Sweep frequency, 5-250,000 cps.
- (ii) Automatic synchronizing.
- (iii) Sweep expansion independent of frequency.
- (iv) Push-pull deflection.
- (v) Single-stroke operation.
- (vi) X Axis Amplifier usable independently
- (vii) Plate connections available on front panel.

Full details on request.



Stabilised Insulation BY MODERN IMPREGNATION METHODS

HYMEG

HIGH-SPEED PRODUCTION

Now, special methods of continuous conveyor impregnation and baking developed with the use of HYMEG have still further reduced processing times to a fraction of those previously believed necessary. Often faster than infra-red baking with none of the defects, reduced handling, absence of special jigs, with complete freedom from blistering, bubbling and porosity, are some of the advantages claimed and substantiated for HYMEG High Speed Production methods.

HYMEGLAS

GLASS FIBRE INSULATION SYSTEM

This integrated system of development is successful in enabling machines to be designed and operated without weak links in the chain of insulation below 200°C. Thus the fullest advantage is taken of modern glass fibre insulation by providing a degree of bonding and insulation at every point in which the uniting of Hymeg impregnation with the Hymeglas as used for subsidiary insulations gives a solid homogeneous winding of equally efficient characteristics and heat resistance throughout.

Hymeglas therefore virtually eliminates any risk of insulation failure and enables motors and the like to operate under abnormal conditions for long periods without risk of electrical breakdown.

Due to the excellent space factor of glass fibre as compared with the more usual asbestos and mica Class B insulations, it is often possible in redesigning with the Hymeglas system to employ larger copper sections with well-known advantages.

The Berger Technical Service—the research work of which produced "HYMEG" and "HYMEGLAS" is available to advise manufacturers on all problems of insulation. Get in touch now with—

LEWIS BERGER & SONS LTD. (Est. 1760)
35, BERKELEY SQUARE, LONDON, W.1.

Telephone: MAYfair 9171.

MANUFACTURERS OF HIGH-PERFORMANCE INSULATING VARNISHES AND ENAMELS



The "ARNINE" (Regd.) Short Wave Aerial

For reception or transmission. Load factor 1.9 Kw. at 7 m/cs. Aerial spans and down lead consist of twin parallel feeder of 300 ohm impedance, polythene insulated. Pack includes all the necessary insulators, fittings, etc., for easy erection.

Model FDA20 — £3 2 6
 .. FDA40 — £3 12 6

ANTIFERRENCE LIMITED

Sales Division :
 67, Bryanston St., Marble Arch, London, W. 1
 Telephone : PADDington 7253/4/5

A5



FOR THE RADIO SERVICEMAN DEALER AND OWNER

The man who enrolls for an I.C.S. Radio Course learns radio thoroughly, completely, practically. When he earns his Diploma, he will KNOW radio. We are not content merely to teach the principles of radio, we want to show our students how to apply that training in practical, every-day radio service work. We train them to be successful.

Write to the I.C.S. Advisory Dept. stating your requirements. Our advice is free.

.....You may use this coupon.....

INTERNATIONAL CORRESPONDENCE SCHOOL Ltd.
 DEPT. 38, INTERNATIONAL BUILDINGS, KINGSWAY, LONDON, W.C.2
 Please explain fully about your instruction in the subject marked X.

Complete Radio Engineering **Radio Service Engineering**
Radio Service and Sales **Elementary Engineering**

And the following Radio Examinations :-
 British Institution of Radio Engineers
 P.M.G. Certificates for Wireless Operators
 City and Guilds Telecommunications
 Wireless Operators and Wireless Mechanics, R.A.F.

I.C.S. students for Examination are coached till successful.

Name..... Age.....
 Address.....

ICS



Realism in Sound Recording

To the exclusive range of sound equipment produced by B.S.R. is now added the D.R. 33 Direct Disc Recorder.

The D.R. 33 incorporates the latest developments in recording technique and is the finest direct recording instrument available. It is supplied in an attractive carrying case and is completely portable. We should be pleased to send you further particulars of this latest production of the B.S.R. Research Laboratory.

Amplifiers, microphones, loudspeakers and accessories.



DIRECT DISC RECORDER

BIRMINGHAM SOUND REPRODUCERS LTD.
 Clarendon Works, Old Hill, Staffs. Phone Cradley Heath 6212/3.
 London Office: 115, Gower Street, W.C. 1. Phone Euston 7515.



STABLE to

Resistors produced by the cracked carbon process remain stable to $\pm 1\%$ of initial value.

★Tolerance $\pm 1\%$
 $\pm 2\%$ $\pm 5\%$

Low temperature co-efficient.

Welwyn carbon resistor

WELWYN ELECTRICAL LABORATORIES LTD.
 Welwyn Garden City, Herts Telephone · Welwyn Garden 78168



Products of Quality & Reliability

MAINS TRANSFORMERS
A. F. TRANSFORMERS
THERMAL DELAY SWITCHES
SMOOTHING CHOKES
POWER RESISTANCES.

Made by
OLIVER PELL CONTROL LTD
 Telephone. WOOLWICH 1422-1426
 CAMBRIDGE ROW · WOOLWICH · S.E.18

Rate 6.- for 2 lines or less and 3.- for every additional line or part thereof, average lines 5-6 words. Box Numbers 2 words plus 1.-. Press Day: March 1948 issue. First post Friday, February 6th. No responsibility accepted for errors.

WARNING

Readers are warned that Government surplus components which may be offered for sale through our columns carry no manufacturer's guarantee. Many of these components will have been designed for special purposes making them unsuitable for civilian use, or may have deteriorated as a result of the conditions under which they have been stored. We cannot undertake to deal with any complaints regarding any such components purchased.

NEW RECEIVERS AND AMPLIFIERS

DEGALLIER'S, Ltd., will re-open for the sale of American receivers when restrictions permit.—Degallier's, Ltd., BCM/DEG 9, London, W.C.1. [8883]

RECEIVER type R.5170A radar, used for anti-jamming devices, radio counter measure; contains 14 modern a.c. valves, including 8 Mullard EF50; all perfect and new; price 50/- each, plus 4/- carriage.

UNCLE TOM'S RADIO CABIN, 5, Seven Stars Court, Manchester, 4. [8965]

BRIERLEY ribbon and armature pick-ups, filters, amplifiers and pre-amplifiers. Arrangements are being made for the demonstration of these products by agents throughout the British Isles. Where arrangements for this have not so far been completed, it is possible for our sales representative to demonstrate in your own home when next in your district.—J. H. Brierley, Ltd., 46, Tittlebarn St., Liverpool, 2. [8266]

1948 Super de luxe five-waveband feeder unit, with tuned R.F. stage and magic eye, 15in x 5 1/2in station-named scale, 10/17, 16/35, 34/100, 200/550, 800/2,000 metres, communication type coil pack, high "Q" I.F. transformers, completely assembled and aligned and ready to connect to audio amplifier.—Send 2/6d stamp for full details to the sole distributors, Coulphone Radio, 58, Derby St., Ormskirk, Lancs. [8959]

W.W. Quality amplifier, built strictly to specification, with or without tone control stage; pre-amplifiers, including hi-fi P.E.C. types; mains and output transformers and chokes for this amplifier wound to W.W. specification; 12 valve, 20 watt, 4-channel electronic mixing; ac/dc amplifier and other ac and ac/dc types; 2 1/2d stamp for particulars, prices, etc., to actual manufacturers.—J. B. Electrical & Electronic Development, Ltd., Hubert St., Bgham 6, Aston Cross 2440.

CONNOISSEUR'S receiver. Combination 10-valve communication receiver and T.R.F. quality set. Fully converted R1155 switched super-het or T.R.F., 9-1,500 metres, with PX4 push-pull quality amplifier. Bass and treble boost (separate controls), gram input and other refinements, £35. Makes ideal radiogram. Write for full details or call for demonstration. We can modify your R1155 similarly or to your requirements. R1155 circuit and values, 2/- post free. Repairs, etc., to all communication and quality receivers.—R.T.S., Ltd., 8, Gladstone Rd., Wimbledon, S.W.19. Libery 3305. [9172]

GOODSELL, Ltd., 40, Gardner St., Brighton.—The Williamson amplifier to W.W. specification fitted with best quality components, Partridge transformers and oil condensers on 425-volt line, price £21; with voltage stabilised power pack (valve controlled) ensuring no volts in excess of 350 for the pre-amp and complete stability where high gain required, super amplifier 26gns; pre-amp including E.F.377 with 4 position bass boost and 4 position treble control and E.F.37 as straight triode for Hi-Fi pick-ups, for use with above, £24/6. Complete new range of feeder units using new Denco 5- and 10-band turrets, improved I.F.T.'s and large attractive glass dials with magic eye, available shortly; send for details. [19169]

CHARLES AMPLIFIERS.—Announcing a new version of their famous HFA1 amplifier—the HFA3 incorporating a pre-amplifier to enable the use of moving coil pick-ups direct; this amplifier in conjunction with the Lexington moving coil pick-up and the B.A.E.C. twin cone speaker provide the highest obtainable fidelity of reproduction; the complete range now comprises amplifier HFA1 7 watt cathode follower output for crystal pick-ups; HFA2 single-ended 3 watt for crystal pick-up; the HFA3 for moving coil pick-ups; full constructional blueprints, 2/6 each; full kits or separate components available or supplied ready assembled; stamp for comprehensive catalogue.—Charles Amplifiers, 1e, Palace Gate, Kensington, W.8.



PARTRIDGE MANUAL

Containing:—Many useful circuits including New 15 watt high quality amplifier with 40 db of negative feedback over three stages.

Also:—Design of Electrical Equipment including Power Supply Units. Articles on Negative feedback and Volume expansion, Acoustical Problems, Sound Reinforcing and Public Address. An appendix consisting of six selected design charts. Cross-over network circuits, etc., etc.



At last the completely revised post-war edition for which you have been waiting.

We regret the delay and advise early application as the issue is limited.

PRICE 5/- POST FREE

COUPON

Please send me post free a copy of the new Partridge Manual. I enclose P.O./Cheque value 5/-.

Name.....

Address.....

ww2

Telephone:

Abbey 2244

PARTRIDGE TRANSFORMERS LTD

76-8, PETTY FRANCE LONDON, S.W.1

HAMBANDER communications receiver covering the amateur bands from 10-160 metres, 6 octal valves, crystal diode noise limiter, bfo, separate bandspread dial, send/receive switch, built-in power pack for ac operation, £22/10; Radiovision preselector covering 0-90 metres, 2 EF50 high gain stages with regeneration, calibrated illuminated dial, built-in power pack for ac operation, £13/15, less valves; export enquiries invited; illustrated brochure from.

RADIOVISION (LEICESTER), Ltd., 58-60, Rutland St., Leicester. [9103]

SPECIAL offer: Midget communication receiver and power pack (M.C.R.I.), 5-valve superhet, complete with aerial and earth equipment, lightweight headphones; range 20-3,000 metres in four bands, operates on any voltage between 97 and 250 A.C. or D.C.; £9/10; send for one now before stocks are exhausted; another special offer: slow motion drives by "Muirhead," 50-1 ratio, 10/- ea, postage 6d; also milliameters, 0-1, 15/- ea; send for 6-page list; trade supplied.—L. Wilkinon, Wholesalers, 204, Lower Addiscombe Rd., Croydon. Add. 2027. [8264]

UNIVERSAL ELECTRONIC PRODUCTS, 36, Marylebone High St., London, W.1. Tel. No. Wel. 4058. Our U.E.7 amplifier is designed for the connoisseur who requires the best possible reproduction together with the highest standards of workmanship and we invite you to hear this amplifier demonstrated in conjunction with the Wilkins & Wright pickup and latest type speakers, including the new Wharfedale Corner Cabinet model. We specialize in high-fidelity sound reproduction for the home, clubs, concert halls, etc., and will undertake the design and construction of equipment to meet your own requirements.

RDIO TRADES MANUFACTURING CO. (EALING), Ltd., 141, Little Ealing Lane, W.5 (Ealing 6962), pioneers in the manufacture of the "Williamson" amplifier and now the basic circuit in G.E.C. book, are producing a superb edition of this famous amplifier which is without doubt the finest reproducer yet evolved. Using Partridge transformers and other parts throughout of the finest quality, built on heavy gauge chassis, there is no other amplifier offered at such a reasonable price, tested and aligned, £25/10. 3-valve pre-amplifier of new design giving perfect control of bass treble, £10, complete. Kit of parts with Partridge transformers, £20. 10in speakers, £2. 12in speakers and gram motors with pick up also supplied. Full details (stamp) from R.T.M.C. Ltd. as above. [9038]

RECEIVERS, AMPLIFIERS—SECOND-HAND

AS new Eddystone 504 receiver in perfect condition; offers.—Box 4975. [9035]

R.C.A. 77E Comm. Ix, 31 mes-550kcs, Xtal, etc., perfect; £30.—Box 4964. [9019]

R.C.A. AR88 Communications receiver, excellent condition; £60.—Box 4767. [8972]

SALE, 1155A, as new, fitted S. meter, noise limiter, KT61, power pack, etc.; 20 gns, or offers.—Box 4963. [9018]

15-WATT amplifier, Callaro turntable and pickup, 12in Goodman's speaker in cabinet; £25 lot.—Box 212. [7747]

4-VALVE mains chassis, long/medium, per feet, Westinghouse rectifier H.T.8, valve SAVB; offers.—Box 4526. [8952]

HIGH quality A.C. mains amplifiers, 4 watt o.p., almost new; s.a.e.; £7.—Haigh, 108a, Nightingale Road, Carshalton, Surrey. [9034]

HOWARD 12-valve comm. recr. guaranteed first-class cond., Xtal and Avo oscillator; first offer over £20 secures.—Box 4461. [8852]

CIVILIAN communications receiver, 45 mc/s, 550 kc/s, write for details; £15 or offer.—Easterbrook, 302, Raeburn Av., Surbiton.

TWO Philips chassis 6v A.C., 110/- each; £15; 72 plugs and sockets, offers.—Box 4509. [9018]

C.R.100 with 12-inch Magnavox speaker, excellent condition; £55 or near offer.—G. Rice, 2, Woodlands, N.W.11. Spe. 4915

TELEVISION console, Marconi 704, overhauled including new power pack, splen did condition; £75.—Cook, 412, St. Richard's Rd., Deal, Kent. [9107]

H.R.O. Xtal phasing, "S" meter, power pack, 9 coils (incl. 1 duplicate), few spare valves, 'phones, good condition; £55 or nearest.—Box 5108. [9159]

SOUND SALES.—DX+1 Hi-fi tuner, variable selectivity, nearly new, £12; S.S.14W amplifier, £18; perfect.—Myatt, 50, Ribblesdale Rd., S.W.16, Streatham 0751. [8949]

"WIRELESS WORLD" 2 R.F. quality tuner for use with "Wireless World" quality amplifier, new, £5/10, less valves, which are easily obtainable.—Box 4506. [8915]

TELEVISION set, experimenter selling own complete receiver, 12in electrostatic tube; all post-war circuits, but no cabinet; demonstrated by appointment; £45 cash.—Davies, 32, Clovelly Av., N.W.9. [9031]



THIS USEFUL NEW FOLDER-

... tells you all about the complete range of Henley SOLON Electric Soldering Irons, for the standard voltage ranges of 200/220 and 230/250: 65 watt and 125 watt models fitted with oval-tapered bits or pencil bits and 240 watt models fitted with oval-tapered bits are available.

Write Today for the new folder ref. Y.10 describing



W. T. HENLEY'S TELEGRAPH WORKS CO. LTD. (Engineering Dept.) 51-53 Hatton Garden, London, E.C.1

YOU can become a first-class RADIO ENGINEER

We are specialists in Home-Study Tuition in Radio, Television and Mathematics. Post coupon now for free booklet and learn how you can qualify for well-paid employment or profitable spare-time work.

T. & C. RADIO COLLEGE
North Road, Parkstone, Dorset

(Post in unsealed envelope, id. stamp)
Please send me free details of your Home-Study Mathematics and Radio courses.

NAME

ADDRESS

W.V.68

SCOTT Phantom. 2 chromed chassis, speaker, 16 valves, 4 bands, var. selectivity, 16 watts, sep. bass and treble controls, perfect condition; offers over £35.—Box 4773. [8997]

H.R.O. Kx, with S-meter, Atal, 6 coils, 480 kc/s to 30 mc/s continuous coverage, less speaker and power pack, excellent mechanical and electrical cond.; offers over £38.—Box 4518.

CHARLES H.P.'s high gain amplifier, Lexington, Rothermel senior, cosmocord, Briery ribbon pick-ups. W. & W. scratch filter, B.A.E.C. 12in speaker, used experimentally only; £30.—Box 4969. [9026]

W.W.Q.A.12w. (ncw), W.W.Q.A. super receiver, recently rebuilt, fitted 6 new valves, Hartley Turner 12in eng. speaker; reasonable offer accepted.—Hopkinson, 44, St. Mary's, Thetford, Norfolk. [8944]

WIRELESS WORLD quality amplifier with PX25s Magnavox 66 loudspeaker, Simpsons ac motor and crystal pick-up on plywood playing board, £28 complete outfit.—4, King, Clacton Rd., St. Osyth, Essex. [9043]

RECEIVER, BC348N, A.C. extras, spares, R instructions, L.S. Trip-tit multi-meter, 20,000 o.p.v., valve tester (American), 35 valves, Tx and Rx, all perfect; exchange Leticia, (Contax); or offers, singly or lot; details, s.a.c.—Box 4523. [8945]

7-VALVE Service communications receiver by Pye, new, unused, in original packing, 16-2,000 metres, built-in M.C. speaker, separate power pack; price includes phones, aerial, insulators, spare bulbs and fuses.—Thrupp, 5, Eldon Grove, London, N.W.3. [9089]

A.W.II. cinema amplifier, double channel, containing 9 moving coil meters, Igranic transformers, etc., also 4 Epoch 18in cinema speakers (some cones damaged), collection of valves L6A, PP 25/500; seen Clacton.—Offers whole or items to Box 4977. [9049]

THREE-STAGE resistance capacity minia ture amplifiers with three tested 174 midjet valves, 20/- each, post free; in aluminium case, 22/-; spare 174 valves, guaranteed, 6/- each; holders, 6d each.—Littler, 24, Stanley Rd., Whalley Range, Manchester, 16.

AMERICAN B.C. 342 10-valve Communicat ions receiver, 1.5-18 mc/s, 6 switched bands, B.F.O. and crystal phasing 110-volt a.c., in excellent condition, with wiring diagram; £20 or near offer; transformer, 220-250 volts a.c., available.—Apply Mr. Stanton, 1394, High Rd., Whetstone, N.20. Hillside 2488.

25 parallel push pull three channel input choice of 6 tone pitches, stand-by switch, matchmaker output transformer, etc., 2 mics and stands, two 15 watt P.A. speakers, complete with all leads and spare set of valves, £60.—12, Hartland Court, Friern Barnet, N.11. Enterprise 1807. [9070]

NATIONAL NC81X receiver, 10 tubes, Xtal filter, S meter, 10-160 bands, 230V A.C., £30 or best offer; Canadian R103 short-wave 6v car radio, as new, £15 or best offer; A.P.W.8345 receivers, suitable television, complete as new with 6-£F50s, 3 diodes, £5; as above, but damaged, valves O.K., £2.—Sykes, Oldfield Rd., Honley, Huddersfield.

SPECIAL salvage offer.—18-valve set, with S valves, £2 each, carr. 10/- extra; these sets have been stored in the open for a time and case and chassis are more or less rusty, but the components outlined below are mainly in good usable condition; 4 slug-tuned air speed coils about 3 meters, and tuning condenser, 2 I.L. chokes, mains trans (2,000 cs), h.v. metal rectifier and approx 150 res and cons. In addition to the above items, there are switches, VCs, sockets, etc., which may be damaged or faulty. If crate is required, send £1 deposit, returnable; send stamped and addressed envelope for lists please.—H. ENGLISH, The Maltings, Rayleigh Rd., Hutton, Essex. [9045]

TEST EQUIPMENT INSTRUMENTS

MOST makes in stock, some on terms.—Write for details and list of radio and electrical spares, new and ex-Govt., to The Instrument Co., 244, Harrow Rd., London, W.2.

COSSOR double beam oscillograph, as new; £50.—Box 4515. [8931]

WEE megger, 250 volts, new condition, id. approval, £5.—Box 476. [9047]

TAYLOR model 90 universal meter; £12.—Quick, Fairfield, Alvechurch, Wores.

"Q" meter, surplus to requirements, as new and in perfect condition; £95.—Summersby, Mill Lane, Margate. [8873]

BRIDGE in leather case, Siemens balsk, 1/50 to 50k ohms, precision job, bargain, £6/10.—51, Fairway, Stafford. [9041]

SIGNAL generator, Type E, Model 1, new, cost £20, sell £15.—Moore, Northumberland Avenue, Berwick-on-Tweed. [9046]

AVO model 40, Westonmeter 785 (20,000 OPV), Mullard RC bridge, as new.—Ball, 27, Hillsborough Rd., Garrowhill. [9014]

LASKY'S RADIO
EVERYTHING FOR THE AMATEUR AND SERVICEMAN

Condensers. 2 mfd. 350 v.w. 1/11 each. 4 mfd. 425 v.w. 3/- each. 4 mfd. 500 v.w. (bolt fixing) 4/6 each. 8 mfd. 450 v.w. 8/- each. 8 mfd. 450 v.w. (T.C.C. Micropack) 4/6 each. 8 mfd. 500 v.w. (Dobiller Driftic) 4/- each. 16 mfd. 350 v.w. 4/6 each. 16 mfd. 450 v.w. (can type) 4/9 each. 16 mfd. 500 v.w. 5/6 each. 8 x 8 mfd. 500 v.w. (millet can) 5/9 each. 8 x 8 mfd. 500 v.w. (cardboard block) 5/9 each. 8 x 16 mfd. (can type) 8/6 each. 8 x 16 mfd. 500 v.w. (cardboard block) 8/6 each. T.C.C. Cathodray 1 mfd. 6000 v.w. 15/- each. 8 mfd. 750 v.w. (block oil filled) 7/6 each. All values small condensers from 5 pf. to .5 mfd. 350-500 v.w. 7/1d. each.

Large stock of bias condensers 50 x 50, 50 x 12, 75 x 12, 20 x 12, 25 x 25, etc.

Speakers. P.M. Less Trans. All 3 ohm. V.C. 2 1/2in. 27/-; 3 1/2in. 29/6; 5in. 16/9; 10in. 35/-; P.M. With Trans. 3 ohm. V.C. 6 1/2in. 27/6; 8in. 27/6; 12in. speakers, prices on application.

M.E. Speakers. 5in. Rola 1000 ohm. field with Pen 0/7, 25/6; 6 1/2in. 1500 ohm. field L.T. 23/-; 8in. 2400 ohm field with Pen Trans. 36/6.

Tuning Condensers. 2 gang .0005 10/6 each; complete with slow motion drive, 13/6 each.

C.F. Transformers, 465 K.Cs. High Q with or without fly lead, air or iron cored, 7/6 each. L.T. 23/-; 8in. Weare's 4 x 3 coils. All types in stock, A.E., H.F., O, etc., 3/- each.

Connecting Wire. 19 dr. yds. Systalofex. Tinned Copper Wire, 16, 18, 20, 22 Gauge.

Valves. A few examples from our extensive stocks. All at B.O.T. prices: 6B91, 6X91, 11L92, DAF91, 11B, UB121, UY21, ECH91, UCH91, KT66, PM24, EP22, PKN30C, VMP4G, 1D5, FV4500, FC2A, FC2M, CB131, CBL1, C133, 10P14, 10F9, 10F13, 10L111, 10C1, O224, 305, 45Z5, 43, 25A6, 80, 606, 12S47, 61B7, 12K7, 6K7, 6K4, 6V6, 42, 6J7, and Hundreds more. Let us know your requirements.

We also have a large stock of mains transformers, chokes, O/trans., coil packs, pick-ups, etc.

All our goods carry our unconditional guarantee, satisfaction or your money refunded. Send 1d stamp for our current list and bulletin of Ex-Service goods.

LASKY'S RADIO
370, Harrow Road, Paddington, W.9
Phone CUningham 7979
Hours: Mon. to Sat. 9.30 a.m. to 6 p.m. Thurs. half day

COULPHONE RADIO
"The Return of Post Mail Order Service."

58 DERBY STREET, ORMSKIRK, LANCs.
Phone: Ormskirk 498. Grams: Couphone, Ormskirk.

NEW GOODS ONLY.
C.W.O. or C.O.D. Post 8/-, over 5/-.

MAINS TRANSFORMERS

PRIMARIES for 200/30/50 volts. Universal 4, 5 and 6.3 v. L.T.s. 300-0-300 v. 60 mA., 23/6; 350-0-350 v. 100 mA., 28/6; 450-0-450 v. 200 mA. 4 v., 8 a. C.T., 4 v. 4 a. C.T., 4 v. 4 a., 45/-; 450-0-450 v. 200 mA., 6.3 v. 4 a. C.T., 6.3 v. 4 a. C.T., 5 v. 3a., 45/-; 450-0-450 v. 200 mA., 6.3 v. 6 a. C.T., 4 v. 2 a. C.T., 5 v. 3 a., 47/6; 1,250-1,000-750-0-1,000-1,250 v. 300 mA. (no L.T.s.) 115/-; 4 v. 6.3 v. 6 a. C.T. (Filament), 17/6; Auto (Filament), 4v. to 6.3 v. 4a. (or vice versa), 13/6.

SMOOTHING CHOKES

15 H. 40 mA. 300 ohm., 5/-
20 H. 80 mA. 425 ohm., 6/6
15 H. 90 mA. 240 ohm., 7/-
20 H. 100 mA. 425 ohm., 13/6
20 H. 200 mA. 150 ohm., 22/6
30 H. 200 mA. 350 ohm., 25/-

VALVES

BVA and TUNGBRAM SENT C.O.D.

OUTPUT TRANSFORMERS

Midget Power Pen., 5/6. Std. Univ., with C.T., 7/6. Large Univ., with C.T., 12/6. Heavy Duty Univ., for 3, 8 and 16Ω, 22/6. Extra Heavy Univ., 37/6. SPECIAL (to author's specification), for quality amplifier, described in April and May issues of "The Wireless World," 67/6.

COILS, COIL PACKS, etc.

WEYMOUTH TRF. COILS. M. and L. with cct., pair 9/6. "P" Type, 2/9 ea.

SUPERHET 3 W.B., with cct., 465 kc/s., pair 11/6.

WEYMOUTH COIL PACKS. Completely aligned, 36/6.

SUPER FEEDER UNIT. 5 waveland. R.F. Stage Magic Eye. Complete with 5 valves, £19 18s.

I.F. TRANSF. Midget, 18 p. Standard, 17/6 p. J.B. MIDGET 2-GANG CONDENSERS. .0005 L/Tr. 11/6; W/Tr., 12/6. 3-gang L/Tr., 15/6.

KITS. 4v. Batt. 8/H. 5 v. A.C./D.C. or A.C./S.H.

MUIRHEAD PRECISION REDUCTION DRIVES. 34:1, 12/6. J.B., Full Vision, 6:1, 12/6.

SUNDRIES

LINE CORD. 3 amp. 500 ft., 2 w., 2/3 yd.; 3 w., 2/6 yd. P.B. Wire, 3d. yd.

MAINS DROPPERS. 3 a. 800Ω/4/6; 2 a., 1,000Ω, 4/3. CARBON RESISTORS (50Ω to 5 MΩ), 1 w. 6d.; 1 w., 9d.

EDDYSTONE SHORT WAVE GEAR.

BOMAC SUPER CAR RADIO. VIDOR PORTABLES.
Send 21d. stamp for new 24-page Catalogue.

PROGRESS instruments, modulated signal generator, 100 kc/s-30 mc/s; 7gus; s.a.e. lists other instruments.—Box 4522. [8943]

B.P.L. sig. gen., new, model R.S.600, 100 kc/s-30 mc/s; offers over £18/10.—Fremington, 9, Gordon St., Ayr, Scotland. [8950]

2-3 range universal meter with cabinet and V.V.M. kits by MacLachlan, new; 15gns, or nearest.—162, Dudley Rd., Grantham. [8942]

AVO 7 meter, £18; mains oscillator, £12; valve tester, £15; all new; offer for lot.—155, Chipstead Valley Rd., Coulsdon. [9006]

METERS, 0-1 ma flush, square, 2in. new, extra, AM, tested 18/6; c.w.o.—A. C. Steadman, 230, Chellaston Rd., Shelton Lock, Derby.

2IN thermocouple moving coil milliammeters. 0-350m/a, new ex-Gov.; a bargain at 5/6 each, £3 per doz., post free.—J. McMillan, 5, Oakfield Road, Bristol, 8. [8767]

FOR sale, Marconi B.F.O. (0-40 kc/s) Muirhead valve voltmeter (0-50 volts), Marconi variable attenuator (0-minus 105 db.), Marconi Ekco distortion meter.—Box 4965. [9020]

1000—0 to 5 m/amps.—Moving coil am-meters, 2in flush mounting, packed sep., 5/- ea. (min. 1 doz.)—Stanwell & Leatherbarrow, Ltd., 6, Stanley St., Liverpool, 1. [10050]

FREQUENCY meter, EC 221.—Crystal controlled 126 kc/s to 20 mc/s; accuracy better than 0.01%; new £45; 45-page manuals giving circuit and full details 7/6.—V.E.S., 46, Windmill Hill, Ruislip Manor, Middlesex.

MICRO ampers.—Model 505, D.C., Turner Electrical Instruments, F.S.D., 100-100, moving coil, zero set screw, dead beat, 2½in. dial, ¾in diameter, moulded bakelite case. Govt. surplus, new, in original cartons, 1st grade; 30/- Below.

AMMETERS—Range 0-100, moving coil with leads and shunt, by Victoria Instrument Co., ¾in flush fitting, bakelite case, zero set screw, dead beat, Govt surplus, new, in original cartons 1st grade; 25/- Below.

VOLT meters.—Range 0-120, moving coil, by Victoria Instrument Co., ¾in flush fitting bakelite case, zero set screw, dead beat, Govt surplus, new, in original cartons, 1st grade; 22/6.—Below.

TEDDINGTON ENGINEERING CO., High St., Teddington, Middx. Kin. 1193-4. [8583]

NEW! Miniature! The "Tracetite"! A pocket signal tracer, self contained with high output, to handle every type of signal; faults probe-traced on the spot in seconds; plans, details, layout, 2/6 from E. Bradley, Whinnie Knowe, Sennen, Cornwall; s.a.e. list.

0-1 milliameters (FSD), moving coil, boxed, 15/-; oscillators (battery), 30/-; Morse keys, 15/- each, dozen 12/-; ac ht eliminators, 120v output, 30 milliamps, 21/-; dipole aerials, 2/-; all items new, plus postage, c.w.o.—Radio Stores, 39-41-43, High St., Salfrey, Birmingham. [8892]

SERVICOMETER model 1212, a new precision instrument employing five valves meter indication designed for speedy location of faults, measurement of tuning coil inductance, measurement capacitance, checking efficiency, aerial, earth installations, frequency measurement 100kes to 20mes, 12 months guarantee; price £14/17/6.—Radio Development Co., Moretonhamstead, Devon. [8876]

WAVEMETERS, superb laboratory instruments, unused, consisting thermostatically controlled crystal oven, 9 valves, including crystal and heterodyne oscillators, mixer and deadbeat stages, frequency 15-2,500kc/s, 230v, 50 cycle, weight 12lb, with crystal, valves, meter and circuit diagram, £220; less valves and meter, £16; as above, but frequency, 1,000kc/s-30mc/s, £30; carriage extra.—120, Wychall Rd., Northfield, Birmingham. [9101]

NEW LOUSPEAKERS £6/10.—New Baker super quality 12in auditorium p.m. speakers with triple cone, manufactured by Baker's Selhurst Radio, the pioneer manufacturers of moving coil speakers since 1925, wide frequency range, even response, ideal for quality reproduction, fitted with magnet having an exceptionally high flux density in the air gap, a speaker in a class of its own.

£5/18/6.—New Baker model 12C single-cone 12in p.m. speakers, built on the lines of the auditorium model, suitable for public address equipment, acoustical output being very good even when fed with a modest two-valve receiver.

£6/19/6.—New Baker super power cinema p.m. speakers with 18in triple cone giving wide frequency response free from objectional resonances speech is clear and natural and music is reproduced with exceptional realism, ideal where power handling capacity plus realistic reproduction is required; send 2½d stamp for leaflet giving details of above; also amplifiers and constructional details of new acoustical cabinet, designed to extend loud-speaker frequency range; prompt delivery per passenger train.

BAKER'S Selhurst Radio, 75, Sussex Rd., South Crofton Tel. Cro. 4226 [9097]

STILL MORE BARGAINS

Selected from our wide range.

RELAYS. Siemen's High Speed lab., relays in brass case on ebonite circular base with contacts, £3 each. G.P.O. Polarized relays fitted contacts, in brass case with glass top and terminals, 45/- Few relays with coils in good condition but less contacts, soiled, 20/-.

GALVOS. D.C. moving coil suspension mirror Galvo, reflection type of Tinsley 100 ohms sensitivity 2½ micro. amps per 1 inch of scale at one metre, in polished case with glass front, £8 10s. Moving coil bridge Galvo, flush panel, 2½in. scale 25-0-25, new, 75/- Sub-divided Ohm Boxes by leading makers, .05, .05, .1, 2, 4, 2, 1, 2, 2, 4, 10, 10, 10, 40, 20, 20, with plugs, 40/-.

MEGGER. Evershed bridge megger with decade resistance box S.H. guaranteed. Evershed Wee meggers, new, from stock.

RESISTANCES. Var. slide vit. enamelled tube with laminated brush and slides, 14 ohms 5 amps., suitable with 50/70 volt dynamo for charging circuits at 5 amps., 25/- each. As new.

METERS. Ironclad A.C. voltmeters, G.E.C. 4in. switchboard, 0-60 volts, 45/- Ammeters to match, 0-40 amps., 45/- Frequency meter 40/60 cy. Crompton F.G. Ironclad switchboard, 50 volts 6½in. x 6½in. x 4in. with lamp on top to illuminate dial, £5 5s.; transformer for 230 volts A.C., 35/- extra. Ammeter to match, 0-50 amps., A.C., 75/- Voltmeter to match, 0-75 volts A.C., 65/- D.C. moving coil, Elliott voltmeter, 3½in., panel with back connection, 130/260 volts, 30/-.

TRANSFORMERS. Auto type, 230/110v. 85 watts 25/-, 100 watts 30/-, 150 watts 35/-, 350 watts 65/- 1 K.W. £7 10s. Double wound transformers 230v./20v. 2 amps. 30/-; 12v. 3 amps. 32/6. B.T.H. Transformer, 200/230/250v., 50 cy. input 2 volts 20 amps. and 75 volts 6 amps. output with 15 taps, 70/- Carriage paid England and Wales.

DYNAMOS. D.C. 12 volts 10 amp. C.A.V., new condition; shunt wound, carbon brushes, £4. 50/70 volt D.C. 10 amps. shunt wound, ball bearings 1,000 r.p.m., £14; 30 volts 5 amp., £5; 24 volts 40 amps. £10.

SWITCHES Dewar key panel type, 7-pole C.O. flush fitting, 5/- Yaxley 3-pole 3-way, 3/6; 8-pole 1-way, 3/6. D.P.C.O. toggle switch 250v. 1 amp., flush panel, 3/3; 8-way Lucas switchbox, 3/6; 6-way, 3/-

CIRCUIT BREAKERS. M.C.S., 7j. amps. A.C., enclosed type, 21/- 24 volt D.C. Solenoids, lift 14 lbs., 15/-

SPARK COILS. G.P.O. ½in. to lin. coil, 6/12 volt operation, 25/-; large 4in. coil on polished wood base, in new condition, heavy contacts, £12 10s. Mercury Interrupter, 110 volts D.C., £2 15s.

SPEED METERS. By A.T. Speedometer Co., 1,500 r.p.m., 4in. dia., black dial, white figures and scale, 20/-

BATTERY. SUPERSEDER, 6 volts D.C., input 230 volts 40 m.a. D.C. output, for Radio receivers, 5½in. x 3½in. x 3½in., ball bearings, model finish, 55/-

TELEPHONES. Wall type constructors' parts, ex-G.P.O., comprising cabinet 8in. x 6in. x 3in., bracket mike, transformer and condenser, mag. bell, switch-hook and contacts, hand mag., ringer P.O. type receiver terminals and connection diagram, 35/- per pair.

MOTORS. D.C. 1/12th h.p., 110 volts, shunt wound, 25/- A few similar machines, 110v. or 220v. needing repair, 12/6, carriage 1/6.

BATTERY CHARGERS. 230 volts A.C. for 6 or 12 volts car accumulators. Send us your enquiries and keep your car accumulator in condition while not in use.

MAGNETS. D.C. Electric magnets, weight 10 oz., lift on 2 volts 1½lb., 4 volts 3lb., 6 volts 4lb., new, surplus, 7/6 each. Permanent powerful flat bar magnets, 2½in. x 1in. x 1/8in., drilled 2 holes each end, and any pole pieces, 2/- pair. The wonder Midget magnets. Alni perm. steel disc; 5/8in. diam., 3/8in. thick, with 3/16in. centre hole, 3/6 each. Large stock of Horseshoe magnets. Send for special Magnet Leaflet, "W.W."

Please include postage for mail orders.

ELECTRADIX RADIOS

214, Queenstown Road, London, S.W.8
Telephone: MACaulay 2159

SEE and hear the Wharfedale corner cabinet at Grand Arcade Radio, Leeds, 1, Tel. 22175.

HIGH quality, precision-built speakers, Hi-Ticonal magnets, detachable diaphragms, die-cast chassis, twin cone.—Broadcast & Acoustic Equipment Co., Ltd. Broadcast House, Tombland, Norwich 26970. [6435]

LOUDSPEAKERS. SECONO-HANO VOIGT H.C. corner horn with bass chamber, as new, £16.—Box 4971. [9029]

HARTLEY-TURNER 215 latest model, unused; £7/10.—Box 4769. [8978]

VOIGT light twin unit with B.B.C. core, for filter, 100/200v field; £20.—Cooper, 12, Rectory Gdns., Northolt, Middx. [9106]

HARTLEY-TURNER energised, with rectifier and output transformer; £4/10.—Kirk, 100, Lakenheath, N.14. [9085]

GOODMANS infinite baffle, perfect, £12; R.K. Senior, 1,000ft field, perfect, £4.—Marshall, 5, Isis Court, Chiswick, W.4. [9010]

VOIGT light coil twin unit; H.C. corner horn with bass chamber, 40w field supply unit; perfect, demonstration, £40.—Box 4870.

VOIGT light twin cone unit in H.C. corner horn, bass chamber and field supply unit; £35 or offer.—51, Manchester St., Cleethorpes. [9067]

VOIGT domestic corner reflector speaker, condition; offers over £40.—32, Kenninghall Rd., Benchill, Manchester. [9121]

BAKER super quality 12in. permanent magnet triple cone speaker, Ticonal magnet, 15 ohms, complete with infinite baffle cabinet in the white, new, £6/10.—Box 4505.

ARDENTE Regal sound system, specially built for stage work, comprising 1 type S.A. 318A amplifier of 15w output, 3 type MC/F8 moving coil microphones with folding stands, 2 type PMCA cabinet loudspeakers, 12in 1 type 524 4-channel mixer, 1 cabin type trunk, cables and connections, slightly used, just checked by makers and in 100% condition; present day replacement value £165; offered for quick sale at £95.—Apply for appointment to view, Challen, Omega Works, Hermitage Rd., Finsbury Park, N.4. Sta. 2288.

MORSE precise equipment for classroom or individual tuition; keys, audio oscillators for both batt. or main operation.—Webb's Radio, 14, Soho St., W.1. Ger. 2089. [2291]

DYNAMOS, MOTORS, ETC. ALL types of rotary converters, electric generator sets, etc., rotary transformers, input 12v dc. output 600v at 250ma; price £4/10 each nett, post paid; J.A.P. No. 2A engines, 1.2 b.h.p. at 2,600 r.p.m., complete and ready for use, £17 nett, ex works.—Ward, Lordcroft Works, Haverhill, Suffolk Haverhill 253/4.

LARGEST and most comprehensive range in the country, British and U.S.A. types, at Board of Trade prices; send for list (valves available) free, s.a.e.; valves sent c.o.d.; retailers not supplied.

RANSOM, Bond St., Brighton. [7223]

GRAMOPHONE AND SOUND EQUIPMENT SIMON SOUND SERVICE have recorders in stock. [8713]

WILKINS & WRIGHT coil pickup, as new and perfect.—Box 4516. [8932]

COIL pickup, Wilkins & Wright; £5, unused.—9, Whitehall Gdns., Chingford, E.4. [8937]

WIRE recorder—immediate playback, wipe-off, perfect; offers over £75.—Box 5020.

BRIERLEY armature pickup, sapphire, transformer with tone compensator, as new, perfect, £4/10.—201, Plum Lane, S.E.18. [7532]

MARCONI model 239 radiogram, little used, £40; Audix gram unit, unused, £7/10.—Hunt, 169, Pettits Lane, Romford. [7223]

TRANSFORMERS, tone control and filter chokes, for all "W.W." circuits.—R. Clark, 30, Langland Crescent, Stanmore, Middx. Wor. 5321. [7532]

PREMIER "Super" M.C. microphone with transformer and stand; £3/15; "Feig" recording tracker, 10/—R. E. Smart, Stragglethorpe Grange, Brant Broughton, Lincoln.

VOIGT loudspeaker unit and mahogany corner horn, beautifully made; also field rectifier unit and Voigt pickup with transformer and corrector; offers for the lot or separately; can be seen working.—Box 4972.

PICK-UPS—Lexington Senior with screened L transformer and two sapphires, as new, £5/10. Acos crystal with sapphire stylus, as new, £2.—Also Avo Universal Minor, perfect, £6.—34a, Ayleswade Rd., Salisbury.

BRITISH SOUND RECORDING ASSOCIATION covers all interests of the professional and amateur recording engineer and quality reproduction enthusiast; "Sound Recording," the official journal, Vol. 3, No. 1, 2/6 post free.—Details of the Association and membership application form from, Hon. Membership Sec., H. J. King, 48, Mount View Rd., N. Chingford, London, E.4. [9080]



NEW G.P.12 CRYSTAL PICK-UP

with permanent sapphire stylus

—was fully described in *The Wireless World's* recent article "Crystal Pick-ups—Basis of Design for Fidelity Reproduction."

This remarkable pick-up, which represents the ultimate in high-fidelity reproduction, is now available in limited quantities through your radio dealer, price 96/- incl. P.T.



FREE ILLUSTRATED FOLDER describing this new pick-up may be obtained by returning the coupon below.

TO COSMOCORD LTD.
ENFIELD, MIDD.

Please send folder of ACOS Pick-ups.

NAME _____
ADDRESS _____
W.W.

OPPORTUNITIES IN RADIO



Get this **FREE Book!**

"ENGINEERING OPPORTUNITIES"

reveals how you can become technically-qualified at home for a highly-paid key-appointment in the vast Radio and Television Industry. In 108 pages of intensely interesting matter, it includes full details of our up-to-the-minute home study courses in all branches of **RADIO and TELEVISION**, A.M. Brit. I.R.E., A.M.I.E.E., City & Guilds, Special Television, Servicing, Sound Film Projection, Short Wave, High Frequency, and General Wireless Courses.

We Definitely Guarantee
"NO PASS—NO FEE"

If you're earning less than £10 a week, this enlightening book is for you. Write for your copy today. It will be sent **FREE** and without obligation.

**BRITISH INSTITUTE OF
ENGINEERING TECHNOLOGY**

388b, Shakespeare House,
17/19, Stratford Place, London, W.1.

INFINITE Baffle corner deflectors, scientifically designed acoustic chambers as reviewed "Wireless World" June; send for catalogue.—Broadcast & Acoustic Equipment Co., Ltd., Broadcast House, Tombland, Norwich 26970. [6434]

RECORDING equipment and accessories, blank discs, cutters, radio units, mixer units, a complete recording equipment for £75; send 3d in stamps for descriptive catalogue to University Recording Co., 113, Milton Rd., Cambridge. [8476]

MATEURS.—Your call sign recorded, a double-sided 10in record, 3 mins. playing time each side, 17/6, male or female voice, high quality, long lasting; 5in sample sent free.—Write your own scrips to D. Grafton, 53, Old Steine, Brighton. [9076]

CORRECTION.—Radio Unlimited, 16, Carnarvon Rd., Leyton, advertised price of Goodmans 12in speakers should have read Model T2/1205/15, £6/15; Axion Twelve, £9/8; we wish to apologise for any inconvenience caused by the mistake. [9016]

PROFESSIONAL recording machines, blank discs, cutters, trailer needles, etc., from stock; recording amplifiers, matching transformers, ribbon and m.c. microphones; full trade terms.—Sound Discs (Supplies), Ltd., 83a, Bold St., Liverpool. [8979]

LEXINGTON Junior pick-up, as new. £3/15; D.C. Avo Minor, plus case, perfect. £3; 0.300 micro-ammeter, R.H. zero, £3; 1200-0-1200, 500 m/a. TX, TR, with 3 L.I. windings; 20 copies, electronics, radio, etc. 1943-1946 offers.—Conway, 21, Cleveley Ave., Rochdale. [8979]

RADIOGRAM motors, auto changers, playing desks, pick-ups, amplifiers, chassis, cabinets, speakers, accessories, microphones, etc.; rotational deliveries of the new silent drive motor and turntable; details on request; new lists available; s.a.e. please.—Radio Unlimited, 16, Carnarvon Rd., Leyton. [8836]

RADIOGRAMPHONE units, including the new Audix non-magnetic; full list on request; also radiogram chassis, cabinets, accessories; various colours, moulded bakelite; Rola 10in speakers, 30/-; 4-wave radiogram chassis, £14, inc. tax; 3-wave radio tuners, £5/5; many other short supply lines.—Radio Unlimited, 16, Carnarvon Rd., Leyton. Callers, 272, Romford Rd., Forest Gate.

TECENIFON, Ltd., manufacturers of direct disc recording equipment and accessories, precision built traverse gear complete with first-class cutting head, we manufacture and specialise in sapphire pick-ups on the market and inc. a push-in model for light-weight pick-ups; we manufacture specials in quantity to specification.—Technifon, Ltd., 99, Belgrave Rd., London, S.W.1. Vic. 8814.

S.H.E.F.I. moving-coil pick-up is now available for both home trade and export; it combines for the first time high fidelity with high output voltage, enabling it to directly replace normal moving iron pick-ups without any extra amplification; it has an exceptionally clean response with no undesirable resonances, thereby requiring needle scratch. Price, in walnut and black plastic finish, 40/- each retail, including transformer, plus 10/4 purchase tax; wholesale and retail enquiries invited; illustration sent on request.—Brooks & Bohm, Ltd., 90, Victoria St., S.W.1.

CHARLES AMPLIFIERS welcome lovers of recorded music to their new premises where their high fidelity amplifiers can be heard together with Lexington Connoisseur and Rothermel pick-ups and B and A.E.C. Vitavox, and Wharfedale speakers, B and A.E.C. acoustic chambers, infinite corner baffle deflectors, etc.; we like you to bring your own familiar records for comparison; this is a service devoted entirely to the high fidelity reproduction of music; one minute from the Albert Hall and Kensington High St. Station; buses 73, 49, stop at the door.—Charles Amplifiers, 1e, Palace Gate, Kensington, London, W.8 [6642]

COMPONENTS—SECOND-HAND, SURPLUS

DUBILIER paper conds., metal cased, 6mf, 1,000v wkg., 5/- ea.; I.R.O. coil-packs, 50-100 kc/s, 100-200 kc/s, 15/- ea.—Box 4969, "SOUTH-WEST", London amateurs, for your Denon stockist, and all other constructors' components, call at Servio Radio, 156, Merton Rd., Wimbledon. Tel. Liberty 6525. "YOU'LL probably get it at Smith's, Edgware Rd.!" Everything for the constructor, from a 1/10 watt resistor to a radiogram cabinet; lowest prices, biggest variety.—Near Metropolitan Music Hall, Pad. 5891. [8005]

SPECIAL offer! Complete range of components for constructing T.R.F. superhet sets, radio cabinets, coil packs, amplifiers, etc., at bargain prices; send for details.—Hands Radio Supplies, 103, Turnpike Lane, Hornsey, N.8. 18938



'MINOR' INSULATION TEST SET

Compact and inexpensive without sacrificing accuracy and reliability. Weighs only 3lbs. Height allows for full swing of generator handle. Ranges up to 20 megohms 500 volts.



CONTINUITY TESTER

This latest addition to the Record Ohmmeter range is enclosed in a moulded bakelite case of pleasing appearance. Equipped with self-contained dry battery. Specially designed test spikes and leads can be supplied, also a "test and carry" case in which the instrument may be used without removal. Ranges:—0.3—0/30 ohms, 0/30—0.300 ohms, 0/500—0.50,000 ohms, 0/100—0/200,000 ohms.

THE RECORD ELECTRICAL CO., LTD., Broadheath, Altrincham, Cheshire. Tel.: Altrincham 3221/2. Grams: "Infuslon," Altrincham. LONDON: 28, Victoria St., S.W.1. Phone: Abbey 5148



ALL-WAVE SIGNAL-GENERATORS Type 5 & 6

These high-quality precision instruments 200-240 volts AC Type 5, 100-250 volts AC/DC Type 6, have a coverage of 100 Kc/s to 30 Mc/s in 5 ranges. Calibrated by hand against a standard frequency accurate to 0.01%. Constructed in B.A.60 alloy and finished black and cream. Price 14 Gns. Type 5 or 6. Immediate delivery.

Illustrated leaflets on application to:

**R.R. DEVELOPMENT
LABORATORIES LTD**
BARNARD ROAD • BRADFORD



THE "FLUXITE QUINS" AT WORK

"We once used to rouse up like men
When the kitchen clock buzzed at seven-ten,
But this gadget you see
Fixed by FLUXITE—and me
Gets us up with a boom from Big Ben!"

See that FLUXITE is always by you—in the house—garage—workshop—wherever speedy soldering is needed. Used for over 40 years in Government works and by leading engineers and manufacturers. Of all Ironmongers—in tins, 10d., 1/6 & 3/-.

TO CYCLISTS! Your wheels will NOT keep round and true unless the spokes are tied with fine wire at the crossings AND SOLDERED. This makes a much stronger wheel. It's simple—with FLUXITE—but IMPORTANT.

The FLUXITE GUN puts FLUXITE where you want it by a simple pressure. Price 1/6, or filled, 2/6.



ALL MECHANICS WILL HAVE

FLUXITE
IT SIMPLIFIES ALL SOLDERING

Write for Book on the ART OF "SOFT" SOLDERING and for Leaflets on CASE-HARDENING STEEL and TEMPERING TOOLS with FLUXITE. Price 1d. each.

FLUXITE LTD.

(Dept. W.W.), Bermondsey Street, S.E.1

CLYDESDALE for ex-Services electronic bargains.

BRAND new half-wave dipole aerial with reflector and crossarm approx. 6 metres for wall bracket or mast mtg., dipole 9ft 3in, crossarm 4ft 11½in, reflector 9ft 7in with 39ft. co-axial cable and plug at 21/- each, carriage paid; brand new R1224 battery superhet receiver 5 valves, 3 wavebands, 30-300 metres complete less batteries at £5/14/6d. carriage paid; brand new R1481 V.H.F. receiver with 10 valves and stabiliser, less power supply for 65-86 mc. at £9/14/6, carriage paid; brand new Wheatstone Bridge test set at 50/- carriage paid; brand new AN/APA-1 C.R. unit at 97/6; carriage paid, plus 1,000 of other items.—Send for illustrated list. Clydesdale Supply Co., Ltd., 2, Bridge St., Glasgow, C.5. Tel. South 2706. [9081]

A MATEUR has for sale quantity components, some unused, s.a.e. lists.—Axtell, 97, Main St., Dregburn, Ayrshire. [9054]

B. & H. RADIO for radio components, test gear and meters; trade only; stamp for list.—Huntley St., Darlington 2198. [8974]

PARK RADIO OF MANOR PARK, 676-8, Romford Rd., E.12. Tel. Hford 2066. To help break the monotony of these columns we offer over and above everything radio:—**MICRO-TELEPHONES**, self-energising, no batteries required, work marvellously over long distances; ideal for keeping in touch with the bedridden without running up and down stairs; excellent also for intercommunication between shop and office, farm outhouses, etc. outdoors, only one wire is necessary—use earth return; these also make fine underpillow extension speakers, play the kids to sleep, or listen to the end without disturbing the wife, 2/6 each.

GANG condensers, escutcheons, transformers, etc., to be sold regardless of cost.—Send stamped addressed envelope for full particulars to Retail Sales, Ltd., 6, Chiltern Parade, Sycamore Rd., Amersham, Bucks. [8670]

TELEVISION aerial equipment, 5 types fully waterproofed, aerials available, poles, lashings, all types of feeder in stock; send for brochures; aerials installed.—Wolsey Television, Ltd., 87, Brixton Hill, S.W.2. Tulse Hill 1240.

G6YA, Western Gateway Headquarters for radio equipment and information. Radio components in stock for immediate delivery. L.F. Chokes, 250ma, 15/20H, 100 or 200 ohms, 10/6 ea.; 500ma, 15/20H, 80 ohms (size 6½in x 6½in x 4½in), 35/- ea.

VARLEY transformer, 500-5,000, 120ma 4v 5a, 4v 4a, 4v 1a, 30/- each.
ELECTROLYTIC condensers, 4-8 mfd, block can 450v wkg. (size 2½in x 2in x 1½in), with fixing feet, 5/6 each. 4-4 med. 3,000v, wkg., oil filled (size 5½in x 7in x 9in), 25/- ea.
POTENTIOMETERS, wire wound, 10 watt rating, 1,000 to 50,000 ohms (long spindle), 5/6 ea.; short spindle with slotted screwdriver control, 2/6 ea. Above are selections from our extensive range. S.a.e. will bring you winter catalogue showing ninety-eight special offers.

ARTHUR H. RADFORD, G6YA, 28, Be-1,minster Parade, Bristol, 3. Tel. 64314 [9040]
15000 Selenium rectifiers by S.T.C. and Westinghouse, 5 types, 30 ma to 220 m.a., 50 to 360 volts, all new tested stock, substantially discounted for quantities.—Apply for full technical data and prices. Partridge, Wilson & Co., Ltd., Davenset Electrical Works, Leicester. [8120]

COPPER wires, enamelled, tinned, Litz, cotton, silk covered, all gauges; B.A. screws, nuts, washers, soldering tags, eyelets; ebonite and laminated bakelite panels, tubes, coil formers; Tufinol rod; headphones, flexes, etc.; list s.a.e.; trade supplied.—Post Radio Supplies, 33, Bourne Gardens, London, E.4.

GOV'T. surplus components, meters and units, switches, pots, resistors, conds., screened flex, etc., meters from 500 microamps to 50 amps incl., R.F. types; volt meters, etc., 40 varieties from 2/6 to 30/- each; Ad. Mod. 6332A, 34/-; A.M. output tester, 25/-; 15 watt amplifiers (12v), £8/10; all carr. paid; s.a.e. for bargain list.—Hoyle, 320, Dewsbury Rd., Wakefield. [8917]

UNIVERSAL ELECTRONIC PRODUCTS, 36, Marylebone High St., London, W.1. Tel. No. Wel. 4058. Precision-built gearbox dial drive units, giving 2 ratios, 8-1 and 90-1. Entirely free from backlash. Few only. 18/6 post free. Send s.a.e. for particulars of our high-performance superhet tuning units. Special receiving or transmitting equipment constructed to specification. [9145]

KITS of radio receivers from £7/8; 4- and 5-valve, new materials, table models, semi-midget, our latest kit.—Wylwyn Star 1948 has connections for gramophone pick-up, extensions to loudspeaker, A.V.C., 6 hours average time for constructing; full details, diagrams with each kit; c.w.o. or c.o.d.—Isherwoods, Reme House, 81, Plungington Rd., Preston. Tel. 3348. Estd 1936. [6788]

ARMSTRONG

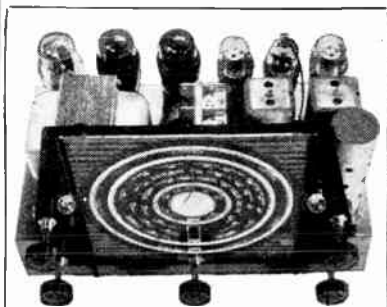

Model RF103

10 VALVE ALL-WAVE SUPERHET RADIOGRAM CHASSIS.

SPECIAL FEATURES

- ★ 10 VALVE CIRCUIT.
- ★ R.F. PRE-AMPLIFIER.
- ★ WAVE BAND EXPANSION.
- ★ LARGE GLASS SCALE.
- ★ 3 STAGES A.V.C.
- ★ TREBLE LIFT CONTROL. (Operates on both radio and gramophone.)
- ★ PLUS 6 db. BASS LIFT ON GRAMOPHONE. (To restore bass cut on some records.)
- ★ 10 WATT PUSH-PULL OUTPUT

To export buyers we can confidently recommend RF103 to any firm abroad who contemplates making a high-grade Radiogram or Console radio receiver.

The lively short-wave performance coupled with the excellent quality reproduction ensure an outstanding performance.

We will gladly make any alterations to the specification to meet individual requirements.

To home buyers demonstration model now available to interested callers to hear, and technical specification now available on request.

It is hoped that a number (very limited unfortunately) will be available for early delivery.

The above model is for A.C. Mains.

We also have a similar model Type UNI 103 for DC/AC Mains.

★ ★ ★

ARMSTRONG WIRELESS & TELEVISION CO. LTD.
WARLTERS ROAD, HOLLOWAY, LONDON, N.

Phone: NORTH 3213

A NEW TELERADIO CHASSIS
Model A70

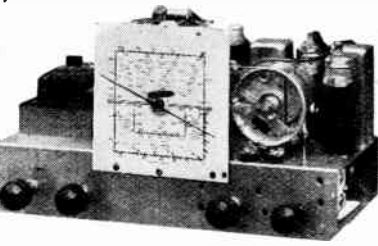

6-Valve A/C MAINS R/G CHASSIS, 15-50, 200-600, 540-2,000 Metres with TUNING INDICATOR, TONE CONTROL.

14 Gns. plus P. Tax.

Also available as tuning unit feeding push-pull amplifier. Blueprints can be supplied for home construction if desired.

Send 2d. stamp for full illustrated lists to
THE TELERADIO CO.,
157, FORE STREET, LONDON, N.18
Totl. : 3386

MIDLAND INSTRUMENT Co.
OFFER GOVT. SURPLUS STOCK

ELIMINATORS, 200/250-v. A.C., output 120v. 30-m/amp. D.C., fitted neon stabilizer, brand new, 40/-
MOTORS, fitted centrifugal pump, 12/24-v. A.C./D.C., for liquids, brand new, 35/-
CAMERA controls, fitted 12-v. motor, clockwork escapement, solenoid, etc., 20/-
Ditto, brand new, in wood cases, 25/-
EX-30V UNITS, fitted 11-valve VR8A (4), GV6 (2), VR67 (2), VR92 (2), VR84, also relays, var-conds, chokes, 50 resistors, 40 conds., chassis with cover, 35/-
AMPLIFIERS, 1134, 2-valves, triode and Q.P.P., 2-v. and 120-v. operation, ideal for microphone, pick-up or loudspeaking inter-com., with modification diagram, brand new, in transit cases, 30/-
ELECTRIC FANS, 12-v. A.C./D.C. powerful blast, brand new, 25/-
AERIAL VARIOMETERS, No. 19 Set, 3/6
ATTENUATORS, type 17, 3/6
SELECTOR switches, 12/24-v. impinging, operates Yaxley switch, 3/6
FLASHER MOTORS, TYPE "E", 12/24-v. geared motor, contact breaker, suppressor, etc., brand new, 20/-
CONNECTORS, 5C/430, bakelite 2-way, 4d.; boxes of 50, 12/6
JONES PLUGS, with sockets to fit, 6-way, 2/6; 10-way, 3/6; 12-way, 4/6
ALTIMETERS, aneroid barometer movements, brand new, boxed, 15/-
SPARK COILS, 12-v., fitted trembler and cond., approx. 1in. spark, brand new, 12/6
RECEIVING SET R122A, range 1 to 9-mc/s (30 to 300-metres), fitted 5-valves, superhet, 2-v. and 120-v. battery operation, Muirhead dial, a very smart set, brand new, 27/10/-, carriage 10/- extra
CONTACTORS, master type 1, a high-grade clockwork movement, giving 2-impulses per sec., brand new, 25/-
Remote contactors for the above, 120-impulses for 1-rev., etc., 12/6
35/- the two instruments.
HAND GENERATORS, generates 6-v. at 5-amp., complete with handle, brand new, 30/-, cut-out for same, if required to charge accumulators, 5/- extra
MOTOR GENERATORS (D.C. dynamos), 12-v. 500-watt, 30/-, carriage 5/- extra
Other voltage and wattage output generators in stock. Also hundreds of other interesting Radio, Electronic and Mechanical items to offer, send for our current lists, 2d. with S.A.E.
Orders over 30/- post-paid, carriage extra. Note increase in postage rates. No C.O.D. orders under 20/-
Moorpool Circle, Birmingham, 17
Tel. : HARborne 1308 or 2664

MORTONS now have a full range of the famous test gear resistors: Type A mid-geet, 1 1/2in x 2 1/2in 1,000Ω .2a, 600Ω .3a, 4/9 ea; 1,500Ω .15a, 5/-; Type B, 1 1/2in x 3 1/4in, 1,000Ω .2a, 600Ω .3a, 750Ω .3a, 5/- ea; 1,500Ω .15a, 5/3. Also 5w R.M.A. coded wirewound from 50Ω to 2,500Ω (34 values), 1/6 ea; 10w, 2/- ea. Adjustable 5w 2 1/2in x 1/2in one slider, 50, 100, 150, 200, 250Ω only, 1/9 ea.
FROM Mortons, 13, Camden Rd., Walthamstow, London, E.17. Trade supplied. [8862]

VARIABLE selective I.F.s, high gain, 465 Kcs, permeability trimmed, Albin coil packs, 3 or 4 wavebands, adjustable iron dust cores, complete with circuit and test sheets, from 36/6; dials to match, 3/6; ceramic 0.3 droppers, 5/6; Summersby high gain coils, adjustable dust cores, low loss formers, 3/3 each; I.F. filters, 465kc, 2/6; 2 gangs, 9/6. 2-speed drives, 2/-; terms cash with order or c.o.d. over £1, postage 6d extra.—Castle Radio, 11, Mill Lane, Margate. [8916]

NEW STC selenium rectifiers, f.w. bridge connected, damp-proof finish: 17v 6a 12/1; 2a 15/5; 3a 21/6; 4a 25/-; 5a 27/-, all p.f.; 36v 2a 29/6; 30v 5a 43/6; 50v 4a 53/8. all post 10d. Heavy duty type, 7in sq. A1 cooling fns: 17v 6a 34/1, p. 1/-; 16v 10a 43/8, p. 1/-; 33v 6a 63/8, 30v 10a 71/2, 28v 20a 139/3, 54v 6a 89/6, 90v 6a 166/4; all p. 1/3. STC replacements for all valve-type chargers.—Pearce, 66, Gt. Percy St., London, W.C.1 (nr. "Angel")

RADIO components to list price value of £20 for only 50/-; our assortment includes P.O standard relays, air dielectric condensers, selenium rectifiers, wire wound potentiometers, transformers, chokes, electrolytics, jacks, insulators, signal lamps, plugs and sockets, tag panels, i.f. transformers, r.f. chokes, block condensers, etc., etc.; our purchase of a complete Ministry of Supply store makes this unprecedented offer possible; order a sample parcel and come back for more.—M.O.S., 24, New Rd., London, E.1. [8745]

TELEVISION spares! For constructors: We have a good selection of components: CRM91 tubes, £11/6/10; rubber masks, £1/2/6; E.I.T. trans., from £3/2/6; focus and scanning coils, line output trans., RF coilformers, 1/2in, threaded with dust iron cores (adjustable), EF50, EA50, EL38, KT45, Pen46, AC5/pen, AC6/pen, T41, U21, SU2150, etc., all at manufacturers' list prices; all caps of television condensers, 70-750 ohm twin and screened feeder, 1,000 radio valves and spares; send s.a.c. for lists.—Porritt, 13, Wastdale Rd., S.E.23.

HARRY JAMES PRODUCTIONS, 270, Leith Walk, Edinburgh, 6.—Mail order specialists, c.o.d. or cash with order. Electrolytics, new not W.I. surplus, B. I. Hunts, etc., 8mid blocks, 3/6; 16+8 blocks, 6/6; 8+8 can, 6/3; 16 can, 5/6; 8mid B.I. tubular, 4/-; 25mid 25v, 2/2. T.R.F. chassis, 4/6; chokes, midgeet 5/-, standard 7/-; T.R.F. coils, M. & L., 8/6 pair; coil packs, 16-50, 200-590, 800-2100, complete with trimmers switch, etc., mounted on one unit, 32/-; condensers, .1, .01, .05, 500v 8d each; variable 2-gang .0005, 12/-; with trimmers, 13/6; loudspeakers, 5in P.M., 19/6; 6 1/2in energised 1,000ohms, 29/6; 8in P.M., 25/- resistors, 1/2 watt 6d, 1 watt 9d, volume controls, long spindle, W/S 5/6, L/S 3/6; transformers, 350-0-350 80ma British or American heaters, 30/-; output multi-ratio, 9/-; valve holders, 5.7-pin and Octal, 7d; Amphenol type, 9d; voltage droppers, .2a 1,000ohms, 3/9; .3a 800-ohms, 4/9; line cord, 3-core, .3a, 9d ft. Valves, C.o.d. Large stocks of British and American types. Enquire for anything in radio, S.a.c. for lists. [8851]

SPEAKER trans., tapped output, ultra-midgeet, 5w midgeet 5/6, standard 8/-; P.P. output (6L6 valves, A/A load 6,600-ohms), output 7.5 and 15ohms, 21/-; P.P. modulation trans. for 807 valves, audio power 30 watts, 2-1, at 12/6; chokes, ultra-midgeet 40ma 5/-, midgeet 50ma 5/6, standard 100ma 8/6; hv. duty 150/200ma 12/6; "Ruco" tuning assembly, assembled and fully wired for s.m.l. waves. On chassis, dial, pointer, I.F.s coils, padders, etc. Series heater wiring for use with 6k8g, 6k7g valves, complete, factory tested and aligned, with circuit, 25/-; 5v superhet, fully drilled chassis, 1 1/2 x 5 1/2 x 2 1/4in, 7/-; Weymouth midgeet i.c. I.F. trans. 465 Kcs, brand new, pr. 18/9; standard I.F. trans., pr. 15/-; ditto I.F.s 2Mcs, each 2/-; M/L t.r.f. coils with reaction circuit, pr. 7/6; M/L i.c. t.d.f. pr. 10/6; SML, aer & osc, pr 10/6; sleeving, all colours, 1 mill, 35/40 yard reels, 1/6; twin variable resistance, 300 ohm, 1 amp, 25/-; Yaxley type, 3-pole, 2-wav, 2/-, 4-pole 3-wav 3/-, 4-pole 4-wav 3/6; nice type D.P.P.V. 2/6; comprehensive lists, nonthly; 2d stamp enquiries; postage extra all orders.
O. GREENLICK, 265, Whitechapel Rd., London, E.1. Tel. Bishopsgate 5907. [8799]

POTENTIOMETERS

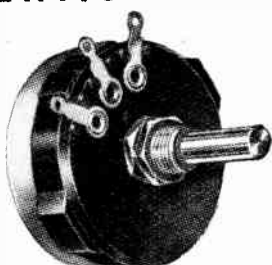

by **RELIANCE**

Type T.W. Wire Wound	
Rating	RANGES
5 Watts Max. (linear)	10-100,000 Ω Max. (linear)
3 Watts Max. (graded)	100-50,000 Ω Max. (graded)
	100-10,000 Ω Non-inductive
Type S.G. Composition	
1 Watt Max.	2,000 ohms to 2 megohms

CHARACTERISTICS: (both types) linear, log., semi-log., inverse log., non-inductive, etc.
FULL DATA FROM:
RELIANCE
Manufacturing Co. (Southwark) Ltd., Sutherland Rd., Higham Hill, London, E.17. Telephone: Larkswood 3245

GOVT. SURPLUS, UNUSED
CONDENSERS
of all types . . .

We can offer, FOR IMMEDIATE DELIVERY from very generous stocks, a wide range of ultra-high quality fixed paper Condensers, from .001μF to 8μF. Also STOCKS of small, genuine MICA Condensers from .00001 (10 pf) to .01μF (10,000pf). Prices are exceedingly moderate.

Enquiries are invited for manufacturers requirements, wholesale and export only for bulk quantities, and for scheduled deliveries over a period, as required. Condensers of close or very close tolerance can be supplied within about one week.

Please request our 4 page bulletin CONSEVEN 011147
CLAUDE LYONS LTD.
180, Tottenham Court Rd., London, W.1 and 76, Oldhall St., Liverpool 3, Lancs.

PRECISION TRANSFORMERS



Impregnated High Grade Transformers to 2% tolerance. Supplied in all voltages. Special list on application.

ALL NEW PRODUCTS

Q-Max 50-1 5.M.	66/-
Do. 8-1 5.M.	15/6
Do., 2in. dials	9d.
Do. Nameplates	6d.
Do. "5" Meter	59/6
Chassis Cutters, 3in., 2in.	9/6
Keys for 3in., 2in.	9d.
Chassis Cutters, 1 1/2in., 1 1/4in., 1 1/8in.	12/6
Keys for above	1/-
Stand-offs, 1in., 6d.; 1in., 9d.; 1 1/2in.	1/-
Flexible Drives	6/-
100 pp. Twin Var. (small)	10/6
Westinghouse Rec. 1.5 or 10 ma	10/-
Jones 8-way Plugs and Sockets	10/9
Thermal Delays	10/-
Filament Trans.-All Ratings Multi-Speaker Trans.	12/5
Cer. Variables (all capacities)	
Test Prods.	2/6
.25 mfd. 5 kV Condensers	23/6
.1 mfd. 6 kV. Condensers	15/6
Crystals, "P" Coils ± 1 per cent. Resistors, Speakers, etc.	

HIGH "Q" CIRCUITS FOR DISCERNING AMATEURS

Illustrated catalogue 6d. post free.

BERRY'S

(SHORT WAVE) LTD.

25, HIGH HOLBORN, LONDON, W.C.1

(Opp. Chancery Lane). Tel. HOLborn 6231.

G. A. RYALL, 65, Nightingale Lane, London, S.W.12.—Mail order only, postages extra, c.o.d. £1 or over, please send large envelope for our full list; U.S.A. make metal cased 500v tubular 0.1mf, 7/6 dozen; Silver mica, 200pf, 300pf, 400pf, 500pf, 4/6 dozen; 500v wkg. Micamoulded 0.004mf, 4/- dozen; Mica 0.01mf, 3-2/-; Mansbridge 1mf 500v wkg., 3-2/-; all condensers guaranteed; Amphenol type British 5-pin valve holders, 4/6 dozen; U.S.A. paxolin 4-5-6-pin, 3/6 dozen; volume controls, 10,000 medium spindle, 1/6 250,000ohm short spindle, 1/6; Bar type 3-gang, 0.0004mf short spindle, 5/-; Bar type 4-gang, 0.0004mf, 5/-; Resistors, 1/4watt, 1/2watt, 100 ohms to 2 meg level assortment, 40-5/-; Plastic group boards, drilled, less tags, 9w, types, 3-1/6; Switches SB.2P. miniature, 2/-; 3B.2P. 6w, 5P. total, 2/6; 2B.3P. 3w, 2/3; Res panels, 5-way with 25mf and three res., 1/3; Twelve-way group boards with 9-1watt and 1/2watt res., 2/-; all new; twenty types in stock; Octal plugs, cap and socket, 3-2/6, with tags 3-3/-; high resistance phones, with sponge earpads, with good class microphone a wired in to plug, rubber padded, plug type 10H/10991, 10/9 pair; Metal boxes, black finish with quarter-inch paxolin panels, fixing lugs and corner sockets, size 8 1/2 x 7 1/2 x 3 1/2 in deep, 6/9 each complete; International Octal valve holders, Paxolin chassis type, 4/6 dozen; Metal-cased tubulars, 0.5mf, 350v, at 71d C., wire ends, 3-2/6; Fifteen relays in carrying rack, mounted, with cover, 42/6. [8928

M.A.N.F.A.C.T.U.R.E.S.; hug stocks all components, 8/M, M/A, P.T. and block condensers, close tolerance resistors and all types resistances, potentiometer, laminations, valve holders, glass cartridge fuses, 1 1/4in; suppliers to leading manufacturers; all goods guaranteed.—L. E. Simmonds, 10, Valencia Rd., Stanmore, Mx. Grimsdyke 608.

SELECTOR switches, 5-bank, 25-way, per bank 20/- each; toggle switches, telephone jacks, press switches, 20-way tag boards, E.S. holders, lead ends, E.S. holders, screwers, Yaxley type switch, 3-pole 2-way, each 18/-; dozen; voltmeters, 0-40, ampmeters, 0-50, 15/- per pair; condensers, 8mf 700 volt, 6/- each; condensers, 4+4, 500 volt, 3/6 each; condensers, 1mf 250 volt, 6/- per dozen; rotary switches, 5-section, 10-pole, 15/- each; 10-section, 20-pole, 25/- each; 0.0003 tuning condensers, 3/- each; relays, 200 ohm, 3/- each; delivery by return.—Particulars, H. S. F. Denford, Box Trees Mill, Wheatley, Halifax, Yorks.

R.R.H. RADIOCORP. LTD., The Leicester Specialists, offer from their comprehensive stocks: Woden de luxe potted output transformers, pri 7,000Ω, sec 3-15Ω, 25watts, 29/6; do., potted smoothing choke to match, 10h, 150ma, 25/-; 20, 40 and 80m Eddystone 4-pin coils, 5/- set of 3. Headphones, brand new Ericsson 12Ω, 12/6 pr; do., Utah, Chicago 240Ω, luxury job, 15/- pr; tuning condensers, 160pF 3-gang, ceramic insulation, Wingrove & Rogers, 7/6; do., .0005 3-gang, 7/6; single gang, 300pF, 1/6. Meters, 3in flush type, 0-100 microamps (10,000Ω/v), 21/-; 0-20 ac, 12/6. 10-0-10ma dc, 12/6; 1-01ma dc, 12/6; 0-20a dc, 15/-; 350-0-350 millivolts dc, 15/-; 0-500 microamps dc, 25/-; 0-100% modulation (1mA Isd), 25/-; 2in square flush type, 0-1ma, 25/-; 50-0-50a, 7/6; 0-20v dc, 12/6; 0-5a ir, 7/6; 0-3a ir, 7/6; 1 1/2in flush type, 0-500 microamps, 7/6. Bargain parcels: Service type multi-way plugs and sockets, 12 asstd., 5/-; Systoflex, 72yds asstd., 5/-; new resistors and condensers, 25 asstd., 5/6; 50 asstd., 10/6; 100 asstd., £1. Satisfaction guaranteed or money refunded without question. Latest lists free on request. Trade supplied.—Frith Radiocraft, Ltd., Leicester. Tel. 58927. [9143

THE N.R.S. "Overseas 5," 5-valve 3-wave superhet assembly for ac mains, £6/17/6 universal model £6, consisting of all main components, factory mounted on chassis, only small resistors, capacitors required to complete, valves, speakers and highly polished veneered cabinets available; send postage full specifications; component bargains: Selenium metal rectifiers, very compact, 250v 45ma 5/-, 350v 70ma 8/6; filament transformers, ideal converting midgets to ac, 6.3v 1.5 amp, 12/6; standard shrouded mains transformers, input 110-250v, 300-0-300, 6.3 and 5v output, 27/6; superior portable-tuned I.T.S., 465 kc/s, 13/6 pair; high-flux p.m. speakers, 5in, less trans., 17/6, 6 1/2in with 24/6, 8in R. & A. less 21/-, with 27/6; revolutionary new high "Q" 3-wave iron-cored coil packs, unusually compact, 33/-; immediate safe despatch all Avo instruments; Pullin ten thousand o.p.v. multimeters, ac/dc/ohms, 10gns; Polar 0.0005 2-gangs, 8/6; electrolytics, 8 plus 16, 350v, 7/-; 25 plus 25, 200v (ideal midgets), 7/6; 25mfd bias, 2/3; send postage for special W.W. monthly bargain list; terms, c.w.o. or c.o.d., postage strictly extra under £5.—N. R. S., 66, Park Rd., London, N.W.3. G9139

GALPINS

ELECTRICAL STORES

408, HIGH STREET, LEWISHAM,

LONDON, S.E.13

Phone : LEE GREEN 0309

TERMS : CASH WITH ORDER (NO C.O.D.)

EX-GOVT. (GEC) ELECTRIC FANS., 12 volts AC/DC laminated field, complete with 5in. impeller. New boxed, 25/- each, 1/- post. Transformer to suit 230 volts input/10/16 volts at 4 amps. output, 32/6 each.

MAINS VARIABLE RESISTANCES. Ex-Govt. (new) slider type, 4500 ohms to carry 0.7 amps., 30/- each; 4,000 ohms .25 amps, 35/- each. Worm wheel control slider type, 60 to carry 1 1/2 amps., 27/6 each; 5.7 ohms 8 amps., 32/6 each. Dimmer resistances stud switch arm type, 2,700 ohms to carry .27 amps., 30/- each.

EX-GOVT. (NEW) MAINS TRANSFORMERS, 200/250 volts 50 cys. 1 ph. input 525/0/525 volts 150 M/amps. 6.3 v. 5 a., 5 v. 3 a. output standard rating, 35/-, post 2/- Mains Smoothing Chokes, 10 Hy. 150 M/amps. 180 ohms D.C. Resistance, 8/6 each. Ditto, 100 M/amps., 5/6 each, post 9d. Smoothing Condensers (oil filled), 4 M.F. 1,000 volt working, 3/6 each. All the above can be offered in large quantities. Please write for special quotation.

EX-R.A.F. MICROPHONE TESTERS (new). These consist of a FERRANTI 0 to 450 Microamp 2 1/2in. scale meter shunted to I.M/A incorporated Westinghouse Rectifier, the whole encased in polished teak case calibrated at present 0 to 10 volts, 32/6 each.

EX-R.A.F. POWER UNITS, TYPE 225 (new). Containing the following components: 3-V.U.III Rectifier Valves, 1-5U4G 2-EB 34s, 3-Multi Contact Relays, High Voltage Condensers, Chokes, Transformers, etc. To clear, 65/- each.

EX-R.A.F. ROTARY CONVERTORS, D.C. to A.C., 12 volts D.C. to 220 volts 50 cys. 1 ph. A.C. at 100 watts, 85/- each. Ditto, Admiralty Pattern, 110 volts D.C., Input 230 volts A.C. output at 200 watts, £12/10/- each. C/F Ditto, 220 volts D.C. Input, same output, £15, C/F. Another, 24 volts D.C. Input, 50 or 100 volts 50 cys. 1 ph. at 300 watts, £3/15/- each, C/F.

EX-R.A.F. CRYSTAL CALIBRATORS UNITS, Type 18 R.A.F. serial No. 10a/15237. These units contain 100 K/c.s. xstal 2-EF 50 valves and numerous other items all new and unused, 35/- each.

SPECIAL OFFER METERS, ALL NEW BOXED. Moving Coil First-grade Instruments, 0 to 20 volts 10/- each, or 3 for 25/-; 0 to 40 volts, 12/6 each; 0 to 100 amps., 15/- each; all 2in. scale. 0 to 25 volts A.C. calibrated 50 cys., 25/- each; 0 to 4 amps. Thermo Coupled, 25/- each; 0 to 3,500 volts Electrostatic, 35/- each, all 2 1/2in. scale.

MAINS TRANSFORMERS (AUTO WOUND). Voltage Changers tapped 10, 20, 25, 90, 130, 150, 190, 210, and 230 volts, all at 1,000 watts, a combination of 34 voltages can be obtained from this Transformer, new ex-Govt. stock, £5/10/- each, carriage 5/- Mains Booster Transformer, tapped 0, 6, 10, 19, 175, 200, 220, 225, 240, and 250 volts at 1,500 watts (new ex-Govt.), £5/5/- each, carriage 5/- Another 200 volts input 240 volts output at 2,500 watts, £7/10/-, carriage 7/6. Another 2 to 1 ratio, 110 volts input 220 volts output or vice versa at 4,000 watts, £12/10/-, carriage 10/- Another 230 volts input tapped output 40, 41, 42, 44, 46, 47, 49, and 52 volts at 100 amps., £15 each, carriage 10/-; the latter two are double wound. Another auto. wound, tapped 0, 110, 150, 190, 210, and 230 volts at 1,500 watts, £6/10/- each, carriage 5/- Ditto, 2,000 watts, £7/5/-, carriage 5/-

EX-NAVAL CATHODE RAY RECTIFIER UNITS. These units are new and weigh 90 lbs. Consisting of high voltage condensers, 15 volume controls, chokes, approx. 100 resistances and condensers all coloured, coded or marked, valve and tube holders (no valves), transformers are included but are for 500 cys., price to clear, 42/6 each, carriage paid.

MAINS TRANSFORMERS, EX-GOVT. All 50 cys. input 230 volts input 500/0/500 volt at 250 M/amps. L.T. 5 v. 3 a., 37/6 carriage 3/6. Another 50 volts at 30 amps. output, 75/- each, carriage 6/- Another two L.T. windings, 6 1/2 volts at 10 amps., 27/6 each. Another 230 volts input 700 volts at 150 M/amps., 4 v. 2 a., 4 v. 1 a. output, 27/6 each, carriage 3/6. Another 700/0/700 volts 80 m.a. 12 v. 1a., 4 v. 2 a. output, 30/0/- each.

HENRY'S

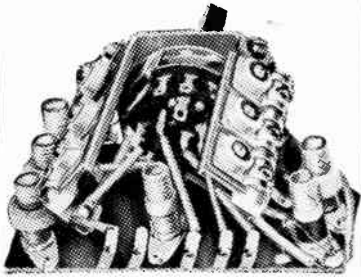

"Q" MIDGET COIL PACK. Size only 3 1/2 in. x 2 1/2 in. x 1 1/2 in. deep. Comprising 6 ultra-midget iron-core coils wound on Polystyrene formers, wave-change switch, trimmers, etc. Three wave band for 465 k.c.s., superhet operation. Aligned and ready for use. Complete with suitable 3 Valve S'Het circuit. A definite advance in Coil construction. **PRICE ONLY 33/-**.

Other 3 Wave Superhet coil packs in stock include Wearite, Weymouth and Atkins.

MIDGET I.F. TRANSFORMERS 465 k.c.s. Wearite E1 - pr. Weymouth 16/8 pr.

WEARITE 4 P. COILS. - Full range is kept in stock and can be supplied at 3/- each.

VALVES. We can definitely supply per return. 1S5 and 1R5 at 15/10. 3S4 and 1T4 at 14/- each. 85L6GT, 25A6, 25Z6, 68L7, 68C7, 5Y3GT, 12SA7, 12SK7GT, 12SQ7GT, 12K6GT, 12K7GT, MKT4 5 pin, etc., etc. All at current controlled prices.

PUSH PULL OUTPUT TRANSFORMER. To suit either 2-6L6 or 2-PX4. Rated 80 m.a. D.C. each half. To match 2, 4, 8 or 15 ohm speech coils. 18/- each.

A STAMP WILL BRING OUR LATEST COMPONENT LIST.

CASH WITH ORDER, OR C.O.D. (over £1).

5, HARROW ROAD, W.2
PAD 1008/9

PITMAN
Radio
Books

CATHODE RAY TUBE
HANDBOOK

By S. K. Lewer, B.Sc. Sets out the basic principles of design, construction and operation of the cathode ray tube. Second edition. 6s. net

THERMIONIC VALVES IN
MODERN RADIO RECEIVERS

By Alfred T. Wits, A.M.I.E.E. A special handbook for all engaged in commercial radio work. Second edition. 10s. 6d. net

A DICTIONARY
OF ELECTRICAL TERMS

By S. R. Roget, M.A., A.M.Inst.C.E., A.M.I.E.E. A handy guide to electrical engineering technology, including radio communications. Fourth edition. 12s. 6d. net

WIRELESS TERMS EXPLAINED

By "Decibel." A helpful guide to the technical terms used in books on wireless and in manufacturers' catalogues. Second edition 3s. net

Sir Isaac Pitman & Sons Ltd
Parker Street, Kingsway, W.C.2

SUPPLIERS of high-grade radio components including television and high fidelity radio equipment; all types of radio and electronic apparatus built to your specification; large stocks of close tolerance resistors.—Rogers Developments Co., 12, Macclesfield St., W.1.

SELENIUM metal rectifiers, charger kits, S.T.C. etc. Add postage 7d up to 15/-, 1/2 over 15/-. Circuit and data supplied. S.T.C. 12v 3 amp selenium rectifier with 50-watt transformer and ballast bulb for 2v to 12v charger. 45/-; ditto for 2v. 6v only 42/-; 6v 2 amp rectifier with transformer and ballast bulb for 2v. 6v charger. 35/-; 12v 1 amp rectifier with transformer and ballast bulb for 2v to 12v charger. 35/-; 12v 4 amp rectifier with 75-watt transformer and ballast bulb for 2v to 12v charger. 62/-; 12v 6 amp rect. with 140-watt trans. and ballast bulb for 6v, 12v charger. 45/-; trickle charger 2v rectifier with trans. for 2v trickle charger, 13/6; heavy duty charger kits for small radio store transformer, selenium rectifier, ballast bulb, no ammeters or rheostats needed, for 1 to 20 cells 1 amp. 95/-; ditto 2 amp. 46/5, guaranteed one year. Rectifiers only, 12v 3 amp S.T.C., 21/-; 12v 4 amp, 25/-; 12v 5 amp, 27/6; giant 12v 6 amp. with alloy cooling fins. 33/-; 24v 2.5 amp. 32/6; 12v 2 amp. 12/6; 24v 4 amp. 42/-; 6v 0.5 amp. 5/6; 6v 2 amp. 9/6; also 12v 1 amp. 10/6. H.T. rectifiers, small space selenium. 250v 60ma, 9/6; ditto bridge 100ma full wave, 16/6; 110v 60ma 9/-; 120v 20ma eliminator type. 7/-; also 350v-0-350v 80ma, 13/6; instrument rectifiers, 5ma. 12/6; crystal diodes. 2/5; Rola Bin P.M. speakers, less trans. 17/6; Rothermel Senior bakelite pick-ups, 52/6; Lustraphone m/c mikes. 58/6; 80-watt fluorescent chokes. 230v. 19/6.—Champion, 43, Uplands Way, London, N.21. Tel. Lab 4457. [9170]

SUPREME RADIO, 746b, Romford Rd., Manor Park, London, E.12: 2-gang 000.5 condensers with feet, 9/6; line cord, 20/- doz. yds.; tubular condensers 0.01, 0.01, 0.05, 5/6 doz.; 6mf cond. or cardboard, 39/- doz.; can type 16 mfd., 4/3 ea.; 16+8, 7/- ea.; 16+16, 7/3; 8+8+8, 7/3; 24+8, 7/3; 8+8, 6/-; 4mf can. 15/- doz.; condensers clips, 4/6 doz.; resistances, sizes from 220Ω to 2.2 meg. 1/2 watt, 3/- doz.; assorted wv res. 1 and 2 watt, handy sizes, 2/6 doz.; V/c's 50k short spindle, 12/- doz.; standard V/c's with sw long spindle, 100k and 50k, 42/- doz.; 5k up to 2 meg., 4/6 ea.; 250k less sw, 2/6 ea.; 2,000Ω wv. less sw. job line. 12/- doz.; all wave glass dials, 8in x 5in, 3/6 ea.; midget knobs, less grub screws, 1/- doz.; 4-pin UX ceramic valveholders, 1/- doz.; Mazda octal valveholders, 3/6 doz.; anchoring tags on Paxalin panel, 3/- gross; grid cap and lead on panel with 57Ω res. attached, 4/- doz.; Paxalin panels with anchoring tags, 3-4-11 way 3-way, 1d; 1 watt carbon res., 27,000, 75,000, 4/- doz.; 10,000 5w. 5/- doz.; 0.0005 mica fixed condensers, 2/6 doz.; Westectors, 1/8 ea.; meter rectifiers, 5ma, 5/6 ea.; Coraxial plug and socket, 1/6; earphones, 50Ω with headbands, 4/6 pair; high resistance earphones, 8/- pair; earphone inserts or mike, 3/-; ex-Government test meters, see last month's advert., if you do servicing send s.a.e. All enquiries 6d extra for postage all orders under £5. No c.o.d. [9056]

SOUTHERN RADIO'S wireless bargains.— Latest radio publications: Amateur Transmitters' Construction Manual, 2/6; Radio Repairs Manual, 2/6; Can and Portable Radio Manual, 2/6; Radio Valve Manual, alternative and equivalent British and American valve types, 3/6; Radio Circuits, receivers, transmitters, power packs, etc., 2/6; Short Wave Handbook, 2/-; Ultra Short Wave Handbook, 2/6; Manual of Direct Disc Recording, 2/6; Test Gear Construction Manual, 1/6; Radio Pocket Book, colour code, formulas, etc., 1/-; Bulgin Radio Service Manual, 2/6; Radio Constructors Manual, 3/-; Television Constructors Manual, 3/-; Radio Aerial Handbook, 2/6; Radio Hints Manual, 2/6; Amplifiers, fully illustrated, 2/-; Radio Resistance Chart, resistance values at a glance, 1/-; Ten Hows for Radio Constructors, 1/-; Radio Reference Handbook, cloth bound, up to date information on all aspects of radio, 12/6. American Service Manuals, Crosley-Belmont, Sparton Emerson, Stewart Warner, Fada, 12/6 per volume; postage extra on all publications; send 21-d stamp for full list of latest publications; ex-Army throat mikes, brand new, with 3ft lead and jack plug, 4/6 each, post 6d; Lufbra adjustable hole cutters, for use on wood, metal or plastic, 5/-, post 6d; relays, brand new, Post Office, 30 ohm, 400 ohm plus 200 ohm, 150 ohm and 500 ohm, 2/9 each, post 6d; Tannoy carbon microphone inserts, 2/6 each, post 6d; A.C. motors, input 200/250 volts A.C., revs 2,000 r.p.m., constant speed, power 1/8hp, consumption under 1/2 amp, weight 20lbs approx., 22/15 each, carriage 5/-.

SOUTHERN RADIO SUPPLY, Ltd., 46, Lisle St., London, W.C.2. Gerrard 6653. [8926]

High Quality

TRANSFORMERS
and
CHOKES

Made specially for your requirements. All coils layer wound and insulated between layers.

Our modern factory is fully equipped with vacuum and pressure impregnators and all the latest testing equipment.

POWER OUTPUTS
up to 4 K.V.A.

AUDIO RATINGS
3-200 watts

AUSTIN MILLS LTD.
LOWER CARRS,
STOCKPORT

Established 20 years. Phone: STO 3791

Specialists
in

HIGH POWER - HIGH QUALITY

PUBLIC ADDRESS
SYSTEMS
★
AMPLIFIERS
from 150 W to 1kW

W. Bryan Savage Ltd

WESTMORELAND ROAD, LONDON, N.W.9

Telephone: Colindale 7131

You're **SURE** to get it at
STERN'S
ESTABLISHED 25 YEARS

Avo Meters. Universal Minor, £8 10s. No. 7. £19 10s. Sig. Gen., £13. Valve-Tester, £16 10s.

Electrolytics. Dulibier, 8 mfd. 500 v. 4/- (Canned). 4 1/2, 8-8 mfd. 500 v., 6/6; 16 mfd. 500 v., 6/6; 8-16 mfd. 500 v., 8/6; T.M.C. 8-16 mfd. 450 v., 7/6; 32 mfd. 450 v., 5/9; 16-16 mfd. 450 v., 11/-; 4 mfd. 450 v., 3/6.

I.F. Transf. 465 kc's. Wearite Midget Iron-core, 21-pair. Weymouth Perid. Tuned, 18 0/9 pr. Service Cap. Tuned, 12 6/9 pr. (110 kc's., 15/- pr.)

Coils. T.R.F. Matched pair M. & L., 6/9 pr. Weymouth T.R.F. Matched pair. M. & L., 9/6. 8 Hef Matched pair, S.M. & L., 11 6/6 and 8 9 pr. Wearite "P" Coils—complete range A., H.F., (osc., A.F. and B.F.O.), 3/- each.

Tuning Cond. (Two Gang). .0005 mfd., 8/6 (with Trim, 12/6). .00035 mfd. (with Tr.), 10/6. Midget .0001 mfd., 5/-; Midget .00035 mfd., 12/9.

Resistances. Most values available in 1/2, 1, 3, 5, 10, and 20 watt, from .01, 4d. each.

Condensers. Tubular, .1, .01, .5, .05 mfd., etc., at 9d. each.

Potentiometers. Centralab, 5k, 10k, 25k, 50k, 100k, 1, 1/2, and 2 meg., less Switch, 4/3, with Switch, 6/-. Midget with Switch, 1 and 1 meg., 6/-.

M Coil Speakers. Page 5in. P.M., 15/-. Rola 5in. P.M., 21/6. (Enerq. 1,000 ohm with Tr., 29/6). Rola 8in. P.M., 24/-. (Enerq. 1,500 ohm, 31/6 or 2,000 ohm, with Tr., 36/6). Goodmans 14in. P.M., 35/-. Rola 10in. P.M., 32/6 or Enerq. 1,500 ohm, with Tr., 36/6.

Filament Transf. Input 200-230-250 v. Output 5v. 4a. and 6.3v. 4a. (both tapped 4v.), 27/6.

Auto Transf. Input 200-230-250 v. Output tapped 4v., 5v., 15v. and 24v. at 3 amp. Ideal Charger Transf., 27/6.

M Transf. 250-0-250v., 80 m/a., 6.3v. 4a. (tapped 4v.), 5v. 2 1/2a. (tapped 4v.), 31/6. 350-0-350v., 80 m/a., 6.3v. 4a., 5v. 3a., 30/- (or at 130 m/a., both tapped 4v., 37/6). 400-0-400v. 150 m/a., 5v. 2 1/2a., 6.3v. (C.T.), 3a., 6.3v. (C.T.), 3a., 47/6.

Ex-Govt. Ultra Midget 9 out Transf., 32-1, and P-Pull Interval Transf., 2.5-1 each half, both 1 1/2in. x 1 1/2in., 3/- each. Also Ex-Pull Interval, 2.5-1 each half, and Output Transf. 60-1, both 1 1/2in. x 1 1/2in., 3/- each.

★ Send 2/6 stamp for Stock List. When ordering please cover packing and postage.

STERN RADIO LTD.
115, FLEET STREET, E.C.4.
Telephone: CENTRAL 5814 and 2280.

LONDEX for RELAYS



for A.C. and D.C.
2 VA Coil consumption from 2 to 600 volts and tested to 2000 volts, Aerial Changeover Relays, Mercury Relays, Measuring Relays and Time Delay Relays.

Multiple contact Relay LF Ask for leaflets RE WW

LONDEX LTD SYDNEY MANUFACTURERS OF RELAYS 207 ANERLEY ROAD LONDON S.E.20 6258-9

ANTENNAE rods, suit car aerials, 4ft long by 1/4in diam. coppered molybdenum steel; 3/16in brass spigot one end; enquiries invited, very large quantity available; also thousands rotary transformers, suit conversion to fractional h.p. mains motors.—Auto Collections, Ltd., 126, St. Albans Av., W.4 (Chiswick 1601), or 15, Lawrence St., Northampton.

American BC610 tuning units, with 3 variable 1/4in shaft condensers, 1 P.P.T. switch, coils, crystal holder, plated case, etc., 8/-; new ID8 Octal 1.4 volt multi-valves, 20/-; new 954, 955 acorns, 10/-; new 957 acorns, 1.4 volts, 10/-; all post paid (send for lists of metal valves, lighthouse valves, A.C. relays, transformers, vibrators, chassis and components).—Jack Porter, Ltd., 22-31, College St., Worcester. [9030]

RADIO CLEARANCE, Ltd., 27, Tottenham Court Rd., W.1 Mus. 9188.—10 valve S.W. Receivers, R1481, range 65-86 m/ps, RFVR65, osc. VR66, mix. VR65, 3 I.F.s VR53's, DET9 AVC EB34, AP VR57, output VR67, 6in S.M. dial, B.F.O., tuning meter, RF and LF Gain controls, require P.P. 250V H.T., 6.3v L.T. All brand new in wooden transit cases; as our previous lot, and we are now able to offer these sets, which lend themselves readily to modification for 5mtes, P.M., etc., at £7/19/6. Circuit diagram supplied with each receiver. P.M. speakers, large magnets. All speech coil, 5in less trans., 16/11; 5in with trans., 19/11; 10in with trans., 37/6, all new and boxed. Electrolytics, 8mf 170v, 2/3; 16+24 350v, 5/6; 16+10mf 350v, 5/6; 16+32mf 350v, 5/6; 32mf 350v, 4/-; 8+8mf 350v, 4/-; 8mf 450v, 3/3; 50mf 12v, 1/9; 100mf 12v, 1/-; 100mf 6v, 1/- Moving coil milliameters, 0-10ma, 2in square, 9/6; 0-30ma, 2 1/2in circular, 8/6; 0-150ma, 2in square, 9/6; 0-200ma, 2 1/2in circular, 10/-. 0-1ma 2 1/2in circular, calibrated 10-100, 15/11. All the above are flush mounting, .750 micro amp, 2 1/2in plug in, calibrated for use with thermocouple as radiation meter, 8/6. Meter rectifiers 1ma bridge type, 6/11; ex-R.A.F. visual indicators, type 3, with 2 Weston 300 micro amp movements, 5/-; cross over needle with 2 60 micro amp movements, 5/11. Gang condensers, single, 0.0005, 2/11; single 0.00015, 2/3; 2 gang 0.0005 with electrolytic, 10/6. 4 gang 0.0005, 8/6. Volume controls with S.W. 2 1/2in spindle, 10K, 25K, 50K, 100K, 250K, 500K, 1m, 2m, 5/-; Volume controls, carbon, no S.W., 10K, 20K, 50K, 100K, 2/- [9168]

WANTED EXCHANGE, ETC.
WANTED, Voigt light twin unit and corner horn, or separately.—Box 4974. [9035]
WANTED, Mazda type 12h c.r.t.—Wood, 389, Heathway, Dagenham, Essex, 8973
WANTED, small quantity wire, as used in magnetic wire recorders.—Box 5106.

AUDIO frequency laboratory wishes to purchase the following equipment of reputable manufacturers (Marconi, Muirhead, Salford, Dawe, etc.); distortion factor meter, wave analyser, microvoltmeter, A. F. attenuator, sensitive valve voltmeter, impedance bridge, 5-watt audio oscillator, noise meter, oscilloscope.—Write to Box S19/1, Harwood Press (Advertising), Ltd., 47, West St., Harrow, Middx.

REPAIRS AND SERVICE
MAJNS transformers rewound, new transformers to any specification.
MOTOR rewinds and complete overhauls; first class workmanship, fully guaranteed.
P. M. ELECTRIC Co., Ltd., Potters Bldgs. Warser Gate, Nottingham, Est. 1917. Tel. 3855

MAJNS transformer rewound and constructed to any specification; prompt delivery.—Brown, 3, Bede Burn Rd., Jarrow, [3460]
LOUDSPEAKER repairs, British, American, L any make, moderate prices.—Singer Speakers, 12, Pembroke St., London, N.1. Terminus 4355. [3308]

ELECTRICAL measuring instruments skillfully repaired and recalibrated.—Electrical Instrument Repair Service, 329, Kilburn Lane, London, W.9. Tel. Lad. 4168. [6935]

REWINDS and conversions to mains and output transformers, from 4/6; pp equipment a speciality.—N.I., rewinds, 4, Brecknock Rd., N.7. Tel. Arnold 3300. [6283]

SERVICE with a Smile.—Repairers of all types of British and American receivers; coil rewinds; American valves, spares, line cord.—F.R.I., Ltd., 22, Howland St., W.1. Museum 5675. [1575]

REPAIRS to moving coil speakers, cones, coils fitted field rewind or altered; speaker transformers, clock coils rewind, guaranteed satisfaction, prompt service; no mains trans accepted.
L.S. REPAIR SERVICE, 49, Trinity Rd., Upper Footing, London, S.W.17. Balham 2359.

STURDY rewinds, mains transformers, S chokes and fields; we give prompt delivery and guarantee satisfaction; 14 years' experience; prices on request.—Sturdy Electric Co., Ltd., Dipton Newcastle-on-Tyne. [4316]

M. WILSON LTD

NOW IN STOCK
IMMEDIATE DELIVERY
SPECIAL
VARIABLE SELECTIVITY I.F. TRANSFORMER

465 kc's., giving the choice of three degrees of selectivity. 1. High Selectivity. 2. Medium. 3. High Fidelity. Controlled by three position switch. Iron core, screened. The second I.F. is centre tapped on both primary and secondary to reduce clamping. Circuit diagram supplied. Price £1 per pair.

NEW CIRCUIT
A/C.T.R.F. High Fidelity Receiver. 5 Valves.
2 H.F. stages, infinite impedance detector, Triode output. Two wave-bands, Medium and Long. Provision for P.U. and Ext. Loudspeaker. Blue prints, 3/6, two practical and one theoretical.

6-VALVE SUPERHET CIRCUIT
3 Wavebands. A.C. only. A circuit that will please the most critical.

This circuit has been designed to receive all worthwhile stations on the medium wave band (200-540 metres) with a high fidelity output. Short Waves (16-47 metres) are as good as obtained on some purely short-wave receivers. Australia and America have been received regularly by many of our customers at loudspeaker strength. Long Wave: The few stations now operating are well received.
Blue Prints. 2 Practical and 1 theoretical with detailed priced list of components, 3/6 per set.

CIRCUIT No. 20
10 valves, 6 wave-bands, 12 watts (undistorted)

Output Superheterodyne Receiver
This set is noted for its fine quality of reproduction on radio and gram. We have received much appreciation and congratulations from customers on its performance. A demonstration model is available at our premises at 307 High Holborn.
FULL SIZE BLUE PRINTS (2 practical and 1 theoretical) and priced list of components 5/-. Any component may be purchased separately.

We are always pleased to demonstrate Receivers built from our blue prints without obligation, and you are cordially invited to call, see and listen.

One minute's walk from Chancery Lane Underground Station.

307, HIGH HOLBORN.
LONDON W.C.1. Phone: HOLborn 4631

THE "WILLIAMSON" AMPLIFIER

If you are very critical of the reproduction from the average "quality" amplifier, this is the instrument for you. The designer claims this to be "virtually distortionless," to which we would add that the "attack" and transient response sets quite a new standard. We are now producing this amplifier to specification with first-grade components in chassis form at:—

£27. 10. 0

We shall be happy to arrange demonstrations by appointment. Orders are being handled strictly in rotation. A limited number of acoustically designed cabinets are also available.

L. P. DISMORE
(formerly MORTON & DISMORE)
52c Oldchurch Rd., Chingford, E.4
Phone: SIL 4987.

HILL & CHURCHILL LTD. BOOKSELLERS SWANAGE, DORSET

Available from Stock:

Fink, " Radar Engineering " ...	42/-
Fink, " Principles of Television Engineering " ...	33/-
Kiver, " Television Simplified " ...	27/-
Zworyking & Morton, " Television " ...	42/-
Skilling, " Fundamentals of Electric Waves " ...	18/-
Lauer, Lesnick & Watson, " Servo-mechanisms Fundamentals " ...	21/-
Emery, " Ultra High Frequency Radio Engineering " ...	18/-
Sarbacher & Edson, " Hyper and Ultra High Frequency Engineering " ...	36/-

Postage extra.

CATALOGUE ON APPLICATION

THIS — Does these —



ACCURATELY and QUICKLY
Chassis, Brackets, Shrouds, Condenser and Transformer clips —
TREPANNING Steel or Aluminium.
Five sizes—12" to 36"
Full particulars from
A. A. TOOLS, (W),
197A, WHITEACRE ROAD
ASETON-UNDER-LYNE

COVENTRY RADIO

Component Specialists since 1925

T.C.C. CONDENSERS. 450/550 volt—
2 mfd. 3/3d., 4 mfd. 3/9d., 8 mfd. 4/6d., 8-8 mfd. 7/6d.

350 volt.—2 mfd. 3/-, 4 mfd. 3/3d., 8 mfd. 3/9d., 16 mfd. 4/9d., 8-16 mfd. 7/6d., 16-24 mfd. 9/-.

Wearite "P" Coils. All types in stock, 3/-
Wearite 465 kc. I.F. Transformers, pr. 20/-
HIGHEST GRADE COMPONENTS ONLY.
No Rubbish.

Send for our 1948 list, price 3d. post paid.
COVENTRY RADIO
DUNSTABLE ROAD, LUTON, BEDS.

SEND US YOUR LIST

of requirements, and we will immediately let you know which items—usually 99.5%—we can supply FROM STOCK, and the prices.

Present constant changes in supplies and prices make the issue of a worth-while Catalogue almost impossible, but we DO carry the most comprehensive stocks of Radio Components, Valves, Material and Test Equipment in the trade!

For a new experience in PROMPT and diligent attention send your enquiries today, PRINTING your name and address in block capitals, and enclosing 2jd. stamp.

WIRELESS SUPPLIES UNLIMITED
(Proprs. Unlimitex Radio Ltd.)
264-266, Old Christchurch Road,
BOURNEMOUTH, Hants.

A REWIND service which duplicates or modifies as required; transformers, loud speakers, etc; prompt returns.—Raldel Services, 49, Lr. Addiscombe Rd., Croydon. Cro. 6537.

R EWINDS; mains, output transformers, R fields, chokes, etc.; wave-winding and H.F. coil repairs, all makes; 25 years' experience; reasonable charges; prompt delivery.—H. W. Forrest, Shirley, B'ham. Shi. 2483.

R EWINDING of all types of transformers, R chokes, etc.; quick service; motor rewinds of all types; replacement bobbins supplied; new transformers to any specification.—Radio & Transformer Services, 570, Manchester Rd., Hollinwood, Lancs. [8638]

L OUDSPEAKER and transformer repairs "almost by return of post"; we offer the quickest service in the trade, at competitive prices. Send 1d for our monthly service bulletin. Dept. W.—A.W.F. Radio Products, Ltd., Borough Mills, Bradford, Yorks. Tel. 22838.

L OUDSPEAKER repairs, any make, reasonable prices, prompt delivery, to the trade and quality fans; 25 years' combined experience with Rola, Magnavox, Goodmans, Celestion.—Sound Service Radio, 80, Richmond Rd., Kingston-on-Thames. Kin. 8008. [4977]

R EWINDS, mains transformers, speaker field coil, chokes, high-grade workmanship, day delivery; new transformers constructed to customers' specification, singly or in quantities.—Metropolitan Radio Service Co., 1021, Finchley Rd., N.W.11. Speedwell 3000. [3719]

24 -HOUR service, 6 months' guarantee, any transformer rewind, mains outputs and i.f.s., etc., all types of new trans., etc., supplied to specification; business heading or service card for trade prices.—Majestic Winding Co., 180, Windham Rd., Bournemouth.

C OIL specialists.—Tuning and oscillator coils, I.F., L.F. and mains transformers, re-wound and wound to specification; wave-winding, I.S. repairs.—Electronic Services (R.T.R.A.), 17, Arwenack St., Falmouth, Cornwall; and 49, Uxbridge Rd., Ealing, W.5.

R EWINDS.—Armaturs, fields, transformers, pickups, vacuum cleaners, gram. motors, speakers refitted new cones and speech coils, All guaranteed and promptly executed. New vacuum cleaners, most popular makes. Send stamped addressed envelope for list of radio spares and c.o.d. service.—A.D.S. Co., 261-5, Lichfield Road, Aston, Birmingham, 6. [8238]

L OUDSPEAKER repairs.—L. Cottenham, the leading repair specialist of the North, for your loudspeaker repairs; all types repaired, fields rewound to any resistance, field replacement bobbins, keen competitive prices and quick service; send to L. Cottenham, Loudspeaker Repair Factory, Whetley Lane, Bradford, Yorks; enquiries immed. attention.

N ATIONAL RADIO SERVICE & TELEVISION CO.—Trade service; engineers; immediate service any district; rewinds to all types transformers, armatures, motors, loudspeaker cones, speech coils fitted, British and American components and valves; enquiries invited for contract trade service; multiple transformer winding.—63, High St., St. John's Wood, N.W.8. Primrose 6725. [6752]

MISCELLANEOUS

S PEECH disability; Mr. H. V. Hemery consults at Wigmore Hall Studios, W.1.

W. W., Jan., 1943-Aug., 1947; £3 or nearest. 54, Bredon St., Long Eaton, Nottingham.

W ALNTU radiogram cabinets, many samples, few only. 35x32x18; stamp details.—Walters, 501, Hale End Rd., E.4.

W OULD any capable amateur make, for remuneration, a receiving set for a 6-valve amplifier.—Lampard, 2, Lexden Rd., Colchester. [9002]

20 tons 22 and 26 gauge single rayon covered copper instrument wires available for immediate delivery; samples sent on request.—Box 4502. [8909]

C IRCUIT diagrams (in-individual designs to order; chassis layouts suggested, data and technical advice for radio enthusiasts; special tuition by correspondence.—Write, R. G. Young, 3a, Bridges Rd., Wimbledon.

C OPPER and resistance wire, silk, rayon, cotton and asbestos covered, 15 to 46 swg; Litz wire, 27/42, 27/44 and 27/46; 10 tons in stock at 10% under market price.—C. Leatherbarrow, Ltd., Grand Bldgs., W.C.2. Whitehall 3948. [8829]

S END s.a.e. for our new bargain list of racks, panels, amplifiers, aluminium and dural sheet, dural tube; for example, type 27 R.F. units, 25/-; post free; salvage R.1155s (without valves and cases), useful for spares, 35/-, carriage free.—Fanthorpe, 6,8, Hepworth's Arcade, Hull. [89K7]

A LWAYS sure of a good reception.—Radio Craft, 21/6; C.Q., 21/6; Radio News Q.S.T., 21/6; Life (International), 40/-; Look, 25/-; Saturday E. Post, 55/-, etc.—For full list of all other American magazines, send s.a.e. to Willen, Ltd. (Dept. 52), 120, St. Georges Rd., London, E.10. [9037]

—DO YOU OWN THESE?—

BC.348. This much coveted receiver has a frequency range of 200-500 Kc. and 1.5-18 Mc/s. Six position switch brings separate frequency calibrated dial into position and superline Vernier tuning unit gives three states I.F.—crystal filter—voltage stabiliser—automatic noise compensation—constant sensitivity on all bands—phone and speaker output—all standard 6.3 volt valves—complete with plug-in Dynamotor for 28 volts. Note this can be removed and standard A.C. mains equipment can easily be fitted in its place. (We will supply details, or do the job if required.) Brand new and complete. PRICE £32 10s., plus 10/- carriage.

BC.312. Battery version of the famous BC.342. brand new, complete with spare valves. PRICE £25. For more details see our November advertisement or drop us a card.

R.208. The Army precision receiver, covers 10-60 Mc/s. Built-in power pack for A.C. mains or 6-volt battery inputs—built-in speaker—phone jacks—Muirhead slow motion drive—A.F. gain—B.F.O. frequency control—R.F. gain—test panel on front—complete with all valves and in grey metal cabinet. £12 10s., carriage 30/- extra. £1 will be refunded on return of packing case.

DATA BOOKS. Copied from official publications, giving circuit diagrams, component values and useful notes. BC.342—BC.348—BC.312—BC.221—R.208—R.103A—R.107—M.C.R.1—R.1155—W/8.22—RT.18—W/8.19—R.1116A—all at 2/3 each, also Walkie-Talkie 58, 3/6—Demobbed Valves, 2/6. WINTER LIST free on application with stamp.

BULL'S EX-GOVERNMENT DEPOT

42-46 WINDMILL HILL, RUGLIP MANOR,
MIDDLESEX.
Open Sats. till 5 p.m. Weekdays till 6 p.m.

RADIO BATTERY TESTER

Use "Quixo" method
of battery testing.

Reliable results. Guaranteed.

Send for interesting leaflet
R115 on battery testing.



RUNBAKEN · MANCHESTER 1

EDDYSTONE '640'

We are now booking orders for this first-class communications receiver.

Demonstration model on view at our Show Room.

EDDYSTONE '504' in stock.

52 Page Catalogue of Components & Accessories 1/- Post Paid.

B.T.S.

The Radio Firm of the South.
63, London Road, Brighton 1,
Sussex.

TELEVISION

The advance in Radio Technique offers unlimited opportunities of high pay and secure posts for those Radio Engineers who have had the foresight to become technically qualified. How you can do this quickly and easily in your spare time is fully explained in our unique handbook "Engineering Opportunities." Full details are given of A.M.I.E.E., A.M.Brit.I.R.E., City & Guilds Exams, and particulars of up-to-date courses in Wireless Engineering, Radio Servicing, Short Waves, Television, Mathematics, etc., etc.

We Guarantee "NO PASS—NO FEE"

Prepare for to-morrow's opportunities and future competition by sending for your copy of this very informative 112-page guide NOW—FREE.

BRITISH INSTITUTE OF ENGINEERING TECHNOLOGY (Dept. 388)

17, Stratford Place, London, W.1

The perfect balance

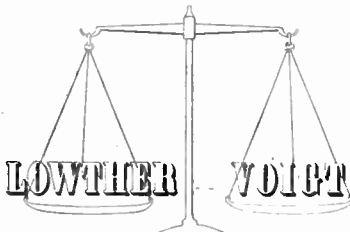

= towards perfection =

THE LOWTHER MANUFACTURING CO.
Lowther House, St. Mark's Road,
BROMLEY, KENT.
Rav. 5225.

Our original post-war plans have met many man-made setbacks.



REVISED PLANS are evolving. Please don't write, phone, or call. We will advise when ready.

VOIGT PATENTS LTD.

"PERIMET" ELECTRODE
Soldering and Brazing Tool
Operates from 4 or 6 Volt Accumulator or Transformer.



15s. Post free.
MAINS TRANSFORMER. 3 Heats. 35s. Post free.
HOLBOROW & CO.,
71, Weymouth Bay Avenue, Weymouth.

RANSOM
FOR RADIO VALVES

At B.O.T. prices, British and American, these are only a selection of our 10,000 valves held in stock. Please send for our comprehensive Valves Available List, free, enclosing S.A.E. for reply. Postage 6d. extra, C.W.O. or C.O.D. Retailers not supplied.

MULLARD.—KT32, KF35, KBC32, KL35, FC2, FC24, VP2, 8P2, PM2M, TDD2A, PM2A, PM22A, PM202, PM22D, QP22B, EM1, EM4, EM35, EOC34, EOC35, EOC32, ECH35, EK32, EP6, EP9, FP22, EP36, EP37, EP39, EP50, EP54, EC31, EC32, EC33, EB34, EBC3, EBC33, EOC31, EL2, EL3, EL33, EL35, EL37, EL38, EL50, EBL31, EB91, PM24M, TT4, TH4B, VP4, VP4A, VMB, RP4, EP4B, 204A, 214B, TDD4, 345V, 904V, 164V, PEN4VA, PEN4DD, C14, CCH35, TH30C, FC13, FC13C, CBL31, UCH21, UBL21, UY21, EBL21, ECH21.

AMERICAN RANGE.—15, 18, 26, 31, 32, 34, 37, 39/44, 41, 43, 46, 71A, 76, 77, 80, 83, 84, 89, 2151, 635, 617, 6A4, 6W7, 6D8, 9E5, 6T7, 6A6, 6A7, 6A8, 6B8, 6C5, 6F6, 6H6, 6K7, 6J7, 6K8, 6B7, 6K5, 6K7, 6G8, 6K6, 6F8, 6J8, 6AG6, 6Q7, 6B6, 6C6, 6D6, 6U7, 25A6.

OCTAL RANGE.—X65, KTW61, KTW63, KTZ63, KTW62, HG3, L63, D63, DH63, DL63, KT61, KT63, KT66, X73M, Z76, W76, Z61, KTZ41, DL74M, KT74, KTW74, X71, KT73, KT71, KT76, Z62, KBZ73.

OSRAM.—X22, W21, Z21, Z22, HD24, LP2, P2, KT24, QP2, MHD34, M5F4, M54B, VM54B, VMP4G, X41, W42, MH41, MH4, M4, MKT4, D41, D42.

H. RANSOM,
4 BOND STREET, BRIGHTON, Phone: Brighton 5803

MINISTRY OF CIVIL AVIATION.—Appointment of Radio Mechs. Grade II. APPLICATIONS are invited for appointment as radio mechanics at civil aviation radio stations in the United Kingdom. Candidates must possess a knowledge of the fundamental principles of radio and radar with a general knowledge of one or more of the following radio aids for navigation: Direction Finding, Loran, Gee, Radar Beacons, A.C.I.I. or G.C.A. They should also have had practical experience in the use of tools, filing, drilling, hard and soft soldering, cabling and wiring and be experienced in the use of electrical and radio measuring instruments including cathode ray oscilloscopes. The possession of City and Guilds Certificates in Radio Communication and Technical Electricity will be an advantage. The pay will be 115/- per week, inclusive, rising by annual increment of 5/- a week to a maximum of 150/- a week. Applications which must be in writing stating date of birth, full details of qualifications and experience and quoting the reference C.A. Est/RM should be addressed to the Establishment Division, Ministry of Civil Aviation, 10, Fleet St., London, E.C.4. [8981

RADIO engineer, experienced in practical television, permanency and good prospects.—Courtenay Davis, 12, Station Rd., Harpenden. Tel. 418. [9163

FULLY skilled radio and television service engineer with pre-war experience, good wages and pleasant working conditions; permanency.—Tel Harrow 5063. [9116

JUNIOR engineer required for development of radio components by progressive company in Surbiton area; degree or equivalent in electrical engineering essential.—Box 3903.

JUNIOR laboratory assistant with some knowledge of physics and some electrical training.—Write, giving details of experience, age, etc. to: A. H. Hunt, Ltd., Bendon Valley, S.W.18. [8354

SECRETARY to research manager of progressive company in Surrey required; Matriculation certificate or equivalent essential; position would suit ex Service woman with radio or radar experience.—Box 4772.

REQUIRED for radio factory in South Wales, near Aberdare, experienced radio and television design engineer.—Write, stating age, qualifications, experience and salary required, to Box R. F. E. Smith's Library, Aberdare. [9091

TECHNICAL representative, aged 30 to 40, domiciled in the Manchester area preferred, to contact manufacturers of radio and electronic equipment in North Country.—Write, stating age, experience and salary required, Box 4960. [9012

JUNIOR laboratory assistant, 20-22, with some knowledge of chemistry, preferably up to Inter-B.Sc. standard, for raw material and process testing.—Write, giving details of experience, age, etc. to: A. H. Hunt, Ltd., Bendon Valley, S.W.18. [8353

DEVELOPMENT engineer required for test gear and measuring instrument design; some previous experience and suitable technical qualifications essential.—Send full particulars to Taylor Electrical Instruments, Ltd., 419, Montrose Ave., Slough. [9140

LEARNING Company requires junior development engineer (inter B.Sc. standard) preferably with experience in radio or communications work; commencing salary between £350 and £400 (according to experience) with excellent prospects for advancement.—Box 4967.

SERVICE engineers and assistants for ship-borne centimetric radar equipment required; applicant should be prepared to live in a port and travel as work requires; preference will be given ex-Naval men.—Box PP.1912, W. H. Smith & Son, Manchester, 3.

TECHNICAL sales representatives required by electro-medical specialists; sales experience essential, also technical knowledge of valve circuits; salary, commission and expenses; areas: London, S.E. England, North Midlands; car owners preferred.—Details Box 5110. [9162

SENIOR draughtsman required for company manufacturing radio and electrical equipment, good salary, prospects and 5 days week.—Write, giving full details of experience and salary required, to Taylor Electrical Instruments, Ltd., Montrose Ave., Slough, Bucks. [9139

AN opportunity is now open for an engineer with first-class experience in designing radio and electrical equipment to join company as chief engineer; excellent prospects for a man with the right experience, initiative and organising ability.—Write to Box 5084 [9141

REQUIRED for radio factory in South Wales, near Aberdare, small parts mechanical designer, preferably experienced in radio and television production.—Write, stating age, qualifications, experience and salary required, to Box R. F. E. Smith's Library, Aberdare. [9092

A.C.S. RADIO

SPECIALISTS IN SHORT WAVE

High Quality Audio, Sound Film and Television Equipment—offer a wide range of Components and accessories for the Experimenter and Home Constructor.

COMPONENTS

by Eddystone, Raynart, Hamrad, Ladgear, Wolen, etc., including Variable condensers, transmitting, receiving and neutralising types; Fixed Condensers, mica, paper block and tubular, electrolytic and silver mica; Coils and Coil Formers, including Weirite "P" Series, Ivalek range, ceramic and D13 Formers, Mains Transformers and Smoothing chokes; R.F. Chokes; R.F. Meters and Test Gear; Loudspeakers from 3in. to 12in., including the famous Voigt Units; Amplifiers by G.I. Products and Leake; Metal Cabinets and Chassis by Eddystone. Full range of valves, including Mullard, Marconi, Osram, Mazda, Cosor and Tungsten receiving types. U.S.A. types including V.H.F. series 6AK5, 3001, 9002, 9003 series; Transmitting types by Standard E.M.I., etc.; also U.S. types 807, 35T, 100TH, TZ40, 808, 866A, HY50, RK20 A, RK100, etc.

COMMUNICATIONS RECEIVERS

Our second-hand list "S.W.W." is revised every few weeks and details our current stock of receivers. We are generally able to offer models by NATIONAL, HALLCRAFTERS, R.C.A., etc., as well as Oscillators, Test Gear, etc. This list, together with our Component Catalogue "W.W.", will be gladly sent on request to—A.C.S. RADIO.

44 WIDMORE RD BROMLEY, KENT
Phone Ravensbourne 0156

Beethoven
ROTARY CONVERTORS
220 D.C. to 220 A.C.
Details from—
BEETHOVEN ELECTRIC EQUIPMENT LTD.
Beethoven Works, Chase Road, London, N.W.10

WIRELESS CABINETS

Manufacturing capacity available with speedy delivery of Cabinets and Speakers of all sizes and designs to individual requirements. (Trade enquiries only.)
BIRNEY SMALLWOOD PRODUCTS LTD.,
"Swan Works," Fishers Lane, London W.4.

THESE ARE IN STOCK

- Radar System Engineering. Ed. by L. N. Ridenour. 45s. Postage 9d.
 - Radio Engineering, Volume I. By E. K. Sandeman. 45s. Postage 10d.
 - Television. By V. K. Zworykin and G. A. Morton. 42s. Postage 8d.
 - The Mathematics of Wireless. By Ralph Stranger. 7s. 6d. Postage 5d.
 - Radio Data Charts. By R. T. Beatty. 7s. 6d. Postage 5d.
 - Electricity Meters and Meter Testing. By G. W. Scubbings. 16s. Postage 6d.
 - Network Analysis and Feedback Amplifier Design. By H. W. Bode. 42s. Postage 8d.
 - The Wireless World Valve Data. 2s. Postage 2d.
- We have the finest selection of British and American Radio Books. Complete list on application.

THE MODERN BOOK CO.
(Dept. W.1),
17-23, PRAED STREET, LONDON, W.2

1948

POWER UNITS, CHOKES, OUTPUTS For all published designs.

Skilful engineering, latest technique with new versatile mountings and ease of connections. Robust, silent working, accurate ratings, ensure long and satisfactory service.

A Transformer for the quality amplifiers or the smallest midget receiver, we make it.
Power trans. for W.W. Quality, 57/6.
Output Transformer for 15 ohm., 60/-.

Your choice from 77 production units, or Kits of Transformers and Chokes for building your own amplifiers, 42/6 set of three. Kits of these components are available for amplifiers up to 40 watts.

Write for 1948 Supplement.

(Illustrations of new types cannot be shown in this limited space.)

1948 New Models in factory-built amplifiers. Now incorporating bass and treble boosting, improved de luxe versions of all previous models.

Example AC/10 PLUS for home gram, with two inputs, impedance filters for any pick-up, bass boost couplings, etc., £10.

Our AC/18 and AC/18MIC models now greatly improved. Ask for details.

If you are unable to obtain G.L. Products from your local dealer, please write us. Full catalogues on transformers, amplifiers, speakers, microphones, spares, etc., send 3d. stamp.

**GENERAL LAMINATION PRODUCTS
LIMITED**
BROADWAY, BEXLEYHEATH

Are you missing the
**GREATEST
BARGAINS in
Ex M.O.S.
Stock?**



New and unused in sealed tropicalised packing.

Rotary Transformers Type 79.
Input 26 volts. Output 300 volts, 220 mills, plus 150 volts, 6 M.A.

16/-
POST FREE

ALSO Ex R.A.F. New and Unused in Sealed Cartons. Motor Generator, Gear Box, Blower, etc. Input 9 volts. Output 450 volts, 500 mills. Motor revs. approx. 1,500. Gear box approx. 12 R.P.M. plus 1 R.P.M. May be made into an efficient A.C. Motor by removal of D.C. Brushes and putting field in series with H.T. Brushes and Mains. Post free **30/-**

Send stamped addressed envelope for illustrated lists.

WIRELESS INSTRUMENTS (Leeds) LTD.
54-56, THE HEADROW, LEEDS, 1

YOUNG engineer required as representative of leading electronic instrument manufacturers, London area; C. & G. Grade III or equivalent Service qualifications; state age, experience and salary required.—Box 4966. [9021]

ASSISTANT engineer required for our laboratory engaged on the design of radio broadcast receivers; applicant must have held similar position for three or more years.—Write in first instance stating full particulars and salary required to the Personnel Manager, McMichael Radio, Ltd., Wexham Rd., Slough.

TECHNICAL Assistant wanted for technical control of all processes in experimental valve manufacture; experience in this type of work essential; some knowledge of high vacuum technique and glassworking practice desirable; West London area.—Applications including academic qualifications, age, experience, and salary required, to be addressed to Box 4975.

TECHNICAL assistant required by well-known company situated West London district for investigation of improved processes in cathode ray tube manufacture; degree in chemistry or an equivalent qualification desirable; industrial experience on similar work an asset.—Applications, which should include full details of training, experience, age, and salary expected, to be addressed Box 4962.

ENGINEER required for laboratory investigation and measurements in conjunction with radio and electronic devices; experience in electron optics desirable, with ability for original design; applicants should have reached accepted standard of education and carry adequate production-design experience; West Middlesex area.—Apply giving age, full details of education and experience to Box 4770.

TECHNICAL assistant required by large electrical manufacturer; applicants should have had practical experience in the servicing of radio receivers, and be familiar with the design and operation of dealer test gear; selected candidate would be required to submit reports and compile instruction books on test gear and give practical demonstrations.—Write, giving full details of age, experience and salary required, to Box 4501. [8908]

ST. DUNSTAN'S requires an assistant for research work in connection with sound recording and other electronic aids for blind people. Applicants should have an Honours Degree in Physics and/or communications engineering, preferably with practical experience in this branch of electronics. Initial salary according to qualifications in the region of £450-£550 with superannuation under F.S.S.U.—Apply to St. Dunstan's Research Dept., 8, Hinde St., Manchester Square, W.1.

PUBLICITY department of large electrical engineering firm requires assistant to take charge of publication of sales promotion literature; work comprises sub-editing of material and direction of presentation and printing; essential qualifications, good education and personality, B.Sc. (electrical engineering), age 27 to 45; leadership and administrative ability, originality and good artistic appreciation, knowledge of type and of reproduction processes; previous experience of similar duties.—Write, giving full particulars of experience, and state salary required, to Box N5377, A.K. Adgn 212a, Shaftesbury Av., W.C.2.

E.M.I. ENGINEERING DEVELOPMENT, Ltd., have vacancies in their design drawing office for the following:—(a) Senior electro-mechanical designer-draftsman. (b) Senior mechanical designer-draftsman. (c) Senior electrical designer-draftsman. The above are required on electronic, tele-communication, and electro-mechanical engineering; only 1st class designer draughtsmen need apply. Vacancies offer excellent prospects on high-class work of paramount national importance.—Apply, stating age, fullest details of experience, together with salary required, to Personnel Department, E.M.I. Ltd., Blyth Rd., Hayes, Middlesex. [9118]

B.B.C. invites applications for the post of engineer in the audio frequency section of the research department, based in London. Candidates must possess a university degree, or equivalent qualifications, in physics or electrical engineering and must have taken tele-communication as part of their training. A knowledge of electrical measurements, measuring instruments and experience in microphone and loudspeaker technique is essential. The work includes research into microphones and loudspeakers and embraces all other aspects of audio frequency research and development. Preference will be given to a candidate with the ability to guide development work in drawing office and workshops. Musical ability is an advantage. The salary is on a grade rising by annual increments of £40 to a maximum of £890 per annum. Applications, stating age, qualifications and experience, should reach the Engineering Establishment Officer, Broadcasting House, London, W.1, within 14 days of the appearance of this advertisement.

THE BRITISH NATIONAL RADIO SCHOOL

ESTD. 1940

A privately owned personally conducted coaching service by post

SERVICE SATISFACTION

SINCERITY

PLUS A GUARANTEE
that really means Something

ORIGINATORS of the B.N.R.S.

FOUR YEAR PLAN

Covers full syllabus of A.M.I.E.E., A.M. Brit. I.R.E., and C. & G.

Radio and Telecommunications Examinations at a cost of

8^d. PER DAY

Free Booklet from:

**Studies Director, B.N.R.S.,
66, ADDISCOMBE Rd., CROYDON**

Phone: Addiscombe 3341

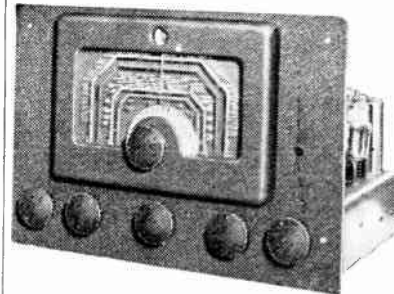

PEERLESS TYPE 1047 RADIO CHASSIS

Those who visited our stand at Radiolympia were quick to appreciate that this chassis, with its workmanlike design and generous specification, provides the enthusiast with something out of the ordinary at a reasonable price.

Among its principal features are:—

- 10 stage superhet circuit.
- 10 valves (including magic eye).
- RF amplifier.
- 2 IF stages.
- 4 wave bands.
- 10 Watts push-pull output.
- Tropicalised components.

Communications enthusiasts should write for details of our 1546 Chassis.

PEERLESS RADIO LIMITED
374, Kensington High St., LONDON, W.14

Phone: WEstern 1221

THE CHARLES BRITAIN Duo Channel Amplifier Chassis.

An entirely new departure in amplifier design giving completely independent control of bass and treble.

This is achieved by incorporating two entirely separate amplifiers on one chassis. One of these amplifiers is a push pull combination which drives a 12in. speaker for reproduction of the bass. The other is a two stage amplifier driving an 8in. speaker for the treble.

The discriminating user can, by means of the two controls provided, control the amount of signal handled by each amplifier, thereby increasing the bass or treble as desired. Complete with 7 valves; 3 GJ5, 3 6Y5, 1 6U4 and two speakers, Goodmans 12in. P.M. and Rola 8in. P.M.

For operation from A.C. mains 200-250 volts, 50 cps. and fully guaranteed for 12 months. Price £24 carriage paid. For further details of this and other amplifiers send for illustrated brochure, "W.W."

EX-U.S. NAVY Aircraft Radio Receiver Unit.

This outfit 'a complete in a Black metal case size 12in. x 12in. x 8in., and contains in addition to a host of useful components, ten International octal metal cased valves including 2 6H6, 6 6SH7, etc. Super quality Rotary Generator, relay I.F. transformers etc. PRICE £29/6 each, carriage and packing 7/6 extra.

Order early to be sure of securing this extraordinary bargain.

CHARLES BRITAIN (RADIO) LTD.

Radio House, 2, Wilson St. London E.C.2

Telephone: BIS 2965

WARD ROTARY CONVERTERS

For Radio, Neon Signs, Television, Fluorescent Lighting, X-ray, Cinema Equipment and nnumerable other applications.

We also manufacture:—

Petrol Electric Generating Plants, H.T. Generators, D.C. Motors, etc., up to 15 K.V.A.

CHAS. F. WARD LERDSCROFT WORKS, HAVERHILL, SUFFOLK

Telephone: Haverhill 253 & 4.

100 kcs.
QUARTZ
CRYSTAL
UNIT
Type
Q5/100



For Secondary Frequency Standards

★ Accuracy better than 0.01%. ★ New angles of cut give a temperature coefficient of 2 parts in a million per degree Centigrade temperature change. ★ Vitreous silver electrodes fired direct on to the faces of the crystal itself, giving permanence of calibration. ★ Simple single valve circuit gives strong harmonics at 100 kcs. intervals up to 20 Mcs. ★ Octal based mount of compact dimensions. PRICE 45/- Post Free

Full details of the Q5/100, including circuit are contained in our leaflet Q1. Send stamp to-day for your copy

THE QUARTZ CRYSTAL Co., Ltd.
63-71 Kingston Road,
NEW MALDEN, SURREY
Telephone: MALden 0334

B.B.C. invites applications to fill a vacancy in the research department of the engineering division; the work involves theoretical and practical investigations on aerials, transmitters, and systems of modulation; practical experience of such work is desirable, but not essential; applicants must possess recognised academic qualification, including a knowledge of the theory of wave propagation, and an aptitude for original investigation; the salary is on a grade rising by annual increments of £25 to a maximum of £580 per annum; good promotion prospects; the successful candidate will be based at Oxford, but will later be transferred to a permanent base near London.—Applications, stating age, qualifications and experience, should reach the Engineering Establishment Officer, Broadcasting House, London, W.1, within 14 days of the appearance of this advertisement. [8990

B.B.C. invites applications for a number of posts for senior and junior engineers in the designs department in London. Applicants should have a university degree in engineering or an equivalent qualification, preferably in communication subjects. The work of the department covers design of testing equipment and transmission equipment for music and for 405-line television, the design of transmission apparatus for teleprinter and telephone carrier transmission, and for the various systems of disc and magnetic recording and reproducing equipments used in broadcasting. Specialist knowledge and experience in design work in any of the above is essential in the higher grades and will be an advantage in all cases. Starting salaries dependent on qualifications and experience; appointments will be in grades ranging from £580 per annum maximum for junior designers, to £995 per annum maximum for senior designers. Applications, stating age, qualifications and experience, should reach the Engineering Establishment Officer, Broadcasting House, London, W.1, within 14 days of the appearance of this advertisement.

B.B.C. invites applications for two posts of engineer in the field strength section of the research department based at Oxford. Candidates should possess a university degree, or a recognised diploma, and should have taken telecommunication as part of their training. They must be capable of conscientiously carrying out experiments involving radio frequency measurements in any part of the British Isles and should have an interest in field strength measurement work and allied problems of propagation applicable to broadcasting. Experience of transmitter and aerial work and the use of receiving equipment is desirable. The successful candidates will be based at Oxford in the first instance, but will be required to spend a large proportion of their time away from base, and at a later date the base will be transferred to the London Area. The salary is on a grade rising by annual increments of £30 to a maximum of £890 per annum. Applications, stating age, qualifications and experience should reach the Engineering Establishment Officer, Broadcasting House, London, W.1, within 14 days of the appearance of this advertisement. [8999

THE MULLARD ELECTRONIC RESEARCH LABORATORY invites applications for the following posts: (1) A senior scientist to lead a group working on ultra high radio frequency circuits in close association with valve laboratory and on centimeter wave projects; he should have a good honours degree in physics or electrical engineering or mathematics, at least, four years experience in the UHF field and be capable of both experimental and theoretical treatment of problems in this field. It is expected that the age of the successful candidate will be between 27 and 35 years and his salary between £650 and £1,000 a year according to experience and ability. (2) Scientists for both the group mentioned above and other groups working on super-sonics, electronic measurement and control, television and radio component design. They should have similar academic qualifications to the senior man and preferably some experience of research work. It is expected that the successful candidates will be between 20 and 30 years and their salaries between £350 and £700 a year according to qualifications. Applications should be made to the Manager, Mullard Research Laboratories, Salfords, Nr. Rehill, Surrey. [9017

SITUATIONS WANTED

EX-R.A.F. Cpl. Radar Fitter, 21, ambitious, energetic, educated to H.S.C. standard, seeks interesting post with plenty of scope.—Box 5005.

SALES engineer (32) seeks post based West London area; final City and Guilds, 7 yrs. with large manufacturer, wide representative experience; specialist communication and industrial instrumentation, medical equipment.—Box 4959 49011

HIGH FIDELITY

We welcome all enthusiasts to our new premises. We carry stocks of Partridge and Varley Transformers and Chokes, matched output valves, matched resistors, high quality loudspeakers: P.U.s., gramophone motors, baffles, Bass reflex cabinets, and all components for High Fidelity Receivers and Amplifiers. Complete equipments are also available. Our price list is available and we will be glad to send you a copy on receipt of your address and 2½d. stamp.

ROGERS DEVELOPMENTS CO.

12, MACCLESFIELD STREET,
SHAFTESBURY AVENUE, W.1.

Telephone: GERrad 8256.

U.S.A. RADIO AIRCRAFT RECEIVERS, TYPE CCT-46145, MADE BY STROMBERG-CARLSON.

These Ex-Govt. 6-Valve receivers are brand new and packed in original cartons. Overall dimensions approx. 10 1/2 in. x 4 1/2 in. x 5 1/2 in. high containing removable plug-in dynamotor for 24.28 volts. Valves are one 12K8, three 12SK7, one 12SR7 and 12A6, three Permeability-tuned I.F. Transformers, Input aligning condenser and main tuning condenser originally intended for use with remote control but easily adapted for direct tuning on the Medium Waveband, 620-1,500 Kc/s.

Circuit diagrams now available for the above receiver at 5/- each post paid.

Other equipment available.
R.1147A Receiver. 30/- plus 5/- carriage, etc.
A.M.6A Indicator. 22/5/- plus 5/- carriage, etc.
Walkie-talkie type 6ST RECEIVER ONLY, complete with aerial and box of spare valves, £1/10/- plus 2/6 carriage, etc.

Mail orders and enquiries promptly satisfied.

Shop Hours—9-5.30 Mon.-Fri. 9-1 Sat.

ALEC DAVIS (Supplies) LTD.
18, Tottenham Court Road, London, W.1.
Tel.: MU5em 4639.

TRANSFORMERS & COILS TO SPECIFICATION.

MANUFACTURED OR REWOUND.
Filter Coils a Speciality.

JOHN FACTOR LTD.
9-11 EAST STREET, TORQUAY, DEVON.
Phone: Torquay 2162

"WEYRAD" PERMEABILITY TUNERS

SUPERHET OR T.R.F.

AS EXHIBITED AT

RADIOLYMPIA

SEND FOR
DETAILS

WEYMOUTH RADIO
MFG. CO., LTD.
CRESCENT WORKS, WEYMOUTH

SAPPHIRE JEWEL POINT



The
GOLDRING
PERMANENT NEEDLE

ERWIN SCHARF
49-51a, DE BEAUVOIR RD.,
LONDON, N.1.

Tel.: Clissold 7713-0941. Cables: Echovox, London.

★
'Radiospares'
Quality Parts
The
Service Engineer's
First Choice
★

CALLING AMATEURS
with **BUCCLEUCH**
Precision Built Equipment



STEEL CHASSIS SMOOTH BLACK
17" x 10" x 2 1/2", 9/9.
17" x 10" x 2 1/2", 9/9.
PANELS-CRACKLE
19" x 3 1/2", 4/-
19" x 7", 6/9;
19" x 8 1/2", 7/9;
19" x 10 1/2", 8/9.
ANGLE BRACKETS 12 1/2" long, pr. 7/6.
(All in Bright Aluminium, same cost.)
COMPLETE RACK ASSEMBLY
(Rigid 4-Pillar), 63", £3/5s. 3 1/2", £2/5s.
Chassis, to order, 1d sq. inch.
(Include sides when costing.)
PUNCHING CHARGES UP TO 1/2", 2/-
VALVE HOLES, 1 1/4" or 1 1/2", 6d.
METER HOLES, etc., 1/6.
SQUARE HOLES, 2/-
BUCCLEUCH RADIO MANUFACTURERS
& 2 MELVILLE TERRACE, EDINBURGH. 9
"Grams": "Therm." Edinburgh.
Factory: Wheatfield St., Edinburgh.

YOUNG man, 23, good theoretical knowledge radio circuits and fault-finding seeks practical experience, remuneration of less importance than need for experience.—Box 4768.

ENGINEER, middle 30s, C and G Finals in radio communication and technical electricity, seeks change; experienced production testing and test gear and receiver development; some television knowledge.—Box 5103. [9151]

GRADUATE engineer of mechanical faculty, with wide experience, managing director of big tele-radio communication factory abroad, specialist in mass production, time and motion study, tools and machine fixtures designing, thorough knowledge of limits and precision fittings for engineering, etc., now seeks appointment in London.—Box 5078. [9120]

FINANCIAL PARTNERSHIPS
WANTED, active interest in sound radio, electric, P.A. or relay concern; £1,500 to £2,000.—Box 5022. [9078]

EXPANDING company offers active partnership to experienced engineer with good working knowledge of aeriels, amplifiers and test instruments; excellent possibilities for keen, hard-working man; capital £500 to £1,000.—Box 4961. [9013]

ENGINEERING careers and qualifications

BOTH Government and industry have announced and emphasised that young men with technical knowledge and qualifications must receive every chance to rise to the highest positions within their capacity, in post-war engineering and allied industry; write to-day for "The Engineer's Guide to Success"—200 courses free—which shows you how you can become A.M.I.E.E., A.M.I.A.E., A.M.I.Mech.E., A.F.R.Ae.S., etc., and covers all branches in radio, automobile, mechanical, electrical, production, aeronautical, etc. THE Technological Institute of Great Britain, 82, Temple Bar House, London, E.C.4. [4918]

POSTAL courses of instruction for amateur radio transmitting licence, P.M.G. Certificates in wireless telegraphy, Ministry of Civil Aviation Certificate, radio engineering and television; also instruction at school.—Apply, British School of Telegraphy, Ltd., 179, Clapham Rd., London, S.W.9. (Estd. 40 years).

ENGINEERING opportunities.—Have you had your copy of this free guide to A.M.I.Mech.E., A.M.I.E.E., and all branches of engineering, building and plastics? Become technically trained on "no pass—no fee" terms for higher pay and security.—For free copy write B.I.E.T. (Dept. 387B), 17, Stratford Place, London, W.1. [6939]

THE Institute of Practical Radio Engineers have available Home Study Courses covering elementary, theoretical, mathematical, practical and laboratory tuition in radio and television engineering; the text is suitable coaching matter for I.P.R.E. Service entry and progressive exams; tuition fees at pre-war rates—are moderate.—The Syllabus of Instructional Text may be obtained, post free, from the Secretary, 20, Fairfield Rd., Crouch End, N.8. [6722]

AGENCIES
CONTACTS desired with overseas radio importers.—Box 5047. [9104]

AGENTS WANTED
MANUFACTURERS require representatives throughout the U.K. to market their special moving coil pick-ups and other specialities.—Write to Box 4468. [8866]

BUSINESSES FOR SALE OR WANTED
BUSINESS with four-roomed flat, six good agencies, sales and service, S.W. London, shop, £200 p.a. inc.; flat £120 inc.; profit £1,250 p.a.; price £1,500 s.a.v.—Write, Box 5083. [9136]

RADIO and electrical retail repairs, lock-up shop, centre large village near Essex coast; annual turnover approx. £1,000; price, inc. fixtures, fittings, test gear, etc., £550 plus s.a.v.; low rent, moderate lease, audited accounts.—Apply c/o E. Crabb, 65, South Primrose Hill, Chelmsford. [9042]

TECHNICAL TRAINING
A.M.I.E.E., City of Guilds, etc., on "No Pass—No Fee" terms; over 95% successes; for full details of modern courses in all branches of electrical technology send for our 112-page handbook, free and post free.—B.I.E.T. (Dept. 388A), 17, Stratford Place, London, W.1. [6270]

BOOKS, INSTRUCTIONS, ETC.
RADAR Engineering, Fink, 42/-; Principles of Radar, M.I.T., 30/-; Terman, Radio Engineers Handbook, 42/-; Henney, Radio Engineers Handbook, 35/-; Knowlton, Standard Handbook for Electrical Engineers, 60/-; this offer includes latest advance in price; over 400 titles of the McGraw Hill Publications are in stock at H. G. Baskett, 201, Uxbridge Rd., West Ealing, W.13. [9050]

How to make "Hi-Fi"

Apart from the shortage of materials we have to export an appreciable proportion of what we make. This means that many of the citizens of this small country of ours have to "make do and mend" if they want Hartley-Turner reproduction, which is natural and realistic even if it sounds somewhat different from other "hi-fi."

A general grasp of the whole problem can be got by reading "New Notes in Radio" (5th edition, 3/8, post free) which is now recognised as of the same high standard as everything else we produce.

Our promised leaflet service is nearly ready and it will be supplemented by a series of Technical Bulletins (details of which will be sent on request) giving every detail of the construction of our equipment. These and the necessary component parts will be ready during February.

Alas—you will still have to buy the Hartley-Turner Speaker (price £9) for neither you nor anyone else can make it and there just isn't any substitute. But at least it is available in somewhat limited quantities.

H. A. HARTLEY CO. LTD.
152, HAMMERSMITH RD., LONDON, W.6.
Riverside 7387.

L-R-S IN STOCK

AVOMETERS	
Model 7	Cash price £19 10 0
Avomitor AC/DC Universal meter ...	£8 10 0
Valve tester, complete	£16 10 0
Avomitor DC meter	£4 4 0
Oscillator, mains	£13 0 0

Please let us have your enquiry for other models

All Avometers available on convenient terms
Morphy Richards Auto Electric Irons, Chrome super quality 39/6 post 1/-.

Illustrated list of any of the above items 1d.

The LONDON RADIO SUPPLY CO.
(The L.R. Supply Co. Ltd.) Est. 1925
BALCOMBE SUSSEX

IRON DUST CORED COILS

of Exceptional Efficiency and Stability

AERIAL AND OSCILLATOR, short, medium, or long wave, size 1in. x 1in. 7/6 pair.
AERIAL AND OSCILLATOR, medium or long wave, size 1in. x 1in. 6/9 pair.
DUAL WAVE COILS, medium and long wave aerial and h.f. 9/6 pair.
I.F. TRANSFORMERS, Standard Frequency 465 Kc/s. Size, 1in. diam. x 1in. high. 9/6 each.
MINIATURE ROTARY SWITCH, 4 pole, 3 way, 3/9 each.
CONDENSERS, Silvered Mica, .0001 mfd., 4/- doz.
AVOMETER, Model 7, £19/10/-.
All coils fitted with adjustable iron cores, and supplied with circuit diagram.

TERMS: Cash with order or C.O.D. on orders over £1.

MONOCHORD RADIO

(Established 1929)

17 Streatham Hill, London S.W.2
Phone: Tulse Hill 1051/2

VIBRO-ARC ELECTRIC METAL ENGRAVING PEN

Engraves, etches, marks writes . . . on

BRASS, COPPER
SILVER, NICKEL
ALUMINIUM,
CHROMIUM,
Hardened
Steel



Operates from 4 or 6 volt Accumulator or A.C. Transformer Order C.O.D. or C.W.O.

Sole Distributors: **BULLS W W** 246 High St. Harlesden N.W.M. Retail 15% with Full instructions

A.B. OAK

The wave change switch with silver-plated double contacts.
A.B. METAL PRODUCTS LTD., Great South-West Road, Feltham, Middx.
wafer switches

PHOTO-ELECTRIC CELLS

for Talking Picture Apparatus.
Catalogue now available
RADIO-ELECTRONICS LTD., St. George's Works, South Norwood, London, S.E. 25.

MORSE CODE TRAINING



There are Candler Morse Code Courses for **BEGINNERS AND OPERATORS.**

Send for this Free "BOOK OF FACTS" It gives full details concerning all Courses.

THE CANDLER SYSTEM CO., (Room 55W), 121 Kingsway, London, W.C.2
Candler System Co., Denver, Colorado, U.S.A.



THE COMPLETE SERVICE FOR SOUND RECORDING AND REPRODUCTION

- ★ Mobile and Static Continuous Recording Outfits.
- ★ Recording Amplifiers.
- ★ Moving Coil and Crystal Microphones
- ★★ Sapphire Pointed Reproducing Styli and Cutters.
- ★ Blank Recording Discs from 5in. to 17in. Single or Double sided.
- ★ Light-weight moving iron, permanent sapphire and moving coil pick-ups.
- ★ Label and Envelope Service.
- ★ A comprehensive range of accessories to meet every requirement of the sound recording engineer.
- ★★ And our latest development (of special interest to users of sapphire or delicate pick-ups)—The *Simtrol*. This is a controlled micro-movement easily fitted for use with any type of pick-up to eliminate the danger of damage to the record or pick-up. This is achieved by a vernier lowering action of the pick-up head to the record.

Write for comprehensive lists or call at Recorder House for demonstration.

RECORDER HOUSE, 48/50 GEORGE ST. PORTMAN SQUARE, LONDON, W.1.

Telephone: WEL 2371/2 Telegrams: Simsale, Wesdo, London



Manufacturers of
LOUDSPEAKERS
•
LAMINATIONS
•
SCREENS
In
RADIOMETAL
•
PERMALLOY
•
SILICON ALLOYS

ELECTRICAL SOUND & TELEVISION PATENTS LTD.
12, Pembroke Street, London, N.1. Terminus 4355
2/4, Manor Way, Boreham Wood, Herts. Elstree 2138

METERS!

Our comprehensive range of brand new meters includes the following types at the lowest prices yet offered. Add postage and packing as requirements.

- | | |
|--|--|
| 0-8 v. D.C. M.C. 2 1/2 in. round, 7/- | 0-40 v. D.C. M.C. 2 in. square, 7/- |
| 0-300 v. D.C. M.C. 2 in. square, 7/- | 0-5 m/a D.C. M.C. 2 in. square, 10/- |
| 0-30 m/a D.C. M.C. 2 1/2 in. round, 6/9 | 0-50 m/a D.C. M.C. 2 1/2 in. round, 7/- |
| 0-30 120 m/a D.C. M.C. 2 in. square, 7/- | 0-500 m/a D.C. M.C. 2 1/2 in. round, 7/3 |
| 0-1.5 amp. D.C. M.C. 2 1/2 in. round, 7/6 | 0-10 amp. D.C. M.C. 2 1/2 in. round, 7/6 |
| 50-0-50 amp. D.C. M.C. 2 in. square, 7/6 | 0-500 m/a R.F. Thermo 2 in. square, 7/3 |
| 0-2.5 amp. R.F. Thermo 2 in. square, 7/- | 0-4 amp. Aerial Ammeter with push button shorting switch, 10/- |
| 0-100 m/a D.C. M.C. 2 1/2 in. square, with push button shorting switch, 12/6 | 0-14 amp. D.C. M.I. 5 in. ironclad round, 37/6 |
| 0-10 amp. H.F. Hot Wire 5 in. 30/- | |

0-1500 v., 0-2000 v., 0-3000 v. Electrostatic all 27/6 each.
Foundation Meter 1.5 m/a D.C. F.S.D. Calibrated volts ohms, 15/-
Or our selection of 6 assortments for 35/-



Mail Order Supply Co., Dept. WW,
24, New Road, London, E.1.
Phone: Stepney Green 2760-3906.

New Models Available

By extending the range of Lustraphone Moving-Coil Microphones, users anxious to obtain the best instrument for the

job will find in these models everything they want in terms of good reproduction and lasting dependability.



MOVING-COIL MICROPHONES

Leaflet from:
LUSTRAPHONE LIMITED
84, Belsize Lane, London, N.W.3
Telephone: Hampstead 5389 and 5515

The **TCC**
Tough Guys
 are endowed with almost
Perpetual Life!



IN THE BEST SETS YOU'LL SEE T.C.C.

T.C.C. Paper Capacitors in rectangular metal cans are the new generation of the old familiar green cans so popular years ago. Many of these old time Capacitors are still giving yeoman service to-day. The new types, however, have the added advantage of recent years of intensive research and development, thereby adding considerably to their prolongation of life.

They are mechanically and electrically tough, and will withstand the most severe conditions, including continuous operation at 71° C (see pages 17 to 21 of List 132/RD/47).

Details of higher working voltages may be had on application.

THE TELEGRAPH CONDENSER CO. LTD.

RADIO DIVISION

NORTH ACTON · LONDON · W · 3

TELEPHONE: ACORN 0061

THERE ARE MANY BRANDS OF SOLDER MADE IN U.S.A.—YET
American manufacturers of radio

**and electrical
 equipment prefer
 British made**

ERSIN MULTICORE SOLDER



"The girls on our wiring line are loud in their praises of Ersin Multicore Solder. I find it superior to that which we are now using and the flux is non-corrosive. I have instructed our factory to switch over to Ersin Multicore Solder."



"We are using this on radio production lines with very good results. I believe this is being used with greater success than other solder previously used. We have proved to our own satisfaction that Ersin Solder is not corrosive."



"After testing your Multicore Solder on our production lines, we found it to be the fastest solder we ever used. One of its salient advantages is its extraordinary effectiveness in the soldering of tarnished metals."



"I have found Ersin Multicore Solder excellent for electrical instrument work as the fluxing action is such that a minimum of solder is used in producing a neat job. I also use Ersin Solder in instrument construction where there is danger of distortion when heating with a flame. Joints made in this manner with Ersin Solder have less solder on the outside of the work due to the excellent penetration of Ersin flux."

Despite the fact that there are freight charges and duties to be paid on the importation into U.S.A. of Ersin Multicore Solder and its higher initial cost, many American radio concerns prefer to import this British made solder for use in the manufacture of their equipment. They find that the use of Ersin Multicore—which alone has 3 cores of extra-active non-corrosive Ersin flux—effects great savings in material and labour costs, giving high speed precision soldering without waste. It will pay you to use only Ersin Multicore Solder.

The Finest Cored Solder in the World



Ersin Multicore Solder is supplied on nominal 7 lb. reels for use by manufacturers. Prices on application. The prices for the size I Carton illustrated are detailed below:

Catalogue Ref. No.	Alloy Tin-Lead	S.W.G.	Approx. length per carton	List price per carton (subject)
C 16014	60/40	14	38 feet	s. 6 d. 0
C 16018	60 40	18	102 feet	6 9
C 14013	40 60	13	25 feet	4 10
C 14016	40 50	16	53 feet	5 3

MULTICORE SOLDERS LTD.
 MELLIER HOUSE, ALBEMARLE STREET, LONDON, W.1. REGent 1411