

# Wireless World

RADIO and ELECTRONICS

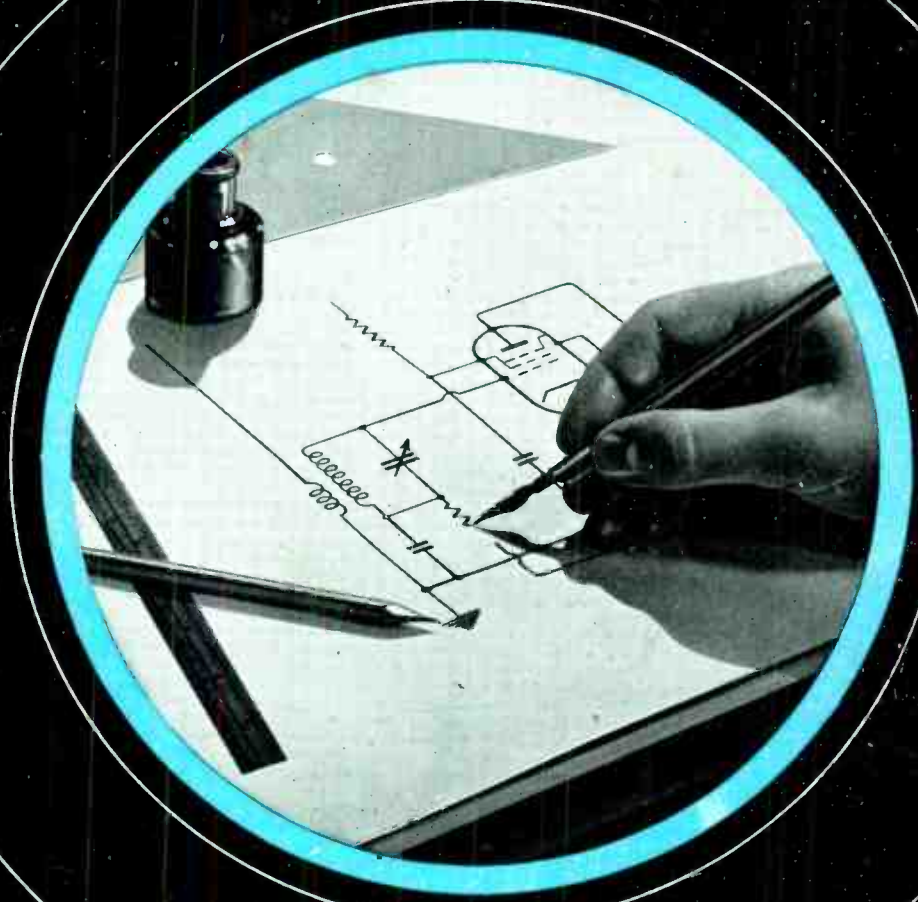

JUNE 1945

1/6

Vol. LI. No. 6

IN THIS  
ISSUE :

TROPICAL PROPAGATION PROBLEMS

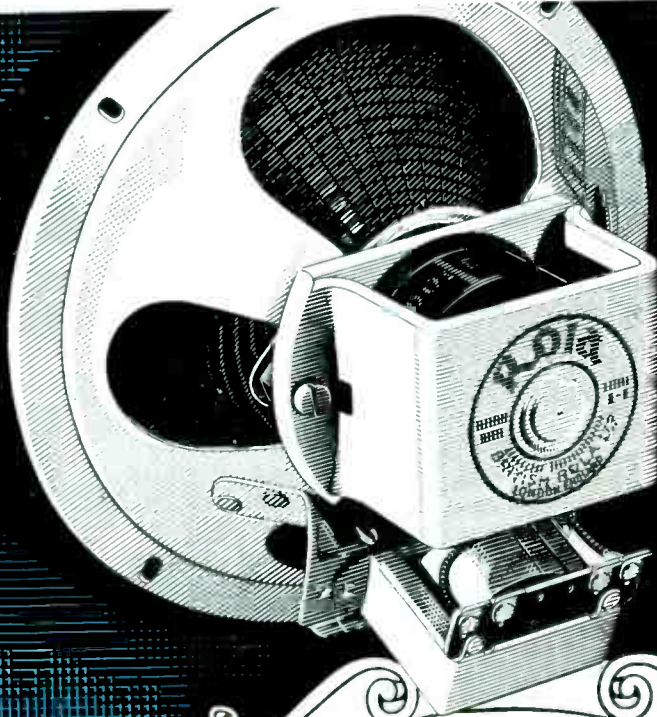

As a manufacturer of  
a **Mains Transformer**  
may we ask —

*are you fully acquainted with*

**Rola** { **LAMINATIONS ?**  
**CLAMPS ?**  
**COVERS AND**  
**SHROUDS ?**

**BRITISH Rola LIMITED**

**GEORGIAN HOUSE, BURY STREET, ST. JAMES'S  
LONDON S.W.1. ENGLAND**



*Registered Trade Mark*

**PRECISION  
TESTING INSTRUMENTS**

**H**IGH accuracy, simplicity, exceptional versatility and proven reliability have won for "AVO" Instruments a world-wide reputation for supremacy wherever rapid precision test work is demanded. There is an "AVO" Instrument for every essential electrical test.

*Orders can now only be accepted which bear a Government Contract Number and Priority Rating.*

*Sole Proprietors and Manufacturers*

**THE AUTOMATIC COIL WINDER & ELECTRICAL EQUIPMENT CO. LTD.,** Winder House, Douglas Street, London, S.W.1. 'Phone: VICtoria 3404/8

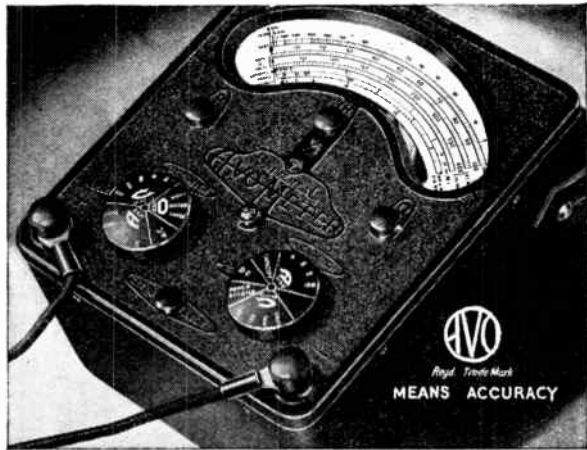

The MODEL 7 50-Range Universal

**AVOMETER**

Electrical Measuring Instrument

A self-contained, precision moving-coil instrument, conforming to B.S. 1st Grade accuracy requirements. Has 50 ranges, providing for measuring A.C. & D.C. volts, A.C. & D.C. amperes, resistance, capacity, audio-frequency power output and decibels. Direct readings. No external shunts or series resistances. Provided with automatic compensation for errors arising from variations in temperature, and is protected by an automatic cut-out against damage through overload.

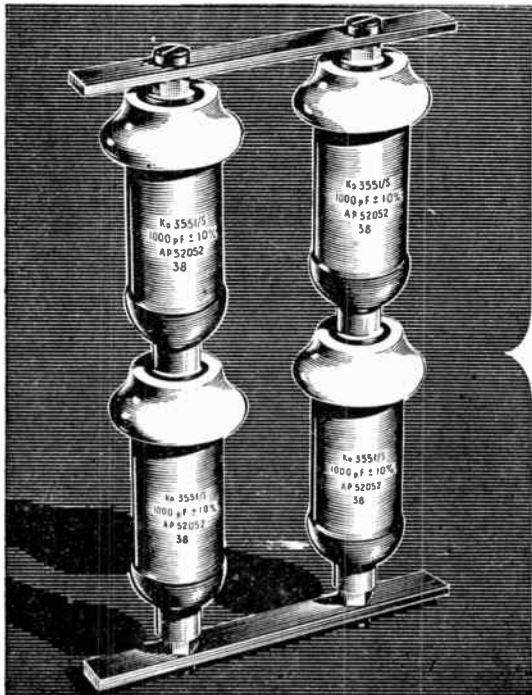

**CERAMIC Pot CAPACITORS**

IN SERIES/PARALLEL COMBINATION

*extend the useful range of voltage, load and current . . . . .*

FOR RADIO COMMUNICATION, BROADCASTING,

TELEVISION, NAVIGATION . . . and

HIGH FREQUENCY EQUIPMENT FOR INDUSTRIAL, MEDICAL, & SCIENTIFIC PURPOSES . . . . .

*Full details on request*

**UNITED INSULATOR CO. LTD., 12-22 LAYSTALL ST., EC1**

Tel : Terminus 7383 (5 lines)      Grams : Colanel, Smith, London.

**THE PIONEERS OF LOW-LOSS CERAMICS**

# SENSITIVE INSTRUMENTS

Specialising in the manufacturing of robustly constructed sensitive Moving Coil and Rectifier instruments, we are regularly supplying these with sensitivities as low as 20  $\mu$ A full scale in both Moving Coil and Rectifier Types.

These instruments are also available as Thermocouple types as low as 1.25 mA full scale. Spade type or Knife Edge pointers and Mirror scales are available on most instruments and illuminated dials can be supplied on Model 400 and 500 instruments.



MODEL 200  
2" SCALE



MODEL 350  
3½" SCALE

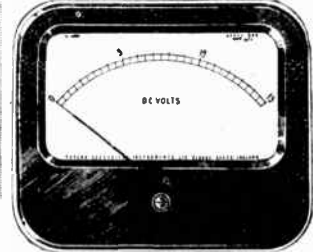

MODEL 500 5" SCALE



MODEL 400  
4" SCALE



MODEL 200  
2" SCALE



MODEL 250  
2½" SCALE



MODEL 250  
2½" SCALE

**Taylor**  
electrical instruments Ltd.

**IMMEDIATE DELIVERY.** For some time past we have been carrying a small varied stock of most ranges of moving coil instruments. We are able to give immediate delivery for urgent orders.

Please send your enquiries to—

**TAYLOR ELECTRICAL INSTRUMENTS LTD.** 419-424 MONTROSE AVENUE, SLOUGH, BUCKS.  
TEL: SLOUGH 21381 (4 lines) "GRAMS: "TAYLINS," SLOUGH.

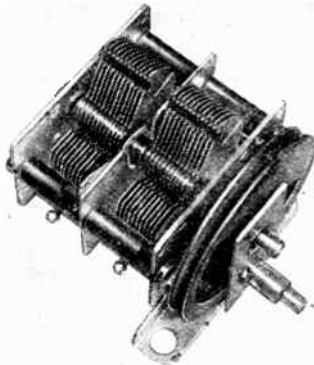

## M.G.R.N. 1, 2 or 3 GANG CONDENSER

This is made in various capacities up to 540mmf. of Rigid construction, with smooth slow motion drive and with tropical finish. The Spindle is tapped 6 BA for attachment of pointer. An indicator can be driven by cord from the drum disc. Built in trimmers can be supplied if required.



**JACKSON**

**BROS (LONDON) LIMITED**  
KINGSWAY · WADDON · SURREY  
TELEPHONE: TELEGRAMS: WALFILCO,  
CROYDON 2754-5 PHONE, LONDON

For  
**Reliability**

Just  
**TRIX**

Quality  
**SOUND**  
Equipment

THERE ARE TRIx AMPLIFIERS FROM 5 to 500 WATTS FOR PRIORITY WORK

**THE TRIx ELECTRICAL CO. LTD.**  
1-5, MAPLE PLACE, TOTTENHAM CT. RD.  
LONDON, W. 1.  
Tele. MUSEUM 5 817 Grams & Cables: TRIx RADIO, WESDO, LONDON.



**"Everything  
O.K. Sir !"**

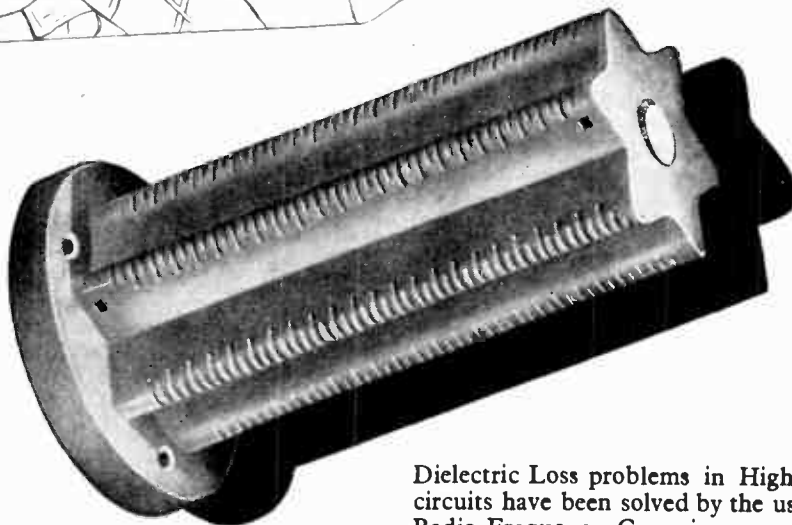

Dielectric Loss problems in High Frequency circuits have been solved by the use of Bullers Radio-Frequency Ceramics.

Many years of research and development in our Laboratories have brought these materials to a high degree of efficiency.

They are in constant use for transmission and reception and play an important part in maintaining communication under all conditions.

**Made in Three  
Principal Materials**

**FREQUELEX**

An insulating material of Low Dielectric loss. For Coil formers, Aerial Insulators, Valve Holders, etc.

**PERMALEX**

A High Permittivity Material. For the construction of Condensers of the smallest possible dimensions.

**TEMPLEX**

A Condenser Material of medium permittivity. For the construction of Condensers having a constant capacity at all temperatures.



**BULLERS LTD..**

THE HALL, OATLANDS DRIVE,  
WEYBRIDGE, SURREY.

Telephone : Walton-on-Thames 2451

Manchester Office : 196, Deansgate, Manchester.

**Bullers**

**LOW LOSS CERAMICS**





**HY-MEG IMPREGNATED**

**ELECTRICAL APPARATUS**

**USE HY-MEG THE MODERN TIME-SAVING IMPREGNATING MEDIUM**

Your products, too, can be assured of a longer life under all working conditions . . . .



Executives in charge of the production of electrical apparatus calling for impregnation, should send for the HY-MEG Booklet "Stability in Insulation". It describes fully how HY-MEG scientifically overcomes problems arising both in production and operation. Apply on Business Heading or Card and enclose 2d. to comply with the Control of Paper Orders.

**LEWIS BERGER & SONS LTD., (Established 1760) LONDON, E.9 'Phone: AMHerst 3321**

**MANUFACTURERS OF INSULATING VARNISHES AND ENAMELS**



**HEWLETT - PACKARD  
LABORATORY  
INSTRUMENTS**

FOR SPEED AND ACCURACY

**ELECTRONIC ENGINEERING  
SERVICES LIMITED**

24 Stanley Road Heaton Moor  
Stockport

SOLE BRITISH DISTRIBUTORS

## M.R. SUPPLIES

are able to despatch immediately from present stock the following first-class and brand new Radio, Electrical and Technical Equipment. All prices nett.

**S.T.C. METAL RECTIFIERS.** 12 v. (or less) at 1½ amp., 12/6; 12 v. (or less) at 10 amps., 52/6. (We are now out of stock of the 6-amp. model.)

**STEP-DOWN MAINS TRANSFORMERS,** prim. 200/250 v., Sec. 7, 11 and 15 v. at 2 amps., 20/- (suitable for 12/6 Rectifier). Prim. 200/250 v., Sec. 22 v. 2 amps., 18/6. Prim. 200/250 v., Sec. 5, 12 and 17 v. at 6 amps., 49/6.

**SLIDING RESISTANCES,** 100 ohms 1 amp., 300 ohms 0.7 amp., 400 ohms 0.5 amp., 10 ohms 3 amps. and 4 ohms 5 amps., fully enclosed with bushed cable entry and good smooth action, any one 25/-. **RADIAL REGULATORS,** front of board mounting with protective cover over faceplate. Res. 1 ohm to carry 25 amps. in 25 stud taps., 79/6 (carr. 2/-).

**LONDEX RELAYS,** 230 v. A.C. coil with 3-pole change-over silver contact switch, breaking 6 amps. at 230 v., 45/-.

**MILLIAMMETERS** by prominent London maker. High-grade precision moving coil instruments, reading 0/1 m.a., the ideal base for combined meter. Flush mtg. 2½", 52/6; 3¼", 67/6. Also a few 0/500 micro-amps., same make, 3¼", 75/-.

**ROTHERMEL PIEZO-CRYSTAL PICK-UPS.** Small supply again in stock. Senior black bakelite model, complete with arm, 78/6. **STROBOSCOPIC SPEED TESTERS** (50 cycle) showing 78, 79 and 80 r.p.m. On cardboard only, 1/-.

**GRAMPIAN MOVING COIL MICROPHONES,** in square suspension frame with mounting boss, model MCR, 24 4s. Also same make, Senior model MCS, for highest quality work. Handsome all-plated instrument with local on-off switch and quick release, 27 5s. **ROTHERMEL PIEZO-CRYSTAL MICROPHONES.** The original and famous D.104 in plated housing, suspension rings and 6ft. screened cable, 25 5s.

Also same make, highest fidelity SOUND CELL P.C. MICROPHONES, in globular mesh housing, for recording and all important work, 210 10s. Also same make, deaf-aid insert type, only 1½" dia., 29/6. **MICROPHONE STANDS,** all chrom. collapsible floor type, extending to 5' 6" and collapsing to 2', 45/6. **G.E.C. PROJECTOR SPEAKERS,** with 42" all-metal expon. horn and 15-ohm. P.M. 10-watt unit, 210 5s. (carr. 7/6). Big demand at present—secure your requirements now.

**HEAVY DUTY OUTPUT TRANSFORMERS.** Limited supply again available. Handling 25 watts A.C. at high fidelity. Tapped prim. and sec. with C.T. for push-pull and providing 11 ratios from 12/1 to 75/1, finished in cast brackets with terminal panels, weight approx. 10 lbs., 59/6 (desp. 2/-). **GRAMPIAN OUTPUT TRANSFORMERS,** small replacement type providing 8 ratios and suitable for all speakers, 9/6.

**POWER TRANSFORMERS.** Prim. 230 v. Secs. 760/0/760 v. 150 m.a. and 4 v. 4 a., finished brackets and terminal panels, weight approx. 12 lbs., 59/6 (desp. 2/-). **VOLTAGE CHANGING TRANSFORMERS,** 100/110 to 200/250 v. and vice versa, with counterunk terminal blocks, 75 va., 29/6; 120 va., 37/6.

**PYROBIT ELECTRIC SOLDERING IRONS,** the most popular we have ever handled. "Instrument" model with pencil bit, 22/- Spare bits, adjustable angle, 4/6. Spare Elements, 3/6 (230/250 v. only).

**G.E.C. AMPLIFIER COVERS.** Large size, 26¼" long by 17¼" wide, by 15" high, in fine grey enamelled sheet steel with louvered ventilation, and all fittings, crated ready for despatch (List 55). Sent carr. pd. for 47/6. Also same finish, 15" long by 8½" wide by 10" high, with two plated top handles and very smart (List 35/-), 17/6. (We cannot despatch these.)

Please include sufficient for despatch, where not stated.

**M.R. SUPPLIES, 68, New Oxford Street, London, W.C.1**  
(Telephone: MUSeum 2958)

# Callender

## RADIO FREQUENCY CABLES



We are manufacturing all types of low loss and low capacity cables for use at high frequencies.

We shall be pleased to make available the experience of our extensive research and technical organisations in connection with special cable problems directly related to the war effort.

CALLENDER'S CABLE & CONSTRUCTION CO. LTD. HAMILTON HOUSE, VICTORIA EMBANKMENT, LONDON, E.C.4

*All over the World*

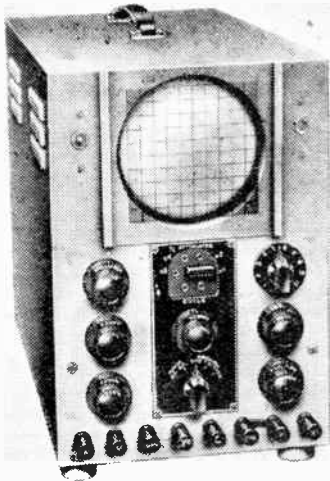

**STATIC TWO-DIMENSIONAL**  
*visual delineation of any recurrent law.*

**RELATIVE TIMING OF EVENTS**  
*and other comparative measurements with extreme accuracy.*

**PHOTOGRAPHIC RECORDING**  
*of transient phenomena.*

**SIMULTANEOUS INDICATION**  
*of two variables on a common time axis.*

INDUSTRIAL INDICATING and TESTING afford increasing scope for the Cathode Ray Tube as the only device with the above inherent features, of which the last is unique in the Cossor DOUBLE BEAM Tube.

The Model 339 Cossor Oscillograph thus equipped is invaluable on all problems of research, production or operational testing, when the effect examined is applied as a voltage. When recurrent the traces are studied visually and when transient are recorded photographically, using Model 427 camera.

**A. C. COSSOR LTD.,**  
INSTRUMENT DEPT.

Cossor House, London, N.5

Phone: CANonbury 1234 (33 lines).  
Grams: Amplifiers Phone London.

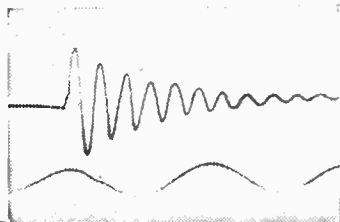

# OKERIN WAXES

AND DIELECTRIC COMPOUNDS TO GOVERNMENT SPECIFICATIONS—FOR

- CONDENSERS
- CABLES
- TRANSFORMERS
- COILS

A.I.D. AND C.I.E.M.E. TYPE APPROVED FOR ARCTIC AND TROPICAL CONDITIONS

Used and Recommended for Service Components

**ASTOR BOISSELIER  
& LAWRENCE LTD.**

SALES DEPT.

NORFOLK HOUSE, NORFOLK ST., STRAND, LONDON, W.C.2  
Telephone: TEMple 5927

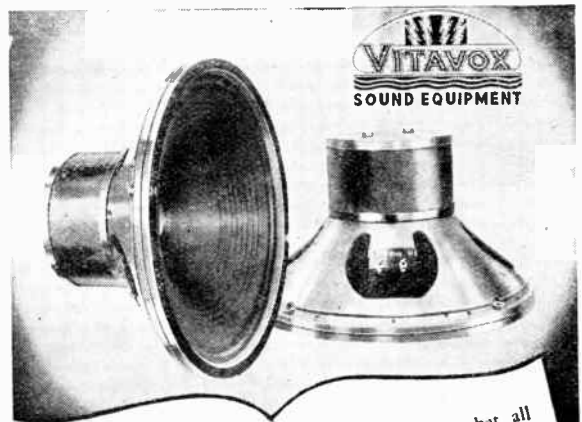

It is a fact that although VITAVOX K12/10 and K12/20 P.M. Speakers are not available in unlimited quantities, their quality is such that they are well worth waiting for.

It is a fact too that all specification figures are actual and not nominal.  
**VITAVOX LIMITED,**  
WESTMORELAND  
RD., LONDON, N.W.9.  
Phone Colindale 8671/3



# LINAGLOW LIMITED

offer  
**COMPONENTS**  
for  
**TELEVISION**

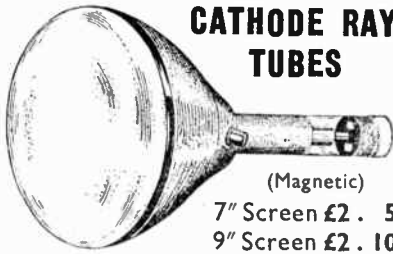

**CATHODE RAY TUBES**

(Magnetic)

7" Screen £2. 5  
9" Screen £2. 10

**LINE SCANNING OUTPUT TRANSFORMERS.**  
Brand new, ex-televison. 12/6 each.

**HIGH VOLTAGE TRANSFORMERS.**  
200/250 v., 4,000 v., 2 v. 2 amp. Brand new, ex-televison. 21/- each.

**HOLDER FOR C.R. TUBE.**  
Complete with mounting base, scanning and focussing unit with coils. Brand new, ex-televison. 25/- each.

**COMBINED MAINS AND HIGH VOLTAGE TRANSFORMERS.**  
350-0-350 4 v. 3a., 4 v. 2a., 4 v. 2 a., 6 v. 3.5 a., 100 m.a., 4,500 v. 5 m.a., 190/250 v., 50/- each.

## DE LUXE ALL-WAVE SERVICE SIGNAL GENERATOR

A.C. Mains 200/250 v. 50 cycles. Range covers from 20 M.C. to 100 K.C., all fundamentally in 5 bands without gaps. S/M Dial direct calibration in frequencies. Coarse and fine output attenuator. Internal modulation 400C/S Iron-cored coils. The Generator is entirely screened in heavy metal cabinet. Dim. 10" x 10" x 12". Each **16 Gns.**

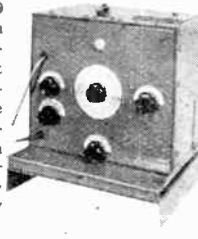

**SERVICE KITS.**  
85. 1 8-mfd. 400/500 v. Electrolytic. 12 each assorted tubular paper condensers. Carbon Wire End Resistors. New, ex-televison. 3 yds. sleeving. 10/8.  
86. 1 8-mfd. 400/500 v., 1 32-mfd. 320 v. Electrolytics. 25 each assorted tubular paper condensers and carbon wire-end resistors. 1 volume control. New, ex-televison. 3 yds. sleeving. 25/-.  
87. 2 8-mfd. 400/500 v., 1 4-mfd. 400/500 v., 1 32-mfd. 320 v. Electrolytics. 12 each assorted tubular paper condensers and carbon wire-end resistors. New, ex-televison. 2 volume controls. 39/6.  
88. 3 8-mfd. 400/500 v., 3 32-mfd. 320 v., 1 8 x 8-mfd. 400/500 v. 2 4-mfd. 400/500 v. 25 each assorted tubular paper condensers, and carbon wire end resistors. 6 yds. sleeving. 6 yds. P.V.C. cable, 3 tone controls, 6 assorted valveholders. New, ex-televison. 25.

**N.B.**  
Owing to depleted staff, we can only accept Cash with order. No C.O.D. Delivery 14 days.

**WESTINGHOUSE H.W. DETECTOR.** 36 v. R.M.S. 0.25 m.a., 5/6.

**MAINS TRANSFORMERS.** 350-0-350 4 v. 6 amp. C.T., 4 v. 2 amp. 100 m.a. Heavy laminations, pre-war stock. Bargain 27/6; 350-0-350 6.3 v. 3 amp. C.T., 3 v. 2 amp. 100 m.a. 32/6.

**PUSH-BUTTON UNITS.** Complete with escutcheon and knobs, 4-way, new, 6/-.

**L.F. CHOKES.** 20 henrys. 150 m.a., 16/8.

**SLOW MOTION DRIVE.** 8-1. Complete with drum and spindle, 3/-.

**WIRE WOUND RESISTORS.** 50-1. 500 ohms, 5-watt type, 1/9 each. 10-watt type, 2/3 each

**HIGH VOLTAGE BRAIDED SLEEVING.** 1 and 1/2 mm., first-class quality, 3/6 per dozen yards.

**P.V.C. CABLE.** 14/36, Red, Green, Blue, Yellow and Black. 2/- per dozen yards.

**MAINS DROPPER RESISTORS.** 0.2 amp. 350 ohms, with fixing feet. 6/9 each.

**WANDER PLUGS.** In 2 colours. 3/- per doz.

**PORTABLE REXINE-COVERED AMPLIFIER CARRYING CASES** fitted with handle for 8in. or 10in. speaker and microphone holder, metal corner protecting plates, rubber buffers, suitable for auditorium extension loudspeaker or amplifier construction, size 15in. x 16in. x 10in. Price £2.19.6.

**LIBERTY SIX.** All-wave 6-valve Constructors' Kit. 15-50, 200-500, 1,000-2,000 metres. A super-sensitive and selective circuit. Hundreds of satisfied users. Brief specification: Frequency Changer with two valves, separate oscillator, six tuned circuit, 465 K.C.s, Iron cored I.P.s. Separate tone and volume controls, 5 watt output, 8in. P.M. Speaker with baffle and output transformer, all valves, chassis, practical and theoretical diagrams. Parts List, Nuts, Bolts, and Wire, ready to assemble. 200/250 volts, A.C. Including purchase tax. 16 gns. Case and packing, 5/- extra.

As above with the addition of Magic Eye Tuning Indicator and parts. 17 gns. Case and packing 5/- extra.

**T.R.F. 3-WAVEBAND 4-VALVE CONSTRUCTOR'S KIT.** 17-2,000 m. Aluminium screened coils, excellent short-wave reception (the special coils used in this circuit give a performance equal to a superhet) 4 1/2 watts output, complete with loudspeaker, all parts, wiring and theoretical diagram—nothing extra to purchase. Chassis dim.: 12in. x 8in. x 6in. to top of dial. 200/250 v. A.C. 11 1/2 gns., including tax. Case and packing, 5/- extra.

## 2 SPECIAL KIT OFFERS

**KIT 1.**—Tuning heart suitable for 6-valve superhet, comprising variable condenser and slow-motion drive, set of iron-cored I.P.'s 465 K.C.'s Litz wound, aerial coil, R.F. transformer and oscillator coil. All trimmers and padders with wave change switch for 3-wave bands, S.M. and L. Also circuit diagram for complete set, £2 9s. 6d.

**KIT 2.** Tuning heart for 5-valve superhet, comprising variable condenser and slow-motion drive, set of iron-cored I.P.'s 465 K.C.'s Litz wound, aerial coil and oscillator coil. All trimmers and padders with wave change switch for 3-wave bands, S.M. and L. Also circuit diagram for complete set, £2 19s. 6d.

**SPECIAL OFFER BATTERY CHARGERS.** 1 amp. type. 2, 6 or 12 volt. 200/240 volt input. Finished in black metal cabinet. Small and compact. £3.19.6 each.

**CAR AERIALS.** Telescopic scuttle fixing, extending to 4ft. 6in. Ebonite insulators, nickel plated, 22/6 each.

**VIBRATORS.** 4-pin, 6-volt, best quality American, 12/6 each.

**WIRE-END CARBON RESISTORS.** 1/2, 1 and 2 watt. Manufacturers' types. New, ex-televison. Parcel of 50 assorted, 12/6.

**TUBULAR PAPER CONDENSERS.** 350/500 v. D.C. working. New, ex-televison. .001, 3/-; .0025, 4/-; .01, 6/-; .02, 7/-; .04, 8/-; .05, 9/-; .1, 10/-; .25, 12/-; .5, 21/-; per dozen. Parcel of 50 assorted, 22/6.

## WESTINGHOUSE METAL RECTIFIERS EX-G.P.O.

Suitable for small chargers, relays, etc., 12 v. full wave 100 m.a., 7/6. 6 v. H/wave 50 m.a., 6/- 4 v. H/wave 30 m.a., 5/- 2 v. H/wave 15 m.a., 4/6. H.I. 2 1/2 v., G.C., 10 m.a., 3/6.



**LOUDSPEAKER TRANSFORMERS.** Pentode Output 40 : 1, 50 m.a., 4/6. Midget multi-ratio 60 : 1, 80 : 1, 40 m.a., 8/6. Multi-Ratio 40 : 1, 60 : 1, 80 : 1 and push-pull 80 m.a., 12/6. Pentode Output 12/15 ohms. 100 m.a., 12/6. Heavy duty, multi-ratio 24 : 1, 41 : 1, 48 : 1, 58 : 1, 82 : 1, 116 : 1 and P.P. 80 m.a., 15/6. 3 : 1 Intervalve, 10/6. Pushpull Output 20-watt, 4,000-0-4,000 Primary. 2.5, 7.5 and 12/15 ohms secondary, 25/-.

**P.M. LOUDSPEAKERS.** 3 ohm Voice Coll. Rola, Goodman and Celestion. 6 1/2" with transformer, 30/-, 8" with transformer, 32/6. 2 1/2", 27/6. 3 1/2", 30/-, 5", 22/6. 8", 24/- 10" with transformer, 37/6. 12", £6.15.0. 10" Mains Energised 350 ohms, 35/-, B.T.H. Model R.K. 10" Mains Energised Loudspeakers, 1,000 ohms field, 15 ohms speech, weight 24 lbs., re-conditioned as new. Ideal for P.A. work. £6.6.0. See transformers above to suit.

**AERIAL AND OSCILLATOR COILS.** Best D.S.C. wire wound, colour coded on bakelite formers. Short, Medium and Long Wave, 16/50 m.; 200/550 m.; 1,000/2,000 m.; with circuit diagram, 15/- the set.

**I.F. TRANSFORMERS.** 465 K.C.s Iron-cored Litz wound, aluminium can. Limited quantity, 17/6 matched pair. 9/6 each.

**S.M. & L. T.R.F. COILS.** Phillips, best quality in screened aluminium cans, 17-51, 220-585, 725-2,000 metres. These coils equal to performance of superhet). Complete with circuit diagram, 9/6 the pair.

**M & L T.R.F. AERIAL COILS.** Aluminium screened Phillips, 200-585, 725-2,000 metres, complete with circuit diagram 2/9 each.

**WAVE CHANGE SWITCH** to suit all above coils, 5/9 each.

**SCREENED INTERLACED FLEXIBLE MICROPHONE CABLE.** Twin 6 yards for 6/9. Single, 1/- per yard.

**VALVES.** American Types at B.O.T. controlled retail prices. For replacement purposes only. 6F5, 12AF5, 12AF5, 12AF5, 1H5, 9/2, 5Y3, 1CS, 11/-, 6Q7, 12Q7, 11/7; 6F8, 8K6, 6K7, 12J7, 12BJ7, 6V6G, 12/10; 6A8, 6B8, 6SA7, 14/-.

Also British valves at manufacturers' list prices. 6X5, U4, U6, 11/-; H14DD, TDD4, 11/7; AO/VP2, CL4, EF39, KTW61, PEN45, SP41, 8P42, T41, VP41, 12/10. D1 Blade 1" Peanut valve, with valveholder, 12/10. E013, X69, 12Z3, 25Z5, 35Z4, 14/- AC6Pen, EL35, PEN 49, U21, 6L5, 18/3. Prices include Purchase Tax, add 3d. per valve post. \* Post Office permit necessary.

**RADIO MECHANIC'S LONG-NOSED PLIERS.** Ex-tovt. stock, reconditioned like new, exceptionally cheap, 4/- Extra long-nosed, 8 1/2, 10/6.

**RADIO MECHANIC'S SIDE CUTTERS.** Ex-tovt. stock, reconditioned like new, exceptionally cheap, 4/6.

**VARIABLE CONDENSERS** 2-gang (small), .0005 ceramic with trimmers, fixing feet, slow-motion drive, dial frame and pointer, 17/9. 3-gang .0005 ceramic insulation with slow drive, pointer and dial frame, 12/6. Midget 2-gang .00035, 10/9. 3-gang .0005 ceramic insulation. Special offer, 7/9.

**VOLUME CONTROLS.** 1, 5, 10, 20, 25, 50 and 100 thousand ohms. 1, 1 and 2 meg. without switch, 4/9 each. As above with switch, 6/9; 100,000 ohms, 1 meg., double pole switch, best American, 7/6. 2,000 ohms only, wire wound, 3/-, 1,000 ohms only carbon, with screw adjustment 1/6 each. Midget 1 meg. with switch, 7/6.

**ENAMELLED COPPER WIRE.** 30 s.w.g. 1 lb. spools, 5/- per spool.

**LINE CORDS.** 3-way heavy duty, 3 amp., 360 ohms., 9/6; 480 ohms, 13/6; 600 ohms, 15/9; 2-way, 360 ohms, 5/6; 480 ohms, 7/6; 600 ohms, 9/3.

**SYNCHRONOUS MOTOR.** 200/250 v. A.C. 12 m.a., suitable for adaptation for electric clocks, time switches, etc., Speed of rota 200 r.p.m. Supplied with spare gears, 27/6.

**RELAYS.** Complete with circuit breaking switch 200/250 v. A.C. 60/80 v. D.C. 300 m.a. 15-amp. switch, each 7/6.

**VALVEHOLDERS.** Amphenol type. International or English octal, chassis mounting, 1/- each; 10/6 per dozen. English water type, 4-8-pin, 6 for 2/6.

**SUPERIOR QUALITY KNOBS.** Ex-televison. Suitable for radio, for tin. spindles. With grub screw 1 1/4in., 1/3. 2in., 1/9. White Ivorine fin. with grub screw 9d. each.

## WESTINGHOUSE METAL RECTIFIERS EX-G.P.O.



Suitable for chargers, etc., H/wave H.T. 150/400 v. 50/200 m.a., 22/6.

◆ **CALLERS** to Show Rooms, 2 HIGHGATE HIGH ST., N.6.

'Phone: MOUntview 9431

## LINAGLOW LIMITED

HOURS OF BUSINESS: Mon. to Fri. 9 a.m. to 5.30 p.m.

Nearest Tube—Archway

◆ **POST ORDERS** to Dept. M.O.42, 61 HIGHGATE HIGH STREET, N.6.

'Phone: MOUntview 9432

# WEBB'S Radio

WE SUPPLY ALL REQUIREMENTS FOR  
LABORATORY USE AND THE HOME  
EXPERIMENTER.

## EDDYSTONE COMPONENTS

World renowned high frequency components, now easier  
in supply and the following are some available from stock:—

No. 916 Stand-off Beehive Insulator	...	...	...	1/3
No. 999 Aerial Insulator	...	...	...	1/-
No. 1019 Midget Stand-off Insulator	...	...	...	6d.
No. 1094 Microdenser 18 mmfd.	...	...	...	5/6
No. 1129 " 40 " "	...	...	...	6/-
No. 1093 " 60 " "	...	...	...	6/6
No. 1130 " 100 " "	...	...	...	7/3
No. 1131 " 160 " "	...	...	...	7/6
No. 1010 H. F. Choke 5/180 metres	...	...	...	2/-
No. 1022 " " (Transmitting)	...	...	...	3/-
No. 1009 Flexible Coupler	...	...	...	2/6

Please note the above are a selection only of **EDDYSTONE**  
Components, for details of available range, please send 2½d.  
stamp.

## METERS

We have space for listing a small selection only of our large  
stocks of instrument meters always available from stock:—

Taylor Model 400 (4½in. x 4½in. overall with 3½in. dial)

Microamps 0/20	...	£10 5 4	...	0/50	...	£7 14 0
				0/100	...	£7 6 8
Milliamps 0/1	...	£5 1 9	...	0/100	...	£4 18 4

Ernest Turner, dual range Voltmeters 0/300 and 0/600 volts  
D.C., high accuracy with external precision resistor box  
£4 5 0

Q.M.C. flush mounting standard size 2½in. instrument,  
0/1 milliamps ... .. £2 17 6

Sangamo Weston flush, 2½in. meters, 0/50 microamps £3 19 0

## SPECIAL, CALLERS ONLY

Metal Screening Cabinets, similar to Eddystone No. 1061,  
6½in. wide by 6in. deep, 7in. high. Hinged top lid, removable  
front panel, and internal chassis. Finished black crackle.  
Ideal for small receivers and instruments ... each 10/-

14 Soho Street, Oxford Street,  
London, W.1

Telephone: Gerrard 2089

We are available 9 a.m. till 6 p.m. for OFFICIAL business,  
but please note our SHOP HOURS—10 a.m. to 4 p.m.  
(Saturdays 10 a.m. to 12 noon.)

**Once again** FILM INDUSTRIES LIMITED  
pioneers of Public Address Equipment, offer:—

**Horn Loudspeaker**  
£9.10.0.

**M.C. Microphone**  
£4.0.0.

**Cone Loudspeaker**  
£3.0.0.



OF COURSE, PRIORITIES HAVE FIRST CONSIDERATION.

**F.I. for P.A.**

**FILM INDUSTRIES LIMITED**

60, PADDINGTON ST., W.1.

Phone: WELBECK 2385.



## FAMOUS FASTENERS

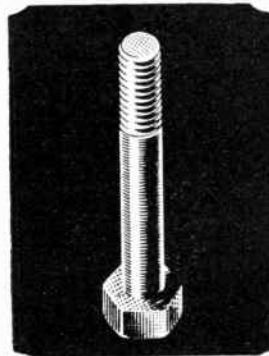

### HIGH TENSILE HEXAGON BOLT

Three distinct tests ensure the standard of Linread  
Bolts. The first is checking of raw material, the  
second is specialised Quality Control during manu-  
facture, and the third, inspection of finished products.

Specialists in Cold Forging: Roll Threaded Screws; Solid and  
Tubular Rivets; Nuts and Bolts in all metals; Small Pressings;  
Auto and Capstan-turned Parts.

LINREAD LTD., STIRLING WORKS, COX ST., BIRMINGHAM, 3.

TELEPHONE No.: GEN. 3951 P.B.X.

TELEGRAMS: "LINREAD BIRMINGHAM."

London Office: Clifton House, Euston Road, London, N.W.1.

Tele. No.: Euston 6385.

**Linread**  
SPECIALISTS IN COLD FORGING

# ELECTRONICS



Many Osram valves now on the secret list will be available, when priority ceases, to meet the needs of electronic designers in every sphere.

made it possible!

*Hullo, Red Section, tanks at 9 o'clock—follow me—*

and as one well-knit unit the flight goes hurtling down to its target, tied together with an invisible electronic link. Close command in the air depends on radio communications, and at the heart lies the electronic valve.

OSRAM VALVES have been in the forefront of electronic development during the war, and will bring to the pursuits of peace many well-tried electronic devices to speed, smooth and make safer our way of life.

**Osram**  
PHOTO CELLS

**G.E.C.**  
CATHODE RAY TUBES

**Osram**  
Valves

Adv. of The General Electric Co. Ltd., Kingsway, London, W.C.2.

**THE STATIC  
CONDENSER Co. Ltd.**

★ *Manufacturers of  
STATIC  
CONDENSERS*

**TOUTLEY WORKS,  
WOKINGHAM, Berks**  
Telephone: WOKINGHAM 708

*Constant Voltage*



**TRANSFORMERS**

LINE VOLTAGE VARIATIONS OF  
 $\pm 15\%$  REDUCED TO  $\pm 1\%$

Typical specification  
 Input Voltage ... 190-260 v. 50 c.p.s.  
 Output Voltage ... 230 v.  $\pm 1\%$   
 Max. load ... 150 watts  
 Input power factor over 90%

Prices on application. Write for details

**ADVANCE COMPONENTS LTD.**

BACK RD. SHERNHALL ST., WALTHAMSTOW, E17. PHONE: LARKSWOOD 43667

**Wharfedale  
MIDGET 3½-inch UNIT**

**ALCOMAX MAGNET**

Flux Density 8,000 lines

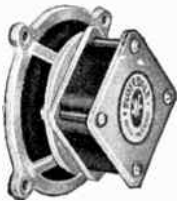

Speech Coil 15 ohms or 2/3 ohms.  
The first Wharfedale Unit using  
the new ALCOMAX magnet  
steel which gives extremely high  
flux density with small size.  
Designed for use as Microphone  
or Midget Speaker. Very sensitive.

PRICE  
**28/6** Supplies are available for  
(list) **PRIORITY ORDERS ONLY**

**WHARFEDALE  
WIRELESS WORKS**

(Sole Proprietor : D. E. BRIGGS)

HUTCHINSON LANE • BRIGHOUSE • YORKS

'Phone : BRIGHOUSE 50.

Telegrams : "WHARFDEL."

**PUBLIC  
ADDRESS**

It only needs **R.S.**  
to make it perfect

The installation of R.S. Equipment puts you well on the way to perfection in Public Address. For example the "Universal Fifteen" which is now coming off our production lines in reasonable quantities is a "truly portable" Portable which, when assembled for transport, is surprisingly compact. What is more, it operates efficiently on all voltages from 200 to 240 on either AC or DC mains. We will gladly send you fullest details on request.

*R.S. Amplifiers*

R.S. AMPLIFIERS LTD • 3-4 HIGHFIELD ROAD • SHEPPERTON • MIDDX  
TELEPHONE: WALTON • ON THAMES 1019

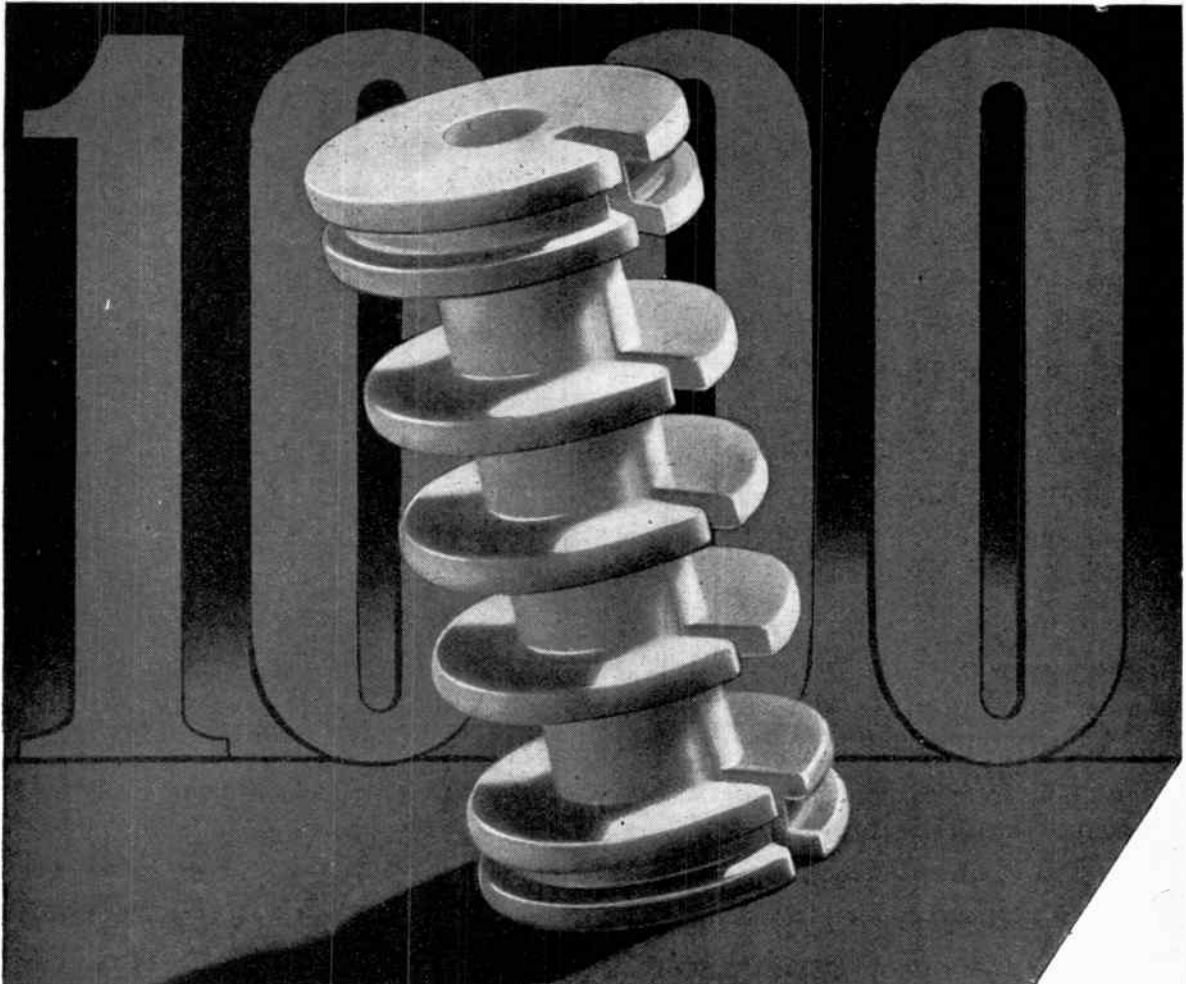

## one in a thousand

Ten years ago we introduced the first British-made low-loss ceramic. To-day the range of Frequentite components covers more than a thousand pieces of every shape and size.

With such a store of manufacturing experience we are able to offer advice backed by practical knowledge on your insulation problem. Please consult us before you finalize your design.



## STEATITE & PORCELAIN PRODUCTS LIMITED

Head Office: Stourport-on-Severn, Worcs.

Telephone: Stourport 111

Telegrams: Steatain, Stourport

S.P.24

Designed and Built to meet  
**EXACT** requirements

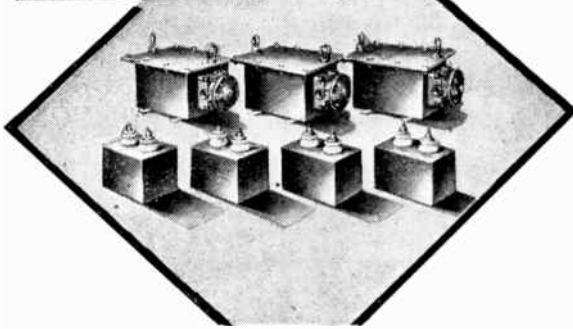

**WEGO CONDENSERS**  
"BUILT BY SCIENTISTS FOR SCIENTISTS"  
**WEGO CONDENSER CO. LTD.**  
BIDEFORD AVENUE · PERIVALE · GREENFORD · MIDDX.  
TELEPHONE : PERIVALE 4277

consult us on your  
**PLASTIC PROBLEMS**

**COSMOCORD LTD · ENFIELD**

Listen to the   
**Stentorian**  
S P E A K E R S

we meant a lot before  
the war

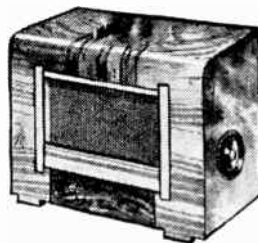
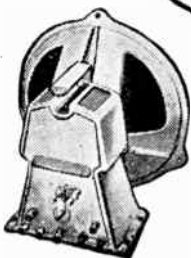

we'll mean a  
lot more soon!

**WHITELEY ELECTRICAL RADIO  
CO. LTD. · MANSFIELD · NOTTS**



**FOR THE  
RADIO SERVICEMAN  
DEALER AND OWNER**

The man who enrolls for an I.C.S. Radio Course learns radio thoroughly, completely, practically. When he earns his Diploma, he will KNOW radio. We are not content merely to teach the principles of radio, we want to show our students how to apply that training in practical, every-day radio service work. We train them to be successful!

Special terms for Members of H.M. Forces and discharged disabled members of H.M. Armed Forces

-----You may use this Coupon-----

**INTERNATIONAL CORRESPONDENCE SCHOOLS Ltd.**

DEPT. 38, INTERNATIONAL BUILDINGS, KINGSWAY, LONDON, W.C.2

Please explain fully about your instruction in the subject marked X

Complete Radio Engineering. Radio Service Engineers.  
Elementary Radio.

And the following Radio Examinations :-

- British Institution of Radio Engineers.
- P.M.G. Certificates for Wireless Operators.
- City and Guilds Telecommunications.
- Wireless Operator and Wireless Mechanic, R.A.F.

Name..... Age.....

Address.....

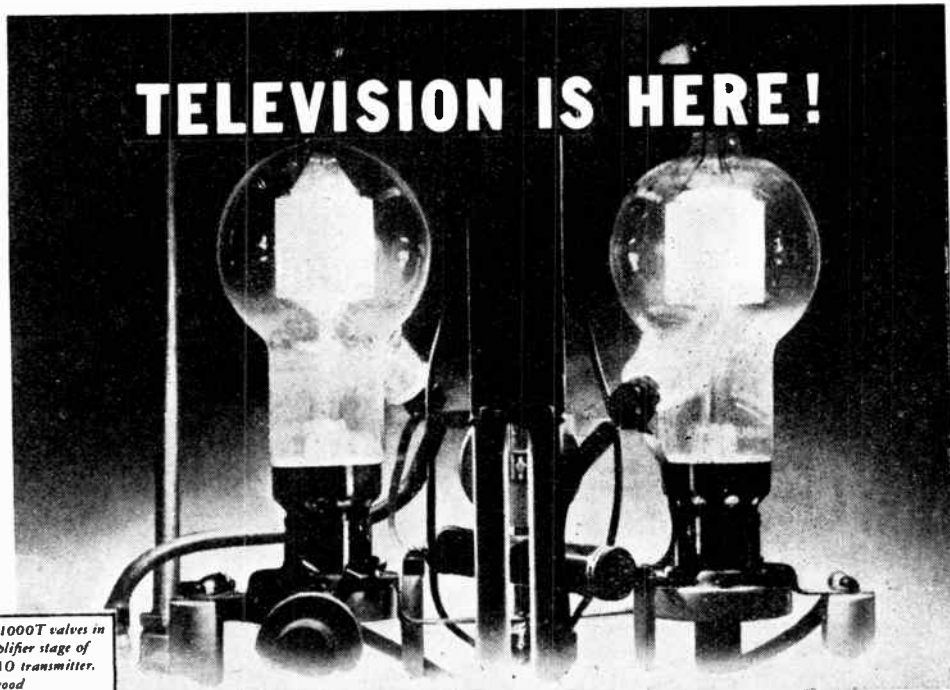

*Eimac 1000T valves in an amplifier stage of W6XAO transmitter, Hollywood*

## At Don Lee Hollywood... Station KTSL using EIMAC VALVES since 1938



*Julia Lee Wright, noted Home Economics Director of "The Family Circle" magazine being interviewed, and telecast revealing tricks of her trade.*



*Two young comedians, Robert Sweeney and Hal March, currently on transcontinental radio show, give a preview of their talents for television broadcast over W6XAO.*

Work on television station W6XAO (Commercial station KTSL) began in November 1930; and thirteen months later, Dec. 23, 1931, it was on the air on the ultra high frequencies, the first present day television to operate on schedule. Today the station occupies elaborate copper sheathed studios which stand 1700 feet above Hollywood with an antenna on a 300-foot tower.

The program log shows almost every type of presentation. Highest in interest and achievement are the remote pick-ups and special event broadcasts made simultaneously or recorded on film for release later. Studio presentations, especially those directed to war activities, have become a duration standard.

Under the direction of Harry R. Lubcke, television station KTSL will

be in daily schedule immediately after the war. Mr. Lubcke says: "We have been using Eimac valves in our television transmitter since about 1938... We have found them good and reliable performers... their design is such that a favorable ratio of power output to valve and circuit capacitance is obtained... we look forward to using new Eimac valves which may be forthcoming."

Here again is a statement from a leader in the field, which offers clear evidence that Eimac valves are first choice of leading electronic engineers throughout the world.

*Follow the leaders to*



EIPEL-McCULLOUGH, Inc., 991 San Mateo Avenue, San Bruno, Calif.  
Plants located at: San Bruno, California and Salt Lake City, Utah  
Export Agents: Fraser & Manson, 301 Clay St., San Francisco 11, Calif., U. S. A.

Write for your copy of *Electronic Telesis*—a 64 page booklet fully illustrated—covering the fundamentals of Electronics and many of its important applications in laymen's language.

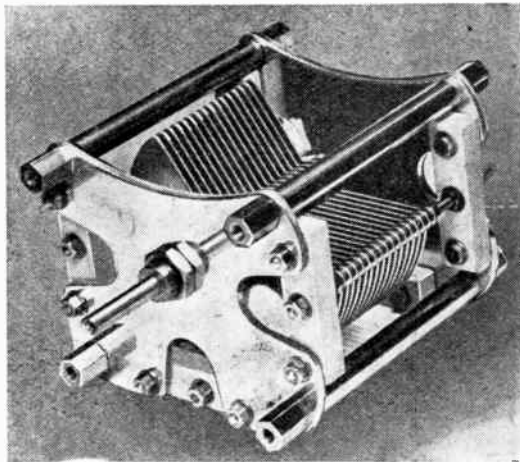

TYPE S.L.C. LINEAR CAPACITY

*"Cyldon"*  
*Variable Capacitors*

**SYDNEY S. BIRD & SONS LTD.**  
CAMBRIDGE ARTERIAL ROAD, ENFIELD.

## LOOKING AHEAD

The day that hostilities cease may be a little late to start deciding who shall supply the Transformers and Chokes for your post-war product.

Why not let us have a rough idea NOW of what you will want, and let us submit suggestions and proto-types?

Just at the moment we are extremely busy making hundreds of thousands of transformers for the battle front, but we are able to devote a certain amount of thought and planning for post-war.

Installed in our new factory is the very latest in Coil Winding Machines, vacuum impregnating plant, test equipment, and everything necessary for the production of the finest transformers that are made.

Drop us a line and let us show you the latest fashions. You are bound to be interested!

**WODEN** TRANSFORMER CO. LTD.  
MOXLEY ROAD, BILSTON, STAFFS.  
Telephone: BILSTON 41959-0

*Above the Bandsaws  
jarring note!*

**WHERE  
NOISE-  
LEVEL  
IS HIGH!**



In any noisy workshop, "music - while - you - work" demands a projector-type loudspeaker. Lately, P.A. engineers have not been able to tackle these "high-noise-level" spots, but now Grampian are able to announce the release of the Grampian type PVH Projector-Speaker. Go over your P.A. systems now and see where this type PVH would improve audibility. Early delivery can be given.

**GRAMPIAN SPEAKER** — Projector Type P.V.H. Unit. Max. loading 10 watts. Impedance 15 ohms. Horn, length 42", diam. 24". Cut off, 170 C.P.S. PRICE **£13.5**

Both types available for early delivery.

**GRAMPIAN MICROPHONE, TYPE M.C. 8.** Pressure operated. Swivel stand - adaptor. Frequency 70 - 8000 c. Impedance 20 ohms. sensitivity 42 d.b. PRICE **£7.5**

**GRAMPIAN**  
LOUDSPEAKERS

GRAMPIAN REPRODUCERS LTD., Hampton Road, Hanworth, Middx.

Scientific G3A

## MINIATURE or MIDGET



*Originators,  
designers & manufacturers of Midget Valves*

HIVAC LIMITED, Greenhill Crescent, Harrow on the Hill, Middx. Phone: HARROW 0893



**FOR WAR SERVICE AND  
POST-WAR PLEASURE**

*The most famous set makers fit*

# MAZDA

RADIO  
VALVES



THE EDISON SWAN ELECTRIC CO. LTD., 155 CHARING CROSS ROAD, LONDON, W.C.2

B

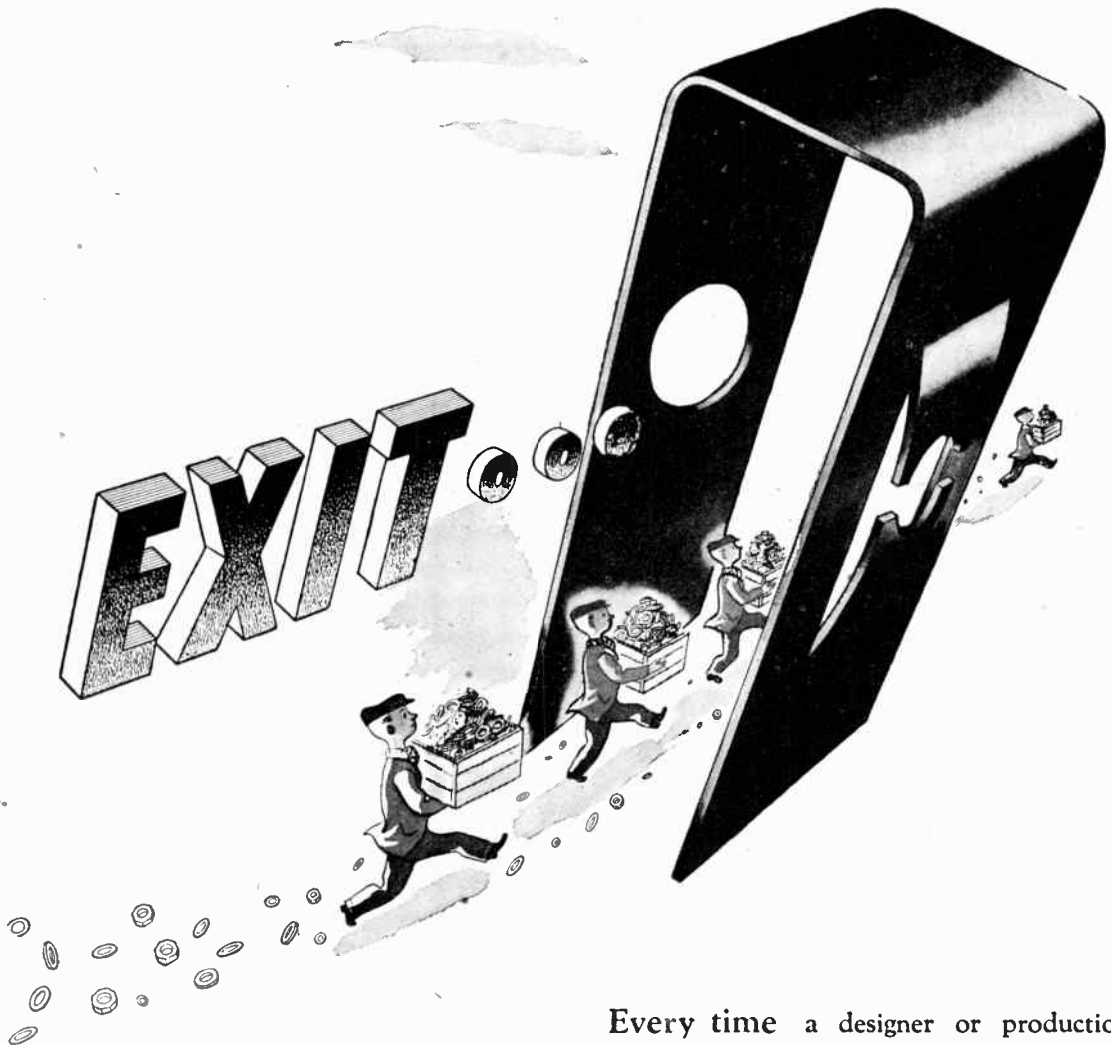

### THAT'S Fixed THAT!

Type CA 725.

Fixing knobs to shafts. Sounds simple but if you're a radio manufacturer you know what a headache it can be. The Spire fixing was designed to solve that particular problem. The CA 725 is made to measure for shafts of various diameters. Then it is snapped into position in the hub of the knob and the knob pushed straight on to the shaft.

Don't think of Spire as a 'kind of nut'. It is a great deal more than any nut. It is a simplified and sure method of fixing. Especially awkward fixings!

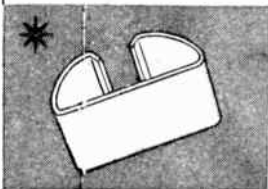

# Spire

\* **A BETTER way of fixing**

*Simmonds Aerocessories Limited • Great West Road • London • A Company of the Simmonds Group*

Every time a designer or production engineer decides to use some form of Spire fixing, he puts a few thousand (or a few million) nuts and washers out of a job. No more fumbling and holding the bits together with one hand while you get to work with the other. Spire fixing can tackle and simplify most light assembly jobs. The best thing is to send us the job—or the drawings. If a Spire fixing will improve the job we'll design it for you and show it to you in a week or two. Then you can judge for yourself.

# Wireless World

Proprietors :  
ILIFFE & SONS LTD.

Managing Editor :  
HUGH S. POCKOCK.  
M.I.E.E.

Editor :  
H. F. SMITH

Editorial, Advertising  
and Publishing Offices:

DORSET HOUSE,  
STAMFORD STREET,  
LONDON, S.E.1.

Telephone :  
Waterloo 3333 (35 lines).  
Telegrams :  
"Ethaworld, Sedist, London."

△

PUBLISHED  
MONTHLY

Price : 1/6

(Publication date 26th  
of preceding month)

Subscription Rate :  
Home and Abroad  
20/- per annum.

Radio and Electronics

35th YEAR OF PUBLICATION

JUNE 1945

MONTHLY COMMENTARY	161
AC/DC COMPARATOR	
By W. H. Cazaly	162
TROPICAL BROADCASTING	
By T. W. Bennington	165
STABLE VHF OSCILLATORS	
By B. J. Solley	170
THE NEW RECEIVERS	
SLOW-SPEED RELAYING	174
By W. Stockman	175
VALVE TESTING	
By Dr. F. E. Planer	176
TELEVISION STANDARDS	
By O. J. Russell	177
VALVE PIONEER	179
LETTERS TO THE EDITOR	180
WORLD OF WIRELESS	183
RADIO TEXTBOOKS	
By Thomas Roddam	186
UNBIASED	
By Free Grid	188
GRAPHICAL SYMBOLS	189
RANDOM RADIATIONS	
By "Diallist"	190
RECENT INVENTIONS	192

Branch Offices :

COVENTRY :

8-10, Corporation Street,  
Telephone : Coventry 5210.  
Telegrams :  
"Autocar, Coventry."

BIRMINGHAM :

Guildhall Buildings,  
Navigation Street, 2.  
Telephone :  
Midland 2971 (5 lines).  
Telegrams :  
"Autopress, Birmingham."

MANCHESTER :

260, Deansgate, 3.  
Telephone :  
Blackfriars 4412 (4 lines).  
Telegrams :  
"Iliffe, Manchester."

GLASGOW :

26B, Renfield Street, C.2.  
Telephone : Central 4857.  
Telegrams : "Iliffe, Glasgow."

△

As many of the circuits and  
apparatus described in these  
pages are covered by patents,  
readers are advised, before  
making use of them, to satisfy  
themselves that they would  
not be infringing patents.

VIBRATORS • TRANSFORMERS • SWITCHES • COILS

## MEET A GREAT LITTLE I.F!

Specially designed to give the maximum gain and selectivity combined with lilliputian dimensions\*. Wearite I.F. Transformers are provided with one-hole fixing, the terminal wires being fed through insulated bushings thus preventing movement after mounting. They are available in the following "preferred" frequencies.

M.400.....460 Kc/s    M.405.....1.6 Mc/s  
M.411.....2.1 Mc/s    M.415.....4.86 Mc/s  
M.418.....9.72 Mc/s

as well as in frequencies for particular applications.

- Coils enclosed in pot-type iron dust cores
- Tuning by means of adjustable iron dust centre cores
- Fixed tuning condensers contained in screening can

\* Dimensions :—  $\frac{1}{8}$ " square x  $1\frac{1}{8}$ " high.

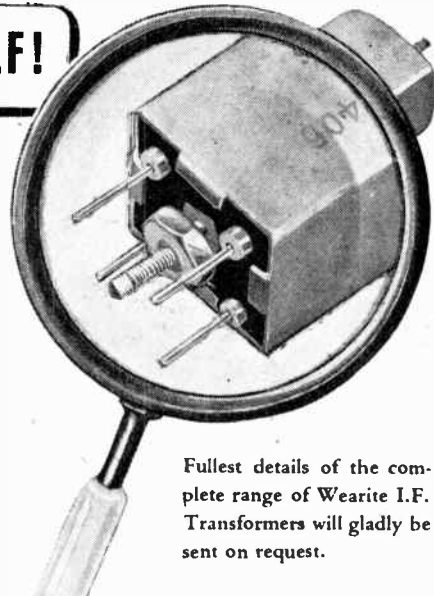

Fulllest details of the complete range of Wearite I.F. Transformers will gladly be sent on request.

# WRIGHT & WEAIRE LTD

A Name as Old as the Radio Industry

HIGH ROAD    TOTTENHAM    LONDON    N 17    TELEPHONE: TOTTENHAM 3847-9

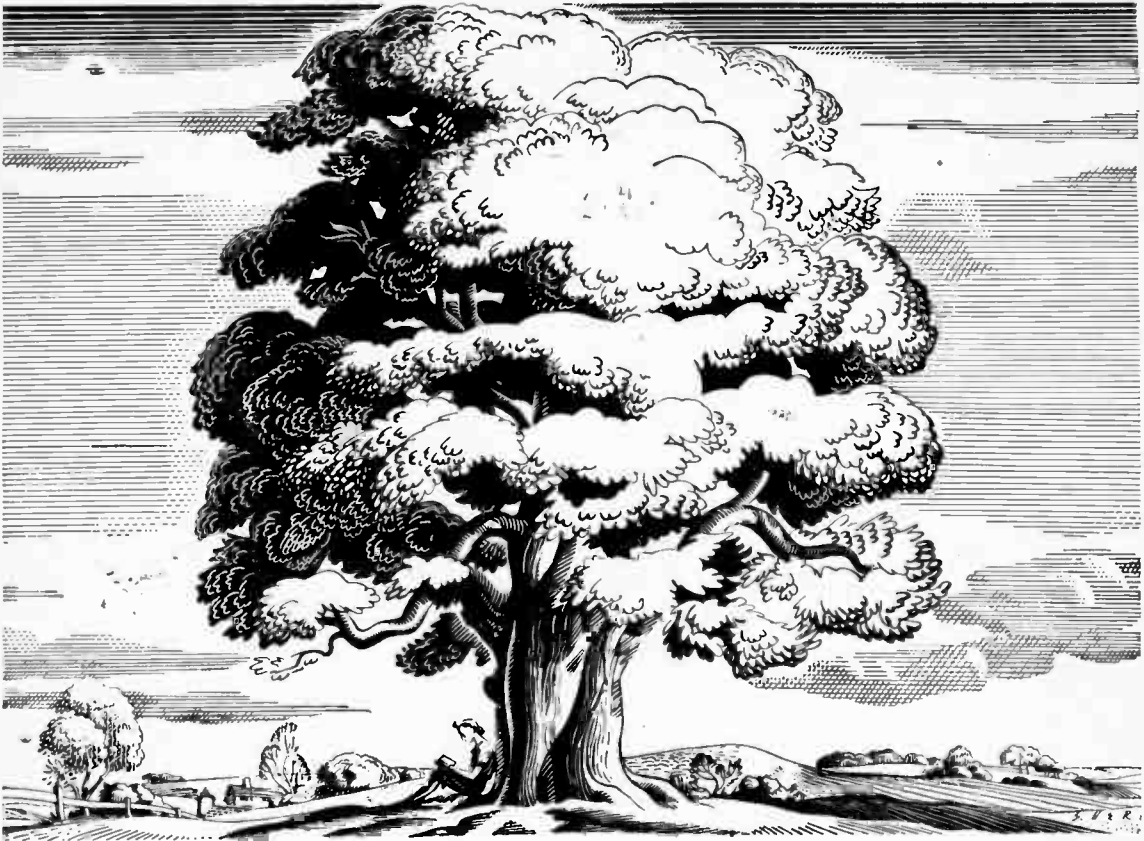

## —and the roots go deep . . . .

Firm and enduring, the great tree stands, its roots spreading deeper and wider through the long years of steady growth.

So, too, have great industrial organisations like that of Philips grown and developed. The many Philips achievements and the high reputation of their products are rooted in persistent research, highly-qualified engineering

personnel, modern and efficient factories and long-accumulated knowledge and experience of the application of electricity to the needs of the modern world.

**PHILIPS**   
**LAMPS ★ RADIO ★ X-RAY**  
**COMMUNICATIONS EQUIPMENT**  
**AND ALLIED ELECTRICAL APPLIANCES**

PHILIPS LAMPS LIMITED, CENTURY HOUSE, SHAFTESBURY AVENUE, LONDON, W.C.2 (871)

# Wireless World

Radio and Electronics

Vol. LI. No. 6

JUNE 1945

Price 1s. 6d.

## Monthly Commentary

### *Wireless Contributions to Victory*

**I**T is a black mark against radio that Hitlerism rose to power largely by exploiting mob psychology with the help of the speech amplifier and loudspeaker, devices first developed for radio purposes. That fact has been freely admitted by Germans. Broadcasting was afterwards used as one of the most powerful agencies for consolidating that evil power. But, as we said a month or two after the outbreak of war, "If wireless put Hitler in, it will assuredly play an important part in getting him out."

That prophecy has now been fulfilled. Indeed, to over-stress the contributions of wireless to victory would be difficult; all those concerned have justifiable cause for pride. More than once, at times of gravest national peril, wireless has come to the rescue. There is the highest authority for saying that in the Battle of Britain the part played by radiolocation was decisive; without its help our 40 or 50 squadrons of fighters—all we then possessed—could not have been used to such good effect. And we believe that it will ultimately be agreed that the contribution of radiolocation to curbing the submarine menace has been equally impressive. But the official story of this has not yet been told; for the present we must accept a tribute paid by Grand Admiral Doenitz, Hitler's successor as German Führer. "At the end of 1943 and the beginning of 1944," he said, "one development became very obvious, which long ago—even in peacetime—we had feared; that the enemy might deprive the U-boat of its essential feature—the element of surprise—by means of radiolocation. By these methods he has conquered the U-boat menace. . . It was not superior strategy or tactics that gave him success in the U-boat war, but superiority in scientific research."

Writing soon after the 1914-1918 war, the German Admiral Scheer said: "The English received the news of our movements through their directional wireless which they already had in use, but which was only introduced by us at a much later period. . . In possessing [direction-finding stations], the English had a great advantage in

the conduct of the war." Thus it would seem that, just as we were ahead of our enemies in the technique of the older form of direction-finding, so we have maintained our lead over them in the newer "reflection direction-finding" (to use one interpretation of the mystic letters RDF). We of *Wireless World* like to think that our own humble contribution—the organisation of the National Wireless Register in 1938—played some small part in the success of radiolocation by helping to find the right men to develop and operate the gear.

In acclaiming the new applications of our technique we must not forget the part played by communications in general. In many directions the broad strategy of the war has been such that we have stood to gain more from wireless than has the enemy, who has been fighting mostly at the end of internal lines of communication.

All of us have good cause for gratification in the thought that wireless has done so much, but we must not rest on our laurels. The Pacific war will probably call for the use of communications and similar devices on an ever-growing scale, and there is also the more difficult task of adapting wartime technical developments to peacetime needs. For that it is essential that the earliest publication should be made of much detailed information that is still under the security ban.

Here *Wireless World* is anxious to play its part. Ever since the journal was taken into the confidence of the authorities on the subject of radiolocation long before the outbreak of war, we have been on our guard against making even oblique references to matters which might give the enemy an inkling of what was afoot. But we feel that the time has now come when we should be able to publish freely most of the information that will be of value in expediting the change-over from war to peace, and in particular in helping the export trade to establish itself. And another of our functions will be to serve as an unprejudiced medium for discussion of the many problems that must be solved if wireless is to play its part in the winning of the peace.

# AC/DC COMPARATOR

## A Simple Method of Calibrating AC Meters

By W. H. CAZALY

THE device to be described enables DC and AC at audio-frequency to be compared closely enough for the calibration of workshop AC meters directly against DC meters. Usually AC meters are calibrated indirectly through the medium of thermocouples, which are expensive in themselves for the lower ranges of current indication (a 25 mA vacuo-junction, for example, costs three or four pounds) and require to be used with microammeters which are rather expensive instruments. It is also possible to mark the dial of a DC meter in RMS terms if the AC to be measured is rectified for use by the meter, but some calculation is involved and rectifiers vary so much in their characteristics that selection of individual testing are necessary for accurate results. Although the average workshop is usually equipped with more than one AC meter, they may cover very different ranges, so that one cannot be readily checked against another, and, especially with the contemporary shortage of meters, it is seldom that one really good meter can be kept for use solely as a standard. The advantages claimed for the device described here are cheapness of apparatus, no necessity for precision in any of its components, ease of construction from readily obtainable parts, little demand for skill in manipulation, direct expression of RMS values of AC in terms of the current readings on the DC meter used as a standard, and accuracy—conservatively from 1 to 5 per cent.—quite high enough for most workshop requirements. A further advantage lies in the ability to compare fairly low AC and DC—of the order of 20 mA.

The device is based on the fact that the resistance of a small low-wattage incandescent filament lamp—the ordinary torch bulb, for instance—varies considerably with the temperature of the filament. This temperature is dependent, for a given set of physical conditions, on the power dissipated in the filament, and at all

frequencies but those so low that the filament has time to cool between peaks of AC, the RMS value of sine-wave AC used to heat the filament is the same as DC in amperes that would heat the filament to the same temperature. Thus AC produces the same resistance change in the filament as equivalent DC and this may be used to compare their magnitudes. The idea is not a new one, of course, but the author does not recall its use in the form now proposed, except in a bolometer circuit for RF measurements which is not very suitable for use at AF. Another effect of filament tem-

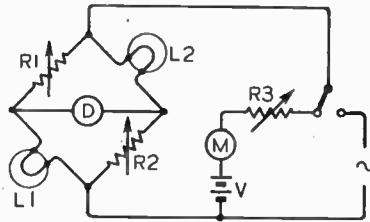

Fig. 1. Basic circuit of comparator.

perature, the emission of light, is well known and employed in AC/DC comparators that contrast light intensities produced by AC and DC, but these forms of comparator require rather large amounts of light and are not very accurate without special apparatus. The device under discussion, however, is operable with the filaments below visible heat.

The basic circuit used is that shown in Fig. 1. This is a bridge in which two lamps, L1 and L2, and two variable resistances of low temperature coefficient, R1 and R2, form the elements. Since these elements are resistive, the bridge can be balanced with either DC or AC energising current. A DC energising source is shown consisting of a rheostat R3, a DC meter M, and a battery V. The switch S connects the bridge at will to either the DC supply or the circuit (not shown) supplying the AC to be compared. Opera-

tion is basically as follows:—First, S connects the bridge to the unknown AC that is to be compared. If this AC is sufficient to heat the bridge lamp filaments enough for their resistances to be changed appreciably from what they are when cold, the bridge can be balanced by adjustment of R1 and R2. Next, S is switched to the DC supply. Without altering the settings of R1 and R2, the DC then passed, controlled by R3 and measured by the meter M, is adjusted until balance is indicated by the detector D. This DC will be making the filament resistances of L1 and L2 change to the same extent as was brought about by the unknown AC previously used to energise the bridge. If the AC is sine-wave, the value in amperes of the DC equals the RMS magnitude in amperes of the AC.

As will become apparent, this device is not particularly suitable for ordinary measurement of AC, because the power required is considerable compared with that which is necessary to operate ordinary AC meters. Its prime use lies in the calibration of AC meters. The simple basic circuit shown in Fig. 1 has a major disadvantage from the viewpoint of simplicity and cheapness; it requires balance detectors that are sensitively responsive to DC and to AC. For DC, a very sensitive galvanometer could be used; for AC a valve voltmeter of high sensitivity or a vibration galvanometer might be used. These instruments are more in the nature of somewhat expensive laboratory, rather than workshop, equipment. However, this disadvantage can be removed by superposing 1,000 c/s AC on the DC for balance purposes, which enables high-inductance headphones, which are cheap and one of the most sensitive of balance detectors at that frequency, to be used. When the AC being compared is at 500-1,500 c/s, it can provide its own balancing note in the phones, but at lower or high frequencies, to which either the phones or the ear are not very

sensitive, 1,000 c/s can still be superposed. It is essential only that this 1,000 c/s balancing component should be too small to make any appreciable difference to the heating of the filaments. As, however, balancing current of the order of 2 or 3 mA at 1,000 c/s is sufficient for the purpose, even with a low-impedance bridge such as this, no difficulty arises on this account.

The circuit in practical form with 1,000 c/s superposition is given in Fig. 2. The 1,000 c/s component of the energising current is introduced by means of a transformer T<sub>1</sub>, which can be fed from some audio-frequency source such as a BFO or a small valve oscillator. The secondary of this transformer is wound of wire of sufficient thickness to carry the compared currents without overheating, and is tapped to provide various amounts of balancing component. The author made a suitable transformer out of a speaker transformer, the original secondary being replaced by a winding tapped at every 20 turns up to about 160, which gave a good selection of taps for experimental purposes. Since the impedance of the bridge is low, a telephone transformer with a fairly high step-up ratio is practically a necessity to match high-

possible alternative to a BFO and input transformer may consist of a simple valve oscillator built on the lines of the circuit given in Fig. 3. The valve should be of the medium impedance type—say, 3,000-6,000 ohms. The grid condenser may be 0.01 μF and the grid leak 50,000 ohms. The transformer should be of the cheap variety, which is not very satisfactory for AF amplification owing to lack of adequate inductance in its windings, but which is more likely to provide about 1,000 c/s than a better component. This transformer is adapted by taking off about a quarter of the secondary winding and putting on, in the space thus left, a third (output) winding. This winding may consist, for comparison of currents of the order of 0.5 A, of 26 SWG wire, of as many turns as possible to fill the space and tapped at every 20 turns (for experimental purposes). The output need not be of good sine waveform, but the oscillator should not squegg, as the high-order harmonics so produced may, on account of the stray reactances of the bridge, partially obscure the balance point.

The values of R<sub>1</sub> and R<sub>2</sub> depend on the ratings of the lamps used in the bridge. The choice of lamps is governed by the

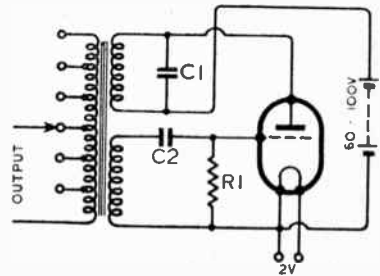

Fig. 3. Valve oscillator for production of 1,000 c/s balancing component. For constructional details, see text.

cate that car type lamps exhibit similar variations of resistance with temperature and could be used for the comparison of AC and DC of the order of several amperes. From the graphs, an idea of suitable values for R<sub>1</sub> and R<sub>2</sub> may be gathered. For maximum sensitivity to changes in energising current, the bridge should be balanced when all ratios

$$\frac{R_1}{L_1} = \frac{R_2}{L_2} = 1.$$

The

bridge can be balanced, of course, when R<sub>1</sub> and R<sub>2</sub> are different, but in those conditions the current divides unequally through the bridge, heating one lamp more than the other, which reduces the sensitivity of the bridge to changes on energising current and therefore its ability to discriminate between closely adjacent values of current. If R<sub>1</sub> and R<sub>2</sub> are made smoothly variable from 1 or 2 to about 50 ohms, lamps rated at from 6 V, 0.04 A to 6 V, 0.5 A can be used, for the comparison of currents of the order of 20 mA to 1 A. The total current energising the bridge when ratios are unity is twice the current through one lamp, and the voltage required to pass this total current is twice that required across the lamps. In practice the author, being unable to obtain suitable commercial rotary vari-

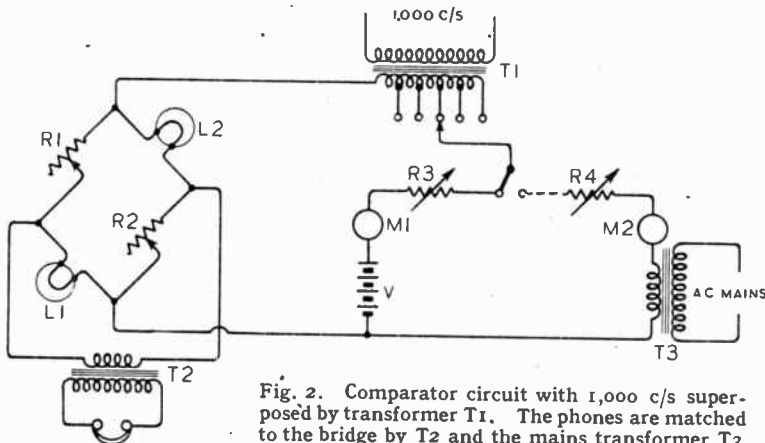

Fig. 2. Comparator circuit with 1,000 c/s superposed by transformer T<sub>1</sub>. The phones are matched to the bridge by T<sub>2</sub> and the mains transformer T<sub>3</sub> provides an AC source of voltage roughly equal to that of the DC battery V. M<sub>1</sub> is the DC meter used as a standard, and M<sub>2</sub> the AC meter being calibrated. See text for values of R<sub>1</sub> and R<sub>2</sub>.

impedance phones to the bridge. Again a speaker transformer was found suitable. A valve amplifier between this transformer and the phones adds considerably to the ease with which balance can be found, but is not essential. A

orders of magnitude of the currents it is wished to compare. No precise knowledge of the characteristics of the lamps is needed in using the device, but as a matter of interest and to initiate design, some rough measurements were

able resistances, made up a couple of slide-contact devices by winding the wire from (unused) electric fire spirals (straightened) in the form of grids, on the lines shown in Fig. 5. Contact was made by crocodile clips. Crude as this idea is, it worked and was perhaps excusable in the sixth year of war. For very low-rated lamps, such as the 6 V, 0.04 A type (used in the rear lamps of some cycle dynamo lighting sets),  $R_1$  and  $R_2$  may have to attain as much as 150 ohms each when the full rated current is being passed through these lamps, and it is more convenient to use normal rotary variable resistances.

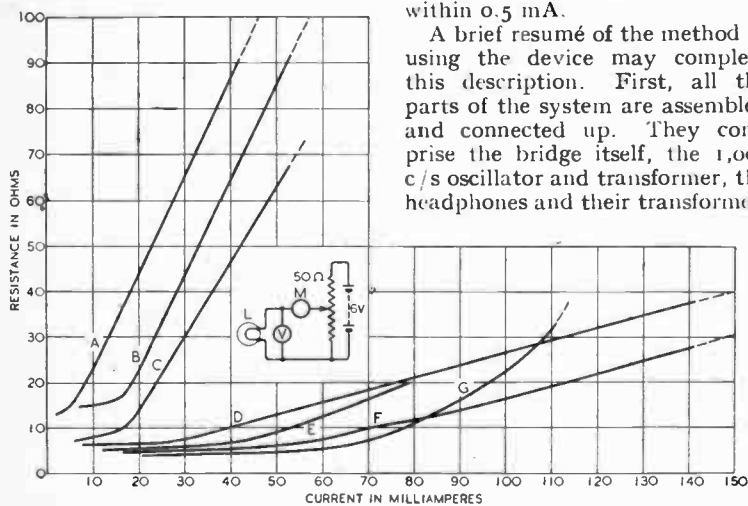

Fig. 4. Current/resistance curves for a representative series of lamps. A, 6 V, 0.04 A; B, 6 V, 0.06 A; C, 3.5 V, 0.06 A; D, 6 V, 0.15 A; E, 3.5 V, 0.15 A; F, 6 V, 0.3 A; G, 3.5 V, 0.15 A (American lens-tip type).

The best lamps to use are those which have the steepest IR curves. It will be seen from Fig. 4 that filament resistance does not begin to change much until certain minima of current are exceeded. These conditions, represented by the flat portions of the curves, are probably due to the surface area of the filaments being sufficient to radiate small amounts of heat as fast as they are set up. Once the creation of heat in the filaments exceeds this probably fairly steady loss, temperature, and therefore resistance, rises steadily and almost linearly. The thicker the filament, the longer is the flat part of the curve, and the longer the filament, the greater the overall resistance change. Thus, the 6 V, 0.04 A type of lamp exhibits the steepest

curve and, in practice, enables sharp balances to be obtained with quite low currents. So far, this is

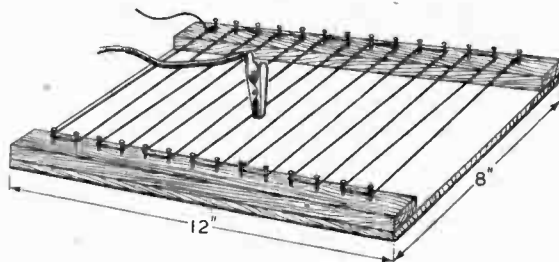

Fig. 5. Slide-contact variable resistance. A straightened electric fire spiral is stretched across a simply made rack. Two of these elements are needed, one each for  $R_1$  and  $R_2$ .

the lowest rated lamp the author has been able to procure, and has made possible the comparison of AC and DC of the order of 20 mA within 0.5 mA.

A brief resumé of the method of using the device may complete this description. First, all the parts of the system are assembled and connected up. They comprise the bridge itself, the 1,000 c/s oscillator and transformer, the headphones and their transformer,

justed, alternatively with  $R_1$  and  $R_2$ , until exactly the desired current is passing through the bridge. The bridge is then disconnected from the DC source and connected to the AC circuit. The AC rheostat is now adjusted until balance is again obtained. The AC then being passed will have an RMS value equal to the DC current previously passed. Then the process is repeated with the next desired calibration current. In this way the scale of the AC meter can be fully marked against corresponding DC meter indications. With proper care, meters can be calibrated to within 1 or 2 per cent. of the DC used as a comparison standard, which is amply accurate for workshop purposes.

the DC meter that is to be used as a standard with the DC controlling rheostat, and an accumulator battery of twice the voltage of one of the lamps. The AC meter that is to be calibrated or checked, another rheostat to control the current through it, and a course of AC such as a mains transformer with a low-voltage secondary constitute the AC circuit by which the bridge can be energised. For calibration, the bridge is connected first to the DC supply, and the current adjusted by means of the rheostat  $R_3$  to the value it is desired to compare. Then, by manipulation of the slide-contact resistances  $R_1$  and  $R_2$ , the bridge is balanced (i.e., minimum sound heard in the headphones). The resistance  $R_3$  may have again to be ad-



FM "WALKIE-TALKIE." This American Signal Corps pack transmitter-receiver, type SCR 300, has been used to some extent by the British Army. The set, measuring 17" x 12" x 7 in., weighs 35 lb.



# TROPICAL BROADCASTING

## Choice of Frequencies

By T. W. BENNINGTON

IT has for a long time been recognised that the factors affecting the choice of wavelengths suitable for a local broadcasting service are not the same in tropical as in temperate countries. The medium-wave broadcasting band — whatever may be its deficiencies and drawbacks—still has much to recommend it for local broadcasting in the temperate zones. The ground wave has a *moderately* good range, so that fairly good coverage can be attained for a given power radiated; the noise level is (usually) relatively low so that not too great a field intensity is required to provide a workable signal with a properly designed receiver, and a good number of broadcast channels (perhaps not enough) can be accommodated without leading to complications in receiver design.

In the tropics the situation is radically different, principally because the radio noise intensity is usually so high on the medium waves that an excessively high field strength is necessary to provide a workable signal. Consequently the range for a given radiated power is excessively low, and coverage is therefore very poor. For tropical broadcasting it would appear therefore that the short waves ought to be used, for on these the radio noise intensity is much lower.

### Tropical Broadcasting Bands.—

These facts were readily recognised at the 1938 Cairo Conference and for local broadcasting in tropical countries the 120-metre (2.3-2.5 Mc/s), 90-metre (3.3-3.5 Mc/s), and 60-metre (4.965-5.5 Mc/s) bands were allocated. Noise on these frequencies is much lower than on the medium-wave band, though of course it is necessary, if good coverage is to be attained, that sky wave, and not ground wave transmission should be effected. The range of the ground wave is even smaller than on the medium waves. That is why different frequencies were allocated to the stations for day and for night working; it was

The technical problem of providing economical broadcast coverage for wide tropical areas is likely to assume importance after the war, especially with regard to the British Crown Colonies and Protectorates. "Long-short" wavelengths will probably be used for the purpose, and it is concluded here that, considered in the light of present knowledge, the existing channel allocations in these bands are inadequate.

necessary to take account of the diurnal ionosphere variations. But knowledge of the ionosphere was not at a very advanced stage at that time (it can hardly be deemed to be so even now, though much more has been learned) and it may be that, had more been known about the subject, these particular tropical broadcast bands would not have been chosen. It would seem, for example, that, because the sun's rays are stronger in the tropics than in temperate regions, the ionisation of both the refracting and absorbing layers of the ionosphere would be higher. If this is so the use of higher frequencies for local short-wave broadcasting would be not only possible but absolutely necessary, than for a similar *short-wave* service in the temperate zones. Let us therefore consider some of the factors affecting broadcasting in the tropics, and see whether any better results might be achieved if other arrangements were in force.

**The Tropical Zone.**—Geographically, if not ionosphericly, the tropical zone comprises those regions lying between the parallels of latitude  $23\frac{1}{2}$  deg. N. and  $23\frac{1}{2}$  deg. S. If the ionosphere conditions do not correspond with the geographical ones, then the obvious course would be to define the tropical broadcasting zone as

that within which the ionosphere exhibited tropical characteristics. The geographical limits to the zone in which the use of the tropical bands allocated by the Cairo Conference was permitted were, in fact, the parallels of latitude 30 deg. N. and S. But the definition of the "radio tropical zone" is not quite so simple.

Although it is true that the ionosphere will set the high limit to the frequencies of use over a given distance and, to some extent, the lower limit also, still it is largely conditions of temperature and climate that control the noise, at least on the lower frequencies. For the tropics are the breeding ground of the thunderstorms which give rise to noise, and although the noise itself is propagated by way of the ionosphere, the efficiency of such propagation will vary very much with frequency. In fact, it is evident that neither the zones of greatest noise intensity nor the regions of the ionosphere where the ionisation is at a "tropical" level, will correspond exactly with the geographically defined tropical zone. Nevertheless, for the sake of simplicity we may assume that they do, and in that way reduce the matter to a workable basis without committing any very great error.

Within the tropics lie some of the most populous countries of the world, including the following countries of the British Commonwealth: Anglo-Egyptian Sudan, Australia (northern part), British Guiana, British Honduras, British Somaliland, Burma (southern part), India (southern part), Kenya, Malaya, Oceania, Rhodesia (Northern and Southern), Tanganyika, West African Colonies, and West Indies (large part).

When the enormous size of these tropical regions is considered, together with the fact that they are not usually at a very advanced stage of economic development, it is seen that there is an additional reason for the use of short waves for the broadcasting service. If the medium waves

**Tropical Broadcasting—**

were used the service areas would—during daylight—be limited by the distance range of the ground wave, and this, even if the noise level were relatively low, would not be great enough economically to serve such large areas, most of which are of an entirely rural character. Far too many stations would be required. By the use of short waves however, the distance range of a station is much enhanced, because the transmission is effected by the sky wave, and therefore the service area—albeit the service given is now of the second grade—is very much larger.

**The Main Requirements.—**

It may be well at this stage to define, in the main, the characteristics of what constitutes a suitable wavelength for local broadcasting in the tropics. The term "local broadcasting" is used in this article in contradistinction to the term "long-distance broadcasting." It means that service is given in an area which stretches from the transmitter outwards though the limits of the area may be many hundreds of miles distant.

- (1) It must be of so high a frequency that the radio noise intensity is relatively low, and so only a moderate field of

intensity is necessary to give a workable signal.

If this entails a frequency on which the ground wave range is so small that the sky wave must be used to give the required coverage—and our previous considerations indicate that it will—then

- (2) It must be of high enough frequency at any particular time of day that the ionospheric absorption is not too great; otherwise the distance range will be reduced and the coverage limited.
- (3) It must be of low enough frequency at any particular time of day that energy radiated even at the greatest angles to the horizontal will not penetrate the refracting layer of the ionosphere; otherwise there will be an undesirable skip zone.

We may now examine the conditions on various frequencies in order to see which of them will best fulfil the above requirements. Let us consider the noise situation first.

As has been mentioned before in these pages,<sup>1</sup> atmospheric noise is caused by the radiation of radio frequency energy by lightning strokes in thunderstorms, and it is in the tropics that these thunder-

<sup>1</sup> See "Radio Noise" *Wireless World*, Nov. 1914.

storms most frequently occur. The noise emanating from the thunderstorms is propagated both as a ground wave and as a sky wave, so that most of the radio noise in temperate zones originates in the thunderstorms of the tropics. Owing to the nature of the current pulses in the lightning strokes more radio energy is radiated at low than at high frequencies, so the noise intensity in the first instance decreases with increasing frequency. Its intensity in any particular geographical zone will, however, vary with frequency in a complex manner—depending not only on the noise intensity produced, but also on the propagation characteristics for the various frequencies.

But so far as the tropics are concerned—at least the land areas within them—we may assume that they are either within the actual thunderstorm-producing areas or so close to them as to be affected mainly by the noise ground waves. This assumption may not be quite true all the year round, since the noise zones move north and south with the seasons, but at least it is justified as showing the worst conditions to be expected.

If we examine the tropical noise intensity on one or two spot frequencies this will give us an idea as to how the noise decreases with

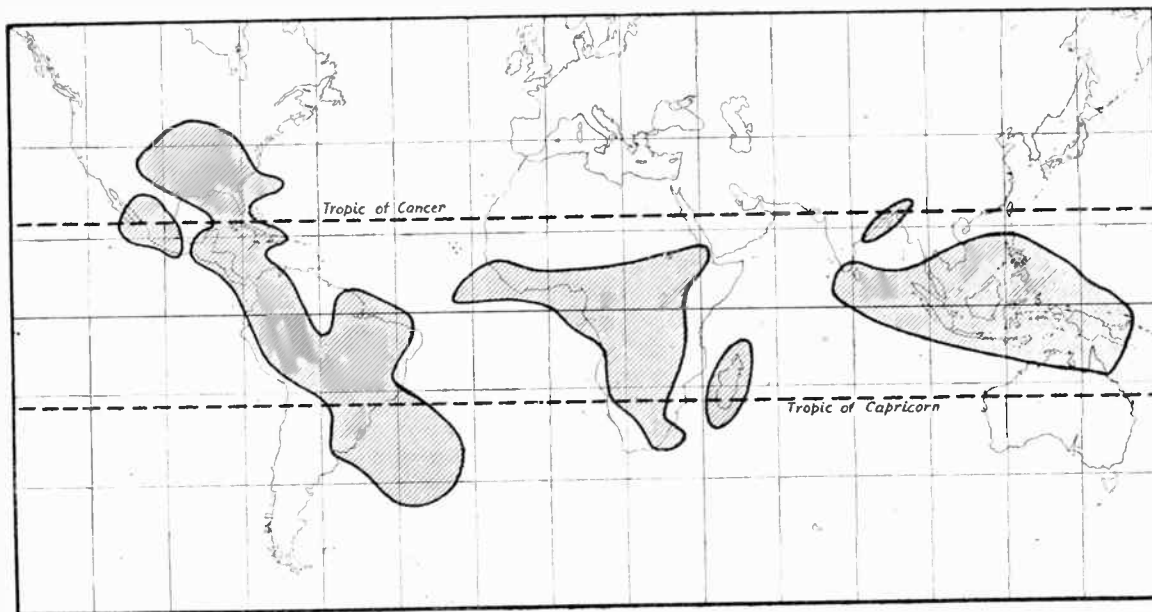

Thunderstorm areas of the world, where most of the radio noise is produced (from the thunderstorm charts of Dr. C. E. P. Brooks).

increasing frequency, and enable us to see which frequency bands are most likely to fulfil requirement (1) above. The measurement of noise presents certain difficulties such that it is found more convenient to measure, not the noise intensity itself but the intensity of a signal which is at a specified level above the noise. In the case of broadcast reception a greater signal-to-noise ratio is necessary than for most other radio services, and in highly developed countries a figure of 40 db. is considered desirable and is in fact generally

quency somewhere near the middle of the medium-wave band may be compared with that of 1.0 millivolt/metre, the minimum field intensity for broadcast reception in a quiet country district in the British Isles. But it must be stressed that both these figures—3.6 mV/m. in the tropics and 1.0 mV/m. in this country—are for districts where there is no man-made noise, and in all the urban districts of the countries considered considerably higher field intensities are in fact required. In the tropics the man-

night local time, so we may take the above figures of required field intensity as applying roughly to the whole period between noon and midnight.

**Range and Coverage.** — The next step is to find out the maximum distance at which the required field intensities would be maintained on the various frequencies. We will ignore for the moment the question as to whether the ionisation of the refracting layer would be high enough to refract the frequencies

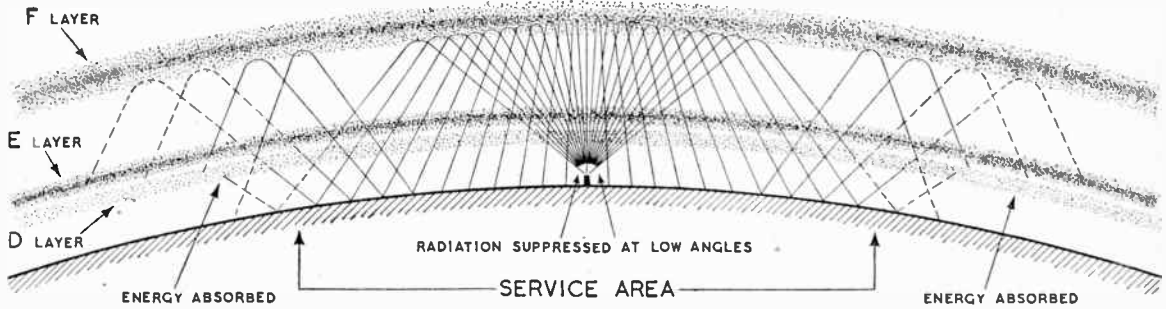

Idealised picture of a local short-wave broadcasting service, using F layer skywave transmission.

achieved. However, the minimum requirement for tolerable reception is that the signal field intensity should be 20 db. above that of the noise. Such figures, giving the minimum field intensity necessary to provide a satisfactory signal in the presence of the noise, would be directly to our purpose, but reliable data on this subject applicable to the tropical zone are extremely scanty. However, the following figures are obtained from a careful consideration of what data are available.

**Minimum Field Intensity for satisfactory tropical broadcast reception (20 db signal/noise ratio)**

1 Mc/s. μV/m	2 Mc/s. μV/m	4 Mc/s. μV/m	8 Mc/s. μV/m
3,600	1,550	570	170

The above figures are indicative of the situation considering the noise alone, at what is, generally speaking, the worst season of the year, and it is seen that on 4 Mc/s the required field intensity is approximately one-sixth, and on 8 Mc/s one-twentieth of that on the medium waves. The figure of 3.6 millivolts/metre for a fre-

quency is usually particularly bad because of the common use of large numbers of electric fans, and these practically control the required field intensity on short waves in many districts. One reliable authority gives the following values of required field intensity in the presence of such man-made noise: 4 mV/m. on 2.3 Mc/s, 2 mV/m. on 4.6 Mc/s, and 1 mV/m. on 9.4 Mc/s and higher, when only 100 μV/m. was necessary in the absence of the noise.\* So, the noise situation being a very variable one, we may continue to work with the figures given in the table, bearing in mind that they are for quiet districts only.

There is, of course, a diurnal variation in the radio noise intensity, the thunderstorm production being dependent upon the diurnal variation in temperature, and other meteorological effects. This variation in the noise intensity is such that a maximum occurs in the late afternoon and a minimum in the early morning, and it is of a considerable magnitude. There is not a *great* difference in the intensity of the noise, however, between noon and mid-

night, or whether they would penetrate through it. We will assume the former condition to apply.

On the frequencies 1 Mc/s and 2 Mc/s—within or near the medium-wave band—propagation would be by ground wave only during the day, and at night there would be sky wave propagation also. On the other frequencies considered only the sky wave would be of real importance, both by day and by night. The range for the required field intensities shown above for the various frequencies would depend upon a number of factors, chief of which are (a) the power radiated, (b) directivity of the aerial system, (c) ground absorption, (d) ionospheric absorption.

In order to arrive at some figures which will give an indication of the conditions to be met we must therefore make various assumptions. We will assume, in the first place, a radiated power of 50 kW and the use of a non-directive aerial system, it being remembered that we aim to give local all-round coverage. We need not here concern ourselves with the type of aerial which would be necessary for this purpose, but it ought to be mentioned that in

\* All-India Radio.

**Tropical Broadcasting—**

practice, its directivity in the vertical plane would be a matter of considerable importance. The ground absorption will depend, of course, upon the nature of the terrain, and will be no different in the tropics from that encountered in temperate zones, so we may consult the usual data for transmission over a good earth in a temperate zone in order to determine the distance range of the ground wave.

On those frequencies where the sky wave is made use of it is ionospheric absorption which will determine the range. This is more difficult to assess than the ground absorption, and little data are available. The ionospheric absorption occurs mainly in the lowest part of the ionosphere and is dependent upon the amount of ionisation in the absorbing region. This will be much greater in the tropics than in temperate regions, because in the tropics the sun is more directly overhead and its ionising rays are therefore stronger. It is evident that the ionisation will vary greatly with time of day, being greatest at midday and practically negligible during darkness, owing to the high recombination rate in the absorbing region. The ionospheric absorption in the tropics then will be negligible at night and no different from what it is in temperate zones, and between sunrise and sunset it will vary in amount, with the maximum occurring at noon. In order to determine the sky wave ranges then we will estimate the effect of ionospheric absorption at noon and at midnight only, in order to indicate the worst and the best conditions likely to be met.

Ionospheric absorption varies inversely, of course, with frequency, it being less on the higher frequencies because the rate of collision between the electrons and ions in the ionosphere—which are its intrinsic cause—depends upon the magnitude of their motion when acted upon by the radio wave, and this is less when the electric field of the wave reverses itself more frequently in a given time. The distance range will therefore increase markedly as the frequency is increased.

Taking all the above factors into consideration the following are the estimated ranges for the required field intensities on the different

frequencies we are considering.

Thus, on 1 Mc/s and 2 Mc/s the ground wave only is of use during the day, and on 1 Mc/s

that *economical* coverage is attained if the transmitter has a range of 500 miles. It should be noted also that the ionospheric

Estimated distance range for required field intensity for 50 kW radiated

	1 Mc/s	2 Mc/s	4 Mc/s	8 Mc/s
Noon	50* miles	38* miles	220 miles	820 miles
Midnight	270	460	1,350	3,300

\* Ground wave only.

(300 m) owing to the high field intensity required to overcome the noise, this only has a range of 50 miles. On 2 Mc/s (150 m) though the required field intensity is less, this is more than counteracted by the increased ground absorption, and so the distance range falls to only 38 miles. On 4 Mc/s (75 m) sky wave propagation is obtained and the distance range goes up to 220 miles, whilst on 8 Mc/s (37 m) it is further increased to 820 miles, because both the noise intensity and the ionospheric absorption are reduced.

At night the ionospheric absorption becomes of a very low value and so the distance range on all the frequencies is much enhanced, though it is, of course, still much smaller on the lower frequencies than the higher, because of the greater field intensity required to overcome the noise on the lower frequencies.

The net result of our investigations, so far, is to show that (a) the higher the frequency the better will the coverage be, *provided that the wave does not penetrate the ionosphere*, and (b) that at the time of day when the ionospheric absorption is highest *economical* coverage can only be obtained on frequencies higher than 4 Mc/s, though at night it could probably be obtained on frequencies nearly down to 2 Mc/s. (For reasons mentioned earlier on, the *degree* of coverage aimed at is usually less in tropical than in more highly developed countries, and it has here been considered

absorption varies markedly over the day, and that the ranges would be greater over most of the day than those shown for noon.)

**Conditions for Refraction.**—But it is evident that it will be no good using 4 Mc/s or 8 Mc/s at any time of day if the ionosphere refracting layer permits it to penetrate, even at the highest elevation angles, for the production of a skip zone surrounding the transmitter must be avoided. So we had better examine the conditions in order to see what is the *highest* frequency which will be refracted.

It is assumed that the wave will be refracted at the F or F<sub>2</sub> layer. If the wave is to be returned at all distances from the transmitter outwards it is necessary to use a wave which is below the critical frequency of the refracting layer at any time of day. Then it will be returned at vertical incidence and at all greater angles of incidence, and the earth will be illuminated by the downcoming rays from the transmitter outwards. The critical frequency varies very much, of course, with time of day and season of year, but, as has already been said, because the ionising rays of the sun are stronger in the tropics than in temperate zones, the critical frequency will be generally higher there. The use of higher frequencies than for the same purpose in a temperate zone will therefore be possible.

The following table gives approximately the estimated lowest

Estimated lowest critical frequencies for tropical zone, F<sub>1</sub> F<sub>2</sub> layer

	Midnight Mc/s	Diurnal Minimum Mc/s	Noon Mc/s	Sunset Mc/s
June ... ..	4.0	3.0	6.5	6.0
March and Sept. ...	4.0	3.5	8.5	7.5
December ... ..	3.5	2.5	7.5	5.0

critical frequencies of the F and F<sub>2</sub> layers throughout the geographical tropical zones for four significant times of day and for four seasons of the year.

It is seen that the critical frequency varies in a rather complicated way with the seasons, and this is to be expected because we are considering an area which extends into opposite hemispheres. It should be noted, however, that although the seasonal variations are in the opposite sense in the two hemispheres the ionospheric variations are not necessarily so, being somewhat more complicated than we can deal with here. However, the figures given are thought to be valid for the whole of the geographical tropics, and it is seen that highest daytime frequencies prevail at the equinoxes and lowest night-time ones during December.

As has already been said, it is advantageous for several reasons to make use of the highest frequencies possible, but obviously it would not be advisable in a local broadcasting service to make too frequent changes in the working frequency, either diurnally or seasonally.

The table indicates, in the first place, that 2.5 Mc/s (120-metre band) is hardly ever necessary—it is certainly the lowest frequency ever necessary—for night-time use. It is to be noted that a local broadcasting service is not often required to function between midnight and sunrise local time. 3.5 Mc/s (90-metre band) is shown to be a very useful and even necessary frequency for use during local evening hours up to midnight—but 5.0 Mc/s (60-metre band) is too high for night-time use, and, we see, somewhat too low for the daytime. It might, of course, be of considerable use as an intermediate frequency for use during certain periods of the day, as, for example, around sunset at certain seasons. But it is evident that over considerable periods of the day a higher frequency than this should be employed, and, if it is to be of some use at all seasons of the year, this would appear to be in the region of 6.5 Mc/s (46 metres). This would have a considerable period of utility all the year round ranging from 6 to 11 hours daily, according to the season. It might be thought that the use of a fre-

quency so high as 6.5 Mc/s for local broadcasting would lead to unwanted distance ranges, and thus to interference with other services operating on or near the same frequency band outside the tropics. There are two ways in which this could be prevented: (a) by restricting the use of 6.5 Mc/s to certain hours when the ionospheric absorption is relatively high and thus the range is relatively small and the wave is not likely to reach to distances where it can cause interference; (b) by adjusting the elevation angle of the aerial system so that low-angle radiation does not take place. This latter step is in any case necessary if a local area is to be served, i.e., the energy must be radiated at relatively great elevation angles, and that radiated at low angles would be a waste of power so far as service within the area was concerned.

There remains the possibility of energy reaching to great distances by multiple hops at the greater angles, but if the wave is only used when high ionospheric absorption necessitates its use this danger should not be great.

It seems, therefore, that in

dark, when 3.5 Mc/s is of most use, it is almost negligible.

The figures do indicate, however, that economical coverage of tropical areas could be accomplished by the use of these frequencies. Even where there is a considerable amount of man-made noise the field intensities, at least at distances somewhat less than those shown above, should be adequate for satisfactory reception. Incidentally, to put down the same field at 500 miles as it is estimated would be put down by a 50 kW transmitter on 6.5 Mc/s at 700 miles, a transmitter operating at the middle of the medium-wave band would have to radiate about 53,000 kW.

There remains the possibility of covering an area by making use, not of the F layer of the ionosphere, but of the E layer instead. This could be done during the daytime only and by the use of a relatively low frequency. However, this would introduce considerable complications into the aerial arrangements, for a different angle of elevation would have to be employed when using the E than when using the F. Furthermore, as the ionospheric

Utility of bands

	3.5 Mc/s	5.0 Mc/s	6.5 Mc/s
Most important period of use.	Early morning and late night according to season.	Late afternoon and early evening according to season.	Period ranging from 0900 to 1500 in December to 0800 to 1900 at equinox.
Approximate ranges at time of use.	750 miles.	600 miles.	700 miles.

order to provide efficient service in tropical countries at all seasons and necessary times of day the use of the two higher of the tropical broadcasting bands at present in use is desirable, together with that of an additional band at about 6.5 Mc/s. The utility of these three bands would seem to be somewhat as is indicated in the above table.

The above figures for distance are, of course, very approximate. The ionospheric absorption varies markedly throughout the indicated periods of use and the ranges vary accordingly. In the afternoon, for example, when 5.0 Mc/s is of use there is still appreciable absorption, whereas after

absorption decreases markedly with increasing frequency there does not seem much point in using a relatively low frequency in order to secure reflection from the E, when a higher one may be relied upon to be reliably returned from the F.

GEAR FOR AMATEURS

IT is expected that amateur transmitters will soon need a large quantity of components, accessories and other apparatus; to help the industry to meet this demand, the Radio Society of Great Britain (Little Russell Street, London, W.C.1) has issued a list of what is likely to be needed. Copies are available to manufacturers.

# STABLE VHF OSCILLATORS

## Design of a Tunable Line Oscillator for 280-450 Mc/s

By B. J. SOLLEY

**B**OTH for laboratory and communication purposes it is desirable that an oscillator should have a high degree of frequency stability. At the higher frequencies this becomes even more important, since with direct modulation a mixture of AM and FM is detrimental to efficient operation.

At the lower frequencies highly stable operation is obtained most commonly by thermostatically controlled quartz crystals. The technique of frequency multiplication is useful for extending the range of operation up to the limit of useful power amplification at the higher frequencies. Above this limit resonant transmission lines and cavities are employed in order to obtain a comparable degree of frequency control, temperature compensation being used where the greatest possible constancy is desired.

In the case of lines of very high Q the maintenance of temperature constancy is rendered more difficult by the large physical size of the line elements and various methods of compensation have been devised to overcome the effects of temperature changes. In the case of copper a change in length of about 16 parts per million per degree Centigrade occurs and a frequency change of corresponding order results. At certain frequencies the frequency change may be even greater than this due to changes in inductance with skin effect.

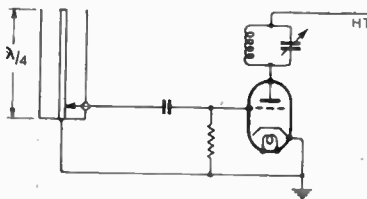

Fig. 1. Tuned-grid, tuned-anode oscillator with quarter-wave resonant line as the grid circuit.

In the absence of thermostatic control the most useful methods of combating temperature effects are: (1) the use of materials of

low expansion coefficient, such as "Invar," and (2) automatic capacity compensation. The second method makes use of a small capacity formed by a disc placed in close proximity to the line and so disposed that the capacity decreases as the line length increases, so providing a compensating frequency adjustment. The capacity law may be so adjusted as to provide good compensation over a range of frequencies without the need for adjustment, and this law is readily calculable in any particular case. Unlike crystal control circuits, however, much greater consideration must be given to the manner of connecting a resonant line into an oscillator since the frequency is very sensitive to reactive loading and the Q is maintained only under conditions of extremely light resistive loading. At the higher frequencies at which lines are used the power factor of many materials increases rapidly and the advantages of an initially high Q resonator may be easily forfeited, unless the greatest care is exercised in the design. Some indication of the difficulties which may be encountered in this respect can be gained from the author's experiences in the development of a tunable oscillator for laboratory use in the 50-100 cm. range.

### Design Requirements

The instrument was required to fulfil the need for an oscillator with a carrier of high stability and low power, capable of being amplitude or pulse modulated, with inappreciable resultant FM content, and having smooth continuously variable frequency adjustment, with the minimum of controls, covering a range of 280 to 420 Mc/s.

The overriding consideration of frequency stability pointed to the use of a resonant line as the tuning element at the frequency speci-

fied, in order to obtain a high Q with the possibility of some form of micrometer tuning adjustment.

A consideration of the conventional methods of using lines at these frequencies shows that there are two basic systems, using acorn valves at low power. These are shown in Figs. 1 and 2. The first is the well-known tuned-grid tuned-anode circuit with the resonant line acting as the stabilising element in the grid circuit operating in the  $\frac{1}{4}$ -wave shorted mode.

The features which decided against the use of this circuit, and its variations, in the present case were the dual tuning adjustments and the manner of connecting the plate tank circuit.

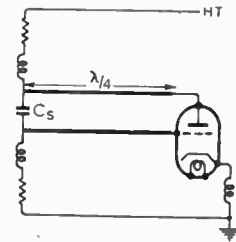

Fig. 2. Colpitts oscillator with quarter-wave tuned line frequency control.

The circuit of Fig. 2 is the more popular Colpitts oscillator adapted for use with lines. The cathode choke is inserted in order to permit the cathode to assume a potential determined by the grid-cathode and plate-cathode capacities. More efficient operation is sometimes obtained by the use of a  $\frac{1}{4}$ -wave concentric line for the cathode-heater feed so as to present a higher impedance between cathode and ground. Tuning may be accomplished by varying (a) the line length, by means of a sliding shorting condenser, (b) a capacitor placed at or near the potential antinode at the valve end of the line, or (c) the condenser  $C_s$ . When the latter method is used the end of the line is no longer a potential node and may commonly assume

a potential about half of that which exists at the other end of the line. With this system the mode of resonance may vary effectively from a  $\frac{1}{4}$ -wave to a  $\frac{3}{8}$ -wave condition.

The principal objections to this circuit are due to the direct connection of the valve into the line, thus presenting a substantial resistive and reactive loading due to

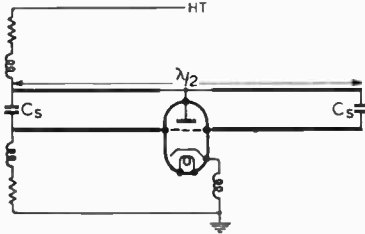

Fig. 3. Colpitts circuit with half-wave line.

the grid-anode capacity. The reactive loading has the effect of increasing the line length, which must be shortened in order to restore the frequency. This results in loss of  $Q$  in addition to the loss caused by the power factor of the valve capacity.

An improvement is effected with push-pull operation since the effective loading is halved. Similar improvement may also be obtained by the use of the single-valve circuit shown in Fig. 3. In this case the valve is placed at the centre of a half-wave line shorted at each end. The valve loading is thus shared equally between the two  $\frac{1}{4}$ -waves each side of the valve. A third method suggested to overcome the defects mentioned consists in the use of a  $\frac{1}{4}$ -wave line as before, but with the valve tapped down to a point

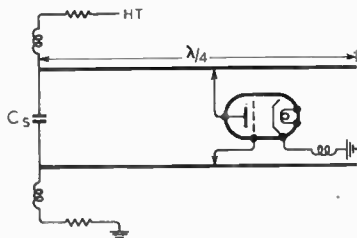

Fig. 4. Quarter-wave line tapped to reduce losses.

of lower impedance nearer the short. This case is shown in Fig. 4. A considerable gain in stability is obtainable by using the method of Fig. 4, but as will be shown later, an even better

performance can be achieved with a similar circuit using a different coupling principle.

The problem of damping, and the maintenance of high  $Q$ , led to a reconsideration of some previous work on the design of a selective absorption wavemeter operating in approximately the same range of frequency and using a concentric line. Briefly, this wavemeter consisted of a capacity-tuned concentric  $\frac{1}{4}$ -wave line of high  $Q$ , the variable tuning capacity having the form of a spring-loaded plunger facing the "open" end of the inner member and actuated by means of a micrometer screw with zin. thimble of special design. A coverage of 260 to 435 Mc/s is obtained for a linear plunger travel of 5 mm. at the rate of one turn per mm., giving a total of 500 scale divisions of the thimble.

The high  $Q$  of this line is maintained by attention to the following points:—

1. The ratio of radii is 3.4, this being nearly the optimum value with any given outer radius.
2. An outer diameter of  $2\frac{1}{2}$ in. is used, giving a theoretical  $Q$  of 4,000 or more for a silver-plated line.

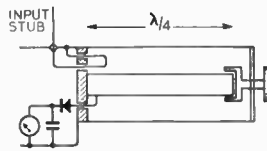

Fig. 5. Concentric line wavemeter of high  $Q$ .

3. No connections are made at or near the high potential end of the line. For example, the small input coupling loop projects only a short distance into the cavity of the line; the detector is tapped into the inner member at a small distance from the short, equal to about 5 per cent. of the line, and the inner member is practically self-supporting from the centre of the shorting block, a polystyrene spider being used to maintain concentricity at a position about  $\frac{1}{4}$  of the line, reckoning from the shorted end.

These details are illustrated in the diagram of Fig. 5. All the conductors pass through the shorting block via small holes in push-fitted ebonite or polystyrene bushes. No details of the micrometer are shown.

The excellent results obtained with this instrument seemed to ensure a ready-made basis for the design of a stable tunable oscillator, if the problem of valve loading could be solved to permit the use of a small acorn triode. The familiar technique of tapping the valve down the line was tried and discarded as being unsuitable since the minimum tap position for the bare maintenance of oscillations was still found to give

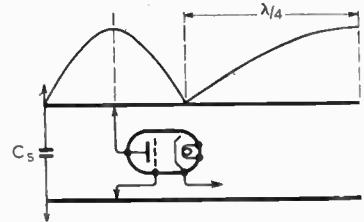

Fig. 6. Complex wave distribution giving increased frequency of operation.

excessive damping, in addition to undesirable capacity loading. A curious point of some interest was found to be present with this type of coupling, namely, the possibility of complex wave distribution. Under certain conditions it was found that a frequency very much higher than that to be expected from calculation could be obtained. An investigation of this effect with a twin line of greater length showed that this was due to multiple  $\frac{1}{4}$ -wave operation. One distribution most readily obtainable is shown in Fig. 6. The valve capacity is equally distributed between the two "deficient"  $\frac{1}{4}$ -wave sections, and the third section is a complete  $\frac{1}{4}$ -wave, so that the resultant oscillations may have a frequency greater than twice the original frequency for normal distribution. This distribution is easily obtained when the cathode tuning is favourable, and is analogous to the vibration of a string in harmonic mode.

### Loop Coupling

Experiments along these channels showed that any direct connection to the line at positions at all in excess of about 5 per cent. of the line-length resulted in considerable damping. Thus for one particular case, with the valve tapped in at the minimum position for oscillation, the  $Q$  had been reduced to some two or three hundred. As a consequence it was

**Stable VHF Oscillators—**

decided to try purely indirect coupling by means of a loop, so as to eliminate any direct connection and to remove the valve and its mountings from the field of the line. A series of experiments were made using the circuit of Fig. 7 with a Mullard RL18 valve as oscillator, this being of a type convenient for making the necessary connections and capable of oscillating up to a limit of some 800 Mc/s.

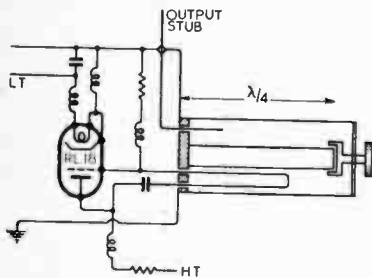

Fig. 7. Quarter-wave oscillator with external valve and loop coupling.

In the first experiment the loop dimensions were 3 cm. by 1 cm. of No. 16 SWG copper wire. No oscillations were obtained. When the loop was increased to 4 cm. by 1 cm. oscillations were detectable, with the plunger fully home (plunger face about 1 mm. from the end face of the inner member) at a frequency of 344 Mc/s. On reducing the tuning capacity the frequency rose steadily to 396 Mc/s and then the oscillations seemed to stop. It was found that the frequency had jumped to a new value of 337 Mc/s. Further reduction in tuning capacity resulted in only a slight rise to a maximum of 341 Mc/s at minimum capacity setting. On reversing the tuning procedure the frequency dropped slightly to 334 Mc/s, then jumped up suddenly

to 383 Mc/s, from which value it decreased steadily to its initial value of 344 Mc/s for maximum capacity setting.

Evidently the circuit couplings were producing the same effect as is frequently obtained with tight mutual coupling to single-valve oscillators, and known as Ziehen or frequency-jump effect.

During these experiments it was noted that a rather high degree of frequency constancy was present at various points, and that the tuning calibration below the "break" corresponded roughly with that obtained using the same line in its wavemeter function. It was assumed, therefore, that the nearly uniform frequency present above the break must correspond to the loop resonant frequency.

It is known that, unlike the usual double-frequency effect in passive coupled circuits, in the case of an oscillator where a double frequency results from tight coupling of a secondary mesh, the oscillations cannot occur on both frequencies at once, although it can occur on either according to the distribution of impedance between the two meshes. This proved to be the case in the present oscillator.

**Loop Dimensions**

In this case the solution to the jump effect appeared to be the obvious one of displacing it so as to occur "outside" the desirable range of the instrument. In order to achieve this a closer investigation of the jump effect was undertaken, using loops of various dimensions. Curves were drawn indicating the behaviour of the system for each change. Some of these are reproduced here in Fig. 8. In each case a plot of the line is given operating in its wavemeter function, since this represents fairly closely the natural

resonance of the tuned line by itself.

For the first three curves of Fig. 8, the low-frequency portion of each one, i.e., above the break, indicates that oscillations are

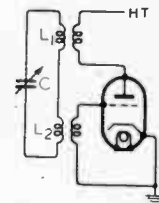

Fig. 9. Meissner oscillator circuit.

taking place at a frequency determined by the loop dimensions, while the high-frequency portion of each curve, below the break, shows that the frequency at each point corresponds fairly closely to the natural frequency of the line itself. The actual frequency obtained is somewhat higher in each case than that of the line. This may be attributed to the fact that the loop coupling reduces the reactance of the line in accordance with the usual theory of coupled circuits. This effect is therefore quite opposite to that which usually results due to the valve capacity, as in previous circuits, and as such constitutes a very valuable gain, since it permits the use of a slightly longer line and hence of a greater initial Q. In the last curve of Fig. 8 the break point has been displaced to a position "outside" the range of the line, and the frequency is dominated by the line tuning only.

The system is very similar to the Meissner oscillator circuit shown in Fig. 9. Here the grid and plate coils are coupled not directly but via a resonant link circuit  $L_1, L_2, C$ , which is designed for high Q and controls the frequency of oscillations. The resemblance is further substantiated by the fact that under certain conditions the loop may be in-

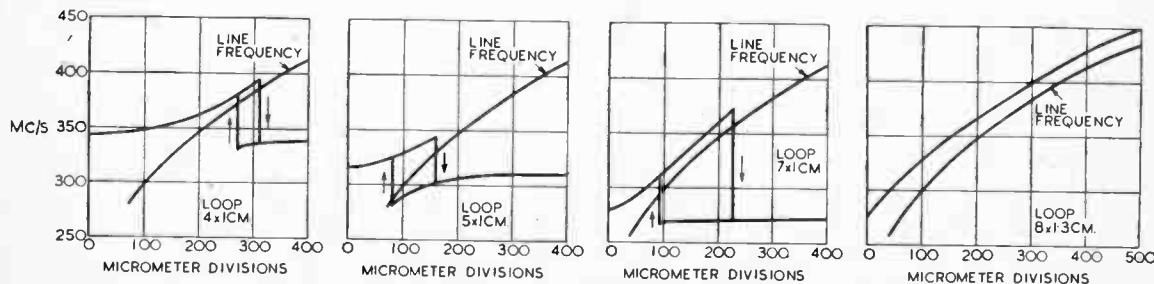

Fig. 8. Influence of loop dimensions on frequency jump effect.



duced to take charge of the frequency with little influence due to the line. This could be produced with heater-cathode chokes of certain value, and may be explained on the basis of cathode potential changes. If the cathode is permitted to assume a potential sufficient to provide a high degree of grid-anode coupling at the loop frequency, then the loop becomes a preferred resonant circuit with consequent loss of control by the line. Thus, optimum limits were found necessary for the choke values, outside of which the effects mentioned could occur. In the later experiments these consisted

other than a slight extension of the frequency range.

Some indication of the potentialities of the oscillator may be gained from the following representative figures:—

Frequency shift for 12 valve replacements=0.16 Mc/s at 338 Mc/s.

Frequency shift for 50 per cent. modulation at 400 c/s with 10 mW output=0.11 Mc/s at 317 Mc/s.

Maximum drift on stabilised power pack for four one-hour periods=0.11 Mc/s at 317 Mc/s.

Maximum overall calibration

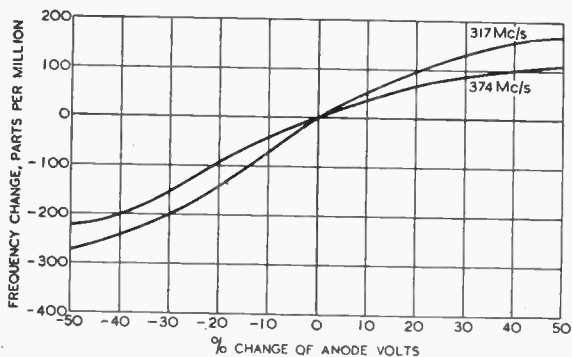

(Right) Inner conductor of concentric line and coupling loop.

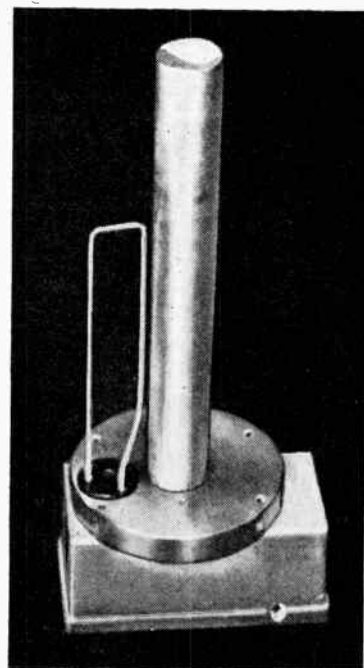

(Left) Fig. 10. Frequency stability of oscillator of Fig. 7 at 317 and 374 Mc/s.

These figures represent a considerable improvement over any other oscillator of comparable simplicity of design which has been tried. Further refinements could without doubt be made for purposes where an even higher degree of constancy is desired. The most obvious one would be to use a line of larger diameter in silver-plated "Invar" or similar material, with some capacity compensation along the lines previously described.

of five turns of No. 22 SWG wire wound on 1/4 in. diameter polystyrene formers with one turn spacing.

It appears then that the oscillator is intermediate in character between a Meissner and a Colpitts. Were the loop split into independent grid and plate sections with no direct coupling, the circuit would then be a true Meissner. The physical difficulty of achieving this is evident from the nature of the tuning line, in the field of which both sections must be placed for coupling into the line. An analogous situation arises in the case of magnetostriction oscillators, in which grid and plate coils may be so approximated that self-oscillation may result when the rod is removed, the frequency being that of the coupling coils.

### Oscillator Stability

Some curves illustrating the stability of the present oscillator are given in Fig. 10. The performance was found to be quite adequate for the purpose for which it was required, and no attempts were made to obtain any improvement in the instrument

change over one year=0.75 Mc/s from 280 to 450 Mc/s.

The latter figure includes changes due to mechanical factors associated with the tuning mechanism. An identical oscillator fitted with a pre-set end-cap and tuned to 400 Mc/s has given an overall frequency change of the order of 0.2 Mc/s at the end of a one-year period.

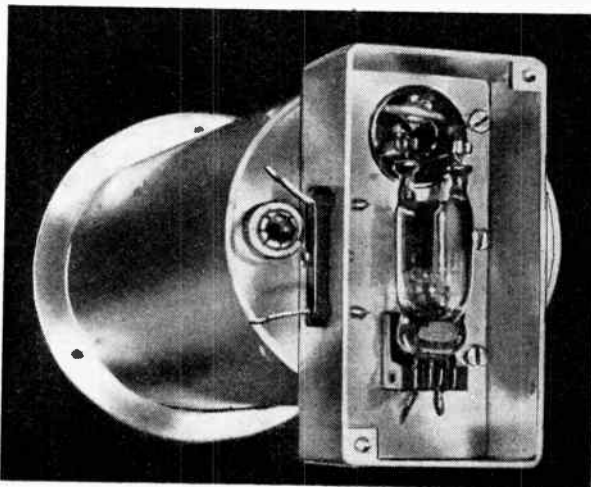

View of end of quarter-wave line with screened valve mounting.

# THE NEW RECEIVERS

Discussion on "Design of Broadcast and Television Receivers for the Post-war Market" :  
Radio Section, I.E.E., 17th April, 1945

THE discussion was opened by L. H. Bedford, M.A., B.Sc., who said that the two main factors influencing the trend of design after the war would be (a) the expansion of television and (b) the increase of labour costs in the radio industry relative to the average increase for industry as a whole. Television would alter the pre-war ratio of simple to elaborate sets. The latter might be expected to be replaced by television receivers, the broadcast sound receiver being eventually regarded as the "second set." The solution of the economic problem of supplying sets at price levels which would be regarded as "good value" appeared to lie in the mechanisation of manufacturing

methods, the standardisation of components, including valves, and the omission of unnecessary elaborations, e.g., the "magic eye." Push-button tuning, although technically frivolous, represented a logical answer to the public demand for simplification of controls, and was likely to be a permanent feature of all but the simplest sets.

The very extensive development of radar during the war appeared to affect television only to a limited extent; apart from a much-extended knowledge of pulse and time-base circuits, the main advance appeared to be in the production of improved screens and electron guns for cathode-ray tubes.

In the discussion which followed it was pointed out that the home market would be able to absorb only a fraction of the potential output of the radio industry if it continued at its present level of production. There was,

however, a world shortage, but we should have to act quickly and improve our production planning if we were to compete successfully with other countries for this market. For the immediate post-war period we should concentrate on sets designed primarily for export which could also be sold in the home market.

The pre-war broadcast receiver attempted to combine too many functions; it was difficult to tune on short waves and the quality of reproduction from the local station was often spoilt by AVC. There was much to be said for the idea of two sets for every household—a quality receiver for the local station and, for long-distance reception, one of the export models.

## Valve Standardisation

In the past, British sets for export were often equipped with American valve types to facilitate servicing; there was an urgent need for a comparable British standard range of valves.

The development of miniature components during the war would have some influence on design, particularly in relation to car radio receivers and "personal" portables, but it was necessary to guard against the temptation to reduce unduly the size of high-powered sets until we had also discovered a "miniature watt."

A lively argument developed on the desirability of including a "magic eye" tuning indicator. Several speakers claimed that it gave them satisfaction to know that they were accurately tuned, even if they could not detect any difference by ear. Others suggested that an ordinary broadcast receiver should be tuned by ear and that provided the quality was acceptable the exact tuning point was immaterial.

On the question of providing higher quality of reproduction of sound transmissions, it was held that too much emphasis had in the past been given to high frequencies in the "kilocycles" re-



WHERE WE LEFT OFF.—A good example of a "television only" receiver of 1939—the Murphy A56V. The equipment embodied 15 valves, plus 3 rectifiers, and cost £30. Picture size was 7½ins. by 6in.

gion and that there was a tendency to overlook distortion at the lower end of the scale. The taste of the general public, long debased by hearing only cheap receivers, would have to be re-educated before high-quality sets could be regarded as a commercial proposition, and to accomplish this it would be necessary to set aside a B.B.C. channel—probably at UHF—which could be relied upon to maintain the highest quality throughout the day.

The opener's remarks on the limited contribution which radar technique has to make to the development of television receiver design were generally welcomed as a salutary check to popular misconceptions fostered by imagina-

tive articles in the lay Press.

In the present state of the art, projection methods could not compete economically with direct viewing of the image on the fluorescent screen. There was a strong case for standardising ordinary cathode-ray tubes, and here we might give a lead to valve manufacturers. The development of tubes for projection was a legitimate field for unrestricted competition.

Picture Brightness

There was room for improvement in the brightness of direct viewing screens, so that they could be used in a normally lighted room. A tube face with a surface designed to discriminate

against reflections from external sources would facilitate a solution.

Simplification of controls in post-war television sets was essential; both focusing and synchronising controls should disappear, leaving only those for main tuning, sound volume and brightness. The cost of the set to the purchaser should include any special aerial equipment needed. There would be a limited market for comprehensive instruments with provision for broadcast, television and gramophone reproduction. If housed in a single cabinet this would make an unwieldy piece of furniture, and it was worth while considering the possibility of building such equipment on the unit system.

# SLOW-SPEED RELAYING

## Reducing Bandwidth at the Transmitter and Restoring it at the Receiver

By W. STOCKMAN

(Editor of "Populär Radio," Stockholm)

IN long-distance relay transmission of speech and music the quality is usually more or less destroyed by atmospheric and selective fading. When listening a short time ago to a special broadcast relayed by the Swedish broadcasting network, the following idea, which the writer had in 1942, again turned up. A speech, which is to be broadcast, might be recorded on disc or tape and, in later modulating the transmitter, reproduced at a lower speed. The speech frequency would then be lowered in the same proportion as the speed ratio. When receiving this transmission, the speech would be recorded at the lower speed and afterwards reproduced at the correct speed. Making use of this process, the bandwidth of the receiver may be reduced in proportion to the speed ratio without cutting any high frequencies,

and as a consequence the noise level will be lowered and the influence of selective fading reduced. Ordinary fading can be minimised by using diversity receiving equipment.

Of course the transmission cost would be increased due to the increased sending time, but would it not be worth the extra cost to have the speech transmitted with greatly increased clarity and without laying undue strain on the listeners' ears? The method seems quite feasible as tape recording is often used both at transmitter and relay station.

Naturally this method makes it impossible for listeners outside the service area of the relaying station to receive the transmission with ordinary apparatus, but this

fact seems to be rather unimportant when the transmission is intended for a different country.

In practice a frequency range of perhaps 100-5,000 c/s would be transposed to 20-1,000 c/s. The lower frequencies in this range will, using ordinary equipment, be reduced in the modulating amplifier of the transmitter and in the low-frequency circuits of the recording apparatus, but in the case of speech this may be rather an advantage, and in music transmission it is better to lose some bass notes than having the entertainment value spoiled by severe noise and distortion.

Using the new method, the transmitting station in getting into touch with the relaying station would only have to announce for example: "This speech will be transmitted at one-fifth normal speed."

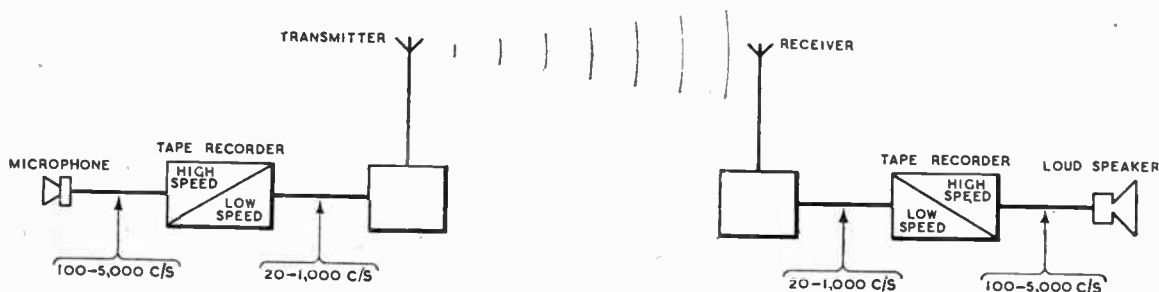

Illustrating the process of frequency transposition at transmitter and receiver.

# VALVE TESTING

## Rapid Determination of Amplification Factor and Anode Impedance Under Operating Conditions

By F. E. PLANER,  
Ph.D., M.Sc.

IT is often necessary to determine rapidly the approximate values of the amplification factor and anode impedance of a valve. While there exist, of course, bridge circuits which enable these quantities to be measured quickly and accurately, such instruments may not always be available. The setting up of suitable bridges, or the measurement of the static valve characteristics, in particular in the case of multigrid valves, where the operating conditions would have to be established first, is often a somewhat lengthy process.

The following notes describe a simple method which allows the rapid determination of these two quantities without requiring any major changes in existing circuits.

Fig. 1 shows the equivalent circuit of a resistance-coupled amplifying valve having an amplification factor  $\mu$  and anode impedance  $P$ .  $R$  is the anode load across which the output voltage  $E_1$  appears, and  $E_0$  is the generator voltage which is given by  $-\mu E_g$ , where  $E_g$  is the alternating voltage impressed upon the grid of the valve.

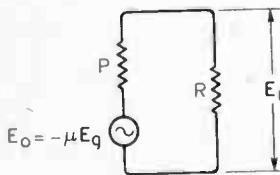

Fig. 1. Equivalent circuit of a resistance-coupled amplifying valve.

If now the load resistance is shunted by a condenser having a capacity  $C$ , as shown in Fig. 2, the output voltage will fall to a new value,  $E_2$ . Connecting this condenser across the anode load does not affect the operating conditions of the valve, and both the anode and cathode potentials remain unaltered. If the frequency of the generator and the values of  $C$  and  $R$  are known,  $\mu$  and  $P$  may be determined merely by measur-

ing the AC grid voltage  $E_g$  and the output voltages with and without the condenser connected across  $R$ .

The anode impedance  $P$  may then be found as follows:—

Referring to Fig. 1,  $E_1 = \frac{E_0 R}{P + R}$ .

Similarly  $E_2 = \frac{E_0 Z}{P + Z}$ , where  $Z$  is the impedance of  $C$  and  $R$  in parallel. Substituting for  $Z$  it will be found that the absolute value of  $E_2$  is given by the expres-

$$E_2 = \frac{E_0 R}{\sqrt{(P + R)^2 + \omega^2 C^2 R^2 P^2}}$$

Dividing  $E_2$  by  $E_1$ , and solving for  $P$  finally gives for the anode impedance:—

$$P = \frac{I}{\frac{\omega C}{\sqrt{(E_1/E_2)^2 - 1}} - \frac{1}{R}}, \text{ where}$$

$$\omega = 2\pi \times f \text{ (frequency in c/s).}$$

If a decade condenser box is available or a beat frequency oscillator, either  $C$  or  $f$  may be varied until  $E_2$  is exactly 3 db. below  $E_1$ , or  $E_1 : E_2 = 1 : 0.707$ . The above expression then simplifies to  $P = I/(\omega C - 1/R)$ .

Once  $P$  has been determined  $\mu$  may be found from the expression for  $E_1$ . Disregarding the negative sign which merely indicates the phase relationship, we have

$$E_1 = \mu E_g \frac{R}{P + R}$$

$$\text{or } \mu = \frac{E_1}{E_g} \left( \frac{P}{R} + 1 \right)$$

It is evident that the value of  $C$  must not be comparable with that of the stray capacitance of the circuit, and the frequency should be chosen accordingly. Either 50 c/s. or 1,000 c/s. will in general be found quite suitable for the measurement.

The method may be extended to inductive anode loads, but the

resulting expressions will then become more complex. One application of the above principle would consist in the provision of

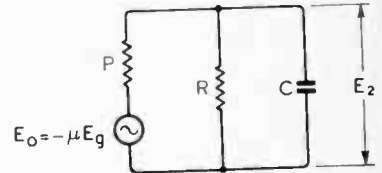

Fig. 2. The addition of a condenser  $C$  across the anode load resistance causes a fall in the AC output voltage. If  $C$ ,  $R$  and the frequency are also known the amplification factor and anode impedance may be calculated.

suitable push-button operated condensers in electronic devices enabling rapid checks on valve characteristics to be made.

### HARDY ANNUAL

THE aim of the compilers of the B.B.C. Year Book for 1945 has been to review, not merely the broadcasting history of 1944, but the work of five years of wartime broadcasting and its effect upon the B.B.C.'s activities last year.

Wireless World readers will be especially interested in the article by Sir Edward Appleton who, in reviewing recent radio progress, adds "it is my view that revolutionary changes in our ordinary radio services, such as broadcasting and television, are not to be expected as a result of the intensive effort of recent years." If local stations for ultra-short-wave broadcasting are added to our present services in this country, Sir Edward states that it is almost certain that at least some of them will use FM.

In the article by H. Bishop, chief engineer, some interesting facts on the extension of the Engineering Division and the Training School are given. In 1939 the Division numbered 1,300, last year there were over 4,000. Over 800 women and 1,600 men have passed through the Training School since it was opened in 1941 for the training of wartime recruits to the Engineering Division.

The book, which includes 40 pages of photographs and a comprehensive reference section, costs 2s. 6d.

# The right tool for each job

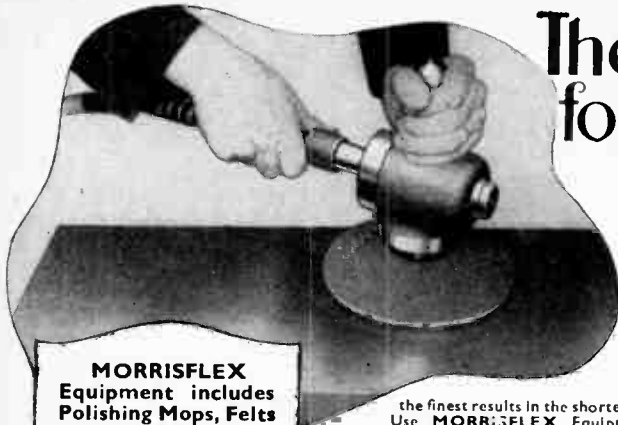

**MORRISFLEX**  
Equipment includes  
Polishing Mops, Felts  
and Felt Cones.

**Rotary Rasps**  
for Woodworking.

**Mounted Points.**

**MORREX**  
Industrial Wire  
Brushes.

**REX**  
Rotary Files and  
Cutters.

**Sanders & Grinders,**  
etc.

the finest results in the shortest time and at minimum cost. Use **MORRISFLEX** Equipment for scaling, sanding, polishing, tube brushing, removing paint and rust; for rasping woodwork, and many other operations. **MORRISFLEX** Equipment is available in overhead suspension, bench and floor type machines, the two latter being readily portable.

Write for Catalogue

On Air Ministry,  
Admiralty and  
War Office Lists



# Morrisflex

## FLEXIBLE SHAFT EQUIPMENT

Shirley 1237 B. O. MORRIS LTD., SHIRLEY, BIRMINGHAM, Grams: Morrisflex, B'ham

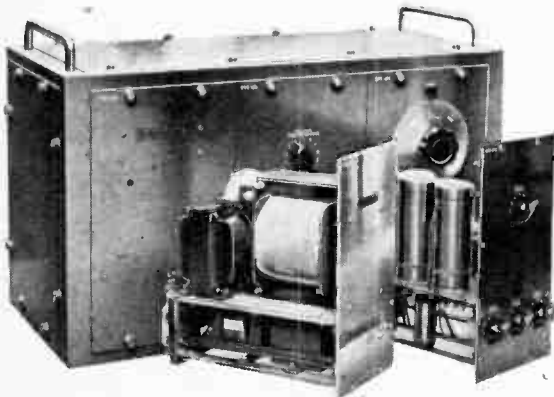

### ACOUSTICAL UNIT CONSTRUCTION PROVIDES

AC operation • 12 volt DC operation • Independent base and treble controls • Controlled negative feed-back • Self contained radio unit • Radio/mic/gram mixing • Up to six microphones simultaneously • Electronic mixing • Stand-by switching  
Frequency response 1 db down at 50 and 10,000 cps • Overall gain 105 db • Medium and low output impedances • Two impedances for all microphone inputs • 30-35 watts output

A new booklet "Addressing the Public," is now available at 1/- post free. Send for your copy now.

# Prack IN MINIATURE

This new Acoustical development is yet a further milestone in the progress of amplifier design. The unit construction of the "U" series means instant adaptability to varying applications and the avoidance of the compromises necessary in a single "multi-purpose" chassis. Each unit is designed to fulfil efficiently its allotted purpose and to give the highest standard of performance.

Orders just now can only be accepted on the highest priorities.

# ACOUSTICAL

MANUFACTURING CO., LTD.  
HUNTINGDON • TELEPHONE 361



... in fact before doing anything at all about Transformers you should consult a specialist. For example you must bear in mind that we have set our maximum size at 10 k.v.a. because we know that in this way only can we maintain the quality you want. You should know too that we planned and equipped a whole factory just to produce Transformers (power, audio frequency or chokes up to 10 k.v.a.) and specialised!

By the way the dictionary will tell you that a 'micron' is the millionth of a metre but a pukka transformer expert uses the term as a 'measure of vacuum' and you know, if you have really read our previous advertisements, what a difference an odd spot of 'vac. impreg.' can make to the performance and long life of a Transformer.

Remember 3 1/2's up to 10 k.v.a.

Don't let all that nonsense about microns confuse you... just bear in mind that Parmeko specialise in designing and producing Transformers and accordingly our Transformers have got what it takes... just remember that and you won't go far wrong.

PARMEKO LTD., LEICESTER. Makers of Transformers.

Technical Reasons Why

★ **ERSIN**  
**MULTICORE SOLDER**

Is the Finest Cored Solder in the World

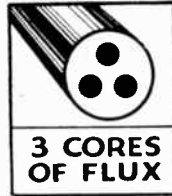

Three Cores of Flux ensure flux continuity. No lengths without flux are wasted. Consistent high quality joints are obtained with comparatively unskilled labour. Exactly the correct proportions of solder to flux are provided. Separate fluxing operations are obviated and no extra flux is required. The three cores of flux being evenly distributed over the cross section of the solder provide thinner solder walls than otherwise. This gives rapid melting and speeds up soldering. The flux does not tend to run out of the cores; so there is always a supply available for the next joint. The utmost economy of solder and flux is achieved.



Ersin, contained in the three cores of Ersin Multicore Solder, is the fastest non-corrosive flux. Possessing all the non-corrosive advantages of rosin, it enables joints to be speedily made on oxidised or "difficult" surfaces such as nickel. Ersin not only avoids oxidation during soldering but removes surface oxide already present—this is particularly advantageous in respect of materials that have been in stock or apparatus that is being serviced. The use of Ersin Multicore, with correct soldering technique, avoids "HR" or dry joints.

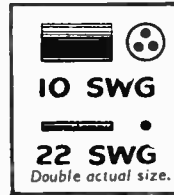

Ersin Multicore Solder is made in most gauges between 10 and 22 S.W.G. (.128—028") (3.251—7.109 m/m). For general radio and electrical production and maintenance 13 and 16 S.W.G. are in most demand.



Five alloys of Ersin Multicore Solder, made from virgin metals, are available—all antimony free. Under present circumstances 45% tin and 55% lead is the most widely used alloy.

Technically, Ersin Multicore Solder is far superior to any other cored solder. A practical laboratory or production test will demonstrate this and show you that it is the most economical solder to use. The majority of British and overseas manufacturers already enjoy the advantages of Multicore. If you do not, and are engaged upon Government contracts, write for further technical information and free samples.

Single reel rate nominal 1 lb. reels.
13 SWG - 4/10
16 SWG - 5/3
Above prices subject to usual trade discount.
‡ cwt.—ton lots at bulk rate. 6d. cartons for home use, available at most good radio and electrical dealers, ironmongers, etc.

**MULTICORE SOLDERS LTD.** Commonwealth House,  
New Oxford St., London, W.C.1 Tel.: CHAncery 5121-2

# TELEVISION STANDARDS

## Has the 405-line System Been Fully Exploited?

By O. J. RUSSELL,  
B.Sc.

THE problem of the development of television as a general medium of entertainment, has been the subject of intense discussion in technical circles recently. The proposals outlined in the Report of the Television Committee have been the main reasons for this renewed interest in television. It is felt, however, that certain ideas that have been expressed by various persons, neglect quite a few important technical considerations, while on the other hand important factors which, although not exactly within the province of technical designers, are still of importance in the development of a television entertainment service, have been neglected.

Possibly the most controversial point in the Report, and the point that has raised the most heated discussion, is the proposal to retain the present definition standard of 405 lines, interlaced. The proposal has been attacked in general upon the grounds that this is an inadequate standard of definition, and that it is wrong to commit the country to this standard for some years to come. This attitude is clearly expressed by R. W. Hallows, who regards the proposal as "flogging the almost dead horse of 405 line television."<sup>1</sup> It is generally recognised that the suggested 1,000-line system proposed as the next advance in British television technique, is unlikely to be technically or economically practicable for many years to come.

It is extremely interesting, however, to consider whether a standard of 405 lines actual definition is inadequate. There is a strange dearth of information upon the actual resolution of current high definition systems. This is all the more puzzling when it is recalled that the theory for calculation of resolving power of television systems using accurately defined apertures has been exhaustively studied. In actual practice, however, the effective spot size of modern electronic television systems is a rather ill-defined patch

approximately circular in shape. Current trends in America are expressed by the adoption of 525-line transmission standards, which necessitate vestigial sideband transmission in order to accommodate the necessary bandwidth at the lower carrier frequencies. It has been proposed that British standards should be amended to the higher number of lines, in order to utilise the radio bandwidth available most effectively. The bandwidth required for 525-line transmission would be 3.2 megacycles, as compared with the 1.9 megacycle video bandwidth required for the Alexandra Palace signals.

### Comparison With Cinema Standards

A consideration of the necessary number of lines required for a satisfactory television image may lead us to some startling conclusions. While no definite resolution figures have been published upon the performance of high definition systems, it seems reasonably certain that nothing like the theoretical resolution has ever been attained. Naturally, resolution of television images is referred to the cinema screen as standard, which for all practical purposes, may be taken as perfection. Some figures are available for the resolution of cinema film emulsion,<sup>2</sup> but the actual resolution attainable in a normal projector is less than this. Factors such as the projection lens aberrations, inevitable mechanical imperfections in the projector, coupled with shrinkages and distortions of the film itself, reduce the definition appreciably. The resolution of a projected image from a 16 mm. film under the best conditions corresponds to about a 700-line image in the centre of the field, but only to 300 lines or so at the edge of the field. The resolution of the cinema under ideal conditions, may attain to a stan-

dard of 1,000 lines, but it is doubtful if the average cinema definition really exceeds perfect 600-line standards at the centre of the picture. The estimates made by various workers upon the required minimum definition for cinema standard definition make rather interesting reading. Thus an early article by J. H. Owen Harries,<sup>3</sup> based upon a figure of 0.00065 radian for the resolving acuity of the human eye, and assuming the best cinema seats with a viewing angle of 30 degrees, places the definition as that of a perfect 308 lines. When the London high-definition service was opened, surprise was expressed at the use of 405-line definition, which was tacitly assumed to be more than adequate. The opinion has been expressed that 405-line images were capable of results little short of perfection. Thus E. Wikkenhauser<sup>4</sup> "... according to many theoretical investigations, a 240-line image gives ample definition for home use, and the 405-line picture would have a definition nearly equal to a large cinema screen, *which definition is really not necessary for the home*" (my italics).

Furthermore, we may quote E. H. Traub<sup>4</sup> as showing that a definition of the order of a perfect 240 lines should be entirely adequate: "It has been shown again both on paper and in practice, that 180 lines represents a highly satisfactory definition sufficient for a public service, and that 240 lines gives a picture of such excellence as to leave no room for criticism whatsoever. To go beyond this figure would be to go beyond the capabilities of the resolution of the human eye, which can be regarded as a minute of arc under the worst conditions." In the same symposium of representative opinion, E. L. Gardiner,<sup>4</sup> after pointing out that in some instances mechanical systems (in which the spot size is accurately defined) gave better pictures than some cathode ray systems using many more lines, comes to remark . . . "Opinion

**Television Standards—**

has during the last year been unanimous that 240 lines represents a definition which is quite satisfactory for the majority of purposes," and further goes on to say . . . "I would advocate the use of a 180-line standard . . . at 50 frames as quite adequate for entertainment purposes."

While it is clear therefore, that a definition standard of 405 lines is adequate when fully exploited, it is also clear that the quality of the images as received on normal commercial receivers was nowhere near the maximum theoretical resolution. It is questionable whether the actual home receiver definition was even equivalent to that theoretically attainable from a 200-line image. The absence of any definite figures upon the performance of television receivers is thus more understandable. It appears fairly certain that a perfect 405-line image would be adequate for all purposes and would even approach the maximum necessary for home use. It may therefore be a little premature to abandon all interest in the present standards, as Mr. Hallows would have us do.

**Spot Size**

One of the main factors reducing the effective resolution of electronic television receivers is the increase in size with brightness of the cathode ray spot. Further, the cathode ray spot itself is not sharply defined, and it seems possible that some improvement in the production of a more accurately defined spot may be expected. It seems rather pointless to increase the number of scanning lines when the spot size

is already too large. It is as well to remember that American 441 line receivers employing 6-inch tubes deliberately sacrificed bandwidth as the performance of the cathode ray tube was unable to exploit the full bandwidth.

It is perhaps as well to remark that this "modulation increase of spot size" is a problem which so far has defied solution by vacuum tube engineers. •To quote E. L. Gardiner again, "Unfortunately the public, and a great many engineers of limited television experience, still imagine that the number of scanning lines employed is the deciding factor in the clarity and excellence of a received image. While this is largely true of image analysis at the transmitter, it does not hold very closely by the time the viewing screen is reached, owing to the loss in image quality arising from distortion and high frequency losses through the system." This remark seems true enough to repeat to-day, as a number of factors are often overlooked, which are of vital importance in deciding the quality of the television image. It must be remembered, for example, that the iconoscope type of camera does not provide a true DC level, and has no clearly defined contrast characteristic analogous to a photographic "gamma." The recent American orthicon camera apparently does have a stable gamma characteristic, and provides a definite DC level. It is probable that some of the improved performance of the new American systems may be due to this new camera, rather than to the increase in the number of scanning lines.

From the above it will be fairly clear that no undue concern need be felt at the prospect of British television standards remaining at the present definition level of 405 lines for a considerable period. At the same time it is to be noted that a great deal of experimental work needs to be done before the performance obtained with the present system reaches the maximum practicable. Some of the points which need investigation have been touched on in this article.

**Interlacing**

There is a further point that might be investigated is the desirability of retaining interlacing, or of employing a sequentially scanned picture. It appears certain that interlacing does offer a number of difficulties, and some improvement in the resolution of images might be achieved by employing vestigial sideband transmission to accommodate a 405-line image sequentially scanned at 50 frames per second. Such a transmission could be received upon present receivers with the minimum of alteration, and for a further slight cost the old receivers could be modified to utilise fully the extended bandwidth.

It should perhaps be pointed out that technical considerations are not the only considerations necessary for the provision of a public television service, and that aesthetic and psychological factors may be of considerable importance.<sup>5, 6</sup>

**References**

- <sup>1</sup> "Television Committee's Report," by R. W. Hallows, *Wireless World*, May, 1945, pp. 130-132.
- <sup>2</sup> "Optical and Mechanical Characteristics of 16 mm. Motion Picture Projectors." *Nat. Bureau of Standards Circular C. 437*.
- <sup>3</sup> "Some Developments in Tele-Analysis," by J. H. Owen Harries, *Journal Television Society*, Vol. 1, No. 1, pp. 1-12.
- <sup>4</sup> "High Definition Television Service in England." *Journal Television Society*, Vol. 2, pp. 34-43.
- <sup>5</sup> "Objectives for Post-War Television," by J. Worthington, Miner, *Journal Television Society*, Vol. 4, No. 2.
- <sup>6</sup> "Television After the War," by O. J. Russell, *Journal Television Society*, Vol. 4, No. 3, pp. 60-64.

**TO WHAT BASE USES**

" . . . Then try Virgo pills. You simply swallow two of these pills with a glass of water. Now watch what happens . . ." Reproduced from the "New Yorker."



# VALVE PIONEER

## The Late Sir Ambrose Fleming

IT is with regret we record the death of Sir Ambrose Fleming, D.Sc., F.R.S., in his 96th year, on April 18th.

John Ambrose Fleming was educated in London at University College, Gower Street, and at the Royal College of Chemistry. He graduated B.Sc. and worked at South Kensington under Professor F. Guthrie and presented his first scientific paper on "The Contact Theory of the Galvanic Cell" at the inaugural meeting of the Physical Society in 1874.

He relinquished in 1877 a teaching post at Cheltenham College, taken up in 1874, to go to Cambridge chiefly with the object of working under Clerk Maxwell in the then recently erected Cavendish Laboratory. There for two years, he says, "I enjoyed Maxwell's stimulating teaching and intercourse." In the year that Maxwell died, 1879, Fleming was appointed scientific adviser to the Edison Telephone Co., and three years later to a similar position with the Edison Electric Light Co., formed to introduce incandescent electric lighting into this country.

In 1885 he was appointed Professor of Electrical Engineering at London University; a position he held until 1926.

It was in October, 1904, that Fleming, then scientific adviser to the Marconi Company, whilst studying phenomena in incandescent lamps which had already been observed by Edison, dis-

covered that a perfect device for rectifying the current induced in a receiving aerial existed in a high-vacuum tube containing two electrodes.

In the following month Fleming took out the fundamental patent, No. 24,850, covering the thermionic valve. The title of the patent was "Improvements in Instruments for Detecting and Measuring Alternating Electric Currents." This valve, which was soon used in practical wireless reception by the Marconi Company, was the first technical application of the emission of electrons from an incandescent conductor *in vacuo*.

The early Fleming valves had carbon filaments surrounded by a metal cylinder, but in 1908 Fleming found that tungsten wire possessed advantages in that it could be heated to a higher temperature.

Writing in *Wireless World* in 1925, Fleming states: "I was well aware that the anode current could be reduced by holding near the valve a permanent magnet, but unfortunately it did not occur to me in sufficient time that this could be controlled by inserting a grid or spiral wire or metal mesh cylinder between the anode cylinder and the filament, and giving to this grid small positive or negative potentials."

Fleming was the author of many scientific papers and standard text books, amongst them, "Fifty Years of Electricity"

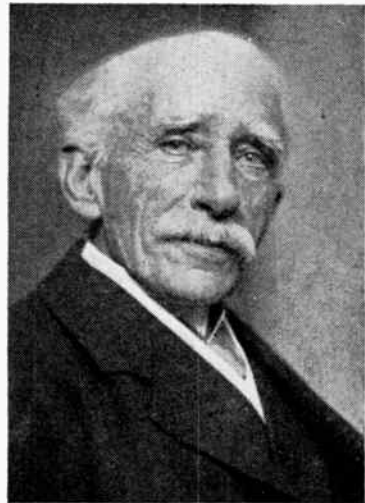

(1921) and "The Thermionic Valve" (1919), published from the offices of *Wireless World*.

Sir Ambrose received many awards and honours for his work in electrical physics. In 1892 he was elected a Fellow of the Royal Society, and in 1910 was awarded the Society's Hughes Medal. In 1921 he received the Albert Medal (R.S.A.), in 1928 the Faraday Medal (I.E.E.), in 1931 the Duddell Medal (Physical Society), and in 1935 the Kelvin and Franklin Medals. He was knighted in 1929.

### PICTURE TRANSMISSION

ELEVEN photo-telegraphic services, handling nearly 2,000 illustrations a month, are now operated by Cable and Wireless; before the war there were only three services (to Melbourne, New York and Buenos Aires) transmitting about 45 illustrations monthly.

As the result of technical improvements, speed of transmission has been speeded up threefold. With the present sub-carrier frequency-modulation system the time needed to transmit a photograph 10in. by 6in. is something between 6 and 10 minutes, depending on propagation conditions.

As apparatus becomes more readily available, photo-telegraphic gear will be installed at all the more important of the company's stations. One of the latest additions is a service, at present working experimentally, between London and Colombo, Ceylon. This is a part of C and W's plans to develop telecommunications generally in the SEAC area.

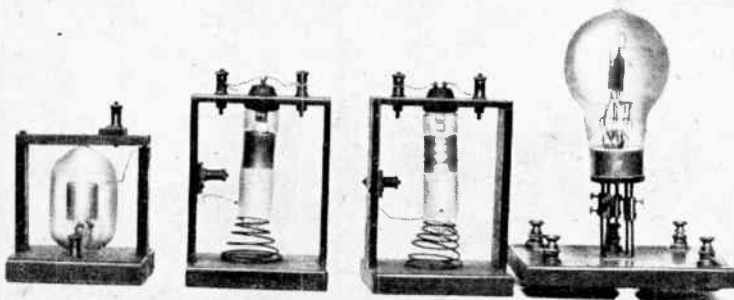

Some early types of Fleming thermionic valves.

## Letters to the Editor

# Sets for Export • Misuse of Channels • Tone Control • Television Problems

### Export Warnings

I HAVE read with interest the various comments regarding the post-war export market. To my mind the British manufacturer will have to plan on a vastly different scale from that of the past. Having spent a considerable time in both the Far and Near East I, personally, would have hesitated to recommend any British set of the domestic export type. One British domestic receiver which I purchased in the Southern Province of Ceylon arrived in a far from happy condition; no care had been taken regarding the packing. The wood of which the cabinet was made suffered from two major defects; the veneer soon started to blister and crack, while the wood or glue seemed to be the staple diet of white ants. Valves were of a type unobtainable in Ceylon. The aerial coil (of the high inductance type) soon frizzled out, presumably because lightning currents were too much for the 42-SWG wire with which it was wound. Little attention had been paid to mains fluctuations or "tropicalisation"; even the loudspeaker voice coil distorted physically.

My experience has been that the average American set arrives well packed, uses a standard type of

valve which one can obtain anywhere east of Gibraltar, care is paid to even the small metal parts and, into the bargain, an excellent service organisation ensures that spares, circuit diagrams, etc., are freely available for some years after the sale.

If we enter the field with the intention of competing with our American friends, then a drastic overhaul of our present valve and component industry is required. Furthermore, this must be backed up by efficient servicing organisations both on the part of component and set manufacturer.

Two solutions appear worthy of consideration: (1) To set up a manufacturing concern at a suitable point in the Near East. (2) For the various manufacturing concerns to agree on a common manufacturing policy and to handle their goods through a common servicing organisation. Solution No. 1 saves shipping and has also the advantage that the many and varied problems become apparent during the manufacturing process. It suffers from the disadvantage of requiring complete agreement between our large and small manufacturing concerns. This, of course, is a little too much to hope for. One could hardly imagine our thousands of valve types being

reduced to a mere dozen, all using the same type of base.

Solution No. 2 might be more acceptable to the industry as a whole. It should entail complete standardisation of such items as valves, loudspeakers, transformers, chokes, IF, wave-change switches and certain components. To ease the spares situation and also to assist sales, standardisation should follow normal current American practice wherever practicable. All approved items should bear a national mark as a guarantee of workmanship and design to an agreed specification. Lastly, a controlling authority should be empowered to ban export of any goods or equipment not up to specification.

My concluding comment is that we now have the opportunity both at home and abroad to establish a sane, sound industry. Let us profit by our past mistakes.

JOHN BANNER.

Bredon, nr. Tewkesbury.

### Channel "Hogging"

THE subject of Frequency Allocations, raised in the May *Wireless World*, is very important, but there are some aspects of it which have not been mentioned yet in your pages. As an amateur transmitter I may perhaps be accused of bias, but there does seem to be a good deal of evidence that the present allocations are unsatisfactory. The number of frequencies allotted to fixed and mobile stations appears to bear little relationship to the actual use made of these frequencies. A frequent comment made by amateurs on the operation of commercial fixed services is "Do these stations ever send any traffic?" The general impression is that commercial stations have registered many more frequencies than they use, and even those frequencies which are in use are mainly employed for sendings V's and other channel-holding but otherwise useless transmissions.

It may be relevant to quote here from the *T & R Bulletin*,



FROM HAMBURG.—Philip Walker, Engineer in Charge for the B.B.C. on the Western Front, and a contributor to *Wireless World* before the war, was the first person to speak from Hamburg after the surrender of the city. He sends us this photograph of Wynford Vaughan Thomas, B.B.C. War Correspondent, speaking from a Hamburg studio for War Report on the first day the station operated under British control.

June, 1937. A careful check was maintained on the band of frequencies between 7,300 and 7,500 kc/s, to ascertain the actual use made by commercial stations of these frequencies. At that time 281 stations were registered at Berne for operation in this band. Though the check was world-wide in scope, and lasted for nine months, only 26 of these stations were heard; the number in regular operation being 16. Of stations not registered at Berne, 47 were heard, but only eight of them on more than one occasion.

It appears that commercial stations spend at least 60 per cent. of their actual operation time in sending V's. Surely this kind of wasteful transmission is unnecessary in the present state of the radio art? It would be enlightening to discover how many of the 45,000 frequencies registered at Berne are ever used, and the proportion of time spent in useful traffic handling. Comparing the sparse occupancy of the commercial bands with the intense occupancy of the meagre amateur bands in pre-war days, it is difficult to understand why the amateur bands are looked upon as fair prey for new services, such as radio heating, not to mention old services such as broadcasting. The commercial stations are able to register as many channels as they desire and give the impression, on paper, that they are in desperate need of fresh channels. There should be some kind of an "occupancy" stipulation to prevent the wholesale appropriation of frequencies in this way.

"SIGNALMAN."

### Television "Fallacies"

I WAS surprised to find an old hand like R. W. Hallows perpetuating some fallacies about television in your May issue.

Fallacy number one is to use the London area as any sort of guide. If sound broadcasting had depended for its early success on this area it would have taken another five years to get going. In point of fact, the percentage of licences to houses was, up to the outbreak of war, lower in the London area than in most other thickly populated areas.

The reason, I would suggest, lies somewhere between the very complete entertainment facilities

of the capital and pure lack of enterprise in trying new things.

Fallacy number two concerns screen size, and here one finds Mr. Hallows assuming that every television user has large rooms, a large family or perpetually entertains large groups of friends. In fact, the average home has rooms of, say, 100 to 150 sq. ft. and the average viewing group, like the average listening group, will be about four people. For this average home the 7in. by 6in. or 10in. by 8in. picture of pre-war television sets was quite big enough.

The final fallacy is that of standards of definition, and here I smell the cloven hoof of the cinema world. The fact is that there are more picture elements in the 405-line pre-war standard picture than in any 8-mm., 9.5-mm. or 16-mm. home movies. That is a simple matter of arithmetic and photographic emulsion grain size. Incidentally, I wonder if there are 20,000 home cinema fans in London. In the case of the 31-mm. film the position is one of almost equality. The symmetrical arrangement of the elements in the television picture as compared with the haphazard photographic emulsion, appears to be more readily noted by the eye, although I must say that on most of the large picture screens that I saw before the war where lines were visible, the picture was not properly interlaced. In any case the 10in. by 8in. picture viewed at six feet is the same size rela-

tively as a three-foot picture at about twelve feet, and as a full-size cinema screen in the most expensive and presumably best seat in the house.

I have avoided technical references, but those interested are referred to Myers' "Television Optics," and the references therein form a complete statement of the case against fallacy three. By all means let us have the best possible television, but let us not be blinded by false premises into delaying our restart, and further deluding the long-suffering public.

C. W. SHEFFIELD.

High Wycombe, Bucks.

### In Defence of Electrolytics

S. GOULD'S remarks (in your April issue) on the "nightmare" of wiring on the underside of some small chassis are timely, but I cannot agree with him on the subject of high-voltage electrolytics.

My experience in the Services has shown me that, provided the manufacturer has had some say in the design—especially the size and method of termination—the modern product is as good as, and sometimes better than, the other components in the set.

D. B. EDWARDS.

Harrow, Middlesex.

### Valve Colour Code ?

THERE has been a certain amount of discussion lately on standardisation of radio valves, and it can only be hoped

### NEWS CENTRE.

—Men of Royal Signals operating the radio equipment at the "Hôtel Scribe", Paris, whence correspondents' copy has been transmitted to this country. This one-time fashionable hotel was turned into a news nerve centre. Bedrooms were converted into broadcasting and recording studios and teleprinters and transmitters installed.



Letters to the Editor—

that pressure being brought to bear will influence all those concerned.

At this juncture it would be a good plan to colour-code valves. The criterion, in my opinion, should be not the *use* made of the valve, but its *useability*, i.e., the code should indicate heater volts (for parallel connection) and heater amps. (for series connection).

The object can be achieved with six colours. The following table shows how the colours might be used for "body" and "dome" markings on the valve envelopes:—

Colour	Lower 2/3	Upper 1/3
Black	1.4V DC	150 mA
Red ...	2V DC	200 mA
Gold ...	4V AC	300 mA
Green	5V AC	—
Blue ...	6.3V AC	—
Grey	Higher voltage	Higher current

Metallised valves of all DC and of the 4V AC types would be unicoloured black, red and gold respectively. 6.3V valves would be metallised blue upwards to the dome, while the dome colour would indicate the heater current for their application in series circuits.

Clear-envelope valves could be coded by small coloured rings near the base for volts and near the dome for current.

The colours suggested are easily remembered, as they closely correspond to the sequence used for the resistor code.

K. E. MARCUS.

Uxbridge, Middlesex.

"A New Versatile Tone Control Circuit"

READERS may be interested in the following modification of the usual tone control circuit, as outlined in G. N. Patchett's article in the March issue.

The accompanying diagram

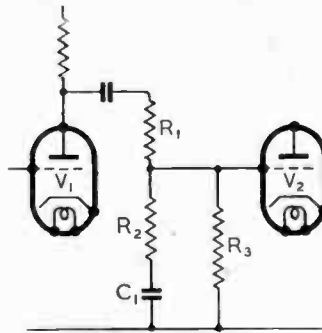

(a)

(a) shows a circuit sometimes used for bass boost, the operative components being  $R_1$ ,  $R_2$  and  $C_1$ .

$R_3$  has to be included as a grid leak for  $V_2$ , and its presence modifies the performance of the circuit since its shunting effect on the combination  $R_2 C_1$  may be serious at low frequencies.  $R_3$  sets a limit, in fact, to the degree of bass boost obtainable.

There is no reason, however, why  $R_3$  should not be transferred to the input side of the tone control circuit, as in diagram (b) where it has no effect on the performance of the bass boost circuit, while still providing the necessary DC path between the grid and cathode of  $V_2$ .

Surely Mr. Patchett is not justified in suggesting that if bass or

treble boost is used in an amplifier the output stage must be capable of handling a "much greater output than normal"; i.e., that a 10-db. boost in the bass calls for ten times the output power? Since such tone control is normally used to correct for a loss in another part of the chain; e.g., recording

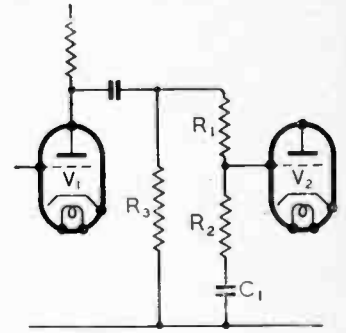

(b)

or pick-up characteristic, or in intervalve couplings, it is unlikely that the output stage would be called upon to handle an abnormal amount of power. The implication is only true if one is attempting to correct for loud-speaker deficiencies by "cooking" the amplifier characteristic.

DOUGLAS WINGET.

London, N.W.10.

Hearing Aids

ALEXANDER POLIAKOFF'S letter in the May issue of *Wireless World* must surely be a revelation to hearing-aid users in this country. I use a "Micro-electric" aid of American make, sold at 28 guineas. I was asked 47 guineas for a valve aid before the war, and have never seen anything under £20. How can deaf people avoid exploitation if they are unaware of any reliable organisation likely to help them? I have been asked many times for advice on hearing aids; the high price and fear of being "had" is always a deterrent to purchase. There is an assured market for a reliable instrument at a fair price. More publicity by the National Institute for the Deaf would help us a lot.

R. B.

Catalogue Received.—Radio Instruments, Ltd., Purley Way, Croydon, have produced an illustrated list of transformers and chokes which will be available as soon as the necessary materials are released. Mains as well as coupling transformers are described and a range of transformers with toroidal windings is mentioned.

Books issued in conjunction with "Wireless World"

	Net Price	By Post
FOUNDATIONS OF WIRELESS. Fourth Edition, by M. G. Scroggie ...	7/6	7/10
TELEVISION RECEIVING EQUIPMENT, by W. T. Cocking ...	10/6	10/10
RADIO LABORATORY HANDBOOK, by M. G. Scroggie. Second Edition ...	12/6	12/11
WIRELESS SERVICING MANUAL, by W. T. Cocking. Sixth Edition ...	7/6	7/10
HANDBOOK OF TECHNICAL INSTRUCTION FOR WIRELESS TELEGRAPHISTS, by H. M. Dowsett and L. E. Q. Walker. Seventh Edition ...	30/-	30/7
RADIO DATA CHARTS. Third Edition, Revised by J. McG. Sowerby, B.A., Grad. I.E.E. ...	7/6	7/10
RADIO INTERFERENCE SUPPRESSION, by G. W. Ingram ...	5/-	5/4
LEARNING MORSE. 335th thousand ...	6d.	7½d.
INTRODUCTION TO VALVES, by F. E. Henderson ...	5/-	5/4
RADIO WAVES AND THE IONOSPHERE, by T. W. Bennington ...	6/-	6/3

Obtainable from leading booksellers or by post from

ILIFFE & SONS LTD., Dorset House, Stamford Street, London, S.E.1

# WORLD OF WIRELESS GALPINS

## B.B.C. STANDARD FREQUENCIES

FOUR of the frequencies employed by the B.B.C. are now controlled to within  $\pm 1$  part in  $10^6$  of the nominal frequency. The following frequencies can, therefore, be used as a reference standard: 200, 6,180, 9,510 and 17,810 kc/s.

Reception of one or more of these frequencies should generally be possible throughout the world for a period each day.

Transmission times may, unfortunately, change with alterations in the B.B.C. services, but the present schedule (GMT) is:—

200 kc/s	0400-1330,	1430-0045
6,180	0400-1330,	1430-2215, 2230-0045
9,510	0400-0800,	1730-0215
17,810	0900-1515	

## CINEMA TELEVISION

REPORTS from America indicate that there is a growing tendency to link television and cinema interests. This is borne out by the proposals recently made by the Society of Motion Picture Engineers for television frequency allocations for the cinema industry.

The proposals include an allocation of 60 channels in a band of 1,200 Mc/s for an immediate cinema television service with a standard of definition of 800 lines. It is pointed out, however, that 1,200-line trans-

mission is necessary, even for monochrome, to equal the definition of modern films.

For future development of the service it is requested that a band of 10,000 to 20,000 Mc/s above 6,000 Mc/s be allocated for relay services and colour transmission.

Proposals for the allocation of 75 channels of 20 Mc/s bandwidth for a cinema television network have previously been made by the U.S. National Theatre Television Service as recorded in our January issue.

## LICENCE RECORD

IT has just been announced that the record total of 9,710,850 wireless receiving licences in Great Britain and Northern Ireland was reached by the end of March this year. As will be seen from the graph reproduced on this page, there has been a steady increase in the number of licences since December, 1941. Previous to this date there had been a gradual decline from the previous record of 9,153,382 reached in August, 1940.

The remarkable thing is that, despite the shortage of receivers and the many sets that remain unusable because of the shortage of replacement components, the total of licence holders continues to rise.

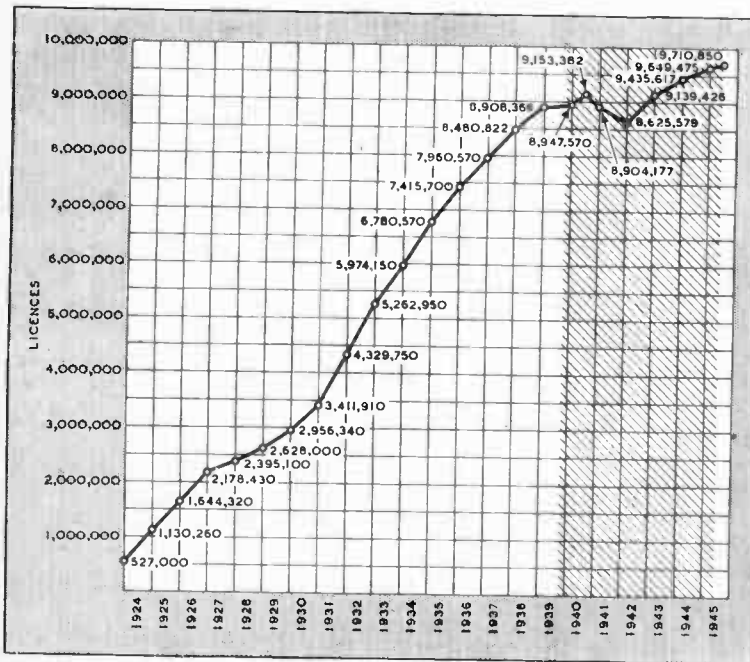

Effect of the war on broadcast receiver licensing.

**ELECTRICAL STORES**  
**"FAIRVIEW,"**  
**LONDON ROAD, WROTHAM,**  
**KENT.**

TERMS: Dash with order. No C.O.D.  
 All prices include carriage or postage.

**ELECTRIC LIGHT CHECK METERS**, first-class condition, electrically guaranteed, for A.C. mains, 200/250 volts 50 cy. 1 phase 5 amp. load, each 12/6.

**SOLID BRASS LAMPS** (wing type), one-hole mounting, fitted double contact, S.B.C. holder, and 12 volt 16 watt bulb. 4/-.  
**TUNGSTEN CONTACTS**,  $\frac{1}{4}$  in. dia., a pair mounted on spring blades, also two high quality pure silver contacts,  $\frac{1}{4}$  in. dia., also on spring blades, fit for heavy duty, new and unused. There is enough base to remove for other work. Set of four contacts, 4/-.

**ROTARY CONVERTER**, input 40 volts D.C., output 75v., 75 mA, A.C., also would make good 50v. motor or would generate. 22.  
**AUTO TRANSFORMERS**, Step up or down, tapped 0-110-200-220-240; 1,000 watts. 25.  
**POWER TRANSFORMER**, 4kW, double wound, 400 volts and 220 volts to 110 volts, 50 cycle, single phase. Price 220.  
**AUTO TRANSFORMER**, step up or step down, 500 watts, tapped 0-110-200-220-240 volts. 23 10s.  
 $\frac{1}{2}$  WATT WIRE END RESISTANCES, new and unused, price per doz., 5/-, our assortment.

**MOVING COIL AMPMETER** by famous maker. 2in. dia., flush mounting, reading 0-10 amps. F.S.D., 20 mA, price 27/6.  
**AMPLIFIER COMPONENTS** from dismantled American 10 and 20 watt amplifiers, all metal cases and compound filled.  
**INPUT TRANSFORMERS**, ratio 12 to 1, centre tapped, price 15/-.

**P.P. OUTPUT TRANSFORMER**, ratio 6.2 to 1, centre tapped, price 10/-.  
**BLOCK CONDENSERS**, cap. 10 MF., 250v. D.C. working, 7/6 each.  
**CABINET LOUDSPEAKER**, for extension only, 5 watt output, 8in. dia. cone, high quality, size of cabinet 16 x 14 x 8 1/2 in. x 1/4 thick, cabinet slightly marked at top, price 23.  
**SMALL M.L. ROTARY CONVERTER**, in cast all. case, size 14 x 4 1/4 x 4 1/4 in., permanent magnet fields, converters need attention, not guaranteed. 30/-.

**POWER TRANSFORMER**, suitable for arc welding, input 230v., 50 cycle, 1 PH, output 50 volts at 200 amps., price 217; ditto, output 150 amps, 215; ditto, output 100 amps, 212.  
**TRANSFORMER** for rewinding only, approx. 2kW, weight complete with clamps, 45 lbs., price 30/-.

**DYNAMO**, slow speed, only 500 r.p.m., output 25v.-10 amps., shunt wound, adjustable brush gear, ball bearing, condition as new, weight 60 lbs., a real high-grade job. Price 27 10s.  
**50 VOLT MOTOR**, D.C., input 4 amps,  $\frac{1}{2}$  h.p., ball bearing, double ended shaft  $\frac{1}{2}$  in. dia., slow speed, only 500 r.p.m., shunt wound, condition as new, also make good slow speed generator. Price 50/-.

**AUTO TRANSFORMERS**, tapped 0-110-200-220-240v., 1 1/2 KW., 27 10s.; 2 KW., 210.  
**50 VOLT D.C. MOTOR**, shunt wound, ball bearing,  $\frac{1}{2}$  h.p., speed 900 r.p.m., in new condition, make good generator. Price 27.

**MOVING COIL AND M.I. METERS.**  
 FOR FULL DETAILS OF ABOVE AND OTHER GOODS, SEND FOR LIST, 24d.

**World of Wireless—**

Moreover, the rise is at a rate as great as, if not greater than, the pre-war years when it was expected saturation point would shortly be reached.

**I.E.E. REPORT**

THE report of the Council of the Institution of Electrical Engineers presented at the 73rd annual general meeting on May 10th records that, in response to a request from the Postmaster-General, the Council has reconstituted the Committee on Electrical Interference with Broadcasting. The chief task of the new committee is to review the recommendations contained in the Report made in July, 1936, and to consider the desirability of modifications resulting from the introduction of new forms of high-frequency equipment.

At the request of the Air Ministry, a Committee on Radio Requirements for Civil Aircraft has been set up. Its task will be to formulate technical airworthiness requirements for the design and installation of radio equipment in civil aircraft. In view of the urgency of the task, the work of the Committee is being expedited by all possible means.

The total membership of the Institution has reached a new record—26,665; this is an increase of 2,107 on the previous year. There are at present 12,568 corporate members on the register. It is stated that the formation of local Radio Groups has resulted in a marked increase in the membership of the Radio Section, which is now over 2,600.

**DR. E. B. MOULLIN**

BY his appointment to the new Chair of Electrical Engineering at Cambridge University, Dr. E. B. Moullin returns to the electrical laboratory which he laid out and equipped between 1920 and 1929 when he was a lecturer at the University. Dr. Moullin, who holds the M.A. degree of both Cambridge and



Dr. E. B. MOULLIN.

Oxford, was appointed Donald Pollock Reader in Engineering Science at Oxford in 1929, which position he still holds.

It is understood the University has been trying to establish the Chair for some years, and that it has now been made possible by the support of the I.E.E., of which Dr. Moullin is a vice-president. He was chairman of the Wireless Section in 1939-40, and is also a member of the Radio Research Board.

Dr. Moullin's considerable research in radio engineering is well known. His studies include work on radio-frequency measurements, background noise in receivers, aerials and dielectric losses. He invented the original thermionic voltmeter manufactured by the Cambridge Instrument Company.

**R.C.M.F. REPORT**

THE annual report of the Radio Component Manufacturers' Federation refers to the need for the establishment of some form of central research organisation to cover the whole field of radio development. The view of the Radio Industry Council, expressed in the report, is that any plans for the establishment of a radio research organisation must provide for control to be placed in the hands of the industry. In particular, the council will oppose any plans which involve surrendering the initiative in research to a Government establishment or scientific body outside the industry.

The question of financing such a research organisation is raised by the R.C.M.F., and the suggestion is made that the R.I.C. investigate the possibilities of diverting a proportion of the annual licence fee to this purpose.

The following member firms constitute the Council of the Federation for the ensuing year: Belling and Lee, British Rola, A. F. Bulgin and Co., Morgan Crucible Co., Plessey, Reliance Electrical Wire Co., Tannoy Products, Telegraph Condenser Co., Telephone Mfg. Co., Westinghouse Brake and Signal Co., Wingrove and Rogers, Wright and Weaire.

**"SPECTEMUR AGENDO"**

THIS is the phrase on a symbolic design presented to the Radio Industries Club and reproduced on the chairman's report presented at the 14th annual general meeting. Translated, it is "By our deeds so shall we be known."

The report records a 21 per cent. increase in membership, which now totals 495. Taking into consideration the membership of the two affiliated clubs in Scotland and Wales, the grand total is 793.

It is recorded that the collections for the Electrical Industries Benevo-

lent Association, taken at the monthly luncheons, amounted approximately to one hundred guineas during the past year.



**SIR ROBERT RENWICK, Bart.,** Controller of Communications, Air Ministry, and Controller of Communications Equipment, Ministry of Aircraft Production, who has been elected President of the Radio Industries Club for 1945/46.

**IN BRIEF**

**America's Old Sets.**—According to a recent survey undertaken in the United States for Sylvania Electric Products, more than 29 per cent. of America's broadcast sets are over seven years old, whilst a further 31 per cent. are between five and seven years old.

**Patents in America.**—It has been announced in New York that the Philips Company in America will, after July 1st, issue its own patent licences direct to manufacturers. Hitherto, sub-licensing under the 700 Philips U.S. patents has been done by large American companies, mainly by R.C.A.

**School Broadcasting.**—The growing importance of school broadcasting in the new educational system was stressed recently at a meeting of the Central Council for School Broadcasting. The Council's report on the work of the past year states that the number of registered listening schools is now about 14,000. The first summer school, for tutors in training institutions of all kinds, to discuss school broadcasting, will be held in London this year. A school in Tottenham is to be wired in the most up-to-date way as an experiment in post-war installation, and, when completed, can be inspected by anyone interested, by arrangement with the local authority.

**Back Numbers.**—Our Publishers are anxious to obtain copies of *Wireless Engineer* for the months of January, February and March, 1945. If any of our readers have these back issues, and are prepared to dispose of them, will they please communicate with our Publishers.

**FM Possibilities.**—It is learned from a recent survey of 111 stations affiliated to the U.S. Blue Network that only one does not intend introducing fre-

quency modulation. At present only three of the stations are operating FM transmitters, but 35 have applied for construction permits and a further 65 intend making application. The remaining seven are undecided.

**B.S.W.L.**—Details of the activities of the British Short-Wave League, which recently celebrated its tenth anniversary, have been received from the Hon. Secretary, Norman Stevens. The League gives free technical advice to its members, has a "components clearing service" and a station identification service. Further details are available from the Hon. Sec., 53, Madeley Road, London, W.5.

**Radio Relay Statistics.**—The number of subscribers to radio relay exchanges is still rising—an increase of 24,000 is recorded for the three months to December, 1944, making a total on that date of 551,703.

**Short-wave Society.**—The Edgware Short-wave Society is being reformed and a general meeting is to be held at the Edgware Conservative Constitutional Club on June 2nd. Old and prospective new members can obtain particulars from E. R. Radford, Hon. Sec., 1, Gibbs Green, Edgware, Middx.

**Talking Books.**—The Central Library of the National Institute for the Blind has now available 464 talking books, each containing an average of 10 double-sided solid-stock 12in. discs, cut at 200 grooves per inch and rotating at 24 r.p.m. Over 1,700 specially designed reproducers have been issued by the Talking Book Library to individuals and institutions for the blind for use with the "books." Restrictions on record materials, etc., have limited the number of new "books" to 25 a year, and made it difficult to replace worn or broken records.

**New Zealand's practice of broadcast-**ing her Parliamentary sessions, in full, on a special wavelength by the 60-kilowatt transmitter 2YA is of interest in view of the recent suggestions that the sessions in the British Parliament should be broadcast. Apart from a few wartime secret sessions, or when information has been given which might have been of value to the enemy, all the speeches in the Dominion's House of Representatives are broadcast.

**Quick Work.**—All right-thinking members of the communication branch of wireless realise that time is the essence of the contract; they will appreciate the quick work of the Cable and Wireless mobile unit which provided telegraphic and facsimile services for the Press during the closing phases of the war in N. Italy. The unit, following the rapidly advancing troops, started to select a site at Lavezzola and to erect aerial masts at dawn on one day; by noon of the same day telegraphic communication with London was established. By midnight of the next day pictures of the fall of Bologna had been transmitted to London.

**Radio Industry Council** has now moved back to its old offices, and its address and that of the Radio Manufacturers' Association, Radio Manufacturers' War Export Group, British Radio Equipment Manufacturers' Association, and the Inter-Services Component Manufacturers' Council is 59, Russell Square, London, W.C.1.; telephone: Museum 6901-5.

**Channel Islands Appeal.**—As we go to Press we have received the following appeal from Radio House, 20, Halkett Place, St. Helier, Jersey:—"As 99 per cent. of the sets of this island were confiscated during the German occupation we are badly in need of gear and would like to get in touch with manufacturers or distributors and restock."

**PERSONALITIES**

**Frank Allen**, who was, until recently, works manager of the Aylesbury factory of E. K. Cole, Ltd., has now been appointed general works manager (Radio Division) and will control the Company's radio factories.

**G. F. Mansbridge** has relinquished the chairmanship of Dubilier Condenser Company, but remains a director.

**W. H. Goodman**, deputy chairman of Dubilier Condenser Company, succeeds G. F. Mansbridge as chairman.

**E. J. Warren**, general manager in India of General Electric Co. (India), Ltd., has retired for health reasons.



**E. M. LEE, B.Sc.**, (Belling and Lee), the new chairman of the Radio Component Manufacturers' Federation.

**A. J. Emery**, who has been in charge of the Bombay Branch of General Electric Co. (India), Ltd., succeeds E. J. Warren as general manager.

**MEETINGS**

**Television Society**

"The Human Eye and the Photo Cell," by W. Sommer, D.Phil., at 6.0 at the I.E.E., Savoy Place, London, W.C.2, on May 29th.

**Institute of Physics**

**Electronics Group.**—"Glass-to-Metal Seal Design," discussion to be opened by W. J. Scott, B.Sc.(Eng.), and "High Vacuum Pumps," introduced by Dr. R. Witty, at 2.30 in the Fyvie Hall, The Polytechnic, 309, Regent Street, London, W.1, on June 9th.

**Institution of Electronics**

"Principles of Triode Design," by J. H. Fremlin, M.A., Ph.D., at Royal Society of Arts, John Adam Street, Adelphi, London, W.C.2, at 5.30 on June 4th.

**North-West Branch.**—Joint meeting with Manchester and District Branch of the Institute of Physics. "Design of Electron Guns of Radial Symmetry" by H. Moss, Ph.D., B.Sc., at 6.30 at Reynolds Hall, College of Technology, Manchester, on June 1st.

**SOON  
CRONAME**

*Designing and  
Engineering*

will again be a factor in the plans of far-sighted manufacturers of electronic equipment. From building precision parts for wartime devices the Croname group will turn to the processing of mechanical and decorative items for the electronic industry.

A place in the Crowe schedules has meant attractive, practical, saleable merchandise to many. Our facilities may be valuable to you.

Dial Scales.  
Tuning Mechanisms.  
Pointers. Escutcheons.  
Precision Controls. knobs.

Exclusively Represented in Great Britain by

**FRANK HEAVER LTD.**  
Kingsley Road, Bideford, N. Devon.

*Croname Incorporated*  
FORMERLY  
*(Crowe Name Plate & Manufacturing Co.)*  
CHICAGO, ILL. U.S.A.

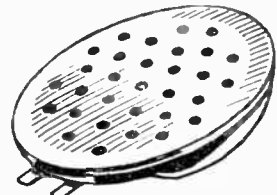

**H.A.5 DEAF-AID  
CRYSTAL MICROPHONE**

**A**STATIC will be ready to serve you again with high quality piezo-electric devices when the 'All-Clear' of Victory sounds. Astatic deaf-aid microphones can be supplied only if Import Permits are established. Model H.A.5 illustrated is used as standard by America's leading hearing-aid instrument makers.



**THE ASTATIC CORPORATION  
CONNEAUT, OHIO, U.S.A.  
and  
TORONTO, CANADA.**

—Exclusively Represented by—  
**Frank Heaver Ltd.** Kingsley Road  
Bideford N. Devon

# RADIO TEXTBOOKS

## Plea for Co-operative Effort

By THOMAS RODDAM

IN recent numbers of *Wireless World* there has been some lively correspondence about the textbook situation. So much interest has been shown that a full-blooded examination of the position seems to be justified. It may be over-optimistic, but this writer thinks that if enough people realise the position, something might happen. It is not enough to know that the textbooks on radio are bad; this fact must be realised with all its implications. The correspondents, I am glad to see, agree with this view. There are a lot of bad little books, and I can wish the authors condemned to an eternity of reading the reviews of their books by G. W. O. H. in a contemporary.

Every bad book means one less good one—Gresham's Law<sup>1</sup> is always turning up. Every publisher with a bad book on his list has less money, and nowadays less paper, for the author of a good book. Nor is this all. Every bad book which is sold to the engineers of Ruritania decreases their respect for British radio engineering. Of course, export trade doesn't depend only on technical matters. Tariffs, currency problems, bribery and blackmail all play their part. Nevertheless, the opinion of the technical men has some weight. Bad textbooks mean fewer exports; trade follows the blurb. It is therefore in the interest of British industry to encourage the production of some really good textbooks on radio, solely as goodwill publicity abroad. I had resolved not to mention any specific works in this article, but one example must be given. All my generation has a considerable respect for German mathematical physicists, based entirely on our knowledge of the great classic by Courant and Hilbert. What we think of the Germans now is not relevant; mathematics is non-political and, as Hardy says, "Real mathematics has no effects on war."<sup>2</sup> This aspect of things is particularly im-

portant as a long-term policy. Textbooks affect the engineer at the beginning of his career. Habits of thought are formed which persist long after they are known to be without justification. The students of to-day are the chief engineers of to-morrow; they must be made to believe that this country has some good radio engineers in it.

This goodwill aspect of textbooks will, I think, be accepted by the reader. I hope he will also accept the application of Gresham's Law to publishing, and, quite as important, to book buying. Every bad book bought means one guinea less for buying good books, and a sense of frustration which discourages the student and makes him spend his next guinea on something more reliable.

Having decided that textbooks must be written, how can some encouragement be given to eligible young men? This problem always makes me fall into a deep reverie, only distinguishable from sleep by a skilled observer. If we consider what sort of people our potential authors are we may get some sort of answer. They may be in what is delicately called academic life. They have plenty of spare time, and they have the unrivalled advantage of being able to use their textbook draft as a lecture course and thus "try it on the dog." That, as in the traditional form, "the dog it was that died" does not seem to discourage them. The difficulty is that there is no way in which the full-time lecturer on radio can keep up to date. Without a wholesale reform I cannot see the books we want coming from this source.

### Industrial Authors' Handicaps

In industry there are better-equipped potential authors. But the trouble is that they have too much to do, and they cannot relax their ordinary work at all or they will fall behind in the vicious

struggle for existence. If industry took a more long-sighted view this would be changed, and a model is found in a paper in the *Proceedings of the I.R.E.*, which describes the organisation of a very well-known American firm. Engineers there are expected to devote quite a useful part of their time to what might be called "private ventures." In this country such an outlook is uncommon. Another thing that discourages the industrial authors is uncertainty. Actually this discourages all the potential authors, but it is less important to the lecturer, who must prepare his notes anyway. A textbook is, in the economic sense, capital, but it seems difficult for the technical writer to find a publisher without actually writing the whole book. Few men will sink years of their spare time in a speculation of this sort, especially when they do not know what the reward will be—or even if there will be any reward at all.

### Government Servants

There remain the potential authors in Government establishments. To find out why they don't write books I bought from the Stationery Office a book of rules for the employees of one Ministry. When the appropriate paragraph is translated into the King's English, it says that any public servant who wishes to publish a book on anything at all must submit the full text before he can get permission. That is, the book must be written before the author is told whether he will be allowed to publish it. Further, if the Stationery Office decide that they would like to print it, the author must agree to their terms. If Government ink or Government paper is used, of course, this is a most serious matter. In addition, the library facilities in most Government establishments are so inadequate, and the opportunities of doing "library research" so few, that the actual work of writing any general textbook is impossible. We cannot hope for textbooks from Government ser-

<sup>1</sup> "Bad money drives out good."

<sup>2</sup> *Mathematicians Apology*, G. H. Hardy. Cambridge University Press, 1940.



vants until there has been some change in administrative policy.

I started this article in the hope that I could leave the solution of these problems to correspondents. I must, however, produce some suggestions. What is required is an enlightened publisher, backed, as one correspondent has suggested, by an enlightened Government department, who would commission a series of textbooks. Authors would be asked to write books and guaranteed a definite reward, with royalties beginning only when some number of copies had been sold. Government intervention to secure the co-operation of industrial employers in allowing the chosen men to devote perhaps one day a week to this work would be most important. Special tax concessions to authors would mean that the payments would not need to be so high: if entertainment tax is not paid for Restoration plays, authors of scientific books should not be made to pay income tax on their earnings, which are the result of work of rather more importance to the nation. The details of a scheme of this sort can only be worked out with State intervention, for so much of the recent work which must be included has been done for State use. Only a really authoritative control can free authors from some of their normal work to help with such a scheme. The difficulties are, of course, great. There are the difficulties which keep the scientists out of the Government establishments in peacetime; there are the difficulties which the machinery of Government itself creates.

**What do we Want?**

A separate problem is raised if we imagine we are editors of such a series. What sort of textbooks does the radio engineer want? Here it is every man for himself and the devil take the hindmost. I, to start you talking, am prepared to expose the barrenness of my desires. First, I should like to see some really good advanced mathematical texts for engineers. Books which tell the engineer how to solve the sort of equation which crops up are needed: at the moment we thumb our way through Whittaker and Watson with a glassy stare. Then a series is needed on the fundamentals of

radio technology; valves, components and engineering practice. Finally, the real heart of the thing, books on propagation, circuits and aerials, complete the radio engineer's library. I will not here risk suggesting authors for those books. To do so would be to ask for trouble.

The problem is a straightforward one. We need radio textbooks to train our engineers and to advertise our national research. The authors need money to buy food and drink. All that remains is to provide a catalyst, which will start the authors off on the long road to fame. If the publishers cannot do it alone, the Government and the radio industry should be prepared to co-operate.

**ARRL HANDBOOK**

**C**OPIES of the 1945 edition of the American Radio Relay League's annual publication "The Radio Amateur's Handbook" are now becoming available in this country. It contains some 512 pages with 1,278 illustrations, 133 charts and tables and 240 basic formulæ covering almost every aspect of radio communication.

A considerable quantity of new material is included, particularly in those sections devoted to the very high frequencies. For example, the chapter on the theory and operation of valves contains a description of the Klystron velocity-modulated valve and the magnetron, which are used for the generation of RF oscillations up to and even beyond 30,000 Mc/s (1 cm). It is anticipated that when amateur licences are restored in America frequency allocations will be made in these regions of the radio spectrum.

The expansion in the quantity, and quality, of the material on UHF practice and theory is in part due to the many American amateurs now enrolled in the WERS (War Emergency Reserve Service) for which a large amount of 2½- and 1½-metre mobile radio equipment is required. Much of this gear is home-made.

There is a number of new pieces of test equipment, again largely of the UHF kind. Mention should also be made of a very ambitious 12-valve communications set covering 1.75 Mc/s to 30 Mc/s and embodying a crystal IF filter, noise limiter, signal strength meter and many other up-to-date refinements. Full constructional details, including coil winding data, are given.

The handbook can be obtained direct from A. F. Bird, 66, Chandos Place, London, W.C.2, the price being 12s. 6d., plus 7d. by post; or it can be ordered for delivery from America through the Radio Society of Great Britain, New Ruskin House, Little Russell Street, London, W.C.1, the price in this case being 10s. 6d. For security reasons copies cannot be sent from America direct to Services or Government establishment addresses.

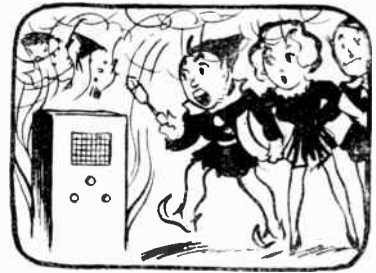

THE "FLUXITE QUINS" AT WORK

"Good Gracious! Our radio's aight,  
We shan't hear the Brains Trust tonight."  
"Don't worry, my pet,  
I'll soon fix the set,  
All it needs is a spot of FLUXITE."

See that FLUXITE is always by you—in the house—garage—workshop—wherever speedy soldering is needed. Used for over 30 years in Government works and by leading engineers and manufacturers. Of all Ironmongers—in tins, 8d., 1/4 & 2/8.

Ask to see the FLUXITE POCKET BLOW LAMP, price 2/6.

TO CYCLISTS! Your wheels will NOT keep round and true unless the spokes are tied with fine wire at the crossings AND SOLDERED. This makes a much stronger wheel. It's simple—with FLUXITE—but IMPORTANT.

The FLUXITE GUN puts FLUXITE where you want it by a simple pressure. Price 1/6, or filled, 2/6.



ALL MECHANICS WILL HAVE

**FLUXITE**

IT SIMPLIFIES ALL SOLDERING

Write for Book on the ART OF "SOFT" SOLDERING and for Leaflets on CASE-HARDENING STEEL and TEMPERING TOOLS with FLUXITE. Price 1d. each.

**FLUXITE LTD.**

(Dept. W.W.), Bermondsey Street, S.E.1

# UNBIASED

By *FREE GRID*

## Beating the Ionosphere

IT is well known that, of those of the B.B.C.'s broadcasts of speeches and commentaries from the U.S.A. which are not transmitted direct at the time of broadcasting, some come over via the SW beam link and are recorded for later rebroadcasting, while others come over in the form of actual recordings, being presumably sent by plane. At least, that is what I, in my ignorance, have always supposed, but an American G.I. with whom I was arguing about the matter in a pub recently tells me that these moth-eaten methods have long since been discarded in favour of an entirely new system developed by technicians in the land of big things.

We had just been listening to a talk from the other side of the water which was so strikingly free from atmospherics, fading and other ionospheric bugbears that I had commented upon it, since only half an hour previously I had tossed my SW receiver into a corner at home in disgust at the poor and, indeed, almost impossible conditions for transatlantic reception. The whole affair was, in fact, very puzzling and I should probably have been pondering over the matter yet if my American friend had not volunteered to explain the new technique.



Saludos Amigos.

It was, so he told me, not a case of a trained listener versed in the art of piecing together a speech punctuated by ear-splitting interference, and subsequently typing it out and hearing it read by a B.B.C. announcer. This is an old and perfectly legitimate dodge which used often to be adopted in such circumstances. Nowadays, however, there is a far better method. The speech is pieced together and typed out as

before, but the few clearly intelligible words which do get through are also carefully recorded and handed over to a faithful disciple of Rudolf Pfenniger. By listening to the record of these few fragmentary words he is able quickly to create a mental image of all the delicate cadences and tonal inflections of the speaker and is soon able to transpose the typescript by hand into the necessary undulations on a blank gramophone disc.

For the benefit of those of you who have grown up since the war began I would explain that Rudolf Pfenniger was the Teutonic gentleman who first demonstrated the practicability of reproducing the human voice on a record by means of digital indentations, no vocal recordings being carried out at all.

## PA Historians Forward!

AS I have often had occasion to point out in these columns, nobody puts their foot into it more firmly than the B.B.C. programme-wallahs when they embark falteringly on the perilous seas of historical reminiscence. Probably the most notable instance of it was when they gave a resumé of the momentous happenings of the year 1914.

At enormous expense (probably her return bus fare) they secured the services of a well-known political hostess of the day who gave us a moving account of certain dramatic incidents which occurred at her salon on "Friday, July 30th." Let me hasten to explain that I am not blaming the good lady in the slightest. She was probably earning every penny of her return bus fare by adhering faithfully to the script of her memories which the B.B.C. had typed out for her. I do, however, blame the B.B.C.'s historical hash-up department, not only for putting the words into her mouth but for persisting in its pigheadedness in reproducing this programme from a recording some time later. I had not only pointed out in these columns that there was no such date as Friday, July 30th, in 1914, but had, in addition, drawn attention to certain other departures from that strict historical accuracy which we have a right to expect in our programmes.

I do feel, however, that I owe the B.B.C. some sort of apology, for its petty peccadilloes pale into insignificance beside a truly appalling

anachronism committed by others to which several readers have drawn attention and which I have since verified in person. The anachronism occurs in a much-publicised film dealing with the life of President Wilson which was recently thrust upon us. Apparently the producer, or whoever is responsible, is so utterly ignorant of developments in the realm of sound reproductions that he imagines that microphones,



Another Anachronism.

loudspeakers and all the other ghastly paraphernalia of a modern election meeting were available to political aspirants in 1916. In one scene, in particular, there is clearly depicted a microphone with a battery of loudspeakers in the offing, and very modern-looking apparatus it is too.

Now I do not intend to enter into a discussion as to the exact date when some misguided individual first thought of putting the fearsome weapon of sound reinforcement into the hands of politicians, but I am quite sure that it was not in 1916 nor until a good many years afterwards—not even in a land of cacophony-tolerant people like the U.S.A. True, de Forest put the grid into the valve in 1912 and so made PA theoretically possible, but many bitter years of heart-rendering cacophonous caterwaulings had to be endured by the patient American public before speech from a loudspeaker became really intelligible.

I have a perfectly clear recollection of hearing the truly fearful bel-lows of the "Stentorphone" on Blackpool pier in 1921 and wrongly put down my inability to understand what was said to my ignorance of the Lancashire dialect. Just possibly the Stentorphone, which, incidentally, used compressed air to produce its nerve-shattering effects, flourished in the U.S.A. before 1921, but certainly not as early as 1916. At any rate, if anybody can bring forth reasonable proof that this incident in the picture is not a truly glaring anachronism, I will publicly eat my bowler and umbrella. The Editor will, of course, act as final arbiter regarding any so-called proof that may be adduced.

# GRAPHICAL SYMBOLS

## Standardising Inter-Service Practice

IT is understood that a revised set of recommended graphical symbols is shortly to be issued by The British Standards Institution. In the meanwhile, the various telecommunication branches of the Services have been in need of standardised and generally agreed symbols for use in diagrams, particularly for those for illustrating newly developed practice. To meet this need, the Inter-Services Radio Circuit Symbols Committee has now issued a provisional list of symbols. This publication is intended for Service use exclusively, but no doubt the recommendations made will have some influence on the ultimate choice of symbols for general use.

between switches and semi-fixed links. In (6), which is the general symbol for a fuse, two conductors seem unnecessary. No. 7 is another symbol that seems to have little graphical connection with the device—a microphone—that it represents, but (8) a piezo-electric crystal, gives a better idea of this device—at any rate when it is used for frequency control—than the symbol generally employed. The arrow in a valve symbol (9) to indicate variable- $\mu$  characteristics is almost redundant nowadays, as the nature of the valve will be evident from its function in the circuit. Finally, the growing tendency to provide standardised symbols for devices used in

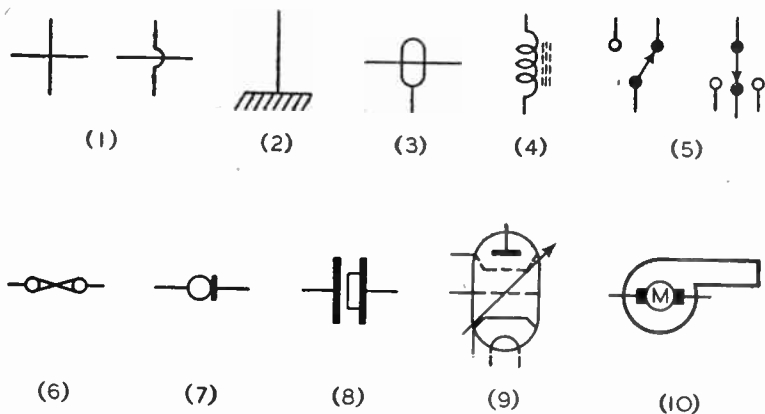

A few of the symbols to which attention may usefully be drawn are accordingly reproduced here from the Services book. The long-standing controversy over the representation of crossing conductors has been side-tracked by giving the two methods as alternatives (diagram 1). The symbol for "chassis, with no direct earth connection" (2) may be compared with the well-established practice of showing the chassis as the thickened base-line of the diagram. The screened line symbol (3) seems to be lacking in graphical quality, an advantage certainly possessed by (4) which represents a dust-cored inductor. Arrowheads on the arms of switches (5) seem to help in emphasising the essential difference

highly specialised apparatus is shown at (10), which indicates a motor blower.

### MORE RADIO HEATERS

WE learn from Rediffusion, Ltd., that recent improvements in supplies of materials make it possible to obtain delivery of the Redifon RH2 radio heater unit within a week or two of ordering.

This model has an output of the order of 250 watts at 50 Mc/s and is designed for experimental or small-scale production processing of plastics, synthetic glues, vulcanised rubber, etc. It may also be used for dehydration and eddy current heating.

The cost of the generator is £150, complete with matching unit, and the price includes instruction of the purchaser's staff in using the set, making electrodes, etc. An experimental screened heating chamber is available as an extra, price £12, or £17 with its own coupling transformer.



The new Vortexion 50 watt amplifier is the result of over seven years' development with valves of the 6L6 type. Every part of the circuit has been carefully developed, with the result that 50 watts is obtained after the output transformer at approximately 4% total distortion. Some idea of the efficiency of the output valves can be obtained from the fact that they draw only 60 ma. per pair no load, and 160 ma. full load anode current. Separate rectifiers are employed for anode and screen and a Westinghouse for bias.

The response curve is straight from 200 to 15,000 cycles in the standard model. The low frequency response has been purposely reduced to save damage to the speakers with which it may be used, due to excessive movement of the speech coil.

A tone control is fitted, and the large eight section output transformer is available to match, 15-60-125-250 ohms. These output lines can be matched using all sections of windings, and will deliver the full response to the loud speakers with extremely low overall harmonic distortion.

PRICE (with 807, etc., type valves) £18.10.0

Plus 25% War Increase

MANY HUNDREDS ALREADY IN USE

Supplied only against Government Contracts

**VORTEXION LTD.**  
**257, THE BROADWAY.**  
 WIMBLEDON, S. W. 19.  
 Phone: L1Berly 2814

# RANDOM RADIATIONS

By "DIALLIST"

## Times Change

HAD anyone suggested to an assembly of either practical radio men or physicists twenty-five years ago that it would ever be necessary to make national and international allocations of frequencies from 25 megacycles per second upwards, his remarks would probably have been greeted with the loudest of loud laughter. If, undeterred by this, he had gone a step further by predicting that there would one day be a scramble for channels up to 30,000 Mc/s and that experimental work on even higher frequencies would be contemplated seriously, his audience might have shaken their heads sadly over the unfortunate delusions under which the poor fellow was labouring. It was, you see, known (!) to all sane men that for good and sufficient reasons (as it then appeared) frequencies above 3 Mc/s could not possibly have any commercial future. As for those of the order of 25 Mc/s, they were clearly useless outside the laboratory . . . and here was a fellow prophesying that not merely 25 Mc/s, but 250 Mc/s, 2,500 Mc/s and—supreme height of folly—25,000 Mc/s and above would have a big part to play in the world's communications. Pathetic that anyone should be haunted by such impossible ideas!

## At the Gallop

Twenty-five years is a short space of time, but it has seen the most astonishing developments in wireless technique. No department of applied science affecting the life and well-being of man has seen comparable advances in the time. There has been progress in our clothes, our furniture, our bicycles, our motor cars, our lighting, our heating systems, and in a thousand and one other things that affect our daily life. But all that might be termed normal, steady progress. Even in the air there have been no spectacular leaps forward: the aircraft of to-day, though faster, more reliable and capable of conveying bigger loads to greater distances, are direct descendants of the kind that might be expected of those of the 1920's. Medical science has, perhaps, made greater advances than most other branches, though it has still not found solutions of such age-old problems as lumbago, asthma and the common cold. But wireless has gone forward all the time at the

gallop and there seems to be no slackening of the pace. The short waves proved to be not useless but invaluable for telecommunications. The ultra-short waves were next harnessed and set to do useful work. Now it is the turn of the microwaves down to a length of about one-centimetre, which undoubtedly have a big future for many purposes. Next may come the turn of that so far almost unexplored belt in the frequency spectrum which contains the frequencies intermediate between those producing the effects which we know as wireless on the one hand and heat on the other.

□ □ □

## A Record Audience

NEVER have I seen the I.E.E. Lecture Theatre so packed as it was on the occasion of Sir Edward Appleton's paper on "The Scientific Principles of Radiolocation." I took a guest, and, expecting that there would be a crowd, I urged him to be in good time. At these functions tea is normally at 5 o'clock and the lecture at 5.30. We got there at about five minutes to five and found the theatre to all appearances already full. Deciding on the instant to cut out tea, we secured what must have been almost the last two seats available. And during the next half hour there was an unceasing inflow. They packed the gangways, the exhortation thrown on the screen by lantern slide to "sit familiar" was obeyed until we sat so close that not even a giant shoe horn could have inserted one more. They stood, the rear ranks on chairs, in the open doorways. In any event there must have been many latecomers who had no chance of hearing the lecture, and it was good to hear Sir Harry Railing, the President, announce that Sir Edward Appleton had agreed of the goodness of his heart to repeat his admirable lecture at a later date. The fact that the audience was so big is a sure proof of the interest taken in radiolocation and of the desire of electrical engineers who had not been engaged in it during the war to know more about it. That being so, it is a thousand pities that in the interests of security those who were there may say nothing of what Sir Edward spoke of in his lecture. I can't, therefore, tell you anything about the tale that he unfolded. I may, though, say that he, too, was bound by the security fetters and that there was much that he had to leave unsaid.

## A Queer Idea

EVERYWHERE one goes one meets folk who indulge in a strange kind of wishful thinking. Despite the mass of evidence to the contrary that doesn't need much looking for, they are convinced that wireless sets, radiograms and television receivers are going to be much cheaper after the war than they were before it. Ask them why they are of this way of thinking and they murmur the blessed phrase "mass production," and seem to think that it is the last word on the subject. Well, we had mass-production before the war, though admittedly not on the scale that will be seen when peace returns. But even large-scale mass-production can't nullify the huge increases that there have been in wages, taxes, rates and the cost of raw materials, machinery and power. The motor industry has already announced that the prices of cars will be up by something like 40 per cent., and we might as well face the facts in radio. Wages, one of the biggest of overhead expenses, have risen by about 80 per cent. in the wireless factories. Again, no one can say when purchase tax is coming off; for certain rather guarded recent utterances by those in authority one gathers that it won't anyhow be immediately after the end of the war. In my view the cost of wireless sets has never debarred people from buying them, so long as they were good. But I'd like to see the radio industry scotching authoritatively the queer ideas about cheaper and cheaper post-war wireless sets that have been fostered by some section of the lay press. It's no good living in a fool's paradise.

□ □ □

## Monitoring

THIS war has produced some strange jobs! One of the queerest I have come across is that of a recorder in the B.B.C.'s monitoring department. Since the early days of the war every enemy transmission by wireless from long, medium or short-wave broadcasting stations has been tuned in and taken down *verbatim*. The records are most carefully scrutinised, for there is no knowing when a useful piece of information may be obtained by reading between the lines. I've met people who have held these jobs and they agreed

that despite long spells of boring monotony, they had on the whole a most interesting time when listening in on the monitor receivers. I can well believe it. I've not been able to do a great deal of listening to enemy stations myself during the war, but once or twice I've heard carelessly censored or unguarded sentences that have given quite a lot away. Sauce for the goose is, of course, sauce for the gander and our enemies no doubt monitored our transmissions just as assiduously as we monitored theirs. I have an idea, though, that they didn't learn from them much that they weren't meant to learn.

□ □ □

Sets for India

THE letter from H. K. L. Arora in the last issue of *Wireless World* on sets for the Indian market raised some interesting points. It is curious that British makers should have neglected this market so much in the past, believing that it was too small to be worth bothering about. Certain foreign firms were by no means of the same way of thinking. They saw that if wireless in India had small beginnings it was bound eventually to be a big thing and they went for the market wholeheartedly—and successfully. Of my many British friends in India, there wasn't one who had a set made in this country—or at any rate I can't call one to mind. They wanted British-made sets, but they could not get the kind that they needed. Now that the war has more or less wiped the slate clean by closing down production all over the world, I do hope that our manufacturers will realise the possibilities of the Indian market and that they will export sets that meet all requirements. But it is essential that they should be thoroughly conversant with those special requirements.

Catalogues Received

PAMPHLET describing moving-coil microphones made by Lustraphone, Ltd., 84, Belsize Lane, London, N.W.3.

Price list of amplifiers, receivers and components from H.P. Radio Services, Ltd., 55, County Road, Walton, Liverpool, 4. Price 1d.

Catalogue of "Radio Service Aids" from V.E.S., Radio House, Melthorpe Drive, Ruislip, Middlesex. Price 3d.

GOODS FOR EXPORT

The fact that goods made of raw materials in short supply owing to war conditions are advertised in this journal should not be taken as an indication that they are necessarily available for export.

*It's the hidden details that count*

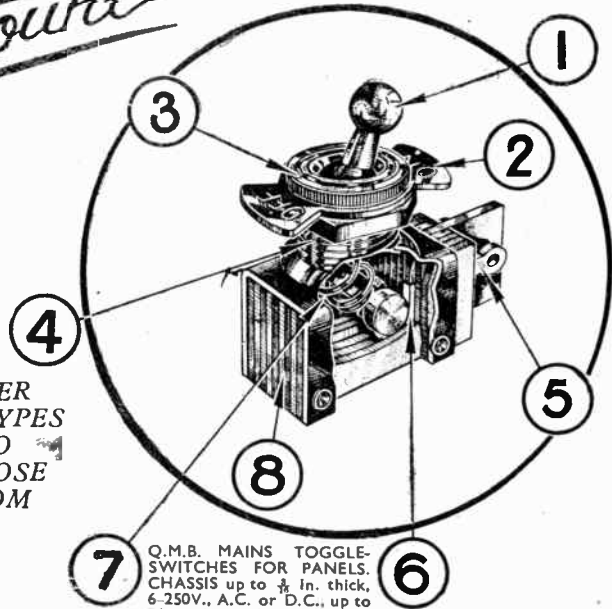

OVER 200 TYPES TO CHOOSE FROM

Q.M.B. MAINS TOGGLE-SWITCHES FOR PANELS. CHASSIS up to 1/2 in. thick. 6-250V., A.C. or D.C., up to 5A-peak; also SPECIAL LOW-VOLTAGE TYPES.

- 1 — Quick-action controlled by nickel-plated dolly (i.e., lever) picoted in the fixing-bush.
- 2 — Indication-plates, keying to the fixing-bush, are made with normal codings:—On-off; off-on; Radio-gram; etc.
- 3 — One-hole fixing (max. thickness 3/16 in.) by 1/2 in., 32 t.p.i. bush, with knurled front finger-nut.
- 4 — Rear-of-panel nut, essential for firm fixing, for tightening behind panel.
- 5 — Silver-plated solder tags (integral with fixed contacts), accept wires up to 18 S.W.G. or equivalent.
- 6 — Massive silver-plated contacts, self-cleaning, ensuring low contact resistance, even at minimum voltage-rating.
- 7 — Compression-spring "tumbling" action, ensuring q.m.b. and firm contact pressure, even under acceleration, of the order of 7-g.
- 8 — Insulant-stacking of approved materials of tropical grade, maintaining any leak-to-earth current at a negligible percentage of circuit current. (Output I.S.C.C.-allocated at present.)

*The choice of Critics*



A. F. BULGIN & CO. LTD., BYE PASS RD., BARKING, ESSEX

RIPpleway 3474 (5 lines)

(The name "BULGIN" is registered Trade Mark)

# RECENT INVENTIONS

## INTERACTION BETWEEN WAVE GUIDES

ONE wave guide is coupled to another through the electron stream of a cathode-ray tube, the combination acting as an amplifier or as an oscillation-generator.

As shown, the electron stream from a "gun" K flows through the tube to a target T. Two wave guides, W1 and W2, one serving as an input, the other as an output, are folded about the tube in a zig-zag fashion so that the relatively slow electrons meet the same phase conditions at each of the points A, B, C, at which they encounter the faster-moving fields in the guide. Under these conditions, the electron stream will be "bunched" or velocity modulated by the guide W1, and will deliver up energy to the similarly arranged output guide W2. Correct phasing is ensured (a) by the length of the folds in the guide, and (b) by adjusting the accelerating voltage applied to the stream.

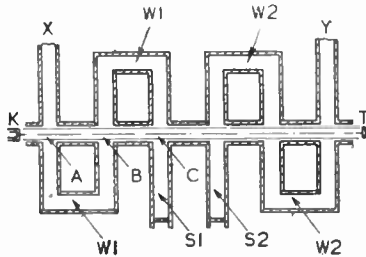

Electronic coupling between wave guides.

Each wave guide is terminated by quarter-wave stubs S1, S2, so that the reflected energy is in phase with that prevailing at the points where the guide crosses the stream.

The wave in the guide is of the H1 type, that is, the electric field vector is transverse to the axis, as is the passage of the bunched electrons across the openings shown. The device will generate sustained oscillations if the points X, Y are back-coupled through a wave guide of appropriate length.

*Electrical Research Products Inc. Convention date (U.S.A.) May 17th, 1940. No. 564890.*

## DC AMPLIFIERS

WITH direct coupling, as used for amplifying very low frequencies, the mean anode voltage of one valve is transferred to the grid of the next, so that a heavy counter-bias from large batteries is usually required to avoid overloading.

According to the invention, there is included in the anode-to-grid lead a thermo-sensitive element having a negative temperature resistance, such as a directly heated "Thermistor," i.e., a mixture of manganese and nickel oxides. The falling resistance of this device modifies the ohmic response of the other elements in the coupling in such a way that, whilst the full range of the anode swing is transferred, the mean voltage on the grid is reduced to

## A Selection of the More Interesting Radio Developments

one-quarter of the mean anode voltage. *Standard Telephones and Cables, Ltd.; P. K. Chatterjea; and T. C. Scully. Application date May 14th, 1943. No. 565609.*

## SHORT-WAVE AERIALS

ONE end of a flexible wire is wound around a drum, and the other end is connected to an insulating cord, which passes over a pulley at the top of a supporting mast and then down to a second drum mounted on the same shaft as the first, so that the effective length and therefore the tuning of the aerial can be adjusted by rotating the drum shaft. The arrangement is suitable for military vehicles, motor boats and the like.

A transmission line feeder is coupled to the first drum through a wiper contact in series with an inductance which serves to reduce the shunt capacity of the aerial to earth. A metal ball or other capacity-loading device may be inserted between the top end of the wire and the insulating cord, to reduce the physical height of the aerial.

*Standard Telephones and Cables, Ltd., and E. O. Willoughby. Application date, May 8th, 1943. No. 565526.*

## AIRCRAFT INDICATORS

IN order to observe various meter readings when flying in the dark, or under conditions of low visibility, it is usual to coat the dials with a luminous paint which glows when subjected to ultra-violet light. But if a cathode-ray indicator is amongst those to be read, the projected ultra-violet rays will cause the whole of the screen to fluoresce, thereby blotting out any significant signal.

To overcome this difficulty, the "window" end of the CR tube is painted or sprayed, say with nitro-cellulose containing a small amount of picric acid. This solution is transparent to ordinary light, but not to ultra-violet rays.

*Standard Telephones and Cables, Ltd., and H. Wolfson. Application date May 10th, 1940. No. 565694.*

## TUNING INDICATORS

BY using control voltages taken from various points of the receiving circuit an auxiliary cathode-ray device is arranged to give automatically and simultaneously the following tuning indications:—(a) The operating wave-band by a vertical deflection of the electron stream into alignment with one or other of, say, three horizontal scales, and (b) the actual tuned frequency by the horizontal deflection of the stream along the selected scale. In

both these cases the control voltages are applied to the deflecting plates of the CR tube from potentiometerappings which are ganged with the wave-change switch and tuning knob respectively. (c) The intensity of the incoming signal (or the accuracy of the tuning adjustment) by the vertical height of the indicating mark formed on the screen, this being controlled by a voltage applied to one of the deflecting plates from the 1F amplifier. (d) The signal output is shown by the width of the mark as determined by a voltage applied across the other deflecting plates from a tapping on the resistance in the AF stage of the set. When these indications are no longer required, the cathode-ray tube can be switched to "stand-by."

*Philips Lamps, Ltd. Convention date (U.S.A.) May 25th, 1942. No. 565795.*

## CATHODE-RAY OSCILLATORS

THE main stream of a cathode-ray tube is focused on to a secondary-emission target T, and the released electrons are forced to oscillate across a positively biased grid. As they leave the target, the secondary electrons are attracted by a relatively positive open grid G, but are retarded and reversed in direction first by the relatively negative bias on a cylinder P, and again by the negative charge of the primary stream, so that they are kept oscillating between these limits. A second grid G1 feeds energy from the moving mass to a tuned output circuit, which is also connected to a feed-back grid G2 lying in the path of the primary stream. The arrangement can be used as an amplifier, generator or frequency-changer.

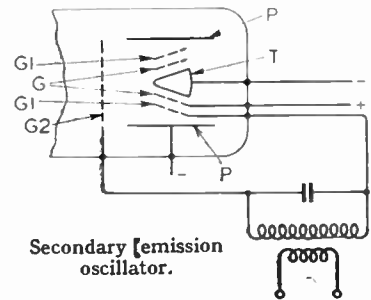

Secondary emission oscillator.

Alternatively, the method of "bunching" or velocity modulation can be applied to the tube. One resonator unit is set in the path of the primary stream, and another in the path of the secondary electrons, and the two units are back-coupled.

*Flowerdale, Ltd.; A. Perelmann; and L. Young. Application date February 11th, 1943. No. 566067.*

The British abstracts published here are prepared with the permission of the Controller of H.M. Stationery Office, from specifications obtained at the Patent Office, 25, Southampton Buildings, London, W.C.2, price 1/- each.

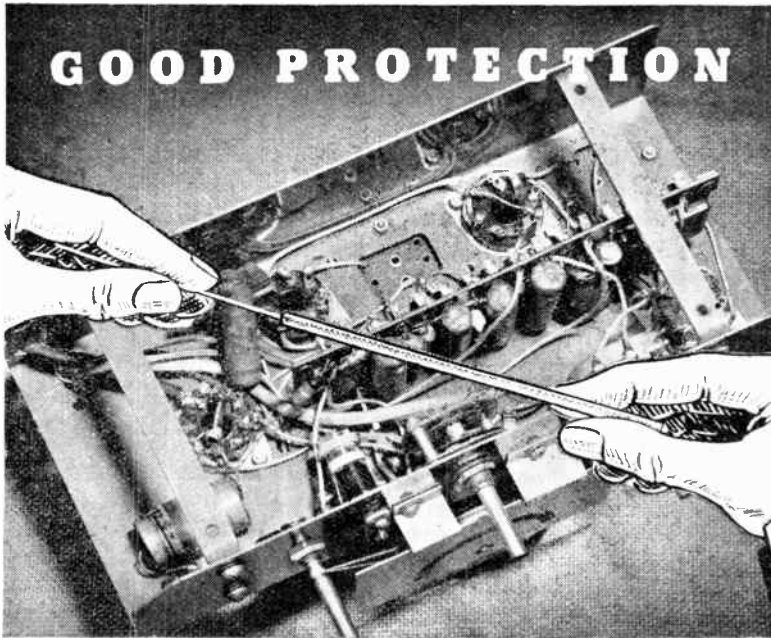

"DELAFLEX" Sleeveings adequately fulfil the vital functions of protection and insulation at every point in the internal wiring of all Radio and Electrical apparatus. "DELAFLEX" is available in i.d. of from 0.5 mm. to 35. mm. in varying types to Specification. The Rolled Silk range is specially made for use in tropical equipment. Fullest details, samples and prices gladly sent on request.

**Delaflex**  
*Insulating Sleeveing*

**DE LA RUE INSULATION LTD**

IMPERIAL HOUSE · 84 REGENT ST · LONDON · W1 (REGENT 2901)

ROLLED SILK  
METAL SCREENED  
VARNISHED COTTON  
WOVEN FIBRE GLASS  
VARNISHED ART SILK

HOW HIGH IS THE SKY?

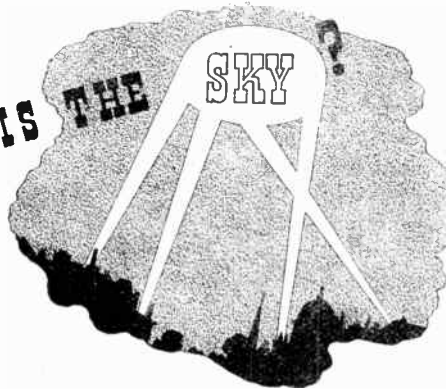

Measurement has become a science in itself. In electrical communications it must encompass the globe, yet remain accurate to very much less than a hairs-breadth; it must daily serve the communications engineer yet anticipate the trend of development and research.

Thus to describe measurement in communications is equally to define the function of Marconi Instruments

Ltd., makers of the highly specialised equipments which have reduced once complicated testing problems to the level of routine problems.

We spare just a moment to review with satisfaction our endeavours of recent years—the tasks of to-day are no less vital and the expectations for to-morrow no less momentous in a world where communications will spread the truth to the far corners of the earth.

**MARCONI**  **INSTRUMENTS, LTD**

ST. ALBANS, HERTS.

Telephone : St. Albans 4323-6

Rate 6/- for 2 lines or less and 3/- for every additional line or part thereof, average lines 5-8 words. Box Numbers 2 words, plus 1/- Press Day; July 1945 issue, first post Friday, June 8th. No responsibility accepted for errors.

Under Defence Regulations 1939, Statutory Rules and Orders 1940, Number 1689, a permit (199G) must be obtained before sale or purchase of certain electrical and wireless apparatus particularly such valves and apparatus as are applicable to wireless transmission.

#### NEW RECEIVERS AND AMPLIFIERS

**H. P. RADIO SERVICES, Ltd., offer:**  
**CIVILIAN** radio receivers (splendid performance), ac superhet £12/3/4, battery superhet £10/19; 5w ac/dc amplifier with valves, neat chassis construction, £6/10; Rothemel crystal grammo. pickups, 78/9; home ac batt. chargers, output 12v 1 amp, £2/19/6; mains transformers, 80ma 27/6, 120ma 35/-; step-down trans., 230-110v, 60w, 30/-, 100w 35/-; bell trans., 5/11; 1st grade line cord, 0.3amp, 3-core, 60 ohms per ft, 2/6 per yd; vol. controls, with sw, 4/6, without 3/6; Itola 8in pm speaker, 19/6; Celestion 8in, fitted with trans., 29/6; Celestion 8in, mains energised, 2,000 ohms field, with trans., 36/-; Vitavox 12in pm, £6/18/6; universal output trans., 7/6; Meico moving coil microphone trans., Meico floor stands, 42/6; microphone trans., 70/1, 3/6; carbon mikes, 2/6; conds., 500v 2mfid 2/6, 4mfid 3/9; vibrators, Mallory 6v 6-pin, UX base, 12/-; bases, 1/-; 12v vibrators, small square case, 10/-; plug & distributor suppressors, 2/3 ea.; dynamo conds., 2/6; telescopic car aerials, n.p. bumper fitting, 21/-; cathode ray tube, Mullard or Cossor 3in electrostatic, with base, £3/6; (TTC Argon relays, 25/-; HyR2A Mullard rectifiers, 20/-; Mullard universal measuring bridges, 15gns; Mullard B100 cathode ray unit with 3in tube, 12gns; radio valves, large stock; milliammeters, 0-1ma, highest grade, 3½in 73/6, 4½in 90/-; radio chassis, enam. grey, drilled, 10x8x2½in, 2/6; 4B.A. screws & nuts, 5/- gross; bargain parcel for experimenters, 14lb., contains trans., conds., rheostats, resistances, 100s nuts, bolts, washers, etc., 12/-; books, "Radio Pocket Book," 1/-; "Radio Valve Manual," 3/6; "Radio Circuits," 2/-; "Amplifier Manual," 2/-; "Radio Inside Out," 4/6; "Manual of Disc Recording," 2/-; "Radio Test Gear Construction," 1/6; "Short Wave Handbook," 2/-; all new goods; satisfaction guaranteed; s.a.e. with enq.; postage extra under £4.  
**H.P. RADIO SERVICES, Ltd.,** 55, County Rd., Liverpool, 4. [3834]

**W.W. Qual. amplifier,** £16; Brierley pick-up parts & trans., 42/-; s.a.e.—Box 3453.

**COMMUNICATION** receivers. —Remember "Dale" after the war.—Dale Electronics, Ltd., 152-6, Gt. Portland St., W.1. Mus. 1023.

**COMMUNICATION** receivers.—As soon as civilian supplies recommence we shall be at your service.—A.C.S. Radio, 44, Widmore Rd., Bromley, Kent. [3805]

**4-VALVE** ac/dc Midget kit set, complete with all components, selective, no overlapping valves, 5in speaker, chassis, 10x4x2½, nothing else to buy; immediate delivery, £8/10.—Henry's, 5, Ilarrow Rd., Edgware Rd., London, W.2. [3832]

**QUALITY** amplifiers, 200-250v ac, 5 watt 8½gns., 12 watt £14; s.a.e. for fully illustrated leaflet and copy of "Design for Quality", immediate deliveries.—J. H. Brierley (Gramophones and Recordings), Ltd., 403, Mill St., Liverpool, 8. Lark Lane 1709. [3796]

**AMPLIFIERS**.—Complete equipment for P.A. industrial, dance and stage installations and portabye apparatus from 15 to 150w; early deliveries; illustrations and spec. on request.—Broadcast and Acoustic Equipment Co., Ltd., Broadcast House, Tombland, Norwich 26970. [2963]

**BAKER'S**.—New 7-valve "Wireless World" Quality amplifier with tone control stage, 8 watts push-pull triode output, price includes super Quality triple cone, 12in permanent magnet speaker, with large output transformer and all valves; also as above but with 15 watts tetrode output, ideal for realistic reproduction for public address; limited orders only; 2½d. stamp for particulars, prices, etc.—Bakers Selhurst Radio, Tel. Croydon 4226.

**NEW** 10w "W.W." Q.A.; separate power pack; R.F. pen. and infinite imp. det. tuner; R.F. pen. gram. input with frequency correction; smoothing and decoupling by large paper condensers; constructed entirely from highest grade components; strong polished oak radiogram cabinet; reconditioned Garrard U.5 motor; Garrard pick-up; Vitavox high-fidelity speaker in large acoustic chamber; at cost, £75.—80, Burtleigh Gdns., N.14. [3795]

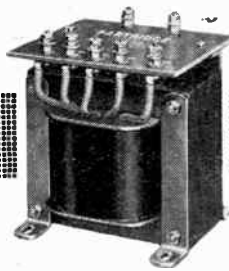

For the past 15 years we have devoted our energies exclusively to the manufacture of Transformers and Chokes. Although we continue to be very active in the field of Research and Development, we are nevertheless giving much of our attention to increasing our range of mounting facilities.

Illustrated above is one of the varied range of styles which is now in preparation. If you would like a copy, please write to us (enclosing 1d. stamp) and we will send you one immediately it is ready.

Telephone:

Abbey 2244

**PARTRIDGE**  
**TRANSFORMERS LTD**

76-8, PETTY FRANCE, LONDON, S.W.1

## ARMSTRONG

ARMSTRONG has always had the name for Quality.

When this war has been brought to a successful conclusion our new range of ARMSTRONG CHASSIS will prove that our reputation was built on a firm foundation.

**ARMSTRONG WIRELESS & TELEVISION CO. LTD.**  
 WALTERS ROAD, HOLLOWAY, LONDON, N.7

Phone: NORTH 3213

#### RECEIVERS, AMPLIFIERS—SECOND-HAND

**MURPHY** Allwave, offers; wanted, Hallcrafters SX28; details, price.—Box 3452.

**RADIO** sets, amplifiers and radio surdries; list free; state needs.—A.C.S. Radio, 44, Widmore Rd., Bromley, Kent. [3806]

**PROTOTYPE** television set by well-known manufacturer, 10-inch tube and mirror, complete with console cabinet; £20.—Box 3443.

**W.W. Qual. amplifier** Straight 6 rec, 2 feeders, profes. built, regardless expense; Magnavox 66, as new; offers.—Box 3457. [3820]

**HALLCRAFTER** dual-diversity model DD1 23v communication receiver, 4.5 metres to 550 metres, for sale; send for full particulars.—Box 3461. [3824]

**DUICETTO** 20w amplifier. Philips 5w amplifier, R.C.A. 20w amplifier, all with valves; "W.W." 1930-1944 issues, unbound; offers.—Pollard, 1, Broomfield Rd., N.13.

**HALLCRAFTERS** 13-valve Super Skyrider S.X.17, communications receiver, 8 meter, crystal filter, 1,000' electrical bandwidth, excellent condition, technical manual, no speaker; £65, or near offer.—Box 3464.

**AMBASSADOR** receiver-amplifier P.A.143, ac grammo and micro jacks, 2 Pen 45 in push-pull output, 20 hours running only; best offer over £21.—King, Easons, Underhill Lane, Clayton, Sussex. [3773]

**NATIONAL H.R.O.** Senior receiver, complete with 2½v tubes & 4 sets of coils, 1.7 mc/s to 30 mc/s, 1938 model, less power pack & speaker, absolutely perfect condition; wanted, Taylor 85a meter, I.M.V. Hypersensitive pick-up with trans. & matching unit; Voigt corner horn speaker, complete.—Exchange or reasonable offers to W. Gearing-Sherratt, 82, High St., Newport, I. of W. Tel. 2504. [3810]

#### NEW LOUSPEAKERS

**£5/18/6**.—New Baker Super Quality 12in Auditorium permanent magnet speaker with triple cone, manufactured by Bakers Selhurst Radio, the pioneer manufacturers of moving coil speakers since 1925, wide frequency range, even response, ideal for quality reproduction, fitted with magnet having exceptionally high flux density in the air gap, suitable for public address equipment when quality reproduction is first consideration; send 2½d. stamp for leaflet giving details of above and constructional details of a new acoustic chamber designed to extend loud speaker frequency range; also constructional details of an infinite baffle cabinet; every music lover interested in realistic reproduction should write for leaflet.

**£8/19/6**.—New Baker super power cinema 2½d. permanent magnet speaker with 18in triple cone of new design, giving wide frequency response free from objectionable resonances; speech is clear and natural and music is reproduced with exceptional realism; fine engineering job, extremely sensitive, ideal for public address equipment when power handling capacity, plus realistic reproduction, is required; present deliveries of speakers three to four weeks.—Bakers Selhurst Radio, 75, Sussex Rd., S. Croydon. Tel. Croydon 6813.

#### DYNAMOS, MOTORS, ETC.

**E.D.C.C.** converter, 240v dc to 230v ac, 100 watts, for radio; offers.—10, Heathview Crescent, Dartford. [3843]

**NEW** ac motors, ¼hp, high starting torque, 200-250v, £4/15; ½hp, £5/5; ¾hp £7/5; 1hp, £9/7/6; all other sizes available; also machinery.—John W. W. Steel, Bingley, Yorks.

**ELECTRADIX** dynamos and motors at bargain prices, dynamos, ht and lt G.E.C. double current, 6v and 600v, weight 17lb, 37/6 p.kg. and carr. paid; supplied Eng. and Wales only; refund 5/- on returned cases; dc motors, 1-5th hp and ¼hp dc motors, enclosed, silent, 220 to 250v, 1,500 revs, double-end ¼in shaft, first grade make, guaranteed, 1-5hp, £27/10 each; ¼hp £24 each; all carr. paid Eng. and Wales; others in stock.—Electradix, 214, Queenstown Rd., Battersea, London.

**SIEMENS** H.T. dynamo, 1,500v, 1.36a, £5/10; Regalite type XP500 complete charging equipment, charging board, starter, etc., input 230v 50 cycles, i.t. 8v 60a. h.t. 150v 1a, easily charges 100 cells daily; brush gear, requires slight attention, £22/10.—52, Standishgate, Wigton. [3748]

**ALL** types of rotary converters; electric motors, battery chargers, petrol-electric generator sets, etc., in stock, new and second-hand; supplied against priority orders only.—WARD, 37, White Post Lane, Hackney Wick, E.9. Tel. Ambers 1393. [1988]

#### CABINETS

**SPECIAL** offer to clear.—Loudspeaker cabinets, polished oak, 12/6 and 15/6. polished walnut, 17/6 each, delivered in any quantity; any type of radio cabinet made to order; send us your enquiries.—Waldenberg Bros., Ltd., New York Rd., Leeds, 2. [3030]



**NEW MAINS EQUIPMENT**  
**VORTEXION** mains transformers, chokes, etc., are supplied to G.P.O., B.B.C., L.P.T.B.; why not you? Imitated but unequalled; orders can only be accepted against Government contracts.  
**VORTEXION, Ltd.**, 257, The Broadway, Wimbledon, London, S.W.19. Lib. 281.

**TEST EQUIPMENT**  
**O**UR 15 yrs. experience as designers of test equipment in kit form at your service.  
**KITS** include 45-range ac/dc Multimeter (7gns. with BS 1st grade, 1,000 O.P.V. meter), R.F. oscillators, R.C. bridges, V volt-meters, Signal Tracers, etc.; 8-page list sent on receipt of s.a.e. and particulars of requirements.  
**MacLachlan and Co., Strathyre.** [3774

**10 METERS** for sale, Turner, Weston, Fer-ranti; s.a.e. for list, lot or separate.—Box 3451. [3807

**HUMS'** capacity and resist. bridge, sell or exchange test equip.—Brown, Carharrack, Redruth, Cornwall. [3830

**VOMETER**, model 40 universal, leads, clips and prods, perfect condition; nearest offer to £18.—Apply Box 3463. [3835

**COSSOR** linear portable mains oscillograph (catalogue No. 3295), little used, new cond., complete; best offer secures.—Box 3441. [3835

**MULLARD** master test board, complete with cards, perl. cond., any insp, type 7629, 25/- or offer; Savage M type microphone, comp. with chromium ring and stand; also W.B. moving coil mic. (req. slight att.), offers.—Owen, 538, Mansfield Rd., Nottingham. [3835

**R.C.A.** electronic voltmeter and ohmmeter (bridge and valve voltmeter), latest model, brand new, 6 ranges, from 0.05 to 1,000 volt ac/dc and from 0.1 ohm to 1,000 megohm; £28.—Apply 61, Highgate High St., or Tel. Mountview 9431. [3850

**CAMBIDGE** Unipivot Galvo, £9; W.W. modulated oscillator, less batteries, 80/-; R.A. 7in. speaker, £1; Belling Lx suppressor, 1.300, £1; Westinghouse h.t.B. 7/6; Rothermel crystal pick-up, 50/-.—Daniels, 16, Sinclair Drive, Liverpool, 18. [3855

**MAINS** transformers, shrouded 200-250 primaries, type A, 350-0-350, 100ma 4v 3amp and 4v 5amp, 25/-; type C as A but 6v and 5v heaters, 25/-; type B as A but 200ma secondary, 42/6; type D as C but 6v and 5v heaters, 42/6; type E as C but 500-0-500 secondary, 42/6; type F as E but 6v and 5v heaters, 42/6; 15 watt, 35/-; 25 watt, 35/-; 200ma smoothing choke, 17/6; many other lines available; send 1d. stamp for complete list.—V.E.S., Radio House, Ruislip, Mdx. [3855

**MORSE** practice equipment for class room or individual tuition; keys, audio oscillators for both batt. or main operation.—Webb's Radio, 14, Soho St., W.1. Ger. 2089. [2291

**GRAMPHONE AND SOUND EQUIPMENT**  
**H.M.V.** hypersensitive P.U. and trans. £6. Park 18, Loring Rd., Whetstone, N.20. [3855

**HYPERS-SEN** Marconi pick-up, £5; metal tonearm Marconi pick-up also; Pallard induction motor, Swiss made, offers £13 3/4. 22. [3855

**R**ECORDING discs suitable for all types of machine; Sapphire Stylus and recording accessories in stock; enquiries invited.—Write to Simon Sound Service (Evacuation address), The Cottage, Greveling Ct., Virginia Water, Sv. [3855

**H.M.V.** auto-record player chassis, £20; 30-watt amplifier (2 PX25As in push pull, 2 spare PX25As), multi output transformer, £25; Garrard AC4 motor; offers?—Hardy, Chichester House, Chichester Terrace, Brighton 7. [3801

**VALVES**  
**L**OOK out for valves and circuit analyser; details later.—London Sound Labs., Ltd., 40, South Molton Lane, Bond St., London, W.1. [3855

**ALL B.V.A.** valves available, also number of discontinued types; list prices; pro forma or c.o.d.—David Robinson, Ltd., 100, High St., Bedford. [3421

**O**UR adaptors will help in replacing unobtainable valves; send 7d. for interesting booklet on valve replacements; trade enq. invited.—V.E.S., Radio House, Ruislip. [3855

**COMPONENTS—SECOND-HAND, SURPLUS**  
**ACORN**s, 95d, 95d, 50/-; 955, 45/-; vibrators, 6v 4pin, 13/6; linecord, 2-core, 0.3amps, 60 ohms, per ft., 1/-; 3-core, 0.3amps, 60 ohms, per ft., 1/1; 3-core, 0.15amps, 100ohms, per ft., 1/2; service sheets, various, 10/6 dozen.—J. Bull & Sons, 246, High St., Harlesden, N.W.10. (See our display ad on page 31.) [3849

**RADIO** and electrical engineers.—Ex-Gov. side cutters, 22/6 1/2 doz.; long-nosed insulated pliers, 22/6 1/2 doz.; 42/- doz. pres. carriage paid, guaranteed brand new mains transformers, 4v or 8v heaters, 80 mA, 28/6; 120 mA, 37/6; multi output transformers, standard size, 6/6; carriage paid orders £5; s.a.e. for list radio spares.—A.D.S. Co., 261-35, Lichfield Rd., Aston, Birmingham. 6. [3299

# PREMIER RADIO

**ALL POST ORDERS TO:**  
**JURLEE WORKS, 167, LOWER CLAPTON ROAD, LONDON, E.5.** (Amherst 4723.)

**CALLERS TO:**  
**JURLEE WORKS or 169, FLEET STREET, E.C.4. (Central 2833)**

Send for details of other accessories available. All enquiries must be accompanied by a 2d. stamp.

**ELECTRIC HOUSEHOLD IRONS**, 5 lb., pre-war quality, with lead, 33/6.

**METERS**. First grade army type Universal Test Meters in shockproof bakelite cases, ranges 10, 100, 500 volts up to 1,000 ohms per volt A/C and D/C, 1, 10, 100 mA D/C, 0-50,000 ohms. £8 15s.

**FIRST GRADE METERS**. 3 1/2in. diameter, 1 millamp, £2 12s.; 500 microamps, £2 18s. 6d. 4 1/2in. 1 millamp, £3 5s.; 500 microamps, £3 11s. 6d. Westinghouse Meter Rectifier for either type, 10c. 100, 500, 1000 mA, 10/-. Any value multiplier, 2/6 each.

**SUPER QUALITY AMPLIFIERS**, 12 watts output, high and low gain inputs with mixer, treble and bass controls, two DB 30-11,000 cycles, negative feedback, 2, 4, 8 and 15 ohms output, £14 14s.

**AC/DC AMPLIFIERS**, 5 watts output, high gain, frequency feedback, £3 8s.

**BATTERY CHARGES** for 2 v. batt. at 1s., 25/-; for 2, 4 or 6 v. batt. at 1s., 45/-; for 6 v. batt. at 1s., 30/-; for 2, 6 or 12 v. batt. at 1s., 49/6; for 6 v. batt. at 4s., 23 10s.; 12 v. 4 amps., £4 10s.

**MAINS TRANSFORMERS**, 300 + 300 v., 60 m/a. three 4 v. 2-3 a. windings, 25/-; 350 + 350 100 m/a, 5 v. 2-3 a., 25/-; 2-3 a., 29/-; 350 + 350 100 m/a, three 4 v. 2-3 a. windings, 25/-; 350 + 350 150 m/a, two 4 v. 2-3 a., two 4 v. 1 a. windings, 30/-; 350 + 350 150 m/a, 5 v. 2 a., 6.3 v. 2 a., 6.3 v. 2 a., 36/-; 500 + 500 250 m/a, 5 v. 3 a., 6.3 v. 2 a., 6.3 v. 4 a., 65/-; 425 + 425 200 m/a, 4 v. 2-3 a., 4 v. 2-3 a., 3-6 a., 47/-; 350 + 350 150 m/a, 4 v. 1-2 a., 4 v. 2-3 a., 36/-; 500 + 500 150 m/a, four 4 v. 2-3 a. LT windings, 47/-.

**1-VALVE BATTERY S.W. RECEIVER**, with 2-volt valve, 4 coils, 12-170 m. handpiped tuning, 55/-, including tax.

**STEEL CHASSIS**, 10 x 8 x 2 1/2in., 7/-; 16 x 8in., 8/6; 20 x 8in., 10/6.

**SHORT-WAVE COILS**, fit octal sockets, 4-pin aerial coils, 9-15, 12-26, 22-47, 41-94, or 76-170 m., 2/6 each; 150-350 or 255-550 m., 3/-; 400-1000 or 1000-2000 m., 4/-; 6-pin H.F. Trans., 9-15, 12-26, 22-47, 41-94 or 76-170 m., 2/6. S.W. chokes, 10-100 m., 1/3; 6-2000 m., 2/6.

**SHORT-WAVE CONDENSERS**, easily ganged 15 mmd. 2/11; 25 mmd. 3/3; 40 mmd., 3/3; 100 mmd., 3/11; 160 mmd., 4/8; 250 mmd., 5/8; shaft couplers, 7d.; flexible ditto, 1/8. Dual handpiped for use with 2-gang, 6/6.

**MIDGET "P" TYPE COILS**, 12-35, 16-47, 34-100, 91-261, 280-750, 700-2000, 200-567, available as H.F. trans., aerial, or osc. coils, 2/3 each. Yaxley type wafers, 1/- each, 1/2 each, 1/4 each; locators, 2/- each; wafers, 1/- each. Small 2-gang condensers: 0.0005, 15/-; matched pairs from core 455 K.C. I.P. trans., 15/- pair; midget type, 21/- pair. 60 mmd. trimmers, 1/-; osc. paddler, 75d mmd., 1/9; B.P.O. coil, 2/3.

**PUSH BUTTON TUNING PACKS**, 16-47, 200/550, 1000/2000 metres, completely wired, adjustable iron cores, aerial and osc. coils, with superhet circuit, 30/-.

**CONDENSERS**, 4 mf. 450 v., 7/6; 2 mf. 350 v., 3/9; 50 mf. 30 v.w., 3/-; 50 mfd. 3 v., 2/3. Repairer's kit, 20 our assortment resistors and condensers, three 8 mf. 450 v. electrolytic, six octal sockets, 12 yds. pushback, 35/- the lot.

**CRYSTAL PICKUPS**, Comocord, £2 11s.; Rothermel super, £3 18s. 9d.

**AMERICAN VALVES**, 4525, 3525, 2525, 12SK7, 12SJ7, 2526, 6V6, 6F6, 5Z4, 80, 6I7, 6KT. Many others available.

**SUPER GIANT PUSH-PULL INTER-VALVE TRANSFORMERS**, 21/-; midget type, 12/6.

**MIDGET ALUMINATE RADIO**, AC/DC. We can supply circuit and all parts for sale. Write for details.

**MOVING COIL SPEAKERS**, Rola 6 1/2in. or 8in. P.M., no trans., 25/-; Plessey 8-in. P.M. with trans., 29/6. Goodmans 3 1/2in. P.M. with 3 or 15 ohm voice coil, no trans., 30/-; 8in. 1200 ohm energised, 35/-; 35/-, 35/-, 35/- standard or P.P. trans. for any voice, 10/6. Super quality giant Matchmaker output transformers, match any tube single or P.P. to any voice coil, 7-watt, 22/6; 15-watt, 30/-; 30-watt, 49/6; 60-watt, 59/6.

**CROKES SH.**, 300 ohms, 30 mA, 4/6; 3011, 400 ohms, 60 mA, 3/5; 3011, 100 mA, 400 ohms, 19/6; 3011, 185 ohms, 150 mA, 25/-; 2511, 250 mA, 120 ohms, 39/6.

**SUNDRIES**, 2 mm. Syntronic, 2 1/2 yd. yd.; resino-cored solder, 6d. per coil or 4/6 per lb.; screened 2-pin plugs and socket, 9d.; ditto, 8-pin, 2/-; Octal sockets, 10d.; ditto, amphenol type, 1/3. Valve screens, 1/2 doz., 2/-; vibrators, 4-pin, 12/6. 50ft. Indoor Aerial, 2/6.

VALUE! Matt has it!

**LINE CORD**—2-way 2/6 per yd, 3-way 3/- per yd (approx. 60ohms per foot).

**SPEAKERS**—Celestion P.M. 2 1/2in, less trans., 27/-; 8in P.M. with trans, 27/6; 6 1/2in P.M. (multi-ratio trans), 28/6; Rola 6 1/2in P.M. with trans, 28/6.

**TWO gang condensers**, 0.0005 with trimmers, 12/6; Midget coils h.f. and aerial, 5/- per pair.

**VOLUME controls** (all values) 1-watt, 3/6; w/switch 4/6, mains transformers 4v and 6v, 27/6; Rothermel (crystal) pick-ups, metal, 88, 23/13/6; Senior de luxe, £3/18/9; condensers, all types in stock, 2's, 8's, 16's, 20/20, 500v working; 0.1, 0.01, 0.25, 0.05, 25x25, etc. Resistances, 1/2 and 1 watt; all values 1/- each, 10/6 per doz.

**LET us quote you for all your requirements.** Cash with order plus postage.

**MATT RADIO SERVICE**, 152, Richmond Rd., Kingston-on-Thames, Surrey [3758

**SOUTHERN RADIO'S** wireless bargains:—

**LATEST** radio publications.—"Radio Valve Manual," equivalent and alternative American and British types with all data, 3/6; "Radio Circuits," fully illustrated receivers, power packs, etc., 2/-; "Amplifiers," fully descriptive circuits, 2/-; "Radio Pocket Book," Formulas, tables, colour code, etc., 1/-; "Radio Coil and Transformer Manual," 2/-; "Test Gear Construction Manual," 1/6; "Short Wave Handbook," 1/-; "Manual of Direct Disc Home Recording," 2/-; "10-How's for Radio Constructors," 1/-.

**POST Office paper conds.**, 2mf, upright, used but guaranteed perfect, 2/6; Mainsbridge conds, 2mf, 3/6; lmd, 3/-; 2.5-2.5+1 (6mfd), 7/6.

**ACE P.O.** microphones, complete, ready for use, with trans, 7/6; permanent crystal det., 2/6; crystal & catswhisker, 9d; insul. push-back wire, 25yds 5/-; insul. sleeving, assd. colours, 3/6 doz yd; lthas, single screened wire, 10/- doz yds; twin screened wire, 17/- doz yds; power rheostats, 10 ohms 4/6; 30 ohms 6/6; push button switches, 3-way 4/-, 8-way 6/- (with knobs); escutcheons for 8-way p.b. switches, 1/6; pointer knobs, black, brown, special instrument types, 1/2in fitting, 1/- ea.; round black or brown knobs, 1/2in, 1/- ea.; resistances, brand new wire ends, 1/4, 1/2, 1 & 2 w., mostly low values, 30/- per 100 res; heavy cut 1 1/2 chokes, 30 hys, 250ohms, 100ma, 1/6; 500ohms 16/-; 1,000ohms, 17/6; Yaxley type rotary switches, 11-way single bank, 6/6, brand new; soldering tags, incl. spade ends, 6/- gross; Multicon mica conds, 28 capacities in one, 0.0001 upwards, 4/-; mounting valve holders, English & American types, 1/- ea.; trimmers, 30pf, 1/- ea.; hundreds more bargains.

**SOUTHERN RADIO SUPPLY Co.**, 46, Lisle St., London, W.C. Gerrard 6653. [3785

**CHARLES BRITAIN RADIO (K. H. EDE)**, offers more bargains in radio spares.

**SERVOICE kits**—No. 1: One 8mfd tub, 450v, one 2mf, 25v can, 6.005 tub, 1/6. No. 2: Two 16mfd tubs, 450v, one 17mfd, Yaxley type doz asstd. conds, one mains dropper, 30/6. No. 3: Four 8mfd tubulars, 450v, 2 2mfd Mainsbridge, 24 asstd. tubs and ceramics, 32/6; rotary converters, 11v in, 480v out at 40mA, 35/6; heavy duty smoothing chokes (ex H.M.V.), 12/- ea.; Celestion speakers, 6in, p.m., with trans, 26/6 ea; 8in less trans, 21/- ea; Rola mains energised, 1,000 ohm field, 30/- ea.

**TUNING** condensers, Midget 2-gang 13/6, 3-gang 10/-; short-wave precision job on ceramic base 8/6; Yaxley type switches, 4-pole 2-way, 3-pole 4-way, 3/9 ea; 2-pole 2-way, 2/6 ea; Yaxley replacement wafers, 2-pole 4-way, 6/6 doz; volume controls, 1/4, 1/2, 1, 2 meg, with switch Centralab, 6/- ea; Dubilier less switch, all values, 3/- ea.

**1.17Z** wound m.w. coils, P type a. and h.f., 5/6 pr.; push-button units, ex R.D.G., with all-wave coils, pads and trimmers (faulty), 15/- ea; sleeving 1mf, 2/- doz yds; push-back wire, 2/- doz yds; Mainsbridge condensers, ex G.P.O., 2mfd 350v, 2/- ea; 1mfd, 1/-; dials, Marconi, glass, 3-band, 1/6; ditto, vertical type, 2/-; Ivorine dials Home, Forces, etc., 2/- ea; paper dials for Midgets, 8/- doz. THIS month's special offer: 110kc i.f. trans and osc. coils, ex Ekco, 5/- per set. Send s.a.e. for latest list; now available; terms: cash or c.o.d. over £1.—Charles Britain Radio (temp. address), "Eureka," Surrey Gardens, Egham, Surrey. [3852

**COSMOCORD** crystal pick-ups, 51/-; Philips C carbon mikes, with table stand and coupling box, £3/17/6; Crypton chargers, 2, 6 and 12 volts at 1 amp metal rectifiers, £4/4; miniature M.W. coils, h.f., with reaction and A, 6/- pr, with circuit; Philips 3-wave A. and h.f. coils 7/6 pr still available; c.r. tubes, B.V.A. valves, bridges, Vitavox speakers, p.a. equipment, new & second-hand, etc.; s.a.e. list.—Gregory, Union St., Cheddar, Som. [3813

# LASKY'S RADIO

370, Harrow Rd., Paddington, W.9  
(Op. Padd. Hospital.) Phone: Cunningham 1979

**This month's Special Offer!**

## 4-VALVE CONSTRUCTORS KIT

3-waveband. Exceptionally well made chassis size 13 1/2" x 6 1/2" x 3", complete with the following new and guaranteed parts: 2-gang variable .0005 with trimmers and large modern three-hand dial and glass. Pointer, Slow Motion disc and drive with pulley wheels, spring, cord and brackets, complete with push button unit with buttons and bakelite escutcheon, 2 pilot lamp holders, 8+8 mfd. electrolytic condenser, 500 volt wkg. vol. control, 1 meg. with switch, 3 paxodlin panels A/E, L.S. and P.U., 3 yds. mains lead and plug, knobs, etc. £3 5s. each. Postage and packing 2/- extra.

**SPEAKERS.** Rola 5" P.M., 21/6; 8", 23/6; 6 1/2", 22/6. Goodman's 3 1/2", 3 ohms v.c., 30/-; 5", 22/-; 10", 39/6. 12" Vitavox, £8 10s. 6" Rola energised 1,000 ohms held with trans., 32/6. 10" Celestion, with large output trans. P.M., 45/6. 8" Plessey P.M. with trans., 24/6.

**MAINS TRANSFORMERS.** Primary 200/240/40 volt. Sec., 4 v. 4 amp., 4 v. 2 amp., 350-0-350 120 m/a, 30/-; 6.3 and 5 volt types, 135 m/a, 32/6.

**LINE CORD,** exceptionally good quality, 70 ohms per foot, 4/9 yd. Slow Motion Dial and Drive, 2/6 each. Side cutters, insulated type, 4/5. 24 Assorted Condensers as per last month, £1 19s. 6d. post free. Synstoxes, 1 to 3 mm., 1/3 to 4/6 dozen. 2-Gang Condensers, .0005 with ceramic trimmers, 15/6; less trimmers, 13/6; 3-gang with trimmers, 13/6; less trimmers, 11/6.

**Mains Droppers,** 2 and 3 amp., 5/9 and 6/6. T.R.F. Midget medium high gain coils, H.F. and aerial, from 5/6 on. With diagram, 7/6 pr. Speaker Transformers, midget types, pentode shrouded, 5/9. Class B output, 80 m/a, 9/6. Class B Driver, 9/-. Valve Holders, all types, 7/6 dozen. Large Steel Chassis, size 14" x 10 1/2" x 1 1/2", 7/6 each. Midget Smoothing Chokes, 500 ohms, 60 m/a, 6/6 each. Resistances. Cards of 35 assorted 1/4 and 1 watt 21 1s. 6d. card.

5,000 new and boxed English and U.S.A. mains and battery valves in stock at list prices. Send list for lists. See previous adverts. for other goods. Send us your requirements, C.O.D., but cash with order preferred.

# YOU can become a first-class RADIO ENGINEER

We are specialists in Home-Study Tuition in Radio, Television and Mathematics. Post coupon now for free booklet and learn how you can qualify for well-paid employment or profitable spare-time work.

## T. & C. RADIO COLLEGE

2 The Mall, Ealing, W.5

(Post in unsealed envelope, 1d. stamp.)

Please send me free details of your Home-Study Mathematics and Radio Courses.

NAME .....

ADDRESS .....

W.W.40

C. A. RYALL, 36, Huron Rd., London, S.W.17. Mail order only, no c.o.d. under £1 please.

**INPUT** strips, 2inx3 1/4in, with terminal screws, 2-way, 2/6 doz; and/or mounting strips, 2-way, spaced for all and Iwatt resistances, 2/6 doz octal 8-pin plugs, with insulated metal cap, complete with international octal chassis type base, 1/3 ea, 3 for 2/6; ditto, with solder tags, to take heavy gauge wire, 1 1/4 ea, 3 for 3/-.

**MINIATURE** 4-pin plugs, robust pins, with metal caps, complete with socket, 3 for 1/6, per doz 4/9; valve holders, chassis type, our regular line in these available once again, 5- and 7-pin British 4, 5 and 6-pin UX American, international octal for 2V6, etc., all 4/6 per doz, or per 100 29/6. **DIAL** plates, oblong, 5 1/2x2 1/2, Varley, 200-550, etc., transparent, 4/16; Burniept 4-band dial 8x5 1/2, s.w. on lower half of scale, 1 1/6 ea.

**SPECIAL** offer T.C.C. mica cond., double 0.0001x0.0001, 5 (10 condensers) for 1/3; Hunts' 0.01 mica, 1/- ea; Yaxley type low loss switches, single-pole, double-throw, 2-bank, 2/9; single bank 2/3.

**TEN-WAY** cable, good conductors, 1/3 yd. 3yds 2/9; push-back connecting wire, stranded, 2 colours, cotton covered, 12yds 2/3; twin rubber flexible, one cover, for mains leads, etc. 3 yds 2/9; Morganite long spindle vol. controls, 10,000ohms less switch, 3/9; Centralab 150ohm vols, less switch, 3/9. **RFIF** colour coded resistances, 2w, 680, 6,800, 140,000, 1,500,000, 220,000, 470,000, 820,000, 2 1/3; Eric 3w 680ohms, 1/3 ea. **MIKROPHONE** capsules by Standard Telephones, 3/9 ea; hf chokes on ebonite bobbins, 5,000ohms, 1/3 ea. [3816]

**SUPREME RADIO,** 746, Romford Rd., Manor Park, London, E.12. Tel. III 1260. Est. 15 years.

**EVERYTHING** for the radio engineer, from a rewind to a valveholder.

**MIDGET** 2-gang 0.0005 condensers, V, with trimmers, split vans, fixing bkts., 12/6; midget coils, A.H.F.M.W., high gain, T.R.F., with circuit, 8/6; M.L. with circuit, 10/6; midget dials, med., 4inx3 1/2, ivory, 1/9; speakers, 3 1/2in p.m., less trans, 25/-, with trans, 30/6; 6 1/4in Celestion, with trans, 27/6, less trans, 22/6; midget knobs, 1/4in spindle, 8d ea.; pointer, 10d ea.; 8in Celestion speakers, with trans., 26/6; 8in Rola, less trans., 21/-; R. and A.E.M.C. 8in speakers, 1,200 ohms, with trans., 32/6; Marconi mains trans., 350-350, 4v, 2a, 6v 4a, 19/6; speaker trans, midget, 5/6; 40mils. P. and P., 7/6; smoothing chokes, 60 mils, 6 and 10, heavy duty, 100 mils. 10/-; mains droppers, 0.3a, 800 ohms, slider-fixing feet, 5/6; 0.2a, 1,000 ohms, 4/6; line cord, 60 ohms, per ft, 3-way 5/6, 2-way 4/6 yd; V.C.s, 2,000 ohms, 2meg, with sw, 5/6, less sw, 4/-; 2,000-10,000, wire wound, less sw., 5/6; bias condensers, 25mfd 25v w 2/3, 50mfd 50 v w 3/-; trimmers 40pfd, T.C.C. 9d.; slow-motion drives, 1/- ea.; screen wire, S 1/-, D 1/6 yd; screen caps, octal and standard, 9d ea.; I.F. trans., 1/- ea, or 10/- doz; 0.1+0.1mfd 350v w dc and 250v w ac, 1/6 ea.; metal speaker cabinets, nice finish, gold, green, grey, 17/6; s.a.e. all; heavy enquiries; cash with order; no c.o.d.; 6d extra for postage under £5.

**BATTERY** charger kits and rectifiers, mikes, transformers, electrolytics, metal rectifier, 2v 0.5a type with transformer, makes ideal trickle charger for 2v wireless cell, with circuit; 13/6, post 7d.

**METAL** rectifier, 12v 2.5a type, with transformer and ballast bulb for 2v to 12v charger; 46/6; rectifier only, 22/6, postage 6d. As above but for 2v-6v only, 39/6, post 10d; rectifier only, 11/6, postage 7d.; metal rectifier, 12v lamp, with transformer and ballast bulb for 2v, 12v charger, 32/6, postage 9d.; rectifier alone, 9/6. 12v 4amp rectifier with transformer (120-watt), for 6v-12v charger £4, post 2/-, extra for 5amp rectifier, 10/-. Instrument rectifiers for meters, bridge type, bakelite, very good make, new goods, 1mA and 5mA, 18/6; 10mA to 50mA 15/6; also a few only, Hunts 8mids, 450v surge proof electrolytics, tubular type, 6/9 ea.

**METAL** rectifier, 12v 1.5amp, with transformer and ballast bulb for 2v to 12v charger, will charge six cells at 1.4amp, 35/-, postage 10d; also a similar kit to charge three to twenty cells at 1amp, ideal for the small radio store, £5 10/-; metal rectifier, 12v 3amp, with transformer for 12v charger, 50/-.

**ROTHERMFL** D.104 crystal microphones, a really first-class crystal mike at a reasonable price, £4 10/-; mains transformers for amplifiers, 120-watt size, weight 15lb, 400v-0-400v, 120mA, 6.3v and 5v, suit 6L6 tubes, 42/6, postage 1/8. **CHAMPION,** 43, Uplands Way, London, N.21. Tel. Lab. 4457. [3851]

# RADIO SPARES

MAINS TRANSFORMERS.		Primarys 200/250 volts.
Secondarys 350-0-350 volts.		
Type A.	80 ma., 4v, 3a., 4v, 2ja.	32/6
Type B.	80 ma., 6.3v, 5a., 5v, 2ja.	32/6
Type C.	100 ma. Ratings as type A	34/6
Type D.	100 ma. Ratings as type B	34/6
Type E.	120 ma. Ratings as type A	37/6
Type F.	120 ma. Ratings as type B	37/6
Type H.	200 ma. Three L.T.s of 4v. and 4v. for rectifier. Ratings as required	47/6
Type I.	200 ma. Three L.T.s of 6.3v. and 5v. for rectifier. Ratings as required	47/6
Secondarys 500-0-500 volts.		
Type J.	200 ma. L.T. windings as type H	52/-
Type K.	200 ma. L.T. windings as type H	52/-
Type L.	250 ma. L.T. windings as type H	56/-
Type M.	250 ma. L.T. windings as type H	56/-
Secondarys 250-0-250 volts.		
Type N.	200 ma. L.T. windings as type H	47/6
Type O.	200 ma. L.T. windings as type H	47/6
Type P.	300 mbs. L.T. windings as type H	60/-
Type Q.	300 ma. L.T. windings as type H	60/-
Secondarys 400-0-400 volts.		
Type R.	120 ma. 4v, 3a., 4v, 2ja.	40/-
Type S.	120 ma. 6.3v, 5a., 5v, 2ja.	40/-
Type T.	80 ma. L.T. windings as type R	35/-
Type U.	80 ma. L.T. windings as type R	35/-
Secondarys 425-0-425 volts.		
Type V.	120 ma. L.T. windings as type R	39/-

Types H to Q are provided with two L.T. windings, centre tapped. Please note that owing to dimensions and weight of types H to Q, kindly add 2/6 for carriage and packing. **MULTI RATIO OUTPUT TRANSFORMER.** 120 ma. 15 watts, tapings for GL5 in push-pull; PX4 in push-pull; low impedance triode; low impedance pentode; high impedance triode, 37/6; complete instructions with each unit.

## H. W. FIELD & SON

COLCHESTER ROAD, HAROLD PARK, ESSEX



**Improved Germinal CLIPS**

Well made of steel, double ridged for strength. Teeth on three sides of lower jaw and special design of upper jaw ensure firm grip and good contact.

**Wingard**  
patented

CHURCH ROAD · HENDON · LONDON · N.W.4

## THESE ARE IN STOCK

**TIME BASES. SCANNING GENERATORS.**  
By O. S. Puckle, M.I.E.E. 16/-. Postage 5d.

**FOUNDATIONS OF WIRELESS.**  
By M. G. Scroggie, B.Sc., A.M.I.E.E. 7/6. Postage 4d.

**TELEVISION RECEIVING EQUIPMENT.**  
By W. T. Cocking, A.M.I.E.E. 10/6. Postage 4d.

**RADIO RECEIVERS AND TRANSMITTERS.**  
By S. W. Amos and F. W. Kellaway. 21/-. Postage 5d.

**THE MATHEMATICS OF WIRELESS.**  
By R. Stranger. 7/6. Postage 5d.

**WIRELESS WORLD VALVE DATA.**  
Operating condition and base connections of the principles, types and makes. 2/-. Postage 2 1/2d.

**VALVE REPLACEMENT MANUAL FOR RADIO SERVICE ENGINEERS.**  
By A. C. Farnell and Arthur Woffenden. 6/-. Postage 2 1/2d.

We have one of the Finest Stocks of Technical Books in the Country.

**THE MODERN BOOK CO.**  
(Dept. W.3), 19-23, Praed St., London, W.2.



No. 2

Again "Lockwood" craftsmanship has been utilised to house valuable apparatus.

Our illustration shows an "X-Ray" Camera case in polished Oak, used for Britain's Mass Radiography.

This advertisement forms part of a series showing some of our wartime activities.

When circumstances permit we shall again be able to make beautiful cabinet-work and furniture for peacetime enjoyment.

**LOCKWOOD & COMPANY**  
HARROW, MIDD. BYRON 3704

**SEXTON'S** for  
SALES, SERVICE & SATISFACTION

**AMERICAN RADIO VALVES.** Types as under at controlled prices. 35Z4GT, 35Z5GT, 45Z5GT, 5Y3GT, 6X4, 12Z6GT, 105GT, 105GT, 105GT, at 11/- each. 635GT, 6E5GT, 12E5GT, at 9/2 each. 128J7GT, 128K7GT, 25L6GT, 6K7GT, 6L7G, 6J7GT, 43A, 1A7GT, 6K6GT, 42G, 6V6G, at 12/10 each. 609G, 619G at 11/- each. 6Q7GT, 45G, 75G, 11/7 each. 6A7G, 6A8GT, 6K8GT, at 14/- each. 6T5/6T541 (Magic Eye), 14/8 each, plus 4d. postage.

**LOUDSPEAKERS.** "Goodman's" Midget speaker, 3 1/2 in. size, P.M. 2-3 ohms, 30/- each. "Celebration" 8 in. size, with trans. P.M., 27/6. "Magnavox" 8 in. P.M., with multitap transformer, 30/- each. "Rola" 5 in. P.M., less transf., 21/6 each. "Celebration" 10 in. mains energised 2,000 ohms field, 37/6 each, all post paid.

**TUNING CONDENSERS.** .0005 three-gang large type, with slow-motion drive, mounted on metal frame which can be detached to suit any radio, 12/6 each, post paid. Two-gang Midget type, 12, each, three-gang, 12/6 each, post paid.

**RADIO service box-spanners,** 2, 3, 4, 5, 6, B.A., wooden-handled, 3/- each, post paid. Steel box-spanners, with tommy bar, set of three, 2, 4, 6, B.A., 2/6, post paid.

**LINE CORD,** 50 ohms per foot, 1/6 per yard. "P" type H.F. and Aerial coils, 4/- per set. Step up or down auto. transformers, 100-watt type, 20/- each.

**LOUDSPEAKER cabinets,** veneered walnut, 19/6 each, cheaper quality, 7/- each.

**ELECTRIC ALARM CLOCKS,** beautiful metal casing, perfect timekeeper, gentle waker, for A.C. mains only, 42/- each.

**ELECTRIC SMOOTHING IRONS,** for A.C./D.C. mains with thumb rest, connector guard, etc., 4 lbs. weight, finest nickel finish throughout, complete with 2 yards of heavy flex and connector, 30/-, post paid.

**TERMS.—Cash with order only.** We regret that owing to staff shortage we are unable to despatch C.O.D. or pro-forma invoices. Send 1d. stamp for latest list.

**J. E. SEXTON & CO., LTD.**  
164, Gray's Inn Rd., London, W.C.1  
Tel.: Terminus 1304, 4842

**L INECORD,** best 3-way, 0.3amp, 60Ω/ft, 3/3 yd.—Clifton Lab., 28, Park Drive, Grimsby.

**SPEAKERS,** all p.m., 5in 22/-, 3 1/2in 30/-, 6in, 25in, 8in, 22/6, Rols, Goodman, Plessey and Celestion, all less trans.

**SPEAKER trans.,** 3w pen 7/6, midget pen 6/-, centre tapped 6/6.

**CHOKES,** 15by 60ma 7/6, 100ma 12/6.

**CRYSTAL mikes,** first class brush crystal with screened flex, 23/3.

**SOLDERING irons,** 60w 230v, light, 14/6; all usual lines competitive prices. See other ads. in this issue or send 1d. for list to Radiosales, BCM/Sales, London, W.C.1.

**LOOK out for valves and circuit analyser;** details later.—London Sound Labs., Ltd., 40, South Molton Lane, Bond St., London, W.1.

**PRICE list 1d., unqualified range; example value:** Yaxley 4-bank 6-way switches, 5/6.—Taylor, 1/2w 4d., 1/2w 6d., 1watt 9d.

**RESISTORS,** 0.0001 to 0.005 9d., 0.01 to 0.05 1/-, 0.25 1/6, 0.5 2/6, 0.1 9d.; bias elecs, 25/25s 2/6, 50/12s 2/6, 10mld/50v 2/6.

**VALVE holders,** 4 and 5-pin 6d., 7- and 9-pin 9d., Max. and Int. octal 9d., all American; No. UX at 9d. each.

**VOLUME controls,** most values, with and without s.w., 5/6 and 4/6.

**MANY other lines, 1d. for list.—Radiosales BCM/SALES, London, W.C.1. [3725**

**MAINS transformer,** Partridge, 4v 3a, 4v 2a, 300-0-300, 60mA, 32/6; 'phones, Brown's A, 4,000ohms, 50/-; inter-valve transformers, Partridge, heavy duty, 30/-; Ferranti A.F.5 30/-, Ferranti A.F.6 35/-, Ferranti O.P.M.1, output, 25/-; metal rectifier, H50, 5/-;—BM R.L.D.O., London, W.C.1. [3715

**SERVICEMEN.—The following products are well designed and of high quality; volume controls, carbon type, all values, with or less switch, wire-wound resistors, 1 to 60 watts; dropper resistors, 0.2 and 0.3amp; line cords and razor resistors; terms and quotations on req.—Dagole, Ltd., 35, High St., Ruimslip, Mdx.**

**BUILD your own Wizard 4-v. universal med. wave, also Dorset 3-v. battery receiver. SIMPLICITY itself; both give splendid tone and volume; very clear point-to-point wiring instructions, circuit diagram, full-size component lay-out drawings; British valves; we sell any item separately; your queries answered free, s.a.e.; Wizard circuit, including alternative wiring for 7- and 5-pin valves, 5/-; Dorset circuit, including instructions for pick-up and tone control, 3/6.**

**NO callers; letter only.—Weldona Radio Accessories, Ltd., 23, Burlington Rd., Swanage.**

**BUY your components direct, and save pounds. Build our M.W. "Super Victory Four." Highly satisfied users everywhere; circuit, drilled chassis, brackets, rivets, and everything to build this cabinet, £2/2; set is supplied for £7/19/6; cabinets, £2/2; detailed circuit separately, 1/6; chassis, 4/6; chassis, valveholders, speaker, 2-gang condenser and dial, all assembled, £2/19/6; dial MW/SW; gold/black, punched for dial lamp, 1/-; send 1d. for interesting lists.**

**BUCCLEUCH RADIO MANUFACTURERS,** 1 and 2, Melville Terrace, Edinburgh.

**HENRY'S offer.—465 If trans., iron core, 14/- pr.; ose coils, 46S, K.C., 3/6; med. wave aerial coils with trimmers, 4/3 ea.; Midget T.R.F. coils, 6/6 pr.; Bulgin twin fuseholders, 2/9; T.C.C. 4x4x2x2x1x0.5, med., 450v wkg., 17/6; T.C.C. 2mfdx 1mf, 600v wkg., 5/-; Mallory 6v vibrators, 4-pin, 12/6; 2-gang conds. with trimmers, 14/-; 3-gang, 12/6; W.6 Westector, 5/-; 11-way single pole switches, 5/-; 12 and 0.3 line cord, 2 or 3-way, 50-60 ohms per ft, 3/- yd, best quality; .01 1,500v wkg. TUB, 1/6 ea., 15/- doz; Celestion 6 1/2 P.M. with trans., 27/6; Goodman's 5in P.M., 22/6; 3 1/2in P.M., 30/-; send for lists.**

**HENRY'S, 5, Harrow Rd., Edgware Rd., London, W.2 [3833**

**GRAMOPHONE RADIO, Station Rd., New Cross, London, N.12.—Prompt mail order service. New goods only. All orders over 5/- post free. Electrolytics, 8x450 9/6, 8x8 450 12/6, 25x25 2/6, 25x50 3/-, 50x50 3/3; speakers, P.M., less transf, 3 1/2in 29/-, 5in 21/6, 6 1/2in 22/6, 8in 24/-, 10in 35/-; with transf, 6 1/2in 27/-, 8in 30/-, 10in 42/6; mains transf, 350-0-350v 100mA, 4 or 6v l.t., 28/6; bobbins only 15/6; 425-0-425v 200mA, 4v 8a, 4v 4a, 4v 4a or 6.3v 4a, 6.3v 3a, 5v 3a, 52/6; smoothing chokes, 20hy, 200mA, 21/6; energised speakers with transf, 1,200 or 2,000 ohms, 35/-; B.S. 1st grade 0.1 mA meters, 4 1/2in dia, 70/-; volume controls, all values, less sw, 3/9, with sw 5/-; dropper resistors, 800Ω 0.3amp, fixing feet, 2 variable taps, 5/6; 2nm ins. sleeving, A.I.D. spec, 2d yd; push back wire, 50ft 3/-, 100ft 5/6; tuning condensers, 2-gang 12/6, 3-gang 12/6; speaker transf, universal, 8/6, 15w 21/-, 30w 37/6; s.a.e. for comprehensive list. [3803**

**AUSTERITY RADIO LIMITED**

**SPECIAL KIT!**  
**ULTRA-SHORT & SHORT WAVE SUPERHETERODYNE**  
5-100 Metres A.C.  
5 valves (including Rectifier) with Sm. P.M. Speaker, Blue Prints and instructions supplied. Price 12 Gns.  
**A Guaranteed Receiver**

**MAINS TRANSFORMERS.** 350-0-350, 150ma, 2 L.T.s, 6.3 v, 5 a.; 1 v, 4 a.; 1 v, 2 a.; 4 v, 2 1/2 a.; can be used with international or English valves, colour coded. Mains Input tapped 200/220/240 A.C. 50/-, post 1/11. 400-0-400; 120 ma.; L.T.s, 4 v, 2 1/2 a.; 4 v, 4 a.; 4 v, 2 a.; 4 v, 2 a.; Long Colour Coded Leads, with high insulation. (200/220/240) Mains Input Tappings. 45/-, post 1/11. 350-0-350; 80 ma.; 4 v, 4 a.; 4 v, 2 a.; A.C. Mains Input 230. 30/-, post 8d. 300-0-300; 80 ma.; 4 v, 4 a.; 4 v, 2 a.; A.C. Mains Input 230. 30/-, post 8d. 350-0-350, (chassis Mounting, Shrouded, 4 v, 4 a.; 4 v, 2 a., Input 200/220/240. 35/-, post 9d. 300-0-300. 75 ma., Chassis Mounting, Shrouded, 4 v, 4 a.; 1 v, 2 a.; Input 200/220/250. 37/6. Mains Transformers wound to specification.

**L.F. TRANSFORMERS.** Midget, 3:1, 4:1, 5:1 ratios, 6/- each.  
**L.F. CHOKES,** 15 Hy., 80 ma., 1,000 ohms, tapped at 300 and 640. Price 12/6 each. 30 Hy., 80 ma., 1,000 ohms. Price 17/6. Small 10 Hy., 50 ma., 380 ohms, 8/6.

**PUSH-PULL Input Transformers,** heavy duty. Split secondary windings ratio 4:1. Price 10/6. Small for Parallel Feed Standard, 6/-.

**OUTPUT TRANSFORMERS.** Standard Pentode, midget 7 ohms, 7/6; Pentode, small, 8/6. Multi-ratio, standard, 12/6.

**I.F. TRANSFORMERS.** 465 kc. with trimmers, screened, 11z wound. Small, 15/- pair.  
**MIDGET H.F. CHOKES.** 2/6.

**4-VALVE, 4-WATT GRAMOPHONE AMPLIFIER CHASSIS**  
Assembled on black Crackle-finished chassis fitted with separate Tone Control, Volume Control with on/off switch, sockets for microphone, gramophone and extension speaker, Hum free, good quality reproduction, A.C. only. Input 200/250 v. Size overall, 8 x 6 1/2 x 7 in. Ready to play. Price, 10 Gns.  
Theoretical and practical Blue Prints of the above available separately, 3/6 per set.

**CONDENSERS.** 2-gang, small, 2 trimmers, fixing brackets, .0005 ceramic insulation, boxed, 14/6.  
**Coils.** Short Wave, 16 to 50 metres, on 14/6.  
**Formers,** colour coded A. & H.F. with reaction, boxed matched pairs, 4/- with circuit. Aerial and Oscillator Coils, Long, Medium and Short (10-50 m.) on one former, 12/6 pair.  
**Medium Wave T.R.F.,** Ac. & H.F. Midget, with Circuit, 6/6 per pair.  
**Line Cord.** 3-core, 3 amp, 60 ohms per foot, 5/- per yard.

**BLUE PRINTS**  
1 Theoretical and 2 Practical, to each of the following circuits, 3/6 per set.  
No. 1. A.C.; T.R.F.; 3 valves, Medium Wave only.  
No. 2. A.C.; T.R.F.; 4 valves, Long, Med. & Short.  
No. 3. A.C.; T.R.F.; 4 valves, Short Wave only.  
No. 4. A.C.; Superhot 4 valves; Short and Medium Waves.  
No. 5. A.C./D.C.; Superhot 4 valves; Short & Med. Waves.  
No. 6. Battery; T.R.F.; 3 valves, Short Wave only.  
No. 7. Battery; T.R.F. 3 valves; Long, Medium and Short Waves.  
No. 8. Battery; T.R.F. 4 valves; Long, Medium and Short Waves.  
No. 9. Battery; T.R.F.; 3 valves, Short Wave only.  
No. 10. Battery; T.R.F.; 4 valves, Short Wave only.  
No. 11. Battery 2 1/2 watt; Amplifier, 3 valves, Push-Pull.

**307, HIGH HOLBORN, LONDON W.C.1 Phone HOLborn 4631 [3803**

**ELECTRADIX**

**MOVING COIL HEADPHONES, P.M. less headbands.** Here is a wonderful opportunity to secure highly sensitive headphones with coils energised by the famous ALNI magnets.

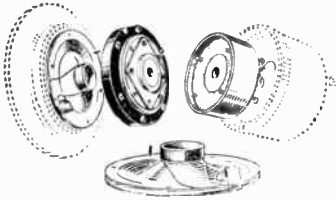

These moving coil sound units have a 45 ohm, 1/2 inch coil. They can also be used as miniature mikes, or as a miniature loudspeaker if matching transformer is used. Size 1 1/2 in. overall, in bakelite case with 3 in. front flange. As new. Price each 12/6, or per pair, 24/-.

**SUPERSEDERS. H.T. Battery** Superseders for Radio Receivers. 6 volts to 110 v. 15 m.a. The Army, the Navy, and the Air Force use small Rotary Superseders; a 5 1/2 lb. midget type taking less space than your old H.T. Battery. Last for ever and cost little more than a few months run on H.T. Battery. Size is only 5 1/2 in. x 3 1/2 in. x 3 1/2 in., beautifully made, model finish, ball bearings, etc., and takes small current from your accumulator. Latest model and guaranteed 12 months. £3.15.0 each.

**TRANSFORMERS for rewind 3 K. W.** New type with stampings 4 1/2 in. x 6 in. x 7 1/2 in., windings damaged by blitz. Can be taken apart to make a number of smaller units. Weight with damaged wire is 65 lb. Limited number at 70/-, carriage extra.

Please include postage for mail orders.

**ELECTRADIX RADIOS**

214, Queenstown Road, Battersea, London, S.W.8  
Telephone: M A Caulley 2159

**"VIBRO-ARC" Engraving Pen**

10/-



Post Free

For rapid engraving any metal—hard or soft. Operates from 4-6v. Battery or A.C. Transformer.

**HOLBOROW, 98, Borough Road, Yorks.**

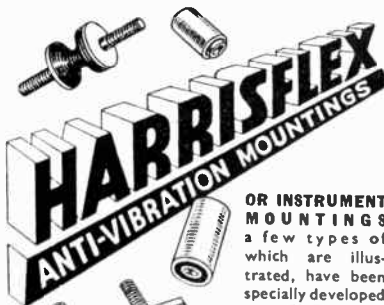

**OR INSTRUMENT MOUNTINGS** a few types of which are illustrated, have been specially developed to take care of different frequencies and to control vibration. Types and sizes available to carry varying loads (Rubber to metal bonded).

**HARRISFLEX BEARINGS LIMITED**  
TIDDINGTON ROAD · STRATFORD-ON-AVON

**LINE cord, the finest quality obtainable.** L with heavy asbestos insulation, 60-70 ohms per foot, 2-way 1/2, 3-way 1/5 per foot; p.m. speakers, with transformers, 6 1/2 in 30/-, 8 in 32/6, 10 in 45/-; Morse tappers and buzzers, 5/- retail line, 3/3 each; B.V.A. valves at list prices; carriage and packing extra, c.o.d. or c.w.o.—Park Radio Service, 27, Upper St., London, N.1. [3519]

**LINECORD, 0.3amp, 3-way, 3/6 per yd;** un-drilled chassis, 8x7x2 1/2, 3/- ea., doz lots at 2/3 ea.; volume controls, 0.25, 0.5, 1.0 meg. short spindles, no switch, 2/6 ea.; American oct. valve-holders, 2/6 doz; 2mm sleeving, 2/9 doz yds; resin core solder, 4/6 lb; 18G. tnd. cpr. wire, 4/- lb; Midget medium wave coils, 5/- pair; Midget 60ma chokes, 6/6 ea.; Multitap output transformers, 8/6 ea.; 0.2 amp droppers, 5/-; 0.3amp, 5/6 ea.; both with fixing feet; mains transformer replacement bobbins, 4v, or 6.3v heaters, 17/6; electric soldering irons, 12/6; black set knobs, bushed, 7/6 doz; "Meico" moving coil microphones, massive all-chrome quality job, £5/5; solder tags, 2/- gross; etc.; large stocks valves, all service requirements, list 1d., orders above 10/- post free (mail order only).—A. Hunkelsberg, "Hazeljohn", Crofton Lane, Orpington.

**COTTON-COVERED copper instrument wire,** 14b reels, 18, 20, 22, 24 gauges, 1/6; 26, 28 gauges, 1/9; 30, 32, 2/-; 34g 2/3; silk covered ditto, 20z reels, 24, 26, 28g, 1/6; 30, 32, 34, 36g, 1/9; 42g, 2/-; 16g double silk, 1lb, 5/-; B.A. thread screws, 1 gross useful sizes, 2/6; ditto, nuts, 2/6 gross; assorted gross screws and nuts, 2/6; ditto, brass washers, 1/6 gross; fibre washers, 1/8 gr; assorted solder tags, 2/- gr; assorted small eyelets and rivets, 1/3 gr; rubber-covered stranded copper wire, 1d. yard; heavier quality, 1 1/2d. yd; very heavy quality, 2 1/2d. yd; ideal for aerials, earths, etc.; tinned copper connecting wire, 20ft. coil, 6d.; ditto, rubber covered, 10ft, 6d.; finest quality push-back wire, 12 yards, 2/3; single cotton-covered tinned copper wire, 25g, 12 yards, 9d.; 50 yds, 3/-; twin bell wire, 12 yds, 1/9; heavier quality, 12 yds, 2/3; flat rubber-covered ditto, 3d. yard; twin flat braided electric cable, 6d. yard; all postage extra.—Post Radio Supplies, 33, Bourne Gardens, London, E.4. [3593]

**THE Simplex Four, complete constructional details of this most successful midget ac/dc receiver** (total cost of construction £9), including theoretical and full scale layout-wiring diagrams, with instructions, 4/6; midget aerial and h.f.m. wave high gain, T.H.P. coils, 9/- pair; short wave, aerial and oscillator coils, i.t. at 465kc, 5/6 pair; ditto m. wave coils, 9/- pair; midget 2-gang variable 0.0005mfd condensers, 15/-; midget chassis de luxe, sprayed grey, 10 1/2 x 6 x 2 in, drilled 4 valve holes, etc., 9/6; Simplex midget chassis, drilled 4 valves, and all component fixing holes, speaker cut-out, etc., electro zinc finish, 11 x 4 1/2 x 2 in, 7/6; midget dials, m. wave, station names, etc., ivorine, 4 x 3 1/2 in, 2/-; midget chokes, and speaker transformers, 7/6 each; Celestion 8 in. p.m., with trans, 27/6, 10 in ditto, 40/-; R. and A. 8 in M.E. speaker, with trans, 1.200ohms field, 35/-; mains transformers, brand new, Marconi, standard input 350-350, 4v, l.t.s, 35/-; ditto 5v, 6.3v, 30/-; R.G.D. 400-400v, 200ma, three 4v, l.t.s, 45/-; 250mfd, 25vw, bakelite cased, electrolytic, 4/6; mains droppers, 0.3amp, 800ohms, fixing feet, taps, 5/6; volume controls, long spindle with switch, 50,000, 1mg and 2mg, 6/6 each; com prehensive list issued monthly, 2 1/2d., s.a.o. en quires; postage all orders.—O. Greenlick, 34, Baneroff Rd., Cambridge Heath Rd., London E.1. Sta. 1334 [3771]

**WANTED. EXCHANGE, ETC.**

- WANTED, I.M.V. hypersensitive pick-up.—Box 3447. [3791]
- WANTED, oscillograph Cossor 3339 or 339. BM/ARY, London, W.C.1. [3831]
- WTD., V.G. recording motor or similar.—198, Lunt Rd., Bilston, Staffs. [3841]
- WANTED, Proc. I.R.E., Aug.-Oct., 1943 inc.; offers sale or loan to Box 3456.
- WTD., 25D8GT valve; will exch. 70I.7 or 128A7.—30, Colwell Rd., Leicester.
- WTD., 5-22 Hallicrafters rec. good price paid.—Williams, Birchington Hall, Kilburn. Tel. Ma. 1164. [3809]
- WE offer cash for good modern communication and all-wave receivers.—A.C.S. Radio, 44, Widmore Rd., Bromley. [1541]
- WTD., single ac gram. motor, any make, but good cond.; reasonable price.—Gawley, Anahilt, Blackamoore Lane, Maidenhead.
- WANTED, H.R.O. PV-O dial, with or without condensers; your price paid G2WZ.—13, Tretawn Gdns., N.W.7. Mill Hill 4400.
- WTD., Western Electric 639AA cardioid mike, high quality needle armature or moving coil pick-up. BM/ZEMC, London, W.C.1
- WTD., new or s/b 2 Weirite iron-core coils, type TG, and 1 ditto, type AD.—Particulars to 70, Enborne Rd., Newbury.

**LUSTRAPHONE LTD**  
PATENT NO. 556137

**"M.C." Microphones**  
A Quality Product  
High Sensitivity  
Even Response  
Internal Shock Absorption  
**ASK FOR ONE AND TRY IT FOR YOURSELF!**

84 BELSIZE LANE · LONDON · N.W.3  
TEL. HAMPSTEAD 5389 and 5515

**REWINDS**  
Armatures, Fields, Transformers, Pick-ups, Fractional H.P. Motors, Speakers Refitted New Cones & Speech Coils.  
All Guaranteed and promptly executed  
Valves, B.V.A. and American, good stocks. Send stamp-d addressed envelope for list of Radio Spares, and C.O.D. Sundry.

**A.D.S. Co.** 281-3-5, Lichfield Road, ASTON, BIRMINGHAM, 6

**WARD ROTARY CONVERTERS**  
Petrol Electric Generating Plants, H.T. Generators, D.C. Motors, Frequency Changers, etc., up to 25 K.V.A.

**CHAS. F. WARD**  
37, WHITE POST LANE, HACKNEY WICK, E.9  
Phone: Amherst 1393

**'SELECTEST' is Coming**

... will interest every Electrical and Radio Engineer.

**SALFORD ELECTRICAL INSTRUMENTS LTD.**  
PEEL WORKS · · · · · SALFORD · 3



**SOLON**  
INDUSTRIAL  
ELECTRIC APPLIANCES

**SOLON**  
ELECTRIC  
SOLDERING  
IRON

The SOLON  
Electric Soldering  
Iron Illustrated is rep-  
resentative of a range  
which includes models with  
various types of bits suitable for  
a wide variety of jobs. Full details  
are given in Folder Y.9, which  
also describes other SOLON  
Industrial Appliances.

Solon Electric Soldering Irons are, of  
course, only available for essential  
war work.

W. T. HENLEY'S TELEGRAPH  
WORKS COMPANY LIMITED  
WESTCOTT, DORKING, SURREY

# RADIO SIMPLIFIED

By John Clarricoats

This work by a well-known authority is a masterpiece of elucidation, compression and instruction. It has been specially prepared for all those making their first study of radio, and requiring a good basic knowledge of the subject, in the shortest possible time—this is the ideal book. The explanations are simple and lucid, all theory not absolutely essential to the understanding of the various points has been rigidly excluded, and there are no less than fifty interesting diagrams to illustrate the text.

Second edition

4s. 6d. NET

## PITMAN

PITMAN HOUSE, PARKER ST., KINGSWAY, W.C.2

W.T.D., universal Avo Minor, also E.M.I. or Avo test oscillator (batt. model); good price paid.—Macdonald, Brae Gdns., Dingwall, Ross-shire. [3827]

WANTED urgently, copies of Proc. I.R.E.E., April, 1944, Electronics, Feb., 1943, Q.S.T., June, 1944; state prices.—Research Library, E.M.I., Ltd., Hayes, Mdx. [3789]

WANTED by St. Dunstan's for training war-blinded, direct recording equipment, on loan, or would purchase.—Sound Recording Dept., St. Dunstan's, 9-11, Park Cres., W.1.

URGENTLY wanted, twin high-frequency speakers for Scott Philharmonic receiver; also Voigt speaker and horn, with bass chamber.—Details and price to Hampshire, 7, Grosvenor Hill, S.W.19. [3812]

WE buy for cash, new, used, radio, electrical equipment all types; especially wanted, radios, radiograms, test equipment, motors, chargers, recording gear, etc.—If you want to sell at the maximum price, call, write or phone to University Radio, Ltd., 22, Lisle St., Leicester Square, W.C.2. Ger. 4447.

WANTED, Philips valve tester with cards, L.F. oscillator beat freq. for choice, mains driven valve voltmeter reading to 100 volts, old copies of "Trader" Service Sheets, I.F. bridge with drive and indicator; instruments described in "Wireless World" would be suitable, but they must be in working order and calibrated.—Box 3446. [3790]

URGENTLY required for work of National importance, any back numbers from 1936 to 1944 of any British or American radio magazines, such as "Radio Craft," "Radio News," "Communications," "R.C.A. Bulletin," "Radio," "Wireless Engineer," "Electronics," "Bell Telephone Journal," "Proceedings of I.R.E.E.," etc., etc.; best prices will be paid; these are required to complete Technical Research Library.—Reply to Mr. Bernard, Bernards (Publishers), Ltd., The Grampians, West Gate, W.6. Tel. Shepherd's Bush 2581 (day and night). [3585]

### REPAIRS AND SERVICE

MAINS transformers rewound and constructed to any specification; prompt delivery.—Brown, 3, Bede Burn Rd., Jarrow. [3460]

REWINDS and conversions to mains and output transformers, fields, etc., from 4/6.—N.L. Rewinds, 4, Brecknock Rd., N.7. [3840]

ACCURATE radio rewinds, mains transformers, fields, op. transformers, etc.—Southern Trade Services, 297-299, High St., Croydon. [2882]

LOUDSPEAKER repairs, British, American, any make; moderate prices.—Sinclair Speakers, 12, Penbroke St., London, N.1. Terminus 4355. [3308]

ALL types of radio receivers serviced; Murphy and Pilot specialist; valves in stock; sound repairs for 13 years.—T. E. Fevver, F.I.P.R.E., 50, Vine St., Uxbridge.

RADIO repairs quickly executed to all makes, English or American; lowest possible prices.—The Music Box, 89, London Rd., London, S.E.1. (Tel. Waterloo 4460 and 6766.)

"SERVICE with a Smile."—Repairers of all types of British and American receivers; coil rewinds; American valves, spares, line cord.—F.R.L., Ltd., 22, Howland St., W.1. Museum 5675. [1575]

MAINS transformers service, repairs, rewinds, or construction to specification of any type, competitive prices and prompt service.—Sturdy Electric Co., Ltd., Dipton, Newcastle-upon-Tyne. [3084]

TRANSFORMER rewinds, special designs manufactured, all types fields, chokes, outputs, etc.; rewound; moderate charges, quick delivery, guaranteed high-class work.—H. W. Forrest, 67, Burnham Rd., Shirley, Birmingham. Shi. 2483. Est. 1922. [3652]

REWINDS, mains transformers, field coils, chokes, high-grade workmanship, 7-day delivery; new transformers constructed to customers' specification, singly or in quantities.—Metropolitan Radio Service Co., 1021, Finchley Rd., N.W.11. Speedwell 3000. [3719]

24-HOUR service, 6 months' guarantee, any transformer rewind, mains, outputs and i.f.s., etc., all types of new equipment supplied to specification; business heading or service card for trade prices.—Majestic Winding Co., 180, Windham Rd., Bournemouth. [3592]

TRANSFORMER rewinds and replacement coils, machine lacer wound on bakelite formers, interleaved, impregnated and clearly marked, rewinds £1, post paid, standard types to 70 watts; replacement coils, 15/6; larger types and additional secondaries pro rata; discount to trade; delivery by return post most types in common use; state model and iron size when ordering coils; cash with order or c.o.d.; fully guaranteed.—Radio Services, Field St. Works, Blackpool, R.T.R.A. Service members. Tel. 1774. [3328]

## LONDON CENTRAL RADIO STORES

See our previous  
advertisements for  
Components &  
Accessories

- Amplifiers • Speakers • Mains Transformers • D.C. Moving Coil Milliammeters and Voltmeters • Potentiometers • Resistors, Vitreous Enamelled, Carbon, Wirewound and Sliding • Push Button Units • Condensers • Yaxley Type Switches • Vibrators • Valve Holders • Trimmers • Electric Soldering Irons • Slewing • Screened Copper Wire, etc.

23, LISLE STREET  
LONDON, WC2  
Telephone GERrard 2969

## WHAT'S THE WATTAGE?

Answers!  
**FLIK-O-DISK**  
Quick!



### The Electrical and Radio Engineers' OHM's Law Calculator

Examples of problems answered in a flash:

- What will be the voltage when current I flows through resistance R?
  - What will be the voltage with watts value W and I current flowing?
  - What is the current flowing where watts value is W and voltage is E?
  - What current will flow through R resistance where voltage is E?
  - What will be the resistance where current I flows at voltage E?
  - What will be the resistance where watts W is at voltage E?
  - What will be the resistance where watts W is at current I?
  - What is the wattage at voltage E through resistance R?
  - What is the wattage of current I through resistance R?
  - What will be the wattage of I current at E voltage?
- The scales read from 1 millivolt to 1,000 volts. From 1 ohm to 1,000,000 ohms. From 1 millamp to 10 amperes. From one-tenth of a milliwatt to 10,000 watts.

PRICE  
**6/6**

The calculator is sold complete and with full instructions at Radio Stores and Stationers. If unable to obtain, write to **IONIC LABORATORIES LTD.**, Dent, W., Cranbourne Terrace, SALT HILL, SLOUGH, BUCKS, for name and address of your nearest stockist.



## W. BRYAN SAVAGE LTD.

Expert assistance in the solution of problems relating to

- TRANSFORMERS, CHOKES
- AMPLIFIERS
- POWER UNITS

and Specialised Equipment embodying

### ELECTRONIC CONTROL

WESTMORELAND RD., N.W.9  
COMPTONDALE 7131

## BERRY'S (SHORT WAVE) LTD.

for Prompt delivery of Quality

### RADIO AND ELECTRONIC COMPONENTS

including: C.R. Tubes, 14", 55"-; 21". £3 6s.; 41". £6 12s. I.F. Transformers, 7.6. Crystal microphone, 75/-, Crystal Pick-up, 78 9. 0-1 Meters, 59/6. 8-1 Slow motion drive, station named dial, escutcheon and glass, 8 6. Metal cabinets, finishes crackle black with hinged lids, chassis and panels, 39/6 and 63/-, Speakers, 21", 27", 3", 30", also 6" to 12". Jacks and Jackplugs, 2/6 each, also Crystal filters, Ceramic tuning, reaction and differential condensers, trimmers, standoffs; Ceramic Amphphenol, Paxolin and Bakelite valve bases (all types). For detailed Catalogue send S.A.E. for List "W.W." to

**25 HIGH HOLBORN, LONDON, W.C.1**  
Telephone: Holborn 6231

## ROMAC RADIO CORPN. LTD

THE HYDE · HENDON · LONDON N.W.9

Designers and Makers of

### RADIO & ELECTRONIC DEVICES

### AMERICAN MIDGETS HANDBOOK

Describing with many circuit diagrams the peculiarities of small American (Midget) radios. Especially written for service men, most likely faults and their remedies with hints on wartime substitutes for unobtainable parts are all given. The valve data section gives bases and working characteristics of the 50 or so valves used in midgets.

**Price 2/6**  
from booksellers or by post, 2/8.

**V.E.S. (W),**  
Radio House, Malthorne Drive, Ruislip, Mdx.

## "ENGINEERING OPPORTUNITIES"

This unique handbook shows the easy way to secure A.M.I.Mech.E., A.M.Brit.I.R.E., A.M.I.E.E., City and Guilds, etc.

**WE GUARANTEE—**  
"NO PASS—NO FEE."

Details are given of over 150 Diploma Courses in all branches of Civil, Mech., Elec., Motor, Aero., Radio, Television and Production Engineering, Tracing, Building, Govt. Employment, R.A.F. Maths., Matriculation, etc.

Think of the future and send for your copy at once—FREE.

**B.I.E.T., 387, SHAKESPEARE HOUSE,**  
17, STRATFORD PLACE, LONDON, W.1.

**R**EWINDS, mains transformers, layer wound, wax impregnated, chokes, O/P transformers, clock coils, field coils, pick-ups, complete repairs, competitive prices, prompt service, 12 months' guarantee; trade queries invited.—W. Groves, Manufacturing Electrical Engineer, 154, Ickneild Port Rd., Birmingham, 16.

**T**O radio dealers and service engineers only.—Loudspeakers repaired quickly, or materials supplied; also big stocks of all components; send your trade card or billhead and 1d. stamp for our current lists.—A.W.F. Radio Products, Borough Mills, Sharpe, 81 Bradford, Yorks. [3410]

**B**EVY-GREE, Ltd., 25, Jamaica St., Bristol, 2. west.—Transformer rewinds within 5 days, all standard types, 15/6; new transformers supplied to specification; speaker repairs to all popular makes, 7/10 days; specialists in rewinds to fractional h.p. motors, pick-ups, etc.; list on application. [3844]

**D**EGALLIER'S, Ltd.—"Service with a guarantee." If you cannot get your receiver serviced, let American specialists do the job; first-class workmanship only; specialising in Air-King, Belmont, Challenger, Detroit, deWald, Emerson, Ferguson, Garod, Halliometer, Hammerlund, McMurdo, Med-west, Majestic Pilot, Philco, Sparton, etc., also any British set. Remember, for 15 years we have handled as distributors American receivers; s.a.e. with all enquiries.—Degallier's, Ltd., 9, Westbourne Court, London, W.2.

**MISCELLANEOUS**  
RUBBER stamps.—V. E. S., Radio House, Ruislip. [3209]

**P**OST Office Megger, in good order; price £5.—John Steel, Bingley. Tel. 1066.

**C**HASSIS made to order; average charge 6/-; estimates given.—J. Cheyne, 40, Dudley Gdns., Leith. [3792]

**T**IME recorders.—Write for particulars.—Gledhill-Brook Time Recorders, Ltd., 84, Empire Works, Huddersfield. [2419]

**W**IRELESS shop, Bayswater, London, turn-over, repairs and sales £100 weekly. limited co.; £500, plus stock.—Box 3444.

**W**IRELESS Paris agent seeks agency for France of British wireless and television manufacturers. 1st answers to Emile Lindo, 14, Bank St., Newquay, Cornwall. [3777]

**C**HASSIS, brackets, clamps, shrouds, etc., made quickly, accurately with professional finish in A.A. benders, used by large radio mfrs., invaluable to experimental engineers.—Full details free from A. A. Tools, 197a, White acre Rd., Ashton-u.-Lyne. [3770]

**S**YNCHRONOUS motors, Sangamo, 200-250 volts ac, 50r, self-starting, fitted reduction gears; ideal movements for time switches, industrial, darkroom, electric clocks, etc.; rotor speed 200 rpm, final speeds available: 1 rev. 12mins, 22/6; 1 rev. 30mins, 25/-; 1 rev. 60mins, 25/-; consumption 2½ watts; size 2½x2½x1½.

**R**EV. counters, ex-meters drum type, 0-999, automatic reset to zero on completion; 3/6 each.

**P**ROJECTION lenses, lin focus, ideal for 9.5 or 16mm films, soundheads, etc, oxidised mounts, 1¼in long, ½in diameter; 5/- each; terms, cash with order. Regd. post and packing 1/- extra.—H. Francis, Scientific Stores, 58, New Oxford St., W.C.1. Mus. 9594. [3601]

**E**LECTRIC guitar units, complete constructional details (8 1/2 page plus prints) of three proven, approved electro magnetic units which convert an ordinary guitar to an electric model; my units are being used by professional and amateur guitar players all over the country, 5/-.

**E**LECTRONIC one string fiddle, an amazing instrument not to be confused with the old-fashioned type, outstanding response and tone; full details, 3/6.

**A**C/DC AMPLIFIER, portable, 6-8 watt output, 4 valve, plus rect. phase-splitter, neg. current, feed-back, push-pull output, specially designed for use with above instruments, p.u. or mike; full constructional details, 3/6; stamp for full list of data sheets covering tested and guaranteed designs.

**S**PARKS' DATA SHEETS (W), 9, Phoebe Rd., Brockley, London, S.E.4. [3723]

**E**STABLISHED radio component manufacturers invite applications for sole agencies in the following areas: North of England, Manchester, Wales, Western Counties, East Anglia.—Applications, preferably from established agents carrying non-competitive radio lines and with good connections in the trade, should give full details, in confidence, and be forwarded to Sales Manager, Box 3448. [3794]

**TUITION**

**A** POSTAL training in electrical engineering—power or radio; individual correspondence tuition by highly qualified engineers with wide teaching and technical experience. Elementary or advanced courses. Preparation for recognised examinations. Pre-service training specially arranged.—G. B., 18, Springfield Mount, Kingsbury, N.W.9. [1731]

# COVENTRY— RADIO

*Component Specialists since 1925*

Output Transformers, standard tapped 70 M/A.	s. d.
L.F. Chokes, 75 M/A., 12H, standard size	8 6
Jacks, Midget, with single M. and B. switching	6 6
I.F. Transformers, 465 kc., best screened	2 0
	7 6

OUR 1d. LIST also contains details of 15 to 25,000 ohm-wire-wound potentiometers, 3 to 250 pf. postage-stamp trimmers, condensers, ¼- to 40-watt resistors, instrument wires, Yaxley 1- to 5-bank switches, transformers, volume controls and dozens of other good quality components.

**PROMPT SERVICE, COMPLETE SATISFACTION**  
**THE COVENTRY CO.**  
191, DUNSTABLE ROAD, LUTON.  
Open until 6.30 pm. Saturdays.

## HILL & CHURCHILL

BOOKSELLERS

### SWANAGE DORSET

ENGLISH & AMERICAN  
BOOKS IN STOCK ON  
RADIO AND  
TELECOMMUNICATION

CATALOGUE ON APPLICATION

## BATTERY CHARGERS & TRICKLE CHARGERS



Trouble-free Chargers fitted with selenium all-metal rectification. Good allowance on your old Charger. Thirty years experience behind every Runbaken product. Booklet R.15, describing 12 Models, on request.

**RUNBAKEN-MANCHESTER 1**

## INSTRUMENT WIRES, ETC.

Gauge, covering and continuity guaranteed. 14-16-18-20-22-24-26-28-30-32-38 awg. enam. 2/8, 3/-, 3/8, 3/6, 3/9, 4/-, 4/3, 4/6, 4/9, 5/-, 6/- per lb., smaller quantities reels 3s. extra. 1- to 3-lbs. reels, 1/- extra. 4- to 8-lbs. reels, 2/6 extra. All reels returnable. Also many other interesting Radio and Electronic items. Lists, 1d. S.A.E. Orders over 30/- post free.

**MIDLAND INSTRUMENT CO.,**  
18, HARBORNE ROAD, BIRMINGHAM, 17.

## SOUND EQUIPMENT

*real Sales with Service*

Personal consultation and advice is freely given on the combination of equipment best suited to your particular need. Any make demonstrated without obligation.

Stockists of **VITAVOX High Quality Equipment.**

# R. G. JONES

OF MORDEN

**MORDEN PARK SOUND STUDIOS**  
London Road • Morden • Surrey  
Phone: MITcham 3448

# 3 Q 5

is the type we get most enquiries for. We have to say sorry. But from our stock of 10,000 valves we can supply nearly all types required. Please order C.O.D. Under 10/- C.W.O. 2/d. stamp with Enquiries B.O.T. prices.

**MULLARD**, PM21L, 5/10; 2D4A, EB34, 6H6, 6/9; 354V, HL13C, 9/2; AZ1, 5/4, VP2, PM22A, 10V2, DW4/500, DW4/350, 1W4/500, AZ3, UR3C, UR1C, 5V4, 1L/-; AC/14, TD14, 6K7, EL3C3, EL3C5, 1L/7; FC2, FC2A, TH2, SP4, 8F4B, VP4, VP4A, VP4B, VP13A, Pen4A, PenA4, 25L6, C14, EFS, EL3, EF39, PM24M, 6J7, 12/10; TH4, ECH3, ECH35, EF5, EF6, TH30C, 6AS, 14/-; PenB4, 14/8; EBL1, Pen41D, 15/3; 164V, 17/1; EL35, 6U4, 18/3; Pen 428, 30/5

**MARCONI OSRAM**, H1.2, 5/10; D41, 6/9; 1.01, 7/4; 301, 302, 303, 304, 8/6; H124, MH4, MH14, 6L5, 163, 9/2; Y63, 10/2; KT2, MU14, U10, U14, U50, W21, Z22, 11/-; DL63, MH41, MH14, PK4, 11/7; M14, 12/2; KT41, KT61, KT63, KTW41, KTW61M, KTW63, KTZ63, VMP4G, X24, 6J7, MSP4, 12/10; X41, X61M, X63, X65, 14/-; KT3K, 14/8; KTZ41, 15/3; KT66, U18/20, U52, 18/3; PX25, 24/4; GT10, GU50, 30/5

**MAZDA**, HL23, 5/10; DD41, 6/9; P220, 7/4; AC/P, HL21DD, HL1320, HL231D, 9/2; Pen25, 3215VM, 3D10, V1210, V122, C15, U7, U7, U4020, 11/-; AC/HLDD, HL41DD, HL133, 11/7; AC/VP1, AC/VP2, AC2Pen, AC5Pen, Pen 45, Pen 385, Pen 3520, SP41, SP42, TP23, TP25, TP26, VP41, VP133, 12/10; ACTP, 14/-; AC/SG, Pen45DD, PenD14020, QP25, 15/3; TP1340, 18/3; DC/P, 24/4

**COSSOR**, DD14, 6/9; 210DDT, 41MTL, 9/2; 220HPT, 431U, 210VPA, 210VPT, 11/-; OM3, 21, 202DDT, 11/7; OM9, 220TH, MSPen, MSPenB, MVSPen, 42MP-Pen, 133PA, 12/10; MP-Pen, 16/6

**BRIMAR**, 10D1, 6/9; 6C5, 9/2; 1B5, 11/-; 6R7, 6T7, 11D3, 11D5, 11/7; 6AG6, 6K6, TD3, 7D5, 25A6, 12/10; 90P2, 1512, 14/-; 6B7, 6G8, 15/3

**TUNGSRAM**, H1210, 11/210, 5/10; DD13, 6/9; 1P220, 1215, 7/4; H113, 9/2; APV4, 8P2B5, 8P2D, 6X5, 11/-; DDT48, 6Q7, 11/7; H11018, H11118, 6K7, 6V6, APP4B, APP4C, 12/10; MH1118, MH1405, TX4, TX4A, V048, 14/-

**AMERICAN**, 1A4, 1B5, 1C5, 1O7, 1D5, 1D7, 1E5, 1F5, 1G4, 1H5, 1I5, 1H4, 1H5, 1H6, 135, 136, 1P5, 2A6, 2A7, 2B6, 2B7, 2E5, 6A6, 6B7, 6D5, 6D7, 6D8, 6H6, 6A8, 6L6, 6L7, 6P5, 6SF7, 6Y5, 6Z5, 7A7, 7A8, 12A, 12A5, 12E5, 12J5, 12Z5, 10, 14, 15, 17, 19, 20, 22, 24, 26, 32, 35, 36, 37, 38, 40, 46, 48, 50, 53, 55, 55A, 55S, 56, 57, 59, 71A, 81, 82, 84, 85, 89, 99, H141D, Pen141

### VALVES AND ADAPTORS

In the cases where we cannot supply the exact valves or equivalent, we can get your set going with a valve and adaptor, the additional cost being 4/6.

### MODERN AIDS

"TESTSCOPE," the vast pocket instrument for tracing faults. Enables 20 tests AC/DC, complete with leads, 37/6.

"ELCO" Electrical Light Weight Soldering Iron (state voltage), 13/6. "FLICK-O-DISK," a novel calculator of Ohm's Law problems, 6/6.

CAR AERIALS, telescopic, nickel-plated, 21/-.

### RADIO LITERATURE

- Equivalent Charts, 1/7.
- Handbook on American Midgets, 2/7.
- Manual of Br. & Am. Valves, 3/6.
- Radio Simplified, 4/9.
- Basic Radio, 5/3.
- Radio Inside Out, 4/9.
- Receiver Servicing, 6/3.
- Receiver Circuits Book, 6/3.
- Various Service Sheets, 10/6 doz.

## J. BULL & SONS

(Dept. W.W.)  
246, HIGH STREET,  
HARLESDEN, N.W.10  
(See our Classified Advt. on page 25.)

## LONDEX for RELAYS

### for A.C. and D.C.



Midget Relay M.L.  
(For D.C. only)

2VA Coil consumption from 2 to 600 volts and tested to 2,000 volts, Aerial change-over Relays, Mercury Relays, Measuring Relays, and Time Delay Relays.

Ask for leaflet  
205/WW

## LONDEX LTD

MANUFACTURERS OF RELAYS  
205 ANFIELD ROAD, LONDON N.17

LEARN Morse code the Candler way.—See advertisement on this page. (1292)  
RADIO training.—P.M.G. exams and I.E.E. Diploma; prospectus free.—Technical College, Hull. (0611)

MATHEMATICS.—Expert personal postal tuition; Metric, Inter., radio maths; prospectus and advice free from S.T.T.C., 8, Ascupart House, Portswood, Southampton. I.E.E. Corporate Member, successful teacher. I can coach limited number private pupils. I.E.E., Brit. I.R.E. and City and Guilds examinations; correspondence only.—Box 3414.

RADIO Engineering.—Television and Wireless Telegraphy, comprehensive postal courses of instruction.—Apply British School of Telegraphy, Ltd., 179, Clapham Rd., London, S.W.9 (Eald. 1906). Also instruction at school in wireless for H.M. Merchant Navy and R.A.F. (9249)

THE Tuition Board of the Institute of Practical Radio Engineers have available home study courses covering elementary, theoretical, mathematical, practical and laboratory tuition in radio and television engineering; the text is suitable coaching matter for I.P.R.E. Service-entry and pre-ressive exams; tuition fees—at pre-war rates—are moderate.—The Syllabus of Instructional Text may be obtained post free from the Secretary, Bush House, Walton Avenue, Henley-on-Thames, Oxon. (1452)

### TECHNICAL TRAINING

A.M.I.E.E., City and Guilds, etc., on "No pass—no fee" terms; over 90% successes. For full details of modern courses in all branches of electrical technology send for our 112-page handbook, free, post free.—B.I.E.T. (Dept. 388A), 17, Stratford Place, W.1.

GREAT possibilities exist for technically qualified engineers, key men in wartime and afterwards. Through the home-study courses of the T.I.G.B. take a recognised engineering qualification, such as A.M.I.Mech.E., A.M.I.E.E., A.F.R.A.E.S., A.M.I.Chem.E., C. and G., etc., in which examinations the T.I.G.B. students have passed 25 FIRST PLACES and hundreds of passes. Write today for "The Engineer's Guide to Success"—free—containing the world's widest choice of engineering courses covering all branches, including aeronautical, mechanical, electrical, wireless, chemical, etc.

THE TECHNOLOGICAL INSTITUTE OF GREAT BRITAIN, 82, Temple Bar House, London, E.C.4. (3836)

### PATENT NOTICES

RADIO electric patents. Well-known London radio component manufacturers are open to consider patents or designs for post-war period.—Write Progress, c/o Alfred Bates & Son, Ltd., 130, Fleet St., London, E.C.4.

THE proprietor of British Patent No. 531963, entitled "Device for producing vibrato in sound amplifying systems and the like," offers same for license or otherwise to ensure practical working in Great Britain.—Inquiries to Singer, Ehlert, Stern & Carlberg, Steger Building, Chicago, 4, Illinois, U.S.A.

### SITUATIONS VACANT

RADIO service manager required, technically well educated.—Godfrey Industries, Ltd., Brundall, Norwich. (3808)

DEPARTMENT of Scientific and Industrial Research, National Physical Laboratory, Teddington.

MEN or women are required for abstracting technical papers on radio and allied subjects. A good reading knowledge of French and German, with at least one other language, together with some knowledge of the physical sciences, is required; or alternatively a good knowledge of radio with a reading knowledge of French and German. Salary £250 to £500 p.a., inclusive of war bonus, & will be fixed according to age, qualifications & experience.

APPLICATIONS, which must be in writing, stating date of birth, full details of qualifications and experience (including a list in chronological order of posts held) and quoting Reference Number P.N.122, should be addressed to the Ministry of Labour and National Service, Appointments Department, (A.3), Sardinia St., Kingsway, London, W.C.2.

CONDENSER engineer.—Applications are invited from senior engineers to discuss a post with a telecommunications company in Southern England in connection with the development after the war of electrical condensers of paper, ceramic and mica dielectric types.—Box 3445. (3786)

LEADING manufacturers and exporters of sound film equipment require technical sales correspondents, preference given to keen young man with business experience as well as technical background, must be methodical, accurate and quick at figures, interesting possibilities for hard worker able to take responsibility when required.—Write full details of qualifications, experience, age, salary, to Box 3462. (3825)

## RADIO INSTRUMENT CO.



Radio Products  
294, BROADWAY,  
BEXLEYHEATH, KENT

## TRANSFORMERS

AND

## SOUND EQUIPMENT

Our Post-war Programme  
has commenced

## NEW! PRODUCTIONS LITERATURE DEALER DISCOUNTS

Write for further details and our  
New Catalogue T.55 (2½d.)

THE RADIO INSTRUMENT CO.  
BROADWAY, BEXLEYHEATH

## MORSE CODE TRAINING

There are Candler Morse Code Courses  
for Beginners and Operators.



SEND NOW  
FOR THIS  
FREE

"BOOK OF FACTS"  
It gives full details concerning the following  
Courses:—

JUNIOR Scientific Code Course for beginners. Teaches a necessary code fundamentals scientifically.

ADVANCED High-speed Telegraphing for operators who want to increase their w.p.m. speed and improve their technique.

TELEGRAPH Touch Typewriting for those who wish to become expert in the use of the typewriter for recording messages and for general commercial uses.

Code Courses on Cash or Monthly Payment Terms.

### IRREFUTABLE EVIDENCE

of the value of the Candler System of Morse Code Training is given in the "24 extracts from students' letters," included with every "Book of Facts."

### COUPON

Please send me a Free Copy of Candler "Book of Facts."

NAME .....

ADDRESS .....

.....

Post Coupon in *unsealed* envelope to London Manager

THE CANDLER SYSTEM CO. (Room 55W),  
121 Kingsway, London, W.C.2.

Candler System Co., Denver, Colorado, U.S.A. (1645)

**A**SSISTANT to sales manager required by leading West End retailers specialising in high-grade British and American radio components; must have sound technical knowledge and a pleasing personality; generous salary offered; excellent references required; ex-Serviceman preferred.—Write to Box 121, Parris Advertising, 121, Kingsway, W.C.2.

**P**HILIPS have post-war vacancies for senior engineer-designers, well experienced in the fields of radio and television telecommunications; no offer of engagement can be made until regulations permit; applications are invited from engineers over 30; a degree standard in light electrical engineering is essential, together with a background of practical experience which will be of assistance in undertaking design work for mass production; salary by arrangement and according to qualifications.—Applications with full details to the Secretary, Philips Lamps, Ltd., New Rd., Mitcham Junction, Surrey. [3797]

**O**VERSEAS employment.—Radio telegraph inspector required for the Nigerian Government Posts and Telegraphs Department for one tour of 12 to 24 months in first instance; salary £600 a year; separation allowance for married men between £36 and £156 a year, according to number of children; outfit allowance £60; free quarters and passages; the duties of the post are those of a construction foreman engaged on the installation of radio diffusion or relay systems, including fitting central receiving stations with diversity reception receivers, aerial arrays, etc., and subscribers' lines and apparatus; candidates should preferably have had experience with a company operating radio relay services in England or elsewhere; a sound practical knowledge of radio reception apparatus is of more importance than experience in underground and overhead distribution. WRITTEN applications (no interviews), giving the following essential details: (1) full name, (2) date of birth, (3) qualifications and experience, (4) name and address of present employers, (5) details of present work, should be sent to the Secretary, Overseas Manpower Committee (Ref. 1436), Ministry of Labour and National Service, York House, Kingsway, London, W.C.2. Applications will not be acknowledged. [3788]

## AFTER THE WAR!

The advance in Radio Technique after the war will offer unlimited opportunities of high pay and secure posts for those Radio Engineers who have had the foresight to become technically qualified. How you can do this quickly and easily in your spare time is fully explained in our unique handbook.

Full details are given of A.M.I.E.E., A.M.Brit.I.R.E. City & Guilds, Exams, and particulars of up-to-date courses in Wireless Engineering, Radio Servicing, Short Waves, Television, Mathematics, etc., etc.

**We Guarantee "NO PASS—NO FEE"**

Prepare for to-morrow's opportunities and post-war competition by sending for your copy of this very informative 112-page guide NOW—FREE.

**BRITISH INSTITUTE OF ENGINEERING TECHNOLOGY (Dept. 388)**  
17, Stratford Place, London, W.1

## TRANSFORMERS & COILS TO SPECIFICATION.

MANUFACTURED or REWOUND.  
**STANLEY OATTELL LTD.,**  
9-11, East Street, TORQUAY, Devon.  
Phone: Torquay 9102.



15, SILVERDALE LONDON, S.E.28

**WE LOOK FORWARD** to the time when private enterprise is again free to 'lift' life above the utility level.

**VOIGT PATENTS LTD.**

### SITUATIONS WANTED

**M**AN, changing occupation, requires practical experience radio.—Box 3454. [3817]

**R**ADIO engineer, production test and inspection executive with design experience; £600; free August.—Box 3440. [3778]

**R**ADIO engineer, 30, wishes to engage with small business in Midlands area on receiver design and testing; at present working on Government priority equipment.—Box 3449.

**T**RUST-class representative radio, television requires appointment manufacturer, excellent technical knowledge; covered East Midlands Counties; car owner.—Box 3458. [3821]

**R**ADIO engineer, 29, B.Sc., 1st class Hons., 5 years on U.I.F. research, desires post war position with smaller firm.—Box 3450.

**S**ERVICE engineer seeks post, London area. 12 years' practical exp., refs., own car and test gear.—Box 3459. [3822]

**W**ANTED now or post-war, representative. sales engineer, manager or other supervisory post, Scotland or England; 10 years radio and electrical sales, servicing and maintenance, present employed supervisory capacity prominent Government concern, experienced factory rate fixing, time and motion study.—Box 3460. [3823]

### BOOKS, INSTRUCTIONS, ETC.

**A**DAPT your cine projector for sound films! —These books show you how. "Practical Sound Conversion for Amateurs," 5/6; "Adapting the 200B," 3/-; "Converting the Kodascope, etc.," 3/6; parts supplied; list, stamp.—Cinelux, Ltd., 88, Greenfield Ave., Carpenders Pk., Watford. [3689]

**S**ALE, one copy each of following: "Modern Radio Servicing" (£2), "Radio Physics Course" (£2), "Radio 'Trouble Shooters' Handbook" (£2), all by Ghiradi, and "Automatic Record Changers and Recorders," by Hilder (£2); perfect condition, newly received from U.S.A.—B.M/D/L, London, W.C.1. [3787]

**"ENGINEERING Opportunities"** — free 112-page guide to training for A.M.I.Mech.E., A.M.I.E.E., and all branches of engineering and building; full of advice for expert or novice; write for free copy and make your peacetime future secure.—B.I.E.T. (Dept. 387B), 17, Stratford Place, London, W.1.

I am the c.g.s. unit of energy—you'll find me in every radio circuit.

HULLO. —I'M AN **ERG!**



## ERG

ERG is the trade mark that will identify our products of quality—small parts for big jobs.



**ERG RESISTORS LTD.**

1021a, FINCHLEY ROAD, LONDON, N.W.11. PHONE: SPEEDWELL 6967

## FAN DISC LOCK NUT VIBRATION PROOF

This nut holds locked on one thread against all vibration. Only a fraction of the cost, space and weight of solid nuts. All sizes. All threads. R.H. and L.H.

SEND FOR SAMPLES and interesting literature.



## FAN DISC LTD

NORTHWOOD ST., ST PAUL'S, BIRMINGHAM 3

# Remember-Walter

RADIO RADIO RADIO  
**STAMPINGS • CHASSIS • PRESSINGS**

FARM LANE, FULHAM, S.W.6. TELEPHONE: FULHAM 5234

C.R.C.4



# 5 mm/f't

NEW LOW LEVELS in capacity and attenuation of CO-AX Cables mean new possibilities in electronic equipment design both for the war effort and for the post-war electronic age.

**BASICALLY BETTER AIR-SPACED**

## CO-AX LOW LOSS CABLES

**TRANSRADIO LTD. IS THE HIGHWAY BEACONSFIELD 4-BUCKS.**



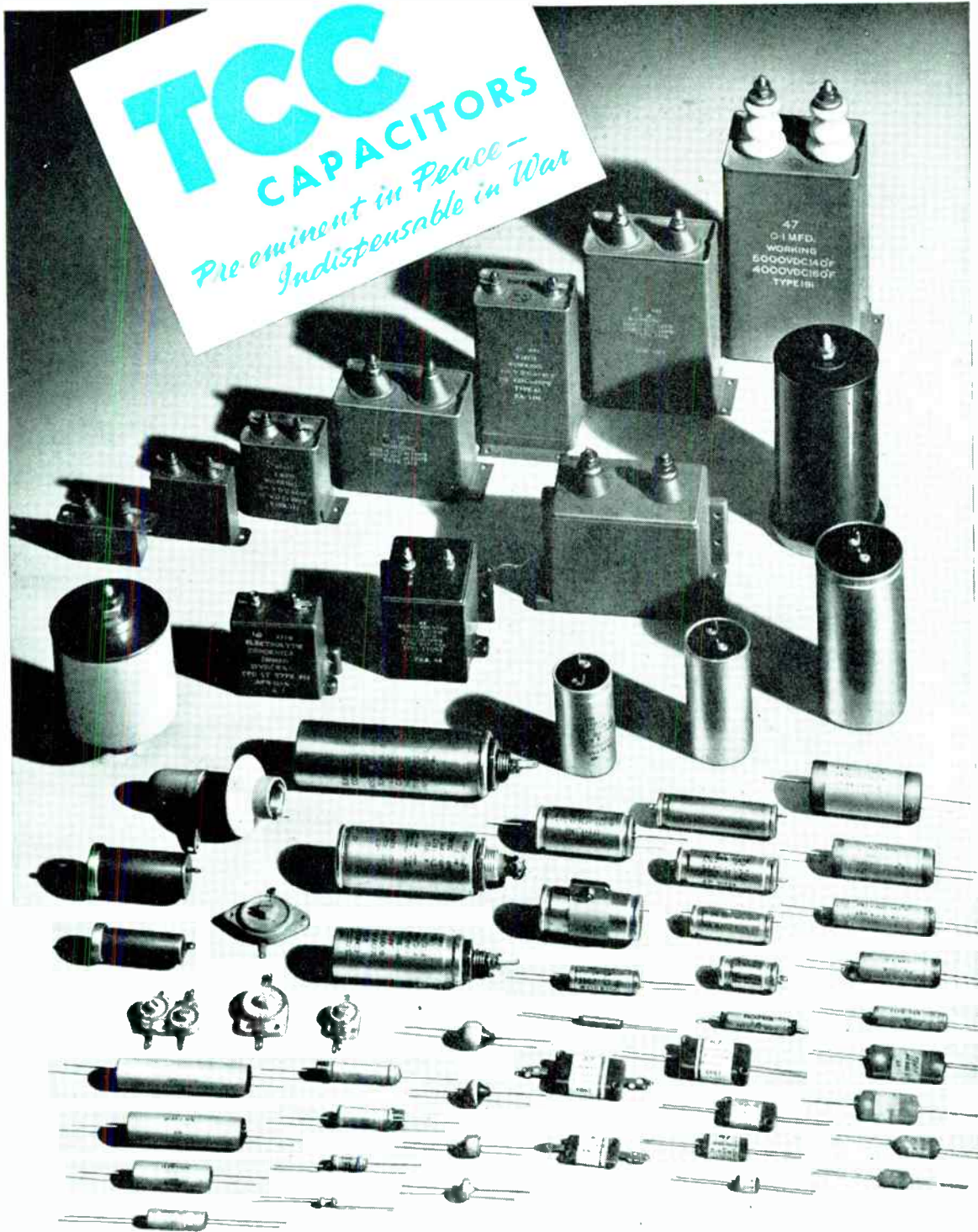

ADVERTISEMENT OF THE TELEGRAPH CONDENSER CO. LTD.

The illustration shows a central coiled spring antenna assembly. At the top, a large cylindrical component is shown in two views: one from the side and one from the front, revealing internal contacts. To the right, another large cylindrical component is shown in a similar two-view perspective. Below these are several smaller components: a small ring-shaped part, a small cylindrical part with a ring, a small cylindrical part with a protrusion, a small cylindrical part with a ring and a protrusion, a small cylindrical part with a protrusion, a small cylindrical part with a ring and a protrusion, and a small cylindrical part with a protrusion. A scale bar at the bottom indicates inches, with markings for 1, 2, and 3. The entire assembly is enclosed in a rounded rectangular frame.

inches 1 2 3

**BELLING & LEE LTD**  
CAMBRIDGE ARTERIAL ROAD, ENFIELD, MIDDX

GA