

# Wireless World

RADIO • ELECTRONICS • ELECTRO-ACOUSTICS



JUNE 1944

1/6

Vol. L. No. 6

IN THIS  
ISSUE :

PENTODE-DIODE VALVE VOLTMETER

## “AS USUAL”

Not 'similar'; not 'something like' — but the same. Not merely the same to look at either. But the same in performance, the same in behaviour. That is what you expect from Ceramic Condensers. And you expect too, that the performance will be of a considerably high order.

The illustration shows a Ceramic Transmitting Condenser.



TYPE  
APPROVED

---

---

# DUBILIER

---

---

CONDENSER CO. (1925) LTD.



C.R. Casson 2

*So much depends on them*



"AVO" Electrical Testing Instruments are actively engaged on the fighting and factory fronts, sharing a great responsibility with a proud sense of duty and high confidence in the future.

*It will therefore be appreciated by our numerous trade friends that we can now only accept orders which bear a Government Contract Number and Priority Rating.*



*Electrical*  
TESTING  
INSTRUMENTS

*Sole Proprietors & Manufacturers:-*

**THE AUTOMATIC COIL WINDER & ELECTRICAL EQUIPMENT CO., LTD.**  
WINDER HOUSE · DOUGLAS STREET · LONDON · S.W.1 · TELEPHONE VICTORIA 3404/8

*British Aircraft  
Use*

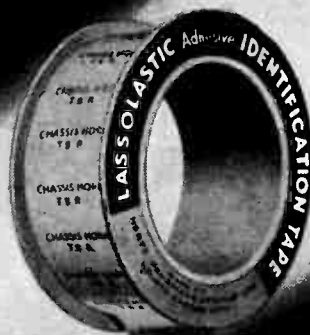

*FOR QUICKER, EASIER,  
CABLE & PIPE LINE MARKING*

DURABLE - LEGIBLE - INDELIBLY PRINTED IN ANY COLOUR  
CAN BE USED WITHOUT TOOLS - RESISTANT TO FLUIDS AND HEAT

HERTS PHARMACEUTICALS LTD. WELWYN GARDEN CITY



The advanced designs... the vastly improved techniques... the developments as modern as tomorrow... all these as applied to Sound Equipment will one day be available to you in their most efficient form in 194-R.S. Equipment; for although we cannot build for your customers today we are not unmindful or unaware of their needs in the future. And neither are we unprepared! We can promise that you will be as proud to sell the things to come as we are to build them.

**R S  
AMPLIFIERS**

R. S. Amplifiers, Ltd., 3-4, Highfield Road, Shepperton, Middx  
Tel.: Walton-on-Thames 1019

**Varley**  
**TRANSFORMERS  
and CHOKES**  
For **RELIABILITY**  
SEND US YOUR ENQUIRIES  
**OLIVER PELL CONTROL LTD**  
CAMBRIDGE ROW, BISHOPSGATE ROAD, WOODWICH, LONDON SE1

*"The Voice of the Services"*

**SIGNALLING  
EQUIPMENT**  
LTD.

**Manufacturers of**  
Small Transformers, Heavy Duty Resistances, Plugs and Sockets, Fuse Holders, Electric Bells, Buzzers, and Switches. Also Plastic Mouldings, Coil Windings, Light Pressings, Turned Parts, and other components and accessories for the Wireless and Electrical Trades

**Merit House, Southgate Road, Potters Bar**  
Phone: Potters Bar 3133. Telegrams & Cables: Sel, Potters Bar

**F.W.S.CO.**

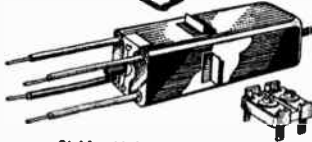

Sickles Midget Transformer and Trimmer.

**WORLD'S LARGEST RADIO COIL MANUFACTURERS**

- RADIO FREQUENCY INDUCTORS
- INTERMEDIATE FREQUENCY TRANSFORMERS
- RADIO FREQUENCY COIL CHOKES
- MICA COMPRESSION CONDENSERS
- AIR DIELECTRIC CONDENSERS
- MICA MOULDED CONDENSERS
- SICKLES SILVER CAP CONDENSERS
- GANGED PERMEABILITY TUNING COMMUNICATIONS EQUIPMENT
- F.M. EQUIPMENT PARTS
- U.H.F. RADIO EQUIPMENT
- SPECIAL ELECTRONIC EQUIPMENT



The F. W. SICKLES Co.  
CHICOPEE, MASS., U.S.A.

**RAYTHEON**

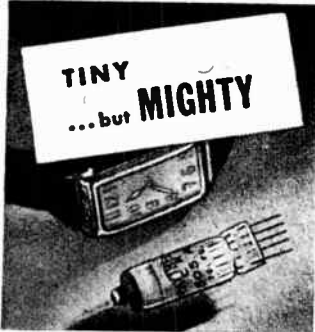

**RAYTHEON "FLAT" HEARING AID TUBES**

THEY'RE tiny, but mighty when it comes to dependable hearing aid performance. And mighty popular, too, because of their long life and low battery drain. That's why RAYTHEON flat hearing aid tubes are standard equipment in leading electronic hearing aids. Through continuous growth over these past 5 years Raytheon has become the world's largest supplier of hearing aid tubes.

WORLD'S LARGEST EXCLUSIVE TUBE MANUFACTURERS



**RAYTHEON**  
PRODUCTION CORPORATION  
NEWTON, MASS., U.S.A.

P. R. MALLORY & CO. Inc.  
**MALLORY VIBRATORS**

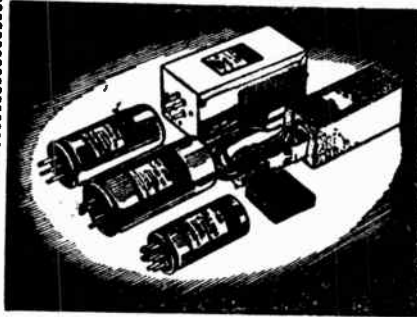

**IDEAS WILL POP FOR YOU**

IN the crucible that is war production, ideas pop into reality in bewildering numbers. Co-operative progress in techniques in chemical, metallurgical and electrical applications of materials, has contributed astounding gains to man's control over Nature's resources. Comparatively few can have more than a vague notion of industrial accomplishment for the war effort. But the discoveries that have mechanized warfare and conquered the air, that have developed transportation and supplies to marvellous wartime results, represent ideas that will pop into an amazing variety of commercial contributions to post-war living standards.

**P. R. MALLORY & CO. INC.**  
INDIANAPOLIS, INDIANA,  
U.S.A.

Radio and Electronics Division

- ALSO
- "MYKROY" CERAMIC INSULATING MATERIALS
- "IDEAL" RECHARGEABLE CELLS AND CHARGERS
- GENERAL ELECTRONIC VACUUM CONDENSERS

**FOR THE FUTURE**

These Manufacturers will help solve your post-war problems. Register your name now for full details which will be sent you when supply conditions again permit.

**FRANK HEAVER LIMITED**

Kingsley Road, BIDEFORD,  
N. Devon

**G.I.**



**THE SEEING EAR**

SYMBOLIC of modern electronic equipment—these human senses amplified and extended to limitless range . . . through fog and smoke . . . beyond the limits of normal sight and hearing . . . our fighting forces now SEE and HEAR at distances and under conditions that amaze the uninitiated. Such are the remarkable accomplishments of a war-inspired American Electronic Industry. Censorship shrouds the Seeing Ear in secrecy, but . . . in to-morrow's day of peacetime production G.I. will adapt its share of Seeing Ear developments to new products and to modernization of its pre-war products. Many of these new ideas will have direct applications in our Record Changers—Variable Condensers —Push Button Tuners—and other products.

**THE GENERAL INSTRUMENT CORPORATION**  
ELIZABETH, N.J., U.S.A.



TWO-WAY radio communication systems, like the plastic-cased beauty illustrated, are one of the new developments leading industrial designers are thinking of to speed the work of a busy post-war world. Applications of this compact, plastic-cased 'walkie-talkie' are almost unlimited. Naturally, this is only one of thousands of uses plastics will be put to after the war, but it will serve to remind you that post-war planning is being done . . . Kurz-Kasch designers, engineers, tool-makers and moulders . . . specialists for a generation in plastic planning and moulding will help you with your problems.



**KURZ-KASCH INC.**  
Planners and Moulders for the Age of Plastics  
DAYTON · OHIO · U.S.A.

# BAIRD TELEVISION RECEIVERS MODEL T 26

**A New Purchase!**

Every receiver is in perfect working order. Cabinet dimensions 3ft. 4in. high, 20in. wide, 17in. deep. Picture screen size 10in. by 8in. Pick-up sockets are fitted enabling it to be used as a Gramophone Amplifier. Extra loudspeaker sockets. 14 valves. Simple to operate. Only two main controls, one for picture contrast and the other for sound broadcast.

**PRICE**  
**£32.10.0**

Purchaser to make arrangements for collection.



**P.A. AMPLIFIERS.** Output 15 watts, 6 valves. 200-250 A.C. Pre-Amplifier for microphone, gramophone and radio terminals. Multi-range output, 2.5 ohms to 15 ohms. Fitted two volume controls, and tone control. In metal cabinet, Price, Carr. paid **£18.10.0**

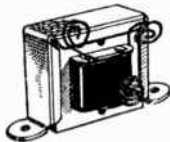

### PENTODE OUTPUT TRANSFORMERS

Well made and efficient Suitable for Small Speakers. Size 1 1/4 x 1 1/4 x 1 1/4 ins., **7/-**

**MANSBRIDGE Type Metal-Cased CONDENSERS**  
**350V. WORKING.** 2 mfd., 4 x 1 x 1 1/2 in. ... **2/6**  
**500v. W.K.G.** 2 mfd., 2 1/2 x 2 x 1/2 in. ... **5/8**  
2 mfd., 4 x 1 1/2 x 2 in. ... **4/6**

**LARGE CROCODILE CLIPS**  
2 1/2 x 1/2 in. Powerful spring grip, 1/3 each or 12/- per doz.

**ELECTRO-MAGNETIC RELAYS**  
Brand new surplus stock, make and break units to operate on 1 1/2 v. at 15 m.a.; to clear stock ... **5/9**

Our goods being surplus to manufacturers' requirements cannot be repeated when stocks are sold.

★ No lists issued. As all goods are described as fully as possible we cannot reply to requests for further details.

### ELECTROLYTIC CONDENSERS

Metal Cased. 250 mfd., 100v. working, 5 x 3 x 3 in. With terminals ... **12/6**

### MANSBRIDGE Type CONDENSERS

Metal Cased. 10 mfd., 350v. working, 4 1/2 x 3 x 2 1/2 in. ... **10/6**

### "MUTER" PUSH-BUTTON UNITS

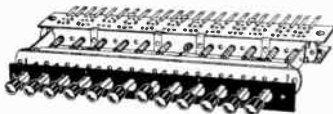

**12-Button Unit.** Complete with buttons and escutcheon, as illustrated ... **8/6**

**8-Button Unit,** with mains switch rated 125v. at .3 amp. and 250v. at 1 amp. Complete with knobs but no escutcheon ... **5/6**

### MAINS TRANSFORMERS

A special line of newly manufactured British transformers. 300.0-300v. at 80 ma., 6.3v. 3a., **37/6**  
5v. 2a. size ... **17/6**  
Post and packing, 1/3 extra.



### [POLARISED] DOUBLE-ACTING RELAYS

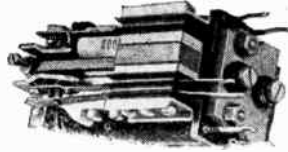

Telephone type with polarised differential movement. Two 500-ohm windings. Large diameter contacts ... **17/6**

## LONDON CENTRAL RADIO STORES

**23 LISLE STREET, LONDON, W.C.2**

GERRARD 2969

## LONDON CENTRAL RADIO

Miscellaneous Offers:

**Special Offer. BRAND NEW RESISTORS**  
Wire ends, 1/2, 1/4 and 1 watt. Assorted and useful values. 30/- per 100 or 4/8 per doz. lots.

**YAXLEY TYPE W/C SWITCHES.** 2" spindles 4-way, 3-bank, with shielded osc. section, 6/3; 5-way, 6-bank, with 3 screened sections, 7/3; 3-way, 3 double banks, without shields, 4/6.

**100,000 OHM POTENTIOMETERS,** 1/2" spindle, 3/9.

**VITREOUS ENAMELLED RESISTORS.** 10 ohms 10 watts. 3/6.

**WIRE WOUND POTENTIOMETERS.** 50,000 ohms. Less switch. 5/6.

**LOUDSPEAKERS.** Celestion 8in., with transformer, 29/6. Goodmans P.M. without transformers: 5in., 21/-; 8in., 30/-; Post and pack., 1/6 each extra.

**OAK SWITCHES.** 2 1/2 in. spindle, complete with knob. 4-way, 2-bank with connecting block, 4/-; 4-way, 2-bank, 3/3.

**PLATINUM CONTACTS.** Double Spring, mounted on ebonite, 1/6.

**CONDENSERS.** First-class 0.1 mfd., oil-filled, 5,000 v., working, only 11/6 each.

**TWIN SCREENED PICK-UP LEADS,** fitted 2 plugs, 8ft. 6in. long, 2/9.

**ELECTRO-MAGNETIC COUNTERS.** Ex-G.P.O., every one perfect, electro-magnetic, 500 ohm coil, counting to 9,999, operated from 25 v.-50 v. D.C., many industrial and domestic applications, 6/-.

**SCANNING AND DEFLECTOR COILS.** Ex-television receivers, assembled complete in metal frame, 7/6.

**ELECTRIC SOLDERING IRONS.** 200-250 v., 65/75 w., 12/6.

**BRASS ROD.** Screwed brass rod, 2 B.A., 4 B.A. and 6 B.A., 12in. lengths, useful for many purposes, 5/6 doz. lengths.

**VALVE-HOLDERS,** brand new, Mazda octal, 1/-.

**VALVE-HOLDERS.** Paxolin, 5-, 7-, and 9-pin, 7d. each, 6/- doz.

**REACTION CONDENSERS.** Fine quality job, 0.0003 mfd., to clear at 2/3 each.

**TUBULARS.** Wire-end tubular condensers, 0.1 and 0.01 mfd., 350 v. working, 1/-.

**T.C.C. TUBULAR CONDENSERS,** 0.1 mfd., 6,000 v. D.C. test, 5/9.

**T.C.C. CONDENSERS** in metal cases, special offer, much reduced to clear, 4 x 4 mfd., 70 v. working, 2/6 each.

**EX-GOVT. PLUGS AND JACKS,** as previously advertised, 5/9.

**EX-G.P.O. PLUGS, 1/6.**

**METAL SCREENED ANODE VALVE-CAPS,** with short screened lead, 9d.

**TRIMMERS.** Postage stamp 40 PF., 6d. Twin 40+40 PF., 1/-.

**ELECTRIC RAZOR RESISTANCES.** Universal output, in strong metal case, 10/- each.

**VALVES.** EA50, Mullards, to clear, 10/6 each.

**CERAMIC VALVE-HOLDERS,** brand new, low loss, 7-pin, 1/5 each.



# GRAMPIAN

**'SOUND IN SOUND'**

- ★ SPEAKERS
- ★ AMPLIFIERS
- ★ MICROPHONES

WHEN HAPPY DAYS ARE HERE AGAIN



GRAMPIAN REPRODUCERS LTD HAMPTON ROAD HANWORTH. MIDDLESEX.

Telephone: FELtham 2657-3

1 2 3 inches

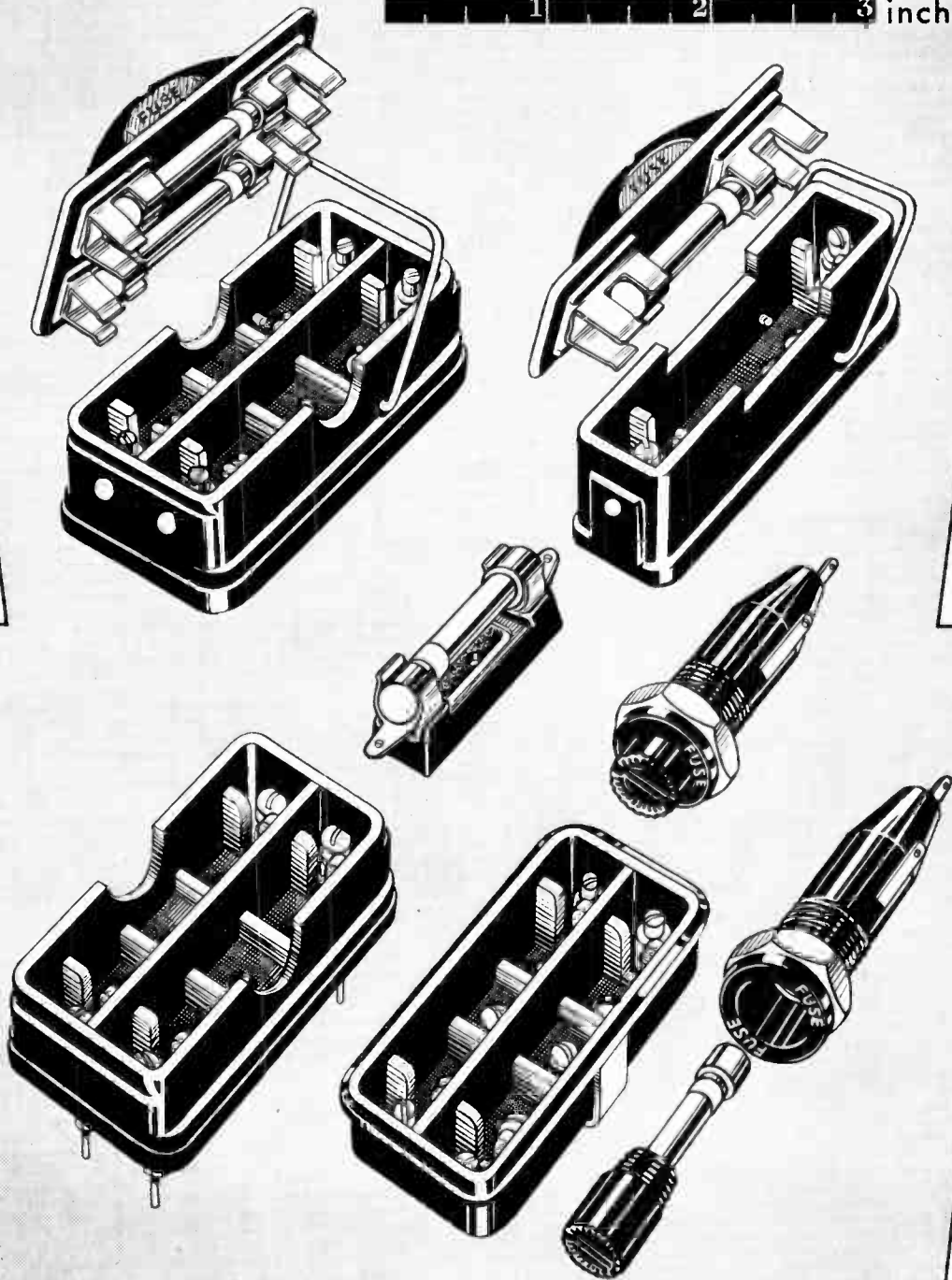

**BELLING & LEE LTD**  
CAMBRIDGE ARTERIAL ROAD, ENFIELD, MIDDX

GA 8788

World Radio History

## CONCENTRATING ON WAR NEEDS

Like many of our friends we are now primarily engaged in supplying the Services with those essentials needed to win the war.

It is with this in view that we, here at Diamond H, are concentrating on war requirements. Nevertheless, we have not forgotten our peace time business. On the contrary, the change over to war production has still enabled us to continue our association with most of our customers. The trust that has been placed in us is fully appreciated.

When peace comes we assure all our friends that we shall be as ready and well equipped to meet their demands as we have been in meeting the war requirements.

We have not forgotten what post-war development will mean.

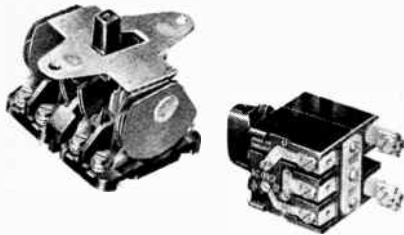

# DIAMOND SWITCHES

*Famous for Fifty Years*

GUNNERSBURY AVENUE, CHISWICK, W.4

## TAYLOR VALVE TESTER

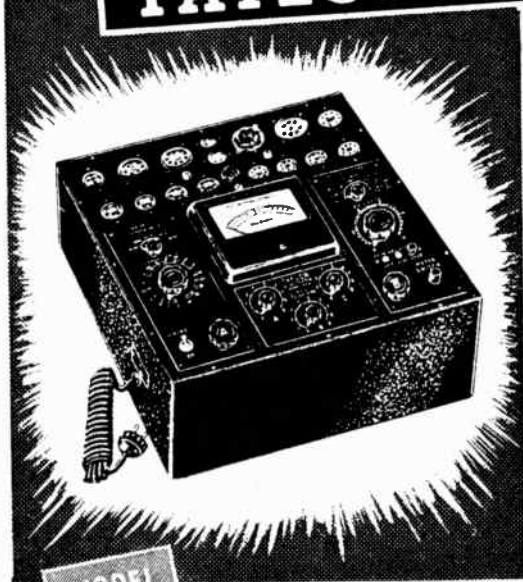

MODEL  
45A

Please write for  
technical brochure.

This new and improved Taylor Valve tester measures the Mutual Conductance of all types of amplifying valves and also checks the emission of Diodes and Rectifying valves

Two ranges of Mutual Conductance measurement are available being 3 mA/V full scale and 15 mA/V respectively. Anode and Screen Volts can be adjusted to suit the valve under test and a variable supply of Grid Volts is also available. A switch gives a choice of 17 different filament Volts covering from 1.1 Volts to 117 Volts.

Sixteen valve holders are provided to cover all the popular British, American and Continental types. Separate tests are available for checking Continuity, Element Shorts and Heater to Cathode Leakage. The three selector switches ensure that the correct voltage is applied to every pin of the valve under test.

A comprehensive book of instructions is issued with each instrument, complete with a valve chart giving settings for over 2,000 valves of all makes.

The instrument is operated from A.C. Mains and a mains adjustment is provided covering from 200-250 Volts at 40-100 cycles.

Model 45A/S Price £15 15 0

**Taylor**  
electrical instruments Ltd.

Send your enquiries to:

**TAYLOR ELECTRICAL INSTRUMENTS LTD.,**  
419-424 Montrose Avenue, Slough, Bucks.  
Telephone: Slough 21381 (4 lines) Grams: "Toyline, Slough"





### Prices drop on these Six Eimac Valves

Vacuum valves are now being massed produced on a vast scale at Eimac. The use of new manufacturing techniques has effected great savings which Eimac is passing along to users. The new prices listed below are now in effect.

	Old Price	New Price
304-TH . . . . .	\$ 65.00	\$ 50.00
304-TL . . . . .	65.00	50.00
450-TH . . . . .	75.00	60.00
450-TL . . . . .	75.00	60.00
750-TL . . . . .	175.00	135.00
1000-T . . . . .	175.00	100.00
1500-T . . . . .	225.00	185.00
2000-T . . . . .	300.00	225.00

Write today for new price sheet which covers these changes and provides essential data on all Eimac valves. Remember Eimac valves are first choice of leading engineers throughout the world... first in the new developments in electronics.

EITEL-McCULLOUGH, INC., 801 San Mateo Ave., SAN BRUNO, CALIF.  
 Plants located at San Bruno, California and Salt Lake City, Utah

Follow the leaders to **Eimac** VALVES

Export Agents: FRAZAR & HANSEN  
 301 Clay Street - San Francisco, California, U.S.A.



*Search for June*



The trite saying above has no connection with this advertisement except to catch the attention of you hard boiled business men. We want only to remind you that Parmeko of Leicester concentrate on the design and production of efficient TRANSFORMERS and any job we turn out (either "special" or in quantity) is just as good as a transformer can be and certainly better than most! What were you saying - something about cost? Well we're not expensive, that is a fact, - but on the other hand we ought to warn you that we are not cheap because a Parmeko transformer is made up to a standard not down to a price. How about letting us work out a price for you to judge for yourself? . . . just send it on to us because we would like to know you anyway . . . and we think it would profit you to know us.

★ Problems in transformer design and construction are the constant interest of our research department—we are very busy on war work but have time for post-war planning.

PARMEKO LTD., LEICESTER  
MAKERS OF TRANSFORMERS

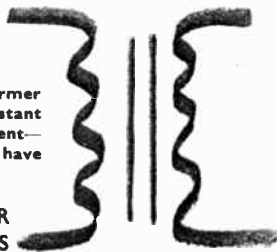

## M.R. SUPPLIES

have the following high-grade and brand new ELECTRICAL and INDUSTRIAL EQUIPMENT in stock and available for immediate delivery or collection. All prices nett cash.

**POWER TRANSFORMERS.** Prim. 230 v. 50 c. Secs., 1700-0-1700 v. 400 m.a. and 6.3 v. 5 amps, high insulation, finished with brackets and terminal panels, weight 55 lbs., £13 10s. ex here.

**POWER PACKS** by prominent maker, for 60-watt amplifiers. 200/250 v., supplied with two Oram U.13 Rectifiers. Smoothed H.T. delivery 400 v. 345 m.a. and 6.3 v. for 8 heaters. Heavy duty output transformer is incorporated in the power pack providing taps for 2.5, 5, 7.5, 15 and 600 ohm loading. In sturdy closed chassis form, weight 48 lbs. £22 ex here.

**G.E.C. CURRENT FED MICROPHONES.** Require no amplifier—work direct from 12-volt accumulator. Supplied with appropriate transformer for matching to 15 ohm coil. The trouble-free system for instant and concise announcements, as used by police, on board ship, for A.R.P., etc. Complete, £9 17s. 6d.

**G.E.C. PROJECTOR P.A. SPEAKERS** with P.M. M/Coil 15-ohms Projector Unit (with built-in line transformer) and 42-inch all-metal Horn, handling 10 watts. Complete £10 5s. (carr. 7/6).

**GOODMAN 3-INCH P.M. MOVING COIL MICROPHONE/SPEAKER UNITS.** High efficiency model with weight alnico magnet. Perfect for mike, speaker and intercom. systems. Imp. 12-ohms, 30/- . We now have suitable microphone TRANSFORMERS, miniature type in approx. 1 1/2-in. cube munmetal boxes (harm-free) at 21/-.

**ROTHERMEL-BRUSH PIEZO-CRYSTAL MICROPHONES.** To-day's most remarkable offer. In black bakelite housing, 2 1/2-in. dia., with plated mounting boss tapped 1/16-in. thread, fitted 6ft. screened lead. Fully recommended and always approved. 42/- . Suitable TABLE STANDS, chrom., extending, 25/- .

**FLOOR STANDS, chrom.,** portable, ext. to 5ft. 6in., with "easy mount" adaptor, 45/6.

**MINIATURE PIEZO-CRYSTAL MICROPHONES** (Rothermel-Brush). Only 1 1/2-in. dia. Made for desk-aid, but quite suitable for all microphone uses. In aluminium housing but no front grille, 29/6.

**CENTRALAB "T" PAD PADERS** for Sound Projection (or other) control. For 500, 200 and 50 ohm lines (3 models) controlling three channels. (Pre-war list £4.) Diagram with each. Last few at 42/6 each.

**SLIDING RESISTANCES, 100 watts,** 30/- . Fully enclosed, 6 1/2-in. long. Following range now in stock: 400 ohms 0.5 amp, 200 ohms 0.7 amp, 100 ohms 1 amp, any one 25/- . Also a few special model, same size, 172 ohms, suitably graded for a current taper of 1 to 0.07 amps at 12 volts, 29/6.

**STAGE DIMMERS.** Constantly rated and with carbon break flicker switch and "off" position. For controlling staled load from full bright to blackout at 220/240 v. With screw motion drive and handwheel. 1000 watts, 26 17s. 6d. 1600 watts, 28 8s. (We cannot despatch.)

**TOGGLE PRESSES** (S.T.C.). Double-acting, precise tool suitable for all small pressing operations in many trades. Pressure 1 1/2 tons, weight 150 lbs. Delivery from stock, £30 nett ex this address.

**ERICSSON HEADPHONES** again in stock! 2,000 and 4,000 ohms (our choice) with adjustable headbands and lead, 25/- pair.

**"PYROBIT" ELECTRIC SOLDERING IRONS, 230/250 volt "Instrument" model** for small work. Only 9 1/2-in. long, with efficient radiation for hand comfort. With pencil bit, 21/- . Extra adjustable angle bit, if required, 4/6. "PYROBIT" NEON TESTERS, with screwdriver, 100/750 v. AC/DC, 9/6.

M.R. SUPPLIES, 68, New Oxford Street, London, W.C.1

(Telephone: MUScum 2958)

**ADASTRA**  
SECTIONAL STEEL  
RADIO MASTS  
Send for Catalogue WQ/330  
POLES LTD. TYBURN RE-ERDINGTON  
BIRMINGHAM 24



ADVERTISEMENT OF THE TELEGRAPH CONDENSER CO., LTD.

GA



**GOODMANS**  
*New* **T 2-12"**  
**LOUDSPEAKER**

for the **SERVICES**  
and all **PUBLIC ADDRESS PURPOSES**  
including **FACTORIES, WORKSHOPS,**  
**CANTEENS, ETC.**

*Goodmans*  
**LOUDSPEAKER & TELEPHONE ENGINEERS**

**INDUSTRIES, LTD.**  
**WEMBLEY, MDX.**



is sure to be tough going  
—but the result will be  
decisive — we've prepared  
for it right down to the  
last detail. Masteradio  
electrical equipment will  
be in it on land, sea and  
air operations



## *Masteradio* **VIBRATOR PACKS**

As supplied to the **WAR OFFICE, AIR MINISTRY,**  
**POST OFFICE** and other **GOVERNMENT DEPARTMENTS**

**MASTERADIO LTD · VIBRANT WORKS · WATFORD HERTS**

# WAXES OKERIN

## AND DIELECTRIC MATERIALS

Cable, Condenser, Coil, Transformer and Resistance  
Impregnating, dipping, sealing, filling and finishing.

**A.I.D. and C.I.E.M.E. TYPE AP-  
PROVED WAXES** to meet both  
**ARCTIC and TROPICAL conditions.**

TELEPHONE: WEST DRAYTON 2189

**ASTOR BOISSELIER  
& LAWRENCE LTD**

**MIDDLESEX OIL & CHEMICAL WORKS**

**WEST DRAYTON, MIDDLESEX**

# ◆ LINAGLOW LIMITED ◆

## “LIBERTY SIX”

**SIX-VALVE SUPERHET CONSTRUCTORS KIT**  
**ALL-WAVE 16-50m., 200-560m., 1,000-2,000m.**

**Brief Specification:** Frequency changer with two valves, separate oscillator, Six Tuned Circuit. 465 KC. Iron cored I.F.s. Separate tone and volume, 5-watt output, 8" P.M. speaker with baffle and output transformer, supplied with all valves, chassis, Practical and Theoretical wiring diagram and Parts Lists, Nuts, Bolts and Wire, ready to assemble, 200/250 volts A/C.

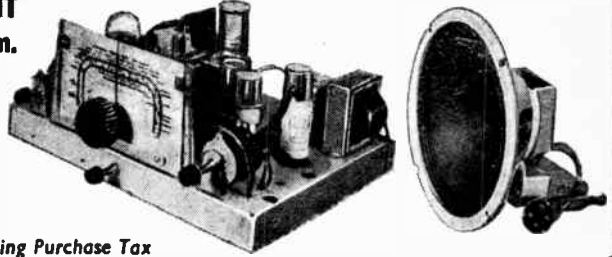

Carriage paid **£16 . 16 . 0** Including Purchase Tax

**30-WATT P.A. AMPLIFIER.** A high quality Amplifier, using finest components and Red "E" Valves. Class A B Circuit: 200/240 volts A.C. Chassis, finished in dark grey. 16-gauge steel. Brand new pre-war manufacture. Amplifier is fitted with Multi-Ratio output Transformer to take from one to forty-four, 5,000 ohm speakers, also 16 ohm speaker and 600 ohm line. Separate Standby Switch. Amplifier with valves suitable for gram. **£35 10 0** microphones and radio inputs.

**PORTABLE P.A. AMPLIFIER.** Specification: 4-valve Amplifier Unit in metal cage, microphone, one speaker, all cables, contained all in one cabinet and collapsible type tripod, floor stand AMU 11 2 1/2 v. 5 watt max. num., suitable for hall averaging 600 people. Input jack provided, transverse current carbon type microphone, separate volume controls for microphone and gramophone input. Variable tone control. **29 Gns.**

**MICROPHONES.** De Luxe Piezo Crystal microphones in chromium case. Specification: 60 D.B. below 1 volt. Frequency response 30/8,000 C.F.S. .... **6 Gns.**  
 As above—Standard model in bakelite case ..... **3 Gns.**  
 2-tier Stands for above, 25/-.  
**HIGH FIDELITY MOVING COIL MICROPHONE.** 25 ohm impedance, frequency response level 50-8,000 cycles. 78 DB below 1 v. .... **£5 15**

**SCREENED INTERLACED FLEXIBLE MICROPHONE CABLE.** Single. Special Offer, 9d. per yd. Twin, 1/3 per yd. Super quality Twin, rubber insulated, 1/9 per yard.

**TUBULAR PAPER CONDENSERS.** 350-500 v., D.C. working .0001, .0003 mid., 4/- doz.; .001, .004 mfd., 6/- doz.; .01 mid., 7/- doz.; .05 mfd., 9/- doz., 1 mfd., 12/- doz.; 23, 5 mfd., 15/- doz.; or assorted parcel of 50 for 27/6. Minimum orders, 1 doz. any type.

**SILVER MICA CONDENSERS.** Flat wire-end Assorted values, 17/6 per 100.

**UNIVERSAL RAZOR RESISTANCE.** Suitable for practically every type of electric Razor, drops voltage from 200/250 to 100/110 v. Supplied in safety metal cage with asbestos lining. Specification: 1,500 ohms with adjustable slider, 10/6.

**UNIVERSAL RESISTOR.** Suitable for practically every type of American and British AC/DC Receiver. Supplied in safety cage with asbestos lining. Specification: 760 ohms, 3 amp., with four sliders for adjustable tappings, 12/6.

**VALVE HOLDERS—AMPHENOL TYPE.** International or Mazda Octal, chassis mounting, 1/-.  
**TUBULAR STEEL FRAMES.** Cadmium plated for radi chassis mounting and many other purposes, drilled ready for use—18in. high x 14in. wide, very useful for swivel frame in Radio Laboratory, 7/6 the pair.

**LINE CORDS.** 2-way 360 ohms, 8/6; 480 ohms, 11/-; 600 ohms, 13/9; 3-way heavy duty, 3 amp., 360 ohms, 13/6; 480 ohms, 17/6; 600 ohms, 21/-.

**VALVES—AMERICAN TYPES AT B.O.T. CONTROLLED RETAIL PRICES. FOR REPLACEMENT PURPOSES ONLY.** 1H5, 12F5, 12S75, 9/2; 1A5, 10S, 5Y3, 2S75, 3S24, 11/-; 6J7, 12Q7, 11/7; 6F6, 6K7, 12J7, 3S15, 12/10; 6A8, 6B8, 6K8, 6CA7, 12SA7, 14/-; 83, 15/3.

Also British Valves at Manufacturers' List Prices. AC/ME, 10/8; U04, U06, U07, 11/-; HL1ADD, TDD4, 11/7; AGVF2, OL4, EF39, KTW61, Pen 45, SP41, SP42, T41, WF41, 12/10; D1 Diode 1in. Peanut Valve with valve holder, 12/10; B0113, F013, X63, 14/-; AC6Pen, EL35, Pen 45, U21, 18/3.

\* Post Office Permit necessary.  
 All prices include Purchase Tax. Add 3d. per valve postage.

### SERVICE KITS

- SKF.** 1 8-mfd. 400/500v. Aluminium Can Electrolytic; 6 each silver Mica Condensers, Resistors, Trimmers. 12/9.
- SKG.** 1 32-mfd. 325v. Aluminium Can Electrolytic; 6 each Silver Mica Condensers, Resistors, Trimmers and Tubular Paper Condensers. 15/9.
- SKH.** 1 8-mfd. 400v., 1 32-mfd. 325v. Aluminium Can Electrolytics; 12 each Resistors; Silver Mica Condensers; Trimmers and Tubular Paper Condensers; 2 4-point pushpull switches, 1 tone control. 35/9.
- SKI.** 12 8-mfd. 400 v.; 12 32-mfd. 325v.; 1 16 x 8 f.mfd. 400v.; 1 24-mfd. 250v. Electrolytics; 12 each Silver Mica Condensers; Resistors; Trimmers; Tubular Paper Condensers; 2 4-point pushpull switches; 2-tone controls. 23/10/6.

**MAINS TRANSFORMERS.** 200/250, 350-0-350, 6.3 v. 3 amp., 5 v. 2 amp., 120 m.a. abraded, 42/6; 300-0-300 4v. 6 amp., 4 v. 2 amp., 150 m.a., 42/-; 325-0-325, 4 v. 6 amp., 4 v. 2 amp., 2 v. 1.5 amp., 150 m.a., 45/-; 350-0-350, 6.3 v. 3 amp., 5 v. 2 amp., 100 m.a., 37/6; 325-0-325, 6.3 v. 3 amp., 4 v. 2 amp., 100 m.a., 42/-.

**AUTO TRANSFORMER.** Step up or down, 110/220/240 v. 100-watt, 35/-.

**ADJUSTABLE CAR AERIALS.** Chrome bar roof fixing, complete with suction rubbers, etc., 15/-.

**SCREWED LEADS.** 8ft. long, fitted 2 Wander plugs, suitable for Gram, Mike, Pick-up, etc., 4/6.

**3in. GOODMAN P.M. LOUDSPEAKER.** Extra heavy magnet for Midgets and communication sets, 30/-.

**LOUDSPEAKER TRANSFORMERS.** Push-Pull output tapped Primary and Secondary, 120 m.a., ratios 10:1, 5:1 and 3.5:1, 15/-; Multi-Ratio and Push-Pull transformer, ratios 30:1, 45:1, 60:1, 90:1 and P.F. Class B, 75 m.a., 12/6. Heavy duty multi-ratio transformer, ratios 24:1, 41:1, 48:1, 58:1, 82:1, 116:1, 80 m.a., 15/6. Class B and Q.P.F., 75 m.a., 12/6. Triode/ Pentode 40 m.a., 8/9.

**LOUDSPEAKERS.** P.M. 3-ohm voice coil without transformer, 6in., 21/-; 8in., 25/6; 10in., 28/6. 6in. Celestion, 22/6. 10in. Main Energised, 250, 500, 1,200, 2,000 ohms field, 35/- each; 10in. B.T.H. Model B.K. Main Energised, 1,000 ohm field, 15 ohms speech, weight 25 lbs., reconditioned as new, 28/6. Ideal for P.A. work. Directional Baffle for B.K., 3ft. x 2ft. 6in. x 1ft. 6in., felt-lined with suspension hooks, made from lin. ply, as new. 23/15/- each. 8in. Celestion with Transformer, 37/6.

**L.F. TRANSFORMERS.** 465 kc/s. Iron cored with flying lead. Aluminium Can. Limited quantity. 9/6 each.

**VOLUME CONTROLS.** 1,000, 5,000, 10,000, 20,000, 25,000, 50,000, 100,000-ohm; 1, 1.1 and 2 megohm, without switch, 4/9 each. As above, with switch, 6/9. 100,000 ohms Double Pole Switch, best American, 7/6. **WIRE WOUND** best American, New, ex television, 2,000 and 10,000 ohms, 5/- each.

**WIRE END CARBON RESISTORS.** New, ex television cabinet, 1, 1.1 and 2-watt. Assorted parcel of 100, 35/-.

**GAMBIT STAYS SELF-LOCKING,** best Bronze finish, 5/- each.

**3-gang .0003 VARIABLE CONDENSERS,** with geared slow-motion ball drive, pointer and dial frame. Ceramic insulation, 14/6.

**12in. AUDITORIUM P.M. LOUDSPEAKER CHASSIS,** Ticonal magnet, 10 ohms, 12/15 watts. Exceptionally sturdy construction, 27/15/6 each.

**6 ASSORTED VOLUME AND TONE CONTROLS,** with and without switch, 19/6.

**L.F. SMOOTHING CROCKERS.** Finest quality, 20, 40 and 60 henrys, 160 m.a., 15/9 each.

**SWITCHES.** D.F. 4-point push-pull, 9d.

**FLAT FLEX.** 9-way, 14/36, 18/20ft. lengths, suitable for amplifiers, extension speakers, remote control and many other purposes. Finest quality pre-war manufacture, 7/6 per coil.

**LOUDSPEAKER FRETS.** Coppered brass, 8 1/2 x 7in., 3/6, 14 1/2 x 9 1/2in., 8/9.

**SILK-COVERED BAFFLE BOARDS.** 12 x 9in., 1/2in. ply, 6in. hole, 4/6.

**50-OHM CENTRE-TAPPED RESISTOR,** tapped at 25 ohm for pilot lamps, 2/-.

**ALUMINIUM VALVE CAPS.** Special price 6d.

**SUPERIOR QUALITY KNOBS,** ex television, suitable for radio. For pin. epindles with grub screw. 1 1/2in., 1/9; 1in., 1/3; 3/4in., 9d.

**GATHODE RAY TUBES, Mullard & Mazda, 7in., £3 10 0, 9in., £4 18 0**

**HOLDER,** for above, complete with mounting base scanning and focusing unit with coil .. **47/6**

**HIGH VOLTAGE TRANSFORMER** for above, 200/250 v., 4,000 v., 2 v., 2 amp. .... **47/6**

**Line Scanning Output Transformer** ..... **12/6**

**0.1 T.O.C. 4,000 v.w. Condensers** for above. Brand new ..... **8/6**

**RECTIFIERS FOR ABOVE,** U04 at 11/-; U21 at 18/3.

**Plywood Frame and Rubber Mount** for Cathode Ray Tube, also suitable for loudspeaker baffle, 7in. hole ..... **7/6**

## CAR RADIOS

### NEW AMERICAN 5-VALVE SUPERHET CAR RADIOS

**18 1/2 gns. including P.T.**

2 Wavebands (200-2,000 metres). Push-button and Manual Controls. 6-volt. Built-in Speaker. Complete with roof-top bar Aerial. Small and compact. 7 x 5 x 12in. Crackle finished enamel.

◆ **CALLERS to Show Rooms,**  
**61 HIGHGATE HIGH ST., N.6.**  
 Phone: MOUnview 9432.

**LINAGLOW LIMITED**  
 HOURS OF BUSINESS 9 a.m. to 5.30 p.m.  
 Saturday, 9.30 a.m. to 12.30 p.m.

◆ **POST ORDERS to Dept. M.O.18**  
**3 HAMPSTEAD LANE, N.6.**  
**CASH WITH ORDER ONLY.**

# WEBB'S RADIO

**INTERESTING COMPONENTS AVAILABLE  
FOR POST ORDERS**



### CONDENSERS

	£	s.	d.
Three-gang .00042 Ceramic Insulation ... ..	10	6	
Three-gang .0005 Bakelite Insulation with built-in dual-ratio drive (5/1 and 80/1) ... ..	12	6	
Single .0002, .00016, .0001 S.W. ceramic ... All	5	0	
T.C.C. Electrolytic Bias 350 mfd. 25v. ... ..	7	0	
T.C.C. Paper 2 mfd. 150v. round metal can, 2 1/2" x 3/4"	3	6	
T.C.C. Paper 1 mfd. 250v. square metal can, 2 1/2" x 1 1/2" x 9/16"	3	9	
T.C.C. Paper 8 mfd. 1500v. Metal Can ... ..	1	17	6
.01 Mica Condensers 500v. D.C. ... ..	1	6	

### SWITCHES

faxley Pattern 3 wafers, each wafer 2-pole 5-way ... ..	5	6	
6 wafers, 3 wafers each 2-pole 4-way and 3 wafers 2-pole 3-way ... ..	6	6	
2 wafers, each wafer 2-pole 3-way ... ..	4	6	
1 wafer, 2-pole way ... ..	3	6	

### DRIVES

Telsen S.M. Dials, suitable for short-wave or general purpose receivers ... ..	2	0	
Dual-ratio epicyclic drives, to fit 1/2" shaft ratios 6/1 and 100/1 ...	5	0	

### LOUDSPEAKERS

Celestion 8" Loudspeakers, with transformer ... ..	1	10	0
Loudspeaker output transformers, suitable mains pentode to 2 1/2 ohms ... ..	8	6	

### PUSH BACK WIRE

In 100-yard coils, finest quality available in eight different colours per 100 yds.	8	6	
---	---	---	--

### VALVEHOLDERS

British Baseboard Skeleton low loss 5- and 7-pin ... ..	1	0	
All types U.S. sockets ... ..	1	0	

### MICROPHONE STANDS

Collapsible Floor Type, suitable for Band or P.A. work ... ..	2	2	0
---	---	---	---

### CHOKES

L.F. CHOKES, 10h. 50 m/A. ... ..	6	0	
----------------------------------	---	---	--



**FOR CONTRACT AND PRIORITY WE OFFER  
FROM STOCK**

Amplifiers, A.C. operated, 15 and 30 watt audio output.  
Wide range of meters from 0/50 microamps upwards.  
High voltage smoothing condensers.  
Wire-wound volume controls from 400 to 50,000 ohms.  
Wire-wound resistors 50 to 200 watts, all values.  
6- and 12-volt Vibrator Packs.  
Crystal and moving-coil microphones.

**14 Soho Street, Oxford Street, London, W.1**

Telephone : Gerrard 2089

We are available 9 a.m. till 6 p.m. for OFFICIAL business,  
but please note our SHOP HOURS—10 a.m. to 4 p.m.  
(Saturdays 10 a.m. to 12 noon.)

# WODEN

"SOUND" BUSINESS

**OFFER  
TWO UNSURPASSED  
PUBLIC ADDRESS AMPLIFIERS**

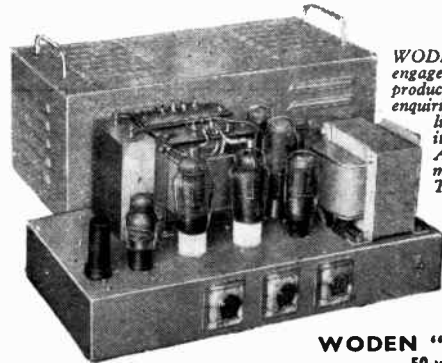

*WODEN are naturally engaged chiefly on war products, but welcome enquiries now, where licences and priorities permit, for Amplifier Equipment, Replacement Transformers, Special Power Packs, etc.*

### WODEN "CLASSIC" 50-watt

### WODEN "JUNIOR" 15-watt

TOTALLY ENCLOSED, SOLIDLY BUILT INSTRUMENT GIVING FULL 15-WATTS UNDISTORTED OUTPUT. IMPEDANCE 8 AND 16 OHMS. INPUT FOR GRAMOPHONE AND MOVING COIL MICROPHONE. A.C. OPERATION.

AN EXTREMELY ROBUST AND WELL DESIGNED TOTALLY ENCLOSED AMPLIFIER, GRAMOPHONE AND MOVING COIL MICROPHONE. INPUTS AND OUTPUT 8, 16 AND 250 OHMS. THE IDEAL AMPLIFYING SYSTEM FOR A.B. PURPOSES, DANCE BANDS, WORKS, AND ALL PUBLIC ADDRESS USES.

**PLAN YOUR POST-WAR REQUIREMENTS FOR  
SOUND BUSINESS WITH WODEN NOW.**

**WODEN TRANSFORMER CO. LTD., Commonwealth House,  
New Oxford Street, London, W.C.1. Phone : CHAncery 6541 (3 lines).**

**HIVAC**  
THE SCIENTIFIC  
VALVE  
BRITISH MADE

*Specialists in*  
**MIDGET  
VALVES**

**HIVAC LIMITED**  
Greenhill Crescent,  
Harrow on the Hill, Middx.

Telephone: Harrow 0895.

# Erie INSULATED Ceramicons

REG. U.S. PAT. OFF.

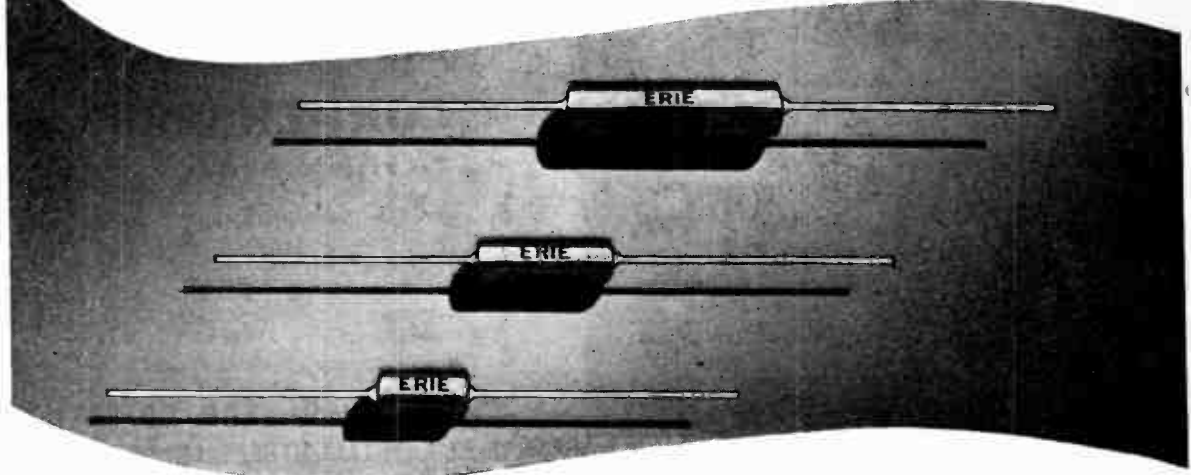

## Have 5 Inherent Advantages

- ① COMPLETELY ENCLOSED
- ② GREATER  
MECHANICAL STRENGTH
- ③ MORE DIRECT AND UNIFORM  
ELECTRICAL PATH
- ④ CAN BE LOCATED  
ANYWHERE IN CHASSIS
- ⑤ BETTER PROTECTION  
AGAINST HUMIDITY

WHAT do the five advantages of Insulated Ceramicons listed here mean to you? From the standpoint of design, they mean a more compact, efficient lay-out. Insulated Ceramicons can be located *anywhere* in the chassis without regard to the proximity of other components. They make possible shorter leads which are *musts* in higher frequency circuits. They mean greater protection against humidity...so important in modern war equipment. They provide extra insurance against breakage in handling on the assembly lines or damage from shock and vibration in actual service. The method of attaching wire leads to the silver electrodes provides a more uniform and direct electrical path.

Erie Insulated Ceramicons, for temperature compensating applications, are made in three sizes and in capacities up to 360mmf. Erie "Hi-K" Insulated Ceramicons, for by-pass and blocking condensers, are available up to 4,700 mmf.

Where your specifications call for capacities within the above ranges, specify Erie Insulated Ceramicons

*Raise the Standard of War Savings — Invest To-day*

**ERIE RESISTOR LTD., LONDON, ENG.**

ERIE, PA. TORONTO, CANADA.

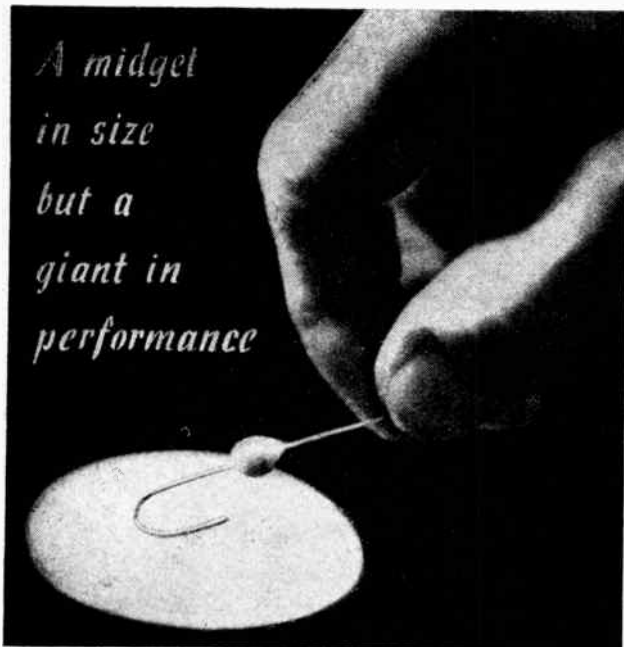

*A midget  
in size  
but a  
giant in  
performance*



## **CERAMIC PEARL TYPE CONDENSERS**

**TYPE APPROVED**

A mighty important little fellow for maintaining vital radio communications is this U.I.C. Pearl Type Ceramic Condenser.

*Diameter 7 mm. max. Length 9 mm. max.  
Capacity range 0.5pF—5pF. Capacity Tolerance  
Plus/minus 20%. Test Voltage 1500v D.C.*

Suitable for tropical and arctic conditions.

**UNITED INSULATOR CO. LTD.  
12-22, LAYSTALL STREET, LONDON, E.C.1**

Tel.: TERminus 7383 (5 lines) Grams.: Calanel, Smith, London

**THE PIONEERS OF LOW LOSS CERAMICS**



*Listen to this...*

A Mohammedan negro sings passionately to the accompaniment of his harp. These skilful musicians with their most curious instruments know the fascination of the minor key and tune up accordingly.

**AND ON THE FACTORY FRONT**

*Trust*  
**TRIX**  
*Quality SOUND Equipment*

AVAILABLE FOR PRIORITY ORDERS. SEND FOR DETAILS

The **TRIX ELECTRICAL CO., LTD.** New Address: 1-3, MAPLE PLACE, TOTTENHAM CT. RD., LONDON, W.1.  
Tel: MUSeum 5817. \*Grams & Cables: TRIXADIO, WESDO, LONDON.

## **Rectifiers**

for

**H.T., L.T. and G.B.  
supplies to amplifiers,  
receivers and transmitters**

**DETECTION & A.V.C.**

**OPERATION OF  
TELEPHONE AND  
TELEGRAPH SYSTEMS**

*In fact, whenever D.C. is required from an  
A.C. Supply, there is nothing more efficient  
or reliable than*

 **WESTINGHOUSE** 

**METAL RECTIFIERS**

**WESTINGHOUSE BRAKE & SIGNAL CO. LTD.,  
PEW HILL HOUSE CHIPPENHAM WILTS.**



*Service  
Engineers*



**REPAIRING DOMESTIC RADIO**

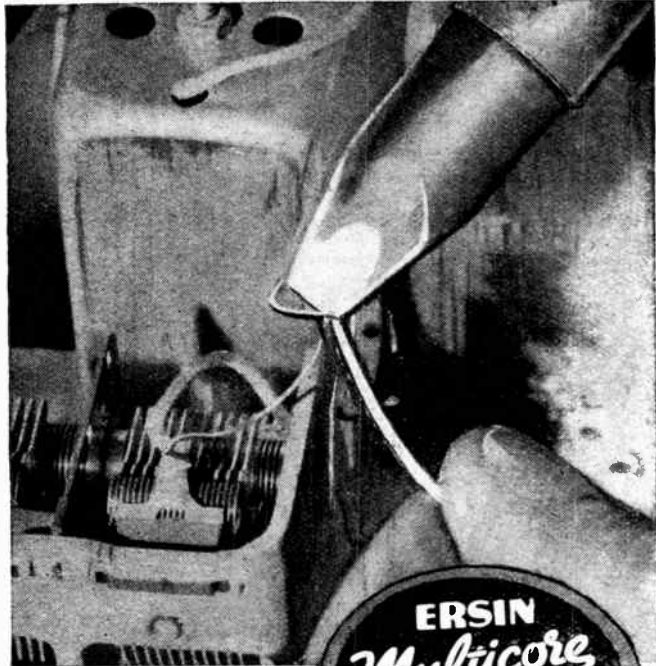

**MAY**

**NOW**

**USE**

**ERSIN**

**MULTICORE**

**THE SOLDER WIRE WITH 3 CORES  
OF NON-CORROSIVE ERSIN FLUX**

● Ersin Multicore—the A.I.D. approved solder wire containing three cores of active non-corrosive Ersin flux, has been adopted by the leading makers of radio and electrical apparatus in preference to other forms of solder because it provides speedy and efficient soldering with complete immunity from corrosive or dry joints.

● Because of the economy of metals effected in using Ersin Multicore and the fact that the repair of domestic radio is now rated as an "Essential Home Civil Requirement," Service Engineers, too, can now enjoy the advantages of the finest cored solder in the world.

● Stocked by the leading radio and electric factors. There may be slight delays in delivery, but insist on Multicore, and you will receive your share in turn. In case of extreme difficulty write to Multicore Solders Ltd., giving name and address of usual factor. Firms engaged upon Government Contracts are invited to write for free technical information and samples.



Nominal 1 lb. reels

**13 S.W.G. - 4/10**

**16 S.W.G. - 5/3**

above prices subject  
to usual trade discount.

**MULTICORE SOLDERS LTD. COMMONWEALTH HOUSE, NEW OXFORD ST., LONDON, W.C.1. Tel. CHAncery 5171/2**

★ IN THE DEVELOPMENT AND  
MANUFACTURE OF  
*Radio Frequency* **CABLES**  
**B.I.** HAVE PLAYED A LEADING PART

★ . . . and though supplies are directed to the Services, the experience gained over a considerable manufacturing period is available for the benefit of approved users.

Note.—From fundamental principles, B.I. have made outstanding contributions to design and construction of cables for radio frequency transmission and have perfected production technique.

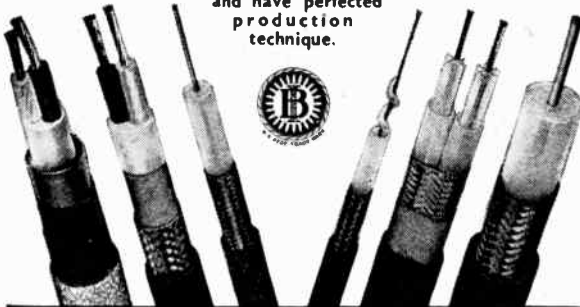

© BRITISH INSULATED CABLES LTD. PRESCOT, LANCs.

*Audio Amplifiers  
and Sub-assemblies  
to critical standards*

In addition to Standard Amplifiers the activities of Acoustical include Special Amplifiers for Industrial Applications, Microphones, Transformers, Coil Winding, Sheet Metal Work, Stampings, Switch Assemblies, etc.

 **ACOUSTICAL**  
MANUFACTURING Co. LTD.  
HUNTINGDON - TEL: 361

## *Lister Electronic Products Co.*

CLEVELAND,

OHIO

### SPECIALISTS IN UHF EQUIPMENT

MULTI-CHANNEL  
FREQUENCY MODULATED KEYING LINKS

MULTIPLE CRYSTAL HOLDERS  
FOR UP TO 100 CRYSTALS

TEST GEAR:—HF AND UHF OSCILLATORS,  
CRYSTAL CONTROLLED MULTIVIBRATORS

AUTOMATIC ALARM SYSTEMS

INDUCTION HEATING FURNACES

### **PRIORITIES ONLY**

For details write to:—

*Electronic Engineering Services, Ltd.*

SOLE BRITISH DISTRIBUTORS



24 STANLEY ROAD, HEATON MOOR, STOCKPORT

*The*  
**LOUDSPEAKER**  
YOU KNOW BY EAR  
*now making*  
**EVERY WAR EFFORT**

**BRITISH Rola LIMITED**  
DEVIZES • LONDON • BIDEFORD  
ENGLAND



**"Everything  
O.K. Sir !"**

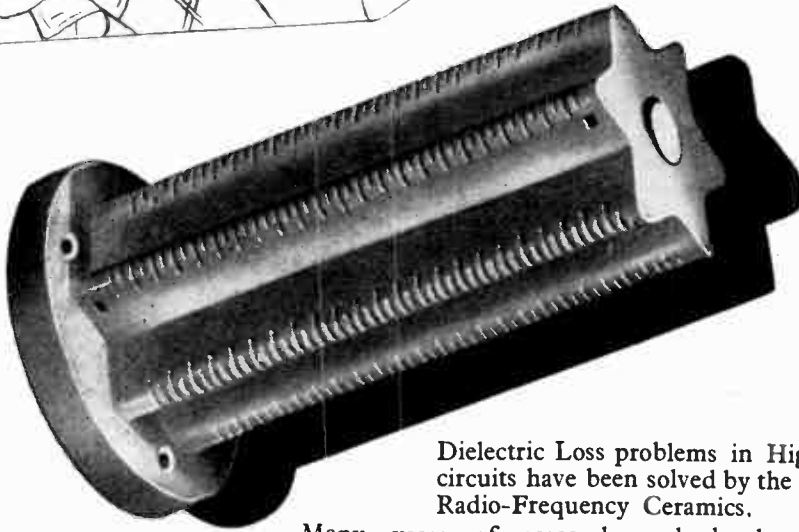

Dielectric Loss problems in High Frequency circuits have been solved by the use of Bullers Radio-Frequency Ceramics.

Many years of research and development in our Laboratories have brought these materials to a high degree of efficiency.

They are in constant use for transmission and reception and play an important part in maintaining communication under all conditions.

**Made in Three  
Principal Materials**

**FREQUELEX**

An insulating material of Low Dielectric loss. For Coil formers, Aerial Insulators, Valve Holders, etc.

**PERMALEX**

A High Permittivity Material. For the construction of Condensers of the smallest possible dimensions.

**TEMPLEX**

A Condenser Material of medium permittivity. For the construction of Condensers having a constant capacity at all temperatures.



**BULLERS LTD.,**  
THE HALL, OATLANDS DRIVE,  
WEYBRIDGE, SURREY.  
Telephone : Walton-on-Thames 2451  
Manchester Office : 196, Deansgate, Manchester.

**Bullers**

**LOW LOSS CERAMICS**

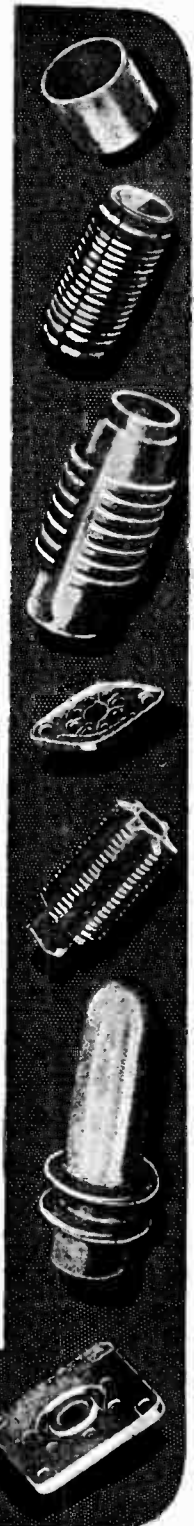



## Swan song

They say that when the swan sings it is about to die. Our swan (which the artist has tricked up out of a Spire fixing) heralds the demise of the millions of nuts and washers that it replaces. Spire fixings take many forms. They do the job of a nut and washer, but they do it with more efficiency and less effort on the part of the operator. Many Spire fixings are integral with the component that is to be fixed so that no nut or washer at all is needed. The Spire 'idea' is not restricted to 'nut and bolt' assemblies. Whenever there is a fixing, clamping, holding job to do there is a chance that Spire could help you. So if you will tell us your immediate assembly problem — we shall gladly design yet another. It may not be as elegant as the Swan but it will do a job of work reducing your assembly time and saving material and cost for you.

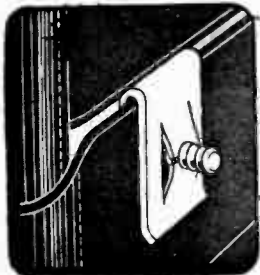

### THAT'S Fixed THAT!

Here's a little chap in action. Reference No. NU 531. Its uses are legion. Wherever there is blind assembly work, wherever your operatives are fumbling with nuts and washers the NU 531 will save time and cost and a lot of bad temper. Clip it into position and it stays 'put' until you are ready to tighten up the screw. No washer needed of course.

# Spire

★ **A BETTER way of fixing**

*Simmonds Aerocessories Limited • Great West Road • London • A Company of the Simmonds Group*

# Wireless World

Radio • Electronics • Electro-Acoustics

34th YEAR OF PUBLICATION

JUNE 1944

Proprietors :  
ILIFFE & SONS LTD.

Managing Editor :  
HUGH S. POCOCK,  
M.I.E.E.

Editor :  
H. F. SMITH.

Editorial, Advertising  
and Publishing Offices :

DORSET HOUSE,  
STAMFORD STREET,  
LONDON, S.E.1.

Telephone :  
Waterloo 3333 (35 lines).

Telegrams :  
"Ethaworld, Sedist, London."



PUBLISHED  
MONTHLY

Price : 1/6

(Publication date 25th  
of preceding month)

Subscription Rate :  
Home and Abroad  
20/- per annum.

MONTHLY COMMENTARY .. .. .	161
PENTODE-DIODE VALVE VOLTMETER By T. A. Ledward, A.M.I.E.E. .. .	162
TELEVISION SURVEY By R. W. Hallows, M.A., A.M.I.E.E. .. .	166
UNIVERSAL MEASURING INSTRUMENT (concluded) By G. A. Hay, B.Sc. .. .	170
RADIO JUBILEE .. .. .	173
SIMPLE MODULATION MEASUREMENTS By G. S. Light, B.A.Sc. .. .	174
HIGH SELECTIVITY AT AUDIO AND INTER- MEDIATE FREQUENCIES By E. Lloyd Thomas, B.Sc., A.C.G.I. .. .	175
RADIO HEATING EQUIPMENT—III By L. L. Langton, A.M.I.E.E. .. .	179
RANDOM RADIATIONS. By "Diallist" .. .	182
WORLD OF WIRELESS .. .. .	184
NEWS IN ENGLISH FROM ABROAD .. .	186
LETTERS TO THE EDITOR .. .. .	187
RECENT INVENTIONS .. .. .	190
UNBIASED. By Free Grid .. .. .	192

Branch Offices :

COVENTRY :  
8-10, Corporation Street,  
Telephone : Coventry 5210.  
Telegrams :  
"Autocar, Coventry."

BIRMINGHAM :  
Guildhall Buildings,  
Navigation Street, 2.  
Telephone :  
Midland 2971 (5 lines).  
Telegrams :  
"Autopress, Birmingham."

MANCHESTER :  
260, Deansgate, 3.  
Telephone :  
Blackfriars 4412 (4 lines).  
Telegrams :  
"Iliffe, Manchester."

GLASGOW :  
26B, Renfield Street, C.2.  
Telephone : Central 4857.  
Telegrams : "Iliffe, Glasgow."



As many of the circuits and  
apparatus described in these  
pages are covered by patents,  
readers are advised, before  
making use of them, to satisfy  
themselves that they would  
not be infringing patents.

## Miniature I.F. Transformers

DESIGNED FOR MAXIMUM  
GAIN AND SELECTIVITY IN  
THE SMALLEST DIMENSIONS

The coils are contained in enclosed pot-type iron dust cores, tuning adjustments being obtained by means of adjustable iron dust centre cores.

Fixed tuning condensers are contained inside the screening can.

The following frequencies are preferred standards but others are available for particular applications :—

M.400 - - 460 Kc/s. M.405 - - 1.6 Mc/s.  
M.411 - - 2.1 Mc/s. M.415 - - 4.86 Mc/s.  
M.418 - - 9.72 Mc/s.

Wartime restrictions prevent our accepting orders other than those covered by priority numbers.

The illustration shows the actual size of the Unit which is provided with one hole fixing, the terminal wires being fed through insulated bushings which, in turn, prevent movement of the transformer when mounted in position.

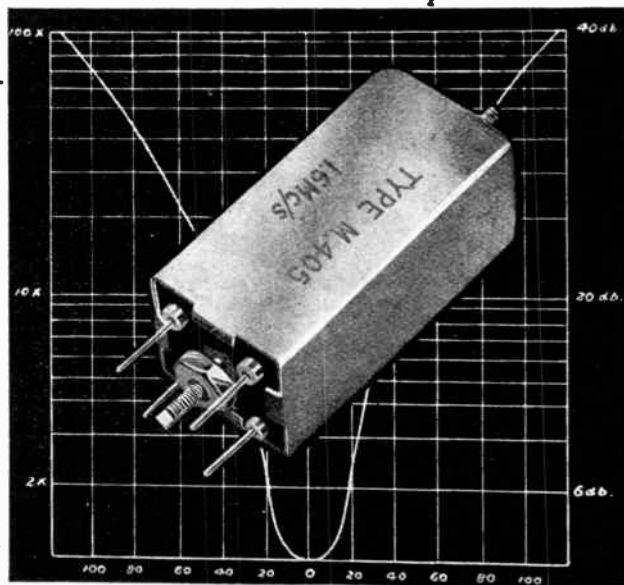

**WRIGHT & WEAIRE LTD.**

HIGH ROAD, TOTTENHAM, N.17.

Telephone : TOTtenham 3847-8-9.

*Over twenty years of  
experience and research  
are behind the advanced  
technique of today . . .*



**MULLARD**  
**THE MASTER VALVE**  
**A Valve for Every Purpose**

DOMESTIC · COMMERCIAL · INDUSTRIAL · SCIENTIFIC · MEDICAL · EXPERIMENTAL

THE MULLARD WIRELESS SERVICE CO. LTD., CENTURY HOUSE, SHAFTESBURY AVENUE, LONDON, W.C.2. (77 rev.)

# Wireless World

Radio • Electronics • Electro-Acoustics

Vol. L. No. 6

JUNE 1944

Price 1s. 6d.

## Monthly Commentary

### *Anti-Interference Legislation*

CONTRIBUTORS to this journal have stressed the fact that, when the war ends, a unique opportunity will arise for reducing machine-generated interference with wireless reception. When that time comes, many of the existing interfering appliances, both industrial and domestic, will be due for replacement. It behoves everyone concerned with any aspect of wireless to do what he can to ensure that these worn-out appliances are replaced by new ones embodying reasonable precautions against the generation and radiation of interference.

It is generally accepted that legislation is essential to achieving this end. That principle was supported as long ago as 1936, when a representative Committee, by no means devoted only to wireless interests, decided in favour of it. Legislation should be ready before the mass-production of electrical equipment is resumed after the war. We do not suggest that it would be practicable now to introduce a comprehensive Bill laying down precise limits for permissible interference; that might come later. What is needed is a stop-gap measure, establishing the simple principle that after the war it will be illegal to sell, install or operate electrical equipment without taking reasonable precautions against radiating interference.

We are glad to see that the urgency of anti-interference legislation is being recognised. The house journal of Murphy Radio is appealing to the firm's dealers to use their opportunities to spread the idea among users of broadcast receivers, while Dr. R. L. Smith-Rose, in a Commemoration Meeting address before the I.E.E., recently pointed out that, if we are to gain the maximum benefit from wartime advances in short-wave technique, anti-interference legislation will be necessary.

In common justice it seems inescapable that users of wireless equipment are entitled to legal protection against avoidable interference in just the same way as the public is protected by law against other nuisances.

**Combined Sound-Vision Broadcasting.**—Much has been said and written during recent months on the technical aspects of our post-war television

system, and many valuable suggestions have been made for re-establishing the service on the best possible lines. The other side of television—the “programme side”—is surveyed on another page, and our contributor makes the suggestion that the sharp line of demarcation hitherto drawn between sound and vision broadcasting should be removed; in a word, we should have one kind of broadcasting, using sound or vision, or both together, as appropriate for the subject to be presented. That proposal will arouse some controversy. But it must be admitted that hardly anything could do more to hasten the spread of television than the constant reminders of its existence that would thus be given to those not equipped with a “combined” receiver.

**Variable- $\mu$  or Variable- $\mu$ ?**—Our associated journal, *Wireless Engineer*, in an Editorial in the May issue draws attention to yet another example of the confusing and indiscriminate use of two terms to describe one quality, namely, the special characteristics of RF and IF amplifying valves designed for control of volume by variation of grid bias.

There seems little doubt that “variable- $\mu$ ” was originally intended to be an abbreviation for “variable mutual conductance,” and in any further contraction “variable- $g$ ” should logically have preference over “variable- $\mu$ ,” which, although phonetically the same as “variable- $\mu$ ,” implies quite another thing, namely, variable amplification factor. As our companion journal points out, “the amplification factor is also variable to some extent, but that this is merely incidental is shown by such textbooks as the ‘Admiralty Handbook of Wireless Telegraphy,’ which uses ‘ $m$ ’ for amplification factor, and not ‘ $\mu$ .’”

For our part we advocate the continuance of “variable- $\mu$ ,” not only because it is the more firmly established but because when we draw valve curves to show variable- $\mu$  characteristics they are invariably curves of anode current against grid volts, the slope of which is an index of mutual conductance.

# PENTODE-DIODE VALVE VOLTMETER

## Linear Calibration Down to Less Than 0.1 Volt

By

T. A. LEDWARD,

A.M.I.E.E.

THE ideal valve voltmeter would have infinite impedance at all frequencies; it would have an evenly divided instrument scale, and would be adaptable for reading either peak, mean, or RMS values. Also, the scale range would be changeable at will and supply voltage variations would not affect the accuracy. As it is not possible to obtain all these features together, it is necessary to decide which are of most importance for any particular work, and to choose the most practical and convenient instrument for the purpose in view.

The instrument to be described was designed in the first instance for experimental work with audio frequencies, and a low scale range was needed. In order, however, to extend its usefulness, provision was made for a number of voltage ranges and also for DC tests. An external RF diode may be connected, if desired, for radio frequency work, but separate calibration will then be needed.

In order that the apparatus should be fairly robust and not usually expensive, it was decided to use a type of indicator that a great many experimenters possess, namely, a 0-1 milliammeter. Further, in order that the milliammeter should not

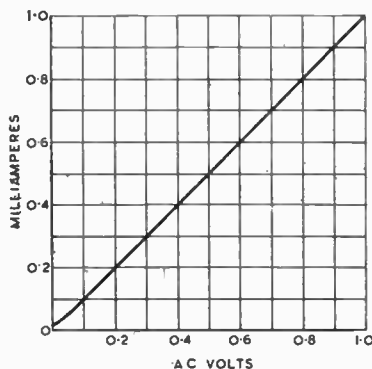

Fig. 1. The linear calibration curve gives useful readings below 0.1 volt.

require a special scale, and to obtain good readings at the lower end of the scale, a straight line calibration was desirable with a

full-scale reading of 1 volt. The advantage of straight line calibration is very great at low readings, as it is possible with a 0-1-volt range to obtain clear readings well below 0.1 volt, which would

The principle will be most readily understood by reference to the equivalent circuit of Fig. 3. This is a bridge circuit which is balanced for DC, so that no current normally flows through the instrument M, the resistances  $R_a$ ,  $R_1$ ,  $R_2$ , and  $R_3$  being equal.  $R_a$  is the internal resistance of the valve. The valve, when AC is applied to the grid, acts as a

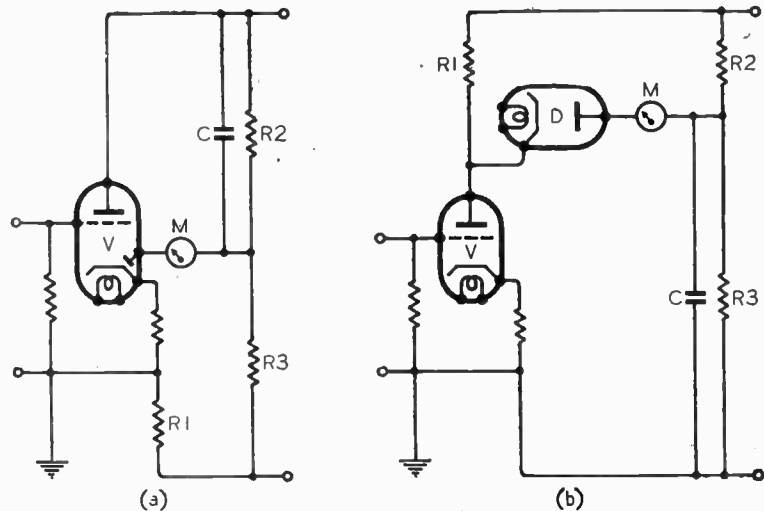

Fig. 2. (a) Basic circuit and (b) modified form with earthed negative HT.

not be possible with a "square law" scale. Although it is not possible to maintain true straight line calibration right down to zero (except for DC tests), it will be seen from the curve of Fig. 1 that it is linear from full scale down to less than 0.1 volt, and is direct reading on the mA scale over this range. Even below 0.05 volt the curve is steep enough to obtain clear readings by reference to the calibration curve, or by specially marking the scale at this end.

The original circuit in its simplest form is shown in Fig. 2 (a), but the basic arrangement was subsequently altered to that of Fig. 2 (b). This modified circuit is to be preferred because it allows the negative HT and the cathode end of the valve input to be at earth potential, which is of some importance at the very high audio frequencies.

generator V, which injects AC into one arm of the bridge and thus produces an AC voltage across the points Y and Z, to which the instrument M is connected in series with the rectifier D. The condenser C, connected across  $R_3$ , is made large enough to offer a negligible impedance to the lowest frequency used, and thus increases the AC voltage across YZ, while not affecting the DC balance. The valve V is biased to work on the straight part of its characteristic, so that no DC component exists in the voltage across YZ except by virtue of subsequent rectification by the diode D. The AC voltage across YZ is thus proportional to the valve input voltage, and rectification gives a reading on M that is proportional to the mean value of the input voltage.

In the basic circuit of Fig. 2 (b) a triode valve is shown, but a



pentode is to be preferred on account of the lower effective input capacitance.

An important consideration with mains-operated measuring apparatus is the effect of variations of mains voltage. Where a stabilised source is not available it is essential that supply voltage variations should affect the apparatus as little as possible. The simple form of bridge circuit can, by suitable choice of component values and by adding a series HT resistor, be made insensitive to reasonable changes in HT voltage, but cathode temperature needs to be correct for maintenance of a DC balance. Variation of the cathode temperature, and consequently of  $R_a$ , will unbalance the bridge, and the need for continual re-balancing can be quite troublesome. If, however, either  $R_1$  or  $R_3$  is automatically varied by the same amount as  $R_a$ , the balance will remain undisturbed.

The most satisfactory way to make either  $R_1$  or  $R_3$  vary in the same manner as  $R_a$  when the supply voltage varies is to use, in place of one of these resistors, a similar valve to  $V$ . This has been done in the final circuit as shown in Fig. 4, in which  $V_2$  replaces  $R_1$ , and includes the diode  $D$ . Each of the valves  $V_1$  and  $V_2$  is a Mullard  $PEN_4DD$ , this being the most suitable standard valve available at the time the instrument was made. The diode sec-

are provided for the instrument  $M$  and are adjusted to give a 1-volt full-scale reading for AC and DC respectively. A switch  $S_1$  is used to select the appropriate resistor, and in the case of DC tests the diode is cut out, as it is not required. This allows

and HT volts and current are quite low, approximately 90 volts across each valve with an anode current of 8 mA, so that the valves should have a long life.

The pentode screen resistor is connected directly to the anode, and although this is not usual the

arrangement gives a much higher impedance—provided the correct value of resistance is used—than if the valve were used as a triode. In fact, the input impedance is the same as if the screen resistor were connected to HT positive, but raised in value to give the correct screen voltage, as in the normal pentode circuit. The sensitivity would be increased by this latter arrangement, but the extra sensitivity is not required in the present instance and

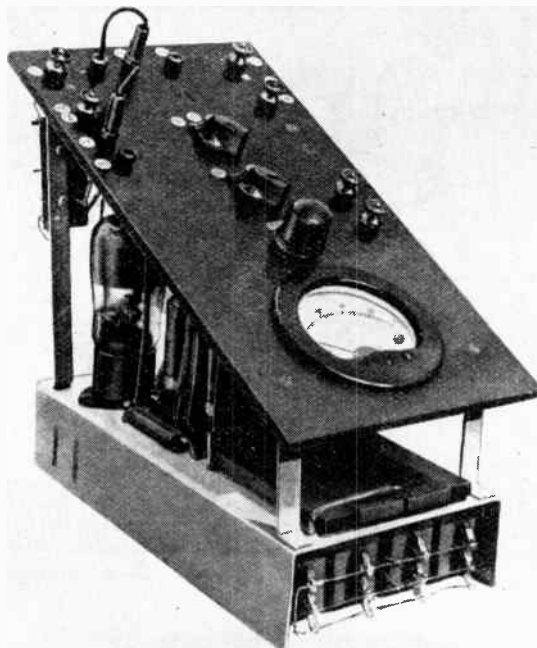

View of pentode-diode valve voltmeter removed from its case.

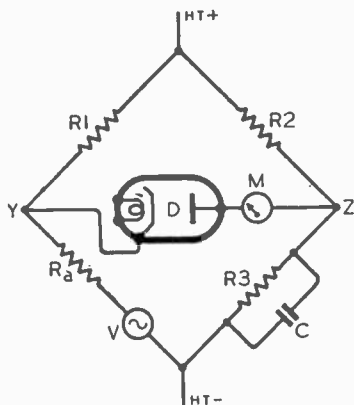

Fig. 3. Equivalent bridge circuit of Fig. 2 (b)

tion of  $V_1$  is not required, but it was necessary that the cathode and heater should be the same as in  $V_2$ , hence the same type of valve was used.

Two series resistors  $R_{15}$  and  $R_{16}$

straight line calibration for DC tests right down to zero. It may be mentioned that the AC resistor may be dispensed with, if desired, and the grid bias resistor in the cathode circuit adjusted until full-scale deflection is obtained for exactly 1-volt AC. If the deflection is found to be less than full scale for 1 volt with the bias resistor value as given in Fig. 4—and this may possibly happen with a different valve—then the bias resistor must be reduced until full-scale deflection is obtained. This is because the bias resistor also gives negative feedback.

The correct values for the instrument series resistors will have to be determined by trial, but, as a guide, the following values were required in the writer's case, where the instrument  $M$  had an internal resistance of 75 ohms:  $R_{15}$ , 135 ohms;  $R_{16}$ , 24,030 ohms.

Although power valves are used, they are only lightly loaded

the arrangement shown in Fig. 4 is preferred. The effective input capacitance of the valve is  $31 \mu\mu F$ , measured at 18,000 c/s. This is increased by a further  $8 \mu\mu F$  by switching arrangements on the input side.

If the input to  $V_1$  is derived from a source which gives continuity across the input terminals, the grid resistor  $R_{10}$  may be disconnected by opening switch  $S_2$ —for which a plug and socket may be used—in order to give the highest possible input impedance. If the input circuit includes a series condenser, or whenever the higher voltage ranges are in use, then  $S_2$  must be closed.

The higher voltage ranges are provided by a sectionalised grid resistor as shown; a switch  $S_3$  selects the appropriate grid resistor tapings. A further 10/1 multiplier is provided by means of a separate 9 megohm resistor. A plug and socket switch  $S_4$  is used for this multiplier.

**Pentode-Diode Valve Voltmeter—**

Apart from the 1 volt range available with no shunting resistance across the input, ranges of 1, 10 and 100 volts are available with an input resistance of 1 megohm, while ranges of 10, 100 and 1,000

inductance, carbon resistors are better than wire-wound. Good carbon resistors will vary slightly in value with temperature change and change of applied voltage, but the ratios are not likely to alter appreciably. The ratios and

resistors R7, R8 and instrument series resistors R15, R16. The balance adjusting potentiometer R4 should also be wire-wound.

A suitable panel layout is shown in Fig. 5. The mains supply unit is separate and is of standard form. A metal case for screening the instrument should be provided. It is an advantage to separately screen V1, and sufficient screening can be most readily provided by coating the glass bulb with "Aquadag," unless a metallised valve is available. The coating should be connected to the cathode pin. The switches, where provided, should be of a good low capacitance type, such as the "Yaxley," and the metal frames of the switches should be earthed.

The DC calibration is, of course, a simple matter, and the AC calibration may be carried out just as simply with a 50-cycle mains supply.

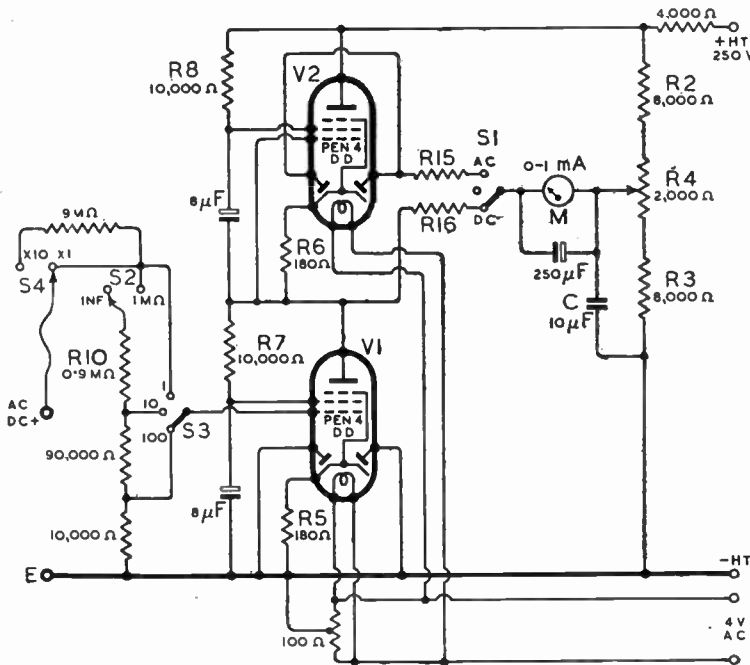

Fig. 4. Circuit diagram of final instrument. R15 and R16 are adjusted to give 1 volt full-scale reading for AC and DC respectively.

volts are available with an input resistance of 10 megohms. The input impedance on AC must, of course, take into account the effective grid capacitance of V1 and will depend upon the frequency.

The 100 and 1,000 volt ranges are only intended for DC and low frequencies—such as 50 c/s supply mains. Any attempt to measure high voltage AC of high audio frequency by direct connection to the instrument would probably result in considerable error due to stray fields, and due to valve capacitance altering the voltage divider ratio.

It is obvious that on any range other than 0-1, the accuracy will depend upon the correct ratio of the grid resistor sections, so that resistors must be carefully chosen. Wire-wound resistors of such high values are rather a luxury, and it should be remembered that it is the resistance ratios that matter and not the absolute values. A further consideration is that as regards bulk, self-capacitance and

accuracy of indication can be checked quickly at any time by applying known values of DC voltage. This is a great convenience. It must be admitted that some patience is required in the initial construction of these voltage dividers if reasonably good accuracy is required, and it would help considerably if satisfactory variable potentiometer type resistors were available, especially as these could be readjusted from time to time if it were found necessary. The ordinary carbon volume control is too bulky for this particular purpose. The writer has made some special straight carbon potentiometers with sliders and these are no larger than fixed 1-watt resistors. They are undergoing a test in the present voltmeter and appear to be satisfactory, but it will necessarily be some months before it is possible to say whether they can be relied upon.

Wire-wound resistors should be used for the bridge arms R2, R3; cathode resistors R5, R6; screen

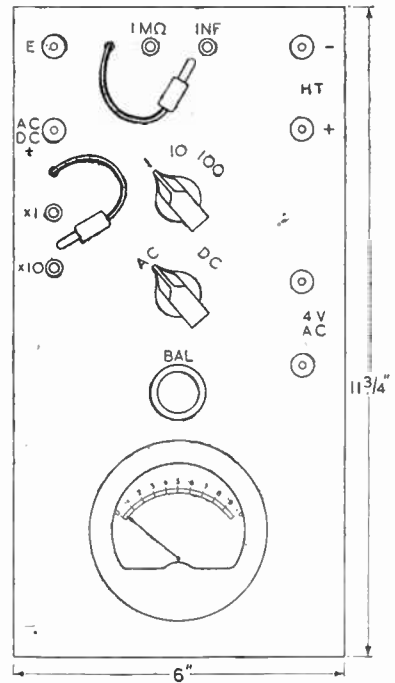

Fig. 5. Panel layout adopted in the writer's instrument.

The satisfactory operation up to 18,000 c/s was checked by the writer by means of the oscillator described in an earlier article (W.W., Sept., 1943), and an Elliott 10 mA thermocouple. The latter was connected in series with a non-inductive resistor across the input terminals of the valve volt-

meter. The reading of a microammeter connected to the thermocouple was kept constant at different frequencies, while the reading of the valve voltmeter was noted. The test circuit is shown in Fig. 6. A constant reading was obtained on the valve voltmeter from 25 to 18,000 cycles. The thermocouple output is, of course, proportional to the RMS value of the current, which in turn is proportional to RMS voltage, but the waveform was good enough to give a constant mean value of current, and thus of resistor volts, when the RMS value was maintained constant. The valve volt-

beyond the scope of the present article and will depend largely upon the frequency range desired. If, say, a full-scale reading for 100 mV or less is required at one frequency only, such as 50 c/s, then a single valve with either resistance or transformer coupling may be used before the AC input to V1. If, however, a wide frequency band is to be covered with

POLICING THE ETHER

U.S. Monitoring Service

MORE than one hundred fixed stations are employed by the Radio Intelligence Division of the U.S. Federal Communications Commission for the maintenance of "law and order" in American radio traffic.

The R.I.D. maintains twelve main monitoring stations, 90 secondary stations (one or more of which are located in each of the 48 States and in the territories and possessions) and three radio intelligence centres at Honolulu, San Francisco and Washington.

In addition to these fixed stations, which are usually located in isolated places far from the nearest town in order to secure ideal listening conditions, thirty mobile units now maintain a continuous patrol of the entire 5,000-mile coast line of the Continental United States. These coastal units are particularly on the watch for any radio transmitters on shore which might be communicating with an enemy ship at sea relative to the departure, location or cargoes of departing vessels. It is claimed the system is so organised that a clandestine signal originating anywhere in American territory can be traced down.

When an intruder is detected three or more monitoring stations collaborate in getting a bearing on the signal. The final task of running down the offender is performed by monitoring officers using cars fitted with the latest type of detection equipment.

Fig. 6. Schematic test circuit for checking calibration at high audio frequencies.

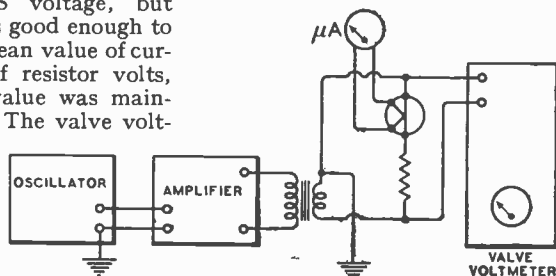

meter reading is, as previously stated, proportional to the mean value of the voltage. At 25 c/s there is noticeable vibration of the milliammeter pointer, although the instrument is shunted by a 250  $\mu$ F electrolytic condenser, but the vibration disappears completely as 50 c/s is reached.

There is one point about calibration that should be carefully noted: Reference to the curve of Fig. 1 will show that the electrical zero does not coincide with the mechanical zero. This applies to AC only. The volts zero corresponds to 0.02 mA scale indication. This means that the DC balance of the bridge is deliberately upset by means of the balance adjustment R4 to give a reading of 0.02 mA with zero input. The reason for this is that the linear volts scale from under 0.1 volt to full scale then coincides with the mA scale. Another advantage is that it is much easier to set the volts zero to 0.02 mA than to set it to zero mA, because if the latter course were adopted it would be possible to carry the adjustment too far without knowing it, as the current cannot reverse. (When the diode is cut out for DC tests a true zero adjustment is, of course, possible.) The balance adjuster takes the form of a potentiometer R4.

If it is desired to obtain a full-scale reading for very much less than 1 volt, an external amplifier will be necessary. The description of a suitable amplifier is

such a low voltage range, it is suggested that the better procedure would be to use an external diode to feed V1 and a single RF pentode to feed the diode.

Low DC ranges are, of course, slightly more difficult. In conclusion it may be stated that for the general requirements mentioned in this article the arrangement described has been found to be very satisfactory and was adopted after much consideration and experimental work with different circuits.



THE FIRST of the much-talked-of German radio-controlled "tanks" to fall into our hands. Having driven the vehicle, carrying an 800 lb. explosive charge, towards its objective the driver dismounts and directs it by radio for the final few hundred yards. It then drops its charge, which is fitted with a time fuse, and is backed to the driver by radio control. The vehicle, 12 ft. long, 6 ft. wide and 4 ft. high, is slightly smaller than a Bren carrier.

# TELEVISION SURVEY

## Plea for an "All-in" Sound Vision Service

By R. W. HALLOWS,  
M.A., A.M.I.E.E.

**B**EFORE we come to consider the future of television when peace has once more come to the world it may be well to see just what it had achieved when, on September 1st, 1939, the threat of war closed down for the time being the activities of the B.B.C.'s Television Department and hid technical progress and developments behind a veil of secrecy. We may well ask whether, at that fateful moment, television had in fact reached a point at which what it had to offer was acceptable to the public, which had for so long been clamouring for the reception of vision as well as sound broadcasts in its own homes. Was the position in the autumn of 1939 such that we could feel that television had at last found its feet? Were we working on the right lines? If, in a word, there had been no war and development had continued to follow the path that it was taking in 1939, would the television receiver be found today in the homes of the great majority of moderately well-to-do folk? Or would some radical change in technique, or in the matter broadcast, or in both, have been required to enable it to achieve the popularity which it seemed for so long to be on the point of gaining, yet never actually managed to gain?

Of one thing there can be "no possible, probable shadow of doubt": the public wanted television and was prepared to receive with open arms the kind of television that answered its requirements. The television of pre-war days cannot fully have met those requirements, or its history during the two years of broadcasting from the Alexandra Palace would have been very different. Something was amiss. If we can find what it was—what it

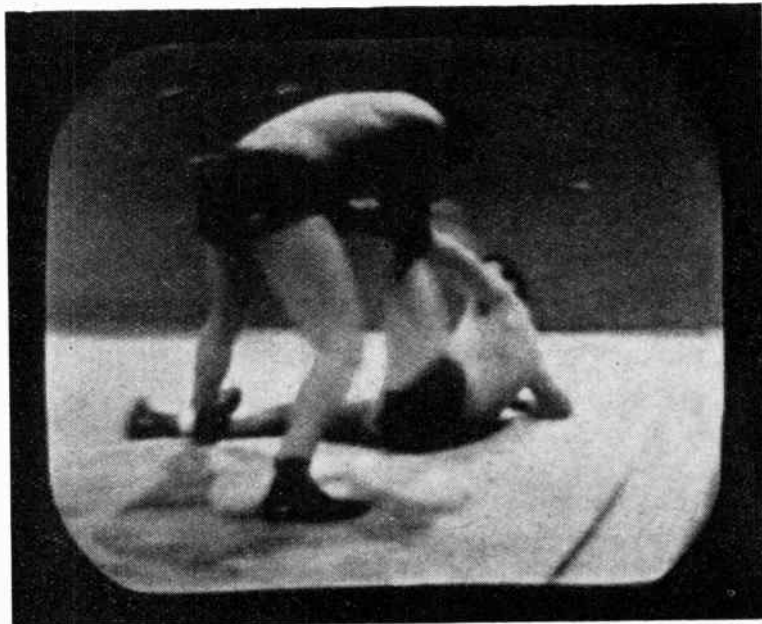

The growth of television is closely linked with abatement of the interference nuisance. This un-retouched photograph hardly gives an adequate idea of the "annoyance value" of motor ignition interference (note the white spots).

was that deterred the man in the street from accepting the gift which he had been demanding so long and so loudly—we may be able when the war is over to give television the impetus that it lacked in the past to ensure its wide and rapid popularity. That television can and will become popular I am convinced. I am equally sure that this could not have been brought about by the methods in vogue up to 1939.

Television has a curious history in this country—and it must never be forgotten that ours was the first to develop it. And its history here has been repeated to a great extent in the United States. Sometime before the war (in 1937, I think it was) a big American firm wrote to me. They were thinking, the letter said, of taking up the manufacture on a large scale of components for television receivers. Knowing what I did of the progress of television in this country, would I advise them on the wisdom or otherwise of this course? In my reply I said that I had followed closely the infancy of television in America and, so far as I could

see, its story there would be exactly parallel to its story here. It had already been boosted, boomed and balleyhooed by the American lay press. Great expectations had been aroused in the bosom of the man in the street, who was already saying in the United States, as he had said here, that he wouldn't be happy till he got it. It would be found, I predicted, that the public would eat every word that the lay press gave them on television and would ask for more; would fill the correspondence columns with letters yearning for the newest boom to mankind; would pack demonstration theatres to suffocation, loudly applauding what they were shown there. They would in fact show every sign of being ready to absorb television receivers as fast as they could be placed on the market; but when those receivers were available would be very coy indeed about buying them.

That, I foretold, would be the early history of television in the United States and I advised the firm against the line of action

that they had in mind. "Unless," I added, "people in your country can put their finger on what is lacking here in television and can discover how we have so far failed to give the would-be viewer what he really wants." The history of television in the United States from the first broadcasts until that country came into the war was very much as I had forecast. And there is a good deal to be learned from the fact that what happened in our country happened also in the United States of America.

There were those who ascribed the slowness of our folk to acquire television receivers to the natural caution of the Briton: before buying something new he likes to make sure that this apparatus

the mass of our people. But in 1938 television receivers were being offered at prices less than those of the wireless sets that sold as fast as they could be turned out in the early days of sound broadcasting. Nor would prices have deterred the American public with its higher wage-levels and its vast use of deferred payment systems. No, the peoples of both countries were of the opinion that something was lacking, and so long as that "something" remains lacking television is not going to make the strides it should make. It must be a very important "something" if the already eager public would not respond to the terrific free publicity that television received both here and in America.

mistakes, which must not be repeated when a fresh start is made, were responsible for the fact that television as a source of home entertainment has hitherto been a partial failure instead of a resounding success. The first of these was that when the technical development of television had reached a stage at which it was completely fit to provide entertainment in the homes of the people, we did not know what to do with it, and we forced it to take on rôles for which it was entirely unsuited. The second vital mistake was that television broadcasting was divorced from normal sound broadcasting instead of being made part and parcel of it, a point on which more will be said in a moment. Meantime, let us consider the suggestion that we didn't know what to do with television when we had it.

### "Terribly Artificial"

Just what did we do with it? Well, the B.B.C. put on special television programmes, quite separate and distinct from those of the normal sound schedule, lasting two or three hours a day. The programmes included plays, cabaret and films, the plays and the cabaret being mostly specially written and produced to suit the technical requirements of television broadcasting. There were also, if I remember rightly, attempts at some kind of newsreel, illustrated talks on such feminine matters as cooking and dress-making, visits to the Zoo in the children's hour and illustrated hints and tips on how to do this and that. There was something terribly artificial about the bulk of such televised programmes: one felt that they had been devised, produced and transmitted not because they were worth transmitting, but simply because television was in being and *something* had to be scratched together to show off its paces. As entertainment they had not sufficient value to induce more than a few thousand people of the ten to twelve millions living in the area served to buy television receivers; and those who did buy made less and less use of their sets for bringing in the regular programmes—once the novelty had worn off after the first fortnight or so. What they did use their sets for was the reception of television broadcasts



The high cost and complexity of dramatic presentation by television is suggested by this photograph, taken in the Alexandra Palace studios shortly before the war.

will not quickly be rendered obsolete by some new discovery. But in America, the land of constantly recurring new things, there is no such natural reluctance to take the plunge. Others, again, held that the cost of television sets put them beyond the reach of

Innumerable opportunities have come my way of discussing television both with owners of receiving apparatus and with people who might have become owners but didn't. Thinking over and sifting out what they have said convinces me that two cardinal

**Television Survey—**

of big sporting and other events as these occurred. Had there been Derbys and Boat Races, Cup Tie Finals and Lord Mayor's Shows every day the entertainment value of television would never have been in doubt. But there weren't and there won't be. Also, television must surely have a wider task to perform than that. So what is to be done about it?

**Vision + Sound = Broadcasting**

That brings me to the second great mistake that was made—the gulf that was fixed between sound broadcasting and vision broadcasting. I do not mean that the vision broadcasts were not accompanied by sound, for of course they were. What I am driving at is that the main programmes continued to be devised with a view to their effects on the ears of listeners, and that special programmes were drawn up for television that appealed to both eye and ear. It was a major error to foster the idea that there were two kinds of broadcasting. From the very first they should have been merged into one complete whole. Broadcasting with no qualifying epithets. The sound programmes, which had amply proved their entertainment value by bringing about the annual sale in Great Britain of some nine million ten-shilling receiving licences, should have been modified gradually so as to enable them to absorb and make part of themselves the new feature, vision.

Please do not imagine that I am advocating that vision should accompany all items of all programmes. When the war is ended we shall presumably return to regional and national programmes. I would make the latter, to begin with, at any rate, the complete programme, and would have it transmitted from start to finish on very short, medium and long wavelengths. Any item that lent itself to vision as well as sound—and, as I have already suggested, programmes would be so modified from their present form as to include a considerable number of these—would be illustrated by means of television transmission and reception. Those who had not means of receiving vision, or who were receiving on the medium or long waves, would still obtain genuine entertainment from their

loud speakers; but the broadcast in its entirety would be received only by those who had both loudspeakers and viewing screens in use during the illustrated items. Careful planning and production would be needed to ensure that the illustrated items were sufficiently numerous and of the right kind. Above all, it would be essential that they should be neither incomprehensible nor just plain dull to those without vision receiving facilities. There is nothing impossible, or even very difficult in these requirements. Programmes produced on the lines indicated would make sound reception alone the "penny plain" and sound-cum-vision reception the "two-pence coloured" of broadcast entertainment.

It will be asked what kind of modified programmes I have in view. How, again, can we be sure of a supply of items free from the artificiality of so large a proportion of the pre-war television broadcasts? Certain items, such as the daily dozen, practical hints on gardening, cooking, dress-making, household jobs and the like lend themselves readily to illustration, the verbal descriptions being always such that those receiving with loudspeaker only can follow easily what is being done. The film critic and the theatre critic can show samples from the plays or films under review, again making sure that their descriptions are adequate.

Cabaret, music hall shows, plays and so on are probably accompanied throughout by vision transmissions. Soloists, orchestras and bands are most likely confined to sound only.

**Hot News**

That is a beginning: there is much more to be done. Of one thing there is no doubt, and that is that the public likes descriptions and illustrations of events of the day. It is to that liking that the daily and weekly papers owe their present enormous circulations. Hitherto the branch of broadcasting confined to sound has rather tended to limit its activities in these directions to what may be called major events, whether sporting or otherwise. But there is always plenty going on that is of general interest. Sound film recording units of the mobile type could bring in a rich harvest every day of illustrations and running commentary.

Space does not allow me to go more into detail about the make-up of programmes; but the reader will see for himself that the field is immense and the possibilities almost unlimited. And he will, I believe, be disposed to agree that with programmes of the kind suggested there would be a real inducement to everyone who could afford to become the owner (and user) of a sound and vision receiver.

I have said little about the

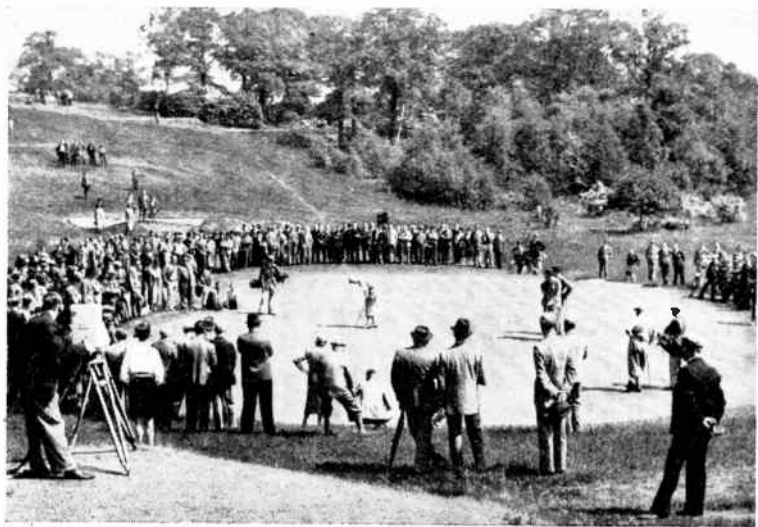

Undoubtedly the most popular features of our pre-war television service were "actuality" broadcasts, such as this transmission of an International professional golf match.

technical side of the matter because I do not think that shortcomings there were to any great degree responsible for the failure of television in pre-war days to achieve popularity. Enormous strides have been made during the war in both VHF and CRT techniques, so that I do not feel that we need worry unduly about the technical aspect. I do, though, very much hope that the radio manufacturers will take to heart the need to put an end to the separation of television broadcasting from what we used to regard as "normal" sound broadcasting. It is the combination of sound and vision that should be normal. To sell as "television receivers" sets capable of bringing in vision as well as sound on all the broadcasting wavelengths would be ridiculous. These should be known simply as "broadcast receivers," sets able to deal with sound alone being termed "broadcast receivers (sound only)."

### VHF High Fidelity

As I see it, the rapid development of a network of VHF stations over the country is to be expected as soon as peace returns. At first these stations may relay the sound and vision components of a single programme. Later we may hope for alternative programmes: it should be but a matter of time for a selection of VHF illustrated programmes to be available in all but the most isolated places. This will mean that genuine high-fidelity reproduction of sound is possible everywhere, and it is to be hoped that the radio industry will not fling away this priceless gift, as it tried to do in the years before the war came upon us by two acts of folly. First, many television receivers were made whose AF sides were incapable of doing justice to the available high-fidelity transmissions of the sound accompaniment to television. Secondly, though the B.B.C. was willing to transmit the complete national sound programme on VHF with high fidelity, the industry would have none of it, holding that if the man in the street once heard what sound reproduction by wireless *could* be like, he would plague the life out of them by demanding the impossible—high-fidelity on all wavelengths and from sets at all prices. The sensible attitude would have been

to welcome high-fidelity transmissions, to explain to the public that they were receivable to perfection only on the very short waves by sets that could not be sold at low prices, and to spur on the B.B.C. to establish more and more VHF transmitters.

### Anti-interference Legislation

Apart from what has been said so far, there is one factor on the technical side which does not concern the VHF receiver (sound or vision) itself, but may yet be a decisive factor in the success or otherwise of VHF broadcasting—and vision can be broadcast only on the very high frequencies. This is interference, particularly that radiated by motor car ignition systems. Various kinds of anti-interference aerial systems were designed and used before the war; but they were palliatives at best and not always very effective. It is scarcely going too far to say that that VHF reception of sound-cum-vision or of sound only was too unsatisfactory to have much if any entertainment value in most houses near which there was any considerable volume of motor traffic. A particularly knowledgeable wireless dealer with much pre-war experience of television said to me recently: "If the authorities tackle the problem of motor car interference firmly, television will be a success; if they don't, it hasn't a hope."

There is a great deal in this. No matter how attractive programmes on the lines already suggested might be, nor what degree of perfection of reproduction of transmission was achieved, no one could take much pleasure in sound continually accompanied by machine-gun effects or in images marred by the "snowstorms" with which many of us were all too familiar. There is no doubt that this kind of interference can be dealt with successfully if the necessary legislation is introduced. If VHF radio is possible between plane and ground or between plane and plane, the suppression methods that have been developed must be effective and they cannot have serious effects on the all-important liveliness of aero engines. Though it employs coil and battery ignition as a rule, the car engine should be equally susceptible to effective suppression.

To sum up: television is bound,

sooner or later, to come into its own. Whether it does so rapidly or only after the lapse of some considerable time will depend mainly upon the action taken as soon as the war is over. The man in the street is as eager for it as ever he was; but he will not buy it simply as a novelty. Television has long passed the stage when any kind of image on the viewing screen was enough. What the public wants from it is genuine entertainment, and that can be given only if its transmissions are merged with those of sound to form the parts of a complete whole—the broadcast programme. The public is satisfied that television is technically capable of providing what it wants, and it will be still more satisfied on that score when it knows of the improvements that are now waiting to see the light of day. On two vitally important points it has still to be satisfied: that television and sound mean better entertainment than sound alone, and that the programmes sent out can be received without frequent and disturbing interference. Once it becomes confident about these things television will not just march forward: it will gallop.

### THE WIRELESS INDUSTRY

WE have received an illustrated booklet giving technical details of the domestic standard fuse plug and socket made by Dorman and Smith, Ltd., Ordsal Electrical Works, Salford, Manchester, 5. The fuse takes the place of one of the pins of the plug and is easily replaceable.

A substitute for the ordinary split battery plug is now available in the Titen spring battery plug which is being distributed by London and Provincial Factors, Ltd., "Wanie House," Aylmer Parade, E. Finchley, London, N.2. The retail price is 2d. each.

W. F. Newell, B.Sc., who has been associated with Weston Instruments for more than ten years, has resigned from Sangamo Weston, Ltd., and is taking up the position of Technical Contracts Manager with the Automatic Coil Winder and Electrical Equipment Co.

### COVER ILLUSTRATION

OUR cover shows a group of T.C.C. small transmitting condensers, made from thimble-shaped ceramic mouldings with silvered electrodes fired on to inner and outer surfaces. Capacities of the largest size illustrated (overall length about 3½ in.) range from 0.0006 to 0.00175 μF. Working voltages of this type of condenser are up to 10,000 V DC.

# UNIVERSAL MEASURING INSTRUMENT

## 2—Practical Details

By G. A. HAY, B.Sc.

THE basic principles involved in the design were described in the first part of this article, which now concludes with details of a practical instrument.

Fig. 1 shows the complete circuit. It is arranged round a Mullard EM1 CR tuning indicator with cathode feed-back, arranged as a DC null indicator, to which can be connected by switching various filters, standard resistances, a diode rectifier, etc.

Power for the instrument is supplied from an internal power unit. The advantages of this scheme are numerous, as the power is always available so long as a 250V AC supply is at hand; the habit of batteries of being run down just when they are wanted is well known. A half-wave rectifier is used, as the current drain is only about 20 mA. Smoothing is conventional, and a supply of about 320V at 20 mA is obtained.

Since the instrument was completed, the writer's attention has been drawn to the desirability of screening the power transformer in measuring instruments.\* While the absence of this has so far caused no trouble, its inclusion would no doubt be advisable.

The output from the unit is applied to a potential divider, which splits the output broadly into two parts, 200V for operation of the "magic eye," and 120V for the potentiometer giving the comparison voltage. The latter is developed across an S.130 neon stabiliser which ensures a constant reference voltage. In addition, there is a semi-variable tapping to give 100V positive to "earth" for operation of the megohm-meter.

Although a completely stabilised HT supply would be an advantage, it was felt that the extra complication was not justified, as it is unnecessary for rough measurements. When using the instrument for

\* "Transformer Screening." T. A. Ledward, *Wireless World*, Jan. 1944.

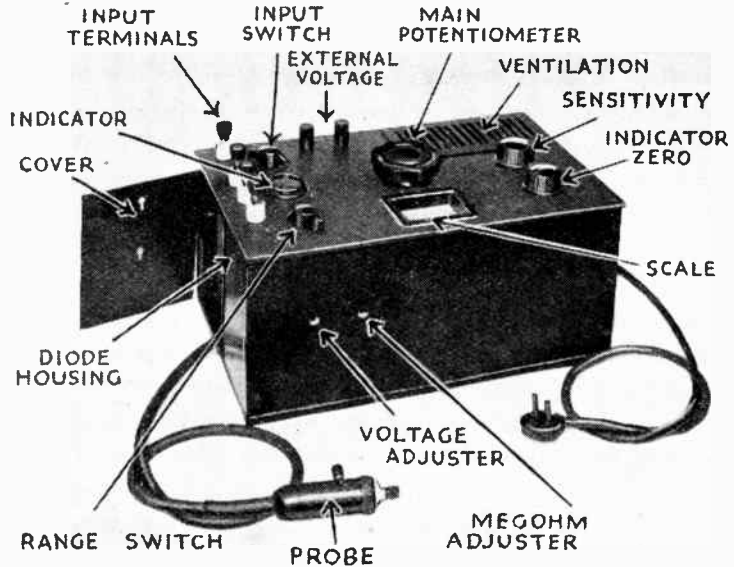

### Ranges :

- (1) Alternating peak voltages from 0.1 to 100V at 20 c/s to 60 Mc/s. Input resistance 5 M $\Omega$ . Accuracy  $\pm 5$  per cent. below 1V;  $\pm 2$  per cent. up to 10V;  $\pm 1$  per cent. above 10V.
- (2) DC voltages from 5 mV to 100V. Input resistance practically infinite. Accuracy  $\pm 0.5$  per cent. above 1V.
- (3) Resistance from zero to 1 M $\Omega$ , or insulation from 1 M $\Omega$  to 1,000 M $\Omega$ .
- (4) Bridge indicator, AC or DC or both, with sensitivity of about 2 mV.

exact work one must also stabilise the heater supplies, and this is best done by using a 250V stabilised AC source.

The EM1 is connected between earth and +200V, with an adjustable cathode resistor, 2000 $\Omega$  fixed in series with 5000 $\Omega$  variable. This gives variable sensitivity which is useful when rough measurements are to be made, ensuring that the settings are not too critical. The cathode return is made to a 400 $\Omega$  potentiometer in the main potential divider, which acts as a zero adjuster and enables one to set the shadow to the most convenient reference position. This zero setting is constant for all DC and resistance measurements, and also constant at a different setting for all AC ranges. The exact reference setting to be used depends on a number of factors. Maximum sensitivity is obtained at

a shadow angle of about 45 deg., and if there is a mark on the target here, this is best used. Sometimes pieces of dust, grit, etc., can be shaken from the base of the valve on to the target by inverting and tapping sharply. Failing that, it is quite satisfactory to adjust the shadow to zero angle. Other CR indicators than the EM1 can be used, but to the writer's knowledge all have a much larger target current. This makes the initial cathode bias larger, and the backing-off bias must be greater, with a greater risk of zero shift. It seems that the type with a single shadow in place of the maltese cross pattern always suffers from this disadvantage—which, of course, does not affect the normal use of the tube.

In an earlier model the standard voltage was measured by an internal voltmeter of B.S.1 accu-



racy. Subsequently a Cossor S.130 neon stabiliser was used to give an output of about 115V at a tube current of 15mA. This is used as the comparison voltage, the 5000Ω voltage adjustment dropping it to 100V across the potentiometer network, which consumes 5 mA. The potentiometer track, R5, consists of a 20 watt, type P.I.W. Reliance potentiometer arranged with a 6in. diameter rotating scale, viewed through a window fitted with a hair-line: for the 100V range this is connected across the whole supply, in switch position 3. In the other two switch positions, 1 and 2, resistance networks are brought into circuit which reduce the voltage across R5 to 1V and 10V respectively. The total resistance of the whole network remains constant and equal to R5 at any switch position. The calculation of resistance values is straightforward but tedious, and only the results are given here; they are expressed as functions of R5:

$$R6 = 0.9.R5 \quad R7 = 0.09.R5$$

$$R8 = \frac{10.R5}{99} \quad R9 = \frac{R5}{99}$$

It is suggested that these resistors be wire-wound (of the same wire as used in R5), and adjusted by

comparison with R5 as standard in a conventional bridge circuit. In fact it is best for all the resistances except the megohm values to be wire-wound, as this reduces the risk of zero shift due to temperature changes. If it is desired to measure a voltage greater than 100—either AC or DC—an external source of voltage can be connected to the terminals marked, which are normally short-circuited by a link.

The switching arrangements in the grid circuit of the EM1 are necessary to connect the various filter circuits to the grid. Although it was originally thought that switches would be unsatisfactory because of low insulation resistance it has been found in practice that Yaxley wafers are satisfactory provided that points between which low leakage is desired are kept on different wafers. It is also necessary to keep the wafers clean and dry and use resin flux only in soldering.

In switch position 1 the instrument is set for use as a bridge indicator. The input is connected across terminals "High" and

"Low" and the slide-back control set at zero. This use of the meter is effective throughout the audio range. In using it one must remember the extreme sensitivity of the indicator, and the difficulties which may be experienced due to external electrostatic fields. If the alternating voltage under investigation is superimposed on a DC component, the latter can either be balanced out by the slide-back voltage, or removed by a condenser-resistance filter, which can be built up as a separate unit (see Fig. 1). If the bridge does not present a complete path to DC looking from the detector terminals, a resistance must be connected across these. This can conveniently be R18 in the filter unit just mentioned.

In switch position 3, DC voltages can be measured, again using terminals "High" and "Low," the former being positive. AC components are removed by an internal filter consisting of a 5MΩ

TABLE

R1	10Ω	R15	3750 Ω
R2	10 MΩ	R16	400 Ω tapped
R3	5 MΩ		150 Ω
R4	1 MΩ	R17	1 MΩ "standard" ±1 per cent.
R5	20,000 Ω	R18	1 MΩ
R6	See text	C1	100 μF silvered mica
R7	See text	C2	0.01 μF mica
R8	See text	C3	0.01 μF mica
R9	See text	C4	4 μF electrolytic
R10	5000 Ω	C5	4 μF electrolytic
R11	3000 Ω	C6	0.01 μF mica
R12	5000 Ω		
R13	4000 Ω		
R14	2000 Ω		

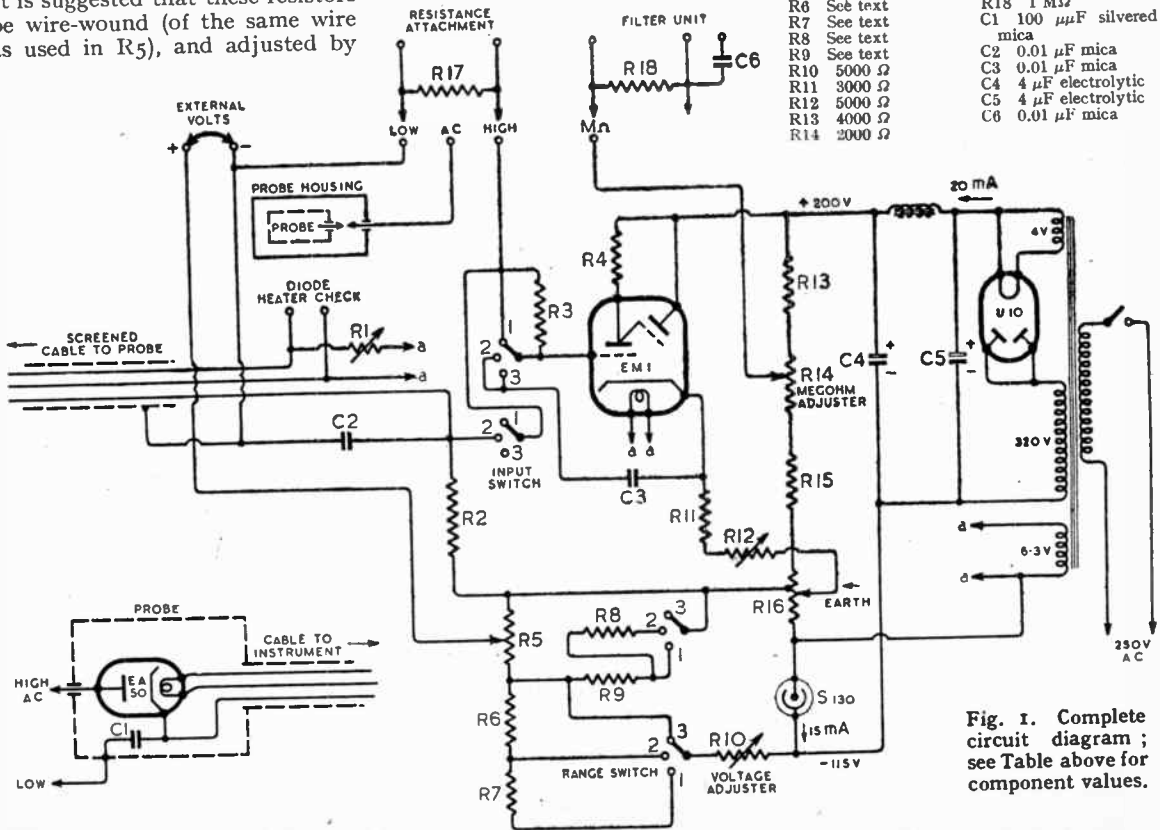

Fig. 1. Complete circuit diagram; see Table above for component values.

**Universal Measuring Instrument**

resistance and  $0.01 \mu\text{F}$  condenser. A DC path across the input is again necessary. Readings are taken on the main scale A (see Fig. 3), graduated from 0 to 100 in 1V steps, the appropriate multiplying factors 0.1 and 0.01 being used on the 10V and 1V ranges respectively. Resistance and insulation are also measured in this position, and this is done by connecting an external  $1 \text{ M}\Omega$  standard to the appropriate terminals. For resistances below  $1 \text{ M}\Omega$ , the standard, which is fitted with rigid spade connectors, is placed between terminals "M $\Omega$ " and "High," the unknown between "High" and "Low," and scale A used with a multiplying factor of 10,000. The range switch then operates in the same way as for DC voltage. For resistances above  $1 \text{ M}\Omega$ , the standard is connected between "High" and "Low," the unknown between "High" and "M $\Omega$ ," and scale D used. This scale is calibrated by calculation from the expressions given in the first part of this article. The multiplying factors on the range switch are now the reciprocal of those shown, e.g. on range 1 the scale reading is multiplied by 100.

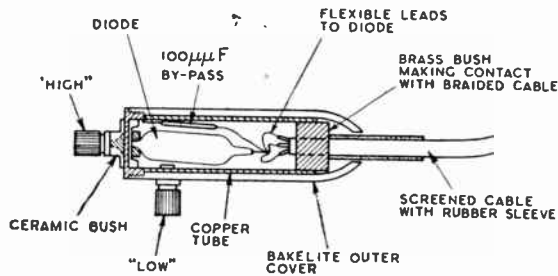

Fig. 2. Construction of probe. The diode anode is fixed to the hollow terminal with Wood's metal.

The megohm adjuster is best set as follows. Having set the EM1 zero and the voltage adjuster to give correct DC voltage readings, the standard megohm is connected across "High" and "Low," the scale set to  $1 \text{ M}\Omega$ , and another external standard megohm connected across "M $\Omega$ " and "High." The megohm adjuster is then set until the EM1 zero is again reached. This procedure is only necessary when precise readings are wanted. If approximate results will suffice, the megohm adjuster can be set until there is a PD between the

"M $\Omega$ " terminal and earth of 100V, measured by a low-consumption voltmeter. Once set, the megohm adjuster need rarely be altered except for exact measurements.

In switch position 2, the diode rectifier is connected for AC voltage measurements. In all cases the peak voltage is indicated, and if RMS values are desired the form factor of the voltage waveform must be taken into consideration. The diode is made in the form of a probe, connected by a three-way screened cable. A Mullard EA50 is used, the 6.3V heater being run at 5V to reduce heater-cathode leakage and PD's due to initial electron velocity. This voltage is adjustable by a pre-set variable resistance, and for most accurate low voltage measurements it is necessary to check this periodically. For audio- and low radio-frequency work the probe can be pushed into a housing in the body of the instrument, where the diode anode terminal makes contact with a tag connected to the terminal "AC." The probe is thus protected from unnecessary mechanical damage. This housing can be seen on the left of the photograph with its cover alongside.

The probe is shown in section in Fig. 2. Only a  $100 \mu\text{F}$  silvered mica bypass condenser is included in the probe, and as this is inadequate below 100 kc/s, it is supplemented by a  $0.01 \mu\text{F}$  mica condenser in the main instrument. Essential points to

watch in construction are: (1) a short path from the diode anode to its terminal and from the cathode through the condenser to the earthy terminal, (2) screening as complete as possible to minimise stray induced voltages, (3) screening and good insulation of the cable to the main instrument, (4) ceramic insulation wherever possible in the RF circuits to reduce losses at ultra-high frequencies.

The permanence of calibration of the diode voltmeter is mainly dependent on the heater current as described above; if this is

adjusted when a new diode is brought into use to give the same contact potential as the old one then the calibration will alter by only a negligible amount—this being due to differing AC resistance. The meter is thus truly independent of changing valve characteristics. The theoretical value for the input resistance is of the order of  $5 \text{ M}\Omega$ , while approximate measurements show

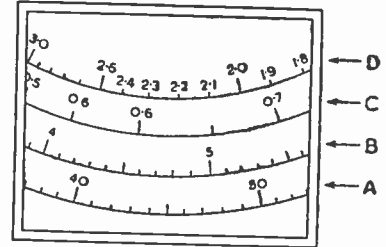

Fig. 3. Part of the scale showing the method of graduation.

a value somewhat lower than this at 50 c/s and about 10V input.

Calibration of the potentiometer is done against a sub-standard voltmeter and external potentiometer. When the 100V DC range A is calibrated it serves also for the 10V and 1V DC and 100V AC ranges and also the  $1 \text{ M}\Omega$  resistance range. The 10V and 1V AC ranges must be calibrated separately, however, with a known heater voltage on the diode. It is probably sufficient to use the equations given in the first part of the article to graduate the D scale by comparison with the DC voltage ranges. A section of the scale, as seen through the escutcheon, is shown in Fig. 3.

A general idea of the appearance can be gathered from the photograph: of course, considerable latitude exists in design details. On account of compensation for errors and independence of valve characteristics the meter can be relied on as an accurate standard or as a DC to AC transfer instrument against which other AC meters can be checked or calibrated.

**GOODS FOR EXPORT**

The fact that goods made of raw materials in short supply owing to war conditions are advertised in this journal should not be taken as an indication that they are necessarily available for export.

# RADIO JUBILEE

## 25th Birthday of I.E.E. Wireless Section

**O**F late we have had many reminders that wireless has not merely grown up, but has attained a riper maturity. The basic idea of using electromagnetic waves as a means of communication is now just over half a century old, while even relative newcomers to the art, such as the B.B.C. and several firms manufacturing broadcasting equipment have recently celebrated their coming-of-age. The Silver Jubilee of the Wireless Section of the Institution of Electrical Engineers comes as another reminder. In the words of the President of the I.E.E., the Section was formed in 1919 "to provide a forum to present and discuss papers dealing with wireless and to recognise and provide for, within the framework of this Institution, the specialised requirements of engineers interested in wireless." Membership, which is now over 1,900, represents all branches—industrial, academical, Armed Forces and Government departments.

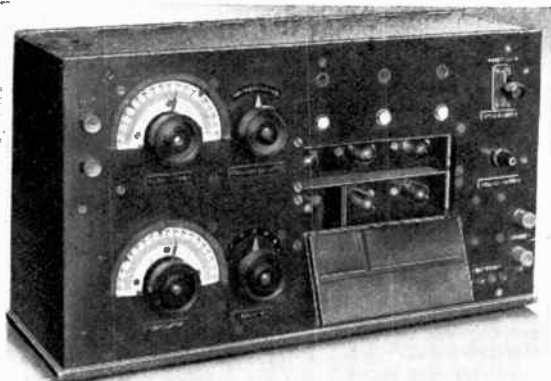

One of the first superheterodyne receivers to be built in Europe; a Standard Telephones and Cables production of 1924. This and other apparatus illustrated on this page were among the historical exhibits on show at the I.E.E. Wireless Section Commemoration Meeting.

At a Commemoration Meeting, held on May 3rd, six past chairmen of the Section delivered addresses to a large and distinguished audience, which included representatives of all the wireless industrial associations and the Radio Society of Great Britain. Delegates of the Commonwealth Communications Council representing the Dominions and India were present.

Dr. W. H. Eccles surveyed the technical events that led up to the founding of the Section 25

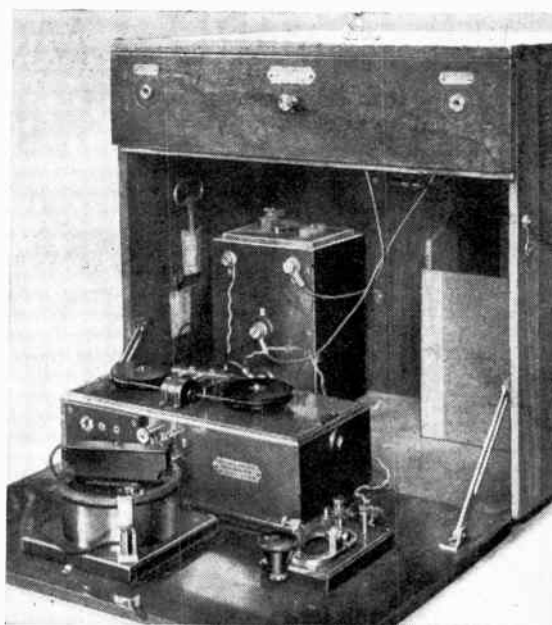

A "transceiver" of 1912; combined Marconi spark transmitter and receiver, including magnetic detector.

years ago. Professor G. W. O. Howe maintained that the outstanding achievements of the early days of wireless telegraphy were accomplished in spite of principles and theories as then enunciated. Theory was revised after each successive practical step. In particular, ideas about the ionosphere and long-distance propagation were vague until well after long-distance communication had actually been achieved.

The history of wireless in the Navy was dealt with by Admiral Sir Charles Kennedy-Purvis. He recalled that the first tuned-circuit Naval apparatus, installed in about 1900, worked on wavelengths rated as 395 and 1,150 feet.

The difficult task of forecasting future developments was most capably undertaken by Dr. R. L. Smith-Rose, who stressed the possibilities of using recent developments in VHF (over 100 Mc/s) for services with ranges up to 100 miles. That would relieve congestion on bands with world-wide ranges. Increasing knowledge of ionosphere conditions will make for more economical distribution of frequencies.

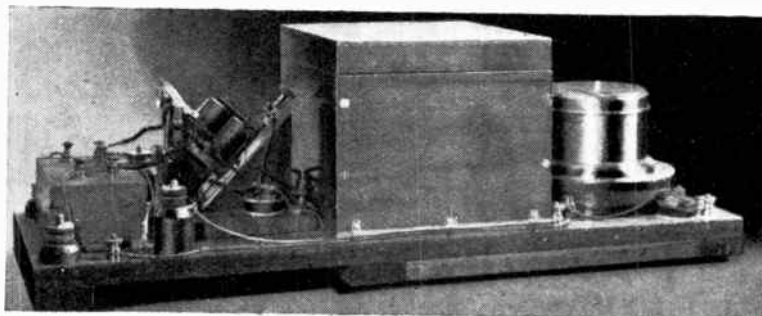

A Marconi coherer unit of about 1900, comprising coherer, tapper, relay (for actuating morse inker), RF transformer and battery.

# SIMPLE MODULATION MEASUREMENTS

## Change of RMS Value as an Indication of Modulation Depth

IT is the purpose of this article to discuss the possibilities of one of the simplest methods of modulation measurement, namely the increase in RF current when modulation is applied.

When a sine wave carrier, the instantaneous value of whose current is  $i_1 = I_1 \sin 2\pi f_1 t$ , is amplitude modulated by another sine wave whose instantaneous value is  $i_2 = I_2 \sin 2\pi f_2 t$ , it can be shown that the equation of the resulting wave is

$$i = I_1 \sin 2\pi f_1 t + \frac{1}{2} I_2 \cos 2\pi(f_1 - f_2)t - \frac{1}{2} I_2 \cos 2\pi(f_1 + f_2)t$$

The three terms on the right-hand side are respectively carrier, lower side band and upper side band. For complete modulation  $I_1 = I_2$ , thus each side band has half the amplitude of the carrier, and therefore a quarter as much power, since all these currents are necessarily flowing through the same circuit resistance. For a modulation factor of "m" the amplitude of each side band is  $\frac{1}{2}m$  times that of the carrier. Thus the RMS value of the modulated carrier is  $\sqrt{1 + (\frac{1}{2}m)^2 + (\frac{1}{2}m)^2} = \sqrt{1 + \frac{1}{2}m^2}$  times that of the unmodulated carrier, and the relationship is worked out for typical values in the table.

A thermocouple or hot-wire meter reads RMS current values, and if one of these be connected in the tuned circuit of a modulated oscillator or amplifier or into a coupled circuit its reading will give an indication of the depth of modulation. Some standard signal generators employ this device; in one well-known make the internal modulation is set at 80 per cent., and the "Set

By G. S. LIGHT, B.A.Sc.

Mod." mark on the meter is calibrated to represent 14.9 per cent. more current than at the "Set Carrier" mark.

The aerial current of a transmitter can thus be used to indicate depth of modulation by speech or tone. In one mass production factory the percentage modulation

should be divided on a logarithmic basis. Typical figures for a scale approximately 10in. in length are given in the caption to the illustration. It happens that convenient values are obtained by multiplying the common logarithm of the RF ampere readings by 2, so that readers requiring intermediate values may obtain them in this way. In the case of the percentage modulation scale an example will make the working clear. From the table 50 per cent. modulation is equivalent to an increase of RF current of 6 per cent., i.e., multiplying by a factor of 1.06. The log. of this is 0.0253, and multiplying by 2 gives 0.506in. or 0.51in. to the accuracy with which the scale can be drawn.

The above calculations hold only for a sinusoidal waveform of modulating voltage, but in practice slight departures do not make a noticeable difference and agreement to within 5 per cent. can always be obtained with oscilloscope methods.

Low modulation depths are hard to estimate, and the method should only be used for modulation factors exceeding 0.5. The upper part of the RF ammeter square-law scale is best for observing small changes. Further, over-modulation is *not* shown, and must be guarded against, since for this condition the needle falls *back* from the 22.5 per cent. point.

Finally, results will be inaccurate if the carrier itself varies when modulation is applied; this may happen if the RF regulation is poor due to low excitation, or if there is unsymmetrical modulation.

Modulation (per cent.)	m	Current Increase (per cent.)
10	0.1	0.25
20	0.2	1.0
30	0.3	2.25
40	0.4	4.0
50	0.5	6.0
60	0.6	8.6
70	0.7	11.5
80	0.8	14.9
90	0.9	18.5
100	1.0	22.5

of transmitters is rapidly determined from aerial ammeter readings. A special slide rule (see sketch) is used to save a separate calculation for each set. The "Carrier" mark is set to the unmodulated aerial current and the percentage modulation read off direct from the modulated current reading.

In order that the percentage relationship shall hold good at any part of the scale it is necessary that both RF scale and slider

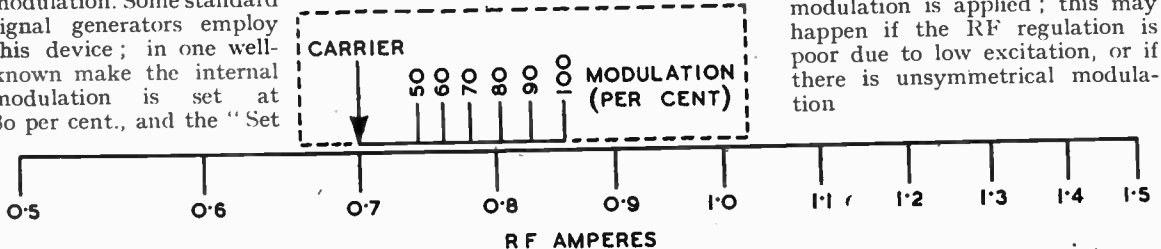

Slide rule for calculating percentage modulation from change of aerial ammeter reading. Essential dimensions for a "10-inch" rule are as follows. Distance of RF ampere readings from left-hand end of scale: 0.6, 1.58in.; 0.7, 2.94in.; 0.8, 4.10in.; 0.9, 5.10in.; 1.0, 6.06in.; 1.1, 6.90in.; 1.2, 7.68in.; 1.3, 8.39in.; 1.4, 9.02in.; 1.5, 9.64in. Distance of modulation percentages from "Carrier" mark: 50, 0.5in.; 60, 0.72in.; 70, 0.95in.; 80, 1.20in.; 90, 1.48in.; 100, 1.76in.

# *Angles on* **BRIMAR PRESTIGE**

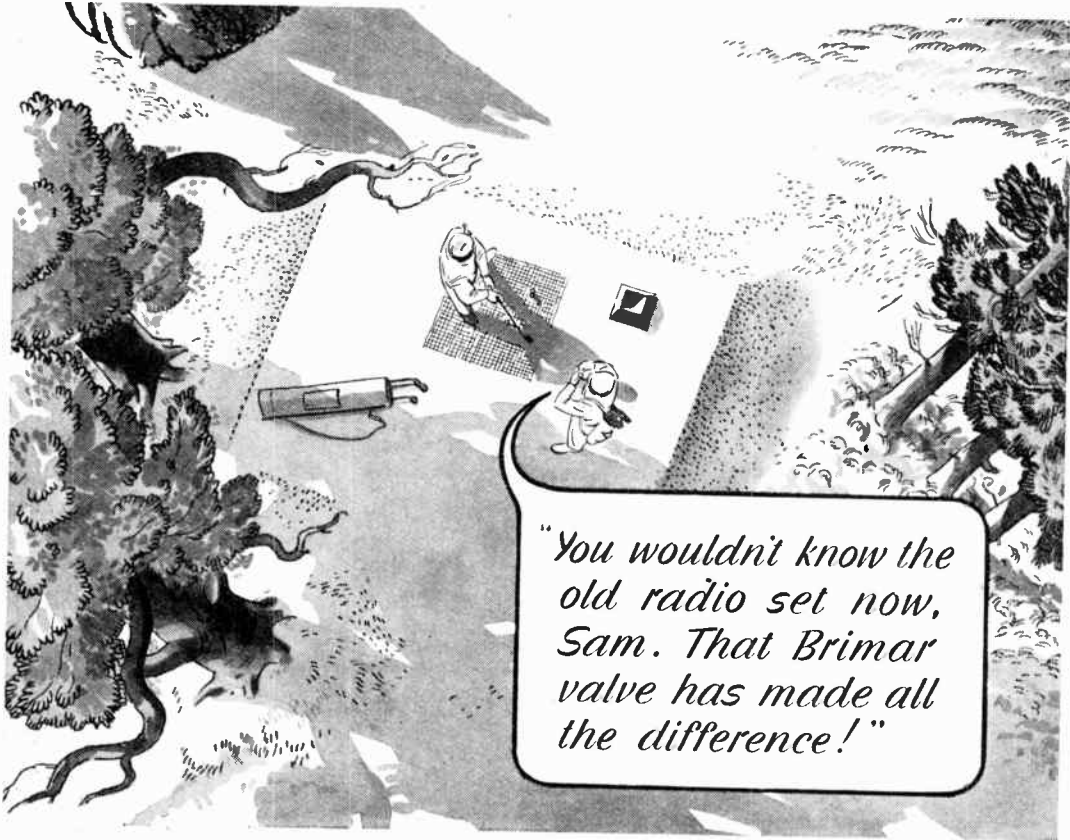

*Every radio set gives its peak performance when the correct Brimar Valves are used. Engineers know how closely and unfailingly they conform to specification.*

# **BRIMAR**

**BVA**

# **VALVES**

**STANDARD TELEPHONES AND CABLES LIMITED, FOOTSCRAY, SIDCUP, KENT.**

# Rotary Cutting, Filing, Grinding and Polishing - *Economy and Accuracy*



Use **MORRISFLEX** Flexible Shaft Equipment, and **REX** Rotary Files and Cutters for cutting, filing, grinding and polishing components of aluminium, Elektron, non-ferrous alloys and ferrous metals. For metal buffing and cleaning we supply **MORREX** Rotary Wire Brushes, and **MORRISFLEX** Rotary Polishing Mops and Felts, also Felt Cones. **MORRISFLEX** Rotary Rasps are ideal for woodworking, and attachments for **MORRISFLEX** machines include Sanders and Grinders.

**MORRISFLEX** machines are available in overhead suspension, bench and floor types. Their use ensures speed with accuracy, and a high degree of finish. Write for Lists.

**B. O. MORRIS LTD.**  
SHIRLEY,  
BIRMINGHAM.

Shirley 1237.

\*Grams :  
Morrisflex, Birmingham.

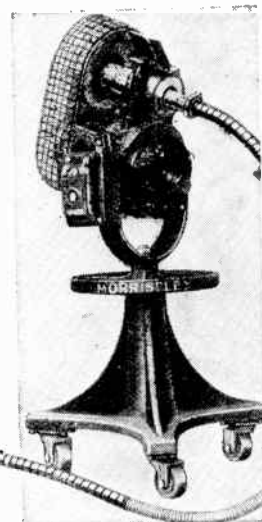

## MORRISFLEX

### FLEXIBLE SHAFT EQUIPMENT

## QUART POTS AND THE QUANTUM THEORY

There is more than one possible answer to the problem of the quart and pint pot, but to the question of measurement in electrical communications there must be only *one* answer—and it is the function of Marconi instruments to provide it. For Marconi's have pioneered not only an ever widening range of communication equipments, but also the

art of testing the many instruments in this specialised field. To-day the testing difficulties which once beset the electrical engineer are solved by the precision measuring apparatus of Marconi Instruments Limited. Their specialists are at your service for consultation on any specific problems.

# MARCONI INSTRUMENTS LTD

ELECTRA HOUSE • VICTORIA EMBANKMENT • LONDON, W.C.2

# HIGH SELECTIVITY

## at Audio and Intermediate Frequencies

IT is often an object in the design of communications equipment to construct a circuit having a very selective characteristic which responds to a narrow band of frequencies while greatly attenuating all other frequencies outside this pass-band.

At radio frequencies it is customary to use filter circuits

### A Stable Negative Resistance Circuit with Applications in Wave Analysers, Etc.

By

E. LLOYD THOMAS,  
B.Sc., A.C.G.I.

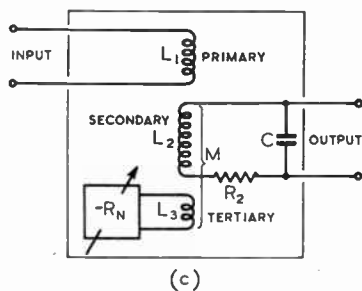
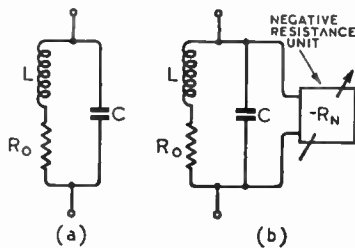

Fig. 1. Showing the successive stages in the development of the selective circuit described in the text. Formulæ for the effective "Q" of circuits (b) and (c) are worked out in the Appendix.

incorporating crystal resonators for this purpose, but at low and intermediate frequencies this method is not available and in the past it has been necessary to resort to more or less elaborate chains of tuned circuits. Such networks, for even a moderate degree of selectivity, are bulky and troublesome to adjust. Moreover, it is not usually practicable to vary either the width of the pass-band or its position in the frequency spectrum.

It is the purpose of this article to describe a method of obtaining high and variable selectivity at relatively low frequencies which avoids these difficulties. The re-

sulting circuit, based on the application of controlled negative resistance to a single tuned coil, may also be used as an inter-stage coupling in a filter-amplifier to realise a very high stage gain.

Consider, to begin with, the factors which determine the selectivity of an isolated tuned circuit, Fig. 1 (a). The losses in such a circuit are mostly due to the resistance of the inductive element; and the "Q" factor, which is usually taken as a measure of the selectivity, may be written as the ratio of the reactance of the coil to its resistance.

Now, the "Q" of a coil for use at any given frequency is governed by its size, shape, and construction, and by the material of the core on which it is wound. Although some improvement can be effected by using stranded wire and a core of appropriate magnetic material, it is not possible at these frequencies to obtain a natural "Q" of more than a few hundred with a coil of reasonable size.

Fig. 2. Relation between the effective "Q" of the circuit of Fig. 1 (b), and the value of the applied negative resistance for a coil having a natural "Q" of 50. The curve for the transformer-coupled system has a similar shape.

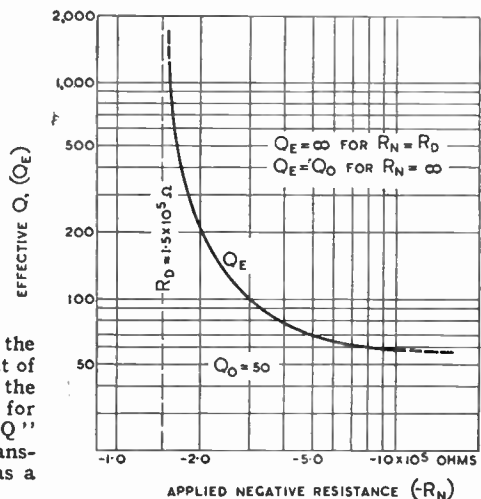

For many purposes such a value is inadequate. Moreover, a coil having a magnetic core tends to overload, owing to saturation of the core material, when the potential across it exceeds a few

volts. This causes undesirable distortion which can only be avoided completely by reverting to an air-cored coil.

Even if it were possible to construct a very low loss coil, the damping imposed on it by the associated circuit and valves would limit the effective selectivity. Indeed, the higher the natural "Q" of the coil the more serious would be the damping.

In the present system these difficulties are overcome by taking a coil of normal construction and raising its "Q" by artificial means. The successive stages in the development of the circuit are set out in Fig. 1, and a short mathematical analysis of the design will be found in the Appendix.

The simplest practical arrangement consists of a negative resistance device of the voltage-controlled type connected directly across a parallel-tuned circuit, Fig. 1 (b). The relation between the effective "Q" of the combination, which is higher than that of the tuned circuit alone, and the value of the applied

negative resistance is derived in Appendix 2, and shown graphically in Fig. 2. As the negative resistance is decreased, the effective "Q" increases; slowly at first, and then more rapidly, until

**High Selectivity—**

when the value of the negative resistance equals the natural dynamic resistance of the tuned

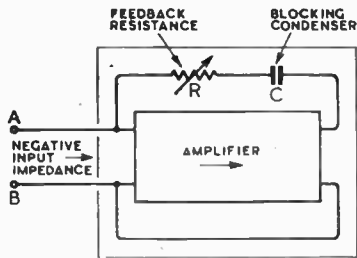

Fig. 3. The basis of the negative resistance unit is an amplifier having its output coupled regeneratively to its input.

circuit the "Q" is infinite. If the negative resistance is decreased still further, the circuit becomes unstable and will tend to go into oscillation.

Before any use can be made of this selective element, some means must be provided for coupling it in a circuit. For this purpose it is convenient to convert the tuned coil into a transformer by adding a coupling winding. The tuned winding then becomes the secondary and the coupling winding the primary.

The usefulness of this system depends entirely on the characteristics of the negative resistance unit. Unless the value of negative

resistance applied to the tuned circuit can be varied easily and yet remain constant over a fairly wide range of applied voltage, then the method will have only a very limited field of application. Most of the simple negative resistance devices, such as the dynatron, are unsuitable because they are not very stable or flexible, and usually suffer from non-linearity. Fortunately, a negative resistance circuit that has been developed fairly recently satisfies these requirements. It is based on the fact that if the output of an amplifier is coupled regeneratively to its input, then the system may behave as a negative resistance to any circuit connected across its input terminals (Appendix 1 and Fig. 3). The value of negative resistance developed is determined by the gain of the amplifier and the amount of feedback. If the gain is stabilised by the application of negative feedback, the negative resistance may be made almost independent of valve and supply voltage variations.

Since a two-stage resistance-capacitance coupled unit of this type is only linear for inputs up to a few volts, it is unsuitable for direct connection when the voltage across the tuned winding may exceed this value. However, the difficulty may be overcome by adopting transformer coupling if a

third winding, of comparatively few turns tightly coupled to the secondary, is added to the transformer and the negative resistance unit connected across this coil. The optimum number of turns for this tertiary is closely linked with the design of the negative resistance unit, and should be determined experimentally to give the best results (Appendix 3).

The final arrangement, Fig. 1(c), will function satisfactorily at any frequency at which a suitable amplifier, free from appreciable phase shift, can be constructed for the negative resistance unit. With a little care it should be possible to cover the range from 50 c/s. to at least 500 kc/s.

The circuit diagram of a practical circuit is shown in Fig. 4, the component values given being suitable for the frequency range 5—50 kc/s. It will be seen that three valves are used ; two of them in the negative resistance unit.

Component Values (Fig. 4)

R1	1 megohm	C1	5,000 $\mu\text{F}$
R2	1,200 ohms.	C2	8 $\mu\text{F}$
R3	4,700 "	C3	8 "
R4	390,000 "	C4	8 "
R5	100,000 "	C5	0.1 "
R6	33,000 "	C6	0.1 "
R7	2,700 "	C7	10—100 $\mu\text{F}$
R8	470,000 "	C8	40 $\mu\text{F}$
R9	2,200 "	C9	0.5 "
R10	100,000 " (max.)	C10	0.5 "
R11	270 "	C11	8 "
R12	1,000 "	V1	6J7 or SP. 41
R13	10,000 "	V2	6J7 or SP. 41
		V3	6V6 or PEN. 45

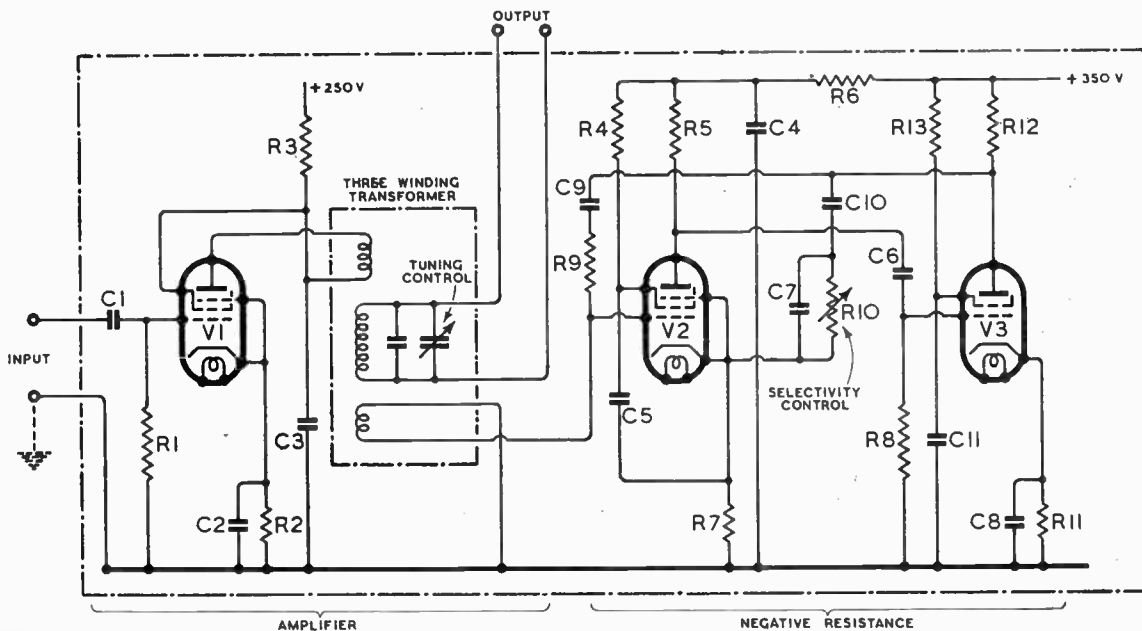

Fig. 4. Circuit diagram of a practical filter-amplifier based on the system of Fig. 1 (c).



The signal is fed to the circuit via the amplifier valve  $V_1$ , in whose anode circuit is connected the primary of the transformer, and the output is taken from the tuned secondary. Owing to the high effective "Q" of the secondary the primary impedance may

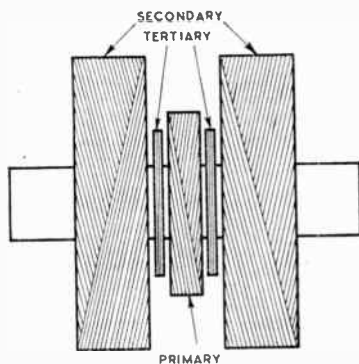

Fig. 5. Suitable construction for three-winding transformer.

be very high. Consequently a small low-slope pentode, such as the 6J7, is sufficient in this position to develop almost any output that may be required.

The negative resistance unit comprises a two-stage resistance-capacitance coupled amplifier with positive and negative feedback applied according to the principles already discussed. The first valve ( $V_2$ ) is a pentode of the same type as  $V_1$ , connected as a voltage amplifier. The second valve ( $V_3$ ) supplies most of the power dissipated in the tuned circuit, and must be chosen according to the output voltage required. For outputs up to about 100 volts peak across the tuned circuit a pentode or tetrode of the medium-power output type is satisfactory. The anode of  $V_3$  is coupled back to both the grid and cathode of  $V_2$ , each feedback path consisting of a resistance in series with a blocking capacitor of negligible reactance.

It is convenient to control the selectivity of the stage by choosing a suitable fixed value for the positive feedback resistance ( $R_9$ ) and making the negative feedback resistance ( $R_{10}$ ) variable. The latter is in effect a selectivity control, a decrease in resistance reducing the gain of the negative resistance unit and therefore the selectivity. The purpose of the small capacitor ( $C_7$ ) connected

in parallel with  $R_{10}$  is to suppress parasitic oscillation by causing heavy degeneration at high frequencies.

It is advisable to use separate anode supplies for the amplifier and negative resistance valves in order to reduce the possibility of instability when working with very high selectivity.

The exact mechanical form adopted for the circuit will be determined by individual requirements. It will be sufficient here to indicate some of the more important factors governing this aspect of the design.

Owing to the high selectivity small mechanical and electrical changes are liable to have a considerable effect on the performance of the stage and every precaution should be taken to make the structure rigid and stable.

Particular care must be taken with the screening of the transformer in order not to spoil the high "Q" of the tuned winding. For this reason electro-magnetic screening is preferable to magnetic, and the screening box should not be too small. Copper is the most suitable material for this box, and it should be remembered that a considerable thickness, at

Fig. 6. Selectivity curves obtained with the circuit of Fig. 4 at a frequency of 10 kc/s, for various settings of the selectivity control. The curve  $Q_0=50$  shows the performance of the stage before applying negative resistance.

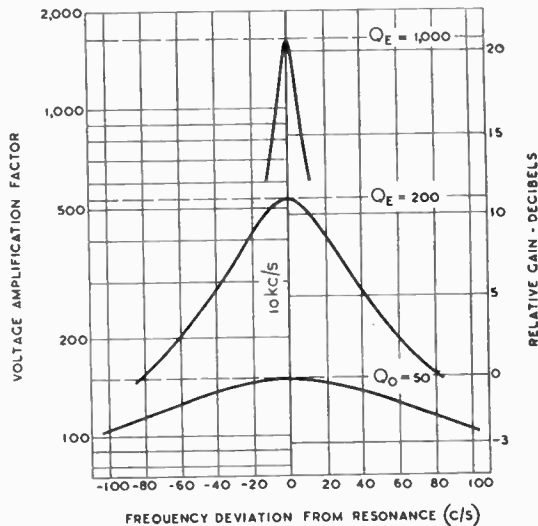

least 0.1 in. at 10 kc/s is necessary for effective screening at these comparatively low frequencies. If aluminium is used, this thickness must be increased by about 50 per cent.

A suitable construction for the three-winding transformer is shown in Fig. 5. Since there is no great advantage to be obtained by using stranded wire at low frequencies, the windings consist of five coils of plain copper wire

wave-wound on a bakelised paper former. The secondary is wound in two halves, in opposite directions on either side of the primary, so that a balanced output may be obtained if desired. The tertiary, also in two sections, is wound by hand into the gaps between the primary and secondary.

Experiments carried out with this circuit at a frequency of 10 kc/s showed that, with a transformer secondary having a natural "Q" of only 50, an effective "Q" of 1,500 could be realised before the system became unstable. Owing to the small frequency differences involved, the selectivity of the stage was estimated by feeding a steady signal to it, and then measuring the change in capacitance required to detune the output circuit by a given amount. It may be shown (Appendix 4) that with a "Q" of 1,000 at this frequency the bandwidth for 3 db. loss is only 10 c/s.

Since the amplification of the

stage depends on the dynamic resistance of the tuned circuit, which is in turn proportional to the "Q," the enhanced selectivity due to the application of negative resistance is accompanied by a corresponding rise in sensitivity. With a "Q" of 800, for example, a voltage amplification factor of 1,000 can be achieved quite easily. This is illustrated by the curves of Fig. 6.

It should be noted that the

**High Selectivity—**

tuning of the transformer secondary is not entirely independent of the selectivity control. The effect is quite small, however, for it can be shown that if the "Q" is raised from 500 to 1,000, the resonant frequency changes by only 1 c/s. in 10 kc/s.

Apart from the more obvious applications, such as to variable selectivity IF amplification and to AF filtering, it is suggested that this circuit might form the basis of a practical wave analyser. It would also prove useful for demodulation, in separating the carrier from an amplitude modulated signal, as the following experiment will show.

A 10 kc/s. carrier, amplitude modulated to 80 per cent. at 400 c/s, was fed to the grid of the amplifier valve while the modulation depth of the output from the transformer was observed on an oscilloscope. As the selectivity control was advanced the sidebands became more and more attenuated until, when the bandwidth had been reduced to about 12 c/s., the modulation depth was too small to detect and the output consisted of the amplified carrier alone. In fact, with a selectivity of this order the circuit will convert square pulses of carrier into a steady unmodulated signal.

**APPENDIX****1. The Negative Resistance Unit.**

If the amplifier in Fig. 3 has an infinite input impedance, a voltage amplification factor  $N$  and negligible phase shift, then the current that will flow if a voltage  $v = V \sin \omega t$  is impressed on the terminals AB is

$$i = \frac{V \sin \omega t - N \cdot V \sin \omega t}{Z} \\ = \frac{(1 - N)}{Z} \cdot V \sin \omega t$$

where  $Z$  is the impedance of  $R$  and  $C$  in series. The input impedance of the device is therefore

$$Z_i = \frac{v}{i} = \frac{Z}{(1 - N)}$$

which is negative if  $N > 1$ . If the reactance of the blocking capacitor is negligible compared with  $R$  (which includes the output resistance of the amplifier) then  $Z_i$  is a pure negative resistance of magnitude  $\frac{R}{(N - 1)}$

The output resistance of the amplifier and the reactance of  $C$  impose a lower limit on the value of input resistance that can be obtained.

**2. Direct Coupled Negative Resistance.**

The natural "Q" of the tuned circuit of Fig. 1 (b) is  $Q_0 = \frac{\omega L}{R_0}$

where  $\omega = 2\pi \times$  frequency. The natural dynamic resistance of the circuit is

$$R_D = \omega L \cdot Q_0 = \frac{\omega^2 L^2}{R_0}$$

and the effective dynamic resistance when a resistance  $-R_N$  is connected in parallel with the circuit is

$$R_{D'} = \frac{R_N R_D}{(R_N - R_D)} = \frac{\omega^2 L^2}{\left(R_0 - \frac{\omega^2 L^2}{R_N}\right)} \\ = \omega L \cdot Q_E$$

The effective "Q" of the combination is therefore

$$Q_E = \frac{R_{D'}}{\omega L} = \frac{\omega L}{\left(R_0 - \frac{\omega^2 L^2}{R_N}\right)}$$

which is infinite when  $R_N = R_D$ .

**3. Transformer Coupled Negative Resistance.**

The complete solution of the three-winding transformer circuit (Fig. 1 (c)) is somewhat involved and unnecessary when, as is usually the case, all that is needed is a rough idea of the value of negative resistance required to realise a given "Q". However, an approximate solution can be obtained if the system is reduced

to a two-winding transformer, either by neglecting the primary (only possible if the anode resistance of the amplifier valve is very high compared with the primary impedance) or by modifying the resistance of the secondary to allow for the damping effect of the amplifier valve.

If  $R_N$  is the magnitude of the negative resistance connected across the tertiary, and  $M$  is the mutual inductance between the secondary and tertiary, it may be shown that the effective series resistance of the secondary is approximately

$$R_E = \left(R_2 - \frac{\omega^2 M^2}{R_N}\right)$$

The effective "Q" of the tuned winding is therefore

$$Q_E = \frac{\omega L_2}{R_E} \doteq \frac{\omega L_2}{\left(R_2 - \frac{\omega^2 M^2}{R_N}\right)}$$

(Compare this with the expression obtained for the direct-coupled system.)

**4. Measurement of Selectivity.**

If the difference in capacitance between the two settings of the tuning capacitor for which the voltage across the tuned winding is  $\frac{1}{\sqrt{2}}$  times that at resonance is  $\delta C$ ,

and the total tuning capacitance is  $C$ , then it may be shown that

$$Q_E \doteq \frac{2C}{\delta C}$$

and the bandwidth for 3 db loss is

$$\delta f \doteq \frac{f_0}{Q_E} = \frac{\delta C}{2C} \cdot f_0$$

where  $f_0$  is the resonant frequency.

**Books issued in conjunction with "Wireless World"**

	Net Price	By Post
FOUNDATIONS OF WIRELESS. Fourth Edition, by M. G. Scroggie, in preparation ... ..	7/6	7/10
TELEVISION RECEIVING EQUIPMENT, by W. T. Cocking ... ..	10/6	10/10
RADIO LABORATORY HANDBOOK, by M. G. Scroggie. Second Edition ... ..	12/6	12/11
WIRELESS SERVICING MANUAL, by W. T. Cocking. Sixth Edition ... ..	7/6	7/10
HANDBOOK OF TECHNICAL INSTRUCTION FOR WIRELESS TELEGRAPHISTS, by H. M. Dowsett and L. E. Q. Walker. Seventh Edition ... ..	30/-	30/7
WIRELESS DIRECTION FINDING, by R. Keen. Third Edition ... ..	30/-	30/7
RADIO DATA CHARTS. Third Edition, Revised by J. McG. Sowerby, B.A., Grad. I.E.E. ... ..	7/6	7/10
RADIO INTERFERENCE SUPPRESSION, by G. W. Ingram ... ..	5/-	5/4
LEARNING MORSE. 335th thousand ... ..	6d.	7½d.
INTRODUCTION TO VALVES, by F. E. Henderson ... ..	5/-	5/4
VALVE REPLACEMENT MANUAL, by A. C. Farnell and A. Woffenden ... ..	6/-	6/2

Obtainable from leading booksellers or by post from  
ILIFFE & SONS LTD., Dorset House, Stamford Street, London, S.E.1

# RADIO HEATING EQUIPMENT

## III. High-powered Valves : Automatic Control Devices

By L. L. LANGTON, A.M.I.E.E.

It has been indicated that it is advisable that the power capabilities of a radio heater should be sufficient to compensate for losses, which will be unavoidably large in some applications. In general use the equipment may rarely be operated at maximum efficiency, for, in seeking always to satisfy the factors governing efficiency, the industrial application will be somewhat restricted.

Valves employed for generating radio power in larger equipments are designed to facilitate dissipation of heat generated at the anode. When power of the order of kilowatts is to be dissipated the temperature rise of the anode would be very great were no measures adopted to restrict it.

The first group of larger valves is that having glass envelopes and more or less conventional internal construction. The anodes in these valves become very hot, and the envelopes are of considerable size, so that the dissipating area may be large. Their power handling capabilities are limited by the temperature at which glass softens, about 450 deg. C., and valves of this type are obtainable for powers up to about 2.5 kW. Another type of valve has an envelope of silica, which softens at a temperature of about 1,500 deg. C., the power capabilities of such valves being correspondingly greater.

For powers exceeding 2.5 kW, copper anode valves are normally employed. Fins may be fitted to the copper anode to increase the heat-dissipating area when air cooling is employed and, with forced air circulation, valves up to 5 kW are obtainable. Larger valves are normally water-cooled and are manufactured up to powers exceeding 100 kW. Even higher powers are possible with the demountable type of valve, which requires pumping equipment to maintain the vacuum.

The anode of the Osram Type ACT9 is fitted with external cooling fins and is rated for a power dissipation of 800 watts in free air or 1100 watts with forced air cooling. It is suitable for use up to at least 15 Mc/s.

(Right) Water cooling in the Osram Type CAT9 enables the valve to dissipate 18kW at the anode. The maximum operating frequency is 20 Mc/s. In this photograph the water jacket has been removed to show the cylindrical anode.

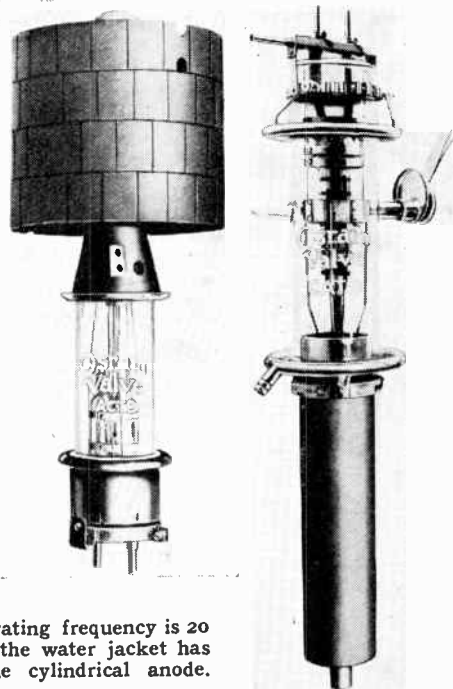

Two precautions should be particularly observed when operating large valves. It is often necessary to arrange a circulating system of soft water for cooling valves, as ordinary mains water in many districts is unsuitable. The LT voltage must be applied gradually, as the cold resistance of a tungsten filament is only about one-tenth of the resistance when up to full emission temperature. If full LT voltage is applied when starting, the reaction between the magnetic fields due to the current in each tungsten wire of the filament may bow the wires out on to the grid.

There are many factors governing the upper frequency at which a valve may be operated successfully. The electron transit time and inter-electrode capacitance are controlled by the physical dimensions and disposition of the electrodes, the position in which connections are brought out and the potentials applied to the electrodes. The leads from the electrodes have to be brought out through pinches made of glass or similar material and, in the case of copper anode valves, such

material forms the seal of the anode. The loss factor of the pinch or seal material imposes a further limitation on the frequency at which power may be generated. Manufacturers usually indicate the maximum anode voltage which may be safely applied when working at given frequencies.

The normal run of transmitting valve is not designed to operate efficiently above 30 Mc/s, and at this frequency the power capability is reduced according to the type of valve to about 50 to 70 per cent. of that at 10 Mc/s. The highest frequencies commercially used in dielectric heating are around 100 Mc/s and special valves are required for their generation. High frequencies of this order must be employed when the voltage gradient through the dielectric heated is required to be low, and also when an attempt is being made to heat materials having very low loss factors. The valves needed for UHF generation are much more expensive than normal valves of equivalent power, and comprehensive precautions against loss must be taken in the whole equipment.

**Radio Heating Equipment—**

The capital cost of such a generator would, of course, greatly exceed that of one which operates below 30 Mc/s. The satisfactory heating of most thermosetting plastics does not, however, require frequencies in excess of 30 Mc/s.

For HT supply, the hot cathode mercury vapour valve is usually employed, and rectifies AC transformed up to the required voltage. It should be noted that it is essential, particularly in large generators, to isolate the HT transformer from RF currents. These will heat and may sometimes even burn the insulation at the ends of the transformer winding. Efficient RF chokes and by-pass condensers should be included in the HT circuit to shunt RF current from the transformer.

Apart from safeguarding the

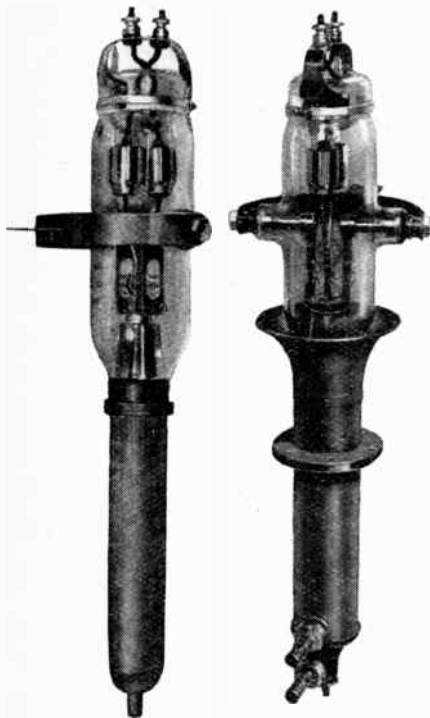

Two views of the Mullard Type TX12-20 valve with and without water-cooling jacket. The maximum anode dissipation is 18 kW, and the maximum operating frequency 20 Mc/s.

transformer against breakdown, this precaution is vital to reduce interference injected into the mains. Even with efficient RF filters preceding the transformer primary, it is better to minimise

**Wireless World**

RF in the HT circuit. In larger equipments, the transformer and rectifier are usually housed separ-

The mercury vapour valve is a very satisfactory rectifier, provided that certain precautions are

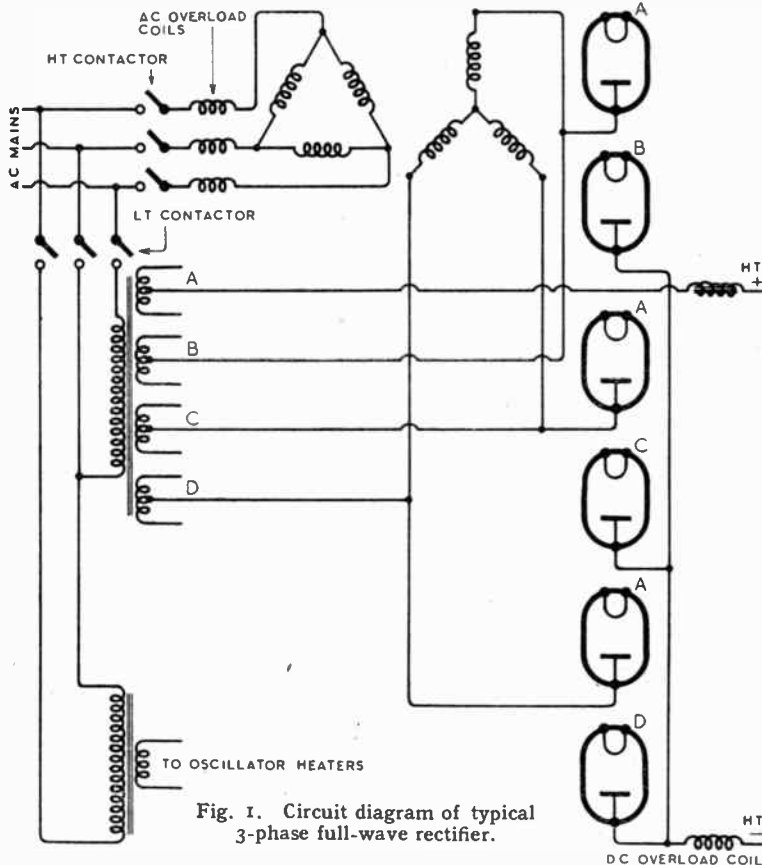

Fig. 1. Circuit diagram of typical 3-phase full-wave rectifier.

ately from the oscillator and although the screening of the oscillator compartment may be adequate the fact that HT leads and end turns of the transformer will radiate may be overlooked. The necessity for the adequate screening of the entire equipment is increased by the fact that the mercury vapour rectifiers may themselves burst into violet parasitic oscillation, unless steps are taken, such as the fitting of stopper resistances or RF chokes, to obviate this risk. A recent editorial sounded a note of warning regarding the interference propensities of radio heating, and mentioned the crippling legislation which will probably follow if the users of radio heating do not exercise care in reducing interference. The author intends later to discuss the question of radiation and interference, and the above points are mentioned at this stage to emphasise the gravity of the matter.

observed. In operation its resistance is very small and the voltage drop across it correspondingly low. The electron emission from the cathode will, if the anode voltage exceeds about 15, ionise the mercury vapour molecules and a blue glow permeates the tube when this occurs. The heavy ions will, if they impinge upon the cathode across a drop exceeding 20 volts, destroy the emitting surface.

If a very heavy load were imposed, the voltage drop across the rectifier would increase, and it is essential to include a choke in the output to limit the instantaneous current that may flow. With a condenser across the output and no limiting choke the instantaneous charging current of the condenser may impose a load large enough to result in the destruction of the cathode.

The first precaution is that the cathode must be given sufficient time to reach full emission tem-

perature before volts are applied to the anode. If this is not done some mercury molecules will be ionised before full emission is achieved and the voltage drop across the valve will, under these conditions, exceed 20, with the consequent destruction of the cathode. Manufacturers prescribe the peak reverse voltage at which the valve may be operated, and if this voltage is exceeded the valve will arc over. The arcing point is controlled in a given valve by the mercury vapour pressure, which is in turn dependent upon the temperature of the atmosphere surrounding the valve.

The second precaution is that there must be no large change in ambient temperature, particularly if the valve is operated nearly up to its peak reverse voltage (which it usually is).

The type of rectifier circuit used will depend to some extent upon the power of the generator. For 2 kW and below single-phase mains supply is usual, while 3-

tion the RMS ripple voltage will be of twice supply frequency and will be equal to 48.3 per cent. of the DC voltage. With 3-phase full-wave rectification, the RMS ripple voltage will be of six times supply frequency and will be equal to 4.2 per cent. of the DC voltage.

The output from a single-phase rectifier must be smoothed before being applied to the generator, but in the case of 3-phase full-wave rectification this is not vital. However, if smoothing is employed the choke required will be of comparatively small inductance, as the frequency of the ripple voltage is six times that of the mains supply.

A circuit diagram of a three-phase full-wave rectifier is given in Fig. 1. The transformer has delta primary and star secondary connections, the secondary RMS voltage per leg being 0.428 of the rectified DC voltage, the secondary RMS current being 0.816 of the DC current and the average

fitted. Where mercury vapour rectifiers are employed it is also essential to include a device which will not permit the application of anode voltage until their cathodes are up to full mean temperature.

The magnetic contactor, operated by push buttons and the contacts of relays associated with various safety devices, forms a satisfactory method of control, particularly on large equipments. A circuit diagram of such an arrangement is given in Fig. 2, which should be studied in conjunction with Fig. 1. The control circuit operates at mains voltage supplied by a single-phase or between lines of a three-phase supply.

Start-button controls are normally on open-circuit and, when pressed, contact is made. Stop-button controls are normally on closed-circuit and, when pressed, the circuit is opened. Magnetically operated contactors are normally open-circuited and connect the mains supply to the transformer when the contactor coil is energised. There is in a magnetically operated contactor an auxiliary contact, called the maintaining contact, and this closes when the contactor operating coil is energised.

The maintaining contact is wired in parallel with the start-button, and, when this is operated with all the switches and relay contacts in the control circuit closed, the contactor coil is energised and the start-button circuit is completed by the maintaining contact, after the finger has been removed from the button. If a stop-button is operated or any relay contact in the circuit opens, the contactor coil will be no longer energised, and the mains connection to the transformer broken.

It will be noted in Fig. 2 that there are two separate control circuits, one for the LT transformers that supply filament current for the oscillator and rectifier, and the other for the HT transformer. A small transformer, the primary of which is across the LT contactor coil, energises a thermal delay switch, and on operation this will transfer the AC to the bridge metal rectifier, the output of which energises relays 1 and 2. Relay 1 has two contacts, one normally open and the other normally

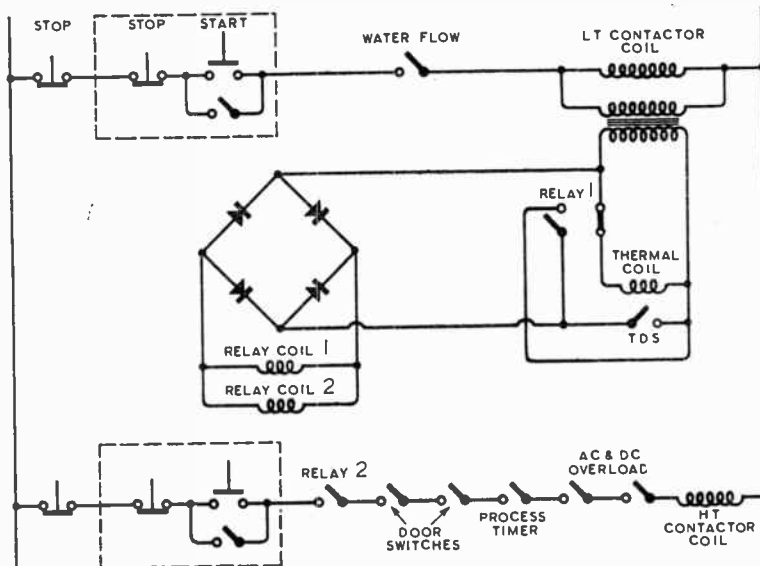

Fig. 2. System of control and safety switches in a high-powered RF generator.

phase mains supply is customary for larger equipments. The supply to most industrial undertakings, excepting the very smallest, is 3-phase, and if a heavy load were imposed on one phase serious unbalancing would result.

An advantage obtained by the use of 3-phase rectification is a large reduction in the AC ripple imposed on the rectified DC. With single-phase full-wave rectifica-

tion the RMS ripple voltage will be of twice supply frequency and will be equal to 48.3 per cent. of the DC voltage. With 3-phase full-wave rectification, the RMS ripple voltage will be of six times supply frequency and will be equal to 4.2 per cent. of the DC voltage.

With all equipments having a high-tension supply voltage which would be dangerous to the user, safety devices must be incorporated. No portion of the equipment must be accessible when in operation, and on any door or sliding panel switches must be

**Radio Heating Equipment—** closed. These will, on operation, disconnect the thermal delay switch winding, while still maintaining the supply to the metal rectifier. The contact of relay 2 is in the HT control circuit, and will close when the thermal delay switch has operated and permit the operation of the HT contactor.

Included in the LT control circuit are the contacts of a relay which is controlled by a water flow switch, incorporated in the supply pipes to water-cooled valves. Until cooling water is flowing it will not be possible to start the equipment. Where forced air cooling is employed, the air flow is made to operate a switch which controls this relay.

Door switches and DC and AC overload relay contacts are included in the HT control circuit, as are any contacts associated with process timing controls which switch off the equipment after a stipulated interval. This arrangement enables the HT to the generator to be disconnected

without affecting the LT supply, and at the same time ensures that the anode voltage shall not be applied to the mercury vapour rectifiers before full cathode emission is achieved.

Process timing controls which are capable of being varied over a wide range are advantageous for repetition production purposes. For most eddy current heating applications, particularly that of surface hardening, the process times required will be fairly short, ranging from about 3 to 30 seconds. With dielectric heating the process times will be somewhat longer, and may extend up to four or five minutes.

The process timing control must be precise in operation, for the tolerance which can be allowed on, say, a 10-second heating time must obviously be small. Switches operated mechanically by a synchronous motor may be used, but it is also possible to devise satisfactory electronic methods, using relays controlled by discharge tubes in resistance-capacity circuits.

for recognition, and only 17 years ago there were front-rank men of science who laughed out of court the suggestion that there was such a thing as an F layer—let alone two of them. The whole business reminds me of the story of a professor of mathematics who published calculations showing the impossibility of hitting a golf ball more than 30 many yards. His son read the paper, took driver and ball—and performed the impossible. So often there is a factor which is either overlooked or regarded as of negligible importance in the calculations; then, when what they appeared to show couldn't be done is done, revision brings out the importance of that factor after all. Theory and practice must always go hand in hand: theories, when all is said and done, are tentative until practice has confirmed them or otherwise; practice without theory seldom leads to the best possible results.

□ □ □

### Who Invented Radar?

AN awful lot of nonsense has been written, mainly in the lay papers, in endeavours to prove that this man or that was the inventor of what used to be known as Radiolocation and is now termed Radar. Again, there have been attempts to demonstrate that if an individual cannot be given the credit, it can at all events be assigned to one country. The truth is that the basic principle on which radar is founded—the reflection of VHF radiation—was world-wide knowledge years ago. Those who visited the National Physical Laboratory's "sideshow" at the Radio Exhibition at Olympia in 1936 or 1937 (or was it even earlier?) may remember the film which showed how this principle was used to measure the height of the E and F layers by transmitting impulses vertically upwards and measuring the time taken for the reflections to return to earth. It was not for some time that any attempt was made to extend the idea to the pin-pointing of aircraft in flight, though the possibility of doing so was no doubt recognised in many countries by scientists working on independent lines. It is one thing to realise possibilities and quite another to produce a practical working system which gives the answers under the exacting conditions of modern warfare. I doubt whether any person can justly claim to have invented radar or whether any country can truly assume the honour of having been its birthplace. But, to come down to the brassiest of brass tacks, this country of ours had in operation when the war broke out real honest-to-goodness working systems which

## RANDOM RADIATIONS

—By "DIALLIST"—

### Silver Jubilee

THE Silver Jubilee celebrations of the Wireless Section of the Institution of Electrical Engineers was a great show. I don't suppose there has ever been such a gathering of the eminent figures of the world of technical radio. Almost every well-known man of the present day seemed to be there, and the survivors of pioneer days were to be seen in strength. In fact, whilst chatting at the preliminary tea with the Editor of *Wireless World* and Capt. S. R. Mullard and "Cathode Ray," I said that almost the only link with the old days that I hadn't seen was Mrs. Raymond, of Lisle Street, who used to supply so many of us with components! At the meeting itself the task of telling the story of wireless was assigned to former Chairmen of the Section, each being given one aspect to deal with. One of the most entertaining speakers was Professor G. W. O. Howe, Technical Editor of *Wireless Engineer*, who insisted that wireless had made such enormous strides, not because of, but in spite of, the theorists. He said that if Marconi had consulted eminent scientists before making his attempt

to transmit across the Atlantic he would never have made it, for he would have known that success was impossible! Again and again, he told us, men of science said that things couldn't be done—and the practical men just went on and did them. Admiral Sir Charles Kennedy-Purvis had more to say in the same strain from the Navy's point of view. "Our experts," he told us, "used to produce calculations showing the impossibility of this or that. Well, we just blundered in and did these things; then the experts revised their figures."

### Theory and Practice

The trouble is, I believe that physicists and mathematicians do not always see the full implications of their calculations. Hertz wrote to an inquirer that there was no possibility of ever using electromagnetic waves for the transmission of telephony. The short waves were handed over to radio amateurs because (a) the authorities then regarded the amateurs as a nuisance, and (b) it had been proved (!) that these waves were useless for long-distance communication. The E, or Heaviside, layer had a long struggle

did all that was asked of them—and I very much doubt whether radar had reached a similar state of development in any other country at that time.

□ □ □

Receiver Prices

THE prices of both new and second-hand wireless receiving sets are fixed by regulations if they are sold by dealers in the ordinary course of business. But, as "Free Grid" has recently pointed out, the rules do not apply to private transactions. Nor do they to auction sales. The other day one of these was taking place at a house not far from mine, and being on leave at the time, I looked in to see whether there was anything tempting on offer. One thing I did notice was a table model receiver dating from about 1938, whose original price had been in the neighbourhood of £12. To my knowledge it had been in regular use all these years, so that it had certainly had plenty of wear and tear. In pre-war days the value of a six-year-old set—that is, the amount a dealer would allow for it in part exchange—was a matter of shillings. The bidding for this one started at £10 and ran briskly to £15, at which it was knocked down.

□ □ □

War and Progress

IT is lamentable but none the less true that many departments of applied science make far greater advances in wartime than in the days of peace. Wireless, for example, was in a comparatively rudimentary state when the last war broke out, but by the time that the Armistice came the stage was all set for the development of world communications and of broadcasting. And when this war is over progress almost as spectacular may be revealed in many directions. The reason, I suppose, is that in war development becomes a matter of life or death. Money *must* be found for research, and the energies of manufacturers directed willy nilly to activities for which no opening of a commercial kind may then be apparent. In the last war one firm of lamp manufacturers was asked to make radio valves. They agreed with a sigh: "We suppose you realise," said they, "that you are asking us to instal machinery and equipment for which there can be no possible use after the war!" And so in wartime research and development go forward at a pace unheard of in peace. It's a thousand pities that it should take a war to do this; tragic, again, that science should have to be applied mainly to the devising of methods of death and destruction. But out of evil

comes good sometimes, and this is certainly true of the wartime speeding up of scientific activities.

□ □ □

The Ways of Neons

IT hasn't come my way to make much use of neons except in HF fields. Hence I was puzzled at first over something that occurred a few days before writing this. In my home there is an upstairs corridor leading to a couple of bedrooms which had always seemed to me to need a small light of its own that could be switched on or off at either end. Being on leave and thinking of jobs to do, the one of putting in this light seemed just what I wanted to fill in a wet afternoon. I fixed it up in the normal way, with a couple of two-way switches with three wires between them. As time was short and I had some good-quality three-core flex, I used that for the job. A 15-watt lamp gave ample light, and I wondered whether a neon might not possibly fill the bill. It didn't, so, preparing to replace the 15-watter, I switched off. Or, rather, I turned over first one of the switches and then the other, but the neon continued to glow—not, of course, at full brilliance, but there was a distinctly visible luminescence at the end of one of the supports. Reversing the mains leads had no effect. Disconnecting at the junction with the mains, I tested the circuit with a 500-volt megger and obtained an "infinity" reading. A capacity effect, I suppose.

□ □ □

Pedantic ?

THE other day when looking through a little book that had just come into my hands I was interested to see that the author insisted that the correct plural of radius vector was radii vectores. I wonder what readers (and particularly my old Vine Street dock-mate "Free Grid," who, like myself, had something of a classical upbringing) think of that. If the expression were good Latin, I'd plump for radii vectores, even though it be rather a mouthful. But it isn't good Latin. "Vector" to Cæsar or Cicero would have meant a carrier and "radius" a rod or a spoke; neither would be able to make anything of "radius vector." As, then, it's simply a convenient expression that we have made up out of two Latin words, to which we've given specialised meanings entirely different from any that they had when Latin was Latin, I contend that the only thing to do is to treat it as English and make the plural "radius vectors." And, by the way, do let us be consistent; I don't think I have come across "vectores" as the plural of vector in normal mathematical works. Have you ?

# GALPINS

## ELECTRICAL STORES

"FAIRVIEW,"  
LONDON ROAD, WROTHAM,  
KENT.

TERMS: Cash with Order. No C.O.D.  
All prices include carriage or postage.

**MOTOR-DRIVEN PUMP**, for oil or water, motor 220v. D.C., 1 amp., 1,250 r.p.m., maker Keith Blackman. **£6 10s.**

**MASSIVE GUNMETAL WINCH**, complete with long handle, for use with ½ in. dia. wire cable, weight 50 lbs., condition as new. **£3.**

**ELECTRIC LIGHT CHECK METERS**, first-class condition, electrically guaranteed, for A.C. mains, 200/250 volts 50 cy. 1 phase 5 amp. load, 11/- each.

**SOLID BRASS LAMPS** (wing type), one hole mounting, fitted double contact, S.B.C. holder, and 12 volt 16 watt bulb. 3/6 each, or 30/- per doz.

**TUNGSTEN CONTACTS**, ½ in. dia., a pair mounted on spring blades, also two high quality pure silver contacts, ½ in. dia., also on spring blades, fit for heavy duty, new and unused. There is enough base to remove for other work. Set of four contacts, 5/-.

**RESISTANCE UNITS**, fireproof, size 10 × 1½ in wound chrome nickel wire, resistance 2 ohms to carry 10 amps. **2s. 6d.** each.

**3-PHASE TRANSFORMER**, 410v. to 240v. at 2kW, size of core 14in. by 11in. by 5 square inch section. **£10.**

**TAPE MACHINE**, fitted Klaxon 220v. D.C. motor geared drive, rheostat control, 18 ohm relay, complete with tape reel and tape. **£10.**

**AIR PRESSURE GAUGE** by famous maker. 10in. dia., reading 0-4,000 lb per square inch, as new, in case. **£7 10s.**

**SWITCH FUSE** in wrought iron case, 3-way, for 400 volts at 40 amp. **4s. 5/-.**

**MOVING COIL METERS**, a pair by a famous maker, one reading 0-70v., the other 0-10 amp., 2in. dia., flush mounting, both 1,000 ohms per volt. **£5** the pair.

**METER MOVEMENT** for recalibrating, moving coil, 4in. scale, deflection not known. Price **20/-.**

**MOVING COIL** ampmeter reading 0-350 amps., 6in. dia., switch board type. Price **£3 10s.**

**100 v. MOTOR BLOWER**, ¼ h.p. motor, direct current, series wound, 4in. dia. inlet and outlet to Blower. Price **£5.**

**H.T. TRANSFORMER**, case 14 × 9 × 8in., no oil, input 200/240v.; output 10,000 volts centre tapped, 3kW., intermittent rating. **£15.**

**VIR CABLE**, 200 amp., 10/33, in good condition, in approx. 30 yard lengths. **£5** per coil.

**MAINS AMPLIFIER**, 110/250v. A.C., approx. 5 watts, 3v., no valves, size of case 16 × 11 × 7in., metal rectifier H.T., by famous maker. **£5.**

**TANGENT BELL**, 250v. D.C., 12in. gong, weather-proof. **£4.** Ditto, 6in. gong for 110v. D.C. **30/-.**

**MAINS AMPLIFIER**, 110/250v. A.C., approx. 6 watts, 4v., no valves, 2in. dia. moving coil output meter, size of case 16 × 12 × 12in. **£5.**

**ROTARY CONVERTER**, D.C. to D.C. input 48 volts, output 2,500 volts at 1 kW., constant rating, as new. **£10.**

**ROTARY CONVERTER**, input 40 volts D.C., output 75v., 75 m/A, A.C., also would make good 50v. motor or would generate. **£2.**

# WORLD OF WIRELESS

## PRESS AND RADIO

THE long-standing controversy in the United States regarding the common ownership of newspapers and broadcasting stations has been ended by the F.C.C. announcement that it will not "adopt any general rule with respect to newspaper ownership of radio stations," applications for licences being considered on their individual merits.

The statement continues: "Aside from the specific question of common ownership of newspapers and radio stations, the Commission recognises the serious problem involved in the broader field of the control of the media of mass communications and the importance of avoiding monopoly of the avenues of communicating fact and opinion to the public."

## TELEVISION IN THE STATES

THE National Broadcasting Company of America has outlined its post-war television policy. In a statement to the network's affiliated stations it is predicted that an eastern network of television stations extending from Washington to Boston will be the first link in a nation-wide chain of stations.

Despite the fact that the N.B.C.'s parent company R.C.A. has carried out extensive research and development work on radio relay systems, no definite statement has been made on the means likely to be employed for linking the stations. It is, however, disclosed that plans are made for the installation of between 6,000 and 7,000 miles of co-axial cable in the next five or six years. The statement adds "the ultimate determination of which is to be used will be governed by the relative efficiency of service they render and their comparative costs."

With regard to the present allocation of 18 channels for the use of television stations, which, it is considered, is sufficient for its present needs but may prove inadequate for future requirements, the statement concludes, "If the television [frequency] allocation now in existence were to be changed substantially and a new start in the higher frequencies were required, it would retard the establishment of television as a practical service for a period of years that cannot now be definitely forecast. It is to be hoped, therefore, that post-war television will be permitted to continue on the present frequency allocations."

The Vice-Chairman of the U.S. Radio Technical Planning Board suggests that the Federal Communications Commission should grant post-war licences to commercial

television stations on pre-war standards, or with such modifications as can readily be introduced, for a period of at least six years. His point was that receiving sets at present in use would not be rendered obsolete. At the end of this period, during which experiments could continue on frequencies not at present utilised for television, transmitters would be permitted to change to a different standard if they wished to.

Our U.S. contemporary *Broadcasting*, referring to the post-war cost of television receivers, states that there has been a reduction of 60 per cent. to 80 per cent. in the cost of manufacturing CR tubes.

## A.B.S.I.E.

IT was recently announced that the B.B.C. had placed a medium-wave transmitter at the disposal of the American Office of War Information for "political warfare" purposes.

The two wavelengths to be employed, 307.1 and 267.4 metres, are both allocated to the B.B.C. under the Lucerne wavelength allocation plan and up to the outbreak of war were employed, respectively, by the Lisnagarvey (N. Ireland Regional) and Stagshaw (N.E. Regional) stations.

A special studio has been equipped in London for the exclusive use of the station, which is known as A.B.S.I.E.—American Broadcasting Station in Europe.

It is understood programmes from the studio will also be transmitted on short waves.

## NEW U.S. STATIONS

IN pursuance of the plan of the U.S. Office of War Information to increase the number of international short-wave stations in the States to 36, four 50-kW transmitters are being erected on the Pacific Coast. These transmitters, which it is hoped to have in use in October, will be operated by the N.B.C. for the Government. The call letters KNIB and KNBC have been allocated to two of the transmitters.

The C.B.S. will operate a similar station to be erected at another point on the Pacific Coast in the near future.

According to *Broadcasting*, 21 transmitters are at present being used by the O.W.I., some of them having a power of 100 kW. Ten of these stations being on the West Coast, with their transmissions beamed to the Far East, their call letters, including KGWI, KWID, KWIX, KWU, KWY, KRCA and KROJ, are not well known in this country.

## HEROIC RADIO OFFICERS

THE Lloyd's War Medal for bravery at sea has been awarded to three radio officers.

Senior Radio Officer C. S. Marshall received his medal for outstanding courage and devotion to duty. By employing every means and improvisation available he did all that was possible to send out a distress message when the ship in which he was sailing was torpedoed and severely damaged.

Senior Radio Officer J. F. Wilson sacrificed his life by remaining at his post after the crew were ordered to abandon the sinking ship. He managed to repair the transmitter and get a message through to one of H.M. destroyers and was not seen again.

Chief Radio Officer S. D. Haines also stayed behind after the crew had been ordered to leave in an effort to repair the wireless gear and to send out a distress message.

Chief Radio Officer R. F. Cole receives the M.B.E. Although injured and dazed by the explosion which wrecked his ship, he struggled amongst the debris in the wireless room to get away a distress message on an emergency set, and left only when ordered to his boat by the Master.

## WHAT THEY SAY

RADIO is part of the heritage of the modern child, and the teacher owes a duty to his pupils to seek to train their taste in using it.—*A. C. Cameron, secretary, Central Council for School Broadcasting, in an address to the Royal Society of Arts.*

I was, for a time, one of the die-hards who opposed the revolutionary introduction of short waves [into Naval communications] in about 1923.—*Admiral Sir Charles Kennedy-Purvis, at I.E.E. Wireless Section Commemoration Meeting.*

As to the future, Birmingham will be the first city outside London to have television, but more than that cannot at present be stated.—*Percy Edgar, Midland Regional Director, B.B.C.*

Television, under present standards, is not good enough. It can be good enough (and very quickly) if we do not wantonly dissipate, but use intelligently, the advantage the present hiatus affords us. . . .—*W. Miner, in "Electronics."*

. . . . We must, however, take exception to one minor point: On page 54, it is stated that the leakage resistance of an 0.1 $\mu$ F wax-impregnated capacitor is between 5 and 50 megohms. If capacitors of



European manufacture are that bad, American manufacturers of such items need have no fear of European competition in post-war markets.—*J. H. P. reviewing E. E. Zepler's book, "The Technique of Radio • Design," in "Radio" (U.S.A.).*

Has the advice of the B.B.C. technicians been sought in the matter of radio reception in the steel houses the Government propose to erect?—*R. Moscrop, in a letter to "News Chronicle."*

**IN BRIEF**

**Canadian S-W Station.**—Priorities have now been granted American manufacturers for the provision of the equipment for the 50-kW short-wave station to be erected at Sackville, New Brunswick, by the C.B.C. It was originally expected to cost \$800,000, but will now cost around \$1,100,000. The station, which will be equipped with two 50-kW transmitters, is expected to be testing in October and ready for service by January 1st, 1945.

**American Sets.**—The Board of Trade states that 36,000 American broadcast receivers have already arrived and a further 7,000 are expected shortly. 12,000 sets have already been distributed and a further 12,000 will be available soon.

**Long-distance FM.**—A C.B.C. station on Mount Royal, Montreal, is receiving FM transmissions from a station at Mount Washington, New Hampshire, U.S.A., 170 miles away!

**Sir Ernest Fisk.**—The recent thirty-fifth Kelvin Lecture at the Institution of Electrical Engineers was preceded by the presentation to Sir Ernest Fisk of the Certificate of Honorary Membership. He was elected an Honorary Member by the Council of the I.E.E. earlier this year.

**B.B.C. Reappointment.**—Sir Allan Powell has been reappointed Chairman and Governor of the B.B.C. He has consented to serve in order to ensure continuity of policy for such further period as might be decided.

**Radiolocation Award.**—The Thomas Gray Memorial Trust Prize of £50, offered by the Royal Society of Arts for inventions connected with the "Improvement and Encouragement of Navigation," has been awarded for 1943 to Drs. J. T. Randall and H. A. H. Boot for their valuable invention in connection with radiolocation. The citation states, "Eminent service has been rendered to the Merchant Navy by their invention for the greater safety of life at sea."

**C.B.C. Expenditure.**—Announcing the gross annual revenue of the Canadian Broadcasting Corporation for the past year at \$2,489,224. Dr. Augustin Frigon, acting general manager of C.B.C., said that expenses amounted to \$1,245,870. It is noteworthy that \$457,000 of this sum went to pay line rentals.

**Sharing Wavelengths.**—The Irish Government has given permission for the Vatican City broadcasting station to use, temporarily, the frequency 565 kc/s (531 metres) which was allocated to Ireland under the Lucerne plan. It is understood the Vatican transmitter is using a power of only 1 kW, so that there should not be any interference with the transmissions from the 100-kW Athlone station.

**Short-wave Transmission.**—"Radio Waves and the Ionosphere" is the title of a new book to be issued by our Publishers. Written by T. W. Bennington, it gives a lucid description of the factors affecting the propagation of short waves. Copies will be available shortly, price 6s.

**Invasion Radio.**—800 wireless sets to equip a division was the recent estimate given by Lt. Gen. Sir Colville Weymss, Colonel-Commandant of Royal Signals. "Good communications," he said, "are vital to any operations, especially those involving all the complications of an invasion."

**Radio Pictures.**—A commercial phototelegram service between Naples and London has been opened by Cable and Wireless, and pictures will now be accepted at the rate of £1 15s. 9d. up to 120 sq. cms. and £2 8s. 6d. for those over 120 sq. cms. up to 234 sq. cms. The service is at present one way only

**OF OUR ABILITIES AND FACILITIES WE GIVE GLADLY**



PARAMOUNT above all else is the necessity of meeting urgent and immediate demands for the protection of cherished liberty.

Astatic's engineering and manufacturing facilities are therefore first at the disposal of Allied Governments.

Astatic will be ready to serve you again with high quality piezo-electric devices when the "All Clear" of Victory sounds. Register your name with our Representative for your future benefit.



THE ASTATIC CORPORATION  
YOUNGSTOWN, OHIO, U.S.A.  
TORONTO, CANADA.

—Exclusively Represented by—  
Frank Heaver Ltd. Kingsley Road, Bideford, N. Devon

**HOME SAFELY— THANKS TO RADIO**



THE far reaching achievements of the electronics industry are being made available to the Armed Forces in ever increasing quantities. Crowe is proud of its proven ability to produce precisely made electronic control mechanisms in large numbers.

★  
Exclusively Represented by  
Frank Heaver Ltd.,  
Kingsley Road,  
Bideford,  
N. Devon.



**CRONAME RADIO COMPONENTS**

CROWE NAME PLATE AND MANUFACTURING CO.  
CHICAGO, ILL. U.S.A.



Photo: Odhoms Press

COL. DAVID SARNOFF, President of the Radio Corporation of America, now a member of General Eisenhower's headquarters staff, was recently a guest of the Radio Industries Club in London. With him are Sir Noel Ashbridge, Deputy Director-General of the B.B.C., who was re-elected as President of the Club for a second year, and (right) the Chairman of the Club, H. de A. Donisthorpe, whose seventh year of office was celebrated at the meeting by a presentation from the members.

## World of Wireless—

—Naples to London. The circuit between London and Buenos Aires, which was originally opened in March, 1937, but suspended in 1942 at the instigation of the Argentine Government, has been reopened. The rate for phototelegrams is £11 17s. 6d. for a minimum of 150 sq. cms.

Institute of Physics.—At a meeting of the Electronics Group of the Institute on June 10th, at 2.30, in the rooms of the Royal Society, Burlington House, London, W.1, Drs. M. Pirani and B. P. Dudding will open a discussion on "Some Aspects of High Vacuum Technique, viz.: High Vacuum Gauges and Glass Manipulation."

Scottish Branch.—At the request of physicists employed in industry in Scotland the Board of the Institute of Physics has authorised the formation of a Scottish Branch to give local opportunities for the interchange of knowledge and experience of applied physics. The inaugural meeting took place in Glasgow on April 22nd.

## NEWS IN ENGLISH FROM ABROAD

Country : Station	Mc/s	Metres	Daily Bulletins (BDST)	Country : Station	Mc/s	Metres	Daily Bulletins (BDST)
<b>Algeria</b>				<b>French Equatorial Africa</b>			
Algiers .. .. .	8.965	33.46	1700, 1800, 1900, 2000, 2200, 2300	FZI (Brazzaville) ..	11.970	25.06	2045, 2245
	12.110	24.77	1800, 1900, 2000, 2200				
<b>America</b>				<b>India</b>			
WRUW (Boston) ..	6.040	49.67	0900	VUD3 (Delhi) .. .	7.290	41.15	0630, 1000, 1500, 1750
WCBN (New York) ..	6.060	49.50	0900	VUD4 .. .	11.790	25.45	0630
WLWK (Cincinnati) ..	6.080	49.34	0700, 0800	VUD3 .. .	11.870	25.27	0630, 1000, 1500
WKRD (New York) ..	6.100	49.18	0100, 0300, 0600, 0700, 0800, 0900				
WOOC (Wayne) ..	6.120	49.03	0300, 0400, 0500, 0800, 0900	<b>Iran</b>			
WBOS (Boston) ..	6.140	48.86	1000, 1100	EQB (Teheran) ..	6.155	48.74	2325
WCBX (Brentwood) ..	6.170	48.62	0800				
WGEO (Schenectady) ..	6.190	48.47	0800	<b>Mozambique</b>			
WKTM (New York) ..	6.370	47.10	0100, 0300, 0400, 0500, 0600, 0700, 0800, 0900, 1000	CR7BE (Lourenco Marques) .. .	9.830	30.52	2150
WGEO (Schenectady) ..	7.000	42.86	0600, 0800	<b>Newfoundland</b>			
WKLJ (New York) ..	7.565	39.66	0300, 0400, 0500, 0600, 0700, 0800, 0900, 1000	VONH (St. John's) ..	5.970	50.25	0015
WLWO (Cincinnati) ..	7.575	39.61	0700, 0800, 0900	<b>Palestine</b>			
WOOW (New York) ..	7.820	38.36	0300, 0400, 0500, 0800, 0900	Jerusalem .. .	11.750	25.53	1715
WGEO (Schenectady) ..	9.530	31.48	1000, 11,00, 1200	<b>Portugal</b>			
WCRC (New York) ..	9.590	31.28	1000, 1100	CSW6 (Lisbon) ..	11.040	27.17	2100
WNBI (New York) ..	9.670	31.02	1000, 1100, 1200				
WKRD (New York) ..	9.897	30.31	1000, 1100, 1200	<b>Spain</b>			
WLWO (Cincinnati) ..	11.710	25.62	2200, 2300	EAQ (Aranjuez) ..	9.860	30.43	2150†
WRUW (Boston) ..	11.730	25.57	1400				
WGEX (Schenectady) ..	11.790	25.44	2200	<b>Sweden</b>			
WCRC (Brentwood) ..	11.830	25.36	1530, 1630, 2145, 2200	SBU (Motala) .. .	9.535	31.46	2320†
WGEO (Schenectady) ..	11.847	25.32	1800, 2200	SBP .. .	11.705	25.63	1800
WGEX (Schenectady) ..	11.847	25.32	1200, 1400, 1700				
WOOW (Wayne) ..	11.870	25.27	1400, 2200	<b>Switzerland</b>			
WBOS (Boston) ..	11.870	25.27	1200	HER3 (Schwarzenburg) ..	6.345	47.28	2250
WRCA (New York) ..	11.893	25.22	1100, 1200	HER4 .. .	11.765	25.50	2250
WRUS (Boston) ..	15.130	19.83	1400, 1700, 1800, 1900				
WOOC (Wayne) ..	15.190	19.75	1400, 2200	<b>Syria</b>			
WBOS (Boston) ..	15.210	19.72	2200	FXE (Beirut) .. .	8.035	37.34	1835
WLWK (Cincinnati) ..	15.250	19.67	1745, 1900, 2200, 2300				
WCBX (Brentwood) ..	15.270	19.65	1530, 1630, 2145, 2200	<b>Turkey</b>			
WGEO (Schenectady) ..	15.330	19.57	1745, 1900, 2200	TAP (Ankara) ..	9.465	31.70	1900
WRUW (Boston) ..	17.750	16.90	1700, 1800				
WLWO (Cincinnati) ..	17.800	16.85	1400, 1745, 1800, 1900	<b>U.S.S.R.</b>			
WCBN (New York) ..	17.830	16.83	1530, 1630	Moscow .. .	7.300	41.10	0000, 1900, 2000, 2100, 2200, 2300
					7.322	40.92	1900
<b>Australia</b>					8.940	33.56	1340
VLI4 (Sydney) ..	7.240	41.45	1615		9.480	31.65	0200, 0300
VLG (Melbourne) ..	9.580	31.32	1615		9.860	30.43	1340
					10.445	28.72	0645, 1340
<b>Belgian Congo</b>					11.830	25.36	1700
Leopoldville .. .	15.167	19.78	1300		11.950	25.11	0047, 0200, 0300, 1300, 1340, 1420
					12.190	24.61	1340
<b>Brazil</b>					12.260	24.47	1320
PRL8 (Rio de Janeiro) ..	11.715	25.61	2130†		15.040	19.85	0047
					15.230	19.70	0047
<b>China</b>					15.760	19.05	1800
XGOY (Chungking) ..	9.635	31.14	1600, 1800, 2230	<b>Vatican City</b>			
				HVJ .. .	5.970	50.25	2115
<b>Ecuador</b>							
HCBJ (Quito) ..	12.455	24.09	0100, 2130				
				<b>Algers</b> .. .	kc/s	Metres	
<b>Egypt</b>					1,176	255	0200, 1500, 1900, 2000, 2100, 2300
Cairo .. .	7.510	39.94	1945, 2200		565	531	1440†, 1945, 2310 (Sun. 2300)
				<b>Tunis</b> .. .	868	345.6	0000, 0100, 0200, 2000, 2100, 2200, 2300

It should be noted that the times are BDST—two hours ahead of GMT.

† Sundays excepted.

## Letters to the Editor

# New Contrast Expansion Circuit • Cathode-Follower Output

### Contrast Expansion

THE article by Mr. M. O. Felix (March issue) describing a contrast expansion circuit induces me to comment on some aspects of his design.

In deducing the operating condition of the circuit Mr. Felix makes the assumption that the output resistance due to the controlled valve is much less than the resistance of the potential divider formed by  $R_1$  and  $R_2$ . Under

these conditions, however, the voltage transfer efficiency of the circuit would be very poor, and very high input levels would be necessary. It can be shown that the equation of operation of this circuit is:—

$$\text{Output} = \frac{R_2}{\text{Input} \left( R_1 + R_2 + \frac{R_1 \cdot R_2 (1 + \mu)}{R_a} \right)}$$

The circuit by which Mr. Felix obtains the control voltage for the variable-gain valve is open to criticism. When the slider of  $R_5$  in circuit (a) in the accompanying diagram is at its upper end the input to the whole circuit will be shunted by the control rectifier, with consequent severe distortion of the signal.

The author states that, by the use of a diode shunting  $R_4$ , asymmetrical time-constants for charge and discharge of 0.02 and 2 seconds can be obtained. The time of charge of  $C_1$ , however, will depend on the total series impedance of the charging circuit, which will include  $C_2$ ,  $C_3$ , the part of  $R_5$  above the slider, the diode conduction resistance and the impedance of the circuit feeding the unit. This time is thus greatly dependent upon the setting of  $R_5$  and is unlikely to be as low as 0.02 second. The charges acquired by  $C_2$  and  $C_3$  detract from the available control voltage and may interfere with the operation of the circuit.

To achieve very rapid charging of  $C_1$  considerable power at low impedance is required, and as this is unlikely to be available at the input a separate control amplifier is desirable. This is an added complication, but gives increased available control voltage and freedom from input shunting.

When using asymmetrical delays the rapid rise in gain—in this case rise in output resistance—is accompanied by a correspondingly rapid rise or fall in the anode current of the controlled valve, and this causes a pulse to appear in the output, with unpleasant effects. This fault is inherent in a stage

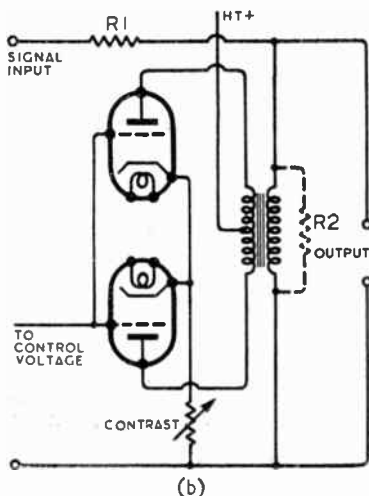
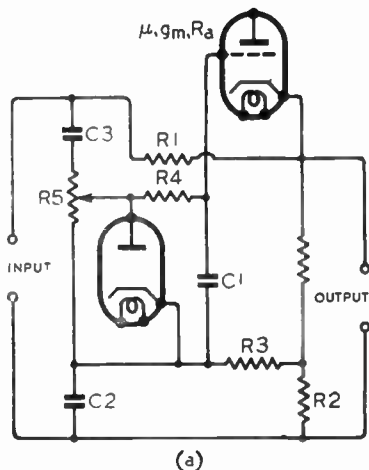

Contrast expansion circuits. (a) due to M. O. Felix and (b) a modification of the circuit originally suggested by D. T. N. Williamson.



THE "FLUXITE QUINS" AT WORK.

"Get this aerial over here, see!  
Then we'll fix it with FLUXITE" said EE.  
"Well! That just beats the band.  
Come on OI! Lend a hand."  
"I will when I'm rid of this tree!"

See that FLUXITE is always by you — in the house — garage — workshop — wherever speedy soldering is needed. Used for over 30 years in Government works and by leading engineers and manufacturers. Of all Iron-mongers—in tins, 8d., 1/4 & 2/8.

Ask to see the FLUXITE SMALL-SPACE SOLDERING SET—compact but substantial—complete with full instructions, 7/6.

TO CYCLISTS! Your wheels will NOT keep round and true unless the spokes are tied with fine wire at the crossings AND SOLDERED. This makes a much stronger wheel. It's simple—with FLUXITE—but IMPORTANT.

The FLUXITE GUN puts FLUXITE where you want it by a simple pressure. Price 1/6, or filled, 2/6.



ALL MECHANICS WILL HAVE

# FLUXITE

IT SIMPLIFIES ALL SOLDERING

Write for Book on the ART OF "SOFT" SOLDERING and for Leaflets on CASE-HARDENING STEEL and TEMPERING TOOLS with FLUXITE. Price 1d. each.

FLUXITE LTD.

(Dept. W.W.), Bermondsey Street, S.E.1

**Letters to the Editor—**

whose anode current changes with change of slope, and it can only be obviated by the use of a constant-current amplifier (*Wireless Engineer*, January, 1944) or a balanced or push-pull system.

The inherently low output resistance of the cathode follower necessitates a potential divider  $R_1, R_2$  of low value which is a considerable disadvantage, as the preceding stage must be of very low output resistance—preferably not greater than one-tenth of  $R_1$ . This may be overcome by the use of an impedance-matching transformer of suitable ratio to give a secondary impedance of about  $0.1M\Omega$ . The circuit could then be fed from a triode with an AC resistance of about 10,000 ohms.

The use of a valve or valves as a variable impedance would seem to have some advantages over their use as a conventional variable-gain amplifier for the purpose of contrast expansion, in that the impedance can be inserted at a point of higher signal level without distortion and is adapted to "single-ended" connection, avoiding the necessity for phase-splitting devices.

The circuit of my own contrast expansion unit (September and December, 1943, issues) could be simplified somewhat by omitting the phase-splitter  $V_1$  and the bias network  $R_{17}, R_{18}, R_{19}$  and  $C_{10}$ , and substituting for  $V_2$  and  $V_3$  a variable-impedance stage of the nature of that shown in diagram (b). The valves might possibly be combined in a double triode or triode-connected pentode. The bias supply is no longer necessary since this type of stage requires a control voltage which increases negatively to give increased "gain"; the control rectifiers would require rearrangement to give a voltage in this sense.

This is the simplest arrangement using asymmetrical delays which is likely to be satisfactory.

DAVID T. N. WILLIAMSON.

London, W.14.

### Cathode Follower Output Stage

SOME of your readers in this part of the country have read C. J. Mitchell's article on a "Cathode Follower Output Stage" in your April issue with considerable interest. We are

afraid, however, that the author's analysis is unsound.

After stating that in this circuit the valve is triode-connected, and that as a triode the AC2/Pen has  $R_A=2,500$  ohms, he nevertheless continues to talk of output powers of 3 or  $3\frac{1}{2}$  watts. Now it can be shown graphically that even if the valve had ideally linear characteristics only 1 watt of output power would be available without going into regions of positive grid volts, and with any real triode-connected valve an even smaller output will be obtained. Not even cathode-follower connection will do much to reduce the distortion if grid current flows. Here are figures for three typical valves:—

	Output as	
	Pentode	Triode
GF6	3.25 watts.	0.85 watts.
KT63	3.0 "	.7 "
KT66	7.25 "	2.2 "

These show that the output power available with triode connection is only about one-quarter that available with pentode connection.

One must conclude, therefore, that Mr. Mitchell has an efficient loudspeaker for which a maximum undistorted output power of rather less than 1 watt is sufficient. Within this limitation very good quality will, no doubt, be obtained.

E. F. GOOD.

Malvern.

IN his article in your April issue C. J. Mitchell quotes a result which is obscured by the usual "equivalent circuit" treatment of the cathode follower.

The equivalent circuit indicates that for a given signal input between grid and earth, maximum power output is obtained by matching the load to the output impedance (approx.  $1/g_m$ ), as with my other generator. This is the usual "impedance-matching" result. But unlike a normal amplifier, the maximum input (grid-to-earth) which a cathode follower can handle is *not* independent of the load, so that in order to obtain maximum power output, proper choice of both load and signal input is necessary; this leads to the result obtained by your contributor, i.e., matching to twice the anode slope resistance of the valve. There is no confusion between the two cases, as he

seems to imply; the difference lies merely in the operating conditions. In the first the available signal is limited by other considerations; in the second it can be chosen for maximum output.

Richmond. J. W. HUGHES.

### Author's Reply

IN reply to your correspondent, E. F. Good, I agree that the claimed output of  $3\frac{1}{2}$  watts from a triode-connected AC2/Pen appears rather optimistic, and I must confess that I was surprised at the result myself. When the circuit was tested, the input was increased until most of the persons listening to the test programme noticed distortion; the output was then measured by observing the cathode potential fluctuations on a cathode-ray oscilloscope. The total peak-to-peak swing was found to be 375 volts (approx.), which corresponds to an output of  $3\frac{1}{2}$  watts. When the input was increased still more, the total peak-to-peak swing was more than 450 volts, and a considerable difference between positive and negative excursions of the cathode potential was obvious.

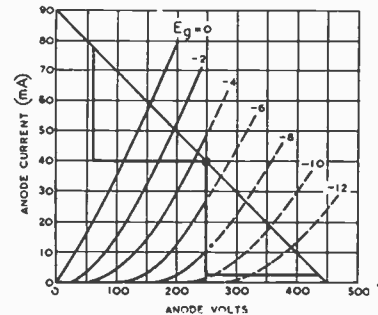

Characteristics of AC2/Pen when connected as a triode.

Under these conditions there is no doubt that the distortion introduced within the valve was enormous, but the large negative feed-back reduces this distortion in the same proportion as it reduces the gain of the circuit. Obviously, there are limits to the extent to which feed-back can correct distortion, but with 100 per cent. negative feed-back as much as 50 per cent. distortion can be reduced to negligible proportions. I enclose two diagrams, one showing the characteristics of the AC2/Pen, when triode connected, and the other showing the modified input waveform of a

cathode follower giving an output containing 2 per cent. second harmonic distortion. It is seen from this last figure that the distortion produced within the valve is in the order of 35 per cent.

Replying to Dr. Hughes' comments, I agree with his statements that as a rule there should be no confusion between the two cases quoted, but I have met several

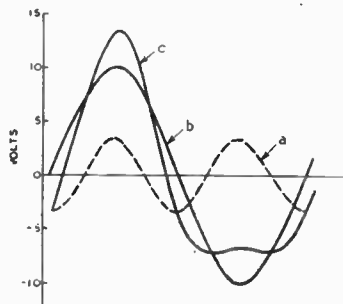

Waveforms in cathode follower stage (a) harmonics in output (b) difference between output and input voltages at a fundamental frequency  $f$ . (c) Resultant input. Input voltage (grid - to - earth) = 180 V. Output voltage = 170 V + 3.5 V second harmonic. Resultant input = 180 - (170 + 3.5 at  $2f$ ) = 10 + 3.5 at  $2f$ .

people who labour under the belief that the load in a cathode follower should be matched to the output impedance of the circuit; one of my colleagues, in fact, suggested that by designing an output stage with a sufficiently low output impedance, it might be possible to dispense with a loudspeaker coupling transformer. My remarks concerning the theory of the cathode follower were essentially brief and were purely for the guidance of readers not acquainted with the circuit.

Iford. C. J. MITCHELL.

### Anti-interference Motors

YOUR contributor "Diallist" (May issue) is in error regarding the maximum speed of induction motors working on a 50-c/s supply.

The synchronous speed of any induction motor on any frequency is given by the expression "speed equals 60 times  $f$  divided by  $P$ ," where  $P$  is the number of pairs of poles. The minimum number of poles is obviously two, which is one pair, therefore, the speed is equal to 60 times 50 divided by one, which is equal to 3,000 r.p.m. Owing to its charac-

teristics the squirrel cage machine always has a slight amount of slip, and the actual speed would therefore be of the order of 2,950 r.p.m. With regard to the starting conditions of the induction motor, when switched on direct it takes from  $\frac{1}{2}$  to 6 times full load current, depending on the design of the machine, but in the case of a toy motor, such as used for a vacuum cleaner no disturbance whatever to the domestic mains should be caused.

JOHN H. P. DE VILLIERS.  
Bearsden, Dumbartonshire.

"DIALLIST" does not deal with the limitations of this type of motor.

Very large numbers of induction motors are in use where the type is applicable. The reasons that it is not even more extensively used are: (1) Separate machines are needed for AC and DC operation; an important point where the apparatus must be inexpensive or of universal application. (2) Starting torque is poor. (3) Speed is not variable over a wide range. (4) Special starting switches must be used on any but the smallest sizes. (5) Power/weight ratio is not so good as in the universal motor. (6) The ratio stalling torque/full load torque is low. Thus for applications needing high speed, high starting torque, wide speed variation or small bulk, the induction motor is inappropriate.

To obtain greater speed by means of gears is hardly practical. The gears would need to be of very high quality, pressure lubricated. Maintenance would be prohibitive. Further, as the power output of a motor depends on the speed, a geared drive would impose a very heavy load initially on a motor of poor starting characteristics.

The commutator motor can be made practically non-radiating by wiring it so that the field is electrically on both sides of the armature. The circuit is: one end of each field coil to a brush, other end of each field coil to a mains lead. The coils then act as effective chokes at the armature frequency and that reduces radiation. Condensers can be added if needed. Earth the frame and keep all condenser leads short.

H. H. JONES.  
Stourbridge, Worcs.

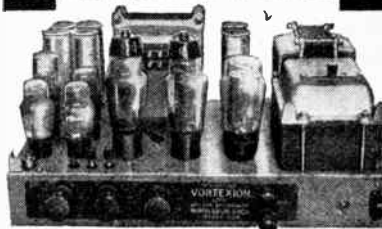

The new Vortexion 50 watt amplifier is the result of over seven years' development with valves of the 6L6 type. Every part of the circuit has been carefully developed, with the result that 50 watts is obtained after the output transformer at approximately 4% total distortion. Some idea of the efficiency of the output valves can be obtained from the fact that they draw only 60 ma. per pair no load, and 160 ma. full load anode current. Separate rectifiers are employed for anode and screen and a Westinghouse for bias.

The response curve is straight from 200 to 15,000 cycles in the standard model. The low frequency response has been purposely reduced to save damage to the speakers with which it may be used, due to excessive movement of the speech coil.

A tone control is fitted, and the large eight-section output transformer is available to match, 15-60-125-250 ohms. These output lines can be matched using all sections of windings, and will deliver the full response to the loud speakers with extremely low overall harmonic distortion.

PRICE (with 807, etc., type valves) £18.10.0

Plus 25% War Increase

MANY HUNDREDS ALREADY IN USE

Supplied only against Government Contracts

**VORTEXION LTD.**  
257, THE BROADWAY,  
WIMBLEDON, S. W. 19.  
Phone: L1Berly 2814

# RECENT INVENTIONS

## FM RECEIVERS

**F**REQUENCY-MODULATED signals are first passed through the initial stages A of a normal superheterodyne receiver, and are then fed in push-pull to the two inner grids of a pentode valve V, the third grid of which is biased to a slightly higher level than the other two. The result is that current through the valve is cut off, except at those times when the FM wave passes through zero. This occurs momentarily twice in each cycle, the valve V then operating to discharge

## A Selection of the More Interesting Radio Developments

this interval are thus absorbed or shunted to ground.

*Standard Telephones and Cables, Ltd., P. K. Chatterjea and D. M. Ambrose. Application date July 24th, 1942. No. 558927.*

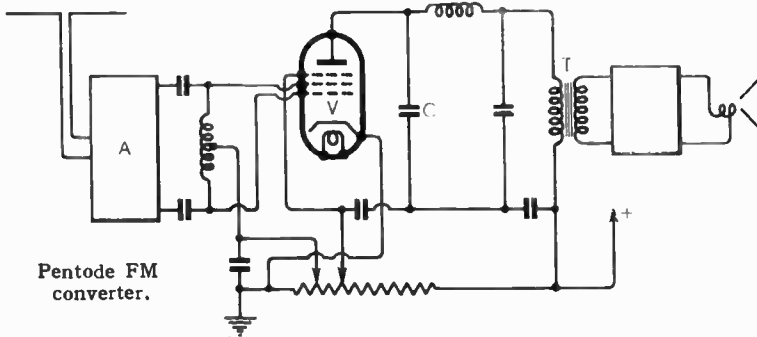

Pentode FM converter.

a shunt condenser C, which is permanently connected to a positive source of voltage through the input transformer T of the loudspeaker.

The rate of condenser discharge thus varies with the original modulation frequency, and the corresponding charging current into the condenser will actuate the loudspeaker. For satisfactory reproduction it is necessary (a) that its conducting periods are shorter than the time-constant of the condenser C and (b) that the time-constant of the condenser charging circuits is greater than the longest period between consecutive discharges through the valve.

The pentode valve can be replaced either by a multivibrator or by a blocking oscillator, provided the time-constants of these devices are adjusted as described above.

*Marconi's Wireless Telegraph Co., Ltd. (assignees of C. W. Hansell). Convention date (U.S.A.) June 17th, 1941. No. 556724.*

## TELEVISION SCANNING

**B**ECAUSE of the high self-inductance of the magnetic deflecting coils and of the transformer coupling them to the saw-toothed oscillator, resonance conditions are liable to occur particularly during the fly-back period of each scanning cycle, and so give rise to undesirable oscillations.

To remedy this state of affairs a hard valve is connected between the chassis or earth and the scanning coils and transformer, including the casual capacities which tend to resonate. The valve is normally biased beyond "cut-off," so that it cannot distort the scanning stroke, but is automatically unblocked during each fly-back stroke. Any parasitic oscillations produced in

primary winding of the aerial coupling transformer and thus damps the signal input to an extent which depends upon its effective resistance, this in turn being controlled by the prevailing temperature of the heating filament.

The latter may be connected to the L1 supply through a variable resistance to give manual control, or it may be coupled to an existing source of AVC.

The "Thermistor" also serves to safeguard a highly sensitive set from the effect of too-powerful signals.

*Standard Telephones and Cables, Ltd., C. T. Scully and L. W. Houghton. Application date June 5th, 1942. No. 557864.*

## AC GENERATORS

**S**YNTHETIC substances are known which show a marked falling off in resistance as the voltage applied to them is increased. This characteristic is applied to generate an alternating or oscillatory current from a DC source, without the use of electron valves or mechanically moving parts.

The principle of the invention is illustrated in diagram (a), which shows a bridge circuit with a "negative resistance" element K, of the kind mentioned, in one of the arms. One diagonal of the bridge is fed from a DC source, the adjustment being such that the potential of the point 2 is higher than that of the point 4, so that

## AERIALS!

**A** SHORT-WAVE aerial with a broad band characteristic consists of two bow-shaped radiators which are arranged to form a loop with one end left open, the other end being "closed" through a coupling condenser. The two opposite ends are joined by two lateral wires, forming a transmission line to the centre of which the main feeders are connected.

A certain asymmetry is introduced by the insertion of a loading condenser nearer to the "open" end of each of the bow-shaped radiators. In addition, the transmission line wires are "crossed" between the centre feed-point and the same open end. The aerial impedance is thus made to appear resistive and capacitive when viewed from the main feeder in the direction of the closed end, whilst it is resistive and inductive towards the open end.

As the signal frequencies vary, the reactances alter in opposite directions, thus maintaining the effective impedance resistance over a comparatively wide operating band.

*Standard Telephones and Cables, Ltd. (Assignees of A. Alford). Convention date (U.S.A.) April 12th, 1941. No. 557942.*

## CONTROLLING SIGNAL STRENGTH

**A** THERMALLY sensitive resistance is connected in series with a receiving aerial to serve as a volume control. The resistance device, known as a "Thermistor," may be designed to have either a positive or negative temperature coefficient. It is conveniently mounted inside a glass tube, with or without a separate heating filament.

In one arrangement, the "Thermistor" is shunted across the

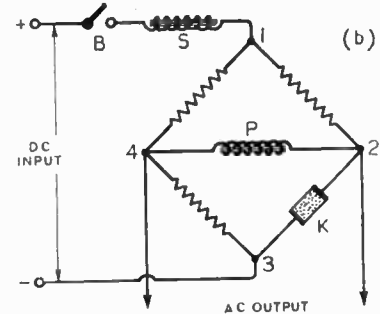
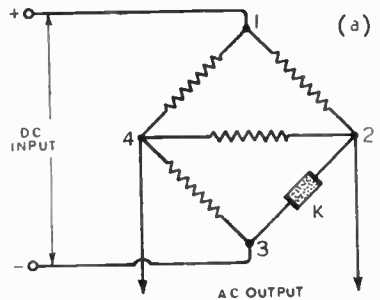

Negative resistance AC generator.

a current flows through 2, 4. Any increase in the DC input voltage will now cause the resistance of K to fall, and so reverse the direction of the current through the line 2, 4.

Diagram (b) shows a circuit arrangement in which the diagonal 2, 4 in-

cludes the primary winding P of a transformer, the secondary S being in the DC supply line. When the switch B is closed, the first surge through P induces a back EMF across S which, as it reaches K, causes the primary current through P to reverse, as explained above. This in turn reduces the voltage across K and so restores the original current through P. The cycle will be constantly repeated, until the switch B is opened.

R. J. Stevens. Application date August 13th, 1942. No. 557342.

**VISUAL TUNING INDICATORS**

"THERMISTOR" is the trade name of a mixture of certain metallic oxides which exhibits a marked change in electric resistance with variation of temperature. The control heat may be due to current passing directly through the mixture, or the latter may be indirectly heated by a separate filament.

"Thermistor" tuning indicator.

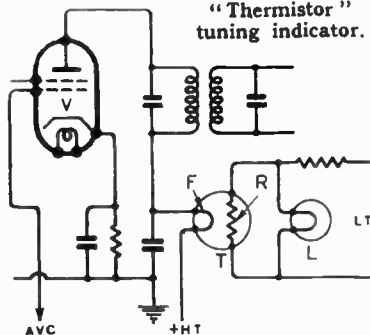

According to the invention a "Thermistor" is used to increase the sensitivity of visual tuning-indicators, and, in particular, to allow an ordinary small incandescent lamp to be used.

As shown, the valve V is the last IF amplifier of the set, and its anode current is passed through the filament of a "Thermistor" tube T, thereby indirectly heating the sensitive resistance R. An incandescent lamp L is inserted, in parallel with the device T, across the usual LT supply.

When the set is correctly tuned the anode current falls to a minimum, so that the heating effect on the element R is low and its resistance is high. The lamp L then takes maximum current and glows brightly. At any "off-tune" setting, the anode current rises, the resistance of R drops, and the indicator lamp is dimmed. Alternatively, the lamp may be connected in series with the sensitive resistance R, the tuning point then being indicated by minimum instead of maximum brilliance.

Standard Telephones and Cables, Ltd., and D. M. Ambrose. Application date June 5th, 1942. No. 557862.

The British abstracts published here are prepared with the permission of the Controller of H.M. Stationery Office, from specifications obtainable at the Patent Office, 25, Southampton Buildings, London, W.C.2, price 1/- each.

The

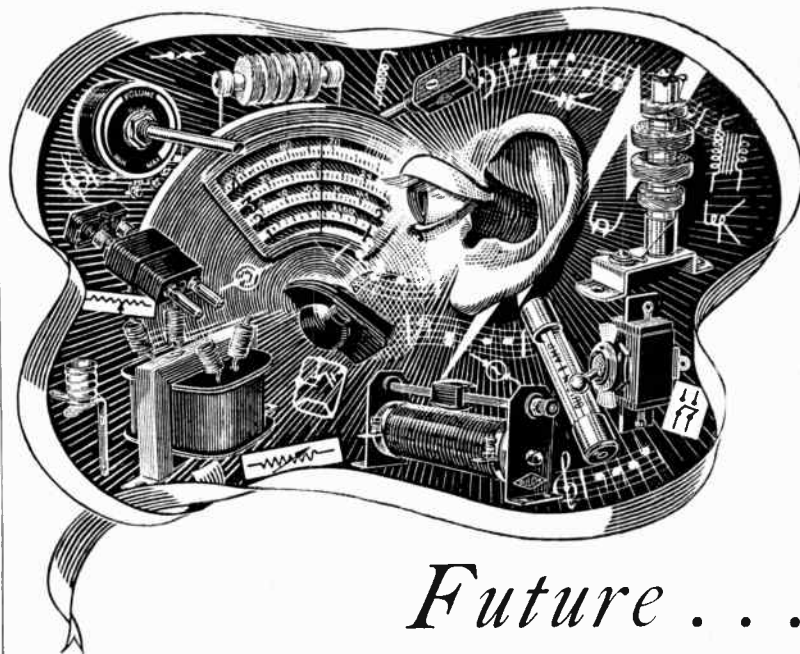

Future . . .

FORWARD in time of war, to a future full of promise. The shape of things to come? Perhaps only dimly seen at present, but great things are in store. And you may be assured that in all phases and in all applications BULGIN RADIO PRODUCTS will make their contribution. Until then, we ask your kind indulgence; orders must quote Contract and Priority Nos.

"The Choice of Critics"



Registered Trade Mark

A. F. BULGIN & CO. LTD., BYE PASS RD., BARKING, ESSEX  
Radio and Electrical Component Manufacturers.  
TEL.: RIPPLEWAY 3474 (5 lines).

## Radiomancy

RADIO has been pressed into the service of men for all sorts of purposes, ranging from its original function of a message carrier to that of a healer of the ills to which the flesh is heir. It has even been used for divining the presence of water; it was pointed out some time ago that the Rhabdomancer's rod, or whatever he calls it, is in reality nothing but a dipole and that USW is in some manner or another at the bottom of the whole business. It will, in fact, probably be remem-

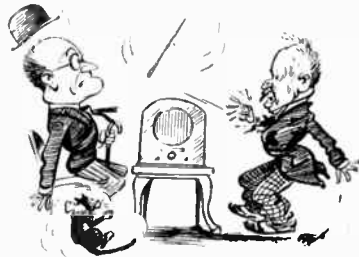

Radio-rhabdomancy.

bered that I myself conducted certain experiments in this matter and got very misleading results owing to the dowsing rod leaping into the air when brought near a loud-speaker, owing to the wetness of some of the B.B.C. programmes.

I see, however, that according to a well-known Sunday journal the latest use to which radio has been put is prophesying the future and so rivalling astrology. "According to a well-known radiologist" (*sic*), says this journal, "the war, or at any rate the German part of it, will end on Friday, October 27th." Nor is this the final wonder of radio science. According to the same journal, I learn that, since the invention of radiolocation, ships are being navigated across the ocean by means of the "Radio Sextant," which takes the place of the old-fashioned sextant in which you looked through a sort of telescope and measured the angle twixt sun and horizon.

The modern radio sextant contains a USW transmitter which shoots out a string of waves at the sun, which hit it and bounce back to you. The beauty of the idea, of course, is that it doesn't matter whether the sun is obscured by cloud or mist provided that you have some rough idea of the part of the heavens at which to aim.

I must confess that this radio sextant idea sounds delightfully simple, and even the fact that it

## By FREE GRID

takes about eight minutes for the waves to get to the sun and another eight minutes to get back doesn't entirely invalidate the idea, as the error due to the quarter-of-an-hour lag is constant and can be allowed for. Nevertheless, there are still one or two snags about the idea which occur to my unromantic mind. The first snag, of course, is our old friend spatial attenuation, and I am wondering how many kilowatts the sextant has to have fed to it. Then, of course, there is the question of getting through the various ionospheric layers. I wrote to the technical correspondent of the newspaper concerned, asking for a little light on these mysteries, but he has taken refuge in the Official Secrets Act and the various Defence Regulations, and I can't get anything out of him.

## Radio to the Rescue

THE instinct to join a queue immediately we see one has become so strong in us that we are apt to tack ourselves on to one automatically, sometimes with extremely embarrassing results. In my own case I have not infrequently fallen in behind a queue of waiting females and wasted much valuable time before being made aware by the titters of my fellow queuers-up that it was no place for a member of my sex, with the result that I have crept shamefacedly away without even finding out what the queue was really for.

In pre-war days it was a frequent habit of mine to take my place in a theatre queue, not because I was unable to afford the luxury of booking a more expensive seat, but for the very simple reason that I almost invariably derived far more pleasure and æsthetic satisfaction from the efforts of the queue entertainers than I did from the far less gifted performers inside the theatre. In fact, I made it an invariable rule to leave the queue as soon as it started to enter the theatre, thereby exciting

on more than one occasion the suspicions of the police, who made it their business to enquire of the remainder of the queue whether any body had lost his wallet or other valuables.

Nowadays, owing to the drastic effects of the military and industrial call-up, more often than not the queue entertainment is provided by a seedy-looking individual operating a dilapidated gramophone or wireless receiver carried in a still more dilapidated pram, notwithstanding any infringement that might be of the rights and privileges of the B.B.C. and the Performing Right Society. But the P.M.G. presumably has no objection to the practice, now that the ban on wireless in road vehicles has been lifted. In any case, is not a pram a pavement vehicle?

It was while reflecting on these matters the other evening after a damp and dismal two hours in a queue that the idea came to me of rationalising and centralising the best remaining talent among the queue entertainers and distributing it *via* the ether. Unfortunately, the B.B.C. refused to be interested in the idea, even when I pointed out that it was a golden opportunity for them to interlard the turns liberally with their own moral uplift stuff, since, of course, the queuers-up would be utterly at their mercy and compelled to listen unless they thought it worth while to sacrifice their places in the queue. That, I was forced to admit, a great many of them might do. My idea, if adopted in the case of all types of

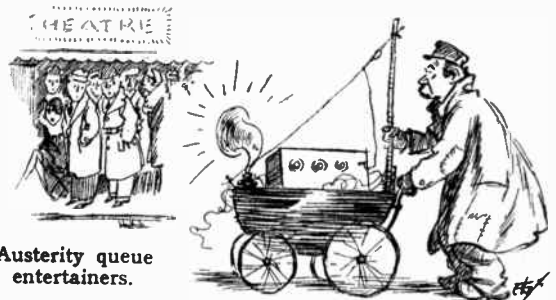

Austerity queue entertainers.

wartime queues, would become so popular, more especially if television were added after the armistice, that it could become an end in itself, queues forming for the sole purpose of enjoying the entertainment. Seats and other amenities would eventually have to be provided, and an entirely new industry would be born, so bringing much new grist to the Chancellor of the Exchequer's mill.





## Magnets

He earns no medals; his name will never make headlines; his way of life is modest and his work unexciting.

But to us he is an individual, a personality; not just a number on the time clock. He is a skilled man — and more, because for years his skill has been allied to the Philips tradition of doing things more efficiently; of making things just that much better.

He melts metals—very special metals which are used for making 'Ticonal'\* permanent magnets of unusual power and unique properties; an outstanding Philips' invention. He is one of the thousands of Philips workpeople who gave you, before the war, the Philips products you knew and trusted so well. His skill is a vital asset to the nation today.

\* Registered Trade Mark.

# PHILIPS



## RADIO ★ LAMPS

## AND ALLIED ELECTRICAL PRODUCTS

PHILIPS LAMPS LTD., CENTURY HOUSE, SHAFTESBURY AVENUE, W.C.2 (24F)

# WHARFEDALE FACTORY SPEAKERS

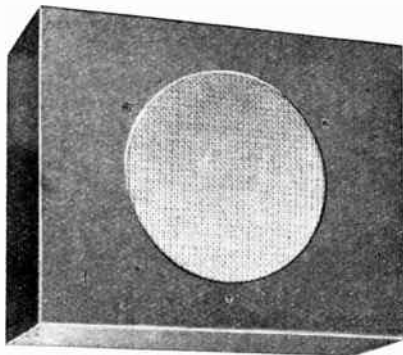

SIZE: 15½" by 12½" by 6½".

DELIVERY 3 to 4 WEEKS for PRIORITY ORDERS ONLY.

With 10" Bronze Unit 65/- Transformer - - - 7/6 extra  
With 10" Golden Unit 95/- Truqual Volume Control 8/6 ..  
Remote Volume Control 17/- ..

## WHARFEDALE WIRELESS WORKS

SOLE PROPRIETOR: D. E. BRIGGS

HUTCHINSON LANE, BRIGHOUSE, YORKS.

\*PHONE: BRIGHOUSE 50.

\*GRAMS: "WHARFDEL."



## FOR THE RADIO SERVICEMAN DEALER AND OWNER

The man who enrolls for an I.C.S. Radio Course learns radio thoroughly, completely, practically. When he earns his Diploma, he will KNOW radio. We are not content merely to teach the principles of radio, we want to show our students how to apply that training in practical, every-day radio service work. We train them to be *successful!*

Special terms for members of H.M. Forces.

-----You may use this Coupon-----

### INTERNATIONAL CORRESPONDENCE SCHOOLS Ltd.

DEPT. 38, INTERNATIONAL BUILDINGS, KINGSWAY, LONDON, W.G.2

Please explain fully about your instruction in the subject marked X

Complete Radio Engineering. Radio Service Engineers.  
Elementary Radio. Television.

And the following Radio Examinations:—

British Institution of Radio Engineers.  
P.M.G. Certificates for Wireless Operators.  
Provisional Certificate in Radio Telephony  
and Telegraphy for Aircraft.

City and Guilds Telecommunications.  
Wireless Operator and Wireless Mechanic, R.A.F.

Name..... Age.....

Address.....

### THE PAST—

In the past, almost a matter of more years than we care to remember, the name "RAYMART" was, to readers of this journal, synonymous with ample supplies of a very wide range of reliable and well designed radio components. Then—WAR.

### THE PRESENT—

Our name is as good as ever, but our supplies for the Public are, unfortunately, at a rather low ebb; you see we, too, are now serving the SERVICES and doing our full share to help the Allied Nations along the road to Victory.

### THE FUTURE—

The future, which will mean so much to you, will also mean a very great deal to us; we earnestly want to again have the pleasure of being of service to our many old friends, and to meet the needs of those who, whilst serving their country, have gained a valuable insight into the realms of radio science. Here's to the future—YOURS as well as OURS.

### A BRIGHT SPOT!

We are fortunate in being able to offer you English and American Valves. We have large stocks. In the case of American Valves, we are in a position to accept WHOLESALE orders.

Please send stamp when enquiring about types available.

# RAYMART

CRAFT A CREED

48, HOLLOWAY HEAD, BIRMINGHAM, I.



*"Plus ça change  
plus c'est la  
même chose"*

\*(THE MORE IT CHANGES,  
THE MORE IT IS THE  
SAME THING)

Although over 95% of Sprague Condensers now being produced are different from those of pre-war days, the primary insulation, the basic dielectric the fundamental processes did not spring full-fledged overnight, but are "the long result of time." Specifications change, the capacitors change to meet them, but always, Sprague Condensers are good Condensers because of the long years of basic engineering behind them.



SPRAGUE SPECIALTIES COMPANY

North Adams, Mass., U.S.A.  
103, Grove End Gardens,  
London, N.W.8.

# SPRAGUE

CAPACITORS KOOLOHM  
RESISTORS

**CLASSIFIED ADVERTISEMENTS.** Rate 6/- for 2 lines or less and 3/- for every additional line or part thereof, average lines 5-6 words. Each paragraph charged separately. Free Day - July issue, first post Friday, June 9th, one day earlier at branch offices. Box Numbers 5 words, plus 1/- Deposit System; particulars on request. No responsibility accepted for errors.

Ode

# Partridge

No. 32

## Summer

Summer looking forward to the Autumn.  
 Summer looking forward to next Spring.  
 Summer saying Hitler's almost finished.  
 Summer wond'ring what July will bring.  
 Summer smiling, wise and most mysterious.  
 Summer talking much, through back of neck.  
 Summer thinking of their post-war problems.  
 Summer working long, while others wreck.  
 Summer wrestling hard with many troubles.  
 Summer feeling tired but won't give way.  
 Summer on their toes all keen and eager.  
 Summer dreaming of old times so gay.  
**SUMMER!** well, it's here—or very nearly!  
 Think not lightly that the Victory's won.  
 Only at the cost of toil and sorrow  
 Can we move from darkness to the sun.

# N. Partridge

Transformer Manufacturers,

76-78, PETTY FRANCE, LONDON, S.W.1. Telephone: A88ey 2244.

# ARMSTRONG SERVICE

Is almost back to normal!

We can now service receivers and return most of them in seven days.  
 One can never tell what the future holds but whilst this happy state of affairs lasts we can also undertake the repair and overhaul of receivers other than own make including American types.

All enquiries should be addressed

to

**ARMSTRONG (Radio Service Dept.)**

WALTERS ROAD, HOLLOWAY, LONDON, N.7  
 Phone: NORTH 3213.

### NEW RECEIVERS AND AMPLIFIERS

**N**EW midget home-made ac radio; any offers?—5, Bodley Rd., New Malden.  
**PYE** radio, £20/8, operates from 6v l.t.—R. K. Wilson, Alnwick. [2696]

**30-WATT** ac amplifiers, precision built instruments, input and output channels to requirements; early deliveries.—Below.

**150-WATT** racks, comprising 5 amplifiers as above intercoupled, fitted for remote control for industrial installations; send for full details and illustrations; complete equipment, including speakers and microphones, etc., available.—Below.

**18-WATT** ac/dc amplifiers, mixing input channels, bass and treble controls, input and output transformers; 15gs.—Below.

**DANCE** and stage transportable equipment, comprising 15-watt amplifier as above, m/c mike, adj. stand, 2 speakers, cables; 36gs.—Broadcast & Acoustic Equipment Co. Ltd., Broadcast House, Tombland, Norwich. [2024]

**41-WATT** Quality amplifiers, 8gs. complete, 200-250v. ac.; s.a.e. for particulars.—John Brierley, 1, St. Paul's Av., Lytham St. Annes. [2752]

**AC/DC** 4-valve M.W. receiver; build the Wizard in an evening! Set of instructions, clear wiring diagram, component layout, theoretical circuit, parts list and prices, 5/- post free; uses British valves, obtainable from us; many equivalents; components sold separately; your queries answered free s.a.e.—Franklin Developments, Weldona, The Avenue, London, N.3. [2625]

**£24/10** only.—New 7-valve "Wireless World" Quality amplifier with tone control stage, 8watts push-pull triode output, price includes super Quality triple cone, 12in permanent magnet speaker with large matched output transformer and all valves; as above but with 15watt tetrode output, £25/10; ideal for realistic reproduction for public address, limited number available.—Bakers Selhurst Radio, 75, Sussex Rd., S. Croydon. Tel. Croydon 4226 for demonstration. [2772]

**H.P. RADIO SERVICES, Ltd.**, offer new Philips 11-valve television chassis, complete power pack and scanning coils, no valves, £12/10, one only; new radio chassis, comprising 7 screened coils, 31 condensers, 30 resistances, 8 valve-holders (octal), one volume control, etc., 29/6; 5-watt a.c./d.c. amplifiers, 3-valve chassis type, £6/10, tested, including three valves; New Crosley 6-valve 2-waveband car radios, all suppressors, etc., included, 16gs.; car radio aerials, telescopic, 19/-; under running board type, 18/6; roof type, 25/-; Rothermel crystal gramophone pick-ups, £3/18/9 (as supplies permit); 2-volt 45-amp-glass accumulators, 11/-; 120v. h.t. batteries, 15/6; Meico moving-coil microphones, 5gs.; Rothermel crystal mike, on table stand, 90/-; Shaftesbury crystal mike heads, chromium plated, 5gs; American GT valves, most types; purchase by post with confidence; carriage paid over £5.—H.P. Radio Services, Ltd., 55, County Rd., Liverpool, 4. Tel. Aintree 1445. Etab. 1935. [2730]

### RECEIVERS, AMPLIFIERS—SECOND-HAND

**R.G.D.** a.c. radiogram, burr walnut; £50.—56, Clayhall Ave., Ilford, Wanstead 3488.

**AMPLIFIERS**, specialist built, 12 watt, less o.p. trans, £12/10; 5-watt, complete, £5/10. Cornwall—Box 112. [2686]

**H.M.V. Console** All-world rad., telev., model 1850; also Philco car radio, 12v; no dealers.—Tel. SPR. 1911, evenings. [2694]

**FERRANTI** Arcadia, long and medium waves, 4 valves and rectifier, good working order, little used; £14.—Box 3118. [2709]

**358X** communication receiver, as new; also 70w. amplifier, Taylor layout; also Brush crystal hand-mike.—Offers to Box 3123. [2731]

**HALLICRAFTERS** SX-17 communications receiver with loudspeaker, 500 kc/s to 63 Mc/s, 100-230 volts a.c.—Offers to Box 3126. [2742]

**W.W.** Quality amplifier and Rola G12 P.M. speaker, unused, £30; E.M.I. grammo. motor, £3/10.—Fowler, 209, Darkes Lane, Potters Bar, Middx. [2721]

**MURPHY** A40C 14-valve luxury console, 12 watts P/P, high fidelity, 10 wave-band, V/selectivity, automatic tuning correction, etc., perfect.—Offers to Box 3130. [2743]

**NATIONAL** high frequency receiver, type H.R.O., with 6 coils, frequencies ranging from 48M/cs to 30M/cs, with power packs for 6v dc and 110v ac, with auto-transformer for 200-230v ac.—31, Horn Lane, Acton, W.3. Acorn 0653. [2703]

**OWNER** of Senior HRO, complete with 4 coils and power pack, wishes to exchange this receiver for a Hallcrafters SX.28 or a Hammarlund Super-Pro; cash adjustment either way.—Reply Mr. Bee, 25, The Grampians, Western Gate, London, W.6. [2630]

Advertisers and buyers are reminded that under Defence Regulations 1939, Statutory Rules and Orders 1940, Number 1689, a permit (T 99 G) must be obtained before sale or purchase of certain electrical and wireless apparatus, particularly such valves and apparatus as are applicable to wireless transmission.



Illustration shows a 125-watt standard model.

**SOLON Electric**  
**SOLDERING IRON FOR INDUSTRIAL USE**

**W. T. HENLEY'S TELEGRAPH WORKS CO. LTD.**  
 Engineering Dept., Milton Court, Westcott, Dorking, Surrey

## RADIO SPARES

**MAINS TRANSFORMERS.** PRIMARIES, 200/250v Secondaries 250-0-350v. Type 80, 80 ma., 4v. 5s. 4v., 2ja., 32/6. Type 100ma., 4v., 6s., C.T. 4v. 2ja., 33/9. Type 86, 120ma., 4v., 5s., 4v., 2ja., 36/-. Type 91A, 120ma., 6.3v., 6s., 5v., 2ja., 36/-. Type 200A, 200ma., 4v., 6s., 4v., 2ja., 42/6. 400-0-400 Rec., Type 493, 150ma., 4v., 6s., 4v., 2ja., 39/6.

**TRANSFORMER BOBBINS.**—H.M.V. Model Nos. 440, 512, 542, 1103, 1300. Marconi Model Nos. 262, 372, 286, 288, 878, 883. Philco, Model Nos. 444, 537, 551. Ekco, Model Nos. AC71, 85, AW108. Murphy, Model Nos. A24, 25, 30, 34, 35. Bush, Model Nos. 8UG52, 61, PB51, 63, 63, 73, AC7. Ultra, Model Nos. 25, 44, 48, 50, 66, 115. G.E.C., 4v., and 4v., 4v. and 13v., 6.3v. and 5v. These bobbins are very well made and are exact replacements 24/-.

**MAINS DROPPING RESISTORS.** 2 amp., 950 ohms, 6/9. 3 amp., 600 ohms, 6/-. Fitted with sliding clip and provided with feet for chassis mounting.

**OUTPUT TRANSFORMERS.** Power, Pentode, Class B and Q.P.F., 11/-. Power, Pentode, 25/30 ma., Midget, 9/6. Power, Pentode 12 ma., Midget, 6/9. Heavy Duty Pentode, 100 ma., 12/6.

**DRIVE TRANSFORMERS.** Class B, 9/-. Bobbins only, 6/9.

**LINE CORD.** 3-way, 3 amp., 185 ohms, per yard, 4/11. 2-way, 2 amp., 185 ohms, per yard, 4/11.

**CHOKES, SMOOTHING.** 20 henries, 100 ma., 12/6. 11 henries, 70 ma., 9/6.

**SPEAKERS.** Collection, Rola, etc., Sin. P.M. with multi ratio transformer, 30/-. Without transformer, 24/-. Orders accepted by post only and those of 10/- or less should be accompanied by cash. Please include postage with order. PRICE LIST, 2d. stamp.

**H. W. FIELD & SON**  
 Colchester Rd., Harold Park, Essex.

**Mail Order Component House  
WAVEBAND RADIO Ltd.**

**VOLUME CONTROLS** with switch; fine stock. 2 meg, 1, 1/2, 100,000, etc., 5/9 ea. Less sw. type, 3/6. Very fine **MAINS TRANSFORMER** offer: 350-0-350 v. 80 m.a., 6.3 v. 3 a., 5 v. 2 a. (or 4 v. British type), 37/6. 75 w. **AUTO TRANSFORMERS**, 27/6. O.P. Trans., multi ratio, 7/6. Class "B" Q.P.P. 7/6. **HEAVY DUTY CHOKES**, 30 hen. 120 m.a. 200 ohm, 14/6. Replacement **BOBBINS** for 4 v. or 6 v. Transformers, 18/6. **Phillips AERIAL COILS**, 6/6. Two yard length Metal Braided Slewing, 2/-.

**NEW MODEL Voltage Droppers** with fixing feet; 800 ohm 3 amp., 5/9. 2 amp. 1,000 ohm, 5/-. **SILVER MICA Condensers**, packets 12 asst'd, 5/6. American 100 v. Razors, can be used on 200-250 v. with a WAVEBAND special RR/88 Razor resistor, 7/6.

**TUBULAR Phillips wire end paper Condensers**; Service Kit of 50 FOR ONLY £1. "SERVISOL" Switch Cleaner, 8-oz. tin, 5/-. "Servisol" Cabinet Cleaner, 3 bottles in carton, 3/-. **NEW GUN TYPE RADIO Solder Iron**, with pointed bit, 14/6. Set of **TRIMMER TOOLS**, 14 box spanners and screw drivers, in leatherette case, 30/-. Bakelite **BELL Trans.**, 5/6. **NEW G.P.O. Type TABLE MIKE** with trans. fitted, 7/6. **SPADE TERMINALS**, 5/6 doz. **CROCODILE CLIPS**, 4/6 doz.

**TECHNICAL PUBLICATIONS.** We wish to thank "Wireless World" readers for their letters of appreciation.

Amplifier and P.A. Manual, 2/3. 66-Page Radio Valve Manual, 3/9. Radio Circuits, 2/3. Direct Disc Recording, 2/3. Service Signalling Manual, 1/3. "RADIO INSIDE OUT," a complete Guide Book for Amateur and Professional, 4/9. Manual of Science, Heat, Light, Sound, 2/3. Tool Makers Manual, 1/3. Full set of these 8 Service Books sent for 18/6 only, if you quote "W.W.1644," when ordering.

EXCLUSIVELY MAIL ORDER.

**WAVEBAND RADIO LTD.**  
Egyptian House, Piccadilly, London, S.W.1

**MORSE CODE TRAINING**

There are Candler Morse Code Courses for Beginners and Operators.

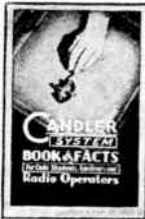

SEND NOW FOR THIS FREE "BOOK OF FACTS" It gives full details concerning the following Courses :-

**JUNIOR Scientific Code Course for beginners.** Teaches all the necessary code fundamentals scientifically.

**ADVANCED High-speed Telegraphing for operators** who want to increase their w.p.m. speed and improve their technique.

**TELEGRAPH Touch Type-writing** for those who wish to become expert in the use of the typewriter for recording messages and for general commercial uses.

Code Courses on Cash or Monthly Payment Terms.

**IRREFUTABLE EVIDENCE**

of the value of the Candler System of Morse Code Training is given in the "24 extracts from students' letters," included with every "Book of Facts."

**COUPON**

Please send me a Free Copy of Candler "Book of Facts."  
NAME .....  
ADDRESS .....

Post Coupon in 1d. unsealed envelope to London Manager  
**THE CANDLER SYSTEM CO. (Room 55W),**  
121 Kingsway, London, W.C.2  
Candler System Co., Denver, Colorado, U.S.A. (644)

**1939 Delco 7-valve superhet, self-change** radiogram, 16-2,000 metres, English walnut cabinet. After 6 p.m., Ric. 3880. 27, Lauderdale Drive, Petersham. [2714]

**QUALITY amplifier**, dual output stage, 8 or 20 watts, class A, high gain dual mixing input, adjustable bass boosting, negative feedback, optional 20DB, contrast expansion, separate power supply chassis with 100 mA, spare for other gear, large matched p.m. speaker, medium-wave radio unit, handsome black cracked rack and panel construction, used five hours only, owner now off mains; £26, or nearest offer.—Box 3131.

**Wanted**  
V.H.F. receiver, National 1-10 or similar type wanted.—Box 3113 [2689]

**WANTED** Emerson COLW or similar midget superhet.—Partica to Box 3127.

**WANTED**, Ever-Ready all-dry battery, portable; state price and condition.—Box 3136. [2761]

**HALLICRAFTERS** S.29, Sky Traveller; state price wanted.—Bolt, 62, Hamilton Rd., Alford, Lincs. [2732]

**STRAIGHT** receiver for W.W.Q.A., or tuning components for same.—Aldridge, 38, Brookside South, East Barnet, Herts. [2739]

**WE** offer cash for good modern communication stands, all-wave receivers.—A.C.B. Radio, 44, Widmore Rd., Bromley. [1541]

**EXPERIMENTER** in R.A.F., urgently requires a communication receiver; state price and full particulars to Warrant Officer Parvin, c/o G.P.O., Bampton, near Bridlington.

**WE** buy at your price, used radiograms, radios, amplifiers, converters, test meters, motors, pick-ups, all radio and electrical accessories, etc.; we call and pay spot cash.—Tel. Eust. 1966, or Ger. 4447. University Radio, Ltd., 238, Euston Rd., N.W.1. [2536]

**LONDON CENTRAL RADIO STORES** will pay good prices for receivers, radiograms, amplifiers, dynamos, converters, test equipment, electric gramophone motors, and all radio and electrical accessories.—London Central Radio Stores, 23, Lisle St., London, W.C.2. Gerrard 2969. [9836]

**NEW LOUDSPEAKERS**  
Broadcast P.M. loud-speakers, 3 models: 12in 12watt 15,500 lines, 1 1/2in dia, voice coil; 12in 25watt 18,000 lines, 1 1/2in dia, voice coil; 15in 40 watt 18,000 lines, 2 1/2in dia, voice coil; machined and precision built instruments, Ticonal magnets, detachable diaphragms, die-cast chassis, uniform response, superior standards in fidelity, sensitivity, accuracy, tonal quality, appearance and finish; prompt deliveries; specifications and illustrations upon request.—Broadcast & Acoustic Equipment Co., Ltd., Broadcast House, Tombland, Norwich. [2537]

**£5/15** only.—Brand new Baker super magnet speaker with triple cone, manufactured by Bakers Selhurst Radio, the pioneer manufacturer of moving coil speakers since 1925, wide frequency range, even response, ideal for quality reproduction, fitted with magnet having exceptionally high flux density in the air gap, suitable for public address equipment when quality reproduction is first consideration; send 2/6d. stamp for leaflet giving details of above and constructional details of a new acoustic chamber designed to extend loud speaker frequency range; also constructional details of an infinite baffle cabinet; every music lover interested in realistic reproduction should write for leaflet.

**£8/15** only.—Brand new Baker super power wide cinema permanent magnet speaker with 18in triple cone of new design, giving wide frequency response free from objectionable resonances; speech is clear and natural and music is reproduced with exceptional realism; fine engineering job, extremely sensitive, ideal for public address equipment when power handling capacity plus realistic reproduction is required.—Bakers Selhurst Radio, 75, Sussex Rd., South Croydon. Tel. Croydon 4226 for demonstration. [2773]

**LOUDSPEAKERS SECONDHAND**  
**BAKER'S** 18in P.M. speaker, list £8/15, unused; offers.—Gregory, 51, Higher Rd., Urmston, Manchester. [2726]

**EPOCH**, 14in, perfect, £9; 2 Broadcast 12in MC/PM, used once, £20.—Wells, Church St., Kenninghall, Norwich. [2718]

**Wanted**  
**GOODMAN** auditorium speaker, 10in or 12in.—Write Box 3116. [2707]

**VOICET** speaker, with or without corner or P.A. type horn, required urgently; your price paid without quibble.—49, Buttermere Rd., Bradford, Yorks. [2763]

**HARTLEY-TURNER** duodes, energised type only, preferably 2,500 ohms, field coil approx.—H. J. Leak and Co., Ltd., 470, Uxbridge Rd., W.12. Tel. Shepherds Bush 5628.

**DYNAMOS, MOTORS, ETC.**  
**E.D.C.** rotary converter, 250v dc to 250v 50c. 1.09 amps, no cover; £8.—Potters Bar 3554.

**LASKY'S RADIO 370, HARROW RD., PADDINGTON, W.9**

(Op. Padd. Hospital). Phone: Uxningham 1976

**THIS MONTH'S SPECIAL OFFERS**  
24 assorted Condensers, consisting of 8 mfd. 500 v., 4 mfd. 200 v., 32 mfd. 350 v. (can type), 2 mfd. 500 v., 1 mfd. 500 v., 5 mfd. 250 v., .25 mfd. 500 v., .05 mfd. 500 v., 1 mfd. 350 v., .01 mfd. 350 v., etc., etc. All for £2. Post free. **SATISFACTION GUARANTEED.**

**SPECIAL BARGAIN FORSET BUILDERS**  
Grey cellulosed steel radio chassis, including 27 mica condensers, 30 resistances, tubular condensers, 8 mfd. 500 v. condenser, 8 octal valve holders, volume control and screened coils, with trimmers, etc., etc. Size 8in. x 12in. x 1 1/2in. Price £1 9s. 6d., plus postage.

Servisol at 5/- per tin, Systoflex, assorted, at 2/3, 2/6 and 3/- doz.

Volume Controls, 1/2 and 1 meg. less switch, at 2/9 each, with switch, 5/9 each. 2 and .3 amp. mains droppers, 4/9, 5/9 and 7/6 each. .3 amp. 3-way line cord, 70 ohms, per foot, best quality, at 5/9 yd.

Slow Motion Dial and Drive Escutcheon type, 2/6 each. Resistors, assorted, Kit of 48 1/2, 1/4 and 1 watt at 30/- lot.

Smoothing Chokes, Midget type, 650 ohms 60 mA., 6/6 each, larger type 180 ohms 160 mA., 15/6 each. Medium and long wave coils with reaction at 10/6 per pair. Universal Speaker Transformers, 7/6, class B and Q.P.P. driver and output types, 9/6. Pentode S/Trans., 5/9 each. Solder, Resistances, tin copper wire, soldering irons, knobs, toggle switches, 2 and 3 gang condensers, etc. **SPEAKERS.** Rola P.M., 5in., 19/6; 6 1/2in., 21/6; 8in., 23/6 each. Goodmans 3 1/2in. P.M., 27/6; 10in., 39/6 each. Celestion 10in. P.M., with Pentode Transformer, 45/6.

In stock over 5,000 new boxed English and U.S.A. mains and battery valves. Send 1d. for our lists of valves, mains transformers, etc.

Send us your requirement C.O.D., BUT CASH WITH ORDER PREFERRED.

**COVENTRY RADIO**

COMPONENT SPECIALISTS SINCE 1925.

A FEW ITEMS FROM OUR LATEST LISTS

Oak, 2 wafer, 4 position switches ..... 3/6

Switch Plugs, 5 amp. 2-pin ..... 1/-

Sleeving. All colours. 1 1/2 mm. doz. yds. 2/6

Output Transformers. Mains Pentode ..... 7/6

I.F. Transformers. 1st grade, 465 kc. ... 7/6

Mains Transformers, 4- or 6-volt ..... 29/6

Coil Formers. Small Paxolin, 3d. per doz. 2/6

Condensers, Resistors, "P" Coils, Valves, Valve Holders, Wires, etc., etc.

Send 1d. Stamped Envelope for Latest Lists.

Prompt Service. Satisfaction Guaranteed.

**THE COVENTRY COMPANY,**  
191, DUNSTABLE ROAD, LUTON.

**Cabinets?**

Increased production facilities enable us to give immediate attention to orders for urgent requirements and we are now in a position to accept further contracts or sub-contracts for Government work.

We specialise in **AMPLIFIER and EXTENSION SPEAKER CABINETS**

All enquiries should be accompanied by Priority No.

**HIRSH & HYAMS, LTD.**  
Cabinet Manufacturers,  
93, Hackney Road, London, E.2. Bish.4012

**WANTED**, rotary converter, 110 volts dc to 230 volts ac.—W. E. Dixon (Ripon), Ltd., Ironmongers, Ripon. (2692)

**E.D.C. rotary converter**, 240v dc/230v ac, 0.78 amps, makers' sound-proof cabinet, filters, etc.; £17/10.—Box 3121. (2720)

**E.D.C.**, 11volts d.c. input, output 500v d.c., 80ma, with interference suppression, sprung mounted; £5/10.—Henry's, 5, Harrow Rd., Paddington, W.2. Pad. 2194. £17/78

**ALL types of rotary converters**, electric motors, battery chargers, petrol-electric generator sets, etc., in stock, new and second-hand; supplied against priority orders only.

**WARD**, 37, White Post Lane, Hackney Wick, E.9. Tel. Amherst 1393. (1988)

**ELECTRADIX** dynamos and motors at bargain prices, dynamos, ht and lt G.E.C. double current, 8v and 600v, weight 17lb, 37/6, pkg. and carr. paid; supplied Eng. and Wales only; refund 5/- on returned cases; D.C. motors, 1/5th hp and 1/4hp do motors enclosed, silent, 220 to 250v, 1,500 revs, double-end 1/2in shaft, first grade, make guaranteed, 1/5th hp, £3/10 each; 1/4hp, £4 each; all carr. paid, Eng. and Wales; others in stock.—Electradix, 214, Queenstown Rd., Battersea, London, S.W.8.

**Wanted**

**WANTED**, rotary converter, 220 dc to 230 ac, 50 cycles, 140 watts.—Box 3115.

**WANTED**, rotary converter, any size.—Hull, 221, City Rd., London, E.C.1. (2428)

**TEST EQUIPMENT**

**A.M.E.R.** radio test equipment for sale, s.a.e., list.—Box 3128. (2745)

**VOMETER** Universal, accurate; best offer secures.—Box 3122. (2728)

**OSCILLATOR**, Avo all-wave, mains model; new; offers; s.a.e.—Box 3129. (2747)

**COSSOR** double beam c.r. tube, new; offers.—Smedley, North End, Yatton, Som. (2740)

**36 range Universal Avometer**, 12gms. or near offer.—G.—5JV, 198, Harrow View, Harrow, Middx. (2720)

**COSSOR** oscillograph, Model No. 3295, in perfect condition; offers?—Napier's, 127, Prestwick Rd., Ayr. (2723)

**TEST** rack, incl. sig. gen., valve voltmeter, universal bridge, etc.; also 8in c.r. tube.—Details from Green Shutters, Warren Rd., Worthing. (2755)

**MILLIAMPMETERS**, 0.1 ma, etc., a few high-grade instruments available; reasonable prices.—H.P. Radio Services, Ltd., 55, County Rd., Liverpool, 4. (2789)

**WESTON** analyser, model E772, with carrying case 1.900 o.p.v., perfect, new condition; best offer over £20.—Ralph, 16, Stokes Rd., Purbrook, Portsmouth, Hants. (2771)

**METERS**, Weston, Ferranti, Elliot, etc., Ferranti transformers, chokes, AFCS, etc., condensers, valves and other gear.—Tel. Mac 3138, 100, Manor St., S.W.4. (2760)

**TESTSCOPE**, indispensable to radio service engineers; makes 20 lists; interesting booklet on request; from all wholesalers or direct; send for leaflet "R.1."—Runbaken, Manchester. (2702)

**VOMETERS**—Model 7, £19/10; £10, £17/10; Uni., £8/10; D.C., £3/10; good stocks for immediate release to those holding Government priority contracts only, and H.M. Services. Callers only; no correspondence possible.—Judge, 676, Romford Road, Manor Park, E.12, Ilford 2066. (2640)

**COSSOR** 3343 ganging osc., f.m., a.m., r.f. and audio and 3332 oscilloscope, perfect, £35; large Evershed 500v megger, in case, as new, £22; Ferranti flush 100 and 150ma fused m.c. meters (10ma without shunt), 32/6 each; Osram 4081 2 1/2in c.r. tube, with base, 1 G.T. 1b and 2 G.T. 1c triodes, new, £6/10.—Hall, 10, Pickmere Av., Blackpool. (2777)

**UNIVERSAL** Avimeter, £8/15, new; Ferranti 2-range Grade 1, m/c voltmeter, 0.200, 0.400, £2; 0.5 ma Turner milliammeter, £1/10; 0.100 ma, G.E. milliammeter, £1/10; quartz crystal, in mount, 154/4 kcs, £1; condenser (var.), 0.300 pf, Grade 1, hand-made instrument, for bridge, etc., 10/-, or offers.—Scott, 34, Clarendon Rd., W.5. (2750)

**Wanted**

**HUNTS** capacitor analyser, or similar.—164, Cromwell Rd., Workborough. (2713)

**COILWINDERS** (per National importance); state make, type, price, Box 3135.

**OFFER** of £15 for Hunts Capacitor Analyser.—Hughes, 6, St. Tudwals Terrace, Pwllheli. (2746)

**VOMETER** and Universal Avometer, new or second-hand, provided latter in perfect order.—75, Bennett's Way, Shirley, Croydon, Tel. Spring Park 2345. (2766)

**METER** wanted urgently, Booton 160-A Q meter or other equivalent; this instrument is required for work of urgent national importance; a good price will be offered for same.—Reply Box 3120. (2710)

**EX-SERVICEMAN** urgently requires universal meter; good price given for first-class instrument.—Box 3132. (2754)

**ELECTRADIX**

**PETROL ELECTRIC PLANTS.**

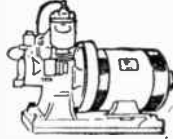

Pelopone or Stuart 500-watt cyl. 2-stroke, water-cooled self-oiling engine; mag. ign. coupled to 50/70 volts, 10 amps. shunt dynamo, 1,000r.p.m. £42. 3 kW. ASTER 4-Cyl. W.C. Engine. Coupled to 100/150v., 25 amps.

Crompton D.C. Dynamo. 4 1/2 kW. AUSTIN. 4-cyl. water-cooled Engine, mag. ignition and 110 volts 25 amps. Dynamo, horizontal Twin Petrol A.B.C. engine, fan-cooled, coupled 1 1/2 kW. D.C. dynamo 50/70 volts 25 amps. mag. ignition.

PETROL ENGINES. Almost new; twin cyl. Douglas, fan-cooled, governed, mag. ignition, light weight, 2 1/2 h.p. £25.

POWER TRANSFORMERS. 150 watt Foster, 400 cycles, 230 volts to 15 volts C.T., 10 amps., £3. 500 watt Foster, 440 volts 50 cycles to 110 volts, 5 amps., £4 15s. 1 kW Powquip, 250 volt 50 cycles to 50 volts, 20 amps., £9. 1 kW Ferranti 100v. 50/100 cycles to 10,000 volts, £8 10s 2 kW. Foster, 50 cycles, 200/230 volts, 4,000 volts, £9 10s. 3 kW Metvick, 400 volts 50 cycle to 600 volts, oil, £9 10s. 4.3 kW Foster, 400 volts 50 cycles to 60 volts to 72 amps., £12.

**DYNAMOS—MOTORS—ROTARIES.**



For essential and experimental work, permit free. Fine modern quarter-horse D.C. motors, 200 to 250 volts, enclosed, drip-proof, silent bearings, flange or base fixing, double end shaft, 1/2in. dia., 1,450 revs.; size, 7 1/2in. x 7in.; weight, 35 lbs. Compound. We fully guarantee. 1/5th h.p., £3 10s. 1/4 h.p., £4. Larger powers in stock. State wants.

WIND DRIVE DYNAMOS, slow speed, 6 or 12 volt. Details and price on application. New 1-cyl. Magnets, 65/-.

SUNDRIES. Vee Pulleys for 1/2in. belt, turned steel 4in. x 4 1/2in., 4/6 and 5/-. Motor Flexible Couplings for 1/2 h.p. and 1/4 h.p., 6/- each. Endless Belts, vee or flat, 5/6 each. 4 wing Fan Blades, 1/6. Liquid Level 5in., for motor shaft, 1/6. Liquid Level Indicators with float geared to watch-dial panel gauge, 9in. rise and fall, 7/6. Battery Charge indicators, Mentor thermal type signal light, 2 1/2in. dial, flush panel, 6 volt and 12 volt, 5/- each. Horseshoe Magnets, permanent steel, all sizes, 3/6 to 4/6. Terminal Covers, A.M. bakelite with two securing screws. Domino size, 9d. each or 7/6 doz. H.M.V. Resistors, glass cased, wire ends, 1 watt, .01, .025, .05, 1/2-er set of 3 or 2/6 doz. Multiple Connection Strips of soldering tags, telephone type moulded mounting, in 80 or 100 ways, at 3/6 and 4/- each. G.P.O. Plugs, 2/- each. Panel G.P.O. Jacks, 1/6 each. Small Solenoids, "Gemi" 6 volts 1 1/2 amps., iron-plunger, 6/6. Electric Counters to 10,000 revs., G.P.O. 5/6. Field telephone Cable for emergencies, 1/2 and 1/4 mile drums.

REORDER PARTS. Spare parts, new, Chart Drum and Clips, 5/6. Magnetic Clutch, 6 volts, complete, 25/-. 9in. Traverse Shaft, 4in. threaded 120 to inch with bearings, 12/6. Stylus, with carriage rods and brackets, 7/6. 5-pin plugs, with panel socket and cords, midget type, 4/6 pair.

CONDENSERS. Ultra Short Wave variable air condensers, 16 m.mfd. Troluit insulation ball-bearings. Surplus to a Govt. contract and new, 5/-.

CAMBRIDGE TOWNSEND BUZZERS. The highest note and smallest Buzzer made, used by Government on wave-meters, ample platinum contacts, 10/-. Other Buzzers: Practice, bakelite-cased, 3/6. Square metal-cased buzzer, 7/6.

CRYSTAL SETS, are valveless radio receivers requiring no batteries. Mark III ex R.A.F. double detector, 85/-. The Wall Nut for shelter or table, 42/-. Victory Pocket bakelite set, 35/-.

For other Bargains see previous advertisements of

**ELECTRADIX RADIOS**

214, Queenstown Road, Battersea, London, S.W.8

Telephone: MACaulay 2159

**VOMETER** or Minor, Taylor oscillator, valve tester, megger; bankers, Lloyds—Partics., prices, Ramage, Bigby Rd., Brigg.

**NEW MAINS EQUIPMENT**

0-350 4v 4a, 4v 2a c.t., 222/30/50 input, 30/-; auto 250-110, 100 watts, fixing feet, 30/6.—33, Manley Rd., Sale, Manchester. (2748)

**VORTEXION** mains transformers, chokes, etc., are supplied to G.P.O., B.B.C., L.P.T.B.; why not you? Imitated but unequalled; orders can only be accepted against Government contracts.

**VORTEXION**, Ltd., 257, The Broadway, Wimbledon, London, S.W.19. Lib. 2814.

**MORSE EQUIPMENT**

**MORSE** inker, paper tape record, clockwork drive, Siemens; £6, offers.—32, St. Johns Crescent, Harrogate. (2725)

**MORSE** practice equipment for class-room or individual tuition; keys, audio oscillators for both battery or main operation.—Webb's Radio, 14, Soho St., London, W.1. Tel. Gerrard 2089. (2291)

FOR sale, 6 clockwork morse inkers, £12 each; 1 3-stick Wheatstone perforator, £10; several single and double current glass top P.O. relays, £2 each; morse practice sets with platinum key contacts, tuning fork buzzers, telephone terminals, etc., mounted on polished wood boxes, new condition, £5 each.—Whale, The Grove, Brompton Av., Colwyn Bay. (2699)

**GRAMOPHONE AND SOUND EQUIPMENT**

**GAMBRELL** Novotone tone compensator, as new, £2/15; wanted, 6N7G, preferably new.—Lewis, 158, Maidstone Rd., Rochester.

**RIBBON** microphone, brand new, with R transformer, perfect condition; 11gn.—Write, L. Norris, 148, South Esk Rd., Forest Gate, E.7. (2734)

**COILS** for filters, tone controls, etc., all types of transformers for "W.W." circuits.—R. Clark, 30, Langland Crescent, South Stanmore, Middx. (2570)

**RECORDING** engineer offers consulting service for disc-film-tape, etc.; advice, diagrams; tests and reports; general design and information all aspects of sound recording.—S.a.e. with enquiries BM/DFAD, London, W.C.1.

**Wanted**

**RADIOGRAM** cabinet; also motor; good condition essential.—Box 3124. (2733)

**AUTO** change or ordinary gram. unit.—Partics., price, Rundle, Betchworth, Surrey.

**WANTED**, gramophone turntable and pick-up, a.c.—J. and S. Farr Nottingham.

**H.M.V.** Hyper-sensitive or Telefunken TD1001 pick-up required, in good condition, urgently.—Box 3133. (2757)

**AUTOCHANGE** or turntable and pick-up complete, 240v ac, suitable for mounting in radiogram.—Write Box 3117. (2708)

**WANTED**, high quality moving coil pick-up and transformer.—Price, make and full details to Hodson, 83, Fecitt Brow, Blackburn. (2768)

**CABINETS**

**WALNUT** radiogram cabinet for sale, size 5in high x 25in wide x 18in; best offer over £10 secures.—Box 314. (2700)

**COMPONENTS—SECOND-HAND, SURPLUS RADIOSALES.**

BCM/Ses 9, London, W.C.1, offer (post extra) —

**RESISTANCES**, all popular valves, 1/4 watt, R. 4d.; 1/2 watt, 6d.; 1 watt, 9d. each.

**CONDENSERS**, tubulars, 0.0001 to 0.005 at 9d., 0.01 to 0.05, 1/-; 0.1 at 6d.

**VALVE-HOLDERS** (paroxlin, chassis), octal 7- and 9-pin at 9d., 4- and 5-pin at 6d.

**VOL. controls**, 5,000, 10,000, 25,000, 4 1/2 m.m., 1 m.m., without switch 3/6, with 4/6.

**MAINS** dropper, resistors, 1,000 ohm 2/6, 5 amp, 4/6; 750 ohm 0.3 amp, 5/6; all with sliders. (2756)

**LONDON CENTRAL RADIO STORES**—See our displayed advert., page 4, this issue.—London Central Radio Stores, 23, Lisle St., London, W.C.2. Ger. 2969. (2359)

**EX-G.P.O.** slide cutters, ex-G.P.O. long-nose pliers, insulated handles, slightly used, but as new, 18/6 6 pairs, 36/- doz. pairs, post paid; sample pair 4/-, post paid.—A.D.S. Co., 261-35, Lichfield Rd., Aston, Birmingham, 6.

**ALL** radio enthusiasts will find much to interest them; send 1d. stamp for latest list, or call at Berry's (Short Wave), Ltd., 25, High Holborn, W.C.1 (Tel. Holborn 6231).

**TRANSFORMERS**, 100 watts, 110-210, 230, 250 volts (step up, step down), 27/6 each; limited number; cash with order or c.o.d.—London Sound Laboratories, Ltd., 40, South Molton Lane, Brook Street, London.

It would be an exaggeration to say we have everything in radio, but we have nearly every valve, resistance, condenser, etc.; pay us a visit, it will save you a lot of time.—Berry's (Musical), Ltd., 10, London Ed., Camberley, Surrey. (2522)



## TRANSFORMERS

All our standard models are in production. The demand is heavy—we ask your kind indulgence in event of delay—every effort is being made to expedite orders promptly.

### THIS MONTH'S ATTRACTIONS

#### CARBON RESISTORS.

An extensive range of values are offered in colour coded,  $\frac{1}{2}$  and 1 watt resistors, 5/-, 6/-, 8/6 doz.

#### CONDENSERS.

Paper tubular types, exceptionally good quality, mostly 450 volt working, all sizes up to .5 mfd. From 6/- to 12/6 doz.

#### MICA AND SILVER MICA.

Eighteen different capacities up to .01. Postage stamp mics from 6/- doz. Silver mica, 3/6 doz.

#### SPEAKERS, P.M.

Eight inch P.M. with Transformers, 29/6.  
Six inch P.M. less Transformers, 21/-.  
Ten inch 6 watt with Transformers, 35/-.  
Ten inch, 2,000 ohm fields with Transformers, 35/-.

#### RECTIFIERS.

Metal rectifiers for eliminators and power packs, 200 volt 100 m.a., 25/-.  
Transformers to suit, 25/-.

#### SPEAKER TRANSFORMERS.

Standard size tapped primary, 5/6.  
Midget size tapped primary, 4/6.  
Replacement bobbins only for Rola, Goodman, etc., transformers tapped Triode/Pentode, 27/- doz., 2/8 each.

All these components, together with specifications of our range of "GL" products, are described in the latest Yellow List (1d.). Are you on our mailing list for the "GL" MONTHLY MAIL (One shilling p.a.)?

**THE RADIO INSTRUMENT CO.**  
294, BROADWAY, BEXLEYHEATH, KENT.

'Phone: Bexleyheath 3021.

# YOU can become a first-class RADIO ENGINEER

We are specialists in Home-Study Tuition in Radio, Television and Mathematics. Post coupon now for free booklet and learn how you can qualify for well-paid employment or profitable spare-time work.

## T. & C. RADIO COLLEGE

2 The Mall, Ealing, W.5

(Post in unsealed envelope, 1d. stamp.)

Please send me free details of your Home-Study Mathematics and Radio Courses.

NAME .....

ADDRESS .....

W.W.29

## CHARLES BRITAIN RADIO (K. H. Ede)

offers real bargains in radio spares!  
**SERVICE KITS.**—No. 1: One 8mfd 450v tubular, one 2mfd+0.25 350v Mansbridge and 6 assorted resistances, 11/6 per kit. Kit No. 2: Two 16mfd 200v small can condensers, one 0.3 mains dropper with var. tap, and one 60ma choke, £1 10/6. Kit No. 3: Two 8mfd 450v tubulars, two 16mfd 200v can condensers, two 2mfd+0.25 Mansbridge, 1 doz assorted tubular and mica condensers, and 6 small 0.2 Mansbridge, £2/5 per kit.

**VOLUME** controls, long spindle, with switch, Centralab and Erie, 50,000, 100,000,  $\frac{1}{2}$ ,  $\frac{1}{4}$ , 1 and 2 meg, 5/- each, or less switch, values as above, plus 5,000, 10,000 and 25,000ohm, 3/- each.

**TUBULAR** condensers, 1,000v test, 0.1, 9/- doz; 0.05, 0.01, 7/6 doz; 0.004, 0.002, 0.001, 5/6 doz; B.I. condensers, 0.04, 350v, 5/- doz; 0.001, 450v, 4/6 doz.

**DUBILIER** mica condensers, 0.0001, 0.0002, 0.00015, 5/- doz; 0.001, 0.002, 6/- doz; 2 doz assorted 8/6; 0.01 mica, 1/- each; U.I.C. Ceramic condensers, 4,000mf±5%, 6/- doz. Special offer: Parcel containing 4 each of the above condensers (except 0.01 mica), making 56 in all, for 2/6.

**STEEL** chassis, 9 $\frac{1}{2}$ in×5in, drilled for 2 valves, 2/- each; Telsen 8.M. illuminated disc drives, with esutcheon, boxed with instructions, 2/- each.

**T.F.** transformers—465 K/c, Litz wire, in aluminium cans, with trimmers, 10/- per pair; wave-change switches, Vaxley type, 2pt 3-way, 4pt 2-way, 3/6 each.

**DIALS.**—H.M.V. glass dial, 3-wave, 7in×3 $\frac{1}{2}$ in, 1/6 each; celluloid L. and M.W., 7 $\frac{1}{2}$ in×5in, 1/3 each; small dials for Midgets, station named, 3in×4in, 9d. each.

**MAINS** transformers, 350-0-350 100ma, 4v and 6v types, pre-war quality, 27/6 each; pentode speaker trans, 6/- each; mains droppers, 1,000ohm, 0.2amp, with 2 var. taps, 4/6 each; Little Maestro type, 0.3a, 5/6 each, or 2 for 9/-.

**VALVEHOLDERS**, octal and Brit 7-pin, 7/6 doz; grid caps, Oct and Brit, 1/- doz; spindle extenders, 1/- doz; sleeving 3d per yd, or doz for 2/6.

**TWO-VALVE** M.W. battery set, chassis wired up ready for testing, less valves: 10/- each.

**THIS** month's special offer: Mansbridge condensers, 600v test (all O.K. but unknown capacities), including 1mfd, 6/- doz; terms: cash or c.o.d. over £1.—Charles Britain Radio (temp. address), "Eureka," Surrey Gardens, Evingham, Surrey. [2737]

**INSULATING** tape, in various widths, very adhesive; 2/- per lb.; reductions for quantities.—Parade Radio & Electrical Service Co., 3, Kingsbury Parade, Kingsbury Rd., N.W.9.

**FERRANTI** AF5, AF5c, AF5c, 14/-; AF3, OPMI, OPMIC, 10/-; G.E.C. galv., 30/-; tapped 15,000ohm, 60w resistors, 2/-; quantity valves and components: stamp stating requirements, W.W. from Aug., '32.—170, Whill St., Motherwell. [2741]

**BARGAINS.**—Due to war conditions, a radio and electrical workshop is compelled to close down; tremendous bargains are being offered in order to clear quickly; send stamped addressed envelope for lists.—R. H. Bury, 31, Ventnor St., Rochdale, Lancs. [2775]

**LEVY'S RAPID RADIO**, 32, High St., Leatherhead, Surrey, offer for sale the following components: 0.1mfd mica condensers, 1/- each; 0.02mfd mica 1/- each; 0.002 mfd mica, 1/- each; 0.05mfd mica, 1/- each; 0.01mfd mica, 1/- each;  $\frac{1}{2}$ -watt resistances, all values, 6d. each, 5/6 doz; volume controls, w/s, 10,000ohms, 20,000ohms,  $\frac{1}{4}$  meg,  $\frac{1}{2}$  meg, 1 meg, 6/6 each; pilot bulbs, all types, British or American, b.c. or e.c.; Celestion 8in p.m. speakers, 29/6 each; Bell transformers, 6/6 each; full stock of English and American valves available at B.O.T. controlled prices; terms, cash with order only; orders above 50/-, post free; send us your requirements. [2705]

**RECTIFIERS**, charger kits.—Metal rectifier, 2v amp, with transformer, makes ideal trickle charger for 2v cell, 13/6, post 7d.; instrument rectifiers for meters, bridge type, bakelite, good make, brand new goods, 1ma, 5ma, 18/6, post 3d.; 10ma, 50ma, 15/6; transformer, rectifier and ballast bulb for 2v to 12v 2.5a charger, 59/6, post 10d.; rectifier alone 34/6, post 7d.; transformer, rectifier, ballast bulb for 2v to 12v  $\frac{1}{2}$ amp charger, 38/6, post 10d.; rectifier alone, 12/3; transformer, rectifier, ballast bulb for 2v, 6v, 2amp charger, 42/6, post 10d.; Rothermel Bullet crystal microphones, black crackle finish, £3; also de luxe moving coil mikes, massive construction, plated, reproduction equal to a well-known £20 moving coil mike, £5/10; 10-1 milliammeter, 65/-, post 10d.; Rothermel bakelite crystal pick-ups, 78/9.—Champion, 42, Howitt Rd., London, N.W.5. [2770]

## "UNIVERSAL CIRCUITS"

by R. S. Roberts, M.Brit.I.R.E., A.M.I.R.E.

Three folders and a thirty-six page booklet, presenting the main principles of radio circuit operation in a concise and convenient form for the pocket.

- I. The Transmitter.
- II. The T.R.F. Receiver.
- III. The Superheterodyne Receiver.

By means of hinged flaps, the charts give a large number of recognised alternatives for each stage. To assist the student in memorising and understanding these, a logical five-colour scheme has been adopted throughout.

"Grid Leak" says: "The Charts and Notes are really intended for students and teachers of radio, but are extremely useful to every radio engineer."

Price complete 6/3 post free, from

**The Bookstall**  
**NORTHERN POLYTECHNIC**  
HOLLOWAY, LONDON, N.7

*Yours to a tenth of a thou*

A highly skilled staff of craftsmen combined with the most up-to-date machines enable us to handle light engineering production with microscopic accuracy. We also realise that you want delivery promises kept.

**Wingard**  
MA LTD.

Precision Engineers  
EUGENE WORKS, EDGWARE ROAD, HENDON, N.W.9

## WARD ROTARY CONVERTERS

Petrol Electric Generating Plants, H.T. Generators, D.C. Motors, Frequency Changers, etc., up to 25 K.V.A.

**CHAS. F. WARD**  
37, WHITE POST LANE, HACKNEY WICK, E.9  
'Phone: Amherst 1393

**SALFORD Selenium**  
**PHOTO-ELECTRIC CELLS**

**ENLIGHTENMENT ON LIGHT**

• A Range of Standard sizes available — mounted or unmounted. Special sizes to order.

Please address enquiries to—  
**SALFORD ELECTRICAL INSTRUMENTS LTD.**  
PEEL WORKS, SALFORD, J  
Telephone: Salford 5483 & 5484. Telegrams: Salford 110. Proprietors: THE GENERAL ELECTRIC CO. LTD., OF ENGLAND



We're doing our best, too! And although we don't fear physical violence, we do fear your grouches when we disappoint you on Transformer deliveries. But in these days of heavy priority work orders pile up and supplies get short and, regretfully, we must say more often than we should like, "Sorry, no transformers." So please don't shoot us—we're doing our best.

## GARDNERS RADIO LIMITED

*Manufacturers of Very Good Transformers*  
 SOMERFORD • CHRISTCHURCH • HANTS

## PITMAN'S for Radio Books

### THE COMPLETE MORSE INSTRUCTOR

By F. Tait, Telegraphist and Wireless Operator, Central Telegraph Office, London. A complete course for Service trainees by an experienced operator. Adequate exercises in sending of Morse are provided in carefully graded lessons, and the importance of practice in receiving is emphasised. There is a section on Semaphore. 2s. net.

### EXPERIMENTAL RADIO ENGINEERING

By E. T. A. Rapson, A.C.G.I., D.I.C., etc. Assisted by E. G. Ackermann. Sets out a number of experiments and methods of measurement suitable for a three or four years' course in radio engineering at a technical college. The majority may be carried out with standard laboratory equipment. Third edition. 8s. 6d. net.

### WIRELESS TELEGRAPHY: Notes for Students

Compiled by W. E. Crook. A book which has been used as a textbook for an operator's course with satisfactory results. The book is applicable to any kind of wireless operating. Third edition. 7s. 6d. net.

### ELEMENTARY HANDBOOK FOR WIRELESS OPERATORS

By W. E. Crook, A.M.I.E.E., A.F.R.A.E.S. This book, written by an R.A.F. instructor, is ideal for the man who wants to become a wireless operator. It gives him all the essential information in a clear, easy-to-understand manner. Second edition. 4s. net.

39, PARKER STREET  
 KINGSWAY, LONDON, W.C.2

G. A. RYALL, 69, Wharfedale Gdns., Thorn-ton Heath, Surrey.—Please note new temporary address; mail order only; no c.o.d. under 20/- please.

T.C.C. 0.1 non-inductive tubul. cond., in Pax. tubes, type 330, 350v wks., 7/6 doz.

PAXOLIN strip, 2 1/2 in wide, 12 in lengths. 3 1/6 and 100 25/-; short lengths cut group board size, 6 1/3; Wearite switches, ebonite with silver-plated contacts, for 2hi and band pass, with dial lights, 1/8 each.

TWO-WAY screened flexible, good quality. 1/3 yard, three yards 2/9; twin screened, high insulation and cotton outer cover 1/9 yard, 4-way 2/3 yard.

TEN-WAY cable, good conductors, 1/3 yard, three yards 2/9; ten-way cable, including three Samp conductors for low tension circuits, 2/- yard, three yards 4/9.

OCTAL 8-pin plugs with base, complete with insul. metal cap, 1/3 each, three for 2/9

MORGANITE long spindle 10,000 vol. con. less switch, 3/9; 1meg with switch, 4/9; 50,000ohm Central with switch, 4/9.

5-PIN plug and sockets, no metal caps, suitable semi-permanent connections, 4 1/3.

DIAL plates, oblong, 5 1/2 x 2 1/2 approx., Burndept, Varley, Vidor, with station names, 4 assorted for 1/6.

BURNDIPT portable set dials, 4 1/2 in x 2 in approx., 2, 1/3; Burndept 4-band 8x5 1/2 s.w. on lower half dial, 1/6 each; Burndept 4-band dials, 9x4 1/4, 1/6 each.

MICROPHONE capsules by Standard Tele-phones, 3/9 ea.; Centralab vc, less switch, long spindles, 5,000ohms, 1/2 meg, 3/9 ea.

INPUT strips, 2 in x 3 in, 2-way, 2/6 dozen; I with terminal screws, 3/3 dozen; anchor or mounting strips, 2/3 dozen, 5-way.

SPECIAL offer T.C.C. double mica cond. 0.0001x0.0001 five (ten condensers) for 1/3; Hunts 0.01 mica cond., 1/- ea.; hf chokes on ebonite bobbins, 5,000ohms, 1/3 ea.

ERIE colour coded resistances, 2-watt type. E 680, 6,800, 140,000, 150,000, 220,000, 470,000, 820,000, 2 1/3; Erie 3-watt, 680, 18,000, 1/3 each.

YAXLEY type low loss switches, single pole 4d.; 2 bank, 2/9, single bank 2/3.

CLYDON and Plessey trimmers, 70mm, 2, 1/6; 1,000 and 2,000ohm, 2, 1/-; low value oddments, 2, 1/-.

TWIN rubber flexible cable, new, for mains leads, etc. (one cover), 1/3 yd, 3 yds 2/9; push-back connecting wire, stranded, 2 colours, cotton-covered, 12yds 2/3. [2735]

N. PARTRIDGE.—15/1, 10/1, O.F. 200m/A. w. 8 1/2 lb., 35/-; S. G. Brown's "A" phones, 4,000ohms, brand new, 45/-; Clarke's "Atlas" h.t. elim., 200/-; 250 w.a.c. 25ma, 60/-; Peranti AF5, 20/-, all perfect.—A. A. Hewson, 28, Signhills Ave., Cleethorpes. [2688]

B.A. thread screws and nuts, large stock, 1 gross assorted useful sizes, 2/6; ditto washers, 1/6 gross; fibre washers, 1/6 gross; assorted solder tags, 2/- gross; rubber-covered stranded copper wire, 1d. yard; heavier quality, 1 1/2 d. yard; very heavy quality, 2 1/2 d. yard; ideal for aeriels, earths, etc.; kinned copper connecting wire, 20ft coil, 6d.; ditto, rubber-covered, 10ft coil, 6d.; finest quality resin-cored solder, 1/2 lb 2/-; Wood's metal stick, 2 1/2 in x 1/4 in, 1/-; cotton-covered copper instrument wire, 1/4 lb reels, 18, 20, 21, 22, 23, 24 gauges 1/6; 26 gauge, 1/9; 42 gauge double silk-covered, 2oz. reel, 2/-; sensitive permanent crystal detectors, Tellurium-zincite combination, complete on base, guaranteed efficient, 2/6; reliable crystal, with silver case, whisker, 6d.; reconditioned headphones, complete, 4,000 ohms, 12/6; all postage extra.—Post Radio Supplies, 33, Bourne Gardens, London, E.4. [2698]

COULPHONE RADIO, New Longton, nr. Preston.—New goods only; Tungfram and B.V.A. valves; mains transfs., 350v 100 ma. 4v 6a, 4v 2.5a, or 6.3v 3a, 5v 3a, 33/6; mains transf. bobbins, windings as above, 17/6; p.h.u. speakers, less transf., Rola 5u 21/6, 6 1/2 in, 22/6, 8in 24/-, Plessey 10in, powerful magnet, 35/-, Celestion, with pen. trans., 8in 30/-, 10in, heavy duty magnet, 45/-; 8in energised, 2,000 ohms field, pen. transf., 32/6; power-pen, output transf., 7/6; push-pull Universal, 2,000 ohms field, pen. transf., 4, 1, 6/6; quality inter-valve push-pull transf., 22/6; mains dropper resistors, 800 ohm, 2 adj. taps, 5/6; push-back wire, 100ft 5/6, 50ft 3/-; carbon resistors, 50 ohms to 5 meg, 1/4 w ad., 1/2 w 6d., 1w 9d.; switch cleaner, 2/6 bott.; cored solder, 4/6 lb tin; cop. wire, 2/3 1/2 lb; 1/4 in shaft, couplers, 6d.; lin bakelite knobs 1/4 in; sleeving, 2mm, 3d. yd.; condensers, 50mfd 12v, 25mfd 25v, 21, 25mfd 50v, 2/9; 50mfd 50v, 3/3; tubular and silver mica, all sizes; valve holders, 1d. per pin; vol. controls, with sw, 5/9; less sw, 4/9; electro-micro. soldering irons, 60w, 12/6; smoothing iron elements, 450w, 2/3; fire spirals, 750w, 2/-; 1,000w, 2/6; s.a.e. for stock list. [2722]

# AUSTERITY RADIO LIMITED

## CONSTRUCTORS' KITS T.R.F.

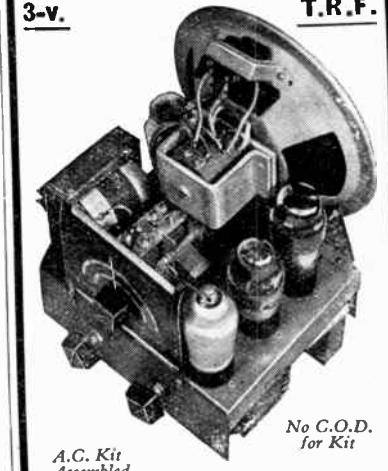

No C.O.D. for Kit

A.C. Kit Assembled. Delivery approximately One Month. New Litz-wound coils are now supplied with these Kits which give good quality reception of R.F.C. programmes. Complete with chassis 8in. x 6 1/2 in. x 2 1/2 in. Valves, M.C. Speaker and wiring diagram. (Regret, no cabinets.) 3 controls. A.C. 3-V. (+ RECTIFIER) KIT. V.M.H.F. Pen., Triode, L.F. Pen., Rectifier, M.C. Speaker. Price 10 gns. Post 1/1, plus 3/6 packing (returnable). BATTERY 3-V. KIT. V.M.H.F. Pen., Triode Detector and Output Tetrode, P.M. Speaker Price 27. Post 1/1, plus 3/6 packing (returnable).

\*ALL-WAVE PERMEABILITY TUNED 10-way PUSH BUTTON UNITS, complete with buttons. Superhet 465 Kcs. 30/-. No circuit supplied. AERIAL AND OSCILLATOR COILS, complete, with I.F. Transformers, 110 Kcs., screened, 20/- per set. CHOKES, 50 ma., 380 ohms, 7/6. PARALLEL FEED TRANSFORMERS. Midget ratio 3:1, 4:1, 6:1; 4:1, 6:1. TAYLEY TYPE SWITCHES, 2-bank, 2-pole, 4-way, 4/6; single bank, 3-pole, 5-way, 4/6. W.V. VALVE HOLDERS. 7-pin, chassis mounting, 10/4. PAXOLIN PANELS. 12 x 9 x 1 in. approx. 3/6 3-GANG CONDENSERS, ceramic insulation, .0025, 8/6; also STANDARD .0006 ceramic insul. 12/6. SEORT-WAVE COILS. 3 bands covering 12-50 metres. Aerial and H.F. mounted on screened switch. Wired up to terminal output connections. All numbered. 11" spindle. Complete with circuit. 20/-. A. & H.F. TRANSFORMERS with reaction colour coded, 10/6 a pair 465 KCS. I.F. TRANSFORMERS. Iron-cored, unscreened, small, 15/- pair. MAINS TRANSFORMERS. Universal, A.C. input, 230 v. output, 300-0-300, 6.3 v., 4 amp., 5 v., 2 amp., 4 v., 2 amp., 4 v., 4 amp., 80 ma. Screened primary colour coded—a good replacement transformer, especially for sets using inlaid valves, 32/6 each. Standard Replacement, input 200/250 A.C. output 350-0-350, 80 ma., 4 v., 4 amp., 4 v., 2 amp. Screened primary, 30/- each. Standard, input 200/250 A.C., output 350-0-350, 150 ma., 6.3 v., 5 amp., 5 v., 2 amp., 35/- each. VOLUME CONTROLS. 10,000, 100,000 ohms, 1, 4, 1 and 2 meg, with switch, 6/6 each, 5,000, 10,000, 25,000 and 50,000 ohms, less switch, 4/- each. CHASSIS. Undrilled steel, painted, new, 10 x 8 x 2 1/2 in., 7/6; 8 x 6 x 2 1/2 in., 4/6 each. OCTAL CABLE PLUG AND SOCKET, 2/- L. F. CHOKES, 20 by 500 or 1,000 ohms, 100 ma., 16/- TOGGLE SWITCHES. Miniature On-off, single pole, 2/6. MEDIUM WAVE COILS. Midget. Prim. and Sec. windings. Litz wound, 8/6.

307, HIGH HOLBORN, LONDON W.C.1. Phone: HOLborn 4631

# Answers! FLIK-DISK Quick!

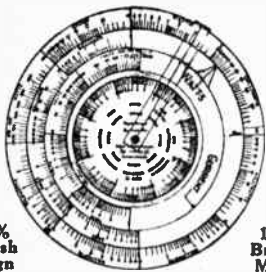

100%  
British  
Design

100%  
British  
Made

Answers all OHM'S LAW problems—for example

What will be the voltage when current I flows through resistance R?

What will be the voltage with watts  $W$  and I current flowing?

What is the current flowing where watts value is  $W$  and voltage is  $E$ ?

What current will flow through  $R$  resistance where voltage is  $E$ ?

What will be the resistance where current I flows at voltage  $E$ ?

What will be the resistance where watts  $W$  is at voltage  $E$ ?

What will be the resistance where watts  $W$  is at current I?

What is the wattage at voltage  $E$  through resistance  $R$ ?

What is the wattage of I current at  $E$  voltage?

What will be the wattage of I current at  $E$  voltage?

The scales read from 1 millivolt to 1,000 volts. From 1 ohm to 1,000,000 ohms. From 1 millamp to 10 amperes. From one-tenth of a milliwatt to 10,000 watts.

FULL INSTRUCTIONS WITH EACH INSTRUMENT.

PRICE 4/6 Postage 3d

Order at once whilst deliveries are good

IONIC LABORATORIES LTD.

6 Cranbourne Terrace, Salt Hill, SLOUGH, BUCKS, ENG.

## SEXTON'S

— for —

### SALES, SERVICE, SATISFACTION

"Here it is." Build the "WIZARD FOUR" radio receiver. No Main Transformer, no chokes, no line cords. All components are readily obtainable from practically any radio dealer. Why wait until after the war? The "WIZARD FOUR" can be built at home without any previous knowledge of radio construction. Explicit instructions are given, theoretical circuit, point-to-point wiring diagram, component layout, and diagram for using alternate valves, 7-pin or octal base, showing readily the necessary connections and list of components with the correct specified values that are necessary to construct this "WIZARD FOUR." This circuit has been tested to the full and we recommend the "WIZARD FOUR" to you with every confidence. Send for complete instructions, 5s. post paid.

**AMERICAN RADIO VALVES.** At Board of Trade controlled prices. Types as follows: 12BF6, 12F5, 6F5, 6E5, 11E, at 9/2 each. 25Z6, 35Z4, 35Z5, 1C5, 5Y3, 5Y4, 1N5, 6C6, 6D8, 80, at 11/- each. 6Q7, 12Q7, at 11/7 each. 1A7, 6L7, 6F6, 6K7, 36, 25L6, 42, 43, at 12/10 each. 6A8, 6SA7, at 14/- each. 70L7, 12A7, 83, 6B8, at 15/3 each. 50L6GT, 12SK7GT, 12B3GT, at 12/10 each, postage 4d.

**VOLUME CONTROLS.** Less weight, 3,000 and 5,000 ohms,  $\frac{1}{2}$  and 1 meg, at 2/8 each.

**EXTENSION LOUDSPEAKERS.** "Rola" 3 ohm voice coil, less trans. size, 6in., at 21/6; with trans., 29/6. "Rola" 3 ohm voice coil, less trans., size 8in., at 24/-. "Celestion" 8in. with trans., at 29/6 each. "Goodmans" 3 1/2in. 12 ohm. voice coil, ideal for microphones, communication sets, etc., at 30/- each.

**SPANNERS.** Wooden handled box type, invaluable for service work, 2, 3, 4, 6BA, at 3/4 each. Sets of 2, 4 6BA, box spanners, with tommy bar, at 3/6 per set.

**TERMS:** Cash with order only. Send 1d. stamp and S.A.E. for latest list of electrical appliances and radio components available from stock.

### J. E. SEXTON & CO., LTD.

164, Gray's Inn Road, London, W.C.1.

Tel.: Terminus 1304 and 4842.

HENRY'S offer T.C.C. 2mfd. 1,000v wkg. 7/6; T.C.C. 1,000mfd, 25v wkg, 10/-; T.C.C. 1mfd, 200v wkg, small type, 2/-; 5in wire-wound instrument rheostats, 500ohms, 8/6; small 3-gang 0.0005, with trim, 10/-; t.r.f. coils, med. and long, with reac, 10/- pr; Midget t.r.f. coils, med. wave, with trim, 9/- pr; Bulgin twin fuses, 2/- complete; twin mains h.f. sup. chokes, 3/6; Goodman's 3 1/2in p.m., 27/6, trans to match 7/6; 0.2 line cord, 750 and 900 lengths, 2-way, 10/-; small mains trans, input 200-250, output 13v, cent. tap., 3amps, 12/6; shortwave h.f. chokes, 2/-; Centralab vol. controls, with sw, 6/-, long spin, 5,000, 10,000, 25,000, 100,000, 1/2 meg.; all types of British and American valves in stock; call or write—Henry's, 5, Harrow Rd., Paddington, W.2. Pad. 2194. [2779]

**SOUTHERN RADIO'S** wireless bargains—Standard Telephone carbon microphone inserts, 4/- each; screws and nuts, assorted, gross of each (2 gross in all), 10/-; soldering tags, including spade ends, 6/- gross; 2mfd condensers, Post Office upright, paper type, used, but fully guaranteed, high working voltage, 2/6 each; Philco 3-point car aerials, excellent for short-wave and home aerials, 7/6; limit tone arms, universal fitting, for sound boxes and pick-up heads, Ace P.O. microphones, complete with transformer, ready for use with any receiver, 7/6; Eric resistances, brand new, wire ends, 1/4, 1/2, 1 and 2 watts, mostly low values but a very useful selection, 100 resistances for 30/-; Multicon mica master condensers, 28 capacities in one, from 0.0001, etc., etc., 4/- each; special offer of latest radio publications: "Radio Valve Manual," equivalent and alternative American and British types, with all necessary data, 3/6; "Radio Circuits," fully illustrated, receivers, test equipment, etc., etc., 2/-; "Services Signalling Manual," international code, Morse, etc., etc., 1/-; "Radio Manual," formulas, tables, colour code, etc., 1/-; crystals (Dr. Cecil), 6d.; with catswhisker, 9d.; complete crystal detectors, 2/6; Telsen reaction condensers, 0.0001, 1/9; Telsen large disc drives, complete boxed (type W184), 2/6; 25 yards push-back insulated wire, 5/-; insulated sleeving, assorted, yard lengths, 3/6 doz.; single screened wire, dozen yards, 10/-; metal cased condensers, 0.1, 0.1, 0.1, 2/6; power rheostats, Cutler-Hammer, 300ohms, 4/6; push-button switches, 3-way 4/-, 2-way 6/- (complete with knobs); bakelite escutcheon plates for 8-way p.b. switches, 1/6; knobs for p.b. switches, 6d.; coil formers, ceramic and paxolin, 12 assorted sizes, 7/6; 20 assorted tubular condensers, up to 0.1, 15/-; 24 assorted mica condensers, 12/6; hundreds more bargains.—Southern Radio Supply Co., 46, Lisle St., London, W.C. Gerrard 6653.

**COULPHONE RADIO,** New Longton, nr. Preston.—Tungram and B.V.A. valves, hundreds in stock, post and packing free; rectifiers 5Y3G, 5Z4G, 80, equiv. U12, U14, etc., 10/-; really prompt service; s.a.e. for list and enquiries. [2545]

**VALVES.** We have over 5,000 new and boxed English and U.S.A. mains and battery valves in stock, including 6A7, 6A8, 25Z4, 75, 5Z4, U50, 35Z5, 1D5, 35L6, 6F6, 6F13c, VP2, 8P4, PX4, PEN4, 125Q7, TDD4, UUS, 6K7, 11Z26, 6Q7, 6K8, 6X5, 6R8, 14W350, U12, 12A8, 12Q7, 6SA7, 6SK7, 6PN36c, etc., etc.; send 1d. stamp for latest list—"Lark's" Radio, 379, Harrow Rd., Paddington, W.2 (opposite Paddington Hospital)

**VALVES,** British and American, many types in stock; Midget aerial and h.f. medium wave, t.r.f. high gain coils, ideal for the Midget t.r.f. receiver, 9/- pair; Midget receiver chassis, drilled for four valves, 10 1/2 by 6 by 2in, grey, first-class heavy quality, designed for the Midget receiver, 9/6; Midget 3-gang condenser, with slow motion drive, 12/6; Midget l.f. smoothing chokes, 50-60ma, 7/6; heavy duty smoothing chokes, superior job, 120ma, 200ohms, 15/- 80ma, 500ohms, 12/6; Midget speaker trans. (pen.) 7/6; standard (pen.) 9/-; Midget knobs, highly polished black, ditto brown, and standard knobs, 9d., 8/- doz.; replacement field coils for standard 8in speakers, 400ohms, 5/-, 48/- doz.; line cord, 600ohms per foot, 0.3 amp, 3-way, 6/6 yard; universal mains droppers for all receivers, 1,000ohms, 0.2amp, fitted two variable taps, 4/6; 750ohms, 0.3amps, ditto tops, 5/6; superior quality dropper, fixing feet, etc., 800ohms, 0.3amp and 950ohms, 0.2amp, 7/6; wire wound potentiometers, 2,000ohms, for bridges, etc., 6/6; dials, three wavebands, Ivorine, station names, in colours, 7 by 4in, 1/6; nuts, screws, 4BA brass round heads, 6/- gross; 6BA cheese heads, sheradised, 5/- gross; toggle switches, on/off, 3/-; S.P.D.T., 3/6; aerial and h.f. m. and l. wave, t.r.f. reaction, boxed, 12/6; Licence N. Ireland, 2/6d. for comprehensive list, s.a.e. with enquiries, postage on all orders.—O. Greenlick, 34, Bancroft Rd., Cambridge Heath Rd., London, E.1. Stepney Green 1334.

## HILL & CHURCHILL

BOOKSELLERS

### SWANAGE DORSET

ENGLISH & AMERICAN  
BOOKS IN STOCK ON

### RADIO AND TELECOMMUNICATION

CATALOGUE ON APPLICATION

## SPEAKER REPAIRS

by Specialists

TRADE ONLY

Send trade card and 1d. stamp for current list published monthly.

We hold an export licence for Northern Ireland.

A.W.F. RADIO PRODUCTS

Borough Mills, Sharpe Street, Bradford, Yorks.

Tel.: 11926.



For high quality  
loud speakers  
when the good  
times come again.

The Courts,  
Silverdale, London

## CERAMIC PARTS

METALLISED  
AND  
TINNED

E. & M. DEVELOPMENTS LTD.  
482, IPSWICH ROAD, SLOUGH, BUCKS.  
Tel.: SLOUGH 21435.

## AMERICAN MIDGETS HANDBOOK

Describing with many circuit diagrams the peculiarities of small American (Midget) Radios. Especially written for service men, most likely faults and their remedies with hints on wartime substitutes for unobtainable parts are all given. The valve data section gives bases and working characteristics of the 80 or so valves used in midgets.

Price 2/6

from booksellers or by post, 2/8.

V.E.S. (W.)

Radio House, Melthorpe Drive, Ruislip, Mdx.

## WANTED TO PURCHASE

A small or medium-sized Cycle and Radio Business (retail). Any district considered if well populated and with good post-war prospects. Full particulars in first instance to Box 3119, c/o Wireless World.

## REWINDS

MAINS & OUTPUT TRANSFORMERS, FIELD COILS, PICK-UP COILS, ARMATURES PROMPTLY EXECUTED

Phillips and Ekco D.C. Converters bought, sold and exchanged. Valves, B.V.A. and American, good etc. etc. Send stamped addressed envelope for price list

A.D.S. Co. ASTON, BIRMINGHAM, 6



**VALVES**

This is part of our current stock of valves. If all their equivalents were mentioned, it would be found that we can supply either the exact valve or a suitable replacement for almost any type. Wherever possible please order C.O.D. Stamp with enquiries please.



**PRICES STRICTLY B.O.T. RETAIL**

**BATTERY**—210HL, 1D210, 5/10; P220, PM2A 7/4; 210DDT, HD24, TDD24, 9/2; 210SPT, 210VPA, 210VPT, 215BQ, 220HT, 220/OT, HP210, K50M, K72, KT4, PM12M, PM2A, SP2, SP210, VP210, VP2B, W21, Z21, Z22, 11/-; 210FG, FC2, FC2A, X24, 12/10.  
**A.C. TYPES**—2D4A, 9/9; 41MP, 354V, AC/HL, MH4, MHL4, 9/2; AZ1, DW2, AZ31, DW4-350, IW4-350, MUI4, U10, 11/-; 402P, AC044, MH41, MHD4, PX4, TDD4, 11/7; 42MP/Pen, ACVP1, AC/Pen, AC2/Pen, AC5/Pen, KT41, KT263, MKT4, M5P/Pen, MVS/Pen, MVS/PenB, PenA4, Pen4VA, SP4, VP4, VP4B, 12/10; AC/TR1, AC/TP, FC4, MK40, TH4, TH41, VHT4, 41MR3, 14/-; KT32, KT32C, PenB4, 14/8; MP/Pen, 16/6; FW4/500, KT68, 18/3; FX25, PP5/400, 24/4; Pen428, 30/5.  
**UNIVERSAL**—2D13A, 9/2; OY1, U3, UR1C, UR3C, U4020, 11/-; 11D3, TDD19C, 11/7; 7D3, 8D2, 9D2, 138FA, CL4, CL33, Pen36C, SP13, SP1320, VP1 SA, VP1 SC, 12/10; CBL1, CBL31, PenDD4020, TH21C, 15/3; TH30C, 14/-.  
**MAZDA**—HL23, 5/10; HL23DD, 9/2; Pen25, U6, U6B, U6U, U4020, VP23, 11/-; HL411D, HL133DD, 11/7; Pen45, Pen383, SP41, TP23, TP28, VP41, VP133, 12/10; AO/TP, TH41, TH233, 14/-; QP28, PenDD4020, 16/3.  
**E TYPES**—EM4, 11/-; EB33, EBC33, 11/7; CL4, CL33, EF8, EF9, EL3, EL33, 12/10; OCH33, ECH2, ECH3, EOH35, EF5, EP6, EK2, EL2, 14/-; EBL1, EB31, 15/3; EL5, 16/6; EL35, 18/3.  
**AMERICAN**—OZ4, 1A5, 1C5, 1H5, 2A6, 2A7, 2B7, 2F, 5U4, 5Y3, 5Z4, 6A4, 6A6, 6A6G, 6A7, conversion, 6B8, 6C5, 6C6, 6D6, 6C8, 6E2, 6F9, 6F5, 6H6, 6J7, 6J8, 6K8, 6K7, 6K8, 6L6, 6L7, 6F6, 6Q7, 6R7, 6SP7, 6V6, 6X5, 6Z5, 10, 1. 12Q7, 12SF5, 12Z5, 15, 24, 25, 25A6, 25L6, 25Y6, conversion, 25Z4, 25Z6 conversion, 25Z6, 32, 33, 34, 35, 37, 38, 42, 46, 47, 48, 50, 53, 57, 71A, 75, 76, 78, 80, 81, 82, 85, 89, 185R8 (Ballast), O1 Barretter.

**VALVES AND ADAPTORS**

In the cases where we cannot supply the exact valve or equivalent, we can get your set going with a valve and adaptor, the additional cost being 4/6.

**SPARES**

**KIT OF 12 TRIMMER TOOLS** in American cloth folder. Very handy, 30/-.  
**SPAREKES**, tin, W/Trans, 32/6.  
**LIME CORD**—3 amp, 3 core 50 ohms per yd. extremely good quality, 9/9 per yd.  
**CELLULOSE CEMENT** for speaker valve and most other repairs, 5/- tin.  
**SERVISOL**, more than a switch cleaner, 5/- tin.  
**MAINS TRANSFORMER**, 350-0-350 4-volt heaters, 29/3.  
**VOLUME CONTROLS** with switch, 7/6.  
**VALVE EQUIVALENT CHARTS**, 1/7 post free.  
**BOOKLET OF AMERICAN MIDGETS**, 2/7.

**J. BULL & SONS**

(Dept. W.W.)

246 HIGH ST., HARLESDEN, N.W.10

**2000** valves, British and American; send stamped envelope for comprehensive list.—Napier, 127, Prestwick Rd., Ayr.  
**5000** valves, all types, including output rectifiers, etc., also a few tax-free ones left; s.a.e.—Davies, 28, Mount Vernon Crescent, Barnsley. [2406]

**OUR** adaptors will help in replacing unobtainable valves; send 7d. for interesting booklet on valve replacements; trade enquiries invited.—V.E.S., Radio House, Ruislip. [1885]

**Wanted**

**TWO** Mazda AC/SPI, new or good second-hand.—Ingham, Westville Ave., Ilkley.  
**WANTED**, Mullard A50 valve, 4-pin, or equivalent urgently.—J. and S. Farr, 18-20, Parliament St., Nottingham. [2767]  
**NEW** boxed valves wanted, any quantity. Dealers' and service men's complete stocks bought.—J. Bull and Sons, 246, High St., Harlesden, N.W.10. [2155]

**REPAIRS AND SERVICE**

**LOUDSPEAKER** repairs, British, American, any make; moderate prices.—Sinclair Speakers, 170, Copenhagen St., London, N.1. Terminus 4355. [2415]

**ALL** types of radio receivers serviced; Murphy and Pilot specialist; valves in stock; sound repairs for 13 years.—T. E. Fevyer, F.I.P.R.E., 50, Vine St., Uxbridge. [1575]

**SERVICE** with a smile.—Repairers of all types of British and American receivers; oil rewinds; American valves, spares, line cords.—F.R.I., Ltd., 22, Howland St., W.1. Museum 877. [1575]

**MAINS** transformers service, repairs, rewinds, or construction to specification of any type, competitive prices and prompt service.—Sturdy Electric Co., Ltd., Dipton, Newcastle-upon-Tyne. [9651]

**MAINS** transformers rewound, 48 hours service; state make and type of instrument from which removed, 17/6; output transformers, 4/6, post paid; c.w.o.—Express Radio Service, Southside St., Plymouth. [2654]

**MEASURING** instrument repairs; all makes of meters and instruments skillfully repaired by experts; prompt service for essential purposes.—Rumbaken Electrical Repairs, Meter Dept. (R152), Manchester, 1. [2704]

**24-HOUR** service, 6 months' guarantee, any transformer rewind; mains 15/6; outputs, 4/-; i.f. transformer 3/-; all types new equipment supplied to specification.—Majestic Winding Co., 180, Windham Rd., Bournemouth. [2764]

**REWINDS** mains transformers, field coils and chokes, high grade workmanship, seven to ten days' delivery; new transformers manufactured against Government contracts.—Metropolitan Radio Service, 1021, Finchley Rd., Golders Green, London, N.W.11. [2603]

**MAINS** transformers rewound, return post delivery popular types to 70 watts, £1 (trade dis.) specials quoted or c.o.d.; machine layer wound, specially impregnated and interleaved coils, better than new; state make, model number, etc.—Radio Service, Field St. Works, Blackpool, R.T.R.A. Service Members.

**DEGALLIERS**, Ltd.—Service with a guarantee. If you cannot get your receiver serviced, let American specialists do the job; first-class workmanship only; specialising in Air-King, Belmont, Challenger, Detroit, deWald, Emerson, Ferguson, Garod, Hallicrafter, Hammerland, McMurdo, Midwest, Majestic, Pilot, Philco, Sparton, etc., also any British set. Remember, for 15 years we have handled as distributors American receivers; this is self-explanatory; s.a.e. with all enquiries.—Degalliers, Ltd., 9, Westbourne Court, London, W.2. [2715]

**MISCELLANEOUS**

**PHOTO-ELECTRIC** cells, 90 volts, 21/- each.—Universal Electrical Co., 221, City Rd., London, E.C.1. [2429]

**T.R.M.** recorders—Write for particulars.—Gledhill-Brook Time Recorders, Ltd., 84, Empire Works, Huddersfield. [2419]

**M.C.** Browne mike, with stand and trans., £9/10; BTH P.U., £3; Marconi P.U. head, £3.—Brook, Dored, N. Lopham, Diss.

**RUBBER** stamps made up to your special requirements and design, typical example, stamp showing name, address and profession; 9/6 post free.—V.E.S., Radio House, Ruislip. [1884]

**MANUFACTURERS!!!**—Radio wholesaler wishes to increase regular stock lines by the addition of new types of radio products.—Will manufacturers or agents please send full particulars to Box 3134. [2758]

**A**CTIVE participation and controlling interest required in small but modern and progressive precision engineering and radio development concern, approximately 20 mile radius of London; finance and excellent post-war contacts immediately available for the right type of business.—Apply Box 3101.

**PREMIER RADIO**

**MAINS TRANSFORMERS**

Wire-ends. All L.T. Windings Centre Tapped.  
 SP. 300 300-0-300 v. 60 m.a., 4 v. 2-3 a., 4 v. 2-3 a., 4 v. 2-3 a. 25/-  
 SP. 350A 350-350 v. 100 m.a., 5 v. 2 a. (not C.T.), 6.3 v. 2-3 a., 4 v. 2-3 a. 29/-  
 SP. 350B 350-350 v. 100 m.a., 4 v. 2-3 a., 4 v. 2-3 a., 4 v. 2-3 a. 29/-  
 SP. 351 350-350 v. 150 m.a., 4 v. 1-2 a., 4 v. 2-3 a., 4 v. 3-4 a., 4 v. 3-4 a. 36/-  
 SP. 351A 350-350-150 m.a., 4 v. 3 a., 4 v. 2-3 a., 4 v. 1 a., 4 v. 1 a. 39/-  
 SP. 352 350-350 v. 150 m.a., 5 v. 2 a., 6.3 v. 2 a., 6.3 v. 2 a. 38/-  
 Auto Transformers. Step up or down. 100-125 v. to 200, 230 or 250 v. A.C. 60 m.a., 21/-; 1-25 watts, 27/6; 250 watts, 37/6.

**PREMIER SMOOTHING CHOKES**

Type	Current	Henrys	Res.	Prices
C 60/400	60 MA	25-34 H	400 ohms	13/-
C 100/400	100 MA	20-34 H	400 ohms	19/6
C 150/180	150 MA	20-34 H	185 ohms	25/-
C 200/145	200 MA	20-34 H	145 ohms	29/6
C 250/120	200 MA	25 H	120 ohms	39/6

**MATCHMAKER UNIVERSAL OUTPUT TRANSFORMERS**

Will match any output valves to any speaker impedance, 11 ratios from 13-1 to 80-1, 5/7 watts, 22/6; 10/15 watts, 30/-; 20/30 watts, 49/6; 50/60 watts, 59/6.

**STEEL CHASSIS**

Un drilled.  
 10 x 8 x 2 1/2" ..... price 7/- each.  
 16 x 8 x 2 1/2" ..... price 8/6 each.  
 20 x 8 x 2 1/2" ..... price 10/6 each.

**NEW PREMIER S.W. COILS**

4- and 6-pin types, now have octal pin spacing and will fit International Octal valve holders.

Type	Range	Price	Type	Range	Price
0A	9-15 m.	2/6	0B	9-15 m.	2/6
0A4	12-26 m.	2/6	06A	12-26 m.	2/6
04C	22-47 m.	2/6	06B	22-47 m.	2/6
04B	41-94 m.	2/6	06C	41-94 m.	2/6
04D	76-170 m.	2/6	06D	76-170 m.	2/6
04E	150-350 m.	3/-			
04F	255-510 m.	3/-			
04G	490-1,000 m.	4/-			
04H	1,000-2,000 m.	4/-			

**CHASSIS MOUNTING OCTAL HOLDERS**

104d. each.  
 New Premier 3-Band S.W. Coil, 11-25, 25-38 38-86 m., 4/9.

2 Push-Pull Switches to suit above, 9d. each.  
 Bakelite Dielectric Resonance Condensers.

0001 m.f. 1/3, 0003 m.f. 2/6, 0005 m.f. 2/9 each  
 0003 m.f. Differential ..... 2/11 each  
 S.W. H.F. Choke, 10-100 m. .... 1/3  
 Brass Shaft Couplers, 3in. bore ..... 7/4 each  
 Flexible Couplers, 3in. bore ..... 1/6 each

**SWITCHES**

QMB, panel mounting, split knob type, 2 point on/off, 2/- each. Double pole on/off, 3/6 each.

**VOLUME CONTROLS**

Carbon type, 20,000 and 2 meg., 3/9 each.  
 5,000, 10,000 4/6 each.  
 and 100,000 4/6 each.  
 Wire Wound Type, 10,000 ohms, 5/6 each.  
 Valve Screens for International and U.S.A. types, 1/2 each.  
 Resin-Cored Solder, 6d. per coil.  
 Push-Back Connecting Wire, 21d. per yard.  
 Systoflex Sleeving, 2 mns., 2/6 per doz. yards.  
 Screened Braided Cable, Single, 1/3 per yard.  
 Twin, 1/6 per yard.

**MOVING COIL SPEAKERS**

Goodmans 3in. P.M. Speaker, 15 ohms voice coil, 30/-.  
 Bola 3in. P.M. Speaker, 3 ohms voice coil, 25/-.  
 Bola 5in. P.M. Speaker, 3 ohms voice coil, 25/-.  
 Above speakers are less output transformer.  
 Pentode Output Transformers, 34 watts, price 10/6 each.  
 Celestion or Plessey 5in. P.M. Speaker, 29/6.  
 Celestion 10in. P.M. Speaker, 49/6.  
 The above speakers are fitted with output transformers.

**Premier 1-Valve de Luxe Radio Model S.W.** Receiver, complete with 2-volt valve, 4 coils covering 12-170 metres. Built on steel chassis and panel, Bandspread tuning, 55/-, including tax.

**I.F. TRANSFORMERS, IRON CORED**

450-470 kc., plain and with flying lead, 7/6 each.

Send for details of other Accessories available.

**ALL ENQUIRIES MUST BE ACCOMPANIED BY A 21d. STAMP.**

**PREMIER RADIO CO.**

ALL POST ORDERS TO :

JUBILEE WORKS, 167, LOWEE CLAPTON ROAD, LONDON, E.5, (Amherst 4723.)

CALLERS TO :

JUBILEE WORKS or 169, FLEET STREET, E.C.4. (Central 2833)

**ENGINEERING OPPORTUNITIES**



This unique handbook shows the easy way to secure A.M.I.Mech.E., A.M.Brit.I.R.E., A.M.I.E.E., City and Guilds, etc.

**WE GUARANTEE—“NO PASS—NO FEE.”**

Details are given of over 150 Diploma Courses in all branches of Civil, Mech., Elec., Motor, Aero, Radio, Television and Production Engineering, Tracing, Building, Govt. Employment, R.A.F. Maths., Matriculation, etc.

Think of the future and send for your copy at once—FREE.

**B.I.E.T., 357, SHAKESPEARE HOUSE 17, STRATFORD PLACE, LONDON, W.1.**

**SYNCHRONOUS** motors, "Sangamo" 200-250v a.c., 50 c, enclosed pattern, self-starting fitted, with reduction gears, ideal movements for time switches, electric clocks, etc.; Rotor speed 200 r.p.m., final speed of drive, 12 min. approx., consumption 3 watts, size  $2\frac{1}{2} \times 2\frac{1}{2} \times 1\frac{1}{2}$ , 25/- each; wire-wound resistances, non-inductive, ideal for meter shunts, resistance boxes, etc.,  $2\frac{1}{2}\%$  accuracy, wound on bakelite bobbins,  $\frac{7}{16} \times \frac{1}{4}$  in.; one of each of the following ratings, 25, 50, 100, 200, 400, 600, 1,000 and 2,000 ohms, 5/6 per lot, post paid; large quantities available; rev counters, ex meters, drum type, 0-999 automatic reset to zero on completion, 3/6 each; projection lenses, 1 in focus, ideal for 9.5 or 16mm films, sound heads, etc.; oxidised mounts,  $1\frac{1}{4}$  long,  $\frac{3}{16}$  diam, 5/- each; terms, cash with order.

H. Franks, Scientific Stores, 58, New Oxford St., W.C.1. Tel: Museum 9594. [2693]

**SITUATIONS VACANT**  
**REPRESENTATIVE** required by London firm of radio component manufacturers; splendid post-war opportunity; connection not essential, but one acquainted with the purchasing departments of the leading radio set manufacturers preferred.—Write "Representative," c/o Alfred Bates and Son, Ltd., 130, Fleet St., E.C.4. [2736]

**SITUATIONS WANTED**  
**RADIO** engineer desires change, 16 years' exp., lab. or production.—Box 3125.

**TECHNICAL TRAINING**  
**A.M.I.E.E., City and Guilds, etc.**, on "No pass—no fee" terms; over 90% successes. For full details of modern courses in all branches of electrical technology send for our 112-page handbook, free and post free.—B.I.E.T. (Dept. 388A), 17, Stratford Place, London, W.1. [2432]

**GREAT** possibilities exist for technically qualified engineers, key men in wartime and afterwards. Through the home-study courses of The T.I.G.B. take a recognised engineering qualification, such as A.M.I.Mech.E., A.M.I.E.E., A.F.R.Ae.S., A.M.I.Chem.E., C. and G., etc. in which examinations the T.I.G.B. students have passed 25 **FIRST PLACES** and hundreds of passes. Write today for "The Engineer's Guide to Success"—free—containing the world's widest choice of engineering courses covering all branches, including aeronautical, mechanical, electrical, wireless, chemical, etc.

**THE TECHNOLOGICAL INSTITUTE OF GREAT BRITAIN**, 82, Temple Bar House, London, E.C.4. [1403]

**TUITION**  
**LEARN** Morse code the Candler way.—See advertisement on page 26. [1292]  
**RADIO** training.—P.M.G. exams and I.E.F. Diplomas; prospectus free.—Technical College, Hull. [0611]

**BATTERY CHARGERS & TRICKLE CHARGERS**



Trouble-free Chargers fitted with selenium all-metal rectification. A few Agencies available. Thirty years experience behind every Runkbaken product. Book's R.15, giving an all-in-one view and describing 12 Models, on request.

**RUNKBAKEN MANCHESTER**

**LONDEX for RELAYS**

The wide range of Londex Relays includes a variety of

**TYPES APPROVED**  
 by  
**AIR MINISTRY**  
**M.A.P.**  
**ADMIRALTY**



Multiple contact Relay LF.

Ask for details and leaflet SPN/WW.

**LONDEX LTD**  
 MANUFACTURERS OF RELAYS  
 207 ANERLEY ROAD, LONDON S.E.20

**—PHOTO-ELECTRIC CELLS—**

Se/Te on gold-alloy, super-sensitive to light, permanent, operate relay without or with Valve Amplifier, perfect reproduction of Speech and Music from sound track of films; large tube 3 1/2 in. from top to valve pin base, 1 in. diam., 38/-; small tube 2 in. from top to terminal base, 1/2 in. diam., 30/-; operate on 40-100 volts, connections blue print free. Despatch by return.

**GEFA INSTRUMENTS**, 38a, York Street, TWICKENHAM, Middx. POPesgrove 6597

*R. K. Dundas*

**LIMITED**

Experimental and Aeronautical Engineers and Scientific Instrument Makers. Manufacturers of Precision Mechanical, Electro-Mechanical and Thermionic Instruments. Electro-Medical and Industrial Apparatus, Time Interval Measurement and Counters, DC Amplifiers and Recorders. Specialised Design Enquiries Welcomed

**THE AIRPORT, PORTSMOUTH**  
 Telephone: 74874.

**COACHING** for P.M.G. examinations; 150 typical 1st and 2nd class technical questions, price by post 5/-.—The North Eastern School of Wireless, 69, Osborne Rd., Newcastle-upon-Tyne, 2.

**RADIO** Engineering.—Television and Wireless Telegraphy, comprehensive postal courses of instruction. Apply British School of Telegraphy, Ltd., 179, Clapham Rd., London, S.W.9 (Estd. 1906). Also instruction at school in wireless for H.M. Merchant Navy and R.A.F. [9249]

**ENGINEERING** Opportunities.—Free 112 page guide to training for A.M.I.Mech.E., A.M.I.E.E., and all branches of engineering and building; full of advice for expert or novice; write for free copy and make your peacetime future secure.—B.I.E.T. (Dept. 387B), 17, Stratford Place, London, W.1.

**POSTAL** training in electrical engineering—power or radio; individual correspondence tuition by highly qualified engineers with wide teaching and technical experience. Elementary or advanced courses. Preparation for recognised examinations. Pre-service training specially arranged.—G. B., 18, Springfield Mount, Kingsbury, N.W.9. [1731]

**T**he Tuitionary Board of the Institute of Practical Radio Engineers have available home study courses covering elementary, theoretical, mathematical, practical and laboratory tuition in radio and television engineering; the text is suitable coaching matter for I.P.R.E., Service-entry and progressive exams; tuitionary fees—at pre-war rates—are moderate.—The Syllabus of Instructional Text may be obtained post free from the Secretary, Bush House, Walton Avenue, Henley-on-Thames, Oxon. [1462]

**PATENT NOTICES**  
**RADIO** electric patents.—Well-known London radio component manufacturers are open to consider patents or designs for post-war period. Write Progress, c/o Alfred Bates and Son, Ltd., 130, Fleet St., London, E.C.4.  
**T**he proprietor of British Patent No. 531963, entitled "Device for Producing Vibrato in Sound Amplifying Systems and the Like," offers same for license or otherwise to ensure practical working in Great Britain.—Enquiries to Singer, Ehlert, Stern and Carlberg, Steger Building, Chicago, 4, Illinois, U.S.A. [2727]

**BOOKS, INSTRUCTIONS, ETC.**  
**WEBB'S** radio map of the world locates any station heard, size 40x30in, 4/6, post 6d., on linen, 10/6, post free.—Webb's Radio, 14, Soho St., London, W.1. Tel. Gerard 2089. [9947]

**Wanted**  
**CIRCUIT** diagram French set, Montana T9.—White Steading, Hele Hill, nr. Taunton.

**BERRY'S (SHORT-WAVE) LTD.**

Stock all types of  
**VALVES & COMPONENTS**

Send S.A.E. (1d. stamp) for List "W."  
 Telephone: HOLborn 6231.

**25, HIGH HOLBORN, LONDON, W.C.1**

**Remember-Walter**

**J.C.H. LTD**

RADIO                      RADIO                      RADIO

**STAMPINGS • CHASSIS • PRESSINGS**

FARM LANE, FULHAM, S.W.6      TELEPHONE: FULHAM 5234

It isn't . . . . . isn't what ?  
 Isn't a watt !  
 It's the c.g.s. unit of energy.

**WHAT'S "ERG" ?**

ERG is the trade mark identifying a line of products that will be available when we've finished the biggest job of all.

**ERG RESISTORS LTD.**  
 1021a, FINCHLEY ROAD, LONDON, N.W.11  
 PHONE: SPEEDWELL 6987



Printed in England for the Publishers, LITTLE AND SONS LTD., Dorset House, Stamford Street, London, S.E.1, by THE CORNWALL PRESS LTD., Paris Garden, Stamford Street, London, S.E.1. "Wireless World" can be obtained abroad from the following—AUSTRALIA and NEW ZEALAND: Gordon & Gotch, Ltd. INDIA: A. H. Wheeler & Co. CANADA: Imperial News Co.; GORDON & GOTCH, Ltd. SOUTH AFRICA: Central News Agency, Ltd.; WILLIAM DAWSON & SONS (S.A.), Ltd. UNITED STATES: The International News Co.

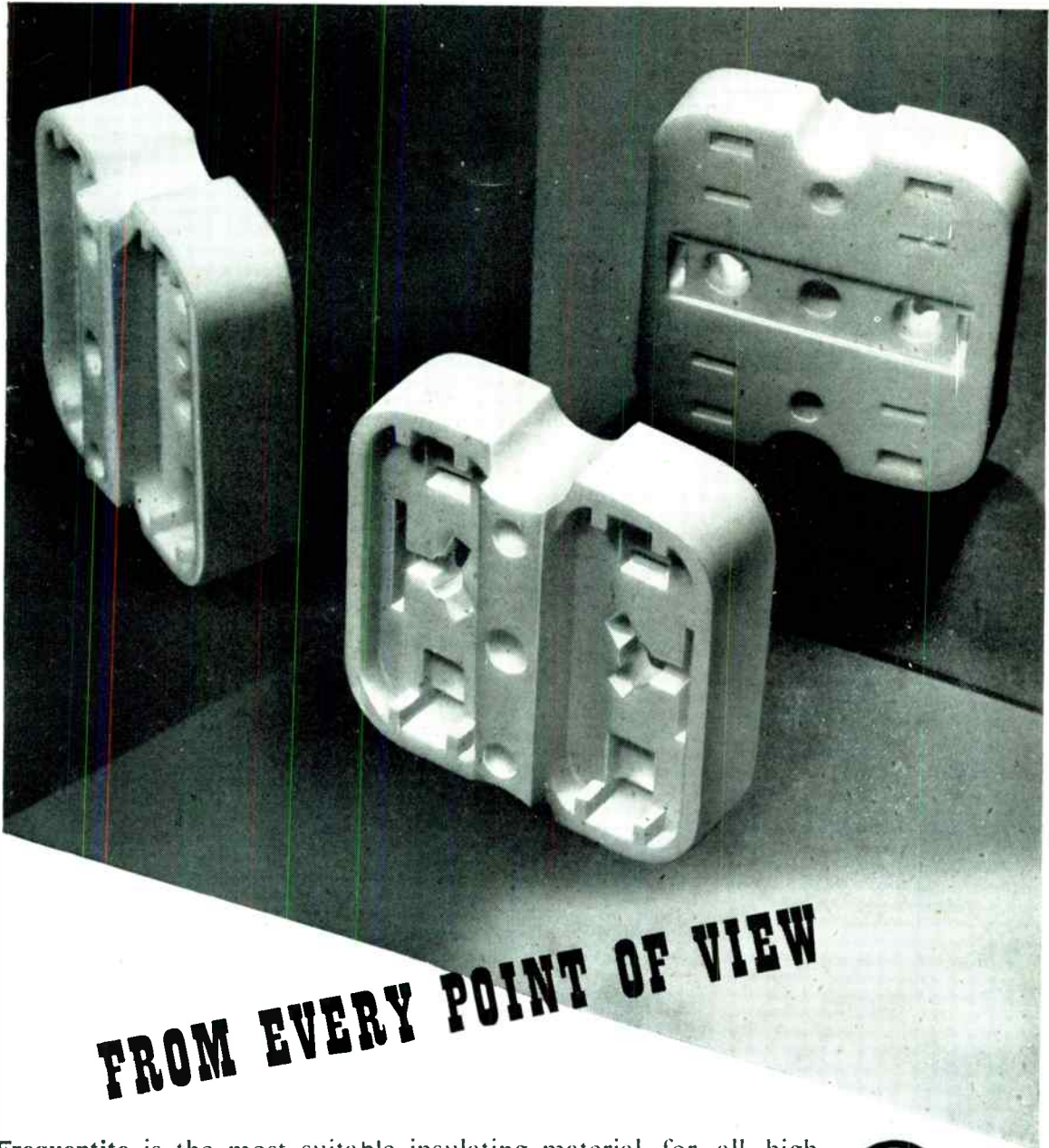

**FROM EVERY POINT OF VIEW**

Frequentite is the most suitable insulating material for all high frequency applications. Ten years ago we introduced the first British-made low-loss ceramic, and consultation with us before finalising the design of new components is a wise precaution.



**STEATITE & PORCELAIN PRODUCTS LTD.**

Head Office: Stourport-on-Severn, Worcester.

Telephone: Stourport 111.

Telegrams: Steatite, Stourport.

S.P.32

# ELECTRONIC DEVICES *for* SCIENCE *and* INDUSTRY



The G.E.C. are specialists in valves and other electronic devices which find many applications in industry and scientific research.

The following are a few of the classes of electronic tube which have already found their place in industry.

**VACUUM AMPLIFYING VALVES**

For all cases in which the amplification of small voltages is required, with continuous control of amplification over a wide range of frequencies.

As self oscillators for generation of high frequency voltage and power.

**VACUUM RECTIFIERS**

For Extra High Tension Voltages in cable and condenser testing, etc.

For power rectification at medium and high voltages.

For radio frequency detection. In peak voltmeters.



**HOT CATHODE MERCURY VAPOUR RECTIFIERS**

For high current rectified outputs in radio transmitters and power circuits.

**GASFILLED RELAYS (THYRATRONS)**

For trigger controls and various industrial research work used where an instantaneous release of power is required from a low voltage source.

**PHOTO CELLS**

Vacuum or gasfilled—with various characteristics both in applied voltages and colour response.

**ELECTROMETER VALVES**

Used in conjunction with glass electrode for pH determination.

**CATHODE RAY TUBES**

For acoustic tests, sound and waveform analysis, pressure indication, chemical analysis, educational demonstrations, monitoring, laboratory instruments, electro-medical and biological investigation, navigation aids, etc.