

Wireless World

RADIO • ELECTRONICS • ELECTRO-ACOUSTICS



NOV. 1943

1/6

Vol. XLIX. No. 11

ELECTRONIC VOLTAGE REGULATORS

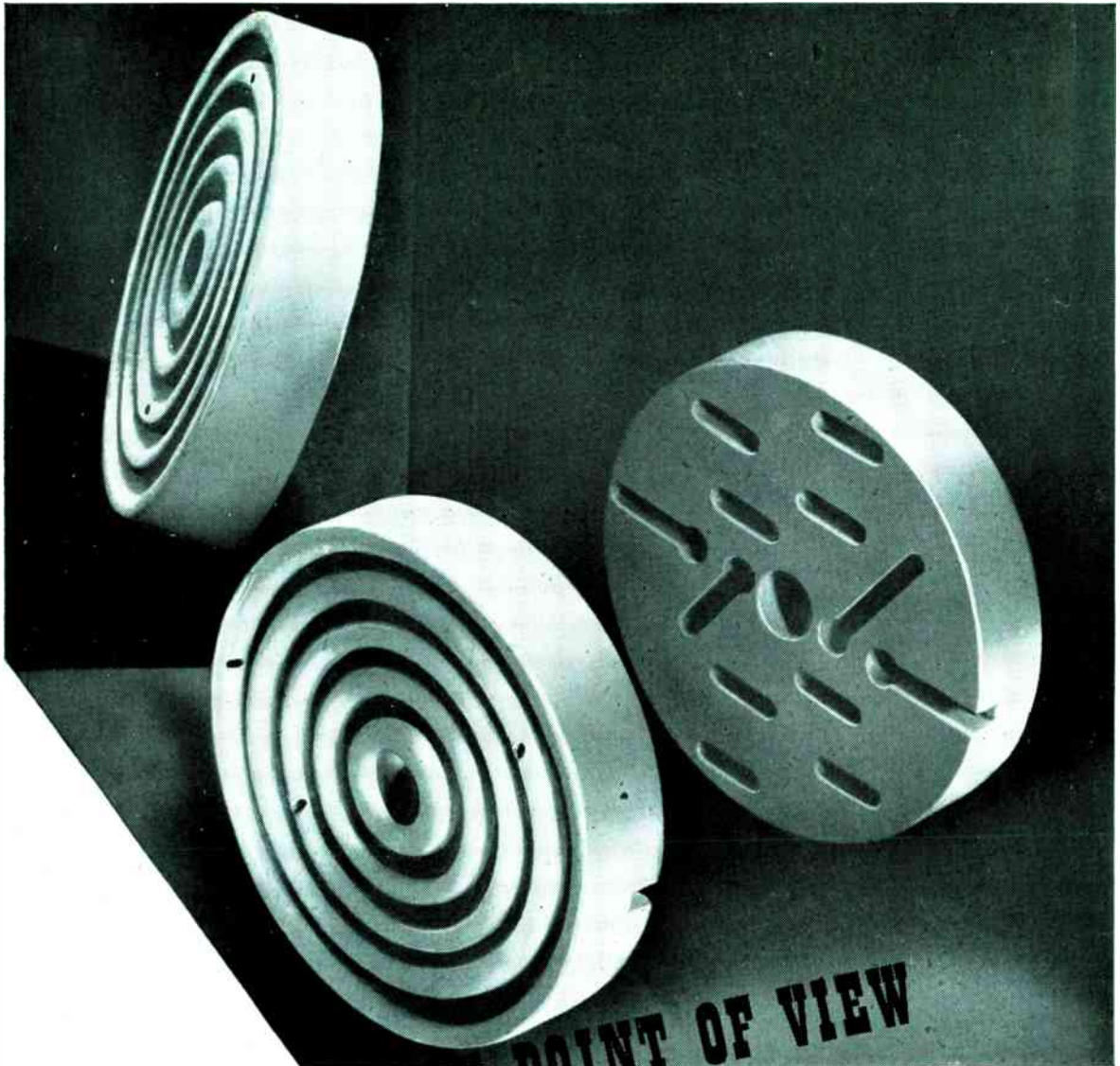

FROM EVERY POINT OF VIEW

Frequentite is the most suitable insulating material for all high frequency applications. Ten years ago we introduced the first British-made low-loss ceramic, and consultation with us before finalising the design of new components is a wise precaution.



STEATITE & PORCELAIN PRODUCTS LTD.

Head Office: Stourport-on-Severn, Worcester.

Telephone: Stourport 111.

Telegrams: Steatins, Stourport.

8, P. 33

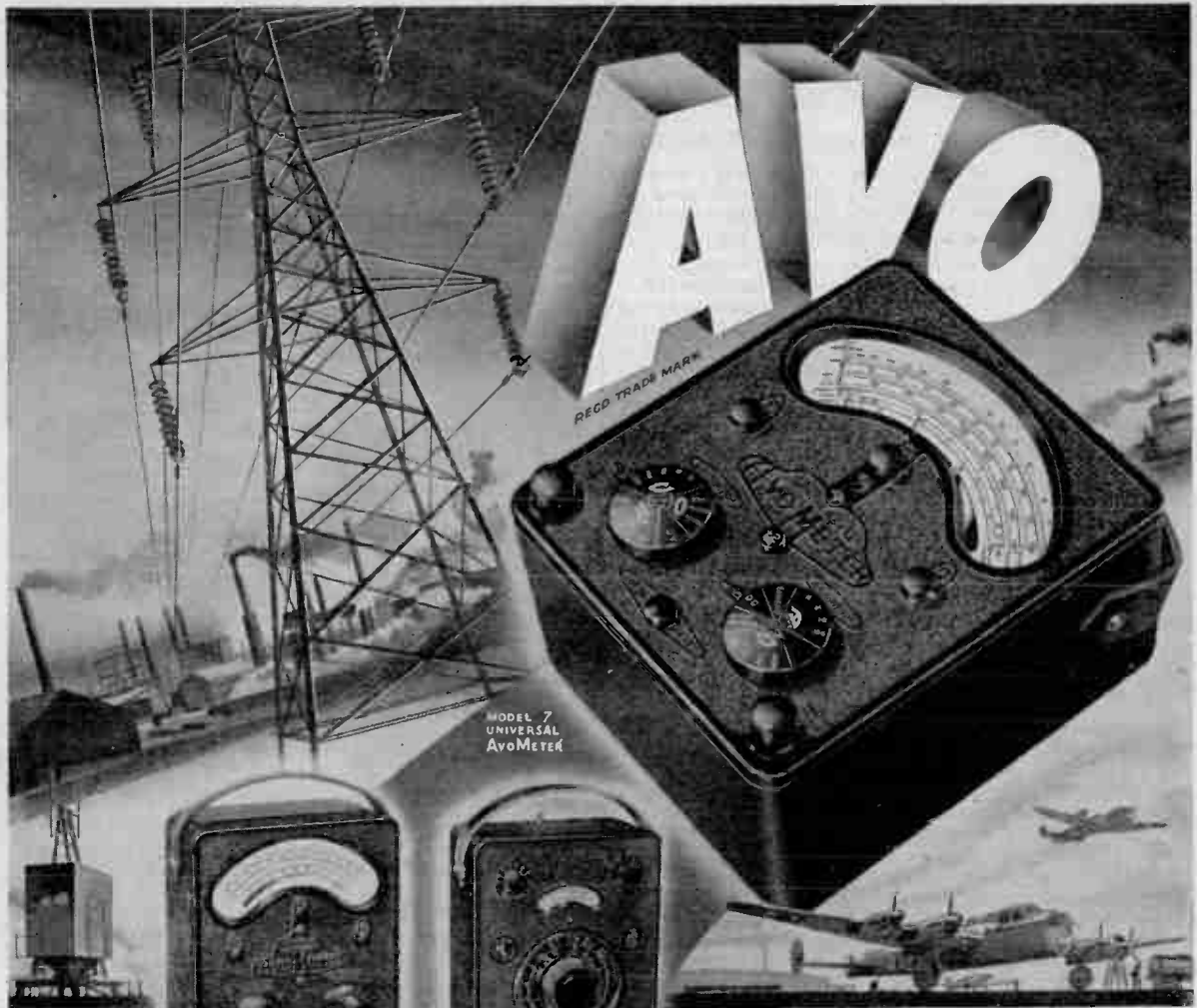

AVO

REGD TRADE MARK

MODEL 7
UNIVERSAL
AvoMeter

MODEL 40
UNIVERSAL
AvoMeter

THE "AVO"
TEST
BRIDGE

THE "AVO"
VALVE TESTER

THE
ALL WAVE
"AVO" OSCILLATOR

THE world-wide use of "AVO" Electrical Testing Instruments is striking testimony to their outstanding versatility, precision and reliability. In every sphere of electrical test work, on active service and in industry, they are maintaining the "AVO" reputation for dependable accuracy, which is often used as a standard by which other instruments are judged.

Orders can only be accepted which bear a Government Contract Number and Priority Rating.

THE AUTOMATIC COIL WINDER & ELECTRICAL EQUIPMENT CO., LTD.
 WINDER HOUSE · DOUGLAS STREET · LONDON · S.W.1 TELEPHONE: VICTORIA 3404/7

WHY ERSIN MULTICORE

the Solder wire with 3 cores of non-corrosive ERSIN FLUX is preferred by the majority of firms manufacturing the best radio and electrical equipment under Government Contracts.



WHY THEY USE CORED SOLDER

Cored solder is in the form of a wire or tube containing one or more cores of flux. Its principal advantages over stick solder and a separate flux are:

- (a) it obviates need for separate fluxing (b) if the correct proportion of flux is contained in cored solder wire the correct amount is automatically applied to the joint when the solder wire is melted. This is important in wartime when unskilled labour is employed.

WHY THEY PREFER MULTICORE SOLDER. 3 Cores—Easier Melting
Multicore Solder wire contains 3 cores of flux to ensure flux continuity. In Multicore there is always sufficient proportion of flux to solder. If only two



cores were filled with flux, satisfactory joints are obtained. In practice, the care with which Multicore Solder is made means that there are always 3 cores of flux evenly distributed over the cross section of the solder,

so making thinner solder walls than single cored solder, thus giving more rapid melting and speeding up soldering.

ERSIN FLUX

For soldering radio and electrical equipment non-corrosive flux should be employed. For this reason either pure resin is specified by Government Departments as the flux to be used, or the flux residue must be pure resin. Resin is a comparatively non-active flux and gives poor results on oxidised, dirty or "difficult" surfaces such as nickel. The flux in the cores of Multicore is "Ersin"—a pure, high-grade resin subjected to chemical process to increase its fluxing action without impairing its non-corrosive and protective properties. The activating agent added by this process is dissipated during the soldering operation and the flux residue is pure resin. Ersin Multicore Solder is approved by A.I.D., G.P.O., and other Ministries where resin cored solder is specified.

PRACTICAL SOLDERING TEST OF FLUXES

The illustration shows the result of a practical test made using nickel-plated spade tags and bare copper braid. The parts were heated in air to 250° C, and to identical specimens were applied 1/2" lengths of 14 S.W.G. 40/60 solder. To

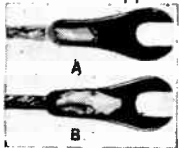

sample A, single cored solder with resin flux was applied. The solder fused only at point of contact without spreading. A dry joint resulted, having poor mechanical strength and high electrical resistance. To sample B, Ersin Multicore Solder was applied, and the solder spread evenly over both nickel and copper surfaces, giving a sound mechanical and electrical joint.

ECONOMY OF USING ERSIN MULTICORE SOLDER

The initial cost of Ersin Multicore Solder per lb. or per cwt. when compared with stick solder is greater. Ordinary solder involves only melting and casting, whereas high chemical skill is required for the manufacture of the Ersin flux and engineering skill for the Multicore Solder incorporating the 3 cores of Ersin Flux. However, for the majority of soldering processes in electrical and radio equipment Multicore Solder will

show a considerable saving in cost, both in material and labour time, as compared either with stick solder or single cored solder. Cored solder ensures that the solder and flux are put just where they are required, and by choice of suitable gauge, economy in use of material is obtained. The quick wetting of the Ersin flux as compared with resin flux in single core resin solder ensures that with the correct temperature and reasonably clean surface, immediate alloying will be obtained, and no portions of solder will drop off the job and be wasted. Even an unskilled worker, provided with irons of correct temperature, is able to use every inch of Multicore Solder without waste.

Soft solders are made in various alloys of tin and lead, the tin content usually being specified first, i.e. 40/60 alloy means an alloy containing 40% tin and 60% lead. The need for conserving tin has led the Government to restrict the proportion of tin in solders of all kinds. Thus, the highest tin content permitted for Government contracts without a special licence is 45/55 alloy. The radio and electrical industry previously used large quantities of 60/40 alloy, and lowering of tin content has meant that the melting point of the solder has risen. The chart below gives approximate melting points and recommended bit temperatures.

| ALLOY Tin Lead | Equivalent B.S. Grade | Solidus C.° | Liquidus C.° | Recommended bit Temperature C.° |
|-------------------|--------------------------|----------------|-----------------|------------------------------------|
| 45/55 | M | 183° | 227° | 267° |
| 40/60 | C | 183° | 238° | 278° |
| 30/70 | D | 183° | 257° | 297° |
| 18.5/81.5 | N | 187° | 277° | 317° |

VIRGIN METALS—ANTIMONY FREE

The wider use of zinc plated components in radio and electrical equipment has made it advantageous to use solder which is antimony free, and thus Multicore Solder is now made from virgin metals to B.S. Specification 219/1942 but without the antimony content.

IMPORTANCE OF CORRECT GAUGE

Ersin Multicore Solder Wire is made in gauges from 10 S.W.G. (.128"—3.251 m/ms) to 22 S.W.G. (.028"—.711 m/ms). The choice of a suitable gauge for the majority of the soldering undertaken by a manufacturer results in considerable saving. Many firms previously using 14 S.W.G. have found they can save approximately 33 1/3%, or even more by using 16 S.W.G. The table gives the approximate lengths per lb. in feet of Ersin Multicore Solder in a representative alloy, 40/60.

| S.W.G. | 10 | 13 | 14 | 16 | 18 | 22 |
|--------------|----|------|------|------|-------|-----|
| Feet per lb. | 23 | 44.5 | 58.9 | 92.1 | 163.5 | 481 |

CORRECT SOLDERING TECHNIQUE

Ersin Multicore Solder Wire should be applied simultaneously with the iron, to the component. By this means maximum efficiency will be obtained from the Ersin flux contained in the 3 cores of the Ersin Multicore Solder Wire. It should only be applied directly to the iron to tin it. The iron should not be used as a means of carrying the solder to the joints. When possible, the solder wire should be applied to the component and the bit placed on top, the solder should not be "pushed in" to the side of the bit.



MULTICORE SOLDERS LTD., BUSH HOUSE, W.C.2. 'Phone Temple Bar 5583/4



**T H E R E I S N O S U B S T I T U T E
F O R
E N G I N E E R I N G E X P E R I E N C E**

*

And this is obviously a matter of extent, intensity and time.

Take Electrical condensers for instance—simple in conception maybe—but demanding infinite experience and skill, to satisfy the exacting operating conditions of modern requirements. The fulfilment of these has meant the whole time occupation of highly skilled specialists, working at high pressure, in this way to earn, along with their countrymen in other spheres, the right of survival.

What a wealth of experience and technical excellence will be available to all, when happier times arrive ; and nowhere more than in Dubilier Condensers.

DUBILIER
CONDENSER CO. (1925) LTD.



NUMBER
IN SERIES

PRIMER of RUBBER BONDING

AN ELEMENTARY EXAMPLE TO PROVE A POINT

**OUT-OF-DATE METHOD
of LOCKING rubber**

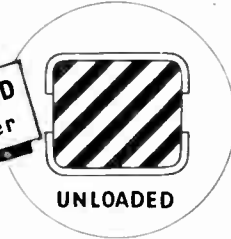

UNLOADED

Large rubber volume; no bond between rubber and metal; metal cupped pressings to contain rubber.



LOADED IN SHEAR

Small part of total rubber in work; severe stresses at metal edges; high friction and abrasion potential.



LOADED IN COMPRESSION

High stress concentration at metal edges; limited "compression" movement.

TO-DAYS METHOD of BONDING rubber



UNLOADED

High duty bond between metal and rubber; stress reducing "pips" at metal edges; precision moulded with rubber and metal.



LOADED IN SHEAR

Reduced rubber volume; freedom for shear movement within controlled limits; no stress or abrasion concentration.



LOADED IN COMPRESSION

All rubber in work; freedom from abrasion; controlled deflection; cheap metal parts.



This series, in the form of a PRIMER, should be of value to engineers and designers when they are exploring the possibility of embodying rubber as an integral part of engineering systems. We need hardly say that individual problems of vibration will receive full consideration if sent to us at Dunstable.



This is an example



RB.18

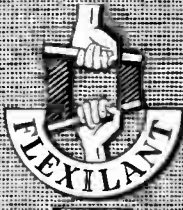

RUBBER BONDERS LTD

Engineers in Rubber bonded to metal

FLEXILANT WORKS - DUNSTABLE - BEDS.

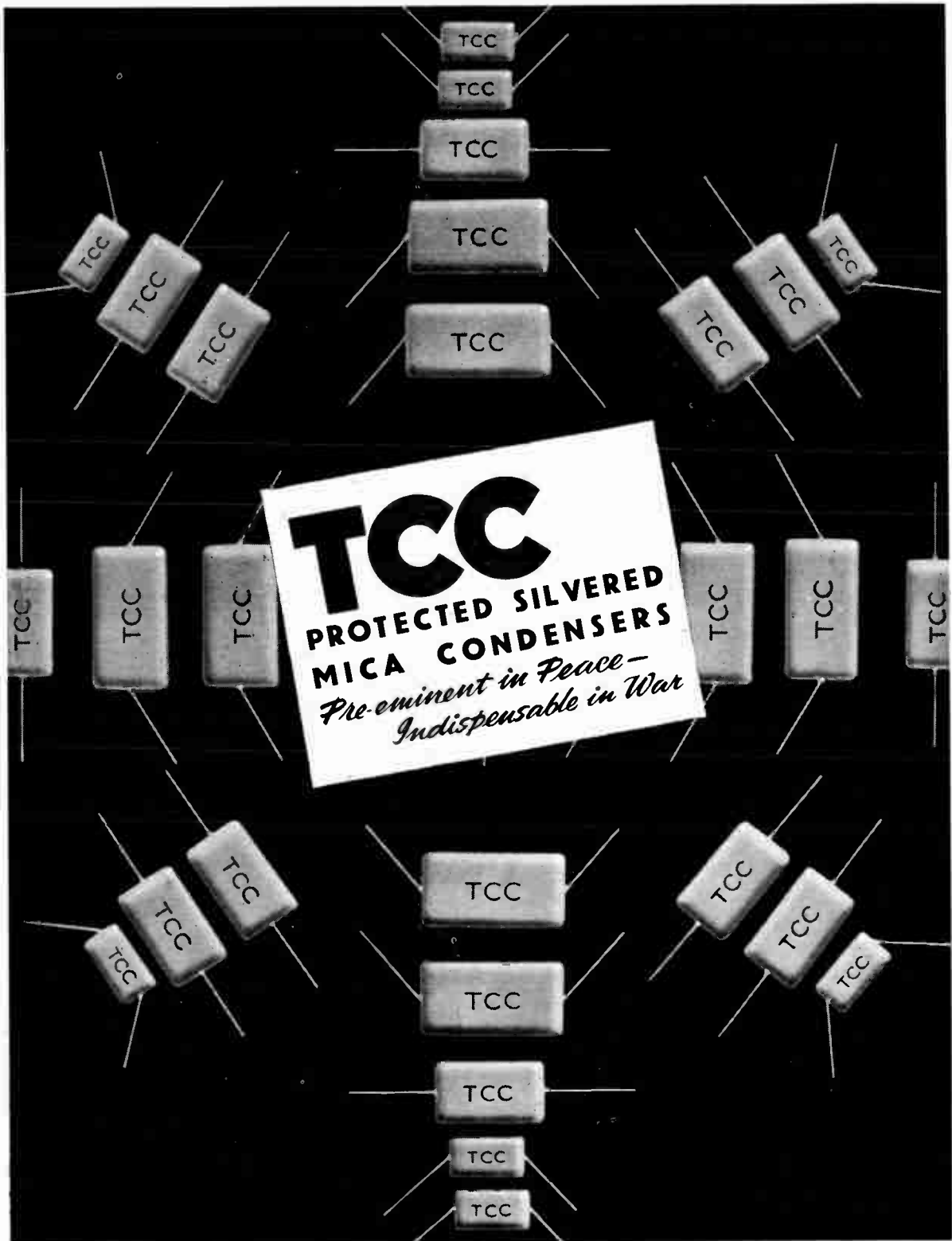

ADVERTISEMENT OF THE TELEGRAPH CONDENSER CO., LTD.

GA

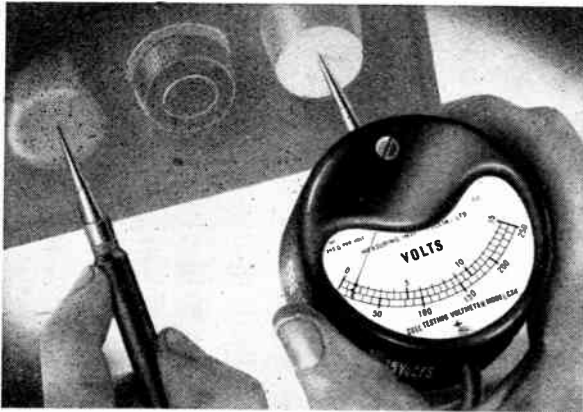

The illustration shows model CT4 double range cell testing voltmeter

ADAPTABILITY



IN THE AIR ON THE LAND ON THE SEA UNDER THE SEA

Make Sure That Your Electrical Measuring Instruments

Are Designed For The Purpose

Specialization in electrical development has dispensed with the need for 'makeshifts'. M.I.P. instruments, over a period of years have been called upon to fill so many important specific requirements that every possible contingency has been met and catered for. To-day M.I.P. precision measuring instruments are available in types for many conditions. For accurate recording always specify M.I.P.



Send us your measurement problem

**MEASURING INSTRUMENTS
(PULLIN) LTD.
ELECTRIN WORKS, WINCHESTER ST., ACTON, W.3**

ROLA

LOUD
SPEAKERS

THE WORLD'S FINEST REPRODUCERS

TRANSFORMER
LAMINATIONS

Core Widths $\frac{1}{4}$ " to 1" (E's and I's.)
EIGHT STOCK SIZES

A Comprehensive Bulletin together with details of Associates' Covers and Clamps with design data will be sent to manufacturers on request.

BRITISH ROLA LIMITED

MINERVA ROAD · PARK ROYAL · N.W.10 · W.II, London 4322

WRITE FOR
CATALOGUE
W.O./330

★ ADASTRA ★

RADIO MASTS

POLES LTD TYBURN RD ERDINGTON,
BIRMINGHAM, 24.

Enquiries should be accompanied by Government Priority Reference

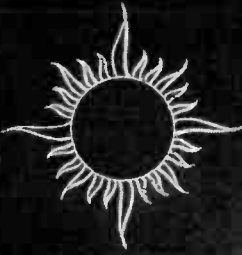

SYMBOLS OF PRECISION

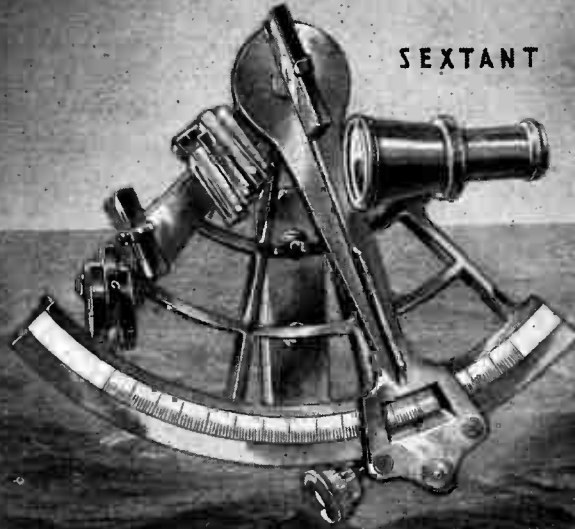

SEXTANT



MAZDA

**RADIO
VALVES**

THE EDISON SWAN ELECTRIC CO. LTD.



155, CHARING CROSS RD., LONDON, W.C.2

For full particulars write to Technical Service Department

*In all Air Warfare
Condensers are at work*



TRADE **HUNTS** MARK
The
Home of Condensers

ADVT. of A. H. HUNT LTD LONDON, S.W.18 EST. 1901

Precisely!



*for accurate
testing it
must be*

TAYLOR METERS

Write for complete details to:

TAYLOR ELECTRICAL INSTRUMENTS, Ltd., Montrose Av., Slough, Bucks
Telephone: Slough 21381 (4 lines).

Greenwood

*Wartime installations show more
conclusively than ever that*

you can

trust

TRIX

30-watt Amplifier
with Radio.



Quality
SOUND
Equipment

There are TRIX amplifiers
from 5-500 watts.
Send for details.

To priority order only

TRIX ELECTRICAL CO. LTD., 65, Bolsover St., London, W.1.
Phone: EUS 5471 2, Grams: Trizadio, Wendo, London.

F.W.S.CO.

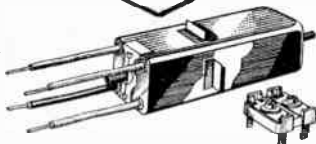

Sickles Midget Transformer and Trimmer.

OUR greatly increased manufacturing facilities in the War effort, coupled with our added production knowledge, will materially benefit you 'when Victory is won.' Quality has always been the dominant consideration in the design—in the choice of materials and in the method of manufacture of our products; and we look forward with confidence to the day when we shall once again continue our relationship with the Radio Industry of Great Britain with greater cordiality than ever before.

**I.F. TRANSFORMERS
AERIAL AND OSCILLATOR COILS
TRIMMER AND PADDER CONDENSERS
COIL FORMS, etc.**



**The F. W. SICKLES Co.
CHICOPEE, MASS., U.S.A.**

**RAYTHEON
- PROGRESS -**



THEY who are fighting under every climatic condition know the superior performance qualities of RAYTHEON tubes... their unfailing response even under wartime rigid requirements. They will not forget that RAYTHEON tubes in war even surpassed their peacetime records for long life, trouble-free operation and high quality performance.

The RAYTHEON trade mark will be familiar to thousands of servicemen and dealers when they come back to their peacetime work. they will not forget that RAYTHEON tubes unfailingly performed their duty in every emergency.

**WORLD'S LARGEST
EXCLUSIVE
TUBE MANUFACTURERS**



**RAYTHEON
PRODUCTION CORPORATION
NEWTON, MASS., U.S.A.**

**P. R. MALLORY & CO. Inc.
MALLORY**

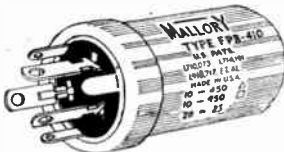

FP CAPACITORS

- Eliminate the need of special condensers.
- Less engineering expense in condenser applications.
- Less labour in assembling to chassis.
- Eliminate the need of hardware for mounting.
- Materially reduce rejects in factory and in the field.
- Eliminate 'custom-made' condensers for each application.
- Greater uniformity eliminates the need for other parts to stabilise circuit performance.
- Encased in metal and protected in all climates.
- Smaller sizes simplify design and conserve chassis space.

**P. R. MALLORY & CO. INC.
INDIANAPOLIS, INDIANA,
U.S.A.**

Radio and Electronics Division



FOR THE FUTURE

These Manufacturers will help solve your post-war problems.

Register your name now for full details which will be sent you when supply conditions again permit.

**FRANK
HEAVER
LIMITED**

**Kingsley Road, BIDEFORD,
N. Devon**

G.I.

**VICTORY
PRODUCTION**

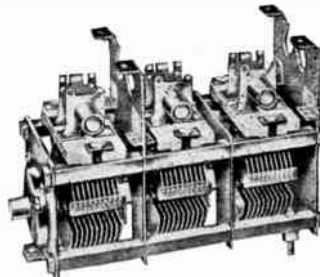

WHEN the mission of complete victory is accomplished, General Instrument will help "Win the Peace" by making the best use of still greater knowledge and experience in the manufacture of variable condensers and drives.

**THE GENERAL INSTRUMENT
CORPORATION
ELIZABETH, N.J., U.S.A.**

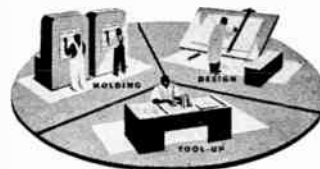

WHEN you think of plastic mouldings for post-war products we suggest you consult the Kurz-Kasch "Plastic Round Table"—a group of specialists in design, materials, tool-up and moulding. Kurz-Kasch can give you complete service under one roof, one responsibility.



KURZ-KASCH INC.
Moulders of Plastics,
**DAYTON · OHIO
U.S.A.**

ANNOUNCEMENT

WE regret that owing to pressure of Service requirements, orders for Loudspeakers and Microphones can only be accepted when accompanied by Government Contract Numbers.

A comprehensive range of Instruments is being manufactured, including Loudspeaker Units from 2½" diameter to 12" diameter; Special High Power Loudspeakers in Cabinets suitable for Tropical conditions; Hand Microphones, also Special High Sensitivity Compact Light-weight Microphones for field use; Telephone Receivers, Moving Coil Headphones, etc.

GOODMANS
INDUSTRIES LIMITED
WEMBLEY, MIDDLESEX.
LOUDSPEAKER & TELEPHONE ENGINEERS

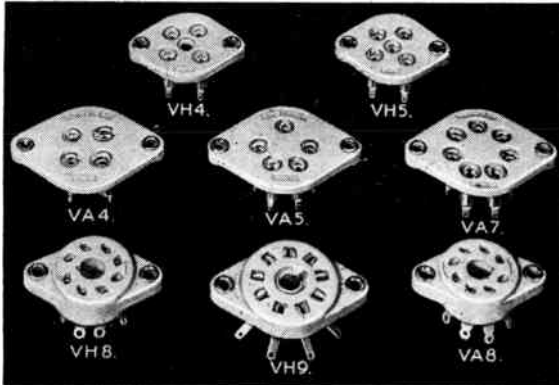

STANDARD FEATURES OF RAYMART VALVEHOLDERS

NOTE THE THREE LATEST TYPES

TYPE VH8
Mazda Octal
1/3 each.

TYPE VA8
International
Octal
1/3 each.

TYPE VH9
British "E"
type
1/9 each

We have a civilian
allocation.

Bases. These are of the famous "RMX" low-loss Ceramic. Contacts. Resilient bronze alloy, sterling silver plated, minimum contact resistance. Fixing. Floating nickel-plated eyelet (4BA clearance) fitted in strengthening boss in Ceramic. Metal floating bushes prevent cracking of Ceramic plates. Soldering. Pierced solder tag at end of sockets.

Types manufactured: English 4- and 5-pin, American 4.5, and large 7-pin.

NOTE: English types VH4 and VH5 are made in three different types with two different fixing centres.

Enquiries invited from Government Departments, Traders and Servicemen.

RAYMART
48, HOLLOWAY HEAD, BIRMINGHAM, I.
Telephone: Midland 3254.



ON ALL
GOVERNMENT
LISTS



Resistors

MANUFACTURED BY

ERG RESISTORS LIMITED

1021a, FINCHLEY ROAD, LONDON, N.W.11

PHONE: SPEEDWELL 6967

**WALTER SWITCHES
ARE MADE FOR**



**WALTER
INSTRUMENTS, LTD.**

Earls Court Exhibition Buildings, Earls Court, London, S.W. 5

FULHAM 6192

C. R. Casson 7

*A midget
in size
but a
giant in
performance*

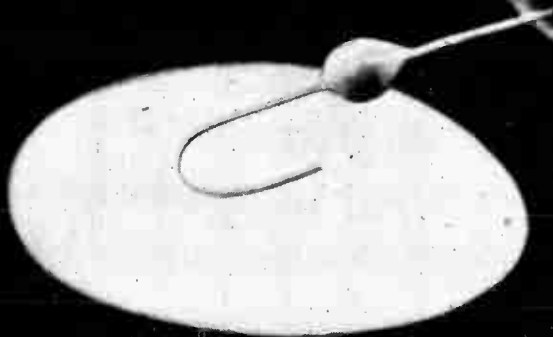

A mighty important little fellow for maintaining vital radio communications is this U.I.C. Pearl Type Ceramic Condenser.

Diameter 7 mm. max. Length 9 mm. max. Capacity range 0.5pF—5pF. Capacity Tolerance pl/mn 20%. Test Voltage 1500v D.C.

Suitable for tropical and arctic conditions.

UNITED INSULATOR CO. LTD.
12/22, LAYSTALL STREET, LONDON, E.C.1

Tel. : TERminus 7383 (5 line.)

Grams. : Calanel, Smith, London



CERAMIC
PEARL TYPE
CONDENSERS
TYPE APPROVED

THE PIONEERS OF LOW LOSS CERAMICS

Value proved by long service

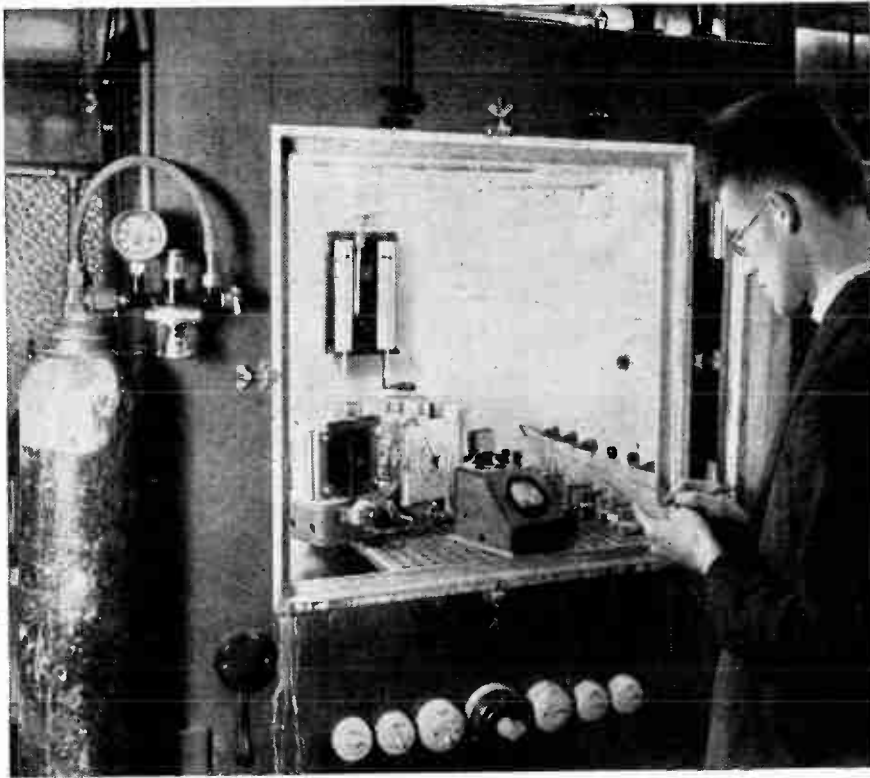

Osram Valves

MADE IN
ENGLAND

Ever since the advent of radio Osram Valves have been closely connected with all the progressive stages of development in radio science. Intensive research still goes on, and improvements in design and technique to keep pace with the advancing times will ultimately be of benefit to all.

Advt. of The General Electric Co. Ltd., Magnet House, Kingsway, London, W.C.2



Clear as a
Crystal

AND HERE IS THE REASON . .

. . . the answer has been found in Bullers Low Loss Ceramics to the problem of Dielectric Loss in High Frequency circuits.

Years of Laboratory research and development have brought these materials to a high degree of efficiency. To-day they are in constant use for transmission and reception, and play a vital part in maintaining communications under all conditions.



**Made in
Three
Principal
Materials**

FREQUELEX

An Insulating material of Low Dielectric Loss, for Coil Formers, Aerial Insulators, Valve Holders, etc.

PERMALEX

A High Permittivity Material. For the construction of Condensers of the smallest possible dimensions.

TEMPLEX

A Condenser material of medium permittivity. For the construction of Condensers having a constant capacity at all temperatures.

BULLERS, LTD.
THE HALL,
OATLANDS DRIVE,
WEYBRIDGE, SURREY

Telephone :
Walton-on-Thames 2451
Manchester Office :
196 Deansgate, Manchester.

Bullers

LOW LOSS CERAMICS

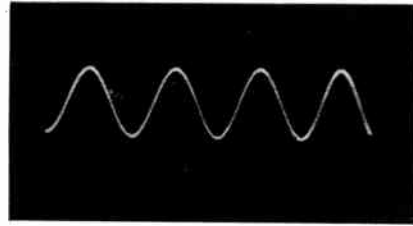

B.S.R. STANDARD SINE WAVE SOURCES

TYPE LO.800A. OSCILLATOR

—an actual oscillogram of output voltage is illustrated—gives good waveform even below 10 c.p.s. This necessitates a minimum "pull-in" between the two H.F. oscillators. Superlative design results in an almost perfect waveform from the lowest to highest frequencies. The output voltage is constant to within a few per cent. over the frequency range. This Model is chosen as a Standard by most Departments. Stable, reliable. Indispensable to all serious workers.

Output up to 5 watts. Three range output voltmeter incorporated—0-250, 0-50, 0-10.

Four output impedances, 5000, 1000, 600 and 15 ohms.
Frequency ranges (3 models),
0-1500, 0-2500 and 0-50000 c.p.s.



**BIRMINGHAM SOUND
REPRODUCERS LTD.,**
Claremont Works, Old Hill, Staffs.
Cradley Heath 8212/3. Grams: Electronic, Old Hill

HIVAC
THE SCIENTIFIC
VALVE
BRITISH MADE

Specialists in
**MIDGET
VALVES**

HIVAC LIMITED
Greenhill Crescent,
Harrow on the Hill, Middx.

Telephone: Harrow 0895.

LINAGLOW LIMITED

Radios

7-Valve Superhet Receiver

Specification: 3-WAVEBAND 15/52, 200/550, 800/2,000 metres. Separate tone and volume control, gramophone pick-up connections. Circuit in brief: Triode Hexode Freq. Changer followed by 465KC I.F. Stage, which includes a High Efficiency Iron-cored 2nd I.F. Quality Diode Detector feeding Triode Amplifier followed by Phase Inverter and two 6V6 valves in Push Pull,

30-Watt P.A. Amplifier.

A High Quality Amplifier, using finest components and Red "E" Valves. Circuit: High Resistance input feed through two separate input sockets or through pre-amplifier socket into two series connected valves with tone and volume control followed by twin valve acting as Amplifier and Phase Inverter feeding into two High Wattage Output Pentodes connected in Negative feed back. Class A B Circuit: 200/250 volts A.C. chassis finished in dark grey. 16 gauge steel. Brand new pre-war manufacture. Amplifier is fitted with Multi-Ratio Output Transformer to take from one to forty-four 5,000 ohm speakers, also 15 ohm speaker and 600 ohm line. Separate Stand-by Switch.

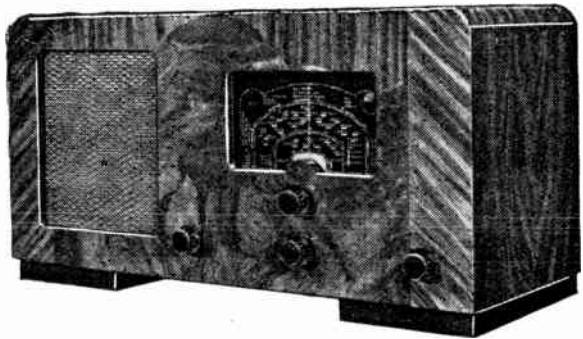

giving a Power Output of 8.5 watts. Contained in very well finished walnut veneered cabinet. 200/250 A.C. Horizontal Model, illustrated (Dim. 24in. x 12in. x 11in.) **33 guineas**

Amplifier with valves suitable for gram. microphone and radio inputs, **Price £35 10 0**

Amplifier with valves and 20in. Horn P.A. Speaker and output transformer, **Price £45 0 0**

RADIO MECHANIC'S TOOLS. Set of 3 screwdrivers, bright steel shaft, insulated handles, also set of 3 Box Spanners, 2, 4 and 6 B.A., with Tommy Bar, at 10/6 complete set.

RADIO MECHANIC'S ELECTRIC SOLDERING IRON. 230/250 v. AC/DC. Nickel plated body, pencil bit, complete with flex, 13/6.

TUBULAR PAPER CONDENSERS. 350-500 v., D.C. working. .0001, .0003 mfd., 4/- doz.; .001, .004 6/- doz.; .01, 7/- doz.; .05 mfd., 9/- doz.; .1 mfd. 12/- doz.; 23 mfd. 15/6 doz.; or assorted parcel of 50 for 27/6. Minimum orders, 1 doz. any type.

SILVER MICA CONDENSERS. Flat wire-end. Assorted values, 17/6 per 100 (not more than 5 alike).

VOLTAGE DROPPING AND LINE CORD REPLACEMENT RESISTORS.

.3 amp. 750-ohm LINE CORD RESISTOR Chassis mounting with adjustable slider, at 6/6. As above, .2-amp., at 5/8.

SPECIAL HEAVY DUTY RESISTORS. 5-watt, for bias, etc., all values from 25 to 2,000 ohm, with copper clips, 1/9 each. Similar to above, but 10-watt, 2/3.

50-ohm centre tapped resistor, tapped at 25 ohm, for pilot lamps, 2/-.

SPECIAL MULTI-LINE CORD RESISTOR. 5 tappings 50 ohm, 1 tapping 750 ohm, with slider, .2 amp., 8/6. 950 ohm .2 amp. Chassis mounting, heavy duty on porcelain former, 3 adjustable tappings, 8/6 each.

UNIVERSAL RESISTOR, suitable for practically every type of American and British AC/DO Receiver, supplied in safety metal cage with asbestos lining. Specification:—750 ohms, .3 amp. with four sliders for adjustable tappings, 12/6 each.

UNIVERSAL RAZOR RESISTANCE, suitable for practically every type of Electric Razor, drops voltage from 200/250 to 100/110 v. Supplied in "safety" metal cage with asbestos lining.

Specification:—1,500 ohms with adjustable slider, 10/6.

LINE CORDS. 2-way, 360 ohms, 8/6; 480 ohms, 11/-; 600 ohms, 13/8. 3-way heavy duty, .3 amp., 360 ohms, 13/8; 480 ohms, 17/6; 600 ohms, 21/-.

LOUDSPEAKER TRANSFORMERS. Tapped Pentode Output, 75 m.a., ratios 42:1 and 55:1, at 10/6; Pentode output, 75 m.a., ratio 35:1, at 9/6; Push-Pull output, tapped Primary and Secondary, 120 m.a., ratios 10:1, 5:1, 3.5:1, at 15/-.

MAINS TRANSFORMERS. 200/250, 350-0-350, 4 v., 6 amp., 4 v., 3 amp., 120 m.a. or 6 v., 3 amp., 5 v., 2 amp., 37/6 each.

Special Offer of SERVICE KITS

No. K.1. 1 8-mfd. 450 v. electrolytic, 6 asstd. silver mica condensers, 6 asstd. carbon wire-end resistors, 6 asstd. 1-, 2- and 3-gang I.F. and aerial trimmers, 10/6 per kit.

No. K.2. 1 8 x 8 mfd. 450 v. electrolytic, 6 asstd. silver mica condensers, 6 asstd. carbon wire-end resistors, 6 asstd. 1-, 2- and 3-gang I.F. and aerial trimmers, 6 asstd. tubular paper condensers, 12/6 per kit.

No. K.3. 1 each 8 x 8 mfd. and 8 mfd. 450 v. electrolytic, 6 asstd. silver mica condensers, 6 asstd. carbon wire-end resistors, 6 asstd. 1-, 2- and 3-gang I.F. and aerial trimmers, 6 asstd. tubular paper condensers, 1 push-pull 4-point radio switch, 22/6 per kit.

No. K.4. 2 each 8 x 8 mfd. and 8 mfd. 450 v. electrolytics, 6 asstd. silver mica condensers, 6 asstd. carbon wire-end resistors, 6 asstd. 1-, 2- and 3-gang I.F. and aerial trimmers, 50 asstd. tubular paper condensers, 3 asstd. volume and tone controls, 2 lengths 360 ohm line cord, 3 push-pull 4-point radio switches, 1 roll insulating tape, 1 tone control, 42/6 per kit.

No. K.5. 3 8-mfd., 2 8 x 8 mfd. 450 v. electrolytics, 1 25 x 12 v., 1 5 x 5 x 35 v., 50 asstd. silver mica condensers, 50 asstd. 1-, 2- and 1-watt carbon wire-end resistors, 50 asstd. 1-, 2- and 3-gang I.F. and aerial trimmers, 50 asstd. tubular paper condensers, 3 asstd. volume and tone controls, 2 lengths 360 ohm line cord, 3 push-pull 4-point radio switches, 1 roll insulating tape, 2 line cord replacement resistors, 24/12/6 per kit.

No. K.6. 12 8 mfd., 6 8 x 8 mfd. 450 v. electrolytics, 1 16 x 8 mfd. 500 v., 1 16 x 16 mfd. 500 v., 1 32 mfd. 350 v., 1 25 x 12 v., 1 25 x 25 v., 1 5 x 5 x 35 v., 1 50 x 50 x 12 v., 1 10 mfd. x 25 v., 200 asstd. silver mica condensers, 200 1-, 2- and 1-watt carbon wire-end resistors, 200 1-, 2- and 3-gang I.F. and aerial trimmers, 100 wire-end tubular paper condensers, and tone controls, 1 pentode output transformer, 1 push-pull output transformer, 2 rolls insulating tape, 3 line cord replacement resistors, 4 lengths 360 ohm 2-way line cord, 6 push-pull 4-point radio switches, 144 soldering tags, 1 set radio mechanic's tools, 6 Amphenol type valve holders, 24 yards pushback wire, 222/10.

AUTO-TRANSFORMERS. Step up or down, 110/210/220/240 v. 100-watt, 32/6.

LOUDSPEAKERS. Rola P.M. 3-ohm voice coil, without transformer, 5in., 21/-; 6 1/2in., 22/6; 8in., 25/6. Any of the above can be supplied with pentode output transformer at 10/6 extra. With multi-ratio at 15/- extra.

8 1/2in. GOODMAN P.M. LOUDSPEAKER. Extra heavy magnet for Midgets and communication Sets. Price 25/6 each.

DPDT SWITCHES. Panel mounting, P.O. type, 2/6 each. VOLUME CONTROLS. 1,000, 5,000, 10,000, 20,000, 25,000, 50,000, 100,000-ohm; 1/2, 1, 1 and 2 megohm, without switch, 4/9 each. As above, with switch, 6/9 each.

CYCLE DYNAMOS. Complete with brackets for fitting and leads. Special Offer, 15/9 each.

FLAT FLEX. 9-way, 14/36, 18/20ft. lengths, suitable for amplifiers, extension speakers, remote control and many other purposes. Finest quality pre-war manufacture, 7/6 per coil.

L.F. CHOKES. 20 hys., 100 m.a., brand new, 16/9.

OAK VENEERED LOUDSPEAKER CABINETS. Modern design, fitted silk and baffle. Dim.: 12in. x 12in. x 8in., 25/-; As above, but complete with 8in. P.M. speaker, 49/6.

ATTRACTIVE EXTENSION LOUDSPEAKER in Walnut Cabinet, dim.: 9in. x 7in. x 7in., at 32/6.

VALVE HOLDERS—AMPHENOL TYPE. International or Mazda Octal, chassis mounting, at 1/- each.

VALVES

LEASE-LENDED AMERICAN TYPES AT B.O.T. CONTROLLED RETAIL PRICES. FOR REPLACEMENT PURPOSES ONLY.

1H5, 6J5, 12F5, 12SF5, at 9/2; 1A5, 1C5, 1N5, 12Z3, 25Z5, 35Z4, 35Z5, at 11/-; 6Q7, 12Q7, 12SQ7, at 11/7; 1A7, 6F6, 6K7, 12J7, 12K7, 12SK7, 25L6, 35L6, 36, 42, 50L6, at 12/10; 4A8, 6K8, 68A7, 128A7, at 14/-; 25A7, 32L7, 70L7, 83, 6B8, at 15/3.

Also British Valves at Manufacturer's List Prices. AC/MK, at 10/6; UU6, UU7, at 11/-; TDD4, at 11/7; AC/VP2, CL4, EF39, KTW61, VP41, at 12/10; AC/TP, ECH3, FC13, X63, X65, at 14/-; EL35, at 18/4.

All above prices include Purchase Tax. Add 3d. per valve postage.

HUMDINGERS. 30, 25,000 and 50,000 ohms, 6d. each.

SCREENED INTERLACED FLEXIBLE MICROPHONE CABLE. Single. Special Offer, 9d. per yd. Pre-War Super quality, 1/3 per yd. Twin, 1/8 per yd.

BATTERY LEADS. 4-way with Wander Plugs, best quality, 1/3 each.

D.P. SWITCHES. 4-point push-pull, usual price 1/6. 9d. each.

CALLERS to Show Rooms, 61 HIGHGATE HIGH ST., N.6.

Phone: MOUntview 9432.

LINAGLOW LIMITED

HOURS OF BUSINESS 9 a.m. to 5.30 p.m.

Saturday, 9.30 a.m. to 12.30 p.m.

POST ORDERS to Dept. M.O.4,

3 HAMPSTEAD LANE, N.6.

CASH WITH ORDER ONLY.

An APPRECIATION

—to readers of the
Wireless World

Behind the advertising now appearing in the National, Provincial, and Trade Press is a sincere wish on our part to render to all owners of our products a maintenance service that will ensure continued listening.

A good deal of the success of our effort arises from the generous help given to owners of our receivers by Service Engineers and readers of this journal and we are appreciative and grateful for this valuable support.

We are convinced that there is still much to be done. We are, therefore, continuing to draw the attention of owners of our receivers to our own readiness to help and to emphasise the value of the local dealer who is qualified and ever ready to help.

ULTRA ELECTRIC LIMITED

WESTERN AVENUE, ACTON, W.3

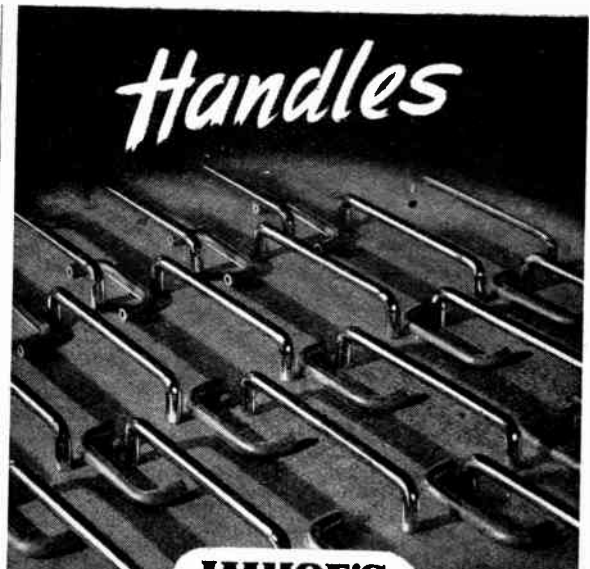

Handles

IMHOF'S

If you have a handle problem and you are on Priority Work, why not have a word with IMHOF'S Engineering Division? We have successfully handled many of every shape and size, perhaps we can grasp yours too.

ALFRED IMHOF, LTD., 112-116, NEW OXFORD STREET, LONDON, W.C.1. TEL.: MUSEUM 5944

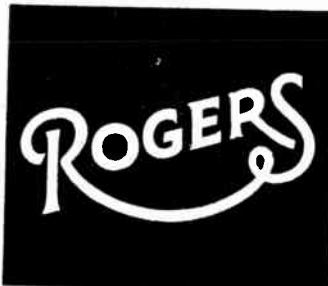

Postwar industry will be making wider use of industrial electronic technique developed during recent years. In this work Rogers Radio Tubes—the tubes which opened the way to all-mains wireless—have played and will play a recognised part. Rogers with an established reputation for quality, produce all standard types of radio receiving tubes, power tubes for radio transmission, audio frequency amplification and industrial electronic applications generally. At present engaged solely on official work, they look forward to future co-operation over a wide field of industry.

ROGERS RADIO TUBES LTD.

TORONTO (ONTARIO) CANADA

A subsidiary of BROADCAST RELAY SERVICE LIMITED,
VICTORIA STATION HOUSE, VICTORIA ST, LONDON, S.W.1.

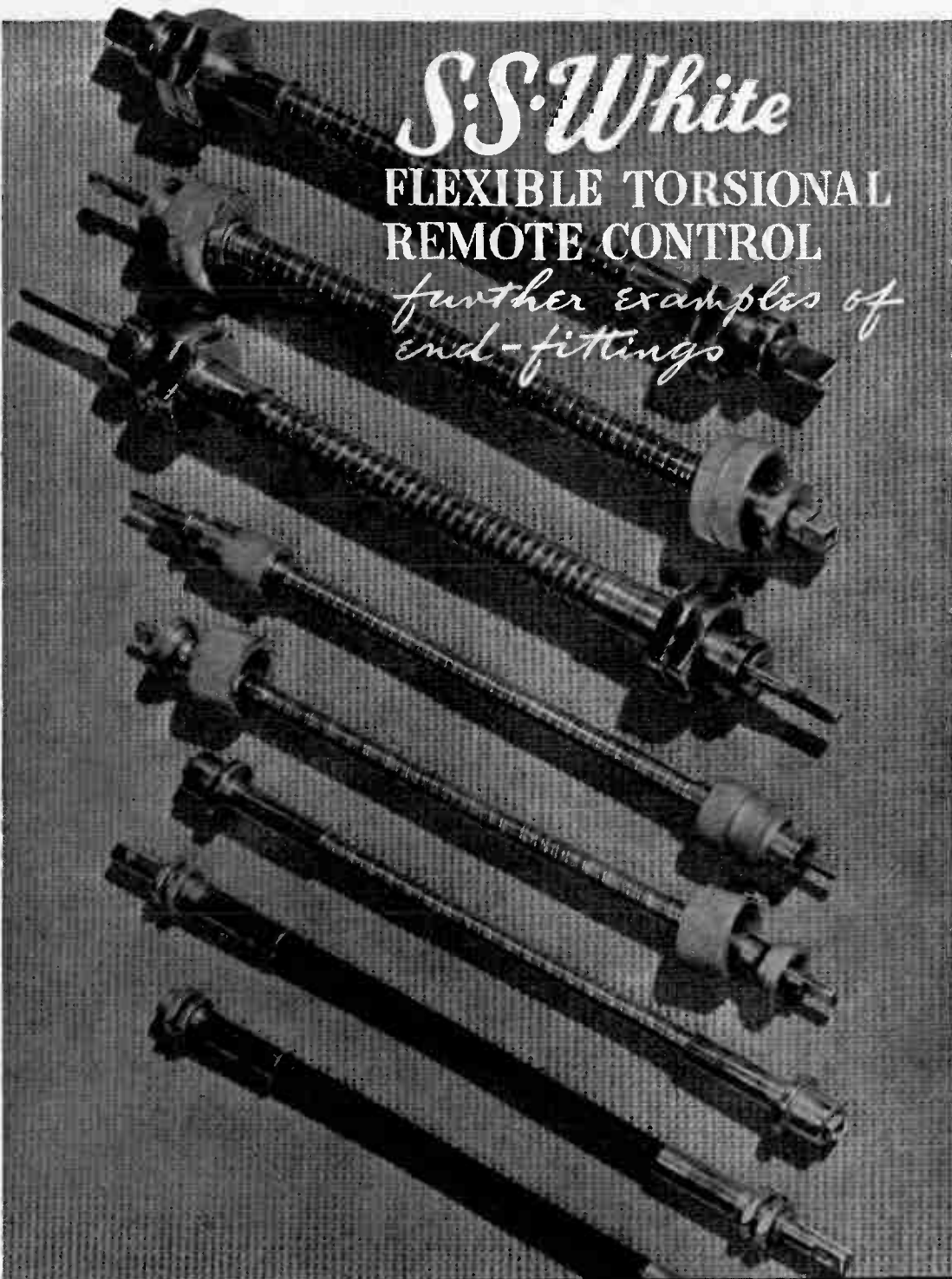

S.S. White

FLEXIBLE TORSIONAL REMOTE CONTROL

*further examples of
end-fittings*

THE S. S. WHITE COMPANY • BRITANNIA WORKS • ST. PANCRAS WAY • CAMDEN TOWN • LONDON N.W.1.
Cable Address : WHICODENTA, WESDO, PHONE, LONDON Telephone : EUSTON 4758 - 4759

W.I.16

Robert Sharp and Partners

B

WHARFEDALE

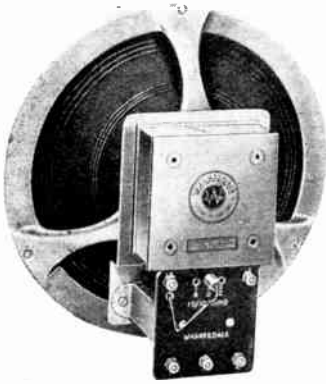

GOLDEN CHASSIS

Basically unchanged since 1935 . . . and still in the forefront to-day!

The Response Curve here shown was taken nearly 7 years ago and it has been found impossible to improve on it by any change in the Cone. Improvements to the suspension have brought the Cone Resonance down to below 75 C.P.S. Used by B.B.C., G.P.O., etc.

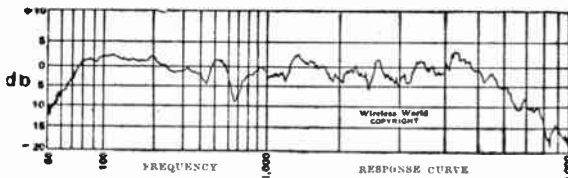

PRICE 70. - (without Transformer). PRIORITY ORDERS ONLY
WHARFEDALE WIRELESS WORKS
 HUTCHINSON LANE, BRIGHOUSE, YORKS.

MUSIC WHILE YOU WORK

For buildings up to 5,000 sq. ft.
 EARLY DELIVERY

For full details of equipment please write:

R. M. ELECTRIC LTD.

TEAM VALLEY
 GATESHEAD, 11

Electronic Engineering Services, Ltd.

24 STANLEY ROAD HEATON MOOR
 STOCKPORT
 TELEPHONE HEATONMOOR 3107

FOR AMERICAN EQUIPMENT

TRANSMITTERS AND RECEIVERS: A WIDE RANGE OF BOTH A.M. AND F.M. AVAILABLE. SPECIAL U.H.F. HIGH GRADE EQUIPMENT BUILT TO SPECIFICATION.

INSTRUMENTS: TEST GEAR OF NON-STANDARD TYPE BUILT TO SPECIFICATION.

MIDGET COMPONENTS: VALVES, CRYSTAL EARPHONES, VARIABLE & FIXED CONDENSERS, RESISTORS, CHOKES, ETC.

GENERAL: WE WELCOME ENQUIRIES FOR EQUIPMENT AND COMPONENTS UNOBTAINABLE IN THIS COUNTRY.

PRIORITIES ESSENTIAL.

The Voice of the Services



SIGNALLING EQUIPMENT

LTD.

Specialists in Morse Equipment

Makers of Small Transformers, Heavy Duty Resistances, Plugs and Sockets, Fuse Holders, Electric Bells, Buzzers, and Switches. Also Plastic Mouldings, Coil Windings, Light Pressings, Turned Parts, and other components and accessories for the Wireless and Electrical Trades

Merit House, Southgate Road, Potters Bar
 Phone: Potters Bar 3133. Telegrams & Cables: Sel, Potters Bar



GRAMPIAN

'SOUND IN SOUND'

- ★ SPEAKERS
- ★ AMPLIFIERS
- ★ MICROPHONES

WHEN HAPPY DAYS ARE HERE AGAIN



GRAMPIAN REPRODUCERS LTD. HAMPTON ROAD, HANWORTH, MIDDLESEX.

Telephone: FELtham 2657-8

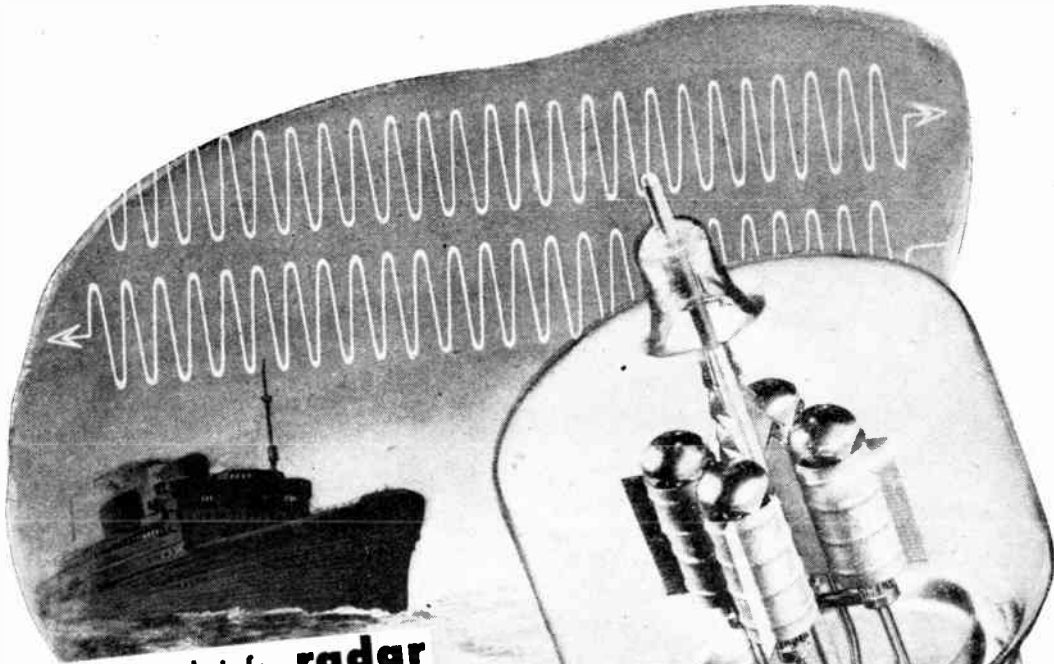

electronic briefs: radar

Radar is a method of transmitting ultra-high-frequency radio waves to an object which reflects the wave back to its source. The time required for the round trip from the transmitter to the object and back to the receiver is the measure of the distance to the object. The direction is established through the use of directional wave transmission.

High transmitter power is essential in radar for the amount of energy which is reflected is extremely small. Plate voltages are in the order of tens of thousands of volts and plate currents are measured in tens of amperes. The vacuum valves used in such equipment must be capable of operating efficiently and dependably over long periods under extremely heavy loads.

High voltage, high frequency, operation at absolute peak emission...ability to stand momentary overloads of as much as 400%...unconditional guarantee against emission failure due to gas released internally...are the features which marked Eimac valves as ideal for this important application. These are some of the reasons why Eimac has been "Standard" in Radar transmitters for the past number of years. Just one more proof that Eimac valves are first in the important new developments in electronics.

EIMAC
3041

EITEL-McCULLOUGH, INC., SAN BRUNO, CALIF.
Export Agents
FRAZAR & HANSEN, 301 Clay Street San Francisco, California
Follow the leaders to

Eimac
VALVES



Accessory after the fact

WHEN Balzac designed his house, with artistic eccentricity he made no provision for the staircase. It had to be built on outside.

Simmonds AEROCESSORIES are not accessories after the fact. Whether they lengthen the life of a power unit, as in the case of the Fram Oil and Engine Cleaner, or whether, like the Simmonds Nut or the Spire Nut, they save time, materials and labour, they are designed to be an integral part of the whole.

Designed after a specialised diagnosis of a given problem, Simmonds products anticipate the needs of the planner. They are AEROCESSORIES before the fact.

S I M M O N D S

In high service to
AERONAUTICAL, INDUSTRIAL & MARINE
Construction

THE SIMMONDS NUT · PINNACLE NUT · SPIRE NUT · SIMMONDS INSTRUMENTS,
CONTROLS AND ELECTRONIC PRODUCTS · FRAM OIL AND ENGINE CLEANER

SIMMONDS AEROCESSORIES LTD.
GREAT WEST ROAD, LONDON

A COMPANY OF THE SIMMONDS GROUP

LONDON MELBOURNE MONTREAL PARIS NEW YORK

Wireless World

Radio • Electronics • Electro-Acoustics

33rd YEAR OF PUBLICATION

NOVEMBER 1943

Proprietors :
ILIFFE & SONS LTD.

Managing Editor :
HUGH S. POCKOCK,
M.I.E.E.

Editor :
H. F. SMITH.

Editorial, Advertising
and Publishing Offices :

DORSET HOUSE,
STAMFORD STREET,
LONDON, S.E.1.

Telephone :
Waterloo 3333 (35 lines).

Telegrams :
"Ethaworld, Sedist, London."

△

**PUBLISHED
MONTHLY**

Price : 1/6

(Publication date 25th
of preceding month)

Subscription Rate :
Home and Abroad
20/- per annum.

| | |
|---|-----|
| EDITORIAL. Restarting Television | 319 |
| CINEMA SOUND QUALITY. By J. Moir, A.M.I.E.E. | 320 |
| RADIO DATA CHARTS—12. By J. McG. Sowerby, B.A., Grad.I.E.E... .. | 324 |
| NEWS IN ENGLISH FROM ABROAD | 326 |
| ELECTRONIC VOLTAGE REGULATORS. By F. Livingston Hogg. | 327 |
| COMMANDO SIGNALS | 332 |
| SINGLE-VALVE FREQUENCY DIVIDER. By Patrick F. Cundy, A.M.I.E.E., (G2 MQ) | 335 |
| " WIRELESS WORLD " BRAINS TRUST | 338 |
| LOW-TENSION SOLDERING IRONS | 340 |
| WORLD OF WIRELESS | 342 |
| LETTERS TO THE EDITOR | 344 |
| RECENT INVENTIONS | 346 |
| RANDOM RADIATIONS. By " Diallist " | 348 |
| UNBIASED. By Free Grid | 350 |

Branch Offices :

COVENTRY :
8-10, Corporation Street.
Telephone : Coventry 5210.
Telegrams :
" Autocar, Coventry."

BIRMINGHAM :
Guildhall Buildings,
Navigation Street, 2.
Telephone :
Midland 2971 (5 lines).
Telegrams :
" Autopress, Birmingham."

MANCHESTER :
260, Deansgate, 3.
Telephone :
Blackfriars 4412 (4 lines).
Telegrams :
" Iliffe, Manchester."

GLASGOW :
26B, Renfield Street, C.2.
Telephone : Central 4857.
Telegrams : " Iliffe, Glasgow."

△

As many of the circuits and apparatus described in these pages are covered by patents, readers are advised, before making use of them, to satisfy themselves that they would not be infringing patents.

" HYPERLOY "

TRANSFORMERS AND CHOKES

A range of high-performance, space-saving Components designed to meet the most exacting requirements of modern Electronic and Communications equipments.

- Small in size
- Weighing only 2 oz.
- Meeting the most rigid Tropical Specification
- Easily mounted in any position
- Manufactured in a variety of windings to meet many diverse applications

★ Owing to wartime restrictions on supply of raw materials, it is not possible to supply Wearite Components for purposes other than those connected directly with the war effort.

WRIGHT & WEAIRE LTD.

HIGH ROAD, TOTTENHAM, N.17

Telephone : TOTTENHAM 3847-8-9





X-Rays

There are no fanfares for him; no news-reels show him in action; he wields no weapons more lethal than a slide-rule. But he is instrumental in placing a great invisible power in the hands of others.

He—and his colleagues of the research and development laboratories — have made it possible to see deep into the heart of the metal of vital things like aero engines and gun barrels, to make sure that no hidden flaws exist; they have

given to doctors and surgeons an ally of ever-increasing power and scope for diagnosis and cure; to them belongs much of the credit for the part which mass radiography will play in the final elimination of the scourge of tuberculosis.

He and his colleagues have contributed greatly to Philips leadership in the field of X-rays. Their knowledge and experience are of vital importance to the nation today.

PHILIPS



RADIO ★ LAMPS

AND ALLIED ELECTRICAL PRODUCTS

PHILIPS LAMPS LTD., CENTURY HOUSE, SHAFTESBURY AVENUE, W.C.2 (28D)

Wireless World

Radio • Electronics • Electro-Acoustics

Vol. XLIX. No. 11

NOVEMBER 1943

Price 1s. 6d.

Restarting Television

A No. 1 Post-war Priority

IT is perhaps significant, and certainly gratifying, that several prominent figures in the world of wireless have, in recent public pronouncements, made more than passing reference to the problems involved in restarting our television service. That the service should be restarted with a minimum of delay when the war ends will, we think, be generally agreed in wireless circles, but perhaps not quite so readily among the general public or even by the Government. In a period of shortages—and we can expect them to persist for some time after the war—it can be argued with every show of plausibility that a form of entertainment with a very limited audience is by no means a “No. 1 priority.” But to do so is to take a very short view; it would be a thousand pities if we were to lose through niggardliness the lead in television established before the war. In any case, television is likely to develop into something much greater than a vehicle for light entertainment, and we feel no shame in pleading for the diversion of the tiny fraction of our national resources necessary for its early re-establishment.

To ensure a quick start, a decision must be made at once on the standards of transmission to be adopted. The alternatives before us have been clearly stated by the Deputy Director-General of the B.B.C., and are reported elsewhere in this issue. Briefly, we can reinstate the service almost at once with virtually 1939 standards, or we can wait for a considerable time until a much more advanced system is put into operation. Sir Noel Ashbridge stressed the fact that there is no worth-while middle course or compromise. Accepting that, it seems easy to make a choice; let us begin where we left off; any kind of service is better than no service at all. But that is not the whole story.

The arguments for and against retaining the pre-war standards for immediate post-war use were ably presented by T. E. Goldup in his recent inaugural address as Chairman of the Wireless Section of the I.E.E. In support of the “ready-made” system, he pointed out that the carrier frequency employed (45 Mc/s) gives a minimum of

trouble from echoes, and allows standard valve types to be used in receivers, for which the manufacturing technique is already well established. Further, the system probably lends itself quite well to extension to the provinces.

In discussing points in favour of an improved system, Mr. Goldup put improved definition, of a standard comparable with that of the cinema, as the main factor. That implied an increase in bandwidth and carrier frequency, the practical adoption of which depend “upon a large number of very controversial technical considerations.” Experimental work in this direction was welcomed as likely to lead, not only to improved definition, but also to colour representation and a wider range of subjects for the television camera.

Mr. Goldup then put forward a suggestion that we think, if it were given effect, would have the desired results of “getting things moving” and stimulating public interest and support. He said: “Those who are expert in the problems of television transmission and reception realise the magnitude of the problem of increasing picture definition, and it may be best in the immediate post-war period for the old television system to be run side by side with an improved system in an experimental stage. Then by gradual solution of the technical problems, this improved system may finally arrive at a stage fulfilling all the requirements of high definition and having regard in addition to the economics of the problems.”

To that suggestion we would make only one addition—and that not an original one. It has, we believe, already been suggested that, should it be decided to embark on a transmission system of higher definition, it should be conducted during the experimental period as a parallel service, but that a provincial area should be used as a testing ground. Naturally, the area would be carefully chosen to give the benefit of the service to the greatest density of population. The “London service” would, of course, be carried on with existing standards until such time as a national standard was decided upon.

CINEMA SOUND QUALITY

Investigating the Causes of Good and Bad Reproduction

THE quality of the sound in cinemas has often been the subject of criticism, sometimes with justification, but the writer thinks that critics are in error in trying to place the general responsibility on any one link in the chain, believing that trouble is produced all the way from the recording company that "cooks" the recording amplifier characteristic to suit their own particular reproducer (deficient in "top" response) to the cinema proprietor who expects the underpaid and overworked operator to service the fairly intricate electro-mechanical equipment responsible for the sound.

By

J. MOIR, A.M.I.E.E.

(Research Dept., The British Thomson-Houston Co., Ltd.)

cedure and after installation complete overall checks were carried out by the outside construction staff to make certain that an unlucky combination of tolerances had not resulted in something unsatisfactory.

In spite of these precautions the desired uniformity in sound quality was not obtained, and it was decided to investigate the problem. In so far as the re-

outside staff to give us their opinion on the cinemas in their district, classifying them as "above average," "average" and "below average." This step was taken to eliminate as far as possible personal preference in the matter of sound quality and to reduce the effect of variation in sound recording. Experience has shown that it is unwise to criticise the sound in a cinema on the results of one film, unless that film has been used for quality tests previously and the results are well appreciated.

Generally we found that where sound was adversely criticised, the "intimacy" was said to be poor. Intimacy is difficult to define, but is here understood to indicate the closeness of association of sound and picture. When intimacy is poor it is difficult to define the sound source as being coincident with the picture action. The critic is uncertain of the reason for the poor sound, while being perfectly certain that it is unsatisfactory.

Intimacy or accurate sound focus must be fully understood

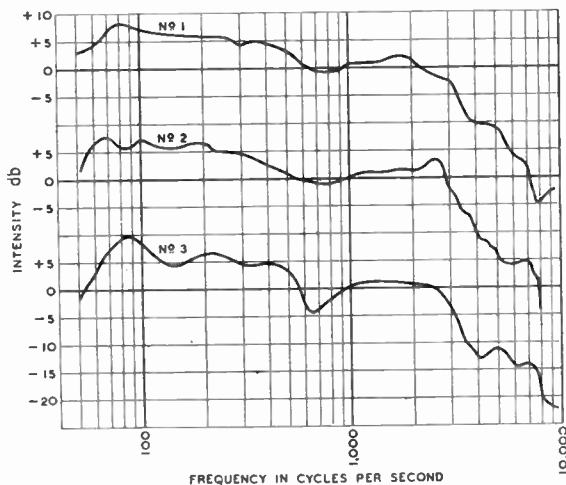

(Left) Fig. 1. Frequency characteristics in three typical theatres. Although the curves are similar the sound in theatre No. 1 was excellent throughout, No. 2 was generally below average and No. 3 was good in parts.

The results that are to be described were the outcome of an investigation into only one aspect of the problem, the question as to why identical reproducers exhibited such widely varying results when installed in different cinemas.

By 1936 the company with which the writer is associated had installed a very considerable number of identical reproducers in cinemas of many different designs with results which differed all the way from being very satisfactory to, shall we say, not so satisfactory. During manufacture the individual sections of the equipment were held to close tolerances by a rigid test pro-

(Right) Fig. 2. Frequency characteristics in different parts of the theatre No. 3 in Fig. 1. Curves (a) and (b), sound quality good. Curves (c) and (d), quality inferior.

ducers were all of the same type and in good adjustment, the problem in this instance was largely acoustical.

The first step was to ask the

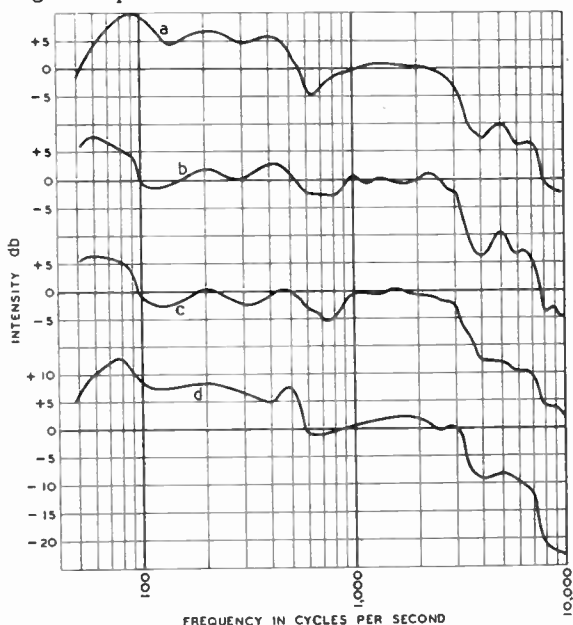

and achieved if stereophonic sound is to have practical applica-

tion in the cinema, because the fundamental requirement of stereophonic sound is that movements of the sound focus across

the good and bad positions in theatre No. 3 (Fig. 2). Indeed it is worthy of comment that in the first five cinemas checked the

sound quality was almost inversely proportional to what might have been expected from the critical study of the frequency characteristics alone. This result led to prolonged checking and rechecking

none of the characteristics obtained in the cinemas compares even remotely with the normal axial frequency response curves of the high-frequency loudspeakers obtained in the usual free-space testing condition. In Figs. 1 and 2, for example, the characteristic falls away above 2000 c/s., while Fig. 4 is the frequency characteristic of an identical loudspeaker obtained under test conditions. Early in the investigation the frequency response characteristics in the cinema were modified until a substantially level acoustic output was obtained to between 5,000 and 5,500 c/s. The aural results were considered unacceptable by the whole of the listening group, and after repeated tests the response characteristics represented in Figs. 1 and 2 were found to give the best aural results. Similar listening tests have been carried out in America, with the result shown in Fig. 5. The method employed in getting this characteristic was generally the same as that outlined above, modification being made to the equipment until the aural results met the approval of a listening group. In comparing Fig. 5 with Figs. 1 and 2 it should be remembered that the optimum frequency characteristic will depend to some extent on the reverberation-time / frequency curve. This information is not given for the American cinemas, and may explain the slight difference in the shape of the curves.

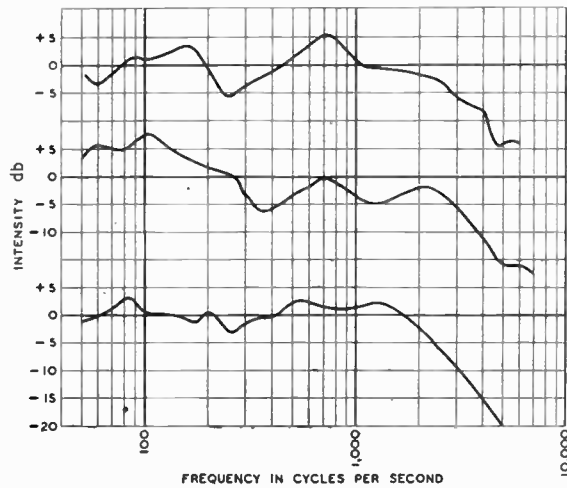

Fig. 3. Typical frequency characteristics for three Hollywood theatres.

the screen may be appreciated and followed by the audience.

Extremes in each district were chosen for further tests to ensure that known factors were not primarily responsible for the observed differences. Frequency characteristic and reverberation time were measured at many points in each theatre and the results compared. Results obtained in three typical theatres will serve to indicate the nature of the problem.

In theatre No. 1 sound was excellent throughout, and had received very favourable comments from many quarters. Theatre No. 2 was generally below average, while in theatre No. 3 sound was generally very good, but at certain points was poor.

Frequency Characteristics

Typical frequency characteristics taken in the three theatres are shown in Fig. 1, while Fig. 2 contains more detailed data on the frequency characteristic at four typical points in theatre No. 3. Curves (a) and (b) in Fig. 2 were recorded at points where the sound quality was considered to be above average, and curves (c) and (d) at points where the sound quality was below average.

Consideration of these results made it evident that there is no significant difference in the frequency response between the good and bad halls of theatres Nos. 1 and 2 (Fig. 1) or between

of the measuring apparatus without revealing any fault. The accuracy of the technique was further confirmed by the results obtained in three leading Hollywood theatres by American investigators.¹ These are shown in Fig. 3, and it is apparent that

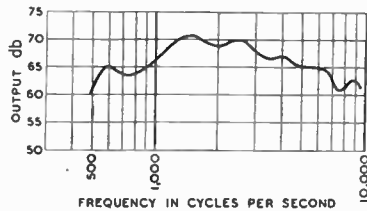

Fig. 4. Axial frequency response of HF speaker used in theatres of Figs. 1 and 2.

the frequency characteristics are comparable with those in Figs. 1 and 2.

It is of interest to observe that

¹ F. Durst and E. J. Shortt: *Journal of the Society of Motion Picture Engineers*, 1939, 32, p. 169.

Fig. 5. Overall frequency characteristic (adjusted for best aural results) published by American investigators.

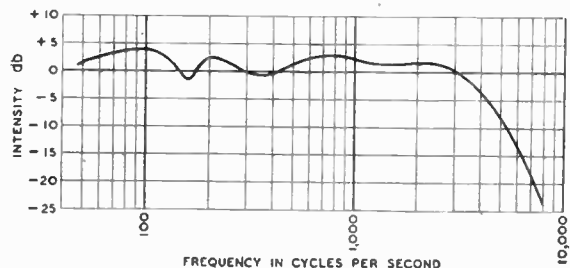

Reverberation Time

The results in the three cinemas are representative of the results in many cinemas investigated, and have led to the conclusion that either frequency response is not the major factor or that the measured frequency characteristic does not represent the characteristic to which the ear responds. Attention was therefore directed towards the acoustic properties of the halls and later to a study of

Cinema Sound Quality—

methods of instantaneous sound measurements.

Reverberation time is defined as the time taken for a diffuse sound field to be attenuated by 60 db., and is obviously a function of the

times at 500 c/s for the three theatres previously discussed, and the reverberation time measurements in theatre No. 3 at the four positions (a), (b), (c) and (d), at which the frequency characteristics were measured.

There was still the possibility that the reverberation time varied widely with frequency, although this was unlikely because the furnishing and constructional arrangements of the theatres were generally similar. The possibility was investigated, with the results shown in Fig. 7. This is a record of the reverberation-time/frequency curves for theatres No. 1 and 2, and Fig. 8 shows

Considerable data have already been published on the optimum reverberation time as a function of theatre volume and frequency. This information is the result of several theoretical studies and field experience. Fig. 9 represents the author's optimum time/volume relation together with the recommendation of another large organisation,² curve B being the 1931 figures and curve C published in 1936, presumably the result of further field experience. An average curve is repeated in Fig. 10, and added to this are the 500 c/s reverberation times of several good and bad theatres. No consistent differences are apparent.

In passing it is of interest to note that on certain assumptions³ it is possible to derive the optimum shape of the reverberation-time/frequency curve, and while the calculated curve is in general agreement with the measured results in theatre No. 2 below 500 c/s it departs widely at higher frequencies where, according to the calculated curve, the reverberation time should increase to approximately 150 per cent. at 4,000 c/s. The suggested rise in the theoretical curve has little support in the author's or other investigators' practical experience, which agree in requiring that the reverberation time should decrease steadily above 3,000 c/s.

For obvious reasons the measured times apply to the theatre's empty con-

¹ W. A. MacNair: *Journal of the Acoustical Society of America*, 1930, 1, p. 242.
² S. K. Wolf and C. C. Potwin: *Journal of the Society of Motion Picture Engineers*, 1936, 27, p. 386.
³ V. O. Knudsen: "Architectural Acoustics" (John Wiley & Sons, New York).

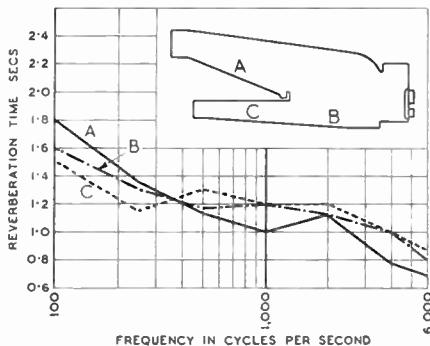

(Above) Fig. 6. Reverberation time at three positions in a theatre with balcony.

(Right) Fig. 7. Reverberation-time/frequency characteristics for theatres No. 1 and No. 2 of Fig. 1.

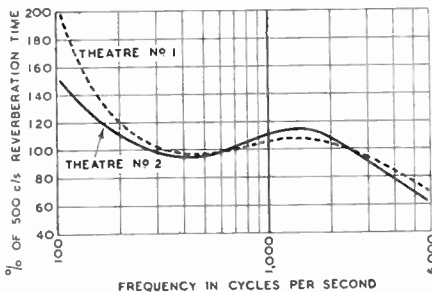

sound-absorbing property of the interior surfaces of the auditorium. In a uniform rectangular enclosure there is little doubt that a single value represents the reverberation time for the enclosure, but in a hall with a balcony (see, for example, Fig. 6) there is reason to doubt whether a single rate of decay exists for the complete enclosure, or whether it might not be more accurate to consider the enclosure as three separate spaces coupled by the balcony openings. (Check tests were made in a typical theatre, and the results shown in Fig. 6 suggested that the variations are not sufficient to justify consideration as three separate coupled spaces.

Table 1 gives the reverberation

the similar characteristics for the four positions in theatre No. 3. Here again the differences are not sufficient to account for the differences in the aural result.

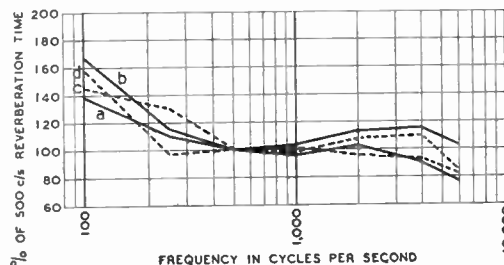

(Above) Fig. 8. Reverberation-time/frequency characteristics for the four positions in theatre No. 3 (see Fig. 2).

(Right) Fig. 9. Optimum reverberation time in relation to theatre volume.

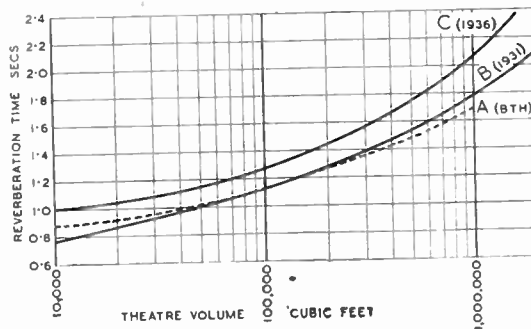

TABLE 1

| Theatre | Measured | Optimum | Sound Quality |
|-----------|----------|---------|---------------|
| No. 1 ... | 1.29 | 1.38 | Above average |
| No. 2 ... | 1.2 | 1.4 | Below average |
| No. 3 ... | 1.13 | 1.3 | Average |

| Location | 500 c/s Reverberation Time | Sound Quality |
|----------|----------------------------|---------------|
| (a) ... | 1.11 | Above average |
| (b) ... | 1.21 | Above average |
| (c) ... | 1.14 | Below average |
| (d) ... | 1.11 | Below average |

dition, although the suggested optimum figures are intended to hold with approximately two-thirds of the audience present. It is known that the presence of an audience modifies the acoustic condition, generally leading to improved sound quality if any effect is at

theatres with about two-thirds of the audience present have reverberation times far below the generally assumed figures. The effect, however, is common to all theatres, and cannot contribute to an explanation of observed differences between similar cinemas.

The results of the foregoing measurements, which are typical of many other examples, have convinced the author that reverberation times and frequency characteristics are not the main

frequency modulation. My opinion is that the requirements can best be met by medium-carrier wave broadcast for national coverage, and by ultra-short-wave regional distribution for the densely populated centres."

In this inaugural address as Chairman, Mr. Goldup ranged over many other wireless topics; he presented a brief but highly informative historical review of valve manufacture, surveyed developments in broadcast and television technique, and detailed the progress made in radio communications. Leaving technical topics, he then went on to survey the organisation of the broadcast industry through the various trade organisations. His views on the transmission standards desirable for our post-war television service are commented upon editorially in this issue.

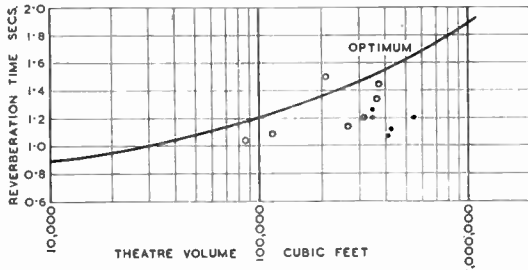

(Above) Fig. 10. Reverberation times of some good theatres (black dots) and bad theatres (circles) in relation to the optimum reverberation time curve.

(Right) Fig. 11. Reverberation time in a small auditorium (a) empty, (b) with full audience.

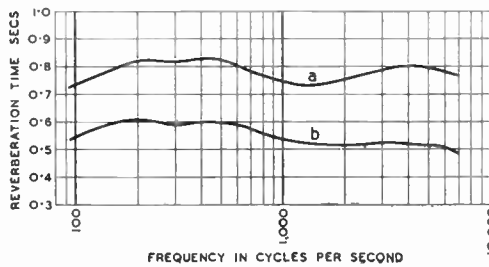

all noticeable. Knowing the reverberation time of the empty theatre it becomes an easy matter to recalculate the probable time with the audience present, but, as a check, the effect of an audience in a small theatre was measured, the data being presented in Fig. 11.

It becomes obvious that modern

criteria, judged by the subjective assessment of sound quality in large auditoria, unless they depart very widely from optimum conditions. Of much greater importance is the path or paths taken by the sound reaching the listener and this aspect will be dealt with in the next instalment.

(To be concluded.)

BOOK REVIEW

Automatic Record Changers and Recorders. By John F. Rider. Pp. 732. Published by J. F. Rider Publishing Co., 404, Fourth Avenue, N.Y., U.S.A. Price 6 dollars. (Obtainable in this country at 38s. from H. K. Lewis, 136, Gower Street, London, W.C.1.)

Although originally compiled, about two years ago, by the prolific Mr. Rider as an encyclopedia of American types of automatic gramophone record changer, among the full service instructions given in this big quarto-paged volume, copiously illustrated with explanatory diagrams and photographs, are included data on various equivalent types to the British, e.g., Garrard RC4, RC5 series.

The first four chapters deal with (1) motors and their maintenance, (2) so-called "home recording" and play-back equipment (of considerable interest to direct disc recordlists are the complete circuits of certain American recording units, e.g., Presto, Fairchild, R.C.A.), (3) descriptions of the four basic types of auto-changer, i.e., the "drop," the "throw-off or ejector," the "turn-over," and the "two-side non turn-over," (4) a step-by-step analysis of the R.C.A. 152-C record changer, to enable any type of record changer to be dissected and its functioning understood.

The following major portion of this book, which can be recommended to anyone for whom the subject has a special appeal, is devoted to the manufacturers' service information, closing with a comprehensive index. D. W. A.

(Another book is reviewed on page 331.)

BROADCAST DISTRIBUTION

Economics of Wire and Wireless

SPEAKING before the Wireless Section of the Institution of Electrical Engineers, on Oct. 13th, T. E. Goldup, the new Chairman of the Section, touching upon some of the problems of broadcast distribution, referred to the vexed question of "wire versus wireless." He said: "... wire distribution of the modulated carrier frequency would have the advantage that several channels could be accommodated using one cable, but highly skilled work would be necessary to connect listeners to this system, and complete coverage in outlying districts would be impracticable.

"The programme coverage of the whole country by the present means

in the medium-wave band, whilst an economic proposition, has some disadvantages, such as liability to interference and fading, but these are problems capable of being overcome to a very great extent in practice; in fact, it would appear that none of the wire systems can compete with medium-wave carrier broadcasting, either economically or from the point of view of coverage. High-quality reproduction, low noise level and freedom from interference can be obtained in the wired system, but at an increased cost. These technical advantages are also obtainable by the use of ultra-short-wave regional distribution systems, possibly employing

RADIO DATA CHARTS—12

Inductance, Capacity and Frequency : Short Wave

THIS chart and the two that will follow deal with the resonant frequency of tuned circuits in different ranges of the radio spectrum. The charts themselves present no difficulty in use and require very little explanation, so it is proposed to recapitulate some of the more important aspects of the underlying theory together with some practical details and notes on the use of the charts. It will be found that details most apposite to one particular chart may not appear with it but with one of the others; the three charts and their notes should therefore be considered as one article.

Fundamentals—To a very large extent the science (or possibly art) of radio depends on the ability to receive desired signals to the exclusion of others, and this is normally carried out with tuned circuits. In fact it would not be too much to say that the tuned circuit is the basis of wireless. There could be (and once were) receivers without valves, but a receiver without a tuned circuit would be a most unmanageable affair in these days of the crowded ether.

A tuned circuit is a network presenting a rapid change of impedance with frequency having a maximum or minimum at one unique frequency. By the judicious use of such networks signals of this one unique frequency can be separated from signals of all other frequencies, and so we have a device capable of selecting desired or rejecting undesired signals.

There are two basic tuned circuits—the *series* and the *parallel* combinations of capacitance and inductance. Since the inductance will normally consist of a coil of wire (under special conditions it can be a valve) it will necessarily have some resistance. The condenser too will inevitably have some losses which may be regarded as an equivalent series or shunt resistance, and these losses will be contributed by the energy lost in the dielectric used for in-

By

J. McG. SOWERBY,

B.A., Grad I.E.E.

(By permission of the Ministry of Supply)

ducting the electrodes of the condenser. Fortunately condenser losses can be made very small even at high frequencies by using air as dielectric, as in parallel plate or concentric cylinder types, the plates being fixed by the minimum of solid dielectric which should be of quartz, ceramic material, polystyrene or other low-loss plastic. Thus it is usual (though not invariably entirely justified) to regard the losses as appearing in the inductive arm alone.

The Series Tuned Circuit.—

The simpler of the two tuned circuits is the series or acceptor circuit shown in Fig. 1. The impedance between the two terminals may be written

$$Z = r + jX_L - jX_C$$

Where X_L & X_C are the reactances of L and C respectively and r is the resistance of the coil.

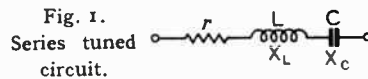

The absolute value (or modulus) of the impedance may be written

$$|Z| = \sqrt{r^2 + (\omega L - 1/\omega C)^2} \quad \dots \quad (1)$$

It is obvious from a glance at this equation that the minimum impedance occurs when the expression in the brackets is nothing (since it can never be negative); i.e. when $\omega L = 1/\omega C$, and so $\omega^2 = 1/LC$ or since $\omega = 2\pi f$,

$$f = \frac{1}{2\pi\sqrt{LC}} \quad \dots \quad (2)$$

At this frequency, then, the imaginary term of (1) disappears and the impedance, falling to a minimum, becomes simply the resistance r . The frequency given by (2) is called the resonant frequency and this is the formula which everyone knows.

Having found the resonant

frequency it will now be interesting to calculate the currents and voltages in the circuit. By Ohm's law, the current in the circuit must be $I = E/Z$ where I = current and E = applied voltage; and the current must, by Kirchhoff's laws, be the same at all points in the circuit. But at resonance $I = E/r$. Now the resistance of a coil can be made quite low compared to its reactance at radio (or even audio) frequency, so at resonance the current will be very much higher than at any other frequency. But the current passes through L and C and so the voltage across either of them must be the product of the current and the appropriate reactance.* In addition, the two reactances are equal at the resonant frequency, hence the voltages across them will be equal. We may write the voltage (E_R) across one of them as

$$E_R = E\omega L/r = E/r\omega C \quad \dots \quad (3)$$

The factor $\omega L/r$ is known as the Q of the coil and the voltage across the coil is seen to be the voltage (E) applied to the whole circuit multiplied by this factor. A coil of $Q = 50$ is by no means unusual and in a series circuit such a coil would produce across its terminals a voltage 50 times as great as the applied voltage. For this reason the Q of a coil is sometimes referred to as its magnification, but it truly magnifies the voltage only in the case of the series tuned circuit, and the meaning of the term would not be immediately obvious from consideration of the parallel tuned circuit alone—though it is clear enough from the above. It may perhaps be wondered where the voltage across the coil or condenser "goes to" when the circuit is considered as a whole. The explanation is quite simple, however, as the voltages across the coil and condenser are out of

* This is not strictly accurate except when $r = 0$ since the voltage across r cannot in practice be separated from the voltage across L . For practical purposes, however, no serious error is introduced.

ABAC No. 12
[Third Series]

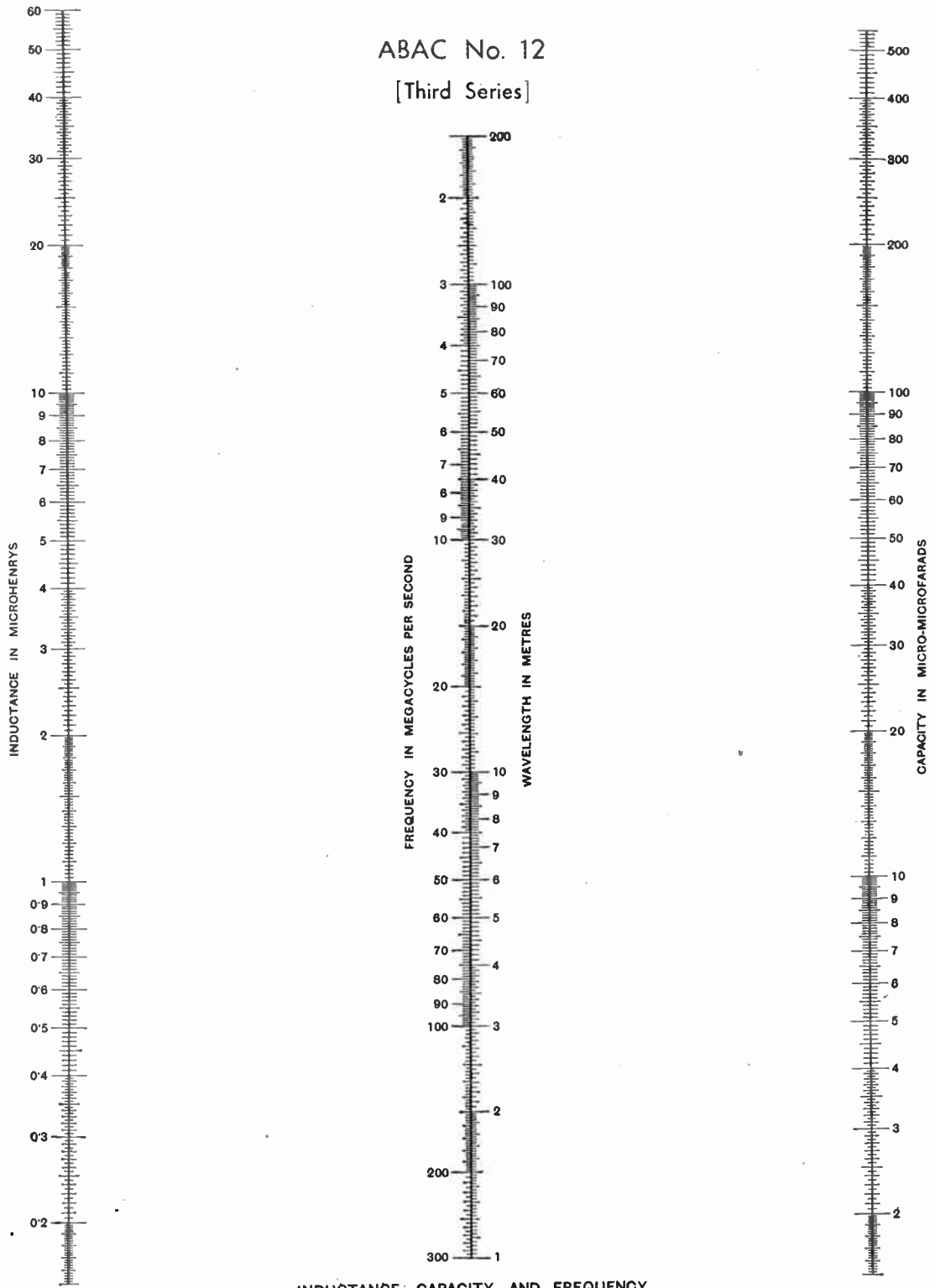

INDUCTANCE CAPACITY AND FREQUENCY
SHORT WAVE

Wireless World
COPYRIGHT

Radio Data Charts—

phase with one another and so cancel out leaving only the voltage drop across r which is, of course, the applied voltage E .

Practice—The series resonant circuit is used for a number of purposes—usually for filtering out unwanted signals of a specific frequency. It might be used, for instance (though better circuits could be designed), for removing the 9 kc/s heterodyne between stations in receivers of large bandwidth. However, it is the parallel

tuned circuit (Fig. 2) which is most used in radio receivers and the theory will be dealt with later. For most practical purposes it may be taken that the resonant

Fig. 2. Parallel resonant circuit.

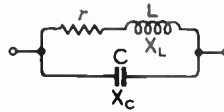

frequency of this circuit is given by $f = 1/2\pi\sqrt{LC}$ which is the same as for series resonance, and the chart is based on this formula since it is simple and both

series and parallel circuits can be calculated with it.

The Chart.—The chart needs no key, being very simple in operation; it is only necessary to connect two of the quantities f , L , and C together with a ruler when the third will appear opposite the ruler on the appropriate scale. The procedure is rapid and is well adapted to making numerous determinations.

Example.—To what frequency do $4\mu\text{H}$ and $12\mu\mu\text{F}$ resonate? Ans. 22.97 Mc/s (13.06 metres).

NEWS IN ENGLISH FROM ABROAD

| Country : Station | Mc s | Metres | Daily Bulletins (BST) | Country : Station | Mc s | Metres | Daily Bulletins (BST) |
|---------------------------------|--------|--------|--|-----------------------------|--------|--------|------------------------------------|
| Algeria | | | | India (continued) | | | |
| Algiers | 8.965 | 33.46 | 1600, 1700, 1800, 2100, 2200 | VUD4 | 9.590 | 31.28 | 0800, 1300, 1550 |
| | 12.110 | 24.77 | 1700, 1800, 2100 | VUD3 | 15.290 | 19.62 | 0800, 1300 |
| America | | | | Mozambique | | | |
| WRUW (Boston) .. | 6.040 | 49.67 | 0800 | CR7BE (Lourenco Marques) .. | 9.830 | 30.52 | 1155, 1712, 1915 |
| WLWO (Cincinnati) .. | 6.080 | 49.34 | 0600 | | | | |
| WC'BX (Brentwood) .. | 6.170 | 48.62 | 0500 | Newfoundland | | | |
| WGEO (Schenectady) | 6.190 | 48.47 | 0515 | VONH (St. John's) .. | 5.970 | 50.25 | 2315 |
| WKTM | 6.370 | 47.10 | 0200, 0300, 0400, 0500, 0600, 0700, 0800, 0900 | Palestine | | | |
| | | | | Jerusalem | 11.750 | 25.53 | 1615 |
| WLWK (Cincinnati) .. | 7.575 | 39.60 | 0600, 0700, 0800, 0900 | Portugal | | | |
| WC'RC (Brentwood) .. | 9.650 | 31.09 | 0600 | CSW6 (Lisbon) .. | 11.040 | 27.17 | 2000 |
| WLWO (Cincinnati) .. | 11.710 | 25.60 | 1100, 1200, 1300, 2100, 2200 | Spain | | | |
| | | | | EAQ (Aranjuez) .. | 9.860 | 30.43 | 1815‡ |
| WC'RC (Brentwood) .. | 11.830 | 25.36 | 1100, 1200, 2200 | Sweden | | | |
| WGEA (Schenectady) | 11.847 | 25.33 | 1300, 1400, 1500, 1600, 1700, 2300 | SBU (Motala) .. | 9.535 | 31.46 | 2220‡ |
| | | | | SBP | 11.705 | 25.63 | 1700 |
| WBOS (Hull) | 11.870 | 25.27 | 1200 | Switzerland | | | |
| WKTM | 11.893 | 25.22 | 0000, 2300 | HER3 (Schwarzenburg) | 6.165 | 48.66 | 2150 |
| WKRD | 12.967 | 23.14 | 0000, 1300, 1400, 1500 | HER4 | 9.535 | 31.46 | 2150 |
| WBOS (Hull) | 15.210 | 19.72 | 2100 | Syria | | | |
| WLWK (Cincinnati) .. | 15.250 | 19.67 | 1400, 1500, 1600, 1700, 1800, 1900, 2000, 2100, 2200 | Beirut | 8.035 | 37.34 | 1820 |
| | | | | Turkey | | | |
| WGEO (Schenectady) | 15.330 | 19.57 | 1100, 1200, 2200 | TAP (Ankara) .. | 9.465 | 31.70 | 1800 |
| WRUL (Boston) .. | 15.350 | 19.54 | 1500, 1600 | U.S.S.R. | | | |
| WLWO (Cincinnati) .. | 17.800 | 16.85 | 1500, 1600, 1700, 1800, 1900, 2000 | Moscow | 5.890 | 50.93 | 2300 |
| | | | | | 6.980 | 42.98 | 1240, 1700, 2300 |
| Australia | | | | | 7.300 | 41.10 | 1800, 2000, 2100, 2200, 2300 |
| VLI10 (Sydney) .. | 9.580 | 31.32 | 1515 | | 7.560 | 39.68 | 2300 |
| VLI3 (Melbourne) .. | 11.710 | 25.62 | 0800 | | 10.445 | 28.72 | 1240 |
| VLI2 (Sydney) .. | 11.872 | 25.27 | 0800 | | 11.830 | 25.36 | 1600 |
| VLI9 (Melbourne) .. | 11.900 | 25.21 | 1515 | | 12.190 | 24.61 | 1240 |
| VLI3 (Sydney) .. | 15.320 | 19.58 | 1030 | | 15.230 | 19.70 | 0415, 1240 |
| | | | | | 15.750 | 19.05 | 1240 |
| Brazil | | | | Vatican City | | | |
| PRI.8 (Rio de Janeiro) | 11.715 | 25.61 | 2030‡ | HVJ | 5.970 | 50.25 | 2015 |
| China | | | | Algers | kc s | Metres | |
| XGOY (Chungking) .. | 9.635 | 31.14 | 1500, 1700, 2130 | | 1176 | 255 | 0100, 1400, 1800, 1900, 2000, 2200 |
| Ecuador | | | | Athlone | 565 | 531 | 1340‡, 1845, 2210 |
| HCJB (Quito) .. | 12.455 | 24.09 | 0000, 2030 | Tunis | 868 | 345.6 | 0000, 0100, 2000, 2100, 2200, 2300 |
| Egypt | | | | | | | |
| Cairo | 7.510 | 39.94 | 1840, 2100 | | | | |
| French Equatorial Africa | | | | | | | |
| FZI (Brazzaville) .. | 11.970 | 25.06 | 1945, 2145 | | | | |
| India | | | | | | | |
| VUD3 (Delhi) .. | 7.290 | 41.15 | 0800, 1300, 1550 | | | | |

It should be noted that the times are BST, one hour ahead of GMT. The timing of some of the bulletins may be changed to compensate for the reversion from Summer to Standard Time in some countries. ‡ Sundays excepted.

ELECTRONIC VOLTAGE REGULATORS

Simplified Method of Design : Estimation of Performance

AN electronic voltage regulator is a most useful device, particularly for test gear and such apparatus where mains voltage fluctuations are troublesome. Many types are known, but it is proposed in this article to concentrate on one particular circuit and some modifications to it; to show how a suitable regulator can be designed in a simple manner. The circuit is the one which I consider to be most universally applicable to radio work.

Much has been published on the subject, particularly in the literature of physics, but with few

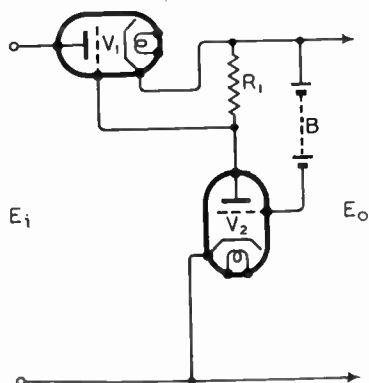

Fig. 1. Basic circuit of type of voltage regulator discussed in this article.

exceptions these articles describe particular stabilisers and give details of their performances, good, bad and indifferent, which is of little help to busy engineers. The formulae which have been published are, in general, inapplicable without considerable information on the valves to be used, in such a way that direct measurements are usually necessary. Other writers emphasise the methods of designing the power unit, and gloss over the actual electronic stabiliser. I may have been unfortunate, but the many articles I have read in the past years on the subject all fall to a greater or lesser extent under these strictures. The reason is not far to seek, to my mind. It is that in practice there is no alternative to "hit and miss," and a good deal of intelli-

By F. LIVINGSTON HOGG

gent guessing. I am therefore describing in detail the method of controlling the guesswork which I have evolved for my own use, which has served well for some years, and has helped to design regulators which are not based on unsound operating conditions. The method is empirical, and can usually be completed on paper from makers' catalogues and figures with a reasonable hope of obtaining the desired results.

The basic circuit is shown in Fig. 1. The input from a rectifier or other source is passed to the load through a valve V_1 . This valve obtains its bias from the anode current of V_2 through R_1 . The anode current of V_2 is controlled by the battery B. It is clear that if the input voltage rises, the output voltage tends to rise. This causes the grid of V_2 to become more positive, which increases the anode current through R_1 . This biases V_1 more negatively, and hence reduces the variation of output voltage by an amount depending on the amplification of the circuit V_2 , R_1 , and the slope of V_1 , among other things. Obviously the battery B has to be of slightly higher voltage than the required output, which is very inconvenient, although other more economical arrangements are possible.

For all normal purposes we can, fortunately, use a gas-filled stabiliser tube instead of the battery B, by rearranging the circuit as shown in Fig. 2 (a). N_1 holds the cathode of V_4 at a definite voltage above earth. P_1 is adjusted so that the voltage on the grid of V_4 is the required amount below the voltage on its cathode.

Now let us go through the circuit and consider its limitations and design requirements. First of all, we need to know the performance of the rectifier or other source, i.e. its regulation and range of variation with mains voltage, etc. Then we can see that V_3 will have to pass a little more than the full load current, and also, if it is to regulate, it must be biased negatively. This means that the voltage drop across it may be considerable. The minimum figure is likely to be about 100 volts in an average case. V_4 is a straightforward resistance-coupled amplifier, and therefore its performance is dependent on the anode voltage available, the valve, and the resistance R_2 . N_1 may drop from 55 to 150 volts according to the type of tube used. This means that there is a limit to the lowest output voltage available, as that voltage must be the sum of the voltages across R_2 , V_4 and N_1 . In general this drop cannot easily be much less than 65 volts plus the drop across N_1 , or about 120 volts. The current in N_1 may

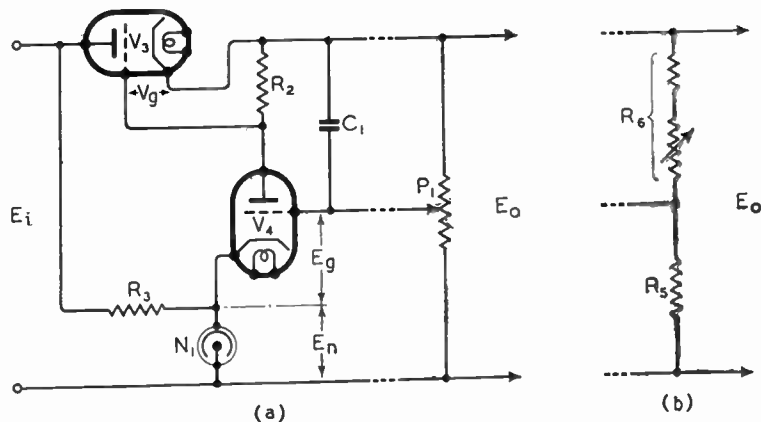

Fig. 2. (a) Circuit arrangement using a neon lamp instead of the battery in Fig. 1. (b) Practical arrangement of potentiometer P_1 .

Electronic Voltage Regulators—
be restricted by makers rating to a range which is above the working current of V_4 . In this event a shunt resistance R_3 from the HT input line to the cathode of V_4 will enable the current to be brought up to a suitable amount.

Some users of these circuits complain that they require adjustment very frequently, and that they are not inherently very stable, unless batteries are used in place of the gas discharge tube. In using such devices I have found a good many unstable and variable ones, but the trouble has always been due either to amplifier instability, i.e. tendency to oscillate, or to the potentiometer P_1 . This latter is often made high, from 100,000 ohms to 2 megohms. Now the grid of V_4 is not supposed to take current, neglecting leakage, etc. What happens is that, although the total resistance of P_1 remains constant, the tapping point appears to vary from time to time, usually taking up a different value each time the apparatus is switched on. This is not surprising, considering the absence of current through the tapping point; and when the voltage across the resistance is of the order of maybe a hundred volts or more, it is obvious that a minute variation in resistance will produce a noticeable variation

in bias on V_4 . It is interesting to work out the degree of constancy required for P_1 for a given case. After that, the maker of the potentiometer will no longer be blamed! A better device than the potentiometer is a combination of fixed and variable resistances, as shown in Fig. 2 (b). In any case, the variable resistance should be wirewound.

The design may now be started. Let us assume some values for an example:—

Output voltage E_0 to vary from 350 to 190 volts, continuously.

Output current I_0 to vary from 75 to 10 mA, independently.

Mains input to rectifier varies ± 8 per cent.

Regulation of rectifier from 10 to 75 mA, 10 per cent.

Stabiliser tube working voltage 55. (S.T.C. type 4313C.)

The next step is to make a table. Columns are lettered and rows numbered so that any square may be identified. Columns A and B are filled in thus: Rows 1, 2 and 3 are filled in with E_0 max and I_0 max in each case. Rows 4, 5 and 6 have E_0 max I_0 min. Rows 7, 8 and 9 have E_0 min I_0 max, and finally the remaining rows E_0 min I_0 min. Each row in the four sets is for normal, maximum and minimum rectifier output voltages (E_p , column C). Assume a safe value of 150 volts

for the drop across V_3 in row 1, column D. Obviously C.1 is then 500 volts. C.2 and C.3 are therefore plus and minus 8 per cent. on this figure. C.7, C.8 and C.9 correspond to C.1, C.2 and C.3; the remaining rows have a further 10 per cent. added for the rise due to the regulation, as the current is low. We can now fill in the rest of D, E_p-E_0 , whence column E, watts dissipation in V_3 . Having completed the table thus far, we must find a suitable valve for V_3 . A DO24 or PX25 triode suits excellently. But, as we know the anode current and voltage of this valve, we can read off the necessary bias from the maker's anode current/anode voltage curves, which gives column F.

R_2 must now be chosen. In general it will not be found advantageous to use a higher value than 0.1 or 0.2 megohm. Although the stage gain rises as R_2 is increased we have a fixed volt drop across R_2 . The decrease in anode current which follows means reduced slope in the valve, so that a compromise must be made. In this example 0.2 megohm will be assumed. The voltage across R_2 is given in F, so that we can at once complete G, the current through R_2 . We must now choose V_4 . Let us take a 6Q7G, a high- μ triode. Column H shows the voltage across this valve, found

| | A | B | C | D | E | F | G | H | I | J | K | L | M | N |
|----|------------------|---------------|------------------|--------------------|----------------|---------------------|---|----------------------|---------------------|-----------------|---------------------------------------|---|---------------------|---------------------------------------|
| | E_0 (volts) | I_0 (mA) | E_p (volts) | V_3 Volt drop | V_3 Watts | V_3 Bias volts | Current in R_2 (0.2 megohm) (microamps) | V_4 Anode volts | V_4 Bias volts | R_2 (ohms) | Effective output variation (volts) | Using stabilizer tube (Fig. 3) | | |
| | | | | | | | | | | | | Current in R_2 (0.5 megohm) (microamps) | V_4 Bias volts | Effective output variation (volts) |
| 1 | 350 | 75 | 500 | 150 | 11.5 | -6 | 30 | 289 | Bias -5.5 | 53600 | — | 122 | Bias -4.9 | — |
| 2 | 350 | 75 | 540 | 190 | 14.3 | -11 | 55 | 285 | +0.27 | | +1.7 | 132 | +0.1 | +0.64 |
| 3 | 350 | 75 | 460 | 110 | 8.3 | -1 | 10 | 293 | -0.27 | | -1.7 | 114 | -0.1 | -0.64 |
| 4 | 350 | 10 | 550 | 200 | 2 | -23 | 115 | 272 | +0.75 | | +4.8 | 156 | +0.44 | +2.8 |
| 5 | 350 | 10 | 605 | 255 | 2.6 | -30 | 150 | 265 | +1.01 | | +6.4 | 170 | +0.6 | +3.8 |
| 6 | 350 | 10 | 495 | 145 | 1.5 | -16 | 80 | 279 | +0.48 | | +3 | 142 | +0.3 | +1.9 |
| 7 | 190 | 75 | 500 | 310 | 23.3 | -27 | 135 | 108 | Bias -2.2 | 24500 | — | 164 | Bias -2.1 | — |
| 8 | 190 | 75 | 540 | 250 | 26.3 | -32 | 160 | 103 | +0.13 | | +0.45 | 174 | +0.1 | +0.35 |
| 9 | 190 | 75 | 460 | 270 | 20.3 | -22 | 110 | 113 | -0.13 | | -0.45 | 154 | -0.1 | -0.35 |
| 10 | 190 | 10 | 550 | 360 | 3.6 | -44 | 220 | 91 | +0.42 | | +1.4 | 198 | +0.33 | +1.2 |
| 11 | 190 | 10 | 605 | 415 | 4.2 | -51 | 255 | 84 | +0.58 | | +2 | 212 | +0.46 | +1.6 |
| 12 | 190 | 10 | 495 | 315 | 3.1 | -37 | 185 | 98 | +0.26 | | +0.9 | 184 | +0.2 | +0.69 |

by subtracting from A the stabiliser tube drop, 55 volts, plus F. From the maker's curves we can then get the corresponding bias for the given anode voltage and current in V_4 , which we fill in I. As high values of R_2 are used, however, it may be difficult to read the curves closely enough. To get over this difficulty we fill in I.1 and I.7, and then enter in the rest of I the changes in bias which have to be made.

The maker's anode current/anode voltage curve helps us here. The amplification factor of the valve is near enough a constant. By means of this fact, and a little careful interpolation, all the necessary information can be obtained. If we read off the corresponding anode voltages at the required current for two adjacent bias curves we can interpolate to find the bias corresponding to the known anode voltage.

The Potential Divider

The next step is to evaluate R_6 and R_5 in Fig. 2 (b), which replace P_1 . A convenient value for R_5 would be 10,000 ohms. This will result in a constant bleed current of about 5 mA. The relationship between the resistances is:

$$\frac{R_6}{R_5} = \frac{E_o - E_n + E_g}{E_n - E_g}$$

As E_g is so small we may approximate:

$$R_6 = R_5 \left(\frac{E_o}{E_n} - 1 \right)$$

We then get two extreme values for R_6 corresponding to the maximum and minimum values of $E_o = 53,600$ and $24,500$ ohms. It is worth while to split R_6 into a fixed portion and a variable, so that it cannot be reduced below 24,500 ohms. These values should be built up on test, so that the correct operating range is covered and no more, otherwise the regulator may be unjustifiably blamed for failure. In this case a variable of 50,000 ohms would be suitable. On test the value of 24,500 ohms should be built up until the lowest allowable output is attainable on minimum current and maximum mains volts, the variable being at minimum. The variable can then be shunted by a fixed resistance of the order of 75,000 ohms, so that at maximum variable resistance the maximum voltage and current output are

obtained on low mains volts. This adjustment takes about as long to do as to describe, and is a good safeguard in exchange for a couple of extra fixed resistances. In what follows, the built-up values of R_6 are treated as single resistances.

The potential divider formed by R_5 and R_6 reduces the efficiency of the regulator by a factor:

$$\frac{R_5}{R_5 + R_6}$$

Remembering this, the performance of the whole may be tabulated in column K. K.1 and K.7 are reference points, the others are found thus: K.2. is given by: $(R_5 + R_6)/R_5$ times the bias difference I.2, and so on.

This is the actual change of output voltage, which we have saved ourselves much difficulty by assuming absent. Fortunately, this is quite near enough for practical purposes. We have now completed the design of the circuit shown in Fig. 2 (a) and (b).

A glance at the table shows that there are three lines only which are of major importance. These are:

(1.) Line 3, when E_i is a minimum, and E_o and I_o are both at maximum. In this case the bias on V_3 is a minimum, and must obviously be kept to -1 volt or even more.

(2.) Line 8, when E_i and I_o are maximum, and E_o minimum.

(3.) Line 11, when E_i is a maximum and E_o and I_o are both at minimum. In this case the anode voltage on V_4 is at its lowest, and the corresponding anode current is at maximum. The limit is the lowest desirable bias on V_4 , which may be $-\frac{1}{2}$ volt.

If we are sure that V_3 and V_4 are being arranged to work efficiently, and are going to have the right order of voltages on them, these three lines are all that need be worked out for a new design, but until all pitfalls are understood, it is better to work out the complete table, and to study the effect of the various obvious changes of values which would be made.

This worked example is a very inefficient regulator, but it has been deliberately chosen so that the principles of operation may be clearly understood. A considerable improvement would be obtained by using say a Brimar 8D2 pentode in place of the 6Q7G, as is mentioned later. In more efficient regulators, the bias changes often become so small as to be difficult to estimate, and the experienced designer will merely ensure that V_4 works at the maximum efficiency allowed by conditions, using the table only for V_3 . When the necessary test gear is available, the overall amplification of this stage V_4 may be measured at audio frequency

under the various working conditions, and the optimum values then chosen for a particular case. This is especially useful in the case of the screen voltage on a pentode, which sometimes prefers rather peculiar values.

Now even if we use the best possible arrangement of this circuit

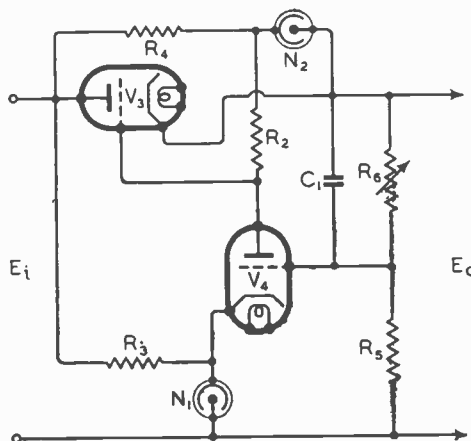

Fig. 3. Circuit designed to increase the efficiency of V_4 .

This gives maximum watts dissipation on the anode of V_3 . If valve manufacturers did not read *Wireless World*, I would admit that I usually allow a 10 per cent. margin over maker's rating, as the condition is not often a working one.

there is still a residual change, small though it may be. Let us consider how this can be improved. Obviously V_4 cannot work under the best conditions, as typified by ordinary resistance-coupled amplifier technique, with a given anode resistance, because

Electronic Voltage Regulators—

of the limited anode voltage across the resistance, with correspondingly low anode current. The circuit of Fig. 3 shows a method of dealing with this. If we use the same anode resistance as before, the anode current will be increased greatly, or alternatively, the anode resistance may be raised for the same current.

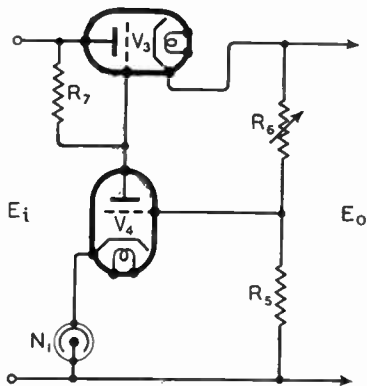

Fig. 4. Commonly used alternative circuit to that of Fig. 3 which is less efficient in practice.

Two components only are added, R_4 and N_2 . R_4 is chosen to bring the tube current to a reasonable value. If a 4313C stabiliser tube is used, it might be about 50,000 ohms in our example. The voltage in D shows the range that the tube has to cover without exceeding the maximum current rating. The maximum current is about 7 mA, so that this requirement is met. At the other extreme the minimum current will be of the order of 1 mA—this is also in the regulating range of the tube. Now it is clear that the change to the circuit has increased the volt drop across R_2 by the amount of the tube drop, 55 volts. We can now fill in columns L, M and N of our table. We take advantage of the increased voltage to raise R_2 to 0.5 megohm. Then by comparing K and N we can see the improvement obtained by using this device. Note that the voltage across V_4 is unaltered. To be accurate, the currents in V_3 should be recalculated, allowing for the shunt circuit across it. This shows the efficiency to be less, particularly at low currents, than appears from N.

It is seen that despite the apparent advantages at first sight of this method, which has been

suggested by more than one writer, the actual improvement is slight, being greatest at the high-voltage, high-current end. In this case it is scarcely worth while to use the extra tube, but when the bias on V_3 has a small range, close to zero bias, the method is valuable.

A method often proposed instead of the above, with the same end in view, is simply to connect R_2 to the anode of V_3 instead of to the cathode, Fig. 4. Unfortunately this circuit is not as good as it looks. As the bias on V_3 varies, so does the volt drop across R_7 varies in the same way, and in such a direction that it opposes regulation, i.e. it necessitates a correspondingly larger change in bias on V_4 . The increase in amplification obtained by the higher possible value of R_7 and the higher anode current to V_4 is usually much more than offset by the opposing variations. In fact it can be shown that if the amplification of V_4 is constant in the two cases, the stabilising effect is reduced by a factor equal approximately to the amplification factor of V_3 . If V_4 gives lower amplification, this must be allowed for in a comparison, but I have not met a case yet in practice where the balance was not in favour of the cathode connection.

It is necessary to point out here a disadvantage of the method of Fig. 3. First, stabilising tubes are not perfect, they have small spasmodic variations which may be of the order of a few tenths of a volt. Each additional tube therefore has its deleterious effect. Secondly, the changes in current in column I. are much smaller

Fig. 5. Circuit with voltage and current compensation for fluctuations of input voltage and load.

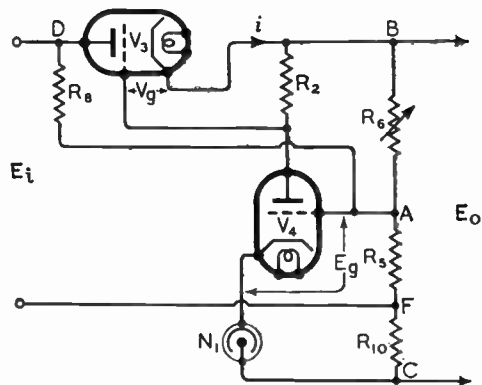

than in G. Thus any valve or circuit irregularities will show up far more in the former case. It is always as well to keep the anode current reasonably large, to minimise these spasmodic valve irregu-

larities. Failure to do so has sometimes caused complaints of unstable regulation.

Supposing we want still better regulation. There are two little-known devices we can use to improve matters. These were both described by Lindenhovius and Rinia in *Philips Technical Review*, Vol. 6, No. 2, 1941, which is not readily available in this country, and the principles involved will therefore be dealt with in detail. B. Banerjee, in the *Indian Journal of Physics*, Vol. 16, Pt. 2, 1942, also puts forward similar ideas, independently.

There are two kinds of output variation we have to consider, variation caused by fluctuating input voltage, and that caused by fluctuating load. The methods to be described deal with these two cases.

Treating these points separately first, let us consider what must occur if the regulation were really perfect, as we assumed in our example. In Fig. 5 ignore for the moment R_{10} . It is clear that for constant output voltage with varying input voltage, we would have to produce a certain change in voltage at A, across R_6 , related to the input variations. Now if we feed a small portion of the input voltage through R_8 to A, the variation required will be obtained in the correct phase. In the table the first three lines show a change of input voltage of ± 40 volts. The corresponding change on the grid of V_4 is approximately ± 0.27 volt. Then if R_5 is 10,000

ohms and R_6 53,600 ohms, the required value of R_8 will be about 14 megohms. (R_5 and R_6 are effectively in parallel, as if the regulation is perfect, the internal resistance as seen across the out-

put terminals is zero.) Of course a different value of R_8 is required for each output voltage: for lines 7, 8 and 9 in the table it should be nearly 2½ megohms. In practice it is often possible to compromise; an intelligent guess is made at R_8 , which is made variable, and a good compromise found by experimentally varying the input voltage and noting changes. The compromise value is then built up from a number of fixed resistances as may be required.

Here again we have made an assumption which must not be overlooked. Obviously the current through R_8 will increase

Fig. 6. Compensated bridge circuit suggested by Lindenhovius and Rinia.

the volt drop across R_5 . To keep the output voltage constant in the first case above, R_6 would have to be increased to about 57,500 ohms. In practice this can usually be neglected.

The second case may be considered similarly, ignoring R_8 in Fig. 5. If the output voltage is constant, variations in load cause changes in the load current. This means that corresponding changes must be applied to point A as above. This can be done by adding R_{10} and thus changing the position of R_5 . R_{10} may be estimated as was R_8 . A variable resistance of 100 ohms is good for experiment, and a compromise can usually be found which meets requirements. For the two voltages quoted, the values of R_{10} would be 15 and 8 ohms approx.

If both voltage and current compensation are used together, as shown in Fig. 5, rather lower values of R_{10} are required, as owing to the impedance of the rectifier circuit, E_i rises or falls as the current falls or rises. This reduces R_{10} above to 8 and 5 ohms. In other words, voltage compensation is a misnomer, for the first arrangement also gives a certain amount of current compensation.

These compensating devices

usually render the stabiliser tube device of Fig. 3 unnecessary, except when a large power valve or valves are to be used over a range which is always close to zero bias.

When compromise is made in the values of the compensating resistances, perfect compensation is obtained only at one voltage or current, with over-compensation taking place on one side, and under-compensation on the other

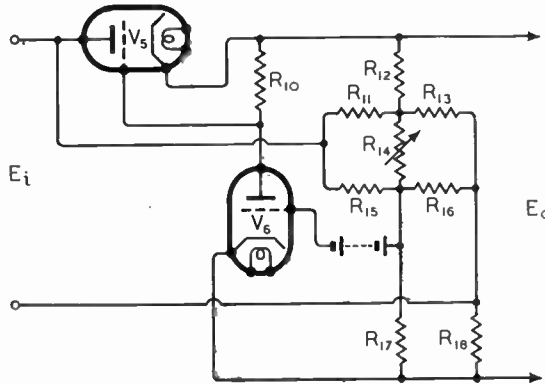

side. In practice, the approximately compensated circuit is almost invariably better at all points than the corresponding uncompensated one.

A further arrangement was suggested by Lindenhovius and

Rinia which, they claim, enables the two compensations to be made independent of variation of output voltage caused by the controls. The method involves the setting up of a rather complicated bridge network, but might be of great value when the highest precision is required. Using this arrangement with battery bias instead of a stabiliser tube, an output variation of less than 0.004 per cent. is claimed for a mains variation of 5 per cent. The circuit principle is shown in Fig. 6. The relationships of the network are given as:

$$\frac{R_{11}}{R_{12}} = \frac{R_{15}}{R_{17}} \div n\mu - 1$$

$$\text{and } \frac{R_{13}}{R_{12}} = \frac{R_{16}}{R_{17}} \div nSR_{18} - 1$$

where n = overall amplification of V_6 .

S = mutual conductance of V_6 .

μ = amplification factor of V_6 .

R_{14} is of suitable value to give the required output voltage variation. This circuit could obviously be adapted to use a stabiliser tube instead of a battery. I have not tried it, as all practical cases have so far been met with the other simpler circuits, but it is included for completeness, as it is not readily available elsewhere.

(To be concluded.)

BOOK REVIEW

The Technique of Radio Design. By E. E. Zepler, Ph.D. Pp. 311 + XII; 260 figures. (Chapman & Hall, 11, Henrietta Street, London, W.C.2.) Price 21s.

DR. ZEPLER'S book should serve as an introduction to the "back-room" of receiver design, and provide the inexperienced engineer with the practical design data and methods of measurement and test which cannot be included in theoretical studies and are usually acquired only slowly by experience. The practical viewpoint of the author is emphasised by the use of formulæ in which the constants have been reduced to the simplest numerical form; for example, a textbook of electrical theory would give the capacitance of a parallel-plate condenser as $A/4\pi d$ "absolute electrostatic units," but it is here given as $A/11.3d$ pF., which is more to the point for practical applications. Most of the chapters are on general subjects, such as "The Amplifier Stage," "Selectivity," and "The Principles of Screening," but there is also "Problems of

Detection and Frequency-Changing," devoted to these particular stages of a receiver.

The only serious criticism is of a tendency for the author to write in terms of the high-class communications receiver and neglect the mass-produced broadcast receiver which formed 80 per cent. of the output of the pre-war British radio industry. For the latter, it is unfortunately not true that the average receiver has two stages of preselection, with a tendency to increase this to three stages (p. 145). This point may be regarded as merely bad design in the cheaper class of receiver, but the statement that with a flat AVC characteristic the manual AF gain control need only have a range of 1:3 (see p. 179) is surely not applicable to broadcast receivers of any type. Provided this tendency to concentrate on the communications receiver is realised, the book will give a good insight into the development of a new receiver design.

D. A. B.

(Another book is reviewed on page 323.)

COMMANDO SIGNALS

Wireless in a "Corps d'Elite"

SPEED of operation and the high mobility of the modern short-range wireless set make it an obvious means of communication for the type of warfare in which Commandos are engaged.

Although signals sections are a more or less recent addition to Commandos, they have played an important part in a great many



Man-power! A Commando signaller, complete with No. 18 pack transmitter-receiver scaling a roof-t. cliff, which, incidentally, was much more nearly vertical than this photograph would suggest.

operations ranging from small raids on enemy or enemy-occupied coasts to the large-scale landings in Algeria, Tunis, Sicily and Italy. As the scale of operations becomes bigger and more complicated, it is certain Commando Signals will have an increasingly important part to play.

Most of the officers and men in Commando Signals have volunteered from the Royal Corps of

Hauling equipment up the cliff. This piece of apparatus is the No. 21 set complete with aerial in carrying case.

Signals for this hazardous, but far from humdrum, work. In addition to the badge of R. Signals on their green berets, they wear the Combined Operations badge, above which are the words "Commando Signals."

The function of Commando Signals is to provide all means of communication required by Commando troops on operations. This includes communications between landing parties, between landing parties and their headquarters and between troops ashore and ships and assault craft off-shore.

Each Commando (the term used for a unit which can be compared with a small, but highly offensive, battalion) has a signal section for communication between parties of its own men and back to its own landing craft. For providing communications between two Commandos or between Commandos and other troops taking part in a landing, there is a Special Service Brigade Signal Troop. It is not, however, proposed to deal with the work of this branch, but to confine ourselves to Commando Signals.

In addition to being a first-class operator, a Commando signaller must be a fully trained Commando soldier, for not only has



Combined Operations Command badge, embroidered in red on blue, worn on the upper arm by men of Commando Signals.

he to carry out his signal duties under the extremely difficult and often arduous conditions of Combined Operations, but also must be able—and equipped—to take a hand in fighting if the need arises. Great importance is attached to physical fitness and ability to march fast while carrying additional weight, as it is highly probable signallers will have to keep pace with Commando assault troops who are not encumbered with wireless gear. All equipment used by signallers must be capable of being carried by the operators; if necessary for some days.

Probably the best way of describing the work of Commando Signals is to give some details of an exercise in which *Wireless World* was privileged to take part. The "scheme" was an exercise in signals communications



involved in the landing on one beach of two parties, each of which was attacking different objectives some two miles inland. It is perhaps noteworthy that the majority of the men taking part in the exercise had been on actual operations.

The two forces (Red and Blue) taking part took to the boats from the headquarters ship. During the passage in the landing craft wireless silence was maintained by the signal section with each force which, as will be seen from the diagram, was equipped with two receivers—a No. 18 and a No. 46.

A beach-marking party had preceded our landing on a beach backed by high cliffs. The No. 18 sets were taken from their waterproof cases and fastened on the backs of the signallers. Ropes having been lowered over the cliff by the advance units, the signal-

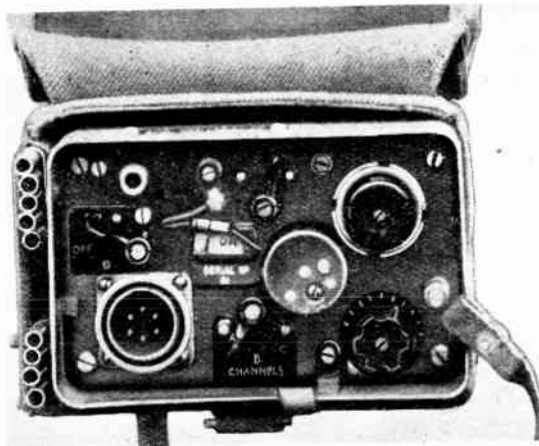

Operating panel of the No. 46 transceiver.

advance through barbed-wire entanglements and over rough country, contact was maintained between the two forces and headquarters. Even with the comparatively short ranges employed, signal strength dropped to R1 on one or two occasions in screened positions.

As soon as the advance headquarters had landed and taken up their position about 200 yards inland, contact was made with the two forces which were halted to get the No. 18 sets into operation and to reorganise signal procedure. It was now the task of the operator of the "46" set with each party to concentrate on maintaining communication with his opposite number in the other force, leaving communication with headquarters to the larger No. 18 set.

It should be pointed out that the No. 21 set shown in the diagram with the advance headquarters is a heavy transmitter-receiver which is carried by two or three men. For hauling up this heavy gear a rope "railway" was rigged up from beach to cliff top.

From the foregoing brief description of the exercise, which was typical of the continuous training undertaken by Commando signallers, it can be seen that the apparatus required must be capable of being set up quickly, of withstanding shocks, simple in operation and, as far as possible, waterproof.

An Instrument Mechanic is included in each operational section, and it is his job to maintain the gear in use, and to set the

apparatus to the frequencies selected for the operation in hand. His equipment includes spanners, screw-driver, soldering kit (a small blow-lamp is used for heating) and test meter.

The No. 18 set is a pack transceiver (combined transmitter - receiver in which some components are common to both) with a frequency coverage of from 6 to 9

Mc/s. This was briefly described in our issue of September, 1942.

An interesting, and very much lighter, set is the No. 46 transceiver designed especially for Combined Operations. At present it is not possible to give more than a few brief details of the design of this set, which is crystal controlled on three fixed frequencies. The panel is very neat in layout and includes a press-button send-receive switch, a three-channel selector switch, on-off switch with visual indicator, vernier tuning

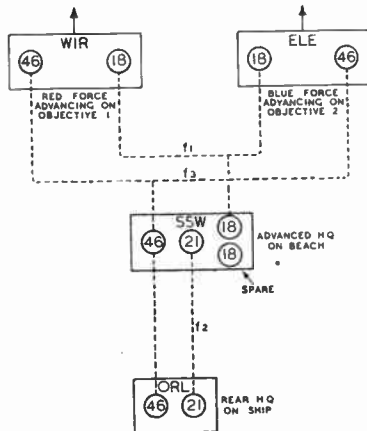

Signal diagram for the operation described, showing that each channel of communication is duplicated. Call signs of each "station" and types of transceiver used are indicated. Frequencies used: f1, 7430; f2, 5320; f3, 8140 kc/s.

lers, some with sets on their backs, scaled the 100ft. cliff—no mean feat of strength and agility.

Having overcome slight "enemy" opposition, contact was made by the operators of the No. 46 sets with the headquarters ship, after which the two forces advanced inland toward their respective objectives.

On receiving the information that the landing had been successful, the advance headquarters embarked and proceeded to the beach.

During the first part of the



The No. 46 set unpacked for stationary operation with a heavy type of aerial. The case on the right contains the two batteries.

Commando Signals

knob, aerial socket and six-pin connector for battery supply, phones and throat microphone.

The waterproofing of the set is completed by a rubber sheath passing over the plug and socket connector on the panel. The two combined HT/LT batteries (one is carried as a spare) are protected from dampness by being enclosed in a waterproof bag before being

positions corresponding to the predetermined frequencies.

One mode of carrying the No. 22 set is on a hand cart as shown on the accompanying photograph. The waterproof cover on the truck can be erected to provide protection for the operator as well as the set. These hand carts, the body of which can, if required, be lifted from the chassis, are used to transport

the normally conflicting qualities required in the tough fighting soldier and in the technician have been successfully combined in one of the newest wireless branches of the Services.

HENLEY'S EDUCATION SCHEME

WE have received a copy of an illustrated booklet which is handed to every boy on entering the service of W. T. Henley's Telegraph Works Company and Henley's Tyre and Rubber Company. This booklet outlines a scheme which is intended to enable all youths joining the Henley organisation to see what chances there are open to them and how they can train themselves for their careers.

Dr. P. Dunsheath, director and chief engineer of W. T. Henley's Telegraph Works, as chairman of the Education Committee, has been largely responsible for the success of the scheme, which was launched in 1942.

Every boy is given the option of undertaking a course of training extending over a period of years. On a selected day each week, boys who have shown that they can benefit from such privileges and have been accepted for the course are released entirely from their normal duties in order that they may attend approved classes at selected educational institutions near to their place of employment. They are expected to devote themselves wholeheartedly to the courses laid down for them during this day, and to attend a recognised educational establishment of their own choosing at least one other evening in the week, for which purpose wherever practicable they will be released from shift work or overtime. In addition, they must undertake to carry out the homework in connection with their day course to the satisfaction of the education authorities.

The subjects selected for the day periods are of a more serious and fundamental nature, but a good deal of freedom is given in the selection of subjects for the evening courses. Boys are paid for the time spent at the day establishment, and all fees, both for the day and evening courses, are paid by Henley's.

The scheme is not only intended to produce better workmen, better foremen, better managers, but also better citizens, and in addition to every encouragement being given to the boys to enlarge their mental outlook, physical training classes form an important part of the scheme.

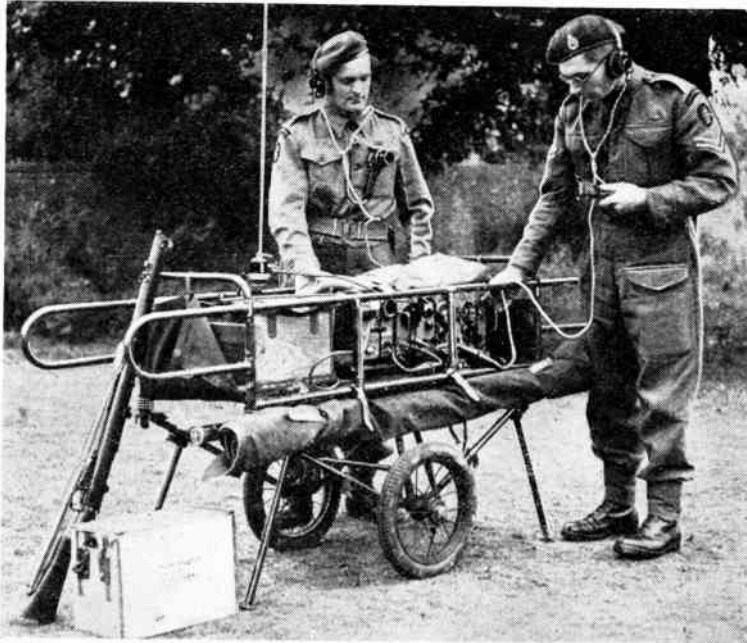

This complete station, the No. 22 set, can be carried on a light tubular-steel handcart, as illustrated.

inserted in the case which, carried on the operator's back, also contains headphones and laryngophones.

The set itself is carried on the chest of the operator in a waterproof case measuring approximately 12x8x4in., and employs an 8ft. sectional rod aerial.

A much heavier set, the No. 22, is employed for headquarters work. It is a combined transmitter-receiver deriving its power from two 12-volt accumulators with which 30 hours continuous working is possible. A working range of some 30 to 40 miles is claimed for this set, which operates on phone, CW or MCW. Output is of the order of 3 watts. One of the many interesting points in design is a mechanical method of pre-setting the tuning to two frequencies. When rotated, the two dials automatically stop at

heavy apparatus over long distances.

Another method of transport for this set is as a three-man pack. The first carries the set in a special harness similar to an alpine carrier; the second the power unit on his back and two satchels containing the AF gear and the long fishing-rod aerial, and the third the large 12-volt accumulator.

A lighter transportable transmitter is the No. 21. This set, which derives its HT from a medium-sized accumulator through a vibrator, operates on phone, CW and MCW in the 19 to 31 and 4.2 to 7.5 Mc/s bands. A feature of the set is that it has provision for remote control.

This brief description of the work of Commando signallers, and of some of the gear they must be capable of operating and maintaining will, it is hoped, show that

SINGLE-VALVE FREQUENCY DIVIDER

Another Application of the "Transition" or Negative Transconductance Oscillator

By

PATRICK F. CUNDY,

A.M.I.E.E. (G2MQ)

THIS article describes theoretical and practical work to demonstrate the close analogy between the Herold "negative transconductance" oscillator and the two-valve Franklin or multivibrator oscillator, and shows how the negative transconductance oscillator, like the multivibrator, may be used as a frequency divider.

It has been customary to call the negative transconductance oscillator the "Transitron," but since no use is actually made of any transit time phenomenon the name is rather unfortunate. Throughout the present paper the arrangement will be referred to as the Herold oscillator, since it is

starts to flow, and since no increase in cathode current is possible the G_2 current falls. The period of falling screen current I_{G_2} lasts until G_3 is somewhere in the positive region and all electrons passing through G_2 are accelerated onwards. I_{G_2} has then fallen to a value determined by the number of electrons colliding with the G_2 structure and no further reduction in I_{G_2} can occur. The theoretical characteristic is therefore as shown in Fig. 1, and it will be noted that over the centre range this is the inverse of a normal triode I_a/E_g curve.

This characteristic is even more pronounced in the case of a heptode, in this case the G_1 (oscillator grid) and the G_2 (oscillator anode) are returned to cathode and the inverted characteristic appears between G_4 (signal grid) and the G_3 plus G_5 screen. The reason for the higher negative slope is that the signal grid of a heptode is wound with a much closer pitch than the suppressor of a pentode and the limiting conditions occur with considerably less positive or negative potential (Fig. 1). A triode-

application considerably; this point will be dealt with more fully later on.

The heptode does not show as great an increase of slope as it might. The screen current consists of two parts, that which flows from G_3 exhibiting the negative slope characteristic, while that from G_5 exhibits a normal positive slope similar to that of the anode. The nett screen current is determined by the difference between these two characteristics and the

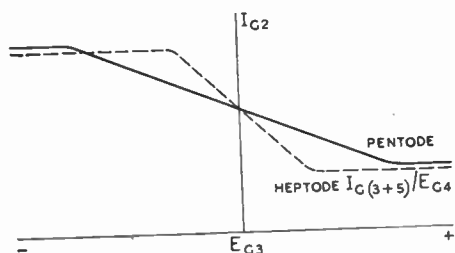

Fig. 1. Negative transconductance effect in pentode and heptode valves.

believed that the first published reference to an oscillator of this type was made under E. W. Herold's name.¹

Negative Transconductance Effect

If a normal pentode has its inner or working grid G_1 returned to cathode or to some value of fixed bias it tends to set a limit to the total cathode current (providing no large change of screen voltage E_{G_2} occurs) and the suppressor potential will determine how this limited cathode current is divided between the anode and the screen. With a high negative potential on the suppressor grid G_3 the anode current is cut off and all the cathode current flows to the screen G_2 . As this negative potential is reduced there is no change in G_2 current until a point is reached when anode current

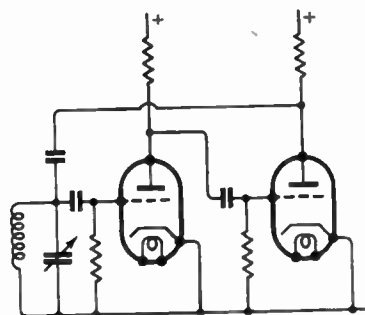

Fig. 2. Franklin two-valve oscillator.

hexode also shows this effect but the triode grid strapped internally to the G_3 grid modifies its

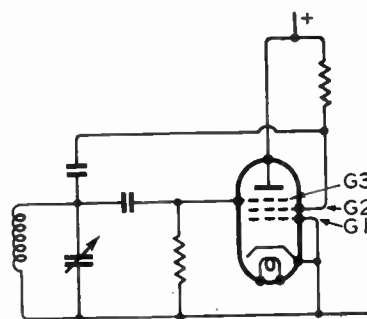

Fig. 3. Basic connections of the Herold oscillator.

value of the negative slope is not as high as it could be. A valve with the two parts of the screen brought out separately would show a further increase in negative slope, and, as will be mentioned later on, would have a further important advantage.

Analogy Between Franklin and Herold Oscillators

In order to secure oscillations in a circuit associated with a triode valve it is necessary to feed back from the anode circuit a potential that is in phase with the grid voltage, and since the anode and grid potentials are normally in opposite phase, some external means must be found of securing additional phase reversal in the feedback path. In most single valve oscillators this is achieved by a second winding or a tapping point on the coil. A second valve may be used, however, to obtain this phase reversal, and the result

Single-Valve Frequency Divider— is the well-known Franklin oscillator (Fig. 2).

Since the pentode valve used as described above has an E_{G3}/I_{G3} characteristic which is the reverse

oscillator, oscillations will continue at a frequency determined by the resistance-capacity constant of the coupling (Fig. 4 (b)). Again C1 and C2 can be replaced by a single condenser. A similar

leak, there is also an electron current to the grid. Until this charge has fallen to the bend in the positive region no change occurs in the anode or screen current; when the bend is reached there is an increase in screen current, a fall in screen potential, and G3 is driven negative again. It is clear that the ratio of the periods B to C (Fig. 6) can never be 1 : 1 because of the grid current when G3 is positive; the lower the value of the grid leak (which means a larger condenser for the same frequency) the more nearly equal these periods will be. The effect of the triode grid, when a triode-hexode is used, is to increase very considerably the grid current in period C and shorten the duration to approximately 1/50th of period B.

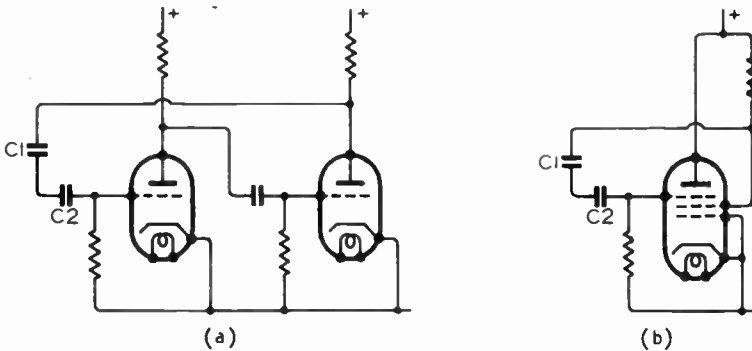

Fig. 4. Without the tuned circuit both the Franklin circuit (a) and Herold circuit (b) will continue to oscillate and can be used for frequency division.

of a normal triode I_a/E_g characteristic no external phase reversal is necessary, and oscillation is secure by coupling straight back from G2 (Fig. 3). This is basically the Herold oscillator. If the tuned circuit is omitted from a Franklin oscillator, the necessary phase relationship for oscillation is still present, and oscillation continues with a complicated wave form and a frequency largely determined by the resistance-capacity constants of the intervalve couplings. This is the multivibrator² (Fig. 4 (a)).

arrangement has been used as an oscilloscope time base,⁴ but the implication that it could also be used as a frequency divider has not hitherto been explored as far as the author is aware.

Operation of an Untuned Herold Oscillator

A valve was set up in the circuit shown in Fig. 5, an oscillograph being placed in turn at the points indicated. The resulting waveforms are shown in Fig. 6 (not to scale). The theory of operation developed to fit in with these findings is as follows:

Starting from point (a) on the E_{G3} curve, the operating point is assumed to be far to the left of Fig. 1, that is E_{G3} is considerably negative. This charge slowly leaks away through the grid leak until the bend in the curve is reached. During this period there is no change in I_{G2} , and consequently no change in E_{G3} or I_a . As the charge falls the potential of G3 passes the bend and the G2 potential starts to rise rapidly; this in turn pulls G3 positive with it, occasioning a further sharp fall in I_{G2} , a rise in E_{G2} , and an increase in I_a , the operating point swinging abruptly far to the right of Fig. 1 (E_{G3} positive). E_{G3} is held positive by the condenser charge; this leaks away more rapidly than when the grid was negative because, in addition to the current flow through the grid

Methods of Synchronising

Two possible points for injecting the synchronising signal are apparent, either at G1 or G3. Although G1 is suggested in the

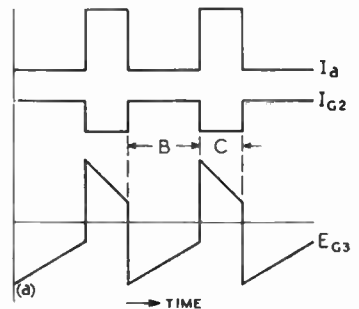

Fig. 6. Waveforms of anode current, screen current and suppressor grid voltage in the circuit of Fig. 5.

time base application mentioned⁴ it was not found possible to rely on this method for frequency divisions of a higher order than about 3 : 1. Injection on G3

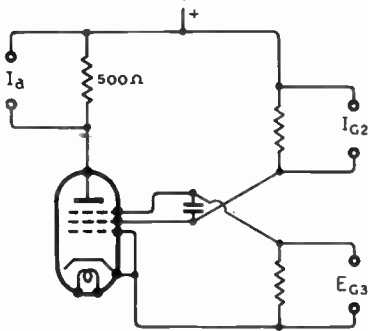

Fig. 5. Circuit of untuned Herold oscillator showing points at which oscillographic records of current and voltage were taken.

In practice, C1 and C2 are replaced by a single condenser of somewhat larger value than is used for the Franklin oscillator. Under certain conditions this arrangement can be made to divide frequencies.³ If the tuned circuit is removed from a Herold

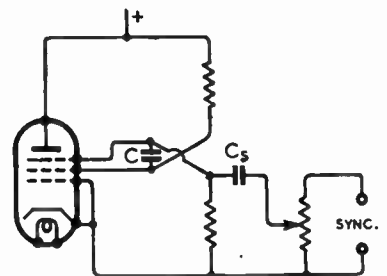

Fig. 7. Method of injecting synchronising signal for frequency division. $C_5 = C/10$ (approx).

through a small condenser was more successful in practice (Fig. 7). A positive pulse will initiate the swing positive of G_3 potential or a negative pulse will initiate the swing negative of the G_3 . When, as is usual for divider service, the synchronising source is a sine wave, then both the positive, and negative swings may be used,

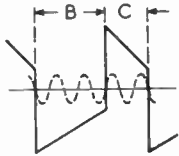

Fig. 8. Frequency division by four with B:C=5:3.

providing the ratio B to C in Fig. 6 is suitably adjusted. Fig. 8 shows the case for division by four when the ratio B to C is 5 : 3.

Output Coupling

The output of a Franklin oscillator or a multivibrator can be taken from grid or anode of either triode. The coupling must be fairly loose, however, and a buffer valve is usually necessary to prevent variation in the output circuit constants from upsetting the oscillation frequency or waveform. A multivibrator functioning as a divider thus requires three valves per dividing stage. An "Untuned Herold" oscillator could be coupled from either G_3 or G_2 , but since G_3 is already in use for the synchronising signal,

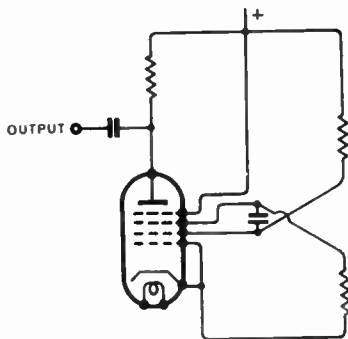

Fig. 9. In a hexode oscillator with separate screens the output could be taken from the anode without a buffer stage.

G_2 is, in fact, the only available electrode. The usual buffer stage is, of course, necessary. If a valve of the frequency-changer type with separated screens was available, the buffer could be eliminated. Considering the hexode section only of a normal triode-hexode, G_1 would be returned to

cathode and not used, G_2 would function as the G_2 in the pentode case, G_3 as the pentode suppressor, G_4 as the pentode anode which is at earth potential with respect to the signal, and the anode as the output electrode. G_4 would act as an electrostatic screen and the output would be isolated in the same manner as a Dow oscillator (Fig. 9). The number of valves per dividing stage would then be reduced to one.

Performance of Apparatus

A three-valve, crystal-con-

with a piece of black paper so that only the tips of the 100 kc/s waves are visible. The "extra" waves (appearing between the 100 kc/s wave tips) in the divided waveform are due to amplification by the divider and the harmonic amplifier of a strong second harmonic generated by the crystal oscillator; 20 kc/s harmonics are detectable up to 15 Mc/s with the amplifier anode circuit untuned, and well beyond 30 Mc/s when the amplifier anode circuit is tuned.

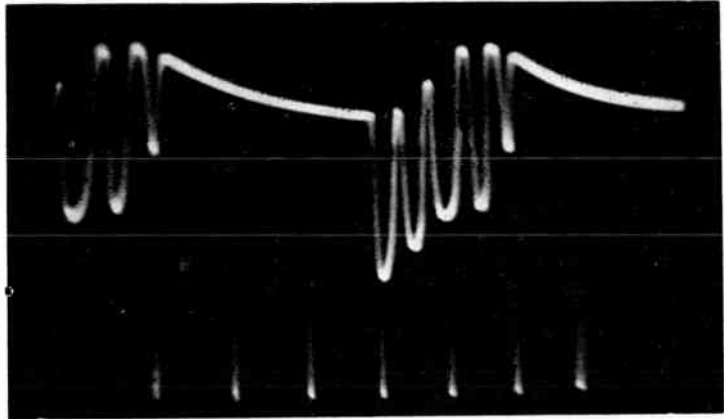

Fig. 10. Oscillograph of output from a three-stage frequency divider.

trolled frequency sub-standard has been constructed using the single-valve divider circuit. The first valve is a 1000 kc/s-100 kc/s dual crystal oscillator, the second valve is a 5 : 1 divider which may be switched into the 100 kc/s circuit, and the last valve is a harmonic amplifier. The oscillograph (Fig. 10) shows the output of the amplifier with the divider switched in and out. With the divider out the oscilloscope screen was covered

Bibliography

- ¹ "Negative Resistance and Devices for Obtaining It," by E. W. Herold, *Proc. I.R.E.*, Oct. 1935.
 - ² "Multivibrator Action," by E. Hughes, *Wireless World*, Nov. 1942.
 - ³ "Frequency Measurements," *Amateur Radio Handbook*, 2nd Ed., p. 219.
 - ⁴ "A Single-valve Time Base Circuit," by B. C. Fleming-Williams, *Wireless Engineer*, April 1940, p. 161.
- The references 2 and 3 are not the original publication of the relevant data, but are good recent expositions of the subjects.

WARTIME "QUALITY" AMPLIFIER

Since it was first introduced some nine years ago the "Wireless World" Quality Amplifier has enjoyed such constant popularity that all the back numbers containing descriptions of the various versions are now out of print. There is still a steady demand for information on the subject, and, to meet it, we are describing, in our December issue, wartime simplifications of the circuit designed to suit prevailing conditions.

FREQUENCY CHECKING

WITH the completion of a new 10-kW transmitter, WWY, at Beltsville, Maryland, the American National Bureau of Standards has extended its transmissions of standard frequencies, which are radiated throughout the 24 hours. The service now includes: Standard radio frequencies of 5, 10 and 15 Mc/s; standard audio frequencies; musical pitch (440 c/s corresponding to A above middle C); and time signals. The accuracy of the frequencies is better than 1 in 10⁷.

Broadcasting stations, research establishments, and the Forces make extensive use of the transmissions.

“Utility” Broadcast Receivers

QUESTION No. 15. Assuming that it is decided we are to have a “utility” broadcast receiver, what, in the opinion of the Wireless World Brains Trust, is the most suitable circuit arrangement? W. FORD.

“CODON” argues the case for a superheterodyne.

THE specification of a receiver grows from the performance desired, so let us first be clear about what is expected from the so-called “utility” receiver. (1) It must receive Home and Forces programmes under wartime conditions. (2) It must be as simple to operate as the sets to which the public has been accustomed for the past five or ten years. (3) It must be built as a sound engineering job to have a reasonable life; shortage of materials will continue for some time after the war, and in any case there must be some delay in restarting normal production, so the “utility” receiver will not be scrapped on Armistice night in the expectation of buying a new high-performance receiver next morning.

The two-valve detector-LF combination relies on reaction for the sensitivity and selectivity needed in all but the most favourable circumstances, and the use of reaction on the aerial circuit is not admissible to-day. It was bad enough in the early days when half the users of radio receivers had some technical knowledge, and the others regarded the apparatus with awe; to-day, nobody will

“Codon” consider that a det.-AF set like the standardised German *Kleinempfänger* shown in this diagram (copied from a German manufacturer’s blueprint) would be quite unsuitable here

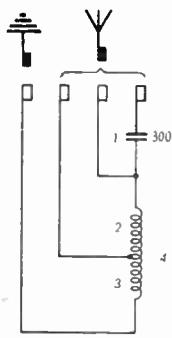

trouble to learn how to handle a wireless set, and the distribution of thousands of receivers capable of oscillating would cause pandemonium. The art of obtain-

ing adequate selectivity with the aid of reaction and volume control calls for even more skill than obtaining sufficient volume, and even for the reception of Home and Forces programmes selectivity may be necessary. It must be remembered that the “utility” receiver is required to work under wartime conditions (unlike the German *Volksempfänger*, which was a peacetime proposition), and this may still include operation during air raids; now the BBC must have expended much effort on their system which avoids a complete shut-down during air raids, but gives a service which may be reduced in strength and liable to fading in particular districts. It would be a pity to waste this service by providing receivers which could not profit by it because (a) they had no AVC, and (b) their selectivity was so poor that after dark any reduction in field-strength from the BBC would result in a neighbouring German station breaking through. The straight two-valve set is therefore, inadequate for wartime conditions.

If we are driven to a superheterodyne, what is the simplest type of such a receiver that can be made? A two-valve set containing frequency-changer, IF cir-

quency-changer, but its sensitivity would be very low. Reaction from the output valve on the IF circuits would help, and could not radiate at signal frequency, but an output pentode probably would not give smooth reaction and a band-pass circuit is a difficult subject for reaction. A scheme which is attractive on paper is to use frequency-changer, double-diode-triode, and output pentode, with reaction from the triode section of the DDT on the IF circuits. The additional AF gain from the triode section of the DDT would be very welcome, but we are still up against the problem of applying reaction to an IF circuit which must (for adequate selectivity) consist of a band-pass transformer or other multi-circuit arrangement. In addition, the voltage at the diode will be very low, perhaps a tenth of a volt, so that it will not suffice to provide AVC of any kind; even if we use a special circuit in which the triode acts as AVC amplifier (either RF or DC) there is only the frequency-changer to control. Although the circuit has the attraction of very little increased HT current consumption (perhaps $1\frac{1}{2}$ mA for a high-impedance DDT) it does not seem a very practical proposition.

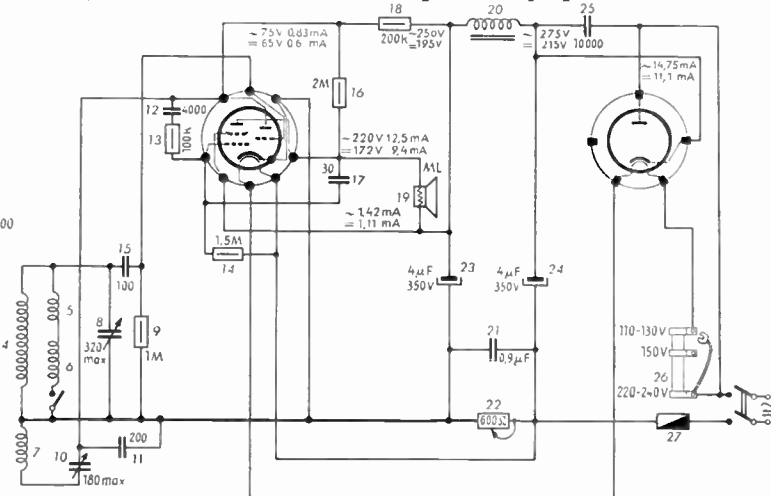

cuits but no IF valve, and detector-output valve is the minimum; it could give adequate selectivity by means of the IF circuits, and a slight degree of AVC on the fre-

The next possibility is frequency-changer, IF valve, and double-diode-pentode output valve. Admittedly the DD-Pen is not a common type of valve,

International Telecommunications

Post-war Radio Developments

but it has been made and no doubt could be produced without undue difficulty. We now have reasonable sensitivity and selectivity without reaction, a fairly high signal level (say, 5 to 10 volts) at the diodes, which makes AVC possible, and both frequency-changer and IF valves to control so that AVC can be reasonably effective. This seems the most promising arrangement to try, and the power-supply system must be scrutinised for any possible economy now. The output valve will presumably be of high sensitivity but only moderate power-handling capacity, with an anode current of perhaps 20 to 25 mA; with only two other valves, the total anode current will be too small to energise the field of a loudspeaker with winding of normal resistance, and any increase of HT voltage above that required by the valves involves higher ratings of smoothing condensers, etc., so that a PM speaker is indicated. This should in itself be simpler to make, since it has no hum-bucking coil. We now need a smoothing choke (since the speaker field is no longer available for this purpose) which appears to involve additional iron and copper; but this can be more than off-set by omitting the mains transformer and building the set as an AC/DC model. Since 4-V 1-A valves are practically obsolete, it is assumed that 6.3-V valves would be used in any case, so that the heater consumption of a series-wired set presents no great difficulty. It would, however, mean that the set would have to be sold complete in cabinet, to protect the user against contact with the live chassis, etc., but in any case the idea of selling a loose receiver chassis and leaving the purchaser to find a housing for it is probably bad. Wood is likely to be more readily available for a cabinet than plastics, and the elaborate press tools required for a moulded cabinet would probably be prohibitive even if moulding material were available.

The suggested design is therefore a three-valve (+ rect.) AC/DC superhet. in a simple wooden cabinet, the valves being frequency-changer, IF amplifier, and double-diode-pentode as detector and output valve.

IN his inaugural address, delivered on October 7th, Col. Sir A. Stanley Angwin, Engineer-in-Chief of the G.P.O., the new President of the Institution of Electrical Engineers, dealt with the question of international organisation of telecommunications after the war and its repercussions on developments in this country.

After describing the existing machinery for formulating international regulations, Sir Stanley explained why the allocation of frequencies was the most difficult of all the problems to be dealt with. The growth of aviation and extended use of the frequency spectrum will accentuate these difficulties after the war. Rational technical considerations, rather than political, must in future serve as a guide.

International regulations must cover wavelengths ranging from roughly 5 metres to 30,000 metres. On the subject of shorter wavelengths, Sir Stanley said: "Under certain circumstances and over shorter distances this difficulty of interference may also occur in the very short wavelengths, and it is difficult to determine a border line at which it may be said that national regulation alone is sufficient and that there is no need for international regulation. The practicability of using relay stations, i.e., a receiving station associated with a re-transmission station, in order to extend the transmission distances of short and very short wavelengths, accentuates the need for agreement on allocation."

Stressing the need for radical changes in the present allocations, partly brought about by new applications of wireless developed during the war, the speaker urged that priority should be given to those mobile services—marine and aeronautical—for which there is no alternative to radio. "The needs of long-distance telegraph, telephone and broadcasting services must also be met by radio until further development of line facilities makes their partial or complete replacement possible." Concluding his remarks on this subject, he said: "A full de-

velopment of the art of communication can only be expected if a sound plan is designed and applied for the regulation of the ether. This must be based not only on specific allocation to services, but on other fundamental principles such as the regulation of the power of transmitters, methods of transmission and limitations of causes of interference. The necessity for these regulations is, perhaps, more apparent in the case of broadcasting than in other applications of radio."

Future of Television

On the subject of television it was considered that the present standard of definition, which falls short of that accepted for cinema pictures, was the first field for advance. That, and the development of colour and stereoscopic transmission, will necessitate the use of much higher carrier frequencies.

"It is with a developing and expanding art such as television that international regulation and standardisation require most careful and judicious planning. Too early crystallisation will cramp development, but lack of co-ordination may lead to chaos. It is, perhaps, not too much to hope that some of the mistakes in the regulation of broadcasting may be avoided, and that such international regulation as may be necessary may be applied to act not only in the interests of television but in the interests of other services requiring to use a similar range of frequencies.

"How far the full exploitation of television will be divided between radio and line transmission has yet to be determined. The use of very much higher frequencies involves limits in the effective transmission coverage of radio. Transmission where necessary over long distances may be by radio relays or by wire, using one of the forms of co-axial cable. How far the employment of micro-waves for radio transmission or the new mechanism of electrical transmission by wave guides will meet the needs of television is one of the intriguing problems of the future."

LOW-TENSION SOLDERING IRONS

Hints on Construction

THERE are two main advantages, in addition to decreased risk of electric shock, in using a comparatively low-voltage heating element (e.g. 12 to 40 volts) in a light soldering iron. Thick heater wire can be used, which is easy to handle in the construction and repair of elements and can fairly readily be obtained from old electric fire or flat-iron elements—a consideration in these times. Secondly, the iron can be run from accumulators if mains supplies are inconvenient or not available. The disadvantages are that such irons cannot economically be used with series resistance on DC mains, owing to the comparatively heavy current they require, and for use of AC mains a step-down transformer is necessary. The latter disadvantage, however, is not very serious, as suitable transformers are easily constructed and are not bulky.

There are two possibilities. Either an old or burnt-out mains-voltage electric soldering iron can be altered by the fitting of a low-voltage element in place of the original element, or an entirely new iron can be constructed if a non-standard type is needed for special work. In each case the first consideration is that of the low voltage heating element. This may consist of a length of comparatively thick wire (usually nickel-chrome) wound on a slip of mica. The wire may be obtained from an electric fire or flat-iron element. The length of this wire in the soldering iron element is determined by the ratio of the wattage required for the soldering iron, to the wattage of the fire or flat-iron element being used. Thus,

$$l_1 : l_2 :: W_1 : W_2 \text{ or } l_1 = \frac{l_2 W_1}{W_2}$$

where l_1 is the required length of wire for the projected soldering iron element, l_2 is the measured total length of wire in the fire or flat-iron element, W_1 is the wattage of the projected iron and W_2 the wattage of the fire or flat-iron element. An extra half or one

inch may be added to l_1 to connect it to the power leads.

Two examples will be given. The first assumes that a 230-volt 450-watt flat-iron element is available, the wire on which when unwound is 16ft. long (the length will, of course, vary with the wattage of the element being used, its type, etc.). The wattage of the projected iron is, say, 65. Thus, l_2 is 192 inches, W_2 is 65, W_1 is 450. Then

$$l_1 = \frac{65 \times 192}{450} \text{ or } 27.7 \text{ inches}$$

approximately.

It would be safe to take 28 inches as the total length required, including sufficient to join on to the power leads.

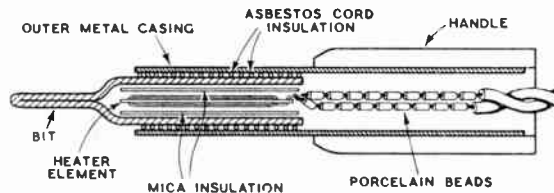

Fig. 1. Sectional sketch (not to scale) showing construction of the iron. The bit is made of a single piece of copper, bent to shape. To avoid losses, clearances between the heater element and the copper should be as small as possible.

The second example assumes that a fire element rated at 1.5 kW is available, with a length of 20ft. of wire.

$$l_1 = \frac{65 \times 240}{1,500} \text{ or } 13 \text{ inches}$$

approximately.

The current and voltage requirements have next to be found. The 450-watt element carries very nearly 2 amp. normally; the 1.5 kW element carries a trifle over 6.5 amps. Since each is to handle 65 watts, the voltage required, given by $E = \frac{W}{I}$, is $\frac{65}{1.9}$ or approximately 35 volts for the 2 amp. element and $\frac{65}{6.5}$ or 10

volts for the 6.5 amp. element. The former would be very suitable for use with a mains transformer, the latter for use with, say, two 6-volt car batteries in series.

Construction depends on the requirements of the user and what is available in the way of materials. Fig. 1 shows the structure of a light iron constructed by the author for instrument work. The attachment of the resistance wire of the element to the power leads is not very easy. Soldering is out of the question, of course, owing to the heat during work, and brazing, silver soldering and riveting all present awkward technical difficulties without the proper equipment. In the end, the author carried out a successful electric weld between the resistance wire and the copper lead, using a 60-ah. 2-volt accumulator. The method, referring to Fig. 2,

consists essentially of momentarily shorting the accumulator across the junction of resistance wire and copper lead, the current so passed being heavy enough to fuse the two together. It can be done with a clamp and one movable welding electrode as shown. The power leads of the iron are then insulated from each other and the metal shaft of the iron by porcelain beads or short bits of glass tubing up to the point where they remain cool enough while in use for soldering to the flex leads of the power supply.

The size of the copper bit is not critical provided the element inside or beside it dissipates the required wattage. A large bit merely takes an inconveniently long time to reach working temperature, and if it is too large, the loss of heat through an excessive cooling surface may prevent it ever reaching the working heat. It has the advantage of holding a considerable body of heat so that it is not too quickly cooled when applied to largish work. A small bit gets very hot in a short time and this may cause pitting or burning; moreover, when

GALPINS

ELECTRICAL STORES

"FAIRVIEW,"
LONDON ROAD, WROTHAM,
KENT.

TERMS: Cash with Order. No C.O.D.

Regret Orders from Eire and Northern Ireland cannot be accepted.

SUPER SENSITIVE RELAYS, multi leaf, P.O. type, very low M/A working, as new. Price 15/- each, post free.

D.C. MOTOR, shunt wound, condition as new, high grade, ball bearing, 1/2 h.p., 110 volts. Price 40/-, carriage paid.

AUTO-TRANSFORMER, 2,000 watts, tapped 0-110-200-220-240 volts, as new. Price **£8.10.0**, carriage paid.

VOLTMETERS, 2 1/2 in. dia., panel mounting moving coil, modern type, by famous maker 10 v. range, F.S.D. 5 m.a. Price 32/6, post free.

AMPMETERS, description as above. Ranges 0-1 and 0-20 amps., F.S.D. 15 m.a. State which reading required. Price 25/- each, post free.

DUBILIER RESISTORS, new lead and wire ends, 2 watt, 30,000 ohm, 1/6 each or 15/- per doz., post free. Ditto, 1 watt, 5,000 ohm., 8/6 per doz., post free.

RESISTANCE MATS, size 8in. by 6in., set of four. 80, 80, 150 and 690 ohms, carry 1/2 to 1 amp. Price, set of four, 5/-, post free.

MOVING COIL MOVEMENTS, needing slight repair, modern type, famous makers, deflection 10 m.a. Price 15/-, post free.

RECORDING AMPMETER, in ironclad case, meter movement wants repair, no pen, clock perfect, range 0-3 amps. Price **£7**, carr. paid.

MOTOR-DRIVEN PUMP, for oil or water, motor 220v. D.C., 1 amp., 1,250 r.p.m., maker Keith Blackman. Price **£6 10s.**, carr. paid.

200 AMP. KNIFE SWITCHES, S.P., D.T., in first-class condition. 15/- each.

200 AMP. CABLE, V.I.R., as new, rubber cover perfect, size 37/13, lengths 30 to 40 yds. Price in lengths, 5/- per yard, carr. paid.

ROTARY CONVERTOR, D.C. to D.C., input 11 volts, output 1,100 volts, 80 watts, will operate successfully on 6 volt input. Price 50/-.

MASSIVE GUNMETAL WINCH, complete with long handle, for use with 1/2 in. dia. wire cable weight 50 lbs., condition as new. Price **£3** carriage paid.

ELECTRIC LIGHT CHECK METERS, well-known makers, first-class condition, electrically guaranteed, for A.C. mains, 200/250 volts 50 cy. 1 phase 5 amp. load, 10/- each; 10 amp. load, 12/6, carriage 1/-.

1/2 WATT WIRE END RESISTANCES, new and unused, assorted sizes (our assortment). 6/- per doz., post free.

SOLID BRASS LAMPS (wing type), one hole mounting, fitted double contact, S.B.C. holder, and 12 volt 16 watt bulb. Price 3/6 each, post free, or 30/- per doz., carriage paid.

TUNGSTEN CONTACTS, 1/4 in. dia., a pair mounted on spring blades, also two high quality pure silver contacts, 1/4 in. dia., also on spring blades, fit for heavy duty, new and unused. There is enough base to remove for other work. Price, the set of four contacts, 5/-, post free.

REDUCTION GEAR BOX, right angle drive, ratio 50 to 1, ball bearing, shafts 7/16in. and 5/16in., in new condition. Price 25/- each, carr. paid.

ROTARY CONVERTER, D.C. to A.C. Input 22 volts D.C. (twenty-two). Output 100 volts at 140 M/A, 50 cycle, single phase, ball bearing, in first-class condition, no smoothing. Price **£5**, carr. paid.

applied to large work, it cools very quickly. For instrument work, a small hot iron is very desirable, since its use avoids heat being spread to other parts of the instrument either through having to hold the iron on to the work for

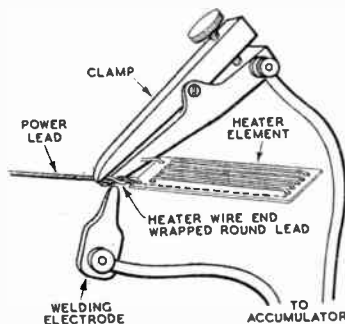

Fig. 2. Suggestions for an improvised electric welder for joining the power leads to the leading-out wires of the heater element. The accumulator leads must be of heavy cable, as short as possible.

a long time or through radiation from a large surface. If it is merely a matter of replacing a mains-voltage element by a low voltage one, the dimensions will have been fixed and need not be altered, provided the new element is rated at the same wattage as the old one.

A few details of a suitable transformer may be of service. The author removed the HT and LT secondaries from an old receiver type 80-watt mains transformer—counting the turns on one of the secondaries which was rated at 4 volts 2 amp. There were 25 turns, indicating 6 turns

per volt. To run a 35-volt iron, therefore, 215 turns of 20 SWG DCC wire were wound on as the secondary with taps at the 210th and 205th turn. To start work, the full 215 turns were used; when the iron was at working heat and had to be put aside for a while, it was switched to 205 turns, which kept it warm. More taps could, of course, be provided. To run a 10-volt 6.5 amp. iron, the secondary would have been 65 turns of, say, 16 or 18 SWG DCC wire, with taps at 57, 60 and 63 turns, and the leads from the secondary to the iron of ample gauge to carry the heavy current without overheating and to avoid voltage drop.

W. H. C.

AMERICAN SERVICE MANUALS

SERVICE data on a number of American broadcast sets is given in manuals now being published by Champion Electric Corporation, 84, Newman Street, London, W.1. The first volume, which has already appeared, deals with a number of Sparton and Emerson models; diagrams are given, with much data on voltage, alignment, chassis layouts, etc. Volumes II and III, which will probably be available by the time this appears in print, will each contain data on a number of Belmont and Crosley sets. The price of the volumes is 12s. 6d. each by post from the address given above.

Kolster-Brandes.—A recent notice in the electrical trades Press referred to Kolster-Brandes, Ltd., which went into voluntary liquidation on May 2nd, 1938, and not to the present company.

Books issued in conjunction with "Wireless World"

| | Net Price | By Post |
|---|-----------|---------|
| FOUNDATIONS OF WIRELESS , Fourth Edition, by M. G. Scroggie, in preparation ... | 7/6 | 7/10 |
| TELEVISION RECEIVING EQUIPMENT , by W. T. Cocking ... | 10/6 | 10/10 |
| RADIO LABORATORY HANDBOOK , by M. G. Scroggie, Second Edition ... | 12/6 | 12/11 |
| WIRELESS SERVICING; MANUAL , by W. T. Cocking, Sixth Edition ... | 7/6 | 7/10 |
| HANDBOOK OF TECHNICAL INSTRUCTION FOR WIRELESS TELEGRAPHISTS , by H. M. Dowsett and L. E. O. Walker, Seventh Edition ... | 30/- | 30/7 |
| WIRELESS DIRECTION FINDING , by R. Keen, Third Edition ... | 30/- | 30/7 |
| RADIO INTERFERENCE SUPPRESSION , by G. W. Ingram ... | 5/- | 5/4 |
| LEARNING MORSE , 335th thousand ... | 6d. | 7½d. |
| INTRODUCTION TO VALVES , by F. E. Henderson ... | 5/- | 5/4 |
| VALVE REPLACEMENT MANUAL , by A. G. Farnell and A. Woffenden ... | 6/- | 6/2 |

Obtainable from leading booksellers or by post from

ILIFFE & SONS LTD., Dorset House, Stamford Street, London, S.E.1

WORLD OF WIRELESS

B.B.C.'s FUTURE

SOME of the technical problems that the B.B.C. will have to face when reorganising its service after the war were recently reviewed by Sir Noel Ashbridge, the new Deputy Director-General of the Corporation. The occasion was a luncheon of the Radio Industries Club, of which Sir Noel is President; the members took the opportunity of congratulating him on his appointment.

Sir Noel pointed out that, thanks to the installation of much new plant for war purposes, the B.B.C. should be in a position to give its home listeners a better service when this apparatus could be turned to peacetime uses. Many changes might take place, but it was probable that the long-wave station would have to be retained in order to serve isolated communities.

On the question of possible uses of ultra-short waves and frequency modulation, it was emphasised that the significant thing here was the use of very short waves for a broadcasting service—that in itself was a revolutionary and important change, and the method of modulating the waves was a matter which followed from it. P.M. had its virtues, but it was not an essential part of a USW distribution system, of which one of the principal advantages was the possibility of providing a large number of programme channels. Here Sir Noel touched upon the programme side; did we really want a great multiplicity of programmes, and would it not be better to concentrate, say, on three first-rate ones instead of 12 of a mediocre standard?

In reinstating the television service, we will have the alternative of restarting soon after the war ends with virtually the pre-war standards, or of waiting for a very con-

siderable time until a much more advanced system can be put into operation. Sir Noel considered as quite impracticable the suggestion that, after a short wait of a year or less, it would be possible to put into operation a system with substantial improvements over that of 1939; there is a wide gulf between the laboratory stage and the operational stage.

Oversea broadcasting on short waves would continue to be an important side of the B.B.C.'s work, but Sir Noel thought that the ultimate success of this service would depend on the extent to which the transmissions were received abroad by "diversity" and similar methods, with subsequent rediffusion to local listeners.

RADIO INDUSTRY COUNCIL

THE formation of the Radio Industry Council, which is representative of the Radio Manufacturers' Association, the British Radio Valve Manufacturers' Association and the Radio Component Manufacturers' Federation, was announced at the end of September.

The official announcement states: "This Council will present the unified view of the manufacturing side of the radio industry in all matters of common concern and will represent and speak for that side of the industry as a whole, particularly in regard to the many problems which will face it in the post-war period."

F. B. Duncan, of Marconiphone, Chairman of the R.M.A. for the current year, has been elected Chairman of the Council on which there are four representatives of each of the associations.

The offices of the Council are at 59, Russell Square, London, W.C.1, telephone, Museum 4033, and the Secretary is R. P. Browne, O.B.E., B.Sc.

U.S. POST-WAR SETS

PLANS for the production of sets in the United States immediately after the war have been laid by American manufacturers. From the plans it appears new sets, including combined AM/FM models, are to be available within about two months of the cessation of hostilities.

Referring to television, our American contemporary, *Broadcasting*, states: "It is still an unknown quantity on anything approaching a national basis. There must be television transmissions on something other than a localised basis before mass production of sets is undertaken." It is reported that the mass production of cathode-ray tubes for the armed forces has made it possible to reduce the cost of the sizes likely to be used in home television sets from \$80 to \$20.

DEATH OF AMERICAN PIONEER

WITH the recent death of John S. Stone at the age of 74, America has lost one of the last of its wireless pioneers. Dr. Lee de Forest, with whom he was associated for many years, writes in the *Proceedings of the Institute of Radio Engineers*:

"The radio engineering profession has lost one of the few who remained of the original pioneers of wireless. And none of those early researchers into the great new realm revealed by the immortal experiments of Hertz can begin to compare with Stone in clear-sighted mathematical analyses of the basic principles on which the science of radio is founded. He was the first of us all to reduce to concise analytical terms the fundamentals of synchronism, mapping precisely the laws of resonant, tuned circuits, then but dimly understood."

LIFEBOAT RADIO

A TECHNICAL Committee has been set up by the Ministry of War Transport to enquire into the efficiency of the radio equipment of lifeboats.

The Radio Officers' Union, which was represented on the Committee, reports that investigation reveals that the occasions when successful use was made of lifeboats' radio equipment does not amount to as good a percentage as it would wish. Failures were found to be due to a number of causes in which, of course, the destruction of the gear and the boats figured largely.

In cases where the apparatus failed to function after being safely transferred to the boats the cause

BI-DIRECTIONAL LOUDSPEAKER, one of a large number used in the public-address system developed by Ardent Acoustic Laboratories and recently installed at the L.N.E.R. Waverley Station, Edinburgh. This loudspeaker is designed to radiate a narrow channel of clear speech, to con-

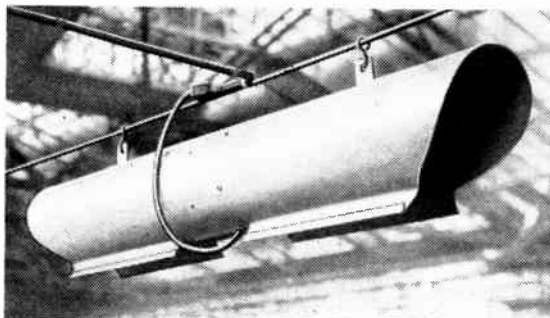

fine announcements to any particular platform, and to prevent intelligible speech being heard on adjacent platforms to which the information is not applicable.

has, in several instances, been the accumulator. The small unspillable type used is said to require more attention than the ordinary wet type, and the R.O.U. stresses the necessity of giving every attention to the equipment.

B.B.C. NEWS ON SHORT WAVES

A CONSIDERABLE reshuffling of times and wavelengths took place in the B.B.C. European Service on October 4th. This was necessitated by the return to Standard Time on the Continent.

In addition to these changes, a growing number of new call signs are being used by the B.B.C. The latest newcomers are:—

GVZ 9.64 Mc/s 31.12 m. GWE 15.44 19.44
GWC 15.07 19.91 GVQ 17.73 16.92
GWD 15.42 19.46

The latest schedule of news bulletins broadcast by the B.B.C. in English on short waves is given below. The times are BST.

| | |
|-------|---|
| 0015† | 25.53, 25.68, 30.53, 31.32 |
| 0045‡ | |
| 0206 | 25.68, 30.53, 31.32, 48.43, 49.10. |
| 0345 | 25.68, 30.53, 30.96, 31.32, 41.96, 42.13. |
| 0415‡ | 42.46, 48.43, 49.10. |
| 0550 | 25.68, 30.53, 30.96, 31.32, 42.13, 48.43, 49.10. |
| 0700 | 19.44, 19.91, 25.53, 25.68, 30.53. |
| 0900 | 31.55, 42.13. |
| 1000 | 25(2), 31(4), 41(2), 49. |
| 1200 | 13.97, 16.79, 16.84 19.42, 19.44, 19.60, 19.91, 25.53. |
| 1400 | 13.97, 16.64, 16.79, 16.84, 16.92, 19.44, 19.60, 19.91, 25.53. |
| 1600 | 13.97, 16.64, 16.79, 16.84, 16.92, 19.44, 19.46, 19.60, 24.92, 25.53, 25.68, 31.55. |
| 1700 | 16.59, 16.64, 16.92, 19.60, 19.66, 25.53. |
| 1745 | 24.80, 25.38, 41.49, 49.10. |
| 1900 | 16.79, 16.92, 19.66, 19.82, 25.29, 25.53, 31.25, 31.55. |
| 2045 | 16.92, 19.66, 25.53, 31.25. |
| 2145 | 16.79, 19.46, 25.29, 31.55, 42.46. |
| 2245‡ | 25.53, 25.68, 30.53, 31.32, 31.61, 41.32, 41.75, 41.96, 48.98, 49.42, 49.50, 49.92. |
| 2300 | 31.55, 42.46. |
| 2345 | 25.53, 25.68, 30.53, 31.32. |

† Sundays only. ‡ Sundays excepted.

Where the actual wavelength on which a transmission is broadcast is not known a bracketed figure is given to indicate the number of wavelengths employed in that band.

PORTABLE RECORDING TREND

IN the recent seventeenth broadcast of the "B.B.C. Close-Up" series dealing with its recording crews, an engineer, M. Pulling, stated that the trend in recording equipment for "on-the-spot" work was towards a light and convenient design that could be used by a one-man commentator-cum-operator. The method to be employed in this development was not mentioned.

In this connection it is interesting to note that men of the U.S. Army Air Force on reconnaissance over enemy territory can now dictate their observations to a new recorder. The magnetic method on steel wire is the system used, and more than 60 minutes' continuous speech can be recorded on a spool containing nearly 4,000 yards of

wire. The sounds can subsequently be erased and the wire used again. It is reported that the entire mechanism is contained in a small box weighing about 9lb.

IN BRIEF

I.E.E. Nikola Tesla Commemoration.—At an ordinary meeting to be held at 3 p.m. on November 25th at the Institution of Electrical Engineers, Dr. A. P. M. Fleming will lecture on the life and work of Nikola Tesla, who died early this year, and whose name was primarily linked with projects for the wireless transmission of power. The lecture will be illustrated by examples of his experimental work.

B.B.C. in Canada.—S. J. de Lotbinière, who for many years was in charge of the B.B.C. Outside Broadcast Department and was recently appointed Director of Empire Programmes, is going to Canada to open a B.B.C. office in Toronto.

Wireless Section, I.E.E.—On November 3rd, J. Kemp will deliver a paper before the Wireless Section on "Wave Guides in Electrical Communication." K. I. Jones and D. A. Bell will open a discussion on "The Role of Ultra-high Frequencies in Post-war Broadcasting" at the meeting on November 16th. "Enemy Airborne Radio Equipment" is the subject of the paper to be given by C. P. Edwards on November 24th. Each of these meetings commences at 5.30 p.m.

Brit.I.R.E.—John L. Baird will lecture on "Colour and Stereoscopic Television" at a meeting of the British Institution of Radio Engineers to be held at 6.30 p.m. on October 28th at the Institution of Structural Engineers, 11, Upper Belgrave Street, S.W.1.

Polyglot.—In a recent review of the progress of the oversea services of the Nazi broadcasting organisation, which began regular short-wave transmission in 1933, the German journal *Weltrundfunk* announced that news bulletins are now broadcast in 53 languages.

Scientific Photography.—"The Photography of Cathode-ray Oscillograph Traces" is the subject of papers to be given by N. Hendry and W. Nethercot at a meeting of the Association for Scientific Photography to be held at 2.30 on Saturday, November 13th, at the Institution of Electrical Engineers, Savoy Street, London, W.C.2.

Interchanging Valves.—We have received from V.E.S., 4, Melthorne Drive, Ruislip, Middlesex, a copy of their publication "Valves and Their Interchangeability." It shows how, with the aid of V.E.S. valve base adaptors, substitutes can be found for over 250 British and American valves of various types. Copies of the booklet may be obtained from the above address, price 7d., including postage.

Electrical Industries Red Cross Fund.—Among names appearing in the latest lists of subscriptions to this Fund are: E. K. Cole, Ltd. (£300); Garforth Radio Services (£2 2s.). Contributions are still urgently needed; details of the appeal can be obtained from the Joint Secretaries, c/o The E.D.A., 2, Savoy Hill, London, W.C.2.

CROWNAME
RADIO
COMPONENTS



THE radio industry is contributing its share towards the assurance of a free world. As a part of that industry, CROWE will continue its peacetime leadership when the assurance is won.

CROWE NAME PLATE AND MANUFACTURING CO.
CHICAGO, ILL. U.S.A.

Exclusively Represented by

Frank Heaver Ltd. Kingsley Road, Bideford, N. Devon



Come lovely Flowers

And so it is that from the darkness of the present hour will emerge a brighter day when the brain and brawn of modern industry will be utilised in further peacetime products and pursuits. While serving the Government to-day we are broadening both creative and manufacturing possibilities for a happier world to-morrow. Astatic engineers are available to work in co-operation with electronic engineers in the development of new wartime equipment, especially as it may have to do with pickup and transmission of sound. Astatic crystal microphones, pickups, cartridges and recording devices will be available again for your use when those brighter days are here. Register your name with our Representative for your future benefit.

ASTATIC

THE ASTATIC CORPORATION
YOUNGSTOWN, OHIO, U.S.A.
TORONTO, CANADA.

Exclusively Represented by
Frank Heaver Ltd. Kingsley Road, Bideford, N. Devon.

Improving the Ohmmeter : Public Taste in Reproduction : "Tracking Arm" or "Tone Arm" ?

Design of Ohmmeters

THE recent article by F. Livingston Hogg on the design of ohmmeters induces me to comment on certain aspects of the fundamental design of instruments of the type described which does not in the past appear to have received adequate consideration. I should point out at the outset that my remarks apply only to multi-range ohmmeters in which it is desired to attain the best possible performance of which this type of instrument is capable, and it may be remarked that if every precaution is taken, the performance can be of quite high order.

A feature of this type of ohmmeter is the non-linear scale, and the fact that the inherent percentage accuracy with which a resistance can be measured varies considerably according as the reading occurs near mid-scale, where the accuracy is highest, or near either end of the scale, where the accuracy falls to zero. It will be recognised that this is quite different from the ordinary uniformly divided scale of which the accuracy is highest at full scale. A special feature of multi-range instruments is that the high accuracy only needs to be maintained over a range of resistance values governed by the ratio between successive ranges. The most convenient ratio between successive ranges is evidently 10 and it therefore follows that the best performance needs to be maintained over one decade. The most convenient decade is one running from 1 to 10 or a decimal multiple or submultiple thereof.

The best overall performance is clearly attained when the chosen decade covers the greatest possible length of the instrument scale, and when the maximum deviation of the inherent accuracy at any reading from the mean accuracy over the decade is a minimum. Both of these criteria are satisfied by a mid-scale value of $(10)^{\frac{1}{2}} = 3.162$ or decimal multiple thereof, and not with the usually adopted mid-scale

values of 5 or 10. In addition, a further advantage results from the choice of 3.162 as mid-scale value in that the two auxiliary decades which can be accommodated on the scale, one above and one below the primary decade, are each of equal length, whereas they are unequal for other mid-scale values.

The accompanying table compares the performance with the alternative mid-scale values, and there is little doubt that, if a ratio between successive ranges of 10

highest resistance value which can be *accurately* measured on it; that is, the upper value of the principal decade, and not by some ultra-high value which can only be measured with a probable error approaching 100 per cent., and which only leads to confusion in use. An example of the latter arrangement is to be found in an otherwise excellent commercial instrument which has three ranges called 10,000 ohms, 100,000 ohms and 1 megohm respectively. How, then, is one to guess that a resist-

| Mid-Scale Value | 3.162 | 5 | 10 |
|---|-----------|-----------|-----------|
| | Per cent. | Per cent. | Per cent. |
| Scale length occupied by decade 1-10 as percentage of total scale | 51.6 | 50 | 40.9 |
| Maximum deviation of accuracy from mean accuracy over decade 1-10 as percentage of latter | 15.6 | 28.7 | 43.5 |
| Scale length occupied by decade 0.1-10 as percentage of length of decade 10-100 | 100 | 50.1 | 19.8 |

is presumed, the optimum mid-scale value is 3.162. In addition, it is suggested that commercial multi-range ohmmeters of the type under discussion should have the principal decade marked in black and the supplementary portion of the scale on either side of it marked in red, in a similar manner to that adopted for the C and D scales of normal slide rules having extended scales. A measurement which results in a reading on the red portion of the scale then gives prompt warning that, for greater accuracy, a higher or lower range should be used, as the case may be. In the event of a ratio between ranges of 100 being adopted, the optimum mid-scale value is $(100)^{\frac{1}{2}} = 10$, which gives two decades, 1-10 and 10-100, of equal length and which should both be marked in black, thus corresponding to the A and B scales of a slide rule.

If the arrangement suggested be adopted it would seem logical to name each range after the

ance known to be about 2,000 ohms should, for greatest accuracy, be measured on the 1-megohm range?

P. d' E. STOWELL.
Edinburgh, 3.

[The author writes: I read Mr. Stowell's letter with great interest, and would point out that his analysis of the accuracies of various decades leads to the following conclusion: The most accurate decade on any scale of the type under discussion runs from mid-scale value times $10^{\frac{1}{2}}$ to mid-scale value divided by $10^{\frac{1}{2}}$.

It is not essential that this decade run from 1 to 10, in fact it may be undesirable for it to do so. In practice the actual mid-scale value chosen usually depends essentially on other considerations. If on the high ohmmeter we changed to a mid-scale figure of 3.162, we could have either 0.3162 megohm or 3.162 megohms for our highest range. The lower figure is often too low, and would limit the use-

fulness of the instrument. The higher figure would necessitate a voltage of over 400 volts on the prods unless a very much more sensitive, and therefore less robust, meter were used.

On the low ohmmeter, most of the instruments I have made have had a mid-scale value of 0.35 ohm, but they are harder to line up than when 0.5 ohm is used, and the practical difference is usually negligible.

On the other hand, I consider Mr. Stowell's suggestion for marking the most accurate decade an excellent one. I think that the mid-scale value should be chosen from practical considerations, and the accurate decade marked, as suggested; or else the other decades might be bracketed off and marked, "Use higher range" or "Use lower range." The latter would eliminate the necessity for two-colour printing.

I agree wholeheartedly with Mr. Stowell's remarks about the misleading descriptions on some universal meters. My personal preference is that a decade multiplying factor be specified. Every time I use a certain type of instrument a mental calculation has to be made as to what the range factor really is. A good instrument therefore comes in for disparagement, which would not have been the case had the makers adopted the point of view expressed.—ED.]

Musical Taste

I WOULD like to make a protest against the view, expressed by several of your correspondents and now by your contributor "Diallist," that listeners to jazz music are particularly liable to prefer topless reproduction in order to "palliate the horrid noises" produced by jazz orchestras. Whilst I admit that there are many so-called jazz fans who do prefer excessive top cut, those who really listen to music (jazz or otherwise) always, I find, prefer the best reproduction available. The noises are certainly not horrid if listened to in the right way, or they would be turned off completely; not merely muffled. Incidentally, the products of crooners and dance bands are in no sense jazz.

In my opinion, the causes of the prevalent taste for "mellow" tone are (in order of importance)

(a) sales propaganda in the early days of the moving coil speaker; (b) valve hiss, harmonic distortion and noise from interfering stations, the effects which are all reduced by top cut, (c) use of radio as a background for other activities. It is surprisingly difficult to "talk down" a high fidelity receiver even when it is operated at a very low acoustic level.

P. B. FELLGETT.
Cambridge.

Pick-up "Tracking Arms"

MAY I thank Mr. A. C. Robb (your October issue) for proffering the term "tracking arm" in place of my suggestion, "carrying arm" for pick-ups?

Actually, in the first draft of my letter, in which this point was raised (June, 1943, issue), I included the term as an alternative, but eventually deleted it, as it has a direct disc recording connotation, e.g., cutting-head tracking arm (mechanism), etc., and if ever used without the description "pick-up" it might cause confusion. Of course, neither term is original, as both have been used before in gramophonic literature, but the important consideration is to standardise on one or the other, in preference to the misnomer "tone arm."

DONALD W. ALDOUS.
Torquay, Devon.

BOOK RECEIVED

Radio Control for Model Aircraft. By Peter Hunt.—Intended to enable a model-aircraft enthusiast to construct a radio-controlled model, this book begins with a brief outline of radio communication, and continues with details of suitable transmitters, receivers, relays and their adjustment, selector mechanisms and servo motors, audio-frequency control, closing with installation methods. Many circuits and photographs are given. Of course, as the author mentions, under wartime conditions amateur radio transmissions are not permissible, and only experiments with miniature receivers can be undertaken at present. Pp. 63. Published by Harborough Publishing Company, Allen House, Newark Street, Leicester. Price 2s.

GOODS FOR EXPORT

The fact that goods made of raw materials in short supply owing to war conditions are advertised in this journal should not be taken as an indication that they are necessarily available for export.

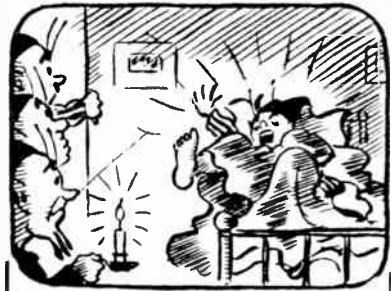

THE "FLUXITE QUINS" AT WORK

Young Ol had a nightmare last night,
All due to a rash oversight.
Guilty conscience, no doubt,
Fancy wiring without
The wonderful help of FLUXITE.

See that FLUXITE is always by you—in the house—garage—workshop—wherever speedy soldering is needed. Used for over 30 years in Government works and by leading engineers and manufacturers. Of all Ironmongers—in tins, 8d., 1/4 and 2/8.

Ask to see the FLUXITE SMALL-SPACE SOLDERING SET—compact but substantial—complete with full instructions, 7/6.

TO CYCLISTS! Your wheels will NOT keep round and true unless the spokes are tied with fine wire at the crossings AND SOLDERED. This makes a much stronger wheel. It's simple—with FLUXITE—but IMPORTANT.

The FLUXITE GUN puts FLUXITE where you want it by a simple pressure. Price 1/6. or filled, 2/6.



ALL MECHANICS WILL HAVE

FLUXITE
IT SIMPLIFIES ALL SOLDERING

Write for Book on the ART OF "SOFT" SOLDERING and for Leaflets on CASE-HARDENING STEEL and TEMPERING TOOLS with FLUXITE. Price 1d. each.

FLUXITE LTD.
(Dept. W.W.), Bermondsey Street, S.E.1.

RECENT INVENTIONS

"STREAMLINED" AERIALS

A FRAME aerial, particularly suitable for use on a radio-controlled aircraft, is wound so as to present minimum air-drag in the direction of motion of the craft. In one arrangement the coils are wound as on the surface of a cone, i.e., with progressively increasing diameters. They are then slightly stretched out along the common axis, and are finally turned or "flattened," so that all the coils be substantially in the plane containing that axis. This gives a streamlined contour in the direction of motion. In practice, the coils are wound directly on a plane wedge-shaped former.

Alternatively, the aerial may consist of a series of flat coils arranged in spaced groups or sections, each section being slightly larger in diameter than the one preceding it, so that the complete assembly fits conveniently into a streamlined casing. In addition, each section may consist of two separate but similar windings, set at right angles to each other.

Standard Telephones and Cables, Ltd. (communicated by International Standard Electric Corpn.). Application date February 27th, 1942. No. 552949.

SHORT-WAVE AERIALS

FOR television and certain other forms of signalling, it is desirable that the impedance of the aerial should remain approximately constant over a given range of wavelengths. One known aerial arrangement of this kind consists of three parallel wires, separated by only a small fraction of the mean operating wavelength. The middle wire is broken at its centre and connected to a pair of feed-lines, the two outer wires are continuous and all three wires are connected together or short-circuited at each end.

Owing to their close proximity and consequent tight coupling, the currents flowing through any given cross-section of the system will be in the same direction, of equal amplitude, and of the same instantaneous phase.

The inventors have discovered that if instead of simply short-circuiting the

A Selection of the More Interesting Radio Developments

outer extremities of the wires they are bonded together for a distance extending for, say, one-tenth of their total length, as measured from each end, the impedance of the aerial as a whole will remain substantially constant over a frequency variation of from 56 to 66 megacycles.

Philips Lamps, Ltd. (communicated by N. V. Philips Gloeilampfabrieken). Application date October 31st, 1941. No. 552911.

TRIGGERED RELAYS

THE figure shows a two-stage relay which is triggered by specific values of the applied input voltage, so that it can be used, say, in combination with a photo-electric cell to operate a load circuit in response to critical values of the prevailing light intensity. The arrangement will also serve to deliver constant square-shaped pulses in response to a sinusoidal input wave or to any wave having a periodically repeated slope, irrespective of the steepness of that slope.

The anode of the valve V_1 is coupled to the grid of V_2 through resistances R_1 , R_2 , R_3 , the resistance R_2 being shunted by a condenser C if it is desired to introduce a given delay. In addition, both valves are intercoupled by a common cathode impedance such as the resistance R_4 .

If the valve V_1 is initially biased to cut-off, a rising positive voltage applied across the input terminals I will cause V_1 to conduct so that its anode voltage falls. The resulting negative voltage transferred to the grid of V_2 will cause that valve to cut-off, whereupon the valve V_1 passes the full output. When the output voltage is reduced, the sequence is reversed and the full output is again delivered to the terminals O .

The winding of an electromagnet relay may replace the anode resistance R_1 lag or overlap between input and output voltages may be reduced by varying the time-constant or reactance of the intervalve couplings.

Cinema-Television, Ltd., and T. Nuttall. Application date September 29th, 1941. No. 552301.

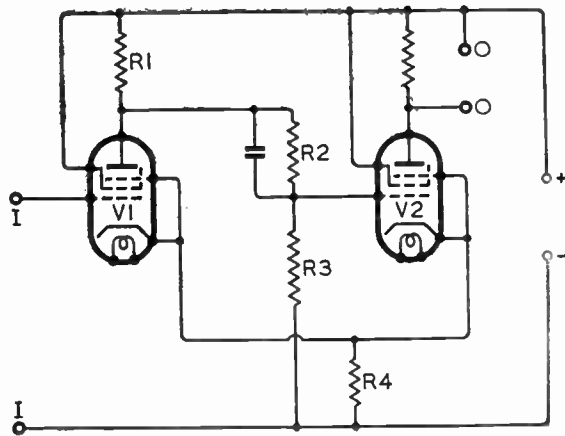

Relay trigger circuit.

CATHODE-RAY TUBES

THE intensity of the electron stream through a cathode-ray tube is controlled by voltage applied to an impedance Z in the lead to the cathode K , where it is common both to the grid-cathode and anode-cathode circuits.

This reduces the shunt capacity of the tube, and so improves its response to the highest frequencies, as compared with the usual method of applying the input voltage direct to the control grid G . In the latter arrangement, the total input capacity consists of that shown

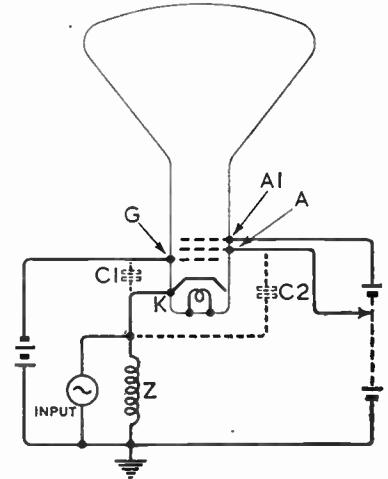

Cathode-controlled CR tube.

at C_1 , plus the capacity between the grid G and the first anode A , both of which provide parallel shunts to earth.

In the arrangement shown, the total shunt capacity is the sum of the capacities C_1 and C_2 . The advantage arises from the fact that the capacity C_2 is obviously much smaller than that existing between the control grid G and the anode A .

Since the control voltage across Z is also, in effect, applied to the first anode A , the overall slope of the tube is correspondingly increased. This serves to counteract the effect of the negative back-coupling introduced by the position of the impedance Z .

Philips Lamps, Ltd. (communicated by N. V. Philips' Gloeilampfabrieken). Application date October 14th, 1941. No. 552743.

REMOTE TUNING CONTROL

A SEMI-CONDUCTOR, such as a mixture of manganese and nickel oxides, having a high negative temperature coefficient of resistance, is connected, either in series or shunt, with a fixed reactance to form the variable element in a remote tuning-control system. The element is inserted as a whole, either in series or shunt with the main oscillatory circuit, the frequency of which is then controlled by indirectly heating the semi-conductor, preferably by means of an auxiliary current.

Alternatively, the semi-conductor is inserted in the cathode lead of a control valve whose grid-cathode capacity is shunted across the main oscillatory circuit. The frequency of the latter is then regulated from a distance through the known Miller effect by indirectly heating the semi-conductor, thereby altering the shunt reactance of the control valve.

Standard Telephones and Cables, Ltd., and C. W. Earp. Application date October 3rd, 1941. No. 552431.

TELEVISION IN COLOUR

SUCCESSIVE images, produced when the televised object is subjected, say, to red, blue, and green light, are radiated from the transmitter. These are reproduced in black and white by the receiver, and are viewed in rapid succession through colour filters, which are changed in synchrony with those used in transmission.

It is found, in practice, that the response of the photo-electric mosaic screen, forming part of the transmitting tube, is not equally sensitive to each of the three primary colours. In addition, other unbalanced effects can arise from inherent defects in the colour filters, as well as from the type of lighting used in the studio which may show an undue proportion either of red or blue energy.

In order to compensate for all such irregularities three auxiliary lamps, each emitting one of the primary colours, are arranged in front of the television transmitting camera, and on the object side of the ordinary colour disc. The intensity of the light from each lamp is separately adjustable, by hand or otherwise, to provide the extra floodlighting required to ensure the proper balance of colours in the picture as seen in the receiver.

Marconi's Wireless Telegraph Co., Ltd. (Assignees of E. I. Anderson). Convention date (U.S.A.) February 11th, 1941 No. 553255.

GASEOUS INSULATORS

THE dielectric properties of air, nitrogen and other gases are utilised in various electrical devices such as condensers and co-axial transmission lines.

It is known that dichloro-difluoromethane, commonly known as "freon," possesses the property of absorbing the energy of free electrons to a marked degree. This, of course, reduces the tendency of such electrons to ionise and so diminish the dielectric strength of any gas in which they may be present.

The inventors claim the use of any gaseous insulator containing up to 5 per cent. of "freon."

Standard Telephones and Cables, Ltd. (Assignees of H. Skilling). Convention date (U.S.A.) November 27th, 1940. No. 553560.

The British abstracts published here are prepared with the permission of the Controller of H.M. Stationery Office, from specifications obtained at the Patent Office, 25, Southampton Buildings, London, W.C.2, price 1/- each.

DIRECTIONAL SYSTEMS]

RELATES to direction finders of the kind in which two frame aeriels, F, F1, set at right angles, are each connected through separate amplifiers, A, A1, to the deflecting plates of a cathode ray tube. Each amplifier is of the superhet type, and both are coupled to the same local oscillator. If the resulting trace is to give an accurate indication of the direction of the incoming signal it is essential that the two amplifiers should have identical characteristics, both as regards gain and phase-displacement.

In order to test the set in this respect, an auxiliary switch S allows both the aeriels to be earthed through a common resistance, so that the same input signal can be applied to each of the amplifiers. In addition, one of the amplifiers is provided with independent gain-control and phase-adjusting means, B.

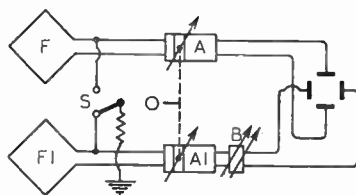

CR direction finder.

If, when the earthing switch is closed, the cathode ray trace appears as an ellipse, the gain and phase controls are adjusted until this is converted into a straight line. The amplifiers are then correctly balanced, and the testing switch can be opened for ordinary directional observation.

Philips Lamps, Ltd. (communicated by N. V. Philips' Gloeilampenfabrieken). Application date February 16th, 1942. No. 553618.

PIEZO-ELECTRIC CRYSTALS

FOR operation at frequencies of 1,500 kc/s and upwards, a piezo-electric oscillator can be mounted between electrodes which also serve as clamps or supports. At lower frequencies, say of the order of 200 kc/s, the crystal is not usually clamped, but is arranged to rest freely on one electrode with a small air gap separating it from the other electrode. The relatively small "free" movement thus allowed may result in undesirable frequency fluctuations of as much as 20 to 30 cycles per second.

To avoid this source of irregularity a plate crystal is clamped between two or more pairs of two-diameter steel pins. Each pin has a comparatively large massive shank which is screwed or fixed to the main supporting frame, and a comparatively small and flexible continuation or "tine" which is pressed against and clamps the crystal in position.

The arrangement, in effect, forms a cantilever support, the dimensions of the flexible tine being calculated on known principles to have a resonant frequency equal to that of the crystal.

F. D. Bliley and C. Collman. Convention date (U.S.A.) July 1st, 1940. No. 552386.

The Improved VORTEXION 50 WATT AMPLIFIER CHASSIS

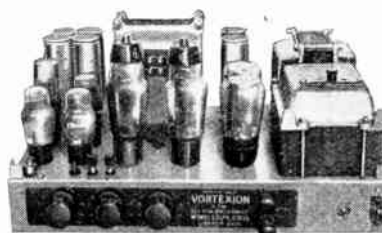

The new Vortexion 50 watt amplifier is the result of over seven years' development with valves of the 6L6 type. Every part of the circuit has been carefully developed, with the result that 50 watts is obtained after the output transformer at approximately 4% total distortion. Some idea of the efficiency of the output valves can be obtained from the fact that they draw only 60 ma. per pair no load, and 160 ma. full load anode current. Separate rectifiers are employed for anode and screen and a Westinghouse for bias.

The response curve is straight from 200 to 15,000 cycles. In the standard model the low frequency response has been purposely reduced to save damage to the speakers with which it may be used, due to excessive movement of the speech coil. Non-standard models should not be obtained unless used with special speakers loaded to three or four watts each.

A tone control is fitted, and the large eight-section output transformer is available in three types: 2-8-15-30 ohms; 4-15-30-60 ohms or 15-60-125-250 ohms. These output lines can be matched using all sections of windings and will deliver the full response to the loud speakers with extremely low overall harmonic distortion.

PRICE (with 807 etc. type valves) **£18.10.0**

Plus 25% War Increase

MANY HUNDREDS ALREADY IN USE

Supplied only against Government Contracts

VORTEXION LTD.

257, The Broadway, Wimbledon, S.W.19

'Phone: LIBerty 2814

RANDOM RADIATIONS

By "DIALLIST"

Quality at a Distance

FROM a reader who lives in the farthest parts of Cornwall comes a wail about the impossibility of obtaining good quality in the reproduction of broadcast programmes in such distant places. He proposes means of effecting an improvement and asks if I've any suggestions to make. I have. Lots! His idea, briefly, is this: It may be easy, says he, for those who live almost on the doorstep of a 50-kW station and use ten-valve receivers to obtain something that at any rate gives the impression of decent quality; but the listener in a far-off place can't have it, no matter what he does. Why, he asks, do I have to pick up and amplify *both* sidebands when it seldom happens that more than one of them is "spoilt by monkey chatter"? A single sideband, clean and clear, would make up to 10,000 cycles available for the loudspeaker. And he proposes to ensure that the single sideband, if supplied, would be clean and clear by using a six-foot frame aerial designed for very sharp minima. There is a lot to be said for single-sideband broadcasting and, unless my memory is at fault, P. P. Eckersley has said most of it. But the idea has not caught on and I do not think that it will. We shall have to find other solutions of the quality-at-a-distance problem. The one that appeals to me most is to cover the country with a network of small relay stations, transmitting with frequency modulation for choice. That, I believe, is what will eventually happen, for it seems to be the only way in which television can be brought into the homes of those who live far from the densely populated districts. As I see it, such stations as we have at present will continue to broadcast with AM for a considerable time and some will be retained for a very long time. But the place of the majority will gradually be taken by the low-powered FM network, combining speech and music with vision transmissions. Television will then be available to all who provide themselves with vision receivers. Those who either don't want them or can't afford them will have the speech and music for their entertainment. The great advantage of FM is that it makes high-quality transmission and reception possible and eliminates interference to a very large extent. It has to be done on very high frequencies. Therefore the range is limited and

the old mutual interference problems, which have hitherto made the evolution of international broadcast wavelength schemes so difficult, just disappear. The FM sound-cum-vision scheme, then, has a great deal to recommend it.

Wired Broadcasting

The alternative—if it is strictly an alternative—is wired broadcasting, which has caused such a flutter in the dovescotes of late. Whatever may be said for this kind of entertainment distribution, it will never meet the requirements of the large body of amateur radio enthusiasts. Their strength was considerable before the war; it will be vastly greater when peace comes back, for so many men and women in all the three Services have acquired a sound elementary (or even advanced) knowledge of the workings of radio and have developed a deep enthusiasm for it. Both the old hands and the wireless war-babies will be filled with the itch to have lots of knobs to twiddle and the burning desire to improve the performance of any apparatus that comes their way that are characteristic of the wireless fan. They will never be satisfied with "piped" broadcasting. As I have said, they will be a large body, and I think they will make themselves felt. I expect to see the wired system developed considerably, but I do not think it is going to oust ether-borne broadcasting, at any rate not for a very long time to come. There are some, I know, who think that the wireless set should be just as much a piece of furniture as the piano. Few people, with the exception of professional pianists or piano tuners, know much about the theory or the inner workings of the instrument, or tune or adjust their own pianos. Why, then, say the supporters of wired broadcasting, should the ordinary person bother his head over the innards of the radio receiver or care two hoots about wireless problems? If by the "ordinary person" they mean he or she who neither knows nor cares anything about wireless, I agree wholeheartedly. But, as I have shown, the number of people back in civil life when the war is ended who do know something and do care a lot is going to be very large. Everybody wants and needs a hobby, and wireless is going to be the hobby of a far bigger section of our people than has ever previously been the case. Lots of these people have had a good deal

to do with cathode-ray tubes, and television will be just meat and drink to them. Wired broadcasting probably would not give them that, and certainly it would not give them the scope that their enthusiasm for real radio craves. An FM and television relay network seems to me to be by far the best way of satisfying everyone's demand.

□ □ □

Drinking It In

WHAT people in the Army (and Services) have learned about wireless during the war is almost incredible. One of the best radio mechanics that I have had was in civil life a crofter in the far north of Scotland. His home is more than 60 miles from the nearest railway station and such things as electricity in general, and wireless in particular, were complete mysteries to him in 1939. Nor had he ever used any but the simplest of tools. To-day he will trace a fault in a highly complex piece of electrical apparatus and put it right. He has a respectable knowledge of theory and a burning enthusiasm for all departments of wireless. He is a first-rate hand at small, neat soldering jobs and a good all-round mechanic. Then I know girls who as soon as they look at you will discuss the mathematical analysis of detection or bowl you fast ones in the shape of questions on aerial theory. Yes, the number of girls who have taken to Radar and other departments of wireless as ducks take to water is remarkable. I have had hundreds of them through my hands and all but a very small percentage work like niggers, are as keen as mustard and just drink in what you teach them. Many of them, I believe, will be real radio fans when they return to civil life.

Service-men

One thing we should not be short of when the war is over is good radio service-men. Thousands have had a very thorough training in wartime, and after the complicated gadgets with which they have had to deal the ordinary broadcast receiver, mains or battery, that needs an overhaul will be just money for old rope to them. Before the war the really efficient service-man was far too rare. Too many were just dabblers, who found anything but the simplest fault beyond them. I have come across instances of sets returned to the makers for repair—and needless expense imposed on

their owners—on account of break-downs of the most elementary kind; troubles that could have been tracked down quickly and set right by any moderately competent man. We shall have no more of this kind of thing, for properly trained men will be available. And they will be duly qualified, too, if the theoretical and practical exam. inaugurated by the Radio Trades Examination Board receives the backing that it deserves.

□ □ □

HT Batteries

THE distribution of radio HT batteries still seems to be rather unsatisfactory. There are places where you can buy them as easily as shelling peas and others where they are rarer than eggs. Curiously enough, the localities where they are most readily available are often towns, where, presumably, the majority of receivers are mains-operated. The greatest need for them is in villages and hamlets where there is no electric light, and consequently all sets are battery-operated. And it is just in the out-of-the-way parts of the country that they are scarcest. The position should be looked into without delay, for many people go weeks without wireless because they cannot obtain HTBs. Why, I wonder, do we still retain the term "tension"? I believe we borrowed it from the French many years ago. I suppose we will go on using it; though as we speak of grid batteries and filament batteries I would have thought that plate battery was simpler. The Americans have simplified things to the utmost by speaking of A batteries (filament), B batteries (plate) and C batteries (grid). We might do worse than add these terms to our borrowings from them.

"WIRELESS WORLD" DIARY, 1944

THIS annual publication, issued from these offices, is now ready. In addition to the usual features of a pocket diary, it contains a 77-page reference section, which has again been revised. As supplies are limited, our publishers advise readers to obtain copies without delay from a bookseller, bookstall or stationer. The price, including purchase tax, is 3s. 1d.

THE WIRELESS INDUSTRY

THE Twickenham office (13a, King Street) of the Edison Swan Electric Company has now been closed and the staff has returned to 155, Charing Cross Road, London, W.C.2.

An illustrated brochure giving technical information about "Mycalex" insulating material has recently been issued by the Mycalex Co., Ltd., Ashcroft Road, Cirencester.

COMMUNICATIONS DEPEND...

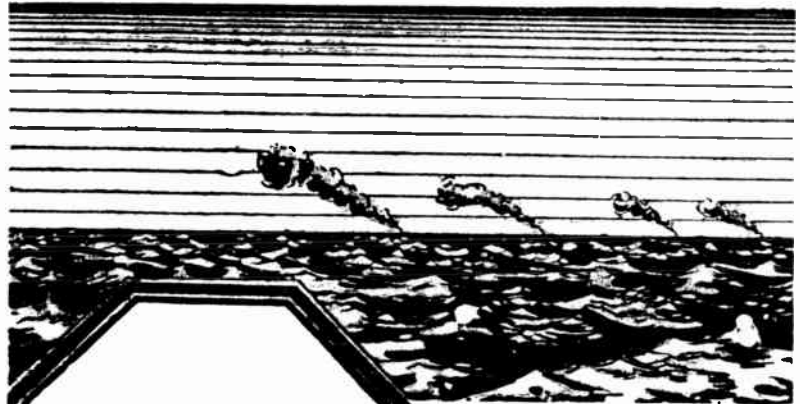

*The Choice
of Critics*

BULGIN FOR KNOBS

The largest and most extensive range in the world. Over fifty models from which to choose. All sizes and shapes, for different classes of work or operation. Nearly every type has brass-insert, steel grub-screws are fitted, well sunk. For 0.25in. dia. shafts and other sizes. Finely moulded and highly polished. The highest class instruments use Bulgin_Knobs exclusively.

ON SMALL PARTS...

IN countless instances quite intricate pieces of apparatus are wholly dependent on the proved reputation and reliability of their component parts.

All products from the House of Bulgin are pre-eminent for superior design and workmanship and every article bearing our Trade Mark has to pass exacting and exhaustive tests during the course of its production.

We ask the kind indulgence of the Trade on delivery until peaceful conditions return.

"The Choice of Critics"

BULGIN

REGISTERED • TRADE • MARK

A. F. BULGIN & CO. LTD., BYE PASS RD., BARKING,

TEL.: RIPPLEWAY 3474 (4 lines).

ESSEX

UNBIASED

"Aux Armes"

IT is astonishing how swiftly came complete vindication of the words I wrote last month to the effect that plans were being made by the mandarins and moguls of St. Martin's-le-Grand to impose upon us after the war a system of "conducted carrier" broadcasting over the network of gaspipes which are still the sole conductors of laid-on light and heat to a great many of the houses in our larger cities and towns. Scarcely had I laid my pen aside and despatched my manuscript to the Editor than there came the official announcement of the appointment of the erstwhile chief of a famous gas company to the all-powerful position of sole Director-General of the B.B.C.

The old saying that whom the gods would destroy they first make mad seems particularly applicable to certain wireless men who seem so concerned with debating the technical issues that they quite fail to realise that unless the political aspect of this question is tackled they will soon have no technical problems to wrangle over. Even in the technical field I am ashamed to see wireless engineers of repute giving voice to the opinion that the "wired" system is capable of giving better quality and less interference than its ether-borne counterpart. If, in 1896 or thereabouts, automobile engineers had admitted publicly that horse-drawn vehicles were more dependable and capable of giving better service than cars, where would our luxury limousines be to-day? No, they kept their real opinions to themselves and set to work quietly to make their publicly expressed views come true, and radio men would do well to emulate their example and remember the old Scottish proverb that it is an ill bird that fouls its own nest.

In order to realise the full implications of this country going



Engaged on intimate work.

"all-wired," and, therefore, totalitarian in its broadcast listening, it is only necessary to imagine what

By

FREE GRID

would have happened if this proposed regimentation of our aural pleasures had been in existence in 1939. It is certain that one of the programmes that would *not* have been fed to us would have been the one provided daily by Lord Haw-Haw, which has become one of the bright and amusing spots that liven up the drab grey of the dry and dreary wastes of the B.B.C.'s ponderous efforts to educate, inform, and uplift us. In fact, I feel so strongly about the way he managed to keep us cheerful in the "wee small hours of the war" when there didn't seem much to be cheerful about that I hope he won't be forgotten when the victory honours list is published and Mr. Bevin is forced to direct many erstwhile war workers into the factories of the hard-pressed makers of coronets and other insignia of nobility.

The establishment of a "wired" broadcasting service in this country would only be the thin edge of the wedge, for gaspipes would eventually give place to AC mains, and it would be then that our real days of slavery would begin. I have it on the authority of one who is employed on very intimate work in the household of a high Government official that plans are already afoot to mass-produce AC clocks and to emulate the feat of Abanazar in "Aladdin" and offer these in exchange for the old "clockwork" or mechanical time-pieces of our households.

The idea is simple. Since we should have no wireless sets we should have no chance of listening to time signals from abroad and should be dependent on the Government grid-controlled clocks. It will

then be a simple matter for those in authority to arrange for the AC frequency to be deliberately lowered in the daytime, so slowing down our clocks, and for the reverse process to be applied at night, thus getting extra working hours out of us without our knowledge. It behoves us, therefore, to sink our petty differences and rally behind the Editor in his campaign. *Aux armes, mes amis.*

What the Sunspots Foretell

THE full significance of the fact that, as explained in the October issue of *Wireless World*, the present sunspot cycle is apparently drawing to a premature close now, instead of next year, is probably appreciated by comparatively few readers. On those few, however, it will without doubt have the same effect as it has had on me and cause them to search feverishly in their attics and lumber rooms for their long-disused television sets. If one of the Editor's correspondents is to be believed, it means nothing more nor less than the imminent down-



Feverishly searching.

fall of Adolf and all that he stands for.

I am no astrologer, but I could not help but be struck by the significance of the facts pointed out by this correspondent, whose letter the Editor published in the March, 1942, issue of this very factual journal under the attention-compelling title of "What the Sunspots Foretell." The letter in question pointed to the remarkable phase relationship between the curve of the present sunspot cycle and that tracing the Adolf-appeasement cycle.

It was on January 30th, 1933, that Adolf commenced his rise to infamy, and it was about that time that the present dying sunspot cycle commenced to rise, reaching its maximum height in 1937-8, when the Adolf-appeasement curve also reached its maximum. In 1939 came the outbreak of war, and with it the steady decline of both the sunspot and the appeasement curves. Is it too much, therefore, to hope that this is not mere coincidence, but that there is, as the Editor's correspondent intimated, some esoteric connection between the two curves and that we may hope ere long to see our television receivers aglow with life once more?

EDDYSTONE



Interchangeable coil units versus Switched Coils

The Eddystone designers have eliminated switch contact trouble and dead-end effect by the use of separate coil units, ensuring the utmost reliability. In addition the frequency range can be considerably extended. In place of the commonly used range of, approximately, 26,000 to 600 Kc/s., the 358X covers all frequencies from

31,000 to 40 Kc/s.

Complete technical details available in 30-page Instructional Booklet on "358X," including all circuit values. Price 2/6 post free.

358X



WEBB'S *Radio*

14, SOHO ST. LONDON. W. 1. Phone; GERrard 2089

THE RECEIVER MAY BE INSPECTED between 9 a.m. and 4 p.m. (Saturdays 9 a.m. to 12 noon).

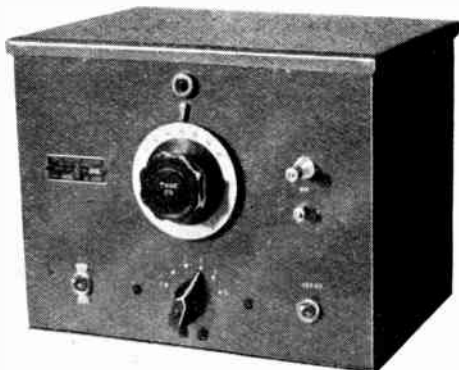

**A DENCO PRODUCT
FREQUENCY SUB-STANDARD
TYPE DFS. 1A**

A compact, inexpensive and useful instrument, operating from A.C. Mains. Provides a Quartz Crystal controlled signal, every 100 or 1,000 kc., from 100 kc. to 50 mc., for receiver calibration, etc.

Available to priority order only.

Details of this and other specialised radio products from

DENCO, Clacton-on-Sea, Essex



TYPE : V.S.3
VOLTS : 230 A.C.
OUTPUT : 1.25 K.V.A.

The "Brimain" Power Unit is a robust and sturdy Petrol Electric Generator designed specially for the provision of power and light for the operation of 16 mm. Projectors—Sound or Silent—where light load surge and instability are liable to damage valuable equipment. The output is ample for all standard projectors. Fulllest details gladly sent on request.

**BRIMAIN
Power Units**

BRITISH FILMS LTD., 199, PICCADILLY, LONDON, W.1.
Tel. : Regent 2828. Works : 260, High Road, Balham, London, S.W.
Tel. : Battersea 8506.

Varley

**TRANSFORMERS
and CHOKES
For RELIABILITY**

SEND US YOUR ENQUIRIES

OLIVER PELL CONTROL LTD
CAMBRIDGE ROW, BURRAGE ROAD, WOOLWICH LONDON SE

Superspeed
**CORED
SOLDER**
A.I.D. APPROVED
H. J. ENTHOVEN & SONS LTD.
230 THORNTON ROAD, WEST CROYDON, SURREY
THORnton Heath 2462

Remember-Walter
J.C.H. LTD

RADIO STAMPINGS • RADIO CHASSIS • RADIO PRESSINGS

FARM LANE, FULHAM, S.W.6. TELEPHONE : FULHAM 5234

BASICALLY BETTER...

Air Insulation
is the basic principle of

CO-AX
LOW LOSS CABLES
Unequalled
H.F. PROPERTIES

TRANSRADIO LTD. Inc. TELEQUIPMENT CO. 16 HIGHWAY, BEACONSFIELD.

CLASSIFIED ADVERTISEMENTS. Rate 6/- for 3 lines or less and 3/- for every additional line or part thereof, average lines 5-6 words. Each paragraph charged separately. Press Day: December issue, first post Tuesday, November 9th, and day earlier at branch offices. Box Numbers: 5 words, plus 1/- Deposit System: particulars on request. No responsibility accepted for errors.

Ode Partridge No. 26

MAKE & MEND

If your clothes are getting shabby
And you've whiskers on your cuffs,
If your shoes have split their sides with
wear and tear,

If your pants and vests are hole-y
And your socks are like a sieve,
Then it's surely time to think about
repair.

If you've reached that stage of terror
Where you're half afraid to stoop
Lest your trouser seams part company as
you bend,

Just invest a modest 3d.
At your local paper shop
On the handy pocket booklet "Make &
Mend."

That's clothes! But what of Radio?
If your set's a bit "off song"
And you think it needs a little overhaul,
Look up your files of "Wireless World"
And tackle the job yourself,
Then you'll save the busy Serviceman a call.

N. Partridge

Transformer Manufacturers,
76-78, PETTY FRANCE, LONDON,
S.W.1. Telephone: ABBey 2244.

ARMSTRONG SERVICE

OUR Service Department is still at
your service.

Despite the many changes caused by
over four years of war, and the
difficulties in material and valve
supplies, we have managed to main-
tain a very large proportion of
Armstrong Chassis in good working
order.

IN ADDITION
to practically all Armstrong Chassis,
including very old models, we can
now undertake the repair and
overhaul of many other makes
of receivers, including American
types.

ARMSTRONG MANUFACTURING CO.
WALTERS ROAD, HOLLOWAY, LONDON, N.7
Phone: NORth 3212

NEW RECEIVERS AND AMPLIFIERS
30-WATT ac amplifiers, precision built in-
struments, input and output channels
to requirements; early deliveries.—Below.
150-WATT racks, comprising 5 amplifiers
as above intercoupled, fitted for re-
mote control for industrial installations; send
for full details and illustrations; complete
equipment, including speakers and micro-
phones, etc., available.—Below.

18-WATT ac/dc amplifiers, mixing input
channels, bass and treble controls, in-
put and output transformers; 18gns.—Below.
DANCE and stage transportable equipment,
comprising 18-watt amplifier as above,
m/c mike, adj. stand, 2 speakers, cables; 36gns.—
Broadcast & Acoustic Equipment Co., Ltd.,
Broadcast House, Tombland, Norwich. 26970.

£24 Quality amplifier, with tone control
stage, 8-watt push-pull triode output, price
includes super quality triple cone permanent
magnet speaker with large output transformer
and all valves; as above but with 15-watt
push-pull tetrode output with inverse feed
back, £25, ideal for quality reproduction;
limited number available.—Bakers Sellhurst
Radio, 75, Sussex Rd., South Croydon. [2134

RECEIVERS, AMPLIFIERS—SECOND-HAND
HAMMARLUND Comet Pro, first class, con-
dition; £30.—Brix 2960, c/o W.W.
SCOTT 16-valve, 1939, perfect condition;
offers.—Frew, Back St., Tarbolton. [2126

W. Pretuned receiver, new.—Rumbold, 25,
King's Rd., New Haw, Weybridge. [2148
COMMUNICATIONS receiver SX17, 500kc/s
to 63mc/s.—Offers, Box 2951, c/o W.W.

HALLICRAFTER SX25, separate speaker,
12 tubes, crystal cont.; £50.—Box 2955.
MARCONI model 292 radiogram, £50, at
East Grinstead.—Box 2949, c/o Wireless
World. [2083

"W.W." amplifier and feeder unit, profes-
sionally built for cinema, new, unused,
very sound job; £30, plus parking and carr.;
stamp.—Capper, Gorsebank Lane, Baslow.

10-12-watt amplifier for ac. mains, complete
with large moving coil speaker, in grey
and chromium case and high quality medium
wave radio unit; £14 complete.—Box 2957,
c/o Wireless World. [2116

RADIOGRAM—Straight Six set and
W.W.Q. amplifier, Rola G12 speaker,
Piezo pick-up, high grade walnut cabinet, all
new and perfect; £60.—Deadman, 6, Abingdon
Rd., Hensington, London, W.8. [2101

McMurdo Silver Model VI, 20 valves,
comprising chromiumed chassis, am-
plifier, 18in speaker, all-wave, de luxe features,
massive speaker, cabinet on which set rests;
£120.—A.C.S. Radio, 44, Widmore Rd., Brom-
ley. [2102

COMPLETE P.A. equipment, ex large fac-
tory, approximately 100 watts, rack and
panel, elect. gram. T.T., 25 M.C. speaker horns
and 7 cabinet type, push-pull circuit, mains
transformer defective, 200 V.A.C.; inspectable
at Hantley, Boorne and Stevens, Ltd.,
Reading. [2077

7 BATTERY amplifiers for microphone and
gramophone stages III.2, LP2 and Class
B PD220A, offered £10 each; 1 3-watt a.c.-d.c.
200-250 volts amplifier, carbon microphone and
speaker, £12; 1 8-watt a.c.-d.c. 200-250 volts
amplifier, 2 speakers, gramophone and micro-
phone plugs, no microphone, £14; aerial equip-
ment, 40-56 5mm R.T.; 35/2 per 100 yards;
copper earth rods, sold 12in 1/9, 18in 2/6;
stand-off bracket, 2/-; carriage extra, cash
with order.—Larg's, Whitehall St., Dundee.

Wanted
COMMUNICATION receiver, with matched
speaker.—37, Cranborne Rd., Potters Bar.
WE offer cash for good modern communica-
tion and all-wave receivers.—A.C.S.
Radio, 44, Widmore Rd., Bromley. [1541

HALLICRAFTERS SX25 or SX28 receiver
urgently required, with matched speaker;
high price given for perfect instrument.—Box
2965, c/o Wireless World. [2141

WANTED, Hallicrafter or other first class
communications receiver, must be in per-
fect condition; state price and details.—951,
Finchley Rd., London, N.W.11. [2072

WANTED, modern high-performance com-
munications receiver, 2 r.f. stages,
crystal filter, full band-spread, signal strength
meter, pre-selector; good price paid for first
class set, complete with matched speaker and
servicing manual.—Box 2947, c/o W.W.

LONDON CENTRAL RADIO STORES will
pay good prices for receivers, radio-
grams, amplifiers, dynamos, converters, test
equipment, electric gramophone motors, and
all radio and electrical accessories.—London
Central Radio Stores, 23, Lisle St., London,
W.C.2. Gerrard 2969. [9836

WANTED urgently, Ribbon microphone,
highest quality type, preferably with
calibration curve. R.C.A. or similar.—Instruc-
tional Screen, Ltd., 9, Upper Berkeley St.,
W.1. Tel. Ambassador 2351. [2075

Advertisers and buyers are reminded that under
Defence Regulations 1939, Statutory Rules and
Orders 1940, Number 1689, a permit (T 99 G)
must be obtained before sale or purchase of
certain electrical and wireless apparatus, par-
ticularly such valves and apparatus as are ap-
plicable to wireless transmission.

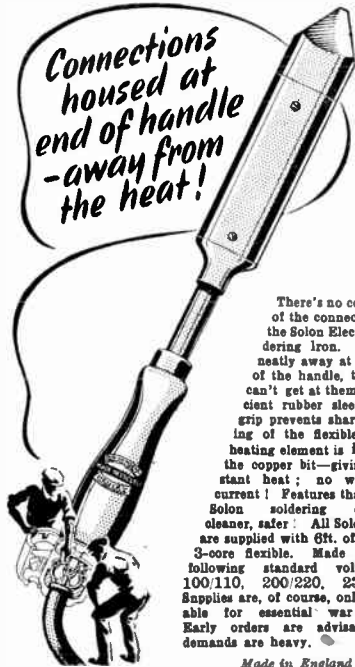

There's no corrosion
of the connections in
the Solon Electric Solder-
ing Iron. Tucked
neatly away at the end
of the handle, the heat
can't get at them. Em-
cient rubber sleeve cord
grip prevents sharp bend-
ing of the flexible. The
heating element is inside
the copper bit—giving con-
stant heat; no waste of
current! Features that make
Solon soldering quicker,
cleaner, safer: All Solon irons
are supplied with 6ft. of Henley
3-core flexible. Made for the
following standard voltages—
100/110, 200/220, 230/250.
Supplies are, of course, only avail-
able for essential war work.
Early orders are advisable, as
demands are heavy.

Made in England

Illustration
shows standard
340 watt model.
Other types and
sizes for various
specialised jobs.



W. T. HENLEY'S TELEGRAPH WORKS CO. LTD.
Engineering Dept., Milton Court, Westcott, Dorking, Surrey

RADIO SPARES

MAINS TRANSFORMERS. Primaries, 200/250v
Secondaries, 350-0-350v.

Type 80. 80 ma., 4v. 5a, and 4v. 2 1/2a. ... 27/6
Type 1C. 100 ma., 4v. 6a, CT, 4v. 2 1/2a. ... 31/-
Type 44. 120 ma., 4v. 6a, 4v. 2 1/2a. ... 35/-
Type 65. 120 ma., 6.3v. 5a., 5v. 2 1/2a. ... 35/-
The latter two, types 44 and 65, have static screens
and are of special quality.

AUTO TRANSFORMERS. 110/200-250v.,
100 watts ... 30/-

CLASS B DRIVER TRANSFORMERS ... 8/-
OUTPUT TRANSFORMERS.

Class B and Q.P.P., 8/-; Tapped Power, Pentode,
Class B and Q.P.P., 11/-; Heavy Duty Pentode,
100 ma., 13/8.

CHOKES. Smoothing.
11 Henries, 70 ma., 7/6; 20 Henries, 100 ma., 12/6.

CHOKES. High Frequency ... 3/6
MAINS DROPPING RESISTORS.

.2a. 950 ohms, 6/9; .3a. 800 ohms ... 6/9
Fitted with sliding clip and provided with feet for
chassis mounting.

FIELD COILS. HEAVY DUTY, 1,500 ohms,
2,000 ohms, 2,500 ohms ... 12/-

SPECIAL OFFER.
Very fine quality sleeving, 2 mm. ... 2/6 doz. yds.
Mica Washers for electric iron con-
tacts insulating ... 1/- per doz.

PLEASE NOTE—Orders accepted by post only, and those of
10/- or less should be accompanied by cash. Please include
postage with order. Orders over 10/- in value can be sent C.O.D.

H. W. FIELD & SON
14 Colchester Road, Harold Park, Essex.

The **“PYROBIT”** New

SOLDERING IRON

for Precision Instrument Work
Can be operated like a pencil



With only 45 watts a Bit Temperature of over 300°C is obtained

For all Voltages from 6—250 volts.

The AGRU ELECTRIC TOOL MFG. CO. LTD.
123 HYDE ROAD
ARDWICK, MANCHESTER, 12
Telephone: ARDwick 4284

MORSE CODE TRAINING

There are Candler Morse Code Courses for Beginners and Operators.

SEND NOW FOR THIS FREE “BOOK OF FACTS” It gives full details concerning the following Courses:—



JUNIOR Scientific Code Course for beginners. Teaches all the necessary code fundamentals scientifically.

ADVANCED High-speed Telegraphing for operators who want to increase their w.p.m. speed and improve their technique.

TELEGRAPH Touch Type-writing for those who wish to become expert in the use of the typewriter for recording messages and for general commercial uses.

Code Courses on Cash or Monthly Payment Terms.

IRREFUTABLE EVIDENCE of the value of the Candler System of Morse Code Training is given in our advertisement on PAGE 29 of the OCTOBER issue.

COUPON

Please send me a Free Copy of Candler “Book of Facts.”

NAME.....

ADDRESS.....

Post Coupon in 1d. unaffiliated envelope to London Manager

THE CANDLER SYSTEM CO. (Room 55W),
121 Kingsway, London, W.C.2
Candler System Co., Denver, Colorado, U.S.A. (1143)

NEW LOUDSPEAKERS

CELESTION 55 energised loudspeaker, 2,500 field, 15 ohms voice, brand new, boxed, £6 10; Benjamin ac field kit, boxed, £2 10.—Rodmell, 25, Ormonde Av., Hull. [2070]

£3/15 only.—Brand new super quality triple cone permanent magnet speaker made by Bakers Selhurst Radio, the pioneer manufacturers of moving coil speakers since 1925, wide frequency range, even response, ideal for qual. reproduction, 1in speech coil.

£4/15 only.—As above, but fitted with 1½ inch speech coil and magnet having exceptionally high flux density in the air gap, suitable for public address equipment when quality reproduction is first consideration; send 2½d. stamp for leaflet giving details of above and constructional details of infinite baffle cabinet; every music lover interested in realistic reproduction should write for leaflet.

£8/15 only.—Brand new super power cinema permanent magnet speaker with 18-inch triple cone, will handle 20 watts U.D.O., ideal for quality public address equipment.—Bakers Selhurst Radio, 75, Sussex Rd., South Croydon. [2135]

BROADCAST 12in P.M. loud speakers, precision built instruments to lab. standards and micrometer accuracy, Ticonal magnets, demountable diaphragm and magnet assemblies, perfect and permanent alignment, extended frequency range, uniform response, superior acoustical characteristics, maximum sensitivity, highest efficiency.—Broadcast & Acoustic Equipment Co., Ltd., Tombland, Norwich. 26970. [2025]

LOUDSPEAKERS SECONDHAND

GOODMAN 12in P.M. Auditorium speaker; £7/10.—Box 2954, c/o *Wireless World*.

HARTLEY-TURNER Duode, all accessories, perfect; best offer, or part exchange small lathe.—Box 2962, c/o *Wireless World*. [2132]

Wanted

GOOD price for Hartley-Turner in perfect condition.—29, Serle Av., Blackpool.

BENJAMIN whistle filter for Magnavox duode speaker, 15 ohms coil.—Stanton, Ditton Grange, Ditton Hill, Surrey. [2117]

MORSE EQUIPMENT

FULL range of transmitting keys, practice sets and equipment for Morse training.—Webb's Radio, 14, Soho St., London, W.1. Tel. Gerrard 2089. [9553]

TEST EQUIPMENT

ROSSOR 3332 oscilloscope, good cond.; £25.—Box 2948, c/o *Wireless World*. [2073]

HALICRAFTER signal strength meter type SM13; offers.—Box 2958, W.W.

AVOMETER, latest new 40 model; £25, or exchange for Leica camera.—BM/JNS, London, W.C.1. [2127]

FERRANTI electrostat voltmeter, moving coil, range 0-3, 500v, unused; what offers?—Box 2961, c/o *Wireless World*. [2131]

TESTSCOPE, used everywhere by radio service engineers, makes 20 important tests; send for interesting leaflet “R.I.”—Runbaken, Manchester, 1. [1074]

Wanted

0.1 mA Ferranti or similar.—Pierions, 8 Mess. R.N. Signal School, Plymouth.

NEW MAINS EQUIPMENT

VORTEXION mains transformers, chokes, etc., are supplied to G.P.O., B.B.C., L.P.T.B.; why not you? Imitated but unequalled; orders can only be accepted against Government contracts.

VORTEXION, Ltd., 257, The Broadway, Wimbledon, London, S.W.19. Lib. 2814.

GRAMOPHONE AND SOUND EQUIPMENT

VOIGT moving coil pick-up, as new; nearest offer £6 secures.—Box 2952, c/o W.W.

E.M.I. amplifier, with valves, 30-watt model P.A. 150, new, Bakers' 8-watt amplifier, with radio unit and speaker coil.

GARRARD automatic record changer, complete recording equip., 12-watt Quality quality amplifier, play-back speaker with microphone, 12in blanks (40); m.c. pick-up.

ONE 30v 6amp 3-circuit charger, with spare valve; 1 30v 6amp charger less valve; 1 110-volt 440 transformer, 500 watts, Davenset charger, type MG(5, 5 circuits).

HARTLEY-TURNER duode de luxe speaker, P.P. output transformer, 2,000 ohms field; Voigt m.c. speaker, with wooden horn; special 45-watt m.c. speaker in cabinet; Pamphonic m.c. twin cone speaker, 18in cone; W.W. Quality tapped speaker transformer.

ONE ½hp a.c. motor, 250v 50 cycles; 1 230-volt dc to 230 ac converter with filter.

TAYLOR universal meter, model 90, as new; offers for lot or singly will be accepted.—W. and D. McKissock, 9, Bruce St., Dunfermline. [2139]

COILS for filters, tone controls, etc., all types transformers for W.W. circuits accurately wound.—R. Clark, 69, Longley Av., Alperton, Mdx. [2097]

SOUTHERN SOUND STUDIOS—Please see our displayed advertisement, page 32, September issue.—Southern Sound Studios, 4, Bittacy Park Avenue, Mill Hill, N.W.7. [1989]

SEXTON'S for SALES, SERVICE, SATISFACTION

BUILD YOUR OWN RADIO RECEIVER. A Four-Valve Universal Mains Radio can be easily constructed at home from components which are readily obtainable from practically any radio dealer. We offer to you comprehensive instructions which contain theoretical circuit, point to point wiring diagram and component layout and list of components with the correct specified valves that are necessary to build the “VICTORY. UNIVERSAL FOUR” at 7/6 for complete instructions. Delivery 8th November. Limited quantity only. All orders will be treated in strict rotation. You will be amazed at the performance of this model when comparing with the high price radios at present on the market.

BRIVARON BRITISH MADE VALVES. American types: 80, 5Y3, 5Y4, 5 volt rectifiers, RF.120 4 volt rectifier, type RF.30 equivalent to 1D5, URIC at 11/- each.

HAND CRYSTAL MICROPHONES. With 7 ft. screened cable, manufactured by Brush Crystal Co., Ltd., at £3.5s. each.

REPLACEMENT COILS for American Midget superhet. receivers, two types at 2/6 each.

VARIABLE CONDENSERS. 2 gang 2 x .0005 at 9/- each. 3 gang 3 x .0005 at 9/6 each.

BOX SPANNERS. Set of three, 2, 4, and 6BA, with tommy bar, at 3/6 per set.

LINE CORDS. 2-way, best quality, 350 ohms, at 7/6. 450 ohms at 9/6. 600 ohms at 12/-.

GOODMAN'S 3½in. P.M. Speakers 12 ohms voice coil, ideal for microphones, communication sets at 30/- each.

EXTENSION LOUD SPEAKERS. “Rola” 3 ohm voice coil size, 5in. at 21/- each. Size 6½in. at 22/6. Size 8in. at 24/-, less trans. “Celebration” 8in. chassis model with Universal Trans. 3 watts, at 36/- each.

VENEERED WOOD POLISHED CABINETS. Suitable for 6½in. and 8in. speakers, excellent quality, 25/- each.

CYCLE DYNAMOS, with brackets and lead, less lamp, at 15/6 each. Limited quantity.

TERMS: Cash with order only. Send 1d. stamp and S.A.E. for list of electrical appliances, valves, components, etc.

J. E. SEXTON & CO. LTD.
164, Gray's Inn Road, London, W.C.1
Tel.: Terminus 1304 and 4842.



W. BRYAN SAVAGE LTD.

Expert assistance in the solution of problems relating to

- TRANSFORMERS, CHOKES
- AMPLIFIERS
- POWER UNITS

and Specialised Equipment embodying

ELECTRONIC CONTROL

WESTMORELAND RD., N.W.9
COLINDALE 7131

AFTER THE WAR!

The advance in Radio Technique after the war will offer unlimited opportunities of high pay and secure posts for those Radio Engineers who have had the foresight to become technically qualified. How you can do this quickly and easily in your spare time is fully explained in our unique handbook.

Full details are given of A.M.I.E.E., A.M.Brit.I.R.E.E., City & Guilds Exams., and particulars of up-to-date courses in Wireless Engineering, Radio Servicing, Short Waves, Television, Mathematics, etc., etc.

We Guarantee “NO PASS—NO FEE”

Prepare for to-morrow's opportunities and post-war competition by sending for your copy of this very informative 112-page guide NOW—FREE.

BRITISH INSTITUTE OF ENGINEERING TECHNOLOGY (Dept. 388)
17, Stratford Place, London, W.1

H. WILSON

NOW

AUSTERITY RADIO, LTD.

CONSTRUCTORS' KITS

See July issue for illustration and details of Constructors' A.C. and Battery 3-v. Kits. Delivery approximately one month.

3-gang CONDENSERS .00025 with ceramic insulation, 7/6.

3-gang CONDENSERS .0005, ceramic insulation, with trimmers, 10/6.

AERIAL AND H.F. TRANSFORMERS with reaction medium and longwave iron cored on medium waves loading coil on long waves. 10/- per pair.

SHORT-WAVE COILS on Paxolin Formers 16-50 metres approx., 1/8 each. Midget Medium Wave Oscillator only, 1/6 each.

MAINS VOLT DROPPING RESISTORS. 2 amp. 1,000 ohms, 2 variable sliders, 6/-; .3 amp. 750 ohms, 2 variable sliders, 7/-.

10-WATT WIRE-WOUND RESISTORS, 2,000, 500 and 150 ohm, 2/6 each.

PADDERS. Twin ceramic .0003 mmfd. (max.) and .0006 mmfd. (max.), 1/6 each.

CHASSIS. Undrilled steel, painted, new, 10 1/2 x 8 x 2 1/2 in.; 7/6; 8 x 6 x 2 1/2 in., 4/6 each. Drilled for 3-v. 8 x 6 x 2 1/2 in., 5/6.

WESTECTORS. Type W6, 5/- each.

SWITCHES. New, Yaxley type midget, single bank, single pole, 4-way, 2/9 each. Single bank, 3-pole, 3-way, 3/6 each; 3-bank, 2-pole, 3-way screened, 7/6 each; 4-pole, 3-way, midget, 4/6 each; 2-bank, 2-pole, 3-way, 5/- each.

PARALLEL FEED TRANSFORMERS. Midget. Colour coded circuit, 6/-, H.F. Choke Amplifier, 2/6 each. Short-wave double wire wound Filament Choke for electronic reaction coupling, 2/- each.

VALVE HOLDERS, 4-, 5-, 6-, 7-pin Paxolin/6d. International Octal, 9d. each. Short-wave Ceramic 5-pin, 1/6 each.

OCTAL CABLE PLUG AND SOCKET, 2/-.

T.C.C. AIR-SPACED TRIMMERS, 0 to 35 mmfd., 1/- each.

CONDENSERS. Tubular, .0005 mfd. to .005, 6d. each .02 to .1, 9d. each. Mica, .01, .001 mfd., 2,200 volt test 1/8. Silver mica, .00015, .0002, .0005, .00005 mfd. 9d. each.

VOLUME CONTROLS. 1/2 and 1 meg., with switch, 6/6 each. 25,000 and 50,000 ohms, less switch, 4/- each.

VARIABLE CONDENSERS. Single .0005 mfd., 2-speed drive with pointer, knob and dial, no escutcheon required. Single hole fitting for portables, crystal sets, etc., 6/-, Short-wave Tuning Condensers, 30 mmfd., 2/6.

SPEAKER OUTPUT TRANSFORMER. Heavy duty Pentode, 10/- each.

PAXOLIN. Polished, flat, strong, 18 x 2 1/2 x 3/32nds approx., 1/6 each. Soldering Tags, 3d. dozen. Terminal Strips, from 3d. to 9d. Eyelets, 1/2 to 1/6 gross. Resistor, 1-watt, 6d.; 1-watt, 1/- each, most values available. Spiro Clips, 2 a 1d. Flexible Couplings available. Large, 1/-, Dial Lamp Holders, 6d. each. A1, A2, E Panels, 6d. Systodex, coloured, plain and striped, 4d. per yd. length.

A good selection of shop-sold and odd components available to callers only. Cheap. Licence to export to Northern Ireland and Irish Free State.

★ Please add postage for enquiries and mail orders. C.O.D. orders accepted.

Owing to present circumstances, prices are subject to increase without notice.

51-52 CHANCERY LANE.
LONDON, W.C.2. Telephone HOLBORN 4531

H.M.V. auto record player, model 117 dc; £20 or near offer.—Box 2968, c/o W.W.

Wanted

QUALITY low-imped. pick-up, with hum coil, suitable fibres.—15a, Borneo St., S.W.15.

WANTED, Garrard standard type magnetic pick-up, complete or head only.—Lindsay, 47, Queen's Rd., Bradford, Yorks. [2147]

WANTED, 230v ac motor and turntable, 33 and 78 rpm; also moving-coil pick-up.—Emblem, 263, Marshalls Cross Road, St. Helens, Lancs. [2098]

CUTTING heads required urgently, any condition; please state make and price required.—Box 2953, c/o Wireless World. [2099]

A/C/AC-DC record players, 230v, 12in turntable, magnetic or crystal pick-ups, var. speed; cond. and price.—James, Post Office, Tintinhull, Yeovil. (2093)

WANTED, Plus-o-gram or similar cabinet to accommodate radio on top, drawer for turntable, compart. for records, dark colour.—Waterre, 42, London Wood, Keston, Kent.

ELECTRIC gram. motors, 2 crystal pick-ups; sale or p.e. Garrard auto-record player.—Box 2959, c/o Wireless World. [2123]

SAPPHIRE gramophone needles wanted.—1, Chapel St., Rishton, Lancs. [2125]

URGENTLY required to purchase, any type of recording equipment, either sound on discs or sound on films, also 16mm sound projectors; this equipment is required for urgent Government work and for use in connection with service entertainments.—Full details, including date, age, condition and model No. and when can be seen and inspected, should be forwarded immediately to Southern Sound Studios, 4, Bittacy Park Ave., Mill Hill, N.W.7.

DYNAMOS, MOTORS, ETC.

FOR sale, 2 G.E.C. 1/30hp motors, 100-115v d.c., 2,000 r.p.m., shunt wound, little used; 20/- each.—Box 2933, c/o W.W. [2103]

EKCO CV101 vibrator converter, 200-250 dc 200-250 ac, 100 w, incl. spare new vibrator; £7; (London).—Box 2964, c/o W.W.

ALL types of rotary converters, electric motors, battery chargers, petrol-electric generator sets, etc., in stock, new and second-hand; supplied against priority orders only.

WARD, 37, White Post Lane, Hackney Wick, E.8. Tel. Amhurst 1393. [1988]

E.D.O. rotary converter, 230 dc to 230 a.c., 180 watts, dc. gram motor, H.M.V.'s sound order, £4; unused Mazda valves, DCSG. DCHL, DCPen.—W. R. Service, 16, Terrace Rd., Buxton. [2069]

L.T. dynamos for charging, Lucas-Rotax, 6-12v 8 amps dc, 3rd brush, weight 11lb, size 8in x 4 1/2 in, unused ex W.D., cost £10, to clear 17/6 each; ht and lt G.E.C. double-current 6v and 600v, 17lb ditto, 27/6; all carr. paid England and Wales.—Electradix, 214, Queenstown Rd., Battersea, S.W.8. [1748]

Wanted

7860C cylindrical dc/ac converter unit, to operate Philips 785AX receiver off 100/110v ac supply.—Gamble, Duchally, Auchterarder, Perthshire. [2145]

COMPONENTS—SECOND-HAND, SURPLUS VALVES, Ferranti voltmeter, photo electric cell, for sale.—Duncan, Norwinstow. [2090]

35 Reliance 200 ohm 15-20w pots; others for lot or each.—Box 2956, c/o Wireless World. [2111]

SOUTHERN RADIO'S wireless bargains: Screws and nuts, assorted gross of ea. (2 gross in all), 10/-; soldering tags, including spade ends, 6/-; Philco 3-point car aerials, excellent for short wave and home aerials, 7/6; limit tone arms, universal fixing for all types of sound boxes and pick-up heads, 10/-; Ace P.O. microphones, complete with trans., ready for use with any receiver, 7/-; metal panels, undrilled rigid, 18 1/2 in x 8 1/2 in, 2/6; circular magnets, very powerful, 1 1/2 in diameter by 1/2 in thick, 1/6 each, 15/- per dozen; Erie resistances, brand new, wire ends, all low value from 0.8 ohms upwards, a few higher value are included in ea. parcel, 1/4, 1/2, 1 and 2-watt, 100 resist. for 30/-; Multicon Master mica condensers, 28 capacities in one, from 0.0001, etc., etc., 4/- each. Special assorted parcel for Service men: 100 Erie resistances (description above), 24 assorted tubular condensers, 6 reaction condensers, 0.0001, 12 lengths insulated sleeving, 75lb. push-back connecting wire, soldering tags, screws, wire, etc., 65/-, all brand new. Crystals, (Dr. Cecil), 6d, with cat's whisker, 9d; complete crystal detectors, 2/6; 75t wire for aerials, etc., 2/6; 25 yds push-back wire, 5/-; Telsen reaction condensers, 0.0001, 1/9 each; Telsen large disc drives, complete with knob, etc. (boxed), type W184, 2/6 ea.; insulated sleeving, assorted, yd lgths., 3/6 dozen; single screened wire, doz. yds, 10/-; speaker units, unshrouded, Midget type, 4/-; metal cased condensers, 0.1+0.1+0.1, 2/6; many bargains for callers—Southern Radio Supply Co., 46, Lisle St., London, W.C. Gerrard 6633. [1846]

PREMIER RADIO

METERS

0-100 ma. Moving Iron AC or DC, Bakelite Case, flush mounting, 2 1/2ins. diameter. Price 12/6 each.
Premier 1-valve de Luxe Battery Model 5.W. Receiver, complete with 2-volt valve, 4 coils covering 12-170 metres, a built on steel chassis and panel, 55/-, including tax.

I.F. TRANSFORMERS, IRON CORED 450-473 kc., plain and with flying lead, 5/6 each.

NEW PREMIER S.W. COILS

4- and 6-pin types, now have octal pin spacing and will fit International Octal valve holders.

| 4-PIN TYPE | | 6-PIN TYPE | |
|------------|---------------|------------|---------------|
| Type | Price | Type | Price |
| 04 | 9-15 m. 2/6 | 05 | 9-15 m. 2/6 |
| 04A | 12-26 m. 2/6 | 06A | 12-26 m. 2/6 |
| 04B | 22-47 m. 2/6 | 06B | 22-47 m. 2/6 |
| 04C | 41-94 m. 2/6 | 06C | 41-94 m. 2/6 |
| 04D | 76-170 m. 2/6 | 06D | 76-170 m. 2/6 |

CHASSIS MOUNTING OCTAL HOLDERS 10jd. each.
New Premier 3-band S.W. Coil, 11-25, 25-38, 38-86 m., 4/9.
Rotary Wave Change Switch, to suit above, 1/6.
Bakelite Dielectric Reaction Condensers. 0001 mf. 1/3, 0003 mf. 2/8, 0005 mf. 2/9 each.
0003 mf. Differential 2/11 each
2-gang 0005 mf. Condensers, with trimmers 5/6 each

H.F. CHOKES

S.W. H.F. Choke, 10-100 m. 1/3
Standard H.F. Choke 1/-
Binocular H.F. Choke 1/6

SHORT WAVE CONDENSERS

Troital insulation. Certified superior to ceramic. Air-brass construction. Easily ganged.
15 mmfd. 2/11 100 mmfd. 3/11
25 mmfd. 3/3 160 mmfd. 4/8
40 mmfd. 3/3 250 mmfd. 5/8
Brass Shaft Couplers, 1in. bore 7jd. each
Flexible Couplers, 1in. bore 1/2 each
7-pin Ceramic Chassis mfg. English fitting Valve Holders, 1/6 each.
Amphenol Octal Chassis mounting Valve Holders. International type, 1/3 each; English type, 1/3 each.

RESISTANCES

Mains Resistances, 660 ohms .3A Tapped. 360 x 180 x 60 x 60 ohms, 5/6 each.
1,000 ohms, 2A Tapped. 900, 800, 700, 600, 500 ohms, 5/6 each.
1 watt all values, 5d. each.
1 watt all values, 7d. each.
4 watt from 50 to 2,500 ohms, 1/- each.
8 watt from 100 to 2,500 ohms, 1/8 each.
15 watt from 100 to 10,000 ohms, 2/- each.
25 watt from 100 to 20,000 ohms, 2/9 each.

SWITCHES

QMB panel mounting, split knob type, 2 point on/off, 2/- each.
Double pole on/off, 3/6 each.

VOLUME CONTROLS

Carbon type, 20,000, 50,000, 1 meg., 1 meg. and 2 meg., 3/9 each. 5,000, 10,000 and 1 meg., 4/6 each.
Wire Wound Type, 5,000 and 10,000 ohms, 5/6 each.
Valve Screens for International and U.S.A. types, 1/2 each.
Resin-Cored Solder, 7jd. per coil.
Push-Back Connecting Wire, 21d. per yard.
Systodex Sleeving, 2 min., 2/8 per doz. yards.
Screened Braided Cable, Single, 1/3 per yard.

MOVING COIL SPEAKERS

Rola 5 in. P.M. Speaker, 3 ohms voice coil, 21/-
Rola 6 1/2 in. P.M. Speaker, 3 ohms voice coil, 25/-
Rola 8 in. P.M. Speaker, 3 ohms voice coil, 25/-
Above Speakers are less output transformer.

Send for details of our Morse Equipment, Valves, and other Accessories available.

ALL ENQUIRIES MUST BE ACCOMPANIED BY A 2d. STAMP.

PREMIER RADIO CO.

ALL POST ORDERS TO:

JUBILEE WORKS, 167, LOWER CLAPTON ROAD, LONDON, E.5. (Amherst 4723.)

CALLERS TO:

JUBILEE WORKS or
169, FLEET STREET, E.C.4. (Central 2833.)

LASKY'S RADIO

370, Harrow Road, Paddington, W.9

(Op. Padd. Hospital.) Phone: Cunningham 1979

OFFER FOR SALE THE FOLLOWING:

| | |
|---|-------------------|
| U.S.A. Octal Base Valve Holders | 7/6 doz. |
| Assorted V. Conds., less Switch... | 2/9 each |
| Volume Controls, 1, 1/2 & 1 meg., with Switch | 5/9 each |
| Volume Controls, 1/2 meg., less Switch, for Midgets | 3/6 each |
| 2 mfd. 600 v. Block Paper Cond. | 2/6 each |
| 10 mfd. 500 v. Block Paper Cond. | 5/6 each |
| .0023 mfd. 2,000 v. tubular | 1/- each |
| .02 " 2,000 v. " | 1/- each |
| .25 " 2,000 v. " | 1/6 each |
| .05 " 500 v. " | 1/- each |
| .50 " 12 v. " | 1/4 each |
| .25 " 25 v. " | 1/6 each |
| .10 " 25 v. " | 1/6 each |
| .1 " 350 v. " | 6/- doz. |
| Toggle Switches | 3/6 each |
| Systolex | 3d. each 2/6 doz. |

SPECIAL OFFER.

Over 100 Assorted Condensers and Resistances, all high voltages, at 25/-, post free. We have a Large Stock of English and U.S.A. Mains and Battery Valves in Stock.

SPEAKERS.

Rola Sin., 19/6; 6in., 21/-; 8in., 23/6; 10in., 31/6 in stock, less transformer, P.M., 3 ohms Voice Coil. Goodmans 3 1/2 P.M., 12 ohms Voice Coil, 25/- each. Universal Output Speaker Transformers, Pentode, Power, etc., 7/6 each. 6 1/2" P.M. Speakers with Universal Output Transformer, 29/6 each. 4v. + 4v. 350/0/350 best quality Mains Transformers centre tapped, 35/- each. 7-pin English V. Holders, 9d. each, 8/- doz. .3 amp Line Cord, 3-way, 70 ohms per foot. Best quality 5/9 per yard. 24 Assorted Radio Dials and Escutcheons at 10/- the lot.

Send us your requirements. C.O.D., BUT CASH WITH ORDER PREFERRED.



FOR THE RADIO SERVICE MAN, DEALER AND OWNER

The man who enrolls for an I.C.S. Radio Course learns radio thoroughly, completely, practically. When he earns his diploma, he will KNOW radio. We are not content merely to teach the principles of radio, we want to show our students how to apply that training in practical, every-day, radio service work. We train them to be successful!

INTERNATIONAL CORRESPONDENCE SCHOOLS

Dept. 38, International Buildings, Kingsway, London, W.C.2

Please explain fully about your Instruction in the subject marked X.

Complete Radio Engineering
Radio Service Engineering
Elementary Radio Television

And the following Radio examinations:

British Institution of Radio Engineers
P.M.G. Certificate for Wireless Operators
Provisional Certificate in Radio Telephony and Telegraphy for Aircraft

City and Guilds Telecommunications
Wireless Operator & Wireless Mechanic, R.A.F.

Name..... Age.....

Address.....

LONDON CENTRAL RADIO STORES.

Manufacturers' surplus components collected from all over the country; real bargains for discriminating radio enthusiasts; no extra charges for postage, packing, etc.; this avoids confusion.

SPEECH transformers, brand new, ex. well-known speaker maker, ratio 30:1, a fine job; 6/9 each.

RELAYS.—Brand new, surplus stock from Standard Telephones, electro-magnetic make and break units to operate on 1 1/2 volts at 15mA; to clear stock, 5/9 each.

MOTOR tuning.—Fine brand new 3-gang .0005mfd condenser, no trimmers, designed for motor drive, large diameter driving disc and reduction gear for slow motion manual drive; 13/6 each.

BRASS rod.—Screwed brass rod, 2B.A. and 4B.A., 12-inch lengths, useful for many purposes; 5/6 doz lengths.

VALVEHOLDERS, all brand new, Celestion Amphenol, Mazda and International octal; 1/- each.

CONDENSERS, tubular wire end, made by Plessey, 25mfd, 25 volt working, 50mfd, 12 volt working; 1/9 each.

RESISTANCES.—Assorted wire-end resistances by best makers, ideal for servicemen and experimenters; to clear, 3/6 doz, 13/3 for 50, 23/6 for 100.

CERAMIC valveholders, brand new, low loss, 7 pin; 1/5 each.

CONDENSERS.—First-class .1mfd oil-filled, 5,000 volt working; only 11/6 each.

T.C.C. tubular condensers.—.1mfd, 6,000 volt dc test, 8/9 each; also 2mfd tubulars, 30 volt working, 2/6 each.

T.C.C. condensers in metal cases, special offer, much reduced to clear, 4x4mfd, 70 volt working; 2/6 each.

SPEAKER transformers for Pentode output valves; 5/10 each.

VIBRATORS.—Brand new American synchronous self-rectifying vibrator units, 12 volt input, 280 volt output, 65mA, fitted with 7 pin American base; 16/- each.

COUNTERS.—Ex. G.P.O., every one perfect, electro-magnetic, 500 ohm coil, counting to 9,999, operated from 25v-50v dc, many industrial and domestic applications; 6/-

VALVEHOLDERS.—Paxolin, 7 and 9 pin; 7d. each, 6/- doz.

DROPPING resistances.—To replace 2- and 3-way line cords, with diagram showing connections, .3amp, in strong metal case, 13/- each; without case, 10/- each.

ELEC. razor resistances, universal input, in strong metal case; 10/- each.

TRIMMING tools.—Fine set of 12 bakelite handle trimming tools in roll-up leatherette case, ideal for servicemen; 35/- set.

REACTION condensers.—Fine quality job, .0003 mfd, to clear at 2/3 each.

TUBULARS.—Vego wire-end tubular condensers, .1 and .01mfd, 400v working; 1/-

VALVEHOLDERS.—Side contact, 8-pin type, in bakelite, 1/9 each; anode bakelite valve caps, 10d. each.

DIAL lamps.—Philips' screw type dial lamps for dial illumination, 15 watt; 1/9 each.

SPEECH coil ribbon wire, enamelled copper, gauge approx. 20 thou. by 5 1/2 thou.; 3/3 per lb. reel.

EARPHONES.—Single, ex-Government, 750 ohms; 4/- each.

EXTENSION speakers.—Brand new, first-class p.m. loud speakers, in beautifully polished cabinets, 61/6; rexine covered, 57/6.

FLEXIBLE drives.—Ideal for remote control in radiograms, etc., approx. 2ft. lgth.; 4/3.

DECORATIVE cabinet grilles, 4-bar, 1 1/2in x 1 1/2in wide, solid brass chrome-plated, 2/6 each; heavier quality, 3/6; also rectangular speaker grilles, 7 1/2in x 5 1/2in, 1/6.

VALVES.—EA50, Mullards; to clear, 10/6 each.

BLEEDER resistances, 100-250 ohms; 2/9 each

PLUGS and jacks.—Ex-Govt., powerful phosphor-bronze springs, ensuring perfect contact, overall lgth., incl. 1/2in threaded shank, 3/2in, supplied with nut for panel mtg.; complete with best quality plug, 5/9.

SCANNING and detector coils, Philips' ex-television receivers, complete in metal frame; 8/6 each.

PUSH button units.—Permeability iron-cored coil units, 6 spring loaded switches, 16/- each, 8 switch unit (no coils), 4/6 each; 12 switch unit (no coils or switches), 2/6 each.

SEE also our display advt. on p. 31.

NO extra for postage, etc.

LONDON CENTRAL RADIO STORES, 23, Lisle St., London, W.C.2. [2112]

HILL AND CHURCHILL BOOKSELLERS SWANAGE DORSET

ENGLISH & AMERICAN BOOKS IN STOCK ON RADIO AND TELECOMMUNICATION

CATALOGUE ON APPLICATION

Cabinets?

Increased production facilities enable us to give immediate attention to orders for urgent requirements and we are now in a position to accept further contracts or sub-contracts for Government work.

We specialise in AMPLIFIER and EXTENSION SPEAKER CABINETS, METAL BOXES & CHASSIS.

All enquiries should be accompanied by Priority No.

HIRSH & HYAMS, LTD.

Cabinet Manufacturers, 93, Hackney Road, London, E.2. Bish. 4012

BATTERY CHARGERS & TRICKLE CHARGERS



for all purposes "QUICK-CHARGE" CHARGERS well known for reliability

Booklet R.15, giving useful information and describing 12 Models, on request

RUNBAKEN-MANCHESTER

GECALLOY RADIO CORES

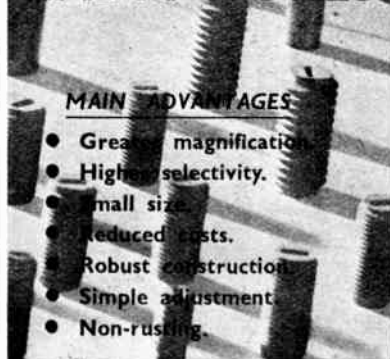

MAIN ADVANTAGES

- Great magnification
- High selectivity.
- Small size
- Reduced costs.
- Robust construction
- Simple adjustment
- Non-rusting.

Salford Electrical Instruments Ltd.

PEEL WORKS, SILK STREET, SALFORD, 3 Telephone: 5Lack: 668 (10 lines) Proprietors: The General Electric Co. Ltd. of England

Crossing bridges before you come to them

Although old wives may say "No," we at (Gardners Radio have found that to cross our designing and production bridges before we come to them is more than worth while for you and for us. It is just another reason why Gardner components always have that "tailor-made" air about them. . . why they are always so fit for the job they are given. And nowhere in the Gardner range is our "bridge-crossing" technique better exemplified than in the Small Power Transformers up to 4 kva. So when next you need this type of component and "bridge-crossing" is Al priority in the spec., our co-operation is yours for the asking.



GARDNERS RADIO LIMITED
SOMERFORD · CHRISTCHURCH · HANTS

Trained men get GOOD JOBS

Now is the time to prepare yourself for the future. There will be splendid opportunities for technically trained men to secure well-paid employment, or start radio businesses of their own.

Even if you know nothing about radio, we can train you. Our specialised method of Home-Study Tuition is a proved success. Hundreds of our students now doing important work owe their progress solely to our training.

Post coupon now for free details of our Home-Study Courses in:

- Radio Reception,
- Transmission,
- Servicing,
- Television,
- Radio Calculations,
- Mathematics.

T. & G. RADIO COLLEGE,
2, THE MALL, EALING, W.5

(Post in unsealed envelope, 1d. stamp.)

Please send me free details of your Home-Study Mathematics and Radio Courses.

NAME.....
ADDRESS.....
W.W.21

G. A. RYALL, 69, Wharfedale Gardens, Thornton Heath, Surrey.—Please note new temporary address; mail order only.

FRIE resistances.—1W, 680 ohms, 3/ doz.; Erie 2W 3.80, 140,000, 270,000, 1/6; Erie 3W, 6,800 ohms, 2 1/6

TC.C. 0.1 non-inductive tubular condensers, in paxolin tubes, type 330, 350v wks., 6/6 dozen, 75/- gross.

SLOW motion (epicycle) drives, in well-finished brass, ratio 8-1, shaft 1 1/2 in long, 1/4 in dia., drilled to take pointer, 1/3 each.

PAXOLIN strip, 2 1/2 in wide, 12 in lengths, 3 1/6 and 100 25/-; short lengths cut group board size, 6 1/3.

THIMBLE top, cap, 24 1/3; insulating tape, black, 1/3 lb; Wearite switches, ebonite with silver-plated contacts, for 2H and band pass with dial lights, 1/6 each.

YAXLEY switch screens, approx. 4 in x 3 1/2 in, drilled mounting flange, 3 for 1/3.

5-PIN plugs and sockets, complete with metal insulated cap, 2 for 1/6. (2130)

WALNUT radio cabinets, 21in h, 14 1/2 in w, 11in d, beautiful finish, hinged back, £2/15 each; Venner 1/- slot elec. meter, complete with 200-250 volt 50 cy. motor, £2/10 each.—Electric, 99, George St., Croydon.

SOUTH Yorkshire dealer, joining Forces, wishes to clear whole of stock, including Voigt corner horn and unit, 60 test meters, 2,000 valves, oscilloscope, p.a. amplifiers, microphones, rotary converters, speakers, etc.; stamp for list.—Box 2963, c/o H.W. (2137)

LASKY'S RADIO, 370, Harrow Rd., Paddington, W.9 (opposite Paddington Hospital), offer for sale the following condensers: 0.0025mfd 2,000v tubular, 1/- each, 0.02mfd 2,000v at 1/- each, 0.23mfd 2,000v at 1/6 each, 0.05mfd 2,000v at 1/- each, 0.002mfd 2,000v at 1/- each; 2mfd cond., 700v, at 2/6 each; 50mfd 12v tubular, 1/6 doz; 25mfd 25v tubular, 18/- doz; 1mfd 350v tubular, 6/- doz; 10mfd 50v tubular, 1/6 each; speakers, speaker output transformers from 6/-; 6 1/2 in moving coil speakers; Rola 5in P.M. speaker, 3 ohms voice coil, 19/-; Rola 6 1/2 in P.M. speaker, 3 ohms voice coil, 21/-; Rola 8in P.M. speaker, 3 ohms voice coil, 23/6; above speakers are less output trans.

COUPLPHONE Radio, New Longton, nr. Preston.—New goods only. Tungstran valves, English and Amer. rectifiers, 10/6; mains trans, 350v 100mA, 4v 6A, 4v 2 1/2 A, 32/6; 350v 120mA, 6.3v 3A, 5v 3A, 32/6; Rola p.m., less transf., 5in 20/-, 6 1/2 in 22/-, 8in 24/-, 10in 29/6; cored solder, 4/6 lb, tin. cop. wire, 2/3 1/2 lb; 2mm Systoflex, 3d. yd.; Barr, resist., 6/-; line cord replace. resist., 800 ohm, 2 adj. taps, 6/9; Parafed L.F. transf., 4: 1, 4/9; 50mfd 12v 2/-, 25mfd 25v 2/-; Erie resist., 1w 9d., 1/2w 6d., 1/4w 4d.; Pushback wire, 100ft 6/-; swifch cleaner, 2 3 bott.; out. trans., 7/6; bell transf., 6/6; valveholders, 1d. per pin; Staneleo el. solder, irons, 21/-; tub. and mica cond., V cont., with sw. 5/9, less sw. 4/9; a.e. for stock list.

BA thread screws and nuts. Large stock. Enquiries invited. One gross assorted useful sizes, 2/6; ditto washers, 1/6 gross; fibre washers, 1/6 gross; assorted solder tags, 2/- gross; rubber-covered stranded copper wire, 1d. yard; heavier quality, 1 1/2d.; very heavy, 2d. yard, ideal for aeriels, earths, etc.; enamelled copper wire, 26 gauge, 1/2 lb. reel. 1/3; tinned copper connecting wire, 1/2 lb., 1/-; finest quality resin-cored solder, 1/2 lb., 2/-; Wood's metal stick, 2 1/2 in. x 1/4 in., 1/-; sensitive permanent crystal detector, Tellurium-zincite combination, complete on base, guaranteed efficient, 2/6; wireless crystal with silver cat-whisker, 6d.; new single earphone, 750 ohms, made originally for the Air Ministry, 5/6; reconditioned headphones, complete, 4,000 ohms, 12/6; all postage extra.—Post Radio Supplies, 67, Kingscourt Rd., London, S.W.16.

BATTERY charging kits, transformer and rectifier for 2v half amp trickle charger, 13/6, post 7d.; charges your 2v wireless cell at home overnight; transformer, rectifier, ballast bulb for 2v to 12v 2.5 amp charger, 59/6, post 10d.; ditto for 2v, 6v, 2.5 amp, 42/6, post 10d.; 2v, 6v, 1.5 amp, 34/6, 2v, 6v, 0.8 amp, 29/6, post 9d.; no ammeter or rheostat needed with these kits, full instructions supplied; metal rectifiers for battery chargers, 12v 3 amp, 34/6, post 7d.; 6v 2.5 amp, 15/6, post 7d.; 6v 0.5 amp, 6/3, post 4d.; instrument rectifiers for meters, bridge type, bakelite, very good make, 1ma 18/6, 5ma, 10ma, 50ma, 15/6, postage 3d.; h.t. metal rectifiers, 250v 60ma, 16/6, postage 6d.; milliampmeters, 1ma, full scale, 4-inch, flush mounting, suitable for use in test meters, 65/-, post 10d.; Rothermel "bakelite" crystal pickups, latest type, magnificent reproduction, 78/6; Rothermel "Bullet" microphones, few still available at £3; well known D.104 type crystal microphone, 95/-; three only moving coil mikes, very good make, £6/6 each.—Champion, 42, Howitt Rd., London, N.W.3. (2136)

ELECTRADIX

BATTERSEA BARGAINS

SALE LIST. We have a new list in print which will be ready shortly. Regulations require us to charge for these, limited in number, and if you want one, send 6d. for List and postage, and it will be sent at once when ready.

POWER TRANSFORMERS. Single phase 50 cycles 35 KVA, 35,000 watts, by Brit. Elec. Transf. Co. 220 volts to 110/110 volts, £30. 5 KVA 220 volts to 5,000 volts and 500 volts, £10. 2 KVA Foster 200 volts to 4,000 volts, £8 10s. 1 1/2 KVA Zenith 100 volts to 6,000 volts, £8. 3KVA 400 volts SP 50 cycles to 600 volts, oil filled, by Metvick, £9. 2 KVA 230 volts SP 400 cycles to 11,500 volts, C.T., oil filled, Foster, £8 10s. 1 KVA 1,000 volts SP 50 to 20,000 volts, oil filled, by J. & P., £7. 1 KVA 240 volts to 17 volts 57 amps, 4 taps to 6 volts, air SP 50, by G.E.C., £7. 1/2 KVA 230 volts to 4 volts 10 amps., air SP 50, by A.M., £4 15s. All as new.

TRANSFORMER COMPONENTS. Stampings Control limits supply. We offer some 100-watt transformers for rewinding. Complete, good class but unknown ratios. Sold for re-making, 22/6. Larger 250-watt size, 27/6. Stalloo Sheets for Transformer Stampings, 38in. x 6in., 1 3 each. Radio Mains Transformers, 57/6.

SUNDRIES. 6in. Pocket Thermometers, nickel case, Vet Type, for animals, 90/100 deg., 1/6. H.M.V. Resistors, glass cased, wire ends, 1/2 watts, .01, .025, .05 and 1 meg., 1/- per set of 4, or 2/9 per doz. Screened Mike Cable, flexible sheath, single core, 1/2 per yard. Multiple Connection Strips, of soldering tags, telephone type moulded mounting, in 25, 50, 75 or 100 ways, at 2/6, 3/-, 3/6 and 4/- each. G.P.O. Plugs, 2/- each. Terminal Covers, bakelite, with two securing screws, size of domino, 9d. G.P.O. Vertical Telegraph Galvos, slightly damaged but in working order, 7/6. Mentor Battery Indicators, thermal type signal light, thermal type, 2 1/2 in. dial, flush panel, 6 volt and 12 volt, 5/-. Small Solenoids, "Gemi," 6 volts, 1 1/2 amps., iron plunger, 6/6. Oldhams Miners Lamps, all-metal, for accumulator or dry cell, 7/6. 4-way Cords, long, suit mikes or handcom phones, 2/-. Old Electric Clock movements, A.C. or D.C., ratchet drive with gearing, very soiled, 12/6. Electric Counters to 10,000 revs., G.P.O., 5/6.

COVERS. Light Metal ventilated covers for test boards, resistances, chargers, etc., special arch shape to contain 6 1/2 in. x 5 in., with terminal cover extension, 3/-, postage 6d. **CABINETS.** Oak cabinets with hinged lid and front door, 10in. x 10in. x 7 1/2 in. overall, 7/6. Packing 1/- extra. **HEADPHONES,** 12/6. Headbands only for 2 earpieces, 2/6. **Govt. Cords,** 2/6. Crystal parts, as advertised. **MORSE KEYS.** We have some ex-G.P.O. Quad Keys, in blitzed condition, needing overhaul, 12/6.

CONDENSERS. Ultra Short Wave variable air condensers. Trolit insulation ball-bearings. Surplus to a Govt. contract and new, 5/-.

SHIP'S RADIO (not domestic). T. 8-valve Receiver, 600 metres. Direction-finding Desk Aeriels. Lifeboat portable 3-valve battery receiver.

RADIOGONIOMETER Direct Finders, £4 10s.

ELECTRIC PUMPS. Centrifugal Stuarts direct-coupled Govt. Model, throws 120 gals. per hour. 12 volts D.C. for tanks and caravans, £4 4s. Mains model, 220 volts A.C. and D.C., £6 6s. Twin piston rotary R pumps, belt-driven by 1/2 h.p. motor, D.C. or A.C., £9 10s.

AIR COMPRESSORS, BLOWERS, DYNAMOS, MOTORS AND ROTARIES. See selection advertised by us on page 29, October.

CHARGERS. Tungar double circuit, 200/240v A.C. mains to D.C. 60 volts, 10 amps., £16. Davenset Garage Charger, complete, as new A.C. mains to 30 volts 6 amps. D.C., £14. Westinghouse Metal A.C. to 8 volts 15 amps., £22. Ditto to 8 volts 32 amps., D.C., £35.

Remember that we are almost next door to Queen's Road Station, Battersea, S. Ry., but if you cannot call send stamped envelope for answer to enquiries. Please include postage for mail orders.

ELECTRADIX RADIOS

214, Queenstown Road, Battersea, London, S.W.8

Telephone: M A Caulay 2189

**THE RADIO INSTRUMENT CO.
MAINS TRANSFORMERS**

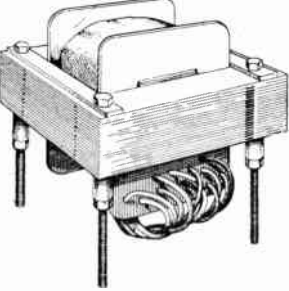

For Commercial Receiver replacement, Amplifiers and all Industrial Installations. Details of full range in previous issues of the "Wireless World".
SPEAKER TRANSFORMER replacement hobbins, fitting standard Rola Celestian and Goodmans Lams tapped Power/Pen, 27/-.
THE FAMOUS OP12 output transformer, 50 watts multi-ratio, data charts on application. For large amplifiers, 39/6.
DELIVERY. Priority orders take precedence, delay on some models unavoidable, although every effort is made to provide a steady flow for the maintenance of receivers and for civilian use.

SUNDRY COMPONENTS.
Metal braided screened sleeving, 6d. per yard.
Braided screened wire, 12 yards coils 10/6 or 1/- yd. Push-back wire, single 22G, 12 yds. 1/8.
10mft. 25v. Bias condens., 1.3, 1.2/- dozen. (Special offer).
SWITCHES. Panel toggles SP on/off 2/11. DPDT 3/11.
Lighting flex. Twin maroon 14/36, 7/6 doz.; 23/36 9/6 doz. yds.
Speakers, 8in. PM extra large mag. with trans., 27/6.
Polished oak cabinets for above, 27/6.
Details of these and many other accessories useful to the service engineer will be found in our Components Catalogue (24d.) Trade counter facilities now available.

**THE RADIO INSTRUMENT CO.
294, BROADWAY, BEXLEYHEATH, KENT.**
*Phone: Bexleyheath 3021.

"UNIVERSAL CIRCUITS"

by R. S. Roberts, M.Brit.I.R.E., A.M.I.R.E.

Three folders and a thirty-six page booklet, presenting the main principles of radio circuit operation in a concise and convenient form for the pocket.

- I. The Transmitter
- II. The T.R.F. Receiver
- III. The Superheterodyne Receiver

By means of hinged flaps, the charts give a large number of recognised alternatives for each stage. To assist the student in memorising and understanding these, a logical five-colour scheme has been adopted throughout.

"Grid Leak" says: "The Charts and Notes are really intended for students and teachers of radio, but are extremely useful to every radio engineer."

Price complete 6/3 post free, from

**The Bookstall
NORTHERN POLYTECHNIC
HOLLOWAY, LONDON, N.7**

**COVENTRY—
RADIO**

COMPONENT SPECIALISTS SINCE 1925

| | |
|--|-----------|
| ERIE RESISTORS, 20 assorted, 1/4, 1 and 2 watt. . . | 12 6 |
| CONDENSERS, 20 assorted, .0001 to .1 mfd. . . | 10 - |
| SWITCHES, Toggle Q.M.B., N.F., 2 9. D.F. . . | 3 6 |
| COILS, S. M. or L. wave, aerial or osc., P type . . | 2 6 |
| COIL FORMERS, 6 ass., small sizes | 1 6 |
| I.F. TRANSFORMERS, 465 kc., screened | 6/- & 7/6 |
| L.S. TRANSFORMERS, Power/Pentode | 9 6 |
| MICROPHONE TRANSFORMERS, screened | 6 6 |
| METAL RECTIFIERS, H.T. at 18 mA with L.T. at 25 amps. | 20/- |
| I.F. SCREENING CANS. Very useful, aluminium . . | 6d. |
| ROLA P.M. SPEAKERS, 5in., 6 1/2in., 8in., from . . | 21 6 |
| VOLUME CONTROLS, MAINS TRANSFORMERS, TRIMMERS, GANG CONDENSERS, SLEEVING, WIRE, FLEX, etc. | |

TERMS:—Cash with order. Quotations, lists, stamp please.

**THE COVENTRY CO.,
191, DUNSTABLE ROAD, LUTON.**
*Phone: Luton 2677

Wanted
HARTLEY-TURNER S.O. o.p. transmr.—George, 6, Elhurst Av., Northampton.
BELLING and **LEE** Set End Eliminates for skyrod aerials; several wanted.—Box 2966, c/o *Wireless World*. [2142]

VALVES
A CORNS, 954 40/-, 955 50/-; cash or c.o.d.—Frost, Castle St., Brighton. [2039]
5000 valves, all types, including output, rectifiers, etc., s.a.e.—Davies, 28, Mount Vernon Crescent, Barnsley. [1848]
FERRANTI 0/15ma, 60/-; Victoria 0/10ma, 50/-; Victoria 0/100 microamp, 60/-; Mullard AP4, 50/-; Osram HA2, 35/-; all new.—Box 2967, c/o *Wireless World*. [2143]

OUR adaptors will help in replacing unobtainable valves; send 7d. for interesting booklet on valve replacements; trade enquiries invited.—V.E.S., Radio House, Ruislip. [1885]
MULLARD, AZI, DW4/500, EB11, FC4, M1W4/500, PenA4, PM2Ba, TDD4, EL3, PenBa, MAZDA, AC/HLDD, AC/ME, AC/VP1, AC/VP2, HL2, HL22, HL23, HL1320, S215VM, PenDD; sent c.o.d.—Larg's, Whitehall St., Dundee. [2122]

WE have a large stock of new and boxed valves, all guaranteed, at retail prices, plus tax; also U.S.A. lease-lend types for replace.; send your requirements.—Lasky's Radio, 370, Harrow Rd. (opposite Paddington Hospital), Paddington, W.9. [2105]

1,000 valves in stock.—PM22A, 11/-; Pen A4, 12/10; Pen 4DD, 15/3; 2D4B, 6/9; TH2521, 14/-; AC5/PenDD, 15/3; FC13, 14/-; 8P130, 12/10; AC/TP, 14/-; UG5, 11/-; 431U, 11/-; IC5GT, 11/-; H15GT, 11/-; DLI, 1/-; 80, 11/-; 45, 11/7; CL33, 12/10; CL4, 12/10; CBL1, 15/3; U50, 11/-; DC2/Pen, 30/5; 35Z4G, 11/-; 25Z4G, 11/-; 12J5GT, 9/2; 6Q7GT, 11/7; 12SQ7GT, 11/7; send s.a.e. for valve and wireless parts lists, 2d.—Ransom, 9 and 34, Bond St., Brighton. Retailers not supplied.

VALVES, British and American, many types in stock: 10 mfd 600v working, block paper condensers, 8/-; Midget mains smoothing L.F. chokes, 300 ohms, 5/-; superior quality, 2-gang, 0005, condensers, brand new, 5/-; wire-wound potentiometers, 2,000 and 20,000 ohms, 6/6; mains transformers, prim. 200, 220, 240v output, 350-350, 80 mills, 4v 2A, 4v 4A, 35/-; dials, 2 wavebands, station names, etc., coloured, handsome job, 7in by 3in, 1/6; to replace all line cords, droppers, mounted in handsome "Radiator" cage, with instructions, 12/6; Universal mains droppers, for all receivers, 1,000 ohms, 2 amp, fitted 2 variable taps, 4/6; 750 ohms, 3 amp, do taps, 5/6; tubular electrolytics, wire ends, 8mfd, 150v, working, 3/6; full range speakers, volume controls, condensers, etc., etc., everything for the serviceman's licence to export to N. Ireland; lists available; stamped addressed envelope with all enquiries, please; postage on all orders.—O. Greenlick, 34, Bancroft Rd., Cambridge Heath Rd., London, E.1. Stepney Green 1334. [2120]

Wanted
VALVES wanted, must be new, any quantity from one upwards; also test equipment, service sheets and spares.—J. Bull and Sons, 246, High St., Harlesden, N.W.10. [2074]

REPAIRS AND SERVICE
MIDWEST, McMurdo, Belmont, Crosley, Ferguson, etc., valves; the American experts.—Bennett's, 4, Humberstone Drive, Leicester. [2049]

METROPOLITAN RADIO SERVICE Co. guarantee repairs to American and British receivers.—1021, Finchley Rd., N.W.11. Spe. 3000. [9641]

ALL types of radio receivers serviced. A. Murphy and Pilot specialist; valves in stock; sound repairs for 13 years.—T. E. Feyrer, F.I.P.R.E., 50, Vine St., Uxbridge.

"SERVICE with a Smile."—Repairers of all types of British and American receivers; coil rewinds; American valves, spares, line cords.—F.R.I. Ltd., 22, Howland St., W.1. Museum 5675. [1575]

MAINS transformers service, repairs, rewinds, or construction to specification of any type, competitive prices and prompt service.—Sturdy Electric Co., Ltd., Dipton, Newcastle-upon-Tyne. [9651]

DEGALLIER'S, Ltd.—"Service with a guarantee." If you cannot get your receiver serviced let American specialists do the job; first-class workmanship only; specialising in Air-King, Belmont, Challenger, Delco, Petrola, deWald, Emerson, Ferguson, Garod, Hallicrafter, Hammlerand, Lalayette, Meisner, McMurdo, Midwest, Majestic, Pilot, Philco, Player, Sparton, Stronberg-Carlson, Wells-Gardner, etc., also any British set. Remember, for 14 years we have handled as distributors American receivers; this is self-explanatory; s.a.e. with all enquiries.—Degallier's, Ltd., 9, Westbourne Court, W.2. [2129]

NEW VALVES FIRST GRADE

LEADING MAKES AT PRE-WAR PRICES
TUNGSRAM DD113 and DD1138, 9/6. H129, TX21 and HF218, 11/6. SP220 and P215, 6/-, SP4 (7-pin), 10/6.
BARRISTERS, C1 (side-contact) and C1C (4-pin), 9/-.
AMERICAN types 6K7G, 10/6. 26, 33, 35, 1F5G, 1A4E and 1B4E, 9/-, 6B8G, 6J8G, 7A8, 7C8, 6Y5V, 11/6.
PHILCO 2-band coils, R.F., Aerial or Oscillator (125 kc.), ea., 6/-; with trimmers, 8/-; with trimmers and cans, 10/-.
PHILCO 1F Transformers, 260 kc., with trimmers, 3/6. 451 kc., with trimmers and cans, 10/-.
PHILCO 3-band oscillator coils (451 kc.) with trimmers, 10/-.
FIXED Condensers, terminal or tag end, 4/- dozen assorted; wire-ended, 6/-.
FIXED Resistors—1/2-watt, 4/- dozen assorted; 1 watt, 6/6.
MAINS TRANSFORMERS, 200-250 input, 250v. H.T., 4v. L.T. for metal rectifier, 15/-.
PARCELS of assorted components still available at £1 (see last month's advert.). Satisfaction guaranteed.
TERMS: Cash with order. Postage and packing extra. Please send stamp with enquiries.

E. H. ROBINS TRADING CO., LTD.,
43, Kyle Crescent South, Whitechurch, Glam.

R. K. Ludas
LIMITED
Experimental and Aeronautical Engineers and Scientific Instrument Makers. Manufacturers of Precision Mechanical, Electro-Mechanical and Thermionic Instruments. Electro-Medical and Industrial Apparatus, Time Interval Measurement and Counters, DC Amplifiers and Recorders. Specialised Design Enquiries Welcomed
THE AIRPORT, PORTSMOUTH
Telephone: 74874.

"ENGINEERING OPPORTUNITIES"
This unique handbook shows the easy way to secure A.M.I.Mech.E., A.M.Brit.I.R.E., A.M.I.E.E., City and Guilds, etc.
WE GUARANTEE— "NO PASS—NO FEE."
Details are given of over 150 Diploma Courses in all branches of Civil, Mech., Elec., Motor, Aero, Radio-Television and Production Engineering, Tracing, Building, Govt. Employment, R.A.F. Maths., Matric., etc.
Think of the future and send for your copy at once—FREE
**B.I.E.T., 387, SHAKEPEARE HOUSE
17, STRATFORD PLACE, LONDON, W.1.**

TESTOSCOPE
Make 30 important tests A.C./D.C. Used everywhere by Electricians, Wireman and Service Engineers. Interesting booklet "R14" on testing, free. From all Wholesalers or direct.
RUNBAKEN -- MANCHESTER -- I

WARD ROTARY CONVERTERS
Petrol Electric Generating Plants, H.T. Generators, D.C. Motors, Frequency Changers, etc., up to 25 K.V.A.
CHAS. F. WARD
37, WHITE POST LANE, HACKNEY WICK, E.9
*Phone: Amherst 1393

Radio Necessities!

Real Value-for-Money Offers.

A NEW GANGING TOOL OUTFIT. 14 assorted spanners and screw drivers, polished ebonite, with plated metal parts, complete in carrying wallet. Don't miss one of these invaluable kits; it will save hours of unnecessary work. 30/- kit.

"SAFETY" Line Cord Replacement Resistor, 3 amp., in "Radiator" type case, with 3 amp. 750 ohm resistor. Easy fixing with instructions. 10/-. Razor resistor in cage, 1,250 ohm with var. tapping. 7/6.

BRITISH MAINS TRANSFORMER. 350-0-350 v., 4 v. 4 a., 4 v. 2 a., 90 ma. 37/6.

VOLUME CONTROLS. Enormous stocks, every value, less switch. 3/6.

CRYSTAL MICROPHONES on Table Stand. 67/6. Genuine D.104 Rothermel Crystal Microphone. 79/6.

CARBON RESISTORS on cards of assorted 48 1-w. 35/-, 72 1/2-watt. 27/6. Gross parcels 1-w. ungraded and unmarked resistors. 20/-, 24 asst. Paper Condensers up to .5 mfd. 14/-.

Wire wound resistors from 25-2,000 ohm, 5-watt. 1/4. 10-watt. 1/6. 1,000 ohm .2 amp. Resistors, with 2 var. sliders. 5/-.

DUBILIER 12 mfd. 25 v. Condensers. 1/4. Sleeving, very best quality, 2 mm. 2/6; 3 mm., 3/6; 5 mm., 4/6 doz. yds.

SERVISOL. The trade's best switch cleaner. 6 oz. tin, 5/-.

BAKELITE BUZZERS. 3/6. Banna plugs and sockets, 5/- doz. A.C. Eliminators, 25 ma. 75/-.

New Table Carbon Microphone with Transformer, very excellent finish. 7/6. 6 1/2 in. PM Speaker, in really good leatherette case. 47/6. Limited quantity **RADIO INSIDE OUT**, the famous Serviceman's Guide Book. Full of useful hints, data, codes, and specified replacement parts for hundreds of popular Receivers. 4/9 post paid.

Exclusively Mail Order.

WAVEBAND RADIO LTD. (Dept. WW/91), 30 QUEENSGATE, LONDON, S.W.7.



Precision Engineering production calls for up-to-date machines and a highly skilled staff. These, of course, we have, but—in light Engineering products especially, delivery dates are most useful when they are adhered to. YOU know that—so do we.



Precision Engineers
EUGENE WORKS, EDGWARE ROAD, HENDON, N.W.9

LONDEX for RELAYS

The wide range of Londex Relays includes a variety of

TYPES APPROVED by

AIR MINISTRY
M.A.P.
AND ADMIRALTY

Ask for details and leaflet SPN/WW.

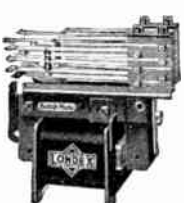

Multiple contact Relay LF.

LONDEX LTD
MANUFACTURERS OF RELAYS
PHONES: 707 AMERLEY ROAD, LONDON, S.E.20

MISCELLANEOUS

RUBBER stamps made up to your special requirements, and design, typical example, stamp showing name, address and profession; 9/6 post free.—V.E.S., Radio House, Ruistip. [1884]

SITUATIONS VACANT

CIVILIAN technical officer (temporary) required by a Government Department near London, with (1) expert knowledge of direct and alternating current generators, regulating gear and switchgear, rotary and static converters, internal combustion engines, primary and secondary batteries, radio communication senders, receivers and station accessories, telephone and transmission apparatus, including hand sets, carrier telephony and voice frequency telegraph equipment, teleprinter and cable laying plant; or (2) ability to assess modern designs of above equipment for maintenance spares. Experience of R.A.O.C. provision offices or R.E.M.S. workshops desirable but not essential; duties include compilation of schedules of spares and supervision of technical assessors carrying out similar work; salary up to £480 and Civil Service War Bonus (£256/10 at present at £480).—Written applications (no callers), quoting Q.1684S, stating date of birth, name and address of present employer, and setting out industrial record to Ministry of Labour and National Service, Appointments Department, Q.S. 24, Kingsway, London, W.C.2. [2113]

TECHNICAL TRAINING

GREAT possibilities exist for technically qualified engineers, key men in wartime and afterwards. Through the home-study courses of The T.I.G.B. take a recognised engineering qualification, such as A.M.I.Mech.E., A.M.I.E.E., A.P.R.A.E.S., A.M.I.Chem.E., C. and C., etc., in which examinations the T.I.G.B. students have gained 25 FIRST PLACES and hundreds of passes. Write today for "The Engineer's Guide to Success"—free—containing the world's widest choice of engineering courses covering all branches, including aeronautical, mechanical, electrical, wireless, chemical, etc.

THE TECHNOLOGICAL INSTITUTE OF GREAT BRITAIN, 82, Temple Bar House, London, E.C.4. [1403]

TUITION

LEARN Morse code the Candler way. See advertisement on page 26. [1292]

RADIO training.—P.M.G. exams and I.E.E. Diploma; prospectus free.—Technical College, Hull. [0811]

COACHING for P.M.G. examinations; 150 typical 1st and 2nd class technical questions, price by post 5/-.—The North Eastern School of Wireless, 89, Osborne Rd., Newcastle-upon-Tyne, 2. [2081]

RADIO Engineering.—Television and Wireless Telegraphy, comprehensive postal courses of instruction. Apply British School of Telegraphy, Ltd., 179, Clapham Rd., London, S.W.9 (Estd. 1906). Also instruction at school in wireless for H.M. Merchant Navy and R.A.F. [9249]

ENGINEERING Opportunities.—Free 112-page guide to training for A.M.I.Mech.E., A.M.I.E.E., and all branches of engineering and building; full of advice for expert or novice; write for free copy and make your peacetime future secure.—B.I.E.T., (Dept. 387B), 17, Stratford Place, London, W.1. [1482]

A POSTAL training in electrical engineering—power or radio; individual correspondence tuition by highly qualified engineers with wide teaching and technical experience. Elementary or advanced courses. Preparation for recognised examinations. Pre-service training specially arranged.—G. B., 18, Springfield Mount, Kingsbury, N.W.9. [1731]

THE Tuitionary Board of the Institute of Practical Radio Engineers have available home study courses covering elementary, theoretical, mathematical, practical, and laboratory tuition in radio and television engineering; the text is suitable coaching matter for I.P.R.E., Service-entry and progressive exams; tuitionary fees—at pre-war rates—are moderate.—The Syllabus of Instructional Text may be obtained post free from the Secretary, Bush House, Walton Avenue, Henley-on-Thames, Oxon. [1482]

PATENT NOTICES

THE proprietor of the Patent No. 508580 for "Improvements in or relating to radio receiving sets" is desirous of entering into arrangements by way of licence and otherwise on reasonable terms for purpose of exploiting same and ensuring its full development and practical working in this country.—Address all communications in the first instance to Haseltine Lake and Co., 28, Southampton Buildings, Chancery Lane, London, W.C.2.

BOOKS, INSTRUCTIONS, ETC.

BACK copies of "Wireless Engineer" required.—Communicate with Box 2950, c/o Wireless World. [2084]

★ TELEVISION ★ ANNOUNCEMENT

Just purchased!

A Stock of
H.M.V.-PYE-ULTRA-DECCA
TELEVISION (with sound) SETS

Also a few
TELEVISION (vision only) SETS

In addition we have a limited quantity of

COSSOR TELEVISION and RADIO RECEIVERS

All the above are complete in Cabinets

—FOR CALLERS ONLY—

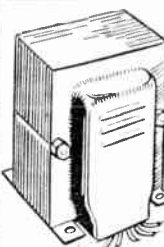

MAINS TRANSFORMERS

200/250 v. A.C. 50 v. 1 Phase. 400-0-400 v., 250 m.a. 4w, 5a, C.T., 4v. 2 a., C.T., 2v. 2 a., 4v. 3 a. Size 4 1/2 x 5 x 3 1/2 deep. Weight, 59/- 12 lb.

200/250 v. A.C. 1 Phase 300-0-300 v., 250 m.a., 4 v. 5 a., 4 v. 2 a. Size 4 1/2 x 4 1/2 x 3 1/2. Weight, 10 lb. 46/6

MERCURY SWITCHES (Brand New)

These switches are of the best manufacture and not easily obtainable today. Quick make and break and will carry 5 amps. Many hundreds of useful applications. Small quantity to clear.

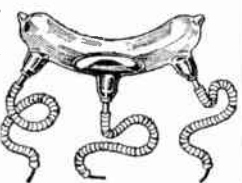

Price 8/6



MILLIAMMETERS

Ferranti moving coil milliammeters. 0-5 milliamps. Panel mounting, size 2 3/16 x 2 3/16. A fine instrument, brand new, and packed in original cartons (Regd. Post) 63/6

P.M. MOVING COIL LOUDSPEAKERS

8 in. without transformers 24/6
With transformers 27/6



ALL PRICES INCLUDE POSTAGE

See our Classified Advert. on p. 28

LONDON CENTRAL RADIO STORES

23, LISLE STREET, LONDON, W.C.2
GERRARD 2969

VALVES

This is part of our current stock list of types available and many representing equivalents to numerous valves not mentioned; a stamped envelope will bring you any information about any other particular valve you may desire. If out of stock we may send equivalents. All at Board of Trade controlled prices. C.O.D.

A27D, AC4L, ACME, AC044, ACP, ACPen, ACTH1, ACTP, ACVP1, ACVP2, AC2Pen, AC5Pen, AZ1, AZ31, B63, C14, C13E, D41, D63, DD13, DD14, D1T, D1Pen, DD2A, DL63, DW2, EBC3, EBC33, EBL1, EBL3, ECH2, ECH3, ECH35, EP5, EP6, EP8, EP9, EP33, EK2, EL2, EL3, EL5, EL35, EM4, FE2A, FC4, FC13, FC13C, FW4500, H63, HD24, H14, HL13, HL13C, HL21DD, HL22, HL23, HL41DD, HL133DD, HL1320, HP210, IW4-350, K72, KT24, KT32, KT33C, KT41, KT61, KT63, KT66, KTW61, KTW65, KTZ63, L63, LP210, LP2, LP220, MH41, MH14, MHL4, MKT4, M5Pen, M5Pen, M5PenB, M5PenC, MX40, OM4, OM6, OM9, P2, Pen41D, Pen4VA, PenA4, Pen25, Pen45, Pen451D, Pen46, Pen428, PenB4, PM2A, PM12M, PM22A, PM24A, PM25, PP5-400, PX4, PX25, RF30, RF120, SF4, NP4B, SP13, SP13C, SP1320, TH4, TH4B, TP1340, TD12, TD14, TD13C, TX4, TX41, U5, U10, U12, U14, U17, U21, U30, U52, U15, U17, UR1C, UY31, VMP4G, V048, VP2, VP2B, VP4, VP4A, VP4B, VP13A, VP13C, VP20, VP23, VP41, VP133, VP210, VP1320, W21, W42, X21, X24, X41, X61, X64, X65, Y61, Z14, Z21, 074, 1A4, 1A5, 1A7, 1B4, 1C5, 1C7, 1H5, 1H6, 1F4, 1G5, 1H44, 1N5, 1Q5, 1R6, 2A5, 2A7, 2B7, 2D4B, 2F, 2XP, 4D1, 4THA, 5V4, 5Y3, 5Y4, 5V4, 5Z4, 6A3, 6A6, 6AG6, 6A8, 6B4, 6B6, 6B7, 6B8, 6C6, 6C8, 6D5, 6D6, 6F6, 6F7, 6F8, 6H6, 6J7, 6K6, 6K7, 6K8, 6L6, 6L7, 6P5, 6R7, 6Q7, 6Q7, 6TH8, 6V6, 6X5, 6Z6, 7B7, 7B6, 7D5, 8D2, 8A1, 9D2, 10, 10A, 10D1, 11D3, 12P5, 12J5, 12J7, 12Q7, 12S47, 12R5, 12R47, 15, 15A1, 15D2, 19, 20A1, 20D1, 24, 25A6, 25B6, 25Z4, 25Z5, 26, 27, 29, 30, 31, 32, 33, 34, 35, 35Z4, 36, 37, 38, 39, 41MH1, 41MP, 41MP6, 41RTH, 42, 42MPPen, 431U, 46, 48, 49, 50, 52, 53, 56, 57, 58, 59, 71A, 75, 77, 78, 79, 80, 81, 82, 84, 85, 89, 117Z6, 150B, 2101DT, 210P3, 2101F, 2108PT, 210VPA, 210VPT, 21M4, 220B, 220TH, 290L4, 994V, 1821, RF30 replaces—TRIC, U4020, ID5, 408UA, 14/8; RF120 replaces—U10, U12, U14, MU14, MU14, DW3, DW1, IW3, IW4, 1821, U04, 11.

Our famous CONVERSION UNITS to replace almost unobtainable valves:

DA61 13/6, DH30 16/3; U88 22/9; D12, DFI, U30, 25RE, 35RE, 25Y5, 25Z5, 15/6; 606, 616, MPT4, VMS4, VP4, VP23, 18, 43, 77, 78, 2161, 17/8; X30, X31, X32, 18/6; CY1, CY2, UR2, UR3, UR3C, URY, 19/-; AC2Pen1D, PenDD61, 19/9 are in ever-increasing demand and being allocated in fair rotation. C.O.D. only.

Just published—Valves Comparative Tables, with quick reference index covering B.V.A. and non-B.V.A. types, 1/7, postage paid.

J. BULL & SONS
246, HIGH ST., HARLESDEN, N.W.10.

CLASSIFIED ADVERTISEMENTS intended for the **DECEMBER** issue can be accepted up to **First Post** Tuesday, November 9th.

REQUIRED, service sheets, all types, good price paid; also service oscillator.—Evans, 15, Church Rd., Shirley, B'ham. [2118]

WEBB'S radio map of the world locates any station heard, size 40x30in. 4/6, post 6d., on linen, 10/6, post free.—Webb's Radio, 14, Soho St., London, W.1. Tel. Gerard 2089. [9947]

URGENTLY required, copies of Sowerby's "Foundations of Wireless," 3rd edition, in good condition.—Price and particulars to the Secretary, Glasgow Wireless College, 3, Park Gardens, Glasgow, G.3. [2082]

WANTED, B.W., Mar. Ang., 1942, good cond. for binding.—J. C. Finlay, Upper Lintz Farm Burnopfield, Newcastle-on-Tyne.



for INDUSTRIAL CANTEENS, AIR FORCE, ARMY and NAVY CAMPS, SCHOOLS, etc.

Special units with built-in Radio can be delivered in 14 days.

Catalogue on application.
Scottish Distributors: British Electrical & Manfg. Co., Ltd. 133, West Campbell Street, Glasgow. Telephone: Central 3286.



MATRICULATION
brings Success & Security

Whatever your age, you can now study for the all-important Matriculation Examination at home on "NO PASS—NO FEE" terms. "MATRIC" is the accepted passport to all careers, and opens up opportunities which would otherwise be completely closed to you. Ensure the success and security of you and yours through post-war difficulties by writing for our valuable "Guide to Matriculation" immediately—FREE.

B.T.I. (Dept. 114)
356, Oxford Street, London, W.1.



Insulating delicate Instrument Panels against vibration and shock. Types and sizes available to carry varying loads (Rubber to Metal Bonded).



Type I is a popular and simple Instrument Mounting used extensively on aircraft, etc. Two Studs Rubber Bonded. Designed to carry substantial loads for its size.

HARRISFLEX BEARINGS LIMITED
TIDDINGTON ROAD · STRATFORD-ON-AVON

SPEAKER REPAIRS by Specialists
Any make, British or American Best Service
TRADE ONLY Moderate Charges
Also Components for Service Men at keenest prices. List Id. Holders of Export Licence for Northern Ireland.
A. W. F. RADIO PRODUCTS
13, Llycraff Road, Bradford, Yorks. 'Phone: 11926

VOIGT
For high quality loud speakers when the good times come again.
The Courts, Silverdale, London
VOIGT PATENTS LTD. S.E.26. 'Phone: 5YD 6666.

Radio Service
REWINDS, Mains 25/-, Output from 6/-, Field Coils, 9/-. PROMPT DELIVERY.
VALVES (B.V.A.). Send for list—good select.
PHILIPS D.C. CONVERTERS—Bought—Sold—and Exchanged.
S.A.E. to:—
A.D.S. CO. 261/3/5, Lichfield Road, ASTON, BIRMINGHAM, 6

INVENTORS

The world-wide Simmonds Organisation has established new methods and new products in many industries with great success. Simmonds Development Corporation seeks new ideas and inventions of brilliance and ingenuity to be developed by the technical resources and marketing knowledge of the Simmonds Group.

ALL COMMUNICATIONS MUST BE IN WRITING IN FIRST INSTANCE TO—

SIMMONDS DEVELOPMENT CORPORATION LTD. 2-3 NORFOLK ST. W.C.2

The **SIMMONDS GROUP**
LONDON
MELBOURNE
PARIS
NEW YORK
LOS ANGELES

Printed in England for the Publishers, ILIFFE AND SONS LTD., Dorset House, Stamford Street, London, S.E.1, by THE CORNWALL PRESS LTD., Paris Garden, Stamford Street, London, S.E.1. "Wireless World" can be obtained abroad from the following—AUSTRALIA and NEW ZEALAND: Gordon & Gotch, Ltd. INDIA: A. H. Wheeler & Co., Canada: Imperial News Co., Gordon & Gotch, Ltd. SOUTH AFRICA: Central News Agency, Ltd.; WILLIAM DAWSON & SONS (S.A.), Ltd. UNITED STATES: The International News Co



ELECTRO-MEDICAL
EQUIPMENT

DRAWING OFFICE
EQUIPMENT

H.F. ELECTRIC
FURNACES

SPECTROGRAPH
ANALYSIS EQUIPMENT

Interference created by above is suppressed by H.F. mains filters and screened rooms.

We supply screened rooms of any dimensions and H.F. mains filters 15 and 300 amperes maximum loadings.

**AERIAL SYSTEMS
DESIGNED & INSTALLED**

An Engineer with many years' experience in the work is available for consultation and practical assistance on all aspects of the subject of suppression on land or sea, either at the source of interference or at the receiver.

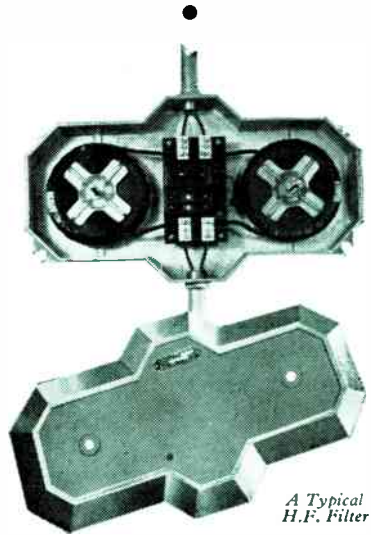

A Typical H.F. Filter

BELLING & LEE LTD
CAMBRIDGE ARTERIAL ROAD, ENFIELD, MIDD'X

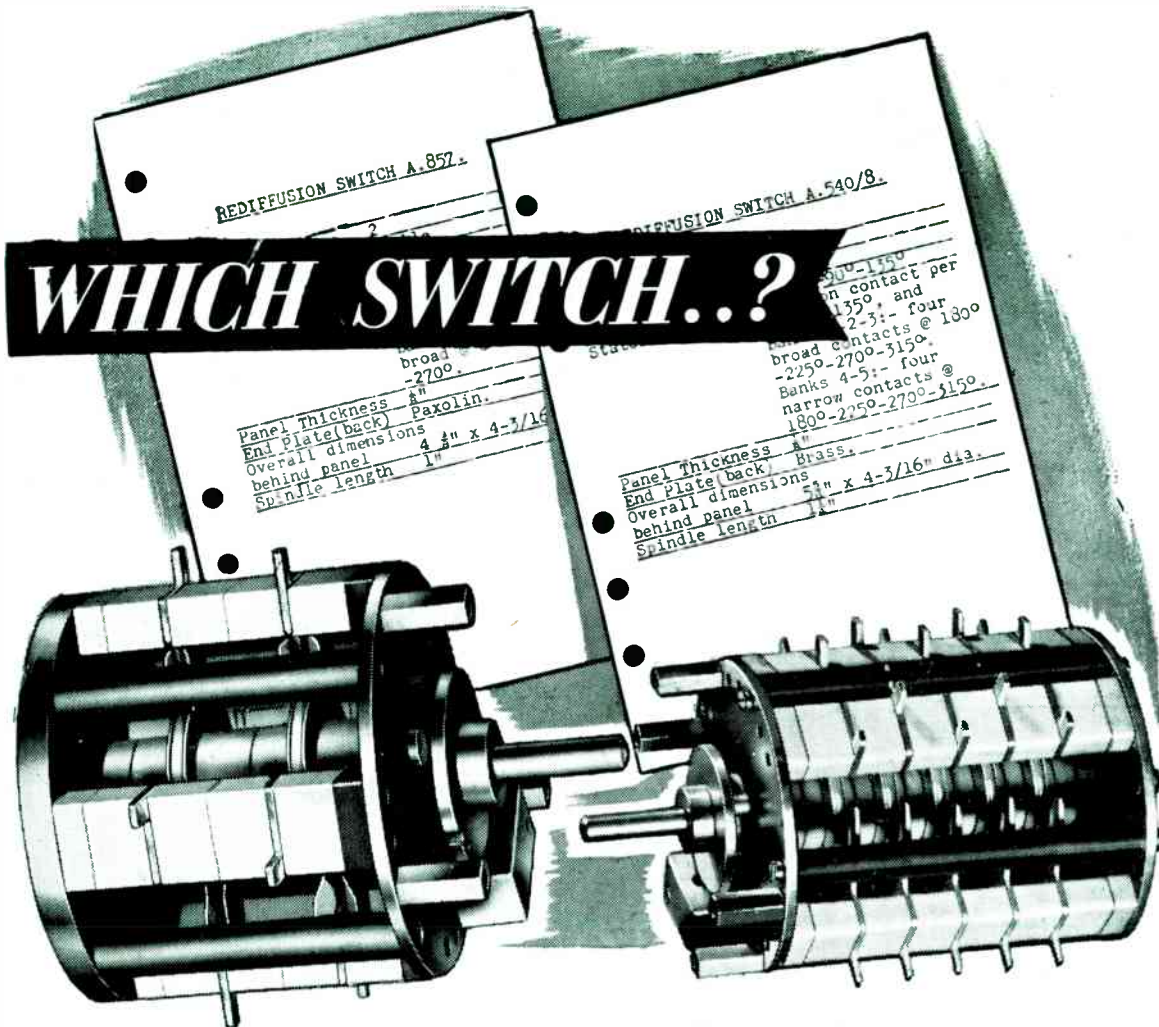

These Redifon Type S.I. switches are built to a wide range of specifications, for switching radio frequency circuits at peak voltages up to 4,000 with currents up to 20 amps.

A limited number can be made for priority users. Prices on application, stating the circuit requirements.

REDIFFUSION LTD

Designers and manufacturers
of Radio Communication and
Industrial Electronic Equipment



A SUBSIDIARY OF BROADCAST RELAY SERVICE LIMITED
VICTORIA STATION HOUSE • VICTORIA STREET • LONDON • S.W.1 (PHONE VICTORIA 8831)