

# Wireless World

RADIO • ELECTRONICS • ELECTRO-ACOUSTICS



OCT. 1943

1/6

Vol. XLIX. No. 10

MULTI-PURPOSE TEST METER

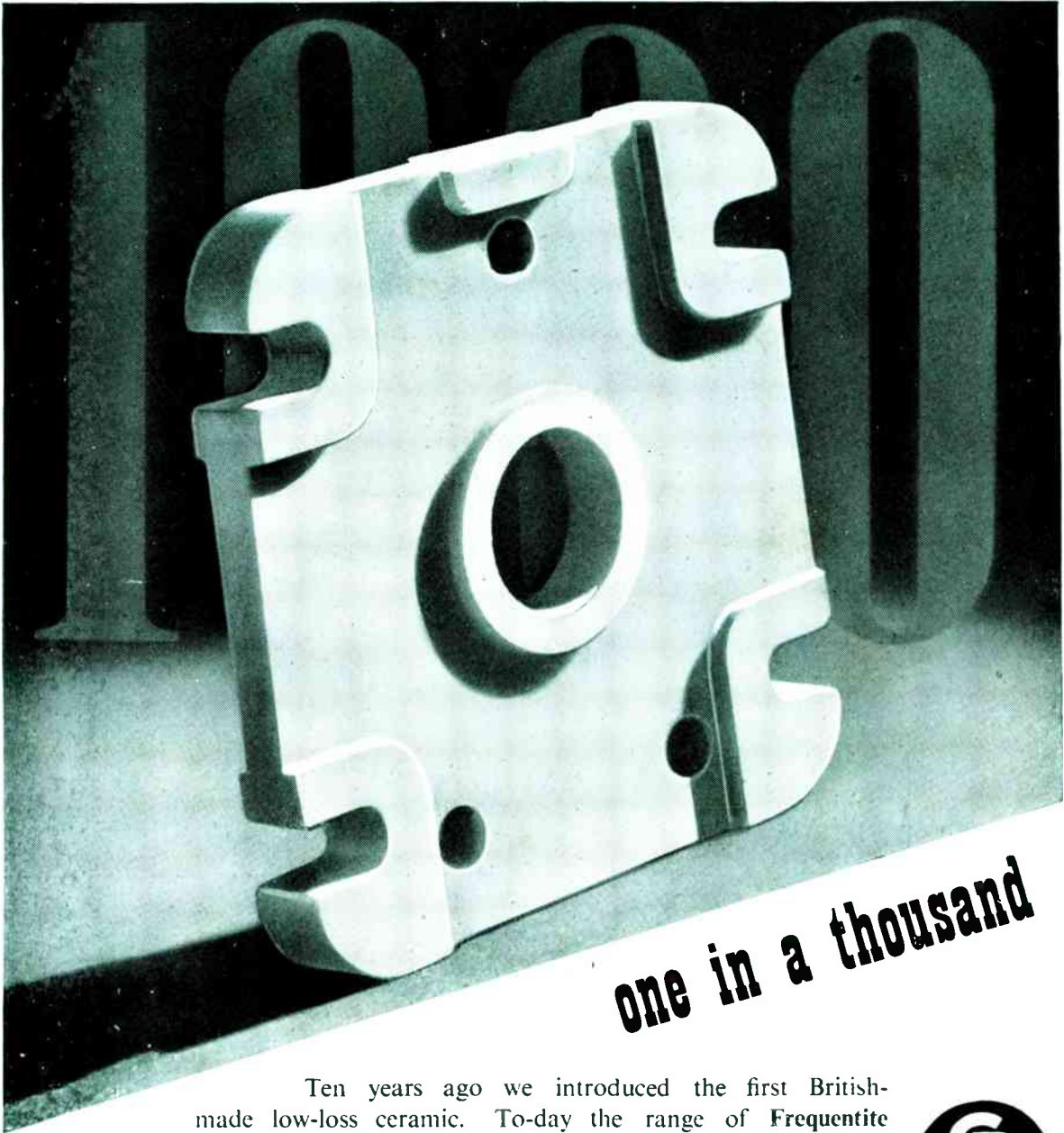

**one in a thousand**

Ten years ago we introduced the first British-made low-loss ceramic. To-day the range of Frequentite components covers more than a thousand pieces of every shape and size. With such a store of manufacturing experience we are able to offer advice backed by practical knowledge on your insulation problem. Please consult us before you finalize your design.



**STEATITE & PORCELAIN PRODUCTS LTD.**

Head Office: Stourport-on-Severn, Worcs.

Telephone: Stourport 111.

Telegrams: Steatoin, Stourport.

S.P.26



**T**HE demand for "AVO" Electrical Testing Instruments for H.M. Forces is now such that we regret we can no longer accept orders for ordinary Trade or private purposes. Orders already accepted will be despatched as soon as possible.

Orders from Government Contractors or Essential Works can be accepted, but they must bear a Contract Number and Priority Rating, and even these orders will necessarily be subject to delayed delivery.

We take this opportunity of expressing to the Electrical and Radio Trades our appreciation of their co-operation and patience during the considerable and unavoidable delays that have occurred in executing their orders. We feel confident that our customers will appreciate that we, in common with other manufacturers, are prompted by the universal desire to assist towards a speedy and satisfactory termination of hostilities.

THE AUTOMATIC COIL WINDER & ELECTRICAL EQUIPMENT, CO., LTD.  
WINDER HOUSE, DOUGLAS ST, LONDON, S.W.1. Phone Victoria 34047.



# Clearing all Obstacles . .



In our last announcement we emphasised our traditional caution in development.

In the early days of manufacturing Toggle Switches we were faced with many obstacles—tools, moulds, materials, production, quality, precision, price — but we surmounted them all and went right ahead.

The result is that we are in "full cry" helping many manufacturers to get their equipment on to the field in time.

Perhaps we can help you too.

4 amp. 250v. S.P. toggle switch. Also available in S.P. 2-way, D.P. on and off and 2-way. With bakelite or metal levers. Also in 6 amp. capacity.

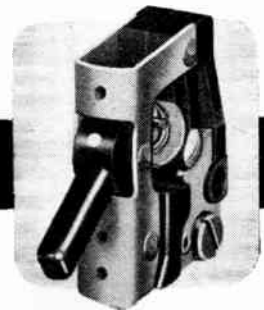

## DIAMOND SWITCHES

*Famous for Fifty Years*

GUNNERSBURY AVENUE, CHISWICK, W.4

*Between us windings*

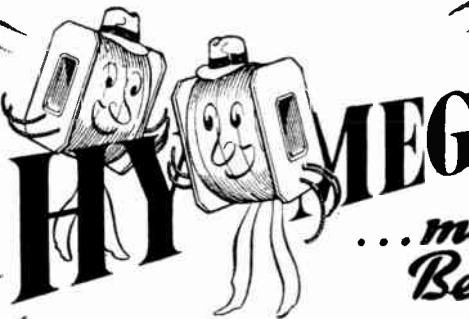

*... makes Bigger & Better Production*

**HY-MEG IMPREGNATING VARNISH V. 6934.** Made specially for enamelled wire windings : but is equally suitable for Rayon and Glass-covered wire.

**I**MPREGNATORS of wire windings, especially fine wire, who are troubled with problems such as the attacking of enamelled wire or the failure of the impregnating medium under tropical service conditions, are advised to send for particulars of the new HY-MEG Process.

Briefly, HY-MEG provides complete impregnation with perfect through-drying by polymerisation even in the deepest and most complicated windings, and produces in shorter-than-usual stoving time a solid homogeneous plastic which safely withstands extreme working conditions and tropical heat. These facts are evidenced by the general Government approval of HY-MEG impregnated components. HY-MEG can be used with confidence in the knowledge that supplies are always available; both quality and quantity of your production will be improved.

**INSULATE WITH**

**HY-MEG**  
**TO BE SURE**

**Put YOUR Problem before our BRAINS TRUST** Send us details of any particular insulation problem that is worrying you. The "bench of experts" whose research and wide experience created HY-MEG will be glad to elucidate it for you.

LEWIS BERGER & SONS LTD (Established 1760) LONDON E.9 'Phone: AMHerst 3321

MANUFACTURERS OF INSULATING VARNISHES AND ENAMELS



**“OUT OF RESISTANCE TO AGGRESSION  
SHALL COME  
LASTING BENEFIT TO MANKIND”**

\*

A great truth ; and equally true in other ways for it is from the function of a resistance in an electrical circuit that millions of complex instruments, upon which we are so dependent, derive their results. It is essential however, that the quality of the resistance in all cases shall be of the highest.

In a world where the use of electrical and radio devices has reached an unprecedented peak, the many and varied conditions in which resistances are required can be but inadequately imagined. Somebody must know about such things however, and who better than we whose care and privilege it is to develop and manufacture all kinds of dependable resistances to satisfy the most exacting modern operating demands.

What a wealth of technical excellence in resistances will be available to industry when better times arrive.

**DUBILIER**  
CONDENSER CO. (1925) LTD.



## MICROMETERS WON'T MEASURE MICROVOLTS

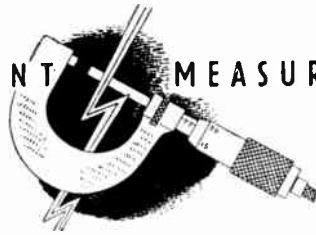

Performance in communication instruments is measured by a highly specialised range of testing apparatus. Nothing so simple as the micrometer—but just as accurate in measurement.

The production of this test gear is an art which Marconi Instruments have made their own; for within the Marconi organisation are unique facilities for the

anticipation, and solution, of major testing problems.

Thus, for manifold requirements, there is today a Marconi measuring device, created and fabricated by specialists steeped in knowledge and experience since the earliest days of Radio. And in this specialised field our advisory service is both resourceful and the best informed.

# MARCONI Instruments Ltd

S T . A L B A N S · H E R T S · T E L E P H O N E 4 3 2 3

1916



1943

It's  
happening  
in  
Radio,  
too!

Between Verdun and Tunisia is a great advance in weapons and technique. But while paratroopers fight in the public eye, the radio war goes on "behind the scenes." The benefits of modern development will not be seen until domestic radio sets are built again. Masteradio are looking ahead to that happy time and invite you to register NOW without obligation for post-war priority, stating home or car radio interest. Write: Masteradio, Ltd., Watford, Herts.

**Masteradio**  
IS LOOKING AHEAD

★ One of a Series of Advertisements  
appearing in the National Press

MASTERADIO LIMITED • WATFORD • HERTS

# ROLA

## LOUD SPEAKERS

THE WORLD'S FINEST REPRODUCERS

## TRANSFORMER LAMINATIONS

Core Widths  $\frac{1}{4}$ " to  $1\frac{1}{2}$ " (E's and I's.)

EIGHT STOCK SIZES

A Comprehensive Bulletin together with details of Associated Covers and Clamps with design data will be sent to manufacturers on request.

BRITISH ROLA LIMITED

MINERVA ROAD · PARK ROYAL · N.W.10 · WILLODEN 4322



# LONDON CENTRAL RADIO STORES

## Latest Offers

### SPECIAL! MANUFACTURERS' STOCK

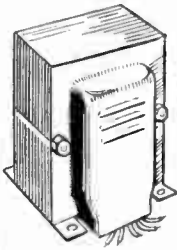

**MAINS TRANSFORMERS**  
200/250 v. A.C. 50 v. 1 Phase. 400-0-400 v., 250 m.a. 4 v. 5a, C.T., 4 v. 2a, C.T., 2 v. 2a., 4 v. 3a. Size 4½ x 5 x 3½ deep. Weight, 12 lb. Post, **57/6** etc. 2/-  
200/250 v. A.C. 1 Phase 300-0-300 v., 250 m.a., 4 v. 5a., 4 v. 2a. Size 4½ x 4½ x 3½. Weight, 10 lb. Post **45/-** etc., 2/-

**CHOKES**  
140 ohms 150 m.a. Size 4in. x 2½ x 3½in. Weight, 4½ lb. Post, etc., 1/1. **25/-**

**SPEECH TRANSFORMERS**  
New, ratio 30:1. Post, etc., 1/-. **6/8.**  
**MAINS SPEAKER TRANSFORMERS**  
Heavy duty for Pentode output. Post 1/- **21/6.**



**MILLIAMMETERS**  
Ferranti moving coil milliammeters. 0-5 milliamps. Panel mounting, size 2 3/16 x 2 3/16. A fine instrument, brand new, and packed in original cartons **62/6**

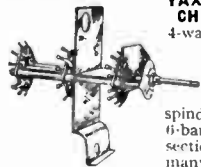

**YAXLEY Type WAVE-CHANGE SWITCHES**  
4-way, 3-bank, with shielded oscillator section. Length from stop plate, approx. 5 in., spindle 2in. **5/6.** 5-way, 6-bank, with 3 screened sections, adaptable to many uses. Length from stop plate approx. 6½in., spindle 2in. **6/6.** 3-way, 3 double banks, without shields, 2in. spindle. Length 6½in. **5/6.** Post, etc., 9d. each.

**YAXLEY PATTERN SWITCHES**  
5-way, single-bank, with on-off mains switch, carrying 1 amp. at 250 v., 2in. spindle with knob. **5/6.** 3-way, single-bank, 1in. spindle, with knob ... **2/9**  
Post, etc., 6d. extra.



**OAK SWITCHES**  
2½in. spindle, complete with knob, 4-way, 2-bank, with connecting block **4/6**  
4-way, 2-bank ... **3/9**  
Post, etc., 6d.



**MAKE AND BREAK UNITS**  
Ex famous manufacturer, brand new electro-magnetic make and break relays to operate on 1½ volts at 15 m.a. **5/6**  
Postage 4d. extra.

### PRESS BUTTON UNIT PERMEABILITY IRON CORED COILS

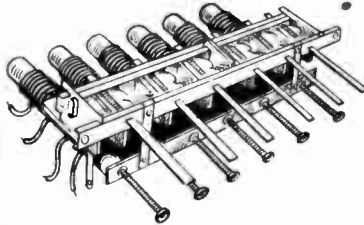

These well made units are supplied exactly as illustrated. **15/-**  
Post, etc., 9d.

### ELECTRO-MAGNETIC COUNTERS

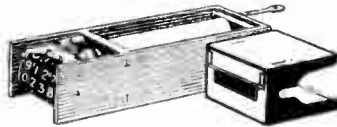

500 ohms. coil. Counting up to 9,999. Operating from 25 v. to 50 v. D.C. Many industrial and domestic applications. (S.H., ex-G.P.O., all perfect.) Postage 9d. ... **5/6**

### CHASSIS



As illustrated. 12 x 4½ x 2½in., drilled for 5 valves, etc. Enamelled blue ... **4/-**  
Post, etc., 7d.

### TRIMMER CONDENSERS

Non - drift air dielectric, 60 mmfds., suitable for S.W. work. Price **1/3**  
Plus post., 3d. extra.  
Also two models in bakelite mouldings (as illustrated). 150 p.f. Size 1 7/8 x 1/9 1.000 p.f. Size 1 7/8 x 1/4 2/6  
Post, etc. 4d.



These Trimmers are available to the Trade and Manufacturers in quantity.



### AMERICAN VIBRATOR UNITS

Synchronous Self Rectifying  
12 v. input, 280 v., output, 65 m.a.  
Filled with 7-pin American bases. Post, etc., 8d. **15/6**



### I.F. TRANSFORMERS, 465 kc.

Post, etc., 9d. ... 7/6 per pair

### 3-GANG VARIABLE CONDENSERS

Ceramic mounted. Less trimmers ... 8/6  
Post, etc., 9d.

### MERCURY SWITCHES (Brand New)

These switches are of the best manufacture and not easily obtainable today. Quick make and break and will carry 5 amps. Many hundreds of useful applications. Small quantity to clear. Price **8/6**  
Post etc., 6d.



### EX-BAIRD High Voltage TELEVISION TRANSFORMERS

6,000 v. approx. Fitted with Porcelain insulated terminals, as illustrated. Size 3½ x 6½ x 3½. **20/-**  
Post, etc., 2/-  
4,000 v. approx. Size 4in. x 3½ x 3½. **10/6**  
Post, etc., 1/6

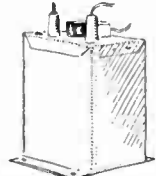

### 7-PIN CERAMIC VALVEHOLDERS.

1/6. Post, etc., 3d.

### PLUGS AND JACKS.



These ex-Govt. Jacks have powerful phosphor-bronze springs ensuring a perfect contact. Overall length, including 1/4" threaded shank, 3½in. Supplied with nut for panel mounting. Price complete with best quality Plug (as illustrated). Post, etc., 3d. ... **5/6**

### T.C.C. CONDENSERS

4+4 mfd. 70 v. D.C. wkg. 23. Post 3d.

7-Pin VALVEHOLDERS 9d. each or 7/6 doz.

### ON-OFF TOGGLE SWITCHES



Finest quality. Turn movement, 1½in. spindle. Post, etc., 3d. extra **2/6**

### CELESTION 8in. P.M. LOUD SPEAKERS

Pentode output, with transformer. New **29/6**  
Post, etc., 2/-.

LONDON CENTRAL RADIO STORES, 23, LISLE ST. GERard 2969 LONDON, W.G.2

# WEBB'S *Radio*

## MORSE PRACTICE EQUIPMENT FOR CLASSROOM AND INDIVIDUAL TUITION

£ s. d.

Schools Type Oscillator, A.C. operated, 2½ watts output, tapped for varying numbers of telephones, or loud speaker ..... 7 10 0

Junior Oscillator, A.C. operated, for up to three pairs of telephones..... 2 5 0

Battery Operated Oscillator, works from G.B. battery, or 2-volt accumulator..... 1 7 6

### Practice type keys :

Metal U.S.A. Pattern..... 4 6

G.P.O. Bar type on wooden base ..... 8 6

### Operating type keys :

G.P.O. Bar type, polished lacquered brasswork on wooden base ..... 1 2 6

### Loudspeakers :

8in. P.M. Loudspeakers in polished wood cases, size 10½in. high by 11in. wide by 6in. deep, with output transformer tapped for pentode and triode ..... 3 5 0

Or in Rexine covered cabinets (same size) in grey, blue or brown..... 3 5 0

### Short Wave Tuning Condensers :

Wavemaster, ceramic insulation, .0001, .00016, .0002 ..... each 5 0

Eddystone Cat. No. 978 Trimmers..... 4 9

Cydon, ceramic insulation, .000025..... 3 6

### Mica Trimmers :

Mica, high-grade trimmers, in 40pf, 250pf, 450pf, 100 + 100pf. .... each 1 0

### Crystal Filters :

Simmonds Band Pass Crystal Filter Units 46S Kc/s available in alternative bandwidths, 300 c/s and 1500 c/s ..... each 4 10 0

Additional charge of 1/- for postage and packing on orders below 10/-.

We have facilities for the Service of communication and normal broadcast receivers. Private customers must please realise that **GOVERNMENT PRIORITY** repairs necessarily take precedence.

14 Soho Street, Oxford Street, London, W.1  
Telephone : Gerrard 2089

We are available 9 a.m. till 6 p.m. for OFFICIAL business, but please note our **SHOP HOURS**—10 a.m. to 4 p.m. (Saturdays 10 a.m. to 12 noon.)

# WHARFEDALE FACTORY SPEAKERS

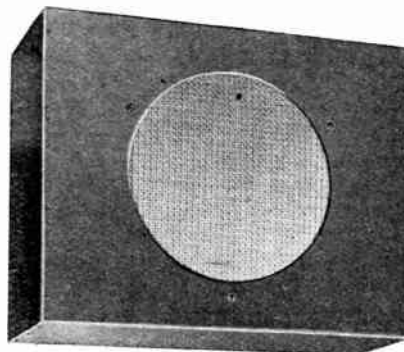

SIZE : 15½" by 12½" by 6½".

DELIVERY 3 to 4 WEEKS for PRIORITY ORDERS ONLY.

With 10" Bronze Unit 65/- } Transformer - - - 7/6 extra  
With 10" Golden Unit 95/- } Truqual Volume Control 6/6 ..  
Remote Volume Control 17/- ..

## WHARFEDALE WIRELESS WORKS

SOLE PROPRIETOR : D. E. BRIGGS  
HUTCHINSON LANE, BRIGHOUSE, YORKS.  
'PHONE : BRIGHOUSE 50. 'GRAMS : "WHARFEDALE."

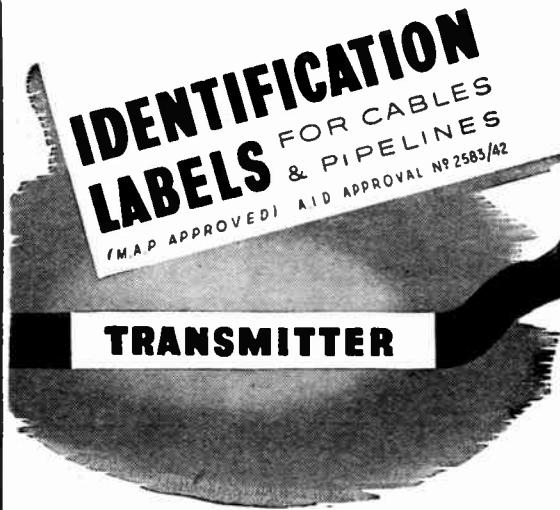

Indelibly printed on white or coloured fabric for use in conjunction with transparent adhesive tape.

• Guaranteed 2/3 day delivery service.

# P. P. PAYNE & SONS LTD

HAYDN ROAD NOTTINGHAM Phone : 64335  
BUSH HOUSE LONDON Phone : TEMple Bar 6356



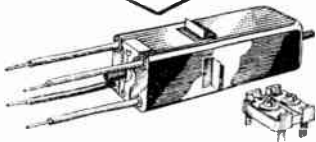

Sickles Midget Transformer and Trimmer.

OUR greatly increased manufacturing facilities in the War effort, coupled with our added production knowledge, will materially benefit you when Victory is won. Quality has always been the dominant consideration in the design—in the choice of materials and in the method of manufacture of our products; and we look forward with confidence to the day when we shall once again continue our relationship with the Radio Industry of Great Britain with greater cordiality than ever before.

**I.F. TRANSFORMERS  
AERIAL AND OSCILLATOR COILS  
TRIMMER AND PADDER CONDENSERS  
COIL FORMS, etc.**



**The F. W. SICKLES Co.  
CHICOPEE, MASS., U.S.A.**

# RAYTHEON

- PROGRESS -



THEY who are fighting under every climatic condition know the superior performance qualities of RAYTHEON tubes... their unflinching response even under wartime rigid requirements. They will not forget that RAYTHEON tubes in war even surpassed their peacetime records for long life, trouble-free operation and high quality performance.

The RAYTHEON trade mark will be familiar to thousands of servicemen and dealers when they come back to their peacetime work...

they will not forget that RAYTHEON tubes unflinchingly performed their duty in every emergency.

**WORLD'S LARGEST  
EXCLUSIVE  
TUBE MANUFACTURERS**



**RAYTHEON  
PRODUCTION CORPORATION  
NEWTON, MASS., U.S.A.**

# P. R. MALLORY & CO. Inc. MALLORY

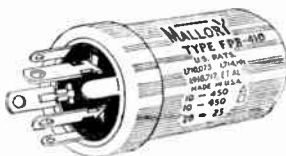

## FP CAPACITORS

- Eliminate the need of special condensers.
- Less engineering expense in condenser applications.
- Less labour in assembling to chassis.
- Eliminate the need of hardware for mounting.
- Materially reduce rejects in factory and in the field.
- Eliminate 'custom-made' condensers for each application.
- Greater uniformity eliminates the need for other parts to stabilise circuit performance.
- Encased in metal and protected in all climates.
- Smaller sizes simplify design and conserve chassis space.

**P. R. MALLORY & CO. INC.  
INDIANAPOLIS, INDIANA,  
U.S.A.**

*Radio and Electronics Division*



## FOR THE FUTURE

These Manufacturers will help solve your post-war problems.

Register your name now for full details which will be sent you when supply conditions again permit.

**Frank Heaver Ltd.  
Kingsley Road  
Bideford  
N. Devon**



## VICTORY PRODUCTION

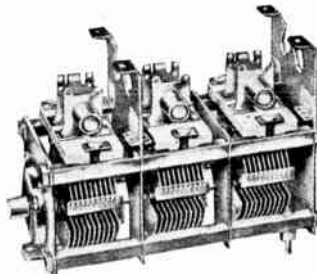

WHEN the mission of complete victory is accomplished, General Instrument will help "Win the Peace" by making the best use of still greater knowledge and experience in the manufacture of variable condensers and drives.

**THE GENERAL INSTRUMENT  
CORPORATION  
ELIZABETH, N.J., U.S.A.**

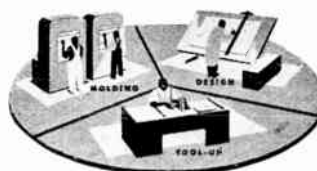

WHEN you think of plastic mouldings for post-war products we suggest you consult the Kurz-Kasch "Plastic Round Table"—a group of specialists in design, materials, tool-up and moulding. Kurz-Kasch can give you complete service under one roof, one responsibility.



**KURZ-KASCH INC.  
Moulders of Plastics,  
DAYTON · OHIO  
U.S.A.**

## ANNOUNCEMENT

**W**E regret that owing to pressure of Service requirements, orders for Loudspeakers and Microphones can only be accepted when accompanied by Government Contract Numbers.

A comprehensive range of Instruments is being manufactured, including Loud-speaker Units from 2½" diameter to 12" diameter; Special High Power Loudspeakers in Cabinets suitable for Tropical conditions; Hand Microphones, also Special High Sensitivity Compact Light-weight Microphones for field use; Telephone Receivers, Moving Coil Head-phones, etc.

## GOODMANS INDUSTRIES LIMITED

WEMBLEY, MIDDLESEX.

LOUDSPEAKER & TELEPHONE ENGINEERS

## M.R. SUPPLIES

offer from stock the following brand new RADIO, ELECTRICAL and INDUSTRIAL EQUIPMENT of our usual dependable quality. All prices nett cash.

**TOGGLE PRESSES** (by S.T.C.). Senior and new Minor models here in stock. Double-acting, precise tool, suitable for all small pressing operations in many trades. Senior, weight 130 lbs., pressure 1½ tons, £30 nett. Minor, weight 80 lbs., pressure ½ ton, £23 nett. (Supplied by us to many important users.)

**SYNCHRONOUS TIME SWITCHES.** 200/250 v. 50 c. Capacity, 10 amps. Precision made, complete movements, without housing. Fitted with removable solar device which automatically adjusts the positions of the riders to switch "on" at dusk and "off" at dawn (or vice versa), with instant pre-set for any month and for B.S.T. and B.D.S.T. This device can be readily dispensed with, if not required, using the two spare riders provided. Full instructions supplied. Self-starting, silent and brand new, 72/6. Also special model in 4in. by 4in. by 6in. weatherproof cast iron housing, same voltage and capacity, with fully enclosed gearing, 97/6. A real opportunity for factory, laboratory and domestic use in process timing, time signalling, blackout warning, alarm clock, switching radio, etc.

**LODEX RELAYS.** 200/250 v. A.C. 2-watt coil, with triple-pole change-over 6-amp. high tension switching, 42/6. Also U.S.A. make, enclosed, with 4/12 v. D.C. coil (250 m.a.) with 6-amp. single-pole "make" switch, 6/6.

**ROTHERMEL-BRUSH PIEZO-CRYSTAL MICROPHONES.** Continuation of our very popular offer of these specially housed D.104 Microphones. Fitted knuckle-joint for angle adjustment and direct-fixing mounting boss (½in. thread). Response level to about 8,000 c/s. Sensitivity—60 db. with about 5ft. screened lead, 75/-. Suitable Floor Stands, chromium, folding to 2ft. ext. to 5ft. 6in., 37/6

**ROTHERMEL-BRUSH MINIATURE MICROPHONES** (Piezo-Crystal). Only 1½in. dia. and capable of very high performance. In aluminium housing with short screened lead but no front grille. Made for deaf-aids but perfect for all other microphone uses, cardophone, piano and guitar repeater, etc., and useful in research depts., 27/6.

**TRANSFORMER BOBBINS.** Firm. 200/400 v., secs.—350/0/350 75 m.a., 4 v. 3 a., 4 v., 4 a. Core opening 1½ by 1½in. by 1½in. through. Semi-standard replacement for many sets incl. Marconi, Pye, Lissen, etc. Here is the solution to re-wind problem, 18/6.

**BATTERY CHARGER KITS.** Comprising S.T.C. 9 v. 2-amp. Metal Rectifier and appropriate 220/240 v. Mains Transformer, the pair, 32/6. (Or with high-grade 0.25 Ammeter by Ferranti, Weston, etc., 59/6.) Diagram supplied.

**ROTHERMEL PIEZO-CRYSTAL PICKUPS.** Limited delivery of the latest black bakelite model at pre-war price, plus P.T.; total, £3.18.9. Early application advised.

**PUBLIC ADDRESS SPEAKERS.** Latest model G.E.C. comprising 10-watt P.M. Projector Unit (15 ohms imp.) with built-in line transformer, and 42in. round all-metal Horn, 210.5.0. (Carr. 7/6 extra.) Also G.E.C. INDUSTRIAL SPEAKERS in 9in. metal drum with front and rear grille and built-in multi-transformer, handling 5 watts, 45/-. (Packing and carriage, 2/-)

**STAGE DIMMERS.** Constantly rated and both with carbon break flicker switch and "off" position. For controlling stated load from full bright to blackout at 220/240 v. With screw motion drive and hand-wheel. 1,000 watts, 28.6.0. 1,500 watts, 27.15.0. (Part carr. 5/- in returnable case.)

**ERISON HEADPHONES,** new, 2,000 ohms, with headband, 25/- pair. Also same make, second-hand, 2,000 ohms, 3/9 each single phone.

**CENTRALAB VOLUME CONTROLS.** Following range only: 5,000, 10,000, 50,000, 250,000, 500,000 ohms and 1 megohm. Less switch, 3/11. With switch, 5/3.

Please include sufficient for postage and packing. Excess refunded.

**M.R. SUPPLIES, 68, New Oxford Street, London, W.C.1.**

(Telephone: MUSeum 2958)

## TRANSFORMERS FOR THE TROPICS

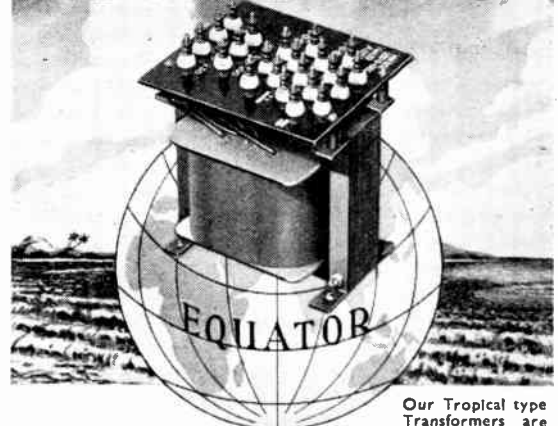

Vacuum  
Impregnation  
ensures  
reliable  
service under  
most arduous  
conditions.

# WODEN

TRANSFORMER CO.

Thornley Street, Wolverhampton  
Tel.: Wolverhampton 22829

Our Tropical type  
Transformers are  
made to  
specifications  
D.T.D. 1000  
or  
K. 110

MAKERS OF TRANSFORMERS, POWER PACKS, & SPECIAL RECEIVING & TRANSMITTING APPARATUS

# SYMBOLS OF PRECISION

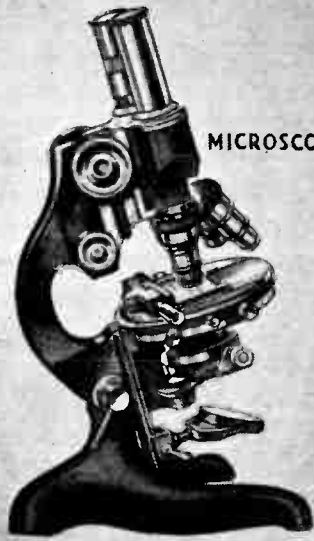

MICROSCOPE



# MAZDA RADIO VALVES

THE EDISON SWAN ELECTRIC CO. LTD.  155, CHARING CROSS RD., LONDON, W.C.2

*For full particulars write to Technical Service Department*



# 74 RANGE UNIVERSAL TAYLORMETER



Combining a very wide range of measurements with high sensitivity and accuracy.

Self-contained A.C. and D.C. Volt ranges available up to 5,000 volts.

A.C. and D.C. Current ranges from 50  $\mu$ A to 10 Amperes full scale.

Resistance measurements from 0.1 ohms to 50 Megohms with internal batteries.

Capacity and Inductance measurements can be made with special adaptor.

Some delay in delivery is unavoidable, but every effort is being made to meet Trade requirements.

Nett Price

MODEL 83a (4,000 ohms per volt A.C. and D.C.) 15 gns.

MODEL 83c (20,000 ohms per volt A.C. and D.C.) 19 gns.

# TAYLOR METERS

Write for complete specification to—  
**TAYLOR ELECTRICAL INSTRUMENTS LIMITED**  
 MONTROSE AVENUE, SLOUGH, BUCKS. SLOUGH 21381 (4 lines)

*Wartime installations show more conclusively than ever that*

**you can**

*Trust*

# TRIX

Quality SOUND Equipment

*To priority order only*

30 watt Amplifier Model T633

There are TRIX Amplifiers from 5-500 watts  
Send for details

TRIX ELECTRICAL CO. LTD., 65, Bolsover St., London, W.1.  
 Phone: EUS. 6471.2. Grams: Tri-radio, Wendo, London.

## NO OBJECTION !

"No objection can be urged against the British-made Raymart 'Speed' key, a specimen of which has been submitted to us for test. The usual flat American knob has been replaced by a taller one of the British pattern, and there is no tendency to manipulate the key by methods other than those approved in this country. The key is rigidly constructed and is extremely light in action; being fitted with heavy silver contacts it is suitable for serious work, and can be recommended either for practice purposes or otherwise."

The above quotation is taken from a "Wireless World" test report in issue dated May, 1942.

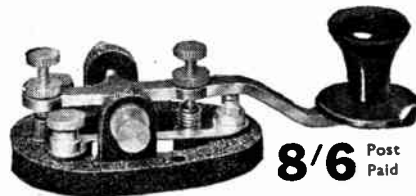

This Raymart "Speed" Key combines all that is best in British and American key design. It will give years of useful service.

**8/6** Post Paid

### IMPORTANT NOTICE

As the whole of our output of Raymart VCX and MCX Variable Condensators is going to the Services, please do not embarrass us by sending orders for these. Immediately we can resume general delivery we will advertise the fact. Sorry, but Services must come first.

**VALVES.** We are authorised lease-lend distributors and can supply the following types from stock for replacement purposes.

- 1A5GT, LC5GT, 1H5GT, 1T5GT, 6A8GT, 6F5GT, 6F6, 6F6GT, 6J5GT, 6JAG, 6K7GT, 6K7, 6Q7GT, 12J7FT, 12A7, 12A8GT, 12Q7GT, 12SK7GT, 12SJ7GT, 12SQ7GT, 12Z3, 25A6GT, 25A7GT, 25L6GT, 70L7GT, 36 & 83, 35L6GT.

# RAYMART

CRAFT A CREED

Send stamped, addressed envelope with all enquiries.

Telephone: MIDLAND 3254

**48 HOLLOWAY HEAD, BIRMINGHAM, I**

# Exide

## **BATTERIES**

## **FOR RADIO**

are playing their part in the great national effort. They are as indispensable to the purposes of war as to those of peace

THE CHLORIDE ELECTRICAL STORAGE COMPANY LIMITED  
Grosvenor Gardens House, Grosvenor Gardens,  
London, S.W.1

W.R. 8B/43

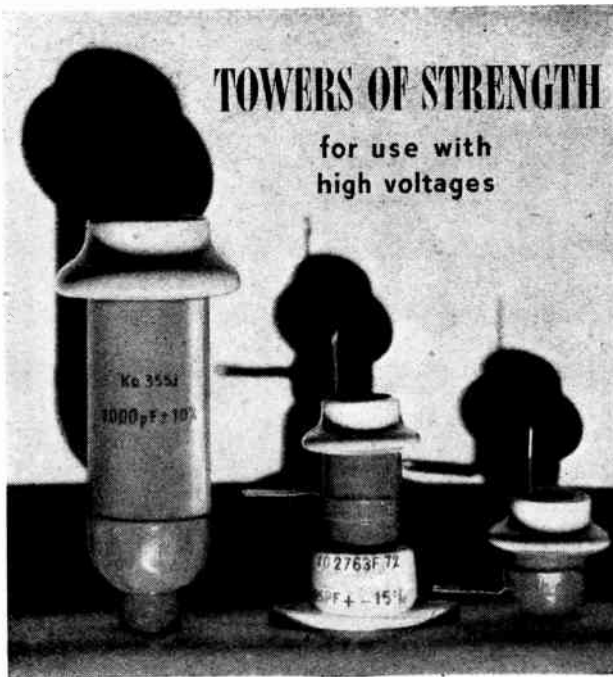

**TOWERS OF STRENGTH**

for use with  
high voltages



The outstanding characteristics of U.I.C. Ceramic Pot Condensers are their high break-down strength, low loss factor, and small dimensions. *Test Voltage* up to 15 KV D.C. or 10 KV R.M.S. *Working Voltage* up to 7.5 KVD.C. or 5 KV R.M.S. *Radio Frequency Working Load* from 2.5 to 15 KVA according to type. *Capacity Range* 20pF to 1250pF. Made to Specification K.110. Full details on request.

**UNITED INSULATOR CO. LTD.**  
12-22, LAYSTALL STREET, LONDON, E.C.1

Tel.: TERminus 7383 (5 line\*) Grams.: Calanel, Smith, London

**THE PIONEERS OF LOW LOSS CERAMICS**

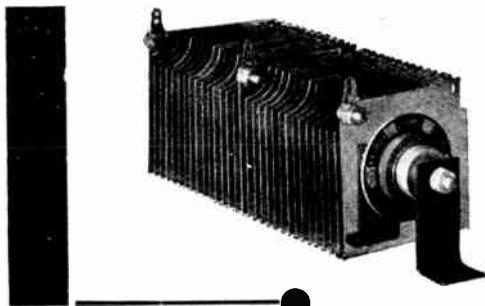

Designed for **RELIABILITY**  
Built for **RELIABILITY**  
And *proved* in actual service  
to be **THE WORLD'S MOST**  
**RELIABLE**

**WESTINGHOUSE**  
metal rectifiers

Westinghouse Brake & Signal Co. Ltd., Pew Hill House, Chippenham, Wilts.

**HIVAC**  
THE SCIENTIFIC  
VALVE  
BRITISH MADE

*Specialists in*  
**MIDGET  
VALVES**

**HIVAC LIMITED**  
Greenhill Crescent,  
Harrow on the Hill, Middx.

Telephone: Harrow 0895.



# ◆ LINAGLOW LIMITED ◆

## Radios

### 7-Valve Superhet Receiver

**Specification:** 3-WAVEBAND 15/52, 200/550, 800/2,000 metres. Separate tone and volume control, gramophone pick-up connections. Circuit in brief: Triode Hexode Freq. Changer followed by 465KC I.F. Stage which includes a High Efficiency Iron-cored 2nd I.F. Quality Diode Detector feeding Triode Amplifier followed by Phase Inverter and two 6V6 valves in Push Pull

### 30-Watt P.A. Amplifier.

A High Quality Amplifier, using finest components and Red "E" Valves. Circuit: High Resistance input feed through two separate input sockets or through pre-amplifier socket into two series connected valves with tone and volume control followed by twin valve acting as Amplifier and Phase Inverter feeding into two High Wattage Output Pentodes connected in Negative feed back. Class A B Circuit: 200/250 volts A.C. chassis finished in dark grey. 16 gauge steel. Brand new pre-war manufacture. Amplifier is fitted with Multi Ratio Output Transformer to take from one to forty-four 5,000 ohm speakers also 15 ohm speaker and 600 ohm line. Separate Stand-by Switch.

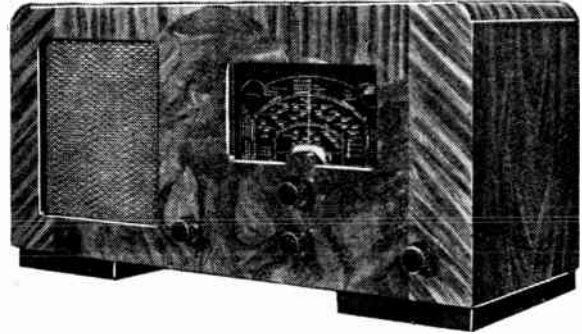

giving a Power Output of 8.5 watts. Contained in very well finished walnut veneered cabinet. 200/250 A.C.  
Horizontal Model, illustrated (Dim. 24in. x 12in. x 11in.) ..... **33 guineas**  
Vertical Model (Dim. 20in. x 16in. x 10in.) ..... **29½ guineas**  
These radio sets can be heard in our showrooms.

Amplifier with valves suitable for gram. microphone and radio inputs, **Price £35 10 0**  
Amplifier with valves and 20in. Horn P.A. Speaker and output transformer, **Price £45 0 0**

### VOLTAGE DROPPING & LINE CORD REPLACEMENT RESISTORS

*suitable for every make of radio receiver, comprehensive ranges mentioned below.*

950 ohm .2 amp. Chassis mounting, heavy duty porcelain former, 2 adjustable tappings, 8/6 each; as above, 800 ohm, .3 amp., 8/6 each.  
.2 amp. 675 ohm, tapped 100, 100, 425 and 50 ohms, suitable for Ekco and other makes, 4/- each.  
.2 amp. 840 ohm, tapped 100, 100, 475, 115 and 50 ohm, for Ekco, etc., 4/-.  
.2 amp. 945 ohm, tapped 100, 100, 545 and 100 ohm, for Halcyon, etc., 4/6.  
.2 amp. 510 ohm, tapped 60, 105, 85 and 260 ohm, for Coscor, etc., 4/6.  
.2 amp. 750 ohm, with adjustable slider, suitable for Maestro, 6/6.  
.3 amp. 547 ohm, tapped 80, 80, 387 ohm, for Ferranti, etc., 7/6.  
.3 amp. 1,014 ohm, tapped 82, 82, 320 and 530 ohm, for Double Decca, 7/6.  
.3 amp. 781 ohm, tapped 45, 45, 332, 166 and 193 ohm, for Ferguson, etc., 9/6.  
.3 amp. 823 ohm, tapped 45, 45, 290, 166 and 277 ohm, for Ferguson, etc., 9/6.  
**SPECIAL HEAVY DUTY RESISTORS**, 5-watt, for bias, etc., all values from 25 to 2,000 ohm, with copper clips, 1/9 each. Similar to above, but 10 watt, 2/3.  
50 ohm centre tapped Resistor, tapped at 25 ohm, for pilot lamps, 2/-.  
.3 amp. **LINE CORD RESISTOR**, 360 ohm, 6/6; .3 amp. **LINE CORD RESISTOR**, with slider, any resistance obtained up to 750 ohm, 7/6.  
**SPECIAL MULTI-LINE CORD RESISTOR**, 5 tappings 50 ohm, 1 tapping 750 ohm, with slider, .2 amp., 8/6.

**RADIO MECHANIC'S TOOLS**. Set of 3 screwdrivers, bright steel shaft, insulated handles, also set of 3 Box Spanners, 2, 4 and 6 B.A. with Tommy Bar, at 10/6 complete set.

**RADIO MECHANIC'S ELECTRIC SOLDERING IRON**, 230/250 v. AC/DC. Nickel plated body, pencil bit, complete with flex, 13/6.

**LINE CORDS**. 2 Way, 360 ohms, 8/6; 480 ohms, 11/-; 600 ohms, 13/6. 3 Way heavy duty .3 amp., 360 ohms, 13/6; 480 ohms, 17/6; 600 ohms, 21/-.

**TUBULAR PAPER CONDENSERS**, 350-500 v., D.C. working. .0001, .0003, mfd., 4/- doz.; .001, .002, .003, .004, 6/- doz.; .01, .025, .05 mfd., 7/- doz.; .08, .1 mfd., 12/- doz.; .2, .25, .3 mfd., 15/6 doz.; or assorted parcel of 50 for 27/6. Minimum orders, 1 doz., any type.

**LOUDSPEAKER TRANSFORMERS**. Pentode output 75 m.a., 9/6; Heavy Duty Multi-ratio, 100 m.a., 12/6; Heavy Duty Pentode, 100 m.a., 10/6; Universal Output and Push-Pull, 100 m.a., 12/6; Push-Pull Output, 120 m.a., 15/-.

**MAINS TRANSFORMERS**, 200/250, 350-0-350, 4 v., 6 amp., 4 v., 3 amp., 120 m.a., or 6.3 v., 3 amp., 5 v., 2 amp., 37/6 each.

**LOUDSPEAKERS**. Rola P.M., 3 ohm voice coil without transformer, 5in., 21/-; 6in., 22/6; 8in., 25/6. Any of the above can be supplied with pentode output transformer at 10/6 extra. With multi-ratio at 12/6 extra.

**3in. GOODMAN P.M. LOUDSPEAKER**. Extra heavy magnet for Midgets and communication sets. Price 25/6 each.

**DPDT SWITCHES**. Panel mounting, P.O. type, 2/6 each. **VOLUME CONTROLS**, 5,000, 10,000, 25,000, 50,000, 100,000 ohm; ½, 1 and 2 megohm, without switch, 4/9 each. As above, with switch, 6/9 each.

**CYCLE DYNAMOS**. Complete with brackets for fitting and leads. Special Offer, 18/9 each.

**AUTO-TRANSFORMERS**. Step up or down, 110/210/220/240 v., 100-watt, 32/6.

### VALVES LEASE-LEND AMERICAN TYPES AT B.O.T. CONTROLLED RETAIL PRICES. FOR REPLACEMENT PURPOSES ONLY.

1H5, 6F5, 6J5, 12F5, 12SF5, at 9/2; 1A5, 1C5, 1N5, 1T5, 5Y3, 25Z5, 35Z4, 35Z5, at 11/-; 6C7, 12Q7, 12SQ7, at 11/7; 1A7, 6F6, 6J7, 6K7, 12J7, 12K7, 12SJ7, 12SK7, 25A6, 25L6, 35L6, 36, 42, 50L6, at 12/10; 6A8, 6SA7, 12A8, 12SA7, at 14/-; 25A7, 32L7, 70L7, 83, at 15/3. Also British Valves at Manufacturer's List Prices.

AC/ME, at 10/6; UT6, UU7, at 11/-; TDD4, at 11/7; AC/VP2, CL4, EF39, KTW61, VP41, at 12/10; AC/TP, ECH3, PC13, X63, X65, at 14/-; KT33C, at 14/8; EL35, at 18/4.

All above prices include Purchase Tax. All Orders taken in Strict Rotation. Cash with Order. Add 3d. per valve postage.

POST OFFICE PERMIT MUST BE OBTAINED TO PURCHASE THIS VALVE.

**FLAT FLEX**. 9-way, 14/36, 18/20ft. length, suitable for amplifiers, extension speakers, remote control and many other purposes. Finest quality pre-war manufacture. 7/8 per coil.

**L.F. CHOKES**. 20 hys., 100 m.a., brand new, 16/9.

**WALNUT VENEERED LOUDSPEAKER CABINETS**. Modern design, fitted silk and baffle, 35/- . As above, but complete with 5in. P.M. speaker, 55/-.

**VALVE HOLDERS-AMPHENOL TYPE**. International or Mazda Octal, chassis mounting, at 1/- each.

**SCREENED INTERLACED FLEXIBLE MICROPHONE CABLE**, Single, Special Offer, 9d. per yd. Pre-war Super Quality, 1/3 per yd.

**BATTERY LEADS**. 4-way with Wander Plugs, best quality, 1/3 each.

**D.P. SWITCHES**. 4 point push/pull, usual price 1/6, 9d each.

### SPECIAL OFFER OF SERVICE KITS, as follows:

No. 1.—1 8 x 8 mfd. tubular can-type electrolytic condenser, 500 v.d.c.w., 25 assorted silver mica wire-end condensers, 25 assorted ½, 1- and 1-watt carbon wire-end resistors, 25 assorted 1-, 2- and 3-gang I.F. and aerial trimmers. £1 7s. 6d. per kit.

No. 2.—3 8 x 8 mfd. tubular can-type electrolytic condensers, 500 v.d.c.w., 100 assorted silver mica wire-end condensers, 100 assorted ½, 1- and 1-watt carbon wire-end resistors, 50 assorted 1-, 2- and 3-gang I.F. and aerial trimmers, 50 assorted wire-end tubular paper condensers, 3 assorted volume and tone controls. £4 12s. 6d. per kit.

No. 3.—3 8 x 8 mfd. tubular can-type electrolytic condensers, 500 v.d.c.w., 1 8 mfd. tubular can-type 500 v.d.c.w., 1 25 mfd. x 25 v., 1 50 x 50 mfd. x 12 v., 1 50 x 50 x 2.550 v., 1 32 mfd. 350 v., 1 5 x 5 x 35 v., 200 assorted silver mica wire-end condensers, 200 assorted ½, 1- and 1-watt carbon wire-end resistors, 100 assorted 1-, 2- and 3-gang I.F. and aerial trimmers, 100 assorted wire-end tubular paper condensers, 6 assorted volume and tone controls, 3 lengths 2-way 360-ohm line cord. £3 8s. per kit.

No. 4.—12 8 x 8 mfd. tubular can-type electrolytic condensers, 500 v.d.c.w., 4 8 mfd. tubular can-type 500 v.d.c.w., 1 16 x 8 mfd. 550 v. Block, 1 16 x 16 mfd. 500 v., 1 50 mfd. x 20 v., 2 32 mfd. aluminium can-type, 350 v.d.c.w., 1 50 x 50 x 2—15,550 v., 1 5 x 5 x 35 v., 1 50 x 50 x 12 Mallory type condenser, 500 assorted silver mica wire-end condensers, 500 assorted ½, 1- and 1-watt carbon wire-end resistors, 250 assorted 1-, 2- and 3-gang I.F. and aerial trimmers, 100 assorted wire-end tubular paper condensers, 50 assorted wire-end wire-wound resistors, 15 assorted volume and tone controls with and without switch, 1 pentode output transformer, 1 multi-ratio output transformer, 1 push-pull output transformer, 3 rolls insulating tape, 6 blocked line cord replacement resistors, 6 lengths 2-way 360-ohm line cord. £29 10s. per kit.

### ◆ PLEASE NOTE ◆

◆ **CALLERS to Show Rooms, 61 HIGHGATE HIGH ST., N.6**  
Phone: MOUNTVIEW 9432.

Owing to staff shortage and volume of orders we are unable to accept C.O.D. orders until further notice.  
**CASH WITH ORDER ONLY.**  
No pro-forma invoices.

◆ **POST ORDERS to Dept. M.O.2, 3 HAMPSTEAD LANE, N.6.**

"THERE'S A GENTLEMAN HERE  
FROM THE PEOPLE WHO DO THAT  
QUICK CABLE BINDING SYSTEM  
-HELLERMANN- WE ASKED"  
HIM TO CALL & DEMONSTRATE



Our Advisory Service will be pleased to co-operate—

**HELLERMANN ELECTRIC LTD.** GOODTRIC WORKS, OXFORD. Oxford 2403



WHICH IS YOURS?

It's just as perplexing to choose the right type of Sound Equipment from the many that are normally available. Many P.A. Systems look the same on superficial examination. But only in actual service and performance does their true character develop. Which is, of course, one of the principal reasons why so much R • S Equipment is in demand in directions that precludes our supplying other than very small quantities of a greatly restricted range for normal purposes. If however, you would like to know just what Sound Equipment bearing the name R • S you can still offer to your customers, we'll gladly send you our latest catalogue if you'll send a penny stamp.

**R • S**  
AMPLIFIERS

R • S Amplifiers, Ltd., 3-4, Highfield Road, Shepperton, Middlesex.  
Telephone: Walton-on-Thames 1019.

When they have  
finished their  
vital war service



**DAGENITE**

AND

**PERTRIX**

—the dependable **BATTERIES**  
will again be available  
to all

FOR RADIO, CARS, MOTOR  
CYCLES, COMMERCIAL VEHICLES, AIRCRAFT, ETC

Sales Concessionaires: **HOLSUN BATTERIES LTD.**  
137 Victoria Street, London, S.W.1.

D10b.



# P.V.C. CABLES

OBTAINABLE FROM STOCK  
AT ALL OUR BRANCH OFFICES

*To minimise the use of rubber for cable dielectrics and sheathings a thermoplastic material (polyvinyl chloride or P.V.C.) has been approved by the Cable Planning Officer of the Ministry of Supply.*

*We have been prominently associated with the successful development of P.V.C. and are manufacturing all types of P.V.C. cables and flexible cords in accordance with Amendment No. 3 (June 1943) to B.S. 7 : 1939.*

CALLENDER'S CABLE & CONSTRUCTION CO. LTD. HAMILTON HOUSE, VICTORIA EMBANKMENT, LONDON, E.C.4

All over the World



# B.I. RADIO MATERIALS

We have had a long experience in the manufacture of all kinds of Cables and Wires, Static Condensers, Insulators and Ironwork, Telephone Cords and Copper Earthing Rods, for Radio use.



U.K. Regd. Trade Mark

## BRITISH INSULATED CABLES LTD.,

*Cable Makers and Electrical Engineers*

Head Office: PRESCOT, LANCS. Tel. No.: PRESCOT 6571

# WAXES OKERIN

## AND DIELECTRIC MATERIALS

Cable, Condenser, Coil, Transformer and Resistance Impregnating, dipping, sealing, filling and finishing.

A.I.D. and C.I.E.M.E. TYPE APPROVED WAXES to meet both ARCTIC and TROPICAL conditions.

TELEPHONE: WEST DRAYTON 2189

## ASTOR BOISSELIER & LAWRENCE LTD

MIDDLESEX OIL & CHEMICAL WORKS

WEST DRAYTON, MIDDLESEX

*War Savings Campaign*

*Yes! Talkies in Daylight!*

**AND IN THE OPEN AIR...**

The large fleet of Daylight Mobile Cinemas operated by British Films, Ltd., cover thousands of miles each year, bringing entertainment news and views to places and people so remote or so busy that "the pictures must come to the people." Naturally, in these days, such a valuable service is fully engaged on work of National Importance; but fullest information on the post-war potentialities of the Mobile Daylight Cinema as it can affect your business will gladly be sent on request.

# BRITISH FILMS LTD.

*Pioneers in Mobile Cinemas*

Head Office: 199, PICCADILLY, LONDON, W.1. Tel.: REGent 2828  
Works: 260, HIGH RD., BALHAM, LONDON, S.W. Tel.: BATerse 8506

## BASICALLY BETTER...

FROM THE COMPLETE RANGE MAY BE QUOTED:

Char. Imped. Ohms.	70	214
Capacity mmf./ft.	16.3	5.2
Att'n db/100ft. 100Mc.	0.11	
Dielectric Constant.	1.23	1.25

*Air Insulation...*

*is the basic principle of*

# CO-AX CABLES

*Unequaled H.F. Properties*

*There is a CO-AX Cable for every H.F. Purpose*

TRANSRADIO LTD. Inc. TELEQUIPMENT CO. 16 HIGHWAY BEACONSFIELD

# WHY ERSIN MULTICORE

the Solder wire with 3 cores of non-corrosive ERSIN FLUX is preferred by the majority of firms manufacturing the best radio and electrical equipment under Government Contracts.



## WHY THEY USE CORED SOLDER

Cored solder is in the form of a wire or tube containing one or more cores of flux. Its principal advantages over stick solder and a separate flux are :

- (a) it obviates need for separate fluxing
- (b) if the correct proportion of flux is contained in cored solder wire the correct amount is automatically applied

to the joint when the solder wire is melted. This is important in wartime when unskilled labour is employed.

## WHY THEY PREFER MULTICORE SOLDER. 3 Cores—Easier Melting

Multicore Solder wire contains 3 cores of flux to ensure flux continuity. In Multicore there is always sufficient proportion of flux to solder.



If only two cores were filled with flux, satisfactory joints are obtained. In practice, the care with which Multicore Solder is made means that there are always 3 cores of flux evenly distributed over the cross section of the solder,

so making thinner solder walls than single cored solder, thus giving more rapid melting and speeding up soldering.

## ERSIN FLUX

For soldering radio and electrical equipment non-corrosive flux should be employed. For this reason either pure resin is specified by Government Departments as the flux to be used, or the flux residue must be pure resin. Resin is a comparatively non-active flux and gives poor results on oxidised, dirty or "difficult" surfaces such as nickel. The flux in the cores of Multicore is "Ersin"—a pure, high-grade resin subjected to chemical process to increase its fluxing action without impairing its non-corrosive and protective properties. The activating agent added by this process is dissipated during the soldering operation and the flux residue is pure resin. Ersin Multicore Solder is approved by A.I.D., G.P.O., and other Ministries where resin cored solder is specified.

## PRACTICAL SOLDERING TEST OF FLUXES

The illustration shows the result of a practical test made using nickel-plated spade tags and bare copper braid. The parts were heated in air to 250° C, and to identical specimens were applied 1/2" lengths of 14 S.W.G. 40/60 solder. To

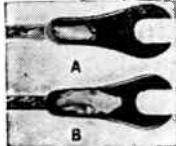

sample A, single cored solder with resin flux was applied. The solder fused only at point of contact without spreading. A dry joint resulted, having poor mechanical strength and high electrical resistance. To sample B, Ersin Multicore Solder was applied, and the solder spread evenly

over both nickel and copper surfaces, giving a sound mechanical and electrical joint.

## ECONOMY OF USING ERSIN MULTICORE SOLDER

The initial cost of Ersin Multicore Solder per lb. or per cwt. when compared with stick solder is greater. Ordinary solder involves only melting and casting, whereas high chemical skill is required for the manufacture of the Ersin flux and engineering skill for the Multicore Solder incorporating the 3 cores of Ersin Flux. However, for the majority of soldering processes in electrical and radio equipment Multicore Solder will

show a considerable saving in cost, both in material and labour time, as compared either with stick solder or single cored solder. Cored solder ensures that the solder and flux are put just where they are required, and by choice of suitable gauge, economy in use of material is obtained. The quick wetting of the Ersin flux as compared with resin flux in single core resin solder ensures that with the correct temperature and reasonably clean surface, immediate alloying will be obtained, and no portions of solder will drop off the job and be wasted. Even an unskilled worker, provided with irons of correct temperature, is able to use every inch of Multicore Solder without waste.

## ALLOYS

Soft solders are made in various alloys of tin and lead, the tin content usually being specified first, i.e. 40/60 alloy means an alloy containing 40% tin and 60% lead. The need for conserving tin has led the Government to restrict the proportion of tin in solders of all kinds. Thus, the highest tin content permitted for Government contracts without a special licence is 45/55 alloy. The radio and electrical industry previously used large quantities of 60/40 alloy, and lowering of tin content has meant that the melting point of the solder has risen. The chart below gives approximate melting points and recommended bit temperatures.

ALLOY Tin Lead	Equivalent B.S. Grade	Solidus C.°	Liquidus C.°	Recommended bit Temperature C.°
45/55	M	183°	227°	267°
40/60	C	183°	238°	278°
30/70	D	183°	257°	297°
18.5/81.5	N	187°	277°	317°

## VIRGIN METALS—ANTIMONY FREE

The wider use of zinc plated components in radio and electrical equipment has made it advantageous to use solder which is antimony free, and thus Multicore Solder is now made from virgin metals to B.S. Specification 219/1942 but without the antimony content.

## IMPORTANCE OF CORRECT GAUGE

Ersin Multicore Solder Wire is made in gauges from 10 S.W.G. (.128"—3.251 m/ms) to 22 S.W.G. (.028"—.711 m/ms). The choice of a suitable gauge for the majority of the soldering undertaken by a manufacturer results in considerable saving. Many firms previously using 14 S.W.G. have found they can save approximately 33 1/3%, or even more by using 16 S.W.G. The table gives the approximate lengths per lb. in feet of Ersin Multicore Solder in a representative alloy, 40/60.

S.W.G.	10	13	14	16	18	22
Feet per lb.	23	44.5	58.9	92.1	163.5	481

## CORRECT SOLDERING TECHNIQUE

Ersin Multicore Solder Wire should be applied simultaneously with the iron, to the component. By this means maximum efficiency will be obtained from the Ersin flux contained in the 3 cores of the Ersin Multicore Solder Wire. It should only be applied directly to the iron to tin it. The iron should not be used as a means of carrying the solder to the joints. When possible, the solder wire should be applied to the component and the bit placed on top, the solder should not be "pushed in" to the side of the bit.



ERSIN MULTICORE SOLDER WIRE is now restricted to firms on Government Contracts and other essential Home Civil requirements. Firms not yet using Multicore Solder are invited to write for fuller technical information and samples.

**MULTICORE SOLDERS LTD., BUSH HOUSE, W.C.2. 'Phone Temple Bar 5583/4**





## No Plan

**F**OR lack of wise planning many a job starts off on the wrong foot. Man without plan gets nowhere and the first layout affects all that follows.

Simmonds AEROCESSORIES speed up manufacture, simplify assembly and save both material and manpower. But they cannot do their best work if they are brought in belatedly, as an afterthought. To contribute most to the product, they must first figure in the plan.

In these decisive days no one can afford to be wise after the event.

# S I M M O N D S

*In high service to*  
AERONAUTICAL, INDUSTRIAL & MARINE  
*Construction*

THE SIMMONDS NUT · PINNACLE NUT · SPIRE NUT · SIMMONDS INSTRUMENTS,  
CONTROLS AND ELECTRONIC PRODUCTS · FRAM OIL AND ENGINE CLEANER

SIMMONDS AEROCESSORIES LTD.  
GREAT WEST ROAD, LONDON  
A COMPANY OF THE SIMMONDS GROUP

LONDON MELBOURNE MONTREAL PARIS NEW YORK



# Wireless World

Radio • Electronics • Electro-Acoustics

33rd YEAR OF PUBLICATION

OCTOBER 1943

Proprietors :  
ILIFFE & SONS LTD.

Managing Editor :  
HUGH S. POCOCK,  
M.I.E.E.

Editor :  
H. F. SMITH.

Editorial, Advertising  
and Publishing Offices :

DORSET HOUSE,  
STAMFORD STREET,  
LONDON, S.E.1.

Telephone :  
Waterloo 3333 (35 lines).

Telegrams :  
"Ethaworld, Sedist, London."



PUBLISHED  
MONTHLY

Price : 1/6

(Publication date 25th  
of preceding month)

Subscription Rate :  
Home and Abroad  
20/- per annum.

EDITORIAL. Wireless "Jargon" .. .. .	287
MULTI-PURPOSE TEST METER. By R. F. Blackwell, B.Sc., and D. G. Becker .. .. .	288
WIRELESS BADGES .. .. .	293
LONG-DISTANCE SHORT-WAVE TRANSMISSION. By T. W. Bennington .. .. .	297
" WIRELESS WORLD " BRAINS TRUST .. .. .	301
SUNSPOTS .. .. .	303
RADIO DATA CHARTS.—No. 11 : Frequency and Wavelength. By J. McG. Sowerby, B.A., Grad.I.E.E. .. .. .	304
USE OF VALVES (concluded) By J. R. Hughes, A.M.I.E.E. .. .. .	306
UNBIASED. By Free Grid .. .. .	310
WORLD OF WIRELESS .. .. .	311
LETTERS TO THE EDITOR .. .. .	313
RANDOM RADIATIONS. By "Diallist" .. .. .	316
RECENT INVENTIONS .. .. .	318

Branch Offices :

COVENTRY :  
8-10, Corporation Street.  
Telephone : Coventry 5210.  
Telegrams :  
" Autocar, Coventry."

BIRMINGHAM :  
Guildhall Buildings,  
Navigation Street, 2.  
Telephone :  
Midland 2971 (5 lines).  
Telegrams :  
" Autopress, Birmingham."

MANCHESTER :  
260, Deansgate, 3.  
Telephone :  
Blackfriars 4412 (4 lines).  
Telegrams :  
" Iliffe, Manchester."

GLASGOW :  
26B, Renfield Street, C.2.  
Telephone : Central 4857.  
Telegrams : " Iliffe, Glasgow."



*As many of the circuits and apparatus described in these pages are covered by patents, readers are advised, before making use of them, to satisfy themselves that they would not be infringing patents.*

## "HYPERLOY"

### TRANSFORMERS AND CHOKES

A range of high-performance, space-saving Components designed to meet the most exacting requirements of modern Electronic and Communications equipments.

- Small in size
- Weighing only 2 oz.
- Meeting the most rigid Tropical Specification
- Easily mounted in any position
- Manufactured in a variety of windings to meet many diverse applications

★ Owing to wartime restrictions on supply of raw materials, it is not possible to supply Wearite Components for purposes other than those connected directly with the war effort.

**WRIGHT & WEAIRE LTD.**  
HIGH ROAD, TOTTENHAM, N.17

Telephone : TOTTENHAM 3847-8-9



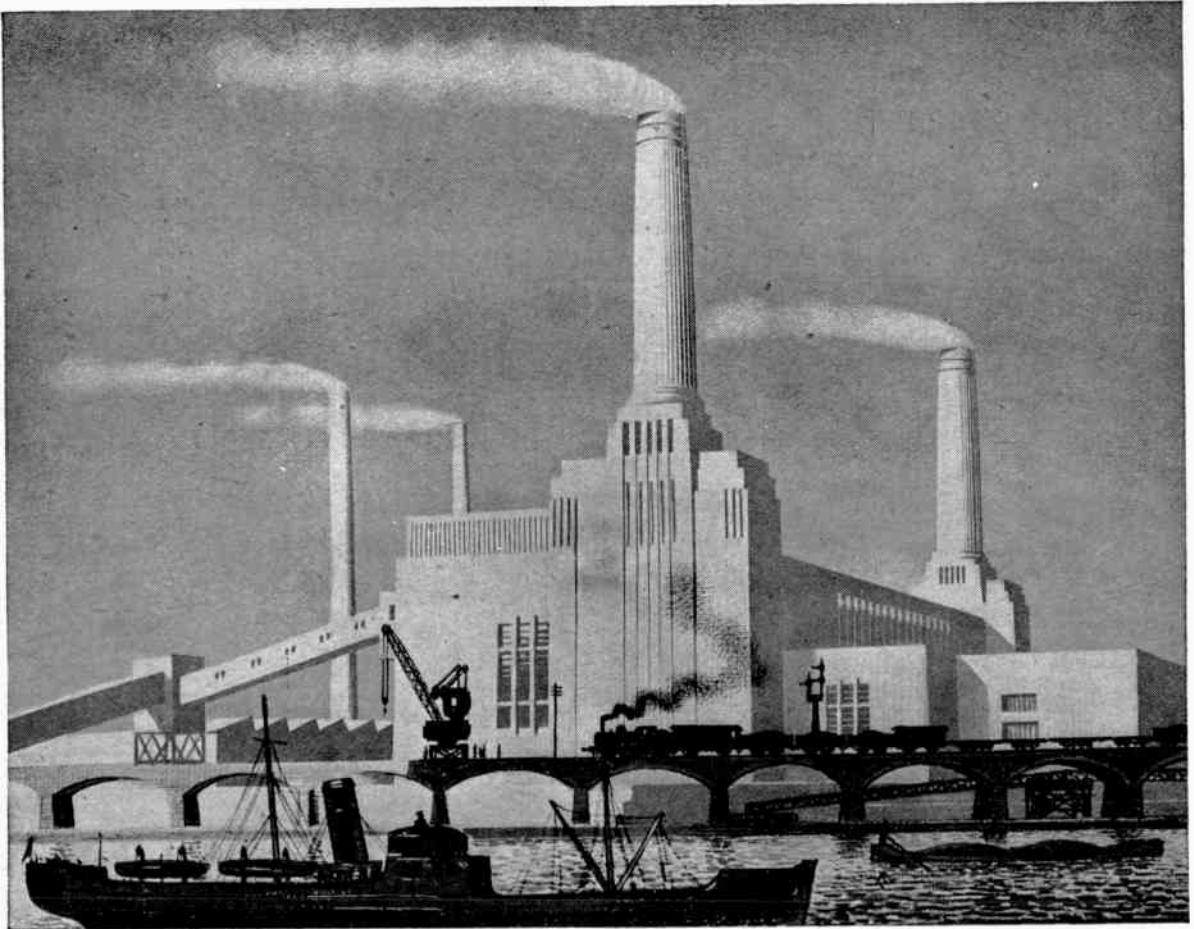

## Valves and Chimneys

White vapour issuing from industrial chimney-stacks is a sign of an efficient combustion system; black smoke indicates incomplete combustion, and shows that fuel is going to waste.

Many industrial concerns now make use of an electronic device consisting of an arrangement of valves and a light sensitive cell, which is capable

of giving a record of smoke density, or of regulating the combustion process to ensure maximum efficiency.

This is another example of the ever-increasing usefulness of the thermionic valve—not only contributing to greater industrial efficiency, but also foreshadowing far-reaching benefits to the community.

# MULLARD

THE MASTER VALVE

*A Valve for Every Purpose*

DOMESTIC · COMMERCIAL · INDUSTRIAL · SCIENTIFIC · MEDICAL · EXPERIMENTAL

THE MULLARD WIRELESS SERVICE CO. LTD., CENTURY HOUSE, SHAFTESBURY AVENUE, LONDON, W.C.2. (58)

# Wireless World

Radio • Electronics • Electro-Acoustics

Vol. XLIX. No. 10

OCTOBER 1943

Price 1s. 6d.

## Wireless "Jargon"

### *Avoiding Misleading and Unintelligible Terms*

IN every rapidly developing art there is a risk that the terminology peculiar to that art will get out of hand; the hastily coined words and phrases used to describe new things and processes will lack aptness, intelligibility and elegance. That has happened more than once during the spectacular growth of wireless, particularly during the period of rapid expansion of broadcasting. One of the best—or the worst—examples of the phraseology of that period is the expression "all-mains," used to denote a broadcast receiver or other piece of apparatus that functioned without batteries of any kind. Some time before the war we reported a court case where it was ruled that the buyer of a set so described was entitled to expect something that would work on any kind of mains supply. One can imagine that the learned judge, after giving the ruling, muttered to himself, "That should show these wireless people that they must be more careful with their jargon." This legal ruling ran contrary to generally accepted usage in wireless circles, but few will deny that "all-mains" was, to say the least, an ambiguous description.

At the present time, intensive development of certain wireless techniques is going on "in the back rooms" under conditions that are likely to prove a forcing ground for the evolution of an undesirable jargon. When the developments concerned come out into the open, the new terminology may well be unintelligible, not only to the layman but also to technicians outside the inner circle. We plead with those responsible for the coining and standardising of additions to the vocabulary of wireless to take some thought for the future, and to realise that a hastily adopted word or expression that is misleading or ambiguous may all too easily pass into the language and cause endless confusion and misunderstanding in later years.

One of the aims to strive for, when dealing with matters likely to come within the ken of layman, is to use words that will be understood by both layman and technician. It is not always necessary to have two languages, one for the inner circle and

the other for the rest. Above all, one should avoid using existing words in a sense that runs contrary to the accepted usage of the language.

Another principle is that no new expression should be coined unless we are certain that it is necessary. An example of something to be avoided is to be found in "video" and "viseo," applied to television in a mistaken attempt to match up with "radio" and "audio" in the designation of frequencies. Fortunately, most of us were content to speak of "vision frequency," and the coined words never had a very wide currency.

### *Corrupting Our Vocabulary*

Apart from the question of misleading, inapt or unnecessary new expressions, care should be taken that the meaning of clearly defined existing words of our vocabulary is not corrupted. The B.B.C. should be particularly careful to set a good example when it has occasion to refer to the means by which it distributes its programmes. Perhaps, now that we have a wireless engineer as Deputy Director-General, to say nothing of an ex-wireless man as Editor-in-Chief, we shall no longer hear announcers say, "Howard Marshall, *broadcasting to us* from Algiers . . ." One does not "broadcast" to an individual, or even to a great Corporation, in spite of the fact that one may be using a broadcasting station temporarily for point-to-point transmission.

In these matters we do not presume to set up as arbiters of taste, or to impose on contributors or correspondents a rigidly standardised technical vocabulary. It has always been the policy of *Wireless World* to conform with what it judged to be the best usage, only avoiding widely accepted expressions when they seemed to be misleading or ambiguous. In any case, complete standardisation of our terminology is quite impossible; it is always growing and under constant revision to keep pace with new developments. Given a little care on the part of those who can exert influence on the choice of words, this natural process of growth seems preferable to attempts at rigid control.



# MULTI-PURPOSE TEST METER

Mains-operated Instrument Measuring  
RF and AF Voltage, DC and AC  
Voltage, and Current, and Resistance

By

R. F. BLACKWELL, B.Sc., and D. J. BECKER

(Murphy Radio, Ltd.)

MUCH routine work in the radio laboratory consists of DC and AC voltage and current measurements, rough checking of resistance, and measurement of RF and AF voltage. A unit was built covering all the above requirements, and as commercial instruments are difficult to obtain it was thought that a description of it would be of interest.

The ranges covered are:—

Voltage, DC and AC : 0-10, 0-100, 0-500, 0-1,000 volts.

Current, DC : 0-1, 0-10, 0-100 mA, 0-1, 0-10 amps.

Current, AC : 0-10, 0-100mA, 0-1 amp.

Resistance : 0-10,000 ohms, 0-1 megohm.

Valve Voltmeter, RF and AF : 0-1, 0-10, 0-100 volts.

Valve Voltmeter, DC : 0-5, 0-50, 0-500 volts.

A 1mA meter is used for all measurements. There are two scales, the lower graduated for resistance ranges and the upper divided linearly and numbered 0-5 and 0-10 for all other ranges.

volt. In Fig. 2 (a), if  $V$  volts produce full-scale deflection, and the resistance of the meter movement is  $r$  ohms, the required series resistance,  $R$  ohms, is given by  $R = 1,000 V - r$ .

In the meter used,  $r$  is 118 ohms and can be neglected on all ranges except perhaps the lowest.

**DC Current Meter.**—The meter movement alone is used for the 1mA range; for 10mA a shunt resistance of value  $r/9$  ohms is switched across the meter and on the 100mA and higher ranges a tapped shunt is used (see Fig. 2 (b)). The advantage of this method

The 10mA range shunt resistance has a value of 13.1 ohms, and is made up of 1 yard of 36 SWG DSC Eureka. Fig. 3(a) gives dimensions of a suggested former, and shows the method of twisting the tinned copper wire terminal tags.

The tapped shunt resistor  $R_1$  consists of two 5in. lengths of 16 SWG bare Eureka in parallel, mounted on the switch wafer. The resistance is adjusted by running solder along the wire.  $R_2$  (4½in. of 22 SWG DSC Eureka) and  $R_3$  (12in. of 28 SWG DSC Eureka) are mounted on the same former (Fig. 3 (b)). These resistors should be adjusted by comparing the meter reading with that of an instrument that is known to be accurate, rather than adjusting to the calculated values. The lengths specified above are sufficient to allow for adjustment.

An abbreviated table of resistance wire constants is given on p. 290; more complete details† may be found in an earlier



Front view of test meter showing range switches and zero setting controls.

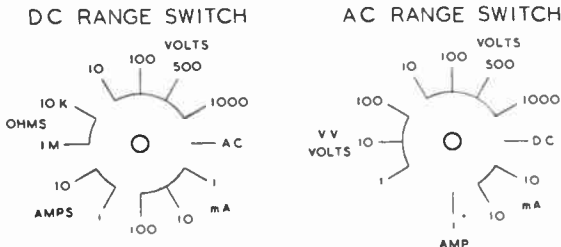

Fig. 1. Arrangement of twelve-position range switches.

Two twelve-position switches are used for selecting all ranges (see Fig. 1). The other controls are two zero-setters for the resistance ranges and one for the valve voltmeter.

**DC Voltmeter.**—As a 1mA movement is used, all ranges have a resistance of 1,000 ohms per

is that on the high-current ranges, accuracy of calibration is not affected by variations in switch contact resistance.

Resistance values are given by\* :— $R_1 = r/9,900$ ;  $R_2 = r/1,100$ ;  $R_3 = r/110$ .

In this case  $r = 118$  ohms, hence,  $R_1 = 0.012$  ohms;  $R_2 = 0.108$  ohms;  $R_3 = 1.08$  ohms.

\* A general formula (see Fig. 2 (c)) is

$$R_n = \frac{I_m \cdot i}{I_n(I_m - i)} \cdot r,$$

where  $m$  is the total number of ranges required on tapped shunt,

$R_n$  ohms = resistance to tap for  $n$ th range,

$I_m$  amps = current for full scale deflection on lowest range,

$I_n$  amps = current for full scale deflection on  $n$ th range,

$i$  amps = full scale deflection current of meter,

$r$  ohms = resistance of meter.

† "Designing Resistances," by R. F. Blackwell, *Wireless World*, July, 1941.

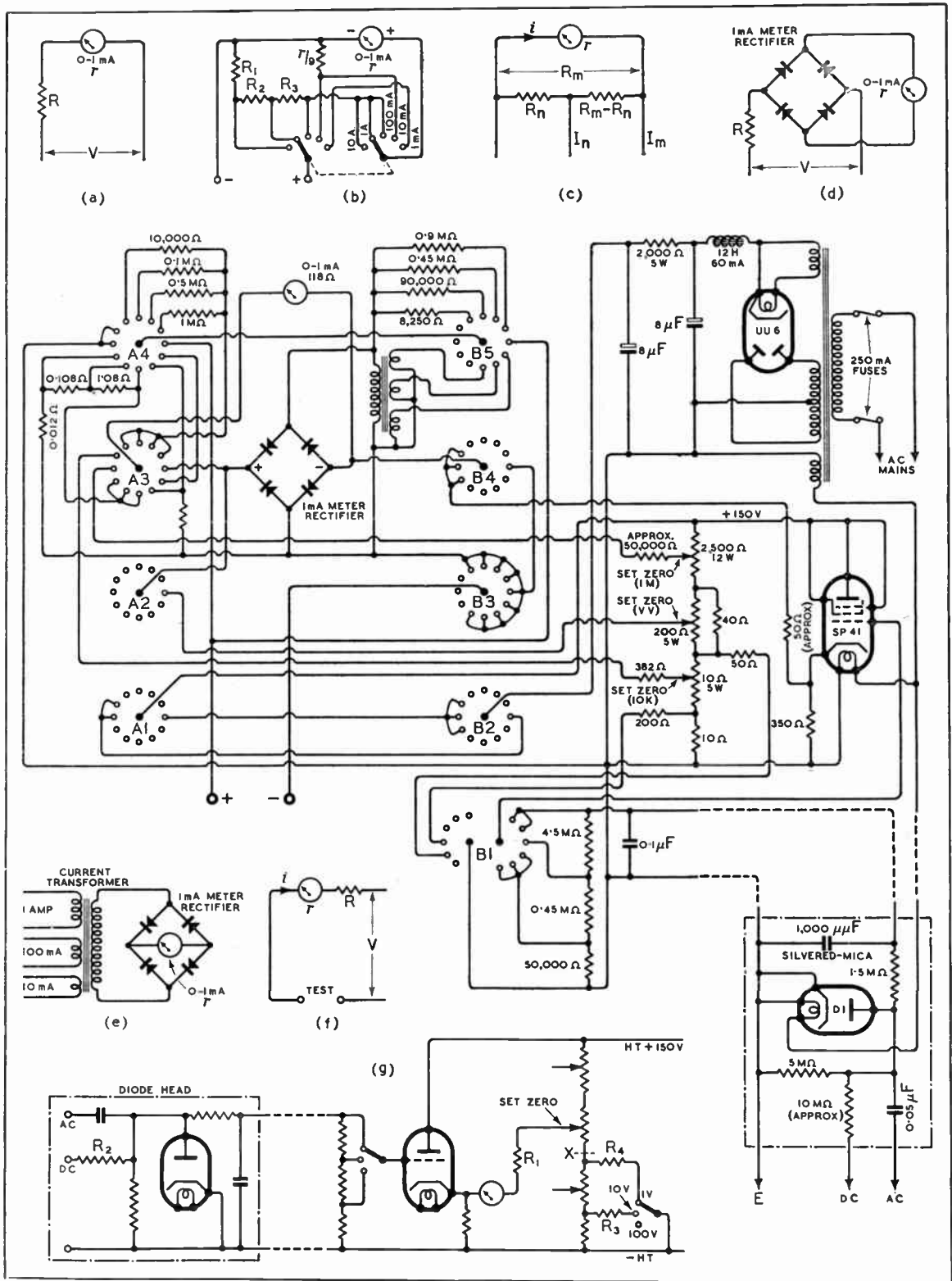

Fig. 2. Complete circuit of test meter and schematic diagrams showing basic circuits for various functions

**Multi-purpose Test Meter**— article. The resistance of Eureka wire may differ by as much as 10 per cent. from the values shown in the table. The figures given are also substantially correct for Constantan.

**AC Voltmeter.**—A Westinghouse 1mA meter rectifier is used (see Fig. 2 (d)). The DC current output from this type of meter

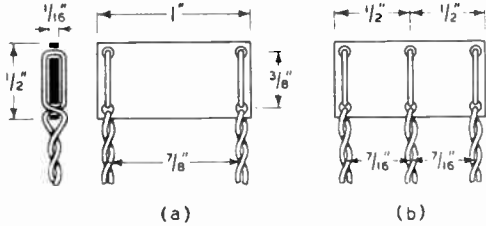

Fig. 3. Current meter shunt formers.

rectifier is proportional to the mean value of AC input. For a sinusoidal waveform, on which most measurements are made, RMS value = 1.11 × mean value. From the manufacturer's data, the p.d. across the AC terminals of a 1mA rectifier is 0.9 volt, for a meter current of 1mA. Hence, the series resistance R ohms required for V volts RMS full-scale deflection is

$$R = \frac{V - 0.9}{0.001} \times \frac{1.11}{1,000V - 900} \text{ ohms.}$$

Therefore, R for 10 volts full scale deflection = 8,250 ohms,

R for 100 volts full scale deflection = 90,000 ohms,

R for 500 volts full scale deflection = 450,000 ohms,

R for 1,000 volts full scale deflection = 900,000 ohms.

The 0-10 volt range should be **EUREKA WIRE**

SWG	Ohms per Yard	Current Rating*
16	0.21	6.0
18	0.37	4.3
20	0.66	3.0
22	1.09	2.2
24	1.77	1.5
26	2.65	1.00
28	3.91	0.76
30	5.58	0.59
32	7.35	0.47
34	10.1	0.37
36	14.8	0.28
38	23.8	0.19
40	37.2	0.15
42	53.6	0.13

\* Amperes for 100° C. temperature rise, wire coiled in air with free radiation.

calibrated against an accurate meter, as the scale is non-linear due to the measured voltage being comparable with 0.9 volt, the p.d. across the rectifier. From the maker's data, the output of the rectifier is uniform for frequencies up to 100 kc/s.

**AC Current Meter.**—A current transformer is used in conjunction with the meter rectifier (Fig. 2 (e)). The ranges covered are 0-10 mA, 0-100 mA and 0-1 amp.

As a current of 1.11 mA is required from the secondary to give full scale deflection on the meter, the turns ratios, not allowing for losses, are as follows:—

- 1 amp. range, ratio = 1,000/1.11 : 1 = 900 : 1,
- 100 mA range, ratio = 100/1.11 : 1 = 90 : 1,
- 10 mA range, ratio = 10/1.11 : 1 = 9 : 1.

For linear scale-shape, the voltage drop in the secondary winding should not be more than 0.1 volt. Hence the maximum permissible resistance of the secondary is 0.1/1.11 × 10<sup>-3</sup> = 90 ohms. To keep the secondary turns as low as possible a single turn primary winding is used on the 1-amp. range; thus the secondary turns are 900. To keep losses low the stampings must be made of a high-permeability material, such as Mumetal; a set of Mumeta stampings was available with the following dimensions:—

- Core, 3/4 in. square,
- Overall size of stamping, 1 7/8 in. × 2 1/4 in.,
- Winding area, 1 in. long by 0.3 in. deep,
- Weight of set of stampings, 3/4 lb.

It was found that, to allow for iron loss, the secondary turns should be reduced to 880; 38 SWG ESS (enamelled and single silk) copper is used for the secondary, giving a resistance of 70 ohms. The primary windings are:—

- 10 mA range, 100 turns 38 SWG Enam or ESS,

- 100 mA range, 10 turns 28 SWG Enam or ESS,
- 1-amp. range, 1 turn 20 SWG Enam.

The secondary is wound on first and the other windings in the order shown above. There are two layers of Empire tape between the secondary and the primaries and one layer between each primary. The stampings are interleaved.

Fig. 4 shows the frequency characteristic of the transformer on the 10 mA range.

**Ohmmeter.**—There are two ranges, covering resistance values from 10 ohms to 1 megohm. The fundamental circuit is shown in Fig. 2 (f).

If the meter, of which the resistance and full scale deflection are r ohms and i mA respectively, is connected in series with a resistance of value R ohms across a voltage V, then, for full scale deflection (with "Test" terminals shorted)

$$R + r = 1,000V/i \dots (1)$$

If now a resistance R' ohms is connected across "Test," then its value for half scale deflection of the meter is given by

$$R' + R + r = 1,000V/0.5i \dots (2)$$

From equations (1) and (2), R = R' - r and V = iR' × 10<sup>-3</sup>.

In this instrument, r = 118 ohms, i = 1 mA and the mid-scale readings are 500 ohms and 50,000 ohms; hence the values of R are 382 and 49,900 ohms respectively; the corresponding values of V are 10.5 and 50 volts. These voltages

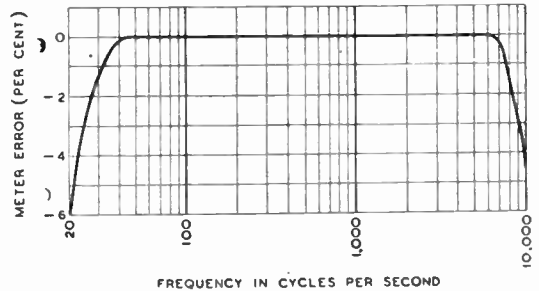

Fig. 4. Frequency characteristic of AC current meter.

are supplied from a mains-operated power pack by means of a voltage divider network, the tappings being variable over a small range to provide zero-ohms adjustment. The internal resistance of the supply should be small compared with (R + r);



in this case, the internal resistances are 15 and 700 ohms respectively.

**Valve Voltmeter.**—A high-frequency diode rectifier of small dimensions (Mazda D1\*) is housed with its associated smoothing components in a cylindrical container; this is connected to the main instrument through about a yard of 3-core cable. A 5-pin Belling-Lee plug and socket are used for the connection on the front panel, but it would be

of the control valve, the value of which depends on the setting of the range switch. This would necessitate resetting the zero when the range is changed. This is automatically compensated for by shunting the lower end of the power pack voltage-divider by  $R_3$  on the 10v. AC and 50v. DC ranges, and  $R_4$  on the 1v. AC and 5v. DC ranges.

The DC ranges were originally the same as the AC (0-1, 0-10, 0-100 volts) but trouble was ex-

perienced when the valve voltmeter was connected across a low-resistance circuit, as this reduced the standing bias due to the diode, thus altering the zero setting. The simplest method of eliminating this effect is to use a

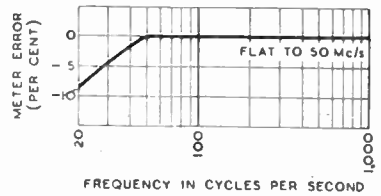

Fig. 5. Frequency characteristic of valve voltmeter.

divider with the diode load and therefore reduces sensitivity.  $R_2$  is chosen to give ranges to fit in with the calibrated scale, viz. 0-5, 0-50, 0-500 volts.

As the input resistance on the DC ranges is high, approximately 13 megohms, the shunting effect on a high resistance source of voltage is small.

In high-resistance circuits it is advisable to measure only voltages of which the positive side is earthy; if the negative side of the source is earthy, the leakage resistance and capacitance of the HT line to the chassis are shunted across the source, as the negative side must be connected to the "live" lead of the valve voltmeter.

The 10- and 100-volt AC, and 50- and 500-volt DC ranges are substantially linear, and no further calibration is required. For greatest accuracy on the 1-volt AC and the 5-volt DC ranges separate calibrations should be

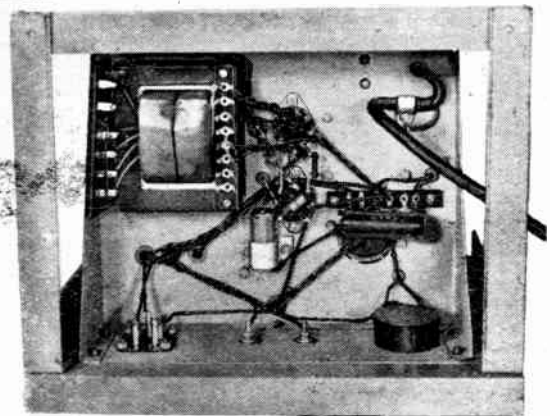
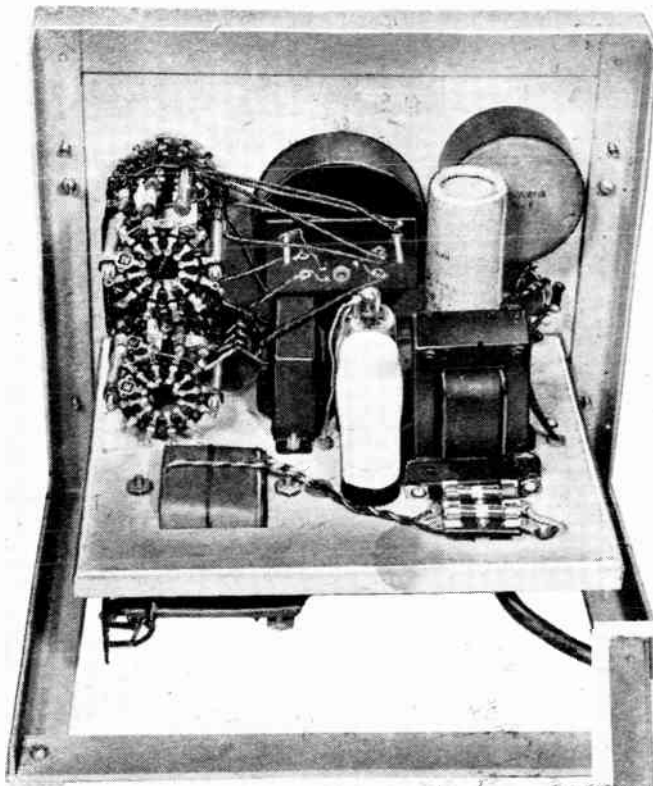

Back views with cover removed showing components above and below the horizontal sub-panel.

sufficient to run the cable through a bush.

The rectified voltage from the diode head is applied to a meter control valve, the supply voltages for which are taken from the power pack. A potential-divider circuit across the HT supply voltage is used to "back-off" the meter (Fig. 2 (g)). The range is changed by tapping-down the diode load resistance. The standing current through the diode produces a small voltage across this resistance; this voltage applies a negative bias to the grid

made; this is due to the non-linear characteristic of the diode. The frequency characteristic is flat between 50 c/s and 50 Mc/s (see Fig. 5). It was not measured above 50 Mc/s, but the error is

made; this is due to the non-linear characteristic of the diode.

The frequency characteristic is flat between 50 c/s and 50 Mc/s (see Fig. 5). It was not measured above 50 Mc/s, but the error is

\* A similar valve is the Mullard EA50, which has a 6.3-volt heater.

**Multi-purpose Test Meter—**

probably small up to at least 100 Mc/s.

The meter control valve is an SP41 (high-slope RF pentode) connected as a triode. Two other types were tried: the HL41 (medium-slope triode)—approximately 5 per cent. loss in sensitivity, which can be compensated for by reducing the meter series resistance  $R_1$  (Fig. 2 (g)); the P41 (high-slope triode)—sensitivity as the HL41, but in this case a 70 ohm resistance must be inserted at the point X in the voltage-divider circuit of Fig. 2 (g) to enable the zero to be set. Differences in sensitivity between individual specimens of these types were small, in all cases it was possible to allow for this by adjusting the meter series resistance  $R_1$  (Fig. 2g). The following valves would probably be suitable: 41MHL, AC2HL, 354V, MH4, HL4G, EF50 and Z62.

The following table gives some idea of the working conditions of the valves:

	SP41	HL41	P41
Anode current (mA)	4.2	5.0	12.2
Anode voltage ..	146	148	138
Cathode voltage ..	1.6	1.9	4.8

All measurements were made on the 0-1v. AC range, with the meter set to read zero.

If a voltage much larger than full scale is applied to the input, the current through the 1 mA meter does not exceed about

2 mA; most meters can withstand this overload without harm.

The input capacitance of the diode head is  $7.5 \mu\mu\text{F}$  with a short flexible lead and  $6.5 \mu\mu\text{F}$  with a rigid prod.

Adjustment of resistors is carried out as follows:—

(1) Meter series resistance  $R_1$  to give 1v. full scale deflection on most sensitive AC range.

(2) Input resistance  $R_2$  to give 5v. full scale deflection on most sensitive DC range.

(3) Compensating resistances  $R_3$  and  $R_4$  adjusted so that the zero-setting does not change on the 10v. and 1v. AC ranges respectively when switching from the 100v. range.

**Power Pack.**—The power requirements are 4v. 1.4A for the rectifier heater (UU6), 4v. 1.5A for the SP41 and D1 heaters and 150 volts 50 mA DC for the valve voltmeter and ohmmeter sections.

A standard type of mains transformer was available, with two 4-volt windings and an HT winding of 350-0-350 volts. It is necessary to reduce the rectified HT voltage by means of a series resistor. A more suitable HT secondary voltage would be 250-0-250, which, with a choke input filter, would give the required voltage without the series resistance. The choke must be capable of withstanding a high AC voltage across its terminals. A 150-0-150 volt winding with a condenser input filter would be equally suitable.

**Switching.**—The complete circuit is shown in Fig. 2. It will be seen that there are two switch-wafer banks, A and B, A consisting of four single-pole, 12-way units and B of one two-pole 6-way and four single-pole 12-way units.  $A_1$  and  $B_1$  are mounted nearest the front panel.  $A_3, A_4, B_4, B_5$  switch the various ranges,  $A_1, A_2, B_2, B_3$  ensure that the HT supply voltage to the valve voltmeter and ohmmeter is switched on only in certain positions, and  $B_1$  selects the valve voltmeter ranges and switches the valve voltmeter set zero compensating circuit.

**Constructional Notes.**—The chassis is fixed to a vertical frame-mounted front panel. The front panel is 9in. by 12in. and the chassis 8in. by 10in. A detachable cover is held by two screws on the vertical frame members; examination of the photographs will make clear the layout details.

The diode head consists of two discs of insulating material of diameter  $1\frac{1}{8}$ in. held together by two  $\frac{3}{8}$ in. brass pillars, 3in. long. A length of paxolin tube slides over this assembly, and is fixed by screws into the insulating discs. One of the discs has two wander-plug sockets, one for AC, the other for DC; either a flexible lead or a rigid prod can be plugged into these sockets, according to the type of work in hand. The earth connection is a permanent short flexible lead terminating in a crocodile clip, which can conveniently be attached to the nearest part of the chassis.

The  $0.05 \mu\text{F}$  diode input coupling condenser should have a high resistance and a low inductance; the tubular type with wire ends fits best into the small space available. It should be remembered that the working voltage of the condenser must be high enough to withstand the DC component when measuring an RF voltage at the anode of a valve. The condenser leads are as short as possible, and thus it is connected directly between the AC input socket and the diode anode clip.

In conclusion, we wish to express our thanks to Mr. E. A. Goldring, for the photographic illustrations, and to Murphy Radio, Ltd., for permission to describe this apparatus.

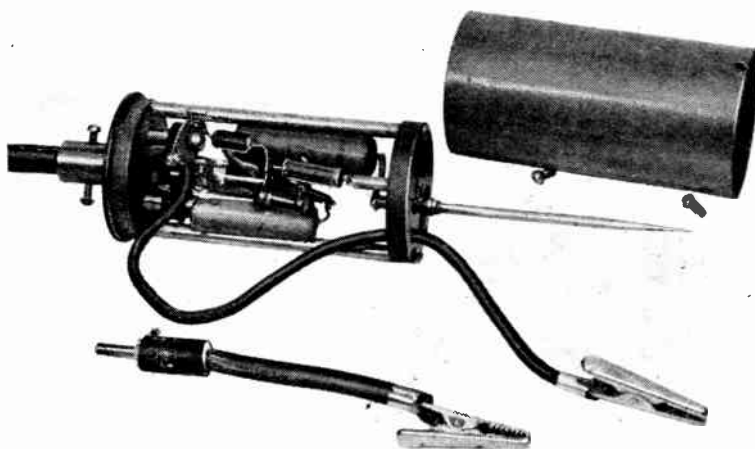

Valve voltmeter head with cover removed.

# WIRELESS BADGES

## Radio Insignia in the Forces

Among the many wireless badges worn by members of the British and American Forces, there are some not quite so well known as the easily recognisable R.A.F. "Sparks" or "Hand and Lightning" badge; moreover, on enquiry at the War Office, it was learned that a number of the emblems seen in some of the shops "supplying everything for the sailor, soldier and airman" are unauthorised and should not be worn by members of the Forces. It is, therefore, with the intention of facilitating the recognition of wireless personnel and of giving some facts about the duties of the wearers of wireless badges that these notes have been prepared.

### ROYAL NAVY

**I**N the Senior Service there are a number of different categories of Wireless Telegraphist. The badge for each of these is based on the same design, with additional stars or a crown to in-

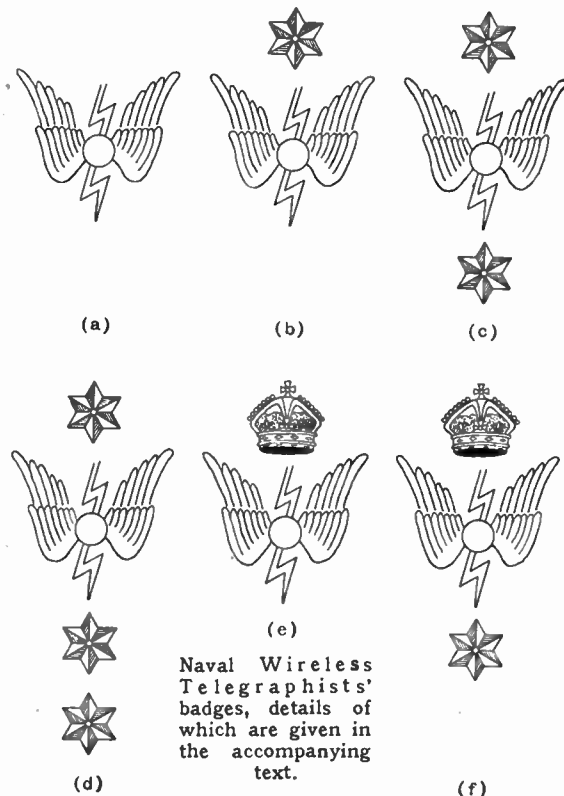

Naval Wireless Telegraphists' badges, details of which are given in the accompanying text.

dicating the wearer's non-substantive rating. Embroidered in red on a navy blue background for working dress but in gold for No. 1 dress, the badges, with the exception of that for Chief Petty Officer Wireless Telegraphist, are worn on the right arm.

Boy Telegraphists, Ordinary

Telegraphists and Telegraphists (not trained operators) wear badge (a) in the accompanying illustration. These are the junior ratings in the W/T Branch of the Royal Navy.

Trained Operators (W/T) wear badge (b) and are, as the rating infers, telegraphists who are trained to operate the W/T gear in general use on H.M. Ships.

Wireless Telegraphists 3rd Class wear badge (c), and have a higher standard of technical training. They have to be well versed in the complexities of Naval wireless procedure and may be the senior W/T rating in small ships.

Badge (d) is worn by Wireless Telegraphists 2nd Class (ratings below Petty Officer) who are in many cases the senior W/T ratings in destroyers, etc.

Wireless Telegraphists 2nd Class (Chief Petty Officer and Petty

Officer Telegraphists) wear badge (e) and are usually the senior W/T ratings in large destroyers (Tribal Class), cruisers, etc.

There are comparatively few Wireless Telegraphists 1st Class (f). They are Chief Petty Officer Telegraphists, Petty Officer Telegraphists and Leading Telegraph-

ists of not less than four years' seniority. First Class C.P.O. Tels. and P.O. Tels. usually serve in Flag Ships and Capital Ships. In the case of C.P.O.s the badge is worn on the lapels of their jackets.

### NAVAL AIR ARM

**T**HE maintenance of Naval airborne radio equipment is the duty of the wireless ratings in the Naval Air Arm.

Radio Mechanics in the Naval Air Arm, who wear a peaked cap with red badge, and jacket with the distinguishing badge on the right sleeve, serve in aircraft carriers and in Naval Air Stations at home or abroad. A Radio Mechanic in the Naval Air Arm may be attached either to a squadron, for the maintenance of the squadron's equipment, or to a carrier or station for general radio maintenance duties.

On satisfactorily completing their technical and Service training, ratings in this branch are advanced to Leading Radio Mechanic and subsequently are eligible, if proficient, for advancement to the rating of Acting Petty Officer, Petty Officer and Chief Petty Officer.

The actual operation of Naval



Naval Air Arm Radio Mechanic's badge.



**Wireless Badges—**

airborne radio equipment is normally carried out by the Observer or by the Telegraphist Air Gunner of the aircrew except in single-seater fighters, where, of course, the pilot operates his own equipment. Nearly all Observers are now officers who, in common with all Naval Air Arm officers, are distinguished by the letter "A" worn in the curl of the officer's gold lace on each cuff, while on the left sleeve is worn the Observer's badge. The Tele-



Badge worn above the gold "distinction" lace by Observer officers of the Naval Air Arm.

graphist Air Gunner wears the seaman's class of uniform and has on his right arm the distinguishing badge illustrated below.

As in all branches of the Navy, Leading ratings wear a single "foul anchor" and Petty Officer ratings crossed "foul anchors" surmounted by a crown on the left sleeve. Chief Petty Officers do not normally

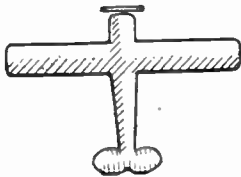

Telegraphist Air Gunner's badge.

wear sleeve badges but have on each lapel the badge of their branch and three gilt buttons on the cuff of each sleeve.

**W.R.N.S.**

**I**N the women's branch of the Senior Service there are two radio categories, viz., Wireless Telegraphists and Radio Mechanics. Both these categories wear the same design of badge on

**Wireless World**

the right arm; it is identical for Petty Officers, Leading Wrens and Wrens. In the case of Chief Wrens a smaller badge with a crown above the wings is worn on each side of the collar of the jacket.



Badge at present worn by Chief Wren Wireless Telegraphists on the collar of their jackets. The design is light blue with red inset in the crown.

Wren Wireless Telegraphists operate, and to some extent maintain, communication apparatus at Naval shore stations in this country and oversea.

Radio Mechanics, a compara-



Petty Officers, Leading Wrens and Wren Wireless Telegraphists and Radio Mechanics wear this light blue embroidered sleeve badge.

tively new W.R.N.S. category, maintain and repair radio apparatus.

**ROYAL SIGNALS**

**N**O distinctive badge is worn by wireless personnel in the Royal Corps of Signals. It is, however, the "wireless corps," and it is, therefore, appropriate that the badge of the corps is reproduced in this collection of wireless emblems.

The well-known figure of Mercury—the messenger of the gods—standing on a globe is a fitting symbol for the Corps, the motto of which is "Certa Cito" (Sure and Swift). Formed in 1920, the

Corps' task is to maintain the Army's lines of communication, which include wireless, through-



The badge of Royal Signals.

out the widely dispersed fields of operation.

The distinguishing flash of the Corps is blue and white.

**R.E.M.E.**

**T**HE formation of the Corps of Royal Electrical and Mechanical Engineers a year ago has brought together in one corps the wireless personnel that were previously in various units of the Army (with the exception of Royal Signals personnel).

There are two badges worn by R.E.M.E. personnel who are responsible for the maintenance of telecommunications apparatus, which includes radar, wireless and line equipment.

Armament Artificers (Radio) and Radio Mechanics, who repair



R.E.M.E. badge.

and maintain radar apparatus, wear a red embroidered wireless flash on a navy blue background.

Armament Artificers (Wireless) and Wireless Mechanics, who are responsible for the maintenance and repair of wireless and line communication apparatus, wear a badge of similar design to that worn by Radio Mechanics, but embroidered in white.

Both badges are worn on the right arm; in the case of Warrant Officers on the forearm below the rank badge, by N.C.O.s above the rank chevrons and by other ranks on the upper arm below the formation sign, etc.

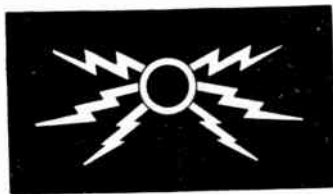

The design of the two R.E.M.E. wireless badges.

A.T.S.

MANY members of the Women's Auxiliary Territorial Service (A.T.S.) will be seen wearing the badge of Royal Signals above the left breast pocket of their tunics. These Auxiliaries are attached to the Corps, and may be carrying out the same duties as the men Operators, Wireless and Line. This means that they must have a certain amount of technical knowledge and be qualified morse operators. They are known colloquially as "OWLS."

Members of the A.T.S. attached to R.E.M.E., who have passed the requisite trade tests for Radio Mechanic or Wireless Mechanic wear the same badge as men of the same category.

R.A.F. AND W.A.A.F.

THE well-known "Hand and Lightning" badge is the only trade arm badge worn in the



R.A.F. "Spark's" badge. A light blue design on a background of Air Force blue.

Royal Air Force and Women's Auxiliary Air Force, and is common to all signal trades. Air

Radio Observer's brevet. The wing and letters are in silver and the laurel in brown.



crews and ground staff concerned with the operation and maintenance of radar and communication apparatus wear this distinctive badge on the right upper arm. Wireless Operators in air crews are usually Air Gunners, and, therefore, wear the A.G. brevet over the left breast pocket.

A badge less frequently seen worn by members of the R.A.F. is the Radio Observer's brevet. This is worn above the left breast pocket by commissioned and non-commissioned officers of air crews who handle the UHF gear. Although the R.O. brevet has been superseded by the navigator's "N" brevet, men who qualified for it in the past are still permitted to wear it.

MERCHANT NAVY

THERE are three classes of Radio Officer in the Merchant Navy and they are distinguished



Merchant Navy Radio Officers' Distinction Lace. (a) First Radio Officers, (b) Second, and (c) Third.

by waved lines of gold braid worn on the cuffs of their jackets. The standard Merchant Navy cap badge is worn by Radio Officers.

First Radio Officers wear two lines of 1/4 in. gold braid with a diamond between them. In the case of Second Radio Officers the diamond is omitted, whilst Third

Radio Officers wear one band only.

AIRWAYS

ALTHOUGH not in the Forces, it is perhaps permissible to include in this survey of wireless heraldry the insignia worn by Radio Officers in the employ of British Overseas Airways. They wear the cap badge of the Corporation and a wing over the left breast pocket, as do all the members of air crews. Their rank is distinguished by waved bands of



(a) First, (b) Second, (c) Third Radio Officers of British Overseas Airways.

Waved lines of gold braid worn by First (a), Second (b) and Third (c) Radio Officers of British Overseas Airways.

gold braid worn on the cuffs of their blue jackets.

First Radio Officers wear three lines of braid, Second Officers—two, and Third Officers—one.

U.S. NAVY

THERE is one design of badge for the three radio categories in the Artificer Branch of the United States Navy.

Radiomen operate standard naval transmitting and receiving equipment, maintain and care for radio batteries and adjust and repair DF apparatus and sound equipment. Enciphering and de-

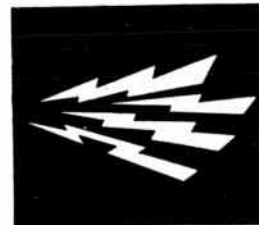

Radiomen, Radio Technicians and Telegraphers in the U.S. Navy wear this badge.

ciphering is also undertaken by Radiomen.

The general maintenance of

**Wireless Badges—**

radio equipment in the U.S. Navy is the duty of another category, that of Radio Technician.

A category authorised only in time of war is that of Telegrapher. Men of this grade are telegraph

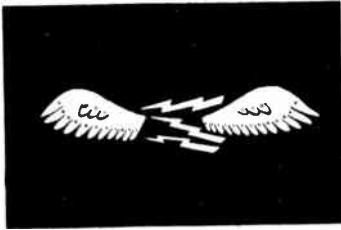

Radiomen in the Aviation Branch of the U.S. Navy are identified by this badge.

operators at Naval cable stations.

There is one radio category in the Aviation Branch, which is equivalent to the British Naval Air Arm. Designated Aviation Radiomen, their qualifications are very similar to their counterparts in the Artificer Branch. Their duties are, however, mainly associated with aircraft radio equipment.

In each of the above specialist grades there are four ratings: 3rd Class, 2nd Class, 1st Class and Chief. The radio badge is worn by each grade between the American eagle and chevrons on the left sleeve. The number of chevrons indicates the rating; one being worn by 3rd Class, two by 2nd Class, and three by 1st Class and Chief ratings. In the case of the latter a fourth semi-circular braid surmounts the chevrons.

**U.S. SIGNAL CORPS**

LIKE our own Royal Signals, the United States Signal Corps is responsible for the Army's communication systems and, in addition, for ground com-

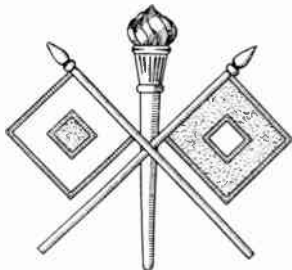

U.S. Signal Corps badge. The flags are enamelled red (shown stippled) and white for officers.

**Wireless World**

munications of the U.S. Army Air Force. Many members of the Corps are now in this country and can be recognised by the Corps' distinguishing badge of crossed signalling flags. The badge is gilt and is worn on the lapels of their jackets.

**U.S. ARMY AIR FORCE**

RADIO operators in U.S. Air Force Crews do not wear a distinctive badge. The metal wings they wear above the left breast tunic pocket are the same as those worn by all N.C.O. combat crew men.

Of the ten members of a Fortress crew four normally hold commissions—pilot, co-pilot, navigator and bombardier—whilst the remainder, including the radio operator, are sergeants.

It is perhaps noteworthy that men of the U.S. Air Force crews who are currently engaged in operations wear a patch of blue cloth behind the metal wings.



Communications Technician's badge.

A badge that is not very common but might be seen in theatres of operation in which there are units of the U.S. Army Air Force, is that shown above. Civilian communications technicians attached to the Air Force wear this gold emblem symbolising radio on a blue triangular base on the sleeve of their service uniforms. The wearer is a specialist who, because of physical disability, age, or the importance of his civil occupation, cannot be called to the colours and is, therefore, temporarily attached to the Air Force.

**SERVICE-MEN'S EXAM.**

IN last month's *Wireless World* a draft syllabus of the examination to be conducted by the Radio Trades Examination Board was published. Since then, the Board has made slight modifications and

added a few extra subjects; the final syllabus is printed below.

The first examination will be held on Saturday, May 20th, 1944, and thereafter in May of each year. It will be conducted in principal technical schools throughout Great Britain, and will comprise a three-hour written paper and a three-hour practical test.

Candidates must have been fully engaged in wireless service work for not less than three years, but a full-time course in servicing or radio engineering at a recognised technical school will count as one year towards the required period. The examination fee is two guineas.

The Secretary of the Board (address: 9, Bedford Square, London, W.C.1) will be pleased to give any further information required.

**Part 1.—Fundamental Principles of Radio.**—(1) Current/voltage relationships in AC and DC circuits. (2) Primary and secondary cells. (3) Theory of magnetism; magnetic screening. (4) Laws of induction; mutual and self-inductance. (5) Electrostatics; electrostatic screening. (6) Resonance; series and parallel resonant circuits. (7) Modulation, methods of. (8) Thermionic valves. (9) Rectifiers; rectification and detection. (10) Electro-magnetic waves; simple wave theory. (11) Aerials and transmission lines. (12) Amplifiers and oscillators. (13) Receiver circuit practice. (14) Reproducers and pick-ups.

**Part 2.—Practical Applications.**—(1) Principles and uses of test meters; resistors; rating and coding. (2) Primary and secondary cells; tests; charging; battery charging plants. (3) Permanent and electro-magnets, and their uses. (4) Transformers; RF, IF, AF and mains. (5) Condensers, fixed and variable. (6) Tuned circuits and alignment. (7) Diode, triode, tetrode, pentode and frequency-changing valves; gas-filled types. (8) Copper-oxide and selenium rectifiers; methods of rectification; simple filters. (9) Receiver power supplies; battery, mains, AC/DC, rotary and vibratory converters. (10) Wave propagation; interference and its suppression. (11) Aerial and earth installation; coupling devices. (12) RF, IF, and AF amplifier circuits; degeneration and regeneration; negative feed-back; oscillators; distortion and instability. (13) Sound amplification and relay practice; methods of mixing; reflexed circuits. (14) Receivers; TRF, super-sonic heterodyne and super-regenerative. (15) Automatic gain control; tuning indicators; automatic frequency control; automatic tuning devices. (16) Tone control and correction circuits; noise suppression circuits. (17) Loudspeakers, microphones and gramophone pick-ups; methods of matching. (18) Practical safety precautions.

**Part 3.—Practical Examination.**—(1) Soldering technique. (2) Use and maintenance of test equipment and tools. (3) Valve testing (HT, LT and GB batteries supplied). (4) Correction of typical receiver faults, which may include realignment (circuit diagrams, chassis layouts and oscillators supplied). (5) Testing components. (6) Loudspeaker and pick-up adjustment



Long-distance

# SHORT-WAVE TRANSMISSION

## Simplified Explanation of the Behaviour of Obliquely Incident Waves

By T. W. BENNINGTON

IN a previous article<sup>1</sup> the behaviour of radio waves in the ionosphere was discussed in as simple language as possible, in the hope that such treatment of the subject would render some of its points understandable to the non-mathematical reader. The article confined itself almost exclusively to the behaviour of a wave when sent vertically upwards. Dr. Martin Johnson, in his July article<sup>2</sup> dealt with some of the more complicated phenomena in greater detail, while in a previous article<sup>3</sup> he had something to say on the subjects of "refraction" and "total reflection" of radio waves.

A wave or "ray" of radio energy which is sent vertically upwards will, if it is of such a frequency as to be reflected from the ionosphere, return to earth at a point immediately beneath that where it is reflected. Rays which are intended to return to earth at points far distant from the transmitter must go upwards obliquely, so as to enter the ionosphere at a smaller angle to its lower boundary than did the vertical ray. It is the purpose of this article to explain—so far as is possible in the same simple language as was used in the former article—how the behaviour of the wave in the ionosphere is modified by the obliquity of its upward path.

Let us, first of all, recall one or two points appertaining to the behaviour of the vertically travelling ray. We remember that it travels through the ordinary air towards the ionosphere with a velocity of 300,000,000 metres per second, but, on entering the region where the air is "ionised," its

wave velocity increases. But because the ionosphere is what Dr. Martin Johnson calls a "dispersive" medium, i.e. because its effects upon the wave vary with the wave frequency, the signal as a whole travels *slower* in the ionosphere than in ordinary air—its "group velocity" is less. Eventually it comes to a complete stop, is "reflected" and then sent travelling downwards again. As we increase the frequency of the wave the effect of the ionosphere upon it gets less and less, so that it penetrates further and further into the region before undergoing "reflection." Continuing to increase the frequency eventually results in the wave penetrating the ionosphere altogether, and the frequency just below that at which the penetration of any ionosphere

much for the vertical ray. Let us now digress for a moment and consider some points from what—so far as the obliquely travelling radio ray is concerned—is a closely analogous case, i.e. the behaviour of a ray of light when it passes from a dense into a less dense medium. Those who have done any school "physics" may recognise the diagram of Fig. 1; it illustrates what happens to the light ray under these conditions. So long as it is moving through a uniform medium, light travels in a straight line, but as soon as it enters a medium of different optical density it is deflected from the straight path and continues on in a new direction; the phenomenon is known as "refraction."

In Fig. 1 the shaded area represents the dense medium and the unshaded area that which is less dense, while AB is the surface of separation between the two. A line drawn at right angles to this surface—as at CD—is called the "normal" to this surface or boundary. IO is the light ray approaching the surface obliquely so as to reach O—the point of "incidence"—at an angle to the normal. The angle which it makes with the normal at the point of incidence is called the "angle of incidence." Instead of continuing its course in a straight line in the new medium—as shown by the dotted line—the ray is refracted or bent, so as to travel along the line OQ, and it is because the new medium is less dense than the other that the

direction of the bending is *away* from the normal. The angle made with the normal in the new medium is called the "angle of refraction." The *amount* of bending to which the ray is subject will depend on the relation between the densities of the two

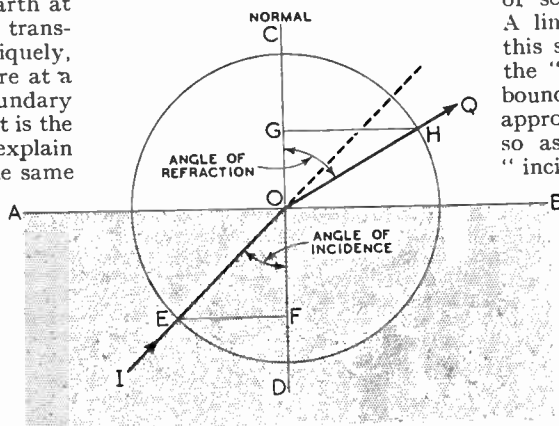

Fig. 1. What happens to a light ray passing from one medium to another.

layer occurs is called the "critical" frequency of that layer. This critical frequency, then, is the highest frequency which is returned by the ionosphere for a wave sent vertically upwards.

**Refraction of a light ray.**—So

<sup>1</sup> "Radio Waves in the Ionosphere," *Wireless World*, April, 1943.

<sup>2</sup> "Waves in Metals and the Ionosphere," *Wireless World*, July, 1943.

<sup>3</sup> "Waves in Dielectric Materials," *Wireless World*, June, 1943.

**Short-wave Transmission—**

media, and, if we compare the angle of refraction with the angle of incidence, we shall obviously obtain some information on this point. Suppose we describe a circle about the point of incidence and then drop perpendiculars to the normal from the points where it cuts the incident and refracted rays—as at EF and GH in Fig. 1—then the ratio of EF to GH is a measure of the bending to which the ray has been subject, and hence of the relative densities of the two media. This ratio is called the "refractive index," and a little thought will show that, if we consider this ratio as the

Fig. 2. How "total reflection" is obtained by increasing the angle of incidence of the ray.

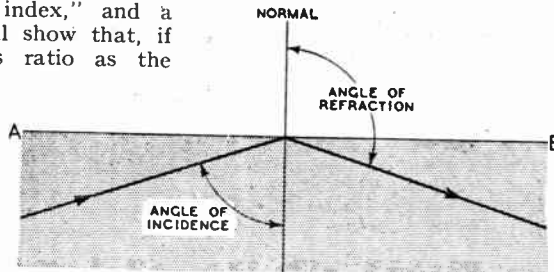

refractive index of the less dense medium, then it will always be less than unity. The relation between the angle of incidence and the angle of refraction is such that the sine of the angle of incidence is equal to the sine of the angle of refraction multiplied by the refractive index.

If we increase the angle of incidence—by making the ray path more oblique—then the angle of refraction will increase also, and if this process is continued we eventually get an angle of refraction of  $90^\circ$ , when the path of the refracted ray is exactly along the surface of separation. A further increase in the angle of incidence leads to the result shown in Fig. 2. The angle of incidence has been so increased that the angle of refraction is *greater* than  $90^\circ$ —the light ray cannot penetrate into the new medium at all, but is "totally reflected" at its surface. This will occur when the sine of the angle of incidence is equal to the refractive index of the new medium—the sine of an angle of refraction of  $90^\circ$  being, of course, 1.0.

**Rays of Radio Energy.**—Now we can return to our ray of radio energy, which is approaching an ionosphere layer where it will undergo refraction in a somewhat similar manner to that in which

the light ray was deflected from its course.

It will be clear that there is, for a given height at which the ionosphere refracting layer may lie, a different angle at which the radio wave must enter the layer for every distance outwards from the transmitter. For a given layer height the greater the distance the greater will be this angle of incidence at the layer be. Also for a given distance, the lower the layer the greater will the angle be.

We have been talking about a "ray" of radio energy as though there were only one such ray to be considered. But we must always remember that in practical cases, even with an aerial system which narrows the radiated energy into a "beam" in the vertical plane, there will really be a whole "pencil" of such rays going up side by side, and making a number of different angles of incidence at the layer boundary.

Now such obliquely incident rays can be returned from the ionosphere with a far lower ionisation in the layer than is necessary to return a vertically incident ray. Or—another way of looking at it—with a given ionisation density in the layer the greater the angle of incidence the higher the frequency which will be refracted. The highest frequency which will be refracted so as to come down at any particular distance thus depends on the critical frequency at vertical incidence and the angle of incidence appropriate to that distance. It is called the "maximum usable frequency" (MUF) for that distance.

The full theory concerning obliquely incident rays and relating the critical frequency at vertical incidence to the MUF at oblique incidence is very complicated, and we cannot go into it in any detail in this article. But we

can, perhaps, briefly consider its main implications.

**Refraction of the Radio Ray.**

—Let us start off by supposing that both the earth and the ionosphere are flat. The ionosphere behaves to the radio ray entering it from ordinary air like the rare medium behaves to the light ray entering it from the dense medium. The wave path is bent away from the normal to the lower boundary of the ionosphere layer, so that the wave path makes a smaller angle with the lower boundary than it would have done had it not been refracted at the point of incidence.

The refracting properties of the layer upon the radio wave are due to the presence of the free electrons within it, and the electron concentration is not constant throughout the medium. Fig. 3 gives an idea as to how the electron concentration is assumed to vary with height in one of the ionosphere layers, and it will be seen that, looked at from the ground, it increases with height within the layer up to the point of maximum concentration, i.e. at the centre of the layer. So that

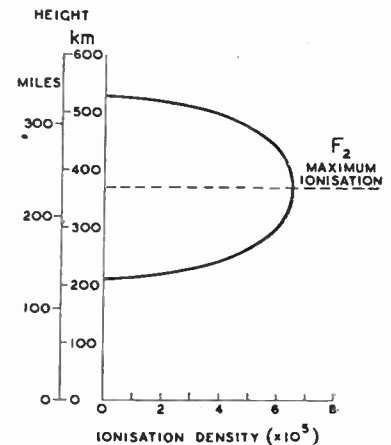

Fig. 3. How electron density varies with height in an ionosphere layer.

the refracting properties of the layer upon the radio wave constantly increase as the wave penetrates further into the layer.

Still imagining that the ionosphere is flat, let us try and sort things out so that the effect of this increasing free electron density upon the wave becomes clearer.

Suppose that, instead of increasing constantly with height, the electron density within the layer were itself in a series of thin "layers," as shown in Fig. 4, each thin "layer" having a constant electron density which was greater than that of the "layer" next

below it. Then we should get the effect shown in the figure—an effect similar to that shown by the light ray we have just been discussing. The radio ray would be refracted away from the normal each time it came to the boundary of one of the thin layers, and it is easily seen that its path would become more and more oblique until eventually the angle of refraction would exceed 90° and the ray would then start travelling downwards again. This occurs at the point X in Fig. 4.

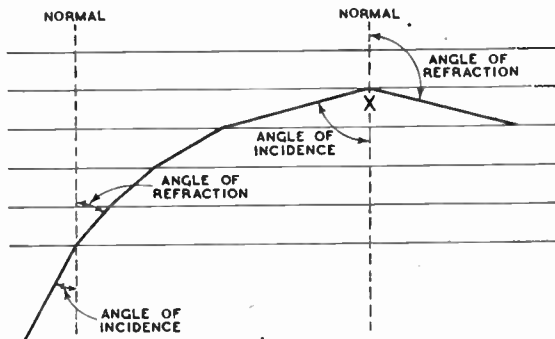

Fig. 4. Refraction of a wave by layers of increasing electron density.

With the continuously increasing electron density that does in fact exist it means that the wave path is gradually bent round so that it travels in a wide sweep and thus eventually arrives at the lower surface of the ionosphere layer again, whence it continues in a straight line towards the ground. Perhaps a good way to picture the effect is to imagine that the top part of the wave as being further into the ionosphere than the bottom part, as is pictured in Fig. 5.

Then, because it is in a region where the free electrons are denser, it travels with a greater velocity than does the bottom part of the wave. If the top of the wave travels faster than the bottom the wave direction cannot be in a straight line, but will bend away from the regions of high electron density to those where it is low, and the ray is therefore bent away from the normal to the lower boundary.

In order to understand the relation between the critical fre-

quency at vertical incidence and the M.U.F. at oblique incidence it is best to look upon the ionosphere as having a refractive index which gets smaller as the electron density gets greater. The relation between the wave's angle of incidence and its angle of re-

fraction is the same as in the case of the light ray entering the rare medium; namely, that the sine of the angle of incidence is equal to the sine of the angle of refraction multiplied by the refractive index. So when the wave is at the top of its trajectory and the angle of refraction is thus 90 deg.—whose sine is 1.0—the angle of incidence is equal to the refractive index. The wave will therefore penetrate into the layer until the refractive index is reduced to a value equal to the sine of the angle of incidence, and will thereafter be travelling downwards again. This means that it must penetrate furthest into the layer when the angle of incidence is 0 deg. (vertical incidence) and least when it is 90 deg.

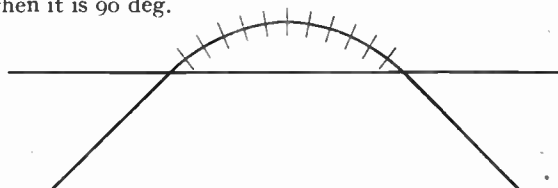

Fig. 5. Bending of the wave path within a refracting layer.

Thus with a given refractive index (given electron density) the wave will penetrate less and less far as the angle of incidence is increased, or, if it is allowed in each case to penetrate to the point of maximum electron density, then higher and higher frequencies can be used as the angle of incidence is increased. The MUF for any distance is this related to the critical frequency and to the angle of incidence occasioned by that distance and the height at which

the refracting layer lies. The MUF for a flat ionosphere is in fact equal to the critical frequency multiplied by the secant of the angle of incidence (the secant is 1.0 at 0 deg. and infinity at 90 deg.).

**Effect of Ionosphere Curvature.**

—The curvature of the ionosphere is responsible for some modification to this law. Because of the curvature the angle between the wave path and the thin "layers" of electron density which we used in our illustration would alter with increasing height. The result of this is that the wave path is completely turned round in a region where the refractive index is higher (the electron density is lower) than would be the case if the ionosphere were flat. There are other results of the curvature which we need not go into here, but, summing up its effect, it may be said: (a) That it results in higher frequencies being returned for any angle of incidence than would be the case if the ionosphere were flat; (b) the modification to the flat ionosphere case which it introduces is least when there is a thin, sharp reflecting layer of ionosition and greatest when the ionosphere gradient is low; i.e. when the electron density increases only slowly with height.

— In the curved ionosphere, then, the highest frequency returned (MUF) for a given maximum density of electrons in the layer will increase as the angle of inci-

dence is increased. This means firstly, that for a given set of ionosphere conditions of height and critical frequency the greater the distance the higher will be the MUF, and, secondly, because for a given distance the lower the layer the greater the angle of incidence, the lower the layer the higher the MUF for a given distance will be.

If, then, we know the critical frequency and virtual height of the layers—or have available



**Short-wave Transmission—**

predictions of what their values will be we can calculate the MUF appropriate to any distance by multiplying the critical frequency by a factor which has been worked out on the basis of the theory just mentioned. We can then work on this MUF or on any frequency below it, though we should endeavour to work as near to it as possible, because otherwise our wave will be heavily "absorbed" in the ionosphere. We must not work on a *higher* frequency than the MUF, for if we do the rays of energy, which we want to come down at the distance we are aiming at, will penetrate the layer and the location will fall within the skip distance (see Fig. 6).

**Finding the MUF.**—As has been said, the accurate calculation of the MUF is complicated, because of the complexity of the theory, but if we multiply the critical frequency by an MUF factor which is typical of the time of day and season of year this will be accurate enough for most purposes—it will at least enable us to estimate our working frequency with *some* degree of precision. This MUF factor will obviously be greater for the E layer than for the F, because of the greater height at which the latter lies. Also, for the F layer, it will vary considerably with time of day and season of year because the height at which the F lies varies diurnally and seasonally.

Table I is a set of typical MUF factors which was published some time ago by the National Bureau of Standards of Washington (with a few additional values inserted) and gives these for various distances, times of day and seasons, and for communication *via* differ-

ent layers. A little intelligent interpolation will yield values suitable for intermediate distances and for other seasons and times of day.

If, therefore, we have available

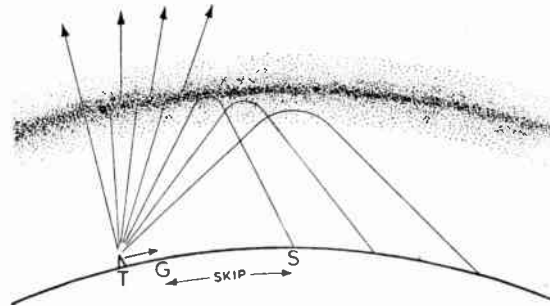

Fig. 6. The phenomenon of skip distance. T-G, range of ground wave; G-S, skip zone.

critical frequency data for each hour of the day, and we wish to find the MUF for any particular distance outwards from the transmitter, it is merely necessary to read off the critical frequency for the appropriate time *at the centre of the transmission path* and multiply it by the appropriate factor from the Table. Then we should work on the highest frequency available to us which is below the MUF, changing frequency to the next lower band when our frequency tends to exceed the MUF.

**Effect of the E layer.**—The maximum distance over which it is possible to transmit with a single hop is, on the average, about 2200 miles by the F or F2 layers and about 1250 miles by the E. Beyond 2200 miles the transmission will be by multiple hops and then the situation is somewhat more complicated, it being necessary to examine the whole transmission path, in order to find the lowest MUF which exists at any point over the path.

Transmission on short waves is

usually by way of the F or F2 layers, though we should always bear in mind the fact that if during the day we use a frequency far below the F2 MUF appropriate to the distance over which we

are transmitting, the wave may be refracted at the E, and not reach the F at all. During summer day, however, the E layer ionisation does reach a high enough value for the layer to "blot out" the F2 entirely for transmission at certain angles, during which time the E is the *controlling* layer for short-wave transmission. What this means is that, at the elevation angles for which it occurs, the E layer critical frequency and the angle of incidence the ray makes at the E *determine the MUF*, and any frequency which is high enough to penetrate the E at this elevation angle will also penetrate the F. It will not occur for the shortest distances because in this case the angle of incidence at the E is small and there is thus more tendency for a wave to penetrate the layer. Then at a certain angle it will occur and will continue out to the maximum distance possible for transmission by the E. Beyond this distance the F2 layer MUF will still continue to rise with increasing angle of incidence at that layer, and so the MUF is again controlled by the F2.

In calculating the MUF for any distance from the measured critical frequency by the use of such factors as those in Table I it is merely necessary, during the summer day, to multiply the critical frequency of each layer by the factor appropriate to the distance and layer. Then, whichever calculation yields the highest MUF indicates which of the layers will *control* the transmission over that distance.

TABLE I.—MUF FACTORS

	Transmission Distance in Miles						
	310	620	930	1250	1550	1850	2200
E layer ... ..	2.0	3.4	4.4	4.8	—	—	—
F layer							
<i>Winter:</i>							
Midnight ... ..	1.2	1.5	1.8	2.2	2.8	2.85	2.9
Noon ... ..	1.2	1.6	2.1	2.6	2.9	3.1	3.4
<i>Summer:</i>							
Midnight ... ..	1.2	1.4	1.7	2.1	2.5	2.7	2.8
Noon ... ..	1.2	1.5	1.8	2.2	2.5	2.8	2.9

# Inspection ..

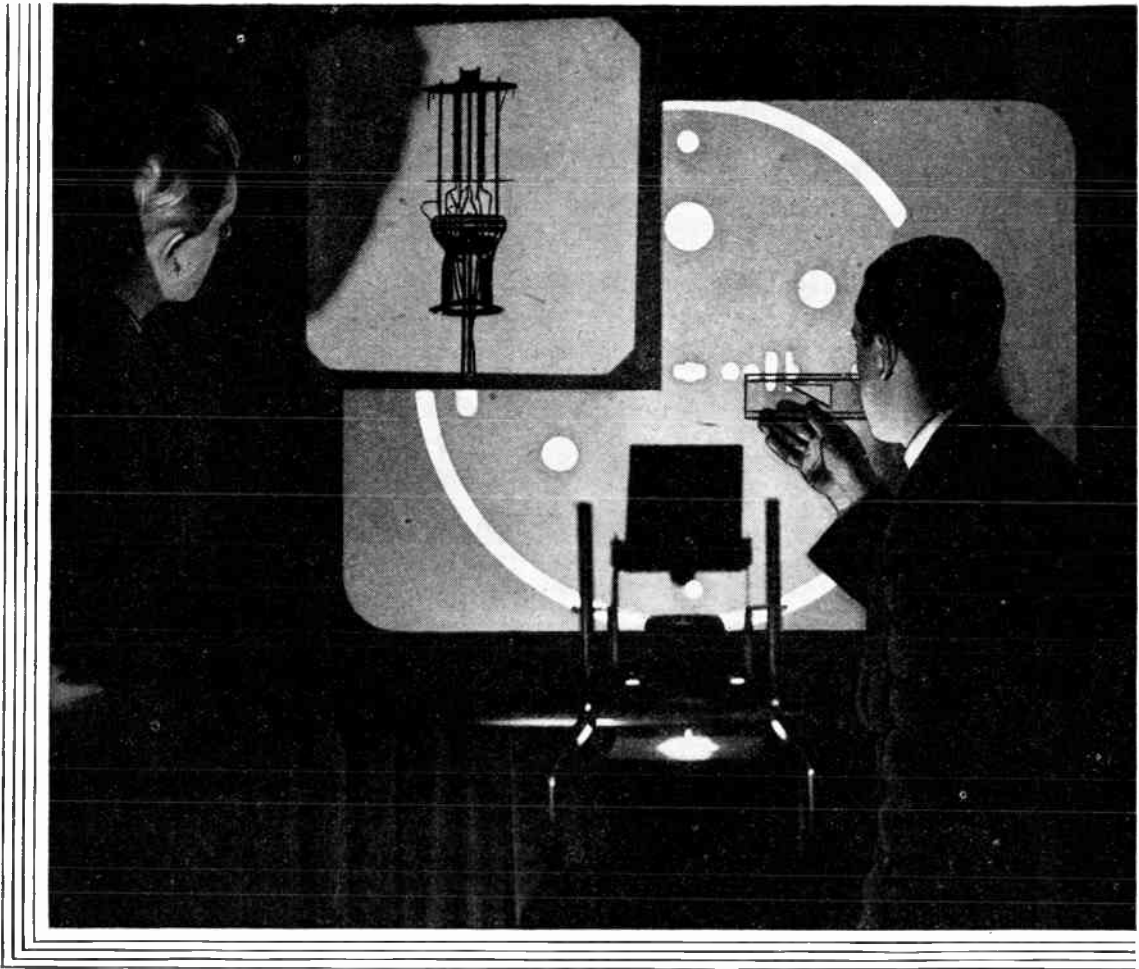

BY means of the epidiascope accurate and speedy inspection is facilitated. Our illustration shows greatly enlarged images of a top mica and partially assembled beam tetrode. Another example of the care which characterises every phase in the manufacture of Brimar Valves.

**BRIMAR**  
 (BVA)  
**VALVES**

**STANDARD TELEPHONES AND CABLES LIMITED, FOOTSCRAY, SIDCUP, KENT.**

# "to Insulate"

Practically all waxes are used to "separate or isolate," but the degree of insulation provided by the different types of waxes varies enormously.

There is obviously no higher degree of insulation required than that of electrical components and apparatus in intense electrical fields, especially in the extremes of conditions to which they are subjected to-day.

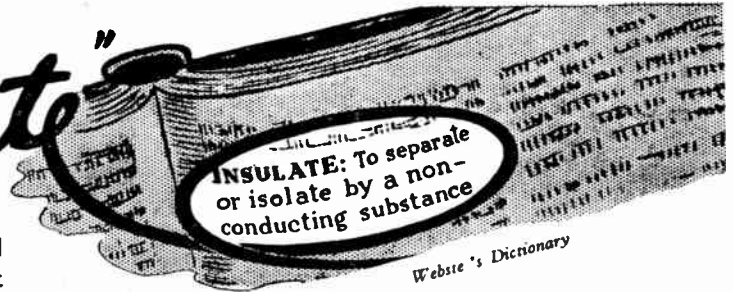

*We specialise in the supply of*  
**WAXES** *for all*  
**purposes—under all conditions**

Our technical advice is at your disposal.

If you have any problem of

**IMPREGNATING—DIPPING—FILLING**  
 we, as consultants to the Industry, shall be glad to offer you a solution.

**CLAUD CAMPBELL & CO. LTD.**  
 4, LLOYDS AVENUE—LONDON—E.C.3  
 Telephone Nos. :—ROYAL 5403/4/5.

## Rotary Cutting, Filing, Grinding and Polishing—*Economy and Accuracy*



Use **MORRISFLEX** Flexible Shaft Equipment, and **REX** Rotary Files and Cutters for cutting, filing, grinding and polishing components of aluminium, Elektron, non-ferrous alloys and ferrous metals. For metal buffing and cleaning we supply **MORREX** Rotary Wire Brushes, and **MORRISFLEX** Rotary Polishing Mops and Felts, also Felt Cones. **MORRISFLEX** Rotary Rasps are ideal for woodworking, and attachments for **MORRISFLEX** machines include Sanders and Grinders.

**MORRISFLEX** machines are available in overhead suspension, bench and floor types. Their use ensures speed with accuracy, and a high degree of finish. Write for Lists.

**B. O. MORRIS LTD.**  
 SHIRLEY,  
 BIRMINGHAM.

Shirley 1237.

Grams :

Morrisflex, Birmingham.

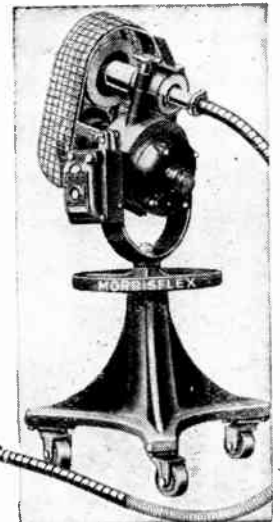

# MORRISFLEX

## FLEXIBLE SHAFT EQUIPMENT



## Wireless World Brains Trust

# Wired Broadcasting and Television. Standardised Voltages : Summing Up

**MORE VIEWS ON QUESTION No. 12. Is wired broadcasting wanted and would it be in the best public interest to adopt it as the main means of distribution ?**

**O. S. PUCKLE, best known for his work in the advancement of cathode-ray technique, considers this question largely in relation to the parallel problem of television distribution. He writes :—**

**B**EFORE the question of wired broadcasting can be adequately discussed it is essential to have experience of a regular television transmission covering large areas of the country. We do not know what the public reaction to television will be: it may be that a television programme will replace one sound programme and not be required to be additional thereto. In any case few will deny that the television service must be installed before wire broadcasting policies are decided upon.

With regard to the discussion in *Wireless World* I cannot "go all the way" with any of those who have expressed views on the subject. My reasons for my present opinions, which are of course liable to modification with later experience, are as follows:—

(a) I have had considerable experience in broadcast listening, in common with most people in this country, but I have had no experience with wire broadcasting. I am, however, prepared to admit (for the sake of this argument only) that wire broadcasting can be perfectly free from interference and would in this sense be preferable to radio broadcasting on the present wavelengths. I am however, inclined to think that FM broadcasting would be very little different from wire broadcasting in this respect, and USW broadcasting may bring about similar results if the frequency be chosen at a sufficiently high value.

(b) The B.B.C. provides, in wartime, two alternative programmes, and I think it is true to say that, in many cases, there were three available B.B.C. programmes during peacetime. For

many people this is quite sufficient, but it is not sufficient for everybody, as is apparent from the fact that Luxembourg had a tremendous number of listeners before the war. Although I personally did not appreciate either the quality or the material of these transmissions, there is no doubt whatever that it was much appreciated by the majority of the people in this country. This must therefore be taken to prove either that the type of programme or the way in which it was "put over" appealed to a greater extent than do the B.B.C. programmes. On the other hand it may just have been the result of a desire to be able to change over to something different.

These remarks are intended to convey that the public requires more than two or three varied programmes, and I believe the wire broadcasting people state that they could produce six different programmes. If, however, six programmes were produced by one organisation, I do not think the public would be any more satisfied than they are at present; in other words, I believe that it is not so much the number of programmes as the variety of treatment which the public desires, and this variety of treatment is not likely to be provided by *any one organisation*.

(c) The great value of radio broadcasting over wire broadcasting is, of course, the fact that no site is inaccessible to radio broadcasting, but there are many houses in this country where wire broadcasting could be received only at considerable expense for the installation of the necessary service. The residents in these houses must not be denied the right to receive news and entertainment and, therefore, broadcasting must remain, apart from the necessity for providing programmes for English-speaking persons outside this country. This means that any wired broadcasting service must be *an additional service*.

(d) There is an extremely important political aspect of broadcasting. If it were possible for people in this country to receive only wired programmes, I should consider it absolutely essential that rival concerns should be permitted to provide alternative services. Since, however, we have wireless sets which are capable of receiving B.B.C. programmes, and which can also receive those of other countries, some of which are in the English language, this political difficulty does not arise. If, however, a single wire broadcasting system were to provide a substantial portion of the news and entertainment of this country it would, in my opinion, create the possibility of an extremely dangerous political situation.

### Safeguards Needed

I have no doubt whatever about the honesty of the present Government or of its desire to tell the truth, but we are living in difficult times, when holders of strong opinions desire to enforce their will and their opinions on large numbers of their fellow citizens and even on those of other countries. It is thus supremely important that it should not be possible for any body of opinion, by control of the dissemination of news and information throughout the country, to impress its will upon large sections of the public.

For this reason alone, and quite apart from the fact that a number of programmes would not, in my opinion, satisfy the public if they came from one source, it appears to me that the existence of wire broadcasting alone in any section of the community, is quite unthinkable unless rival organisations have equal facilities for providing a service to every house. Furthermore, the broadcasting lines must be free from Government or other sequestration.

I have no objection to wire broadcasting so far as its effect on the public is concerned, except for the reasons given above, but it should be arranged that the

**Wireless World Brains Trust—**

broadcasting is done at radio frequency and a switch and aerial, together with the necessary frequency-selecting circuits must be provided so that the equipment may be used as a radio broadcast receiver when so desired.

(e) There is a further national and industrial reason which might render wire broadcasting a disadvantage. In this respect, I am not certain whether it is proposed that the wire broadcasting interests would provide their own receivers or whether they would be manufactured by a number of existing radio manufacturers, and that the public would be allowed to choose the particular receiver they wish to use. It is of the utmost importance that the public should be allowed to "pick its fancy."

To conclude, it appears to me that there are three possibilities for our post-war service:—

(1) To continue as at present, relying only upon the B.B.C. to provide our home entertainment. This is not entirely satisfactory, since it does not provide for separate programme - producing organisations. To achieve this we might:

(2a) Share the entertainment between the B.B.C. service and preferably two wire broadcasting organisations with a proviso that a single receiving instrument shall be used for both purposes and that the wire broadcasting interests shall provide a radio-frequency signal at the receiving end (as is done by the B.B.C.) but that the apparatus for converting it into sound shall be made by any manufacturer, and that the general public shall have a free choice as to the make of set they shall buy.

(2b) Share parts of the available B.B.C. programme time with other concerns whose duty it would be to provide programmes using B.B.C. studios and transmission systems. This would ensure different production methods and would introduce the variety for which the general public appears to hunger.

Finally, since wire broadcasting must be an additional service, there is no possibility of an economy in the receivers which might compensate for the increased cost of the broadcasting lines.

**MORE VIEWS ON QUESTION  
No. 14. Why was the "odd" voltage of 132,000 adopted for the main transmission lines of the Grid System?**

**J. S. FORREST, of the Central Electricity Board, sums up on this question and also touches on the related one of the general "oddness" of supply voltages.**

THIS question may most conveniently be considered in two parts (a) Why are high-tension voltages multiples of 11?, and (b) Why was the voltage of 132 kV adopted for the main Grid system?

(a) Last month C. R. Cosens made the interesting suggestion that the multiples of 11 arise from the fact that the voltage of the Daniell cell is roughly 1.1V. This may have had something to do with the use of 110V and 220V for the early DC supplies, but it is noteworthy that the pioneer and historic Deptford installation (1890) operated at 10,000V AC. In the case of high-voltage systems, there seems to be no doubt that the factor of 11 results from the practice of allowing for a 10 per cent. voltage drop in the transmission line. In fact, a document on Standard Voltages issued by the International Electrotechnical Commission (Publication No. 38-1938) specifies two series of voltages—"maximum voltages," multiples of 11, and "receiving-end voltages," multiples of 10. Similarly, British Standard Specification No. 77-1932 (now superseded), gives figures of 3,000, 10,000 and 30,000 for the "declared voltages," and 3,300, 11,000 and 33,000 for the corresponding "station voltages." It should be noted that the 10 per cent. voltage drop is an internal drop in the transmission system, and must not be confused with

the voltage variation at the consumer's terminals.

Many modern high-voltage systems, however, take the form of networks and interconnectors through which power may flow in either direction. The conception of "sending-end" and "receiving-end" voltages therefore no longer applies, and must be replaced by that of the "system voltage." It has happened that the former "sending-end" or "maximum voltages," i.e., the multiples of 11, have been generally adopted for the standard system voltages. Thus, at the present time, the most widely used system voltages are 11, 33, 66, 110, 132 and 220kV. Those interested will find the present standard system voltages in the revised British Standard Specification No. 77, published in 1939. This Specification also defines the standard AC distribution voltage as 230V (equivalent to 400V between lines).

(b) For any given power transmission system there is a most economical voltage which is determined by the transmission distance, the characteristics of the load, and the cost of plant (not only the line but also the terminal switchgear and transformers). The determination of the economic voltage is not a simple matter, largely owing to the fact that the characteristics of the load may be variable or not accurately known. For the present purpose, however, it may be sufficient to note that a voltage of the order of 1kV per mile is usually found to be satisfactory. Bearing in mind the transmission distances encountered in Great Britain it is seen that a voltage of 100-200kV would be required for the main Grid lines. Further, well-established power systems working at 33kV and 66kV were in operation in this country in pre-Grid days so that 132kV is seen to be a logical value for the main Grid voltage. There would have been no great technical difficulty in adopting a higher voltage, as 220kV lines were in service in the United States in 1923. Twelve years' operating experience, however, have confirmed the correctness of the original decision. Thus, the "odd" value of 132kV when considered against its proper background is seen to be almost the obvious choice!

### Wireless World

#### Increase in Price

It is regretted that rising costs of production compel our Publishers to increase the price of this journal from 1s. 3d. to 1s. 6d. The increase takes effect with the present issue.

# SUNSPOTS : Close of the Present Cycle

DR. SETH B. NICHOLSON, of the Mount Wilson Observatory, recently announced that a sunspot group has been observed in the relatively high solar latitude of 32 deg. North. This may have been the first sunspot belonging to a new cycle of solar activity, and its appearance is therefore, evidence that the present cycle is coming to an end. This event was, in fact, expected to occur about 1944.

The cycles of solar activity are of significance in radio in that the amount of ionisation produced by the sun in the upper atmosphere varies in phase with them. Thus the critical frequency of the ionosphere layers is much higher at sunspot maximum than at the minimum, and consequently higher working frequencies must be used for short-wave transmission at the former period than at the latter.

The present solar cycle commenced in 1933, and its progress—in terms of the annual means of the sunspot relative numbers—is shown in the graph of Fig. 1. An inspection of this would seem to indicate that the cycle would come to an end about 1944, but precision on this point is by no means easy, since the cycles vary considerably in length.

Besides varying in size, and in the frequency of their appearance



Fig. 1. Annual means of sunspot numbers during the present solar cycle.

—which is what is indicated in Fig. 1—the sunspots also change their latitude as the cycle progresses. At the beginning of a cycle they occur on the solar surface in two belts which are situ-

ated in about 30 deg. North and South latitude. As the cycle progresses these belts gradually drift towards the solar equator, and, towards the end of the cycle, they are situated in about 8 deg. North and South latitude. But, some time before the sunspots finally cease to appear in these regions, a fresh phase of activity gives rise to sunspots which appear in the high latitudes again, and then a new cycle commences. So that, at the minimum of the cycle, there are four belts in which the sunspots occur, two in high and two in low latitudes, on either side of the solar equator. The appearance of a sunspot in a high latitude is, therefore, a sign that the current cycle is coming to an end. Fig. 2 is a graph on the shift in the mean latitude of the sunspots during the cycle which began in 1913 and came to an end in 1923, and serves to illustrate this point. The solar activity increased rapidly from 1924 onwards.

## The New Cycle

It is not a necessary implication, however, that, as soon as the minimum is passed, there will be a great decrease in solar activity and a consequent big increase in the working frequencies for short-wave transmission. Although this does occur sometimes, an examination of former sunspot cycles shows that, more often than not, there is, during the first year after the minimum period, very little increase in the solar activity. It is during the second year of the new cycle that the big increases most often occur.

There is one other interesting change in sunspot phenomena which takes place at the end of a cycle. The sunspots most often appear in pairs, the one which lies in the forward position with

regard to the direction of the sun's rotation being known as the "leader" spot, and its companion as the "follower." These sunspots have opposite magnetic polarity, and during any one cycle

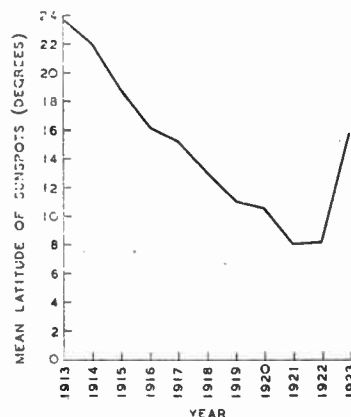

Fig. 2. Shift in mean latitude of sunspots during the solar cycle 1913-1923.

the relative polarity of the leader is, for example, always of North magnetic polarity, and the follower always of South polarity. At the end of a cycle this polarity is reversed, so that the leader and follower sunspots of the new cycles are reversed in magnetic polarity compared with those of the old cycle. In the case of the group observed at Mount Wilson the leader spot was so little in advance of the follower that it was hard to say whether it had a different polarity to the leader spots of the present cycle or not.

T. W. B.

## "DESIGN OF SIMPLE OHMMETERS"

THE mathematical expression (15) on page 269 of the previous issue was incomplete. It should have been an equation reading  $R = R_{36} /$  (divided by the expression given).

## GOODS FOR EXPORT

The fact that goods made of raw materials in short supply owing to war conditions are advertised in this journal should not be taken as an indication that they are necessarily available for export.



# RADIO DATA CHARTS—11

## Frequency and Wavelength

By

J. McG. SOWERBY,

B.A., Grad.I.E.E.

(By permission of the Ministry of Supply)

THERE has been some discussion in recent months concerning the most desirable nomenclature for frequency and wavebands; but before coming to this, let us get one or two fundamental ideas straight. The very simple equation connecting frequency and wavelength is

$$\text{Frequency} \times \text{Wavelength} = \text{Velocity of propagation.}$$

The frequency ( $f$ ) of the wave is the number of complete alternations per second, and since the wave is travelling with velocity ( $v$ ),  $f$  alternations will pass a given point in one second. In the same time one wave will have travelled a distance numerically equal to  $v$ , and so  $f$  waves will occupy this same distance. From this the length ( $\lambda$ ) of one wave may be found by dividing  $v$  by  $f$ , and the equation above is simply a more convenient way of writing the same thing.

It will be realised at once that the fundamental quantity in the equation is the frequency. The wavelength is, so to speak, merely a by-product of the velocity, which in turn depends on the medium in which the wave is being propagated. For example, suppose we have an oscillator working at a fixed frequency and this is coupled to an aerial. Then the wavelength of the alternations in space may be found from the equation by putting 300,000,000 metres per sec. for the velocity. This is the velocity of propagation of wireless waves in free space and is equal to the velocity of light; this is hardly surprising since the only material difference between a beam of wireless waves and a beam of light is the frequency—that of light being enormously the higher.

We have now a wavelength associated with our fixed frequency oscillator, but this is not unique. To see the truth of this we may couple our oscillator to a transmission line loaded by inductances (such lines are used in telegraphic work). Under these conditions the velocity of propagation may fall to a tenth of its previous value (i.e. to 30,000,000 metres/sec.) and the wavelength

on the line will be correspondingly shortened. Now we have *two* different wavelengths associated with our oscillator, and of course there can be innumerable others in between. Thus, academically, we should always think in terms of frequency, since it is fixed, and never in terms of wavelength, which is variable.

However, things are not quite as bad as this, for it is fortunate that in most radio work the velocity of propagation differs from the velocity of light by only a very small percentage, so for practical purposes we may regard this as our standard velocity and compute all wavelengths on this assumption.

In the early days of wireless it was the custom to use wavelengths almost exclusively; later there was a tendency to use frequency—modern communication sets are calibrated in terms of frequency, for example. Nowadays, measurements at frequencies of the order of 100 to 1000 Mc/s are carried out with transmission line sections, lecher wire systems, or other methods where a length is measured; so it is natural to think in terms of wavelength. At higher frequencies still cavity resonators are used, and here it becomes natural to think in terms of frequency again as the system is analogous to the Helmholtz resonator. Hence there will be points in the radio spectrum where it will be convenient to think in terms of frequency and others where wavelength will

be the better viewpoint. The moral is for the radio engineer to have equal facility in the use of either. This is, perhaps, a counsel of perfection, but it is hoped that this chart may be of some help.

As mentioned above there has recently been some discussion as to the best method of dividing the radio spectrum into various bands. We cannot repeat here all the arguments for and against the various schemes, but in the author's opinion the best yet put forward appeared in *Wireless World* (Feb. 1943, p. 51). A table which was published then is repeated here with some minor modifications.

The chart is based on the equation  $f$  (kc/s)  $\times$   $\lambda$  (metres) = 300,000. and it is labelled to correspond with the table. Band 1 is omitted from the chart as the wavelength at these frequencies is seldom required, being of the order of miles. Band 7 is at present of interest only to a very few and so is also omitted. Bands 2 to 5 inclusive appear on the chart which, it should be noted, is not a proper abac at all in so far as no ruler or straight-edge is required for its use. It is only necessary to find by inspection the appropriate band on which the required frequency (or wavelength) appears, when the corresponding wavelength (or frequency) can be read opposite it on the adjacent scale.

### Example

What is the wavelength corresponding to 400 kc/s (0.4 Mc/s)? Find the right band by inspection—in this case band 3. Opposite 400 kc/s on the frequency scale appears 750 metres on the wavelength scale. This is the required figure.

Band	Frequency	Frequency Name	$\lambda$ in Metres	Waveband Name
1	Below 30 kc/s	Very low	Above $10^4$	Myriametre
2	30–300 kc/s	Low	$10^4$ – $10^3$	Kilometre
3	300 kc/s–3 Mc/s	Medium	$10^3$ – $10^2$	Hectometre
4	3–30 Mc/s	Medium high	$10^2$ –10	Decametre
5	30–300 Mc/s	High	10–1	Metre
6	300–3000 Mc/s	Very high	1–0.1	Decimetre
7	3000–30,000 Mc/s	Ultra high	0.1–0.01	Centimetre

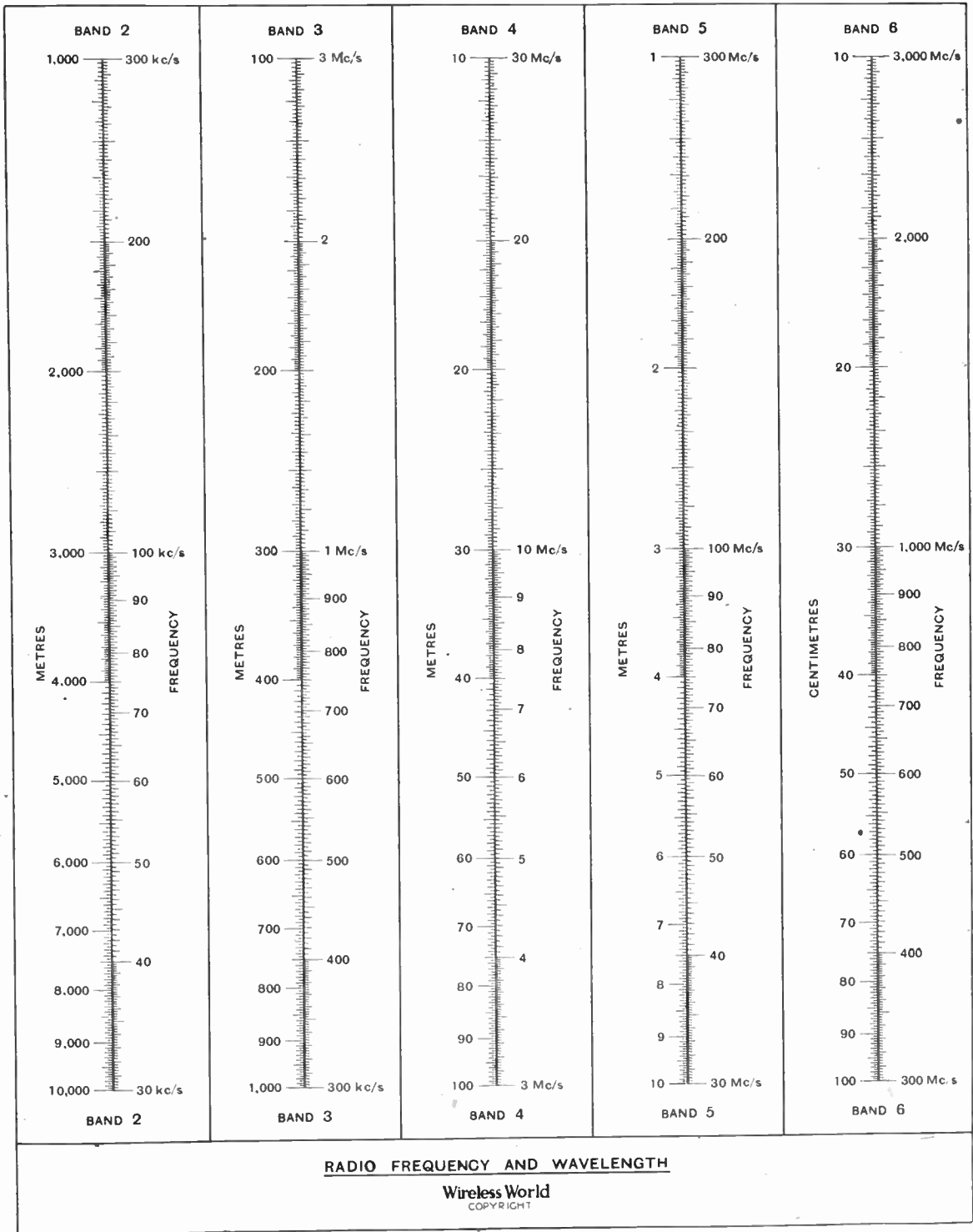

# USE OF VALVES

## Safety Precautions to Prevent Overrunning

GRID emission of a thermionic nature was considered in the preceding section of this article. It is necessary to consider a further effect which may occur when a valve is used under conditions where grid positive current is flowing. For example, grid positive current will flow to the control grid of a valve operating under "positive drive Class B" conditions or, momentarily due to overload, in the case of a valve which is nominally working under Class A conditions. The flow of electrons to the grid in such cases as have been mentioned may result in electrons being released by impact from the grid material. This form of grid emission, arising from electron bombardment, is known as grid secondary emission and will result in the grid losing electrons, probably to the anode. Thus the flow of electrons from the grid, by secondary emission, offsets the arrival of electrons to the grid from the cathode. This phenomenon is illustrated in Fig. 1.

Starting at a point in the neighbourhood of  $V_g=0$ , the grid current is zero. If the grid is made more positive, electrons are attracted to it, thus constituting a grid positive current. This current rises to a maximum at a point shown on the diagram where  $V_g=A$ , and subsequently it begins to fall because of the increasing loss of electrons from the grid arising from the resultant grid secondary emission. As the positive grid voltage is still further increased and the bombardment of the grid becomes greater, the secondary emission increases and the grid negative current will eventually attain the same numerical value as the grid positive current which is causing it. At this point,  $V_g=B$ , the total external grid current is zero. Beyond this point the value of the grid negative current becomes numerically greater than the grid positive current, and thus the resultant grid current is negative. At a still higher value of positive grid voltage, a further effect becomes apparent when the

By J. R. HUGHES, A.M.I.E.E.  
(British Radio Valve Manufacturers' Ass'n)  
(Concluded from page 259 of previous issue)

potential gradient around the grid is such that the secondary electrons move back to the grid itself rather than to the anode. This, of course, results in a drop of the grid negative current and at the point  $V_g=C$  the total external grid current once more becomes zero. From here on, the grid current is increasingly positive.

It will be apparent from the above that there are three sets of conditions under which the external grid current can be zero and that the corresponding grid voltage can be either  $V_g \sim 0$ ,  $V_g=B$  or  $V_g=C$ .

If the grid of a valve has no DC connection to the cathode the external grid current is evidently zero. It may be, however, that the valve is operating at the point C on its grid characteristic and that the grid, consequently, is at a large positive potential. Under these conditions a considerable electron current will be flowing to the grid and an equally considerable electron current flowing from the grid as a result of secondary emission. The condition is a stable one and the valve may remain in this state indefinitely. Obviously, since the grid potential is large and positive, the anode current of the valve will be considerably higher than the normal and the effect of this will be to increase the anode dissipation and thus damage the valve.

This is one very important reason for the insistence in the Code of Practice that "... in no circumstances should valves be operated without a DC connection between each electrode and the cathode."

Mention is also made in BS. 1106 of the practice of "keying" by opening the screen circuit of a valve whilst the normal anode and grid voltages are maintained. This is another example of the operation of a valve without a DC connection between each electrode and the cathode.

The phenomenon of grid secondary emission, moreover, is of importance even if the grid has a DC connection to the cathode. Referring again to Fig. 1, it will be seen that two dotted lines are included, marked  $R_1$  and  $R_2$ . These are simply the current/voltage characteristics for two values of resistance, drawn on the same co-ordinates as the grid current curve. The flow of grid negative current in a valve circuit where a DC connection exists between the grid and the cathode gives rise to a voltage drop down the DC resistance of such polarity that the grid becomes positive with respect to the cathode.  $R_1$  and  $R_2$  are assumed to be two values of external grid resistance where, of course,  $R_1$  is greater than  $R_2$ .

Considering first the operation of the valve with an external grid connection having a resistance  $R_1$ , it will be observed that the grid current curve and the  $R_1$  characteristic intersect at the two points D and E. These two intersections are conditions of equilibrium which, once established, may be maintained without the application of any external EMF to the grid. At D the equilibrium is unstable, but if a positive potential having a value greater than E is applied to the valve grid and then removed, the grid voltage falls towards zero until the stable point of equilibrium E is reached. Thus a momentary application to the valve grid of a positive potential greater than E (as, for example, by a condition of overload) may result in the phenomenon known as "grid-locking."

On the other hand grid locking is impossible in the case of the same valve operating with the smaller value of external grid resistance  $R_2$  because that dotted line nowhere intersects the grid current characteristic.

This argument further emphasises the requirement that the DC connection between each electrode and the cathode should have the minimum practicable resistance. The Code of Practice in fact states "... the apparent advantage of an 'open-circuited' elec-



trode, or of a high resistance path, may be defeated by the valve's secondary emission characteristics."

**Grid Rectification Biasing.**—The very common use of grid rectification to obtain a bias voltage, particularly in cases of valves used as oscillators or RF power amplifiers, is the subject of another precaution covered by BS.1106. This type of circuit is no doubt well known and consists of a condenser and resistance used in conjunction with a valve which is being driven into grid positive current on part of each cycle. This grid positive current produces an accumulation of electrons in the grid condenser and the mean charge potential is adjusted to the desired value by an appropriate choice of condenser capacity and grid-leak resistance.

In the event that the valve drive is cut off for any reason, the flow of electrons to the condenser every cycle will cease whilst the leakage of electrons through the grid-leak resistance will continue until, finally, the potential across the condenser will fall to zero. As the biasing potential drops the anode current will rise and may very greatly exceed the rated anode current. To avoid the damage to the valve which can arise in these circumstances the Code of Practice recommends that grid rectification biasing should never be used alone. It mentions one of the possible methods of avoiding the risk described, by recommending that some of the desired bias potential should be secured in the normal manner by a resistance in the cathode lead. Thus if the grid rectification bias fails the increasing anode current will produce an increasing cathode bias and thus can save the valve from damage. For any particular application it is very desirable that the valve manufacturer's advice should be taken as to the minimum cathode bias which will ensure a reasonable security against damage.

**Miscellaneous.**—It will be of interest to consider briefly two lesser known miscellaneous points which are covered by the Code of Practice.

The first reads: "It is, in general, undesirable that valves should be operated in such circuit conditions that the cathode cur-

rent is normally cut off." This practice, which is often adopted in equipments which are required intermittently but at short notice, may be permissible with some valves but it should not be adopted without first taking the advice of the valve manufacturer. When a valve is operated in a normal manner the cathode emission carries with it minute quantities of impurities in the cathode coating. These impuri-

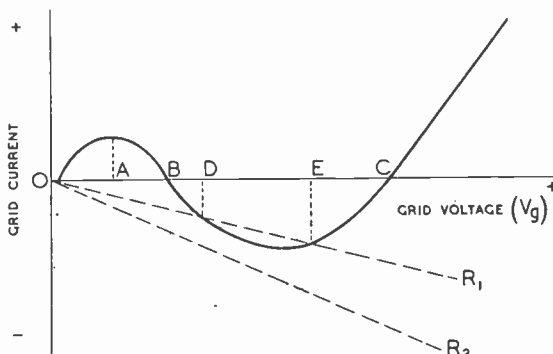

Fig. 1. Current/voltage characteristic of a grid in a valve containing another electrode at a positive potential.

ties are deposited elsewhere in the valve and have only a negligible effect upon the useful life. On the other hand, if the cathode is maintained at operating temperature but the cathode current is cut off as, for example, by cutting off the anode voltage, these minute quantities of impurities fall back on to the cathode itself with the result that the cathode surface is slowly "poisoned" and its emissivity decreased.

A further cause of cathode "poisoning" may arise from the presence in the bulb of very small quantities of residual gas. Under the operating conditions the residual gas is ionised by collision as has already been discussed, whereas this will not be the case if the cathode current is cut off. It can be shown that un-ionised residual gas is less rapidly reabsorbed than when ionised and accordingly, in the absence of space current, residual gas may remain and result in cathode "poisoning."

The second of the two miscellaneous points referred to is concerned with contact potential.

The contact potential between any two electrodes in a valve is defined very simply in the Code of Practice as the "voltage corresponding to start of positive current to any electrode." Evidently, the assessment of the voltage at which a current starts to

flow between two electrodes is dependent upon the sensitivity of the method used to detect the current and it is therefore usual in practice to define the contact potential as the potential at which the positive current reaches some small arbitrary value. The value of the contact potential is dependent upon the two surfaces under consideration and any variation in either of the surfaces will produce a change of contact potential.

The question of contact potential is of importance in a number of cases, but particular mention might be made of the case of the cathode/grid potential in high-gain triodes. With these valves, where the contact potential may easily be of the same order as the bias voltage, it is obviously important that due regard should be paid to it.

The Code of Practice emphasises that "circuits which are critical as regards control of contact potential should be avoided . . ." This condition must be observed because, as has been stated, the contact potential is dependent in any given case upon the electrode surfaces. Contact potential therefore changes with temperature and throughout the life of the valve and cannot be regarded as a stable or constant quantity.

**Mercury Vapour Rectifiers.**—A far smaller number of valve users is concerned with mercury vapour rectifiers than with "hard" valves of one sort or another. Partly because of this but partly because each mercury vapour application tends to be regarded as an individual engineering problem in itself, mercury vapour rectifiers are not taken quite so much for granted as are "hard" valves. Nevertheless BS.1106 does include a short section dealing with this subject.

**Use of Valves—**

The essential difference between a vacuum rectifier and a mercury vapour rectifier is that the latter contains a certain amount of mercury, partly in liquid form and partly vapour, depending upon the temperature conditions. When a potential difference is applied between the anode and the heated cathode an electron stream flows in the normal manner, and in their passage from the cathode to the anode electrons will collide with mercury vapour molecules and produce a state of ionisation. The positive ions on account of their high mass and the low potential gradient move towards the cathode at a relatively low velocity, and will neutralise the space charge existing between the cathode and the anode.

In a vacuum valve the presence of the space charge has the effect of reducing the space current and of necessitating the use of relatively high anode potentials. To remove the space charge entirely in a vacuum rectifier would require the application of very high anode voltages which might damage the valve by excessive anode dissipation and liberation of gas. The cathode, moreover, would be rapidly destroyed by the bombardment of positive ions which would be travelling at an extremely high velocity on account of the large potential between the anode and the cathode.

The introduction of mercury vapour into the valve and the consequent neutralisation of the space charge without the need for very great anode potentials, permits the anode current of the mercury vapour valve to approach the total emission of the cathode, whilst avoiding the risk of cathode damage from high-velocity bombardment.

The potential difference which is necessary between the anode and the cathode in a mercury vapour rectifier in order to produce a satisfactory ionisation of the vapour is usually less than 20V. Thus, provided the anode voltage is of that order, the anode current will be unrestricted by the presence of a space charge and will only be limited by the emission available from the cathode. The principal property of the mercury vapour rectifier therefore is that it will pass a relatively large current with only a very

small potential difference across it. The very low value of the rectifier's resistance and its practically constant voltage drop require the use in practice of a limiting resistance in series with the rectifier.

If it should happen that the anode voltage were applied to the rectifier, before an adequate amount of mercury had been

cathode is heated before the application of the anode voltage. Mercury vapour rectifier cathodes are normally of the high current low voltage type having a considerable thermal capacity, and an appreciable time is required for the cathode to reach its operating temperature. Subsequent to this the heated cathode will cause the evaporation of a certain amount of mercury until a new state of equilibrium exists inside the bulb. If the valve has not been recently used, or if it has been disturbed so that the mercury may have splashed on to the emissive coating of the cathode, it will be necessary to take still greater care that an adequate preheating time is allowed. In the latter event, for instance, the presence of liquid mercury actually on the cathode will result in very rapid evaporation and an excessive mercury vapour pressure around the cathode. If the anode voltage were applied whilst this condition persisted, arcing would take place between the electrodes and the valve would be damaged. In these exceptional cases it will generally be found that the manufacturer recommends the preheating time of between 15 and 30 minutes but for the routine starting of valves in regular use, the preheating time is less than this and may even be as short as a minute. In either case the length of the preheating time depends upon the size of the valve and upon the room temperature and it is safest to make sure that the recommended times for any particular type are known.

It is a common practice, and a very good practice, to make use of automatic time delay switches to take care of the necessity for a preheating time. These switches are generally thermal in principle and their release time, which is obviously determined by the rate of cooling of the bi-metal element, is far from negligible. It can happen, therefore, that the rectifier might be switched on again, soon after switching it off, before the delay switch has had time to return to the unoperated condition. If this should happen it is obvious that the anode voltage and the filament voltage will be applied to the rectifier simultaneously. The chance of this occurring is, no doubt, small, but it is a point well worth remembering.

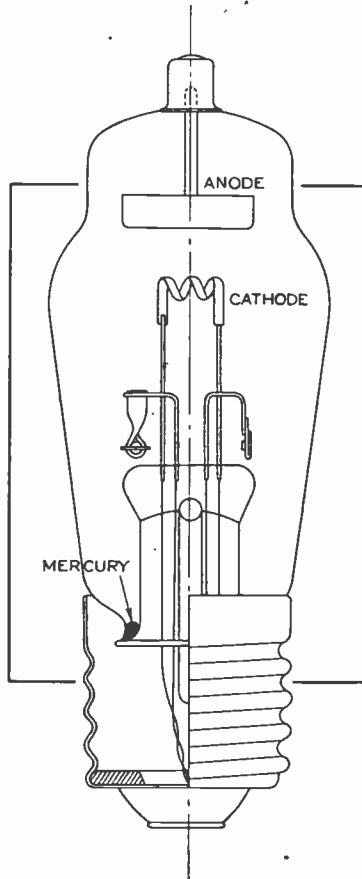

A typical mercury vapour rectifier.

vaporised, the flow of electrons from the cathode to the anode would result in an insufficient number of positive ions to neutralise the space charge. The internal resistance would be excessively high and the voltage drop across the rectifier would accordingly be high also. Under these conditions, the velocity of such positive ions as did exist would be sufficient to cause cathode damage by bombardment, and partly for this reason a preheating time is always specified in the case of mercury vapour rectifier.

By preheating time is meant the period during which the

The factor of temperature is always of considerable importance in the operation of mercury vapour rectifiers. The degree of ionisation of the mercury is dependent upon the pressure, and hence upon the temperature of the gas, as is also the rate of de-ionisation. If in any mercury vapour rectifier the temperature of the condensed mercury is too low, vaporisation and subsequent ionisation will be insufficient to bring about the desired condition of low voltage drop across the valve. If, on the other hand, the temperature is too high, then de-ionisation will be retarded. It will be remembered that the process of ionisation is effected by the flow of electrons from the cathode to the anode on each half-cycle when the anode is positive with respect to the cathode, and it is, therefore, evident that ionisation is required to take place in a time short compared with the length of one half-cycle. Similarly, the vapour must de-ionise at the beginning of each succeeding half-cycle rapidly enough to ensure that de-ionisation is sufficiently complete to enable the rectifier to withstand the peak inverse voltage. If the process of de-ionisation is retarded, the internal resistance of the rectifier will be too low to withstand the peak inverse voltage and breakdown and destruction of the cathode surface will result. It is, therefore, necessary to control the operating temperatures of mercury vapour rectifiers and with large valves of this class, when normal ambient temperatures are likely to vary unduly, some form of forced air temperature control must be employed.

The published data covering mercury vapour rectifiers always specifies a limiting range of condensed mercury temperature, and due attention must be paid to this if reliable service is to be expected from the valve.

The very high current-carrying capacity of mercury vapour rectifiers, as compared with vacuum rectifiers, gives rise to the need for a special precaution in the case of the larger directly heated types. With these it may well happen that the anode current is of the same order as the filament-heating current. Moreover, as has already been stated, the voltage drop across the rectifier is so low that it

may be of the same order as the filament-heating voltage. If the anode and filament voltages are connected in phase or 180 deg. out of phase, as would be the case in a normal bi-phase half-wave circuit, maximum current to the anode will coincide on each half-cycle with peak positive voltage at one or other end of the filament. This will tend to draw more emission from one end of the filament than from the other, and will also result in unequal amplitude of current in the two halves of the filament. For this reason the Code of Practice lays down that with large directly heated mercury vapour rectifiers, the anode voltage and the filament voltage should be arranged to be substantially 90 deg. out of phase. If this is inconvenient, steps may be taken to reverse the filament terminals at regular intervals, but if this is not possible, the rectifier will usually have to be operated with reduced ratings.

### "INTRODUCTION TO VALVES"

THIS popular book, of which a second edition has just been issued, was originally written for those who, with little or no previous experience, are called upon to handle valves, CR tubes and allied devices. Though the introductory chapters cover valve theory, it deals largely with practical circuit applications of valves.

A new chapter describing specialised valves, such as those for very high frequencies, including the magnetron, has now been added. Electron multipliers, "magic eye" tuning indicators and cold cathode rectifiers are also dealt with. Minor revisions have also been made.

"Introduction to Valves" is by F. E. Henderson, A.M.I.E.E., of the G.E.C., and is issued by our publishers at 5s. (by post, 5s. 3d.).

### ELECTRICAL INDUSTRIES RED CROSS FUND

THE total of covenanted subscriptions and donations to this Fund now amounts to over £17,000. Among the names of firms with wireless interests which appear in the latest lists issued are Ferranti, Ltd. (£200), and Kolster-Brandes, Ltd. (£100). The sums given represent covenanted annual subscriptions for seven years or for the duration of war.

Information can be obtained from the Joint Secretaries of the Fund, c/o The E.D.A., 2, Savoy Hill, London, W.C.2. Contributions should be sent direct to the Electrical Industries' Red Cross Fund, St. James's Palace, London, S.W.1.

# GALPINS

—ELECTRICAL STORES—

"FAIRVIEW,"  
LONDON ROAD, WROTHAM,  
KENT.

TERMS: Cash with Order. No C.O.D.

Regret Orders from Eire and Northern Ireland cannot be accepted.

**DYNAMO** by Crompton, output 50/75 volt, 25 amp. D.C., speed 1,750, four-pole, shunt wound, large ring oiler bearings, complete with pulley, ready for immediate use. Price £10 carriage paid.

**SUPER SENSITIVE RELAYS**, multi leaf, P.O. type, very low M/A working, as new. Price 15/- each, post free.

**PRE SELECTOR SWITCH**, complete with very sensitive relay, 3-arm rotary, 48 contacts, as new. 30/- each, post free.

**D.C. MOTOR**, shunt wound, condition as new, high grade, ball bearing,  $\frac{1}{2}$  h.p., 110 volts. Price 40/-, carriage paid.

**AUTO-TRANSFORMER**, 2,000 watts, tapped 0-110-200-220-240 volts, as new. Price £8.10.0, carriage paid.

**VOLTMETERS**, 2 $\frac{1}{2}$  in. dia., panel mounting moving coil, modern type, by famous maker 10 v. range, F.S.D. 5 m.a. Price 32/6, post free.

**AMPMETERS**, description as above. Ranges 0- $\frac{1}{2}$  and 0-20 amps., F.S.D. 15 m.a. State which reading required. Price 25/- each, post free.

**DUBILIER RESISTORS**, new lead and wire ends, 2 watt, 30,000 ohm, 1/6 each or 15/- per doz., post free. Ditto, 1 watt, 5,000 ohm., 6/6 per doz., post free.

**RESISTANCE MATS**, size 8 in. by 6 in., set of four. 80, 80, 150 and 690 ohms, carry  $\frac{1}{2}$  to  $\frac{1}{4}$  amp. Price, set of four, 5/-, post free.

**MOVING COIL MOVEMENTS**, needing slight repair, modern type, famous makers, deflection 10 m.a. Price 15/-, post free.

**RIGHT ANGLE DRIVE**, mounted in gunmetal box, all ball bearing,  $\frac{1}{2}$  in. dia. shafts, as new. 12/- each, carriage paid.

**RECORDING AMPMETER**, in ironclad case, meter movement wants repair, no pen, clock perfect, range 0-3 amps. Price £7, carr. paid.

**MOTOR-DRIVEN PUMP**, for oil or water, motor 220v. D.C., 1 amp., 1,250 r.p.m., maker Keith Blackman. Price £6 10s., carr. paid.

**200 AMP. KNIFE SWITCHES**, S.P., D.T., in first-class condition. 15/- each.

**200 AMP. CABLE**, V.I.R., as new, rubber cover perfect, size 37/13, lengths 30 to 40 yds. Price in lengths, 5/- per yard, carr. paid.

**DYNAMO**, maker C.A.V., output 20 volts, 10 amps., speed 1,500 r.p.m., ball bearing. Price £5.

**ROTARY CONVERTOR**, D.C. to D.C., input 11 volts, output 1.100 volts, 80 watts, will operate successfully on 6 volt input. Price 50/-.

**MASSIVE GUNMETAL WINCH**, complete with long handle, for use with  $\frac{1}{2}$  in. dia. wire cable weight 50 lbs., condition as new. Price £3 carriage paid.

**ELECTRIC LIGHT CHECK METERS**, well-known makers, first-class condition, electrically guaranteed, for A.C. mains, 200/250 volts 50 cy. 1 phase 5 amp. load, 10/- each; 10 amp. load, 12/6, carriage 1/-.

**$\frac{1}{2}$  WATT WIRE END RESISTANCES**, new and unused, assorted sizes (our assortment). 6/- per doz., post free.

**SOLID BRASS LAMPS** (wing type), one hole mounting, fitted double contact, S.B.C. holder, and 12 volt 16 watt bulb. Price 3/6 each, post free, or 30/- per doz., carriage paid.

**TUNGSTEN CONTACTS**,  $\frac{1}{4}$  in. dia., a pair mounted on spring blades, also two high quality pure silver contacts,  $\frac{1}{4}$  in. dia., also on spring blades, fit for heavy duty, new and unused. There is enough base to remove for other work. Price, the set of four contacts, 5/-, post free.



## Do You Know?

IN pre-war days to be a regular reader of *Wireless World* always tended to set a man somewhat apart from his fellows as being one possessed of superior knowledge and intelligence, and this was true even of the man who bought it solely for the purpose of wrapping up his fish and chips; it at least showed that he appreciated the fact that the good quality of the paper on which it was printed rendered it more greaseproof than lesser journals. In fact, it is true even to-day, as a "Waaf" of my acquaintance tells me that she always carries a copy because it creates a good impression among those in authority, thereby opening the gateway to certain privileges denied to the less wise virgins in her unit.

However, *Wireless World* readers, like other great men of science, appear to be somewhat shaky where the more elementary facts of their chosen subject are concerned, judging by a recent experiment which I carried out in London. It is, I think, betraying no secrets to the enemy when I say that the attention-compelling cover of this journal is to be seen everywhere



"A Waaf of my acquaintance"

nowadays in tubes, buses and other public places, being pored over by studious young men in uniform muttering angry disagreement to themselves as they peruse its pages. I have, for some weeks past, made it my business to get into conversation with them by using my own copy of the journal as a medium of introduction and have been truly astonished at the amount of ignorance they have displayed concerning the veriest elements of radio and electrical science, whilst at the same time being on terms of the greatest familiarity with abstruse aspects of it, which would be not unworthy of my own attention.

By

## FREE GRID

My stock question to them has been the seemingly simple and elementary one: "What is the speed of electricity?" In the most part I have received the instantaneous and unthinking reply: "186,000 miles-per-second," and have had quite a task explaining that I am not seeking their opinion on the speed of ether waves but of the humble electron moving round a simple DC circuit like that of an electric torch.

I am wondering if I was singularly unfortunate in my choice of questionees (Government-sponsored word) or whether the majority of you are equally ignorant. Please let me know on a postcard. The Editor's decision will be final, even if he doesn't know the proper answer himself.

## "All for Adolf"

I AM particularly glad to see that the Editor is taking a firm line on the question of wire or wireless broadcasting, since it is a course which I have been urging on him for a long time. It is quite evident, however, that neither he nor his Brains Trustees are as well informed as myself regarding the true extent of the underground preparations that are being made to deprive us of our ethereal freedom.

I can scarcely believe that such normally well-informed people as those whose views on the subject have been published in the *Wireless World* Brains Trust—D. A. Bell in particular—can be unacquainted with the latest developments in "conducted carrier" technique as their remarks would lead me to believe, and I can only assume that the grim jest contained in the use by the "All-Metal" protagonists of the expressions "piped transmissions" must have escaped their notice.

The truth of the matter is, of course, that the programmes are to be distributed to us along the gas mains—surely a very appropriate medium for them—for the very simple reason that in our larger cities with their huge preponderance of gaunt pre-war houses, mostly occupied by the less fortunate sec-

tion of the community, gas is still the only illuminant available—and this in spite of the much-vaunted "grid."

With modern "conducted-carrier" high-frequency technique the absence of ordinary electrical insulators is no disadvantage as very little energy will be dispersed in the surrounding soil. Actually, gas pipes possess the very great ad-



"Prelude to piped programmes."

vantage that there is no noisy and troublesome AC or DC to filter out. Naturally a certain amount of interference will travel along the pipe, but it can easily be "choked off" by winding the mains in the form of an inductance at the point where it enters the house, an arrangement which I myself first brought to notice in these pages in the case of water pipes as long ago as September 18th, 1934. The original sketch is reproduced herewith.

There does, of course, remain the problem of the dwellers in our ancient villages who still pig-headedly prefer the tangible light of oil lamps to the "flowing" promises of the Central Electricity Board. This is, however, to be solved by the use of helicopters (now being developed at the taxpayers' expense for alleged war purposes) to hover over the villages and distribute broadcasting communally by giant loud speakers. The programmes will be beamed to the helicopters direct from London. In this manner it is hoped to get the inhabitants of each village to club together and pay for mains to be laid on to their locality in order to stop the infernal racket overhead, thus saving the lighting and heating authorities a lot of expense.

Personally speaking, Adolf's "New Order" seems to me by far the lesser evil of the two, and I am seriously thinking of rousing the masses to support him with the stirring slogan of "All for Adolf." After all, even a Volksempfänger is preferable to no wireless at all.

# WORLD OF WIRELESS

## B.B.C. DIRECTORS

FOLLOWING the resignation through ill-health of Sir Cecil Graves, Joint Director-General of the B.B.C., the Board of Governors has appointed the remaining Joint Director-General, Robert Foot, as sole Director-General and executive officer of the Corporation.



Sir Noel Ashbridge.

The Governors have also made a new appointment, that of Editor-in-Chief, and have chosen W. J. Haley, who, with the D.G., will be jointly responsible for the character and quality of the Corporation's output. Mr. Haley, who served as a wireless operator at sea during the latter part of the Great War, is joint managing director of the Manchester Guardian and Evening News, Ltd., and a director of Reuters and of the Press Association.

General approbation will be felt in wireless circles by the appointment of a technician to the important post of Deputy Director-General. Sir Noel Ashbridge, who has been appointed to this office, joined the B.B.C. in 1926 as Assistant Chief Engineer, becoming Chief Engineer in September, 1929. For six years prior to joining the B.B.C. he was with Marconi's at the experimental station at Writtle, Chelmsford. He is a member of the Radio Research Board and Past-President of the I.E.E.

Sir Noel's successor as Controller of the Engineering Division is H. Bishop, at present Assistant Controller. He came to the B.B.C. from the Marconi Company just after the first Chief Engineer, P. P. Eckersley, early in 1923. Previously he had worked on the original 2LO

transmitter at Marconi House, London. In 1929 he was appointed Assistant Chief Engineer.

R. T. B. Wynn, who has been appointed Assistant Controller, Engineering Division, also came to the B.B.C. from the Marconi Company in 1926 as head of the Technical Correspondence Department, becoming Senior Superintendent (Engineering) in 1935.

## I.E.E. PRESIDENT

THE first meeting of the 1943-44 Session of the Institution of Electrical Engineers will be held on Thursday, October 7th, at 5.30, when Col. Sir A. Stanley Angwin, who takes up his appointment as President on September 30th, gives his inaugural address.

Sir Stanley, who was created a Knight-Bachelor in June, 1941, has been Post Office Engineer-in-Chief for the past four years, having previously been Deputy Engineer-in-Chief. He joined the Post Office in 1906 and has contributed largely to the design of the Post Office transmitting stations and the introduction of the co-axial cable for the television service.

Sir Stanley has represented the Post Office at many international telecommunications conferences and is a member of the Television Advisory Committee.

## AUSTRALIAN RADIO

SIR ERNEST FISK, chairman of Amalgamated Wireless (Australia), was the guest of honour at



H. Bishop, who succeeds Sir Noel Ashbridge as B.B.C. Controller of Engineering.



## Come lovely Flowers

And so it is that from the darkness of the present hour will emerge a brighter day when the

brain and brawn of modern industry will be utilised in further peacetime products and pursuits. While serving the Government to-day we are broadening both creative and manufacturing possibilities for a happier world to-morrow. Astatic engineers are available to work in co-operation with electronic engineers in the development of new wartime equipment, especially as it may have to do with pickup and transmission of sound. Astatic crystal microphones, pickups, cartridges and recording devices will be available again for your use when those brighter days are here.

Register your name with our Representative for your future benefit.

# ASTATIC

THE ASTATIC CORPORATION  
YOUNGSTOWN, OHIO, U.S.A.  
TORONTO, CANADA.

Exclusively Represented by

Frank Heaver Ltd. Kingsley Road,  
Bideford, N. Devon.

# CROWNAME

RADIO COMPONENTS

THE radio industry is contributing its share towards the assurance of a free world. As a part of that industry, CROWE will continue its peacetime leadership when the assurance is won.



CROWE NAME PLATE AND  
MANUFACTURING CO.  
CHICAGO, ILL. U.S.A.

Exclusively Represented by

Frank Heaver Ltd. Kingsley Road,  
Bideford, N. Devon.

## Wireless World

### World of Wireless—

the August luncheon of the Radio Industries Club. Speaking of the development of beam transmission between Great Britain and Australia, he stressed the need for the development of communication systems within the British Empire.

Australia's two broadcasting systems, the National Service, based on the B.B.C., and the Commercial Service, operated by private enterprise and financed by advertisement revenue, include 140 comparatively low-powered transmitters. Sir Ernest gave the latest figure of Australia's licence holders as 1,500,000, each of whom pays £1 per annum.

### NEWS IN MORSE

A REVISED schedule of transmissions of official news bulletins radiated in morse from the G.P.O. stations has been received since that published last month. Although intended for oversea listeners, the transmissions may be heard in this country. The call signs and the wavelengths employed are:—

GAA	.....	14.72m	GCP	.....	27.86m
GIA	.....	15.27	GIH	.....	28.17
GAD	.....	15.40	GAY	.....	33.67
GID	.....	22.13	GBC5	.....	34.56
GIM	.....	23.13	GIJ	.....	42.95

The times (GMT) of the broadcasts and the call signs of the transmitters radiating them are:—

*0045	: GBC5, GIJ.
0930	: GIA, GID, GIH.
1302	: GAD, GIA, GID.
1602	: GAD, GIA, GID.
1800	: GIM, GCP, GAA.
*2000	: GIM, GBC5.
2330	: GAY, GIH.

Transmissions marked with an asterisk are continuations of the preceding broadcasts.

The B.B.C.'s morse transmissions of news in English are now radiated from 0045 to 0100 (GMT) on seven wavelengths in the 49- and 41-metre bands.

### RADIO OFFICERS' BRAVERY

THE Lloyd's Medal for bravery at sea has been awarded to Radio Officer George Kenmure Garstin. Although it was obviously only a matter of minutes before his ship, which was torpedoed whilst sailing in convoy to Russia, would sink, Radio Officer Garstin, having heard the order to abandon ship, refused to leave the wireless cabin until he was satisfied that the messages he had sent out for help had been received. The Medal was also awarded posthumously to Third Radio Officer Richard Phillips, who lost his life in rescue attempts after he had succeeded in getting a portable transmitter into a lifeboat.

### BRIT. I.R.E.

SIR LOUIS STERLING presided at the annual general meeting of the British Institution of Radio Engineers held on September 3rd

(not 16th, as stated last month).

At the conclusion of the business Sir Ernest Fisk, first president and immediate past-president of the Institution of Radio Engineers of Australia, addressed the meeting. He gave an interesting survey of the history of wireless telegraphy and broadcasting from the beginning of the century, describing some of the technical and prejudicial difficulties that had to be overcome before direct Empire communication, so essential to Australia, could become an accomplished fact.

He said he looked forward to the time when the two Institutions could work in co-operation.

### U.S. SHORT-WAVE STATIONS

PERMISSION has been granted the World Wide Broadcasting Foundation of Boston, Mass., to erect two new short-wave transmitters at Scituate, Mass. Like the existing World Wide transmitters WRUL, WRUW and WRUS, and, in fact, all short-wave stations in the States, the new transmitters will be operated by the owners, but the programmes will be supervised by the Office of War Information.

Call signs have not yet been allocated to these latest outlets for the "Voice of America," which will operate on 6.04, 9.70, 15.35, 17.75 and 21.46 Mc/s.

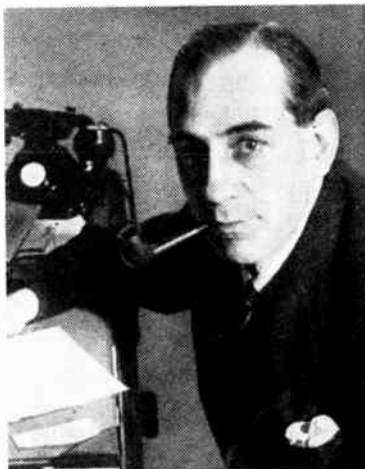

R. T. B. Wynn, the new Assistant Controller (Engineering Division) of the B.B.C.

### IN BRIEF

**Receiving Licences.**—In Great Britain and Northern Ireland the total number of receiving licences is now well over 9,250,000.

In Sweden the number of wireless licences at the end of June was 1,670,188, that is, 259 licences per 1,000 inhabitants.

### New Radio-phototelegraphic Service.

—It is announced by Cable and Wireless that a phototelegraph service between London and Sweden commenced on August 21st last.

### B.B.C. Short-wave Bulletins.

Various short-wave services of the B.B.C. are being increased as the tempo of the war quickens. The latest list includes transmissions in 49 languages. The following schedule of transmissions of news in English on short waves will be in use from September 26th. Times are given in BST.

0015†					
0045†	25.53,	25.68,	30.53,	31.32.	
(206)					
0345	25.68,	30.53,	30.96,	31.32,	41.96.
0530	42.13,	42.46,	48.43,	49.10,	
0605	19.91,	25.47,	25.53,	25.68,	30.53.
	31.25,	31.32,	31.55,	42.13.	
0715	19.66,	19.91,	25.47,	25.53,	25.68.
	30.53,	31.25,	31.32,	31.55,	42.13.
0830	16.92,	19.60,	19.66,	19.91,	25.47.
	25.53,	25.68,	30.53,	31.55,	42.13.
0900	24.80,	25.58,	31.12,	31.25,	31.32.
	31.61,	31.75,	31.88,	41.01,	41.32.
	41.96,	42.46,	48.43,	48.98,	49.59.
1200	13.97,	16.64,	16.79,	16.84,	19.44.
1400	19.60,	19.91,	25.53.		
1600	13.97,	16.64,	16.79,	16.84,	16.92.
	19.44,	19.46,	19.60,	19.91,	24.92.
	25.68,	31.55.			
1700	16.59	16.64,	16.92,	19.60,	19.66.
	25.53.				
1900	16.92,	19.60,	19.66,	19.82,	25.29.
	25.53,	31.25,	42.46.		
2045	16.92,	19.60,	19.66,	25.53,	31.25.
2145	16.94,	25.29,	30.53,	31.41,	31.55.
	31.88,	41.49,	41.75,	41.96,	42.46.
	48.98,	49.42,	49.92.		
2245‡	25.53,	25.68,	30.53,	31.32.	
2300	31.25,	42.46.			
2345	25.53,	25.68,	30.53,	31.32.	

† Sundays only. ‡ Sundays excepted.

### Institution of Electrical Engineers.—

The Wireless Section of the Institution is holding its first meeting of the new Session at 5.30 on Wednesday, October 13th, when T. E. Goldup, chairman, will present his inaugural address. An informal meeting of the Institution will be held at 5.30 on Monday, October 25th, when the president will open a discussion on "How Far is International Standardisation in the National Interest?"

**I.E.E. Students' Section.**—Officers elected for the 1943-1944 Session of the London Students' Section of the Institution are as follows: J. D. McNeil, chairman; C. C. Barnes, vice-chairman; H. Shorland, hon. secretary; B. Rosenblum, hon. assistant secretary.

**Waste Paper.**—The salvaging of waste paper is still a national necessity. During the first six months of this year fifty-seven tons of waste paper were salvaged by the main branches of the B.B.C. Strict economy by the Corporation in the use of new paper has resulted in a substantial saving of new supplies.

**"News in English from Abroad."**—It is regretted that pressure on our space this month has necessitated this regular feature being held out.

### ERRATUM

**"Wide-range R-C Oscillator";** September issue.

The expression  $\sqrt{2.R}$  (p. 263, 9th line from bottom of col. 3) should read  $\sqrt{2.R}$ ; the square root sign applies only to the figure 2 and not to R.



## Letters to the Editor

### Contrast Expansion and Distortion. Pick-up "Tracking Arms"

#### Contrast Expansion

IN discussions of the objects and drawbacks of automatic compression followed by expansion, it is desirable to distinguish between two classes of communication systems.

In one class, any transgression of a certain output level incurs the immediate penalty of non-linear distortion. This class includes amplitude - modulated carrier systems, and systems in which one link such as a power valve may overpass the limits of its linear action.

In a second class, a level exists, below the distortion level, which may be exceeded occasionally without penalty, provided that the practice does not, so to speak, become a habit.

This earlier restriction may be imposed by cross-talk into adjacent lines, or by the heat dissipation of valves. In frequency-modulated carriers, an occasional splash into a neighbouring frequency band may be permitted, provided that it occurs rarely. In lateral gramophone recording, a rather wider swing is permissible to the groove, if the chance of a wide swing on the neighbouring grooves is small. It is in systems of the latter class that distortionless "compansion" becomes possible and useful. If the compressor and expander circuits have equal responses both in phase and amplitude, they will together introduce no distortion of any sort into the system, and will escape the objections of Mr. Hughes in his letter of July, 1943.

I have had experience of such a system in a gramophone recorder and reproducer. I found a short time-constant of the order of 30 milliseconds suitable both for onset and recovery.

As a footnote, I would like to express my disillusionment with automatic contrast expansion used otherwise than with a few selected records, or with records made with a compressor the inverse of the expander. The most unhappy results are obtained

when attempting to undo the work of a control engineer who has brought up the gain during a quiet passage to unity signal/cough ratio.

C. E. G. BAILEY.

Mullard Radio Valve Company,  
London, W.C.2.

IT seems rather regrettable that the present correspondence on volume expansion has produced so little "meat," while the letter from J. R. Hughes only serves to increase the confusion. It is accepted that a good volume expander greatly enhances the dramatic appeal of a suitable recording and that surface noise is considerably reduced, but Mr. Hughes appears to believe that the distortion introduced on transients is such a disadvantage that volume expanders are not worth while.

Mr. Hughes does not produce any data to support this last point (in fact such data is not available), but attempts to decry the value of judgment tests with a lot of vague statements that listening tests of this type are unsatisfactory. Judgment tests form the backbone of any method of assessing sound quality and are in widespread use by all the research laboratories engaged on acoustical development. When put to critical test they have shown surprising agreement. With five minutes' thought, I found it possible to write down twelve different types of distortion that an electro-acoustical system might introduce. Quantitative data on the quality deterioration introduced is available on only three of the twelve. In the present stage of the art there is therefore no means of assessing quality other than the use of judgment tests.

The ideal is well known (Mr. Hughes, paragraph 5) but it cannot and never will be obtained, and it becomes necessary to find out what departures from perfection are permissible before the ear detects the departure. This is plain common sense.

Regarding transient distortion,



THE "FLUXITE QUINS" AT WORK

*One day young OO had a fright,  
Thought the radio set was alight,  
With unerring aim  
She extinguished the flame  
(And old EH—mending wires—with Fluxite.)*

See that FLUXITE is always by you—in the house—garage—workshop—wherever speedy soldering is needed. Used for over 30 years in Government works and by leading engineers and manufacturers. Of all Ironmongers in tins, 8d., 1/4 and 2/8.

Ask to see the FLUXITE SMALL-SPACE SOLDERING SET—compact but substantial—complete with full instructions, 7/6.

**TO CYCLISTS!** Your wheels will NOT keep round and true unless the spokes are tied with fine wire at the crossings AND SOLDERED. This makes a much stronger wheel. It's simple—but FLUXITE—but IMPORTANT.

The FLUXITE GUN puts FLUXITE where you want it by a simple pressure  
Price 1/6, or filled, 2/6.



ALL MECHANICS WILL HAVE

# FLUXITE

IT SIMPLIFIES ALL SOLDERING

Write for Book on the ART OF "SOFT" SOLDERING and for Leaflets on CASE-HARDENING STEEL and TEMPERING TOOLS with FLUXITE. Price 1d. each

**FLUXITE LTD.**  
(Dept. W.W.), Bermondsey Street, S.E.1.

## Letters to the Editor—

I have said that the distortion may be there, but is so small that it is absolutely indistinguishable on the vast majority (99 per cent.) of records. The surface noise reduction is a real advantage and is clearly apparent on every record, while the increase in dynamic range is surprising on at least 50 per cent. of the records.

Complete quantitative data on the effect of small transient distortions is lacking but the two following items are of some value.

On looking back over my pre-war results I note that on a volume expander designed in 1936, I found that at 400 cycles the 2nd harmonic was 52 db. and the 3rd harmonic 40 db. down on the fundamental. To express the transient distortion is more difficult. One might express this mathematically as the output voltage obtained from an input Heaviside function, or one might portray the output wave graphically, but there is no method of correlating this with "how does it sound." Regrettable, but that is the present position. Judgment tests were very favourable, as mentioned in my first letter.

Volume expanders can be built with an "opening time" of 10 millisecs. and a "closing time" of 1 to 2 seconds without any particular difficulty, and I am afraid that it never occurred to me to design expanders with other than unequal opening and closing times.

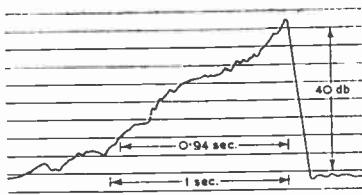

Mr. Hughes does not seem to like this, but perhaps he will tell us which instrument produces a sudden decline in power output and after that, what he thinks will happen in any room in which it is played. The accompanying record, taken with a high speed level recorder in my room (14ft. x 12ft.), represents the 256-cycle note on the piano, sounded for as short a period as I was able. It will be seen that, starting from the right, the rate of rise is limited by the recorder characteristic (300 db/sec.) but a 30-db

decay requires a period of 0.94 sec. This is the justification for rapid opening and long closing times in expander circuits.

Regarding the suggested method of introducing non-linear distortion (final paragraph of Mr. Hughes' letter) as an alternative to amplitude control, a little consideration will show that if this is applied to a volume compressor/expander circuit using an auxiliary control tone (the probable solution for sound film) the phase characteristic requirements of the system become impossible of attainment, while if the standard expander types are used, the overall distortion is likely to be tremendous owing to the difficulty with the frequency characteristic of the transmission channel.

In conclusion, volume expanders are not without their disadvantages (like any car) but so far nobody has mentioned them. I rather suspect that the critics have little practical experience.

Rugby J. MOIR.

## Pick-up Mounting

IN the recent correspondence on gramophone pick-ups the pivoting systems for the tracking arms were usually not described, and at least one writer was having trouble on this account. Since the discussion died down I have evolved what appears to be as simple and satisfactory a construction as possible, and it is described below.

The tracking arm is of  $\frac{1}{4}$  in. copper tubing bent into an "S" shape to secure the best tracking conditions. At the bearing end a  $1\frac{1}{2}$  in. length of bicycle spoke is soldered transversely through the tube. This forms the bearing pin, and it rotates in two  $\frac{1}{8}$  in. bearings. These are carried on a sheet-brass yoke, which is sweated to a  $\frac{3}{8}$  in. length of  $\frac{3}{16}$  in. rod which is carried on a  $\frac{1}{8}$  in. steel ball, forming a footstep bearing in the mounting pillar.

Since the arm is counter-balanced the pressure on the walls of the traversing bearing is always small and the stiffness slight. The frictional effects caused by the bearing using the cycle spoke are also slight because of the small diameter of the pin.

Satisfactory connection for the earthy side of the circuit is made through the footstep bearing. A short coiled length of No. 28

SWG wire is used for the live side.

There is practically no slackness in the system as a whole and the pick-up tracks satisfactorily on all records with a 12-gm. needle-tip pressure.

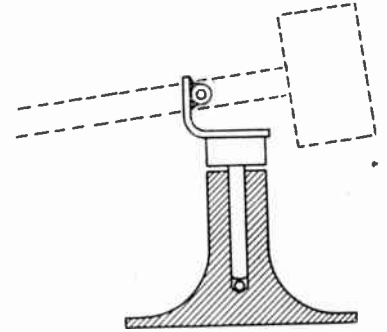

It has been suggested that the torsional resonance of the tracking arm is least when the arm is as low as possible. There is a further means of reducing the resonance. If the axis of the arm passes through the point of contact of the needle with the record there is no torque applied to the arm. This condition can be approached by sloping the tracking arm downwards towards the pick-up head so that its axis passes as near the needle tip as possible.

Finally, I would draw attention to my use of the term "tracking arm," which I consider more suitable than the title "carrying arm" suggested by Mr. Aldous.

A. C. ROBB.

Upton, Ches.

## Wire or Wireless?

IN your September issue, under the heading "Against Wired Broadcasting," you state that "most wireless men object to a system that threatens the expansion of their technique."

Surely this statement cannot be applied to wired broadcasting.

In the system of wired broadcasting developed by the G.P.O. and described by Dr. Walmsley in the *Journal of the Institution of Electrical Engineers*, provision was made in the design of the apparatus used at the subscribers' end for the receiving of programmes sent out by means of wired broadcast and also for the reception of radiated programmes.

The inference is that wired broadcast is not intended to replace radiated programmes, but is there as an alternative, to be

used at the discretion of the subscriber.

It appears, therefore, that far from threatening the expansion of wireless technique, wired broadcasting opens up opportunities for the expansion of development in existing fields, and also opens new fields for the research into and development of wired broadcast systems.

The set manufacturers who, as stated, represent 80 per cent. of the wireless industry, would be called upon to develop receivers capable of receiving both radiated and wired broadcast programmes.

The firms representing the other 20 per cent. would have, in addition to their existing work, the development and manufacture of the apparatus required for wired broadcasting, i.e., transmitters, carrier frequency amplifiers, etc.

RALPH T. LAKIN.

Mansfield, Notts.

AS a keen radio man—but not at all interested in the economic welfare of the radio manufacturer—I feel the point of view of the quality enthusiast has not been sufficiently stressed in the “wire *versus* wireless” controversy.

A wired carrier-current system would seem definitely to offer the ideal means of meeting our requirements for modulation frequencies up to at least 15 kc/s with high signal/noise ratio and freedom from the defects and irritations of the purely radio path—interference, heterodynes, selective fading, etc.

The one danger with wired broadcasting seems to be the attempt to provide too many channels. Eckersley has proposed six—surely unnecessary!—with modulation frequencies up to 8 kc/s; while admitting that the quality would be as good, probably better, than most commercial receivers provide at the present, I should be dead against such a limitation of frequency range. Reduce the number of channels and allow us at least one high quality signal covering programmes free of recorded matter and bad land lines.

That high quality is appreciated even by the uninitiated is easily shown, and I think that on this score alone, a special service of a single channel of this nature is worthy of consideration and the

results, provided always, of course, that the terminations did it justice, would be a self-advertisement.

R. W. BATT.

Cosham, Hants.

“CONTRAST EXPANSION UNIT”

IN the article under this title by D. T. N. Williamson in the last issue the diagram (Fig. 4) showing the waveform of a struck string was inadvertently reversed; the maximum amplitude should have appeared at the left of the diagram, thus:—

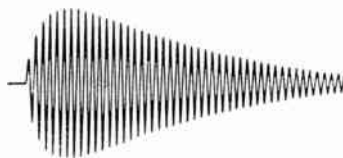

Fig. 4

At the same time we are taking the opportunity of redrawing Figs. 2 and 3 to bring out the essential points of the author's original drawings more clearly. Fig. 2 (b) should have shown the original contrast of (a) at the instant of amplitude increase (the expansion being additional to this).

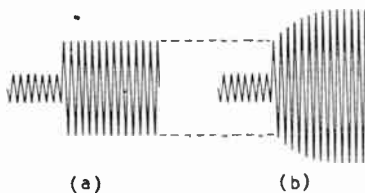

Fig. 2

Similarly, Fig. 3 should show the initial change in amplitude followed by a further reduction under the influence of a long time constant.

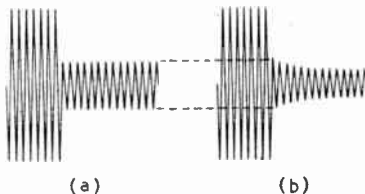
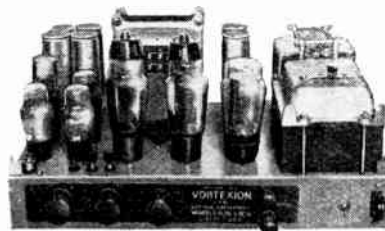

Fig. 3

In Fig. 7 the electrolytic condenser C10 should be connected with its positive terminal to chassis and negative to the junction of R17 and R18. Also the resistance next to the cathode of V1 should be R2 and not R4.

# The Improved VORTEXION 50 WATT AMPLIFIER CHASSIS



The new Vortexion 50 watt amplifier is the result of over seven years' development with valves of the 6L6 type. Every part of the circuit has been carefully developed, with the result that 50 watts is obtained after the output transformer at approximately 4% total distortion. Some idea of the efficiency of the output valves can be obtained from the fact that they draw only 60 ma. per pair no load, and 160 ma. full load anode current. Separate rectifiers are employed for anode and screen and a Westinghouse for bias.

The response curve is straight from 200 to 15,000 cycles. In the standard model the low frequency response has been purposely reduced to save damage to the speakers with which it may be used, due to excessive movement of the speech coil. Non-standard models should not be obtained unless used with special speakers loaded to three or four watts each.

A tone control is fitted, and the large eight-section output transformer is available in three types: 2-8-15-30 ohms; 4-15-30-60 ohms or 15-60-125-250 ohms. These output lines can be matched using all sections of windings and will deliver the full response to the loud speakers with extremely low overall harmonic distortion.

PRICE (with 807 etc. type valves) £18.10.0  
Plus 25% War Increase  
MANY HUNDREDS ALREADY IN USE  
Supplied only against Government Contracts

## VORTEXION LTD.

257, The Broadway, Wimbledon, S.W.19

Phone: LIBerty 2814



# RANDOM RADIATIONS

By "DIALLIST"

## The Daniell

THE suggestion made by a *Wireless World* Brains Trustee that the factor eleven in the 132 kV of the grid power lines can be traced back to the 1.1-volt EMF of the Daniell cell is interesting and I have an inward feeling that he may be right. Only one thing is against it and that is that 132 kV is the voltage of power lines in one or two other countries. Had this figure been used in Britain alone, I'd have swallowed the Daniell explanation hook, line and sinker. The Daniell certainly was in use before the volt came along and persisted for some time afterwards. I'm sure I can remember seeing it in old books on electricity. It may well have lingered on even amongst technicians, for we have a national fondness for retaining weird, out-of-date units such as "hand," "cran," "sitting," "chaldron," "leash" and "square." Even the "leaguè" as a measure of distance remained in regular use until comparatively recent times. Do you remember Jules Verne's *Journey to the Centre of the Earth*? I seem to recall that the professor in that highly imaginative work made electrical apparatus, containing a Runkorff coil, which produced a pressure of a vast number of Daniells. If the Daniell was an accepted measure of EMF in Jules Verne's time, it might easily have been used in the calculations of those who designed and laid out the earliest electricity supply systems. On this hypothesis our Grid voltage is really 120 kilodaniells (help!) and the round figures of which we are all so fond are preserved beneath the overlying crust of the volt.

## And the Hertz

What has happened to the Hertz, meaning a cycle-per-second? It seems to have dropped out of use altogether. When the first of the great Plans (the Geneva, wasn't it?) for ending Europe's broadcasting chaos was adopted the ultra-correct B.B.C. always gave the frequencies in kilohertz in all the station-lists that it published. The man-in-the-street much preferred the wavelengths, in which he has been brought up, to the (to him) new-fangled frequencies. So far as he swallowed the latter at all, he swallowed them in kilocycles and would have nothing to do with kilohertz. Some rather pedantic technical authors strove to uphold

the Hertz and its various compounds, but others were content with kilocycles-per-second. Nowadays most people say and write just kilocycles or megacycles, though the "per-second" part is retained in the written abbreviations always used, kc/s and Mc/s. Hertz did such wonderful pioneer work in wireless that it seems a pity that his name cannot be commemorated by a wireless unit of measurement. Curious—isn't it?—that to achieve the spelling of your name with a small letter is one of the highest pinnacles of scientific fame?

□ □ □

## Utility Sets

ONE correspondent writes that he couldn't disagree with me more over what I wrote recently on the subject of utility sets. After reading his letter carefully I can't quite make out why! He is a quality enthusiast; so am I. He feels that the manufacturers have in the past taken the wrong line by emphasising the station-getting powers of their sets in their advertisements and so on; so do I. He wants an adequate number of new receivers to be available as soon as possible to the public; I want the same thing. Where, perhaps, we do differ is in two points, not, so far as I can recall, mentioned in my notes, but stressed in his letter. My correspondent thinks that (a) now is the time to educate the public up to high-quality reception, and (b) that it is possible to produce low-priced utility receivers that will give such quality. I can't see eye to eye with him in either of those contentions. At the moment the majority of listeners seem to desire two things mainly from their wireless sets: news and light entertainment. And for neither of these is high-quality reception of paramount importance. If you want proof that quality doesn't matter—that it is actually repugnant to the tastes of most of those who listen to dance bands and such-like, observe the setting of their tone controls when modern music is coming in. In an least eight cases out of ten you'll find that such "top" as the set may have—and that often isn't much—has been removed in order to produce the mellow (i.e., topless) reproduction that seems essential to palliate the horrid noises made by muted trumpets, jazz clarinets and other queer instruments, including the strident female crooner.

## In Self-defence

Speaking of crooners reminds me that that eminent critic Mr. James Agate has offered an explanation of the reason why they use microphones when performing on the stage before an audience. I'd always thought that it was due to the fact that their bleating voices were too feeble to fill an auditorium of any size. Mr. Agate has come to a different conclusion. Most of them, says he, become known to the great mass of the people by their broadcasting. Those who hear them use receiving sets either inherently incapable of good quality, or so "toned down" that the reproduction is queerly distorted. Having heard crooners and other alleged singers under these conditions, they conclude that this is what their efforts really sound like. If they went to theatres and heard their favourites performing without distortion introduced, wilfully or incidentally, by microphone, amplifier and loudspeaker, they would feel that something was lacking and would be disappointed. In other words, they have come to prefer the distorted sounds associated with "canned" music to the real thing.

## The Price of Quality

Few, I think, will agree with my correspondent's second contention: that you can mass-produce quality receivers at a low price under wartime conditions. The average purchaser doesn't realise that whilst it is a comparatively inexpensive business to turn out sets that will bring in lots of stations, the bits and pieces necessary for good-quality reproduction are far from being cheap or easy to make. It's the AF side of the set that eats up the money, unless you are content to put up with a fair amount of distortion. My own feeling is that whilst the war is on it is best to accept moderate quality of reproduction—just as we accept moderate quality in so many other things—in order to be able to satisfy the big demand for new sets to replace those that are worn out and beyond repair. Broadcast reception is a necessity rather than a luxury in the wartime home, and the only way to enable as many as possible of our nine million licensed listeners to have it is to ensure a regular supply of new sets, sufficient to replace the old ones that pass out. In present circumstances there would seem to be no means

of doing this unless the new sets are of simple type and made up of more or less standard parts. Therefore I support the utility set—but as an emergency measure only.

□ □ □

### Post-war Channels

WHETHER or not wired broadcasting is developed as a competitor of the existing wireless variety there is little doubt that the medium- and long-wave stations of Europe will continue their activities for some time after the blessed return of peace. And what a grand opportunity there will be to settle the allocation of broadcasting channels on a rational basis. The last pre-war plan continued the 9-kilocycle separation between channels on the medium-wave band and adopted something even smaller on the long waves, if my memory isn't at fault. Now a separation of 9 kc/s is not enough if receiving sets are to reproduce speech and particularly music with good quality. We can't do with less than 10 kc/s, and we must see that it is adopted. The 9-kc/s basis was agreed upon because in those rather turbulent times nothing better could be done.

### What Separation ?

As I've said, 10 kc/s is the smallest channel separation that is going to be satisfactory from the quality point of view. We know that it is possible to fit in large numbers of stations on a 10-kc/s basis if there is a supervising authority armed with real powers, for it has been done with most satisfactory results in the U.S.A., where the Federal Communications Commission can and does enforce its decisions, banishing recalcitrant stations from the ether if need be. And there is another reason why the 10-kc/s separation is so much to be desired. The broadcasting bands divide themselves automatically in the most convenient way. On the medium-wave band we have channels on 550, 560, 570 kc/s and so on up to 1,500; there are no odd kilocycles or decimal parts of kilocycles to remember. And we can leave out the final nought in every case, calling them simply channels 55, 56, 57 and so on. Not only are these easy to remember, but they also make the calibration of broadcast receiver dials simplicity itself. American receivers made for home use are often calibrated in this way. It is rare to hear wavelengths mentioned by Americans when speaking of their broadcasting stations: they find channel No. 72 much easier to remember than 416.6 metres.

## COMMUNICATIONS DEPEND...

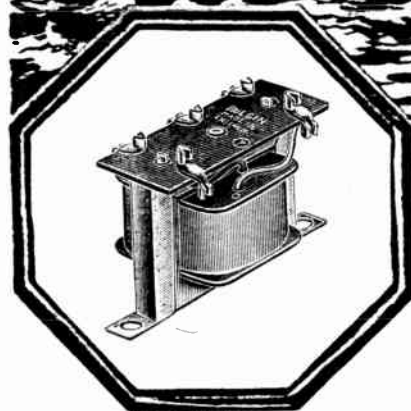
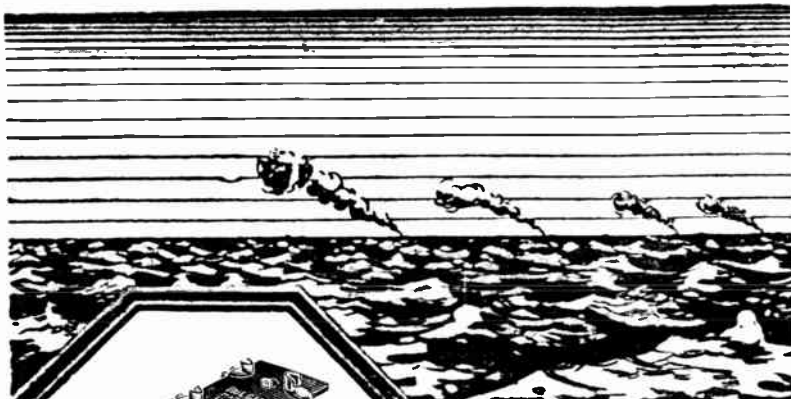

## ON SMALL PARTS...

In countless instances quite intricate pieces of apparatus are wholly dependent on the proved reputation and reliability of their component parts.

All products from the House of Bulgin are pre-eminent for superior design and workmanship and every article bearing our Trade Mark has to pass exacting and exhaustive tests during the course of its production.

We ask the kind indulgence of the Trade on delivery until peaceful conditions return.

*The Choice  
of Critics*

**BULGIN**

FOR

**TRANSFORMERS**

THE largest and most extensive range of midget and ultra small intervalve (voltage) transformers in the world. Provided with high- $\mu$  cores and carefully proportioned windings of finest enamelled-copper wires. All joints welded; mono-metallic from start to finish for long life under all conditions.

**"The Choice of Critics"**

**BULGIN**

REGISTERED • TRADE • MARK

A. F. BULGIN & CO. LTD., BYE PASS RD., BARKING,

TEL. : RIPPLEWAY 3474 (4 lines).

ESSEX

# RECENT INVENTIONS

## HEARING-AID AMPLIFIERS

THE diagram shows a portable microphone set in which negative feedback is used to ensure fidelity, and positive feedback to counteract the loss in gain as the battery runs down. Provision is also made to adapt the tonal response of the microphone to meet high or low levels of local noise.

Both the microphone M and the receiver Q are preferable of the piezo-electric type. A tapping P from a resistance shunting the output transformer T applies negative feedback (a) through a resistance R, condenser C and resistance R<sub>1</sub> to the grid of the last amplifier V<sub>3</sub>, and (b) through resistances R<sub>2</sub>, R<sub>3</sub> and a condenser C<sub>1</sub> to the screen grid of the first amplifier V<sub>1</sub>. As the resistance of battery HT increases, a proportional positive feedback is applied to the grid of the valve V<sub>2</sub> through a resistance R<sub>4</sub> and the condenser C<sub>2</sub>. It will be observed that

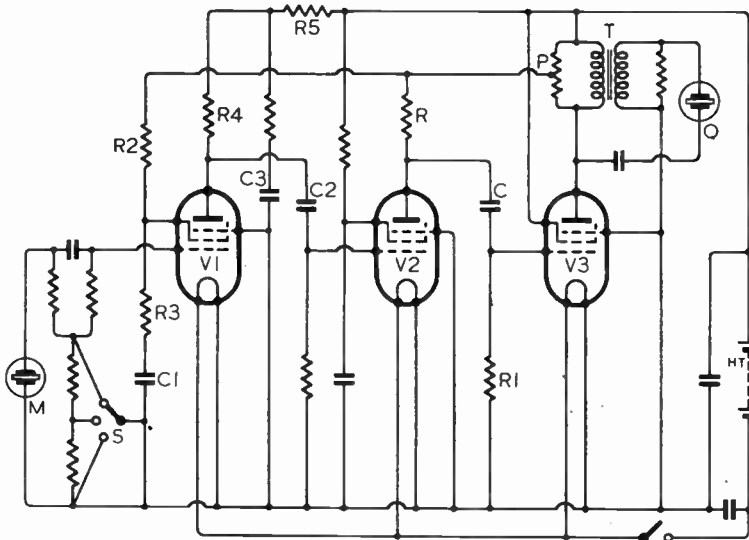

Battery amplifier with gain compensation.

the resistance R<sub>4</sub> is in the anode circuit of V<sub>1</sub>, and is also in series with the normal decoupling circuit R<sub>5</sub>, C<sub>3</sub> of the battery. A switch S allows the frequency response of the microphonic input to be varied to suit the personal needs of the user or to counteract abnormal local conditions.

Western Electric Co., Inc. Convention date (U.S.A.) December 24th, 1940. No. 552331.

## ELECTRO-MECHANICAL METERS

VARIATIONS of mechanical force are converted into equivalent voltages and are measured by a valve the gain of which is automatically controlled to give a straight-line law as between the mechanical and electrical values.

For instance, the pressure inside the cylinder of an internal combustion

## A Selection of the More Interesting Radio Developments

engine is applied to a diaphragm forming one plate of a variable condenser, which, in turn, constitutes one of the arms of a capacity bridge. High-frequency oscillations are applied to one diagonal of the bridge, and a voltage-modulated in accordance with the pressure variations is taken from the other diagonal and applied to the grid of a pentode amplifier. The output from the amplifier is fed to a diode from which a negative feedback is applied to control the gain of the amplifier so that the original non-linearity of the condenser response is corrected.

Philips Lamps, Ltd. Application date September 19th, 1941. No. 552098.

## RADIO ALTIMETERS

THE distance of a reflecting body can be measured by noting the time taken by a reflected radio wave to return to its point of origin. One known method of ascertaining the required time interval, which is of the order of microseconds, is to vary the frequency of the outgoing wave over a constantly repeated cycle, and to measure the beat-frequency set up between the outgoing and returning waves. Usually the same aerial serves both for transmission and reception.

In practice, the aerial tuning is fixed to coincide with the middle frequency of the repeated cycle. This means that the efficiency of the system necessarily falls off towards both extremes of the frequency sweep.

In the present arrangement the tuning of the aerial is linked through ganged condensers with the circuits of the carrier-wave generator, so that the exploring wave is radiated at maximum efficiency at all times. Since the difference between the highest and lowest operating frequency is only a small percentage of the carrier frequency, the small amount of detuning experienced by the incoming reflected wave is immaterial.

Standard Telephones and Cables, Ltd., and E. O. Willoughby. Application date September 26th, 1941. No. 552260.

## SIGNAL-TO-NOISE RATIO

THE total "noise energy" in the circuits of a receiver is proportional to the product of the power of the noise and time during which it persists. Accordingly if a receiver is made active only at intervals of, say, 1/5,000 of a second, repeated 500 times a second the resulting noise will be reduced by approximately ten-to-one in power. This will not, of course, improve the signal-to-noise ratio when receiving continuous signals.

If the outgoing signal is radiated in intermittent pulses, it can be transmitted at a much higher level of instantaneous or "peak" power than is possible for sustained or continuous operation. If the intermittent activities of the transmitter and receiver are synchronised a considerable improvement in signal-to-noise ratio is achieved, and this can be still further improved by the use of directive aerials.

The specification describes a system of pulsed transmission and reception which embodies the above-mentioned principle.

Marconi's Wireless Telegraph Co., Ltd. (Assignees of C. W. Hansell). Convention date (U.S.A.) December 27th, 1940. No. 552482.

The British abstracts published here are prepared with the permission of the Controller of H.M. Stationery Office, from specifications obtainable at the Patent Office, 25, Southampton Buildings, London, W.C.2, price 1/- each.

## CATHODE-RAY TUBES

THE fluorescent screen of a cathode-ray tube is laid directly on the inside wall of the glass bulb, the usual intervening layer of transparent metal being omitted. Its place is taken by coating the corresponding part of the external glass with a thin layer of gelatine containing lithium chloride or an electrolyte, such as phosphoric acid. This is covered, in turn, by a protective layer of transparent lacquer.

The arrangement prevents distortion due to external fields and allows, say, an oscillograph trace to be measured by a pair of callipers without hand-capacity effects, or a television picture to be closely examined without being distorted by the breath of an observer.

Philips Lamps, Ltd. (communicated by N. V. Philips Gloeilampenfabrieken). Application date October 14th, 1941. No. 552173.





## Diamonds

Outwardly, he is just an ordinary sort of man, doing his job in a quiet, unassuming way. But we know his history and his background, and can appraise the highly specialised skill which has been traditional in his family for generations. There are not very many like him in this country to-day.

He is a diamond driller; the products of his craftsmanship go into the thousands of diamond dies required

every year by industry for producing the delicate wires for the filaments of electric lamps and radio valves; for high precision scientific instruments and a host of other specialised purposes. He is one of the thousands of Philips workpeople who gave you, before the war, the Philips products you knew and trusted so well. His skill is a vital asset to the nation to-day.

# PHILIPS



## RADIO ★ LAMPS

## AND ALLIED ELECTRICAL PRODUCTS

PHILIPS LAMPS LTD., CENTURY HOUSE, SHAFTESBURY AVENUE, W.C.2 (25)

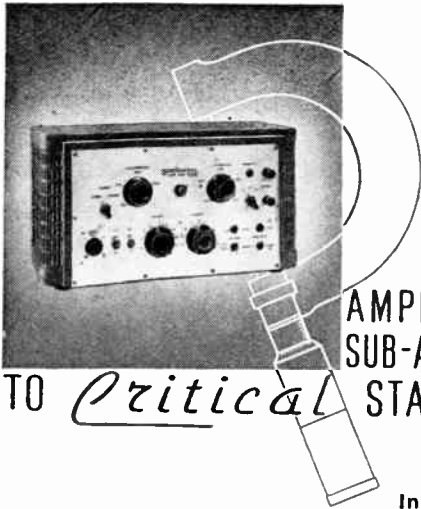

**AUDIO AMPLIFIERS & SUB-ASSEMBLIES TO *Critical* STANDARDS**

In addition to Standard Amplifiers the activities of Acoustical include Special Amplifiers for Industrial Applications, Microphones, Transformers, Coil Winding, Sheet Metal Work, Stampings, Switch Assemblies, etc.



**FOR THE RADIO SERVICEMAN DEALER AND OWNER**

The man who enrolls for an I.C.S. Radio Course learns radio thoroughly, completely, practically. When he earns his Diploma, he will KNOW radio. We are not content merely to teach the principles of radio, we want to show our students how to apply that training in practical, every-day radio service work. We train them to be *successful!*

Special terms for members of H.M. Forces.

-----You may use this Coupon-----

**INTERNATIONAL CORRESPONDENCE SCHOOLS Ltd.**

DEPT. 38, INTERNATIONAL BUILDINGS, KINGSWAY, LONDON, W.C.2

Please explain fully about your instruction in the subject marked X

Complete Radio Engineering. Radio Service Engineers.  
Elementary Radio. Television.

And the following Radio Examinations:—

British Institution of Radio Engineers.  
P.M.G. Certificate for Wireless Operators.  
Provisional Certificate in Radio Telephony  
and Telegraphy for Aircraft.

City and Guilds Telecommunications.  
Wireless Operator and Wireless Mechanic, R.A.F.

Name..... Age.....

Address.....

*On National Service* WITH.. 



**ROYAL ORDNANCE FACTORIES** ★



**AIRCRAFT WORKS** ★



**ASSEMBLY PLANTS** ★



**SCIENTIFIC INSTRUMENT MAKERS** ★

... IN FACT, wherever a high-grade light lubricating and penetrating oil is required



is 'on the job'. 301 uses in Factory, Workshop and Office.

Enquiries to:

Sole Manufacturers:  
A. S. BOYLE CO. LTD.,  
Chenies Street, London, W.C.1

Trade Distributors:  
ROLLINS & SONS (Ldn.) LTD.  
107 Fleet Street, London, E.C.4

**MUSIC WHILE YOU WORK**

For buildings up to 5,000 sq. ft.  
EARLY DELIVERY

For full details of equipment please write:

**R. M. ELECTRIC LTD.**

TEAM VALLEY  
GATESHEAD, 11

**M·O·R·S·E**

**COMPLETE PRACTICE UNIT**

as supplied to many branches of H.M. Services

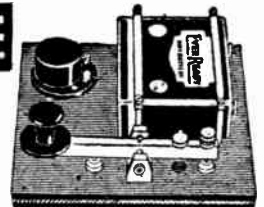

No. 1261. Complete Morse Practice Unit. Heavy commercial Key with nickel silver contacts and sensitive triple adjustment. High-tone Buzzer with silver contacts, mounted on bakelite base with cover. Battery Holder, complete with 4.5 Ever

Ready battery. All metal parts heavily nickel plated, and the whole mtd. on polished Mahogany Base, 6 1/2 in. x 6 1/2 in. Post paid,

**29/6**

Send 1d. stamp for Illustrated List

**SIGNALLING EQUIPMENT LTD., (Dept. 8)**  
Merit House, Southgate Road, Potters Bar. 'Phone: Potters Bar 3133

**CLASSIFIED ADVERTISEMENTS.** Rate 6/- for 2 lines or less and 3/- for every additional line or part thereof, average lines 5-6 words. Each paragraph charged separately. Press Day: November issue, first post Monday, October 11th, one day earlier at branch offices. Box Numbers: 5 words, plus 1/- deposit. System: particulars on request. No responsibility accepted for errors.

Ode

# Partridge

No. 25

"Where are we?"

The 'phone directory does not give

Our newest number and abode  
So if you wonder where we live  
'Tis not in Street or Lane or Road

Nor yet King's Buildings as before

Nor Park or Crescent, Drive or Hill,

'Tis not in Gardens or The Gore  
Where we your urgent needs fulfil.

If still you seek our new address  
These rhyming lines may serve, perchance,

On your taxed mem'ry to impress  
That we are now in Petty France.

We hope you'll call around one day

At seventy-six-stroke-eight,  
first floor,

But should time press, lift 'phone and say,

"Gimme Abbey Two-two-four-four."

## N. Partridge

Transformer Manufacturers,

76-78, PETTY FRANCE, LONDON, S.W.1. Telephone: ABBey 2244.

# ARMSTRONG SERVICE

OUR Service Department is still at your service.

Despite the many changes caused by over four years of war, and the difficulties in material and valve supplies, we have managed to maintain a very large proportion of Armstrong Chassis in good working order.

IN ADDITION

to practically all Armstrong Chassis, including very old models, we can now undertake the repair and overhaul of many other makes of receivers, including American types.

**ARMSTRONG MANUFACTURING CO.**

WALTERS ROAD, HOLLOWAY, LONDON, N.7  
Phone: NORth 3213

### NEW RECEIVERS AND AMPLIFIERS

**30-WATT** ac amplifiers, precision built instruments, input and output channels to requirements; early deliveries.—Below

**150-WATT** racks, comprising 5 amplifiers as above intercoupled, fitted for remote control for industrial installations; send for full details and illustrations; complete equipment, including speakers and microphones, etc., available.—Below.

**18-WATT** ac/dc amplifiers, mixing input channels, bass and treble controls, input and output transformers; 18gns.—Below.

**DANCE** and stage transportable equipment, comprising 18-watt amplifier as above, m/c mike, adj. stand, 2 speakers, cables; 36gns.

—Broadcast & Acoustic Equipment Co., Ltd., Broadcast House, Tombland, Norwich, 26976.

**£24** Only, new 7-valve "Wireless World"

**Quality Amplifier**, with tone control stage, 8-watt push-pull triode output, price includes super quality triple cone permanent magnet speaker with large output transformer and all valves; as above but with 15-watt push-pull tetrode output with inverse feedback, £25, ideal for quality reproduction; limited number available.—Bakers Selhurst

Radio, 75, Sussex Rd., South Croydon. [2040

**RECEIVERS AMPLIFIERS—SECOND-HAND**

**R.M.E.69**, AC Xtal, etc.; best offer, above

**R.£45** secure; stamp for details to BM/LASDO, W.C.1. [1998

**1938 R.M.E. 69** for sale. What offers?

**HOWARD 450A**, 12-valve, 10w, 0.5-65 Mc., crystal, dual i.f. speaker, perfect; nearest

**£40.—72, Leopold Avenue, Birmingham 20.**

**STRAIGHT Six**, with separate push-pull amplifier, Magnavox duode speaker, no cabinet.—Offers to Carr, 94, Sandford Rd., Chelmsford. [2068

**H.M.V. 650** 10-valve 5-band set, used under

**100** hours, appearance and condition as new, 5 new spare valves; £40, or near offer.—

Highlands, Slough Rd., Iver Heath, Bucks.

**FOR** sale, sound cell microphone, with built-in pre-stage amplifier, by Brian

Savage, £25; no offers.—Instructional Screen, Ltd., 9, Upper Berkeley St., W.1. Tel. Ambassador 2351. [2031

**NATIONAL H.R.O.** Junior communications

receiver, new 1940, power pack 230 volts a.c., speaker to match, coil units cover 10-20,

20-40 metres; offers invited.—Whitaker, Hopewell, Lighthelm, Halifax. [2044

**EDDYSTONE** All-World Eight superbatter

low consumption, battery 13 to 580

metres, tropical finish with separate speaker, perfect condition; Edinburgh district; offers.—

Box 2943, c/o Wireless World. [2050

**R.S. a.c./d.c.** 15w portable amplifier, 3 controlled inputs, 2 speakers, m.c. mike

and stand, portable grammo. Collaro universal motor, crystal pick-up; all £50 or near offer.

—Parfrey, 22, Denham Rd., Epsom. [2056

**FOR** sale, high-class public address amplifier, 6v operated output, 30w undistorted,

with two 12in 6v energised speakers on separate 4ft baffles; £40.—Sound and Scene Services (London), Ltd., 145, Wardour St., London, W.1. [1993

**AMPLIFIER** in self-contained metal cabinet. 2 stages push-pull, output 45 watts, Class B using DA 30s separately biased, finest quality compounds throughout, anodes metered, £45 or near offer; also loud speaker, £12.—

At 122, London Rd., Gloucester. Tel. 4178.

**QUALITY R.G.**, 2RF, diode, triode, tuner, t.c. stage, 10watt Q.A. amplifier,

4-valve contrast expansion unit, Garrard automatic r.c. built into walnut R.G. cabinet, B.T.H. Senior a.c. RK Celestion m.c. Tweeter spk., on separate baffle.—Offers to Astin, 49, Worsley Rd., Worsley. [2059

**WONDERFUL** automatic gramophone m/c by National Instrument Co., Michigan,

U.S.A., plays 10 records, any side, in any order, repeats or cancels any record or plays continuously, entirely remote controlled by push buttons, in walnut cabinet, a.c. 200-250 volts only; cost £300, accept £150.—Hewett, Flint Cottage, Buckhold, Pangbourne, Berks. [2028

Wanted

**WANTED**, Radiogram, with record changer, for A.C. 230-250v.—Box 2936, c/o Wireless World. [2003

**LONDON CENTRAL RADIO STORES** will pay good prices for receivers, radiograms, amplifiers, dynamos, converters, test equipment, electric gramophone motors, and

all radio and electrical accessories.—London Central Radio Stores, 23, Lisle St., London, W.C.2. Gerrard 2969. [19836

**HALLICRAFTERS** communication receivers

**SX-17, SX-24, SX-25, SX-28** or Model

**DD-1**, each with matched speaker for operation on 230 volts a.c.; also R.M.E. 70 receiver with

matched speaker for use on 230v a.c. and R.M.E. DM-36 band expander; state age, conditions and price to Box 2919, Wireless World.

Advertisers and buyers are reminded that under Defence Regulations 1939, Statutory Rules and Orders 1940, Number 1689, a permit (T 99 G) must be obtained before sale or purchase of certain electrical and wireless apparatus, particularly such valves and apparatus as are applicable to wireless transmission.

# LASKY'S RADIO

370, Harrow Rd., Paddington, W.9

(Op. Padd. Hospital.) Phone: Cunningham 1979

OFFER FOR SALE THE FOLLOWING

LIST OF COMPONENTS:

U.S.A. Octal Base Valve Holders	9d. each	7/6 doz.
Wander Plugs, assorted	3d. each	2/6 doz.
Assorted Volume Controls, less Switch	...	2/9 each
Volume Controls, 1/2 & 1 meg., with Switch	...	5/9 each
Volume Controls, 1/2 meg., less Switch, for Midgets	...	3/6 each
2 mfd. 600 v. Block Paper Condensers	...	2/6 each
.15 mfd. 2,000 v., tubular	...	1/6 each
.02 .. 2,000 v. "	...	1/- each
.25 .. 2,000 v. "	...	1/6 each
.05 .. 500 v. "	...	1/- each
.002 .. 2,000 v. "	...	1/- each
50 .. 12 v. "	...	1/4 each
25 .. 25 v. "	...	1/6 each
10 .. 25 v. "	...	1/6 each
.1 .. 350 v. "	...	6/- doz.
Toggle Switches	...	3/6 each
Spade Terminal Tags	9d. doz.	7/6 gross
Systolex	3d. each	2/6 doz.
Mains Chokes, 70 ohms	...	6/6 each

**SPECIAL OFFER.**

Over 100 Assorted Condensers and Resistances, all high voltages, at 25/-, post free. We have a Large Stock of English and U.S.A. Mains and Battery Valves in Stock.

**SPEAKERS.**

Rola 5in., 6in., 8in. and 10in. in stock, with or without transformer, P.M., 3 ohms Voice Coil, Goodmans 3 1/2 P.M., 12 ohms Voice Coil, 25/- each. Universal Output Speaker Transformers, Pentode, Power, etc., 7/6 each. 6 1/2 P.M. Speakers with Universal Output Transformer, 29/6 each.

Send us your requirements. C.O.D., BUT CASH WITH ORDER PREFERRED.

L.R.S

# STUART PUMPS

As supplied to Govt. Depts. & County Councils

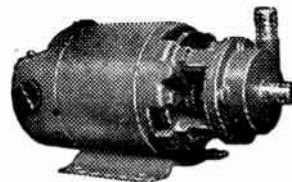

These Centrifugal Pumps are ideal for Machine Tool Cooling and all pumping purposes—hot or cold water. Supplied complete with foot-valve, strainer and hose union. Suitable rubber hose available from stock.

No. 10	100 gals. per hour.	Carr. 2/- extra.	£5 2 6
No. 11	280 gals. per hour.	Carr. 2/- extra.	£6 6 0
No. 12	560 gals. per hour.	Carr. 3/- extra.	£7 12 0

Please send 2yd. stamp for specification.

**THE STUART AUTOMATIC FLOAT SWITCH** is the best method of controlling water. Post Paid level. Price complete with all fittings... £2 6 0

**LONDON RADIO SUPPLY CO.**

Est. 1925

Ardingly Road, Balcombe, Sussex



**Come to the point!**

It's hot—all the time! That's because the heating element is housed inside the bit in the Solon Electric Soldering Iron. Soldering is easier; you get a neater, cleaner job in less time. All internal connections are housed at end of handle away from heat. A robust cord grip prevents sharp bending of the flexible lead. Complete with 6ft. Hensley 3-core flexible Solon irons are made for the following standard voltages:—100/110, 200/230, 230/250

Supplies are, of course, only available for essential war work. Early orders are advisable, as demands are heavy.

*Mfd. in England*

Illustration shows a 125-watt standard model.

**SOLON**  
Electric  
SOLDERING IRON FOR INDUSTRIAL USE

W. T. HENLEY'S TELEGRAPH WORKS CO. LTD.  
Engineering Dept., Milton Court, Westcott, Dorking, Surrey

**SEXTON'S for SALES, SERVICE, SATISFACTION**

Electric Smoothing Irons, super quality, for 100/110 volt, 200/220 volts, 230/250 volt, AC DC mains, 5-3½ lbs. weight, strong wooden handle with plated thumb rest, dome, connector guard and rest, ground and polished sole plate, complete with 6ft. flex @ 32/6 each.\*

Electric Kettles, 230/250 volt, 2½ pint size, sprayed gold with flex, suitable for AC DC mains, @ 75/- each. American Lease-Lend Radio Valves. At Board of Trade Controlled Prices as under, inclusive of purchase tax. Types: 1C5GT, 5Y3GT, 25Z6GT, 35Z4GT, 35Z5GT, @ 11/-; 1H5GT, 6F5GT, 12F5GT, @ 9/2; 6A8GT, 12A8GT, 12SA7GT, 6K8GT, 6SA7GT, @ 14/-; 6F6GT, 12K7GT, 12M7GT, 12MK7GT, 25L6GT, 35L6GT, 50L8GT, 6J7GT, 6K7GT, 36 @ 12/10; 35L7GT, 70L7GT, 83, @ 15/3; 6Q7GT, 12Q7GT, 129Q7GT, @ 11/7. Postage 4d. These valves are sold for immediate replacement only.\*

Brivaron British-made Valves. American types: 40, 5Y3, 5Y4, 5-volt rectifiers, RF120 4-volt rectifier type, RF30 equivalent to 1D5, URIC, @ 13/7 each. Coils. Set of two coils, long, medium and reaction and H.F. coil, @ 5/- per set.

Line Cords, 2-way, best quality, 350 ohms, at 7/6; 450 ohms, at 9/6; 600 ohms, @ 12/-.

Goodman's 3½in. P.M. Speakers. 12 ohms voice coil, ideal for microphones, communication sets, @ 30/- each.

Extension Loud Speakers. "Rola" 3 ohm voice coil, size 6½in., at 22/6; size 8in., @ 24/-. Less Trans. "Celestion" 8in. chassis model with Universal Trans., 3 watts, @ 36/- each.

Veneered Wood Polished Cabinets, suitable for 6½in. and 8in. speakers, excellent quality, 25/- each.

Volume Controls, 1 meg. only, with switch, @ 6/6 each; ½ and 1 meg., without switch, @ 4/6 each.

Cycle Dynamos, complete with bracket and lead, less lamps, @ 15/6 each. Limited number available.

TERMS: Cash with order only. Send 1d. stamp and S.A.E. for latest list of electrical appliances, radio valves, components, etc.

We regret Trade Orders cannot be accepted for items marked thus \*.

**J. E. SEXTON & CO. LTD.**  
164, Gray's Inn Road, London, W.C.1  
Tel.: Terminus 1304 and 4842.

WE Offer Cash for Good Modern Communication and All-Wave Receivers.—A.C.B. Radio, 44, Widmore Rd., Bromley. [1541] LATEST Model G.E.C. No. 4018 radio-gramophone for use on 230 volt a.c., also hypersensitive H.M.V. or Marconi pick-up and arm; scratch filters; state model, price, age, etc.—Box 2916. *Wireless World*. [1931]

**NEW LOUDSPEAKERS**  
£1/9/6.—High quality 3½in. permanent magnet loudspeakers delivered from stock.—The Dale Electric Co., 13, Tretawn Gardens, London, N.W.7. [2016]

**BROADCAST** 12in P.M. loud speakers, precision built instruments to lab. standards and micrometer accuracy, Ticonal magnets, demountable diaphragm and magnet assemblies, perfect and permanent alignment, extended frequency range, uniform response, superior acoustical characteristics, maximum sensitivity, highest efficiency.—Broadcast & Acoustic Equipment Co., Ltd., Tombland, Norwich. 26970. [2025]

£3/15 only.—Brand new Super Quality triple cone permanent magnet speaker, made by Bakers Selhurst Radio, the pioneer manufacturers of moving-coil speakers since 1925; wide frequency range, even response, ideal for quality reproduction; limited number available under list price; send 2½d. stamp for leaflet describing above and giving constructional details of infinite baffle cabinet; every music lover interested in realistic reproduction should write for leaflet now; £8/15 only, brand new super power cinema n.m. speaker with 18in cone, will handle 20 watts U.D.O., ideal for quality p.a. equipment.—Bakers Selhurst Radio, 75, Sussex Rd., South Croydon. [2041]

**SECOND-HAND LOUDSPEAKERS**  
H.M.V. elliptical, large pot.; offers.—146, Elgar Ave., Tolworth, Surbiton. [1999]

HARTLEY-TURNER duode, 2,500ohms field, 4ohms speech; £4/10.—17, Newlyn Rd., Welling, Kent. [2058]

**Wanted**  
VOIGT unit, with or without field supply, urgently required.—Rigg, 100, Dudley Port, Staffs. [2065]

**MORSE EQUIPMENT**  
FULL range of transmitting keys, practice sets and equipment for Morse training.—Webb's Radio, 14, Soho St., London, W.1. Tel. Gerrard 2089. [9553]

**MORSE** tape recorder, P.O. type with key and galvo, clockwork drive, new condition; first £10/10 secure.—16, Rochester Gdns, Ilford. Val. 3611. [2008]

**TEST EQUIPMENT**  
OSCILLOSCOPE, new, 2½in tube, usual controls; £20, or near offer.—Box 2942, c/o *Wireless World*. [2045]

**AVO** all-wave oscillator (battery model), absolutely new condition; what offers? Box 2941, c/o *Wireless World*. [2042]

**AVOMETER**, Model 7, perfect condition, A guaranteed; nearest offer £30.—Lear, Feltham Ave., E. Molesey, Surrey. [2013]

**TESTSCOPE**, used everywhere by radio service engineers, makes 20 important tests; send for interesting leaflet "R.I."—Rushaker, Manchester. [1074]

**ONE** d.c. and h.r. Avo Minor, Ferranti m/c meters, 2½in 0-500 microamps, two 2in 0-1 ma meters, 0-5v, 0-50v scales respectively, flush mounting, perfect; offers.—Box 2938, c/o *W.W.* [2047]

**Wanted**  
AVO test bridge.—Price, etc., Parker, 589a, Blue Group, Home Forces. [2035]

**WANTED**, small cathode-ray tube.—Sharpe, 181, Wragby Rd., Lincoln. [2039]

**GOOD** Service oscillator wanted; top price paid.—Morgan, 137, Shirehall Rd., Sheffield. 5. [2027]

**OSCILLOGRAPH** tube, vacuum, 3 to 5in. perfect.—Price, etc., to Precco, 242, Parkside Av., Barnhurst, Kent. [2053]

**HUNTS** or similar condenser tester, Mullard H valve tester, also Model 7 Avometer.—Owen, 538a, Mansfield Rd., Nottingham.

**LARGE** quantity of radio parts; would exchange for Resistance Capacity Bridge and Wee Megger.—Jones, 7, Harland Rd., Bridlington, E. Yorks. [2047]

**NEW MAINS EQUIPMENT**  
VORTEXION mains transformers, chokes, etc., are supplied to G.P.O., B.B.C., L.P.T.B.; why not you? Imitated but unequalled; orders can only be accepted against Government contracts.

**VORTEXION**, Ltd., 257, The Broadway, Wimbledon, London, S.W.19. Lib. 2814.

**GRAMPHONE EQUIPMENT**  
COILS for filters, tone controls, etc., all types of transformers for "W.W." circuits accurately wound.—R. Clark, 69, Longley Ave., Alpertown, Middx. [2043]

**SOUTHERN SOUND STUDIOS**—Please see our displayed advertisement, page 32, September issue.—Southern Sound Studios, 4, Bittity Park Avenue, Mill Hill, N.W.7. [1989]

**COVENTRY RADIO**

DUBILIER 75,000 ohm, 3-watt RESISTORS	1/3
RESISTORS, 20 assorted, ½, 1 and 2 watt	12/8
CONDENSERS, 20 assorted, .0001-1 mfd.	10/-
SWITCHES, Toggle, Q.M.B., S.F.	2/9
L.S. TRANSFORMERS, Power/Pentode	7/8
I.F. TRANSFORMERS, 465 kc., screened	6/-
COILS, S. M. or L. serial or osc.	2/6
MICROPHONE TRANSFORMERS, 1st grade	6/6
ROLA P.M. SPEAKERS, 5in., 6½in., 8in. from	21/6
COMPONENTS, Large and varied stock. Mains Transformers, Condensers, Resistors, Switches, Valve Holders, Wire, Flex, etc.	
5,000 B.V.A. VALVES always in stock.	

TERMS: Cash with order. Quotations, stamp, please.

**COVENTRY CO.** EST. 1925  
191, DUNSTABLE ROAD, LUTON.  
Phone: LUTon 2677.

**"SYSTEMATIC RADIO SERVICING"**

A method for organising the repair-shop, devised and employed by J. Bull. Also a catalogue of many Radio Service Aids including "History of Faults," "Job Cards," which almost repair the sets, "Valve Base Data Cards," and perhaps most important, a Rectifier which will replace any of the popular Universal valves such as 12Z3, 25Z5, 1D5, U30, 40SUA, etc. Price 1/7 p.f.

**V.E.S.,**  
(W) Radio House, Meltham Drive, Ruislip, Mdx.

**AFTER THE WAR!**

The advance in Radio Technique after the war will offer unlimited opportunities of high pay and secure posts for those Radio Engineers who have had the foresight to become technically qualified. How can you do this quickly and easily in your spare time is fully explained in our unique handbook.

Full details are given of A.M.I.E.E., A.M.Brit.I.R.E.E., City & Guilds Exams., and particulars of up-to-date courses in Wireless Engineering, Radio Servicing, Short Waves, Television, Mathematics, etc., etc.

**We Guarantee "NO PASS—NO FEE"**  
Prepare for to-morrow's opportunities and post-war competition by sending for your copy of this very informative 112-page guide NOW—FREE.

**BRITISH INSTITUTE OF ENGINEERING TECHNOLOGY** (Dept. 388)  
17, Stratford Place, London, W.1

**GECALLOY RADIO COILS**

**MAIN ADVANTAGES**

- Great magnification
- High selectivity.
- Small size
- Reduced costs.
- Robust construction
- Simple adjustment
- Non-rusting

**Salford Electrical Instruments Ltd.**  
PEEL WORKS, SILK STREET, SALFORD, 3  
Telephones: BLAckfriars 6688 (6 lines)  
Proprietors: The General Electric Co. Ltd., of England

# PREMIER RADIO

## METERS

0-100ma. Moving Iron AC or DC, Bakelite Case, flush mounting, 2 1/2ins. diameter. Price 12/6 each.

## CHASSIS

Lead coated steel, undrilled.  
16 x 8 x 2 1/2" ..... price 7/- each.  
20 x 8 x 2 1/2" ..... price 10/6 each.

## I.F. TRANSFORMERS, IRON CORED

450-473 kcs., plain and with flying lead, 5/6 each.

## NEW PREMIER S.W. COILS

4- and 6-pin types, now have octal pin spacing and will fit International Octal valve holders.

### 4-PIN TYPE

Type	Range	Price	Type	Range	Price
04	9-15 m.	2/6	06	9-15 m.	2/6
04A	12-26 m.	2/6	06A	12-26 m.	2/6
04B	22-47 m.	2/6	06B	22-47 m.	2/6
04C	41-94 m.	2/6	06C	41-94 m.	2/6
04D	76-170 m.	2/6	06D	76-170 m.	2/6
04E	150-350 m.	2/-			
04F	255-550 m.	3/-			
04G	490-1,000 m.	4/-			
04H	1,000-2,000 m.	4/-			

### 6-PIN TYPE

Rotary Wave Change Switch, to suit above, 1/6.  
Bakelite Dielectric Reaction Condensers.  
0001 mf. 1.3 0003 mf. 2/6 0005 mf. 2/9 each  
0003 mf. Differential 2/11 each

## CHASSIS MOUNTING

8-36 m. 4/9.  
New Premier 3-Band S.W. Coil, 11-25, 25-38, 38-86 m. 4/9.  
Rotary Wave Change Switch, to suit above, 1/6.  
Bakelite Dielectric Reaction Condensers.  
0001 mf. 1.3 0003 mf. 2/6 0005 mf. 2/9 each  
0003 mf. Differential 2/11 each

## OCTAL HOLDERS

New Premier 3-Band S.W. Coil, 11-25, 25-38, 38-86 m. 4/9.  
Rotary Wave Change Switch, to suit above, 1/6.  
Bakelite Dielectric Reaction Condensers.  
0001 mf. 1.3 0003 mf. 2/6 0005 mf. 2/9 each  
0003 mf. Differential 2/11 each

## H.F. CHOKES

S.W. H.F. Choke, 10-100 m. .... 1/3  
Standard H.F. Choke ..... 1/-  
Binocular H.F. Choke ..... 1/6

## SHORT WAVE CONDENSERS

Trolitol Insulation. Certified superior to ceramic. All-brass construction. Easily ganged.  
15 mmfd. .... 2/11 100 mmfd. .... 3/11  
25 mmfd. .... 3/3 160 mmfd. .... 4/8  
40 mmfd. .... 3/3 250 mmfd. .... 5/8  
 brass Shaft Couplers, 1/4 in. bore ..... 7/4 each  
Flexible Couplers, 1/4 in. bore ..... 1/2 each  
7-pin Ceramic Chassis mtg. English fitting Valve Holders, 1/6 each.  
Amphenol Octal Chassis mounting Valve Holders. International type, 1/3 each; English type 1/3 each.

## RESISTANCES

Mains Resistances, 660 ohms 3A Tapped. 360 x 160 x 60 ohms, 5/6 each.  
1,000 ohms, 2A Tapped. 900, 800, 700, 600, 500 ohms, 5/6 each.  
1 watt all values, 5d. each.  
1 watt all values, 7d. each.  
4 watt from 50 to 2,500 ohms, 1/- each.  
8 watt from 100 to 2,500 ohms, 1/6 each.  
15 watt from 100 to 10,000 ohms, 2/- each.  
25 watt from 100 to 20,000 ohms, 2/9 each.

## SWITCHES

Q.M.E. panel mounting, split knob type, 2 point on/off, 2/- each.  
Double pole on/off, 3/6 each.

## VOLUME CONTROLS

Carbon type, 20,000, 50,000, 1 meg., 1 meg. and 2 meg., 3/9 each. 5,000, 10,000 and 1 meg., 4/6 each.  
Wire Wound Type, 5,000 and 10,000 ohms, 5/6 each.  
Valve Screens for International and U.S.A. types, 1/2 each.  
Resin-Cored Solder, 7 1/2 lb. ctd.  
Push-Back Connecting Wire, 2 1/4 lb. per yard.  
Systoflex Sleeving, 2 mm., 2/6 per doz. yards.  
Screened Braided Cable, Single, 1/3 per yard.  
Twin, 1/6 per yard.

## MOVING COIL SPEAKERS

Rola 5 in. P.M. Speaker, 3 ohms voice coil, 21/-  
Rola 6 1/2 in. P.M. Speaker, 3 ohms voice coil, 25/-  
Rola 8 in. P.M. Speaker, 3 ohms voice coil, 25/-  
Above Speakers are less output transformer.  
Morse.—The Premier Oscillator supplied complete with valve, on steel chassis, price 27/6. Practice key 3/3, TX key 5/10, Super Key 11/6. Brown's Headphones 19/6 pair. 3-Henry Chokes (as used in Oscillator), 10/-. High pitched Buzzer, adjustable note, 3/- each.

Send for details of our Microphones, Valves, and other Accessories available.

ALL ENQUIRIES MUST BE ACCOMPANIED BY A 2 1/2d. STAMP.

# PREMIER RADIO CO.

ALL POST ORDERS TO:

JUBILEE WORKS, 167, LOWER CLAPTON ROAD, LONDON, E.5. (Amherst 4725.)

CALLERS TO:

JUBILEE WORKS or 169, FLEET STREET, E.C.4. (Central 2833.)

FOR sale, "Parmeka" disc recorder, as new, fitted with "Watts" cutting head, £2100; no offers.—Instructional Screen Ltd., 9, Upper Berkeley St., London, W.1. Ambassador 2351. [2032

## Wanted

AUTO record changer, a.c. only.—H. A. Dickens, Herriotts Lane, Wellingborough.  
GARRARD A.C. motor, with turntable and auto-brake.—Details to C. B. Vaughan, 10, Merridale Crescent, Wolverhampton. [2001  
WANTED, Telefunken 1001 pick-up; state price.—L. Stratton, 27, Margravine Gdns., London, W.6. [2002

H.M.V. Hypersensitive or Voigt pick-up, all-wave a.c. service oscillator, Mullard or Cossor oscilloscope; price, etc.—8/Sgt. Johnson, R.C.A.F. Station, Digby, Lincoln. [2007  
A.C. or a.c.-d.c. electric gramophone record player for operation on 230v supplies, 12in turntables, supersensitive pick-ups, scratch filters, single or dual instruments with fade-out controls if two turntables, etc.; state model, age, condition, price.—Box 2918, *Wireless World*. [1933

WANTED, record player (230 ac or ac/dc), preferably with automatic changer, hypersensitive pick-up essential; also modern dual-turntable playing desk with fade-outs, etc., and matched hypersensitive pick-ups; super-quality amplifier and matched speakers also considered.—Box 2931, *Wireless World*.

## NEW COMPONENTS

BCM/TELRAD for bargains; all new goods guaranteed.

TCNE controls, U.S.A. made, 25,000ohms, 2in spindle; 3/6 each.

BATTERY testers, to take small flash lamp; 4d. each.

SINGLE earphones; at 4/6 each.

CERAMIC trimmers, as used by Philips; 4/- doz. or 5d. ea.

VARIABLE resistors, wire wound, 30ohms, porcelain base, all-metal rotary arm; 27/6 doz. or 2/6 ea.

SEND 2d. for list; permit for Northern Ireland.—Orders and enquiries to BCM/Telrad, London, W.C.1. [2048

COMPONENTS—SECOND-HAND, SURPLUS LONDON CENTRAL RADIO STORES offer the finest radio and electrical bargains.

ELECTRIC soldering irons, 200-250v, 75 watts; 12/6; post 8d.

PUSH-BUTTON mechanism only unit, complete with buttons; 4/6; post 9d.

T.C.C. condensers, 0.1mfd 5,000v, dc wkg.; 9/6 each; post 8d.

SCREENED cable, fine quality, heavy duty, 15 strand, 30 gauge, 5mm rubber covering, with two layers of Empire tape, 1/9 yd.

RUBBER covd. flex, wire, tinned copper, approx. 17 strands, 9ft. lengths; 3d. yd.

PHILCO bleeder resistances, in metal cans, 100, 150, 250ohms; all 10w; 2/6; post 3d.

TUBULAR condensers, 0.5mfd, 500v working; 2/6; post, etc., 4d.

MULLARD EA50 diodes, 60mmx12mm overall, 6.3v heater at 15a; 10/6; post 3d.

POTENTIOMETERS, carbon: 700,000ohms, less switch, 3/6; 100,000ohms, with 2-pole m and b switch, 4/6; post 6d.

LONDON CENTRAL RADIO STORES, 23, Lisle St., London, W.C.2. Gerrard 2969.

CLIX patent 5 amp 2 pin plug tops, 12/- doz.—Amurs, 76 King St., Belfast. [1985

LASKY'S RADIO, 370, Harrow Rd. Paddington, W.9. (opposite Peddington Hospital), offer for sale the following condensers: 0.15mfd 2,000v at 1/6 each, 0.02mfd 2,000v at 1/- each, 0.23mfd 2,000v at 1/6 each, 0.05mfd 2,000v at 1/- each, 0.002mfd 2,000v at 1/- each; 2mfd cond., 700v, at 2/6 each; 50mfd 12v tubular, 16/- doz.; 25mfd 25v tubular, 18/- doz.; 0.1mfd 350v tubular, 6/- doz.; 10mfd 25v tubular, 1/6 each; speakers, speaker output transformers from 6/-; 6 1/2in moving coil speakers: Rola 5in P.M. speaker, 3 ohms voice coil, 21/-; Rola 6 1/2in P.M. speaker, 3 ohms voice coil, 25/-; Rola 8in P.M. speaker, 3 ohms voice coil, 25/-; above speakers are less output transformer. [2021

COULPHONE Radio, New Longton, nr. Preston.—New goods only. Tungram valves, mains transfs., 350v 120mA, 4v 8A, 4v 2 1/2A, 4v 1 1/2A, 33/6; 350v 120mA, 6.3v 3A 5v 3A, 32/6; Celestion, 6in p.m., with transfs., 24/6; Rola p.m., less transfs. 5in 20/-, 6 1/2in 22/-, 8in 24/-, 10in 28/6; cored solder, 4/6 lb; tin. cop. wire, 2/3 1/2lb; 2mm Systoflex, 3d. yd; Barr. resist., 6/-; line cord replace. resist., 800 ohm 2 edj; taps, 6/9; Parfed L.F. transfs., 4.1, 4/8; 50mfd 12v 2v, 25mfd 25v 2/-; Erie resist., 1w 9d., 1/4w 6d., 1/4w 4d.; Pushback wire, 100ft 6/-; switch cleaner, 2/3 bott.; out. trans., 7/6; bell transfs., 6/6; valveholders, 1d. per pin; Stanelco el. solder, irons, 21/-; tub. and mica cond., V cont., with sw, 5/9, less sw, 4/9; s.a.c. for stock list.



See July issue for illustration and details of Constructors' A.C. and Battery 3-v. Kits. Delivery approximately one month.

**SUPERHETERODYNE PERMEABILITY TUNED AERIAL AND OSCILLATOR (465 Kc/s) 6-BUTTON COIL UNITS.** 2-wave bands. Permeability tuned by adjustable knurled metal knobs. Complete with 3-position tone control, coupling condensers, buttons, dial lamp holder, colour coded condensers and circuit diagram for a 3-v + rectifier superheterodyne receiver. A brand new precision component. 30/-.

A demonstration receiver incorporating the above can be heard at our address.

**AERIAL AND OSCILLATOR (465 Kc/s) COIL UNITS.** 3-wavebands, mounted on a screened switch with associated condensers and resistors. Less trimmers, wired up ready for use; a first-class component, wiring diagram. 22/6.

**AERIAL AND H.F. TRANSFORMERS** with reaction, medium and long waves. Iron cored on medium waves loading coil on long waves. 10/- per pair.

**SHORT-WAVE COILS** on Faxonlin Formers 16-50 metres approx., 1/6 each. Midget Medium Wave Oscillator only, 1/6 each.

**MAINS VOLT DROPPING RESISTORS.** 2 amp, 1,000 ohms, 2 variable sliders, 6/-; .3 amp, 750 ohms, 2 variable sliders, 7/-.

**10-WATT WIRE-WOUND RESISTORS,** 2,000, 500 and 160 ohm, 2/6 each.

**FADDEES.** Twin ceramic .0003 mmfd. (max.) and .0006 mmfd. (max.), 1/6 each.

**CHASSIS.** Undrilled steel, painted, new, 10 1/2 x 8 x 2 1/2in. 7/6; 8 x 6 x 2 1/2in. 4/6 each. Drilled for 3-v. 8 x 6 x 2 1/2in., 5/6.

**WESTECTORS.** Type W6, 5/- each.

**SWITCHES.** New, Yaxley type midget, single bank, single pole, 4-way, 2/9 each. Single bank, 3-pole, 3-way, 2/6 each; 3-bank, 2-pole, 3-way screened, 7/6 each; 4-pole, 3-way, midget, 4/6 each; 2-bank, 2-pole, 3-way, 3/- each.

**PARALLEL FEED TRANSFORMERS.** Midget Colour coded circuit, 6/-, H.F. Choke Amplion, 2/6 each. Short-wave double wire wound Filament Choke for electronic reaction coupling, 2/- each.

**VALVE HOLDERS.** 4, 5, 6, 7-pin Faxonlin. 6d. International Octal, 9d. each Short-wave Ceramic 6-pin, 1/6 each.

**OCTAL CABLE PLUG AND SOCKET, 2/-.**

**T.C.C. AIR-SPACED TRIMMERS,** 0 to 35 mmfd., 1/- each.

**CONDENSERS.** Tubular, .0005 mfd. to .005, 6d. each; .02 to 1. 9d. each. Mica, .01, .001 mfd., 2,250v 100v, 1/6. Silver mica, .00015, .0002, .0005, .00005 mfd., 9d. each.

**VOLUME CONTROLS.** 1 and 1/2 meg., with switch, 6/6 each. 25,000 and 50,000 ohms, less switch, 4/- each.

**VARIABLE CONDENSERS.** Single .0005 mfd., 2-speed drive with pointer, knob and dial, no cutcheton required. Single hole fitting for portables, crystal sets, etc., 6/-. Short-wave Tuning Condensers, 30 mmfd., 2/6.

**SPEAKER OUTPUT TRANSFORMER.** Heavy duty Pentode, 10/- each.

**PAXOLIN.** Polished, flat, strong, 18 x 2 1/2 x 3/32nds approx., 1/6 each. Soldering Tags, 3d. dozen. Terminal Strips, from 3d. to 9d. Eyelets, 1/2 to 1/8 gross. Resinors, 1-watt, 6d.; 1-watt, 1/- each, most values available. Nipiro Clips, 2 a 1d. Flexible Coupling Joints, large, 1/-, Dial Lamp Holders, 6d. each. A1, A2, E Panels, 6d. Systoflex, coloured, plain and striped, 4d. per yd. length.

A good selection of shop-soiled and odd components available to callers only. Cheap. Licence to export to Northern Ireland and Irish Free State.

★ Please add postage for enquiries and mail orders C.O.D. orders accepted.

Owing to present circumstances, prices are subject to increase without notice.

**51-52 CHANCERY LANE, LONDON, W.C.2. Telephone HOLBORN 4831.**



# Born Healthy

The birth of a modern transformer is no easy delivery. At hundreds of critical moments eyes, hands and tools must work in closest co-operation so that these important components will be born strong and healthy . . . and built to stay that way. And nowhere in the Gardner range of "healthy" components is "pre-natal" care so evident as in our Small Power Transformers up to 4 kva. So when next you have a specification of which this type of Transformer is part and "health" is of primary importance, our co-operation is yours for the asking.

*We regret that at present Small Power Transformers are available for highest priority orders only.*



**GARDNERS RADIO LIMITED**  
SOMERFORD · CHRISTCHURCH · HANTS

## Trained men get GOOD JOBS

Now is the time to prepare yourself for the future. There will be splendid opportunities for technically trained men to secure well-paid employment, or start radio businesses of their own.

Even if you know nothing about radio, we can train you. Our specialised method of Home-Study Tuition is a proved success. Hundreds of our students now doing important work owe their progress solely to our training.

Post coupon now for free details of our Home-Study Courses in :

- Radio Reception,
- Transmission,
- Servicing,
- Television,
- Radio Calculations,
- Mathematics.

### T. & C. RADIO COLLEGE, 2, THE MALL, EALING, W.5

(Post in unsealed envelope, 1d. stamp.)

Please send me free details of your Home-Study Mathematics and Radio Courses.

NAME.....  
ADDRESS.....  
W.W.21.....

**C. A. RYALL**, 69, Wharfdale Gardens, Thornton Heath, Surrey.—Please note new temporary address; mail order only.

**ERIE** resistances.— $\frac{1}{2}$ W, 680 ohms, 3/doz.; Erie 2W, 3,900, 140,000, 270,000, 3 1/6; Erie 3W, 6,800 ohms, 2 1/6.

**T.C.C.** O.I. inductive tubular condensers, in paxolin tubes, type 330, 350v wks., 6/6 dozen, 75/- gross.

**S**LOW motion (epicycle) drives, in well-finished brass, ratio 8-1, shaft  $1\frac{1}{2}$ in long,  $\frac{1}{2}$ in dia., drilled to take pointer, 1/3 ea.

**PAXOLIN** strip,  $2\frac{1}{2}$ in wide, 12 in lengths, 3 1/6 and 100 25/-; short lengths cut group board size, 6 1/3.

**T**HIMBLE top caps, 24 1/3; insulating tape, black, 1/3 lb; Wearite switches, ebonite with silver-plated contacts, for 2hi and band pass with dial lights, 1/6 each.

**Y**AXLEY switch screws, size approx. 4in  $\times$   $3\frac{1}{2}$ in, drilled with mounting flange, 3 for 1/3.

**5-PIN** plugs and sockets, complete with metal insulated cap, 2 for 1/6. [2038]

**H**ARTLEY TURNER duode, p.p.l.l. trans., Westinghouse rectifier, £10; W.W.Q.A., Wards, London, £10.—Mr. Hopkinson, 44, St. Mary's Estate, Thetford, Norfolk. [2063]

**A** FAIRLY large quantity of surplus stock of valve deaf aid components is being offered to traders or radio enthusiasts; large numbers of fine moulded boxes, leatherette cases, many complete with small chassis containing midjet valves, earphones, microphones, etc.; an offer for the lot would be preferred; can be seen by appointment only.—Box 2946, c/o *Wireless World*.

**B**A. thread screws and nuts. Large stock. Enquiries invited. One gross assorted useful sizes, 2/6; ditto washers, 1/6 gross; fibre washers, 1/6 gross; assorted solder tags, 2/- gross; rubber-covered stranded copper wire, 1d. yard; heavier quality, 1 1/4d.; very heavy, 2d. yard, ideal for aerials, earths, etc.; enamelled copper wire, 26 gauge,  $\frac{1}{2}$ lb. reel, 1/3; tinned copper connecting wire,  $\frac{1}{2}$ lb., 2/-; finest quality resin-core solder,  $\frac{1}{2}$ lb., 2/-; Wood's metal stick,  $2\frac{1}{2}$ in.  $\times$   $\frac{1}{4}$ in., 1/-; sensitive permanent crystal detector, Tellurium-zincite combination, complete on base, guaranteed efficient, 2/6; wireless crystal with silver cats-whisker, 6d.; new single earphone, 750 ohms, made originally for the Air Ministry, 5/6; reconditioned headphones, complete, 4,000 ohms, 12/6; all postage extra.—Post Radio Supplies, 67, Kingscourt Rd., London, S.W.16.

**B**ATTERY charging, l.t. metal rectifiers, B 12v 3amp, 34/6, post 7d.; 6v 2.5amp, 15/6, post 7d.; 6v 0.5amp, 6/3, post 4d.; all with circuit; charger kits, need no ammeter or rheostat, transformer and rectifier for 2v to 12v 2.5amps, 58/6, post 10d.; 2v, 6v 2.5amp, 42/6; 2v, 6v 1.5amp, 34/6, postage 10d.; 2v,  $\frac{1}{2}$ amp, 14/6; instrument rectifiers for meters, bridge type, bakelite, very good make, 1ma, 18/6; 5ma, 10ma, 15/6; 50ma, 12/6, post 3d.; h.t. rectifiers, 250v 60ma, 16/6, post 6d.; Rothermel bakelite crystal pick-ups, latest model, marvellous reproduction, 73/6, post 10d.; famous Bullet crystal microphones, head lamp shape, tilting mount, black crackle finish, 60/-; also a few D.104 aluminium diaphragm crystal mikes, 95/-; Rothermel make; miliampmeter, 4in diam, 2ma, full scale, 65/-; ditto, 1.5ma, 65/-.—Champion, 42, Howitt Rd., London, N.W.3.

**S**OUTHERN RADIO'S wireless bargains: Screws and nuts, assorted gross of ea. (2 gross in all), 10/-; soldering tags, including spade ends, 6/-; Philco 3-point car aerials, excellent for short wave and home aerials, 7/6; limit tone arms, universal fixing for all types of sound boxes and pick-up heads, 10/-; Ace P.O. microphones, complete with trans., ready for use with any receiver, 7/-; metal panels, undrilled rigid, 18 1/2in.  $\times$  8 1/2in., 2/6; circular magnets, very powerful, 1 1/2in diameter by  $\frac{1}{2}$ in thick, 1/6 each, 15/- per dozen; Erie resistances, brand new, wire ends, all low value from 0.8 ohms upwards, a few higher value are included in ea. parcel,  $\frac{1}{4}$ ,  $\frac{1}{2}$ , 1 and 2-watt, 100 resist. for 30/-; Multicon Master mica condensers, 28 capacities in one, from 0.0001, etc., etc., 4/- each. Special assorted parcel for Service men: 100 Erie resistances (description above), 24 assorted tubular condensers, 6 reaction condensers, 0.0001, 12 lengths insulated sleeving, 75ft push-back connecting wire, soldering tags, screws, wire, etc., 65/-, all brand new. Crystals (Dr. Cecil) 6d., with cat's whisker, 9d; complete crystal detectors, 2/6; 75ft wire for aerials, etc., 2/6; 25 yds push-back wire, 5/-; Telsen reaction condensers, 0.0001, 1/9 each; Telsen large disc drives, complete with knob, etc. (boxed), type W184, 2/6 ea.; insulated sleeving, assorted, yd lgths., 3/6 dozen; single screened wire, doz. yds. 10/-; speaker units, unshrouded, Midget type, 4/-; metal cased condensers, 0.1+0.1+0.1, 2/6; many bargains for callers—Southern Radio Supply Co., 46, Lisle St., London, W.C. Gerrard 6693. [1845]

**R. K. Dundas** LIMITED

Experimental and Aeronautical Engineers and Scientific Instrument Makers. Manufacturers of Precision Mechanical, Electro-Mechanical and Thermionic Instruments. Electro-Medical and Industrial Apparatus, Time Interval Measurement and Counters, DC Amplifiers and Recorders. Specialised Design Enquiries Welcomed

**THE AIRPORT, PORTSMOUTH**  
Telephone: 74874.

## HILL AND CHURCHILL BOOKSELLERS SWANAGE DORSET

ENGLISH & AMERICAN BOOKS IN STOCK ON RADIO AND TELECOMMUNICATION

CATALOGUE ON APPLICATION

## Cabinets?

Increased production facilities enable us to give immediate attention to orders for urgent requirements and we are now in a position to accept further contracts or sub-contracts for Government work.

We specialise in AMPLIFIER and EXTENSION SPEAKER CABINETS, METAL BOXES & CHASSIS.

All enquiries should be accompanied by Priority No.

### HIRSH & HYAMS, LTD.

Cabinet Manufacturers,  
93, Hackney Road, London, E.2. Bish. 4012

### ENGINEERING OPPORTUNITIES



This unique handbook shows the easy way to secure A.M.I.Mech.E., A.M.Brit.I.R.E., A.M.I.E.E., etc.

**WE GUARANTEE—“NO PASS—NO FEE.”**

Details are given of over 150 Diploma Courses in all branches of Civil, Mech., Elec., Motor, Aero, Radio-Television and Production Engineering, Tracing, Building, Govt. Employment, R.A.F. Maths., Matric., etc.

Think of the future and send for your copy at once—FREE

**B.I.E.T., 387, SHAKESPEARE HOUSE 17, STRATFORD PLACE, LONDON, W.1.**



# IRREFUTABLE EVIDENCE!

Readers of this journal will have noted that advertisements relating to the Candler System of Morse Code Training often contain extracts from letters sent in by Candler students. Their opinions are all *unsolicited* and their original letters may be inspected at the London office.

In this advertisement we have only space for nine "extracts," but these are indicative of the great value and the thoroughness of the training covered by the Candler Junior and Advanced Courses.

Read these extracts from letters received:

"I am still getting on all right with the course, and I find that my receiving speed has increased to 15 w.p.m., and my sending to 18 w.p.m."

Ref. 8032. R. E. G.

"I am making more progress than I ever anticipated... I am now doing over 20 w.p.m., thanks to the course."

Ref. 9687. W. D.

"I have improved beyond all my wildest expectations and in a recent test under R.A.F. conditions and supervision, I passed 100 per cent., sending 35 w.p.m. receiving ditto. I have worked entirely on my own."

Ref. 7838. W. P.

"My progress at present is fine. Slight difficulties are occurring with some signals, but these are gradually being overcome. May I congratulate you on such a fine course."

P.S.—Have been accepted as W/T operator in the Royal Navy."

Ref. 8768. T. D.

"I have obtained an appointment with Marconi's thanks partly to the course."

Ref. 9627. G. P.

"I had no knowledge of Code before taking the Candler Junior Course, now I have a perfectly spaced sending speed of 26 w.p.m., and a receiving speed of 25 w.p.m. I think this proves to the full the absolute value of Candler training... I obtained my P.M.G. Special Certificate and am going to sea very shortly as second Radio Officer in the... Co."

Ref. 7925. A. H. M.

"I am pleased to state that I have already found a marked improvement in both sending and receiving, and all my former difficulties have become less and less. After only two lessons I can now send 5 w.p.m. faster and receive two or three letters behind."

Ref. 9248. T. C.

"My progress has been quite satisfactory, and I now manage to pick up press reports from GBR daily, which I find very interesting and which I think bears ample testimony to the efficiency of your methods."

Ref. 8496. A. W.

"I have derived great benefit from the course and can recommend it for anyone who wants to learn Morse correctly."

Ref. 3962. A. P. C.

There are Candler Morse Code Courses for Beginners and Operators.

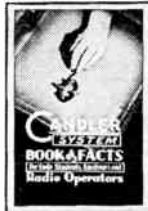

SEND NOW FOR THIS FREE

"BOOK OF FACTS" It gives full details concerning the following Courses:—

JUNIOR Scientific Code Course for beginners. Teaches all the necessary code fundamentals scientifically.

ADVANCED High-speed Telegraphing for operators who want to increase their w.p.m. speed and improve their technique.

TELEGRAPH Tenth Type-writing for those who want to become expert in the use of the typewriter for recording messages and press as received.

Code Courses on Cash or Monthly Payment Terms.

## COUPON

Please send me a Free Copy of Candler "Book of Facts."

NAME.....

ADDRESS.....

Post Coupon in 1d. unsealed envelope to London Manager

THE CANDLER SYSTEM CO. (Room 55W),

121 Kingsway, London, W.C.2

Candler System Co. Denver, Colorado, U.S.A. (1048)

8 MFED 500v tub. condensers, 7/6 ea.—Amurs (Retail), 76, King St., Belfast. [1984  
NEW E.M.I. moving coil microphone, type 201; £14.—Smythe, 118, Burdon Lane, Belmont, Surrey. [2030  
TRANSFORMERS (Ferranti), AF5C. ratio 1/3.5, and AF3; offers (stamp).—Bushell, Little Burstead, Essex. [1992  
DISWAN Tungar battery charger, 60 2-volt cells, A.C., cat. No. 68021, unused; price £12.—Box 2937, c/o Wireless World.  
FERRANTI a.c. unit, comprising trans., rectifier, chokes, resistances, 5 valves h.t., 2 l.t., new; 6gns.—11, Abbotshall Av., Southgate, N.14. [2061

### Wanted

"W.W." 2 R.F. tuner urgently wanted.—Rigg, 100, Dudley Port, Staffs. [2066

FERROCART coils G.1, 2, 3, also G10.3.—C. F. Gibbs, 93, Pennygate, Spalding.

EDDYSTONE full vision dial, cat. No. 1070.—Cooner, 18, Union St., Bainsford, Falkirk.

WANTED (by amateur), a 913 902 or similar cathode ray tube, set of 4-pin Eddy-stone coils, precision slow motion tuning control.—Box 2939, c/o Wireless World. [2010

SKYRO) aerial, complete with accessories as supplied by Messrs. Belling and Lee, Ltd., for chimney stack anchorage; state price and condition.—Box 2917, Wireless World.

WANTED, A.C. turntable and Sound Sales or similar quality output transformer for 7,000 ohms push-pull to 15 ohms.—Woodhall, Green Park Hotel, Aston Clinton, Bucks.

### DYNAMOS, MOTORS, ETC.

FOR sale, Crompton-Parkinson converter, 220 d.c.—220 a.c., 100watts.—Box 2944, c/o Wireless World. [2054

FOR sale, 2 G.E.C. 30hp motors, 100-115v d.c., 2,000 r.p.m., shunt wound, little used; 20/- each.—Box 2933, c/o W.W.

ALL types of rotary converters, electric generator sets, etc., in stock, new and second-hand; supplied against priority orders only. Wick, E.3. Tel. Amberst 1393. [1988

CRYPTO converter, 350watt, 220v d.c. to 230v a.c., 200v d.c.—215v a.c., sound-proofed, screened and filtered; best offer over £20.—Trotman, 42, Thornlaw Rd., W. Norwood, S.E.27. [2051

L.T. dynamos for charging. Lucas-Rotax, 6-12v 8 amps dc, 3rd brush, weight 11lb, size 8in x 4 1/2 in, unused ex W.D., cost £10, to clear 17/6 each; ht and lt G.E.C. double-current 6v and 600v, 17lb ditto, 27/6; all carr. paid England and Wales—Electradix, 214, Queenstown Rd., Battersea, S.W.8. [1748

MOTOR alternator, input 110v d.c. output 230 volts 1,850 watts 600 cycles. £12/10; Crypto commutating rectifier, input 200/250v a.c. output 15v 5a d.c., with switchboard £15; Janette rotary converter, 220v d.c. to 230v a.c., 300 watts 50 cycles. £12/10; Neco 220v d.c. to 12v 12a d.c., £4.—Below

HUNDREDS in stock, rotary converters, dynamos, motors a.c. and d.c., lighting sets, switchboards, meters and wiring accessories.—Harris, Strouds, Bradford, Berks.

### VALVES

ROGERS valves, few only, pair 2x3s, 6B6M, etc.; 28.—German, 109, St. William's Way, Rochester, Kent. [2052

5000 valves, all types, including output, rectifiers, etc., s.a.e.—Davies, 23 Mount Vernon Crescent, Barnsley. [1848

OUR adaptors will help in replacing unobtainable valves; send 7d for interesting booklet on valve replacements; trade enquiries invited.—V.E.S., Radio House, Ruislip. [1885

VALVES, Valves. Valves.—Napiers have a huge selection of British and American valves, suitable for mains or battery radios. A stamped addressed envelope brings you our comprehensive list.—Napiers, 127, Prestwick Rd., Ayr. [1997

WE have a large stock of new and boxed valves, all guaranteed, at retail prices, plus tax; also U.S.A. lease-lend types for replace., send your requirements.—Lasky's Radio, 370, Harrow Rd. (opposite Paddington Hospital), Paddington, W.9. [2020

VALVES, British and American, many types in stock; coils, midget aerial and H.F. transformers, medium wave only, no reaction, ideal for T.R.F. midgets, 8/6 per pair; superior quality, 2-gang, 0.0005 condensers, brand new, 8/-; tubular electrolytics, wire ends, 8mf, 150 volts working, 3/6; line cord replacement units, mounted in radiator cage, with instructions, 12/6; everything for the serviceman, full range droppers, mains transformers, speakers, sleeving, etc., etc., lists available; stamped addressed envelope with all enquiries, please; postage on all orders.—O. Greenlick, 34, Bancroft Rd., Cambridge Heath Rd., London, E.1. Stepney Green 1334. [2036

# ELECTRADIX

We suggest you carefully read this list of bargains, it contains many unusual ones and supplies of some are very limited.

SURVEYING THEODOLITE, by E. R. Watts; Director 5, Mark 1, No. 3,595, in new condition with tripod and telescopic level staff. Preference to Services. £40.

B.T.H. Double electric gramo. turntables, AC/DC, standard pick-ups mains, in steel cabinet, 15in. x 3 1/2 in. x 10in. For entertainment, works, or canteen. £23.

G.E.C. Radiogram, 5-valve, A.C. mains, complete in walnut console, in good order. £14.

HUN 5hips Wireless, ex Admiralty Prize. 8-valve Telefunken ship wall Receiver, in large cast aluminium water-tight case, complete with valves, £17 10s. A ditto set at £17. One 5-valve Telefunken auto-Radio Alarm "5.O.5." fitted 2 master relays, 4 auto-selectors and 20 sub-relays. Screened coils, power transf. for 150 volts. All for ship W/L, £24 10s. Two metal enclosed Rotary Deck Aerials, for direction finding reception. Complete with cabin wheel, etc., for above, £6 10s. each.

ONE Telefunken three-valve 5/W 5hp Receiver, 13.9 to 100 metres, less one valve, £4 15s.

MOTOR AIR COMPRESSORS, Michelin, direct-coupled to motor, on wheeled trolley with storage tank, £15. New Vickers high-speed rotary compressor, multi-blade, new £5 10s. 1 1/2 cu. ft. vertical compressor, only £3 10s. 2 Large Blowers, coupled to Crypto 5 h.p., D.C. motor, 5in. outlets, £23 10s. 5 Small high-pressure Blowers to 12in. water gauge, 1/6th h.p., D.C. 220 volts, suit organ, £6 10s. Electric Water Pumps, £6 10s.

ROTARY CONVERTERS, radio type, fitted smoother, and filters are scarce. We have the following new machines from Canada: 75-watt size, input 6 volts D.C. to 100 volts, 50/60 cycles A.C., £12. Next size, 100 watts, Input 110 volts D.C. to 110 volts, 50/60 cycle A.C., £14 10s. Another size, 150 watts, input 220 volts D.C. to 110 volts, 50/60 cycle A.C., £16 10s. We have some large Crypto and E.D.C. machines and also 500 cycle H.F. machines and smaller ones, 50 volts D.C. to 75 volts, 25 amp. A.C., 50 cycles, £3 10s.

3 1/2 KW Electric Welding Dynamo by Siemens Bros., 65 volts, 55 amps., 1,680 revs., £23 10s. A.C. to D.C. Motor Generator, 210 volts A.C. to 15 volts, 12 amps. D.C., 1,400 revs., £15.

CHARGERS. Tungar double circuit, 200/240v. A.C. mains to D.C. 60 volts, 10 amps., £16. Davenset Garage Charger, complete, as new. A.C. mains to 30 volts 6 amps. D.C., £14. Westinghouse Metal A.C. to 8 volts 15 amps., £22. Ditto to 8 volts 32 amps. D.C., £35.

MOTORS AND DYNAMOS. Croydon D.C. shunt dynamos or motors, 100 volts, 1 amp., 28-1/2 h.p. 110 and 220v. D.C. motors, £4. Induction 1/2 h.p. 230 v. 1,425 revs., 50 cycles A.C., £4 15s. 50v. 8 amp., 2,000 revs. Dynamo, £5 10s. 1/2 h.p. D.C. Motor, 1,750 revs., ball bearing, 500 volts, with pulley, £5. 240 volts 1 h.p., City Electric, 1,000 revs., ball bearing, 2-groove pulley, £10. 2 h.p. 220 volts E.D.C., 1,400 revs., £15. 3 KW Dynamo, 110 volts, 27 amps., £17. 460 volts, 6 h.p., D.C. Siemens Bros., 1,680 revs., £25. 500 volts 6 h.p. Crypto, 2,250 revs., double end shaft, £27 10s.

Winter is coming. Windmill builders want a slow-speed 12-volt automatic Dynamo, 600/1,000 revs., 10 amp. output. Price £5.

VALVES, American Replacement valves, 6- and 7-pin in Nos. 2A7, 48, 49, 53, 59, 79, etc., 6/6 each, to callers only. No Post. No Cartons. EXCITER lamps and photo cells.

FOR THE QUICKEST WAY TO ELECTRADIX HOUSE, see MAP on page 32 September issue of this journal.

When sending enquiries, please enclose stamped addressed envelope. Thank you.

ELECTRADIX RADIOS

214, Queenstown Road, Battersea, London, S.W.8.

Telephone Macaulay 9169



FOR THE QUICKEST WAY TO ELECTRADIX HOUSE, see MAP on page 32 September issue of this journal.

When sending enquiries, please enclose stamped addressed envelope. Thank you.

ELECTRADIX RADIOS

214, Queenstown Road, Battersea, London, S.W.8.

Telephone Macaulay 9169

*Answers!*  
**FLIK-o-DISK**  
*Quick!* TRADE MARK

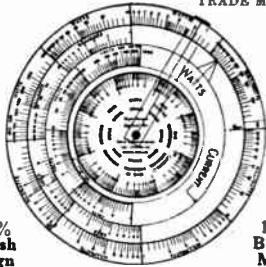

100% British Design      100% British Made

*Answers all OHM'S LAW problems—for example:*  
What will be the voltage when current I flows through resistance R?  
What will be the voltage with watts value W and I current flowing?  
What is the current flowing where watts value is W and voltage is E?  
What current will flow through R resistance where voltage is E?  
What will be the resistance where current I flows at voltage E?  
What will be the resistance where watts W is at voltage E?  
What will be the resistance where watts W is at current I?  
What is the wattage at voltage E through resistance R?  
What is the wattage of current I through resistance R?  
What will be the wattage of I current at E voltage?

The scales read from 1 millivolt to 1,000 volts. From 1 ohm to 1,000,000 ohms. From 1 milliamp to 10 amperes. From one-tenth of a milliwatt to 10,000 watts.

**FULL INSTRUCTIONS WITH EACH INSTRUMENT**  
**PRICE 4/6 Postage 3d.**  
**Order at once whilst deliveries are good**  
**IONIC LABORATORIES LTD.**  
6, Cranbourne Terrace, Salt Hill, SLOUGH, BUCKS, ENG.

**FOR SERVICE ENGINEERS,**  
Set Constructors, Radio Students, etc.  
**ASSORTED, NEW AND SECOND-HAND COMPONENTS, £1 PER PARCEL.**

Each parcel containing all the following: Single and twin-gang variable condensers, tuning coil, 6 resistors, 6-grid-leaks, 6 fixed condensers, 6 valve-holders, 6 insulators, 3 switches, volume-control, HT smoothing choke or energised speaker pot, Audio-transformer or choke, connecting wire, fuse wire, terminals, tags, name-plates, insulated hooks, earth-clips, bulb-holders, knobs, dials, screws and nuts, wood-screws. Wonderful value. Satisfaction Guaranteed.

*Terms: Cash with order. Postage and packing 2/- extra. Stamp with all enquiries please.*

**E. H. ROBINS TRADING CO., LTD.,**  
44, Kyle Crescent South, Whitchurch, Giam.



**For high quality loud speakers when the good times come again.**

The Courts, Silverdale, London  
VOIGT PATENTS LTD S.E.26. Phone: SYD 6666.

**SPEAKER REPAIRS** by **Specialists**

Any make, British or American      Best Service  
TRADE ONLY      Moderate Charges

Also Components for Service Men at keenest prices. List 1d. Holders of Export License for Northern Ireland.

**A. W. F. RADIO PRODUCTS** Phone: 11926  
13, Lilycroft Road, Bradford, Yorks.

**DALE ELECTRIC COMPANY.**—Most of the valves we listed last month are still available.—The Dale Electric Company, 13, Tretawn Gardens, London, N.W.7. [2060]

**VALVES** available.—Brimar, 4D1, 6A7, 6A8G, 7D5, 8D2, 11D2, 15D2, 25A6G, 42, 78, Mullard, DW4/500, EL3, IW4/500, Pen4DD, 6L6G, 354V, 1H5G, 1A7G; Marconi, KT35, KT63, X65; Mazda, AC/ME, AC/TP, AC/VP1, HL/22, HL23, HL1320, Pen453DD, Pen3520, UUs, UU7, VP133, VP1322; sent c.o.d.—Larg's, Whitehall St., Dundee. [2014]

**1,000** valves in stock.—PM22A, 11/-; Pen A4, 12/10; Pen 4DD, 15/3; 2D4B, 6/9; TH2321, 14/-; AC5/PenDD, 15/3; FC13, 14/-; SP13C, 12/10; AC/TP, 14/-; UUs, 11/-; 431U, 11/-; IC5GT, 11/-; IH5GT, 11/-; DLL, 11/-; 80, 11/-; 45, 11/7; CL33, 12/10; C14, 12/10; CBL1, 15/3; U50, 11/-; DC2/Pen, 30/5; 35Z4G, 11/-; 25Z4G, 11/-; 12J5GT, 9/2; 6Q7GT, 11/7; 12SQ7GT, 11/7; send s.a.e. for valve and wireless parts lists, 2d.—Ransom, 9 and 34, Bond St., Brighton. Retailers not supplied.

**Wanted**  
**A** CORN pentodes, three 954 type urgently required.—Rigg, 100, Dudley Port, Staffs.  
**WANTED,** 2 Ostar Ganz valves, No. K3560, for 200-200V, in good condition.—Offers to Frynne, Wymondham House, Leicester. [2026]

**VALVES** wanted, any quantity from one upwards; also test equipment, service sheets and spares.—J. Bull, 246, High St., Harlesden, N.W.10. [9732]

**LOEWE** three-in-one type N.F.B. hearing aid valve req., Fil. 4 V, anode 90-200V, used valve in good cond. accept.—R.H.P., Griffin & Tatlock, Ltd., Kemble St., W.C.2.

**REPAIRS AND SERVICE**  
**METROPOLITAN RADIO SERVICE Co.** guarantee repairs to American and British receivers.—1021, Finchley Rd., N.W.11. Spe. 3000. [9641]

**MIDWEST,** McMurdo, Belmont, Crosley, L Ferguson, etc., valves; the American experts.—Bennett's, 4, Humberstone Drive, Leicester. [2049]

**A** CCURATE radio rewinds, mains transformers, fields o.p. transformers, etc., and all loudspeaker repairs.—Southern Trade Services, 297-299, High St., Croydon. [1715]

**M** AINS transformers service, repairs, rewinds, or construction to specification of any type, competitive prices and prompt service.—Sturdy Electric Co., Ltd., Dipton, Newcastle-upon-Tyne. [9651]

**A** LL types of radio receivers serviced, Murphy and Pilot specialist valves in stock, sound repairs for 13 years.—T. E. Fevyer, F.I.P.R.E., 50, Vine St., Uxbridge.

**"SERVICE with a Smile."**—Repairers of all types of British and American receivers; coil rewinds; American valves, spares, line cords.—F.R.L. Ltd., 22, Howland St., W.I. Museum 5675. [1575]

**D** EGALLIER'S, Ltd.—"Service with a guarantee." If you cannot get your receiver serviced, let American specialists do the job; first-class workmanship only; specialising in Air-King, Belmont, Detrola, de Wald, Emerson, Ferguson, Garod, Hallicrafter, Hamerland, Lafayette, Midwest, Majestic, Pilot, Philco, Stronberg-Carlson, Wells-Gardner, etc., also any British or Continental set. Remember, for 14 years we have handled American receivers; this is self-explanatory; s.a.e. with all enquiries.—Degallier's, Ltd., 9, Westbourne Court, London, W.2. [1995]

**MISCELLANEOUS**  
**I** NVENTOR wishes to contact manufacturers with view to development on cash or royalty basis of an "Ultra-high Frequency Radio Altimeter."—Box 2940, c/o *Wireless World*. [2922]

**SWLs** and ex-transmitters, exchange cards! Send your QSL card, replies guaranteed.—Pete Graw, Sea Breezes, Harstold Rd, Littlehampton, Sussex. [1987]

**R** UBBER stamps made up to your special requirements and design, typical example, stamp showing name, address and profession; 9/6 post free.—V.E.S., Radio House, Ruislip. [1884]

**PATENT NOTICE**  
**T** HE Proprietors of Letter Patent No. 427980 relating to vacuum tube bases and pins therefor desire to grant licences under the patent to interested parties on reasonable terms for the purpose of exploiting the same and ensuring its full commercial development and practical working in this country.—Enquiries to be addressed to Cruikshank & Fairweather, 29, Southampton Buildings, Chancery Lane, London, W.C.2. [2012]

**SITUATION VACANT**  
**M** ANAGER required for radio shop, Central London, preferably with knowledge amateur short-wave trade.—Full pars., salary reqd., to Box 2945, c/o *Wireless World*.



**W. BRYAN SAVAGE LTD.**

Expert assistance in the solution of problems relating to

- TRANSFORMERS, CHOKES
- AMPLIFIERS
- POWER UNITS

and Specialised Equipment embodying

**ELECTRONIC CONTROL**

**WESTMORELAND RD., N.W.9**  
**COLINDALE 7131**

**"UNIVERSAL CIRCUITS"**  
by R. S. Roberts, M.Brit.I.R.E., A.M.I.R.E.

Three folders and a thirty-six page booklet, presenting the main principles of radio circuit operation in a concise and convenient form for the pocket.

- I. The Transmitter
- II. The T.R.F. Receiver
- III. The Superheterodyne Receiver

By means of hinged flaps, the charts give a large number of recognised alternatives for each stage. To assist the student in memorising and understanding these, a logical five-colour scheme has been adopted throughout.

"Grid Leak" says: "The Charts and Notes are really intended for students and teachers of radio, but are extremely useful to every radio engineer."

Price complete 6/3 post free, from

**The Bookstall**  
**NORTHERN POLYTECHNIC**  
**HOLLOWAY, LONDON, N.7**

**LONDEX for RELAYS**

The wide range of Londex Relays includes a variety of

**TYPES APPROVED**  
by  
**AIR MINISTRY**  
**M.A.P.**  
**AND ADMIRALTY**



Ask for details and leaflet SPN/WW.      Multiple contact Relay LF.

**LONDEX LTD**  
MANUFACTURERS OF RELAYS  
ADDRESS: 207 ANERLEY ROAD, LONDON S.E.20

*Yours to a tenth of a thou'*

A highly skilled staff of craftsmen combined with the most up-to-date machines enable us to handle light engineering production with microscopic accuracy. We also realise that you want delivery promises kept.



**Wingard (MA) LTD.**

Precision Engineers  
**EUGENE WORKS, EDGWARE ROAD, HENDON, N.W.9**



**never let you down**

**CLASSIFIED RADIO RECEIVER DIAGRAMS**

By E. M. Squire. This work gives a diagrammatic survey of modern radio receivers, and provides the practical radio man, service engineer, dealer, and amateur with a ready reference to a representative selection of the types of circuit likely to be met with in the majority of receivers. 10s. 6d. net.

**BASIC CALCULATIONS FOR R.A.F. GROUND DUTIES (RADIO, WIRELESS, AND ELECTRICAL TRADES)**

By A. E. Druett, B.Sc.(Eng.) Lond., A.M.I.Mech.E. Applies to R.D.F. and Wireless Mechanics, Wireless Operators, and Electricians, Groups I and II. The syllabus for the proficiency examination is adequately covered, and fully worked solutions to the exercises are included. 3s. 6d. net.

**EXPERIMENTAL RADIO ENGINEERING**

By E. T. A. Rapson. Assisted by E. G. Ackermann. This book sets out a number of experiments and methods of measurement suitable for a three or four years' course in radio engineering at a technical college. 8s. 6d. net.

**SHORT-WAVE RADIO**

By J. H. Reyner. An invaluable volume, recommended to all students of radio engineering as a reliable textbook on modern developments in the use of short, ultra-short, and micro-waves. 10s. 6d. net.

★ *Pitman's Radio List contains the details of many books which are in constant use by mechanics and engineers. Why not send for FREE copy?*

39, PARKER STREET, KINGSWAY  
**PITMAN BOOKS**

**THE RADIO INSTRUMENT CO.**

Manufacturers and Distributors of Radio Components, MAINS TRANSFORMERS. Primary, 0/210/230/250 v. Secondaries 350-0-350v. (except Z types).

- Type  
A 80ma. 4v. 2a. and 4v. 4a. CT. 25/-  
B 80ma. 5v. 2a. and 6.3v. 4a. CT. 25/-  
S 80ma. 4v. 2a. and 4v. 2a. and 4v. 4a. CT. 28/-  
T 100ma. 4v. 2a. and 4v. 2a. and 4v. 2a. and 4v. 4a. CT. 32/6  
X 120ma. 4v. 3a. and 4v. 6a. CT. 35/-  
Y 120ma. 500/0/500 4v. 3a. and 4v. 6 amp. 39/6  
Z 120ma. 500/0/500 5v. 3a. and 6.3v. 6 amp. 39/6  
OPI2 OUTPUT TRANSFORMER. Primary 120ma., 12 ratio. Four secondary windings. Suit single or push pull connection, triodes or pentodes. Outputs in excess of 50 watts can be obtained, low percentage of distortion due to high primary inductance. Exceptional "top" without harmonics. For multiple speakers and huge output. Full data chart on request. 39/6  
DELIVERY of all transformers is regulated by the Essential Works Contracts. Quote priority numbers when available.

CHOKES. Smoothing, CH1 80ma., 8/6. CH2 100ma., 17/6. CH3 20ma., 22/6. DC. Resistance of all above types 500 ohms. FR2 type field replacement choke 2,000 ohms, 17/6.  
MANS CHOKES for insertion of mains leads, 2 amp. capacity. 2/9. (Condensers for above, 1 mfd. 2.250v. test, 1/9)

AUTO TRANSFORMERS. 60 watt types, 22/6.  
SPEAKER REPLACEMENT BOBBINS. Centre tapped Power/Pentode. Standard Rola and Celestion, Goodmans stock. 2/9 each. 30/- doz.

VOLUME CONTROLS. All valves, long shafts, less sw. 4/-, with sw. 5/6.  
SWITCHES. Toggle, SP211 DPDT, 3/6. Wave change 6-bank 4-wave, 8/6.  
ROTHERMEL SENIOR PICK-UPS. Ebony bakelite, 3/18/9, incl. tax.

SPEAKERS. A limited number. EIGHT-INCH PM. Units by famous maker. Large, powerful magnet with special high flux. Fitted with Pentode Matching trans. 29/6.  
VALVES. Large stock of pre-war types. Write for lists.

MAIL ORDERS. Please include postage. C.O.D. available.  
All enquiries for new lists must be accompanied by 2jd. stamp.

For full details of our products, write to:—

**THE RADIO INSTRUMENT CO.**  
294, BROADWAY, BEXLEYHEATH, KENT.

\*Phone: Bexley Heath 3021.

**TUITION**

PERSONAL tuition required, practical and theoretical radio; N.W. district.—Box 2923, c/o *Wireless World*. [1946

**L**EARN Morse code the Candler way. See advertisement on page 29. [1292

**R**ADIO training.—P.M.G. exam. and I.E.E. Diploma; prospectus free.—Technical College, Hull. [0611

**S**HORT postal course for 1st or 2nd class P.M.G. certificates, with occasional optional attendances; Nth. London, 2 mins. station.—BCM/Radiocerts (2), W.C.1. [2034

**R**ADIO Engineering.—Television and Wireless Telegraphy, comprehensive postal courses of instruction; Apply British School of Telegraphy, Ltd., 179, Clapham Rd., London, S.W.9 (Estd. 1906). Also instruction at school in wireless for H.M. Merchant Navy and R.A.F. [9249

"**E**NGINEERING Opportunities"—free 112-page guide to training for A.M.I.Mech.E., A.M.I.E.E., and all branches of engineering and building; full of advice for expert or novice; write for free copy and make your peacetime future secure.—B.I.E.T. (Dept. 537B), 17, Stratford Place, London, W.1.

**A** POSTAL training in electrical engineering—power or radio; individual correspondence tuition by highly qualified engineers with wide teaching and technical experience. Elementary or advanced courses. Preparation for recognised examinations. Pre-service training specially arranged.—G. B., 18, Springfield Mount, Kingsbury, N.W.9. [1731

**T**HE Tuitionary Board of the Institute of Practical Radio Engineers have available home study courses covering elementary, theoretical, mathematical, practical, and laboratory tuition in radio and television engineering; the text is suitable coaching matter for I.P.R.E., Service-entry and progressive exams.; tuitionary fees—on pre-war rates—are moderate. The Syllabus of Instructional Text may be obtained post free from the Secretary, Bush House, Walton Avenue, Henley-on-Thames, Oxon. [1462

**TECHNICAL TRAINING**

A.M.I.E.E., City and Guilds, etc., on "No pass—no fee" terms; over 95% successes. For full details of modern courses in all branches of electrical technology send for our 112-page handbook, free and post free.—B.I.E.T. (Dept. 388A), 17, Stratford Place, London, W.1.

**G**REAT possibilities exist for technically qualified engineers, key men in wartime and afterwards. Through the home-study courses of The T.I.G.B. take a recognised engineering qualification, such as A.M.I.Mech.E., A.M.I.E.E., A.F.R.A.E.S., A.M.I.Chem.E., C and G, etc., in which examinations the T.I.G.B. students have gained 25 FIRST PLACES and hundreds of passes. Write to day for "The Engineer's Guide to Success"—free—containing the world's widest choice of engineering courses covering all branches, including, aeronautical, mechanical, electrical, wireless, chemical, etc.

**T**HE TECHNOLOGICAL INSTITUTE OF GREAT BRITAIN, 82, Temple Bar House, London, E.C.4 [1403

**BOOKS, INSTRUCTIONS, ETC.**  
"W.W." bound vols. X to XIV incl., per feet; £3.—24, Arundel Rd., Cheam.

**W**ANTED, a copy Jan., Feb., Mar., April, May, 1943, issues W.W.; will pay 2/6 per issue.—Box 2932, c/o *Wireless World*.

**W**EBB'S radio map of the world locates any station heard, size 40x30in, 4/6, post 6d., on linen, 10/6, post free.—Webb's Radio, 14, Boho St., London, W.1. Tel. Gerard 2089. [9947

**BATTERY CHARGERS & TRICKLE CHARGERS**

for all purposes  
"QUICK-CHARGE" CHARGERS  
well known for reliability  
Booklet R.15, giving useful information and describing 12 Models, on request

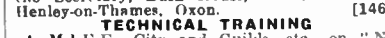

**RUNBAKEN-MANCHESTER**

**SERVICING. Publisher desires articles**

(approx. 3,000 words) relating to the following:—Test equipment. General fault finding. Trimming and aligning. Valve replacements (suggested equivalents). Cathode ray. Interference suppression. Loudspeakers (selection and repair). Hints on war-time servicing. Practical, but unusual methods on servicing and testing. Note: Articles may be submitted in rough form. We will re-read where necessary. List subjects covered and state remuneration desired. Write to Box 109, Parris, 121, Kingsway, London, W.C.2.

**VALVES**

This is part of our current stock list of types available and many representing equivalents to numerous valves not mentioned; a stamped envelope will bring you any information about any other particular valve you may desire. If out of stock we may send equivalents. All at Board of Trade controlled prices. C.O.D.

- A27D, AC1H, ACME, AC0-44, ACP, AC-Pen, ACTH1, ACTH4, ACTP, ACVP2, AC2Pen, AZ1, AZ31, B63, C50B, CL4, CL33, D41, D63, DD13, DD14, DDD1, DD-Pen, DIT2A, DH73M, DL63, DW2, EBC3, EBC33, EBL1, EBL31, ECH2, ECH3, ECH35, EP5, EP6, EP8, EP9, EP39, EK2, EK3, EL2, EL3, EL5, EL32, EL25, EM4, FC2, FC2A, FC4, FC13, FC13C, FW4-500, H63, HD24, HL2, H14, HL13C, HL21D, HL22, HL23, HL41D, HL133D, HL1320, HP120, HP4106, KT24, KT32, KT33C, KT41, KT66, LTW61, KT63, KT263, L63, LP2, LP220, MH41, MHD4, MH14, M5Pen, M5-PenB, M5V-Pen, MX40, OM4, OM6, OM9, OP, P, Pen4D, Pen45, Pen45D, Pen40, Pen48, Pen5A, Pen5A, PM2A, PM2B, PM22A, PM24A, PM25, PF5-400, PX4, PX25, QP25, RF30, RF120, SP4, SP13, SP13C, SP1320, TH4, TH4B, TP1340, TDD2, TD14, TDD13C, TX4, TX41, U/P, U/SL, U5-U12, U14, U17, U31, U50, U52, U55, U57, URIC-UY31, WMP49, V045, VP2B, VP4A, VP4B, VP13A, VP13K, VP20, VP21, VP23, VP41, VP133, VP210, VP1320, V824/K, W4-500, W21, W42, WD40, X22, X24, X41, X61M, X64, X65, Y61, Z14, Z21, 1A4B, 1A5, 1A7, 1B5, 1C5, 1N5, 1C7, 1D5, 1F4, 1G5, 1H5, 1H6, 1J6, 1Z4, 2J27, 2H4B, 2H3A, 2F, 2X3, 4D1, 4TH4, 5Y4, 5Y3, 5Y4, 5Y4, 5A3, 6A5, 6A8, 6B6, 6B8, 6L6, 6C8, 6D5, 6D6, 6P6, 6F7, 6F8, 6H6, 6J7, 6K6, 6K7, 6K8, 6L6, 6I7, 6N6, 6P5, 6Q7, 6R7, 6S7, 6S8, 6Q7, 6TH8, 6V5, 6V6, 6X5, 6Z3, 6Z5, 12Z5, 7A8, 7B7, 7B8, 7C8, 7D5, 7D2, 9A1, 9D2, 10, 10A, 10D1, 11A2, 11B3, 11B5, 12P5, 12P5, 12J5, 12J7, 12Q7, 12S47, 12SP5, 12SK7, 12S47, 13SP4, 15A2, 15D2, 19, 20A1, 20D2, 24, 24A, 25A5, 25B6, 25A6, 25Z4, 26, 27, 29, 30, 31, 32, 32E, 33, 34, 35, 35Z4, 36, 37, 38, 39, 41MH1, 41MP, 41MPG, 41STH, 42, 42MP1en, 431V, 46, 48, 50, 52, 53, 56, 57, 59, 75, 77, 78, 79, 81, 82, 83, 85, 89, 117Z, 117ZB, 150A-40, 150B, 164V, 220MPG, 210DDT, 210HE, 210LF, 210FG, 210SPG, 210ST, 210VPA, 210VPT, 220B, 220HPT, 220-OT, 220FA, 220V80, 290L4, 354V, 866, 904V, 1821.
- R.F.30 replaces URIC, U4020, 1D5, 40SUA, 11/-.  
RF120 replaces U10, U12, U14, MU12, MU13, 1W3, 1W4, 1W5, 1W4, 1821, U-3, 11/-.

Our famous CONVERSION Units to replace almost unobtainable valves:

- DAC1 13/6, DH30 10/3; 117B 22/9; DL2, DF1, U30, 25RE, 35RE, 25V5, 25Z5, 15/6; 6C6, 61D6, MPT4, VMS4, VP4, VP23, 18, 43, 77, 78, 2151, 17/6; X30, X31, X32, 18/6; CV1, CV2, UR2, T.R.3, UR3C, UR41, 19/-; AC2PenD1, PenD16P, 19/9 are in ever-increasing demand and being allocated in fair rotation. C.O.D. only.

Just published: Valves Comparative Tables, with quick reference index, covering B.V.A. and non-B.V.A. types. 17, postage paid.

**J. BULL & SONS**  
246, HIGH ST., HARLESDEN, N.W.10.

**WARD ROTARY CONVERTERS**

Petrol Electric Generating Plants, H.T. Generators, D.C. Motors, Frequency Converters, etc., up to 25 K.V.A.

**CHAS. F. WARD**  
37, WHITE POST LANE, HACKNEY WICK, E.9  
\*Phone: Amherst 1393

**Radio Service**

REWINDS, Mains 25/-, Output from 6/-.  
Field Coils, 9/-.  
PROMPT DELIVERY.  
VALVES (B.V.A.). Send for list—good selection.  
PHILIPS D.C. CONVERTERS—Bought—Sold—and Exchanged.  
S.A.B. 10/-

281/3/5, Lichfield Road,  
**A.D.S. Co. ASTON, BIRMINGHAM, 6**



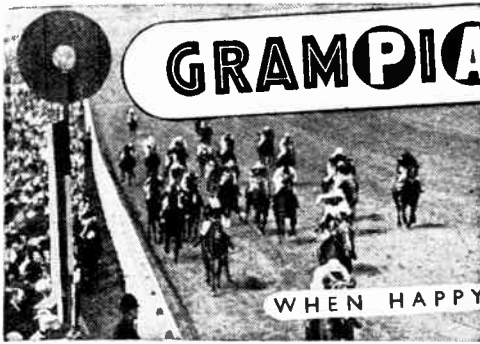

# GRAMPIAN

'SOUND  
IN SOUND'

Remember, just as "Grampian" products are giving the Nation essentially efficient service in war-time, so will they serve you when peace permits.

- ★ SPEAKERS
- ★ AMPLIFIERS
- ★ MICROPHONES

WHEN HAPPY DAYS ARE HERE AGAIN



GRAMPIAN REPRODUCERS LTD. HAMPTON ROAD, HANWORTH, MIDDLESEX. Telephone: FELtham 2657-8.

## IF ITS TRANSFORMERS OR CHOKES

Let the manufacturers of VARLEY products assist you.

SEND US YOUR ENQUIRIES. Standard units available up to 1/2 K.W. or to your specification.

**OLIVER PELL CONTROL LTD**  
CAMBRIDGE ROW, BURRAGE ROAD, WOOLWICH, LONDON SE



ON ALL GOVERNMENT LISTS



## Resistors

MANUFACTURED BY

**ERG RESISTORS LIMITED**  
1021a, FINCHLEY ROAD, LONDON, N.W.11

PHONE: SPEEDWELL 6967

# Remember-Walter

J.C.H. LTD

RADIO STAMPINGS • RADIO CHASSIS • RADIO PRESSINGS

FARM LANE, FULHAM, S.W.6. TELEPHONE: FULHAM 5234

C.R.C.4

## MARTIN'S HAVE IT—IN STOCK :

- Mains Transformers. Well made Standard Replacements, 4-v. and 6.3-v., 37/6 each.
- .01 and .03 Tubular Fixed Condensers, 1,500 V.D.C., 9d. each.
- .05 Tubular Fixed Condensers, 1,500 V.D.C., 1/3 each.
- .0001 Reaction Condensers, 2/- each. Boxed.
- Zakley Type Switches, 4 way, 1-bank, 2-pole, 3/6 each.
- Resistors, 1 watt, 100 ohms to 2 meg., mixed, 72/- gross.
- Resistors, 1/2 watt, 100 ohms to 2 meg., mixed, 63/- gross.

- Dropper Resistors, wire wound 1,000 ohms, variable superior type, fitted 2-hole fixing lug, 5/9 each.
- 10-watt Resistors, 800 ohms, wire wound, 2/6 each.
- 2-Gang Condensers, .0005, with slow motion drive. Brand new. Boxed, 9/- each.
- 3-Gang Condensers, .0005, new, 7/- each.
- Volume Controls and Tone Controls, all values, with switch, 6/6 each; without switch, 4/6 each.
- Valve Holders, 7-pin British, 8d. each.
- Replacement Valves for American Midgets, and British receivers, nearly all types in stock—all at controlled prices.

**MARTIN'S (Edmonton) LTD.** 3/4 The Broadway, Edmonton, London, N.9. TOTenham 4188.

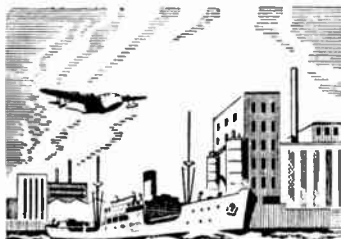

## INVENTORS

We invite new inventions which, guided by the technical knowledge, manufacturing facilities and world-wide marketing organisation of the Simmonds Group, may be developed to play vital parts in modern industry.

ALL COMMUNICATIONS MUST BE IN WRITING IN FIRST INSTANCE TO—

The **SIMMONDS GROUP**  
LONDON  
MELBOURNE  
PARIS • NEW YORK  
LOS ANGELES

**SIMMONDS DEVELOPMENT CORPORATION LTD. 2-3 NORFOLK ST. W.C.2**

Printed in England for the Publishers, ILIFFE AND SONS LTD., Dorset House, Stamford Street, London, S.E.1, by THE CORNWALL PRESS LTD., Paris Garden, Stamford Street, London, S.E.1. "The Wireless World" can be obtained abroad from the following: AUSTRALIA and NEW ZEALAND: Gordon & Gotch, Ltd. INDIA: A. H. Wheeler & Co. CANADA: Imperial News Co.; Gordon & Gotch, Ltd. SOUTH AFRICA: Central News Agency, Ltd.; Wm. Dawson & Sons (S.A.), Ltd. UNITED STATES: The International News Co.



*Going one better*  
**IN COMMUNICATIONS**

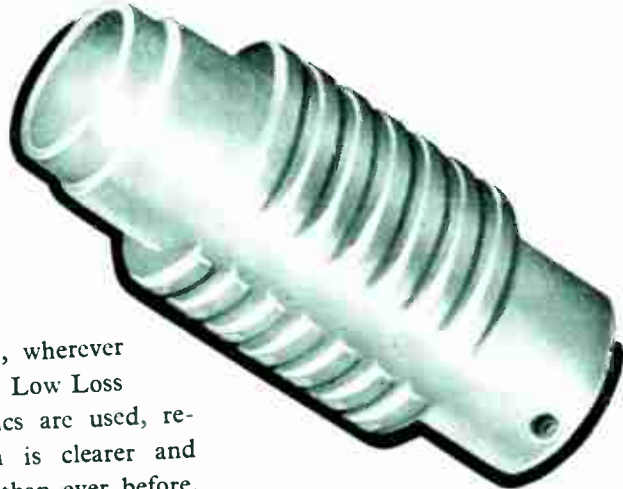

To-day, wherever Bullers Low Loss Ceramics are used, reception is clearer and better than ever before.

Years of research in Bullers Laboratories have developed these materials to such a high level of efficiency that Dielectric Loss is virtually eliminated. Bullers Ceramics are now playing a vital part in maintaining communications under all conditions.

**BULLERS LIMITED**  
 THE HALL, OATLANDS DRIVE, WEYBRIDGE, SURREY  
 Telephone : Walton-on-Thames 2451  
 Manchester Office : 196 Deansgate, Manchester

**Bullers**

**LOW LOSS CERAMICS**

**Made in Three Principal Materials :**

**FREQUELEX.** An Insulating Material of Low Dielectric Loss For Coil Formers, Aerial Insulators, Valve Holders, etc.

**PERMALEX.** A High Permittivity Material. For the construction of Condensers of the smallest possible dimensions.

**TEMPLEX.** A Condenser material of medium permittivity. For the construction of Condensers having a constant capacity at all temperatures.





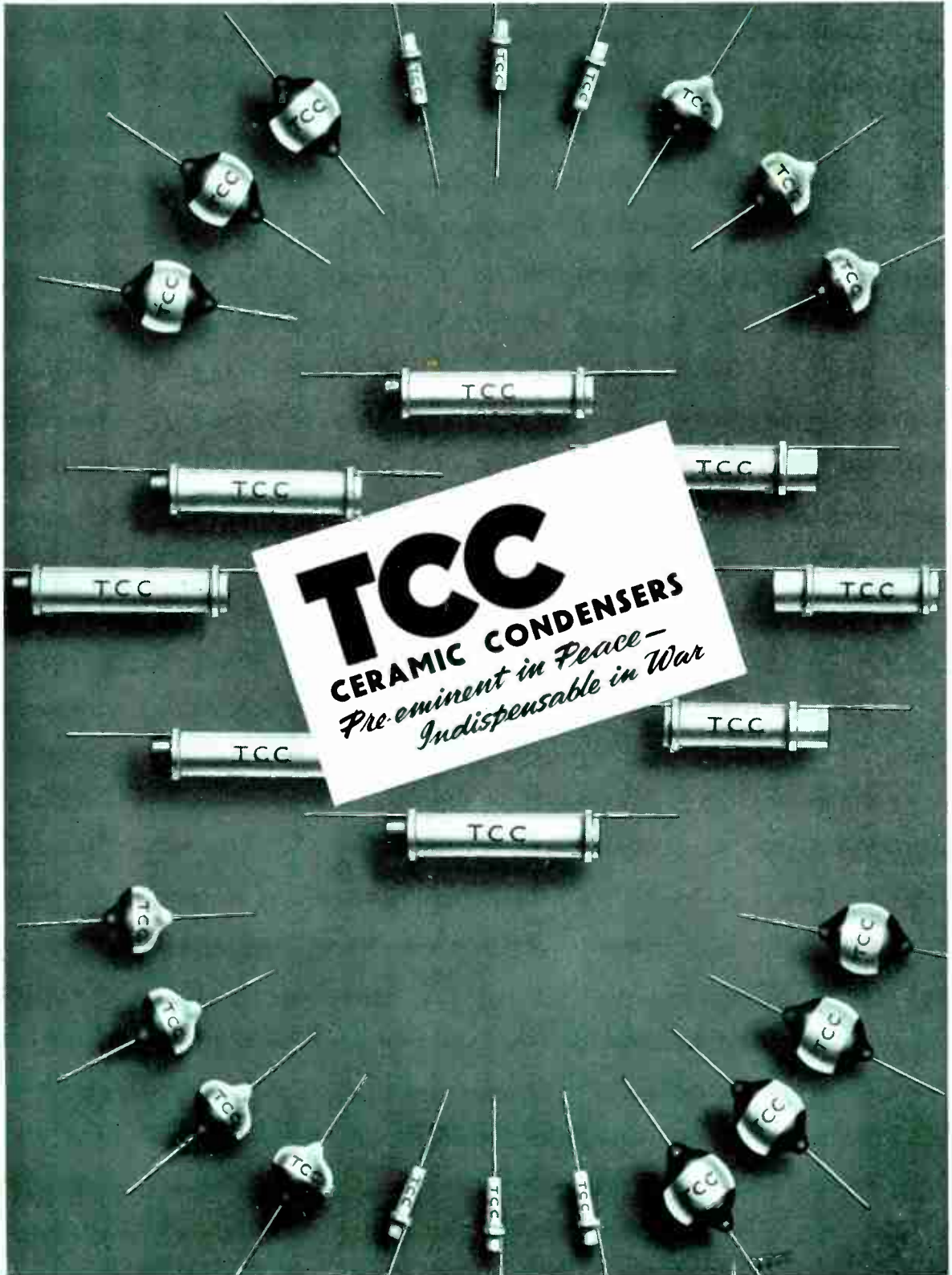

ADVERTISEMENT OF THE TELEGRAPH CONDENSER CO., LTD