

# Wireless World

RADIO • ELECTRONICS • ELECTRO-ACOUSTICS



MAY 1943

1/3

Vol. XLIX, No. 5

S-W BROADCASTING STATION LIST



**“OUT OF RESISTANCE TO AGGRESSION  
SHALL COME  
LASTING BENEFIT TO MANKIND”**

\*

A great truth ; and equally true in other ways for it is from the function of a resistance in an electrical circuit that millions of complex instruments, upon which we are so dependent, derive their results. It is essential however, that the quality of the resistance in all cases shall be of the highest.

In a world where the use of electrical and radio devices has reached an unprecedented peak, the many and varied conditions in which resistances are required can be but inadequately imagined. Somebody must know about such things however, and who better than we whose care and privilege it is to develop and manufacture all kinds of dependable resistances to satisfy the most exacting modern operating demands.

What a wealth of technical excellence in resistances will be available to industry when better times arrive.

**DUBILIER**  
CONDENSER CO. (1925) LTD.





**T**HE Model 7 Universal AvoMeter is the world's most widely used combination electrical measuring instrument. It provides 46 ranges of readings and is guaranteed accurate to B.S. first grade limits on D.C. and A.C. from 25 to 100 cycles. It is self-contained, compact and portable, simple to operate and almost impossible to damage electrically. It is protected by an automatic cut-out against damage through

severe overload, and is provided with automatic compensation for variations in ambient temperature.

The AvoMeter is one of a useful range of "Avo" electrical testing instruments which are maintaining on active service and in industry the "Avo" reputation for an unexcelled standard of accuracy and dependability—in fact, a standard by which other instruments are judged.

*Some delay in delivery of Trade Orders is inevitable, but we shall continue to do our best to fulfil your requirements as promptly as possible.*

**ONE INSTRUMENT**  
measures:—

Current, A.C. and D.C. (0 to 10 amps.)  
Voltage, A.C. and D.C. (0 to 1,000 v.)  
Resistance up to 40 megohms  
Capacity (0 to 20 mfd.)  
Audio-frequency Power Output (0 to 4 watts)  
Decibels ( - 10 Db. to + 15 Db.)

Sole Proprietors and Manufacturers:

**AUTOMATIC COIL WINDER & ELECTRICAL EQUIPMENT Co., Ltd.**, Winder House, Douglas St., London, S.W.1

Telephone: VICTORIA 3404/7

A

# *It was just a coil of wire . . .*

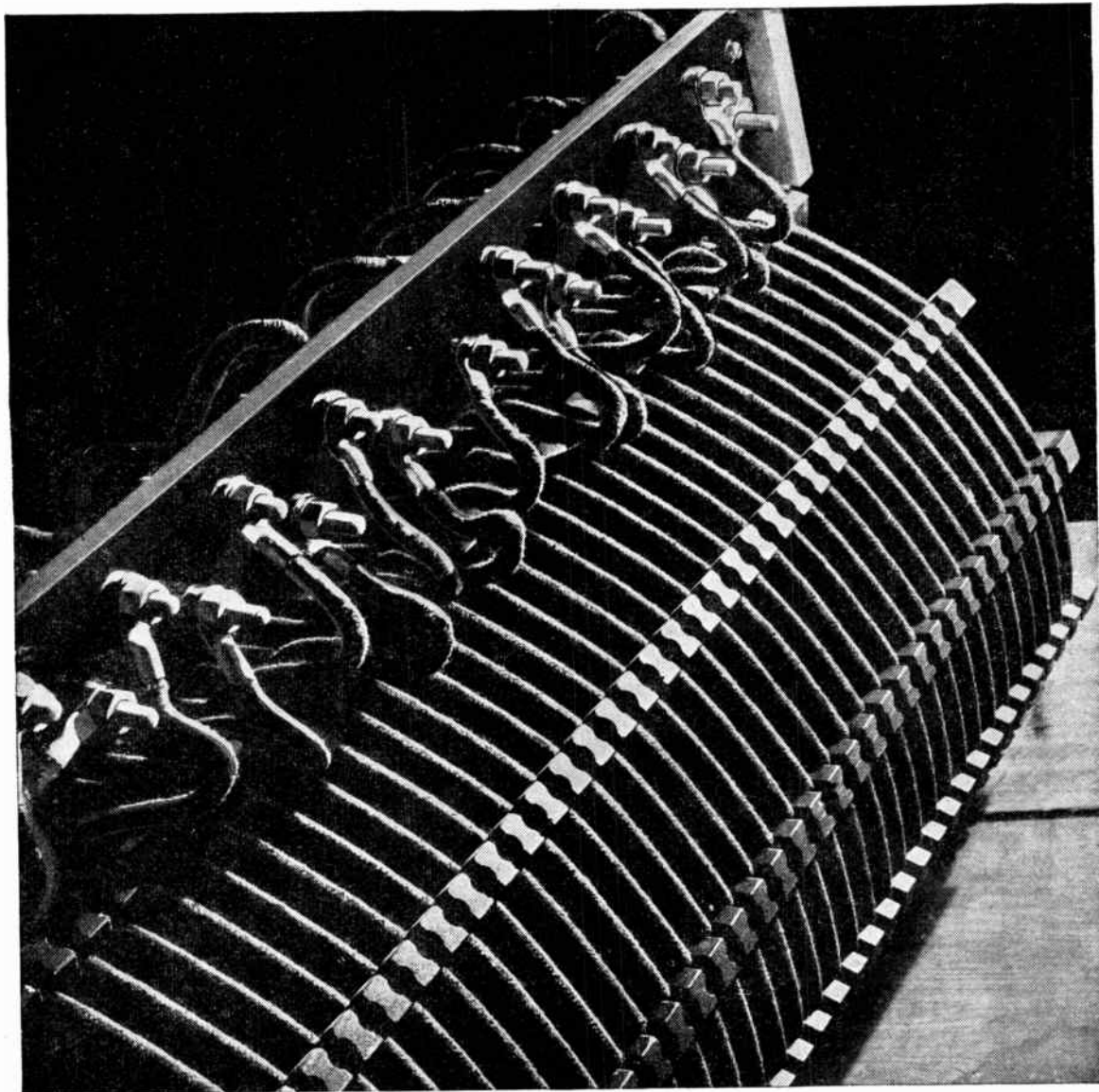

*. . . now it is an inductance coil which has to meet the stern demands of a communication system that goes on day and night. One more example of Rediffusion products used in Rediffusion communication equipment.*

**REDIFFUSION LIMITED**  
A subsidiary of  
**BROADCAST RELAY SERVICE LIMITED**

DESIGNERS AND MANUFACTURERS OF COMMUNICATION EQUIPMENT  
VICTORIA STATION HOUSE • VICTORIA STREET • LONDON • S.W.1 (PHONE VICTORIA 8831)

**SYMBOLS OF PRECISION**

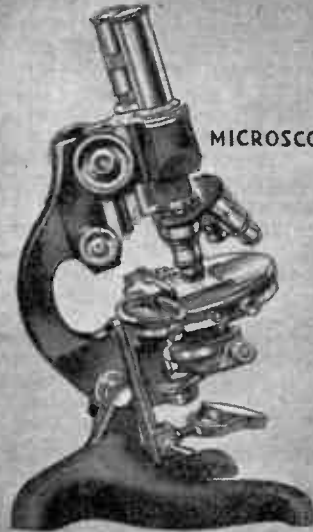

MICROSCOPE



# **MAZDA**

**RADIO  
VALVES**

THE EDISON SWAN ELECTRIC CO. LTD.



155, CHARING CROSS RD., LONDON, W.C.2

*For full particulars write to Technical Service Department*

# WHY ERSIN MULTICORE

the Solder wire with 3 cores of non-corrosive ERSIN FLUX is preferred by the majority of firms manufacturing the best radio and electrical equipment under Government Contracts.



## WHY THEY USE CORED SOLDER

Cored solder is in the form of a wire or tube containing one or more cores of flux. Its principal advantages over stick solder and a separate flux are:

- (a) it obviates need for separate fluxing  
(b) if the correct proportion of flux is contained in cored solder wire the correct amount is automatically applied to the joint when the solder wire is melted. This is important in wartime when unskilled labour is employed.

## WHY THEY PREFER MULTICORE SOLDER. 3 Cores—Easier Melting

Multicore Solder wire contains 3 cores of flux to ensure flux continuity. In Multicore there is always sufficient proportion of flux to solder. If only two cores were filled with flux, satisfactory joints are obtained. In practice, the care with which Multicore Solder is made means that there are always 3 cores of flux evenly distributed over the cross section of the solder,

so making thinner solder walls than single cored solder, thus giving more rapid melting and speeding up soldering.

## ERSIN FLUX

For soldering radio and electrical equipment non-corrosive flux should be employed. For this reason either pure resin is specified by Government Departments as the flux to be used, or the flux residue must be pure resin. Resin is a comparatively non-active flux and gives poor results on oxidised, dirty or "difficult" surfaces such as nickel. The flux in the cores of Multicore is "Ersin"—a pure, high-grade resin subjected to chemical process to increase its fluxing action without impairing its non-corrosive and protective properties. The activating agent added by this process is dissipated during the soldering operation and the flux residue is pure resin. Ersin Multicore Solder is approved by A.I.D., G.P.O., and other Ministries where resin cored solder is specified.

## PRACTICAL SOLDERING TEST OF FLUXES

The illustration shows the result of a practical test made using nickel-plated spade tags and bare copper braid. The parts were heated in air to 250° C. and to identical specimens were applied 1/2" lengths of 14 S.W.G. 40/60 solder. To

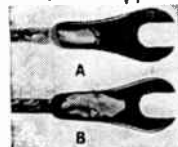

sample A, single cored solder with resin flux was applied. The solder fused only at point of contact without spreading. A dry joint resulted, having poor mechanical strength and high electrical resistance. To sample B, Ersin Multicore Solder was applied, and the solder spread evenly over both nickel and copper surfaces, giving a sound mechanical and electrical joint.

## ECONOMY OF USING ERSIN MULTICORE SOLDER

The initial cost of Ersin Multicore Solder per lb. or per cwt. when compared with stick solder is greater. Ordinary solder involves only melting and casting, whereas high chemical skill is required for the manufacture of the Ersin flux and engineering skill for the Multicore Solder incorporating the 3 cores of Ersin Flux. However, for the majority of soldering processes in electrical and radio equipment Multicore Solder will

show a considerable saving in cost, both in material and labour time, as compared either with stick solder or single cored solder. Cored solder ensures that the solder and flux are put just where they are required, and by choice of suitable gauge, economy in use of material is obtained. The quick wetting of the Ersin flux as compared with resin flux in single core resin solder ensures that with the correct temperature and reasonably clean surface, immediate alloying will be obtained, and no portions of solder will drop off the job and be wasted. Even an unskilled worker, provided with irons of correct temperature, is able to use every Inch of Multicore Solder without waste.

## ALLOYS

Soft solders are made in various alloys of tin and lead, the tin content usually being specified first, i.e. 40/60 alloy means an alloy containing 40% tin and 60% lead. The need for conserving tin has led the Government to restrict the proportion of tin in solders of all kinds. Thus, the highest tin content permitted for Government contracts without a special licence is 45/55 alloy. The radio and electrical industry previously used large quantities of 60/40 alloy, and lowering of tin content has meant that the melting point of the solder has risen. The chart below gives approximate melting points and recommended bit temperatures.

ALLOY Tin Lead	Equivalent B.S. Grade	Solidus C.°	Liquidus C.°	Recommended bit Temperature C.°
45/55	M	183°	227°	267°
40/60	C	183°	238°	278°
30/70	D	183°	257°	297°
18.5/81.5	N	187°	277°	317°

## VIRGIN METALS—ANTIMONY FREE

The wider use of zinc plated components in radio and electrical equipment has made it advantageous to use solder which is antimony free, and thus Multicore Solder is now made from virgin metals to B.S. Specification 219/1942 but without the antimony content.

## IMPORTANCE OF CORRECT GAUGE

Ersin Multicore Solder Wire is made in gauges from 10 S.W.G. (.128"—3.251 m/ms) to 22 S.W.G. (.028"—.711 m/ms). The choice of a suitable gauge for the majority of the soldering undertaken by a manufacturer results in considerable saving. Many firms previously using 14 S.W.G. have found they can save approximately 33 1/3%, or even more by using 16 S.W.G. The table gives the approximate lengths per lb. in feet of Ersin Multicore Solder in a representative alloy, 40/60.

S.W.G.	10	13	14	16	18	22
Feet per lb.	23	44.5	58.9	92.1	163.5	481

## CORRECT SOLDERING TECHNIQUE

Ersin Multicore Solder Wire should be applied simultaneously with the iron, to the component. By this means maximum efficiency will be obtained from the Ersin flux contained in the 3 cores of the Ersin Multicore Solder Wire. It should only be applied direct to the iron to tin it. The iron should not be used as a means of carrying the solder to the joints. When possible, the solder wire should be applied to the component and the bit placed on top, the solder should not be "pushed in" to the side of the bit.



ERSIN MULTICORE SOLDER WIRE is now restricted to firms on Government Contracts and other essential Home Civil requirements. Firms not yet using Multicore Solder are invited to write for fuller technical information and samples.

**MULTICORE SOLDERS LTD., BUSH HOUSE, W.C.2. 'Phone Temple Bar 5583/4**

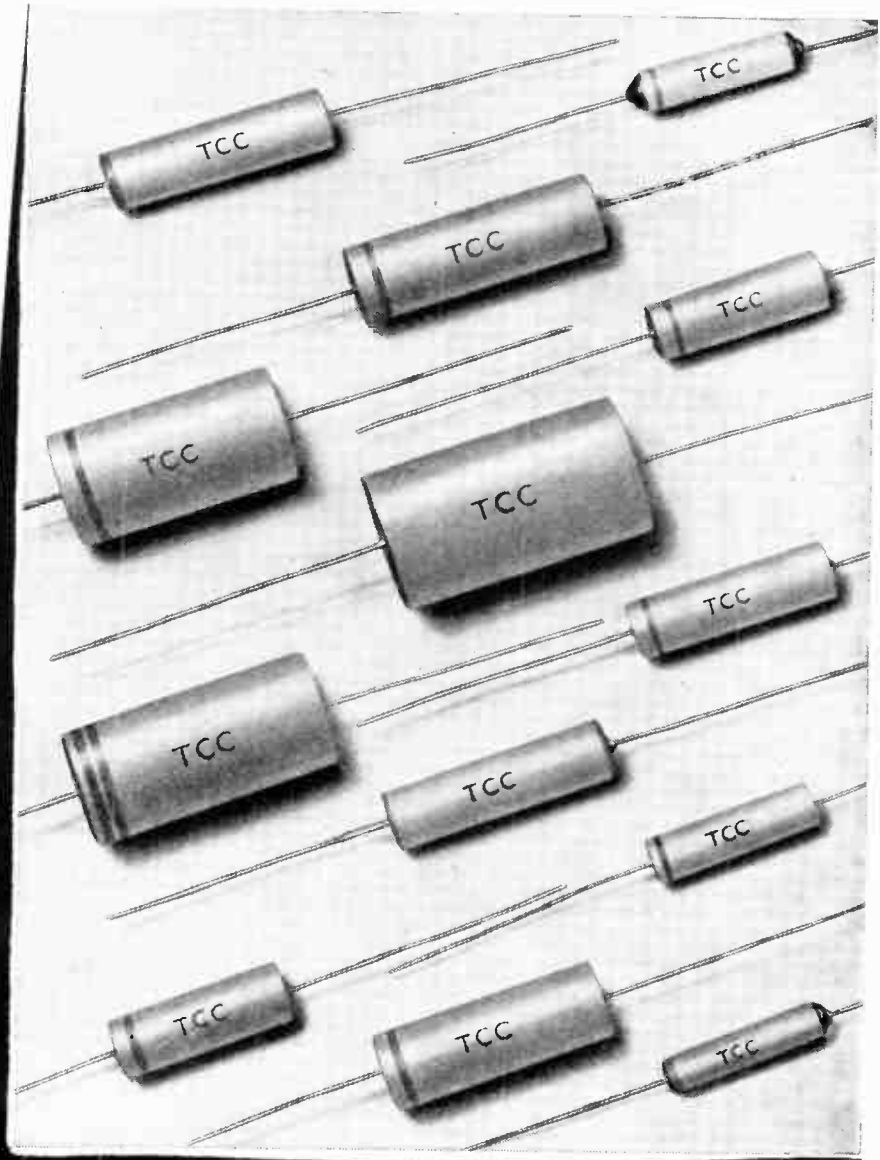

# TCC

**PRE-EMINENT IN PEACE  
INDISPENSABLE IN WAR**

ADVERTISEMENT OF THE TELEGRAPH CONDENSER CO., LTD.  
G.P. 7703

*British Aircraft Use*

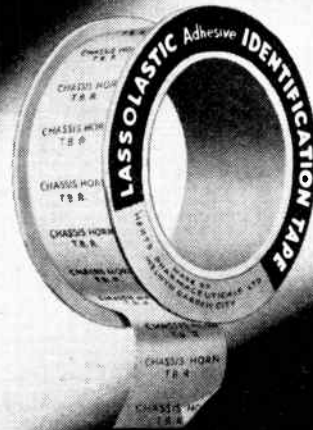

**FOR QUICKER, EASIER,  
CABLE & PIPE LINE MARKING**

DURABLE - LEGIBLE - INDELIBLY PRINTED IN ANY COLOUR  
CAN BE USED WITHOUT TOOLS - RESISTANT TO FLUIDS AND HEAT

HERTS PHARMACEUTICALS LTD. WELWYN GARDEN CITY

*Automatic Radiotelephone*



SIX CHANNEL  
50/70 WATT  
LCE SERIES

NO OPERATOR  
NEEDED

Requires only  
AERIAL  
DIAL TELEPHONE  
POWER SUPPLY

FOR SHIP-TO-SHORE  
OR POINT-TO-POINT  
COMMUNICATION

Prompt deliveries  
from manufacturers  
against good priorities

LORAIN COUNTY  
RADIO CORPORATION  
LORAIN, OHIO, U.S.A.

For details write to :—

*Electronic Engineering Services, Ltd.*  
SOLE BRITISH DISTRIBUTORS

24 STANLEY ROAD, HEATON MOOR, STOCKPORT  
TELEPHONE HEATONMOOR 3107

**IDENTIFICATION  
LABELS** FOR CABLES  
& PIPELINES  
(M.A.P. APPROVED) A.I.D. APPROVAL No 2583/42



Indelibly printed on white or  
coloured fabric for use in conjunc-  
tion with transparent adhesive tape.

• Guaranteed 2/3 day delivery service.

**P. P. PAYNE & SONS LTD**  
HAYDN ROAD NOTTINGHAM Phone: 64335  
BUSH HOUSE LONDON Phone: TEMple Bar 6356



# LONDON CENTRAL RADIO STORES

FOR RADIO

BARGAINS

## HEAVY DUTY MAINS TRANSFORMERS

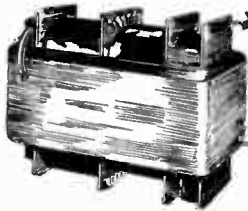

350 - 0 - 350 v., 120 m.a., 6.3 v. 5 amps., 4 v. 3 amps., 4 v. 1 amp. Input 100/250 v. Dimensions 5 1/2 x 5 1/2 x 4 1/2 in. Free wiring diagram. **32/6** Post., etc., 2/-

## YAXLEY Type WAVE-CHANGE SWITCHES

4-way, 3-bank, with shielded oscillator section. Length from stop plate approx. 5 1/2 in., spindle 2 in. ... **5/6**  
5-way, 6-bank, with 3 screened sections, adaptable to many uses. Length from stop plate approx. 6 1/2 in., spindle 2 in. ... **6/6**  
3-way, 3 double banks, without shields, 2 in. spindle. Length 6 1/2 in. **5/6**. Post., etc., 9d. each.

## ON-OFF TOGGLE SWITCHES

Finest quality. Turn movement. 1 1/4 in. spindle. Post., etc., 3d. extra ... **2/6**

## TWIN ON-OFF SWITCHES

Carries 1.5 amp. at 250 v. Well made, with excellent snap action. Price **4/6** Post., etc., 3d. extra.

## EX-GOVT. PLUGS & JACKS



These Jacks have powerful phosphor-bronze springs ensuring a perfect contact. Overall length, including 1/4 in. threaded shank, 3 1/4 in. Supplied complete with Plug **5/6** Price ... Post., etc., 3d. extra.

**CHASIS** Drilled for 9 valves, also rectangular hole 6 1/2 x 2 1/2 in. Size 16 1/2 x 9 1/2 x 2 in. **3/6** Also 11 1/2 x 9 1/2 x 2 1/2 in. and 11 1/2 x 7 x 2 1/2 in. **3/6** 12 x 9 x 3 in., drilled for 10v. transformer, etc. ... **5/6** Post., etc., 10d. extra.

**PHILIPS Oil Filled CONDENSERS** 0.1 mfd. 5,000 D.C. working. With porcelain insulated terminals. Size 2 1/2 high x 3 1/2 x 2 in. Post., etc., 9d. ... **10/6**

## JUST RECEIVED—A NEW STOCK of

## SUPREMUS H.T. BATTERY ELIMINATORS

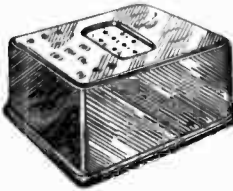

We have made a further purchase of these well-known H.T. Mains Supply Units in handsome bakelite cases.

Tappings: 40, 60, 80, SGH, 100, SGL, 125 v.

## Model E25A for 200-250v. A.C. 40-100~

Here is an opportunity for battery set owners, who have A.C. mains current available, to be independent of the battery situation. Owing to post and rail conditions these are available **60/-** TO CALLERS ONLY. Price ...

## ELECTRO-MAGNETIC COUNTERS

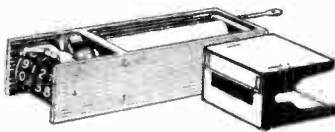

500 ohms coil. Counting up to 9,999. Operating from 25v. to 50v. D.C. Many industrial and domestic applications. (S.H., ex-G.P.O., all perfect.) Postage 9d. **5/6**

## EX-BAIRD HIGH VOLTAGE TELEVISION TRANSFORMERS

6,000 v. approx. Fitted with Porcelain insulated terminals, as illustrated. Size 3 1/2 x 6 1/2 x 3 1/2. Post., etc., 2/- **20/-**

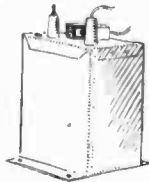

4,000 v. approx. Size 4 in. x 3 1/2 x 3 1/2. Post., etc., 1/6. **10/6**

## PHILIPS SCANNING & DEFLECTOR COILS

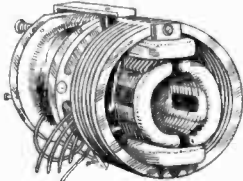

Assembled complete in metal frame, as illustrated. **7/6** Post. and pkg., 1/1 extra.

## ELECTRIC SOLDERING IRONS

200/250 v. 75 watts. Post., etc., 8d. extra ... **12/6**

NO LISTS NO PRO-FORMA INVOICES

## BRAND NEW MERCURY SWITCHES

These switches are of the best manufacture and not easily obtainable today. Quick in a ke and break and will carry 5 amps. Many hundreds of useful applications.

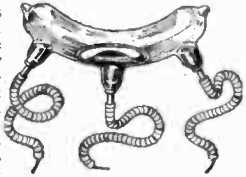

Small quantity to clear. Price ... **8/6** Post., etc., 6d.

## OAK VIBRATOR UNITS

— Synchronous —

Input 6 volts. Output 250 volts 60 m.a. approx. These well-known units are fitted with 6-pin American bases ... **15/6** Post., etc., 8d.



## LOUDSPEAKERS

**ROLA** 5 in. P.M. **22/6** less transformer Post. and pkg., 1/6 extra.  
**ROLA** 8 in., less transformer ... **24/-**  
**CELESTION** 8 in. P.M. Pentode Output. **30/-** New ... Post., etc., on above, 2/- extra.

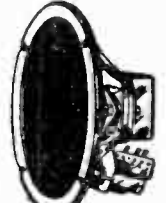

## OAK SWITCHES

2 1/2 in. spindle, complete with knob. 4-way 2-bank, with connecting block, **4/6**. 4-way, 2-lk., **3/9**. Post., etc., 6d.

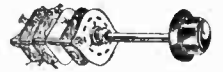

## T.C.C. ELECTROLYTIC CONDENSERS

4 x 4 mfd. 70v. D.C. working. Reversible. Size 1 1/2 x 2 1/2 x 1 in. Post. **5/-** and packing, 3d.

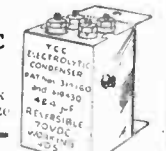

## PHILIPS WET ELECTROLYTICS

50 mfd. 310v. working ... **9/6** Post. & pkg., 9d. extra

## YAXLEY PATTERN SWITCHES

5-way, single-bank, with on-off mains switch, carrying 1 amp. at 250v., 2 in. spindle with knob ... **5/6**  
3-way single-bank, 1 in. spindle with knob ... **2/9** Post., etc., 6d. extra.

## EX-GOVT. POTENTIOMETERS

Wire-wound. In bakelite case, 5,000 ohms. 2 in. dia. x 1 in. Without knob. **5/6** Post., etc., 6d.

LONDON CENTRAL RADIO STORES, 23, LISLE ST. GERard 2969 LONDON, W.C.2

*It's what's in between  
that matters ...*

## *Especially between* ENAMELLED WIRE WINDINGS

The HY-MEG process of impregnation offers many advantages to the radio and light component manufacturer. Its deeper penetration and more complete expulsion of air and moisture; its perfect through-drying qualities (although calling for as much as 50% less stoving time) commend it particularly for deep and complicated fine enamelled wire windings.

The enamel is unaffected by HY-MEG which sets plastic hard and stays hard under extreme working and tropical conditions—a fact clearly reflected in the general Government approval of components which are HY-MEG impregnated.

In short, HY-MEG sets new standards of quality and quantity in production and, because it is independent of materials in short supply, enables output to progress without risk of interruption.

INSULATE WITH

**HY-MEG**

TO BE SURE

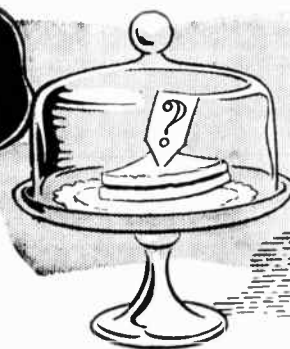

### GIVE OUR 'BRAINS TRUST' YOUR PROBLEMS

The panel of experts whose experience and research created HY-MEG would be glad to have details of any insulation problem holding up your production; and to place their extensive laboratory facilities at your disposal.

**HY-MEG**  
**IMPREGNATING VARNISH**  
V6934. Made specially for enamelled wire windings: but is equally suitable for Rayon and Glass covered wire.

LEWIS BERGER & SONS, LTD. (Established 1760) LONDON, E.9. Phone: AMHerst 3321

MANUFACTURERS OF INSULATING VARNISHES AND ENAMELS

*In tune with  
tomorrow -*

**Masteradio**  
A NAME OF NOTE IN RADIO—FOR CAR—FOR HOME

Register NOW without obligation  
for post-war priority

MASTERADIO LTD · WATFORD · HERTS

★ One of a series of Advertisements  
appearing in the National Press

MASTERADIO ARE LOOKING AHEAD!

**HIVAC**  
THE SCIENTIFIC  
VALVE

BRITISH MADE

*Specialists in*  
**MIDGET  
VALVES**

**HIVAC LIMITED**  
Greenhill Crescent,  
Harrow on the Hill, Middx.

Telephone: Harrow 0895.

# STABILITY



## FIXED CERAMIC CONDENSERS

1 & 2 Pearl Type.  
3 & 4 Hat Type.  
5 & 6 Disc Type.

Highest Mechanical  
and Electrical Sta-  
bility whatever the  
climatic conditions.  
Type approved.

# UNITED INSULATOR CO LTD

12-20 LAYSTALL ST., LONDON, E.C.1

Telephone TERminus 7383

Telegrams : Calanel, Smith, London

*The Pioneers of Low-loss Ceramics*

# The glory of the future..



... when the harsh roar of battle gives place to the merry music of "fiddle, 'cello and big bass drum," Goodmans Loudspeakers will be available again to reproduce music's most transient note with a faithfulness rarely achieved in the commercial sphere.



## GOODMANS

Makers of

### HIGH GRADE LOUDSPEAKERS

Priority Orders only can be accepted

GOODMANS INDUSTRIES, LTD., LANCELOT ROAD, WEMBLEY, MIDDLESEX

# TUNGSRAM VALVES

Our production of Radio Valves is both large and continuous. So, too, is the demand for them for urgent purposes. Some are available for domestic use, but the range is necessarily limited. You may be assured of our willing help whenever possible.

Announcement of

BRITISH TUNGSRAM RADIO WORKS LTD., WEST RD., TOTTENHAM, N.17

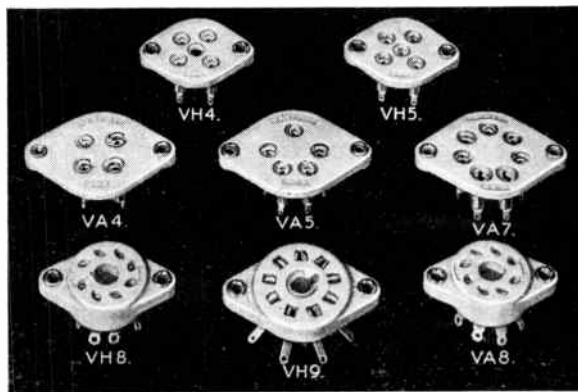

THREE NEW RAYMART VALVEHOLDERS

TYPE VH8, Mazda Octal, 1/3 each. TYPE VA8, International Octal, 1/3 each.

TYPE VH9, for the new British "E" type valves, 1/9 each.

These three types have ribs between each contact to increase the effective distance between, and also to prevent tracking. Their Pierced solder tag connections protrude through base of Ceramic. Other features are standard with other types.

#### Standard Features of Raymart Valveholders

**Bases.** These are of the famous RMX low-loss Ceramic. **Contacts.** Resilient bronze alloy, sterling silver plated, minimum contact resistance. **Fixing.** Floating nickel-plated eyelet (4BA clearance) fitted in strengthening boss in Ceramic. Metal floating bushes prevent cracking of Ceramic plates. **Soldering.** Pierced solder tag at end of sockets.

Types manufactured : English 4- and 5-pin, American 4, 5 and large 7-pin. **NOTE :** English types VH4 and VH5 are made in three different types with two different fixing centres.

Enquiries invited from Government Departments, Traders and Servicemen.

**RAYMART** 48 HOLLOWAY HEAD, BIRMINGHAM, 1  
Telephone : Midland 3254.

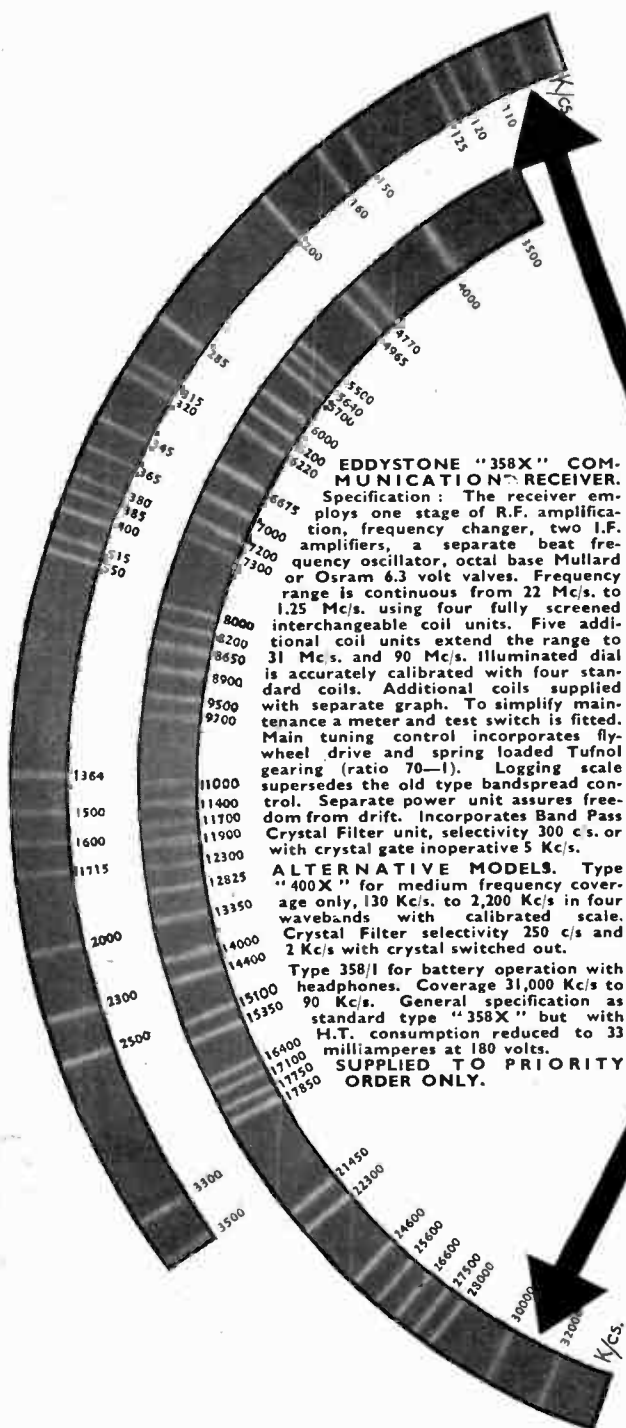

**EDDYSTONE "358X" COMMUNICATION RECEIVER.**  
 Specification: The receiver employs one stage of R.F. amplification, frequency changer, two I.F. amplifiers, a separate beat frequency oscillator, octal base Mullard or Osram 6.3 volt valves. Frequency range is continuous from 22 Mc/s. to 1.25 Mc/s. using four fully screened interchangeable coil units. Five additional coil units extend the range to 31 Mc/s. and 90 Mc/s. Illuminated dial is accurately calibrated with four standard coils. Additional coils supplied with separate graph. To simplify maintenance a meter and test switch is fitted. Main tuning control incorporates fly-wheel drive and spring loaded Tufnol gearing (ratio 70-1). Logging scale supersedes the old type bandspread control. Separate power unit assures freedom from drift. Incorporates Band Pass Crystal Filter unit, selectivity 300 c/s. or with crystal gate inoperative 5 Kc/s.

**ALTERNATIVE MODELS.** Type "400X" for medium frequency coverage only, 130 Kc/s. to 2,200 Kc/s. in four wavebands with calibrated scale. Crystal Filter selectivity 250 c/s and 2 Kc/s with crystal switched out.

Type 358/1 for battery operation with headphones. Coverage 31,000 Kc/s to 90 Kc/s. General specification as standard type "358X" but with H.T. consumption reduced to 33 milliamperes at 180 volts.

**SUPPLIED TO PRIORITY ORDER ONLY.**



# EDDYSTONE '358X' Communication Receiver

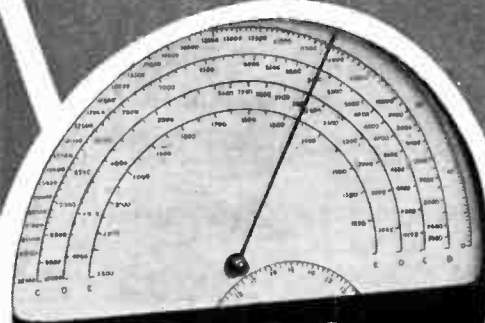

## WIDE FREQUENCY RANGE

In these days of ever changing frequency allocation the Eddystone "358X" meets all emergencies with a coverage from 31Mc/s to 90Kc/s.

# WEBB'S RADIO

**THE SHORT-WAVE SPECIALISTS**

The receiver may be inspected at  
**14, SOHO STREET, LONDON, W.1.**  
 Between 10 a.m. and 4 p.m. (Sats. 10 a.m. to 12 noon.)  
 Telephone: GERrard 2089.



*On every battlefield*

**Condensers are at work**

Perfect communication by radio is essential in all modern war operations, from grand strategy down to the smallest tactical manœuvre. Nothing but the very best of apparatus is good enough.

TRADE **HUNTS** MARK

The  
**Home of Condensers**

Advt. of A. H. HUNT LTD., LONDON, S.W.18. EST. 1901

*Wartime installations show more conclusively than ever that*

**you can**

*trust*

**TRIX**

30-watt Amplifier with Radio.



There are TRIX amplifiers from 5-500 watts. Send for details.

Quality  
**SOUND**  
Equipment

*To priority order only*

TRIX ELECTRICAL CO. LTD., 65, Bolsover St., London, W.1.  
Phone: EUS 6471/2. Grams: Trizadio, Weedo, London.

**CELESTION**

**VALVEHOLDERS**

Manufactured under "Amphenol" Licence

Preferred by radio engineers because of their Strength, Efficiency and Uniform Contact  
Supplied against Priority orders only.  
Send for List of English and American types.

**AMPHENOL**

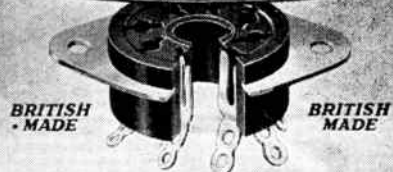

**CELESTION LTD.**

(Engineers).

**KINGSTON-UPON-THAMES, SURREY.**

Telephone: KINGSTON 5656-7-8.

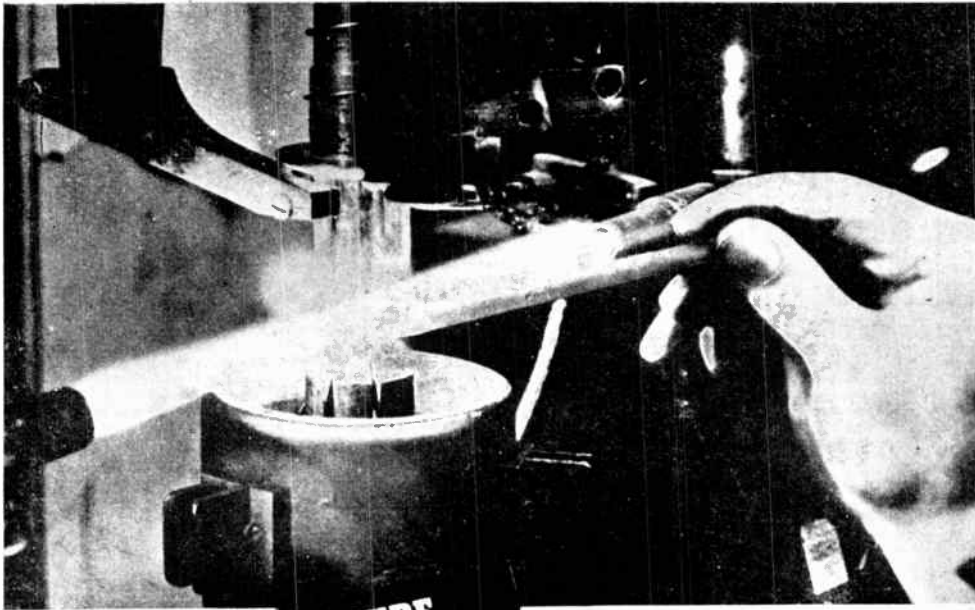

*Glass tubing becomes finished filament stem with leads sealed in position on this special upright lathe.*

**VACUUM TUBE**  
*Performance*  
**IN THE MAKING...**

"Trifles make perfection and perfection is no trifle" ... The tiniest part of every Eimac valve is a "tremendous trifle," handled with the utmost care ... the greatest skill. In an Eimac 304T valve there are more than fifty separate parts which pass through many fabricating operations before they are ready to be assembled into the valve. Through all these steps great care is taken to hold the dimensions of each part to a very close tolerance ... to make every welded joint perfectly solid. Such painstaking care in the fabricating of each part, plus the achievement of extremely high vacuum ... helps provide the outstanding performance capabilities which have made Eimac valves famous. In the toughest jobs you'll find Eimac valves in the key sockets most every time. They are first choice among leading engineers throughout the world.

Follow the leaders to



•Michelangelo (C. C. Colton)

Manufactured by

**EITEL-McCULLOUGH, INC.**  
SAN BRUNO, CALIFORNIA, U. S. A.

Export Agents: FRAZAR & CO., Ltd., 301 Clay St., San Francisco, California, U. S. A.

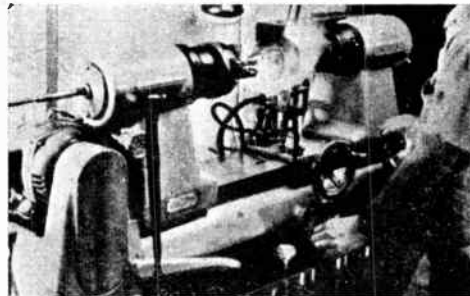

*Glass bulbs are annealed after valve is fully assembled. This operation relieves stress and strain in the glass itself which may have been induced during manufacture.*

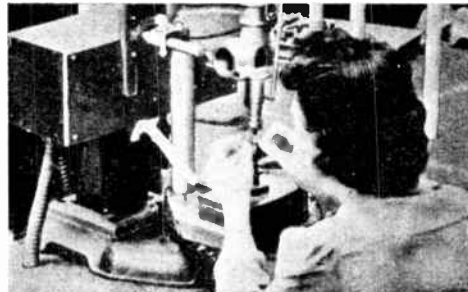

*Deft fingers work steadily with tiny parts which are faultlessly produced. Here plate sections are being welded together in routine production.*

# ROGERS

It was the development of Rogers Radio Tubes that first led the way to the all-mains operated wireless set.

In their chosen field Rogers still lead the way. Their productions include all standard types of radio-receiving tubes, power tubes for radio transmission, audio frequency amplification and industrial electronic applications generally. Government requirements call for the entire output of the plant at the present time but after the war this pioneer firm will be fully at the service of industry over the widest range of electronic applications.

**ROGERS RADIO TUBES LTD.**

**TORONTO (ONTARIO) CANADA**

A subsidiary of BROADCAST RELAY SERVICE LIMITED, LONDON, S.W.1

WRITE FOR CATALOGUE  
W.O./330

## ADASTRA

### RADIO MASTS

POLES LTD TYBURN RD ERDINGTON.  
BIRMINGHAM. 24.

Enquiries should be accompanied by Government Priority Reference

**EXAMINATION**

Examination of metals used in WESTINGHOUSE PRODUCTS includes physical test of tensile strength, and the illustration shows the process of checking the yield point of a specimen.

Though Westinghouse Rectifiers are unfortunately in short supply, the groundwork of research and experiment is laying the foundation of the advanced Rectifiers of tomorrow. May the day soon dawn when these Rectifiers once more will be available for all uses.

*Westinghouse Rectifiers*

WESTINGHOUSE BRAKE & SIGNAL CO., LTD.  
PEW HILL HOUSE, CHIPPENHAM, WILTS.

# ROLA

## LOUDSPEAKER PRICE LIST for 1943

(This cancels all previous catalogues)

	Price with Standard Tapped Transformer		Price without Transformer	
	£	s. d.	£	s. d.
5Z Energised	1	10 6	1	2 0
6Z "	1	11 6	1	3 0
8ZK "	1	17 0	1	6 0
10ZK "	1	19 0	1	8 0
G12 "	Cancelled until further notice			
5Z-5.5-P.M.	1	9 0	1	0 6
5Z-7.5-P.M.	1	10 0	1	1 6
6Z-5.5-P.M.	1	10 0	1	1 6
6Z-7.5-P.M.	1	11 0	1	2 6
8Z-6.5-P.M.	1	15 0	1	4 0
8Z-8.5-P.M.	1	16 6	1	5 6
8Z-9.5-P.M.	1	19 0	1	8 0
8Z-12-P.M.	2	1 0	1	10 0
8Z-15-P.M.	2	4 6	1	13 6
8Z-20-P.M.	1	17 0	1	6 0
10Z-6.5-P.M.	1	18 6	1	7 6
10Z-9.5-P.M.	2	1 0	1	10 0
10Z-12-P.M.	2	3 0	1	12 0
10Z-15-P.M.	2	6 6	1	15 6
10Z-20-P.M.	2	6 6	1	15 6
G12-P.M.	Cancelled until further notice			

NOTE.—If a Type No. 42U Universal Transformer is required instead of a Standard Tapped Transformer, 15/6 should be added to the price of a speaker without transformer.

**BRITISH ROLA LIMITED**  
MINERVA ROAD, PARK ROYAL, N.W.10.

Phone: WILlesden 4322.



# RUBBER-TO-METAL BONDING

The Problem of Insulating delicate instrument panels from vibration and shock by means of Flexilant Mountings

## "FLEXILANT" Mountings: Examples from the SERIES.

The "Flexilant" Mounting of which several varieties are illustrated here is so accurately made that its displacement under load can be calculated to within .010" of requirements. The series is designed to carry loads of from 1 to 451 lbs. per mounting and these may be arranged with bolt axis at 90° to position, or the complete mounting may be inverted. The mountings can be supplied with or without holder and they can be arranged so that two utilize the same bolt.

We should appreciate the opportunity of helping with your vibration problems.

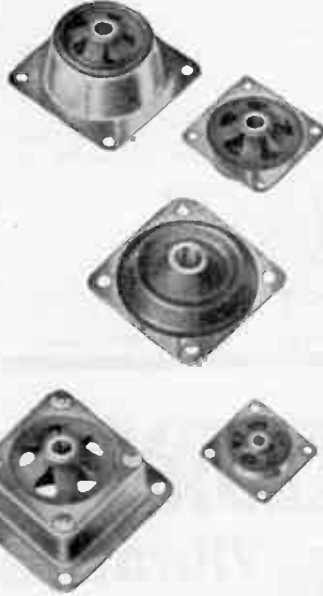
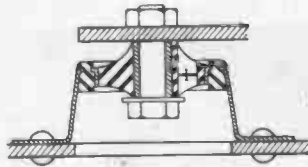

**RUBBER BONDERS Ltd.**  
*Engineers in Rubber bonded to metal*

**FLEXILANT WORKS • WATLING STREET • DUNSTABLE, BEDS.**  
TELEPHONE: DUNSTABLE 715      TELEGRAMS: FLEXILANT, DUNSTABLE

A Short Review of FLEXILANT Products is available on enquiry . . .



R.R. 17



*Spotlight on* **QUALITY**

From every aspect the searching spotlight of close inspection reveals the inherent quality that is built into R • S Sound Equipment. Which is just one of the reasons why it has been chosen for a job for which quality is the premier qualification. And why, of course, we cannot just now supply you with all you ask. There is, however, a small range available to you, and if you would like to know about it we'll gladly send you a catalogue in exchange for a penny stamp.

**R • S**  
*Amplifiers Limited*

3-4, Highfield Rd., Shepperton, Middlesex. Tel.: Walton-on-Thames 1019.

W.W. 8/43

P. R. MALLORY & CO. INC.  
**MALLORY**

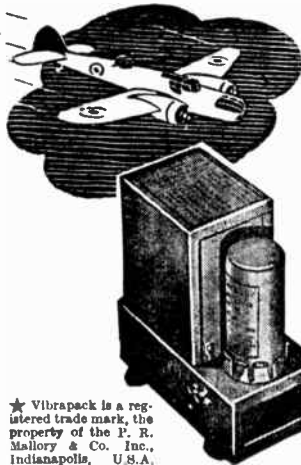

**Vibrators are always dependable**

Along every front Mallory has pioneered in Vibrator design to ensure safety, dependability and long service.

Mallory offers synchronous and non-synchronous Vibrators for 6, 12 and 32 volt input, also a complete range of "STRATOSPHERE" Vibrators plus the world famous Mallory "VIBRAPACK" (Regd. Trade Mark).

Mallory engineers are at your disposal.

★ Vibrapack is a registered trade mark, the property of the P. R. Mallory & Co. Inc., Indianapolis, U.S.A. Units which do not bear this trade mark are not of genuine Mallory manufacture.

**P. R. MALLORY & CO. INC.**  
INDIANAPOLIS, INDIANA, U.S.A.  
RADIO AND ELECTRONICS DIVISION

Represented exclusively in Gt. Britain by  
**FRANK HEAVER LTD.,** Kingsley Road, Bideford, N. Devon, Eng.

**WHARFEDALE**

**GOLDEN CHASSIS**

As supplied to the B.B.C.

Speech Coil 2-3 ohms:  
Flux Density 10,000 lines,  
7-8 watts • 10" Chassis

Although we are making more than ever of this excellent Loud Speaker the output is absorbed by the B.B.C. and other Priority users.

PRICE 70/-  
(Less Transformer)

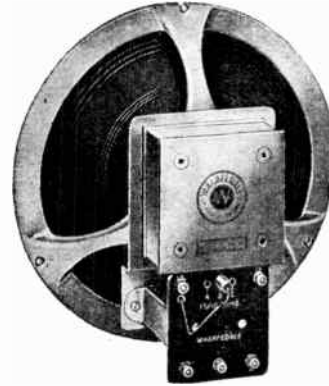

**RESPONSE CURVE**

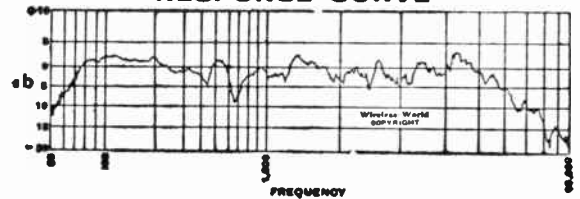

**WHARFEDALE WIRELESS WORKS**

SOLE PROPRIETOR: D. E. BRIGGS

HUTCHINSON LANE, BRIGHOUSE, YOKS.  
PHONE: BRIGHOUSE 50. GRAMS: "WHARFDEL."

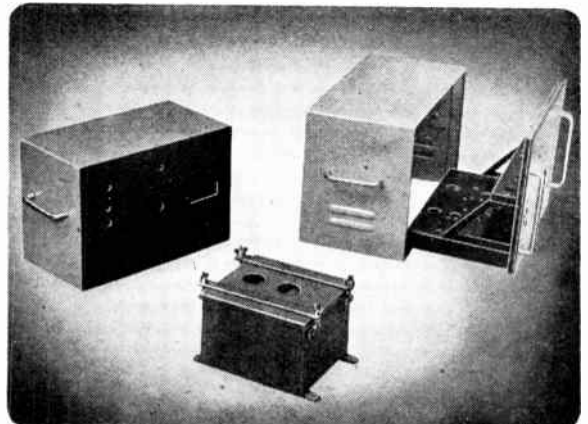

A skilled team of workers in an efficiently equipped modern factory produces to an unusually high standard all types of metal instrument cases, radio chassis, panels, brackets, boxes and other metal components. We are also able to undertake the design and manufacture of complete amplifying equipment for special requirements.

**PRIORITY ORDERS ONLY**

Engineering and Electrical Contractors to the Admiralty, Air Ministry and Ministry of Supply.

**IMHOF'S**

ALFRED IMHOF LTD. 112-116, New Oxford Street, London, W.C.1.

# NEVILLE'S

Model LW  
Coil Winding Machine

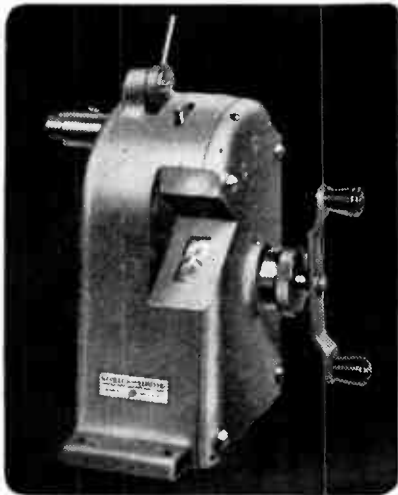
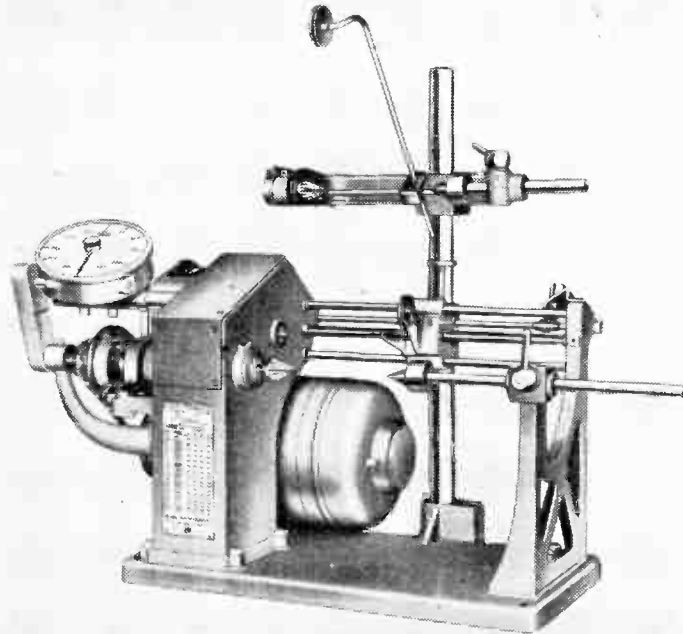

Model HW  
Hand Coil Winding Machine

SPECIALISTS  
in the design and manufacture of  
COIL WINDING MACHINES  
TAPING MACHINES  
WIRE COVERING MACHINES  
ARMATURE AND STATOR  
COIL WINDERS

NEVILLE'S (LIVERPOOL) LIMITED  
SIMMONDS TOWER · GREAT WEST ROAD · LONDON



A DIVISION OF THE SIMMONDS GROUP  
LONDON · MELBOURNE · PARIS · NEW YORK · LOS ANGELES

# B.I. CONDENSERS



*for arduous conditions*

B.I. Tropical Type Paper Condensers in Moulded Tubes, (U.K. Patent No. 506024 and application pending) are designed to operate continuously in extremely arduous conditions of temperature and humidity.

**BRITISH INSULATED CABLES LTD.**  
Head Office: PRESCOT-LANCS. Tel. No: PRESCOT 6571

# WAXES OKERIN

## AND DIELECTRIC MATERIALS

Cable, Condenser, Coil, Transformer and Resistance Impregnating, dipping, sealing, filling and finishing.

**A.I.D. and C.I.E.M.E. TYPE APPROVED WAXES** to meet both **ARCTIC and TROPICAL** conditions.

TELEPHONE : WEST DRAYTON 2189

## ASTOR BOISSELIER & LAWRENCE LTD

MIDDLESEX OIL & CHEMICAL WORKS

WEST DRAYTON, MIDDLESEX

## M.R. SUPPLIES

offer FROM STOCK the following brand new **PUBLIC ADDRESS and ELECTRICAL MATERIAL** of our usual dependable quality. All prices nett cash.

**ROTHERMEL D.104 PIEZO-CRYSTAL MICROPHONES.** The well-known original plated model, in makers' boxes, 15s only at £4 18 6 each. Early application advisable as these will soon be sold. (We are still able to supply our special knuckle-joint model, as previously advertised, at 72/6 each.)

**ROTHERMEL-BRUSH SPECIAL MINIATURE MICROPHONES.** Only 1 1/4 in. dia., but capable of very high performance. In aluminium housing with short screened lead, but with no front grille. Although made for deaf-aid, these are suitable for public address, recording, and all other uses. 27/6. Very popular offer; hundreds in use. Instructions with each.

**G.E.C. MODEL 2283 MOVING COIL MICROPHONES.** Response level 50-9,500 c/s., sensitivity—50 db. In superior chromium housing with back terminals and mounting boss. Imped., 15 ohms. A few left at £5 18 6 each.

**MICROPHONE FLOOR STANDS.** Collapsible type, 5ft. 6in. to 2ft., chromium plated, to suit all microphones listed above (except 27/6 model), 37/6.

**PUBLIC ADDRESS SPEAKERS.** Latest model G.E.C. brand new. Immediate delivery from stock held here. 10-watt **PROJECTOR TYPE** comprising 15 ohm P.M. unit and Round Metal Horn, 42in. long, £10 5 0 (carr., 7/6).

The following are offered to **CALLERS ONLY**: Same Unit as above with 42in. Horn as above, but with compressed fabric flare, £9 9. Also same Unit with 30in. dispersive Horn, fabric flare 21in. square, £8 17 6. Any of the above supplied with 1688 12-watt Unit at £2 extra. Also a few G.E.C. Semi-Projector types with enamelled wooden horns, handling 8 watts, second-hand, perfect, at £5 15 each. We have the finest range of P.A. Speakers available at the moment.

**STAGE DIMMERS.** Constantly rated and all with carbon break flicker switch and "off" position and all brand new. For controlling stated load from full bright to black-out. With Slider control, 1,000 watts, £4 10 6; 1,500 watts, £8 8. With Screw Motion Drive and Handwheel, 1,000 watts, £6 6; 1,500 watts, £7 15. (Part carriage on any one, 5/- in returnable crate.)

**SLIDING RESISTANCES.** 100 watts. Fully enclosed housing 6 1/2 in. long. Following range: 4 ohms 5 amps., 10 ohms 3 amps., 100 ohms 1 amp., 200 ohms 0.7 amp., 400 ohms 0.5 amp., any one 22/6. Any other values made up to order against Government priority only. Quick delivery.

**MEASURING INSTRUMENTS** by Weston, Ferranti, Elliott, etc. (We cannot select particular maker, but will do our best.) Housing, 2 1/2 in. square flange, flush panel mtg., requiring 2in. mounting hole, black bakelite with back terminals, **M/COIL MILLIAMMETERS**, 0/150 milliamps, 32/6. In same size and style, **THERMO-COUPLED M/COIL AMMETERS**, 0/2 1/2 amps. These are ideal for charging panels, model railways, etc., and have the advantage of reading accurately on D.C. or any frequency of A.C. Very useful instruments, 37/6. These meters are all second-hand ex-Govt. and are in excellent condition and lab. tested. Many important buyers.

**RELAYS.** Compact enclosed model with 4-12 volt D.C. coil and single-pole "make" switch, 6/6.

**STEP-DOWN MAINS TRANSFORMERS.** Tapped primaries, 200/250 v. Secondary 7, 11 and 15 volts at 2 amps, 15/8. Secondary 12 and 17 volts at full 5 amps., 45/-.

**TOGGLE PRESSES** as advertised in April issue. A few more now available, £30 nett. Details on request.

Please estimate packing and post where not stated.

**M.R. SUPPLIES, 68, New Oxford Street, London, W.C.1.**

(Telephone : MUSeum 2958)



# Resistors

ON ALL GOVERNMENT LISTS

## ERG RESISTORS LIMITED

1021a, FINCHLEY ROAD, LONDON, N.W.11

### BASICALLY BETTER...

*Air Insulation*  
is the basic principle of

# CO-AX

LOW LOSS CABLES  
*Unequaled*  
H.F. PROPERTIES

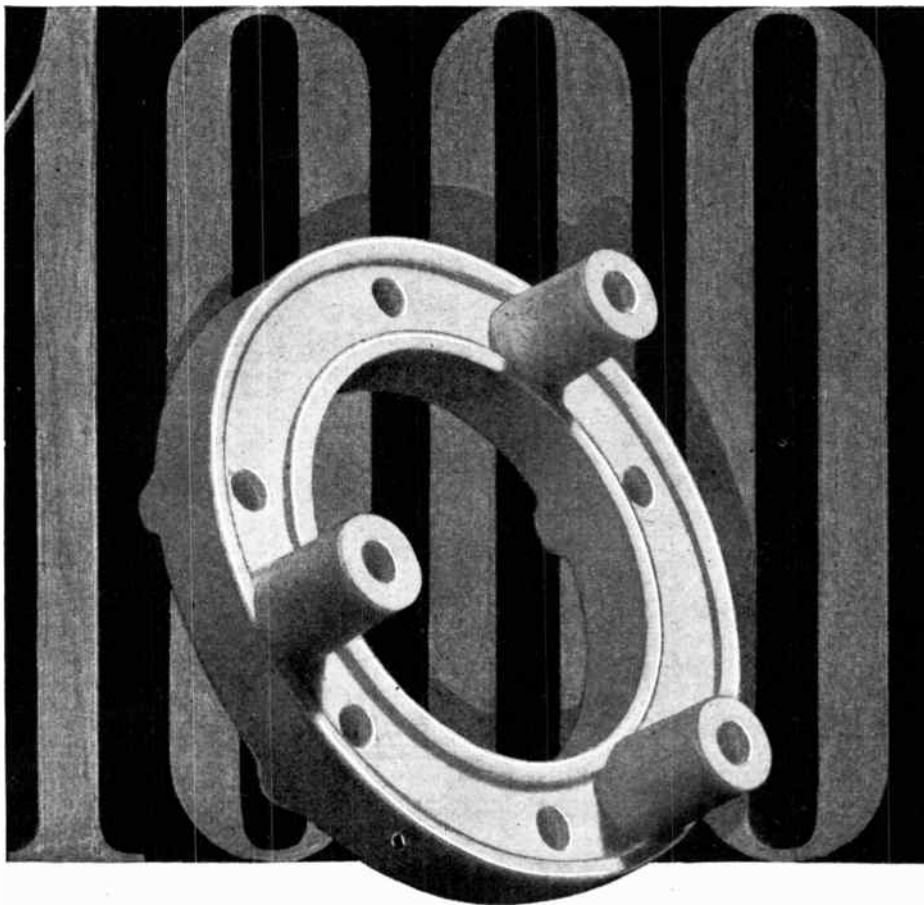

## ONE IN A THOUSAND

Ten years ago we introduced the first British-made low-loss ceramic. To-day the range of FREQUENTITE components covers more than a thousand pieces of every shape and size.

With such a store of manufacturing experience we are able to offer advice backed by practical knowledge on your insulation problem. Please consult us before you finalize your design.



## STEATITE & PORCELAIN PRODUCTS LIMITED

Head Office: Stourport-on-Severn, Worcs. Telephone: Stourport 111. Telegrams: Steatoin, Stourport.

S.P.17

*Audio Amplifiers  
and Sub-assemblies  
to critical standards*



In addition to Standard Amplifiers the activities of Acoustical include Special Amplifiers for Industrial Applications, Microphones, Transformers, Coil Winding, Sheet Metal Work, Stampings, Switch Assemblies, etc.

 **ACOUSTICAL**  
MANUFACTURING Co. Ltd.  
HUNTINGDON - TEL: 361

**TAYLOR-METER**  
A NEW **38** RANGE  
UNIVERSAL METER

Sensitivity — 1,000 ohms per volt on all voltage ranges.

**D.C. VOLTS.** 7 ranges from 0—0.25 to 1,000 v.

**A.C. VOLTS.** 6 ranges from 0—2.5 to 1,000 v.

**OUTPUT.** 5 ranges from 0—2.5 to 500 v.

**D.C. CURRENT.** 5 ranges from 0—1 mA to 2.5 Amps.

**A.C. CURRENT.** 5 ranges from 0—1 mA to 2.5 Amps.

**RESISTANCE.** 3 ranges from 1 ohm to 1 megohm with internal battery.

**RESISTANCE.** 1 range from 1,000 ohms to 10 megohms with external 60 volt battery.

**DECIBELS.** 6 ranges from —22db to plus 60 db.

**METER.** 5 Scales covering A.C. and D.C. Measurements and also Ohms and Decibels.

**SCALE LENGTH.** Outer scale is 3½ inches long.



**TAYLOR MODEL 90**  
Supplied complete with leads and test prod, internal battery and instruction book.

**£11-11-0**

**TAYLOR ELECTRICAL INSTRUMENTS Ltd.**  
Montrose Avenue, Slough, Bucks.  
Telephone: Slough 21381

British made by

**TAYLOR**



**KURZ-KASCH**  
RADIO KNOBS—DIALS  
INSTRUMENT KNOBS

NOT only are modern plastics materially helping to win the war, but they will also help in designing those better post-war days.

We patiently await the time when we shall once again be able to help equip your radio receivers and instruments with those well designed and good looking mouldings and, no doubt, with other items resulting from plant expansion and new developments.

Register your name with our Representative now. He will forward you information on our products as soon as they become available.

**KURZ-KASCH INC.**  
Moulders of Plastics,  
DAYTON, OHIO, U.S.A.

Exclusively Represented by  
**Frank Heaver Ltd.** Kingsley Road,  
Bideford, N. Devon

"Eenie, Meenie,  
Miney, Mo—"

When it comes to horses, "pick-ing 'em out with a pin" is probably as good a method as any. And the "Eenie, Meenie" way is the only way in children's games. But in the choice of transformers, taking chances is not worth the risk. It is an element that has no place in the manufacture of any Gardner product and its absence is particularly noticeable in the range of Small Power Transformers up to 4 kva. So when next you need this type of component and the specification says in effect, "no 'Eenie, Meenie,'" please ask for our co-operation.

We regret that at present Small Power Trans-formers are available for highest priority orders only.



**GARDNERS RADIO LIMITED**  
SOMERFORD • CHRISTCHURCH • HANTS

**F.W.S.CO.**

**I.F. TRANSFORMERS**  
of all types  
**AERIAL & OSCILLATOR COILS**  
**TRIMMER & PADDER**  
**CONDENSERS**  
**"SILVERCAP" CONDENSERS**  
**COIL FORMS, etc.**

Our increased manufacturing facilities, our added knowledge in the production of equipment for the Allied forces, will benefit you in due course.

We are making many specialised and intricate parts for the war effort, and we are happy to assist in winning that final unconditional surrender of the enemy forces.

Sickles transformers, coils, trimmers and many new parts will be ready for you again as soon as conditions permit.

Register your name with our Representative now. He will forward you information on our products as soon as they become available.

**The F.W. SICKLES Co.**  
**CHICOPEE,**  
**MASS., U.S.A.**

Exclusively Represented by  
**Frank Heaver Ltd.** Kingsley Road,  
Bideford, N. Devon

# ◆ LINAGLOW LIMITED ◆

## SPECIAL OFFER of SERVICE KITS as follows

**VALVES.** Lease-Lend American types at B.O.T. controlled retail prices. For replacement only. 1A5, 1C5, 1H5, 1T5, 5Y3, 6A8, 6F5, 6F6, 6J5, 6J7, 6K7, 6Q7, 6SA7, 12A7, 12A8, 12F5, 12J7, 12K7, 12Q7, 12Z3, 12SA7, 12SJ7, 12SK7, 12SQ7, 25A6, 25A7, 25L6, 25Z6, 32L7, 35L6, 35Z4, 35Z5, 36, 47, 50L6, 70L7, 83.

Also British valves at manufacturers' list prices. AC/ME, AC/VP2, ACTP, CL4, ECH3, ELH3, EL35, EF39, FC13, KT33C, KTW61, TDD4, UU6, UU7, VP41, X63, X65.

**LOUDSPEAKERS.** Rola P.M. 3 ohm voice coil, with pentode output transformer, 5in., 24/6; 6in., 27/6; 8in., 32/-. Without transformer, 5in., 19/6; 6in., 22/6; 8in., 25/6. Celestion 8in. P.M., with transformer, 27/6. R.G.D. 10in. energised moving coil, 1,200 ohm field, 2.5 ohm speech coil, corrugated cone, without transformer, 30/- each. With heavy duty multi-ratio matching transformer, 42/-. Any of the above can be supplied with multi-ratio output transformers, add 5/- per unit.

**LOUDSPEAKER TRANSFORMERS.** Philips Pentode 45 m.a., 5/6; Philips Heavy Duty Pentode, 60 m.a., 8/6; H.M.V. Multi-ratio, 100 m.a., 10/6; Cossor output multi tap, 60 m.a., 10/6; Universal output and push-pull, 60 m.a., 12/6.

**MAINS TRANSFORMERS.** 210/230/250, 350-0-350, 70 m.a., 6.3v., 1.5 amp., 4v., 2.4 amp., 28/6; 200/230/250, 300-0-300, 100 m.a., 6.3v., 3 amp., 5v., 2 amp., 35/-.  
**AUTO TRANSFORMERS.** Step up or down, 110/230v., 75 watt, 27/6; 110/210/220/240v., 100 watt, 32/6.

### VOLTAGE DROPPING RESISTORS AND LINE CORD REPLACEMENTS

Suitable for every make of radio receiver, comprehensive ranges mentioned below.

- 950 ohm 2 amp. Chassis mounting, heavy duty on porcelain former, 2 adjustable tappings, 8 6 each; as above, 800 ohm 3 amp., 8/6 each.
- 2 amp. 675 ohm, tapped 100, 100, 425 and 50 ohms, suitable for Ekco and other makes, 4/- each.
- 2 amp. 840 ohm, tapped 100, 100, 475, 115 and 50 ohms, for Ekco, etc., 4/-.
- 2 amp. 945 ohm, tapped 100, 100, 100, 545 and 100 ohms, for Halcyon, etc., 4/6.
- 2 amp. 785 ohm, tapped 50, 50, 50, 50 and 535 ohms, for I'ye, Lissen, etc., 4 6.
- 2 amp. 510 ohm, tapped 60, 105, 85 and 260 ohms, for Cossor, etc., 4 6.
- 2 amp. 660 ohm, tapped 150, 360, 120 and 30 ohms, for Pilot Major Maestro, etc., 4 9.
- 3 amp. 547 ohm, tapped 80, 80, 387 ohms, for Ferranti, etc., 7/6.
- 3 amp. 1,014 ohm, tapped 82, 82, 320 and 530 ohms, for Double Decca, 7 6.
- 3 amp. 781 ohm, tapped 45, 45, 332, 166 and 193, for Ferguson, etc., 9/6.
- 3 amp. 823 ohm, tapped 45, 46, 290, 166 and 277 ohm, for Ferguson, etc., 9/6.
- 3 amp. 660 ohm, tapped 180, 360, 120 and 30 ohms, for Pilot Little Maestro, etc., 8/6.

**SPECIAL HEAVY DUTY RESISTORS.** 5-watt, for bias, etc., all values from 25 to 2,000 ohm, with copper clips, 1/9 each.  
Similar to above, but 10-watt, 2/3.

**SPECIAL 2.2 ohm Resistor,** for converting dry battery sets for use with 2-volt accumulator, 2 6.

**50 ohm centre-tapped Resistor,** tapped at 25 ohm, for pilot lamps, 2 -.

**SPECIAL VOLTAGE DROPPING RESISTANCE,** for Electric Razors, 1,150 ohm, 2/6.

**3 amp. LINE CORD RESISTOR.** 360 ohm, 6/6; 3 amp. LINE CORD RESISTOR, with slider, any resistance obtained up to 750 ohm, 7 8.

**SPECIAL MULTI-LINE CORD RESISTOR.** 5 tappings 50 ohm, 1 tapping 750 ohm, with slider, 2 amp., 8 6.

**BARRETT VALVES, TYPE C.I.** 2 amp., 8'6 each.

**No. 1.—1 8x8 mfd. tubular can-type electrolytic condenser, 500 v.d.c.w., 25 assorted silver mica wire-end condensers, 25 assorted 1/2, 1/4 and 1 watt carbon wire-end resistors, 25 assorted 1-, 2- and 3-gang I.F. and aerial trimmers. 21 7 6 per kit.**

**No. 2.—3 8x8 mfd. tubular can-type electrolytic condensers, 500 v.d.c.w., 100 assorted silver mica wire-end condensers, 100 assorted 1/2, 1/4 and 1 watt carbon wire-end resistors, 50 assorted 1-, 2- and 3-gang I.F. and aerial trimmers, 50 assorted wire-end tubular paper condensers, 3 assorted volume and tone controls. 24 12 6 per kit.**

**No. 3.—6 8x8 mfd. tubular can-type electrolytic condensers, 500 v.d.c.w., 200 assorted silver mica wire-end condensers, 200 assorted 1/2, 1/4 and 1 watt carbon wire-end resistors, 100 assorted 1-, 2- and 3-gang I.F. and aerial trimmers, 100 assorted wire-end tubular paper condensers, 6 assorted volume and tone controls. 28 8 0 per kit.**

**No. 4.—DE LUXE SERVICE ENGINEER'S KIT.** 15 8x8 mfd. tubular can-type electrolytic condensers, 500 v.d.c.w., 3 8 mfd. tubular can-type 500 v.d.c.w., 2 32 mfd. aluminium can-type, 350 v.d.c.w., 1 16 mfd. electrolytic condenser, 350 v.d.c.w., 3 32x32 tubular electrolytic condensers, 175 v.d.c.w., 1 50x50x2 block electrolytic condenser, 15/550 v.d.c.w., 1 50x50x12v. Mallory type condenser, 500 assorted silver mica wire-end condensers, 500 assorted 1/2, 1/4 and 1 watt carbon wire-end resistors, 250 assorted 1-, 2- and 3-gang I.F. and aerial trimmers, 100 assorted wire-end tubular paper condensers, 50 assorted wire-end wire wound resistors, 15 assorted volume and tone controls, with and without switch, 1 pentode output transformer, 1 multi-ratio output transformer, 1 push-pull output transformer, 3 rolls insulating tape, 6 assorted line cord replacement resistors. 229 10 0 per kit.

**ROLA 10in. P.M. corrugated cone loudspeakers,** without transformer, 30/-; with pentode output transformer, 3 ohm speechcoil, 37/6; with multi-ratio output transformer, 42/-.

**RADIO CABINETS.** Walnut veneered, attractive design, dim. 10in. x 12in. x 10in. Dial aperture 5in. x 7in., drilled for tuning tone and volume controls, 39/6 each.

**RADIO CABINETS.** Walnut veneered, suitable for extension loudspeaker, dim. 9in. x 7in. x 7in. Bargain, 10/6 each.

**WALNUT VENEERED LOUDSPEAKER CABINETS.** Modern design, fitted silk and baffle, suitable for 8in. or 10in. speakers, 35/-.

**DE LUXE WALNUT VENEERED CABINET.** Suitable for American Midget sets. Overall dimensions, 14in. x 7in. x 6in., drilled three hole, 32/6 each.

**BATTERY LEADS,** 4-way, with Wander plugs, best quality, 1/3 each.

**ELECTROLYTIC CONDENSERS.** We have many types and sizes in stock. Send us your requirements. To mention a few—10x16, 10x8, 32x32, 25x12v., 25x25v., 24x8, 6 mfd., 6x6, 5x5x35v., 50x50x2, 50x50x12v., etc.

**TUBULAR PAPER CONDENSERS, 350-500v.,** D.C. working. .00005, .0001, .0003, .0006 mfd., 4/- doz.; .001, .0015, .002, .003, .004, 6/- doz.; .01, .025, .03, .05 mfd., 7/- doz.; .08, .1 mfd., 12/- doz.; .15, .2, .25, .3 mfd., 15/6 doz.; .5 mfd., 18/- doz.; or assorted parcel of 50 for 27/6. Minimum orders, 1 doz. any type.

**FIXED CARBON RESISTORS.** Wire ends, assorted and useful values. 1/2-watt, 24/-; 1-watt, 30/-; 1-watt, 36/-; 2-watt, 55/- per 100. Minimum orders, 50 assorted. Assorted parcel for 23. Contains 25 1/2-watt, 50 1-watt, 50 1-watt, 25 2-watt, 10 3-watt.

**FIXED WIRE WOUND RESISTORS.** Wire ends, 4-watt (500, 1,000, 3,000, 4,000 and 5,000 ohm only), 110/-; 10-watt (800 ohm only), 150/- per 100. Minimum orders, 12 of any value.

**SILVER MICA CONDENSERS.** Flat wire end. Assorted and useful values, 17/6 per 100 (not more than 5 alike).

**LOUDSPEAKER FRETS,** coppered brass, 8in. x 7in., 3/6; 10in. x 16in., 10/6.

**I.F. AND AERIAL TRIMMERS.** 12 assorted and useful values for 2/6.

**VOLUME CONTROLS.** 5,000, 10,000, 25,000, 50,000, 100,000 ohm; 1/2, 1/4, 1 and 2 megohm, without switch, 4/9 each. As above, with switch, 6/9 each.

**FLAT FLEX,** 9-way, 14/36, 18/20ft. lengths, suitable for amplifiers, extension speakers, remote control and many other purposes. Finest quality pre-war manufacture, 7/6 per coil.

**OSRAM TUBULAR PILOT BULBS,** 6.2v., .3amp. MMS or B.C., Round, 1/- each, including tax.

**HUMDINGERS.** 30, 25,000 and 50,000 ohm, 6d. each.

**INSULATING TAPE.** Best quality British and American manufacture, 1/2in., 1/4lb. reel, 9d.; 1/2in., 1/4lb. reel, 1/4; 2in., 1 lb. reel, 2/3.

**AMPHENOL OCTAL CHASSIS MOUNTING VALVE HOLDERS,** 1/3 each. 7-pin Chassis Mounting Valve Holders, 6d. each.

**L.F. CHOKES.** 20 hys., 100 m.a., brand new, 16/9.

**EVER-READY QUICK-START CAR BATTERY,** 6 volt, new, in metal container, with carrying handle, 12/6 each, plus tax.

**DPDT SWITCHES,** panel mounting, P.O. type, 2/6 each.

**SCREENED INTERLACED FLEXIBLE MICROPHONE CABLE,** pre-war quality, single, 1/3; twin, 1/6; triple, 1/9 per yard.

**SPECIAL OFFER.—C.A.V.,** 60 volt H.T. Accumulators, type G.103, 5,000 m.a., at 1,000 hour rate, in strong carrying case, with handle, in used condition, as new, 25/- each.

### ◆ PLEASE NOTE ◆

◆ **CALLERS to Show Rooms,**  
**61 HIGHGATE HIGH ST., N.6**  
Phone: MOUnview 9432.

When ordering replacement parts for American or British Radios, please state Model No. and, if possible, forward faulty component with your order.  
2fd. stamped addressed envelope must accompany all enquiries.  
C.O.D. or CASH WITH ORDER.

◆ **POST ORDERS to Dept. M.O.7,**  
**3 HAMPSTEAD LANE, N.6.**

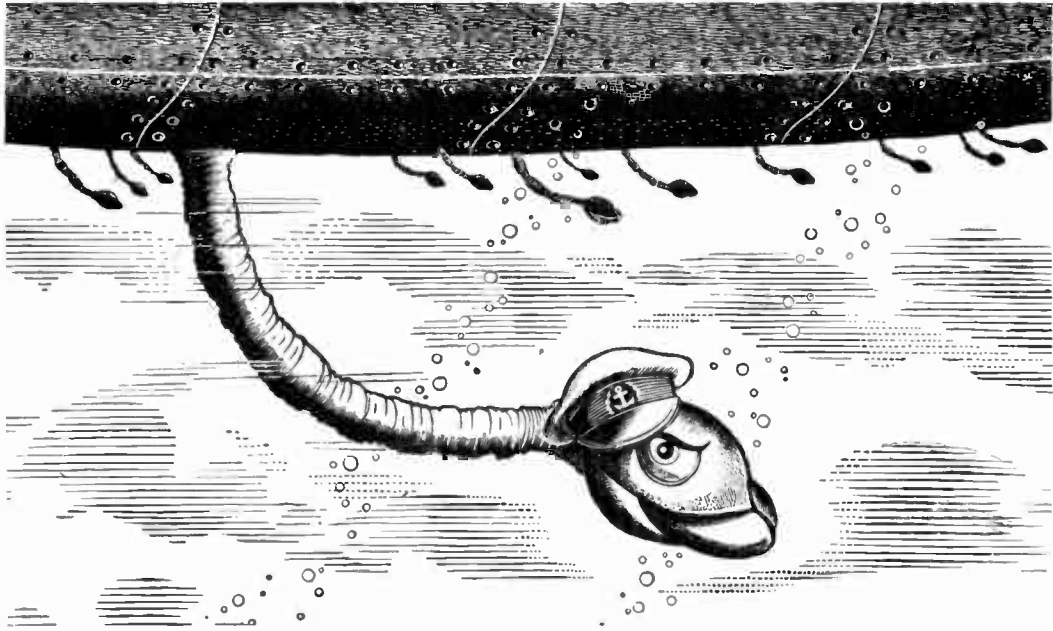

## No passengers

SCIENCE is discouraging the barnacle. There is no room for "passengers" on the smooth surface of the streamlined age.

Industry, too, distinguishes an AEROCESSORY from an accessory. It knows the AEROCESSORY as a revolutionary product which, far from being an adjunct, is conceived and designed specifically to solve a vital need of production and is blue-printed as an integral part of the whole.

The AEROCESSORY, moreover, is a product sired by the high limits of precision engineering essential to the exacting needs of aeronautics—standards which are becoming every day equally appreciated by all industry in this the Air Age.

# S I M M O N D S

*The Creative Impulse in*  
AERONAUTICAL, INDUSTRIAL & MARINE  
*Construction*

THE SIMMONDS NUT · PINNACLE NUT · SPIRE NUT · SIMMONDS GAUGES,  
INSTRUMENTS AND CONTROLS · FRAM OIL & ENGINE CLEANER

SIMMONDS AEROCESSORIES LTD.,  
GREAT WEST ROAD, LONDON  
A COMPANY OF THE SIMMONDS GROUP

LONDON, MELBOURNE, PARIS, NEW YORK.



# Wireless World

Radio • Electronics • Electro-Acoustics

33rd YEAR OF PUBLICATION

MAY 1943

Proprietors :  
ILIFFE & SONS LTD.

Managing Editor :  
HUGH S. POCOCK,  
M.I.E.E.

Editor :  
H. F. SMITH.

Editorial, Advertising  
and Publishing Offices :

DORSET HOUSE,  
STAMFORD STREET,  
LONDON, S.E.1.

Telephone:  
Waterloo 3333 (35 lines).

Telegrams:  
"Ethaworld, Sedist, London."

△

PUBLISHED  
MONTHLY

Price : 1/3

(Publication date 25th  
of preceding month)

Subscription Rate  
Home and Abroad  
17/- per annum.

EDITORIAL. Broadcasting after the War .. .. .	127
INTERFERENCE FROM POWER LINES. By J. S. Forrest, M.A., B.Sc., F.Inst.P. .. .. .	128
RADIO DATA CHARTS—7 : Tuned Circuits at Audio Frequencies. By J. McG. Sowerby, B.A., Grad.I.E.E. .. .. .	132
SHORT-WAVE BROADCASTING STATIONS .. .. .	134
NEWS IN ENGLISH FROM ABROAD .. .. .	136
NEEDLE ARMATURE PICK-UP. By G. A. Hay, B.Sc. .. .. .	137
FREQUENCY MODULATION.—V : Demodulation, Theory of the Discriminator. By Christopher Tibbs, A.M.I.E.E. .. .. .	140
ELECTROMAGNETIC FIELDS IN RADIO.—IV : Stationary Waves and Velocities of Travel. By Martin Johnson, D.Sc. .. .. .	144
WORLD OF WIRELESS .. .. .	148
LETTERS TO THE EDITOR .. .. .	151
UNBIASED. By Free Grid .. .. .	154
" WIRELESS WORLD " BRAINS TRUST .. .. .	155
RANDOM RADIATIONS. By " Diallist " .. .. .	156
RECENT INVENTIONS .. .. .	158

Branch Offices :

COVENTRY :  
8-10, Corporation Street.  
Telephone : Coventry 5210.  
Telegrams :  
" Autocar, Coventry."

BIRMINGHAM :  
Guildhall Buildings,  
Navigation Street, 2.  
Telephone :  
Midland 2971 (5 lines).  
Telegrams :  
" Autopress, Birmingham."

MANCHESTER :  
260, Deansgate, 3.  
Telephone :  
Blackfriars 4412 (4 lines).  
Telegrams :  
" Iliffe, Manchester."

GLASGOW :  
26B, Renfield Street, C.2.  
Telephone : Central 4857.  
Telegrams : " Iliffe, Glasgow."

△

As many of the circuits and  
apparatus described in these  
pages are covered by patents,  
readers are advised before  
making use of them, to satisfy  
themselves that they would  
not be infringing patents.

## Exclusive features

of the  
**'STRATOSIL'**  
series of  
**SEALED  
VIBRATORS**  
for use at all altitudes

- 1 All steel construction—even to the rivets—ensuring uniform expansion under extremes of temperature.
- 2 Reed driving coil—wound on a bakelite moulded bobbin to meet all climatic conditions.
- 3 Metal can, sponge rubber lined—Acoustically and electrically shielding the Vibrator.
- 4 Driving contact of non-tarnishable precious metal—ensuring starting under the lightest of pressures and voltages.
- 5 Contacts ground almost to optical limits.
- 6 Stack assembly. Mica and steel only are used.
- 7 International Octal base sealed by the WEARITE STRATOSIL process.

Embodying " Oak Manufacturing Co.'s " patents 460470, etc.

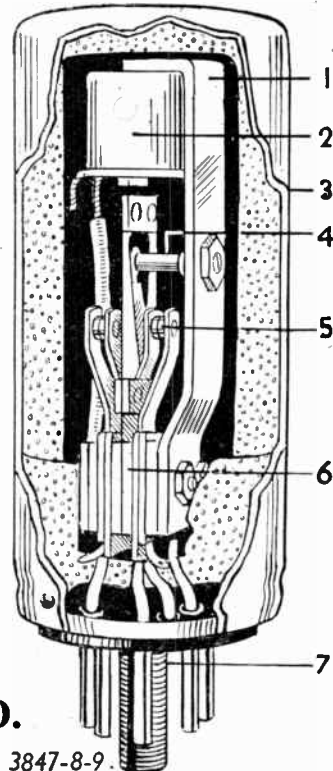

## WRIGHT & WEAIRE LTD.

HIGH ROAD, TOTTENHAM, N.17. Telephones : TOTtenham 3847-8-9

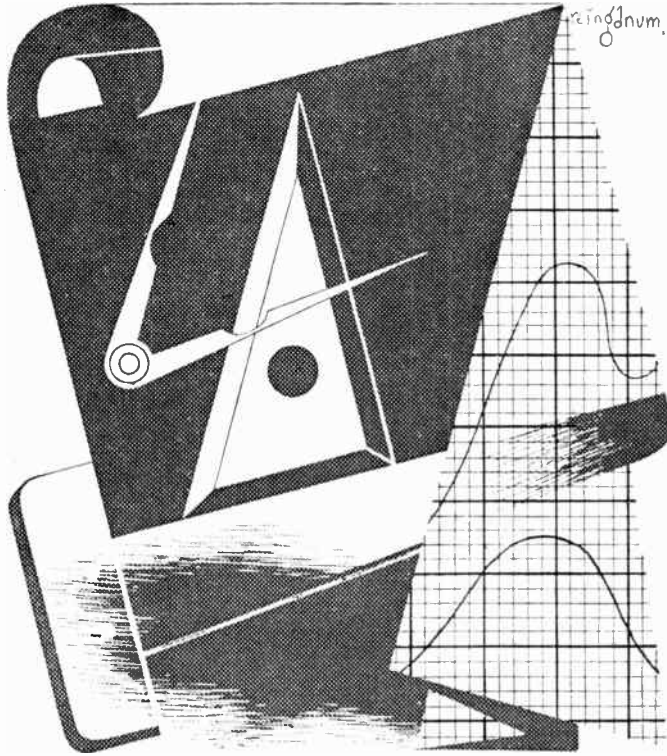

## PLANNING

*Through the whole wide sweep of Philips activities in the field of electricity there is evidence of inspired planning . . . not for the moment only, but also for those needs which will depend on discoveries and developments yet to emerge from the laboratory and the drawing board.*

# PHILIPS



INCANDESCENT AND DISCHARGE LAMPS · FLUORESCENT LIGHTING · RADIO RECEIVERS AND TRANSMITTERS · COMMUNICATIONS EQUIPMENT · THERMIONIC VALVES AND OTHER DEVICES · X-RAY EQUIPMENT FOR ALL PURPOSES · ELECTRO-MEDICAL APPARATUS · ARC AND RESISTANCE WELDING PLANT AND ELECTRODES · MAGNETS AND MAGNETIC DEVICES · SOUND AMPLIFYING INSTALLATIONS

PHILIPS LAMPS LIMITED, CENTURY HOUSE, SHAFESBURY AVENUE, LONDON, W.C.2 (125H)

# Wireless World

Radio • Electronics • Electro-Acoustics

Vol. XLIX. No. 5

MAY 1943

Price 1s. 3d.

## Broadcasting After the War

### *Some Problems of the Industry*

WHEN the war ends, one of the basic problems—if not *the* basic problem—of the wireless industry will be to find the best means of employing the vastly increased productive power which it has acquired during the war years. Given post-war economic conditions of the kind we all hope to see, there will certainly be great expansion in all fields of radio, but there is no doubt that, with proper organisation, the industry will be able to meet all the demands made upon it.

The various problems with which the industry will be faced are already being considered in detail, and, more than a year ago, the Radio Manufacturers' Association appointed a Committee whose task it was to prepare suggestions; these were published as a part of the recent R.M.A. Annual Report, to which reference is made elsewhere in this issue.

The Committee's suggestions emphasise the dependence of the broadcast section of the industry on the transmitting side, particularly with regard to the technical means to be adopted after the war for distributing programmes. Throughout the report one can detect a feeling of uneasiness that future developments may react unfavourably on the industry. In particular, the possibility that wire distribution may take the place of "space" broadcasting is clearly viewed with apprehension.

There are obviously some grounds for these fears. It is stated in the report that "discussion with G.P.O. officials seemed to suggest that they favour the development of a wire broadcasting system in this country. It is not contemplated, however, that this will be developed to the exclusion of individual reception through space, and the continuance of both systems side by side seems certain." Apart from this, we know that the idea of wire broadcasting is still having influential support in other quarters. On the other hand, strong opposition is also forthcoming, but most of the objections voiced by the industry leave too many loopholes, and would fail to convince an unprejudiced arbitrator.

Our own opposition to wire broadcasting is

founded on a rather different basis. When the subject last became pressing, in January, 1942, we ignored the purely technical arguments for and against, and were prepared to admit—but only for the sake of argument—that wire had all the virtues and none of the vices of wireless. But we maintained—and our conviction has since been strengthened—that, whatever may happen in the distant future, the world is not ready for the wire system. The freedom of wireless broadcasting is real and worth struggling for: after the war, it must, during the reconstruction period, have every chance to play its part in founding a permanent peace.

### *Data for Planning*

Apart from the fundamental question of wire *versus* wireless, other important questions as to the means of broadcast transmission will arise. For example, we have been promised at least an experimental frequency-modulation transmission; has America's experience led us to believe that it would be desirable to provide a nation-wide service as soon as possible? What standards are to be employed in our post-war television service, and does the B.B.C. intend to devote to television such a proportion of its revenue that it will become comparable in importance to sound broadcasting? These factors would profoundly affect receiver manufacturing programmes. Without advance knowledge of what is going to happen, it is clearly impossible to plan production efficiently; indeed, to plan it at all. In our view, lack of long-term planning will react, during the post-war era, to the disadvantage of both industry and public. At present, the industry learns of impending changes in transmission methods merely as a matter of courtesy; not as a right.

Consideration of these questions, and many similar ones that arise, forces us to the conclusion that the voice of those who make the receivers should be heard at the councils of those who plan the transmission services. Reception and transmission are complementary; without co-operation, neither can function at its best.

# INTERFERENCE FROM POWER LINES

## Its Nature and Extent

By J. S. FORREST,  
M.A., B.Sc., F.Inst.P.

PARTLY owing to the fact that there is, in the ordinary sense, no method of suppression, and partly because radio engineers and power engineers do not always appreciate each other's difficulties, radio interference from high-voltage power lines presents a difficult problem. When a case of power line interference arises the radio engineer may notice audible or visible discharges on the line insulators, and he frequently dismisses the matter by remarking that the line is "under-insulated." The power engineer, on the other hand, knows that the line is fulfilling its primary purpose efficiently, and is unable to see why slight "corona" or "brush dis-

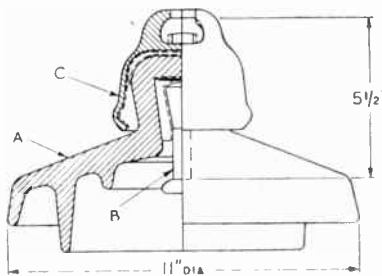

Fig. 1. Cap-and-pin insulator unit (Bullers) A, porcelain shell; B, steel pin; C, malleable cast iron cap.

charge," involving a negligible leakage current, should cause the disturbance. Moreover, he knows that the complete elimination of all discharges on high-voltage lines is not possible under humid weather conditions even with a generous level of insulation, and the best of modern insulators. It is the object of this article to attempt to present the problem of radio interference from the dual point of view of one interested both in radio and in power engineering; the characteristics of the interference will be described and possible remedial measures will be discussed.

It must be emphasised at the outset that power lines are not major sources of radio interference. Gill and Whitehead\*, for example, report that in an analysis of 1,000 cases taken at random, only 2 per cent. were due to overhead power

In a recent paper\* before the Institution of Electrical Engineers on "The Characteristics and Performance in Service of High-Voltage Porcelain Insulators," the writer of this article described some investigations which had been made on power line radio interference. The article is based on the information given in the paper and the ensuing discussion

lines. The subject has nevertheless received much attention, due partly to the fact that when cases do arise suppression may be impossible, and partly because the elimination of the fundamental cause of power line interference would, *ipso facto*, result in an improved insulator in other respects.

### Types of Interference

It is convenient to classify power line interference into "normal" and "abnormal" interference. The interference which is inseparable from the operation of high-voltage lines, even with all the power system equipment in perfect order, is termed "normal" interference. "Abnormal" interference, on the other hand, is due to some abnormal condition or fault on the power equipment which gives rise to spark discharges. Such discharges may be produced by inadequately earthed metalwork or faulty conductor joints. As an example of "abnormal" interference a case may be cited in which a spare conductor on a high river crossing was not efficiently connected to earth. A charge was induced on the spare conductor due to its proximity to the live circuit on the same towers, and a small spark discharge occurred from the conductor to earthed metal. Thus the arrangement constituted quite an efficient spark transmitter which caused widespread interference with broadcast reception. Although intense interference is produced in such cases, it does not give rise to a

serious problem because the location of the cause is comparatively easy. "Normal" interference which is an inevitable concomitant of the operation of power lines, cannot be dealt with so easily, however, and it is with this type of interference that the remainder of the article is concerned. "Normal" interference is generated by the line insulators, and it may be helpful to describe briefly the various types of insulator used on high-voltage power lines.

Porcelain or glass is used for high-voltage line insulation, and the most widely used type of insulator is the cap-and-pin unit; details of a typical unit are shown in Fig. 1. Various numbers of such units are assembled in series in strings, a string of two or three units being used for 33-kV lines, and ten units for 132-kV lines. Cap-and-pin units are suitable for use

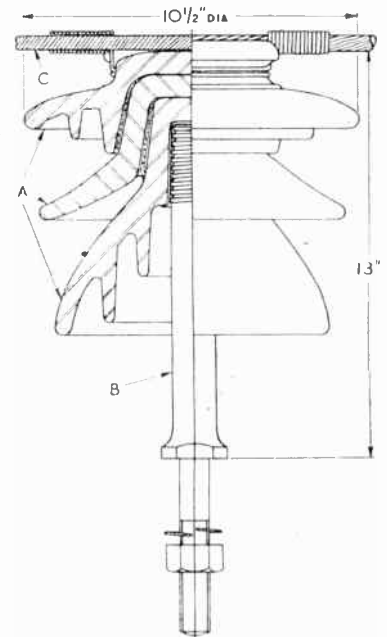

Fig. 2. 33-kV pin-type insulator (Taylor, Tunncliffe & Company) A, porcelain shells; B, steel pin; C, line conductor

both at suspension positions in which the insulator string hangs vertically, and at tension positions in which the string is horizontal.

\* Journal I.E.E., 1938, Vol. 83, p. 345.

\* Journal I.E.E., 1942, Vol. 89, Part II, p. 60.

For voltages of 33 kV and below, pin type insulators are commonly used (Fig. 2); this type of insulator consists of a porcelain shell, or several porcelain shells cemented together, and is fixed to the pole cross-arm by means of a steel spindle. The line conductor is attached to the head of the insulator by a wire binding. The pin insulator is not suitable for tension positions; an insulator such as the

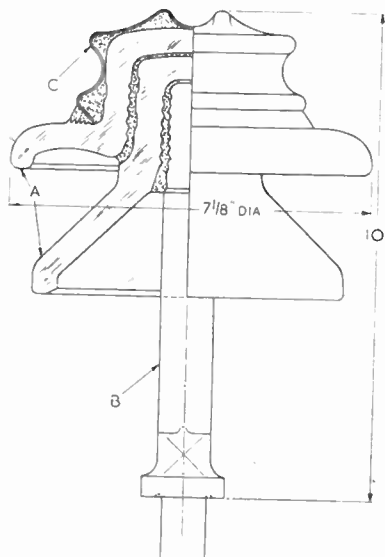

Fig. 3. 11-kV pin-type insulator with metal cap (Pilkington Bros.) A, toughened glass shells; B, steel pin; C, copper or aluminium cap.

cap-and-pin type which will sustain the conductor tension must be used at these points on the line. In some cases pin insulators are provided with a metal cap to which the conductor is attached, and Fig. 3 is an example of a toughened glass insulator of this type. The only remaining type of insulator which need be mentioned is the line post insulator, shown in Fig. 4; for the present purpose, the most significant feature about this insulator is that the capacitance between the conductor and earth is lower than in the equivalent pin insulator.

**Effect of Dampness**

When high-voltage power lines are in normal operation small spark discharges occur on the insulators, and these discharges, in common with all spark discharges, contain components of radio fre-

quency, so that a radio frequency disturbing field is radiated from the line conductors. The intensity of the discharges increases under damp weather conditions, and when the insulators become dirty. The fundamental cause of the spark discharges, and hence of the interference, is to be found in the electrical properties of a porcelain or glass surface. Such a surface will, in foggy and humid weather—particularly in districts subject to industrial pollution or salt spray—become coated with a conducting film. The immediate effect of this film is to reduce the surface resistance of the insulator from, say, 1,000 megohms to 10 megohms. There is, however, a further secondary effect due to the fact that the resistance of the conducting film is not constant but increases as the applied voltage is increased. This effect may colloquially be described as being due to the "drying-out" of the surface film.

Now the voltage across an insulator unit under humid weather conditions is determined by the product of the leakage current, and the surface resistance of the unit. It follows, therefore, that the potential distribution over a string of units in series becomes unstable, as any tendency to depart from uniformity leads to a still further departure in the same direction. The ultimate result is that, as the humidity increases the distribution of potential becomes highly irregular. For example, Fig. 5 (a) shows the fairly uniform voltage distribution which is obtained on a 132-kV ten-unit string under dry weather conditions, while in polluted and humid atmospheres the distribution becomes very irregular, as shown in Fig. 5 (b). It will be seen that on five out of ten units the voltage is

Fig. 4. Line post insulator (Lapp Insulator Company, U.S.A.)

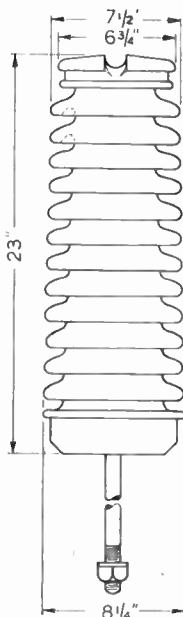

negligible, and, consequently, four of the remaining units are operating at much more than their normal working voltage. A similar argument applies to portions of the surface of each individual unit so that spark discharges occur on the surfaces of the units, and also across the highly stressed units. The surface leakage current flowing under such conditions is approximately 1 mA, although sudden surges of current having a value of approximately 50 mA occur when spark-over of a few of the insulator units in the string takes place.

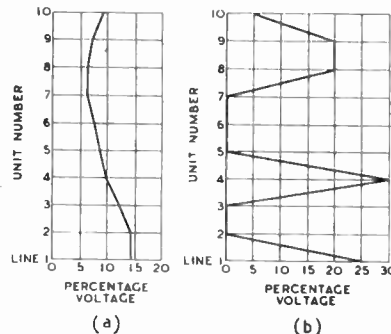

Courtesy "Journal I.E.E." Fig. 5. Potential distribution on 10-unit insulator string. (a) Relative humidity 42% (b) Relative humidity 95%.

It follows from the preceding discussion that the intensity of the interference from a power line should be profoundly affected by the weather conditions. In practice, this is found to be the case; in dry weather the interference is negligible, while the interference is most intense under foggy conditions in industrial districts. Similar conditions sometimes occur on lines in coastal areas due to salt spray. These facts are expressed quantitatively in Fig. 6, which gives the value of the interfering field under a 132-kV line insulated with strings of ten cap-and-pin units. The measurements were made with a Marconi-Ekco Type TF379 Interference Measuring Set.

The results obtained exhibit a number of interesting features. It will be noted, for example, that in fog the interfering field increases to one hundred times the dry weather value, i.e., increases by 40 db. For comparison purposes, the field strengths (pre-war) of the long wave and medium wave broadcasting stations are also plotted on

**Interference from Power Lines—**

the diagram, and it is seen that for a receiver situated under the power line a background of interference would be obtained on both these stations in foggy weather. Further, it would be impossible to receive stations having field strengths of less than  $100\mu\text{V/m}$ . The results also show that the interfering field decreases as the frequency increases, so that transmission line interference has relatively little effect on short-wave reception. This is in sharp contradistinction to interference due to motor cars, which is most intense on short waves and negligible on medium and long.

Fortunately, the interfering field attenuates rapidly at right angles to the line, and Fig. 7 gives the results of some measurements made at various distances from the line in dry and in foggy weather on a frequency of 1,000 kc/s. (The approximate intensity of the interference

line, while at a distance of 100 yards from the line the interfering field has a value of only a few microvolts per metre.

It is extremely difficult to make measurements even under the worst weather conditions at distances of 100-150 yards from a power line as the interference level is very low and the noise due to the line is difficult to distinguish from the general background of noise due to other sources of interference. It seems, however, that the field strength of the "normal" interference at a distance of several hundred yards from the line must be very low, and the writer knows, of no well-authenticated case of "normal" interference at distances of more than half-a-mile from a line. It should be remarked that although the interference is generated on the insulators it is propagated with little attenuation along the conductors, and so does not

pin insulators is similar to that which has just been described. Lines insulated with pin-type insulators, however, often give rise to much more intense interference. Moreover, this intense interference occurs in dry weather, and may decrease in wet or humid weather. In this case, the interference is due to discharges between the conductor or tie wires and the insulator head. If there is imperfect contact between the conductor and the head, the charging current of the insulator gives rise at the point of contact to a spark discharge which produces intense interference. In humid weather, on the other hand, the insulator head is covered with a conducting film, with the result that these discharges may be reduced in intensity.

**Investigating Interference**

Cases of power line interference present many pitfalls for the inexperienced investigator. The power line is usually the most obvious possible source of the trouble, and many instances have occurred in which it has been wrongly convicted.

For example, if a line insulated with strings of cap-and-pin units is involved it should be verified that the interference is most intense in humid weather, and that it varies with frequency in accordance with Fig. 6. Caution should be exercised in coming to conclusions on the variation of the interference with frequency as the sensitivity of most receivers varies considerably over the various wave-bands, and a peak in the sensitivity characteristics of the receiver may easily be mistaken for a peak in the intensity of the interference. Receivers with automatic gain control may also give misleading indications.

Cases are often reported in which the power line is "proved" to be the source of the interference on the grounds that DF bearings taken on the noise intersect on a certain tower. It has been explained above that the interfering field is radiated from the whole length of the line conductors so that DF bearings in the usual sense cannot be obtained, and any results of this type are likely to be spurious. Finally, the investigator should carry out a test in co-operation with the supply authority in order to determine whether or not the interference disappears when the line is switched-out and earthed.

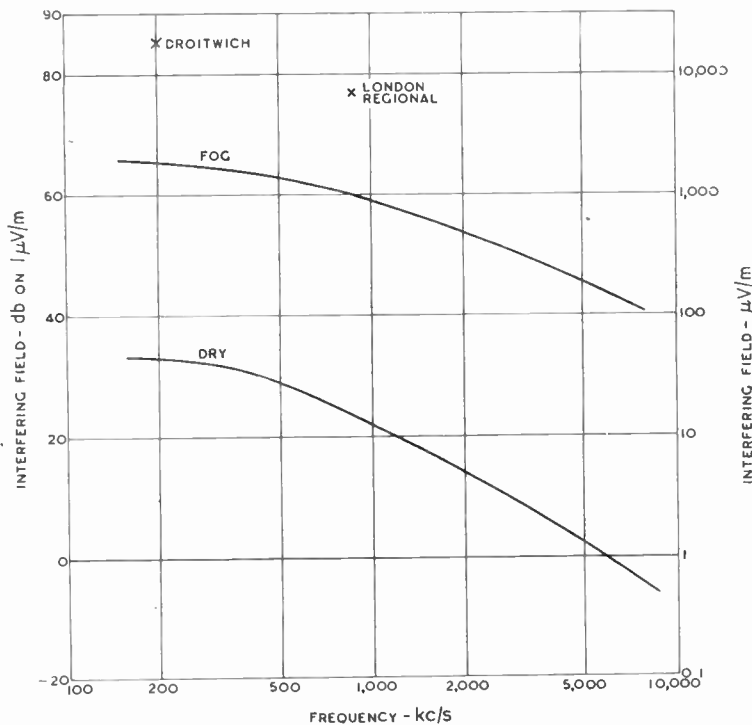

Courtesy "Journal I.E.E."

Fig. 6. Interfering field underneath a 132-kV line.

at other frequencies can be obtained with the help of Fig. 6.) It will be noted that at a distance of 50 yards from the power line the interfering field in foggy conditions is reduced to less than one-tenth (25 db. below) the value under the

vary greatly along the line. A line therefore produces a band of interference of uniform width, and Fig. 8 may be helpful in visualising this.

Interference due to 33-kV and 66-kV lines insulated with cap-and-

The results of this apparently simple test must be interpreted with care owing to the variable

be applied to the power line, it must be emphasised that it is useless to make any modifications at a single

the energy in the spark discharges, and consequently, the interference, is reduced. The interference from ordinary pin-type insulators can also be reduced by the use of a conducting paint, or conducting glaze, on the head of the insulator in order to eliminate spark discharges at this point. These remedial measures are, however, all palliatives rather than cures.

It has been explained that the fundamental cause of the "normal" type of interference potential lies in the highly irregular potential distribution which occurs on a vitreous surface in a humid atmosphere. Under such conditions, the potential distribution may become so non-uniform that the insulator gives rise not only to radio interference, but may even flash-over and interrupt the electricity supply. The ideal insulator would be one in which a uniform potential distribution was maintained under all conditions, and it has been shown by full-scale tests that this end can be achieved if each unit or element of a complete insulator is given a fixed and relatively low value of resistance—of the order of 1 megohm per kilovolt of applied voltage. One method of manufacturing such "stabilised" insulators is to use a glaze having a suitable value of

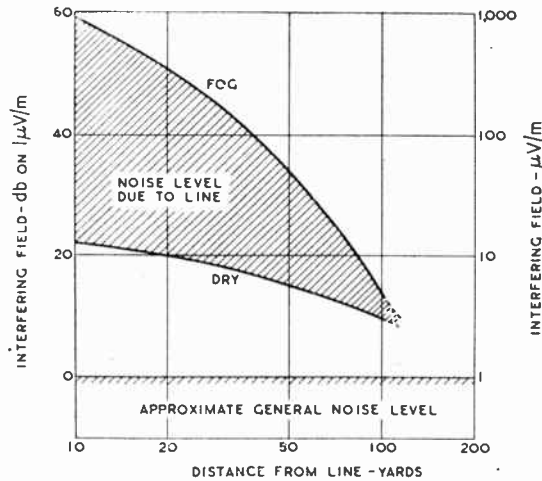

Fig. 7. Variation of interfering field (at 1,000 kc/s) with distance from 132-kV line.

nature of most interfering noises, and it is best to arrange for an observer to make a continuous log of the noise level while independent arrangements are made to carry out the switching operations on the line. By comparing the observer's log with the times of switching a definite conclusion can usually be reached.

When the interference has been traced to a power line, consideration must be given to means of eliminating, or at least reducing, the trouble. In cases of "abnormal" interference the cure is usually obvious when the source of the interference has been located, but there is, unfortunately, comparatively little that can be done when "normal" interference is involved. Sometimes, however, reception conditions can be improved to some extent by the application of remedial measures either at the receiver or on the power system.

If a site can be found for the aerial sufficiently remote from the power line (see Figs. 7 and 8) to give the desired signal-to-noise ratio then satisfactory reception can be obtained by using a screened aerial feeder, and by screening thoroughly the receiver and its power supply. Improved reception conditions can also be obtained when it is possible to increase the strength of the received signals, or to work on a higher frequency. In addition, frequency modulation should prove beneficial.

Regarding measures which can

for technical reasons. An improvement can often be effected by cleaning the insulators, although this improvement is clearly temporary, and it is usually difficult for the supply authority to arrange for insulator cleaning at frequent intervals. Insulators incorporating an oil bath have much improved radio interference characteristics in humid weather, but, for obvious reasons, this type of insulator is not favoured by transmission line engineers. Further, it is not applicable at tension positions. The line insulation

Fig. 8. Interfering field contours in dry weather and in fog at 1,000 kc/s.

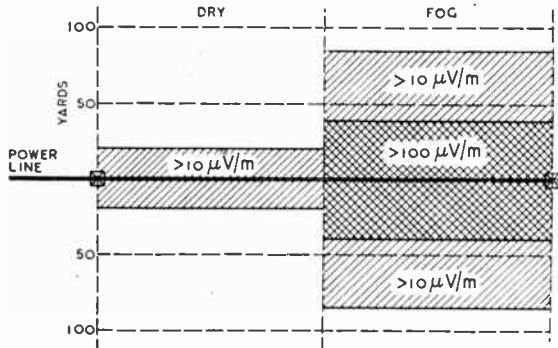

may be increased by adding extra units, but a limit is soon reached due to the reduction in the clearance between the conductor and the tower, and the improvement in interference obtained by this method is usually disappointing. In the case of lines insulated with pin-type insulators, some improvement can be effected by using insulators with metal caps (Fig. 3) or by installing line post insulators (Fig. 4). The latter type of insulator has a much lower capacitance than the normal pin type so that

resistivity. The development of a glaze with the required properties is a difficult ceramic problem, but it is anticipated that a satisfactory solution to the problem will be found before long. The stabilised insulator will not only be a great improvement from the point of view of the power engineer, but will also be "interference-free." Radio engineers can therefore be assured that insulation technicians are doing everything possible to bring this development to a satisfactory conclusion.

# RADIO DATA CHARTS—7

## Tuned Circuits at Audio Frequencies

By

J. MCG. SOWERBY,

B.A., Grad. I.E.E.

(By Permission of the Ministry of Supply)

THE tuned circuit is not in such general use at audio frequencies as it is at radio frequencies, but there are occasions when a parallel or series tuned circuit has application in the audio range, and the purpose of this abac is to reduce the labour of computation. It is especially useful when a number of calculations have to be made. Such a case might arise in the design of an audio test oscillator to give a number of fixed frequencies by switching a number of condensers in rotation into circuit with a fixed inductance.

The chart is based upon the almost universally known formula :

$$f = \frac{1}{2\pi\sqrt{LC}}$$

However, it is sometimes not fully realised that this formula is only an approximation of the general relation :

$$f = \frac{1}{2\pi\sqrt{\frac{LC}{1+r^2}}}$$

A little calculation will show that the error introduced by neglecting the resistance  $r$  of the coil will, except for very accurate work, be quite unimportant. Even when the "Q" of the coil falls to 4, the tuned frequency as calculated by the approximate formula is still within 1 per cent. of the truth as given by the exact relation; and when the "Q" falls as low as this the exact resonant point becomes rather indeterminate, as the resonance curve becomes very "flat." Nevertheless, for accurate work it should be remembered that the chart gives only the approximate answer.

The uses of tuned circuits at audio frequencies are various, and examples that spring immediately to the mind are audio test oscillators, detectors for AC bridges, selective amplifiers for various purposes, and tone-control circuits. Possibly their widest use is in the last-named application. For example, it is quite feasible to introduce a tuned circuit resonating at about 8,000 c/s to boost the treble previously cut by the selective circuits of a receiver. This can also be arranged to give a very sharp cut-off at about 10,000 c/s, with consequent benefit.

If, in addition, the tuned circuit can be damped by a variable resistance, variable boost can be obtained, and with the increased flexibility some improvement can be expected in receiver performance even under widely varying conditions. One high-fidelity set of a few years ago had a treble boost of this nature (though without the variable feature) in operation on radio reception, with quite acceptable results, in spite of possible transient distortion.

There is no reason, of course, why a series circuit should not be used to provide an attenuation when and where required. Some pick-up "stratch" filters come into this category. Circuits have been devised using a tuned circuit in conjunction with positive or negative feedback to provide large gains or attenuations in the audio range to compensate for peaks or troughs in the overall response curve due to other components.

In the construction of tone control arrangements with tuned circuits there are one or two practical points which are worth repeating here. The coils should not, as a general rule, be iron-cored components (unless iron dust cores are used), because the iron core adds materially to the effective resistance of the coil thus lowering the "Q."

A high "Q" may easily be reduced by a shunt resistance, whereas a low "Q" cannot be raised without the use of other components (such as an extra valve stage with positive feedback). In addition, the coil will have a varying inductance with changing signal strength—unless very special alloys are used for the core—and the resonant peak will shift correspondingly. This may be of importance in some applications.

The losses in the condenser side of the circuit will, of course, add to the effective resistance, but in general these can be ignored in comparison with coil losses. It is fairly safe to say that at audio frequencies all reasonably good condensers can be regarded as perfect.

Coming back to coils, there is the question of hum pick-up. As far as possible a coil used for tone control should be well shielded by a screen or box of iron or magnetic alloy, and it should not be placed near transformers and chokes carrying AC power. In cases where hum is already present, relief can often be obtained by orienting the axis of the coil to a new position—to be found by experiment. Finally it only remains to emphasise the oft-repeated advice to do the tone controlling at an early stage where the signal level is low.

Now for the chart. In this case the operation is so simple that no key is required. It is only necessary to join the respective values of inductance and capacity with a ruler, and the tuned frequency is shown on the centre scale. Similarly, capacity and frequency, or inductance and frequency, may be used in conjunction to find inductance and capacity respectively. A single illustrative example should suffice.

*Example.*

A slab coil of 0.32 Henrys (320 mH) is to be tuned to 7,500 c/s for treble boost in a receiver. What is the value of the condenser required for this set-up?

Set the ruler on 0.32 on the inductance scale at the right, and 7,500 c/s on the frequency scale, and the answer is read off the right hand capacity scale. It is 0.0014μF.

### ABACS WHICH HAVE ALREADY APPEARED IN THIS SERIES:—

"Output Transformer Ratios".....	Oct. 1942
"Effect of a Screening Can on the Inductance and Resistance of a Coil".....	Nov. 1942
"The Characteristic Impedance of Transmission Lines".....	Jan. 1943
"Attenuation of Transmission Lines".....	Feb. 1943
"Q" of Quarter-wave-length Resonant Line".....	Mar. 1943
"Length of Capacity-loaded Quarter-wave-length Transmission Line".....	Apr. 1943



ABAC No. 7

[Third Series]

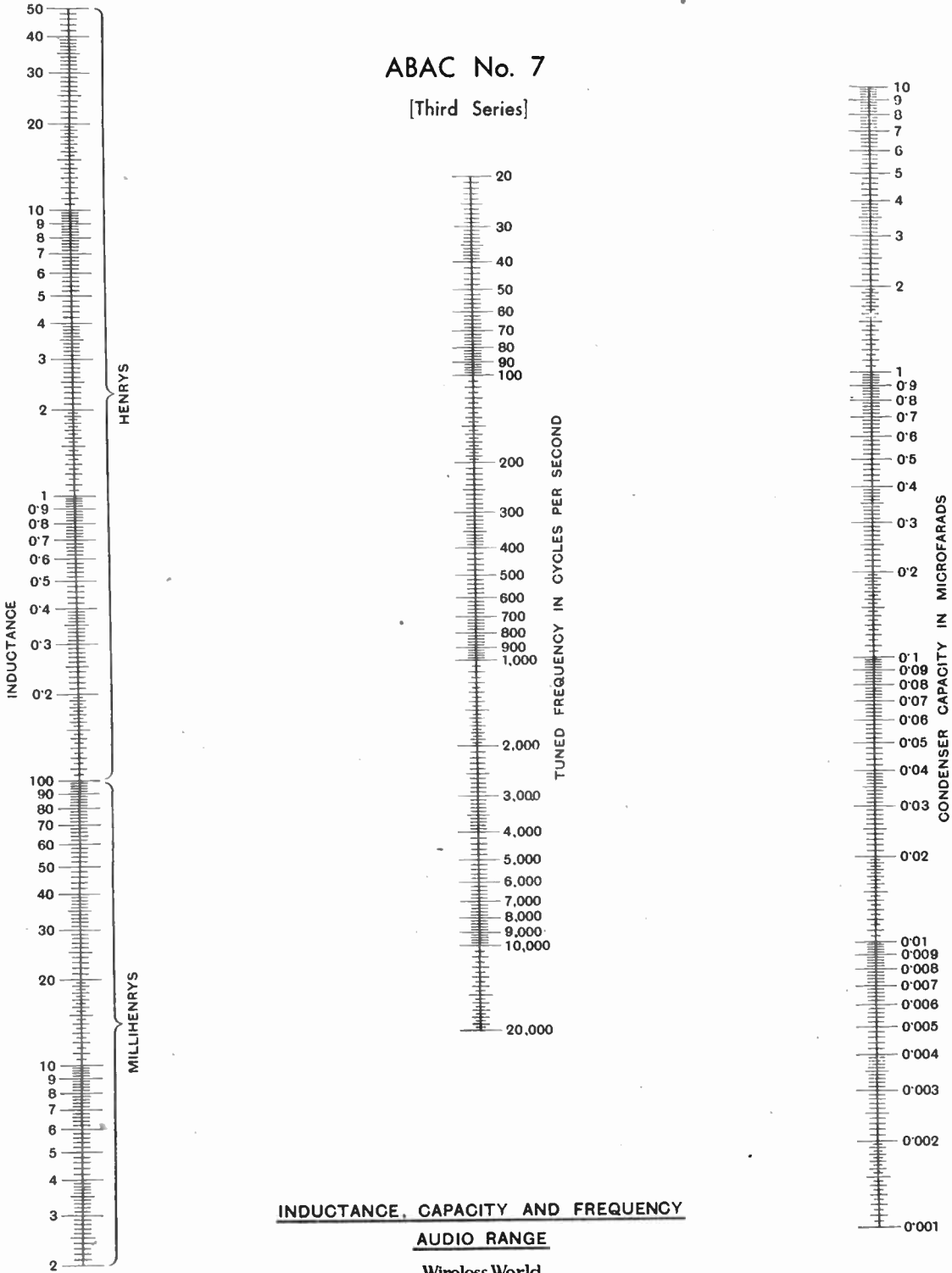

Wireless World  
COPYRIGHT

# SHORT-WAVE BROADCASTING STATIONS

## Arranged in Order of Frequency

Some of the stations listed are of comparatively low power, while others, owing to their geographical position, operating frequencies and times of working, are heard in this country only under favourable conditions. They are, however, included in order that the list may be as comprehensive as possible. Owing to paper restrictions this list cannot be repeated for some time. Any major changes will be noted in our pages.

Station	Call Sign	Mc/s	Metres	Station	Call Sign	Mc/s	Metres
Accra (Gold Coast) .. ..	ZOY	4.915	61.04	British Oversea Service ..	GRK	7.185	41.75
Vatican City .. ..	HVJ	5.970	50.25	Moscow (U.S.S.R.) .. ..	—	7.200	41.67
Moscow (U.S.S.R.) .. ..	RNE	6.000	50.00	Moscow (U.S.S.R.) .. ..	—	7.210	41.61
Mexico City .. ..	XEBT	6.000	50.00	Calcutta (India) .. ..	VUC2	7.210	41.61
Montevideo (Uruguay) ..	CXA2	6.000	50.00	Sydney (Australia) .. ..	VLQ4	7.220	41.55
Colon (Panama) .. ..	HP5K	6.005	49.96	British Oversea Service ..	GSW	7.230	41.49
Johannesburg (South Africa)	ZTJ	6.007	49.94	San Francisco (U.S.A.) ..	KWID	7.230	41.49
Pretoria (South Africa) ..	ZRH	6.007	49.94	Bombay (India) .. ..	VUB2	7.240	41.44
Pernambuco (Brazil) .. ..	PRA8	6.010	49.92	San Francisco (U.S.A.) ..	KGEI	7.250	41.38
Sydney (Nova Scotia) .. ..	CJCX	6.010	49.92	British Oversea Service ..	GSU	7.260	41.32
British Oversea Service ..	GRB	6.010	49.92	Lisbon (Portugal) .. ..	CSW8	7.260	41.32
Delhi (India) .. ..	VUD3	6.010	49.92	Madras (India) .. ..	VUM2	7.270	41.27
Havana (Cuba) .. ..	COCO	6.010	49.92	Delhi (India) .. ..	VUD3	7.290	41.15
Moscow (U.S.S.R.) .. ..	RW96	6.030	49.75	Moscow (U.S.S.R.) .. ..	—	7.300	41.10
Lourenco Marques (Mozambique)	CR7AA	6.035	49.71	British Oversea Service ..	GRJ	7.316	41.01
Moscow (U.S.S.R.) .. ..	—	6.040	49.67	U.S.A. Service .. ..	WBS	7.355	40.79
Boston (U.S.A.) .. ..	WRUL*	6.040	49.67	Moscow (U.S.S.R.) .. ..	RWG	7.360	40.76
British Oversea Service ..	GSA	6.050	49.59	Point-à-Pitre (F.W.I.) ..	FG8AH	7.440	40.32
Philadelphia (U.S.A.) .. ..	WCAB	6.060	49.50	Moscow (U.S.S.R.) .. ..	RKI	7.520	39.89
Antananarivo (Madagascar) ..	—	6.063	49.48	Moscow (U.S.S.R.) .. ..	—	7.545	39.76
Motala (Sweden) .. ..	SBO	6.065	49.46	Moscow (U.S.S.R.) .. ..	—	7.560	39.68
Toronto (Canada) .. ..	CFRX	6.070	49.42	U.S.A. Service .. ..	WDJ	7.565	39.66
British Oversea Service ..	GRR	6.070	49.42	Lobita (Angola) .. ..	CR6AA	7.614	39.40
Vancouver (Canada) .. ..	CFKX	6.080	49.34	Moscow (U.S.S.R.) .. ..	—	7.770	38.61
Cincinnati (U.S.A.) .. ..	WLWO	6.080	49.34	Cairo (Egypt) .. ..	SUX	7.865	38.14
Lima (Peru) .. ..	OAX4Z	6.082	49.32	Beirut (Syria) .. ..	—	8.035	37.34
Nairobi (Kenya) .. ..	VQ7LO	6.083	49.31	Kuibyshev (U.S.S.R.) .. ..	—	8.050	37.27
Percira (Colombia) .. ..	HJFK	6.090	49.26	Moscow (U.S.S.R.) .. ..	RIA	8.070	37.17
Toronto (Canada) .. ..	CRCX	6.090	49.26	Rabat (Morocco) .. ..	CRN2	8.188	36.64
Cape Town (South Africa) ..	ZRK	6.097	49.20	Casablanca (French Morocco)	CNP	8.795	34.11
Moscow (U.S.S.R.) .. ..	—	6.100	49.18	U.S.A. Service .. ..	WJP	8.810	34.05
Bound Brook (U.S.A.) .. ..	WNBT†	6.100	49.18	Santiago (Cuba) .. ..	COKG	8.960	33.48
Fortaleza (Brazil) .. ..	PRE9	6.105	49.14	Algiers .. ..	TPZ2	8.965	33.46
British Oversea Service ..	GSL	6.110	49.10	Moscow (U.S.S.R.) .. ..	—	8.990	33.37
Kharbarovsk (U.S.S.R.) .. ..	—	6.115	49.06	Moscow (U.S.S.R.) .. ..	—	9.010	33.30
Brentwood (U.S.A.) .. ..	WCBX§	6.120	49.02	Havana (Cuba) .. ..	COBZ	9.030	33.22
Montevideo (Uruguay) ..	CXA4	6.125	48.98	Libreville (French Eq. Africa)	FHK	9.320	32.19
Perth (Australia) .. ..	VLW	6.130	48.94	Geneva (Switzerland) ..	HBL	9.345	32.10
Kuibyshev (U.S.S.R.) .. ..	—	6.130	48.94	Dakar (French W. Africa)	FGA	9.405	31.90
Noumea (New Caledonia) ..	FK8AA	6.130	48.94	British Oversea Service ..	GRI	9.410	31.88
Moscow (U.S.S.R.) .. ..	—	6.140	48.86	Havana (Cuba) .. ..	COCH	9.437	31.79
Hull (U.S.A.) .. ..	WBOS	6.140	48.86	British Oversea Service ..	GRU	9.450	31.75
Medellin (Colombia) .. ..	HJDE	6.145	48.82	Moscow (U.S.S.R.) .. ..	—	9.465	31.70
British Oversea Service ..	GRW	6.150	48.78	Ankara (Turkey) .. ..	TAP	9.465	31.70
Winnipeg (Canada) .. ..	CJRO	6.150	48.78	Brentwood (U.S.A.) .. ..	WCBX§	9.480	31.65
Teheran (Iran) .. ..	EQB	6.155	48.74	St. John's (Newfoundland)	VONG	9.482	31.64
Kuibyshev (U.S.S.R.) .. ..	—	6.155	48.74	Moscow (U.S.S.R.) .. ..	—	9.500	31.58
Quebec (Canada) .. ..	CBFW	6.160	48.70	Chungking (China) .. ..	XGOY	9.500	31.58
Schwarzenburg (Switzerland)	HER3	6.165	48.66	Rio de Janeiro (Brazil) ..	PRF5	9.500	31.58
San Pedro (Costa Rica) .. ..	TILS	6.165	48.66	Mexico City .. ..	XEWW	9.500	31.58
Brentwood (U.S.A.) .. ..	WCBX§	6.170	48.62	Rio de Janeiro (Brazil) ..	PRL8	9.505	31.56
British Oversea Service ..	GRO	6.180	48.54	British Oversea Service ..	GSB	9.510	31.55
Buenos Aires (Argentina) ..	LRA2	6.180	48.54	Moscow (U.S.S.R.) .. ..	RW96	9.520	31.51
Schenectady (U.S.A.) .. ..	WGEA‡	6.190	48.47	Pretoria (South Africa) ..	ZRG	9.523	31.50
Vatican City .. ..	HVJ	6.190	48.47	Schenectady (U.S.A.) ..	WGEA‡	9.530	31.48
San Francisco (U.S.A.) .. ..	KGEI	6.190	48.47	Moscow (U.S.S.R.) .. ..	—	9.530	31.48
British Oversea Service ..	GRN	6.190	48.47	San Francisco (U.S.A.) ..	KGEI	9.530	31.48
Lisbon (Portugal) .. ..	CS2WD	6.200	48.39	Calcutta (India) .. ..	VUC2	9.530	31.48
Havana (Cuba) .. ..	COCW	6.320	47.47	Motala (Sweden) .. ..	SBU	9.535	31.46
Santa Clara (Cuba) .. ..	COH1	6.455	46.48	Suva (Fiji) .. ..	VPD2	9.535	31.46
Guatemala City .. ..	TGWB	6.480	46.30	Schwarzenburg (Switzerland)	HER4	9.535	31.46
Geneva (Switzerland) .. ..	HBQ	6.675	44.94	Melbourne (Australia) ..	VLG2	9.540	31.45
Cairo (Egypt) .. ..	SUR	6.784	44.24	Schwarzenburg (Switzerland)	HER10	9.545	31.43
Moscow (U.S.S.R.) .. ..	—	6.975	43.01	San Francisco (U.S.A.) ..	KGEI	9.550	31.41
Kuibyshev (U.S.S.R.) .. ..	—	6.980	42.98	Moscow (U.S.S.R.) .. ..	—	9.550	31.41
Moscow (U.S.S.R.) .. ..	—	6.980	42.98	Vatican City .. ..	HVJ	9.550	31.41
British Oversea Service ..	GRS	7.065	42.46	Bombay (India) .. ..	VUB2	9.550	31.41
Valladolid (Spain) .. ..	FET1	7.070	42.43	Lima (Peru) .. ..	OAX4T	9.562	31.37
Tangier (Spanish Morocco) ..	—	7.090	42.31	Kharbarovsk (U.S.S.R.) ..	—	9.566	31.36
British Oversea Service ..	GRM	7.120	42.13	Hull (U.S.A.) .. ..	WBOS	9.570	31.35
British Oversea Service ..	GRT	7.150	41.96	Madras (India) .. ..	VUM2	9.570	31.35

Station	Call Sign	Mc/s	Metres	Station	Call Sign	Mc/s	Metres
British Oversea Service .. .. .	GSC	9.580	31.32	Santa Clara (Cuba) .. .. .	COHI	11.765	25.50
Sydney (Australia) .. .. .	VLQ6	9.580	31.32	Moscow (U.S.S.R.) .. .. .	RNE	11.766	25.60
Melbourne (Australia) .. .. .	VLG	9.580	31.32	Boston (U.S.A.) .. .. .	WRUL*	11.790	25.45
Cincinnati (U.S.A.) .. .. .	WLWO	9.500	31.28	Santiago (Chile) .. .. .	CB1180	11.800	25.42
Delhi (India) .. .. .	VUD4	9.590	31.28	British Oversea Service .. .. .	GSN	11.820	25.38
Philadelphia (U.S.A.) .. .. .	WCAB	9.590	31.28	Colonia (Uruguay) .. .. .	CXA11	11.820	25.38
British Oversea Service .. .. .	GRY	9.600	31.25	Bound Brook (U.S.A.) .. .. .	WNBI†	11.820	25.38
Moscow (U.S.S.R.) .. .. .	RAL	9.600	31.25	Moscow (U.S.S.R.) .. .. .	—	11.830	25.36
Rio de Janeiro (Brazil) .. .. .	PRF5	9.600	31.25	Delhi (India) .. .. .	VUD4	11.830	25.36
Cape Town (South Africa) .. .. .	ZRL	9.606	31.23	Brentwood (U.S.A.) .. .. .	WCBX§	11.830	25.36
Panama City .. .. .	HP5J	9.610	31.22	Perth (Australia) .. .. .	VLW3	11.830	25.36
San Jose (Costa Rica) .. .. .	TIPG	9.615	31.20	Lourenco Marques (Mozambique)	CR7BF	11.835	25.35
Sydney (Australia) .. .. .	VLQ	9.615	31.20	Lisbon (Portugal) .. .. .	CSW5	11.840	25.34
Montevideo (Uruguay) .. .. .	CXA6	9.620	31.19	Lyndhurst (Australia) .. .. .	VLW7	11.840	25.34
Quebec (Canada) .. .. .	CBFX	9.630	31.15	Schenectady (U.S.A.) .. .. .	WGEA‡	11.847	25.33
Bogota (Colombia) .. .. .	HJCT	9.630	31.15	Rio de Janeiro (Brazil) .. .. .	PRF5	11.855	25.31
Chungking (China) .. .. .	XGOY	9.635	31.14	British Oversea Service .. .. .	GSE	11.860	25.30
Colonia (Uruguay) .. .. .	CXA8	9.640	31.12	Schwarzenburg (Switzerland)	HER5	11.865	25.28
Brentwood (U.S.A.) .. .. .	WCBX§	9.650	31.09	Hull (U.S.A.) .. .. .	WBOS	11.870	25.27
Vatican City .. .. .	HVJ	9.660	31.06	Sydney (Australia) .. .. .	VLQ2	11.870	25.27
Buenos Aires (Argentina) .. .. .	LRX	9.660	31.06	Sydney (Australia) .. .. .	VLQ7	11.880	25.25
Perth (Australia) .. .. .	VLW5	9.665	31.04	Kharbarovsk (U.S.S.R.) .. .. .	—	11.885	25.24
Bound Brook (U.S.A.) .. .. .	WNBI†	9.670	31.02	Bound Brook (U.S.A.) .. .. .	WNBI†	11.890	25.23
San Francisco (U.S.A.) .. .. .	KGEI	9.670	31.02	Montevideo (Uruguay) .. .. .	CXA10	11.895	25.22
Havana (Cuba) .. .. .	COCQ	9.670	31.02	Suva (Fiji) .. .. .	VPD2	11.895	25.22
Teheran (Iran) .. .. .	EQC	9.680	30.99	Moscow (U.S.S.R.) .. .. .	RNE	11.900	25.21
Mexico City .. .. .	XEQQ	9.680	30.99	Chungking (China) .. .. .	XGOY	11.900	25.21
Sydney (Australia) .. .. .	VLQ5	9.680	30.99	Moscow (U.S.S.R.) .. .. .	—	11.910	25.19
Moscow (U.S.S.R.) .. .. .	RW96	9.684	30.98	Rabat (Morocco) .. .. .	CNR2	11.940	25.13
Guatemala City .. .. .	TGWA	9.685	30.98	Brazzaville (French Eq. Africa)	FZI	11.970	25.06
British Oversea Service .. .. .	GRX	9.690	30.96	Moscow (U.S.S.R.) .. .. .	RNE	12.000	25.00
Buenos Aires (Argentina) .. .. .	LRA1	9.690	30.96	British Oversea Service .. .. .	GRV	12.040	24.92
Boston (U.S.A.) .. .. .	WRUL*	9.700	30.93	British Oversea Service .. .. .	GRF	12.095	24.80
Valparaiso (Chile) .. .. .	CB970	9.700	30.93	Algiers .. .. .	FPZ	12.110	24.77
Forte-de-France (F.W.I.) .. .. .	—	9.705	30.92	Aden .. .. .	ZNR	12.115	24.76
Lourenco Marques (Mozambique)	CR7BE	9.710	30.90	Moscow (U.S.S.R.) .. .. .	—	12.190	24.61
Chungking (China) .. .. .	XGOA	9.720	30.86	Sverdlovsk (U.S.S.R.) .. .. .	—	12.225	24.54
Moscow (U.S.S.R.) .. .. .	—	9.720	30.86	Reykjavik (Iceland) .. .. .	TFJ	12.235	24.52
Lisbon (Portugal) .. .. .	CSW7	9.740	30.80	Moscow (U.S.S.R.) .. .. .	—	12.240	24.51
Durban (Natal) .. .. .	ZRO	9.750	30.77	Quito (Ecuador) .. .. .	HCJB	12.455	24.09
New York (U.S.A.) .. .. .	WDL	9.750	30.77	Rabat (Morocco) .. .. .	CNR	12.831	23.38
Baghdad (Iraq) .. .. .	HNF	9.820	30.55	Kuibyshev (U.S.S.R.) .. .. .	—	13.010	23.06
British Oversea Service .. .. .	GRH	9.826	30.53	Moscow (U.S.S.R.) .. .. .	—	13.210	22.71
Lourenco Marques (Mozambique)	CR7BE	9.830	30.52	U.S.A. Service .. .. .	WHL6	13.442	22.32
Havana (Cuba) .. .. .	COCM	9.835	30.51	Moscow (U.S.S.R.) .. .. .	—	13.770	21.79
Moscow (U.S.S.R.) .. .. .	—	9.860	30.43	U.S.A. Service .. .. .	WDO	14.470	20.73
Aranjuez (Spain) .. .. .	EAQ	9.860	30.43	Geneva (Switzerland) .. .. .	HBJ	14.538	20.63
Sverdlovsk (U.S.S.R.) .. .. .	—	9.865	30.42	Lisbon (Portugal) .. .. .	CSW	14.600	20.55
U.S.A. Service .. .. .	WHL5	9.897	30.32	Moscow (U.S.S.R.) .. .. .	RKI	14.717	20.38
U.S.A. Service .. .. .	WRX	9.905	30.28	Moscow (U.S.S.R.) .. .. .	RKI	15.040	19.95
Vatican City .. .. .	HVJ	9.980	30.06	Teheran (Iran) .. .. .	EPB	15.100	19.87
Quito (Ecuador) .. .. .	HCJB	10.000	30.00	Vatican City .. .. .	HVJ	15.120	19.84
Kuibyshev (U.S.S.R.) .. .. .	—	10.040	29.88	Boston (U.S.A.) .. .. .	WRUL*	15.130	19.83
Cairo (Egypt) .. .. .	—	10.055	29.83	British Oversea Service .. .. .	GSF	15.140	19.82
Leopoldville (Belgian Congo) ..	OPM	10.140	29.59	Motala (Sweden) .. .. .	SBT	15.150	19.80
Rio de Janeiro (Brazil) .. .. .	PRF5	10.220	29.35	Bound Brook (U.S.A.) .. .. .	WNBI†	15.150	19.80
Belize (British Honduras) .. .. .	ZIK2	10.600	28.30	Melbourne (Australia) .. .. .	VLG7	15.160	19.79
Benguela (Angola) .. .. .	CR6RY	10.869	27.60	Mexico City .. .. .	XEWV	15.160	19.79
Lisbon (Portugal) .. .. .	CSW6	11.040	27.17	Suva (Fiji) .. .. .	VPD2	15.160	19.79
Geneva (Switzerland) .. .. .	HBO	11.402	26.31	Fortaleza (Brazil) .. .. .	PRE9	15.165	19.78
Havana (Cuba) .. .. .	COCY	11.460	26.18	Guatemala City .. .. .	TGWA	15.170	19.78
Santa Clara (Cuba) .. .. .	COHI	11.500	26.09	Moscow (U.S.S.R.) .. .. .	RW96	15.180	19.76
Moscow (U.S.S.R.) .. .. .	—	11.500	26.09	British Oversea Service .. .. .	GSO	15.180	19.76
Moscow (U.S.S.R.) .. .. .	RIC	11.640	25.77	Quebec (Canada) .. .. .	CBFZ	15.190	19.75
British Oversea Service .. .. .	GRG	11.680	25.68	Rio de Janeiro (Brazil) .. .. .	PRF5	15.190	19.75
Kuibyshev (U.S.S.R.) .. .. .	—	11.700	25.64	Bound Brook (U.S.A.) .. .. .	WNBI†	15.190	19.75
Panama City .. .. .	HP5A	11.700	25.64	Ankara (Turkey) .. .. .	TAQ	15.195	19.74
Motala (Sweden) .. .. .	SBP	11.705	25.63	Chungking (China) .. .. .	XGOX	15.200	19.74
Montreal (Canada) .. .. .	CBFY	11.705	25.63	Hull (U.S.A.) .. .. .	WBOS	15.210	19.72
Melbourne (Australia) .. .. .	VLG3	11.710	25.62	San Francisco (U.S.A.) .. .. .	KGEI	15.210	19.72
Cincinnati (U.S.A.) .. .. .	WLWO	11.710	25.62	Lisbon (Portugal) .. .. .	CSW4	15.215	19.72
Moscow (U.S.S.R.) .. .. .	—	11.710	25.62	Kharbarovsk (U.S.S.R.) .. .. .	—	15.230	19.70
Winnipeg (Canada) .. .. .	CJRX	11.720	25.60	Melbourne (Australia) .. .. .	VLG6	15.230	19.70
Rio de Janeiro (Brazil) .. .. .	PRL8	11.720	25.60	Cincinnati (U.S.A.) .. .. .	WLWO	15.250	19.67
San Francisco (U.S.A.) .. .. .	KGEI	11.730	25.58	Lourenco Marques (Mozambique)	CR7BD	15.255	19.66
Boston (U.S.A.) .. .. .	WRUL*	11.730	25.58	British Oversea Service .. .. .	GSI	15.260	19.66
Buenos Aires (Argentina) .. .. .	LRA3	11.730	25.58	Brentwood (U.S.A.) .. .. .	WCBX§	15.270	19.65
Vatican City .. .. .	HVJ	11.740	25.55	Lourenco Marques (Mozambique)	CR7BG	15.285	19.63
Santiago (Chile) .. .. .	CB1174	11.740	25.55	Delhi (India) .. .. .	VCD3	15.290	19.62
Loanda (Angola) .. .. .	CR6RC	11.740	25.55	Buenos Aires (Argentina) .. .. .	LRU	15.290	19.62
British Oversea Service .. .. .	GSD	11.750	25.53	Montevideo (Uruguay) .. .. .	CXA18	15.300	19.61
Guatemala City .. .. .	TGWA	11.760	25.51	British Oversea Service .. .. .	GSF	15.310	19.60
Lyndhurst (Australia) .. .. .	VLR8	11.760	25.51	Sydney (Australia) .. .. .	VLQ3	15.315	19.59

Station	Call Sign	Mc/s	Metres	Station	Call Sign	Mc/s	Metres
Schenectady (U.S.A.) .. .. .	WGEA†	15.330	19.57	Brentwood (U.S.A.) .. .. .	WCBX§	17.830	16.83
San Francisco (U.S.A.) .. .. .	KGEI	15.330	19.57	Rio de Janeiro (Brazil) .. .. .	PRL8	17.860	16.81
Boston (U.S.A.) .. .. .	WRUL*	15.350	19.54	Moscow (U.S.S.R.) .. .. .	—	17.910	16.75
British Oversea Service .. .. .	GRE	15.385	19.50	Lourenco Marques (Mozambique)	CR7BI	17.915	16.74
Moscow (U.S.S.R.) .. .. .	RW96	15.410	19.47	British Oversea Service .. .. .	GRQ	18.030	16.64
British Oversea Service .. .. .	GRD	15.448	19.42	British Oversea Service .. .. .	GVO	18.083	16.59
Moscow (U.S.S.R.) .. .. .	—	15.490	19.37	Geneva (Switzerland) .. .. .	HBF	18.450	16.26
New York (U.S.A.) .. .. .	WCP	15.565	19.27	Geneva (Switzerland) .. .. .	HBH	18.480	16.23
Tunis (N. Africa) .. .. .	—	15.650	19.17	Moscow (U.S.S.R.) .. .. .	—	18.540	16.18
Moscow (U.S.S.R.) .. .. .	—	15.715	19.09	Leopoldville (Belgian Congo) .. .	OPL	20.040	14.97
New York (U.S.A.) .. .. .	WCW	15.850	18.93	Boston (U.S.A.) .. .. .	WRUL*	21.460	13.98
British Oversea Service .. .. .	GRA	17.710	16.94	British Oversea Service .. .. .	GSH	21.470	13.97
Boston (U.S.A.) .. .. .	WRUL*	17.750	16.90	Schenectady (U.S.A.) .. .. .	WGEA†	21.500	13.95
Bound Brook (U.S.A.) .. .. .	WNBI†	17.780	16.87	Philadelphia (U.S.A.) .. .. .	WCAE	21.520	13.94
Hull (U.S.A.) .. .. .	WBOS	17.780	16.87	British Oversea Service .. .. .	GSJ	21.530	13.93
British Oversea Service .. .. .	GSG	17.790	16.86	Hull (U.S.A.) .. .. .	WBOS	21.540	13.93
Chungking (China) .. .. .	XGOX	17.800	16.85	British Oversea Service .. .. .	GST	21.550	13.92
Guatemala City .. .. .	TGWA	17.800	16.85	Brentwood (U.S.A.) .. .. .	WCBX§	21.570	13.91
Sydney (Australia) .. .. .	VLQ8	17.800	16.85	Schenectady (U.S.A.) .. .. .	WGEA†	21.590	13.89
Cincinnati (U.S.A.) .. .. .	WLWO	17.800	16.85	Bound Brook (U.S.A.) .. .. .	WNBI†	21.630	13.87
British Oversea Service .. .. .	GSV	17.810	16.84	British Oversea Service .. .. .	GRZ	21.640	13.86

\* These frequencies shared with WRUS and WRUW.  
 † These frequencies shared with WRCA.

§ These frequencies shared with WCRC and WCDA.  
 ‡ These frequencies shared with WGEO.

## NEWS IN ENGLISH FROM ABROAD

### REGULAR SHORT-WAVE TRANSMISSIONS

Country : Station	Mc/s	Metres	Daily Bulletins (BDST)	Country : Station	Mc/s	Metres	Daily Bulletins (BDST)
<b>America</b>				<b>French Equatorial Africa</b>			
WRUW (Boston) ..	6.040	49.67	0900	FZI (Brazzaville) ..	11.970	25.06	2145
WLWO (Cincinnati)	6.080	49.34	0700, 0800, 0900, 1000, 1100	<b>India</b>			
WBOS (Hull) ..	6.140	48.86	1000, 1100	VUD3 (Delhi) ..	7.290	41.15	0900, 1400, 1650
WCRC (Brentwood)	6.170	48.62	0700	VUD4 .. .. .	9.590	31.28	0900, 1400, 1650
WGEA (Schenectady)	6.190	48.47	0700	VUD3 .. .. .	15.290	19.62	1400
WBS .. .. .	7.355	40.79	0700, 0800, 0900, 1000	<b>Mozambique</b>			
WDJ .. .. .	7.565	39.66	0200, 0300, 0400, 0600, 0800, 0900, 1000	CR7BE (Lourenco Marques) ..	9.830	30.52	1255, 1812, 2015
WJP .. .. .	8.810	34.05	0200, 0300, 0400	<b>Switzerland</b>			
WGEO (Schenectady)	9.530	31.48	2200, 2300	HER3 (Schwarzenburg)	6.165	48.66	2150
WCBX (Brentwood)	9.650	31.09	0600, 0700	HER5 (Schwarzenburg)	11.865	25.28	2150
WNBI (Bound Brook)	9.670	31.02	0100	<b>Spain</b>			
WRUW (Boston) ..	9.700	30.93	0000, 2200	EAQ (Aranjuez) ..	9.860	30.43	1915
WDL .. .. .	9.750	30.77	1100	<b>Sweden</b>			
WHL5 .. .. .	9.897	30.32	0000, 1100, 1200	SBU (Motala) ..	9.535	31.46	2320‡
WRX .. .. .	9.905	30.28	0700, 0900, 1000	<b>Syria</b>			
WLWO (Cincinnati)	11.710	25.82	2000, 2100, 2200, 2300	Beirut .. .. .	8.035	37.34	1920
WRUL (Boston) ..	11.790	25.45	0000, 2200	<b>Turkey</b>			
WCDA (New York)	11.830	25.36	0000, 1200, 1300, 1400, 1630‡, 1830, 2200	TAP (Ankara) ..	9.465	31.70	1900
WGEA (Schenectady)	11.847	25.33	1400, 1500, 1600, 1700, 1800, 1900, 2000	<b>U.S.S.R.</b>			
WBOS (Hull) ..	11.870	25.27	1300, 2000, 2200, 2300‡	Moscow .. .. .	6.980	42.98	0000, 0035, 1340, 1800,
WHL6 .. .. .	13.442	22.32	1300, 1400, 1500, 1600, 1700, 1800, 1900, 2000, 2100, 2200		7.300	41.10	0000, 1900, 2100, 2200, 2300
WDO .. .. .	14.470	20.73	1500, 1800, 1900, 2100		7.360	40.76	0000
WBOS (Hull) ..	15.210	19.72	1500, 1800		7.560	39.88	0000
WCBX (Brentwood)	15.270	19.65	1630‡, 1830, 2200		11.830	25.36	1700
WGEO (Schenectady)	15.330	19.57	1500, 1800		12.190	24.61	0035, 0200
WRUL (Boston) ..	15.350	19.54	1200, 1300, 1400, 1500, 1600		15.230	19.70	0515, 1340
WCW (New York) ..	15.850	18.93	2000	Kharbarovsk	8.050	37.27	2130
WLWO (Cincinnati)	17.800	16.85	1600, 1700, 1800	Kuibyshev .. .. .	11.700	25.64	0700, 1500, 1545
WCRC (Brentwood)	17.830	16.83	1200, 1300, 1400, 1630‡, 1830, 2200		13.010	23.06	0700, 1500, 1545
<b>Australia</b>				<b>Vatican City</b>			
VLQ5 (Sydney) ..	9.680	30.99	0755	HVJ .. .. .	5.970	50.25	2015
VLG3 (Melbourne) ..	11.710	25.62	0755	<b>MEDIUM-WAVE TRANSMISSIONS</b>			
<b>Brazil</b>				<b>Ireland</b>			
PRL8 (Rio de Janeiro)	11.720	25.80	2130	Radio Eireann ..	565	531	1440‡, 1945, 2310
<b>China</b>							
XGOY (Chungking)	11.900	25.21	1500, 1700, 1815, 2230				

It should be noted that the times are BDST—two hours ahead of GMT.

‡ Sundays excepted.

# NEEDLE ARMATURE PICK-UP

## Design Giving Good Frequency Response and Low Amplitude

THE great improvements in the fidelity of mechanical recordings which have appeared in the past few years make it possible for the best music to be enjoyed at home under more comfortable conditions than in the average concert hall. The complete appreciation of such, however, demands the greatest absence of distortion in the acoustic output of the gramophone. It is now a relatively simple matter to make the electrical circuits of a reproducing system almost completely distortionless, and, as usual, the weak links are the loud speaker and gramophone pick-up. The writer feels that least attention has been devoted to the pick-up, although its design is in many ways simpler than that of the speaker, due to the fact that there is no question of power efficiency involved. An article<sup>1</sup> describing the design of a high-quality moving coil pick-up has been published recently in this journal, and it is the purpose of this article to show how the problem has been tackled from an entirely different angle.<sup>2</sup>

A pick-up is essentially a device for transferring the vibrations from the record groove to a moving system, and then converting these vibrations into electrical output. The first process presents the more difficult problem, as we are not able to fix the needle rigidly to the walls of the groove, but must rely on contact provided by mere pressure. The choice of the value of this downward pressure is important, as it affects the whole design of the pick-up. It depends mainly on two considerations: (1) the wear produced on the record and needle, and (2) the force required to prevent the needle from jumping out of the groove. The first is a function of the *pressure* (i.e., force per unit contact area), and the second depends on the *total downward force* on the needle point.

### Needle Contact

There are three courses open to the pick-up designer. Either we can use a soft needle such as a fibre and tolerate needle wear with consequent loss of high notes and general lack of clarity, or we can use a very hard needle such as a

## Distortion

By

G. A. HAY,  
B.Sc.

diamond point, which will give record wear but no needle wear. The third course is to use a needle of moderate hardness, such as steel, and allow mutual wear on both record and needle. This seems rather a drastic course, but a necessary corollary is to reduce the pressure at the needle point to as small a value as possible consistent with stable operation. The total downward force on the needle head is fixed by the maximum amplitude on the record groove at any given frequency, and hence to ensure a small pressure it is essential to provide the maximum contact area between needle point and groove walls and bottom. It is for this reason that the writer views with dislike the recent attempts to use a broad needle which rides on the walls of the groove, when the pressure must be very high due to the small contact area.

### Downward Force

Turning now to the force required to keep the needle in the groove, as the record groove is roughly triangular in cross-section, any sideways force produced on the needle point is also accompanied by an upward vertical component due to the inclined plane effect of the groove wall. Assuming the angle of this to be 45 degrees (an underestimate), the downward force necessary will be exactly equal to the lateral force on the needle. In practice it will be advisable to make it many times greater to ensure complete freedom from groove jumping. It has been found with the type of needle suspension discussed below that a downward force of about ten grams is entirely adequate for all modern recordings. Actually, adjustment is provided by the movement of a counterweight.

The mass of the pick-up and arm depends on (a) this downward force, (b) the lateral force exerted by the needle on the body of the

pick-up, and (c) the possible mechanical resonances of the pick-up as a whole. Factor (a) would seem to indicate an optimum mass of pick-up head equal to the required downward force on the record surface. This, of course, would result in an extremely light pick-up. Factors (b) and (c), however, indicate that a rather different course should be pursued. In the first place, a sideways force on the needle due to the record groove will first tend to move the needle sideways, and then the whole body of the pick-up. If the mass of the latter is small, then the total resultant angular motion of the needle relative to the body of the pick-up will be reduced by the sideways motion of the arm as a whole. This effect in any practical case will be small, but it can still be further minimised by making the tone arm and head relatively heavy, and counterbalancing by means of a weight. Secondly, the whole bass characteristic of the pick-up depends on its mass, and if we are to avoid a pronounced resonance in the audible bass region we must make the instrument relatively heavy. This point will be elaborated later. The only disadvantage, so far as the writer knows, of a heavy counterbalanced pick-up was pointed out by Mr. Brierley,<sup>1</sup> that of difficulty in following the groove in the case of a badly warped record. Against this may be set the writer's experience, and that of others,<sup>3</sup> that it requires a very badly warped record to cause groove jumping, and this is likely to be unsatisfactory for other reasons.

### Mechanical Resonances

The mechanical resonances present in a pick-up affect its performance considerably. Such resonances are harmful, not only because they give rise to a large increase in electrical output at the resonant frequency, but also because the increased amplitude of needle movement causes excessive record wear where notes of the resonant frequency occur. This causes distortion of all other notes existing on the record at that point. There are three possible modes of vibration of a conventional pick-

### Needle Armature Pick-up—

up,<sup>4</sup> (1) the so-called bass resonance, due to the whole instrument vibrating about the tone arm pivot, controlled by the elasticity of the needle in its suspension; (2) the torsional vibration of the pick-up head about the axis of the tone arm, controlled in the same way; (3) the treble resonance, caused by the vibration of the needle system about its axis, controlled by the needle suspension and stiffness of the needle itself.

### False Bass

The bass resonance affects the trend of the lower part of the curve materially. Modern recordings have a falling characteristic below 250 c/s to about 14 db. down at 50 c/s. It has been the custom in the past to compensate for this by placing the bass resonance at about 50 c/s, giving a false increase in output, and hence a more or less complementary lift in the bass. Not only does this increase record wear, but the increased amplitude of needle vibration is liable in certain circumstances to cause bad amplitude distortion. The alternative course is to aim at a flat response and correct for the recording electrically in the amplifier. It is impracticable completely to eliminate the bass resonance, and the method of placing it at 15-20 c/s results in the output being well maintained at 50 c/s. No record wear is caused, as frequencies of 15-50 c/s are not recorded. This requires a heavy pick-up and light damping of the needle, the latter also greatly reducing the tendency towards groove jumping.

The torsional resonance is relatively unimportant, as its effect is inaudible and only measurable if a gliding tone record is used. It will, however, cause record wear, and for this reason it is advisable to reduce it in magnitude as far as possible. The most satisfactory method of doing this, which the writer believes is original, is to make the tone arm axis as near as possible to the surface of the record. This reduces the moment of torsional forces due to the elasticity of the arm about the needle point, and in practice a peak and trough not more than 1 db. high are obtained. With the tone arm about 1 in. above the record surface, this peak was 10 db. high, and other irregu-

larities appeared below the resonant frequency, which had a value of about 250 c/s.

The treble resonance is the most troublesome of all. In the average commercial moving iron pick-up it appears between 2,000 and 3,000 c/s, and causes record wear, excessive and unnatural brilliance, and excessive scratch due to the shock excitation of the needle resonance by the random surface irregularities.<sup>5</sup> There are two methods of driving this up beyond the audible range; either the stiffness of suspension can be increased or the armature mass reduced. We have already decided that a free suspension is desirable, and so we must choose the second alternative. The limit is reached when the armature is formed by the needle itself—the so-called needle armature pick-up. By adopting this construction it has been found possible to make the treble resonance of the

fit the groove closely and also act as armature, should be of small dimensions and mass, and consist of a suitable magnetic material. It should be suspended in a magnetic field by a fairly light but well-damped suspension, and the clearance between needle and pole pieces must be relatively large to reduce amplitude distortion. The tone arm should be as near to the record surface as possible to reduce the forces tending to stimulate torsional resonance.

### Design Details

The design shown in Fig. 1 has been found to cover the above requirements, and to give remarkably good reproduction. The magnetic field is provided by an "Eclipse" horseshoe magnet which is roughly 1 in. in diameter and  $\frac{3}{8}$  in. thick. Any reasonably small magnet taken from an old pick-up will serve the same purpose,

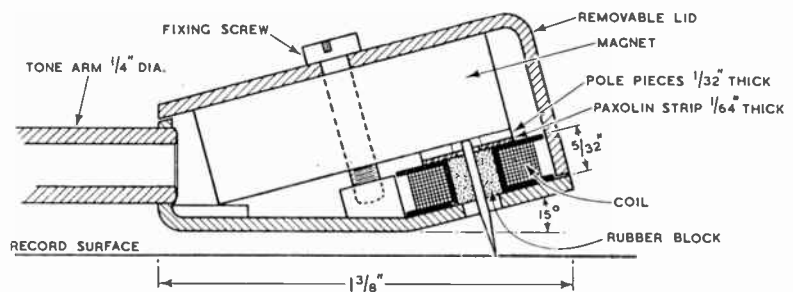

Fig. 1. Lay-out and approximate dimensions of pick-up.

order of 15,000 c/s, at which frequency it does no harm.

Finally, the pivoting arrangements must be considered. In order to reduce record wear on the sides of the groove, it is essential that the pivots should be of the highest quality, both laterally and vertically, and in practice ball bearings are necessary. Moreover, the turntable must be dead level to reduce any tendency for the pick-up to swing and press against one wall of the groove more than the other.

Turning now to the final design, the following is a brief summary of the requirements. The pick-up as a whole should be relatively heavy, pivoted very lightly, the bearings being exactly horizontal and vertical, and counterbalanced to reduce the downward force on the needle point to about ten grams. The needle, which should

although the dimensions of the case will have to be adjusted to suit. The pole pieces and coil form one unit, the former being cut out of  $\frac{1}{2}$  in. Stalloy transformer laminations to the shape shown in Fig. 2. These pieces are cemented on to a paxolin supporting piece, which has a hole cut in the middle to clear the needle. This piece is cemented in turn to the coil, which in the writer's model was removed from an old B.T.H. Minor pick-up. Suitable data are given in Fig. 2 for a similar coil if this has to be wound.

The needle is embedded in a rubber block, being held in place merely by the friction between the needle and rubber. Originally an interchangeable unit was used, the whole unit, rubber and all, being removed when changing the needle. This was subsequently found to be unnecessary, and the latest model

consists of a permanently fixed rubber block into which needles are pushed, being held by a pair of fine-nosed pliers. When inserting the needle for the first time into the block, it is essential to take the greatest care to place the needle centrally between the pole pieces, or amplitude distortion will

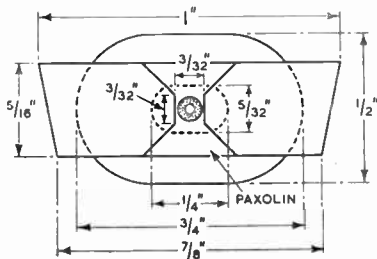

Fig. 2. Details of pole pieces and coil. The coil has approximately 3,000 turns of 47 SWG enamelled wire.

result. Subsequent insertions will follow the original hole if reasonable care be taken.

The needles originally used were the H.M.V. Silent Stylus miniature type, but the Columbia Type 99 are exactly equivalent. The type of rubber has naturally a big effect on the response, and it has been found that the rubber used in pencil erasers is the most suitable. In the writer's experience there is little deterioration in high note response after fifty 12in. playings on heavy orchestral records, and this probably represents a good compromise between quality and economy. The rubber block will eventually need renewal, but this will certainly not be necessary more than once a year with fairly constant use.

The pole pieces are not fixed to the magnet poles, but are merely held down by magnetic attraction. In addition, the bolting down of the cover on top of the magnet clamps the whole assembly together and down to the base-plate. The tone arm consists of a  $\frac{1}{4}$ in. diameter brass tube, soldered into the brass pick-up case, and bent horizontally to give correct tracking. The use of a longer arm than usual is beneficial in reducing the angle of inclination of the pick-up to the tone arm axis, and thus reducing the overhang of the needle point over the turntable axis at the centre of the record. With a tone arm  $11\frac{1}{2}$ in. long, the pick-up must

be inclined to the tone arm axis at an angle of 18 deg., and the needle must be  $\frac{1}{2}$ in. in advance of the record centre: the tracking error is then about  $1\frac{1}{2}$  degrees.<sup>6</sup>

The trailing angle of the needle is important. The cutting stylus used in recording is vertical, and it is reasonable to suppose that best results would be obtained with a vertical reproducing needle. Actually, the best compromise between high note response and scratch seems to be obtained with an angle of about 15 degrees from the vertical.

The pivoting arrangements in the writer's present instrument are not satisfactory. They consist of inferior ball races as fitted to medium quality pick-ups, and a relatively big force is required to move the pick-up sideways. It is particularly important that the vertical movement should be free, as the heavy counterweight imposes a relatively large downward force on this pivot. Connection to the coil is made by means of a single cotton-covered stranded flex, to give freedom of movement. The earthy end of the coil is connected to the metal frame of the instrument. The case is built up of  $\frac{1}{8}$ in. brass sheet, bent and soldered, this in conjunction with the magnet giving a satisfactorily large mass. The counterweight was cast in one-half of an aluminium container in which 35 mm. Leica films were sold: it is merely a tight push fit on a brass rod forming a back extension of the tone arm, enabling small adjustments to be easily made.

### Hum

Due to the all-metal construction of the case, troubles from electrostatic pick-up are negligible. There is a certain amount of magnetic hum pick-up from power transformers, however, and, although not noticeable during playing on account of the low sensitivity and the high gain needed, this is rather troublesome to get rid of completely. Experiments with hum-bucking coils have not so far proved successful in reducing this to zero, but screening with Mumetal would probably be effective.

The response curve given by the author's pick-up is shown in Fig. 3. This is the actual output from a Decca EXP55 test record corrected below 250 c/s for the constant amplitude characteristic. The region

between 6,000 and 8,000 c/s and the torsional resonance were deduced from an H.M.V. gliding tone record, DB4037. The average output from normal orchestral records is of the order of 10 mV RMS. Although measurements above 8,000 c/s were impossible, it is believed that the treble resonance lies at about 15,000 c/s, and being used in conjunction with a speaker with an excellent top response, gives rise to excessive scratch. It has been found that most recordings are improved by a gradually falling characteristic in the treble, and this greatly reduces the effect of the treble resonance. In addition, full compensation in the bass is required, for which suitable circuits and data have been given from time to time in this journal.<sup>7</sup>

In use, the pick-up gives a high degree of fidelity. Top response, as judged by the upper strings, is excellent, while double basses and organ pedal notes are reproduced at correct pitch, instead of an octave higher. A musical, but non-technical friend, who is also an organist, has discovered pedal notes

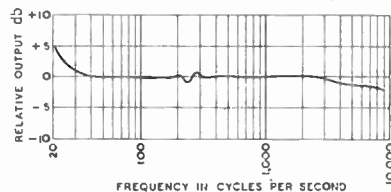

Fig. 3. Response curve of finished pick-up taken with HMV DB4037 and Decca EXP55 and corrected for recording characteristic. Zero db corresponds to about 15 mV.

on organ records which he has never heard before using a crystal pick-up. Due to the large gap, audible harmonic distortion is entirely absent.

There is only one fault: bad records do really sound awful. Perhaps this is not such a disadvantage, after all?

### References to "Wireless World" Articles

- <sup>1</sup> "A Moving Coil Pick-up," J. Brierley, July 1942.
- <sup>2</sup> Correspondence, G. A. Hay, September 1942.
- <sup>3</sup> Correspondence, J. H. Mole, August 1942.
- <sup>4</sup> "Getting the Best from Records," P. G. A. H. Voigt, March 1940.
- <sup>5</sup> "Gramophone Record Scratch," M. G. Scroggie, November 1939.
- <sup>6</sup> "Pick-up Alignment," E. A. Chamberlain, March 26th 1930.
- <sup>7</sup> "An Electric Gramophone," M. G. Scroggie, May 11th and July 27th 1939.

# Frequency Modulation—V

## DEMODULATION: THEORY OF THE DISCRIMINATOR

**T**HERE are a number of circuits for demodulating an FM transmission, some have a small distortion factor, others may be simple to line up or offer a high efficiency; each has its own merits. There is, however, one arrangement that has become so popular in America that it can for all practical purposes be regarded as the standard frequency-modulation discrimination. It was first introduced as a method of developing the control voltage required by receivers incorporating AFC<sup>1,2</sup>.

The discriminator circuit shown in Fig. 1 is almost exclusively used in the modern FM receiver. It represents a very satisfactory compromise, combining as it does, high efficiency and production stability.

The circuit arrangement is such that the waveform applied to the two diodes produces voltages across the loads R<sub>1</sub> and R<sub>2</sub>, which tend to cancel each other out. When the signal applied to both diodes is equal there will be zero voltage across the output. If, however, the signal applied to D<sub>1</sub> is larger than that applied to D<sub>2</sub> then the voltage across R<sub>1</sub> will be larger than that across R<sub>2</sub>. This will result in a positive voltage across the output terminals. If the voltage applied to D<sub>2</sub> is the larger then the output will be negative.

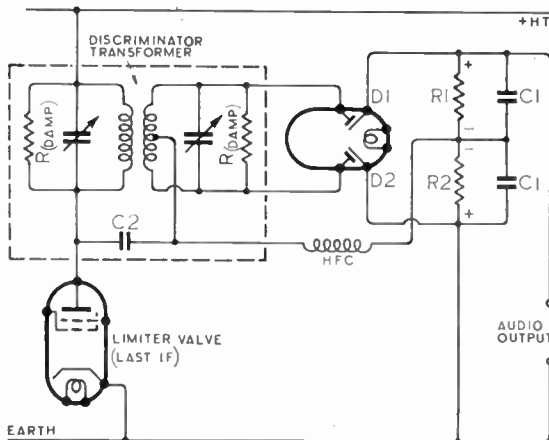

Fig. 1. Type of discriminator circuit used in modern American frequency-modulation receivers.

A graphical method of demonstrating the effect of variations in circuit constants is used to explain the principles underlying the design of the discriminator circuit now in general use.

By **CHRISTOPHER TIBBS,**  
A.M.I.E.E.

Before it is possible to discuss the means by which the voltage applied to the two diodes is to vary with frequency, it is necessary for one to investigate some of the fundamental properties of a parallel

Fig. 2. Universal frequency/phase angle curve for a parallel tuned circuit. It will be noted that there is a substantially linear relation between frequency and phase, provided the band  $\pm 40$  to  $\pm 45$  degrees is not exceeded.

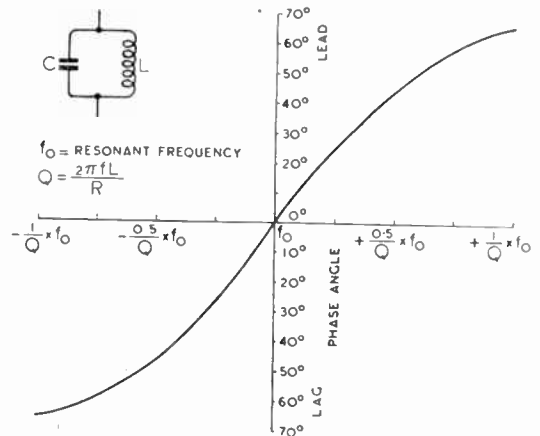

Fig. 2 shows this change of phase angle plotted against a frequency base which is expressed in terms of the circuit Q. By expressing the frequency in this way it is possible to apply the curve to any resonant frequency or circuit Q. This curve is in fact the universal phase angle curve for all parallel tuned circuits.

The first important point to note is that this phase angle curve is not strictly linear anywhere; but that the departure from straight-

tuned circuit. Below resonance the inductive arm has the lower impedance, while at frequencies above resonance it is the capacity which has the lower, and therefore controlling impedance. In short, at frequencies below resonance the circuit is inductive and above it is capacitive. The conditions existing result in a gradual change of phase angle from lagging to leading as the frequency is increased, the actual change-over taking place at the circuit's resonant frequency.

ness is fairly small if the band used does not exceed  $\pm 40$  to  $\pm 45$  deg. The second point, is that the frequency band occupied by any given phase change is directly dependent on the circuit Q. If, as an example, the resonant frequency is taken as 5 Mc/s and the circuit Q as 25, then the working range of the phase angle curve (i.e.  $\pm 45$  deg.) will correspond to a frequency change of approxi-

mately  $\pm \frac{0.5}{Q} \times 5 \text{ Mc/s} = \pm 100$  kc/s. Similarly if the Q is increased to 50 then a phase change of  $\pm 45$  deg. will take place when the frequency is modulated over  $\pm 50$  kc/s.

Having briefly considered the phase shift occurring in a parallel tuned circuit, it is possible to return to the functioning of the discriminator proper. The whole



basis of its operation is the phase change which results from the modulation of the incoming carrier above and below the frequency to which the discriminator transformer is tuned. The detail functioning will be explained with the aid of two examples. The first case is that for no frequency modulation and the second that for maximum frequency modulation.

The conditions existing in the discriminator transformer when there is no frequency modulation are shown in Fig. 3. Diagram (a) emphasises the fact that at resonance the only phase shift between primary and secondary voltages results from the 90 deg. lag due to the mutual inductive coupling. The actual voltages applied to the diodes are shown in Fig. 3(b).

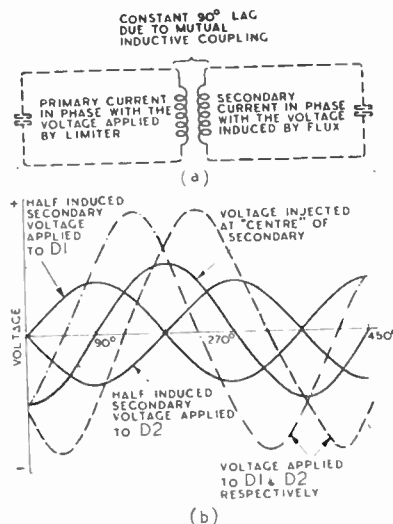

Fig. 3. (a) Phase shift conditions existing in the discriminator transformer at resonance. The total lag between the primary, and the induced secondary voltage is 90 degrees. (b) Induced voltages applied to the two diodes, and voltage injected at the centre of the secondary winding. The addition of this 90-degree leading voltage produces an exactly equal increase on both diodes.

Referred to the centre tap, half the induced secondary voltage is fed as a positive signal to one diode, while the other half is applied as a negative signal to the second diode.

Due to the 90 deg. lag between the primary and the secondary, the voltage injected through C2 (Fig. 1), to the secondary centre tap, will be 90 deg. in advance of the secondary induced voltage. The phase relations of the injected and induced secondary voltages are

shown in Fig. 3(b). The vector addition of these signals forms the actual voltage applied to the diodes and is indicated by the dotted waveforms. As a result of applying these equal voltages to both

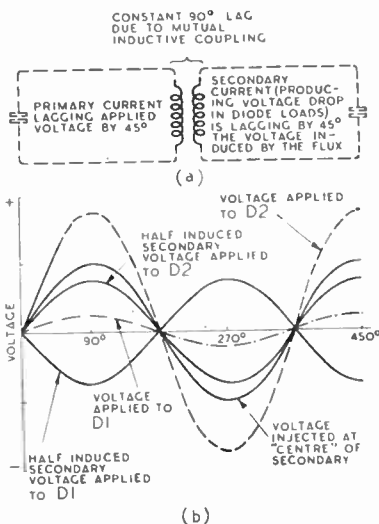

Fig. 4. (a) Showing the phase shift conditions existing in the discriminator transformer when passing a carrier frequency of  $-\frac{0.5}{Q} \times f_0$  (see Fig. 2).

There is a total lag of 180 degrees between the applied primary voltage resulting from the induced secondary current. (b) Addition of the induced voltage and the injected voltage produce a far larger signal on D2 than on D1.

diodes, there are equal but opposing voltages across the two loads (R1 and R2). The total voltage across the discriminator output terminals is therefore zero. To sum up, a carrier having a frequency the same as that to which the discriminator is tuned, produces zero output voltage.

The second example assumes the condition existing at a maximum frequency modulation. This frequency is assumed to be that which will produce a phase lag of 45 deg. between the voltage and current in a parallel tuned circuit.

With the aid of Fig. 2 it has earlier been shown that such a phase lag is produced by a carrier  $\frac{0.5}{Q} \times f_0$

below the circuit resonant frequency. One of the previous examples given shows that with an IF of 5 Mc/s and a Q of 25 this frequency will be -100 kc/s.

Fig. 4(a) shows that under the above conditions there is a phase lag of 180 deg. between the applied primary voltage and the induced secondary voltage. This lag takes place in three steps. In the primary of the discriminator transformer, the "flux producing current" will lag the applied voltage by 45 deg. To this must be added the constant 90 deg. lag due to the mutual inductive coupling. In the secondary, the current (which in flowing through the diode loads produces the output voltage), is lagging 45 deg. behind the voltage "applied" by the flux. Adding up these three component phase shifts there is a total lag of 180 deg. between the primary voltage applied by the last IF valve (the limiter) and the induced secondary voltage.

The voltage conditions existing at maximum frequency modulation as the result of this lag are shown in Fig. 4(b). Again the centre-tapped secondary results in half the induced voltage being applied as positive to one diode, and half as negative to the other. The total voltages applied to D1 and D2 are shown by the dotted curves.

The application of a large signal

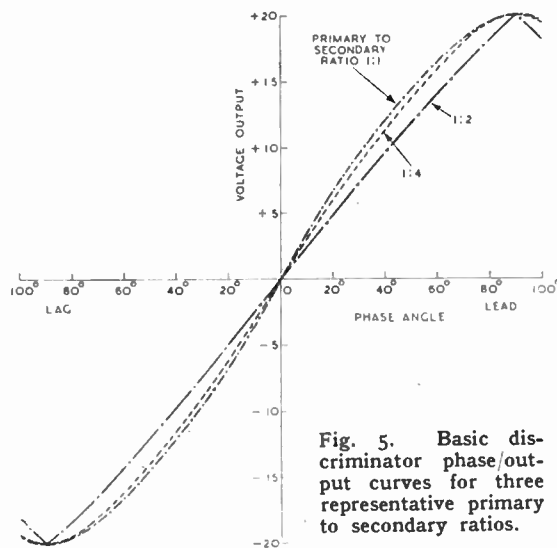

Fig. 5. Basic discriminator phase/output curves for three representative primary to secondary ratios.

**Frequency Modulation.—V**

to D<sub>2</sub> and a small one to D<sub>1</sub> results in the voltage across R<sub>2</sub> being large while that across R<sub>1</sub> is positive and correspondingly small. The output is therefore built up of a small positive voltage across R<sub>1</sub>,

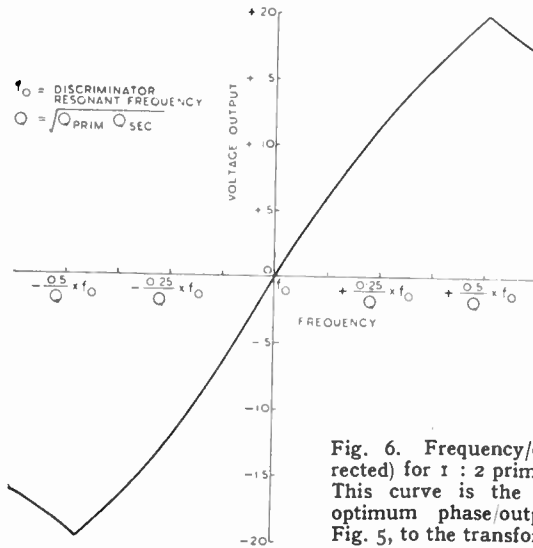

Fig. 6. Frequency/output curve (uncorrected) for 1 : 2 primary to secondary ratio. This curve is the result of adding the optimum phase/output curve shown in Fig. 5, to the transformer's frequency/phase curve.

which is swamped by the large negative voltage across R<sub>2</sub>.

Conversely an increase in frequency will produce a positive output voltage. The overall frequency to output voltage curve of the discriminator is shown in Fig. 8.

In order to make clear the effect which circuit variations have on the performance of the discriminator, it has been broken down into its three main controlling factors. These factors in order of their importance are: (1) the mean tuned circuit Q; (2) the ratio of primary to secondary voltage (determined by the primary-to-secondary turns ratio); (3) the transformer selectivity curve (as determined by its coupling).

The series of curves which follow demonstrate the contribution made by each of these factors to the overall characteristic.

**Transformer Turns Ratio**

The three curves drawn in Fig. 5 show the discriminator voltage output plotted against the phase difference between the injected and induced secondary voltages. These curves form the basis of the discriminator characteristic; they show the actual relation between phase shift and output voltage. The first is that obtained with equal primary and secondary sig-

nals; it will be noted that this curve and that calculated for a 1 : 4 step-up ratio both depart widely from the ideal straight line response. The third, that for an equal primary and half secondary voltage, approaches very close to the ideal. By employing this turns ratio minimum correction will be required to produce an overall linear characteristic. It can therefore be stated that the optimum primary to secondary turns ratio is that which produces the same voltage across the primary as across

to output curve (Fig. 5) with the transformer's frequency-change to phase-change curve. As the phase shifts of the primary and secondary are directly additive, this curve has the same shape as the universal phase angle curve shown in Fig. 2. The only alteration is that the phase shift scale has now to be multiplied by two. That portion of the universal phase shift curve between 0 and ± 45 deg. (with its scale doubled to read 0 to 90 deg.) is therefore added to the optimum phase change to output curve (Fig. 5). The result, which takes the form of the uncorrected discriminator frequency to output curve is shown in Fig. 6.

It should be noted at this point that the shape of the frequency-to-phase angle curve (Fig. 2) is not materially altered by any reasonable changes in transformer coupling. The 90 deg. lag mentioned earlier, between primary and secondary, is added to a further 90 deg. lag between the energy transferred back from the secondary to the primary. This reflected energy balances out part of the primary energy and in so doing produces the familiar double humped response curve. It does not, however, greatly affect the shape of the frequency to phase change curve for either primary or secondary.

As pointed out earlier the circuit Q controls the frequency band over which any given change of phase angle occurs. The value of Q selected should therefore be such that a ± 40 deg. phase change occupies a frequency band comfortably in excess of the FM swing it is desired to demodulate. This

the half secondary (i.e., an approximate ratio of 1 : 2 between the primary and full secondary turns).

It should be noted that fairly good results can be obtained with any reasonable turns ratio. If, however, a ratio of other than 1 : 2 is used the extra correction which has to be provided by other discriminator variables is larger than it need be. The amount by which the response is liable to vary throughout a production run is therefore unnecessarily increased.

**Effect of Q**

The curve shown in Fig. 6 combines the optimum phase-change

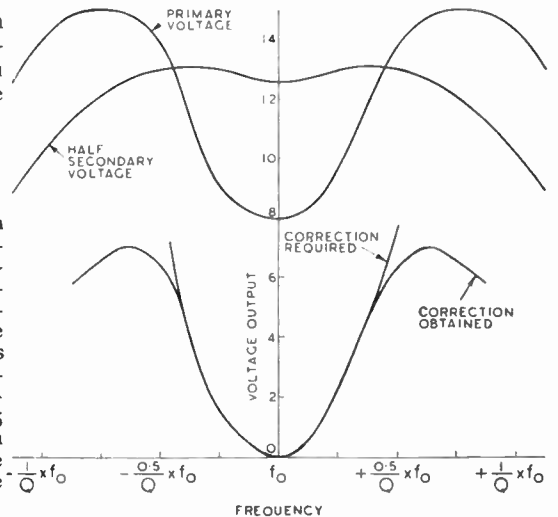

Fig. 7. Correction curve giving the voltage necessary to correct for the non-linearity of the basic frequency/output curve shown in Fig. 6. This compensation is obtained with a transformer coupling 1.5 times critical which gives the double humped response curves shown.

is necessary in order to cover slight mistuning and transmitter over-modulation.

**Effect of Coupling**

There is only one further variable to be taken into account before the final characteristic can be drawn. The curves so far developed have

it is possible to provide almost exactly the correction voltage required. The curves shown in Fig. 7 for primary and secondary response are obtained with a coefficient of coupling which is 1.5 times critical. Unlike the normal IF transformer the most important curve is that of the primary.

Although the secondary curve shows some double humping it is the primary which is the more important. The correction provided by the combined primary and half secondary response curves is also shown in Fig. 7. The closeness

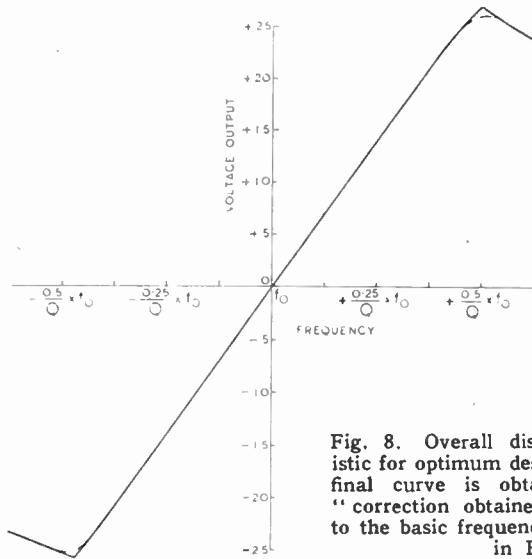

Fig. 8. Overall discriminator characteristic for optimum design throughout. This final curve is obtained by adding the "correction obtained" shown in Fig. 7, to the basic frequency/output curve shown in Fig. 6.

all assumed a constant input voltage over the frequency band. While it is unnecessary to consider the IF response proper, as it is blanketed by the limiter stage, it is very necessary to take into account the response of the discriminator transformer itself. This remark should not be taken to mean that the IF response is unimportant. The amplitude changes caused by a bad IF response will not directly affect the output voltage, but the phase changes which accompany them may wreck the receiver performance.

As the basic frequency to output curve (Fig. 6) invariably departs from the limiter characteristic required, the discriminator transformer "amplitude" response, which so far has not been considered, must be made to provide the necessary correction. This is obtained by producing a double-humped response curve. In practice, therefore, the discriminator transformer is always overcoupled.

The frequency to output curve shown in Fig. 6 is some 20 to 25 per cent. down on a strictly linear output. The actual error over the frequency band is shown in the form of a "correction required" curve in Fig. 7. By overcoupling

with which it corresponds to the correction required should be noted.

**Overall Characteristic**

The overall discriminator characteristic for optimum design throughout is shown in Fig. 8. This curve is produced by the addition of the "correction obtained" curve in Fig. 7 to the frequency to output curve shown in Fig. 6. It should be noted that the strictly linear part of the curve extends over a band corresponding to approximately  $\pm 40$  degrees phase shift on the universal phase angle curve shown in Fig. 2. The windings must therefore be resistance damped to bring their Q down so that a  $\pm 40$  deg. phase shift occurs over the frequency band occupied by the maximum FM swing it is desired to demodulate.

All the features exhibited in this optimum curve have previously been shown in various characteristics published from time to time. There have, however, been very few curves published which demonstrate an optimum design. Such curves will in practice have slightly rounded extremities as shown by the dotted lines in Fig. 8.

The condenser C<sub>2</sub>, the RF choke and R<sub>1</sub> and R<sub>2</sub> are all uncritical.

The maximum output voltage from the discriminator is almost double that supplied by the limiter stage. In practice it is between 20 and 60 volts, depending on the operating conditions of the limiter valve. This large discriminator output undoubtedly reduces the difficulties normally encountered in the audio amplifier, and at the same time it materially assists in securing the high fidelity reproduction which is one of the main claims made for FM.

**BIBLIOGRAPHY**

1. "Automatic Frequency Control," by D. E. Foster and S. W. Seeley. *Proc. I.R.E.*, March 1937.
2. "Theory of the Discriminator Circuit for AFC," by H. Roder. *Proc. I.R.E.*, May 1938
3. "FM Receivers," by Marvin Hobbs. *Electronics*, August 1940.
4. "A Receiver for Frequency Modulation," by J. R. Day. *Electronics*, June 1939.
5. "Frequency Modulation: Part 6—FM Reception," by K. R. Sturley. *Electronic Engineering*, April 1942.

**MISUSE OF VALVES**

*Code of Practice for the Guidance of Inexperienced Designers*

WITH the growing use of valves in heavy engineering equipment and other "non-radio" applications, cases of failure are being reported from causes which could have been avoided if the responsible designer had realised that valves are not always miraculous fool-proof devices. Many are highly individualistic types whose idiosyncrasies must be studied and allowed for if the valves are to function reliably and without fuss.

To help newcomers to avoid the grosser errors which might result in valve failure, the British Radio Valve Manufacturers' Association has drawn up a code of practice covering such points as method of mounting, provision of ventilation, heater voltage regulation, heater-cathode insulation, control, screen and suppressor grid voltages and their method of application. Although most of the precautions indicated will be observed as a matter of course by radio designers, some may be new and there are a number of details, such as heater-cathode potential difference, maximum glass temperatures and permissible percentage heater voltage variation, the values of which may have slipped the memory.

The British Standards Institution has endorsed the code as a War Emergency British Standard and has issued it in the form of a leaflet (B.S.1106:1943) which may be obtained from the B.S.I., 28, Victoria Street, London, S.W.1, and for which a charge of 1s. is made.

# Electromagnetic Fields in Radio—IV.

## STATIONARY WAVES AND VELOCITIES OF TRAVEL

THROUGHOUT these articles we have been developing the single principle that radio transmission can be understood in terms of an electric field and a magnetic field mutually generating each other: the condition that they should do so emerged from experiments with electron beams, interpreted through a vector notation, and was summed up in a simplified treatment of Maxwell's equations. This condition required the two fields to move together with a unique velocity which is also the ratio between electrostatic and electromagnetic systems of measurement.

Two practical questions obviously call for attention: first, what proof is there that free-space radio transmission has this velocity which was theoretically related to a system of units?; second, what happens if the waves are confined to an enclosed region, or are "tied" to a conductor such as an aerial? The two questions are closely related, since the velocity of "travelling" waves can be inferred from measurements upon "stationary" waves. The modern use of the latter in UHF resonators, as well as the need to understand aerials and transmission lines, makes the turning of our previous "free-space" waves into "stationary waves by reflection" an urgent necessity.

**Nodes and Antinodes at the Reflection of a Wave.**—When a radio experimenter is ordered to confine his radiation within the interior of a closed building to avoid interfering with outside receivers, what happens to his travelling fields? Are they absorbed by, or are they reflected from, the walls? One possibility is seen when his deliberate shielding confines his moving electric and magnetic vectors to the interior of a box which becomes a region filled with "stationary waves": for very short waves, not more than a metre in length, the "box" may fit the wave pattern precisely and become the "closed resonator" which dominates modern UHF technique.

By

MARTIN JOHNSON,  
D.Sc.

An intermediate instance occurs in the coaxial feeders of short-wave sets, where the fields are confined in all directions but the far end at which they are allowed to emerge. An ordinary aerial is in this sense an unscreened transmission line, and may be the seat of a system of stationary waves.

Quantitative tracing of all these possibilities involves solving Maxwell's equations with particular "boundary conditions," that is to say, with conditions inserted to denote what happens to our E and H vectors at a discontinuity between air and metal or between one dielectric and another. Since we showed that Maxwell's equations can be solved in terms of a wave mechanism, we shall be able to see how travelling waves give rise to stationary waves by imagining how the amplitude of an E wave or an H wave behaves at any such boundary.

Suppose, then, that the radio wave, in which electric field vector E and magnetic field vector H are mutually perpendicular, strikes a copper plate across its track. Very little energy penetrates and most is reflected; but, since the conductor cannot maintain a large difference of potential along its low resistance face, the wave pattern adjusts itself so that E becomes zero at the metal surface. Now a property which we emphasised in the moving wave was that E and H are in phase, the maxima of each of them occurring at the same distance measured along the direction of travel. We therefore find a first distinction between stationary waves formed in front of a reflecting surface and the freely travelling waves in space: in the former E and H have lost their phase agreement. For the low resistance along the face of the conducting barrier, which made E zero there, makes this into a place of maximum

current flow, and hence maximum amplitude in the H accompanying the current. The places in the wave pattern where amplitudes are zero are called nodes, and the places of maximum amplitude are the antinodes. This terminology is the same also for sound waves and other mechanical periodic patterns.

Before illustrating in Fig. 1 the way nodes of E fit antinodes of H instead of agreeing in phase, for stationary waves, let us return to the equations of simple waves derived from the foundations of such ideas in the preceding article: slight modification of these will serve to show the phase change and also why the pattern has become stationary instead of progressive.

### Forward and Backward Waves.

By picturing the generation of vibrations from circular motion we showed that the pattern of any vectorial quantity such as E or H was represented along a distance  $x$

by an amplitude equal to  $r \sin \frac{2\pi x}{\lambda}$

at any instant, and that a similar diagram represented the pattern at a given spot changing as time goes on, the corresponding function

being  $r \sin \frac{2\pi t}{T}$ . Here  $\lambda$  is a wave-

length, T is time for completion of a whole cycle, and  $r$  is the maximum amplitude of the vibration. Since we are concerned with what happens at distances in front of a reflecting plate, we take positive values of  $x$  as measured outwards from the plate. The wave approaching the latter is therefore moving in the direction of *diminishing*  $x$ . After time  $t$ ,  $x$  must be replaced by  $x + vt$  in the wave expression, since the shape of the wave remains constant when its description is transferred to a new reference point at  $x = -vt$ . Since distance  $\lambda$  is covered in time T, the velocity  $v$  is  $\lambda/T$ . The wave approaching the plate is

therefore  $r \sin \frac{2\pi}{\lambda} \left( x + \frac{\lambda}{T} t \right)$  or  $r \sin 2\pi \left( \frac{x}{\lambda} + \frac{t}{T} \right)$ . Travel in the opposite

direction, or  $r \sin 2\pi\left(\frac{x}{\lambda} - \frac{t}{T}\right)$  gives the other wave returning towards increasing  $x$  if the plate is neither transparent nor absorbing, but reflects the energy back to where it came from. The resulting pattern in front of the plate is the sum of these, and the two sines compound into the following product of the separate  $x$  and  $t$  terms

$$2r \sin\left(\frac{2\pi x}{\lambda}\right) \cos\left(\frac{2\pi t}{T}\right).$$

Whether or not one is familiar with the purely mathematical steps which turn such an addition into a product, the detail exhibited in this last expression for the amplitude of combined advancing and receding waves is worth noticing, for it shows that at any point at given distance the vibration goes through a complete sequence of values periodically as time goes on, repeating whenever  $t$  becomes a multiple of  $T$ . But only at certain places (the antinodes) is the full amplitude reached. Indeed at some other places (nodes) it remains permanently zero. Since a sine is zero for angles  $0, \pi, 2\pi, 3\pi$ , etc., but is unity for angles  $\frac{\pi}{2}, \frac{3\pi}{2}, \frac{5\pi}{2}$ , etc., whereas a cosine is zero for  $\frac{\pi}{2}, \frac{3\pi}{2}$ , etc., and unity for  $0, \pi$ , etc., we

see that our expression for the compounded pattern is justifiably "stationary," the maxima and minima occurring at fixed values of  $x$  and there being no longer any forward or backward travel. Yet the advancing and receding waves do not neutralise one another, and oscillation still occurs, but "on the spot" instead of "progressively in space." Inserting the above zeros of the sines and cosines, nodes are

found at  $x=0, x=\frac{\lambda}{2}$ , etc., and antinodes at  $x=\frac{\lambda}{4}, x=\frac{3\lambda}{4}$ , etc.

This detailed picture is suited to express the behaviour of the E vector, since the metal boundary insisted that no electric intensity could be maintained there. But H has its maximum at the same spot, so in all our H expressions sines are to be replaced by cosines and vice versa, giving the stationary waves of magnetic flux as

$$2r \cos\left(\frac{2\pi x}{\lambda}\right) \sin\left(\frac{2\pi t}{T}\right).$$

This agrees with our earlier remark that the electric and magnetic fields fall out of phase by a quarter period when stationary waves are formed by the reflection. Current

nodes therefore occur at  $x=\frac{\lambda}{4}$ , etc., and current antinodes at  $x=0$ , etc.

Fig. 1 (a) shows five instantaneous "snaps" of the electric field in such a stationary system produced by reflection at the left-hand edge of the diagram, the instants being at  $0, \frac{1}{8}$  cycle,  $\frac{1}{4}$  cycle,  $\frac{3}{8}$  cycle,  $\frac{1}{2}$  cycle, while Fig. 1 (b) shows the state of the magnetic field at the same instants. It must be remembered, of course, that while any flat picture represents E and H in the same plane, one of them must actually be vibrating perpendicularly to the diagram.

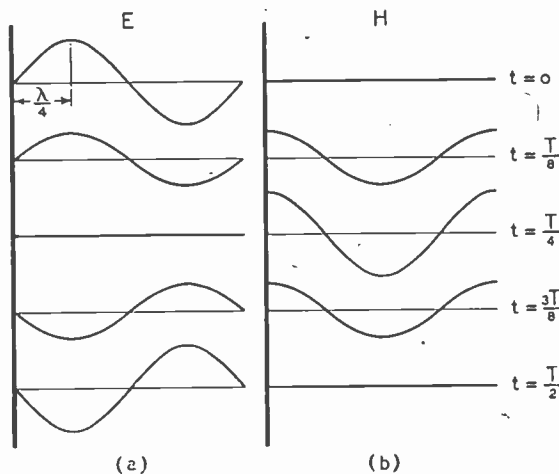

author in an earlier *Wireless World* series, an aerial as a "transmission line" has an impedance whose matching or mismatching controls the reflections at its ends and hence

Fig. 1. Instantaneous diagrams of the way in which the amplitude of stationary waves varies with distance from a metallic reflector situated at the left-hand edge of each curve.

**Waves on Aerials.**—Instead of travelling in free space until the obstacle is met, a wave may be "guided" along a conductor, as in the previous article illustrating the lines of force terminating perpendicularly to a perfect conductor and being distorted along an imperfect one. A fresh kind of discontinuity then arises when the end of this guide is reached. Reflection of the wave again occurs, but at such an insulating termination an electric intensity can be maintained, but the current flow must be zero. Hence this "open" point of reflection will show a node in H and an antinode in E, whereas previously we found the "closed" or "short-circuit" barrier showed a node in E and an antinode in H.

Apart from this exchange in phasing, stationary waves of the pattern already illustrated can occur along a conductor such as an

aerial just as they occur in front of a conducting barrier. The latter is obviously a plane mirror, but the optical analogy for the aerial is not so simple.

At the grounded end of an aerial the situation may again tend to the E node and current antinode, according to the nature of the earth and its reflecting power and the aerial's length as a fraction or multiple of wavelength. Useful analogy can be drawn from the stationary waves of sound, for instance, in organ pipes; perhaps enough has here been said for the reader to recognise in such and in conventional antenna diagrams the features of phase separation and stationary pattern for which we have been deriving detailed explanation. As discussed by the

stationary waves set up on it; but to digress here into how stationary waves decide when an aerial is a good radiator and when a transmission line is a good feeder would be to trespass from field theory into circuit theory.

**Velocity Measurement from Stationary Waves.**—We began this article by demanding proof that our theory connecting speed of travelling waves with the ratio of units "c" was confirmed in practice. A pattern of stationary waves such as we have been discussing gives excellent material for velocity measurement, although it does not travel at all. For there is a universal relation in all wave motion, mechanical or electrical, connecting velocity of travel  $v$ , frequency  $n$  cycles per unit time, and  $\lambda$  the wavelength, such that  $v=n\lambda$ . Hence if a pattern of

**Electromagnetic Fields—**

stationary radio waves, preferably of very short  $\lambda$ , is made to form between two reflector plates and the frequency measured by any electrical meter device, it only becomes necessary to obtain  $\lambda$  in order to infer the velocity with which free waves would travel in that particular medium. This is done by locating antinodes of the E vector, for instance, by the glow of a neon lamp; we showed earlier that these antinodes occur at  $\frac{\lambda}{4}$ ,  $\frac{3\lambda}{4}$ ,  $\frac{5\lambda}{4}$ , etc., so that their separation gives the size of  $\frac{1}{2}\lambda$ .

**Velocity Measurement from Travelling Waves.—**

By different adaptations of the method just described, radio velocity in air has been inferred by many, from Hertz, the earliest "spark" worker, who gave  $3 \times 10^{10}$  cm. per sec., to a recent user of accurate valve generators who claims the greater precision  $2.9978 \times 10^{10}$ . It would satisfy our enjoyment of direct proof to confirm by actual speed measurement instead of relying on frequency and wavelength; but this speed (about 186,000 miles per second) is such that extremely fast shutters are required to interrupt the beam. We want apparatus compact enough to be mechanically movable at comparable speeds, so wavelengths far less than a millimetre are needed to be accurately confined and controlled by such. So we measure the velocity of light, remembering that light and radio waves are precisely similar electromagnetic phenomena differing only in their wavelength and frequency, not their velocity in empty space. It is relevant here to remind ourselves of the range of these wavelengths along the whole electromagnetic spectrum; in radio we descend from thousands of metres to a few centimetres, and certain experimental waves even shorter overlap the heat radiation spectrum which extends from below a millimetre to regions approaching the wavelengths of visible light, say  $7 \times 10^{-5}$  cm. at which the red end of the visible spectrum becomes detectable by eye. We cannot "see" beyond about  $4 \times 10^{-5}$  cm., and the waves pass into the ultra-violet to which photo plates and photo-cells and certain biological structures are sensitive. Between  $10^{-6}$  and  $10^{-7}$  cm. the properties of electromagnetic waves pass into

the X-ray region, and finally at about  $10^{-9}$  cm. into the rays from radium and the cosmic rays which appear to come from nuclear atomic reactions in distant parts of the universe. There seem conclusive reasons for thinking that "c" is the velocity of all these, so that the easiest to measure, visible light, affords the most accurate refinement in deciding on this universal natural constant, whether obtained by astronomical observation of Jupiter's satellites, for instance, or by some laboratory method.

ture is controlled by a micrometer screw. For the image to be visible with a given setting of the micrometer, either the octagonal reflector must be stationary or must be rotating at exactly the speed required for the light after its 44-mile journey to catch the next face of the rotating octagon, or the one beyond, in an orientation accurately in the same line as if the original face had remained stationary. The slightest alteration in speed brings imperfect parallelism at the instant light returns, and the

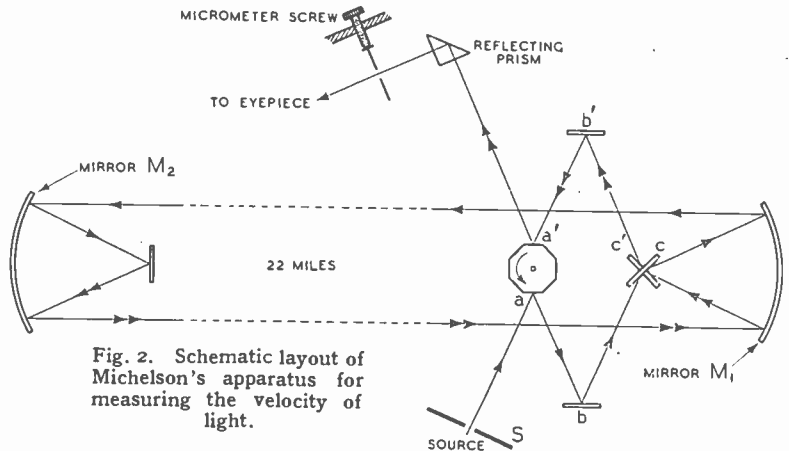

Fig. 2. Schematic layout of Michelson's apparatus for measuring the velocity of light.

We proceed to give one example of the latter. The essence of most such experiments is to revolve a reflector or a toothed wheel, whose serrations form an intermittent "cut-off" or shutter, fast enough for light returning from a measurable distance to find the neighbourhood of its origin altered since setting out, and therefore a shift of focus to be an indication of speed.

In an example of such general procedure, consider Michelson's apparatus of 1926 (Fig. 2). Light from an illuminated slit S is reflected from one face of an octagonal mirror rotating at about 500 revs. per second, and is then reflected at b and c and the large concave mirror M, of 30 feet focus and 2 feet aperture. The light travels thereafter in a parallel beam to another station 22 miles away, whence another concave mirror M<sub>2</sub> and a small flat reflector return it back to M<sub>1</sub>. We have indicated by arrows the track of one possible ray only. This is ultimately sent by c' and b' to a', a face of the octagon parallel to the original a, and is observed as an image of the slit S in an eyepiece in front of which a movable ap-

erture needs adjustment to catch the deviated ray. Using the utmost refinement of distance measurement and of the speed of rotation (by means akin to the standardisation of radio frequencies) hundreds of experiments gave "c" as between  $2.99756$  and  $2.99796 \times 10^{10}$ , after correction, since  $0.00067$  in these figures is accounted for by the difference between air and vacuum or free space travel.

**"c" as Ratio of Electromagnetic and Electrostatic Units.**—At the very beginning of these articles on fields we showed that if the electric and magnetic effects moved together at all they could only travel with a speed equal to the ratio between the two ways of detecting electricity, that derived from a force which appears magnetic and that derived from a force which appears electrostatic. Hence if any quantity be measured accurately in these two kinds of unit, there ought to emerge a ratio giving numerically the speed of radio waves, or some close connection such as the square of "c." A simple example has been to measure *electromagnetically* the charge on a

condenser whose capacity in *electrostatic* units is accurately calculable.

This latter, which we denote by  $C_e$ , can be computed as  $kA/4\pi d$ , where A is area of plates,  $k$  dielectric constant, and  $d$  the separation between plates. A cylindrical condenser with guard-rings to avoid "edge errors" is perhaps the best to use. To determine  $C_m$ , on the other hand, the capacity in electro magnetic units, recollect that a quantity of charge (which is the capacity multiplied by the voltage) can be estimated through the sudden kick  $\theta$  of a ballistic (or impulse-recording) galvanometer. If the strength of the field magnet of this instrument is  $H$ , the area of its coil A, its natural period of swing T, the discharge of the condenser through it after applying voltage V

$$\text{gives } C_m V = \frac{GT}{2\pi AH} \theta, \text{ in which G is}$$

a constant depending on the calibration of the particular galvanometer. This may be fixed by observing the steady deflection  $\theta_1$  when a fraction of V, say  $V/n$ , drives a current through a high resistance R, so that  $G\theta_1 = \frac{AHV}{nR}$

$$\text{Hence } C_m = \frac{T}{2\pi nR} \frac{\theta}{\theta_1}. \text{ The earliest}$$

determination of  $C_e/C_m$ , which, since capacity involves a square of fundamental quantities, involves the square of "c," yielded a velocity  $2.905 \times 10^{10}$ . A more recent measurement with modern refinements gave 2.90781. Agreement with the various velocities we have quoted is so close that the identification of radio speed with ratio of units becomes sure.

**Group Velocity, Phase Velocity and "c" as Limit to all Speeds.**—

We commented in the previous article on the wide significance of "c" as a velocity of all "free space" radiation, and as a limiting speed which the fastest "material bodies" ( $\beta$ -ray electrons from radium) can only approach but never exceed or even equal. This natural constant is so remarkable a feature of electrical phenomena that we make no apology for having stressed its derivation and measurement in greater detail than is customary among its daily utilisers in radio; it is, in some way not yet understood, a basic property of our ability to make any scientific or technical measurements at all,

since all signals and information whatever are limited to this speed, including sight.

Our next problem is the diminution of this velocity when any material is substituted for the free space. We already met this in correcting velocity from air to vacuum standards. In the dielectrics of our condensers, or in the

terms, and some phase velocity characterises each of those components. The group velocity gives the speed of the point at which all the waves reinforce each other, and the speed at which the characteristic shape of the resulting group must travel. In empty space, and very nearly so in air, all the velocities in electromagnetism are

the same "c," but where mechanical or electrical waves move through denser material it is by no means impossible for a medium to impose conditions in which the phase velocity of the sine components may fall below that of the group. This happens in certain fluids

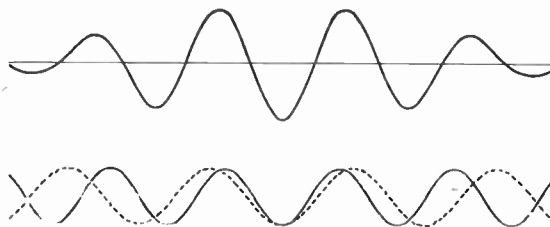

Fig. 3. Analysis of a wave group into two sine waves of slightly differing wavelength. If their speeds are not identical, the group centred at the point where the two reinforce each other will travel at a speed differing from that of either wave.

ionosphere, or in a RF coil exhibiting the "skin effect" the retardation of electromagnetic waves becomes of great practical importance.

Before starting on this problem it will be worth mentioning briefly the source of various objections to "c" as limit, commonly raised by any enquiring mind faced with this apparently arbitrary barrier to indefinite speeds. Most of these objections refer only to our possibility of imagining higher speeds which would, however, not possess the property we associated with the Poynting vector, that of carrying energy. For example, imagine ourselves swinging a radio beam which reached from here to the stars—the distant end could swing as rapidly as we please if it were far enough away, since the linear velocity at the tip of a rotating radius is proportional to the length of that radius. But the Poynting flux of energy would still be only along the beam and limited to "c" in that direction.

Again, a "group" velocity may either exceed or be exceeded by a "phase" velocity, and it is only the former that carries the energy in radio and is what we actually measure in the velocity experiments. In any "dispersive" material, that is to say one where a mixture of wavelengths have differing speeds imposed on them by the material itself, the total disturbance may be regarded as made up of many superposed sine

and in some vibrating metal specimens. On the other hand, in watching ripple crests on a pond emerging behind and dying out in front of an advancing group we see the group velocity less than that of the individual waves.

Fig. 3 shows the simplest case of a group analysed into two sine waves only, of differing wavelength. If their speeds are not quite the same, the point of reinforcement will travel differently from either wave. For electromagnetic waves we have no means whatever of observing the separate waves, so the practical velocity is always that of the group, the reception of energy being in every case what we detect and measure in obtaining the constant "c" or its diminished magnitude in various materials.

**"AMPLITUDE MODULATION UP TO DATE"**

It has been pointed out that in the above article in our March issue the impression may have been given that extended positive-peak operation was one of the advantages given by cathode modulation. Actually, the remarks on extended positive-peak operation, starting p. 656, col. 2, "It is also claimed that by its use . . ." apply to normal anode modulation, though the principle could be adapted to give a higher normal idling efficiency in a grid- or cathode-modulated stage.

The misunderstanding has arisen as the result of condensing the original text in preparing it for the printer.

# WORLD OF WIRELESS

## WHY "E" AND "F" LAYERS?

SIR EDWARD APPLETON'S lecture on the "Exploration of the Ionosphere" before the Wireless Section of the Institution of Electrical Engineers on April 7th was a masterly exposition of progress during the past eleven years in this particular field of research. As Sir Stanley Angwin remarked, "He made the language of the physicist understandable by the engineer."

Sir Edward stated that he had recently received a letter from Dr. Dellinger, the American physicist, asking what was the reason for labelling the layers of the ionosphere "E" and "F." To this he had replied that when he discovered the E layer he gave it this designation, as it left other letters below, as well as above, for the labelling of further discoveries!

## RATIONALISED RADIO

REPRESENTATIVES of six of the leading radio manufacturers recently paid a three-day visit to a training centre of Royal Signals, with a view to rationalising the radio requirements of the Army. For manufacturers personally to investigate the Army's requirements is an innovation; previously the Army's needs have been investigated mainly by experts of the Ministry of Supply, and their findings conveyed to the manufacturers.

The long-term policy is to reduce the number of types of sets used in the Army, while covering the extended range of requirements. This will mean a considerable reduction in the number of spares carried by a unit.

It is learned from the Ministry of Supply that close co-operation exists between technicians in this country and in the United States and Canada "with a view ultimately to the rationalisation of production on an inter-Allied basis."

## SETS AND COMPONENTS

OF the 125,000 receivers which were in process of manufacture in April, 1942, 65,000 had been made available by December 31st. This fact was recently made known by the President of the Board of Trade in reply to a question in the House of Commons.

He also stated that there were 125,090 sets in process of manufacture on January 1st this year, and he hoped these would be completed and released at the same rate as last year.

Asked whether he would make valves and spare parts for receivers more easily available, Mr. Dalton stated that in addition to the imports of valves from America the production of valves in this country for civilian sets was very considerable.

As regards components, the principal difficulty had been with electrolytic condensers, but steps have already been taken to increase the production of these.

## R.M.A. REPORT

PROVISIONAL specifications and circuit diagrams for a battery and a mains utility set have been prepared by the Radio Manufacturers' Association in consultation with the B.B.C. The sets call for the minimum of materials in short supply, and utilise valves and components in common production for the Services. These facts are revealed in the recently published annual report of the R.M.A., from which it is also learned that "it has been no part of the policy of the R.M.A. to press for civilian radio production. A decision as to the necessity and extent of manufacture for civilian purposes can only be made by the Government."

Civilian receiver sales for last year are reported to be 20,795 for export (value £178,598) and 107,317 for home use (value £1,226,887).



S. R. Mullard, M.B.E., M.I.E.E., the new president of the R.M.A.

The difficulties of the retail trade in handling receiver repairs is dealt with in the report. An enquiry in February, 1942, revealed that 10 per cent. of the country's 8,600,000 odd licensed receivers were not in use; half of these were awaiting repair, the other half being short of some part which was not likely to be available in the near future. Some 240,000 repairs were being accepted each month by the 4,000 retailers from whom these details were received. The repairs were being undertaken by 3,260 skilled and 2,160 semi-skilled employees.

The shortage of components and accessories is stated to have been a considerable impediment in the execution of repairs, but was not considered to be the major cause.

## RADIO OFFICERS HONOURED

THE enterprise, skill, and perseverance of the First Radio Officer of a torpedoed merchant vessel in restoring to working order the life-boat's oil-covered transmitter resulted in the securing of assistance and the rescue of forty-two persons.

For his outstanding resource and energy throughout, First Radio Officer Arthur M. Arthurs was made a Member of the Order of the British Empire.

Lloyd's War Medal for bravery at sea was recently awarded to Chief Radio Officer G. W. Jennings, who, when his ship was torpedoed and set on fire and so badly damaged that she was abandoned, remained in the wireless cabin to the last to make certain that his distress signals had been received.

Twenty-four hours after being landed Mr. Jennings heard that another ship needed a Chief Radio Officer and at once volunteered.

## AIRCRAFT RADIO OFFICERS

AN agreement has recently been concluded between British Overseas Airways Corporation and the Radio Officers' Union regarding the terms and conditions of service of radio officers employed by the Corporation.

The standard annual rates of basic pay to Third Radio Officers is £300, for Second Radio Officers from £325 to £450, and for First Radio Officers from £450 to £550. Annual increments at the rate of £25 are payable to Second and First Radio Officers until the maximum salary appropriate to the grade is attained.

Officers employed in connection with flights or services operating between the United Kingdom and countries outside Europe, or whilst posted to a base outside the United Kingdom, receive additional overseas pay. If engaged on trans-oceanic routes between the Americas and Africa or Europe, additional trans-oceanic pay at the following annual rates will be received: Third Officer £150. Second Officer £175. First Officer £200.

Uniform is provided by the Corporation.

## THE LATE R. W. PAUL

WE record, with regret, the death of Robert William Paul, the well-known electrical instrument maker, at the age of 73. He started business as an instrument maker in Hatton Garden, London, in 1891. His firm amalgamated with the Cambridge Scientific Instrument Company in 1919, under the title of the Cambridge and Paul Instrument Company, now the Cambridge Instrument Company. Mr. Paul was a



member of the I.E.E., and a past vice-president of the Physical Society. In 1938 he was awarded the Duddell medal.

His name will always be associated with the unipivot galvanometer which he produced in 1903. Older readers of *Wireless World* will recall that Mr. Paul was also interested in the development of loud speakers and contributed to the pages of this journal on the subject. He was also one of the pioneers of cinematography, having developed in 1895 a method of projecting moving pictures.

Mr. Paul's versatility is further demonstrated by his production, in collaboration with the late Sir William Bragg, of the Bragg-Paul pulsator, to aid breathing in cases of respiratory paralysis.

**DF PIONEER**

**N**EWs has recently been received of the death in January of Dr. Ettore Bellini, who, in collaboration with Commandant A. Tosi, produced the Bellini-Tosi system of direction finding. The system, which employs fixed aerials in conjunction with a goniometer having a rotating search coil, was widely used in the Marconi Company's DF gear. Bellini, who was an electrical engineer in the Italian Navy, filed a patent as long ago as 1907 for "sense" finding, or the avoidance of 180-degree ambiguity.

**"MUSIC WHILE YOU WORK"**

**T**HE Court of Appeal has upheld the recent decision of Mr. Justice Bennett that the relaying of music to factory workers is a public performance and constitutes an infringement of the rights of the Performing Right Society in any broadcast music of which the Society holds the copyright.

Licences for the relaying of music in factories, whether provided by gramophone records or the B.B.C.'s broadcast transmissions, must be obtained from the Society. The fee is calculated at the rate of 1d. per worker per annum for an hour's music a day.

The fact that the B.B.C. has a comprehensive fee for its transmissions of music does not alter the situation. Its licence is "for domestic and private use only."

**BRIT. I.R.E. HOUSE-WARMING**

**T**HE new headquarters of the British Institution of Radio Engineers, 9, Bedford Square, London, W.C.1, were officially opened on March 30th. The guests, among whom were included many prominent personalities in the world of wireless, were received by the president, Sir Louis Sterling. After outlining the aims and objects of the Institution the general secretary, Graham D. Clifford, spoke of the possibilities of extending its activities to cover all English-speaking countries.

**B.B.C. SHORT-WAVE NETWORKS**

**R**ECENT changes in the schedules of the B.B.C.'s short-wave transmissions makes this an opportune moment to give some details of the organisation of the various Services.

There are two main Divisions responsible for the transmissions radiated to countries overseas; these are the Overseas and Empire Services. Each of these Services is sub-divided, for programme purposes, into coloured "networks," which have been defined as "an association of a particular suite of studios, a variable group of transmitters, and the chain of equipment and telephone lines connecting the two."

Three networks carry the programmes of the Oversea Service to the Empire and to English-speaking peoples overseas. These are:—

**Red Network:** Broadcasts in English to the Empire and to the U.S.A.

**Green Network:** Broadcasts in English to the British Forces overseas and also broadcasts in Empire and Far-Eastern tongues.

**Purple Network:** At present limited to broadcasts in Afrikaans.

The European Service is divided into four networks—brown, blue, yellow, and grey—each of which is directed to a specified group of countries.

While the present issue of *Wireless World* is current, the following schedule of the times (BDST) of the B.B.C.'s short-wave transmissions of news in English and the wavelengths on which these are radiated will be operative.

0306:	25.68,	30.53,	31.32,	48.43,	49.10.
0445:	25.68,	30.53,	30.96,	31.32,	41.96, 42.13,
					42.46, 48.43.
0630:	25.68,	30.53,	30.96,	31.32,	42.13, 48.43,
					49.10.
0815:	19.82,	25.53,	25.68,	30.53,	31.25, 31.55,
					42.13.
0930:	16.84,	19.50,	19.82,	25.53,	25.68, 30.53,
					31.55, 42.13.
1000:	30.96,	31.25,	31.32,	31.75,	31.88, 41.01,
					41.75, 41.96, 49.42, 49.59.
1300 & 1500:	13.97,	16.64,	16.79,	16.84,	19.42,
					19.50, 19.82, 25.53, 25.68.
1700:	13.97,	16.64,	16.79,	16.84,	19.42, 19.82,
					25.68, 31.55.
1800:	16.59,	16.64,	16.84,	19.50,	19.66, 25.53,
					25.68.
2000:	16.84,	19.50,	19.66,	25.29,	25.53.
2245:	19.66,	25.53,	25.68,	30.96,	31.25, 31.88,
					41.49, 49.92.
2345*:	25.53,	25.68,	30.53,	31.32.	

\*Sundays excepted.

The Morse transmissions of news in English, German, and French are now radiated at 0230, 0300, and 0330 (BDST) respectively in the 49-metre band.

**TEACHING RADIO**

**T**HE aim of the Convention of University Radio Teachers, opened by Sir Stafford Cripps, Chairman of the Radio Board, on April 10th, was to give those present, by direct contact with members of the Services, a better idea of the tasks their students will have to perform when their training is complete.

Sir Stafford stated that "We were met with a clear insufficiency of scientific personnel when this great expansion of the manufacture and use of wireless took place." He referred

**OF OUR ABILITIES AND FACILITIES WE GIVE GLADLY**



PARAMOUNT above all else is the necessity of meeting urgent and immediate demands for the production of cherished liberty.

Astatic's engineering and manufacturing facilities are first, therefore at the disposal of Allied Governments.

Astatic will be ready to serve you again with high quality piezo-electric devices when the "All Clear" of Victory sounds.

Register your name with our Representative for your future benefit.



THE ASTATIC CORPORATION  
YOUNGSTOWN, OHIO, U.S.A.  
TORONTO, CANADA.

Exclusively Represented by  
**Frank Heaver Ltd.** Kingsley Road, Bideford, N. Devon



**VARIABLE CONDENSERS — DRIVES — AUTOMATIC TUNERS**

THE manufacture of precision products by the volume production assembly line method is a speciality of the General Instruments Corporation. Radio receiver set manufacturers are more than familiar with General Instruments variable condensers, automatic tuners and precision drives. Although domestic set production has ceased for the time being, the time is rapidly approaching when it will once again be possible to proceed with this production. General Instruments will have new ideas based on the latest scientific research to offer the radio manufacturing industry.

Always remember General Instruments **VARIABLE CONDENSERS — DRIVES — AUTOMATIC TUNERS**

Register your name with our Representative now. He will forward you information on our products as soon as they become available.

**THE GENERAL INSTRUMENT CORPORATION**  
**ELIZABETH, N.J., U.S.A.**

Exclusively Represented by  
**Frank Heaver Ltd.** Kingsley Road, Bideford, N. Devon

**The World of Wireless—**

to the distinguished work in organising the recruiting and training of personnel done by the Wireless Personnel Committee of the Radio Board.

He paid tribute to the work of the technical colleges in training very large numbers of radio mechanics for the Services, and to the Universities for the training of the more highly skilled scientists, officers, research workers and development engineers.

In conclusion, Sir Stafford laid considerable stress on the need for the scientist and technician to be prepared to tackle post-war problems.

**MAGNETIC MATERIALS**

**A**N informal discussion on "Modern Magnetic Materials" was opened jointly by G. A. V. Sowter, B.Sc., M.I.E.E., and A. J. Tyrrell, A.M.I.E.E., at the meeting of the British Institution of Radio Engineers on March 26th. This discussion was in place of the previously announced paper on "Selective Methods in Radio Reception."

Mr. Sowter described a new alloy which, while possessing excellent magnetic properties, was composed entirely of non-magnetic materials. A permanent magnet "pot" just over an inch in diameter was exhibited, for which it was claimed that a speaker fitted with it would handle an output of two watts.

**I.R.E. MEDAL OF HONOUR**

**F**OR his achievement in the development of modern electronics, including its application to radio-telephony, and for his contribution to the welfare and work of the [American] Institute of Radio Engineers," Dr. William Wilson has been awarded the I.R.E. Medal of Honour.

After periods of research in electronic physics at Manchester, Cambridge, Giessen and Toronto Universities, he undertook research work in

industry, and since 1914 has been with the Western Electric Company and the Bell Telephone Laboratories.

Dr. Wilson was born in Preston in 1887 and received his D.Sc. degree from Manchester University in 1913.

**CHANTING MORSE**

**A**T.S. trainees for the latest branch of Royal Signals to be opened to them—that of Operator Wireless and Line (OWLS)—are taught morse by a system of chanting—"dit dah, A." They do not see a printed morse symbol, their training being entirely oral.

To simulate actual working conditions, trainees are grouped in networks of three "stations" for practice handling of traffic. By means of a test board an overseer can listen to the operators' key work and can cut in on "phone" to correct any shortcomings. Their technical training is very elementary, as they are not expected to undertake more than external running repairs to sets in their charge.

**HIRE PURCHASE**

**T**HE Hire Purchase (Control) Order, referred to in the March issue, by which the hire purchase of receivers was prohibited, has now been superseded. By a new Order, the Hire Purchase and Credit Sale Agreements (Control) Order, new receivers of the domestic or portable type and hearing aids are now obtainable by hire purchase.

**PAUSING FOR BREATH**

**W**HEN addressing the Radio Industries Club, C. O. Stanley, O.B.E., suggested that broadcast receiver manufacturers should, for a few months after the war, produce their pre-war models unchanged. This would give them an opportunity to take stock and plan new productions in the light of existing post-war conditions.

**IN BRIEF**

**French Licence Fees.**—Increased licence fees for wireless receivers were introduced in France early this year. The new fees are 25 francs for crystal sets and 175 francs for all other receivers intended for home use. Where sets are installed in halls or other public assembly places the fee is 350 francs. If a charge is made for admission to the hall the fee is doubled.

**Rationing Receivers.**—Vouchers are now required by Nazis for the purchase of receivers. It is learned from the *U.I.R. Bulletin* that purchase vouchers are granted only for the needs of the Army and civilians who are victims of the war or meet with accidents during their war work.

**Radiolocation Pioneer Honoured.**—The honorary degree of Doctor of Laws is to be conferred on Sir Robert Watson Watt, pioneer of radiolocation, by the University of St. Andrews.

**Royal Engineers.**—Although the third wartime reunion of the Royal Engineers' Wireless Association, 1914/1918, held at Newbury, Berkshire, on March 13th was only in "skeleton form" owing to the various restrictions, it was a considerable success. Capt. H. de A. Donisthorpe, the vice-president, was in the chair.

**R.M.A.**—At the first meeting of the newly elected Council of the Radio Manufacturers' Association, F. B. Duncan, joint general manager of Marconiphone, was appointed chairman, and E. J. Power, managing director of Murphy, vice-chairman.

**Institution of Electrical Engineers.**—The Wireless Section of the Institution of Electrical Engineers is holding its next meeting at 5.30 on Wednesday, May 5th, when a paper on "The Frequency Synthesiser" will be given by H. J. Finden. The last meeting of the Session will be on May 11th at 5.30, when an informal discussion on "Factors Determining the Choice of Carrier Frequencies for an Improved Television System" will be opened by B. J. Edwards.

**Brit. I.R.E.**—The date of the April meeting of the British Institution of Radio Engineers has been changed to Friday, April 30th, at 6.30. It is learned that the Institution has been elected to full membership of the Parliamentary and Scientific Committee.

**Quartz Crystals.**—The Minister of Supply has appointed a Controller of Quartz Crystals. All communications relating to the supply of quartz crystals should be addressed to the Controller, R. L. Prain, Portland House, Tothill Street, S.W.1. Telephone: Abbey 7788.

**Resignation.**—We are informed that L. J. Mold has resigned his directorship of Taylor Electrical Instruments.

**In the advertisement of C.B. Engineering Company, X.L. Works, Robin Hood Gate, Kingston Vale, S.W.15, which appeared in our April issue, the district was incorrectly given as S.W.19.**

**The Minister of Supply** recently stated that the public had responded magnificently to appeals for salvage in the past, but still more waste paper was needed for essential war purposes; otherwise the needs of everyday life would inevitably be still further curtailed.



**REPAIR AND MAINTENANCE** of transmitters and receivers under Service conditions in the desert are simulated for the personnel of the Royal Armoured Corps on arrival in Egypt.

## Letters to the Editor

# Expansion and Distortion • Future of Broadcasting • Transitron Modifications

### Contrast Expansion

I HAVE read with considerable interest the correspondence in your columns on contrast expansion and, while heartily supporting the plea for automatic compression at the transmitting or recording end, I must agree with Mr. J. Moir (your March issue) that contrast expansion used with manually controlled orchestral broadcasts and recording is a really worth-while measure, if only for the marked reduction in background noise.

I cannot, however, agree with Messrs. Hughes (January issue) and Moir that contrast expansion must either degrade transient response or increase amplitude distortion of low audio-frequencies. This conclusion is based on the assumption that the "pick-up" and "decline" delays are equal, as is the case with the majority of contrast expansion units, and in my opinion is at the root of the unsatisfactory results experienced by so many people. With this type of equipment the time delays cannot be reduced below about 0.1 second without introducing amplitude distortion, and with this delay transient response is poor, and a reduction in realism results from the loss of the echo at the end of loud passages due to the rapid fall in gain, giving a flat, lifeless performance.

In my own equipment the pick-up and decline delays are adjusted to about 0.02 second and 2 seconds respectively, by shunting the resistance in the resistance-capacitance delay circuit with a diode. The delay times are controllable within quite wide limits by suitable choice of component values. It might be thought that a decline delay of 2 seconds would be excessive, but it gives the advantages that "flutter" does not occur during loud staccato passages, and that reverberations are faithfully reproduced. I have not yet heard any musical performance which was adversely affected by this delay.

The results are much superior to those which I obtained with the more normal type of contrast expansion unit, no deterioration in transients or increase in amplitude distortion being audible. Care

must be taken to ensure that the low-frequency "thump" generated by the rapid change in gain of the expansion unit is reduced below audibility, but this is not difficult, and should not cause trouble unless a large amount of bass boost is used in the amplifier. It is preferable on this account to arrange that the tone controls precede the expansion unit, the amplifier having a falling characteristic below 100 c/s, this being equalised by the tone control.

In my experience an expansion of only 15-20 db. is required to transform a performance lacking in vigour into one which has all the punch of Toscanini, but an adequate reserve of output must be available for best results.

DAVID T. N. WILLIAMSON.  
Edinburgh.

### Post-war Broadcasting

AT the British Association conference on "Science and the Citizen" (March 20th-21st), the session on "Radio and the Cinema," which was nominally concerned with the distribution of scientific knowledge through these two media, did in fact cover the whole field of the future of broadcasting. Perhaps this is not surprising when Sir Allen Powell (Chairman of the B.B.C. Board of Governors) was presiding, and Sir Robert Watson Watt was the first speaker, but it would be a pity if, because it was not a technical meeting, technicians overlooked the suggestions made there on technical as well as general policy.

Sir Robert Watson Watt said the listener needed four freedoms: (1) Freedom from interference, (2) freedom from distortion, (3) freedom of choice, (4) freedom from distraction. The first depends on design of equipment; on atmospheric, which can be combated by choice of wavelength; and on man-made static which is a social rather than a technical problem. The second depends on band-width and circuit design. The third requires a large increase in the number of channels, which would be a reversal of the present policy of sacrificing aesthetic values to the economic coverage of wide areas. Coupled with

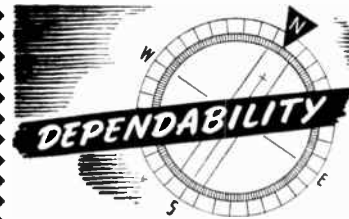

THE Crowe organisation is known to radio manufacturers throughout the world for dependable service and excellent quality of its many products.

Now devoted exclusively to production for Victory, with some items assisting directly in your Country's great efforts, we look forward to the time when our expanded facilities will be available for continuing our pleasant relationship with the British Radio manufacturing industry.

## CROWE

### RADIO COMPONENTS

ESCUTCHEONS • TUNING CONTROLS  
DIALS • REMOTE CONTROLS  
POINTERS, ETC.

Crowe Name Plate & Manufacturing Co.

3701 Ravenswood Avenue  
CHICAGO, ILL., U.S.A.

Exclusively Represented in Great Britain by  
Frank Heaver Ltd. Kingsley Road,  
Bideford, N. Devon

## RAYTHEON

It is typically American to accomplish yesterday's impossibilities to-day. Raytheon research laboratory to-day and every day is delving into seemingly impossible Radio Electronic Tube problems... and solving them in an incredible space of time.

This unending scientific research carried on at Raytheon to aid the armed forces during the present conflict will, when we are one more on a peacetime basis, give Raytheon tubes the advantage of these newly-developed electronic principles. Your new Raytheons will be the product of the latest scientific research.

### WORLD'S LARGEST EXCLUSIVE TUBE MANUFACTURERS

Register your name with our Representative now for your future benefit.

RAYTHEON  
PRODUCTION CORPORATION  
NEWTON, MASS., U.S.A.

Exclusively Represented by  
Frank Heaver Ltd. Kingsley Road,  
Bideford, N. Devon

## Letters to the Editor—

the need for a large number of channels, the avoidance of transmission via the ionosphere points to the use of much higher frequencies for broadcasting, and a further advantage of this would be the elimination of international difficulties, since these stations would all be of strictly limited range.

Here Sir Robert went farther than most of us would wish, and said that, on the principle that you should never use radio if you can do the job without it, all urban areas (towns of population 5,000 upwards) should have their programmes distributed by wire.

Dr. McClean, in the course of a statement on behalf of the Association of Scientific Workers, suggested that the B.B.C. ought to undertake fundamental scientific research, because it is a very wealthy Corporation; later in the meeting Sir Allen Powell countered this by saying that far from being wealthy, the B.B.C. would be "broke" if it did not receive from the Government an annual grant several times greater than the licence revenue. (The ordinary listener will surely comment on this that if the B.B.C. is spending £10 millions a year on the present "Home" and "Forces" programmes, it's time someone else took over the job; but if most of the money is going on the Overseas propaganda services, it is only right that it should be paid for out of general Government resources, not out of the licence fees.)

The idea of having specialist B.B.C. Governors (including one scientist) was opposed by the chairman, and the B.B.C. was criticised

for its failure to broadcast talks on scientific subjects.

Radio will undoubtedly be important in the post-war world, and I recommend all who are interested in it, whether as an industry, as a social force, or just as entertainment, to look out for any hints such as these from those who are at the head of technical development and B.B.C. policy; otherwise they may lose the chance of putting forward their views before the plans for the future of broadcasting are fixed.

D. A. BELL.

London, N.21.

## Transitron Oscillators

I WAS very interested in recent *Wireless World* articles on the Transitron Oscillator, as I have been using a similar circuit for some years. However, two important improvements are embodied in my own circuit, shown in the accompanying diagram, which is used for heterodyne frequency meter work.

First, all who have had practical experience of any form of RF oscillator will appreciate the advantages obtained by having one end of the LC circuit at earth potential to both DC and RF. Secondly, one very important feature of the Dow or ECO circuit, as it is commonly employed, is that the output is usually obtained from the anode circuit load, the coupling between this and the frequency determining circuit being via the electron stream of the valve. These two important advantages can be embodied in the Transitron oscillator if a heptode valve is substituted for the RF pentode shown by Mr. Chambers. In general, the upper frequency

limit of oscillation of the Transitron and similar circuits is limited by the electron transit time, and in the case of the X63 and similar heptodes this limit lies between 30 and 40 megacycles. I have no experience of the limits

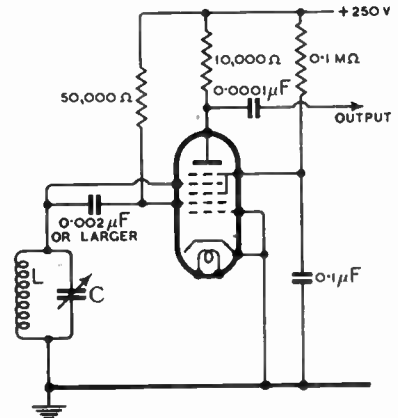

Transitron oscillator circuit with heptode valve (Osram X63, American 6A7, etc.)

that may be reached with heptodes especially designed for UHF work.

It may be added that if a resistance is substituted for the LC circuit, it then becomes a current controlled relaxation oscillator, that will oscillate at an audio frequency continuously variable by varying the resistance. If such use is intended it will be advisable to increase the value of the screen-suppressor coupling condenser to, say, 0.1 mfd. in order that the reactance may be small compared to the grid leak resistance to transmit satisfactorily the lowest frequency to be used. The circuit will then work satisfactorily down to a few c/s.

E. A. DEDMAN, G2NH.

New Malden, Surrey.

## Books issued in conjunction with "Wireless World"

	Net Price	By Post
FOUNDATIONS OF WIRELESS, by A. L. M. Sowerby. Third Edition revised by M. G. Scroggie	6/-	6/4
TELEVISION RECEIVING EQUIPMENT, by W. T. Cocking	10/6	10/10
RADIO LABORATORY HANDBOOK, by M. G. Scroggie. Second Edition	12/6	12/11
WIRELESS SERVICING MANUAL, by W. T. Cocking. Sixth Edition	7/6	7/10
HANDBOOK OF TECHNICAL INSTRUCTION FOR WIRELESS TELEGRAPHISTS, by H. M. Dowsett and L. E. Q. Walker. Seventh Edition	27/6	28/1
WIRELESS DIRECTION FINDING, by R. Keen. Third Edition	30/-	30/7
RADIO INTERFERENCE SUPPRESSION, by G. W. Ingram	5/-	5/4
LEARNING MORSE. 335th thousand	6d.	7½d.
INTRODUCTION TO VALVES, by F. E. Henderson	4/6	4/10
VALVE REPLACEMENT MANUAL, by A. C. Farnell and A. Woffenden	6/-	6/2

Obtainable from leading booksellers or by post from

ILIFFE & SONS LTD., Dorset House, Stamford Street, London, S.E.1

## "P.M.G. Examinations": Reply to Criticisms

THE principal objection raised by critics of my article is that the pay and prospects of Radio Officers do not justify any increase in the standards of training and examinations. My views are:—

(1) As the equipment on ships becomes more specialised and the fitting of modern equipment becomes general employers will, in their own interests, be obliged to staff the ships with men capable not only of operating, but maintaining such gear.

(2) The present conditions of pay and prospects of Radio

Officers are, in part, due to the ease with which students may be trained and the short time required to reach the P.M.G. examination standard. This results in a permanent surplus of operators in training except in exceptional times, such as the present war.

(3) After the war is over there will be a very large number of men holding special certificates who will wish to continue as Radio Officers and who will need a higher qualification. It is probable that only a small proportion of these men will be required permanently. An immediate increase in the standard would ensure the selection of those best fitted for the work.

(4) Since the war began the pay of Radio Officers has materially increased—exclusive of war risk bonus—and an increase of examination standards may help in retaining this increase.

Mr. Lamb, who writes on behalf of the Radio Officers' Union, does not agree that the present P.M.G. examinations are stereotyped.

He goes on to say that any increase in the technical standard now in force would not materially assist the Radio Officer, since he is first and foremost a telegraphist.

After making the surprising admission—for the R.O.U.—that the chance the Radio Officer has of obtaining a position commensurate with the financial outlay and mental effort entailed in obtaining a certificate of increased standard is doubtful, Mr. Lamb then contradicts his previous criticisms.

He briefly outlines a scheme which in its implications goes much farther than that I suggested.

Mr. Lamb suggests a fourth or extra first-class certificate. This certificate covers advanced radio practice both for marine and shore purposes. It will demand, therefore, a greatly increased standard of basic training apart from the study a Radio Officer will need to do while at sea and at school preparing for the examinations for the various grades of certificates.

No doubt, as Mr. Lamb suggests, some such scheme as that I have suggested will be adopted, and I would like to emphasise the great importance of the basic training courses to men at sea studying alone, and whose time at school is necessarily limited.

WM. M. MOORE.

The Marine School,  
South Shields.

## ELECTRICAL INDUSTRIES RED CROSS FUND

### Wireless Section's Contributions

"HOPE and the Red Cross make life worth living to us here; they are our salvation of mind and body." So writes a sergeant major who is a prisoner of war, and sergeant majors are not notorious as sentimentalists. This sentence not only summarises the efforts made by the Red Cross and St. John Joint War Organisation for prisoners of war, but the word "salvation" crystallises both the urgent need for such efforts and the success that is attending them.

By the provision of regular food parcels to supplement deficiencies of diet, by the despatch of books, games and sports equipment to combat boredom, by arrangements for educational facilities, by its special care for prisoners who are ill or blinded or deaf, the Red Cross has done much to earn such high praise and deep gratitude.

The services to prisoners of war have tended to overshadow the other great responsibilities which rest on the Red Cross and St. John, but as the war develops first one and then another aspect is thrown into relief.

During the heavy air raids in the past the Red Cross amplified the work done by official relief services in every conceivable way, and was instrumental in saving hundreds of lives, bringing thousands back to health, and restoring the faith of hundreds of thousands by little acts of comfort throughout the country. There is still a *Luftwaffe*. The Red Cross must stand prepared.

As for the future, who dare hope for final victory without a heavy increase in Service casualties? The Red Cross must be, and is, ready to supplement basic medical treatment provided by the Forces with comforts for the sick and wounded.

Care for the children, assistance on a vast scale to our allies, particularly Russia, comfort for those who, safe themselves, have husbands or sons missing, prisoners or wounded—how impossible it is briefly to summarise the great task of the Red Cross.

At the time of going to press over £14,000 has been contributed to the Electrical Industries Red Cross Fund. Among recent subscriptions from wireless firms and those with wireless interests are the following:—

COVENANTED SUBSCRIPTIONS	
	£ s.
Bush Radio, Chiswick .....	200 0
Micanite and Insulators Co., London	100 0
Creed and Co., Croydon .....	100 0
Sun Electrical Co., London .....	50 0
Radio Gramophone Development Co., Bridgnorth .....	21 0
Michael Black, Glasgow .....	10 10

#### DONATION

Ward and Goldstone, Manchester ... 50 0

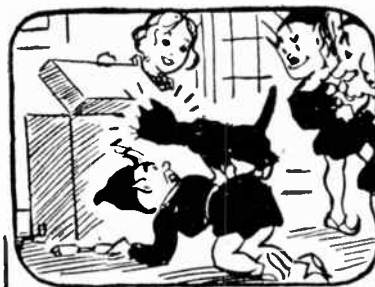

THE "FLUXITE QUINS" AT WORK

"Music? Well, I'll eat my hat!  
FLUXITE's a grand cure for that.  
Those squeaks—they're not mice,  
They'll be gone in a trice,  
But for goodness sake call off this cat!"

See that FLUXITE is always by you—in the house—garage—workshop—wherever speedy soldering is needed. Used for over 30 years in Government works and by leading engineers and manufacturers. Of all Iron-mongers—in tins, 8d., 1/4 and 2/8.

Ask to see the FLUXITE SMALL-SPACE SOLDERING SET—compact but substantial—complete with full instructions, 7/6.

TO CYCLISTS! Your wheels will NOT keep round and true unless the spokes are tied with fine wire at the crossings AND SOLDERED. This makes a much stronger wheel. It's simple—with FLUXITE—but IMPORTANT.

The FLUXITE GUN puts FLUXITE where you want it by a simple pressure. Price 1/6, or filled, 2/6.



ALL MECHANICS WILL HAVE

# FLUXITE

IT SIMPLIFIES ALL SOLDERING

Write for Book on the ART OF "SOFT" SOLDERING and for Leaflets on CASE-HARDENING STEEL and TEMPERING TOOLS with FLUXITE. Price 1d. each.

FLUXITE LTD.

(Dept. W.W.), Bermondsey Street, S.E.1

# UNBIASED

## Remember Southampton

By  
**FREE GRID**

**E**VEN those of you who confine your reading to the Editorial and Recent Inventions pages of this journal, counting the rest as so much dross, will be aware that proposals have been put forward that the B.B.C. programmes should, after the war, be distributed over the electric mains.

These proposals, which were well ventilated in this journal early in 1942, leave me quite cold, but I must offer a warning to the B.B.C., the P.M.G., and any other would-be Hitlers of the ether. If any attempt is made to force this system on us, and thus compel us to listen to whatever is pumped along the mains, instead of being able to roam the ether at will, the result will be the establishment of highly mobile "bootleg" wireless transmitters in stratospheric aircraft, in order to give the people "freedom programmes."

I raise this matter now as it has come to my ears that a very subtle scheme is being prepared by the pan-jandrum of Portland Place and the moguls of St. Martins-le-Grand to swing a large proportion of the population over to acceptance of the idea of non-wireless broadcasting. The scheme, which is magnificent in its daring, and Machiavellian in its subtlety, consists of nothing less than the establishment of a multi-wavelength USW station on the roof of every Post Office, and the linking of

would be far too busy on the 'phone to bother about whether we were driving on the wrong side of the road or cutting in. Since each car would have a channel permanently allotted to it, even the USW part of the spectrum would become uncomfortably crowded with the great increase in cheap motoring after the war, and thus some force would be lent to the argument of the wired wireless protagonists that wireless must be reserved for services where it is impossible to use the "carrier" system.

If the scheme does come into being my first act will be to try to bring the whole thing to a *reductio ad absurdum* by agitating for every pedestrian who desires it to be allocated a personal USW channel and to be supplied with lightweight apparatus in order to link him with the nearest G.P.O. exchange. In any case, the scheme will be defeated as decisively as was the great G.P.O. Southampton conspiracy in 1939.

## A DC Dilemma

**A**CCORDING to reports which reach me from a confidential source near Whitehall, it appears that users of electrical energy are well to the fore in the matter of fuel saving. There is nothing very extraordinary about this, for, after all, when slipping out to the "local" for your morning magnum it is quite a simple matter to turn the electric fire off, whereas to heave a bucket of water over a coal fire is a messy business.

that in certain districts where the supply is DC the consumption of electricity was going up instead of down, and I determined to get at the cause by making a house-to-house call.

After experiencing one or two un-



fortunate contretemps in which, owing to mistaken identity, old clothes and other salvage were thrust into my arms, so that the scent got on me rather than I on the scent, I retired to the local hostelry in a very low state. By one of those strokes of good fortune which do happen sometimes, I stumbled simultaneously on the explanation of the mystery and some pre-war beer, the latter being served to me by a sympathetic barmaid who said that my appearance reminded her of a favourite uncle, a gravedigger by profession, who had overstrained himself while digging for victory on his allotment.

With such an excellent conversational opening, it was not long before I was on terms of intimacy with the whole bar, which included several *Wireless World* readers, and I soon learned that the cause of the great increase in current consumption in this and other DC districts was the terrible dearth of DC mains valves. AC valves were, as I knew from personal experience, considerably easier to obtain, with the result that people were simply substituting them in their DC sets and running them in series with an external resistance of large ohmage and amperage, if I may be permitted so to express myself. Certain other adjustments have to be made, of course, but the salient fact is that the heater consumption of each set is increased no less than five times, since AC valves take a full amp. at 4 volts instead of 0.2 amps. at a higher voltage, as do their DC counterparts. Possibly, Major Lloyd George may be interested in this startling fuel leakage and be able to dam it by exerting strong pressure in the right quarter to get a few more DC valves made available.

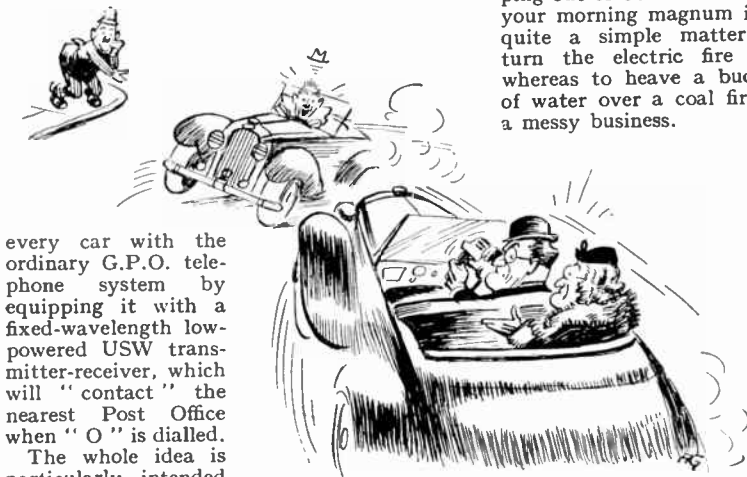

every car with the ordinary G.P.O. telephone system by equipping it with a fixed-wavelength low-powered USW transmitter-receiver, which will "contact" the nearest Post Office when "O" is dialled.

The whole idea is particularly intended to appeal to women, with their love of ceaseless and senseless chatter, and it would at any rate relieve us unfortunate motorists of the bugbear of back-seat women drivers. They

**Back-seat driver bugbear.**

However, in spite of the fact that electricity users set a good example to the nation, I was greatly puzzled when examining some statistics to find

## Wireless World Brains Trust

### Radio's Jubilee Year?

Question No. 11.—Who first conceived the idea of using electromagnetic waves as a means of communication? It seems strange that Clerk Maxwell and Hertz who, respectively, postulated mathematically and experimentally proved the existence of the waves, should apparently have had no thoughts on the practical uses—to our generation so obvious—to which their discoveries might be put.

J. HARMON.

*This seems to be best dealt with as an "open question," as we doubt if any of our regular "Brains Trustees" would claim any special knowledge on the dawn of wireless history. Replies for publication are therefore invited from anyone having information on the subject. In the meanwhile, a few notes may be of interest, if only because the question is opportune. Whatever the precise answer may prove to be, it seems highly probable that the practical conception of electromagnetic wave communication is now almost exactly 50 years old.*

WE can find no record that Clerk Maxwell ever expressed any views on the practical uses of electro-magnetic waves. The outlook of Hertz was apparently equally academic; but when a German engineer named Huber suggested in 1889 the use of the waves for telephonic communication, Hertz discouraged the idea on the ground that the telephone would not respond to RF oscillations.

The first prediction of a practical communications application mentioned in G. G. Blake's "History of Radio Telegraphy and Telephony" is credited to Sir William Crookes, the physicist. "In 1892 he wrote an article in the *Fortnightly Review* in which he foreshadowed telegraphic communication from one place to another across free space by means of electro-magnetic waves, and he suggested the possibility of tuning, so that many stations might signal simultaneously. . . ."

Though the name of Nikola Tesla, who died early this year, is primarily linked with projects for the wireless transmission of power, his claims to priority in the field of signalling must also be considered. The American journal *Communica-*

*tions* for January, 1943, in an obituary notice, says of Tesla: "As early as February, 1893, he described a wireless transmitter, in general but nevertheless correct terms, and further stated that 'a properly adjusted self-induction and capacity device could be set in action by resonance at any point within a certain radius of the source.' This, he said, would lead to 'transmitting intelligence, or perhaps power, to any distance through the earth.'" The use of the word "through" may suggest earth-current signalling, but it seems certain that wave telegraphy was intended. In a book published in Belgrade in 1936 to commemorate Tesla's 80th birthday it is stated that he made similar public statements in 1892.

Another claimant to the honour of having early appreciated the practical possibilities of the work of Clerk Maxwell and Hertz is the Russian physicist, Popov. In fact, it is possible (though, according to Ellison Hawks' "Pioneers of Wireless," not conclusively proved) that, in 1895, he was the first to demonstrate true radio-telegraphy. In the same book it is established that in December, 1895, Popov wrote: "I entertain the hope that when my apparatus is perfected it will be applicable to the transmission of signals to a distance."

Just as Tesla's main interest laid in the transmission of power, so Popov was chiefly concerned with the investigation of atmospheric disturbances by means of the coherer with which his name is linked. It is strange that both these pioneers should have followed relatively unprofitable paths when the technique of a much more valuable application of electro-magnetic waves was opening up to them. It is certain that, when Popov's recorded prediction was made, Marconi had for some time been actively engaged in harnessing Hertzian waves to communication. Possibly his aims and aspirations were already on record, but we can trace no published statement. The first Marconi patent application, specifically covering signalling, was filed only some seven months after Popov's statement was made.

## The Improved VORTEXION 50 WATT AMPLIFIER CHASSIS

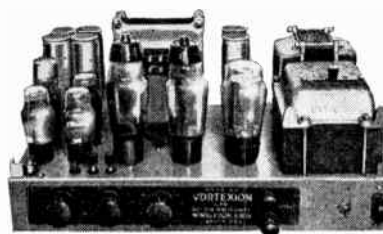

The new Vortexion 50 watt amplifier is the result of over seven years' development with valves of the 6L6 type. Every part of the circuit has been carefully developed, with the result that 50 watts is obtained after the output transformer at approximately 4% total distortion. Some idea of the efficiency of the output valves can be obtained from the fact that they draw only 60 ma. per pair no load, and 160 ma. full load anode current. Separate rectifiers are employed for anode and screen and a Westinghouse for bias.

The response curve is straight from 200 to 15,000 cycles. In the standard model the low frequency response has been purposely reduced to save damage to the speakers with which it may be used, due to excessive movement of the speech coil. Non-standard models should not be obtained unless used with special speakers loaded to three or four watts each.

A tone control is fitted, and the large eight-section output transformer is available in three types: 2-8-15-30 ohms; 4-15-30-60 ohms or 15-60-125-250 ohms. These output lines can be matched using all sections of windings and will deliver the full response to the loud speakers with extremely low overall harmonic distortion.

PRICE (with 807 ecc. type valves) **£18.10.0**

Plus 25% War Increase

**MANY HUNDREDS ALREADY IN USE**

Supplied only against Government Contracts

## VORTEXION LTD.

257, The Broadway, Wimbledon, S.W.19

\*Phone: Liberty 2814

# RANDOM RADIATIONS

By "DIALLIST"

## Radio Waves

THE delightfully simple account of the adventures of radio waves in the ionosphere which T. W. Bennington gave us last month must have appealed to a wide circle of readers. I hope that he will be able later to give his ideas on two very interesting subjects for which he then had no space. The first of these concerns echoes, particularly those of long delay. There must be few short-wave enthusiasts who have not heard radio echoes; perhaps the best known instance before the war was that of the B.B.C.'s 13-metre service, which was a beamed transmission. In many localities in this country this transmission was accompanied by what is known as the "tunnel effect"; the announcer sounded just as though he were speaking in a reverberating tunnel; every syllable had its echo. This echo was undoubtedly due to double reception of the transmission. One heard it first at the end of its short journey from Daventry to one's aerial. Then, having gone round the world, it arrived again about one-seventh of a second later. But the most curious of radio echoes are those of long delay, about which a considerable amount of data was obtained by observers a year or two before the war. I forget now the longest delay that can be vouched for, though I recall that the observation of delays of 25 seconds and more was claimed. Various explanations were put forward, some of them highly improbable. It was, for instance, suggested that waves which had penetrated the reflecting layers and made their way out into space might be turned back to earth by the moon, the sun or some other heavenly body. Echoes of about 2½ seconds' delay were certainly recorded; this fits in with the time needed for the double journey to the moon and back, and the temptation to conclude that the moon was the reflector proved irresistible to some.

## Between the Layers?

Attractive as the idea might be at first sight, it would not hold water, for there were far too many echoes whose delay did not fit the time for the return journey to any heavenly body. My own belief is that the waves responsible for these echoes never leave the ionosphere at all. I imagine one part of a transmission reaching the F<sub>1</sub> layer at such an angle that it penetrates it and continues up to the lower surface at F<sub>2</sub>. Turned back from there, it arrives at the upper surface of F<sub>1</sub> at such an angle that it bounces upwards again. And

so its journey continues, round and round the world between the two F layers, until finally it manages to re-penetrate the lower and come back to earth once more. A longer wave might conceivably make a similar voyage of great length in the space between the upper surface of the Heaviside Layer and the lower of the first Appleton. Or, again, the circling of the globe might take place by a short-wave transmission between the top of F<sub>2</sub> and the bottom of F<sub>3</sub>—if there is such a layer. If these processes are possible—and I don't see why they should not be in certain states of ionisation of the reflecting layers—echoes with enormous delays may occur without there being any need for the waves to travel out into space and back again.

## Differential Fading

Another interesting problem of wave propagation is that of differential fading. Every short-wave man knows this curious and not very pleasant form of distortion, which is often pronounced in long-distance reception. The proper balance of the audio-frequencies is continually being upset. At one moment certain frequencies are over-emphasised, whilst others practically disappear. At the next these frequencies may be more or less normal, but others are affected. The phenomenon is closely bound up with the fact that when the reflecting surfaces are in a state of disturbance transmissions of different frequencies have different adventures on meeting them. Diversity reception depends on this fact. The receiving apparatus is so designed that it passes to the audio stages only the best received signal at any moment. Various schemes (that of our own G.P.O. will be recalled) were afoot when the war broke out to counteract the fading of carriers by complex kinds of diversity reception; but how we're ever going to devise anything to straighten out differentially fading sidebands, I do not know. I have no doubt that it could be done, but the apparatus required would be of staggering complexity and size.

□ □ □

## Those Prophets

THERE must be few articles more enjoyable for the lay journalist to write than the ever-recurring "Science After the War," "Science in Ten Years' Time," and the like. He can let imagination and pen run riot, and the wilder his predictions the more the man-in-the-street will enjoy what he has to say. In the many articles of the kind that I have come

across in the last twelve months there are one or two predictions by the seers into the future of applied science that crop up again and again. In fact, they have been made so often now that the public must be coming to regard them almost as certainties. One of them concerns the pocket "personal" wireless set—a kind of midget combination of transmitter and receiver which will enable its owner to call up and communicate with his friends wherever he or they may be. There is nothing improbable about the small transmitter-receiver; it was in existence long before the war. But, "pocket"? Well, that is an elastic term, and, of course, pockets can be of any size, from the little one that ought to contain the ticket you never can find to the variety favoured by poachers and gamekeepers, which can accommodate a hare and a brace of pheasants without being unduly strained. "Vest pocket" should be a more rigid definition of size, but I have known it applied by enthusiastic designers to gadgets that would have needed something more like a haversack to contain them! Anyhow, I do not see any likelihood of genuine pocket transmitter-receivers arriving in the near future—unless some revolutionary invention in radio methods is made.

## Exit the Telephone?

Still less do I agree with the possibility of the set which would enable anyone provided with it to call other users or to be called by them. There are certain little problems involved connected with channels. So far as we can see at present it is difficult enough to make the available channels go round amongst broadcasting and commercial stations, whose number is minute compared with that of the potential users of personal sets. I do not think that the telephone's existence is threatened just yet. Incidentally, what would be the equivalent of "number engaged" with the personal set? Can you imagine the state of mind of a personal wireless enthusiast who is being called by half a dozen people at the same time? And there would be no soothing "Sorry you've been trrrrrroubled."

## Not Just Yet

And there is the other old stager about television in every home when peace is with us again. I do not doubt that there will be a huge increase in the number of privately owned television receivers, especially if television programmes become such that everybody wants to enjoy them. But frankly I cannot see the television set being taken, in the near future, out



COMMUNICATIONS DEPEND...

of the luxury class, as was possible with the wireless set at quite an early stage in its development. By the time that broadcasting had begun in this country it was possible to make a crystal receiving set for a very modest outlay. But there is no equivalent for the crystal set in television, whose receiving equipment, so long, at any rate, as we work on present lines, must always require a cathode-ray tube and a comparatively large number of valves. Our manufacturers must have learnt a lot about the mass production of tubes and valves during the war, and no doubt all kinds of new machinery have been installed for the purpose, but I do not see prices coming down all that much. I would be inclined to put the lowest price for a sound-and-vision receiver with a small tube at about £25, and the public showed years ago that it was not attracted by small viewing screens. On the whole, we can feel fairly safe in prophesying that it will be some little time before the number of television sets in use is as great as the present number of wireless receivers—and the day of television in every home is still farther off than that.

□ □ □

Metres and Yards

HAVE you ever come across one very useful and simple rule of thumb for converting metres into yards? The metre is a yard, plus ten per cent. It works out surprisingly well if you do not need extreme accuracy. For instance, a yard is 36 inches; ten per cent. of 36 is 3.6; 36+3.6 is 39.6 inches. Try it against the other rule for converting kilometres to miles; a kilometre is five-eighths of a mile, or 8 kilometres equal 5 miles. (This, by the way, is a very close approximation, as you can see by comparing the mile and kilometre scales of, say, an inch-to-the-mile map.) Well, according to formula No. 1, 8 km=8,000 m.=8,800 yards. Working the rest in your head, 5 miles=10 half-miles. Half a mile is 880 yards; 880 x 10 = 8,800. Some day, I suppose we will adopt the metric system officially in this country and save ourselves much work and many headaches.

"RADIO WAVES IN THE IONOSPHERE"

THE word "curve," in the 5th line of the 1st paragraph on p. 99 of our April issue, should read "wave."

GOODS FOR EXPORT

The fact that goods made of raw materials in short supply owing to war conditions are advertised in this journal should not be taken as an indication that they are necessarily available for export

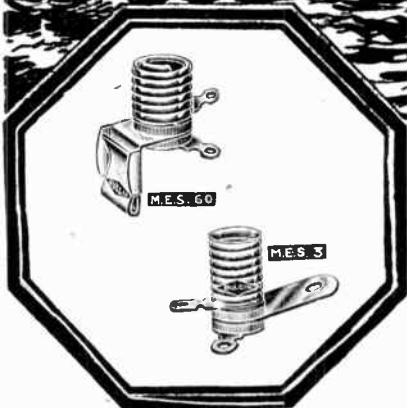
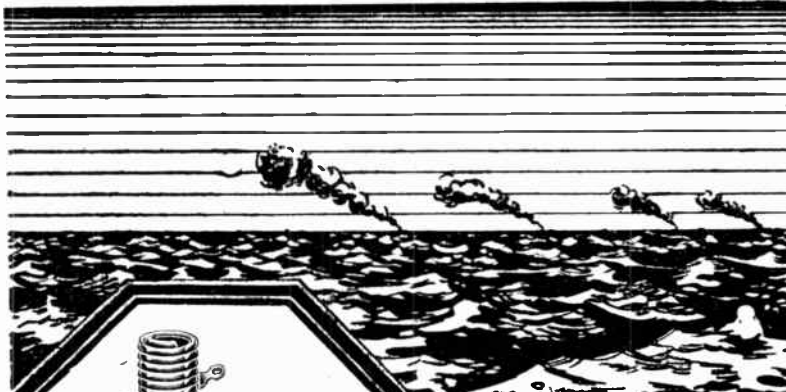

ON SMALL PARTS...

IN countless instances quite intricate pieces of apparatus are wholly dependent on the proved reputation and reliability of their component parts.

All products from the House of Bulgin are pre-eminent for superior design and workmanship and every article bearing our Trade Mark has to pass exacting and exhaustive tests during the course of its production.

We ask the kind indulgence of the Trade on delivery until peaceful conditions return.

The Choice of Critics

BULGIN FOR M.E.S. HOLDERS

The largest and most extensive range in the World. All kinds of lamp-caps are accommodated, including M.E.S. and E.S., to B.S.598, and M.B.C. (the new miniature bayonet cap, single-contact). In the large range there is a full choice of fixing-brackets, -strips, and -clips both 'live' and 'dead.' The screw types are made in rolled, drawn and -embossed, spring-grip, etc. A lampholder for every use.

"The Choice of Critics"

BULGIN

REGISTERED TRADE MARK

A. F. BULGIN & CO. LTD., BYE PASS RD., BARKING, ESSEX  
TEL.: RIPPLEWAY 3474 (4 lines).

# RECENT INVENTIONS

## DIRECTIVE AERIALS

TWO conical conducting surfaces C, C<sub>1</sub> are arranged coaxially with their apices close together. The cones are coupled to a small loop L which is fed from a two-wire transmission line passing up through a tubular screen S connected to the lower cone. The size of the loop L is considerably less than half a wavelength, so that the amplitude and phase of the current it carries are substantially the same at all points.

Under these conditions the waves are guided outwards, as from an "electromagnetic horn," and form a vertically

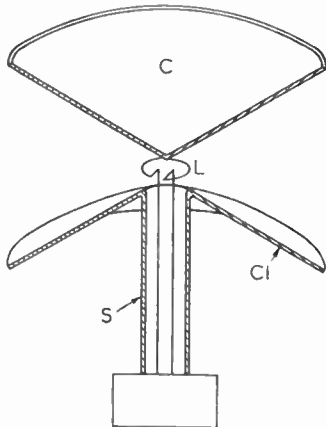

Flat beam radiator.

polarised beam which extends uniformly in all directions in the horizontal plane.

*Standard Telephones and Cables, Ltd. (Assignees of W. L. Barrow). Convention date (U.S.A.) December 9th, 1939. No. 548,193.*

## TUNING BY VOLTAGE CONTROL

THE tuning of an oscillatory circuit is varied by the application of a control voltage to the grid of a valve shunted across it, the arrangement being applicable either for phase or frequency modulation, or for the automatic tuning of a superheterodyne receiver.

The control valve includes a screening grid which carries a high positive bias, and an anode at cathode potential.

The anode and cathode are shunted across the circuit to be controlled, whilst the control grid is coupled to it. The input oscillations serve to produce a space-charge, or virtual cathode, between the screening grid and the anode, and this, in turn, induces in the anode a current which is in quadrature with the input and of a magnitude which is determined by a potentiometer adjustment of a DC biasing voltage applied to the control grid.

One branch of the anode circuit is earthed through an impedance, while a parallel branch is coupled to the circuit under control. For frequency modulation the control grid is coupled to the output from a microphone, while for automatic frequency control it is coupled to the output from a discriminator valve.

*Sir L. Sterling. Convention date (U.S.A.) April 27th, 1940. No. 548948.*

## A Selection of the More Interesting Radio Developments

### TELEVISION FROM FILMS

IN a television transmitter of the disector type, the picture is first focused on to a photo-electric cathode, and the resulting electron stream is then moved across a scanning aperture to allow each elementary area to pass in turn on to an electron-multiplier. When such a tube is used for developing television signals from a cinema film, it is found that any irregularity of emission from the surface of the photo-electric cathode becomes very noticeable.

According to the invention this defect is compensated by using a cylindrical lens to distort the image projected from the moving film on to the photo-electric cathode. The resulting electron stream is then scanned through a vertical slit, instead of through the usual square aperture, so that the defective point is "averaged" with all the other points on a transverse elementary strip of the cathode. The effect of the original bad point is therefore toned down or glossed over.

*Standard Telephones and Cables, Ltd. (Assignees of H. E. Ives). Convention date (U.S.A.) September 24th, 1940. No. 549890*

### SCREENING CANS

A SCREENING can is provided with an internal fitting which automatically presses the valve firmly on to its base. The fitting is made from a single strip of metal with, say, four projecting lugs F. The strip is first bent into a circle, and the lugs are horned up to form V-springs as shown. As the can is forced home over the flange N, the fitting slides up against the top lip, and the V-springs hold the valve from vibration.

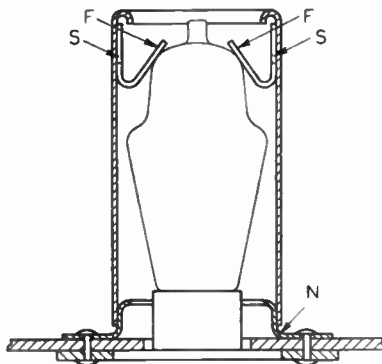

Valve location.

If necessary, the can can be made high enough to screen more completely the top connection of the valve, the holding spring then being anchored against an inside flange formed some distance from

the open end. The device is compact, cheap and easy to manufacture.

*Standard Telephones and Cables, Ltd.; L. W. Houghton; and S. J. Holdstock. Application date June 11th, 1941. No. 549970.*

### TELEVISION PROJECTORS

IN order to make the most effective use of the light available from the fluorescent screens of a cathode-ray television receiver, it is collected by a concave mirror M which projects it back on to a plane mirror PM having a central aperture in which the fluorescent screen is located. The plane mirror is arranged at such an angle, say 45 deg., that none of the light reflected by it can reach the concave mirror, but passes, as shown by the arrows, directly on to the viewing screen VS.

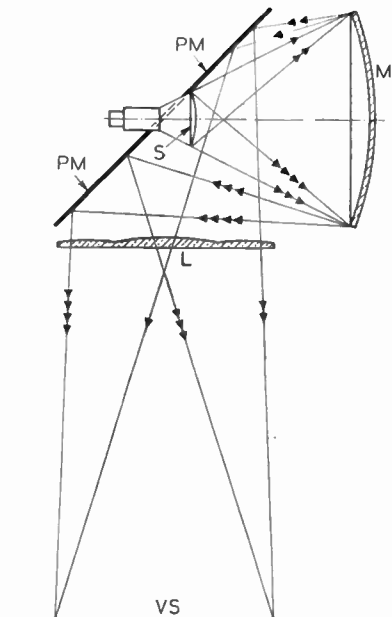

Large-screen television.

In order to minimise spherical aberration and similar optical troubles, a "correcting" lens L is interposed between the mirror PM and the viewing screen. Various positions of the mirror PM are possible, but an analysis shows that the one in which it is tangential to the upper periphery of the fluorescent screen, as indicated in the drawing, is the most effective.

*Philips Lamps, Ltd. (Communicated by N. V. Philips' Gloeilampenfabrieken). Application date January 12th, 1942. No. 548750.*

The British abstracts published here are prepared with the permission of the Controller of H.M. Stationery Office, from specifications obtainable at the Patent Office, 25, Southampton Buildings, London, W.C.2, price 1/- each

# T I M I N G T I M E

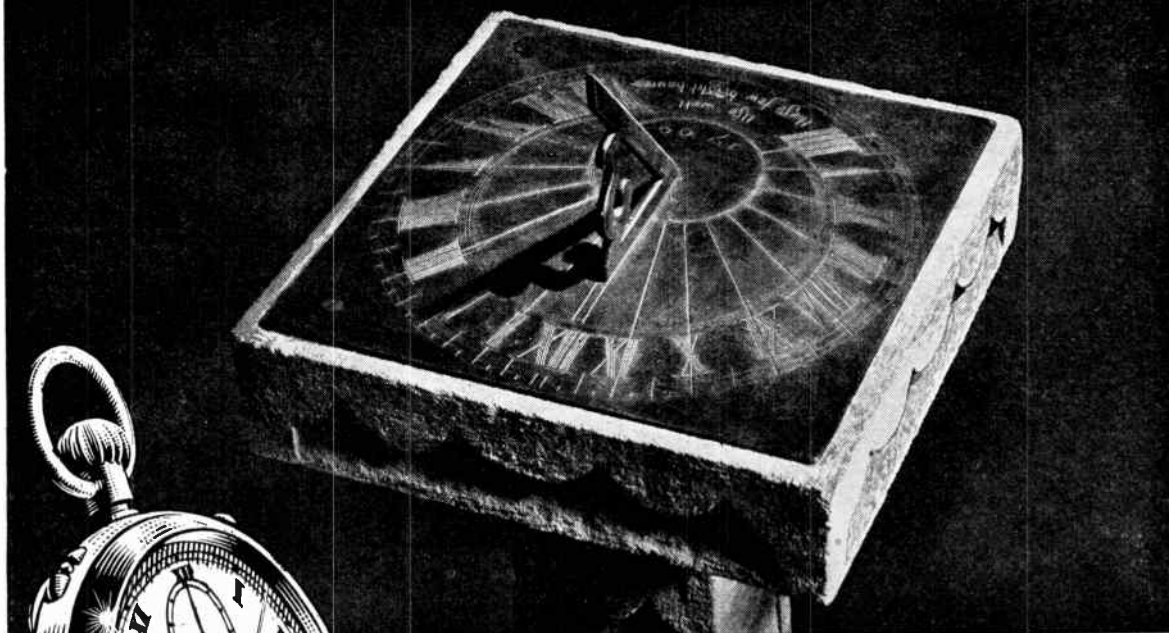

The accurate timing of watches and clocks is normally a lengthy procedure and involves keeping the instrument under observation for a considerable period.

The development of the Thermionic Valve and Cathode Ray Tube have made possible the design of special apparatus by means of which any timepiece can be regulated with great precision in a matter of minutes.

This is yet another example of the important part which the valve plays in solving specialised problems of control which arise in almost every industry.

COMMERCIAL  
INDUSTRIAL  
SCIENTIFIC  
MEDICAL  
EXPERIMENTAL  
DOMESTIC

## MULLARD

THE MASTER VALVE

*A Valve for Every Purpose*

THE MULLARD WIRELESS SERVICE CO. LTD., CENTURY HOUSE, SHAFTESBURY AVE., LONDON, W.C.2 (47)

**CLASSIFIED ADVERTISEMENTS.** Rate 6/- for 2 lines or less and 3/- for every additional line or part thereof, average lines 5-6 words. Each paragraph charged separately. Press Day: June issue, first post Tuesday, May 11th, one day earlier at branch offices. Box Numbers: 5 words, plus 1/-. Deposit System: particulars on request. No responsibility accepted for errors.

Ode

# Partridge

No. 23

## TRULY RURAL

The Agricultural Minister  
Asks all to volunteer  
To help the hard-pressed farmer  
To grow more food this year.

Four bob a day is all I pay  
For bed, three meals and tent,  
But ground sheet, blankets, mattress too  
Are loaned me free of rent.

Among the things I have to take  
Ere starting to dig roots,  
Ara towels, mug, a cake of soap,  
Old clothes and good stout boots.

A wisp of straw between my teeth,  
Knife, fork and spoon in hand,  
A couple of plates, a pillow slip,  
I'm ready for the land.

For one whole week my Bardic chair  
I leave, with greatest joy,  
And for a modest bob an hour  
O'll be a Varmer's Boy.

### N. Partridge

Kings Buildings, Dean Stanley Street,  
LONDON, S.W.1. Vic. 5035.

# ARMSTRONG SERVICE

After three years of war and despite the changed conditions we have succeeded in keeping our Service Department in operation.

Many difficulties have arisen owing to material and valve shortage but on the whole we have managed to maintain a very large proportion of Armstrong Chassis in good working order.

We can still undertake the repair and overhaul of practically all Armstrong Chassis including very old models.

**ARMSTRONG MANUFACTURING CO.**  
WALTERS ROAD, HOLLOWAY, LONDON, N.7  
Phone: NORTH 3213

**NEW RECEIVERS AND AMPLIFIERS**  
HIGH fidelity ac/dc amplifiers, 18 watts, U.D.O. mixing input channels, bass and treble controls, input and output transformers, octal base valves, complete chassis, 18gns.—Below.

**DANCE** and stage transportable amplifying equipment, comprising amplifier as above, m/c microphone, adj. stand, 2 auditorium speakers, cables; 36gns.—Broadcast and Acoustic Equipment Co., Ltd., Broadcast House, Tombland, Norwich. [1661]

**£22/10** only.—New 7-valve "Wireless World" Quality amplifier, with tone control stage, 8 watts push-pull triode output, price includes Super Quality triple cone 12in permanent magnet speaker with large matched output transformer and all valves; as above but with 15-watt tetrode output, £24; ideal for quality reproduction; limited number available.—Bakers Selhurst Radio, 75, Sussex Rd., S. Croydon. [1698]

**RECEIVERS, AMPLIFIERS—SECOND-HAND**  
**R.M.E.69** noise limiter, ac model, excellent; best offer over £45.—G.S.C.P., 33, Manley Rd., Sale, Cheshire. [1651]

**McMURDO** Silver Guthman 8-valve communication RX and spare valves, ac model, excellent condition.—Offers to box 2855, c/o Wireless World. [1663]

**GUTHMAN** super silver communication receiver, 1939 model 8 valve, as new, 6 bands, 5 to 650 meters; £40.—Broadcast and Acoustic Equipment Co., Ltd., Broadcast House, Tombland, Norwich. [1662]

**MODIFIED** Decca amplifier (p.p.6V6), in carrying case, with pick-up gramophone motor and detachable speaker, m/c microphone, adj. folding stand, complete, as new, £38.—Box 2859, c/o Wireless World. [1689]

**W.W.** 12-watt amplifier and feeder unit, unused, £30; W.W. output transformer, unused, 25/-; 7in. cone American Magnavox 2,000ohm field, £5; carriage and packing extra.—Capper, Gorsebank Lane, Baslow, Derbyshire. [1679]

**TWO** Super Pye radio consoles, one eleven waveband, fine quality, bandspread tuning, new, £68; one ac/dc fourteen valve communication, G12 speaker, export model, 200-250v, walnut console cabinet, £75.—Prospect 2889.—49, Clifford Ave., London, S.W.14.

**LISTS** now available in following sections: sets and amplifiers, speakers, valves, meters, battery chargers, resistances, switchgear, transformers, batteries, rotary converters, lighting sets, dynamos, motors, special machines, cinema and photo equipment, scientific instruments, household appliances, miscellaneous; stamp please and state sections required.—Harris, Strouds, Bradfield, Berks. [1654]

**Wanted**  
**SOUND** Sales Tri Channel amplifier or similar type.—Blake, Watchful, Great Yarmouth. [1693]

**TROPHY 6** or Hallicrafters S19-R, £29; S20-R, SX24.—R. H. Hatton, 21, Lincoln Cres., Enfield, Middx. [1701]

**WE** Offer Cash for Good Modern Communication and All-wave Receivers.—A.C.S. Radio, 44, Widmore Rd., Bromley. [1541]

**S.S.** Trichannel amplifier, complete with 8 speakers; also Rola G12 energised.—Hodgson, Meadow View, Pickersleigh Rd., Malvern. [1680]

**NATIONAL "HRO," "100XA," "One-Ten" Hallicrafters, "SX24," "SX25,"** Eddystone 358; good price.—Box 2841, Wireless World. [1656]

**NATIONAL H.R.O.** Communications Receiver Required, 230 volts A.C.; must be late model, in good condition; state lowest cash price.—Box 285a, 75-79, Farringdon St., London, E.C.4. [1557]

**HALLICRAFTERS** SX-28 receiver, with matched speaker; R.M.E. model 70 with matched speaker; D.B. 20 to match R.M.E. model 70; no priorities available; all for use with 230 ac.—Box 2853, c/o Wireless World. [1668]

**LONDON CENTRAL RADIO STORES** will pay good prices for receivers, radiograms, amplifiers, dynamos, converters, test equipment, electric gramophone motors, and all radio and electrical accessories.—London Central Radio Stores, 23, Lisle St., London, W.C.2. Gerrard 2969. [9836]

**NEW LOUDSPEAKERS**  
**£3/15** only.—Brand new Super Quality triple cone permanent magnet speaker, made by Bakers Selhurst Radio, the pioneer manufacturers of moving-coil speakers since 1925; wide frequency range, even response, ideal for quality reproduction; limited number available under list price; send 21d. stamp for leaflet describing above and giving constructional details of infinite baffle cabinet; every music lover interested in realistic reproduction should write for leaflet now.—Bakers Selhurst Radio, 75, Sussex Rd., S. Croydon. [1699]

Advertisers and buyers are reminded that under Defence Regulations 1939, Statutory Rules and Orders 1940, Number 1689, a permit (T 99 G) must be obtained before sale or purchase of certain electrical and wireless apparatus, particularly such valves and apparatus as are applicable to wireless transmission.

## A 65-watt SOLON for general use



This 65-watt Industrial type SOLON Electric Soldering Iron is fitted with an oval tapered bit—a shape which is suitable for most general work. For specialised work the pencil bit model is recommended, whilst bigger jobs call for the 125-watt or 240-watt models.

Supplies of these various models are only available for essential work, of course, and due to heavy demands it is necessary to order well in advance to avoid disappointment in delivery.

Details of this and other models sent on request.

## SOLON Electric SOLDERING IRON

MADE FOR USUAL STANDARD VOLTAGES

W. T. HENLEY'S TELEGRAPH WORKS CO. LTD.  
Engineering Dept., Milton Court, Westcott, Dorking, Surrey

## L.R.S. STUART PUMPS

As supplied to Govt. Depts. & County Councils.



These Centrifugal Pumps are ideal for Machine Tool Cooling and all pumping purposes—hot or cold water. Supplied complete with foot-valve, strainer and hose union. Suitable rubber hose available from stock.

No. 10.	100 gals. per hour.	Carr. 2/- extra	£5 2 6
No. 11.	280 gals. per hour.	Carr. 2/- extra	£8 6 0
No. 12.	560 gals. per hour.	Carr. 3/- extra	£7 12 0

Please send 21d. stamp for specification.

**The STUART AUTOMATIC FLOAT SWITCH** is the best method of controlling water—Post Paid level. Price complete with all fittings .. £2 6 0

**LONDON RADIO SUPPLY CO.**  
Est. 1925  
Ardingly Road, Balcombe, Sussex.

# GALPINS

## ELECTRICAL STORES

### "FAIRVIEW,"

#### LONDON ROAD, WROTHAM, KENT.

Please Note Change of Address!

This Business is now transferred permanently to the above address, where all Mail Orders will receive strict personal attention.

TERMS: Cash with Order. No C.O.D.

Regret Orders from Eire and Northern Ireland cannot be accepted.

**ELECTRIC LIGHT CHECK METERS**, well-known makers, first-class condition, electrically guaranteed, for A.C. mains, 200/250 volts 50 cy. 1 phase 5 amp. load, 10/- each; 10 amp. load, 12/6, carriage 1/-.

**1 KW. FIRE ELEMENTS**, mounted on fireproof porcelain, for 220 volts, as new, easily mounted. Price 6/6, post free.

**1 KW TRANSFORMER**, input 100 volts at 100 cycles, single phase, output 10,500 volts, centre tapped to earth. Price **£4 10s.**, carriage forward.

**ROTARY CONVERTER**, D.C. to D.C. Input 12 volts; output 1,100 volts at 30 M/A, ex R.A.F., can also be used as double output generator. Price 50/-, carriage paid.

**X-RAY TRANSFORMER**, in oil-filled tank, medium size, input 120 volts, 50 cycles, 1 ph., output 45,000 volts at 2kW, intermittent rating, in perfect order. Price **£20**, carriage paid.

**ROTARY CONVERTER**, D.C. to D.C., input 48 volts, output 2,500 volts at 1 kW, condition as new and in perfect order. Price **£10**, carriage paid.

**1/2 WATT WIRE END RESISTANCES**, new and unused, assorted sizes (our assortment), 6/- per doz., post free.

**150,000 VOLT X-RAY TRANSFORMER**, large size, weight 12 cwt., input 120 volt, 50 cycle, single phase; output 150,000 volts at 10 KVA, intermittent rating, mounted in steel tank, oil filled, in good working order. Price **£45**, carriage paid.

**DYNAMO**, output 20 volt, 15 amp., shunt wound, interpolate, slow speed, ball bearing, condition as new. Price **£3 10s.**, carriage paid.

**SOLID BRASS LAMPS** (wing type), one hole mounting, fitted double contact, S.B.C. holder, and 12 volt 16 watt bulb. Price 3/6 each, post free, or 30/- per doz., carriage paid.

**HEADPHONES**, 120 ohm, secondhand, complete with headband and cords, in perfect working order. Price 7/6 per pair, post free.

**INSTRUMENT METAL RECTIFIERS**, by famous makers, 10 M/A, full load, connect your D.C. meter to A.C. working. Price 15/- each, post free.

**TUNGSTEN CONTACTS**, 1/4 in. dia., a pair mounted on spring blades, also two high quality pure silver contacts 1/4 in. dia., also on spring blades, fit for heavy duty, new and unused. There is enough base to remove for other work. Price the set of four contacts, 5/-, post free.

**220 VOLT DYNAMO**, 9 amp. output, by Lancaster Dynamo Co., shunt wound, speed 1,500 R.P.M., condition as new. Price **£10**, carriage paid.

**POST OFFICE RELAYS**, small type, high resistance, twin blade, very low milliamps operation, as new. Price 7/6 each, post free.

**VOLTMETERS**, 2 1/2 in. dia. panel mounting, moving coil, modern type, by famous makers, range 0-120 volts, F.S.D. very low. Price 32/6, post free.

**AMP METERS**, description as above, range 0-1 1/2 amps. Price 25/-, post free.

**KLAXON MOTORS**, 220 v. D.C., 1/10th h.p., shunt wound, ball bearing, fitted reduction gear giving speed of 700 r.p.m., high grade job, condition as new. Price 50/-, carriage paid.

**D.G. MOTOR**, shunt wound, condition as new, high grade, ball bearing, 1/4 h.p., can be supplied in 110 or 220 volts as ordered. Price either voltage, 40/-, carriage paid.

**SECONDHAND LOUDSPEAKERS**  
**MAGNAVOX** 33 Duode, as new, with o.p. transformer, Westinghouse energising; offers.—Box 2857, *Wireless World*. [1685]  
**PHAMPONIC** 18in. super speaker, with rectifier, as new; offers, or exchange.—Box 2856, c/o *Wireless World*. [1684]  
**VOIGT** speaker for sale or exchange for coil winder; cash adjustment.—Box 2863, c/o *Wireless World*. [1704]

**Wanted**  
**TWEETER** m.c., p.m. or energ.—Leslie, Kingston, Liberton, Edinburgh. [1675]  
**WANTED**, two G.12 speakers.—Price and condition to Masteradio, Ltd., Watford, Herts. [1650]  
**WANTED**, Rothermel Piezo crystal tweeter speaker.—Sharpe, 172, Headlands, Northampton. [1652]  
**VOIGT** corner horn, and Voigt twin diaphragm unit complete, must be perfect; send full details and price.—Cross, Mill Lodge, Lodge Lane, Salfords, Redhill. [1702]  
**P.M.** 12in speakers, Rola G.12 p.m. or similar make, 2 (two) required urgently for Services entertainment; also 1 electric gramophone motor and turntable.—State price and condition to Box 2849, c/o *Wireless World*. [1648]

**NEW MAINS EQUIPMENT**  
**VORTEXION** mains transformers, chokes, etc., are supplied to G.P.O., B.B.C., L.P.T.B.; why not you? Imitated but unequalled; orders can only be accepted against Government contracts.  
**VORTEXION**, Ltd., 257, The Broadway, Wimbledon, London, S.W.19. Tel. Lib. 2814. [9942]

**MORSE EQUIPMENT**  
**FULL** range of transmitting keys, practice sets and equipment for Morse training.—Webb's Radio, 14, Soho St., London, W.1. Tel. Gerrard 2089. [9553]

**TEST EQUIPMENT**  
**SIGNAL** generator, Mullard GM 2880 F, new condition; offers.—Box 2858, c/o *Wireless World*. [1687]  
**EDISWAN** 6in, type AH, C.R. tube, E.H.T. transformer and 2 high voltage condensers, all perfect and unused; £8.—Box 2850, c/o *Wireless World*. [1653]  
**TESTSCOPE**, used everywhere by radio service engineers, makes 20 important tests. Send for interesting leaflet "R1".—Runbaken, Manchester, 1. [1074]

**Wanted**  
**MILLIVOLTMETERS** wanted for essential work.—Thomas Bolton, 24, Avenue Rd., Leamington Spa. [1688]

**OSCILLATOR** and valve tester, Avo preferred.—Brockbank, 2, Oakthorpe, Windermer, Westmorland. [1676]

**WANTED**, E.M.I. wee megger or similar.—Price and particulars to Owen, 538, Mansfield Rd., Sherwood, Nottingham. [1692]  
**SM8** type "8" meter, by Hallicrafters, complete with plug for receiver's socket; perfect condition essential.—Box 2852, c/o *Wireless World*. [1667]

**GRAMOPHONE EQUIPMENT**  
**COLUMBIA** heavy induction gramo motor, in oak playing desk, with 12in turntable and Marconi hypersensitive pick-up and arm.—Offers Box 2862, c/o *Wireless World*. [1703]  
**COILS** and condensers for filter unit to J. Brierley's specification ("W.W." April), guaranteed 2% accuracy, coils 8/6 each, set of four 30/-; condensers, 3/- each; post free; your own coils adjusted, 2/6 each, postage extra.—R. Clark, 69, Longley Ave., Alperton, Middx. [1682]

**COMPONENTS—SECOND-HAND, SURPLUS**  
**FORMO** ceramic ribbed 2x1 1/2in coil formers, with 2 1/2x1/2x1/4in 5 hole base, without fittings, 4/6 per doz.; 50/- per gross.—A.C.S. Radio, 44, Widmore Rd., Bromley. [1674]

**ROTHERMEL**, "Bullet" crystal microphones for stand mounting, latest type, with tilting mount, black crackle finish, headlamp shape, excellent tonal quality, at a modest price, £3, post 7d.; heavy plated floor stands for above, 57/6; desk stands, 30/-; few only, famous D.104 mikes with aluminium diaphragm, plated housings, £4/15; miniature deaf aid type crystal microphones, 42/6, post 6d.; bakelite bell transformers, 6/9; postage 5d.; trickle charger type metal rectifiers, 2v 0.3amp, 3/6, post 4d.; 6v 0.5amp metal rectifiers, 6/3; 12v 0.5amp, 11/9, post 4d.; instrument type rectifiers for meters, bridge type, bakelite, 15/6; one only Weston 100mA meter, second-hand, seals unbroken, 32/6; also one only second-hand 1 milliamp movement, good make, 65/-; also two only 1 milliamp movements, new, 82/6; three only battery chargers, very good make, 2v to 12 v up to 5amps variable, metal rectification, ammeter fitted, brand new, £11/10.—Champion, 42, Howitt Rd., London, N.W.3. [1686]

# ELECTRADIX BARGAINS

★ METER MOVEMENTS ★  
**Moving Coil and Magnet Systems, 10/-**

**MAGNETS**, The Wonder Midget 2-oz. Permanent Magnet Disc of Alal Steel. Tremendous magnetic force and only 1.3/16in. dia. x 1/4 in. thick, with soft centre for drilling. One leaps off the table to meet another. Uses: Any magnetic duty, metal separation, magnetic chucks and lifters. Cut-out core, polariser, solenoid cores, head-phone re-magnetisers, etc., 2/6 each, 4/6 pair. A.G.D.G. Mains Magnet, 2 wound poles, 110 or 220 volts, 7 lb. lift, 5/6. Small 12-volt solenoids, 2in. x 1/2 in. plunger, 6/6.



**LIGHT RAY CELLS**, Selenium Bridge Disc of Alal Steel. Raycraft Model, 21/- Electro cell, self-generating, light meter type, 35/-. Raycraft Ray Set with relay, 42/-. Gas-filled Photo Cells W.E. type, for sound on film, 70/- Relay enclosed 10,000 ohm tele-type, 22/6. For other Relays see special leaflet, 2d.

**CABINETS**, Suitable for test set apparatus, mike amplifier, oscillator, portables, etc. 9in. x 9in. x 6 1/2 in., with double doors. A very fine ex-W.D. job, in mahogany, canvas covered. Chassis, panel 4 transformers, a 5-tap switch and rheostat is included. All-in price, 45/-.

**DIMMERS or REOSTATS** with "off" 0 to 1 ohm and will carry up to 3 amps., for regulation on 8 to 12 volts, dimming or band circuit, battery charge model control, etc. One-hole fixing with panels with bracket for other fixing. Hollow knob has socket for min. bulb, glowing when circuit alive. New U.S.A. Atena make, in carton, 2/6. Worth 5/-. Large 40 amp. ironclad grid Rheos with heavy 10 stand circuit to drop 220 volts to 46 volts. Size 3 1/2 in. x 1 1/2 in. x 1 1/2 in., 25/10/-, 110-volt ditto, 16in. x 1 1/2 in. x 1 1/2 in., £2/10.



**HANDCOMB**, Government all-metal Field Handcomb, Micro-telephones or Transceivers for portable or fixed telephones. The famous No. 16 Handcomb used in so many field sets. Sturdily built with mike finger switch. As new, but no cord, 12/6. Limited number available. Similar Handcomb, less switch and no cord, 7/6. A Home Guard can make a complete pocket telephone with these, a mike, transformer, buzzer and a torch battery.



**BUZZERS**, Neat brass cased Buzzer, 4/6 Heavy type, Bakelite cased, 5/6. D.3 Buzzers, multiple windings, no contacts, 5/-. Townsend Micro Buzzer (as illus.), 10/-. Perfect Morse. Home training with a practice Recording Ink, spring drive, needs no battery; marks direct on tape with dead key. For notice or expert. Govt. type, £3/10/-.



**DYNAMOS**, 6/12 volts, 8 amps high speed Aero Lucas, Rotax, 17/6. Vee Pulleys for 1/2 in. belt, 4/6. Flex Couplings, 1/2 to 1 1/2 in., 6/-. Water Tanks, 5ft. x 1 1/2 in., with fittings, 90/-. Small type, 6 x 3 x 2 1/2 in., 2/-. Welded steel high pressure type, 8 1/2 in. x 2 1/2 in., 3/6.

**CHARGERS**, We have some specially large Westinghouse 230-volt Rectifier Chargers for 15 amps. and 32 amps. at 8 volts for priority delivery from stock. All sizes supplied now from 1 amp. upwards. Ask for new price leaflet.

**TRANSFORMERS**, Special line of 5 watt, 1,000-volt transformers, A.C. mains, for Neon ozonizers, C.R. tubes, condenser test, etc., 7/6.



**TURNTABLES**, Ball-bearing, for table sets, etc., bakelite body, 4in. dia., 2/- each.

**WE CAN STILL SUPPLY** Wheatstone Bridges, Sullivan and Tinsley Mirror Galvos, Scales and Stands; Siemens High-speed Relays, Radiogoniometers, Wavemeters, Meggers, A.C. Panel Voltmeters, Rotaries and Alternators, 10,000 ohm Relays, etc.



Switches and Plug Sockets on Ebonite Panel Mahogany Case

**LAB. GEAR**, Mirror Galvos, Sullivan Marine Reflecting vertical M.C. suspen., £9/10/-. Tinsley Ballistic ditto, £4/10/- Mahog. Stand Scales for Spot use, £2/10/-. Wheatstone Bridges and 142M Resistance boxes quoted for. A number of ex-W.D. Wheatstone Bridges, less coils, cheap. Circuit testing G.P.O. Vertical Galvos, 35/-. Mag. Ringer and A.C. Bell, 25/-.

Please add postage for all mail orders.  
 Send stamped envelopes for replies to all enquiries.

**ELECTRADIX RADIOS**,  
 19, Broughton Street, Battersea, London, S.W.9  
 Telephone · Macculay 2159

# SEXTON'S for SERVICE

## AMERICAN LEASE-LEND VALVES

Types and prices as under at Board of Trade Controlled Prices, inclusive of Purchase Tax:—  
 1A5GT, 1C5GT, 1T5GT, 5Y3GT, 12Z3GT, 26Z6GT, 35Z4GT, 35Z5GT, at 11/- each. 1H5GT, 6F5GT, 12F5GT, 12F5GT, at 9/2 each. 6A8GT, 12A8GT, 12A7GT, 6A7GT, at 14/- each. 6F6GT, 12K7GT, 12J7GT, 12S7GT, 12K7GT, 26A8GT, 26L8GT, 36L8GT, 60L8GT, 61V7GT, 6K7GT, 36, 47, at 12/10 each. 12A7G, 26A7GT, 70L7GT, 70L7GT, 83, 12B9GT, at 15/3 each. 6Q7GT, 12Q7GT, 12S7GT, 45, at 11/7 each. Postage and packing 4d. These valves are sold only for immediate replacements.  
 Non-Lease-Lend American Valves at standard prices, incl. of Tax, 4s, 4s, at 10/8 each. 6A7, at 11/7 each. 6D6, 6D6 (Magic Eye), at 10/8 each. 19B6GT, 1A7GT, at 21/8 each. Postage and packing 4d.  
 Brivaron British Made Valves equivalent to American types 80 and English U.12, at 13/7 each. Postage and packing 4d.

## EXTENSION LOUDSPEAKERS

"Rola," 3 ohms voice coil, less Trans. Size 5in., at 17/9 each; 6in., at 19/9 each; 8in., at 24/- each; 10in., at 27/6 each. "Celestion," Model CT.104, with Universal Trans., 8in. chassis, 3 watts, at 36/- each. Model CT.108, with Universal Trans., 8in. chassis, 5 watts, at 43/- each. Suitable cabinets for all models can be supplied. Prices upon application.  
 Barretters, .2 amp, suitable for replacement of Philips 01, at 3/6 each. Postage and packing 4d.  
 Electric Soldering Irons as used by all leading Radio Manufacturers. Universal voltage, at 12/8, 14/6, 17/8 each, with leads and two-pin plug. Postage 9d.  
 Electric Smoothing Irons. Super quality, 5-5 1/2 lb weight, strong bolt through handle, heavily plated body connector guard and rest, unslated bottom, complete with heavy three-wire flex and three-pin 5 amp plug, at 31/3. Smaller model, heavily plated throughout, 2-3 1/2 lb weight, with two-pin 5 amp plug and flex, at 27/8. Postage and packing 1/- each.  
 Terms: Cash with order only. Owing to shortage of staff we regret that we are unable to despatch orders O.O.D., or send pro forma invoices. All prices above include purchase tax where applicable.  
 Send 1d. stamp and S.A.E. for latest list of all Valves, Radio Components, Electrical Fittings and Accessories, etc.

## J. E. SEXTON & CO. LTD.

164, Gray's Inn Road, London, W.C.1  
 Telephone: TER. 1304, 4842.

# Radio Officers' Pay!

"On and after April let all applicants holding the P.M.G. 'Special' certificate first entering the marine wireless service will be known as assistant radio officers. Their commencing rate of pay will be 28 per month, which will increase to 32."

War risk money is additional to all these rates."

Vide "Wireless World," p. 108, April issue.

## LEARN MORSE CODE THE CANDLER WAY

'Andler students say:—

"A few weeks ago I obtained my P.M.G. Special certificate, and I am going to sea very shortly as a 2nd Radio Officer in the '...' Co. Thank you for the interest you took on my behalf, and for the help which enabled me to pass the examination."  
*Ref. No. 7928. A. H. M.*

"Just a few lines in appreciation of your Course. I am glad to say that I have sat for and passed the P.M.G.'s 'Special Certificate,' and am waiting for a berth as 3rd Radio Officer."  
*Ref. No. 8122. D. C.*

"My progress at present is fine. Slight difficulties are occurring with some signals, but these are gradually being overcome. May I congratulate you on such a fine Course. Have been accepted as W/T Operator in the Royal Navy."  
*Ref. No. 8768. T. F. W. D.*

The originals of these and many similar letters can be inspected at the London Office.

### SEND FOR FREE "BOOK OF FACTS."

It tells you all about the Candler Code Courses.

**JUNIOR Scientific Code Course for Beginners.** Teaches all the necessary code fundamentals scientifically.

**ADVANCED High-speed Telegraphing for Operators** who want to increase their w.p.m. speed and improve their technique.

Terms: Cash or Monthly Payments.

## COUPON

Please send me a Free Copy of Candler "Book of Facts."

NAME .....

ADDRESS .....

Post Coupon in 1d. unsealed envelope to London Manager  
**THE CANDLER SYSTEM CO. (Room 55W),**  
 121 Kingway, London, W.C.2

Candler System Co., Denver, Colorado, U.S.A. (548)

**LONDON CENTRAL RADIO STORES** offer the finest radio and electrical bargains.  
**6 PUSH-BUTTON** mechanism only unit, complete with buttons; post, etc., 9d. extra; 4/6.

**T.C.C.** condensers, 0.1mfd 5,000v, dc wkg; post, etc., 8d. extra; 9/6 each.

**SCREENED** cable, fine quality, heavy duty, S 15 strand, 30 gauge, 5mm rubber covering, with two layers of Empire tape, 1/9 per yard.

**RUBBER** covered flexible wire, tinned copper, approx. 17 strands, 9ft lengths, 3d per yard.

**PHILCO** bleeder resistances, in metal cans. 100, 150, 250ohms; all 10w; post, etc., 3d. extra; 2/6 each.

**TUBULAR** condensers, 0.5mfd, 500v working; 2/6; post, etc., 4d.

**MULLARD** EA50 diodes, 60mmx12mm overall, 6.3v heater at 15amps; post and pkg. 3d. extra; 10/6 each.

**PHILIPS** Potentiometers, carbon: 700,000 ohms, less switch, 3/6; 100,000ohms, with 2-pole M. & B. switch, 4/6; post and pkg. 6d. extra.

**LONDON CENTRAL RADIO STORES, 23, Lisle St., London, W.C.2. Gerrard 2969.**

**FERRANTI** electrostatic 3in flush 0-1500v £3; G.E.C. monitor tube, 4053, £2; Mazda T11, 30/-; 0-50 ampmeter, 4in flush approx. 7.5ma fa, 30/-; Hunts electrolytics 8+8, 700v, 8/6; Eddystone gear; stamp list.—Box 2861, c/o Wireless World. [1694]

**COULPHONE** RADIO, New Longton, nr. Preston.—Brand new goods only; mains transfs., 350-350 120ma, 4v 6a, 4v 2.5a, 28/6; p.m. speakers with transfs. 8in Celestion, 24/6; 5in Rola, 22/6; Tungram valves; cored solder, 4/6 lb; Barretter resistors, 6/-; line cord replacement resistors, 800 ohm, 2 adjust. taps, 6/9; electrolytics, 50mfd, 50-volt, 3/3; Erie 1-watt resistors, all values, 9d. each; pushback wire, 100ft coil, 6/-; switch cleaner, 2/3 bottle; power-pentode transformers, 7/6. S.A.E. for stock list. [1660]

**RADIO** service supplies.—Rola 8in p.m. speakers, no trans., 23/-; volume controls, less switch, 1, 1/2 and 1/4meg, 4/- each, 45/- doz; long spindle, 1/4 diameter, a few with s.p. switch, 6/- each, 70/- doz; good quality bakelite knobs, walnut, 1/2in, with fixing screw, 7/6 doz; Mullard 1-watt resistors, 5/6 doz; 0.0005 reaction condensers, 2/3 each; fixed condensers, 0.1, 0.01, 7/- doz; 0.005, 6/- doz; 0.25, 12/6 doz; 0.5, 15/- doz; sleeving, 2/6 doz yards; cards of assorted mains droppers, Murphy, Pye, Ferranti, etc., 7 on card, 35/-; Servisol, 5/- per tin; barretter resistors, 4/- each; valves, replacements for English 4-volt and 5-volt rectifiers, American 80, 5Y4, 5Y3, 14/6 each; PM2, 7/4; PM252, 7/4; HL4T, 9/2; PM22A, 11/-; 6F6G, 12/10; 7A7E, 12/10; 6A8G, 14/-; 6F9, 12/10; EBL1, 15/3; 6K8G, 14/-; PM2A, 7/4; cash with order only; regret no c.o.d.; no lists; please add estimated postage on all orders under 15/-.—Provincial Radio and Electrical Supplies, 72, Abbey St., Nuneaton. [1700]

**SOUTHERN RADIOS** Wireless Bargains:  
 6/- gross assorted screws, 6/- 6/- gross solderings tags, including spade ends, 6/- 7/6, Philco 3-point car aerials. Make excellent short-wave and home aerials. Complete with fixing bolts, etc., 7/6. 10/- limit tone arms. Universal fixing for all types of sound box and pick-up heads, 10/- 7/- Ace "P.O." microphones, complete with transformer. Ready for use with any receiver, 7/- 30/-, Erie resistances, 100 assorted resistances, 4, 1/2, and 2 watt. Sizes from 0.8 ohm upwards. Brand new, with wire ends, 100 for 30/-. 65/- special assorted parcel for Servicemen. 100 Erie resistances, assorted sizes, from 0.8 ohms upward, 1/4, 1/2, 1 and 2 watt; 24 assorted tubular condensers, 0.01, 0.05, 0.1, etc., up to 6 mfd. 50 volt; 6 reaction condensers; 12 lengths sleeving; 75ft. push-back wire; soldering tags, screws and wire. All brand new, 65/- 1/6, powerful circular magnets, 1 1/2in. diameter by 1/2in. thick, 1/6 each, 15/- per dozen. Tungram H.R. 210 valves. General purpose battery type, 4/9; crystals (Dr. Cecil), 6d. each, 5/6 per dozen; with cats-whisker, 9d. each, 8/- dozen; complete crystal detectors, 2/6; 75ft. covered wire for aerials, etc. 2/6; 25 yds. push-back wire, 5/-; crystals cups, 6d. each, 5/- dozen; Telsen reaction condensers (0.0001), 1/9 each, 18/- dozen; Telsen large disc drives, complete with escutcheon, knob, etc. type W184, 3/- each, 30/- dozen; insulated sleeving, assorted yard lengths, 4/- per dozen; single screened wire, 12 yds., 10/-; M.E.S. holders (miniature screw bulb holders), metal, 7/2d. each, 6/- per dozen. Many other bargains for callers.—Southern Radio Supply Co., 46, Lisle St., London, W.C. Gerrard 8653. [1699]

# AMBITIOUS ENGINEERS



Whatever your age or experience — you must read this highly informative guide to the best paid Engineering posts.

The Handbook contains particulars of:  
**A.M.I.C.E.**  
**A.M.I.Mech.E.**  
**A.M.I.E.E., A.M.I.A.E.,**  
**A.M.Brit.I.R.E.**

and other important Engineering Examinations, and outlines courses in all branches of **Civil, Mechanical, Electrical, Automobile, Radio and Aeronautical Engineering, Govt. Employment, Draughtsmanship, Building Matriculation, "R.A.F. Maths,"** etc.

## WE GUARANTEE 'NO PASS-NO FEE'

If you are earning less than £10 a week you cannot afford to miss reading "Engineering Opportunities"; it tells you everything you want to know to secure your future, and describes many chances you are now missing. Write for your copy of this enlightening guide to permanent well-paid posts NOW—FREE.

**BRITISH INSTITUTE OF ENGINEERING TECHNOLOGY, 387a, Shakespeare House, 17, Stratford Place, London, W.1.**

# TESTOSCOPE



Makes 30 important tests, 100 to 750 volts, A.C. or D.C. Used everywhere by Electricians, Wiremen, etc. From Wholesalers or direct. Send for leaflet "R.14."

**RUNBAKEN -- MANCHESTER -- I**

# GECALLOY

## N.F. ALLOY POWDER

THE LATEST DEVELOPMENT IN MAGNETIC POWDER METALLURGY



**MAIN ADVANTAGES:**  
 1. Higher Permeability.  
 2. Higher Particle Specific Resistance.  
 3. Low Eddy Current Loss.  
 4. Non-Blasting.

**Salford Electrical Instruments Ltd.**  
 PEEL WORKS, SILK STREET, SALFORD, 1  
 Telephone: BLAckfriars 6688 (6 lines)  
 Progressors: The General Electric Co. Ltd., England



**A.C. & BATTERY  
CONSTRUCTORS' KITS**  
3-v. **T.R.F.**

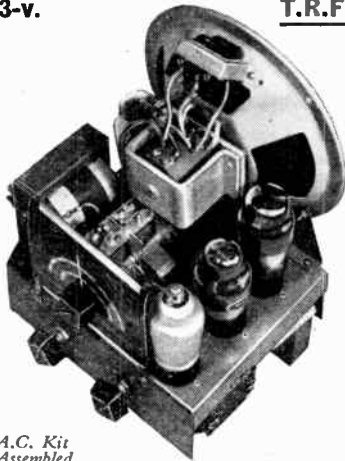

A.C. Kit  
Assembled.

When assembled these Kits give excellent reproduction on Medium and Long Waves. Supplied complete with chassis 8in. x 6in. x 2 1/2in., Valves, M.C. Speaker, and wiring diagram. (Regret, no cabinets.) 3 controls.

**A.C. 3-V. (+RECTIFIER) KIT.** V.M.H.F. Pen., Triode, L.F. Pen., Rectifier, M.C. Speaker. Price £9 9s. Post 1/1, plus 3/6 packing (returnable).

**BATTERY 3-V. KIT.** V.M.H.F. Pen., Triode Detector and Output Tetrode, P.M. Speaker. Price £6 10s. Post 1/1, plus 3/6 packing (returnable).

Orders executed in rotation. Delivery approx one month. No C.O.D.

● **CALL FOR DEMONSTRATION** ●

**MAINS TRANSFORMERS.** 350-0-350, 120 m.a., 6.3v. 5 amp., 5v. 2 amp. Colour coded. Brand new. 35/-. Postage 11d.

**STANDARD 3-GANG .0005 CONDENSER,** with trimmers, new, boxed. 7/6.

**2-GANG CONDENSER,** .0005, with trimmers, 7/6.

**MIDGET 2-GANG .0005,** S.M. drive and dial. 10/-.

**A. & H.F. COILS,** dual ranges reaction, coloured wires, circuit. 8/6 per pair.

**ALL-WAVE H.F. CHOKES,** shielded. 4/6.

**NEW STEEL CHASSIS,** undrilled, painted 10 x 8 x 2 1/2, 7/6; 8 x 6, 4/6.

**10-WATT WIRE WOUND RESISTORS,** 2,000, 500, 150 ohms. 2/6 each.

**RESISTORS,** 1/2-watt, 4d.; 1/4-watt, 6d.; 1 watt, 1/-.

**LINE COIL REPLACEMENT RESISTORS,** 750 ohm with variable tapping, 5/6; 800 ohm, 50 tapped, 3/6.

**PARALLEL FEED SCREENED L.F. TRANSFORMER,** small, 8/-.

**SCREENED CABLE,** Twin. 1/9 per yd.

**MICA CONDENSERS,** .001, 2,200v. test, 1/6; .0001, 1/-; .01, 1/6.

Licence to export to Northern Ireland and Irish Free State. Please add postage for enquiries and mail orders.

**51-52 CHANCERY LANE.**  
LONDON, W. 2. Telephone MO1804N4331

**G. A. RYALL, "Arnehurst,"** Marsh Lane, Taplow, Bucks.—All goods except loud speakers as advertised in last issue still available. [1658]

**LASKY'S RADIO,** 370, Harrow Rd., Paddington, W.9, offer for sale the following condensers: .15mf 2,000v at 1/6 each, .02mf 2,000v at 1/- each, .23mf 2,000v at 1/6 each, .05mf 2,000v at 1/- each, .002mf 2,000v at 1/- each, 2mf 400v cans 4/3 each, 4mf 400v block 5/9 each, 50mf 12v tubular 16/- doz., 25mf 25v tubular 18/- doz., .1mf 350v tubular 6/- doz., 10mf 25v tubular 1/6 each; speakers, speaker output transformers from 6-: 6 1/4in. Rola speakers, less transformers, at 17/6, plus postage; 8in Rola speakers, less transformers, at 21/-, plus postage; 5in Rola speakers, less transformer, 17/6 plus postage; 8in Rola speakers, with transformers, 27/6, plus postage; terms cash with order or c.o.d. Send us your requirements. [1673]

**Wanted**  
**SKYROD** aerial complete, as issued by Belling Lee and Co.; state price, etc.—Box 2851, c/o *Wireless World*. [1666]

**OYNAMOS, MOTORS, ETC.**  
ALL types of rotary converters, electric motors, battery chargers, petrol-electric generator sets, etc., in stock, new and second-hand.

**WARD, 37,** White Post Lane, Hackney Wick, E.9. Tel. Amherst 1393. [0518]

**L.T. dynamos** for charging. Lucas-Rotax, 6-12v 8amps dc, 3rd brush, weight 11lb, size 8in x 4 1/2in, unused ex W.D., cost £10, to clear 17/6 each; 1st and 1st G.E.C. double-current 6v and 600v, 17lb ditto, 27/6; all carr. paid England and Wales.—Electrix, 19, Broughton St., London, S.W.8. [1695]

**Wanted**  
**WANTED,** Philips converter unit, 110-145v, type 7830 C-15.—Dr. Gallagher, County Mental Hospital, Chester. [1706]

**VALVES**  
USED valves, 40 mains and 24 battery type, all serviceable, £4 lot.—Box 2860, c/o *Wireless World*. [1690]

If you cannot obtain that wireless valve, try Dowsett and Co., Ltd., 48, Grove Rd., Eastbourne. Stamp reply. [1670]

**5000** valves, all types, outputs, rectifiers, etc., s.a.e.—Davies, 28, Mount Vernon Crescent, Barnsley. [1649]

**WE** have a large stock of new and boxed valves, all guaranteed, at retail prices, plus tax; also U.S.A. lease-lend types for replacement; send us your requirements.—Lasky's Radio, 370, Harrow Rd., Paddington, W.9. [1672]

**1000** valves in stock; UU5, UU6, UU7, AC/SPEN, PEN45, PEN45DD, TH4B, VP44, PEN383, TP1340, AC/TP, QP22B, TP26, 35, 45, 80, 35Z4GT, 6Q6GT, 1I7Z6GT, 6K7G, 6L7G, KT1W61, 5Y3G, 6C6G, 6D6G, 6V6G, 6F6G; send s.a.e. for valve and wireless parts lists, 2d.—Ransom, 9 and 34, Bond St., Brighton. [1697]

**UNIVERSAL** valves for receiver replacement only. 50L6, 12J7, 12K7, 12SK7, 25L6, 12/10 each; 35Z5, 25Z6, 35Z4, 1A5, 1T5, 1I/- each; also 70L7, 128Q7, 12Q7, 1H5, 6A8, etc., etc., at controlled prices. All "GT" types. British and other American valves always in stock. S.A.E. please.—The Dale Electric Company, 13, Tretawn Gardens, London, N.W.7. [1696]

**Wanted**  
**VALVES** wanted, any quantity from one upwards; also test equipment, service sheets and spares.—J. Bull, 246, High St., Harlesden, N.W.10. [9732]

**PHILIPS** rectifying valve wanted, type DC1/50, Philips power triode, type MC1/50, new or second-hand.—Please state price to Copeman, 22, Greenford Gdns., Greenford, Middx. [1664]

**REPAIRS AND SERVICE**  
L.T.P. repair all mains transformers and chokes, prompt delivery.

**LONDON TRANSFORMER PRODUCTS,** Ltd., Willesden, N.W.10. Wil. 6486 (3 lines). [9552]

**MIDWEST, etc.,** we are the American experts.—Bennett's, 4, Humberstone Drive, Leicester. [1683]

**INSTRUMENTS** of all types repaired and calibrated; work guaranteed.—McKissock, 9, Bruce St., Dunfermline. [1681]

**TRANSFORMERS,** motor rewinds, repairs of all descriptions; to the wireless trade.—Marshall, 137, Windmill Lane, Nottingham. [1627]

**METROPOLITAN RADIO SERVICE Co.** guarantee repairs to American and British receivers.—1021, Finchley Rd., N.W.11. Spe. 3000. [9641]

**PREMIER RADIO**

**Premier 1-Valve de Luxe Battery Model S.W. Receiver,** complete with 2-volt valve, 4 coils covering 12-170 metres. Built on steel chassis and panel, 55/-, including tax.

**PREMIER MICROPHONES**

**Transverse Current Mike,** High-grade large output unit. Response 46-7,500 cycles. Low hiss level, 23/-.

**Premier Super-Moving Coil Mike,** Permanent Magnet model requiring no energising. Sensitivity 96db. Impedance 16 ohms. Excellent reproduction of speech and music, 25/5/-.

**Microphone Transformers,** 10/6 each. **Chromium Collapsible Type Microphone Stand,** 52/6.

**NEW PREMIER S.W. COILS**

4- and 6-pin types now have octal pin spacing and will fit International Octal valve holders.

4-PIN TYPE			6-PIN TYPE		
Type	Range	Price	Type	Range	Price
04A	9-15 m.	2/6	06	9-16 m.	2/6
04B	12-26 m.	2/6	06A	12-26 m.	2/6
04B	22-47 m.	2/6	06B	22-47 m.	2/6
04C	41-94 m.	2/6	06C	41-94 m.	2/6
04D	76-170 m.	2/6	06D	76-170 m.	2/6
04E	150-350 m.	3/-	<b>CEASIS</b>		
04F	255-550 m.	3/-	<b>MOUNTING</b>		
04G	490-1,000 m.	4/-	<b>OCTAL HOLDERS</b>		
04H	1,000-2,000 m.	4/-	10/d. each.		
New Premier 3-Band S.W. Coil, 11-25, 25-38, 38-86 m., 4/9.					
Rotary Wave Change Switch, to suit above, 1/6.					
Bakelite Dielectric Reaction Condensers					
0001 mf. . . . . 1/3					
0003 mf. . . . . 2/6					
0005 mf. . . . . 2/9					
0003 mf. Differential. . . . . 2/11					
2-Gang 0005mf. Condensers, with trimmers . . . . . 5/6 each					

**H.F. CHOKES**

S.W. H.F. Choke, 10-100 m. . . . . 10/d.  
Standard H.F. Choke . . . . . 1/-  
Binocular H.F. Choke . . . . . 1/6

**SHORT WAVE CONDENSERS**

**Trolit Insulation.** Certified superior to ceramic All-brass construction. Easily ganged.  
15 m.mfd. . . . . 2/4  
100 m.mfd. . . . . 3/-  
25 m.mfd. . . . . 2/2  
160 m.mfd. . . . . 3/7  
40 m.mfd. . . . . 2/6  
250 m.mfd. . . . . 4/-  
**Bram Shell Couplers,** 1 in. bore. . . . . 7/d. each  
**Flexible Couplers,** 1 in. bore. . . . . 1/2 each  
**7-10in Ceramic Chassis mtr.** English fitting Valve Holders, 1/6 each.

**"LEARNING MORSE?"**

Then purchase one of the new practice Oscillators. Supplied complete with valve, on steel chassis, 27/6. Practice key, 3/3. TX key, 5/9. Super model on wooden base, 11/6.  
**Brown's Headphones,** 19/6 pair.  
**3-Henry Chokes,** 10/-.  
**Good Quality Buzzer,** 3/-.

**ELECTROLYTIC CONDENSERS**

Tubular wire end type, 25 mf. 25v., 1/6 each; 50 mf., 50v., 3/- each.

**RESISTANCES**

**Mains Resistances,** 680 ohms. 3A Tapped. 360 x 180 x 60 x 60 ohms, 5/6 each.  
1,000 ohms 2A Tapped. 900, 800, 700, 600, 500 ohms, 5/6 each.  
1 ohm ± 1%, suitable for Bridges, 5/-.  
**Valve Screens** for International and U.S.A. types, 1/2 each.  
**Push-Back Connecting Wire,** 2d. per yard.  
**Resin-Cored Solder,** 7/d. per coil.  
**Flexoflex Soldering,** 2 mm., 2/6 per doz. yards.  
**Waterproof Covered Cable,** 3-way, 1/3 per yard; 5-way, 1/6 per yard.  
**Screened Braided Cable,** Single, 1/3 per yard; Twin, 1/6 per yard. Maximum lengths 6 yards approx.

**MOVING COIL SPEAKERS**

**Celestion 3 in. P.M. Speaker,** 25/-.  
Above speaker is complete with output transformer.  
**Rola 5 in. P.M. Speaker,** 3 ohms voice coil, 21/-.  
**Rola 6 in. P.M. Speaker,** 3 ohms voice coil, 25/-.  
**Rola 8 in. P.M. Speaker,** 3 ohms voice coil, 25/-.

ALL ENQUIRIES MUST BE ACCOMPANIED BY A 2/d. STAMP.

**PREMIER RADIO CO.**

ALL POST ORDERS TO:  
**JUBILEE WORKS, 167, LOWER CLAPTON ROAD, LONDON, E.5. (Amherst 4723.)**

CALLERS to:  
**JUBILEE WORKS** or  
169, FLEET STREET, E.C.4. (Central 2638.)

# LASKY'S RADIO

for  
Valves, Speakers, Condensers and  
Components.

OUR SPECIAL OFFERS for this month

## 24 ASSORTED CONDENSERS AND ELECTROLYTICS

consisting of 1mf. 350v., 50mf. 12v., 2mf. 400v. can, 16mf. 500v. can, 4mf. 400v. block, .23mf. 1,000v., .02mf. 1,000v., 25mf. 25v., 8mf., etc., etc. All for £2, post 6d.  
24 Assorted Dials, Escusions and Slow Motion Drive. All for 10s., post free.

**PARCEL OF COMPONENTS**  
consisting of Volume Controls, Valve Holders, U.S.A., Octal and English 7-pin, Pushback, Wire, Condensers, Electrolytics, Resistors, etc., etc. All for £1 10s., plus 6d. postage.

**VALVES! VALVES! VALVES!**  
We have a large selection of English and U.S.A. valves in stock as per example:

1A5, 5Z3, 5Z4, 6A8, 6F6, 6K6, 6K7, 6K8, 1C5, 6Q7, 12A8, 12Q7, 12S7, 25L6, 25Z6, 6B8, 32L7, 35L6, 35Z4, 35Z5, 50L6, 70L7, 11Z6, 6, 8, 0, 6X5, 12B8, 12F5, 617, etc., etc. All at B.O.T. Fixed Retail Prices Plus Tax.

English AC, AC/DC and Battery Valves as follows:  
U50, HL4, HL13, MVSYPN, VP4, SP4, FC4, MU14, X65, MU12, U12, ECH3, DW4/500, EBL1, FC2, UUS, X63, KTW61, KT63, WD40, TDD4, etc., etc.  
Speakers, Speaker Transformers, Volume Controls, with and without switch.

Send us your requirements.

**LASKY'S RADIO,**  
370, Harrow Road, Paddington, W.9.

Telephone: Cunningham 1979.

CASH WITH ORDER OR C.O.D.



**F**OR THE  
RADIO SERVICE  
MAN, DEALER  
AND OWNER

The man who enrolls for an I. C. S. Radio Course learns radio thoroughly, completely, practically. When he earns his diploma, he will KNOW radio. We are not content merely to teach the principles of radio, we want to show our students how to apply that training in practical, every-day, radio service work. We train them to be successful!

### INTERNATIONAL CORRESPONDENCE SCHOOLS

Dept. 38, International Buildings,  
Kingsway, London, W.C.2  
Please explain fully about your instruction in the subject marked X.

Complete Radio Engineering  
Radio Service Engineers  
Elementary Radio Television  
And the following Radio examinations:  
British Institution of Radio Engineers  
P.M.G. Certificate for Wireless Operators  
Provisional Certificate in Radio Telephony and Telegraphy for Aircraft  
City and Guilds Telecommunications  
Wireless Operator & Wireless Mechanic, R.A.F.

Name..... Age.....  
Address.....

**A**CCURATE radio rewinds, mains transformers, fields o.p. transformers, etc., and all loudspeaker repairs.—Southern Trade Services, 75a, George St., Croydon. [1039]

**M**AJNS transformers service, repairs, rewinds, or construction to specification of any type, competitive prices and prompt service.—Sturdy Electric Co., Ltd., Dipton, Newcastle-upon-Tyne. [9651]

**S**ERVICE with a Smile.—Repairers of all types of British and American receivers; coil rewinds; American valves, spares, line cords.—F.R.I., Ltd., 22, Howland St., W.I. Museum 5675. [1575]

**A**LL types of radio receivers serviced, Murphy and Pilot specialist; valves in stock; sound repairs for thirteen years.—T. E. Fewyear, F.I.P.R.E., 50, Vine St., Uxbridge, Middx, U.K. 3007. [1655]

**R**EWINDING of every type of radio transformer, design and manufacture to specification; amplifiers designed and manufactured, service and maintenance.—Radio and Transformer Services, 570, Manchester Rd., Hollinwood, Lancs. Tel. Fai. 2507. [1677]

**D**EGALLER'S, Ltd.—Service with a Guarantee. If you have an English or American receiver that needs servicing, let American specialists do the job; any set handled from a T.R.F. Midget to a 30-valve Scott; first-class workmanship only; when forwarding, chassis and valves needed only; send s.a.c. with enquiries.—Degaller's, Ltd., 9, Westbourne Court, London, W.2. [1468]

**P**ATENT AGENTS AND SERVICE BUREAU.—Consultants and registered agents for British, foreign and Colonial patents, design and trade mark registrations, investigations and searches.—Thanet House, 231, Strand, W.C.2. Central 7330. [1609]

**T**UITION  
L EARN Morse code the Candler way. See advertisement on page 28. [1292]

**R**ADIO training—P.M.G. exams and I.E.E. Diploma; prospectus free.—Technical College, Hull. [0611]

**M**ORSE and wireless.—Evening tuition. Students prepared for Govt. examinations; particulars, stamp.—Masters, 15, Wilmington Ave., Chiswick, W.4. [1657]

**R**ADIO Engineering—Television and Wireless Telegraphy, comprehensive, postal courses of instruction. Apply British School of Telegraphy, Ltd., 179, Clapham Rd., London, S.W.9 (Est. 1906). Also instruction at school in wireless for H.M. Merchant Navy and R.A.F. [9249]

**E**NGINEERING Opportunities.—Free 112 page guide to training for A.M.I. Mech.E., A.M.I.E.E., and all branches of engineering and building; full of advice for expert or novice; write for free copy, and make your peacetime future secure.—B.I.E.T. (Dept. 387B), 17, Stratford Place, London, W.1. [1665]

**A**POSTAL Training in Electrical Engineering—power or radio; individual correspondence tuition by highly qualified engineers with wide teaching and technical experience. Elementary or advanced courses. Preparation for recognised examinations. Pre-service training specially arranged.—G. B., 18, Springfield Mount, Kingsbury N.W.9. [1647]

**T**HE Tuitionary Board of the Institute of Practical Radio Engineers Have Available Home Study Courses Covering Elementary, theoretical, mathematical, practical, and laboratory tuition in radio and television engineering; the text is suitable coaching matter for I.P.R.E. Service-entry and progressive exams; tuitionary fees—at pre-war rates—are moderate.—The Syllabus of Instructional Text may be obtained post free from the Secretary, Bush House, Walton Avenue, Henley-on-Thames, Oxon. [1462]

### TECHNICAL TRAINING

**G**REAT possibilities exist for technically qualified engineers, key men in wartime and afterwards. Through the home-study courses of The T.I.G.B. take a recognised engineering qualification, such as A.M.I. Mech.E., A.M.I.E.E., A.F.R.Ae.S., A.M.Chem.E., C. and G., etc. In which examinations, the T.I.G.B. students have gained 25 FIRST PLACES and hundreds of passes. Write today for "The Engineer's Guide to Success"—free—containing the world's widest choice of engineering courses covering all branches, including aeronautical, mechanical, electrical, wireless, chemical, etc.

**T**HE TECHNOLOGICAL INSTITUTE OF GREAT BRITAIN, 82, Temple Bar House, London, E.C.4. [1403]

### BUSINESSES FOR SALE OR WANTED

**R**ADIO and electrical business, Hampton, Middx., est. 15 years, modern shop premises, stock, fitted workshop and instruments, Westinghouse charging plant, 5cwt. van; complete £1,100; owner for military service.—Write Box 2864, c/o Wireless World. [1705]



## W. BRYAN SAVAGE LTD.

Expert assistance in the solution of problems relating to

● TRANSFORMERS, CHOKES

● AMPLIFIERS

● POWER UNITS

and Specialised Equipment embodying

ELECTRONIC CONTROL

WESTMORELAND RD., N.W.9.  
COLINDALE 7131

## AFTER THE WAR!

The advance in Radio Technique after the war will offer unlimited opportunities of high pay and secure posts for those Radio Engineers who have had the foresight to become technically qualified. How you can do this quickly and easily in your spare time is fully explained in our unique handbook.

Full details are given of A.M.I.E.E., A.M.Brit.I.E.E., City & Guilds Exams., and particulars of up-to-date courses in Wireless Engineering, Radio Servicing, Short Wave, Television, Mathematics, etc., etc.

We Guarantee "NO PASS—NO FEE"

Prepare for to-morrow's opportunities and post-war competition by sending for your copy of this very informative 112-page guide NOW—FREE.

**BRITISH INSTITUTE OF ENGINEERING TECHNOLOGY (Dept. 388)**

17, Stratford Place, London, W.1.

## PHILCO VALVES, 1A4E, 1B4E and 24, 6/-; 6K7G, 12/106 2101, 8/-; 15, 11/-; 1A4, 1C6 and 6B8S, 14/-

PHILCO Aerials, 3-point car type, suitable indoors or outdoors, 7/6 complete.

PHILCO dipole aerial Transformers, with L, M and S wave switch, 10/-.

PHILCO aerial, H.F. and oscillator Coils, 2-band, from 3/- 3-band, from 10/-.

PHILCO IF Transformers, 125 kc/s, 8/-; 451 and 465 kc/s, 10/-.

PHILCO Volume Controls, with switch, 8/-.

PHILCO Padding Condensers, from 1/-.

PHILCO Fixed Condensers, 1,000 volts test, .0001, .00025 and .005, 1/- each; .01 and .015, 1/6; .05, .09 and .15, 2/-; .02 + .05, 2/6; .05 + .05, 3/6.

PHILCO Components, assorted parcels for servicemen and amateurs at far below pre-war cost, £1, £2, £3 and £5.

No lists, please send stamp with enquiries. Terms, cash with order. Postage extra.

**E. H. ROBINS TRADING CO. LTD.**  
44, Kyle Crescent South, Whitechurch, Glam.

## LONDEX for RELAYS

for A.C. and D.C.

**TWO STEP RELAY LF/F8**  
(Heavy Silver Contacts)



First Impulse "ON," Second Impulse "OFF."

Also Aerial Change-over Relays.

Ask for leaflet 88A/WW

## LONDEX LTD

MANUFACTURERS OF RELAYS  
207, ABERLEY ROAD, LONDON S.E. 20





**Consult  
BRITISH FILMS LIMITED**

Specialists in the construction of  
**MOBILE CINEMAS AND  
ASSOCIATED EQUIPMENT.  
"BRIMAIN" POWER UNITS.**

PRIORITY ORDERS ONLY

Head Office : 199 PICCADILLY, LONDON, W.1  
Tel. REGENT 2828



**Specialists in Morse Equipment**

Makers of Small Transformers, Heavy Duty Resistances, Plugs and Sockets, Fuse Holders, Electric Bells, Buzzers, and Switches. Also Plastic Mouldings, Coil Windings, Light Pressings, Turned Parts, and other components and accessories for the Wireless and Electrical Trades

**Merit House, Southgate Road, Potters Bar**  
Phone : Potters Bar 3133. Telegrams & Cables : Sel, Potters Bar

**HILL AND CHURCHILL  
BOOKSELLERS**

**SWANAGE DORSET**

ENGLISH & AMERICAN  
BOOKS IN STOCK ON  
RADIO AND  
TELECOMMUNICATION

CATALOGUE ON APPLICATION



For high quality  
loud speakers when  
the good times  
come again.

The Courts, Silverdale, London, S.E.26  
Phone : BYD 6666

**Rewinds Service**

**REWINDS.** Transformers—Mains, 25/-.  
O.P., 6/-. Fields, Pick-ups, Coils, Chokes,  
Rewinds.

**VALVES.** We may have those you want.  
S.A.E. to :  
**A.D.S. Co.** 261/3/5, Lichfield Road,  
Aston, Birmingham, 6.



**MOVING COIL  
MICROPHONES**

are skilfully designed to ensure a high standard of efficiency, durably made to give lasting satisfaction . . . . are to be depended upon in the biggest job—in the front line of communications.

**MICRAMATIC ELECTRICAL  
INSTRUMENTS CO.**

360, STATION RD., HARROW, Middx.  
Telephones : HARrow 1064/5. Telegraphic Address : MEICO, HARROW

**Appointment Vacant**

Director of research and development, to take complete charge of these departments, required by a London firm of Electrical Engineers manufacturing radio frequency, acoustic and electrical instruments. First class qualifications in Physics or Electrical Engineering essential, coupled with wide industrial experience. Write, stating full particulars, to Box 2821, *Wireless World*.

**MATRICULATION  
brings Success & Security**

Whatever your age, you can now study for the all-important Matriculation Examination at home on "NO PASS—NO FEE" terms. "MATRIC" is the accepted passport to all careers, and opens up opportunities which would otherwise be completely closed to you. Ensure the success and security of you and yours through post-war difficulties by writing for our valuable "Guide to Matriculation" immediately—FREE.

**B.T.I. (Dept. 114)**  
356, Oxford Street, London, W.1.

**KESSLERS, (London) LTD**

For TURNING and MACHINING of  
PLASTIC MATERIAL  
SIGNAL LAMP CAPS  
SCREW CUTTING IN BAK.FABRIC  
Albion House, 201-3, Church St., London, N.16  
Tel. : CLissold 6247

**WARD ROTARY  
CONVERTERS**

Petrol Electric Generating Plants, H.T. Generators, D.C. Motors, Frequency Changers, etc., up to 25 K.V.A.

**CHAS. F. WARD**  
37, WHITE POST LANE, HACKNEY WICK, E.9  
Phone : Amherst 1393



**INVENTORS**

We invite new inventions which, guided by the technical knowledge, manufacturing facilities and world-wide marketing organisation of the Simmonds Group, may be developed to play vital parts in modern industry.

*The*  
**SIMMONDS  
GROUP**  
LONDON  
MELBOURNE  
PARIS · NEW YORK  
LOS ANGELES

**SIMMONDS DEVELOPMENT CORPORATION LTD · BUSH HOUSE · W.C.2**

Printed in England for the Publishers, JIFFE AND SONS LTD., Dorset House, Stamford Street, London, S.E.1, by THE CORNWALL PRESS LTD., Paris Garden, Stamford Street, London, S.E.1. "The Wireless World" can be obtained abroad from the following: AUSTRALIA and NEW ZEALAND: Gordon & Gotch, Ltd. INDIA: A. H. Wheeler & Co. CANADA: Imperial News Co.; GORDON & GOTCH, Ltd. SOUTH AFRICA: Central News Agency, Ltd.; Wm. Dawson & Sons (S.A.), Ltd. UNITED STATES: The International News Co.

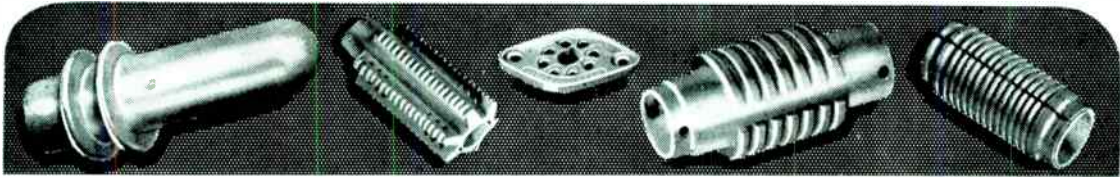

*Clear as a  
Crystal*

**AND HERE IS  
THE REASON..**

••• the answer has been found in Bullers Low Loss Ceramics to the problem of Dielectric Loss in High Frequency circuits.

Years of laboratory research and development have brought these materials to a high degree of efficiency. To-day they are in constant use for transmission and reception, and play a vital part in maintaining communications under all conditions.

**Made in Three Principal Materials**

**FREQUELEX**—An Insulating material of Low Dielectric Loss, for Coil Formers, Aerial Insulators, Valve Holders, etc.

**PERMALEX**—A High Permittivity Material. For the construction of Condensers of the smallest possible dimensions.

**TEMPLEX**—A Condenser material of medium permittivity. For the construction of Condensers having a constant capacity at all temperatures.

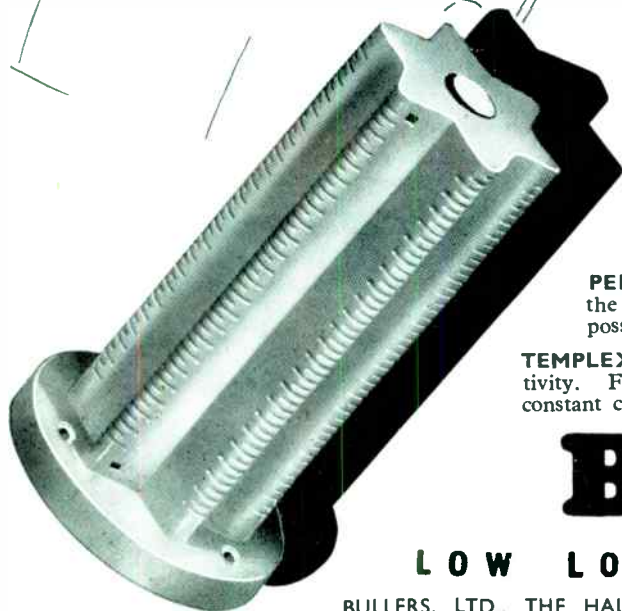

**Bullers**

**LOW LOSS CERAMICS**

BULLERS, LTD., THE HALL, OATLANDS DRIVE, WEYBRIDGE, SURREY  
Telephone : Walton-on-Thames 2451. Manchester Office : 196, Deansgate, Manchester.



## WIRELESS TELEGRAPHY BOARD

SPECIFICATION K.110 (Revised Nov., 1942)

### Electrical Telecommunication Apparatus for use in Damp, Tropical Climates

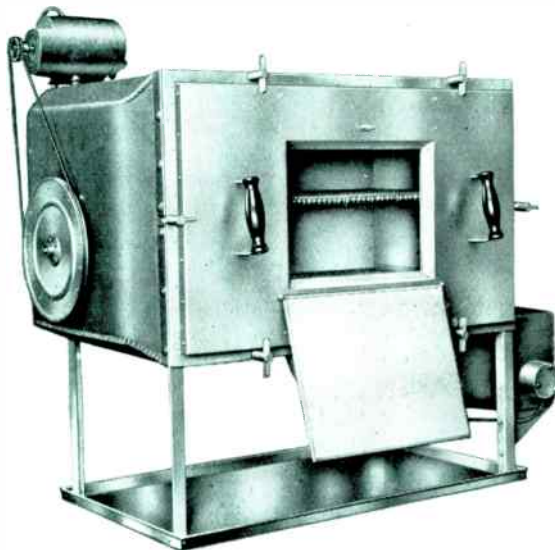
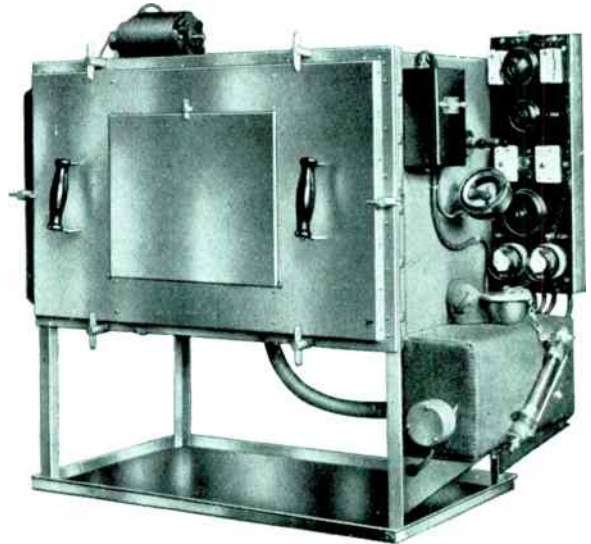

*By* testing your products in a chamber of this design you are assured of recording results identical to those that will be obtained by the testing authorities of all the services. Each equipment is supplied with its individual performance curve superimposed on that of the prototype now in use at R.A.E.

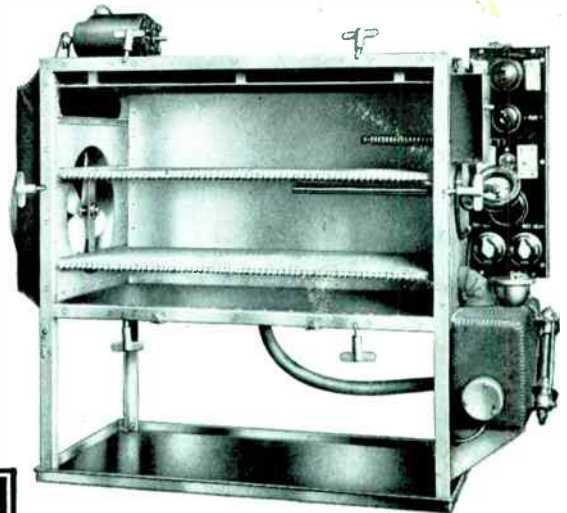

We are actually in production with Humidity Chambers to this specification, identical to those supplied by us to the parent research establishments of the services.

Deliveries are steady though slow—materials are difficult—considerable orders are already in hand, please help us to help you by advising us in good time as to your requirements.

**BELLING & LEE LTD**  
CAMBRIDGE ARTERIAL ROAD, ENFIELD, MIDDX