

4<sup>D</sup>

# The Wireless World

THE PRACTICAL RADIO JOURNAL

with Complete Foreign Programmes

Friday, September 1st, 1933.

## BURTON CLASS "B" CONVERSION UNIT

This unit is intended to be added to existing battery sets in order that moving coil reproduction may be obtained. It contains a specially designed driver and output transformer, and the whole unit is housed in a highly polished brown bakelite case. The unit takes an average current of 6 m.a. and is capable of delivering 2 watts output without distortion.



35/-

Made by C. F. & H. BURTON, Progress Works, WALSALL.

## TELSEN Intermediate Frequency TRANSFORMER COILS



Specified by the designer of the "Wireless World" NEW MONODIAL SUPER. Ideal for every superhet where lasting efficiency is the first essential. Totally screened. The world's finest value at the new reduced price of **7'6**

**TELSEN FOR EVERYTHING IN RADIO**

Announcement of the Telsen Electric Co., Ltd., Aston, Birmingham.

## EVERY TEST

D.C. AND A.C. WITH **ONE** COMPLETE INSTRUMENT



The Avometer is the only complete testing instrument which gives direct readings in amps, volts and ohms without the necessity for mathematical calculations. It is indispensable to the Service men of leading radio manufacturers as the only instrument that adequately meets their needs.

Two models, one for D.C. only, 8 GNS. and the Universal Avometer giving both D.C. and A.C. readings (50 cycles) 12 GNS. Deferred Terms if desired.

Illustrated Pamphlet post free.

## The AVOMETER

BRITISH MADE

AUTOMATIC COIL WINDER & ELECTRICAL EQUIPMENT CO., LTD., Winder House, Douglas Street, London, S.W.1 Telephone: Victoria 3105-7.

## COLVERN FERROCART COILS

There is now a Ferrocart Coil for practically every modern radio receiver. . . . We have written a booklet explaining the advantages of Ferrocart coils and containing suitable circuit diagrams. . . .

May we send you a copy? It's free!

MANCHESTER RADIO EXHIBITION STAND No. 32.

COLVERN LIMITED, ROMFORD, ESSEX.

London Wholesale Depot: 150, King's Cross Road, W.C.1.

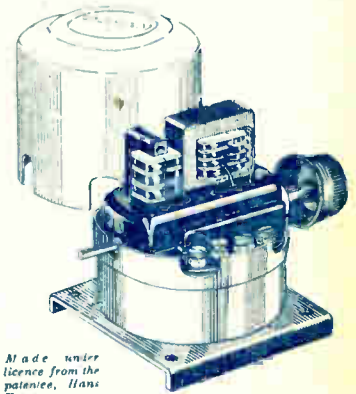

Made under license from the patentee, Hans Vogt.

# NOW YOU CAN BUILD A SET FOR BOTH A.C. & D.C. MAINS

## Tungram produce an A.C.—D.C. Universal Valve

Tungram have achieved it—a Universal Valve which works on both A.C. and D.C. mains.

With these Tungram Universal Valves any circuit can be built. All valves, including rectifier, are indirectly heated—there is practically no hum—and they are really economical, for the mains consumption is only 35 watts.

Your dealer stocks them—go to him to-day! Or post the coupon for full particulars and circuit diagrams.

### THERE IS A TUNGSRAM VALVE FOR EVERY RADIO NEED

Type	Amp. Fac.	Slope mA V	Use	Price
H.P. 2018	5,000	3.5	H.F. Pen Det freq. changer	14 6
H.P.E. 2118	2,000	3.5	V <sub>min</sub> H.F. Pen A.V.C. Mixer	14 6
S.S. 2018	900	3.0	S.G.H.F. Det.	14 6
S.E. 2118	700	3.0	V <sub>min</sub> steep Slope S.G.	14 6
S. 2018	400	1.2	S.G.H.F. Det.	14 6
S.E. 2018	400	1.4	V <sub>min</sub> S.G.H.F.	10 6
R. 2018	40	3.0	Steep Slope Det.	10 6
G. 2018	25	4.0	Det. L.F.	13.-
P. 2018	7	2.5	Power driver	17.-
P.P. 2018	80	3.0	Multier. Output	17.-
P.P. 4018	60		ditto	17.-
V. 2018			½ Wave Rect.	10 6
P.V. 4013			Fullwave Rect.	

All Valves 18 Ampere indirectly heated for series heating.

# TUNGSRAM UNIVERSAL VALVES



TO TECHNICAL DEPT., TUNGSRAM LTD.,  
72, OXFORD STREET, LONDON, W.1.

Please send me full details of Tungram Universal A.C.-D.C. VALVES, AND OF THE COMPLETE TUNGSRAM RANGE.

NAME

ADDRESS

W.W.

Mention of "The Wireless World," when writing to advertisers, will ensure prompt attention.



The Wireless World

# PROGRAMMES from ABROAD

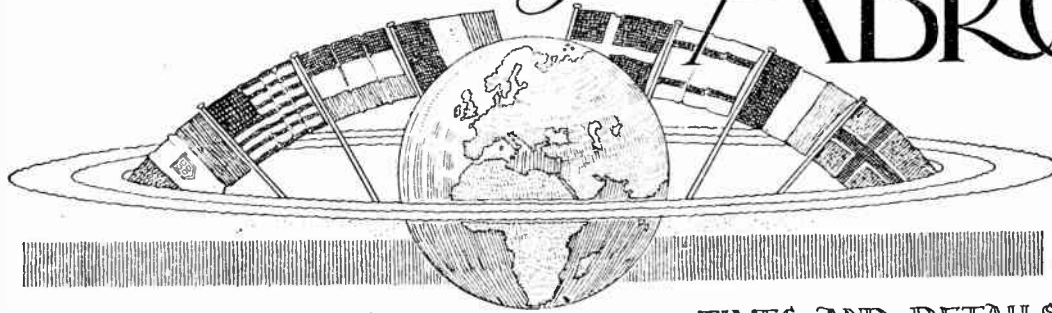

BROADCASTING STATIONS  
ARRANGED IN ORDER  
OF WAVELENGTH

TIMES AND DETAILS OF  
FULL WEEK'S FOREIGN  
TRANSMISSIONS

Metres.	kc s.	kW.	Station.	Tuning Positions.	Metres.	kc s.	kW.	Station.	Tuning Positions.
1935	155	7	Kaunas (Kovno) (Lithuania) .. .. .	.....	453.2	662	4	Milan (Vigentino) (Italy) (Relays Rome) ..	.....
1875	160	8.5	Hilversum (Holland) (Kootryk, experimental, 50 kW., after programme hours.	.....	450.3	666	20	Madona (Latvia). (Relays Riga) .. .. .	.....
1796	167	40	Lahti (Finland) .. .. .	.....	447.1	671		Paris, Ecole Supérieure, PTT (7.0 kW.); Tjnkun (0.15 kW.), Notodden (0.08 kW.) Alesund (0.35 kW.) (Norway) (relays Oslo).	.....
1725	174	75	Radio Paris, C.F.R. .. .. .	.....	441.2	680	50	Rome, IRO. (S.W. Station, 2 RO on 25.4 m.)	.....
1635	183.5	60	Berlin (Deutschlandsender) (Germany). (S.W. Stn. DJA on 31.38 m., DJB on 19.73 m., DJC on 49.83 m., DJD on 25.51 m., DJE on 16.86 m.)	.....	435.4	689	55	Stockholm, SASA (Sweden) .. .. .	.....
1554.4	193	30	Daventry National .. .. .	.....	430.4	697	2.5	Belgrade (Yugoslavia) .. .. .	.....
1538	195	7	Ankara (Angora) (Turkey) .. .. .	.....	424.3	707	2	Madrid, EAJ7 (Union Radio) .. .. .	.....
1481	202.5	500	Moscow, RVI (Old Komintern) (Russia)	.....	424.3	707	100	Moscow, Imini Stalina (Russia)	.....
1446	207.5	13	Eiffel Tower, FL, Paris .. .. .	.....	419.5	715	1.5	Berlin, Funksunde (Germany) .. .. .	.....
1412	212.5	120	Warsaw 1 (Poland) .. .. .	.....	416.4	720.5	5	Rabat (Morocco) .. .. .	.....
1380	217.5	100	Novosibirsk, RV76 I (Russia) .. .. .	.....	413	725	60	Athlone (Irish Free State) .. .. .	.....
1354.4	221.5	30	Motala (Sweden). (Relays Stockholm)	.....	408.7	734	16	Katowitz (Poland) .. .. .	.....
1350	222	0.5	Tunis-Kasbah (Tunisia) .. .. .	.....	403.8	743	25	Sottens (Radio Suisse Romande) (Switzerland)	.....
1304	230	100	Moscow, WZSPS (Trade Union) (Russia)	.....	398.9	752	25	Midland Regional. (Daventry) .. .. .	.....
1230	244	0.6	Boden (Sweden). (Relays Stockholm)	.....	394.2	761	12	Bucharest (Roumania) .. .. .	.....
1200	250	5	Stamboul (Turkey) .. .. .	.....	389.6	770	120	Leipzig (Germany) .. .. .	.....
1200	250	21	Reykjavik (Iceland) .. .. .	.....	385.1	779	8	Toulouse (Radiophonie du Midi) (France)	.....
1190	252	200	Luxembourg .. .. .	.....	385.1	779	10	Stalino, RV26 (Russia) .. .. .	.....
1170	256	25	Tashkent, RV11 (Russia) .. .. .	.....	381	788	16	Lwow (Lemberg) (Poland) .. .. .	.....
1154	260	75	Kalundborg (Denmark). (Relays Copenhagen)	.....	376.4	797	50	Scottish Regional (Falkirk) .. .. .	.....
1154	260	20	Monte Ceneri (Switzerland) .. .. .	.....	372.2	806	1.5	Hamburg (Germany) .. .. .	.....
1117	268.5	40	Moscow, Popoff RV58 (Russia) .. .. .	.....	370.1	810.5	0.8	Radio, LL, Paris .. .. .	.....
1083	277	60	Oslo (Norway) .. .. .	.....	368.1	815		Seville, EAJ5 (Union Radio) (1.0 kW.); Galicia EAJ1 (0.2 kW.) (Spain); Bolzano (1.0 kW.) (Italy); Helsinki (10 kW.) (Fin- land) (relays Lahli); Kharkov, RV20 (10 kW.) (Russia).	.....
1071	280	35	Titlis, RV7 (Russia) .. .. .	.....	368.1	815	0.7	Fredriksstad (Norway). (Relays Oslo)	.....
1035	290	36	Kiev, RV9 (Russia) .. .. .	.....	364.1	824	1	Bergen (Norway) .. .. .	.....
1000	300	100	Moscow, RV39 (Russia) (S.W. Stn. on 50 m.)	.....	363.6	825	13	Algiers (Algeria) .. .. .	.....
938	320	20	Kharkov, RV4 (Russia) .. .. .	.....	360.6	832	60	Mühlacker (Stuttgart) (Germany) .. .. .	.....
857	350	160	Leningrad (Russia) .. .. .	.....	355.9	843	50	London Regional (Brookmans Park) ..	.....
840	357	18.5	Budapest (Hungary) .. .. .	.....	352.1	852	7	Graz (Austria). (Relays Vienna) .. .. .	.....
825	363.6	50	Sverdlovsk, RV5 (Russia) .. .. .	.....	348.8	860	7.6	Barcelona, EAJ1 (Spain) .. .. .	.....
760	395	1.3	Geneva (Switzerland). (Relays Sottens)	.....	348.8	860	10	Leningrad, RV70 (Russia) .. .. .	.....
720	416.6	20	Moscow, RV2 (Experimental) (Russia)	.....	345.2	869	11.5	Strasbourg, PTT (France) .. .. .	.....
690	434.6	1.5	Oulu (Uleaborg) (Finland) .. .. .	.....	341.7	878	35	Brno (Brunn) (Czechoslovakia) .. .. .	.....
680	441.2	0.6	Lausanne (Switzerland). (Relays Sottens)	.....	338.2	887	15	Brussels II, Velthem (Belgium). (In Flemish)	.....
574.7	522	7	Ljubljana (Yugoslavia) .. .. .	.....	335	896	5	Cadiz (Spain) .. .. .	.....
569	527	0.25	Freiburg-im-Breisgau (Germany). (Relay Stn.)	.....	334.4	897	1.9	Poznan (Poland) .. .. .	.....
568.1	528	2	Grenoble (France) .. .. .	.....	331.5	905	50	Milan (Italy). (Relays Turin) .. .. .	.....
563	533	16	Wilno (Poland). (Relay Station) .. .. .	.....	328.2	914	60	Poste Parisien (France) .. .. .	.....
560	536	0.25	Augsburg (Germany). (Relays Munich) ..	.....	325	923	60	Breslau (Germany) .. .. .	.....
560	536	1.5	Kaiserslautern (Germany). (Relays Munich)	.....	321.9	932	10	Göteborg (Sweden). (Relays Stockholm)	.....
550	545	18.5	Budapest No. 1 Lakihegy (Hungary) .. ..	.....	318.8	941	0.25	Dresden (Germany). (Relays Leipzig) ..	.....
542	554	10	Sundsvall (Sweden). (Relays Stockholm) ..	.....	318.8	941	1.5	Naples, INA (Italy). (Relays Rome) ..	.....
537.6	558	3	Palermo (Italy) .. .. .	.....	315.8	950	1.6	Marseilles, PTT (France) .. .. .	.....
533	563	60	Munich (Germany) .. .. .	.....	312.8	959	0.7	Radio Vitus (Paris). (S.W. Stn. on 43.75 m.)	.....
525	571	15	Riga (Latvia) .. .. .	.....	312.8	959	1.7	Cracow (Poland) .. .. .	.....
517.2	580	100	Vienna (Bisamberg) (Austria) .. .. .	.....	309.9	968	50	Genoa, IGE (Italy). (Relays Turin) ..	.....
509	589	15	Brussels No. 1, Velthem (Belgium). (In French)	.....	307	977	0.75	West Regional (Washford Cross) .. .. .	.....
500.8	599	20	Florence, IPI (Italy). (Relays Turin) ..	.....	304	986	13	Zagreb (Yugoslavia) .. .. .	.....
495.8	605	1.2	Trondheim (Norway) .. .. .	.....	304	986	13	Bordeaux Lafayette, PTT (France) .. ..	.....
488.6	614	120	Prague, (Czechoslovakia) .. .. .	.....	301.5	995	50	North National (Manchester) .. .. .	.....
480	625	50	North Regional (Manchester) .. .. .	.....	298.8	1004	11	Tallinn (Esthonia) .. .. .	.....
472.4	635	60	Langenberg (Germany) .. .. .	.....	296.1	1013	20	Huizen (Holland). (7 kW. before 4.40 p.m.)	.....
465.8	644	1.5	Lyons la Doua, PTT (France) .. .. .	.....	293.5	1022	0.7	Limoges, PTT (France) .. .. .	.....
459.4	653	60	Beromünster (Schweizerischer Landessender) (Switzerland) .. .. .	.....	293.5	1022	2.6	Kosice (Czechoslovakia) .. .. .	.....
453.2	662	0.25	San Sebastian, EAJ8 (0.6 kW.); Pori (1.0 kW.) (Finland); Danzig (0.5 kW.) (relays Helsinki); Klagenfurt (0.5 kW.) (Austria) (relays Vienna); Jönsgrunn (0.7 kW.) (relays Oslo); Tromsø (0.1 kW.) Bodo (0.5 kW.) (Norway); Uppsala (0.15 kW.) (Sweden) (relays Stockholm).	.....	291	1031	13.2	Viipuri (Viborg) (Finland). (Relays Helsinki)	.....
					288.3	1040	50	Scottish National (Falkirk) .. .. .	.....
					288.3	1040	1	Bournemouth (Relay Station) .. .. .	.....
					286	1049	0.8	Montpellier (France) .. .. .	.....
					284.8	1053	0.7	Lyons (Radio-Lyon) (France) .. .. .	.....

BROADCASTING STATIONS ABROAD (In Order of Wavelength)

Table with columns: Metres, kc s., kW, Station, Tuning Positions, Metres, kc s., kW, Station, Tuning Positions. Lists various international broadcasting stations and their technical specifications.

PRINCIPAL SHORT-WAVE STATIONS

(N.B.—Times of Transmission, given in parentheses, are approximate only and represent B.S.T.)

Table with columns: Metres, kc s., Call Sign., Station, Tuning Positions, Metres, kc s., Call Sign., Station, Tuning Positions. Lists principal short-wave stations with call signs and transmission times.



# FOREIGN SUNDAY PROGRAMMES

SEPTEMBER THE THIRD

## ATHLONE

725 kc s, 413 metres; 60 kW. Relayed by Cork, 1,337 kc/s, 224.4 metres.—8.30 p.m., Time Signal.—8.31, Bessie O'H, Bourke's Instrumental Trio. 8.50, Music by the Kilmurray Choir. 9.10, The Silver Candlestick—Sketch, by Dorothy Day and Company. 9.40, Tenor Solos by Peter Dunn. 9.55, Instrumental Trio (cont'd.). 10.15, Bass-Baritone Solos by M. O'C. Maguire. 10.30, Traditional Trio Concert. 11.0, Time, News, Weather and Close Down.

## BARCELONA

EAJI, 160 kc/s, 348.3 metres; s kW.—2.0 p.m., Gramophone Music. 2.30 (in an interval), Theatre Notes. 3.0, Sextet Concert. 4.0, Programme for Hospitals and Benevolent Institutions, with Gramophone Music. 5.0-6.30, Interval. 6.30, Agricultural Talk in Catalan, followed by Gramophone Records. 7.0, Orchestral Concert. 7.30, Song Recital by Ricardo Fuste (Baritone). 8.0, Dance Music from the Casa Llibre. 9.0, Orchestral Music. 9.20, Talk: The Catalan Parliament. 9.30, Song Recital. 10.0, Selection from Musical Plays, on Gramophone Records. 11.45, Chess Lesson. 12 Midnight, Close Down.

## BARI

1,112 kc/s, 269.8 metres; 20 kW.—10.45 a.m., Agricultural Notes. 11.5, Bible Reading. 11.35, Sacred Music, relayed from the Church of San Domenico. 1.0 p.m., Giornale Radio. 1.10 to 2.15, Gramophone Music. In the interval at 1.55, Weather, and at 2.0, Time and Announcements. 5.0, See Turin. 8.0, Sports Notes and Giornale Radio. 8.20, News in Albanian. 8.25, Giornale Radio. 8.30, Time and Announcements. 8.35, Weather. 8.45, Concert of Songs and Operetta Music. In the interval, Art Notes. 10.30, Gramophone Music. 10.55, News Bulletin.

BASLE.—See Schweizerischer Landessender.

## BELGRADE

697 kc/s, 430.4 metres; 2.8 kW.—5.0 p.m., Dance Music on Gramophone Records. 6.55, Time Signal and Programme Announcements. 7.0, Talk. 7.30, Concert by the Radio Quartet. 8.0, Choral Concert. 9.0, Concert by the Station Orchestra. Soloist: Evka Mitche (Songs) and Emanuel Böhm (Xylophone). In an interval at 9.45, Time Signal, Sports Notes, and News. 10.45, Cigány Music relayed from the Dva Jelena Restaurant.

## BERLIN

DEUTSCHLANDSENDER (Reichsender), 183.5 kc/s, 1,635 metres; 60 kW.—6.0 a.m., Gymnastics, from Berlin (Funkstunde). 6.15, News, followed by the Day's Motto, Morning Hymn and Harbour Concert, from Hamburg. 8.0, Three Talks for Farmers. 8.55, Chimes from the Garrison Church and Concert by the Pratorias Choral Society. 10.5, Weather, from Berlin (Funkstunde). 11.0, Recitation of Poems addressed to Hitler. 11.15, Weather for Shipping. 11.30, See Leipzig. 12 Noon, Parade Marches of German Regiments, on Gramophone Records. 12.55 p.m., Time Signal. 1.0, Concert from Breslau. 2.0, When we are Grown-up Opera for Schools (Blumenant). 2.25, Hans Hermann Wilhelm reads from his own Works. 3.0, Talk: The Great War in Palestine. 3.30, Political Literature. 4.0, See Breslau. 5.0, Concert from Frankfurt. 6.0, Gramophone Concert of Waltzes by Strauss and Lehár. 7.0, A Merry Zoo—Programme in Verse (Drews), with Gramophone Illustrations. 7.30, Radio Report: The Opening Ceremony of the International University Sports in Turin (on Gramophone Records). 8.0, Harvest Time—Concert by the Station Orchestra, conducted by Balzer; Soloist, Adelheid Holz (Songs); Vintagers' Dance from Eines Menschen Lied (Siegel); Recitative and Aria from The Seasons (Haydn); Songs (Richard Strauss); (a) Traum durch die Dämmerung, (b) Feindliche Vision, (c) Waldsclücklein; Pfandwaise (Weingartner); Regenwetterlied (Haas); The Summer Symphony (Haydn). 9.0, See Langenberg. 10.0, Weather and News. In the interval at 10.45, Weather. 12.30 a.m. (Monday), Close Down.

## BERLIN

FUNKSTUNDE, 715 kc/s, 419.5 metres; 1.5 kW.—11.30 a.m. to 2.0 p.m., See Leipzig. 2.0, Talks for Garden City Dwellers. 3.0, Report of Harvest Festival—Thanksgiving, from Tegel (on Gramophone Records). 3.30, Radio Report. 4.0, Concert of Light Music. 5.20, Part Relay of the Football Match, Berlin v. Hamburg, from Gesundbrunnen. 5.45, Choral Music. 6.0, Concert of Light Music (cont'd.). 6.30, Radio Report. 7.0, Recital of Contemporary Songs by Fred Drissen (Baritone). 7.25, Harvest Festival Dialogues. 7.55, Sports Notes. 8.5, Im Reich des Indra—Operetta (Lincke). In the interval from 9.0 to 9.10, Report from the Thousand-Year-Old Town of Tangermünde (on Gramophone Records). 10.0, News. 10.15 (approx.), Dance Music. In the interval from 11.0 to

## PRINCIPAL EVENTS OF THE DAY:

### AT HOME

**NATIONAL LONDON REGIONAL** Orchestral concert, relayed from the Kursaal, Ostend. Service relayed from Wesley's Chapel, City Road, London.

**MIDLAND REGIONAL** Roman Catholic service from the Cathedral of St. Chad, Birmingham.

**NORTH REGIONAL** Roman Catholic service from St. Anne's Cathedral, Leeds.

**WEST REGIONAL** Programme of favourite selections from the Oratorios.

**SCOTTISH REGIONAL** Service from St. Cuthbert's Church, Edinburgh.

**BELFAST** Service from Carlisle Memorial Methodist Church, Belfast.

### ABROAD

**BRUSSELS (No. 1)** 5.0 p.m. The Station Orchestra, conducted by Meulemans.

**BRUSSELS (No. 2)** 8.0 p.m. Extracts from opera: "Tannhäuser" (Wagner), by the Station Symphony Orchestra.

**BUDAPEST** 12.20 p.m. The Opera House Orchestra, conducted by G. Dohnanyi.

**HEILSBURG** 8.10 p.m. The Königsberg Opera House Orchestra, conducted by Wolfgang Brückner.

**HUIZEN** 2.40 p.m. The Residence Orchestra, relayed from Scheveningen. 9.10 p.m., The Wireless Orchestra, conducted by Nico Treep.

**STRASBOURG** 6.50 p.m. Chamber music.

**TURIN** 8.40 p.m. Opera: "Le Jongleur de Notre Dame," by Massenet.

**VIENNA** 7.10 p.m. Schubert song recital.

**WARSAW** 12.15 p.m. The Station Orchestra, conducted by Oziminski.

11.10, Topical Talk. 1.0 a.m. (Monday), Close Down.

BERNE.—See Schweizerischer Landessender.

BEROMUNSTER.—See Schweizerischer Landessender.

BODEN.—See Stockholm.

BODO.—See Oslo.

## BRATISLAVA

1,076 kc/s, 279 metres; 11 kW.—12.15 p.m., Concert of Operetta Music. 1.30, See Prague. 1.45 to 1.50, Hydrographic Report. 4.0, See Prague. 6.0, Talk: America—the Film Paradise. 6.15, Humorous Programme, relayed from Kosice, 1,022 kc/s, 293 metres. 6.55, Report. 7.0, See Prague. 7.5, See Brno. 8.5, See Prague. 9.5, See Moravská-Ostrava. 10.0, See Prague. 11.0 (approx.), Close Down.

BREMEN.—See Hamburg.

## BRESLAU

923 kc/s, 325 metres; 60 kW. Relayed by Gleiwitz, 1,184 kc/s, 253 metres.—12 Noon, Concert by the Silesian Philharmonic Orchestra, conducted by Georg Dohrn. 2.0 p.m., Agricultural Talk. 2.20, Rischka Lieder Recital by Magda Pfeiler (Contralto), with the Composer at the Piano: Kindertod; Waiderspruch; Goldene Wiegen-schwingen; Abendlied; Der Tod; Vigilien; Geistliche Dämmerung; Verklärung. 3.0, Programme for Children. 3.35, Talk: Fatalities on Mont Blanc. 4.0, Concert by the Riesengebirge Choir, relayed from Schreiberhau; Gott du bist meine Zuversicht (Otto); Heidenheimat die wir schauen (Weinzierl); Die Winde rauschen, die Wolken ziehn (Fischer); Der Morgen dämmert, der Wald ruht still (Hoffmann); Ich ruhe still in hohen grünen Gras (Wendel); Wie blüht er in Glase (Seidel); Folk Song, Es ist ein Schmirler, der heisst Tod (arr. Geilsdorf); Folk Song, Ich hört ein Vöglein pfeifen (arr. Schauss); Folk Song, Es laget vor dem Walde (arr. Jünger); Folk Song, Kein Feuer, keine Kohle (arr. Wollgast); Folk Song, Das Lieben bringt gross' Freud (arr. Lagner); Folk Song, Die Gedanken sind frei (arr. Keldorfer). 5.0, Concert by Fabrich-Ehmk and his Orchestra, relayed from the Café Vaterland. 6.0, German Dentists' Conference, relayed from the University. 6.30, Pianoforte Recital by Willy Koppmann. 6.55, Reading and Sports Notes. 8.0, Radio Report of the People's Festival at Glatz. 8.30, A German Evening—Variety Programme. 10.0, Austria, 10.20, Time and News. 10.45, Dance Music, relayed from Berlin (Funkstunde). 12 Midnight (approx.), Close Down.

## BRNO

878 kc/s, 342 metres; 35 kW.—5.30 p.m., Gramophone Music. 6.0, German Transmission—A Radio Sketch, followed by Popular Concert. 7.0, See Prague. 7.5, Literary Programme. 8.5, Violin Recital: Sérénade mélancolique, Op. 26 (Tchaikovsky); Capriccio (Bachänder); Perpetuum mobile, Op. 34 (Ries); Zigeunerweisen (Sarasate). 8.35, Czech Humour—Recitations. 8.55, Gramophone Music. 9.5, See Moravská-Ostrava. 10.0, See Prague. 11.0 (approx.), Close Down.

## BRUSSELS (No. 1)

1.1.N.R., 590 kc/s, 509 metres; 15 kW.—9.45 a.m., Gardening Talk. 10.0, Concert by the Small Station Orchestra, conducted by Lecmans; Overture, Sous la Régence (Brussels-mans); Four songs without Words (Mun-mans); Norwegian Wedding Procession (de Solim); Norwegian Wedding Procession (de Solim); Selection from La Favorita (Donizetti); Gramophone Records: (a) Die Lorelei blume (Schumann), (b) Rencontre (Faure); Valse des Fleurs (Tchaikovsky); Torero Ramon (Kostal). 11.0, Gramophone Concert. 12 Noon, Concert by the Radio Orchestra, conducted by Walpot. Soloists: Morel (Tenor) and Platel (Baritone); Overture, Les Hirondelles (Hirschmann); Valse des blondes (Ganne); Baritone Solos: Two Symphonic Rhapsodies (Coates); Tenor Solos: Slav Rhapsody No. 2 (Friedemann); Potpourri, Was die Donau erzählt (Morena). 1.0 p.m., Le Journal Parlé. 1.10, Concert, conducted by Fellmann, relayed from the Grand Hotel, Antwerp. In the interval at 1.30, Reading of Fables (La Fontaine) on Gramophone Records. 5.0, Concert by the Station Symphony Orchestra, conducted by Meulemans; Overture, A Life for the Czar (Glinka); Adoration (La Gaze); Rhapsody No. 2 (Liszt); Waltz, Myrthenblüthen (Strauss); Gothic Minuet (Boellmann); Dances villageoises (Grétry); Slav Dances (Dvorak). In the interval at 5.30 (approx.), Gramophone Music. 6.0, Gramophone Music. 6.15, Concert by the Cecelia Vocal Trio, 6.45, Gramophone Music. 7.15, Religious Address. 7.30, Wireless Notes and Review of Music. 8.0, Concert by the Radio Orchestra, conducted by Walpot; March, Stars and Stripes (Sou-s); Waltz Potpourri (Robrecht); Overture, Les Saltimbanques (Ganne); Souvenir de Spa (Meurice); Selection from Phi-Phi (Christine); March, Sambre et Meuse (Planquette). 8.40, Revelation—sketch (Tristan Bernard). 8.45, Baba Yaga (Lidov) on Gramophone Records. 8.50, Expedition nocturne—sketch (Tristan Bernard). 9.0, Concert, relayed from the Kursaal, Ostend. After the Con-

cert, Le Journal Parlé, followed by Dance Music, relayed from the Kursaal, Ostend.

## BRUSSELS (No. 2)

1.1.N.R., 587 kc/s, 338.2 metres; 15 kW.— Programme in Flemish. — 10.0 a.m., Gramophone Concert Sonata Appassionata (Beethoven); Allegretto, from Sonata, Op. 31, No. 2, Finlandia (Sibelius); Three Pieces from La Mer (Debussy). 11.0, Concert by the Small Station Orchestra, conducted by Lecmans. 12 Noon, Concert, relayed from the Grand Hotel, Antwerp. 1.0 p.m., Le Journal Parlé. 1.10, Concert by the Radio Orchestra, conducted by Walpot. Soloists: Morel (Tenor), and Platel (Baritone); Overture, La Belle Hélène (Offenbach); Baritone Solos. Selection from Good News (de Sylva-Brown); Tenor Solos; Potpourri of Flemish Songs (Walpot). 5.0, Dance music, relayed from the Kursaal, Ostend. 5.30, Sports Notes. 6.30, Concert by the Small Station Orchestra, conducted by Lecmans. 7.15, Religious Talk. 7.30, Musical Review. 8.0, Extracts from Tannhäuser—Opera (Wagner), by the Station Symphony Orchestra, conducted by Meulemans and Mme. Briffaux (Soprano), and De Quick (Baritone). 8.45, A Sketch (Van Zyl). 9.10, Concert by the Symphony Orchestra, conducted by Meulemans. 10.0, Le Journal Parlé. 10.10, Dance Music, relayed from the Casino, Knocke.

## BUCHAREST

761 kc/s, 394 metres; 12 kW.—5.0 p.m., Light Music and Romanian Music by the Marco Orchestra. In an interval at 6.0, Radio Journal. 7.0, Reading. 7.20, Dance Music on Gramophone Records. 7.40, Educational Talk. 8.0, Saxophone Solos by Seidmann. 8.20, Concert by the Kreuzer Schrammel Quartet. 8.50, Talk. 9.5, Popular Romanian Music by the Faucia Luca Orchestra. 9.45, Radio Journal.

## BUDAPEST

545 kc/s, 550.5 metres; 18.5 kW. Also relayed on 840 metres from 7.15 p.m. till Close Down.—9.15 a.m., News. 10.0, Catholic Service. 11.15, Protestant Service. After the Service, Time and Weather. 12.20 p.m. (approx.), Concert by the Opera House Orchestra, conducted by Ernst Dohnanyi; Soloist, Alexander Vegh (Violin); Overture to The Hebrides Suite (Mendelssohn); Fantasia in F minor (Schubert-Dohnanyi); Violin Concerto (R. Strauss); Symphony No. 11 (Beethoven). 2.0 p.m., Gramophone Music. 3.0, Agricultural Talk. 3.45, Music by the Lajos Veres Cigány Band. 4.45, Talk on Turgenyev. 5.15, Concert by a Workers' Choral Society. 6.0, Humorous Talk. 6.30, Concert relayed from the Luna Park. 7.15, Ein Taugenichts—a Good-for-Nothing Operetta (Marthon). 9.45, News. 10.0, Pianoforte Recital by Stefanini; Chaconne (Bach-Busoni); Variations on a Theme of Bach (Liszt); Symphonic Etudes (Chopin). 10.50, Concert by the Karl Bura Cigány Band, relayed from the Ketter Restaurant.

CASSEL.—See Frankfurt.

## COPENHAGEN

1,067 kc/s, 281 metres; 0.75 kW. Relayed by Kalundborg, 260 kc/s, 1,153.8 metres.— 8.0 a.m., Gymnastics for Women. 8.15, Gymnastics. 9.0-9.30, Talk. 10.0, Divine Service Relay. 11.30, Weather. 11.40, News. 12 (Noon), Town Hall Chimes. 12.2 p.m., Concert by the Station Orchestra, conducted by Emil Reesen; Overture, La rencontre improvise (Gluck); Concerto for Strings (Lully-Weingartner); Overture, The Magic Flute (Mozart); Suite, Le tombeau de Couperin (Ravel). 1.0-2.0, Language Lessons. 1.0, Talk in English: Proper Names in the English Dictionary. 1.20, Talk in German: The Pre-war German Novel. 1.40, Talk in French: Holidays in Zealand. 2.0, Gramophone Records. 2.30, Programme for Children. 3.0, Concert by the Station Orchestra, conducted by Lanny Gröndahl; Soloist: Elsebeth Riegels (Songs). 5.0 (also on Skamlebaek, 31.51 metres), Divine Service Relay. 6.20, Talk: A Visit to the Chicago World Fair. 6.50, Weather and News. 7.15, Time. 7.30, Talk. 8.0, Town Hall Chimes. 8.2, Concert of Light Music, relayed from the Radio Exhibition; March (Evans); Waltz (Beyer); Selection from The Flower of Hawaii (Abraham); Die Spieluhr der Pompadour (Noack); Metropolitan (Bloom); Addio a Napoli (Muzilli); Marimba Solo, Bit of rhythm (Kjaer). 8.45, En Tvekamp—Radio Scenes from the Radio Exhibition. 8.55, Selection from Otello—Opera (Verdi), on Gramophone Records. 9.10, Haydn Music by Mogens Hansen (Violin), Ludwig Gunder (Viola), and Otto Lützhöft (Cello); Divertissement in A for Violin, Viola and Cello; Trio in D for Violin, Viola and Cello. 9.30, The Hansen Family—a Humorous Episode (Jens Løcher). 9.45, Instrumental Concert, relayed from the Radio Exhibition. 10.15, News. 10.25, Instrumental Concert, relayed from the Radio Exhibition. 11.0, Dance





SEPT. 3rd

SUNDAY

continued

In the intervals: Topical Talk. Recital of Poems and Giornale Radio. SALZBURG.—See Vienna.

SCHENECTADY

WGY, 790 kc/s, 379.5 metres; 50 kW.—Relayed at intervals by W2XAF on 31.48 metres; and by W2XAD on 19.56 metres.—8.0 to 10.0 p.m. (approx.). New York Relay. 8.0, Wayne King's Orchestra. 8.30, Radio Philpit. 9.0, Fiddlers Three. 9.15, Woodroot Institute. 9.30, Temple of Song. 12.45 to 3.45 a.m. (Monday), New York Relay. 12.45, Russian Symphonic Choir. 1.0, Variety Programme. 2.0, Manhattan Merry-Go-Round. 2.30, American Album of Familiar Music. 3.0, Popular Programme. 3.15, Impressions of Italy. 3.45, Sunday at Seth Parker's from New York, followed by Programme Resumé.

SCHWEIZERISCHER LANDESENDER

BEROMUNSTER, 653 kc/s, 459 metres; 60 kW: Baslo, 1,229 kc/s, 244.1 metres; and Berne, 1,220 kc/s, 245.9 metres.—5.0 p.m. till Close Down. Programme from Zürich. 5.0, Gramophone Music. 5.30, Ballad Recital. 6.0, Gramophone Concert. 6.30, Talk: The Small Republican State of Andorra. 7.0, Time and Sports Notes. 7.5, Hawaiian Guitar Music. 7.50, Concert by the Frohst Quartet. 8.30, Talk on Architecture. 9.0, News. 9.10, Dance Music. 10.15, Sports Notes. 10.20 (approx.), Close Down.

SOTTENS.—See Radio-Suisse Romande.

STOCKHOLM

689 kc/s, 436 metres; 55 kW. Relayed by Boden, 244 kc/s, 1,229.5 metres; Göteborg, 932 kc/s, 322 metres; Hörby, 1,166 kc/s, 257 metres; Motala, 221.5 kc/s, 1,354.0 metres; Östersund, 389 kc/s, 770 metres; and Sundsvall, 554 kc/s, 542 metres.—9.0 a.m., Talk: The Necessity of Mineral Foods for Domestic Animals, relayed from Uppsala, 662 kc/s, 453.2 metres. 9.30, Gramophone Music. 10.10, Esperanto Programme. 10.50, Talk for Workers, relayed from Falun, 977 kc/s, 307 metres. 11.0, Divine Service, relayed from Hudiksvall, 1,327 kc/s, 226 metres. 12.45 p.m., Weather. 1.0, Sports Talk. 3.45, Report on the European Motor Cycle Grand Prix, relayed from Saxtorp. 5.5, Trio, Op. 49 (Mendelssohn), for Violin, Cello and Piano. 5.30, Reading. 6.0, Evensong. 7.15, Weather and News. 7.35, Talk. 8.0, Concert by the Station Orchestra. Soloist: Carl Achatz (Flute). Overture, The Bartered Bride (Smetana); First Suite from L'Arlésienne (Bizet); Flute Concertino (Chaminade); Nocturne (Franck); Pieces (Stan-

Gramophone Concert. 10.0 (approx.), Close Down.

PARIS

POSTE PARISIEN, 914 kc/s, 328.2 metres; 60 kW.—10 a.m., Gramophone Music. 10.20, Press Review. 10.30, Sponsored Concert. 11.0, Concert by the Raymond Verney Orchestra. 12.15 p.m., Sponsored Concert. 12.30, Half-an-Hour of Fantasy by Paul Weill. 1.0, Interval. 1.30, Sponsored Programme. 2.0 to 7.0, Interval. 7.0, Le Journal Parlé. 7.5, Sports Notes. 7.15, Gramophone Music. 7.30, Catholic Review. 8.0, Concert by Ter-Abramoff and his Orchestra. Soloist: Marex Lieven (Songs). 10.15, News.

PARIS

RADIO PARIS, 174 kc/s, 1,725 metres; 75 kW.—7.45 a.m., Gramophone Music. 8.0, News and Weather. 8.30, Physical Culture. 12 Noon, Religious Address by the Reverend Father Padé. 12.20 p.m., Sacred Music. 12.45, Gramophone Concert. 1.30 to 2.30, Programme in English by the I.B.C. 1.30, Gramophone Concert. 2.0, Concert of Dance Music: Signature Tune; Happy Feet; My Darling (Jones); How could you surrender; Lazy Bines; Till she comes back; In a little second-hand Store; Day and Night; I love to Yodel; Bird Songs at Eventide (Coates); Signature Tune. 3.0 to 3.30, Programme in English. Orchestral Concert: Over There; Bal masqué (Fletcher); Waltz from The Merry Widow (Lehár); Passing Show, 1914 (Finck); Selection from The Belle of New York (Kerker). 4.0, Popular Concert. 6.30, Gramophone Concert of Light Music. 7.0, Variety Concert. 8.0, Radio Paris Music Hall. In the intervals at 8.30 and 9.15, News. 9.30, Concert of Light Music. 10.30 (approx.), Close Down.

PITTSBURGH

KDKA, 980 kc/s, 305 metres; 50 kW. Relayed by W8XK on 48.86 metres and 25.27 metres.—5.15 to 6.15 p.m., Radio City Concert, from New York. 7.0, Boys of Wyncastle. 7.15 to 10.0, New York Relay. 7.15, Radio Forum. 7.30, Variety Concert. 8.0, National Opera Concert. 9.0, Welsh Musical Festival. 9.30, Organ Recital. 10.0, Vesper Services. 11.0, News. Among Masters. 11.15, Weather. Sports. 11.30, Jack Pettis' Orchestra. 12 Midnight to 1.30 a.m. (Monday), New York Relay. 12.0, Borah Minuscich. 12.15, Jules Lande. 12.30,

Wisdom of the Ages. 1.0, Concert. 1.50, Pathé News of the Air. 1.45 to 2.45, New York Relay. 1.45, Floyd Gibbons. 2.0, Gull Headliners. 2.50, Walter Winchell. 2.45, Programme to be announced. 3.30, Orchestral Concert from New York.

PORSGRUND.—See Oslo.

PRAGUE

614 kc/s, 488.6 metres; 120 kW.—11.0 a.m., Military Band Concert, relayed from Poděbrady. 12 Noon, Chimes. 12.5 p.m., News. 12.15, See Bratislava. 1.30 to 1.45, Agricultural Talk. 4.0, Military Band Concert, relayed from Kralovska Oboza. 5.30, Gramophone Music. 6.0, German Transmission: Review of the Musical Programmes of the Slovak Broadcasting Stations. Concert—Comedy in Three Acts (Bahr). News in German. 7.0, News. 7.5, See Brno. 8.5, Concert of Light Music. 8.35, Recital of Hiking Songs. 9.0, Time Signal. 9.5, See Moravska Ostrava. 10.0, Time and News. 10.20, Gramophone Concert. 11.0, Close Down.

RADIO-SUISSE ROMANDE

SOTTENS, 743 kc/s, 403 metres; 25 kW.; and Geneva, 395 kc/s, 760 metres.—7.0 p.m. (from Geneva), Catholic Address. 7.30 (from Geneva), Sports Notes, News, and Announcements. 8.0 (from Geneva), Piano-forte Recital of Jazz Music. 8.25 (from Geneva), Recitation of Poems. 8.45, Concert by the Radio-Suisse Romande Orchestra. 9.50, News and Weather. 10.0, Concert (cont'd). 10.30 (approx.), Close Down.

RUJUKAN.—See Oslo.

ROME

Call 1RO, 680 kc/s, 441 metres; 50 kW. Relayed by Naples, 941 kc/s, 319 metres; and 2RO, 11,810 kc/s, 25.4 metres, from 5.15 p.m.—10.0 a.m., Sports Notes and Amusement Guide. 10.30, Agricultural Notes. 10.45, Bible Reading. 11.0 (approx.). See Turin. 12 Noon to 12.30 p.m., Interval. 12.30, Orchestral Concert. 1.30, See Turin. 1.45 (approx.) to 2.30, Orchestral Concert. In the interval at 2.0, Time and Announcements. 5.0, See Turin. After the Concert, Vocal and Instrumental Concert. Sports Notes in the intervals. 6.30, Weather. 7.30, Sports Notes, Popolavoro and News. 7.45, Soprano Solos. 8.0, Time and Announcements. 8.30, Results of the International University Sports at the Mussolini Stadium, Turin. 8.45, Sten-trello—Operetta in Three Acts (Cuscinà).

RADIO POWER PLANT MACHINES FOR EVERY NEED

ROTARY TRANSFORMERS

Models for all Purposes! D.C. to D.C. Models for supplying H.T. Current for Public Address. D.C. to A.C. Models for operating A.C. Receivers and Radiogramophones from D.C. Mains.

ANODE CONVERTERS

Give H.T. Current from L.T. Battery. Special models for McMichael, Philips, Eddystone, Gecophone, Mavox, Peto-Scott, Scott Sessions and other Short-Wave Receivers.

LOOK FOR THE NEW

M-L ANODE CONVERTERS

FOR CAR RADIO . . .

Also Synchronous Gramophone Motors, Mains Transformers, Motor Generators, etc.

Write NOW for Illustrated Literature and Technical Catalogue from Rotax Radio Dept. (1), Willesden Junct., London, N.W.10.

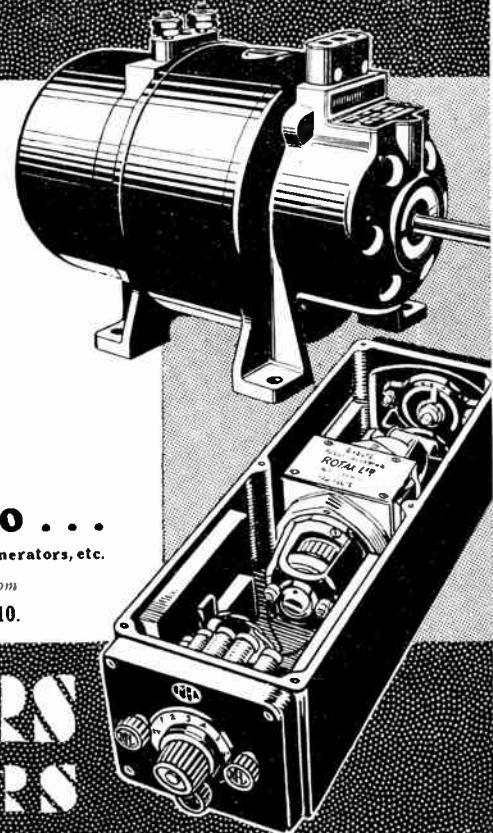

ROTARY TRANSFORMERS & ANODE CONVERTERS

# The ELECTRIC GRAMOPHONE MOTOR

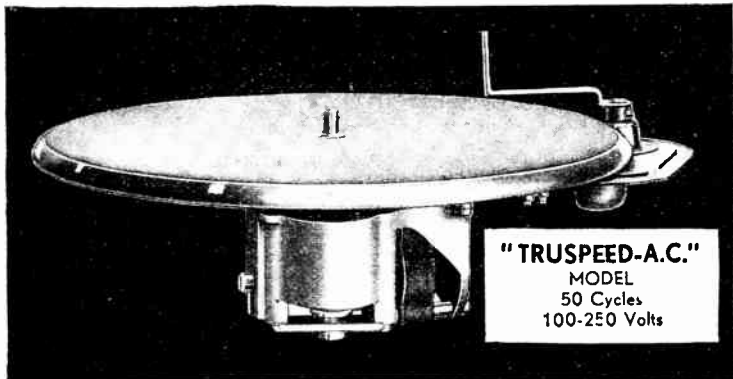

Made for all Standard Voltages  
A.C. and D.C.

Four models from which to choose  
all fitted with automatic stop switch  
*Your local dealer stocks them!*

**BTH RUGBY**  
THE BRITISH THOMSON-HOUSTON COMPANY LIMITED, RUGBY, ENGLAND

A1540N

Player's  
Please  
Everyone



NCC 176

SEPT. 3rd

**SUNDAY**

continued

(ford): (a) Drake's Drum, (b) Devon, O Devon, (c) Home, (d) The Old Superb; Waltz, The Blue Danube (Joh. Strauss); Barcarolle from The Tales of Hoffmann (Offenbach); March (Asch), 9.25, An Idyll (Herbert Grevenius), 10.0, Orchestral Concert, 11.0 (approx.), Close Down.

**STRASBOURG**

869 kc/s, 345 metres; 11.5 kW.—9.30 a.m., Orchestral Concert, conducted by Maurice de Villers, 10.45, Protestant Service, 11.30, Catholic Service in German, 12 Noon, Classical Music on Gramophone Records, 12.45 p.m., News, 1.0, Time Signal, 1.30 to 4.30, The Passion Play—Part II, Choruses from the Oratorios of Bach, Mendelssohn and Vidal, with Orchestral Accompaniment, relayed from the Théâtre de la Passion, Nancy, 4.30, Light Music on Gramophone Records, 5.15, Orchestral Concert of Variety Music, conducted by Roskam, 6.0, Medical Talk, 6.15, Sports Talk, 6.30, Concert of Chamber Music: Sonata in A for Violin and Piano (Handel); Trio in C minor for Violin, Viola and Cello (Beethoven); String Quartet No. 13 (Mozart), 7.30, Time and News, 7.45, Gramophone Music, 8.0, Press Review in German, Lottery Results and Announcements, 8.30, Alsatian Programme: 's Spiel mit d'r Lary—Play in Three Acts (Raymond Buchert). In an interval at 9.30, Press Review, 10.30, Dance Music, relayed from the Savoy, 12 Midnight (approx.), Close Down.

**STUTTGART**

MUHLACKER, 832 kc/s, 360.5 metres; 10 kW. Relayed by Freiburg, 527 kc/s, 570 metres.—10.0 a.m., Catholic Service, 10.50 to 11.30, Interval, 11.30, See Leipzig, 12 Noon, Orchestral Concert, conducted by Karl Körner, relayed from Glotterbad, 1.0 p.m., Gramophone Music, 2.0, Agricultural Talk, 2.30, Gramophone Records of Marches and Dances, 3.30, Programme for Children, 4.30, See Frankfurt, 6.0, Reading of a Swabian Tale (Gapp), 6.25, Recital of Almannic Folk Songs, with Lute accompaniment, 7.0, Sports Notes, 7.20, Arbeiter-sommer—Programme of Songs and Recitations (arr. Martin Lang), 8.0, See Frankfurt, 10.0, See Munich, 10.20, Time and News, 11.0, See Munich, 12 Midnight, Close Down.

SUNDSVALL.—See Stockholm.

**TOULOUSE**

779 kc s, 385 metres; 8 kW.—11.0 a.m., Dance Rehearsals, 11.30, Instrumental Solos: Fire Dance (Falha); Minuet (Mozart); La précieuse (Kreisler); Czardas (Monti), 11.45, Chansonettes, 12 Noon, Operetta Music: Selection from (a) Le Jour et la Nuit (Lecocq), (b) Ciboulette (Halin), and (c) Comtesse Maritza (Kálmán), 12.15 p.m., Comic Opera Music: Chorus from Cavalleria Rusticana (Mascagni); Duet from Act One of Manon (Massenet); Chorus from Mirella (Gounod), 12.30, Accordion Solos, 12.45, Operetta Music: Selection from (a) Mascotte (Andran), (b) Paganini (Lehár), (c) Encore cinquante centimes (Yvain), (d) The Desert Song (Romberg), 1.0, Amusement Guide and Market Prices, 1.5, Orchestral Music, 1.30, Sound Film Music, 1.45, Balalaika Music and Russian Songs, 2.0, Sound Film Music, 2.15, Programme by a Viennese Orchestra: Potpourri (Jessel); Oblièz-moi (Teclater); Tales from the Vienna Woods (Joh. Strauss); The Blue Danube (Joh. Strauss); Hungarian Potpourri, 2.45, Agricultural Report, 3.0, Concert Version of Les Cloches de Corneville—Operetta (Planquette), 4.15, Accordion Solos, 4.30, Music by an Argentine Orchestra, 4.45, Sound Film Music, 5.0, The Dansant, 5.45, Opera Music: Selection from: (a) L'Africain (Meyerbeer), (b) Il Trovatore (Verdi), and (c) Sigurd (Reyer), 6.0, News, 6.15, Light Music, 6.30, Operetta Music: Selection from: (a) Le Voyage en Chine (Gabriel Marie), and (b) La Vie parisienne (Offenbach), 6.45, Cello Solos: Romance sans paroles (Faure); Spring Song (Mendelssohn); Rondo (Boccherini); Minuet (Mozart), 7.0, Military Music, 7.15, News and Horse Racing Results, 7.30, Sound Film Music, 7.45, Choral Music, 8.0, Orchestral Music, 8.15, Extracts from Operetta, 8.30, Opera Music: Prelude to Werther (Massenet); Selection from Cavalleria Rusticana (Mascagni); Overture, Manon (Massenet), 8.45, Hunting Horn Solos, 9.0, Selection from Les Erianyes (Massenet), 9.30, Opera Music: Selection from: (a) Lohengrin (Wagner), (b) Hérodiade (Massenet), and (c) Faust (Gounod), 9.45, Instrumental Solos, 10.0, Orchestral Music, 10.15, News, 10.30, Concert for Listeners in Morocco, 11.0, Light Music, 11.30, Comic Opera Music, 11.45, Music by a Viennese Orchestra, 12 Midnight, News, 12.5 a.m. (Monday), Accordion Solos, 12.15, Vocal Tangos, 12.30, Close Down.

**TRIESTE**

1,211 kc/s, 247.7 metres; 10 kW.—9.40 to 9.55 a.m., See Turin, 10.20, Agricultural

Talk, 10.40 to 11.0, Religious Address, 11.0 (approx.) till Close Down, See Turin.

TRONDHEIM.—See Oslo.

**TURIN**

273.7 metres; 7 kW. Relayed by Milan 905 kc s, 331.5 metres; Genoa, 959 kc s 312.8 metres; and Florence, 599 kc s 500.8 metres.—9.40 to 9.55 a.m., Giornale Radio, 10.20, See Trieste, 10.40, Religious Address, 11.0, Mass from the Church of the Annunciation, Florence, 12 Noon, Bible Reading, 12.15 p.m., Interval, 12.30, Orchestral Concert, In the interval at 1.0, Time and News, 1.30, Sponsored Music 1.45 to 2.0, Gramophone Music, 4.30, Orchestral Concert, In the interval, Sports Notes, 5.0, Opening of the International University Sports from the Mussolini Stadium, Turin, 6.15, Weather and Gramophone Music, 6.30, Giornale Radio and Sports Notes, 6.45, Interval, 7.0, Time and Dopplavoro Announcements, 7.10, Gramophone Music, 8.0, Announcements, Giornale Radio and Sports Notes, 8.30, Talk on the following Transmission, 8.40, Le Jongleur de Notre-Dame—Opera (Massenet). In the intervals, Talk and Theatre Notes, After the Programme, Giornale Radio.

**VIENNA**

581 kc/s, 517 metres; 100 kW. Relayed by Graz, 852 kc/s, 352.1 metres; Innsbruck, 1,058 kc/s, 283 metres; Klagenfurt, 662 kc/s 453.2 metres; Linz, 1,220 kc s, 245.9 metres and Salzburg, 1,373 kc s, 218.5 metres.—10.0 a.m., Report of the Special Meeting in Connection with the Opening of the Twenty-fifth Vienna Fair, 10.40, Chamber Music String Quartet in B flat, Op. 13 (Beethoven); Burlesque for String Quartet (Alfred Ull), 11.20, Sacred Choral Music and Address, 12.5 p.m., Concert by the Wiener Symphoniker, conducted by Hugo Gottesmann: Sereade in E flat, Op. 3 (Mjaskowski); The Fifth Symphony in D minor—From the New World (Dvorak) 1.10 to 2.10, Concert, conducted by Rudolf Pelm, 2.20, Time and Review of the Week's News, 2.40, Agricultural Talk, 3.0, Relay from Gross-Weikersdorf of a Patriotic Demonstration and the Meeting of the Schmieda Valley Catholic Youth Society, 4.0, Review of Books, 4.25, An Entertainment, 4.50, Radio Report of the Mitropa Cup Final—Austria v. Ambrosiana relayed from Milan, 5.50, Gramophone Concert, 6.15, Talk: On the Banks of the Wannee, 6.40, Joseph Gregor reads from his own Works, Introductory Talk by Erwin Weill, 7.10, Schubert Song Recital by Hans Dulha (Baritone): Liebesbotschaft; Kriegers Ahnung; Frühlingssehnsucht; Ständchen; Anienhalt; In der Ferne; Abschied Der Atlas; Ihr Bild; Das Fischermädchen Die Stadt; Am Meer; Der Doppelgänger; Die Taubenpost, 8.5, Time, Sports Notes and Programme Announcements, 8.15, Bunte Abend, The Wiener Symphoniker, the Bohème Quartet, Fritz Indhoff and Fil Mar (Songs), and Maryan Rawicz and Walte Landauer (Recital on Two Pianos), 10.0, News, 10.15, Cigány Music from the Kette Restaurant, Budapest.

**WARSAW**

212.5 kc s, 1,411 metres; 120 kW.—11.57 a.m., Time Signal and Fanfare from Torun Cathedral, 12.5 p.m., Programme Announcements, 12.10, Weather, 12.15, Concert by the Station Symphony Orchestra, conducted by Oziminski, Soloist: Minc, Percussion (Soprano), Overture, Der Paria (Moniuszko) Gipsy Dance (Debussy); Suite (Silver); Soprano Solos: (a) The Convert (Moniuszko) (b) Two Songs (Marck), (c) Song from The Snow Maiden (Rimsky-Korsakov); Symphony in G, No. 6 (Haydn); Soprano Solos: (a) Aufträge (Schumann), (b) Was will die gläserne Träne (Schumann), (c) Two Songs (Brahms); Le Ronet d'Omphale (Saint Saëns), 2.0, Agricultural Talk, 2.15, Agricultural Report and Weather Forecast, 2.20, Accordion Recital of Popular Yugoslav Music, 2.45, Agricultural Programme, 3.5, Gramophone Music, 4.0, Programme for Children, 4.15, Reading for Children, relayed from Lwów, 788 kc s, 381 metres, 4.30, Opera Arias by Minc, Zmigrod-Pedyczkowska, Arias from: Il Seraglio (Mozart), Manon Lescaut (Puccini); Hamlet (Thomas); Louise (Charpentier); and Turandot (Puccini), 5.0, Talk for Workers, 5.15, Talk on Harvest Festivals, 6.0, Gramophone Music, 6.35, Programme Announcements, 6.40, Miscellaneous Items, 7.0, Reading, relayed from Cracow, 959 kc s, 312.8 metres, 7.40, Answers to Technical Correspondence, 8.0, Concert by the Station Orchestra, conducted by Gorzysky, Soloist: Salecky (Tenor), Selection from Der Teufelsreiter (Kálmán); Overture, Gipsy Love (Lehár); Three Tenor Solos; Selection from Frühling im Wienerwald (Ascher); Three Tenor Solos; Album Leaf (Glyndmark); March from Zizi (Kreisler), 8.50, Radio Journal, 9.0, Humorous Programme, relayed from Lwów, 10.0, Dance Music, 10.40, Weather and Police Notes, 10.45, Dance Music (contd.).

ZURICH.—See Scheizerischer Landessender.



# MONDAY

## SEPTEMBER THE FOURTH

### PRINCIPAL EVENTS OF THE DAY:

#### AT HOME

- NATIONAL LONDON** "Strife," a drama, by John Galsworthy. Promenade concert from Queen's Hall, London.
- REGIONAL MIDLAND** Orchestral concert.
- REGIONAL NORTH** Orchestral concert from the Spa, Whitby.
- REGIONAL WEST** Orchestral concert.
- REGIONAL SCOTTISH** Choral and orchestral concert.
- REGIONAL BELFAST** "Things that go bump in the Night," a programme for the fireside.

#### ABROAD

- BARCELONA** 7.0 p.m. The Station Trio.
- BRUSSELS** 5.0 p.m. The Station Symphony Orchestra.
- BRUSSELS (No. 1)** 8.0 p.m. The Station Symphony Orchestra.
- BRUSSELS (No. 2)** 9.30 p.m. The Opera House Orchestra, conducted by Fridl.
- BUDAPEST** 10.15 p.m. Danish music, by the Station Orchestra.
- COPENHAGEN** 10.35 p.m. Orchestral concert, relayed from Kiel.
- HAMBURG** 6.0 p.m. Orchestral concert, conducted by Eysoldt.
- LANGENBERG** 8.5 p.m. Musical journey round the world.
- STRASBOURG** 6.30 p.m. Grieg orchestral concert, conducted by Maurice de Villers.
- STUTT GART** 8.5 p.m. Orchestral concert, conducted by Karl Assmus, relayed from Baden-Baden.
- WARSAW** 8.0 p.m. Operetta: "The Bayadere," by Kálmán.

Talk. 7.30, Le Journal Parlé. 8.0, Concert by the Station Symphony Orchestra, conducted by Kumps: Overture, Benvenuto Cellini (Berlioz); Night on the Bare Mountain (Mussorgsky); Cor Anglais Solo, Air from Manfred (Schumann); Symphony in E flat (Mozart). 8.45, Talk: The Librado Congress at Antwerp. 9.0, Concert (contd.); Symphonic Variations (Gilson); Gramophone Records, (a) Song of the Viking Guest from Sado (Rimsky-Korsakov), and (b) Koutchak's Song from Prince Igor (Borodin); Petite Suite (Dupuis); Gramophone Record, Distant Echo of my Youth from Eugene Onegin (Tchaikovsky); Gollywog's Cake-Walk (Debussy). 10.0, Le Journal Parlé. 10.10, Gramophone Dance Music.

### BUCHAREST

761 kc/s. 394 metres; 12 kW.—5.0 p.m., Concert by the Station Orchestra. March (Pueck); Waltz, Frühlingsstimmen (Strauss); Overture, Orpheus in the Underworld (Offenbach); Selection from Tannhauser (Wagner); Selection from Paganini (Lehár); Grieg Potpourri (Urbach); The Caravan (Niemann); Indian Intermezzo (Kretelbey); Hopak (Tchaikovsky). In an interval at 6.0, Radio Journal. 7.0, Reading. 7.20, Gramophone Music. 7.40, Educational Talk. 8.0, Concert by the Sarvas Trio. Trio in B. Op. 8 for Violin, Pianoforte and Cello (Brahms) Trio in F (Saint-Saëns). In an interval at 8.30, Talk. 9.15, Dance Music by the Marcel Zaharia Syncop Accorders, relayed from the Lido. 9.45, Radio Journal.

### BUDAPEST

545 kc/s. 550.5 metres; 18.5 kW.—Also relayed on 840 metres from 8.0 p.m. till Close Down. 5.0 p.m., Gramophone Concert. 6.0, Programme for Workers. 6.30, Music by the Lajos Kiss Gypsy Band. 7.30, Reading. 8.0, Kondor and Nador Song Recital. 9.10, News. 9.30, Concert by the Opera House Orchestra, conducted by Fridl: Overture, The Bohemian Girl (Balfe); Suite, Scènes napolitaines (Massenet); Carnival in Paris (Svendsen); Prædium (Janáček); Valse triste (Vevey); Intermezzo from Der Kriegsgefangene (Goldmark); Extracts from the Ballet Argirus (Gayay). 10.5, Weather. 10.40, Pianoforte Recital. 11.20, Dance Music from the Rajnapark Café.

CASSEL.—See Frankfurt.

### COPENHAGEN

1,067 kc/s. 281 metres; 0.75 kW. Relayed by Kalundborg, 260 kc/s, 1,153.8 metres.—12 Noon, Town Hall Chimes. 12.2 to 2.0 p.m., Concert from the Wivex Restaurant. 3.20, Talk for the Housewife. 3.30, Instrumental Concert: Overture, Undine (Lortzing); Waltz, All Wien (Ziehrer); Chanson triste (Tchaikovsky); Selection from Don Cesar (Delinger); Serenade (Rachmaninov); Overture, Lysistrata (Lütker); March, Sevilla (Prohn); Selection from La Favorita (Donizetti); En ryant (Florent Schmitt); Im schönen grünen Holzland (Petras); Pizzicato (Morena); Minuet (Danning); Intermezzo (Meyer-Helmond); March, Uncle Teddy (Pueck). In the interval at 4.15, Reading. 5.30, Exchange and Fish Market Prices. 5.45, Dramatic Programme. 6.15, Elementary English Lesson. 6.45, Weather. 6.54, Report of the Workers' Radio Association. 7.0, News. 7.15, Time Signal. 7.30, A Discussion. 8.50, Concert by the Radio String Orchestra, conducted by Emil Reesen: Serenade in E flat for String Orchestra (Wolf-Ferari); Acuarélas Valencianas (Charvri). 9.5, Pianoforte Recital by Percy Grainger: Two Pieces (Grieg); Paraphrase on a Theme from Der Rosenkavalier (R. Strauss-Grainger); Four Pieces (Percy Grainger): (a) English Sea Shanty, One more day, my John, (b) The Hunter in his Career, (c) The Londonderry Air, (d) Country Gardens. 9.30, A Radio Grotesque (Pijet). 10.0, News. 10.15, Concert of Danish Music by the Station Orchestra, conducted by Emil Reesen: Overture, Correggio (J. P. E. Hartmann); Selection from the Music to On the Bosphorus (Lange-Müller); Overture, Maskarade (Carl Nielsen); Legende (Fini Henriques); Tarantella from Fête galante (Schierbeck). 11.0, Dance Music from the Nimb Restaurant. In the interval at 12 Midnight, Town Hall Chimes. 12.30 a.m. (Tuesday), Close Down.

GORK.—See Athlone.

DANZIG.—See Heilsberg.

DRESDEN.—See Leipzig.

### FECAMP

1,328 kc/s. 225.9 metres; 10 kW.—11.0 a.m. to 12 Noon, Programme in English by the I.B.C. 11.0, Happy Hour. Part I. Military Band Music: Signature Tune; March, Old Comrades (Teike); Hobokomoko (Reeves); Under the Double Eagle (Tapiero); Selection from The Pirates of Penzance (Sullivan); Prædium (Järnefeld); Cornet Solo, Il bacio (Arditi); Valse des Alouettes (Drigo); Parade of the Tin Soldiers (Jessel). Part II. Dance Music: Talking to you about me (Snyder); Adorable (Whiting); My Love Song (Burnaby); My first Love to last (Whiting); In a second-hand Store (Nelson); You're mine, you (Green); I cover the

**ATHLONE**  
725 kc/s. 413 metres; 60 kW. Relayed by Cork, 1,337 kc/s, 224.4 metres.—1.30 to 2.30 p.m., Time Signal, Weather Report, Stock Exchange Quotations, and Gramophone Music. 6.0, Programme for Children. 6.45, News. 7.0, Gaelic Talk. 7.15, Poultry Talk. 7.30, Time Signal. 7.31, The Station Orchestra. 8.0, Tenor Solos by J. P. Burke. 8.15, Pianoforte Solos by Fred May. 8.30, Sending Grandpa to Heaven—Sketch, by H. Fraser and Company. 9.0, Soprano Solos by Nellie Ryan. 9.15, Organ Recital by J. O'Brien, relayed from St. Francis Xavier's Church. 9.45, Sponsored Programme. 10.45, News, Weather Report, and Close Down.

**BARCELONA**  
ÉAJ1, 860 kc/s. 348.8 metres; 8 kW.—7.0 p.m., Concert by the Station Trio: Selection from Siegfried (Wagner); Larghetto (Dennas); Wedding Day on Trollhøgen (Grieg); Chanson de l'abeille (Puccini); Rocco Minuet (Haydn); Pastoral (Lovreglio); Selection from Cavalleria rusticana (Mascagni). 8.0, Request Gramophone Records. 8.20, Sports Notes. 8.30, Exchange and Talk in Catalan. 9.0, Gramophone Music, followed by News. 10.0, Chimes from the Cathedral, Weather and Exchange. 10.5, Humorous Review of the Week's Events in Verse. 10.15, Music by the Radio Orchestra: Paso doble, Sevillana (Liberte and Leo); Habanera, El esclavo (Coto); Waltz, Was Blumen träumen (Translatur). 10.30, Duets and Songs from Operetta by the Radio Orchestra, Juan Barrabas (Tenor) and Rita Esteban (Songs): Duet from The Dollar Princess (Fall); Serenade (Delmas); Selection from The Merry Widow (Lehár); Duet, Sibyll (Jacobi); Legend (Dvorak); Song, El principe bohemio (Millan); Intermezzo (Hupfermann); Duet from Eva (Lehár); Dance of the Merry Mascoles (Kretelbey). 11.30, Topical Talk. 12 Midnight, News, followed by Concert from the San Sebastian Casino. 1.0 a.m. (Tuesday), Close Down.

**BARI**  
1,112 kc/s. 269.8 metres; 20 kW.—8.0 p.m., Agricultural Notes, Tourist Talk and Duplicity Announcements. 8.20, Giornale Radio and Weather. 8.30, Time and Announcements. 8.35, Weather. 8.45, Turandot Opera in Three Acts (Puccini). In the intervals, Reading and Art Notes. After the Opera, News Bulletin.

BASEL.—See Schweizerischer Landessender.

**BELGRADE**  
697 kc/s. 430.4 metres; 2.8 kW.—5.0 p.m., Yugoslav Songs. 6.55, Time Signal and Programme Announcements. 7.0, Concert by the Station Orchestra. 7.50, Talk. 8.30, Programme from Zagreb, 977 kc/s, 307 metres. 10.30, Time and News. 10.45 (approx.), Gypsy Music from the Zanatski Dom Restaurant.

**BERLIN**  
DEUTSCHLANDSENDER REICHSENDER, 183.5 kc/s, 1,635 metres; 60 kW.—2.0 p.m., Gramophone Music of Famous Singers. 3.0, Talk for Women. 3.30, Weather and Exchange. 3.45, Review of Book on Politics. 4.0, See Breslau. 5.0, Talk: The Political Education of the Man in the Street. 5.25, Recital of Music by Mutich Composers, by Prühl (Soprano), Hartmann (Baritone) and Scholz (Pianoforte); Songs from The Chinese Flute, Op. 41 (Frankenstein); The Birke Cycle, Op. 8 (Maly); Songs from Six Voice Pictures, Op. 5 (Westermann); Stille der Nacht from Drei Hymnen der Nacht (Hansegger); Hälfte des Lebens, Op. 22, No. 1 (Sachse); Brunnen des Lebens, Op. 34, No. 3 (Sachse); Songs from Die Hebelgesänge (Pottgiesser). 6.0, Poems. 6.5, Programme for Young People. 6.25, Dialogue: The Coming Theatre Season. 6.50, Weather and News. 7.0, Transmission for all German Stations, relayed from Berlin (Funkstunde). 8.0, Today's Motto. 8.5 (approx.), Concert from Stuttgart. 9.15, Germans in Venice: Radio Sequence (Lübeck). 10.0, Weather, News and Sports Notes. 10.25, Talk: The Stars and Human Destiny. 10.45, Weather for Shipping. 11.0, Concert from Leipzig. 12 Midnight, Close Down.

**BERLIN**  
FUNKSTUNDE, 715 kc/s. 419.5 metres; 1.5 kW.—4.30 p.m., Concert by the Berlin Wireless Orchestra, conducted by Otto Frickhoff: Ballet Music from Les petits riens (Mozart); Symphony No. 104 in D—the London (Haydn). 5.30, Reading (Dr. Rudolf Presher). 5.50, Extracts from Der Danisnend (Wickand), for the Bi-Centenary of the Author's Birth. 6.20, Partita in E for Violin (Bach). 6.40, The Funkstunde Station informs its Listeners. . . . 6.45, Topical Talk. 7.0, Transmission for all German Stations: Concert of Bavarian and Swabian Music by a Wind Band and the Station Choir. 8.0, Lottery Announcement. 8.5, Extracts from Die Zwillingssel—Opera in Three Acts (Erwin Dressel). 9.25, East Germany—A Radio Sequence in Four Acts. 9.55, News. 10.10 (approx.), Dance Music from the Tiergarten. In the interval from

11.0 to 11.5, Topical Talk. 12 Midnight (approx.), Close Down.  
BERNE.—See Schweizerischer Landessender.  
BEROMUNSTER.—See Schweizerischer Landessender.  
BODEN.—See Stockholm.  
BODO.—See Oslo.  
**BRATISLAVA**  
1,076 kc/s. 279 metres; 11 kW.—2.50 p.m., Jan Bella Concert for his Ninetieth Birthday. 3.50 to 4.0, See Prague. 5.45, See Prague. 6.5, P. Quartets (Jan Bella) by the Station Quartet. 6.55, Report. 7.0, See Prague. 7.10, See Brno. 7.10, Literary Talk. 8.25, See Moravská-Ostrava. 9.0, See Prague. 10.15 (approx.), Close Down.  
BREMEN.—See Hamburg.

**BRESLAU**  
923 kc/s. 325 metres; 60 kW. Relayed by Gleiwitz, 1,184 kc/s, 253 metres.—1.5 p.m., Gramophone Concert: Overture, Boreaccio (Suppé); Hungarian Rhapsody No. 6 (Liszt); Selection from Madame Butterfly (Puccini); Potpourri, Aus der guten alten Zeit (Kock); Rhineland Song Potpourri (Hannemann); March, Hoch Heidecksburg (Herzer). 1.45, Time and News. 2.5, Recital of Marching Songs to the Guitar by Georg Heider. 2.30, Gramophone Concert: March Potpourri, Alle mit uns (Robrecht); Selection from Frasquita (Lehár); Melody (Peterson-Berger); Waltz, Tales from the Vienna Woods (Joh. Strauss-Gebhardt); Andras Hofer-Marsch (Blankenburg). 3.0, Agricultural Prices. 3.20, Book Review. 3.40, Talk: The Influence of Climate on a Nation's Health and Political Economy. 4.0, Concert by the Silesian Symphony Orchestra, conducted by Gerhard Ewald Rischka. Overture, Peter Schmolli (Weber); Kinder-Suite (Schumann-Rischka); Selection from Der Rosenkavalier (R. Strauss); Overture, Cagliostro (Joh. Strauss); Eine Sängereifahrt nach Wien (Silving); March Potpourri, Die Wache zieht auf (Kochmann). 5.30, Agricultural Prices. 5.35 (approx.), Talk on German Culture. 5.50, Programme to be announced. 6.10, Violin Recital by Walter Dittrich: Sonata in D (Handel); Variations on a Theme of Corelli (Tartini); Perpetuum mobile (Briess); Siebente-Mazurka (Wieniawski). 6.20, Talk: The Organization of the Nazi Movement. Nazi Women's Organisations. 6.50, Weather and News. 7.0, Transmission for all German Stations, relayed from Berlin (Funkstunde). 8.0, Silesian Vespers—Literary and Musical Programme by the Station Orchestra and Choir, conducted by Ernst Prade. Soloists: Käthe Heibig (Soprano), Herbert Heidrich (Tenor), Gerlad Bertermann (Baritone), and Hermann Gaupp (Recitations). 9.0, Announcements. 9.10, Erich Hoinkis reads from his own Works. 9.30, Chamber Music: Gotthold Riehter

(Harpsehord), Rudolf Vornung (Viola d'amore), and Fritz Binnowsky (Viola da Gamba). Sonata in D for Viola d'amore and Harpsehord (Hammer); Tocata in E Minor for Harpsehord (Bach); Sonata for Viola da gamba and Harpsehord (Abel); Concerto for Viola d'amore, Viola da gamba and Harpsehord. 10.15, Time and News. 10.35, Technical Talk. 10.45, Talk: The Junction of the Save and the Danube. 11.0 (approx.), Close Down.

**BRNO**  
878 kc/s. 342 metres; 35 kW.—6.5 p.m., Gramophone Music. 6.25, German Transmission; News, followed by Talk: Iron and Steel. 7.0, See Prague. 7.10, A Radio Revue. 8.10, See Bratislava. 8.25, See Moravská-Ostrava. 9.0, See Prague. 10.30 (approx.), Close Down.

**BRUSSELS (No. 1)**  
I.N.R., 590 kc/s. 509 metres; 15 kW.—12 Noon, Concert by the Small Station Orchestra, conducted by Leemans. 1.0 p.m., Le Journal Parlé. 1.10, Gramophone Concert. 5.0, Concert by the Station Symphony Orchestra, conducted by Kumps: Overture, Russian and Ludmilla (Glinka); Serenade (Glazunov); The Flight of the Bumble Bee (Rimsky-Korsakov); Dance of the Tumblers (Rimsky-Korsakov); Peer Gynt Suite, No. 1 (Grieg); Nocturne (Brenta); Danse Sacrée (Desprez); Suite (Kalkman). 6.0, Talk: Elocution and Plastic Art. 6.15, Gramophone Records: Quintet in B minor (Brahms); Aria from The Barber of Seville (Rossini); Ballet Music from Isolde (Messager). 7.15, Talk: Accountancy. 7.30, Le Journal Parlé. 8.0, Symphonic Fantastique (Berlioz) on Gramophone Records. 8.45, Talk by Theo Fleischman: Brussels Programmes for the season 1933-1934. 9.0, Concert, relayed from the Kursaal, Ostend. After the Concert, Le Journal Parlé, followed by Dance Music by Robert Kers and his Cabaret Kings and the Orquestra tipica de Tangos Argentines, relayed from the Kursaal, Ostend.

**BRUSSELS (No. 2)**  
N.I.R., 887 kc/s. 338.2 metres; 15 kW. Programme in Flemish.—12 Noon, Extracts from Iolanthe—Opera (Sullivan), on Gramophone Records. 1.0 p.m., Le Journal Parlé. 1.10, Concert by the Small Station Orchestra, conducted by Leemans. 5.0, Gramophone Records: Sonata in G (Schubert); Overture, Euryanthe (Weber). 5.45, Programme for Children. 6.30, Concert by the Small Station Orchestra, conducted by Leemans: Overture, The Gipsy Baron (Strauss); Old Spanish Song (Aubert); Russian Dance (Tchaikovsky); Fantasia for Violin (Wig); Potpourri, From Gluck to Wagner (Schreiner); Cor Anglais Solo, Theme from Tristan and Isolde (Wagner); March (Kricka). 7.15, Talk on Folklore. 7.20,

SEPT. 4th

MONDAY

continued

Waterfront (Green); I'm getting sentimental over you (Bafmann); Signature Tune. 12 Noon, French Programme. 1.30 to 6.0 p.m., Programme in English by the I.B.C. 4.30, The Nursery Corner: Music, Story, and Birthday Greetings. 5.0, Concert for Chichester and Bogner Listeners. Light Music: Signature Tune; Night by the Sea; Rhapsody in Blue (Gershwin); The Busy Bee (Bendix); Pianoforte Solo, Still I love her (Gaskill); Romance (Löhrl); Selection of Old Music Hall Memories; Spring Blossoms awoken (Löhrl); War Marching Songs (arr. Somers); The Enchanted Forest (Gauglberger). 5.30, Concert for Hastings and Eastbourne Listeners. Operetta Programme: Selection from Wild Violets (Stolz); The Night was made for Love, from The Cat and the Fiddle (Kern); Selection from White Horse Inn (Stolz-Benatzky); My Hero, from The Chocolate Soldier (O. Strauss); If I am dreaming, from The Dubarry (Müllacker); Selection from No No Naneette (Youmans); One alone, from The Desert Song (Romberg); Selection from The New Moon (Romberg); Signature Tune. 6.0, French Programme. 10.0 (approx.) till Close Down. Programme in English by the I.B.C. 10.0, Dance Music: Signature Tune; Bells of Normandy; Stay out of my Dreams; Talking to you about me; My! Oh, My! I shall still keep smiling along; Land of Love and Laughter; Hiawatha's Lullaby; I lay me down to sleep; Piccadilly; Someone to care for; Play it Hot; Won't you stay to tea?; Body and Soul; Under my Umbrella; Chansonnette (Prim); And so I married the Girl; Sylvia; Signature Tune. 11.0, Talkie Time. Sound Film Music: Signature Tune; Sitin' in the Dark; Selection from The Kid from Spain (Kalmar); Love Songs of the Nile, from A Night in Cairo (Brown); Adorable (Whiting); Two Songs from Your Lips say "No"; Happy Ending, from This Week of Grace (Davies); Sweep from Falling for you (Ellis); The Whip, from Golden Dawn (Kalmán); Talkie Potpourri. 11.30, Club Concert for Nantwich Listeners. Part I, Members' Request Half Hour: Signature Tune, The Chim Song; Moonlight on the Alster (Fetras); Roses of Picardy (Haydn Wood); With me Gloves in me and; Old Jim's Christmas Hymn (Gray); The Clock and the Dresden Figures (Ketelbey); Waltz, Très jolie (Waldteufel); The Sea Road (Haydn Wood); The Phantom Brigade (Myddelton). 12.5 a.m. (Tuesday), News Bulletin in English. 12.10 (approx.), Club Concert. Part II: When Work is through; Swanee Stomp; Love, here is my Heart; Masquerade; Conchita; Signature Tune. 12.30, Dance Music by the Blue Mountaineers (Electrical Transcriptions); There's a Cabin in the Pines; Jog along; Wherever you are; You've got me crying again; Two Buck Tim from Timbuctoo; Love you funny thing; When it's lamp lightin' time; The Language of Love; Bahama Mama; Won't you stay to tea?; There's a tiny little Hair; Moonlight, the Danube and you. 1.0, Dance Music: Signature Tune, Bells of Normandy; Out in the Open; You'll never get up to Heaven that way; Little Miss Muffet; Sylvia; Waltzing in a Dream; You've got me crying again; Pop Gun; No more Love; It's the Band; In Eger on the Tegera Sea; This is the Rhythm for me; We belong together; I sigh for you, Rio Rita; It pays to advertise; They all do the Rumba; London Bridge is falling down; Signature Tune. 2.0, I.B.C. Goodnight Melody and Close Down.

FLENSBURG.—See Hamburg.

FLORENCE.—See Turin.

## FRANKFURT

1,157 kc/s, 259.3 metres; 17 kW. Relayed by Cassel, 1,220 kc/s, 245.9 metres; and Trier, 1,157 kc/s, 259.3 metres.—4.30 p.m., See Munich. 5.45, Exchange. 6.0, A German Almanac. 6.10, Programme to be announced. 6.25, Talk on Ivan Turgeniev. 6.45, Review of the Day's News. 6.50, Time, Programme Announcements, Weather and Exchange. 7.0, Transmission for all German Stations, relayed from Berlin (Funkstunde). 8.0, Songs of the Rhine and the Mosel. 8.30, Dialogue: With Field Batteries on the Western Front and in Italy. 9.0, A Newly Discovered Haydn Symphony—Recital with Commentary. 10.0, Topical Talk. 10.15, Time and News. 10.45, See Leipzig. 12 Midnight (approx.), Close Down.

FREDRIKSSTAD.—See Oslo.

FREIBURG.—See Stuttgart.

GENEVA.—See Radio-Suisse Romande.

GENOA.—See Turin.

GLEIWITZ.—See Breslau.

GOTEBORG.—See Stockholm.

GRAZ.—See Vienna.

HAMAR.—See Oslo.

## HAMBURG

806 kc/s, 372 metres; 1.5 kW. Relayed by Bremen, 1,112 kc/s, 269.8 metres; Flensburg, 1,319 kc/s, 227.4 metres; Hanover, 530 kc/s, 566 metres; and Kiel, 1,292 kc/s, 232.2 metres.—6.0 p.m., Variety Programme. 6.45, Exchange. 6.50, Weather. 7.0, Transmission for all German Stations, relayed from Berlin (Funkstunde). 8.0, Concert of Old Hamburg Music by the Hermann Erdlen Chamber Music Orchestra and Lotte Ackers-Ulman (Violin). Symphony in C No. 3

(C. P. E. Bach); Sonata from Musikalische Frühlingsfrüchte (Becker); Presto (Teleman); 8.35, News. 8.45, Good Morning, Mr. Fisher!—Musical Joke in One Scene (Friedrich) with Music for Two Pianofortes by Ginnatis. 9.45, Jos. Magnus Wehner reads from his own Works. 10.15, News. 10.25, Topical Talk. 10.35 (from Kiel), Concert by the Orchestra of Unemployed Musicians, conducted by Hans Döring. Overture, William Tell (Rossini); Selection from Rigoletto (Verdi); Spanish Dance (Sarasate); Waltz (Prigge); Selection from Das Dorf ohne Glocke (Künneke); Intermezzo, Ferdinand and Miranda (Humperdinck); Waltz, Zigeunerliebe (Strauss); Husarenritt (Spindler); March (Blankenburg).

HANOVER.—See Hamburg.

## HEILSBURG

1,085 kc/s, 276.5 metres; 60 kW. Relayed by Danzig, 662 kc/s, 453.2 metres.—1.5 p.m., Italian Opera Music on Gramophone Records: Prelude and Scene from Aida (Verdi); Overture, The Barber of Seville (Rossini); Duet from I Pagliacci (Leoncavallo); Aria from La Bohème (Puccini); Selection from Tosca (Puccini); Selection from Rigoletto (Verdi); Finale from Act III of Ernani (Verdi); Intermezzo from Madame Butterfly (Puccini). In the intervals at 1.20 and at 2.0, News. 3.0, Agricultural Prices and Exchange. 3.30, Programme for Children. 4.0, Concert by the Small Station Orchestra, conducted by Eugen Wilcken: Overture, The Battle of Legnano (Verdi); Rhapsody No. 1 (Brahms); Geschichten aus dem Ennstal (Paehnerweg); Hokuspokus (Leuschner); Little Ida's Flowers (Klenau); Pastoral Suite (Scasola); Hoffballtänze (Lanner); Selection from The Geisha (Jones); Overture, The Bird Fancier (Zeller). In the interval at 4.50 (approx.), Talk: Anniversaries of the Week. 5.45, Talk on Hermann von Wissmann, the African Colonist. 6.15, Agricultural Prices. 6.25 (from Danzig), Talk on Daniel Gabriel Fahrenheit. 6.50, Weather. 7.0, Transmission for all German Stations, relayed from Berlin (Funkstunde). 8.0, Political Announcements and Weather. 8.10, Max Dauthendey Memorial Programme—Literary and Musical Radio Sequence (arr. Ernst Jersch). 8.50, Song Recital by Charlotte Halnel (Soprano). Songs (Schubert): (a) So lasst mich scheiden, (b) Trockene Blumen, (c) Gretchen am Spinnrad; Songs (Schumann): (a) Der Nussbaum, (b) Mit Myrthen und Rosen; Songs (Brahms): (a) An eine Aolsharfe, (b) Geheimnis, (c) Botschaft. 9.20 (from Danzig), Reading (Friedrich Hebbel). 9.45, Elementary English Lesson. 10.15, Weather and News.

## HILVERSUM

Announced HUIZEN, 1,013 kc/s, 296.1 metres; 20 kW. (7 kW. up to 4.40 p.m.).—Programme of the Christian Radio Society (N.C.R.V.). 12.10 p.m., Organ Recital by Jan Zwart: Prelude and Fugue in C (Bach); Pastoral in F (Bach); Prelude and Fugue in D Minor (Bach); Potpourri of Psalms (Zwart); March on a Theme from The Messiah (Handel-Guilman); Allegretto on a Theme of Mendelssohn (Guilmant); Choral on a Theme of Handel (Guilmant); Potpourri of Sacred Songs (Zwart); Intermezzo from the Symphony No. 6 (Zwart); Adagio from the Symphony No. 4 (Widor); Toccata from the Symphony No. 5 (Widor); Potpourri of Sacred Songs (Zwart). 1.40, Broadcast for Schools. 2.15, Gardening Talk. 2.55, Gramophone Music. 3.40, Bible Reading and Sacred Music. 4.40, Gramophone Music. 4.55, Sacred Songs and Violin Solos. 5.55, Gramophone Music. 6.10, Answers to Correspondence. 6.40, Police Notes. 6.55, Religious Report. 7.30, Answers to Correspondence. 7.40, Concert for the Thirty-fifth Anniversary of the Reign of Queen Wilhelmina: The Station Orchestra, conducted by Hurk; Psalm 42 (Weiss); Neerland en Oranje (Maas); March, Jubileum (Vlesing); March, Piet Hein; Jubilmarsch (Ogier); Oranje-marsch (Scholten); Neerlands Vlag (Tierolf); Overture, Soli Deo Gloria (Rugers); Gramophone Music; Van U zyn alle dingen (Bastiaans); Heilig God, voor Wien slechts waarheid; Myn tijt gaat wech; In 't Voorhout (Heye); Waak op Nederland (Diepenbeek); Holland (Schuijter); The Land by the Sea (Viotta). 8.40, Talk: The Mission at Celebes. 9.10, Concert (cont'd.): La Czarine (Ganne); Selection from The Gipsy Princess (Kalmán); Marche lorraine (Ganne); News; Huldigungsmarsch (Boer); Mein Wunsch (Albrecht); Italian Caprice (Tchaikovsky); Neu Berlin (v. Blon); Clarinet Concertino (Coenen); Through Bolts and Bars (Crach); Piece (Vlesing). 10.30, Gramophone Music. 11.10 (approx.), Close Down.

HORBY.—See Stockholm.

## HUIZEN

Announced HILVERSUM, 1,875 metres; 8.5 kW. Programme of the Workers' Radio Society (V.A.R.A.). 11.40 a.m., Concert by the Small V.A.R.A. Orchestra, conducted by de

Groot; Melody; Le bon vieux Temps (Mouton); Two Italian Serenades (Michele); Three Irish Pieces (Auseil); Turkish March (Mozart); Hungarian March (Fueick); Basque Waltz (Urtmann); Kleiner Wiener Marsch (Kreiser). 12.25 p.m., Song Recital by Eline Henrica (Soprano); Aria from L'Enfant prodige (Debussy); Chanson triste (Duparc); Ständchen (R. Strauss); Serenade (Lange). 12.40, Concert by de Notenmakers: March, Hail to the Spirit of Liberty (Sonsa); Waltz from The Arabian Nights (Strauss); Two Airs (Tosti); Cordova (Lozano-Salabert); Selection from Mariska (Lehar); Love Moon (Rico); In a Hungarian Inn (Rines); Selection from Casanova (Lincke). 1.25, Song Recital (cont'd.): Aria from The Bartered Bride (Smetana); Aria from La Traviata (Verdi). 1.40, Organ Recital by Jong: Bercene de Joelyen (Godard); Andante (Haydn); Minuet (Haydn); Selection from Viktoria and her Hussar (Abraham); The Dolls' Concert (Sarony). 2.10, Recitations. 2.40, Gramophone Music. 3.25, Interval. 3.40, Concert by De Notenmakers. 4.10, Programme for Children. 4.40, Concert by the V.A.R.A. Orchestra, conducted by de Groot: Selection from The Vagabond King (Prim); Lolita (Buzzi-Pecchia); Marechiaro (Tosti); Estudiantina (Waldteufel); Serenata (Braga); Salut d'amour (Elgar); Liszt Potpourri (Urbach); Bolek (Leopold). 5.25, Recitations. 5.40, Concert (cont'd.): Mattinata (Leoncavallo); Norwegian Bridal Procession (Grieg); Melody in F (Rubinstein); Tambourin chinois (Kreiser); Strauss Potpourri (Koringold). 6.10, Talk on Music. 6.40, Concert by De Fierfluiters, conducted by Ray Forest. Soloist: Esther Philippe (Songs). In the interval at 7.10, Talk on the Dutch Fair. 7.40, 808 Messages. 7.42, Press Review and Gramophone Music. 8.0, Promenade Concert relayed from London. In the interval, Recitations. 10.25, Concert by Gaspar Lajos and his Cigary Band. 11.40 (approx.), Close Down.

INNSBRUCK.—See Vienna.

## JUAN LES PINS

1,205 kc/s, 249 metres; 0.8 kW.—12.30 p.m., Amusement Guide and Variety Items. 1.0, News. 1.15, Radio Concert. 8.0, Amusement Guide, Financial Notes and News. 8.10, Sports Notes. 8.20, Press Review. 8.30, Radio Concert. 9.0, News and Weather. 9.15, Un Châle brodé—Play (M. Manicau).

KALUNDBORG.—See Copenhagen.

## KATOWICE

734 kc/s, 408 metres; 16 kW.—6.35 p.m., History Talk. 7.20, Announcements and Gramophone Music. 7.40 till Close Down, See Warsaw.

KIEL.—See Hamburg.

KLAGENFURT.—See Vienna.

KOSICE.—See Prague.

## LAHTI

167 kc/s, 1,796 metres; 40 kW. Relayed by Helsinki, 815 kc/s, 368.1 metres.—6.10 p.m., News in Swedish. 6.15, Agricultural Bulletin. 6.25, Choral Concert of Sacred Music, conducted by Kurt Thomas. 7.10, Talk. 7.30, Recital of English Poems. 7.50, Concert by the Station Orchestra, conducted by Haapanen: Fantasia (Purcell); Introduction and Allegro (Dowland); Serenade (Elgar); Two Melodies (Debussy); Two Pieces (Percy Grainger): (a) Molly on the Shore, (b) Mock Morris; Londonderry Air (arr. Percy Grainger); Dance (Bantock). 8.45, News in Finnish. 9.0, News in Swedish.

## LANGENBERG

635 kc/s, 473 metres; 60 kW.—1.0 p.m., Orchestral Concert, conducted by Eysoldt: Overture, The Caliph of Bagdad (Boieldieu); Waltz, Rudolfsklänge (Strauss); Lyric Suite (Mausz); Italian Romance, Marica (Marco); Schubert Potpourri (Urbach); Slav Rhapsody (Friedemann); In the Temple of the Bells (Yoshitomo); March, Mit Standarten (Blon). In an interval at 2.0 (approx.), Announcements. 2.30, Cattle Market Prices. 3.30, Economic Notes and Time Signal. 3.50, Programme for Young People. 4.30, Topical Talk. 4.40, Talk: Westphalian Legends. 5.0, Song Recital on Gramophone Records. 5.30, Talk on Hermann von Wissmann, for his Eightieth Birthday. 6.0, Orchestral Concert, conducted by Eysoldt: Coronation March (Kretschmer); Overture, Ruyady Laszlo (Erke!); Romance (Tchaikovsky); Hungarian Capriccio (Ferraris); Ballet Music, Über allen Zauber Liebe (Lassen); Scenes from Die toten Augen (d'Albert). 6.45, Announcements. 7.0, Transmission for all German Stations, relayed from Berlin (Funkstunde). 8.0, Announcements. 8.5, Berlin—London—New York—Milan—Berlin—Musical Journey Round the World. 10.5, News. 10.30, Concert of Chamber Music for Pianoforte and Wind Instruments: Quintet in E Flat (Mozart); Theme with Variations, Op. 34 (Blumer); Sextet, Op. 6 (Thuille). 12 Midnight (approx.), Close Down.

LAUSANNE.—See Radio-Suisse Romande.

## LEIPZIG

769.9 kc/s, 389.6 metres; 120 kW. Relayed by Dresden, 941 kc/s, 319 metres.—4.0, Wind Instrument Concert, relayed from Altenburg: March, Oberst Hummstsch (Curtis); Overture, Mignon (Thomas); Die Musik kommt! (Zimmer); Waltz, Douausagen (Fueick); Coburg March; Military March; March, Am schönen Rhein (Schwartz). 5.0, Book Review. 5.20, Organ Recital by Hans Anderdonath, relayed from the Ligner Schloss, Dresden; Toccata for Organ (Bach); Symphonic Fantasia and Double Fugue in F, Op. 27 (Fährmann). 5.50, Announcements. 6.0, Talk: The Employment Exchange in the Struggle against Unemployment. 6.20, Flute Recital. 6.50, To-day's News. 7.0, Transmission for all German Stations, relayed from Berlin (Funkstunde). 8.0, Sunday's Events. 8.10 (from Dresden), Mandoline and Zither Concert. 9.0, Agnes Bernauer—Tragedy (Friedrich Hebbel). 10.30, News. 10.45, Concert by the Station Orchestra, conducted by Blumer; Soloists, Günther Odrich and Otto Reinhardt (Trumpet). 12 Midnight (approx.), Close Down.

LINZ.—See Vienna.

## LJUBLJANA

522 kc/s, 574.7 metres; 7 kW.—7.0 p.m., Concert by the Station Orchestra. 8.0, Talk in Esperanto. 8.30, Concert by a Vocal Quartet. 9.15, Weather and News. 9.30, Programme relayed from the Fair. 10.30, Gramophone Music. 11.0 (approx.), Close Down.

## LUXEMBOURG

252 kc/s, 1,191 metres; 200 kW. Italian Programme.—7.30 p.m., Second and Third Acts of Rigoletto—Opera (Verdi) on Gramophone Records. 8.30, Programme of Variety Music. 8.50, News in French. 9.0, Tello Recital with Orchestral Accompaniment. 9.45, News in German. 9.55, Variety Music by the Station Orchestra, conducted by Henri Pensis. 10.15, Variety Music and Dance Music on Gramophone Records.

## MADRID

EAJ7, 707 kc/s, 424.3 metres; 2 kW.—8.0 p.m., Chimes, Exchange and Radio Journal. 9.15, News. 9.30 (approx.), Close Down.

## MADRID

EAQ, 10,000 kc/s, 30 metres; 20 kW.—11.30 p.m., Concert of Light Music. In an interval at 11.45, Radio Chronicle. 12.35 a.m. (Tuesday), Sports Notes. 12.40, Light Music. 1.0 (approx.), Close Down.

MALMO.—See Stockholm.

## MILAN

VIGENTINO, 662 kc/c, 453.2 metres; 4 kW.—8.45 p.m. till Close Down, See Rome.

## MORAVSKA-OSTRAVA

1,137 kc/s, 263.8 metres; 11 kW.—6.30 p.m., German Transmission: Theodor Körner Memorial Programme, followed by Amusement Guide. 7.0, See Prague. 7.10, See Brno. 8.10, See Bratislava. 8.25, A Comedy. 9.0, See Prague. 10.15 (approx.), Close Down.

MOTALA.—See Stockholm.

MUHLACKER.—See Stuttgart.

## MUNICH

563 kc/s, 533 metres; 60 kW. Relayed by Augsburg and Kaiserslautern, 536 kc/s, 560 metres; and Nürnberg, 1,256 kc/s, 239 metres.—2.50 p.m., Ballad Recital. 3.15, Programme for Children. 3.35 (from Nürnberg), Reading. 3.55, Weather and Market Prices. 4.5, Talk: Reminiscences of a Prisoner of War. 4.30 (from Nürnberg), Orchestral Concert, conducted by Michael Bayer: Overture, Rübzahl (Weber); Ballet Music from Faust (Gounod); Czardas (Michiels); Selection from Alessandro Stradella (Flotow); Waltz, Rendez-vous (Waldteufel); Italian Serenade (Holmes); March, Unter Freiheitsstern (Blankenburg). 5.45, Talk. 6.5, Pflüzer Song Recital by Erik Wildhagen (Baritone). 6.30, Review of Books. 6.50, Time and Weather. 7.0, Transmission for all German Stations, relayed from Berlin (Funkstunde). 8.0, Concert by the Station Orchestra, conducted by Karl List. Soloist: Anita Wich (Soprano). Ein Volkstrümphstück (Wallnöfer); Rheinische Nachtmusik (Niemann); España (Chabrier); Two Arias for Soprano and Orchestra: (a) Aria from The Pearl Fishers (Bizet), (b) Aria from Don Pasquale (Donizetti); German Dances (Schubert-Weber); Overture, Der Waffenschmied (Lortzing). 9.0, Talk: The German and the Russian Revolutions. 9.20, A Radio Sequence. 10.20, Time and News. 11.0, Programme from Leipzig. 12 Midnight (approx.), Close Down.

NAPLES.—See Rome.

NOTODDEN.—See Oslo.

## OSLO

277 kc/s, 1,083 metres; 60 kW. Relayed by Fredriksstad, 815 kc/s, 368.1 metres; Hamar, 522 kc/s, 574.7 metres; Notodden, 671 kc/s,

SEPT. 4th

MONDAY

continued

447.1 metres; Porsgrund, 662 kc/s, 453.2 metres; and Rjukan, 671 kc/s, 447.1 metres. —5.30 p.m., Concert by the Radio Ensemble. 6.30, Talk on Sport. 7.0, Advertising Notes, Weather and News. 7.30, Recital of Norwegian Songs. 8.0 Time Signal. 8.2, Sunday—Play in One Act (Claude Roger-Marx, translated by Vilhelm Dybwad). 8.45, Pianoforte Recital: Sonata in B Flat Minor, Op. 1 (Alban Berg); Mephistowalzer (Liszt). 9.10, Review of Foreign Affairs. 9.40, Weather and News. 10.0, Topical Talk. 10.15, Talk in English: Impressions of America. 10.30 (approx.), Close Down.

OSTERSUND.—See Stockholm.

PALERMO

558 kc/s, 537.6 metres; 3 kW.—8.0 p.m., Dopplavoro Notes, Tourist Talk, Agricultural Notes, Report of the Royal Geographical Society and Giornale Radio. 8.20, Gramophone Music. In an interval at 8.30, Time and Announcements. 8.45, Concert of Chamber Music. Gallési (Oboe), Scala (Pianoforte), Manno (Violin), Micozzi (Clarinet): Oboe Solos, Andante and Scherzo (Hoffman); Sonata in A for Pianoforte and Violin (Franck); Clarinet Solos, Prelude and Rondo (Boumard); Oboe Solo, from the Suite (Cord); Clarinet Solos: (a) Rio gaio (Giacchino), (b) The Gazelle (Wallenhandt); Sonata in F for Pianoforte and Violin (Grieg). 10.15, Light Music on Gramophone Records. 10.55, News.

PARIS

EIFFEL TOWER, Call FLE, 207.5 kc/s, 1,445.7 metres; 13 kW. Time Signals (on 2,650 metres) at 10.26 a.m. and 11.26 p.m. (Preliminary and 6-dot Signals)—6.45 p.m., Theatre Notes. 7.0, Le Journal Parlé. 8.45, Concert, relayed from the Casino Viehy (See Strasbourg). 11.15 (approx.), Close Down.

PARIS

POSTE PARISIEN, 914 kc/s, 328.2 metres; 60 kW.—7.0 p.m., Gramophone Music. 7.15, Le Journal Parlé. 7.30, Hot Jazz on Gramophone Records. 8.0, Cécile Chaminade Song Recital by Paul Puyen: Sans amour; Rêve d'un soir; Au firmament; Si j'étais jardinier; Erin; Tu me dirais. 8.30, Songs by Max Régner. 9.10, Sponsored Gramophone Concert. 10.10, News.

PARIS

RADIO PARIS, Call CFR, 174 kc/s, 1,725 metres; 75 kW.—7.30 a.m., Weather and Physical Culture. 7.45, Gramophone Records: La ronde des Lutins (Rozani); Bells Across the Meadows (Ketyly); La Chasse aux Caillies (Paradis); Roses from the South (Strauss). 8.0, Weather and Press Review. 12 Noon, Gramophone Concert: Minuet ébriette (Adam); Novella (d'Ambrosio); Charity (Fauré); Slav Dance (Dvorák-Kreisler); Retour de Vèpres (Busser); Sélénie Rossarini (Kreisler); Amoureux (Gounod); Jota (Falba); L'air (Iahn); Dance (Konguel); La Barbe blanche (Hüe); Carnival in Venice (Geim); Chanson de Barberine (Loret); Spanish Dance No. 5 (Granados); Bonsoir, Madame la Lune (Marinier); Tu n'as jamais compris (Marinkovitch); Ce que disent les Cloches (Massenet); Sonata for Violin and Oboe (Mihalovitch); Paris angéliens (Franck); Sonata in G (Alzart-Grieg); Elegy (Massenet); Chante, Rossignol (Fijan); Souvenir (Perzov-Zargevski); Five Poems (Ferroud); Arabesque No. 1 (Debussy); Soir (Fauré); Chanson Villageoise (Popper); Roussignolet (Despourrins); Polichinelle (Rachmaninov); Les Mamanis (Delmet); Valse-Caprice, No. 2 (Philipp); Arioso (Delibes). In the interval at 1.0 p.m., Exchange and Weather, and at 1.30, Exchange. 2.0, Exchange. 3.45, Exchange and Market Prices. 7.0, Agricultural Notes. 7.10, Gramophone Records: Spanish Dances (Sarasate); Frisson de Feuilles (Sauer); L'ange de la Mer (Goublier); Impromptu in A Flat (Schubert); The Silver Ring ('Chaminade); Abendlied (Schumann); Melody (Tchaikovsky). 7.50, Commercial Prices and News. 8.0, Pianoforte Recital by Regnaud Weingartner. 8.30, News and Weather. 8.40, Review by Paul Reboux. 8.45, Talk and Reading: The Origin of the French Theatre in Canada, Some Canadian Poets. 9.15, Press Review and News. 9.30, Chamber Music on Gramophone Records; Ballad No. 1 in F Minor (Chopin); Fêtes galantes (Debussy); Mandoline (Debussy); Five Mazurkas (Tansman); Six French Songs (Taffelre); String Quartet No. 2 (Mihailid).

PITTSBURGH

KDKA, 980 kc/s, 306 metres; 50 kW. Relayed by W8XK on 48.85 metres and 25.27 metres.—7.30 p.m., Pontiac, Home Forum. 8.0, Betty and Bob, from New York. 8.15, Words and Music, from New York. 8.45, Human Values. 9.0, Radio Guild from New York. 10.0, Enle Tom Guild from New York. 10.15, Tarzan of the Apes. 10.30, and Betty, from New York. 10.45, Orphan Singing Lady, from New York. 11.0, Press News, from New York. 11.30, Pittsburg Reeler. 11.45, Sports, A Song. 11.50, Pittsburg Spotlights. 11.55, to 3.0 a.m. (Tuesday), New York Relay. 11.45, Lowell Thomas. 12.0, Amos 'n' Andy. 12.15, Baby Rose Marie. 12.30, Popular Programme. 1.0, Yesterday and To-day. 1.30, Potash and

Perlmutter. 1.45, Guild and Shefter. 2.0, Sinclair Minstrels. 2.30, Melody Moments. 3.0, Silver Toppers.

PORSGRUND.—See Oslo.

POZNAN

896 kc/s, 335 metres; 1.9 kW.—7.20 p.m., Miscellaneous Items and News. 7.35, Theatre Notes and Programme Announcements. 7.40, See Warsaw. 10.0, Time Signal, Sports and Police Notes. 10.15 (approx.), Close Down.

PRAGUE

614 kc/s, 488.6 metres; 120 kW.—2.50 p.m., See Bratislava. 3.50, Weather Report. 3.55 to 4.0, Exchange. 5.45, Gramophone Music. 5.55, Hint; for the Housewife. 6.5, Agricultural Talk. 6.10, Gramophone Music. 6.15, Talk: Divorce and Separation. 6.25, News in German. 6.30, German Transmission: Talk by Roderich Menzel: Experiences as a Participant in the International Tennis Championship, 1933. 7.0, Chimes and News. 7.10, See Brno. 8.10, See Bratislava. 8.25, See Moravská-Ostrava. 9.0, Time Signal. 9.2, Orchestral Concert of Music by Jan Levoslav Bella. 10.0, Time and News. 10.15, Talk: Creative Art in Czecho-Slovakia. 10.30, Close Down.

RADIO-SUISSE ROMANDE

SOTTENS, 743 kc/s, 403 metres; 25 kW.; and Geneva, 395 kc/s, 760 metres.—1.0 p.m. (from Geneva), Financial News. 1.10 (from Geneva), Gramophone Concert. 2.0 to 3.28, Interval. 3.28, Time Signal from Neuchâtel Observatory. 3.30, Concert by the Radio Lausanne Orchestra, conducted by Moser. 5.0 (from Lausanne), Programme for Children. 5.30 to 7.0, Interval. 7.0 (from Geneva), Talk: The Century of Speed. 7.30 (from Geneva), News. 8.0 (from Geneva), Depuis six mois—One Act Comedy (Mauray). 8.30 (from Lausanne), Programme for the Centenary of L'École normale in the Vaud Canton. 9.30 (from Lausanne), Pianoforte Recital by Olga Daragan. 9.50, News. 10.0 (from Lausanne), Song Recital by Gustave Dutoit (Bass). 10.30 (approx.), Close Down.

REYKJAVIK

250 kc/s, 1,200 metres; 21 kW.—9.5 p.m., Musical Programme. 9.30, Weather Report. 9.40, Musical Programme and Announcements. 10.0, Chimes and News. 10.30, Reading. 11.0, Popular Music by the Radio Quartet, with Songs.

RJUKAN.—See Oslo.

ROME

Call 1RO, 680 kc/s, 441 metres; 50 kW. Relayed by Naples, 941 kc/s, 319 metres; and 2RO, 11,810 kc/s, 25.4 metres, from 5.15 p.m.—12.30 p.m., Gramophone Music. 1.0, Gramophone Concert. In the interval from 1.30 to 1.45, Giornale Radio and Exchange. 2.0, Time and Announcements. 4.30, Giornale Radio and Exchange. 4.45, Children's Radio Review. 5.10, Announcements. 5.15, Vocal and Instrumental Concert: Paolo Leonori (Cello), Elisa Capolino (Soprano) and Adolfo Facchini (Tenor); Cello Solos: (a) Aria, (b) Minuet (Hüe); Soprano Solos: (a) Romance from The Force of Destiny (Verdi), (b) Torna, amore (Buzzi-Peccia); Tenor Solos: (a) Aria from Tosca, and (b) Aria from Turandot (Puccini); Cello Solo: Oriental Dance (Rachmaninov); Duet from L'Amico Fritz (Mascanzi). 6.40 (Naples), Shipping and Sports Notes. 6.45, Dopplavoro Notes, Radio Journal, Tourist and Agricultural Reports, and Market Prices. 7.20, News in Foreign Languages. 7.40, Giornale Radio. 8.0, Time and Announcements. 8.5, Gramophone Music. 8.15, Talk. 8.30, Giornale Radio and Sports Notes. 8.45, Concert of Light Music. Talk in the interval. 10.55, Giornale Radio.

SALZBURG.—See Vienna.

SCHENECTADY

WGY, 790 kc/s, 379.5 metres; 50 kW. Relayed at intervals by W2XAF on 31.48 metres and by W2XAD on 19.55 metres.—9.0 p.m., Book News by Levere Fuller. 9.15, Soloist, from New York. 9.30 to 10.0 (approx.), Radio School of the Theatre. 12.45 a.m. (Tuesday), Stock Reports and Baseball Scores. 1.0, Succynland Sketch, from New York. 1.30, Felix Ferdinand's Burgomasters. 1.45, Ferde Grofé's Orchestra, from New York. 2.0, A. and P. Gypsies, from New York. 2.30, Horse Sense Philosophy. 2.45 to 3.30, New York Relay. 2.45, Musical Programme. 3.0, Contented Programme. 3.30, Popular Programme, from New York, followed by Programme Resumé.

SCHWEIZERISCHER LANDESENDER

BEROMUNSTER, 653 kc/s, 459 metres; 60 kW.; Basle, 1,229 kc/s, 244.1 metres; and Berne, 1,220 kc/s, 245.9 metres.—11.59, Time Signal from Neuchâtel Observatory and Weather. 12 Noon (from Basle), Gramophone Music. 12.30 p.m., Time and News. 12.40 (from Basle), Gramophone Music. 1.25 (from Basle), Time, Weather and Exchange. 1.35, Interval. 5.0 (from Zürich), Fashion Talk for Women. 5.30 (from Berne), Light Music on Gramophone Records. 6.30 till close down. Programme from Zürich. 6.30, Talk: Natural Homespun and its Industrial Value. 7.0, Time and Weather. 7.5, Gramophone Music. 7.30, English Lesson. 8.0, Italian Music. 8.30, Talk: Manchukuo. 9.0, News. 9.10, Rölli's Verlobung—Comedy (Schmeiter). 10.15 (approx.), Close Down.

phone Music. 12.30 p.m., Time and News. 12.40 (from Basle), Gramophone Music. 1.25 (from Basle), Time, Weather and Exchange. 1.35, Interval. 5.0 (from Zürich), Fashion Talk for Women. 5.30 (from Berne), Light Music on Gramophone Records. 6.30 till close down. Programme from Zürich. 6.30, Talk: Natural Homespun and its Industrial Value. 7.0, Time and Weather. 7.5, Gramophone Music. 7.30, English Lesson. 8.0, Italian Music. 8.30, Talk: Manchukuo. 9.0, News. 9.10, Rölli's Verlobung—Comedy (Schmeiter). 10.15 (approx.), Close Down.

SOTTENS.—See Radio-Suisse Romande.

STOCKHOLM

689 kc/s, 436 metres; 55 kW. Relayed by Boden, 244 kc/s, 1,225.5 metres; Göteborg, 932 kc/s, 322 metres; Hörby, 1,166 kc/s, 257 metres; Motala, 221.5 kc/s, 1,354.4 metres; Ostersund, 389 kc/s, 770 metres; and Sundsvall, 554 kc/s, 542 metres.—5.5 p.m., Folk Music. 5.25, Talk in Norwegian. 5.45, Gramophone Music. 6.45, Interview with Some Delegates to the Twelfth International Congress of History and Art. 7.15, Weather and News. 7.30, Cabaret Programme. 8.15, Talk: Life in Finland. 8.45, Poetry and Music of the Eighteenth Century. 9.45, Weather and News. 10.0 (from Göteborg), Concert by Wertheimer's Orchestra: Overture, Die Fledermaus (Joh. Strauss); Selection from The Flying Dutchman (Wagner); Valse des fleurs (Tchaikovsky); Potpourri (arr. Ottosen); Potpourri of Hungarian Songs and Dances, Hungaria (arr. Leopold). 11.0 (approx.), Close Down.

STRASBOURG

869 kc/s, 345 metres; 11.5 kW.—11.30 a.m., Light Music on Gramophone Records. 12.15 p.m., Grieg Music on Gramophone Records. 12.45, News. 1.0, Time and Exchange. 1.5, Dance Music on Gramophone Records. 2.0 to 3.30, Interval. 3.30, Orchestral Concert, conducted by Brouillac, relayed from the Casino, Vichy: Overture, Martha (Flotow); An den Frühling (Grieg); Solvieg's Song (Grieg); Ballet Music from Le Miracle (Huc); Melody: First Movement from The Unfinished Symphony (Schubert); Selection from The Tales of Hoffman (Offenbach); Hydropathen-Walzer (Gungl). 5.0, Gramophone Music. 5.15, Orchestral Concert, conducted by Roskam: Marche française (Filipucci); Waltz, Etincelles (Waldteufel); Minuet (Paderevsky); Overture, Giroflé-Girofla (Lecocq); Pianoforte Solo; Selection from Tosca (Puccini-Berghes); Ballet italien (de Bozi). 6.0, Literary Review. 6.15, Review of the Week in German. 6.30, Grieg Concert, conducted by Maurice de Villers; March from Sigurd Jorsalfar; Lyric Suite; Three Norwegian Dances; Peer Gynt Suite. 7.30, Time and News. 7.45, Light Music on Gramophone Records. 8.15, Press Review in German, Lottery Results, and Announcements. 8.45, Concert, relayed from the Casino, Vichy. Soloists: Soetens (Violin) and Scerville (English Horn). Overture, Genoveva (Schumann); Violin Concerto in E Flat (Mozart); Entr'acte from Act III of Tristan and Isolde (Wagner); English Horn Solo; First Romanian Rhapsody (Enesco); La ville rose (Roussel); Poem, for Violin and Orchestra (Chausson); Symphony, with Organ Accompaniment (Saint-Saëns). 11.15 (approx.), Press Review.

STUTTGART

MUHLACKER; 832 kc/s, 360.5 metres; 60 kW. Relayed by Freiburg, 527 kc/s, 570 metres.—12 Noon, Orchestral Concert, conducted by Karl Assmus, relayed from Baden-Baden: Hungarian March (Schubert-Liszt); Overture, Amid Nature (Dvorak); Entr'acte from Rosamunde (Schubert); Ballet Suite (Reger); Selection from Oberon (Weber); Introduction to Lorelei (Bruch); Potpourri-Walzertrümpe (Robrecht). 1.15 p.m., Time and News. 1.30, Gramophone Music. 2.0 to 2.15, Programme arranged by the Post Office, with Gramophone Music. 2.30, Spanish Lesson. 3.0 to 3.30, Elementary English Lesson. 4.30, See Munich. 5.45, Talk: Experiences in South-West Africa. 6.10, Legal Talk. 6.35, Time and News. 7.0, Transmission for all German Stations, relayed from Berlin (Funkstunde). 8.5, Orchestral Concert, conducted by Karl Assmus, relayed from Baden-Baden: Festival Overture (Lassen); Ballet Music from Prometheus (Beethoven); Second Movement from the Symphony from the New World (Dvorak); Waltz from Gipsy Love (Lelár); Triumphant March from Aida (Verdi). 9.15, See Berlin (Deutschlandsender). 10.0, Time and News. 10.45 (approx.), See Leipzig. 12 Midnight, Close Down.

SUNDSVALL.—See Stockholm.

TOULOUSE

779 kc/s, 395 metres; 8 kW.—6.15 p.m., Hawaiian Guitar Solos. 6.30, Operetta Music; Selection from (a) Les Cloches de Corneville (Planquette), (b) Begonia (Pujol), (c) Rose Marie (Friml), (d) Monsieur Beaucaire (Messager), and (e) New Moon (Rom-

berg). 6.45, Music by an Argentine Orchestra. 7.0, Light Music. 7.15, News. 7.30, Extracts from La Péri (Dukas). 7.45, Comic Opera Music: Songs from Mirella (Gounod); Cavatina from Romeo and Juliet (Gounod); Cavatina from The Pearl Fishers (Bizet). 8.0, Military Music. 8.15, Operetta Music: Selection from (a) Véronique (Messager), (b) Gillette de Narbonne (Audran), (c) Les Cloches de Corneville (Planquette), (e) Les Cloches de Corneville (Planquette), 8.30, Orchestral Music. 8.45, Sound Film Music. 9.0, Concert by the Toulouse Symphony Orchestra. In the interval, Light Music. 10.15, News. 10.30, Concert for Listeners in Morocco. 11.0, Light Music. 11.15, Dance Music. 12 Midnight, News. 12.5 a.m. (Tuesday), Instrumental Solos. 12.15, Orchestral Music. 12.30, Close Down.

TRIESTE

1,211 kc/s, 247.7 metres; 10 kW.—5.10 p.m. till Close Down, See Turin.

TRONDHEIM.—See Oslo.

TURIN

273.7 metres; 7 kW. Relayed by Milan, 331.5 metres; Genoa, 312.8 metres; and Florence, 500.8 metres.—5.10 to 6.0 p.m., Orchestral Concert. 6.40, Giornale Radio, Dopplavoro Announcements, and Gramophone Music. 7.0, Time, Tourist Report, and Gramophone Music. 7.10, Agricultural Notes and Market Prices. 7.20, News in Foreign Languages. 7.40, Gramophone Music. 8.0, Announcements, Giornale Radio, Sports Notes and Weather. 8.15, Sponsored Concert. 9.15, A Comedy in One Act. 10.0, Chamber Music. 11.0, Giornale Radio.

VATICAN CITY

15,120 kc/s, 19.84 metres (Morning), and 5,969 kc/s, 50.26 metres (Evening); 10 kW.—11.0 to 11.15 a.m., Religious Information in Italian. 8.0 to 8.15 p.m., Religious Information in Italian.

VIENNA

581 kc/s, 517 metres; 100 kW. Relayed by Graz, 852 kc/s, 352.1 metres; Innsbruck, 1,058 kc/s, 283 metres; Klagenfurt, 662 kc/s, 453.2 metres; Linz, 1,220 kc/s, 245.9 metres; and Salzburg, 1,373 kc/s, 218.5 metres.—3.0, Time and Announcements. 3.20, Gardening Talk. 3.30, Talk. 3.55, Gramophone Concert of Popular Music. 4.35, Programme for Young People. 5.0, Talk: The Symphonies of Brahms and Bruckner. 5.25, Song and Pianoforte Recital, by Annemarie Hönel (Soprano), and Emmy Dradzik: Soprano Solo: (a) Provincial Song, (b) Aus den östlichen Rosen, (c) Stille Liebe, (d) Schneckglöckchen, (e) Die Kartenlegerin; Pianoforte Solos: (a) Chromatic Fantasia and Fugue (Bach), (b) Intermezzo, Op. 118, No. 2 (Brahms). 6.5, Talk: A Walk through the Vienna of the Baroque Period. 6.25, Books of Reference in Connection with the Week's Talks. 6.30, Talk: Modern Ecclesiastical Art. 7.0, Topical Talk. 7.15, Time and Announcements. 7.25, Macbeth—Opera in Four Acts (Verdi), relayed from the State Opera House. In an interval, Announcements. 10.15, Dance Music by the Broadway Boys, relayed from the Café Palmhof.

WARSAW

212.5 kc/s, 1,411 metres; 120 kW.—11.57 a.m., Time Signal and Fanfare from St. Mary's Church, Cracow. 12.5 p.m., Popular Orchestral Concert, relayed from the Bagatelle Restaurant. 12.25, Polish Press Review. 12.33, Weather. 12.35, Orchestral Concert (contd.). 12.55, Radio Journal. 1.0 to 2.55, Interval. 2.55, Gramophone Music. 3.5, News. 3.10, Announcements. 3.15, Gramophone Music. 3.25, Economic Notes. 3.35, Gramophone Music. 3.45, Traffic Report. 3.50, Gramophone Music. 4.0, Concert by the Poznan Opera House Orchestra, relayed from Ciechocinek; (conductor: Tyllja); Overture, Ruy Blas (Mendelssohn); Waltz, Plmie d'or (Waldteufel); Ballet égyptien (Luigini); Selection from Countess Mariza (Kálmán); Ballet Music from Henry VIII (Saint-Saëns). 5.0, Talk in French. 5.15, Song and Pianoforte Recital by M. Pomorska (Soprano) and Mme. Swieicka (Pianoforte); Soprano Solos: Arias from: (a) L'Enfant prodige (Debussy), (b) Turandot (Puccini); Pianoforte Solos: (a) Theme with Variations (Paderevsky), (b) Impromptu in C Minor (Rozkyevy), (c) Tracvienne (Niewiadomsky); Soprano Solos: (a) Agnes (Rozkyevy), (b) Lullaby (Kassern), (c) Song (Nowowiejski); Pianoforte Solos: (a) Prelude and Humoresque (Wertheim), (b) Serenade (Zarembsky); Soprano Solos: (a) Après un rêve (Fauré), (b) Serenade (Massenet), (c) Pastorale (Bizet). 6.15, Talk on Economics. 6.35, Gramophone Music. 6.55, Military Notes. 7.20, Miscellaneous Items. 7.35, Programme Announcements. 7.40, Literary Talk. 8.0, Die Bajadere—Operetta (Kálmán). In the intervals: Agricultural Report and Radio Journal. 10.0, Dance Music, relayed from Ciechocinek. 10.25, Music, relayed from Ciechocinek. 10.35, Weather Report and Sports Notes. 10.40, Dance Music, relayed from Ciechocinek (contd.).

ZURICH.—See Schweizerischer Landessender.



ATHLONE

725 kc/s, 413 metres; 60 kW. Relayed by Cork, 1.37 kc/s, 224.4 metres.—1.30 to 2.30 p.m., Time Signal, Weather Report, Stock Exchange Quotations and Gramophone Music. 5.0, Programme for Children. 6.40, News. 7.0, Gaelic Reading. 7.15, Poetry Recital by May Pitchford. 7.30, Time Signal. 7.31, Concert of Sinding and Sibelius Music by the Station Orchestra. 8.0, Scandinavian Ballads by Fearoid O Lochlainn. 8.15, Traditional Fiddle Solos by May Kavanagh. 8.30, Irish Music by the Station Orchestra. 9.0, Soprano Solos by Lily Christie. In an interval at 9.10, Orchestral Music. 9.45, Sponsored Programme. 10.45, News, Weather and Close Down.

BARCELONA

EJAJ, 860 kc/s, 348.8 metres; 8 kW.—7.0 p.m., Concert by the Station Trio: Selection from Don Giovanni (Mozart); Piece romantique (Chaminade); Gavotte (Chaminade); Aria from Louise (Charpentier); Serenade (van den Eynde); Siegmund's Love Song from The Valkyrie (Wagner); Selection from A Masked Ball (Verdi). 8.0, Request Gramophone Music. 8.30, Exchange and Talk. 9.0, Gramophone Music, followed by News. 10.0, Chinese, Weather, Messages for Seamen and Exchange. 10.5, Sponsored Programme. 10.30, Concert by the Station Orchestra: Catalan Symphony (Ribera); Nocturne (Field); Ball des géants (Sancho Marraco); Violin Solo: Ballet Music from Sylvia (Delibes); Waltz in A (d'Ambrósio). 11.15, Concert from the Café Español. In the interval at 12 Midnight, News. 1.0 a.m. (Wednesday), Close Down.

BARI

1,112 kc/s, 269.8 metres; 20 kW.—8.0 p.m., Agricultural Notes, Tourist Talk, and Popolavoro Announcements. 8.20, Giornale Radio and Weather. 8.30, Time and Announcements. 8.35, Weather. 8.40 (approx.), Quartet Concert: Overture, Le trame deluse (Cimarosa); Serenade galante (Anaclei); Prelude to Act II of I goliardi (Cassini); Pleniunio (Del Buono); Suite, Spagna (Giannico); Selection from Ernani (Verdi); L'uto gentile (Gargano); Romance (Anaclei); Prelude to Act IV of La Traviata (Verdi); Intermezzo, Mormorio del mare (Salvetti); Serenata, C'era la luna (De Martino); Popular Spanish Dance (de Ibez). In the interval, Literary Notes. 10.30, Gramophone Music. 10.55, News.

BASLE.—See Schweizerischer Landessender.

BELGRADE

697 kc/s, 430.4 metres; 2.8 kW.—6.55 p.m., Time Signal, Programme Announcements, and Gramophone Music. 7.20, Reginald Howard sings his own Songs: (a) Fantasy in Bells, (b) Where do I want to go, (c) Chinese Suite, (d) All change for Happiness, (e) That's all that matters to me. 8.0, A Radio Play. 8.30, European Concert relayed from Berlin (Deutschlandsender). 10.0, Time, News, and Gramophone Music. 10.40, Dance Music from the Ratnicki Dom Restaurant.

BERLIN

DEUTSCHLANDSENDER (REICHSENSENDER), 183.5 kc/s, 1,635 metres; 60 kW.—1.45 p.m., News. 2.0, Gramophone Concert: Pianoforte Solos by Sergei Rachmaninov: (a) Etude tableau in A minor (Rachmaninov), (b) Waltz in C minor (Chopin); Cello Solos by Pablo Casals: (a) Nocturne in E flat (Chopin), (b) Tondilla (de Laserna); Soprano Solos by Mafalda Salvatini: (a) Aria from Tosca (Puccini), (b) One Fine Day from Madame Butterfly (Puccini); Soprano Solos by Elisabeth Rethberg: (a) Aria from Carmen (Bizet), (b) Aria from Cavalleria rusticana (Mascagni); Violin Solos by Georg Kulenkampf: (a) Humoresque (Dvorak), (b) Hungarian Dance in G minor (Brahms); Pianoforte Solos by Claudio Arrau: (a) Carmen Fantasia (Bisont), (b) Etude in E (Chopin). 3.0, Talk for Young People: A Visit to the Karl May Museum. 3.30, Weather and Exchange. 3.45, Political Dialogue. 4.0, Concert from Leipzig. 5.0, Talk for Women: The Chicago World Fair. 5.20, Chamber Music by Beethoven and Brahms: Part I, Pianoforte Solos (Brahms) by Willy Stech; Ballad in G minor; Intermezzo in E flat minor; Rhapsody in B minor. Part II: Pianoforte Trio in B flat, Op 11 (Beethoven). 6.0, Poems. 6.5, Talk: A Criticism of the German Middle Classes. 6.30, Political Press Review. 6.50, Weather and Announcements. 7.0, Transmission for all German Stations, relayed from Stuttgart. 8.0, To-day's Motto. 8.5, A Political Cabaret. 8.35, European Concert by the Berlin Philharmonic Orchestra, conducted by Erich Kleiber: Two Preludes to Palestina (Pfitzner); Wieland der Schmied (Hausegger); Alpine Symphony, Op. 4 (R. Strauss). 10.0, News. 10.25, Radio Report of the Swimming Championships at the International University Sports in Turin (on Gramophone Records). 10.45, Weather. 11.0, Orchestral Concert of Modern Italian Music. 12.30 a.m. (Wednesday), Close Down.

BERLIN

FUNKSTUNDE, 715 kc/s, 419.5 metres; 1.5 kW.—4.35 p.m., Concert by the Station Orchestra, conducted by Hanns Steinkopf. 6.15,

TUESDAY SEPTEMBER THE FIFTH

PRINCIPAL EVENTS OF THE DAY:

AT HOME

- NATIONAL LONDON Promenade concert from Queen's Hall, London. "Stufe," a drama, by John Galsworthy. REGIONAL MIDLAND Band programme. REGIONAL SCOTTISH REGIONAL Orchestral concert. BELFAST Orchestral concert. ABROAD ATHLONE 7.31 p.m. Concert of Sinding and Sibelius music, by the Station Orchestra. BARCELONA 7.0 p.m. The Station Trio. BERLIN (Deutschlandsender) 8.30 p.m. European concert by the Berlin Philharmonic Orchestra, conducted by Erich Kleiber. BRESLAU 5.55 p.m. Pianoforte recital: Music of the Baroque Period. COPENHAGEN 7.30 p.m. The Tivoli Orchestra and soloists. HAMBURG 10.30 p.m. The Philharmonic Orchestra. HILVERSUM 7.40 p.m. Concert by the K.R.O. Orchestra. POSTE 8.30 p.m. Concert by the Station Orchestra. PARISIEN STOCKHOLM 8.0 p.m. "Pictures from Italy and Spain," concert, by the Station Orchestra. STRASBOURG 6.30 p.m. Orchestral concert, conducted by Maurice de Villers.

Concert by the Berlin Wireless Choir, conducted by Heinz Karl Weigel: Soloist: Alexander Ecklebe (Pianoforte); Gott im Ungewitter—for Mixed Choir and Pianoforte (Schubert); Two Pieces for Women's Choir and Pianoforte: (a) Triolett, (b) Tamburinschlägerin (Schumann); Hunting Chorus from Rosenmunde (Schubert), for Mixed Choir and Pianoforte. 5.30, Summer in the Village—a Radio Sequence. 6.0, Review of Social Politics. 6.15, Review of Books. 6.40, The Funkstande informs its Listeners. 6.45, Topical Talk. 7.0, Transmission for all German Stations, relayed from Stuttgart. 8.0, Lottery Announcements. 8.5, Report on Gramophone Records. 8.30, European Concert relayed from Berlin (Deutschlandsender). 10.0, News. 10.30 (approx.), See Hamburg. In the interval from 11.0 to 11.5, Talk by the Chief of Police. 12 Midnight, Close Down.

BERNE.—See Schweizerischer Landessender. BEROMUNSTER.—See Schweizerischer Landessender.

BODEN.—See Stockholm.

BODO.—See Oslo.

BORDEAUX-LAFAYETTE 986 kc/s, 304 metres; 13 kW.—6.20 p.m., Radio Journal. 7.40, Exchange and News. 7.50, Gramophone Music. 8.30, See Paris (Eiffel Tower).

BRATISLAVA

1,076 kc/s, 279 metres; 14 kW.—6.5 p.m., Jan Bella Concert for his Ninetieth Birthday: Songs; Pianoforte Sonata. 6.55, Report. 7.0, See Prague. 8.55, See Brno. 9.25, See Moravská-Ostrava. 10.0, See Prague. 11.0 (approx.), Close Down.

BREMEN.—See Hamburg.

BRESLAU

923 kc/s, 325 metres; 60 kW. Relayed by Gliwicz, 1,184 kc/s, 253 metres.—1.0 p.m., Weather. 1.2 (approx.), Gramophone Concert: Overture, Die Zwillingesbrüder (Schubert); Minuet from the Quartet No. 6 (Dittusdorf); Guitar Solo, Fandanguillo (Turina); Selection from Der Rosenkavalier (R. Strauss); Fantasia in D Minor for Pianoforte (Mozart); Valse serenade (Tchakovsky); Waltz from Intermezzo (R. Strauss); Concert Waltz, Op. 47 (Glazunov); Three German Dances, Nos. 6, 4, and 2 (Haydn). 1.45, Time and News. 2.5, Lieder Recital by Lotte Roschütz (Soprano); Songs (Grieg): (a) An das Vaterland, (b) Hoffnung, (c) Eros, Songs (Reger): (a) Oben in den Birnenbaum, (b) Kleine Marie, (c) Ich werde Soldat, (d) Das Blatt im Buche, (e) Herzens-Tausch, (f) Mittag, (g) Wenn die Linde blüht; Songs (R. Franz): (a) Wald-Lied, (b) Aus meinem grossen Schmerzen, (c) Willkommen, mein Wald, (d) Vöglein, wolin so schnell. 2.35, Gramophone Concert.

3.0, Market Prices. 3.15, Review of Books. 3.35, Programme for Children. 4.0, Concert by the Station Orchestra, conducted by Bruno Janz: Overture, Nachklänge aus Ossian (Gade); Selection from Elektra (R. Strauss); Selection from William Rateliff (Mascagni); Suite from American Forest Idylls (MacDowell); Selection from Das Blumenwunder (Künneke); Operetta Potpourri (Fetras); Diavoletta (Lindemann); Serenade from Friderius Rex (Roland); Drömmelbilder (Lambog); Waltz, O selbiger Mai (Joh. Strauss); March, Preussens Gloria (Piefke). 5.30, Market Prices. 5.32 (approx.), Talk: Tales and Poems about Datzig. 5.55, Pianoforte Recital—Music of the Baroque Period. 6.25, Talk: The Basis of German Socialism. 6.50, Weather and News. 7.0, Transmission for all German Stations, relayed from Stuttgart. 8.0, Reminiscences of Old Soldiers of the National Socialist Movement. 8.30, European Concert relayed from Berlin (Deutschlandsender). 10.0, Austria. 10.20, Time and News. 10.40, Talk: Productions at the Breslau Municipal Theatre. 10.55, Political Press Review. 11.15, Light Music and Dance Music from the Admiral-Saal. 12.30 a.m. (Wednesday), Close Down.

BRNO

878 kc/s, 342 metres; 35 kW.—6.15 p.m., Talk: Feminine Influences on the Lives of Great Men. 6.25, German Transmission: News, Talk on Books for Young People and Agricultural Report. 7.0, See Prague. 8.55, A Tragedy (Karl Stransky). 9.25, See Moravská-Ostrava. 10.0, See Prague. 11.0 (approx.), Close Down.

BRUSSELS (No. 1)

I.N.R., 590 kc/s, 509 metres; 15 kW.—12 Noon, Concert by the Small Station Orchestra, conducted by Pierre Lecmans: Overture, The Thieving Magpie (Rossini); Suite, At the Circus (Armandolai); Serenata (Caccioli); Selection from Gipsy Love (Lehar); Si vous l'avez compris (Deza); Waltz, Give me a moment, please (Whiting-Harding); Selection from Trouvez-moi (Moretti). 1.0 p.m., Le Journal Parlé. 1.10, Acts III and IV of André Chenier—Opera (Giordano) on Gramophone Records. 5.0, Concert by the Station Symphony Orchestra, conducted by Arthur Meulmans: Overture, Masaniello (Anber); Humoresque (De Greef); Minuet from Orpheus (Gluck); Mardi gras (Dancaen); Selection from Lika (Van Oost); The Blue Danube (Strauss); Norwegian Wedding Procession (Grieg). 6.0, Talk: Dancing in Belgium. 6.15, Gramophone Records: Quartet No. 3 (Delagrée); Nocturne (Schelling). 6.50, Concert by the Small Station Orchestra, conducted by Pierre Lecmans: Overture, Juro (Guillemin); Russian Song (Akimenko); Dance of the Elves (Henriques); Pianoforte Solo: Hungarian Rhapsody No. 12 (Liszt); Serenade

(Rachmaninov); Cramignon (Gillon); Selection from The Grand Duchess of Gerolstein (Offenbach). 7.15, Protestant Address. 7.20, Art Notes and Review for Women. 8.0, Gramophone Music. 8.15, Pierrot-Narcisse—Scene (Albert Giraud). 8.30, European Concert, relayed from Berlin (Deutschlandsender). 10.0, Le Journal Parlé. 10.10, Gramophone Concert.

BRUSSELS (No. 2)

N.I.R., 887 kc/s, 338.2 metres; 15 kW.—Programme in Flemish. 12 Noon, Gramophone Concert. 1.0 p.m., Le Journal Parlé. 1.10, Concert by the Small Station Orchestra, conducted by Lecmans: Festival Overture (Leutner); Cantilène (Gollin); Serenade (de Boeck); Selection from La Navarraise (Masset); Serenade, Les Tresors de Columbine (Drigo); Cramignon (Gillon); Terezo Ramon (Kostal). 2.0, Report on the Cycle Races at Brasschaet. 6.30, Extracts from The Mikado—Opera (Sullivan) on Gramophone Records. 7.0, Gramophone Music. 7.15, Talk. 7.30, Talk: Tunnels under the Escaut. 8.0, Concert by the Station Symphony Orchestra, conducted by Meulmans. Soloist: Nancy Vellaz (Songs). Overture, William Tell (Rossini); Tarantella, La Danza (Rossini); Songs: (a) La Vita Fugge (Pizzetti), (b) Due Sonetti del Berni (Malipiero), (c) Io sono la Madre (Respighi); Prelude and Sicilienne from Cavalleria rusticana (Mascagni); Selection from The Daughter of the Regiment (Donizetti), followed by a Sketch. 9.0, Concert by the Radio Orchestra, conducted by Franz André. Soloist: Nancy Vellaz (Songs). March, Gramada (José); Waltz, Autumn (Albeniz); Rondalla española (Fallá); Five Songs (Fallá); Aragonese (Fallá); Escules (Ibert); Waltz (Turina); The Student Passes By (Ibert). 10.0, Le Journal Parlé. 10.10, Gramophone Concert.

BUCHAREST

761 kc/s, 394 metres; 12 kW.—5.0 p.m., Light Music and Romanian Music by the Motot Orchestra. In an interval at 6.0, Radio Journal. 7.0, Reading. 7.20, Gramophone Music. 7.40, Educational Talk. 8.0, Song Recital. 8.20, Concert by the Station Orchestra: Overture (Rust); Ballet Suite from Kassya (Delibes); Selection from The Czarevitch (Lehar); Selection from Viktoria and her Hussar (Abraham); Waltz, Estudiantina (Waldteufel); March, Frühlingskinder (Blaukberg). In an interval at 9.0, Talk. 9.45, Radio Journal.

BUDAPEST

545 kc/s, 550.5 metres; 18.5 kW. Also relayed on 840 metres (from 8.30 p.m. till Close Down.—5.0 p.m., Talk. 5.30, Recital of Viennese Songs with Schrammel Accompaniment. 6.10, Reading. 6.30, Gramophone Music. 7.30, Talk. 8.0, Guitar Recital by Nicoulas Fritz. 8.30, European Concert, relayed from Berlin (Deutschlandsender). 10.0, News, followed by Music by the Toll Cigány Band. 11.0, Music by the Lantos Dance Band, relayed from the Hotel Royal, with Karl Vajda (Popular Songs).

CASSEL.—See Frankfurt.

COPENHAGEN

1,067 kc/s, 281 metres; 0.75 kW. Relayed by Kalundborg, 260 kc/s, 1,153.8 metres.—12 Noon, Time Signal and Chimes from the Town Hall. 12.5 p.m., Concert by the Max Skalka String Ensemble, relayed from the Hotel d'Angleterre. 2.0 to 3.0, Interval. 3.0, Concert by Louis Prell's Instrumental Ensemble: Soloist: André Bech-Nielsen (Songs). 5.0, Programme for Children. 5.30, Exchange and Fish Market Prices. 5.45, Talk. 6.15, Elementary German Lesson. 6.45, Weather. 6.54, Wireless Notes. 7.0, News. 7.30, Concert by the Tivoli Concert Orchestra and Soloists: Conductor: Schmedler-Petersen; Overture and Duet from The Daughter of the Regiment (Donizetti); Symphonic Poem, Phaeton (Saint-Saëns); Cello Solos: (a) Minstrel's Song (Glazunov), (b) Sicilienne (Fauré), (c) Spanish Dance (Granados-Kreisler); Coronation March from Fête galante (Schierbeck); Bürenfest in Tivoli (Gunder Knudsen). After the Programme, Weather Report. 8.30, Talk: The Warm Springs of Iceland. 9.0, Concert (contd.): Overture, Rosamund (Schubert); Songs (Schubert): (a) Dem Unendlichen, (b) Ariette der Claudine, (c) Sprache der Liebe, (d) Seligkeit; Violin Solos: (a) Three Dances from The Damnation of Faust (Berlioz), Andante and Rondo in D (Mozart); Elizabeth's Aria from Tannhäuser (Wagner); Entry of the Gods into Valhalla from The Rheingold (Wagner); Leonora Overture No 3 (Beethoven); Concerto in A Minor for Four Pianofortes and Orchestra (Bach); Variations on a Theme of Mozart with Flute Obligato (Drouot); Overture, Rienzi (Wagner). In an interval at 10.10, News and Reading (Zangwill). 11.30 (approx.), Close Down.

CORK.—See Athlone.

CRACOW

959 kc/s, 312.8 metres; 1.5 kW.—7.5 p.m., Talk: Old Cracow. 7.20, Miscellaneous Items and News. 7.35, Programme Announcements. 7.40, See Warsaw. In an interval at 10.25, Sports Notes. 11.0 (approx.), Close Down.

DANZIG.—See Heilsberg.

DRESDEN.—See Leipzig.









# comes over the "Border"

## An Apology

We would ask the kind indulgence of those Readers whose enquiries are awaiting detailed replies. Most of these outstanding enquiries are of an involved nature, requiring special costings and specifications. They are, however, being dealt with as rapidly as possible. We are, however, still maintaining our definite policy and promise regarding deliveries and all orders are executed by return.

"C.A.C." CABINETS, KITS & SETS are not strangers to Scotland, but this is the first time we have brought a complete display for the inspection of our Scottish friends. When you visit the **GLASGOW RADIO EXHIBITION** you will receive a warm welcome at our **STAND No. 2<sup>A</sup>**

"C.A.C." has been associated with the radio industry since its inception and throughout its ever-changing conditions "C.A.C." has kept intimate touch with every development, determined to offer to the public only products which embody the most advanced ideas in Radio technique.

Its position is unique in many ways. The Technical Staff is second to none in the country. As Technical Consultant, "C.A.C." has obtained the services of Mr. W. I. G. Page, B.Sc., the well-known designer until recently on the staff of "The Wireless World," and whose reputation in designing sets of ultra-modern technique is widely known. The Radio Manufacturing Department and the Cabinet-making side of the business are now housed in a large modern factory, and the most up-to-date machinery, covering an area of about 13,000 sq. feet, has been installed.

This happy and unique combination of highly specialised Receivers, built into the best that Cabinet-makers' craftsmanship can produce, is sufficient to ensure that only Receivers of outstanding performance and appearance will be offered to the public.

*Trade Enquiries Invited.*

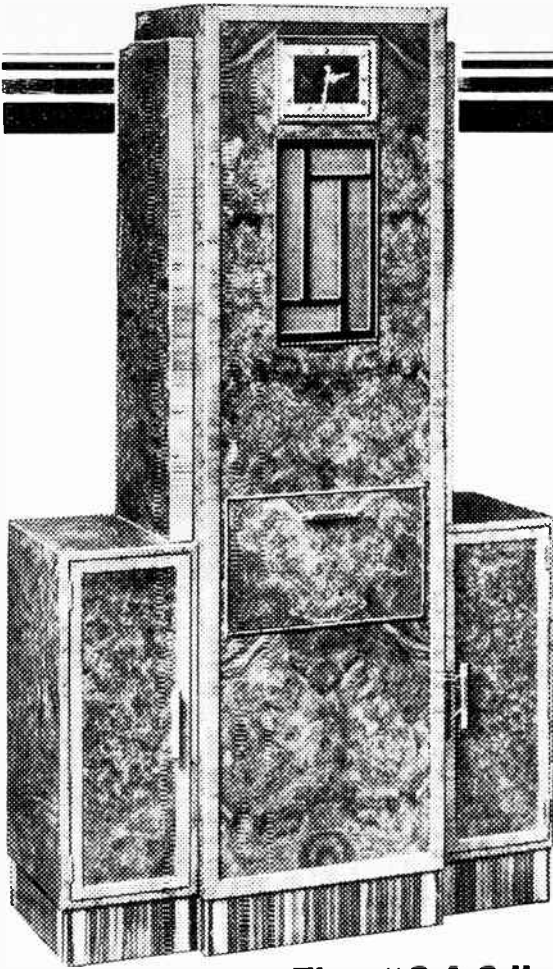

## The "C.A.C." GRANDFATHER CLOCK CABINET

This handsome and original piece of furniture represents the very last word in Radio-gramophone Cabinet design and has proved one of our most popular selling lines at Olympia. There is provision for accommodation of almost any type of Receiver, whilst the Gramophone motor and Pick-up fit into the sliding compartment below. The two side compartments allow for the storage of gramophone records or can be fitted as a cellar etc. Price **14 GNS.**

## THE "WARWICK" CABINET DE LUXE

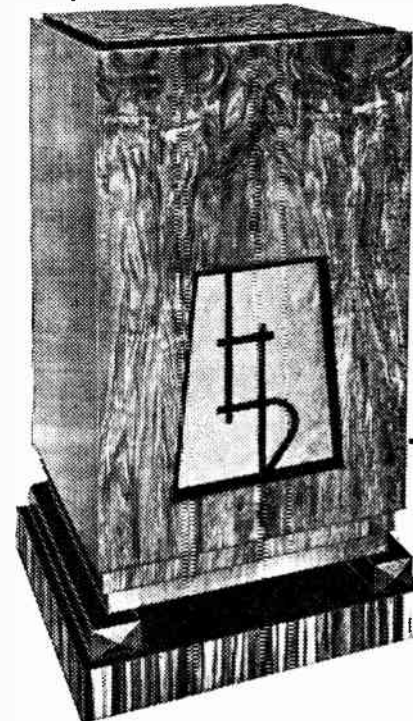

This cabinet was specially designed for "The Wireless World" New Monodial Super and is manufactured in specially selected figured walnut with ebony base and macassar ebony base.

PRICE **£5-10-0**

*Our 1933-4 Catalogue is now ready. Send a post card for a copy to-day.*

## THE "C.A.C." PENTAGRID SUPERHET

A four-valve A.C. Superhet of highly specialised technique using a Pentagrid Converter as a single-valve frequency changer, which performs the dual functions of oscillator and first Detector in the most efficient manner known. In the I.F. stage a variable-mu Pentode is used, which adds its contribution to A.V.C. The third valve is one of the new double Diode Pentodes, which gives almost perfect automatic volume control, and the fourth valve is a Cathin Pentode. The output is in the order of 2½ watts, whilst the sensitivity of this Receiver is a revelation. The four special valves give an overall performance equal to that of any six-valve superhet on the market.

PRICE **14 GUINEAS**

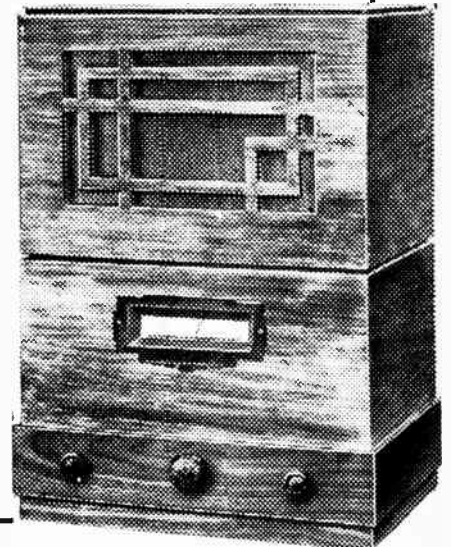

## "C.A.C." KITS for "The Wireless World" NEW MONODIAL SUPER FERROCART CLASS "B"

### KIT "A" RECEIVER UNIT:

Comprising the Designer's first specified components (less Chassis, Panel, Valves and Cabinet) - **£10-19-6**

### KIT "B" POWER UNIT:

Comprising the Designer's first specified components (less Chassis and Valves) - **£8-13-6**

*Detailed Pric. List Free on Application.*

### ALUMINIUM CHASSIS

correctly drilled with side members, finished in French-grey cellulose. Receiver Chassis, **10-**; Power Unit Chassis, **7 6.** "C.A.C." Panel, 14" 10", in Polished Oak, Walnut or Mahogany, **2-**; Valves; Receiver (s), **24-4-6.** Power Unit (1), **£3-0-6.**

**KIT "A."** Complete (less Valves, Batteries, Cabinet and Loud Speaker) - **£7-11-0**

**KIT "B."** Complete with Valves (less Batteries, Cabinet and Loud Speaker) - **£9-17-3**

**KIT "C."** Complete with Valves, Cabinet and Loud Speaker (less Batteries) - **£13-9-3**

**CABINET,** beautifully finished in Figured Walnut exclusively specified by the designer and manufactured in our own factory - **£1-12-6**

*(Front drilled, if desired, without extra charge.)*

### CONSTRUCTION

We shall be pleased to undertake the construction of the above receivers to customers' own requirements. Only highly skilled technicians, under the personal supervision of Mr. W. I. G. Page, B.Sc., are entrusted with this work. This ensures that the results obtained by the designer will be duplicated.

## CITY ACCUMULATOR Co. Ltd.

18-20, NORMAN'S BUILDINGS (off Central Street), LONDON, E.C.1  
 Telephones: Radio Dept.— Clerkenwell 6206. Telegrams: Cabinet Dept. "Cityacco. Barb, London."

# Achievement!

The success of the new R. & A. Reproducers has exceeded all expectations. The world famous Challenger is now available in 5 models, and the new Alpha P.M.M.C. Reproducer, introduced at Radiolympia, has evoked the highest praise. If you desire the finest possible reproduction of broadcast speech and music, you must have an R. & A. Reproducer.

## The 1934 'CHALLENGER' SERIES

The CHALLENGER series 1934 comprises 5 models; a type for every output, and CHALLENGER performance needs no comment; its reputation is world-wide.

Standard Model for use with Super Power and Pentode Outputs. Includes 3-ratio Transformer.

### OTHER 'CHALLENGER' MODELS -

- TYPE "B" for Class B Amplification. (B8 for Cossor, and B15 for Mullard and Mazda Class B Valves.)
- "P" An extension Instrument for Commercial Receivers.
- "Q" for Quiescent Push-Pull. (15,000 ohms Platc-to-plate Load.)

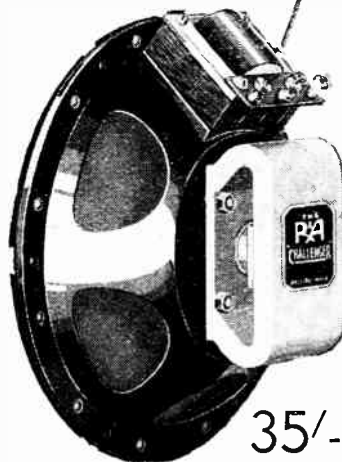

35/- COMPLETE

## The Triumph of the R. & A. 'ALPHA'

The success of the new ALPHA P.M.M.C. Reproducer has been overwhelming. Its ingenious construction (protected by Letters Patent), and its amazing fidelity of reproduction have fired the enthusiasm not only of the Trade, but also of the thousands of spectators at Olympia who heard this remarkable reproducer demonstrated. Its immunity from damage, ingenious system of diaphragm support and brilliance of reproduction is an outstanding achievement. It handles inputs as high as 7 watts undistorted A.C. without distress.

### TWO MODELS

Two Models are available - STANDARD MODEL with 6-ratio Transformer, and MODEL B, with Universal Transformer for Class B operation. Diameter, 10 1/2 in.; depth, 5 in.; weight, 8 lb.

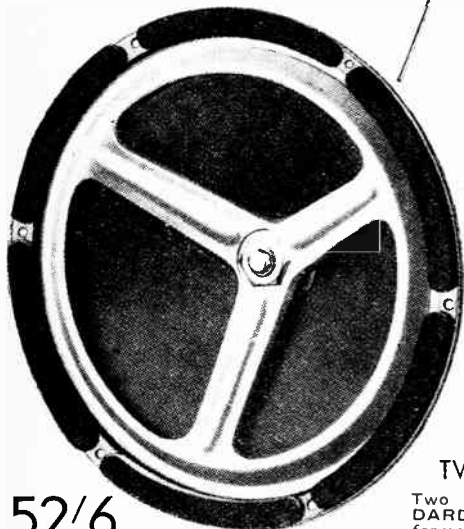

52/6 COMPLETE

Write for new leaflet of the complete range of R. & A. Reproducers and ask your dealer to demonstrate.



REPRODUCERS & AMPLIFIERS Ltd.  
FREDERICK STREET, WOLVERHAMPTON.

# OLYMPIA'S centre of attention was the LION EXHIBIT



Olympia's most outstanding Exhibit was the Lion H.T. Battery Stand. Never has there been such an exhibit—never have you had such an opportunity of SEEING quality being built into the Batteries you use. You could see for yourself the up-to-date machinery, the modern-as-the-minute methods. It was proof positive of the claims of the Lion H.T. Battery that it is definitely the finest battery made.

Next battery you buy . . . be sure it is a Lion. It will give you MORE power and you will pay LESS for it.

BRITISH FROM START TO FINISH  
SOLD UNDER LIMITED LICENCE

LOW Prices!	
60 Volt H.T.	4/6
100 Volt H.T.	7/-
120 Volt H.T.	9/-
9v. G.B. 10d.	
4 1/2 v. Pocket Lamp Battery	4 1/2 d.

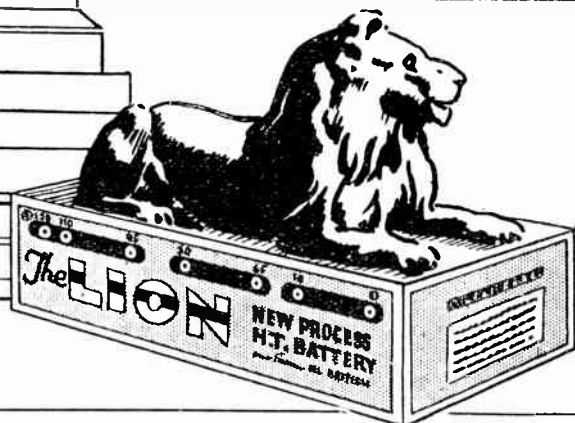

VINCES DRY BATTERIES LIMITED,  
LION WORKS, GARFORD ST., LONDON, E.14  
Telephone: EAST 1902.

The most informative & sought after book at Olympia!

**Choosing your CONDENSERS AND RESISTANCES**

**An up-to-date guide for the Constructor and Set User**

**DUBILIER**  
1933-4

- MICA CONDENSERS
- NEW PAPER CONDENSERS
- NEW ELECTROLYTIC HIGH, MEDIUM, AND LOW VOLTAGE CONDENSERS
- NEW COLOUR CODED RESISTANCES
- LATEST TYPE RESISTANCES
- MOTOR RADIO SUPPRESSORS
- ANTI-INTERFERENCE FILTERS

**Supplied FREE**

To **DUBILIER CONDENSER CO. (1925), LTD.**,  
VICTORIA ROAD, NORTH ACTON, LONDON, W.3.  
Please send me a copy of the new Dubilier Booklet.

Name .....

Address .....

W.W. USE BLACK LETTERS

Gives full details of the latest developments in Condenser and Resistance design.

Advertisements for "The Wireless World" are only accepted from firms we believe to be thoroughly reliable.





**MOVING COILS  
give you the  
NEWEST  
& BEST**



**29 PM**

Model  
from  
**27/-**

**OLYMPIA AGAIN PROVED  
BLUE SPOT SUPERIORITY**

*Some Special Features:*

**NO WARPING OR FOULING IN GAP**  
Special moisture proof new process Cmc and Speech Coil ensure positive protection against warping, and fouling in the gap.

**EASY MATCHING** Special transformers fitted with terminal or plugs and sockets for easy valve matching to all outputs. No troublesome switch contacts. (Q.P.P. Pentode models 2, 0 extra).

**EXTENSION SPEAKERS** Fit extra Blue Spot speakers to your set and have Radio throughout the house. Special Extension models without transformers are supplied for sets already incorporating suitable transformers.

**OTHER FEATURES** Magnets forged from highest grade materials, balanced response over all frequencies, clear, pure tone—true top, true middle, true bass, and brilliant in attack.

*Send for Catalogue W.W.S.O.S. giving full range of Blue Spot Moving Coil and Moving Iron Speakers. Prices 5/6 to 87/6.*

**THE BRITISH BLUE SPOT COMPANY LTD**  
BLUE SPOT HOUSE, 64-66 ROSOMAN'S T., ROSEBERY AV., LONDON, E.C.1  
Telephone: Clerkenwell 3570. Telegrams: "Bluespot, Islins, London."

Distributors for Northern England, Scotland and Wales: H. C. RAWSON (Sheffield and London), Ltd., 100 London Road, Sheffield; 22 St. Mary's Parsonage, Manchester; 177 Westgate Road, Newcastle-upon-Tyne; 37, 38, 39, Clyde Place, Glasgow.

*"I must get my Blue Spot!"*

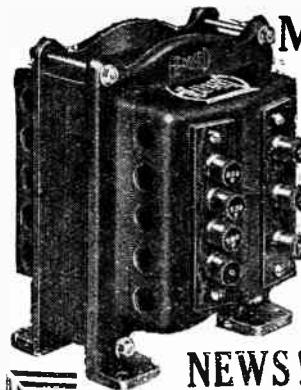

**MAINS APPARATUS  
for every purpose!**

*Units, Transformers,  
Chokes and Amplifiers*

**NEWS!**

Two special Portable Amplifiers suitable for speech amplification in small halls, Models H.5 (5 watts) at £19 10s. and H.10 (10 watts) at £23 5s. nett. New Mains Transformers include three for use in Chargers employing Philips Rectifiers, and three for use with the new Westinghouse HT. 12 and HT. 13 Rectifiers. Models AO. 2 and AO.3 Home Battery Chargers have been redesigned. Mains Units and Assembled Kits retain the same outputs at the same prices but minor improvements have been effected which should make them even more popular.

Because Heayberd have been specialising in the production of Mains Apparatus since broadcasting began; because Heayberd components and mains units have been specified and used by leading designers all over the country; because only the best British materials are used in the manufacture of Heayberd products; and because the design and construction of all Heayberd apparatus is technically sound—it will pay you to ask for Heayberd when ordering Mains Components. Write TO-DAY for full information.

(Stand No. 39—Manchester Radio Exhibition.)



**POST COUPON**  
Enclose 3d stamps for the NEW 1933 Handbook "Mains Power for your Radio"—packed with hints, illustrations and circuit diagrams.

Mr. \_\_\_\_\_  
Address \_\_\_\_\_

**F. C HEAYBERD & CO., 10, FINSBURY STREET, LONDON E.C.2**  
(One minute from Moorgate Station.)



*A Satisfied User  
of the Ideal Aerial*



**"RECEPTICON"**

**INSULATED COPPER AERIAL**

"Recepticon" can be used either as an indoor or outdoor aerial or as an earth. It is a seven-strand insulated aerial cable drawn from pure electrolytic copper and protected with a weatherproof covering, and is definitely non-corrosive. The conductivity of the aerial is, of course, extremely high, so that when "Recepticon" is fitted perfect satisfaction is assured. Obtainable from all wireless dealers or if in difficulty apply direct to the manufacturers.

**THE CONCORDIA ELECTRIC WIRE CO. LTD.,**  
NEW SAWLEY, Nr. NOTTINGHAM.

PRICES.	
25 ft.	7½d.
50 ft.	1/3
75 ft.	1/10
100 ft.	2/6

**NOW RELEASED**

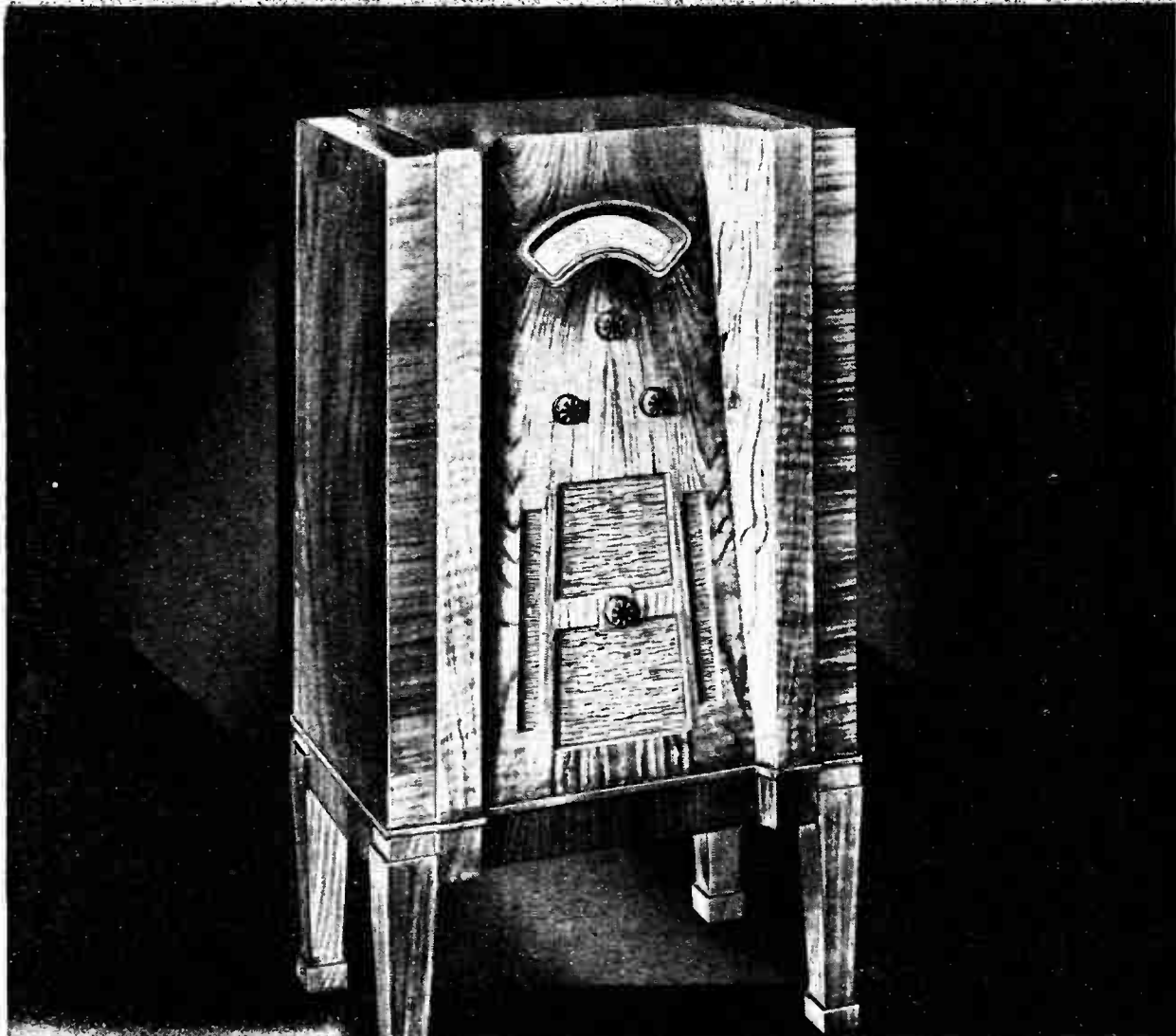

**G.E.C.  
RADIO**

**G.E.C. Console Superhet 5**

The Console Model of the G.E.C. Superhet 5—the receiver which has set the 1934 standard of radio performance. New superheterodyne principles provide vividly real reproduction and complete station-separation. Tuning by station names, speaker silencing key, oversize energising moving coil loud speaker with one control, internal aerial for local stations. Richly-figured walnut cabinet. A.C. Mair's Model.

**HIRE PURCHASE TERMS** Deposit £1 10 0 and 12 monthly payments of £1 10 0.

**£17.17.0**

**MADE IN ENGLAND**

Sold by all Radio Dealers.

**WRITE FOR FOLDER BC.6671.**

**The sets with the big name behind them**

*Advt. of The General Electric Co. Ltd., Magnet House, Kingsway, London, W.C.2*



KINGS  
OF THE  
AIR

# "MAINS" VOLUME FROM BATTERY SETS

*without increased H.T. consumption*

With a Class "B" Output stage volume equal to that of a powerful mains receiver can be obtained from battery sets without increasing H.T. consumption. The conversion of your present battery receiver into an up-to-date Class "B" Set is not difficult. Send the coupon below for Folder giving full details of this remarkable system of Amplification.

## COSSOR CLASS "B" VALVES

### COSSOR 240 B.

Filament volts 2.0; Filament amps 0.4; Anode volts 150 max.; Max. Anode Current Swing 50 mA.; Max. Peak Applied Signal (Grid to Grid) 40 volts; Static Anode Current at  $V_a=100$ ,  $V_g=0$  (each half) 1.5 mA.

Price **14/-**

### COSSOR 220 B.

Filament volts 2.0; Filament amps 0.2; Normal Anode volts 120; Max. Anode Current Swing 35 mA.; Max. Peak Applied Signal (Grid to Grid) 40 volts; Static Anode Current at  $V_a=100$ ,  $V_g=0$  (each half) 1.25 mA.

Price **14/-**



To A. C. COSSOR LTD., Melody Dept., Highbury Grove, London, N.5.

Please send me, free of charge, a copy of Folder No. L.93, which tells me how to use Class "B" Amplification.

Name .....

Address .....

W.W. 1/9/33.

A. C. Cossor Ltd.,  
Highbury Grove, London, N.5. Depots at  
Birmingham, Bristol,  
Glasgow, Leeds, Liverpool,  
Manchester, Newcastle,  
Sheffield, Belfast,  
Cardiff and Dublin.

♥3358

Mention of "The Wireless World," when writing to advertisers, will ensure prompt attention.



# The Wireless World

THE  
PRACTICAL RADIO  
JOURNAL  
23rd Year of Publication

No. 731.

FRIDAY, SEPTEMBER 1ST, 1933.

VOL. XXXIII. No. 9.

Proprietors: ILIFFE & SONS LTD.

Editor:  
HUGH S. POCOCK.

Editorial,  
Advertising and Publishing Offices:  
DORSET HOUSE, STAMFORD STREET,  
LONDON, S.E.1.

Telephone: Hop 3333 (50 lines).  
Telegrams: "Ethaworld, Watloo, London."

COVENTRY: Hertford Street.

Telegrams: "Cyclist, Coventry."  
Telephone: 5210 Coventry.

BIRMINGHAM:

Guildhall Buildings, Navigation Street. 2.  
Telegrams: "Autopress, Birmingham."  
Telephone: 2070 Midland (3 lines).

MANCHESTER: 260, Deansgate, 3.

Telegrams: "Billie, Manchester."  
Telephone: Blackfriars 4412 (4 lines).

GLASGOW: 26B, Renfield Street, C.2.

Telegrams: "Billie, Glasgow." Telephone: Central 4857.

PUBLISHED WEEKLY. ENTERED AS SECOND  
CLASS MATTER AT NEW YORK, N.Y.

Subscription Rates:

Home, £1 rs. 8d.; Canada, £1 rs. 8d.; other  
countries abroad, £1 3s. 10d. per annum.

*As many of the circuits and apparatus described in these  
pages are covered by patents, readers are advised, before  
making use of them, to satisfy themselves that they would  
not be infringing patents.*

## CONTENTS

	Page
<b>PROGRAMMES FROM ABROAD, pp. 1-XXIV</b>	
Editorial Comment .. ..	189
Thunder and Lightning .. ..	190
Unbiased .. ..	192
Simple Measurements on Receivers and Components .. ..	193
News of the Week .. ..	195
Practical Hints and Tips .. ..	196
The Iconoscope .. ..	197
New Class "B" Output Valve ..	198
Binaural Reception .. ..	199
Thoughts on Olympia .. ..	200
Glasgow Show Plan and Guide ..	202
Broadcast Brevities .. ..	203
Correspondence .. ..	204
Readers' Problems .. ..	205

## EDITORIAL COMMENT

### Broadcasting Hours

*Are They Too Long?*

**A** RECENT Leader in which we called attention to the unwarranted amount of criticism levelled at the B.B.C. programmes has brought us a number of letters from readers, one or two criticising us for championing the B.B.C. programme policy, but the majority endorsing heartily our point of view that much of the criticism of programmes is undeserved. We take note, in particular, of the remarks of one correspondent, who, whilst agreeing that the average of the programmes is good, contends that the task of maintaining good programmes over so many hours is a well-nigh impossible one and consequently we cannot expect to avoid the probability that some portion of the matter sent out will be of poor standard.

We have ourselves from time to time in the past raised the question as to whether the B.B.C., in compiling new programmes for so many hours, is not setting itself a rather impossible task. Separating entertainment and the talks from those portions of the programme which may be regarded as service, it would seem that there is room for a certain amount of repetition without spoiling the present character of the programmes. The alternative programme scheme seemed to pave the way for economies of this nature, for we could then have a first-class programme repeated from other stations on different evenings of the week. If this repetition never takes place many fine broadcasts are missed by a proportion of listeners because their other engagements have made it impossible to listen-in at the particular time the broadcast took place. To have a second chance of listening-in

to all the more important broadcast performances would be an undoubted benefit to listeners in general. It would, incidentally, reduce the number of hours when fresh material had to be provided for broadcasting, and it is possible that in some instances it would be permissible for "repeat" performances to be carried out through the medium of records of the original transmission.

### Television Post Cards

*The Purpose of the B.B.C.*

**W**E mentioned in last week's issue that the request which is now being made to those who see the broadcast transmissions to send a post card to the B.B.C. is for the purpose of arriving at some idea of the size of the television audiences of these broadcasts.

This action on the part of the B.B.C. is, we understand, a direct result of a suggestion put forward by *The Wireless World* some time back that it was of importance to everyone concerned in the development of television in this country, to have this information.

We have noticed that in certain directions this action on the part of the B.B.C. has been interpreted as being intended to provide an excuse for the B.B.C. to discontinue the transmissions when they find that they have a very limited audience. We do not think that there is any reason to feel anxiety on this score. The B.B.C. has a contract to continue these transmissions for some considerable time to come and, in any case, it is obviously absurd to suppose that if there was sufficient justification for starting a year ago, there is any excuse for stopping transmissions now, at a time when so many new developments seem likely to emerge shortly from the experimental stage.

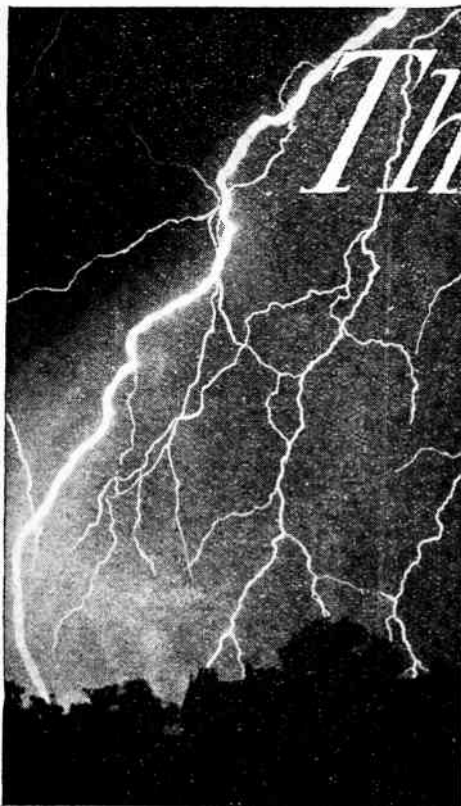

# Thunder and Lightning

## How Wireless Aerials are Affected

By J. F. HERD, A.M.I.E.E.

*AERIALS were at one time popularly believed to act as a kind of collector of lightning discharges. Experience shows that aerials are very rarely struck during the thunder season in comparison with the number of lightning discharges that take place. This summer has proved to be no exception.*

**T**HE thunderstorm season has been and is still with us and appears, from newspaper accounts, to have had its usual crop of things, including aerials, "struck by lightning." This always serves to remind us—at least to remind me—how extremely little we know yet about this, one of Nature's oldest and most magnificent phenomena.

Whether he likes it or not, the wireless enthusiast is compelled to affect some interest in thunder and lightning, since lightning discharges are believed to be the cause of most if not, indeed, all of those atmospheric phenomena which so often militate against summer-time reception, especially on the longer wave band. In passing, too, it is to be recalled that Popoff—a Russian scientist, not the perhaps better-known character in "The Merry Widow"—actually used an elevated aerial to observe the effect of distant thunderstorms, wireless atmospheric phenomena, a year before Marconi used the same arrangement to radiate controlled wireless waves.

### Isolated Targets

Although the daily press reports grizzly details of things struck by lightning, it is surprising how rarely this occurs and how little damage is done by these amazing impulses. Incidentally it is very noticeable that wireless aerials are by no means readily struck. Many Jonahs of a few years ago regarded every aerial as a potential collector of lightning flashes and envisaged them being struck in their thousands. One simple explanation is obvious. It is that the *average* domestic broadcast aerial is not incomparably high with regard to its surroundings, and is therefore in no greater prominence from the point of view of attracting, as it

were, a concentrated field to facilitate a discharge path. It is well known that a single tall tree, standing, for example, in splendid isolation in the middle of an open space is one of the worst forms of shelter that one can seek from rain in a thunderstorm. In such a case there is a definite possibility of the tree acting in the manner described, while, once it is struck there is the well-known possibility of "side-flashing" from the trunk of the tree to persons standing beneath its shady boughs. It is side-flashing of this type which is always the danger to the vicinity when any object is struck by lightning.

The same erratic tendency is seen in the lightning flash itself, giving the zig-zag appearance so familiar. These erratic tendencies can be observed in artificial high-voltage discharges—discharges much less in intensity than those produced naturally. For example, watching successive flash-overs at the National Physical Laboratory high-voltage plant, the erratic nature of the path can be seen changing even during one flash-over. The longer zig-zag path—rather than the straight and narrow one—is due, apparently to differences of ionisation in different parts of the air, causing the longer geometrical path to be, from the electrical point of view, the shorter.

It is interesting to consider the enormous electrical quantities contained in a lightning flash. It is, of course, impossible to make any direct measurement of the effective current in the discharge itself, but it is possible to infer typical values from its effect on circuits and instruments of known electrical dimensions at known distances from the flash.

The classical work on this subject is

that of the Cambridge scientist, Prof. C. T. Wilson, who has estimated that the potential reached in a thunder cloud just before the discharge is of the order of one thousand million ( $10^9$ ) volts. Professor Wilson has also estimated that the discharge involves a displacement of the order of 20 coulombs in a period about one thousandth of a second, giving a mean current of about 20,000 amperes. This is, of course, the average value during the time of the discharge and must be greatly exceeded at some process of the discharge. It appears possible that instantaneous values of over 100,000 amperes are reached. The electrical power associated with a lightning flash is thus several thousand kilowatt hours. All of this energy does not, of course, appear at the earth's surface, since much of it is used up in the air channel. Many of the most powerful strokes, however, must deliver a large proportion of their energy to the earth.

A fairly reasonable domestic load for all lighting and a number of electric power appliances works out at between 1,500 and 2,000 kilowatt hours per year, so that a single lightning discharge has enough energy to keep a modern suburban dwelling fully electrified for about a couple of years. No wonder things happen when

this supply is released in a thousandth of a second!

The above figures of current and voltage help to explain such things as the side-flashing already mentioned. For example, in the case of the simplest lightning conductor the wire may have to carry a current of well over 20,000 amperes, so that every ohm of resistance in it has a drop of over 20,000 volts across it. A local resistance or bad connection, or a

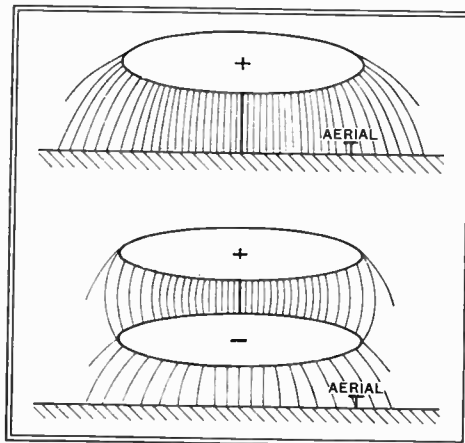

Showing how an intense electric field may be built up about a wireless aerial due to a thundercloud, even when the aerial is not in or near the path of the final discharge which is shown in heavy line.

**Thunder and Lightning.—**

bad earth amounting to ten ohms may thus raise the potential to well on towards a million volts. Apart from the heat developed at the resistance, this will give definite tendencies to side flash if the discharge can gap over a length of air which is easily ionised and made conductive.

In the case of a wireless aerial acting as an involuntary lightning conductor, the presence of anything giving a high impedance to earth would thus explain the various erratic things that have been described in cases where aerials have been struck. In a case described in one well-written technical account, which the writer had the chance of seeing, a series aerial condenser was completely shattered for reasons which are obvious from the above argument. The inside of the set was described as looking as if it had been sprayed liberally with pitch. Side flashing also occurred from the aerial to a lead base round the chimney stack, and at two different places in the wall beside the down lead.

It is well known that some lightning discharges take place between cloud and earth while others occur from cloud to cloud. This is quite apart, of course, from the so called "summer lightning" when the sky is widely illuminated, especially towards the horizon, by the reflected effects of flashes that may be many miles - even a hundred miles—away. Experts are not agreed as to the proportion

of lightning flashes which are of the cloud to earth or the cloud to cloud variety. Neither are meteorologists fully agreed about the exact mechanism which gives rise to the thunder cloud and its enormous electrical charges. Although this would appear to have a distinct bearing on the nature of the discharge. Despite the small number of earth-surface casualties that occur (in relation to the total number of lightning flashes) one has the impression that there have been more such casualties this summer than one usually sees reported.

**We are Still Learning**

Does this then mean that these summer lightning-storms have been characterised by a greater number of cloud-to-earth strokes, or is it just bad luck? The wireless investigation of atmospheric is, of course, helping to cast light on thunder-

storms, and wireless methods are now available for revealing both the place of origin and the nature of the impulse received at a distance. At the last N.P.L. annual invitation visit, a cinema film was exhibited showing the cathode-ray direction finders which reveal the direction of individual atmospheric. It has been estimated that taking the world as a whole there are about 1,000 lightning discharges per second at any time. The figures of kilowatt hours thus wasted during the course of a year simply do not bear thinking about.

Apart from the case of an aerial being directly hit by lightning there are still possibilities of considerable inductive effects due to lightning. During the process of building up a thundercloud there are very considerable electrostatic fields created between cloud and earth. This can be seen from the diagram on the previous page. Here an aerial can be in an intense electric field even though it is not below the point where discharge finally

even with many that are not actually visible but where the aerial is nevertheless within the extensive region that has come under the wide scope of this electrostatic field. In addition to this more or less local effect the sudden destruction of this field has the effect of setting up an electromagnetic wave which travels out into space in the form of an atmospheric—a natural signal sent out by a powerful transmitter with an excellent large radiating aerial!

**Protecting the Aerial**

Despite the few cases of wireless aerials being struck by lightning, there seems no doubt that protection of the domestic aerial from the effects of lightning—even from the relatively minor induced charges just described—is a real and wise precaution. Many earthing devices exist, and most outdoor aerials are fitted with *some* such device. For the best protection it is usually recommended that the

earthing switch should be outside the house and suitably protected against weather. This unfortunately results in it not being used, particularly as a routine method overnight or when the house is unattended. Some meticulous citizens might manage to remember it, but one fears that the average man is rather casual about it. The next best technical solution, and one much more likely to be used, is to have an indoor switch

immediately at the point of entry. Best of all however, is an automatic device which needs no switching, and gaseous conductors are now available for the purpose, fitted usually, with the familiar serrated edge spark gap or "lightning arrester." In fitting the aerial, too, precautions may be taken to minimise the possibilities of side-flashing. Broadly, these can be summed up in the form of keeping down resistance and inductance of down-leads and even more, of earth-lead. Sharp bends in the down lead should be avoided, and the earth-lead should be as short and straight as possible—as indeed it should be in any case.

There is very little chance of an indoor aerial being struck unless the whole house "gets it." Induced voltages of the type described, are still set up in an indoor aerial, but switching protection is hardly necessary except in the very nearest of discharges.

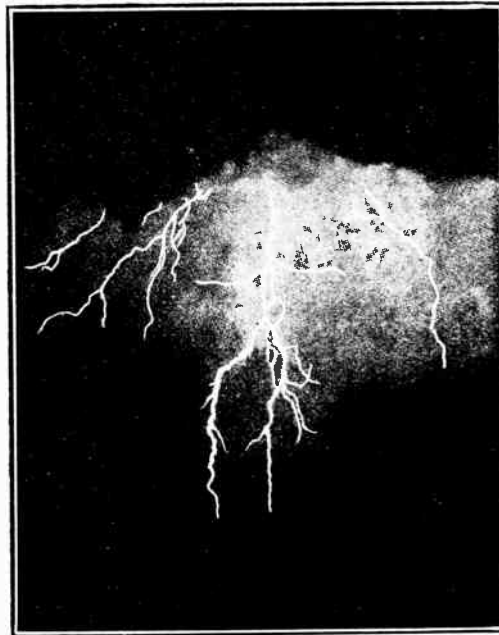
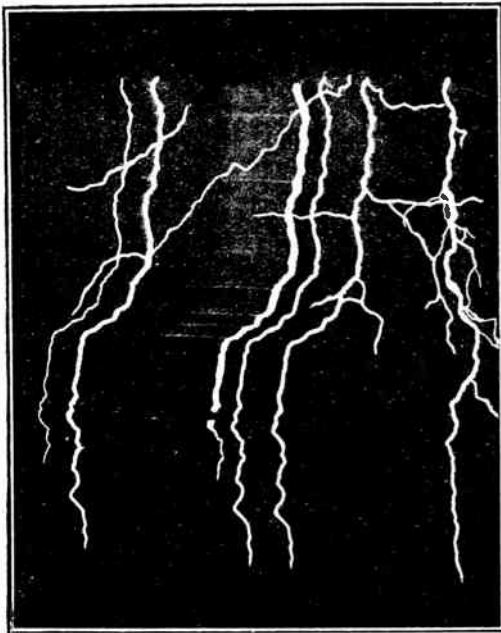

Photographs of a lightning flash, the left-hand picture was taken by camera moving from right to left; the right-hand picture is of the same flash taken by a stationary camera.

occurs. Even in the case of what ultimately becomes a cloud-to-cloud discharge, not hitting the earth at all, immediately prior to the discharge the lower side of the cloud nearer to the earth gives rise to extremely high electric fields at the surface of the earth. These fields, even although they are static or in the process of slow building up, will obviously have an effect on aerials in their vicinity. When the aerial has a low d.c. path to earth this does not matter, but a series condenser giving a high resistance d.c. path to earth may get uncomfortably charged. A series air condenser in a big aerial can often be seen to spark due to this cause. In either of these cases the sudden destruction of this electric field (due to the discharge taking place) gives rise to the induction of a big transient voltage in the aerial. This is, of course, the very strong atmospheric which is heard when a visible flash occurs, and





Accelerating the heart beats.

## Reminiscences

EVERYTHING this year seems to have militated against my getting a view of the Olympia Show, and if it had not been for the solace afforded by *The Wireless World* Show Report I should have been plunged into a barren sea of utter despair. I have already told how the carelessness (or carefulness?) of a van driver outside Olympia laid me low when I was just in sight of the Delectable Country. Thereafter, from my sick-bed I tried to obtain first-hand day-to-day Show reports, but was thwarted by the fact that the little Grid Leaks, the only people I could have relied upon, were away at a wretched holiday camp in the wilds of Central Europe. Ultimately I had to fall back on the services of Mrs. Free Grid, of whom I will say that she did her best. She provided me with a sort of "bird's"-eye view.

Among other things she reported a truly distressing lack of grammar on the part of the exhibition authorities, since, over every entrance door, was printed a large sign: "NO PASS-OUTS." The expression "pass-out" is uncouth enough without such a glaring mess-up in the plural.

Apparently the most spectacular exhibit, notwithstanding the B.B.C. show, was that provided by the General Post Office, and I was rather pained to hear that a thing that attracted most people to the G.P.O. section savoured more of a side-show at Hampstead Heath on a Bank Holiday than a demonstration at a serious scientific exhibition. This was an apparatus for reproducing heart-beats on a loud speaker, where the microphone was held in the cardiac region. The arrangement, I was told, was superintended by a damsel who applied the microphone to the chests of young men and demonstrated how her close proximity accelerated their heart-beats.

I was grieved to learn that the Show revealed one of the features which disgraces certain other exhibitions held at Olympia, at which it is quite impossible to proceed from stand to stand without being followed by a parasite in the form of a part-exchange dealer pestering one with the

# UNBIASED

By FREE GRID

enquiry: "Thinking of making a change, sir?"

Two or three young men at the Radio Show were armed with forms which, after requesting details of a set which an intending customer might think of exchanging in part payment for a new one, asked the singularly naïve question: "Is the tone, sensitivity, and selectivity of your present set good, bad, or indifferent?" Do the mutts honestly think that, faced with such a question, the customer is going to cry "Stinking fish"?

## Big Business

I REALLY think that when it comes to exhibitions the wireless people must be the envy of every other industry in the country; in fact, judging by the way the business flows in at Olympia, I cannot for the life of me see why they keep the Show open for more than one day, or at the outside two; and neither can I understand why every business man in the country doesn't sell out all his other interests and get into the radio business without delay.

One well-known firm, with a factory many acres in extent, stated that they sold the whole of their output up to Christmas time before the Olympia Show was an hour old. Quite a number of firms nearly equalled this record, and one firm of international repute exceeded it, for they announced that during the run of the Show they had sold all their factory output for two years.

I do seriously think that, for the good of the radio industry generally, this blatant bunk ought to be suppressed.

## Those Crystal Sets

I HAVE been overwhelmed in such an avalanche of letters and offers of help as the result of my note the other week concerning the dearth of crystal sets and parts thereof that I scarcely know how to thank readers. Not only did I receive letters giving me the addresses of numerous establishments where I could still buy



At knock-out prices.

crystal sets, but a large number of readers were kind enough to search over their old discarded radio gear and send me bits and pieces sufficient to make a very handsome crystal set.

In addition, many others offered me complete sets at knock-out prices. I am astonished to learn that they do exist in quite considerable quantities in various shops. One well-known dealer in wireless gear whose establishment I overlooked in my original quest, although it was well known to me, forwarded me his catalogue showing that the humble crystal set is still listed. I must confess, however, that I was considerably astonished to hear from the Editor that a well-known London firm had written to him stating that they sold over one thousand gross of crystals during the last radio season, more especially since another well-known crystal expert has written to inform me that, so far as he is concerned, the crystal trade has dwindled to vanishing point. Still, we live and learn.

## A Souvenir

WOMEN never seem to be able to go anywhere, even for a day's visit, unless they bring back a wretched present or souvenir for somebody at home, even if



Functions beautifully.

it only be a paltry china ornament with "A Present from Margate" scrawled on it in gold letters, and Mrs. Free Grid's visit to Olympia was no exception. In this case, however, it was an extremely useful present, consisting of a volume control which is mounted on a weighted strap for slinging across the arm of the fireside chair in much the same way as certain ash-trays. The volume control functions beautifully, the "control" being spread nicely over practically the whole movement of the knob instead of crowded up at one end as in the case of some of them.

Everything in the garden was lovely until I became so satisfied with my present that I wished to buy another. I need scarcely say that, as is the way of all women, Mrs. Free Grid had completely forgotten the name, or even the exact locality, of the stand whence she bought it. The result is, of course, that my desire to possess a spare one has increased a thousand-fold; indeed, it has almost assumed the dimensions of the cravings of a drug-addict.

# Simple Measurements on Receivers and Components

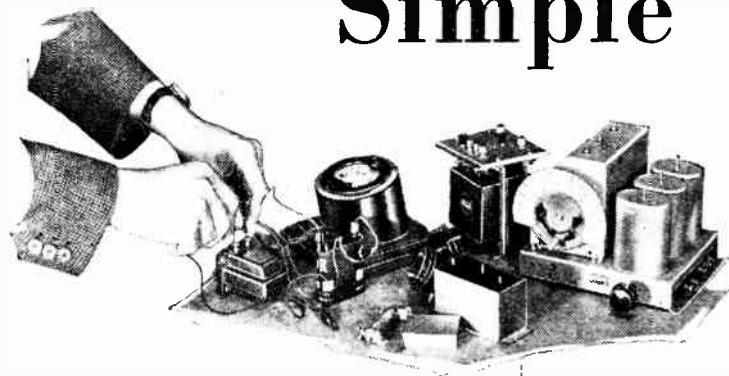

A MODERN wireless receiving set is unquestionably a somewhat complicated piece of electrical apparatus, with many components, each of which must function properly if the set is to give the best results. The valves, of course, are the most important of these components, and, even though they may be faultless, their efficient operation and their span of useful life depend on the correct voltages being applied to their various electrodes. For instance, if a grid bias voltage is too low the anode current may be excessive, and, apart from the lowering of efficiency and the introduction of distortion, the emitting cathode of the valve itself may be impaired.

It is perhaps a little surprising to find how often the electrical conditions prevailing in the circuits of a newly constructed receiver are left to chance, even by those who exhibit quite a high degree of skill in constructing their own sets, either from specifications such as those given from time to time in *The Wireless World* or from designs of their own. The assumption is commonly made that, the greatest care having been taken in following the constructional data, and in making theoretical calculations, everything is bound to be well from the electrical point of view! This may be so to a certain extent in many cases, but how much trouble and doubt may be avoided if only a simple measuring instrument such as a milliammeter were available.

## Testing a New Set

When the set is completed and the valves are carefully put into their sockets comes the thrilling moment when the first trial is to be made, and the final adjustments effected. It is particularly at this stage that the possession of at least one meter is of the greatest value in enabling rapid and correct adjustments to be made and possibly in preventing damage to one or more of the valves. For even in the hands of the most skilful constructor it is possible for an error to occur in the wiring, or a short-circuit somewhere in the set—no one is infallible. Without the use of a meter it is possible that the fault would only be found at considerable cost.

Faulty components at times cause a deal of trouble, and with the aid of a suitable meter many can be tested before being built into the set. What is more distress-

*It is essential to be able to make simple measurements and tests on a receiver before being certain that it is being operated under proper conditions. Quite an inexpensive instrument is capable of imparting to the skilful owner much valuable information.*

## Many Uses of an Inexpensive Meter

By S. O. PEARSON, B.Sc., A.M.I.E.E.

ing than to discover a faulty component in a more or less inaccessible part of a completed receiver?

Finally, there is the question of maintaining a receiving set in good working order, and here again the possession of a meter is of the greatest value, whether the set be a home-constructed or bought one. There comes a time when the performance of the receiver shows signs of deteriorating and the trouble must either be found by the owner or the set be sent away to an "expert." One need not dwell on which will be the less costly procedure! If it is a battery set maybe the H.T. battery is running low, maybe not—a meter would tell. Perhaps one of the valves is losing its emission—a meter would show which, and the faulty valve could be replaced accordingly. If the receiver were sent away to be serviced it is quite likely that a complete set of new valves would be recommended, and the owner would have no means of disputing the soundness of the advice. It is very commonly argued by the servicing agent that if one valve is deteriorating the remainder will follow very shortly, but this is by no means the case.

From all points of view the acquisition of at least one reliable meter is sound economy.

### The Best Type of Instrument

In view of the foregoing remarks a brief survey is given below of the most suitable meter or meters to procure and the most useful applications. Without doubt the most serviceable instrument, if only one is to be purchased, is one with both milliamperage and voltage ranges, preferably of the moving-coil type. Miniature moving-iron instruments, especially of the polarised type (that is, with definite positive and negative terminals), are, however,

quite suitable, though usually not quite so accurate as the moving-coil type; and moving-iron voltmeters take a comparatively heavy current. The actual instrument chosen must, of course, depend on the depth of the purchaser's pocket, but it should be realised that even a cheap meter costing only a few shillings is most useful and enables a great many tests to be made. After all, the price of a meter is only a fraction of the cost of the receiver itself, and will without question pay for the outlay in a comparatively short time. Of course, the best policy is to buy the best meter one can afford.

The question of the most suitable ranges to choose for both milliamperes and volts depends to a large extent on the type of the receiver; for instance, whether it be battery or mains operated. The milliamperage range should be a little greater than the anode current of the output valve, and the maximum voltage range must be a little above the H.T. voltage required by the set. Taking as an example a battery set requiring 100 volts H.T. and consuming normally 15 to 20 milliamperes, a suitable meter would have a voltage range of 120 and a current range of 24 milliamperes. (The combination of 120 volts and 24 milliamperes is a practical one because 24 is a multiple of 120, so enabling the same scale divisions to be used for both ranges.) A low-voltage range, say, up to 12 volts, would be of great value for measuring filament voltages, low-tension battery and grid bias battery voltages. This would be in addition to the 120-volt range.

Naturally, a useful arrangement is to have a separate voltmeter and ammeter, each with two or more ranges. In purchasing a voltmeter, choose where possible an instrument with the highest resistance in ohms per volt. A voltmeter with a resistance of 100 ohms per volt would take a current of one-hundredth of an ampere

### Simple Measurements on Receivers and Components—

or 10 milliamperes with full scale deflection on all ranges. Voltmeters with lower resistance than this take more current and in many circumstances render satisfactory voltage measurements difficult.

Readers with a working knowledge of Ohm's law and a little skill in the winding of resistances will agree that a single sensitive or low-reading milliammeter can be made to operate over various current and voltage ranges by using it in conjunction with different parallel (shunt) or series resistances respectively. Instructions for extending the ranges of such an instrument were given in *The Wireless World* of January 29th, 1930. It should be realised that the actual movement of the instrument is identically the same for a voltmeter as for a milliammeter—it is only the equivalent resistance of the combination and its method of connection to the circuit that determines its function.

### Testing of Components

Although good components can be relied upon to conform to the makers' rating within a fair degree of accuracy, it is, nevertheless, advisable to check some of the more important ones where facilities permit and where the test is practicable with the milliammeter or voltmeter available.

One of the most useful applications of a meter is the checking of individual components by simple tests before inclusion in a set under construction, or of suspect components in a set which has failed to give satisfactory results. For instance, simple tests can be made for continuity of circuit through resistances, coils, and transformer windings. It is only necessary to connect a meter in series with the resistance or coil under test and apply an appropriate voltage to the ends of the circuit so formed. If current flows there is no break in the circuit.

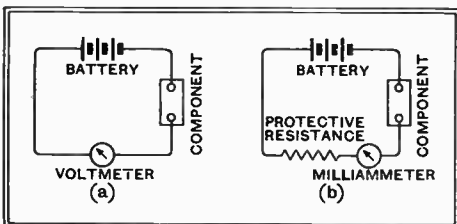

Fig. 1.—Simple test for continuity of circuit through a resistance or other component. A voltmeter should be used for preference as at (a), but a milliammeter may be employed if a safety resistance is included as at (b).

It is most strongly advised to use a *voltmeter* for this purpose to guard against the flow of excessive current when the component being tested has low resistance—a voltmeter has high resistance and cannot be damaged if the voltage of the testing battery used is not greater than the range of the instrument. The circuit arrangement is shown in Fig. 1 (a). If a milliammeter is used, an extra resistance of a few thousand ohms must be connected in series, as shown in Fig. 1 (b) to limit the

current to a safe value. In the case of very high resistances, such as grid leaks, the current may be too small to be indicated at all, even though the circuit is continuous, and this particular test fails.

Condensers may be tested in a similar way, but as a good condenser has no conducting circuit through it, the conditions are reversed, and zero reading on the instrument scale shows that there is no short circuit in the condenser, and that the insulation between the plates may be satisfactory. But this test gives no proof that one set of plates may not be entirely disconnected from its corresponding terminal. With large capacity condensers, however, such as those employed for smoothing and decoupling, there is a very simple method of finding out if the internal connections are in order. On first closing the circuit there should be a preliminary deflection or kick of the meter needle due to the momentary charging current. If a continuous deflection remains after the initial kick, either the insulation is faulty or there is an internal short circuit. As before, a voltmeter should be used if possible or a milliammeter, safeguarded by a protective series resistance, could be employed.

Variable air condensers can be tested for internal short circuit in the same way; the rotor should be turned through the full range whilst the meter pointer is watched. Any sudden deflection shows that the rotor blades are touching those of the stator, or a particle of metal dust may be lodged between them.

To test the insulation between the primary and secondary windings of a transformer, or between each winding and the core, the procedure is the same as for a condenser.

### Measurement of Resistance

The direct measurement of the value of a resistance is not quite so simple and straightforward as Ohm's law would appear to indicate, but as it is of such great advantage to be able to measure a doubtful resistance at times, an example of simple measurement is given here with explanations of the special precautions to be taken.

Ohm's law tells us that the current passed by a resistance is equal to the applied voltage divided by the resistance in ohms. The voltage is the driving force or electrical pressure, and the current is the resulting flow of electrons. If a resistance of  $R$  ohms is connected across a battery whose terminal voltage is  $E$ , the current flowing will be  $E/R$  amperes. But if a milliammeter is included in series with the resistance, as in Fig. 2 (a), to measure the current, the latter will be less than  $E/R$  amperes, because *the milliammeter itself possesses resistance*. If  $x$  is the resistance of the milliammeter in ohms, the total resistance across the battery is  $R+x$  ohms, and it is this value which is given by the ratio of volts to amperes. Obviously, then, the milliammeter resistance must be known before a test of this nature can be made, unless, of course, the

milliammeter resistance is negligibly small compared with the resistance to be measured, in which case it can be ignored. It is not a very simple matter to determine the resistance of the milliammeter if no other instruments are available, but very often the resistance is given by the maker or would be furnished on request.

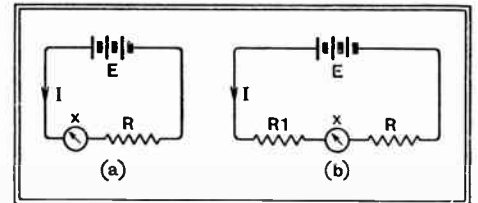

Fig. 2.—Measurement of resistance with a milliammeter and a battery of known voltage  $E$ . The circuit is shown at (a). The resistance of the milliammeter  $x$  must be allowed for. To guard against a possible short circuit in the resistance  $R$  a safety resistance  $R_1$  should be inserted temporarily as shown at (b) and explained in the text.

With the aid of a battery of known voltage and a milliammeter of known resistance, it is possible to check resistances over quite a wide range of values. A single accumulator cell gives very nearly 2 volts (except immediately after charging), and so, if an accumulator of several cells is available, several testing voltages are ready to hand. Suppose that one has a milliammeter reading up to a maximum of 24 milliamperes, and that its resistance is 15 ohms, and suppose, further, that it is desired to check a resistance rated at 250 ohms. A convenient current for measurement would be of the order of 20 milliamperes, or 0.02 ampere, and the voltage necessary to drive this current through 250 ohms would be, by Ohm's law,  $0.02 \times 250 = 5$  volts. So one would use a 4-volt accumulator in the circuit of Fig. 2 (a). Suppose that the current is found to be 14.5 milliamperes with 4 volts applied; then the total resistance is  $4 \div 0.0145 = 276$  ohms. Deducting the 15 ohms resistance of the meter gives 261 ohms for the component under test.

### A Wise Precaution

It should always be remembered that a milliammeter is a vulnerable instrument and very easily damaged by an excess of current. Consequently, every precaution must be taken to prevent an accidental jar. If, for instance, the resistance  $R$  of Fig. 2 (a) happened to be short-circuited, the milliammeter would be ruined. A safety resistance  $R_1$  of the same order of magnitude as  $R$  could be included temporarily as at (b) in Fig. 2. If the current rises considerably when the terminals of  $R$  are bridged over with a piece of wire, all is in order, and the safety resistance may be taken out of circuit prior to making the actual measurement.

\* \* \*

In a second part of this article an account will be given of simple tests and measurements which can be made on a completed receiver, and how a meter can be used to give a visual indication of the performance of a receiver.



*Higgs*

# HIGGS SUPERHETS "UP-TO-DATE DESIGN"

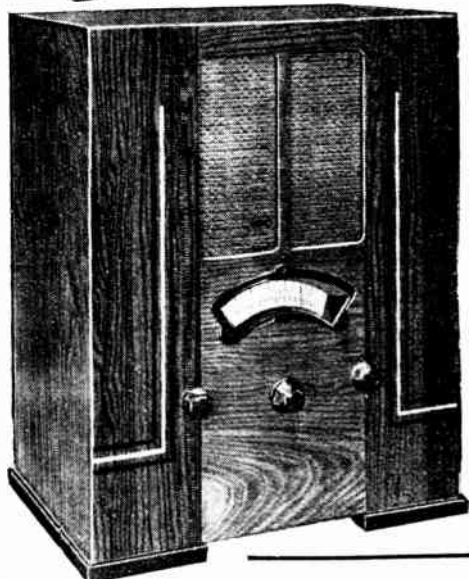

"The set is a pleasant one to handle . . . pleasing quality with no trace of harshness or irritating resonance. There is a commendable absence of background . . . Stations stand out with exceptional clarity. The sensitivity is excellent. As regards selectivity . . . ZEESEN was received absolutely clear of both DAVENTRY and RADIO PARIS at good strength and without side band 'splashing'."

Says "THE WIRELESS WORLD," July 28th, 1933.

		RECEIVER RADIOGRAM	
<b>SUPER-A</b>	Six-valve Superhet } (A.C. Mains)	18 GNS.	29 GNS.
<b>SUPER-B</b>	Six-valve Superhet } (Battery)	18 GNS.	27 GNS.
<b>SUPER-C</b>	Six-valve Superhet } (A.C. D.C.)	20 GNS.	31 GNS.
<b>SUPER-D</b>	Six-valve Superhet } (D.C. Mains)	18 GNS.	29 GNS.
<b>GARRARD AUTO-RECORD CHANGER</b>		4 GNS. EXTRA	

**HIGGS (GREAT BRITAIN) LIMITED, WESTBOURNE PLACE, HOVE TEL. 2904. SUSSEX.**



## NO MORE HAPHAZARD MATCHING!

Seventeen transformer ratios for really accurate matching to any power valve or pentode and four ratios for Class B or QPP all available on one speaker by a simple switch adjustment! Added sensitivity due to the "Mansfield" magnetic system and better balance through accurate matching give a performance you must hear to believe!

'MICROLODE' type  
P.M.4A - 42/-  
P.M.6 - 32/6



## 'MICROLODE' feature

(Regd. Trade Mark)

Write now for the W.B. 'MICROLODE' folder.

WHITELEY ELECTRICAL RADIO CO. LTD., DEPT. W, RADIO WORKS, MANSFIELD, NOTTS.

# IGRANIC

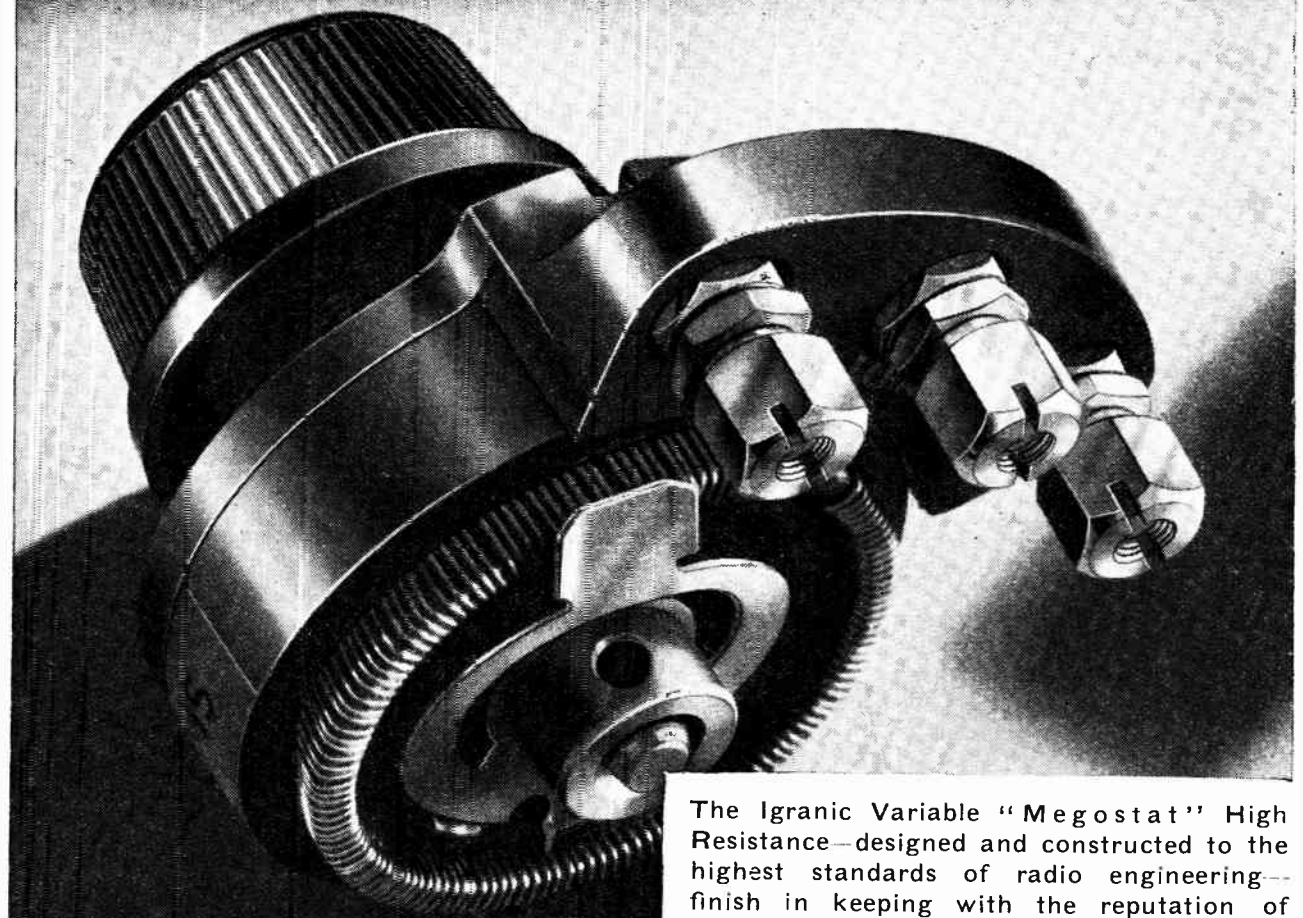

The Igran Variable "Megostat" High Resistance—designed and constructed to the highest standards of radio engineering—finish in keeping with the reputation of Igran—special contact preventing wear and ensuring constant resistance value—can be used as a volume or tone control, as a variable grid leak or as stabilizing resistance, etc., in single hole fixing—at the reduced price of 3/6 in four sizes—another example of that efficiency of performance and reasonableness in price which are typical of every item in the Igran range. Let Igran Components be the making of your set.

Write for fully illustrated Catalogue No. U.353.

Igran Electric Co. Ltd.  
149 Queen Victoria St.,  
E.C.4.



# NEWS of the WEEK

## Current Events in Brief Review

### All Eyes on Glasgow

GLASGOW, where the Scottish Radio Exhibition opens tomorrow in the Kelvin Hall, has been a stronghold of wireless since the days when 5SC (of blessed memory!) first transmitted the voice of the then British Broadcasting Company.

Of recent shows in Glasgow the most notable was that held last year in the same hall under the auspices of the *Glasgow Weekly Herald*. This year's Show—the first to be sponsored by the Radio Manufacturers' Association—will be a close replica, if on a smaller scale, of the Olympia Exhibition. With nearly eighty stands and a radio ballroom, the Glasgow Show bids fair to make new records both in attendance and business transacted.

A complete guide, with plan, appears on page 202.

### The Prince of Wales

ROYAL recognition of wireless has been very marked in recent years, and the Prince of Wales will be carrying on the tradition when he honours the Radio Manufacturers' Association by attending the Annual Dinner in November under the chairmanship of Mr. W. W. Burnham.

This will be the first time that His Royal Highness has been present at this annual dinner.

### All in 135 Minutes

MR. J. HUNTER, of Blackheath, London, whose station G2ZQ is one of the best-known in Europe, has put up yet another amateur transmitting record. In two and a quarter hours on one evening recently, he communicated with amateurs in New Zealand, Palestine, Argentine, French North Africa, the United States and England using the 20-metre band.

### Future of Radio Paris

AS a sequel to the purchase of Radio Paris by the State, members of the station staff have received formal notice that their engagements will expire without renewal from December 3rd next. It is expected, however, that the whole of the staff will be re-engaged.

### Luxembourg Stands Firm

RADIO LUXEMBOURG, it seems, intends to stand by its guns and continue transmissions on the 1,100-metre wavelength, despite the decrees of the International Broadcasting Union. According to a recent visitor, the management contend that it is impossible for an "international" station to work on an exclusive wave of 210 metres. It is hoped that this will be recognised at the forthcoming Amsterdam Conference of the Union.

The Luxembourg transmitter is open to inspection by visitors, who are enabled to see the studios through soundproof windows.

### Programmes on Tap

THE peril attaching to the tapping of wires belonging to a wireless relay company was brought home to Mrs. Stanley, of Moorthorpe (Yorks.), when she was fined £1 last week for having fraudulently abstracted a quantity of electricity. Mr. E. H. Moorhouse, prosecuting on behalf of Economic Radio, Ltd., explained how, on July 21st, following much interference, it was found that Mrs. Stanley had tapped the wires and attached a loud speaker, with the result that some fifty or sixty subscribers on the far side of her house were cut off. The current consumed by Mrs. Stanley was only assessed at 1s., but the tracing and making good of the damage was 15s.

### Kettering Radio Show

THE first annual radio exhibition at Kettering is to be held on September 14th, 15th and 16th in the Co-operative Central Hall under the auspices of the Kettering Radio and Physical Society.

### Musical Murder

INVESTIGATION into a recent Paris murder revealed that a loud speaker was switched on in the flat in which the two victims, a mother and her son, were put to death. French detectives consider that the murderer had tuned in before making his attack in order to stifle any compromising sounds.

### Lectures on Wireless

A COURSE of twelve lectures on "Wireless Science" are to be given at Morley College, 61, Westminster Bridge Road, London, S.E.1, by Mr. H. S. Ryland. The lectures will be given on Friday evenings at 7.30, beginning on September 22nd. Full particulars regarding fees may be obtained on application to the Secretary.

### French Radio Revelations?

IMPORTANT revelations concerning the immediate future of French broadcasting and the development of the high-power scheme are expected when M. Laurent-Eynac, the Postmaster-General, speaks at the Paris Wireless Show Banquet. The Show, which is international in scope, will be held in the Grand Palais, Paris, from September 6th to September 17th. In addition to exhibits by practically the entire French radio industry, the "Salon" will contain a special section devoted to anti-static devices, the use of wireless in aviation, marine and Colonial services, and practical demonstrations of the manufacture of gramophone records.

A wave of wireless enthusiasm seems to be sweeping France, due to the development of the Ferrié scheme and the realisation that the State is going ahead with the development of broadcasting.

### Pitch Pine for Radio Masts

THE increasing use of wood in the construction of wireless masts has greatly encouraged the timber trade. "The Timber Trades Journal" refers, with gratification, to the new German wireless tower erected at Rothsurven, near Breslau, which is built entirely of wood and is claimed to be the tallest wooden structure in the world. Its height is 400ft.

It is stated that German engineers combed the world for the best structural material available, and ultimately chose pitch pine, which is said to excel all other woods in homogeneous strength properties, and provides large dimensions relatively free from knots and defects. Its high content of resin acts as a natural preservative; in addition, pitch pine is not apt to check and split, and its shrinkage factor is very low,



THE BERLIN SHOW. Changed political conditions have made their impression on the famous German radio exhibition, which has just been held under the shadow of the Radio Tower, or Funkturm, in Berlin.

### 5-metre Tests in London

TRANSMISSIONS on 42.2 metres (7,097 k.c.) and 5 metres (5,600 k.c.) are being carried out to-day (Friday) and on Sunday next by Dr. C. G. Lemon (G2GL) at 72a, North End Road, W.11. The schedule is as follows:—*Friday*: 5 metres, 10.45 p.m. to 11 p.m.; 42.2 metres, 11 p.m. to 11.15 p.m. *Sunday*: 42.2 metres, 10.30 a.m. to 11 a.m., 11.30 a.m. to 12 noon; 5 metres, 11 a.m. to 11.30 a.m. Similar schedules will be followed throughout next week.

### The Winning District

DISTRICT 15 of the Radio Society of Great Britain secured first place in the National Field Day organised recently by the Society, in which portable transmitters and receivers were operated by eighteen groups of amateurs from the R.S.G.B.'s nineteen administrative districts.

District 15 covers West London and Middlesex, and during the Field Day the call signs G6WN and G6YK were used, on the 160 and 80 metres, and on 40 and 20 metres bands respectively. A total of 364 points was obtained, with 64 contacts with other amateurs.

### Dr. Koon Speaks

"EVEN the rubbing of a careless finger over a half-day's growth of beard may completely confuse a radio-audience," writes Dr. Cline M. Koon in his booklet, "The Art of Teaching by Radio," just published by the U.S. Office of Education. Dr. Koon advises the broadcaster to avoid heavy breathing, keeping time with his feet, clearing his throat or clicking his finger-nails. The announcer and operator, too, should play their part by making the speaker comfortable and at ease, allowing him to sit and roll up his shirt-sleeves.

It is very important that the broadcaster should assume a friendly, respectful attitude.

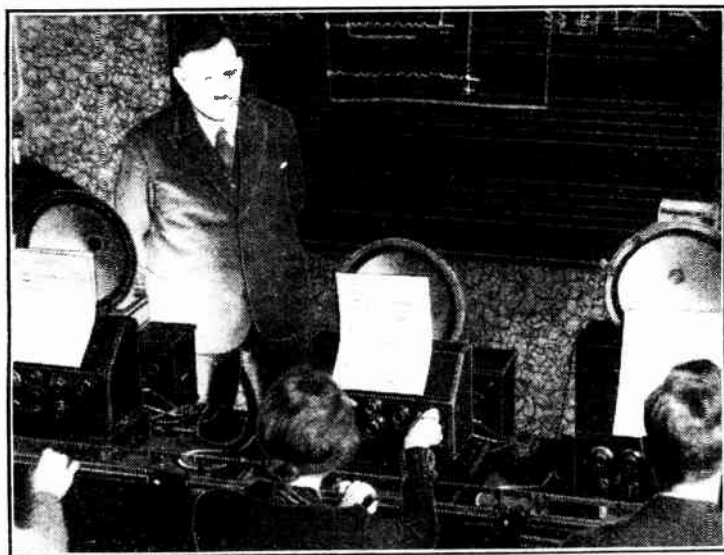

ELECTRICAL MUSIC. So high an authority as the Berlin State Academy of Music has now recognised the possibilities of the thermionic valve as a musical instrument. The photograph shows a Trautwein class under the direction of the inventor, Dr. Trautwein.



# Practical HINTS and TIPS

IT is not difficult to see that the continuity and general condition of an earth connection cannot be checked by the methods ordinarily adopted in testing other circuits. A fairly good indication that something is wrong is often afforded

### Testing the "Earth"

by the fact that a general decline in signal strength is accompanied by a change in tuning, more capacity being needed to bring the aerial circuit into resonance with a given wavelength. But this latter effect is likely to pass unnoticed in a modern gang-tuned receiver.

To ascertain definitely whether the earth lead is broken, it is usual to make a test for continuity between the normal earth connection and a second extemporised "earth"; if all is well there should be negligible resistance between these two points. But the converse does not of necessity hold true; possibly the temporary and unknown "test earth" may itself be of high resistance.

A reader, who evidently believes in taking no unnecessary chances, describes a method of testing the earth connection for which he has made provision in his own installation. The details will be obvious from a consideration of Fig. 1, from which it will be seen that, in addition to the usual connection to the buried earth plate, a second lead, solely for testing purposes, has been soldered to it. The end of this lead, when not in use, is coiled up and concealed in a tin buried just below the surface of the ground.

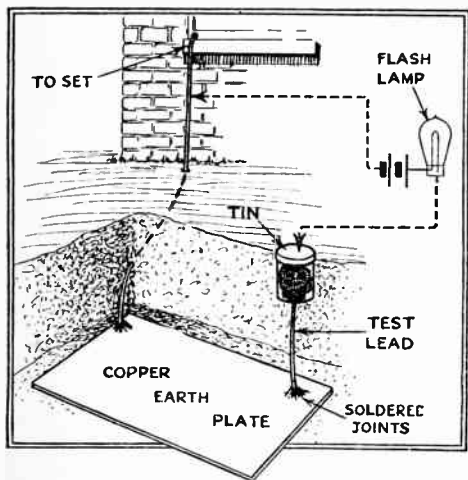

Fig. 1.—Perhaps over-cautious, but— . . . . . How to make provision for testing a buried earth connection.

Although it must be admitted that precautions of this nature are hardly necessary in most cases, the provision of a testing lead in this manner involves very little extra trouble, and may save a lot of unnecessary work in the future, especially if the earth plate be deeply buried.

### AIDS TO BETTER RECEPTION

ALTHOUGH modern D.C. valves work at a higher voltage and a considerably lower current than their prototypes, it is generally necessary to dissipate a considerable wattage in the main voltage-absorbing resistance, which is wired in series with the heaters.

### D.C. Set Precautions

This energy is, of course, finally dissipated in the form of heat, and so an appreciable temperature rise may be expected.

Instances have recently come to light where heat generated in this way has adversely affected paper-dielectric by-pass or smoothing condensers by melting the sealing compounds generally used in the manufacture of these components. It is accordingly wise to make sure that the condensers are mounted in a cool position, and certainly not in the immediate vicinity of the main resistance. In any case, provision for ventilation of the complete set should be made.

IT was recently pointed out that many liberties may be taken with regard to the layout of the L.F. section of a receiver. Unlike the H.F. amplifier, it is but seldom that the result of doing so will be to cause instability or some other mani-

### Transformer Interaction

festation of undesirable interaction. But, in view of the fact that the L.F. amplifier and power supply equipment are often designed nowadays as a single self-contained unit, it is perhaps as well to point out that a common—perhaps the most common—cause of mains hum is interaction between power and L.F. transformers. Fortunately it is seldom difficult to overcome this trouble by an experimental alteration in the relative positions of these components.

IT is rather a pity that we are all prone to expect rather too much from new developments. Take Class "B" amplification; it is proving a real boon to those who are forced to use batteries for H.T. supply, but for mains use in ordinary sets

### For Batteries Only

it presents special problems, and, generally speaking, has few attractions. In spite of this there seems to be a tendency, among those who have mains available, to swing over to the new system.

In doing this they are certainly making a mistake; the older and more conventional circuits, with mains-driven valves and a liberal supply of anode current, may be expected to yield better results, and to involve fewer complications and less cost.

IN a recently published reply to a reader's query, it was pointed out that the system of automatic volume control employed in the original A.C. Monodial is impracticable for the D.C. version of the same set, due to the fact that no surplus H.T. voltage is available for the A.V.C. valve.

### A.V.C. for the D.C. Monodial

It will be clear, however, that this objection does not apply when a user of the D.C. set is willing to employ an H.T. battery for the controlling valve. Although there may be a natural reluctance to use batteries in an otherwise "all mains" set, the plan is nevertheless quite a practical one, and the extra valve may be wired as shown in Fig. 2.

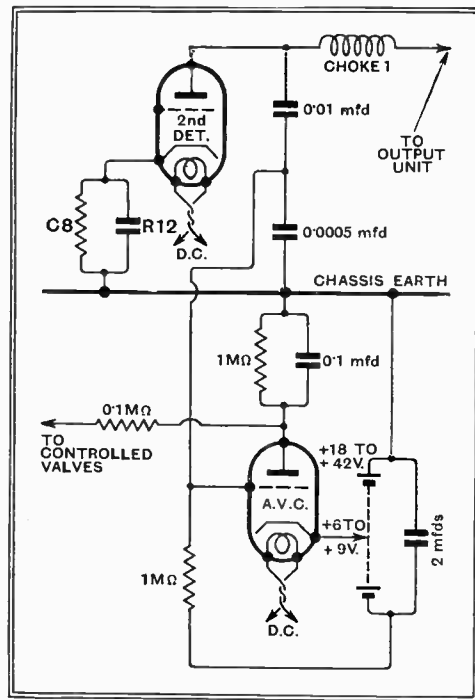
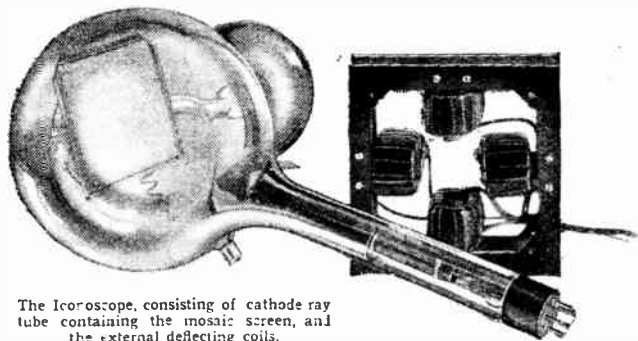

Fig. 2.—The addition of an A.V.C. valve to the D.C. Monodial.

It is opportune to point out that, although a relatively high anode voltage is needed for the A.V.C. valve when full control has to be maintained in the neighbourhood of a powerful station, no such necessity arises in "wirelessly" remote localities where overwhelmingly strong signals are not to be expected. Where the input from the aerial cannot reach a high value, quite a small anode voltage suffices, and, according to a user of this system, a measure of control is still obtainable if the H.T. voltage be reduced to as little as 18 volts. The extent of delay in the action of the A.V.C. system is easily controlled by varying the cathode tapping on the H.T. battery; this determines, of course, the working bias of the grid. Incidentally, a Marconi or Osram D.H. valve has been found suitable for A.V.C.

# The ICONOSCOPE



The Iconoscope, consisting of cathode ray tube containing the mosaic screen, and the external deflecting coils.

## America's Latest Television Favourite

**A**N interesting step towards practical television was announced at a recent convention held in Chicago by the Institute of Radio Engineers; the "Iconoscope" of Vladimir Zworykin relating to the use of a cathode ray tube in place of a scanning disc. The Iconoscope is claimed to be several thousand times as efficient as the scanning disc even when it is working far below its theoretical maximum efficiency. It makes it possible to transmit twenty pictures, or more, per second, with a detail corresponding to as many as 250 lines per square inch. The most important feature of the device, however, is its power of imitating the human eye in regarding a picture continuously and in possessing a certain degree of retentivity. It replaces mechanical scanning and several stages of amplification; it is entirely electrical and has no moving parts.

The Iconoscope consists of two devices—a photoelectric mosaic on which the picture is focused by a lens system, and a cathode ray gun which fires at this screen a stream of electron projectiles. The elements of the device are shown in the drawing of Fig. 1. The signal plate upon which the picture is focused may be about 4 x 5 inches in dimensions and on its surface are millions of small photocells, each consisting of a minute silver globule sensitised by caesium. These minute photocells like a mosaic are deposited on an insulating plate, such as a thin sheet of mica, and the back of this plate is made conductive by a metal coating. Since both the photocell and the metal coating are conductors, and they are insulated from one another by mica, each individual photocell forms a small condenser with the metal plate. This capacity amounts to several hundred micro-microfarads per square centimetre, and the sensitivity of the photocells is equal to that of the modern caesium oxide type cells.

### How the Image is Translated

Now, suppose a scene, say, of a well-lighted outdoor landscape is focused upon this plate. Since there are varying degrees of light and shade, there are varying currents flowing from the individual photocells. These currents charge the condensers associated with the photocells

according to the flow of current, and the picture is thus translated into an electrostatic screen made up of many thousand electrical charges, each condenser being charged according to the intensity of the light falling upon its photocell.

Within the same glass bulb as the mosaic is the electron gun which throws a beam of electrons at this screen and which is made to sweep across the screen horizontally and vertically by means of deflecting coils, as in an ordinary cathode ray tube. Whenever an electron hits a photocell it neutralises part of the charge on the associated condenser. This discharge current is picked up, amplified, and transmitted to the receiving cathode ray beam which is moving across a fluorescent screen in synchronism with the scanning beam. The varying discharge currents modulate this receiving beam and hence the screen at the receiver.

### Increase in Light Values

The Iconoscope apparently solves one of the worst problems of television, that of getting sufficient light from each point so that the resulting photocurrent can be effectively amplified for use at the receiver. In his description Dr. Zworykin states that a desirable picture would involve some 70,000 picture elements. If there are twenty pictures per second, the time of transmission of each element would be  $1/1,400,000$  of a second. This is unimportant provided that the light intensity is sufficient to actuate the photocell in this small time. This is where the difficulty lies, however, for the photocell delivers a current depending upon the product of the light intensity and the time during which this light acts. If the time be decreased, the current is reduced. With a scanning disc the current falls as the square of the number of picture elements because the time decreases for any increase in the number of holes. It has been virtually impossible, therefore, to televise outdoor scenes because of the difficulty of getting enough light.

Again following Dr. Zworykin's reasoning, suppose it be desired to televise this outdoor scene. A camera with a lens working at a speed of  $F 4.5$  would focus on a plate about  $1/10$  lumen. Now, if a scanning disc were used to take this picture apart and transmit it into a photo-

cell of average sensitivity, say, 10 microamperes per lumen, a single picture element would produce a current of the order of  $1.43 \times 10^{-11}$  ampere. In the time available this would produce a charge of  $1 \times 10^{-17}$  coulomb, corresponding to about 63 electrons. All this means that tremendous amplification is necessary if an outdoor scene is to be transmitted successfully.

The trouble with the scanning disc system of taking the picture apart is that the light from a single point of the scene affects the photocell for such a short space of time. If the photocell could see all of the picture all of the time, as is true of the human eye, the efficiency or light gathering power compared to that of a disc scanner would increase as the number of picture elements. Thus with 70,000 elements the Iconoscope, which accomplishes this seeing-all-at-once, is theoretically 70,000 times as efficient as the scanning disc and hence the amplification may be reduced to a vast degree. Actually the efficiency of the Zworykin device does not reach this figure, but it is stated to be several thousand times as good as the scanning disc.

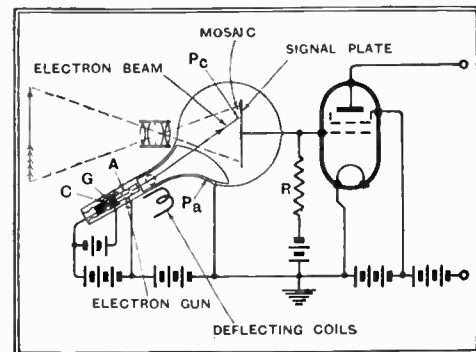

Fig. 1.—Elements of the Iconoscope device.

The mosaic of photocells has the entire picture focused upon it, resulting in the continuous emission of electrons according to the degree of light and shade in the picture. Once in each repetition of the picture the charge on the condenser acquired by each element of the mosaic is released by the cathode ray beam.

The fact that the transmitting screen is 4 x 5 inches in size is no indication that the receiving screen is limited to this size. In fact, Zworykin claims methods of projecting the picture from the fluorescent end of the cathode ray tube upon a larger external screen by lenses and mirrors.

Dr. Zworykin's paper, when available for publication, will contain many most interesting facts with reference to the composition of the mosaic, the size of the cathode ray beam: when it hits the screen, the detail secured, etc. In the opinion of well-known American engineers it marks another landmark in the history of television.

# New Class "B" Output Valve

## Operating Data and Curves for the Marconi and Osram B.21

FROM the point of view of the battery user, Class "B" amplification is one of the most important of recent developments, and it is interesting to see that the Marconiphone and Osram G.E.C. Class "B" valve departs from normal practice in several particulars. The valve consists of the usual two triodes in a single glass envelope, but these triodes have com-

Of even more importance, however, is the reduction in the tendency towards the generation of parasitic oscillations. These are often found in the circuit comprising the leakage inductance of the transformer and the stray capacities, and occur in that valve circuit which is for the moment idle. Due to the lower amplification factor of the B.21 there is not this same tendency towards parasitic oscillation, and the makers claim that it is consequently easier to obtain good quality reproduction. The point is well brought out by the oscillograms of Fig. 1, which are both taken for an output of 250 milliwatts. The upper photo shows the waveform of the output of a zero-bias type Class "B" valve when fed with a sine wave input. It will be seen that a fairly strong high-frequency oscillation is superimposed on the main output. The lower oscillogram refers to the B.21 valve, and it will be obvious that, although there is still a high-frequency oscillation present, it is much smaller in amplitude, and the reproduction obtainable is correspondingly improved.

Constructionally, the bulb of the valve is unusually shaped, and the upper narrow portion grips a mica bridge holding the electrode assembly, and so increases the rigidity. Instead of a single fine grid for each triode, two rather coarse-mesh concentric grids are used, thus giving an unusually robust construction. It is, of course, fitted to the standard 7-pin base.

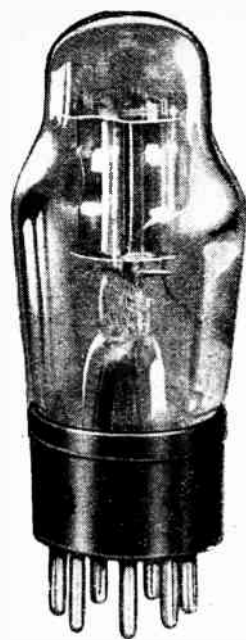

To sum up, it will thus be seen that the valve differs radically from other types, and, although it consists actually of two valves in a single glass envelope, its filaments consume no more than 0.2 ampere at 2 volts. The input impedance is high, some 36,000 ohms, resulting in a reduced tendency towards parasitic oscillation, and the valve needs negative grid bias.

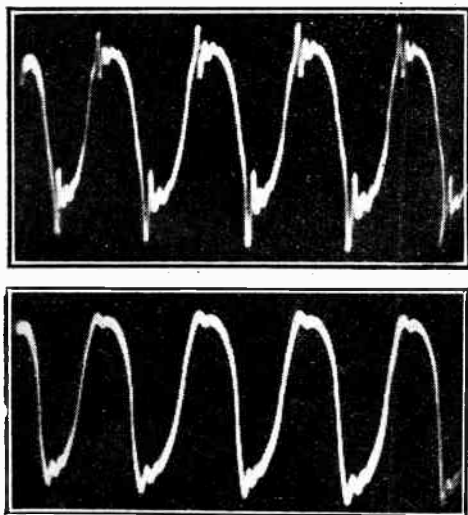

Fig. 1.—The upper oscillogram shows the output of a zero-bias Class "B" valve, and the lower that of the B.21.

### Operating Conditions

Three alternative operating conditions are recommended by the makers. The first is for maximum economy, and with 120 volts anode supply a bias of  $4\frac{1}{2}$  volts is needed. The load impedance must be 18,000 ohms, and the driver transformer can have a step-down ratio of 1.5:1 from the L.21 driver valve. The standing anode current of the output valve is then 1.7 mA. and the output is 750 milliwatts.

The moderate economy condition leads to an output of 800 milliwatts for the same anode voltage, and the bias can be only 3 volts. The load now becomes 12,000 ohms and the driver transformer can be between 1.5:1 step-down and 1:1 ratio.

The condition for maximum output, however, necessitates an L.P.2 driver and an 8,000 ohm load on the Class "B" valve, the standing anode current of which increases to 3.5 mA. The output is 1,200 milliwatts with a 120 volts H.T. supply, and 2,000 milliwatts with 150 volts. In this latter case  $4\frac{1}{2}$  volts bias is needed, and the standing current becomes 4 mA.

Considerable latitude in the operating conditions is thus permissible.

As is usual in Class "B" working, it is advisable to connect a 0.005 mfd. condenser across each half of the output transformer primary. When using the lower values of load impedance a somewhat higher capacity is better.

Fig. 2 shows the characteristics of the valve, and Fig. 3 the grid current curves.

paratively low amplification factors. At zero grid bias, therefore, the anode current is quite high, and the anode current cut-off point is not reached until some 4 to 6 volts negative bias is applied to the grids. The valve, therefore, is normally biased by this amount, and this leads to several important points.

First, grid current does not flow for a small signal input, with the result that the input impedance is high, and the system is more like a triode Q.P.P. arrangement than true Class "B." Secondly, with a large input grid current does not flow throughout the whole cycle of the input voltage, but only during a portion of it. The input impedance, therefore, is much higher than that of the zero-bias type of valve, and less power is required to operate it.

One important result of this lies in the possibility of reducing the ratio of the driver transformer, in some cases to a 1:1 ratio. Under certain conditions, moreover, it even becomes practicable to employ a step-up ratio. There is, therefore, an appreciable gain in amplification and a smaller signal input is necessary at the grid of the driver for full output.

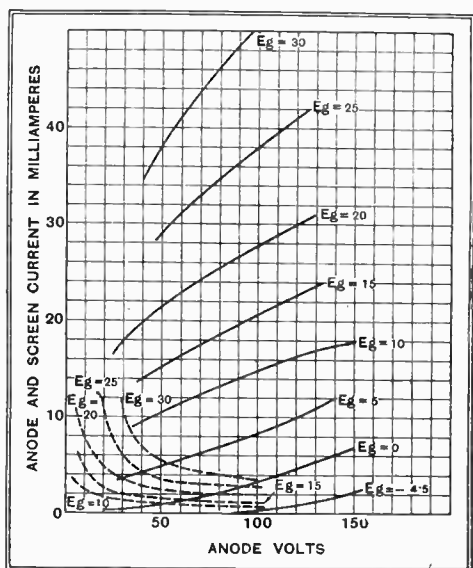

Fig. 2.—Anode volts-anode current curves of the B.21.

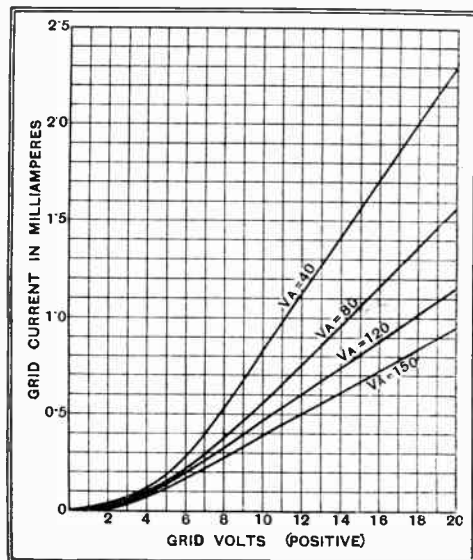

Fig. 3.—Grid volts-grid current curves of the B.21.

### New Catalogues Received

Wright & Weaire, Ltd., 740, High Road, Tottenham, London, N.17.—25-page booklet describing "Wearite" components well illustrated and containing many useful theoretical diagrams and explanatory drawings of coil assemblies. The price is 3d.

A. F. Bulgin & Co., Ltd., Abbey Road, Barking.—Of the 80 pages contained in this well-illustrated and informative catalogue 25 are devoted to a Technical Manual dealing with the many applications of Bulgin components.

F. C. Heyberd & Co., 10, Finsbury Street, London, E.C.2.—1934 catalogue of Radio Mains Equipment; a 36-page booklet dealing with H.T. units, battery chargers and mains transformers. Twelve pages are devoted to eliminator kits, a theoretical circuit diagram being given for each model. The price is 3d. post free.



# Binaural Reception

## An Acoustic Illusion Telephonically Achieved

By HARVEY FLETCHER

Acoustical Research Director  
Bell Telephone Laboratories

*ABILITY to locate sounds is mainly due to interaction between the two ears. Stopping up one ear renders location of sounds almost impossible. Interesting experiments with telephone links to demonstrate this facility are described in this article.*



**D**URING the winter and spring of last year a strange figure inhabited the American Academy of Music in Philadelphia. Looking him full in the face, one met unblinking eyes and a slight smile, fixed and unfading; and this evidence of inhumanity was confirmed by looking at him in profile, for just in front of his ears microphones were set into his cheekbones. Thus Oscar, a tailor's dummy, though less than human in appearance, was given one capacity that was more than human; that of instantly communicating to others exactly what he heard, exactly as he heard it. To listen through the receivers connected to Oscar's microphones was to put oneself in Oscar's place. This capacity of Oscar's gave him an important position in the tests of musical reproduction conducted by the Bell Laboratories in cooperation with Dr. Leopold Stokowski and the Philadelphia Symphony Orchestra.

### Locating Sounds

When one hears a sound one can usually locate approximately its point of origin—its distance and direction. The mechanism by which this location is accomplished is not altogether understood, but the interaction of the two ears seems to have much to do with it, for stopping up one ear destroys the ability almost completely. In listening to an orchestra under the two conditions the difference in effect is quite similar to that between a view seen in full perspective with both eyes and in flat panorama with only one.

It is to be expected that any two sound-apprehending devices could double for the ears. Two microphones, placed the same distance apart as human ears, could be independently connected by two receivers. A person putting the receivers

to his two ears would be acoustically transported to the location of the microphones no matter at what distance from them he might actually be, hearing all sounds as he would if his ears were in the positions of the microphones. Oscar duplicates the conditions of normal hearing as nearly as possible, not only by supporting the microphones the proper distance apart, but by modifying the sound field near them as a human head modifies it near the ears.

In the extent to which they approach the conditions of normal hearing, systems for transmitting sound can be roughly divided into four classes, as represented in Fig. 1. In "monaural" systems, such as the commercial telephone, a single transmitter is connected to a single receiver. "Diotic" systems, in which the transmitter is connected to two receivers, one for each ear, are familiar to those who have used double head telephone receivers. "Mixed" reception is found in the similar use of double receivers to monitor a loud-speaking public address

the two receivers, only a few experimental examples have been built.

From the familiar monaural condition the change to the diotic produces mainly the effect of an increase in the loudness and fullness of the sound, and of a shift of its apparent source to the centre of head. Changing to the mixed condition adds a roughness to the sound, but leaves its loudness and apparent source as they were when reception was diotic. With the final change to the binaural condition the apparent sources of sound move to approximately their proper locations in space, and the apparent reverberation is greatly reduced.

### Importance of Frequency Response

To provide for the experiments in Philadelphia, a binaural system which would reproduce speech and music faithfully in all respects, microphones, amplifiers and receivers of the highest quality were used in the two channels, transmitting extremely wide ranges of frequency and volume. Since the response of a receiver depends upon the person's ear upon which it is placed, perfect reproduction requires a different equalisation for each person. In these experiments, however, only a single equaliser was used, which was an average for a group of listeners. By its use the frequency characteristics of the system were corrected, so that all observers agreed that the reproduction was exceptionally faithful.

Striking evidence of the naturalness which can be secured with such a binaural system was obtained at several formal demonstrations in Philadelphia. When the guests had put to their ears the receivers connected to Oscar, who was in another room, someone would say confidentially in Oscar's ear. "Please move over." A surprisingly large number of the guests would start to obey the command before realising that it came from

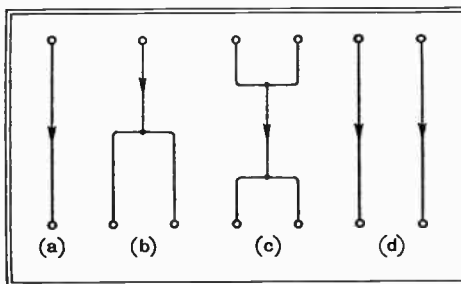

Fig. 1.—Systems of transmission can be roughly divided into four classes: monaural (a), diotic (b), mixed (c), and binaural (d).

system, in which two microphones are used to pick up the programme and their outputs are mixed. Of "binaural" systems, in which the outputs of two microphones are separately conducted to

**Binaural Reception—**

the receivers. Afterwards someone would whisper in first one and then the other of Oscar's ears, and would tear paper, jingle keys or thump a tambourine to illustrate the fidelity of the system to sounds of high frequency. Finally Oscar would be brought out and set in the midst of the audience, so that they could compare for themselves the direct with the transmitted sounds.

Experiments showed that the advantage of using Oscar, instead of two microphones less dramatically mounted, was confined to cases in which the sounds originated quite near the microphones. For tests of the reproduction of music, therefore, two microphones were hung from a bar. It was found that, when the localisation effect of the system is disregarded, the best place for the microphones is relatively near the orchestra, where the tones are brilliant because absorption has not diminished the high frequency components as it has by the time the sounds reach remote parts of the hall. The localisation is such, however, that observers sitting at the rear of the hall, where they can see the orchestra, prefer to have the microphones near them, even at the expense of tonal brilliance, for otherwise they find themselves discomforted by being acoustically in one place and visually in another.

This effect has even been noticed by observers in another room, where a screen placed the source of sound at a certain apparent visual distance.

In comparisons of binaural with loud speaker reproduction, even the inconvenience of wearing head receivers does not prevent most observers from preferring the binaural system. In an attempt to rate the worth of the binaural system, observers were asked to note their preference between monaural reproduction of the full frequency range and binaural reproduction of various limited frequency ranges. Even when all frequencies over about 2,800 cycles per second were suppressed in the binaural system more than a third of the observers preferred it.

To give a wider public the unique experience of being put in the other man's place by a trick of the ear, a binaural system has been set up. In this Oscar II will appear in a glass booth somewhat similar to that shown in the title picture, and observers who hold to their ears a pair of telephone receivers will feel as if transported to Oscar's position, there to be addressed by his companion. The system will furnish to those who use it dramatic proof that there is no longer any limitation, except expense, to the acoustic fidelity which electrical transmission systems can achieve.

the general mass of people does not know what it does want, and the manufacturers, assuming that what is thought is wanted is a large number of foreign stations, continue to offer sets in which quality of reproduction is subservient to the demand for the reception of distant stations. In the course of my everyday life I come across a very large number of listeners of all classes, and I know of only two people who neglect the reception of B.B.C. programmes entirely for foreign stations; it so happens that both these people are completely devoid of any sort of musical or educational appreciation. Many people wish from time to time, to tune in distant stations for the sake of special programme items, but, with several foreign stations at their present quality and power, quality of reproduction is just as important as when receiving the local B.B.C. transmissions. Radio can give exceedingly good and natural entertainment, but the time must surely come when the public will wake up to the possibilities of the science and then, perhaps, we will have some technical progress in the direction of quality of reproduction.

**Quality Should Come First**

As much money should be devoted to quality as is now spent on increasing selectivity and sensitivity to make reproduction from a local station really worth listening to, for the cheap set sounds very bad on a good transmission. The consequence of selling large numbers of sets giving distorted reproduction is to drive still more firmly into the public mind the idea that the sounds produced are the kind of sounds that radio is expected to produce. Were this truly the case, there would be every justification for the B.B.C. to spoil the quality of its transmissions to an extent where it would be equal to that of the average commercial set; if such did happen it would be found that the final results were so bad that the radio industry would die out. In case anyone takes exception to this statement, I would like to point out that I did not meet with a single radio-gramophone at the show which was capable of getting the best out of a good gramophone record;

## Thoughts on Olympia

By a Critic of Quality

In the Following Article a Wireless Engineer Gives His Personal Impressions of the Show

**I** SET out to examine the exhibits at the Radio Show from a viewpoint differing from that of the official *Wireless World* reporters, because I am not so concerned with giving a complete description of the various manufacturers' achievements as in indicating what I think are desirable or undesirable trends of development.

I am one of those who have always held very strong views on the necessity of preserving the true function of radio apparatus, namely, to give in the homes of subscribers to the broadcasting service a true and faithful reproduction of what that service offers. This being so it is natural that I should examine the show to see what progress has been made in this direction.

Most manufacturers are of the opinion that the largest amount of money is to be made by selling the largest possible number of sets. Past experience shows this opinion to be a sound one, but, as the largest sales are made by the cheapest articles, it follows that cheapness calls for the sacrifice of excellence, so that we have a state of affairs in which the receiver most suited to the needs of the listener is generally much too expensive for him. The portable set craze of a few years ago was the start of the trouble. At that time sets were not very good no matter what the price paid, but some mis-inspired genius conceived the idea of making still worse sets, but appealed to the public to appreciate the convenience of

portable radio. Tens of thousands of these sets were sold, and I am convinced that 99.9 per cent. of them were never shifted out of the room in which they were first placed; we have the result that performance was spoiled to secure a property that the public did not require or appreciate, and, at the same time, the public taste was so spoiled that a demand for good sets has not yet made itself evident. It is notorious that



**WIRELESS AND THE POLICE.** Few police organisations dare forgo the benefits of radio. Here is a scene in the radio receiving room at police headquarters, Rio de Janeiro, which has just been equipped with a Marconi installation.

**Thoughts on Olympia -**

to do this calls for an exceedingly good amplifier and loud speaker which will do useful work up to far more than 6,000 cycles, although it is a commonplace that records cut off below this figure: I mention the point to show a close connection between the comparative merits of a record going through a good L.F. apparatus, and a good B.B.C. transmission going through a poorly designed set. Present reproduction is obtained in spite of receivers and not owing to their inherent "excellence" of design. With one or two solitary pioneers excepted, we would be in a bad way indeed were it not for a responsible technical press.

**The Superhet Stampede.**

The superheterodyne principle of reception seems to have become the master rather than the servant of the manufacturer. It can fairly safely be assumed that this journal was responsible for the return of the superhet. to favour, but it does not follow that *The Wireless World* recommended that every manufacturer (with one or two notable exceptions) should go "super mad." This type of receiver is very suitable for the home constructor owing to the ease with which it can be made to work satisfactorily; on the other hand, for equal selectivity and sensitivity, the straight multi-stage set is a very troublesome beast for the amateur. It would seem to be equally troublesome to the professional, who has little excuse, with all his facilities, for rushing to the superheterodyne principle where the straight set, properly designed, would meet the case better.

It should be borne in mind that the manufacturer can and does purchase ready-made ganged coils and condensers for superhets., and almost any schoolboy could finish the design of the set. It takes real brains, however, to design a really good straight receiver, for the usual canned or iron cored coils are not by any means good enough, and possess certain disadvantages which preclude their use in a satisfactory design; the consequence is that the technician has to design "from the ground up," and that, I fancy, is a task beyond the capabilities of many in the industry.

I was interested to find several firms who were making a speciality of building a "limited number of high grade receivers for the connoisseur." In one or two cases there was evidence of real thought and research behind the receivers shown, but a word of warning might not be out of place to those manufacturers contemplating entering this field. In every ten or so listeners there is one man who wants something better than he can find in the ordinary way, and that man is going to choose his special set on performance and nothing else. The inclusion of a conventional set in an elaborate cabinet, and a multiplicity of valves does not make a "high grade set for the connoisseur" although the showy outside may appeal to the bloated plutocrat; most of the real searchers after something good whom I have met have usually been somewhat hard up, so everything should be devoted to the one purpose of giving superlative performance; one manufacturer told me he started with an "exquisite cabinet" and fitted the set in afterwards; the idea is, at any rate, original, but has little else to commend it.

Moving-coil speakers continue to get smaller and cheaper, and some people may say that putting this type of speaker

within the reach of everybody is progress, but I must confess that I do not see how it can be. The function of a loud speaker is to translate into sound what is put into it electrically, and I did not find any manufacturer showing on his stand how this was done with less distortion than heretofore. If the midget set idea is responsible, then the midget set is a menace to the future of broadcasting.

The real novelty merchants this year were the valve makers, and some very interesting and amusing things can be done with the new types now available. The wholesale adoption of A.V.C. has, in most cases, only been made possible by the work done in valve laboratories, so we will give credit here in the proper place. In the space at my disposal I cannot say much about valves, but a point that is not sufficiently realised about Class B amplification is that it is only really useful on substantially constant modulation; the power provided is truly astonishing considering the size of the valves, but it should be remembered that this power is only undistorted when the output stage is going "all out" with the circuit arrangements usually given: most Class B output stages require positive bias. The constantly varying modulation of transmissions carrying music means that, for most of the time, the power stage is under-run and a particularly unpleasant form of distortion is set up which can be very irritating to sensitive ears. Do not, therefore, design your new A.C. set and expect to get from two 5-watt what you would obtain from two 25-watt valves.

Components generally showed a great improvement, both in the elimination of unworthy designs and in the introduction of new features of great use to the home constructor. It can safely be said that component manufacturers are giving better value for money, but it is disappointing to find that the perfect volume control has not yet been invented.

I think the time has come to abolish the scheme of piping through fifth-rate gramophone



**CAR RADIO: MILITARY VERSION.** A typical scene during the recent manoeuvres in Hampshire, showing a wireless car in action.

phone records for the edification of the public through the medium of speakers on exhibitors' stands. This proves nothing to anyone beyond the fact that the B.B.C. is up against enormous difficulties in turning out presentable noises. I would imagine that actual demonstration on the stands would give the public an opportunity of hearing for themselves the difference between the various sets offered; if exhibitors were rigidly tied down to receiving and reproducing only, say, the Regional programme, at not more than 5 watts output, we would soon be able to separate the grain from the chaff. Were such an obviously sensible arrangement put into force, I can well imagine the howls of protest that would go up from the less capable manufacturers, but it would be a good thing for technique, and that is all that concerns me.

A bright show, a pretty show and, in all probability, a selling show, but rather a disappointment for the student of quality reception. I think I will leave it at that.

**The Radio Industry**

AMONG the latest productions of the Eveready Co. are two special H.T. batteries for sets including Class "B" amplification. Type No. W.1210 is rated at 135 volts plus 18 volts for grid bias purposes, and tappings are arranged in accordance with suggestions recently put forward in *The Wireless World*.

It is understood that Scotland Yard and other police authorities are already using, in their wirelessly equipped vehicles, a new type of Champion sparking plug, in which the necessary interference-suppressing apparatus is built into the body of the plug, and connected in series with the central electrode. Various

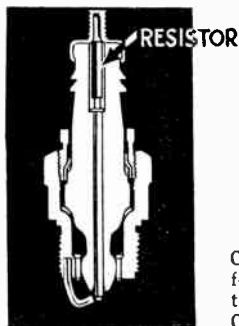

Complete with interference suppressor: section through the new Champion sparking plug.

types of plug, to suit different engines, are available with this special feature.

Valves for the current season are fully described in the latest edition of the Mullard Valve Guide for 1933-4. This 88-page booklet

is full of technical information, and, apart from data relating purely to valves, a number of circuit diagrams are given, together with advice on the best operating conditions for the latest types. Copies are available for readers.

Tungram have just introduced an equivalent of the American R.C.A. Type 88, full-wave mercury-vapour rectifier. It is rated for an A.C. input of 500 volts to each anode, and for a continuous D.C. output of 125 mA.

Changes of address: the Leeds branch of Siemens Electric Lamps and Supplies, Ltd., is shortly to be moved from 129, Park Lane, to 54, Wellington Street, Leeds, 1. The new telephone number will be Leeds 27395.

The Automatic Radio Gramophone Co., Ltd., notify us that their new address is: Crown Street Hall, Brighton.

Spare parts for "Standard" wet H.T. batteries, which are no longer to be obtained from the original manufacturers, are now being produced by the Wet H.T. Battery Co., of 26, Lisle Street, London, W.C.2.

Mr. T. W. Small, inventor of the well-known "Capchart" record changer, is now in London, staying at the Carlton Hotel. He would welcome a visit from British manufacturers who might be interested in the production of his new fully automatic record changer, operating without the use of gears, chains or sprockets.





September 1st to September 9th

IN last week's issue, the third of our special Olympia Show numbers, we dealt in some detail with the exhibits of interest on the stands of every manufacturer. Now the Show moves on to Glasgow, and to-day, September 1st, the Scottish Radio Exhibition opens at

Kelvin Hall, closing on September 9th. Nearly all the standholders at the Kelvin Hall were also exhibitors at Olympia, so that our Olympia stand-to-stand report of last week may also be taken as a guide to the Scottish Exhibition, a plan of which is included on this page.

Full List of Exhibitors

Local addresses of firms are given in some instances

EXHIBITOR.	STAND.	EXHIBITOR.	STAND.	EXHIBITOR.	STAND.	EXHIBITOR.	STAND.
Amalgamated Press, Ltd. ... Fleetway House, Farringdon St., London, E.C.4.	26	Columbia Graphophone Co., Ltd. ... 98, Clerkenwell Rd., London, E.C.1.	33A	Hustler, Simpson & Webb, Ltd. ... 317, Hoe St., Walthamstow, London, E.17.	12	Radio Gramophone Development Co., Ltd. ... 18-20, Frederick St., Birmingham.	13
Balcombe, Ltd., A.J. ... 52-58, Tabernacle St., London, E.C.2.	29	Cossor, Ltd., A.C. ... 21, Waterloo St., Glasgow.	31	Hutchison, E. W. ... 196, Crow Rd., Jordanhill, Glasgow, W.2.	58	Radio Instruments, Ltd. ... 121, West Campbell St., Glasgow.	63
Ballantine, Robert ... 103-1, St. Vincent St., Glasgow, C.2.	65	Cuthbertson & Co., Ltd. ... 11, West Nile St., Glasgow, C.1.	66	Igranie Electric Co., Ltd. ... 50, Wellington St., Glasgow.	23	Robertson, James ... 95, West Nile St., Glasgow, C.1.	22
Belling & Lee, Ltd. ... Cambridge Arterial Rd., Enfield, Middlesex.	56	Denholm, J. Stuart ... 32, Kilmarnock Rd., Glasgow.	49	Hiffe & Sons Ltd. ... Dorset House, Stamford St., London, S.E.1.	52	Ross & Adam, ... 68, Gordon St., Glasgow.	73
Bernard Jones Publications, Ltd. ... 58, Fetter Lane, London, E.C.4.	62	Dulcetto-Polyphon, Ltd. ... 2-3, New man St., London, W.1.	7	Honia, Ltd. ... 58, City Rd., London, E.C.1.	30	Scottish Radio Retailers' Association, ... 156, St. Vincent St., Glasgow, C.2.	59
Biggar, Ltd., Alexander ... 102, Sauchiehall St., Glasgow, C.2.	18	Econasign Co., Ltd. ... 92, Victoria St., London, S.W.1.	2	Johnson Talking Machine Co., Ltd. ... 96, Clerkenwell Rd., London, E.C.1.	51	Siemens Electric Lamps & Supplies, Ltd. ... 25, Cadogan St., Glasgow.	11
Black, Ltd., Michael ... 80, Blythswood St., Glasgow, C.2.	28	Edinburgh Rubber Co. ... 182, Rose St., Edinburgh.	8	McMichael Radio, Ltd. ... Wexham Rd., Slough, Bucks.	27	Thompson, Diamond & Butcher, ... 34, Farringdon Rd., London, E.C.1.	55
Blackadder, William ... 101, Union St., Glasgow, C.1.	60	Edison Swan Electric Co., Ltd. ... 153, West George St., Glasgow, C.2.	37	Maehel & Sons, Thomas ... 45, Gt. Western Rd., Glasgow.	48	Thomson & Brown Bros., Ltd. ... 65, Mitchell St., Glasgow.	53
Block Batteries, Ltd. ... Abbey Rd., Barking, Essex.	67	Epoch Radio Mfg. Co., Ltd. ... Exmouth House, Exmouth St., London, E.C.1.	61	Mareoniphone Co., Ltd. ... 10, West Campbell St., Glasgow.	35	Turner, James ... 2310-2311, Dumbarton Road, Yoker, Glasgow.	20
Britannia Batteries, Ltd. ... 233, Shaftesbury Ave., London, W.C.2.	69	Ever Ready Co. (G.B.), Ltd. ... Hercules Place, Holloway, London, N.7.	30	Muir & Bryden, ... Dumbreck Rd., Glasgow, S.1.	57	Ultra Electric, Ltd. ... Erskine Rd., London, N.W.3.	42
British Blue Spot, Ltd. ... 37-39, Clyde Place, Glasgow.	4	Ewing & McIntosh, ... 125-7, Sauchiehall St., Glasgow, C.2.	1	Mullard Wireless Service Co., Ltd. ... 56, Bothwell St., Glasgow.	36	Varley (Oliver Pell Control, Ltd.) ... 11, Bothwell St., Glasgow.	25
British Broadcasting Corporation ... Broadcaster House, London, W.1.	71	Ensign, Ltd. ... 70-78, York St., Glasgow	47	Murdoch, McKillop & Co., Ltd. ... 101, Hope St., Glasgow, C.2.	21	Westinghouse Brake & Saxby Signal Co., Ltd. ... 82, York Rd., King's Cross, London, N.1.	6
British Rola Co., Ltd. ... Minerva Rd., Park Royal, London, N.W.10.	19	Ferranti, Ltd. ... Hollinwood, Lancashire.	38	Newnes, Ltd., George ... 8-11, Southampton St., London, W.C.2.	17	Whiteford & Co., James, ... 5, Oswald St., Glasgow, C.1.	9
"Broadcaster" ... Long Acre, London, W.C.2.	51	Forbes Bros., Ltd. ... 50, Sauchiehall St., Glasgow, C.2.	71	North British Machine Co., Ltd. ... 209, Clyde St., Glasgow, C.1.	16	Whiteley Electrical Radio Co., Ltd. ... Victoria St., Mansfield, Notts.	70
Brown & Co. (Simplex), Ltd. ... 116, West Nile St., Glasgow, C.1.	21	General Electric Co., Ltd. ... Magnet House, 71, Waterloo St., Glasgow.	31	Partridge, Wilson & Co. ... 200, St. Vincent St., Glasgow, C.2.	14	Wireless & Gramophone Trader, ... Dorset House, Stamford St., London, S.E.1.	3
Bulgin & Co., Ltd., A. F. ... Abbey Rd., Barking, Essex.	72	Gramophone Co., Ltd. ... 98, Clerkenwell Rd., London, E.C.1.	33	Paterson, Sons & Co., Ltd. ... 111-152, Buchanan St., Glasgow.	46	Wireless World ... 5, Oswald St., Glasgow, C.1.	52
Clarke & Co. (M'o), Ltd., H. ... 21, Oswald St., Glasgow.	41	Harper & Co., William ... 93, Holm St., Glasgow.	40	Philips Lamps, Ltd. ... 6 S, Cadogan St., Glasgow.	43	Woolfson, Ltd., Philip ... 165, Tringate, Glasgow.	50
Cohen, S. W. ... 7-15, King St., Glasgow, C.1.	15	Hellesens, Ltd. ... Morden Rd., S. Wimbledon, London, S.W.19.	45	Portadyne Radio, Ltd. ... Portadyne Works, Gorst Rd., London, N.W.10.	61	Wylie, Hill & Co., Ltd., R. ... 29, Buchanan St., Glasgow.	5
Cole, Ltd., E. K. ... Ekco Works, Southend-on-Sea, Essex.	32	Hunter, James R. ... 42, West Nile St., Glasgow, C.1.	10	Pye Radio, Ltd. ... Africa House, Kingsway, London, W.C.2.	41	Young's (Glasgow), Ltd. ... 40, Stockwell St., Glasgow, C.1.	63

# Broadcast Brevities

By Our Special Correspondent

## A New "Music Hall" ?

I AM able to reveal that the B.B.C. is conducting negotiations for acquiring an old skating rink in Maida Vale and transforming it into a dazzling "Music Hall." Here, in a vast and lofty building covering an area of 58,000 square feet, the Corporation will run a restaurant, green rooms for artistes, and several minor studios in addition to the large hall from which vaudeville and variety will be broadcast free from the restrictions attaching to Broadcasting House.

## Secret Negotiations

Up to the moment of writing the utmost secrecy has been observed in connection with these arrangements, although it has long been apparent to informed onlookers that the B.B.C. was straining at the leash in regard to studio accommodation. The B.B.C. tenure of "No. 10," the famous wharf studio, is exceedingly precarious as the L.C.C. has the power to take over the building at very short notice, and may exercise its prerogative; yet the wharf is the B.B.C.'s only real large studio, apart from the Concert Hall at Broadcasting House, which is admittedly too small to accommodate the National Orchestra.

## Space for 250 Singers

At Maida Vale it should be possible to rehearse the entire orchestra of 117 players as well as the National Chorus of 250 voices.

Until recently the hall was used as offices for the Ministry of Health.

## The Big Three

THIS morning at 10 o'clock Colonel Dawnay enters upon his duties as Director of the B.B.C.'s Output Department. Structural alterations have already been effected at Broadcasting House to enable the new Director to keep in close touch with the Director-General and the Controller.

## Sir John Reith for America

The party is likely to be broken up for a little while in the near future when Sir John Reith responds to the invitation of Mr. Aylesworth, President of the National Broadcasting Company of America, to attend the opening of "Radio City," the great new centre of entertainment between Fifth and Sixth Avenues, New York.

## Strange . . .

Sir John will probably be included among the speakers, and as the ceremony will be broadcast and relayed across the Atlantic, British listeners will have one of those rare opportunities of hearing the "D.G." on the ether. Strange that Sir John should cross the Atlantic to speak to his own flock, but this is a strange world, as the boxer said when he "came to" in the television studio.

## The Boxing Match

Which reminds me that the boxing match in Studio Bb last week made a good showing on the television screen although the figures were rather small.



WHERE IS IT? The mystery building in West London which, according to our Special Correspondent, the B.B.C. hopes to transform into a "Music Hall" for vaudeville shows as well as choral and orchestral concerts.

## Problem for Television Talkers

I learnt one thing on that occasion, namely, that the television talker requires a technique rather different from that of the ordinary broadcast speaker closeted in a talks studio. There is nothing more irritating than a close-up of an immovable face continuing for ten minutes!

How our profound but undemonstrative speakers will get over the difficulty I know not, but I am convinced that plastic features and sparkling eyes are a necessity.

## Electric Piano Broadcast

IT was delightful to hear the Neo-Bechstein piano broadcast on Saturday last, and gratifying to reflect that the innovation was the outcome of a suggestion first made in these columns.

The instrument gives most puzzling effects. Sometimes one detects the authentic pianoforte tone but more often the impression is of an orchestral combination with organ background.

## Bedtime Stories

FOR a long time there has been a bathroom in Broadcasting House. Now there is a bedroom, which has been placed at the disposal of Empire announcers for use between their spells of night duty.

I understand, however, that the occupants will not make their announcements from the bedside, although several of the tribe at Broadcasting House would be quite capable of announcing in their sleep. In fact, they often do.

## Mr. Stanley Baldwin

TWELVE talks under the general title, "National Character," will be broadcast during the autumn. On September 25th, Mr. Stanley Baldwin, M.P., will introduce the series in a twenty-minutes' broadcast on the National wavelength.

The subject is one very much after Mr. Baldwin's heart; for the series will attempt to describe the salient features of the British character both in its strength and weakness. An interesting aspect of the series will be the introduction of a foreigner at the microphone, to tell listeners about various aspects of our national character as they appear to him.

## Hitler Relay Declined by B.B.C.

THE publication in a B.B.C. journal of sympathetic remarks concerning the German broadcasting chiefs who have been sent to the Oranienberg Internment Camp, brought an unexpected offer from the Reich Rundfunk Gesellschaft of a special relay from the Camp.

Apparently the intention was that British listeners should have an opportunity of hearing a first-hand account of the happy and orderly conditions obtaining in the Camp. The item was offered to the B.B.C. for Tuesday evening, August 22nd, but the B.B.C. declined the honour. It is significant that the relay, which would have been broadcast throughout Germany at the same time, was cancelled.

## They Dreamt They Dwelt . . .

IT is scurvy treatment for the B.B.C. Publications Department to be harried from pillar to post, seeing that it is from the activities of this branch that the Corporation derives a goodly percentage of its income.

## . . . in Marble Halls

Nevertheless, it is the Publications who have had to move into that old chateau, No. 10, Portland Place, which in the last week or two has been transformed into a modern office. It was the Publications Department which was farmed out in Southampton Street, Strand, in the old Savoy Hill days, so it is natural, I suppose, that they should be the first to leave the crowded pleasure dome in Portland Place.

## Cause and Effect

A FRIEND of mine was not surprised to read last week of the decision to transfer "Nine Days' Wonder" from Olympia to the Palladium. He was attending the revue, and was actually seated near to Mr. George Black, of the General Theatres Corporation. Half-way through the show, when the audience was rocking with laughter, a loud voice was heard to say, "My word! This would make George Black sweat if he heard it!"

A few minutes later George Black was hurrying towards the stage door to interview Mr. Maschwitz, and the sequel was made public next morning.

# Correspondence

The Editor does not hold himself responsible for the opinions of his correspondents.

Correspondence should be addressed to the Editor, "The Wireless World," Dorset House, Stamford Street, S.E.1, and must be accompanied by the writer's name and address.

## Valves or Stages

WITH reference to the suggested new designation for receiving sets given in your issue for August 4th, we should like to express the opinion that the suggested idea of describing a set by its stages is likely to lead not only to a very great deal of confusion but also to open up the path for misrepresentation.

As an indication of the confusion that is likely to arise, it would appear to us that, working to the suggested definition given in your leader, the Ferranti "Gloria" Console, described on pages 78 and 79 of the same issue, is actually a seven-stage receiver and not a six-stage as described by you, seeing that in the second detector there are three anode-to-cathode electron streams.

When the Ferranti Company first placed its receivers on the market, it described its three-valve mains receiver plus a rectifier as a three-valve set, and, as the result of considerable experience, it was found that this led to endless confusion, bearing in mind that the people who buy sets in general know next to nothing about them.

Further, the standard practice in the case of American receivers, was to include the rectifier as a valve, and such competition has had to be met in a suitable way.

We have always made it very clear in our specification as to the purpose of each individual valve, but we think that it is utterly absurd for manufacturers to be placed in the position of having to tell the man in the street that certain of the valves in their receivers are valves, whilst the rectifying valve, which is probably more correctly a valve than any of the others, is not a valve.

It appears probable that to describe a set by the number of its valves or by the number of its stages is likely to be very misleading in any case, and does not, in these days, necessarily give any indication of the performance of the receiver, so for this reason Ferranti, Ltd., have this year gone still farther than any of the foregoing proposals, and do not in any of their descriptions call their sets by the number of valves that they contain, although this may be found from the technical data included in the literature concerning the sets in question.

FERRANTI, LTD.

J. BAGGS, Sales Department Publicity.

## The Correct Application of A.V.C.

MAY I be permitted to express some views on the application of A.V.C. to receivers in this country in view of the recent correspondence on this subject?

Firstly, I am entirely in agreement with Mr. Redfern that A.V.C. is undoubtedly desirable in the serious listener's receiver, but only when that receiver has been designed as a whole to incorporate A.V.C. and to overcome its associated disadvantages (such as those enumerated in Mr. Haynes' letter). Apart from the valuable correction of fading, an inexperienced person can leave the volume control set and tune in station after station without getting on the nerves of other people present by

making a series of blasts and over-loading the output valve. Perhaps I had better use the word "almost," because automatic volume control, *i.e.*, automatic levelling up of the volume delivered by the loud-speaker on all stations, will never be possible unless broadcasting stations come to some agreement as to the minimum and maximum modulation limits desirable. At present the difference in modulation levels is only too evident when operating an A.V.C. receiver with a milliammeter in the anode circuit of one of the controlled valves. Actually, the function which we loosely call "A.V.C." is concerned only with the carrier amplitude and not the modulation depth, so that two stations whose field strengths are equal at the aerial may produce average volume levels at the loud speaker in the ratio of about 2 to 1. This is annoying, but cannot be helped. However, the manual volume control is a convenient compensator.

The strongest criticism against A.V.C. is the apparent loss of selectivity. When tuning from one to another of two adjacent stations with a good A.V.C. receiver the

side bands are so enormously amplified by the A.V.C. action that there is no silent gap between the two stations. Because of this effect, A.V.C. is entirely unsuitable for inclusion in simple sets with few or flatly tuned circuits where the resonance curve of the tuned circuit does not fall away very steeply at the sides. Although this reduction of selectivity is stated to be apparent only, nevertheless the selectivity of the receiver as a whole is definitely reduced if it cannot, with A.V.C., receive as many stations free of interference as it can without.

The criticisms on the score of background mush have been adequately dealt with by Mr. Redfern, but it does not appear to be generally realised that, apart from quiet A.V.C., which is a luxury only likely to be found in highly priced instruments, it is quite a simple matter to suppress this interference as well as all other between-station noises.

If the receiver be fitted with a device giving visual indication when the set is in resonance with the wanted station, why then we can short out all the undesirable noises between stations with a silencing switch and tune in our station quietly and accurately, the switch being opened only when the station has been correctly tuned in; so that instead of the quality varying from a high-pitched cacophony gradually down to the natural tone, the natural tone is there immediately the station is heard. This meets most of the criticisms fired at A.V.C., and works delightfully in practice, particularly when signals can be faintly heard in the "silent" position, so that the operator can tell whether the programme is desirable before inflicting it on other listeners.

As regards atmospheric interference it is difficult to be certain whether or not A.V.C. is beneficial, and one must not make wild claims. It has been found possible, during the recent thundery conditions in London to receive the London Regional on an A.V.C. set with a 100-foot aerial with scarcely any interference, although distant stations were unintelligible through mush and crashes. This is due to the receiver being rendered so insensitive by the strong carrier of the local station that no appreciable amplification is given to the static picked up by the aerial.

There seems to be no justification in practice for contrasting the two systems of simple and delayed A.V.C., for when the former is correctly applied the "throttling effect" is quite negligible on a weak signal. It has been found possible to make a six-valve A.C. superhet. with loose H.F. and I.F. couplings for selectivity and a diode-tetrode for A.V.C. with no delay action, which has an absolute sensitivity of 2.5 microvolts over the tuning range, *i.e.*, to produce the standard output of 50 milliwatts. This is considerably better than some receivers using the same number of stages and delayed A.V.C.

Per pro ELDECO RADIO, LTD.;

R. C. RICKARD.

London, W.1.

## ON WHAT AUTHORITY?

HERE is a reproduction of a notice to consumers typical of many issued by electricity supply authorities. They probably believe themselves that they are justified in insisting that wireless sets should be connected to the lighting circuit; otherwise

### MEXBOROUGH URBAN DISTRICT COUNCIL.

#### ELECTRICITY DEPARTMENT

### NOTICE.

Consumers are reminded that Wireless Sets must not be used on a Heating circuit, and the employees of this Department have instructions to disconnect any apparatus which contravenes the regulations in this way.

J. B. FELTHAM, M. Inst.E.E.  
Engineer and Manager.

they would surely not have the audacity to issue such notices.

We believe that the lighting rate can only be exacted where electricity is used for purposes of illumination, and we have already offered space in our correspondence columns to any supply authority which cares to argue the point.

# READERS' PROBLEMS

THESE columns are reserved for the publication of matter of general interest arising out of problems submitted by our readers. Readers requiring an individual reply to their technical questions by post are referred to "The Wireless World" Information Bureau, of which brief particulars, with the fee charged, are to be found at the foot of this page.

## I.F. Transformer Tuning

WHILE operating his superheterodyne receiver (modelled on the original Monodial), a correspondent has noticed that signal strength is appreciably increased by removing the screening cover of one of the I.F. transformers; he asks us to say what may be deduced from this experience.

It would appear probable that the transformer in question is tuned to too high a frequency. The effect of removing the cover is to increase the inductance of the coils and so to lower the resonant frequency. It is quite possible that, by this alteration, the out-of-tune circuit is accidentally brought into line with the others.

## A Process of Elimination

THE circuit adopted by a reader for his four-valve battery set might have been chosen for no other purpose than to illustrate the principles of fault finding by a process of elimination! Similarly, the fault that exists provides a particularly good example of how a logical line of reasoning may be applied.

In Fig. 1 is reproduced in skeleton form the part of the receiver in question. The fault takes the form of an almost continuous rustling or "frying" noise, evident while the set is being operated as a radio receiver, but entirely absent on switching the pick-up into circuit. Removal of the H.F. valve does not lessen the noise, although, of course, it prevents the reception of signals.

As the pick-up is connected to the grid circuit of the first L.F. amplifier, it can be assumed quite definitely that from this point onwards no fault can exist, and, further, that the batteries, etc., which are common to all valves, are in order. Again, the fact

"frying" noise is often due to the leakage of high-tension current through a path of fairly high, but changing, resistance.

## Anti-Interference Aerials

SEVERAL questions have lately been received from sufferers from man-made static on the question of fitting screened aerial down-leads as a palliative. Articles which appeared in the issue of August 18th will have already provided the answer to most of these questions, but there are one or two other points that might be cleared up.

A screened aerial down-lead can do nothing to reduce interference of the type that affects all parts of the aerial more or less equally. For instance, strong radiation from an overhead tramway line will be found almost always to come within this category. The same applies to overhead power wires, which will probably affect the horizontal part of the aerial just as much as the down-lead.

Little benefit is likely to accrue from fitting a shielded down-lead unless a good part of the aerial can be erected well clear of the source of interference.

Before going to the trouble of altering the aerial, it is a good plan to try the effect of fitting a simple filter in the supply leads of a mains-operated set. A large proportion of the interference may be reaching the receiver in this way.

## From the L.F. Point of View

THERE is nothing basically wrong with tuned anode H.F. coupling, but nevertheless it has rather gone out of fashion during the last year or two. Probably the most serious objection that can be urged against this system is that it allows L.F. impulses to be fed back directly to the

circuit of the H.F. valve, a suitable decoupling system. The values of the decoupling components must be effective both at H.F. and L.F.; the usual 1,000 ohms and 0.1 mfd. is almost useless.

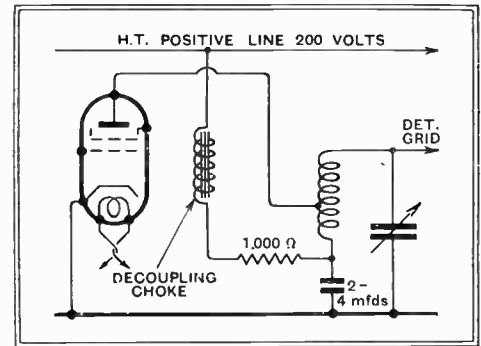

Fig. 2.—Reducing voltage loss: decoupling for a tuned-anode H.F. stage.

A reader who has constructed an H.F.-det.-2 L.F. set with a tuned anode H.F. coupling finds that motor-boating can only be prevented by inserting such a large value of decoupling resistance that the sensitivity of the H.F. stage is seriously impaired.

In asking our advice, he says nothing about the capacity of the associated bypass condenser; if he has not tried a large capacity (from 2 to 4 mfd.) we recommend him to do so. If this course fails, we suggest the use of a high-inductance choke as a decoupling device in the manner shown in Fig. 2; this should give good L.F. decoupling without undue loss of H.T. voltage.

As there is a faint possibility that this choke may be ineffective as an H.F. decoupling device, the existing 1,000-ohm resistance might be left in circuit, as indicated in the diagram.

## As You Were

THE practice of fitting "noise suppressors" in sets with A.V.C. seems to have given rise to a misconception as to the "background noisiness" of sets with this form of control.

For instance, a correspondent, who is undecided as to whether to fit automatic volume control, appears to think that this addition to his set will result in a noisier

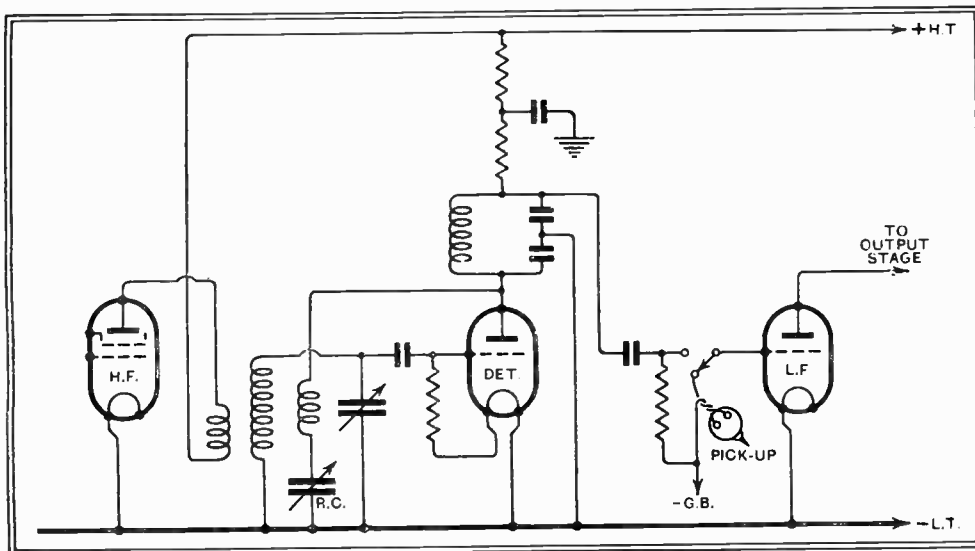

Fig. 1.—A simplified circuit diagram to illustrate the tracing of faults by a process of elimination.

that removal of the H.F. valve makes no difference indicates that the fault cannot lie in this valve or in the circuits preceding it.

All that remains, therefore, is the detector valve, and here, or in the associated circuits, the defect is certain to be found. A

detector grid from the source of H.T. supply, and thus L.F. oscillation or motor-boating may be provoked.

Short of employing some other form of H.F. coupling, the only way to prevent this kind of feed-back is to employ, in the anode

## The Wireless World INFORMATION BUREAU

THE service is intended primarily for readers meeting with difficulties in the construction, adjustment, operation, or maintenance of wireless receivers described in *The Wireless World*, or those of commercial design which from time to time are reviewed in the pages of *The Wireless World*. Every endeavour will be made to deal with queries on all wireless matters, provided that they are of such a nature that they can be dealt with satisfactorily in a letter.

Communications should be addressed to *The Wireless World* Information Bureau, Dorset House, Stamford Street, London, S.E.1, and must be accompanied by a remittance of 5s. to cover the cost of the service. The enquirer's name and address should be written in block letters at the top of all communications.



back-ground than previously, and that a suppressor will be virtually necessary.

This is a mistake. Automatic volume control does nothing whatever to increase background noises, but it does rather tend to make these noises more evident. This is because the set, when tuned to a powerful carrier wave is automatically desensitised, and if the ratio of signal-to-noise is favourable the background will appear to be quiet.

Noise suppression in A.V.C. sets is a luxury and a desirable refinement, but it is by no means a necessity.

### Building the New Monodial

IT is perhaps as well to point out that, in assembling the new Monodial Super, it is necessary that the ganged tuning condenser should be raised above the baseboard by interposing the distance pieces (or spacing tubes) supplied with the condenser. Otherwise the height of the spindle will be found unsuitable for the special dial which was used in the original model.

### NEW MAINS-OPERATED AUDIO-FREQUENCY OSCILLATOR

DESIGNED especially for laboratory use, the new A.C. mains-operated audio-frequency oscillator introduced by Standard Telephones and Cables, Ltd., Connaught House, Aldwych, London, W.C.2,

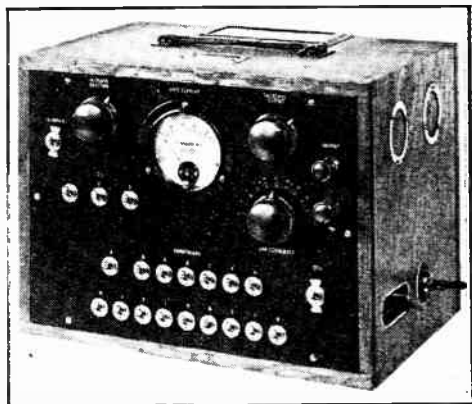

Mains-operated audio-frequency oscillator, a Standard Telephones product.

covers a range of 20 to 10,000 c/s in a number of graduated steps. The circuit consists of three valves, an oscillator, an amplifier, and a mains rectifier for H.T. supply, and provision is made for checking the frequency on controlled 50 c/s supply mains.

The output has a very small harmonic content, hum level is low, and the frequency stability is within  $\pm 0.2$  per cent. throughout.

The construction follows conventional wireless practice, for all components are mounted on a stout metal chassis and housed in a strong oak cabinet fitted with a carrying handle, the price is £42.

A thermo-ammeter set and an attenuator are available; the former costs £12 10s. complete, while the price of the latter is £15.

This instrument will serve for test and measurements on L.F. amplifying equipment, L.F. components, as well as for inductance and capacity bridge work.

# LABORATORY TESTS

## A Review of Manufacturers' New Products

### GRAHAM FARISH LIGHTNING GARD

AT this season there is always the possibility that an outdoor aerial may be struck by lightning. Admittedly the risk

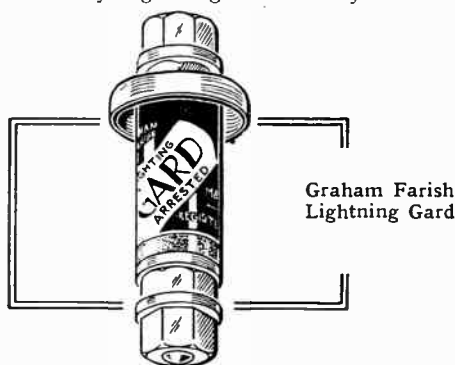

is small, but as adequate safety devices are now obtainable at small cost it is hardly worth while exposing the receiver to this danger, for far more serious consequences than a damaged set may result.

The Graham Farish Lightning Gard has been designed to afford protection in such cases, and it consists of an insulated barrel into each end of which is screwed a brass stud. These are separated by a thin annular washer. The device must, of course, be located outside the building so that a direct path to earth is available.

The aerial down lead and the lead to the aerial terminal of the set join to the top terminal on the Gard, while the lower terminal is joined direct to an earth connection. The earth wire from the set can be taken either to the same earthing point or to any other that may be convenient inside the building.

The device in no way affects reception, but in the event of the aerial being struck by lightning the charge ionises the small spark gap and passes direct to earth.

The price is 1s. 6d., and the makers are Graham Farish, Ltd., Masons Hill, Bromley, Kent.

### PREH SEVEN-PIN VALVE HOLDER

A SEVEN-PIN valve holder for chassis mounting, and suitable for use with Class "B" output valves, has been introduced by the Preh Manufacturing Co., Ltd., 13-15, Broadwater Road, Welwyn Garden City, Herts. The sockets are made from phosphor-bronze strip, bent and shaped to form a resilient contact for the pins. These are assembled on a moulded bakelite base.

Several different makes of Class "B" valves were inserted in the holder, and in

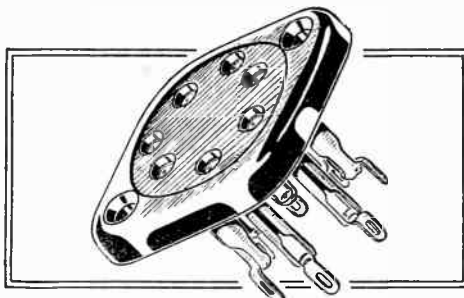

Preh seven-pin valve holder suitable for Class "B" output valves.

every case a perfectly satisfactory contact was made between the valve pins and their respective sockets. Although rigidly fixed to the base plate, the sockets possess sufficient resilience to ensure correct alignment in all cases, for the valve slides into its socket quite smoothly and without undue pressure.

Soldering tags, which are part of the socket, are provided, and the price is 1s.

### DISTANT RECEPTION NOTES

MONTE CENERI has definitely closed down for alterations and will not be at work again until towards the end of September. Kalundborg, therefore, remains clear, and is providing very fine reception at present.

I had thought that the transmission interfering with Huizen on 1,875 metres was Kaunas, but I have now identified it as a Russian station. Interference has been very severe on some recent days.

Last year Mexico, Cuba, the Argentine and a number of other countries in South America brought high-powered transmitters into operation. The range of many of these stations was so great that they were very well heard in this country. A great deal of interference was caused with U.S.A. transmissions and it was decided to call a Pan-American Conference to try to straighten matters out.

That conference is sitting at the present time, and high hopes are entertained that its deliberations will be successful. It is all to the advantage of long-distance listeners in this country that they should, for last winter one not infrequently found Argentine stations jamming those in the U.S.A. and vice versa.

Now that the evenings are drawing in numbers of medium-wave stations are to be received at any time after about 7 p.m., and by eight o'clock even with a smallish set one has as big a selection of alternative programmes as could be desired.

Motala continues to come through well on the long waves. Other good stations between 1,000 and 2,000 metres are Huizen (Hilversum programmes), Radio-Paris, Warsaw and Kalundborg.

Between 200 and 550 metres Prague, the Poste-Parisien, Langenberg, Breslau, Heilsberg, Toulouse, Rome, Strasbourg, Bero-münster, Stockholm, Leipzig and Vienna are nearly always to be found coming in well when required. Stations now returning to form are Brno, Belgrade, Berlin Witzleben, Katowice, Bordeaux, Genoa, Bratislava, Moravska-Ostrava, Hörby, Frankfurt and Gleiwitz. D. EXER.

**Theory of Thermionic Vacuum Tubes**, by E. Leon Chaffee, Ph.D. Written primarily as a textbook based on the author's lectures at Harvard University, it comprises a very complete book of reference on matters relating to low-power valves. The author states that a second volume dealing with power amplifiers, rectifiers, etc., is in preparation. Pp. 652 + xxiii., with 362 diagrams and 6 plates. Published by McGraw Hill Publishing Co., Ltd., New York and London. Price 36s.

# Three TELSEN I.F. TRANSFORMER COILS *are specified for the* 'NEW MONODIAL SUPER'

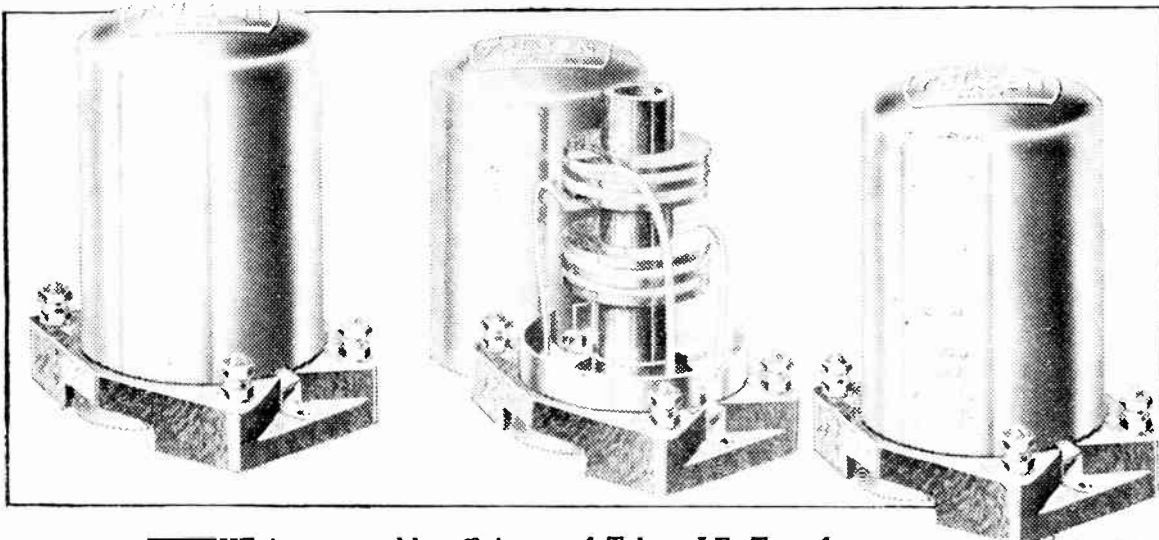

**T**HE incomparable efficiency of Telsens I.F. Transformer Coils makes them the first choice for every superhet. Each Coil consists of two tuned circuits, comprising a band-pass intermediate frequency filter tuned to 110 k.c. by two pre-set balancing condensers fitted in the base. These condensers can be adjusted for different values of stray capacities, by means of the small milled wheels projecting from the sides of the base, the filter coupling also being adjustable for optimum conditions of quality and selectivity. The designer of the famous NEW MONODIAL SUPER acknowledged the pre-eminence of these outstanding coils by specifying them in his set. Follow his lead. Insist on Telsens I.F. Transformer Coils whether you build the NEW MONODIAL SUPER or any other good superhet. Price per coil

**7/6**

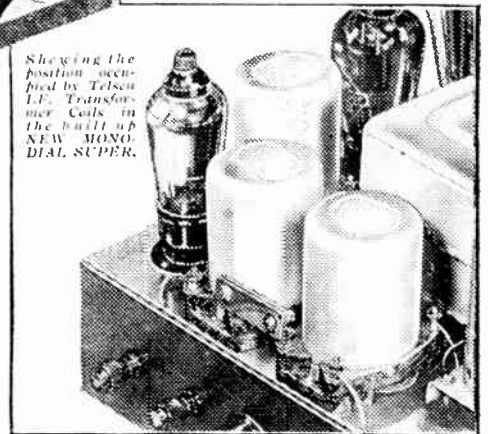

Showing the position occupied by Telsens I.F. Transformer Coils in the built-up NEW MONODIAL SUPER.

**TELSEN NOW COVER EVERY COIL REQUIREMENT — AT LOWEST PRICES !**

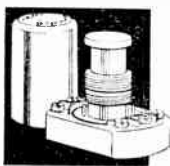

**TELSEN IRON-CORED SCREENED COILS**  
Single - 8/6  
Twin Matched - 17/-  
Triple Matched 25/6



**TELSEN SUPERHET COILS**  
(Type No. S 330) 21/6

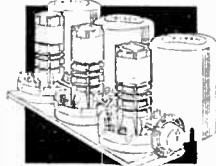

**TELSEN BAND-PASS & OSCILLATOR COIL UNIT**  
21/6

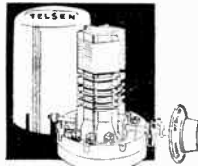

**TELSEN SCREENED TUNING COILS**  
Single - 7/-  
Twin Matched 14/6  
Triple Matched 21/6

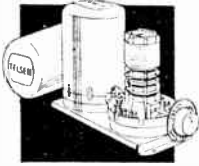

**TELSEN BAND-PASS COIL UNIT**  
14/6

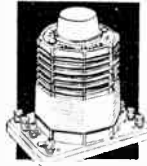

**TELSEN DUAL-RANGE AERIAL COIL**  
5/6



**TELSEN H.F. TRANSFORMER COIL**  
4/6

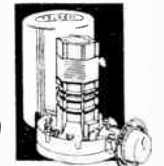

**TELSEN OSCILLATOR COIL**  
7/6

## **TELSEN FOR EVERYTHING IN RADIO**

ANNOUNCEMENT OF THE TELSEN ELECTRIC CO., LTD., ASTON, BIRMINGHAM

*Advertisements for "The Wireless World" are only accepted from firms we believe to be thoroughly reliable.*

# MISCELLANEOUS ADVERTISEMENTS

## NOTICES.

**THE CHARGE FOR ADVERTISEMENTS** in these columns is

12 words or less, 3/- and 3d. for every additional word.

Each paragraph is charged separately and name and address must be counted.

**SERIES DISCOUNTS** are allowed to Trade Advertisers as follows on orders for consecutive insertions, provided a contract is placed in advance, and in the absence of fresh instructions the entire "copy" is repeated from the previous issue: 13 consecutive insertions 5%; 28 consecutive, 10%; 52 consecutive, 15%.

**ADVERTISEMENTS** for these columns are accepted up to **FIRST POST ON MONDAY MORNING** (previous to date of issue) at the Head Offices of "The Wireless World," Dorset House, Stamford Street, London, S.E.1, or on **SATURDAY MORNING** at the Branch Offices, 19, Hertford Street, Coventry; Guildhall Buildings, Navigation Street, Birmingham, 2; 280, Deansgate, Manchester, 3; 26n, Renfield Street, Glasgow, C.2.

Advertisements that arrive too late for a particular issue will automatically be inserted in the following issue unless accompanied by instructions to the contrary. All advertisements in this section must be strictly prepaid.

The proprietors retain the right to refuse or withdraw advertisements at their discretion.

Postal Orders and Cheques sent in payment for advertisements should be made payable to **ILIFFE & SONS Ltd., and crossed & Co. Notes** being untraceable if lost in transit should not be sent as remittances.

All letters relating to advertisements should quote the number which is printed at the end of each advertisement and the date of the issue in which it appeared.

The proprietors are not responsible for clerical or printers' errors, although every care is taken to avoid mistakes.

## NUMBERED ADDRESSES.

For the convenience of private advertisers, letters may be addressed to numbers at "The Wireless World" Office. When this is desired, the sum of 6d. to defray the cost of registration and to cover postage on replies must be added to the advertisement charge, which must include the words Box 000, c/o "The Wireless World." All replies should be addressed to the Box number shown in the advertisement, c/o "The Wireless World," Dorset House, Stamford Street, London, S.E.1. Readers who reply to Box No. advertisements are warned against sending remittances through the post except in registered envelopes: in all such cases the use of the Deposit System is recommended, and the envelope should be clearly marked "Deposit Department."

## DEPOSIT SYSTEM.

Readers who hesitate to send money to advertisers in these columns may deal in perfect safety by availing themselves of our Deposit System. If the money be deposited with "The Wireless World," both parties are advised of its receipt.

The time allowed for decision is three days, counting from receipt of goods, after which period, if buyer decides not to retain goods, they must be returned to sender. If a sale is effected, buyer instructs us to remit amount to seller, but if not, seller instructs us to return amount to depositor. Carriage is paid by the buyer, but in the event of no sale, and subject to there being no different arrangement between buyer and seller, each pays carriage one way. The seller takes the risk of loss or damage in transit, for which we take no responsibility. For all transactions up to £10, a deposit fee of 1/- is charged; on transactions over £10 and under £50, the fee is 2/6; over £50, 5/-. All deposit matters are dealt with at Dorset House, Stamford Street, London, S.E.1, and cheques and money orders should be made payable to Iliffe & Sons Limited.

**SPECIAL NOTE.**—Readers who reply to advertisements and receive no answer to their enquiries are requested to regard the silence as an indication that the goods advertised have already been disposed of. Advertisers often receive so many enquiries that it is quite impossible to reply to each one by post. When sending remittances direct to an advertiser, stamp for return should also be included for use in the event of the application proving unsuccessful.

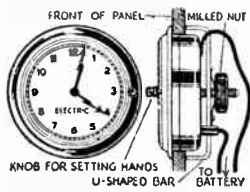

**FIT THIS ELECTRIC CLOCK TO YOUR SET!**  
NO MAINS NEEDED!  
KEEPS CORRECT TIME!  
NO WINDING!

Works off small battery lasting 12 months, or can be plugged into G.B. Battery without affecting reception. Uses practically no current. Fits into hole 3 1/2" dia. in any panel up to 1/2" thick. Easy to fix—no screws required. Only 1/4" from front of panel to back of case. Swiss movement. Handset from front. Nickel plated bezel. Useful addition to any set.

**RIVERSIDE MFG. CO. LTD.**  
Dept. 20, Crisp Rd., Hammersmith, W.6  
Telephone: Riverside 0392.



COMPLETE WITH BATTERY  
POSTAGE 6D

## Now the Show is over . . . .

and reflection is the order of the day, there is no doubt that the "W.W."

## NEW MONODIAL

will be the choice of the radio connoisseur.

**I**N response to many queries last month, we are again offering our Monodial constructional and servicing facilities to readers in all parts of Great Britain. Consult us NOW! You will benefit by our condensed experience gained in building and servicing sets for "W.W." readers during the last 7 years.

Our Workshops test apparatus has been considerably augmented and we are ready to build for you a de-luxe NEW MONODIAL and if necessary to fit it in a period cabinet, and to supply and instal all necessary associated components. If desired, any apparatus can be supplied for a first deposit of 12 1/2% with the balance over 1 year.

*This extract from a letter entirely unsolicited regarding the original Monodial, is illuminating.*

"I should like to place on record my appreciation of the excellent job you have made of the Monodial Superhet set which I recently ordered from you. Results have been most pleasing and I am highly satisfied with the whole outfit . . . . I shall have great pleasure in recommending your Firm to any of my friends . . . ."



# SCOTT SESSIONS & CO.,

Radio Engineers and Consultants,  
MUSWELL HILL, LONDON, N.10

Cables: "Tropist, London."  
Contractors to H.M. Government Depts., &c.

## RECEIVERS FOR SALE.

**ARMSTRONG** Late 4 Universal A.C. D.C. 4-valve Chassis, specially efficient S.G. circuit, pentode output: 75/-; with 5 valves, 114/-.

**ARMSTRONG** 1934 Battery 3 Chassis, metal construction, 2 tuned circuits, S.G., pentode output, built-in speaker, 45/- with valves 69/-; above chassis have remarkable performance, 2 years' guarantee, approval—Armstrong Co., 100, King's Rd., N.W.1. [3395]

**H.M.V.** 532 10-valve Superhet. Radiogram, A.C., new test £84/-; first cheque for £30 securities.—A.E.L., 198, South Park Rd., Wimbledon, S.W.19. [3347]

**3-STAGE** Amplifier, D060 output, valves, twin "Unit" motors, pick-ups, speakers, A.C. motor, M.L. converter, 6v. 5a. and 650v. 0.1a., cut-out, etc.; fit 4 215 securities.—Riley, 70, Broadway, Chelsea. [3372]

**40/-**—Eliwan D.C. all electric, S.G., det. and pentode, without valves, with motor to break up; transformers, output choke, 2,000v., with drum drives, coils, smoothing unit, resistances and condensers, etc.

**£3/19/6**—Mavis Radio 2-valve, A.C., with Ultra speaker, complete with valves, unopened; list £9/10.—Kay, 167 City Rd., London, E.C.1. [3352]

**DEMOM RADIO PRODUCTS.**—Monodials built, converted, repaired, or fitted; official Wireless League repairers; fully equipped laboratory; estimates free; trade supplied. White House, Rosehill Park West, Sutton, Surrey. Tel.: 4591. [3389]

"**WIRELESS WORLD**" New Monodial, built and supplied as kits; your old Monodial converted, including components and valves, £11; trade supplied.—London Radio Development Services, Ltd., 56, Hazel Rd., Kensal Rise, N.W.10. Phone: Willesden 0385. [2987]

**CIFEL** D.C. 2-valve Sets, detector, pentode, Magnavox M.C., Osram valves, packed in makers' unopened cartons at £3 19/6, c.o.d., carriage paid; also Mavox D.C. 2-valve, detector, power, Sonohorde M.C., £3 12/6. W. Burns and Co., 287, City Rd., London, E.C.1. [3374]

**1933** Gambrell Halford A.C. 7-8 Superhet Chassis, complete valves, speaker, 4 1/2 watts, undistorted output, new March, under makers' guarantee until February, 1934, must sacrifice, moved D.C. district; £15, or offer, cost £25/10.—45, Ellington Rd., Cranleigh Gardens, Muswell Hill, N.10. [3355]

**NOTICE** for Special Bargains.—T. W. Thompson and Co., of 17, Stratton Ground, Westminster, have just purchased a large consignment of H.M.V. and other components, including mains amplifiers, Marconi transformers, chokes, rotary converters, speakers, condensers, and thousands of other parts, all of which will be advertised in a display advertisement in next week's "Wireless World." Do not buy until you have perused this advertisement; tremendous bargains will be offered. [3377]

## MAINS EQUIPMENT

**N.P.** Chargers for A.C. mains. Trade list free.

**N.P.** Have most efficient chargers from 62 6, complete ready for use.

**N.P.** Have one or two chargers slightly soiled at bargain prices. List.

**N.P.** Have Motor-Dynamo 16 amps. complete, £6; Valve set 6 amps, £4; another 40 volts, 2 circuits, 3 amps., and 4 amps. bargain; £8.—Nash Products, Ltd., Steebford, Birmingham, 9. [3371]

## Mains Equipment.—Contd.

**VORTEXION**, Wimbledon, for 99.9% reliable transformers.

**IF You Haven't Tried Them Yet Ask Someone** who has, or call and inspect complimentary letters.

**ALL Standard Models** Delivery by Return; all secondaries centre tapped.

**GUARANTEED** 12 Months, and within 5% normal and 2 1/2% super models, neat shrouding with detachable feet, as used by Government Departments, etc., etc.

**VORTEXION**, New monodial transformer, 200-250, 50 cycles, 425-0-425, 120 m.a., 4v. C.T., 3a., 4v. C.T., 1a., 4v. C.T., 1a., 4v. C.T., 6a., screen primary, open type, 20/-; shrouded, 22/-; super shrouded, 26/-; 10 henry choke, 5/6; 20 henry choke, 8/6.

**VORTEXION**, Ferrisart III, 350-0-350, 60 m.a., 4v. 2.5, C.T., 4v. 3.5, C.T.; open type 15/6, shrouded 16/-; post 9/-.

**VORTEXION**, 250-0-250, 4v. 1 to 2a., 4v. 2 to 4a.; open type 10/6, shrouded 12/6; post 9/-.

**VORTEXION**, Super model for H.T.8 or 9 or 10, 4v. 1 to 2, 4v. 2 to 4; open type 14/6, shrouded 16/6; post 1/-.

**VORTEXION**, 2 1/2-watt Monodial A.V.C. model; open type 14/6, shrouded 16/6; post 1/-.

**VORTEXION**, 5 watt Monodial A.V.C. model, 400-0-400, 120 m.a., 4v. 6a., 4v. 3 1/2a., 4v. 2, 4v. 1a., super screened; 2C/-, shrouded 24/-.

**VORTEXION**, 350-0-350, 120 m.a., 4v. 2 to 5a., 4v. 2 to 4a., 4v. 2.5a.; open type 14/6, shrouded 16/6.

**VORTEXION**, 400 or 450 or 500v., 120 m.a., 4v. 2 to 5, 4v. 2 to 5, 4v. 2 to 5; open type 19/-, shrouded 23/-.

**VORTEXION**,—400 or 450 or 500, 150 m.a., 4v. 4a., 4v. 2.5, 4v. 2, 4v. 2, 4v. 2, core size 2 1/2 in. x 1 1/2 in., a super job, 2% regulation; 35/- shrouded with terminals, less terminals, 30/-; open type 26/-; post 1/3.

**VORTEXION** Auto Transformers to B.E.S.A. Specification, 100, 110, or 120v. to 200, 220 or 240 volts, 60 watts, 7/3, post 9/-; 120 watts, shrouded 12/6, open type 10/6, post 1/-; 240 watts, open 14/6, shrouded 16/6, post 1/-; 500 watts 30/-, 2,000 watts £4 10.

**VORTEXION** 600-watt Transformers; £4 10, carriage free.

**VORTEXION** 30h. at 60 m.a. Chokes, 5/6; 40h. at 60 m.a., 8/6; 30h. at 150 m.a., 200 ohms, 10/6 open type, 12/6 shrouded.

**VORTEXION** 200v. 30 m.a. Eliminators, 110 or 220 input with 4v. 4a. winding; 37/6.

**VORTEXION**, Transformers made to your specification. All standards in stock. Phone all hours.

**VORTEXION** (S. A. Brown), 182, The Broadway, Wimbledon, Tel.: Libert, 2814. [3117]

**M-L** Rotary Transformer (H.F.A.), D.C. to A.C., 85 watts output.—335, Green Lanes, Harringay. [3346]

**TANTALUM** for A.C. Chargers, H.T. and L.T.—Blagwell's Metallurgical Works, Ltd., Garston, Liverpool [2139]

**POWERITE** Mains Transformers, a real engineer's job with 3 years' guarantee; competitive prices; lists free; trade enquiries invited. Nasco Wireless Products, Pitville works, Tower Rd., Aston, Birmingham. [3306]

Mention of "The Wireless World," when writing to advertisers, will ensure prompt attention.

**Mains Equipment.—Contd.**

**SERADEX** Radio Products, as specified by the "Wireless World" and other wireless journals.

**SERADEX** Battery Chargers, new illustrated catalogue of battery chargers, rectifiers, eliminators, etc., now ready; free for stamp.

**SERADEX** Mains Transformers, as specified for "Glasgow Herald," "Kelvin A.C. Three," super type, with engraved terminal strips, heavy aluminium clamps, screened primaries, 200-250 volts.

**SERADEX** V.T.1, 250.0-250v. 60m.a., 2.0-2v. 1a., 2.0-2v. 3.4 amp.; 17/6.

**SERADEX** V.T.7 Special Model for Monodial Superhet, as specified, with primary terminals, and secondary leads, colour coded; £1/17/6.

**SERADEX** W.H.3, for use with Westinghouse H.T.8 or H.T.9, 240v. 200m.a., tapped at 200v., 2.0-2v. 2ga., and 2.0-2v. 2.4a.; 21/.

**SERADEX** Filter Chokes, new improved models, low D.C. resistance, and capacity, high inductance and carrying capacity.

**SERADEX** 4030 Choke, 40h., 20h., carry 30m.a., resistance 850 ohms; 4/6.

**SERADEX** C.30 Heavy Duty Constant Inductance Choke, 30h., at 120 m.a., resistance 280 ohms; 15/.

**SERADEX** C.504 Super-power Constant Inductance Choke, 50h., at 200 m.a., 100 ohms resistance; £1/11/6.

**SERADEX** Heavy Duty Resistors, type G.1500, 15 watts, up to 1,500 ohms. 2 3; 5,000 ohms 2 6; 50,000 ohms, 2/9; type G.3000, 30 watts, 9d. advance on above prices; intermediate sizes at no extra cost.

**I.D.** Brings Full Range of Catalogues From Makers.—Note new address after September 4th.

**TREVOR PEPPER**, 575d, Moseley Rd., Birmingham, 12. Phone: Calthorpe 1618. Telegrams: Seradex, Birmingham. [3375]

**HOYNE'S** Transformers and Chokes the Best Obtainable, perfect insulation, regulation and reliability, used exclusively by discriminating set manufacturers, all fitted with tapped and screened primaries, filaments all centre tapped, stout cast aluminium clamps fitted to all models, also clearly marked terminal strips.

**HOYNE'S** Components are Guaranteed for One Year.

**HOYNE'S** Transformers Built to Your Specifications, at very competitive prices.

**HOYNE'S** New Monodial Super Model, 425.0-425v. 120 m.a., 4v. 3a., 4v. 1a., 4v. 1a., 4v. 6a., 17/6, post 1/3; super model, 24/., post 1/3; chokes for same, 10h., 20h., 16/6 the pair, post 1/3.

**HOYNE'S**—250.0-250v. 60 m.a., 4v. 1.2a., 4v. 2.4a.; 10/., post 9d.

**HOYNE'S**—250.0-250v. 60 m.a., 4v. 1.2a., 4v. 2.4a.; 4v. 1a.; 12/6, post 1/3.

**HOYNE'S**—350.0-350v. 60-70 m.a., 4v. 2.3a., 4v. 3.4a., 12/6, post 1/3, Ferrocart III model.

**HOYNE'S**—350.0-350v. 70-60 m.a., 4v. 2.3a., 4v. 3.4a., 4v. 1.2a.; 13/6, post 1/3.

**HOYNE'S**—350.0-350v. 120 m.a., 4v. 2.3a., 4v. 4 Ca., 4v. 1.2a.; 16/., post 1/3.

**HOYNE'S**—500.0-500v. 140 m.a., 4v. 2.4a., 4v. 4.6a., 4v. 2a., 4v. 2a.; 27/6, carriage 1/6; weight 12lb.

**HOYNE'S**—0.110-135v. 90 m.a., 4v. 2.4a., suitable for H.T.6 or 7; 10/., post 9d.

**HOYNE'S**—200v. 200 m.a., 4v. 2.4a., 4v. 1.2a., suitable for H.T.8; 13/6, post 1/3.

**HOYNE'S**—0.200-240v. 200 m.a., 4v. 2.4a., 4v. 1.2a., suitable for H.T.8 or 9; 14/6, post 1/3.

**HOYNE'S**—Line transformers and chokes always in stock; we can also supply all components.

**M. J. HOYNE**, Offices and Works, 8a, Gladstone Rd., Wimbledon, S.W.19. Tel.: Liberty 3303. [3107]

**NOTICE** for Special Bargains.—T. W. Thompson and Co., of 17, Stratton Ground, Westminster, have just purchased a large consignment of H.M.V. and other components, including mains amplifiers, Marconi transformers, chokes, rotary converters, speakers, condensers, and thousands of other parts, all of which will be advertised in a display advertisement in next week's "Wireless World." Do not buy until you have perused this advertisement; tremendous bargains will be offered. [3378]

**CABINETS.**

**RADIOGRAM** Cabinets; fully illustrated list free; remarkable values.—Gilbert, Cabinet Maker, Swindon. [1686]

**DYNAMOS, ETC.**

**M.L.** Converter, 12-18 volts to 400 volts, 150 m.a., perfect order; £3, or offer.—Gayford, Little Waltham, Chelmsford. [3350]

**ROTARY** Converters, E.D.C. Co.'s manufacture, as new, D.C. to A.C., with output of 220 watts.—Apply Electricity Works, Newquay, Cornwall. [3335]

**ROTARY** Converters, 220 volts D.C. to 200 volts A.C., capacities up to 0.44 K.V.A., cheap.—Milo Engineering Works, Milo Rd., East Dulwich, S.E.22. Sydenham 4422. [3225]

**NOTICE** for Special Bargains.—T. W. Thompson and Co., of 17, Stratton Ground, Westminster, have just purchased a large consignment of H.M.V. and other components, including mains amplifiers, Marconi transformers, chokes, rotary converters, speakers, condensers, and thousands of other parts, all of which will be advertised in a display advertisement in next week's "Wireless World." Do not buy until you have perused this advertisement; tremendous bargains will be offered. [3380]

**GRAMOPHONES, PICK-UPS, ETC.**

**B.T.H.** Cinema Type Pick-ups, brand new, 17/6, carriage paid, cash with order, or c.o.d. Send for list.—Ward, 12, Tredegar Rd., Bow, E.3. Tel.: Advance 3668. [3363]

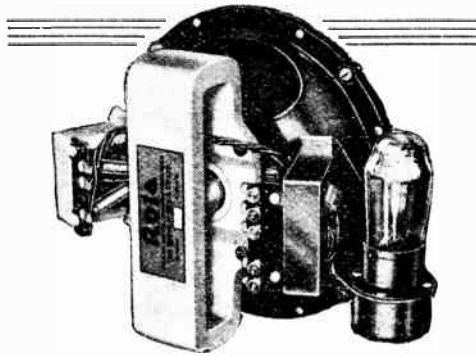

**ROLA CLASS B SPEAKER AMPLIFIER Unit**

**Are You a Battery Set Owner?**

**If so . . .**

You can fit a Rola Class B Speaker Amplifier Unit in 5 seconds and increase the volume and sensitivity about 5 times. Write to-day for full particulars and for the Rola folder.

**Model A—** for MULLARD P.M.2B, B.T.H. PD220, COSSOR 220B, STANDARD 13BI, HIVAC B220, MARCONIPHONE B21, G.E.C. B21, CLARION B22.

**Model B—** for COSSOR 240, FERRANTI HP2, CLARION B24.

**PRICE**

(Both Models Without Valve)

**57/-**  
Price with Valve 71/-



**THE BRITISH ROLA CO. LTD.,**

Minerva Rd., Park Royal, N.W.10.  
Phone: Willesden 1322-54-5.

**ROLA SPEAKERS**  
for better Radio Reception

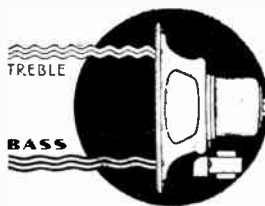

**LOUD-SPEAKERS.**

**B.T.H.** RK Moving Coil Speakers, guaranteed new, unused, manufacturers' surplus, original price.

**6** Guineas, highly sensitive and wonderful tone response, will handle up to 10 watts output, available for 6v., 100v., 200v. D.C., 30/., also A.C. models.

**£2 10/;** carriage paid, c.o.d., or cash with order; the best value in speakers obtainable today.—O. H. Seckamp, First Avenue House, High Holborn, London, W.C.1, 4th floor; office No. 582a. Phone No.: Holborn 6609. [1425]

**4** Bakers F.P. A.C. moving coil speakers, as new, half price.—Box 7933, c/o The Wireless World. [3393]

**10/-**—Lamphugh Silver Ghost, 2,200 ohms, with output transformer, unopened; list 47/6; c.o.d., carriage paid. Kay, 167, City Rd., London, E.C.1. [3351]

**30/-**—B.T.H., R.K. moving coil speakers, 6in. cone, new and unused, guaranteed; these speakers are the type used in cinema sound equipment; suitable for public address work; weight 30lb., and are vastly superior to the cheap speakers now on the market, 100 volts, 150 volts, and 200 volts D.C.

**27/6**—6-volt D.C. speakers, as above; £2 7/6 speaker as above for 100-250 volts A.C., complete with field rectifier.

**THESE** speakers are identical to Senior R.K., but for cone diameter. [3362]

**NOTICE** for Special Bargains.—T. W. Thompson and Co., of 17, Stratton Ground, Westminster, have just purchased a large consignment of H.M.V. and other components, including mains amplifiers, Marconi transformers, chokes, rotary converters, speakers, condensers, and thousands of other parts, all of which will be advertised in a display advertisement in next week's "Wireless World." Do not buy until you have perused this advertisement; tremendous bargains will be offered. [3379]

**CHAL** ELECTRIC offer Brand new boxed set manufacturers' surplus Rola Speakers, all fitted hum buckers, state if Power or Pentode Transformer F6 110-175v. D.C. (2,000 ohms); 90-130v. D.C. (2,500 ohms); 150-200v. D.C. (4,700 ohms); 200-250 D.C. (6,500 ohms) listed at 35/., at 18/-; F7 voltages as above list, 47/6, at 25/- each; permanent magnets F6P.M. listed at 49/6, at 28/-; F7P.M. listed £3 at 33/-; Ultra 951P.M., a real hefty job with Power-Pentode transformer listed £4/15, at 47/6; Rola Dual Compensated (2) F6 list £3/10, at £2; (1) F8 and (1) F7 list £4/5, at 47/-—All goods Carriage Paid, Cash with Order, or C.O.D.—Chal Electric, 6, Conduit St., London, W.1. [3221]

**TRANSMITTERS.**

**QUARTZ** Oscillating Lenses; 2/6.—Smith, Bryn Rolyn, Colwyn Bay. [3358]

**VALVES.**

**HIGH** Efficiency American Tubes, all types; 7/6-10/6.—26, Moss Grove, Urston. [3360]

**GUARANTEED** Brand New, and any valve differing from the makers' characteristics will be exchanged free; all latest types.

**H.** L.210s, 11210s, L.210s, 210H.L.S., 210H.F.S., P.M.1H.F.S., P.M.2S., P.M.2AS., L.P.2S., 220P.S., 215P.S., D.H.S., 41M.H.S., M.H.4S., A.C./H.L.S., A.C./2H.L.S., 354V.S., D.C./3H.L.S., 162S., M.L.4S., A.C./P.S., 164V.S., 104V.S., P.M. 24S., 442B.U.S., 1807S., 84V.B.S., 84V.S., M.S.4B.S., M.S.G. H.A.S., A.C./S.G.S., A.C./S2, 41M.S.G.S., D.S.B.S., 215 S.G.S., P.M.12S., P.M.12AS., Pen.4VS., V.M.S.4S., M.M.4Vs., P.T.41s, P.T.41Bs, D.P.T.S., A.C. Pens., 620TS, 680Ps.

**ALL** the Above Valves at Full List Prices; prompt delivery; send for list.

**NEWMAN**, 303, Roman Rd., E.3. [2892]

**ALL** Types of Brand New American Valves in Stock, first class makes: 247S, 235S, 224S, 236S, 237S, 233S, 245S, 244S, 12/., 227S, 226S, 280S, 245S, 9/6; 242S, 232S, 11/.; U.X.210S, 15/.; U.X.250S, 7 watts output, 16/.; 238S 14/6; post paid, cash with order or c.o.d. Send for valve list.—Ward, 12, Tredegar Rd., Bow, E.3. Tel.: Advance 3668. [3364]

**COMPONENTS, ETC., FOR SALE.**

**R.** SELECTED Parts for Sale, as new; any c.o.d. or "Wireless World" deposit system, which we recommend if in doubt as to the splendid value offered; we take risk of damage in transit to our customers; goods tested for callers and guaranteed.

**AMPLION** Public Address Microphone, £3; Ready Radio Senior Instant matching transformers, new, 10.25-1, 15/9; G.L.C. Senior induction motor, 47/6; set Colven battery Super Five coils, 10/.; set Colven single dial super battery coils, 15/-; Mullard H.T. eliminator, complete, 150v. 30m.a., 240v. input, 30/-; Six-Sixty eliminator, 200v. 25m.a., and G.B., 32/6; Ekco A.C.25, 47/6; Atlas A.C.244, 39/6.

**PAIR** Varley Q.P.P. Input and Output, 19/.; Wearie and Lewcos super het. coils, 5/-; 3-range oscillators, 7/6; 8-way bases, 4/6; K.B. universal gramophone motor, auto stop, 16in. tuntable, 30/-; new T.C.C. 2,000ml. electrolytic, 9/-; T.C.C. ditto, 250ml. 100v., 8/6; Novotone J., 30/-; Grahe L.F. choke coupling units, 3/9; Lotus new 4-gangs, 15/9.

**RYALL'S** Mains Condensers, 4mf., 250v. working, 2/6; 4mf., 500v. working, 4/6; 4mf., 750v. 6/6; 2,000v., 17/6; Ryalls condenser blocks, 2.4mf., 2.2mf., 500v. working, 8/6; Dubilier 2x2, 500v. working, 2/6.

**RYALL'S** Mains Transformers, 250v. 60 m.a., 4v. 1 amp, 4v. 3 amp., 10/6; 350v., 12/9; H.T.7, with 4v. 4 amp., 10/6; 4v. 3 amp. only, 6/9; chokes, 25/9, at 60m.a., resistance 260 ohms., 6/9; 20h., at 100m.a., 8/9; 10h., 8/9, for Monodial; 40h., at 100m.a., 10/6.

**RYALL'S** RADIO Offer Reliable Resistances, 1 watt, suitable for all "Wireless World" sets where a 1 watt resistance is specified, in values 100, 500, 1,000, 2,000, 5,000, 6,000, 10,000, 25,000, 30,000, 75,000, 150,000, 250,000, 20,000, all values stated in ohms, 6d. each, guaranteed one year, wire ends, new goods.

**WE** Hold a Large Stock of First Class Radio Apparatus, meters, resistances, condensers, heavy chokes, and all set requirements, at bargain prices, all modern goods.

**RYALL'S** RADIO, 33, Chancery Lane, London, W.C.2 (nearest Tube Chancery Lane; Bus 67 passes door, or tram to Savoy St.), Holborn 3529. Open Saturday afternoon. Close 7 p.m., Thursdays 1 o'clock, Saturday 6 p.m.

**R** [3354]



**ALL LOUDSPEAKERS  
ARE CLAIMED TO BE  
PERFECT EXCEPT THE  
HARTLEY TURNER**

But still our customers tell us that our imperfect speaker sounds more realistic than any of the others. Curious!

D.C. Model **7 Gns.**  
A.C. Model **8 Gns.**

**DEMONSTRATIONS DAILY AT OUR OWN  
ROOMS, AND AT**

**LONDON RADIO SUPPLY CO.,  
11 OAT LANE, NOBLE STREET, E.C.2,**

who can supply on  
Hire Purchase Terms

If you cannot call write for our 32-page technical booklet "NEW NOTES IN RADIO," sent for a 1½d stamp.

**HARTLEY TURNER RADIO LTD.,  
THORNBURY ROAD,  
ISLEWORTH, MIDDLESEX.  
Tel: Hounslow 1854**

**CHALLIS  
TRANSFORMERS  
CONSTRUCTORS  
AND SET MAKERS**  
send your enquiries  
to us for all  
**MAINS  
TRANSFORMERS**  
**NEON SIGNS**

**NEON TRANSFORMERS  
RADIO TRANSFORMERS**  
our Speciality.

Quotation on application.

**CHALLIS  
TRANSFORMERS Ltd.  
RUGBY.**

**Components, etc., for Sale.—Contd.**

**P**REMIER Summer Sale.  
**T**HE Last Week.  
**10%** Discount on All Orders of £1 and Over.  
**M**ANY Prices Reduced Apart from Discount.

**P**REMIER SUPPLY STORES Offer the following Set Manufacturers' Surplus New Goods at a fraction of the Original Cost, all goods guaranteed perfect, carriage paid over 5/-, under 5/- postage 6d. extra (Ireland, carriage forward).

**E**LIMINATOR Kits, including transformer, choke, Westinghouse metal rectifier, T.C.C. condensers, resistances and diagram, 120v. 20 m.a., 20/-; trickle charger 8/- extra; 150v. 30 milliamps, with 4v. 2.4 amps. C.T., L.T. 25/-; trickle charger 6/6 extra; 250v. 60 milliamps, with 4v. 3.5 amps. C.T., L.T. 30/-; 200v. 100 milliamps, with 4v. 3.5 amps. C.T., L.T. 49/6; 300v. 60 milliamps, with 4v. 3.5 amps. C.T., L.T. 37/6.

**E**LLIOTT First Grade Moving Coil Meter— in the Following Ranges:—0-10, 0-30, 0-50, 0-100, 0-150 milliamps., also 250v. flush type, 17/6, projecting 15/.

**R**OLA Moving Coil Speakers, complete with humbuck-coils and output transformer, please state whether power or pentode required; P6 2,000 or 6,500 ohm, listed 35/-, at 17/6; F7, 2,000 or 6,500 ohm, listed 47/6, at 23/6; A.C. conversion kit for any of above, 10/-.

**S**PECIAL Offer.—Reisz type microphone with transformer, a really professional job, listed at £12; our price 52/6.

**H**EAVY Duty Variable Resistances, wound on porcelain, 2,000 ohms 1.4 amp., 5,000 ohms 1.2 amp., 120 ohms 1 amp., all the above values, 3/6 each.

**T**.C.C. Condensers 750v. working, 2 mf. 3/6, 4 mf. 6/-, 4 mf. 400v. working 4/-, 250v. working 1 mf. 1/-, 2 mf. 1/9, 4 mf. 2/6, 1,500v. working Standoff insulators 5 mf. 1/6, 2 mf. 6/-, aqueous electrolytic 440v. working, 4 mf. 3/-, 8 mf. 3/6.

**D**UBILIER Condensers.—.01 mica 6d., .01 mica 1,000v. working 1/-.

**A**LL the Following Lines 6d. each or 5/- per dozen; 4 and 5 pin chassis mounting valve holders; shielded screen grid or pentode leads 1-watt wire end resistances, any value; T.C.C. condensers; hum dingers; on-off switches push-pull, polar gauging devices.

**F**ERRANTI Condenser Blocks 300v. working 4 4 2-2, all separate, 5/-.

**P**OLAR 3-gang 0.0005 Condensers, split coil valves, totally screened, disc drive; 6/11.

**A**MSCO Triple-gang 0.0005 Condensers, with trimmers, 4/11.

**O**RMOND 0.0005 Condensers, 1, 3; 2-gang semi shielded, 2/6.

**W**ESTERN ELECTRIC Main-Transformers, input 200-250 volt, output 500-0.500 volt, at 150 milliamps., 4v. 4a., 4v. 2.5a., 4v. 2a., 4v. 1a., 4v. 1a., massive job; 19/6.

**T**.C.C. Electrolytic Condensers, 10 mf., 100 volts working, 1/-; 15 mf. 1/3.

**S**PECIAL Offer of Mains Transformers manufactured by Philips, input 100-115v. or 200-250v., output 180-0.180 volts, 40 m.a. 4v. 1a., and 4v. 3a., 4/6; 200-0.200v., 4v. 1a., 4v. 3a., 4/6.

**A**LL Premier Guaranteed Mains Transformers have engraved terminal strips with terminal connections, input 20-250 volts, 40-100 cycles, all windings paper interleaved.

**P**REMIER H.T.8 Transformer, 250v. 60 m.a., rectified, with 4v. 3.5a. c.t. L.T., and screened primary, 15/-; with Westinghouse rectifier, 25/-.

**P**REMIER H.T.9 Transformer, 300v. 60 m.a., rectified, with 4v. 3.5a. c.t. L.T., and screened primary, 15/-; with Westinghouse rectifier, 26/-.

**P**REMIER H.T.10 Transformer, 200v. 100 m.a., rectified, with 4v. 3.5a. c.t. L.T., and screened primary, 15/-; with Westinghouse rectifier, 26/-.

**P**REMIER Mains Transformer, output 135v. 80 m.a., for voltage doubling, 8/6; 4v. 2.3a. c.t. L.T. 2/- extra; Westinghouse rectifier for above, giving 180v. 30 m.a., 8/6.

**P**REMIER Mains Transformers, output 250-0-250 volts, 60 m.a., 4v. 1.2a., 4v. 2.3a. 4v. 3.4a. (all c.t.), with screened primary; 15/-.

**P**REMIER Mains Transformers, output 350-0-350 volts, 90 m.a., 4v. 3.5a., 4v. 2.3a. (both c.t.), with screened primary; 15/-.

**P**REMIER Mains Transformers, output 400-0-400 volts, 100 m.a., 4v. 4.5a., 4v. 2.3a., 4v. 2.3a., with screened primary; 15/-.

**P**REMIER Auto Transformers, 100-110 200-250 volts or vice versa, 60-watt, 7/8; 100 watt, 10/-.

**S**PECIAL Offer of Manufacturers' Type Transformers, any input, output 250-0-250 volts, 60 m.a., 4v. 1a., 4v. 3a. (both c.t.), 8/6; H.T.8 transformer, with 4v. 3.4a. (c.t.), 8/6; with rectifier, 18/6.

**A**MPHION Mains Transformers, input 100-250 volts, output 350-0-350 volts, 120 m.a.; 4v. 5a., 4v. 2a., 6v. 1a. (all c.t.); 17/6.

**F**ILAMENT Transformers, polished and engraved terminal boards, N.P. terminals, 4v. 3.4a., 5/-; 10v. 3a., 6/6; 12v. 1a., 5/-; 4v. 4.6a., 6/6; 14v. 4a., 6/6; 22v. 1a., 6/-; 6v. 2a., 5/-; 9v. 1a., 5/-; 25v. 3a., 15/-.

**P**REMIER Chokes, 40 m.a., 25 hys., 4/-; 65 m.a., 30 hys., 6/-; 150 m.a., 30 hys., 10/6.

**P**YE Chokes, 20 or 32 hys., 4/-; Premier multi-ratio output transformers, giving 15 different ratios 7/6.

(This advertisement continued on next page.)

**'SOUND'**

FOR ALL POWER EQUIPMENT FROM 2 TO 150 WATTS UNDISTORTED OUTPUT. FOR QUALITY AMPLIFICATION CONSULT:—

**TANNOY**

STANDARD EQUIPMENT FOR ALL PURPOSES, AND FULL RANGE OF P.A. SPEAKERS.

Tannoy Products (Guy R. Fountain Ltd.),  
Canterbury Grove, West Norwood,  
LONDON - - - S.E.27.

**EQUIPMENT**

**FIRST CLASS REPRODUCTION**

AN UNREPEATABLE OPPORTUNITY TO SECURE A REAL R.T.H.

**R. K. LOUDSPEAKER**

GUARANTEED NEW AT BARGAIN PRICES

**Specification**—4in. diameter cone Moving Coil Loudspeaker giving full bass response and handling the output from the heaviest power valve. Far superior to many small modern moving coil speakers. Weight 30 lbs. Field winding to suit 6, 100, or 250 volts D.C. Send cash with order or C.O.D.

Telephone Holborn 6109

**O. H. SEEKAMP, FIRST AVENUE HOUSE, HIGH HOLBORN LONDON, W.C.1**

**R. K. SPEAKER**  
Originally listed at £6. 6. 0  
Now offered to: **30/-**  
A.C. MODELS £2. 10. 0



Write for Illustrated Catalogue of

**RADIO-GRAMOPHONE CABINETS**

of exclusive modern design made by craftsmen in highly figured oak, Walnut or Mahogany, just free.

**REMARKABLE VALUES.** Cabinets made to order a speciality.

Made, under licence, of the **HOWE BOX BAFFLE.** Recommended by the B.I.C. Full details on request.

**GILBERT**  
Cabinet Maker - - - SWINDON  
Estimates Free. Est. 1886



SEND FOR LITERATURE OF

**Silver Ghost**

Lamplugh Radio Ltd. Coventry.

Silver Ghost Reproducers MASTERS OF SOUND



**MOTOR CYCLE**

Every Thursday 3d.



Components, etc., for Sale.—Contd.

(This advertisement continued from previous page.)

**P**REMIER Eliminators, input 200-250 volts, 40-100 cycles, A.C. incorporating Westinghouse metal rectifiers, output 250v. 60 m.a., S.G. and 120v. tap, 42 6; with 4v. 4a. e.t. L.T. 7 6 extra.

**B**RITISH RADIOPHONE Wire Wound Potentiometers, with matrix switch incorporated, 5,000 ohms, 10,000 ohms, 50,000 ohms, 100,000 ohms, 250,000 ohms, any value; 3 6.

**P**REMIER Eliminators, output 150v. at 30 m.a., S.G., and 100v. taps, with 4v. 3-4a. e.t. L.T., 37 6; or with trickle charger, 42 6.

**P**REMIER Eliminators, output 120v. at 20 m.a., S.G., and 100v. taps, 27 6; with L.T. trickle charger incorporated, 35 -.

**P**REMIER D.C. Eliminators, output 120v. at 20 m.a., S.G. and 100v. taps; 15 -.

**A**CCUMULATOR Chargers, 200-250 volts A.C., all incorporating Westinghouse metal rectifiers; 2, 4, and 6v. at 1/2 amp., 12 6; 2, 4, and 6v. at 1 amp., 17 6; 12v. 1a., 27 6; 6v. 2a., 35 -; 12v. 2a., 35 -; 12v. 1.5a., 30 -; 6v. 3a., 39 6; 30v. 3a., 42 6.

**A**MPHION High Inductance Chokes, resistance 2,500 ohms, 80 henries 60 m.a.; 5 6.

**W**ESTINGHOUSE Metal Rectifiers; 120v. at 20 m.a., 6 6; 180v. at 30 m.a., 8 6; 8v. at 1/2 amp., 6 6; 6v. at 1 amp., 9 6.

**K**OLSTER BRANDES Electric Gramophone Motors, complete with turntables and automatic stop, 100-250v., A.C. and D.C.; list price £5, to clear £2.

**B**T.H. Induction Type (A.C. only) Electric Gramophone Motors, 100-250v.; 30 - complete.

**A**MPHION Moving Coil Speakers, type E.M.644, dual fields, 2,500 and 5,000 ohms (100 and 200v.), with output transformer, 12 6; A.C. conversion kit for this speaker, 10 - extra.

**W**ESTERN ELECTRIC Condensers, 250v. working, 1 mfd. 6d., 2 mfd. 1 -; 500v. working, 1 mfd., 1 -.

**T**.C.C. Condensers, 250v. working, 4x4-1 mfd., 3 6; 300v. working, 4x4-2-2 mfd., 6 -; 6x4-2x2x2 mfd., 37 6; working, 6, 11; 4x4-1, 6 -.

**S**PECIAL Offer of Wire Wound Resistances, 4 watts, any value up to 10,000 ohms, 1 -; 8 watts, any value up to 15,000 ohms, 1 6; 15 watts, any value up to 50,000 ohms, 2 -; 25 watts, any value up to 50,000 ohms, 2 6; 50 watts, any value up to 50,000 ohms, 3 6.

**W**IRE Wound Potentiometers, 15,000 ohms, 1 6; Centralab Potentiometer volume controls, 50,000 ohms, 2 -; wire wound Charostat Potentiometer, 50,000 ohms, 2 6; Colvostats, logarithmically wound Potentiometers, 6,000 ohms, 1 9.

**F**OR Callers only.—The following valves, guaranteed new:—

**T**HE Last Few Western Electric 3211-D Valves, 10v. 3a. filament, 750 1,000v. plate, 50-65 m.a., impedance 3,500 ohms, amplification factor 12; cost £5; to clear at 15 -.

**P**HILIPS 328 Valves for L.T. Charging, 5 6; 329 Barretter lamps, 2/-.

**H**ARLEY Pick-ups with aim and volume control; 12 6.

**P**REMIER SUPPLY STORES, 20-22, High St., Clapham, S.W.4. Macaulay 2188. Closed 1 week Wednesdays, open to 9 o'clock Saturdays. Nearest Station, Clapham North Underground.

**P**REMIER. [2368]

**G**ILBERT INDUSTRIES' Parcels.

"A" "B" "D" and Condenser Parcels, as advertised in issues August 4th and August 11th, still available by return of post.

**G**ILBERT INDUSTRIES, Ltd., 519, London Rd., West-cliff-on-Sea. [13283]

**G**ENUINE Manufacturers' Surplus by Leading Makers.

**D**DOUBLE Smoothing chokes mounted, sound robust job, 120 m.a., 14-28 henrys each, usual price 35 -, our price 6 6 each, 9d. postage; single ditto, 4 6 each.

**C**HOKES, small, iron core, 2,000 ohms for output or choke coupling; 1 6 each, 3d. postage.

**A**.C. H.T. Eliminator 220 V to 240 V with 4 tappings; total output 150 V at 25 m.a.; for use with D.W.2 or Phillips 1821 valve; price 35 -, carriage 1 3.

**M**AINS Transformers for Eliminators, output 250-0-250 at 60 M.A., 4 V at 1 Amp; state input when ordering; price 6 6, postage 9d.

**14** mfd. Block Condensers, 250 V a.c. working, 6-4-2-1-1, 4 - each, postage 6d.

**R**ESISTANCES, wire wound, finest quality at ridiculous prices; 3,000, 5,000, 8,000, 40,000, 65,000 ohms, all 5 Watt, worth 5 6 each; 6d. each, post 3d.

**W**IRE Wound Potential Dividers, 60 Watt wound three sections, 4,500 ohms, 3,000 ohms, 2,000 ohms, 1 6 each, postage 4d.; 5 Watt ditto, 20,000 ohms, 20,000 ohms, 20,000 ohms, 1 - each, postage 3d.

**P**OTENTIAL Dividers wound 2 sections, 5 Watt; 40,000 and 23,010 ohms; 40,000 and 80,000 ohms; 40,000 and 100,000 ohms; 30,000 and 50,000 ohms at 1/- each, postage 3d.

**P**OTENTIAL Dividers wound 5 sections, 5 Watt; 250, 165, 100, 100, 100 ohms; 1 6, postage 3d.

**2** Separate 60 Watt Resistances on One Tube, 2,500 ohms and 500 ohms, 1 6 each, postage 4d.

**3** Separate Resistances on One Tube, 2,500 ohms, 1,000 ohms, 30 ohms; 1 - each, postage 3d.

**100-000**, 200,000, and 300,000 ohms 1 Watt Type Resistances at 4 6 per dozen, postage 3d.

**2** MEG, 0.1 Meg, 0.5 Meg Leaks; 0.001, 0.0001, 0.015 fixed condensers all 3 - per dozen, postage 3d.

**R**.C. Coupling Units, 1/- each, postage 3d.

**1** MFD Condensers, 250 V d.c. working, 6d. each, postage 2d.; 4 mfd condensers, 250 V d.c. working, 1 6 each, postage 4d.

**G**OODS Order value 20 -, carriage free.

**E**ACH Article is tested before despatch and guaranteed first class manufacture; cash with order; all goods despatched same day. Surplus Radio, 32, Queensway, Ponders End, Middx. [2322]

# CLIX Chassis Mounting VALVEHOLDERS Specified

and recommended by designers of EXHIBITION SETS

Wireless World MODERN BATTERY FOUR also Amateur Wireless: SIGNPOST FOUR, TRIODYNE; Practical Wireless: 1934 SUPERSET CLIX "AIRSPRUNG"

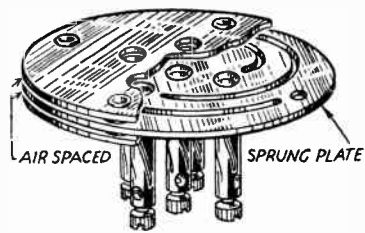

ANTI-MICROPHONIC, NON-METAL 4-Pin, 1/2. \*5-Pin, 1/3. STANDARD TYPE: 4-Pin, 8d. 5-Pin, 9d. FLOATING TYPE: \*7-Pin, 1/-

\* Specified for the Modern Battery Four. Obtainable from all Dealers.

## "A MATTER of CONNECTION"



LECTRO LINX LTD., 79a, Rochester Row, S.W.1.

25 GNS. H.S.P.

RADIOGRAM

A.C. D.C.

WITH GARRARD AUTO RECORD CHANGER

As Illustrated

A product of outstanding performance and merit.

Send for Illustrated Lists.

Name .....

Address .....

We are Actual Makers. Handsome Cabinet, Radiogram plays eight tunes, Coil Speaker. Agencies vacant.

**H.S.P. WIRELESS CO. LTD.,**  
Langford Works - Weston-Super-Mare.

Components, etc., for Sale.—Contd.

**S**OUTHERN RADIO Wireless Bargains.—Set manufacturer's guaranteed surplus:—

**V**ARIABLE Condensers.—British Radiophone 4-gang superhet type, fully screened and trimmers, 0.0005, 8 9 (list 45 -). Same type, complete with dial knob and eschelecon, 12 9 (list 50 -). Hydra block condensers, new, 16 mfd., 2-2+8-2-1+1, 1,000 volt test (made for Canadian Marcomphone Co.), 8 9; 4 mfd., 2 6; 2 mfd., 1 9; 1 mfd., 1 -; all 750 volt. Polar 3-gang condensers, 0.0005, fully screened, complete trimmers, dial, knob, eschelecon; 11 -.

**S**PEAKERS.—Celestion Soundex permanent magnet, 16/- (list 27 6); Rola F6 permanent magnet, 28/- (listed 49 6); D.C. mains energised, 2,500 to 6,500 ohms, complete with humbucking coils and transformers, 16 6 (list 39 6); Peter Gras-man dynamic speakers and chassis, 10 6 each (list 35 -); G.M.C. 8-ohm speakers, complete in magnificent cabinet, 19 6 (listed £3 15); Ormond speakers, complete in cabinets, 10 - (listed 25 -). Dr. Nesper Tefag speakers, 11 6 (listed 55 -).

**C**ONSTRUCTORS' Kits.—Ready Radio "303" battery 3-valve kits, less valves, 18/- each; (complete with 3 Mullard valves (P.M.11.P., P.M.2, 2D.X.), 35 - each (list 70 -); Ready Radio Meteor screen grid 3-valve kit, less valves, 26 -; with 3 Mullard valves (P.M.12a, P.M.2D.X., P.M.2a), 49 - (list £5 7 6); Universal Radio 3-valve kits, ready assembled on chassis, 12 6 (listed 45 -).

**R**EADY RADIO S.T.400 Kits, as specified by Scott Taggart; £2 19 6 each (list £4 17 6).

**R**EADY RADIO Meteor Screen Grid 3-valve "A" Kit, complete with cabinet, permanent magnet speaker (less valves), £3 7 6, with 3 Mullard valves, £4 10 (list £8 17 6); Mullard Radio for Million 3-valve A.C. kit, complete with 3 Mullard A.C. valves (Pen. 4V, 35dV, 8dV), £3 10 (list £6 10); Mullard Radio for Million 3-valve battery kits, complete with 3 Mullard valves, £3 3 (list £6 2 6); all kit brand new, in original sealed cartons.

**B**RITISH General Tuning Units, Band Pass, 10 k.c., aerial or anode; 5/- (list 14 6).

**A**LL Goods Guaranteed New and Perfect, and sent carriage paid.

**P**LEASE Note.—We have opened branches at 271-275, High Rd., Willesden Green, N.W.10, and at 46, Lisle St., W.C.2, where callers are cordially invited to inspect our large stocks of wireless bargains. Please send all post orders to 323, Euston Rd., N.W.1.

**S**OUTHERN RADIO, 323, Euston Rd., London, N.W.1 (near Warren St. Tube). Phone: Museum 6324. [3390]

**M**ILDWAY RADIO EXCHANGE Offers the Following, in sound and perfect:—

**F**ERRICART F1, F2, F3, 25/-; Radio Pax, 35/-; Colvern triple coil unit, type C.A.L., 32 6; K.G.R. coils, 5 6; Lewcos Band Pass filter, 7/-; S. Peak coils, 5/6; Lewcos A.W.C. chokes, 6 -; Lissen 3-gang superhet coils, 14 -; Lewcos frame aerials, 10 -.

**W**ESTINGHOUSE H.T.T.I. with Rich and Buddy transformer, 30 -; H.T.B. 11/6; Heayherd 250x250, 4 volt, 6 amps., 4 volt 1 amp., 15/-; R.I. E.V.35, 15 -.

**M**ETERS, Weston type 506, 0-10 volts, 0-20 amps., 7 6; 301, 0-10m.a., 20/-; 505, 0-50m.a., 15 -; 0-150 volt, 15/-; Ferranti triple range, 250 volt, 10 volt 100 m.a., 30 -; valve tester, 55/-.

**B**T.H. Senior P.M. Speaker, 50/-; Junior, 20/-; Celestion P.P.M., 20/-; W.B.P.M.3, 20 -.

**A**LL Post Paid, e.o.d. extra.

**C**LISSOLD 5001.

**24**, Mildmay Grove, LONDON, N.1. [3356]

**P**EPPER Offers the Following under Usual Guarantee; cash refunded if dissatisfied.

**M**ANY of Last Week's Bargains Still Available.

**N**OVOTONES, Type S; listed £5, boxed, 42 6.

**E**POCH E.8 Speakers, with 8in. cones, 2,500 fields as new, 13 6; Amplion ditto, 6,500 fields, 12 6; Magnavox D.C.142, 2,500, boxed, £1 7 6; Watnet units, 3/6.

**F**ERRANTI B.1 Chokes, 10 6; R.I. Hypercore, second-hand chokes, 9 3; 60h. 35 m.a. chokes, tapped for pentodes, 9 11; ditto, 60h. 50 m.a., 10 9.

**B**INOWAVES, boxed, A, C, and E, 2 11 each; P.W. Dual-wave Starturus Titans, M.M.3 stars, Wearite Touchstones, T.G.S.A.'s, despatch selector units, Formo dual-range, with bases, Talismans, R.2R.s, etc., 1 11 each; Lissen triple S.W., 2 11; T.O.S.G., 4 3; B.P.E.G., 5/3; O.T.I., O.T.2, 4 11; 0.2s., 4 6; 0.3s., 2/3; Varley R.P.9 and 10, 5 3 each; Tels-n W.76, 3 9.

**C**ARRIAGE Paid over £2.—Trevor Pepper, 575d. Muscle, Rd., Birmingham, 12. [3376]

**M**R.D. Co.'s Second Clearance Week, prior to restocking; all carriage paid, or call.

**10**/- Parcels Contain 8 A-sorted Resistances, 8 fixed condensers, 1 potentiometer, 1 2-gang condensers, trimmers, 1 T.C.C., 2 mfd. cond., 5/-; parcels contain 6 resistances, 6 condensers, 1 potentiometer, 1 T.C.C., 2 mfd. cond., 2 6; parcels contain 3 resistances, 3 condensers, 1 handsome S.M. dial.

**A**LL Parcels Guaranteed Perfect, and unsurpassed value. —Mains Radio Development Co., 4-6, Muswell Hill Rd., London, N.6. [3394]

**C**HAL ELECTRIC Offers New Set Manufacturer's Surplus, all carriage paid; cash with order or C.O.D.

**V**ARIABLE Condensers, J.B.Nu Gang (3-gang), complete with disc drive, covers, trimmers, eschelecon, light knob, etc. 17 6; 2-gang, fitted as above, 9 6; Polar Star (3-gang 1933), complete, fitted as above, list 30 6, at 18 -; Uniknob 2-gang, fitted as above, complete 10/-; Utility 2-gang, fitted as above, 8 6.

**C**OILS (6 sets each only).—Colvern Ferricart, F1, F2, F3, ganged, 32 -; Varley Nicore (1), B.P.30 and 2B.P.31, 28 -; Varley sets, B.P., 19 ganged, 25 6; record changers, Garrard, 200-250 A.C., complete with pick-ups, list £10, at £7 10.

(This advertisement continued on next page.)

Components, etc., for Sale.—Contd.

(This advertisement continued from previous page.)  
**PICK-UPS**.—B.T.H. Senior 1933, with volume control, list 2 guineas, at 29/-; Harley 1933, with volume control, list 27/6 at 15/-.

**MAINS Transformers**.—Philips, with screened primary, 250-0-250 at 75 m.a., 4 volts 1 amp., 4 volts 5 amps., 12/6; 500-0-500 at 120 m.a., 4 volts 2.5 amp., 4 volts 2 amps., 4 volts 5 amps., 23/-; 450-0-450 at 120 m.a., same L.T. windings as 500 job, 22/-; 350-0-350 at 120 m.a., same L.T. windings as above, 21/-; all L.T. windings and C.T.

**CHOKES**.—50 henry 75 m.a. (300 ohms) 8/6; 50 henry 60 m.a. (400 ohms), 8/6; 20 henry 120 m.a. at 350 ohms, at 10/6; 30 henry 60 m.a. (350 ohms), 6/6.

**SMOOTHING Condensers**.—C.E.C. Murphy, etc., 800 test 250 A.C. working, 1 mfd. 1/1, 2 mfd. 1/9, 4 mfd. 2/6; all the following 1,500 D.C., test 500 A.C., working 800 peak, 1 mfd. 1/9; 2 mfd. 2/4, 4 mfd. 4/-; Multiple Banks, separate tappings, 20 mfd., 4+4+2+2+2+2+1+1 at 11/-, 11 mfd., 4+2+2+2+1. at 6/9.

**ASK for Special Quotation for Anything You May Need**.—Chal. Electric, No. 6, Conduit St., London, W.1. [3392]

**NORTH LONDON WIRELESS MART**, 54, Malden Rd., N.W.5, offers the following surplus—all guaranteed:—

**CELESTION Soundex P.M.**, M.C. speakers, with universal transformers, in sealed boxes; 15/-.

**MULLARD Grid Leaks**, all sizes, 4d. each, 3/- dozen; Philips Resistances, 1 watt, all sizes, 6d. each, 5/- doz.

**MANUFACTURERS' Type Matched D.R. Coils**, 6d. each, 5/- doz.; Cylind double drum extenders, 6/6.

**ASSEMBLY Packet**.—6 lengths genuine Systoflex, 6 yards twin silk red and black flex, 6 yards single 2 mm. flex, roll insulating tape, 1/2 gross solder tags, 6 yards 22g. T.C. wire; 3/3.

**COLVERN K.21, K.22, K.23 coils**, 14/-; pair K.B.L.C.'s and K.G.R.; 14/-.

**NORTH LONDON WIRELESS MART**, 54, Malden Rd., N.W.5, offers the above surplus. [3391]

**BIRMINGHAM RADIO MART'S** Weekly Selection guaranteed Manufacturers and Bankrupt Stocks; all perfect.

**RESISTANCES**.—Eric, H.M.V., etc., 100 to 100,000 ohms; our assortment, 3/- doz.; different values.

**POTENTIOMETERS**, wirewound: Radiophone, 5,000, 15,000, 50,000, 100,000, 25,000, Colvern 3,000, 6,000; all 2/3.

**TRANSFORMERS**.—Wearite 350 350 9/6; H.T.8, 8/6; R.I.300/300, 12/6; all with filament windings, not stripped models; Philips, 200/200, 4/-.

**CONDENSERS**, Polar-Tub 3-gang, 10/6; 2-gang, 6/-; Radiophone 4-gang superior, 10/-; 2-gang, 6/-; all screened with trimmers; fixed T.C.C., Dubilier, etc., 0.0001 to 0.01, 3/- doz., our assortment.

**CONDENSER Packs**.—T.C.C. 4+4+1, 3/9; 4+4+1+1+1+5, 4/6; T.C.C. 800 wkg., Helsby 500 V.A.C. working, 3/9; T.C.C. 15mfd. electrolytics, 1/-.

**DUAL FADERS**.—Magnum, 2/9; A.E.D., 3/3; H.F. chokes, Varley, Pye, Radiophone, screened 1/6.

**NEW Amplion Six Console Rola Speaker**, 28.G., push-pull, one only, 8 guineas.

**METERS**, Raynarts famous 2" dia. nickel flush, any reading above 25m.a., 5/9; Full list stamp.

**THOUSANDS Bargains**.—Converters, telephones, short-wave gear, speakers.—The Square Dealers, "Raymart," 19, John Bright St., Birmingham. [3365]

**EBURY BRIDGE RADIO** Offer the Following Stupendous Bankrupt and Set Manufacturers' Surplus Bargains.

**A.C. H.T. Eliminators**, 200-250v. 50 v. input, 150v. 30 m.a. output, 2 pos. tappings, one fixed, one variable, Westinghouse rectified, finest components, guaranteed; special summer price, 25/-; post 1/3; also in 100-110 volts.

**GENUINE Reisz P.A. Microphones**, for all amplifiers up to 60 watts, straight line response; 55/-; plated stand with rubber suspension, 15/-; post free.

**EX-EKCO Mains Transformers**, suitable Ferrocart III, tapped input, 200-250 volts, outputs 350-0-350v. 60/70 m.a., 4v. 2 a., 4v. 3 to 4 a. (C.T.), 9/6, post 9d.; a real bargain; few only.

**EX-EKCO Smoothing Chokes**, 50h. 50 m.a. C.I.; 5/6; post 6d.; few only.

**PHILIPS Mains Transformers**, 200-250v. input, outputs, 200-0-200v. 40 m.a., 4v. 1 a., 4v. 3 a., a super bargain; 4/6, post 9d.

**PHILIPS Heavy Duty Smoothing Chokes**, 50h. 75 m.a.; 4/6; post 9d.

**WESTINGHOUSE Metal Rectifiers**, guaranteed, 120v. 15 m.a., 3/-; 120v. 20 m.a., 3/3; post 6d.

**WONDERFUL Summer Offer of Electric Clock**, complete movements, 200-250v. A.C., 50 cycles; 16/6, post 6d.; write full details; snap yours now.

**D.C. Motors**, various makes, B.T.H., Emerson, etc., all in perfect condition, guaranteed, 250v., make fine dynamos, 230-50v., 1 1/2 amp., nearly new; 22/6, real bargain.

**CHASSIS Valve Holders**, 4 and 5-pin, 3d. each, 2/6 doz.; Dubilier 1 watt metallized 25,000, 10,000, 6d. each; 50,000, 100,000, 5 watt, 1/- each (vacuum), post above 1/2d.; T.C.C. 15 mfd. 100v. working, 1/3; 9 mfd. (4+4+1+1) 500v., 5/-; Wego 2 mfd. 1,000 volt., 2/-; 9 mfd. (4+2+2+1), 500v., 3/6, post 6d.; T.C.C. 4 mfd. 500v., 2/3, post 3d.; in perfect condition.

**SEND for Our Bargain List**, all goods 3 days' approval against cash, or c.o.d.

**EBURY BRIDGE RADIO Co.**, 33, Ebury Bridge Rd., S.W.1 (near Victoria Station); No. 11 bus to Ebury Bridge), Sloane 8407. Closed Thursday afternoon. [3383]

**THREE Wearite Superhet Intermediates**, 10/- set; 120v. wet nickel iron battery, 30/-—Hawtreys, 3, Brocas Terrace, Eton. [3349]

**"UNDISTORTED POWER OUTPUT"**



The capabilities of all Savage amplifiers are quoted in terms of "undistorted power output"—but in more senses than the purely theoretical one. Savage reproduction shows you just how good really good reproduction can be. Savage has had years of experience in amplifier work of all kinds—experience that has been turned to good account in the latest models. It is that that makes the difference—but come and hear Savage "undistorted power output" for yourself. Or, if you are unable to get along, write for particulars stating the class of amplifiers in which you are interested. No obligation, of course.

**SAVAGE SOUND SYSTEM**  
 56/58, CLERKENWELL ROAD, LONDON, E.C.1  
 Phone: Clerkenwell 3068 9.

**For PERFECT VOLUME CONTROL — WATMEL POTENTIOMETERS**

Our Policy this year is to specialise in Potentiometers. You can therefore, be certain when purchasing a Watmel Potentiometer that you are obtaining the very best from a firm that is concentrating on this type of component.

This resistance meets with the requirements for a volume control which will have an equal variation of volume for the rotation of the knob. This is specially important for the control of the grid bias of the new variable-Mu valves.

Here is illustrated the Watmel Type 2 Potentiometer with mains switch.

Price  
 Square Law Winding 8/6  
 Without Mains Switch 6/6  
 Type 1.  
 Standard Winding 5/-

Please write for the interesting Watmel book on volume control Free.

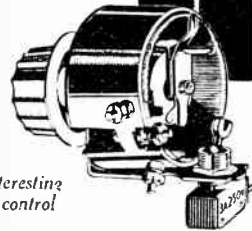

**WATMEL WIRELESS Co., Ltd., Imperial Works, High Street, EDGWARE.**  
 Telephone: Edgware 0323

Components, etc., for Sale.—Contd.

**8/9**—3-gang 0.0005, on die-cast chassis, trimmers, with illuminated drum drive, made for H.M.V.—Kay, 167, City Rd., London, E.C.1. [3353]

**MAINS Transformers**, 350-0-350v., 100 m.a., 4v. 5a. e.t., 4v. 2a., 4v. 2a., 200-250v. input; 10/6, post-1/2; Amalgamated Services, 161, Wardour St., W.1. [3348]

**SPECIAL Clearance Bargains**.—Projectors (9, 16 and 35 mm.), 30/-; Cameras, from 20/-; everything for Movies, Walkies and Talkies; inspection invited.

**ILLUSTRATED ENTERPRISES**, 159, Wardour St. (facing Film House), London, W.1. Phone: Gerrard 6889. [3004]

**EPTON First Again!** Just in and a few only! Utility 2-gang Mica Condensers, complete with Horizontal Full-vision scale, Uniknob model, escutcheon, etc.; 8/11.

**REGENTONE Cabinets**; Radiophone Potentiometers; Fixed Condensers and Banks (Dubilier, T.C.C., Wego); 1-watt, 1-watt, and 5-watt Resistors (Dubilier, Laew); Coils, Transformers, etc. Complete List in:—

**EPTON'S Bargain Bulletin**.—Send stamp to 93, New Rd., Chingford, E.4. [3397]

**WEST END RADIO STORES' Special Set Manufacturers' Bargains**.—Marconi 535 walnut radiogram cabinets, a few only, 39/6, carriage forward; other types in stock.

**HEAYBERD Mains Transformers**, 350-0-350v., 4v. 4a., 4v. 2a., 6/6; British H.T.8 trans., 200v., 180 m.a., 4v. 3a., 4v. 1a., 4/9.

**NEW 27 6** Harlie Pick-up, with volume control, 12/6; Harlie tone selector, 2/9, boxed.

**UTILITY 2-gang 0.0005**, with external trimmer, 3/6; Polar 3-gang 0.0005, fully screened, 7/6.

**T.C.C. 4 mfd.**, 400v., working condensers, type 80, 3/6; ditto 250v., working, 2/6.

**N. and K. Ferrand Inductor Speakers**, new, 22/6; Wates 2-watt resistances, 20,000 ohms to 5 meg., 3d. each.

**T.C.C. 8.25 mfd.**, 250v., working condenser, bank-tapped, 2/6; Wates distance switches, single pole 3/11, double pole 4/6.

**BROWNIE 2 valve A.C. Chassis**, wired, metal rectifier; 17/6; postage extra on all orders.—West End Radio Stores, 14, Lisle St., Leicester Sq., London. Also at 392, Colindale Lane, Brixton. [3396]

**TELEPHONES**, hand, 4/6; pedestal, 7/6; bells, 3/-; microphones, 1/-; 2/6 and 4/6; transformers, 2/6; block condensers, 2M.F., 1/-; 4M.F., 2/-; 8M.F., 4/-—Below.

**SYNCHRONOUS Motor**, 220V, 1 phase, any cycles, A.C., suitable for electric clocks, etc., 10/-, post free; single valve microphone amplifiers, 7/6; Hot wire milliammeter, 0-500 M.A., 4/-—Below.

**WATERTURBINE** one to two horse power, with reduction gear and drive, £3 10; desiccating machine, fitted vacuum pump, gauges, 110V d.c. motor, etc., would convert to splendid air compressor for spraying; £2 10.—Below.

**SPARK Coils**, ten inch, complete, in good order, £3; one 1/2 inch, 6/6; two inch, 15/-; ignition coils, 5/-; rotary converter, 12V. D.C. input, 30V. I.A. A.C. output, 15/-; X-Ray control switchboard, as new, £2 10.

**DYNAMOS**, for charging, 100v.-20a., £7; 220v.-15a., £8; 100v.-10a., £4; 60v.-15a., £5; 40v.-8a., £3 15; 30v.-10a., £3 5; 20v.-8a., 30/-; 12v.-5a., 20/-; also cut-outs, meters, regulators, resistances, etc.—Below.

**CAALPIN**, 31, Bunfield Rd., Lewisham, London, S.E.13. All goods cash with order or C.O.D.; all goods guaranteed; Works and Stores, 14, Lomput Hill, Lewisham, S.E.13; all correspondence to private address.—Write me your wants, all letters answered. [3359]

**NEW Boxed Surplus**.—Gramophone motors complete with turntable, etc., B.T.H. Sycho Blue, 25/-; Collaro Empire, 40/-; carriage part. Radio, 183, Laburnum Grove, Portsmouth. [3373]

**DIANTON Converter**, 200 D.C. to 230 A.C., 35/-; Ferranti O.P.M.3, Igranic G chokes, 8/6; Ekco D.C. H.T., L.T., G.B., 22/6; S.G.3, D.C. receiver, £2 15—Jervis, Dryden Rd. Fleetwood. [3369]

**MOVING Coil Mill-Ameters**, 0-50, 10/6 each; 2 milliamps and 120v., 17/6 each; other ranges in stock; alterations, repairs of every description.—The Victoria Electrical Co., 47, High St., Battersda, S.W.11. [0355]

**A. F.S. Co.**: A.F.4, 8/6; A.F.3, 12/6; A.F.12C., 6/6; R.L. Hypermu, 7/6; G.E.C. Hiltux, 8/6; Radiophone 366 4-gang with cover, 12/6; Oldham H.T. charger, 18/-; cash or c.o.d. Bolton, 13, Ashville Rd., Leytonstone, E.11. [3368]

**FERRANTI A.F.4**, 7/9; A.F.3, 11/6; A.F.5, 18/6; O.P.M.1C., O.P.M.2C., O.P.M.5C., O.P.M.2, 14/-; O.P.I., O.P.3C., O.P.6C., 7/6; B.I., E.2 chokes, 10/-; set 4 Lewcos Super Sixty Coils, 18/6. Bostock and Stomhill, 1, Westbourne Terrace, S.E.23. [3367]

**DISPOSAL of Edison-Bell Radio Works**.—Amateurs should write for complete list of speech amplifiers, eliminators, valves, and all new radio components, for sale at knock-out prices to clear quickly; 100 Plesy 3-gang condensers, 10/- each.—Write, Engineer, Edison-Bell Works, Glengall Rd., S.E.15, for list, or, better still—call and inspect. [3259]

**RADIO Auction**.—Sold to highest bid received by next Thursday! Blue Spot pick-up, type 33; parts for Ferrocart III as kit or separate, with valves; Ferranti 50 milliammeter; Pola P.M. loud-speaker with malogany fire-wood baffle; Colvern and Wearite I.F. transformers; Edlstone transmitting and receiving gear; full list on application.—Snowden, Sandilands, Walton-on-Thames. [3370]

**NOTICE for Special Bargains**.—T. W. Thompson and Co., of 17, Stratton Ground, Westminster, have just purchased a large consignment of H.M.V. and other components, including mains amplifiers, Marconi transformers, chokes, rotary converters, speakers, condensers, and thousands of other parts, all of which will be advertised in a display advertisement in next week's "Wireless World." Do not buy until you have perused this advertisement; tremendous bargains will be offered. [3381]

**CLASS "B" COMPONENTS.**

**SOUND SALES, Ltd.**, for Class "B" Components. List "B.B." on request.—Tremlett Grove, Highgate, N.19. (0401)

**MISCELLANEOUS.**

**EASY Payments.**—We supply, by easy payments, components, accessories, and sets; any make; 10% down, balance spread over 11 months. Send list of requirements to London Radio Supply Co., 11, Oat Lane, London, E.C.2. (0337)

**ENGINEERS and Technical Workers of All Kinds.**—A proper training by post in your spare time will take you through your right examination, the employment is waiting. Our advice on all careers free. Dept. 92, The Bennett College, Ltd., Sheffield. (0395)

**NOTICE for Special Bargains.**—T. W. Thompson and Co., of 17, Strutton Ground, Westminster, have just purchased a large consignment of H.M.V. and other components, including mains amplifiers, Marconi transformers, chokes, rotary converters, speakers, condensers, and thousands of other parts, all of which will be advertised in a display advertisement in next week's "Wireless World." Do not buy until you have perused this advertisement; tremendous bargains will be offered. (3382)

**AMBITIOUS Men** Qualify for a well-paid post by studying at home with the T.E.G.B. Write today for "The Engineer's Guide to Success," 144 pages, free, which contains the widest selection of engineering and wireless course in the world, and shows you how to become A.M.I.E.E., A.M.I.Mech.E., A.Rad.A., etc. State branch, post or qualification that interests you. The Technological Institute of Great Britain, 82, Temple Bar House, London, E.C.3. (Founded 1917, 15,000 successes.) (2725)

**PATENT AGENTS.**

**PATENTS and Trade Marks.** British and foreign. Geo. and Co. (H. T. P. Geo. Member R.S.G.B. and A.M.I.E.E.), 51-52, Chancery Lane, London, W.C.2. Phone: Holborn 1525. (0901)

**REPAIRS.**

**REPAIRS.** Rebuilding to any set; highest quality work only; lowest charges; estimates given free; distance no object. L. Eastwood, Radio Manufacturers' Consultant, Ltd., of His Master's Voice and Marconi Wireless Telegraph Co., Telephone: Clerkenwell 4520. Address: 10, Herder Rd., Fulham, S.W.6. (3545)

**GUARANTEED Repairs by Experts;** specialists for repairs to S. G. Brown and Amphion radio apparatus, also loud-speakers, headphones, pick-ups, Blue Spots, any type rework, remagnetised and adjusted; 4/- post free, mains transformer repairs; terms to trade.—Howell, 51, Morley Hill, Enfield, Middlesex. (9716)

**REPAIRS to Loud-speakers, transformers and headphones, 4/-; Blue Spots and Wufas, 5/- post free; moving coils a speciality, new cones fitted; eliminators and mains transformers quoted for prompt service; satisfaction guaranteed; discount to trade.** Loud Speaker Repair Works, 5, Balham Grove, London, Battersea, 1521. (0394)

**TUITION.**

**R.T.I. Training Methods are Recognised;** write for particulars of home study, for non-appointments; secure Certificate of Proficiency and become "A.M.R.T.I." Radio Training Institute, 85, New Oxford St., London, W.C.1. (2947)

**QUALIFIED Radio Engineers are Always in Demand,** and our Home Study Course will enable you to qualify for a good post; many students already placed this season; prospectus free. Northern Counties Wireless School, Preston. (0559)

**FINANCIAL PARTNERSHIPS.**

**PARTNERSHIP available,** Brighton, suit technical wireless man, £250; additional £100, genuine scope, exceptional opportunity. Box 7934, c/o *The Wireless World*. (3336)

**EXCHANGE.**

**EXCHANGE:** Your Set or Components for a 1934 Receiver; best allowance. Radio Exchanges, 114, Ramitz Drive, Westcliff-on-Sea. (3234)

**HIGH Allowances Made on Second-hand Goods in Part Payment for New Sets or Components;** easy payments available; we have tremendous stocks tested second-hand goods; send list of your requirements for quotation. Bostock and Stomill, 1, Westbourne Terrace, S.E.25. (3366)

**WANTED.**

**WANTED,** Westinghouse charger, any model, A.C.—Crannage Radio, Uckfield, Sussex. (3292)

**SPOT Cash for Modern Components, etc.** Economic Radio Co., 96-98, South Lambeth Rd., S.W.8. (3291)

**SECOND-HAND Goods in Part Payment for New, private experimenter.** Box 7526, c/o *The Wireless World*. (3357)

**MODERN Straight Five, "Wireless World," June, 1932,** receiver unit chassis only, without valves; £4 offered if to specification. B. Lewis, 31, Elwell Way, Beckenham. (3361)

**HIGH Class Radio Sets and Parts Wanted for Cash,** no obsolete parts please; parcels may be sent, same receiving immediate attention. Mildmay Radio Exchange, 24, Mildmay Grove, London, N.1. Clissold 5901. (3197)

**SITUATIONS VACANT.**

**YOUNG Man, 17-20,** for service dept. of radio stores, N. London, good technical knowledge of modern receiver. Write, stating wages, experience to Box 7932, *The Wireless World*. (3364)

**IF You Wish to Enter the Wireless Profession with a Thorough Training,** or if you wish to improve your present position you will need the certificate issued by Britain's leading wireless college. This is not a correspondence college. Apparatus of all leading makes installed for instructional purposes. Boarders accepted. Training fees can be paid after appointment. Prospectus free.—Wireless College, Colwyn Bay. (0288)

**HERE IT IS!**

**THE CONSTRUCTION OF RADIO POWER UNITS AND AMPLIFIERS**

Your complete guide to the construction of Radio Power Units. A 32-page publication which deals fully and clearly with the theory and practice of the subject, giving full working instructions and diagrams for the building of eight different units—AC and DC—from modest to super-power output.

Published by Ferranti, it may be looked upon with confidence as a responsible and authoritative treatise. As such, it is only natural that the components recommended are of unsurpassed quality and unquestioned reliability. The fact that many of these components bear the Ferranti name will be taken as a guarantee that the completed Power Units are entirely safe and exceptionally efficient.

This Booklet W522, as well as a 16-page list of all Ferranti Mains Components, will be sent, post free 4½d. Address enquiries to Dept. \*W.\*

The full range of Ferranti Mains and General Radio Components may be inspected at Stand No. 38, Scottish National Radio Exhibition, Glasgow; also at Stand No. 20, Main Hall, Northern National Radio Exhibition, Manchester.

**FERRANTI**

**MAINS COMPONENTS**

FERRANTI LTD. HOLLINWOOD, LANCASHIRE.  
London: Bush House, Aldwych, W.C.2.

**FOR HIRE FULLY EQUIPPED PUBLIC ADDRESS VAN** Sent anywhere in British Isles, also **RADIO, MICROPHONE, & GRAMOPHONE AMPLIFIERS** giving exceptional quality and volume, suitable for Dances, Sports, Meetings, Fetes, etc., from 15/- per day. McMichael Portable Sets 15/- a week: £2-12-6 a month.

**ALEXANDER BLACK, LTD**

**WIRELESS CONSULTANTS**

**55, EBURY STREET, LONDON, S.W.1.**

ESTABLISHED IN 1925. SLOANE 1655.

Trade inquiries Invited.

**SERVICE SETS OF ALL TYPES.**

Supplied, Serviced and Visited in any district, or may be sent or Full Test and Report at 2/- per valve-holder, portables 1/6 per valve-holder.

**CHARGE YOUR OWN ACCUMULATOR** at less than a penny. The Axden Unit suitable for 2 or 4 volts, at 14/6 post free. Output 1 amp. Particulars on application. Traders supplied.

**THE ARDEN AGENCY,** Wollaston, WELLINGBOROUGH.

**SERADEX ELIMINATORS BATTERY CHARGERS, etc.** New Illustrated Catalogue now ready.

**TREVOR PEPPER,** 575, Moseley Road, BIRMINGHAM, 12.



# SEND FOR OUR NEW SEASON'S CATALOGUE

*The Choice of Critics*

**BULGIN**  
BRITISH MADE  
RADIO PRODUCTS

**BIGGER & BETTER THAN EVER**

**269 ILLUSTRATIONS**

More Radio Components than ever are included in this New Season's Catalogue. The Guide to Home Constructors.

ASK FOR CATALOGUE No. 153 "W"

*Enclose 2<sup>d</sup> Postage.*

**A. F. BULGIN & CO. LTD., ABBEY RD., BARKING.**

London Showrooms: 9, 10, 11, Cursitor Street, Chancery Lane, E.C.1.

Telephone: Grange Wood 3266, 3267.  
Telephone: Holborn 2072.

WRITE FOR BOOKLET "RADIO CONNECTIONS"

**BELLING-LEE**  
FOR EVERY RADIO CONNECTION

Advt. of Belling & Lee, Ltd., Cambridge Arterial Road, Enfield, Middlesex

**Situations Vacant.—Contd.**

**YOUNG** Man (17-22), radio and gramophone trade, near Croydon, keen on music and practical wireless, and preferably able to typewrite, outstanding chance for right man; enclose photograph if possible.—Box 7872, c/o *The Wireless World*. [3325]

**SITUATIONS WANTED.**

**YOUNG** Man, resident London, capable and adaptable. seeks responsible position; wide experience modern radio.—Box 7935, c/o *The Wireless World*. [3385]

**WIRELESS** Engineer, 28, desires situation, 1st class P.M.G., 5 years factory experience, all types sets, references.—Box 7935, c/o *The Wireless World*. [3387]

**AUCTION SALES.**

By Order of C. O. Cullen, Esq., the purchaser of Yagerphone, Ltd., MESSRS. **FULLER HALL & FOULSHAM**

are instructed to offer for SALE by AUCTION in LOTS TO SUIT LARGE AND SMALL BUYERS, on the Premises, Ponders End, on WEDNESDAY, SEPTEMBER 20th, 1933, and DAY FOLLOWING, at 11 o'clock a.m. each day, the

CONTENTS OF THE WORKS of **YAGERPHONE LIMITED,** including

4,000 WIRELESS and GRAMOPHONE SETS and CABINETS, SPEAKER and SPEAKER CABINETS, 300 MAINS and BATTERY CHARGERS, 500 PORTABLE GRAMOPHONES, 2,500 "COLLARO" and "GARHARD" DOUBLE, SINGLE SPRING and INDUCTION MOTORS, "Parneko" H.T. Transformers, ENGINEERS' MACHINE TOOLS, including S.S. and S.C. LATHES, "BLISS" POWER PRESSES, "THIEL" NO. 3 FILING MACHINE, "PALLAS" HORIZONTAL MILLING MACHINE, Fly Presses, Guillotines, Shaping and Drilling Machines, also the OFFICE FURNITURE, FIXTURES and FITTINGS.

Catalogues (when ready) may be obtained of Messrs. Fuller Hall & Foulsham, Auctioneers and Valuers to the Wireless and Gramophone Trades, 125, High Holborn, W.C.1. (Tel.: Holborn 2405 2 lines.)

NOTE.—The FACTORY at PONDERS END, which is a MODERN TWO-STORY STRUCTURE with 15,700 sq. ft. of FLOOR SPACE, is to be let on Lease.

# EPOCH

## MOVING COIL SPEAKERS

The Finest in The World in Each of Their Price-classes.

Ask your dealer or call for a demonstration at Exmouth House.

Send for New Booklet W.S.5a. It is free.

**EPOCH RADIO MANUFACTURING Co. Ltd.**  
Exmouth House, Exmouth St., London E.C.1

At the Junction of Rosebery Avenue and Parrington Road.

Phone: Clerkenwell 6096 (4 lines)

What is **ENGINEERING OPPORTUNITIES**?  
250 pages

"ENGINEERING OPPORTUNITIES" is a 250-page Hand-book that has been prepared after years of patient search into the possibilities of various Engineering Careers. It shows clearly and definitely the way in which you may carve out a successful career in your chosen branch of Engineering irrespective of your age, education or experience. Among a host of other things, it outlines Home-Study Courses in all branches of Civil, Mech., Elec., Motor, Aero., Wireless and "Talkie" Engineering and shows the way to pass A.M.I.C.E., A.M.I.Mech.E., I.E.E., A.M.I.A.E., M.I.M.T., G.P.O., Matriculation, Civil Service and other Examinations.

"ENGINEERING OPPORTUNITIES" is a unique Hand-book that you should most certainly read. Send for your copy today—FREE of any cost.

**BRITISH INSTITUTE OF ENGINEERING TECHNOLOGY, 387, SHAKESPEARE HOUSE, 29 31, OXFORD STREET, LONDON, W.1.**

# Grippleshell Aerial Brackets

are simple and economical to install and avoid unsightly poles. Write for leaflet to:—

**PARTRIDGE WILSON & CO., Dept. 29, Davenset Works, Leicester.**

**IF YOU CAN AFFORD TO BUY**

**PARMEKO**

**THE SATISFACTION OBTAINED WILL WELL REPAY YOU**

**PARTRIDGE & MEE, LTD.**  
LEICESTER AND LONDON.

SPECIALISTS IN HIGH QUALITY TRANSFORMERS, CHOKES, SPEAKERS, AMPLIFIERS

**PEAK** *The Height of Condenser Perfection*  
**NON-INDUCTIVE CONDENSERS**

Type CB7	Type T12
Tested 100V V.D.C. working Voltage 500 V.D.C.	Tested 240V V.D.C. working Voltage 800 V.D.C.
.01 mfd. ... 2 -	1 mfd. ... 3 6
.1 " ... 2 -	.25 " ... 3 6
.25 " ... 3 3	.5 " ... 3 6
.5 " ... 2 6	1.0 " ... 4 6
1.0 " ... 2 6	2.0 " ... 7 -
2.0 " ... 3 6	4.0 " ... 11 6
4.0 " ... 6 -	6.0 " ... 17 9
6.0 " ... 7 3	8.0 " ... 22 -
8.0 " ... 19 3	

Recently added to the Peak range, the Types C.B.7. and T.12 provide striking proof of the justice of our claim — that PEAK CONDENSERS offer unequalled value. A study of the prices in conjunction with the characteristics will be illuminating and convincing. If you want first grade British made condensers at the lowest prices your choice must be PEAK.

Fully guaranteed, Peak condensers are regularly specified for "Wireless World's" Sets. Remember these facts and specify Peak for your



**NEW A.C. MONODIAL**  
THEY ARE AVAILABLE FROM STOCK

Write at once for new list to

Wheatleef House, Carmelite Street, **WILBURN & COMPANY** London, E.C.4  
Northern Distributors : W. Andrew Bryce & Co., Bury, Lancs.

*The* **ELEMENTARY PRINCIPLES of WIRELESS TELEGRAPHY and TELEPHONY**

Third Edition (1930) Revised by O.F. Brown, B.Sc.

by R. D. BANGAY

The standard book of instruction for wireless students. Deals thoroughly with modern developments. Leaflet with full particulars and synopsis of chapters sent on request.

**PRICE**  
7/6 by post 8/-

From all leading Booksellers or direct from the Publisher.

**LIFFE & SONS LTD., Dorset House, Stamford St., London, S.E.1**

**PUBLIC ADDRESS**

5.9 Watt Gramophone

Amplifier



Operate entirely from A.C. Main Supply. Realistic reproduction - frequency curve gradually flat from 50 to 10,000 cycles.

AMPLIFIER - A 2 stage parallel fed transformer circuit employing standard Marconi MB14, Mazda PPS 400 and Micromesh A3 triode valves. Main transformer primary suitable 200-250 volts, 50 cycles. GRAMOPHONE MOTOR, A "Garrard" totally enclosed motor. PICK-UP AND TONE ARM - Latest type Belling-Lee pick-up and tone arm in bronze. 40-ohm. The above components are mounted in solid oak cabinet, with output transformer, volume and tone controls, mains on-off switch, warning indicator lamp, needle cups, plugs and socket connections. LOUD SPEAKERS - The speakers supplied are standard Rola TG and FT, dual matched and carefully balanced before leaving the works. Mounted on special baffle board 1.20" square and 1/4" thick.

SEND FOR LIST.

**W. ANDREW BRYCE & CO.**  
Woodfield Works, Tile St., BURY, Lancs.

London: WILBURN & CO. Wheatleef House, Carmelite St., E.C.4.

**INDEX TO ADVERTISEMENTS.**

	PAGE		PAGE		PAGE
Amplion (1932), Ltd.	15	Electricity Radios	15	Partridge, Wilson & Co.	16
Arden Agency		Electro Dynamic Constructor Co., Ltd.	16	Pepper, Trevor (Sendex)	15
Automatic Coil Winder & Elec. Equipment Co., Ltd.	Front Cover	Epoch Radio Mfg. Co., Ltd.		Peter Scott Co., Ltd.	
Barber & Colman, Ltd.	19	Exc. Tel. Co., Ltd.		Picketts	
Belling & Co., Ltd.	19	Foran, Ltd.	15	Philco, Ltd.	vi.
Birmingham Sound Reproducers, Ltd.	15	General Electric Co., Ltd.	5	Playboys	
Black, Alexander, Ltd.	18	Gilbert, J. C.	12	Radio Gramophone Development Co.	Back Cover
Black Batteries, Ltd.	18	Gresham Electric Batteries, Ltd.		Reproducers & Amplifiers, Ltd.	2
British Blue Spot Co., Ltd.	4	Hayes Turner Radios, Ltd.	12	Riverside Mfg. Co., Ltd.	10
British General Manufacturing Co., Ltd.	16	Hayes, Robert	4	R.T.A., Ltd. (M.I. Equipment)	v.
British Inst. of Eng. Tech.	16	Hickel, F. C. & C.	4	Savage, W. Bryan	14
British Radiophone Co., Ltd.	11	Higgs, Geo. J. Belmont, Ltd.	17	S. D. Sessions & Co.	10
British Radio Co., Ltd.	11	H.S.P.	5	Stokamp, O.	12
British Thomson-Houston Co., Ltd.	11	Ipswich Electric Co., Ltd.	8	Tabney Products	12
Bryce, W. Andrew & Co.	17	Jacks, B.S.		Tolson Electric Co., Ltd.	Front Cover & 9
Bulgin, A. L. & Co., Ltd.	16	Lampkin Radio, Ltd.	12	Tungsten Electric Lamp Works (G.B.), Ltd.	Inside Front Cover
Burton, C. F. & H.	Front Cover	Leeds, E.M., Ltd.	15	Vince, Dry Batteries, Ltd.	2
Challis Transformers, Ltd.	12	Lyne, Canada, Ltd.	4	Watnel Wireless Co., Ltd.	14
Cray Accumulator Co., Ltd.	4	Marsden, Geo. Ltd.		Westinghouse Brake & Saxby Signal Co., Ltd.	Inside Back Cover
Clyburn, Ltd.	Front Cover	Metropolitan Vickers Electric Co., Ltd.		Whitely Electrical Radio Co., Ltd.	7
Consolidated Electric Works Co., Ltd.	4	Miles Radio Co., Ltd.		Wilburn & Co.	17
Cosson, A. Co., Ltd.	4	Partridge & Mee, Ltd.	17	Wingrove & Rogers, Ltd. (Polor)	
Dalbier Condenser Co. (1925), Ltd.	3				
Eastick, J. J. & Sons					

Radio Data Charts. For the keen amateur. By post, 4/10.

The *plate-less*  
**ACCUMULATOR**  
*revolution*



**DOUBLE CAPACITY**

LOW TENSION

*halves your re-charging*

No bigger than your present 40 a.h. accumulator, costing little more, a Block plate-less accumulator lasts you twice as long per charge—gives 80 a.h.! Far more durable, too—and handsome, in its richly coloured bakelite. (Detachable hand-lamp fitting, 10/6.)

**"CONDENSED" HIGH TENSION**

*no need for dry battery expense*

Because a Block cell gives twice the capacity for its size, a Block H.T. accumulator of usual capacity can be condensed to half the usual bulk! So give up expensive dry batteries—the new accumulator in its beautiful bakelite casket is little bigger and is remarkably inexpensive. Relieves you at once of radio's biggest nuisance.

**BLOCK**  
PLATE-LESS ACCUMULATORS

Block Batteries Ltd., Abbey Road, Barking, Essex. Tel: Grangewooa 3346/7

**PRICES**

L.T. 80 a.h. 2v. . . . . 11/6  
H.T. 60v. 5000m.a.h. 14 1/2" x 4 1/2"  
x 5 1/2" 37/6. 30v. 8 3/16" x 4 1/2"  
x 5 1/2" 21/-

TAS. Bb. 51.

**RADIO  
DATA  
CHARTS**

A  
**SERIES OF ABACS**

providing most of the essential  
Data required in Receiver Design

By

**R. T. BEATTY, M.A., B.E., D.Sc.**

Reprinted from  
"The Wireless World"

(1930)

"Radio Data Charts" provide designers of wireless apparatus with a ready and convenient means of solving problems without having recourse to complicated formulæ and mathematics.

By the use of the charts it is possible to tackle all the more familiar problems in radio receiver design, such as, for example, finding the relationship between inductance capacity and frequency, and working out the design of high frequency transformers. All keen amateurs will appreciate this helpful book.

(39 CHARTS and more than  
50 Diagrams)

**Price 4/6 net**

By post 4/10

Published from the Offices of  
"THE WIRELESS WORLD"

From all leading booksellers or direct  
from the Publishers

**ILIFFE & SONS LTD.**

Dorset House,

Stamford St., London, S.E.1

W.W.93

Mention of "The Wireless World," when writing to advertisers, will ensure prompt attention.

# WEDNESDAY

## SEPTEMBER THE SIXTH

### PRINCIPAL EVENTS OF THE DAY:

#### AT HOME

**NATIONAL LONDON REGIONAL** A music hall programme.  
Promenade concert from Queen's Hall.

**MIDLAND REGIONAL** Opening of the Second Annual Radio Exhibition at Nottingham.

**NORTH REGIONAL** Songs from "A Shropshire Lad," by A. E. Housman.

**WEST REGIONAL** Instrumental concert.

**SCOTTISH REGIONAL** Running commentary on the Highland Games, from the Green of Charlestown, of Aboyne.

**BELFAST** The Fourth Holiday Parade, relayed from Portrush.

#### ABROAD

**BARCELONA** 7.0 p.m. The Station Trio.

**BARI** 8.40 p.m. Chamber music.

**BRUSSELS** 9.0 p.m. Concert from the Kursaal, Ostend.

**(No. 1)**

**COPENHAGEN** 8.10 p.m. The Station Symphony Orchestra, conducted by Nicolai Malko.

**EIFFEL TOWER** 8.30 p.m. Symphony concert, conducted by E. Flament.

**HUIZEN** 7.55 p.m. The V.A.R.A. Orchestra, relayed from The Hague.

**OSLO** 8.2 p.m. The Station Orchestra, conducted by Hugo Kramma.

**ROME** 9.45 p.m. Selection from opera: "Le Maschere," by Mascagni.

**STRASBOURG** 8.30 p.m. Symphony concert from the Casino, Vichy.

**TURIN** 8.30 p.m. Operetta: "The Merry Peasant," by Fall.

(Unanison); Aux étoiles (Duparc); Réverie (Debussy); Aspiration (Dubois); Gramophone Record: Invitation au voyage (Duparc); En bateau (Debussy); The Nile (Leroux); Escapes (Ibert), 7.15, Weekly Radio Review and Film Notes, 7.30, Medical Talk, 2.0, Concert by the Radio Orchestra, conducted by Knips, Golliwog's Cake Walk (Debussy); Rhapsody in Blue (Gerstwin); Fox-trot (Ravel); Ronde burlesque (Schmitt); Suite of Viennese Waltzes (Gilsen), 8.45, Talk: The Middle Classes, 9.0, Concert, relayed from the Kursaal, Ostend, After the Concert, Le Journal Parlé, followed by Symphony No. 3 in A (Brahms), on Gramophone Records, 10.55, Christus Vincit (Liszt).

#### BRUSSELS (No. 2)

N.I.R., 887 kc/s, 338.2 metres; 15 kW. Programme in Flemish.—12 Noon, Concert, conducted by Felleman, relayed from the Grand Hotel, Antwerp, 1.0 p.m., Le Journal Parlé, 1.10, Concert Relay (contd.), 5.0, Dance Music, relayed from the Kursaal, Ostend, 6.0, Gramophone Records, with Commentary: Phœton (Saint Saëns); Wallenstein's Camp (d'Indy), 6.45, Gramophone Music: Fourteen Songs (Sinon); Overture, Alphonse und Estrella (Schubert), 7.15, Reading, 7.30, Book Review, 8.0, Armée—Radio Sketch (Putnam), 8.45, Knokkelbeen—Operetta in Three Acts (Hullebroeck). In the first interval, Gramophone Records: Hungaria (Doucet); Schön Rosmarin (Kreisler); La Craquette (Cherice); Polka rondo (Balleron); The Clock is playing (Blamw). In the second interval, Le Journal Parlé.

#### BUCHAREST

761 kc/s, 394 metres; 12 kW.—5.0 p.m., Concert by the Station Orchestra: March (Lindemann); Waltz from Casanova (Lincke); Overture, Marinarella (Fucik); Selection from La Bohème (Puccini-Tavan); Fantasia on Themes from Coppélia (Delibes-Fetras); Romanian Potpourri (Welsch); Italian Serenade (Schebke); English Song and Waltz (Euchs-Michalov); Serenade (Amadei). In an interval at 6.0, Radio Journal, 7.0, Reading, 7.20, Romanian Music on Gramophone Records, 7.40, Educational Talk, 8.0, Violin Solos, 8.30, Talk, 8.45, Horn Solos, 9.45, Pianoforte Recital by Etienne Bernhardt: Fantasia and Fugue in G minor (Bach-Liszt); Spanish Rhapsody (Liszt); Spanish Dance (Falla); The Juggler (Tuch), 9.45, Radio Journal, 10.0, Concert, relayed from the Piccadilly Restaurant.

#### BUDAPEST

545 kc/s, 550.5 metres; 18.5 kW. Also relayed on 840 metres from 7.20 till Close Down.—5.0 p.m., Concert by the Concert Orchestra, 6.15, Talk, 6.45, Song Recital by Palitai, 7.20, Schön war die Welt im K.u.K.—Radio Play (Büky), 9.20, News, 9.40, Pianoforte Recital by Karolyi: Sonata in B minor (Chopin); Legende (Liszt); Rhapsody No. 12 (Liszt), 10.15, Weather Report, followed by Music by the Alexander Bura Cigány Band, 11.0, Gramophone Music.

CASSEL.—See Frankfurt.

#### COPENHAGEN

1,067 kc/s, 281 metres; 0.75 kW. Relayd by Kalundborg, 260 kc/s, 1,153.8 metres.—12 Noon, Time and Chimes from the Town Hall, and Weather Forecast, 12.15 p.m., Talk, 12.25, String Ensemble Concert, relayed from the Bellevue Strandhotel, 1.15, Educational Talk, 1.45, Interval, 2.30, Programme for Children, 3.0, Orchestral Concert, relayed from the Wivex Restaurant, 5.0, Gramophone Music, 5.30, Exchange and Fish, Market Prices, 5.45, Talk, 6.15, French Lesson, 6.45, Weather, Announcements and News, 7.15, Time Signal, 7.30, Agricultural Talk, 8.0, Chimes from the Town Hall, 8.2, Humorous Item, followed by Weather Forecast, 8.30, Concert by the Station Symphony Orchestra, conducted by Nicolai Malko, Soloists: Else Brems (Songs) and Louis Preil (Violin), Overture, Euryanthe (Weber); Songs from: (a) Amadis de Gaule (Lully), and (b) L'Enfant prodige (Debussy); Symphonie classique (Prokofiev); Prélude à l'Après-midi d'un Faune (Debussy); Andante and Finale from the Violin Concerto in B minor (Saint-Saëns); Suite from Tsar Saltan (Bimsky-Korsakov), 10.15, News, 10.30, Reading (Jacobsen), 10.55, Dance Music relayed from the Arena. In the interval at 12 Midnight, Time and Chimes from the Town Hall, 12.30 a.m. (Thursday), Close Down

CORK.—See Athlone.

DANZIG.—See Heilsberg.

DRESDEN.—See Leipzig

#### FECAMP

1,328 kc/s, 225.9 metres; 10 kW.—11.0 to 12.0 Noon, Programme in English by the I.B.C., 11.0, Happy Hour, Part I, Orchestral Music: Signature Time; Overture, Die Fledermaus (Joh. Strauss); Demande de reprise (Coleridge-Taylor); Song: Mountain Lovers (Squire); Vienna, City of my Dreams (arr. Reeve); Selection from Wild Violets (Stolz); Song: A Bachelor Gay (Tate); The Dance of the Tea Dolls (Smith

#### ATHLONE

25 kc/s, 413 metres; 60 kW. Relayd by Cork, 1,337 kc/s, 224.4 metres.—1.30 to 2.30 p.m., Time Signal, Weather Report, Stock Exchange Quotations and Gramophone Music, 6.0, Programme for Children, 6.45, News, 7.0, Gaelic Talk, 7.15, German Lesson, 7.30, Time Signal, 7.31, Concert by the E. James's Brass and Reed Band, 8.30, Soprano Solos by Eileen Hayden, 8.45, Concert by the Station Orchestra, 9.15, Baritone Solos by A. McNece, 9.25, Talk by Liam O'Gogain: The Sacred Places of Ireland, 9.45, Sponsored Programme, 10.45, News, Weather and Close Down.

#### BARCELONA

EAJ1, 860 kc/s, 348.8 metres; 8 kW.—7.0 p.m., Concert by the Station Trio: Selection from The Flying Dutchman (Wagner); Autumn Song (Eggar); Romance (van Joens); Selection from Lakmé (Delibes); Intermezzo (Lindsay); Gavotte (Massenet); Minuet in D (Schubert), 8.0, Request: Gramophone Records, 8.30, Exchange, 9.0, Gramophone Music, followed by News, 10.0, Times, Weather and Exchange, 10.5, Saranias, by the Albert Marti Cobla, 11.0, Concert Relay, 12 Midnight (approx.), Close Down.

#### BARI

1,112 kc/s, 269.8 metres; 20 kW.—8.0 p.m., Agricultural Notes, Tourist Talk and Dopavoro Announcements, 8.20, Giornale Radio and Weather, 8.30, Time and Announcements, 8.35, Weather, 8.40 (approx.), Concert of Chamber Music, Ita Lombardo (Pianoforte) and Gioconda de Vito (Violin), Pianoforte Solos: (a) The Harmonious Blacksmith (Handel), (b) Caprice Scarlatti; Violin Concerto in G (Brock); Pianoforte Solo: Fantasia and Fugue in G Minor (Bach-Liszt); Violin Solos: (a) Saranand (Gargiulo), (b) Melody (Mussorgsky); Pianoforte Solos: (a) Clair de Lune (Debussy), (b) Golliwog's Cake Walk (Debussy); Violin Solos: (a) Ave Maria (Schubert-Wilhelmy), (b) Caprice No. 17 (Paganini-Principe); Pianoforte Solo: Ballad No. 4 (Chopin); Violin Solo: Scherzo (Wieniawsky). In the interval, Fashion Notes. After the Concert, Dance Music, relayed from the Iran Caffé del Levante, 10.55, News.

BASLE.—See Schweizerischer Landessender.

#### BELGRADE

397 kc/s, 430.4 metres; 2.8 kW.—6.55 p.m., Time, Announcements, and Orchestral Concert, 8.0, Talk, 8.30, Concert by the Grande Royale Orchestra, 10.0, Popular Songs, 10.30, Time and News, 10.45 (approx.), Cigány Music from the Rumunski Kralj Restaurant.

#### BERLIN

DEUTSCHLANDSENDER (REICHSENDER), 183.5 kc/s, 1,635 metres; 60 kW.—12 Noon, Weather, 12.5 p.m. (approx.), Gramophone Concert: Overture, Pique Dame (Suppé); Carnival in Venice (Benedict); Overture, Morning, Noon and Night (Suppé); Overture, Der Opernball (Heuberger); Egyptian Serenade, Amina (Lincke); Overture, Die Feinschmilde (Reissiger); Third Waltz Potpourri (Robrecht); Potpourri of Wanderlieder); Serenade, Il Bacio (de Micheli); Annen-Polka (Joh. Strauss); Potpourri, Auf Fahrt und Waltz; Tenor Solo: Last du schon einmal zugleich gewinkt, gelacht? (Müllcker); Über Berg und Tal (Sommerfeld). Weather and Market Prices after the Concert, 12.55 p.m., Time Signal, 1.45, News, 2.0, Gramophone Concert—Famous Dance Bands: Paul Whiteman's Band: (a) Mississippi Suite (Grofe), (b) Suite of Serenades (Herbert); Jack Payne's Band: (a) Sunny Days (Jason and Burton), (b) Melody (Friend), (c) Dreams; Milja Nikisch Band: Song (Brown and Robinson); Barnabas von Gezy Orchestra: I want nobody but you (Santiago Lopez); Juan Loosas Orchestra: (a) Autumn (Otono), (b) Plegario (Blanco); Ambrose's Band: (a) My Secret Passion (Young), (b) You've got me crying again (Newmann-Jones), (c) Stormy Weather, 2.45, Programme for Children, 3.30, Weather and Exchange, 1.45, Political Dialogues—Leadership (Plato), 4.0, See Hamburg, 5.0, Dialogue: The New Style in Oratory, 5.20, Concert of Light Music, 6.0, Poems, 6.5, Religious Address, 6.35, Wireless Technical Talk, 5.50, Weather and News, 7.0, Transmission for all German Stations, relayed from Breslau, 8.0, To-day's Motto, 8.5 (approx.), Programme in Various German Dialects, 9.0, Military Band Concert from London, 9.40, Prussian Marches on Gramophone Records: Preussens Gloria (Piefke); Unsere Marine (Thiele); Durch Kampf zum Sieg (Blon); Durch Nacht zum Licht (Lankien); Cadet March (Souza); Florenine March (Fucik); Old Conrades (Teike); Entry of the Gladiators (Fucik), 10.15, News, 10.45, Weather, 11.0, See Munich.

#### BERLIN

FUNKSTUNDE, 715 kc/s, 419.5 metres; 1.5 kW.—4.30 p.m., Concert of Light Music, conducted by Max Beng, 5.10, Folk Songs—Report of the Singing at Bad Freienwalde on August 8th (on Gramophone Records), 5.25, Dialogue: The Last Windmill of Berlin and its Miller, 5.45, Zelter and Schubert Song Recital by Marianne Zarms (Soprano); Part I, Zelter: Erster Verlust; Wo geht's Liebelien; Die Spröde; Die Bekohnte, Part II, Schubert: An den Mond; La pastorella; Das Rosenband; An die Nachtigall; Seligkeit, 6.5, See Berlin (Deutschlandsender), 6.40, The Funkstunde informs its Listeners, 6.45, Topical Talk, 7.0, Transmission for all German Stations, relayed from Breslau, 8.0, Lottery Announcements, 8.5, Folk Songs, 8.35, Concert by the Berlin Wireless Chorus, 9.25, Talk, 9.35, Order in the Alphabet—Radio Sequence, 10.0, News, 10.15 (approx.), Dance Music, In the interval from 11.0-11.5, Topical Talk, 12 Midnight, Close Down.

BERNE.—See Schweizerischer Landessender.

BEROMUNSTER.—See Schweizerischer Landessender.

BODEN.—See Stockholm.

BODO.—See Oslo.

#### BRATISLAVA

1,076 kc/s, 279 metres; 14 kW.—5.45 p.m., Gramophone Music, 5.55, Hungarian Transmission: Talk, Reading and Pianoforte Concerto in E Flat (Mozart), 6.55, Report, 7.0, See Prague, 9.5, See Brno, 10.0, See Prague, 10.15 (approx.), Close Down.

BREMEN.—See Hamburg.

#### BRESLAU

923 kc/s, 325 metres; 60 kW. Relayd by Gleiwitz, 1,184 kc/s, 253 metres.—2.5 p.m. (from Gleiwitz), Song Recital by Hans Kaufmann (Bass): Beresina-Lied (Lezler); Bitterlied (Lyra); Jägers Abendlied (Reichardt); s Glatzer Roserl (Scorria); Pöntisches Erwachen (Scorra), 2.30, Gramophone Concert: Potpourri, Walzer auf Walzer (Geisler); Der verliebte Hampelmann (Rust); Duett: Schön ist jeder Tag, den du mir schenkst (Meisel); Balladluster (Meyer-Helmund); Ballettreigen (Carst); Viennese Song: Schrammeln, spielt's ma no an Tanz (Nitzlader); Polka-Mazurka, Frauentz (Joh. Strauss), 3.0, Market Prices, 3.15, Talk, 3.30, Educational Talk, 4.5, Pianoforte Recital by Eva Ebner-Robert: Aufschwung (Schumann); Warum (Schumann); Grillen (Schumann); Der Linden-

baum (Schubert-Liszt); Gnomengeigen (Liszt), 4.35, Readings from the Works of Upper Silesian Poets, 5.5, Song Recital by Lily Jeschoek (Soprano): Willst du dein Herz mir schenken (Bach); Sehnsucht (Hurka); An meine Laute (Reichardt); Mayreigen (Himmrl); Io Canno (Risghini); Das Geheimnis (Gross); Die Spröde (Hyrka); Schäferlied (Haydn); Liebestaumel (Reichardt); Schon klopft mein liebender Busen (Mozart), 5.35, Market Prices, followed by Talk, 5.55, Quartet No. 35 in D, Op. 61 (Haydn), 6.30, Talk, 6.50, Weather, News and Meat Market Prices, 7.0, Transmission for all German Stations: Ihr frommen deutschen Landsknecht gut—Programme of Songs, Rhymes and Jests about the Mercenary Soldier, 8.0, Topical Programme, 8.30, Dance Music by the Station Orchestra, conducted by Bruno Janz, Soloist: Helmut Hallendorf (Tenor), 10.0, Time and News, 10.20, Talk: The Tasks of a National Literature, 10.40, Dance Music by the Conny Franz Band, from the Jahrhunderthalle, 12 Midnight, Close Down.

#### BRNO

878 kc/s, 342 metres; 35 kW.—6.5 p.m., Gramophone Music, 6.25, German Transmission: News, Technical Talk and Talk on Culture and Civilisation, 7.0, See Prague, 9.5, Concert by the Station Orchestra, conducted by Bakala, Soloist: Igno Mann (Songs); Overture, Mignon (Thomas); Songs: (a) Aria from L'Africaine (Meyerbeer), (b) Aria from Carmen (Bizet); Suite, Rossiniana (Respighi); Songs: (a) Aria from La Gioconda (Ponchielli), (b) Aria from The Girl of the Golden West (Puccini); Ballet Music from The Queen of Sheba (Goldmark), 10.0, See Prague, 10.30 (approx.), Close Down.

#### BRUSSELS (No. 1)

N.I.R., 590 kc/s, 509 metres; 15 kW.—12 Noon, Concert by the Small Station Orchestra, conducted by Lecmans, 12.30 p.m., Pianoforte Recital by Jacques Stehmann, Lesguinka (Liapunov); Sonata in D (Scarlett); Three Preludes (Stehmann), 12.45, Concert (contd.), 1.0, Le Journal Parlé, 1.10, Gramophone Records, Le credo du paysan (Goublier); La voix des chénes (Goublier); Ballad Music from The Cid (Massenet), 1.35, Soprano Song Recital by Mlle. Isabelle Draye, Aria from Resurrection (Handel); Aria from Salammbô (Reyer); A nu l'iaie (Goeyens), 1.50, Gramophone Music, 5.0, Symphony in F (Brusselsans), by the Station Symphony Orchestra, conducted by Knips, 5.30, Programme for Children, 6.5, Literary Review, 6.15, Recitation of Poems by Germaine Knops, 6.30, Concert by the Small Station Orchestra, conducted by Lecmans, Recueillement (de Breville); Nocturne



SEPT. 6th

**WEDNESDAY**

continued

Hagan); The Warbler's Serenade (Parry). Part II. Dance Music: Maybe I love you too much; Waiters on Parade; Peter, Peter; No more love; Da Dar, Da Dar; One Tiny Tear; That's what life is made of; I've got to sing a Torch Song; Spanish Eyes; The Shadow Waltz; Signature Tune. 12.0

**NOON, French Programme. 4.30 to 6.0, Programme in English by the I.B.C. 4.30, Programme for Children. 5.0, Gramophone Concert for Portsmouth and Southsea Listeners: Signature Tune: The Night by the Sea; Selection from The Merry Wives of Windsor (Nicolaï); Any time, any Day, Anywhere (Washington); Selection from The Geisha (Jones); Song: I shall remember you; O'er the Hills to Ardentenny (Lauder); Drifting down the Shalimar (Monaco); Petite Suite (Debussy). 5.30, Organ Recital with Songs for Isle of Wight Listeners: American Patrol (Meacham); Indian Love Call (Prinl); Nola (Arnold); Song: Only a Rose (Prinl); A Perfect Day (Jacobs Bond); Love's Garden of Roses (Haydn Wood); Song: Down Vauxhall Way (Oliver); Kashmiri Love Song (Woodforde-Finden); Signature Tune. 6.0, French Programme. 10.0 (approx.) till Close Down, Programme in English by the I.B.C. 10.0, Dance Music: Signature Tune: Bells of Normandy; Let me explain; Standing on the Corner; Put a little Springtime; You did everything for me; Have you ever been lonely?; Round the Bend of the Road; Balloons; How can you say No? (Dubin); Mediterranean Madness; Bananas; It's no use, I'm in love; The World is so small; Love Tales; The Village Band; Southern Serenade; Here's hoping; Signature Tune. 11.0, Sound Film Music: Signature Tune; Sittin' in the Dark; Selection from Die Fledermaus (Strauss); You are my Heart's Delight, from The Land of Smiles (Lehar); Song: Dark Red Roses; There's something about a Soldier (Gay); Song: I'll stay with you (Woods); Song from The Blue Angel (Hollander); Selection from Show Boat (Kern); Signature Tune. 11.30, Concert by the I.B.C. Ireland. Ltd.: Signature Tune: Come back to Erin; The Clatter of the Clogs (Flynn); Serenade d'amour (Blon); Banjo Solo: Fashionette (Glogaw); Irish Song Medley (arr. Griffiths); Ideale (Tosti); Ireland, Mother Ireland (Loughborough); Selection from The Gipsy Princess (Kalmán); Birthday Serenade (Lincke). 12.5 a.m. (Thursday), I.B.C. News Bulletin in English. 12.10 (approx.). Club Concert for Knutsford Listeners: Signature Tune: The Chum Song; Nine Little Miles from Ten-Ten-Tennessee (Sherman); Heebie Jeebies (Atkins); It's a Glory; Really Blue (Venette); Nightfall (Lewis); Alice Blue Gown (Tierney); Sleepy Valley (Sterling); Tea for Two (Youmans); What could be sweeter than love (Brodzky); I want to be happy (Youmans); Give me a Tune (Scott); My Baby (Gilbert); To-day I feel so happy (Abraham); Signature Tune. 1.0, Dance Music: Signature Tune: Bells of Normandy; I'm getting sentimental over you; My Heart was made for love; In a Second-hand Store; In old Vienna; Dancing Butterfly; In the Valley of the Moon; I can't remember; Maria my own; Meet me in the gloaming; When the Wild, Wild Roses bloom; Lover: Stormy Weather; Sweetheart Darlin'; Falling Star; The Gold Digger's Song; Where are you Tonight. 1.57, I.B.C. Goodnight Melody. 2.0 (approx.), Close Down.**

**FLensburg.**—See Hamburg.**Florence.**—See Turin.**FRANKFURT**

1,157 kc/s, 259.3 metres; 17 kW. Relayed by Cassel, 1,220 kc/s, 245.9 metres; and Trier, 1,157 kc/s, 259.3 metres.—2.30 p.m., News for the Saar District. 2.40, Talk: Listen Everybody! 3.0, Weather. 3.10, Time and Exchange. 3.30, Programme for Young People. 4.25, Exchange. 4.30, Concert. 5.45, Exchange. 6.0, Talk: Yesterday's Events. 6.25, Topical Talk. 6.45, Review of the Day's News. 6.50, Time, Programme Announcements, Weather and Exchange. 7.0, Transmission for all German Stations, relayed from Breslau. 8.0, Recital of Max Reger Pianoforte Music. 8.45, See Stuttgart. 9.15, Die Hosenknopf—A Peasant Play in One Act (Neal and Ferner). 10.0, Topical Talk. 10.15, Time and News. 11.0 (approx.), See Munich.

**FREDRIKSSTAD.**—See Oslo.**FREIBURG.**—See Stuttgart.**GENEVA.**—See Radio-Suisse Romande.**GENOA.**—See Turin.**GLEIWITZ.**—See Breslau.**GOTEBORG.**—See Stockholm.**GRAZ.**—See Vienna.**HAMAR.**—See Oslo.**HAMBURG**

806 kc/s, 372 metres; 1.5 kW. Relayed by Bremen, 1,112 kc/s, 269.8 metres; Flensburg, 1,319 kc/s, 227.4 metres; Hanover, 530 kc/s, 566 metres; and Kiel, 1,292 kc/s, 232.2 metres.—4.0 p.m., Johann Strauss Concert by the Hamburg Philharmonic Orchestra,

conducted by Eibenschutz: Overture, A Night in Venice; Perpetuum mobile; Selection from The Gipsy Baron; Waltz, The Blue Danube; Overture, The Queen's Kerchief; Egyptian March. 5.0, Diabolo—Style in the North German Dialect Ballad. 5.30, Hamburg, Bremen and Lübeck—Report on Events in the Senates and Houses of Burgesses of the Hanseatic Free Cities. 6.0, Variety Programme. 6.25, Reading of New Patriotic Poems, with Introductory Talk. 6.45, Exchange. 6.50, Weather. 7.0, Transmission for all German Stations, relayed from Breslau. 8.0, The Warriors of Helgoland—Play (Jbsen). 9.45 (from Bremen), Concert of Choral Music by Bremen Composers: Gondoliera (Lefmann); Indian Lullaby (Lefmann); Feldeinsamkeit (Wendel); Bitte (Wendel); Am Brünnele (Nössler); Mimmeli (Nössler). 10.10, News. 10.30, Topical Talk. 10.40, Concert by the Kampffbund Chamber Orchestra: Concerto grosso in B. No. 1 (Handel); Baroco, Suite for Small Orchestra (Atterberg). 11.10, Serenade from

**HANOVER.**—See Hamburg.**HEILSBURG**

1,085 kc/s, 276.5 metres; 60 kW. Relayed by Danzig, 662 kc/s, 453.2 metres.—1.5 p.m., Concert by the Small Station Orchestra, conducted by Eugen Wileken: March, Mit Schwung und Tücke (Wileken); Overture, Fatmütze (Suppé); Peasant Dances (Pacher-negg); Kermesse villageoise (Filippucci); Selection from Manon Lescaut (Puccini); Ballet Music from Othello (Verdi); Intermezzo; Humoresque (Reger). In the intervals at 1.20 and 2.0, News. 2.30, Sponsored Gramophone Music. 3.0, Market Prices. 3.20, Practical Hints for the Housewife. 3.30, Programme for Children. 4.0, Educational Talk. 4.30, Concert by the Königsberg Opera House Orchestra, conducted by Wolfgang Brückner: Overture, Romeo and Juliet (Tchaikovsky); Selection from The Valkyrie (Wagner); L'apprenti sorcier (Dukas); Second Polonaise in E flat (Liszt); Waltz from Ritter Pasman (Joh. Strauss); Overture, The Hermit's Bell (Mallart). 5.50, Dialogue on Ju-Jitsu. 6.15, Market Prices. 6.20, Talk: Leaders of the Masses in Ancient and Modern Germany. 6.50, Weather. 7.0, Transmission for all German Stations, relayed from Breslau. 8.0, Weather and News. 8.10, Viennese Melodies and their History—Talk with Gramophone Illustrations. 8.40, Mandoline and Zither Recital: March, Dein Ziel entgegen (Lemke); Der Wald—Fantasia on Themes from Mendelssohn's Choral Music (Wälki); Abendlied (Fahr); Descriptive Piece, Freud und Leid (Rückert); Wine, Woman and Song (Strauss); Paraphrase on the Song Spinn, Spinn (Wormsbacher); March, Durch Nacht zum Licht (Laukien). 9.20, Talk: Modern Dances in their New German Settings. 9.40, Dance Music by the Small Station Orchestra, conducted by Eugen Wileken and the Erich Börschel Dance Band. In the interval at 10.15, News. 12 Midnight, Close Down.

**HILVERSUM**

Announced **HUIZEN**, 1,013 kc/s, 296.1 metres; 20 kW. (7 kW. up to 4.40 p.m.).—12.10 p.m. till Close Down, Programme of the Christian Radio Society (N.C.R.V.). 12.10, 'Cello and Pianoforte Recital by van Maanen and J. Rosekrans: 'Cello Solo: (a) Adagio (Bach), (b) Sonata (Birkenstock); Pianoforte Solo: Impromptu, Op. 142. No. 3 (Schubert); 'Cello Solo: (a) Variations on a Duet from The Magic Flute (Mozart-Beethoven), (b) Allegretto grazioso (Schubert), (c) Après un rêve (Faure), (d) Gavotte (Popper). 12.55, Gramophone Music. 1.10, Concert by a Children's Choir. 2.10 to 2.40, Interval. 2.40, Religious Reading. 3.10, Trio Concert, with Songs: Extract from Judas Maccabæus (Handel); Five Songs from Bijlde stemmen (Schultz); Trio No. 5 (Mozart); Songs (Franz): (a) Im Rhein, (b) Widmung, (c) Auf dem Meer, (d) Aus meinen grossen Schmerzen, (e) Für Einen; Andante (Mann); Five Songs; Selection from Le roi d'Ys (Lalo). 4.40, Programme for Children. 5.40, Agricultural Talk. 6.10, Programme to be announced. 6.40, Police Notes. 6.55, Religious Notes. 7.10, Gramophone Music. 7.40, Festival Service for the Thirty-fifth Anniversary of the Coronation of H.M. Queen Wilhelmina, relayed from the Nieuwe Kerk, Amsterdam. 9.40, News, followed by Gramophone Music. 11.10 (approx.), Close Down.

**HORBY.**—See Stockholm.**HUIZEN**

Announced **HILVERSUM**, 160 kc/s, 1,875 metres; 8.5 kW. Programme of the Workers' Radio Society (V.A.R.A.). 11.40 a.m., Concert by the Small Station Orchestra, conducted by de Groot: Overture, The Nuremberg Doll (Adam); The Wedding of the Winds (Hall); Selection from Gasparone (Müllöcker); Ein Puppenhaus (Englemann); Gramophone Music: Le Carmagnole; Réve (d'Ambrósio); Melody, Occhi neri (Mateo); Le jardin de Cupide (Eugène); Dance (Lucchesi); Gramophone Music: Zonnestraal (Bicrenbroodspot); Tosti Potpourri (God-

frey); Betrothal (Wesley); Meditation (Gounod). 1.40 p.m., Concert by De Flerehuiters, conducted by Ray Forest. 2.40, Programme for Children. 3.25, Interval. 3.40, Programme for Children (contd.). 5.10, Organ Recital by Steyer. 5.40, Concert by Eddy Wallis and his Orchestra: Selection from The Last Waltz (O. Straus); The Song of the Violin (Schebek); Selection from Der Rosenkavalier (R. Strauss); Pensa a te (Tosti); Moment musical (Schubert-Thiel); Extracts from Mozartiana (Tchaikovsky-Weninger); Song and Tarantella (Volpatii); Selection from The Bird Fancier (Zeller); Kashmiri Love Song (Woodforde-Finden); Lammisches Glück (Bürger); Drinking Song (Eisler-Uhl); Hungarian Melodies. In the interval, 6.10, Recitations, and at 6.40, Talk. 7.25, Recital of Jewish Songs by Leo Fuld. 7.40, Talk. 7.48, News. 7.55, Concert by the V.A.R.A. Orchestra, relayed from The Hague. Soloist: Marie Vos (Soprano); Overture, The Barber of Seville (Rossini); Cavatina from The Barber of Seville (Rossini); Ballet Music from Sylvia (Delibes); Waltz, Frühlingstimmen (Strauss); Banditengaiop (Strauss); Frisch durchs Leben (Strauss); Air and Overture from Die Fledermaus (Joh. Strauss). 8.55, Concert by Gaspar Lajos and his Gipsy Band. 9.40, Concert by De Flerehuiters, conducted by Ray Forest. Soloist: Busch (Songs). 10.40, Gramophone Music. 11.40 (approx.), Close Down.

**INNSBRUCK.**—See Vienna.**JUAN LES PINS**

1,205 kc/s, 249 metres; 0.8 kW.—12.30 p.m., Amusement Guide and Variety Items. 1.0, News. 1.15, Radio Concert. 8.0, Amusement Guide, Financial Notes and News. 8.15, Reading. 8.30, Press Review. 8.40, Radio Concert. In an interval at 9.0, News and Weather. 11.30, Dance Music by the Billy Arnold Jazz Band, relayed from the Hollywood Restaurant.

**KALUNDBORG.**—See Copenhagen.**KIEL.**—See Hamburg.**KLAGENFURT.**—See Vienna.**KOSICE.**—See Prague.**LANGENBERG**

635 kc/s, 473 metres; 60 kW.—12 Noon, Concert by the Station Chamber Orchestra, conducted by Wilhelm Keiper: Hofballtänze (Lanner); Overture, Der Eriehügel (Kuhlan); Suite, The Tale of Czar Saltan (Rimsky-Korsakov); Selection from La Gioconda (Ponchielli); German Dances (Schubert). 12.50 p.m., News. 1.0 to 2.30, Orchestral Concert, conducted by Wolf. Festival Overture (Leutner); Humoresque (Dvorak); In den Spinnstuben (Dvorak); Hungarian Rhapsody No. 1 (Liszt); Selection from Paganini (Lehar); Ballet Music from Ritter Pasman (Strauss); Chinese Rhapsody (Gabriel-Marck); March, Heldegrüsse (Döring). In the interval at 2.0, News. 3.0, Handwork for Children. 3.30, Exchange and Time Signal. 3.50, Programme for Young People. 4.30 (from Dortmund), Radio Report of the Dortmund Horse Races. 4.45, Talk: Protecting the Private House from Air Attacks. 5.0, Recital on Two Pianofortes. 5.30, Topical Talk. 5.40, Talk for Women: The Companion Help. 6.0, Concert by the Fröhliche Fünf. 6.45, News, Weather and Sports Notes. 7.0, Transmission for all German Stations, relayed from Breslau. 8.0, News. 8.5, Concert by the Station Orchestra, conducted by Kühn; Suite from Idomeneo (Mozart-Busoni); Suite No. 3 (Tchaikovsky). 8.45, See Stuttgart. 9.15, A Flying Visit. 9.40, See Heilsberg. 10.0, News. 10.30, Serenade by the Fröhliche Fünf. 12 Midnight, Close Down.

**LAUSANNE.**—See Radio-Suisse Romande.**LEIPZIG**

769.9 kc/s, 389.6 metres; 120 kW. Relayed by Dresden, 941 kc/s, 319 metres.—3.0 p.m., Hugo Wolf Song Recital on Gramophone Records. 3.35, Market Prices and Weather. 4.0, Till Eulenspiegel and his Servant—Radio Play for Children (Günther Eich). 4.50, Songs by Fred Albert's Mouth Organ Quartet. 5.20, Reading (Käte Scholle). 5.50, Market Prices, Weather and Time. 6.0, Book Review. 6.20, Talk: A Journey in a Balloon. 6.40, Talk. 6.50, To-day's News. 7.0, Transmission for all German Stations, relayed from Breslau. 8.0, Recital of Old and New Folk Dances. 8.45, See Stuttgart. 9.15, Concert by the Leipzig Symphony Orchestra, conducted by Hans Weisbach: Symphony in B flat (Haydn); Fifth Symphony in C minor, Op. 67 (Beethoven). 10.15, News. 10.35, Gramophone Concert of Rhineland Songs.

**LINZ.**—See Vienna.**LJUBLJANA**

522 kc/s, 574.7 metres; 7 kW.—7.0 p.m., Programme for Children. 7.30, Relay from the Fair. 8.0, Literary Programme. 8.30,

Programme from Belgrade. 10.30-11.0, Programme in English by the I.B.C., International Broadcasting Club Concert: Yes, Mr. Brown; Leave a little for me; If you would learn to live; Ich liebe dich, my Dear; Bon Voyage; In a Shanty in Old Shanty Town; This is my love Song; He's got a Wife and Family at Home; Will you dance through life with me. 11.0 (approx.) Close Down.

**LUXEMBOURG**

252 kc/s, 1,191 metres; 200 kW.—Luxembourg Programme. 7.30 p.m., Concert of Classical Music. 8.20, Recital of Songs. 8.50, News in French. 9.0, Pianoforte Recital. 9.30 Music by the Luxembourg Composer, Mer-tens. 9.45, News in German. 9.55, Concert of Light Music. 10.30, Dance Music or Gramophone Music.

**MADRID**

**EAUJ**, 707 kc/s, 424.3 metres; 2 kW.—8.0 p.m., Chimes, Exchange, Radio Journal, Programme for Women, Request Gramophone Records, and Dance Music. 9.15, Topical Review. 9.30 to 11.0, Interval. 11.0, Chimes, Time, and Topical Review. 11.20 (approx.). Scenes in Bohemian Life—Play (Murger, arr. Pacheco). 1.15 a.m. (Thursday), Topical Review. 1.30, Chimes and Close Down.

**MADRID**

**(EAQ)**, 10,000 kc/s, 30 metres; 20 kW.—11.30 p.m., Concert of Popular Music. In an interval at 11.45, Radio Chronicle. 12.40 a.m. (Thursday), Light Music. 1.0 (approx.), Close Down.

**MALMO.**—See Stockholm.**MILAN**

**VICENTINO**, 662 kc/s, 453.2 metres; 4 kW.—8.30 p.m. till Close Down, See Rome.

**MORAVSKA-OSTRAVA**

1,137 kc/s, 263.8 metres; 11 kW.—6.10 p.m., Concert by the Ostrava Mining Band, conducted by Kumpán: Florentine March (Fucik); Waltz, Gebirgskinder (Zichner); Song: Am Meer (Schubert); Overture, Martha (Plotow); Potpourri, From Old Times (Bernhard); Sunday Polka (Hudec); March, The Marshal (Benes). 7.0, See Prague. 9.5, See Brno. 10.0, See Prague. 10.15 (approx.), Close Down.

**MOTALA.**—See Stockholm.**MUHLACKER.**—See Stuttgart.**MUNICH**

563 kc/s, 533 metres; 60 kW. Relayed by Augsburg and Kaiserslautern, 536 kc/s, 560 metres; and Nurnberg, 1,256 kc/s, 239 metres.—4.30 p.m., Orchestral Concert, conducted by Ernst Hagel: Overture, Prinzessit. Goldschuh (Rust); Suite, Im Zirkus (Lautenschläger); Waltz, Badner Grässe (Kauler); Potpourri, Springtime and Love (Roberts); Ein Sommernachtsfest (Siede); Der Tag von Potsdam (Schmalstieg); March, Bergheil (Egert). 5.45, Dialogue: Gliding as a National Sport. 6.5, Musical Programme. 6.25, Talk: The Mysterious Eel. 6.45, Time, Weather and Market Prices. 7.0, Transmission for all German Stations, relayed from Breslau. 8.0, Military Band Concert, conducted by Wilhelm Gundelach: March, Ritter von Schöpf (Päpke); Jubel-Overture (L. Bach); Waltz, The Wedding of the Winds (Hall); Potpourri, Elektrische Funken (Hauser); Frühling's Erwachen (E. Bach); Parade March from Fridericus Rex (Roland); March, Unter dem Siegesbanner (Blon). 9.0, Waldfrieden—One-Act Play (Ludwig Thoma). 9.40, Concert of Light Music. 10.20, Time and News. 11.0, Dance Music. 12 Midnight, Close Down.

**NAPLES.**—See Rome.**NOTODDEN.**—See Oslo.**OSLO**

277 kc/s, 1,083 metres; 60 kW. Relayed by Fredriksstad, 815 kc/s, 368.1 metres; Hamar, 522 kc/s, 574.7 metres; Notodden, 671 kc/s, 447.1 metres; Porsgrund, 671 kc/s, 447.1 metres.—5.30 p.m., Vocal and Instrumental Concert: Fantasia for Flute and Pianoforte (Theoh); Norwegian Songs for two Voices; 'Cello Solo: (a) Larghetto (Händel-Hubay), (b) Chanson villageoise (Popper), (c) Ständchen (Schubert), (d) Slav Cradle Song (Neruda), (e) Die Biene (Schubert); Norwegian Duets. 6.30, Talk for Girls: Girl Guides. 7.0, Advertising Notes, Weather and News. 7.30, Talk: The Past Summer's Weather. 8.0, Time Signal. 8.2, Concert by the Station Orchestra, conducted by Hugo Kramm: Overture, Iphigenia in Aulis (Gluck); Selection from Der Freischütz (Weber); Selection from The Flying Dutchman (Wagner); Selection from Le Bourgeois Gentilhomme (Richard Strauss). 9.0, Jacob Sande reads from his own Works. 9.30, Agricultural Report. 9.40, Weather and News. 10.0, Topical Talk. 10.15, Recital

Songs. 10.45, Dance Music on Gramophone Records. 11.30 (approx.), Close Down.

STERSUND.—See Stockholm.

SEPT. 6th WEDNESDAY continued

Souvenirs. 12 Midnight, News. 12.5 a.m. (Thursday), Opera Music. 12.15, Viennese Music. 12.30, Close Down.

PALERMO

18 kc/s, 537.6 metres; 3 kW.—8.0 p.m., opolavoro Notes, Tourist Report, Agricultural Notes and Giornale Radio. 8.20, Gramophone Music. In an interval at 8.30, time and Announcements. 8.45, Orchestral concert. Soloists: Esmeralda (Corti Soprano), Castagna (Bassoon). Overture, Ury Blas (Mendelssohn); Soprano Solo; (y) Nonna, sorridi (Tosti); (b) Vatinio (Gründeli); Sonata (Porpora-Gui); Andante and Rondo for Bassoon (Milde); Soprano solo: (a) Ogorano, lo rose (De Curtis); (y) Vieni (Denza); Allegretto (Tchaikovsky); Introduction and Polonaise for bassoon (Demersmann); Overture, Russian and Ludmilla (Glinka). In an interval, Talk. 1.0, Songs. 10.55, News.

PARIS

IFFEL TOWER, Call FLE, 207.5 kc/s, 445.7 metres; 13 kW. Time Signals (on 650 metres) at 10.26 a.m. and 11.26 p.m. Preliminary and 6-dot Signals.—6.45 p.m., Talk on Music. 7.0, Le Journal Parlé. 8.30, symphony Concert, conducted by Eduard Lambert. Soloist: Brunian (Clarinet). Old French Songs (Bye); Larghetto for Clarinet and Strings (Mozart); Variations sur une oeuvre d'Auvergne for Double Quintet (Flautist); Divertissement from Miarka (Georges); Andante cantabile (Tchaikovsky); ong (Lehár); Norwegian Dances (Grieg); Waltz, The Blue Danube (Joh. Strauss). 6.0 (approx.), Close Down.

PARIS

OSTE PARISIEN, 914 kc/s, 328.2 metres; 0 kW.—7.0 p.m., Gramophone Music. 7.15, Le Journal Parlé. 7.30, Literary and Musical Programme by Mlle. Claude-Marthe and Dorival. Les elfes (Thomé); Recitation, Nella (Victor Hugo); La ballade du lésepéré (Bemberg). 8.0, Talk on Economics. 8.5, Insurance Societies Report. 9.30, Concert by the Station Orchestra: Overture, Les noces de Jeannette (Massé); Valtz, Amore-tänztänze (Gungl); Berceuse Dupont; Elegy (Rachmaninov); Selection from Le roi d'Ys (Lalo); Overture, Morning, Noon and Night (Suppé); Selection from S.A.R. (Caryl); Canticque d'amour (Georges); Mazurka naturaliste (Ganne); Polka, Le Rhin (Métra). 10.15, News.

PARIS

RADIO PARIS, Call CFR, 174 kc/s, 1,725 metres; 75 kW.—7.30 a.m., Weather and Physical Culture. 7.45, Gramophone Records: Boutin d'Or (Pierini); Waltz (Hirschmann); Mousette (Piccolini); En elle (Courtade). 8.0, Weather and Press Review. 12 Noon, Educational Talk. 12.15 p.m., Concert: Whitsun Cantata (Bach); Sonata for Violin and Piano (Beethoven). 12.20, Organ Recital, relayed from the Gaumont Palace; Selection from Miss Decima (Audran); Pagan Moon (Bryan); n a Persian Market (Kestelhey); Selection from Forty-Second Street (Dubin). 1.0, Exchange and News. 1.5, Musical and Dramatic Programme: Overture, Preciosa (Weber); Hungarian Dances Nos. 2, 5 and 6 (Brahms); Three Pieces (Schumann); (a) Die Leotoshdume, (b) Der Nussbaum, (c) Die beiden Grenadiere; Scenes 3 and 5 from Act I of Polyenete (Cornelle); Scene V, Act II of Berenice (Racine); Scene VIII, Act II of Andromaque (Racine); Scene IV, Act V of Lesole des Femmes (Moliere). In the interval at 1.30, Exchange. 2.0, Exchange. 4.45, Exchange and Market Prices. 7.0, Agricultural Notes. 7.10, Dance Music on Gramophone Records. 7.50, Commercial Prices and News. 8.0, Gramophone Records: Une soirée au Grand Théâtre; Dans les Magasins (Borel-Clerc); Le Tambour de Becon (Borel-Clerc); Act III of Mamam Solibri (Bataille); Two Items by Grock. 8.30, News and Weather. 8.40, Review by Bonnard. 8.45, Gramophone Records: Duet from Veronique (Messager); Ballet Music from Virginie (Bruneau). 9.0, Oh, Papa—Operetta in Three Acts (Yvain), relayed from the Théâtre des Nouveautés.

PITTSBURGH

KDKA, 980 kc/s, 306 metres; 50 kW. Relayd by W8KK on 48.86 metres and 25.27 metres.—7.30 p.m., Pontiac Home Forum. 8.0 to 9.20, New York Relay. 8.0, Betty and Bob. 8.15, Words and Music. 8.30, Happy Days in Dixie. 9.0, Southern Symphonies. 9.30, Frances Ingram. 9.45, News and Markets. 10.0, Uncle Tom and Betty. 10.15, Tarzan of the Apes. 10.30, Singing Lady, from New York. 10.45, Orphan Annie, from New York. 11.0, News, Piano Classique. 11.15, Sports. A Song. 11.30, Pittsburgh Spotlights. 11.45 to 2.30 a.m. (Thursday), New York Relay. 11.45, Lowell Thomas. 12 Midnight, Amos 'n' Andy. 12.15, Baritone Solos by John Herrick. 12.30, Musical Programme. 1.0, Crime Clues. 1.30, Potash and Perlmutter. 1.45, Phil Cook. 2.0, Music Magic. 2.30, Programme to be announced. 3.0, Pan American Concert, from New York.

PORSGRUND.—See Oslo.

PRAGUE

614 kc/s, 488.6 metres; 120 kW.—3.50 p.m., Weather. 3.55 to 4.0, Exchange. 5.45, Gramophone Music. 5.55, Talk: Future Productions of the Cinema. 6.5, Agricultural Report. 6.10, Gramophone Records. 6.25, News in German. 6.30, German Transmission; Talk for Workers. 7.0, Chimes and News. 7.10, Concert by the Ondrick Quartet and Lanhats (Bass); Merry Ditties (Ferny); Trio for Violin, Viola and Cello (Terrasse). 7.50, Talk on Technical Schools. 8.5, On the Berounka River under the Tetin Castle—Play (Krofta). 9.5, See Brno. 10.0, Time and News. 10.15, Announcements in French. 10.30, Close Down.

RADIO-SUISSE ROMANDE

SOTTENS, 743 kc/s, 403 metres; 25 kW.; and Geneva, 395 kc/s, 760 metres.—3.28 p.m., Time Signal from Neuchâtel Observatory. 3.30 (from Lausanne), Concert by the Radio Lausanne Orchestra, conducted by Moser. 5.0, Interval. 6.0 (from Lausanne), Programme for Children. 7.0, Radio Report from Military Man-of-war. 9.0, Concert by the Radio-Suisse Romande Orchestra, conducted by Moser. Part I, Music of Geneva: Concert pour Ninette on Ninon (Dupérier); Melody for Cello and Orchestra (Guignard); Soloist: The Composer; Orchestral Suite, Rêve d'enfant (Wetraz); Toscan Study (Breitenstein); Overture, Argentine Night (Chatelein). Part II, Music of Vienna. 9.50, News. 10.0 (from Geneva), Dance Music. 11.0 (approx.), Close Down.

RJUKAN.—See Oslo.

ROME

Call IRO, 680 kc/s, 441 metres; 50 kW. Relayd by Naples, 941 kc/s, 319 metres; and 2RO, 11,810 kc/s, 25.4 metres, from 5.15 p.m.—12.30 p.m., Gramophone Music. 1.0, Orchestral Concert. In the interval from 1.30-1.45, Giornale Radio and Exchange. 2.0, Time and Announcements. 4.50, Giornale Radio, Exchange and Report of the Royal Geographical Society. 4.45, Children's Radio Review. 5.10, Weather. 5.15-6.0, Orchestral Concert. 6.40 (Naples), Shipping and Sports Notes. 6.45, Dopolavoro Notes and Tourist Report. 6.57, Report of the International Institute of Agriculture (in Italian and English). 7.20, News in Foreign Languages. 7.40, Giornale Radio. 8.0, Time, Announcements and Gramophone Music. 8.25, Giornale Radio and Sports Notes. 8.30, String Quartet in F (Dvorák). 9.15, Con rifiorimento a vostra preghiera—Comedy in One Act (Filippo Ranghì). 9.45 (approx.), Selection from Le Maschere (Opera Mascagni). After the Concert, Dance Music from the Casina Valadier. 10.55, Giornale Radio.

SALZBURG.—See Vienna.

SCHENECTADY

WGY, 790 kc/s, 379.5 metres; 50 kW. Relayd at intervals by W2XAF on 31.48 metres and by W2XAD on 19.56 metres.—9.0 p.m., Business and Professional Women's Club Talk. 9.10, Pop Concert, from New York. 9.30, Texas Cowgirl, from New York. 9.40, Talk: The Mind Age. 9.45 to 10.0 (approx.), Lady Next Door, from New York. 12.45 a.m. (Thursday), Stock Reports and Baseball Scores. 1.0, Variety Programme, from New York. 1.30, Popular Programme. 1.45, Musical Programme. 2.0, Ferde Grofe's Orchestra, from New York. 2.15, Popular Programme. 2.30, Variety Programme. 3.0, Popular Programme, from New York. 3.30, Ship of Joy, from New York, followed by Programme Résumé.

SCHWEIZERISCHER LANDESENDER

BEROMUNSTER, 653 kc/s, 459 metres; 60 kW.; Basle, 1,229 kc/s, 244.1 metres; and Berne, 1,220 kc/s, 245.9 metres.—5.0 (from Basle), Programme for Children. 5.30 (from Basle), Concert of Light Hungarian and Gipsy Music by the Radio Quartet. 5.30 till Close Down, Programme from Zurich. 6.30, Programme for Women. 7.0, Time, Weather, and Market Prices. 7.10, Gramophone Music. 7.30, Elementary English Lesson. 8.0, Zither Music. 8.30, Talk: Travelling in Greece. 9.0, News. 9.10, Old Italian Music. 10.15 (approx.), Close Down.

SOTTENS.—See Radio-Suisse Romande.

STOCKHOLM

689 kc/s, 436 metres; 55 kW. Relayd by Boden, 244 kc/s, 1,229.5 metres; Göteborg, 932 kc/s, 322 metres; Hörby, 1,166 kc/s, 257 metres; Motala, 221.5 kc/s, 1,354.4 metres; Östersund, 389 kc/s, 770 metres; and Sundsvall, 554 kc/s, 542 metres.—5.5 p.m., Programme for Children. 5.45, Gramophone Music. 6.45 (from Göteborg), Songs to the Lute. 7.15, Weather and News. 7.30, Military Band Concert, conducted by Per Berg,

relayed from Umea, 1,201 kc/s, 231 metres. 8.30, Talk. 9.0, Song, Violin and Piano (Recital by Sara Qvarnström, Sven Kjellström and Ingrid Kjelström. Songs: (a) Du Sveriges bygd (Alfhen), (b) Inland myrten och isasminer (Peterson-Berger), (c) Jag minns (Alfvén), (d) En dalnustrålk (Wiklund). Duet for Violin and Piano (Borwald): Two Songs (Sjödinus); Song (Melartin). 9.30, The Practical Corner. 9.45, Weather and News. 10.0, Dance Music by Euders Band, relayed from Berns Hall. 11.0 (approx.), Close Down.

STRASBOURG

869 kc/s, 345 metres; 11.5 kW.—11.30 a.m., Gramophone Concert of Light Music. 12.45 p.m., News. 1.0, Time and Exchange. 1.5, Light Music on Gramophone Records. 2.0 to 3.30, Interval. 3.30, Orchestral Concert, conducted by Bronillac, relayed from the Casino, Viehy: Overture, Chérubin (Massenet); Au jardin des fêtes galantes (Razigade); Lyric Suite (Grieg); Melody; Prélude pour la mort de Tintagiles (Cooly); Selection from Sigurd (Reyer); Waltz, Moonlight on the Alster (Fétras). 5.0, Talk on Electricity. 5.15, Orchestral Concert, conducted by Koskam; March, El Capitan (Sousa); Selection from La Traviata (Verdi); Extase (Ganne); Waltz, Transaktionen (Joh. Strauss); Sérénade, Il Bacio (Micheli); Suite internationale (Tchaikovsky). 6.0, Trio Concert, relayed from Lille, 1,130 kc/s, 265.4 metres. 7.0, Talk: Helping Blind Workers. 7.15, Talk in German on Handwork. 7.30, Time and News. 7.45, Gramophone Music. 8.0, Press Review in German, Lottery Results and Announcements. 8.30, Symphony Concert, conducted by Paul Paray, relayed from the Casino, Viehy. Soloist: Umberto Benedetti (Cello). Overture, Chérubin (Massenet); Suite (Saint-Saëns); Cello Solos: (a) Elégie (Faure), (b) Die Spinnerin (Dunkler); Spring Song (Mendelssohn); Le tombeau de Couperin (Ravel). 10.30 (approx.), Press Review. 10.35, Concert, relayed from the Grand Kléber Tavern. Conductor: Heunne, March, Regimentskinder (Fucik); Waltz, Donauwellen (Favoniev); The Parade of the Tin Soldiers (Jessel). En parcourant mon album à musique (Baillon); Potpourri of Old American Popular Melodies, Fox-Cocktail (Salahert); Potpourri, Old Alsace (Meyer).

STUTT GART

MUHLACKER, 832 kc/s, 360.5 metres; 60 kW. Relayd by Freiburg, 527 kc/s, 570 metres.—12.2 p.m. (approx.), Concert from Leipzig. 1.15, Time and News. 1.30, Extracts from Lohengrin—Opera (Wagner), on Gramophone Records. 2.30, See Frankfurt. 2.40, Programme arranged by the Post Office, with Gramophone Music. 3.33, Programme for Boys. 4.30 (from Freiburg), Orchestral Concert, conducted by Karl Körner; March, Hoch Badner Land (Härtle); Bilder aus Ostpreussen (Notz); Rheinischer Saug (Hannemann); Oberländer für Two Violins and Orchestra (Rumpold); Meissner Porzellan (Francke); Rhapsody on Swabian Songs (Kämpfert). 5.45, Talk: Better Advertisement for Small Traders. 6.10, Talk: Be German and speak German. 6.35, Time and News. 7.0, Transmission for all German Stations, relayed from Breslau. 8.0, See Leipzig. 8.45, Havana in Baden—A Radio Report from the Tobacco Research Laboratories in Foreheim. 9.15, Wind Instrument Concert, relayed from London. 9.40, Reminiscences of the Great War—The Battle of Heligoland. 10.0, Time and News. 10.15 (approx.), Dance Music on Gramophone Records. 11.0, See Munich. 12 Midnight, Close Down.

SUNDSVALL.—See Stockholm.

TOULOUSE

779 kc/s, 385 metres; 8 kW.—6.15 p.m., Chansonnettes. 6.30, Accordion Solos. 6.45, Sound Film Music. 6.50, Talk. 7.15, News. 7.30, Songs by a Russian Choir. 7.45, Instrumental Solos. 8.0, Military Music. 8.15, Opera Music; Selection from (a) Hamlet (Thomas), (b) La Dame blanche (Boieldieu), and (c) Carmen (Bizet). 8.30, Programme by a Viennese Orchestra. 8.45, Sound Film Music. 9.0, Sponsored Concert: Recuerdo de Corrida (Menichetti); Extract from L'Arlésienne (Bizet); Selection from The Gipsy Princess (Kálmán); One-step, Blonde or Brunette (Macieochi); The Death of Aase from Peer Gynt Suite (Grieg); Fox-trot, Maklouf (Menichetti); Varavilla (Rizzi); Hungarian March (Berlioz). In the interval, Songs. 10.15, News. 10.30, Concert for Listeners in Morocco; Parisetet (Prodhomme); Dans une charrette from Cibonlette (Hahn); Gouttes d'eau (Petit); Saint demeure chaste et pure from Faust (Gounod); Vindobona (Leopold); Melody (Merle); Potpée valsante (Poldini); Souvenir des Vosges (Blondiat). 11.0, Dance Music. 11.45, Musical Programme: Selection (Lehár) from (a) The Merry Widow, and (b) The Land of Smiles; Classical

TRIESTE

1,211 kc/s, 247.7 metres; 10 kW.—5.10 p.m., Organ and Violin Recital: Sonata in D for Violin and Organ (Handel). Organ Solos: (a) Toccata (Frescobaldi), (b) Toccata and Fugue in E (Bach), (c) Soeur Monique (Couperin), (d) Intermezzo lirico (Bassi), (e) Scherzo in G minor (Bassi). Pieces for Violin and Organ: (a) Largo (Clarambault), (b) Prelude and Allegro (Pugnani-Kreisler), 6.0 till Close Down, See Turin.

TRONDHEIM.—See Oslo.

TURIN

273.7 metres; 7 kW. Relayd by Milan, 905 kc/s, 331.5 metres, Genoa, 599 kc/s, 312.8 metres, and Florence, 599 kc/s, 500.8 metres.—5.10 p.m., Concert. 6.0-6.5, Weather Forecast. 6.40, Giornale Radio, Dopolavoro Announcements and Gramophone Music. 7.0, Time, Tourist Report and Gramophone Music. 7.10, Agricultural Notes and Market Prices. 7.20, News in Foreign Languages. 7.40, Gramophone Music. 8.0, Announcements, Giornale Radio, Sports Notes, Weather, and Gramophone Music. 8.30, The Merry Peasant—Operetta in Three Acts (Fall). In the intervals, Talk and Literary Notes. 11.0, Giornale Radio.

VATICAN CITY

15,120 kc/s, 19.84 metres (Morning), and 5,959 kc/s, 50.26 metres (Evening); 10 kW.—11.0 to 11.15 a.m., Religious Information in Spanish. 8.0 to 8.15 p.m., Religious Information in Italian.

VIENNA

581 kc/s, 517 metres; 100 kW. Relayd by Graz, 852 kc/s, 352.1 metres; Innsbruck, 1,058 kc/s, 283 metres; Klagenfurt, 662 kc/s, 453.2 metres; Linz, 1,220 kc/s, 245.9 metres; and Salzburg, 1,373 kc/s, 218.5 metres.—3.0 p.m., Time and Announcements. 3.20, Talk: Electricity in Industry in Austria and Other Countries. 3.35, Nature Stories for City Folks. 3.55, Operetta Duets on Gramophone Records. 4.35, Programme for Young People. 5.0, Educational Talk. 5.25, Concert of Contemporary Austrian Music—Frauz Ippisch; The Sedlak-Winkler Quartet and Josef Manowarda (Baritone); String Quintet in D; Songs: (a) Dunkeler Falter, (b) Der Herbst, (c) Bitte, (d) Der Einsiedel. 6.5, Talk: Adventures in the Mountains. 6.30, Talk: African and American Negro Music, with Gramophone Illustrations. 7.0, The Arabian Nights—Concert by the Wiener Symphoniker, conducted by Max Schüberr; Soloist, Georg Maikl (Tenor); Overture, The Caliph of Bagdad (Boieldieu); Dance from Hassan, der Schwärmer (Kienzl); Selection from The Barber of Bagdad (Cornelius); Song from Marouf (Raband); Scheherazade (Rimsky-Korsakov). In an interval at 7.35, Time and Announcements. 8.30, Talk on the Employment Problem. 9.0, Little-known Raimund—Literary Programme. 10.0, News. 10.15, Concert by a Schrammel Trio and Soloists, relayed from the Krantz-Ambassador Hotel.

WARSAW

212.5 kc/s, 1,411 metres; 120 kW.—11.57 a.m., Time Signal and Fanfare from St. Mary's Church, Cracow, 959 kc/s, 312.8 metres. 12.5 p.m., Popular Concert, conducted by Szule, relayed from the Bagatela. In an interval at 12.25, Polish Press Review and Weather Report. 12.55, Radio Journal. 1.0 to 2.55, Interval. 2.55, Gramophone Music. 3.5, News. 3.10, Announcements. 3.15, Gramophone Music. 3.25, Economic Notes. 3.35, Gramophone Music. 3.45, News. 4.0, Gramophone Music. 5.0, Topical Talk. 5.15, Violin and Song Recital, by Oziminski and Wraga (Bass). Violin Solos: (a) Melody (Statkowski), (b) Butterfly (Andrzejowski), (c) Gavotte (Glück-Burmester), (d) Die Biene (Schubert), (e) Mazurka (Hubay), (f) Tarantella (Wienski); Songs: (a) Song (Gottovae-Jakov), (b) Oechi di Fata (Denza), (c) Ouvres tes yeux, biens (Massenet); Violin Solos: (a) Intermezzo from Goplana (Zelenski-Barcoviez), (b) Serenade (Arenski), (c) Gipsy Dances (Saraste); Songs: (a) O Star of Eve from Tambourer (Wagner), (b) Aria from Ernani (Verdi), (c) Aria from The Barber of Seville (Rossini). 6.15, Talk, relayed from Lwów, 788 kc/s, 381 metres. 6.35, Recital of Slay Songs. 7.5, Gramophone Music. 7.20, Miscellaneous Items. 7.35, Programme Announcements. 7.40, Reading. 8.0, Piano-forte Recital by Szpinalski. Variations sérieuses (Mendelssohn); Sonata appassionata (Beethoven); Three Pieces (Schubert-Liszt): (a) Waltz, (b) Ständchen, (c) Der Erbkönig. 8.50, Radio Journal. 9.0, Answers to Agricultural Correspondence. 9.10, Hawaiian Guitar and Song Recital. 10.0, Talk in Esperanto. 10.25, Sports Notes. 10.35, News, Aviation, Weather Report and Police Notes. 10.40, Dance Music, relayed from the Europe Café, Czechoeinek.

ZURICH.—See Schweizerischer Landessender.

## ATHLONE

725 kc/s, 413 metres; 60 kW. Relayed by Cork, 1,337 kc/s, 224.4 metres.—1.30 to 2.30 p.m., Time Signal, Weather Report, Stock Exchange Quotations and Gramophone Music. 6.0, Programme for Children. 6.40, News. 7.0, French Lesson. 7.15, Talk: A Triumph for Christianity. 7.30, Time Signal. 7.31, Illustrated Lecture Recital by H. R. White: Pianoforte Tune Production. 8.0, Soprano Solos by W. Henderson. 8.15, Orchestral Music. 8.30, Pianoforte Solos by F. C. J. Swanton. 8.45, Tenor Solos by James Cowhite. 9.0, Orchestral Music. 9.15, Violin and Harp Solos by Annie Fagan and E. K. Lange. 9.45, Sponsored Programme. 10.45, News, Weather Report and Close Down.

## BARCELONA

EAJ1, 860 kc/s, 348.8 metres; 8 kW.—7.0 p.m., Concert by the Station Trio: Selection from Luisa Fernanda (Moerno Torroba); Vida zingara (Valls); Bolero (Breton); Selection from Los Flamencos (Vives); Danza del maleficio (Romero); Pavane (Albeniz); Cordoba (Fuste). In the interval, Talk. 8.0, Request Gramophone Records. 8.30, Exchange. 9.0, Gramophone Concert, followed by News and Exchange. 10.5, Concert by the Station Orchestra: Paso Doble, Angelillo (Urmental); Waltz, Flott durchs Leben (Translaten); A la memoria de un hebe (Turina); Nocturne (Perey); Oriental Dance (Bortkiewicz); Intermezzo (Kark); Czardas (Michiels). 11.0, El Lliri d'Aigua—Comedy in Three Acts (Soler). In the interval at 12 Midnight, News. 1.0 a.m. (Friday), Close Down.

## BARI

1,112 kc/s, 269.8 metres; 20 kW.—8.0 p.m., Agricultural Notes, Tourist Talk and Dopolavoro Announcements. 8.20, Giornale Radio and Weather. 8.30, Time and Announcements. 8.35, Weather. 8.40 (approx.), Military Band Concert, conducted by Salvatore Rubino: March, Op. 76, No. 4 (Schumann); Overture, Norma (Bellini); Selection from Norma (Bellini); Symphonic Poem, Feste di Roma (Respighi); Selection from L'amico Fritz (Mascagni); Overture, Le Carnaval romain (Berlioz). In the interval, Announcements. 10.30, Gramophone Music. 10.55, News.

BASLE.—See Schweizerischer Landessender.

## BELGRADE

697 kc/s, 430.4 metres; 2.8 kW.—6.55 p.m., Time, Announcements, and Yugoslav Songs. 7.30, Concert by the Station Orchestra. 8.30, Song Recital from Ljubljana. 10.30, Time and News. 10.45 (approx.), Dance Music on Gramophone Records.

## BERLIN

DEUTSCHLANDSENDER (REICHSENDER), 183.5 kc/s, 1,635 metres; 60 kW.—12 Noon, Weather. 12.5 p.m. (approx.), Gramophone Concert; Part I: Chamber Music: Sonata in G for Violin and Pianoforte (Bach); Minuet from the Divertissement in D (Mozart); Romance in F (Beethoven); Moment musical (Schubert); Ständchen (Brahms); Part II: Waltzes: Weener Madeln (Ziehrer); Die Romanziker (Lanner); Waltz from Faust (Gounod); Abendstern (Lanner); Waltz, Frühlingsstimmen (Joh. Strauss); Weather after the Concert. 12.55, Time Signal. 1.45, News. 2.0, Gramophone Concert: Berliner Luft (Löhke); Es rauscht der Wald (Hempele); Mondschein-Walzer (Dörning); Pan und Waldschrat (Rathke); Zug der Gnommen (Bion); Ich möcht' einen Walzer (Kernbach); In the Teahouse of the Hundred Steps (Yoshitomo); Kasperles Wochenende (Plamm); Leucht-käferchens Stelldichein (Siede); Lustiges Wien (Meisel); Nina Nanna (de Michel); Siciliana (Schmalstich); Im Prater blüht wieder die Bäume (Stolz); Czardas (Grossmann). 2.45, Programme for Children. 3.10, Programme for Young People. 3.30, Weather and Exchange. 3.45, Political Dialogues—The King (Paul Ernst). 4.0, See Heilsberg. 5.0, Talk for Women: Attractive Accessories for the Home. 5.20, Cello and Pianoforte Recital of Contemporary Music: Sonata in One Movement for Cello and Pianoforte (Dombrowski); Pianoforte Solos (Hermann Unger): (a) Nocturne—Four Fantasias for Pianoforte, (b) Ukrainisches Skizzenbuch; Elegy for Cello and Pianoforte to the Memory of Gerhard Schjeldrup. 6.0, Poems. 6.5, Programme by Erwin Eckersberg. 6.30, Agricultural Talk. 6.50, Weather and Announcements. 7.0, Transmission for all German Stations: Erbkrank-Erbgesund (Hereditary Health and Ill-health), A Eugenic Radio Play (Konrad Dürre). 8.0, To-day's Motto. 8.5 (approx.), Concert of Opera Music by the Station Orchestra, conducted by Rudolf Pelterka; Soloists, Nina Lützwow and Torkild Noval (Songs); Overture, Rühelzahl (Weber); Aria from Iphigenie auf Tauris (Gluck); Aria from Paris and Helen (Gluck); Prelude to the Fourth Act of Carmen (Bizet); Duet from Das Nachtlager von Granada (Kreutzer); Overture, Il Seraglio (Mozart); Aria from Don Giovanni (Mozart); Selection from Manon (Massenet); Aria from L'Arlesiana (Cilea); Duet from I Pagliacci (Leoncavallo); Prelude to Die Königs-kinder (Humperdinck). 9.15, A Humorous Radio Se-

## BERLIN

quence (Georg Mühlen-Schulte). 10.0, News. 10.25, Radio Report from the German and Italian Student Camps at the International University Sports in Turin (on Gramophone Records). 10.45, Weather. 11.0, Concert from the Nationale Gaststätten. 12.30 a.m. (Friday), Close Down.

## BERLIN

FUNKSTUNDE, 715 kc/s, 419.5 metres; 1.5 kW.—5.50 p.m., Novelletten in E Major and F Sharp Minor, Op. 21, for Pianoforte (Schumann). 6.10, Talk: Architecture in the Third Reich. 6.30, Talk on Pomerania. 6.40, The Funkstunde informs its Listeners. . . . 6.45, Topical Talk. 7.0, Transmission for all German Stations, relayed from Berlin (Deutschlandsender). 8.5, Hunters and Mariners—Fire-side Stories. 8.40, A Radio Report from Siemens's Factory. 9.0 to 1.0 a.m. (Friday), Old and New Dances by the Station Orchestra, conducted by Franz Friedl, Waldemar Haas' Dance Band, Gertrud Callam (Soprano), Arthur Heil (Tenor), and the Station Choir; Commentary by Fred Krüger. In the interval at 10.0 (approx.), News. 1.0 a.m., Close Down.

## BERNE

BERNE.—See Schweizerischer Landessender.

## BERMUNSTER

BERMUNSTER.—See Schweizerischer Landessender.

## BODEN

BODEN.—See Stockholm.

## BODO

BODO.—See Oslo.

# THURSDAY

## SEPTEMBER THE SEVENTH

## PRINCIPAL EVENTS OF THE DAY:

## AT HOME

## NATIONAL

## LONDON

## REGIONAL

## MIDLAND

## REGIONAL

## NORTH

## REGIONAL

## WEST

## REGIONAL

## SCOTTISH

## REGIONAL

## BELFAST

Promenade concert from Queen's Hall, London. Concert Party programme, relayed from the Gaiety Theatre, Afr.

"Sultaniah, a currant tale of the East," by Dorothy Eaves

Three plays: "Bottled Biography," by G. W. Baldwin; "The Black Gate—1381," by A. A. le M. Simpson, and "The Adventure of the Blue Car-buncle," by Conan Doyle.

"The Grand Old Lady," a play, by Froom Tyler.

"Ayont the Hill," a comedy, by Cormac Simpson.

"The Welcome Guest," an Ulster comedy, by L. McAlery.

## ABROAD

## BERLIN

(Deutschland-sender)

## BRESLAU

## BRUSSELS

(No. 1)

## BRUSSELS

(No. 2)

## COPENHAGEN

## HAMBURG

## HILVERSUM

8.5 p.m. Concert of opera music, by the Station Orchestra.

9.10 p.m. Concert version of opera: "Si j'étais roi," by Adam

8.0 p.m. Mozart concert, by the Station Orchestra, conducted by Meulemans.

10.10 p.m. Act I of opera, "Mephistopheles," by Boito, on gramophone records.

8.0 p.m. Concert of English music, by the Station Orchestra and the Fleet Street Choir.

8.10 p.m. Comic opera: "The Barber of Bagdad," by Cornelius.

7.40 p.m. The Dutch Chamber Music Orchestra.

Arthur Galaske: March, Unser Reichskanzler Siegfried Heil (Wrangen); Overture, Der Tambour der Garde (Till); Waltz from Der Obersteiger (Zeller); Selection from Rigoletto (Verdi); Paraphrase on the Song, Grün ist die Heide (Blume); Potpourri of German Marches (Blankenburg); March, Regimentsgruss (Steinbeck); Selection from The Flying Dutchman (Wagner); Einzug der Rosenkönigin (Rhode). 5.25, Market Prices and Topical Talk. 5.50, Lieder Recital by Hilde Seubke (Mezzo-Soprano). 6.20, Talks by Workers and their Leaders. 6.50, Weather, News and Meat Market Prices. 7.0, Transmission for all German Stations, relayed from Berlin (Deutschlandsender). 8.0, Concert by the Silesian Philharmonic Orchestra, conducted by Ernst Hoffmann: Classical Symphony (Prokofiev); Masquerade, an American Rhapsody (McKinley); Harlekins Leben und Lieben (Königsberger). 8.40, Austria . . . . 9.0, News. 9.10, Concert Version of Si j'étais Roi—Opera (Adam). 10.10, Time and News. 10.30, Programme from Berlin Funkstunde. 12 Midnight, Close Down.

## BERLIN

BRNO  
878 kc/s, 342 metres; 35 kW.—6.5 p.m., Gramophone Music. 6.25, German Transmission—News and Reading of a Legend. 7.0, See Prague. 7.10, Radio Report from the Aerodrome. 7.30, See Prague. 8.45, Talk in Italian. 9.0, See Prague. 11.0 (approx.), Close Down.

## BRNO

BRNO  
878 kc/s, 342 metres; 35 kW.—6.5 p.m., Gramophone Music. 6.25, German Transmission—News and Reading of a Legend. 7.0, See Prague. 7.10, Radio Report from the Aerodrome. 7.30, See Prague. 8.45, Talk in Italian. 9.0, See Prague. 11.0 (approx.), Close Down.

BERNE.—See Schweizerischer Landessender.

BERMUNSTER.—See Schweizerischer Landessender.

BODEN.—See Stockholm.

BODO.—See Oslo.

## BORDEAUX-LAFAYETTE

986 kc/s, 304 metres; 13 kW.—6.30 p.m., Radio Journal. 7.40, Report of the International Labour Office. 7.55, News. 8.5, Gramophone Music. 8.30, La Française—Comedy in Three Acts (Briens).

## BRATISLAVA

1,076 kc/s, 279 metres; 14 kW.—6.5 p.m., Gramophone Music. 6.10, Talk: Florence. 6.25, Concert of Light Music. 6.55, Report. 7.0, See Prague. 7.10, See Brno. 7.30, Pail de Carotte—One-Act Play (Renard). 8.45, See Brno. 9.0, See Prague. 11.0 (approx.), Close Down.

BREMEN.—See Hamburg.

## BRESLAU

923 kc/s, 325 metres; 60 kW. Relayed by Gleiwitz, 1,184 kc/s, 253 metres.—12 Noon, Concert by the Station Orchestra, conducted by Bruno Janz. 1.45 p.m., Time and News. 2.5, Suite for Flute and Pianoforte, Op. 7 (Zanke). 2.20, Gramophone Music. 3.0, Market Prices. 3.15, Talk: Little Known Youth Hostels in Lower Silesia. 3.25, Review of Books. 3.45, Programme for Children. 4.10, Concert by a Nazi Orchestra, relayed from the Wappenhof; Conductor,

Violin Concerto in G; Overture, Figaro: Andante for Flute; Minuet from the Symphony in C; Overture, Titus. 8.45, Talk: The Results of the World Conference. 9.0, Concert by the Radio Orchestra, conducted by Franz André: Overture, Les Saltimbanques (Ganne); Franson Potpourri (Sala bert); Moonlight on the Alster (Fetras); Campana a sera (Billi); Passionnément (Messenger); Two Fox-trots (Woods); Potpourri of Old French Airs, Parisiana (Bohuslaw-Leopold); Spanish Dances (Sarasate); Three Mask Dances (Wood). 10.0, Le Journal Parlé. 10.10, Gramophone Music.

## BRUSSELS (No. 2)

N.I.R., 887 kc/s, 338.2 metres; 15 kW. Programme in Flemish.—12 Noon, Concert by the Small Station Orchestra, conducted by Leemans: Overture, Morning, Noon and Night (Suppe); Scènes pittoresques (Massenet); Meditation from Titus (Massenet); Violin Solo, The Canary (Poliakini); Selection from L'air du Temps (Schubert-Berté); Two Gramophone Records; Waltz from The Count of Luxembourg (Lehar). 1.0 p.m., Le Journal Parlé. 1.10, Sacred and Variety Music on Gramophone Records. 5.0, Tchaikovsky Concert by the Station Symphony Orchestra, conducted by Meulemans: 1812 Overture, Extracts from The Nutcracker Ballet; Caprice Italien. 5.45, Programme for Children. 6.30, Grieg Concert on Gramophone Records. 7.12, Announcements. 7.15, Film and Book Review. 7.30, Programme for Housewives. 8.0, Concert by the Radio Orchestra, conducted by Franz André: K.V.R.O. striedje (Meulemans); Overture, La dame blanche (Boieldieu); Humorous Interlude; Intermezzo and Barcarolle from The Tales of Hoffman (Offenbach); Saxophone Solo; Viennese Waltzes (Gillon). 8.45, Talk. 9.0, Concert by the Station Symphony Orchestra, conducted by Meulemans: Fantaisie labouchéne (Boeck); Serenade (Piercé); Canzonetta for Clarinet and Orchestra (Piercé); Fantasia on Two Popular Tounai Airs (Daneau); Interlude in Old Style (Glyzounov); Fantasia, Kamarinskaya (Glika); Carnaval de Paris (Svend-sen). 9.55, Evening Prayer. 10.0, Le Journal Parlé. 10.10, Act I of Mephistopheles—Opera (Boito), by the Cast of the Scala, Milan, on Gramophone Records.

## BUCHAREST

761 kc/s, 394 metres; 12 kW.—5.0 p.m., Light Music and Romanian Music by the Grigoras Dimico Orchestra. In an interval at 6.15, Radio Journal. 7.0, Reading. 7.20, Light Music on Gramophone Records. 7.40, Educational Talk. 8.0, Baritone Solos. 8.20, Concert by the Station Orchestra, conducted by Rogalski: Soloist, Sarvas (Violin); Fugue in A Minor (Bach); Concerto in D for Violin and Orchestra (Beethoven); Suite, Jeux d'enfants (Bizet); Intermezzi goliardici (Boschi). In an interval at 9.0, Talk. 9.45, Radio Journal.

## BUDAPEST

545 kc/s, 550.5 metres; 18.5 kW. Also relayed on 840 metres from 8.15 p.m. till Close Down.—5.30 p.m., Song Recital by Maria Kovacs. 6.15, Concert by the Opera House Orchestra, conducted by Fridl. 7.45, Variety Programme. 8.15, Concert by the Roth String Quartet: Quartet in C flat minor (Dobnanyi); Quartet in a minor (Brahms). 9.15, News. 9.35, Music by the Josef Racz Gygány Band. 10.0, Review of Foreign Politics. 10.45, Concert by the Karolyi Salon Orchestra, relayed from the Café Buda. 11.15, Talk in English: The World Jamboree at Gödöllo, Budapest.

CASSEL.—See Frankfurt.

## COPENHAGEN

1,067 kc/s, 281 metres; 0.75 kW. Relayed by Kalundborg, 260 kc/s, 1,153.8 metres.—12 Noon, Town Hall Chimes and Weather. 12.5 to 2.0 p.m., Concert by a String Orchestra, conducted by Bendix, relayed from the Wivex Restaurant. 3.5, First Movement from the Violin Concerto No. 1 in C (Vieuxtemps). 3.25, Reading of Danish Lyrics. 3.45, Concert by the Station Orchestra, conducted by Lanny Grondahl: Overture, Le Brasseur de Preston (Adam); Waltz from The Sleepless Beauty (Tchaikovsky); Overture, La Traviata (Verdi); Norwegian Rhapsody No. 3 (Svendson); Three Pieces from Sigurd Jorsalfar (Grieg). 4.45, Programme for Boys. 5.30, Exchange and Fish Market Prices. 5.45, Talk. 6.15, Elementary English Lesson. 6.45, Weather Report. 7.0, Press Review. 7.15, Time. 7.16, Programme for the Hundred and Fiftieth Anniversary of Nicolai Grundtvig's Birth, relayed from Grundtvig's House: Community Singing, Talk, and Choral Singing. 8.0, Concert of English Music by the Station Orchestra and the Fleet Street Choir, conducted by T. B. Lawrence: Jerusalem (Parry); The Silver Swan (Gibbons); Lancashire Song, Bobbie Shaftoe; Now is the Month of Maying (Morley); After many a Dusty Mile (Elgar); There's a Bower of Roses (Stanford); Scottish Folk Song, The Campbells are comin'; Blest pair of Sirens (Parry); Baritone Solo, The Vagabond (Vaughan Williams); Welsh Folk Song, The Dove; Come pretty Wag (Parry); Three Songs (Vaughan Williams), (a) Sigh no more Ladies, (b) Drinking Song, (c) Back and Side go Bare; The Blue Bird (Stanford); Hampshire Folk Song, The Song of the Blacksmith; News from Whydah



SEPT. 7th

THURSDAY

continued

(Balfour Gardiner). After the Concert, Weather, 9.30, Topical Talk, 10.15, Saxophone Solos by Egil Mortensen, 10.15, News, 10.30, Quartet in A, Op. 26, for Pianoforte, Violin, Viola, and Cello, 11.0, Dance Music, relayed from the National Scala. In an interval at 12 Midnight, Time and Chimes from the Town Hall, 12.30 a.m. (Friday), Close Down.

CORK.—See Athlone.

CRACOW

959 kc/s, 312.8 metres; 1.5 kW.—7.20 p.m., The Letter Box, 7.35, Miscellaneous Items and News, 7.40, Programme from Warsaw. In an interval at 9.0, Programme Announcements and News, 10.0, Sports Notes, 10.10, Pianoforte Recital, 10.35, See Warsaw, 11.0 (approx.), Close Down.

DANZIG.—See Heilsberg.

DRESDEN.—See Leipzig.

FEACAMP

1,328 kc/s, 225.9 metres; 10 kW.—11.0 a.m. to 12 Noon, Programme in English by the I.B.C. Part I, Military Band Music; Signature Tune; A Life on the Ocean (Binding); Amoretten Tanz (Gungl); Nymphphone Solo, National Emblem (Bagley); The Wedding of the Rose (Jesse); Ca' est Paris (Padilla); Cornet Solo, Carnival of Venice (Briccialdi); Selection from Iolanthe (Sullivan); The Standard of St. George (Alford). Part II, Dance Music: It's the Band; Drifting down to Shalimar; This is the Rhythm for me; I'll see you in the Morning; Pop Gun; Old Man Harlem; That's my Home; Dance pretty Lady; Signature Tune, 12 Noon, French Programme, 4.30 to 6.0 p.m., Programme in English by the I.B.C. 4.30, The Nursery Corner: Music, Story and Birthday Greetings, 5.0, Concert for Worthing and Littlehampton Listeners; Oetel Music and Songs; Signature Tune; The Night by the Sea; Ballet Music from Rosamund (Schubert); Waltz from Der Rosenkavalier (R. Strauss); Song, On the Banks of Allan Water (Horn); La fleur (Raff); The Golliwog's Cake Walk (Debussy); Song, My Ain Folk (Mills); Valse bleuet (Drigo); Moeck Morris (Grainger), 5.30, Concert for Brighton and Hove Listeners, Organ Recital; There's an Organ playing in my Dream (Condor); In the Valley of the Moon (Tobias); Wandering in an old Cathedral Garden (Gilbert); Song, You're still in my heart (Dougherty); Friends once more united (Spoliansky); Song, Letting in the Sunshine (Gay); The Old Spinning Wheel (Hill); Hold me (Schuster); Signature Tune, 6.0, Programme in French, 10.0 (approx.) till Close Down, Programme in English by the I.B.C. 10.0, Dance Music; Signature Tune; Bells of Normandy; Junk Man Blues; I'm sure of everything but you; My Woman; Just a little Home for the Old Folks; A boy and a girl were dancing; I guess I'll have to change my Plans; St. Louis Blues; Young and Healthy; Homonymie Rose; Three Wishes; Underneath the Harlem Moon; Let me give my Happiness to you; Merry-go-round; This is no Dream; Sophisticated Lady; One little Word led to another; Signature Tune, 11.0, Talkie Time Gramophone Records of Film Stars; Signature Tune; Sittin' in the Dark; The Mills Bros.; The Old Man of the Mountain; Maurice Chevalier; My Love Parade; Marlene Dietrich; Blonde Woman (Hollander); Bing Crosby; A Ghost of a Chance (Washington); Jeannette Macdonald; Pardon Madame (Abraham); Jack Hulbert; I want to cling to Ivy; Richard Tauber; Come Gipsy (Kalman); Renate Muller; Just because I lost my heart (Gilbert); Signature Tune, 11.30, Club Concert for Maceheadfield Listeners, Part I, Music from Opera; Signature Tune; The Chum Song; Grand March from Aida (Verdi); Toreador Song from Carmen (Bizet); One fine day, from Madame Butterfly (Puccini); Violin Solo: Hymn to the Sun from The Golden Cockerel (Rimsky-Korsakov); Selection from La Traviata (Verdi); Walter's Prize Song from The Mastersingers (Wagner); Waltz Song from La Boheme (Puccini); Selection from Tannhauser (Wagner), 12.5 a.m. (Friday), News Bulletin in English, 12.10, Club Concert (cont'd.), Part II; There was a poor Musician (Schwartz); Il canto dell' atessa (Bisio); Will you dance through life with me? (Swabach); Farewell (Bundaz); Marion (Hollander); Signature Tune, 12.30, Dance Music: I've got the World on a String; Blues I love to sing; High Society; Hot Feet; My gal Sal; Hey young fella; My pretty Girl; Pink Elephants, 1.0, Dance Music; Signature Tune; Bells of Normandy; Talking to you about me; Have you had a good Day to-day?; My Love Song; I wish I had wings; Sweetheart Darlin'; Meet me in the gloaming; The Gold Digger's Song; Lower; Eric Moon; That's what life is made of; Any time, any day, anywhere; The Old Spinning Wheel; They all start whistling Mary; Look what I've got; Try a little Tenderness; In the Park in Paris, 1.57, I.B.C. Good-night Melody, 2.0, Close Down.

FLENSBURG.—See Hamburg.

FLORENCE.—See Turin.

FRANKFURT

1,157 kc/s, 259.3 metres; 17 kW. Relaye by Cassel, 1,220 kc/s, 245.9 metres; and

Trier, 1,157 kc/s, 259.3 metres.—6.0 p.m., Talk: Turkish Trade Relations with Germany, 6.25, Talk: The Waiter, 6.45, Review of the Day's News, 6.50, Time, Programme Announcements, Weather and Exchange, 7.0, Transmission for all German Stations, relayed from Berlin (Deutschlandsender), 8.0, Opera Concert by the Station Orchestra and Soloists; Selection from Der Freischütz (Weber) and The Valkyrie (Wagner), 9.0, A Radio Report on Odding, 9.45, Concert of Light Music, 10.20, Time and News.

FREDRIKSSTAD.—See Oslo.

Freiburg.—See Stuttgart.

GENEVA.—See Radio-Suisse Romande.

GENOA.—See Turin.

GLEIWITZ.—See Breslau.

Göteborg.—See Stockholm.

GRAZ.—See Vienna.

HAMAR.—See Oslo.

HAMBURG

806 kc/s, 372 metres; 1.5 kW. Relaye by Bremen, 1,112 kc/s, 269.8 metres; Flensburg, 1,319 kc/s, 227.4 metres; Hannover, 530 kc/s, 556 metres; and Kiel, 1,292 kc/s, 232.2 metres.—5.30 p.m., Variety Programme, 6.25, Review of Autumn Books, 6.45, Exchange, 6.50, Weather, 7.0, Transmission for all German Stations, relayed from Berlin (Deutschlandsender), 8.0, Political Address, 8.10, The Barber of Bagdad—Comic Opera in Two Acts (Cornelius). In the interval, News, 10.10, News, 10.20, Topical Talk, 10.30, Old and New German Dances by the Small Station Orchestra, conducted by Gerhard Maass.

HANOVER.—See Hamburg.

HEILSBERG

1,085 kc/s, 276.5 metres; 60 kW. Relaye by Danzig, 662 kc/s, 453.2 metres.—1.5 to 2.30 p.m., Orchestral Concert; March, Immuta Fides (Krummey); Overture, Melanée (Baymann); Rheinisch Waltz (Gretschner); Army March; Ostmarken-Marsch (Schwittmann); Potpourri of Nazi Songs (Loid); Luna-Walzer (Lincke); Potpourri of Soldier's Songs (Hannemann); Badonviller-Marsch (Firt). In the interval, 1.20 and 2.0, News, 3.0, Market Prices, 3.30 (from Danzig), Talk for Young People, 4.0, Concert by the Königsberg Opera House Orchestra, conducted by Wolfgang Brückner; Prelude to Tod und die Nacht (Adelt); Ballet Music from Naïfa (Delibes); Finlandia (Sibelius); Invitation to the Dance (Weber); Three German Dances (Alzart); Waltz, Bei uns z'haus (Doh, Strauss); Potpourri of Wanderlieder, 5.45, Talk: Charlatans and Marxists, Deceivers of the People, 6.15, Market Prices, 6.25, Agricultural Talk, 6.50, Weather, 7.0, Transmission for all German Stations, relayed from Berlin (Deutschlandsender), 8.0, Political Notes and Weather, 8.10, Alfred Brnt reads from his own works, 8.45, Chamber Music of Young West-German Composers, by the Brünnier Quartet; String Quartet, Op. 4 (Heinz Pandl); String Quartet (Hans Humper); 9.30, Elementary English Lesson, 10.0, The Lord Mayor visits the Opera House. After the Programme, News.

HILVERSUM

Announced HILVERSUM, 1,013 kc/s, 296.1 metres; 20 kW. (7 kW. up to 4.40 p.m.).—11.55 a.m. to 1.40 p.m., Programme of the Catholic Radio Society (K.R.O.), 11.55, Concert by the K.R.O. Orchestra, conducted by M. van 't Woud; Mein Vaterstadt Berlin (Lincke); Waltz, Viennese Princess (Brasseur); Suite, Spanish Caprices (Volkmann); Her first Dance (Heykens); Melodies (Rayners); (a) Nina, (b) Love's Memory, (c) In my Dream Garden, (d) Dance of the little Robins; Trost (Lincke); Für mein Liebelien (Wappans); Gramophone Music; Overture, Czar and Carpenter (Lortzing); Selection from Mignon (Thomas); Potpourri, From A to Z (Geiger); Piece (Fetras); March Joyeuse (Piercy), 1.40 till Close Down, Programme of the Christian Radio Society (N.C.R.V.), 1.40, Book-keeping Lesson, 2.40, Gramophone Music, 3.10, Interval, 3.40, Bible Reading and Songs, 4.40, Handicrafts for Young People, 5.10, Pianoforte Recital, 6.10, Talk, 6.25, Dress-making Lesson, 6.40, Police Notes, 6.55, Religious Report, 7.10, Review of the Week, 7.40, Concert by the Dutch Chamber Music Orchestra, conducted by Glastra van Loon; Soloists, Zepparoni (Violin) and v. d. Beek (Cello); Concerto in A for Two Violins and Strings (Vivaldi); Selection from Castor et Pollux (Rameau); Violin Concerto in D (Boccherini); Talk: Largo from the 'Cello concerto in A (C.Ph.E. Bach); Symphony No. 5 in B flat (Schubert); Concerto for Strings (Fitzberg). In the interval at 9.40, News, 10.10, Gramophone Music, 11.10 (approx.), Close Down.

HORBY.—See Stockholm.

HUIZEN

Announced HILVERSUM, 160 kc/s, 1,875 metres; 8.5 kW.—Programme of the Algemeene Vereeniging Radio Omroep (A.V.R.O.), 11.55 a.m., Concert by the Wireless Orches-

tra, conducted by Nico Treep; Overture, Chal Romano (Ketelbey); Oriental Suite (Popy); Selection from Samson and Delilah (Saint-Saëns); Gramophone Music; Waltz, Badner Mad'n (Kozmak); O Sole mio (Di Capua); Lolita (Buzzi Peccia); Polka from The Two Widows (Smetana); Selection from Les Dragons de Villars (Maillart); Gramophone Music; Lehar Potpourri (Hrubý); Waltz, The Wedding of the Winds (Hall); March, Unter freiem Himmel (Morena), 1.55 p.m., Chamber Music by the Hofstad Quartet; Quartet in B flat, Op. 76, No. 4 (Haydn); Symphony in C (Bach), 2.25, Reading, 2.55, Chamber Music (cont'd.); Quartet in F, Op. 18, No. 1 (Beethoven), 3.25 to 3.40, Interval, 3.40, Programme for Hospitals, 4.10, Gramophone Music, 4.40, Programme for Children, 5.20, Organ Recital with Tenor Solos, 6.19, Sports Talk, 6.40, Organ Recital (cont'd.), 7.10, Talk by Dr. Shuter, 7.40, Time, Weather, and News, 7.45, Concert by Kovacs Lajos and his Orchestra and the Wireless Orchestra, conducted by Nico Treep, Part I, Kovacs Lajos and his Orchestra; Merry-go-round (Jones); Serenata (Toselli); Marimba Solo, The Juggler (Grotzsch); Tango (Meisel); Du alter Stefansturm (Brand-Kovacs); March Medley (Ciere), Part II, A Radio Sketch, Part III, The Wireless Orchestra, conducted by Nico Treep; American Patrol (Meacham); Selection from Il Trovatore (Verdi); Turkish Patrol (Michaelis), Part IV, Gramophone Music, Part V, Kovacs Lajos and his Orchestra; Why did I kiss that girl (King); Sleep (Lehbig); I ain't nobody's darling (King); Ros' Nights (Thompson); Wana (Friend); Achtung, Achtung, wir senden (Dostal), Part VI, A Radio Sketch, Part VII, The Wireless Orchestra; March Medley (Morena); Potpourri of Waltzes (Robrecht); In the Shadows (Finck); Melody (Lincke); Selection from The Dollar Princess (Fall); Spanish March, Granada (Garcia), 10.40, News, 10.50, Gramophone Music, 11.40 (approx.), Close Down.

INNSBRUCK.—See Vienna.

JUAN LES PINS

1,205 kc/s, 249 metres; 0.8 kW.—12.30 p.m., Amusement Guide and Radio Concert, 1.0, News, 1.15, Visite de Riquette—Sketch (René Poletti), 1.30, Variety Items, 8.0, Amusement Guide, Financial Notes and News, 8.10, Fashion Review, 8.20, Press Review, 8.30, Radio Concert, In an interval at 9.0, News and Weather Report.

KALUNDBORG.—See Copenhagen.

KIEL.—See Hamburg.

KLAGENFURT.—See Vienna.

KOSICE.—See Prague.

LANGENBERG

635 kc/s, 473 metres; 60 kW.—1.0 p.m., Orchestral Concert, conducted by Eysoldt; March, Preussens Gloria (Piofke); Overture, Theseus (Zeh); Suite, The Land of the Sun (Yoshihomo); Mazurka, Fraunherz (Strauss); Festival Polonaise (Svendsen); Selection from Rigoletto (Verdi); Berenice (Godard); Serenade (Heykens); Kaiserwalzer (Strauss). In the interval at 2.0, News, 2.30 to 3.0, Interval, 3.0, Programme for Children, 3.30, Exchange and Time, 3.50, Tales of Village Society by a Pastor, 4.5, Pianoforte Music by Hans Haass, 4.10, Reading from the Unpublished Works of Peter Kremer, 4.35, Talk: The German Catechism, 4.45, Reading in Dialect, 5.0, Gramophone Music, 5.30, Political Announcements, 5.40, Pianoforte Music (cont'd.), 5.45, German Lesson, 6.0, Concert by the Station Chamber Orchestra, conducted by Wilhelm Keiper; Overture, Hansel and Gretel (Humperdinck); Waltz, Ich suche dich (Eslinger); Suite, Springtime (Nevin); Souvenir an Capri (Bece); Hungarian March (Berlioz); Selection from Paganini (Lehar), 6.45, Weather and News, 7.0, Transmission for all German Stations, relayed from Berlin (Deutschlandsender), 8.0, News, 8.5, Old Chamber Music, 8.30, Queen Elizabeth—A Radio Sequence from Documents and Accomits of the Time (Else Pfaff), 9.30, Symphony Concert by the Station Orchestra, conducted by Buschkatte; Ballet Suite No. 1 (Gluck-Mottl); Symphony in F No. 8 (Beethoven), 10.15, News, 10.35, Serenade and Dance Music, conducted by Eysoldt, 12.30 a.m. (Friday), Close Down.

LAUSANNE.—See Radio-Suisse Romande.

LEIPZIG

769.9 kc/s, 389.6 metres; 120 kW. Relaye by Dresden, 941 kc/s, 319 metres.—4.0 p.m., Programme for Young People, 4.30, Concert by the Station Orchestra, conducted by Wünschmann; Overture, The Barber of Bagdad (Cornelius); Suite for Chamber Orchestra, Op. 48 (Cropp); New Slav Dances (Dvorak); Prelude to Act II of Die Königskinder (Humperdinck); Waltz, Die Rosen der Königin (Voigt); Overture, Le Cheval de Bronze (Auber); Hymn and Violin Triumphant March from Aida (Verdi), 5.50, Economic Notes, News, Weather, and Time, 6.0, Talk: The Place of the Merchant in

National Economics, 6.25, Art Notes, 7.0, Transmission for all German Stations, relayed from Berlin (Deutschlandsender), 8.0, Concert by the Leipzig Symphony Orchestra, conducted by Steffen; Overture in the Italian Style (Schubert); Pastoral, Op. 29 (Bose); Divertimento in F (Haydn); Extract from Impressions (Karg-Elert); Concert Overture; Hamlet, Op. 37 (Gade), 9.0, Scherzo—Radio Parody on a Rehearsal of Shakespeare's As You Like it (Florjan Scidl), 9.30, Talk: The Organisation of the Peasant Class in Thuringia, 9.45, Concert by the Munich Violin Quintet, 10.30, News, LINZ.—See Vienna.

LJUBLJANA

522 kc/s, 574.7 metres; 7 kW.—7.0 p.m., Concert by the Station Orchestra, 8.0, Programme for Women, 8.30, Song Recital, 9.15, Pianoforte Duets, 9.45, Weather and News, 10.0, Concert by the Station Orchestra, 11.0 (approx.), Close Down.

LUXEMBOURG

252 kc/s, 1,191 metres; 200 kW. German Programme.—7.30 p.m., Concert of German Music by the Station Orchestra, 8.10, Humorous Talk in German, 8.20, Recital of Schubert Lieder, 8.50, News in French, 9.0, Variety Concert on Gramophone Records, 9.45, News in German, 9.55, Concert by the Station Orchestra, conducted by Henri Pensis, 10.25, Dance Music.

LYONS

LA DOUA, 644 kc/s, 465.8 metres; 1.5 kW.—7.30 p.m., Radio Gazette for Lyons and the South-East, 8.30, Orchestral Concert, conducted by Gaston Billet, Soloists; Mme. Lamotte (Soprano) and Levrat (Baritone), Part I: Orchestral Music, Part II: Les Noes de Jeannette—Opera in One Act (Massé). After the Concert, News.

MADRID

EAJ7, 707 kc/s, 424.3 metres; 2 kW.—8.0 p.m., Chimes, Exchange, Radio Journal, and Programme for Children, 9.15, Topical Review, 9.30 to 11.0, Interval, 11.0, Chimes, Time, and Topical Review, 11.30, Municipal Band Concert relayed from Rosales, 1.15 a.m. (Friday), Topical Review, 1.30, Chimes and Close Down.

MADRID

EAQ, 10,000 kc/s, 30 metres; 20 kW.—11.30 p.m., See Madrid (EAJ7). After the Programme, Radio Chronicle, 1.0 a.m. (Friday), Close Down.

MALMO.—See Stockholm.

MILAN

VIGENTINO, 662 kc/s, 453.2 metres; 4 kW.—8.45 p.m. till Close Down, See Rome.

MORAVSKA-OSTRAVA

1,137 kc/s, 263.8 metres; 11 kW.—5.25, Programme for Children, 5.45, Gramophone Music, 5.55, See Prague, 6.5, Talk: Healing Properties in Plants, 6.15, See Prague, 6.30, German Transmission: Talks, (a) Crises Past and Present, (b) The Development of Transatlantic Telegraphy, 7.0, See Prague, 7.10, See Brno, 7.30, See Prague, 8.45, See Brno, 9.0, See Prague, 11.0 (approx.), Close Down.

MOTALA.—See Stockholm.

MUHLACKER.—See Stuttgart.

MUNICH

563 kc/s, 533 metres; 60 kW. Relaye by Augsburg and Kaiserslautern, 536 kc/s, 560 metres; and Nürnberg, 1,256 kc/s, 239 metres.—4.30 p.m. (from Nürnberg), Orchestral Concert, conducted by Willi Böhm; March, Er weicht der Sonne nicht (Bliekenburg); Overture, Fraulein Loreley (Lincke); Selection from The Pearl Fishers (Bizet); Two Gipsy Dances (Heidingsfeld); Puppenspiel (Lederer); In a Persian Market (Ketelbey); Sturmgallop (Kozmak), 5.45, Agricultural Talk, 6.15, Harpsichord Recital by Anna Barbara Specker, 6.25, Scenes from the Law Courts, 6.45, Time and Announcements, 7.0, Transmission for all German Stations, relayed from Berlin (Deutschlandsender), 8.0, Concert by the Georg Ebner Orchestra, 8.40, Austria, 9.0, Symphony Concert, conducted by Hans Winter, Soloist: Adelheid Holz (Soprano), Romantic Overture (Thuniele); Five Songs (Donisch): (a) Abend, (b) Trost, (c) Vergessen, (d) Gebet, (e) Segelfahrt; Symphony No. 3 in C (Schumann), 10.20, Time and News.

NAPLES.—See Rome.

NOTODDEN.—See Oslo.

OSLO

277 kc/s, 1,083 metres; 60 kW. Relaye by Fredrikstad, 815 kc/s, 368.1 metres; Hamar, 522 kc/s, 574.7 metres; Notodden, 671 kc/s, 447.1 metres; Porsgrund, 662 kc/s, 453.2 metres; and Rjukan, 671 kc/s, 447.1 metres.—5.0 p.m., Concert from the Hotel Britannia, Trondheim, 6.0, Talk: The Norwegian Language, 6.30, Studio Service, 7.0, Advertising Notes, Weather and News, 8.0, Time Signal, 8.2, Talk on Forestry, 8.30, Glutnarne—Recital of Songs, 9.0, The Trout Quintet



(Schubert), on Gramophone Records. 9.40, Weather and News. 10.0, Topical Talk. 10.15, Recitations. 10.45 (approx.), Close Down.

OSTERSUND.—See Stockholm.

PALERMO

558 kc/s, 537.6 metres; 3 kW.—8.0 p.m., Populavoro Notes, Agricultural Report and Giornale Radio. 8.20, Gramophone Music. In an interval at 8.30, Time and Announcements. 8.45, Variety Concert. In an interval at 9.30, I carabinieri—Comedy in One Act (Lucio d'Ambrà). 10.55, News.

PARIS

EIFFEL TOWER, Call FLE, 207.5 kc/s, 1,445.7 metres; 13 kW. Time Signals (on 2,650 metres) at 10.26 a.m. and 11.26 p.m. (Preliminary and 6-dot Signals).—6.45 p.m., Theatre Notes. 7.0, Le Journal Paris. 8.30, Gramophone Concert: Scheherazade (Rimsky-Korsakov); Selection from La Dame blanche (Boieldieu); Rigaudon (Kreisler); Souvenirs (Blanquet); Doktrinenwalzer (Strauss); Wenn die Zitronen blühen (Joh. Strauss); The Mill in the Black Forest (Eilenberg); Stéphanie Gavotte (Czibulka); Viennoise Waltz (Buxeuil); Tango (Mauprey); Glad Rag Doll (Brown); Laugh, Clown, Laugh (Young); Melody (Ager); Selection from The Flower of Hawaii (Abraham); Salut au Quarante-cinquième (Barat); Alsace-Lorraine (Marcoux). 10.0 (approx.). Close Down.

PARIS

POSTE PARISIEN, 914 kc/s, 328.2 metres; 60 kW.—7.0 p.m., Gramophone Music. 7.30, Concert by Ter-Abramoff and his Orchestra. Selection from The Sleeping Beauty (Tchaikovsky); Foxtrot, Please; Tango, Jalouise; Liebesträum (Liszt); Warum? (Stolz); Waltz from Die Fledermaus (Joh. Strauss); Karpáthi (Bercny); Douskaja (Ter-Abramoff); Steuka rasin (Ter-Abramoff); L'ombre du passé (Ter-Abramoff); Tell me To-night (Spoiakovskij); Caucasian Song, Alavervi (Ter-Abramoff); Waltz, The Blue Danube (Joh. Strauss). In an interval at 8.0, Sponsored Talk. 9.0, Cigány and Jazz Music, relayed from the Restaurant de la Forêt, Le Touquet. 11.0, News.

PARIS

RADIO PARIS, Call CFR, 174 kc/s, 1,725 metres; 75 kW.—7.30 a.m., Weather and Physical Culture. 7.45, Gramophone Records. March (Jurek); Golden Horizon (Defrance); Waltz (Tremolo); Les Sirenes (Waldfenfel). 12 Noon, Protestant Address. 12.30, Gramophone Records of Opera Music. Overture, Benvenuto Cellini (Berlioz); Two Airs from Les Troyens à Carthage (Berlioz); Extracts from Der Freischütz (Weber); Extracts from Hamlet (Thomas); Air from Salambo (Rayet); Selection from Sigurd (Reyer). In the interval at 1.0 p.m., Exchange and News and at 1.30, Exchange. 2.0, Exchange. 3.45, Exchange and Market Prices. 7.0, Agricultural Notes. 7.10, Gramophone Records. Selection from The Desert Song (Rouberg); Two Argentine Melodies (Jekyll); Le marchand petit garçon (Daltroze); Ronde des petits mains (Daltroze); Air; Two Pieces (Ganne); Les Deux Pinsons (Kling); La Fauvette (Kling); Idylle passionnelle (Razigade). 7.50, Commercial Prices and News. 8.0, Dramatic Programme. Part I. Poems. Part II. Boursoctage—One Act Comedy (Warney). 8.30, News and Weather. 8.45, Recital of Old Songs and Duets by Mmes. Champell and Legendre. 9.15, Press Review and News. 9.30, Gramophone Concert. Pianoforte Concerto in B flat (Brahms); La Forêt (Caplet); Chère Nuit (Bachelet); Synchronization (Kreisler); Fantasia on an old Air (Bordes); Elegy (Fauré); Selection from Coppelia (Delibes).

PITTSBURGH

KDKA, 980 kc/s, 306 metres; 50 kW.—Relayed by W8XK on 48.86 metres; and 25.27 metres.—7.30 p.m., Pioneers, KDKA to New York. 7.45, KDKA Home Forum. 8.0, Betty and Bob, from New York. 8.15, Words and Music, from New York. 8.45, Federation of Pennsylvania Women. 9.0, Thursday Special, from New York. 9.30, News and Markets. 9.45, Thursday Special, from New York. 10.0, Casino Orchestra, from New York. 10.15, Tarzan of the Apes. 10.30, Singing Lady, from New York. 10.45, Orphan Annie, from New York. 11.0, News, Piano Classique. 11.15, Sports, A Song. 11.30, Pittsburgh Spotlights. 11.45 to 12.45 a.m. (Friday), New York Relay. 11.45, Lowell Thomas. 12 Midnight, Amos 'n' Andy. 12.15, Concert Footlights. 12.45, Pathé News of the Air. 1.0 to 4.0, New York Relay. 1.0, Captain Diamond. 1.30, Adventures in Health. 1.45, Floyd Gibbons. 2.0, Death Valley Days. 2.30, Wayne King's Orchestra. 3.0, Hands across the Border.

PORSGRUND.—See Oslo.

PRAGUE

614 kc/s, 488.6 metres; 120 kW.—2.50 p.m., Military Band Concert from Moravská-Ostrava. 3.50, Weather. 3.55 to 4.0, Exchange. 5.25, See Moravská-Ostrava. 5.45, Gramophone Music. 5.55, Talk: The Protection of Animals. 6.5, Agricultural

SEPT. 7th

THURSDAY

continued

Report 6.15, Talk for Workers. 6.25, News in German. 6.30, Germans Transmigration; Talk: New Publications. Agricultural Talk. 7.0, Chimes and News. 7.10, See Brno. 7.30, A Travlogue with Songs. 8.45, See Brno. 9.0, Time Signal. 9.2, Orchestral Concert conducted by Otakar Jeremias. Soloist: Suzanne Karin. 10.0, Time and News. 10.15, Orchestral Concert: Waltz (Lanner); Polish Song Potpourri, Polonia (Leopold); Waltz (Ingris); Selection from Norma (Bellini); Tango, Don't tell me Lies Today; Polka (Rezek) 11.0, Close Down.

RADIO-SUISSE ROMANDE

SOTTENS, 743 kc/s, 403 metres; 25 kW.; and Geneva, 395 kc/s, 760 metres.—3.28 p.m., Time Signal from Neuchâtel Observatory. 3.30 (from Geneva), Gramophone Concert. 4.15 (from Geneva), Interlude. 4.40 (from Geneva), Gramophone Concert (cont'd.). 5.30, Interval. 7.0 (from Geneva), Programme for Mountain Lovers. 7.30, News. 7.50 (from Geneva), Tourist Talk in Esperanto. 8.0 (from Geneva), Talk: The History of Geneva. 9.0, Concert by the Radio Suisse Romande Orchestra, conducted by Echenard. Part I: Modern Music. Suite for Little Orchestra (Rosenberg); Le Paravent de laque aux cinq images (Rigaud); Overture on a Jewish Theme\* (Prokofiev); Dance from King David (Honegger). Part II: Brandenburg Concerto, No. 4 (Bach). 9.50, News. 10.0 (from Lausanne), French Love Songs—Lecture Recital. 10.30 (approx.), Close Down.

RUJUKAN.—See Oslo.

ROME

Call 1R0, 680 kc/s, 441 metres; 50 kW. Relayed by Naples, 941 kc/s, 319 metres; and 2R0, 11,810 kc/s, 25.4 metres, from 5.15 p.m.—12.30 p.m., Gramophone Music. 1.0, Humorous Items. 1.5, Orchestral Concert. In the interval from 1.30 to 1.45, Giornale Radio and Exchange. 2.0, Time and Announcements. 4.30, Giornale Radio and Exchange. 4.45, Children's Radio Review. 5.0, Reading. 5.10, Weather. 5.15 to 6.0, Vocal and Instrumental Concert. Maria Ceccarelli (Pianoforte), Carlo Platania (Baritone) and Valeria Passerini (Soprano); Polonaise in C (Beethoven), Baritone Solos: (a) Aria from A Masked Ball (Verdi); (b) Zingari (Leonecavallo); (c) Aria from Dinorah (Meyerbeer). Pianoforte Solos: (a) Etude brillante (Chopin); (b) The Flight of the Humble Bee (Rimsky-Korsakov). Soprano Solos: (a) O cessate di piangere (Scarlatti); (b) Chi vuol la zingarella (Paisiello); (c) Aria from Maton (Massenet); (d) Luisa (di Pietro). 6.40 (Naples), Shipping and Sports Notes. 6.45, Populavoro Announcements and Tourist Report. 7.10, Agricultural Report. 7.20, News in Foreign Languages. 7.40, Giornale Radio. 8.0, Time and Announcements. 8.15, Song Recital by Sandra Belluci (Soprano). 8.45, Variety Programme. 9.45, Fantasia—Comedy in One Act (Lucio d'Ambrà) with incidental Music. 10.30, Concert of Light Music: Selection from Johnny spielt auf (Krenek); Strapasee (Pizzini). 10.55, Giornale Radio.

SALZBURG.—See Vienna.

SCHENECTADY

WGY, 790 kc/s, 379.5 metres; 50 kW.—Relayed at intervals by W2XAF on 31.48 metres, and by W2XAD on 19.56 metres.—12.45 a.m. (Friday), Stock Reports and Baseball Scores. 1.0 to 3.0, New York Relay. 1.0, Variety Programme. 2.0, Captain Henry's Show Boat 3.0, Paul Whiteman's Orchestra, from New York, followed by Programme Resumé.

SCHWEIZERISCHER LANDESENDER

BEROMUNSTER, 653 kc/s, 459 metres; 69 kW.—Basle, 1,229 kc/s, 244.1 metres; and Berne, 1,220 kc/s, 245.9 metres.—6.0 p.m. (from Berne), Gramophone Music. 6.30 till Close Down, Programme from Basle. 6.30, Talk: Bird Life in Autumn. 7.0, Time, Weather, and Traffic Report. 7.10, Verdi Music on Gramophone Records. 7.45, Italian Lesson. 8.30, Pianoforte Recital. 9.0, News. 9.10 (from Basle), Actors in the Studio. 10.30 (approx.), Close Down.

SOTTENS.—See Radio-Suisse Romande.

STOCKHOLM

689 kc/s, 436 metres; 55 kW. Relayed by Boden, 244 kc/s, 1,229.5 metres; Göteborg, 932 kc/s, 322 metres; Hörby, 1,166 kc/s, 257 metres; Motala, 221.5 kc/s, 1,354.4 metres; Ostर्सund, 389 kc/s, 770 metres; and Sundsvall, 554 kc/s, 542 metres.—5.5 p.m., Studio Service, relayed from Uppsala. 6.22 kc/s, 453.2 metres. 5.30, Organ Recital by Gösta Berlin. 5.50, Dialogue. 6.5, Gramophone Music. 7.0, Talk on Broadcast for Schools, relayed from Malmö, 1,301 kc/s, 231 metres. 7.15, Weather and News. 7.30, Talk on Swedish Universities. 8.0 (from Göteborg), Orchestral Concert, conducted by Karl Bornfors: Duce (Peterson-Berger); Waltz (Peterson-Berger); Undine's Dance from Loreley (Catalani); Polonaise in A

(Chopin); Slav Dance No. 8 (Dvorák); Hungarian Dances Nos. 4 and 5 (Brahms); Waltz, Künstlerleben (Joh. Strauss); Torch Dance (Meyerbeer). 8.45, Reading (Ernst Ahlgren). 9.15, Pianoforte Sonata in B Minor, Op. 58 (Chopin). 9.45, Weather and News. 10.0 (from Göteborg), Concert of Chamber Music, conducted by Tor Mann. Soloist: Magnus Jensen (Cello). Suite for Strings (Grieg); Cello Concerto in A Minor (P. E. Bach); Idyll and Lullaby (Aulin); Finale from the Symphony in D for Strings (Mendelssohn). 11.0 (approx.), Close Down.

STRASBOURG

869 kc/s, 345 metres; 11.5 kW.—11.20 a.m., Gramophone Concert of Classical Music. 12.45 p.m., News. 1.0, Time and Exchange. 1.5, Orchestral Concert, conducted by Maurice de Villers. Overture, The Merry Wives of Windsor (Nicolai); Ballet Music from Isolde (Messager); Suite from Der Rosenkavalier (R. Strauss); Symphonic Poem, The Moldau (Smetana); Marche héroïque (Saint-Saëns). 2.0, Programme for Children. 3.0, Interval. 3.30, Orchestral Concert, conducted by Bronilux, relayed from the Casino, Vichy. Overture, Mignon (Thomas); Pavane and Waltz from Etienne Marcel (Saint-Saëns); Orchestral Suite, Pantomime (Lacôme); Melody; Two Spanish Waltzes from La vida breve (Falá); Selection from Grieg's Idylls (Massetet); Cortège burlesque (Chabrier). 5.0, French Elocution Lesson. 5.15, Orchestral Concert, conducted by Roskam. Polonaise and Waltz from Eugene Onegin (Tchaikovsky); Selection from Madame Butterfly (Puccini-Berglio); Suite pour mes petits amis (Messager); Serenade in A (Widor). 6.0, Talk in German: St. Simon and Prudhomme, two Pioneers of Socialism. 6.15, Talk for Women. 6.30, Orchestral Concert, conducted by Maurice de Villers. Overture, King Stephen (Beethoven); The Surprise Symphony (Haydn); Serenade for String Quintet (Mozart); Pieces (Schubert): (a) Minuet, (b) Moment Musical, (c) Marche Militaire. 7.30, Time and News. 7.45, Gramophone Music. 8.0, Press Review in German. Lottery Results and Announcements. 8.30, Choral and Orchestral Concert by the Cercle Musical Messin, conducted by Henri Grabert, relayed from Metz. Overture, Figaro (Mozart); Male Voice Quartet; Les marine de Kernor (Saint-Saëns); Selection from Hansel and Gretel (Humperdinck); Male Voice Quartet; Les montagnards (Rolands); Horn Solo; Melody (E. Bach-Hoffmann); Orchestral Suite, Mascarede (Lacombe); Mixed Choir; Les Espousailles (Tombeile); Selection from Véronique (Messager); Waltz, Morgendblätter (Joh. Strauss); Choir and Orchestra; Marche lorraine (Ganne). In the interval, Press Review.

STUTTART

MUHLACKER, 832 kc/s, 360.5 metres; 60 kW. Relayed by Freiburg, 527 kc/s, 570 metres.—2.0 p.m., Programme arranged by the Post Office, with Gramophone Music. 2.30, Spanish Lesson. 3.0, Elementary English Lesson. 3.30, Programme from Frankfurt. 4.30, See Munich. 5.45, Talk: Birds of Passage. 6.10, Talk on Tradition—The Thirteenth König Karl Regiment. 6.35, Time and News. 7.0, Transmission for all German Stations, relayed from Berlin (Deutschlandsender). 8.0 (from Freiburg), Concert of Folk Music: Accordion March, So geht's zua (Mornischer); Accordion Ländler, Sonnengrass (Claude); Songs to the Lute: (a) Folk Song, Beim Kronenwirt, (b) Folk Song, Er wollte doch fahren ins Heu; March, Wiener Künstler (Schrammel); Karwendler Ländler, for Schrammel Music (Mayer); Songs to the Lute: (a) I woass nit wie mir is, (b) Soldier Song, Hinter Metz bei Paris in Chalons; Accordion: March, Marschbereut (Strub); Viennoise Song for Schrammel Quartet: Das Lercherl von Hernalis; Accordion Solo: March, Wiener Schwallen (Schlögel). 8.40, See Munich. 9.0, Radio Report of the Voluntary Labour Service Campaign against insects in the Rhine District of Karlsruhe, relayed from Rappenswörth. 9.30, Pianoforte Recital: Thirty-Two Variations in C Minor (Beethoven); Scherzo in E Flat Minor, Op. 4 (Brahms); Märchenstunde in C Minor, Op. 25, No. 1 (Mendler). 10.15, Time and News. 10.30 (approx.), Close Down.

SUNDSVALL.—See Stockholm.

TOULOUSE

779 kc/s, 385 metres; 8 kW.—6.15 p.m., Accordion Solos. 6.30, Chansonnettes. 6.45, Violin Solos; Tambourin chinois (Kreisler); Serenade (Toselli); Romance andalousse (Sarasate); Scherzo tarantelle (Wieniavsky). 7.0 (approx.), Suite, Iberia (Albeniz), by a Symphony Orchestra. 7.15, News. 7.30, Comic Opera Music: Chorus from Carmen (Bizet); O Messenger des Dieux, from Thaïs (Massetet); Air from La Basoche (Messager). 7.45, Programme by a Viennoise Orchestra. 8.15, Light Music. 8.30, Opera Music: Selection from (a) William Tell (Rossini); (b) Lohengrin (Wagner); and (c) Faust (Gounod). 8.45, Sound Film Music. 9.0, Concert Version of La Dame Blanche—Opéra

comique (Boieldieu). 9.30, Music by a Symphony Orchestra: Pas des fleurs (Delibes); Selection from Das Nachtlager in Granada (Kreutzer); Le lac de Conie (Galos). 9.45, Concert: You are my Heart's Delight, from The Land of Smiles (Leháry); Ou ne s'embrasse plus, from Le cœur y est (Parsès-Van Parys); Selection from Véronique (Messager); Nachtschwärmer (Ziehrer); Melody (Fetras); March of the Picadors (Oschelt). 10.15, News. 10.30, Concert for Listeners in Morocco: Selection from La Bohème (Puccini); Elsa's Dream, from Lohengrin (Wagner); Ständchen (Schubert); Les rêves sont des bulles de savon (Hermite); Selection from M'ssidior (Bruneau). 11.0, Operetta Music: Overture, Orpheus in the Underworld (Offenbach); Selection from Yes (Xvain). 11.15, Dance Music. 12 Midnight, News. 12.5 a.m. (Friday), Orchestral Music. 12.15, Hunting-Horn Solos. 12.30, Close Down.

TRIESTE

1,211 kc/s, 247.7 metres; 10 kW.—5.10 p.m. till Close Down, See Turin.

TRONDHEIM.—See Oslo.

TURIN

273.7 metres; 7 kW. Relayed by Milan, 331.5 metres; Genoa, 312.8 metres; and Florence, 500.8 metres.—5.10 p.m., Orchestral Concert. 6.0 to 6.5, Weather Forecast. 6.40, Giornale Radio, Populavoro Announcements, and Gramophone Music. 7.0, Time, Tourist Report, and Gramophone Music. 7.10, Agricultural Notes and Market Prices. 7.20, News in Foreign Languages. 7.40, Gramophone Music. 8.0, Announcements, Giornale Radio, Sports Notes, and Weather. 8.20, Talk on the following Transmission. 8.30, Sakuntala—Opera in Three Acts (Alfano). In the intervals, Talk and Art Notes. After the Programme, Giornale Radio.

VATICAN CITY

15,120 kc/s, 19.84 metres (Morning), and 5,969 kc/s, 50.26 metres (Evening); 10 kW.—11.0 to 11.15 a.m. Religious Information in French. 8.0, to 8.15 p.m., Religious Information in Italian.

VIENNA

581 kc/s, 517 metres; 100 kW. Relayed by Graz, 852 kc/s, 352.1 metres; Innsbruck, 1,058 kc/s, 283 metres; Klagenfurt, 662 kc/s, 453.2 metres; Linz, 1,220 kc/s, 245.9 metres; and Salzburg, 1,373 kc/s, 218.5 metres.—12 Noon, Concert by the Wiener Symphoniker, conducted by Holzner. In the interval at 1.0 p.m., Time, Weather and News. 3.0, Time, Weather and Exchange. 3.20, Talk: Electricity in the Kirchen. 3.35, Programme for Children. 3.50, Gramophone Records of the Marek Weber Orchestra. 4.45, Gymnastics for Children. 5.0, Talk: Pottery and Statuary for the Small Garden. 5.25, Concert by Hedi Renda (Soprano), Lissy Siedek (Violin), and Bednarik (Pianoforte). 6.5, Talk: Wild Life in the Autumn Hills. 6.30, Talk: The Landscape and People of Pinzgau. 7.0, Concert of Operetta Music by the Wiener Symphoniker and Franz Zwonik (Tenor). In the interval at 7.35, Time, Weather and News. 8.30, Topical Talk. 8.45, Concert by the Wiener Symphoniker, conducted by Kabasta; Soloist, Maleher (Violin); Concerto grosso No. 11 in B Flat (Handel); The Third Symphony in D Minor (Bruckner). 9.55, News, Weather and Exchange. 10.5, Gramophone Music.

WARSAW

212.5 kc/s, 1,411 metres; 120 kW.—11.57 a.m. Time Signal and Chimes from Turin (the d'Al). 12.5 p.m., Gramophone Music. 12.25, Polish Press Review. 12.33, Weather. 12.35, Gramophone Music. 1.0 to 2.55, Interval. 2.55, Gramophone Music. 3.5, News. 3.15, Announcements. 3.25, Economic Notes. 3.35, Gramophone Music. 3.45, Talk for Boy Scouts. 3.50, Gramophone Music. 4.0, Programme for Children. 4.30, Song Recital by Indiez (Soprano) and Korolkiewicz (Baritone). Two Duets from Rigoletto (Verdi). Duet from Don Giovanni (Mozart): Duet (Badia); Baritone Solos: (a) Bells (Macura); (b) Leaves (Sym); Soprano Solos: (a) Aria from The Magic Flute (Mozart); (b) Aria from Louise (Charpentier). 5.0, Concert of Chamber Music: Quartet in A minor, Op. 59, No. 2 (Beethoven); Quartet No. 2, Op. 10 (Kodaly); 6.0, Solemn Vespers, relayed from Cetm. 7.20, Miscellaneous Items. 7.35, Programme Announcements. 7.40, Reading. 8.0, Concert by the Station Orchestra, conducted by St. Navrot. Soloist: Kochanski (Violin). Overture, Janek (Zelenski); Suite, Impressions exotiques (Mouton); Violin Concerto in E minor (Nardini); Violin Solos: (a) Andantino (Martini); (b) Prelude and Allegro (Pugnani-Kreisler); Gipsy Dance (Debussy); Serenade (Gyldmark); Waltz, (Elliott). 8.50, Radio Journal. 9.0, Agricultural Notes. 9.10, Concert (cont'd.): Norwegian Dances Nos. 2 and 3 (Grieg); Ballet Music from The Demon (Rubinstein); Violin Solos: (a) Chanson de Louis XIII and Pavane (Comperin); (b) Gavotte (Rameau); (c) Sicilienne and Rigaudon (Rameau); (d) Tarantella (Nicolet); Mazurka in D (Chopin-Noskowski); Waltz, Künstlerleben (Strauss); March (Kozłowski). 10.25, Sports Notes. 10.35, News, Weather and Police Notes. 10.40, Dance Music.

ZURICH.—See Schweizerischer Landessender.

**ATHLONE**

725 kc/s, 413 metres; 60 kW. Relayed by Cork, 1,337 kc/s, 224.4 metres.—1.30 to 2.30 p.m., Time Signal, Weather Report, Stock Exchange Quotations and Gramophone Music. 6.0, Programme for Children. 6.45, News. 7.0, Gardening Talk by G. O. Sherrard. 7.15, Talk. 7.30, Time Signal. 7.31, Concert by the Station Orchestra. 8.0, Contralto Solos by Eva Tomsohn. 8.15, Pianoforte Solos by Midge Bradbury. 8.30, The Station Orchestra (cont'd.). 9.0, Bass Solos by J. C. Browner. 9.15, Piccolo Solos by Mollie Flynn. 9.30, Pianoforte-Accordion Solos by J. Carey. 9.45, Sponsored Programme. 10.45, News, Weather and Close Down.

**BARCELONA**

EAJ1, 860 kc/s, 348.8 metres; 8 kW.—7.0 p.m., Concert by the Station Trio: Minuet (Ganne); Serenade (Rachmaninov); Musette (Cahn); Selection from Martha (Flotow); Idyll (Bayer); Hungarian Dance No. 5 (Brahms); Selection from Parsifal (Wagner). 8.0, Request Gramophone Records. 8.30, Exchange. 9.0, Gramophone Music, followed by News. 10.0, Chimes, Weather, Messages for Seamen, and Exchange. 10.10, Concert by the Station Orchestra: Paso Doble, Gaditana (Lizcano de la Rosa); Selection from El domo azul (Arrieta); Waltz (Greenbank); Nocturne (d'Ambrosio); Danzas montañesas (Gorostiza); Melody (Van Dyck). 11.0, Literary and Musical Programme. 11.30, Extracts from an Opera, on Gramophone Records. In the interval at 12 Midnight, News. 1.0 a.m. (Saturday), Close Down.

**BARI**

1,112 kc/s, 269.8 metres 20 kW.—8.0 p.m., Agricultural Notes, Tourist Talk and Dopolavoro Announcements. 8.20, Giornale Radio and Weather. 8.30, Time and Announcements. 8.35, Weather. 8.40 (approx), Concert of Opera Music: Soloists, Milena Barberio (Soprano) and Andrea Mongelli (Bass); Overture, The Force of Destiny (Verdi); Soprano Aria from Lohengrin (Wagner); Bass Aria from La Gioconda (Ponchielli); Extract from La nave rossa (Scarpilli); Soprano Aria from Manon (Massenet); Bass Solo from Manon (Massenet); Selection from Il piccolo Haydn (Cipollini); Intermezzo from La Cabrera (Dupont) Soprano Solo, Fonte tanta e profonda, from Gloria (Cilea); Bass Aria from Salvatore Rosa (Gomez); Selection from Aida (Verdi); Song from L'amico Fritz (Mascagni); Bass Aria from Lucia di Lammermoor (Donizetti). In the interval, Theatre Notes. 10.30, Dance Music, relayed from the Gran Cafe del Levante. 10.55, News.

**BASLE.**—See Schweizerischer Landessender.

**BELGRADE**

697 kc/s, 430.4 metres; 2.8 kW.—6.55 p.m., Time, Announcements and Talk. 7.30, See Bratislava. 10.10, Time and News. 10.25 (approx.), Cigany Music from the Potrosacka Zadruga Restaurant.

**BERLIN**

**DEUTSCHLANDSENDER (REICHSENDER),** 183.5 kc/s, 1,635 metres; 60 kW.—1.45 p.m., News. 2.0, Gramophone Concert. 3.0, Talk: German Girls as Exchange Students in Spain. 3.30, Weather and Exchange. 3.45, Political Dialogue: The Robbers (Ulrich v. Hutten). 4.0, Concert from Leipzig. 5.0, Talk for Workers. 5.25, Choral Concert of German Folk Songs. 6.0, Poem. 6.5, Talk. 6.30, Recital of Street Songs. 6.50, Weather and Announcements. 7.0, Transmission for all German Stations, relayed from Heilsberg. 8.0, To-day's Motto. 8.5, Wink, bunter Wimpel. . . . Play in Verse (Alfred Karrasch), with Music by Walter Gromostay. 9.20, Orchestral Concert. 10.0, News. 10.25, Radio Report of the International University Sports in Turin (on Gramophone Records). 10.45, Weather. 11.0, Concert from Frankfurt. 12.30 a.m. (Saturday), Close Down.

**BERLIN**

**FUNKSTUNDE,** 716 kc/s, 419.5 metres; 1.5 kW.—4.30 p.m., Military Band Concert. In the interval at 5.0, Talk from Berlin (Deutschlandsender). 6.0, Reading: A Chapter from the Life of my Great-Grandfather (Marga Salzwig Schumacher). 6.15, Report of the meeting of Exchange Students at Schloss Köpenick (on Gramophone Records). 6.40, The Funkstunde informs its Listeners. . . . 6.45, Topical Talk. 7.0, Transmission for all German Stations, relayed from Heilsberg. 8.5, The Beginning of the Berlin Theatre—Radio Sequence (Rosskopf). 9.0, Radio Report. 9.50, Programme by Maria Ney. 10.0, News. 10.25 (approx.), Concert by the Station Orchestra, conducted by Willy Gensler. In the interval at 11.0 (approx.), Talk: What they are saying in Berlin. 11.20 (approx.), Dance Music from

**FRIDAY**

SEPTEMBER THE EIGHTH

PRINCIPAL EVENTS OF THE DAY:

**AT HOME**

- NATIONAL LONDON REGIONAL**
- MIDLAND REGIONAL**
- NORTH REGIONAL**
- WEST REGIONAL**
- SCOTTISH REGIONAL**
- BELFAST**

Orchestral concert.  
 "Waltz Time," a Viennese operetta.  
 Orchestral concert from Cheltenham Spa.  
 Orchestral concert from the Pier Pavilion, Llandudno.  
 Variety programme from the New Theatre, Cardiff.  
 "Flodden," a chronicle play, by Christine Orr.  
 Ballad concert.

**ABROAD**

- BARCELONA**
- BRATISLAVA**
- EIFFEL TOWER HAMBURG**
- HUIZEN**
- LANGENBERG MUNICH**
- PRAGUE**
- RADIO PARIS**
- ROME**

7.0 p.m. The Station Trio.  
 7.30 p.m. Opera: "The Bartered Bride," by Smetana, from the National Theatre.  
 8.30 p.m. Beethoven's Sonata, Op. 31, No. 3.  
 8.0 p.m. Haydn, Mozart and Beethoven concert, by the Philharmonic Orchestra.  
 8.10 p.m. Beethoven's Symphony, No. 9 (Choral), in D Minor, by the Residence Orchestra.  
 6.0 p.m. The Station Orchestra.  
 9.20 p.m. The Franconian Chamber Orchestra, relayed from Nürnberg.  
 7.30 p.m. Opera: "Figaro," by Mozart, from the State Opera House.  
 9.30 p.m. Concert of French and Romanian music.  
 8.30 p.m. Opera: "Le Jongleur de Notre Dame," by Massenet.

the Zoological Gardens. 12 Midnight, Close Down.  
**BERN.**—See Schweizerischer Landessender.  
**BEROMUNSTER.**—See Schweizerischer Landessender.  
**BODEN.**—See Stockholm.  
**BODO.**—See Oslo.

**BRATISLAVA**

1,076 kc/s, 279 metres; 14 kW.—2.50 p.m., Concert by the Station Orchestra, conducted by Odchazel; Overture, The Bohemian Girl (Balfe); Mediterranean Suite (Jalowicz); Waltz (Fueik); Intermezzo (Aust); Potpourri of Slovak Songs; Humoresque (Bayer); Galop, Pre-tis-into (Waldteufel); Slovak March (Ecker). 3.50 to 4.0, See Prague. 5.45, See Prague. 6.5, Talk with Gramophone Illustrations; Latin. 6.35, Sports Talk. 6.50, Gramophone Music. 6.55, Report. 7.0, See Prague. 7.25, Talk on the following Transmission. 7.30, The Bartered Bride—Opera in Three Acts (Smetana), relayed from the National Theatre. 10.0, See Prague. 10.15 (approx.), Close Down.

**BREMEN.**—See Hamburg.

**BRESLAU**

923 kc/s, 325 metres; 60 kW. Relayed by Gleiwitz, 1,184 kc/s, 253 metres.—1.0 p.m., Weather. 1.5 (approx.), Gramophone Concert of Scandinavian Music. 1.45, Time, Weather, News and Exchange. 2.5, Pianoforte Recital. 2.30, Gramophone Music. 3.0, Agricultural Report. 3.15, Talk: German Wrought Iron Work in the Great Days of Prussia. 3.30, Programme for Children. 4.0, Orchestral Concert, relayed from Bad Altheide, Conductor, Albin Eschrich; Burkendorfer Marsch (Wagner); Overture, Waldmeister (Joh. Strauss); Valse triste (Sibelius); Pizzicato from Sylvia (Delibes); Selection from The Merry Wives of Windsor (Nicolaï); Waltz, Lotosblumen (Olsen). 5.0, See Berlin (Deutschlandsender). 5.30, Market Prices. 5.35, Reading. 6.0, Topical Talk. 6.25, Talk: The Germans Outside the Reich—The Polish Corridor. 6.50, Weather, News and Market Prices. 7.0, Transmission from all German Stations, relayed from Heilsberg. 8.0, Choral Concert with Gottlieb Richter (Orgau), relayed from the Salvatorkirche; Kyrie and Sanctus from Assumptio est Maria, for Six Part Choir (Palestrina). Organ Solos; Prelude and Fugue in E (Lübeck); Motet for Five Voices, Jesu, Joy of Man's Desiring (Bach). Organ Solo, Fantasia in G (Bach); Fest und Gedenksprüche for Two Four Part Choirs (Brahms). Organ Solo; Canzone (Driechner). Motet for Six Voices; Von der Ewigen Liebe (Thomas). 9.0, Announcements. 9.10, The Mist rises; the Leaves Fall—Reading of Autumn Poems.

10.0, Austria. . . . 10.20, Time, Weather, News, Sports Notes and Programme Announcements. 10.40, Impressions of Silesia by a French Girl. 11.0, Light Music and Dance Music, relayed from the Kurhaus, Bad Altheide. 12.30 a.m. (Saturday), Close Down.

**BRNO**

878 kc/s, 342 metres; 35 kW.—5.45 p.m., Gramophone Music. 5.55, Talk for Women; Careers for Girls. 6.5, Gramophone Music. 6.15, Talk on the Olympic Games. 6.25, German Transmission: News, Sports Notes, and Two Talks: (a) Martin Luther, (b) Inventions. 7.0, See Prague. 7.25, See Bratislava. 10.0, See Prague. 10.15 (approx.), Close Down.

**BRUSSELS (No. 1)**

I.N.R., 590 kc/s, 509 metres; 15 kW.—12 Noon, the Village Fair—Gramophone Concert. 1.0 p.m., Le Journal Parlé. 1.10, Concert by the Small Station Orchestra, conducted by Leemans, Strauss March (Mezzacapo); Ballet Music from Isoline (Messager); Serenade (Leoncavallo); Selection from Rip (Planquette); Hymne à l'Amour (Guillemy); Intermezzo from Tamyris (Mambour); Selection from Trois jeunes filles nues (Moretti). 5.0, Concert by the Radio Orchestra, conducted by Franz André, March (Fauly); Selection from Ceorgio (Ganne); Two Pieces for Small Orchestra (Danceau); Pour mes petits amis (Piermé); Selection from Thais (Massenet); Intermezzo (Van Oost); Ballet Suite (Popy); Valse des blondes (Ganne). 6.0, Talk. 6.15, Request Gramophone Music. 6.30, Retour de vacances—Sketch (Joseph Moumaerts). 6.45, Sonata (Leken), for Pianoforte and Violin, on Gramophone Records. 7.15, Educational Talk. 7.30, Legal Talk and Literary Review. 8.0, Concert by the Radio Orchestra, conducted by Franz André, Hungarian March (Berlioz); Overture, Sémiramis (Rossini); Waltz from Die geschiedene Fran (Fall); Selection from No. No, Nanette (Youmans); Selection from Sadko (Rimsky-Korsakov); Selection from Contes d'Auril (Widow). 8.45, Programme for Ex-servicemen. 9.0, Concert relayed from the Kursaal, Ostend. After the Concert, Le Journal Parlé, and Dance Music by Robert de Kers and His Cabaret Kings, and an Argentine Orchestra, conducted by Antonio di Michele, relayed from the Kursaal, Ostend. 11.0, La Brabançonne.

**BRUSSELS (No. 2)**

I.N.R., 887 kc/s, 338.2 metres; 15 kW.—Programme in Flemish. 12 Noon, Gramophone Record. 12.10 p.m. (approx.), Concert by

the Small Station Orchestra, conducted by Leemans, Neapolitan March (Baldy); Gavotte (Aprice (Bortkiewicz); Waltz, La Sultane (Bucalossi); Viennese Operetta Potpourri (Ilrby). 12.30, Richard Strauss' Songs on Gramophone Records. Ständchen; Morgen; Traum durch die Dämmerung; Freundliche Vision. 12.45, Concert (cont'd.). Selection from The Geisha (Jones); King Cotton March (Sonsa). 1.0, Le Journal Parlé. 1.10, Gramophone Music, Overture to and Concert Version of The Merry Wives of Windsor (Nicolaï); Overture, Le Roi malgré lui (Chabrier). 5.0, National Dances on Gramophone Records. Four German Dances (Mozart); Hungarian Dance (Moszkowsky); Arab Dance from The Nutcracker Suite (Tchaikovsky); Slav Dances Nos. 1 and 2 (Dvorak); German Dances (Schubert); Hungarian Dance No. 5 (Brahms). 5.45, Pallette Programme. 6.30, Concert of Potpourri by the Small Station Orchestra, conducted by Leemans. Tempo, Tempo (Dostal); Was wir lieben (Ganglberger); Polka Potpourri (Lindemann); Potpourri of Hungarian Music (Manfred); Quintessence (Morena). 7.15, Talk. 7.30, Wireless Notes. 8.0, Concert by the Station Orchestra, conducted by Kumps. Soloist: Rosquin (Pianoforte). Part I—Russian Music. Night on the Bare Mountain (Mussorgsky); Pianoforte Concerto in B flat Op. 23 (Tchaikovsky). 8.45, Announcements. 8.55, Talk on the Flemish Patriot Hendrik Conscience, followed by Address and Announcements. 9.5, Concert (cont.). Part II—Flemish for the Fiftieth Anniversary of the Death of Hendrik Conscience. Marche commémorative (Gilsou); Recitation; La rève from Houten Clara (De Vleshouwer); Pianoforte Solos (Meulmans): (a) Extracts from Reflexes, (b) Prelude to Esquisses; Panegyric on Hendrik Conscience; Overture, Begga (Cluytens); March, Klokke Roeland (Tinel). 10.0, Le Journal Parlé. 10.10, Gramophone Records. Overture, Lohengrin (Wagner); Aria from Samson and Delilah (Saint-Saëns); Aria from La Bohème (Puccini). 10.25, Song Recital on Gramophone Records. Chantaine: Song of the Viking from Sadko (Rimsky-Korsakov); Scheidt: Aria from The Flying Dutchman (Wagner); Kipnis: Der Wegweiser (Schubert); Schumann: Adelaide (Beethoven); Mijn Vlaanderen heb ik hartlijk lief (Anthemis).

**BUCHAREST**

761 kc/s, 394 metres; 12 kW.—5.0 p.m., Concert by the Station Orchestra: March (Blaukenburg); Waltz, The Blue Danube (Strauss); Overture, Peter Schmitt (Weber); Selection from La Traviata (Verdi); Selection from Clo-Clo (Lelá); Potpourri (Dostal); Hungarian Dances Nos. 19 and 20 (Brahms); Humoresque and Mazurka (Dvorak). In an interval at 6.0, Radio Journal. 7.0, Reading. 7.20, Educational Talk. 7.40, Opera (to be announced) on Gramophone Records. In the intervals, Radio Journal. After the Opera, Concert by the Motoi Orchestra, relayed from the Monte Carlo Restaurant.

**BUDAPEST**

545 kc/s, 550.5 metres; 18.5 kW.—Also relayed on 840 metres from 8.0 p.m. till Close Down. 5.30, Recital of Hungarian Folk Songs with Accompaniment by the semi Kurina Cigány Band. 6.30, Talk on the Chicago World Fair. 7.0, Military Band Concert. 8.0, A Story of Peace Time—Radio Play (Lestyan). 9.45, News. 10.5, Recital by Kalra Dullien; Largo (Veracini); Allegro (Piooco); Liebestraum (Hubay); Scherzo (Rieger); Dance (Bazzini); Ruralla Hungarica (Dobnanyi); Legend (Hodula); Sonatina (Bartók-Gertler). 10.40, Music by the Veres Cigány Band and the Guttenberg Salon Orchestra, relayed from the Café Ostend, with Interludes by Paul Kalmar.

**CASSEL**—See Frankfurt.

**COPENHAGEN**

1,057 kc/s, 281 metres; 0.75 kW. Relayed by Kalundborg, 260 kc/s, 1,153.8 metres.—12 Noon, Time and Chimes from the Town Hall and Weather Forecast. 12.5 p.m., String Ensemble Concert, relayed from the Bellevue Strandhotel. 2.0, Interval. 3.3, Concert by the Radio Orchestra, conducted by Fritz Mahler; Soloist, Galina Werschowskaya (Pianoforte); Overture, Lucio Silla (Mozart); Minuet from the Fifth Symphony in G flat (Schubert); Waltz, Die Schönbrüner (Ganne); Five Viennese Dances (Beethoven); Pianoforte Solos: (a) Improvptin n 6 (Schubert); Spinnlied (Wagner-Liszt); March, Op. 12 (Prokofiev); Overture, W. J. McMaster (Joh. Strauss); Ball-t Music from Orpheus and Eurydice (Glück); Ochsennuett (Haydn); Kaiserwaizer (Joh. Strauss); Overture, Boccaccio (Suppe). 5.0, Gramophone Music. 5.30, Exchange and Fish Market Prices. 5.45, Talk. 6.15, German Lesson for Beginners. 6.45, Weather and News. 7.15, Time Signal. 7.16, Talk relayed from the University. 8.0, Programme by Per Knutzon. 8.10, Programme for the 150th Anniversary of the Birth of N. F. S. Grundtvig; Talk, and Song Recital. After the Programme, Weather. 9.10, Cello Sonata in E Minor (Aristi). 9.30, A Visit with the Microphone

SEPT. 8th **FRIDAY** continued

To a Cycle Factory. 10.0, News. 10.15, Concert by the Radio Orchestra, conducted by Emil Reeson: Overture, Les Brigands (Offenbach); Ballet Music from La belle Helene (Offenbach); Serenade, Waltz and Polka from Les Millions d'Arlequin (Drigo); Overture, Les Cloches de Corneville (Flanquette); Ballet and Theme from Coppelia (Delibes); Overture, La petite Bohème (Hirschmann). 11.10, Close Down.

CORK.—See Athlone.

DANZIG.—See Heilsberg.

DRESDEN.—See Leipzig.

FECAMP

1,328 kc/s, 225.9 metres; 10 kW.—11.0 a.m. to 12.0 Noon, Programme in English by the I.B.C. 11.0, Philco Happy Hour. Part I. Request Programme of Sea Shanties; Signature Tune; A Life on the Ocean (Binding); The Drunken Sailor (arr. Terry); Shenandoah; A rovin' (arr. Terry); The Midly; Rio Grande (arr. Harris); One Dollar Fifty a Day; Potpourri, Nautical Moments (arr. Winter). Part II. Request Items: Lullaby of the Leaves (Petkerc); Still I love her (Gaskill); Paradise (Brown); Brother can you spare a dime? (Gorney); She didn't say Yes (Kern); Try a little tenderness (Woods); Mam' Girl (Libornio); O Mornah (Washburn); Signature Tune. 12 Noon, Programme in French. 5.0 to 6.0, Programme in English by the I.B.C. 5.0, Orchestral Concert for Southampton and Winchester Listeners. Signature Tune: The Night by the Sea; Wee Macgregor Patrol (Amers); Babes in Toyland (Herbert). Song: The Blackbird's Song (Scott); The Rose Beetle goes a-wooing (Armandola). Song: 'Comin' through the Rye (arr. Smart); Serenade (Pierne). Violin Solo: Cavatina (Raff); Lazy Pete (Kernsten). 5.30, Concert of Light Music for Bournemouth and Weymouth Listeners: The Little Company (Ganglbberger). Xylophone Solo: Jovial Jasper (Green). Song: Peter, Peter (Woods); My Darling (Myers); One little Word led to another; Oh, I wish I could sing a Love Song. Song: You are too beautiful (Rodgers); That little lock of Hair (Verrill); The Old Spinning Wheel (Hill); Signature Tune. 6.0, Programme in French. 10.0 till Close Down, Programme in English by the I.B.C. 10.0, Dance Music. Signature Tune, Bells of Normandy; Look what you've done; On a Dreamy Afternoon; Willow weep for me; Moonlight on the River; The Lady I Love; Bass Drum Dan; The King's Navvy; My Heart's to let; To-night; Always in my Heart; Do you recall?; Drifting and Dreaming; Well! Well! Well!; Everyone says I Love you; Jack in the Box; Little Lady; Signature Tune. 11.0, Sound Film Music. Signature Tune: Sittin' in the Dark; Maurice Chevalier Potpourri; You will remember Vienna (Romberg); Selection from The Kid from Spain (Kalmar). Pianoforte Solo: Why waste your Tears (Holstein); The Song of the Vagabonds (Frim). Pianoforte Solo: Where are you? (McVey); Song of the Drum (Ellis); The Hit Parade. 11.30, Club Concert for Birkenhead and New Brighton Listeners. Part I. Symphony Orchestra. Signature Tune, The Chim Song; Rakoczy March (Berlioz). Violin Solo: Le cygne (Saint-Saëns); Entry of the Little Fauns (Pierne); Dance of the Sylphs (Berlioz); Concert Waltz (Glazunov). Violin Solo: Air on the G String (Bach); The Witch's Ride (Puccini); Minuet from the Petite Suite (Debussy). 12.5 a.m. (Saturday), News Bulletin in English. 12.10 (approx.), Club Concert. Part II: You're mine, you (Green); Peter, Peter (Connolly); Something came and got me in the Spring (Rich); One Tiny Tear (Connolly); Stay out of my dreams (Washington); Signature Tune. 12.30, Dance Music. (Electrical Transcriptions): Here is my Heart: I lay me down to sleep; Old Man Harlem; I can't remember; Castles in the Sand; I've got to sing a Torch Song; In the Valley of the Moon; The Shadow Waltz. 1.0, Dance Music: Signature Tune, Bells of Normandy; Somebody stole my Girl; You've got me; That's what life is made of; Sweetness; I cover the Waterfront; Put on your old Grey Bonnet; I raised my Hat; Whispering; My favourite Band; Merry-go-round; Music hath charms; Sophisticated Lady; My Heart was made for Love; One Hour with You; In old Vienna; A big Bouquet for You; Signature Tune. 1.57, I.B.C. Goodnight Melody. 2.0 (approx.), Close Down.

FLensburg.—See Hamburg.

Florence.—See Turin.

FRANKFURT

1,157 kc/s, 259.3 metres; 17 kW. Relayed by Cassel, 1,220 kc/s, 245.9 metres; and Trier, 1,157 kc/s, 259.3 metres.—6.0 p.m., Talk: Finland's Fight for Freedom. 6.25, Topical Talk. 6.45, To-day's News. 7.0, Transmission for all German Stations, relayed from Heilsberg. 8.0, The Steamers Elsa and Friede—Radio Picture (Karl Klinghardt). 9.0, Variety Items. 9.45, Concert, relayed from London. 10.30, Time and News. 10.45, Orchestral Concert, conducted by Hans Rosbaud. Soloist: Hugo Kolberg

(Violin). Part I.—Beethoven Music. Part II.—Marches and Light Music. 12.30 a.m. (Saturday), Close Down.

FREDRICKSTAD.—See Oslo.

FREIBURG.—See Stuttgart.

Geneva.—See Radio-Suisse Romande.

GENOA.—See Turin.

GLEIWITZ.—See Breslau.

GOTEBORG.—See Stockholm.

GRAZ.—See Vienna.

HAMAR.—See Oslo.

HAMBURG

806 kc/s, 372 metres; 1.5 kW. Relayed by Bremen, 1,112 kc/s, 269.8 metres; Flensburg, 1,319 kc/s, 227.4 metres; Hanover, 530 kc/s, 556 metres and Kiel, 1,292 kc/s, 232.2 metres.—6.0 p.m., Variety Programme. 6.45, Exchange. 6.50, Weather. 7.0, Transmission for all German Stations, relayed from Heilsberg. 8.0, Haydn, Mozart and Beethoven Concert by the Hamburg Philharmonic Orchestra, conducted by Eilenschütz and Richard Gräbe (Clarinet); Symphony No. 92, the Oxiord (Haydn); Clarinet Concerto in A (Mozart); Ballet Music from Prometheus (Beethoven); Overture, The Magic Flute (Mozart). 9.30, Horridoh and Halali: Literary and Musical Programme by the Small Station Orchestra and the Station Male Voice Quartet. 10.0, News. 10.20, Topical Talk. 10.30, Recital of Old and New Music for Two Guitars: Little Divertimento (Sor); Largo and Rondino (Carulli); Pastorale (Coste); Andante from the Sonata in G (Ritter); Classical Waltz (Boho). 11.0, Concert of Light Music.

HANOVER.—See Hamburg.

HEILSBERG

1,085 kc/s, 276.5 metres; 60 kW. Relayed by Danzig, 662 kc/s, 453.2 metres.—1.5 p.m., Concert by the Small Station Orchestra, conducted by Eugen Wilcken; Overture, Der Waffenschmid (Lortzing); Cello Solo, Krotsehak-Romanze (Recktenwald); Friedmann Bach Suite (Leuschner); Selection from La Traviata (Verdi); Catalan Caprice (Albeniz); Serenata napoletana (Sgambati); Waltz, Schwert und Leier (Jos. Strauss); Selection from Der Tenor der Herzogin (Künneke). In the intervals at 1.20 and 2.0, News. 2.30, Programme arranged by the Post Office with Gramophone Records. 3.0, Agricultural Prices and Exchange. 3.30, Programme for Children. 4.0, Talk for Women. 4.30, Police Band Concert: Fest-Hymnus (Sileher); Overture, Le Lac des fées (Anbei); Entr'acte from Rosamunde (Schubert); Waltz, Vive la Danse (Waldeufel); March and Drinking Song (Schreck); Wachtparade (Ruhn); Nibelungen-Marsch (Schnittke); Ballet Scene (Beriot); Tom der Reimer (Loewe); Unter den Hakenkreuz (Beriot). In the interval at 5.10 (approx.), Book Review. 5.45, Talk: The Theatre an Outpost of German Culture on the Eastern Frontier. 6.15, Agricultural Prices. 6.25, Talk: Nazi Storm Troops in East Prussia. 6.50, Weather. 7.0, Transmission for all German Stations: Undine, Opera (E. Th. A. Hoffmann) with Introductory Talk. 8.0, News. 8.10, Hugo Wolf Songs (Words by Eduard Mörike), Hans Eggert (Baritone). 8.55, Chamber Music: Oboc Quartet (Mozart); String Trio, Op. 15 in F Minor (Trenker). 9.35, German Literature of the Great War: Programme of Prose and Verse with Choral Music. 10.15, News.

HILVERSUM

Announced Huizen, 1,013 kc/s, 296.1 metres; 20 kW. (7 kW. up to 4.40 p.m.).—Programme of the catholic Radio Society (K.R.O.). 11.55 a.m., Concert by John Brown's Melodians. 1.25 to 1.40 p.m., Interval. 1.40, Organ Recital by Vissers: Prelude (Aurooy); March from Athalie (Mendelssohn); Allegretto (Rinck); Romance without Words (Lemmens); Flute Concerto (Rinck); Ave Maria (Schubert); Nocturne (Lemmens); Invocation (Lemmens); Melody (Fagel); Adoration (Kallembach); Song without Words (Mendelssohn); March (Mendelssohn). 2.40, Concert by Mlle van Nyk (Pianoforte), van den Berk (Tenor), and Louis Smer (Violin); Winterstümme wüthen dem Wonnemond (Wagner); O del mio dolce ardor (Gluck); Selection from A Masked Ball (Verdi); Pianoforte Solos: (a) Prelude and Fugue (Bach); (b) Sonata, Op. 27, No. 2 (Beethoven); Sonata in E Minor (Bach); Gramophone Records: Pianoforte Solos (Chopin): (a) Waltz, Op. 69, No. 1, (b) Waltz, Op. 64, No. 1, (c) Prelude, Op. 28, No. 15, (d) Scherzo, Op. 31, No. 11; Selection from Hans Heiling (Marschner); Piece (Goublique); Selection from The Mastersingers (Wagner); Le printemps (Milhaud); Titini (Castellanovae); Introduction and Ronco capriccioso (Saint-Saëns). 4.40, Gramophone Music. 5.10, Horticultural Talk.

5.40, Concert by the K.R.O. Boys. 6.40, Police Notes. 6.55, Talk. 7.15, Gramophone Music. 7.40, Concert by the K.R.O. Orchestra, conducted by Gerritsen; Soloist, Borislav Kon (Pianoforte): La procession nocturne (Rabaud); Concerto in F Minor, Op. 21 (Chopin). 8.10, News. 8.15, Gramophone Music. 8.30, Concert (cont'd.): Pianoforte Solos: (a) Fantasia in F Minor (Chopin); (b) Six Etudes, Op. 10 (Chopin); Prelude (Järnefeldt); Selection from Eugene Onegin (Tchaikovsky); Selection from Boris Godunov (Mussorgsky); Suite from Philémon et Baucis (Gounod); Variations, Op. 3 (Szymanovsky); Overture, Frau Luna (Lincke); Selection from Countess Maritza (Kálmán). 10.10, News. 10.45, Concert by Ernesto Arcari and his Italian Orchestra. 11.40 (approx.), Close Down.

HORBY.—See Stockholm.

HUIZEN

Announced Hilversum, 160 kc/s, 1,875 metres; 8.5 kW.—11.40 a.m. to 3.40 p.m., Programme of the Algemeene Vereeniging Radio Omroep (A.V.R.O.). 11.40, Gramophone Music. 12.10 p.m., Concert by Kovacs Lajos and his Orchestra: Gramophone Music in the intervals. 1.50, Reading. 2.10, Pianoforte Recital by Franz Hillen: Fantasia in G (Mozart); Minuet in E Flat (Mozart); Consolation in D Flat, No. 3 (Liszt); Waldesranchen (Liszt). 2.40, Gramophone Music. 3.45 to 7.40, Programme of the Workers Radio Society (V.N.R.A.). 3.45, Concert by the Guarani Trio: Overture (Plannette); Eastern Stars (Löriz); Slav Dance (Dvorak); Spanish Dance (Sarasate); Le petit (Güntraud-Alder); Melody (Venuti); Wine, Woman and Song (Joh. Strauss). 4.30, Programme for Children. 5.10, Organ Recital: Dimah (Akt); Intermezzo and Song (Schrömann); Kiss me goodnight (Nicholls); La bella Tangolita (Abrabam); Im Frühling (Steyn); Caprice viennois (Kreisler). 5.40, Concert by the Small Radio Orchestra, conducted by de Groot: Overture, Große-Girofla (Lecocq); Springtime Suite (Wesly); Romance (Svendson); Waldesgelfister (Zibulka); Whistle for me (Fane); Les marionettes (Philippucci); Funeral March of the Marionette (Gounod); Die Waffen nieder. 6.20, Talk. 6.40, Concert by the Station Orchestra, conducted by de Groot: Volkoutwaak (Gayvaux); Poeme (Fliche); Wien wird bei Nacht erst schön (Stolz); Tempo, tempo (Scholte-meyer). 6.55, Violin Recital: Largo and Allegro (Boer); Humoresque (Ailin). 7.5, Concert (cont'd.). In Mendelssohn's Rosengarten (Urback). 7.20, Violin Recital (cont'd.): Nalse caprice (Wieniawski); Heire Kati (Hubay). 7.30, Concert (cont'd.): Bohemian Dance (Debussy); La danza (Rosini); Frauenherz (Strauss); Motor-March (Rosey). 7.40, Talk arranged by the Liberal Protestant Radio Society (V.P.R.O.). 8.10 to 9.40, Programme of the A.V.R.O. 8.10, symphony No 9 in D Minor (Choral), Op. 125 (Beethoven); by the Residence Orchestra, conducted by Carl Schüricht; relayed from the Kurhaus, Sehevingen; Soloists: Jo Vincent (Soprano), Suzé Luger (Contralto), Louis van Tulder (Tenor) and Willem Ravelli (Bass). In the interval at 8.40, Talk arranged by the V.P.R.O. 9.40 to 10.40, Programme of the V.R.O. 9.40, Religious Notes and News. 9.55, Recitations. 10.25, Gramophone Music. 10.40 till Close Down, Programme of the V.A.R.A.—Gramophone Music. 11.40 (approx.), Close Down.

INNSBRUCK.—See Vienna.

JUAN LES PINS

1,205 kc/s, 249 metres; 0.8 kW.—12.30 p.m., Amusement Guide and Variety Items. 1.0, News. 1.15, Radio Concert. 8.0, Amusement Guide, Financial Notes and News. 8.10, Esperanto Lesson. 8.30, Press Review. 8.40, Radio Concert. In an interval at 9.0, News and Weather Report.

KALUNDBORG.—See Copenhagen.

KIEL.—See Hamburg.

KLAGENFURT.—See Vienna.

KOSICE.—See Prague.

LANGENBERG

635 kc/s, 473 metres; 60 kW.—12.50 p.m., News. 1.0, Orchestral Concert, conducted by Eysoldt: Overture, The Merry Wives of Windsor (Nicolaï); Ballet égyptien (Luignit); Les Fables de La Fontaine (Monton); Das Lied der Quelle (Amadei); Fantasia, Webers Blütenkranz (Schreiner); Traum-Walzer (Millecker); Vergissmännchen (Macheth); Intermezzo, Balala (Masin); March, Via Emma (Creutz). In the interval at 2.0, News. 2.30, Interval. 3.0, Talk: The New German Patent Laws. 3.20, Topical Talk. 3.30, Market Prices. 3.50, Programme for Children. 4.30, Peru—a Radio Sequence of Old Legends (Willi Perdekamp), with Modern Gramophone Records. 5.10, Concert by the Station Orchestra, conducted by Kühn: Overture, The Magic Flute (Mozart); Hungarian Rhapsody No. 1 (Liszt); Suite from The Nutcracker Ballet (Tchaikovsky). 5.45, Reading. 6.0, Concert by the Station Orchestra:

Overture, Genoveva (Schumann); Waltz, Die Romantiker (Lauer); Divertimento No. 1 in E flat (Mozart); Reiter-Marsch (Schubert). 6.45, Weather, Sports Notes, and Market Prices. 7.0, Transmission for all German Stations, relayed from Heilsberg. 8.0, News. 8.5, Concert by the Small Station Orchestra, conducted by Eysoldt: Overture, Wiener Frauen (Lehár); Nocturne, In einer Sommernacht (Spies); Czardas from Coppelia (Delibes); Serenade (Pierne); Loin du bal (Gillet); Rose-Marie (Krome); Faun and Nymph (Königsberger); Stormy Weather (Arlen); Slow Waltz, Heimweh hab' ich (Ludwig); Spanish March (Stauch). 9.0, Bunte Stunde. 10.0, News. 10.20, From Paul Ernst to Hans Johst—a Review of Contemporary German Drama (on Gramophone Records). 10.55, Review of Next Week's Events in West Germany. 11.5, Serenade on Gramophone Records. 11.30 (approx.), Close Down.

LAUSANNE.—See Radio-Suisse Romande.

LEIPZIG

769.9 kc/s, 389.6 metres; 120 kW. Relayed by Dresden, 941 kc/s, 319 metres.—4.0 p.m. (from Dresden), Concert by the Dresden Philharmonic Orchestra, conducted by Gottlieb-Hellmesberger: Overture, Der Beherrscher der Geister (Weber); Waltz from Der Rosenkavalier (Strauss); Selection from Herzog Wildfang (S. Wagner); Waltz, Gruss an Wien (Baussen); Five Pieces for String Orchestra (Joon); Waltz, Pierrot and Pierrette (Lehár); March (Gruber). 5.0, Book Review. 5.20 (from Dresden), Concert by the Dresden Philharmonic Orchestra, conducted by W. Gottlieb-Hellmesberger. Soloist: Rappoldi (Violin). 5.50, Economic Notes, News, Weather and Time. 6.0, Review of Books for the Hitler Youth. 6.20, Agricultural Talk. 6.30, Talk: Charlatans and Marxists—Deceivers of the People. 6.50, Review of the Day. 7.0, Transmission for all German Stations, relayed from Heilsberg. 8.0, Concert by the Borna Wind Band. 8.50, News. 9.0 (from Dresden), Concert of Serenades, relayed from the Zwingli. 10.0, Gaudemus Igitur—Stories of Our Fathers' Student Days. 10.20, News, followed by Sound Film Music on Gramophone Records. 12 Midnight, Close Down.

LINZ.—See Vienna.

LJUBLJANA

522 kc/s, 574.7 metres; 7 kW.—8.0 p.m., See Bratislava. 10.30, Weather and News. 11.0 (approx.), Close Down.

LUXEMBOURG

252 kc/s, 1,191 metres; 200 kW. Dutch Programme. 7.30 p.m., First Symphony (Beethoven). 8.10, Talk in Dutch: Luxembourg and Holland in History. 8.20, Song Recital by Alice Peffer. 8.50, News in French. 9.0, Violin Concerto in D (Beethoven). 9.45, News in German. 9.55, Gramophone Music. 10.25, Gramophone Dance Music.

MADRID

EAJ7, 707 kc/s, 424.3 metres; 2 kW.—8.0 p.m., Chimes, Exchange, Radio Journal and Request Gramophone Records. 9.15, Topical Review. 9.30 to 11.0, Interval. 11.0, Chimes, Time Signal and Topical Review. 11.20 (approx.), Symphony Concert on Gramophone Records: Overture, Così fan tutte (Mozart); A Night on the Bare Mountain (Mussorgsky); Extracts from Daphnis et Chloé (Ravel); Double Concerto in A Minor for Violin and Cello (Brahms); Scheherazade (Rimsky-Korsakov). 1.15 a.m. (Saturday), Topical Review and Programme Announcements for Listeners Abroad. 1.30, Chimes and Close Down.

MADRID

EAQ, 10,000 kc/s, 30 metres; 20 kW.—11.30 p.m., Concert of Popular Music. In an interval at 11.45, Radio Chronicle. 12.40 a.m. (Saturday), Light Music. 1.0 (approx), Close Down.

MALMO.—See Stockholm.

MILAN

VIGENTINO, 662 kc/s, 453.2 metres; 4 kW.—8.30 p.m., till Close Down, See Rome.

MORAVSKA-OSTRAVA

1,137 kc/s, 263.8 metres; 11 kW.—6.20 p.m., Talk for Tourists. 6.25, See Prague. 10.15 (approx.), Close Down.

MOTALA.—See Stockholm.

MUHLACKER.—See Stuttgart.

MUNICH

563 kc/s, 533 metres; 60 kW. Relayed by Augsburg and Kaiserslautern, 536 kc/s, 560 metres; and Nürnberg, 1,256 kc/s, 239 metres.—4.30 p.m., See Stuttgart. 5.45, Talk for the Younger Generation: The Young People's Part in the Reconstruction of Germany. 6.5, Das verlassene Mägdelein



SEPT. 8th

FRIDAY

continued

(Morike), in the settings of Schumann, Goetz, Wolf, and Pfitzner; by Marianne Rau-Höglerer (Soprano). 6.25 (from Nürnberg). Talk: Wilhelm Raabe as a National Prophet. 6.45, Time and Announcements. 7.0, Transmission for all German Stations, relayed from Heilsberg. 8.0, Concert of Schrammle Music: München-Wien (Kornatz); Waltz, Tales from the Vienna Woods (Joh. Strauss); Fantasia on the Song, Ein Vöglein sang im Lindenbaum (Eberle); Upper Bavarian Ländler (Daxenberger); Kärntner Liedermarsch (Seyfert). 8.35 (from Nürnberg), Konrad Gröbel—Radio Sequence. 9.20 (from Nürnberg). Concert by the Francoonian Chamber Orchestra, conducted by Markus Rümmelein: Selection from La part du diable (Auber); Allegro molto from Divertimento No. 11 (Mozart); Entr'acte and Ballet Music from Rosamunde (Schubert); Minuet from The Veil of Pierrette (Dohnányi); Waltz in A (Dvorak); Overture, Die beiden Schützen (Lortzing). 10.0, Austria. 10.20, Time and News.

NAPLES.—See Rome.

NOTODDEN.—See Oslo.

OSLO

277 kc s, 1,083 metres; 60 kW. Relayed by Fredrikstad, 815 kc s, 368.1 metres; Hamar, 522 kc s, 574.7 metres; Notodden, 671 kc s, 447.1 metres; Porsgrund, 662 kc s, 453.2 metres; and Rjukan, 671 kc s, 447.1 metres.—5.30 p.m., Gramophone Music. 6.30, A Visit to a Farm with the Microphone. 7.0, Advertising Notes, Weather, and News. 7.30, An Interview with Fishers at Aalesund. 8.0, Time Signal. 8.2, Concert by the Station Orchestra, conducted by Hugo Kramm: The Nutcracker Suite (Tchaikovsky); The Patriotic Symphony (Tchaikovsky). 9.15, Talk: Who is Krishna Murti? 9.30, Report on Foreign Agricultural Markets. 10.15, Concert of Light Music. 10.45 (approx.), Close Down.

OSTERSUND.—See Stockholm.

PALERMO

558 kc/s, 537.6 metres; 3 kW.—8.0 p.m., Dopolavoro Notes, Tourist Report, Agricultural Notes, Report of the Royal Geographical Society and Giornale Radio. 8.20, Gramophone Music. In an interval at 8.30, Time and Announcements. 8.45, Concert of Popular Music. In the intervals, Talk and Announcements. 10.55, News.

PARIS

EIFFEL TOWER, Call FLE, 207.5 kc s, 1,445.7 metres; 13 kW. Time Signals (on 2,650 metres) at 10.26 a.m. and 11.26 p.m. (Preliminary and 6-dot Signals).—6.45 p.m., Theatre Notes. 7.0, Le Journal Parlé. 8.30, Piano Sonata, Op. 31, No. 3 (Beethoven), played by Marie-Antoinette Pradier. 9.0, Symphony Concert, conducted by Eduard Flament: Petite Suite (Kalkman); Selection from Eugene Onegin (Tchaikovsky); Suite for String (Aubert); Sarabande (Corelli); Siciliana; Gigue (Vivaldi); Juego (Turina). 10.0 (approx.), Close Down.

PARIS

POSTE PARISIEN, 914 kc/s, 328.2 metres; 60 kW.—7.0 p.m., Gramophone Music. 7.5, Sponsored Talk. 7.15, Le Journal Parlé. 7.30, Concert. 8.0, Agricultural Talk. 8.5, Gramophone Music. 8.30, Concert of Viennese Music, with Songs by Leonardo Aramesco. 10.15, News.

PARIS

RADIO PARIS, Call CFR, 174 kc s, 1,725 metres; 75 kW.—7.30 a.m., Weather and Physical Culture. 7.45, Gramophone Records: Marietta (Lucchesi); Les Lilas (Ducle); Boston d'amour (Charpentier); Paire Pato (Ghirlanday). 8.0, Weather and Press Review. 12.30 p.m., Gramophone Records: Ballet Music from The Cid (Massenet); Maundy Thursday in Seville (Turina); Sonata in E (Scriabin); Waltz in A (Brahms); Erikonig (Schubert); Valse romantique (Chabrier); Serenade (Saint-Saens); Hungarian Rhapsody (Schmitt); The Drury Steppes (Gretchaninov); Etude, No. 3 (Chopin); Trio for Piano, Oboe and Bassoon (Poulenc); Two Movements in Symphonic Form (Merrick); La Procession (Frank); Summer Pastoral (Honegger); Three Ecossaises (Chopin); Dance of the Seven Veils, from Salome (R. Strauss); Air from The Seasons (Haydn); On Wings of Song (Mendelssohn). In the intervals at 1.0 p.m., Exchange and News, and at 1.30, Exchange. 2.0, Exchange. 3.45, Exchange and Market Prices. 7.0, Agricultural Notes. 7.10, Social Insurance Report. 7.20, Gramophone Music. 7.50, Commercial Prices and News. 8.0, Modern Symphony Music on Gramophone Records: Concerto for Harpsichord, Flute, Oboe, Clarinet, Violin and Cello (Falla); Symphonie classique (Prokofiev); Viennese Rhapsody (Schmitt). 8.30, News and Weather. 8.40, Review by Pierre Seize. 8.45, Poetry Recital. 9.15, Press Review and News. 9.30, Concert of French and Romanian Music. Pia Igy (Songs), Nicolas Caravia (Pianoforte) and Nicolas Vamasesco (Guitar). Songs with Guitar Accompaniment: (a) Water Song (Heresco), (b) Nostalgia (Paschill), (c) The Cuckoo (Sredicannu); Tocatta for Pianoforte

(Enesco); Songs: (a) For You (Golestan), (b) Autumn Leaves (Otesco), (c) The Rose (Dragoi); Piano-forte Solos: (a) Minstrels (Debussy), (b) Lile joyeuse (Debussy); Songs: (a) Peach Blossom (Simon), (b) Le Ros-signal (Saint-Saens), (c) Waltz Song from Romeo and Juliet (Gounod). 10.15, Tone Poem, A Night on the Bare Mountain (Mus-org-ky) on Gramophone Records.

PITTSBURGH

KDKA, 980 kc/s, 306 metres; 50 kW. Relayed by W8XK on 48.86 metres and 25.27 metres.—4.15 to 5.0 p.m., U.S. Marine Band, from New York. 7.30, Pontiac Home Forum. 8.0 to 9.30, New York Relay. 8.0, Betty and Bob. 8.15, Words and Music. 8.45, Pay Kennedy. 9.0, Gene Quaw Orchestra. 9.30, News and Markets. 9.45, Arcadians, from New York. 10.0, Uncle Tom and Betty. 10.15, Tarzan of the Apes. 10.30, Singing Lady, from New York. 10.45, Orphan Annie, from New York. 11.0, News Reel. 11.15, Sports, A Song. 11.30, Pitts-burgh Spot-lights. 11.45 to 3.45 a.m. (Saturday), New York Relay. 11.45, Lowell Thomas. 12 Midnight, Amos 'n' Andy. 12.15, Roundfliers. 12.30, Orchestral Concert. 1.0, Popular Programme. 1.30, Potash and Perlmutter. 1.45, Rocking Chair Memories. 2.0, Let's Listen to Harris. 2.30, Variety Programme. 3.0, First Nighter.

PORSGRUND.—See Oslo.

PRAGUE

614 kc s, 468.6 metres; 120 kW.—2.50 p.m., See Bratislava. 3.50, Weather. 3.55 to 4.0, Exchange. 5.45, Gramophone Music. 5.55, Reading. 6.5, Agricultural Report. 6.15, Gramophone Music. 6.25, News in German. 6.30, German Transmission: Programme to be announced. 7.0, Chimes and News. 7.10, Talk. 7.25, Introductory Talk to the following Transmission. 7.30, Figaro—Opera in Four Acts (Mozart), relayed from the State Opera House. 10.0, Time and News. 10.15, Close Down.

RADIO-SUISSE ROMANDE

(SOTTENS), 743 kc/s, 403 metres; 25 kW.; and Geneva, 395 kc s, 760 metres.—12.28 p.m., Time Signal from Neuchâtel Observatory. 12.30, News. 12.40 (from Geneva), Gramophone Concert. In the interval at 1.0, Financial Bulletin. 2.0, Interval. 3.28, Time Signal from Neuchâtel Observatory. 3.30 (from Geneva), Gramophone Concert. 4.30 (from Geneva), Programme for Women. 5.30, Interval. 7.0, Talk: The Swiss Chamber of Commerce. 1933. 7.15 (from Lausanne). Talk: Where to spend the Week-end. 7.30, News. 7.35 (from Lausanne). Answers to Correspondence. 8.0 (from Lausanne), Cabaret Concert. 9.20 (from Lausanne), Quartet in E flat (Mozart). 9.50, News. 10.0 (from Lausanne), La nuit d'auvergne x—One-Act Comedy in Verse (Nigondi). 10.30 (approx.), Close Down.

RJUKAN.—See Oslo.

ROME

Call IRO, 680 kc s, 441 metres; 50 kW. Relayed by Naples, 941 kc s, 319 metres, and 2RO, 11,810 kc s, 25.4 metres, from 25.4 metres.—12.30 p.m., Gramophone Music. 1.0, Orchestral Concert. In the interval from 1.30 to 1.45, Giornale Radio and Exchange. 2.0, Time and Announcements. 4.30, Giornale Radio and Exchange. 4.45, Children's Radio Review. 5.10, Weather. 5.15 to 6.0, Song and Piano-forte Recital by Luisa Carlevarini Romano Rasponi (Baritone) and Gisella De Bonitibus (Soprano); Violin Solos: (a) Tambourin (Gossec-Moffat), (b) Contredanse (Beethoven); Soprano Solos: (a) Ninna nanna (Ravensgat), (b) O rondinella (Lattuada); Spanish Songs for Baritone; Violin Solos: (a) Spanish Serenade (Glazunov-Kreisler), (b) Gopak (Mussorgsky); Soprano Solos (Donaudy): (a) Freschi luoghi, (b) Madonna Renzoia. 6.40 (Naples), Shipping and Sports Notes. 6.45, Dopolavoro Notes and Tourist Report. 6.57, Report of the International Institute of Agriculture (in Spanish, German and French). 7.10, Agricultural Report and Market Prices. 7.20, News in Foreign Languages. 7.40, Giornale Radio. 8.0, Time, Announcements, and Sports Notes. 8.30, Le Jongleur de Notre Dame—Opera in Three Acts (Massenet). 10.55, Giornale Radio.

SALZBURG.—See Vienna.

SCHENECTADY

(WGY), 750 kc s, 379.5 metres; 50 kW. Relayed at intervals by W2XAF on 31.48 metres and by W2XAD on 19.56 metres.—9.0 p.m., Vocal Duets by Haber and Curtis. 9.15, May we Present, from New York. 9.30, Talk: The Mind Age. 9.35 to 10.0 (approx.). South Sea Islanders, from New York. 12.45 a.m. (Saturday), Stock Reports and Baseball Scores. 1.0, Cities Service Concert, from New York. 1.30, WGY Farm Forum. 2.0, Variety Programme, from New York. 2.30, Popular Programme, from New York. 3.0, WGY Players. 3.30, Lum and Abner's Friday Night Sociable, from New York. 4.0, Programme Resume.

SCHWEIZERISCHER LANDESSENDER

BEROMUNSTER, 653 kc s, 459 metres; 60 kW.; Basle, 1,229 kc s, 244.1 metres; and Berne, 1,220 kc s, 245.9 metres.—6.30 to 9.0 p.m., Programme from Berne. 6.30, Microphone Report: Castle Burgdorf. 7.0, News. 7.20, Marching Songs. 7.50, Talk: Motor Cars and Motor Travel. 8.20, Military Band Concert. 9.0, News. 9.10, Swiss Italian Programme from Lugano. 10.15 (from Berne), Talk: Autumn Days in Ticino. 10.20 (approx.), Close Down.

SOTTENS.—See Radio-Suisse Romande.

STOCKHOLM

689 kc s, 436 metres; 55 kW. Relayed by Boden, 244 kc s, 1,229.5 metres; Göteborg, 932 kc s, 322 metres; Hörby, 1,166 kc s, 257 metres; Motala, 221.5 kc s, 1,354.4 metres; Östersund, 389 kc s, 770 metres; and Sundsvall, 554 kc s, 542 metres.—5.5 p.m., Scout Report. 5.25 (from Göteborg), Cabaret Programme. 7.0, A Visit with the Microphone. 7.15, Weather and News. 7.30, Concert by the Radio Choir, conducted by Axel Nylander: Part I, Welsh Songs; Part II, Plantation Songs; Part III, English Hunting Songs. 8.10, Talk: Judaism and Christianity, relayed from Uppsala, 662 kc s, 453.2 metres. 8.40, Concert by the Station Orchestra. Soloist: Roman Dukstinsky (Cello). Overture, A Life for the Czar (Glinka); Caucasian Suite (Ippolitov-Ivanov); Cello Concerto in E Minor (Lindner); Selection from Lila Time (Schubert-Berté). 9.45, Weather and News. 10.0, Gramophone Music. 11.0 (approx.), Close Down.

STRASBOURG

869 kc s, 345 metres; 11.5 kW.—11.30 a.m., Gramophone Concert of Variety Music. 12.45 p.m., News. 1.0, Time and Exchange. 1.5, Popular Music on Gramophone Records. 2.0 to 3.30, Interval. 3.30, Orchestral Concert conducted by Bronillac, relayed from the Casino, Vichy: Overture, Figaro (Mozart); Three Entr'actes from Carmen (Bizet); Gipsy Suite, Alpujarra (Anduaga); Melody; Au printemps (Ficvet); Selection from La Bohème (Puccini); Waltz (Fétras). 5.0, Literary Talk. 5.15, Orchestral Concert, conducted by Roskani: Two Step, Le veux (Hollaender); Fox trot, Desert Lover (Gay); Intermezzo, In the Shadows (Fink); Waltz, Wiener Praterleben (Trauslatteur); Tango (Don Azpiaza); Air from The Countess Maritza (Kálmán); Slow Waltz (Kreisler); Violin Solo: Schön Rosmarin (Kreisler); Fox trot, Just Friends (Klammer); Air (Verdun); Waltz, Pomona (Waldteufel); Two Step (Speyer). 6.0, Trio Concert, relayed from Lille, 1,130 kc s, 265.4 metres. 7.0, Topical Talk in German. 7.15, Gramophone Music. 7.30, Time and News. 7.45, Gramophone Music. 8.0, Press Review in German, Lottery Results and Announcements. 8.30, Gala Concert, relayed from the Casino, Vichy. 10.0, Press Review.

STUTTGART

MUHLACKER; 832 kc s, 360.5 metres; 60 kW. Relayed by Freiburg, 527 kc s, 570 metres.—1.15 p.m., Time and News. 1.30, Gramophone Concert. 2.0, Concert arranged by the Post Office. 2.30 to 3.0, Advanced English Lesson. 3.15 (from Karlsruhe), Talk: Sunday Excursions. 3.30 (from Mannheim), Concert. Stephan Pellissier (Pianoforte), Karl Schmitt (Violin), Alfred Färbaeh (Tenor), and Ellen Pfeil (Soprano). Sonata for Violin and Piano-forte (Brahms); Tenor Solos (R. Strauss): (a) Morgen, (b) Wo zu noch Mädchen, soll es frommen, (c) Die Nacht; Soprano Solos (Wagner): (a) Der Engel, (b) Stehe still, (c) Im Treibhaus, (d) Schmerzen, (e) Träume. 4.30 (from Badenweiler), Orchestral Concert, conducted by Albert Hitzig: Overture, Euryanthe (Weber); Waltz, Morgenblätter (Strauss); Selection from André Chénier (Giordano); Variations on the Kaiser Quartet (Haydn); Alemannische Rhapsodie (Rudel); Intermezzo, Liebesszenen (Donat); Selection from The Land of Smiles (Lehár); March, Badenweiler (Fürst). In the interval at 5.0, Talk from Berlin (Deutschlandsender). 5.45, Health Talk: Gymnastics. 6.5, See Berlin (Deutschlandsender). 6.30, Time and News. 7.0, Transmission for all German Stations, relayed from Heilsberg. 8.0, Homage to Truth. 8.20 (from Mannheim), Trio in F Minor, Op. 65 (Dvorák). 8.50, Two People in Love—Wireless Comedy in Two Acts (Wellenkamp). 10.0, See Munich. 10.20, Time and News. 10.45, See Frankfurt. 12.30 a.m. (Saturday), Close Down.

SUNDSVALL.—See Stockholm.

TOULOUSE

779 kc s, 385 metres; 8 kW.—6.0 p.m., News. 6.15, Music by an Argentine Orchestra. 6.30, Military Music. 6.45, Opera Music: Aria from The Magic Flute (Mozart); Elizabeth's

Aria from Tannhäuser (Wagner); The Soldiers' Chorus from Faust (Goitold); Aria from Boris Godunov (Mussorgsky). 7.0, Impressions d'Italie—Symphonic Poem (Charpentier), by the Symphony Orchestra. 7.15, News. 7.30, Accordion Music: Over the Waves (Rosas); Lopeziana (Alter); Annette (Cuvellier). 7.45, Opera Music: Selection from La Traviata (Verdi); Intermezzo from Cavalleria rusticana (Mascagni); Entr'acte from Act III of Lakme (Delibes). 8.0, Music from Sound Films. 8.15, Operetta Music: Selection from (a) Les cloches de Corneville (Planquette), (b) Le pays du soleil (Scotti), (c) The Desert Song. 8.30, Music by a Viennese Orchestra. 8.45, Opera Music: Aria from Madame Butterfly (Puccini); Prologue to I Pagliacci (Leoncavallo); Aria from Carmen (Bizet). 9.0, Symphony Concert, conducted by René Bathon, relayed from the Municipal Casino, Biarritz. In the interval, Songs. 10.15, North African News and Local News. 10.30, Programme for Listeners in Morocco. 11.0, Dance Music. 11.45, Operetta Music: Airs from (a) Le Comte Obligado (Moretti), (b) Fortunio (Messager), (c) Les saltimbanques (Ganne), (d) Encore cinquante centimes (Barde). 12 Midnight, News. 12.5 a.m. (Saturday), Hawaiian Guitar Music. 12.15, Military Music. 12.30 (approx.), Close Down.

TRIESTE

1,211 kc s, 247.7 metres; 10 kW.—5.15 p.m., till Close Down, See Turin.

TRONDHEIM.—See Oslo.

TURIN

1,096 kc/s, 273.7 metres; 7 kW. Relayed by Milan, 905 kc/s, 331.5 metres; Genoa, 959 kc s, 312.8 metres; and Florence, 599 kc s, 500.8 metres.—5.15 p.m., Chamber Music. 6.0 to 6.5, Weather Forecast. 6.40, Giornale Radio, Dopolavoro Announcements, and Gramophone Music. 7.0, Time, Report of the Royal Geographical Society, and Gramophone Music. 7.10, Agricultural Notes and Market Prices. 7.20, News in Foreign Languages. 7.40, Gramophone Music. 8.0, Announcements, Giornale Radio, Sports Notes, and Weather. 8.15, Sponsored Music. 8.30, Variety Programme. 11.0, Giornale Radio.

VATICAN CITY

15,120 kc/s, 19.84 metres (Morning), and 5,969 kc s, 50.26 metres (Evening); 10 kW.—11.0 to 11.15 a.m., Religious Information in German. 8.0 to 8.15 p.m., Religious Information in Italian.

VIENNA

581 kc/s, 517 metres; 100 kW. Relayed by Graz, 852 kc/s, 352.1 metres; Innsbruck, 1,058 kc s, 283 metres; Klagenfurt, 662 kc s, 453.2 metres; Linz, 1,220 kc/s, 245.9 metres; and Salzburg, 1,373 kc s, 218.5 metres.—3.20 p.m., Talk: The International Congress of Trade Journalists. 3.30, Reading for Women. 3.55, Music from Sound Films on Gramophone Records. 4.45, Talk: Petschorski, the Last Home of Russian Monasticism. 5.10, Song Recital by Flora de Grisono (Soprano) and Otto Staeren (Baritone). 5.55, Tourist Report. 6.10, Talk: Gymnastics. 6.25, Weekly Sports Review. 6.35, Faith and Science—Readings from Great Scientists. 7.0, Concert by the Volksoper Orchestra, conducted by Anderieth. In the interval at 7.40, Time, Weather and News. 8.45, Report of the Opening of the German Catholic Conference in Vienna. 9.0, Der Stephansturm—Play (Heinrich Suso Waldeck), with Music by Weissenböck. 10.30, News, Weather and Exchange. 10.45, Dance Music on Gramophone Records.

WARSAW

212.5 kc s, 1,411 metres; 120 kW.—11.57 a.m., Time Signal and Fanfare from St. Mary's Church, Cracow. 12.5 p.m., Popular Concert conducted by Szulc, relayed from the Bagatela. In an interval at 12.25, Polish Press Review and Weather Report. 12.55, Radio Journal. 1.0 to 2.55, Interval. 2.55, Gramophone Music. 3.5, News. 3.10, Announcements. 3.15, Gramophone Music. 3.25, Economic Notes. 3.35, Gramophone Music. 3.45, Aviation Report and Anti-Gas Drill. 3.50, Gramophone Music. 3.55, Maritime and Colonial Report. 4.0, Concert by the Poznan Opera House Orchestra, conducted by Tyjka, relayed from Ciechocinek. Overture, Seniramin (Rossini); Gayotte (Lully); Selection from Tieland (H. Albert); Selection from Viktoria and her Hussar (Abraham). 5.0, Review of Publications. 5.15, Piano-forte and Soprano Song Recital. Piano-forte Solos: (a) Lotus Land (C. Scott), (b) Serenade, Prelude and Dance (Debussy), (c) Mazurka and Etude (Scriabin); Five Songs; Piano-forte Solos: (a) Prelude (Ch), (b) Ukrainian Ballad (Liszt-Balokirev), (c) Dance (Falla), (d) Farnuccia (Falla); Five Songs. 6.15, Talk relayed from Lwów, 788 kc/s, 381 metres. 6.35, Gramophone Music. 6.50, Miscellaneous Items. 7.5, Programme Announcements. 7.10, Topical Talk. 7.30, See Bratislava. 10.0, Dance Music. 10.25, Sports Notes. 10.35, News. Aviation, Weather Report and Police Notes. 10.40, Dance Music (contd.).

ZURICH.—See Schweizerischer Landessender.



## ATHLONE

725 kc/s, 413 metres; 60 kW. Relayed by Cork, 1,337 kc/s, 224.4 metres.—1.30 to 2.30 p.m., Time Signal, Weather Report and Gramophone Music. 5.0, Gramophone Concert. 6.45, News. 7.0, Poetry Recital by C. Murphy. 7.15, Gaelic Talk. 7.30, Time Signal. 7.31, Pianoforte and Violin Duets by Mrs. Miley and L. Thompson. 8.0, Vocal Duets by The Serenaders. 8.30, Orchestral Music. 8.55, Baritone Solos by John Lynskey. 9.10, Talk by Mrs. Edmund Leamy: The Poetry of Joyce Kilmer. 9.30, Maori Songs by Eileen Driscoll (Soprano). 9.45, Sponsored Programme. 10.45, News. Weather Report and Close Down.

## BARCELONA

EAJ1, 860 kc/s, 348.8 metres; 8 kW.—7.0 p.m., Concert by the Station Trio: Selection from Hamlet (Thomas); Selection from The Rhinegold (Wagner); Canto apasionado (d'Azzurro); Air de danse (d'Ambrósio); Selection from Sapho (Massenet); Springtime of Love (Kalkmann); Der Erlkönig (Schubert). 8.0, Request Gramophone Records. 8.30, Exchange. 9.0, Gramophone Music. 9.15, Anti War Talk, followed by Gramophone Music and News. 10.0, Chimes, Weather and Exchange. 10.5, Concert by the Station Orchestra: Paso doble, Ayamonte (Balcells Plaas); Selection from La mazorca roja (Serrano); Habanera, La gondola (Coto); A Night in Venice (Courtoux); Dance, Cloe (Roses); Selection from The Damnation of Faust (Berlioz); Minuet (Solazzi); Overture, Figaro (Mozart). 11.30, Dance Music from the Casa Libre. In the interval at 12 Midnight, News. 1.0 a.m. (Sunday), Close Down.

## BARI

1,112 kc/s, 269.8 metres; 20 kW.—8.0 p.m., Agricultural Notes, Tourist Talk, and Dopolavoro Announcements. 8.20, Giornale Radio and Weather. 8.30, Time and Announcements. 8.35, Weather. 8.40, I Pagliacci—Opera (Leoncavallo) on Gramophone Records. In the interval, Announcements. After the Opera, Dance Music, relayed from the Gran Caffè del Levante. 10.55, News Bulletin.

BASLE.—See Schweizerischer Landessender.

## BELGRADE

697 kc/s, 430.4 metres; 2.0 kW.—6.55 p.m., Time and Announcements. 7.0, Yugoslav Songs. 7.30, Talk. 8.0, Pianoforte Recital by Djordje Stokov: Four Etudes and a Scherzo in B Minor (Chopin); Prelude (Debussy); Oh Fon entend une vieille boîte à musique (De Séverac). 8.30, Songs. 9.10, A Radio Play. 9.40, Time, News, and Orchestral Concert. 11.0, Dance Music on Gramophone Records.

## BERLIN

DEUTSCHLANDSENDER (REICHSENDER), 183.5 kc/s, 1,635 metres; 60 kW.—1.45 p.m., News. 2.0, Gramophone Concert. 3.0, Handwork for Children. 3.30, Weather and Exchange. 3.45, Political Dialogues: The Orient and the Nordic Lands (Johann von Leers). 4.0, Concert from Hamburg. 5.0, Weekly Sports Review. 5.20, A Musical Excursion. 6.0, Poems. 6.5, Review of the Week's Politics. 6.20, Variety Programme. 6.50, Weather and Announcements. 7.0, Transmission for all German Stations, relayed from Langenberg. 8.0, To-day's Motto. 8.5 (approx.), Dance Music by Robert Gaden's and Ferd. Kauffmann's Bands, with an Interlude by Werner Plücker. 10.0, News. 10.45, Weather. 11.0, Concert from Breslau. 12 Midnight, Close Down.

## BERLIN

FUNKSTUNDE, 715 kc/s, 419.5 metres; 1.5 kW.—4.0 p.m., Concert, relayed from the Krollgarten. In the interval at 5.0 (approx.), Talk: Sports in Germany and England. 5.25, Report of the First German Labour Service Exhibition in Frankfurt on the Oder (on Gramophone Records). 5.55, Sonata in A, Op. 69, for Pianoforte and Cello (Beethoven) by Ely Ney and Ludwig Hoelscher. 6.20, Dialogue: With Theodor Fontane through the Mark of Brandenburg. 6.40, The Funkstunde Station informs its Listeners. 6.45, Topical Talk. 7.0, Transmission for all German Stations, relayed from Langenberg. 8.5 to 1.0 a.m. (Sunday), Butter Abend. In the interval at 10.0 (approx.), News. 1.0, Close Down.

BERNE.—See Schweizerischer Landessender.

BEROMUNSTER.—See Schweizerischer Landessender.

BODEN.—See Stockholm.

BODO.—See Oslo.

## BRATISLAVA

1,076 kc/s, 279 metres; 14 kW.—6.25 p.m., Gramophone Music. 6.35, Talk: Patents and the Protection of Inventions. 6.55, Report. 7.0, See Prague. 8.25, Variety Programme.

## SATURDAY

SEPTEMBER THE NINTH

## PRINCIPAL EVENTS OF THE DAY:

## AT HOME

**NATIONAL LONDON** "Waltz Time," a Viennese operetta. Promenade concert from Queen's Hall.  
**REGIONAL MIDLAND** Orchestral programme.  
**REGIONAL NORTH** Variety programme.  
**REGIONAL WEST** Orchestral concert.  
**REGIONAL SCOTTISH** Orchestral concert.

## ABROAD

**BARCELONA** 7.0 p.m. The Station Trio.  
**BARI** 8.40 p.m. Opera: "I Pagliacci," by Leoncavallo, on gramophone records.  
**BRESLAU** 4.10 p.m. The Station Orchestra.  
**BRUSSELS (No. 2)** 8.0 p.m. The Radio Orchestra, conducted by Franz André.  
**BUDAPEST** 8.10 p.m. Operetta: "The Gipsy Princess," by Kálmán, relayed from the Zoological Gardens.  
**COPENHAGEN** 8.0 p.m. Old Danish music, by the Radio Orchestra.  
**MADRID** 11.30 p.m. Concert of popular music.  
**ROME** 8.45 p.m. Symphony concert, conducted by Riccardo Santarelli.  
**TOULOUSE** 7.30 p.m. Petite Suite, by Debussy, played by the Symphony Orchestra. 9.0 p.m., Offenbach concert.  
**TURIN** 8.45 p.m. Symphony concert, conducted by Ugo

10.0, See Prague. 10.15, See Brno. 11.30 (approx.), Close Down.

BREMEN.—See Hamburg.

## BRESLAU

923 kc/s, 325 metres; 60 kW. Relayed by Gleiwitz, 1,184 kc/s, 253 metres.—1.0 p.m., Gramophone Concert. In the interval at 1.45, Time, Weather, and News. 3.0, Agricultural Prices. 3.15, Review of Books on Music. 3.35, Dialogue: Schools for Germans outside the Reich. 3.55, Film Review. 4.10, Concert by the Station Orchestra, conducted by Bruno Janz: Grieg Potpourri (Urbach); Trümmerei (Schumann); Minuet in G (Beethoven); Der Eremit (Schmalstieg); Anatolian Dance (Wenginger); Ballet Suite (Fresco); Ballet Overture (Linke); Serenade, Juanita (Schröder); Egyptian Caprice (Seibold); Air from Der Bettelstudent (Müllöcker); March, Fairs Vaterland (Müllöcker). 5.30, Programme Announcements. 5.40, Das ewige Lied (Gorelitz). 5.55, Topical Talk. 6.20, Basque Festival Days—Talk with Gramophone Illustrations. 6.50, Weather and News. 7.0, Transmission for all German Stations, relayed from Langenberg. 8.0, Kartoffelfest—Variety Programme for Peasants. 9.0, News. 9.10, Request Concert by the Station Orchestra, conducted by Bruno Janz. 10.30, Time, Weather and News. 11.0, Dance Music and Light Music, relayed from the Café Vaterland. 12.30 a.m. (Sunday), Close Down.

## BRNO

878 kc/s, 342 metres; 35 kW.—6.5 p.m., Gramophone Music. 6.25, German Transmission, News. 6.30 (approx.), Song Recital by Marta Marie Pleseh (Soprano) and Leo Meinert (Baritone); Part I, Soprano Solos: Arietta from La Molinara (Paisiello); Aria, Cario mio ben (Giordano); Canzona amorosa (Falconieri); Aria (Caldara); Danza (Durante); Part II, Baritone Solos: Aria from Le Roi de Lahore (Massenet); Aria from Il Taborro (Puccini); Aria from La Gioconda (Ponchielli); Aria from Nero (Boito); Aria from Ernani (Verdi). 7.0, See Prague. 8.25, See Bratislava. 10.0, See Prague. 10.15, Concert by the Station Orchestra, conducted by Gotthard. 11.30 (approx.), Close Down.

## BRUSSELS (No. 1)

I.N.R., 590 kc/s, 569 metres; 15 kW.—12 Noon, Concert by the Small Station Orchestra, conducted by Leemans. Coronation March from The Prophet (Meyerbeer); Suite from Les Erynnies (Massenet); Simple Aveu (Thomé); Selection from Cavalleria rusticana (Mascagni); Guitar for Violin (Moszkovskii-Sarasate); Ballet Music from The Cid (Massenet). 1.0 p.m., Le Journal Parlé. 1.10, Gramophone Concert of Variety Music. 4.45,

Tourist Talk. 5.0, Dance Music by Robert de Kers and his Cabaret Kings and an Argentine Orchestra, conducted by Antonio di Michele, relayed from the Kursaal, Ostend. 6.0, Talk: The Cave-Dwellers in Belgium. 6.15, Gramophone Music. Toccatina (Scarlatti); Pastorale Variée (Mozart); Sonata in F (Händel-Tertis). 6.30, Concert by the Small Station Orchestra, conducted by Leemans. Marche solennelle (Wesly); Romantic Suite (Armandola); Grandmaman (Langer); Selection from The Czarevitch (Lehár); Strauss Waltz Potpourri (H. Weber); One-Step, La bouquetière de Séville (Wyn and Langlois). 7.15, Talk on Eugène Iyasay. 7.30, Le Journal Parlé. 8.0, Gramophone Concert. Prelude to Act III of Lohengrin (Wagner); Overture, The Flying Dutchman (Wagner). 8.15, Les Heures—Radio Play (Francis André). 8.45, Gramophone Concert (cont'd.). Scherzo from the Quartet (Rimsky-Korsakov); Iberian Dance (Nin); Selection from Moineau (Beydts). 9.0, Concert, relayed from the Kursaal, Ostend. After the Concert, Le Journal Parlé, and Dance Music by Robert de Kers and his Cabaret Kings and an Argentine Orchestra, conducted by Antonio di Michele, relayed from the Kursaal, Ostend.

## BRUSSELS (No. 2)

N.I.R., 887 kc/s, 338.2 metres; 15 kW. Programme in Flemish.—12 Noon, Gramophone Concert. 1.0 p.m., Journal Parlé. 1.10, Concert by the Small Station Orchestra, conducted by Leemans: Overture, Russian and Ludmilla (Glinka); Liebestraum (Liszt); Aria from Dinorah (Meyerbeer); Pianoforte Solo, Marigold (Mayer); Russian Rhapsody, Moscow (Leemans); Waltz, Heart to Heart (O. Straus); Potpourri, Music from Many Lands (Salabert). 4.45, Book Review. 5.0, Concert by the Radio Orchestra, conducted by Franz André: Overture, Don Pasquale (Donizetti); Bachelant from Samson and Delilah (Saint-Saëns); An Imaginary Ballet (Coleridge-Taylor); Waltz, Dobors (Waldfenfel); Parfum d'avril (Berry); Three Violin Solos (Crickboom); Selection from Orpheus in the Underworld (Offenbach); Flemish Dances (Blockx); Foxrot, All my Life (Gibbons); Foxrot, Try it once again (Sascha Chwat). 6.0, Petite Suite (Jongen) on Gramophone Records. 6.15, Talk: The Stars and their Poetry. 6.30, Gramophone Music: Quartet Op. 31 for Pianoforte and Strings (Brahms); The Imprisoned Cossacks (Nistschensky). 7.15, Talk on Shortland. 7.30, Agricultural Notes. 8.0, Concert by the Radio Orchestra, conducted by Franz André: Soloist, Boyarin (Balalaika); Overture, La chasse du jeune Henri (Méhul); Military March (Schubert); Waltz, Tendresse (Lauweryns); Lady Dragon Fly (Finck); Balalaika Music: Foxrot from Carmen (Bizet-Dostal); Foxrot, Espagnolasi (Gossiaux); Overture, William Tell (Rossini); Danzas fantásticas (Turina);

Dance Potpourri (R-brecht); Valse fantasique (Glazinov); African Suite (Coleridge-Taylor); Humorous Pieces for Violin (Leonard); Creole Rumba, Antilla (Beauregard); Foxrot, Akrobatik (Caplat). 10.0, Le Journal Parlé. 10.10, Dance Music by the Micoey's Club Band, conducted by Ludo Langlois, relayed from the Casino, Knocse.

## BUCHAREST

761 kc/s, 394 metres; 12 kW.—5.0 p.m., Light Music and Romanian Music by the Sibiceano Orchestra. In an interval at 6.0, Radio Journal. 7.0, Reading. 7.20, Gramophone Music. 7.40, Educational Talk. 8.0, Songs from Operetta. 8.30, Talk. 8.45, Light Music. 9.15, Popular Romanian Music by the Fania Luca Orchestra. 9.45, Radio Journal.

## BUDAPEST

545 kc/s, 550.5 metres; 18.5 kW. Also relayed on 840 metres from 8.10 p.m. till Close Down.—5.30 p.m., Recital of Hungarian Folk Songs. 6.10, Song Recital. 6.55, Radio Report from the Trotting Races. 7.15, Answers to Correspondence. 7.40, Talk. 8.10, The Gipsy Princess—Operetta (Kálmán), relayed from the Zoological Gardens. After the Programme, Gramophone Music.

CASSEL.—See Frankfurt.

## COPENHAGEN

1,067 kc/s, 281 metres; 0.75 kW. Relayed by Kalundborg, 260 kc/s, 1,153.8 metres.—12 Noon, Town Hall Chimes and Weather. 12.5 p.m., Concert by the Max Skalka Ensemble, relayed from the Hotel d'Angleterre. 2.0, Programme relayed from Aarhus. 3.0, Programme for Children. 3.30, Concert by the Radio Orchestra, conducted by Emil Reisen: Overture, Il Guarany (Gomez); Waltz (Ivanovici); Selection from Otello (Verdi); Extracts from the Suite, Pictures from the Ukraine (Akinenko); Hungarian March from The Damnation of Faust (Berlioz); Overture, Robinson Crusoe (Offenbach); Serenade for Strings in E minor (Elgar); Selection from The Three Musketeers (Friml); Polonaise from Eugene Onegin (Tchaikovsky). In the interval, Reading. 5.30, Exchange and Fish Market Prices. 5.45, Talk. 6.15, French Lesson. 6.45, Weather and News. 7.0, News. 7.15, Time. 7.20, Two Talks. 8.0, Time Signal. 8.2, Old Dance Music by the Radio Orchestra, conducted by Lanny Gröndahl: March (Souza); Waltz, Immortellen (Gungl); Jonathan Quadrille (Müllöcker); Helka Mazurka (Lumbye); Polka, Jeux d'esprit (Waldfenfel); Waltz, Pläne d'or (Waldfenfel); Polka-Mazurka (Müllöcker); Waltz (Ivanovici); Gallop (Lumbye). After the Programme, Weather. 9.0, Murder Trial—Radio Play in Six Scenes (Brammer). 10.30, News. 10.45, Recital of Modern Pianoforte Music by Viktor Fischer: Jazz Etude (Meyerhoff); Piece (Meyerhoff); Lights (Evans). 11.0, Dance Music by the Teddy Peterson's Band, relayed from the Wivex-Restaurant. 12 Midnight, Town Hall Chimes and Close Down.

GORK.—See Athlone.

DANZIG.—See Heilsberg.

DRESDEN.—See Leipzig.

## FECAMP

1,328 kc/s, 225.9 metres; 10 kW.—11.0 a.m. to 12 Noon, Programme in English by the I.B.C. 11.0, Happy Hour. Part I: Listeners' Request Half Hour; Signature Tune; Washington Post March (Souza); Selection from The Mikado (Sullivan); Songs: Paradise (Brown); The Sanctuary of the Heart (Ketchley); The Old Folks at Home (Foster-Moore); Selection from The Desert Song (Romberg); There's something about a Soldier (Gay); Selection from The Merry Widow (Lehár). Part II: Request Dance Music: Live, Laugh and Love; Hiawatha's Lullaby; The Clouds will soon roll by; While we danced at the Mardi Gras; Good-night Vienna; Masquerade; Alice Blue Gown; Just once for all 'ime; Signature Tune. 12 Noon, Programme in French. 4.30 to 6.0, Programme in English by the I.B.C. 4.30, The Nursery Corner; Music, Story and Greetings. 5.0, Concert for Tambridge Wells and Isle of Thanet Listeners: Signature Tune; The Night by the Sea; My Lady Dainty (Hesse); Souvenir (Dreda); Xylophone Solo, The Chatter of the Clogs (Flynn); Blumengeluster (Bion); Violin Solo, Chanson bohémienne (Boldi); The Fortune Teller (Herbert); Ay, ay, ay (Freire); March from Sylvia (Delibes). 5.30, Request Concert for Dover and Folkestone Listeners: Selection from The Belle of New York (Kerker); The Sanctuary of the Heart (Ketchley); Love's old Sweet Song (Molloy); Song, A Bachelor Gay (Tate); Accordion Nights; Sahit d'amour (Elgar); Eileen Alanah; Friend o' Mine (Sanderson); Signature Tune. 6.0, Programme in French. 11.0 to 2.0 a.m. (Sunday), Programme in English by the I.B.C. 11.0, Talk: Time; Signature Tune; Sittin' in the Dark; The Match Parade; Sweetheart Darlin'; When Day is Done; Clapham and Dwyer: Making a Talkie; Heaven will protect an honest Girl; Sweetheart, I'm dreaming

SEPT. 9th

**SATURDAY**

continued

of you; When you've fallen in Love; Selection from Song of the West. 11.30, Concert given by the I.B.C. (Ireland), Limited; Signature Tune; Come back to Erin; What's next?; Song, I've got the World on a String; When the Lilac blooms again; Selection of Irish Airs; Goodbye (Fost); Selection from The Desert Song (Romberg); Song of my Heart (McCarthy); Memories of Paris (Christine); Signature Tune. 12.5 a.m., News Bulletin in English. 12.30 (approx.), Club Concert for Middlewich Listeners. Part 1: Programme compiled by Mr. C. F. Lawrence, Clerk to the Middlewich Urban and District Council; Signature Tune; The Chum Song; Selection from Chu Chin Chow (Norton); Song, Her Name is Mary (Stevier); Waltzes from A Waltz Dream (O. Straus); She's the lass for me; My Hero, from The Chocolate Soldier (O. Straus); La Serenata (Braga); Indian Love-Talk (Prinz); Tipperary. Part II: Dance Music; You don't understand; Hiawatha's Lullaby; Sweep; This Lovely Rose; Over the Waterfront. 1.0, Dance Music; Signature Tune; Bells of Normandy; In a Second-Hand Store; I can't remember; Adorable; Hold me; My first love to last; I lay me down to sleep; In the Valley of the Moon; My, oh my!; The Old Spinning Wheel; Out in the open; Hiawatha's Lullaby; Little Miss Muffet; That's what life is made of; Falling Star; Spanish Eyes; Where are you tonight; Signature Tune. 2.0, I.B.C. Good-night Melody and Close Down.

FLensburg.—See Hamburg.

Florence.—See Turin.

**FRANKFURT**

1,157 kc/s, 259.3 metres; 17 kW. Relayed by Cassel, 1,220 kc/s, 245.9 metres; and Trier, 1,157 kc/s, 259.3 metres.—4.30 p.m., Orchestral Concert, conducted by Willi Wilde; March, Kaiser-Parade (Teike); Waltz, Der Himmel voller Geigen (Zichner); Overture, Frühlingsluft (Joh. Strauss-Rotter); Vision orientale (Beer); Hungarian Rhapsody, Pester Karneval (Liszt); Aria (Tonaglia); Melody (Pedrollo); Florentine March (Fueki). 5.45, Market Prices. 6.0, Talk on Economics. 6.25, Time and Announcements. 6.30, Weekly Review. 6.50, Today's News. 7.0, Transmission for all German Stations, relayed from Langenberg. 8.0, Bunter Abend, by the Station Orchestra, the Kardosch Singers and Soloists. 10.30, Time and News. 10.45, Concert from Leipzig.

FREDRIKSSTAD.—See Oslo.

Freiburg.—See Stuttgart.

Geneva.—See Radio-Suisse Romande.

Genoa.—See Turin.

Gleiwitz.—See Breslau.

Göteborg.—See Stockholm.

Graz.—See Vienna.

Hamar.—See Oslo.

**HAMBURG**

806 kc/s, 372 metres; 1.5 kW. Relayed by Bremen, 1,112 kc/s, 269.8 metres; Flensburg, 1,319 kc/s, 227.4 metres; Hannover, 530 kc/s, 566 metres; and Kiel, 1,292 kc/s, 232.2 metres.—4.0 p.m., Concert by the Hamburg Philharmonic Orchestra, conducted by Secker; Overture on a Thuringian Folk Song (Lassen); Ballet Music from Lakmé (Delibes); Selection from Gasparone (Müllbeker); Waltz, Donausagen (Fueki); Overture, Die schöne Galathee (Suppé); March, Viktoria (Blon). 5.0, Tales of Mystery. 5.20, Concert by a Mandoline Club; Comedy Overture (Kela Beler); Paraphrase on the Folk Song, Die König-kinder (Heuze); Waltz-Intermezzo, Dolce far niente (Bleichstein); Paraphrase on the Song Geheimnis (Lilling); March, Feuert Jos (Holzmann). 5.55 (from Bremen), Variety Programme. 6.30 (from Kiel), Religious Address. 6.50, Weather. 7.0, Transmission for all German Stations, relayed from Langenberg. 8.0, Political Address. 8.10, Workday Humour—Variety Programme. 10.0, News. 10.20, Topical Talk. 10.30, Light Music and Dance Music from Berlin (Funkstunde).

HANOVER.—See Hamburg.

**HEILSBURG**

1,085 kc/s, 276.5 metres; 60 kW. Relayed by Danzig, 662 kc/s, 453.2 metres.—11.30 a.m., Concert by the Small Station Orchestra, conducted by Eugen Wilcken; Overture, Das Nachtlager von Granada (Kreutzer); Waltz, Die guten alten Zeiten (Jos. Strauss); The Awakening of the Spring Flowers (Löhr); Ochi zingari (Filippini); Russian Suite (Bullerain); Rhapsody on the Song, La Paloma (Yradier Köhler); Potpourri, From the Rhine to the Danube (Rhode). 1.5 p.m., Concert of Light Music on Gramophone Records. In the intervals at 1.20 and 2.0, News. 2.30, Programme arranged by the Post Office, with Gramophone Records. 3.0, Market Prices. 3.30 (approx.), Programme for Children. 4.0, Concert by the Königsberg Opera House Orchestra conducted by Wolfgang Brückner; Carnival Overture (Dvorak); The First Rhapsody (Liszt); Suite No. 1 from L'Arlesienne (Bizet); Waltz (Waldteufel); Selection from The Carnival Fairy (Kál-

mán); Overture, Morning, Noon and Night (Suppé); Triumphant March from Aida (Verdi). In an interval at 4.50, Radio Report of the ADAC Motor Races. 5.35, Review of Political Books. 5.55, Humorous Items in East Prussian Dialect. 6.15, Agricultural Prices. 6.25 (from Danzig), Zither Recital; Largo (Händel); Intermezzo from Cavalleria rusticana (Mascagni); Hungarian Cigány Music (arr. Voigt); Solveig's Song (Grieg); Waltz from La Bohème (Puccini); Waltz (Tchaikovsky). 6.50, Weather. 7.0, Transmission for all German Stations, relayed from Langenberg. 8.0, Weather and News. 8.10, O alte Burschenherlichkeit (Bachelors Gay) A Cycle of Songs (Franz Hasenöhr). 9.0, Variety Programme, with the Collaboration of the Small Station Orchestra, conducted by Eugen Wilcken. 10.0, News. 10.15 (approx.), Dance Music from Berlin (Funkstunde). 12.30 a.m. (Sunday), Close Down.

**HILVERSUM**

(Announced HUIZEN, 1,013 kc/s, 296.1 metres; 20 kW. (7 kW. up to 4.40 p.m.).—Programme of the Catholic Radio Society (K.R.O.). 11.55 a.m., Sextet Concert: Salut a la musique (Grit); Der Wanderer (Schubert); Unter Italiens blauem Himmel (Eilenberg); Hungarian Dances Nos. 5 and 6 (Brahms); Selection from The Gipsy Princess (Kálmán); Announcements. 12.40 p.m., Programme for Children. 2.0, Festival Programme for the Thirty-Fifth Anniversary of the Coronation of Her Majesty Queen Wilhelmina, relayed from the Stadium, Amsterdam; A Choir of a Thousand Voices, conducted by Theo van der Bijl, a Police Band, and the Amsterdam Gymnastic Societies. 5.10, Gramophone Music. 6.0, Press Review. 6.20, Orchestral Concert: Selection from I Pagliacci (Leoncavallo); Overture, Pique Dame (Suppé); Selection from Der Geist des Wojewoden (Grossmann); Salut d'amour (Elgar); Virginia (H. Wood); The Dwarf's Festival (Noack); Selection from Sigurd Jorsalfar (Grieg). In the interval at 6.40, Police Announcements and Talk. 7.55, Recitations. 8.10, News. 8.15, Concert by the K.R.O. Boys' Orchestra: Alle Männer sind wie Kinder (Meissner); In the Turkish Bazaar (Dreyer); Im Schwarzwald geht ein Mühlenrad (Ru-t); Potpourri, Selige Wiener Zeiten (Morena); Welcher Weg führt zum Glück (Buder); Mondnacht in Abbazia (Lesso-Balerio); Dornröschens Brautfahrt (Rhode); One-step (Penso); Five o'clock Tea with Robert Stolz (Dostal); Selection from Husarenlebe (Doelle); Die Fenster auf der Lenz ist da (Strauss-May); Schön war's Lieblich (Grothe); Slav Rhapsody (Friedemann); Old Father Thames (Wallace); Cuban Love Song (Stothart); Für Dich, mein Baby (Rotter); Finale. In the intervals, Recitations and News. 10.40, Gramophone Music. 11.40 (approx.), Close Down.

HORBY.—See Stockholm.

**HUIZEN**

Announced HILVERSUM, 160 kc/s, 1,875 metres; 8.5 kW. Programme of the Workers' Radio Society (V.A.R.A.).—11.40 a.m., Concert by De Notenkrakers: Stars and Stripes (Songs); Flattergeister (Strauss); Somewhere a voice is calling (Tate); Tango (Canita); Moonlight on the Beams (Lockhart); Lehárana (Geizer); Gramophone Music; Spanish Waltz (Pop); Chanson de la mer (Riconnini); Melody (Rhode). 1.40 p.m., Gramophone Music. 2.20, Talk on the Cinema. 2.40, Concert by De Flierefluiter, conducted by Ray Forest, Soloist: de Booy (Songs). 3.25, Interval. 3.40, Literary Talk. 4.0, Song Recital by de Booy: (a) Im wunderschönen Monat Mai (Schumann), (b) Ich grolle nicht (Schumann), (c) Heidenröslein (Schubert), (d) Die beiden Grenadiere (Schumann). 4.10, Selection from Mignon (Thomas) by Jong (Organ). 4.25, Concert by the Piatrogibas Orchestra, conducted by Carlquist. 4.55, Concert by the A'damsche Orkestveren Orchestra, conducted by Diepenbeek; March from Athalie (Mendelssohn); Overture, Maritana (Wallace); Czardas from Der Geist des Wojewoden (Grossmann); Ein Fest in Aranjuez (Demersman). 5.25, Concert by the Piatrogibas Orchestra (cont'd.). 5.40, Concert by the A'damsche Orkestveren Orchestra (cont'd.) with items by Billy Derby; Zeeland, hoog (Morks); Overture, The Thieving Magpie (Rossini); Danse macabre (Saint-Saëns); Aria (Bach); Willy Derby and his Repertoire; Heil Europa (von Blon); A Toi (Waldteufel); Largo (Händel); The Caravan (Asch); Overture, William Tell (Rossini). 7.40, S.O.S. Messages. 7.45, News. 7.55, Concert of Dance Music by De Flierefluiter, conducted by Ray Forest. 8.40, Concert by a Double Quartet. 9.0, Concert by the V.A.R.A. Orchestra, conducted by de Groot. Soloist: de la Roddele (Taragata and Piccolino). Overture, Martha (Flotow); Taragata Solos: (a) Air from Martha (Flotow), (b) Si vous l'avez compris (Deiza), (c) La Paloma (Yradier); In the Mystic

Land of Egypt (Ketelbey); Piccolino Solos: (a) Fantasy (Pyr) (b) Concert Polka (Rondel), (c) Selection from Les Cloches de Conzeville (Planquette); The Gladiators (Corna). 9.40, Quartet Concert (cont'd.). 9.55, Orchestral Concert (cont'd.): Gasteiner Walzer, Op. 25 (Kern); Telegamme (Strauss); Waltz (Ducheraal); Waltz (Strauss). 10.40, Recitation. 10.55, Concert by De Notenkrakers, conducted by WINS. 11.40 (approx.), Close Down.

INNSBRUCK.—See Vienna.

**JUAN LES PINS**

1,205 kc/s, 249 metres; 0.8 kW.—12.30 p.m., Amusement Guide and Variety Items. 1.0, News. 1.15, Radio Concert. 8.0, Amusement Guide, Financial Notes and News. 8.10, Press Review. 8.20, Radio Concert. In an interval at 9.0, News and Weather.

KALUNDBORG.—See Copenhagen.

KIEL.—See Hamburg.

KLAGENFURT.—See Vienna.

KOSICE.—See Prague.

**LANGENBERG**

635 kc/s, 473 metres; 60 kW.—12.30 p.m., Concert by the Fröhliche Fünf. 12.50, News. 1.0, Orchestral Concert, conducted by Eysoldt; Homage March from Sigurd Jorsalfar (Grieg); Overture, The Naiads (Bennett); Selection from La Bohème (Puccini); Canzonetta (d'Ambrosio); In den Spinnstuben (Dvorak); Träume (Wagner); Ständchen (Schubert); Waltz, Herbststimme (Lincke); Strauss Operetta Potpourri (Schöze). In the interval at 2.0, News. 2.30, Gramophone Concert. 3.30, Market Prices and Time. 3.50, A Singing Lesson. 4.10, Talk: Excursions in the Rhineland and Westphalia. 4.35, Political Address. 4.40, Friedrich Wilhelm Weber—a Radio Picture by Hildegard Schmidt. 5.0, Pianoforte Recital. 5.30, German for Germans. 5.40, Talk: The Highroads of Germany. 6.0, Concert: Gerda Schiller-Rehm (Soprano), Leonie Hähner (Pianoforte), and Mathias Durben (Cello): Three Humoresques for Pianoforte, Op. 20 (Reger); Soprano Solos: Guckguck-Lieder, Op. 45 (Jochem); Two Grotesques, Op. 28, for Cello (Haas): (a) Gespensige stunde, (b) Koboldblume; Four Songs, Op. 76 (Reger): (a) Furchtäschchen, (b) Der Icel, (c) Die Bienen, (d) Zum Schlafen; Pianoforte Solo from Wachtel-männchen, Op. 27 (Haas). 6.50, Announcements. 7.0, Transmission for all German Stations: The Good Old Days—Radio Picture (Christian Jensen), relayed from Cologne. 8.0, News. 8.5, The Symphony in B minor (Schubert) by the Station Orchestra, conducted by Buschkötter. 8.30, Ruhr Gold-Choral Cantata on Westphalian Poems (Georg Nellijs), relayed from Neheim. In the interval at 9.18, Westphalian Programme. 10.15, News. 10.40, All Hands on Deck—Variety Programme. 12 Midnight, Close Down.

LAUSANNE.—See Radio-Suisse Romande.

**LEIPZIG**

769.9 kc/s, 389.6 metres; 120 kW. Relayed by Dresden, 941 kc/s, 319 metres.—12 Noon, Weather and Time. 12.15 p.m. (from Dresden), Concert by the Pletzsch-Marko Trio. 1.0, News and Programme Announcements. 1.15, Concert from Langenberg. 2.30, News. 2.45, Programme for Children. 3.25, Wireless Hints. 3.35, Talk on Chess. 3.45, Economic Notes and Weather. 4.0, Teachers' Millenary Festival Concert, relayed from Teuchern. The Municipal Orchestra, conducted by Hüttenrauch. Overture, William Tell (Rossini); Slav Rhapsody (Friedemann); Selection from Martha (Flotow); Spanish Fantasy, A Festival in Aranjuez (Demersman); Overture, Si j'étais Roi (Adam); March (Forster). 5.30, Book Review. 6.0, German for Germans. 6.20, A Modern Dictionary. 6.30, Das Hexenlied (Max von Schillings-Wildenbruch), on Gramophone Records. 7.0, Transmission for all German Stations, relayed from Langenberg. 8.0, Die schöne Galathee—Comic Opera in One Act (Suppé). 9.0, Review of Agricultural Policy. 9.10, Wireless Cabaret. 10.15, News, followed by Dance Music and Light Music by the Emdé Orchestra. 12 Midnight, Close Down.

LINZ.—See Vienna.

**LJUBLJANA**

522 kc/s, 574.7 metres; 7 kW.—7.0 p.m., Concert by the Station Orchestra. 8.0, Review of Foreign Affairs. 8.30, Programme relayed from the Fair. 9.30, Weather and News. 9.45, Concert by the Station Orchestra. 11.0 (approx.), Close Down.

**LUXEMBOURG**

252 kc/s, 1,191 metres; 200 kW.—French Programme. 7.30 p.m., Concert of French Music by the Station Orchestra, conducted by Henri Pénis. 8.20, Talk in French: Joseph

Hansen. 8.30, Variety Items. 9.0, News in French. 9.10, Alfred Cortot: Pianoforte Concerto in A Minor (Schumann) on Gramophone Records. 9.45, News in German. 9.55, Concert by the Station Orchestra, conducted by Henri Pénis. 10.30, Gramophone Dance Music.

**MADRID**

EAJ7, 707 kc/s, 424.3 metres; 2 kW.—8.0 p.m., Chimes, Exchange, Radio Journal and Request Gramophone Records. 9.15, Topical Review. 9.30 to 11.0, Interval. 11.0, Chimes, Time and Topical Review. 11.20 (approx.), Song Recital and Sextet Concert, followed by Literary Programme. 1.15 a.m. (Sunday), Topical Review. 1.30, Chimes and Close Down.

**MADRID**

EAQ, 10,000 kc/s, 30 metres; 20 kW.—7.0 to 9.0 p.m., Programme for Listeners in the Canary Islands, Guinea, and Europe. 7.0, Concert of Popular Music. 8.15, Talk. 8.30 to 9.0, Light Music. 11.30, Concert of Popular Music. In an interval at 11.45, Radio Chronicle. 12.45 a.m. (Sunday), Light Music. 1.0 (approx.), Close Down.

MALMO.—See Stockholm.

**MILAN**

VIGENTINO, 662 kc/s, 453.2 metres; 4 kW.—8.45 p.m. till Close Down, See Rome.

**MORAVSKA-OSTRAVA**

1,137 kc/s, 263.8 metres; 11 kW.—2.50 p.m., Orchestral Concert. 3.55 to 4.0, See Prague. 5.0, See Prague. 5.45, Gramophone Music. 5.55, Talk: Gold. 6.5, See Prague. 6.25, Concert by a Schrammel Ensemble. 7.0, See Prague. 8.25, See Bratislava. 10.0, See Prague. 10.15, See Brno. 11.30 (approx.), Close Down.

MOTALA.—See Stockholm.

MUHLACKER.—See Stuttgart.

**MUNICH**

563 kc/s, 533 metres; 60 kW. Relayed by Augsburg and Kaiserslautern, 536 kc/s, 560 metres; and Nürnberg, 1,256 kc/s, 239 metres.—4.30 p.m., Concert. 5.45, Programme for Young People. 6.30, Richard Mors Song Recital by Eckard Fricke (Tenor); Herbstfrieden: Ein silbernes Märchen; Das Licht; Der seltene Vogel; Wäscne im Wind. 6.45, Wireless Notes. 7.0, Transmission for all German Stations, relayed from Langenberg. 8.0, Lineke Concert by the Station Orchestra, conducted by the Composer; March, Unsere braunen Jüngens; Festival Overture; Waltz, Nord und Süd; Barcarole; Waltz, Träume der Liebe; Pinguin-Parade. 9.10, Songs and Recitations. 9.30, Dance Music. 10.20, Time and News. 11.0, Concert from Leipzig.

NAPLES.—See Rome.

NOTODDEN.—See Oslo.

**OSLO**

277 kc/s, 1,083 metres; 60 kW. Relayed by Fredriksstad, 815 kc/s, 368.1 metres; Hamar, 522 kc/s, 574.7 metres; Notodden, 671 kc/s, 447.1 metres; Porsgrund, 662 kc/s, 453.2 metres; and Rjukan, 671 kc/s, 447.1 metres.—4.30 p.m., Gramophone Records of Light Music. 5.15, Programme for Children. 6.15, Norwegian Music. 6.45, Talk on Economics. 7.0, Advertising Notes, Weather and News. 7.30, Talk on Architecture. 8.0, Time Signal. 8.2, Concert by the Station Orchestra, conducted by Hugo Kranm; Overture, Tantalsqualen (Suppé); Selection from Der Obersteiger (Zeller); Ballet Suite, Esmeralda (Drigo); Potpourri. 9.40, Weather and News. 10.0, Topical Talk. 10.15, Humorous Recitations. 10.45, Dance Music on Gramophone Records. 12 Midnight, Close Down.

OSTERSUND.—See Stockholm.

**PALERMO**

558 kc/s, 537.6 metres; 3 kW.—8.0 p.m., Dopolarvoto Notes, Tourist Report, Agricultural Notes, Giornale Radio, and Sports News. 8.20, Gramophone Music. In an interval at 8.30, Time and Announcements. 8.45, Quartetto vagabondo—Operetta in Three Acts (G. Pietro). In the intervals, Book Review and News. 10.55, News.

**PARIS**

EIFFEL TOWER, Call FLE, 207.5 kc/s, 1,445.7 metres; 13 kW. Time Signals (on 2,650 metres) at 10.26 a.m. and 11.26 p.m. (Preliminary and 6-dot Signals)—6.45 p.m., Talk on Music. 7.0, Le Journal Parlé. 8.20, L'Avare—Play (Molière). 10.0 (approx.), Close Down.

**PARIS**

POSTE PARISIEN, 914 kc/s, 328.2 metres; 60 kW.—7.0 p.m., Gramophone Music. 7.15, Le Journal Parlé. 7.30, Sponsored Gramophone Concert. 8.0, Talk: The Event of the Week. 8.20, Gramophone Music. 8.30, Sponsored Concert. 9.10, Dance Music by the

Sonora Radio Band, conducted by Fred Hoffmann. 11.0, News.

PARIS

RADIO-PARIS, Call CFR, 174 kc/s, 1,725 metres; 75 kW.—7.30 a.m., Weather and Physical Culture. 7.45, Gramophone Records: España (Blanco); One Hour with you (Whiting); Monte Cristo (Kollar); Tim comes from Paris (Selling). 8.0, Weather and Press Review. 12 Noon, Gramophone Records: Reminiscences (Kock); Fascination (Marchetti); The Forge in the Forest (Eilenberg); La Légende des Flots (Christiné); Le Moulin de la Vierge (Blondiau); Rose d'Amour (Sabatier); Piccolo-Piccolo (Strauss); Romance (Svendsen); Xylophonia (Green); Selection from Hans the Flute Player (Game); Emma Livry (Pirouelle); Je t'aime (Waldteufel); Selection from The Mikado (Sullivan); Liebesfreud (Kreisler); Moorish Serenade (Chapi); The Nightingale (Albiv); Sautz Bébé (Paradis); Blonde amie (Carcel); Suite carnavalesque (Thomé); Italian Caprice (Tchaikovsky); Slav Dances (Dvorák). In the interval at 1.0 p.m., Exchange and News, and at 1.30, Exchange. 2.0, Exchange. 3.45, Exchange and Market Prices. 7.0, Agricultural News. 7.10, Gramophone Records: Voici Paris (Van Hoorebecke); The Marionette (Lucchesi); Miam (Oberfeld); Réver (Bastia); A Torraute (de Loos Hoyos); Chiquita (Wayne); Waltz, Künstlerleben (Strauss); Les enfants terribles (Corbin); En t'élisant vos lettres (Masson); at Twilight (Fraury). 7.50, Commercial Prices and News. 8.0, Gramophone Concert with Songs: Viennese Rhapsody (Schmitt); Songs: Rhapsody (Brahms); Marino in his Repertoire; Moment musical (Schubert-Kreisler); Ronde villageoise (Chabrier); Rhythmes délassés (Daleroz); Vival Flamand (Robillard); La Retraite (de Rille); Two Waltzes (Chopin); Noctette (d'Annunzio); Dance of the Hours from La Gioconda (Ponchielli); Clair Matin (Jeanjean); Escapes (Ibert); España (Chabrier). In the intervals at 8.30, News and Weather, and at 9.15, Press Review and News.

PITTSBURGH

KDKA, 980 kc/s, 306 metres; 50 kW. Relayed by W3XK on 48.86 metres and 25.27 metres.—7.30 to 11.0 p.m., New York Relay. 7.30, Concert Echoes. 8.0, Words and Music. 8.30, Wealth of Harmony. 9.0, Dance Masters. 9.30, Concert Favourites. 10.0, Casino Orchestra. 10.30, Neil Sisters. 10.45, Orphan Annie. 11.0, News, Piano Classic. 11.15, Sports, A Song. 11.30, A Rejoice—Bill and Alex. 11.45 to 12.30 a.m. (Sunday), New York Relay. 11.45, Orchestral Music. 12.0, Baritone Solos by Ross Pearson. 12.15, Annie, Judy and Zeke. 12.30, Jack Pettis' Orchestra. 1.0, Jack Demmy's Orchestra, from New York. 1.30, Brown and Llewellyn, from New York. 1.45, Programme to be announced. 2.0, Tales of the Titans, from New York. 2.30, Programme to be announced. 3.15, Behind the Law.

PORSGRUND.—See Oslo.

POZNAN

896 kc/s, 335 metres; 1.0 kW.—7.20 p.m., Miscellaneous Items and News. 7.35, Theatre Notes and Programme Announcements. 7.40, See Warsaw. 10.0, Time Signal, Sports and Police Notes. 10.15, Dance Music from the Esplanade Café. 11.0 (approx.), Close Down.

PRAGUE

614 kc/s, 488.6 metres; 120 kW.—2.50 p.m., See Moravská-Ostrava. 3.55 to 4.0, Weather. 5.0, Jaroslav Vrchlicky Memorial Programme, relayed from Vysehrad Cemetery. 5.45, Gramophone Music. 5.55, Talk: The Teeth. 6.5, Agricultural Report. 6.10, Gramophone Music. 6.15, Talk for Workers. 6.25, News in German. 6.30, German Transmission: Talk: Max Reinhardt. 7.0, Chimes and News. 7.10, Relay of a Military Band Concert: March (Zita); Overture, Raymond (Thomas); Selection from In the Well (Blodek); Slav Dance No. 7 (Dvorák); Johann Strauss Potpourri (Schlögel); Gavotte (Oberthor); Melody (Pesta); March (Potuznik). 8.10, Talk: Studying Law at a University. 8.25, See Bratislava. 10.0, Time and News. 10.15, See Brno. 11.30, Close Down.

RADIO-SUISSE ROMANDE

SOTTENS, 743 kc/s, 403 metres; 25 kW.; and Geneva, 395 kc/s, 760 metres.—6.15 a.m. (from Lausanne), Gymnastics. 6.30, Interval. 12.28 p.m., Time Signal from Neuchâtel Observatory. 12.30, News. 12.40 (from Geneva), Gramophone Concert. In the interval at 1.10, Financial Report. 2.0, Interval. 3.26, Time Signal from Neuchâtel Observatory. 3.30 (from Geneva), Gramophone Concert. 4.30 (from Lausanne), Programme for the Opening of the Swiss Chamber of Commerce. Address and Concert.

SEPT. 9th SATURDAY continued

5.30, Interval. 7.0 (from Lausanne), Talk: How Popular Novels are Manufactured. 7.30, News. 7.31 (from Lausanne), Talk. 8.0, Concert by the Radio Suisse Romande Concert, conducted by Echenard. 9.0 (from Lausanne), Viennese Programme—Music and Talk. 9.50, News. 10.0 (from Neuchâtel), Dance Music from the Rotonda. 10.20 (approx.), Close Down.

REYKJAVIK

250 kc/s, 1,200 metres; 21 kW.—9.5 p.m., Musical Programme. 9.30, Weather Report. 9.40, Musical Programme and Announcements. 10.0, Chimes and News. 10.30, Reading. 11.0, Concert by the Radio Tio, Choral Music on Gramophone Records, and Dance Music. 2.0 a.m. (Sunday), Close Down.

RJUKAN.—See Oslo.

ROME

Call 1R0, 680 kc/s, 441 metres; 50 kW.—Relayed by Naples, 941 kc/s, 319 metres; and 2R0, 11,810 kc/s, 25.4 metres; from 5.15 p.m.—12.30 p.m., Gramophone Music. 1.0 to 2.0, Orchestral Concert. In the interval from 1.15 to 1.20, Talk on Photography, and from 1.30 to 1.45, Giornale Radio. 4.30 Giornale Radio and Report of the Royal Geographical Society. 4.45, Children's Radio Review. 5.10, Weather. 5.15 to 6.0, Orchestral Concert. 6.40 (Naples), Shipping and Sports Notes. 6.45, Wireless Signals and Popolavop Report. 7.0, Tourist Report. 7.10, Agricultural Report and Market Prices. 7.23, News in Foreign Languages. 7.40, Giornale Radio. 8.0, Time and Announcements. 8.15, Gramophone Music. 8.25, Giornale Radio and Sports Notes. 8.30 (approx.), Sponsored Concert. 8.45, Symphony Concert, conducted by Riccardo Santalbi. Symphony in G, No. 13 (Haydn); Scherzo and March from A Midsummer Night's Dream (Mendelssohn); Talk on Literature and Art. Bourrée fantasque (Chabrier); Selection from Casanova a Venezia (Plek-Mangiagalli); Overture, Rienzi (Wagner); Reading of Poems. 10.30, Dance Music from the Casina Valadier. 10.55, Giornale Radio.

SALZBURG.—See Vienna.

SCHENECTADY

WGY, 790 kc/s, 379.5 metres; 50 kW. Relayed at intervals by W2XAF on 31.48 metres and by W2XAD on 19.56 metres.—12.45 a.m. (Sunday), Stock Reports and Baseball Scores. 1.0 to 4.0, New York Relay. 1.0, Rainbow Reflections. 1.30, Antofal's Cubans. 2.0, Soloist Programme. 2.15, Four Horsemen. 2.30, K-7, Secret Service Spy Story. 3.0, B. A. Rolfe and his Orchestra. 4.0, Programme Resumé.

SCHWEIZERISCHER LANDESENDER

BEROMUNSTER, 653 kc/s, 459 metres; 60 kW.; Basle, 1,229 kc/s, 244.1 metres; and Berne, 1,220 kc/s, 245.9 metres.—6.15 a.m. (from Basle), Gymnastics. 6.35, Interval. 11.59, Time Signal from Neuchâtel Observatory and Weather. 12 Noon to 6.30 p.m., Programme from Berne. 12 Noon, Chamber Music on Gramophone Records. 12.30, Time, Weather, and News. 12.40, Gramophone Music. 1.25, Time, Weather, and Exchange. 1.30, Answers to Correspondence. 1.45, Book Review. 2.5, Ballads on Gramophone Records. 2.30, Report from the Soleure Industrial Exhibition. 3.0, Concert. 3.30, Interval. 5.0, Songs and Recorder Solos by a Village School. 5.30, Light Music on Gramophone Records. 6.0, Talk: Motor Cars and Motor Travel. 6.30 (from Basle), Programme for Children. 7.0, Chimes from Zürich Churches. 7.15 till Close Down, Programme from Basle. 7.15, Time, Weather, and Market Prices. 7.20, Opera and Operetta Music on Gramophone Records. 8.0, Topical Talk. 8.30, Programme to be announced. In the interval at 9.0, News. 10.40, Gramophone Dance Music. 11.0 (approx.), Close Down.

SOTTENS.—See Radio-Suisse Romande.

STOCKHOLM

689 kc/s, 436 metres; 55 kW. Relayed by Boden, 244 kc/s, 1,229.5 metres; Göteborg, 932 kc/s, 322 metres; Hörby, 1,166 kc/s, 257 metres; Motala, 221.5 kc/s, 1,354.4 metres; Östersund, 389 kc/s, 770 metres; and Sundsvall, 554 kc/s, 542 metres.—4.0 p.m., Concert by Herman Martensson's Ensemble: Overture, Nebuchadnezar (Verdi); Barcarolle (Waldteufel); Tango (Albeniz); Bizet Potpourri (Frlaich); Minnet (Boccherini); Waltz, Swedish Melodies (Sandell); Nach-

spiel (Peterson-Berger). 5.5, Talk: A Day in an English School, relayed from Uppsala, 662 kc/s, 453.2 metres. 5.30, Gramophone Music. 6.30, Talk, relayed from Uppsala. 7.0, Song Recital by A-sta Lindelöw, relayed from Malmö, 1,301 kc/s, 231 metres. 7.15, Weather and News. 7.30, Pettersson and Bendel: Radio Comedy (Waldemar Hammarböj). 9.15 (from Sundsvall), Old Dance Music. 10.0, Dance Music by Eiders Augmented Orchestra and a Tango Orchestra. 12 Midnight (approx.), Close Down.

STRASBOURG

869 kc/s, 345 metres; 11.5 kW.—11.30 a.m., Gramophone Concert of Classical Music. 12.45 p.m., News. 1.0, Time and Exchange. 1.5, Variety Music on Gramophone Records. 2.0, Legal Talk in German. 2.15, Classical Music on Gramophone Records. 2.45, Talk on Emmanuel Chabrier. 3.0, Interval. 3.30, Orchestral Concert, conducted by Brouillac, relayed from the Casino, Vichy: Overture, Sérénade (Rossini); Aubade aux mariés (Lacombe); Orchestral Suite (Chaminade); Melody, En hiver (Flevo); Selection from The Huguenots (Meyerbeer); Waltz, Amour et printemps (Waldteufel). 5.0, Gramophone Music. 5.15, Orchestral Concert, conducted by Roskam: March, Eyes Right (McKnight); Waltz, Carlotta (Müllacker); Selection from Flup (Szule); Melody (Kálmán); Roses at Dawning; Whenever you are; English Waltz, Petite princesse (Silesius); Intermezzo, The Phantom Brigade (Myddleton); Foxtrot from Die Dreigroschenoper (Weill); Tango from Countess Maritza (Kálmán); Saxophone Solo: Waltz, Ah! Annabella (Nelson); Foxtrot, My Darling (Meyers); Two Step, Ananda (Grundland). 6.15, French Eloquence Lesson. 6.30, Gramophone Concert of Light Music. 7.0, Tourist Talk. 7.15, Agricultural Talk. 7.30, Time and News. 7.45, Gramophone Music. 8.0, Press Review in German. Lottery Results and Announcements. 8.30, Three One-Act Plays: (a) Tanta Octavie (Paul Bonhomme and Funk-Brentano), (b) La comédie de l'Homme qui épousa une femme muette (Anatole France), (c) Embarras-nous-Folleville (Labiche). 10.30, Press Review. 10.35, Dance Music, relayed from the Savoy. 12 Midnight (approx.), Close Down.

STUTTGART

MUHLACKER, 332 kc/s, 360.5 metres; 60 kW. Relayed by Freiburg, 527 kc/s, 570 metres.—12.20 p.m., A Non-Stop Flight round the World—Gramophone Concert. 1.30, Concert from Langenberg. 2.30, Time and News. 2.50, Young People before the Microphone. 3.0 (from Mannheim), German Folk Songs for Two Violins, Viola and Cello (arr. Kitzmayer). 3.30, Programme for Young People. 4.30, Concert from Munich. 5.45 (from Karlsruhe), Talk: The Life of the Blind. 6.10, Talk: German Culture among Germans outside the Reich. 6.35, Time and News. 7.0, Transmission for all German Stations, relayed from Langenberg. 8.0, See Leipzig. 9.0, Variety Programme from Frankfurt. 10.30, Time and News. 10.50, Concert from Leipzig. 12 Midnight, Close Down.

SUNDSVALL.—See Stockholm.

TOULOUSE

779 kc/s, 385 metres; 8 kW.—6.0 p.m., News. 6.15, Light Music. Mimet from the Quartet in D Minor (Mozart); Chanson triste (Tchaikovsky); Viennese Song (Stolz); Air (Martin). 6.30, Opera Music. Arias from: (a) Samson and Delilah (Saint-Saëns), (b) The Magic Flute (Mozart), (c) Philémon et Baucis (Gounod), (d) Don Giovanni (Mozart). 6.45, Orchestral Music. 7.0, Songs. 7.15, News. 7.30, Petite Suite (Debussy), by the Symphony Orchestra. 7.45, Music from Sound Films. 8.0, Orchestral Music. Glow-Worm Hylil (Lincke); March of the Bedouins (Oseich); Pavane pour une Infante défunte (Ravel); Old Spanish Song (Aubert); Waltz, Spährenklänge (Strauss). 8.30, Light Concert. 9.0, Offenbach Concert. Overture, Orpheus in the Underworld. Airs from (a) La pèricle, (b) The Grand Duchess of Gerolstein, (c) The Drum Major's Daughter; Barcarolle from The Tales of Hoffmann (Offenbach); Air from La belle Hélène. 9.30, Music by a Viennese Orchestra. 10.0, Operetta Music. 10.15, North African and Local News. 10.30, Concert for Listeners in Morocco. Slav Dances, Nos. 6 and 8 (Dvorák); Aria from L'Africaine (Meyerbeer); Air from: (a) White Horse Inn (Benatzky), (b) Melody (Erwin); The Bees' Wedding (Mendelssohn). 11.0, Request Concert. Hawaiian Guitar: O Sole mio (di Capua); Melody (Ténaro); Air from La Juive (Halévy); Melody (Erwin). 11.15,

Dance Music. 12 Midnight, News. 12.5 a.m. (Sunday), Organ Recital, A Perfect Day (Jacobs-Bond); Simple Aven (Thomé); Popular Scottish Songs. 12.15, Orchestral Music. 12.30 (approx.), Close Down.

TRIESTE

1,211 kc/s, 247.7 metres; 10 kW.—5.20 p.m. till Close Down, See Turin.

TRONDHEIM.—See Oslo.

TURIN

1,096 kc/s, 273.7 metres; 7 kW. Relayed by Milan, 905 kc/s, 331.5 metres; Genoa, 959 kc/s, 312.8 metres; and Florence, 599 kc/s, 500.8 metres.—5.20 p.m., Gramophone Music. 6.0 to 6.5, Weather Forecast. 6.35, Giornale Radio, Talk, Gramophone Music and Popolavop Announcements. 7.0, Time, Tourist Report and Gramophone Music. 7.10, Agricultural Notes and Market Prices. 7.20, News in Foreign Languages. 7.40, Gramophone Music. 8.0, Announcements, Giornale Radio, Sports Notes, Weather and Gramophone Music. 8.30, Talk: Events and Problems. 8.45, Symphony Concert, conducted by Ugo Tansiani. In the interval, Book Review. 11.0, Giornale Radio.

VATICAN CITY

15,120 kc/s, 19.84 metres (Morning), and 5,969 kc/s, 50.26 metres (Evening); 10 kW.—11.0 to 11.15 a.m., Religious Announcements in Various Languages. 8.0 to 8.15, Religious Information in Italian.

VIENNA

581 kc/s, 517 metres; 100 kW. Relayed by Graz, 852 kc/s, 352.1 metres; Innsbruck, 1,058 kc/s, 283 metres; Klagenfurt, 662 kc/s, 453.2 metres; Linz, 1,220 kc/s, 245.9 metres; and Salzburg, 1,373 kc/s, 218.5 metres.—12 Noon, Concert by the Wiener Symphoniker, conducted by Holzer. In the interval at 1.0 p.m., Time, Weather and News. 2.0, Interval. 3.0, Time, Weather and Exchange. 3.15, French Lesson. 3.35, Reading of Religious Poems. 4.0, First Pill Session of the German Catholic Conference, relayed from the Stadium: Psalm No. 75 for Mixed Choir and Wind Instruments (Springer); Opening Address by Dr. Imitzer, Cardinal-Archbishop of Vienna; Address by the Papal Legate and Address of Welcome by Dr. Dollfus; Speeches by Dr. Alfred Verdross and Dr. Kurt Schuschnigg, Cabinet Minister; Congregational Singing. 6.0, Talk on Max Reinhardt for his Sixtieth Birthday. 6.25, Concert by a Zither Society. 7.0, Today's Motto. 7.5, Topical Talk. 7.15, Time, Weather and News. 7.25, Song Recital by Adele Kern. 8.5, Report on the German Catholic Conference. 8.15, Aus Beilich der Herzogin Operetta in Three Acts (Griechstaedtén). In the interval at 10.0 (approx.), News, Weather and Exchange. 10.40, Gramophone Music.

WARSAW

212.5 kc/s, 1,411 metres; 120 kW. 11.57 a.m., Time Signal and Chimes from the Cathedral of Torun. 12.5, Gramophone Music. 12.25, Polish Press Review. 12.35, Weather. 12.55, Radio Journal. 1.0 to 2.55, Interval. 2.55, Gramophone Music. 3.5, News. 3.10, Announcements. 3.15, Gramophone Music. 3.25, Economic Notes. 3.35, Gramophone Music. 4.0, Programme for Invalids, relayed from Lwow, 785 kc/s, 381 metres. 4.30, Song Recital by Mme. Ostrowska. Two Songs (Brahms); Traum durch die Dämmerung (R. Strauss); Zingung (R. Strauss); The Swan (Szymanowski); Song (Pankiewicz). 5.0, Topical Talk. 5.15, Concert of Light Music. 6.15, Talk on the Prairies of Canada, relayed from Cracow, 959 kc/s, 312.8 metres. 6.35, Song Recital by Marie Lipowska. Songs (Brahms); (a) Sonntag, (b) Song, (c) Keldensamkeit, (d) Wie list du, meine Königin; Janga (Moniuszko); The Swallow (Zelenka); Jasna Lednica (Rozycski); Song (Nuszkowski); Aria from The Huguenots (Meyerbeer). 7.5, Gramophone Music. 7.20, Miscellaneous Items. 7.35, Programme Announcements. 7.40, Reading: The Nightingale and the Rose (Oscar Wilde). 8.0, Concert by the Station Orchestra, conducted by Navrot: Comedy Overture (Kela Beler); Stephanie Gavotte (Czibulka); Oberkis (Namyslowski); Interlude of Songs; Overture to an Opera (Janota); Boston from Schön ist die Welt (Lehár); Interlude of Songs; Waltz, Frühlingstimmen (Strauss); Czardas from The Countess Maritza (Kálmán); Pavane (Mariotti); Mazurka (Namyslowski). 9.5, Radio Journal. 9.15, Agricultural Notes. 9.30, Concert of Polish Music: Love Song (Stojowski); Melody (Rozycski); Cracovienne No. 1 (Zarambski); Theme with Variations (Brzezinski). 10.0, Dance Music. 10.25, Sports Notes. 10.35, News, Weather and Police Notes. 10.40, Dance Music.

ZURICH.—See Schweizerischer Landessender.

# SIMPLICITY & EFFICIENCY *in Automatic Volume Control*

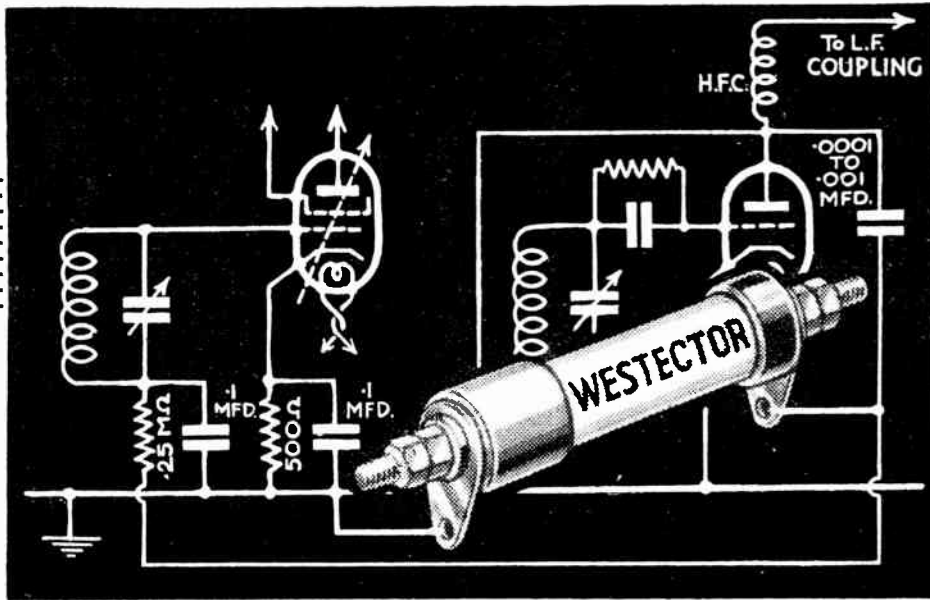

UP to the present, the introduction of Automatic Volume Control to "straight" sets using grid or anode bend detection has necessitated very complicated and costly alterations to a receiver.

But, there is now a much simpler method of obtaining the same result, and involving no material alterations to the receiver. This is made possible by the use of the new Westector, the new high frequency metal rectifier.

The Westector is simply fitted in the detector by-pass circuit, and the D.C. component developed across it by the H.F. present, is used, after passing through a suitable resistance-condenser filter, for controlling the bias applied to the Variable-Mu H.F. Valve.

Full particulars and circuits are given in the 1934 edition of "The All Metal Way." Send 3d. in stamps for a copy.

## The Westinghouse WESTECTOR

**COUPON**

I am interested in A.V.C. Please send me the "All Metal Way," for which I enclose 3d. in stamps.

Name .....

Address .....

W.W. 1/33

**The Westinghouse Brake & Saxby Signal Co., Ltd.,  
82, York Road, King's Cross, London, N.1.**

*Advertisements for "The Wireless World" are only accepted from firms we believe to be thoroughly reliable.*





# "The Aristocrats of the Radio World"

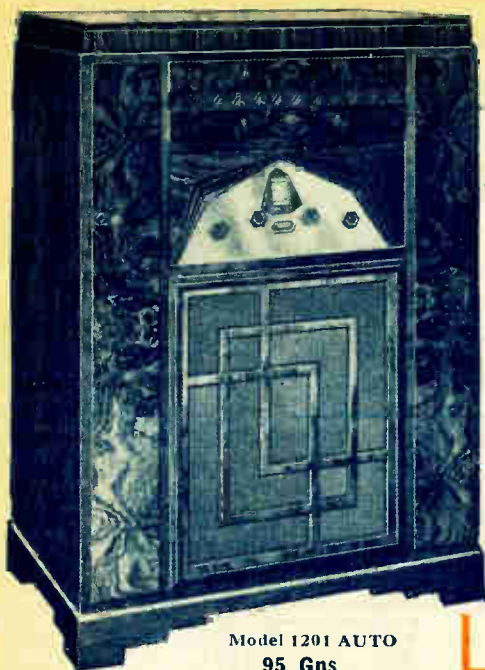

Model 1201 AUTO  
95 Gns.

**Model 1201 Auto (A.C.)**

*Circuit.* A 12 valve superheterodyne Radio Gramophone comprising the following:—Variable mu H.F. stage, band pass coupled to variable mu first detector, triode oscillator, variable mu intermediate stage having six tuned band-pass circuits, followed by a double diode triode valve serving the purpose of the second detector, and **delayed action amplified automatic volume control** operating on three H.F. stages. A further triode valve is used to suppress unwanted noise when tuning between stations. The L.F. amplifier is housed in a separate chassis, and is unique in that resistance-coupled push-pull coupling is used throughout, employing a special circuit. The output stage has an **output of six watts.** *Controls.* Tuning by single control operating illuminated wavelength scale. **Tuning of stations assisted by special visual tuning device which indicates exactly when the station is in tune.** Combined volume control for Radio and Gramophone; tone control; mains switch and gramophone wave-change switch combined. *Speakers.* Twin matched energised moving coil units, mounted on special sub-baffle. Provision for use of external speakers. *Gramophone.* Automatic record changer, enabling eight 10in. or 12in. records to be played in sequence, rejected or repeated as desired, fitted with induction motor and pick-up of improved design. *Cabinet.* Of modern design, made in finely grained figured walnut. Also obtainable in special finishes, and also in **ultra modern design.**

Model 1201 is identical with Model 1201 Auto except that Gramophone is not automatic.

1201 Auto	...	95 gns.
1201	...	86 gns.

(Model 1201 Auto supplied with doors at £16:16:0 extra.)

These new models are a triumph of design, construction and performance, and have justly earned the title of "The Aristocrats of the Radio World." They embody all the qualities associated with the famous 901 model, and possess, in addition, refinements of the highest importance to perfect reception and reproduction. Guesswork in tuning stations is entirely eliminated; the visual tuning device shows when a station is tuned with critical accuracy. Automatic amplified volume control and silent tuning are other refinements. To hear these new models is to enjoy radio and gramophone reproduction as never before; realism and tonal beauty that defy description and evoke the highest praise.



S.P.M. 12  
Dual Matched  
Loud Speakers.

The R.G.D. Type S.P. M12 consists of a pair of matched Permanent Magnet Moving Coil Speakers, and is designed for use with type W12 Auto Amplifier or with any R.G.D. Radio Gramophone input capacity 12 watts undistorted A.C. The cabinet is of heavy and entirely non-resonant walnut of modern design. Dimensions 20in. x 24in. x 7in. deep.

12 Gns

**Model 702 Auto (A.C. or D.C.)**

*Circuit.* A 7 valve superheterodyne Radio Gramophone, comprising the following features:—Variable mu H.F. stage, variable mu first detector, triode oscillator, variable mu intermediate stage, incorporating 7 tuned circuits (4 band-pass), followed by new double diode triode valve, giving diode rectification, **delayed action automatic volume control**, operating on three H.F. stages, also combined with which is the first L.F. stage. This is resistance-coupled to triode output stage, giving an **undistorted output of 2½ watts.** *Controls.* Tuning by single control operating illuminated scale calibrated in wavelengths. Tuning of stations assisted by **special visual tuning device, which indicates exactly when a station is in tune.** Combined volume control for Radio and Gramophone, tone control and main switch; Radio-Gramophone and wave change control combined. *Gramophone.* Automatic record changer enabling eight 10in. or 12in. records to be played in sequence, rejected or repeated as desired, fitted with induction motor and pick up of improved design. *Cabinet* is of improved design in figured and burr walnut, also obtainable in special woods and finishes, and also in **ultra modern design.** *Speakers.* Field energised twin matched moving coil speakers and provision for external speakers.

**Model 702**

*Circuit.* A 7 valve superheterodyne Radio Gramophone, having the same specification as the 702 Auto, except that the Gramophone is not automatic in action.

702 Auto	...	67 gns.
702	...	58 gns.



Model 702 AUTO  
67 Gns.

**THE SUPREME INSTRUMENTS**

**R · G · D**

*= The World's Finest Radiogramophones =*

Write for fully descriptive Catalogue of the complete range of R.G.D. Radio Gramophones and Extension Loud Speakers.

RADIO GRAMOPHONE DEVELOPMENT CO., LTD.,

FREDERICK STREET, BIRMINGHAM, or  
40 DOUGHTY STREET, W.C.1, or  
17, BRIDGE STREET, MANCHESTER.

Makers of "Olympia's Prizewinner for Two Consecutive Years."



# The Wireless World

4<sup>D</sup>

THE PRACTICAL RADIO JOURNAL

with

Complete Foreign Programmes

Friday, September 8th, 1933.

## COLVERN FERROCART COILS

There is now a Ferrocart Coil for practically every modern radio receiver . . . We have written a booklet explaining the advantages of Ferrocart coils and containing suitable circuit diagrams . . .

May we send you a copy? It's free!

MANCHESTER RADIO EXHIBITION STAND No. 32.

COLVERN LIMITED, ROMFORD, ESSEX.

London Wholesale Depot: 150, King's Cross Road, W.C.1.

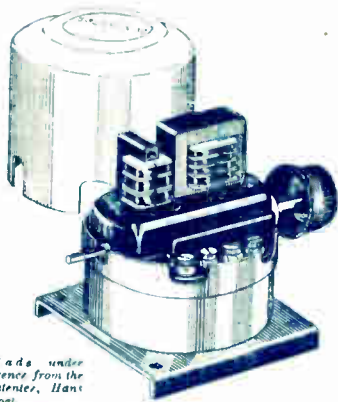

Made under licence from the patentee, Hans Vogt.

## AN OLYMPIC TRIUMPH!



Model 74

Model 74 Battery and All-Electric

Black and Chromium Walnut Finish (as illustrated)

14 GNS.

or 12 monthly payments of £1.7.0

13 GNS.

or 12 monthly payments of £1.5.0

## EKCO RADIO

Write for illustrated folder to

E. K. COLE Ltd., Dept. W.24, Ekco Works, Southend-on-Sea.

## TELSEN Intermediate Frequency TRANSFORMER COILS

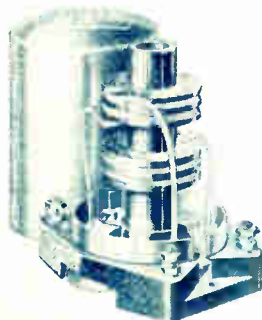

Specified by the designer of the "Wireless World" NEW MONODIAL SUPER. Ideal for every superhet where lasting efficiency is the first essential. Totally screened. The world's finest value at the new reduced price of **7/6**

TELSEN FOR EVERYTHING IN RADIO

Announcement of the Telsen Electric Co., Ltd., Aston, Birmingham.

WHATEVER THE RECEIVER USE

**T.C.C.** ALL-BRITISH CONDENSERS

AND BE SURE



The Telegraph Condenser Co., Ltd., Wales Farm Road, N. Acton, London, W.3



Dx 102

*“This is undoubtedly the best battery I have ever had”*  
 (Sgd.) F. V., Cricklewood, N.W.2.

Most of the leading set-makers fit Exide Batteries for L.T. or Drydex Batteries for H.T. ● Obtainable from Exide Service Stations and all reputable dealers.

# Drydex

by Exide

**DRY BATTERIES FOR WIRELESS**

Exide Batteries, Exide Works, Clifton Junction, nr. Manchester. Branches: London, Manchester, Birmingham, Bristol, Glasgow, Dublin and Belfast

Mention of "The Wireless World," when writing to advertisers, will ensure prompt attention.

# The Wireless World PROGRAMMES from A BROAD

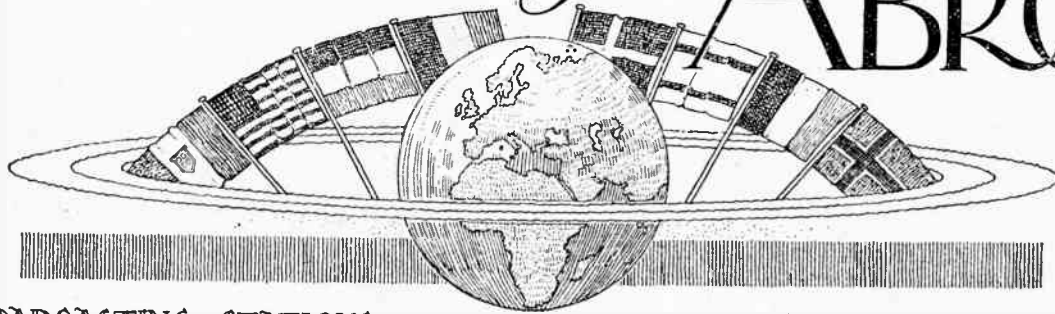

BROADCASTING STATIONS  
ARRANGED IN ORDER  
OF WAVELENGTH

TIMES AND DETAILS OF  
FULL WEEK'S FOREIGN  
TRANSMISSIONS

Metres.	kc/s.	kW.	Station.	Tuning Positions.	Metres.	kc/s.	kW.	Station.	Tuning Positions.
1935	155	7	Kaunas (Kovno) (Lithuania)		453.2	662	0.25	Agen (France)	
1875	160	8.5	Hilversum (Holland) (Kootwijk, 50kW. after 3 p.m.) (V. A.R.A., A.F.R.O. and V.P.R.O. Programmes).		453.2	662	4	Milan (Vicentino) (Italy) (Relays Rome)	
					450.3	666	29	Madona (Latvia). (Relays Riga)	
1796	167	40	Lahti (Finland)		447.1	671	5	Paris, Ecole Supérieure, PTT (7.0 kW.); Rjukan (0.15 kW.), Notodden (0.08 kW.) Mosund (0.35 kW.) (Norway) (relays Oslo).	
1725	174	75	Radio Paris, C.F.R.						
1635	183.5	60	Berlin (Deutschlandsender) (Germany). (S.-W. Stn. DJA on 31.38 m., DJB on 19.73 m., DJC on 49.83 m., DJD on 25.51 m., DJE on 16.88 m.)		441.2	680	50	Rome, IRO. (S.-W. Station, 2 RO on 25.4 m.)	
					435.4	689	55	Stockholm, S.A.S.A. (Sweden)	
1554.4	193	30	Daventry National		430.4	697	2.5	Belgrade (Yugoslavia)	
1538	195	7	Ankara (Angora) (Turkey)		424.3	707	2	Madrid, EAJ7 (Union Radio)	
1481	202.5	500	Moscow, RV1 (Old Komintern) (Russia)		424.3	707	100	Moscow, Imeni Stalina (Russia)	
1446	207.5	13	Eiffel Tower, F.L., Paris		419.5	715	1.5	Berlin, Funk'stunde (Germany)	
1412	212.5	120	Warsaw 1 (Poland)		416.4	720.5	5	Rabat (Morocco)	
1380	217.5	100	Novosibirsk, RV76 1 (Russia)		413	725	60	Athlone (Irish Free State)	
1354.4	221.5	30	Motala (Sweden). (Relays Stockholm)		408.7	734	16	Katowitz (Poland)	
	222	0.5	Tunis-Kashah (Tunisia)		403.8	743	25	Sottens (Radio Suisse Romande) (Switzerland)	
1304	230	100	Moscow, WZSPS (Trade Union) (Russia)		398.9	752	25	Midland Regional. (Daventry)	
1230	244	0.6	Boden (Sweden). (Relays Stockholm)		394.2	761	12	Bucharest (Roumania)	
1200	250	5	Istanbul (Turkey)		389.6	770	120	Leipzig (Germany)	
1200	250	21	Reykjavik (Iceland)		385.1	779	8	Toulouse (Radiophonie du Midi) (France)	
1190	252	200	Luxembourg		385.1	779	10	Stalino, RV26 (Russia)	
1170	256	25	Tashkent, RV11 (Russia)		381	788	16	Lwow (Lemberg) (Poland)	
1154	260	75	Kalundborg (Denmark). (Relays Copenhagen)		376.4	797	50	Scottish Regional (Falkirk)	
1154	260	20	Monte Ceneri (Switzerland). (Temporarily Closed)		372.2	806	1.5	Hamburg (Germany)	
					370.1	810.5	0.8	Radio, L.L., Paris	
1117	268.5	40	Moscow, Popoff RV58 (Russia)		368.1	815		Seville, EAJ5 (Union Radio) (1.0 kW.); Galicia EAJ1 (0.2 kW.) (Spain); Bolzano (1.0 kW.) (Italy); Helsinki (10 kW.) (Finland) (relays Lahti); Kharkov, RV20 (10 kW.) (Russia).	
1083	277	60	Oslo (Norway)		353.1	815	0.7	Fredrikstad (Norway). (Relays Oslo)	
1071	280	35	Tiflis, RV7 (Russia)		354.1	824	1	Bergen (Norway)	
1035	290	36	Kiev, RV9 (Russia)		363.6	825	13	Algiers (Algeria)	
1000	300	100	Moscow RV39 (Russia) (S.-W. Stn. on 50 m.)		360.6	832	60	Mühlacker (Stuttgart) (Germany)	
938	320	20	Kharkov, RV4 (Russia)		355.9	843	50	London Regional (Brookmans Park)	
857	350	100	Leningrad (Russia)		352.1	852	7	Graz (Austria). (Relays Vienna)	
840	357	18.5	Budapest (Hungary)		348.8	860	7.6	Barcelona, EAJ1 (Spain)	
825	363.6	50	Sverdlovsk, RV5 (Russia)		348.8	860	10	Leningrad, RV70 (Russia)	
760	395	1.3	Geneva (Switzerland). (Relays Sottens)		345.2	869	11.5	Strasbourg, PTT (France)	
720	416.6	20	Moscow, RV2 (Experimental) (Russia)		341.7	878	35	Brno (Brunn) (Czechoslovakia)	
690	434.6	1.5	Oulu (Uleaborg) (Finland)		238.2	887	15	Brussels II, Velthem (Belgium). (In Flemish)	
680	441.2	0.6	Lausanne (Switzerland). (Relays Sottens)		335	896	5	Cadiz (Spain)	
574.7	522	7	Ljubljana (Yugoslavia)		334.4	897	1.9	Poznan (Poland)	
569	527	0.25	Freiburg-im-Breisgau (Germany). (Relay Stn.)		331.5	905	50	Milan (Italy). (Relays Turin)	
568.1	528	2	Grenoble (France)		328.2	914	60	Poste Parisien (France)	
563	533	16	Wilno (Poland). (Relay Station)		325	923	60	Breslau (Germany)	
560	536	0.25	Augsburg (Germany). (Relays Munich)		321.9	932	10	Göteborg (Sweden). (Relays Stockholm)	
560	536	1.5	Kaiserslautern (Germany). (Relays Munich)		318.8	941	0.25	Dresden (Germany). (Relays Leipzig)	
550	545	18.5	Budapest No. 1 Lakihegy (Hungary)		318.8	941	1.5	Naples, INA (Italy). (Relays Rome)	
542	554	10	Sundsvall (Sweden). (Relays Stockholm)		315.8	950	1.6	Marsilles, PTT (France)	
537.6	558	3	Palermo (Italy)		312.8	950	0.7	Radio Vitus (Paris). (S.-W. Stn. on 43.75 m.)	
533	563	60	Munich (Germany)		312.8	959	1.7	Cracow (Poland)	
525	571	15	Riga (Latvia)		312.8	959	10	Genoa, IGE (Italy). (Relays Turin)	
517.2	580	100	Vienna (Bisamberg) (Austria)		309.9	968	50	West Regional (Washford Cross)	
509	589	15	Brussels No. 1, Velthem (Belgium). (In French)		307	977	0.75	Zagreb (Yugoslavia)	
500.8	599	20	Florence, IFI (Italy). (Relays Turin)		304	986	13	Bordeaux Lafayette, PTT (France)	
495.8	605	1.2	Trondheim (Norway)		301.5	995	50	North National (Manchester)	
488.6	614	120	Prague, (Czechoslovakia)		298.8	1004	11	Tallinn (Esthonia)	
480	625	50	North Regional (Manchester)		296.1	1013	20	Huizen (Holland). (7 kW. before 4.40 p.m.) (K.R.O. and N.C.R.V. Programmes)	
472.4	635	60	Langenberg (Germany)		293.5	1022	0.7	Limoges, PTT (France)	
465.8	644	1.5	Lyons la Dona, PTT (France)		293.5	1022	2.6	Kosice (Czechoslovakia)	
459.4	653	60	Beromünster (Schweizerischer Landessender) (Switzerland)		291	1031	13.2	Viipuri (Viborg) (Finland). (Relays Helsinki)	
					288.3	1040	50	Scottish National (Falkirk)	
					288.3	1040	1	Bournemouth (Relay Station)	
453.2	662		San Sebastian, EAJ8 (0.6 kW.); Pori (1.0 kW.) (Finland); Danzig (0.5 kW.) (relays Heilsberg); Klagenfurt (0.5 kW.) (Austria) (relays Vienna); Pörsgrün (0.7 kW.) (relays Oslo); Tromsø (0.1 kW.) Bodø (0.5 kW.) (Norway); Uppsala (0.15 kW.) (Sweden) (relays Stockholm).						



BROADCASTING STATIONS ABROAD (In Order of Wavelength)

Table with columns: Metres, kc/s, kW, Station, Tuning Positions. Lists various international broadcasting stations with their respective frequencies and power outputs.

PRINCIPAL SHORT-WAVE STATIONS

(N.B.—Times of Transmission, given in parentheses, are approximate only and represent B.S.T.)

Large table with columns: Metres, kc/s, Call Sign, Station, Tuning Positions. Provides detailed information for principal short-wave stations, including call signs and transmission times.

# FOREIGN SUNDAY PROGRAMMES

SEPTEMBER THE TENTH

## PRINCIPAL EVENTS OF THE DAY:

### AT HOME

- NATIONAL** Service from St. Martin-in-the-Fields.
- LONDON REGIONAL** Organ recital in the Concert Hall, Broadcasting House.
- MIDLAND REGIONAL** Orchestral concert from Droitwich Spa.
- NORTH REGIONAL** Band concert from Manchester.
- WEST REGIONAL** Carolare from the Wesleyan Church, Watchet.
- SCOTTISH REGIONAL** Entertainment by the Yiddish Players.
- BELFAST** Orchestral concert.

### ABROAD

- HILVERSUM** 7.50 p.m. Orchestral concert.
- LEIPZIG** 4.30 and 8.30 p.m. The Symphony Orchestra.
- OSLO** 8.30 p.m. The Station Orchestra.
- PITTSBURGH** 8.0 p.m. National opera concert.
- PRAGUE** 7.45 p.m. Scenes from opera "Carmen," by Bizet.
- ROME** 8.45 p.m. Operetta: "Ihre Hoheit tanzt Walzer," by Ascher.
- STRASBOURG** 8.30 p.m. Opera: "Le roi d'Ys," by Lalo, from the Casino, Vichy.
- TURIN** 8.40 p.m. Opera: "Le Jongleur de Notre Dame," by Massenet.
- VIENNA** 9.0 p.m. The Wiener Symphoniker, conducted by Schönberg.
- WARSAW** 12.15 p.m. The Station Symphony Orchestra, conducted by Oziminski.

appassionato (Saint-Saëns); Three Spanish Songs; Foxtrot, Going, going, gone (Baxter); Tango (Jame Bros.); Foxtrot (Kahn); Melody (Montagne Phillips); Scenes brabantiques (Sarly). In the interval at 8.45, Recitations. 10.0, Review of Periodicals. 10.10, Dance Music from the Casino, Knocke.

### BUCHAREST

761 kc/s, 394 metres; 12 kW.—5.0 p.m., Concert of Light Music and Romanian Music by the Jean Marco Orchestra. 6.0, Radio Journal. 6.15, Concert (cont'd.). 7.0, Reading. 7.20, Dance Music on Gramophone Records. 7.40, Educational Talk. 8.0, Romanian Folk Song Recital by Mlle. Nicolaesco. 8.20, Concert by the Station Orchestra: Romantic Overture (Keler Béla); Lyric Suite No. 2 (Grieg); A Mediterranean Cruise (Jalowitz); Hellasberger Potpourri (Schpold); S'herzino (d'Ambrosio); Two Viennese Dances (Friedmann-Gärtner). In the interval at 9.0, Talk. 9.45, Radio Journal.

CASSEL.—See Frankfurt.

### COPENHAGEN

1,067 kc/s, 281 metres; 0.75 kW. Relayed by Kalundborg, 250 kc/s, 1,133.8 metres.—8.0 a.m., Gymnastics for Women. 8.15, Gymnastics. 9.0 to 9.30, Talk. 10.0, Divine Service Relay. 11.20, Weather and News. 11.45, Sacred Concert from the English Church, The Fleet Street Choir, conducted by T. B. Lawrence. 12.15 p.m., Instrumental Concert. 1.30, Talk in English: Scotland and Scottish Characteristics. 1.50, Talk in German: The Drawing up and Punctuation of German Legal Documents. 2.10, Reading in French. 2.30, Talk for Children. 3.0, Concert of Light Music. 5.0, Divine Service Relay. 6.20, Talk: Marriage and Motherhood among the Aborigines. 6.50, Weather and News. 7.15, Time Signal. 7.30, Talk. 8.0, Town Hall Chimes. 8.2, Concert of Scandinavian Music by the Station String Orchestra, conducted by Emil Reesen. 8.20, Concert of Light Music. 9.15, Sonata for Oboe and Piano, Op. 168 (Saint-Saëns). 9.20, The Hansen Family—Humorous Episode (Jens Locher). 9.45, Concert of Danish Overtures by the Radio Orchestra, conducted by Emil Reesen. 10.5, Selection from Otello—Opera (Verdi) on Gramophone Records. 10.15, News. 10.25, Concert of Operetta Music, conducted by Emil Reesen: Overture, Les Saltimbanques (Ganne); Selection from Barbe-Bleue (Offenbach); Selection from Mam'zelle Nitouche (Hervé); Overture, La jolie Parfumeuse (Offenbach); Selection from Monsieur Beaucaire (Messager). 11.0, Dance Music from the Arena. In the interval at 12 Midnight, Town Hall Chimes. 12.30 a.m. (Monday), Close Down.

GORK.—See Athlone.

DANZIG.—See Heilsberg.

DRESDEN.—See Leipzig.

### FECAMP

1,328 kc/s, 225.9 metres; 10 kW.—11.0 to 12 Noon, Programme in English by the I.B.C. 11.0, Happy Hour. Part I: Orchestral Concert. Signature Tune. Introduction and Valse Lente from Coppélia (Delibes); Hungarian Dance, No. 6 (Brahms); Violin Solo, La Capricieuse (Elgar); Old Spanish Song (Auber); Air de Ballet (Drigo); Morning, from Peer Gynt Suite (Grieg); Pianoforte Solo, Polonaise in A (Chopin); Selection from Il Trovatore (Verdi). Part II: Organ Recital. Sylvan Scenes (Fletcher); Il Baio (Arditi); To a Wild Rose (Macdowell); Schön Rosmarin (Kreisler); Chanson (Fringl); A Brown Bird Singing (Haydn Wood); Till I Wake (Woodford-Finden); Broken Dreams (Spitalny); Signature Tune. 12 Noon, Programme in French. 2.0 to 7.30 p.m., Programme in English by the I.B.C. 2.0, Concert. A Brown Bird Singing (Haydn Wood); Serenade (Toselli); For you Alone (Geehl). 2.15, Orchestral Concert. Signature Tune. The Night by the Sea; Künstlerleben (Strauss); Violin Solo, Hungarian Dance, No. 5 (Brahms); Mignonette (Fringl); Love sends a little Gift of Roses (Openhaw). 2.30, Gramophone Concert. Sweetheart's Yesterday; My Old Kentucky Home (Foster); Some of these Days (Brooks); The Way to the Heart (Lineke); She didn't say Yes (Kern); The old Man of the Mountain; Torador et Andalous (Rubinstein); Animal Antics (Wark). 3.0, Military Band Concert. Marche militaire (Schubert); The Wedding of the Rose (Jessel); Selection from The Belle of New York (Kerker); Naval Patrol (Williams); In a Persian Market (Kotelyny); Policeman's Holiday (Ewing); Balls of Somerset; Tipperary (Judge Williams). 3.30, I.B.C. Members Request Half-Hour. Tales from the Vienna Woods (Strauss); Spring Song (Mendelssohn); Hobo, you can't ride this Train (Armstrong); Selection from Viktoria and her Hussar (Abraham); Ali Baba's Camel (Gay); The Sport of Kings (Flanagan and Allen);

**ATHLONE**  
725 kc/s, 413 metres; 60 kW. Relayed by Cork, 1,337 kc/s, 224.4 metres.—8.30 p.m., Time Signal. 8.31, Music by the Aerial Instrumental Trio. 8.55, The Cosmopolitan Players. 9.25, Contralto Solos by Ellis Denn. 9.40, Violin Solos by Noreen O'Connor. 9.55, Baritone Solos by Myles J. Kelly. 10.10, Accordion Solos by Terry Lane. 10.25, Trio Concert. 11.0, Time Signal, News, Weather Report and Close Down.

**BARCELONA**  
EAJ1, 860 kc/s, 348.8 metres; 8 kW.—6.30 p.m., Agricultural Talk in Catalan and Gramophone Music. 7.0, Concert by the Station Orchestra. 7.30, Song Recital. 8.0, Dance Music, relayed from the Casa Llibre. 9.0, Concert by the Station Orchestra. 9.30, Song Recital. 10.0, Extracts from Musical Comedies on Gramophone Records. 11.45, Chess Lesson. 12 Midnight (approx.), Close Down.

**BARI**  
1,112 kc/s, 269.8 metres; 20 kW.—10.45 a.m., Agricultural Talk. 11.5, Bible Reading. 1.0 p.m., Giornale Radio. 1.10 to 2.15, Gramophone Music. In the interval at 1.55, Weather; and at 2.0, Time and Announcements. 5.30 to 6.30, Gramophone Music. 8.0, Sports Notes and Giornale Radio. 8.30, Time and Announcements. 8.35 (approx.), Concert of Songs and Operetta Music. In the interval, Art Notes. 10.50, Gramophone Music. 10.55, News.

BASEL.—See Schweizerischer Landessender.

**BELGRADE**  
697 kc/s, 430.4 metres; 2.8 kW.—5.0 p.m., Dance Music on Gramophone Records. 6.10, Time Signal and Programme Announcements. 6.15, Report of a Football Match. 7.0, Gramophone Music. 7.10, Violin Recital. 7.50, Recitation. 8.50, Programme relayed from Loznica. 10.0, Time, Sports Notes and News. 10.15 (approx.), Concert by the Station Orchestra.

**BERLIN**  
DEUTSCHLANDSENDER (REICHSENDER), 183.2 kc/s, 1,635 metres; 60 kW.—6.0 a.m., Gymnastics from Berlin (Funkstunde). 6.15, News, followed by Today's Motto, Morning Hymn and Harbour Concert, relayed from Hamburg. 8.0, Agricultural Talk. 8.30, Divine Service in Connection with Luther Week, relayed from the Parish Church, Wittenberg. 9.30, Rural Programme. 11.0, Recital of Religious Poetry: Aura mystica (Löhe). 11.15, Weather. 11.30, See Leipzig. 12.15 p.m., See Hamburg. In the interval at 12.55, Time Signal. 2.0, See Hamburg. 3.0, Orchestral Concert: Waltz, Wiener Bouhons (Strauss); Liebesserenade (Löhrl); Serenade from Les Millions d'Arlequin (Drigo); Schumann Potpourri (Schreyner); A Wedding Day on Trollhøngen (Grieg). 4.0, Talk: The German Landscapes. 4.20, Families can make their own Coffee here—Scenes from an Old Berlin Garden (Erwin Albrecht), with Musical Interludes. 5.45, Talk: My Friend the Reichsminister. 6.0, Hitler Youth Programme: Talk and Songs. 6.30, Der Bettelstudent—Operetta (Müllbacher) on Gramophone Records. 7.0, Programme for Workers. 8.0, See Leipzig. 8.30, Concert from Hamburg. 10.0, News. 10.25, Report of the International University Sports in Turin. 10.45, Weather. 11.0, Concert from Langenberg. 12 Midnight, Close Down.

**BERLIN**  
FUNKSTUNDE, 715 kc/s, 419.5 metres; 1.5 kW.—11.30 a.m., See Leipzig. 12.15 p.m., See Hamburg. 2.0 to 3.0, Talks for Garden City Dwellers. 3.30, Concert by an Orchestra of Unemployed Musicians and the Station Choir. In the interval at 5.0 (approx.), Radio Report of the Hand-Ball Final for the Hitler Cup. 6.30, Hermann Fidlakow talks with three of Berlin's last Cab-Drivers. 7.0, The Romance of Porcelain—Literary and Musical Programme, arranged by Rolf Reissmann. 7.50, Sports Notes. 8.5, Concert by the Station Orchestra, conducted by Camillo Hildebrand; Soloist, Ludwig Hofmann (Bass-Baritone): Comedy Overture (v. Reznicek); Elegie (Grovermann); Aria from The Master-singers (Wagner); Two Pieces (Nielsen); Finlandia (Sibelius); Prelude to La Rosiera (Gnechchi); Piedmontese Dances (Sinigaglia); Aria from La Sonnambula (Bellini); Aria from Simone Boccanegra (Verdi); Prelude to the Third Act of La Traviata (Verdi); Intermezzo from The Jewels of the Madonna (Wolf-Ferrari); Intermezzo from L'Amor Medico (Wolf-Ferrari); Italian Caprice (Tchaikovsky). 10.0, News. 10.20, Report on Gramophone Records of the International University Sports in Turin. 10.30 (approx.), Dance Music, relayed from the Roof Garden of the Eden Hotel. In the interval at 11.0 (approx.), Talk: The German Revolution

as viewed from abroad. 1.0 a.m. (Monday), Close Down.

BERNE.—See Schweizerischer Landessender.

BEROMUNSTER.—See Schweizerischer Landessender.

BÖDEN.—See Stockholm.

BODO.—See Oslo.

**BRATISLAVA**  
1,076 kc/s, 279 metres; 11 kW.—6.35 p.m., Pianoforte Concerto in F, Op. 66 (Dussek). 7.0, See Prague. 7.5, See Brno. 7.45, See Prague. 11.0 (approx.), Close Down.

BREMEN.—See Hamburg.

**BRESLAU**  
923 kc/s, 325 metres; 60 kW. Relayed by Gleiwitz, 1,184 kc/s, 253 metres.—11.50 a.m., Folk Songs by a Children's Choir. 12 Noon, Concert by the Silesian Philharmonic Orchestra, conducted by Prade. 2.0 p.m. (from Gleiwitz), Talk: Bells through the Centuries—Chimes of the Silesian Church, with Illustrations. 2.45, Reading from the Works of Alfons Hayduk. 3.0, Recital of Bandolone Duets. 3.30, Programme for Children. 4.0, Concert from Bad Charlottenbrunn. In an interval from 4.50 to 5.10, Report of the Dablia Show in Halbau. 6.0, Reading (Curt Paqué). 6.25, Song, Flute, and Pianoforte Recital. 7.10, Radio Report of a Festival in Jauer. 7.30, Weather and Sports Notes. 8.0, Concert by the Station Orchestra, conducted by Topitz. Soloists: Bruno Janz (Violin) and Fischer (Clarinet). Overture, William Tell (Rossini); Selection from La Bohème (Puccini); Danse bohémienne (Debussy); Violin Solo, Hejre Kati (Hubay); March, Till Eulenspiegel (Rupperecht); Styrian Dances (Lanner); March, Wien bleibt Wien (Schrammel); Luftartikelwalzer (Joh. Strauss); Clarinet Solo, My Teddy Bear (Ganglberger); Firs Herz und Gemüt (Komzak); Rendezvous bei Lehar (Hrubý); Waltz, Hurenpazier! (Zielhner); Selection from The Merry Widow (Lehár); Galop, Im D-Zug (Blon). In an interval from 9.25 to 9.45, See Munich. 10.20, Time and News. 10.45, Dance Music from Berlin (Funkstunde). 12 Midnight, Close Down.

**BRNO**  
878 kc/s, 342 metres; 35 kW.—12.15 p.m., Military Band Concert. 1.30 to 1.45, Agricultural Talk. 4.0, Programme to be announced. 5.30, Song Recital. 5.45, Reading of Poems. 6.0, German Transmission: Schraummel Quartet Concert, with Songs by Bystričky. 7.0, See Prague. 7.5, Radio Report relayed from Luzice. 7.45 till Close Down, See Prague. 11.0 (approx.), Close Down.

### BRUSSELS (No. 1)

I.N.R., 500 kc/s, 509 metres; 15 kW.—10.0 a.m., Gramophone Concert. 11.0, Concert by the Small Station Orchestra, conducted by Leemans. 12 Noon, Concert by Primas Sylva and his Orchestra. In the interval at 12.30 p.m., Gramophone Music. 1.0, Le Journal Parlé. 1.10, Concert, conducted by André Fellenau, relayed from the Grand Hotel, Antwerp. In the interval at 1.30, Monologues. 2.0, Gramophone Concert. 2.45, Relay of the Opening of the Scheidt Tunnels at Antwerp by H.M. King Albert. 4.45 (approx.), Gramophone Music. 5.0, Concert by the Radio Orchestra, conducted by Franz André: Joyeuse marche (Clabrier); Valse triste (Sibelius); Violin Solo, Spanish Dance (Sara-ate); Farandole (Dubois); Chant hindou (Rimsky-Korsakov); Selection from Hiawatha (Coleridge-Taylor); Petite danse de genre (Marin); Dialogue pastorale en style microphonique (Bruselmans); Waltz, Intermezzo (Siedel); On the Volga (Van Dyck). In the interval at 5.30, Football Report. 6.0, Gramophone Concert. 7.15, Religious Address by the Reverend Father Massaux, O.P. 7.30, Radio Notes and Music Review by Marcel Poek. 8.0, Concert by Pianofort and Strings (Schumann): Soloist: Mlle. Culot. 8.30, Gramophone Music. 8.45, Pity in Literature—Reading from the Works of Victor Hugo. Baudelaire, Rostand, Gineste and Apollinaire. 9.0, Concert from the Kursaal, Ostend, followed by Le Journal Parlé and Dance Music from the Kursaal, Ostend.

### BRUSSELS (No. 2)

N.I.R., 887 kc/s, 338.2 metres; 15 kW. Programme in Flemish.—10.0 a.m., Concert by the Small Station Orchestra, conducted by Leemans. 11.0, Pianoforte Recital on Gramophone Records. 12 Noon, Concert from the Grand Hotel, Antwerp. 1.0 p.m., Le Journal Parlé. 1.10, Primas Sylva and his Orchestra. 1.30, Gramophone Music. 1.45, Primas Sylva and his Orchestra (cont'd.). 2.0 to 5.0, See Brussels 1. 5.0, Dance Music from the Kursaal, Ostend. In the interval at 5.30, Sports Notes. 6.30, Concert by the Small Radio Orchestra, conducted by Leemans. 7.15, Religious Address. 7.30, Music Review. 8.0, Concert by the Radio Orchestra, conducted by Franz André. Soloists, Moulart-Mates (Songs) and Mme. Conchita de Olibera (Spanish Songs); Overture, Piccolino (Günrad). Miniature Suite (Coates); Granada (Albeniz); Cadiz (Albeniz); Three Songs (Sarly); Selection from Tip-Toes (Gershwin); Ballet Music from Henry VIII (Saint-Saëns); Overture, Masaniello (Auber); Waltz Tales from the Vienna Woods (Joh. Strauss). Cello Solo: Allegro

SEPT. 10th

SUNDAY

continued

Cherry Ripe; Moment musical (Schubert); Signature Tune. 4.0, Judge Rutherford's Address, followed by Programme for Children. 4.30, Descriptive Adventure Story. 5.0, Charles Stevens' Concert of Irish Airs, Shamrockland (Stoddon); Song, Father O'Flynn (Stanford); Harp Solo, Irish Melodies; Songs: (a) Phil the Fisher's Ball (French); (b) Killarney (Balfie); Londonderry Air; The Mountains of Mourne (French); Savoy Irish Medley (Dehroy Somers). 5.30, Popular Music of Twenty-Five Years ago. Signature Tune; Jolly Good Company; Yip-Laddy-Lay (Flynn); Poor Old Joe (Foster); Danny Boy (arr. Weatherley); Daisy Bell; After the Ball is Over (Harris); Love's Old Sweet Song (Molloy); The Old Folks at Home; Down at the Old Bull and Bush; Signature Tune. 6.0, Concert. Regimental March of the Gloucestershire Regiment. Announcement by the Lord Mayor of Bristol (Councillor J. T. Wise, J.P.); Brighton; Announcement by the Mayor of Brighton (Councillor Frank G. Beal, J.P.); The Bees Wedding (Mendelssohn); Up from Somerset (Sanderson); Selection from The Student Prince (Romburg); Announcement by Mr. E. J. Taylor, J.P. (Chairman Bristol Development Board); Sussex by the Sea (Ward Higgs); Announcement by Mr. W. H. T. Collings (President Brighton and Hove Chamber of Commerce); Hungarian Rhapsody, No. 2 (Liszt); Gooseberry Tart (Matthews); I do like to be beside the Seaside (Glover); The Song of Songs (Moya); The Floral Dance (Moss); Selection from Lilac Time (Schubert-Berte); Drake's Drum (Stanford); Selection from Merrie England (German). 7.0, Concert of Light Music. Ginger Snaps (Bourdon); Hawaiian Memories; Popular Melodies on a Piano; Danse bagatelle (Bourdon); Amoreuse (Berger); Pianoforte Solo. Just humming Along (Ewing); Jolly Fellows (Vollstedt); The Toymaker's Dream (Golden). 7.30, Programme in French. 9.0 till Close Down, Programme in English by the I.B.C. 9.0, Dance Music. Signature Tune, Happy Feet; Don't be late in the Morning; Falling Star; Old Man Harlem; Where are you Tonight; They all do the Bumba; Sweetheart Darlin'; I cover the Waterfront; The Shadow Waltz; Signature Tune. 9.30, Talkie Time—Times from the Talkies. Signature Tune, Sittin' in the Dark; The Shadow Waltz; Heaven will protect an honest Girl; But for You; Hits from Forty-Second Street; The Moment I saw You; There's Magic in the Air; In the Park in Paris; Selection from The Kid from Spain (Kahmar); Signature Tune. 10.0, Concert of Opera Music; Grand March from Aida (Verdi); One Fine Day, from Madame Butterfly (Puccini); Songs from Cavalleria rusticana (Mascagni); Selection from I Pagliacci (Leoncavallo); Soldiers' Chorus from Faust (Gounod); Waltz Song from La Bohème (Puccini); Prelude to Carmen (Bizet); Softly awakes my Heart, from Samson and Delilah (Saint-Saëns). 10.30, Dance Music. Thank Heaven for You; Blue Bird Singing the Blues; Selection from Show Boat (Kern); Look what I've got; One Tiny Tear; Twelfth Street Rag; In Santa Lucia; The Girl in the Little Green Hat. 11.0, Harry Bradbury Pratt's Broadcast; Chewing Gum; I cover the Waterfront; All over Italy; Sweetheart Darlin'; When Gimble hits the Cymbal; I can't remember; Maybe I love you too much; Goodnight but not Goodbye. 11.30, Concert by the I.B.C. (Ireland) Limited; Signature Tune. Come back to Erin; Selection from The Flower of Hawaii (Abraham); Violin Solo, Indian Love Call from Rose Marie (Friml); Poor Man's Garden (Russell); Poeme (Fibich); Julian (Gartman); Medley of Irish Jigs (Cuvellier); The Song of the Rose (McClulloch); Dance of the Sylphs (Berlioz). 12.5 a.m. (Monday), News Bulletin in English. 12.10 (approx.). Club Concert for Hemel Hempstead Listeners; Signature Tune, The Chum Song; Seven Years with the wrong Woman; Moon over Dixie; Room 1.411; Baby, when you ain't there; Jungle Blues; Peter Peter; Drifting down the Shalimar; In Old Vienna; Love is the sweetest thing; Somebody stole my Gal; Sweetheart Darlin'; I cover the Waterfront; Just an echo in the Valley. 1.0, Dance Music; Signature Tune, Bells of Normandy; The old spinning wheel; I can't remember; We've got the Moon and Sixpence; Lover; We're a couple of Soldiers; Wanderer; Something came and got me in the Spring; Brighter than the Sun; That's my Home; I lay me down to Sleep; Old Man Harlem; It's the Band; Hiawatha's Lullaby; Won't you stay to Tea; There's a tiny, little Hair upon your Shoulder; The Old Spinning Wheel; Signature Tune. 2.0, I.B.C. Goodnight Melody and Close Down.

**FLENSBURG.**—See Hamburg.

**FLORENCE.**—See Turin.

FRANKFURT

1,157 kc/s, 259.3 metres; 17 kW. Relayed by Cassel, 1,220 kc/s, 245.9 metres; and Trier, 1,157 kc/s, 259.3 metres.—11.30 a.m., See Leipzig. 12 Noon, Concert. 1.0 p.m., Gramophone Concert of Light Music. 2.30, Agricultural Notes. 2.40, Agricultural Programme. 3.30, Programme for Children. 4.30, Concert, relayed from Wiesbaden. 6.0, Radio Report on the Motor Races at Bad Neuenahr. 6.25, Humorous Interlude. 7.0, See Berlin (Deutsch-Hausender). 7.50, Sports Notes. 8.5, See Berlin (Funkstunde). 10.0, Topical Talk.

10.20, Time and News. 10.45, See Langenberg. 12 Midnight (approx.). Close Down.

**FREDRIKSSTAD.**—See Oslo.

**FREIBURG.**—See Stuttgart.

**GENEVA.**—See Radio-Suisse Romande.

**GNOIA.**—See Turin.

**GLEIWITZ.**—See Breslau.

**GOTEBORG.**—See Stockholm.

**GRAZ.**—See Vienna.

**HAMAR.**—See Oslo.

HAMBURG

806 kc/s, 372 metres; 1.5 kW. Relayed by Bremen, 1,112 kc/s, 269.8 metres; Flensburg, 1,319 kc/s, 227.4 metres; Hanover, 530 kc/s, 566 metres; and Kiel, 1,292 kc/s, 232.2 metres.—11.15 a.m., German Culture Week—Programme of Music and Addresses, relayed from the Staatstheater. 12.15 p.m., Concert by the Station Orchestra, conducted by Gerhard Maasz. In the interval at 12.55, Time and Weather. 2.0 (from Hanover), The Hitler Youth—Report from Bad Harzburg. 3.0 (from Hanover), Concert of Old Chamber Music for Lyre, Recorder, and Soprano Voice. 3.30, German Heroes: Airships Westward—a Radio Report. 4.0 (from Bremen), Concert by Two Military Bands. 5.20, Travels and Adventures—Reading: Encounters with Tigers in East Siberia. 5.45, Concert of Contemporary Music by the Hamburg Male Voice Choir. 6.15 (from Bremen), Radio Report from Worswede. 7.0, Concert by the Norag Male Voice Quartet and Soloists. 7.40, Sports Notes and Weather. 8.0, Concert by the Station Orchestra, conducted by Richard Richter. Soloist: Jan Gesterkamp (Violin). Leonora Overture No. 3 (Beethoven); Concerto in G Minor for Violin and Orchestra (Brahm). Prelude to the Third Act, Dance of the Apprentices, and Chorus, from The Mastersingers (Wagner); Second Peer Gynt Suite (Grieg); Invitation to the Dance (Weber); First Hungarian Rhapsody (Liszt). In the interval at 8.50, News. 10.0, Time and News. 10.10, Topical Talk. 10.20, Radio Report from Berlin (Funkstunde). 10.45, Light Music and Dance Music from Berlin (Funkstunde).

**HANOVER.**—See Hamburg.

HEILSBURG

1,085 kc/s, 276.5 metres; 60 kW. Relayed by Danzig, 662 kc/s, 453.2 metres.—11.30 a.m., See Leipzig. 12 Noon, Concert by the Königsberg Opera House Orchestra, conducted by Wolfgang Brückner. 2.0 p.m., Chess Lesson. 2.30 (from Danzig), Programme for Young People. 3.0, Gerhard Eschenhagen reads from his book, Besinnung vor dem Aufbruch. 3.25, Songs from a Labour Service Camp at Seckenburg. 4.0, Concert by the Small Station Orchestra, conducted by Eugen Wileken. In an interval at 4.45 (approx.), Racing Notes. 5.30, Talk on the German Language. 6.0, Chamber Music: String Quartet in E minor (von Schillings). 7.0, Paul Ernst Memorial Programme—Dramatic Works (arr. Eberhard Wolfgang Möller). 8.0, Sports Notes. 8.5, Festival Concert relayed from Königsberg Cathedral for its Six Hundredth Anniversary: The Königsberg Teachers' Choir and Opera House Orchestra; Conductor: Paul Fiechow; Soloists: Mia Neusitzer-Thönnissen (Soprano) and Walter Eschenbach (Organ); Three Chorals: (a) Ich lag in tiefer Todesnacht (Eccard), (b) Such, wer da will ein Auser Ziel (Stobäus), (c) Gott des Himmels und der Erden (Albert); Organ Prelude in E minor (Berneker); Chorus from the Cantata, Christus, der ist mein Leben (Berneker); Aria for Soprano and Organ (Fiebach); Die Gnade unseres Herrn Jesu Christi (Fiebach); The Virgin Mary's Song from the Advent Cantata (Besch); Final Chorus from the Resurrection Cantata (Besch). 9.0, Concert from Hamburg. 10.0, Weather and News. 10.5 (approx.). Dance Music from Berlin (Funkstunde). 12 Midnight (approx.). Close Down.

HILVERSUM

Announced HUIZEN, 269.1 metres; 20 kW. 7 kW up to 5.40 p.m.—8.10 a.m., Religious Programme of the Catholic Radio Society (K.R.O.). 9.10 to 11.55, Programme of the Christian Radio Society (N.C.R.V.). 9.10, Sacred Music on Gramophone Records. 9.30, Divine Service from a Church in Middelstum. After the Service, Sacred Music on Gramophone Records. 11.55 to 4.40 p.m., K.R.O. Programme. 11.55, Orchestral Concert, conducted by Gerritsen. 12.40, Talk on Edmund Rosland. 1.0, Concert (contd.). 1.50, Literary Talk. 2.10, Concert by the KRO Boys. 2.40, Gramophone Music. 3.40, Programme for Invalids. 4.40 to 7.25, N.C.R.V. Programme. 4.40, Sacred Music on Gramophone Records. 5.30, Divine Service, relayed from Kralingen. 7.10, Sacred Music. 7.25 till Close Down. K.R.O. Programme. 7.25, Talk. 7.50, Orchestral Concert. Soloist: Smits-huyssen (Baritone). Overture, Prince Igor (Borodin); Aria from Prince Igor (Borodin); Selection from Samson and Delilah (Saint-Saëns); Aria from The Barber of Seville (Rossini); Selection from Louise (Charpentier). 8.40, News. 8.45,

Recitation. 9.5, Concert (contd.). In the interval at 10.0, News. 10.20, Epilogue by the Small Choir. 10.40, Close Down.

**HORBY.**—See Stockholm.

HUIZEN

Announced HILVERSUM, 160 kc/s, 1,875 metres; 8.5 kW. (7 kW up to 3.40 p.m.). Transmitted from Kootwijk on 50 kW. from 3.40 p.m.—8.40 to 11.40 a.m., Programme of the Workers' Radio Society (V.A.R.A.). 8.40, Pigeon Flying Report. 8.43, Horticultural Talk. 9.10, Organ Recital. 9.40, Evangelical Service from the Grootse Kerk, Leenwarden. 11.10, Address. 11.40 to 4.40 p.m., Programme of the Algemeene Vereeniging Radio Omroep (A.V.R.O.). 11.40, Time Signal and Talk. 12.10 p.m., Concert by the Wireless Orchestra, conducted by Nico Treep. 1.40 p.m., Weekly Book Talk. 2.10, Cello Recital. 2.40, Concert, relayed from the Kurhaus, Scheveningen. The Residence Orchestra, conducted by Ignaz Neumark. Soloist: Boleslav Kon (Pianoforte); Overture, Fingal's Cave (Mendelssohn); Concerto in F Minor for Pianoforte and Orchestra (Chopin); Gramophone Music. La procession nocturne (Raband); Polonaise from the Third Suite (Tchaikovsky). 4.10, Gramophone Music. 4.40 to 5.40, Programme of the V.A.R.A. Concert by the Excelsior Mandoline Orchestra. 5.40 to 7.40, Programme of the Liberal Protestant Radio Society (V.P.R.O.). 5.40, Review of Books. 6.25, Divine Service from Beverwijk. 7.40 till Close Down. Programme of the A.V.R.O. 7.40 News. 7.55, Concert by the Wireless Orchestra, conducted by Nico Treep. Soloist: Annie Woud (Contralto). 8.50, Recital of Songs. 9.10, Concert by Kovacs Lajos and his Orchestra, and the A.V.R.O. Girls. 9.55, Gramophone Music. 10.10, Kovacs Lajos and his Orchestra. 10.40, Gramophone Music. 11.40 (approx.). Close Down.

**INNSBRUCK.**—See Vienna.

JUAN LES PINS

1,205 kc/s, 249 metres; 0.8 kW.—12.30 p.m., Amusement Guide and Variety Items. 1.0, News. 1.15, Visite de Colombine—Sketch (E. Bigot). 1.30, Radio Concert. 8.0, Amusement Guide and Sports Notes. 8.15, Radio Concert. 10.0, Popular Programme. 10.30 till Close Down, Programme in English by the I.B.C. 10.30, Orchestral Concert: Waltz, Wiener Bouillons (Strauss); Serenade (Toselli); Intermezzo, Liebesfreud (Kreisler); Hungarian Melodica (Korby); The Skater's Waltz (Waldteufel); Grasshopper's Dance (Bucalossi); Gipsy Moon (Borganov); Roses from the South (Strauss). 11.0, Military Band Concert: A Merry Hunting Day (Partridge); Old Comrades (Teike); Parade of the Tin Soldiers (Jessel); Five Star (Carter); Changing of the Guard (Flotsam and Jetsam). 11.30, Concert of Light Music: Viennese Singing Birds (Trauslauer); Violin Solo: Souvenir (Drlla). Song: Roses at Dawning (Kahn). Pianoforte Solo: Serenade (Hekens). Songs: (a) The Old Spinning Wheel (Hill), (b) Hold me (Schuster). Accordion Solo: Accordion Nights. 12 Midnight, Dance Music: Don't be late in the Morning; In the Valley of the Moon; When my little Pomeranian; Put a little Springtime in the Winter of their Lives; How do you do, Mr. Brown; I'm one of the lads of Valencia; Let's all dance the Polka; Sweetheart; My Darling; My Heart's to let; Sittin' in the Dark; Dip your Brush in the Sunshine; Drifting down the Shalimar; Piccaninies' Heaven; I can't remember; Maybe I love you too much. 1.0 a.m. (Monday), I.B.C. Good-night Melody and Close Down.

**KALUNDBORG.**—See Copenhagen.

**KIEL.**—See Hamburg.

**KLAGENFURT.**—See Vienna.

**KOSICE.**—See Prague.

LANGENBERG

635 kc/s, 473 metres; 60 kW.—11.15 a.m., Concert by the Münster Orchestra, conducted by Jochem. 2.45, Talk on Chess. 3.0, Talk: Country Weddings. 3.15, Light Music on Gramophone Records. 3.30, Thunder and Lightning—Superstition and Strange Customs—a Radio Sequence (Goswin Gath). 4.9, Illustrated Talk: Songs of the Hebrides. 4.30, Concert conducted by Eysoldt. 6.0, See Frankfurt. 6.30, Music from I Padiachi (Leoncavallo) and Cavalleria rusticana (Mascagni) on Gramophone Records. 6.40, Reading in Dialect. 7.0, Programme Grave and Gay. 7.45, Sports Notes. 8.0, Variety Programme. In the interval, Das Liebesfand (The Love Token)—Short Operetta (Kneip). 10.0, Sports Notes. 10.20, Report of the University Sports in Turin (on Gramophone Records). 10.45, Light Music and Dance Music. 12 Midnight, Close Down.

**LAUSANNE.**—See Radio-Suisse Romande.

LEIPZIG

769.9 kc/s, 389.6 metres; 120 kW. Relayed by Dresden, 941 kc/s, 319 metres.—11.30 a.m., Wer sieht selbst erhöht, der soll erniedrigt werden—Cantata (Bach), by the Municipal and Gewandhaus Orchestra, the Choir of St. Thomas, and Soloists. 12 Noon, See Frankfurt. In an interval at

1.0 p.m., Talk: The Voice of the German Populations outside the Reich. 2.0, News. 2.5, Programme Announcements. 2.25, Agricultural Notes. 2.35, Travel Talk: From the Cape to Cairo. 3.0, Choral Concert. 3.30, Concert by the Wind Instrument Quintet of the Dresden State Opera. 4.0, Reading (Friedrich Kayssler). 4.25, Report on Hohnstein Hill-climbing Trials. 4.30, Concert by the Leipzig Symphony Orchestra, conducted by Willy Steffen; Overture, The Nuremberg Doll (Adam); Indian Love Lyrics (Woodforde-Finden); Suite, Bilder aus dem Orient (Unger); Overture, The Crown Diamonds (Anber); Serenade in E minor, Op. 20, for Strings (Elgar); Tarentella from Die Neuberuber (Freudenberg); Overture, William Tell (Rossini). 5.30, See Heilsberg. 6.15, Käsebiere Italienreise—Play (Ludwig Thoma). 7.0, Recital on Two Pianofortes. 7.30, The Great Reformer—Radio Report of the Luther Celebrations at Wittenberg. 8.0, Concert by the Leipzig Symphony Orchestra, conducted by Weber; Soloists: Erna Sereni (Soprano), Willi Wörle (Tenor), and Hermann Reichert (Baritone); Extracts from (a) Euryanthe (Weber), (b) Oberon (Weber), (c) Tannhäuser (Wagner); Soprano Solo: Ballad from The Flying Dutchman (Wagner); Prelude to Act III and Legend of the Grail from Lohengrin (Wagner); Wotan's Farewell and Fire Magic from The Valkyrie (Wagner). 10.15, News. 10.30 (approx.), Dance Music from Berlin (Funkstunde). 12 Midnight (approx.). Close Down.

**LINZ.**—See Vienna.

MADRID

EAJ7, 707 kc/s, 424.3 metres; 2 kW.—9.10 to 10 a.m., Topical Review. 3.0 p.m., Chimes, Time, Theatre Notes and Popular Concert. 5.0, Interval. 8.0, Chimes, Announcements and Dance Music. 9.30, Interval. 11.0, Chimes, Time and Second Anniversary Programme, relayed from Radio Valencia, 1,121 kc/s, 267.6 metres. 1 a.m. (Monday), Dance Music. 1.30 (approx.). Close Down.

**MALMO.**—See Stockholm.

MILAN

VIGENTINO, 662 kc/s, 453.2 metres; 4 kW.—8.45 p.m. till Close Down, See Rome.

**MOTALA.**—See Stockholm.

**MUHLACKER.**—See Stuttgart.

MUNICH

563 kc/s, 533 metres; 60 kW. Relayed by Augsburg and Kaiserslautern, 556 kc/s, 530 metres; and Nürnberg, 1,256 kc/s, 239 metres.—11.30 a.m., See Leipzig. 12 Noon; Military Band Concert from the Feldherrnhalle. 1.0 p.m., Time, Weather and Programme Announcements. 1.10, Agricultural Talk. 1.30, In Praise of Wine—Concert of Baecchanals on Gramophone Records. 2.30, Political Talk. 2.50, Programme for Children. 3.20, Early Harvest—Romantic Suite for Soprano, Tenor, Baritone and Speaking Voices (Köstler and Semmler). 3.50, Wanderings in Bavaria—The Yearly Fair in the Mountains. 4.30, See Leipzig. 5.45 (from Nürnberg), Radio Report: The Storks take Flight—An Experiment by the Rossitter Bird Sanctuary. 6.5, Lieder Recital by Elisabeth Voigt (Soprano). Two Songs (Schumann): (a) Ich wandre nicht, (b) Des Knaben Berglied; Three Songs (Cornelius): (a) In der Ferne, (b) Betschaft, (c) Am Rhein; Daheim (Kant). 6.25, Sonata in E sharp Op. 18 for Violin and Pianoforte (R. Strauss). 6.45, Weather and Sports Notes. 7.0, Der verfluchte Hof—Play in Three Acts (Ernst Hohenstatter). 8.30, Concert by the Station Orchestra, conducted by Winter. Soloists: Hedy Meindl (Soprano) and Goebel (Bass). Overture, Così fan tutte (Mozart); Two Songs for Soprano (Mozart): (a) Aria from Così fan tutte, (b) Aria from The Magic Flute; Andante con moto from the Symphony in C (Schubert); Five Pieces (Wagner): (a) Rome Recitative from Tannhäuser, (b) Prelude to Act III of Lohengrin, (c) Lohengrin's Farewell, (d) Prelude to Act III of The Mastersingers, (e) Walter's Prize Song from The Mastersingers. 9.25, Austria. 9.45, Concert (contd.). Fairy Tale Suite, Cinderella (d'Albert); Two Pieces from the Suite, Le bourgeois gentilhomme; Extract from Gesteinabend war Vetter (R. Strauss); Michel da (Georg Schumann). 10.20, Time, Weather and News. 11.0, Dance Music from Berlin (Funkstunde). 12 Midnight, Close Down.

**NAPLES.**—See Rome.

**NOTODDEN.**—See Oslo.

OSLO

277 kc/s, 1,083 metres; 60 kW. Relayed by Fredriksstad, 815 kc/s, 368.1 metres; Hamar, 522 kc/s, 574.7 metres; Notodden, 671 kc/s, 447.1 metres; Porsgrund, 662 kc/s, 453.2 metres; and Rjukan, 671 kc/s, 447.1 metres.—10.15 a.m., Weather and Roads Report. 10.50, Chimes. 11.0, Divine Service, relayed from the Castle Chapel. 5.0 p.m., Concert conducted by Erling Nielsen, relayed from the Theatre Café; Selection from Tannhäuser (Wagner); Potpourri (Victor Herbert); Carnival Overture (Dvorák); Serenade (Leoncavallo); Ballet Suite (Gretry-Mottl); Dance from Ran (Peterson-Berger); Melody (Leif Otivann). 6.0, Talk. 6.30, Recital of Sacred Songs. 7.0, Extracts from Hiawatha (Longfellow). 7.15, Weather and News. 7.30, Cello Recital, relayed from



**Trondheim, 605 kc/s, 495.8 metres:** Siciliana and Minuet (Giacomo Cervetto); Siciliana (Handel); Melody (Grützmaier); Mazurka in D minor (Popper); Capriccio (Goltermann). 8.0, Time Signal. 8.1, Talk. 8.30, Concert by the Station Orchestra, conducted by Hugo Kramm: Selection from The Bohemian Girl (Balfé); Suite, Scènes pittoresques (Massenet); Norwegian Wedding (Kramer Johansen); Elegy (Rachmaninov); Shadow Dance from Dinorah (Meyerbeer); Melody (Nordraak); Selection from Tieland (d'Albert). 9.10, Weather and News. 10.0, Typical Talk. 10.15, Trio Concert with Songs. 10.45, Dance Music on Gramophone Records. 12 Midnight (approx.). Close Down.

**OSTERSUND.**—See Stockholm.

**PALERMO**

553 kc/s, 537.6 metres; 3 kW.—10.25 a.m., Bible Reading. 10.40, Sacred Music. 11.5, Agricultural Talk. 12.45 p.m., Giornale Radio. 1.0 to 2.0, Light Music. In an interval at 1.30, Time, Announcements, and Weather. 1.30 to 6.30, Gramophone Music. 8.0, Dopolaravoro Notes and Giornale Radio. 8.20, Sports Notes. 8.25, Gramophone Music. In an interval at 8.30, Time and Announcements. 8.45, Symphony Concert, conducted by La Rosa Parodi. In the interval, Talk. After the Concert, Gramophone Music. 10.55, News.

**PARIS**

**EIFFEL TOWER, Call FLE, 207.5 kc/s, 1,445.7 metres;** 13 kW. Time Signals (on 2,650 metres) at 10.26 a.m. and 11.26 p.m. (Preliminary and 6-dot Signals).—1.0 p.m., News. 1.15, Weather. 1.30, Concert by Jean Bos and his Orchestra. Soloists, Henry-Saint-Cricq (Songs); Jean Savoye (Violin) and Jean Bos (Cello). Part I, Bizet Music; Extracts from (a) L'Arlesienne and (b) Carmen. Part II, Saint-Saëns Music. Violin Solo: Le Déluge. Cello Solo: Le Cygne; Selection from Samson and Delilah. 2.45, Radio Report of the Grand Prix at Buffalo. 6.45, Le Journal Parlé. 8.0, Announcements. 8.10 (approx.), Hungarian Song Recital by Mme. Kalliwoda (Soprano). 8.30, Le roi d'Ys—Opera (Lalo), relayed from the Casino, Vichy. 11.0 (approx.). Close Down.

**PARIS**

**POSTE PARISIEN, 914 kc/s, 328.2 metres;** 60 kW.—10 a.m., Gramophone Music. 10.20, Press Review. 10.30, Sponsored Concert. 11.0, Concert of Italian Music. 11.40, Radio Report on the Motor Cycle Grand Prix. 12.15 p.m., Sponsored Concert of Sound Film Music. 12.45, Sponsored Programme. 12.50, Half-an-Hour of Fantasy by Paul Weill. 1.30, Sponsored Programme. In an interval at 2.0 (approx.), Radio Report on the Motor

Cycle Grand Prix. 7.0, Le Journal Parlé. 7.5, Sports Notes. 7.15, Gramophone Music. 7.30, Catholic Review. 8.0, Concert by Ter-Abramomoff and his Russian Orchestra; Soloist: Bossin (Bass). 10.15 (approx.). Close Down.

**PARIS**

**RADIO-PARIS, Call CFR, 174 kc/s, 1,725 metres;** 75 kW.—7.45 a.m., Gramophone Records: Waltz, Sphärenklänge (Jos. Strauss); Au chant des biniois (Sablon); The Whistler and his Dog (Pryor). 8.0, News. 8.30, Physical Culture. 12 Noon, Religious Address. 12.20 p.m., Sacred Music: Andante cantabile (Widor); Allegro (Guilmant). 12.30, Gramophone Concert: March from a Midsummer Night's Dream (Mendelssohn); Berceuse (Fauré); Le colibri (Chausson); La Cinquantaine (Marie); Chanson triste (Duparc); Melody (Rubinstein); Rhapsody, España (Chabrier); Pensée d'autonne (Massenet); Hungarian March from The Damnation of Faust (Berlioz); Serenade (Pierné); Le temps des lilas (Chausson). 1.30 to 2.30, Programme in English by the I.B.C.: The Hyams Bros. Dance Hour: In the Valley of the Moon (Burke); Moths around the Candle Flame (Gordon); Peter Peter (Connelly); Sweetheart darlin' (Stohart); Love Songs of the Nile (Brown); When the King goes by (Connelly); One Tiny Tear (Connelly). 2.0, Concert of Dance Music: Signature Tune, Happy Feet; Love's Tales; Stormy Weather; I cover the Water-front; Good Morning All; The Gold Digger's Song; Stay out of my Dreams; Gipsy Fiddles; But for you; Signature Tune. 3.0 to 3.30, Programme in English by the I.B.C.: Orchestral Concert: March, National Emblem (Bagley); The Water Melon Patch (Bridgwood); Selection from Floradora (Stuart); Waltz, the Missouri (Logan); Potpourri, Community Land (arr. Stoddon). 5.30, Light Gramophone Music. 6.0, Popular Concert. 7.0, Variety Concert. 8.0 to 8.15, Gramophone Music. 8.15, Radio Paris Competition. 8.30, Le Roi d'Ys, Opera (Lalo), relayed from the Casino, Vichy. In the interval at 9.20, Press Review and News.

**PITTSBURGH**

**KDKA, 980 kc/s, 306 metres;** 50 kW. Relayed by W8XK on 48.86 metres and 25.27 metres.—5.15 to 6.15 p.m., Radio City Concert, from New York. 7.0, Boys of Wyncuccelle. 7.15 to 9.0, New York Relay. 7.15, Summer Idyll. 7.30, Variety Programme. 8.0, National Opera Concert. 9.0,

Programme to be announced. 9.30, Organ Recital, from New York. 10.0, Vesper Services. 11.0, News, Among Masters. 11.15, Weather, Sports. 11.30, Houston Kay's Orchestra. 12 Midnight to 2.30 a.m. (Monday), New York Relay. 12 Midnight, Popular Programme. 12.30, Wisdom of the Ages. 1.0, Light Opera. 2.0, Gulf Headliners. 2.30, Programme to be announced. 3.0, Mountain Music, from New York.

**PORSGRUND.**—See Oslo.

**PRAGUE**

614 kc/s, 488.6 metres; 120 kW.—11.0 a.m., Promenade Concert by the Municipal Orchestra, conducted by Wille, relayed from **Teplice Sanov, 12 Noon, Chimes.** 12.5 p.m., News. 12.15, See Brno. 1.30 to 1.45, Agricultural Tak. 3.0, Programme to be Announced. 5.0, Gramophone Music. 6.0, German Transmission: Programme Review; Relay from the Waldstein Chateau at **Teplice Sanov**, followed by News. 7.0, News. 7.5, See Brno. 7.45, Scenes from Carmen—Opera (Bizet). 10.0, Time and News. 10.20, Gramophone Music. 11.0 (approx.). Close Down.

**RADIO-SUISSE ROMANDE**

**SOTTENS, 743 kc/s, 403 metres;** 25 kW.; and **Geneva, 395 kc/s, 760 metres.**—9.55 a.m. (from Lausanne), Chimes. 10.0 (from Lausanne), Protestant Service. 11.15 (from Lausanne), Symphony Music on Gramophone Records. 12.30 p.m., News and Weather. 12.40 p.m. to 8.0, Programme from Lausanne. 12.40, Gramophone Concert. 2.0 to 3.30, Interval. 3.30, Concert by the Radio Lausanne Orchestra, conducted by Moser. 4.45, Accordion Recital by Médar Ferrero, relayed from the Splendid Hotel. 5.30 to 7.0, Interval. 7.0, Catholic Address. 7.40, Sunday Sports Talk. 8.0, Concert by the Radio Suisse Romande Orchestra, conducted by Echenard. 9.0 (from Lausanne), Recitation of Poems. 9.15 (from Lausanne), Song and Pianoforte Recital of Music by Henry Raymond. 9.50, News and Weather. 10.0 (from Lausanne), Violin Recital by Robert Sottens. 10.30 (approx.). Close Down.

**RJUKAN.**—See Oslo.

**ROME**

Call **1R0, 680 kc/s, 441 metres;** 50 kW. Relayed by Naples, 941 kc/s, 319 metres; and **2R0, 11,810 kc/s, 25.4 metres,** from 5.15 p.m.—10.0 a.m., News, Sports Notes and Amusement Guide. 10.30, Agricultural Notes. 10.45, Bible Reading. 11.0 to 12 Noon and

12.30 to 1.15 p.m., See Turin. 1.45, Gramophone Music. 2.0, Time and Announcements. 5.0 (Naples), Programme for Children, Weather and Sports Notes. 5.15, Vocal and Instrumental Concert; Sports Notes in the intervals. 6.30, Weather. 7.30, Sports Notes and News. 7.45, Song Recital by Vera Nadia Piggiali (Soprano). 8.0, Time and Announcements. 8.25, Sports Notes. 8.45, Ihre Höheit tanzt Walzer, Operetta in Three Acts (Ascher). In the intervals: Talk and Theatre Notes; Giornale Radio after the Programme.

**SALZBURG.**—See Vienna.

**SCHENECTADY**

**WGY, 790 kc/s, 379.5 metres;** 50 kW. Relayed at intervals by **W2XAF on 31.48 metres;** and by **K2XAD on 19.56 metres.**—8.0 to 10.0 p.m. (approx.). **New York Relay.** 8.0, Wayne King's Orchestra. 8.30, Dr. F. H. Knube in the Radio Pulpit. 9.0, Fiddlers Three. 9.15, Wildroot Institute. 9.30, to 10.0, Temple of Song. 12.45 to 3.45 a.m. (Monday), **New York Relay.** 12.45, Russian Symphonic Choir. 1.0, Variety Programme. 2.0, Manhattan Merry-Go-Round. 2.30, American Album of Familiar Music. 3.0, Popular Programme. 3.15, Impressions of Italy. 3.45, Sunday at Seth Parker's, from New York, followed by Programme Resumé.

**SCHWEIZERISCHER**

**LANDESENDER**

653 kc/s, 459 metres 60 kW. **Basle, 1,229 kc/s, 244.1 metres;** and **Berne, 1,220 kc/s, 245.9 metres.**—10.0 a.m. (from Basle), Protestant Service. 10.45 (from Basle), Violin and Cello Duets. 11.30 (from Basle), Readings. 12.0 Noon (from Basle), Songs on Gramophone Records. 12.30 p.m., Time, Weather and News. 12.40 (from Zürich), Concert by the Radio Orchestra, conducted by Neppach. 1.30 (from Basle), Agricultural Programme. 2.0 (from Basle), Zither Duets. 2.30 to 5.0, Interval. 5.0 (from Basle), Popular Concert. 5.45 (from Basle), Extracts from Frederica—Operetta (Lohr) on Gramophone Records. 6.0 (from Basle), Talk for Philatelists. 6.30 (from Basle), Reading in French-Swiss Dialect. 7.0 (from Basle), Time and Sports Notes. 7.10, Light Orchestral Concert. 8.0 (from Basle), Talk: Old Frankfurt. 8.30 (from Basle), Violin Recital. 9.0, News. 10.10 (from Basle), Announcement. 10.15 (approx.) (from Basle), Sports Notes.

**SOTTENS.** See Radio-Suisse Romande.

**STOCKHOLM**

689 kc/s, 436 metres; 55 kW. Relayed by **Boden, 244 kc/s, 1,229.5 metres;** **Göteborg, 932 kc/s, 322 metres;** **Hörby, 1,166 kc/s, 257 metres;** **Motala, 221.5 kc/s, 1,354.4 metres;**

**"My dear Watson...!"**

**... IT IS OBVIOUS THE VALVE HAS GONE .."**

*"A broken down grid bias resistance is a fault that, normally, would need some locating, Doctor, but with the aid of an 'All-in-One' Radiometer it took me very little time to test the whole set and eventually narrow down the field until the real culprit was revealed."*

If YOU possess a radio set you should also possess an "All-in-One" Radiometer. With this wonderful instrument you can always keep your set in 100% condition. It tests everything quickly and surely, enabling you to keep the set up to par at all times. Ask to see it demonstrated at your radio dealers or write direct to

**PIFCO LTD., High Street, MANCHESTER, or 150, Charing Cross Road, London, W.C.2.**



**PIFCO ALL IN ONE RADIOMETER**



Standard Model "All-in-One" Radiometer, for Battery Sets only, as shown here. Price **12'6**

De Luxe Model, for Battery Sets, Electric Receivers and Mains Units. Price - - - **£2:2**

©R2





# EDISWAN

Convert  
your  
radio  
into a  
**RADIO-  
GRAM**

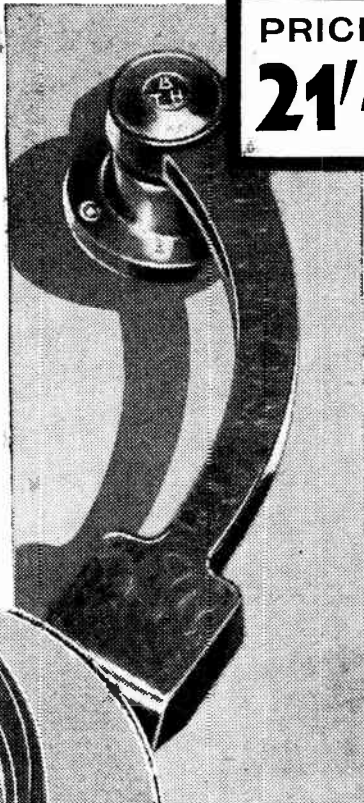

PRICE  
**21/-**

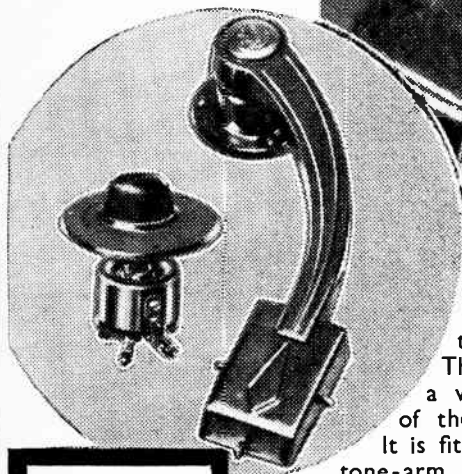

The B.T.H. Pick-up has, since pick-ups were first used, always been acknowledged as the finest obtainable. The "Minor" model is a worthy representative of the latest B.T.H. range.

It is fitted in a highly finished tone-arm moulding. A volume control of the correct value is incorporated in the tone-arm pillar. It is supplied complete with rest and fixing screws. For the connoisseur in radiogram reproduction, the "Senior" model is ideal. It is finished Florentine Bronze and supplied complete with separate volume control.

PRICE

**37'6**



## PICK-UPS and TONE ARMS



The Edison Swan Electric Co. Ltd.  
155 Charing Cross Rd., London, W.C.2

GOOD RADIO DEALERS RECOMMEND EDISWAN

W.207

SEPT. 10th

**SUNDAY**

continued

**Ostersund**, 389 kc/s, 770 metres; and **Sundsvall**, 554 kc/s, 542 metres.—9.0 a.m., Two Talks. 9.30, Gramophone Concert. 10.10, Agricultural Talk from **Jönköping**, 1,490 kc/s, 201.3 metres. 11.0, Divine Service. 12.45 p.m., Weather. 3.0, Vocal and Instrumental Concert, relayed from **Sundsvall**. Reading in the Interval. 4.0, Programme for Children. 4.30, Gramophone Concert. 5.30, Reading. 6.0, Evensong from **Sundsvall**. 7.35, Talk. 8.0, Orchestral Concert. Soloist, Ragnar Hultén (Baritone): Suite for Small Orchestra (Arnold Mendelssohn); Aria con Variazioni and Bourrée from the Suite ancienne (Halvorsen); The Dryad—Ballad for Baritone and Orchestra (Hallén); The Wood is sleeping (Alfvén); Andante religioso for Celeste, Harp and Strings (Alfvén); Suite from Coppelia (Delibes); Baritone Songs; Suite from Sigurd Jorsalfar (Grieg). Reading in an interval. 10.0, Songs to the Lute by Pelle Nordström. 10.15, Military Band Concert, conducted by Bor Lundström, relayed from **Göteborg**. 11.0 (approx.), Close Down.

### STRASBOURG

869 kc/s, 345 metres; 11.5 kW. 9.30 a.m., Orchestral Concert, conducted by Maurice de Villers. 10.45, Protestant Service in German. 11.30, Catholic Service. 12 Noon, Gramophone Concert of Light Music. 12.45 p.m., News. 1.0, Time. 1.1, Classical Music on Gramophone Records. 2.0, Light Music on Gramophone Records. 3.0, Interval. 3.30, Orchestral Concert, conducted by Bronillat, relayed from the Casino, Vichy. Overture, William Tell (Rossini); Entr'acte from Messidor (Brunner); Suite from Les deux pigeons (Messager); Melody; Prelude and Chœur de lune from Werther (Massenet); Selection from Hamlet (Thomas); Waltz, Amoretteintänze (Gungl). 5.0, Gramophone Music. 5.15, Orchestral Concert, conducted by Koskam. 6.0, Medical Talk. 6.15, Sports Notes. 6.30, Orchestral Concert, conducted by Maurice de Villers. Overture, Mignon (Thomas); Selection from I Pagliacci (Leoncavallo); Promenade sous bois (Lacombé); Spanish Song, Alza Morena (Vincent); Orchestral Suite, On the Volga (Dyck); Entr'acte (Pessaro); Waltz, Tout Paris (Waldteufel). 7.30, Time and News. 7.45, Gramophone Music. 8.0, Press Review in German, Lottery Results and Announcements. 8.30, Le roi d'Ys—Opera (Lalo), relayed from the Casino, Vichy. After the Opera, Press Review. 11.0, Dance Music from the Savoy. 12 Midnight (approx.), Close Down.

### STUTTGART

**MUHLACKER**, 832 kc/s, 360.5 metres; 40 kW. Relayed by **Freiburg**, 527 kc/s, 570 metres.—10.0 a.m., Catholic Service. 10.50 to 11.30, Interval. 11.30, See **Leipzig**. 12 Noon, See **Frankfurt**. 1.0 p.m., Topical Talk. 1.15, I Pagliacci—Opera (Leoncavallo), on Gramophone Records. 2.30, Recital of Folk Songs to the Lute by Ruth Kessler. 3.0 (from **Karlsruhe**), Talk: The Skilled Trades. 3.30, See **Frankfurt**. 4.30, Accordion Music in the Black Forest, relayed from **Donauschingen**. A Massed Choir, Accordion Band and Soloists. 6.0, Chopin Pianoforte Recital by Günther Homann. Nocturne in A Op. 32 No. 1; Nocturne in G Op. 37 No. 2; Etude in A flat Op. 25 No. 1; Etude in C sharp minor Op. 49. 6.30, Readings from Alsatian Poets, with Gramophone Interludes. 7.10, Sports Notes. 7.30 (from **Karlsruhe**), Variety Programme. 8.30 to 10.20, See **Munich**. 10.20, Time and News. 10.45, Light Music and Dance Music by the Henry Kasson Band from Greiners' Restaurant. 12 Midnight, Close Down.

**SUNDSVALL**.—See **Stockholm**.

### TOULOUSE

**RADIOPHONIE DU MIDI**, 779 kc/s, 385 metres; 8 kW. Transmits at intervals from 11.0 a.m., Dance Music. 11.30, Light Music. 11.45, Opera Music. 12 Noon, Organ Recital. 12.15 p.m., Military Music and Melodies from Operetta. 12.30, Music by a Viennese Orchestra. 1.0, Amusement Guide and Market Prices. 1.5, Light Music. 1.15, Orchestral Concert. 1.45, Opera Music. 2.0, Trumpet Music. 2.15, Chansonnettes. 2.30, Accordion Music. 2.45, Agricultural Report. 3.0, Concert Version of Carmen—Opera (Bizet). 4.0, Orchestral Music. 4.15, Music from Sound Films. 4.30, Military Music. 4.45, Chansonnettes. 5.0, The dansant. 5.45, Opera Music: Overture, Der Freischütz (Welter); Ballet Music from Hérodiade (Massenet); Selection from Faust (Gounod). 6.0, News. 6.15, Operetta Music. 6.30, Music by a Viennese Orchestra. 6.45, Songs by a Basque Choir. 7.0, Two Steps. 7.15, News and Racing Results. 7.30, Operetta Music. 7.45, Light Music. 8.0, Opera Music: Entr'acte from Carmen (Bizet); Selection from Madame Butterfly (Puccini); Prelude to Cavalleria rusticana (Mascagni). 8.15, Music from Sound Films. 8.30, Military Music. 8.45, Opera Music. 9.0, Scheherzade—Symphonic Poem (Rimsky-Korsakov) by the Symphony Orchestra. 9.30, Accordion Music. 9.45, Arias from Opera. 10.0, Music

by an Argentine Orchestra. 10.15, News. 10.30, Concert for Listeners in Morocco. 11.0, Dance Music. 11.30, Light Music. 11.45, Orchestral Concert: Bourrée, Fantasia (Chabrier); Selection from The Golden Cockerel (Rimsky-Korsakov); Schubert Potpourri (Borté). 12 Midnight, News. 12.5 a.m. (Monday), Music by a Viennese Orchestra. 12.30, Close Down.

### TRIESTE

1,211 kc/s, 247.7 metres; 10 kW.—9.40 to 9.55 a.m., See **Turin**. 10.20, Agricultural Talk. 10.40, Religious Talk. 11.0 till Close Down, See **Turin**.

**TRONDHEIM**.—See **Oslo**.

### TURIN

1,096 kc/s, 273.7 metres; 7 kW. Relayed by **Milan**, 905 kc/s, 331.5 metres; **Genoa**, 959 kc/s, 312.8 metres; and **Florence**, 599 kc/s, 500.8 metres.—9.40 to 9.55 a.m., Giornale Radio. 10.20, See **Trieste**. 10.40, Agricultural Report. 11.0, Mass from the Church of the Annunciation, Florence. 12 Noon, Bible Reading. 12.15 p.m., Interval. 12.30, Orchestral Concert. In the interval at 1.0, Time and Announcements. 1.30, Sponsored Music. 1.45 to 2.0, Gramophone Music. 4.30, Orchestral Concert. In the interval, Sports Notes. 6.15, Weather Forecast and Gramophone Records. 6.30, Giornale Radio and Sports Notes. 6.45, Interval. 7.0, Time and Dopplavoro Announcements. 7.10, Gramophone Music. 8.0, Announcements, News, and Sports Notes. 8.30, Talk on the following transmission. 8.40, Le Jongleur de Notre Dame—Opera (Massenet). In the intervals, Talk and Theatre Notes. After the Opera, Giornale Radio.

### VIENNA

581 kc/s, 517 metres; 100 kW. Relayed by **Graz**, 852 kc/s, 352.1 metres; **Innsbruck**, 1,058 kc/s, 283 metres; **Klagenfurt**, 662 kc/s, 453.2 metres; **Linz**, 1,220 kc/s, 245.9 metres; and **Salzburg**, 1,373 kc/s, 218.5 metres.—11.0 a.m., Concert of Polish Music by the Wiener Symphoniker, conducted by Anton Coirath. Soloist: Francis d'Aranyi (Violin). 12.25 p.m., Gramophone Music. 2.0, Interval. 2.40, Time, Weather, Exchange and Weekly Review. 3.0, Agricultural Talk. 3.20, Book Review. 3.45, Brahms Concert by the Sedlak-Winkler Quartet. Pfersmann (Violin) and Schulhof (Pianoforte). Quartet in C Op. 111; Violin and Pianoforte Sonata in D minor Op. 108. 4.45, Talk: On the Lonely Desert Track. 5.15, Concert by the Wacek Wind Band. 6.50, Georg Rendl reads from his own Works. 7.15, Time, Sports Notes and Programme Announcements. 7.30, German Catholic Conference Programme. Missa Solennis—(Beethoven), by the Wiener Symphoniker and the Dreizehnlindner Choral Society, relayed from St. Stephen's Cathedral. 8.50, Report on the German Catholic Conference. 9.0, Concert by the Wiener Symphoniker, conducted by Schühner. Overture, In the Well (Blodek); Country Suite (Dragoi); Narcissus (Xevin); All Wiener Reigen (O. Strauss); Ballet Music from Die Fledermaus (Strauss); Wo die Zitronen blühen (Strauss); Selection from Rosen aus Florida (Fall-Korngold); Selection from the Ballet, Der Taugenichts von Wien (Salmhofer); Kleine Abendmusik (Grabner). In the interval at 9.50 (approx.), News, Weather and Exchange. 10.45, Dance Music on Gramophone Records.

### WARSAW

212.5 kc/s, 1,411 metres; 120 kW.—9.50 a.m., Programme Announcements. 10.0, Divine Service, relayed from **Wilno**. 5.33 kc/s, 563 metres. 11.57, Time Signal and Fantasia from the Tower of St. Mary's Church, **Cracow**. 12.15 p.m., Programme Announcements. 12.10, Weather. 12.15, Concert by the Station Symphony Orchestra, conducted by Oziminski. 2.0, Talk. 2.15, Agricultural Report and Weather Forecast. 2.20, Gramophone Music. 2.45, Agricultural Talk. 3.5, Gramophone Music. In the interval, News. 4.0, Programme for Young People. 4.30, Song Recital by Lozinska People. 5.0, Talk relayed from **Cracow**. 5.15, Programme from **Cracow**. 5.59 kc/s, 312.8 metres. The Battle of Vienna, Sept. 10th, 1683. 6.35, Programme Announcements. 6.40, Miscellaneous Announcements. 7.0, Talk on the Battle of Vienna (cont'd). 7.40, Wireless Talk. 8.0, Concert by the Station Orchestra, conducted by St. Nawrot. Soloist, Barthe Crawford (Songs); Polonaise from Eugene Onegin (Tchaikovsky); Ballet Music from The Merry Wives of Windsor (Moussinsko); Aria from The Pearl-Fishers (Bizet); Songs; (a) The Lark (Bishop), (b) Roses (Cesek), (c) Clavelitos (Valverde); Hindu Song from Suddo (Rimsky-Korsakov); Tone Picture, The Wedding (Powladowski). 8.50, Radio Journal. 9.0, Variety Programme from **Lwow**. 788 kc/s, 381 metres. 10.0, Dance Music. 10.25, Sports Notes. 10.40, Weather and Police Notes. 10.45, Dance Music (cont'd).

**ZURICH**.—See *Schweizerischer Landessender*.

**ATHLONE**

725 kc/s, 413 metres; 60 kW. Relayed by Cork, 1,337 kc/s, 224.4 metres.—1.30 to 2.30 p.m., Time Signal, Weather Report, Stock Exchange Quotations, and Gramophone Music. 6.0, Programme for Children. 6.45, News. 7.0, Gaelic Talk. 7.15, Talk by Miss O'B. Hitching: Glimpses of Finland. 7.30, Time Signal. 7.32, Pianoforte Recital by Mervyn Williams. 7.45, Tenor Solos by Peter Lynch. 8.0, The Station Orchestra. 8.20, Selections from Money—Sketch by Mary O'Hea and Company. 8.50, Contralto Solos by M. G. Rigg. 9.5, The Station Orchestra. 9.30 to 10.30, Programme by the I.B.C. (Ireland), Ltd. 9.30, Light Music. Shepherd's Boy (Grainger); Song of Songs (Lucas-Moya); Mandoline Solo: Minuet (Bocherini); Hawaiian Guitars: La Paloma (Yradier); Songs: Just two Hearts and a Waltz Refrain (Connelly-Stolz); Hungarian Dance, No. 1, in G Minor (Brahms); Pianoforte Solo: Keyboard Kapers (Stueltje); Dance of the Tea Dolls (Schmidt). 10.0, Concert arranged by the International Broadcasting Company (Ireland), Ltd., on behalf of Hospitals' Trust, Ltd. Signature Tune. Come back to Erin. Huslin' and Bustlin' (Woods); Moonlight on the River (Green); Moon Song (Johnston); The Village Band (Fryburg); My Wishing Song (Burke); You did everything for me (Hoffmann); The Girl in the Little Green Hat (Rich); The Song of the Slave (Green); Peter, Peter (Connelly); There's a Light in your Window (Coomber); Signature Tune. 10.29, I.B.C. Good-night Melody.

**BARCELONA**

EAJ1, 860 kc/s, 348.8 metres; 8 kW.—7.40 p.m., Concert by the Station Orchestra. 7.40, Song Recital by Pepeta Paudet. 8.0, Dance Music, relayed from the Casa Libre. 9.0, Concert by the Station Orchestra. 9.40, Song Recital by Concepcio Calloa. 10.0, An Opera, on Gramophone Records. 1.0 a.m. (Tuesday), Close Down.

**BARI**

1,112 kc/s, 269.8 metres; 20 kW.—8.0 p.m., Agricultural Notes, Tourist Talk, and Dopolavoro Notes. 8.20, Giornale Radio and News in Albanian. 8.30, Time, Announcements, and Weather. 8.35, Turandot—Opera in Three Acts (Puccini). In the intervals, Amusement Guide, After the Opera, News.

**BASEL**.—See Schweizerischer Landessender.

**BELGRADE**

697 kc/s, 430.4 metres; 2.8 kW.—6.55 p.m., Time and Announcements. 7.0, Song Recital. 7.30, Concert by the Station Orchestra. 8.40, A Radio Play. 9.25, Gramophone Music. 9.55, Time, News and Gramophone Music. 10.25, Cigany Music from the Zanatski Dom Restaurant.

**BERLIN**

**DEUTSCHLANDSENDER (REICHSENDER)**, 183.6 kc/s, 1,635 metres; 60 kW.—1.45 p.m., News. 2.0, Gramophone Concert. 3.0, Talk for Women. 3.30, Weather and Exchange. 3.45, Book Review. 4.0, Concert from Breslau. 5.0, Talk: German Legends. 5.20, Concert: Liebeslieder for Voice, Violin, Cello and Pianoforte (Welter); (a) Wir wanderten, von junger Liebe trunken, (b) Still vom Frühjahrsabendhimmel, (c) Gestern weint' ich, (d) Der Becher klingt; Suite in Old Style, Op. 81, for Two Pianofortes (Kamm). 6.0, A Poem. 6.5, Talk: Youth and Sport. 6.25, Talk: Roman, Slav and German Revolutions. 6.50, Weather and Announcements. 7.0, Transmission for all German Stations: Blut und Scholle (Race and Soil)—A Peasant Play (Schneider-Erdenkoben) with Music. 8.0, To-day's Motto. 8.5, Request Concert on Gramophone Records: Deutscher Föhn (Hautstaengen); Waltz from Der Rosenkavalier (R. Strauss); Overture, Fra Diavolo (Amber); Melody (Lortzing); Valentine's Aria from Faust (Gounod); Aus der Jugendzeit (Radecke); Air from The Consul from Nowhere (Künneke); Stosset an, der Rhein soll leben (Batzem-Ebelers); Folk Song: We die Alpenrosen blüh'n; Erinnerung (de Micheli); Sternschuppen (Kauder); Was Blumen träumen (Fraslatour); Lotus Flowers (Ohlsen). 9.0, Talk: Garden Cities. 10.0, News. 10.45, Weather. 11.0, Concert from Leipzig. 12 Midnight, Close Down.

**BERLIN**

**FUNKSTUNDE**, 715 kc/s, 419.5 metres; 1.5 kW.—4.30 p.m., Orchestral Concert, relayed from the Zoo. 5.30, What shall we read?—a Dialogue in a Public Library. 5.50, This Week's Short Story. 6.10, Wolf and Piltzer Recital by Hans Wrauna (Baritone); Songs (Wolf): (a) Wohl denk ich oft, (b) Altes und, was entsetzt, (c) Fühlt meine Seele; Songs (Piltzer): (a) Abblüte, (b) säersprach, (c) Eingelagte Ruder, (d) Lass scharen deiner Rosse huf, (e) Willkommen und Abschied. 6.40, The Funkstunde informs its listeners. . . 6.45, Topical Talk. 7.0, Transmission for all German Stations, relayed from Berlin (Deutschlandsender). 8.5, Mozart Concert: Concerto for Two Violins, (Hoer, Cello and Orchestra; Rondo in D for Harpsichord and Orchestra; Serenade in D, D.O., Concert of Operetta Music on Gramophone Records: Overture, Waldmeister (Joh. Strauss); Tenor Solo from Der Kellermeister (Zeller); Waltz, In lauslicher Nacht, from Die Landstreicher (Zichrer); Tenor Solo:

Komm in die Gondel, from Eine Nacht in Venedig (Joh. Strauss); Overture, Banditenstreiche (Suppe); Duet from The Gipsy Baron (Joh. Strauss); Entry March from The Gipsy Baron (Joh. Strauss); Selection from Gasparone (Müllgcker); Overture, Der Opernball (Heuberger); Selection from Die Fledermans (Joh. Strauss); Selection from The Bird Fancier (Zeller). 10.0, News. 10.15 (approx.), Dance Music, relayed from the Delphi-Palast. In the interval at 11.0 (approx.), Talk: What they are saying in Berlin. 12 Midnight, Close Down.

**BERNE**.—See Schweizerischer Landessender.

**BEROMUNSTER**.—See Schweizerischer Landessender.

**BODEN**.—See Stockholm.

**BODO**.—See Oslo.

**BORDEAUX-LAFAYETTE**

986 kc/s, 304 metres; 13 kW.—6.15 p.m., Radio Journal. 7.45, News and Racing Results. 7.50, Charades, News and Weather. 8.0, Concert of Gramophone Music. 8.45, Gala Concert of French Music, relayed from the Casino, Vichy (See Strasbourg).

**BRATISLAVA**

1,076 kc/s, 279 metres; 14 kW.—6.10 p.m., Trio Concert. 6.55, Talk for Housewives. 7.0, See Prague. 7.10, Concert of Sacred Music. 8.15, See Prague. 9.15, See Brno. 10.0, See Prague. 10.15 (approx.), Close Down.

**BREMEN**.—See Hamburg.

**BRESLAU**

923 kc/s, 325 metres 60 kW. Relayed by Gleiwitz, 1,184 kc/s, 253 metres.—1.0 p.m., Weather. 1.5, Gramophone Concert. 1.45, Time and News. 2.5, Recital of Beethoven Pianoforte Sonatas by Spitteler: Sonata in E Minor, Op. 90; Sonata in C Sharp Minor, Op. 27, No. 2. 2.30, Gramophone Concert of German Music: March, Zum Städtle hinaus (Meissner); Waltz, Loreley-Rheinlänge (Joh. Strauss); Song, Rudesheimer Wein (Hausen); O du herrliche Mosel (Waldmann); Gruss dich Gott, Westfalenland (Peters); Oberschlesien, Heimatland (Lokay); March, Lippe-Deimold, eine wunder-schöne Stadt (Siedle); Durchs Schlesierland marschieren wir. 2.45, Market Prices. 3.0, Concert by the Station Orchestra, conducted by Gerhard Ewald Rischka: Italian Caprice (Tchaikovsky); Ballet Music from Abenteuer einer Neujahrsnacht (Heuberger); Violin Solo: Melodies from Sylvia (Delibes); Waltz, The Wedding of the Winds (Hall); In Baunersbach (Elgar); Waltz (d'Ambrosio); Selection from Drei alte Schachteln (Kollo); March, Feurig Blut (Wiedermann); Overture, Tancred (Rossini); Selection from Hänsel and Gretel (Humperdinck); Little Suite No. 1 (Schumann-Rischka); Overture, Nakiris Hochzeit

(Linke). 5.0, Review of Books. 5.15, Talk. 5.30, Market Prices. 5.35 (approx.), Talk: German Culture. 5.50, Programme to be announced. 6.10, Recital of Modern Music for the Flute. 6.30, Talk: The Organisation of the Nazi Movement—German Christians. 6.50, Weather News and Market Prices. 7.0, Transmission for all German Stations, relayed from Berlin (Deutschlandsender). 8.0, Programme for Workers—From the Community to the Nazis. 8.50, News. 9.0, Talk: Intellectual Gifts. 9.20 (from Gleiwitz), Richard Wetzler Recital: The Orchestra conducted by the Composer, the Gleiwitz Teachers' Choral Society and Marta Mirns (Soprano); Kleist-Overture; Choir: (a) Au den Schlaf, (b) All Menschen herkommen aus der Erde, (c) Urlicht; Songs; Choir: Gesang des Lebens; Second Symphony in A. 10.20, Time and News. 10.40, Wireless Technical Talk. 10.50, Talk: The Youth Hostel Movement. 11.5 (approx.), Close Down.

**BRNO**

878 kc/s, 342 metres; 35 kW.—2.50 p.m., Concert by the Station Orchestra, conducted by Bakala. 3.50 to 4.0, See Prague. 5.45, Gramophone Music. 5.55, Talk for Boy Scouts: Minerals. 6.5, Gramophone Music. 6.25, German Transmission: News, Book Review, and Readings from his own Works by Kurtz. 7.0, See Prague. 7.35, See Moravská-Ostrava. 7.50, See Prague. 9.15, Concert by the Station Orchestra, conducted by Janofa. Soloist: Talman (Tenor). Songs from the Cycle Love and Death (Kricka); Jour d'été à la montagne (Vincent d'Indy); Song Cycle (Krenek); Bergsymphonie (Liszt). 10.0, See Prague. 10.30 (approx.), Close Down.

**BRUSSELS (No. 1)**

I.N.R., 590 kc/s, 509 metres; 15 kW.—12 Noon, Gramophone Concert of Variety Music. 1.0 p.m., Le Journal Parlé. 1.10, Concert by the Small Station Orchestra, conducted by Lecmans: Soloist, Wigy (Violin). 5.0, Classical Dances by the Symphony Orchestra, conducted by Meulemans: Contredanse and Gigue (Grétry); Gavotte and Bourrée (Bach); Polonaise (Glazunov); Minuet (Bocherini); Menuet gothique (Bochmann); Tarantella (Rossini); Waltz, Tales from the Vienna Woods (Joh. Strauss); Minuet (Debussy); Goliwog's Cake Walk (Debussy); Pavane from Mother Goose (Ravel); Passepied from Le tombeau de Couperin (Ravel). 6.0, Talk on Tapestry Work. 6.15, Gramophone Music: Roses of Picardy (Wood-Chapelier); Chanson bohémienne and Cazars (Cazes); Selection from The Love Parade (Schertzinger). 6.30, Music and Dances of Venezuela on Gramophone Records, with Commentary. 7.15, Talk: The Youth of Alessandro Farnese. 7.30, Theatre and Film Review. 8.0, Concert by the Radio Orchestra and Vocal Quartet:

Overture, The Gipsy Baron (Joh. Strauss); Suite, Four Ways (Coates); Songs by the Vocal Quartet, Hungarian Rhapsody No. 12 (Liszt); Havanaise for Violin (Saint-Saëns); Badinage (Jongen); Tenor Solos, (a) Avant d'être capitaine (Alongi), (b) Song (Oberfeld), (c) La chanson du Canard (Raifer); Selection from Viktoria and her Hussar (Abraham). In the interval at 8.30, Recitation (Catalle-Mendes) and at 9.30, Les mentons bleus: Sketch (Courteline). 10.0, Le Journal Parlé. 10.10, Dance Music by Robert de Kers and his Cabaret Kings and an Argentine Orchestra, relayed from the Kursaal, Ostend.

**BRUSSELS (No. 2)**

N.I.R., 887 kc/s, 338.2 metres; 15 kW.—Programme in Flemish.—12 Noon, Concert by the Small Station Orchestra, conducted by Lecmans. 1.0 p.m., Le Journal Parlé. 1.10, Gramophone Music. 5.0, Concert by the Radio Orchestra, conducted by André. Overture Jurlesque (Vandersmissen); Third Suite (de Michel); Algerian Suite (Saint-Saëns); Clarinet Solo, Impromptu (de Boeck); Maligna (Moszkovsky); Humorous Dance (Palmgren); Lioting (Staud); Two Descriptive Pieces (Albeniz). 5.45, Programme for Children. 6.30, Concert by the Small Station Orchestra, conducted by Lecmans. Overture, Tartuffe (La Gye); Spanish Dance Pieces (Laparra); Bird Song at Eventide (Coates); Cello Solo: Hungarian Rhapsody (Popper); Asturias from the Spanish Suite (Albeniz); Selection from Madame L'Archiduc (Offenbach). 7.15, Talk: A National Monument at Baxmade. 7.30, Le Journal Parlé. 8.0, Concert by the Station Symphony Orchestra, conducted by Meulemans. Symphony in C (Wagner); Overture, Oberon (Weber). 8.45, Agricultural Talk. 9.0, Concert (cont'd). Cortège (Roels); Chant d'automne—for Horn and Orchestra (Guillemy); Serenade (Waelput); Mouvement symphonique (Maes); Gramophone Music: (a) Aria from La Gioconda (Ponchielli), (b) Duet from Norma (Bellini); Waltz (Meulemans); Rhapsody, Piet Hein (van Anroy); Librado-March (Alpaetra). 10.0, Le Journal Parlé. 10.10, Gramophone Concert. Overture, Carnaval de Venise (Thomas); Parfum d'éventail (Ghika); Dances from Henry VIII (German); Marionettes (Glazunov); Popular Spanish Suite (Kochansky); Selection from Die Teresina (Oscar Straus); Dance (Popper); Selection from The Gold Diggers of Broadway (Burke); Overture, The Gipsy Baron (Joh. Strauss).

**BUCHAREST**

761 kc/s, 394 metres; 12 kW.—5.0 p.m., Concert by the Station Orchestra: March (Müller); Waltz (Jos. Strauss); Prelude to Lohengrin (Wagner); Strass; Potpourri; Selection from Where the Lark Sings (Lehar). 6.0, Radio Journal 6.15, Concert (cont'd); Selection from Andrea Chénier (Giordano); By the Blue Hawaiian Waters (Kettelboeg); Guitar (Lalo); Parade of the Elephants (de Basque). 7.0, Reading. 7.20, Song Recital on Gramophone Records. 7.40, Educational Quartet. 8.0, Chamber Music by the Theodor-seo Quartet. 8.30, Talk. 8.45, Recital on Two Pianofortes: Concerto in A minor (Bach); Suite, En blanc et noir (Debussy). 9.15, Orchestral Music, relayed from the Restaurant Princiar. 9.45, Radio Journal.

**BUDAPEST**

545 kc/s, 550.5 metres; 18.5 kW. Also relayed on 840 metres from 8.0 p.m. till Close Down.—5.30 p.m., Concert by the Budapest Concert Orchestra. 6.30, Talk for Workers. 7.0, Recital of Hungarian Folk Songs with Cigany Music accompaniment. 8.0, Poems. 8.30, Concert by the Budapest Concert Orchestra, conducted by Ferdinand Zsolt: Suite, Rana (Bizet); Violin Concerto (Butykat); Symphony in B (Haydn). 10.0, News. 10.15 (approx.), Gramophone Music. 11.20, Dance Music from the Rajnapark Café with Paul Fekete in his Repertoire.

**CASSEL**.—See Frankfurt.

**COPENHAGEN**

1,067 kc/s, 281 metres; 0.75 kW. Relayed by Kalundborg, 260 kc/s, 1,153.8 metres.—11.30 a.m., Report of the Opening Ceremony of the Aarhus University. 1.0 to 2.0 p.m., Concert from the Hotel d'Angleterre. 2.50, Talk for the Housewife. 3.0, Concert by the Radio Orchestra, conducted by Lanny Grøndahl. 5.0, Gramophone Records: Aria from L'Elisir d'Amore (Donizetti); Song, Im Rolandsbogen (Mania-Ritzel); Song from The Song I gave you (Kaper and Jürmann); Spanish Dance No. 2 (Sarasate); In the Church (Tchaikovsky); I can't remember (Berlin); Melody (Mireille); Sweet 'til; Ain't she sweet? 5.30, Exchange and Market Prices. 5.45, Agricultural Talk. 6.15, English Lesson. 6.45, Weather. 6.54, Report of the Workers' Radio Society. 7.0, News. 7.15, Time Signal. 7.30, Talk: Lord Kitchener. 8.0, Town Hall Chimes. 8.2, Talk for Women. 8.15, Concert of Opera Music by the Radio Orchestra, conducted by Fritz Mahler; Soloist, Inge Thorsen (Songs); Overture, Alceste (Gluck); Dream Music from Alcina (Handel); Aria from The Magic Flute (Mozart); Suite from Idomeo (Mozart-Busoni); Recitative and Aria from Figaro (Mozart); Overture, The Water Carrier (Tcherubini); Aria from Fidelio (Beethoven);

**MONDAY**

**SEPTEMBER THE ELEVENTH**

**PRINCIPAL EVENTS OF THE DAY:**

**AT HOME**

**NATIONAL** "Hurdy Gurdy," a selection of songs from stage, screen and drawing-room.

**LONDON REGIONAL** "The Fantastic Battle," a play, by Leslie Baily.

**MIDLAND REGIONAL** Military Band programme.

**NORTH REGIONAL** Variety programme.

**WEST REGIONAL** Guards Band concert from the Colston Hall, Bristol.

**BELFAST** "Irish Memories," band programme.

**ABROAD**

**BARI** 8.35 p.m., Opera: "Turandot," by Puccini.

**BRUSSELS** 8.0 p.m. The Station Symphony Orchestra, conducted by Meulemans.

**COPENHAGEN** 8.15 p.m., Concert of opera music by the Radio Orchestra.

**HAMBURG** 8.0 p.m., Wagner concert by the Philharmonie Orchestra, conducted by Eibenschütz.

**HILVERSUM** 9.10 p.m., The Haydn Quartet.

**HUIZEN** 7.45 p.m., Opera: "Der Schauspieldirektor," by Mozart.

**LANGENBERG** 5.30 p.m., Chamber music.

**ROME** 8.30 p.m., Opera: "La leggenda di Sakuntala," by Alfano.

**STRASBOURG** 8.45 p.m., Gala concert of French music from the Casino, Vichy.

**WARSAW** 9.20 p.m., Opera: "The Countess," by Moniuszko.

SEPT. 11th

MONDAY

continued

Leonora Overture No. 1 (Beethoven). 9.25, Radio Report—A Visit to the Coek Factory. 9.55, Introduction and Variations on an Original Theme, Op. 109 (Schubert). 10.15, News. 10.30, Concert by a Mandoline Quartet: Grossmütterchen (Langer); Waltz (Sinding); Oberländer (Gungl); Cradle Song (Satoria); Spanish Dance (Morena) 11.0 (approx.), Close Down.

CORK.—See Athlone.

DANZIG.—See Heilsberg.

DRESDEN.—See Leipzig.

## FECAMP

1,328 kc/s, 225.9 metres; 10 kW.—11.0 a.m. to 12 Noon, Programme in English by the I.B.C. 11.0, Happy Hour. Part I. Military Band Music: Phileo Signature Tune; March, Band Way (Holzmann); Song, The Gay Highway (Drummond); Here, there and everywhere (Bose); Selection from San Toy (Monckton); Jungle Drums (Kettelbey); Song, The Meynel Hunt; Gaiety Echoes (On the Quarter Deck (Alford)). Part II.—Dance Music: Maybe I love you too much; Walter on Parade; Everybody's going but me; Peter Peter; There's a light in your window; Get away old Man; My Donna Rita; Hand me my Walking Cane; Spanish Moon; Drink up; Signature Tune. 12 Noon, Programme in French. 4.30 to 5.0, Programme in English by the I.B.C. 4.50, The Nursery Corner. Music, Story and Birthday Greetings. 5.0, Orchestral Concert for Children and Bognor Listeners: Signature Tune. Night by the Sea; Nautical Anecdotes (arr. Winter); Under Heaven's Blue (Payan); Cello Solo: Harlequinade (Squire); The Song of the Nightingale (Albott); By the Sleepy Lagoon (Coates); Waltz, Wiener Blut (Joh. Strauss); Violin Solo: Because (H. Hardelet); Barcarolle (Waldteufel). 5.30, Concert for Hastings and Eastbourne Listeners. I.B.C. Members' Request Half Hour: The Wedding of the Rose (Jossel); His old Cornet (Robison); Speak to me of Love (Lenoir); Minuet No. 1 (Paderewski); A Troika and a Lady (Andrej); Song of the Islands (King); There hasn't no lies on we (Drake); African Lament (Gilbert); Signature Tune. 6.0, Programme in French. 10.0 till Close Down, Programme in English by the I.B.C. 10.0, Dance Music: Signature Tune, Bells of Normandy; My Coquette; Maybe it's the Moon; The Toy Town Admiral; Whom do you love; Heaven for two; Deep in my Lady's Eyes; Too many Tears; Eccentric; Jericho; My Baby; Sleepy Valley; Steamboat Bill; All of me; In my Bell Bottom Trousers; Masquerade; Signature Tune. 11.0, Talkie Time. Signature Tune. Sittin' in the Dark; Selection from The Love Parade (Scherzinger); In the Park in Parce (Woods); Love Song of the Nile (Brown); O Maiden, my Maiden from Frederica (Lehar); Great Day (Yonmans); Twentieth Century Blues (Coward); March of the Musketeers (Friml); The Woman in the Shoe, from What Price Melody; Signature Tune. 11.30, Club Concert for Hertford Listeners. Part I: Tchaikovsky and Grieg Programme. Signature Tune. The Chum Song; Anita's Dance and The Hall of the Mountain King, from Peer Gynt (Grieg); Two Songs without Words (Tchaikovsky); Hungarian Dance from Swan Lake (Tchaikovsky); Solveig's Song from Peer Gynt (Grieg); Ich liebe dich (Grieg); Waltz from The Sleeping Beauty (Tchaikovsky). 12.5 a.m. (Tuesday), News Bulletin in English. 12.10 a.m. (approx.), Club Concert. Part II: I can't believe it's true; Dixiana Moon; Mr. and Mrs. Sippi; Business in E. 12.30, Dance Music (Electrical Transcriptions): You're mine, you; Here is my heart; Peter, Peter; Sophisticated Lady; In the Valley of the Moon; When the Morning rolls around again; Let bygones be bygones; When my little Pomeranian. 1.0, Dance Music: Bells of Normandy; Under my Umbrella; in a Second-hand Store; I cover the Waterfront; Little Miss Muffet; Waltzing in a Dream; Castles in the Sand; Pop Gun; Stay out of my Dreams; Shuffle off to Buffalo; Look what I've got; You're beautiful to-night, my Dear; Hoko, you can't ride this Train; Drifting under a Summer Moon; Dancing Butterfly; There's a Cabin in the Pines; Signature Tune. 2.57, I.B.C. Good-night Melody. 3.0 (approx.) Close Down.

FLENSBURG.—See Hamburg.

FLORENCE.—See Turin.

## FRANKFURT

1,157 kc/s, 259.3 metres; 17 kW. Relayed by Cassel, 1,220 kc/s, 245.9 metres; and Trier, 1,157 kc/s, 259.3 metres.—4.30 p.m., Concert. 5.45, Economic Notes. 6.0, Talk: Ulrich von Hutten, a German Rebel. 6.25, Variety Item. 6.45, Review of the Day's News. 6.50, Time, Programme Announcements, Weather and Economic Notes. 7.0, Transmission for all German Stations, relayed from Berlin (Deutschlandsender). 8.0, Songs of the Rhine and the Moselle. 8.30, Pianola Music, with Commentary by Hans Rosbaud. Humoresque in G Minor, Op. 20, No. 5 (Reger); Norwegian Wedding March, Op. 19, No. 2 (Grieg); Ballad No. 1 in G Minor (Chopin); Etude, No. 3 (Liszt). 9.0, The Supreme Army Command—Radio Sequence (Paul Laveu). 9.40, Talk: Max Reger. 10.20,

Time and News. 10.45, Concert from Leipzig. 12 Midnight, Close Down.

FREDRIKSSTAD.—See Oslo.

FREIBURG.—See Stuttgart.

GENEVA.—See Radio-Suisse Romande.

GENOA.—See Turin.

GLEIWITZ.—See Breslau.

GÖTEBORG.—See Stockholm.

GRAZ.—See Vienna.

HAMAR.—See Oslo.

## HAMBURG

806 kc/s, 372 metres; 1.5 kW. Relayed by Bremen, 1,112 kc/s, 269.8 metres; Flensburg, 1,319 kc/s, 227.4 metres; Hanover, 530 kc/s, 566 metres; and Kiel, 1,292 kc/s, 232.2 metres.—6.0 p.m. (from Flensburg), Organ Recital from St. Mary's Church; Organ Concerto in D minor (Bach); Prelude and Fugue in G minor (David). 6.25, Hamburg, Bremen, and Lübeck—Report of the Day's Events in the Senates and Houses of Burgesses of the Hanseatic Free Cities. 6.45, Frankfurt Market Prices. 6.50, Weather. 7.0, Transmission for all German Stations, relayed from Berlin (Deutschlandsender). 8.0, Wagner Concert by the Hamburg Philharmonic Orchestra, conducted by Eibenschütz; Soloist, Eva Schlee (Soprano); Prelude to The Mastersingers: Three Songs with Orchestra: (a) Engel, (b) Stehe still, (c) Im Treibhaus; March from The Twilight of the Gods; Siegfried's Rhine Journey from The Twilight of the Gods; Overture, Rienzi; Prelude and Love Song from Tristan and Isolde; Ride of the Valkyries from The Valkyrie; Elisabeth's Aria from Tannhäuser; Overture, Tannhäuser; Kaisermarsch. In the interval at 9.0 (approx.), News. 10.0, Time, Weather, and News. 10.10, Topical Talk. 10.20 (from Kiel), Concert by the Small Orchestra of Unemployed Musicians, conducted by Döring; March and Intermezzo from Carmen (Bizet); Selection from Alessandro Stradella (Plotow); Two Songs (R. Strauss): (a) Ich trage meine Minne, (b) Heimliche Aufforderung; Overture, Bruchino (Rossini); Old Dances (Wood); Potpourri, Wiener Spaziergänge (Komzak); Oriental Dream Fantasy (Holmes); Selection from Wie einst im Mai (Kollo); Waltz, Summer Evening on the Rhine (Zimmer); March, Heil Hitler (Ewers).

HANOVER.—See Hamburg.

## HEILSBURG

1,085 kc/s, 276.5 metres; 60 kW. Relayed by Danzig, 662 kc/s, 453.2 metres.—1.5 p.m., Concert by the Small Station Orchestra, conducted by Eugen Wilken; Overture in G (Azzoni); Selection from Eine Nacht in Venedig (Joh. Strauss); Styrian Humoresque (Spary); A-B-C (Komsak); Tales from Austria (Mader); Overture, La part du diable (Auber). In the interval at 1.20 and at 2.0, News. 2.30 (from Danzig), Exchange and Market Prices. 3.0, Agricultural Prices and Exchange. 3.30, Sports and Folk Dance Programme. 4.0, Concert by the Small Station Orchestra, conducted by Eugen Wilken; Overture, A Life for the Czar (Glinka); Melody (Carena); Lyric Suite (d'Albert Bece); Selection from Die Puppenfee (Bayer); Neapolitan Serenade (Sgambati); La Jota Aragonesa (Albeniz); A Festival in Aranjuez (Demesssemann); Immortellen-Walzer (Gungl); Selection from The Hermit's Bell (Maillart). In an interval, Talk: How to become rich and happy. 5.30, Book Review. 5.45, Soprano Song Recital by Mia Neussitzer-Thönißen. 6.15, Agricultural Prices. 6.25 (from Danzig), Programme relayed from the Municipal Gymnasium. 6.50, Weather. 7.0, Transmission for all German Stations, relayed from Berlin (Deutschlandsender). 8.0, Political Announcements and News. 8.15 (from Danzig), Buiter Abend. 9.45, Elementary English Lesson. 10.15, Weather and News.

## HILVERSUM

Announced HUIZEN, 1,013 kc/s, 296.1 metres; 20 kW. (7 kW. up to 5.40 p.m.). Programme of the Christian Radio Society (N.C.R.V.).—11.40 a.m., Police Notes. 11.55, Gramophone Music. 12.10 p.m., Organ Recital by Jan Zwart; Paraphrase on National Songs (Zwart); Prelude and Fugue in G (Mendelssohn); March of the Priests, from Athalia (Mendelssohn); Fantasia and Fugue (Liszt); Lamentation (Guilmant); Theme and Variations (Guilmant); Paraphrase on Revivalist Songs (arr. Zwart). 1.40, Broadcast for Schools. 2.15, Gramophone Music. 2.25, Talk on Cookery. 2.55, Interval. 3.10, Report of the 19th Maramatha Conference at Zeist. 4.40, Gramophone Music. 4.55, Organ Recital by Klock. 6.10, Answers to Correspondents. 6.40, Police Report. 6.50, Ecclesiastical Notes. 7.0, Answers to Correspondents. 7.25, Report on the Maramatha Conference at Zeist. 8.40, Gramophone Music. 9.10, Concert by the Haydn Quartet; String Quartet in G, Op. 18, No. 2 (Beethoven); String Quartet in F, Op. 96 (Dvorak). In an interval at 9.40, News. 10.10, Gramophone Music. 11.10 (approx.), Close Down.

HORBY.—See Stockholm.

## HUIZEN

Announced HILVERSUM, 160 kc/s, 875 metres; 7 kW. (up to 3.40 p.m.). Transmitted from Kootwijk on 50 kW. from 3.40 p.m. Programme of the Algemeene Vereeniging Radio Omroep (A.V.R.O.).—11.40 a.m., Concert by the Rentmeester Ensemble; Gramophone Records in the intervals. 1.55 p.m., Gramophone Music. 2.10, Violin Recital by Alexander Feinland; Melody (Corelli); Serenade (Tchaikovsky); Serenata andaluzia (Sarasate); Du alter Stefansturm (Brandl-Kreiser). 2.40, Gramophone Music. 3.25 to 3.40, Interval. 3.40, Song Recital by G. Veenbaas. 4.10, Talk on Saunt-Saens, with Gramophone Illustrations. 5.10, Concert by Kovacs Lajos and his Orchestra; Soloist, Hilde Jäger (Songs). 6.40, Talk. 7.10, Gramophone Music. 7.25, Talk. 7.40, Time, Weather and News. 7.45, Der Schauspielerektor—Opera in One Act (Mozart). 9.25, Violin Concerto on Gramophone Records. 9.55, Concert by the Wireless Orchestra, conducted by Nico Treep; March, Fest und treu (Fucik); Waltz, Tesoro mio (Benetti); Serenade (Heykens); Fairy Tale (Heykens); Selection from The Merry Peasant (Fall); Melody (Frederiksen); Melody (Perey); Curro enchaes (Metallo). 10.49, News. 10.50, Gramophone Music. 11.40 (approx.), Close Down.

INNSBRUCK.—See Vienna.

## JUAN LES PINS

1,205 kc/s, 249 metres; 0.8 kW.—12.30 p.m., Amusement Guide and Variety Items. 1.0, News. 1.15, Radio Concert. 8.0, Amusement Guide, Exchange, and News. 8.10, Sports Notes. 8.20, Press Review. 8.30, Radio Concert. 8.45, News and Weather. 9.0, Literary Programme.

KALUNDBORG.—See Copenhagen.

## KATOWICE

734 kc/s, 408 metres; 16 kW.—7.20 p.m., Announcements and Gramophone Music. 7.55, Gramophone Music. 8.15, See Prague. 9.20 till Close Down, See Warsaw.

KIEL.—See Hamburg.

KLAGENFURT.—See Vienna.

KOSICE.—See Prague.

## LANGENBERG

635 kc/s, 473 metres; 60 kW.—12.15 p.m., Concert by the Münster Municipal Orchestra, conducted by Jochum; Prelude to Hansel and Gretel (Humperdinck); Scottish Dances (Beethoven); Petite Suite (de Michel); Selection from Carmen (Bizet); Minuet and Scherzo (Schubert); Selection from La Gioconda (Ponchielli); Liebeslieder-Walzer (Brahms). 1.15, News. 1.30, Orchestral Concert, conducted by Kühn; Overture, The Queen's Kerchief (Strauss); Hungarian Dances (Brahms); Selection from Tosca (Puccini); Three Pieces from Prometheus (Beethoven); Selection from Othello (Verdi); March in C (Mozart). In the interval at 2.0, News. 2.30, Meat Market Prices. 3.30, Exchange and Time Signal. 3.50, Programme for Young People. 4.30, Talk: New Aspects of the Tariff System. 4.45, Pianoforte Solo: Moment musical (Schubert). 4.50, Two Poems. 5.0, Gramophone Records of Instrumental Music. 5.30, Chamber Music. Pianoforte Duets: (Schumann): (a) Geburtstagsmarsch, (b) Bräutchen, (c) Garten-Melodie, (d) Beim Kränzchen, (e) March; Adagio and Polonaise, Op. 91 (Fürstenau); Recital on two Pianofortes: (a) Heroic March (Schubert), (b) Fledermaus Waltz (Strauss-Reicher). 6.15, Ruhrort versus Mühlheim—A Warfare between Towns in the Olden Times. 6.25, Dialogue for Parents: Orphans and Orphanages. 6.45, News and Weather. 7.0, Transmission for all German Stations, relayed from Berlin (Deutschlandsender). 8.0, News. 8.5 to 12 Midnight, Variety Programme. In the interval at 10.0, News. 12 Midnight, Close Down.

LAUSANNE.—See Radio-Suisse Romande.

## LEIPZIG

769.9 kc/s, 389.6 metres; 120 kW. Relayed by Dresden, 941 kc/s, 319 metres.—12 Noon, Concert from Munich. 1.15 p.m., News. 1.30, Gramophone Concert. 2.30, News. 2.45, Art and Film Review. 3.0, Talk: Woman's Position under the New Régime. 3.25, Labour Market Report. 3.35, Market Prices. 4.0, Brahms Song Recital by Maria Berthold-Röschel, with Pianoforte Interludes by Friedhart Sammler; Songs: (a) Am Sonntagmorgen, (b) Feldeinsamkeit, (c) Sapphische Ode, (d) Ständchen; Pianoforte Solo: Intermezzo, Op. 10, No. 4; Songs: (a) Die Maimacht, (b) Auf dem See, (c) Vor dem Fenster; Pianoforte Solo: Intermezzo, Op. 10, No. 3; Songs: (a) Mädchenlied, (b) Meine Lieder, (c) Der Kranz, (d) Nachklang. 4.30, Reading. 5.0, Concert by the Dresden Soloist Ensemble; March, Heil Hitler! (Kerzig); Overture, Nordische Seemannfahrt (Gade); Selection from Lucia di Lammermoor (Donizetti); Natursänger-Walzer (Zielhrer); Intermezzo, Kirschblüte (Altert); Potpourri,

Heimatklänge (Krome); March, Hoch Heideckburg (Anzer). 5.50, Talk. 6.10, Accedotes. 6.30, Recitations. 6.50, To-day's News. 7.0, Transmission for all German Stations, relayed from Berlin (Deutschlandsender). 8.0, See Stuttgart. 9.15, Sunday's News. 9.25, Schweineschlachten (The Pig-killing)—Comedy (August Heinrichs). 10.30, News. 10.45 (approx.), from Dresden), Concert by the Dresden Philharmonic Orchestra, conducted by Ernst Schlicketanz; Overture, The Italian Girl in Algiers (Rossini); Oriental Dance Scene, Baalat (Rüdiger); Selection from Gasparone (Millbeker); Ballet Suite from Namouna (Lalo); Waltz, Lustige Brüder (Vollstedt); Spring Song (Sibelius); Waltz, Die Tanzgräfin (Stolz); Fantasia, Graziella (Mattausch). 12 Midnight (approx.), Close Down.

LINZ.—See Vienna.

## LUXEMBOURG

352 kc/s, 1,191 metres; 200 kW.—Czech Programme. 7.30, Overture, Anacron (Cherubini), on Gramophone Records. 7.50, Talk in Czech: The Dungeons of Luxembourg. 8.0, Orchestral Concert. 8.50, News in French. 9.0, Recital of German Songs, by Elisabeth Corty. 9.25, Quartet Music. 9.45, News in German. 9.55, Concert by the Station Orchestra, conducted by Henri Pénissis; Overture, La dame blanche (Boieldieu); Prelude (Rachmaninov); Wedding Scenes (Smetana); March, Stars and Stripes (Sousa). 10.30, Dance Music on Gramophone Records.

## LWOW

788 kc/s, 381 metres; 16 kW.—7.20 p.m., Announcements and Gramophone Music. 7.35, Programme Announcements. 7.40, See Warsaw. 8.0, Reading in Esperanto. 8.15, See Prague. 9.20, See Warsaw.

## LYONS

LA DOUA, 644 kc/s, 465.8 metres; 1.5 kW.—6.30 p.m., Radio Journal. 7.30, Radio Gazette for Lyons and the South-East. 8.45, Gala Concert of French Music, conducted by Paul Paray, relayed from the Casino, Vichy (See Strasbourg). After the Concert, News.

## MADRID

EAJ7, 707 kc/s, 424.3 metres; 2 kW.—8.0 p.m., Chimes, Exchange, Topical Review and Request Gramophone Records. 9.15, News. 9.30 (approx.), Close Down.

MALMO.—See Stockholm.

## MILAN

VIGENTINO, 662 kc/s, 453.2 metres; 4 kW.—8.30 p.m. (approx.), till Close Down, See Rome.

## MORAVSKA-OSTRAVA

1,137 kc/s, 263.8 metres; 11 kW.—6.30 p.m., German Transmission: Theatre Notes. 7.0, See Prague. 7.35, Reading. 7.50, See Prague. 9.15, See Brno. 10.0, See Prague. 10.15 (approx.), Close Down.

MOTALA.—See Stockholm.

MUHLACKER.—See Stuttgart.

## MUNICH

563 kc/s, 533 metres; 60 kW. Relayed by Augsburg and Kaiserslautern, 536 kc/s, 560 metres; and Nürnberg, 1,256 kc/s, 239 metres.—2.50 p.m., Concert by Maria Wolf and Kettie Nye (Soprano), Paul Niemeyer and Schütz (Flute) and Werner Dommes (Harpischord); Cantata for Soprano and Two Flutes, Phyllis and Thyriss (P. E. Bach); Three Soprano Songs: (a) Lovely Phyllis, (b) Der Bauer (P. E. Bach), (c) Selma (P. E. Bach), Harpsichord Solo: Three Little Fugues (Telmann). Three Soprano Songs: (a) Willst du dein Herz mir schenken (Bach), (b) Die Schlummernde (P. E. Bach), (c) Lyda (P. E. Bach); Aria with obligato Flute (Haendel); Kungtigger Zeiter, eiter Kummer. 3.15, Programme for Children. 3.35 (from Nürnberg), Reading (Volher). 3.55, Weather and Agricultural Notes. 4.5, Talk: Inculcating the Civic Virtues. 4.50, Concert by the Rückert Chamber Orchestra; Overture, Nelmachadnezar (Verdi); Selection from Tannhäuser (Wagner); Waltz, Acceleration (Strauss); Suite from Der Rosenkavalier (R. Strauss); Potpourri, Für meine Freunde (Komzak); Triumph March (Fueick). 5.45, Programme for Young People: Talk by a Young Peasant. 6.5, Concert of German Folk Songs by Robert and Lies Kottie, and Paul Niemeyer (Flute). 6.25, Book Review. 6.45, Time, Weather and News. 7.0, Transmission for all German Stations, relayed from Berlin (Deutschlandsender). 8.5, Tosca—Opera in Three Acts (Puccini), relayed from the National Theatre. 10.20, News. 11.0, Serenade from Leipzig. 12 Midnight, Close Down.

NAPLES.—See Rome.

NOTODDEN.—See Oslo.

## OSLO

277 kc/s, 1,083 metres; 60 kW. Relayed by Fredriksstad, 815 kc/s, 368.1 metres; Hamar, 522 kc/s, 574.7 metres; Notodden, 671 kc/s, 447.1 metres; Porsgrund, 662 kc/s, 453.2



SEPT. 11th

MONDAY

continued

metres; and Rjukan, 671 kc/s, 447.1 metres. 5.30 p.m., Chamber Music by the Radio Ensemble. 6.30, Reading, relayed from Bergen, 824 kc/s, 364 metres. 7.0, Advertising Notes. Weather and News. 7.30, Talk. 8.0, Time Signal. 8.1, Pianoforte and Song Recital, by Ingebjörg Grevig and Arne Haugen. 9.10, Political Review. 9.40, Weather and News. 10.0, Topical Talk. 10.15, Popular French Music on Gramophone Records: Overture, Benvenuto Cellini (Berlioz); Le carnaval des animaux (Saint-Saëns); Ballet Music from the Cid (Massenet); Hungarian March (Berlioz). 11.15 (approx.), Close Down.

OSTERSUND.—See Stockholm.

PALERMO

558 kc/s, 537.6 metres; 3 kW. 8.0 p.m., Dopulavoro Notes, Tourist Talk, Agricultural Notes, Report of the Royal Geographical Society, and Giornale Radio. 8.20, Gramophone Music. In an interval at 8.30, Time and Announcements. 8.45, Concert of Chamber Music: Arena (Pianoforte); Adelfio (Soprano); Micozzi (Clarinet). Two Pianoforte Pieces (Chopin): (a) Andante spianato, (b) Nocturne in C Sharp Minor; Two Songs: (a) Song (Mascagni), (b) Pallide mammole (Trimarchi); Clarinet Solos: Prelude and Rondo (Boumard); Songs: (a) Se (Denza), (b) Le fronde che vedesti rinverdire (Savasta); Clarinet Solos: (a) Rio gaio (Giacchino), (b) The Gazelle (Willenhaupt); Pianoforte Solos: (a) Spanish Dance (Granados), (b) Bolero (Ravel). After the Concert, Light Music on Gramophone Records. 10.55, News.

PARIS

IFFEL TOWER, Call FLE, 207.5 kc/s, 1,445.7 metres; 13 kW. Time Signals (on 2,650 metres) at 10.26 a.m. and 11.26 p.m. (Preliminary and 6-dot signals). 6.45 p.m., Theatre Notes. 7.0, Le Journal Paris. 8.45, See Strasbourg. 11.15 (approx.), Close Down.

PARIS

POSTE PARISIEN, 914 kc/s, 328.2 metres; 60 kW.—7.0 p.m., Gramophone Music. 7.15, Le Journal Paris. 7.30, Hot Jazz on Gramophone Records. 8.0, Concert. Rondo capriccioso, Op. 129 (Beethoven); Songs (Cuvilliers): (a) Chanson (Muide), (b) Au pays d'Amourville, (c) L'Eglise du village; Flute Solos. Songs: (a) Sérénade à Ninon (Delibes), (b) Legend from Xavieres (Dubois), (c) Chanson à la linc (Delacroix), (d) Les Demoiselles d'Avignon (Debussy); Pianoforte Solo: Sillages (Aubert). 9.10, Sponsored Concert. 10.10, News.

PARIS

RADIO PARIS, Call CFR, 174 kc/s, 1,725 metres; 75 kW.—7.30 a.m., Weather and Physical Culture. 7.45, Gramophone Records. Selection from Funny Face (Gershwins); Loin du bal (Gillet); Waltz, Wiener Blut (Joh. Strauss); Correntino (Pizzarro). 8.0, News. 12 Noon, Goutod Concert on Gramophone Records. In the intervals at 1.0, Exchange and News, and 1.30, Exchange. 2.0, Exchange. 3.45, Financial Notes and News. 7.0, Agricultural Report. 7.10, Gramophone Concert. Minuet (Mozart); Le roi a fait battre tambour (de Séverac); Violin Solo, Berceuse (Faure); Les cigales (Chabrier); Cello Solo, The Angel's Serenade (Brazos); Song (Ray); Nocturne and Baginnes from Les Ailes (Ganne); Song (Jekill); Idylle passionnelle (Bazigade); Torna a Surriento (de Curtis); La pumpe d'Arlequin (Darcy); Piece. 7.50, Commercial Prices and News. 8.0, Song Recital on Gramophone Records: Le mariage des roses (Franck); Rencontre (Faure); L'invitation au voyage (Duparc); Aquariles (Debussy); Green (Debussy); Otrande (Hahn); Moi (Hahn); Indiférence (Hahn). 8.30, The Radio-Paris competition, followed by Press Review and Review by Reboux. 8.45, Concert from the Casino, Vichy. (For details, See Strasbourg). In the interval at 10.0, News.

PITTSBURGH

KDKA, 980 kc/s, 306 metres; 50 kW.—Relayed by W8XK on 48.86 metres, and 25.27 metres.—7.30 p.m., Pontiac Home Forum. 8.0, Betty and Bob, from New York. 8.15, Words and Music, from New York. 8.45, Human Values. 9.0, Radio Guild, from New York. 10.0, Uncle Tom and Betty. 10.15, Tarzan of the Apes. 10.30, Singing Lady, from New York. 10.45, Orphan Annie, from New York. 11.0, Press News-Reeler. 11.15, Sports. A Song. 11.30, Pittsburgh Spotlights. 11.45 to 3.0 a.m. (Tuesday), New York Relay. 11.45, Lowell Thomas. 12 Midnight, Amos 'n' Andy. 12.15, Baby Rose Maria. 12.30, Popular Programme. 1.0, Yesterday and To-day. 1.30, Potash and Perlmutter. 1.45, Gould and Shefter. 2.0, Sinclair Minutemen. 2.30, Melody Moments. 3.0, Silver Toppers.

PORSGRUND.—See Oslo.

PRAGUE

514 kc/s, 488.6 metres; 120 kW.—2.50 p.m., See Brno. 3.50, Aviation Weather Report. 3.55, Exchange. 4.0, Interval. 5.45, Gramophone Music. 5.55, Hints for Housewives. 5.5, Agricultural Report. 6.10, Gramophone Music. 6.45, Talk: The Stenographers' Union. 6.25, News in German. 6.30, German Transmission: Talk for Students and Medical Talk. 7.0, Chimes and News. 7.10, Schram-

mel Music. 7.35, See Moravská-Ostrava. 7.50, Pianoforte Sonata in B Minor, Op. 35 (Chopin), by Frantisek Langer. 8.15, Programme in Honour of the Polish Aviators, relayed from the Town Hall. 9.15, See Brno. 10.0, Time and News. 10.15, Review in German: Art and Music in Prague. 10.30 (approx.), Close Down.

RADIO-SUISSE ROMANDE

SOTTENS, 743 kc/s, 403 metres; 25 kW.; and Geneva, 395 kc/s, 760 metres.—6.15-6.30 a.m., Gymnastics Lesson. 12.28 p.m., Time Signal from Nuchâtel Observatory. 12.30, News and Weather. 12.40 (from Lausanne), Gramophone Concert. 1.0 (from Lausanne), Financial News. 1.10 (from Lausanne), Gramophone Concert. 2.0-3.28, Interval. 3.28, Time Signal from Nuchâtel Observatory. 3.30 (from Lausanne), Concert by the Radio Lausanne Orchestra. 5.0 (from Lausanne), Programme for Children. 5.30-7.0, Interval. 7.0 (from Lausanne), Programme for Old People. 7.40 (from Lausanne), News. 7.45 (from Lausanne), Talk: Switzerland in Autumn. 8.0 (from Geneva), Musical Programme. 8.30 (from Geneva), Dramatic Programme. 9.0 (from Lausanne), Soloist Concert. 9.50, News and Weather. 10.0 (from Lausanne), Spanish Song Recital by Julio Christen. 10.30 (approx.), Close Down.

RJUKAN.—See Oslo.

ROME

Call 1R0, 680 kc/s, 441 metres; 50 kW. Relayed by Naples, 941 kc/s, 319 metres; and 2R0, 11,810 kc/s, 25.4 metres, from 5.15 p.m. (approx.).—12.30 p.m., Gramophone Music. 1.0, Gramophone Concert. In the interval from 1.30 to 1.45, Giornale Radio and Exchange. 2.0, Time and Announcements. 4.30, Children's Radio Review. 4.50, Giornale Radio and Exchange. 5.10, Weather. 5.15, Song and Violin Recital: Nolla Ranieri (Violin), Luisa Castellanzi (Mezzo-Soprano), Maria Romano (Soprano), and Carlo Patania (Baritone). Violin Solos: (a) Il canto della lontananza (Malipiero), (b) Polichinello (Kreisler). Mezzo-Soprano Solos: (a) Plaisir d'amour (Martini), (b) Allé, mi fate ridere (Cavalli), (c) Melody (Paradies). Baritone Solo and Duet for Baritone and Soprano from Aida (Verdi). Violin Solos: (a) Serenata napoletana (Sgambati), (b) Canto appassionato (Pizzetti). Quartet from Il Trovatore (Verdi). 6.40 (Naples), Shipping and Sports Notes. 6.45, Dopulavoro and Tourist Report. 7.10, Agricultural Report. 7.20, News in Foreign Languages. 7.40, Giornale Radio. 8.0, Time, Announcements and Gramophone Music. 8.25, Giornale Radio and Sports Notes. 8.30, La leggenda di Sakuntala—Opera in Three Acts (Alfano), with Introductory Talk. Talk and News in the intervals. Giornale Radio after the Opera.

SALZBURG.—See Vienna.

SCHENECTADY

(WGY), 790 kc/s, 379.5 metres; 50 kW. Relayed at intervals by W2XAF on 31.48 metres and by W2XAD on 19.56 metres.—9.0 p.m., Book News by Levere Fuller. 9.15, Musical Programme, from New York. 9.45 to 10.0 (approx.), Lady Next Door, from New York. 10.45 a.m. (Tuesday), Stock Reports and Baseball Scores. 1.0, Socoyland Sketch, from New York. 1.30, Felix Ferdinand's Burgomasters. 1.45 to 3.30, New York Relay. 1.45, Ferd Grof's Orchestra. 2.0, A and P Gypsies. 2.30, Musical Programme. 3.0, Contended Programme. 3.30, Variety Programme, from New York, followed by Programme Résumé.

SCHWEIZERISCHER LANDESENDER

BEROMUNSTER, 653 kc/s, 459 metres; 60 kW.; Basle, 1,229 kc/s, 244.1 metres; and Berne, 1,220 kc/s, 245.9 metres.—5.30 p.m. (Basle). Light Music on Gramophone Records. 6.30 (from Zürich), Programme for Children. 7.0, Time and Weather. 7.5 (from Zürich), Italian Opera Music on Gramophone Records. 7.30 (from Zürich), English Lesson. 8.0 (from Zürich), Viennese Song Recital. 8.30, Dr. de Nora reads from his Memoirs. 9.0, Weather and News. 9.10 (from Zürich), Lecture Recital: The Evolution of the Classic Symphony—Franz Xaver Richter and Carl Ditters von Dittersdorf. 10.15 (approx.), Close Down.

SOTTENS.—See Radio-Suisse Romande.

STOCKHOLM

689 kc/s, 436 metres; 55 kW.—Relayed by Boden, 244 kc/s, 1,229.5 metres; Göteborg, 932 kc/s, 322 metres; Hörby, 1,166 kc/s, 257 metres; Motala, 221.5 kc/s, 1,354.4 metres; Östersund, 389 kc/s, 770 metres; and Sundsvall, 554 kc/s, 542 metres.—5.5 p.m., Accordion Music. 5.30, Microphone Report. 5.45, Gramophone Music. 6.45, Talk. 7.15, Weather Report. 7.30, Talk. 8.0, English Song Recital by Frances Allson: Shaded with Olive Trees (Graves); Weep You no more, sad Fountain (Dowland); What if I speede (Jones); When I am laid in Earth, from

Dido and Aeneas (Purcell); Now sleeps the crimson Petal (Quilter); The Chestnut Blossom (Peterkin); The Ram of Exile (Bax); I heard a Piper piping (Bax); The Nightingale (arr. Sharp); The Riddle Song (Sharp); Roving in the Dew (arr. Butterworth). 8.30, Talk. 9.0, Peterson-Berger Concert by the Radio Orchestra. Soloist: Ernst Törnqvist (Violin). Overture, Sveagaddar; Violin Concerto in F Sharp Minor. 9.45, Time and Weather. 10.0, Couperin Bi-centenary Concert by the Station Orchestra: Dance Suite from Pianoforte Themes of François Couperin (Richard Strauss); Suite, Le Tombeau de Couperin (Ravel). 11.0 (approx.), Close Down.

STRASBOURG

869 kc/s, 345 metres; 11.5 kW.—11.30 a.m., Gramophone Concert of Popular Music. 12.45 p.m., News. 1.0, Time and Exchange. 1.5, Extracts from La masquette—Opera (Audran), on Gramophone Records. 2.0, Interval. 3.30, Orchestral Concert, conducted by Brouillette, relayed from the Casino Vichy: Overture, Arteveldt (Guiraud); Ballet Music (de Séverac), from (a) Le coeur de moulin, (b) La fête des vendanges; Suite, Esclarmoude (Massenet) Melody; Extracts from Rincunes Sevillanos (Turina); Selection from Cavalleria rusticana (Mascagni); Waltz, Roses from the South (Joh. Strauss). 5.0, Gramophone Music. 5.15, Orchestral Concert, conducted by Roskam: Two Step, Pour toi, Rio Rita; Waltz, La rose bleue; Intermezzo, Selira; Tango, Wer weiss, warum...? Cello Solo: Serenade from Les millions d'Arlequin (Drigo); There's a Ring around the Moon; Believe me; Ein stilles Glück from Sissy (Kreisler); Boston, Sag mir Darling; Foxtro, We'll see it through One-step, Papa Papa (Yvain). 6.0, Film Review. 6.15, Review of the Week in German. 6.30, Orchestral Concert, conducted by Maurice de Villiers; The Unfinished Symphony (Schubert); Overture, Hans Heiling (Marschner); Orchestral Suit, Scenes Ascenciees (Massenet); Jota Aragonesa (Saint-Saëns). 7.30, Time and News. 7.45, Light Music on Gramophone Records. 8.15, Press Review in German, Lottery Results and Announcements. 8.45, Gala Concert of French Music, conducted by Paul Paray, relayed from the Casino Vichy: Symphony in B flat (Chausson); Prelude to L'étranger (d'Indy); Oratorio for Soloists, Choirs and Orchestra. Le déluge (Saint-Saëns). 11.15 (approx.), Press Review.

STUTTGART

MUHLACKER, 832 kc/s, 360.5 metres; 60 kW.—Relayed by Freiburg, 527 kc/s, 570 metres.—12 Noon, German Opera on Gramophone Records: Overture, The Barber of Bagdad (Cornelius); Overture, Preciosa (Weber); Waltz from Der Rosenkavalier (Strauss); Extracts from The Mastersingers (Wagner). 12.40 p.m., Recital of Löwe Ballads by Paul Bender (on Gramophone Records). 1.0, Songs by the Comedian Harmonists (on Gramophone Records). 1.15, Time and News. 1.30, Gramophone Records. 2.0 to 2.15, Concert arranged by the Post Office. 2.30, Spanish Lesson. 3.0 to 3.30, Elementary English Lesson. 4.30, See Frankfurt. 5.45, Talk: Alsace, A Lost Territory. 6.10, Talk: Hendrik Conscience, a Pioneer in the Flemish Liberation Movement. 6.40, Time and News. 7.0, Transmission for all German Stations, relayed from Berlin (Deutschlandsender). 8.0, Concert by the Station Orchestra, conducted by Drost: Overture, (Zar and Carpenter) (Lortzing); Symphony in E flat (Mozart); German Dances (Mozart); Kaiserwalzer (Strauss); Overture, Die Elendmats (Joh. Strauss). 9.30, Things one should know. 9.40, Reading of War Stories. 10.0, Time and News. 10.20, Pianoforte Recital by Fritz Hübsh: 32 Variations in C minor (Beethoven); Scherzo in E flat minor, Op. 4 (Brahms); Fairy Tale Sonata in C minor, Op. 25, No. 1 (Mendner). 11.5, Concert from Leipzig. 12 Midnight, Close Down.

SUNDSVALL.—See Stockholm.

TOULOUSE

RADIOPHONIE DU MIDI, 779 kc/s, 385 metres; 8 kW.—6.15 p.m., Opera Music: Arias from (a) Tosca (Puccini), (b) Carmen (Bizet), (c) Sappho (Massenet). 6.30, Accordion Music. 6.45, Dance Music. 7.0, Music from Sound Films. 7.15, News. 7.30, The Fire Bird (Stravinsky), by the Symphony Orchestra. 7.45, Music by a Viennese Orchestra. 8.15, Operetta Music: Melodies from (a) Kadubek (Yvain), (b) Begonia (Mevier), (c) Rose-Marie (Friml). 8.30, Bal Musette. 8.45, Popular Melodies. 9.0, Extracts from Figue Opera (Mozart). 9.30, Sponsored Programme. 10.0, Military Music. 10.15, News. 10.30, Concert for Listeners in Morocco: Waltz (Ziehrer); Extract from Si l'éclair roi (Audran); Selection from Miss Decima (Audran); Melody (Fairman); Demain on fête (Clairon). 11.0, Light music. 12 Midnight, News. 12.5 a.m. (Tuesday), Light Music: You are my Heart's Delight, from The Land of Smiles (Lehar); Waltz; Marionette's Song (Tagliabue); The Mass of St. Hubert (Blondiaux); Dance Tune (Hey-

mann); Au Cœur de la Forêt. 12.30, Close Down.

TRIESTE

1,211 kc/s, 247.7 metres; 10 kW.—5.10 p.m. till Close Down, See Turin.

TRONDHEIM.—See Oslo.

TURIN

1,096 kc/s, 273.7 metres; 7 kW. Relayed by Milan, 905 kc/s, 331.5 metres; Genoa, 959 kc/s, 312.8 metres; and Florence, 599 kc/s, 500.8 metres.—5.10 to 6.0 p.m., Concert. 6.40, Giornale Radio, Dopulavoro Announcements, and Gramophone Music. 7.0, Time, Tourist Report, and Gramophone Music. 7.10, Agricultural Report and Market Prices. 7.20, News in Foreign Languages. 7.40, Gramophone Music. 8.0, Announcements, Giornale Radio, Sports Notes, and Weather. 8.15, Sponsored Concert. 9.15, A Comedy in One Act. 9.45, Violin Recital by Florizel von Reuter: Four Dances (Tchaikovsky-Reuter); (a) Dance of the Dragonfly, (b) Arab Dance, (c) Chinese Dance, (d) Russian Dance; Introduction and Rondo (Vieuxtemps); Rondo, La campanella (Paganini-Reuter). 10.15, Mandoline Concert. 11.0, Giornale Radio.

VATICAN CITY

15,120 kc/s, 19.84 metres (Morning), and 5,969 kc/s, 50.26 metres (Evening); 10 kW.—11.0 to 11.15 a.m., Religious Information in Italian. 8.0 to 8.15 p.m., Religious Information in Italian.

VIENNA

581 kc/s, 517 metres; 100 kW. Relayed by Graz, 852 kc/s, 352.1 metres; Innsbruck, 1,058 kc/s, 283 metres; Klagenfurt, 662 kc/s, 453.2 metres; Linz, 1,220 kc/s, 245.9 metres; and Salzburg, 1,373 kc/s, 215.5 metres.—11.0 a.m., Relay of the Morning session of the German Catholic Congress from the Hofburg. 11.55, Weather. 12.30 p.m., Concert by the Wiener Symphoniker, conducted by Josef Holzer: Overture, Lurline (Wallace); Selection from Der Wallfischmied (Lortzing). 1.0, Time and News. 1.10, Concert (cont'd.): Gespenstermarsch (Dame); Piccolo Solo: Nachtigalls Morgenzug (Recktenwald); Melody (Squire); Das heimwehkranke Wienerkind (Jascha); Waltz, Wild Roses (Ertl); Minuet and Barcarolle from The Tales of Hoffmann (Offenbach); Selection from Bruder Straubinger (Eysler); Gallop, Liebesbotschaft (Joh. Strauss). 2.0, Interval. 3.0, Time, Weather and Exchange. 3.20, Talk: Gymnastics as the Basis of all Sports. 3.35, Reading of Legends about St. Stephen's Cathedral. 4.0, Gramophone Concert. 5.0, Talk: Ecclesiastical Art in Austria in Olden and Modern Times. 5.15, Cello Music by Jeral, Richard Krottschak (Cello) and Otto Schullios (Pianoforte). Adagio; Sérénade viennoise; Danse exotique; Légende; Berceuse; Gipsy Dance. 6.0, Relay of a Political Demonstration from the Trotting Course: Speech by the Chancellor, Dr. Hoffuss. 7.0, Time, Weather and Programme Announcements. 7.10, Gramophone Concert. 8.0, Concert by the Vienna State Opera Choir, conducted by Ferdinand Grossmann, relayed from the German Catholic Congress in the Musikvereinsaal. 10.0, News. 10.15, Report on the German Catholic Congress. 10.25, Concert. Part I—Trio Concert, relayed from the Lehar Hall. Part II—Vocal and Instrumental Concert, relayed from the Hotel Krantz-Ambassador.

WARSAW

212.5 kc/s, 1,411 metres; 120 kW.—11.57 a.m., Time Signal and Fanfare from the Torun Cathedral. 12.5 p.m., Popular Concert, relayed from the Bagatella. 12.25, Polish Press Review. 12.33, Weather Forecast. 12.35, Concert from the Bagatella (cont'd.). 12.55, Radio Journal. 1.0, Interval. 2.55, Announcements. 3.0, Gramophone Records. 3.5, News. 3.10, Announcements. 3.15, Gramophone Music. 3.25, Economic Notes. 3.35, Gramophone Music. 3.45, Traffic Report. 3.50, Gramophone Music. 4.0, Concert by the Poznan Opera House Orchestra, conducted by Tyllia, relayed from Cichocinek: Overture, Halka (Moniuszko); Waltz, Myrthenbluten (Strauss); Selection from The Gipsy Princess (Kalman); Selection from Sylvia (Delibes); Intermezzo (Lederer). 5.0, Talk in French. 5.15, Pianoforte Recital by Irene Kaszowska: Sonata Op. 57 (Beethoven); Two Etudes in G flat, Op. 10, and Op. 25 (Chopin); Waltz from Naida (Delibes-Dohnanyi). 5.50, Song Recital by Laskowski (Teur). 6.15, Talk. 6.35, Song Recital by Mme. Szczepanska: Das Veilchen (Mozart); Wiegeliend (Mozart); Aria from Flys (Moniuszko) Aria from Carmen (Bizet); The Gipsy and the Birds (Benedict); Amoureuse (Chopin); Old Song (Kronenburg); Golden Bird (Niewiadomski). 7.10, Talk: The Battle of Vienna. 7.20, Miscellaneous Items. 7.35, Programme Announcements. 7.40, Reading. 8.0, Answers to Agricultural Correspondence. 8.15, See Prague. 9.20, The Countess—Opera (Moniuszko). In the intervals, Radio Journal, Sports Notes, Weather Report and Aviation and Police Notes.

ZURICH.—See Schweizerischer Landessender.



# TUESDAY

SEPTEMBER THE TWELTH

## PRINCIPAL EVENTS OF THE DAY:

### AT HOME

**NATIONAL LONDON REGIONAL**  
**MIDLAND REGIONAL**  
**NORTH REGIONAL**  
**WEST REGIONAL**  
**SCOTTISH REGIONAL**  
**BELFAST**

"The Fantastic Battle," a play by Leslie Baily. Dedication of the Mission Ship "Southern Cross," relayed from Liverpool. Orchestral concert.

Relay from the Garrick Theatre, Southport.

"The Mad Hatters," relayed from Rhyd Pavilion and Ballroom. Orchestral concert.

Variety programme.

### ABROAD

**ATHLONE**  
**BRUSSELS (No. 2)**  
**HAMBURG**  
**HEILSBURG**  
**HILVERSUM**  
**PALERMO**  
**PRAGUE**  
**STRASBOURG**  
**WARSAW**

10.0 p.m. Concert on behalf of Hospitals' Trust Ltd. 9.0 p.m. The Station Symphony Orchestra.

10.20 p.m. The Philharmonic Orchestra, conducted by Eibenschütz.

9.5 p.m. The Danzig Municipal Theatre Orchestra. 8.40 p.m. The K.R.O. Orchestra, conducted by Geritsen.

8.45 p.m. Orchestral concert.

9.0 p.m. Rameau and Couperin concert by the Station Orchestra, conducted by Jeremias.

8.30 p.m. Orchestral concert from the Casino, Plombières-les-Bains.

8.0 p.m. Song recital by Szlemiuska and Michalowski.

Orchestra, conducted by Otto Frick-hoeffer; Triumph des Lebens, Op. 8—a Rhapsodic Prelude for Augmented Orchestra (Rudolf Peterka); First and Second Movements from the Symphony in C Sharp Minor, Op. 22 (Friedrich de la Motte Fouqué). 9.45, The Fishing Fleet leaves Strahan—a Report (on Gramophone Records). 10.0, News. 10.20 (approx.). See Hamburg. In the interval from 11.0 to 11.5, Radio Report from Moabit. 12 Midnight (approx.). Close Down.

**BERNE**—See Schweizerischer Landessender.  
**BREMEN**—See Hamburg.  
**BREMEN**—See Hamburg.  
**BREMEN**—See Hamburg.  
**BREMEN**—See Hamburg.

### BRATISLAVA

1,076 kc/s, 279 metres; 14 kW.—7.25 p.m., See Moravská-Ostrava. 8.20, See Brno. 9.0, See Prague. 11.0 (approx.). Close Down.

**BREMEN**—See Hamburg.

### BRESLAU

923 kc/s, 325 metres; 60 kW. Relayed by Gleiwitz, 1,184 kc/s, 263 metres.—1.45 p.m., Time and News. 2.5, Chopin Pianoconcert Recital by Käthe Conrad; Polonaise in C Sharp Minor, Op. 26, No. 1; Impromptu in F Sharp, Op. 36; Mazurka in B Minor, Op. 33, No. 4; Prelude in D Flat, Op. 28, No. 15. 2.30, Verdi and Puccini Concert on Gramophone Records; Prelude to the Third Act of Manon Lescaut (Puccini); Selection from A Masked Ball (Verdi); Selection from La Bohème (Puccini); Selection from Il Trovatore (Verdi); Selection from Tosca (Puccini). 3.0, Agricultural Prices. 3.15, Programme for Children. 3.40, Book Review. 4.0, Orchestral Concert, relayed from the Restaurant Vier Jahreszeiten; Florentine March (Fueick); Overture, Ehrenhügel (Kuhlan); Selection from Il Trovatore (Verdi); Potpourri, Diamanten und Perlen (Dostal); Potpourri, Die Falut ins Blaue (Dostal); March, Farewell of the Gladiators (Blankenburg). 5.30, See Heilsberg. 6.20, W. Neumann reads from his own works. 6.50, Weather and News. 7.0, Transmission for all German Stations, relayed from Leipzig. 8.0, Die kämpfende Stadt—Radio Play for the 250th Anniversary of the Siege of Vienna, 1683 (Reimesch). 9.0, News. 9.10 (from Gleiwitz), Programme for the Young Hitlerites of Upper Silesia. 10.3, Austria. 10.20, Time and News. 10.40, Political Press Review. 11.0, Talk: The German Stage. 11.20, Instrumental Cabaret. 12.30 a.m. (Wednesday), Close Down.

### BRNO

878 kc/s, 342 metres; 35 kW.—6.15 p.m., Talk for Workers. 6.25, German Transmission; News, Talk on English Literature and Agri-

cultural Report. 7.0, See Prague. 7.25, Concert of Folk Music. 8.0, Balalaika Music. 8.20, A Farce in One Act. 9.0, See Prague. 11.0 (approx.). Close Down.

### BRUSSELS (No. 1)

I.N.R., 590 kc/s, 9, 509 metres; 15 kW.—12 Noon, Extracts from La Basoche Opera (Messenger), on Gramophone Records. 12.30 p.m., Soprano Song Recital by Elise Zevvaert. 12.45, Light Music. 1.0, Le Journal Parlé. 1.10, Concert by the Small Station Orchestra, conducted by Leemans. 1.30, Musiques foraines (Fl. Schmitt). 5.0, Violin and Pianoconcert Recital by Mlle. Céline and Abel Bourdanduc; Sonata for Violin and Pianoconcert (Viernie); Pianoconcert Solos. 5.30, Programme for Children. 6.5, Talk: Students and Lecturers. 6.15, Concerto grosso No. 4 in A minor (Händel), on Gramophone Records. 6.25, Scenes from Hamlet (Shakespeare), arranged for Radio by Jean Variot. 7.15, Talk for Workers. 7.30, Art Review and Talk for Women. 8.0, Cello and Harp Recital by Marguerite and Jacques Kulmer; Sielienne (Fauré); Waltz for Cello and Harp (Joussy); Gigue (Bach); Prelude for Harp (Debussy); Albumblatt (Schumann); Cello Solo; Allegro appassionato (Saint-Saëns); Poème (Kulmer). In an interval at 8.15, Reading of Poems and Prose by Maurice Carême. 8.45, Talk: Social Events of the Week in Louvain. 9.0, Concert by the Radio Orchestra. Soloist: Boyarini (Balalaika). Overture, The Bohemian Girl (Balle); Two Dances from the Nutcracker Ballet (Tchaikovsky); Balalaika Music; La machine à coudre (Linhant); Zigeunerweisen (Sarasate); Jungle Drums (Kettelbey); Serenade for Horn and Flute (Titt); Balalaika Music; Die Wachtparade kommt (Eilenberg); Melody (Jessel); Radetzky March (Joh. Strauss). 10.0, Journal Parlé. 10.10, Request Gramophone Music. 10.40, Chamber Music; Arioso and Allegro from the Concerto for Viola and Pianoconcert (Golstein); Sonata No. 4 in C minor (Bach). 10.55, Christus vincit (Liszt).

### BRUSSELS (No. 2)

N.I.R., 887 kc/s, 338.2 metres; 15 kW. Programme in Flemish.—12 Noon, Concert by the Small Station Orchestra, conducted by Leemans. 1.0 p.m., Le Journal Parlé. 1.10, Gramophone Concert. 5.0, Concert by the Station Symphony Orchestra, conducted by Meulemans; Overture, Oberon (Weber); Norwegian Dance No. 4 (Grieg); Cossack Dance (Tchaikovsky); Hungarian Dance No. 6 (Brahms); Waltz (Meulemans); Slav Dance No. 3 (Dvorák); Spanish Dance No. 1 (Falga); Marche héroïque (Saint-Saëns). 5.45, Programme for Children. 6.30, Concert by the Station Orchestra, conducted by Leemans; Overture, Juro (Guillemy); Danza Fantastica No. 3 (Turina); Suite, Impressions of Scandinaviania (Frederiksen); Selection from Cydalise et le Chevre-Pied

(Pierne). 7.0, Gramophone Music: March fantasia (Carosio); La débutante (Iras Douque); Waltz, La gran Via (Valverde); Xylophobia (Jou Green). 7.15, Reading. 7.30, Tourist Review. 8.0, Concert by the Radio Orchestra, conducted by André: Einheitslied (Eisler); Overture, Orpheus in the Underworld (Offenbach); Rendez-vous (Aletier); Songs from The Land of Smiles (Lehár), on Gramophone Records; Two Songs (on Gramophone Records): (a) Hymn (Kromolitzky), (b) Two Airs from Adorable (Stolz); Fourteenth Hungarian Rhapsody (Liszt); Potpourri of Stolz Music (Dostal); Interlude on Gramophone Records: (a) Bell Song from Lakmé (Delibes), (b) Air from Manon (Massenet), (c) Variations on a Theme of Proch. 9.0, Concert by the Station Symphony Orchestra, conducted by Meulemans: Prelude (Rachmaninov); Danse macabre (Saint-Saëns); Valse triste (Sibelius); Gramophone Music: (a) Duet from Hamlet (Thomas), (b) Duet from the Last Act of Carmen (Bizet); Fire-Works (Oesterreich (Joh. Strauss)); Marche russe (Ligutti). 10.0, Journal Parlé. 10.10, Dance Music on Gramophone Records.

### BUCHAREST

761 kc/s, 394 metres; 12 kW.—5.0 p.m., Light Music and Romanian Music by the Mloti Orchestra. 6.0, Radio Journal. 6.15, Light Orchestral Music (contd.). 7.0, Reading. 7.20, Instrumental Music on Gramophone Records. 7.40, Educational Talk. 8.0, Song Recital by Mlle. Cretoiu. 8.20, Concert by the Station Orchestra; Overture, The Secret Marriage (Cimarosa); Suite, Venezia misteriosa (Travaglia); Selection from Die Puppenfee (Bayer); Waltz (Kettelbey); Two Hungarian Dances (Brahms). In the interval at 9.0, Talk. 9.45, Radio Journal.

### BUDAPEST

545 kc/s, 550.5 metres; 18.5 kW. Also relayed on 840 metres from 7.30 p.m. till Close Down.—5.30 p.m., Concert. 6.0, Reading. 6.30, Famous Conductors—Toscanini, Stokowski, Bruno Walter, Leo Blech, Mascagni and Siegfried Wagner, Kleiber and Weingartner. 7.30, A Comedy. 9.30, News. 9.50, Concert by the Opera House Orchestra, conducted by Polgar; Overture, Susanna's Secret (Wolf-Ferrari); Fantasia in D minor (Mozart); Suite (Siklos); Dance Caprice (Nagy); Operetta Potpourri (Kontli); Schmetterlingromanz (Garami); Tratsch (Pöör); Ballet Scene (Roussseau); Mai in Granada (Nagy-pal); Turisten-Marsch (Nagy-pal). 10.30, Weather. 11.0, Concert by the Karl Jura Gány Orchestra, relayed from the Ketter Restaurant.

CASSEL.—See Frankfurt.

### COPENHAGEN

1,067 kc/s, 281 metres; 0.75 kW. Relayed by Kalundborg, 260 kc/s, 1,153.8 metres.—12 Noon, Chimes from the Town Hall. 12.2 to 2.0 p.m., Concert from the Wivex Restaurant. 3.0, Concert by the Radio Orchestra, conducted by Emil Reesen. Soloist: Inger Raasloff. Overture, Jean de Paris (Boieldieu); Selection from La Vie Parisienne (Offenbach); Waltz, Siesta (Waldteufel); Three Pieces from the Serenade for Strings (Herbert); Overture, The Italian Girl in Algiers (Rossini); Finnish-Swedish Romances; Overture, The Mikado (Sullivan); Selection from Der liebe Augustin (Fall); Three Pieces from Scènes pittoresques (Massenet); Selection from Scaramouche (Sibelius); Military March (Elgar). 5.0, Programme for Children. 5.30, Exchange and Fish Market Prices. 5.45, Reading. 6.15, Elementary German Lesson. 6.45, Weather. 6.54, Radio Union Notes. 7.0, News. 7.15, Time Signal. 7.30, Talk: Pluto and Modern Times. 8.0, Town Hall Chimes. 8.2, Concert of Scandinavian Folk Music; Swedish Folk Melodies and Dances (arr. Södermann); Danish Folk Melodies (arr. for Strings) (Lanny Gröndahl); (a) En yndig og frydelig Sommertid, (b) Visen om Svend Føljdig; Agnete og Havmanden (Reesen); Norwegian Rhapsody No. 4 (Svendsen); Fantasia on Finnish Folk Melodies (Bohman). 8.45, Galgenmænd—Radio Play in One Act (Rutar Schildt, arr. Kaare Borrisenius). 9.45, News. 10.0, Concert of Contemporary Danish Music. The Wind Instrument Quintet, and Karen Kayser (Songs). Songs with Wind Instrument accompaniment, Op. 17 (Kjell Roikjer): (a) Paa Engen, (b) Cradle Song; (c) Skumring, (d) Døden; Pieces for Piano-forte (Paul Schierbeck); (a) Two Fantastic Etudes, (b) Two Etudes; Serenata invano—for Clarinet, Horn, Bassoon, Cello and Double Bass (Carl Nielsen). 11.0, Dance Music from the Lodbeg Restaurant. In the interval at 12 Midnight, Town Hall Chimes. 12.30 a.m. (Wednesday), Close Down.

CORK.—See Athlone.

DANZIG.—See Heilsberg.

DRESDEN.—See Leipzig.

### FECAMP

1,328 kc/s, 225.9 metres; 10 kW.—11.0 a.m. to 12 Noon, Programme in English by the I.B.C. 11.0, Concert, Part I, Orchestral and

**ATHLONE**  
725 kc/s, 413 metres; 60 kW. Relayed by Cork, 1,337 kc/s, 224.4 metres.—1.30 to 2.30 p.m., Time Signal, Weather Report, Stock Exchange Quotations and Gramophone Music. 6.0, Programme for Children. 6.40, News. 7.0, Gaelic Reading. 7.15, Talk by E. F. MacSweeney; Mount Mellerey Abbey. 7.30, Time Signal. 7.31, Sonata for Piano-forte and Violin, by F. Stone and Nora Richardson. 7.55, Vocal Duets and Solos by C. Butler and R. Sheppard. 8.15, The Station Orchestra. 8.35, Traditional Fiddle Solos by F. O'Higgins. 8.50, Soprano Solos by K. McAffery. 9.5, The Station Orchestra. 9.15, Sketch by Mui Neville and Company. 9.30 to 10.30, Programme by the I.B.C. (Ireland), Ltd. 9.30, Dance Music: Chewing Gum; Rock-a-bye Moon; The Lord Mayor's Show; Have you ever been lonely?; Good Morning Mr. Sun; Love is the Sweetest Thing; The Old Spinning Wheel; Smile and Sing your cares away. 10.0, Concert arranged by the International Broadcasting Company (Ireland), Ltd., on Behalf of Hospitals' Trust, Ltd.: Signature Tune; Come back to Erin; Valse caprice (Rubinstein); Selection from Lilac Time (Schubert); Londonderry Air (arr. Adlington); Serenade (Schubert); Bells across the Meadow (Kettelbey); Pizzicato from Sylvia (Delibes); Colonel Bogey (Alford); Signature Tune. 10.29, I.B.C. Good-night Melody. 10.45, News and Weather.

### BARCELONA

EAJ1, 860 kc/s, 348.8 metres; 8 kW.—7.0 p.m., Trio Concert. 8.0, Request Gramophone Records. 8.30, Exchange. 9.0, Gramophone Music and News. 10.0, Chimes from the Cathedral, Weather Forecast, Messages to Seamen, Exchange Quotations and Market Prices. 10.5, Sponsored Programme. 10.15, Football Results and Gramophone Music. 11.30, Concert by the Station Orchestra; 11.15, Band Concert, relayed from the Café Español. In the interval at 12 Midnight, News. 1.0 a.m. (Wednesday), Close Down.

### BARI

1,112 kc/s, 269.8 metres; 20 kW.—8.0 p.m., Agricultural Notes, Tourist Report, and Popolavoro Notes. 8.20, Giornale Radio and News in Albanian. 8.30, Time and Announcements. 8.35, Weather. 8.45, Choral Concert, conducted by Biagio Grimaldi. 10.0 (approx.). Concert by the Station Quintet; Overture (Monton); Minuet (Licari); Selection from Frederick (Lehár); Mattino nell'asi (Culotta); Calendimaggio (Culotta); Pastoral from La figlia di Jorio (Franchetti); Serenade from I Zingari (Leoncavallo); Suite campestre (Amadei). 10.30, Gramophone Music. 11.0, Giornale Radio.

**BASLE**—See Schweizerischer Landessender

### BELGRADE

697 kc/s, 430.4 metres; 2.8 kW.—6.55 p.m., Time and Announcements. 7.0, Talk. 7.30, Concert by the Goldmark Quintet. 8.0, Song Recital. 8.30, Gramophone Music. 9.0, Concert by the Station Orchestra. 10.0, Time and News. 10.15 (approx.). Popular Songs. 10.45, Gramophone Music.

### BERLIN

**DEUTSCHLANDSENDER (REICHSENDER)**, 183.5 kc/s, 1,635 metres; 60 kW.—1.45 p.m., News. 2.0, Classical Marches and Dances on Gramophone Records. 3.10, Programme for Young People. 3.30, Weather and Exchange. 3.45, Reading (Hermann Eris Buisse). 4.0, See Leipzig. 5.0, Talk for Mothers: Causes of Infant Mortality. 5.20, Concert by the Gaden Orchestra, with Humorous Items by Herbert Ernst Groh. 6.0, Poems. 6.5, Topical Talk. 6.15, Talk: German Americans. 6.30, Political Press Review. 6.50, Weather and News. 7.0, Transmission for all German Stations, relayed from Leipzig. 8.0, Today's Motto. 8.5 (approx.), Rühzahl—Radio Sequence of the Silesian Mountains (Alfred Prugel). 9.0, Dance Music by Hans Bunt and his Band. 10.0, Weather and News. 10.25, Dialogue on Gymnastics. 10.45, Weather. 11.0, Concert from Hamburg. 12 Midnight (approx.). Close Down.

### BERLIN

**FUNKSTUNDE**, 715 kc/s, 419.5 metres; 1.5 kW.—4.30 p.m., Concert from the Golf Hotel at the Zoological Gardens; Overture, A Night in Venice (Joh. Strauss); Märchen-serenade (Grams); Waltz, Hofballtänze (Lammer); Episode (Bort); Selection from The Bird Faucier (Zeller); Tango, Der alte Lindenbaum (Kötscher-Karlück); Tango, In einer Frühlingnacht (Dostal-Fago); Serenade, Maria Lúise (Meissl); Song from Die Kätzchen (Felix); Waltz, Mein Lebenslauf ist Lieb und Lust (Jos. Strauss). 5.30, Pianoconcert Recital of Concert Waltzes: German Waltzes (Schubert-Liszt); Two Forgotten Waltzes; Mephisto-Waltz (Liszt). 6.0, The Life-Stories of German Patriots. 6.15, Review of Books on Aviation. 6.40, The Funkstunde informs its Listeners. . . . 6.45, Topical Talk. 7.0, Transmission for all German Stations, relayed from Leipzig. 8.0, Lottery Announcements. 8.5, Farmhouse, Country Seat and Town Residence—a Social Picture of Two Thousand Years (Walter Gutkehl). 9.0, Concert of Contemporary Music by the Sta-

SEPT. 12th **TUESDAY** continued

**HAMBURG**

806 kc/s, 372 metres; 1.5 kW. Relayed by Bremen, 1,112 kc/s, 269.8 metres; Flensburg, 1,319 kc/s, 227.4 metres; Hannover, 530 kc/s, 566 metres; and Kiel, 1,292 kc/s, 232.2 metres.—6.15 p.m., Görn. zu Bett—Radio Sequence (Henne). 6.45, Market Prices. 6.50, Weather. 7.0, Transmission for all German Stations, relayed from Leipzig. 8.0, Festival Programme for the Centenary of the Rautenhaus; Choral Music and Address by Bishop Müller. 8.45, Topical Talk. 9.0, From Reveille to Lights Out—A Day in the Soldier's Life, in Verse, Song, and Military Music. 10.0, News. 10.20, Concert by the Hamburg Philharmonic Orchestra, conducted by Eibenschütz; Overture to a Shakespeare Comedy (Scheinpflug); Two Swedish Folk Melodies arranged for String Orchestra (Svendson); Suite, Roma (Bizet); Caprice, Jota Aragonesa (Glinka); Overture, Morning, Noon and Night (Suppé); Minuet for Strings (Boltoni); Selection from Liselott (Künneke); Waltz, Herein-spaziert (Zieherl).

HANOVER.—See Hamburg.

**HEILSBURG**

1,085 kc/s, 276.5 metres; 60 kW. Relayed by Danzig, 662 kc/s, 453.2 metres.—1.5 p.m., Gramophone Concert. In the intervals at 1.20 and 2.0, News. 2.30 (from Danzig). Exchange and Market Prices. 3.0, Agricultural Prices and Exchange. 3.30, Musical Improvisations for Children. 4.0, Concert by the Small Station Orchestra, conducted by Eugen Wilcken; Overture, Baccaccio (Suppé); Selection from Das Dorf ohne Glocke (Künneke); Waltz, Rudolfklänge (Jos. Strauss); Selection from The Bartered Bride (Smetana); Waltz, Pariser Strassen-sänger (Ohlsen); Ländler (Pachernegg); Czardas, Karpati Viszhangok (Keler-Bola); Selection from Gipsy Love (Lohár); Overture, Frau Luna (Lincke). In an interval at 4.50, Talk: To-day's Fashions. 5.30, Heilsberg-Laugenberg Exchange Programme: The Storks—Radio Report from the Bird Sanctuaries at Rositten and Essen. 6.15, Agricultural Prices. 6.25, An East Prussian Agricultural Labourer and his Wife Describe their Daily Life. 6.50, Weather. 7.0, Transmission for all German Stations, relayed from Leipzig. 8.0, Weather and News. 8.5, See Stuttgart. 8.35, Wilhelm von Scholz reads from his own Works. 9.5 (from Danzig), Concert by the Municipal Theatre Orchestra, conducted by Hans Lenzer: Romantic Overture (Thuille); Andante from the Symphony in G Minor (Mozart); Ballet Suite No. 1 (Glucke-Mottl); Selection from The Flying Dutchman (Wagner); Overture, The Violin Maker of Cremona (Hubay); Scènes napolitaines (Massenet). 10.0, Political Press Review and News.

**HILVERSUM**

Announced **HUIZEN**, 1,013 kc/s, 296.1 metres; 20 kW. (7 kW. up to 5.40 p.m.).—Programme of the Catholic Radio Society (K.R.O.). 11.40 a.m., Police Report. 11.55, Unveiling of a Statue to the late Monseigneur Zwijssen. Address and Musical Programme. 12.25 p.m., Gramophone Music. 12.40, Concert by the K.R.O. Sextet. 1.25, Interval. 1.40, Programme for Women. 2.40, Gramophone Music. 3.10, Song and Pianoforte Recital by Jan van Bommel and Henk Hermans. 4.40, Gramophone Music. 5.10, Concert by the K.R.O. Boys, conducted by Linstenhouwer: Selection from Forty Second Street (Warren); Foxtrot Potpourri (Strauss-Kabmann); Frag' nicht (May) Ein Melodientraum (Urbach); Kleiner Mann was nun? (Böhmel). 5.55, Gramophone Music. 6.10, Talk. 6.25, K.R.O. Concert (contd.): Melody (Heymann); Glow-worm Idyll (Siede) Mir ist so, ich weiss nicht wie (Heymann). 6.40, Police Report. 6.55, Talk. 7.15, Gramophone Music. 7.25, Talk. 7.40, Gramophone Music. 8.10, News. 8.40, Concert by the K.R.O. Orchestra, conducted by Gerritsen. Soloist: Zepparoni (Violin). Overture, Così fan tutte (Mozart). Violin Concerto in G (Mozart). Ballet Music from Idomeneo (Mozart). 9.30, Gramophone Concert. 9.40, Sonata in G for Violin (Porpora), by Zepparoni. 9.50, Orchestral Concert (contd.): Overture, The Bartered Bride (Smetana); Selection from Die Königskinder (Humperdinck). 10.10, News. 10.15, Violin Solos by Zepparoni; Melody (Johnson); Sonata in B (Alweir). 10.25, Orchestral Concert (contd.): Schweizer Schützengilde (Zimmer); Selection from Das lachende Glück (Lehar); Waltz Dorkinder (Kalmán); An der Mäusel (Dreyer). 10.55, Gramophone Music. 11.40 (approx.), Close Down.

HORBY.—See Stockholm.

**HUIZEN**

Announced **HILVERSUM**: 160 kc/s, 1,875 metres; 7 kW (until 5.40 p.m.). Transmitted from Kootwijk on 50 kW. from 3.40 p.m.—Programme of the Algemeene Vereeniging Radio Omroep (A.V.R.O.). 12.10 p.m., Concert by the Wireless Orchestra, conducted

by Neco Treep. In the intervals, Gramophone Music. 2.40, Gramophone Records. 3.25 to 3.40, Interval. 3.40, Pianoforte Recital by Mies de Jong. 4.10, Concert by a Children's Choir. 4.40, Programme for Children. 5.10, Concert by the Wireless Orchestra, conducted by Neco Treep: Overture, Der Erlenhügel (Kühlan); Selection from The Little Dutch Girl (Kälman); Waltz, Eiskunstler (Ertl); Swauce River (Myddleton); Jahrmaktsrummel (Lincke); Legends (Lindsay-Thoemer); Rhapsody Rag (Leuzberg); Overture, A Night in Venice (Joh. Strauss); Waltz, Estudiantina (Waldteufel); Narzissmädle (Siede); Mazurka, La mousmé (Ganne); March, Old Comrades (Teike). In the interval at 6.10, Talk. 7.10, Talk, with Gramophone Illustrations. 7.40, Time, Weather, and News. 7.45, Variety Programme by Kovacs Lajos and his Dance Band; Mariette Serle (Songs) and Alex de Haas (Entertainer). Gramophone Records in the intervals. 10.40, News. 10.50, Gramophone Music. 11.40 (approx.), Close Down.

INNSBRUCK.—See Vienna.

**JUAN LES PINS**

1,205 kc/s, 249 metres; 0.8 kW.—12.30 p.m., Amusement Guide and Variety Items. 1.0, News. 1.15, Radio Concert. 8.0, Amusement Guide, Exchange, and News. 8.15, Agricultural Report. 8.20, Press Review. 8.30, Radio Concert. 8.45, News and Weather. 9.0, Concert by the Casino Orchestra, conducted by Scotto, relayed from Monte Carlo.

KALUNDBORG.—See Copenhagen.

KIEL.—See Hamburg.

KLAGENFURT.—See Vienna.

KOSICE.—See Prague.

**LANGENBERG**

635 kc/s, 473 metres; 60 kW.—12 Noon, Variety Concert. 1.10 p.m., News. 1.30, Orchestral Concert, conducted by Eysoldt. In an interval at 2.0 (approx.), News. 3.0, Programme for Children. 3.30, Economic Notes and Time Signal. 3.50, Talk: Architecture under the Nazi Regime. 4.5, Serenade (Hadyn) on Gramophone Records. 4.10, Report on the Economic Revival in the Rhineland and Westphalia. 4.30, Political Announcements. 4.40, Talk: The Revolution and the Peasant. 5.0, Duet and Violin Recital, Constanze Fischer (Soprano), Karl Fischer (Tenor), and Paul Müller (Violin). Duets: (a) Verrätene Liebe (Cornelius). (b) Abschied der Vögel (Hildach); Violin Solos: (a) Mazurka (Mlynarski); (b) Spanish Dance (Stasser). Duets: (a) Fliegendes Blatt (Wolff), (b) Agnes, mein reizender Schmetterling (Wolff); Violin Solo: Czardas-Szenen (Hubay). 5.30, Heilsberg-Laugenberg Exchange Programme: The Stork—Radio Report from the Bird Sanctuaries at Rositten and Essen. 6.15, Reading from Grimm's Fairy Tales. 6.30, Italian Lesson. 6.45, Announcements. 7.0, Transmission for all German Stations, relayed from Leipzig. 8.0, Announcements. 8.5, Propaganda Programme for Workers: Toil is the German's Lot and the Nation's Salvation. 9.0, See Hamburg. 10.0, News. 10.20, Review of the Week.

LAUSANNE.—See Radio-Suisse Romande.

**LEIPZIG**

769.9 kc/s, 389.6 metres; 120 kW. Relayed by Dresden, 941 kc/s, 319 metres.—12 Noon, See Stuttgart. 1.15 p.m., News. 1.30, Chamber Music. Eily Opitz (Soprano), Gertrud Buehlow (Contralto), and Alf Nestmann (Pianoforte). Variations on a Theme of Bach, for Pianoforte (Wüllner); Duets (Abt.): (a) Die stille Wassersonne, (b) Surre, surre Käferlein; Pianoforte Solo, Albumblätter (Scholtz); Duets (Holstein): (a) Die Rheinischen Schiffsleute, (b) Am See, (c) Mausfallensprüchelein; Stimmungsbilder, Op. 9 (Bendix); Duets (Hildach): (a) Abschied der Vögel, (b) Wer lehrte euch singen? 2.15, News. 2.30, Talk on Astronomy. 3.0, Verdi Opera Music on Gramophone Records. 3.35, Market Prices. 4.0, Concert by the Friedrichtheater Orchestra of Dessau, Conductor, Gutav Mannbeck. Soloist, Bernhard Lessmann (Violin). Overture to a Comedy (Reznicek); German Rhapsody (Heyse); Selection from Lohengrin (Wagner); Dynamiden-Walzer (Jos. Strauss); Selection from Gri-Gri (Lincke); March in D, Op. 335, No. 1 (Mozart); Violin Concerto No. 1 in G Minor, Op. 26 (Brahm); Overture, Genevieve (Schumann). 5.30, See Heilsberg. 6.15, Exchange, Weather, and Time. 6.25, Book Review. 6.50, To-day's News. 7.0, Transmission for all German Stations: Richard Strauss Concert by the Leipzig Symphony Orchestra, conducted by Hans Weisbach. Soloist, John Gläser (Tenor); Lieder: Tone Poem for Orchestra, Ein Heldenleben. 8.0, Over the Moors—Radio Sequence for the Young, arranged from the Works of Hermann Löns (Wilhelm Maria Mund). 8.50, Songs of the Sudetic Alps, by Irmgard Richter (Soprano) and Alfred Leubner

(Bass). 9.20, Agricultural Notes. 9.30, Dance Music by the Dresden Philharmonic Orchestra and the Kilian Dance Band, conducted by Alfred Schröter. Soloist, Oswin Hartung (Tenor). 10.0, See Munich. 10.20, News. 10.35, Dance Music. 12 Midnight (approx.), Close Down.

LINZ.—See Vienna.

**LUXEMBOURG**

252 kc/s, 1,191 metres; 200 kW.—Belgian Programme. 7.30 p.m., Symphony in D Minor (C. Franck), on Gramophone Records. 8.15, Song Recital by Gustave Simon. 8.50, News in French. 9.0, Concert by the Station Orchestra, conducted by Henri Pensis: Soloist: René Delporte (Pianoforte); Overture, Coriolanus (Beethoven); Symphonic Variations for Pianoforte and Orchestra (C. Franck); Sur le lac (Godard-Salabert); Spanish Songs (Albeniz-Salabert); Ronstymonchty (Wagner); Pastorale (Douliez); Waltz, Lieder der Liebesnacht (Lincke); Selection from The Desert Song (Romberg-Salabert). In an interval at 9.45, News in German. 10.25, Dance Music on Gramophone Records.

**LYONS**

LA DOUA, 644 kc/s, 465.8 metres; 1.5 kW.—6.30 p.m., Radio Journal. 7.30, Radio Gazette for Lyons and the South-East. 8.30, Programme from Paris (Ecole Supérieure), 671 kc/s, 447.1 metres, and News.

**MADRID**

EAJ7, 707 kc/s, 424.3 metres; 2 kW.—8.0 p.m., Chimes, Exchange, Topical Review and Request Gramophone Records. 8.30, Talk and Gramophone Records. 9.15, News. 9.30, Interval. 11.0, Chimes, Time, News and Extracts from Il Trovatore—Opera (Verdi) on Gramophone Records. 1.15 a.m. (Wednesday), News. 1.30, Chimes and Close Down.

MALMO.—See Stockholm.

**MILAN**

VIGENTINO; 662 kc/s, 453.2 metres; 4 kW.—8.45 p.m. (till Close Down, See Rome.

**MORAVSKA-OSTRAVA**

1,137 kc/s, 263.8 metres; 11 kW.—2.50 p.m., Concert by the Station Orchestra, conducted by Plichta. 3.50 to 4.0, See Prague. 5.45, Gramophone Music. 5.55, Talk: Brass Band Music and its History. 6.10, Gramophone Music. 6.15, See Brno. 7.0, See Prague. 7.25, Military Band Concert. 8.20, See Brno. 9.0, See Prague. 11.0 (approx.), Close Down.

MOTALA.—See Stockholm.

MUHLACKER.—See Stuttgart.

**MUNICH**

563 kc/s, 533 metres; 60 kW. Relayed by Augsburg and Kaiserslautern, 536 kc/s, 560 metres; and Nürnberg, 1,256 kc/s, 239 metres.—4.30 p.m., Orchestral Concert, conducted by Erich Kloss; Overture, Lisola disabitata (Haydn); Three Pieces (Beethoven): (a) Adagio from the Pathetic Sonata, (b) Rondino, (c) Minuet; Selection from The Valkyrie (Wagner); Intermzzo from Alona Lisa (Schillings); Suite from As You Like it (Zit-cher); Waltz, Bei uns z'haus (Strauss); Serenade (Kaik); March (Hanfstaengl). 5.45, Talk: Freiherr von Kreittmayr. 6.5, Old Folk Songs in New Arrangements—Concert by the Small Station Choir, conducted by Zengerle. 6.25, Talk: The Reform of Education. 6.45, Time, Weather and Agricultural Notes. 7.0, Transmission for all German Stations, relayed from Leipzig. 8.0, Talk: Industrial Reconstruction. 8.20, Orchestral Concert, conducted by Erich Kloss. 9.15 (from Nürnberg), Variety Programme. 10.0, Austria. 10.20, Time, Weather and News.

NAPLES.—See Rome.

NOTODDEN.—See Oslo.

**OSLO**

277 kc/s, 1,083 metres; 60 kW.—Relayed by Fredriksstad, 815 kc/s, 368.1 metres; Hamar, 522 kc/s, 574.7 metres; Notodden, 671 kc/s, 447.1 metres; Porsgrund, 622 kc/s, 453.2 metres; and Rjukan, 671 kc/s, 447.1 metres.—5.0 p.m., Concert, relayed from the Grand Hotel. 6.0, Programme for Housewives. 6.45, Accordion Recital. 7.0, Advertising Notes, Weather and News. 7.30, Recitations. 8.0, Time Signal. 8.1, Concert by the Station Orchestra, Conducted by Hugo Kramm. Soloist: Anna Tibell (Songs). Fugue and Gigue (Bach); Songs (Gluck): (a) O del mio dolce ardor, (b) Spigae amate; Melody (Pauline Hall); Spanish Songs (Albeniz); Thrimidia (A. Holtnes); Es muss ein Wunderbares sein (Liszt); Weylas Gesang (Wolf); Overture, Romeo and Juliet (Tchaikovsky). 9.10, Talk. 9.40, Weather and News. 10.0, Topical Talk. 10.15, Popular Concert by the Just Nielsen Ensemble. 10.45 (approx.), Close Down.

OSTERSUND.—See Stockholm.

**PALERMO**

558 kc/s, 537.6 metres; 3 kW.—8.0 p.m., Dopolavoro Notes, Tourist Talk, Agricultural

Vocal Music: Signature Tune, The Busy Bee (Bendix); Guitar Solo, Picking my Way (Lang); My Lady Dainty (Hesse); Song, Lettin' in the Sunshine (Gay); When the Convent Bell is ringing (Trevor); Song, I raised my Hat (Pola); I do like to be beside the Seaside (Glover); Dreams on the Ocean (Gungl). Part II, Dance Music: Dancing Butterfly; Hyde Park Corner; I can't remember; What a Lady Josephine must have been; It's the Band; Beautiful Lady; This is the Rhythm for Me; Alice Blue Gown; Signature Tune. 2.0, Programme in French. 4.30 to 6.0, Programme in English by the I.B.C. 4.30, Programme for Children. 5.0, Orchestral Concert for Torquay and Exeter Listeners: Signature Tune; The Night by the Sea; It seems to be Spring; I'm yours; Hittin' the Bottle; Get Happy; I lost my Girl from Memphis; Song, You're still my Sweetheart; Oh, I wish I could sing a Love Song; Old Medley. 5.30, Organ Recital for Plymouth and Devonport Listeners: A Life on the Ocean (Binding); There's Something about a Soldier (Gay); Nola (Arndt); Butterflies in the Rain (Myers); Song, For Good or for Bad (Pearson); Indian Love Call (Frim); The Wooden Soldier and the China Doll (Jones); Bells across the Meadows (Kettleby); Signature Tune. 6.0, Programme in French. 10.0 till Close Down, Programme in English by the I.B.C.: Signature Tune; The Bells of Normandy; I guess I'll have to change my Plans; Young and Healthy; Just a Little Home for the Old Folks; One little Word led to Another; Three Wishes; Pink Elephants; I cover the Waterfront; Hiawatha's Lullaby; My Gal Sal; My Love Song; Meet me in the Gloaming; Adorable; Seven Years with the Wrong Woman; When Gimble hits the Cymbal; Rosa Mia; Hold me; Signature Tune. 11.0, Music from Sound Films; Signature Tune; Sittin' in the Dark; To-day I feel so Happy; Sweep; Selection from The King of Jazz; Live, love and laugh; The Moment I saw you; You are too beautiful; Selection from Puttin' in the Ritz; Selection from Forty-Second Street; Signature Tune. 11.30, Concert by the I.B.C. (Ireland), Ltd.: Signature Tune, Come Back to Erin; Selection of Musical Gems (Shanar); Medley of Irish Jigs (arr. Hamah); The Wayside Shrine (Sherwood); Song, Goin' Home (Dvorak); Love's Dream after the Ball (Zibulka); Mason's Apron Reel (Traditional); Perdita (Cuvellier); The Skaters' Waltz (Waldteufel); Signature Tune. 12.5 a.m. (Wednesday), News Bulletin in English. 12.10 (approx.), Club Concert for Ware Listeners: Signature Tune, The Chum Song; Way out West in Kansas (Robinson); Got Cannibal (Weems); Clarinetitus (Goodman); You Rascal, you Theard; Too many Tears (Warren); You're mine you (Heymann); Dance, pretty Lady; Here is my Heart (Henderson); I sigh for you, Rio Rita (Santengin); Sweetheart Darlin' (Kahn); Maybe I love you too much (Berlin); Waiters on Parade (Ewing); I raised my Hat (Pola); There's a Cabin in the Pines (Hill); Signature Tune. 1.0, Dance Music: Signature Tune, Bells of Normandy; The old Spinning Wheel; Good-night but not Good-bye; Out in the Open; Spanish Eyes; I can't remember; All over Italy; When my Little Pomeranian; Won't you stay to Tea; There's a tiny little Hair upon your Shoulder; I'll see you in the Morning; In the Park in Patee; Put that Sun back in the Sky; Moon Song; Forty-Second Street; Wanderer; I've told every little Star; I wish I had Wings; Have you had a Good Day To-day? Signature Tune. 2.0, I.B.C. Good-night Melody, and Close Down.

FLENSBURG.—See Hamburg.

FLORENCE.—See Turin.

**FRANKFURT**

1,157 kc/s, 259.3 metres; 17 kW. Relayed by Cassel, 1,220 kc/s, 245.9 metres; and Trier, 1,157 kc/s, 259.3 metres.—4.30 p.m., See Munich. 5.30, Laugenberg-Heilsberg Exchange Programme. 6.15, Economic Notes. 6.25, Discussion: A Mainz Building Agreement of 1717 that is still in force. 6.45, Review of the Day's Events. 6.50, Time, Programme Announcements, Weather and Economic Notes. 7.0, Transmission for all German Stations, relayed from Leipzig. 8.5, See Stuttgart. 8.35, Concert, Part I—Suite for Orchestra, Op. 43 (Müller), by the Station Orchestra, conducted by Rosband. Part II—The Orchid Garden—Ten Impressions from the Far East, Op. 76, for Pianoforte (Niemann), played by the Composer. 9.30, Talk by Rolf Gardiner: The Changes in Germany from 1921-1933, through an Englishman's Eyes. 10.0, A German Almanac. 10.15, Time and News. 10.45, Dance Music from Leipzig. 12 Midnight, Close Down.

FREDRIKSSTAD.—See Oslo.

FREIBURG.—See Stuttgart.

GENEVA.—See Radio-Suisse Romande.

GENOVA.—See Turin.

GLEIWITZ.—See Breslau.

GOTEBORG.—See Stockholm.

GRAZ.—See Vienna.

HAMAR.—See Oslo.

SEPT. 12th **TUESDAY** continued

Notes, and Giornale Radio. 8.20, Gramophone Music. In an interval at 8.30, Time and Announcements. 8.45, Orchestral Concert: Soloists, Gallelli (Oboe), Ettore Paladino (Cello); Selection from The Snow Maiden (Rimsky-Korsakov); Oboe Concertino (Wolf-Ferrari); (Cello Solo, Air in D (Bach); Nocturne (Pizzetti); Sonata for Pianoforte and Cello (Beethoven); Waltz (Strauss). In an interval, Talk: The Heroine of Monteleone. After the Concert, Light Music. 10.55, News.

**PARIS**

**EIFFEL TOWER, Call FLE, 207.5 kc/s, 1,445.7 metres;** 13 kW. Time Signals (on 2,650 metres) at 10.26 a.m. and 11.26 p.m. (Preliminary and 6-dot Signals).—6.45 p.m., Theatre Notes. 7.0, Le Journal Parlé. 8.30, Rameau and Debussy Concert. The Symphony Orchestra, conducted by Flamant. Part I: Rameau Music. Selection from (a) Castor et Pollux and (b) Clebre Dardanus; Gavotte; Tambourin. Part II: Debussy Music: Hommage a Rameau; Selection from L'Enfante prodige; Suite hergamasque; Prelude and Interlude from Pelléas et Mélisande; La Fille aux cheveux de lin; Prélude a l'après-midi d'un faune; Petite Suite. 10.0 (approx.), Close Down.

**PARIS**

**POSTE PARISIEN, 914 kc/s, 328.2 metres;** 60 kW.—7.0 p.m., Gramophone Music. 7.15, Le Journal Parlé. 7.30, En nautiques—One-Act Comedy (Chanay). 8.0, Gramophone Music. 8.30, Concert by the Station Orchestra. Soloist: Marguerite Soyser (Songs). Prelude. (Zollner); Piedmontese Dances (Sinigaglia); Selection from Doktor Eisenbart (Zilleher); Adagio for Clarinet (Wagner); Romance (Sibelius); Polish Dance (Scharwenka); Dans l'île voluptueuse (Soyser); Minuet (Grieg); Two Gipsy Dances (Heidingsfeld); Waltz (Ferruccio-Busoni); Two Corsican Melodies (Tomasi); Le petit cimetière arabe (Zucca); Chanson pour mon amour (Zucca); Fleur de Grenade (Bartholomieu); Tendresse (Bachelet). 10.15, News.

**PARIS**

**RADIO PARIS, Call CFR, 174 kc/s, 1,725 metres;** 75 kW.—7.30 a.m., Weather and Physical Culture. 7.45, Gramophone Records. 8.0, News. 12 Noon, Gramophone Concert: Overture, Light Cavalry (Suppé); Quand on a ces yeux là (Borel-Clerc); O sole mio (di Capua); Au bord d'un ruisseau (Benedict); Etourdi (Michaelov); Melody (Faglieffo); Un peu d'amour (Silesu); Melody (Lénoir); Poupées de Paris (Loyraux); Le cœur de ma mie (Dalerozze); Estrellita (Ponce); Nocturne (Ganne); Aubade à Cendriline (Almaby); Selection from Rose Marie (Friml); Sidonie Patuache (Szule); Chanson (Friml); La Douce (Heraux); Melody (Davis-Burke); The Festival of the Gnomes; Marche tartare (Ganne); Ballet égyptien (Luigini); Partir (Gatove). In the intervals at 1.0, Exchange and News, and at 1.30, Exchange. 2.0, Exchange. 3.45, Exchange and Market Prices. 7.0, Agricultural Notes and News. 7.10, Gramophone Concert: Overture, Fra Diavolo (Auber); Contemplation (René); Two Waltzes (Chopin); Minuet (Bocherini); Song of the Volga Boatmen (arr. Kedrov); Eglonne (Rabaud); La Capricieuse (Ries); Scènes pittoresques (Massenet). 7.50, Commercial Prices and News. 8.0, Gramophone Concert: Selection from The Gipsy Princess (Kálmán); Melody; Sérénade badine (Marie); Guignette (Chantrier); Saxophone Marmalade (Rogenthal); Piece; Three o'clock in the Morning (Robledo-Marchetti); Piece (Sundy-Bonsquet); Delphine (Moretti). 8.30, The Radio Paris Competition and Review by Pierre Seize. 8.45, Concert (cont'd.); Estampilla (Romero-Beltrino); Piece (Herb-Brown); Dance (May); Effortement (Ganne); A la godille (Van Boorebeek). 9.0, Pli-Pli—Opéretta (Christine), relayed from the Théâtres des Bouffes-Parisiens. In the interval, Press Review and News.

**PITTSBURGH**

**KDKA, 980 kc/s, 306 metres;** 50 kW. Relayed by W8XK on 48.86 metres and 25.27 metres.—7.30 p.m., KDKA Home Forum. 8.0, Betty and Bob. 8.15, Smiths Play Bridge. 8.30, Words and Music, from New York. 8.45, Congress of Clubs. 9.0, Meredith Wilson Orchestra, from New York. 9.15, Jack Walton's Orchestra, from New York. 9.45, News, Markets. 10.0, L'asino Orchestra, from New York. 10.15, Tarzan of the Apes. 10.30, Singing Lady, from New York. 10.45, Orphan Annie, from New York. 11.0, News, Piano Classique. 11.15, Sports, A Song. 11.30, Pittsburgh Spotlights. 11.45 to 1.45 a.m. (Wednesday), New York Relay. 11.45, Lowell Thomas. 12 Midnight, Amos 'n' Andy. 12.15, Radio in Education. 12.45, Don Carney's Dog Stories. 1.0, Popular Programme. 1.30, Adventures in Health. 1.45, Programme to be announced. 2.0 to 4.0, New York Relay. 2.0, Miniature Theatre. 2.30, Pastorale. 3.0, Musical Memories.

**PORSGRUND.**—See Oslo.

**PRAGUE**

614 kc/s, 488.6 metres; 120 kW.—2.50 p.m., See **Moravská-Ostrava.** 3.50, Aviation Weather Report. 3.55, Exchange. 4.0, Interval. 5.45, Gramophone Music. 5.55, Legal Talk. 6.5, Market Prices. 6.15, Talk for Workers. 6.25, News in German. 6.30, German Transmission: The Doll—Radio Play (Vjka). 7.0, Chimes and News. 7.10, Talk. 7.25, See **Moravská-Ostrava.** 8.20, See **Brno.** 9.0, Rameau and Couperin Concert by the Station Orchestra, conducted by Jeremias. Soloist: Kredha (Harpischord); Orchestral Suite (Rameau); Harpischord Solos (Rameau): (a) Les tendres plaintes, (b) Minuet, (c) L'Égyptienne; Harpischord Solos (Couperin): (a) Le badouline, (b) Les charmes, (c) Les papillons, (d) Le bayolet glittant; Orchestral Suite (Couperin). 10.0, Time and News. 10.15, Gramophone Music. 11.0 (approx.), Close Down.

**RADIO-SUISSE ROMANDE**

**SOTTENS, 743 kc/s, 403 metres;** 25 kW.; and **Geneva, 395 kc/s, 760 metres.**—6.15 to 6.30 a.m. (from Lausanne), Gymnastics Lesson. 12.28 p.m., Time Signal from Neuchâtel Observatory. 12.30, News and Weather. 12.40 (from Lausanne), Gramophone Concert. 1.0 (from Lausanne), Financial News. 1.10 (from Lausanne), Gramophone Concert. 2.0 to 3.28, Interval. 3.28, Time Signal from Neuchâtel Observatory. 3.30 (from Lausanne), Concert by the Radio Lausanne Orchestra. 5.0 (from Lausanne), Programme for Women. 5.30 to 7.0, Interval. 7.0 (from Geneva), Talk: Reptiles, Lizards and Toads. 7.30 (from Geneva), Weather, News and Announcements. 7.45 (from Geneva), Answers to Correspondence. 8.0 (from Geneva), Organ Recital. 8.30 (from Geneva), Couperin Concert. 8.50 (from Geneva), Cabaret Programme. 9.50, News and Weather. 10.0 (from Geneva), Gramophone Music. 10.30 (approx.), Close Down.

**RJUKAN.**—See Oslo.

**ROME**

**Call IRO; 680 kc/s, 441 metres;** 50 kW. Relayed by Naples, 941 kc/s, 319 metres; and **2RO, 11,810 kc/s, 25.4 metres,** from 5.15 p.m.—12.30 p.m., Gramophone Music. 1.0, Concert from Turin. In the interval from 1.30 to 1.45, Giornale Radio and Exchange. 2.0, Time and Announcements. 4.30, Children's Radio Review. 4.50, Giornale Radio and Exchange. 5.10, Weather. 5.15 to 6.0, Orchestral Concert: Cielo d'Italia (Di Dio); Waltz Serenade (Sadun); Bimba menzogna (Visintini); Silvana (Hamud); Suite gothardica (Amadei); Ronda brasiliana (Escobar); Serenade. Di sera a Venezia (Virgili); L'amore cost? (Raimondi). 6.40 (Naples), Shipping and Sports Notes. 6.45, Wireless Signals and Dopplavoro Notes. 7.0, Tourist Report. 7.10, Agricultural Report. 7.20, News in Foreign Languages. 7.40, Giornale Radio. 8.0, Time and Announcements. 8.15, Sponsored Music. 8.30, Sports Notes. 8.45, Orchestral Concert, conducted by Andrea Marchesini. In the intervals, Talk: The Famous Singer Tomango; and Literary Notes. 11.0, Giornale Radio.

**SALZBURG.**—See Vienna.

**SCHENECTADY**

**WGY; 790 kc/s, 379.5 metres;** 50 kW. Relayed at intervals by **W2XAF** on 31.48 metres and by **W2XAD** on 19.56 metres.—12.45 a.m. (Wednesday), Stock Reports and Baseball Scores. 1.0 to 3.30, New York Relay. 1.0, Variety Programme. 1.30, Wayne King's Orchestra. 2.0, Ben Bernie's Blue Ribbon Orchestra. 2.30, Popular Programme. 3.0, Lives at Stake. 3.30, National Radio Forum, from New York, followed by Programme Ré-nué.

**SCHWEIZERISCHER**

**LANDESENDER**

**BEROMUNSTER, 653 kc/s, 459 metres;** 60 kW.; **Basle, 1,229 kc/s, 244.1 metres;** and **Berne, 1,220 kc/s, 245.9 metres.**—5.0 p.m. (from Zürich), Concert by the Small Station Orchestra. 5.30 (from Basle), Light Music on Gramophone Records. 6.30 (from Berne), Talk: The Open-air School. 7.0, Time and Weather. 7.10, Opéretta Music. 7.40 A Lawsuit over a Cat's Paw—Radio Play from the Chinese (Richard Freid). 8.15 (from Berne), Sacred Concert. 9.15 (approx.), Weather and News. 9.25 (from Berne), Popular Programme. 10.15 (from Berne), Talk in Dutch: Have you visited Switzerland in the Autumn?

**SOTTENS.**—See Radio-Suisse Romande.

**STOCKHOLM**

689 kc/s, 436 metres; 55 kW. Relayed by **Boden, 244 kc/s, 1,229.5 metres;** **Göteborg, 932 kc/s, 322 metres;** **Hörby, 1,166 kc/s, 257 metres;** **Motala, 221.5 kc/s, 1,354.4 metres;** **Ostersund, 389 kc/s, 770 metres;** and **Sundsvall, 554 kc/s, 542 metres.**—5.5 p.m., Pro-

gramme for Children. 5.40, Talk. 6.0, Gramophone Concert. 7.0, Microphone Report. 7.15, Time and Weather. 7.30 (from Göteborg). Two Plays (Eugene O'Neill): (a) The Long Voyage Home, (b) In the Zone. 8.15, Military Band Concert, conducted by Per Gründstrom; Coronation March from The Prophet (Meyerbeer); Overture (Tröback); Waltz from the Merry Widow (Lehar); Selection from The Vagabond King (Friml); Gopak (Mussorgsky); Selection from The Three Bears (Cotés). 9.15, Talk from **Malmo, 1,301 kc/s, 231 metres.** 10.0, Song Recital by Harald Falkman, Ueber ein Stündlein (Weingartner); Reue (Weingartner); Schmied Schmeizer (Eyeken); Five Songs (Grieg). 10.20, Concert of Chamber Music for the Bi-Centenary of the Death of Couperin. Sonata in G Minor, for Oboe and Harpischord (Telemann); Apothéose de Lully for Harpischord, Two Violins and Cello (Couperin). 11.0 (approx.), Close Down.

**STRASBOURG**

869 kc/s, 346 metres; 11.5 kW.—11.30 a.m., Light Music on Gramophone Records. 12 Noon, Orchestral Concert, conducted by Maurice de Villers; Part I, Rameau Music: Tambourin; Selection from Hippolyte et Aricie; Suite from Castor et Pollux; Air from Dardanus. 12.45 p.m., News. 1.0, Time and Exchange. 1.5, Orchestral Concert (cont'd.); Part II: Overture, Ruy Blas (Mendelssohn); Suite from Les deux pigeons (Messager); Italian caprice (Tchaikovsky); Joyeuse marche (Chabrier). 2.0, Interval. 3.30, Orchestral Concert, conducted by Bourbié, relayed from the Casino, Vichy; Salut à la France (Scassola); Overture, Mirella (Gounod); Suite, Mascara (Lacôme); Fantasia, Echos d'Auvergne (Bourbié); Selection from Les saltimbanques (Ganne); Waltz, Gold and Silver (Lehar). 5.0, Talk on French Somaliland. 5.15, Orchestral Concert, conducted by Roskam; March (Blankenburg); Waltz, Espanita (Rosey); Overture, Die Felsenmühle (Reissiger); Selection from Rip (Planquette); Esquisses Provençales (Popy); March, Sivole (Marwys). 6.0, History Talk. 6.15, Topical Talk. 6.30, Concert of Chamber Music: Sonata for Two Violins and Pianoforte (Handel); Trio for Strings in C Minor (Beethoven); Sonata for Cello and Pianoforte (Grieg). 7.30, Time and News. 7.45, Gramophone Music. 8.0, Press Review in German. Lottery Results and Announcements. 8.30, Orchestral Concert, relayed from the Casino, Plombières-les-Bains; Overture, Fingal's Cave (Mendelssohn); Selection from The Gipsy Princess (Kálmán); Fantaisie rhapsodique (Dupuis); Selection from The Last Waltz (O. Strauss); Waltz, Roses from the South (Joh. Strauss); Selection from The Valkyrie (Wagner). In the interval, Talk: Plombières in the Romantic Period. 10.0 (approx.), Press Review.

**STUTTGART**

**MUHLACKER, 832 kc/s, 360.5 metres;** 60 kW. Relayed by **Freiburg, 527 kc/s, 570 metres.**—12 Noon, Concert by the Station Orchestra, conducted by Otto Seyfert: Overture, Abu Hassan (Weber); Selection from La Traviata (Verdi); Suite from Sleeping Beauty (Tchaikovsky); Waltz Fantasia (Glinka); Waltz from Das Fürstentkind (Lehar); Selection from Der Tenor de Herzogin (Künneke). 1.15 p.m., Time and News. 1.30, Opera Music on Gramophone Records: Music from Oberon (Weber) and Tristan und Isolde (Wagner). 2.0, Programme arranged by the Post Office, with Gramophone Records. 2.30 to 3.0, Advanced English Lesson. 3.30, Talk: Flowers. 4.0, Talk for Women; German Fashions through three Centuries. 4.30, See **Munich.** 5.30, See **Hellsberg.** 6.15, The Turks before Vienna—Talk in commemoration of the Relief of Vienna on September 12th, 1683. 6.40, Time and News. 7.0, Transmission for all German Stations, relayed from **Leipzig.** 8.0, Talk: You must know... 8.5, An Interview with Dr. Friedrich Bergius, the inventor, relayed from his Private Laboratory at Heidelberg. 8.35, Dance Music on Gramophone Records. 9.0, See **Hamburg.** 10.0, See **Munich.** 10.20, Time and News. 10.40 (from Karlsruhe), Talk: The Theatre. 11.0 (approx.), Programme from **Leipzig.** 12 Midnight (approx.), Close Down.

**SUNDSVALL.**—See Stockholm.

**TOULOUSE**

**RADIOPHONIE DU MIDI, 779 kc/s, 285 metres;** 8 kW.—6.0 p.m., News. 6.5, Dance Music. 6.30, Accordion Music. 6.45, Light Music. 7.0, Spanish Caprice (Rimsky-Korsakov), by the Symphony Orchestra. 7.15, News. 7.30, Arias from Comic Opera. 7.45, Music from Sound Films. 8.0, Sponsored Concert of Opera Music. 8.15, Accordion Music. 8.30, Orchestral Music. 9.0, Arias from Opera; Arias from (a) William Tell (Rossini), (b) Lakmé (Delibes), (c) Rigoleto (Verdi), (d) Samson and Delilah (Saint-Saëns), (e) La juive (Halévy). (f) The Huguenots (Meyerbeer). (g) La Bohème (Puccini), (h) Manon (Puccini). 9.30, Music by a Viennese Orchestra. 10.0, Music by an Argentine Orchestra. 10.15, News. 10.30,

Concert for Listeners in Morocco. 11.0, Dance Music. 11.45, Arias from Opéretta. 12 Midnight, News. 12.5 a.m. (Wednesday), Orchestral Concert: Selection from Viktoria and her Hussar (Abraham); Prelude to Les Erynnies (Massenet); La habanera (Laparra); Selection from The Mikado (Sullivan). 12.30, Close Down.

**TRIESTE**

1,211 kc/s, 247.7 metres; 10 kW.—5.15 p.m. till Close Down, See **Turin.**

**TRONDHEIM.**—See Oslo.

**TURIN**

1,096 kc/s, 273.7 metres; 7 kW. Relayed by **Milan, 905 kc/s, 331.5 metres;** **Genoa, 959 kc/s, 312.8 metres;** and **Florence, 599 kc/s, 500.8 metres.**—5.15 p.m., Dance Music from the Savoia. 6.0 to 6.5, Weather Forecast. 6.40, Giornale Radio, Dopplavoro Announcements and Gramophone Music. 7.0, Time, Report of the Royal Geographical Society, and Gramophone Music. 7.10, Agricultural Notes and Market Prices. 7.20, News in Foreign Languages. 7.40, Gramophone Music. 8.0, Announcements, Giornale Radio, Sports Notes and Gramophone Music. 8.30, Talk on the following Transmission. 8.35, Opéretta in Three Acts. In the intervals, Talk and News. After the Opéretta, Giornale Radio.

**VATICAN CITY**

15,120 kc/s, 19.84 metres (Morning), and 5,969 kc/s, 50.26 metres (Evening); 10 kW.—11.0 to 11.15 a.m., Religious Information in English. 8.0 to 8.15 p.m., Religious Information in Italian.

**VIENNA**

581 kc/s, 517 metres; 100 kW. Relayed by **Graz, 852 kc/s, 352.1 metres;** **Innsbruck, 1,058 kc/s, 283 metres;** **Klagenfurt, 662 kc/s, 453.2 metres;** **Linz, 1,220 kc/s, 245.9 metres;** and **Salzburg, 1,373 kc/s, 218.5 metres.**—11.40 a.m., Talk: The Relief of Vienna (12th September, 1683). 12.5 p.m., Concert by the Wiener Symphoniker, conducted by Max Schönherr. Soloist: Marianne Kurand (Pianoforte). 3.0, Time and Announcements. 3.10, Gramophone Concert of Classical Music. 4.5, Talk: From Granada to Morocco. 4.30, Report on the Catholic Congress, relayed from the Stadium. 5.0, Military Band Concert, relayed from **Salzburg.** 6.15, Talk: With the Lumbermen of Salzburg Backwoods. 6.45, Talk on the Cardinal Piff Memorial Church at Gloggnitz. 7.5, Concert by the Wiener Symphoniker, conducted by Josef Hubzer; Overture, Martha (Flotow); Violin Solo: Chant sans paroles (Tchaikovsky-Kreisler); Waltz, Künstlerleben (Joh. Strauss); Gartenstüchchen (Meyer-Hellmuth); Waltz, Water Symphs (Kretelberg); Minuet (Pauspertl); Song, Rozsika (Leopoldi); Selection from Countess Maritza (Kálmán); March, Preibühel (Blankenburg). 7.55, Time and Announcements. 8.5, The Relief of Vienna—Prize Radio Play (Ernst Dermsey and Karl Hans Strobl). 10.35, News. 10.50, Report on the German Catholic Congress. 11.0, Light Music on Gramophone Records.

**WARSAW**

212.5 kc/s, 1,411 metres; 120 kW.—11.57 a.m., Time Signal and Fanfare from the Tower of St. Mary's Church, Cracow. 12.5 p.m., Gramophone Music. 12.25, Polish Press Review. 12.35, Gramophone Music. 12.55, Radio Journal. 1.0, Interval. 2.55, Gramophone Music. 3.5, News. 3.10, Announcements. 3.15, Gramophone Music. 3.25, Economic Notes. 3.35, Gramophone Music. 3.45, Aviation Report and Anti Gas Drill. 3.50, Gramophone Music. 3.55, Announcements. 4.0, Gramophone Music. 4.50, Answers to Correspondence. 5.5, Song Recital by Mme. Hupert. 5.30, Pianoforte Recital: Chaconne (Handel); Sonata—Les Adieux (Beethoven); Rhapsody in G, Op. 79 (Brahms). 6.15, Talk: The Battle of Vienna. 6.35, Song Recital by Elvire Rove-Staliska. 7.5, Gramophone Music. 7.20, Miscellaneous Items. 7.35, Programme Announcements. 7.40, Topical Talk. 8.0, Soprano and Bass Recital by Szczeniowski and Michalowski; Bass Solos: (a) O. could I but express in Song (Malashkin), (b) I hear your Voice (Balakirev), (c) Night (Gretchaninov), (d) The Raising of Lazarus (Rachmaninov); Soprano Solos: (a) Waltz from Coppelia (Delibes), (b) Vons dansez, Marquise (Léonard), (c) Waltz from Ronco and Juliet (Gounod); Bass Solos: (a) The Old Corporal (Darzonjycki), (b) The Dream (Rachmaninov), (c) Blessed be these Forests (Tchaikovsky), (d) Heroism (Tchaikovsky); Soprano Solos: (a) Berceuse (Gretchaninov), (b) Aria from The Snow Maiden (Rimsky-Korsakov), (c) The Nightingale (Alabiev). 8.50, Radio Journal. 9.0, Agricultural News. 9.10, Jazz Music, relayed from **Cracow, 959 kc/s, 312.8 metres.** 10.0, Dance Music. 10.25, Sports Notes. 10.35, Weather Report and Aviation and Police Notes. 10.40, Dance Music.

**ZURICH.**—See Schweizerischer Landessender.



# OUTSTANDING DESIGNS & WORKMANSHIP

made



the centre of interest at  
Radiolympia and Glasgow

## THE "WARWICK" CABINET DE LUXE

This cabinet was specially designed for "The Wireless World" New Monodial Super and is manufactured in specially selected figured walnut with ebonised base and macassar ebony base. Also supplied as a Radiogram cabinet with raised hinged lid at an additional cost of 2/6.

Price £5 - 10 - 0

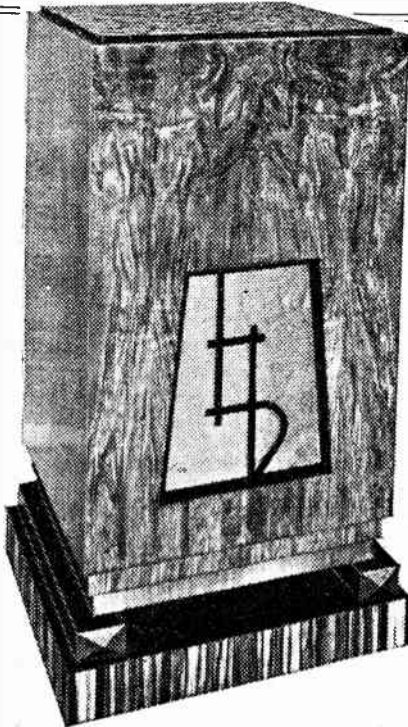

Despite the rush of orders (and there has been a *genuine* rush) at these Radio Exhibitions, we have maintained our published promise of delivery by return of post of all orders for the New Monodial Super Kit of Parts, every component being strictly in accordance with the designer's first choice.

"C.A.C." are fortunate in having the Radio Manufacturing Department and the Cabinet-making side of its business housed in a large modern Factory, covering an area of about 13,000 sq. feet, and the most up-to-date machinery has been installed.

This happy and unique combination of highly specialised Receivers, built into the best that Cabinet-makers' craftsmanship can produce, is sufficient to ensure that only Receivers of outstanding performance and appearance will be offered to the public.

TRADE ENQUIRIES INVITED

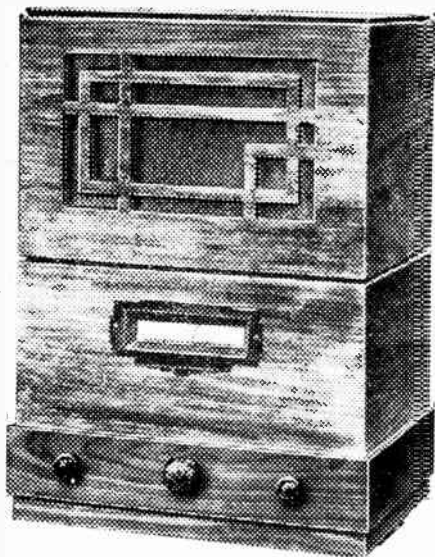

Price 14 GUINEAS

## THE "C.A.C." PENTAGRID SUPERHET

A four-valve A.C. Superhet of highly specialised technique using a Pentagrid Converter as a single-valve frequency changer, which performs the dual functions of oscillator and first Detector in the most efficient manner known. In the I.F. stage a variable-mu Pentode is used, which adds its contribution to A.V.C. The third valve is one of the new double Diode Pentodes, which gives almost perfect automatic volume control, and the fourth valve is a Catkin Pentode. The output is in the order of 2½ watts, whilst the sensitivity of this Receiver is a revelation. The four special valves give an overall performance equal to that of any six-valve superhet on the market.

Our 1933-4 Catalogue is now ready. Send a post card for a copy to-day.

## THE "C.A.C." GRANDFATHER CLOCK CABINET

This handsome and original piece of furniture represents the very last word in Radio-gramophone Cabinet design and has proved one of our most popular selling lines at Olympia and Glasgow Shows. There is provision for accommodation of almost any type of Receiver, whilst the Gramophone motor and Pick-up fit into the sliding compartment below. The two side compartments allow for the storage of gramophone records or can be fitted as a cellarette, etc. PRICE 14 GNS.

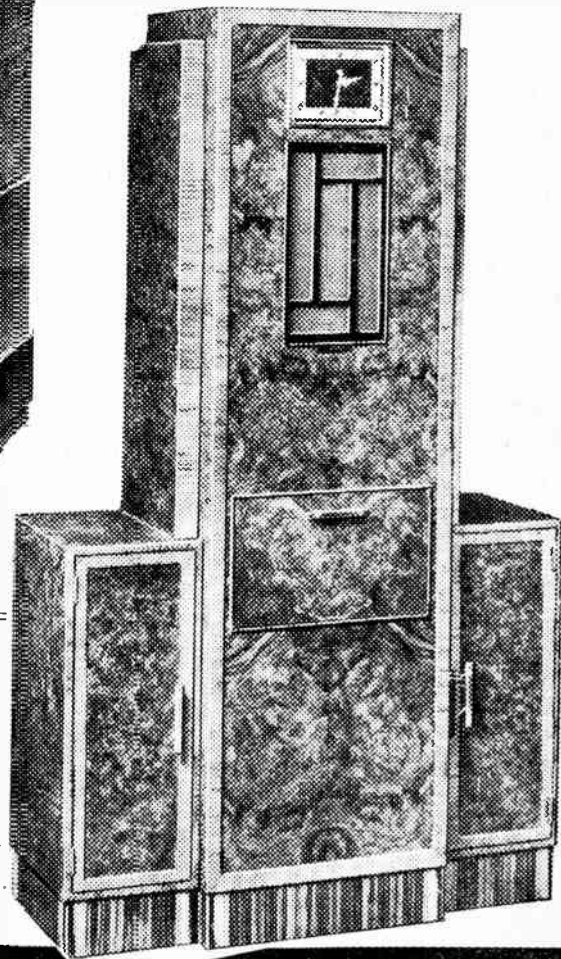

## "C.A.C." KITS for The Wireless World

### NEW MONODIAL SUPER

**KIT "A" RECEIVER UNIT:** Comprising the Designer's first specified components (less Chassis, Panel, Valves and Cabinet) £10-19-6

**KIT "B" POWER UNIT:** Comprising the Designer's first specified components (less Chassis and Valves) £8-13-6

Detailed Price List Free on Application.

**ALUMINIUM CHASSIS** correctly drilled with side members, finished in French-grey cellulose, Receiver Chassis, 10-; Power Unit Chassis, 7/6. "C.A.C." Panel, 11" x 10", in Polished Oak, Walnut or Mahogany, 2/-. Valves: Receiver (5), £4-4-6. Power Unit (1), £3-0-6.

### FERROCART CLASS "B"

**KIT "A."** Complete (less Valves, Batteries, Cabinet and Loud Speaker) £7-11-0

**KIT "B."** Complete with Valves (less Batteries, Cabinet and Loud Speaker) £9-17-3

**KIT "C."** Complete with Valves, Cabinet and Loud Speaker (less Batteries) £13-9-3

**CABINET**, beautifully finished in Figured Walnut exclusively specified by the designer and manufactured in our own factory £1-12-6 (Front drilled, if desired, without extra charge.)

Continuous Demonstrations Daily.

### CONSTRUCTION

We shall be pleased to undertake the construction of the above Receivers to customers' own requirements. Only highly skilled technicians, under the personal supervision of Mr W. I. G. Page, B.Sc., are entrusted with this work. This ensures that the results obtained by the designer will be duplicated.

**CITY ACCUMULATOR Co. Ltd.**

18-20, NORMAN'S BUILDINGS (off Central Street), LONDON, E.C.1

Telephones: Radio Dept.—Clerkenwell 6206. Telegrams: Cabinet Dept. 1038 "Cityacco, Barb, London."



# RADIO DATA CHARTS

## A SERIES OF ABACS

providing most of the essential Data required in Receiver Design

By R. T. BEATTY, M.A., B.E., D.Sc.

(1930)

Reprinted from "The Wireless World"

"Radio Data Charts" provide designers of wireless apparatus with a ready and convenient means of solving problems without having recourse to complicated formulæ and mathematics.

By the use of the charts it is possible to tackle all the more familiar problems in radio receiver design; such as, for example, finding the relationship between inductance capacity and frequency, and working out the design of high frequency transformers. All keen amateurs will appreciate this helpful book.

Price 4/6 net                      By post 4/10

(39 CHARTS and more than 50 Diagrams)

From all leading booksellers or direct from the Publishers  
Published from the Offices of "THE WIRELESS WORLD"

ILIFFE & SONS LTD., Dorset House, Stamford St., London, S.E.1

W.W. 93

# WIRELESS DIRECTION FINDING and DIRECTIONAL RECEPTION

By R. KEEN, B.Eng. (Hons.)

SECOND EDITION (1927)

This volume deals with the principles of the subject and the constructional details of direction finding installations, and includes some information concerning aircraft installation. It describes the principles of Direction and Position Finding in such a way that the subject may be grasped easily by engineers tackling this field of wireless work for the first time. Numerous photographs and diagrams are included, and the book will prove of the utmost use and value to advanced workers who are interested in this aspect of wireless.

Price 21/- net                      By post 21/9

From leading booksellers or direct from the Publishers

ILIFFE & SONS LIMITED

DORSET HOUSE, STAMFORD STREET, LONDON, S.E.1

w.w.68.

# T. W. THOMPSON & Co.

SURPLUS CLEARANCE DEPOT

17, STRUTTON GROUND, WESTMINSTER, S.W.1

ALL GOODS ON THREE DAYS' APPROVAL AGAINST CASH OR C.O.D. (I.F.S. excepted).

Telephone: Franklin 6355.  
Nearest Station,  
St. James's Park (Underground).

Open Weekdays 9 o'clock until 7.30 p.m.  
ANOTHER GREAT PURCHASE OF H.M.V. AND OTHER WELL-KNOWN SET MANUFACTURERS' SURPLUS GOODS. TO BE CLEARED AT RIDICULOUS BARGAIN PRICES. All Goods are guaranteed by us.

**ELECTRIC LIGHT AND POWER CHECK METERS.**—For A.C. Mains 200-250 volts 50 periods. No more wondering as to the amount of current this or that article is using. Here is the check on same. Useful for checking consumption of sub-let flats, charging plants, motors, wireless apparatus or anything using electricity. A few shillings will save pounds. Makers' Westinghouse and other well-known makers. Cost £1.18 each. We are clearing these, in good working order, jewelled pivots, 6/- each, post 1/3. **A.C. HUM** cured by inserting one of these latest design **PHILIPS CHOKES** as used in Philips All-mains Receivers, highest grade nickel iron stamping, special winding, highly impregnated, manufacturers type, 2, 2.5 and 30 henrys. Owing to the huge number of these which we have purchased, we are giving everyone the benefit of purchasing one of these. Price 2/- each, post free, or 20/- dozen. **BARGAINS IN SETS.** **MARCONI 4 VALVE SETS (MODEL 44).**—2 S.G., Det. and Power in mahogany cabinet, tuning valves, 25/3, post 1/6. **MARCONIPHONE 3 VALVE SHORT WAVE RECEIVERS, MODEL 34.**—complete with range of coils 16-29 metres and 29-52 metres and coupling coil, in mahogany cabinet, 25/6, post 1/3. **MARCONI 4 VALVE ALL-MAINS RECEIVERS.**—S.G., Det., L.P. and Power for A.C. mains 200-250 volts 50 periods, Model 520, bargain price, less valves, 52/6. **ROYAL CONVERTERS.**—Electro Dynamic input 220 volts D.C. Output 200-220 volt A.C. 100 watt, complete in fully screened case with hum proof smoothing unit. Perfect condition, listed 12 Gns., to clear, 5/10/- each. **CRYPTO CONVERTERS.**—Input 200-220 volts D.C. output 200 volts A.C. 100 watt complete with starter and hum proof smoother. Price £4/15/-. **CENTRAL DOUBLE VOLUME CONTROLS.**—Listed 10/6, to clear 2/6, post free. **British Radiophone Controls** with combined switch 2/-, post 3d. **EVERETT EDGECLUMBE 0 TO 3 AMP. MOVING COIL AMPMETERS.**—Reading division of 1 amp., useful for Trickle Charging, etc., 9/6, post 6d. **PHILIPS SPEECH TRANSFORMERS.**—2/-, post 3d. **A.C. ELIMINATORS.**—150 volts 30 m.a., 2 pos. tappings (1 variable), Westinghouse Metal Rectified, for 200-250 volt mains, 28/6, new and guaranteed perfect, post 1/-. **RADIOGRAM CABINETS.**—In Walnut, made for 535 Marconi, felt lined lid with auto-stay, cost makers 68/8/-, a handsome piece of furniture, size 3ft. 6in., height 1ft. 5in., width 1ft. 4in. Price £23/-. **REGENTONE ALL-MAINS TABLE CONSOLE CABINETS.**—Polished walnut, size 19in. x 16in. x 10in., beautifully designed, complete with felt lined baffle, 10/6, post 1/-. **COLLARO INDUCTION GRAM. MOTORS.**—(Electric) latest type, complete with automatic stop and all fittings, boxed and unused, £1/7/6, post 1/-. **D.C. ELIMINATORS.**—200-250 volts input, output 150 volts 30 m.a., 2 pos. tappings, 1 variable, all new and guaranteed, 10/6, post 9d. 3 positive tappings and variable, 15/-, post 9d. **WEGO BAKELITE MOULDED CASE CONDENSERS.**—With terminals, 700 volt test, 1 m.f. 1/-, post 3d., per doz. 10/-. 2 m.f. 1/3, post 3d., per doz. 18/-. 3 m.f. 2/8 each, 2/3 each in dozens. Postage on dozens 1/3. **MAINS TRANSFORMERS, EKCO.**—All for 200/250 volt input, tapped outputs 350 0 350 volt 80 m.a. 1 v. 4 amp., and 1 v. 2 amp., 10/6, post 1/-. **REGENSTAT ELIMINATOR VOLTAGE CONTROLS.**—Listed 5/6, to clear 1/-, post 3d.

**ECKERSLEY TROUTON BALANCED ARMATURE SPEAKERS.**—Complete with 12in. chassis and cone, beautiful reproduction, new and boxed listed 27/6, to clear 6/11, post 9d. **MAINS RADIO 2 VALVE ALL-MAINS SETS.**—For 200/250 v. A.C. complete with valves and speaker. List 8 Gns., our price 75/-. **LAMPLUGH MOVING COIL SPEAKERS.**—(Silver Ghost) 200/250 v. D.C. listed 27/6, to clear 10/-, all perfect. A.C. Model 22/6, post 1/-. **CONDENSER BANKS, ETC.**—8.25 m.f., T.C.C., tapped 500 v. 2/6, post 3d. 10.5 m.f., T.C.C., tapped 3/-, post 3d. 8.5 m.f., H.M.V., tapped 2/6, post 1d. 3.6 m.f. Wego, 500 volt tapped 1/9, post 3d. 8 m.f. Siemens 700 v. working, 2/6, post 3d. 4 m.f. Siemens 500 volt, 2/-, post 3d. **FARADAY INTERVAL TRANSFORMERS.**—2/6, post 6d. **FARADAY MAINS CHOKES.**—2/-, post 3d. **PHILIPS 1 WATT RESISTANCES.**—Full range from 100 ohms up to 100,000 ohms, 6d. each, post free. **COMBINED READING VOLTMETERS.**—0-12 and 0-120 volts, 3/- each, post 6d. **AVOMETERS.**—In good working order, 90/- each. **H.M.V. ALL-MAINS POWER AMPLIFIERS.**—Capable of handling 5 watt without distortion, very heavy components, 100, 200/250 volt A.C. mains. Parts alone worth more than we ask, 62/6, carriage forward. **TO BE CLEARED CHEAP.**—100,000 manufacturers' type Edison Bell small fixed condensers, sample box 36 condensers assorted, 1/-, post 3d. **HOUSE TELEPHONES.**—Complete table and desk type, 10/6 each, post 9d. **COLUMBIA 3 VALVE MAINS CABINETS.**—15 x 15 x 10 1/2, 7/6, post 9d. **BRITISH RADIOPHONE 4 GANG VARIABLE CONDENSERS.**—0005 with Trimmers, 8/6, post 9d. **DUR AMESCO 3 GANG VARIABLE CONDENSERS.**—As used in H.M.V. sets with trimmers. Can be dismantled and used as 2 gang, brand new, 9/6, post 6d. **ELECTRIC CLOCKS FOR A.C. MAINS.**—11in. dial, 27/6, 5in. dial Boudoir type, 25/-. Movements only, 17/6, post 9d. **LARGE CONDENSERS.**—Half micro Farad, 10,000 volt, 10/6 each. **CIFEL D.C. ALL MAINS RECEIVERS.**—Complete with valves and magnavox M.C. speaker, 75/- each brand new. **BATTERY CORDS.**—Complete with plugs, 8 and 9 way, 9d., post 3d. **BROWNS METAL ELIMINATOR CASES.**—Size 10 1/2in. x 6in. x 5in., 9d. each, post 6d. **LEAD 1.044 V.I.R. CABLE.**—5/- per 110 yards coils, post 9d. Lead twin cable 1.011, 4/- per dozen yards, post 9d. **MAINS DROPPING RESISTANCES.**—592 Ohms 10 watts, reducing from 200/250 volts to 15 volts 1 amp., 2/- each, post free. **BOXES OF ASSORTED SCREWS, B.A.**—(1 Gross in each) always useful, 6d. per gross box, post 3d. **HIGHEST GRADE REISSZ PATTERN MICROPHONES.**—In heavy polished octagonal aluminium case, with rings for suspension, even response for amplifiers up to 60 watts. Transformers for all models 5/6 extra, nicked and oxidised stand for Heisz, 12/6 extra. Price for Microphone, 55/-, post 1/-. **A.C. VOLTMETERS.**—0-150 volts, 5in. dial, price 17/6, post 9d. **A.C. AMP METERS.**—0-50 amps., 15/6, post 6d. **BROADCAST MICROPHONES.**—Pedestal type with rubber suspension, price 15/6. Watch type pattern, very sensitive, 4/6, post 6d. **WE ADVISE EARLY RESPONSE FOR ALL ABOVE GOODS AS SUCH EXCEPTIONAL BARGAINS WILL BE EARLY CLEARED. WE SHALL BE PLEASSED TO RECEIVE ENQUIRIES WHICH WILL BE PROMPTLY DEALT WITH.**

SEND ONLY 2/6 FOR ANY OF THE NEWEST "BLUE SPOT" P.M. MOVING COIL LOUDSPEAKERS

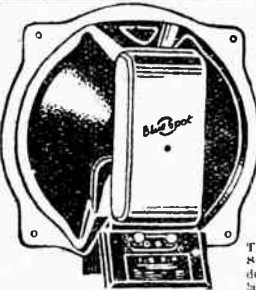

FOR 7 DAYS' TRIAL BALANCE BY MONTHLY PAYMENTS

The new "BLUE SPOT" Speakers are of advanced design and embody all the latest refinements. All these new Permanent Magnet Moving Coil Speakers incorporate Output Transformers with tappings for matching with Power, Pentode and Push-Pull output. They represent the FINEST VALUE obtainable, therefore take advantage of the 7 DAYS' TRIAL offer and easy monthly terms of E. J. HERAUD, Ltd. Send only 2/6 for either model illustrated for 7 days' trial.

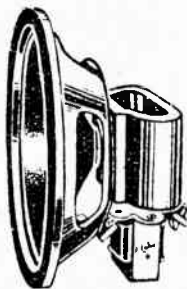

"BLUE SPOT" MODEL 45 P.M., unquestionably a Speaker in a class of its own. Send only 2/6 for 7 days' trial; if satisfied pay further 5/- at once, then six monthly payments of 7/6. (Cash in 7 days, 45/-)

MAHOGANY CABINET MODEL 62 P.M., incorporating the above chassis, 2/6 deposit, 5/- after 7 days, then nine monthly payments of 7/6. (Cash in 7 days, 67/6)

SEND ONLY 1/6 for the famous "PIFCO" ALL-IN-ONE Radiometer



If satisfied, complete purchase by five monthly payments of 2/6. (Cash in 7 days, 12/6). The "Pifco" tests everything—valves, components, circuit, etc., and locates faults instantly. It is essential to every radio user and helps to keep any set in 100% condition.

"BLUE SPOT" MODEL 20 P.M., a brilliant Moving-Coil Speaker at a very moderate price. Send only 2/6 for 7 days' trial; if satisfied, pay further 5/- at once, then six monthly payments of 7/6. (Cash in 7 days, 32/6)

OAK CABINET MODEL 22 P.M., incorporating the above chassis, 2/6 deposit, 5/- after 7 days, then six monthly payments of 7/6. (Cash in 7 days, 45/-)

E. J. HERAUD, Ltd., Dept. WW14, Number One, EDMONTON, LONDON, N.18

Branches: 78, 82, Fore St., Edmonton; 77 West Green Rd., Tottenham; 31, St. James St., Walthamstow; and 139, Herford Rd., Enfield Wash.

"LET'S HAVE A MAN'S COMPONENT TO OUR OWN SPECIFICATION"

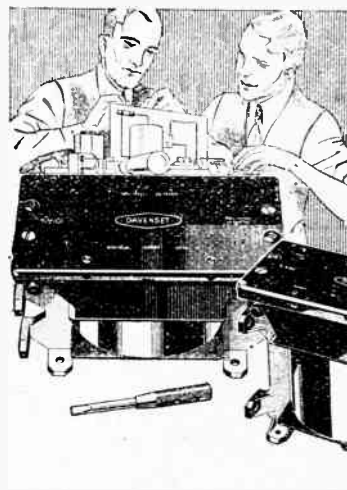

"I notice that several of the Sets described in the Radio Press specify DAVENSET Chokes and Transformers. If they are good enough for the experts they are certainly good enough for me. And besides, I notice that DAVENSET Engineers specialise in making to individual specification. Let's tell them what we want."

DAVENSET CHOKES AND TRANSFORMERS

GLASGOW Radio Show STAND 14

PARTRIDGE WILSON AND COMPANY

Dept. 29, Davenset Works, LEICESTER SCOTTISH BRANCH: 200, St. Vincent Street, GLASGOW C.2.

# Listen!



## **SUPERHET SELECTIVE FIVE**

Electrically operated, for alternating current, in compact acoustically designed cabinet of figured walnut on ebonised base. Superheterodyne circuit with band-pass tuning. Separated illuminated wavelength scales with names of principal stations. Self-contained aerial device. Five Marconi valves, (inc. rectifier). Variable mu I.F. amplifier. Energised moving coil speaker of new type. MODEL 438.

**Price 15 Gns.** Or by Hire Purchase.

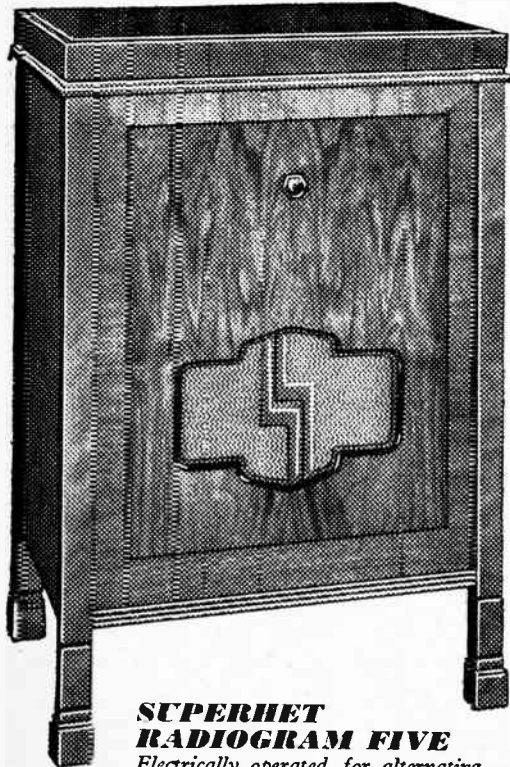

## **SUPERHET RADIOGRAM FIVE**

Electrically operated, for alternating current. Five Marconi valves (inc. rectifier). Variable mu I.F. amplifier. New type moving coil speaker. Superheterodyne circuit with band-pass tuning. Separate illuminated wavelength scales on motor board, with names of principal stations. Self-contained aerial device. Beautiful pedestal cabinet in finely figured walnut. MODEL 512.

**Price 29 Gns.** Or by Hire Purchase.



IN CHOOSING RADIO TO-DAY, from so wide and ever-growing a field of choice, the wise listener places his confidence in a name or a trademark with a reputation to keep up. "HIS MASTER'S VOICE" is the most famous trademark in the world—and all the world knows its meaning. The little dog pricks up his ears and cocks his head sideways because he thinks he hears his master speaking. For thirty years "HIS MASTER'S VOICE" have kept to this ideal—an ideal of the reproduction of sound so real as to be indistinguishable from life. And still to-day, the test of "HIS MASTER'S VOICE" Radio is to LISTEN . . . just listen! By that test you will appreciate the difference—the difference that really matters—between "HIS MASTER'S VOICE" Radio and other sets.

You are invited to apply this test to any of the "HIS MASTER'S VOICE" instruments, and full particulars of the complete range can be obtained from any authorised dealer, or from "His Master's Voice," 98a, Clerkenwell Road, London, E.C.1:

# "His Master's Voice"

"TRUE - TO - LIFE"

# RADIO

The Gramophone Co., Ltd., 98-108 Clerkenwell Road, London, E.C. 1

(Prices do not apply in I.F.S.)

Mention of "The Wireless World," when writing to advertisers, will ensure prompt attention;

# The Wireless World

THE  
PRACTICAL RADIO  
JOURNAL  
23<sup>rd</sup> Year of Publication

No. 732.

FRIDAY, SEPTEMBER 8TH, 1933.

VOL. XXXIII. No. 10.

Proprietors: ILIFFE & SONS LTD.

Editor:  
HUGH S. POCOCK.

Editorial,  
Advertising and Publishing Offices:  
DORSET HOUSE, STAMFORD STREET,  
LONDON, S.E.1.

Telephone: HOp 3333 (50 lines).  
Telegrams: "Ethaworld, Watloo, London."

COVENTRY: Hertford Street.  
Telegrams: "Cyclist, Coventry." Telephone: 5210 Coventry.

BIRMINGHAM:  
Guildhall Buildings, Navigation Street, 2.  
Telegrams: "Autopress, Birmingham." Telephone: 2970 Midland (3 lines).

MANCHESTER: 260, Deansgate, 3.  
Telegrams: "Iliffe, Manchester." Telephone: Blackfriars 4412 (4 lines).

GLASGOW: 26B, Renfield Street, C.2.  
Telegrams: "Iliffe, Glasgow." Telephone: Central 4857.

PUBLISHED WEEKLY. ENTERED AS SECOND  
CLASS MATTER AT NEW YORK, N.Y.

Subscription Rates:  
Home, £1 1s. 8d.; Canada, £1 1s. 8d.; other  
countries abroad, £1 3s. 10d. per annum.

*As many of the circuits and apparatus described in these  
pages are covered by patents, readers are advised, before  
making use of them, to satisfy themselves that they would  
not be infringing patents.*

## CONTENTS

	Page
<b>PROGRAMMES FROM ABROAD, pp. I—XXIV</b>	
Editorial Comment .. ..	207
Delayed Diode A.V.C. .. ..	208
Simple Measurements on Receivers and Components .. ..	211
News of the Week .. ..	214
The Berlin Radio Show .. ..	215
Push-Pull Output Transformer ..	218
Laboratory Tests .. ..	220
Broadcast Brevities .. ..	221
Correspondence .. ..	222
Practical Hints and Tips .. ..	223
Readers' Problems .. ..	224

## EDITORIAL COMMENT

### The Art of Listening Advantages of Indirect Reception

ONCE again broadcast listeners and, in particular, the musicians amongst them, have provoked a discussion on the comparative merits of direct and indirect listening, in the concert hall itself, or through the medium of a broadcast receiver.

On this occasion it is *The Times* which provides the forum, and that eminent musician, Sir Walford Davies, who has endeared himself to all wireless listeners, is responsible for what must be regarded, amongst all the rest, as the most provocative contribution to the discussion.

Disregarding all the limitations, such as frequency response and monaural reception, of which broadcasting engineers are so painfully conscious, Sir Walford boldly states: "Personally I have never in my life enjoyed Beethoven more in any concert room here or abroad than I have enjoyed him 'electrically reproduced' recently."

We suggest that one of the reasons why a musician can claim to get more enjoyment out of electrically reproduced music than from direct listening may be attributable to the fact that in the concert hall it is difficult to give full attention to the music without being distracted by the sense of sight and by the little interferences and interruptions to absorption in the music which go on all round. In listening through the medium of the broadcast receiver it is possible to suppress all extraneous noises and interruptions and, if necessary, put out the lights as well, to remove the disturbing influence of the sense of sight.

If we weigh in the balance the advantages of broadcast listening

against the disadvantages, we think it quite likely that even a jury composed entirely of musicians might give a verdict in favour of broadcast reception, for the reason that, great as are the merits of direct listening from such points of view as quality and the ability to locate sound because we are listening binaurally, the advantages on the side of listening without any distracting noises are greater.

### Faults to Correct

There are two important considerations which militate against satisfactory listening through the medium of a broadcast receiver. The first is that we are still in the position that an enormous proportion of the listeners employ sets which are incapable of reproducing music at a high standard of faithfulness. Secondly, the art of listening has been very poorly developed. Undivided attention is rarely given to a musical broadcast; yet what should we think if in a concert hall the audience provided themselves with novels to read meanwhile, or engaged in conversation with their neighbours?

Fortunately, the remedy for both these objections to our present standard of listening is in the hands of the listener himself; he must learn to understand his set and to judge whether its performance is doing justice to the original transmission, and he must acquire the art of listening before he can begin to judge the relative merits of direct and indirect performance. All this surely leads us to the view that the public should be educated to an appreciation of the capabilities of the modern high quality receiver, and once more we would recommend that the radio industry should install high grade broadcast receivers in suitable places throughout the country for public listening.



# Delayed Diode A.V.C.

## Selecting the Best Operating Conditions

THE various methods by which automatic volume control can be achieved are by now fairly well understood, and it is generally realised that if the initial sensitivity of the receiver is not to be reduced the control should be delayed—that is, it should be inoperative until the signal input exceeds a certain predetermined value. Although there is no mystery about the manner in which circuits of this type function, there are so many different arrangements with which A.V.C. can be obtained that a choice is sometimes difficult. Moreover, having selected the system which is to be used, the problem of choosing the best operating conditions still remains.

The delayed diode A.V.C. circuit is attractive on account of its simplicity, and, although it may not be the best in all circumstances for A.C. operated sets, it remains probably the only entirely satisfactory arrangement which can be used in D.C. mains and battery-operated receivers on account of the limitation in the supply voltage in these cases. For the moment, therefore, let us confine our attention to this system and examine its characteristics in some detail, particularly with regard to the determination of the correct delay voltage.

In Fig. 1 will be seen the fundamental circuit of the delayed diode A.V.C. system in which the valve is shown as a simple duo-diode type, although it may equally well be one of the combination duo-diode-triode or duo-diode-pentode types, or even two separate triodes connected as diodes or two Westectors. The H.F. or I.F. in-

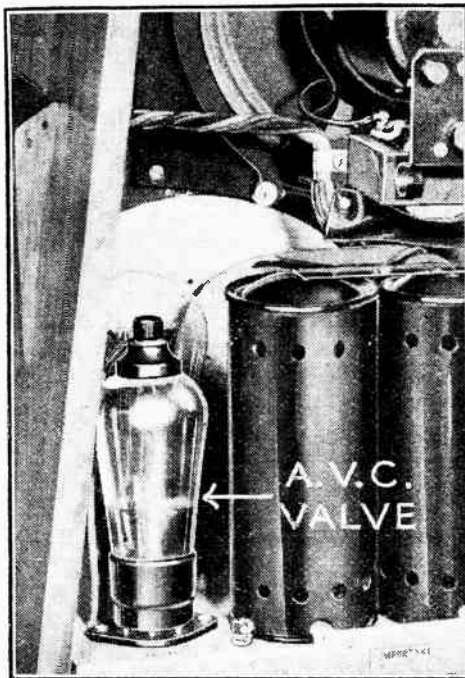

The double-diode valve is usually of the duo-diode-triode type, and in addition to acting as the second detector and providing delayed A.V.C. it gives a first stage of L.F. amplification. The illustration is from the Ferranti Gloria superheterodyne.

put is applied from the tuned circuit to the diode anode A<sub>1</sub>, the cathode connection being completed through the load resistance R<sub>1</sub>. In this circuit, therefore, normal signal rectification takes place, and the L.F. voltages are developed across R<sub>1</sub> and transferred through the H.F. filter and manual volume control to the next valve. The H.F. input is also applied through the small condenser C<sub>1</sub> to the other diode anode A<sub>2</sub>, which is connected to the cathode through the resistances R<sub>3</sub> and R<sub>4</sub>. R<sub>3</sub> is the diode load resistance, and usually has a value in the neighbourhood of 0.5 MΩ, while R<sub>4</sub>, with R<sub>5</sub>, forms part of a potentiometer across the H.T. supply. The cathode, therefore, is biased positively with respect to the earth line, and, as a result, the anode A<sub>2</sub> is biased negatively with respect to its cathode.

The success or otherwise of the A.V.C. system depends very largely upon the amount of this bias, which is usually known as the delay voltage. Until the signal input to the anode A<sub>2</sub> exceeds the delay voltage no rectification occurs in this circuit, and A.V.C. is inoperative. Obviously, therefore, the delay voltage

should equal the detector input obtained from the weakest signal it is desired to receive. On the other hand, if A.V.C. is to be so effective that on the strongest signal the output to the ear is not appreciably louder, the detector input must not rise to more than twice the small input figure, for this corresponds to a change of output of only 6 DB. For this result to be achieved the delay voltage must be equal to the maximum bias required by the H.F. or I.F. stages, and this, in turn, will depend upon the type of H.F. valves employed and upon the number of controlled stages.

A little thought will soon show that in the general case this will lead to the detector being operated at a very large signal input, and this will mean the use of many H.F. stages and but little L.F. amplification. Whether or not this is satisfactory will depend upon many factors, of which cost is by no means unimportant.

### Choosing the Delay Voltage

To put the question upon a practical basis, let us consider the choice of delay voltage for a two H.F. receiver, and let us assume that we wish A.V.C. to commence when the input to the first H.F. valve is 1 millivolt, and that the output must not rise by more than 6 DB when the input is 5 volts. These figures for input correspond roughly to the reception of a moderately

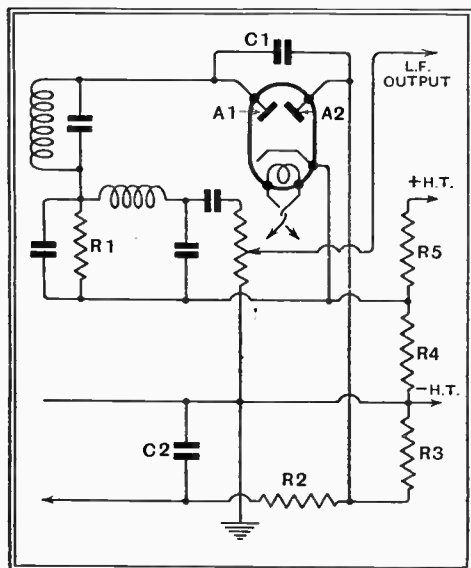

Fig. 1.—The fundamental circuit of the delayed diode A.V.C. system. The control grids of the H.F. valves derive their bias through the resistance R<sub>2</sub>.

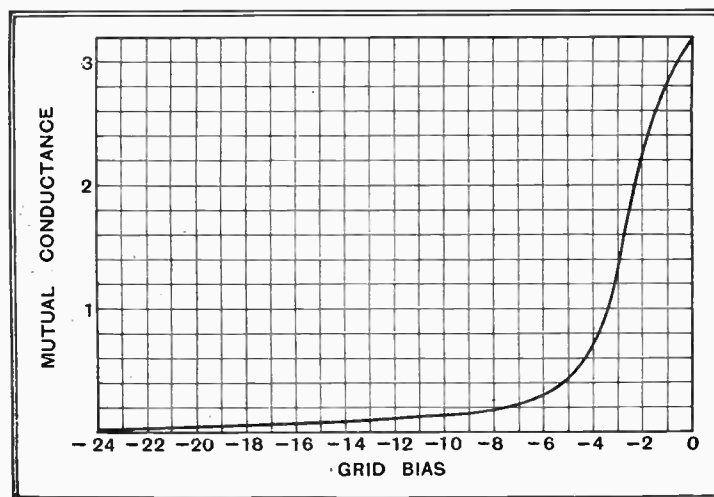

Fig. 2.—The mutual conductance of the V.P.4 valve for any bias voltage can be read off from this curve.

strong foreign station and the local station respectively. For an output ratio of 2-1, or 6 DB, therefore, the input will vary in the ratio 5,000-1, or 74 DB.

Let us suppose that we are using Mullard V.P.4 type H.F. pentodes with an anode supply of 200 volts, and the screens held at 100 volts, the initial bias being -1.5 volts. The curve of mutual conductance with grid bias is shown in Fig. 2. Now in

**Delayed Diode A.V.C.—**

the majority of practical cases, an H.F. valve is operated with a load impedance of quite small value compared with its internal A.C. resistance, and the stage gain is then equal to the product of the mutual conductance and the load impedance when both are expressed in suitable units. Since the amplification per stage is proportional to the mutual conductance, therefore, we can for our present purposes ignore it and work directly in terms of mutual conductance. As it is much easier

volts peak, or, say, 38 and 19 volts. From the data given it is quite easy to plot the A.V.C. curve of the set, and this is shown in Fig. 4; it is usually unnecessary to do so, however.

The design of the A.V.C. circuit itself thus involves no difficulty; we have now to see, however, how these detector operating conditions will fit in with the rest of the receiver. In the first place, we see that on the weakest worth-while signal, on which A.V.C. just begins to operate, we have a detector input of 19 volts peak.

This gives us a D.C. potential across the detector load ( $R_1$  of Fig. 1) of about 16 volts, and for 80 per cent. modulation we shall have an L.F. potential of 12.8 volts peak. This is just sufficient slightly to overload a normal pentode-type output valve with resistance-capacity coupling, but if we wish to use a triode we shall have to use a low-gain L.F. stage preceding it, for a transformer coupling does not fit nicely after a diode. In the L.F. circuits, therefore, there is no special difficulty provided that we use a

diode cannot, therefore, be controlled. This, in turn, involves the use of three H.F. stages, for it would not be possible to obtain the requisite range of control with only a single controlled stage. With an H.F. pentode, however, it should be

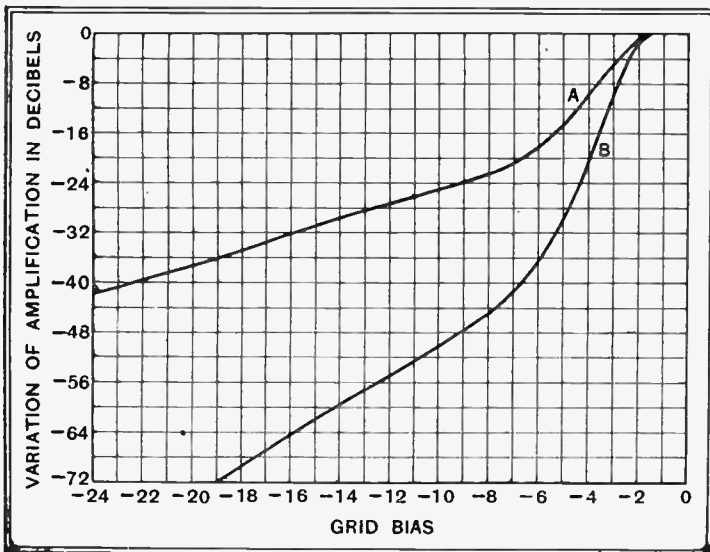

Fig. 3.—The variation of amplification with bias for one (A) and two (B) H.F. stages is shown here.

to work in terms of decibels than voltage ratios, let us convert the curve of Fig. 2 into one showing the drop in amplification resulting from the application of grid bias to a single valve. This is shown in Fig. 3 for one stage, curve A, and for two stages, curve B, and from this we can directly determine the bias required.

Since the signal input varies by 74 DB, and we permit an output variation of 6 DB, the amplification must vary by the difference, or 68 DB. Curve B of Fig. 3 shows that with two controlled stages the amplification drops 68 DB when the bias is -17.5 volts as compared with the initial bias of -1.5 volts. If we assume that this latter is fixed, and does not change with the H.F. valves' anode current, we need a change of bias of 16 volts. This will not be the case when the H.F. valves' bias is derived from a cathode resistance, and then some 17 to 17.5 volts A.V.C. bias will be needed.

**The H.F. and L.F. Stages**

For a bias change of 16 volts the delay voltage must equal the bias voltage and also be 16 volts. The A.V.C. system will then come into action when the detector input is 16 volts peak, assuming 100 per cent. rectification efficiency, and will be 32 volts peak when the output has risen by 6 DB and the input to the first valve by 74 DB. The rectification efficiency, however, is, in practice, more nearly 85 per cent. than 100 per cent., so that the actual maximum and minimum figures for the detector input will be nearer 37.6 and 18.8

pentode output valve.

Let us now consider the H.F. circuits. The detector input for a strong signal is 38 volts peak, but during 80 per cent. modulation it will rise to a maximum of about 68 volts. The preceding H.F. or I.F. stage, therefore, must be designed to give this output without distortion. When using an ordinary variable-mu valve such an output can hardly be obtained without distortion when the valve is biased for local reception, and the stage preceding the

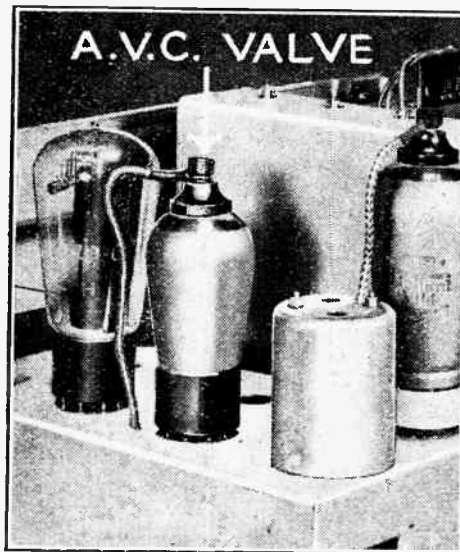

In the duo-diode-triode valve, often employed to give delayed diode A.V.C., the terminal on the top of the bulb is for the triode control grid. (Ekco Model 74 Superheterodyne.)

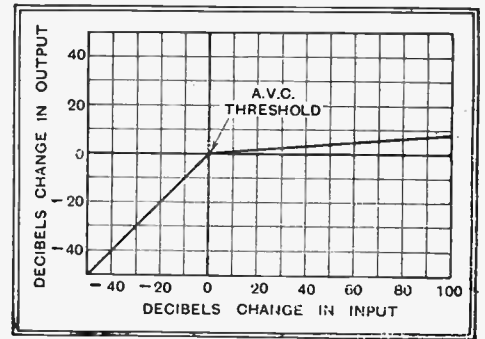

Fig. 4.—The A.V.C. curve for the conditions laid down in the text takes the form illustrated. For signals stronger than the delay voltage, a change of input of 100 D.B. affects the output by only 9 D.B.

just possible to obtain the necessary output without distortion, so that we can then control the stage preceding the diode and so save an H.F. amplifier, unless this should be needed for amplification purposes. The interval coupling is not without importance, however, for in the foregoing it has been assumed that it is of the single tuned circuit type. If a band-pass filter be used, as in many superheterodynes, the valve preceding the detector must be designed to give a distortionless output of at least twice the maximum detector input required, or, in this case, 136 volts peak. This obviously leads to serious difficulties with this method of A.V.C.

**H.F. Stage Gain**

Let us now see whether we can obtain from two stages the degree of amplification which has hitherto been implicitly assumed. The minimum detector input is 19 volts peak, or 13.4 volts R.M.S., and the input to the first valve is  $\therefore$  millivolt. The amplification required, therefore, is 13,400 times, so that the stage gain of each valve must be 116 times for a total of two H.F. stages. Now the amplification per stage is roughly equal to the mutual conductance in mA/V. multiplied by the load impedance of the valve in thousands of ohms. The mutual conductance at minimum bias is 2.4 mA/V., so for a stage gain of 116 times the load resistance must be 48,400 ohms, or, say, 50,000 ohms. This is by no means an abnormally high figure, for even air-cored coils of the small screened type rarely have a dynamic resistance lower than this.

In theory, therefore, there is no difficulty in meeting the requirements which we have assumed. In practice, however, we may find it difficult to obtain the requisite H.F. amplification. It is a common experience that two H.F. stages with air-cored coils are unstable unless the anode connections to the coils are tapped well down, or unless unusually effective screening is adopted. It is a matter of considerable difficulty to obtain an amplification

**Delayed Diode A.V.C.—**

per stage as great as 116 times when two stages are employed without meeting instability problems. It is by no means difficult to obtain this amplification from a single stage, but with two stages it is another story.

It is usually more satisfactory, therefore, to adopt an A.V.C. circuit which does not call for such a large detector input, for then we can use a smaller degree of H.F. amplification and make up for the reduced sensitivity by increasing the L.F. amplification, and in the long run this will often prove the cheaper course. In the case of a superheterodyne, however, this does not necessarily apply, for it is by no means impossible to obtain an amplification much greater than 116 times from a single I.F. stage, and the remaining amplification may be given by the first detector or an H.F. stage. Since the amplification in the different stages is obtained at different frequencies, instability problems rarely arise.

**Battery and D.C. Sets**

In the case of battery and D.C. mains sets there is no real alternative to the delayed diode A.V.C. system for the reason that other methods require a source of voltage additional to the normal H.T. supply for their operation, and this is not usually obtainable in a convenient manner. In an A.C. set additional voltages present little difficulty, and we can employ amplified delayed A.V.C. or delayed square law A.V.C.

It should be pointed out, however, that the difficulties attendant upon the use of delayed diode A.V.C. are greatly reduced if the circuit is designed to give a lesser degree of perfection. If no account be taken of the local station, and the system be designed to give a substantially level output on the weakest to the strongest of

distant stations, it will still counteract fading, and a much smaller delay voltage can be used with a consequent reduction in the normal detector input. This will ease the design of the H.F. circuits and permit a more normal value of L.F. amplification to be used. In order to permit undistorted local reception, however, a local-distance switch must be fitted.

There is, however, a modification of delayed diode A.V.C. which considerably reduces the difficulties attendant upon its use. This is when the control is not confined to the pre-detector stages, but is arranged to operate also upon a variable-mu L.F. valve. It is then unnecessary

to restrict the detector input variations to a 2-1 ratio to obtain good A.V.C., and a very much wider range is permissible. This in turn means that a lower delay voltage can be used with less detector input.

It will be seen, therefore, that the delayed diode A.V.C. system is not necessarily the best, but it has been selected here for description because it is the fundamental circuit upon which most other methods are based, and because the methods of design which have been adopted are capable of simple extension to cover many other circuits. It is hoped to deal with these other arrangements in a further article.

## DISTANT RECEPTION NOTES

### Progress on American 500 kW. Station

**W**ORK on WLW's new 500-kilowatt transmitter at Cincinnati, Ohio, is, I hear, proceeding rapidly. The great 800-foot mast which is to form the vertical aerial is now nearly completed, and it is being used at times for tests with the old transmitter. Since American stations continue to come in well, any reader who is using his set in the small hours may find it worth while to tune to 428.3 metres (700 kilocycles) in search of WLW. During the last twelve months transatlantic stations with wavelengths above about 350 metres have not been too well received, but if history repeats itself stations on higher wavelengths should be well heard during the coming autumn and winter.

During the present month the new 20-kilowatt Lisbon transmitter is due to come into action. Tests may begin at any time now, and the wavelength will probably be that of the present Lisbon station, 282.2 metres (1,063 kilocycles). This will be a Government station, the first of a chain to serve the whole of Portugal. The Lisbon programmes will be relayed for the Portu-

guese Colonies as heretofore by the short-wave transmitter CT1AA on 31.25 metres. There is a possibility that the aerial power of the short-wave station may be increased to some extent.

Beromünster is showing extraordinary strength at the present time, and I have frequently obtained reception from this station at full loud-speaker strength during daylight hours. Other "daylight" stations on the medium waves are Brussels No. 1 and No. 2, Langenburg, Hilversum (Huizen programmes), Prague, Leipzig, Breslau, Poste Parisien, Fécamp, Trieste, with occasionally Strasbourg, Rome and Heilsberg.

Oslo is now usually quite clear of interference, though both the Eiffel Tower and Warsaw are occasionally jammed. There is a small amount of fading on the medium waveband, particularly amongst stations with wavelengths above 450 metres.

Heterodyne interference is not serious at the present time on the medium waveband. The only important stations that have been at all affected are Bari, Turin, and Florence. With the increase in all-round field strength that must occur during the next few weeks rather more heterodynes are to be expected, and it is quite possible that on this account the number of stations receivable free from interference may be smaller during the darker months than it was during the summer—a complete reversal of the old ideas about long-distance wireless reception!

I am still at a complete loss to account for the behaviour of Brno. For perhaps half a dozen months on end we hear absolutely nothing of this station, and then comes a night when Brno is received as strongly and as well as, say, Toulouse. One could understand it if the station were heard fairly well on some nights and very well on others, but the sudden change from complete silence to very big signal strength is puzzling. It is interesting to note that the other big Czechoslovakian station, Bratislava, is also remarkable for intermittent reception. In this case, though, the "good" nights are much more frequent, and I do sometimes hear the station rather feebly.

Motala is now amongst the best of the long-wave stations, other excellent transmissions being Oslo, Luxembourg, Zeesen, and Radio-Paris. In addition to those mentioned as providing daylight reception, the pick of the medium-wave stations are Toulouse, Milan, Göteborg, Nürnberg and Katowice.

D. EXER.



**MODERN MODES IN AMERICA.** This scene at KYW, the broadcasting station in the heart of the great Chicago Exposition, typifies the modern trend in studio fittings and furniture. The announcer's desk is close to the Control window.

# Simple Measurements on Receivers and Components

By S. O. PEARSON, B.Sc., A.M.I.E.E.

*M*ANY practical tests on receivers are suggested in this article, which should be read in conjunction with the contribution on the same subject which appeared in last week's issue

## Finding Faults and Checking Voltages

WHEN the construction of a new receiver is completed it is always advisable to test the circuits before the high-tension voltages are applied to the valves, for an unexpected short circuit can account for a considerable amount of damage in a fraction of a second. This applies more to battery-operated sets and D.C. mains sets than to mains-operated A.C. receivers. One reason is that the filaments of D.C. valves are more delicate than the heater elements of A.C. indirectly heated valves, the fusing current being smaller for the former. The other, and perhaps more important, reason is that a short-circuited H.T. battery, or D.C. mains, gives a far greater current than that obtained from an A.C. eliminator when the output terminals are short-circuited. This is because the internal resistance of an A.C. eliminator and its associated smoothing circuits is comparatively high, and acts as an effective current limiter.

Damage to valve filaments occurs if the high-tension supply is short-circuited in such a way that the current passes through the valve filaments. In the case of a battery-operated set the negative H.T. terminal is connected to the negative end of the filaments, and therefore if the posi-

tive H.T. terminal should accidentally make contact with the wire joining the positive ends of the filaments, the short-circuit current would pass through the latter and burn them out, should the L.T. current be switched off. This is made clear by Fig. 1, in which the dotted line connection represents the unwanted path between H.T. + and L.T. +, which may be due to an error in wiring, a fault in an intervalve component, or an unsuspected contact between a positive H.T. lead and a positive L.T. lead. The arrows indicate the path of the short-circuit current. With the L.T. circuit closed, the short-circuit current would pass mostly through the accumulator, and the valves would probably not suffer. But the H.T. battery would.

It would be interesting to know how many unfortunate ones have had all their valves burnt out through this particular fault! The short-circuit current from an A.C. eliminator would most likely not be sufficiently large to burn out several valve filaments, connected in parallel as they are in an ordinary receiver.

### Testing for Short Circuits

In a battery-operated set one does not find a potential divider connected between H.T. + and H.T. - for the purpose of obtaining an intermediate voltage for screen potentials of H.F. valves; the necessary voltage is taken from a tapping on the H.T. battery. Consequently, the only current coming from the battery under normal conditions is the sum of the anode currents of all valves, from the main positive terminal, and the screen currents of S.G. or variable- $\mu$  valves from a tapping point. *These currents can only flow when the filaments are heated* So, with the filament battery disconnected altogether, one of the first tests to make is to ascertain that no current flows in the H.T. circuits. The correct procedure is to connect a *voltmeter* (or the highest *voltage* range of a composite instrument) in the negative lead from the H.T. bat-

tery, with all valves in their sockets, as shown in Fig. 2, which is a skeleton diagram giving the normal conducting circuits between the H.T. battery and the electrodes of the valves. A milliammeter could be used instead of a voltmeter if a few thousand ohms resistance is connected in series for protective purposes, as explained in Part I of this article.

If the meter gives a reading there is something wrong, and the seat of the trouble must be searched for systematically by a process of elimination. The fault may be in the wiring or in one of the intervalve components; but it is just possible that there may be an internal short circuit in one of the valves themselves. To test for the latter the valves must be withdrawn from their sockets one at a time, and if the meter reading disappears when one of the valves is taken out of its holder, that particular valve is at fault and must be discarded.

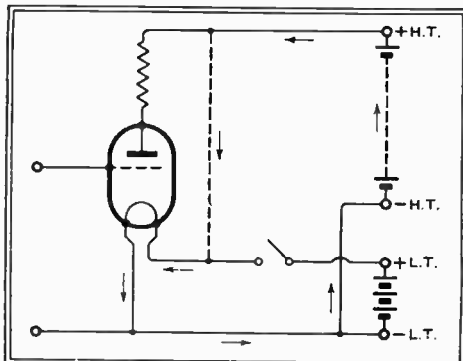

Fig. 1.—How an accidental short circuit between H.T. + and L.T. + leads may result in a burnt-out filament.

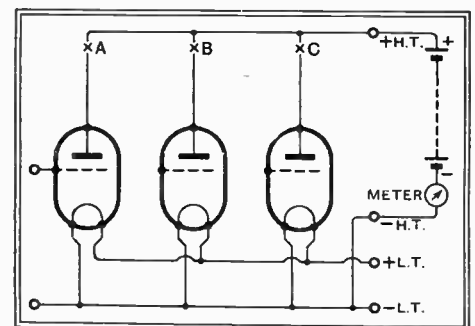

Fig. 2.—Skeleton diagram of a receiver, showing the normal conducting circuits between the H.T. battery and the electrodes of the valves.

If the meter continues to read after all the valves have been removed, there is a short circuit somewhere in the wiring, and the next step is to locate it. The meter should be removed from the negative H.T. lead and connected in turn in the branch leads to the individual anode circuits of the valves, the safety resistance always being included when a milliammeter is used. The correct places are where these leads branch off from the



**Simple Measurements on Receivers**

main H.T. busbar, as marked at A, B, and C in Fig. 2: that is, between the H.T. supply lead and the corresponding components in each anode circuit. Temporary disconnections will have to be made to include the meter. The valves need not be replaced during this test.

If current is found to flow in one of these anode circuits, the discovery of the fault is near at hand, and there are several likely spots to search. Among possible causes are: (a) A faulty decoupling condenser (see Fig. 3); (b) electrical connec-

built in with the set a temporary disconnection can be made.

**Checking Voltages in a Receiver**

When it has been ascertained beyond all doubt that there are no faults in the circuits of the receiver, the H.T. and L.T. voltages can be applied with safety. Of course, where grid bias voltages are obtained from a battery, it is essential to see that the latter, after having been tested with the voltmeter, is connected into the circuit before the H.T. and L.T.

this, the first being that, owing to the internal resistance of the eliminator, the voltage depends to a large extent on the current supplied to the set, unless a neon stabiliser is connected across the terminals. So the voltage of the eliminator must be measured when it is supplying the normal current. Now, an ordinary voltmeter usually consumes several milliamperes; in fact, it may take as much current as the complete set; and so, if an attempt is made to measure the voltage when the set is being supplied with current, an extra load is put on the

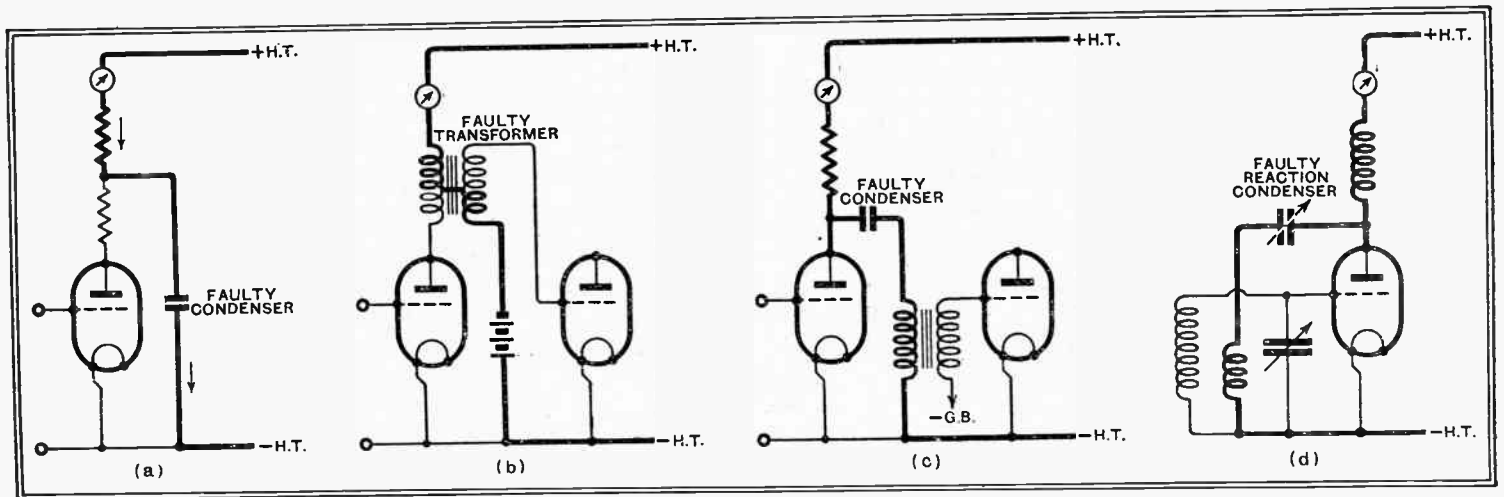

Fig. 3.—Diagram showing how some faulty components are responsible for short circuit or leakage currents. The paths taken by these currents are indicated by the heavy lines.

tion between primary and secondary windings of an intervalve transformer, or between primary winding and an earthed core; (c) a faulty blocking condenser used in conjunction with a parallel-fed transformer or a tuned-grid high-frequency coupling; (d) a faulty reaction condenser. The path of the short-circuit current is indicated in each case by the heavy lines in Fig. 3. If all these components are in order, it is possible that a short circuit may exist in the corresponding valve holder itself. However, the process of elimination is continued until the fault is found.

Should the individual anode circuits and the screen-grid circuit prove to be in order, there must be a direct connection somewhere between the positive H.T. busbar and "earth." Examine carefully for wires which may have got bent out of position and come into contact with another wire or the metal chassis. The voltmeter should finally be connected across the loud speaker terminals to ascertain that no direct current flows there.

The same tests can be applied to an A.C. receiver, but it must be remembered that there will most likely be at least one potential divider circuit, which must be opened temporarily during the tests, and the heaters must be switched off. The A.C. eliminator should not be used for supplying the testing voltage because, if there is a short circuit in the set, the rectifying valve will be damaged. It is better to use a battery of a few volts connected between the H.T. positive and negative terminals of the set. If the eliminator is

voltages are applied. If it is a battery-operated set, the voltage of the H.T. battery should also be checked with the voltmeter, but the accumulator supplying the filaments can be relied upon to give the correct voltage if it is in good condition and has been recently charged.

Where the H.T. supply is obtained from an A.C. eliminator the checking of the voltage at the terminals is not so straightforward. There are two main reasons for

eliminator and a false reading is obtained. An electrostatic voltmeter, which takes no current, or a very high-resistance voltmeter would, of course, give satisfactory readings.

To obtain the actual operating voltage of the eliminator with the use of an ordinary voltmeter, the best procedure is to obtain a regulation curve of terminal volts, plotted against output current, and this involves the use of a separate milliammeter, and requires some means of varying the output current. A device for the latter purpose can conveniently be improvised by using the power output valve of the set; it can be made to take different anode currents by varying the grid bias obtained from a battery. The circuit arrangement of Fig. 4 (a) shows clearly how the calibration is made. The milliammeter must be connected on the eliminator side of the voltmeter so as to register the sum of the currents taken by the valve and the voltmeter. The lowest current reading would be that obtained without connection being made to the valve anode, being the current taken by the voltmeter alone; then other readings are taken with the valve in circuit and with various negative voltages applied to the grid. When changing the tapping point on the bias battery, it is absolutely essential to switch off the H.T. first, otherwise the valve will take excessive current in the anode circuit as soon as the grid is disconnected from the battery, and damage may result. The curve obtained will be more or less a straight line, as in Fig. 4 (b), so only three or four points need be found. With this regulation curve available the

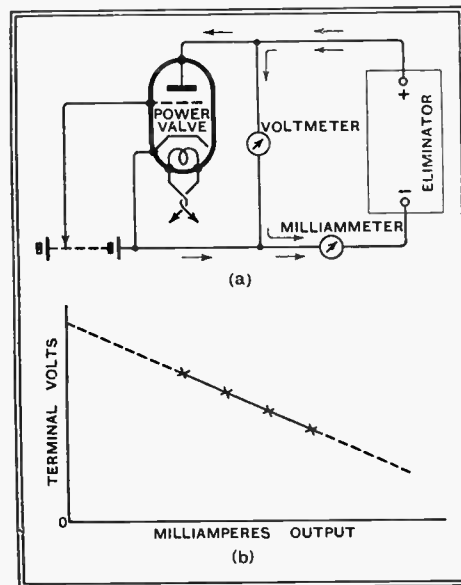

Fig. 4.—(a) How the regulation curve of an eliminator can be found by using a power valve as the variable part of the load. (b) The form of the regulation curve.

**Simple Measurements on Receivers**

eliminator voltage is known for any output current.

The correct anode current of each valve in the set can be computed fairly closely from the characteristics of the valves used, and these currents are usually stated in constructional articles on specific receivers. So the total current to be supplied by the H.T. battery or eliminator is easily estimated. It is impossible to measure directly the voltages at the anodes, grids, and screens of valves with an ordinary voltmeter, because the resistance of the latter is usually smaller than the resistances of the components in the circuits leading to various electrodes. But if each valve is found to take an anode current approximately equal to the estimated value, it is usually safe to assume that the operating voltages are correct.

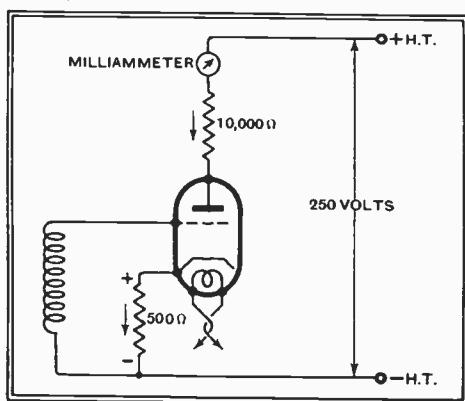

Fig. 5.—Illustrating the example given in the text of finding the anode potential and grid bias voltage.

The first test to make when the supply voltages are applied to the set is to see that the total H.T. current taken is approximately correct, by connecting the milliammeter in one of the leads from the H.T. battery or eliminator. An excessive current may indicate little or no bias voltage at the grid of one of the more powerful valves, such as the output valve. In this event the set must be switched off immediately, and investigations made by examining grid circuits. A bad fault is usually easy to find.

**Checking Anode Current**

It is more usual to find that the total anode current differs from the normal value by a few per cent. only, but if the discrepancy is greater than 25 or 30 per cent. it is worth while checking the currents in the individual anode circuits, to discover which one is incorrect. Naturally the power valve takes the greatest current and should be checked first. Excessive anode current almost certainly indicates a wrong grid bias voltage, and if the set is provided with "automatic" bias the particular bias resistance must be suspected. To ascertain if this is the seat of the trouble the correct bias voltage could be obtained temporarily from a battery. If the anode current is then correct the trouble has been located, the automatic bias resistance being too low; maybe part or all of it is short-circuited. A faulty decoupling condenser would have this effect!

Another very feasible cause of excessive anode current is the breakdown of the blocking condenser used in choke-capacity or resistance-capacity coupling between the grid of the valve in question and the anode of the previous valve. A breakdown of this condenser results in a high positive potential being applied to the grid of the valve; this state of affairs is very serious, because the grid and anode are now virtually in parallel and carry the greatest current the valve is capable of passing. In these circumstances the cathode would be very quickly ruined.

Insufficient anode current would either mean excessive negative grid bias or low emission of the valve filament (or cathode). If the anode current does not increase appreciably when the grid bias is reduced in value it can be assumed that the valve cathode is incapable of giving greater emission. There may be one of two reasons for this: (a) either the filament or heater voltage is below normal, or (b) the valve is getting old and the emission falling off. The cure in either case is obvious.

**Finding Anode and Grid Voltages**

The actual voltage between the anode and cathode of a valve can only be measured directly with an electrostatic voltmeter, a rather costly instrument; but if the resistance of the external anode circuit is known the current can be measured with a milliammeter and the voltage calculated. In the same way grid bias voltage obtained from a resistance in the cathode circuit can be found.

Let us take as an example an A.C. indirectly heated valve, with 10,000 ohms in the anode circuit and 500 ohms in the cathode lead, as in Fig. 5. The milliammeter is connected either in the cathode lead or the anode lead for a triode. Suppose that the current is found to be 6 milliamperes, and that the eliminator gives 250 volts at the terminals. The voltage drop in the anode resistance is  $0.006 \times 10,000 = 60$  volts, and in the 500 ohm bias resistance it is  $0.006 \times 500 = 3$  volts. The total voltage drop in the external resistances is therefore 63, and so the voltage between the anode and cathode of the valve is  $250 - 63 = 187$  volts. The cathode is 3 volts positive with respect to the grid, and so the grid bias is  $-3$  volts.

In the case of a screen-grid valve the bias resistance carries the sum of the anode and screen currents, so in finding the grid bias the milliammeter must be connected in the cathode lead. To find the anode-to-cathode voltage, calculate separately the voltage drop in the anode resistance and in the bias resistance from the individual currents measured in each. Subtracting the sum of these voltages from the eliminator voltage gives the anode potential with respect to the cathode.

The few examples that have been given here should serve to show how useful one or two meters can be. All the tests described for a newly constructed receiver can equally well be applied to one already in use, and faults may be traced with a minimum of trouble and expense. Many

other uses will suggest themselves, not only in tracing faults, etc., but in connection with the operation of the receiver. For instance, a milliammeter in the detector anode circuit enables accurate tuning to be effected visually; and a milliammeter in the anode circuit of any L.F. amplifier valve or the output valve enables one to detect overloading.

**Short Wave Valves**

**Development of Minute Types**

NEW work on the development of valves for use at wavelengths below one metre has recently been described in America.

Disregarding the generally accepted idea that to get oscillations and amplification at lower wavelengths required trick circuits with conventional valves, it was decided instead to remake the valves and use them with conventional circuits. This has now been done experimentally; to make valves work at wavelengths ten times as low as present valves, the dimensions of the valves were reduced by a factor of ten. Reducing the physical dimensions did not change the characteristics, but the inter-electrode capacities were reduced and the limiting wavelength could be taken down much lower. Designers have been successful in making valves which oscillate beautifully at 100 centimetres in well-known circuits and which oscillate without difficulty, though with less power, at 40 centimetres.

Not only will these valves oscillate—they will amplify. Thus at 100 centimetres a stage gain of about 4 with a screen grid valve is not difficult.

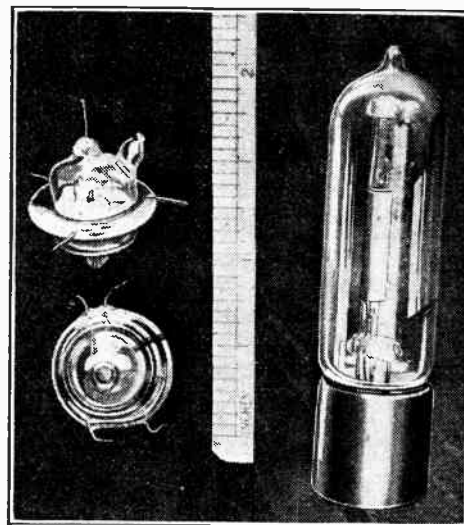

Two of the new valves (approximately actual size) are shown on the left. The valve on the right is a Weco peanut for comparison.

It sounds simple to reduce the dimensions of a valve by a factor of ten, but the problems are many. According to one correspondent the point has not been reached where these diminutive valves can be made in quantity. The tolerances between elements are so small that slight changes in geometry produce large changes in electrical characteristics. But good progress has been made: new valves working well at one metre and less have been made—and television seems nearer. For it is certain that television must go on the ultra-short wavelengths, certainly of the order of 5 metres.

# News of the Week

## Current Events in Brief Review

### There's a Reason

NO fewer than 30,000 Austrian wireless users have refused to pay radio licence fees for "political reasons."

### Here and There

THE Berlin Radio Show, which was open for twelve days, attracted 210,000 visitors—a figure which is considered disappointing

### More Listeners in Ireland

OVER 5,000 additional wireless licences were issued in the Irish Free State up to the end of July, and the total number is now 36,228.

### Medical Radio Code

A CODE of words which should completely cover the needs of medical diagnosis and treatment

### Short Waves from Bandoeng

MR. J. F. W. DE KORT (call sign PK1WK) of Bandoeng, Dutch East Indies, is transmitting on a wavelength of 49.12 metres. His schedule is as follows:—9.30 till 11.30 a.m.; 12.30 to 1.30 p.m.; and 11.45 p.m. to 12.15 a.m.

### "Ultra Shorts" from Yacht

ULTRA-SHORT wave transmissions from a yacht cruising in the Solent will be undertaken by Mr. S. G. Morgan (G6SM) on Sunday next, September 10th. It is expected that transmissions will last from 10 a.m. to 6 p.m., and during this period an attempt will be made to keep in continuous touch with G5BY and G5NN located on Beachy Head.

Reports will be welcomed by G6SM at 3, High Street, Croydon.

### Sir John Cass Institute

COURSES in electricity and magnetism are included in the curriculum of the Sir John Cass Technical Institute, Jewry Street, Aldgate, London, E.C., which resumes classes on Monday, September 25th. Students will be enrolled during the preceding week.

The science courses, which include the electrical studies, are held from 6 to 10 p.m., and full facilities are provided in well equipped laboratories for special investigations and research.

### 2LO "Closes Down"

MONDAY last, September 4th, saw the final closure of what was originally London's first broadcasting station. Marconi House, Strand, which was London's principal radio landmark before the war, has been vacated by the staff of the Marconi Company, who now occupy a section of Electra House, Victoria Embankment.

Marconi House, originally an hotel, was one of the first buildings in London to carry wireless masts, and it was the obvious choice in 1922 when the British Broadcasting Company sought a transmitter site in the heart of the capital. The original 1½ kW transmitter was housed near the roof, and had a remarkably good service area until superseded by a new transmitter on the roof of an Oxford Street store.

During the war Marconi House was an important receiving base for enemy wireless propaganda, and was also used for wireless research, particularly in the development of the thermionic valve.

### Clubs and the Tax

THE new wireless tax is having a bad reception in France, and all kinds of pleas are being put forward by various interests in the hope that the Government may be induced, in special cases, to remit the fee. The radio clubs are especially vocal. They are championed by Dr. Fobean de Courmelles, President of the National

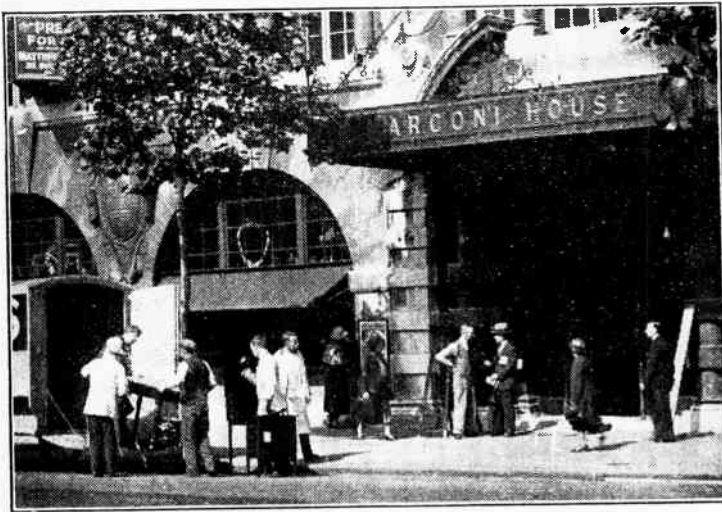

THE ORIGINAL 2LO. Marconi House, Strand, a London landmark for twenty-one years, photographed last week-end during the Marconi Company's removal to Electra House, Victoria Embankment.

in view of the fact that two extra days were allowed, together with a special "Popular Day" with an admission charge of only 6d.

The Olympia Radio Show in London was visited by 225,000 persons in nine days.

### B.A. Studies Television

TELEVISION experiments by the Marconi Company are a feature of this year's British Association meeting which opened at Leicester on Wednesday last, September 6th. Demonstrations are being given of television images on a screen 4ft. square. Fifty line images are shown with a repetition frequency of approximately fifteen per second.

### A Necessary Accomplishment

THE view that everyone should have a working knowledge of wireless is supported by the French Minister of National Education, who dwells on the importance of wireless in the school. All teachers and others in authority, he declares, should be capable of assembling and maintaining a simple radio receiver.

### Should Club Members Specialise?

AN interesting scheme is being adopted by the Thornton Heath Radio Society. During the coming winter each member will make himself thoroughly familiar with a particular phase of radio reception. This should be a great assistance in enabling members to help each other to the best advantage.

by wireless will be contained in Volume II of the new International Code of Signals for Shipping which is to come into use on January 1st, 1934.

### B.B.C. : What Hungary Thinks

HUNGARIAN listeners have just registered their preferences in regard to the programme material of the various European countries. The countries are given in this order: Austria, Italy, Germany, Poland, France, Rumania, and Great Britain.

### Anti-fire Radio

THE forest fire menace has been tackled by radio methods in the Marseilles district. On the wooded heights near the coast seven wireless transmitters have been installed, and during the hot season they are manned by sentinels, ready to communicate immediately with the Marseilles Fire Brigade on the outbreak of fire.

### Another French High Power Station

"A FORMIDABLE instrument for radiating French Southern thought throughout the world" is the description applied to the new Toulouse-Pyrenees broadcasting station now nearing completion near Murat on a plateau some 700 feet above sea level. Its power will be 120 kW. The station, which is the property of the State, is not welcomed by the adherents of Radio Toulouse, who declare that the newcomer is quite unnecessary.

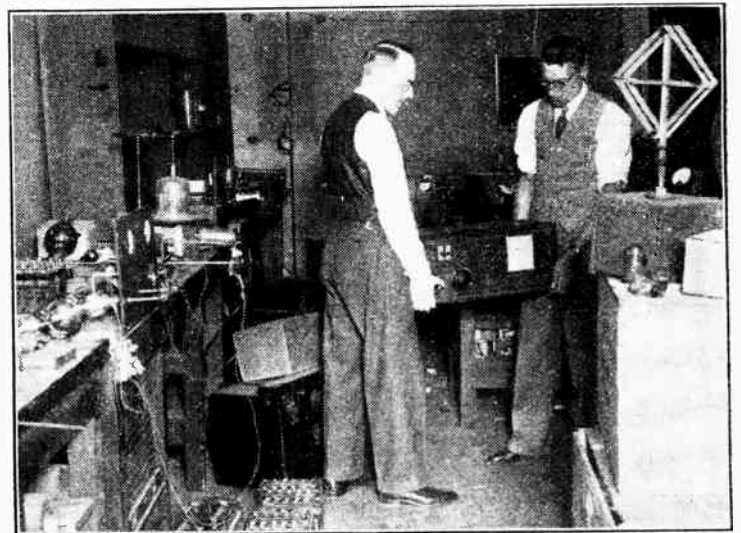

Marchese Marconi's private laboratory in the throes of removal last Saturday. Micro-wave apparatus had to be handled with special care.

### "Ultra Shorts" in the Transvaal

THE Transvaal is developing an interest in the ultra-short waves, and we learn from a correspondent at Witbank that the amateurs in that area are arranging a series of tests.

There has been a considerable revival of radio interest in South Africa on account of the reliability of the B.B.C. short-wave service.

### Federation of Radio Clubs.

The clubs, he points out, use their sets, not for broadcast reception, but purely for experiments and instruction to their members. The members, it is claimed, act as "benevolent recruiting sergeants for radio," increasing the number of licence holders as well as burning out numerous valves for the benefit of the tax collector. (In France there is a special duty on valves.)

# THE NEW HIGH POWER SUPER-HET WITH EXCLUSIVE STATIC SUPPRESSION

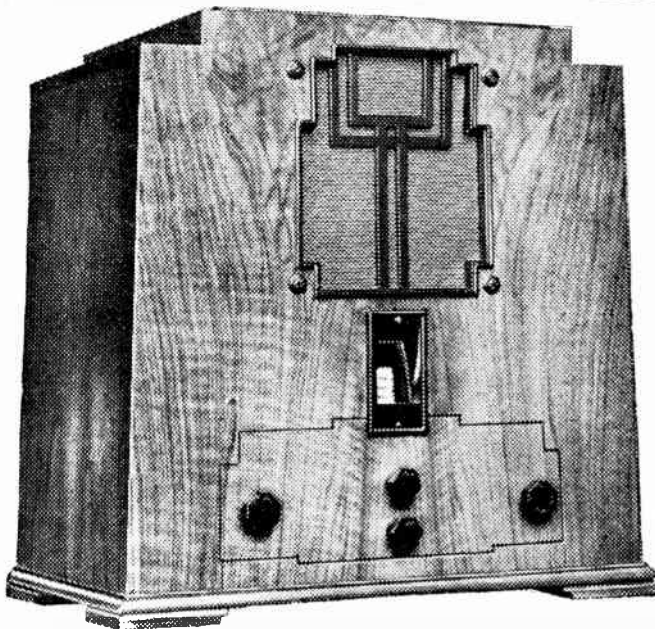
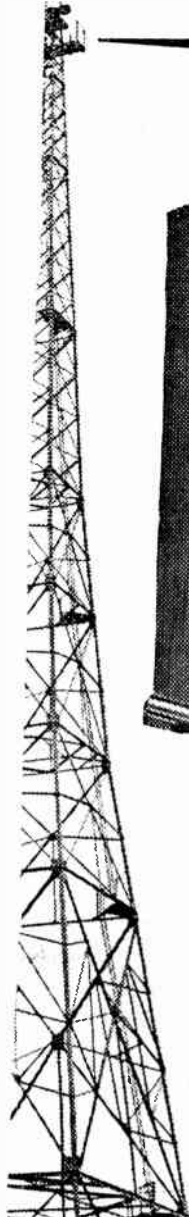

Hear this remarkable new model for yourself and you will realise that in its tremendous power, unprecedented selectivity and perfect tonal quality it is a definite step ahead even for Marconi. Merely to look at the figured walnut cabinet with its unusual lines and beautiful finish is to realise that here is something definitely different, definitely superior. But hear how the full Automatic Volume Control eliminates fading — how the super-selective band-pass circuits cut unerringly through interference — and how the unique Static Suppressor provides a background of silence unbelievable in so powerful a set—then will you decide that Marconi 276 is your ideal 1934 receiver.

Seven valve band - pass super-heterodyne for A.C. Mains.

Absolutely consistent adjacent-channel selectivity.

Unique Static Suppressor, adjustable for minimum background. Genuinely unlimited range.

2½ watts undistorted output — enough for three extra speakers.

Full Delayed Automatic Volume Control.

Duplex tone control adjusting both bass and treble.

Illuminated scale carrying station names and wavelengths.

Superb energised moving coil speaker of wide response.

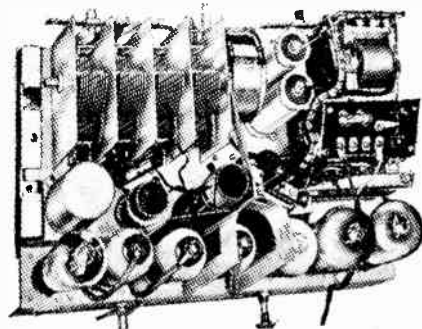

A rear view of the all-steel rubber mounted chassis, which gives some idea of its skilful design and fine engineering construction.

# MARCONI 276-



PRICE **22** GNS.

EXTENDED PAYMENTS GLADLY ARRANGED

ADVERTISEMENT OF THE MARCONIPHONE CO. LTD., RADIO HOUSE, LONDON, W. I.



**Longer life**

---

**unwavering power**

---

**greater selectivity**

---

**from the**



**MADE TO POWER YOUR SET PRECISELY!**

**IF YOURS IS A BEETHOVEN PORT. S.G.4**

you need Ever Ready Batteries — H.T./108 Pop; G.B./9 v. Winner; L.T./2178B.—all made specially for it. If not, simply ask your dealer for the Ever Ready List, showing all popular makes with their special Ever Ready batteries. Your set will be powered perfectly by its appropriate Ever Ready batteries.

THE EVER READY CO. (GREAT BRITAIN) LTD.,  
HERCULES PLACE, HOLLOWAY, LONDON, N.7

**PEAK** *The Height of Condenser Perfection!*  
**NON-INDUCTIVE CONDENSERS**

Type CB7	Type T12.
Tested 1500 V.D.C. working Voltage 500 V.D.C.	Tested 2400 V.D.C. working Voltage 800 V.D.C.
.01 mfd... 2/-	.1 mfd... 3/6
.1 " " " 2/-	.25 " " " 3/6
.25 " " " 2/6	.5 " " " 3/6
.5 " " " 2/6	1.0 " " " 4/6
1.0 " " " 2/6	2.0 " " " 7/-
2.0 " " " 3/6	4.0 " " " 11/6
4.0 " " " 6/-	6.0 " " " 17/9
6.0 " " " 7/6	8.0 " " " 22/-
8.0 " " " 10/3	

Recently added to the Peak range, the Types C.B.7. and T.12 provide striking proof of the justice of our claim — that PEAK CONDENSERS offer unequalled value. A study of the prices in conjunction with the characteristics will be illuminating and convincing. If you want first grade British made condensers at the lowest prices your choice must be PEAK.



Fully guaranteed, Peak condensers are regularly specified for "Wireless World's" Sets. Remember these facts and specify Peak for your

**NEW A.C. MONODIAL**  
THEY ARE AVAILABLE FROM STOCK

Write at once for new list to

Wheatstap House, Carmelite Street, **WILBURN & COMPANY** London, E.C.4  
Northern Distributors : W. Andrew Bryce & Co., Bury, Lancs.



**EARL** MANUFACTURING COY. LTD.  
'AVENUE WORKS'  
HANOVER PARK, S.E. 15  
NEW CROSS O422

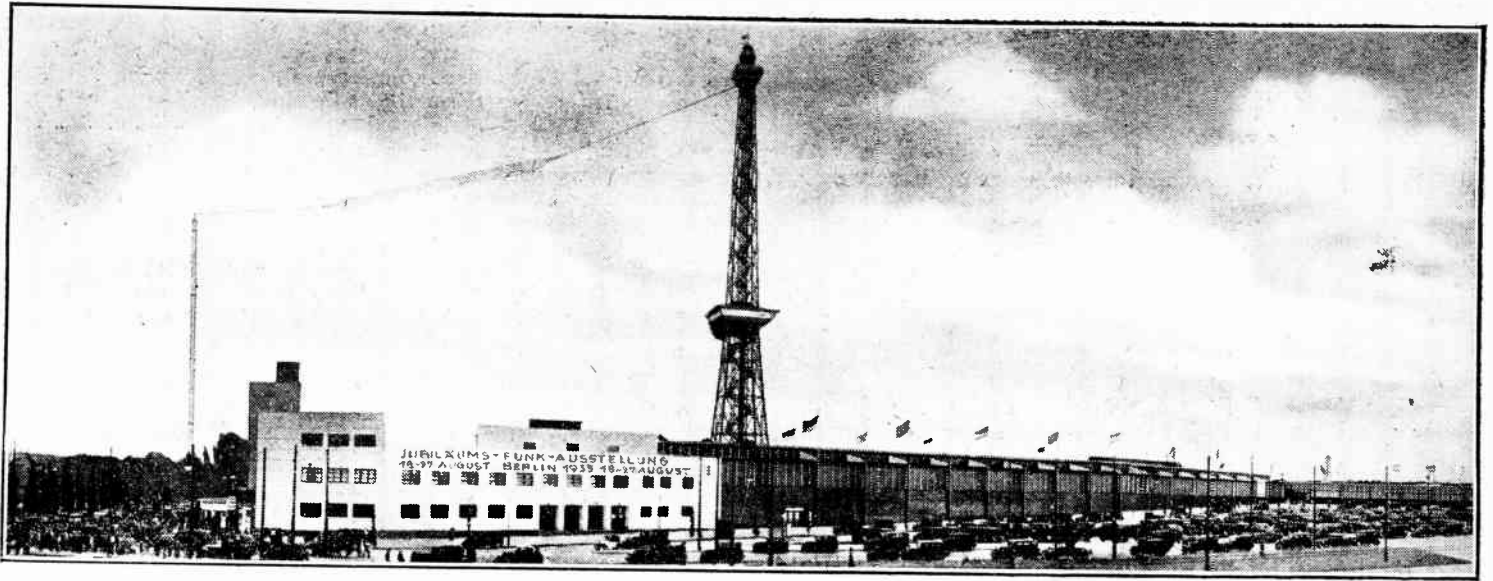

# The Berlin Radio Show

## A Review of the Exhibits

**T**HE German Radio Show, which has just been held in Berlin, has received greater publicity and probably provoked more interest than any previous Berlin Radio Exhibition, partly for the reason that this year broadcasting has taken such an important position in political and Government affairs. The general appearance of the Exhibition this year has undergone

*THIS YEAR'S radio show in Berlin was described as a jubilee since it represented the 10th consecutive Exhibition since Broadcasting began. In the German receivers the greatest ingenuity is displayed in tuning arrangements and other mechanical devices rather than in originality of actual circuits employed. Although not of real technical interest, the introduction of the People's receiver was perhaps the most spectacular feature of the show.*

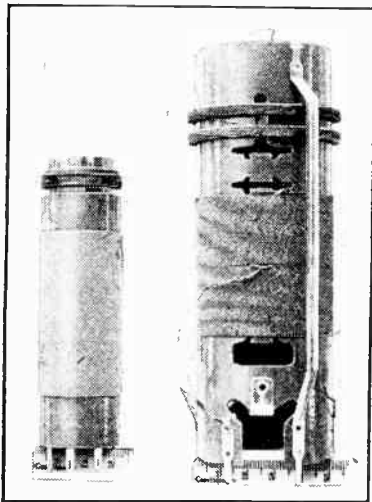

Examples of the new coil assemblies as generally used in the new German broadcast receivers.

a definite outward change indicative of the importance which the German Government now attaches to broadcasting as a means of propaganda. We are, however, not concerned here with the political aspects, and must confine our attention to a review of the technical progress which the exhibits at the Show revealed.

The set manufacturer has had the advantage of new valves of types similar to the new valves in this country to assist him in his designs, and the result is increased range and selectivity of receivers, a large number of superhets, including those employing only a few valves, and automatic volume control in all the more important models.

In view of the need for increased selectivity, practically all receivers have employed coils of high efficiency, and the solid dielectric type of condenser which was popular in Germany in previous years has been replaced by well-built air dielectric condensers. The coils are almost invariably built in cylindrical form with stranded Litz wire. This improvement in tuning circuits has resulted in the appearance of even simple two-valve sets with tuning scales calibrated in station names.

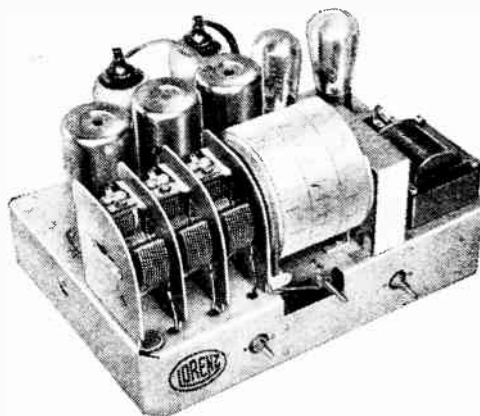

Tuning drum rotatable through 360 degrees in the Lorenz three-circuit receiver.

The German receivers this year are notable for the variety of types of tuning dials, nearly all with station names, and mostly indicating these clearly with illuminated scales. The scales are of very varied construction. One firm, Lange, has two vertical scales, one on each side of the loud speaker; the left-hand scale gives the long-wave station names, and the right-hand those of the 200-600-metre band and the short-wave stations. Another firm, Lorenz, employs a very large drum scale with the station names in three zones side by side; this scale rotates through 360°. The firm

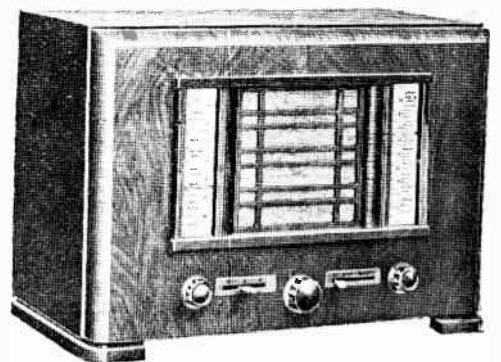

Arrangement of two scales on either side of the loud speaker (Lange).

Dr. Dietz and Ritter uses a pointer situated in front of the scale. Another divides the whole scale into several separate parts, and these three-wave zones are so arranged that only the correct one lights up. Siemens have developed a particularly original tuning device, the "Area" scale. In this there is a transparent band divided into various parts corresponding to the various German station groups and the groups of foreign transmitters. By means of a knob the wanted zone is adjusted behind the spy window. In this way the listener can always find the stations belonging to one locality grouped together. The scale also contains a zone in which all the stations are combined.

**The Berlin Radio Show.—**

Scale illumination is so arranged to-day in all German receivers that the lamp can be easily changed. In all new German receivers the chassis are made of steel throughout. In many cases, in the effort to simplify tuning the wave scales are arranged in the sloping-deck fashion at the top of the receiver. The number of knobs has been kept as low as possible; knobs fulfilling the same kind of functions are often placed on a common spindle. Almost everywhere it has been arranged that only the appropriate parts of the wave scale light up. Examples of chassis are seen in the illustrations.

A great deal has been heard about the

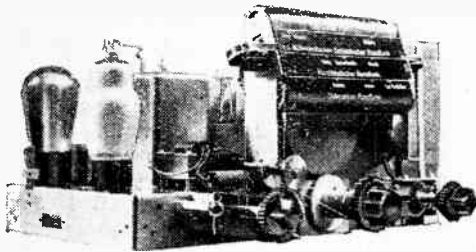

“Areas” (geographical) scale in Siemens chassis.

People’s receiver. A first order for these was for 100,000; before the Show 30,000 of these were sold; and by the end of the first few days of the Show another order for 100,000 had to be placed. This receiver is built in three different types—one for D.C., one for A.C., and one for battery supply. Both the mains types have two valves, a screen grid, and a pentode of 3 watts output. The battery receiver has three valves and employs a Class “B” output stage. The

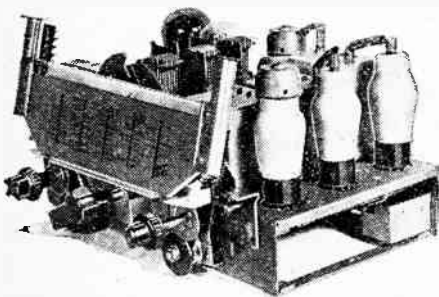

Chassis of a big superhet.

A.C. receiver is in a bakelite case, the others in cases of wood. The chassis is similar in all the receivers; the components are the same throughout, although twenty-eight different German manufacturers build the receivers. The external appearance is also the same, whatever the firm. Every receiver has a moving-iron type of loud speaker. The wave scale in the People’s receiver is not calibrated in station names or wavelengths. The receiver has three adjusting knobs—on the left the aerial coupling, in the middle the wave adjustment, on the right the reaction coupling. All the components have to be approved by the Heinrich-Hertz Institute in Berlin. The

receiver gives reliable reception of the nearest high-power stations and the Deutschlandsender, and also several powerful distant stations. It has no provision for short waves.

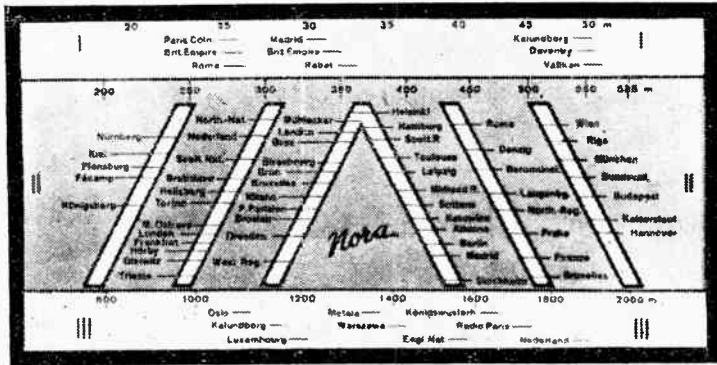

Another tuning scale for three wave ranges (Nora).

In addition to the People’s receiver, which has only one tuning circuit, the industry has built other single-circuit receivers in large numbers; almost all these have provision for short-wave reception, embody a wave-trap circuit, and, as a rule, are so built that the constants of the aerial do not affect the tuning adjustment, so that the receiver can be calibrated in wavelengths.



Simple replacement of the illuminating bulb.

The three-valve two-circuit receiver and the four-valve three-circuit receiver are still being turned out in Germany, but the selectivity has been considerably increased by the use of the new high-frequency pentodes and the low-loss tuning circuits. The two-circuit receiver is almost always provided for short-wave reception. A novelty for

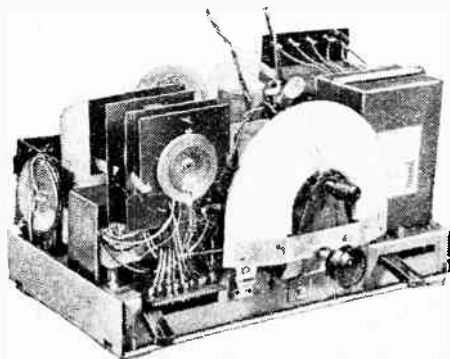

Chassis of the Telefunken two-valve receiver.

Germany, on the other hand, is the three-valve superhet. A volume control and a tone adjuster are always provided. The selectivity is obtained by varying the band filter damping. Most firms build this set to include short-wave reception.

Then comes the four-valve superhet. This has a preliminary stage with high-frequency pentode. It is worthy of note that the Stassfurter Broadcasting Company, in this and in its five-valve superhet, uses coils with iron cores in all important positions.

A mixing and A.V.C. hexode, a high-frequency pentode as preliminary valve, and

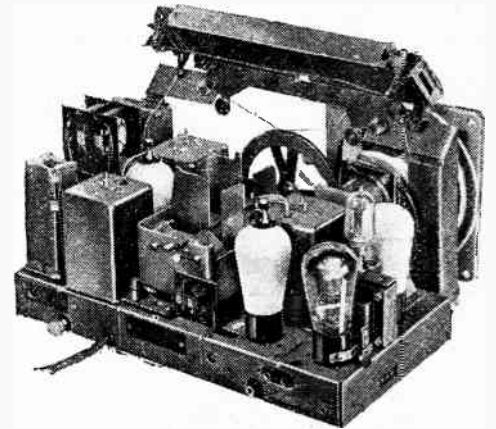

Chassis of the Telefunken three-circuit receiver with four valves.

a binode, usually containing a screen grid amplifier stage, and a six-watt output pentode are the valves used in the big superhets. These are of very high quality, and all possess a so-called interference barrage—that is, an arrangement by which the sensitivity is decreased when interference becomes too strong. This is carried out either by a change of amplification of the preliminary valve, its grid bias being regulated by a switch, or by the use of a compensation device (Stassfurter Broadcasting Company), by which the noise level is decreased without affecting the range, sensitivity, volume, or quality. In addition, all big superhets this year are provided with the A.V.C. hexode, which, together with the



Telefunken four-valve three-circuit receiver.

binode, makes possible the compensation of fading over a very wide range of signal strength. Most big superhets possess also a “crack killer,” and all superhets with five and more valves have, also, an arrangement for optical tuning. Several very different methods are employed for this: Telefunken, Siemens, and the A.E.G. use a shadow instrument; above the wave scale there is a small window with a ground glass disc illuminated by a small glow lamp. In the beam of this lamp there is a small rotatable mag-



**The Berlin Radio Show.—**

netic armature, which normally screens the whole beam. The armature can be moved out of its normal position by means of a coil through which the current to the loud speaker passes. At the maximum strength of signal the shadow cast on the ground glass by the armature is at its narrowest. Other firms use a glow lamp fed by the loud speaker voltage; in these lamps the length of the glow depends on the loud speaker intensity. Still other firms use a millimeter in the anode circuit of the detector valve, the reading indicating the strength of a signal. All big superhets have a tone control and a manual volume control. A novelty in many new German receivers is the provision of a reading lamp, enabling the programme journal to be read even in a dark room.

Worthy of notice is a receiver which can be used either on D.C. or A.C. mains; for A.C. mains one rectifier valve must be inserted (Loewe).

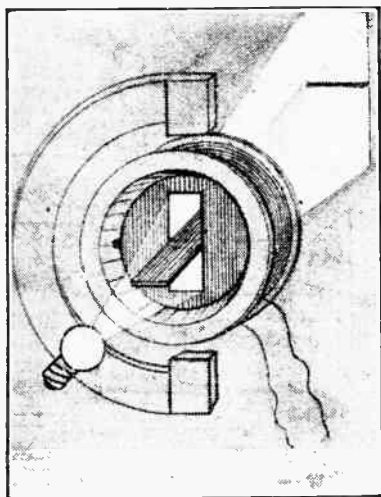

The principle of shadow tuning.

Numerous short wave adaptors have been produced this year. They are all based on the superheterodyne principle.

The battery receiver is not much in demand in Germany this year. It may be assumed, however, that even this season more battery receivers will be turned out as soon as the valve makers have produced the special valves now being developed.

The number of motor-car receivers has been added to by Telefunken. Their receiver is a four-valve superhet.

The moving-coil loud speaker rules the loud-speaker market in Germany this year. The permanent magnet type has been greatly improved.

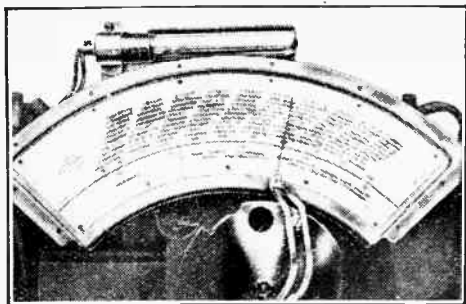

Saba Jubilee super with station names in staggered form.

The Trautonium is now officially sold by Telefunken; it has a quite new form and differs from previous models by possessing two "formant" (tone forming) circuits.

In the field of home recording of gramophone records a whole series of improve-



Telefunken motor-car receiver. Control box on the steering column. Inset: The four-valve superhet receiver.

ments have appeared. Telefunken has produced a high-grade portable instrument, in which, by the introduction of a different needle, the recording sound box can also be used to reproduce the record. Similar equipments are turned out by Grass and

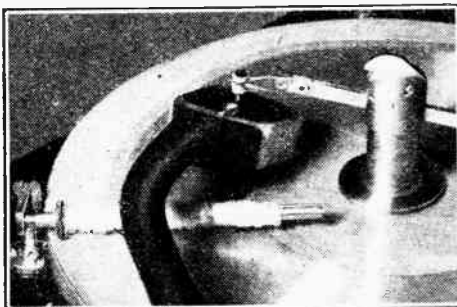

An arrangement for winding up the cut shaving when recording.

Worff and by Budich. The Telefunken apparatus is a high-quality instrument.

A notable Telefunken novelty is the provision of a small rotatable shaft passing across the record in front of the recorder; this rolls up the shaving as it is cut. Numerous new microphones are exhibited, of which the Telefunken new "anateur" microphone is a good example. A new condenser microphone has appeared by von Ardenne.

In the field of components there are not very many, but still a few, novelties.

The Gautzsch Gludlicht Company has developed a testing set which should be particularly useful in the hands of radio traders. At the top of this instrument there is a long glass window. On this there are various signs; for example, the words "Faulty," "Filament Break," "Grid Displacement," "Too little Emission," and so on. If the valve to be tested is pushed into the sockets provided and the knob pressed, the writing on the glass window becomes visible corresponding to the fault shown by the valve. The firm Bittorf and Funke shows a testing set, displaying a whole number of sockets. The firm supplies a template for every type of valve purchasable in Germany. When such a template is laid over the sockets it gives access only to those required for the testing of the particular valve. A switch

is provided which shows a large number of circuit connections corresponding to the volts to be tested for. If the switch is turned from one position to another, an indication is given whether the valve displays the fault corresponding to that position of the switch.

The firm Abrahamsohn makes an instrument for the checking of valve characteristics. This has a transparent glass window divided into squares. Over this window two pointers move; one is connected to the resistance regulating the grid bias, while the other is connected to the moving coil of a meter in the anode circuit of the valve under test. The crossing point of the two pointers gives the anode current corresponding to a given grid bias. Transparent discs can be

High-quality apparatus for recording gramophone records with a glow lamp for observing the modulation.



laid on the glass window on which are marked the valve characteristics of the various valve types on the market. If the valve is a good one, the crossing point of the two pointers must agree more or less exactly with the characteristic line on the disc.

The elimination of interference takes an important place in the Exhibition. New searching equipment for tracing the origin of interference was shown, and kits containing all the various components which anyone can need in order to eliminate the disturbances.

Screened aerial down leads and their accessories have been particularly developed this year, numerous firms participating in this, including Telefunken, A.E.G., Kathrein, Lindner & Co., Pawlick, Ehrl, and others.

In next week's issue a description of the television section of the Berlin show will be included.

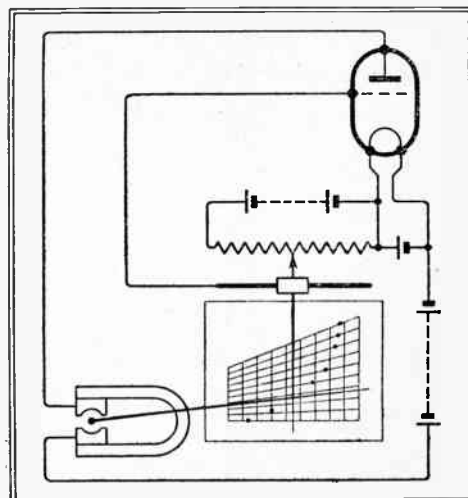

Diagram explaining the principle of an apparatus for checking the valve characteristics.



# Push-Pull Output Transformers

## A Special Design for the New Monodial Super

THE choice of a suitable output transformer is a matter requiring no less care than the selection of an intervalve coupling, if the best reproduction is to be obtained. The output stage is designed to work with a definite value of load impedance—in the case of the New Monodial Super it is 10,000 ohms—but it is rare to find that the loud speaker has the precise value required. The two are joined together, therefore, by means of a transformer with its ratio so chosen that the effective impedance\* of the speaker is altered to the necessary degree. Thus, the speaker may have an impedance of only 1 ohm and the output stage may require a load impedance of 10,000 ohms, but the use of a transformer of 100-1 ratio will result in the equivalent of a 10,000 ohms speaker with a 1-1 ratio transformer.

The question of ratio does not enter into the choice of primary inductance for the transformer, and we can consider the primary as a choke in shunt with the load impedance. Since the reactance of a choke falls with decreasing frequency, it is obvious that the efficiency of transformation will fall at low frequencies. It can be shown that the loss of bass due to this is small if the choke reactance is not lower than the load impedance at the lowest frequency required, but this is not all. As the load and the primary must be considered to be in parallel, the effective load impedance of the output stage falls as the frequency decreases, with the result that the maximum undistorted output obtainable also drops. There is thus a risk of amplitude distortion arising at low frequencies through the use of an output transformer with an inadequate primary inductance.

### The Transformer Primary

If this effect is to be negligible, a higher primary inductance is required than is necessary merely for the maintenance of an even response curve at low frequencies, and in general the primary reactance should not be less than twice the load impedance at the lowest frequency required. For a 10,000 ohms load and a low frequency limit of 50 cycles, this means a primary inductance of some 63 H. or more.

*ALTHOUGH the output transformer is often neglected, it can exercise a profound effect upon the performance of a receiver in regard to the quality of reproduction. In this article, constructional details are given of a push-pull component designed especially for the "New Monodial Super."*

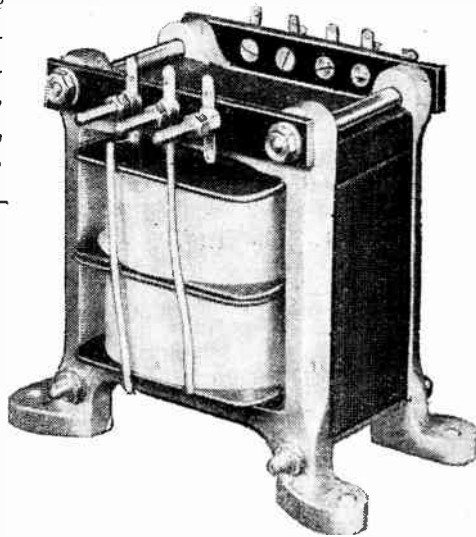

dependent upon the quantity of iron, the number of primary turns, the voltage developed across the primary, and the frequency. For a given voltage and frequency there is a minimum quantity of iron and number of turns which must be used if distortion is to be avoided.

Both primary and secondary resistances must be low if the general efficiency is to be high, and an appreciable proportion of the power delivered by the output stage is not to be lost in the transformer. In theory, maximum efficiency will be secured for a given winding space and number of turns when the secondary resistance is equal to the primary resistance divided by the square of the turns ratio. In practice, however, it is usual to make the secondary resistance rather higher than this for two reasons—because the primary resistance causes a loss of anode voltage

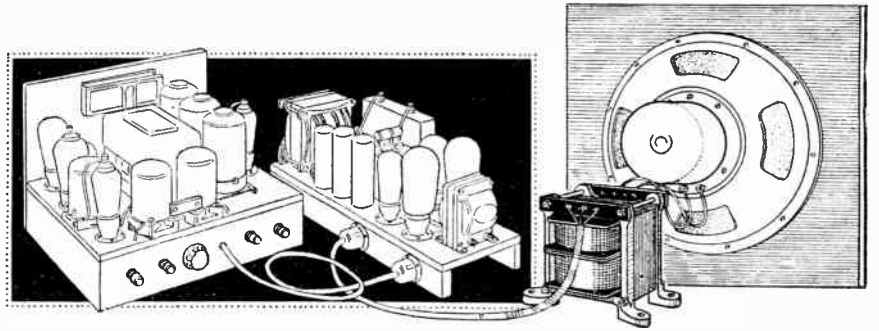

The next point of importance is the power rating. It is more a question of the A.C. volts developed across the primary at the lowest frequency than of actual power, however, and with a 10,000 ohms load and a 6 watts output we must allow for a maximum potential of 245 volts across the load impedance. The flux density in the core must not be allowed to exceed a certain figure if amplitude distortion is to be avoided, and it is

on the output stage, and we like to keep this as small as possible, and because when a high ratio is used the secondary wire gauge demanded by theory is apt to become unwieldy. With any reasonable choice of wire gauges the resistance losses are very small.

### Leakage Inductance

One of the most important points is the question of the leakage inductance, for this governs the high frequency response, and if it be large there will be a loss of high notes. For a given method of winding, the larger the primary inductance the greater the leakage, so that if we aim at perfection in the bass we run a risk of losing the upper register. Obviously, therefore, we cannot afford to make the primary any higher than is strictly necessary. The leakage inductance, however, is not governed merely by the primary inductance, but it depends very largely upon the physical disposition of the windings, and by properly interleaving the primary and secondary it may be kept at a low value. The self-capacity of the windings is fortunately of no practical importance, and a high self-capacity is beneficial rather than otherwise.

It will be seen, therefore, that the choice of an output transformer is a matter of some importance. The primary should be selected according to the output stage with which it is to be used, and the turns ratio according to both speaker and output stage. If the speaker be changed at any time the secondary winding must be appropriately altered, but if a different out-

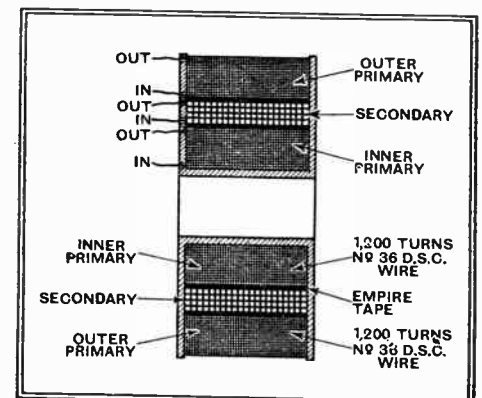

The method of winding can clearly be seen from this drawing of one of the bobbins. The other bobbin is identical save for the direction of winding.

**Push-Pull Output Transformers—**

put stage be employed, then it is to the primary that modifications must be made.

In designing a transformer for the New Monodial Super, another factor enters owing to the use of push-pull, for this necessitates a centre-tapped primary and a symmetrical disposition of the windings. Fortunately, however, the absence of a direct current through the primary renders the use of an air-gap in the core unnecessary, so that fewer turns and a smaller core can be used than if the transformer were for a single output valve.

The arrangement of the windings can clearly be seen from the drawings. Two identical bobbins are used, each carrying one-half of the primary and one-half of the secondary, and the total primary turns on each bobbin are 2,400. No. 36 gauge D.S.C. wire is used for the primary, and on each bobbin all windings are in the same direction. The two bobbins as a whole, however, are wound in opposite directions, so that the two extreme inner ends of the primary are for connection to

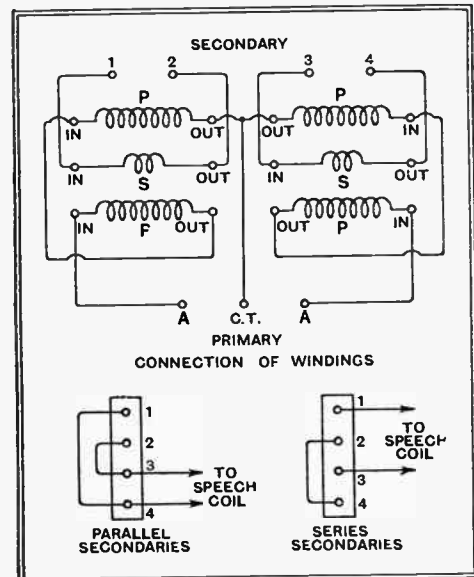

The upper portion of the diagram shows the connections between the windings and the terminals, while the lower gives the speaker connections.

the anodes of the output valves, and the two extreme outers are joined together for the centre-tap. Complete symmetry is thus readily obtainable. The secondaries are connected either in series or parallel, according to the ratio required; in the series connection the two outers are joined together, and the speaker connected to the two inner ends, but in the parallel connection the outer of one winding is joined to the inner of the other, and the outer of the latter is taken to the inner of the first, the two ends thus formed being taken to the speaker.

It is unnecessary to make any attempt at a layer winding for the primary, and it will suffice if the turns are run on as evenly as possible, so that a good surface is maintained for winding the secondary. After winding 1,200 turns a layer of Empire tape should be wrapped round it for insulation purposes, and the secondary can be put in place. Here an even layer winding is essential on account of the thickness

**Table giving winding data for transformer secondary turns to match some leading makes of loud speakers.**

Speaker.	Speech Coil Impedance.	Ratio.	Secondary Turns per Bobbin.	Wire.	Connection of two Secondary coils.
Magnavox Dual .. .. .	0.8 ohm	112-1	42	No. 18 D.C.C.	Parallel
Rola Dual .. .. .	1 ohm	100-1	48	No. 18 D.S.C.	Parallel
Magnavox Single .. .. .	1.6 ohm	79-1	62	No. 20 D.C.C.	Parallel
Rola Single .. .. .	2 ohms	70.7-1	68	No. 20 D.C.C.	Parallel
B.T.H. R.K. Senior and Ferranti M.2. and D.3 .. .. .	15 ohms	25.8-1	93	No. 20 D.S.C.	Series
Ferranti M.1 .. .. .	20 ohms	22.3-1	108	No. 22 D.S.C.	Series

Where both secondaries are normally paralleled, one-half the ratio will be obtained by joining them in series, and it will be suitable for matching a speaker of four times the normal impedance. Thus, the 70.7-1 ratio with paralleled windings for a 2-ohms speaker will give a ratio of 35.35-1 when the secondaries are connected in series and will then match an 8-ohms speaker.

of the wire; the turns should be run on evenly and tightly, but in spite of this there will usually be a tendency for the winding to assume a circular rather than a square shape. After the secondary is completed, therefore, the winding should be gently tapped down with a hammer and a block of wood. Another layer of Empire tape should be placed round the winding, and the outer primary section of 1,200 turns can be wound. The second bobbin should be identical with the first, save that all windings should be in the opposite direction.

During winding the formers should be mounted between stout end cheeks to prevent any tendency for the former to collapse; a small winding machine fitted with a revolution counter is a great help, but not strictly necessary. Owing to the fine gauge of wire used for the primary it is a wise plan to solder a short length of heavier wire to the ends for leading out.

**The Secondary.**

When the coils are completed the bobbins should be placed together and the core inserted. The "T" and "U" pieces are inserted alternatively on opposite sides in the manner of a mains transformer, and when the core is completely filled the end plates can be loosely bolted in place. The core should then be gently tapped home with a hammer, and the clamping bolts finally tightened. Small strips of insulating material carried by the ends of the

trated was built to have a ratio of 112-1, and gave a measured primary inductance of 69 H.; the total primary resistance was only 300 ohms, so that with push-pull valves taking 40 mA. apiece the anode voltage is reduced by some 6 volts only.

The response curve has been measured, and is illustrated here; it will be seen that it is level within 2 DB over the 50 cycles to 8,000 cycles range, and by extrapolation it can be seen that the useful frequency range is considerably greater for a drop of 5DB is probably inaudible.

The materials necessary for constructing the transformer are quite few in number, and consist of:—

- 100 pairs of No. 4 stampings.
- 2 half-size No. 4 bobbins.
- 1 pair of end plates with clamping bolts.
- 1 lb. No. 36 D.S.C. wire.
- 1 lb. wire for the secondary.
- 2 terminal strips, 4 B.A. nuts and bolts, Empire tape.

The transformer iron, bobbins, and end plates employed in constructing the experimental model were supplied by Sound Sales, who would doubtless supply the transformer completely assembled to special order.

Although designed specially for the New Monodial Super, this component may be employed with any apparatus fitted with a similar type of output stage.

**NEW BOOKS**

**Modern Electric Clock**, by Stuart F. Philpott. Sir Isaac Pitman & Sons, Ltd. 1933. Price 7s. 6d. net.

This book appears at a very opportune moment, for the adoption of frequency control in the A.C. supply systems of the leading electricity undertakings has stimulated wide interest in synchronous electric clocks. All the leading makes of this type are described and illustrated and the underlying principles fully explained. This section of the book should be of special interest to wireless users as the two subjects meet on common ground at many points.

The information contained in this manual is essentially of a practical nature and covers every type of electrically energised timepiece. It should prove of considerable value in choosing the best type of mechanism for any given purpose and as a guide in installation and maintenance work.

**"Broadcast Advertising. The Fourth Dimension,"** Television Edition, by Frank A. Arnold.—A descriptive and explanatory account of advertising methods in use in connection with sponsored programmes in the United States, including sample advertising programmes. 1p. 284+xix. Published by John Wiley & Sons, Inc., New York, and Chapman & Hall, Ltd., London. Price 18s. 6d.

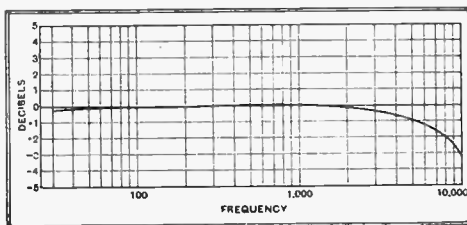

The measured response curve for a 112-1 ratio transformer; the loss at 30 cycles is less than 0.5 DB and at 8,000 cycles it is only 2 DB.

clamping bolts serve for the terminal blocks, and the method of connection should be clear from the drawings.

The accompanying Table shows the number of secondary turns, the gauge of wire, its insulation, and whether the coils are to be connected in series or in parallel, for a number of loud speaker types in more common use. The component illus-

# LABORATORY TESTS

## NEW RADIO PRODUCTS REVIEWED

### GRIPSO SELF-LOCKING TAG AND SOCKET

OF the many new items recently introduced by the Gripso Co., 28, Victoria Street, London, S.W.1, the Self Locking Soldering Tag is of particular interest, for it serves the dual rôle of a fixing for the socket and the media for connecting leads. The socket is passed through a clearance hole in the terminal strip, the locking washer is threaded on the back and the whole firmly fixed in position by a sharp blow with a hammer using a special hollow punch. The hole in the tag is provided with a number of serrations which grip firmly both the socket and the terminal strip.

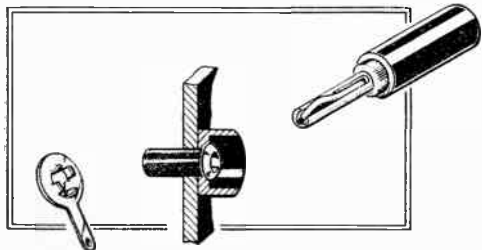

Gripso self-locking tags and sockets, also New Midget wander plug.

Two sizes are available, one with sockets to take  $\frac{1}{8}$  in. plugs at 8d. per dozen sets and the other for  $\frac{3}{16}$  in. plugs costing 1s. per dozen sets. Sockets with erinoid insulated heads engraved or plain and in two colours, also insulating bushes for use with metal panels are available.

With these the new Midget Wander Plug can be used. This has a solid pin slotted on one side and fitted with a strong flexible spring which ensures a good electrical contact. These plugs are for general purpose use and range in price from 1d. to 2d. each according to size. The special hollow punch and die for fixing the tags costs 1s. 6d.

### WHARFEDALE LOUD SPEAKERS

THE units submitted for test were the "Bronze" and "Golden" models. Both are notable for their rugged construction and the generous dimensions of the magnet systems. A notable feature is the method which has been adopted to ensure the exclusion of foreign matter from the air gap. Particles falling in towards the apex of the cone are stopped by a fine-mesh gauze behind the centring spider, while the back of the gap is sealed by a sponge rubber ring surrounding the centre pole-piece.

There is little to choose between the two models from the point of view of efficiency and sensitivity. As regards frequency response the "Golden"

model has a better output in the bass below 100 cycles on account of its larger diaphragm, and in the extreme

top its higher price is again justified. In both models there is an appreciable response at 8,000 cycles, but whereas the "Bronze" model commences to fall off at 4,000 cycles, the output of the "Golden" model is fully maintained up to 5,000 cycles. The bass resonance occurs in the "Bronze" model at 145 cycles and in the "Golden" at 120 cycles, but in neither case is it sufficiently prominent to colour the quality of reproduction. Apart from a slight increase in output in the region of 2,500-3,000 cycles the response in the middle and upper middle registers is in both cases sensibly uniform. The prevailing impression of the quality is one of brightness without too heavy a bass response. Reproduction of speech is exceptionally good.

The output transformers have interleaved and impregnated windings and are of more than usually generous design. Tappings are provided for matching to all types of output stages including Class "B."

Made by Wharfedale Wireless Works, 62, Leeds Road, Bradford, the "Bronze" model costs 39s. 6d. and the "Golden" model 63s.

### AN INEXPENSIVE MICROPHONE

THE G.E.C. Home Broadcaster is an inexpensive microphone having many uses both practical as well as entertaining. It is eminently suitable for Home Recorders, for announcing gramophone record titles at dances and at garden fêtes, as well as broadcasting matter of general interest at these functions, at amateur theatricals and for experimental transmitting work, to mention but a few only of its possible applications.

A normal broadcast receiver having facilities for gramophone reproduction is quite suitable for many of these occasions, the Home Broadcaster being connected by a change-over switch to the pick-up terminals so that either microphone or pick-up can readily be brought into use.

The unit is entirely self-contained, and consists of a sensitive carbon-type microphone, a volume control, an input transformer, and clips for a small torch bat-

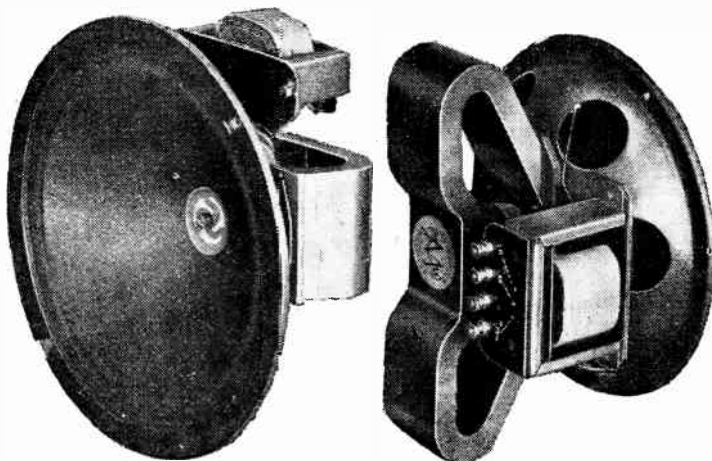

Wharfedale permanent magnet moving coil loud speakers (Left) "Golden" model. (Right) "Bronze" model.

tery; the last two mentioned being accommodated in the base. It is equipped with 25ft. of cable screened to avoid pick-up

### G.E.C. Home Broadcaster, an inexpensive microphone unit.

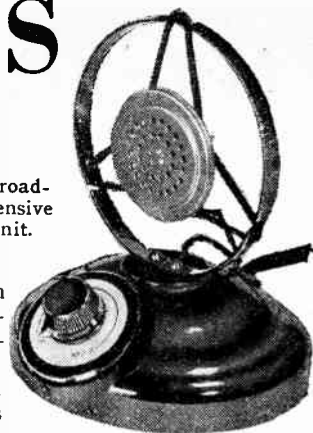

of mains hum and other extraneous electrical noises.

The specimen tested was very sensitive, showed a most satisfactory frequency response, and altogether is an ideal instrument for home and experimental use. The makers are the General Electric Co., Ltd., Magnet House, Kingsway, London, W.C.2, and the price is 18s. 6d.

## The Radio Industry

"NEW Notes in Radio" is the title of an informative little booklet recently issued by Hartley-Turner Radio, Ltd., of Thornbury Road, Isleworth, Middlesex. It presents a good résumé of the principles underlying the design and construction of moving-coil loud speakers, with particular reference to the Hartley-Turner instrument. Much useful information is given on the associated problems of field current supply, L.F. amplifiers, and matching.

In addition to the various screened aerial down-leads, which are already well known, Ward & Goldstone have just introduced a metal screened earth lead. Both the three-stranded conductor and the external wire braiding are of heavy gauge, and the insulation is completely waterproof. The use of a screened earth lead is in some cases beneficial in reducing background noises, and is likely to be particularly useful when a screened aerial system with impedance-matching devices is installed.

British wireless products are getting far afield. According to the Chloride Co., an Exide H.T. accumulator battery of 220 cells has just been despatched to the palace of the Dalai Lama, in the "forbidden city" of Lhasa, the capital of Tibet.

The company also announce a reduction in the prices of several types of dry-cell H.T. battery designed for certain well-known self-contained receivers.

The works of the Harken Electrical Co., Ltd., have now been transferred from Walworth Road, London, S.E., to 18a, South End, Croydon. Under the managing directorship of Mr. E. Harker, recently engineer-in-chief to the Post and Telegraph Department of Ceylon, this firm specialises in radio and other apparatus for use in tropical countries.

We are informed that the servicing of Atwater Kent receivers has now been taken over by the Radio Development Co., of Aldwych House, Aldwych, London, W.C.2. This company also undertake repairs to Pada and other American receivers.

### New Catalogues Received

Blue Spot Loud Speakers and Units: The British Blue Spot Co., Ltd., 94-96, Rosoman Street, Rosebery Avenue, London, E.C.1.

Wharfedale Loud Speakers: Wharfedale Wireless Works, 62, Leeds Road, Bradford.

Oldham "Insured Life" Accumulators: Oldham and Son, Ltd., Denton, Manchester.

Clix Connectors, Terminals, Plugs, Valve-holders, etc.: Electro Linx, Ltd., 79a, Rochester Row, Westminster, London, S.W.1.

# Broadcast Brevities

By Our Special Correspondent

## 200 Kilowatts at Droitwich

BRITISH listeners who have been perturbed by the thought that the B.B.C.'s National transmitter at Droitwich will be limited to a power of only 100 kW. will be glad to learn that the B.B.C. is very much more ambitious than the published announcements would lead one to expect.

I understand that provision will be made for a transmission power of not less than 200 kW.—sufficient to make the British transmitter a match, as it should be, for Luxembourg, hitherto the most powerful station in Western Europe.

## Open-air Drama

The output stage of the great transmitter now nearing completion at the Marconi Works, Chelmsford, will contain four of the new C.A.T. valves, each rated at 50 kW.

Just now there is a real open-air drama being enacted in that Worcestershire meadow, three miles from Droitwich.

It is a fight against time and weather.

The aim is to get the lid on before the wet weather sets in. When once the building has a roof the transmitting apparatus can be installed.

## Testing by March?

He would be a bold man who would prophesy that the B.B.C. will wait until midsummer, 1934, as announced, before sending out test signals.

I am not bold enough to make any such prediction, for I believe that we shall hear the first signals from Droitwich by April, possibly March.

Meanwhile, the masts are ascending inch by inch, and will soon be half as high again as St. Paul's Cathedral, London.

## A Lord Dunsany Play

LORD DUNSANY has written a new play especially for broadcasting. It is called "The Use of Man," and will be heard in the National programme on September 26th. The characters include human beings and the spirits of animals, birds, and insects. Listeners will no doubt recall another of Lord Dunsany's plays—"H"—which has been broadcast on two or three occasions in the past.

## Don't Take This Seriously

"COUNTER Clockwise," by Moultrie Kelsall, which is to be broadcast on September 18th, is a programme designed to explode historical myths. The three myths exploded are, first, that Bruce learned his statecraft from a spider; secondly, that Burns was a haggis addict; and, thirdly, that Bonny Prince Charlie divided up his tartan apparel among the enamoured ladies of the Highlands.

I understand that, on the last occasion on which these sketches were broadcast, some listeners took them seriously, and their national pride suffered in consequence. No disparagement of these national heroes, however, is intended, and the explosions are as mythical as the myths themselves.

Think that out.

## Devolution

NOT decentralisation but devolution, I am told, is the guiding principle in the new organisation which characterises the B.B.C. in all its branches from Land's End to John o' Groat's.

## The Organisation

The scheme can be sketched in a few words. At the head is Sir John Reith; on his left sits Admiral Sir John Cappendale, head of Administration, and on his right Colonel A. C. Dawnay, the new Controller of Output.

Under the principle of devolution this organisation is repeated in miniature, as it were, at each of the Regional headquarters. Thus we find at the Scottish Regional Mr. Melville Dinwiddie in charge; his Administrator is Mr. J. M. A. Cameron, and his Programme Director Mr. Moray McLaren; this form of organisation holds good north, east, south and west.

## A Talented Musician

By the way, I am glad to hear that Mr. Hely-Hutchinson's transfer to the post of music director in the Midland Region does not mean that this extremely talented musician is lost to London audiences. I venture to predict for Mr. Hely-Hutchinson a great musical future, and many listeners will feel that the Midland Region is honoured by the appointment.

## Mr. Aylmer Buesst

Mr. Aylmer Buesst, who is to become chief assistant to Dr. Boulton, is an Australian who has already had a distinguished career as a conductor and will no doubt wield the baton at many broadcast concerts in the near future.

## St. Leger Broadcast

A RUNNING commentary on the St. Leger will be broadcast on Wednesday next, September 13th, by Mr. R. C. Lyle, the well-known racing correspondent, whose descriptions of the Derby and other racing events are always popular with listeners, especially those backing the winner.

## Hunted

NO wonder, during these dog days, the B.B.C. officials wear a hunted look. They are hunted, for the daily Press, robbed of so many sources of intellectual food, such as the Houses of Parliament and the Law Courts, seems to turn naturally to broadcasting for its stunts.

If an official distributes an innocuous circular encouraging lady members of the staff, if they feel so disposed, to enquire what exactly would be their position in the event of marriage, the Press sleuths manage without difficulty to turn the event into a first-class "story."

## No Crèche in Portland Place

Not that very much harm is done, for the B.B.C., after its initial embarrassment, welcomes publicity and rejoices in its ability to explain an entirely well-meant effort on its part to reassure its women employees.

As one member of the staff remarked to



CONTROLLER OF OUTPUT. Col. A. C. Dawnay, who assumed control of the "output" section of the B.B.C. on Monday last.

me: "We wish to be fair all round, but even we cannot be expected to run a crèche."

Why not leave it at that?

## "La Bohème"

SADLER'S WELLS Theatre in Islington will be the venue of a relay in the National programme on September 19th, when Acts I and II of "La Bohème" will be broadcast. It is some time since listeners last heard a relay from this theatre, from which several performances of opera have been successfully broadcast in past years. Act I of Gounod's "Faust" will be relayed from this theatre on September 30th.

## Smash and Grab

A STRONG cast will be heard in "One Good Turn—," described as a "Smash and Grab Presentation of Road House Variety," to be broadcast on September 12th (Regional) and 13th (National). The book and lyrics are by Max Kester and Ray Noble respectively, and the latter's orchestra will take part in the performance. Included in the cast are Anona Winn, Suzanne Botterell, Al Bowly, Bobbie Cumber and Claude Hulbert.

## Bouquets and Broadcasting

THE dear old-fashioned habit of sending up bouquets to the stage at the end of the opera or village concert has never, for some reason, been adopted by broadcast listeners. I have never seen a queue of messenger boys with floral tributes at the back-door of Broadcasting House at the conclusion of the evening programmes.

## If You Send Flowers . . .

I mention the subject only in case you should ever conceive the idea of paying tribute in this manner, possibly when you have heard Mr. Maschwitz's Eight Step Sisters. Make sure that the flowers are absolutely fresh and, if possible, encased in ice. For it has been observed that flowers in the studios are doomed to a short life. The oxygenated air will serve a *prima donna* for ten minutes, but apparently it cannot keep flowers alive for more than a day or two. *Verb. sap.*



# Correspondence

The Editor does not hold himself responsible for the opinions of his correspondents.

Correspondence should be addressed to the Editor, "The Wireless World," Dorset House, Stamford Street, S.E.1, and must be accompanied by the writer's name and address.

## Television

ALTHOUGH it is only recently that I turned up some of my first numbers of *The Wireless World*, this is my first letter to your paper.

I write to support the Hon. Sec. of the Halifax Wireless Club. Experimenters in the North may well ask "What is this television?" I have just dismantled a television set because it was useless to continue attempts at reception. With the transmissions from London Regional I had fairly good results, but London National is hopeless in this locality. I also feel that I was let down in connection with the Fultograph transmissions. Will television come to the same ignominious end? Possibly, unless keen experimenters all over the country, and especially in the North, are allowed a "look in."

"A YORKSHIRE PARSON."

## Electricity Supply

WITH reference to your correspondent's letter on "Continuity of Electric Supply" in your issue of the 25th Aug., I append an extract which may be of some interest:—

Section 12 (2) of the Electricity (Supply) Act, 1919, states: "... there shall be incorporated with this Act the provisions of the Schedule to the Electric Lighting (Clauses) Act, 1899, subject to such exceptions and modifications as may be prescribed by the order constituting the joint electricity authority."

Section 30 (1) of this schedule states: "Whenever the undertakers make default in supplying energy to any owner or occupier of premises to whom they may be and are required to supply energy under the special order, they shall be liable to a penalty not exceeding 40s. for each day on which the default occurs."

From this it is clear that the supplying authority has very definite obligations.

A. K. T.

Teddington, Mddx.

## Eliminating Interference

I HAVE recently visited the German Radio Exhibition and feel that all who saw it must have shared my keen interest in the demonstrations and exhibits of the German Reichspost in connection with the elimination of interference from electrical machinery.

I was particularly struck by one very simple arrangement for eliminating interference from small motors with series field windings which I find was mentioned, though without special comment, by Mr. Bernaert in his article in your issue of July 7th, 1933. I refer to the division of the field winding into two equal parts, one being placed in each supply lead. If a condenser is then placed across the brushes, it forms with the two sections of the field winding a symmetrical filtering arrangement which is stated by the German engineers to result in a substantially complete elimination of interference.

I do not know to what extent such an arrangement would be applicable to the various types of commutator motor for alter-

ing and direct current, but as it involves a change of manufacturing practice, namely the division of the field windings into two similar sections connected one in each main lead, with the armature between them, it would appear to be a matter deserving careful investigation and decision, particularly when it is borne in mind that such motors are extremely common and give rise to a very great deal of troublesome interference.

P. W. WILLANS.

London, W.C. 2.

## Double Channel B.B.C.

### Transmissions

RECENT research into high quality sound reproducing systems has shown that considerable improvement can be obtained by the use of a double channel reproducing system consisting of separate microphones

each with its own amplifier and reproducer. In a recent test a considerable number of observers preferred a double channel system with an upper cut off at 2,800 c.p.s. to a single channel system with a 12,000 c.p.s. limit.

Here we have an excellent opportunity of turning the B.B.C. regional scheme to good use, and I suggest that when two or more stations are radiating the same programme, arrangements should be made to use two microphones. Listeners who were prepared to purchase the extra equipment could then avail themselves of the advantages of a double channel system without any interference with the normal purpose of either station serving listeners with single reproducers. It would be interesting to have comments upon the proposed arrangement.

Rugby.

JAMES MOIR.

## NEW HIGH QUALITY LOUD SPEAKER

### A Moving Coil with Uniform Mechanical and Electrical Impedance

SO far, one of the most successful methods of reproducing sound over a wide range of frequencies has been to use at least two types of loud speaker—a large moving coil cone unit for the low notes and a moving coil horn or "tweeter" for the higher frequencies. Filter circuits are employed to keep out of the respective speaker units the frequencies assigned to the other, and the system is comparatively expensive and by no means easy to design or adjust.

mechanical compliance which considerably extends the high frequency range and enables the performance of the dual unit system to be obtained from a single loud speaker.

The moving coil loud speaker of normal design consists of a coil of wire moving in a strong magnetic field and a cone diaphragm which imparts the coil vibrations to the surrounding air. At low frequencies this coil moves as a piston, but at high frequencies the mechanical impedance is so large that considerable power must be expended to move it. At the same time, the electrical impedance of the speech coil, which is made up of inductance and resistance, increases with frequency so that above 1,000 cycles the loud speaker load no longer matches the impedance of the power valve. This again results in a loss of power. In order to achieve uniform mechanical and electrical impedance over the frequency range, Dr. Olsen divides the speech coil into two sections as shown in the accompanying diagram. The two sections are coupled mechanically by a "crimp" in the paper coil former. This functions as a compliance, which is the mechanical analogy of a condenser. The section of the coil remote from the junction with the diaphragm is shunted by a capacity which by-passes the current in this section above 1,000 cycles. At the same time, the mechanical compliance is adjusted so that the shunted section of the coil remains stationary at frequencies above 1,000 cycles. Thus, only part of the coil is in use, and as the diaphragm is corrugated to reduce its effective area, the mechanical and electrical impedances at high frequencies do not rise appreciably above their normal values.

According to reports, subjective listening tests show that the high-frequency response is decidedly better than that of the present type of moving coil units, and laboratory tests have shown that the acoustic output is practically uniform up to 10,000 cycles as compared with an average cut-off at 5,000 cycles in the average moving coil unit.

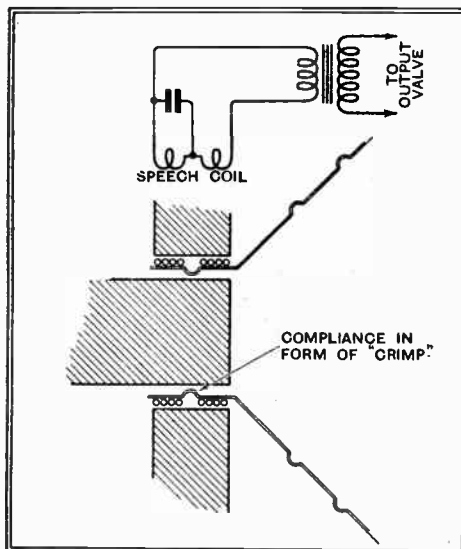

In the Olsen moving coil loud speaker the moving coil is divided into two sections coupled by a mechanical compliance which, in conjunction with a by-pass condenser, short circuits a section of the coil at frequencies above 1,000 cycles.

At the recent I.R.E. Convention in Chicago, a new type of moving coil loud speaker was described by Dr. H. F. Olsen, of the R.C.A. and Victor Corporation. This unit, which has a frequency range from 90 to 10,000 cycles, is based on an interesting combination of electrical capacity and

# PRACTICAL HINTS AND TIPS

**I**N the rush and turmoil of the recent Radio Show it is possible that many visitors overlooked the less spectacular sections of the G.P.O. exhibit. For their benefit, and also for that of readers who were unable to go to Olympia, attention may be drawn to a little-known application of anti-interference filters which was officially advocated by the technical staff in attendance. The Post Office engineers have now had so much experience in these matters that their pronouncements should carry weight.

## A Barrier to Interference.

The more usual type of filter, connected in the mains feed of the receiver itself, has been discussed from various points of view. It is often completely effective, but cannot in any way mitigate the ill-effects of interfering impulses passed into the building by the electrical mains and then re-radiated to the aerial from the house wiring. Clearly, the better plan is to filter out all H.F. energy at the point where the mains enter the building; the main objection to this

## Simplified Aids to Better Reception

No hard-and-fast rules were laid down as to the best type of filter for all circumstances, and it was suggested that experiments should be made with the various circuit arrangements shown in Fig. 1 (reproduced from a Post Office leaflet).

The simplest arrangement, consisting merely of two condensers joined in series across the mains input, and with the junction point earthed, does not introduce any complications. But, as already inferred, where chokes are necessary the greatest care must be taken to avoid an excessive loss of voltage, and before setting to work a rough estimation should be made of the maximum amount of current consumed for domestic purposes. In a small house, where no more than half a dozen 60-watt lamps and the wireless set are in use simultaneously, the total consumption will not exceed some 2 amps., assuming a normal voltage. It is not difficult to wind a pair of chokes with a total resistance of between 0.5 and 1 ohm, and so the loss of voltage should not exceed 2 volts, which is negligible. The Post Office suggests chokes of between 100 and 600 microhenrys inductance, and condensers of 2 mfd.

Chokes of suitable inductance, combined with a D.C. resistance low enough for most domestic installations, may be wound with No. 18 D.C.C. wire, and with a mean diameter of from 2in. to 3in. Between about 100 and 200 turns will be required, depending on the nature of the interference, etc., and the larger windings are most conveniently made up in "pancake" form. Where the load is heavy, a correspondingly heavier gauge of wire should be used for the chokes.

**M**OST amateurs have a high grade moving-coil D.C. voltmeter, but few feel inclined to incur the expense of buying an instrument for measuring A.C. voltages. For equal accuracy, the A.C. instrument is considerably more costly,

### An Improved A.C. Voltmeter

and further, it is seldom that it becomes really necessary. It is not generally known that, without any internal alterations, and without affecting its normal use, a D.C. voltmeter may be converted for reading A.C. with very fair accuracy.

The modification shown in Fig. 2 is suggested for this purpose; assuming the meter to have a very high resistance—in

the order of 1,000 ohms per volt—results will be quite satisfactory. Nothing is needed for the conversion beyond a valve holder, a low-tension battery, and practically any type of valve that may be available. It matters little if the valve has partially lost its emission, and is therefore unsuitable for normal use.

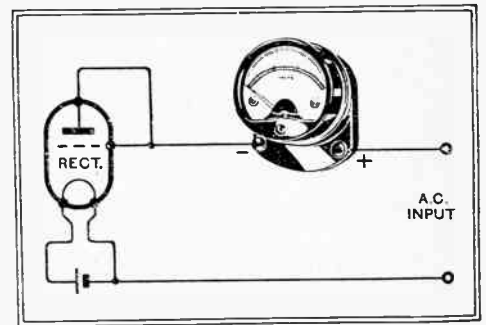

Fig. 2.—In order to read A.C. voltages on a D.C. voltmeter, a rectifier may be inserted in series.

To take a reading, the source of A.C. voltage to be measured is joined across the input terminals, and the voltage indication given by the meter is multiplied by a correction factor of 2.2 to ascertain the R.M.S. value.

An old-type Weeco dry-battery valve is almost ideal for this purpose, as its filament may be heated from a single dry cell, thus overcoming the difficulty of maintaining an accumulator when the set itself is mains operated. If desired, of course, an ordinary 2-volt 0.1 amp. valve may be heated by means of two dry cells, with a series rheostat of 20 ohms.

**I**N an attempt to conserve anode current in Class "B" battery sets as much as possible it is quite usual to over-bias the driver valve in order to keep down the current flowing in its anode circuit to the lowest possible level. It would seem that

### Check the Driver Valve.

sometimes matters are carried rather too far in this direction, with the result that distortion is produced.

The purpose of this note is to point out that the operating conditions of the driver may be checked in the same way as those of a conventional output valve. A milliammeter, connected in the anode circuit, should show a steady current reading while signals are being received; violent kicks during the reproduction of loud passages will indicate overloading, and if they are in an upward direction we have an indication that the driver bias is excessive.

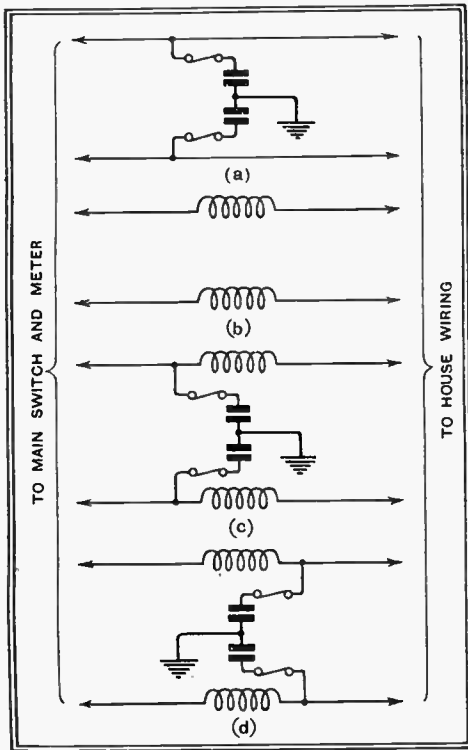

Fig. 1.—For keeping interfering impulses out of the house-wiring system: filter circuits for connection at the point of entry of the mains.

course is that the chokes which will generally be needed must be of lower resistance than those used in a receiver filter, as they have to pass much heavier currents.

# READERS' PROBLEMS

## A.V.C. and Quality

THERE seem to be a few lingering doubts as to whether the use of automatic volume control is compatible with the highest quality of reproduction. Several correspondents have lately expressed doubts as to whether *pianissimo* and *fortissimo* passages will be rendered at their true values when A.V.C. is fitted.

We would hasten to assure them that their doubts are quite unfounded. A.V.C. is not out of place in a "quality" set; it does nothing to smooth out the normal variations in modulation, being operated solely by the average carrier-wave amplitude.

## "Shorted" Volume Control

FOLLOWING conventional practice, a reader, who has built a "2-H.F." set for A.C. mains operation, is using variable-mu valves and has made provision for controlling volume by variation of grid bias.

After working well for some time, the volume control system has now failed, and, further, it is found that operation of the controlling potentiometer has no effect on the anode currents of either of the H.F. valves. Careful tests for insulation and continuity have been made with negative results, and so this reader has decided to ask our help.

As the circuits have been thoroughly tested, presumably with current switched off and possibly with valves removed, we can only think that the fault lies in one of the variable-mu valves, in which defective heater-cathode insulation has probably developed. A breakdown in the heater-cathode insulation of either valve would have the effect of short-circuiting the bias for both H.F. stages.

It is improbable that both valves have failed, and so, to detect the faulty one, we suggest that, with a meter in the common anode circuit, one of these valves should be removed while the set is working. If control of anode current can now be obtained by operation of the grid bias potentiometer, the valve removed is defective, while, if control is still unobtainable, the valve in the set will be responsible for the trouble.

## Mains Periodicity

A CORRESPONDENT, who is using a metal rectifier in a voltage-doubling circuit, has noticed that the D.C. output of his H.T. supply unit is exceptionally high, and

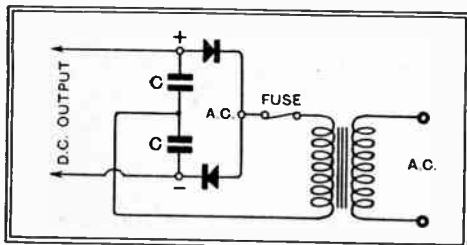

Fig. 1.—A conventional "voltage-doubling" circuit; the reservoir condensers C should be chosen with regard to the periodicity of the mains supply.

that a temperature rise takes place after a few minutes' work. He adds that his mains supply is rated at 80 cycles, and that the power transformer used is stated to be suitable for this periodicity.

THESE columns are reserved for the publication of matter of general interest arising out of problems submitted by our readers.

Readers requiring an individual reply to their technical questions by post are referred to "The Wireless World" Information Bureau, of which brief particulars, with the fee charged, are to be found at the foot of this page.

It seems probable that this reader, who asks for a suggestion as to how his H.T. voltage may be reduced to a normal value, is using reservoir condensers of the usual capacity (4 mfd.) in association with his rectifier. These condensers (marked C in Fig. 1) are in series with the source of A.C. input; when current is supplied at an exceptionally high periodicity they will offer a lower reactance than at the more normal frequency of 50 cycles. According to the latest instructions issued by the makers of the Westinghouse rectifier, the standard capacity of 4 mfd. should be doubled for 25-cycle supplies, and halved for 100 cycles. These values are not critical, and we think that our correspondent might use condensers of 3 mfd. each.

## Loading the Output Stage

THE prospective constructor of a modified version of the New Monodial receiver asks whether it would be possible to omit the intermediate L.F. stage, and to feed a single output valve, giving 5 watts, directly from the double-diode-pentode second detector.

This plan is not to be recommended, for the reason that it would involve the sacrifice of tone correction, which is an important feature of the set. With a tone-correcting coupling in its anode circuit, the D.D./PEN. second detector will certainly not give sufficient output without an intermediate stage, but it could be made to do so by substituting an anode load to about 20,000 ohms.

## Superhet Tests

SUPERHETERODYNE receivers are not prone to H.F. instability; that is one of the attractions of the system. Nevertheless, occasions sometimes arise, just as in straight sets, where the signal-frequency H.F. stage of a superheterodyne breaks into uncontrollable self-oscillation, especially at the lower end of the waveband.

A reader whose set is behaving in this way concludes, quite rightly, that the cause of instability may most easily be localised by isolating the part of the receiver con-

## The Wireless World INFORMATION BUREAU

THE service is intended primarily for readers meeting with difficulties in the construction, adjustment, operation, or maintenance of wireless receivers described in *The Wireless World*, or those of commercial design which from time to time are reviewed in the pages of *The Wireless World*. Every endeavour will be made to deal with queries on all wireless matters, provided that they are of such a nature that they can be dealt with satisfactorily in a letter.

Communications should be addressed to *The Wireless World* Information Bureau, Dorset House, Stamford Street, London, S.E.1, and must be accompanied by a remittance of 5s. to cover the cost of the service. The enquirer's name and address should be written in block letters at the top of all communications.

cerned. He proposes, for purposes of test, temporarily to convert the set into a simple H.F.-det. combination by inserting a pair of phones in series with the first detector anode. As the set is mains-operated, with quite a high anode voltage, it is considered desirable, in the interests of safety, to isolate the phones from the source of H.T., and our advice is sought on this point.

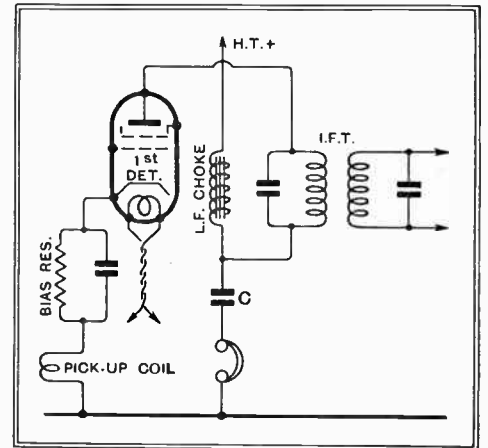

Fig. 2.—Temporary phone connections for testing a mains-operated superheterodyne.

Although one can often do it with impunity, it is risky to connect headphones directly to a mains-operated receiver, and we consider our correspondent is wise to take precautions. Failing a spare output transformer, which may be used for the purpose even if it does not give accurate matching, we suggest the use of a choke-filter arrangement, as shown diagrammatically in Fig. 2. For a choke, almost any inductive winding, such as the primary of a discarded L.F. transformer, will serve, while the condenser may have almost any capacity from 0.1 mfd. upwards; it should be rated at at least the same working voltage as the other condensers in the receiver.

When making a test of this sort it is a good plan to make sure that the oscillator valve is not functioning, as otherwise misleading effects may be introduced if the circuits associated with this valve be tuned to a frequency that will give an audible note when beating with oscillations in the signal-frequency circuits.

## Oscillator Tuning

SEVERAL readers have asked whether an ordinary ganged condenser (without specially shaped plates) may be used for tuning a superheterodyne receiver.

It is possible, by the use of a padding condenser of suitable capacity in series with the oscillator section of the condenser, to obtain sufficiently good alignment of the signal-frequency and oscillator circuits without the use of a special condenser. But the reception of the long waves presents a difficulty, as the capacity of the padding condenser needed will differ from that required for the medium band. This introduces complications in waveband switching, as it will become necessary to make provision for changing over the padding condensers for each band.

For padding purposes it is generally best in such cases to use semi-variable condensers, or one of these in parallel with a fixed capacity.



**ACCURATE  
MATCHING  
AT LAST!**



- 17 transformer ratios for really accurate matching to ANY power valve or pentode and 4 ratios for Class B or QPP *all available on one speaker* by a simple switch adjustment!
- Added sensitivity due to the 'Mansfield' magnetic system! Better balance through really accurate matching! The difference in performance must be heard to be believed.

**'MICROLODE'**

(Regd. Trade Mark)

Type PM4a-42/- Type PM6-32/6  
**MOVING-COIL SPEAKERS**  
With the new Microloode feature and the famous 'MANSFIELD' magnetic system.

Write for the MICROLODE folder.

*"Did you notice one of the radio journals says the 'Microloode' was probably the high spot at Radiolympia?"*

*"It certainly is a very far-reaching development in speaker technique!"*

*We are exhibiting at Stand No. 70, Scottish National Radio Exhibition, Glasgow.*

Whiteley Electrical Radio Co. Ltd., Dept. W, Radio Works, Mansfield, Notts.

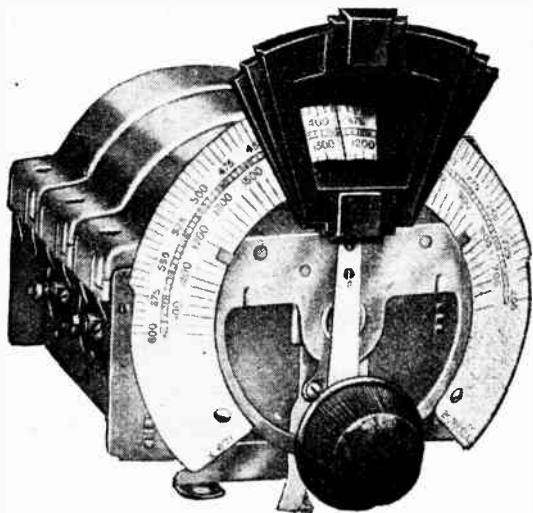

**POLAR 'STAR' THREE GANG**

Cadmium plated steel frame of rigid construction. Universal feet supplied permitting base or side mounting. Trimmers operated from top. Sections matched to within 1/2% or 1 mmfd. (whichever is greater). Bevelled scale, calibrated in degrees and wavelengths.

- |                                      |      |
|--------------------------------------|------|
| 3 x .0005 Condenser only ... ..      | 22/6 |
| " " with Moving Scale drive as shown | 27/- |
| 4 x .0005 Condenser only ... ..      | 30/- |
| " " with Moving Scale drive as shown | 34/6 |

Can also be fitted with Full-Vision "Arcuate," "Horizontal" or "Semi-circular" drives.

NOTE. Super Het type 3 & 4 Gang condensers are available at the same prices shown above.

**WINGROVE & ROGERS LTD.**  
188-9, Strand, W.C.2.

Telephone: Temple Bar 2244. Works: Old Swan, Liverpool.

**POLAR**  
for **SOUND**  
**DESIGN**  
FAMOUS SINCE 1922



SEND FOR  
NEW POLAR  
CATALOGUE

**POLAR 'UNIKNOB'  
TWO GANG**

Steel Frame, Air di-electric trimmer controlled by knob fitted concentrically with tuning knob. Slow motion drive. Scale in wavelengths and degrees.

2 x .0005 - **18/6**

Can be supplied with either of the three Polar "Full Vision" Drives 1/3 extra.

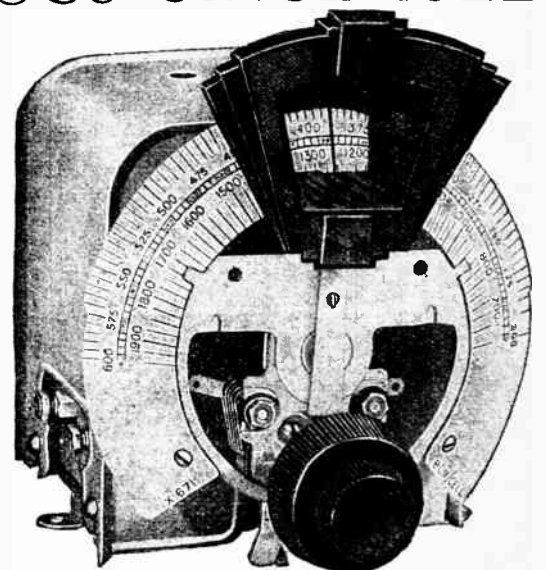



# MISCELLANEOUS ADVERTISEMENTS

## NOTICES.

**THE CHARGE FOR ADVERTISEMENTS** in these columns is

12 words or less, 3/- and 3d. for every additional word.

Each paragraph is charged separately and name and address must be counted.

**SERIES DISCOUNTS** are allowed to Trade Advertisers as follows on orders for consecutive insertions, provided a contract is placed in advance, and in the absence of fresh instructions the entire "copy" is repeated from the previous issue: 18 consecutive insertions 5%; 28 consecutive, 10%; 52 consecutive, 15%.

**ADVERTISEMENTS** for these columns are accepted up to **FIRST POST ON MONDAY MORNING** (previous to date of issue) at the Head Offices of "The Wireless World," Dorset House, Stamford Street, London, S.E.1. or on **SATURDAY MORNING** at the Branch Offices, 19, Hertford Street, Coventry; Guildhall Buildings, Navigation Street, Birmingham, 2; 280, Deansgate, Manchester, 3; 28b, Renfield Street, Glasgow, G.2.

Advertisements that arrive too late for a particular issue will automatically be inserted in the following issue unless accompanied by instructions to the contrary. All advertisements in this section must be strictly prepaid.

The proprietors retain the right to refuse or withdraw advertisements at their discretion.

Postal Orders and Cheques sent in payment for advertisements should be made payable to **LIFFE & SONS Ltd., and crossed & Co. Notes being untraceable if lost in transit should not be sent as remittances.**

All letters relating to advertisements should quote the number which is printed at the end of each advertisement and the date of the issue in which it appeared.

The proprietors are not responsible for clerical or printers' errors, although every care is taken to avoid mistakes.

## RECEIVERS FOR SALE.

**NEW** Monodial Amplifier Unit, assembled complete; £8/8-7. Gravelly Hill North, Birmingham. [3411]

**MONODIAL**, with A.V.C. and valves; £16; may be heard by appointment.—7, Gravelly Hill North, Birmingham. [3410]

**R.G.D. 701** a.c. Radiogram, superb instrument, almost new; bargain at £29.—"Riddlesden," Elm Av., Crosby, Liverpool. [3423]

**1933 Philips 850 C** 4-valve all mains (D.C.), in perfect condition, 8 months old; cost £17/17, sell £8, or offer; call after 7.30 p.m.—5, Burlington Rd., Clapton, E.5. [3408]

**40/-**—Ediswan D.C., all-electric, S.G., det. and pentode, without valves, worth more to break up; transformers, output choke, 2,000s, with drum drives, coils, smoothing unit, resistances and condensers, etc.

**£3/19/6**—Matz Radio 2-valve, A.C., with Ultra speaker, complete with valves unopened; list £8/10.—Kay, 167 City Rd., London, E.C.1. [3352]

**DEMSON RADIO PRODUCTS**—Monodials built, converted, repaired, or kitted; official Wireless League repairers, fully equipped laboratory; estimates free, trade supplied.—White House, Rosehill Park West, Sutton, Surrey. Tel.: 4591. [3414]

**CIFEL D.C.** 2-valve Sets, detector, pentode, Magnavox M.C., Osram valves, packed in makers' unopened carton; at £3/19/6, c.o.d., carriage paid; also Mavox D.C. 2-valve detector, power, Sonochord M.C., £3/12/6. W. Burns and Co., 287, City Rd., London, E.C.1. [3374]

**ARMSTRONG** Latest Universal A.C., D.C. 4-valve Chassis, specially efficient S.G. circuit, pentode output, 75/-, with 5 valves 114/-; Armstrong 1934 Battery 3-chassis, metal construction, 2 tuned circuits, S.G., pentode output, built-in speaker, 45/-, with valves 69/-; above chassis have remarkable performance, 2 years' guarantee, approval.—Armstrong Co., 100, King's Rd., N.W.1. [3444]

## ACCUMULATORS—BATTERIES.

**BATTERIES**, fully guaranteed, 120 volts; 7/6, carriage paid.—Perrins, 69, Gower St., Birmingham. [3399]

## MAINS EQUIPMENT

**N.P.** Chargers for A.C. mains. Trade list free.

**N.P.** Have Most Efficient Chargers from 62/6, complete ready for use.

**N.P.** Have one or two Chargers Slightly Soiled at Bargain Prices. List.

**N.P.**—12-15v. 1/2 to 1 amp. Westinghouse rectifier, soiled, bargain 45/-; another, 35/-; also Tungar valve 15v. 3 amps., 85/-; Philips valve, 79/-; 7.5v. 6 amps., all variable from low amperage and in new condition, fully guaranteed; cannot repeat these bargains; list of others.

**N.P.** Have Motor-Dynamo 10 amps, complete, £6; Valve set 6 amps., £4; another, 40 volts, 2 circuits, 3 amps. and 4 amps., bargain, £8.—Nash Products, Ltd., Stechford, Birmingham, 9. [3433]

**TANTALUM** for A.C. Chargers, H.T. and L.T. Blackwell's Metallurgical Works, Ltd., Garston, Liverpool. [2139]

**A.C.** Charging Plant, unused, cost £18 18, for £6/18/6; write for makers' specification.—Jersey, Cumnor Hill, Oxford. [3424]

# PILOT AUTHOR KITS

Exact to Specification

## NEW MONODIAL

### RECEIVER KIT.

Author's Kit of **FIRST SPECIFIED PARTS FOR RECEIVER PORTION ONLY**, less Plymax Chassis, Panel, Cabinet and Valves  
**Cash or C.O.D. £10-19-6**  
 Carriage Paid  
 Extra for Peto-Scott Plymax Chassis as used by the Author, 14" x 12" x 3". Ready Drilled and Assembled with Runners ... 10 6  
 Peto-Scott Oak faced Ply Panel, Ready Drilled, 14" x 10" ... 2 6

**RECEIVER KIT "A"** as above but with PETO-SCOTT READY-DRILLED AND ASSEMBLED PLYMAX CHASSIS WITH RUNNERS AND PANEL, less Valves and Cabinet, Cash or C.O.D. Carriage Paid, £11-12-0 or Deposit £1-12-0, balance in 11 monthly payments of 20/-.

### POWER UNIT KIT.

Author's Kit of **FIRST SPECIFIED PARTS FOR POWER UNIT ONLY** but less Plymax Chassis and Valves  
**Cash or C.O.D. £8-13-6**  
 Carriage Paid  
 Extra for Peto-Scott Ready-Drilled Plymax Chassis with Runners, 18" x 6 1/2" x 3" ... 7 6  
**POWER UNIT KIT** as above but with READY-DRILLED AND ASSEMBLED PLYMAX CHASSIS, Cash or C.O.D. Carriage Paid, £9-0-0 or 12 monthly payments of 16 6.

### SPECIAL OFFER

**MAGNAVOX (Type 142) MAINS ENERGISED SPEAKER**, suitable for the **NEW A.C. MONODIAL**. List Price £3-5-0. **OUR PRICE 37/6**  
 Cash or C.O.D. Carriage Paid

**FINISHED INSTRUMENTS**—Peto-Scott supply all "Wireless World" Sets as finished receivers, Aerial tested. Cash, C.O.D. or H.P. Send for quotation, no obligation. Peto-Scott have specialised in "Wireless World" Kits and finished instruments for 14 years.

**BUILD your "Wireless World" Set on the PETO-SCOTT PLYMAX CHASSIS used and specified by the Author.**

### COMBINED KIT.

Comprising Receiver and Power Unit Kits with 2 Peto-Scott Ready-drilled Plymax Chassis with Runners and Peto-Scott Ready-drilled Oak Panel, less Valves and Cabinet, Cash or C.O.D. Carriage Paid **£20-12-0** or £3-12-0 Deposit and 11 monthly payments of 35/-.

### COMPLETE KIT.

Comprising Receiver and Power Unit Kits as Combined Kit but with Valves, less Cabinet. Cash **£27-17-0** or C.O.D. Carriage Paid ... or £5-17-0 Deposit; Balance in 11 monthly payments of £2-4-0.

## MODERN BATTERY FOUR

**KIT 'A'** Author's Kit of **FIRST SPECIFIED COMPONENTS** including ready-drilled ply-panel and Peto-Scott assembled and drilled PLYMAX CHASSIS, excluding Valves, Cabinet and Speaker. Cash or C.O.D. **£8-6-9** Carriage Paid ... or 12 monthly payments of 15/3.

**PETO-SCOTT PLYMAX CHASSIS SOLELY SPECIFIED.** Plymax Chassis as specified by the Author, drilled and assembled 10" x 10". Cash or C.O.D. Post **7/6** and Packing 1/3 extra.

## IMMEDIATE DELIVERY CASH - C.O.D. - H.P.

**FOREIGN ORDERS.** Send one-third value of goods with order. Balance (including forwarding charges) payable to our forwarding agents on delivery. Insurance effected if desired. All orders carefully executed and expertly packed by special export staff.

**NOUS DONNONS D'ATTENTION SPECIALE AUX INSTRUCTIONS ETRANGERES.**  
**PETO-SCOTT CO. LTD.**  
 77, CITY ROAD, LONDON, E.C.1.  
 West End Showrooms: 62, High Holborn, London, W.C.1

## NUMBERED ADDRESSES.

For the convenience of private advertisers, letters may be addressed to numbers at "The Wireless World" Office. When this is desired, the sum of 6d. to defray the cost of registration and to cover postage on replies must be added to the advertisement charge, which must include the words Box 000, c/o "The Wireless World." All replies should be addressed to the Box number shown in the advertisement, c/o "The Wireless World," Dorset House, Stamford Street, London, S.E.1. Readers who reply to Box No. advertisements are warned against sending remittance through the post except in registered envelopes; in all such cases the use of the Deposit System is recommended, and the envelope should be clearly marked "Deposit Department."

## DEPOSIT SYSTEM.

Readers who hesitate to send money to advertisers in these columns may deal in perfect safety by availing themselves of our Deposit System. If the money be deposited with "The Wireless World," both parties are advised of its receipt.

The time allowed for decision is three days, counting from receipt of goods, after which period, if buyer decides not to retain goods, they must be returned to sender. If a sale is effected, buyer instructs us to remit amount to seller, but if not, seller instructs us to return amount to depositor. Carriage is paid by the buyer, but in the event of no sale, and subject to there being no different arrangement between buyer and seller, each pays carriage one way. The seller takes the risk of loss or damage in transit, for which we take no responsibility. For all transactions up to £10, a deposit fee of 1/- is charged; on transactions over £10 and under £50, the fee is 2/6; over £50, 5/-. All deposit matters are dealt with at Dorset House, Stamford Street, London, S.E.1. and cheques and money orders should be made payable to Liffe & Sons Limited.

**SPECIAL NOTE**—Readers who reply to advertisements and receive no answer to their enquiries are requested to regard the silence as an indication that the goods advertised have already been disposed of. Advertisers often receive so many enquiries that it is quite impossible to reply to each one by post. When sending remittances direct to an advertiser, stamp for return should also be included for use in the event of the application proving unsuccessful.

## Mains Equipment.—Contd.

**VORTEXION**, Wimbledon, for 99.9% reliable transformers.  
**I**f You Haven't Tried Them Yet Ask Someone who has, or call and inspect complimentary letters.  
**A**ll Standard Models Delivery by Return; all second-aries centre tapped.  
**G**UARANTEED 12 Months, and within 5% normal and 2 1/2% super models, neat shrouding with detachable feet, as used by Government Departments, etc., etc.  
**VORTEXION**—New monodial transformer, 200-250, 50 cycles, 425-0-425, 120 m.a., 4v. C.T. 3a, 4v. C.T. 1a., 4v. C.T. 1a., 4v. C.T. 6a., screen primary, open type, 20/-; shrouded, 22/-; super shrouded, 26/-; 10 henry choke, 5/6; 20 henry choke, 8/6.  
**VORTEXION**—Ferracut 111, 350-0-350, 60 m.a., 4v. 2.5, C.T., 4v. 3.5, C.T.; open type 13/6, shrouded 16/-; post 9d.  
**VORTEXION**—250-0-250, 4v. 1 to 2a., 4v. 2 to 4a.; open type 10/6, shrouded 12/6; post 9d.  
**VORTEXION**—Super model for 11/4 or 9 or 10, 4v. 1 to 2, 4v. 2 to 4; open type 14/6, shrouded 16/6; post 1/-.  
**VORTEXION**—2 1/2-watt Monodial A.V.C. model; open type 14/6, shrouded 16/6; post 1/-.  
**VORTEXION**—5-watt Monodial A.V.C. model, 400-0-400, 120 m.a., 4v. 6a., 4v. 3 1/2a., 4v. 2, 4v. 1a., super screened; 20/-, shrouded 24/-.  
**VORTEXION**—350-0-350, 120 m.a., 4v. 2 to 5a., 4v. 2 to 4a., 4v. 2.5a.; open type 14/6, shrouded 16/6.  
**VORTEXION**—400 or 450 or 500v., 120 m.a., 4v. 2 to 5, 4v. 2 to 5, 4v. 2 to 5; open type 19/-, shrouded 23/-.  
**VORTEXION**—400 or 450 or 500, 150 m.a., 4v. 4a., 4v. 2.5, 4v. 2, 4v. 2.5a.; 2 core size 2 1/4 in. x 1 1/4 in., a super job, 2% regulation; 35/- shrouded with terminals, less terminals, 30/-, open type 26/-; post 1/3.  
**VORTEXION** Auto Transformers to B.E.S.A. Specification, 100, 110, or 120v. to 200, 220 or 240 volts, 60 watts, 7/3, post 9d.; 120 watts, shrouded 12/6, open type 10/6, post 1/-; 200 watts, open 14/6, shrouded 16/6, post 1/-; 500 watts 30/-, 2,000 watts £4/10.  
**VORTEXION** 600-watt Transformers; £4/10, carriage free.  
**VORTEXION** 30h. at 60 m.a. Chokes, 5/6; 40h. at 60 m.a., 8/6; 30h. at 150 m.a., 200 ohms, 10/6 open type, 12/6 shrouded.  
**VORTEXION** 200v. 30 m.a. Eliminators, 110 or 220 v input with 4v. 4a. winding; 37/6.  
**VORTEXION**—Transformers made to your specification. All standards in stock. Phone all hours.  
**VORTEXION** (S. A. Brown), 182, The Broadway, Wimbledon. Tel.: Liberty 2814. [3117]  
**SERADEX** Products, specified for "New Monodial Super," "Modern Battery Four," "Kelvin A.C. Three," "Exhibition Three," etc.  
**SERADEX** Resistances Are Used by the Leading Set Manufacturers; let us quote you for any type of resistance; illustrated lists for stamp.  
**SERADEX** Transformers, as supplied to Lloyds Bank, S. Ltd., and to the largest British manufacturers of mains equipment; new catalogue available soon.  
**SERADEX** V.T.7 Transformer for the New Monodial, primary terminals, heavy aluminium clamps and colour-coded leads, as specified, £1 17 6.  
**SERADEX** Battery Chargers; new illustrated catalogue and real photographs for stamp.  
**SERADEX** V.R.1326a Charger, will charge up to 400 cells per week at very low cost; price, complete, £4/4.  
**TREVOR PEPPER**, 575d, Noseley Rd., Birmingham, 12. Telephone: Calthorpe 1618. Telegrams: Seradex, Birmingham. [3427]

Mention of "The Wireless World," when writing to advertisers, will ensure prompt attention.

Mains Equipment.—Contd.

POWERITE Mains Transformers, a real engineer's job with 3 years' guarantee; competitive prices; lists free; trade enquiries invited.—Nasco Wireless Products, Pittville works, Tower Rd., Aston, Birmingham. [3306]

CRYPTO Charging Plant, 460-500v. D.C., twin machines, each 1/2-5v. 50a. output, switchboard with all controls, meters and cutouts, £40; one machine and starter, £15.—Box 8003, c/o The Wireless World. [3436]

100 Accumulator Chargers, 1/2-amp., 2-6v., in ventilated metal case (Arden, 1932), incorporating Westinghouse rectifier, 10/8; 1 1/2-amp., 21/-; 7 days trial.—Arden Agency, Wollaston, Wellingborough. [3400]

DAVENSET Automatic Charging Board, model A.C.6, little used, condition practically as new; retail list price £49/10, £28, or near offer; deferred terms arranged.—Apply Trewin Bros., Ltd., Queen's Rd., Watford. [3402]

A.C. or D.C. Chargers for 2 to 200 Cells at Low Prices; state requirements; dynamos and rotaries in stock, all sizes; Brown's Genometer, battery supersenders for H.T. for 2v. or 6v. input, 37/6 and 52/6; television and sewing machine universal motors, 25/-; lists.—Electradix Radios, 218, Upper Thames St., E.C.4. [0398]

HOYNE'S Transformers and Chokes the Best Obtainable, perfect insulation, regulation and reliability, used exclusively by discriminating set manufacturers, all fitted with tapped and screened primaries, filaments all centre tapped, stout cast aluminium clamps fitted to all models, also clearly marked terminal strips. HOYNE'S Components are Guaranteed for One Year.

HOYNE'S Transformers Built to Your Specifications, at very competitive prices.

HOYNE'S New Monodial Super Model, 425-0-425v. 120 m.a., 4v. 2a., 4v. 1a., 4v. 1a., 4v. Ga., 17/6, post 1/3; super model, 24/-, post 1/3; chokes for same, 10h., 20h., 16/6 the pair, post 1/3.

HOYNE'S.—250-0-250v. 60 m.a., 4v. 1-2a., 4v. 2-4a.; 10/-, post 9d.

HOYNE'S.—250-0-250v. 60 m.a., 4v. 1-2a., 4v. 2-4a.; 4v. 1a.; 12/6, post 1/3.

HOYNE'S.—350-0-350v. 60-70 m.a., 4v. 2-3a., 4v. 3-4a., 12/6, post 1/3. Ferrisart III model.

HOYNE'S.—350-0-350v. 70-80 m.a., 4v. 2-3a., 4v. 3-4a., 4v. 1-2a.; 13/6, post 1/3.

HOYNE'S.—350-0-350v. 120 m.a., 4v. 2-3a., 4v. 4-6a., 4v. 1-2a.; 16/-, post 1/3.

HOYNE'S.—500-0-500v. 140 m.a., 4v. 2-4a., 4v. 4-6a., 4v. 2a., 4v. 2a.; 27/6, carriage 1/6; weight 12lb.

HOYNE'S.—0-110-135v. 90 m.a., 4v. 2-4a., suitable for H.T.6 or 7; 10/-, post 9d.

HOYNE'S.—200v. 200 m.a., 4v. 2-4a., 4v. 1-2a., suitable for H.T.8; 13/6, post 1/3.

HOYNE'S.—0-200-240v. 200 m.a., 4v. 2-4a., 4v. 1-2a., suitable for H.T.8 or 9; 14/6, post 1/3.

HOYNE'S.—Line transformers and chokes always in stock; we can also supply all components.

M. J. HOYNE, Office and Works, 5a, Gleadstone Rd., Wimbledon, S.W.19. Tel.: Liberty 3303. [3107]

CABINETS.

RADIO-GRAM Cabinets: fully illustrated list free; remarkable values.—Gilbert, Cabinet Maker, Swindon. [1686]

MANUFACTURER'S Clearance Lines of Cabinets for Radiograms, loud-speakers, and radio sets; hifi-treads to select from; send postcard for list; special cabinets for Skyscraper and S.F.400.—H. L. Smith and Co., Ltd., 289, Edgware Rd., London, W.2. [3409]

DYNAMOS, ETC.

ROTARY Converters, E.D.C. Co.'s manufacture, as new, D.C. to A.C., with output of 220 watts.—Apply Electric Works, Newquar, Cornwall. [3335]

ROTARY Converters, 220 volts D.C. to 200 volts A.C., capacities up to 0.44 K.V.A., cheap.—Milo Engineering Works, Milo Rd., East Dulwich, S.E.22. Sydenham 4422. [3225]

ROTARY converter (electro dynamic), filter, case, 230 d.c. (230 a.c., 391 amps.); £10; exchange mains receiver, 240 d.c.—Roydhouse, 28, Brownlow Rd., London, E. [3421]

ROTARY Converters, 200/240 volt D.C. to 200/240 volt A.C., with smoothing and starter Crypto 440 Watts, £8/15; E.D.C. 120 watt in silence cabinet, with smoothing, £7/10; Wates 180 Watt, as above, £7; all nearly new; others from £2/10.—Johnson Engineering, 86, Great Portland St., W.1. [3443]

ELECTRIC DYNAMIC CO.—H.T. generator and charger, output 400 to 720 volts at 600 m.a., complete on slide rails, pulley and resistance meter and cut-out, used for 10 weeks only on Daily Mirror 8 four, cost £20, sell £7, as new; also converter, 110 volts in, 220 A.C. out, 400 watts Crypto, £5, also ton of P.A. equipment, including new valve, power, at half price.—Mobile Amplifiers, 6, Conduit St., W.1. [3435]

GRAMOPHONES, PICK-UPS, ETC.

B.T.H. Cinema Type Pick-ups, brand new, 17/6, carriage paid, cash with order, or c.o.d. Send for list.—Ward, 12, Tredegar Rd., Bow, E.3. Tel.: Advance 3668. [3363]

K-B., brand new electric gramophone motors, Universal, 100-250 A.C., D.C., and clockwork, complete turntable autostop; list £6/15, 30/- cash with order, post free, or c.o.d.—45, Ellington Rd., N.10. [3432]

LOUD-SPEAKERS.

P.M. Speakers Bargain.

LARGE Quantity 8 1/2 in. P.M.M.C. Speakers, made by well-known manufacturer for set maker, highly sensitive, work off any set, 3-ratio transformer; 19/6, post free; money returned if not satisfactory.—Milton Manufacturing Co., Milton St., Coventry. [3415]

B.T.H. R.K. Moving Coil Speakers, guaranteed new, unused, manufacturers' surplus, original price. 6 Guineas, highly sensitive and wonderful tone response, will handle up to 10 watts output, available for 6v., 100v., 200v. D.C., 30/-, also A.C. models.

£2/10; carriage paid, c.o.d., or cash with order; the best value in speakers obtainable to-day.—O. H. Seekamp, First Avenue House, High Holborn, London, W.C.1, 4th floor; office No. 582a. Phone No.: Holborn 6609. [1425]

ROLA the World's Finest Reproducers

If you are building the "NEW MONODIAL" SUPER the Speakers Specified are

ROLA DUAL BALANCED PAIRS Types F6-2500 & F7-2500 with 24B Transformer (Price £4) or ROLA Model F7-2500 with 24 Transformer. Price 47/6

If you think of using any other speaker for this receiver, INSIST on your dealer demonstrating the above speakers before you decide.

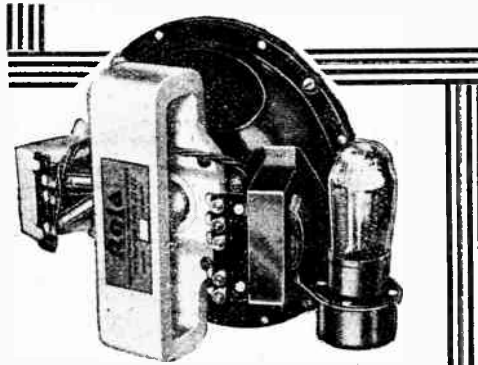

ROLA CLASS B SPEAKER AMPLIFIER UNIT

If you are a Battery set owner you can increase the volume and sensitivity of your receiver about 5 times in 5 seconds by connecting a Rola Class B Speaker Amplifier Unit.

PRICE (LESS VALVE) 57/- (Price with valve 71/-)

The British Rola Co. Ltd.

Minerva Rd., Park Royal, N.W.10. Phone: Willesden 4322-3-4-5.

ROLA SPEAKERS

for better Radio Reception

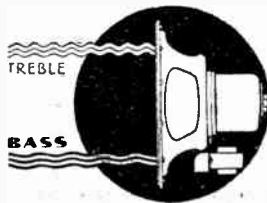

Loud-Speakers.—Contd.

R. and A. "Victor" Loud Speaker; 45/-; very little used.—Montford, 62, Wheelers Rd., Edgbaston, Birmingham. [3400]

SENIOR R.K. 10in., 200-250 D.C., 50/-; Magnavox S.D.C. 144, 7,500, 17/6; O.P.M.4.C. 8/-; O.P.3.C. 8/-; Novotone J, 25/-—45, Ellington Rd., N.10. [3413]

10/-—Lamplugh Silver Ghost, 2,200 ohms, with output transformer, unopened, list 47/6; c.o.d., carriage paid.—Kay, 167, City Rd., London, E.C.1. [3351]

30/-!!!—B.T.H., R.K. moving coil speakers, 6in. cone, new and unused, guaranteed; these speakers are the type as used in cinema sound equipment; suitable for public address work; weight 3lb., and are vastly superior to the cheap speakers now on the market, 100 volts, 150 volts, and 200 volts D.C.

27/6!!!—6-volt D.C. speakers, as above; £27/16 speaker as above for 100-250 volts A.C., complete with field rectifier.

THESE speakers are identical to Senior R.K., but for cone diameter; carriage paid, cash with order, or c.o.d.; send for list.—Ward, 12, Tredegar Rd., Bow, E.3. Tel.: Advance 3668.

CHAL. ELECTRIC Offer New Boxed Set Manufacturers' Surplus Rola Speakers, all fitted hum buckers, state if Power or Pentode Transformer F6 110-175v. D.C. (2,000 ohms); 90-130v. D.C. (2,500 ohms); 150-200v. D.C. (4,700 ohms); 200-250 D.C. (6,500 ohms), listed at 35/-, at 18/-; F7 voltages as above list, 47/6, at 25/- each; permanent magnets F6P.M., listed at 49/6, at 28/-; F7P.M., listed £3, at 33/-; Ultra 95P.M., a real hefty job with Power-Pentode transformer, listed £4/15, at 47/6; Rola Dual Compensated (2) F6, list £3/10, at £2; (1) F6 and (1) F7, list £4/5, at 47/-; all goods Carriage Paid, Cash with order, or C.O.D.—Chal Electric, 6, Conduit St., London, W.1. [3221]

TRANSMITTERS.

QUARTZ Lenses, 2/6; guaranteed to oscillate without reaction.—Smith, Brynrobyn, Colwyn Bay. [3358]

VALVES.

ALL Classes of Valves in Stock, including American A and non-ring valves; send for price list.—R. Newman, 309, Roman Rd., London, E.3. [3446]

ALL Types of Brand New American Valves in Stock, first class makes: 247s, 235s, 224s, 236s, 237s, 235s, 245s, 244s, 12/-; 227s, 226s, 280s, 245s, 9/6; 242s, 232s, 11/-; U.X.210s, 15/-; U.X.250s, 7 watts output, 16/-; 281s 14/6; post paid, cash with order or c.o.d. Send for valve list.—Ward, 12, Tredegar Rd., Bow, E.3. Tel.: Advance 3668. [3364]

COMPONENTS, ETC., FOR SALE.

R. SELECTED Parts for Sale, as new, any c.o.d. or "Wireless World" deposit system, which we recommend if in doubt as to the splendid value offered; we take risk of damage in transit to customers; goods tested for callers and guaranteed.

METERS, moving coil, made for Ryall's Radio, guaranteed one year, and to B.T.H.'s first grade specification, all panel flush type, bakelite case, 0-1 m.a., 25/-; 0-5 m.a., 0-20 m.a., 0-50 m.a., 0-150 m.a., 21/- each; 0-250v., 32/6; 0-300v., 35/-; 1,000-ohm per volt, zero adjuster, size 3/4in.

METERS, as above, moving iron, first grade, air damped, zero adjuster, 0.250v. A.C. 18/-; 0-50 m.a. A.C. and D.C. 15/-; non damped, without zero, 0-12v., 10/-; 0-250v., 12/-; 0-3 amps., 10/-; 0-20 m.a. A.C. and D.C. 10/-; 0-50 m.a., ditto.

SUITCASE Type Cases, in best crocodile leather, 14x14 x8, ample room for 12in. turntable and pick-up, 15/-; set cabinets for 3v. A.C. sets, room for speaker, good appearance, 15/-.

REFRANZI 7-valve Superhet., complete, £9; B.T.H. Junior A.C. speaker, with corrugated cone, separate rectifier, 67/-; Epoch 99% 6v., 47/6; Marconi speaker, early model, 6v., with transformer, splendid reproduction, 15/-.

T.C.C. 2 mt., 350v. working, 1/6; T.C.C. 1 mf. type 84, 1/3; T.C.C. 0.01 mica, type M, 1/-; T.C.C. 250v. working, 4x4, 4/9; ditto, 4x4x1x1 1/2, 5/9; T.C.C. 15 mf., 100v. working, electrolytic, 1/3.

B.T.H. Universal Senior Gramophone Motors, A.C. or D.C., new, complete with auto stop and all fittings; 55/-.

RYALL'S Mains Transformers, 250v. 60 m.a. 4v. 1 amp., 4v. 3 amp., 10/6, 350v. 12/9, H.T.7 10/6, H.T.8 12/9, 4v. 3-5a., L.T. 8/9; chokes, 20H, 120 m.a. 8/9, 25H, at 60 m.a. 6/9, resistance 260 ohms, 40H, at 100 m.a. 600 ohms 10/6; all other models available.

WE Hold a Large Stock of First Class Radio Apparatus, meters, resistances, condensers, heavy chokes, in addition to the goods advertised.

POLAR Star 3-gang Condensers, 15/-; with drive, 17/6; Polar Uniknob 2 gangs, with drive, 8/6; Radiophone 4 gangs, 12/6; with cover and drive, 17/6; Radiophone 4-gang superhet., type, screened, with trimmers, Radiopack type, 9/-, post 9d.; Lotus new 4 gangs, 15/-.

RYALL'S RADIO 33, Chancery Lane, London, W.C.2 (nearest Tube, Chancery Lane; bus 67 passes door, or tram to Savoy St.) Holborn 3529. Open Saturday afternoon, Close 7 p.m., Saturday 6 p.m. Thursday closed all day.

R. [3416]

PEPPER OFFERS the Following Under Usual Money-back Guarantee; carriage paid over £2.

TELSEN Aces, 2/3; amplifiers, 1/9; Pentode correctors, 1/6; tapped Pentode chokes, 4/3; output transformers 1/1; ditto Pentode, 4/9; ditto multi-ratio, 5/3; British-General ditto, 5/3.

FERRANTI O.P.3c. O.P.4c. O.P.M.5. 7/11; Varley P.O.P.P. input, 8/6; Marconi Ideals, 3/11; Lewcos L.F.T.5, 8/11.

R.I. Paraflex, 4/3; Pentams, 7/11; Hypercore chokes, 8/11; Q.P.P. outputs, 8/6; above second-hand.

MAINS Transformers, super types, 400-0-400, etc., 22/6; 150v. 300 m.a., with L.T.'s, 8/11; ditto, stripped; no L.T.'s, 7/6; ditto, H.T.8, 7/6; ditto, H.T.7, 6/6; Mulhard L.T. transformers, 6/3.

SEND Your Enquiries for Any Components, etc.; quotations per return.

TREVOR PEPPER, 575d, Moseley Rd., Birmingham. [3428]

**ALL LOUDSPEAKERS ARE CLAIMED TO BE PERFECT EXCEPT THE**

# HARTLEY TURNER

But still our customers tell us that our imperfect speaker sounds more realistic than any of the others. Curious!

**D.C. Model 7 GNS. A.C. Model 8 GNS.**

**DEMONSTRATIONS DAILY AT OUR OWN ROOMS.**

*If you cannot call write for our 32-page technical booklet "NEW NOTES IN RADIO," sent for a 1d stamp.*

**HARTLEY TURNER RADIO LTD.,**

Thornbury Road, Isleworth, Middlesex.

Tel. Hounslow 1854.

## THE HARTLEY TURNER LOUDSPEAKER

We are demonstrating this remarkable new moving coil loudspeaker daily between 12 and 3 p.m., and 4 and 6 p.m. Other times by appointment.

Easy Payment Terms for the Hartley Turner Moving Coil Unit, complete with special transformer, carriage paid are as follows:—

**D.C. Model, cash price £7.70 or 20/- with order and 11 monthly payments of 12/9.**

**A.C. Model, cash price £8.80 or 26/- with order and 11 monthly payments of 14/-**

We supply all other high-grade radio apparatus on convenient easy payment terms. Please send us your enquiries and a quotation will be sent by return.

**THE LONDON RADIO SUPPLY COMPANY,**  
(Established 1925)

11, Oat Lane, Noble Street, London, E.C.2  
(Off Gresham Street)

Phone: National 1977.



"ENGINEERING OPPORTUNITIES" is a 250-page Hand-book that has been prepared after years of patient search into the possibilities of various Engineering Careers. It shows clearly and definitely the way in which you may carve out a successful career in your chosen branch of Engineering irrespective of your age, education or experience. Among a host of other things, it outlines Home-Study Courses in all branches of Civil, Mech., Elec., Motor, Aero., Wireless and "Talkie" Engineering and shows the way to pass A.M.I.C.E., A.M.I.Mech.E., I.E.E., A.M.I.A.E., M.I.M.T., G.P.O., Matriculation, Civil Service and other Examinations. "ENGINEERING OPPORTUNITIES" is a unique Hand-book that you should most certainly read. Send for your copy to-day—FREE of any cost. BRITISH INSTITUTE OF ENGINEERING TECHNOLOGY, 387, SHAKESPEARE HOUSE, 29 31, OXFORD STREET, LONDON, W.1.

## FIRST CLASS REPRODUCTION

AN UNREPEATABLE OPPORTUNITY TO SECURE A REAL B.T.H. R. K. LOUDSPEAKER

GUARANTEED NEW AT BARGAIN PRICES

**Specification:**—6in diameter cone Moving Coil Loudspeaker giving full bass response and handling the output from the heaviest power valve. Far superior to many small modern moving coil speakers. Weight 30 lbs. Field winding to suit 6, 100, or 200 volts D.C. Send cash with order or C.O.D.

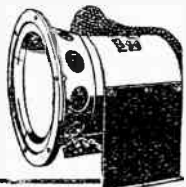

**R. K. SPEAKER**  
Originally listed at £5, 6, 0  
Now offered for **30/-**  
A.C. MODELS £2, 10, 0

Telephone: Holborn 6609

O. H. SEEKAMP, FIRST AVENUE HOUSE, HIGH HOLBORN, LONDON, W.C.1  
4th Floor, Office No. 582A.

## HAVE YOU HAD ?

particulars of the famous "Magnum" Short Wave Adaptor, which is now available for every type of receiver? Full particulars, with a list of short wave stations and free trial offer, on request.

**BURNE-JONES & CO. LTD.**  
296, Borough High St., London, S.E.1

## Components, etc., for Sale.—Contd.

**P**REMIER Summer Sale.  
**T**HE Last Week.  
**10%** Discount on All Orders of £1 and Over.  
**M**ANY Prices Reduced Apart from Discount.  
**P**REMIER SUPPLY STORES Offer the following Set Manufacturers' Surplus New Goods at a fraction of the Original Cost, all goods guaranteed perfect, carriage paid over 5/-, under 5/- postage 6d. extra (Ireland, carriage forward).  
**E**LIMINATOR Kits, including transformer, choke, Westinghouse metal rectifier, T.C.C. condensers, resistances and diagram, 120v. 20 m.a., 20/-; trickle charger 8/- extra; 150v. 30 milliamps. with 4v. 2-4 amps. C.T., I.T. 25/-; trickle charger 6/6 extra; 250v. 60 milliamps. with 4v. 3-5 amps. C.T., I.T. 30/-; 200v. 100 milliamps. with 4v. 3-5 amps. C.T., I.T. 49/6; 300v. 60 milliamps. with 4v. 3-5 amps. C.T., I.T. 37/6.  
**E**LLOTT First Grade Moving Coil Meters in the Following Ranges:—0-10, 0-30, 0-50, 0-100, 0-150 milliamps., also 250v. flush type, 17/6, projecting 15/-.  
**R**OLA Moving Coil Speakers, complete with humbucking coils and output transformer; please state whether power or pentode required; F6, 2,000 or 6,500 ohm, listed 35/-, at 17/6; F7, 2,000 or 6,500 ohm, listed 47/6, at 25/6; A.C. conversion kit for any of above, 10/-.  
**S**PECIAL Offer.—Reisz type microphone with transformer, a really professional job, listed at £12; our price 52/6.  
**H**EAVY Duty Variable Resistances, wound on porcelain, 2,000 ohms 1-4 amp., 5,000 ohms 1-2 amp., 120 ohms 1 amp., all the above values, 3/6 each.  
**T**C.C. Condensers 750v. working, 2 mf. 3/6, 4 mf. 6/-, 4 mf. 400v. working 4/-, 250v. working 1 mf. 1/-, 2 mf. 1/9, 4 mf. 2/6, 1,500v. working Standoff insulators 5 mf. 1/6, 2 mf. 6/-, aqueous electrolytic 440v. working, 4 mf. 3/-, 8 mf. 3/6.  
**D**UBILIER Condensers.—.01 mica 6d., .01 mica 1,000v. working 1/-.  
**A**LL the Following Lines 6d. each or 5/- per dozen: 4 and 5 pin chassis mounting valve holders; shielded screen grid or pentode leads 1-watt wire end resistances, any value; T.C.C. .1 condensers; hum fingers; on-off switches pushpull; polar ganging devices.  
**P**ERRANTI Condenser Blocks 300v. working 4-4-2-2, all separate, 5/-.  
**P**OLAR 3-gang 0.0005 Condensers, split end vanes, totally screened, disc drive; 6/11.  
**A**MSCO Triple-gang 0.0005 Condensers, with trimmers, 4/11.  
**O**RMOND 0.0005 Condensers, 1/3; 2-gang semi shielded, 2/6.  
**W**ESTERN ELECTRIC Mains Transformers, input 200-250 volt, output 500-0.500 volt, at 150 milliamps., 4v. 4a., 4v. 2.5a., 4v. 2a., 4v. 1a., 4v. 1a., massive job; 19/6.  
**T**C.C. Electrolytic Condensers, 10 mfd., 100 volts working, 1/-; 15 mfd. 1/3.  
**S**PECIAL Offer of Mains Transformers manufactured by Philips, input 100-115v. or 200-250v., output 180-0.180 volts, 40 m.a., 4v. 1a., and 4v. 3a., 4/6; 200-0.200v., 4v. 1a., 4v. 3a., 4/6.  
**A**LL Premier Guaranteed Mains Transformers have engraved terminal strips with terminal connections, input 20-250 volts, 40-100 cycles, all windings paper interleaved.  
**P**REMIER H.T.8 Transformer, 250v. 60 m.a., rectified, with Westinghouse rectifier, 25/-.  
**P**REMIER H.T.9 Transformer, 300v. 60 m.a., rectified, with 4v. 3-5a. c.t. I.T., and screened primary, 15/-; with Westinghouse rectifier, 26/-.  
**P**REMIER H.T.10 Transformer, 200v. 100 m.a., rectified, with 4v. 3-5a. c.t. I.T., and screened primary, 15/-; with Westinghouse rectifier, 26/-.  
**P**REMIER Mains Transformer, output 135v. 80 m.a., for voltage doubling, 8/6; 4v. 3-4a. c.t. I.T. 2/- extra; Westinghouse rectifier for above, giving 180v. 30 m.a., 8/6.  
**P**REMIER Mains Transformers, output 250-0-250 volts, 60 m.a., 4v. 1-2a., 4v. 2-3a., 4v. 3-4a. (all c.t.), with screened primary; 15/-.  
**P**REMIER Mains Transformers, output 350-0-350 volts, 50 m.a., 4v. 3-5a., 4v. 2-3a. (both c.t.), with screened primary; 15/-.  
**P**REMIER Mains Transformers, output 400-0-400 volts, 100 m.a., 4v. 4-5a., 4v. 2-3a., 4v. 2-3a., with screened primary; 15/-.  
**P**REMIER Auto Transformers, 100-110/200-250 volts or vice versa, 60-watt, 7/9; 100-watt, 10/-.  
**S**PECIAL Offer of Manufacturers' Type Transformers, any input, output 250-0-250 volts, 60 m.a., 4v. 1a., 4v. 3a. (both c.t.), 8/6; H.T.8 transformer, with 4v. 3-4a. (c.t.), 8/6; with rectifier, 13/6.  
**A**MPHION Mains Transformers, input 100-250 volts, output 350-0-350 volts, 120 m.a., 4v. 5a., 4v. 2a., 6v. 1a. (all c.t.); 17/5.  
**F**ILAMENT Transformers, polished and engraved terminal boards, N.P. terminals, 4v. 3-4a., 5/-; 10v. 3a., 6/6; 12v. 1a., 5/-; 4v. 4-6a., 6/6; 14v. 4a., 6/6; 22v. 1a., 6/-; 6v. 2a., 5/-; 9v. 1a., 5/-; 35v. 3a., 15/-.  
**P**REMIER Chokes, 40 m.a., 25 hys., 4/- 65 m.a., 30 hys., 6/-; 150 m.a., 30 hys., 10/6.  
**P**YE Chokes, 20 or 32 hys., 4/-; Premier multi-ratio output transformers, giving 15 different ratios 7/6.  
**P**REMIER Eliminators, input 200-250 volts, 40-100 cycles, A.C., incorporating Westinghouse metal rectifiers, output 250v. 60 m.a., S.G., and 120v. taps, 42/6; with 4v. 4a. c.t. I.T., 7/6 extra.  
**B**BRITISH RADIOPHONE Wires Wound Potentiometers, with mains switch incorporated, 5,000 ohms, 10,000 ohms, 50,000 ohms, 100,000 ohms, 250,000 ohms, any value; 3/6.  
**P**REMIER Eliminators, output 150v. at 30 m.a., S.G., and 100v. taps, with 4v. 3-4a. c.t. I.T., 37/6; or with trickle charger, 42/6.  
**P**REMIER Eliminators, output 120v. at 20 m.a., S.G., and 100v. taps, 27/6; with I.T. trickle-charger incorporated, 35/-.  
**P**REMIER D.C. Eliminators, output 120v. at 20 m.a., S.G., and 100v. taps; 15/-.  
**A**CCUMULATOR Chargers, 200-250 volts A.C., all incorporating Westinghouse metal rectifiers; 2, 4, and 6v. at 1/2 amp., 12/6; 2, 4, and 6v. at 1 amp., 17/6; 12v. 1a., 27/6; 6v. 2a., 35/-; 12v. 2a., 35/-; 12v. 1.5a., 30/-; 6v. 3a., 39/6; 30v. 3a., 42/6.  
*(This advertisement continued on next page.)*

## "Universal" Mains Valves

THE ONLY ones which operate direct from FULL MAINS VOLTAGE, either A.C. or D.C., without the use of transformers or resistances, and greatly reduce the cost of running your set. Do not confuse these with valves which can only be wired in series.

S100.	S.G. valve for H.F. stages, L.F. couplings. Very high slope. Great amplification. Impedance over 1 million ohms	18/9
825.	S.G. valve for Det.—Audio and H.F. stages. High slope. Impedance 250,000 ohms	18/9
MS18.	S.G. Vari-mu. with variable slope	18/9
MS70.	S.G. Vari-mu. Excellent for A.V. control	18/9
D130.	Outstanding characteristics: High-mu. Triode valve. Impedance 40,000. Amp. factor 100	17/6
PT3.	Multi-grid valve. Very remarkable slope and high internal resistance	19/9
K3500.	Output stage amplifying valve. Dissipation 15 watts. Amplification factor 3. Impedance 500 ohms. Remarkable scale of 6 mA. V.	25/8

Other types and rectifiers as previously listed all in stock. Details on request. Free Blueprint with first order.

## OSTAR-GANZ

'UNIVERSAL'  
HIGH-VOLTAGE MAINS VALVES

Sole Agent for Great Britain:  
**EUGEN FORBAT, 28-29, Southampton Street, Strand, W.C.2**  
Telephone: Temple Bar 8608.

## IF YOUR RECEPTION IS BAD

**SUPERIAL**  
THE AERIAL WHICH MADE BROADCASTING POPULAR  
ELECTRON'S SUPER-AERIAL  
**WILL IMPROVE IT**



Whether it is a bad set or a bad locality SUPERIAL will make your reception definitely better because it is the most efficient and powerful aerial ever devised. The extra heavy rubber insulation stops interference and noises, abolishes mast, insulators and separate leads-in and increases the signal strength. The only efficient indoor or invisible aerial. Lightning proof too—get your £100 Free Insurance to-day. From all dealers.

100ft 3/6: 75ft 2/6: 50ft 1/9: 25ft 1/4  
THE NEW LONDON ELECTRON WORKS LTD EAST HAM LONDON E 6

## Mr. EXPERIMENTER

Follow the lead of the manufacturers and make your connections and nuts positively secure with—

## SHAKEPROOF LOCK WASHERS



AND LOCKING TERMINALS.

British Patent 194937. The twisted teeth bite into the metal and prevent "slacking off." The more the vibration, the tighter they grip.  
**ASK YOUR DEALER FOR "SHAKEPROOF."**



Manufactured by **BARBER & COLMAN Ltd., Brooklands, Manchester**  
Dealers and factors' enquiries to—  
**WM. CLARK (Spare Parts) Ltd., 5, Marshalsea Rd., London, S.E.1.**

SEND FOR LITERATURE OF

## Silver Ghost

Lampugh Radio Ltd. Coventry

Silver Ghost Reproducers MASTERS OF SOUND

# SECRETS OF CELESTION SUPREMACY

No. 1

## Acoustically Perfect Cabinets!

The cabinets in which Celestion Moving-Coil Loudspeakers are housed are acoustically designed as *part of the speaker* and not only as an attractive article of furniture. As a result, reproduction over the whole range of frequencies is of the highest Celestion quality.

It is such *attention to detail* that puts Celestion in the forefront of modern loudspeaker design. The name Celestion stands for high-quality reproduction combined with unfailing efficiency. Celestion speakers can be supplied to match any set or type of output.

Ask your dealer for a demonstration, or write for full details.

PPM 39 Cabinet Model £3-10-0  
PPM 9 Chassis Model £1-15-0

Celestion Ltd., London Road,  
Kingston-on-Thames.

MODEL P.P.M. 39

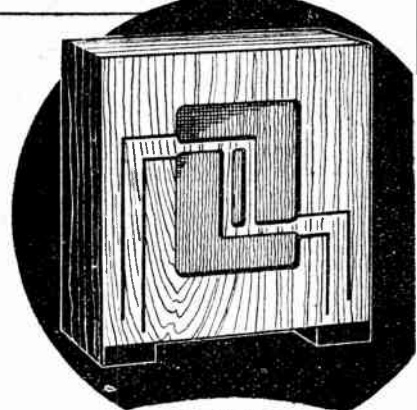

# CELESTION

The Very Soul of Music

THE FOREMOST NAME  
IN SOUND REPRODUCTION

Components, etc., for Sale.—Contd.

(This advertisement continued from previous page.)

**A** MPLION High Inductance Chokes, resistance 2,500 ohms, 80 henries 60 m.a.; 5/6.

**W** ESTINGHOUSE Metal Rectifiers: 120v. at 20 m.a., 6/6; 180v. at 30 m.a., 8/6; 8v. at 1/2 amp., 6/6; 6v. at 1 amp., 9/5.

**K** OLSTER BRANDES Electric Gramophone Motors, complete with turntables and automatic stop, 100-250v., A.C. and D.C.; list price £5, to clear £2.

**B** T.H. Induction Type (A.C. only) Electric Gramophone Motors, 100-250v.; 30/- complete.

**A** MPLION Moving Coil Speakers, type E.M.644, dual fields, 2,500 and 5,000 ohms (100 and 200v.), with output transformer, 12/6; A.C. conversion kit for this speaker, 10/- extra.

**W** ESTERN ELECTRIC Condensers, 250v. working, 1 mfd. 6d., 2 mfd. 1/-; 500v. working, 1 mfd., 1/-.

**T** A.C. Condensers, 250v. working, 4x4x1 mfd., 3/6; 300v. working, 4x4x2x2x2 mfd., 6/-; 6x4x2x2x2 mfd., 375v. working, 6/11; 4x4x1, 6/-.

**S** PECIAL Offer of Wire Wound Resistances.—4 watts, any value up to 10,000 ohms, 1/-; 8 watts, any value up to 15,000 ohms, 1/6; 15 watts, any value up to 50,000 ohms, 2/-; 25 watts, any value up to 50,000 ohms, 2/6; 50 watts, any value up to 50,000 ohms, 3/6.

**W** IRE Wound Potentiometers, 15,000 ohms, 1/6; Centralab Potentiometer volume controls, 50,000 ohms, 2/-; wire wound Clarostat Potentiometer, 50,000 ohms, 2/6; Colverstats, logarithmically wound Potentiometers, 6,000 ohms, 1/9.

**F** OR Callers only.—The following valves, guaranteed new:—

**T** HE Last Few Western Electric 3211 D Valves, 10v. 3a. filament, 750,1,000v. plate, 50-65 m.a., impedance 3,500 ohms, amplification factor 12; cost £5; to clear at 15/-.

**P** HILIPS 323 Valves for L.T. Charging, 5/6; 329 Barretter lamps, 2/-.

**H** ARLEY Pick-ups with arm and volume control; 12/6.

**P** REMIER SUPPLY STORES, 20-22, High St., Clapham, S.W.4. Macaulay 2188. Closed 1 o'clock Wednesdays, open to 9 o'clock Saturdays. Nearest Station, Clapham North Underground.

**P** REMIER. [3388]

**G** ILBERT INDUSTRIES' Parcels.

**A** " "B," "D," and Condenser Parcels, as advertised in issues August 4th and August 11th, still available by return of post.

**G** ILBERT INDUSTRIES, Ltd., 519, London Rd., West-cliff-on-Sea. [3283]

**M** ILMAY RADIO EXCHANGE Offers the Following, sound and perfect.

**R** ADIOPAX, 35/-; Lewco's Band Pass filter, 6/6; A.W.C. chokes, 6/-; superhet. coils with pigtailed, 4/6; O.S.C., 4/6; without pigtailed, 4/-; frame aerials, Lewco's, 10/-; Varley Square Peaks, 5/6; Colvern K.G.R. coils, 5/6; Li-sen 3-gang superhet. coils, 14/-.

**W** ESTINGHOUSE H.T.1 Rectifier, with Rich and Bundy transformer, 30/-; R.J. E.735 mains transformer, 16/-.

**M** ULTITONE Rept., 1-1, 5/9; Toco, 9/6; second-hand Pentonite chokes, 9/6; Nicore I transformers, 9/6; Varley rectatone, 7/6; second-hand hypermu transformer, 8/6; and Pentonite outputs, 8/6.

**A** .C. Motors.—Garrard A.C.4, fully automatic plate and stop, 35/-; Collaro, pick-up and motor combined, type 32, 59/6; Collaro, less pick-up, fully automatic, 37/6.

**F** ERRANTI B5 Chokes, 16/6; A.F.6, 16/-; A.P.3, 11/-; O.P.M.1, 10/-; O.P.M.10, 14/-; O.P.S.C., 12/-; A.F.7, 16/-; O.P.M.13C, 13/6; O.P.M.11C, 13/6; A.F.11c., 17/6; A.F.5c., 19/-.

**K** INGSTON Home Recorders, 5/-; Radiophone 2-gang, fully screened, 10/-; pair Rola Class B, matched P.M. speakers, 55/-; pair Rola D.C. matched speakers, 2,500, 30/-; Amplion M.C.6, 27/6.

**A** LL Carriage Paid; e.o.d. extra.

**O** PEN Thursday; closed Saturday all day.

**C** LISSOLD 5001.

**24**, Milkmay Grove, London, N.1. [3441]

**S** OUTHERN RADIO Wireless Bargains.—Set manufacturer's guaranteed surplus:—

**V**ARIABLE Condensers.—British Radiophone 4-gang, superhet type, fully screened and trimmers, 0.0005, 8/9 (list 45/3). Same type, complete with dial knob and escutcheon, 12/9 (list 50/-). Hydra block condensers, new, 16 mfd., 2-2+8+2+1+1, 1,000 volt test (made for Canadian Marcomphone Co.), 8/9; 4 mfd., 2/6; 2 mfd., 1/9; 1 mfd., 1/-; all 750 volt. Polar 3-gang condensers, 0.0005, fully screened, complete trimmers, dial, knob, escutcheon; 11/-.

**S** PEAKERS.—Celestion Soundex permanent magnet, 16/- (list 27/6); itola F6 permanent magnet, 28/- (list 49/6); D.C. mains energised, 2,500 to 6,500 ohms, complete with humbucking coils and transformers, 16/6 (list 39/6); Peter Grassman dynamic speakers, complete in magnificent cabinet, (list 35/-); G.E.C. Stork speakers, complete in cabinet, 19/6 (list £3 15); Ormond speakers, complete in cabinets, 10/- (list 25/-). Dr. Nesper Telag speakers, 11/6 (list 55/-).

**C** ONSTRUCTORS' Kits.—Ready Radio "303" battery 3-valve kits, less valves, 18/- each; complete with 3 Mullard valves (P.M.1.L.F., P.M.2, 2D.X.), 33/- each (list 70/-); Ready Radio Meteor-screen grid 3-valve kit, less valves, 26/-; with 3 Mullard valves (P.M.12a, P.M.2D.X., P.M.2a), 49/- (list £57/6); Universal Radio 3-valve kits, ready assembled on chassis, 12/6 (list 45/-).

**R** EADY RADIO 3,1400 Kits, as specified by Scott Teggart; £2/19/6 each (list £4/17/6).

**R** EADY RADIO Meteor Screen Grid 3-valve "A" Kit, complete with cabinet, permanent magnet speaker (less valves), £3/7/6, with 3 Mullard valves, £4/10 (list £8/17/6); Mullard Radio for Million 3-valve A.C. kit, complete with 3 Mullard A.C. valves (Pen. 4V, 354V, S.4V), £3.10 (list £6/10); Mullard Radio for Million 3-valve battery kits, complete with 3 Mullard valves, 3/3 (list £6/2/6); all kit brand new, in original sealed cartons.

**B** RITISH General Tuning Units.—Band Pass, 10 k.c., aerial or anode; 5/- (list 14/6).

(This advertisement continued on next page.)

# COLVERN FERROCART COILS

It is impossible to tell you here all about Ferrocart Coils, so we have written a booklet explaining their advantages.

May we send you a copy?  
It's free!

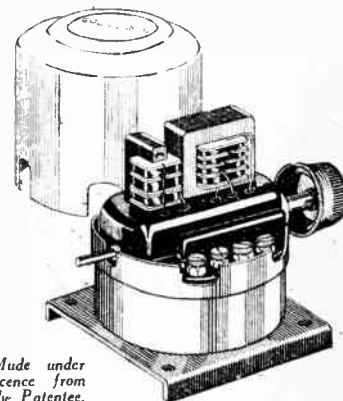

Made under licence from the Patente, Hans Vogt.

Fit Ferrocart Coils in your next receiver...note the difference...the high selectivity...the improved performance.....

**FIT COLVERN AND  
YOU FIT THE BEST**

# COLVERN

MAWNEYS RD., ROMFORD, ESSEX

London Wholesale Depot: 150, King's Cross Road, W.C.1



Components, etc., for Sale.—Contd.

*(This advertisement continued from previous page.)*  
**L.L. Goods** Guaranteed New and Perfect, and sent carriage paid.  
**PLEASE Note.**—We have opened branches at 271-275, High Rd., Willesden Green, N.W.10, and at 4E, Lisle St., W.C.2, where callers are cordially invited to inspect our large stocks of wireless bargains. Please send all post orders to 323, Euston Rd., N.W.1.  
**SOUTHERN RADIO**, 323, Euston Rd., London, N.W.1 (near Warren St. Tube). Phone: Museum 6324 [3390]  
**M.R.D. Co.'s** New Season's Offers; all guaranteed as new; carriage paid, or call.  
**ELECTROLYTICS**, Dubilier, 8 mfd., 450v., working 4/3; smoothing chokes, 30h. 45 m.a. 1/11.  
**COLVERDYNES**, 110 k.c., 6/3; radiophone potentiometers, 5,000 ohms, 7/9; 10,000 ohms, with switch, 2/8; Varley 250,000 ohm, 1/7.  
**BENJAMIN** 5-pin Chassis V-holders, 1/3; half-dozen Polar brass S.M. 0005, 1/6.  
**GUARANTEED** Half-watt Resistors, 500, 1,000, 6,000, 7,000, 10,000, 20,000, 25,000, 40,000, 50,000, 250,000, all 4d. each; 3/6 half-dozen.—Mains Radio Development Co., 4-6, Muswell Hill Rd., London, N.6. [3418]  
**CHAL. ELECTRIC** Offers New Set Manufacturer's Surplus, all carriage paid; cash with order or c.o.d.  
**VARIABLE** Condensers.—J.B. Nu Gang (3-gang), complete with disc drive, covers, trimmers, escutcheon, light knob, etc., 17/6; 2-gang, fitted as above, 9/6; Polar Star (3-gang 1933), complete, fitted as above, list 30/6, at 18/-; Uniknob 2-gang, fitted as above, complete, 10/-; Utility 2-gang, fitted as above, 8/6.  
**COILS** (6 sets each only).—Colvern Ferrocat, F1, F2, F3, ganged, 32/-; Varley Ni-core (1), B.P.30 and 2B.P.31, 28/-; Varley sets, B.P., 19 ganged, 25/6; record changers, Garrard, 200-250 A.C., complete with pick-ups, list £10, at £7/10.  
**PICK-UPS**.—B.T.H. Senior 1933, with volume control, list 2 guineas, at 29/-; Harley 1933, with volume control, list 27/6, at 15/-.  
**SMOOTHING** Condensers.—C.E.C. Murphy, etc., 800 test 250 A.C. working, 1 mfd. 1/1, 2 mfd. 1/9, 4 mfd. 2/6; all the following 1,500 D.C., test 500 A.C., working 800 peak, 1 mfd. 1/9, 2 mfd. 2/4, 4 mfd. 4/-; Multiple Banksall, separate tappings, 20 mfd., 4+4+2+2+2+2+2+1+1 at 11/-, 11 mfd., 4+2+2+2+1, at 6/9.  
**CHOKES**.—30 henry 30 m.a. (500 ohms), 6/-; 30 henry 50 m.a. (450 ohms), 6/3; 30 henry 60 m.a. (600 ohms), 6/6; another (300 ohms), 6/9; 30 henry 75 m.a. (300 ohms), 6/9; 50 henry 60 m.a. (850 ohms), 8/6; 20 henry 120 m.a. (325 ohms), 10/6.  
**MAINS** Transformers.—All tapped and screened primaries, L.T. windings C.T.: 500-0-500, at 120 m.a., 4v. 2.5a., 4v. 5a., 4v. 2a., 21/-; 350-0-350 at 120 m.a., 4v. 2.5a., 4v. 4a., 4v. 1a., 19/-; 250-0-250 at 75 m.a., 4v. 1a., 4v. 5a., 12/6; 250-0-250, 60 m.a., 4v. 1a., 4v. 3a., 4v. 1a., at 12/-. Note.—All transformers, chokes and condensers guaranteed against breakdown for 12 months.  
**RADIO** Gramophone Cabinets, solid walnut (figure), H.M.V. type 531, as used in H.M.V. 70 guinea job, overall 40x27x20, take chassis up to 27x20; cost to make, £12, at £5; packing and carriage 10/- extra (last 10).  
**ASK** for Special Quotation for Anything You May Need.—Chal-Electric, No. 6, Conduit St., London, W.1. [3442]  
**EPSON** First Again!—Polar 3-gang 0.0005 condensers, fully screened, dust-covers, trimmers, split-end vanes, listed 25/-; 9/6.  
**UTILITY** 2-gang 0.0005 Condensers, complete with horizontal full-vision scale, Uniknob, Escutcheon, etc.; 8/11.  
**RESISTORS**, cabinets, potentiometers, condensers, coils, transformers, etc.; complete list in  
**EPSON'S RADIO BULLETIN**.—Send stamp to 93, New Rd., Chingford, E.4. [3429]  
**COMPONENTS** for Sale at Bargain Prices, for callers only.—Newport Surplus Stores, 24a, Newport Court, W.U.2. [3430]  
**MANUFACTURER'S** Surplus.—Mains transformers, chokes, condensers, etc.; stamp list.—Polydync Electric, 25, Clivedon Rd., E.4. [3417]  
**8/9**—3-gang 0.0005, on die-cast chassis, trimmers, with illuminated drum drive, made for H.M.V.—Kay, 167, City Rd., London E.C.1. [3353]  
**AMPLIFIERS**, Hot Wire, 0.5, 2/-; Sullivans, 3/-; new microphone insets, sensitive, Westons, 1/6; Bullet type, 5d.; postage 3d.—Beaton, Chalk Farm Rd. [3404]  
**SPECIAL** Clearance Bargains.—Projectors (9, 16 and 35 mm.), 30/-; Cameras, from 20/-; everything for Movies, Walkies and Talkies; inspection invited.  
**ILLUSTRATED ENTERPRISES**, 159, Wardour St. (facing Film House), London, W.1. Phone: Gerrard 6889. [3004]  
**MOVING** Coil Milli-Ammeters, 0.50, 10/6 each; 2 milliamps and 120v., 17/6 each; other ranges in stock; alterations, repairs of every description.—The Victa Electrical Co., 47, High St., Battersea, S.W.11. [0355]  
**H.D. RADIO ELECTRICAL SERVICE** Offer Set Makers' new Surplus; cash with order or c.o.d.; callers between 1 p.m. and 6 p.m. only; G.E.C. pick-ups (6 only), list 27/6, at 15/-.  
**VARIABLE** Condensers, J.B. Nu Gang, with disc drive escutcheon, knob trimmers, covers, etc., 2-gang, list 17/6, at 10/-; 3-gang, list 22/6, at 17/6; 4-gang, list 31/-, at 20/-.  
**SETS** Assembled for the Trade and Public; ask for quotations; metal chassis constructed to order; state requirements for anything, we will quote.  
**H.D. RADIO ELECTRICAL SERVICE**, 31, George St., Hanover Sq., London, W.1 [3445]

CLASS "B" COMPONENTS.

SOUND SALES, Ltd., for Class "B" Components List "B.B." on request.—Tremlett Grove, Highgate, N.19. [0401]

MISCELLANEOUS.

**EASY** Payments.—We supply, by easy payments, components, accessories, and sets, any make; 10% down, balance spread over 11 months.—Send list of requirements to London Radio Supply Co., 11, Oak Lane, London, E.C.2. [0337]  
**ENGINEERS** and Technical Workers of All Kinds.—A proper training by post in your spare time will take you through your right examination, the employment is waiting. Our advice on all careers free.—Dept. 92, The Bennett College, Ltd., Sheffield. [0395]



There is a model to suit every output. Prices from 21/- to 70/-. Your dealer will demonstrate. REPRODUCEES & AMPLIFIERS, LTD., WOLVERHAMPTON.

THE POLYTECHNIC, REGENT STREET, W.1.

ELECTRICAL ENGINEERING DEPARTMENT. WIRELESS AND HIGH FREQUENCY SECTION. Evening Session, 1933-34.

Courses and Classes, including laboratory work, in WIRELESS AND HIGH FREQUENCY ENGINEERING extending over a period of FIVE YEARS and suitable for those engaged in, or desirous of entering, the Radio, Gramophone, or Talking Film Industries. Courses prepare for the: Graduateship Examination of the I.E.E. and City and Guilds Grouped Course Certificates. Session commences September 25th, 1933. Enrolments: September 18th to 22nd, from 6 to 9 p.m. Full particulars and prospectus from the Director of Education.

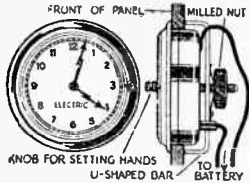

FIT THIS ELECTRIC CLOCK TO YOUR SET! NO MAINS NEEDED! KEEPS CORRECT TIME! NO WINDING!

Works off small battery lasting 12 months, or can be plugged into G.B. Battery without affecting reception. Uses practically no current. Fits into hole 3 1/2" dia. in any panel up to 1/2" thick. Easy to fix—no screws required. Only 1" from front of panel; to back of case. Swiss movement. Hands set from front. Nickel plated bezel. Useful addition to any set. RIVERSIDE MFG. CO., LTD., Dept. 20, Crisp Rd., Hammermith, W.6 Telephone: Riverside 6392. COMPLETE WITH BATTERY POSTAGE 6D

ALUMINIUM COIL COVERS. Manufacturer: WHITE BROS. & JACOBS LTD., CHALK FARM ROAD, N.W.1. TRADE ONLY Telephone: GULLIVER 5148.

LISTEN to the SHORT WAVES. by fitting the "UNIRAD" short wave unit. Built on metal chassis and housed in neat cabinet. This unit can be used as a super hetero-converter or adaptor, range 16 to 52 metres. A.C. or Battery model 37/6, extra coil 40 to 100 metres, 2/6. Also "UNIRAD" Class B unit. Built on metal chassis ready for use, price 25/-, valve extra. Obtainable for cash or C.O.D. from—UNIT RADIO, 12, Pulteney Street, Barnsbury, London, N.1.

EPOCH MOVING COIL SPEAKERS The Finest in The World in Each of Their Price-classes. Ask your dealer or call for a demonstration at Exmouth House. Send for New Booklet W.S.5a. It is free. EPOCH RADIO MANUFACTURING Co. Ltd. Exmouth House, Exmouth St., London, E.C.1 At the junction of Rosbery Avenue and Farringdon Road. Phone: Clerkenwell 6066 (4 lines).

Miscellaneous.—Contd.

AMBITIOUS Men.—Quality for a well-paid post by studying at home with the T.I.G.B. Write to-day for "The Engineer's Guide to Success," 144 pages, free, which contains the widest selection of engineering and wireless courses in the world, and shows you how to become A.M.I.E.E., A.M.I.Mech.E., A.Rad.A., etc. State branch, post or qualification that interests you.—The Technological Institute of Great Britain, 82, Temple Bar House, London, E.C.4. (Founded 1917, 19,000 successes.) [3398]

PATENT AGENTS.

PATENTS and Trade Marks, British and foreign.—Get and Co. (H. T. P. Gee, Member R.S.G.B. and A.M.I.R.E.E.), 51-52, Chancery Lane, London, W.C.2. Phone: Holborn 1525. [0001]

REPAIRS.

CLASS B. Send us your set for free quotation for conversion to Class B.—Unit Radio, 12, Pulteney St., London, N.1. [3401]  
**REPAIRS**.—Rebuilding to any set; highest quality work only; lowest charges; estimates given free; distance no object.—L. Eastwood, Radio Manufacturers' Consultant, Late of His Master's Voice and Marconi Wireless Telegraph Co. Telephone: Clerkenwell 4520. Address: 60, Horder Rd., Fulham, S.W.6. [3345]  
**GUARANTEED** Repairs by Experts; specialists for repairs to S. G. Brown and Amplion radio apparatus, also loud-speakers, headphones, pick-ups, Blue Spots, any type rewound, remagnetised and adjusted; 4/-; post free, mains transformer repairs; terms to trade.—Howell, 91, Morley Hill, Enfield, Middlesex. [9716]  
**REPAIRS** to Loud-speakers, transformers and headphones, 4/-; Blue Spots or Wufas, 5/-; post free, moving coils a speciality, new cones fitted; eliminators and mains transformers quoted for; prompt service; satisfaction guaranteed; discount to trade.—Loud Speaker Repair Works, 5, Balham Grove, London, Battersea 1321. [0394]

TUITION.

R.T.I. Training Methods are Recognised; write for particulars of home study for radio appointments; secure "Certificate of Proficiency" and become "A.M.R.T.I."—Radio Training Institute, 85, New Oxford St., London, W.C.1. [2947]  
**QUALIFIED** Radio Engineers are Always in Demand, and our Home Study Course will enable you to qualify for a good post; many students already placed this season; prospectus free.—Northern Counties Wireless School, Preston. [0399]  
**IF** You Wish to Enter the Wireless Profession with a Thorough Training, or if you wish to improve your present position, you will need the certificate issued by Britain's leading wireless college. This is not a correspondence course. Apparatus of all leading makes installed for instructional purposes. Boarders accepted. Training fees can be paid after appointment. Prospectus free.—Wireless College, Colwyn Bay [0388]

ELECTRIC CLOCKS.

SPECIAL OFFER.—Superior A.C. mains electric clock movements, rotor only 127 revs, drive up to 10-inch hands; 16/6, post 6d.—Write details, Ebury Bridge Radio Co., 23, Ebury Bridge Rd., Sloane 8407. [3426]

EXCHANGE.

HIGH Allowances Made on Second-hand Goods in Part Payment for New Sets or Components; easy payment available; we have tremendous stocks tested second-hand goods; send list of your requirements for quotation.—Bostock and Stennill, 1, Westbourne Terrace, S.E.23. [3420]

WANTED.

TWO Sets of RP 19s., urgent, cheap.—Write Radio, 75, Woodland Rise, N.10. [3419]  
**WANTED**, "Avometer," either model; state price and condition.—13, Edgware Grove, Leeds. [3407]  
**SPOT** Cash for Modern Components, etc.—Economic Radio Co., 96-98, South Lambeth Rd., S.W.8. [3291]  
**A.C.** Chassis, with valves; cheap for breaking up; would consider complete set.—Hore, Ashcroft, Penbury, Kent. [3405]  
**SURPLUS** Components Wanted for Cash; also mains and B battery valves.—24a, Newport Court, Charing Cross Rd., W.C.2. [2491]

**ADVERTISER** Wants Rotary Converter, with smoothing equipment, 100-volt D.C. input, output about 200 watts.—Alcock, West Wellow, Hants. [3412]  
**AVO** or Equivalent Test Set, perfect order; write lowest price or exchange; also small Westinghouse or similar charger.—L.H.C., 17, Electric Parade, E.18. [3425]  
**HIGH** Class Radio Sets and Parts Wanted for Cash, no obsolete parts please; parcels may be sent, same receiving immediate attention.—Mildmay Radio Exchange, 24, Mildmay Grove, London, N.1. Chisold 5001. [3197]

BUSINESSES AND PROPERTY FOR SALE, TO BE LET, OR WANTED.

**RADIO**, cycle and electrical, N.W. district; £175, stock valuation; H.M.V. and Columbia agents; low rental, good living accommodation, garage, charging plant; illness compels immediate sale.—Box 8005, c/o The Wireless World. [3438]  
**ADVERTISER** is Prepared to Purchase Sound Electrical and Wireless Business; principals only invited to submit preliminary particulars, including reasons for sale; audited figures will be required.—Box 8006, c/o The Wireless World. [3439]

SITUATIONS VACANT.

**WANTED**, Junior draughtsman, preferably having radio, amplifier, and post office rack design experience.—Box 8007, c/o The Wireless World. [3440]  
**A LEADING** Public Address Firm, owned and run by one man and staff for the past 4 years, having had all the National newspaper contracts for P.A. works and any other large P.A. job during that period, also representing several firms for the sales of equipment, requires a young energetic man to relieve him, must be willing to travel, devote his whole time to the business, with good sales, or wireless engineering, or business ability; a small investment which will be secured asked only from the right man.—Further particulars Box 8002, c/o The Wireless World. [3439]

Mention of "The Wireless World," when writing to advertisers, will ensure prompt attention.

**ELECTRADIX BARGAINS**

**S. G. BROWN'S BATTERY SUPERSEDER** makes H.T. from your L.T. 2-volt battery, rectified and smoothed. 3 tappings. A boon to those who are not on the mains. **Reduced from £3 15/- to 37/6** **New and Guaranteed**

**SELENIUM CELLS.** Light sensitive resistance, gold grids, moisture-proof. L to D ratio 5 to 1, 5/- each. Mounted in Bakelite, 7/6. Super Model in Oxy-brass body with window, 10/-.

**PHOTO CELLS.** £5 Photo Cells for Talkies, Light Tests, Timing Controls, etc., at bargain prices. Response to light 50 microamps. per lumen 40 watt lamp, 75 c.m. King B.T.P. 15/-; R.C.A. 25/-; Holders 1/-; Beck Prisms, 5/6; Focus Lens, 3/6.

**TELESCOPES.** Cooke monocular prism R.F. with 9-mile distance scale, 7 1/2 in. long, weight 3 1/2 lb., sale 17/6. **Naval Gun Sighting Telescopes**, internal focus ring, 2 1/2 in. long, 2 in. dia., weight 6 lb., magnification 6, for short and long range. Cost £25. Sale, 17/6. **Spotting Telescopes**, 17 in. x 1 1/2 in., by Watson, 25/-; 120 lb. Pressure Gauges 2/6. Watch movements, 1/6.

**DIXMIPANTA, A.C. or D.C.**  
A small A.C. Test Meter that is really a **VEST POCKET TESTER.** A wonderfully versatile moving-iron, multi-range meter for service on A.C. jobs. **No projecting terminals. THREE ranges of volts: 0-7.5, 0-150, 0-300. Used for MILLIAMPS. reads 0-12 1/2 m.a. and 0-75 m.a.**

**From Test Reports on the DIXMIPANTA:**  
**Wireless World:** "The accuracy with which voltage measurements can be made is surprisingly high, indeed, it could not be improved in view of the limitations imposed by the scale."  
**Popular Wireless:** "... one of the most attractive devices of its kind I have ever had come my way."  
"It fulfils its purposes every bit as well as a whole team of separate and more expensive meters."

**MICROPHONE BUTTONS** for all purposes. 1/- Volume Controls, 6d. Announcers No. 11 Mikes, 5/6; Pedestal type, 18/6. **Microphone Carbon Granules.** In glass capsule, enough for four buttons. Grade No. 1, 8d.; No. 2, Medium, 1/-; No. 3, Fine, 1/6; Carbon, solid back, blocks, 3d. Mouthpieces, curved or straight, 10d. Carbon diaphragm, 55 m/m., 4d. Panel Brackets, pivoted, 5/-; Reed Receiver Unit for Amplifier making, 3/-; Headphones, 2/9 pair. Veeder 10,000 Counters, 1/-; Leaflet with diagrams free if stamped envelope sent.

**PARCELS** of experimental odd coils, magnets, wire, chokes, condensers, switches, terminals, etc., post free. 10 lbs. 7/-, 7 lbs. 5/-.

1,000 other Bargains in New Sale List W.  
**ELECTRADIX RADIOS,**  
218, UPPER THAMES STREET, LONDON, E.C.4

Write for Illustrated Catalogue of **RADIO-GRAMPHONE CABINETS**

of exclusive modern design made by craftsmen in highly figured Oak, Walnut or Mahogany, post free. **REMARKABLE VALUES.** Cabinet made to order especially.

Makes under banner of the **HOWE BOX BAFFLE.** Recommended by the B.C.C. Full details on request.

**GILBERT**  
Cabinet Maker - SWINDON  
Estimate Free. Est. 1886



**BOOKS on WIRELESS**  
Write for complete list to **ILIFFE & SONS LTD.**  
Dorset House, Stamford St., London, S.E.1. w.w.1

**Situations Vacant.—Contd.**  
**R**ADIO Technician for Junior Post in Technical Department of well-known Valve Firm Required; circuit technique and measurements.—Write Box 8004, c/o *The Wireless World* [3437]

**SITUATIONS WANTED.**  
**E**X-RADIO Operator, mathematics, wireless engineering, City and Guilds Radio, desires progressive post.—Box 7971, c/o *The Wireless World*. [3405]

**AUCTION SALES.**  
By Order of C. O. Cullen, Esq. **CLEARANCE SALE.**  
MESSRS. **FULLER HALL & FOULSHAM**  
are instructed to offer for SALE by AUCTION in LOTS TO SUIT LARGE AND SMALL BUYERS, on the Premises, Ponders End, on WEDNESDAY, SEPTEMBER 20th, 1933, and DAY FOLLOWING, at 11 o'clock a.m. each day, the **CONTENTS OF THE WORKS** of **YAGERPHONE LIMITED,** including 4,000 WIRELESS and GRAMOPHONE SETS and CABINETS, SPEAKER and SPEAKER CABINETS, 300 MAINS and BATTERY CHASSIS, 500 PORTABLE GRAMOPHONES, 2,500 "COLLABO" and "GAR-RARD" DOUBLE SINGLE SPRING and INDUCTION MOTORS, H.T. Transformers, ENGINEERS' MACHINE TOOLS, including S.S. and S.C. LATHES, "BLISS" POWER PRESSES, "THIEL" NO. 3 FILING MACHINE, "PALLAS" HORIZONTAL MILLING MACHINE, Fly Presses, Guillotines, Shaping and Drilling Machines, also the OFFICE FURNITURE, FIXTURES and FITTINGS.

Catalogues (when ready) may be obtained of Messrs. Fuller Hall & Foulsham, Auctioneers and Valuers to the Wireless and Gramophone Trades, 125, High Holborn, W.C.1. (Tel.: Holborn 2406-2 lines.)

**NOTE.—The FACTORY at PONDERS END, which is a MODERN TWO-STORY STRUCTURE with 15,700 sq. ft. of FLOOR SPACE, is to be let on Lease.**

**NOW READY**  
The completely revised 1934 EDITION of RICH & BUNDY.

**24-Page CATALOGUE**  
OVER 100 Models of Mains Transformers and Power Chokes fully described.  
Valuable information and numerous illustrations.  
**FREE**  
Ask for 1934 Catalogue "W." Free by return of post.  
**RICH & BUNDY LTD.,**  
Transformer Manufacturers,  
New Road, Ponders End, Middlesex.  
'Phone: Enfield 0777.  
Sole Distributors I.F.S.: KELLY & SHIEL LTD., 47, Fleet St., Dublin, C.4.

**FOR HIRE FULLY EQUIPPED PUBLIC ADDRESS VAN**  
Sent anywhere in British Isles, also **RADIO, MICROPHONE, & GRAMOPHONE AMPLIFIERS** giving exceptional quality and volume, suitable for Dances, Sports Meetings, Parties, etc. from 15/- per day.  
Mr. Michael Portable Sets 15/- a week: £2-12-6 a month.  
**ALEXANDER BLACK, LTD**  
WIRELESS CONSULTANTS  
55, EBURY STREET, LONDON, S.W.1.  
ESTABLISHED IN 1925. SLOANE 1655.  
Trade Inquiries Invited.

**AS DEPENDABLE AS THE MAINS THEMSELVES**

**3 SAVAGE STANDARDISED SPECIFICATIONS**



**TYPE A 250-0-250, 60 m.A., 4 v. centre-tapped 1-2 amp., 4 v. centre-tapped 2-4 amp. With electrostatically screened primary. Mfrs.' type:—Price 20/- Standard type with terminals:—Price 25/-.**

**TYPE B 350-0-350, 120 m.A., 4 v. centre-tapped 2-3 amp., 4 v. centre-tapped 6 amp., 4 v. centre-tapped 2 amp. With electrostatically screened primary. Mfrs.' type:—Price 30/- Standard type with terminals:—Price 35/-.**

**TYPE C 500-0-500, 120 m.A., tapped at 465 v. each side. 4 v. centre-tapped 2-3 amp. Twice 4 v. centre-tapped 2 amp., 4 v. centre-tapped 3-4 amp. Mfrs.' type:—Price 43/- Standard type with terminals:—Price 49/-.**

**W. BRYAN SAVAGE**  
56/58, CLERKENWELL ROAD, E.C.1  
'Phone: Clerkenwell 3068 9.

**BOROUGH POLYTECHNIC**  
BOROUGH ROAD, LONDON, S.E.1  
**ELECTRICAL ENGINEERING DEPARTMENT**  
Head of Department: **W. C. S. PHILLIPS B.Sc., M.I.E.E., F.Inst.P.**  
Enrolment begins 18th September, 1933.

A Four Years' Course on **RADIO COMMUNICATION** is provided and Special Courses will be given on **LOUD SPEAKERS AND ACOUSTIC PROBLEMS** on Mondays, 6-7.30 p.m. by the well-known authority **N. W. McLACHLAN, D.Sc., M.I.E.E.**

**TELEVISION** on Thursdays, 8-9.30 p.m. by **J. J. DENTON, A.M.I.E.E.**

For further particulars and for Courses in Electrical Engineering and Physics apply to the Principal, **J. W. BISHAM.**

**INDEX TO ADVERTISEMENTS.**

PAGE	PAGE	PAGE			
Barber & Colman, Ltd. ....	10	Flusite, Ltd. ....	14	Polytechnic, The ....	12
Belling & Lee, Ltd. ....	10	Gener. Electric Co., Ltd. ....	Back Cover	Postlethwaite Bros. ....	12
Benjamin Electric, Ltd. ....	13	Gilbert, J. C. ....	13	Radio Gramophone Development Co. ....	12
Birmingham Sound Reproducers, Ltd. ....	13	Gramophone Co., Ltd. ....	4	Reproducers & Amplifiers, Ltd. ....	12
Black, Alex., Ltd. ....	13	Hartle, Turner Radios, Ltd. ....	10	Rich & Bundy, Ltd. ....	13
Black Batteries, Ltd. ....	13	Herand, E. J., Ltd. ....	3	Riverside Manufacturing Co., Ltd. ....	12
Borough Polytechnic ....	13	Heys, Leonard ....	10	Savage, W. Bryan ....	13
British Inst. of Engineering Technology ....	10	Higgs (Great Britain), Ltd. ....	14	Scientific Supply Stores (Wireless), Ltd. ....	13
British Pix Co., Ltd. ....	14	High Vacuum Valve Co., Ltd. ....	14	Scott Sessions & Co. ....	10
British Rola Co., Ltd. ....	9	Lampugh Radio, Ltd. ....	10	Seakamp, O. H. ....	10
British Thomson-Houston Co., Ltd. ....	10	Electro Linx, Ltd. ....	10	Smith, S. & Sons (Motor Accessories), Ltd. ....	10
Burne-Jones & Co., Ltd. (Magnum) ....	10	London Radio Supply Co. ....	10	Sonochord Reproducers, Ltd. ....	10
Celestion, Ltd. ....	11	Eyone, Claude, Ltd. ....	5	Stratten & Co., Ltd. ....	10
Challis Transformers, Ltd. ....	1	Avicophon Co., Ltd. ....	5	Telegraph Condenser Co., Ltd. ....	Front Cover
City Accumulator Co., Ltd. ....	1	Milnes Radio Co., Ltd. ....	5	Telsen Electric Co., Ltd. ....	Front Cover
Cole, E. K., Ltd. ....	1	Multitone Electric Co., Ltd. ....	5	Thompson, T. W., & Co. ....	3
Colyver, Ltd. ....	1	Nash Products, Ltd. ....	5	Unit Radio ....	12
Dryden ....	1	New London Electron Works, Ltd. ....	10	Varley (Olive) Fell Control, Ltd. ....	12
Duffiler Condenser Co. (1925), Ltd. ....	1	Osborne Clark, A. ....	10	Watnet Wireless Co., Ltd. ....	14
Earl Manfg. Co., Ltd. ....	6	Ostar-Ganz (Hagen Forthal) ....	10	Westinghouse Brake & Saxby Signal Co., Ltd. ....	14
Eastick, J. J., & Sons ....	6	Partridge, Wilson & Co. ....	10	White Bros. & Jacobs, Ltd. ....	Inside Back Cover
Edison Swan Electric Co., Ltd. ....	vi	Pepper, Trevor ....	3	Whiteley Electrical Radio Co., Ltd. ....	12
Electradix Radios ....	13	Petersen Radio ....	3	Wingrove & Rogers, Ltd. (Polar) ....	7
Electro Dynamic Construction Co., Ltd. ....	13	Peto-Scott, Co., Ltd. ....	8	Wilbur & Co. ....	6
Epoch Radio Manfg. Co., Ltd. ....	12	Pifo, Ltd. ....	v	Wright & Weaire, Ltd. ....	6
Ever Ready Co. (Great Britain), Ltd. ....	6				

HIGH IN QUALITY

## EXHIBITION SETS . . . . .

The following *HIVAC* Valves are recommended:  
For "Wireless World"

<b>MODERN BATTERY FOUR</b>	
SG210 .. ..	10 6
H210 .. ..	4 6
D210 .. ..	5 6
B220 .. ..	10 6

THE *HIVAC* VALVE GUIDE "W"

gives our complete range of 2-volt Valves for battery receivers, together with a comparative table of equivalent high efficiency valves at low cost.

WRITE NOW FOR A FREE COPY

*HIVAC* Valves are British Made in our own Factory. From all dealers. If any difficulty, send us P.O. and address of nearest dealer.

LOW IN PRICE

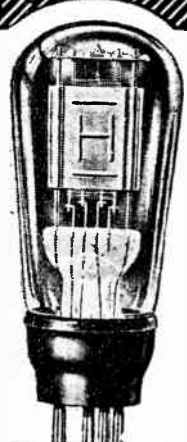

# HIVAC

THE SCIENTIFIC VALVE

HIGH VACUUM VALVE CO. LTD.,  
113-117, FARRINGDON ROAD, E.C.1.

# WATMEL

## POTENTIOMETERS GIVE THE BEST CONTROL

It is obvious that if a firm concentrates on one type of component it is going to turn out a better job than a firm that dabbles in many. This year we are concentrating on potentiometers, and you may rest assured that when you purchase a Watmel potentiometer you are obtaining the very best from a firm that specialises in this type of component.

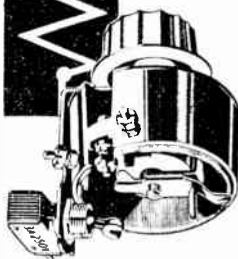

Here is illustrated the Watmel Type 1 Potentiometer.

Any resistance up to 50,000 ohms (Standard Wiring).

Price **5/6**

With quick break Switch

Price **7/6**

Please write for free fully illustrated catalogue that will give you interesting information on Volume Control.

Special models made for manufacturers and for the Export Market. Please write for further particulars.

# Watmel

## POTENTIOMETERS

### GIVE THE BEST CONTROL

WATMEL WIRELESS CO. LTD.,  
Imperial Works, High Street, Edgware.  
Telephone: Edgware 0223. (M.C.91)

*The*  
**ELEMENTARY PRINCIPLES**  
*of*  
**WIRELESS TELEGRAPHY**  
*and*  
**TELEPHONY**  
*by*  
**R. D. BANGAY**

Third Edition  
Revised by O. F. Brown, B.Sc.  
(1930)

THE standard book of instruction for wireless beginners and students. This revised edition brings the whole subject into line with modern developments in wireless. The style is clear and simple and attention is given to the theoretical elements of electricity and magnetism: to the dynamo: and to the properties of waves. A leaflet which gives full particulars of the volume, including a synopsis of the chapters, will be sent on request.

**PRICE**

7/6 net By post 8/-

*From all leading Booksellers or direct from the Publishers*

**ILIFFE & SONS LTD.**  
Dorset House  
STAMFORD STREET, LONDON, S.E.1  
W.W.97

## WHAT "FREE-GRID" THINKS OF THE MODULA ARMCHAIR CONTROL



*"The volume control functions beautifully, the 'control' being spread nicely over practically the whole movement of the knob instead of crowded up at one end as in the case of some of them."*—See page 192, Sept. 1st issue.



Controls the volume from a whisper to full volume. Fitted in a jiffy without tools. Does not affect the tone.

2/11

With Armchair Control 4/-

BRITISH PIX CO. LTD.,

118, SOUTHWARK STREET, LONDON, S.E.1.

# DICTIONARY of WIRELESS TECHNICAL TERMS

Compiled by  
S. O. PEARSON, B.Sc., A.M.I.E.E.  
and issued in conjunction with  
"THE WIRELESS WORLD"

Second Edition. Completely revised and brought up to date

This handy volume is very much more than a Dictionary. It not only takes the technical terms of wireless and explains their meaning, but in doing so it concentrates into a small space a large amount of information on wireless subjects. It has become, in fact, a compendium of current wireless knowledge, and an invaluable handbook for all who are interested in wireless transmission and reception. Diagrams and illustrations are freely interspersed throughout the book to amplify the explanations of the text.

272 pp., bound in cloth boards  
Size 5 by 3 inches

Price 2/- net. By post 2/2

*From all leading booksellers or direct from the Publishers*

**ILIFFE & SONS LTD.**  
Dorset House, Stamford Street, London, S.E.1  
W.W.48

# WEDNESDAY

## SEPTEMBER THE THIRTEENTH

### PRINCIPAL EVENTS OF THE DAY:

#### AT HOME

- NATIONAL LONDON** Running commentary on the St. Leger. Promenade concert from Queen's Hall.
- REGIONAL MIDLAND** Organ recital.
- REGIONAL NORTH** Running commentary on the St. Leger.
- REGIONAL WEST** Choral programme.
- REGIONAL SCOTTISH** "Frac a' the Airts—Tomintoul," relayed from Grantown-on-Spey.
- REGIONAL BELFAST** String orchestral concert.

#### ABROAD

- BARI** 8.45 p.m. Chamber music.
- HAMBURG** 9.10 p.m. Spohr concert by a Symphony Orchestra of Unemployed Musicians, relayed from Hanover.
- HEILSBERG** 10.30 p.m. The Opera House Orchestra, conducted by Bruckner.
- HILVERSUM** 9.10 p.m. The Amsterdam Salon Orchestra, conducted by Kiekens.
- HUIZEN** 5.10 p.m. The Amsterdam Orchestral Society, conducted by Van Diepenbeek.
- LEIPZIG** 9.30 p.m. Opera: "Der Schauspieldirektor," by Mozart.
- PALERMO** 8.45 p.m. Opera: "L'amico Fritz," by Mascagni.
- POSTE** 8.30 p.m. The Station Orchestra.
- PARISIEN STRASBOURG** 8.30 p.m. Symphony concert, from the Casino, Vichy.
- TURIN** 8.30 p.m. Opera: "La leggenda di Sakuntala," by Alfano.

**ATHLONE**  
725 kc/s, 413 metres; 60 kW. Relay by Cork, 1,337 kc/s, 224.4 metres.—1.30 to 2.30 p.m., Time Signal, Weather Report, Stock Exchange Quotations and Gramophone Music. 6.0, Programme for Children. 6.45, News. 7.0, Gaelic Talk. 7.15, German Lesson. 7.30, Time Signal. 7.31, The Station Orchestra. 8.0, Soprano Solos by Mme. A. Heffernan. 8.15, And there was born—Sketch by Flora MacDonald and Company. 8.45, Gaelic Song Recital. 9.0, Harp Solos by Sanchia Pielou. 9.15, Variety Programme by the Nono Brothers. 9.30 to 10.30, Programme by the I.B.C. (Ireland), Ltd. 9.30, Instrumental Solos: Xylophone Solo: The Skaters' Waltz (Waldteufel); Harp Solo: Irish Melodies; Violin Solo: Caprice vicinios (Kreisler); Hawaiian Guitars: My Wai kiki Mermaid; Piano Accordion Solo: Waltz, Gold and Silver (Lehár); Syncopated Pianoforte Solos: Memories of Maurice Chevalier; Organ Solo: Lola (Arnold). 10.0, Concert arranged by the International Broadcasting Company (Ireland), Ltd., on behalf of Hospitals' Trust, Ltd.: Signature Tune, Come back to Erin; There's a Cabin in the Pines; Jog Along; Play, Fiddle, Play; Something came and got me in the Spring; And so I married the Girl; When it's Lamplightin' Time in the Valley; A Broken Rosary; Hyde Park Corner; What a Perfect Combination; Signature Tune. 10.29, I.B.C. Goodnight Melody. 10.45, News and Weather.

**BARCELONA**  
EAJ1, 860 kc/s, 348.8 metres; 8 kW.—7.0 p.m., Trio Concert: Overture, Der Freischütz (Weber); Les Cloches (Debussy); May (Dandolis); Symphonie en fa mine (Desprez); Romance for the Violin Concerto (Lalo); Extase (Ganne); Selection from Don Quixote (Massenet). 8.0, Request Gramophone Records. 8.30, Exchange. 9.0, Gramophone Music and News. 10.0, Chimes, Weather, Exchange and Market Prices. 10.5, Humorous Review of the Week in Verse. 10.15, Orchestral Concert. 11.0, Concert by the Station Orchestra. 11.30, Dance Music, relayed from the Casa Libre. In the interval at 12 Midnight, News. 1.0 a.m. (Thursday), Close Down.

**BERLIN**  
1,112 kc/s, 269.8 metres; 20 kW.—8.0 p.m., Agricultural Notes, Tourist Report and Dopolavoro Notes. 8.20, Giornale Radio and News in Albanian. 8.30, Time and Announcements. 8.35, Weather. 8.45, Concert of Chamber Music: Nilde Pignatelli (Violin), Milena Barberio (Soprano) and Franco Ruggero (Pianoforte); Overture, The Thieving Magpie (Rossini); Violin Solo, Allegro moderato from the Concerto in D (Wieniawski); Soprano Solos, (a) E canta il grillo (Bilili), (b) Nanna-nanna (Graziani); Pianoforte Solos, Prelude and Fugue (Bach); Violin Solo, Scherzo (Dittersdorf-Kreisler); Soprano Solo, Chiamaletto destino (Corcini); Pianoforte Solos (Debussy). (a) La plus que lente, (b) L'isle joyeuse; Overture, The Secret Marriage (Cimarosa); Violin Solo, Chemin du coeur (Seels); Soprano Solo, Di te (Tirindelli); Pianoforte Solo, Elegy (Rachmaninov); Violin Solo, Capriccio (Paganini); Soprano Solo, Fanciulla bruna (Accorinti); Pianoforte Solo, Polonaise, Op. 10, No. 2 (Chopin). In the interval, Art Notes. 10.30, Dance Music from the Gran Caffè del Levante. 11.0, Giornale Radio.

**BASEL**—See Schweizerischer Landessender

**BELGRADE**  
697 kc/s, 430.4 metres; 2.8 kW.—6.55 p.m., Time and Announcements. 7.0, Talk. 8.0, Hebrew Songs. 8.30, Programme from Ljubljana. 10.30, Time and News. 10.45 (approx.), Cigany Music from the Dva Jelena Restaurant.

**BERLIN**  
**DEUTSCHLANDSENDER** (Reichssender), 183.5 kc/s, 1,635 metres; 60 kW.—12.5 p.m., Light Music and Songs on Gramophone Records. 12.55, Time Signal. 1.45, News. 2.0, Gramophone Concert (cont'd.). 3.0, Programme for Children. 3.30, Weather and Exchange. 3.45, Reading (Adalbert Stifter). 4.0, See Hamburg. 5.0, Popular People—Interview with a Postman, a Head Waiter, a Policeman and a Chef. 5.25, Contemporary Chamber Music: Andante from the Pianoforte Trio in C minor (Kirchhoff); Three Miniatures (Juno). 6.0, Poems. 6.5, Religious Address and Sacred Music. 6.35, Wireless Talk. 6.50, Weather and News. 7.0, Transmission for all German Stations, relayed from Hamburg. 8.0, Today's Motto. 8.5, Street Music. 8.45, Two Hundred and Eighteen Days—Radio Play (Arthur Kuhnert). 10.0, Weather and News. 10.45, Weather. 11.10, See Breslau. 12 Midnight (approx.), Close Down.

**BERLIN**  
**FUNKSTUNDE**, 715 kc/s, 419.5 metres; 1.5 kW.—4.30 p.m., Military Band Concert from the Sprengarten, Treptow; March, Hakenkreuz und Schwarz-weiss-rot (Kochmann); Overture, Masaniello (Auber); Almbliatt (Wagner); Selection from Madame Butterfly (Puccini); Waltz, Wiener Bombons (John Strauss); Deutsches Gebet (Hakenberger); Potpourri, Links-rechts-Marsch (Eggert);

Overture, Zampa (Herold); Frauenthor Porzellanpüppchen (Lienke); Trumpet Solo, Der alte Dessauer Der 15. September (Müller). 5.40, Discussion on Handwriting. 6.5, See Berlin (Deutschlandsender). 6.40, The Funk-stunde informs its Listeners. . . . 6.45 Topical Talk. 7.0, Transmission for all German Stations, relayed from Hamburg. 8.0, Lottery Announcements. 8.5, The Folk Song—Part I. Talk: Possibilities of Folk Singing; Part II, Part Relays of Folk Song Concerts from Various Towns. 8.35, Topical Talk. 9.0, Widmungen (Dedications)—a Radio Picture with Music (Erich Fortner). 10.0, News. 10.15 (approx.), Dance Music from the Sprengarten, Treptow. In the interval from 11.0-11.5, Talk: What they are saying in Berlin. 12 Midnight, Close Down.

**BERNE**—See Schweizerischer Landessender.  
**BEROMUNSTER**—See Schweizerischer Landessender.  
**BODEN**—See Stockholm.  
**BODO**—See Oslo.

**BORDEAUX-LAFAYETTE**  
986 kc/s, 304 metres; 13 kW.—6.15 p.m., Radio Journal. 7.45, News. 8.0, Agricultural Talk. 8.15, Gramophone Music. 8.30, Symphony Concert.

**BRATISLAVA**  
1,076 kc/s, 279 metres; 14 kW.—5.55 p.m., Hungarian Programme: Reading, Literary Talk and Hungarian Folk Song Recital. 6.55, Talk for Housewives. 7.0, See Prague. 7.35, See Moravska-Ostrava. 8.15, See Prague. 8.30, See Brno. 10.0, See Prague. 10.15 (approx.), Close Down.

**BREMEN**—See Hamburg.  
**BRESLAU**  
923 kc/s, 325 metres; in kW. Relay by Gleiwitz, 1,184 kc/s, 253 metres.—2.5 p.m. (from Gleiwitz), Song Recital by Thea Fietzek (Soprano). 2.30, Gramophone Concert of Operetta Music. 3.0, Market Prices. 3.30, Talk on Natural Science. 3.50, Reading. 4.15, Pianoforte Recital of Modern Music: Bilder vom Chien-see, Op. 131 (Büchel). 4.50, Talk: The Education of the Youth of the Mining Districts. 5.5, Recital of Well-known Folk Songs by the Ostland Quartet: Sandmännchen; Lachen und Weinen; Gut Nacht; Müllers Abschied; Mein eigen soll sie sein; Hotel, was kommt; Wenn alle Bräunlein fließen; Kapitän und Leutnant. 5.35, Market Prices. 5.40 (approx.), Talk: Racial Strife in the Frontier Province. 5.55, Songs to the Lute. 6.25, Reminiscences of Old Soldiers of the National Socialist Movement. 6.50, Weather, News, and Market

Prices. 7.0, Transmission for all German Stations, relayed from Hamburg. 8.0, A Radio Report from the Private Laboratory of Dr. Friedrich Bergius, in Heidelberg. 8.30 to 10.30, Max Von Schillings Memorial Programme. 8.30, Concert by the Silesian Philharmonic Orchestra, conducted by Carl Schmidt-Beldien: Soloists: Willy Koch (Recitations), Bruno Jagielski (Tenor); Prelude to the Second Act of Ingweldo; Das Hexenlied, Op. 15. 9.20, Memorial Address by Dr. Hermann Matzke. 9.40, Concert (cont'd.): Symphonie Prologue to Sophocles' Oedipus Rex, Op. 11; Glockenlied; Prelude to the Third Act of Der Peiferlag. 10.30, Time and News. 10.50, Reading. 11.10, Light Music and Dance Music from the Cafe Vaterland. 12.30 a.m. (Thursday), Close Down.

**BRNO**  
878 kc/s, 342 metres; 35 kW.—6.25 p.m., German Transmission: News, Talk, Programme for Workers and Topical Notes. 7.0, See Prague. 7.35, See Moravska-Ostrava. 8.15, See Prague. 8.30, Concert by the Station Orchestra, conducted by Bakala, an Instrumental Trio and a Male Voice Quartet: Trios: (a) March (Poldini), (b) Melody (Rachmaninov), (c) Pas des fleurs (Debussy), (d) Intermezzo (Lindsay-Thiemer), (e) Serenade (Lienke), (f) March (Rosey); Selection from The Rose of Stamboul (Fall); Waltz (Nedbal); Idyll (Wieniawsky); Quartets: (a) Three Songs (Dvorák), (b) The Drum (Bendl); Waltz (Fueick); Potpourri (Bernhard). In the interval, Recitation. 10.0, See Prague. 10.30 (approx.), Close Down.

**BRUSSELS (No. 1)**  
I.N.R., 590 kc/s, 509 metres; 15 kW.—12 Noon, Concert by the Small Station Orchestra, conducted by Lecmans: Overture, Le Saltimbanques (Ganne); Ballet Music from Les deux pigeons (Messager); Chanson d'Arlette (De Taque); Selection from Bocaccio (Suppé); Violin Solo, Tambourin chinois (Kreisler); Waltz (Kleiner); Selection from The Nuremberg Doll (Adam); Tarantella (Calabi). 1.0 p.m., Journal Parlé. 1.10, Gramophone Concert: Overture, Poet and Peasant (Suppé); La habanera (Lucena); Carnival (Lucrecia); Suite fantastesque (Messager); Homage March (Wagner); Arabesque (Debussy); Hungarian Dance, Op. 23 (Mozzkowsky); L'annee d'argent (Chaminade); Overture, Abu Hassan (Weber). 5.0, Dance Music relayed from the Century Hotel, Antwerp. 6.0, Talk on Auguste Domany—the Belgian Painter. 6.15, Gramophone Music: Kinder-zenen (Soltau); Scherzo (Rimsky-Korsakov). 6.30, Recitations. 7.0, Overture to Romeo and Juliet (Tchaikovsky), on Gramophone Records. 7.15, Talk: The Museum at Anderlecht. 7.30, Medical Talk. 8.0, Concert by the Radio Orchestra, conducted by André; Soloist, Mme. Marville

(Songs): Extracts from the Dance Suite (Pierné); Pieces (Debussy): (a) Fantoche, (b) Mazurka, (c) Minstrels; Songs: (a) Novembre (Trémisot), (b) L'amour meurt (Crémieux), (c) Le train du rêve (Lenoir); Selection from Monsieur Beaucaire (Messager); Violin Solo: Rondo capriccioso (Saint-Saëns); Dances from The Rebel Maid (Phillips); Suite, Henry VIII (Foulds); Selection from Show Boat (Kern); Trumpet Blues (Lindley); The Man I love (Gershwin); Rhapsody in Blue (Gershwin). In the interval at 8.30, Talk: Berthe Boiscé—a Belgian Writer, and at 9.15, Les avengles—Radio Play (de Ghelderode). 10.0, Journal Parlé. 10.10, Dance Music relayed from the Century Hotel, Antwerp.

**BRUSSELS (No. 2)**  
N.I.R., 887 kc/s, 338.2 metres; 15 kW. Programme in Flemish.—12 Noon, Gramophone Music. 1.0 p.m., Le Journal Parlé. 1.10, Concert by the Small Station Orchestra. 2.0, Radio Report. 5.0, Concert by the Station Orchestra: Joyous Youth (Contes); Burlesque (Foot); Adoration (Lagye); Selection from The Gipsy Princess (Kalman); Last Movement from the 1st Concerto (Vieuxtemps); Scottish Scenes (Godard); Spanish Pieces (Granados); Selection from Le chemin du paradis (Hoymann). 6.0, Gramophone Music: Meditation (Paganetti); Scherzo (Paganetti); Overture, Libussa (Smctana). 6.15, Talk. 6.30, Concert by the Small Station Orchestra: Overture on Jewish Themes (Prokofiev); The Complaint (Lidlov); Bacchanale (Glazunov); Intermezzo and Aria from The Czar's Bride (Rimsky-Korsakov); Air and Trepak for Violin (Satanoff-Dushkin); Orientale (Cui); Extracts from The Seasons (Glazunov); Dance from Kovantchina (Mussorgsky); Gopak (Mussorgsky). 7.15, Economic Review. 7.30, Engineering Notes. 8.0, Concert by the Station Symphony Orchestra, conducted by Gebert: Chaconne (Bach-Hubay); Selection from La dona serpente (Casella); Suite from Pulcinella (Stravinsky). 8.45, Recitation. 9.0, Concert (cont'd.): Music by Johann and Josef Strauss: Overture, Die Fledermaus (Johann); Waltz, Roses from the South (Johann); Polka, Tritsch-Tratsch (Johann); Waltz, Sphärenklänge (Josef); Gallop, Leichte Blut (Johann); Waltz, Tales from the Vienna Woods (Johann); Polka, Pizzicato (Johann and Josef); Kaiser-Walzer (Johann); Overture, The Gipsy Baron (Johann). 10.0, Le Journal Parlé. 10.10, Dance Music on Gramophone Records.

**BUCHAREST**  
761 kc/s, 394 metres; 12 kW.—5.0 p.m., Concert by the Station Orchestra: March (Blankenburg); Waltz (Strauss); Waltz (Suppé); Overture, Pique Dame (Suppé); Selection from Lucia di Lammermoor (Donizetti); Selection from Madame Boniface (Lacôme); Suite, Wedding Scenes (Smctana); Strauss Waltz Suite (Weber); Chante mon ame (Dron). In the interval at 6.0, Radio Journal. 7.0, Reading. 7.20, Romanian Music on Gramophone Records. 7.40, Educational Talk. 8.0, Violin Recital by Sarvas; Sonata No. 2 (Nardini); Melody (Bloch); Ballad in Romanian Style (Rogalski); Spanish Dance from La vida breve (Falla-Kreisler). 8.30, Talk. 8.45, Pianoforte Recital by Mme. Corcorasco. 9.15, Suite for Cello (Saint-Saëns), played by Joseph Thaler. 9.45, Radio Journal. 10.0, Jazz Music, relayed from the Lido.

**BUDAPEST**  
545 kc/s, 550.5 metres; 18.5 kW. Also relayed on 840 metres from 8.0 p.m. till Close Down. 5.30 p.m., Pianoforte Recital. 6.10, Talk: Hunting. 6.45, Concert of Cigany Music. 8.0, Wagner Concert by the Opera House Orchestra, conducted by Ernst Dohmanyi. Soloists: Ella Nemethy, Signund Pilinszky, and Georg Losonezy. Overture, Tambourier; Prelude to Lohengrin; Grail Narrative and Prelude to the Third Act of Lohengrin; Duet and Wotan's Farewell from The Valkyrie; Overture, The Meistersingers. In the interval at 8.50, Talk: The Bayreuth Festival. 9.45, News. 10.0 (approx.), Cigany and Dance Music, with Songs from the Café Ostende. 11.0, Talk in English: Hungary, the Huntsman's Paradise.

**CASSEL**—See Frankfurt.

**COPENHAGEN**  
1,067 kc/s, 281 metres; 0.75 kW. Relay by Kalundborg, 260 kc/s, 1,153.8 metres.—12 Noon, Time Signal and Chimes from the Town Hall. 12.2 p.m., Concert by the Harald Andersen Ensemble, relayed from the Bellevue Strandhotel. 2.0, Interval. 3.0, Gramophone Concert of Variety Music. 3.30, Concert by the Station Orchestra, conducted by Fritz Mahler. In the interval at 4.15 (approx.), Talk for Women. 5.30, Exchange and Fish Market Prices. 5.45, Talk in German: The Musical Revival in Germany. 6.15, French Lesson. 6.45, Weather. 6.54, Announcements. 7.0, News. 7.15, Time Signal. 7.30, Agricultural Talk. 8.0, Time Signal from the Town Hall. 8.1, Concert of Chamber Music by the Thorvald Nielsen Quartet; Extracts from: (a) String Quartet No. 1 in E Flat (J. C. F. Bach), (b) String Quartet No. 4 in G (Haydn). 8.30, Talk. 9.0 to 2.0 a.m. (Thursday),



Radio Ball. 9.0, Dance Music by Louis Preil's Band. 10.0, News. 11.15, Dance Music by the Valencia Band, conducted by Kai Julian. 12 Midnight, Time Signal and Chimes from the Town Hall. 12.1 a.m., Dance Music by the Ritz Band, conducted by Otto Lington. 1.0, Dance Music by the Nimb Band, conducted by Jens Warny. 2.0 (approx.), Close Down.

CORK.—See Athlone.

DANZIG.—See Heilsberg.

DRESDEN.—See Leipzig.

### FECAMP

1,328 kc/s, 225.9 metres; 10 kW.—11.0 a.m. to 12 Noon, Programme in English by the I.B.C. 11.0, Concert. Part I, Request Music: Signature Tune; Over the Waves (Rosas); In a Monastery Garden (Kettelbey); Serenade (Heyskens); The Nightingale in the Lilac Bush (Krome); Guitar Band, Somewhere in Hawaii (Nelson); Bells across the Meadows (Kettelbey); Guitar Band, Sweetheart Lane (Rockwell); Around the Volga (Borchert). Part II, Request Accordion Music: Selection from 'Armen (Bizet); La Javanette (Bozi); Waltz, The Blue Danube (Joh. Strauss); C'est un petit nid (Eblingen); Selection from Congress Dances (Heymann); Duet, Lido Lady (Diero); Lullaby of the Leaves (Malneck); Accordion Nights; Signature Tune. 12 Noon, Programme in French. 4.30 to 6.0 p.m., Programme in English by the I.B.C. 4.30, Programme for Children. 5.0, Concert for Portsmouth and Southsea Listeners: Signature Tune, The Night by the Sea; Johann Strauss Potpourri; Peter, Peter (Woods); Mon rêve (Waldteufel). Bandonion Solo: March, Father Rhine (Porschmann); Woodland Peace (Favilla); Sundown in a Little Green Hollow (Basset); Valse Septembre (Godin); Once on the Rhine (Ostermann). 5.30, Military Band Concert for Isle of Wight Listeners: Coronation March; Selection from Rigoletto (Verdi); Brabazon (Dunn); Song, Route Marching (McCall); Selection from The Geisha (Jones); Song, The Drum-Major (Newton); Valse des Alouettes (Drigo); The Bullfighter's March (Kottau); Signature Tune. 6.0, Programme in French. 10.0 till Close Down, Programme in English by the I.B.C. 10.0, Dance Music: Signature Tune, The Bells of Normandy; It's the Band; We belong together; London Bridge is falling down; In Eger on the Tegera Sea; Won't you stay to Tea; There's a Tiny Little Hair upon your Shoulder; Moonlight, the Danube and You; Sylvia; Play it hot; Land of Love and Laughter; Piccaninny; All over Italy; I lay me down to Sleep; There's a Cabin in the Pines; Jog Along; Let's all be happy together; Smilin' through; When Gimble hits the Cymbal; Signature Tune. 11.0, Music from Sound Films: Signature Tune, Sittin' in the Dark; Selection from Love Me, To-night; Pardon Madame; Sergeant Flagg and Sergeant Quirt; Follow a Star; The Whip; How do you do, Mr. Brown; Selection from Splinters; Signature Tune. 11.30, Club Concert for Hitchin Listeners. Part I, Request Music: Signature Tune, The Chum Song; Selection from The Desert Song (Romberg); Serenade (Toselli); Old Sam (Holloway); Rakoczy March (Berlioz); Brother, can you spare a dime? (Gorney); Three Ha'pence a Foot (Holloway); Loch Lomond (Traditional); Wiener Madli (Ziehrer). 12.5 a.m. (Thursday), News Bulletin in English. 12.10 (approx.), Club Concert (cont'd.). Part II: Kalia (Kern); Harlem Madness (Ager); Dancing Time (Kern); You know what I'll do? (Buchel); Song of the Bells (Pola); Sing a New Song (Wever); Sweetheart Darlin' (Kahn); I'm one of the Lads of Valencia (Lloyd); Bugle Call Rag (Schoebel); Meet me in the Gloaming (Goodhart); My Love Song (Burnaby); Lover (Rodgers); That's what Life is made of (Noble). 1.0, Dance Music: Signature Tune, Bells of Normandy; I've got to sing a Toreh Song; Rock-a-bye; Somebody stole my Gal; I shall still keep smiling along; That's what Life is made of; The Shadow Waltz in a Secondhand Store; Hold me; In the Valley of the Moon; Look what I've got; In Old Vienna; In the Park in Páree; My Heart was made for Love; When It's Lamp-Lightin' Time in the Valley; The Language of Love; My! Oh My!; Signature Tune. 2.0, The I.B.C. Goodnight Melody and Close Down.

FLENSBURG.—See Hamburg.

FLORENCE.—See Turin.

### FRANKFURT

1,157 kc/s, 259.3 metres; 17 kW. Relayed by Cassel. 1,220 kc/s, 245.9 metres; and Trier, 1,157 kc/s, 259.3 metres.—2.0 p.m., News. 2.30, Listen, Everybody—Variety Programme. 3.0, Weather. 3.10, Time and Economic Notes. 3.30, Programme for Young People. 4.25, Economic Notes. 4.30, See Munich. 5.45, Economic Notes. 6.0, Talk: From the Wireless War Zone. 6.25, Topical Talk. 6.45, Review of the Day's Events. 6.50, Time, Programme Announcements, Weather and Economic Notes. 7.0, Transmission for all German Stations, relayed from Hamburg. 8.0, Concert of Operetta Music. 10.0 (from Cassel), Who said that? . . . Sketch (Zauner). 10.20, Time and News. 11.0, See Munich. 12 Midnight, Close Down.

SEPT. 13th

WEDNESDAY

continued

FREDRIKSSTAD.—See Oslo.

FREIBURG.—See Stuttgart.

GENOVA.—See Radio-Suisse Romande.

GENOA.—See Turin.

GLEIWITZ.—See Breslau.

GOTEBORG.—See Stockholm.

GRAZ.—See Vienna.

HAMAR.—See Oslo.

### HAMBURG

806 kc/s, 372 metres; 1.5 kW. Relayed by Bremen, 1,112 kc/s, 269.8 metres; Flensburg, 1,319 kc/s, 227.4 metres; Hanover, 530 kc/s, 566 metres; and Kiel, 1,292 kc/s, 232.2 metres.—4.0 p.m., Concert by the Hamburg Philharmonic Orchestra, conducted by Gerhard Maass. 5.0, Dialect Programme for Young People. 5.30, Hamburg, Bremen and Lübeck: Report on Events in the Senates and Houses of Burgesses of the Hanseatic Free Cities. 6.0 (from Bremen), Edmund Kretschmer Concert by the Bremen Station Orchestra, conducted by Reinhold Krug: Soloist, Maria Lauterbach (Soprano). 6.45, Frankfurt Exchange and Market Prices. 6.50, Weather. 7.0, Transmission for all German Stations: Scenes from a Seaman's Life (Rudolf Künau); Part I, Piloting up the Elbe; Part II, Before the Harbour Board. 8.0, On the Banks of the Elbe: Concert by the Station Choir, the Small Orchestra and Soloists, Conductor, Gerhard Maass. 9.0, Political Address. 9.10 (from Hanover), Spohr Concert by a Symphony Orchestra of Unemployed Musicians, conducted by von Sosen: Soloist, Kurt Brünmann (Violin); Historic Symphony; Variations for Violin and Strings; Overture, The Alchemist. 10.10, Time and News. 10.30, Topical Talk. 10.40, Concert from Langenberg.

HANOVER.—See Hamburg.

### HEILSBURG

1,085 kc/s, 276.5 metres; 60 kW. Relayed by Danzig, 662 kc/s, 453.2 metres.—1.5 p.m., Gramophone Concert. In the intervals at 1.20 and 2.0, News. 2.30, Programme arranged by the Post Office, with Gramophone Records. 3.0, Market Prices. 3.20, Practical Hints for the Housewife. 3.30, Programme for Children. 4.0, Talk for Parents. 4.30, Concert by the Small Station Orchestra, conducted by Wilcken: Overture, Luisa Miller (Verdi); Three German Dances (Reger); Selection from L'Africaine (Meyerbeer); Dances (Humperdinck); Manchurian Sketches (Glam); Modern Ballet Suite (A-mandula). 5.50, Review of Books on Fascism. 6.15, Agricultural Prices. 6.20, Talk on the Art of Pianoforte Playing, with Illustration: The Wanderer—Fantasy in C, Op. 15 (Schubert). 6.50, Weather. 7.0, Transmission for all German Stations, relayed from Hamburg. 8.0, Weather and News. 8.10, Dance Music by the Small Station Orchestra and the Birschel Dance Band. 10.0, Weather and News. 10.30 (approx.), Concert by the Opera House Orchestra, conducted by Brückner: Variations on a Theme of Mozart (Reger); Spanish Rhapsody (Chabrier); Dance of the Gnomes (Beyle); Waltz, Hochzeitsreigen (Lincke); Selection from Frederica (Lehar); Die Ehrenwache (Lehnhardt). 11.30, Close Down.

### HILVERSUM

Announced HUIZEN, 1,013 kc/s, 296.1 metres; 20 kW (7 kW up to 5.40 p.m.).—Programme of the Christian Radio Society (N.C.R.V.). 11.55 a.m., Gramophone Music. 12.10 p.m., Quartet Concert. 1.40, Interval. 2.10, Talk for Stamp Collectors. 2.40, Concert: A. de Vink-Versehoor (Soprano), Bep Glastra van Loon (Soprano), L. Oostdam (Flute), and A. Schellevis (Pianoforte). 4.40, Programme for Children. 5.40, Talk on Agriculture. 6.10, Programme to be announced. 6.40, Police Announcements. 6.55, Religious Information. 7.10, Talk on Russia. 7.40, Concert by the Enterpe Male Voice Double Quartet. In the interval, Gramophone Music. 8.40, Talk. 9.10, Concert by the Amsterdam Salon Orchestra, conducted by Kiekens: Overture, Raymond (Thomas); Waltz, Wiener Bonbons (Strauss); Anatolian Dance (Weininger); Selection from Tiedland (d'Albert); Overture, Si j'étais Roi (Adam); Serenata (Tarenghi); Durch Webers Zauberwald (Urbach); Gavotte (Rameau); Minuet in E Flat (Mozart); Donaubilder (Ertel); March, Durch Sturm und Not (Blankenburg). In the interval at 9.40, News. 10.40, Gramophone Music. 11.10 (approx.), Close Down.

HORBY.—See Stockholm.

### HUIZEN

Announced HILVERSUM, 160 kc/s, 1.875 metres; 7 kW. (up to 3.40 p.m.); Transmitted from Kootwijk on 50 kW. from 3.40 p.m.—11.40 a.m., till Close Down, Programme of the Workers' Radio Society (V.A.R.A.). 11.40 a.m., Concert by De Flierefluiter, conducted by Ray Forest. 12.10 p.m., Organ Recital by C. Steyn. 12.25, Concert (cont'd.). 1.25,

Concert by De Notenkrakers, conducted by Wins. 2.40, Programme for Children. 5.10, Concert by the Amsterdam Orchestral Society, conducted by van Diepenbeek: March from Tannhäuser (Wagner); Overture, Maximilian Robespierre (Litolff); Selection from Il Trovatore (Verdi). 5.40, Recitations. 5.55, Concert (cont'd.): Overture, Zampa (Hérold); Tesoro mio (Becucci); Selection from The Geisha (Jones). 6.25, Topical Talk. 6.40, Concert (cont'd.): The Unfinished Symphony (Schubert). 7.5, Accordion and Pianoforte Solos. 7.20, Concert (cont'd.). 7.40, S.O.S. Messages. 7.42, News. 7.55, Concert by De Flierefluiter, conducted by Ray Forest. 8.25, Song Recital. 8.40, Orchestral Concert, conducted by Feulner: Wasser-Ouverture (Telemann-Feulner); Cassation in F Sharp (Haydn-Feulner). 9.25, Song Recital (cont'd.). 9.50, Orchestral Concert (cont'd.): Piece (Benda); Andante (Cantabich); Eine kleine Nachtmusik (Mozart); Symphony in G Minor (Kunzen-Feulner). 10.40, Dramatic Programme. 10.55, Concert by De Notenkrakers, conducted by Wins. 11.40 (approx.), Close Down.

INNSBRUCK.—See Vienna.

### JUAN LES PINS

1,205 kc/s, 249 metres; 0.8 kW.—12.30 p.m., Amusement Guide and Variety Items. 1.0, News. 1.15, Radio Concert. 8.0, Amusement Guide, Exchange and News. 8.15, Oceanographic Report. 8.30, Press Review. 8.40, Reading. 9.0, News and Weather. 9.15, Radio Concert. 11.30, Concert by the Billy Arnold Jazz Band, relayed from the Holly wood Restaurant.

KALUNDBORG.—See Copenhagen.

### KATOWICE

734 kc/s, 408 metres; 16 kW.—6.50 p.m., Announcements and Gramophone Music. 7.10 to 11.0, See Warsaw. 11.0, The Letter Box, in French.

KIEL.—See Hamburg.

KLAGENFURT.—See Vienna.

KOSICE.—See Prague.

### LANGENBERG

635 kc/s, 473 metres; 60 kW.—12 Noon, Concert by the Münster Municipal Orchestra. 1.15 p.m., News. 1.30, Concert by the Station Chamber Music Orchestra, conducted by Breuer. In the interval at 2.0, News. 3.0, Handwork for Children. 3.30, Economic Notes and Time. 3.50, Programme for Young People. 4.30, Talk: The Peasant and his Small-Holding. 4.55, Political Talk. 5.0, Operetta Potpourri on Gramophone Records. Songs from The Gipsy Baron (Strauss). Der Vögelhauder (Zeller). The Count of Luxembourg (Lehar), Der Obersteiger (Zeller). 5.30, Concert by Maritta Gründgens, Willi Schneider (Bass-Baritone), Hans Porthun (Flute), and Hans Jaass (Pianoforte). Songs: (a) Zusehauen' (Bohm), (b) Mutter (Warren), (c) Es lag wie eine Frau' (Kümmeke), (d) Liebe muss verstanden sein (Kollo), (e) Schau' mir ins Auge (von Wechmar). Flute Solo: Carnival in Venice (Biaccaidi). Bass Songs: (a) Die Drei Weinkenner (Tenschel), (b) Der Schliesische Zecher und der Teufel (Reissiger), (c) Täuschung (Schulz-Weida). 6.15, Programme for Women. 6.35, Once upon a Time—An Old Rhenish Tale. 6.45, News. 7.0, Transmission for all German Stations, relayed from Hamburg. 8.0, News. 8.5, Operetta Every Time—Variety Programme by the Station Orchestra, Small Choir, and Soloists. 10.0, News. 10.30, Serenade by the Fröhliche Fünf. 12 Midnight, Close Down.

LAUSANNE.—See Radio-Suisse Romande.

### LEIPZIG

769.9 kc/s, 389.6 metres; 120 kW. Relayed by Dresden, 941 kc/s, 319 metres.—12 Noon, Weather and Time. 12.5 p.m., Concert by the Leipzig Symphony Orchestra, conducted by Weber. In the interval at 1.15, News and Programme Announcements. 2.0, News. 2.10, Talk for Country Women. 2.30, Dialogue on Motoring. 3.0, Talk: Hermann von Wissmann. 3.35, Market Prices. 4.0, Pianoforte Recital with Commentary. 4.40, Literary and Musical Programme. 5.10, Fairy Play for Children. 5.50, Market Prices, Weather and Time. 6.0, Book Review. 6.20, Talk: The Class Question in the New Germany. 6.50, To-day's News. 7.0, Transmission for all German Stations, relayed from Hamburg. 8.0, Concert by the Leipzig Accordion and Bandonion Orchestra, the Emde Orchestra, conducted by Heinrich Werlé, and Walter Götze (Guitar). 9.0, Reading: Jeremias Gotthelf. 9.30, Der Schauspielerdirektor—Opera in One Act (Mozart). 10.15, News. 10.45, Gramophone Music. 11.0 (approx.), See Munich. 12 Midnight, Close Down.

LINZ.—See Vienna.

### LJUBLJANA

522 kc/s, 574.7 metres; 7 kW.—8.0 p.m., Literary Programme. 8.30, Vocal Octet (Concert. 9.15, Time and Press Review. 9.30, Concert by the Station Quartet. 10.30 to 11.0, Programme in English by the I.B.C.: Dance Music, In Santa Lucia; Rosa Mia; Why waste your tears; Night shall be filled with Music; The Windmill; The Village Band; How are you?; When they're on the Love Parade. 11.0 (approx.), Close Down.

### LUXEMBOURG

252 kc/s, 1,191 metres; 200 kW.—Luxembourg Programme. 7.30 p.m., The Pastoral Symphony (Beethoven), on Gramophone Records. 8.20, Recital of Luxembourg Songs. 8.50, News in French. 9.0, Concert by the Station Orchestra, conducted by Henri Pénis. Overture, Sakuntala (Goldmark); The Rosary (Nevin); Roses of Picardy (Haydn-Wood); Suite, Der Mimesänger (Amadei); Potpourri of Old and New Waltzes (Robrecht). 9.45, News in German. 9.55, Gramophone Concert. 10.25, Dance Music by the Station Jazz Band.

### LWOW

788 kc/s, 381 metres; 16 kW.—6.50 p.m., Announcements and Gramophone Music. 7.5, Programme Announcements. 7.10, See Warsaw. 7.30, See Vienna. 9.0, See Warsaw. 10.40, Gramophone Music.

### LYONS

LA DOUA, 544 kc/s, 465.8 metres; 1.5 kW.—6.30 p.m., Radio Journal. 7.30, Radio Gazette for Lyons and the South-East. 8.30, Vocal and Instrumental Concert. After the Concert, News.

### MADRID

EAJ7, 707 kc/s, 424.3 metres; 2 kW.—8.0 p.m., Chimes, Exchange, Announcements, Fashion Talk for Women, Poetry Reading, Request Gramophone Records, and Dance Music. 9.15, News. 9.30, Interval. 11.0, Chimes, Time, News and Dramatic Programme. 1.15 a.m. (Thursday), News. 1.30, Chimes and Close Down.

MALMO.—See Stockholm.

### MILAN

VIGENTINO, 662 kc/s, 453.2 metres; 4 kW.—8.45 p.m. till Close Down, See Rome.

### MORAVSKA-OSTRAVA

1,137 kc/s, 263.8 metres; 11 kW.—6.25 p.m., Concert of Popular Music by a Country Band. 7.0, See Prague. 7.35, Dance Music by the Station Orchestra. 8.15, See Prague. 8.30, See Brno. 10.0, See Prague. 10.15 (approx.), Close Down.

MOTALA.—See Stockholm.

MUHLACKER.—See Stuttgart.

### MUNICH

563 kc/s, 533 metres; 60 kW.—Relayed by Augsburg and Künreislautern, 536 kc/s, 560 metres; and Nürnsberg, 1,256 kc/s, 239 metres.—4.30 p.m., Orchestral Concert, conducted by Erich Kloss. Overture, The Black Domino (Auber); Melody and Gavotte-Musette (Gluck); Little Suite (Coates); Selection from Li-Tai-Pe (Frankenstein); Waltz, Paysage d'automne (Waldteufel); Hindu Song and Flight of the Bumble Bee (Rimsky-Korsakov); Selection from Der Obersteiger (Zeller); Gallop (Langey). 5.45, On Board the Endon—Reminiscences by Hans Lindner, late of the Emden. 6.5, Pianoforte Recital by Mary Muehl. Sarabande with Variations (Hahn); Nocturne (Respighi); Humoresque (Lyon). 6.26, Talk: The New Worker. 6.45, Time, Weather and Agricultural Notes. 7.0, Transmission for all German Stations, relayed from Hamburg. 8.0, The Czarewitch—Operetta in Three Acts (Lehar). 9.30, Talk: Austria or Germany? 10.30, Time, Weather and News. 11.0, Serenade, conducted by Erich Kloss. 12 Midnight, Close Down.

NAPLES.—See Rome.

NOTODDEN.—See Oslo.

### OSLO

277 kc/s, 1,083 metres; 60 kW. Relayed by Fredriksstad, 815 kc/s, 368.1 metres; Hamar, 522 kc/s, 574.7 metres; Notodden, 671 kc/s, 447.1 metres; Porsgrund, 662 kc/s, 453.2 metres; and Rjukan, 671 kc/s, 447.1 metres.—5.30 p.m., Gramophone Concert. 6.30, Programme for Boys. 7.0, Advertising Notes, Weather and News. 7.30, Talk arranged by Oslo University. 8.0, Time Signal. 8.1, Concert for the Seventy-fifth Anniversary of Catharinus Elling. 9.10, Talk in English: The Radio City, New York. 9.30, Agricultural Notes, Weather and News. 10.0, Topical Talk. 10.15, Concert by the Station

SEPT. 13th

WEDNESDAY

continued

Orchestra, conducted by Hugo Kraum: Four Pieces (Eiling); Holberg Suite for String Orchestra (Grieg); Norwegian Rhapsody No. 2 (Svendsen). 11.15, Dance Music on Gramophone Records. 12 Midnight (approx.), Close Down.

OSTERSUND.—See Stockholm.

PALERMO

558 kc/s, 537.6 metres; 3 kW. 8.0 p.m., Dopplavoro Notes, Tourist Talk, Agricultural Notes and Giornale Radio. 8.20, Gramophone Music. In an interval at 8.30, Time and Announcements. 8.45, L'Amico Fritz—Opera in Three Acts (Mascagni). In the intervals, Talk and Announcements. After the Opera, News.

PARIS

EIFFEL TOWER. Call FLE, 207.5 kc/s, 1,445.7 metres. 13 kW. Time Signals (on 2,650 metres) at 10.26 a.m. and 11.26 p.m. (Preliminary and 6-dot Signals).—6.45 p.m., Theatre Notes. 7.0, Le Journal Parle. 8.30, See Strasbourg. 10.0, Close Down.

PARIS

POSTE PARISIEN, 914 kc/s, 328.2 metres; 60 kW. 7.0 p.m., Gramophone Music. 7.30, Recital of Lyrics set to Music: Adieu au bois (André Theuriot-Thomé); Mini Pinson (Alfred de Musset); Printemps (Louis Bonihet-Thomé). 8.0, Talk on Economics. 8.5, Assurance Societies' Report. 8.30, Concert by the Station Orchestra: Soloist: Resnik (Songs); Overture, Benvenuto Cellini (Berlioz); Selection from The Damnation of Faust (Berlioz); Petite suite (Bouudini). Part I: Overture, Coriolanus (Beethoven); Extracts from The Mastersingers (Wagner); Rhapsody (Brahms). Part II: Kálmán Music. 9.0 (from Lausanne), Introductory Talk to the following Transmission. 9.10 (from Lausanne), Organ Recital by Charles-Faller, relayed from the Cathedral. 9.50, News and Weather. 10.0 (from Lausanne), Dance Music, relayed from the Bel-Air Metropole. 11.0 (approx.), Close Down.

PARIS

RADIO PARIS, Call CFR, 174 kc/s, 1,725 metres; 75 kW.—7.30 a.m., Weather and Physical Culture. 7.45, Gramophone Music. 8.0, News. 12 Noon, Educational Talk. 12.15 p.m., Gramophone Music. 12.30, Organ Recital by Desserie from the Gaumont Palace: Melody (Kahn); Waltz (Chopin); Selection from Show Boat (Kern); A Boy and a Girl were dancing (Revel); Stormy Weather (Kochler). 1.0, Exchange and News. 1.5, Gramophone Concert: Le binion (Durand); Marche lorraine (Ganne); Chansons ardenaises (Jaquemain); La Chiserie and Pandanguillo from Ramuntcho (Piercé); Granada (Albéniz); The Fair at Sorotselinsk (Musorgsky); Prelude on a Popular Chinese Theme (Porter); Norwegian Dance (Grieg); Melody (Monti); Bolero (Ravel). In the interval at 1.30, Exchange. 2.0, Exchange. 3.45, Financial Notes and News. 7.0, Agricultural Report. 7.10, Gramophone Dance Music: Coquin d'amour and Totot (as tort from Embrassez-moi (Mercier); Anque quiera olvidarme (Matamoros); Lullaby of the Leaves (Young); Justamento (Matamoros); Tell me tonight (Spogliandi); Two Melodies (Heymann); You (Moufired); Personne (Moretti); Gitana and La Feria from Les Violettes impériales (Romero). 7.50, Commercial Prices and News. 8.0, Symphony Concert on Gramophone Records: Symphony No. 6—the Pastoral (Beethoven); Réverie—Passion from the Fantastic Symphony (Berlioz); Songs by Marcelle Harel: (a) La cloche (Saint-Saëns); (b) Berceuse (Rhené-Baton); (c) Sonnez les matines (Hiné); (d) Le rossignol s'est tu (Sokolov). In the interval at 8.30, The Radio Paris Competition and Fashion Review. 9.15, News. 9.30, Modern French Music on Gramophone Records: Overture, Patrie (Bizet); Bourrée fantasque (Chabrier); Le cygne (Saint-Saëns); Chanson du Printemps (Gomoud); Ballet Music from Coppélia (Delibes); Bonnton d'or (Piercé); Introduction to Fervaal (d'Indy); Mazurka from Isoline (Messager); Sarabande (Ducasse); Piece (Chaprentier); La ronde des saisons (Bussert); Paysage (Hahn).

PITTSBURGH

KDKA, 980 kc/s, 306 metres; 50 kW. Relayd by WSKK on 48.86 metres and 25.27 metres.—7.30 p.m., Pontiac, Home Forum. 8.0-9.30, New York Relay. 8.0, Betty and Bob. 8.15, Words and Music. 8.30, Happy Days in Dixie. 9.0, Southern Symphonies. 9.30, Frances Ingram. 9.45, News and Markets. 10.0, Uncle Tom and Betty. 10.15, Tarzan of the Apes. 10.30, Singing Lady, from New York. 10.45, Orphan Annie, from New York. 11.0, News, Piano Classic. 11.15, Sports. A Song. 11.30, Pittsburgh Spotlights. 11.45-3.30 a.m. (Thursday), New York Relay. 11.45, Lowell Thomas. 12 Midnight, Amos 'n' Andy. 12.15, Eva LeGallienne. 12.30, Variety Programme. 1.0, Popular Programme. 1.30, Potash and Perimeter. 1.45, Phil Cook. 2.0, History American Legion. 3.0, Quest of Perfect Woman.

PORSGRUND.—See Oslo.

PRAGUE

614 kc/s, 488.6 metres; 120 kW.—2.50 p.m., Concert by the Station Orchestra, conducted by Parik. Introduction to a Ballet (Sehor);

Selection from Two Widows (Smetana); Symphonic Suite (Vojaček); March (Kubini). 3.50, Aviation Weather Report. 3.55 to 4.0, Exchange. 5.45, Gramophone Music. 5.55, Talk: A Motor Tour of the Alps. 6.5, Agricultural Talk. 6.15, Gramophone Music. 6.25, German Transmission: News, Readings for Children, and Programme for Workers. 7.0, Chimes. 7.1, News. 7.10, A Play (Gremila). 7.35, See Moravská-Ostrava. 8.15, Talk: School Reforms. 8.30, See Brno. 10.0, Time and News. 10.15, News in French. 10.30 (approx.), Close Down.

RADIO-SUISSE ROMANDE

SOTTENS, 745 kc/s, 403 metres; 25 kW.; and Geneva, 293 kc/s, 760 metres.—6.15 to 6.30 a.m. (from Lausanne), Gymnastics Lesson. 12.28 p.m., Time Signal from Neuchâtel Observatory. 12.30, News and Weather. 12.40 (from Lausanne), Gramophone Concert. 1.0 (from Lausanne), Financial News. 1.10 (from Lausanne), Gramophone Concert. 2.0 to 3.28, Interval. 3.28, Time Signal from Neuchâtel Observatory. 3.30 (from Geneva), Gramophone Concert. 5.0 to 6.0, Interval. 6.0 (from Geneva), Programme for Children. 7.0 (from Lausanne), Talk: The Prevention of Cruelty to Animals. 7.25 (from Lausanne), Agricultural Report, News and Weather. 7.30 (from Lausanne), Book Review. 8.0, Concert by the Radio Suisse Romande Orchestra, conducted by Robert Echehard. Part I: Overture, Coriolanus (Beethoven); Extracts from The Mastersingers (Wagner); Rhapsody (Brahms). Part II: Kálmán Music. 9.0 (from Lausanne), Introductory Talk to the following Transmission. 9.10 (from Lausanne), Organ Recital by Charles-Faller, relayed from the Cathedral. 9.50, News and Weather. 10.0 (from Lausanne), Dance Music, relayed from the Bel-Air Metropole. 11.0 (approx.), Close Down.

RJUKAN.—See Oslo.

ROME

Call IRO, 680 kc/s, 441 metres; 50 kW. Relayd by Naples, 591 kc/s, 319 metres; and 2RO, 11,810 kc/s, 25.4 metres, from 5.15 p.m.—12.30 p.m., Gramophone Music. 1.0, Orchestral Concert. In the interval from 1.30 to 1.45, Giornale Radio and Exchange. 2.0, Time and Announcements. 4.30, Children's Radio Review. 4.50, Giornale Radio, Exchange, and Report of the Royal Geographical Society. 5.10, Weather. 5.15 to 6.0, Orchestral Concert: Bucharest (Virgili); Piovra d'argento (Costegano); Innamorati (Grimaldi); Barcarolle, Canto d'Imera (Mullé); L'ultima illusione (Visintini-Chiappo); Selection from La Bohème (Puccini); Souvenir de Valse (Frossard); Selection from White Horse Inn (Stolz-Benatzky). 6.40 (Naples), Shipping and Sports Notes. 6.45, Dopplavoro Notes and Tourist Report. 6.57, Report of the International Institute of Agriculture (in Italian and English). 7.10, Agricultural Report. 7.20, News in Foreign Languages. 7.40, Giornale Radio. 8.0, Time, Announcements and Gramophone Music. 8.30, Giornale Radio and Sports Notes. 8.45, Concert of Light Music. Reading in the interval. 11.0, Giornale Radio.

SALZBURG.—See Vienna.

SCHENECTADY

WGY, 790 kc/s, 379.5 metres; 50 kW. Relayd at intervals by W2XAF on 31.48 metres and by W2XAD on 19.56 metres.—9.30 p.m., Pop Concert, from New York. 9.30, Texas Cowgirl, from New York. 9.40, Talk: The Mind Age. 9.45 to 10.0 (approx.), Lady Next Door, from New York. 12.45 a.m. (Thursday), Stock Reports and Baseball Scores. 1.0, Variety Programme. 1.30, Popular Programme. 1.45, Musical Programme from New York. 2.0, Ferdé Grofé's Orchestra, from New York. 2.15, Popular Programme. 2.30, Variety Programme. 3.0, Popular Programme, from New York. 3.30, Ship of Joy, from New York, followed by Programme Résumé.

SCHWEIZERISCHER

LANDESENDER

BEROMUNSTER, 653 kc/s, 459 metres; 60 kW: Basle, 1,229 kc/s, 244.1 metres; and Berne, 1,220 kc/s, 245.9 metres.—5.0 p.m. (from Berne), Programme for Children. 5.30 (from Berne), Gramophone Concert. 6.30 (from Zürich), Talk: Office Work, Now and in the Past. 7.0 (from Zürich), Time, Weather and Market Prices. 7.10 (from Zürich), Gramophone Concert. 7.30 (from Zürich), English Lesson. 8.0 (from Zürich), Gustav Gampfer Programme. 9.0, Weather and News. 9.10 (from Zürich), Lecture Recital: A Survey of the Bach Family's Organ Music. 10.15 (approx.), Close Down.

SOTTENS.—See Radio-Suisse Romande.

STOCKHOLM

669 kc/s, 436 metres; 55kW. Relayd by Boden, 244 kc/s, 1,229.5 metres; Göteborg,

932 kc/s, 322 metres; Hörby, 1,166 kc/s, 257 metres; Motala, 221.5 kc/s, 1,354.4 metres; Östersund, 389 kc/s, 770 metres; and Sundsvall, 554 kc/s, 542 metres.—5.5 p.m. (from Sundsvall), Musical Programme. 5.30, Reading. 6.0, Gramophone Concert. 7.0, The Practical Corner. 7.30, Talk. 8.0, Pianoforte Sonata in F Minor, Op. 57 (Beethoven), by Luisa Gmeiner. 8.30, Talk. 9.0, Popular Programme. 10.0, Dance Music. 11.0 (approx.), Close Down.

STRASBOURG

869 kc/s, 345 metres; 11.5 kW.—11.30 a.m., Gramophone Concert. 12.45 p.m., News. 1.0, Time and Exchange. 1.5, Light Music on Gramophone Records. 2.0, Interval. 3.30, Orchestral Concert, conducted by Broilliard, relayed from the Casino, Vichy: Overture, Le roi Fa dit (Delibes); Symphonic Poem, La halte divine (Trémisot); Suite, Roma (Bizet); Melody, Prelude to Pénélope (Faure); Selection from L'Africain (Meyerbeer); Theresen Walzer (Faust). 5.0, Talk on Electricity. 5.15, Orchestral Concert, conducted by Roskam: Two Step, Wien bleibt Wien; Waltz, Grossmütterchen; Foxtrot, Hiawatha's Lullaby; Tango, Aubade printanière; Foxtrot, Dream Sweetheart; Everything must have an Ending; Mazurka for Violin; Waltz Potpourri No. 2 (Rohrrecht); Tango, Cikanka; Spanish March, The Star of Valencia. 6.0, Trio Concert, relayed from Lille, 1,130 kc/s, 265.4 metres. 7.0, Talk: The After Care of Tuberculous Patients. 7.15, Talk in German: Vocational Instruction in France. 7.30, Time and News. 7.45, Gramophone Music. 8.0, Press Review in German, Lottery Results and Announcements. 8.30, Symphony Concert, conducted by Paul Paray, relayed from the Casino Vichy. Soloist, Denyse Bertrand (Violin): The Unfinished Symphony (Schubert); Violin Concerto in D (Mozart); Selection from Pelléas et Mélisande (Faure); Petite suite (Debussy). 10.0 (approx.), Press Review. 10.15, Orchestral Concert, conducted by Jemine, relayed from the Grand Kléber Tavern: March, Novelty (Pelloni); Waltz, Les sirènes (Waldteufel); Overture, Zampa (Hérold); Lehar Potpourri (Hrubý); Selection from La fille de Madame Angot (Lecocq); Potpourri of Popular Times of 1920 and 1930 (arr. Dostal). 11.15 (approx.), Close Down.

STUTTGART

MUHLACKER, 832 kc/s, 360.5 metres; 60 kW. Relayd by Freiburg, 527 kc/s, 570 metres.—12 Noon, Orchestral Concert, conducted by Karl Assmus, relayed from Baden-Baden. 1.15 p.m., Time and News. 1.30, Quartet in F Minor, Op. 95, No. 11 (Beethoven), on Gramophone Records. 2.0, See Frankfurt. 2.10, Programme arranged by the Post Office, with Gramophone Records. 2.45, Educational Talk: The History of the Races. 3.30, Programme for Children. 4.30, Concert Relay. 5.45, Talk: Flags and the Great War. 6.20 (from Freiburg), Talk: More Optimism. 6.40, Time and News. 7.0, Transmission for all German Stations, relayed from Hamburg. 8.0, Five Minutes for the Young People. 8.5, Concert, conducted by Otto Seyfert, relayed from Bad Cannstatt. March, Prinz Eugen (Strauss); Overture, Banditenstreiche (Suppé); Traumwälder (Müllacker); Selection from Der Betelstudent (Müllacker); O schöner Mai (John Strauss); Selection from The Cousin from Nowhere (Künneke); Waltz, Wiener Frauen (Lehar). 9.30, See Munich. 10.20, Time and News. 11.0, See Munich. 12 Midnight, Close Down.

SUNDSVALL.—See Stockholm.

TOULOUSE

RADIOPHONIE DU MIDI, 779 kc/s, 385 metres; 8 kW.—6.0 p.m., News. 6.15, Dance Music. 6.30, Arias from Opera. 6.50, Talk. 7.15, News. 7.30, Extracts from The Three Cornered Hat (Fallá), by the Symphony Orchestra. 7.45, Light Music. 8.0, Orchestral Music. 8.30, Arias from Opera. 8.45, Accordion Music. 9.0, Lehar Concert: Selection from (a) The Merry Widow, (b) Paganini, (c) The Land of Smiles, (d) Frederica, (e) Frasquita, (f) The Count of Luxembourg; Lehar Potpourri. 9.30, Music from Sound Films. 9.45, Music by a Viennese Orchestra. 10.15, News. 10.30, Concert for Listeners in Morocco. 11.0, Opera Music: Arias from (a) Carmen (Bizet), (b) Rigoleto (Verdi), (c) Roméo and Juliet (Gounod). 11.15, Dance Music. 12 Midnight, News. 12.5 a.m. (Thursday), Tangos. 12.15, Orchestral Music. 12.30, Close Down.

TRIESTE

1,211 kc/s, 247.7 metres; 10 kW.—5.10 p.m., Soprano and Pianoforte Recital by Elettra Canuzzi and Tina Barzal: Tocata and Fugue in D minor for Pianoforte (Bach); Songs (Brahms): (a) Liebeslied, (b) Vergebliches Ständchen; Pianoforte Solos: (a) Romance, Op. 42, No. 1 (Günfeld), (b) Filigrana (Pich-Mangiagalli); Songs: (a) Nel

ridestarni (Cilea), (b) Antica primavera (Santoliquido), (c) Il pescatore canta (Tosti); Pianoforte Solos: (a) Capriccio, Op. 78, No. 3 (Martucci), (b) Prelude No. 2 (Respighi). 6.0 till Close Down, See Turin.

TRONDHEIM.—See Oslo.

TURIN

1,096 kc/s, 273.7 metres; 7 kW. Relayd by Milan, 905 kc/s, 331.5 metres; Genoa, 959 kc/s, 312.8 metres; and Florence, 599 kc/s, 500.8 metres.—5.10 p.m., Concert. 6.0 to 6.5, Weather Forecast. 6.40, Giornale Radio, Announcements and Gramophone Music. 7.0, Time, Tourist Report and Gramophone Music. 7.10, Agricultural Notes and Market Prices. 7.20, News in Foreign Languages. 7.40, Gramophone Music. 8.0, Announcements, Giornale Radio, Sports Notes and Weather. 8.20, Talk on the following Transmission. 8.30, La leggenda di Sakuntala—Opera in Three Acts (Alfano).

VATICAN CITY

15,120 kc/s, 19.84 metres (Morning), and 5,969 kc/s, 50.26 metres (Evening); 10 kW.—11.0 to 11.15 a.m., Religious Information in Spanish. 8.0 to 8.15 p.m., Religious Information in Italian.

VIENNA

581 kc/s, 517 metres; 100 kW. Relayd by Graz, 852 kc/s, 352.1 metres; Innsbruck, 1,048 kc/s, 283 metres; Klagenfurt, 662 kc/s, 423.2 metres; Linz, 1,220 kc/s, 245.9 metres; and Salzburg, 1,373 kc/s, 218.5 metres.—12 Noon, Concert by the Wiener Symphoniker, conducted by Holzer: March, Tiroler Adler (Aehleitner); Overture, Der Court Fool (Müller); Horn Solo: Alte Liesl, gold'n Liesl (Leicht); Spanish Waltz (Mascheroni); Suite, Fairy Land (Tapp); Waltz, Auge d'amour (Waldteufel); Viennese Song (Fall); Schlager Potpourri (Borehart); Entry March of the Gladiators (Fuecik); Descriptive Piece (Barrow); Love Song (Drda); Waltz on an Original Theme (Ziehrer); Two Pieces (Grasser): (a) Heimatgedanken, (b) Styrian Dances; Hungarian Dance (Körke); Viennese Song (Römisich); Selection from Lilac Time (Schubert-Berté). In the interval at 1.0 p.m., Time and Announcements. 3.0, Time and Announcements. 3.20, Talk: Industrial Diseases and Employers' Insurance. 3.35, Talk: Ten Houses for the Small Holder. 3.45, Educational Talk. 4.0, Sound Film Music on Gramophone Records. 5.0, Talk: Flowers for Invalids. 5.15, Theodor Streicher Concert by the Vienna Boys' Choir, Rosette Andray (Contralto), and Herman Zechner (Pianoforte): Songs to Poems by Richard Schenkell; Sonnet (Words by Wildgans); Die Glockenbuben—Symbolic Poem for Boys' Choir and Pianoforte. 5.55, Talk: Technology in Antiquity. 6.20, Reading. 6.45, Talk: The New Vienna War Memorial. 7.5, Topical Talk. 7.20, Time and Announcements. 7.30, Part Relay of the Polish Festival, from the Musikvereinssaal: Address of Welcome by the Polish Government Delegate and Cardinal Hlond of Poland. 8.0, Mass in E minor (Bruckner), by the Hofburg Choir and Orchestra, conducted by Carl Luza. 9.0, Reading. 9.30, News, Weather and Exchange. 9.45, Concert of Waltzes and Ballet Music by the Wiener Symphoniker, conducted by Martin Spörr: Ballet Music from Les petits riens (Mozart); Waltz, Die Schönbrunner (Lanner); Suite from the Ballet Coppelia (Delibes); Emperor Waltz (Strauss); Selection from the Ballet Lazy John (Nedbal). 10.30, Dance Music on Gramophone Records.

WARSAW

212.5 kc/s, 1,411 metres; 120 kW.—11.57 a.m., Time Signal and Fanfare from the Torun Cathedral. 12.5 p.m., Gramophone Music. 12.25, Polish Press Review. 12.33, Weather. 12.35, Gramophone Music. 1.0, Interval. 2.55, Gramophone Music. 3.5, News. 3.10, Announcements. 3.15, Gramophone Music. 3.25, Economic Notes. 3.35, Gramophone Music. 3.45, Announcements. 4.0, Concert by the Poznan Opera House Orchestra, conducted by Tyllia, relayed from Cichocinek: Overture, Banditenstreiche (Suppé); Waltz, The Skaters (Waldteufel); Selection from La Bohème (Puccini); Selection from Samson and Delilah (Saint-Saëns); Song from The Land of Smiles (Lehar). 5.0, Topical Talk. 5.15, Gramophone Music. 5.45, Talk: The Mountains of Silesia, relayed from Katowice, 734 kc/s, 408 metres. 6.5, Violin and Pianoforte Recital by Kaminski and Borunski: Sonata in B flat (Mozart); Sonata in A minor, Op. 105 (Schumann); Sonata in G minor (Debussy). 6.50, Miscellaneous Items. 7.5, Programme Announcements. 7.10, Literary Programme. 7.30, See Vienna. 8.50, Radio Journal. 9.0, Concert of Polish Music by the Station Symphony Orchestra, conducted by Oziminski. Soloist, Dobosz (Tenor): Polonaise in A (Chopin); Entr'acte from Wit Stwos (Zelenki); Overture, Polish Wedding (Nowowiejski); Five Songs, Melody (Noskowski); Gipsy Dance (Noskowski); Dance Suite (Rapakki); Fantasia on Soldiers' Songs (Rybiński); Mazurka from Halka (Moniuszko). 10.25, Sports Notes. 10.35, Aviation Weather Report and Police Notes. 10.40, Dance Music.

ZURICH.—See Schweizerischer Landessender.

## ALGIERS

824 kc/s (364 metres); 18 kW.—8.10 p.m., Shipping Notes. 8.15, Agricultural Report and Weather Forecast. 8.20, Opera Music. Arias from Prince Igor (Borodin), Le Roi d'Ys (Lalo), and The Mastersingers (Wagner). 8.40, Lottery Results. 8.55, News. 9.0, Time. 9.2, Concert of Instrumental Music. 9.45, News. 9.50, Talk. 10.5 Sketches. 10.30, News. 10.35, Dance Music. 10.55, News. 11.0, Oriental Music.

## ATHLONE

725 kc/s, 413 metres; 60 kW. Relayed by Cork, 1,337 kc/s, 224.4 metres.—1.30 to 2.30 p.m., Time Signal, Weather Report, Stock Exchange Quotations and Gramophone Music. 6.0, Programme for Children. 6.40, News. 7.0, French Lesson. 7.15, Talk: Are you a Philosopher? 7.30, Time Signal. 7.31, The Station Orchestra. 7.50, Soprano Solos by Mabel Thrift. 8.5, Piano Solo by Rhona Clarke. 8.25, Lecture Recital: Ballads. 8.55, The Station Orchestra. 9.20, Baritone Solos by Arthur MacNeer. 9.30 to 10.30, Programme by the I.B.C. (Ireland). Ltd. 9.30, Dance Music: Peter, Peter; There's a Light in your Window; What have you got to lose?; Have you ever been lonely?; Farewell to Arms; Stormy Weather; When the Wild, Wild Roses bloom; Put a Little Springtime; Love me to-night; Let's all be happy together. 10.0, Military Band Concert arranged by the International Broadcasting Company (Ireland), Ltd., on Behalf of Hospitals' Trust, Ltd.: Signature Tune; Come back to Erin; Light of Foot (Latham); The Sanctuary of the Heart (Kettelby); Wedded Whimsies (Alford); Overture, Raymond (Thomas); El Abanico; In a Chinese Temple Garden (Kettelby); A Life on the Ocean (Binding); Signature Tune. 10.29, I.B.C. Good-night Melody. 10.45, News and Weather.

## BARCELONA

EAJ1, 860 kc/s, 346.8 metres; 8 kW.—7.0 p.m., Trio Concert. 8.0, Request Gramophone Records. 8.30, Exchange. 9.0, Gramophone Music and News. 10.0, Chimes, Weather, Exchange and Market Prices. 10.5, Concert by the Station Orchestra: Pasadoble, Mi copla (Cepeda and Herranz); Habanera, La ultima lagrima (Cotó); Schatzwalzer (Joh. Strauss); En badiant (d'Ambrosio). 10.30, La Alegria de la Huerta, Musical play in one act (Chueca), followed by Lysistrata—Operetta (Lincke). In the interval at 12 Midnight, News. 1.0 a.m. (Friday), Close Down.

## BARI

1,112 kc/s, 269.8 metres; 20 kW.—8.0 p.m., Agricultural Notes, Tourist Report and Dopolavoro Notes. 8.20, Giornale Radio and News in Albanian. 8.30, Time and Announcements. 8.35, Weather. 8.45, Military Band Concert, conducted by Salvatore Rubino: March, Bianca brigata Regina (Rubino); Intermezzo from Agamemnon (Pizzetti); Selection from Rigoletto (Verdi); Pastorale from the Quintet, Op. 37, No. 2 (Boccherini); Minuet from the Quintet in E (Boccherini); Allegro from Moto perpetuo (Paganini); Prelude, Dance and Finale from Act III of La Gioconda (Ponchielli). In the interval, Talk. 10.30, Gramophone Music. 11.0, Giornale Radio.

BASLE.—See Schweizerischer Landessender.

## BELGRADE

697 kc/s, 430.4 metres; 2.8 kW.—6.55 p.m., Time and Announcements. 7.0, Talk. 7.30, Gramophone Music. 7.45, Cello Recital. 8.30, Programme from Warsaw. 9.10, Song Recital. 9.40, Concert by the Station Orchestra. 10.30, Time and News. 10.45 (approx.), Dance Music on Gramophone Records.

## BERLIN

DEUTSCHLANDSENDER (Reichssender), 183.5 kc/s, 1,635 metres; 60 kW.—1.45 p.m., News. 2.0, Gramophone Concert: The Nutcracker Suite (Tchaikovsky); Second Polonaise (Liszt); Fantasy on Themes from the Old and New World (Dvorák); Valse triste (Sibelius) Slav Dance No. 16 (Dvorák); Russian Folk Song, Black Eyes; Intermezzo, Narcissus (Nevin); Zigeunerin tanze! (Vaek). 2.55, Topical Talk. 3.10, Programme for Young People. 3.30, Weather and Exchange. 3.45, The German Landscape—Reading Krenzach (Müller). 4.0, See Heilsberg. 5.0, Programme for Women. 5.20, Concert of Contemporary Music by Henry Wolf (Songs), and Paul Eggert (Piano-forte). Lieder (Strausser): (a) Ruhelos, (b) Wenn ich wüsste, dass du warten würdest, (c) Worte am Abend; Lieder (Menzen): (a) Marienbild, (b) Gebet; Lieder (Amrath): (a) Das Unterpfand, (b) Tanzlied, Piano-forte Solos: Three Frescoes (Anton). 6.0, Poems: 6.5, An Interview with the Sculptor Eberhard Encke. 6.30, Reading: The Death of Albert Schlagacker. 6.50, Weather and News. 7.0, Transmission for all German Stations, relayed from Munich. 8.0, See Munich. 8.30, Concert of Italian Music by the Station Orchestra, conducted by Hagel. Soloists: Meta Hagedorn-Chevalley (Piano-forte), Vittorio Brero (Violin), and Hans Georg Görner (Organ). Four Old Lute Pieces (Respighi); Piece for String Orchestra and Organ, Ciacona di Tomaso Vitali (Respighi); Two Orchestral Pieces (Bossi):

THURSDAY  
SEPTEMBER THE FOURTEENTH

## PRINCIPAL EVENTS OF THE DAY:

## AT HOME

**NATIONAL** Promenade concert from Queen's Hall.  
**LONDON REGIONAL** Viennese programme.  
**MIDLAND REGIONAL** Choral programme.  
**NORTH REGIONAL** The Bouquets Concert Party from the Spa Theatre, Scarborough.  
**WEST REGIONAL** "Send Her Victorious." A farcical comedy by P. Johnson.  
**SCOTTISH REGIONAL** Harry Gordon and his Company, relayed from Aberdeen.  
**BELFAST** Organ recital.

## ABROAD

**BRUSSELS (No. 2)** 8.0 p.m. The Station Symphony Orchestra.  
**HUIZEN** 7.45 p.m. The Concertgebouw Orchestra, conducted by Van Raalte.  
**LANGENBERG** 5.30 p.m. Concert of 16th and 17th Century Choral Music by the Kantorei of the Leipzig Conservatoire.  
**MUNICH** 7.0 p.m. Orchestral concert, conducted by Theodor Kramm and Ivor Johnson.  
**OSLO** 8.30 p.m. Viola and piano-forte recital by Hugo Johnson.  
**PRAGUE** 7.30 p.m. Opera: "The Secret," by Smetana.  
**ROME** 8.30 p.m. Opera: "Le Jongleur de Notre Dame," by Massenet.  
**STOCKHOLM** 7.50 p.m. Opera-Comique: "Djamileh," by Bizet.  
**WARSAW** 8.0 p.m. The Station Orchestra, conducted by Nawrot.

(a) Siciliana, (b) Gigue; Suite Scarlattiana for Piano-forte and Orchestra (Casella); First Movement from the Concerto romantico (Zaudonai); Three Pieces for Small Orchestra (Martucci): (a) Nocturne, (b) Canzonetta, (c) Gavotte. 10.0, Weather and News. 10.30, Talk: School Children at the International Tennis Championship. 10.45, Weather for Shipping. 11.0, Concert by a Nazi Band, relayed from the Nationale Gaststätte.

## BERLIN

FUNKSTUNDE, 715 kc/s, 419.5 metres; 1.5 kW.—4.30 p.m., Chamber Music: Kurt Schlegler (Flute), Käthe Granit (Violin), Walter Müller (Viola) and Kurt Rasch (Harpichord); Adagio and Allegro from the Sonata in G Minor for Flute and Harpichord (Bach); Extracts from the Sonata in D, Op. 137, for Violin and Piano-forte (Schubert); Extracts from the Serenade in G, Op. 144, for Flute, Violin and Viola (Reger). 5.20, Reading of Contemporary Lyrics (Hanns Johst, Hans Reberg, and Max Barthel). 5.40, Concert by the Charlottenburg Teachers' Choir, relayed from the Trinity Church: Soloist: Ferdinand Bilch (Organ); Benedictus (Snee); Gnädig und barmherzig (Grell); Psalm 23 (Schubert); Abend wird es wieder (Adam). 6.10, Educational Talk. 6.30, Programme from Magdeburg. 6.40, The Funkstunde informs its Listeners. 6.45, Topical Talk. 7.0, Transmission for all German Stations, relayed from Munich. 8.0, See Munich. 8.30, Radio Report on Gramophone Records: The City of Budapest viewed from the Donankorso. 8.40, A Discussion by Two Delegates of the International Students' Congress. 9.0, Dance Music by the Otto Kernbach Band and the Station Choir. In an interval at 10.0 (approx.), Weather and News. 1.0 a.m. (Friday), Close Down.

BERNE.—See Schweizerischer Landessender.

BEROMUNSTER.—See Schweizerischer Landessender.

BODEN.—See Stockholm.

BODO.—See Oslo.

## BORDEAUX-LAFAYETTE

986 kc/s, 304 metres; 13 kW.—6.15 p.m., Radio Journal. 7.40, Talk arranged by the International Labour Bureau. 7.55, Lottery Results and News. 8.5, Concert of Gramophone Music. 8.30, Jalouse—Comedy in Three Acts (A. Bisson and A. Leclercq).

## BRATISLAVA

1,076 kc/s, 279 metres; 14 kW.—2.50 p.m., Concert by the Station Orchestra, conducted by Dyk. 3.50 to 4.0, See Prague. 5.25, See Prague. 6.5, Gramophone Music. 6.10, Talk on Science. 6.25, Violin Recital. 6.55, Talk for Housewives. 7.0, See Prague. 7.10, Programme to be announced, relayed from

Kosice, 1,022 kc/s, 293 metres. 7.25, See Prague. 11.0 (approx.), Close Down.

BREMEN.—See Hamburg.

## BRESLAU

923 kc/s, 325 metres; 60 kW. Relayed by Gliwicz, 1,164 kc/s, 253 metres.—12 Noon, Concert by the Small Silesian Philharmonic Orchestra, conducted by Hermann Behr: Overture, The Thieving Magpie (Rossini); Ballet Music from Don Juan (Glück); Waltz, Op. 39 (Brahms); March from Bocaccio (Suppé); Waltz, Hoffmanns-trahlen (Lanner); Overture, Le lac des fées (Auber); Serenade (Haydn); Minuet (Beethoven); Waltz from The Arabian Nights (Joh. Strauss); Banditen-Galopp (Joh. Strauss). 1.45, Time and News. 2.5, Light Music on Gramophone Records. 3.0, Agricultural Prices. 3.15, Talk: Excursions in Silesia. 3.30, Programme for Children. 4.0, Orchestral Concert, relayed from Bad Salzbrunn, conducted by Max Kaden: Stadium March (Leopold); Overture, Alessandro Stradella (Fiotow); German Waltz (Joh. Strauss); Serenade for Violin and Cello (Stein); Rhapsody No. 1 in B Minor, Op. 79 No. 1 (Brahms-Ralf); March, Fürs liebe Vaterland (Blaukurg); Overture, The Land of Smiles (Lehár); Selection from Der Tenor Herzogin (Künneke). 5.15, Agricultural Prices and Book Review. 5.35, Programme to be announced. 5.55, Talk: Industrial Resources. 6.20, Talk by Workers and their Leaders. 6.50, Weather and News. 7.0, Transmission for all German Stations, relayed from Munich. 8.0, See Munich. 8.25, Request Concert by the Station Orchestra, conducted by Ernst Topitz; Soloist: Hellmut Hallendorf (Tenor). 10.0, Austria. 10.20, Time and News. 10.40, Reading (Heinz Bierkowski). 11.0, Dance Music from Berlin (Funkstunde). 12 Midnight (approx.), Close Down.

## BRNO

878 kc/s, 342 metres; 35 kW.—6.25 p.m., German Transmission: News and a Radio Sketch. 7.0, See Prague. 7.10, Programme to be announced. 7.25 till Close Down, See Prague. 11.0 (approx.), Close Down.

## BRUSSELS (No. 1)

I.N.R., 590 kc/s, 509 metres; 15 kW.—12 Noon, Gramophone Music. In the interval at 1.0 p.m., Le Journal Parlé. 5.0, Concert by the Station Symphony Orchestra, conducted by Knips: Marche lorraine (Ganne); Minuet (Boccherini); Spanish Caprice, La Morena (Chaminade); Waltz, Loin du bal (Berger); Ballet Music from William Tell (Rossini). 5.50, Programme for Young People. 6.0, Talk: The First Results of Socialist Effort in Preventive Medicine. 6.15, Gramophone Music: Mother Goose (Ravel); Selection from The Three Musketeers (Friml); Extracts from Brummel (Hahn); Overture and

Ballet Music from Les Aventures du Roi Pausole (Honegger); Dance Music. 7.15, News for Workers. 7.30, Sports Notes. 8.0, Concert by the Station Orchestra: Burlesque Overture (Méhul); Padilla Potpourri; Fox-Trot (Harrington); Viennese Waltz (de Buxeuil-Closet); Tango (Markush); Selection from New Moon (Romberg); Suite for Orchestra (Chaminade). 8.45, Talk: Young Socialists. 9.0, Concert by the Station Symphony Orchestra: Ballet Music from (a) Faust (Gounod), (b) Sylvia (Delibes), (c) Milenka (Blockx). 10.0, Le Journal Parlé. 10.10, Gramophone Records of Music for Xylophone and Accordion.

## BRUSSELS (No. 2)

N.I.R., 887 kc/s, 338.2 metres; 15 kW. Programme in Flemish.—12 Noon, Gramophone Concert. 1.0 p.m., Le Journal Parlé. 1.10, Schubert concert on Gramophone Records: Military March; The Unfinished Symphony; Ave Maria; Ständchen; Three Songs; German Dances. 5.0, Concert by the Radio Orchestra, conducted by André Slav March (Tchaikovsky); English Scenes (Bantock); Three Dances (Albeniz): (a) España, (b) Granados, (c) Cadiz; Ballet Music from Sylvia (Delibes). 5.45, Programme for Children. 6.25, Gramophone Music: Entry March of the Gladiators (Blankenburg); King Cotton (Souza). 6.30, Programme by the V.J.V.K.A. 7.12, News by the K.V.R.O. 7.15, Talk: Julian Vandeputte. 7.30, Programme for Women. 8.0, Concert by the Station Symphony Orchestra, conducted by Knips: Overture, Finlandia (Sibelius); Valse triste (Sibelius); Eine kleine Nachtmusik (Mozart); Symphonic Poem, The Moldau (Smetana). 8.45, Talk. 9.0, Concert by the Radio Orchestra, conducted by Franz Adria: Rapsodie d'automne (de Bock); Second Rhapsody (Liszt); Norwegian Rhapsody (Svendsen); Fourteenth Rhapsody (Liszt). 9.55, Evening Prayer. 10.0, Le Journal Parlé. 10.10, Extract from Cavalleria rusticana (Mascagni) on Gramophone Records.

## BUCHAREST

761 kc/s, 394 metres; 12 kW.—5.0 p.m., Military Band Concert. In the interval at 6.0, Radio Journal. 7.0, Reading. 7.20, Light Music on Gramophone Records. 7.40, Educational Talk. 8.0, Song Recital by Mlle. Humphreys: Recitative and Aria from Figaro (Mozart); Der Wegweiser (Schubert); Wohin (Schubert); Dein blaues Augen (Brahms); Ständchen (Brahms); Song (Arne). 8.20, Concert by the Station Orchestra, conducted by Rogalsky: Spanish Caprice (Rimsky-Korsakov); Piano-forte Concerto in A (Liszt); Symphonic Dances (Grieg). In the interval at 9.0, Talk. 9.45, Radio Journal.

## BUDAPEST

545 kc/s, 550.5 metres; 18.5 kW.—Also relayed on 840 metres from 8.0 p.m. till Close Down. 5.30 p.m., Gramophone Music. 5.55, Radio Report from the Province of Varadia. 7.5, Military Band Concert, conducted by Richard Friesay. 8.0, Review of Foreign Politics. 8.15, Concert. 8.45, Concert of Gypsy Music relayed from the Café Bodo. 9.45, News. 10.0, Concert by the Melles String Quartet. 11.0, Dance Music on Gramophone Records.

CASSEL.—See Frankfurt.

## COPENHAGEN

1,067 kc/s, 281 metres; 0.75 kW. Relayed by Kalundborg, 260 kc/s, 1,153.8 metres.—12 Noon, Time Signal and Chimes from the Town Hall. 12.2 p.m., Concert by the Max Skalka String Ensemble, relayed from the Hotel d'Angleterre. 2.0, Interval. 2.40, Piano-forte Recital by Lillian Nielsen-Jensen. Impromptu, Op. 142, No. 3 (Schubert); Etudes, Op. 65, No. 6 and Op. 63, No. 10 (Friedman); Etude in E Flat (Liszt-Paganini). 3.0, Opening of Denmark's Garden Cities' Societies' Jubilee Exhibition. 3.30, Concert, conducted by Teddy Petersen, relayed from the Wivex Restaurant. 4.45, Programme for Boys. 5.30, Exchange and Fish Market Prices. 5.45, Reading of Lyrics (Christian Wintners). 6.15, Elementary English Lesson. 6.45, Weather. 7.0, News. 7.15, Time Signal. 7.16, Religious Address. 7.45, Danish Lesson. 8.10, Concert by the Station Symphony Orchestra, conducted by Nicolai Malko, relayed from the State Broadcasting Building. Soloists: Ole Frøsig (Clarinet) and Einar Nørby (Songs); Serenade in C, Op. 48, for Strings (Tchaikovsky); Andante and Finale from the Clarinet Concerto in F Minor (Weber); Overture, Prince Igor (Borodin); Two Arias from Il Seraglio (Mozart); Poème d'extase (Scriabin). 10.15, News. 10.30, Reading (Jacobsen). 10.55, Dance Music, relayed from the National Scala. In the interval at 12 Midnight, Time Signal and Chimes from the Town Hall. 12.30 a.m. (Friday), Close Down.

CORK.—See Athlone.

DANZIG.—See Heilsberg.

DRESDEN.—See Leipzig.

## FECAMP

1,328 kc/s, 225.9 metres; 10 kW.—11.0 a.m. to 12 Noon, Programme in English by the I.B.C. 11.0, Happy Hour; Part I: Orchestral Concert: Signature Tune; Egyptian Serenade, Amna (Lincke); Rose mouse (Bosc); Idylle Bretonne (Gennin); Blumen-



SEPT. 14th THURSDAY continued

gefllster (von Blon); Song The Blackbird in the Apple-Tree (Lubbock); The Song of the Rose (McCullough); Song, Fairy Tales of Ireland (Coates); A Birthday Serenade (Lincke). 11.30, Happy Hour; Part II: Dance Music: Twenty Million People; Rosa Mia; Moon Song; Let me explain; If I ever get a job again; Sweetheart; What did I get in return; Can't we meet again; Signature Tune. 12 Noon, Programme in French. 4.30 to 6.0, Programme in English by the I.B.C. 4.30, The Nursery Corner; Music, Story and Birthday Greetings. 5.0, Concert for Worthing and Littlehampton Listeners: Orchestral Concert; Signature Tune, Night by the Sea; Hungarian Dance No. 1 (Brahms); Invitation to the Waltz (Weber); Ich liebe dich (Grieg); Violin Solo, Spanish Dance (Fallá); Humoresque (Dvorak); Polonaise in A (Chopin); Scarf Dance (Chaminade); The Blue Danube (Joh. Strauss). 5.30, Concert for Brighton and Hove Listeners: Light Music; Coal Black Mammy (Cliff); Song, I shall remember you; Xylophone Solo, Hornpipe (Rosse); Oh could I but express in Song; Selection from He wanted Adventure (Waller); Sweetheart, I'm dreaming of you; Song, Love is King to-day; The Valley of the Poppies (Ancliffe). 6.0, Programme in French. 10.0 till Close Down, Programme in English by the I.B.C.: Signature Tune, Bells of Normandy; The Lady I love; The King's Navee; My Heart's to let; Well, Well, Well!; Seven Years with the wrong Woman; Lover; I cover the Waterfront; Rosa Mia; Jack-in-the-Box; Castles in the Sand; In the Valley of the Moon; Chewing Gum; Maybe I love you too much; The Shadow Waltz; I'm getting sentimental over you; Let's all be happy together; Signature Tune. 11.0, Talkie Time; Signature Tune, Sittin' in the Dark; Monte Carlo Medley; To-day I feel so happy; The Good Companions; Sons les toits de Paris; Just because I lost my heart; Falling in Love again; Just once for all Time; The Flies crawled on the Window; Signature Tune. 11.30, Concert given by the I.B.C. (Ireland). Limited; Signature Tune, Come back to Erin; Selection from Princess Pat (Herbert); Glockenspiel Solo, The Black Forest Clinging Clock (Doppler); Go Home and tell your Mother; The Doll's Song (Offenbach); Fairy Tales of Ireland (Coates); My Hero from The Chocolate Soldier (O. Strauss); Piccolo Solo, Sylvia (La Thuere); Selection from No No Nanette (Youmans); Signature Tune. 12.5 a.m. (Friday), News Bulletin in English. 12.10, Concert for Bishop's Stortford Listeners; Part 1: Tango Band; Signature Tune, The Chum Song; Will you dance through life with me? I kiss your hand Madame; There was a poor Musician; Marion; Farewell. 12.30, Club Concert; Dance Music; Part II: Stay out of my Dreams; Adorable; Sweetheart Darling; Wear a great big Smile; We belong together; Fit as a Fiddle; Taboo, Taboo; Farewell to Arms; Let Bygones be Bygones; Signature Tune. 1.0, Dance Music; Signature Tune, Bells of Normandy; What a Lady Josephine must have been; Letting in the Sunshine; Drifting down the Shamilar; You are too beautiful; I'm getting sentimental over you; I gotta right to sing the Blues; When my little Pomeranian; Hiawatha's Lullaby; There's a Cabin in the Pines; Jog along; Dancing Butterfly; I wanna cook Sheep; I can't remember; Talking to you about me; Peter, Peter; There's a Light in your Window; The Old Spinning Wheel; Castles in the Sand; Signature Tune. 2.0, I.B.C. Goodnight Melody.

FLENSBURG.—See Hamburg.

FLORENCE.—See Turin.

FRANKFURT

1,157 kc/s, 259.3 metres; 17 kW. Relayed by Cassel, 1,220 kc/s, 245.9 metres; and Trier, 1,157 kc/s, 259.3 metres.—4.30 p.m., Concert. 5.45, Economic Notes. 6.0, Talk: The Economic Crisis in Australia. 6.25, Herybert Menzel reads from his own works. 6.45, To-day's News. 6.50, Time and Announcements. 7.0, Transmission for all German Stations, relayed from Munich. 8.0, See Munich. 8.25, Orchestral Concert; Soloist: Robert von Scheldt (Baritone); Carnival Overture (Noetzel); Extracts from the Drei Bäcklin Fantasias, Op. 53 (Woyrsch); (a) Die Tuteninsel, (b) Der Eremit; Selection from The Cycle Songs eines fahrenden Spielmanns (Fronmel); Words by Stefan George; Selection (Pfitzner); (a) Scherzo, Op. 1, (b) Aria from Palestina, (c) Prelude to the First Act of Das Fest auf Solhaug, (d) Die Heinkelmannchen. 10.0, Topical Talk. 10.15, Time and News.

FREDRIKSSTAD.—See Oslo.

FREIBURG.—See Stuttgart.

GENEVA.—See Radio-Suisse Romande.

GENOA.—See Turin.

GLEIWITZ.—See Breslau.

GOTEBORG.—See Stockholm.

GRAZ.—See Vienna.

HAMAR.—See Oslo.

HAMBURG

806 kc/s, 372 metres; 1.5 kW. Relayed by Bremen, 1,112 kc/s, 269.8 metres; Flensburg,

1,319 kc/s, 227.4 metres; Hanover, 530 kc/s, 566 metres; and Kiel, 1,292 kc/s, 232.2 metres.—5.55 p.m., Variety Programme. 6.45, Frankfurt Exchange. 6.50, Weather. 7.0, Transmission for all German Stations, relayed from Munich. 8.0, See Munich. 8.25, The Heroic Flight—Radio Play (Robert Walter). 10.0, Time and News. 10.20, Topical Talk. 10.30, Dance Music by the Small Station Orchestra, conducted by Gerhard Maasz; Soloists: Gerhard Gregor and Gerhard Maasz (Pianoforte).

HANOVER.—See Hamburg.

HEILSBURG

1,085 kc/s, 276.5 metres; 60 kW. Relayed by Danzig, 662 kc/s, 453.2 metres.—1.5 p.m., Concert by the Königsberg Opera House Orchestra, conducted by Brückner; Overture, Fingal's Cave (Mendelssohn); Peer Gynt Suite, No. 2 (Grieg); Rhapsody in B Minor (Hartung); Three Dances (Gretry-MottU); Potpourri, So schön wie's einmal war (Danber); Waltz, Die Abenteuer (Lammer); March (Rotand). In the intervals at 1.20 and at 2.0, News, 3.0, Market Prices. 3.30, Programme for Young People. 4.0, Concert by the Small Station Orchestra, conducted by Wilekon; Overture, Le maschere (Mascagni); Two Old Russian Dances (Clemus); Selection from Ariadne auf Naxos (R. Strauss); Ballet Music from Macbeth (Verdi); Berceuse (Bizet); Overture, Yelva (Reissiger); Suite, Ein Fest im Gnomeneich (Witteborn); Suite, Memories of Cairo (Armandola); March, Mit vereinten Kräften (Strauss). In the interval: Talk: General von Grolmann. 5.40, Book Review. 5.50, Lieder Recital by Honka von Ferenczy; Three Songs (Franz); (a) Wohin, Vöglein so schnell, (b) Für Musik, (c) Stille Sicherheit; Three Songs (Liszt); (a) O komm in Traum, (b) Es muss ein Wunderbares sein, (c) Du bist wie eine Blume; Three Songs (Brahms); (a) Der Tod das ist die kühle Nacht, (b) Schön war, dass ich die weichte, (c) Der Gang zum Lieben. 6.15, Agricultural Prices. 6.25, Agricultural Talk. 6.50, Weather. 7.0, Transmission for all German Stations, relayed from Munich. 8.0, See Munich. 8.25, Weather and News. 8.30, Submarine II—Play (Lerbs). 9.30, News. 9.40, Chamber Music by the Bruiner Quartet, with Margerete Schumacher (Pianoforte); Pianoforte Quintet in E Sharp, Op. 44 (Schumann); Pianoforte Quintet in F Minor, Op. 34 (Brahms). 10.50, Weather and News.

HILVERSUM

Announced HUIZEN, 296.1 metres; 20 kW. (7 kW. up to 5.40 p.m.).—11.40 a.m. to 1.40 p.m., Programme of the Catholic Radio Society (K.R.O.). 11.40, Police Announcements. 11.55, Orchestral Concert. 1.40 p.m. till Close Down, Programme of the Christian Radio Society (N.C.R.V.). 1.40, Book-keeping Lesson. 2.40, Talk for Women. 3.10, Interval. 3.40, Bible Reading, Songs and Organ Solos. 4.40, Programme for Young People. 5.10, Contralto Song Recital by Mme. H.v.d. Kamp. 6.25, Dressmaking Lesson. 6.40, Police Notes. 6.55, Gramophone Music. 7.10, Press Review. 7.40, Orchestral Concert. Soloist: Blaauw (Organ). 8.40, Talk. 9.10, Concert. Selection from Aida (Verdi); Minnet (Bolzoni); Romance (Thomas); Berceuse (Godard); Selection from Samson and Delilah (Saint-Saëns); Overture, The Crown Diamonds (Auber). In the interval at 9.40, News. 10.10, Gramophone Music. 11.10 (approx), Close Down.

HORBY.—See Stockholm.

HUIZEN

Announced HILVERSUM, 160 kc/s, 1,875 metres; 7 kW. (up to 3.40 p.m.). Transmitted from Kootwijk on 50 kW. from 3.40 p.m.—Programme of the Algemeene Vereeniging Radio Omroep (A.V.R.O.). 11.40 a.m., Concert by the Wireless Orchestra, conducted by Nico Gerharz. Soloist: Marie Riener (Soprano). Retraite montmartoise (Bose); Waltz, Dolores (Waldteuffel); Overture, Rund um die Liebe (O. Strauss); Two Songs from Rund um die Liebe (O. Strauss); Selection from A Waltz Dream (O. Strauss); Overture, Indigo and die vierzig Räuber (Joh. Strauss); Songs: (a) Aria from Frederica (Lehár), (b) Aria from Madame Pompadour (Fall), (c) Aria from The Count of Luxembourg (Lehár); Waltz, Wo die Citronen blühen (Joh. Strauss); Selection from The Grand Duchess of Gérolstein (Offenbach); Tango-Serenade, Bolivia (Castalido); Tango (Albéniz); March (Mezzacapo). In the intervals, Gramophone Music. 1.55, Quartet in A minor Op. 29 (Schubert) by the Haydn Quartet. 2.25, Gramophone Music. 2.55, Quartet in E minor (Suetana), by the Haydn Quartet. 3.25 to 3.40, Interval. 3.40, Programme for Hospitals. 4.10, Gramophone Music. 4.40, Just William—Play for Children (Crompton). 5.20, Concert by the Wireless Orchestra, conducted by Nico Treep. Overture, Pique Dame (Suppé); Selection from André Chenier (Giordano); Waltz, Nacht-

schwärmer (Ziehrer); Pumpernickel (Siede); Offenbachiana (Conradi); March (Rossey); Waltz, Roses from the South (Joh. Strauss); Humorous Variations on Was kommt dort von der Höh' (Suppé); Aufzug der Stadtwahe (Jesse); Clair de Lune (Ketelbey); Hollywood March (Leopold). In the interval at 6.10, Sports Talk. 7.10, Talk. 7.40, Time, Weather and News. 7.45, Concert by the Concertgebouw Orchestra, conducted by Albert van Raalte, Soloist: Wim Noske (Violin). Suite, Water Music (Händel); Violin Concerto No. 4 in D (Mozart); The Unfinished Symphony in B minor (Schubert); Symphony No. 6 in B minor—the Pathetic (Tchaikovsky). In an interval, a Play. 9.55, Gramophone Music. 10.10, Concert by Kovacs Lajos and his Orchestra. In an interval at 10.40, News. 11.40 (approx), Close Down.

INNSBRUCK.—See Vienna.

JUAN LES PINS

1,205 kc/s, 249 metres; 8 kW.—12.30 p.m., Amusement Guide and Variety Items. 1.0, News. 1.15, Variety Programme. 8.0, Amusement Guide, Exchange and News. 8.10, Science Review. 8.20, Radio Concert. 8.50, News and Weather. 9.0 Radio Concert.

KALUNOBORG.—See Copenhagen.

KATOWICE

734 kc/s, 408 metres; 16 kW.—7.10 p.m., Sports Report. 7.25, Announcements and Gramophone Music. 7.40 (approx.) till Close Down. See Warsaw.

KIEL.—See Hamburg.

KLAGENFURT.—See Vienna.

KOSICE.—See Prague.

LANGENBERG

635 kc/s, 473 metres; 60 kW.—12 Noon, Concert by the Münster Municipal Orchestra, conducted by Jochem; Overture, The Thieving Magpie (Rossini); Second Suite from L'Arlesienne (Bizet); Kaiser-Walzer (Strauss); Selection from Czar and Carpenter (Lortzing); Little Comedy Overture (Leuschner); Cardas No. 8 (Michiels); March Potpourri, Die Wache zieht auf (Kochmann). 1.15 p.m., News. 1.30, Orchestral Concert, conducted by Eysoldt; March, Hand in Hand (Blum); Overture, Jessonda (Spohr); Tone Pictures from Scandinavia (Frederiksen); Morgens auf dem Erde (Pesse); Children's Dance (Micheli); Waltz, Frühlingszauber (Translatenr); March, Alle mit uns (Robrecht). 2.0 (approx.), News. 3.0, Programme for Children. 3.30, Economic Notes and Time. 3.50, Political Talk. 4.0, German History in Folk Song—Radio Sequence (Lilienfein). 5.0, Recital on Two Pianofortes by Delselt and Haass; Duetto Concertante (Mozart-Busoni); Gavotte and Gigue from the Suite in Old Style (Kann); Canzonetta and Irish Folk Dance from the Concertino (Haass). 5.30, Concert of 16th and 17th Century Choral Music by the Kantorei of the Leipzig Conservatoire, conducted by Kurt Thomas. 6.15, Talk: The Origin of Health Insurance. 6.30, German for Germans. 6.45, News. 7.0, Transmission for all German Stations, relayed from Munich. 8.0, News. 8.5, See Munich. 8.25, Der Trommler (Gottes—Radio Play (Schiferdick). 10.0, News. 10.20, Famous Singers on Gramophone Records. 11.0, Light Music and Dance Music, conducted by Eysoldt. 12.30 a.m. (Friday), Close Down.

LAUSANNE.—See Radio-Suisse Romande.

LEIPZIG

769.9 kc/s, 389.6 metres; 120 kW. Relayed by Dresden, 941 kc/s, 319 metres.—12 Noon, Military Band Concert, conducted by Max Keyn; March, Märkische Kolonnen (Knoch); Overture, Was ist des Deutschen Vaterland (Wilke); Frühlingsgedicht (Richter); Two Alsatian Peasant Dances (Merkling); Waltz, Moonlight on the Alster (Fetras); Die Wache zieht auf (Kochmann); Gardesjäger zu Pferde (Lincke); Prussian March (Golde-Grawert); March, Zum Städtel hinaus (Meissner); Two Marches. 1.15 p.m., News. 1.30, Classic Dances on Gramophone Records. 2.15, Second News. 2.30, Pianoforte and Soprano Recital by Anita Wendt and Elizabeth Christ. 3.0, In the Flying School (A Discussion with Some Boys. 3.20, —A Discussion with Some Boys. 3.20, Film Review. 3.35, Market Prices. 4.30, Concert by the Dresden Philharmonic Orchestra, conducted by Mrazek; Extracts from the Symphony in D, No. 1 (Haydn); Selection from Oberon (Weber); Ballet Music (V. from Oberon (Weber); Ballet Music (V. Dittersdorf); Waltz from The Arabian Nights (Joh. Strauss); Selection from the Suite in A Minor (Sinding); Polonaise in A Minor (Dvorak); Prelude, Air and Gavotte from the Suite for Strings (Wickenshaw). 5.50, Market Prices, Weather and Time. 6.0, Talk: The Menace of Race Suicide. 6.20, Talk on Taxation. 6.50, To-day's News. 7.0, Transmission for all German Stations, relayed from Munich. 8.0, See Munich. 8.25, Orchestral Concert, conducted by Theodor Blumer; Overture, Des Tuffels Lustschloss (Blumer); Suite from Così fan tutte (Mozart-

Stüber); German Folk Song Fantasia, Op. 72 (Blumer); Perpetuum mobile from the Third Suite (Ries); Waltz, Frauenwürde (Jos. Strauss). 9.25, Variety Programme. 10.25, News.

LINZ.—See Vienna.

LUXEMBOURG

252 kc/s, 1,191 metres; 200 kW.—German Programme. 7.30, Gramophone Concert. 7.50, Readings. 8.0, (Concerto in D for Violin and Orchestra (Beethoven). 8.50, News in French. 9.0, Concert by the Station Orchestra, conducted by Henri Pensis. Lyric Suite (Grieg); Hexentanz (MacDowell); Kiss mich (Eysoldt); Melody (Caludi); Selection from Les millions d'Arlequin (Drigo); Selection from White Horse Inn (Stolz-Benatzky); Capricieuse (Kalkmann); Chinese Street Serenade (Siede); Suite from Nell Gwynn (German). 10.20, Dance Music on Gramophone Records.

LOW

788 kc/s, 381 metres; 16 kW.—7.20 p.m., Announcements and Gramophone Music. 7.35, Programme Announcements. 7.40, Programme, relayed from Poznan, 896 kc/s, 335 metres. 8.0 to 10.0, See Warsaw. 10.0, Tenor Song Recital by Hermann Horowitz. 10.15, Programme from Warsaw. 10.40, Gramophone Music.

LYONS

LA DOUA, 644 kc/s, 465.8 metres; 1.5 kW.—6.20 p.m., Radio Journal. 7.30, Radio Gazette for Lyons and the South-East. 8.30, See Strasbourg. 9.10 to 10.15, Concert from Schweizerischer Landessender (Beromünster). 10.15 (approx.), News.

MADRID

EAJ7, 707 kc/s, 424.3 metres; 2 kW.—8.0 p.m., Chimes, Exchange, Announcements, and Programme for Children. 9.15, News. 9.30, Interval. 11.0, Chimes, Time, News and Song Recital. 11.30, Municipal Band Concert from Rosales. 1.15 a.m. (Friday), News. 1.30, Chimes and Close Down.

MALMO.—See Stockholm.

MILAN

VIGENTINO, 662 kc/s, 453.2 metres; 4 kW.—8.30 p.m. (approx.), till Close Down, See Rome.

MORAVSKA-OSTRAVA

1,137 kc/s, 263.8 metres; 11 kW.—6.30 p.m., German Transmission; Song Recital by Hans Lechowicz. Aria from Tosca (Puccini); Aria from I Pagliacci (Leoncavallo); Aria from Cavalleria rusticana (Mascagni); The Legend of the Grail from Lohengrin (Wagner); Ballad from The Tales of Hoffman (Offenbach); Aria from The Gipsy Baron (Joh. Strauss); Two Songs from The Land of Smiles (Lehár). 7.0, See Prague. 7.10, Programme to be announced, from Kosice, 1,022 kc/s, 293 metres. 7.25, See Prague. 11.0 (approx.), Close Down.

MOSCOW

TRADES UNION, 300 kc/s, 1,000 metres; 100 kW.—11.45 a.m., Weather. 2.45 p.m., Weather Report. 3.0, Concert of Music by Liszt, Popper, Doppler, and Brahms, on Gramophone Records. 3.55, Time. 4.0, Topical Talk. 4.30, Extract from Boris Godunov—Drama (Pushkin). 5.30, Choral Concert for Young People, with Introductory Talk. 6.30, Symphony Concert of Music by Balakirev, Glazunov, and Rimsky-Korsakov. Soloist: Edelmann (Pianoforte). 9.0, News. 9.30, Programme Announcements. 9.55, Chimes from the Red Square. 10.5, Press Review.

MOTALA.—See Stockholm.

MUHLACKER.—See Stuttgart.

MUNICH

563 kc/s, 533 metres; 60 kW. Relayed by Augsburg and Kaiserslautern, 536 kc/s, 560 metres; and Nürnberg, 1,256 kc/s, 239 metres.—4.30 p.m., Concert conducted by Erich Kloss; Prelude to Eva (Lehár); Three Pieces (Dvorak); (a) Gipsy Song, (b) Slav Dance, (c) Humoresque; Selection from La Traviata (Verdi); Pieces (Amadei); (a) La canzone della Sorgente, (b) Old Dance Melody; Selection from Der Bettelstudent (Müllbeker); Meditation from Thais (Massenet); Waltz (Carenno); Eine Schattee Soldaten (Siede). 5.45, Agricultural Talk. 6.5, Choral Concert. 6.25, Talk: The Primitive Indian Tribes in America. 6.45, Time and Announcements. 7.0, Transmission for all German Stations; Neue Erde—Radio Play (Andreas Weinberger). 8.0, Monthly Review of International Politics. 8.25, Concert of Light Music. 10.0, Austria. 10.20, Time and News.

NAPLES.—See Rome.

NOTODDEN.—See Oslo.

OSLO

277 kc/s, 1,083 metres; 60 kW. Relayed by Fredriksstad, 815 kc/s, 368.1 metres; Hamar, 522 kc/s, 574.7 metres; Notodden, 471 kc/s, 447.1 metres; Porsgrun, 662 kc/s, 453.2 metres; and Rjukan, 671 kc/s, 447.1



SEPT. 14th

THURSDAY

continued

metres.—5.15 p.m., Concert of Gramophone Music. 6.0, Talk. 6.30, Divine Service. 7.0, Advertising Notes, Weather and News. 7.30, Quartet Concert. 8.0, Time Signal. 8.1, Agricultural Programme. 8.30, Viola and Pianoforte Recital by Hugo Kramm and Ivar Johnsen: Four Etudes (Chopin); Legend for Viola and Pianoforte (Florent Schmitt); Sonata for Viola and Pianoforte (Paul Yvon). 9.15, Recitations in Dialect. 9.40, Weather and News. 10.0, Topical Talk. 10.15, Choral Concert. 10.45 (approx.). Close Down.

OSTERSUND.—See Stockholm.

PALERMO

558 kc/s, 537.6 metres; 3 kW.—8.0 p.m., Dopolavoro Notes, Agricultural Report and Giornale Radio. 8.20, Gramophone Music. In an interval at 8.30, Time and Announcements. 8.45, Concert of Operetta Music: Selection from Frederica (Lehar), Addio, giovinezza (Pietri), The Count of Luxembourg (Lehar), and I pizzì di Venezia (Ranzato). In an interval at 9.30, A Florentine Tragedy—Play in One Act (Oscar Wilde). 10.55, News.

PARIS

EIFFEL TOWER, Call FLE, 207.5 kc/s, 1,445.7 metres; 13 kW.—Time Signals (on 2,650 metres) at 10.26 a.m. and 11.26 p.m. (Preliminary and 6-dot Signals)—6.45 p.m., Theatre Notes. 7.0, Le Journal Parlé. 8.30, Gramophone Concert: Carnaval romain (Berlioz); Selection from Louise (Chapelier); Le Ronec d'Omphale (Saint-Saëns); Norwegian Rhapsody (Lalo); Selection from (a) The Cid (Massenet), (b) Hérodiade (Massenet), (c) Ménéphes (Bruneau), and (d) Samson and Delilah (Saint-Saëns); Les Roses d'Isphahan (Faure); Clair de lune (Faure); Selection from (a) The Queen of Sheba (Gounod), (b) Raymond (Thomas), and (c) Les Deux Pigeons (Messager); Gavotte from Mignon (Thomas); Selection from (a) Rip van Winkle (Planquette), and (b) Zampa (Hérold). 10.0 (approx.). Close Down.

PARIS

POSTE PARISIEN, 914 kc/s, 328.2 metres; 60 kW.—7.0 p.m., Gramophone Music. 7.15, Le Journal Parlé. 7.30, Concert by Ter-Abramo and his Orchestra: Selection from Tamhäuser (Wagner); Hungarian Dance (Brahms); Melody (Oeki-Albi); Foxtrot, Say it isn't so (Irving Berlin); Les étoiles au ciel (Words by Tolstoy); Moment musical (Schubert); Danse macabre (Saint-Saëns); Caucasian Suite (Ippolitov-Ivanov); Selection from A Waltz Dream (O. Strauss); Gipsy Romance. 8.0, Sponsored Talk. 8.10, Gramophone Records. 8.30, Orchestral Concert (contd.). 8.50, Sponsored Programme. 9.0, Variety Concert, relayed from the Restaurant de la Forêt, Le Touquet. 1.0, News.

PARIS

RADIO PARIS, Call CFR, 174 kc/s, 1,725 metres; 75 kW.—7.30 a.m., Weather and Physical Culture. 7.45, Gramophone Music. 8.0, News. 12 Noon, Protestant Address. 12.30 p.m., Gramophone Concert: Overture, The Flying Dutchman (Wagner); Italian Caprice (Tchaikovsky); Die Forelle (Schubert); Ständchen (Schubert); Overture, Euryanthe (Weber); La Campanella (Paganini-Liszt); La Leggerezza (Paganini-Liszt); Widuung (R. Strauss); Le chasseur maudit (Franck). In the intervals at 1.0, Exchange and News, and at 1.30, Exchange. 2.0, Exchange. 3.45, Exchange and Market Prices. 7.0, Agricultural Report. 7.10, Gramophone Concert: Clair matin (Jeanjean); Ma Normandie (Birat); Goyescas (Granados); Arioso from Bevenuto Cellini (Diaz); Cockette (Koch); Matin d'Octobre (Gautier); Serenade amoureuse (Godard); Un soir de Noël (Gavel-Rodor); Variations on a Swiss Theme (Boehm); Melody (Hartush); Indian Lament (Dvorák-Kreisl); Souvenirs-toi from Marion-nous (Borel-Clerc). 7.50, Commercial Prices and News. 8.0, Chamber Music on Gramophone Records: Scherzo (Borodin); Theme with Variations (Sor); Der Nussbaum (Schumann); Seguidilla (Albeniz); Malentendu (Lazzari); Scherzo from the First Quartet (Rimsky-Korsakov); Selection from L'ile heureuse (Chabrier); Trio for Pianoforte, Oboe, and Bassoon (Poulenc). 8.30, The Radio Paris Competition. 8.45, Pierrot qui pleure et pierrot qui rit—Play (Rosland and Hubert). 9.15, News. 9.30, Gramophone Music: Mazepa (Liszt); Symphony on a Mountain Theme (d'Indy); Invocation to Nature, from The Damnation of Faust (Berlioz); Waltz from Der Rosenkavalier (Richard Strauss).

PITTSBURGH

KDKA, 980 kc/s, 306 metres; 50 kW. Relayd by W6XK on 48.86 metres and 25.27 metres.—7.30 p.m., Pioneers. KDKA to New York. 7.45, KDKA Home Forum. 8.0, Betty and Bob, from New York. 8.15, Words and Music, from New York. 8.45, Federation Pennsylvania Women. 9.0, Thursday Special, from New York. 9.30, News and Markets. 9.45, Thursday Special, from New York. 10.0, Casino Orchestra, from New York. 10.15, Tarzan of the Apes. 10.30, Singing Lady,

from New York. 10.45, Orphan Annie, from New York. 11.0, News, Piano Classique. 11.15, Sports, A Song. 11.30, Pittsburgh Spotlights. 11.45 to 12.45 a.m. (Friday), New York Relay. 11.45, Lowell Thomas. 12 Midnight, Amos 'n' Andy. 12.15 a.m., Baby Rose Marie. 12.45, Pathé News of the Air. 1.0 to 4.0, New York Relay. 1.0, Captain Diamond. 1.30, Adventures in Health. 1.45, John Fogarty. Tenor. 2.0, Death Valley Days. 2.30, Wayne King's Orchestra. 3.0, Hands Across the Border.

PORSGRUND.—See Oslo.

PRAGUE

614 kc/s, 488.6 metres; 120 kW.—2.50 p.m., See Bratislava. 3.50, Aviation Weather Report. 3.55, Exchange. 4.0, Interval. 5.25, Programme for Children. 5.45, Gramophone Music. 5.55, Talk. 6.5, Agricultural Programme. 6.15, Talk for Workers. 6.25, News in German. 6.30, German Transmission: Agricultural Report and Talk; Fire Insurance. 7.0, Chimes and News. 7.10, Programme to be announced, relayed from Kosice, 1,022 kc/s (293 metres). 7.25, Talk on the following Transmission. 7.30, The Secret—Opera in Three Acts (Smetana). 10.0, Time and News. 10.15, Concert of Light Music. 11.0 (approx.). Close Down.

RADIO-SUISSE ROMANDE

SOTTENS, 743 kc/s, 403 metres; 25 kW.; and Geneva, 395 kc/s, 760 metres.—6.15 to 6.30 a.m. (from Lausanne), Gymnastics Lesson. 12.28 p.m., Time Signal from Neuchâtel Observatory. 12.30, News and Weather. 12.40 (from Lausanne), Gramophone Concert of Verdi Music. 1.0 (from Lausanne), Financial Notes. 1.10 (from Lausanne), Gramophone Concert. 1.30 (from Lausanne), Swiss Chamber of Commerce Programme, Addresses and Concert of Instrumental Music, relayed from Beaulieu. 4.0 (from Geneva), Gramophone Concert. 5.30 to 7.0, Interval. 7.0 (from Geneva), Talk for Mountaineering Enthusiasts. 7.30 (from Geneva), Weather News and Announcements. 7.50 (from Geneva), Esperanto Programme. 8.0 (from Geneva), Debussy Song Recital by Hugues Cuénoud (Tenor). 8.25 (from Geneva), Readings. 8.45, Concert by the Radio-Suisse Romande Orchestra. Soloist: Victor Deszarzens (Violin). Divertissement No. 7 in D (Mozart); Violin Concerto in A (Mozart); Sextet for Two Clarinets, Two Horns and Two Bassoons (Beethoven). 9.50, News and Weather. 10.0 (from Geneva), Gramophone Concert. 10.30 (approx.). Close Down.

RJUKAN.—See Oslo.

ROME

Call IRO, 680 kc/s, 441 metres; 50 kW. Relayd by Naples, 941 kc/s, 319 metres, and 2RO, 11,810 kc/s, 25.4 metres, from 5.15 p.m. (approx.).—12.30 p.m., Gramophone Music. 1.0, Humorous Programme. 1.5 to 2.0, Concert from Turin. In the interval from 1.30, Giornale Radio and Exchange. 2.0, Time and Announcements. 4.30, Children's Radio Review. 4.50, Giornale Radio and Exchange. 5.0, Reading. 5.10, Weather. 5.15 to 6.0, Song and Cello Recital; Walter Sommer (Cello). Gino Confì (Bass), and Dina Fiumana (Soprano); Cello Solos: (a) Orientale (Cui), (b) Tzigane (Gabriel-Marie); Soprano Solos: (a) Cavatina from Linda di Chamounix (Donizetti), (b) Aria from Lordey (Catalani); Bass Solos: (a) Aria from Macbeth (Verdi), (b) Arioso from Hérodiade (Massenet); Cello Solos: (a) Intermezzo from Goyescas (Granados-Casado), (b) Il flauto, Incendino e lo scabrolo (Cassado); Soprano Solo from Fra Diavolo (André). 6.40 (Naples), Shipping and Sports Notes. 6.45, Dopolavoro and Tourist Report. 7.10, Agricultural Report. 7.20, News in Foreign Languages. 7.40, Giornale Radio. 8.0, Time and Announcements. 8.15, Gramophone Music. 8.30, Le Jongleur de Notre Dame—Opera in Three Acts (Massenet). Talk and News in the intervals. Giornale Radio after the Opera.

SALZBURG.—See Vienna.

SCHENECTADY

WGY, 790 kc/s, 379.5 metres; 50 kW. Relayd at intervals by W2XAF on 31.48 metres and by W2XAD on 19.56 metres.—12.45 a.m. (Friday), Stock Reports and Baseball Scores. 1.0 to 4.0, New York Relay. 1.0, Variety Programme. 2.0, Captain Henry's Show Boat. 3.0, Paul Whiteman's Orchestra. 4.0, Programme Resumé.

SCHWEIZERISCHER LANDESENDER

BEROMÜNSTER, 653 kc/s, 459 metres; 60 kW.; Basle, 1,229 kc/s, 244.1 metres; and Berne, 1,220 kc/s, 245.9 metres.—5.0 p.m. (from Zürich), Concert by the Small Station Orchestra, conducted by Scherbaum. 6.0 (from Zürich), Gramophone Concert. 6.30 (from Berne), Talk: The Fishing Industry. 7.0 (from Basle), Time and Announcements. 7.10, Concert of Italian Music by the Station Orchestra, conducted by Neppach. 7.45 (from Basle), Elementary Italian Lesson.

8.30 (from Berne), Concert by a Tessino Mandoline Society. 8.45 (from Berne), A Visit with the Microphone. 9.0, News. 9.10 (from Berne), Concert of Pre-Classical Music. 10.15 (approx.). Close Down.

SOTTENS.—See Radio-Suisse Romande.

STOCKHOLM

689 kc/s, 436 metres; 55 kW. Relayd by Boden, 244 kc/s, 1,229.5 metres; Göteborg, 932 kc/s, 322 metres; Hörby, 1,166 kc/s, 257 metres; Motala, 221.5 kc/s, 1,354.4 metres; Östersund, 389 kc/s, 770 metres; and Sundsvall, 554 kc/s, 542 metres.—5.5 p.m., Studio Service, relayed from Norrköping, 1,292 kc/s (232.2 metres). 5.30, Concert by Jean Naumann and his Orchestra, relayed from Malmö, 1,301 kc/s (231 metres): Overture, The Merry Wives of Windsor (Nicolaï); Waltz, Wiener Bürger (Ziehrer); Suite, A Mediterranean Cruise (Jalowicz); Stephanie Gavotte (Czibulka); Polka, Tritsch-Tratsch (Joh. Strauss); Potpourri of Russian Airs and Dances, Dubnushka (Schürmann); March, Grüss Gott Wien (Komzak). 6.30, Radio Report. 7.0, Recital of Old Swedish Songs by Nil Svanfeldt. 7.15, Weather and News. 7.30, Talk. 7.50, Djamilah—Opera (Bizet), relayed from the Royal Opera House. 9.25, Reading. 9.45, Weather and News. 10.0, Gramophone Music. 11.0 (approx.). Close Down.

STRASBOURG

869 kc/s, 345 metres; 11.5 kW.—11.30 a.m., Popular Music on Gramophone Records. 12.45 p.m., News. 1.0, Time and Exchange. 1.5, Jean Cras Memorial Concert, conducted by Maurice de Villers. Quintet for Harp, Flute and Strings; Suite for Voice and Pianoforte; Fontaines; Suite for Voice and Orchestra; La flûte de Pan; Entr'acte Music from Polyphème. 2.0, Programme for Children. 3.0, Interval. 3.30, Orchestral Concert, conducted by Broullac, relayed from the Casino, Vico. Overture, Zampa (Hérold); Danse, Zino-Zino (Vidal); Suite from Le collier de saphirs (Pierné); Melody; Ballet Music from Rosamund (Schubert); Tone Picture from The Valkyrie (Wagner); Waltz, Morgenblätter (Joh. Strauss). 5.0, French Elocution Lesson. 5.15, Orchestral Concert, conducted by Roskam. Selection from Poliblat (Nedbal); Après un rêve (Faure); Piedmontese Dance (Sinigaglia); Minuet from the Pianoforte, Sonata (Strieg); Sérénade à l'amour (Fanchey); March, Guignol guoguet (Sali). 6.0, Talk in German: Romanesque Architecture in Alsace. 6.15, Talk for Women: Modern Education. 6.30, Orchestral Concert, conducted by Maurice de Villers. Festival Overture (Leitner); Orchestral Suite, Plein Air (Capri); Selection from Les barbares (Saint-Saëns); Scene and Waltz (Guiraud); Slav Dances Nos. 1 and 3 (Dvorak); Hungarian Rhapsody No. 14 (Liszt). 7.30, Time and News. 7.45, Gramophone Music. 8.0, Press Review in German, Lottery Results and Announcements. 8.30, Gramophone Music. 9.10, Concert from Schweizerischer Landessender (Beromünster). 10.15 (approx.). Press Review.

STUTTART

MUHLACKER, 832 kc/s, 360.5 metres; 60 kW. Relayd by Freiburg, 527 kc/s, 570 metres.—1.30 p.m., Concert from Langenberg. 2.0, Concert arranged by the Post Office. 2.30, Spanish Lesson. 3.0, Elementary English Lesson. 3.30, Programme for Young People. 4.30, See Leipzig. 5.45, Talk: Autumn and the garden. 6.0, Talk: A Visit to Ravensburg a Hundred Years Ago. 6.35, Time and News. 7.0, Transmission for all German Stations, relayed from Munich. 8.0, See Munich. 8.25 (from Karlsruhe), Die Hölz-Schicht—Radio Picture (Franz Moraller). 9.25, String Sextet in B flat, Op. 18 (Brahms) by the Wendling Quartet. Hans Köhler (Second Viola) and Ferdinand Merten (Second Cello). 10.0, See Munich. 10.20, Time and News. 10.40, Greek Song Recital by Anton Knoll: Waldwanderung; Mit einer Primula veris; Die Prinzessin; Mit einer Wasserlilie; Vom Monte Pincio; Jägerlied; Ein Traum; Verborgene Liebe; Im Kahn; Eros. 11.5 (approx.). Close Down.

SUNDSVALL.—See Stockholm.

TOULOUSE

RADIOPHONIE DU MIDI, 779 kc/s, 395 metres; 8 kW.—6.0 p.m., News. 6.15, Orchestral Music. 6.30, Light Music. 6.45, Accordion Music. 7.0, Les Deux Pigeons—Ballet (Messager), by the Symphony Orchestra. 7.15, News. 7.30, Chansonnettes. 7.45, Musical Items. 8.0, Comie Opera Music: Arias from Werther (Massenet); Rigoletto (Verdi); and L'attaque du moulin (Bruneau). 8.15, Orchestra Music: Selection from Light Cavalry (Suppé); Melody (Darcy); By the blue Hawaiian Water (Ketelbey); Valse lumbaine (Mozart); Adagio from Symphony No. 5 (Mahard). 8.45, Music by an Argentine Orchestra. 9.0, Concert Version of Azor—Operetta (Gatachoche). 9.30, Orchestral Music. 9.45, Music by a Viennese Or-

chestra. 10.15, News. 10.30, Concert for Listeners in Morocco. 11.0, Recitations. 11.15, Dance Music. 12 Midnight, News. 12.5 a.m. (Friday), Light Music. - 12.15, Accordion Music. 12.30, Close Down.

TRIESTE

1,211 kc/s, 247.7 metres; 10 kW.—5.10 p.m. till Close Down. See Turin.

TRONDHEIM.—See Oslo.

TURIN

1,096 kc/s, 273.7 metres; 7 kW. Relayd by Milan, 905 kc/s, 331.5 metres; Genoa, 959 kc/s, 312.8 metres; and Florence, 599 kc/s, 500.8 metres.—5.10 p.m., Concert. 6.0 to 6.5, Weather Forecast. 6.40, Giornale Radio, Dopolavoro Announcements and Gramophone Music. 7.0, Time, Tourist Report and Gramophone Music. 7.10, Agricultural Notes and Market Prices. 7.20, News in Foreign Languages. 7.40, Gramophone Music. 8.0, Announcements, Giornale Radio, Sports Notes, Weather and Gramophone Music. 8.25, Talk on the following Transmission. 8.30, A Comedy in Three Acts. After the Comedy, Dance Music. 11.0, Giornale Radio.

VATICAN CITY

15,120 kc/s, 19.84 metres (Morning); and 5,969 kc/s, 50.26 metres (Evening); 10 kW.—11.0 to 11.15 a.m., Religious Information in French. 8.0 to 8.15 p.m., Religious Information in Italian.

VIENNA

581 kc/s, 517 metres; 100 kW. Relayd by Graz, 852 kc/s, 352.1 metres; Innsbruck, 1,058 kc/s, 283 metres; Klagenfurt, 662 kc/s, 453.2 metres; Linz, 1,220 kc/s, 245.9 metres; and Salzburg, 1,373 kc/s, 218.5 metres.—12 Noon, Concert by the Wiener Symphoniker, conducted by Josef Holzer: Overture, William Tell (Rossini). Violin Solo: Rondino (Beethoven); Selection from I Pagliacci (Leoncavallo); Song, Traum durch die Dämmerung (Richard Strauss); Hindu Dance from The Pearl Fishers (Bizet); Two Songs (Schumann): (a) Widuung, (b) Du bist wie eine Blume; Thermen-Walzer (Joh. Strauss); Prelude to Eva (Lehar). 1.0 p.m., Time and News. 1.10 to 2.0, Concert (contd.): March (Eliott); Overlören-Extrakt (Englmann); Song from Der Göttergatte (Lehar); Spanish Dance, The Cachucha (Sullivan); Waltz, Brüderlein fein (Fall); Potpourri, Für meine Freunde (Komzak); March; Heil dir, mein Oesterreich (Obiransky). 3.0, Time and Announcements. 3.20, Educational Talk. 3.30, Programme for Children. 3.55, Trio in B flat, Op. 99, No. 1 (Schubert), on Gramophone Records. 4.35, Talk: The Sound Film and its Future. 4.55, Talk for Women. 5.20, Song and Pianoforte Recital by Flora de Grisogono (Soprano) and Natalie Freundlich; Feierlicher Tanz (Kantiz); Toccatina (Heller); Bagatellen in Jazz (Zador). Songs: (a) Chanson triste (Duparc), (b) Pensée d'autonne (Massenet), (c) Chants d'Orient (Davico); Jardins sous la pluie (Debussy); El vito (Infante). 5.50, Talk: Theatre Week. 6.0, Talk: The Technique of the Brain-Worker. 6.25, The Valkyrie—Opera (Wagner), relayed from the Vienna Opera House. In the intervals at 7.40, Time and Programme Announcements and at 9.40, News. 11.5, Light Music on Gramophone Records.

WARSAW

212.5 kc/s, 1,411 metres; 120 kW.—11.57 a.m., Time and Chimes from Our Lady's Church, Cracow. 12.5 p.m., Orchestral Concert from the Bagatella Garden. 12.25, Review of the Polish Press. 12.33, Weather Report. 12.35, Concert from the Bagatella (contd.). 12.55, Radio Journal. 1.0, Interval. 2.55, Announcements. 3.0, Gramophone Music. 3.5, News. 3.10, Announcements. 3.15, Gramophone Music. 3.25, Economic Notes. 3.35, Gramophone Music. 3.45, Review for Scouts. 3.50, Gramophone Music. 4.0, Programme for Children. 4.30, Song Recital. 5.0, Talk for Women. 5.15, Song and Pianoforte Recital by Mine, Lenczewska-Shawinska and Mine, Robowska. 6.15, Talk: In the Backwoods of Poland. 6.55, Light Music from the Gastro-nomia Café. 7.20, Miscellaneous Items. 7.35, Programme Announcements. 7.40, Talk: Turin's History during Seven Centuries. 8.0, Concert by the Station Orchestra, conducted by Nawrot. Soloist: Umberto Macnez (Tenor). Mazurka (Moniuszko); Suite (Mariotti). (b) Per morir (de Vecchi). (c) Mal d'amore (Buzzi-Peccia), (d) Core'n grato (Cardille); Overture, The Merry Wives of Windsor (Nicolaï); Burlesque Intermezzo (Cullotta); Waltz, Wine, Woman and Song (Strauss). 8.50, Radio Journal. 9.0, Agricultural Notes. 9.10, Concert (contd.). Ballet Suite (Gyldmark); Czardas in G Minor (Brahms); Berceuse (Järnefelt); Prelude (Järnefelt); Songs: (a) O Primavera (Tirindelli), (b) Lolita (Buzzi-Peccia), (c) La Girometta (Sibella); Slav Dances Nos. 1 and 10 (Dvorak); Romance (Rubinstein); Fantastic Oberek (Somenfeld). 10.0, Dance Music from the Gastro-nomia Café. 10.25, Sports Notes. 10.35, Aviation Weather Report and Police Notes. 10.40, Dance Music (contd.).

ZURICH.—See Schweizerischer Landessender.

**ALGIERS**

824 kc/s, 324 metres; 13 kW.—8.10 p.m., Shipping Notes. 8.15, Agricultural Report and Weather Forecast. 8.20, Operetta Music: Songs from Femmes de minuit (Moretti); Cikonlette (Italin); Coups de Roulis (Messager); La reine joyeuse (Cuvillier); and The Count of Luxembourg (Lehar). 8.55, News. 9.0, Time and Lottery Results. 9.10, Concert by the Small Station Orchestra and Soloists. 9.45, News. 9.50, Concert (contd.). 10.35, News. 10.40, Monologues. 10.55, News.

**ATHLONE**

725 kc/s, 413 metres; 60 kW. Relayed by Cork, 1,337 kc/s, 224.4 metres.—1.30 to 2.30 p.m., Time Signal, Weather Report, Stock Exchange Quotations, and Gramophone Music. 6.0, Programme for Children. 6.46, News. 7.0, Gardening Talk by G. O. Sherard. 7.15, Wireless Talk. 7.30, Time Signal. 7.31, Pianoforte Solos by Lilian Conolly. 7.50, Contralto Solos by Doris Hill. 8.0, The Station Orchestra. 8.20, Song Recital by Mr. and Mrs. P. J. Duffy. In an interval at 8.35, Violin Solos by Daphne Garratt. 9.5, The Station Orchestra. 9.30 to 10.30, Programme by the I.B.C. (Ireland). Ltd. 9.30, Sponsored Concert: Something came and got me in the Spring; Just two hearts and a Waltz Refrain; The Frog King's Parade (Marriott); Don't be late in the Morning; Glow Worm Idyll (Lincke); Vienna, City of my Dreams (Zieczynsky); Serenade (Heykens). 10.0, Concert arranged by the International Broadcasting Company (Ireland), Ltd., on behalf of Hospitals Trust, Ltd.: Dance Music: Signature Tune, Come Back to Erin; Smile and sing your cares away; Say it isn't so; In the dim, dim dawning; I'll do my best to make you happy; Sweetheart Darlin'; In the Valley of the Moon; The Lord Mayor's Show; All over Italy; When my little Pomeranian; Signature Tune. 10.29, I.B.C. Good-night Melody. 10.45, News and Weather.

**BARCELONA**

EAJ1, 860 kc/s, 348.8 metres; 8 kW.—7.0 p.m., Trio Concert. 8.0, Request Gramophone Records. 8.30, Exchange. 9.0, Gramophone Music and News. 10.0, Chimes from the Cathedral. Weather Forecast. Messages to Seaman, Exchange and Market Prices. 10.10, Concert by the Station Orchestra. 10.45, Guatemala Spanish-American Programme. 11.0, Symphony Music on Gramophone Records. 11.30, Dance Music, relayed from the Casa Libre. In the interval at 12 Midnight, News. 1.0 a.m. (Saturday), Close Down.

**BARI**

1,112 kc/s, 269.8 metres; 20 kW.—8.0 p.m., Agricultural Notes, Tourist Report and Dopolavoro Notes. 8.20, Giornale Radio and News in Albanian. 8.30, Time and Announcements. 8.35, Weather. 8.45, Songs from Opera by De Sautis Bruno (Soprano) and Signorile (Tenor). Soprano Aria from Loreley (Catalani); Tenor Aria from La Favorita (Donizetti); Soprano Aria from Rigoletto (Verdi); Federico's Lament from L'Arlesiana (Cilea); Soprano Aria from Madame Butterfly (Puccini); Tenor Aria from Werther (Massenet); Soprano Aria from I pagliacci (Leoncavallo); Tenor Solo from Cavalleria rusticana (Mascagni); Duet from L'amico Fritz (Mascagni). In the interval, Fashion Review. After the Recital, Dance Music relayed from the Gran Caffè del Levante. 11.0, Giornale Radio.

BASLE.—See Schweizerischer Landessender.

**BELGRADE**

697 kc/s, 430.4 metres; 2.8 kW.—6.55 p.m., Time and Announcements. 7.0, Concert by the Station Orchestra. 8.30, Programme relayed from Zagreb, 977 kc/s, 307 metres. 10.30, Time and News. 10.45 (approx.), Cigany Music from the Rumnski Kraji Restaurant.

**BERLIN**

**DEUTSCHLANDSENDER (Reichssender)**, 183.5 kc/s, 1,635 metres; 60 kW.—1.45 p.m., News. 2.0, Gramophone Music. 3.0, Programme for Girls. 3.30, Weather and Exchange. 3.45, Reading: The German Landscape—The Rhine (Höderlin). 4.0, See Leipzig. 5.0, Talk: The Future of Girls' Education in Germany. 5.20, Bach and his Contemporaries—Concert on Old Instruments: Eta Mariel-Schneider (Harpischord); Hans Fiegt (Flute); and Friedrich Wilksch (Viola da Gamba); Sonata for Flute and Harpischord (Bach); Sonata for Viola da Gamba and Harpischord (Händel); Harpischord Solos: Three Pieces from Biblischen Historien (Kuhnan); Sonata in E flat for Flute and Harpischord (Bach). 6.0, Poems. 6.5, Dances in Five Languages by Siegel and his Soloists. 6.50, Weather and News. 7.0, Transmission for all German Stations, relayed from Berlin (Funkstunde). 8.0, Today's Motto. 8.5 (approx.). Nazi Programme. 9.0, Programme from Langenberg. 10.0, Weather and News. 10.45, Weather for Shipping. 11.0, See Hamburg. 12 Midnight, Close Down.

**BERLIN**

**FUNKSTUNDE**, 715 kc/s, 419.5 metres; 1.5 kW.—4.35 p.m., Military Band Concert, conducted by Paul Müller, relayed from the

# FRIDAY

## SEPTEMBER THE FIFTEENTH

### PRINCIPAL EVENTS OF THE DAY:

	<b>AT HOME</b>
<b>NATIONAL LONDON</b>	B.B.C. Follies; feature programme. Promenade concert from Queen's Hall.
<b>REGIONAL NORTH</b>	Orchestral concert.
<b>REGIONAL WEST</b>	Variety, relayed from the New Theatre, Cardiff.
<b>REGIONAL SCOTTISH</b>	Orchestral concert.
<b>REGIONAL BELFAST</b>	Choral programme.
<b>BARI</b>	8.45 p.m. Songs from opera.
<b>BRUSSELS (No. 1)</b>	8.0 p.m. The Symphony Orchestra.
<b>HAMBURG</b>	10.30 p.m. Brahms' Sonata in E Minor for 'Cello and Pianoforte.
<b>HEILSBURG</b>	8.10 p.m. The Königsberg Opera House Orchestra, conducted by Brückner.
<b>HÜIZEN</b>	8.10 p.m. The Residence Orchestra, from the Kurhaus, Scheveningen.
<b>LEIPZIG</b>	8.0 p.m. Euripides' drama, "Alcesteis," from the Sylvan Theatre at Dresden-Hellerau.
<b>PALERMO</b>	8.45 p.m. Operetta: "Ideale," by Tosti.
<b>ROME</b>	5.15 p.m. Song and violin recital.
<b>STRASBOURG</b>	8.30 p.m. Gala concert from the Casino, Vichy.
<b>TOULOUSE</b>	9.0 p.m. Symphony concert from the Municipal Casino, Biarritz.

Zoo. 5.30, Humorous Items. 6.0, Anecdotes. 6.15, Programme Announcements. 6.40, The Funkstunde informs its Listeners . . . 6.45, Topical Talk. 7.0, Transmission for all German Stations: Werkmeister Ohle—Drama (Friedrich Arenhövel), arranged for Radio by Kurt Heynicke, with incidental music by Herbert Windt. 8.5, Do not forget us—An Appeal from the East Prussian Frontier (Irmitraut Huglin). 8.50, Extracts from the Pianoforte Concerto in B Minor, Op. 20 (Herman Zilcher), by the Composer and the Berlin Station Orchestra, conducted by Waldemar von Vultée. 9.25, Variations and Fugue on a Theme of Mozart, Op. 132 (Reger), by the Station Orchestra, conducted by Waldemar von Vultée. 10.0, Weather and News. 10.10 (approx.), Dance Music by the Adolbert Lutter Band, relayed from the Zoo. In an interval at 11.0, Announcements by the Chief of Police. 12 Midnight (approx.), Close Down.

**BERNE**.—See Schweizerischer Landessender.

**BEROMUNSTER**. — See Schweizerischer Landessender.

**BODEN**.—See Stockholm.

**BODO**.—See Oslo.

**BRATISLAVA**

1,076 kc/s, 279 metres; 14 kW.—7.10 p.m., See Brno. 8.15, Triangle—Play (Jan Weiss). 8.40, See Prague. 10.30 (approx.), Close Down.

**BREMEN**.—See Hamburg.

**BRESLAU**

923 kc/s, 325 metres; 60 kW. Relayed by Gleiwitz, 1,184 kc/s, 253 metres.—1.5 p.m., Gramophone Concert. Overture, Nakis Hoehzeit (Lincke); Selection from Der Rastelhänder (Lehar); Waltz Potpourri, Wir walden (Kernbach); Song, Das waren Zeiten (Steffen); Kubelik Serenade (Drda); Potpourri, Ernst und Scherz fürs Wiener Herz (Könzack); Serenade, Sicilliana (Schmalstich); Indian Temple Dance (Königsberger); Helene-marsch (Lübbert). 1.45, Time and News. 2.50, Contemporary Songs and Marches on Gramophone Records. 3.0, Agricultural Prices. 3.15, Reading (Holland). 3.35, Programme for Young People. 4.0, Concert by the Station Orchestra, conducted by Topitz. Overture, La dame blanche (Boieldieu); Selection from Tiefland (d'Albert); Der Münesänger (Amadei); Waltz, Tales from the Vienna Woods (Joh. Strauss); Selection from Die Puppenfee (Bayer); Egyptian Serenade, Amnia (Lincke); Deutsche Marscherpöten (Blankenburg). 5.30, Agricultural Prices. 5.35, Programme to be announced. 5.55, Hans Zielowsky Song Recital by Käthe Prans-Thiemann (Contralto). 6.25, Talk: Germans outside the Reich. 6.50, Weather and News. 7.0, Transmission for all German

**BRUSSELS (No. 2)**

887 kc/s, 338.2 metres; 15 kW.—Programme in Flemish. 12 Noon, Gramophone Concert of Variety Music. 1.0 p.m., Journal Parlé. 1.10, Concert by the Small Station Orchestra, conducted by P. Leemans. 5.0, Concert by the Radio Orchestra, conducted by Franz André; Old Madrid (Thotere); Goodnight, Sweetheart (Noble); Le faune et les fées (Kark); Selection from La vie parisienne (Offenbach); Potpourri (Morena); In a Persian Garden (Lehmann); Tango (Lucchesi); Petite suite de concert (Coleridge-Taylor); Berceuse (Goyens); Marche baroque (Goyens). 6.0, Partita No. 1 in B Flat (Bach), on Gramophone Records. 6.15, Readings (Van Scheltema). 6.30, Gramophone Music: Overture, Prince Igor (Borodin); Symphony No. 1, Op. 39 (Sibelius). 7.15, Talk: The Coming Football Season. 7.30, Wireless Notes. 8.0, Concert by the Radio Orchestra, conducted by André; Prelude (Granados); Spanish Dances (Granados); La Feria (Turina); Suite from The Sleeping Beauty (Tchaikovsky); Romanian Dances (Bareh); Woodland Pictures (Fletcher). 8.45, Recitations. 9.0, Concert (contd.): Fantasia on Spanish Themes (Gevaert); Ballet Suite (Popy); Romance for Violin (Marsick); Valse des brunes (Ganne); Selection from The Land of Smiles (Lehar); Cello Solo, La cinquante (Gabriel Marie); Two Hungarian Dances (Brahms); Suite (Saint-Saëns). 10.0, Le Journal Parlé. 10.10, Gramophone Concert of Variety Music.

**BUCHAREST**

761 kc/s, 394 metres; 12 kW.—5.0 p.m., Light Music and Romanian Music by the Dinico Orchestra. In the interval at 6.0, Radio Journal. 7.0, Educational Talk. 7.40, The Barber of Seville—Opera in Three Acts (Rossini), on Gramophone Records. In the intervals: Radio Journal. After the Opera: Music by the Motoi Orchestra, relayed from the Monte Carlo Restaurant.

**BUDAPEST**

545 kc/s, 550.5 metres; 18.5 kW. Also relayed on 840 metres from 7.45 p.m. till Close Down.—5.0 p.m., Orchestral Concert. 6.0, Talk. 6.30, Gramophone Music. 7.15, Short-hand Lesson. 7.45, Hubay Concert by the Budapest Concert Orchestra, conducted by Zolt: Soloists: Anna Bethy and Szentgyörgyi; Third Violin Concerto in G minor; Songs; Scenes from the Czaradas; Symphony No. 2. 9.15, Cigany Band Concert. 9.50, News. 10.25, Pianoforte Recital by Julius Karolyi; Sonata in B minor (Chopin); Legende (Liszt); Rhapsody No. 12 (Liszt). 11.5, Dance Music relayed from the Hotel Royal. In the intervals, Karl Vajda in his Repertoire.

CASSEL.—See Frankfurt.

**COPENHAGEN**

1,067 kc/s, 281 metres; 0.75 kW. Relayed by Kalundborg, 260 kc/s, 1,153.8 metres.—12 Noon, Time Signal and Chimes from the Town Hall. 12.2 p.m., Concert by the Harald Andersen String Ensemble, relayed from the Bellevue Strandhotel. 2.0, Interval. 3.0, Concert by the Odense Orchestra, relayed from Odense. 5.0, Reading (Stevens). 5.30, Exchange and Fish Market Prices. 5.45, Talk. 6.15, Elementary German Lesson. 6.45, Weather. 6.54, Announcements. 7.0, News. 7.15, Time Signal. 7.30, Talk. 8.0, Time Signal from the Town Hall. 8.1, Programme by Per Kuntzon. 8.10, Recital of Danish Songs by Einar Juhl. 8.25, Harpischord Recital of Old Italian Music: Canzona (Poglietti); Toccata (Pasquini); Sonata in C minor (Galuppi). 8.45, Paganini, the Violin King—Radio Play (Gustav Hetsch). 9.45, News. 10.0, Light Gramophone Music. 10.20, Reading from The Speckled Band (Conan Doyle), Danish Translation by Ferndorff-Fessen. 10.45, Dance Music, conducted by Teddy Petersen, relayed from the Wivex Restaurant. In an interval at 12 Midnight, Time Signal and Chimes from the Town Hall. 12.30 a.m. (Saturday), Close Down.

**CORK**.—See Athlone.

**DANZIG**.—See Heilsberg.

**DRESDEN**.—See Leipzig.

**FECAMP**

1,328 kc/s, 225.9 metres; 10 kW.—11.0 a.m. to 12 Noon, Programme in English by the I.B.C. 11.0, Concert; Part I. Light Music: Signature Tune; Evolution of Dixie (Lake); Princess Pat (Herbert); Yip-I-daddy-Lay (Cobb); Some of these Days (Brooks); War Marching Songs (arr. Somers); Selection from Sari (Kalmán); Southern Rhapsody (Hosner); Pulcinello (Aletter); Part II. Dance Music: Cheving Ginn; Smilin' thro'; All over Italy; There's a Cabin in the Pines; When Gimble hits the Cymbal; Seven Years with the Wrong Woman; Lover; Sweetheart Darlin'; Signature Tune. 12 Noon, Programme in French. 4.30 to 6.0 p.m., Programme in English by the I.B.C. 4.30, Programme for Children. 5.0, Gramophone Concert for Southampton and Winchester Listeners: Signature Tune; The Night by the Sea; Music in the Air; That's my Home (Rene); Dear Old Cronies (Lauder); In Old Vienna (Jerome); Still I love her (Gaskill); Tired Hands (Sanderson); Dance of the Nymphs (Birch); Scherzo from A Midsummer Night's Dream (Mendels-

Stations, relayed from Berlin (Funkstunde). 5.0, Concert by a String Orchestra. Soloist: Li Stadelmann (Harpischord); Harpischord Concerto in A (J. C. Bach); Concertino in F Minor (Pergolesi); Harpischord Concerto in D Minor (Bach). 9.0, News. 9.10, Nickel strip zum ersten Male—Comedy (Hans Christoph Kargerl). 10.20, Talk: The Coming Theatre Season. 10.40, Time and News. 11.0, Variety Music on Gramophone Records. 12 Midnight (approx.), Close Down.

**BRNO**

878 kc/s, 342 metres; 35 kW.—2.50 p.m., Popular Band Concert. 3.50 to 4.0, See Prague. 5.45, Gramophone Music. 5.55, Programme for Women. 6.5, Gramophone Music. 6.15, Talk for Workers. 6.25, German Transmission: News, Sports Notes, and Topical Talk. 7.0, See Prague. 7.10, Talk. 7.25, Concert by the Station Orchestra and Soloists: Schafer (Pianoforte); Zdenka Gráfová and Skrivan (Recitations). 8.15, Humorous Item. 8.40, See Prague. 10.30 (approx.), Close Down.

**BRUSSELS (No. 1)**

I.N.R.; 590 kc/s, 509 metres; 15 kW.—12 Noon, Concert by the Small Station Orchestra. 1.0 p.m., Le Journal Parlé. 1.10, Gramophone Music. A Children's Overture (Quilter); Le chat, la belle et le petit lapin (La Fontaine); Doctor Gradus ad Parnassum (Debussy); Gradus ad Humble; The History of France (Humble); La cigale et la Fourmi (La Fontaine); Extracts from Carnaval des animaux (Saint-Saëns); Extracts from Histoires naturelles (Ravel); La fable à Toto (Bach and Laverne); Les beaux jendis (Humble); Extract from L'enfant et les sortilèges (Ravel). 5.0, Concert by the Symphony Orchestra: Overture, Tamerlani (Rossini); Le cygne (Saint-Saëns); Trümmerei (Schumann); Selection from Madame Butterfly (Puccini); Petites piéces (Deleroy); Spring Song (Mendelssohn); Entr'actes from Mignon (Thomas); Ballet Music from Hérodiade (Massenet). 6.0, Talk: The Motor Car and the Amateur. 6.15, Recital of Belgian Songs by Mlle. Lucy Camula and M. Delstanches, accompanied by Fulgence Boland. 6.45, Mendelssohn Pianoforte Recital by Oscar Delvigne. 7.15, Talk: Overcoming Shyness. 7.30, Legal Review and Literary Notes. 8.0, Concert by the Symphony Orchestra: L'apprenti sorcier (Dukas); Symphony in G (Haydn); España (Chabrier); Symphonie Suite (Deleroy); Cantata for 'Cello (Ganne); Second Nocturne (Liszt); Symphony in G (Haydn); España (Chabrier); Flute and Orchestra: Pan and the Shepherds (Monquet); Fantasy on Two Old Carols (Jongen). In the interval at 8.45, Talk: The Economic and Financial Situation of Belgium. 10.0, Le Journal Parlé. 10.10, Request Gramophone Records. 10.25, Accordion Music. 10.40, Dance Music on Gramophone Records. 11.0, La Brabançonne.

SEPT. 15th

FRIDAY

continued

solu). 5.30, Quartet Concert for Bourne-mouth and Weymouth Listeners: Pan and the Wood Gobins (Rathke); Beautiful (Shay); The Blackbird in the Apple Tree (Luhbock); Dreams on the Ocean (Gungl); In Tulip Time beside the Water Mill (Alibout); Wine, Women, and Song (Joh. Strauss); Stephanie Gavotte (Czibulka); When the Convent Bell is ringing (Trevor); Signature Tune. 6.0, Programme in French. 10.0 till Close Down, Programme in English by the I.B.C. 10.0, Dance Music; Signature Tune; The Bells of Normandy; My Darling; One Little Word led to Another; Rosa Mia; Jungle Nights in Haarlem; Peter, Peter; Moon Song; Maybe I love you too much; Smilin' thro'; When Gimble hits the Cymbal; Look what you've done; Jack-in-the-Box; Stay out of my Dreams; I raised my Hat; Whispering; My Heart was made for Love; There's a Cabin in the Pines; Let's all be Happy together; Signature Tune. 11.0, Music from Sound Films: Signature Tune; Sittin' in the Dark; Selection from The Kid from Spain; The Rogue Song; Dance, Pretty Lady; I want to cling to Ivy; Pianoforte Solo, Everyone says I love you; I'll stay with you; There's Magic in the Air; Hits from Forty-Second Street; Signature Tune. 11.30, Club Concert for St. Albans Listeners; Part I, Orchestral Music: March from Tannhäuser (Wagner); Minuet from Berenice (Handel); Violin Solo, Air on the G String (Bach); Softly awakes my Heart, from Samson and Delilah (Saint-Saëns); Humoresque (Dvorak); Violin Solo, Le cygne (Saint-Saëns); Intermezzo from Cavalleria rusticana (Mascagni); Down in the Forest (Ronald). 12.5 a.m. (Saturday), News Bulletin in English. 12.10 (approx.), Club Concert (contd.). Part II: I wanna count Sheep; Put on your Old Gray Bonnet; Crying and sighing; Whispering; Music hath charms; Signature Tune. 12.30, Dance Music (Electrical Transcriptions): Hold me; Sweetheart, Darling; You're mine, you; The Gold-Digger's Song; Stormy Weather; I shall still keep smiling along; Goodnight, but not Goodbye; And so I married the Girl; This lovely Rose; I cover the Waterfront. 1.0, Dance Music; Signature Tune; Bells of Normandy; I've got the World on a String; One Tiny Tear; I'll see you in the Morning; Castles in the Sand; Meet me in the Gloaming; Memories of you; Lover; I wish I had Wings; Have you had a Good Day To-day?; In the Valley of the Moon; Hold me; Chansonnette; The Dirty Glide; Rockin' Chair; Hot Feet; Fiddlin' Joe; My Wishing Song; You did everything for me; Signature Tune. 2.0, I.B.C. Good-night Melody and Close Down.

FLENSBURG.—See Hamburg.

FLORENCE.—See Turin.

## FRANKFURT

1,157 kc/s, 259.3 metres; 17 kW. Relayed by Cassel, 1,220 kc/s, 245.9 metres; and Trier, 1,157 kc/s, 259.3 metres.—6.0 p.m., Reading of a Short Story (Richard Billinger). 6.10, Reading (Valentin Pfeifer). 6.25, Talk: The Municipal Theatres re-open. 6.45, To-day's News. 6.50, Time and Announcements. 7.0, Transmission for all German Stations relayed from Berlin (Funkstunde). 8.0, Variety Concert: The Station Orchestra; (a) March, Donnerwetter, tadellos (Lincke). (b) Overture, Tantalusquäl (Suppe); Six Minutes, Thirty Seconds—Sketch (Berkin-Walften); Saxophone Solos; Topical Talk; Songs (Brahms): (a) Abenddämmerung, (b) Spanisches Lied, (c) Lied, (d) Juchhe; A Meeting between Frederick the Great and Christian Fürchtegott Gellert; Fourteen Variations, Op. 44, for Violin, Cello and Pianoforte (Beethoven); Scene from Danton's Death (Georg Büchner); Songs (Sussick): (a) Deutsches Freiheitslied, (b) Jägerlied, (c) Kampflied; Talk; Folk Music; Popular Sketch; March Potpourri, Alle mit uns (Robrecht). 10.20, Time and News. 10.45, Serenade. 12 Midnight, Close Down.

FREDRIKSSTAD.—See Oslo.

FREIBURG.—See Stuttgart.

GENEVA.—See Radio-Suisse Romande.

GENOA.—See Turin.

GLEIWITZ.—See Breslau.

GOTEBORG.—See Stockholm.

GRAZ.—See Vienna.

HAMAR.—See Oslo.

## HAMBURG

806 kc/s, 372 metres; 1.5 kW. Relayed by Bremen 1,112 kc/s, 269.8 metres; Flensburg, 1,319 kc/s, 227.4 metres; Hanover, 530 kc/s, 566 metres; and Kiel, 1,292 kc/s, 232.2 metres.—6.5 p.m., See Berlin (Deutschlandsender). 6.30, Talk: Gliding on the Sylt Island. 6.45, Exchange and Market Prices. 6.50, Weather. 7.0, Transmission for all German Stations, relayed from Berlin (Funkstunde). 8.0, Political Announcements. 8.10, Das siede Land de Woterkant (Life by the Water's Edge—Radio Sequence in Dialect (Heinrich Andresen) by the Station Choir, the Small Orchestra, conducted by Gerhard Maass and Soloists. 9.0, Concert by the Hamburg Philharmonic Orchestra, conducted by José Eibenschütz. Symphonic Suite Op. 22 (Ehrenberg); Sommeridylle (Reuss). 10.0, Time and News. 10.20,

Topical Talk. 10.30, Sonata in E minor for Cello and Pianoforte (Brahms) by Kurt Friedrich and Joe Hoffman. 11.0, (from Bremen). O'er Land and Sea, Orchestral Concert, conducted by Reinhold Krug. Overture, L'isola disabitata (Haydn); Iceland and the Faroe Islands (Frederiksen); Scenes from the African Bush (Percy); Dawn on the Lido (Nevin); Overture Le lac mandit (Staz); Travel Sketches from Old China (Percy); Waltz, Wellen und Wogen (Strauss); Landschaft auf Haiti (Leuschner); The Globe Trotter (Siede).

HANOVER.—See Hamburg.

## HEILSBURG

1,085 kc/s, 276.5 metres; 60 kW. Relayed by Danzig, 662 kc/s, 453.2 metres.—1.5 p.m., Gramophone Concert: Selection from Liselotte (Kinneke); Aria from The Merry Wives of Windsor (Nicolai); La Czarine (Ganne); La Mousmée (Ganne); The Sphinx Waltz (Popy); Polka with Variations, Napolitanitta (Vacher); Waltz (Vacher); Overture, Semiramis (Rossini); Aria from Il Trovatore (Verdi); Aria from Czar and Carpenter (Lortzing); Viennese Waltz (Bittner); Pariser Einzugsmarsch (Waleh); Unter dem Siegesbanner (Blon). In the intervals at 1.20 and 2.0, News. 2.30, Concert, arranged by the Post Office, with Gramophone Records. 3.0, Agricultural Prices and Exchange Rates. 3.30, Programme for Children. 4.0, (from Danzig), Talk for Women. 4.30, Concert by a Nazi Band: March, Borussia (Teike); Festival Overture, Dein deutschen Volke (Zimmer); Heldenfeier (Goepfert); Huguenot Fantasia (Fetras); Festival Overture, Sieg-Heil (Homann-Webau); Märkische Kolonnen (Kureh); Waltz from Faust (Gounod); Wedding Day on Troldhaugen (Grieg); Selection from The Gipsy Princess (Kálmán); Pankgrafen-Marsch (Schlenk). 5.45 (from Danzig), Talk: Counterfeit Coinage in Earlier Times. 6.15, Agricultural Prices. 6.25, Talk: The German Peasant. 6.50, Weather. 7.0, Transmission for all German Stations, relayed from Berlin (Funkstunde). 8.0, Weather and News. 8.10, Concert by the Königsberg Opera House Orchestra, conducted by Wolfgang Brückner: Prelude to the Third Act of Die Königin (Humperdinck); Präludium (Liszt); Flagellantenanzug (Bleyde); Waltz, Accelerationen (Strauss); Suite No. 1 (Alcheli); Selection from Der Teufelsreiter (Kálmán); March, Bandonville (Fürst). 9.45, Reading (Paul Heyse). 10.15, News.

## HILVERSUM

Announced HUIZEN, 1,013 kc/s, 296.1 metres; 20 kW. (7 kW. up to 5.40 p.m.). Programme of the Christian Radio Society (N.C.R.V.). 10.40 a.m., Concert by the Van der Horst Ensemble: Overture, Der Waffenschmid (Lortzing); Acclamations (Waldfenck); Pensio a te (Tosti); Gramophone Music; Selection from Sylvia (Delibes); Gungl Potpourri (Fetras); Overture, Phédre (Massenet); Valse des fleurs (Tchaikovsky); Selection from Romeo and Juliet (Gounod); The Dutch Windmill (Heykens); Potpourri, Fortissimo (Kálmán). In the interval at 11.40, Police Notes, and at 11.55, Gramophone Music. 12.55 p.m., Song Recital by Mlle. ter Steege (Soprano): Sentio nel Core (Searlatti); Se Florindo è fidele (Searlatti); Songs (Schubert): (a) An die Nachtigall, (b) Liebeschwärmer auf allen Wegen, (c) Schummerlied, (d) Fischerweise, (e) Ständchen; Pianoforte Solos (Chopin): (a) Berceuse, (b) Waltz in A Flat, (c) Waltz in G Sharp, (d) Etude in C Minor, (e) Fantasia Impromptu; Songs (Brahms): (a) Feldensamkeit, (b) Maienkätzchen, (c) Sandmännchen, (d) Vergebliches Ständchen. 1.40, Interval. 2.10, Bible Reading. 2.40, Concert by the Hendriks Trio; Trio in D Minor (Mendelssohn); Gramophone Music; Introduction and Rondo capriccioso (Saint-Saëns); Three Cello Solos (Popper); Gramophone Music; Trio in F Sharp (Chausson). 4.10, Talk for Young Photographers. 4.40, Gramophone Music. 5.10, Gardening Talk. 6.40, Police Report. 6.55, Ecclesiastical Notes. 7.10, Literary Talk. 7.40, Military Band Concert, conducted by Glas, in the intervals at 8.40, Talk, and at 9.40, News. 10.10, Gramophone Music. 11.10 (approx.), Close Down.

HORBY.—See Stockholm.

## HUIZEN

Announced HILVERSUM, 160 kc/s, 1,875 metres; 7 kW. (up to 3.40 p.m.). Transmitted from Kootwijk on 50 kW. from 3.40 p.m.—11.40 a.m. to 3.40 p.m., Programme of the Algemeene Vereeniging Radio Omroep (A.V.R.O.). 11.40, Gramophone Music. 12.10 p.m., Concert by Kovacs Lajos and his Orchestra; Gramophone Music in the intervals. 2.10, Reading. 2.40, Gramophone Music. 3.40 to 7.40, Programme of the Workers' Radio Society (V.A.R.A.). 3.40, Xylophone and Organ Recital; Chinese Street Serenade (Siede); By the Blue Hawaiian Waters (Ketchbey); The King's Horses (Gay); Waltz Potpourri (Robrecht); Melody (Donaldson); Nola (Arndt). 4.30, Programme for Children. 5.10, Concert by

the Station Orchestra, conducted by Hugo de Groot; Pomp and Circumstance (Elgar); Paysage d'Automne (Waldteufel); Selection from The Bayadere (Christine); La petite Tonkinoise (Scott-Christine); Selection from Rigoletto (Verdi); Gramophone Music; Ballet Music from Hlys (Ganne); Overture, Die Fledermans (Strauss). 6.20, Talk. 6.40, Concert by the Station Orchestra, conducted by Hugo de Groot; Soloist, Elize de Haas (Soprano); Selection from Faust (Gounod); Waltz Song from Romeo and Juliet (Gounod); Overture, The Gipsy Baron (Joh. Strauss); Songs: (a) Air from The Gipsy Baron (Joh. Strauss), (b) Song (Joh. Strauss); Selection from Mariska (Lehár); Waltz Song from Paganini (Lehár); Selection from The Land of Smiles (Lehár). 7.40 to 8.10, Programme of the Liberal Protestant Radio Society (V.P.R.O.): Religious Address. 8.10 to 9.55 (approx.), Programme of the A.V.R.O. 8.10, Concert from the Kurhaus, Scheveningen; The Residence Orchestra, conducted by Karl Schriener; Aria, O Mensch bewein' dein' Sünde gross (Bach-Reger); Im Memorial Matris (Landré); The Seventh Symphony in A (Beethoven). In the intervals at 8.40, Talk, and at 9.40, Press Review. 9.55 (approx.) to 10.40, Programme of the V.P.R.O. 9.55, Recitations. 10.25, Gramophone Music. 10.40 till Close Down, Programme of the V.A.R.A.—Organ Recital. 11.40 (approx.), Close Down.

INNSBRUCK.—See Vienna.

## JUAN LES PINS

1,205 kc/s, 249 metres; 0.8 kW.—12.30 p.m., Amusement Guide and Variety Items. 1.0, News. 1.15, Radio Concert. 8.0, Amusement Guide, Exchange and News. 8.10, Esperanto Lesson. 8.30, Radio Concert. 8.45, News and Weather. 9.0, Radio Concert.

KALUNDBORG.—See Copenhagen.

## KATOWICE

734 kc/s, 408 metres; 16 kW.—6.35 p.m., Concert of Light Music. 7.5, Talk: Impressions of Budapest. 7.25, Announcements and Gramophone Music. 7.40-10.40, See Warsaw. 10.40, Dance Music. 11.0, The Letter Box, in French.

KIEL.—See Hamburg.

KLAGENFURT.—See Vienna.

KOSICE.—See Prague.

## LANGENBERG

635 kc/s, 473 metres; 60 kW.—12 Noon, Concert by the Fröhliche Pfif. 1.15 p.m., News. 1.30, Orchestral Concert, conducted by Eysoldt: March, Friedensglocken (Urbach); Symphonic Prelude to Tiedland (d'Albert); Hugo Wolf Suite (arr. Peccer); Romance (Tchaikovsky); La canzone della Sorgente (Amadei); Waltz, An der schönen grünen Narenta (Komzak); Selection from Ihre Hoheit, die Tänzerin (Götze). In the interval at 2.0 News. 3.0 The Air Balloon, in the Past and in the Future—Radio Sequence (Rudolf Predeck). 3.30, Market Prices and Time. 3.50, Programme for Young People. 4.30, Reading (Stefan Andres). 4.55, Political Announcement. 5.0, Concert. 6.15, Talk; Freiherr vom Stein. 6.30, English Lesson. 6.45, Weather, Sports Results and Economic Notes. 7.0, Transmission for all German Stations, relayed from Berlin (Funkstunde). 8.0, News. 8.5, Dance Music by the Station Orchestra. 10.0, News. 10.20, Review of Next Week's Events in West Germany. 10.30, The Porcelain Pavilion Recital of Chinese Lyrics translated by Stefan Andres, Hans Bethge and Richard Wilhelm (arr. Martin Rockenbach) with Introductory Talk: The Real China. 11.30 (approx.), Close Down.

LAUSANNE.—See Radio-Suisse Romande.

## LEIPZIG

769.9 kc/s, 389.6 metres; 120 kW. Relayed by Dresden, 941 kc/s, 319 metres.—12 Noon, Programme from Munich. 1.15 p.m., News and Programme Announcements. 1.30, Chamber Music and Songs on Gramophone Records. 2.15, News. 2.25, Art Review. 2.45, Reading. 3.0, Programme for Children. 3.35, Market Prices. 4.0, Concert by the Symphony Orchestra, conducted by Blumer. Soloists: Huppertz (Cello) and Sammler (Hornium). Overture, Manfred (Schumann). Cello Concerto Op. 104 (Dvorak); Extracts from the Serenade in D Op. 49 (Draesecke); Adagio and Rondo for Harmonium and Orchestra (Weber); Spanish Caprice (Rimsky-Korsakov); Overture, Der Bärenhäuter (Siegfried Wagner). 5.0 (in an interval), Reading of Lyrics by Hans Carossa. 5.30, Talk: New Developments in Co-operative Life. 5.50, Economic Notes, Weather and Time. 6.0, Books for Young Hitlerites. 6.20, Concert by the Dresden Horn Quartet and Paul Scheffel (Flute). Horn Quartet with Flute: Das Waldviertel (Doppler); Quartet; Abschied (Mendelssohn); Flute and Pianoforte: Hirtendylle (Doppler); Folk Song for Quartet: Der Klang des Volkes; Huntsmen's Chorus from Der Freischütz (Weber). 6.50, News. 7.0, Transmission for all German

Stations, relayed from Berlin (Funkstunde). 8.0, Alcestis Drama (Euripides), relayed from the Sylvan Theatre at Dresden-Hellerau. 10.5, News. 10.45, Concert from Frankfurt. 12 Midnight, Close Down.

LINZ.—See Vienna.

## LUXEMBOURG

252 kc/s, 1,191 metres; 200 kW.—Dutch Programme. 7.30 p.m., The Heroic Symphony (Beethoven) on Gramophone Records. 8.30, Ballet Music from Faust (Gounod), on Gramophone Records. 8.50, News in French. 9.0, Song Recital by Mme. Grosfils De Guyper. Aria from La Vivandière (Godard); Aria from Carmen (Bizet); Aria from Manon (Massenet); Aria from Lakmé (Delibes); Waltz from Romeo and Juliet (Gounod). In an interval at 9.20, Talk in Dutch. 9.45, News in German. 9.55, Gramophone Concert. 10.25, Dance Music on Gramophone Records.

## LWOW

788 kc/s, 381 metres; 16 kW.—6.35 p.m., Gramophone Music. 7.20, Announcements and Gramophone Music. 7.35, Programme Announcements. 7.40 to 10.40, See Warsaw. 10.40, Gramophone Music.

## LYONS

LA DOUA, 644 kc/s, 465.8 metres; 1.5 kW.—6.30 p.m., Radio Journal. 7.30, Radio Gazette for Lyons and the South-East. 8.30, Lottery Results. 8.35, Orchestral Concert. After the Concert, News.

## MADRID

EAJ7, 707 kc/s, 424.3 metres; 2 kW.—8.0 p.m., Chimes, Exchange, Announcements and Request Gramophone Records. 9.15, News. 9.30, Interval. 11.0, Chimes, Time and News. 11.20 (approx.), Symphony Concert on Gramophone Records: Les Préludes (Liszt); El puerto (Albéniz); Entr'acte from Rosamund (Schubert); Wedding March (Mendelssohn); Symphony No. 5 (Beethoven); L'après midi d'un faune (Debussy); Pacific (Honegger); Italian Caprice (Tchaikovsky). 1.15 a.m. (Sunday), News. 1.30, Chimes and Close Down.

## MILAN

662 kc/s, 453.2 metres; 4 kW.—8.15 p.m. (approx.) till Close Down. See Rome.

MALMO.—See Stockholm.

## MORAVSKA-OSTRAVA

1,137 kc/s, 263.8 metres; 11 kW.—7.10 p.m., See Brno. 8.40, See Prague. 10.30 (approx.), Close Down.

## MOSCOW

TRADES UNION, 300 kc/s, 1,000 metres; 100 kW.—11.45 a.m., Weather. 2.45 p.m., Weather Report. 3.0, Extracts from The Night in May—Opera (Rimsky-Korsakov) by the Symphony Orchestra and Soloists. 3.55, Time. 4.0, Talk. 4.30, Literary Programme. 5.30, Educational Programme. 6.30, Concert of Waltzes by Strauss, Glinka, Tchaikovsky, and Puccini. 9.0, News. 9.30, Programme Announcements. 9.55, Chimes from the Red Square. 10.5, Press Review.

MOTALA.—See Stockholm.

MÜHLACKER.—See Stuttgart.

## MUNICH

563 kc/s, 533 metres; 60 kW. Relayed by Augsburg and Kaiserslautern, 536 kc/s, 560 metres; and Nürnberg, 1,256 kc/s, 259 metres. 4.30 p.m., See Stuttgart. 5.45, Talk for the Younger Generation. 6.5, Wartisch Song Recital by Stephanie Rose (Soprano). 6.25, Talk: The Matthäus-Kirche in Munich. 6.45, Time and Announcements. 7.0, Transmission for all German Stations, relayed from Berlin (Funkstunde). 8.0, Topical Talk. 8.20, Symphony Concert by the Station Orchestra, conducted by Winter. Soloists: Ado Dammert (Pianoforte) and Cyril Kopatschka (Violin). Pavane from the Coperni Suite (R. Strauss); Pianoforte Concerto in E Flat, Op. 127 (Mozart); Chaconne (Bach-Hubay); Violin Concerto (H. Schubert); March from the Coperni Suite (R. Strauss). 9.30, Choral Concert. 9.50, Reading. 10.20, Time and News.

NAPLES.—See Rome.

NOTODDEN.—See Oslo.

## OSLO

277 kc/s, 1,083 metres; 60 kW. Relayed by Fredriksstad, 815 kc/s, 368.1 metres; Hamar, 522 kc/s, 574.7 metres; Notodden, 471 kc/s, 447.1 metres; Porsgrund, 602 kc/s, 453.2 metres; and Rjukan, 671 kc/s, 447.1 metres.—5.30 p.m., Concert by the Station Orchestra, conducted by Hugo Kraum: Cadet March (Sousa); Overture, Cacadou (Offenbach); Selection from Der Justige Krieg (Joh. Strauss); Mazurka, La Czarine (Ganne); Melancholy (Die Bull); Serenade (Toselli); Russian Fantasy, Dubinuschka (Schirman); March (Eivind Bull Hansen). 6.30, Talk. 7.0, Advertising Notes, Weather and News. 7.30, Concert by a String Orchestra: Military March (Schubert); Love's Dream after the Ball (Czibulka); Hungarian Dance No. 6 (Brahms); Cloches du soir



SEPT. 15th **FRIDAY** continued

(Marzian); Selection from The Merry Widow (Lehar); Ständchen No. 1 (Heykens); Wedding March (Mendelssohn). 8.0, Time Signal. 8.1, Dramatic Programme. 9.30, Agricultural Report. 9.40, Weather and News. 10.0, Topical Talk. 10.15, Recitation. 10.45 (approx.), Close Down.

OSTERSUND.—See Stockholm.

**PALERMO**

558 kc/s, 537.6 metres; 3 kW.—8.0 p.m., Dopulavoro Notes, Tourist Talk, Agricultural Report, Report of the Royal Geographical Society and Giornale Radio. 8.20, Gramophone Music. In an interval at 8.30, Time and Announcements. 8.45, Ideale—Operetta in Three Acts (Tosti). In the intervals, Talk and Book Review. 10.55, News.

**PARIS**

**EIFFEL TOWER**, Call FLE, 207.5 kc/s, 1,445.7 metres; 13 kW. Time Signals (on 2,650 metres) at 10.26 a.m. and 11.26 p.m. (Preliminary and 6-dot Signals)—6.45 p.m., Theatre Notes. 7.0, Le Journal Parle. 8.30, Symphony Concert, conducted by Flamant; Soloists: Manouvrier (Flute), Krabanski (Cello), and Charon (Violin); Selection from (a) Kosiki (Leocoe), and (b) Phryno (Saint-Saëns); Flute Solo; Cello Solo; Musette for Violin and Cello (Pfeiffer); Rose softly blooming (Noletty-Seranges); Minuet (Bolzoni); Waltz (E. Strauss). 10.0, Close Down.

**PARIS**

**POSTE PARISIEN**, 914 kc/s, 328.2 metres; 60 kW.—7.0 p.m., Gramophone Music. 7.5, Sponsored Talk. 7.15, Le Journal Parle. 7.30, Concert. 8.0, Agricultural Notes. 8.5, Gramophone Music. 8.30, Le maître de Chapelle—One-Act Musical Comedy (Duvall and Gay), followed by La serva padrona—Opera-Comique in Two Acts (Pergolesi). 10.15, News.

**PARIS**

**RADIO-PARIS**, Call CFR, 174 kc/s, 1,725 metres; 75 kW.—7.30 a.m., Weather and Physical Culture. 7.45, Gramophone Music. 8.0, News. 12 Noon, Hebrew Programme; Talk and Songs. 12.30 p.m., Gramophone Concert: Impressions d'Italie (Charpentier); Prélude à l'après-midi d'un faune (Debussy); Bonrré fantasque (Chabrier); Wallenstein (d'Indy); La tragédie de Salomé (Schmitt); L'apprenti sorcier (Dukas); Pavane pour une Infante défunte (Ravel); Symphonie Poem, Phaeton (Saint-Saëns); Suite in F (Roussel); Habanera (Aubert); Pastorale d'éto (Honegger). In the intervals at 1.0, Exchange and News, and at 1.30, Exchange. 2.0, Exchange. 3.45, Exchange and News. 7.0, Agricultural Report. 7.10, Social Assurance Report. 7.20, Gramophone Music: Suite funambulesque (Messager); Selection from The Chocolate Soldier (O. Strauss); Melody; Aubade d'amour (Monti); Mon ami Pierrot (Zimmermann); Piece (Sleuicke). 7.50, Commercial Prices and News. 8.0, Gramophone Music: Spanish Songs (Falau); Waltz in A (Brahms); Gipsy Song (Dvorak); Scherzo in B Flat Minor (Chopin); Le tambourin chinois (Kreisler). 8.25, The Radio Paris Competition and Gastronomic Review. 8.40, Le petit due—Operetta (Andran), relayed from Le Théâtre de la Porte St. Martin. In the interval at 9.30, Press Review and News.

**PITTSBURGH**

**KDKA**, 980 kc/s, 306 metres; 50 kW. Relay by W8KK on 48.86 metres and 25.27 metres.—4.15 to 5.0 p.m., U.S. Marine Band, from New York. 7.30, Pontiac Home Forum. 8.0 to 9.30, New York Relay. 8.0, Betty and Bob. 8.15, Words and Music. 8.45, Morin Sisters. 9.0, Gene Quaw Orchestra. 9.30, News and Markets. 9.45, Arcadians, from New York. 10.0, Uncle Tom and Betty. 10.15, Tarzan of the Apes. 10.30, Singing Lady, from New York. 10.45, Orphan Annie, from New York. 11.0, News-Reeler. 11.15, Sports. A Song. 11.30, Pittsburgh Spotlights. 11.45, Lowell Thomas, from New York. 12 Midnight, Amos 'n' Andy, from New York. 12.15 a.m. (Saturday), Silver Toppers. 12.30 to 3.45, New York Relay. 12.30, Lexington Hotel Orchestra. 1.0, Popular Programme. 1.30, Potash and Perlmutter. 1.45, Rooking Chair Memories. 2.0, Let's Listen to Harris. 2.30, Variety Programme. 3.0, First Nighter.

PORSGRUND.—See Oslo.

**PRAGUE**

614 kc/s, 488.6 metres; 120 kW.—2.50 p.m., See Brno. 3.50, Aviation Weather Report. 3.55, Exchange. 4.0, Interval. 5.45, Gramophone Music. 5.55, Talk. 6.5, Market Prices. 6.15, Gramophone Music. 6.25, News in German. 6.30, German Transmission; Talk. The International University Sports at Turin. 7.0, Chimes and News. 7.10, Talk. 7.25, See Brno. 8.40, Concert by the Station Orchestra, conducted by Parik; Dramatic Overture (Pichla); Slovak Suite (Novak); Suite for Small Orchestra (Vendler); Piece (Ostreich); In the interval, Reading. 10.0, Time and News. 10.15, Russian News. 10.30 (approx.), Close Down.

**RADIO-SUISSE ROMANDE**

**SOTTENS**, 743 kc/s, 403 metres; 25 kW; and Geneva, 395 kc/s, 760 metres.—6.15 to 6.30 a.m., Gymnastics Lesson. 12.28 p.m., Time Signal from Neuchâtel Observatory. 12.30, News and Weather. 12.40 (from Lausanne), Concert by the Radio Lausanne Orchestra, conducted by Moser. In the interval at 1.0, Financial Notes. 2.0 to 3.28, Interval. 3.28, Time Signal from Neuchâtel Observatory. 3.30 (from Geneva), Gramophone Concert. 4.30 (from Geneva), Programme for Women. 5.30 to 7.0, Interval. 7.0 (from Lausanne), Talk: The Blind. 7.30 (from Lausanne), News, Announcements, and Weather. 7.35 (from Lausanne), Answers to Correspondence. 8.0, L'Antre fils, Pierre Deconcelle—Comedy in Three Acts. 9.50, News and Weather. 10.0 (from Lausanne), Light (Orchestral Concert. 10.30 (approx.), Close Down.

**RIGA**

572 kc/s, 525 metres; 15 kW.—7.5 p.m., Symphony Concert, conducted by Otto Klemperer, relayed from the National Opera House; Overture, Der Freischütz (Weber); The Unfinished Symphony in B minor (Schubert); Suite from Petronshka (Stravinsky); Fifth Symphony in C minor, Op. 67 (Beethoven). In the interval at 8.0, News. 9.10 (approx.), News. 9.20 (approx.), Dance Music. 10.0 (approx.), Close Down.

RUUKAN.—See Oslo.

**ROME**

Call IRO, 680 kc/s, 441 metres; 50 kW. Relay by Naples, 941 kc/s, 319 metres; and 2RO, 11,810 kc/s, 25.4 metres, from 5.15 p.m.—12.30 p.m., Gramophone Music. 1.0, Orchestral Concert: Danubiana (Kapper); Occhi ridenti (Ricciardi); Nita (Schisa); Autunno (de Curtis); Waltz (Borghesano); Notturno siciliano (di Dio); Saxophone Solo, Fosca Bruna (Piesi); Tabù (Collo). In an interval at 1.30, Giornale Radio and Exchange. 2.0, Time and Announcements. 4.30, Children's Radio Review. 4.50, Giornale Radio and Exchange. 5.10, Weather. 5.15 to 6.0, Song and Violin Recital: Adalberto Simonetti (Violin), Margherita Cossa (Soprano) and Leandro Forti (Baritone). Violin Solos: (a) Prelude (Bach), (b) Waltz (Brahms); Soprano Solos (Schumann): (a) Widmung, (b) Frühlingsnacht, (c) Ich grolle nicht; Baritone Solos: (a) Aria from Figaro (Mozart), (b) Aria from I Puritani (Bellini), (c) Song from Tiedland (d'Albert); Songs: (a) I pastori (Pizzetti), (b) Day by Day, from the Cycle, Poems of Tagore (Alfano); Violin Solos: (a) Rondino (Beethoven-Kreisler), (b) La Caccia (Chiabran-Corti). 6.40 (Naples), Shipping and Sports Notes. 6.45, Dopulavoro and Tourist Report. 6.57, Report of the International Institute of Agriculture (in Spanish, German and French). 7.10, Agricultural Report. 7.20, News in Foreign Languages. 7.40, Giornale Radio. 8.0, Time, Announcements and Sports Notes. 8.15, Sponsored Music. 9.15, Variety Concert: Ballet (Martini); Minuet and Scherzo (Grétry); Ständchen (Schubert); Rondo, Sœur Monique (Conperin); Songs for Tenor. 9.45, La fidanzata d'America—Comedy in One Act (Luigi Bonelli). 10.15, Vocal and Instrumental Concert: Selection from The Third and Fourth Acts of Carmen (Bizet); Duet, Monologue and Finale from Il Tabarro (Puccini); Spanish Caprice (Rimsky-Korsakov). 11.0, Giornale Radio.

SALZBURG.—See Vienna.

**SCHENECTADY**

(WGY), 790 kc/s, 379.5 metres; 50 kW. Relay by intervals by W2XAF on 31.48 metres and by W2XAD on 19.56 metres.—9.0 p.m., Vocal Duets by Haber and Curtis. 9.15, May We Present, from New York. 9.30, Talk: The Mind Age. 9.35 to 10.0 (approx.), South Sea Islanders, from New York. 12.45 a.m. (Saturday), Stock Reports and Baseball Scores. 1.0, Concert, from New York. 1.30, WGY Farm Forum. 2.0, Variety Programme, from New York. 2.30, Popular Programme, from New York. 3.0, WGY Players. 3.30, Lum and Abner's Friday Night Sociable, from New York. 4.0, Programme Résumé.

**SCHWEIZERISCHER LANDESENDER**

**BEROMUNSTER**, 653 kc/s, 459 metres; 60 kW; Basle, 1,229 kc/s, 244.1 metres; and Berne, 1,220 kc/s, 245.9 metres.—12 Noon (from Zurich), Orchestral Concert of Light Music. In an interval at 12.30 p.m., Time and News. 1.25 (from Zurich), Time and News. 1.35 (approx.), Interval. 5.0 (from Basle), Programme for Children. 5.30 (from Basle), Military Band Concert. 6.30 (from Basle), Talk on Wireless. 7.0 (from Basle), Time and News. 7.20 (from Basle), Hungarian Melodies on Gramophone Records. 8.0 (from Basle), Talk: Impressions of the World Jamboree. 8.30, Concert by the

Radio Orchestra. 9.0, Weather and News. 9.10 (from Basle), Concert of Chamber Music. 10.15 (approx.), Close Down.

SOTTENS.—See Radio-Suisse Romande.

**STOCKHOLM**

689 kc/s, 436 metres; 55 kW. Relay by Boden, 244 kc/s, 1,229.5 metres; Göteborg, 932 kc/s, 322 metres; Hörby, 1,166 kc/s, 267 metres; Motala, 221.5 kc/s, 1,354.4 metres; Osteraund, 389 kc/s, 770 metres; and Sundsvall, 554 kc/s, 542 metres.—1.0 p.m., Broadcast for Schools. 5.5 (from Göteborg), Operetta Song Recital by Ingalli Södermann. 5.25, Reading. 5.45, Gramophone Music. 6.45, Legal Talk. 7.15, Weather and News. 7.30, Talk on Swedish Literature, relayed from Uppsala, 1,301 kc/s, 231 metres. 8.0, Concert by a Male Voice Quartet. 8.30, Italian Radio Play (Alessandro di Stefani). 9.45, Weather and News. 10.0 (from Göteborg), Concert by the Liseberg Orchestra, conducted by Karl Borufors; Overture, Der Walfenschmied (Lortzing); Waltz, Dynamisch (Jos. Strauss); Ballet Music from Sylvia (Delibes); Canzonetta noturna (Wallper); Secret d'amour (Larento); Potpourri (Morena); March, Hoch Heidecksburg (Herzer). 11.0 (approx.), Close Down.

**STRASBOURG**

869 kc/s, 345 metres; 11.5 kW.—11.30 a.m., Gramophone Concert of Variety Music. 12.45 p.m., News. 1.0, Time and Exchange. 1.5, Classical Music on Gramophone Records. 2.0, Interval. 3.30, Orchestral Concert, conducted by Brouillac, relayed from the Casino. Vichy; Overture, The Barber of Seville (Rossini); Slav Dance (Chabrier); Suite from La Maladetta (Vidal); Melody; Ballet Music from Le triomphe de l'amour (Bastide); Selection from Dinorah (Meyerbeer); Waltz, Pour toi (Bertin). 5.0, Literary Talk; Erek-mann-Chatrion. 5.15, Orchestral Concert, conducted by Roskam: Two Step, Torea fino (Lucchesi); Waltz Intermzzo (Stelzy); Tango, Ombra e luce (Nissini); Cello Solo; Berceuse from Jocelyn (Godard); Foxtrot, Please (Rainger); Waltz, O Frühling wie bist du so schön (Lücke); April (Allouche); Green Song (Allouche); Intermzzo, Lontanetta (Razigade); Boston, Lover of my Dreams (Coward); One-Step, Don't be late in the Morning (Le Clerc and Mendoza). 6.0, Trio Concert, relayed from Lille, 1,130 kc/s, 265.4 metres. 7.0, Topical Talk in German. 7.15, Gramophone Music. 7.30, Time and News. 7.45, Gramophone Music. 8.0, Press Review in German, Lottery Results and Announcements. 8.30, Gala Concert, conducted by Paul Paray, relayed from the Casino, Vichy; Overture, Leonora No. 3 (Beethoven); Symphonie Poem, Phaeton (Saint-Saëns); La procession nocturne (Rabaud); Prélude à l'après-midi d'un faune (Debussy); Spanish Caprice (Rimsky-Korsakov). 10.0 (approx.), Press Review.

**STUTTIGART**

**MUHLACKER**, 832 kc/s, 360.5 metres; 60 kW. Relay by Freiburg, 527 kc/s, 570 metres.—12 Noon, Concert from Munich. 1.15 p.m., Time and News. 1.30, String Quartet in E Minor (Smetana), on Gramophone Records. 2.0, Concert arranged by the Post Office. 2.30, Advanced English Lesson. 3.30, Song Recital. Käthe Ivers (Soprano), Elisabeth Jentsch (Soprano), Karl Jantz (Tenor), Karl Jentsch (Baritone). Soprano Solos: (a) Klang im Klang, Op. 32a (Schmid), (b) Spanish Song (Delibes), (c) Melody (Dell'Acqua); Tenor Solos: Two Songs from The Land of Smiles (Lehar); Baritone Solo: Spielmannslieder (Fritz Lorleberg); Two Soprano and Tenor Duets: (a) from The Czarevitch, (b) from Paganini (Lehar). 4.15, Talk: Suggestions for Sunday Excursions. 4.30, Concert by the Station Orchestra, conducted by Otto Seyfert. Overture, The Bartered Bride (Smetana); Selection from La Bohème (Puccini); Selection from The Veil of Pierrette (Dobnanyi); Slav Dances (Dvorak); Entry of the Guests, from Tannhäuser (Wagner). 5.45, Medical Talk. 6.5, See Berlin (Deutschlandsender). 6.30, Time and News. 7.0, Transmission for All German Stations, relayed from Berlin (Funkstunde). 8.0, Talk: Things one should know. 8.5, See Langenberg. 9.0, Music which fell flat—Gramophone Concert of Old and Modern Music. 10.15, Time and News. 10.40, Ich wand're alle Tage—Musical and Literary Programme (Gerd Schneider), by the Station String Quartet and Soloists.

SUNDSVALL.—See Stockholm.

**TOULOUSE**

779 kc/s, 385 metres; 8 kW.—6.0 p.m., News. 6.15, Music by a Viennese Orchestra. 6.30, Opera Music: Selection from Lakmé (Delibes), The Fair Maid of Perth (Bizet), and Les Brigands (Offenbach). 6.45, Diver-tissement sur des chants russes (Rabaud), by the Symphony Orchestra. 7.0, Sound Film Music. 7.15, News, Racing Results, Commercial Notes and Market Prices. 7.30, Popular Music. 7.45, Operetta Music. 8.0, Orchestral Music. 8.15, Opera Music: Arias from Lohengrin (Wagner), Faust (Gounod), and Sigurd (Reyer). 8.30, Operetta Music.

8.45, Chansonnettes. 9.0, Symphony Concert, conducted by René Bathon, relayed from the Municipal Casino, Biarritz. In the interval: Airs from Herodiade (Massenet), The Pearl of Brazil (David), and Le Caïd (Thomas). 10.0, Medical Talk. 10.15, North African News followed by Local News. 10.30, Concert for Listeners in Morocco. 11.0, Choral Music. 11.15, Dance Music. 12.0 Midnight, News, Weather and Announcements. 12.5 a.m. (Saturday), Opera Music: Ballet Music from Lakmé (Delibes); Overture, Mirélla (Gounod). 12.15, Military Music. 12.30 (approx.), Close Down.

**TRIESTE**

1,211 kc/s, 247.7 metres; 10 kW.—5.15 p.m., till Close Down, See Turin.

TRONDHEIM.—See Oslo.

**TURIN**

273.7 metres; 7 kW. Relay by Milan, 331.5 metres; Genoa, 312.8 metres; and Florence 500.8 metres.—5.15 p.m., Chamber Music. 6.0 to 6.5, Weather Forecast. 6.40, Giornale Radio, Dopulavoro Announcements and Gramophone Music. 7.0, Time, Report of the Royal Geographical Society and Gramophone Music. 7.10, Agricultural Notes and Market Prices. 7.20, News in Foreign Languages. 7.40, Gramophone Music. 8.0, Announcements, Giornale Radio, Sports Notes and Weather. 8.15, Sponsored Music. 8.30, Symphony Concert, conducted by Alceo Toni. In the interval, Talk. 10.0, Concert of Variety Music. 11.0, Giornale Radio.

**VATICAN CITY**

15,120 kc/s, 19.34 metres (Morning), and 5,969 kc/s, 50.26 metres (Evening); 10 kW.—11.0 to 11.15 a.m., Religious Information in German. 8.0 to 8.15 p.m., Religious Information in Italian.

**VIENNA**

581 kc/s, 517 metres; 100 kW. Relay by Graz, 852 kc/s, 352.1 metres; Innsbruck, 1,058 kc/s, 283 metres; Klagenfurt, 662 kc/s, 453.2 metres; Linz, 1,220 kc/s, 245.9 metres; and Salzburg, 1,373 kc/s, 218.5 metres.—12 Noon, Concert by the Wiener Symphoniker conducted by Josef Holzer. In the interval from 1.0 to 1.10 p.m., Time and News. 2.0 to 3.0, Interval. 3.0, Time and Announcements. 3.20, Talk: Domestic Science and Business Training in the Education of Girls. 3.35, Programme for Children. 4.0, Gramophone Records of the Ferdj Kaufmann Orchestra. 4.25, Talk for Women. 4.50, Talk: Couperin and Rameau. 5.15, Song and Pianoforte Recital. Two Songs (Schumann): (a) Dein Angesicht, (b) Er, der Herrlichste von allen; Two Songs (Schubert): (a) Ave Maria, (b) An die Musik; Songs (Brahms): (a) O wüsst' ich doch den Weg zurück, (b) Wie Melodien zieht es; Pianoforte Solos: Miniatures (Turina); Pianoforte Solos (Ziga Hirschler): (a) Faun, (b) Pan; Pianoforte Solo, Poissons d'or (Debussy). 5.55, Tourist Report. 6.10, Talk: Swimming. 6.25, Weekly Sports Report. 6.35, Talk: Protection from Gas and Air Attacks. 7.0, Concert by the Wiener Symphoniker, conducted by Rudolf Nilius. Soloist: Otto Schullhof (Pianoforte). Two Pieces (Rameau): (a) Overture, Les Indes galantes, (b) Concerto in G Minor; Suite after Rameau for Pianoforte and Orchestra (Otto Schullhof); Suite after Pianoforte Pieces by Couperin (Richard Strauss). In the interval at 7.35, Time and News. 8.20, Talk: Thoughts on the Fatherland. 8.50, Vienna and the Viennese Forest—Concert. The Wiener Symphoniker, conducted by Josef Holzer, with Franz Hoffmann (Tenor). 10.10, News. 10.25, Dance Music from the Café Palmhof.

**WARSAW**

212.5 kc/s, 1,411 metres; 120 kW.—11.57 a.m., Time Signal and Fanfare from Torun Cathedral. 12.5 p.m., Gramophone Music. 12.25, Polish Press Review. 12.33, Weather Report. 12.35, Gramophone Music. 12.55, Radio Journal. 1.0, Interval. 2.55, Gramophone Music. 3.5, News. 3.10, Announcements. 3.15, Gramophone Music. 3.25, Economic Notes. 3.35, Gramophone Music. 3.45, Aviation Report and Anti-Gas Drill. 3.50, Gramophone Music. 3.55, Naval and Colonial Report. 4.0, Light Music by the Gorzynski Jazz Band. 5.0, Book Review. 5.15, Song Recital by Mmc. Gustowska (Mezzo-Soprano) and Znicz (Baritone); Baritone Solos: (a) Aria from Zaza (Leoncavallo), (b) Aria from Le Maschere (Verdi), (c) Aria from Halka (Moniuszko); Mezzo-Soprano Solos: (a) Aria from Sanson and Delilah (Saint-Saëns), (b) L'Om-brra di Carmen (Tirindelli), (c) Venetian Song (Tosti); Baritone Solos: (a) Spring (Tchaikovsky), (b) Song (Bach), (c) Spanish Serenade (Rezkumov); Mezzo-Soprano Solos: (a) Two Songs (Niewiadomski), (b) Il y a des Moments (Wielhorski), (c) Ne tresse pas de Couronne de Fleurs (Glière). 6.15, Talk on Modern Poland. 6.35, Gramophone Music. 7.15, Holiday Hints. 7.20, Miscellaneous Items. 7.35, Programme Announcements. 7.40, Topical Talk. 8.0, Ludomir Rozycki Concert by the Station Symphony Orchestra, conducted by Wolfstal. Soloist: The Composer (Pianoforte). 8.50, Radio Journal. 9.0, Hints for the Week-end. 9.10, Concert (cont'd.). 10.0, Dance Music, relayed from Ciechocinek. 10.25, Sports Notes. 10.35, Aviation Weather Report and Police Notes. 10.40, Dance Music from Ciechocinek (cont'd.).

ZURICH.—See Schweizerischer Landessender.



SATURDAY SEPTEMBER THE SIXTEENTH

PRINCIPAL EVENTS OF THE DAY:

AT HOME

- NATIONAL Boys' Brigade Jubilee programme. MIDLAND REGIONAL Orchestral concert. NORTH REGIONAL Country Dances, orchestral programme. WEST REGIONAL Orchestral concert from the National Museum of Wales.

ABROAD

- BRUSSELS (No. 1) 8.5 p.m. "Le Cid," a Tragedy by Corneille. HEILSBURG 8.5 p.m. Act I of Opera: "Hans Heiling," by Marschner, relayed from Königsberg. HILVERSUM 5.10 p.m. Orchestral concert. HUIZEN 9.55 p.m. Sousa concert by the V.A.R.A. Orchestra. LANGENBERG 5.0 p.m. Recital for Two Pianofortes by Hans Haas and Erich Rummel. OSLO 8.1 p.m. The Station Orchestra, conducted by Hugo Kramm. PALERMO 8.45 p.m. Opera: "L'Amico Fritz," by Mascagni. RADIO PARIS 8.0 p.m. Light Opera: "A Midsummer Night's Dream," by Thomas, from the Casino, Vichy. ROME 8.45 p.m. Opera: "Il pirata," by Bellini. WARSAW 9.30 p.m. Chopin pianoforte recital, by Mme. Rabcewicz.

ALGIERS 824 kc/s, 364 metres; 13 kW.—8.0 p.m., Dance Music. 8.10 p.m., Shipping Notes. 8.15, Agricultural Report and Weather Forecast. 8.20, Military Music. 8.55, News. 9.2, Request Gramophone Concert. 9.40, News. 9.45, Open-air Concert.

ATHLONE

725 kc/s, 413 metres; 60 kW. Relayed by Cork, 1,337 kc/s, 224.4 metres.—1.30 to 2.30 p.m., Time Signal, Weather Report, Stock Exchange Quotations, and Gramophone Music. 6.0, Gramophone Concert. 6.45, News. 7.0, Wireless Talk. 7.15, Gaelic Talk. 7.30, Time Signal. 7.31, The Station Orchestra. 8.0, Pianoforte and Song Recital by G. and S. Neeson. 8.30, Variety Programme by Eva Brennan and Company. 9.10, Orchestral Music. 9.20 Pipe Solos. 9.30 to 10.30, Programme by the I.B.C. (Ireland), Ltd. 9.30, Dance Music: There's something about a soldier; Play fiddle play; Chewing gum; Round the bend of the Road; Hiawatha's Lullaby; Tony's Wife; In the dim, dim, dawning; Let's all be happy together. 10.0, Concert arranged by the International Broadcasting Company (Ireland), Ltd., on behalf of Hospitals Trust, Ltd.; Gramophone Records; Signature tune, Come back to Erin; The Frog King's Parade (Marriot); Moonlight on the Alster (Fetras); Song, Along the Shores of County Down (Morrison); Violin Solo, Serenade to Nicolette (Russell); Pianoforte Solo, Slippery Fingers (Steele); Song, One of the Ruins that Cromwell knocked about; March, Stars and Stripes (Souza); Signature Tune. 10.29, I.B.C. Good-night Melody. 10.45, News and Weather

BARCELONA

EAJ1, 860 kc/s, 348.8 metres; 8 kW.—7.0 p.m., Trio Concert: Selection from Mignon (Thomas); Canzonetta, Op. 35 (Tchaikovsky); Les papillons (Couperin); Gavotte (Königsberger); Ich liebe dich (Grieg); Florentine Serenade (Moret); Selection from Tristan and Isolde (Wagner). 8.0, Request Gramophone Records. 8.30, Exchange. 9.0, Gramophone Music. 9.15, Anti-War Talk, Gramophone Music and News. 10.0, Chimes from the Cathedral, Weather, Exchange and Market Prices. 10.5, Concert by the Station Orchestra: Twostep (Dalman); Selection from Los descamisados (Chena); Habanera, La esmeralda (Cotó); Waltz, Chantilly (Waldteufel); Divertissement (Dotras Vila). 10.45, Mexico — Spanish — American Programme, followed by Dance Music, relayed from the Casa Libre. In the interval at 12 Midnight, News. 1.0 a.m. (Sunday), Close Down.

BARI

1,112 kc/s, 269.8 metres; 20 kW.—8.0 p.m., Agricultural Notes, Tourist Report and Dopolavoro Notes. 8.20, Giornale Radio and News in Albanian. 8.30, Time and Announcements. 8.35, Sports Notes. 8.45, Aida—Opera in Four Acts (Verdi), on Gramophone Records. In the intervals, Talk: The Battle of Lepanto, and Amusement Guide. After the Opera, Giornale Radio. BASLE.—See Schweizerischer Landessender.

BELGRADE

697 kc/s, 430.4 metres; 2.8 kW.—6.55 p.m., Time and Announcements. 7.0, Gramophone Music. 7.30, Recitations. 8.0, Orchestral Concert: Soloist, Jelena Dokic-Djurkovic (Pianoforte). 8.30, A Radio Play. 9.0, I Pagliacci, Opera (Leoncavallo) on Gramophone Records. 10.15, Time and News. 10.30 (approx.), Cigány Music from the Potrosacka Zadruga Restaurant. 11.0, Gramophone Music.

BERLIN

DEUTSCHLANDSENDER (Reichsender), 183.5 kc/s, 1,635 metres; 60 kW.—1.45 p.m., News. 2.0, Gramophone Concert. 3.0, Handwork for Children. 3.30, Weather and Exchange. 3.45, Talk: The German Landscape — the Plains. 4.0, See Hamburg. 5.0, Review of the Week's Sport. 5.20, Folk Songs by a Male Voice Double Quartet and a Horn Ensemble. 6.0, Poems. 6.5, Dialogue: Theatrical Art and the Reich. 6.20, Variety Programme. 6.50, Weather and News. 7.0, Transmission for all German Stations: New German Dance Music—First Performances, from Manuscript, by Robert Gaden and his Band: Manzanilla (Siegel); Heimatklänge (Bortz); Niemand liebt dich so wie ich (Kirchstein); Es klagt die Rose (Pörschmann); Tränen der Liebe (Siegel); Dämmrung (Kudritzki); Komm du meine zärtliche Freundin (Künneke); Funken der Liebe (German); Hast du denn alles vergessen? (Mohr); So ist die Welt (German); Valse-Barcarolle (Pasola); Flotte kleine Beichen (Luwowski); In die Welt hinaus (Siegel). 8.0, To-day's Motto. 8.10 (approx.), An Italian Night—Programme of Dance Music. 10.0, Weather and News. 10.45, Weather for Shipping. 11.0, Programme from Berlin (Funkstunde). 12.30 a.m. (Sunday), Close Down.

BERLIN

FUNKSTUNDE, 715 kc/s, 419.5 metres; 1.5 kW.—4.0 p.m., Light Music and Dance Music, relayed from the Krollgarten. In an interval at 5.0 (approx.), Sports Talk. 5.30, Radio Report on Gramophone Records: Kus-trin—a Hard School. 6.0, Four Ballads for Pianoforte, Op. 10 (Brahms), by Johannes Strauss.

6.20, Descriptive Music—Mountain, Sea and Forest in the Music of Many Lands—Talk, with Gramophone Illustrations. 6.40, The Funkstunde informs its Listeners. 6.45, Topical Talk. 7.0, Transmission for all German Stations, relayed from Berlin (Deutschlandsender). 8.5, Variety Concert. 10.0, Weather and News. 10.10 (approx.), Light Music and Dance Music by Bernhard Homola and his Band, with Song Interludes. 1.0 a.m. (Sunday), Close Down. BERNE.—See Schweizerischer Landessender. BEROMUNSTER.—See Schweizerischer Landessender. BODEN.—See Stockholm. BODO.—See Oslo.

BORDEAUX-LAFAYETTE

986 kc/s, 304 metres; 13 kW.—6.15 p.m., Radio Journal. 7.40, Sports Talk. 7.45, News, Racing Results, and Weather Report. 8.0, Concert of Gramophone Music. 8.30, Le Songe d'une nuit d'été—Opera in Three Acts (Thomas), relayed from the Casino, Vichy.

BRATISLAVA

1,076 kc/s, 279 metres; 14 kW.—7.0 p.m., See Prague. 11.30 (approx.), Close Down.

BREMEN.—See Hamburg.

BRESLAU

923 kc/s, 325 metres; 60 kW. Relayed by Gleiwitz, 1,184 kc/s, 253 metres.—1.0 p.m., Weather. 1.5, Gramophone Concert. 1.45, Time and News. 2.5, Gramophone Concert. 3.0, Agricultural Prices. 3.10, Book Review. 3.30, Talk: The New Type of German Student. 3.50, Film Review. 4.5, Georg Langer reads from his Novel, Die armen Hanse. 4.30, Concert of Light Music by Fahrbaeh-Elmki and his Orchestra, relayed from the Café Vaterland. 5.30, Talk: Coming Events. 5.40, Reading (Oswald Gerhardt). 6.0, Concert by the Kruse Orchestra, relayed from the Goldene Krone Café. 6.50, Weather and News. 7.0, Transmission for all German Stations, relayed from Berlin (Deutschlandsender). 8.0, Programme to be announced. 8.20, Variety Concert by the Station Orchestra, conducted by Ernst Topitz. 10.20, Time and News. 10.50, Dance Music on Gramophone Records. 12 Midnight (approx.), Close Down.

BRNO

878 kc/s, 342 metres; 35 kW.—6.25 p.m., German Transmission: News, and Moravian Folk Song Recital. 7.0 till Close Down, See Prague. 11.30 (approx.), Close Down.

BRUSSELS (No. 1)

I.N.R., 590 kc/s, 509 metres; 15 kW.—12 Noon, Gramophone Music: Selection from Bruni (Verdi); Symphonic Dances (Grieg); March of the Boyards (Halvorsen). 1.0 p.m.,

Le Journal Parlé. 1.10, Concert by the Small Station Orchestra: Overture, Le roi l'a dit (Delibes); Waltz from The Chocolate Soldier (O. Strauss); Selection from Le roi d'Ys (Lalo); Plaisir d'amour (Martini); Spanish Dance for 'cello (Popper); Selection from Rip (Plauquette); Waltz, L'amour, toujours l'amour (Friml); One Step (Calidi). 4.45, Talk: The Prisoner of War. 5.0, Concert by the Station Symphony Orchestra: Overture, Paraglyph 3 (Suppé); Extracts from La fiancée de la mer (Bloekx); Night on the Bare Mountain (Mussorgsky); Turkish Carnival (Luigini); Intermezzo from Cavalleria rusticana (Mascagni); Waltz (Arditi). 6.0, Talk: The Smaller Museums of Brussels. 6.15, Gramophone Music: Waltz from Les cent vierges (Lecoeq); Selection from Cydalise et le chevre-pied (Pierne); London Sketches (Francis-Casadesus); Extracts from Le roi d'Ys (Lalo); Last Movement from Quartet No. 1 (Dittersdorf); La procession nocturne (Rabaud); Impressions of Damascus (Kougel). 7.15, Talk: The Education of the Deaf and Blind. 7.30, Wireless Notes. 8.0, Cantecor (Busser), on Gramophone Records. 8.5, Le Cid—Tragedy in 5 Acts (Corneille). 10.0, Le Journal Parlé. 10.10, Dance Music from the Century Hotel at Antwerp.

BRUSSELS (No. 2)

I.N.R., 887 kc/s, 338.2 metres; 15 kW. Programme in Flemish.—12 Noon, Concert by the Small Station Orchestra, conducted by Leemans. 1.0 p.m., Le Journal Parlé. 1.10, Gramophone Concert. 4.45, Talk. 5.0, Dance Music, relayed from the St. Sauveur Palais de Danse. 6.15, Talk: Libraries in Flanders. 6.30, Concert by the Small Station Orchestra, conducted by Leemans. Soloists: Donizet (Pianoforte), and Gilman (Flute). Overture, Gli Orazii e Curiazii (Cimarosa); Danse sacrée and Danse profane for Pianoforte and String Quartet (Debussy); Air from La Vannina (Bastide); Dances from The Bartered Bride (Smetana); Flute Solo: Bulboul (Poldini); Selection from Cydalise et le chevre-pied (Pierne). 7.15, Talk. 7.30, Film Review. 8.0, Concert by the Station Symphony Orchestra, conducted by Meulemans. Part I: Massenet Music. Overture, Phédre; Suite from La Cigale; Meditation from Thaïs; Ballet Suite; Elégie; Entracte and Air from Don César de Bazan. Part II: Klokke Roeland (Tinel); Petite Suite (Roels); Old Popular Ypres and Poperinghe Songs; Spanish Fantasia (Gevaert); Danse des sorcières (De Boeck). 10.0, Le Journal Parlé. 10.10, Dance Music from the Palais Saint Sauveur.

BUCHAREST

761 kc/s, 394 metres; 12 kW.—5.0 p.m., Concert of Light Music and Romanian Music by the Sibicane Orchestra. In the interval at 6.0, Radio Journal. 7.0, Reading. 7.20, Instrumental Music on Gramophone Records. 7.40, Educational Talk. 8.0, Concert by the Amza Church Choir, conducted

by Lungu. 8.30, Talk. 8.45, Popular Romanian Music by the Fanica Orchestra. 9.45, Radio Journal.

BUDAPEST

545 kc/s, 550.5 metres; 18.5 kW. Also relayed on 840 metres from 8.0 p.m. till Close Down.—5.30 p.m., Cigány Band Concert. 6.30, The Letter Box. 7.0, Gramophone Concert. 8.0, Die Gyurkovics Buben—Operetta in Four Acts (Farkas). 10.20, News. 10.30 (approx.), Cigány Band Concert, relayed from the Café Emke. Soloist: Imre Laszlo (Hungarian Folk Songs).

GASSEL.—See Frankfurt.

COPENHAGEN

1,067 kc/s, 281 metres; 0.75 kW. Relayed by Kalundborg, 260 kc/s, 1,153.8 metres.—12 Noon, Time Signal and Chimes from the Town Hall. 12.2 p.m., Concert by the Bendix String Ensemble, relayed from the Wivex Restaurant. 2.0, Interval. 3.0, Gramophone Concert of Variety Music. 3.30, Concert by the Louis Preils Instrumental Ensemble: Slovak March (Lehár); Waltz (Aarkrog); Manhattan Moonlight (Alter); Laengel (Skovgaard); Suite, The Three Bears (Coates); Wien, du bleibst das verwöhnteste Kind der Welt (Rotter); Pianoforte Solo: Kaskaden (Kapplusch); Two Step, Südlisches Feuer (Gronastay and Borchert); Flower Song (Schräder); Waltz Intermezzo (Kapplusch); Marionetten auf der Spieluhr (Armandola); Selection from Bitter Sweet (Noel Coward); Melody (Filippucci); Hungarian March, Attila (Fucik). 5.30, Exchange and Fish Market Prices. 5.45, Talk. 6.15, French Lesson. 6.45, Weather. 6.54, Announcements. 7.0, News. 7.15, Time Signal. 7.20, Talk. 8.0, Time Signal from the Town Hall. 8.1, Concert of Danish Music by the Station Orchestra, conducted by Launy Gröndahl: Soloist, Hertla Björvig (Songs); Pieces (Lunbye); (a) Kong Frederik VII's Houndmarch, (b) Kolymbine Mazurka, (c) Nordlys Vals, (d) Galop, Salut for August Bourneville; Five Songs: Overture, Et Eventyr i Rosenborg Have (Weyse); Ballet Music from Erlethügel (Kuhlan); Tarantella from Napoli (Paulli). 9.0, Reading. 9.20, Concert of French Opera and Ballet Music by the Station Orchestra, conducted by Launy Gröndahl: Suite No. 2 from Carmen (Bizet); Ballet Music from Faust (Gounod); Suite from Coppélia (Delibes). 10.10, News. 10.25, Cabaret Programme. 10.50, Dance Music, relayed from the Ritz Restaurant. In an interval at 12 Midnight (approx.), Time and Chimes from the Town Hall. 12.15 a.m. (Sunday), Close Down.

CORK.—See Athlone.

CRACOW

959 kc/s, 312.8 metres; 1.5 kW.—7.20 p.m., Miscellaneous Items and News. 7.35, Programme Announcements. 7.40, See Warsaw. In the intervals at 9.15 and 10.25, News and Sports Notes. 12 Midnight (approx.), Close Down.

DANZIG.—See Heilsberg.

DRESDEN.—See Leipzig.

FECAMP

1,323 kc/s, 225.9 metres; 10 kW.—11.0 a.m., to 12 Noon, Programme in English by the I.B.C. 11.0, Happy Hour: Part I—Request Programme: Signature Tune; Victoria March (von Blon); Banjo Solo, The Wedding of the Painted Doll (Brown); Selection from The Merry Widow (Lehár); My South Sea Home (Camillio); In the Sudan (Sibeck); I'd love to be a Sailor (Lauder); Selection from Floradora (Leslie Stuart); Old Music-Hall Memories; Part II—Request Programme of Dance Music: When my little Pomeranian; Shuffle off to Buffalo; I've got the World on a String; One tiny Tear; St. Louis Blues; Cabin in the Cotton; You're getting to be a Habit with me; Stormy Weather; I shall still keep smiling along; Drifting down the Salinair; Signature Tune. 12 Noon, Programme in French. 4.30 p.m. to 6.0 p.m., Programme in English by the I.B.C. 4.30, Programme for Children. 5.0, Concert for Tunbridge Wells and Isle of Thanet Listeners: Signature Tune, The Night by the Sea; Overture, Mignon (Thomas); Minuet from the Petite Suite (Debussy); Song, Comin' through the Rye (arr. Smart); Entrance of the little Fauns (Pierne); Selection from Die Fledermaus (Strauss); Song, My lovely Celia (arr. Lane Wilson); Liebestraum (Lizt); Modern Conception of Russian Melodies (di Filippi). 5.30, Organ Recital for Dover and Folkestone Listeners: Ca c'est Madrid (O'Henry); The Old Spinning Wheel (Hill); Chant sans paroles (Tchaikovsky); My Wishing Song (Burke); Signature Tune. 5.45, Popular Concert: Waltz from Naïa (Delibes); Mors et Vita (Gounod); Liebestraum (Liszt). 6.0, Programme in French. 11.0 till Close Down, Programme in English by the I.B.C. 11.0, Talkie Time: Times from Talkies; Signature Tune, Sittin' in the Dark; Moon Song; You're getting to be a Habit with me; You don't understand; One little Drink; Come out Vienna; There's something about a Soldier; I got Rhythm; The Crooner; Signature Tune. 11.30, Concert by the I.B.C. (Ireland), Ltd.; Signature Tune, Come back to Erin; The Dwarfs' Patrol (Rathke); The Musical Clock of Madame Pompadour (Noack); My Lady Dainty (Hesse); The Minstrel Boy; Lytophone Solo, Fiddlesticks

SEPT. 16th

**SATURDAY**

continued

**HILVERSUM**

Announced **HUIZEN**, 296.1 metres; 20 kW. (7 kW. up to 4.40 p.m.).—Programme of the Catholic Radio Society (K.R.O.). 11.40 a.m., Police Announcements. 11.55, Sextet Concert: Los Marimberos (Bochmann); Serenade (Pierne); Der Himmel voller Geigen (Ziehrer); Melody (Gauglberger); Klänge aus Rumänien (Dauber); Das Narzissenmädchen (Siede); Gramophone Music; Tanzelfchen (Kauler); Selection from The Birdfancier (Zeller); Melody (Ivanovici); Air (Krenzberger). 1.25, Interval. 1.40, Programme for Children. 3.40, Gramophone Music. 4.10, Talk. 4.20, Gramophone Music. 4.55, Sports Talk. 5.10, Orchestral Concert: Ballet Music from Isolde (Messager); Tragedy Overture (Lincke); Waltz, Ballsirenen (Lehár); In the Harbour of Port Said (Armandola); Suite, Four Ways (Coates). In the intervals at 5.25, Recitation, and at 6.0, Press Review. 6.40, Police Announcements. 6.55, Gramophone Music. 7.5, Two Talks. 7.40, Orchestral Concert: March, Wien bleib Wien (Schrammel); Gavotte (Gossec); La Zingara (Ganne); Gipsy Idyl (Percy); Spanish Gipsy Dance (Marquina); Hoch Heidecksburg (Herzer). 8.10, News. 8.15, Concert by the K.R.O. Boys. In the interval at 8.40, The Great Opportunity—Radio Play (Weisz-Bekkers). 9.55, Gramophone Music. 10.10, News. 10.15, Concert (contd.). 10.40, Gramophone Music. 11.40 (approx.), Close Down.

**HORBY**.—See Stockholm.

**HUIZEN**

Announced **HILVERSUM**, 160 kc/s, 1,875 metres; 7 kW. (up to 3.40 p.m.). Transmitted from **Kootwijk** on 50 kW. from 3.40 p.m.—11.40 a.m. till Close Down. Programme of the Workers' Radio Society (V.A.R.A.). 11.40, Concert by Eddy Wadis and his Orchestra. 12.10 p.m., Organ Recital by C. Steyn. 12.25, Concert (contd.). 12.55, Organ Recital (contd.). 1.10, Concert (contd.). 1.40, Gramophone Music. 2.10, Concert by De Fluerelinters, conducted by Ray Forest. Soloist: Weisvaeh (Tenor). 2.55, Talk on Films. 3.25, Concert by the V.A.R.A. Orchestra, conducted by Hugo de Groot. 3.55, Interval. 4.10, Concert (contd.). 4.40, Talk on Hawaii. 5.10, Concert (contd.). 5.40, Literary Talk. 6.0, Concert by the V.A.R.A. Children's Choir, conducted by Leida Hulshier. 6.40, Gramophone Music. 6.55, Dramatic Programme. 7.25, Gramophone Records. 7.40, S.O.S. Messages. 7.43, Press Review. 7.55, Concert by De Fluerelinters, conducted by Ray Forest. Soloist: Esther Philipse (Songs). 8.25, Gramophone Records. 9.10, Concert by the V.A.R.A. Orchestra, conducted by Hugo de Groot: Overture, Poet and Peasant (Suppé); Waltz, Kunstlerleben (Joh. Strauss); Selection from Rose Marie (Friml). 9.40, Song, Pianoforte and Guitar Recital. 9.55, Concert (contd.). Sousa Programme: March, Liberty Bell; Semper Fidelis; Manhattan Beach; King Cotton; Washington Post; Hands across the Sea; Hail to the Spirit of Liberty; Stars and Stripes. 10.25, Song, Pianoforte and Guitar Recital (contd.). 10.40, Concert by the V.A.R.A. Orchestra, conducted by Hugo de Groot. Soloists: Hugo de Groot and Johan Jong (Organ). 11.40 (approx.), Close Down.

**INNSBRUCK**.—See Vienna.

**JUAN LES PINS**

1,205 kc/s, 249 metres; 0.8 kW.—12.30 p.m., Amusement Guide and Variety Items. 1.0, News. 1.15, Radio Concert. 8.0, Amusement Guide, Exchange and News. 8.10, Radio Concert. 9.0, News and Weather. 9.15, Radio Concert (contd.).

**KALUNDBORG**.—See Copenhagen.

**KATOWICE**

734 kc/s, 408 metres; 16 kW.—7.10 p.m., Talk. 7.25, Announcements and Gramophone Music. 7.40 to 11.30, See Warsaw. 11.30, Dance Music.

**KIEL**.—See Hamburg.

**KLAGENFURT**.—See Vienna.

**KOSICE**.—See Prague.

**LAHTI**

167 kc/s, 1,796 metres; 40 kW. Relayed by **Helsinki**, 815 kc/s, 368.1 metres.—4.0 p.m., Concert by the Station Orchestra, conducted by Erkki Linko. 5.0, Talk. 5.25, Talk. 6.15, Military Programme. 8.45, News in Finnish. 9.0, News in Swedish.

**LANGENBERG**

635 kc/s, 473 metres; 60 kW.—1.30 p.m., Orchestral Concert, conducted by Eysoldt. March, Ins blühende Land (Schmidt-Hagen); Overture, Der Improvisator (d'Albert); Selection from The Miracle (Humperdinck); Waltz, Blume aus Spanien (Ailbont); Selection from Tannhäuser (Wagner); Märchen-Ouverture (Rust). In the intervals at 2.0 (approx.), News. 2.30, Gramophone Concert. 3.30, Market Prices and Time. 3.50, Talk: Excursions in the Rhineland and Westphalia. 4.20, Educational Talk. 4.40, Talk: The Various Races of Mexico. 5.0, Recital on Two Pianofortes by Hans Haass and Erich Rummel. Wiener Damen-Ländler, Op. 67

(Schubert); Graetzer Galopp (Schubert); Military March (Schubert); Two Pictures from the East (Schumann); The Kiss Waltz (Strauss-Alberti). 5.30, Concert by the Münster Municipal Orchestra, conducted by Jochem, Prelude to Die Lorelei (Bruch); Rhapsody No. 1 (Friedemann); Suite from The Sleeping Beauty (Tchaikovsky); Potpourri, Major and Minor (Schreiner). 6.15, Recitation of Ballads (Hans Friedrich Binck). 6.45, Weather, Sports Notes and Market Prices. 7.0, Transmission for all German Stations, relayed from **Berlin (Deutschlandsender)**. 8.0, News. 8.5, Harvest Festival Programme, relayed from **Odenthal**: Harvest Thanksgiving and Memorial Service for the Dead of the Great War and the National Revolution. 10.0, News. 10.45, Concert from **Stuttgart**. 12 Midnight, Close Down.

**LAUSANNE**.—See Radio-Suisse Romande.

**LEIPZIG**

769.9 kc/s, 389.6 metres; 120 kW. Relayed by **Dresden**, 941 kc/s, 319 metres.—12 Noon, Concert. 1.15 p.m., News and Programme Announcements. 1.30, See **Langenberg**. 2.30, News. 2.40, Wireless Hints. 2.45, Music Talk. 3.0, Concert by the Leipzig Instrumental Quartet. 3.30, Wireless Notes. 3.45, Economic Notes and News. 4.0, Concert by the Small Station Orchestra. 5.30, Programme for Young People. 6.0, German for Germans. 6.20, A Modern Dictionary. 6.30, Talk: The Wild Animals of Africa. 6.50, Agricultural Review. 7.0, Transmission for all German Stations, relayed from **Berlin (Deutschlandsender)**. 8.0, Political Cabaret. 8.45, German Dances by Ilse Berthold and a Dance Trio, with Introductory Talk. 9.15, Concert by the Station Orchestra, conducted by Blumer; Soloists, Barkin (Soprano) and Liechtenberg (Tenor); Extracts from Der Dumme August (Galler); Extracts from Madi (Stolz); Extracts from Eine Walzernacht (Galler). 10.20, News. 10.30 (approx.), Light Music and Dance Music by the Pleitzsch-Marko Orchestra. 12 Midnight, Close Down.

**LINZ**.—See Vienna

**LJUBLJANA**

522 kc/s, 574.7 metres; 7 kW.—8.0 p.m., Review of Foreign Affairs. 8.30, Concert by the Station Orchestra. 9.30, Time and Press Review. 9.45, Dance Music by the Station Jazz Band. 11.0 (approx.), Close Down.

**LUXEMBOURG**

252 kc/s, 1,191 metres; 200 kW.—French Programme. 7.30 p.m., Trio for Two Violins and Viola (Dvorák). 7.50, Light Music by a String Quintet. 8.10, Symphonic Fantasia (Berlioz), on Gramophone Records. 8.50, News in French. 9.0, Song Recital. 9.30, Concert by the Station Orchestra, conducted by Henri Pensis. Overture, Die Fledermaus (Joh. Strauss); Waltz, Brune on Blonde (Waldteufel); Narcissus (Nevin); Spanish Dances (Moszkowski); The Squirrel (Smith); Humoresque (Dvorák); Sambre et Meuse (Planquette). In an interval at 9.50, News in French. 10.30, Variety Items on Gramophone Records. 10.55, Dance Music by the Station Jazz Band.

**LWOW**

788 kc/s, 381 metres; 16 kW.—6.35 p.m., See **Warsaw**. 7.20, Announcements and Gramophone Music. 7.35, Programme Announcements. 7.40 to 9.15, See **Warsaw**. 9.15, Talk. 9.30, See **Warsaw**.

**LYONS**

**LA DOUA**, 644 kc/s, 465.8 metres; 1.5 kW.—7.30 p.m., Radio Gazette for Lyons and the South-East. 8.30, Orchestral Concert. After the Concert, News.

**MADRID**

**EJAJ**, 707 kc/s, 423.3 metres; 2 kW.—8.0 p.m., Chimes, Exchange, Announcements, and Request Gramophone Records. 9.15, News. 9.30, Interval. 11.0, Chimes, Time, News, Musical Comedy Selection and Literary Programme. 1.15 a.m. (Sunday), News. 1.30 (approx.), Chimes and Close Down.

**MALMO**.—See Stockholm.

**MILAN**

**VIGENTINO**, 662 kc/s, 453.2 metres; 4 kW.—8.30 p.m. (approx.) till Close Down, See **Rome**.

**MORAVSKA-OSTRAVA**

1,137 kc/s, 263.8 metres; 11 kW.—2.50 p.m., Concert by the Station Orchestra, conducted by Plichta: Overture, Maximilian Robespierre (Litolff); Emperor Waltz (Joh. Strauss); Tango (Jirak); Slav Dance and Melody (Sebestik); Selection from The Czarevitch (Lehár); Poème (Fibich); March (Provaznik). 3.55 to 4.0, See **Prague**. 5.45, Gramophone Music. 5.55, Reading. 6.10, Gramophone Music. 6.15, Talk. 6.25, Concert of Folk Music. 7.0, See **Prague**. 11.30 (approx.), Close Down.

**MOSCOW**

(TRADES UNION), 300 kc/s, 1,000 metres; 100 kW.—11.45 a.m., Weather. 2.45 p.m., Trio Concert of Music by Weckerlin and

Couperin; Soloists: Eskova (Soprano), Georgian (Cello), and Gutmann (Pianoforte). 3.55, Time. 4.0, Topical Talk. 4.30, Literary Programme. Part I: Reading of Poetry (Paolo Yashvili). Part II: Dramatic Items. 5.30, Play for Young People. 6.30, Programme to be announced. 9.0, News. 9.30, Programme Announcements. 9.55, Chimes from the Red Square. 10.5, Press Review.

**MOTALA**.—See Stockholm.

**MUHLACKER**.—See Stuttgart.

**MUNICH**

563 kc/s, 533 metres; 60 kW. Relayed by **Augsburg** and **Kaiserslautern**, 536 kc/s, 560 metres; and **Nürnberg**, 1,256 kc/s, 239 metres.—4.30 p.m., Orchestral Concert, conducted by Erich Kloss: Overture, The Caliph of Bagdad (Boieldieu); Movement from the Clarinet Quintet (Mozart); Beethoven Potpourri (Kusche); Waltz, Die ersten Gedanken (Lanner); Selection from The Merry Widow (Lehár); Zigeunerweisen (Sarasate); Wiegenlied (Kricka); March from The Arabian Nights (Strauss). 5.45, The Gliding Champion, Wolf Hirtel, talks with a Boy and a Girl on the Joys of Flying. 6.15, Chamber Music: Suite for Pianoforte, Flute and Violin, Op. 11 (Ambronis); Quintet for Violin, Viola, Cello, Flute and Guitar (Bocherini). 6.45, Wireless Notes. 7.0, Transmission for all German Stations, relayed from **Berlin (Deutschlandsender)**. 8.0, Variety Programme: Choral and Orchestral Music. 10.20, Time and News. 11.0, Concert from **Stuttgart**. 12 Midnight (approx.), Close Down.

**NAPLES**.—See Rome.

**NOTODDEN**.—See Oslo.

**OSLO**

277 kc/s, 1,083 metres; 60 kW. Relayed by **Fredriksstad**, 815 kc/s, 368.1 metres; **Hamar**, 522 kc/s, 574.7 metres; **Notodden**, 671 kc/s, 447.1 metres; **Porsgrund**, 662 kc/s, 453.2 metres; and **Rjukan**, 671 kc/s, 447.1 metres.—4.30 p.m., Concert of Gramophone Music. 5.15, Programme for Children. 6.15, Norwegian Music by Sigbjørn Bernhoff Osa (Hardanger Fiddle) and Solverpig Kjölö (Songs). 6.45, Talk on Economics. 7.0, Advertising Notes, Weather, and News. 7.30, Talk on the Coming Elections. 8.0, Time Signal. 8.1, Concert by the Station Orchestra, conducted by Hugo Kramm: Slav March (Lehár); Suite from Carmen (Bizet); Romanian Rhapsody (Dimitrescu); Aftenlands-kap (Halvorsen); Potpourri, Parisiana (Leopold); Grieg Potpourri (Goldfrey); Lischen et Fritzchen—Opera in One Act (Offenbach). 9.40, Weather and News. 10.0, Topical Talk. 10.15, Old Dance Music by the Akre Trio. 10.45, Modern Dance Music on Gramophone Records. 12 Midnight (approx.), Close Down.

**OSTERSUND**.—See Stockholm.

**PALERMO**

558 kc/s, 537.6 metres; 3 kW.—8.0 p.m., Dopolavoro Notes, Tourist Talk, Agricultural Notes and Giornale Radio. 8.20, Sports Notes. 8.25, Gramophone Music. In an interval at 8.30, Time and Announcements. 8.45, L'Amico Fritz—Opera in Three Acts (Mascagni). In the intervals, Talk and Announcements. After the Opera, News.

**PARIS**

**EIFFEL TOWER**; **Call FLE**; 207.5 kc/s, 1,445.7 metres; 13 kW. Time Signals (on 2,650 metres) at 10.26 a.m. and 11.26 p.m. (Preliminary and 6-dot Signals).—6.45 p.m., Theatre Notes. 7.0, Le Journal Parlé. 8.30, The Cricket on the Hearth—Play (Francisquill after the Novel by Charles Dickens). 10.0 (approx.), Close Down.

**PARIS**

**POSTE PARISIEN**, 914 kc/s, 328.3 metres; 60 kW.—7.0 p.m., Gramophone Music. 7.15, Le Journal Parlé. 7.30, Sponsored Gramophone Concert. 8.0, Talk: The Event of the Week. 8.30, Guy Sargé Concert of Chamber Music. 9.10, Dance Music by the Sonora-Radio Band, conducted by Fred Hoffmann. 11.0, News.

**PARIS**

**RADIO PARIS**, **Call CFR**, 174 kc/s, 1,725 metres; 75 kW.—7.30 a.m., Weather and Physical Culture. 7.45, Gramophone Music. 12 Noon, Gramophone Records: Melody (Hefner-Krier); Serenata (Malatz); Love's Dream after the Ball (Czibulka); Gifle (Viard); Waltz from Faust (Gounod); Piece deux virtuoses (de Nattes); Waltz, Wiener Bonbons (Johann Strauss); Melody (Hefner-Krier); La chasse aux caillots (Paradis); Sur les bords de la Seine (Scotti); Sérénade mauresque (Charf); Selection from O Kay! (Gershwin); The Glow Worm (Lincke); Bimba (Silvestri); Paddy (Jaquet); Bilboquet and his Pig (Bontemps); Dis-moi Josephine (Bela); Un debut au théâtre (Baeh and Lavigne); Potpourri, Fortissimo (Kalman); La poupee d'arlequin (Darey); Sandales do Brazil (Milhand). In the intervals at 1.0, Exchange and News, and at 1.30, Exchange. 2.0, Exchange.

SEPT. 16th

SATURDAY

continued

3.45, Exchange and Market Prices. 7.0, Agricultural Report. 7.10, Gramophone Concert; Selection from La Jour et la nuit (Lecocq); Souvenir (Drlday); Rigaudon (Lacome); Rattle of Spring (Sinding); Moss Rose (Bose); Le chant du berger (Servert-Bergeret); La carterana (Guerrero); Little White Lies (Donaldson); Minnet (Boccherini); In the Shadows (Pinck); Selection from Enlevé-moi (Gaharowe). 7.50, Commercial Prices and News. 8.0, Gramophone Music. 8.15, The Radio Paris Competition. 8.50, A Midsummer Night's Dream—Opera-Comique (Thomas), relayed from the Casino, Vichy. In the intervals at 9.40, Press Review and News.

PITTSBURGH

(KDKA), 980 kc/s, 306 metres; 50 kW. Relay by W8XK on 48.86 metres and 25.27 metres.—7.30 to 11.0 p.m., New York Relay. 7.50, Concert Echoes. 8.0, Words and Music. 8.30, Wealth of Harmony. 9.0, Dance Masters. 9.30, Concert Favorites. 10.0, Casino Orchestra. 10.30, Neil Sisters. 10.45, Orphan Annie. 11.0, News, Piano Classic. 11.15, Sports, A Song. 11.30, A Recreo, Bill and Alex. 11.45, Isaak Walton League. 12 Midnight to 3.15 a.m. (Sunday), New York Relay. 12 Midnight, Baritone Solos by Ross Pearson. 12.15, Ethel Waters. 12.30, Houston Ray's Orchestra. 1.0, Jack Denny's Orchestra. 1.30, Brown and Llewellyn. 1.45, Annie, Judy and Zeke. 2.0, Tales of the Titans. 2.30, Jamboree. 3.15, Behind the Law.

PORSGRUND.—See Oslo.

PRAGUE

614 kc/s, 488.6 metres; 120 kW.—2.50 p.m., See Moravská-Ostrava... 3.55, Aviation Weather Report 4.0, Interval. 5.45, Gramophone Music. 5.55, Talk. 6.5, Agricultural Report. 6.10, Gramophone Music. 6.15, Talk for Workers. 6.25, News in German. 6.30, German Transmission: Songs to the Guitar. 7.0, Chimes and News. 7.10, Talk: Astronomy. 7.25, Talk on the following Transmission. 7.30, Musical Comedy (Jezek), relayed from a Theatre. 10.0, Time and News. 10.15, Brass Band Concert. 11.30 (approx.), Close Down.

RADIO-SUISSE ROMANDE

SOTTENS, 743 kc/s, 403 metres; 25 kW.; and Geneva, 395 kc/s, 760 metres.—6.15 to 6.30 p.m. (from Lausanne), Gymnastics Lesson. 12.28 p.m., Time Signal from Neuchâtel Observatory. 12.30, News and Weather. 12.40 (from Lausanne), Gramophone Concert. Selection from Gipsy Love (Lehar); Waltz, Polenblut (Nedbal); Two Ländler and Two Schottisch by a Village Band. 1.0 (from Lausanne), Financial News. 1.10 (from Lausanne), Light Orchestral Concert. 1.40 (from Lausanne), Report relayed from the Chamber of Commerce, Beaulieu. 5.30 to 7.0, Interval. 7.0 (from Geneva), Talk: The Beginning of Photography. 7.30 (from Geneva), Weather, News and Announcements. 8.0 (from Geneva), Talk: Montaigne: his Work and Personality. 8.30 (from Geneva), Violin Recital by Lidus Klein. 8.50 (from Geneva), The Week's Review. 9.0, Concert of Operetta Music and Neapolitan Songs by the Radio-Suisse Romande Orchestra, conducted by Echenard. 9.50, News and Weather. 10.0, Concert (contd.). 10.30 (from Geneva), Dance Music. 11.30 (approx.), Close Down.

REYKJAVIK

250 kc/s, 1,200 metres; 21 kW.—9.5 p.m., Musical Programme. 9.30, Weather Report. 9.40, Musical Programme and Announcements. 10.0, Chimes and News. 10.30, Reading. 11.0, Concert by the Radio Trio, with Choral Music on Gramophone Records. After the Concert, Dance Music. 2.0 a.m. (Sunday), Close Down.

RIGA

572 kc/s, 525 metres; 15 kW.—6.0 p.m., Chopin Pianoforte Recital. 6.30, The Devil's Money—Play in Three Acts (Aspasie). In the intervals, News. 9.0, Weather. 9.5, Dance Music. 11.0 (approx.), Close Down.

RJUKAN.—See Oslo.

ROME

Call 1R0, 680 kc/s, 441 metres; 50 kW. Relay by Naples, 941 kc/s, 319 metres; and 2R0, 11,810 kc/s, 25.4 metres.—5.15 p.m.—12.30 p.m., Gramophone Music. 1.0, Orchestral Concert. In the interval from 1.15 to 1.20, Talk on Photography, and from 1.30 to 1.45, Giornale Radio. 4.30, Children's Radio Review. 4.50, Giornale Radio and Report of the Royal Geographical Society. 5.10, Weather. 5.15 to 6.0, Orchestral Concert: Napoli-Madrid (Bizzini); Sei tu (Molo); La luna nuova (Pisto); Selection from Addio giovinezza (Pietri); Algerina (Zucoli); One, two, three (d'Anzi);

Serenade. Notte stellata (Di Dio); Ma perche (Visintini). 6.40 (Naples), Shipping and Sports Notes. 6.45, Wireless Signals and Dopplavoro Notes. 7.0, Tourist Report. 7.10, Agricultural Report. 7.20, News in Foreign Languages. 7.40, Giornale Radio. 8.0, Time and Announcements. 8.15, Gramophone Music. 8.30, Giornale Radio and Sports Notes. 8.45, Il pirata. 9.0, Opera in Two Acts (Vincenzo Bellini). In the intervals, Talk and Science Review; Giornale Radio after the Opera.

SALZBURG.—See Vienna.

SCHENECTADY

WGY, 790 kc/s, 379.5 metres; 50 kW. Relay at intervals by W2XAF on 31.48 metres, and by W2XAD on 19.56 metres.—12.45 a.m. (Sunday), Stock Reports and Baseball Scores. 1.0 to 4.0, New York Relay. 1.0, Soloist. 1.15, The Rollickers Male Quartet. 1.30, Sons les Points de Paris. 2.0, Antibal's Cubans. 2.30, K-7, Secret Service Spy Story. 3.0, B. A. Rolfe and his Orchestra. 4.0, Programme Resumé.

SCHWEIZERISCHER LANDESSENDER

BEROMUNSTER, 653 kc/s, 459 metres; 60 kW.; Basle, 1,229 kc/s, 244.1 metres; and Berne, 1,220 kc/s, 245.9 metres.—12 Noon (from Berne), Gramophone Concert. In an interval at 12.30 p.m., Weather and News. 1.25 (from Berne), Time and Announcements. 1.30 (from Zürich), Answers to Correspondents. 1.45 (from Zürich), Book Review. 2.15 (from Zürich), Gramophone Concert. 2.45 (from Zürich), Talk: India Rubber and its Industrial Uses. 3.30, Interval. 5.0, Concert by a Village Orchestra, relayed from Glarus. 5.30 (from Zürich), Gramophone Concert. 6.0 (from Zürich), Talk. 6.30 (from Basle), Talk by Dr. Heinrich Kuhn. 7.0, Chimes from Zürich Churches. 7.15 (from Basle), Time and Announcements. 7.20, Opera and Operetta Music on Gramophone Records. 8.0 (from Basle), Talk on Prince Eugen. 8.30 (from Basle), Cello Duets of Old Franconian Music. 9.0, Weather and News. 9.10 (from Basle), Schubert Concert by the Breite Male Voice Choir. 10.15 (from Basle), Dance Music on Gramophone Records. 11.0 (approx.), Close Down.

SOTTENS.—See Radio-Suisse Romande.

STOCKHOLM

689 kc/s, 436 metres; 55 kW. Relay by Boden, 244 kc/s, 1,229.5 metres; Göteborg, 932 kc/s, 322 metres; Hörby, 1,166 kc/s, 257 metres; Motala, 221.5 kc/s, 1,354.4 metres; Östersund, 389 kc/s, 770 metres; and Sundsvall, 554 kc/s, 542 metres.—4.0 p.m., Concert by the Elite Orchestra. Soloist, Martin Blomquist-Barden (Songs); Overture. Les dragons de Villars (Mallart); Romance (Proman); Four Swedish Songs; Concert Waltz (Moszkowski); Melody (Leonavallo); March Potpourri (Winter). 5.5, Programme for Children. 5.45, Gramophone Music. 6.45, Talk: Autumn in the Mountains. 7.15, Weather and News. 7.30, A Visit with the Microphone. 7.45, Weather and News. 8.30, Concert of Light Music by the Station Orchestra. Soloists: Oluf Nielsen (Violin) and Sigrid Brandel (Songs). 10.0 (from Göteborg), Dance Music. 11.0 (approx.), Close Down.

STRASBOURG

869 kc/s, 345 metres; 11.5 kW.—11.30 a.m., Gramophone Concert of Classical Music. 12.45 p.m., News. 1.0, Time. 1.1, Light Music on Gramophone Records. 2.0, Legal Talk in German. 2.15, Gramophone Music. 2.45, Talk on Emmanuel Chabrier. 3.0, Light Music on Gramophone Records. 4.0, Interval. 5.0, Orchestral Concert, conducted by Maurice de Villers; Overture, Patrie (Bizet); Second Suite from L'Arlesienne (Bizet); Saxophone Solo; Flute Solo; Ballet Music from Le Cid (Massenet); Selection from L'enfant prodigne (Debussy); Bolero (Ravel). 6.15, French Education Lesson. 6.30, Orchestral Concert (contd.); Symphonie Overture, Ekkehard (Schreker); Minuet and Gavotte from Jeu de danse (Schreker); Intermezzo and Scherzo (R. Strauss); Humoresque (Reger); Popular Romanian Dances (Bela-Bartok). 7.0, Tourist Talk. 7.15, Gardening Talk in German. 7.30, Time and News. 7.45, Gramophone Music. 8.0, Press Review in German, Lottery Results and Announcements. 8.30, Concert by the Voelklingen Workers' Choir, conducted by Heinrich Speicher; Song (Flemming); Morgenrot (Nibel); Empor zum Licht (Uttmann); Bundeslied (Billow-Solinger); Hab mein Wagen voll geladen (Malden); Accu-

chen von Tharan (Sileher); In der Ferne (Sileher); Ich hört ein Sichelin rauschen (Kalm); Wohin mit der Freud (Sileher); Ach herziges Herz (Fink); Innsbruck ieu muss dich lassen (Isaac); Echo (di Lasso). 9.30, Dramatic Programme: (a) La chonanne—One-Act Lyric Play (Paul Gavallo) with incidental Music by Edmond Milla; (b) Le fiancé de Margot—One-Act Operetta (Planquette). 10.45, Dance Music, relayed from the Savoy. 12 Midnight (approx.), Close Down.

STUTT GART

MUHLACKER, 832 kc/s, 360.5 metres; 60 kW. Relay by Freiberg, 527 kc/s, 570 metres.—12.20 p.m., Concert by a Nazi Band, relayed from Pforzheim; Entry of the Guests from Taunhäuser (Wagner); Overture, Siez (Schell); Historic Marches (Kaiser); March. Die Helden vom Skagerrak (Segebrecht); March from Fridericus-Rex (Rolland); Badenweiler, March (Fürst); Potpourri, Erinnerungen aus dem Militärleben (Reckling). 2.30, Time and News. 2.50, Mouth Organ Concert. 3.30, Programme from Frankfurt. 4.30, See Munich. 5.45, Talk: Italy's New Organisation, the Dopplavoro. 6.10, Talk: Prehistoric Problems of the Alcmennic District. 6.35, Time and News. 7.0, Transmission for all German Stations, relayed from Berlin (Deutschlandsender). 8.0, Talk: Things One should know. 8.5, National Dances by the Station Orchestra, conducted by Otto Seyfert; Mazurka and Cracoviak, from A Life for the Czar (Glinka); España (Chabrier); Piedmontese Dance (Singaglia); Waltz from Der Rosenkavalier (R. Strauss). 8.45, Concert from Munich. 10.20, Time and News. 10.45, Concert by the Station Orchestra, conducted by Ferdinand Drost; Overture, Rosamunde (Schubert); Suite from Coppélia (Delibes); The Nutcracker Suite (Tchaikovsky); Polonaise from Eugene Onegin (Tchaikovsky). 12 Midnight (approx.), Close Down.

SUNDSVALL.—See Stockholm.

TOULOUSE

779 kc/s, 385 metres; 8 kW.—6.0 p.m., News. 6.15, Operetta Music: Selection from The Dollar Princess (Kálmán); Viennese Operetta Potpourri (Robrecht). 6.30, Sound Film Music. 6.45, Music by a Viennese Orchestra: Song from Frederica (Lehar); Selection from Cocorico (Ganne); The Glow Worm (Lincke); Come Gipsy (Kálmán). 7.0, Spanish Song Recital. 7.15, News, Racing Results, Market Prices and Exchange. 7.30, Ballet Music from Isoline (Messenger). 7.45, Opera-comique Music: Selection from Figaro (Mozart); La Traviata (Verdi) and I Pagliacci (Leonavallo). 8.0, Popular Melodies. 8.15, Light Orchestral Music. 8.30, Operetta Music: Songs from La Mascotte (Audran), Miss Decima (Audran and La basoche (Messenger). 8.45, Music by a Viennese Orchestra. 9.0, Concert: Part I, Extracts from Mignon, Opera (Thomas); Part II, Norwegian Rhapsody (Lalo); Selection from The Queen of Spades (Tchaikovsky); Lullaby from The Fire Bird (Stravinsky). 10.0, Sound Film Music. 10.15, North African News and Local News. 10.30, Concert for Listeners in Morocco; Les Heurs (Waldteufel); Aria from Paganini (Lehar); Overture, Raymond (Thomas); O sole mio (di Capua); Popular Medley. 11.0, Popular Music. 11.15, Dance Music. 12 Midnight, News, Weather and Announcements. 12.5 a.m. (Sunday), Variety Music. 12.30 (approx.), Close Down.

TRIESTE

1,211 kc/s, 247.7 metres; 10 kW.—5.20 p.m., till Close Down, See Turin.

TRONDHEIM.—See Oslo.

TURIN

1,096 kc/s, 273.7 metres; 7 kW. Relay by Milan, 905 kc/s, 331.5 metres; Genoa, 959 kc/s, 312.8 metres; and Florence, 599 kc/s, 500.8 metres.—5.20 p.m., Gramophone Concert. 6.0 to 6.5, Weather Forecast. 6.40, Giornale Radio, Talk, Gramophone Music and Dopplavoro Announcements. 7.0, Time, Tourist Report and Gramophone Music. 7.10, Agricultural Notes and Market Prices. 7.20, News in Foreign Languages. 7.40, Gramophone Music. 8.0, Announcements, Giornale Radio, Sports Notes, Weather and Gramophone Music. 8.30, Talk: Events and Problems. 8.45, Variety Programme. In the interval, Book Review. 11.0, Giornale Radio.

VATICAN CITY

15,120 kc/s, 19.84 metres (Morning), and 5,969 kc/s, 50.26 metres (Evening); 10 kW.—11.0 to 11.15 a.m., Religious Announcements

in Various Languages. 8.0 to 8.15 p.m., Religious Information in Italian.

VIENNA

581 kc/s, 517 metres; 100 kW. Relay by Graz, 852 kc/s, 352.1 metres; Innsbruck, 1,058 kc/s, 283 metres; Klagenfurt, 662 kc/s, 453.2 metres; Linz, 1,220 kc/s, 245.9 metres; and Salzburg, 1,373 kc/s, 218.5 metres.—11.30 a.m., Songs of the Alps, on Gramophone Records: Zillertal, du bist mei Freud; Carinthian Folk Song, Der Wind walt; Der Lange; Du vergannter Kucku; Carinthian Folk Song, Almerausch; Kärntn is lei ans; Gailtaler Jägermarsch (Koschat). 11.55, Weather. 12 Noon, Orchestral Concert, conducted by Ganglbauer; Kaiserjägermarsch (Mühlberger); Overture, Rosamund (Schubert); Waltz, Salzburger Glockenspiel-Kinder (Schmid); Rhapsody (Carl Friedemann); Dance Song from Die Dame mit dem Regenbogen (Gilbert); Waltz, La belle Pole-sane (Lehar); March, Wiener Mädel (Sicz-zynsky); Kirchbach-Marsch (Wacek); Overture, Edelweiss (Konczak); Waltz Song, Wo die Donau fließt (Schaale); Potpourri, Was wir lieben (Ganglbauer); Waltz, Frühlingstimmen (Joh. Strauss); March, Deutsch-Osterreich (Paisperl). 1.0 p.m., Time, Weather, News and Programme Announcements. 1.10 to 2.0, Orchestral Concert. 3.0, Time, Weather and Market Prices. 3.15, English Lesson. 3.40, Talk: Wieland. 4.5, Choral Concert: Anruf (Landau); Bergedacht (Neuhöfer); Lied der Brückenbauer (Beer); Two Pieces (Schubert): (a) Der Entenfernt, (b) Liebe, (c) Widerspruch; Love Song of the Thirteenth Century (Wäss); Lang, lang ist's her; Swabian Dance Song (Moldenhauer); Mailed (Othegraven). 4.45, Talk: Mountaineering in Japan. 5.10, Gramophone Concert: Prelude to Cavalleria rusticana (Mascagni); Song, (Mascagni); Aria from The Huguenots (Meyerbeer); Ballet Music from Samson and Delilah (Saint-Saëns); Flower Song from Carmen (Bizet); Le Carnaval des Animaux (Saint-Saëns). 6.5, Today's Motto. 6.10, Time, Weather, Sports Notes and Programme Announcements. 6.15, Oscar Strauss Concert by the Wiener Symphoniker, conducted by Josef Holzer; Overture, Die Königin; Heut bin ich mit dem Glück perdu—Song from Der Bauergeneral; March and Minuet from Die Prinzessin von Trapezunt; Waltz, Lieben im Mai; Entr'acte and Intermezzo from The Chocolate Soldier; Selection from A Waltz Dream; Song from Jungdietsch's Brautfahrt; Waltz from Didi; Song and Bolero from Das Tal der Liebe; Two Pieces from Marietta: (a) Frauen, ihr macht uns das Leben schön, (b) Man küsst sich, man liebt sich; Overture, Rind um die Liebe. 7.35, Topical Talk. 7.50, Am Ende—Play (Marie von Ebner-Eschenbach). 8.45 (approx.), See Rome. News in the interval.

WARSAW

212.5 kc/s, 1,411 metres; 120 kW.—11.57 a.m., Time Signal and Fanfare from the Tower of St. Mary's Church, Cracow. 12.5 p.m., Gramophone Music. 12.25, Polish Press Review. 12.33, Weather. 12.35, Gramophone Music. 12.55, Radio Journal. 1.0, Interval. 2.55, Gramophone Music. 3.5, News. 3.10, Announcements. 3.15, Gramophone Music. 3.25, Economic Notes. 3.35, Gramophone Music. 3.50, Rifle Club Report. 4.0, Programme for Invalids relayed from Lwow, 788 kc/s, 381 metres. 4.30, Gramophone Music. 5.0, Topical Talk. 5.15, Light Music, relayed from the Gastronomica Café. 6.15, Talk relayed from Lwow. 6.35, Violin Recital by Rosner, Chaconne (Vitali); Prayer (Handel-Flesch); Variations (Tartini-Carli-Kreisler); Introduction and Rondo capriccioso (Saint-Saëns); La Fille aux Cheveux de lin (Debussy); Fire Dance (Falla-Kochanski). 7.20, Miscellaneous Items. 7.35, Programme Announcements. 7.40, Literary Programme. 8.0, Concert by the Station Orchestra, conducted by Nawrot. Soloist: Mira Sololewska (Songs); Overture, Die schöne Galathée (Suppé); Waltz from Eva (Lehar); Songs: Potpourri, Von Wien durch die Welt (Hrubý); Songs; Cracovienne (Szygielynski); Polka (Wronski); Polish March (Hellmesberger). 9.5, Radio Journal. 9.15, Gardening Talk. 9.30, Chopin Pianoforte Recital by Mme. Rabecewicz. Three Etudes in (a) F minor, (b) D flat and (c) A flat; Barcarolle; Fantaisie-Improptu; Berceuse in D flat. Two Mazurkas Op. 23: (a) in B minor and (b) in D. 10.0, Dance Music relayed from the Gastronomica Café. 10.25, Sports Notes. 10.35, Aviation Weather Report and Police Notes. 10.40, Dance Music (contd.).

WILNO

533 kc/s, 563 metres; 16 kW.—7.20 p.m., Weekly Lithuanian Review. 7.35, Programme Announcements. 7.40, See Warsaw. 8.0, Request Music on Gramophone Records. 8.50 till Close Down, See Warsaw.

ZÜRICH.—See Schweizerischer Landessender.

Printed for the Publishers, ILIFFE & SONS LTD., Dorset House, Stamford Street, London, S.E.1, by The Cornwall Press Ltd., Paris Garden, Stamford Street, London, S.E.1.

UNITED STATES—The International News Co., 131, Varick Street, New York. FRANCE—W. H. Smith & Son, 248, Rue Rivoli, Paris; Hachette et Cie., Rue Réaumur, Paris. BELGIUM—W. H. Smith and Son, 71-75, Boulevard Adolphe Max, Brussels. INDIA—A. H. Wheeler & Co., Bombay, Allahabad and Calcutta. SOUTH AFRICA—Central News Agency, Ltd., AUSTRALIA—Gordon & Gotch, Ltd., Melbourne (Victoria), Sydney (N.S.W.), Brisbane (Queensland), Adelaide (S.A.), Perth (W.A.), and Launceston (Tasmania). CANADA—The American News Co., Ltd., Toronto, Winnipeg, Vancouver, Montreal, Ottawa, St. John, Halifax, Hamilton, Gordon & Gotch, Ltd., Toronto; Imperial News Co., Toronto, Montreal, Winnipeg, Vancouver, Victoria. NEW ZEALAND—Gordon & Gotch, Ltd., Wellington, Auckland, Christchurch and Dunedin.



# NEW and Improved



Showing how condenser screws into base for easy fixing.

# DUBILIER PAPER CONDENSERS

This new range of type 9200 non-inductive condensers represents the latest design in Condenser Practice, and embody all the features essential to the Constructor who follows the modern "all metal" trend of design.

The method of fixing these condensers to the chassis which is exclusive to this type of Dubilier Condenser demands only the minimum of space and has been designed by engineers to give absolute satisfaction.

PRICES . 1mfd. 2/6 ; 2mfd. 3/6 ; 4mfd. 7/-

## HERE ARE THE OUTSTANDING FEATURES

1. True non-inductive type of construction.
2. Available for working voltages from 300-900 D.C. peak.
3. Adequate factor of safety for each.
4. New method of fixing to chassis.
5. Aluminium containers with moulded bakelite top of distinctive appearance to match other components.
6. Takes up minimum amount of space on chassis.

**DUBILIER CONDENSER CO. (1925) LTD.,  
 DUCON WORKS, VICTORIA ROAD, NORTH ACTON, W.3**

The ALL-METAL WAY 1934  
 brings you that essential guide to A.C. mains working.  
 "THE ALL-METAL WAY"  
 Send to Dept. W.W.  
 The WESTINGHOUSE  
 BRAKE & SAXBY SIGNAL CO. LTD.  
 82, YORK ROAD, LONDON, N.1

# Over 50,000

wireless enthusiasts already have copies of this book. If you are on A.C. Mains you cannot afford to be without it. It tells you all you want to know about A.C. Mains, and also contains full details of, and circuits for use with, the new Westector. Detection and Automatic Volume Control are dealt with fully. The attached coupon will bring you a copy.

Please send me "The All Metal Way 1934"  
 I enclose 3d. in stamps.

Name .....

Address .....

11.11.33



# of GREAT strength

## BUT LITTLE SIZE

OSRAM "CATKIN" VALVES are essential for modern receiver practice. Immensely strong yet compact in design they are constructed to microscopically precise limits and therefore allow for greatly improved set performance. A set equipped with OSRAM "CATKIN" VALVES gives the highest quality reception.

The all-metal construction of OSRAM "CATKIN" VALVES is a radical departure and results prove beyond dispute that they definitely give more uniform results, complete freedom from microphonicity and more effective screening. A change to OSRAM "CATKIN" VALVES is a change to faultless radio reception.

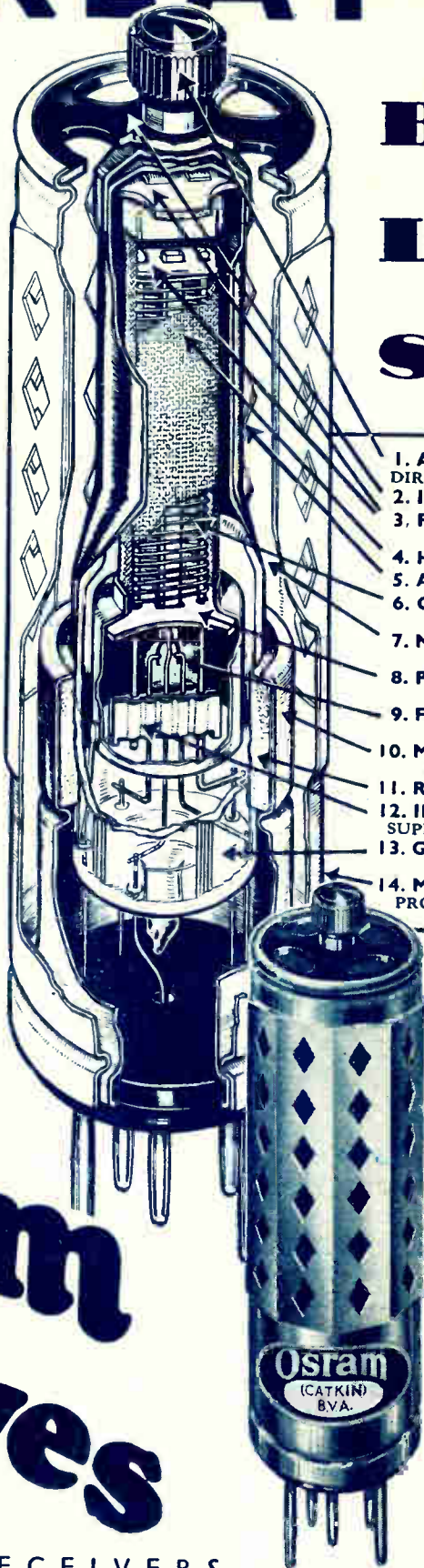

1. ANODE TERMINAL  
DIRECTLY CONNECTED—LOOSE CAP IMPOSSIBLE
2. INSULATION BETWEEN ANODE & SHIELD
3. PRECISION INSULATORS  
LOCKING ELECTRODES
4. HEXAGONAL SCREEN GRID
5. AIR COOLED ANODE
6. CONTROL GRID  
STRAIGHT WIRE CONSTRUCTION
7. METAL ANODE TO GLASS  
VACUUM TIGHT JOINT
8. PRECISION INSULATOR  
LOCKING ELECTRODES
9. FILAMENT CONNECTIONS THE ONLY WELDS  
IN THE ELECTRODE SUPPORT SYSTEM
10. METAL CAPPING SHELL GIVING MINIMUM  
GRID—ANODE CAPACITY
11. RUBBER MOUNTING ANTI-MICROPHONIC
12. INSULATED STEEL CLAMP  
SUPERSEDING DELICATE PINCH OF GLASS VALVE
13. GLASS CIRCULAR SEAL GIVING MAXIMUM  
INSULATION SPACING BETWEEN WIRES
14. METAL SHIELD GIVING MECHANICAL  
PROTECTION AND ELECTRO STATIC SHIELDING

### TYPES AND PRICES

- MS4B High Efficiency Screen-Grid A.C. Mains Valve - 17/6
- VMS4 Improved Variable Mu Screen-Grid A.C. Mains Valve - 17/6
- MH4 High Magnification Detector A.C. Mains Valve - 13/6
- MPT4 Power Pentode A.C. Mains Valve - 18/6

(Other types to follow)

Sold by all Wireless Dealers

**WRITE** for the OSRAM VALVE GUIDE (1933 Edition) sent post free.

"CATKIN" is the Trade Mark of the M.O. Valve Co. Ltd., manufacturers and patentees.

# Osram (CATKIN) Valves

Made in England.  
Covered by World  
Patents.

FOR A.C. MAINS RECEIVERS

**METAL INSTEAD OF GLASS**

Advt. of The General Electric Co. Ltd., Magnet House, Kingsway, London, W.C.2.



4<sup>D</sup>

# The Wireless World

THE PRACTICAL RADIO JOURNAL

with Complete Foreign Programmes

Friday, September 15th, 1933.

## TELSEN Intermediate Frequency TRANSFORMER COILS

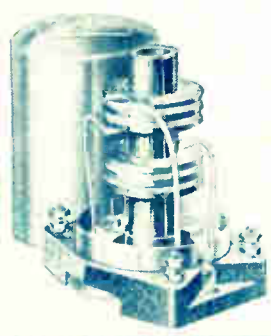

Specified by the designer of the "Wireless World" NEW MONODIAL SUPER. Ideal for every superhet where lasting efficiency is the first essential. Totally screened. The world's finest value at the new reduced price of **7/6**

**TELSEN FOR EVERYTHING IN RADIO**  
*Announcement of the Telsen Electric Co., Ltd., Aston, Birmingham.*

## SONOCHORDE The Supreme Reproducer

Sonochorde has brought sound reproduction to the highest standard of REALISM ever attained . . . you will be astounded at the fine performance, the perfect design and workmanship of these new models. The revolutionary concentric disc suspension which ensures permanent alignment of the speech coil with added sensitivity places Sonochorde in the forefront of advanced speaker craftsmanship. Write to-day for the Sonochorde Broadsheet.

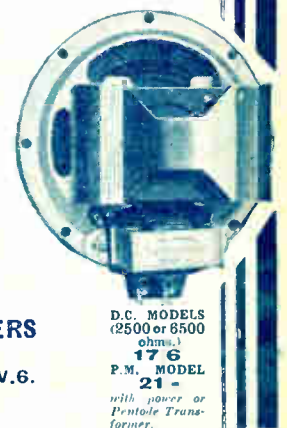

**SONOCHORDE REPRODUCERS LTD.**  
1, Willesden Lane, N.W.6.  
*Phone: Maida Vale 6066 (5 lines)*

D.C. MODELS (2500 or 8500 ohms.) **17/6**  
P.M. MODEL **21/-**  
*with power or Pentode Transformer.*

When you see the name

## DUBILIER



on your resistances you know you have the world's finest!

**1/- EACH**

## GET H.T. CURRENT from your L.T. BATTERY

WITH AN



★ THE ORIGINAL MACHINE for this purpose; first introduced 1924.  
★ Generates pure D.C.  
★ Takes only modest current. ★ Built to last  
MODELS TO SUIT ALL RECEIVERS  
Write for full details!  
ROUX LTD., RADIO DEPT. 3, WILLESDEN, LONDON, N.W. 10



## ANODE CONVERTER

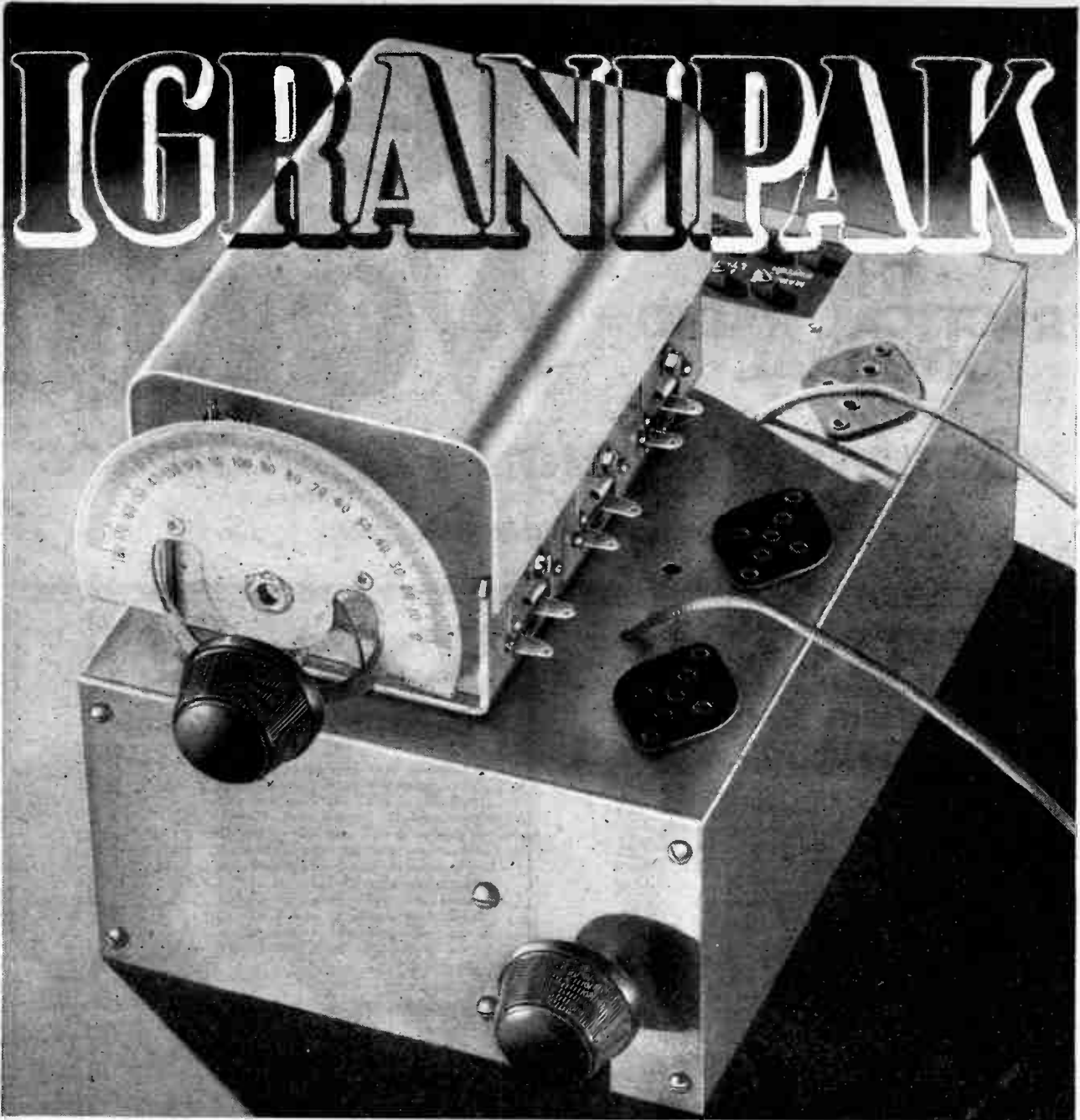

However expert or amateur you may be, this new 'Igranipak' cannot fail to save you time, trouble and expense. 'Igranipak' is a complete and compact tuning unit. Upon its rigid metal chassis are mounted:—screened coils with built-in wave-change switch, Igranic 3-gang condenser with cover, escutcheon and disc drive assembly with pilot lamp attachment, mains switch, three 5-pin valve-holders, grid leak and condenser, engraved terminal board. Wavelengths covered: 210-520m. and 900-2,000m. Complete with instructions and simple circuit diagram

**57/6**

If your local dealer cannot supply you please write to us direct.



Write for fully illustrated Catalogue No. U354.

Igranic Electric Co., Ltd.,  
149, Queen Victoria Street, E.C.4

CVS-88

*Mention of "The Wireless World," when writing to advertisers, will ensure prompt attention.*

The Wireless World

# PROGRAMMES from ABROAD

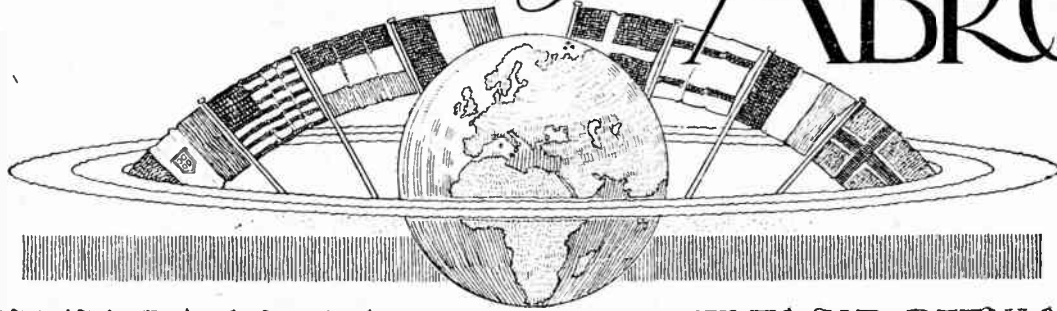

BROADCASTING STATIONS  
ARRANGED IN ORDER  
OF WAVELENGTH

TIMES AND DETAILS OF  
FULL WEEK'S FOREIGN  
TRANSMISSIONS

Metres.	kc s.	kW.	Station.	Tuning Positions.	Metres.	kc s.	kW.	Station.	Tuning Positions.
1935	155	7	Kaunas (Kovno) (Lithuania) .. .. .		453.2	662	0.25	Agen (France) .. .. .	
1875	160	8.5	Hilversum (Holland) ( <i>Kootwyk</i> , 50kW., after 3.10 p.m.) (F.A.R.A., I.F.R.O. and F.P.R.O. programmes.)		453.2	662	4	Milan (Vigentino) (Italy). ( <i>Relays Rome</i> ) .. .. .	
					450.3	666	20	Madona (Latvia). ( <i>Relays Riga</i> ) .. .. .	
1796	167	40	Lahiti (Finland) .. .. .		447.1	671		Paris, Ecole Supérieure, PTT (7.0 kW.); Rjukan (0.15 kW.), Notodden (0.08 kW.), Ålesund (0.35 kW.) (Norway) ( <i>relays Oslo</i> ); Rome, I.R.O. (S.W. Station, 2RO on 25.1 m.) .. .. .	
1725	174	75	Radio Paris, C.F.R. .. .. .		441.2	680	50	Stockholm, SASA (Sweden) .. .. .	
1635	183.5	60	Berlin. (Deutschlandsender) (Germany). (S.W. Stn. D.F.1 on 31.38 m., D.I.B. on 19.73 m., D.I.C. on 19.83 m., D.I.D. on 25.51 m., D.I.E. on 16.86 m.)		435.4	689	55	Belgrade (Yugoslavia) .. .. .	
					430.4	697	2.5	Madrid, EAJ7 (Union Radio) .. .. .	
1554.4	193	30	Daventry National .. .. .		424.3	707	2	Moscow, Imini Stalina (Russia) .. .. .	
1538	195	7	Ankara (Angora) (Turkey) .. .. .		419.5	715	1.5	Berlin, Funkstunde (Germany) .. .. .	
1481	202.5	500	Moscow, RV1 (Old Komintern) (Russia) .. .. .		416.4	720.5	5	Rabat (Morocco) .. .. .	
1446	207.5	13	Eiffel Tower, P.L. Paris .. .. .		413	725	60	Athlone (Irish Free State) .. .. .	
1412	212.5	120	Warsaw I (Poland) .. .. .		408.7	734	16	Katowitz (Poland) .. .. .	
1380	217.5	100	Novosibirsk, RV76 I (Russia) .. .. .		403.8	743	25	Sottens (Radio Suisse Romande) ( <i>Switzerland</i> ) .. .. .	
1354.4	221.5	30	Motala (Sweden). ( <i>Relays Stockholm</i> )		398.9	752	25	Midland Regional (Daventry) .. .. .	
1350	222	0.5	Tunis-Kashah (Tunisia) .. .. .		394.2	761	12	Bucharest (Roumania) .. .. .	
1304	230	100	Moscow, WZSPS (Trade Union) (Russia) .. .. .		389.6	770	120	Leipzig (Germany) .. .. .	
1230	244	0.6	Boden (Sweden). ( <i>Relays Stockholm</i> )		385.1	779	8	Toulouse (Radiophonie du Midi) (France) .. .. .	
1200	250	5	Stamboul (Turkey) .. .. .		385.1	779	10	Stalino, RV26 (Russia) .. .. .	
1200	250	21	Reykjavik (Iceland) .. .. .		381	788	16	Lwow (Lemberg) (Poland) .. .. .	
1190	252	200	Luxembourg .. .. .		376.4	797	50	Scottish Regional (Falkirk) .. .. .	
1170	256	25	Tashkent, RVII (Russia) .. .. .		372.2	806	1.5	Hamburg (Germany) .. .. .	
1154	260	75	Kalundborg (Denmark). ( <i>Relays Copenhagen</i> )		370.1	810.5	0.8	Radio, L.L. Paris .. .. .	
1154	260	20	Monte Generi (Switzerland). ( <i>Temporarily Closed</i> ).		368.1	815		Seville, EAJ5 (Union Radio) (1.0 kW.); Galicia, EAJ4 (0.2 kW.) (Spain); Bolzano (1.0 kW.) (Italy); Helsinki (10 kW.) (Finland) ( <i>relays Lahti</i> ); Khar'kov, RV20 (10kW.) (Russia).	
							0.7	Fredriksstad (Norway). ( <i>Relays Oslo</i> ) .. .. .	
1117	268.5	40	Moscow, Popoff RV58 (Russia) .. .. .		364.1	824	1	Bergen (Norway) .. .. .	
1083	277	60	Oslo (Norway) .. .. .		363.6	825	13	Algiers (Algeria) .. .. .	
1071	280	35	Tiflis, RV7 (Russia) .. .. .		360.6	832	60	Mühlacker (Stuttgart) (Germany) .. .. .	
1035	290	36	Kiev, RV9 (Russia) .. .. .		355.9	843	50	London Regional (Brookmans Park) .. .. .	
1000	300	100	Moscow RV39 (Russia) (S.W. Stn. on 50 m.)		352.1	852	7	Graz (Austria). ( <i>Relays Vienna</i> ) .. .. .	
938	320	20	Khar'kov, RV4 (Russia) .. .. .		348.8	860	7.6	Barcelona, EAJI (Spain) .. .. .	
857	350	100	Leningrad (Russia) .. .. .		348.8	860	10	Leningrad, RV70 (Russia) .. .. .	
840	357	18.5	Budapest (Hungary) .. .. .		345.2	869	11.5	Strasbourg, PTT (France) .. .. .	
825	363.6	50	Sverdlovsk, RV5 (Russia) .. .. .		341.7	878	35	Brno (Brunn) (Czechoslovakia) .. .. .	
760	395	1.3	Geneva (Switzerland). ( <i>Relays Sottens</i> )		338.2	887	15	Brussels H, Velthem (Belgium). ( <i>In Flemish</i> )	
720	416.6	20	Moscow, RV2 (Experimental) (Russia) .. .. .		335	896	5	Cadiz (Spain) .. .. .	
690	434.6	1.5	Oulu (Uleaborg) (Finland) .. .. .		334.4	897	1.9	Poznan (Poland) .. .. .	
680	441.2	0.6	Lausanne (Switzerland). ( <i>Relays Sottens</i> )		331.5	905	50	Milan (Italy). ( <i>Relays Turin</i> ) .. .. .	
574.7	522	7	Ljubljana (Yugoslavia) .. .. .		328.2	914	60	Poste Parisien (France) .. .. .	
569	527	0.25	Freiburg-im-Breisgau (Germany). ( <i>Relay Stn.</i> )		325	923	60	Brosiau (Germany) .. .. .	
568.1	528	2	Grenoble (France) .. .. .		321.9	932	10	Göteborg (Sweden). ( <i>Relays Stockholm</i> )	
563	533	16	Wilno (Poland). ( <i>Relay Station</i> ) .. .. .		318.8	941	0.25	Dresden (Germany). ( <i>Relays Leipzig</i> )	
560	536	0.25	Augsburg (Germany). ( <i>Relays Munich</i> ) .. .. .		318.8	941	1.5	Naples, INA (Italy). ( <i>Relays Rome</i> ) .. .. .	
560	536	1.5	Kaiserslautern (Germany). ( <i>Relays Munich</i> )		315.8	950	1.6	Marseilles, PTT (France) .. .. .	
550	545	18.5	Budapest No. 1 Lakihegy (Hungary) .. .. .		312.8	959	0.7	Radio Vitus (Paris). (S.W. Stn. on 43.75 m.)	
542	554	10	Sundsvall (Sweden). ( <i>Relays Stockholm</i> )		312.8	959	1.7	Cracow (Poland) .. .. .	
537.6	558	3	Palermo (Italy) .. .. .		312.8	959	10	Genoa, IGE (Italy). ( <i>Relays Turin</i> ) .. .. .	
533	563	60	Munich (Germany) .. .. .		309.9	968	50	West Regional (Washford Cross) .. .. .	
525	571	15	Riga (Latvia) .. .. .		307	977	0.75	Zagreb (Yugoslavia) .. .. .	
517.2	580	100	Vienna (Bisamberg) (Austria) .. .. .		304	986	13	Bordeaux Lafayette, PTT (France) .. .. .	
509	589	15	Brussels No. 1, Velthem (Belgium). ( <i>In French</i> )		301.5	995	50	North National (Manchester) .. .. .	
500.8	599	20	Florence, IFI (Italy). ( <i>Relays Turin</i> ) .. .. .		298.8	1004	11	Tallinn (Esthonia) .. .. .	
495.8	605	1.2	Trondheim (Norway) .. .. .		296.1	1013	20	Huizen (Holland). (7 kW. before 4.40 p.m.) .. .. .	
488.6	614	120	Prague (Czechoslovakia) .. .. .		293.5	1022	0.7	Limoges, PTT (France) .. .. .	
480	625	50	North Regional (Manchester) .. .. .		293.5	1022	2.6	Kosice (Czechoslovakia) .. .. .	
472.4	635	60	Langenberg (Germany) .. .. .		291	1031	13.2	Viipuri (Viborg) (Finland). ( <i>Relays Helsinki</i> )	
465.8	644	1.5	Lyons la Doua, PTT (France) .. .. .		288.3	1040	50	Scottish National (Falkirk) .. .. .	
459.4	653	60	Beromünster (Schweizerischer Landessender) (Switzerland).		288.3	1040	1	Bournemouth. ( <i>Relay Station</i> ) .. .. .	
			San Sebastian, EAJ8 (0.6 kW.); Pori (1.0 kW.) (Finland); Danzig (0.5 kW.) ( <i>relays Heilsberg</i> ); Klagenfurt (0.5 kW.) (Austria) ( <i>relays Vienna</i> ); Porsgrunn (0.7 kW.) ( <i>relays Oslo</i> ); Tromsø (0.1 kW.); Bodö (0.5 kW.) (Norway); Uppsala (0.15 kW.) (Sweden) ( <i>relays Stockholm</i> ).						



BROADCASTING STATIONS ABROAD (In Order of Wavelength)

Table with columns: Metres, kc/s, kW, Station, Tuning Positions. Lists various international broadcasting stations and their technical specifications.

PRINCIPAL SHORT-WAVE STATIONS

(N.B.—Times of Transmission, given in parentheses, are approximate only and represent B.S.T.)

Table with columns: Metres, kc/s, Call Sign, Station, Tuning Positions. Lists principal short-wave stations with call signs and transmission times.

# FOREIGN SUNDAY PROGRAMMES

SEPTEMBER THE SEVENTEENTH

## PRINCIPAL EVENTS OF THE DAY:

### AT HOME

<b>NATIONAL</b>	Carolare on the Christian Year, from Swansea.
<b>LONDON REGIONAL</b>	Brass Band concert.
<b>MIDLAND REGIONAL</b>	Light orchestral concert from Leamington Spa.
<b>NORTH REGIONAL</b>	Harvest Festival service from Lancaster Priory.
<b>WEST REGIONAL</b>	Harvest Festival service from Box Parish Church.
<b>SCOTTISH REGIONAL</b>	Service from the Church of the Holy Rude (E), Stirling.
<b>BELFAST</b>	Evensong from St. James' Parish Church, Belfast.
<b>ABROAD</b>	
<b>BRUSSELS (No. 1)</b>	5.0 p.m. The Station Symphony Orchestra, conducted by Kumps.
<b>BRUSSELS (No. 2)</b>	9.0 p.m. Saint Saëns concert by the Station Symphony Orchestra.
<b>BUDAPEST</b>	10.10 p.m. Cigány concert from the Café Ostend.
<b>HAMBURG</b>	12.0 noon. The Philharmonic Orchestra.
<b>HEILSBERG</b>	12.0 noon. The Königsberg Opera House Orchestra.
<b>HILVERSUM</b>	7.55 p.m. The K.R.O. Orchestra, conducted by Gerritsen.
<b>HUIZEN</b>	7.55 p.m. The Station Orchestra.
<b>LANGENSBERG</b>	5.45 p.m. Extracts from "Cavalleria Rusticana" (on gramophone records).
<b>VIENNA</b>	12.0 noon. The Wiener Symphoniker. 8.10 p.m., "A Flight Round the World"; radio potpourri.

## BUCHAREST

761 kc/s, 394 metres; 12 kW.—9.0 a.m., Divine Service. 10.30, Religious Address. 10.45, Sacred Music on Gramophone Records. 11.0, Light Music and Romanian Music by the Jean Dumitresco Orchestra. 12.0 Noon, Symphony Music on Gramophone Records. 12.45 p.m., Radio Journal. 1.0, Romanian Music on Gramophone Records. 4.0, Programme for Peasants. 5.5, Light Music and Romanian Music by the Jean Marco Orchestra. In the interval at 6.0, Radio Journal. 7.0, Educational Programme. 7.20, Dance Music on Gramophone Records. 7.40, Educational Programme (cont'd.). 8.0, Song Recital by Niculesco-Bassu. 8.20, Concert by the Station Orchestra. In the interval at 9.0, Talk. 9.45, Radio Journal.

## BUDAPEST

545 kc/s, 550.5 metres; 18.5 kW. Also relayed on 840 metres from 7.30 p.m. till Close Down.—11.15 a.m., Protestant Service, followed by Concert by the Opera House Orchestra, conducted by Otto Berg. In the interval, Radio Chronicle. 2.0 p.m., Gramophone Music. 3.0, Agricultural Programme. 4.55, News. 5.0, A Hungarian Comedy in Four Acts. 7.30, Military Band Concert. 8.40, Recital by Stefan Zagon. 9.10, Cello Recital by Arnold Földessy. 9.55, News. 10.10, (approx.), Cigány Concert from the Café Ostend. In the interval, Hungarian Folk Songs.

CASSEL.—See Frankfurt.

## COPENHAGEN

1,067 kc/s, 281 metres; 0.75 kW. Relay by Kalundborg, 260 kc/s, 1,153.8 metres.—8.0, Morning Gymnastics. 9.0, Agricultural Talk. 10.0, Divine Service, relayed from the Cathedral, Odense. 11.30, Weather. 11.40, News. 12 Noon, Time Signal and Chimes from the Town Hall. 12.2 p.m., Concert by the Mogens Hansen Instrumental Ensemble. 1.0, Talk in English: The Grand Tour of Scotland. 1.20, Talk in German: The German Novel of the Pre-War Period. 1.40, Talk in French: Among the Ragpickers—a Picture of the Paris Slums. 2.0, Concert. 3.0, Gramophone Concert. 3.30, Programme for Children. 4.0, Orchestral Concert, conducted by Teddy Petersen, relayed from the Wivex Restaurant. 5.0, Divine Service Relay. 6.20, Talk on Napoleon. 6.50, Weather. 7.0, News. 7.15, Time Signal. 7.30, Talk: The Economic Situation in the United States. 8.0, Time Signal from the Town Hall. 8.1, Concert by the Station Orchestra, conducted by Laury Gröndahl. Overture (Nielsen). Waltz (Gungl); Festival Prelude (Andersen); Finale from Die Musikanten (Plotow); Salut Galop (Lumbye). 8.30, Danish Poets roam the World—Programme of Songs and Recitations. 9.10, Orchestral Concert (cont'd.). Overture, Haermandene paa Helgeland (Hartmann); Meister Erik Polka (Lumbye); Prelude to Act II of Thyrring (Gröndahl); Festival Waltz (Möller). 9.35, The Hansen Family—Comic Sketch (Jens Locher). 9.50, Orchestral Concert (cont'd.). The Phantom Brigade (Myddleton); Polonaise from Et Folkesagn (Gade); Mazurka from His Life for the Czar (Glinka); Turkish March (Eilenberg). 9.10, Cello Recital of French Music by Karl Bjarnhof. 10.25, News. 10.35, Orchestral Concert (cont'd.): Overture, Masaniello (Auber); Waltz (Waldteufel); Mazurka (Gade); Anise Galop (Möller). 11.0, Dance Music, conducted by Otté Lington, relayed from the Ritz Restaurant. In an interval at 12 Midnight, Time Signal and Chimes from the Town Hall. 12.20 a.m. (Monday), Close Down.

CORK.—See Athlone.

DANZIG.—See Heilsberg.

DRESDEN.—See Leipzig.

## FECAMP

1,328 kc/s, 225.9 metres; 10 kW.—11.0 to 12 Noon, Programme in English by the I.B.C. 11.9 a.m., Happy Hour. Part I, Orchestral Concert: Signature Tune; French Comedy Overture (Kéler-Béla); Love in Cloverland (Peter); Selection from The Mikado (Sullivan); Pianoforte Solo: Minuet (Paderewski); Sérénade (Piercé); Gavotte from Mignon (Thomas); Life in the Wiener Prater (Translatour). Part II, Organ Recital: Three-Four Waltz Suite, No. 3 (Colleridge-Taylor); Who is Sylvia? (Schubert); Le Cygne (Saint-Saëns); Two Pieces from the Gothic Suite (Boelli); (a) Prière à Notre Dame, (b) Toccata; Menuet antique (Waltzing); The Storm (Shaw); Signature Tune. 12 Noon, French Programme. 2.0 to 7.50 p.m., Programme in English by the I.B.C. 2.0, Concert: M'appari tut' amor (Plotow); O Sole mio (di Capua); Vesti la Giubba (Looneyvallo). 2.15, Light Music: Annie (Lincke); The Valley of the Poppies (Anelli); Annual Antics (Wark); A Birthday Serenade (Lincke). 2.30, Special Request Programme: Swiss Fairytale (Stolz); Will Evans loses his Umbrella; If I had a Girl like you; Caravan; The Blue Train (Gorney); Will Evans unveils a Statue; Stumbling; Bye, Bye, Blues. 3.0, Light Orches-

## ATHLONE

725 kc/s, 413 metres; 60 kW. Relay by Cork, 1,337 kc/s, 224.4 metres.—8.30 p.m., Time Signal. 8.31, Music by the Aeolian Instrumental Quartet. 9.0, Baritone Solos by John F. West. 9.15, The Adventures of Ellis Palmer—Play, by I. P. Mitchell and his Company. 10.0, Soprano Solos by Chrissie Manning. 10.15, Violin Solos by Alice Feeley. 10.20, Music by the Aeolian String Quartet. 11.0, Time Signal, News, Weather Report and Close Down.

## BARCELONA

EAJ1, 860 kc/s, 348.8 metres; 8 kW.—12 Noon, Clames from the Cathedral and Weather Forecast. 2.0 p.m., Gramophone Music. In the interval at 2.30, Theatre Notes. 3.0, Sextet Concert. 4.0, Programme for Hospitals and other Benevolent Institutions, with Gramophone Records. 5.0 to 6.30, Interval. 6.30, Agricultural Talk in Catalan. 7.0, Concert by the Station Orchestra. 7.30, Song Recital by Maria Teresa González (Soprano). 8.0, Concert by the Station Orchestra and Carmen Gombau (Soprano). 9.0, Dance Music, relayed from Hollywood Bar. 10.0, Extracts from Musical Comedies on Gramophone Records. 11.45, Chess Lesson. 12 Midnight (approx.), Close Down.

## BARI

1,112 kc/s, 269.8 metres; 20 kW.—See Rome.

BASLE.—See Schweizerischer Landessender.

## BERLIN

DEUTSCHLANDSENDER (Reichssender), 183.5 kc/s, 1,635 metres; 60 kW.—9.0, Divine Service, relayed from Langenberg. 10.5, Weather, relayed from Berlin (Funkstunde). 11.0, Albert Sergel reads from his own Works. 11.15, Weather. 11.30, See Leipzig. 12 Noon, See Hamburg. In the interval at 12.55 p.m., Time Signal. 2.0, Programme for Children. 2.20, Short Stories. 3.0, Bach Organ Recital by Hans Georg Görner, relayed from St. Mary's Church. 3.30, Wilhelm von Scholz reads from his own Works. 4.30, See Langenberg. 5.0, In the Village Inn. 5.30, Concert Version of The Merry Wives of Windsor—Opera (Neolai), on Gramophone Records. 6.5, Discussion on the Beauties of the Southern Tyrol. 6.35, Märchenbilder (Schumann), by Irngard Veith (Viola). 7.0, Talk: How Nuremberg lost Dürer's most Beautiful Pictures. 7.20, Talk: The Light Athletic Championship—Germany v. France. 7.45, Songs of the Paszta (on Gramophone Records). 8.30, The Rape of the Sabine Women—Farce (Franz and Paul Schönthan), arranged for Radio by Hans Brenneck. 10.0, News. 10.45, Weather. 11.0, Dance Music from Langenberg. 12.30 a.m. (Monday), Close Down.

## BERLIN

FUNKSTUNDE, 715 kc/s, 419.5 metres; 1.5 kW.—11.30 a.m., See Leipzig. 12 Noon, See Hamburg. 2.0 p.m., Talks for Garden City Dwellers. 3.0, See Berlin (Deutschlandsender). 3.30, Concert by an Orchestra of Unemployed Musicians. In the interval at 5.0 (approx.), Radio Report of the Light Athletic Championship—Germany v. France, relayed from Paris. 6.0, Dialogue: True Wonder Tales for Children. 6.30, From the Austrian Alps—A Song Sequence for Tenor, Zither, Pianoforte and Harmonium. 7.0, Talk with Gramophone Illustrations: Insect Music. 7.20, A Family Excursion. 7.50, Sports Notes. 8.5, Das verwunschene Schloss—Operetta in Five Acts (Müllacker). 10.0, News. 10.15 (approx.), Dance Music relayed from the Moka Effi. In the interval at 11.0 (approx.), Talk: The German Revolution as seen from Abroad. 1.0 a.m. (Monday), Close Down.

BERNE.—See Schweizerischer Landessender.

BEROMUNSTER.—See Schweizerischer Landessender.

BODEN.—See Stockholm.

BODO.—See Oslo.

## BRAITSLAVA

1,076 kc/s, 279 metres; 14 kW.—5.40 p.m., Recital of Romanian Songs by Maria Balaceanu. 6.3, Pianoforte Recital by Rudolf Schubert. 6.40, Technical Talk. 6.55, Talk for Housewives. 7.0, See Prague. 7.5, Reading. 7.25, See Brno. 8.0, Mother of the Regiment (Play) in Three Acts (J. K. Tyl). 10.0, See Prague. 11.0 (approx.), Close Down.

BREMEN.—See Hamburg.

## BRESLAU

923 kc/s, 325 metres; 60 kW. Relay by Gleiwitz, 1,181 kc/s, 253 metres.—10.30 a.m., Pianoforte Trio Recital. 11.0, Th. Elbertzhagen reads from his own Works. 11.30, Talk on Chess. 11.45, Talk on Photography. 12 Noon, Concert from Schweidnitz. 2.0 p.m., Agricultural Talk. 2.15, Talk: The Motor. Railway Service. 2.35, Talk: Brumhid and Gudran. 3.0, Month Organ Recital. 3.30, Programme for Children. 4.0, Concert of

Opera Music. In the interval at 6.0, Hanns Weigl reads his story "Der Tod des Bauern." 7.10, Anecdotes about Paul Ernst. 7.30, Weather, Topical Talk and Sports Notes. 8.0, Concert by the Silesian Philharmonic Orchestra. In an interval at 8.0, News. 10.0, Time and News. 10.20, Report from Paris of the International Light Athletic Championship—Germany v. France (on Gramophone Records). 10.45, Dance Music from Berlin (Funkstunde). 12 Midnight, Close Down.

## BRNO

878 kc/s, 342 metres; 35 kW. 11.30 a.m., Report of the Motor Races from the Masaryk Speedway. 11.40, See Prague. 12.15 p.m., See Moravsko-Ostrava. 12.30, Report of the Motor Races (cont'd.). 12.40, See Moravsko-Ostrava. 1.30 to 1.45, Agricultural Talk. 2.15, Report of the Motor Races (cont'd.). 4.0, See Prague. 5.30, Vocal Concert. 6.0, German Transmission: Songs (Schubert-Hofländer). 7.0, See Prague. 7.25, Sketch (Lunge). 8.0, See Bratislava. 10.0, See Prague. 11.0 (approx.), Close Down.

## BRUSSELS (No. 1)

I.N.R., 590 kc/s, 503 metres; 15 kW.—10.0 a.m., Concert by the Small Station Orchestra, conducted by Leemans: Overture, Pierabras (Schubert); Petite suite (Debussy); Cavatina (Raff); Selection from La Favorita (Donizetti); Cello Solo: Berceuse (Leemans); Suite, En Bretagne (Rhené-Baton). 11.0, Gramophone Concert. 12 Noon, Concert, conducted by André Fellemann, relayed from the Grand Hotel, Antwerp: Overture, Poet and Peasant (Suppe); Flo-tow Fantasia (Crisch); Sérénade, Lobita (Boc); Potpourri of Hungarian Melodies (Geizer-Huber); Vibraphone Solo: Campana a Sera (Billo); Fantasia in the Form of a Rhapsody, Explosifs (Donizet). 1.0 p.m., See the Journal Parlé. 1.10, Concert by the Radio Orchestra, conducted by Franz André: Soloists: Géodel (Baritone) and Steurs (Acordion); Czardas (Borch); Slav Caprice (Bayer); A Swammer's Dawn (Horne); Polka, A dany (Desormes); Waltz, Donauwellen (Hranovec); Songs and Acordion Music; Three Airs (Turina); Potpourri of Hungarian Music (Mandros); Hungarian Dances (Brahms). In an interval at 1.30, Recitations. 5.0, Concert by the Station Symphony Orchestra, conducted by Kumps: Overture, Nocturne and Scherzo, from A Midsummer Night's Dream (Mendelssohn); Pavana pour une Infante défunte (Ravel); Valse lente (Sibelius); Symphony No. 1 (Beethoven). 5.30, Football Results. 6.0, Gramophone Concert of Variety Music. 6.45, Programme for Children. 7.0, Symphonic

Poem, Stenka Razin (Glazunov), on Gramophone Records. 7.15, Religious Address. 7.30, Talk on Music. 8.0, Concert by the Station Symphony Orchestra, conducted by Kumps: Overture, Géodeline (Clabrier); Prelude à l'Après-midi d'un faune (Debussy); Symphonic Variations for Cello (Bocmann); Ballet Music from Marouf (Rabaud). 8.40, Saug de Navel—One-Act Comedy (Mizuel Zaubois). 9.0, Concert by the Radio Orchestra, conducted by Franz André: Soloists: De Kock (Baritone); Overture, Le roi Et dit (Delibes); Four Pieces (d'Androsio); Spanish Caprice (Granados); Baritone Solos: Oriental Fantasia (Wieniawsky); Valse à la viennoise (Gédalge); Suite, English Scenes (Bantock); Jazz Novelties. 10.0, Le Journal Parlé. 10.10 (approx.), Close Down.

## BRUSSELS (No. 2)

N.I.R., 887 kc/s, 338.2 metres; 15 kW. Programme in Flemish. 12.0 a.m., Gramophone Concert. 11.0, Concert by the Small Station Orchestra, conducted by Leemans: Overture, Fra Davolo (Auber); Waltz from Sleeping Beauty (Tchaikovsky); Piece (Armandello); Selection from I Pagliacci (Leoncavallo); Gramophone Records: (a) A Valschella (Fosti), (b) O Sole mio (di Capua); Selection from Sylvia (Delibes); L'effe dans la plaine (Brussmans); Dance from Tango at Midnight (Komjati). 12.0 Noon, Concert by the Radio Orchestra, conducted by Franz André: Soloists: Géodel (Baritone) and Steurs (Acordion). 1.0 p.m., Le Journal Parlé. 1.10, Concert conducted by Fellemann, relayed from the Grand Hotel, Antwerp. 5.0, Dance Music relayed from the St. Sauveur Palais de Danse. 5.30, Football Results. 6.0, Finale of Act II of Tannhäuser (Wagner) on Gramophone Records. 6.30, Concert by the Small Station Orchestra, conducted by Leemans: Comic Opera (Kéler-Béla); Weber: Potpourri (Tavau); Aubade à Kiki (De Boeck); Selection from The Grand Duchess of Gerolstein (Offenbach); Eternelle Cantique (Gollub); Potpourri, Radio Budapest (Presi-Priehystal). 7.15, Religious Address. 7.30, Review of Music. 8.0, Concert by the Radio Orchestra, conducted by André: Soloists: De Kock (Baritone); Overture, Morning, Noon and Night (Suppe); España (Chabrier); Selection from Rose Marie (Friml); Songs; Norwegian Rhapsody (Svendson); Guildford Suite (Dumbill). 8.45, Recitation; Maria Lecina (Ruming). 9.0, Saint-Saëns Concert by the Station Symphony Orchestra, conducted by Kumps: Le rouet d'Omphale; La Jeunesse d'Hercule; Cello Concerto; Phaëton. 10.0, Le Journal Parlé. 10.30 (approx.), Close Down.

SEPT. 17th

SUNDAY

continued

tral Concert: Selection from Nülla (Delibes); The Skaters' Waltz (Waldteufel); Xylophone Solo: Dance (Abbey); Evolution of Dixie (Lake); Selection from "Sari" (Kálmán); Violin Solo: Valse Bluettes (Drigo); Pulcinello (Aletzer); March, from Sylvia (Delibes). 3.30, Military Band Concert: Washington Post March (Souza); Amorettenanz (Gungl); The Mill in the Black Forest (Eilenberg); Song: O Mistress Mine (Quilter); L'Entente Cordiale (Allier); Selection from Rigoletto (Verdi); Song: Wayside Rose (Lehár); Turkish Patrol (Michaels). 4.0, Judge Rutherford's Address. 4.15, The Nursery Corner. 4.30, Descriptive Adventure Story. 5.0, Orchestral Concert: Overture, Die Fledermaus (Joh. Strauss); Selection from The Merry Widow (Lehár); The Night was made for Love (Kern); My Hero (O. Straus); Selection from No. No. Nanette (Youmans); Violin Solo: Indian Love Call (Friml); Love will find a way (Fraser Simpson); Selection from The Dubarry (Millbeker-Mackeben). 5.30, Concert: Signature Tune; Jolly Good Company; Parade of the Tin Soldiers (Jessel); When day is done; Coal Black Mammy; Valencia; The Sheik of Araby; The Bells of St. Mary; Sleepy Valley; Happy Dorkies; Signature Tune. 6.0, Brighton-Bristol Alliance Concert: Hands across the Sea; Announcement by Councillor J. Talbot (Chairman of the Brighton Corporation Publicity Committee); Selection from The Merry Wives of Windsor (Nicolaï); Announcement by Mr. Frank Evans (Chairman of the Brighton and Hove Hotels Association); Brighton Camp; The Bee's Wedding (Mendelssohn); Twilight on the Waters (Squire); Devonshire Cream and Cider (Sanderson); Selection from The Pirates of Penzance (Sullivan); Green Hills of Somerset (Coates); Brightonia (Binding); Bells of Somerset; Drake's Drum (Stanford); Lull (Sanderson); The Old Superb (Stanford); Süsses by the Sea (Ward Higgs). 7.0, Instrumental Solos: The Old Folks at Home; The Return of Johnnie; Flapperette (Greer); What aloha means (Alphin); I can't write the Words; The Wedding of the Painted Doll; Tango de Paques; Dream Girl of Yesterday. 7.30, French Programme. 9.0 till Close Down, Programme in English by the I.B.C. 9.0, Ballito Concert of Dance Music: Signature Tune; Happy Feet; I've got to sing a Torch Song; You're mine, you; Somebody stole my Gal; Sweep; Dancing Butterfly; In a Second-hand Store; Stay out of my Dreams; Adorable; Signature Tune. 9.30, Talkie Time: Signature Tune; Sittin' in the Dark; Smilin' Through; The moment I saw you; But for you; Sweetheart Darlin'; Heaven will protect an Honest Girl; There's Magic in the Air; The Whip; Talking to you about me; Signature Tune. 10.0, I.B.C. Members' Request Half-Hour: The Blue Danube (Strauss); Tommy Lad (Margetson); My Heart stood still (Rodgers); The Porter's Love Song (Razaf); Serenata (Toselli); The Birth of the Blues (Henderson); After the Ball (Harris); Colonel Bogey (Alford). 10.30, Concert of Dance Music: My Love Song; In the Valley of the Moon; There's a Cabin in the Pines; Love Songs of the Nile; From me to you; The Shadow Waltz; Stay out of my Dreams; It's Sunday down in Caroline; A Night in June. 11.0, Dance Music by Tommy Kinsman and his Gros Club Band; Signature Tune; Cuban Love Song; Tom Thumb's Drum; What's going to happen to me?; My Sunshine is you; Today I feel so happy; It's a Girl; Rio de Janeiro; Maudie; When I dance with you; Signature Tune. 11.30, Concert arranged by the International Broadcasting Company (Ireland), Ltd., on behalf of Hospitals Trust, Ltd.: Signature Tune; Come back to Erin; Serenade; Farewell my Native Irish Home; Bacchanal from The Seasons (Glazunov); Cello Solo: The Garden of Sleep (de Lara); Ay, Ay, Ay (Freiere); Poor Butterfly (de Phillip); Eileen Alaunah; Charming Episode (Ormandy); Signature Tune. 12.5 a.m. (Monday), News Bulletin in English. 12.10, Club Concert for Mansfield Listeners: Signature Tune; The Chum Song; Rockin' Chair; Rocky Road; I wanna count Sheep; Bugle Call Blues; Crying and Sighing; Sweetness; Put on your Old Grey Bonnet; You've got me; Whispering; My Favourite Band; Nine Little Miles from Ten-Ten-Tennessee; Music bath Charms; It's a Glory; Signature Tune. 1.0, Dance Music: Signature Tune; The Bells of Normandy; It's the Band; That's my Home; Out in the Open; I cover the Waterfront; When Glimble hits the Cymbal; Learn to Croon; Chewing Gum; Lover; I'm getting sentimental over you; Hello; My gal Sal; I raised my Hat; At the Old Pig and Whistle; Seven Years with the Wrong Woman; Rosa Mia; All over Italy; Signature Tune. 2.0, I.B.C. Goodnight Melody and Close Down.

**FLensburg.**—See Hamburg.  
**Florence.**—See Turin.

FRANKFURT

1,157 kc/s, 259.3 metres; 17 kW. Relayed by Cassel, 1,220 kc/s, 245.9 metres; and Trier, 1,157 kc/s, 259.3 metres.—11.30 a.m., See Leipzig. 12 Noon, See Hamburg. 2.0 p.m., Gramophone Concert. 2.30, Two Agricultural Talks. 2.40, Agricultural Programme. 3.30, See Stuttgart. 4.30, Concert, relayed from the Kurhaus, Wiesbaden. 6.0, Talk. 6.30, A Merry Interlude. 7.0, Sports Notes. 7.15, Germany's Lost Colonies in Africa—Radio Sequence (Paul Laven). 8.0, Concert of Opera Music by the Station Orchestra, conducted by Hans Ros-

band. 10.20, Time and News. 10.45, Dance Music from Langenberg. 12 Midnight (approx.), Close Down.

**FREDRIKSSTAD.**—See Oslo.

**FREIBURG.**—See Stuttgart.

**GENEVA.**—See Radio-Suisse Romande.

**GENOA.**—See Turin.

**GLEIWITZ.**—See Breslau.

**GOTEBORG.**—See Stockholm.

**GRAZ.**—See Vienna.

**HAMAR.**—See Oslo.

HAMBURG

806 kc/s, 372 metres; 1.5 kW. Relayed by Bremen, 1,112 kc/s, 269.8 metres; Flensburg, 1,319 kc/s, 227.4 metres; Hanover, 530 kc/s, 566 metres; and Kiel, 1,292 kc/s, 232.2 metres.—11.30 a.m., See Leipzig. 12 Noon, Concert by the Hamburg Philharmonic Orchestra, conducted by Adolf Secker: Overture, Kosanund (Schubert); Polonaise in E (Liszt); Selection from La Traviata (Verdi); Humoresque in E (Humperdinck); Dance from Czar and Carpenter (Lortzing); Overture, Der Bettelstudent (Millbeker); Spanish Caprice (Rimsky-Korsakov); Selection from Tiefland (d'Albert); Norwegian Dances Nos. 1 and 2 (Grieg); Waltz, Roses from the South (Joh. Straus). In an interval at 12.55 p.m., Time and Weather. 2.0, Programme for Children. 3.0, Song Recital by Bertha Hudgren (Contralto) and Otto Abrecht (Tenor). 3.30, Two Towns Meldorf-Heide—Radio Sequence (Werner Perry). 4.30 (from Bremen), Concert by a Nazi Band. 5.30, A Pleasant Sail—Radio Sequence. 6.30 (from Flensburg), Concert by the Flensburg Choir, conducted by Ilse Struck; Soloist: Ilse Struck (Organ). 7.0 (from Hanover), Orchestral Concert, conducted by Otto Ebel von Sosen; Soloists: Harry Moss, Recitations, Karl-Heinz Schulz (Tenor), and Willi Lantelme (Bass). 7.40, Sports Notes and Weather. 8.0, Concert by the Philharmonic Orchestra, conducted by Richard Richter; Soloist: Paul Kötter (Songs); Overture, Der Freischütz (Weber); Durch die Wälder, durch die Auen from Der Freischütz (Weber); Variations on a Theme of Haydn (Brahms); Overture, The Flying Dutchman (Wagner); Walter's Prize Song from The Mastersingers (Wagner); Symphonic Poem, Don Juan (R. Strauss). In the interval at 9.0, Announcements. 10.0 Time and Announcements. 10.10, Hamburg, Bremen and Lübeck a Weekly Review from the Hansatic Free Cities. 10.40, Light Music and Dance Music from Langenberg.

**HANOVER.**—See Hamburg.

HEILSBURG

1,085 kc/s, 276.5 metres; 60 kW. Relayed by Danzig, 662 kc/s, 453.2 metres.—11.30 a.m., Choral Concert from Königsberg. 12 Noon, Concert by the Königsberg Opera House Orchestra, conducted by Wolfgang Brückner. Soloist: Joachim Ausorge (Pianoforte). 2.0 p.m., Talk on Chess. 2.30, Programme for Young People. 3.0, East Prussian Songs and Fairy Tales. 3.30, Diex selbne Müllerin—Song Cycle (Schubert) by Joachim Stein (Tenor). 4.0, Concert by the Small Station Orchestra, conducted by Eugen Wileken. In the interval at 5.0, Sports Notes. 6.0, Talk: Protestant Women's Social Work in East Prussia. 6.25, Reading. 6.50, Chamber Music of the Pre-Classical Period. 7.30, Reading from the Works of Wilhelm Raabe. 8.0, Sports Notes. 8.5, An Operetta, from Berlin (Funkstunde). 10.0, News. 10.15 (approx.), Dance Music from Berlin (Funkstunde). 12 Midnight, Close Down.

HILVERSUM

Announced HUIZEN, 1,013 kc/s, 296.1 metres; 7 kW (until 5.40 p.m.) and 20 kW from 5.40 p.m.—8.10 to 9.10 a.m., Programme of the Christian Radio Society (N.C.R.V.). 8.10, Religions—Programme. 9.10 to 4.40, Programme of the Catholic Radio Society (K.R.O.). 9.10, Gramophone Music. 9.55, High Mass, relayed from the Church of St. Dominique, Amsterdam. 11.25, Gramophone Music. 11.55, Concert by the K.R.O. Boys, conducted by Lu-stenhouwer. 12.40 p.m., Talk. 1.0, Concert (cont'd.). 1.40, Religions Address. 2.10, Extracts from Madame Butterfly—Opera (Puccini), by the K.R.O. Orchestra, conducted by Gerritsen. 2.25, Radio Report of the Opening of the Sports Ground at Harlem. In the interval, Gramophone Music. 4.10, Programme for Invalids. 4.40 to 7.25, N.C.R.V. Programme. 4.40, Religious Programme with Choral Music. 5.20, Divine Service, relayed from a Church in Utrecht. 7.10, Sacred Music on Gramophone Records. 7.25 till Close Down, K.R.O. Programme. 7.25, Football Results. 7.30, Meteorological Talk. 7.55, Concert by the K.R.O. Orchestra, conducted by Gerritsen. Soloist: Boshart (Pianoforte). In the intervals at 8.40, News; at 8.45, Recitations; at 9.35, Recitations, and at 9.55, News. 10.20, Epilogue. 10.40 (approx.), Close Down.

**HORBY.**—See Stockholm.

HUIZEN

Announced HILVERSUM, 160 kc/s, 1,875 metres; 7 kW (until 3.40 p.m.). Transmitted from Kootwijk on 50 kW from 3.40 p.m.—8.10 to 9.40 a.m., Programme of the Workers' Radio Society (V.A.R.A.). 8.10, Announcements. 8.12, Horticultural Talk. 8.40, Organ Recital. 9.0, Talk. 9.20, Organ and Violin Recital by Jong and Wiggelaar. 10.10, Programme of the Liberal Protestant Radio Society (V.P.R.O.): Divine Service relayed from Angersfoort. 11.40 to 4.40 p.m., Programme of the Algemeene Vereeniging Radio Omroep (A.V.R.O.). 11.40, Time Signal. 11.41, Talk. 12.10 p.m., Orchestral Concert conducted by Nico Treep. 1.40, Weekly Book Talk. 2.10, Baritone Song Recital by Hans Merx. 2.40, Gramophone Music. 3.40, Talk: Galsworthy's Novel, Escape. 4.0, Gramophone Music Recital by Hans Merx. 4.40 to 7.40, Programme of the V.A.R.A. 4.40, Orchestral Concert, conducted by de Groot. In the intervals at 5.20, Recitation, and at 6.30, The Adventures of Wakker and Tropenduit. 7.40 till Close Down, Programme of the A.V.R.O. 7.40, Time Signal. 7.41, News. 7.55, Concert by the Station Orchestra, conducted by Nico Treep, a Choir and Soloists: Nicolas Roth (Violin), Grethe Weijnschenk-Hogenbirk (Soprano), and Han Heydenrijk (Contralto). 9.10, Escape—Radio Play (after the Novel by Galsworthy). 9.40, The Singing Babies Sing. 10.0, Orchestral Concert. In the intervals at 10.15, The Singing Babies, and at 10.55, Gramophone Music. 11.40 (approx.), Close Down.

**INNSBRUCK.**—See Vienna.

JUAN LES PINS

1,205 kc/s, 249 metres; 0.8 kW.—8.0 p.m., Amusement Guide and Sports Notes. 8.15, Radio Concert. 9.0, News. 9.15, Recital by Suzanne Quitté. 10.0, The Listeners' Half Hour. 10.30 till Close Down, Programme in English by the I.B.C. 10.30, Light Orchestral Concert: Jollity on the Mountains (Petras); Gipsy Moon (Bor-ganov); Musical Comedy sketch (arr. Hall); Hungarian Melodies (Korbay); Live, love and laugh (Heymann); Liebs-freud (Kreislere); Wiener Bonbons (Strauss). 11.0, Vocal concert. Times of not so long ago (1921-1922); The Old Spinning Wheel (Hill); Landlord, fill the flowing Bowl; Spring Song (Wagner); My Darling (Heymann); Orchestra: Selection from The Maid of the Mountains (Fraser Simpson). 11.30, Instrumental Concert. Organ Solo: Love's Old Sweet Song (Molloy); Pianoforte and Organ: Marigold (Mayer); Violin Solo: Waltz, Estudiantina (Waldteufel); Hawaiian Guitars: I wonder how the Old Folks are To-night (Yellon); Pianoforte with Celesta Accompaniment: Serenade (Heykens); Accordion Solo: Accordion Night; Xylophone Solo: The Skaters' Waltz (Waldteufel); Bandionion Solo: Blaze away (Holzmann). 12 Midnight, Dance Music. Moon Song (Johnston); In the Valley of the Moon (Burke); Hold me (Schuster); I'll see you in the Morning (Marks); I can't remember (Berlin); Piccaninies' Heaven (Johnston); Maybe I love you too much (Berlin); The Lady I Love (Young). 12.30 a.m. (Monday), Dance Music. Let's all dance the Polka; I'm one of the Lads of Valencia; It's within your Power; When my little Pomeranian; Drifting under a Summer Moon; Sweetheart; One little word led to another; My Heart's to let. 1.0, I.B.C. Good-night Melody and Close Down.

**KALUNDBORG.**—See Copenhagen.

**KIEL.**—See Hamburg.

**KLAGENFURT.**—See Vienna.

**KOSICE.**—See Prague.

LANGENBERG

635 kc/s, 473 metres; 60 kW.—11.30 a.m., See Leipzig. 12 Noon, See Hamburg. 2.0 p.m., Reading of a Tale in Crefeld Dialect. 2.20, Dance Music on Gramophone Records. 3.0, Autobiographical Talk by Kathe Kruse on her Fiftieth Birthday. 3.20, Ballet Music from Les petits riens (Mozart) on Gramophone Records. 3.30, Reading. 4.5, Talk on Greenland and the Wegener Expedition. 4.30, Concert of Light Music with Songs. 5.20, Political Talk. 5.30, Radio Report of the Rudolf Oettker and the Rhine Province Races, from the Race Course, Crefeld. 5.45, Selection from Cavellaria rusticana Opera (Mascagni), by the Soloists, Choir and Orchestra of the Scala, Milan (on Gramophone Records). 6.30, Three Tales of the War (Robert). 7.0, Concert of Light Music. 7.20, Festival Programme, relayed from the Church of Saint Lambert, Münster. 8.0, Sports Notes. 8.15, Dances through the Centuries—Radio Sequence. 10.15, News. 10.40, Light Music and Dance Music, conducted by Eysoldt. 12 Midnight, Close Down.

**LAUSANNE.**—See Radio-Suisse Romande.

LEIPZIG

769.9 kc/s, 389.6 metres; 120 kW. Relayed by Dresden, 941 kc/s, 319 metres.—11.30 a.m., Jesu, der du meine Seele—Cantata (Bach), by the Municipal and Gewandhaus-

Orchestra, the Choir of St. Thomas and Soloists. 12 Noon (from Dresden), Concert by the Dresden Philharmonic Orchestra. 2.0 p.m., Weather and Time. 2.5, Programme Announcements. 2.25, Agricultural Notes. 2.35, Programme to be announced. 3.0, Walter Niemann in a Recital of his Own Pianoforte Compositions. 3.30, Programme to be announced. 4.15, Talk with Readings: Carl von Clausewitz, Prussian Poet and Thinker. 4.30, Concert. 5.50, Topical Sports Reports. 6.25 (from Dresden), Quartet in F. Op. 96 (Dvorák), by the Dresden String Quartet. 6.50, Frisch auf, gewandert!—Radio Sequence (Hörsch) with incidental Music. 7.50, Talk: Friedrich Kind, the Librettist of Der Freischütz. 8.0, Der Freischütz—Opera (Weber). 10.15, News. 10.30 (approx.), Dance Music. 12 Midnight, Close Down.

**LINZ.**—See Vienna.

MADRID

EAJ7, 707 kc/s, 424.3 metres; 2 kW.—9.0 to 10.0 a.m., Topical Review. 3.0, Chimes, Time, Theatre Notes, and Popular Concert. 5.0 to 8.0, Interval. 8.0, Chimes, Radio Journal, and Dance Music. 9.30 to 11.0, Interval. 11.0, Chimes, Time Signal, and Science Talk. 11.30, Municipal Band Concert, conducted by Villa, relayed from Rosales. After the concert, Dance Music. 1.30 a.m. (Monday), Close Down.

**MALMO.**—See Stockholm.

**MILAN.**—See Turin.

MORAVSKA-OSTRAVA

1,137 kc/s, 263.8 metres; 11 kW.—12.15 p.m., Orchestral Concert, conducted by Plichta. 12.30, See Brno. 12.40, Concert (cont'd.). 1.30, to 1.50, See Prague. 2.15, See Brno. 4.0, See Prague. 5.30, Gramophone Music. 6.0, See Prague. 7.5, Song Recital. 7.25, See Brno. 8.0, See Bratislava. 10.0, See Prague. 11.0 (approx.), Close Down.

**MOTALA.**—See Stockholm.

**MUHLACKER.**—See Stuttgart.

MUNICH

563 kc/s, 533 metres; 60 kW. Relayed by Augsburg and Kaiserslautern, 536 kc/s, 560 metres; and Nürnberg, 1,256 kc/s, 239 metres.—10.0 a.m., Catholic Service. 10.45, Chimes from Our Lady's Church. 10.55, Orfeo—Opera (Monteverdi) and Lo sposo deluso—Opera (Mozart) (Concert Versions), followed by the Symphony in G Minor (Mozart). 12 Noon, Military Band Concert relayed from the Feldherrnhalle. 1.0 p.m., Time, Weather and Programme Announcements. 1.10, Agricultural Talk. 1.30, Gramophone Concert. 2.30, Talk on Lotteries. 2.40, Political Talk. 3.0, Orchestral Concert, conducted by Erich Kloss. 4.0, Programme for Children. 4.30, Concert. 5.15, Allgäu—Radio Sequence of the Land and the People. 6.0, Johann August Sixt, a Forgotten Contemporary of Mozart—Song Recital by Ingborg Röss. 6.25, Dunes, Amber and Migratory Birds—a Word-Picture of the Baltic Coast. 6.45, Pianoforte Recital by Dr. W. Georgii. 7.15, Weather and Sports Report. 7.30, The Mittenwalder—a Radio Sequence (Josef Bauer-Preisner). 8.20, Military Band Concert, relayed from Neustadt. 9.25, Concert by the Station Orchestra and Soloists: Arias from Carmen (Bizet) with Orchestral Accompaniment; Selection from The Bird Fancier (Zeller). 10.20, News. 11.0, Talk, followed by Dance Music from Berlin (Funkstunde). 12 Midnight, Close Down.

**NAPLES.**—See Rome.

**NOTODDEN.**—See Oslo.

OSLO

277 kc/s, 1,083 metres; 60 kW. Relayed by Fredrikstad, 820 kc/s, 365.8 metres; Hamar, 522 kc/s, 574.7 metres; Notodden, 671 kc/s, 447.1 metres; Porsgrund, 662 kc/s, 453.2 metres; and Rjukan, 671 kc/s, 447.1 metres.—10.15 a.m., Weather and Roads Report. 10.45, Divine Service, relayed from the Tjølling Church. 5.0 p.m., Orchestral Concert conducted by Trygve Christiansen, relayed from the Lyche Restaurant. Russian March (Ganne). 6.0, Talk. 6.30, Sacred Song Recital by Rövde. 7.0, Agricultural Notes. 7.15, Weather and News. 7.30, Recitations. 8.0, Time. 8.1, Concert by the Station Orchestra, conducted by Hugo Kraumm. Overture, Don Giovanni (Mozart); Symphony in G—the Oxyford (Haydn); Spanish Rhapsody (Liszt); Gaetergutt (Grieg); La fille aux cheveux de lin (Debussy); Peleus and neopolitans (Rubinstein); Overture, 1812 (Tchaikovsky). 9.20, Programme to be announced. 9.40, Weather and News. 10.0, Topical Talk. 10.15, Sports Notes. 10.20, Balalaika Recital by Boris Borisov. 10.50, Dance Music on Gramophone Records.

**OSTERSUND.**—See Stockholm.

PALERMO

558 kc/s, 537.6 metres; 3 kW.—10.25 a.m., Bible Reading. 10.40, Sacred Music. 11.5, Agricultural Talk. 12.45, p.m., Giornale Radio. 1.0 to 2.0, Light Music. In the interval at 1.30, Time, Announcements and Weather. 5.30 to 6.30, Gramophone Music. 8.0, Dopplavoro Notes and Giornale Radio. 8.20, Gramophone Music. 8.25, Sports Notes. In the interval at 8.30, Time and Announcements. 8.45, Symphony Concert, conducted

by La Rosa Parodi. In the interval, Talk. After the Concert, Gramophone Music. 10.55, News.

PARIS

**EIFFEL TOWER.** Call **FLE**, 207.5 kc/s, 1,445.7 metres; 13 kW. Time Signals (on 2,650 metres) at 10.25 a.m. and 11.26 p.m. (Preliminary and C-dot Signals).—1.0 p.m., News. 1.15, Weather. 1.30 to 2.30, Concert by the Bos Orchestra. 6.45, Le Journal Parlé. 8.30, Gramophone Concert. Part 1: Classical Music. Part 11: Variety Music. 19.0 (approx.), Close Down.

PARIS

**POSTE PARISIEN**, 514 kc/s, 328.2 metres; 60 kW.—10.0 a.m., Gramophone Music. 10.20, Press Review. 10.30, Sponsored Concert. 11.0, Concert by the Station Quintet. 12.15 p.m., Sponsored Concert of Sound Film Songs. 12.45, Sponsored Programme. 12.50, Half-an Hour of Fantasy by Paul Weill. 1.30, Sponsored Programme. 2.0, Interval. 7.0, Le Journal Parlé. 7.5, Sports Notes. 7.15, Gramophone Music. 7.30, Catholic Review. 8.0, Gramophone Music. 8.30, Reading of Poems (Paul Bourget and Trispar). 8.45, Liszt Song Recital by Edouard Gendron. 9.15, Les uns chez les autres—One-Act Comedy (Paul Gaster). 9.45, Song and Pianoforte Recital by Re-nik (Bass) and Edouard Gendron; Serenade from Faust (Gounod); Capulet's Aria from Romeo and Juliet (Gounod); Aria from A Life for the Czar (Gliuka); Ballad (Missorgsky); Comme la nuit (Bohn); Aria from Faust (Gounod). Pianoforte Solos: (a) Prelude (Boutnikov), (b) Waltz (Arensky). 10.15, News.

PARIS

**RADIO-PARIS**, Call **CFR**, 174 kc/s, 1,725 metres; 75 kW.—7.45 a.m., Gramophone Records: Bambola d'amour (Petrim); Dans ma peniche (Borel-Clerc); Adeline (Gilbert); Ginetta (Mignone). 8.0, News. 8.50, Physical Culture. 12 Noon, Religious Address by the Reverend Father Pade. 12.20 p.m., Sacred Music: Choral in A Minor (César Franck); Improvisation (Widor); Toccata (Gigout). 12.50, Gramophone Concert: Overture, The Thieving Magpie (Rossini); Cavatina from Norma (Bellini); Marionettes (Ghizzano); Si j'étais Jardinier (Chaminade); Valse-poudre (Popy); Aria from André Chénier (Giordano); Le Cygne (Saint-Saëns); Egloune (Rahand); Ariette (Lully); Liebesleid (Krisler); Les Roses d'Espagne (Faure); Sans bois (Stanby); Tom soufre (Catherine); Havanaise (Saint-Saëns); Suite from Les Erynnies (Massenet).

2.0 to 2.30, Programme in English by the I.B.C. Dance Music; Signature Time, Happy Feet; Have you had a good Day today?; Black Knights; One Tiny Tear; My Serenade is You; Down in the Valley; The Old Spinning Wheel; Jack and Jill's Cradle; Hold me; Signature Time. 3.0 to 3.30, Programme in English by the I.B.C. Orchestral Concert: March, The Bhoys of Tipperary (Amers); Love's Old Sweet Song (Molloy); The Warbler's Serenade (Perry); In a Monastery Garden (Ketelbey); Selection from The Quaker Girl (Monckton); Waltz, I love the Moon (Rubens). 5.30, Gramophone Concert: Dance from Le Roi malgré lui (Chabrier); Waltz (Lehar); The Mill in the Black Forest (Eilenberg); O cara mia (Brodyky); Arlequin et Colombine (Lacôme); Selection from Bouton d'or (Piccini); Amour discret (Pesch); Myrto (Petit); Algerian March (Bose). 6.0, Popular Concert. 7.0, Variety Concert. 8.0, Gramophone Concert: Day by Day; Mi Madre (Cazes); Selection from Il est charmant (Moretti); O Sole mio (di Capua); Fascination (Marchetti); Reminiscences (Koeck); L'air, rêve d'un soir (Marino); Parade of the Tin Soldiers (Jessel). 8.30, News. 8.45, Gramophone Concert. In the interval at 9.15, Press Review and News.

PITTSBURGH

**KDKA**, 980 kc/s, 306 metres; 50 kW. Relayed by **W8XK** on 48.86 metres and 25.27 metres.—7.15 to 9.0 p.m., New York Relay. 7.15, Summer Idyll. 7.30, Variety Programme to be announced. 9.50, Organ Recital, from New York. 10.0, Vespers services. 11.0, News and Among Masters. 11.15, Weather and Sports Notes. 11.30, Huston Ray's Orchestra. 12 Midnight, Pathe News of the Air. 12.15 a.m. (Monday), Jules Laude, Violinist. 12.30-2.30, New York Relay. 12.30, Desert Gums. 1.0, Light Opera. 2.0, Gulf Headliners. 2.30, Programme to be announced. 2.45-3.15, New York Relay. 2.45, The Novelists Quartet 3.0, Mountain Music.

PORSGRUND.—See Oslo.

PRAGUE

614 kc/s, 488.6 metres; 120 kW. 11.0 a.m., Military Band concert, relayed from **Podsbrady**. 11.30, See **Brno**. 11.40, Military Band Concert, (cont'd.). 12 Noon, Chimes. 12.5 p.m., News. 12.15, See **Moravska-Ostrava**.

12.30, See **Brno**. 12.40, See **Moravska-Ostrava**. 1.50, Agricultural Programme. 1.50, Talk: The Protection of Children from Tuberculosis. 2.0, Interval. 2.15, See **Brno**. 4.0, Military Band Concert, relayed from the **Kralovska Oboza**. 5.50, Gramophone Music. 6.0, German Transmission; Programme Announcements, Dramatic Programme, and News. 7.0, News. 7.5, Harpsichord and Viola da Gamba Recital; Sonata in E Minor (Abel); Suite in A (d'Hervey); Sonata in D (Hammer). 7.25, See **Brno**. 8.0, See **Bratislava**. 13.0, Time Signal, News, and Sports Report. 10.20, Gramophone Music. 11.0, Close Down.

RADIO-SUISSE ROMANDE

**SOTTENS**, 743 kc/s, 403 metres; 25 kW.; and **Geneva**, 595 kc/s, 760 metres.—9.55 a.m. (from **Geneva**), Chimes. 10.0 (from **Geneva**), Protestant Service, relayed from the Victoria Hall. 11.0 (from **Geneva**), Gramophone Concert. 12.30 p.m., News, and Weather. 12.40 (from **Geneva**), Gramophone Concert. 2.0 to 3.30, Interval. 3.30, Concert by the Radio-Suisse Romande Orchestra, conducted by Robert Echehard. 5.0 to 7.0, Interval. 7.0 (from **Geneva**), Talk: Is Wireless a Benefit to Mankind? 7.30 (from **Geneva**), Sports Notes, News and Announcements. 8.0 (from **Geneva**), Trumpet Solos. 8.20 (from **Geneva**), Dramatic Programme. 8.50 (from **Geneva**), Hullo! Paris. . . . Geneva Calling—A Revue in Nine Scenes, relayed from the Kursaal, Geneva. 10.15 (approx.), News and Weather. 10.30 (approx.), Close Down.

RJUKAN.—See Oslo.

ROME

Call **1RO**, 650 kc/s, 441 metres; 50 kW. Relayed by **Naples**, 941 kc/s, 319 metres; **2RO**, 11,810 kc/s, 25.4 metres, from 5.15 p.m.; and **Milan (Vigentino)**, 662 kc/s, 453.2 metres, from 8.45 p.m.—10.0 a.m., News, Sports Notes and Amusement Guide. 10.10, Agricultural Notes, Bible Reading. 11.0 to 12 Noon and 12.50 to 1.45 p.m., See **Turin**. 1.45, Gramophone Music. 2.0, Time and Announcements. 5.0 (Naples), Programme for Children, Weather and Sports Notes. 5.15 to 6.30, Vocal and Instrumental Concert. Sports Notes in the interval. 6.30, Weather. 7.30, Sports Notes, Dopplavoro Report and News. 8.0, Time and Announcements. 8.30, Sports Notes. 8.40, Introductory Talk to the following transmission. 8.45, "Il Pireta"

Opera in Two Acts (Vincenzo Bellini). In the intervals, Talks. Giornale Radio after the Opera.

SALZBURG.—See Vienna.

SCHENECTADY

**WCY**, 790 kc/s, 379.5 metres; 50 kW. Relayed at intervals by **W2XAF** on 31.48 metres and by **W2XAD** on 19.56 metres.—8.0 p.m. to 10.0 (approx.), New York Relay. 8.0, Wayne King's Orchestra. 8.30, Radio Pulpi. 9.0, Fiddlers Three. 9.15, Wildroot Institute. 9.50, Temple of Song. 12.45 a.m. (Monday) to 3.45, New York Relay. 12.45 a.m., Russian Symphonic Choir. 1.0, Popular Programme. 2.0, Merry-Go-Round. 2.30, American Album of Familiar Music. 3.0, Musical Programme. 3.15, Impressions of Italy. 3.45, Sunday at Seth Parkers, from New York, followed by Programme Resumé.

SCHWEIZERISCHER LANDESSENDER

653 kc/s, 459 metres; 60 kW. Basle, 1,229 kc/s, 244.1 metres; and **Berne**, 1,220 kc/s, 245.9 metres.—10.45 (from **Berne**), Concert of Sacred Music. 11.30 (from **Berne**), Readings from the Works of Swiss Authors. 12 Noon (from **Berne**), Songs in German, French, Italian and French-Swiss, on Gramophone Records. 12.30 p.m., Time, Weather and News. 12.40 (from **Zurich**), Concert by the Radio Orchestra, conducted by Neppach. 1.30 (from **Berne**), Agricultural Programme. 2.50 to 5.0, Interval. 5.0 (from **Berne**), Protestant Service. 5.45 (from **Berne**), Adagio from Symphony No. 7 in E (Bruckner), on Gramophone Records. 6.0 (from **Berne**), Talk on Chess. 6.30 (from **Berne**), Talk: The Jura Mountains. 7.0 (from **Berne**), Time and Sports Notes. 7.10 (from **Berne**), Mass (Rheinbeiger). 8.10 (from **Berne**), A Musical Play (Schubert). 9.5, News. 9.15 (from **Berne**), Swiss Programme. 10.15 (from **Berne**), Sports Notes.

SOTTENS.—See Radio-Suisse Romande.

STOCKHOLM

689 kc/s, 436 metres; 55 kW. Relayed by **Boden**, 244 kc/s, 1,229.5 metres; **Göteborg**, 932 kc/s, 322 metres; **Hörby**, 1,166 kc/s, 257 metres; **Motala**, 221.5 kc/s, 1,354.4 metres; **Ostersund**, 389 kc/s, 770 metres; and **Sundsvall** 554 kc/s, 542 metres.—9.0 a.m., Talk. 9.50, Gramophone Music. 10.10, Agricultural Talk. 10.30, Talk. 11.0, Divine Service Relay. 12.45 p.m., Weather. 3.0, Talk. 3.20, Song Recital by Joseph Hilsop. 3.50, Temperance Talk. 4.15, Gramophone Music. 5.5, Programme for Children. 5.30, Song and Piano



The Sherlock Holmes of Radio

# 100 tests with 8 turns of the knob...

"No instrument in the world makes all tests more easily than the Pifco ROTAMETER. Any component or circuit can be tested quickly and surely. Makes 100 tests. BRITISH MANUFACTURE."

- RANGES:**
- 1.—0-8 volts. For low-tension voltage test.
  - 2.—0-30 volts. For grid-bias voltage test.
  - 3.—0-250 volts. For high-tension voltage test.
  - 4.—BATTERY TEST.
  - 5.—0-20 M.A. For individual valve test.
  - 6.—0-100 M.A. For testing current taken by total valves in set.
  - 7.—0-250 M.A. by total valves in set.
  - 8.—FILAMENT AND RESISTANCE TEST (4,000 ohms). For D.C. and rectified A.C.

Radio testing is revolutionised by the Pifco ROTAMETER. The key to its simplicity lies in the octagonal knob with its eight marked faces—"The Sign of Eight." The symbols on these faces give a range sufficient to test everything in radio. Just turn the knob for test desired, connect the part or circuit up to the ROTAMETER, and the result is there in the window of the instrument.

The Pifco ROTAMETER tests everything. Even itself! The BATTERY TEST registers the voltage of the three No. 495 radiometer cells inside the ROTAMETER. Another point about this wonderful instrument is the Safety Fuse which safeguards it against damage by careless handling.

Get your radio dealer to demonstrate the Pifco ROTAMETER to-day. If any difficulty, write direct to PIFCO, LTD., High Street, MANCHESTER, or 150, Charing Cross Road, London, W.C.2.

PRICE **29/6**

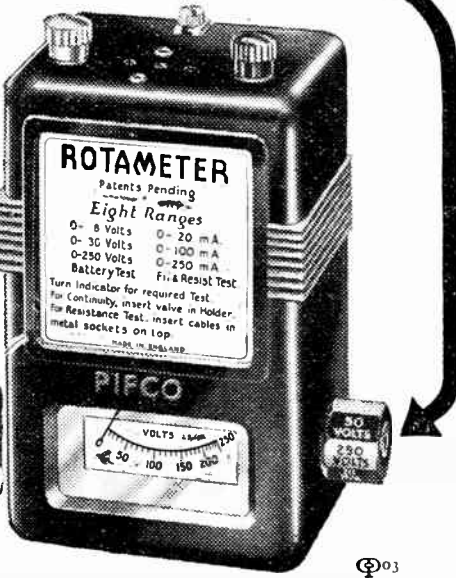

# PIFCO ROTAMETER



## The ELEMENTARY PRINCIPLES of WIRELESS TELEGRAPHY and TELEPHONY

by R. D. BANGAY

Third Edition  
Revised by  
O. F. BROWN, B.Sc.

**T**HE standard book of instruction for wireless beginners and students. This revised edition brings the whole subject into line with modern developments in wireless. The style is clear and simple and attention is given to the theoretical elements of electricity and magnetism; to the dynamo; and to the properties of waves. A leaflet which gives full particulars of the volume, including a synopsis of the chapters, will be sent on request.

P R I C E

7/6 net, by post 8/-

From all leading Booksellers or direct from the Publishers

ILIFFE & SONS LIMITED

DORSET HOUSE, STAMFORD STREET, LONDON, S.E.1

w.w.97

# DICTIONARY of WIRELESS TECHNICAL TERMS

Compiled by S. O. Pearson, B.Sc., A.M.I.E.E., and issued in conjunction with "THE WIRELESS WORLD"

SECOND EDITION

Revised and brought up to date

**T**HIS handy volume is very much more than a Dictionary. It not only takes the technical terms of wireless and explains their meaning, but in doing so it concentrates into a small space a large amount of information on wireless subjects. It has become, in fact, a compendium of current wireless knowledge, and an invaluable handbook for all who are interested in wireless transmission and reception. Diagrams and illustrations are freely interspersed throughout the book to amplify the explanations of the text.

272 pp., bound in cloth boards  
Size 5 by 3 inches

Price 2/- net. By post 2/2

From all leading booksellers or direct from the Publishers

ILIFFE AND SONS LTD.  
Dorset House, Stamford Street, London, S.E.1

W.W.18.

SEPT. 17th

**SUNDAY**

continued

forte Recital by Lisa Tunell and Märta af Klintberg. 6.0, Evensong, relayed from **ESKISTUNA**, 1,220 kc/s, 245.9 metres. 7.35, Reading (Stein Balstad), 8.0, Orchestral Concert. 9.15, One-Act Play (Paul Morand). 9.45, Weather and News. 10.0, Concert by the Station Orchestra; Soloist, Set Svahnöhn (Songs). 11.0 (approx.), Close Down.

### STRASBOURG

869 kc/s, 345 metres; 11.5 kW.—9.30 a.m., Orchestral Concert, conducted by Maurice de Villers. 10.45, Protestant Service. 11.30, Catholic Service in German. 12 Noon, Variety Music on Gramophone Records. 12.45 p.m., News. 1.0, Time. 1.1, Light Music on Gramophone Records. 2.0, Interval. 3.0, Classical Music on Gramophone Records. 4.0, Popular Music on Gramophone Records. 5.0, Orchestral Concert, conducted by Roskam; Two-step (Erwin); Waltz, Roses from the South (Joh. Strauss); Serenade (Toselli); Marcietta (Sude-s); Here's to the Next Time (Hall); By a rippling Stream (Pötkere); Boston, I wake up Smiling (Leslie and Aldert); Saxophone Solo; Simple avec (Thomé); Tango, Pour toi; Waltz, Potpourri No. 1 (Robrecht); Violin Solo; Czardas (Alouti); Foxtrot, Wouldn't it be Wonderful?; Tango, Dans mon rêve bleu (Bazant); One-step, Carabollina, Carabollina (Kálmán). 6.0, Medical Talk. 6.15, Sports Talk. 6.30, Orchestral Concert, conducted by Maurice de Villers; Overture, Zampa (Hérold); Selection from Faust (Gounod); Waltz, Myosotis (Wahlteufel); Japanese Suite (Mouton); Pieces (Chaminade); (a) Idylle Arabe, (b) La chaise à porteurs; Czardas (Grossmann). 7.30, Time and News. 7.45, Gramophone Music. 8.0, Press Review in German, Lottery Results and Announcements. 8.30, In's Ropfers Apotheke—Alsatian Diabot Play in Three Acts (Stoskopf). In an interval at 9.30, Press Review. 10.30, Dance Music, relayed from the Savoy. 12 Midnight (approx.), Close Down.

### STUTT GART

MUHLACKER, 832 kc/s, 360.5 metres; 60 kW. Relayed by Freiburg, 527 kc/s, 570 metres.—11.30 a.m., See Leipzig. 12 Noon, See Hamburg. 1.0 p.m., Topical Talk. 1.15, Der liebe Augustin, after the Novel by Horst Geissler, with Musical Setting by Wilhelm Locks, relayed from the Ufa Palast. 2.0, Classical Music on Gramophone Records. 2.30, Agricultural Talk. 3.0, Pianoforte Recital by Paul Schotte. 3.30, Programme for Children. 4.30, See Frankfurt. 6.0, Richard Arnold Concert by the Ludwig-burg Male Voice Choir. 6.30, Gramophone Music. 6.45, Sports Notes. 7.0, Wie man Rennfahrer wird! (How to become a Racing Motorist)—Radio Play (Mantred von Brauchitsch). 8.0, See Frankfurt. 10.20, Time and News. 10.45, Dance Music from Berlin (Funkstunde). 12 Midnight (approx.), Close Down.

SUNDSVALL.—See Stockholm.

### TOULOUSE

RADIOPHONIE DU MIDI, 779 kc/s, 385 metres; 8 kW. 11.0 a.m., Dance Music. 11.30, Light Music. 11.45, Opera Music: Arias from (a) Herodiade (Massenet), (b) The Prophet (Meyerbeer), (c) William Tell (Rossini), (d) Hamlet (Thomas). 12 Noon, Organ Recital. 12.15 p.m., Military Music and Melodies from Operetta. 12.30, Music by a Viennese Orchestra. 1.0, Amusement Guide and Market Prices. 1.15, Light Music. 1.45, Orchestral Concert; Selection from The Chocolate Soldier (O. Straus); Two Symphonic Movements (Meyrick); Selection from Im Reich der Indra (Lincke); Capriol (Warlock); Humoresque (Dvorák). 1.45, Opera Music. 2.0, Trumpet Music. 2.15, Chansonnettes. 2.30, Accordion Music. 2.45, Agricultural Report. 3.0, Concert Version of Carmen—Opera (Bizet). 4.0, Orchestral Music. 4.15, Music from Sound Films. 4.30, Military Music. 4.45, Chansonnettes. 5.0, The dansant. 5.45, Opera Music: Overture, Der Freischütz (Weber); Ballet Music from Herodiade (Massenet); Selection from Faust (Gounod). 6.0, News. 6.15, Operetta Music. 6.30, Music by a Viennese Orchestra. 6.45, Songs by a Basque Choir. 7.0, Two-Steps. 7.15, News and Racing Results. 7.30, Operetta Music. 7.45, Light Music. 8.0, Opera Music: Entracte from Carmen (Bizet); Selection from Madame Butterfly (Puccini); Prelude to Cavalleria rusticana (Mascagni). 8.15, Music from Sound Films. 8.30, Military Music. 8.45, Opera Music. 9.0, Schéhérazade—Symphonic Poem (Rimsky-Korsakov) by the Symphony Orchestra. 9.30, Accordion Music. 9.45, Arias from Opera. 10.0, Music by an Argentine Orchestra. 10.15, News. 10.30, Concert for Listeners in Morocco. 11.0, Dance Music. 11.30, Light Music. 11.45, Orchestral Concert: Bonrée Fantastique (Chabrier); Selection from The Golden Cockerel (Rimsky-Korsakov); Schubert Potpourri (Berthe). 12 Midnight, News. 12.5 a.m. (Monday), Music by a Viennese Orchestra. 12.30, Close Down.

### TRIESTE

1,211 kc/s, 247.7 metres; 10 kW.—9.40 to 9.55 a.m., See Turin. 9.55, Mass from the Cathedral of San Giusto. 11.0, Religious

Address. 11.20 Agricultural Talk. 12 Noon, till Close Down, See Turin.

TRONDHEIM.—See Oslo.

### TURIN

1,096 kc/s, 273.7 metres; 7 kW. Relayed by Milan, 905 kc/s, 331.5 metres; Genoa, 959 kc/s, 312.8 metres; and Florence, 599 kc/s, 500.8 metres.—9.40 to 9.55 a.m., News, 10.40, Agricultural Talk. 11.0, Mass from the Church of the Annunciation, Florence. 12 Noon, Bible Reading. 12.15 p.m., Interval. 12.30, Orchestral Concert. In the interval at 1.0, Time and Announcements. 1.30, Sponsored Music. 1.45, Gramophone Music. 4.30, Orchestral Concert. In the intervals, Sports Notes and Football Results. 6.15, Weather and Gramophone Music. 6.30, Announcements and Sports Notes. 6.45, Interval. 7.10, Gramophone Music. 8.0, Announcements, News, Sports Notes, and Gramophone Records. 8.45, Variety Programme. 9.45, Talk. 10.0, Orchestral Concert, conducted by Ugo Tansini. 11.0, Giornale Radio.

### VIENNA

581 kc/s, 517 metres; 100 kW. Relayed by Graz, 652 kc/s, 352.1 metres; Innsbruck, 1,058 kc/s, 283 metres; Klagenfurt, 662 kc/s, 453.2 metres; Linz, 1,220 kc/s, 245.9 metres; and Salzburg, 1,373 kc/s, 218.5 metres.—10.0 a.m. and 10.40 a.m., Report on the Austrian Marathon Races, 1933. 10.30, Schubert Pianoforte Recital: Wanderer-Fantasia; Impromptu in B flat, Op. 142. 11.20, Recitations. 11.40, Religious Programme. 12.40 to 2.20 p.m., Concert by the Wiener Symphoniker, conducted by Anton Konrath. Soloist: Wilhelm Winkler (Cello): Symphony in D (Christian Wagenseil); Concerto in G minor for Cello and Orchestra (Bach); German Dances (Schubert-Webern); Nocturne, Intermezzo and Scherzo from A Midsummer Night's Dream (Mendelssohn); Adagio and Allegro (Schumann). Cello Solo, Minuet (Valensin); Music to Molière's Le Bourgeois Gentilhomme (Richard Strauss). 2.25, Time, Programme Announcements and News. 2.45, Centenary Celebrations of the Pilgrimage Church of St. Leonhard, relayed from Tamsveg. 3.30, Agricultural Talk. 3.50, Old Italian Chamber Music: Quartet in A minor for Violin, Viola, Cello (Paganini); Duetto concertante in A for Flute and Guitar (Mauro Giuliani); Concerto in E minor for Guitar and String Quartet (Carulli). 4.50, A Pleasant Interlude—Radio Competition. 5.20, Concert by the Wiener Symphoniker, conducted by Josef Holzer. 6.20, Book Review. 6.45, Talk, with Pianoforte Illustrations: The Evolution of Musical Impressionism. 7.35, Time, Sports Notes and Programme Announcements. 7.45, Sports Notes: I, on the International Football Match—Austria v. Czechoslovakia at Prague; II, on the Vienna-Prague Match at Vienna. 7.50, Reading for Boys. 8.20, A Flight round the World—Radio Potpourri (Viktor Heubly) by the Wiener Symphoniker, the Volksoper Choir, a Wind Instrument Orchestra and a Jazz Band. 9.45, News. 10.0, Concert of Light Music from the Oase.

### WARSAW

212.5 kc/s, 1,411 metres; 129 kW.—11.57 a.m., Time Signal and Fanfare from Torun, for the 700th Anniversary of the Town. 12.5 p.m., Programme Announcements. 12.10, Weather. 12.15, Concert by the Station Symphony Orchestra, conducted by Oziuminski. Soloist: Prywman-Kiszgeer (Mezzo-Soprano); Andante and Scherzo, from the Symphony, Renaissance (Karłowicz). Songs: (a) Aria from The Countess (Mousskoff), (b) Aria from The Snow Maiden (Rimsky-Korsakov). (c) Spanish Song, Adios (Alvarez); Andante from the String Quartet (Tchaikovsky). Songs: (a) Soutag (Brahms), (b) Petit Jean me disais (Wiencławski), (c) Bolero (Niewiadomski); Norwegian Rhapsody (Svendsen). 1.0, Choral Concert, relayed from Poznan Music for the 40th Anniversary of the Polish Association of Choral Societies. 2.0, Agricultural Talk. 2.15, Agricultural Notes and Weather. 2.20, Choral Music, relayed from Bochen. 2.45, Talk: Veterinary Advice. 3.5, Gramophone Music. In the interval, News. 4.0, Weekly Review for Children. 4.15, Reading for Children, relayed from Lwow. 7.8 kc/s, 381 metres. 4.30, Gramophone Records. 5.0, Talk: Children's Health. 5.15, Podolia in Music and in Song—Concert by the Station Orchestra. Soloists: Norska and IZGRYM (Songs); Podolian Suite (Mierozynski); Suite of Podolian Songs and Folk Tunes (arr. Mierozynski); String Trio, Danse montagnarde (Mierozynski). 6.0, Gramophone Records. 6.35, Programme Announcements. 6.40, Miscellaneous Items. 7.0, Reading, relayed from Lwow. 7.40, Wireless Notes. 8.0, Concert by the Station Orchestra, conducted by Nawrot. Soloist: Kulezycka (Songs); Egyptian March (Strauss); Overture, Orphans in the Underworld (Offenbach). Songs: Cracovienne (Rajczak); Oberkis (Namy-slow-ky). 8.50, Radio Journal. 9.0, Humorous Programme, relayed from Lwow. 10.0, Dance Music, relayed from Cichocinek. In the intervals at 10.25, Sports Notes, and at 10.40, News, Weather and Police Notes.

ZURICH.—See Schweizerischer Landessender.

ATHLONE

725 kc s, 413 metres; 60 kW. Relayd by Cork, 327 kc s, 224.4 metres.—1.30 to 2.30 p.m., Time Signal. Weather and Stock Report, followed by Gramophone Music. 6.0, Programme for Children. 6.45, News. 7.0, Gaelic Talk. 7.15, Pianoforte Solos by May Johnson. 7.30, Official Opening of the Irish Wireless and Gramophone Exhibition at the Mansion House, Dublin. 8.0, Music by a String Orchestra. 8.15, Scandinavian Ballads by G. O'Loichlainn. 8.30, Tibbamp Pipe Solos by Leo Rowsome. 8.45, Tenor Solos by P. Kirwan. 9.0, Compromising Martha Play by the Leven Players. 9.30, to 10.30, Programme by the I.B.C. (Ireland). Ltd. 9.30, Dance Music. Peter, Peter, There's a Light in Your Window; Till Tomorrow; Round the Bend of the Road; Always in my Heart; Stormy Weather; I shall still keep smiling along; My Wishing Song; You did everything for me. 10.0, Concert arranged by the International Broadcasting Company (Ireland) Ltd. on behalf of Hospitals Trust Ltd. Signature Time. Come Back to Erin; The Tiger's Tale and When Melodious Songs, from the Suite Americana (Thurhan); Serenade (Heykens); Pan and the Wood Goblins (Rathke); Pianoforte Solo, Rangoon Rice Carriers (Hilobnoke); The Skaters' Waltz (Waldteufel); Violin Solo, Le baloon (St. Denis); Waltz, Tales from the Vienna Woods (Strauss); Signature Time. 10.29, I.B.C. Good-night Melody. 10.45, News and Weather.

BARCELONA

E.A.J.I., 860 kc s, 348.8 metres; 8 kW. 7.0 p.m., Trio Concert. Selection from Parsifal (Wagner); Ball (Bayer); Minne (Ganne); Selection from Martha (Flotow); Melody (Colin); Serenade (Rachmaninov); Hungarian Dance No. 5 (Brahms). 8.0, Reques. Gramophone Records. 8.20, Sports Notes. 8.30, Exchange and Gramophone Records (cont'd.). 9.0, Gramophone Music and News. 10.0, Chimes from the Cathedral. Weather, Exchange and Market Prices. 10.5, Humorous Review of the Week in Verse. 11.0, Concert of Sardanas. 11.0, Concert by the station Orchestra. 11.30, Light Orchestral Concert, relayed from the San Sebastian Casino. In the interval at 12.0 Midnight, News. 1.0 a.m. (Tuesday), Close Down.

BARI

1,112 kc s, 209.8 metres; 20 kW.—See Rome.

BASLE.—See Schweizerischer Landessender.

BERLIN

DEUTSCHLANDSENDER (Reichssender), 183.5 kc s, 1,635 metres; 60 kW. 12.5 p.m. (approx.), Gramophone Concert. 12.55, Time Signal. 1.45, News. 2.0, Gramophone Concert. 3.0, Talk for Women. 3.30, Weather and Exchange. 3.45, Review of Books. 4.0, See Breslau. 5.0, Talks: Schiller's Plays produced by Passaris. 5.20, Violin and Song Recital by Anita Leunertz (Violin) and Rudolf Watzke (Bass-Baritone) Violin Solos: (a) Romance (Svendens). (b) Norwegian Dances (Grieg). (c) Songs: (a) Prinz Eugen. (b) Der Nack. (c) Mädchen sind wie der Wind (Loewe). (d) Jung Dietrich (Pliedemann). (e) Siegfrieds Schwert (Pliedemann). 6.0, Poems. 6.5, Talk on Sport. 6.25, Gramophone Music: Overture, Preciosa (Weber); Gavotte caprice (Bortkiewicz); Delianer Walzer (Joh. Strauss); Meine Gianna (Hauerbach); Stern von Valencia (Stambel); Kleiner Mann, was nun? (Bohmelt); Moonlight on the Mist (Fetras); Waltz, Wiener Extrablatz (Translaten); Waltz, Wiener Zugvögel (Translaten). 6.50, Weather and Announcements. 7.0, Transmission for all German Stations, relayed from Breslau. 8.0, Today's Abbot. 8.5, Austrian Evening. 10.0, News, followed by Report on the International Tennis Championship (on Gramophone Records). 10.45, Weather. 11.0, Programme from Hamburg. 12 Midnight, Close Down.

BERLIN

FUNKSTUNDE, 715 kc s, 419.5 metres; 1.5 kW. 4.30 p.m., Orchestral Concert relayed from the Moka Etti; Am Lago maggiore (Heusser); Waltz Intermezzo, Nachtdalter (Sibel); Selection from Faust (Gounod); Erinnerung (Lublbe); Ein Liebesheld (Kiek Schmidt); Waltz (Brahms); Die himnische Spindel (Kark); Liebesserenade (Lohr); Serenata nostalgica (Marazzi); Moment musical (Schubert); Humoresque (Meyer-Marc). 5.30, Infn von Strauss and Torney discusses her Books. 5.50, The Week's Short Story. 6.10, Sonata in A minor for Violin and Pianoforte (Pizzetti); by Vittorio Breno and Walther Kemper. 6.40, The Funk, staple informs its listeners. 6.45, Typical Talk. 7.0, Transmission for all German Stations, relayed from Breslau. 8.5, St. Martin's Summer Variety Programme. 9.0, Trio in C Op. 57 (Brahms) for Piano-forte, Violin and Cello. 9.30, The Battle of Grossbeeren—Battle Songs of 1813, with Commentary (on Gramophone Records). 10.0, News. 10.40, See Hamburg. In the interval at 11.0 (approx.), Typical Talk. 12 Midnight, Close Down.

BERNE.—See Schweizerischer Landessender.

BEROMUNSTER.—See Schweizerischer Landessender.

BODEN.—See Stockholm.

BODO.—See Oslo.

MONDAY SEPTEMBER THE EIGHTEENTH

PRINCIPAL EVENTS OF THE DAY:

AT HOME

- NATIONAL: Charlot's Hour
LONDON REGIONAL: Promenade concert from Queen's Hall.
MIDLAND REGIONAL: Orchestral concert.
NORTH REGIONAL: Orchestral concert.
WEST REGIONAL: Post-Prandial Polemics on various aspects of Modern Wales.
SCOTTISH REGIONAL: "Counter Clockwise. Three Revolutions for Renegades." feature programme.
BELFAST: Orchestral concert.

ABROAD

- ATHLONE: 10.0 p.m. Concert on behalf of Hospitals' Trust, Ltd.
BRUSSELS (No. 1): 8.0 p.m. Viennese music, by the Radio Orchestra.
BUDAPEST: 9.30 p.m. The Opera House Orchestra, conducted by Ernst Dohmany.
COPENHAGEN: 8.30 p.m. "Music from Old Vienna," by the Station Orchestra.
HAMBURG: 8.10 p.m. Concert of Russian music, by the Philharmonic Orchestra.
HILVERSUM STOCKHOLM: 9.50 p.m. Organ recital.
8.0 p.m. Folk songs of Iceland, Germany, America, Palestine, France, Denmark, and Sweden.
STRASBOURG: 6.30 p.m. Pianoforte recital by Alphonse Foehr.
WARSAW: 8.0 p.m. Operetta: "Frederica," by Lehár (concert version)

BORDEAUX-LAFAYETTE

986 kc s, 304 metres; 13 kW. 6.15 p.m., Radio Journal. 7.45, Talk: Bordeaux, a Century ago. 8.0, News and Market Prices. 8.15, Gramophone Music. 8.30, Concert of Classical and Modern Music.

BRATISLAVA

1,076 kc/s. 279 metres; 11 kW.—6.5 p.m., Concert by the Station Wind Instrument Quintet: Quintet, Op. 23 (Erwin Leandari); A Quintet on a Baydn Trio (Fritz Muth). 6.55, Talk for Housewives. 7.0, See Prague. 7.10, See Moravsko-Ostrava. 7.50, Talk: Slovak Poetry from D.B.S. 8.5, See Brno. 9.5, See Moravsko-Ostrava. 9.25, See Prague. 10.15 (approx.), Close Down.

BREMEN.—See Hamburg.

BRESLAU

923 kc s, 225 metres; 60 kW. Relayd by Gleiwitz, 1,184 kc s, 253 metres. 1.0 p.m., Weather. 1.5 (approx.), Gramophone Concert of Orchestral Music. 1.45, Time and News. 2.5, Recital of Songs by Hedwig Zheczka-Fulmann (Soprano). 2.35, Gramophone Concert: Military March, Op. 31, No. 1 (Schubert); Selection from I. Pagliarelli (Leonevaldo); Melodias from Mexico (Köhler); Selection from Eva (Lohr); Waltz, Gold and Silver (Lehár); Mein Vaterland (Schubert); Selection from National Songs and Dances; Selection from Lilac Time (Schubert-Berte); March, Haerl Hudeckshing (Hetzner). 3.0, Market Prices. 3.15, Review of books. 3.35, Talk: Summer. 4.0, Concert by the Station Orchestra, conducted by Ernst Topitz. Soloist: Friedrich Wagner (tobse and English Horn). Rakoczy Overture (Köler-Belau); Suite, In a Fairy Realm (Ket-Dues); Waltz, Wiener spaten (Witterschek); Aria: schussicht (Hetzner); Tarantella (Meyer-Helmann); Der Gondelfahrer (Schubert); The Musical Box (Ludwig); Romance (Medardis); The Swan of Tuonela (Sibelius); Sienhene (schmalchitz); Overture, Martha (Flotow). 5.30, Weather. 5.35 (approx.), Talk: German Cultural Work. 5.50, Programme to be announced. 6.10, Talk, with Gramophone Illustrations: Orchestral Instruments. 6.30, Talk: The Organisation of the German Freedom Movement. 6.50, Meat Market Prices. 7.0, Transmission for all German Stations; Working Men's Wives in the Daily Struggle (Rudolf Mith and Fritz Wenzel). 8.0, News. 8.10, Concert by the Breslau Teachers' Choral Society. Soloist: Elisabeth Lander (Soprano). 9.0, News. 9.10, Le Colonel Charlot. Radio Play (arr. Alfred Mühl). 10.10, Time and News. 10.45, Wireless Technical Talk. 10.55, Talk by an Englishman on Fascism in Britain. 11.15 (approx.), Close Down.

BRNO

878 kc s, 342 metres; 35 kW. 6.5 p.m., Gramophone Music. 6.25, German Transmission: News and Talk on Sociology. 7.0, See Prague. 7.10, See Moravsko-Ostrava. 7.50, See Bratislava. 8.5, Variety Programme. 9.5, See Mcravsko-Ostrava. 9.25, See Prague. 10.30 (approx.), Close Down.

BRUSSELS (No. 1)

I.N.R., 590 kc s, 509 metres; 15 kW.—12 Noon, Concert by the Small Station Orchestra, conducted by Leemanns. Overture, Paragraphe 3 (Suppé); Introduction and Humoresque (d'Ambrosio); Selection from La Bohème (Puccini); Violin Solo: Desir (Kalkman); In the Mystic Land of Egypt (Ketylby); Milonga (Huguet); Waltz (Hoymann); Soldatini in parata (Limentau); Selection from Pas sur la bouche (Yvain). 1.0 p.m., Le Journal Parlé. 1.10, Gramophone Concert: Overture, Maximilian Robespierre (Litolf); Selection from The Youngen of the Guard (Sullivan); Elogium (Golestan); Selection from Shulamith (Goldstadt); Träumerei (Schumann-Weinet); Selection from Lilac Time (Schubert-Berte); O sole mio (Di Capua); Selection from Peter Pan (Crook). 5.3, Concert by the Station Symphony Orchestra, conducted by Meulemanns. Overture, The Merry-makers (Coates); Suite, Summer Days (Coates); Dances from Nell Gwynn (Germou); Serenade (Elgar); Old English Suite (Ettinger); Petit Suite de concert (Coleridge-Taylor). 6.3, Talk. 6.15, Gramophone Records. 6.45, Violin Recital by Mathieu Crikboom. 7.15, Talk. 7.30, Amusement Guide. 8.0, Concert of Viennese Music by the Radio Orchestra, conducted by André. Soloists: Mire. Farière (Songs) and Geodil (Baritone). Overture, Die Fledermaus (Joh. Strauss); Waltz, Tales from the Vienna Woods (Joh. Strauss); Songs from A Waltz Dream (O. Straus); Waltz, The Blue Danube (Joh. Strauss); Selection from Frühling im Wienerwald (Ascher). 8.45, Recitation—Poem to Silence (Albert Samain, Marie Gevers, Noel Ruet, Yvonne Devetter-Schoenfeld, Claude Berniers and Berthe Bobée). 9.0, Concert (cont'd.): Four Viennese Pieces (Kreisler); Wiener Operetten-Revue (Robrecht); Songs from The Merry Widow (Lehár); Selection from Countess Maritza (Kálmán); Old songs and Old Viennese Dances (Paschenezz); March, Wien blüht Wien (Schrammel). 10.3, Le Journal Parlé.

BRUSSELS (No. 2)

N.I.R., 887 kc/s, 338.2 metres; 15 kW. Programme in Flemish.—12 Noon, Gramophone Music. 1.0 p.m., Le Journal Parlé. 1.10, Concert by the Small Station Orchestra, conducted by Leemanns. 5.0, Concert by the Radio Orchestra, conducted by André; Die kleine Kompanie (Ganglberger); Potpourri

of National Dances (Manfred); Wedding of the Dragon Flies (Barrow); Viennese Song (Fall); Humorous Piece (Caludi); Andante from the Violin Concerto (Saint-Saëns); Anvil Chorus from Il Trovatore (Verdi); Serenade burlesque (Brusselmans). 5.45, Programme for Children. 6.30, Concert by the Small Station Orchestra, conducted by Leemanns. 7.15, Talk: Sports Champions. 7.30, Le Journal Parlé. 8.0, Concert by the Station Symphony Orchestra, conducted by Meulemanns; Soloist, Hellinek (Baritone); Allegro molto from the Second Symphony (Borodin); Introduction and Persian Dance from Kovaustehina (Mussorgsky); Gopak (Mussorgsky); Tarantella (Cui); Andante and Scherzo (Tchaikovsky); Cosacck Dance (Tchaikovsky); Festival in Bagdad from Schéhérazade (Rimsky-Korsakov); Fimral March (De Boeck); Minuet (De Vleeschhouwer); Two Songs; Ballet Music from Kassa (Delibes); Serenade (Glazunov); Two Songs; Waltz; Wienerburger (Zieher); Scherzo (Lalo). In the interval at 8.45, Talk. 10.0, Le Journal Parlé.

BUCHAREST

761 kc/s, 394 metres; 12 kW.—5.0 p.m., Concert by the Station Orchestra: March (Blankenburg); Waltz, The Blue Danube (Joh. Strauss); Overture, Peter Schmitt (Weber); Selection from La Traviata (Verdi); Selection from Clo-Clo (Lehár); Potpourri (Dostal); Two Hungarian Dances, Nos. 19 and 20 (Brahms); Humoresque and Mazurka (Dvorak). In the interval at 6.0, Radio Journal. 7.0, Educational Programme. In the interval from 7.20 to 7.40, Songs on Gramophone Records. 8.0, Harp Duets. 8.30, Talk. 8.45, Talk. 9.5, Quartet in C Minor, Op. 35 (Chausson), by the Metzger Quartet. 9.35, Radio Journal. 10.0, Jazz Music relayed from the Lido.

BUDAPEST

545 kc/s, 520.5 metres; 18.5 kW. Also relayed on 843 metres from 7.30 p.m. till Close Down.—5.30 p.m., Gramophone Music. 6.15, German Lesson. 6.45, Pianoforte Recital. 7.30, Reading. 8.0, Concert conducted by Stefan Bertha. 9.15, News. 9.30, Concert by the Opera House Orchestra, conducted by Ernst Dohmany; Soloist: Zathureczky (Violin); Symphony in C (Schubert); Violin Concerto in A Minor (Glazunov). 10.20 (In an interval), Weather. 11.0 (approx.), Dance Music from the Royal Hotel.

CASSEL.—See Frankfurt.

COPENHAGEN

1,067 kc s, 281 metres; 6.75 kW. Relayd by Kalundborg, 270 kc s, 1,153.8 metres.—12 Noon, Time Signal and Chimes from the Town Hall. 12.2 p.m., Concert by the Max Skalka String Ensemble, relayed from the Hotel d'Angleterre. 2.0, Interval. 3.20, Talk for Housewives. 3.30, Concert by Carl Rydhall's Instrumental Ensemble: Overture, Athalia (Mendelssohn); Waltz (Waldteufel); Melody from The Seasons (Tchaikovsky); Selection from La Favorita (Donizetti); Après l'été (Florent Schmitt); Intermezzo, Azzucato (Pierro); Dance of the Insects (Svendens); Selection from Der Obersteiger (Zeller); Foxtrot (Nelson); Dance of the Bahil azooks (Gabriel-Marie); Prelude and Humoresque (Jörgensen); Dein gedenk' ich Margertha (Meyer-Helmann); March, The Last stand (Myddleton). In the interval at 4.15, Reading. 5.20, Exchange and Fish Market Prices. 5.45, Talk. 6.15, Elementary English Lesson. 6.45, Weather. 6.54, Announcements. 7.0, News. 7.15, Time Signal. 7.30, Discussion. 8.20, Music from Old Vienna—Concert by the Station Orchestra, conducted by Fritz Mahler; Soloist, Marins Jacobsen (Soprano); Cossation in B Flat (Mozart); Aria from Così fan tutte (Mozart); Overture, Fibarrabas (Schubert); Waltz, Die Schönmutter (Lanner); Farewell from Eine Nacht in Venedig (Joh. Strauss); Overture, The Queen's Korcheil (Joh. Strauss). 9.30, Radio Pictures of Daily Life. 10.0, Song recital by Gustav Fomander. 10.20, News. 10.35, Chamber Music by the Station Chamber Orchestra, conducted by Fritz Mahler; Violin Concerto in E (Bach); Glee Music (Telmann). 11.15 (approx.), Close Down.

CORK.—See Athlone.

DANZIG.—See Mitzberg.

DRESDEN.—See Leipzig.

FECAMP

1,328 kc/s, 225.0 metres; 10 kW. 11.0 a.m. to 12 Noon, Programme arranged by the I.B.C. Ltd. 11.3, Happy Hour. Part 1, Orchestral Concert: Waltz, Wienerblut (Strauss); Memories of Paris (Moretti); Banjo Solo: Viva la liberta; Selection from The Desert Song (Romberg); Pale Volga Moon (O'Hagan); Banjo Quartet: Darktown Bandies (Aberley); The Song of the Nightingale (Aibout); Waltz Favourites (arr. Anello). Part 2, Dance Music: At the Old Pig and Whistle; Learn to Croon; A Woman should stick to her Man; Sweetheart Darlin'; Down the Old Ox Road; I Cover the Waterfront; I Raised my Hat; When Gimble hits the Cymbal; Signature Time. 12 Noon, French Programme. 4.30 to 6.3, Programme arranged by the

SEPT. 18th

MONDAY

continued

I.B.C., Ltd. 4.30, Programme for Children. 5.0, Concert for Chichester and Bognor Listeners. Orchestral Concert: Signature Tune. The Night by the Sea: Danse Bagatelle (Bourdon): Crazy Pionette (Frisk): Mandoline Solo: Mandoline (Thomé): Günger Snaps (Bourdon): Hawaiian Memories (Armandola): Xylophone Solo: Snappy Sticks (Robbins): The Dance of the Raindrops (Reeves): Valse bluettes (Drigo). 5.30, Concert for Hastings and Eastbourne Listeners. Military Band Concert: Brabazon (Dunn): Valse des aubettes (Drigo): Song, Route Marching (McCall): Coronation March; Selection from The Geisha (Jones); Jungle Drums (Kettelby): Song, The Drum-Major (Newton): Here, There, and Everywhere (Bose): Signature Tune. 6.0, French Programme. 10.0 till Close Down, Programme arranged by the I.B.C. 10.0, Dance Music. Signature Tune. Bells of Normandy: In My Bell-Bottom Trousers: Deep in my Lady's Eyes: Who do you love?: Learn to Croon: Masquerade: Moon, You're Mine, You: When the Morning rolls around: Here is my Heart: Let bygones be bygones: My Bluebird's Singing the Blues: Castles in the Sand: I cover the Waterfront: Under my Umbrella: Stay out of my Dreams: Signature Tune. 11.0, Talk: Time: Signature Tune. Sitting in the Dark: Please: I want to be happy: You are my Heart's Delight: To-day I feel so happy: There's something about a Soldier: Selection from Love me To-night: I'm playing with Fire: Lover of my Dreams: Signature Tune. 11.30, Concert for Nottingham Listeners. Part 1: Music from Opera: Signature Tune. The Chum Song: Grand March from Aida (Verdi): Toreador Song from Carmen (Bizet): One fine Day, from Madame Butterfly (Puccini): Violin Solo: Hymn to the Sun, from The Golden Cockerel (Rimsky-Korsakov): Selection from La Traviata (Verdi): Walther's Song, from The Mastersingers (Wagner): Waltz Song from La Bohème (Puccini): Selection from Tamhüuser (Wagner). 12.5 a.m. (Tuesday), News Bulletin in English. 12.10, Club Concert. Part 2: Somebody stole my gal; Manhattan; That's what life is made of: I raised my Hat; This Lovely Rose; Signature Tune. 12.30, Dance Music by Jack Hilton and his Orchestra (Electrical Transcriptions): Little Miss Muffet: Hold Me; Out in the Open: You're Mine, You; What a Lady Josephine must have been; Dancing Butterfly; Hyde Park Corner; I can't Remember. 1.0, Dance Music: Signature Tune. Bells of Normandy; When my little Pomeranian; Pop Goo; Under My Umbrella; Thank Heaven for You; No more Love; Something came and got me in the Spring; Wanderer; In a Second-hand Store; The Toy-maker's Dream; There's a Cabin in the Pines; Jog along; Drifting under a Summer Moon; Shuffle off to Buffalo; Down the Old Ox Road; It's the Band; The Old Spinning Wheel; Signature Tune. 2.0, I.B.C. Good-night Melody and Close Down.

FLensburg.—See Hamburg.  
FLORENCE.—See Turin.

FRANKFURT

1,157 kc/s, 259.3 metres; 17 kW. Relayed by Cassel, 1,220 kc/s, 245.9 metres; and Trier, 1,157 kc/s, 259.3 metres.—4.30 p.m., Concert by the Station Orchestra. Soloist: Fritz Kuhlmann (Pianoforte). Part 1: Brillante caprice on the Theme Jota Aragonesa (Glinka): Pianoforte Concerto No. 2 in F minor Op. 21 (Chopin). Part II: Old Dance Music. 5.45, Economical Notes. 6.0, The German Almanac. 6.10, Variety Item. 6.25, Talk: Queer Wills. 6.45, To-day's News. 6.50, Time and Announcements. 7.0, Transmission for all German Stations, relayed from Breslau. 8.0, Variety Concert. 10.0, Topical Talk. 10.20, Time and News. 11.0, See Leipzig. 12 Midnight (approx.). Close Down.

FREDRIKSSTAD.—See Oslo.  
FREIBURG.—See Stuttgart.  
GENEVA.—See Radio-Suisse Romande.  
GENOA.—See Turin.  
GLEIWITZ.—See Breslau.  
GOTEBORG.—See Stockholm.  
GRAZ.—See Vienna.  
HAMAR.—See Oslo.

HAMBURG

806 kc/s, 372 metres; 1.5 kW. Relayed by Bremen, 1,112 kc/s, 269.8 metres; Flensburg, 1,319 kc/s, 227.4 metres; Hannover, 530 kc/s, 566 metres; and Kiel, 1,292 kc/s, 232.2 metres.—6.0 p.m., Concert by the Hamburg Philharmonic Orchestra, conducted by Adolf Secker: Overture, Euryanthe (Weber); Lyric Suite (d'Albert); Czardas from Der Geist des Wojewoda (Grossmann); Symphonic Sketch, In the Steppes of Central Asia (Borodin); Selection from The Gipsy Baron (Joh. Strauss). 6.45, Exchange and Weather. 7.0, Transmission for all German Stations, relayed from Breslau. 8.0, Topical Talk. 8.10, Concert of Russian Music by the Philharmonic Orchestra, conducted by José Eibenschütz: Soloist, Hugo Kolberg (Violin); Symphony No. 5 in E Minor, Op. 61 (Tchaikovsky); Violin Concerto in D, Op. 35 (Tchaikovsky); Overture, Ruslan and Ludmilla (Glinka). 9.40, Concert by the Station Choir and Soloists, Conductor, Gerhard Gregor. 10.10, News. 10.30, Topical Talk. 10.40 (from Kiel), Concert by the Kiel Orchestra of Unemployed Musicians: Overture, Rübzahl (Plotow); Suite, Un giorno in Venezia (Nevin); Selection from Wenn die Liebe erwacht (Künneke); Ländler (Pachernegg); Waltz, Sommerlust (Lüncke); Der kleine Pflücker (Kockert); March, Unsere Marine (Thiele).

HANOVER.—See Hamburg.

HEILSBURG

1,085 kc/s, 276.5 metres; 60 kW. Relayed by Danzig, 662 kc/s, 453.2 metres.—1.5 to 2.30 p.m., Gramophone Concert. In the intervals at 1.20 and 2.0, News. 2.30 (Danzig), Exchange and Market Prices. 3.0, Market Prices. 3.30, Programme for Children. 4.0, Concert by the Small Station Orchestra, conducted by Eugen Wilcken. In the interval at 5.0, Technical Talk. 5.45, Programme from Berlin (Deutschlandsender). 6.15, Market Prices. 6.25 (from Danzig). Talk: Social Welfare Work in Old Danzig. 6.50, Weather. 7.0, Transmission for all German Stations, relayed from Breslau. 8.0, News. 8.10, Concert by the Small Station Orchestra: Overture, Der Bajazzo (Czibulka); Selection from The Daughter of the Regiment (Donizetti), for Flute and Orchestra; Cello Solo: At the Fountain (Davidoff); Pianoforte Solo: Straussiana (Börsehel), with Orchestral Accompaniment; Selection from Louise de Montfort (Bergson), for Clarinet and Orchestra; Violin Solos: (a) Spanish Dance, No. 7, (b) Zapateado (Sarasate); Perpetuum mobile (Joh. Strauss). 9.10, Concert by the Königsberg String Trio: String Trio in D Minor, Op. 141 (Reger); Quartet in F for String Trio and Oboe (Mozart). 9.50, Elementary English Lesson. 10.15, News.

HILVERSUM

Announced HUIZEN, 1,013 kc/s, 296.1 metres; 7 kW. (until 5.40 p.m.), and 20 kW. from 5.40 p.m. Programme of the Christian Radio Society (N.C.R.V.). 11.55 a.m., Gramophone Music. 12.10, Organ Recital by Jan Zwart. 1.40, Broadcast for Schools. 2.15, Talk. 2.55, Gramophone Music. 3.25 to 3.40, Interval. 3.40, Bible Reading and Sacred Songs. 4.40, Violin Duets and Pianoforte Solos: The Golden Sonata (Purcell); Sonata in C minor (Bach); Gramophone Records: Pianoforte Solos: Preludes, Op. 29, Nos. 1, 6, 13, and 15 (Chopin); Violin Solos: (a) Romance (d'Ambrosio), (b) Piece (Rachmaninov); Gramophone Records: Six Duettini (Godard). 6.10, Answers to Correspondence. 6.40, Police Notes. 6.55, Religious News. 7.10, Answers to Correspondence (contd.). 7.40, Choral Concert of Folk Music, conducted by Spoel. Soloists: Mme. Flinterman van Eck (Soprano), Mlle. Born (Mezzo-Soprano), de Vries (Tenor), Segboer (Baritone), and Mme. de Ridder-Spaan (Pianoforte). 8.40, Talk. 9.10, Choral Concert (contd.). 9.40, News. 9.50, Organ Recital: Cherubino's Song (Mozart); Teh Wollt (Mendelssohn); Waltz No. 3 (Chopin); Songs without words (Tchaikovsky); Selection from Manon (Massenet); Elegy (Massenet); Stephanie Gavotte (Czibulka); Serenade (Widor); Erotica (Grieg); Overture, Poet and Peasant (Suppe). 10.40, Gramophone Music. 11.10 (approx.). Close Down.

HORBY.—See Stockholm.

HUIZEN

Announced HILVERSUM, 160 kc/s, 1,875 metres; 7 kW. (until 3.40 p.m.). Transmitted from Kootwijk on 50 kW. from 3.40 p.m.—11.40 a.m. till Close Down, Programme of the Workers' Radio Society (V.A.R.A.). 11.40, Concert by the Eddy Walis Ensemble, Gramophone Records in the interval. 1.40 p.m., Recitations. 1.55, Violin Duets by Mlle. van Wijngaarden and van Sloghem: Sonata in G, No. 1 (Leclair); Sonata in A, No. 2 (Leclair); Duet (Geminiani); Duet in C (Mozart); Duet in B flat (Mozart); Concert Duet, Op. 25 (Leonard). In the interval at 2.25, Recitations. 3.10, Gramophone Music. 3.25 to 3.40, Interval. 3.40, Organ Recital by Steyn. 4.10, Programme for Children. 4.40, Concert by De Notenkrakers, conducted by Wims: Oechi neri (Campanelli); Schwert und Leier (Strauss); Selection from A Kiss in Spring (Kabanov); Noveletta (d'Ambrosio); Venetian Song (Crémiency); Gramophone Records: Marionetten-Groteske (Dreyer); Salut d'amour (Elgar); Tanz der Schmetterlinge (Kockert); Ein Märchen (Leopold); Chanson de Capri (Massenet); Pen-see d'automne (Massenet); Krackoviak (Noskowski); Le baiser (Crémiency); Selection from Paganiini (Lehar). In the interval at 5.25, Recitations. 6.10, Music Talk. 6.40, Concert by the Small V.A.R.A. Orchestra, conducted by de Groot: March from A Waltz Dream (O. Straus); Amoureuse (Berger); Baby Parade (Mammfred); O Sole mio (di Capua); Polka (Dammare); Selection from Lucia di Lammermoor (Donizetti); Marionetten auf der Spieluhr (Armandola); The Grasshopper's Dance (Bucalossi); Waltz Potpourri (Robrecht). 7.38,

8.0.S. Messages. 7.40, Dramatic Programme. 8.0, Symphony Concert relayed from London. 9.25, News. 9.40, Concert by De Notenkrakers. 10.40, Gramophone Music. 11.40 (approx.). Close Down.

INNSBRUCK.—See Vienna.

KALUNDBORG.—See Copenhagen.

KATOWICE

734 kc/s, 408 metres; 16 kW.—6.35 p.m., See Warsaw. 11.0, Talk in Neo-Greek: Jan Sobieski in Vienna.

KIEL.—See Hamburg.

KLAGENFURT.—See Vienna.

KOSICE.—See Prague.

LANGENBERG

635 kc/s, 473 metres; 60 kW.—12.15 p.m., Concert by the Small Station Choir, conducted by Brener. Soloist: Jakob Braun (Violin). Folk Song, Wohlauf in Gottes Schöne Welt; Ständchen (Trunk); Auf der Wiese (Trunk); Three Songs (Othegraven); (a) Rätsel, (b) Die Vögelin, (c) Mein Schätzle ist kein; Violin Solos: (a) Extract from the Violin Maker of Cremona (Hubay); (b) Perpetuum Mobile (Ries); Marschier-Liedchen (Marschner); Speisetzettel (Zöhner); Bergische Heubauand (Brambach). 1.15, News. 1.30, Concert by the Station Chamber Orchestra, conducted by Brener. Tone Poem, Finlandia (Sibelius); Waltz, Hofballtänze (Lammer); Selection from Aida (Verdi); Homage March (Grieg); Negro Lullaby (Clutsam). In the interval at 2.0 (approx.), News. 2.30, Market Prices. 3.0, Talk: Fruit-trees for the Small Garden. 3.30, Talk: Civil Servants and the State in German History. 4.50, Political Talk. 5.0, Famous Conductors and Famous Orchestras—Gramophone Concert. 5.30, Concert of Folk Music, conducted by Knopf. 6.15, A Story of German Colonisation. 6.25, French Lesson. 6.45, Announcements. 7.0, Transmission for all German Stations, relayed from Breslau. 8.0, News. 8.5, Concert by the Station Orchestra, conducted by Buschkötter. Soloist: Hans Haas (Pianoforte). Symphonic Poem, Till Eulenspiegel's Merry Pranks (R. Strauss); Pianoforte Concerto in D (Haydn); Pianoforte Concerto in A, The Coronation (Mozart); Symphony in D minor (Schumann). In the interval, Eulenspiegel greift ein (Eulenspiegel takes a Hand)—A Play of Youth and Age (Hinz Stegawit). 10.15, News. 10.30, Serenade by the Münster Municipal Orchestra. In the interval, Recital of Classic Songs and Ballads by Streinz (Bass) and Grape (Pianoforte). 12 Midnight, Close Down.

LAUSANNE.—See Radio-Suisse Romande.

LEIPZIG

769.9 kc/s 389.6 metres; 120 kW. Relayed by Dresden, 941 kc/s, 319 metres.—3.0 p.m., Talk for Women. 3.35, Market Prices. 4.0, Song and Pianoforte Recital by Karin Brandt (Soprano) Helene Müller-Schäfer (Alto), Herbert Neck (Tenor), and Karl Weiss (Pianoforte): Soprano and Alto Duets from the Balladen und Romanzen, Op. 75 (Brahms); (a) Guter Rat, (b) Waldpurgisnacht; Soprano and Tenor Duets (Schumann); (a) Unterm Fenster, (b) So wahr die Sonne scheint; Pianoforte Solos from the Idyllen, Op. 43 (Lensen); (a) Feld-Wald und Wiesenzüchter, (b) Waldvögelin; Soprano and Alto Duet: Der träumende See (Pitzner); Soprano and Tenor Duets (Schumann): (a) In der Nacht, (b) Tanzlied; Soprano and Alto Duets (Brahms): (a) Boten der Liebe, (b) Hut' du dich. 4.40, Talk: Great German Books—Dr. Faust. 5.0, Talk: The Army Intelligence Corps with Reference to the Battle of the Marne. 5.20, Organ Recital by Ernst Müller relayed from The University Church: Prelude and Choral Paraphrase, Ach, bleib mit deiner Gnade; Theme with Variations. 5.50, News, Weather and Time. 6.0, Italian Lesson. 6.25, Opera and Operetta Music on Gramophone Records. 6.50, Review of the Day's News. 7.0, Transmission for all German Stations relayed from Breslau. 8.0, See Stuttgart. 9.20, News. 9.30, Concert by the Leipzig Symphony Orchestra, conducted by Weisbach: Ballet Suite in D, Op. 130 (Reger); Symphony No. 2 in D, Op. 73 (Brahms). 10.45, News. 11.0 (from Dresden), Concert by the Plietsch-Marko Orchestra. 12 Midnight, Close Down.

LINZ.—See Vienna.

LUXEMBOURG

252 kc/s, 1,191 metres; 200 kW.—12.30 p.m., Concert by the Station Orchestra, conducted by Pensis: Comedy Overture (Lüncke); Selection from Der Freischütz (Weber); Intermezzo No. 1 (Kalkman); Badinage (d'Agreves); Waltz, Mon rêve (Walldtenfel); Norwegian Wedding Procession (Grieg); Selection from The Bird-Fancier (Zeller). 1.30, Gramophone Music. 7.30 till Close Down, Italian Programme. 7.30, Symphony No. 4 in A (Mendelssohn) by the Orchestra of the

Scala, Milan (on Gramophone Records). 8.20, Italian Concert by the Station Orchestra, conducted by Pensis: Soloist, Camille Delmotte (Double-Bass): Double Bass Concerto (Dragonetti); Overture, William Tell (Rossini). 8.50, News in French. 9.0, Italian Song Recital by Gustave Simon, with the Station Orchestra: Aria from Le Maître de Chapelle (Paer); Che fiero costume (Lengrenzi); Solve amiche (Caldara); Spesso vibra (Searlatti); Quella fiamma che m'accende (Marelli); Aria from The Barber of Seville (Rossini); Orchestra: Selection from Madame Butterfly (Puccini). 9.50, News in German. 10.0, Concert by the Station Orchestra, conducted by Pensis: Serenade (Donnez); Nic and Nac (Demaret); Scherzetto (Demaret); Selection from Gri-Gri (Lüncke). 10.25, Dance Music on Gramophone Records.

MADRID

EAJ7, 707 kc/s, 424.3 metres; 2 kW.—8.0 p.m., Chimes, Exchange, Radio Journal, and Request Gramophone Records. 9.15, Topical Review. 9.30 (approx.), Close Down.

MADRID

ARANJUEZ, EAQ, 10,000 kc/s, 30 metres; 20 kW.—12 Noon to 1.0 p.m., Programme for Catalonians in America. 11.30 p.m., Popular Concert. In the interval at 11.45, Radio Chronicle. 12.35 a.m. (Tuesday), Sports and Bull-fighting Notes. 12.40, Light Music. 1.0 (approx.), Close Down.

MALMO.—See Stockholm.

MILAN.—See Turin

MORAVSKA-OSTRAVA

1,137 kc/s, 263.8 metres; 11 kW.—2.50 p.m., Orchestral Concert, conducted by Plietta: Overture in Italian Style (Schubert); Dances (Manfred); Friant (Malat); Polka (Nedbal); Rhapsody in B minor, Op. 25 (Hartung); Waltz (Provanzik); Melody (Higgs); March (Enick). 3.50-4.0, See Prague. 5.45, See Prague. 6.5, Talk on Sports. 6.15, See Prague. 6.30, German Transmission: Two Talks. 7.0, See Prague. 7.10, Concert of Folk Music. 7.50, See Bratislava. 8.5, See Brno. 9.5, Talk: Street Orators. 9.25, See Prague. 10.15 (approx.), Close Down.

MOTALA.—See Stockholm.

MUHLACKER.—See Stuttgart.

MUNICH

563 kc/s, 533 metres; 60 kW. Relayed by Augsburg and Kaiserslautern, 536 kc/s, 560 metres, and Nürnberg, 1,256 kc/s, 239 metres.—4.30, Orchestral Concert, conducted by Erich Kloss: Overture, Undine (Lortzing); Cello Solos: (a) Brise de mer (Leonavallo), (b) Serenade (Drigo); Suite campestre (Amadei); Three Norwegian Dances (Grieg); Selection from Cavalleria rusticana (Masscagni); Waltz (Provanzik); Adoration (Fitzpuci); Old Styrian Suite (Pachernegg). 5.45, Reading for Young People: The Spirit of Frederiek the Great. 6.5, Programme to be announced. 6.25, Sonata for Viola and Pianoforte (Dittersdorf), by Philipp Haas and Richard Staal. 6.45, Time, Weather and Agricultural Notes. 7.0, Transmission for all German Stations, relayed from Breslau. 8.0 (from Nürnberg), Opera (to be announced). 9.0, Talk from the series: The German and the Russian Revolutions. 9.20, Concert by the Station Orchestra, conducted by Hans Winter. Soloist: Margot Leander (Soprano); Overture, The Cid (Cornelius); Dance Fantasia (Weismann); Four Songs for Soprano; Overture, Der Improvisator (d'Albert). 10.20, Time, Weather, News, and Sports Notes. 11.0, Concert by the Station Schrammel Quartet, with Viennese Songs by Paula Menari. 12 Midnight, Close Down.

NAPLES.—See Rome.

NOTODDEN.—See Oslo.

OSLO

277 kc/s, 1,083 metres; 60 kW. Relayed by Fredriksstad, 820 kc/s, 365.8 metres; Hamar, 522 kc/s, 574.7 metres; Notodden, 671 kc/s, 447.1 metres; Porsgrund, 662 kc/s, 453.2 metres; and Rjukan, 671 kc/s, 447.1 metres.—5.30 p.m., Concert by the Station Ensemble. 6.30, Recitations. 7.0, News. 7.30, Political Talk. 8.0, Time Signal. 8.1, Pianoforte Recital by Bergliot Haynveik. 8.35, Saxophone and Pianoforte Recital by Sigurd Rascher and Mlle. Hendrikson. 9.10, Political Review. 9.40, News. 10.0, Topical Talk. 10.15, Song Recital by Erling Aas: Aria from A Masked Ball (Verdi); Songs (Schubert): (a) Ständchen, (b) Die Neben-sinnen, (c) Liebesbotenschaft; Melody (Harum); Fattigmannsträß (Sinding); Song (Westwag); Sweet Mystery of Love (Moya). 10.45 (approx.), Close Down.

OSTERSUND.—See Stockholm.

PALERMO

558 kc/s, 537.6 metres; 3 kW.—8.0 p.m., Dopplavoro Notes, Tourist Talk, Agricultural Notes, Report of the Royal Geographical Society, and Giornale Radio. 3.20, Gramophone Music. In the interval at 8.30, Time

SEPT. 18th

MONDAY

continued

and Announcements. 8.45, Chamber Music; Quartet in C Minor (Beethoven); Tenor Solos: (a) O del mio amato bene (Donaudy), (b) Ballata medievale (Mazzotti); Nocturne from the Quartet in D (Borodin); Tenor Solos: (a) Supremo sono (Santoliquido), (b) Romance (Mazzotti); Two Movements from the Quartet in D (Mendelssohn). 9.45, Talk. 10.0, Gramophone Music. 11.0, Giornale Radio.

PARIS

EFFEL TOWER. Call FLE, 207.5 kc/s, 1,445.7 metres; 13 kW. Time Signals (on 2,650 metres) at 10.25 a.m. and 11.26 p.m. (Preliminary and 6-dot Signals). 6.45 p.m., Theatre Talk. 7.0, Le Journal Parle. 8.30, Orchestral Concert, conducted by Flamant; Four Noctelites for Quartet and Piano (Andrieu); The Nutcracker Suite (Tchaikovsky); Overture and Melodies from The Barber of Seville (Rossini); Indian Rhapsody (Nolety). 10.0 (approx.), Close Down.

PARIS

POSTE PARISIEN, 914 kc/s, 328.2 metres; 60 kW.—7.0 p.m., Concerto in G (J. C. Bach), on Gramophone Records. 7.15, Journal Parle. 7.30, Hot Jazz on Gramophone Records. 8.0, Bizet Song Recital by Paul Pasen. 8.30, Humorous Songs by Max Régner. 9.10, Gramophone Concert. 10.10, News.

PARIS

RADIO-PARIS, Call CFR, 174 kc/s, 1,725 metres; 75 kW. 7.30 a.m., Weather and Physical Culture. 7.45, Gramophone Music; Santander (Van Hoorebecke); Espiegleries (Yatove); Tina (Rolero); Douanewellen (Ivanovitch). 8.0, Weather and Press Review. 12 Noon, Gramophone Concert of Nineteenth Century Opera Music; Extracts (a) Le Roi d'Ys (Lalo), (b) La Gioconda (Ponchielli), (c) Patrie (Paladilhe), (d) Gwendoline (Chabrier), (e) Le roi malgré lui (Chabrier). In the interval at 1.0 p.m., Market Prices, News and Weather, and at 1.30, Exchange. 2.0, Exchange. 3.45, Market Prices. 7.0, Agricultural Notes. 7.10, Gramophone Music; Hungarian Czardas, Sivar (Kun); L'epave (Codiini); Beinezhmüchens Waehparade (Noack); L'ajacienne (Costa); Patria Belgica (Laborov); Allons gai, gai bergeres (Casteley); Fleurs de lune (Poppies); Romance (Cronin); Granada (Garcia); Lusina (Curtis); Arab March (Ganne); Le temeraire (Mongou). 7.50, Market Prices and News. 8.0, Schumann Gramophone Concert. In the interval at 8.30, News, Weather and Sports Notes, and at 8.40, Review by Paul Reboux. 8.45, Five Songs (Dalozzo). 9.0, Bondu sauvé des eaux—Play (Fanchois), relayed from the Théâtre des Mathurins. In the intervals, News.

PITTSBURGH

KDKA, 980 kc/s, 306 metres; 50 kW. Relay by W8XK on 48.86 metres and 25.27 metres.—7.30 p.m., Pontiac Home Forum. 8.0, Betty and Bob, from New York. 8.15, Words and Music, from New York. 8.45, Human Values. 9.0, Radio Guild, from New York. 10.0, Uncle Tom and Betty. 10.15, Tarzan of the Apes. 10.30, The Singing Lady. 10.45, Orphan Annie, from New York. 11.0, Press News-Reader. 11.15, Sports Notes and a Song. 11.30, Pittsburgh Spotlights. 11.45-3.0 a.m. (Tuesday), New York Relay. 11.45, Lowell Thomas. 12 Midnight, Amos 'n' Andy. 12.15, Baby Rose Marie. 12.30, Popular Programme. 1.0, Yesterday and To-day. 1.30, Potash and Perlmutter. 1.45, Gould and Shefter. 2.0, Sinclair Minstrels. 2.30, Melody Moments. 3.0, Silver Toppers.

PORSGRUND.—See Oslo.

PRAGUE

614 kc/s, 489.6 metres; 120 kW.—2.50 p.m., See Moravská-Ostrava. 3.50, Aviation Weather Report. 3.55, Exchange. 4.0, Interval. 5.45, Practical Hints for the Housewife. 5.55, Talk. 6.5, Agricultural Programme. 6.15, Talk for Workers. 6.25, News in German. 6.30, German Transmission Talk on German Universities. 7.0, Chimes and News. 7.10, See Moravská-Ostrava. 7.50, See Bratislava. 8.5, See Brno. 9.5, See Moravská-Ostrava. 9.25, Clementi Pianoforte Sonata Recital by Jan Herman with Commentary; Sonata No. 16 in G Minor; Sonata No. 13 in B Flat. 10.0, Time, News and Sports Notes. 10.15, Talk in German. 10.30, Close Down.

RADIO-SUISSE ROMANDE

SOTTENS; 743 kc/s, 403 metres; 25 kW.; and Geneva, 395 kc/s, 760 metres.—6.15 to 6.30 a.m. (from Lausanne), Gymnastics. 12.28 p.m., Time Signal from Neuchâtel Observatory. 12.30, News and Weather. 12.40 (from Geneva), Gramophone Concert. 1.0 (from Geneva), Financial Notes. 1.10 (from Geneva), Gramophone Music. 2.0 to 3.28, Interval. 3.28, Time Signal from Neuchâtel Observatory. 3.30 (from Lausanne), Concert by the Radio Lausanne Orchestra, conducted by Moser. 5.0 (from Lausanne), Programme

for Children. 5.30 to 7.0, Interval. 7.0 (from Geneva), Talk: Lutheranism in Bologna in the Fifteenth and Sixteenth Centuries. 7.30 (from Geneva), Weather, News, and Announcements. 8.0 (from Lausanne), Accordion Recital by Albert Huard, with Orchestral Accompaniment. 8.45 (from Lausanne), Humorous Items. 9.0 (from Geneva), Popular Programme by a Mandoline Orchestra and a Children's Choir. 9.50, News and Weather. 10.0 (from Geneva), Gramophone Music. 10.30 (approx.), Close Down.

REYKJAVIK

1,200 metres; 21 kW. 9.5 p.m., Musical Programme. 9.30, Weather. 9.40, Mustard Programme and Announcements. 10.0, Chimes and News. 10.30, Reading. 11.0, Popular Concert by the Station Quartet, with Songs.

RIGA

572 kc/s, 525 metres; 15 kW.—6.0 p.m., Agricultural Talk. 6.30, English Lesson. 7.0, Weather Report. 7.5, Orchestral Concert, conducted by Medins; suite, Scènes du Sud (Noëld); Suite, A Day in Venice (Nevin); Suite, Scènes italiennes (Godard). 8.0, News. 8.15, Pianoforte Recital of Lucia Garus Music, by the Composer. 8.45, Orchestral Concert, conducted by Medins; March from Russian and Ladmilla (Glinka); Three Pieces (Tchaikovsky); (a) Arab Dance, (b) Chinese Dance, (c) Trepak; Tareh Dance of the Brides of Kashmir (Rubinstein); Kamarinskaya (Glinka). 9.0, Weather Report. 9.30, Concert by a Mandoline Orchestra. 10.30 (approx.), Close Down.

RJKAN.—See Oslo.

ROME

Call IRO, 680 kc/s, 441 metres; 50 kW. Relay by Naples, 941 kc/s, 319 metres; and 2RO, 11,810 kc/s, 25.4 metres, from 5.15 p.m., and Milan (Vigentino), 662 kc/s, 453.2 metres from 8.45 p.m.—12.30 p.m., Gramophone Records. 1.0, Gramophone Concert. In the interval from 1.30 to 1.45, Giornale Radio, and Exchange. 2.0, Time and Announcements. 4.30, Children's Radio Review. 4.55, Giornale Radio and Exchange. 5.10, Weather. 5.15, Song and Violin Recital by Angelo Parigi (Tenor), Carmen Garcia Cornejo (Soprano), and Nella Ranieri; Violin Solos: Popular Songs and Dances of Brittany (arr. Maugeot); Tenor Solos: (a) Aria from The Secret Marriage (Cimarosa), (b) Intorno all'idolo mio (Cesti), (c) Gran pure in ciel le stiere (Pasquini); Violin Solos: (a) Waltz (Brahms-Horshstein), (b) Spanish Serenade (Carnevali-Corti); South American Songs for Soprano. 6.40 (Naples), Shipping and Sports Notes. 6.45, Dopolavoro Notes and Tourist Report. 7.15, Agricultural Report. 7.20, News in Foreign Languages. 7.40, Giornale Radio. 8.0, Time and Announcements. 8.30, Giornale Radio and Sports Notes. 8.45, Variety Programme. 9.45, Benedetta among the Men—Comedy in One Act (Gian Capor). 10.15 (approx.), Dance Music. 11.0, Giornale Radio.

SALZBURG.—See Vienna.

SCHENECTADY

WGY, 790 kc/s, 379.5 metres; 50 kW. Relay at intervals by W2XAF on 31.48 metres and by W2XAD on 19.56 metres.—9.0 p.m., Book News by Levere Fuller. 9.15 to 10.0 (approx.), New York Relay. 9.15, Solists. 9.45, Lady Next Door. 12.45 a.m. (Tuesday), Stock Reports and Police Notices. 1.0, Societyland Sketch, from New York. 1.30, Fitzgerald Brothers Programme. 1.45 to 3.30, New York Relay. 1.45, Ferd Grofe's Orchestra. 2.0, A. and P. Gipsies. 2.30, Musical Programme. 3.0, Contented Programme. 3.30, Radio Revue, from New York, followed by Programme Resumé.

SCHWEIZERISCHER LANDESENDER

BEROMUNSTER; 653 kc/s, 459 metres; 60 kW.: Basle, 1,229 kc/s, 244.1 metres; and Berne, 1,220 kc/s, 245.9 metres.—6.15 a.m. (from Basle), Gymnastics. 6.35 to 11.59, Interval. 11.59, Time Signal from Schenectady Observatory, and Weather. 12 Noon (from Basle), Operetta Music on Gramophone Records. 12.30 p.m., Time, Weather, and News. 12.40 (from Basle), Song Recital on Gramophone Records. 1.25 (from Basle), Time, Weather and Exchange. 1.30 to 5.0, Interval. 5.0 (from Berne), Programme for Women. 5.30 (from Berne), Variety Concert on Gramophone Records. 6.30 (from Zürich), Talk on Rahel Varuhagen. 7.0, Time and Weather. 7.5 (from Zürich), Gramophone Concert. 7.30 (from Zürich), English Lesson. 8.0 (from Zürich), Concert by the Radio Orchestra. 8.30 (from Zürich), Talk: The Renaissance. 9.0, Weather and News. 9.10 (from Zürich), A Radio Play of Greus Life. 10.15 (approx.), Close Down.

SOTTENS.—See Radio-Suisse Romande.

STOCKHOLM

689 kc/s, 436 metres; 55 kW. Relay by Boden, 244 kc/s, 1,229.5 metres; Göteborg, 932 kc/s, 322 metres; Hörby, 1,166 kc/s, 257 metres; Motala, 221.5 kc/s, 1,354.4 metres; Ostersund, 589 kc/s, 770 metres; and Sundsvall, 554 kc/s, 542 metres.—5.5 p.m., Song Recital by Nils Svanfeldt. 5.20, Talk, relayed from Uppsala, 662 kc/s, 453.2 metres. 5.45, Gramophone Music. 6.45, Elementary German Lesson. 7.30, Talk. 8.0, Folk Songs of the Nations (Iceland, Germany, America, Palestine, France, Denmark and Sweden—Recital by Engel Lund; Iceland: (a) Fjallbrekka (Maelkottthöjón), (b) Bi bi og blaka (Svanbjörnsson), (c) Sprettur (Pentland); Germany: Da unten im Tale (Brahms), (d) Frau Nacthigall (Kickstätt); America: Soldier Boy and Riddle Song from the Appalachian Mountains (arr. Cecil Sharp); Palestine: (a) Jadu halelot bienau (Jevons), (b) Po baare z (Jeevons); France: (a) Jardin d'amour (Weckerlin), (b) La romanesca (Weckerlin); Denmark: (a) Dronning Dagmars död (Reuter), (b) Langt ide i Skoven laa et lille Bjerg (Reuter); Sweden: (a) Stor Ola, lille Ola (Reuter), (b) Kristallen den fina (Reuter). 8.35, Reading. 9.0, Concert by the Erkkä Quartet, relayed from the Royal Academy of Music. 9.45, Weather and News. 10.0, Concert by the Station Orchestra; Soloist, Magda Sjögren (Songs) and Oskar Lindberg (Organ); Concerto in F for Two Violins, Cello and String Orchestra (Handel); Aria from the Septuagesima Cantata (Bach); Aria from the Ode for St. Cecilia's Day (Handel); Organ Solo: Te Deum laudamus (Sgambati); Songs: (a) Gebet (Wolf), (b) Auf ein altes Bild (Wolf), (c) Marienlied (Marx); Variations for Organ (Lindberg). 11.0 (approx.), Close Down.

STRASBOURG

869 kc/s, 345 metres; 11.5 kW.—11.30 a.m., Gramophone Concert of Variety Music. 12.45 p.m., News. 1.0, Time and Exchange. 1.5, Light Music on Gramophone Records. 2.0, Interval. 5.0, Orchestral Concert, conducted by Roskam. Suite in Old Style, Trionon (Lacharme); Waltz, Rose mousse (Bose); Selection from The Geisha (Jones); Two Alsatian Sketches (Gross); Dance Suite (Messager); Intermezzo (Kahnau); March, Le défilé de la Garde (Gile). 6.0, Fortnightly Literary Review. 6.15, Review of the Week. 6.30, Pianoforte Recital by Alphonse Feuhr; Ballade (Grieg); Nocturne in C, Sharp (Chopin); Impromptu in A Flat (Chopin); Valse de Fadien (Chopin); Ronde de nuit (Erh); Cortège champêtre (Erh); Five Chorales (Adam); Three Andalusian Dances (Turina). 7.30, Time and News. 7.45, Gramophone Music. 8.0, Press Review in German, Lottery Results and Announcements. 8.30, Orchestral Concert, relayed from the Strasbourg Fair, Conductor Maurice de Villers. Symphony for Orchestra and Organ (Saint-Saëns); Extracts from the Christmas Oratorio (Saint-Saëns). 10.30 (approx.), Close Down.

STUTTART

MUHLACKER, 832 kc/s, 360.5 metres; 60 kW. Relay by Freiburg, 527 kc/s, 570 metres.—12 Noon, Folk Music on Gramophone Records. 12.20 p.m., Löwe Ballad Recital by Fritz Seierfried on Gramophone Records. 12.35, Pianoforte Concerto No. 1 in D Minor, Op. 15 (Brahms), by Wilhelm Backhaus and the Station Symphony Orchestra (on Gramophone Records). 1.15, Time and News. 1.30, See Langenberg. 2.0, Concert arranged by the Post Office. 2.30, Spanish Lesson. 3.0, Elementary English Lesson. 4.30, See Munich. 5.45, Talk: Lost German Territory Alsace Lorraine. 6.15, Talk: Eugenies in Daily Life. 7.0, Transmission for all German Stations, relayed from Breslau. 8.0, The Tyrol Variety Programme (arr. Karl Köstlin), with the Station Orchestra and the Heinz Munch Zither Trio. 9.20 (from Freiburg), Concert by a Nazi Band. 9.50, Ex-soldiers' Reminiscences. 10.10, Time and News. 10.30 (from Freiburg), Dramatic Programme. 11.0, See Leipzig. 12 Midnight (approx.), Close Down.

SUNDSVALL.—See Stockholm.

TOULOUSE

779 kc/s, 385 metres; 8 kW.—6.0 p.m., News. 6.15, Music by an Argentine Orchestra. 6.30, Popular Melodies. 6.45, Viennese Orchestra. The Wedding of the Rose (Jessel); Waltz, The Blue Danube (Joh. Strauss); The Skaters' Waltz (Waldteufel). 7.0, Songs from Operetta. 7.15, News, Racing Results, and Market Prices. 7.30, Mascarade (Lacôme), by the Symphony Orchestra. 7.45, Opera Music. Arias from: William Tell (Rossini), La Juive (Halévy), and Faust (Gounod). 8.0, Orchestral Pieces. 8.15, Sound Film Music. 8.30, Hunting Horn Solos. 8.45, Accordion Music. 9.0, Concert. Part I: Russian Music; Extracts from Prince Igor (Borodin) and Les cloches du soir (Grebainoff). Part II: Military Music. March from Aida (Verdi);

Fête militaire (Pétil); Ce que c'est qu'un drapeau (La Marelle). Part III: Chansonnettes. 10.0, Music by a Viennese Orchestra. 10.15, North African News and Local News. 10.30, Concert for Listeners in Morocco. The Feast of the Gnomes (Hagen); Trio from Carmen (Bizet); Japanese Lantern Dance (Yoshioto); Melody (Codiini); Slav Dance (Kreislere); Reviens (Christiné). 11.0, Popular Music. 11.15, Dance Music. 12.0 Midnight, News, Weather and Announcements. 12.5 a.m. (Tuesday), Military Music. 12.15, Popular Orchestral Music. 12.30 (approx.), Close Down.

TRIESTE

1,211 kc/s, 247.7 metres; 10 kW. 5.10 p.m. till Close Down. See Turin.

TRONDHEIM.—See Oslo.

TURIN

1,096 kc/s, 273.7 metres; 7 kW. Relay by Milan, 905 kc/s, 331.5 metres; Genoa, 959 kc/s, 312.8 metres; and Florence, 599 kc/s, 500.5 metres.—5.10 to 6.0 p.m., Concert. 6.40, Giornale Radio, Dopolavoro Announcements, and Gramophone Music. 7.10, Agricultural Notes and Market Prices. 7.20, News in Foreign Languages. 7.40, Gramophone Music. 8.0, Announcements, Giornale Radio, Sports Notes, and Weather. 8.15, Sponsored Concert. 9.15, A Comedy in One Act. 9.45, Chamber Music. 10.30, Gramophone Music. 11.0, Giornale Radio.

VATICAN CITY

15,120 kc/s, 19.84 metres (Morning) and 5,969 kc/s, 50.26 metres (Evening); 10 kW.—11.0 to 11.15 a.m., Religious Information in Italian. 8.0 to 8.15 p.m., Religious Information in Italian.

VIENNA

581 kc/s, 517 metres; 15 kW. Relay by Graz, 852 kc/s, 352.1 metres; Innsbruck, 1,058 kc/s, 283 metres; Klagenfurt, 662 kc/s, 453.2 metres; Linz, 1,220 kc/s, 245.9 metres; and Salzburg, 1,373 kc/s, 218.5 metres.—12 Noon, Orchestral Concert, conducted by Otto Waeck. In the interval at 1.0 p.m., News and Announcements. 2.0 to 3.0, Interval. 3.0, Time, Weather, and Market Report. 3.20, Talk on Photography. 3.30, Programme for Children. 3.55, The New World Symphony (Dvorak) on Gramophone Records. 4.35, Reading for Young People. 5.0, Music Talk. 5.25, Recital by Ina Grafins (Soprano) and Walter Höfermayer (Baritone); Songs for Soprano (Hans Schmidt); (a) Die Birken, (b) Im Sommer, (c) Botschaft, (d) Der Liebste schläft, (e) An die Nachtigall, (f) Herbstklage, (g) Füttere, (h) An der Wiege, (i) Früh am Tage, (j) Hirtenweise; Songs for Baritone (Grieg); (a) Glücksbote mein, (b) Geschieden, (c) Lauf der Welt, (d) Eros, (e) Was ich sehe, (f) Zur Johannisnacht; Songs for Baritone (Hugo Wolf); Fühlt meine Seele, (b) Heimweh, (c) Der Musikant. 6.5, Talk: The Crucifixion and the Ecco Homo in German Graphic Art. 6.25, Books and Works of Reference in Connection with the Week's Talks. 6.30, Talk: Old Viennese Water Mills. 7.0, Concert of Variations by the Wiener Symphoniker; Variations on a Theme of Haydn, Op. 56 (Brahms); Istar Variations (d'Indy); Variations and Fugue on a Theme of Mozart (Reger). Variations from the Orchestral Suite No. 1 (Tchaikovsky). In an interval at 7.35, Time, Weather, and News. 8.15, Topical Talk. 8.30, Gramelstaedten Concert by the Wiener Symphoniker, conducted by Holzer; Overture, Waltz, Duet and March from Bub oder Mädel; Waltz and Song from Ruf Befehl der Herzogin; Two Songs from Reklame; Selection from Baechtsnacht; Selection from Glück bei Frauen; Waltz from Madestät Miml; Melodies from Das Schwalbennest; Potpourri from Der Orlov. 10.0, News, Weather, and Announcements. 10.15, Dance Music on Gramophone Records.

WARSAW

212.5 kc/s, 1,411 metres; 120 kW.—11.57 a.m., Time Signal and Fanfare from St. Mary's Church, Cracow. 12.5 p.m., Gramophone Music. In the intervals at 12.25, Press Review and at 12.33, Weather. 12.55, Radio Journal. 1.0, Interval. 2.55, News. 3.0, Gramophone Music. In the intervals at 3.5, News, at 3.25, Economic Notes, and at 3.45, Traffic Report. 5.0, Talk in French. 5.15, Violin and Pianoforte Recital by Ossendowska and Zaleska; Violin and Pianoforte Sonata (Schumann); Pianoforte Solos: (a) Ballad in F Minor (Chopin), (b) Spring Song (Schumann-Liszt), (c) Serenade (Schubert-Liszt), (d) Navarra (Albeniz); Violin Solos: (a) Butterfly (Santrel), (b) Seville (Ossendowska), (c) Serenade, Polichinelle (Kreisler); Tarantella (Wieniawski). 6.15, Talk on Economics. 6.35, Light Music from the Gastronomia Café. 6.55 Military Programme. 7.20, Miscellaneous Items. 7.35, Programme Announcements. 7.40, Book Review. 8.0, Frederica, Operetta (Lehar) (Concert Version). In the intervals, Agriculture (Correspondence) and Radio Journal. 10.30, Sports Notes. 10.40, News, Weather, and Police Notes. 10.45, Dance Music on Gramophone Records.

ZURICH.—See Schweizerischer Landessender.



# TUESDAY

## SEPTEMBER THE NINETEENTH

### PRINCIPAL EVENTS OF THE DAY:

#### AT HOME

**NATIONAL** "La Bohème," by Puccini, relayed from Sadler's Wells.

**LONDON REGIONAL** Excerpt from "Sunny Days," relayed from Largs.

**MIDLAND REGIONAL** Military Band programme.

**NORTH REGIONAL** Concert from the Houldsworth Hall, Manchester.

**WEST REGIONAL** Programme of music by West Country composers.

**SCOTTISH REGIONAL** Excerpt from "Sunny Days," from the Barrfields Pavilion, Largs.

**BELFAST** "Mr. Arthur's Operation," a comedy, by John McCann.

#### ABROAD

**BARCELONA** 7.0 p.m. Trio concert. 10.30 p.m., Wagner concert, by the Station Orchestra.

**BRUSSELS (No. 1)** 9.0 p.m. Beethoven concert, by the Station Symphony Orchestra.

**HAMBURG** 10.30 p.m. The Philharmonic Orchestra, conducted by J. Eibenschütz.

**HILVERSUM** 7.40 p.m. The K.R.O. Orchestra, conducted by Gerritzen.

**PALERMO ROME** 8.45 p.m. Opera: "Andrea Chénier," by Giordano. 8.45 p.m. Light opera: "The Toreador," by Caryl and Monckton.

**WARSAW** 8.0 p.m. The Station Orchestra, conducted by Oziminski.

ish Dances (Blockx). 8.45, Hondsdoelheid - Play in One Act (Goetz). 9.15, Concert by the Radio Orchestra, conducted by Franz André; Song (Eisher); Overture, The Crown Diamonds (Amber); Verdi Potpourri (Morena); Gramophone Records: (a) Bell Song from Lakmé (Delibes), (b) Aria from Manon (Massenet), (c) Variations on a Theme of Proch; Waltz Suite (Tallan); Marche Lorraine (Ganne). 10.0, Le Journal Parlé.

#### BUCHAREST

761 kc s, 394 metres; 12 kW.—5.0 p.m., Light Music and Romanian Music by the Motosi Orchestra. In the interval at 6.0, Radio Journal. 7.0, Educational Programme. In the interval from 7.20 to 7.40, Instrumental Music on Gramophone Records. 8.0, Song Recital by Serban Tassian; Ich groÙe nicht. (Schumann); Tom der Reimer (Loewe); Songs (Capolongo); Aria from Herodiade (Massenet). 8.20, Concert by the Station Orchestra: Overture, Turandot (Weber); Scènes napolitaines (Lassenet); Selection from Gipsy Love (Lehár); Slav Dances, Nos. 1 and 4 (Dvorák). In the interval at 9.0, Talk. 9.45, Radio Journal.

#### BUDAPEST

545 kc/s, 550.5 metres; 18.5 kW. Also relayed on 840 metres from 8.0 p.m. till Close Down.—5.30 p.m., Concert by the Simi Karina Cigány Orchestra. 7.0, Gramophone Music. 7.30, Reading. 8.0, Concert. 8.45, Radio Sketch. 9.30, News. 9.45, Concert by the Budapest Concert Orchestra, conducted by Polgar: Overture (Brüll); Suite, Sunday Afternoon (Biksz Csak); Ballet Music from Carmen (Bizet); Selection from The Daughter of the Regiment (Donizetti); Coronation March from The Prophet (Meyerbeer). In an interval at 10.20, Weather. 11.15, Concert by the Hetenyi Trio, relayed from the Café Simphon.

CASSEL.—See Frankfurt.

#### COPENHAGEN

1,067 kc/s, 281 metres; 0.75 kW. Relayed by Kalundborg, 260 kc/s, 1,153.8 metres.—12 Noon, Time Signal and Chimes from the Town Hall. 12.2 p.m., Concert by the Max skaika String Ensemble, relayed from the Hotel d'Angleterre. 2.0, Interval. 3.0, Concert by Louis Prell's Instrumental Ensemble; Soloist, Rose Marie (Songs); Overture, The Princess in the Golden Slippers (Rust); Dreamland Waltz (Fueck); Selection from Words and Music (Goward); Wien, du bleibst das verwöhnteste Kind der Welt. (Rater); Hungarian (Blockx); Mexican Serenade, Los Marineros (Bochmann); Songs; (a) Le chanson de marionette (Tagliaferro), (b) Old Provençal Folk Song, Rose de Provence, (c) Minuet, Paris est au toi, (d) La baraque d'Yves (Franchant), (e) Seventeenth Century Musette, (f) Breton Folk Song, Le binion; Intermezzo, Sie kommen (Lincke); Waltz-Improvis (Oldenburg-Poulsen); Selection from Fahrt ins Blau (Dostal); Serenade No. 2 (Heykens); Ballad (Windfeld); Melody (Thurban); My Teddybear (Ganglberger); Foxtrot, Confetti (Kapphus). 5.0, Programme for Children. 5.30, Exchange and Fish Market Prices. 5.45, Talk; Liberia, The Negro Republic. 6.15, Elementary German Lesson. 6.45, Weather. 6.54, Announcements. 7.0, News. 7.15, Time Signal. 7.30, Talk on the Danish Legislature. 8.0, Time signal from the Town Hall. 8.1, Ein Bärbaron—Comedy in Five Acts (Richard Schröder). 10.30, News. 10.45, Sonata No. 46 in A flat (Haydn) by Folner Jensen. 11.5, Dance Music by Richard Johansen, relayed from the Loberg Restaurant. In an interval at 12 Midnight, Time Signal and Chimes from the Town Hall. 12.30 a.m. (Wednesday), Close Down.

CORK.—See Athlone.

DANZIG.—See Heilsberg.

DRESDEN.—See Leipzig.

#### FECAMP

1,328 kc s, 225.9 metres; 10 kW.—11.0 a.m. to 12 Noon, Programme in English by the I.B.C. 11.0, Happy Hour, Part I; Military Band Music. Signature Time; The Bull-fighters' March (Kottann); Wood Nymphs (Coates); Cornet Solo: Il Bacio (Arditi); Parade of the Tin Soldiers (Jessel); Praedidium (Järnefeldt); Cornet Solo: Carnival of Venice (Pricciabbi); Jolly Fellows (Vollstedt); Old Panama (Alford). Part II. Dance Music. My Bluebird's singing the Blues (Robin); Sweetheart darling; Thank Heaven for you; Let's all be happy together; Twelfth Street Rag; Lover; I'm getting Sentimental over you; I wish I had Wings; Signature Time. 12 Noon, French Programme. 4.30 to 6.0 p.m., Programme in English by the I.P.C. 4.30, Programme for Children. 5.0, Concert by a Balahika Orchestra for Torquay and Exeter Listeners. Signature Time; The Night by the Sea; Fann (Andreeff); Choir: The Twelve Robbers (Traditional); Troika and a Lady (Andreeff); The Red Saraphan (arr. Leontieff); Solo: Caucasian Gipsy Songs; Russian Folk Song and Dance; Choir: The Cossack Prisoners; Song of the Volga Boatmen. 5.30, Gramo-

**ATHLONE**  
725 kc/s, 413 metres; 60 kW. Relayed by Cork, 1,337 kc/s, 224.4 metres.—1.30 to 2.30 p.m., Time Signal, Weather, Stock Report, followed by Gramophone Music. 4.0, Military Band Concert. 6.0, Programme for Children. 6.40, News. 7.0, Gaelic Talk. 7.15, Wireless Talk. 7.30, Orchestral Concert. 7.50, Mezzo-Soprano Solos by Mary Maguire. 8.5, Violin Solos by Robert Potterton. 8.25, Anglo-Irish Songs by P. J. O'Toole (Tenor). 8.40, Uilleann Pipes Solos by S. MacAonghusa. 8.55, Variety Programme by Tom Madden and Company, with the Station Orchestra. 9.30 to 10.30, Programme by the I.B.C. (Ireland), Ltd. 9.30, Concert. Song, Don't be late in the morning; Piano-forte Solo; Keyboard Kapers (Steede); Me and mine are doin' fine (Connelly); All over Italy (Munroe). 9.45, Hawaiian Band: My Waikiki Mermaid; Maria Mari (di Capua); Steel Guitar Solo: Dear Old Pal of Mine; La Paloma (Yradier). 10.0, Concert arranged by the International Broadcasting Company (Ireland), Ltd., on behalf of Hospitals Trust, Ltd.: Signature Time: Come back to Erin; In the Valley of the Moon; Butterflies in the Rain; What have we got to lose?; How deep is the Ocean?; Smile and sing your cares away; I'll never have to dream again; When the wild, wild Roses bloom; Signature Time. 10.29, I.B.C. Good-night Melody. 10.45, News and Weather.

#### BARCELONA

EAJ1, 860 kc/s, 348.8 metres; 8 kW.—7.0 p.m., Trio Concert Minuet in D (Schubert); Romance (von Goens); Selection from Lakmé (Delibes); Intermezzo (Lindsay); Gavotte (Massenet); A Song of Autumn (Elgar); Selection from The Flying Dutchman (Wagner). 8.0, Request Gramophone Records. 8.30, Exchange and Talk in Catalan. 9.0, Gramophone Music and News. 10.0, Chimes from the Cathedral, Weather, Messages to Seamen, Exchange and Market Prices. 10.5, Sponsored Programme. 10.50, Wagner Concert by the Station Orchestra. Prelude to Act III of Lohengrin; Legend of the Grail from Parsifal; Waltz of the Apprentices and Prelude to Act III, from the Mastersingers; Overture Rienzi. 11.30, Concert, relayed from the Café Español. In the interval at 12.0 Midnight, News. 1.0 a.m. (Wednesday), Close Down.

#### BARI

1,112 kc/s, 269.8 metres; 20 kW.—See Rome.  
BASLE.—See Schweizerischer Landessender.

#### BERLIN

**DEUTSCHLANDSENDER (REICHSEN- DER)**, 183.5 kc/s, 1,635 metres; 60 kW.—1.45 p.m., News. 2.0, Gramophone Concert. 3.0, Handwork for Children. 3.30, Weather and Exchange. 3.45, Reading. 4.0, See Leipzig. 5.0, Talk on Cosima Wagner. 5.20, Concert, Part I; Lieder Recital by Margerete Röll (Mezzo-Soprano); Lob der edlen Musik (Rathgeber); Das Frauenzimmer (Telerman); Lob der Faulheit (Haydn); Liebes Mädchen (Haydn); Männer suchen stets zu naschen (Mozart); Ich sah ein Röschen (Weber); Minnelied (Schubert); Lied im Grünen (Schubert); Frühlingsbotschaft (Brahms); Auf dem Schiffe (Brahms). Part 2: Piano-forte Recital by Käthe Heinemann; Improvis in B flat (Schubert); Wut über den verlorenen Groschen (Beethoven); Arabesque on The Blue Danube (Schubert-Eyler). 6.0, Poems. 6.15 (approx.), Eberhard Wolfgang Müller reads from his Drama, Der Untergang Karthagos. 6.30, Review of Politics. 6.50, Weather and News. 7.0, Transmission for all German Stations, relayed from Frankfurt. 8.0, To-day's Motto. 8.5, Variety Programme by Harald Paulsen and the Gaden Orchestra. 10.0, Weather, Time and Sports Notes. 10.45, Weather for Shipping. 11.0, Concert from Stuttgart. 12 Midnight, Close Down.

#### BERLIN

**FUNKSTUNDE**, 715 kc/s, 419.5 metres; 1.5 kW.—4.30 p.m., Orchestral Concert relayed from the Café Corso. 5.10, Lulu von Strauss-Torney Programme on the occasion of her Sixtieth Birthday. 5.40, Piano-forte Sonata in C (Mozart) by Wolfgang Burgger. 6.0, Modern Lyrics (Gottfried Benn), with Introductory Talk. 6.15, Book Review. 6.40, The Funkstunde informs its Listeners. . . . 6.45, Topical Talk. 7.0, Transmission for all German Stations, relayed from Frankfurt. 8.5, Wagner Concert. The Station Orchestra and Choir, conducted by Otto Frickehofer. Soloist: Wilhelm Winterberg (Baritone). 9.0, Carl Maria von Weber—Last Days and Burial in London and Re-interment Eighteen Years later in Dresden (Heinrich Burkard). The Station Orchestra, conducted by Otto Frickehofer, the Station Choir, conducted by Heinzkarl Weigel, and Soloists: Rosl Seegers (Soprano) and Wilhelm Winterberg (Baritone). 10.0, News. 10.15 (approx.), Dance Music, relayed from the Propia Pavilion. In the interval at 11.0 (approx.), Talk: Stage and Film. 12 Midnight, Close Down.

BERNE.—See Schweizerischer Landessender.

BEROMUNSTER. — See Schweizerischer Landessender.

BODEN.—See Stockholm.

BODO.—See Oslo.

#### BORDEAUX-LAFAYETTE

986 kc/s, 304 metres; 15 kW. 6.15 p.m., Radio Journal. 7.40, News. 7.50, Gramophone Concert. 8.30, Programme to be announced.

#### BRATISLAVA

1,076 kc/s, 279 metres; 14 kW.—6.25 p.m., Violin Recital. 6.55, Talk for Housewives. 7.0, See Prague. 7.10, See Moravská-Ostrava. 7.50, See Prague. 11.0 (approx.), Close Down.

BREMEN.—See Hamburg.

#### BRESLAU

923 kc/s, 325 metres; 60 kW. Relayed by Gleiwitz, 1,184 kc/s, 253 metres.—1.5 (approx.), Gramophone Concert. 1.45, Time and News. 2.5, Song Recital by Elizabeth Pfeffer (Contralto); Four Songs (Richard Trank); (a) Die Stadt, (b) Die Nachtigallen, (c) Unter Blüten, (d) Pan; Six Songs (Graener); (a) Weisser Flieder, (b) Das bitter-süÙe Lied, (c) Verspruch, (d) Männertrien, (e) Mädchenlied, (f) Sommer. 2.35, Request Concert on Gramophone Records: 1812 Overture (Tchaikovsky); Turkish March (Mozart). 3.0, Market Prices. 3.45, Review of Books. 3.35, Programme for Children. 4.10, Concert by the Station Orchestra, conducted by Gerhard Rischka: Overture, Titus (Mozart); Elegy (Sibelius); The Nutcracker Suite (Tchaikovsky); Selection from Der Opernball (Heuberger); Hutzi Putzi (Albhort); Lagunen-Walzer (Jos. Strauss). 5.30, Market Prices. 5.35 (approx.), Talk: German Socialism. 5.55, Topical Programme. 6.20, Carl Alois Schenninger reads from his own Works. 6.50, Meat Market Prices. 7.0, Transmission for all German Stations, relayed from Frankfurt. 8.0, News. 8.10, Concert by the Station Orchestra, conducted by Ewald Rischka. Soloist: Hugo Kolberg (Violin). Overture, Die Geschiebe des Prometheus (Beethoven); Violin Concerto in A (Mozart); The Unfinished Symphony (Schubert). 9.10, Dance Music with Vocal Refrains. 10.0, See Munich. 10.20, Time and News. 10.40, Theatre Talk. 11.0, Dance Music with Vocal Refrains. 12 Midnight, Close Down.

#### BRNO

878 kc/s, 342 metres; 35 kW.—6.25 p.m., German Transmission: News and Talk; Moravia in the Ice Age. 7.0, See Prague. 7.10, See Moravská-Ostrava. 7.50, See Prague. 11.0 (approx.), Close Down.

#### BRUSSELS (No. 1)

I.N.R., 590 kc/s, 509 metres; 15 kW.—12 Noon, Concert by the Small Station Orches-

tra, conducted by Leemans: Military March (Schubert); Minuet (Boccherini); Serenade from Milenka (Blockx); La cinquanteime (Gabriel-Marie); La lettre à Manon (Gillet). 12.20 p.m., Soprano Song Recital by Auita Tourret: Aria from Rinaldo (Handel); Aria from Les dragons de Villars (Maillart); Oh! ses pas incertains (De Boeck). 12.35, Orchestral Concert (cont.): Overture, Ferrabras (Schubert); Overture, Meeresstille und glückliche Fahrt (Mendelssohn); Overture, Titus (Mozart). 1.0 p.m., Le Journal Parlé. 1.10, Extracts from Les Dragons de Villars —Opera (Maillart), on Gramophone Records. 1.35, Piano-forte Recital by Marie-Jeanne Verluist: Perpetuum mobile (Weber); Improvis in B flat (Schubert); Waltz in A flat (Brahms). 1.50, Light Music: Cigány Rhapsody (Kaldman); Frühlingsstimmen (Strauss). 5.0, Concert by the Station Symphony Orchestra, conducted by Kumps: Suite, Arlequin (d'Ollone); Les trois sultanes (Büsser). 5.30, Programme for Children. 6.5, Literary Review. 6.15, Cello Recital by Jean de Nocker. 6.30, Concert by the Small Station Orchestra, conducted by Leemans: Feuilles de voyage (Florent Schmitt); Gramophone Record; Trümmerei (Schumann); Chansons à danser (Bruneau). 7.15, Film Review. 7.30, Art Notes and Talk for Women. 8.0, Concert by the Radio Orchestra, conducted by André; African Suite (Coleridge-Taylor); Algerian Scene (Kotel-bev); Suite marocaine (Delmas); Caucasian Suite (Ippolitov-Ivanov). 8.45, Talk: The Cinematograph. 9.0, Beethoven Concert by the Station Symphony Orchestra, conducted by Kumps. Soloist, Desdin (Violin): Overture, Cariblanus; Violin Concerto. 9.40, Piano-forte Improvisations by Jean Meer. 9.55, Christus Viret (Liszt). 10.0, Le Journal Parlé.

#### BRUSSELS (No. 2)

N.I.R., 387 kc s, 338.2 metres; 15 kW. Programme in Flemish. 12 Noon, Gramophone Concert. 1.0 p.m., Le Journal Parlé. 1.10, Concert by the Small Station Orchestra, conducted by Leemans. 5.0, Concert by the Radio Orchestra, conducted by Franz André; March, Le rive passe (Krier); Foxtrot, Love me to-night (Brown); Oh Dona Clara (Peter-burski); Humorous Variations on a Popular Theme (Blumann); Foxtrot, Antoinette (Oberfeld); Rumba, Azor (Gaharocher); Waltz Potpourri (Robrecht). 5.45, Programme for Children. 6.30, Gramophone Music. 7.0, Soloist Concert: Wien bleibt Wien (Schrammel); Boston, Jane (Carliolato); Melody (Frustadt); March, Hoch und Deutschmeister (Ertl). 7.15, Talk. 7.30, Interview with Lode Backelans of the Literary Museum at Antwerp. 8.0, Concert by the Station Symphony Orchestra, conducted by Kumps: Jubilee March (De Boeck); Humoresque (Gillon); Gramophone Records; Overture, Charlotte Corday (Benoit); Flem-

SEPT. 19th

**TUESDAY**

continued

(Buhl); Wedding March from The Piper of Hamelin (Nessler); Waltz, In lauschiger Nacht (Ziehler).

HANOVER.—See Hamburg.

**HEILSBURG**

1,085 kc s, 276.5 metres; 60 kW. Relayed by Danzig, 662 kc s, 453.2 metres.—1.5 p.m., Gramophone Concert of Popular Music. In the intervals at 1.20 and 2.0, News. 2.30, Programme arranged by the Post Office, with Gramophone Music. 2.45, Market Prices. 3.0, Concert by the Small Station Orchestra, conducted by Eugen Wilcken. 4.0, Musical Improvisations for Children. 4.30, Concert by the Small Station Orchestra, conducted by Eugen Wilcken. Overture, Jean de Paris (Boieldieu); Ballet suite, Esmeralda (Drigo); Waltz, Königs-kinder (Löhner); Selection from Jalka (Fetras); An Eastern Romance (Haynes); Overture, Loreley (Lincke). In the interval at 5.0, Review of Books on Gymnastics. 5.55, Humour in East Prussian Dialect. 6.15, Market Prices. 6.25, Radio Report for Workers. 6.50, Weather. 7.0, Transmission for all German Stations, relayed from Frankfurt. 8.0, Weather. 8.5, Schlossballade—Dramatic Narrative (Walter von Hollander). 9.5, An Hour with the Königsberg Storm Troops—A Radio Sequence. 10.0, Political Press Review, followed by News.

**HILVERSUM**

Announced HUIZEN, 1,013 kc s, 296.1 metres; 7 kW. (until 5.40 p.m.), and 20 kW. from 5.40 p.m. Programme of the Catholic Radio Society (K.R.O.). 11.55 a.m., Sextet Concert. 1.25 to 1.40 p.m., Interval. 1.40, Programme for Women. 2.40, Song, Violin and Piano: Recital: Sonata in G Minor (Tartini); Romance in F (Beethoven); Songs: (a) Aria from The Magic Flute (Mozart), (b) Aria from The Valkyrie (Wagner); Violin Solos: (a) Spanish Dance, Op. 22 (Sarasate), (b) Viennese Caprice (Kreisler), (c) Sérénité (Vieuxtemps); Songs: (a) The First Kiss (Brandts-Buys), (b) Junge Liebe (Mann), (c) Musica proibita (Gastaldon). 3.40, Programme arranged by the H.I.R.P. (Holbrew Radio Society). 4.50, Gramophone Music. 5.10, Concert by the K.R.O. Boys. 6.40, Police Notes. 6.55, Gramophone Music. 7.5, Talk: Lenin and Gandhi. 7.25, Talk. 7.40, Concert by the K.R.O. Orchestra, conducted by Gerritsen: Overture, Donna Diana (Reznicek); Selection from Otello (Verdi); Polovtsian Dances from Prince Igor (Borodin). 8.10, News. 8.15, Talk: James Watt. 8.25, Concert (cont'd.). Soloist: George van Renesse (Pianoforte). Academic Festival Overture (Loutner); Pianoforte Concerto in E flat (Liszt); Waltz, Frühlingsstimmen (Strauss); Pianoforte Solos: (a) Rondo in D (Schubert), (b) Waldesrauschen (Liszt), (c) Consolation in E (Liszt), (d) Au bord d'une source (Liszt); San Lorenzo (Silva); Overture, Gri-Gri (Lincke); Ernst und Scherz für's Wiener Herz (Kotzack); Waltz, Freut euch des Lebens (Strauss). In the interval at 9.10, Gramophone Records. 10.10, News. 10.15, Concert of Light Music by the K.R.O. Boys, conducted by Lu-tschowwer. 11.40, Close Down.

HORBY.—See Stockholm.

**HUIZEN**

Announced HILVERSUM, 160 kc s, 1,875 metres; 7 kW. (until 3.40 p.m.). Transmitted from Kootwijk on 50 kW. from 3.40 p.m. Programme of the Algemeene Vereeniging Radio Omroep (A.V.R.O.). 11.40 a.m., Report of the Opening of the Dutch Parliament. Speakers: W. Vogt and D. Hans. 1.40 p.m., Concert. 2.10, Baritone Song Recital by Gerard Holtmans. 2.40, Gramophone Music. 3.40, Violin Recital by Colette Frantz: Sonata in A (Vivaldi); Romance in G (Beethoven); Havanaise (Saint-Saëns); Perpetuum mobile (Ries). 4.10, Concert by a Children's Choir, conducted by Jacob Hamel. 4.40, Programme for Children. 5.10, Concert by the Station Orchestra, conducted by Nico Treep: Overture, Flotte Bursche (Suppé); Suite, La Feria (Lacôme); Tranmere (Schumann); Gavotte (Popper); Melody (Kálmán); Selection from Waltzes from Vienna (Strauss-Kerngold); The Vision of Fuji San (Kettelbey); Madrid (Speyer); Los Banderilleros (Volpatti); Von Wien durch die Welt (Hrbny); Ideale (Tosti); Marchiare (Tosti); Czardas (Michiel). In the interval at 6.10, Talk. 7.10, Talk. 7.40, Time Signal. 7.41, News. 7.45, Gramophone Music. 8.10, Tattoo. 8.40, Gramophone Music. 9.10, Concert by Kovacs Lajos and his Orchestra. 9.40, Talk. 10.10, Concert (cont'd.). 10.40, News. 10.50, Gramophone Music. 11.40 (approx.), Close Down.

INNSBRUCK.—See Vienna.

KALUNDBORG.—See Copenhagen.

**KATOWICE**

734 kc s, 408 metres; 16 kW.—7.40 p.m. till Close Down. See Warsaw.

KIEL.—See Hamburg.

KLAGENFURT.—See Vienna.

KOSICE.—See Prague.

**LANGENBERG**

635 kc/s, 473 metres; 60 kW.—12 Noon, Concert by the Fröhliche Fünf. 1.15 p.m., News. 1.30, Concert by the Station Orchestra, conducted by Werner Göhre: Overture, Giróll-Girólla (Leocop); Donaulieder-Walzer (Strauss); Selection from The Geisha (Jones); Andalusian Romance (Sarasate); Rondino (Sibelius); Zigeunerständchen (Nehf); Potpourri, Für alle (Dostal). In the interval at 2.0, News. 3.0, Programme for Children. 3.30, Exchange and Time. 3.50, Review of Educational Books. 4.10, Reading (Wilhelm von Scholz). 4.30, Tales of Australian Adventures by a Ship's Cook. 5.0, Pianoforte Recital by Hans Haass: Polonaise in C Sharp Minor (Chopin); Alt-Wien (Niemann); Two Pieces (Godard); (a) Au Matin, (b) Mazurka; Nocturne (Keller); Rigoletto Paraphrase (Liszt); Waltz (Burgmüller). 5.30, Something for Everybody—Gramophone Concert. 6.15, Political Announcement. 6.25, Italian Lesson. 6.45, News. 7.0, Transmission for all German Stations, relayed from Frankfurt. 8.0, First General News. 8.5, Bunter Abend. 10.5, News. 10.25, West German Weekly Review.

LAUSANNE.—See Radio-Suisse Romande.

**LEIPZIG**

769.9 kc s, 389.6 metres; 120 kW. Relayed by Dresden, 941 kc s, 319 metres.—12 Noon, Concert from Munich. 1.15 p.m., News and Programme Announcements. 1.30, German Folk Songs (on Gramophone Records). 2.15, News. 2.30, Review of Books for Young People. 3.0, Song and Pianoforte Recital by Margerete Steffen (Mezzo-Soprano), Werner Drosihn (Baritone), and Friedbert Sammler (Pianoforte). 3.35, Market Prices. 4.0 (from Dresden), Concert by the Dresden Philharmonic Orchestra, conducted by Hilmar Weber: Overture, König Drosselbart (Hanel); Ballet Suite from Lazy John (Nedbal); Selection from The Barber of Bagdad (Cornelius); Second Norwegian Rhapsody in A (Svendsen); Hilarer Waltz (Dehnert); Ballet Music from Ritter Pausan (Strauss); Selection from Don Caesar (Dellinger). 5.50, Economic Notes, News, Weather and Time. 6.0, Dialogue for Parents: The Nervous Child. 6.20, Talk: Mussolini before he became Duce. 6.50, Review of the Day's News. 7.0, Transmission for all German Stations, relayed from Frankfurt. 8.0, (from Dresden), Concert by the Dresden Soloist Ensemble: Overture, Berliner Luft (Lincke); Moonlight on the Alster (Fetras); Descriptive Piece (Diecker); Flower suite (Siedel); Selection from Der Vagabund (Zeller). 8.40, Gaudeamus igitur—stories of our Father's Student Days. 9.0, see Berlin (Funkstunde). 10.15, News. 10.45, See Stuttgart. 12 Midnight, Close Down.

LINZ.—See Vienna.

**LUXEMBOURG**

252 kc s, 1,191 metres; 200 kW.—12.30 p.m., Concert by the Station Orchestra, conducted by Henri Pénis: March (Lincke); Waltz, Longchamps fleuris (Waldteufel); Overture, Nera (Reisinger); By the Blue Hawaiian Waters (Kettelbey); Czardas (Grossmann); Selection from Martha (Flotow); Leucht-käferchen's Stelldichein (Siede). 1.30, Gramophone Concert. 7.30 till Close Down, Belgian Programme. 7.30, Pianoforte Concerto No. 2 in C Minor (Rachmaninov), on Gramophone Records. 8.20, Concert of Belgian Music by the Station Orchestra: Prelude to Henry VIII (Gilson); Songs d'amour (Marsick); Comme mentent les feuilles (de Taeye); Fantasia on Two Songs of Tournai (Dancan); Overture, Sous la régence (Brusselmans). 8.50, News in French. 9.0, Quartet for Oboe, Violin, Viola, and Cello (Mozart). 9.20, Concert by the Station Orchestra: Norwegian Dances (Grieg); Rhapsody in Blue (Gershwin). 9.45, News in German. 9.55, Variety Music on Gramophone Records. 10.30, Dance Music.

**LWOW**

788 kc s, 381 metres; 16 kW.—7.20 p.m., Announcements and Gramophone Music. 7.40, See Warsaw. 10.0, Violin Recital. 10.15, Dance Music relayed from Warsaw. 10.40, Gramophone Music. 11.0 (approx.), Close Down.

**LYONS**

LA DOUA, 644 kc/s, 465.8 metres; 1.5 kW.—7.30 p.m., Radio Gazette for Lyons and the South-East. 8.30 p.m., Gala Concert, conducted by Waerscey, relayed from the Opera House; Soloists, Trillat (Pianoforte), Guénot (Songs), Trier (Cello), and Yvonne Brothier (Songs). Overture, Le Roi d'Ys (Lalo); Pianoforte Concerto No. 5 (Saint-Saëns). Songs: (a) Les berceurs (Faure), (b) An emetièrre (Faure), (c) Song (Mus-sorgsky), (d) La vague et la cloche (Duparc), (e) The Two Grenadiers (Schumann), Symphony in D Minor (César Franck); Joy-euse marche (Chabrier); Cello Concerto (Lalo). Songs: (a) Aria from Richard Cœur

de Lion (Grétry), (b) The Song of the But-terfly (Campra), (c) Serenade (Gounod), (d) Song from Chérubin (Massenet), (e) Adieu (Faure), (f) Clair de lune (Faure), (g) Romance (Debussy), (h) Waltz Song from Isolide (Messager); L'Apprenti sorcier (Dukas).

**MADRID**

ARANJUEZ, EAQ, 10,000 kc/s, 30 metres; 20 kW.—11.30 p.m., Popular Concert. In the interval at 11.45, Radio Chronicle. 12.45 a.m. (Wednesday), Light Music. 1.0 (approx.), Close Down.

**MADRID**

EAJ7, 707 kc/s, 424.3 metres; 2 kW.—8.0 p.m., Chimes, Exchange, Radio Journal, and Request Gramophone Music. 8.30, Talk by Joaquín España Cantos, followed by Gramophone Records (cont'd.). 9.15, Topical Review. 9.30 to 11.0, Interval. 11.0, Chimes, Time Signal, and Topical Review. 11.20 (approx.), Faust—Opera (Gounod) on Gramophone Records. 1.15 a.m. (Wednesday), Topical Review and News. 1.30, Chimes and Close Down.

MALMO.—See Stockholm.

MILAN.—See Turin.

**MORAVSKA-OSTRAVA**

1,137 kc s, 263.8 metres; 11 kW.—7.0 p.m., See Prague. 7.10, Recitations and Music. 7.50, See Prague. 11.0 (approx.), Close Down.

**MOSCOW**

TRADES UNION, 300 kc s, 1,000 metres; 100 kW.—11.45 a.m., Weather. 2.25 p.m., Weather. 3.0, Popular Concert. 3.55, Time. 4.0, Topical Talk. 4.30, Literary Programme. 5.30, Talk: The Development of the Soviet Union. 6.30, Concert of Spanish Songs and Dances. 9.0, News. 9.30, Programme Announcements. 9.55, Chimes from the Red Square. 10.5, Press Review.

MOTALA.—See Stockholm.

MUHLACKER.—See Stuttgart.

**MUNICH**

563 kc/s, 533 metres; 60 kW. Relayed by Augsburg and Kaiserslautern, 536 kc/s, 560 metres; and Nürnberg, 1,256 kc/s, 239 metres.—2.20 p.m., Concert of Chamber Music. 3.0, Programme for Housewives. 3.55, Weather and Agricultural Notes. 4.5, Talk: The Changes in the Broadcasting World. 4.30, See Frankfurt. 5.45, Talk: The Native Indian Tribes in America. 6.5, Max von Schillings Pianoforte Recital by Wilhelm Kempff; Hellhinkel; Trotz; Invocation; Dies und das. 6.25, Talk: Clairvoyants and their Dupes. 6.45, News. 7.0, Transmission for all German Stations, relayed from Frankfurt. 8.0, See Stuttgart. 9.0, Michael Gaissmayr—Peasant Drama (Franz Kranewitter). 10.0, Austria. 10.20, News.

NAPLES.—See Rome.

NOTODDEN.—See Oslo.

**OSLO**

277 kc/s, 1,083 metres; 60 kW. Relayed by Fredriksstad, 820 kc s, 365.8 metres; Hamar, 522 kc/s, 574.7 metres; Notodden, 671 kc/s, 447.1 metres; Porsgrund, 662 kc/s, 453.2 metres; and Rjukan, 671 kc/s, 447.1 metres.—5.0 p.m., Gramophone Concert. 6.0, Talk for Housewives. 6.45, Musical Programme. 7.0, News. 7.30, Talk on Narcotics. 8.0, Time Signal. 8.1, Concert by the Station Orchestra, conducted by Hugo Kraum: Selection from The Queen's Kerchief (Joh. Strauss); Ballet Suite from Namouna (Lalo); Songs (Schubert): (a) Die Rose, (b) Der König in Thule; Songs (Schumann): (a) Jägerlied, (b) Der Abendstern; Serenade (Reidarson); Barcarolle (Liedlich); Selection from Turandot (Puccini); Waltz, La plus belle (Waldteufel). 9.10, Recitations. 9.40, News. 10.0, Topical Talk. 10.15, Variety Music, relayed from Bergen. 824 kc s, 364 metres. 10.45 (approx.), Close Down.

OSTERSUND.—See Stockholm.

**PALERMO**

558 kc/s, 537.6 metres; 3 kW.—8.0 p.m., Popolavaro Announcements, Tourist Talk, Agricultural Notes, and Giornale Radio. 8.20, Gramophone Music. In the interval at 8.30, Time and Announcements. 8.45, Andrea Chénier—Opera in Three Acts (Giordano). In the interval, Talk and Announcements. After the Opera, Giornale Radio.

**PARIS**

EIFFEL TOWER, Call FLE, 207.5 kc/s, 1,445.7 metres; 13 kW. Time Signals (on 2,650 metres) at 10.26 a.m. and 11.26 p.m. (Preliminary and 6-dot Signals).—6.45 p.m., Talk on the Theatre. 7.0, Le Journal parlé. 8.30, Concert of French Music from the Opera House, Lyons.

phone Concert for Plymouth and Devonport Listeners. My Lady Dainty (Hesse); River, stay 'way from my Door; Witches' Ride (Puccini); That Futuristic Rag (Bloom); The Porter's Love Song (Razaf); I'd love to be a Sailor (Lauder); A Woman should stick to her Man (Iida); Selection from The Flower of Hawaii (Abraham); Signature Tune. 6.0, French Programme. 10.0 till Close Down, Programme in English by the I.B.C. 10.0, Dance Music. Signature Tune: Bells of Normandy; Won't you stay to Tea?; There's a Tiny Little Hair upon your Shoulder; Hiawatha's Lullaby; That's my Home; Old Man Harlem (Vallee); We're a couple of Soldiers; I can't remember; Brighter than the Sun (Noble); Lover (Rodgers); Sweetheart Darlin'; In Old Vienna; Somebody stole my Gal; Just an Echo in the Valley; Love is the Sweetest Thing; When Gobble hits the Cymbal; Chewing Gum; Learn to Croon; Signature Tune. 11.0, Sound Film Music. Signature Tune: Sittin' in the Dark. The Shadow Waltz (Dubin); You are too beautiful; Reaching for the Moon; Hits from Forty-Second Street (Warren); Love Songs of the Nile (Brown); Heaven will protect an Honest Girl (Weston); In the Park in Parre (Rainger); You don't understand (Ellis); Signature Tune. 11.30, Concert arranged by the International Broadcasting Company (Ireland), Ltd., on behalf of Hospitals Trust, Ltd. Signature Tune: Come back to Erin; Cour brisé (Gillet); Irish Medley (arr. Somers); Song: Come back to Sorrento (de Curtis); Once on the Rhine (Ostermann); Song: Love's Pleading (Pecora); General Mulcahy (Brace); Pianoforte Solo: Sweetheart I'm dreaming of you (Brody); Minnet No. 1 (Paderewski); Signature Tune. 12.5 a.m. (Wednesday), I.B.C. News Bulletin in English. 12.10 (approx.), Concert for Bulwell Listeners. Part I: Tango Band. Signature Tune: The Chum Song; The Song of the Rose (Bottero); I'll keep you in my Heart always (Gartman); Jealousy (Gade); Julian (Donata); There was a poor Musician (Schwartz). Part II: Dance Music. Alabama Song; Old Man Harlem; That's what life is made of; Here is my Heart; Adorable; I gotta right to sing the Blues; My first love to last; Moon over Dixie; Signature Tune. 1.0 a.m., Dance Music. Signature Tune: Bells of Normandy; Dance pretty Lady; Maybe I love you too much; Waiters on Parade; I raised my Hat; Good-night but not good-bye; I shall still keep smiling along; Forty-Second Street; Put that Sun back in the Sky; In the Park in Parre; Hyde Park Corner; This is the Rhythm for me; Alice Blue Gown; I wish I had Wings; What a Lady Josephine must have been; Thank Heaven for you; My, oh, my!; Signature Tune. 2.0, I.B.C. Good-night Melody and Close Down.

FLENSBURG.—See Hamburg.

FLORENCE.—See Turin.

**FRANKFURT**

1,157 kc/s, 259.3 metres; 17 kW. Relayed by Cassel, 1,220 kc/s, 245.9 metres; and Trier, 1,157 kc/s, 259.3 metres.—4.30 p.m., Concert. 5.45, Economic Notes. 6.0, Discussion. 6.45, Today's News. 6.50, Time and Announcements. 7.0, Transmission for all German Stations: Tallyho!—The Hunting Season starts. 8.0, Friedemann Bach—Opera in Three Acts (Graener), relayed from the State Theatre, Cassel. 10.15, Time and News. 10.45, See Stuttgart. 12 Midnight (approx.), Close Down.

FREDRIKSSTAD.—See Oslo.

FREIBURG.—See Stuttgart.

GENEVA.—See Radio-Suisse Romande.

GENOA.—See Turin.

GLEIWITZ.—See Breslau.

GOTEBORG.—See Stockholm.

GRAZ.—See Vienna.

HAMAR.—See Oslo.

**HAMBURG**

806 kc s, 372 metres; 1.5 kW. Relayed by Bremen, 1,112 kc s, 265.9 metres; Flensburg, 1,319 kc s, 227.4 metres; Hanover, 530 kc s, 566 metres, and Kiel, 1,292 kc s, 232.2 metres.—5.30 p.m., Variety Programme. 6.45, Exchange and Market Prices. 6.50, Weather. 7.0, Transmission for all German Stations, relayed from Frankfurt. 8.0, Das Schicksal der Expedition Rüdiger (The Fate of the Rüdiger Expedition) Radio Play (Ernst Hoffmann and Walter Bernhard Sachs). 9.30, Pianoforte Recital by Wilhelm Ammermann: Paritta No. 6 in E minor (Bach); Variations in F minor (Haydn). 10.0, Time and News. 10.20, Topical Talk. 10.30, Concert by the Hamburg Philharmonic Orchestra, conducted by José Eibenschütz: Romantic Overture (Thouille); Spinning Song and Intermezzo from Twelfth Night (Humperdinck); Suite, Aus badischen Länden (Kämpf); First Norwegian Rhapsody (Halvorsen); Overture, Pique Dame (Suppé); Waltz Intermezzo

SEPT. 19th

TUESDAY

continued

PARIS

POSTE PARISIEN, 914 kc/s, 328.2 metres; 60 kW.—7.0, Schubert Gramophone Concert; Ballet Music from Rosamunde; Ständchen; Selection from Lilac Time (Schubert Bertel); 7.15, Le Journal Parle; 7.30, Concert; 8.30, Concert by the Station Orchestra, conducted by Théodore Mathieu; Melody (Koebe); Scherzo (Hoffmann); Nocturne and Musette (Sibelius); Waltz (Meyer-Helmund); Moorish Dances (Nicodé); Entr'acte and Hymn (Fieltz); Arabian Serenade (Bleyer); The Eagle (MacDowell); Andante (Göllermaun); Dramatic Dances (Bantock); 10.15, News.

PARIS

RADIO PARIS, Call CFR, 174 kc/s, 1,725 metres; 75 kW.—7.30 a.m., Weather and Physical Culture. 7.45, Gramophone Music: Comment veux-tu que j'oublie (Puig and Heikill); Indian Song (Combelles); En rehasant vos lettres (Masson-Kick); El Capitán (Souza). 8.0, Weather and Press Review. 12 Noon, Gramophone Concert: Extracts from Pelléas et Mélisande (Fauré); Galli-Urvi; Hymn to the Sun, from The Golden Cockerel (Rimsky-Korsakov); Scherzo (Borodin); Aria from The Seasons (Haydn); Granada (Albeniz); Le Chasseur maudit (Franck); Menuet antique (Ravel); La vie antérieure (Duparc); Mephisto-Walzer (Liszt); Cortot; Pianoforte Concerto (Schumann); Retour de Vèpres (Bussier); Serenade (Strass); Finlandia (Sibelius). In the interval at 1.0 p.m., Market Prices, News and Weather, and at 1.30, Exchange, 2.0, Exchange, 3.45, Exchange and Market Prices. 7.0, Agricultural Notes. 7.10, Gramophone Music: Madeleine-Bastille (Floral-Loyraux); Le plus joli rêve (Azezo); Al fresco (Herbert); Il suffit d'un sourire (Borel-Clerc); Vivons nos rêves (Bud-Green); Charmaine (Rapee); O Tamara (Haket-Seidler); Mama Lenz (Girenet); Vers toi (Chapou-Rodot); American Successes of 1921-1922; Selection from Si (Yvain); Madrid (Alek). 7.50, Market Prices and News. 8.0, Gramophone Concert: Phaeton (Saint-Saëns); Largo (Vivaldi); Valse capricieuse (Rubinstein); Minuet (Mozart); Seguidillas (Albeniz); Harvesters' Song (Mendelssohn); Vivat Flamand; Gramophone Records. 8.30, See Lyons la Doua. In the intervals, News and Announcements.

PITTSBURGH

KDKA, 980 kc/s, 306 metres; 50 kW. Relayed by W8XK on 48.86 metres and 25.27 metres.—8.15 p.m., Words and Music, from New York. 8.45, Congress of Clubs. 9.0, Meredith Wilson Orchestra, from New York. 9.15, Jack Walton's Orchestra, from New York. 9.30, News and Market Prices. 10.0, Casino Orchestra, from New York. 10.15, Tarzan of the Apes. 10.30, The Singing Lady, from New York. 10.45, Orphan Annie, from New York. 11.0, News and Piano Classique. 11.15, Sports Notes and a Song. 11.30, Pittsburgh Spotlights. 11.45-12.45 a.m. (Wednesday), New York Relay. 11.45, Lowell Thomas. 12 Midnight, Amos 'n' Andy. 12.15, Radio in Education. 12.45, Carney's Dog Chats. 1.0-2.30, New York Relay. 1.0, Pastoral. 1.30, Adventures in Health. 1.45, The Rollickers. 2.0, Miniature Theatre. 2.30, Programme to be announced. 3.0, Musical Memories, from New York.

PORSGRUND.—See Oslo.

PRAGUE

614 kc/s, 488.6 metres; 120 kW.—2.50 p.m., Concert by the Rudolf Sivan Orchestra. 3.50, Aviation Weather Report. 3.55, Exchange, 4.0, Interval. 5.45, Talk: The Book Market and the Crisis. 5.55, Talk. 6.5, Agricultural Programme and Market Prices. 6.15, Programme for Workers. 6.25, News in German. 6.30, German Transmission; Sports Report. 7.0, Chimes and News. 7.10, See Moravska Ostrava. 7.50, Talk: The Reformed Schools. 8.5, Jealousy—Comedy in One Act (Novak). 8.50, Concert by the Station Orchestra, conducted by Jirak; Symphonic Variations, Op. 78, for Full Orchestra (Dvorak); Symphony No. 2 in D (Brahms). 10.0, Time, News, and Sports Notes. 10.15, Gramophone Music. 11.0, Close Down.

RADIO-SUISSE ROMANDE

SOTTENS, 743 kc/s, 403 metres; 25 kW.; and Geneva, 395 kc/s, 760 metres.—6.15 to 6.30 a.m. (from Lausanne), Gymnastics Lesson. 12.28 p.m., Time Signal from Neuchâtel Observatory. 12.30, News and Weather. 12.40 (from Geneva), Gramophone Concert. 1.0 (from Geneva), Financial News. 1.10 (from Geneva), Gramophone Music. 2.0 to 3.28, Interval. 3.28, Time Signal from Neuchâtel Observatory. 3.30 (from Lausanne), Concert by the Radio Lausanne Orchestra, conducted by Moser. 5.0 (from Lausanne), Programme for Women. 5.30 to 7.0, Interval. 7.0 (from Geneva), Talk. 7.30 (from Geneva), Weather, News, and Announcements. 7.45 (from Geneva), Answers to Correspondence. 8.0 (from Geneva), Talk: Can one make a Living in the Colonies? 8.15

(from Geneva), Chamber Music: Quartet (Haydn); Five Pieces (Casella). 9.0 (from Geneva), Cabaret Programme. 9.50, News and Weather. 10.0 (from Geneva), Gramophone Concert. 10.30 (approx.), Close Down.

REYKJAVIK

250 kc/s, 1,200 metres; 21 kW.—9.5 p.m., Musical Programme and Announcements. 10.0, Chimes and News. 10.30, Reading. 11.0, Cello Recital by Thorhallur Arnason, followed by Sonata in E flat, Les Adieux (Beethoven) on Gramophone Records.

RIGA

572 kc/s, 525 metres; 15 kW.—6.0 p.m., French Lesson. 6.30, Talk. 7.0, Weather Report. 7.5, Concert of Opera Music, conducted by Medins. Soloist: Vilija Lambert (Songs). In the intervals at 8.0 and 9.0, News and Weather. 9.30, Light Music.

RJUKAN.—See Oslo.

ROME

Call 1RO, 680 kc/s, 441 metres; 50 kW. Relayed by Naples, 941 kc/s, 319 metres; and 2RO, 11,810 kc/s, 25.4 metres, from 5.15 p.m., and Milan (Vigentino), 662 kc/s, 453.2 metres, from 8.45 p.m.—12.30 p.m., Gramophone Music. 1.0 to 2.0, Concert from Turin. In the interval from 1.30 to 1.45, Giornale Radio and Exchange. 4.30, Children's Radio Review. 4.55, Giornale Radio and Exchange. 5.10, Weather. 5.15 to 6.0, Orchestral Concert. 6.40 (Naples), Shipping and Sports Notes. 6.45, Lesson in Morse and Dopolavoro Notes. 7.0, Tourist Report. 7.10, Agricultural Report. 7.20, News in Foreign Languages. 7.40, Giornale Radio. 8.0, Time and Announcements. 8.15, Sponsored Music. 8.30, Sports Notes. 8.45, The Torcador—Opera in Three Acts (Caryl and Monckton). In the interval, Reading: A Visit to the House in which Shakespeare was born (Guido Pugno). Giornale Radio after the Opera.

SALZBURG.—See Vienna.

SCHENECTADY

WGY, 790 kc/s, 379.5 metres; 50 kW. Relayed at intervals by W2XAF on 31.48 metres and by W2XAD on 19.56 metres.—12.45 a.m. (Wednesday), Stock Reports and Baseball Games. 1.0 to 3.30, New York Relay. 1.0, Blackstone Plantation. 1.30, Wayne King's Orchestra. 2.0, Ben Bernie's Blue Ribbon Orchestra. 2.30, Popular Programme. 3.0, Lives at Stake. 3.30, National Radio Forum, from New York, followed by Programme Resume.

SCHWEIZERISCHER

LANDESENDER

BEROMUNSTER, 653 kc/s, 459 metres; 60 kW.; Basle, 1,229 kc/s, 244.1 metres; and Berne, 1,220 kc/s, 245.9 metres.—6.15 a.m. (from Basle), Gymnastics. 6.35 to 11.59, Interval. 11.59, Time Signal from Neuchâtel Observatory and Weather. 12 Noon (from Zürich), Orchestral Concert. In an interval at 12.30 p.m., Time, Weather, and News. 1.25 (from Zürich), Time, Weather, and Exchange. 1.30 to 5.0, Interval. 5.0 (from Zürich), Concert by the Small Station Orchestra. 5.30 (from Basle), Light Music on Gramophone Records. 6.30 (from Berne), A Microphone Report from Schloss Valengin. 7.0, Time and Weather. 7.5 (from Berne), Talk on Sunday Excursions. 7.15 (from Berne), Tragedies of the Desert—Three Short Stories (Ben Gavriel). 7.45 (from Zürich), Talk on the following Transmission. 8.0 (from Zürich), The Flying Dutchman—Opera in Three Acts (Wagner), relayed from the State Theatre. In an interval at 9.45 (approx.), Weather and News. 10.30 (approx.), Close Down.

SOTTENS.—See Radio-Suisse Romande.

STOCKHOLM

689 kc/s, 436 metres; 55 kW. Relayed by Boden, 244 kc/s, 1,229.5 metres; Göteborg, 932 kc/s, 322 metres; Hörby, 1,166 kc/s, 257 metres; Motala, 221.5 kc/s, 1,354.4 metres; Östersund, 389 kc/s, 770 metres; and Sundsvall, 554 kc/s, 542 metres.—5.5 p.m., Programme for Children. 5.45, Gramophone Music. 6.45, French Lesson. 7.15, Weather and News. 7.30, Talk, relayed from Malmö, 1,301 kc/s (231 metres). 8.0, Concert by the Station Orchestra; Soloist: Erik Strömblad (Bassoon); Overture (Wintor); Spanish Fantasy; A Festival in Aranjuez (Demersmann); Introduction and Polonaise for Bassoon and Orchestra (Jacob); Waltz from The Sleeping Beauty (Tchaikovsky); Danish Folk Melody (Sandby); Selection from Glückliche Reise (Künneke); Blues from Jonny spielt auf (Krenek); Foxtrot (Kapp Lusch); The Gladiators' March (Souza). 9.15, Literary Talk. 9.45, Weather and News. 10.0, Song and Pianoforte Recital by Ebba Högfeldt-Larka and Gunnar de Frumerie; Pianoforte Solo: Fantasia on Der Wanderer,

Op. 15 (Schubert); Songs (Brahms): (a) Sapphische Ode, (b) Wie Melodien zieht es mir, (c) Wiegelied, (d) Die Maimacht, (e) Der Schmied; Pianoforte Solo: La Campanella (Liszt). 11.0 (approx.), Close Down.

STRASBOURG

869 kc/s, 345 metres; 11.5 kW.—11.30 a.m., Gramophone Concert. 12 Noon, Orchestral Concert, conducted by Maurice de Villers; Overture, Coriolanus (Beethoven); The Jupiter Symphony (Mozart); The Nutcracker Suite (Tchaikovsky); Divertissement (Lalo); Le rouet d'Orphale (Saint-Saëns); Ballet Music, La boîte à joujoux (Debussy). In the interval at 12.45, News, and at 1.0, Time and Exchange. 2.0, Interval. 5.0, Talk on French Morocco. 5.15, Orchestral Concert, conducted by Roskam; Overture, Fran Lina (Lincke); Waltz Intermezzo, Flirtation (Steck); Foxtrot, In my Hide-Away (Binfort); Rumba, Cuban Holiday; Tango, Tu n'es plus rien; Saxophone Solo: Hindi Song (Rimsky-Korsakov); Waltz, Adam (Zeller); Foxtrot, Miss Elizabeth Brown (Gay); Slow Waltz, Betty (Allouche); Intermezzo, Dorrischen Brautfahrt (Rhode); Foxtrot, How deep is the Ocean (Berlin); Foxtrot, Deux buns emarades (Marbot); Tango (Lucchesi); Two Step, Viva España (Tan Herék). 6.0, Talk. 6.15, Topical Talk. 6.30, Chamber Music: Quartet for Strings (Beethoven); Trio for Violin, Cello and Pianoforte (Debussy). 7.30, Time and News. 7.45, Gramophone Music. 8.0, Press Review in German, Lottery Results and Announcements. 8.30, Concert, relayed from Lyons. 10.30, Press Review.

STUTTGART

MUHLACKER, 832 kc/s, 360.5 metres; 60 kW. Relayed by Freiberg, 527 kc/s, 570 metres.—12 Noon, Concert from Munich. 1.15 p.m., Time and News. 1.30, Gramophone Music. 2.0, Concert arranged by the Post Office. 2.30, Advanced English Lesson. 3.0, Programme for Children. 3.30, Talk on Flowers. 4.0, Talk for Women: Women in Politics. 4.30, See Frankfurt. 5.45, Programme to be announced. 6.10, Talk: The Sufferings of the Saar Miners. 6.35, Time and Announcements. 7.0, Transmission for all German Stations, relayed from Frankfurt. 8.0, Concert by the Station Orchestra, conducted by Ferdinand Drost and the Station Quartet; Overture, The Bartered Bride (Smetana); Ballet Music from Acts II and III of The Bartered Bride (Smetana); Symphonic Poem, The Moldau (Smetana); Second and Fourth Movement from the String Quartet in D (Dvorak); Polovstian Dances from Prince Igor (Borodin). 9.30, Humour from Alsace (arr. Willy Kipp). 10.15, Time and News, followed by Talk on Austria. 10.45, Concert by the Station Orchestra, conducted by Gustav Gährig; Overture, The Italian Girl in Algiers (Rossini); Verdi Potpourri (Hobby); Romance (Lescaudal); Waltz, Künstlerleben (Joh. Strauss); Overture, Poppea (Suppé); Polka, Bitt' schön (Joh. Strauss); Potpourri, Bei Lied und Wein (Armandola). 12 Midnight (approx.), Close Down.

SUNDSVALL.—See Stockholm.

TOULOUSE

779 kc/s, 385 metres; 8 kW.—6.0 p.m., News. 6.15, Chamber Music: Theme with Four Variations (Tchaikovsky); Trio in D minor (Mendelssohn). 6.30, Popular Melodies. 6.45, Music by Argentine Orchestra. 7.15, News, Racing Results and Market Prices. 7.30, Sound Film Music. 7.45, Opera Music: Barcarolle from The Tales of Hoffmann (Offenbach); March from The Mastersingers (Wagner); Polonaise from Boris Godunov (Musorgsky). 8.0, Opera-comique: Extracts from The Pearl Fishers (Biset); La Basoche (Messager); and Lakmé (Delibes). 8.15, Acordion Music. 8.30, Military Music. 8.45, Chansonnettes. 9.0, Extracts from Rigoletto—Opera (Verdi). 9.30, Concert. Part I: Orchestral Music. Part II: Opera Arias. 10.0, Music by a Viennese Orchestra. 10.15, North African News and Local News. 10.30, Concert for Listeners in Morocco; Selection from Cavalleria Rusticana (Mascagni); Selection from La Bohème (Puccini); Dolorita (Charabon); March from The Prophet (Meyerbeer); Perdita (Cuvellier). 11.0, Dance Music. 11.45, Orchestral Music. 12 Midnight, News, Weather and Announcements. 12.5 a.m. (Wednesday), Orchestral Concert. 12.30 (approx.), Close Down.

TRIESTE

1,211 kc/s, 247.7 metres; 10 kW.—5.10 p.m. till Close Down, See Turin.

TRONDHEIM.—See Oslo.

TURIN

1,096 kc/s, 273.7 metres; 7 kW. Relayed by Milan, 905 kc/s, 331.5 metres; Genoa, 959 kc/s, 312.8 metres; and Florence, 559 kc/s,

500.8 metres.—5.10 p.m., Dance Music, relayed from the Savoia. 6.0 to 6.5, Weather. 6.40, Giornale Radio, Dopolavoro Announcements, and Gramophone Music. 7.0, Time, Report of the Royal Geographical Society, and Gramophone Music. 7.10, Agricultural Notes and Market Prices. 7.20, Weather. 7.40, Gramophone Music. 8.0, Announcements, Giornale Radio, Sports Notes, and Gramophone Music. 8.25, Talk on the following Transmission. 8.30, An Operetta in Three Acts. In the intervals, Talk and Literary Notes. After the Operetta, Giornale Radio.

VATICAN CITY

15,120 kc/s, 19.84 metres (Morning) and 5,969 kc/s, 50.26 metres (Evening); 10 kW.—11.0 to 11.15 a.m., Religious Information in English. 8.0 to 8.15 p.m., Religious Information in Italian.

VIENNA

581 kc/s, 517 metres; 15 kW. Relayed by Graz, 852 kc/s, 352.1 metres; Innsbruck, 1,058 kc/s, 283 metres; Klagenfurt, 662 kc/s, 453.2 metres; Linz, 1,220 kc/s, 245.9 metres; and Salzburg, 1,373 kc/s, 218.5 metres.—1.0 p.m., Concert by the Wiener Symphoniker, conducted by Holzer; March (Gangbergler); Italian Suite (Kostal); Waltz, Tomperle (Czibulka); Sprich nicht von ewiger Liebe (Gränichstaedt); Hymn to the Sun, from The Golden Cockerel (Rimsky-Korsakov); Two Icelandic Melodies (Svendson); Potpourri, Eine Singsfahrt nach Wien (Sivling). 2.0 to 3.0, Interval. 3.0, Time, Weather and Market Prices. 3.20, Talk: Gymnastic Competitions. 3.30, Operetta Concert on Gramophone Records; Overture, Les Cloches de Corneville (Planquette); Selection from Die Fledermaus (Strauss); Song from Der Obersteiger (Zeller); Duet from Schön ist die Welt (Lehar); Song from The Gipsy Baron (Strauss); Tango Song from Beklame Gränichstaedt); Song from The Land of Smiles (Lehar). 4.20, Talk: Wood and Plain in Folk Lore. 4.50, Talk: Dangers to Health in the Engineering Workshop. 5.5, Chamber Music: Three Sonatas for Two Violins, Bass and Continuo (Mozart); Romance in A (Reger); Elevation (Bitté); Bagatelles for Two Violins, Cello and Harpsichord (Dvorak). 5.50, Talk: The Earth Gas Fire at Mediasch, Transylvania. 6.45, Instrumental Concert: Magda Bajos (Violin); Beate Reichert (Cello), and Otto Schullhof (Pianoforte); Melody for Violin (Glück); Cello Solos: (a) Airy (Baeh), (b) Tocatta (Frescobaldi-Cassado); Rondo in E flat for Pianoforte (Hummel); Cello Solos: (a) Minuet (Debussy), (b) Guitare (Moszkowski); Pianoforte Solos: (a) Two Arabesques (Reinhold), (b) Waltz; Violin Solo: Faust Fantasia (Wieniawski). 7.45, Time, Weather and Programme Announcements. 7.50, Reading: The German National Theatre in Vienna under Josef II. 8.20, Concert by the Wiener Symphoniker, conducted by Clemens Krauss; Symphony in F minor, Op. 12 (Richard Strauss); Pictures from an Exhibition (Mussorgsky-Ravel). 8.50, News, Weather and Announcements. 10.5, Instrumental Concert, relayed from the Hotel Kranz Ambassador. After the Concert, Announcements.

WARSAW

212.5 kc/s, 1,411 metres; 120 kW.—11.57 a.m., Time Signal and Chimes from Turin, for the 70th Anniversary of the Town. 12.5 p.m., Gramophone Music. In the intervals at 12.25, Press Review, and at 12.33, Weather. 12.55, Radio Journal. 1.0, Interval. 2.55, Gramophone Music. In the intervals at 3.5, News, at 3.25, Economic Notes, and at 3.45, Aviation Report. 3.55, News. 4.0, Concert by the Poznan Symphony Orchestra, relayed from Ciechocinek. 5.0, Wireless Notes. 5.15, Soprano and Violin Recital by Bernawska (Soprano) and Kaminski (Violin); Songs: (a) Aria from La Gioconda (Ponchielli), (b) Aria from Le Cid (Masse-net), (c) Aria from Manon (Puccini), (d) Aria from Cavalleria rusticana (Mascagni); Violin Solos: (a) Sonata in E (Francoeur), (b) Havannaise (Saint-Saëns), (c) Malagena (Sarasate); Songs: (a) Twilight (Koelling), (b) O si ma tristesse (Glier), (c) Sous ma fenêtre (Rachmaninov); Violin Solo; Suite, Much ado about Nothing (Korngold). 6.15, Talk: Poland Today. 6.35, Song Recital. 7.5, Gramophone Music. 7.20, Miscellaneous Items. 7.35, Programme Announcements. 7.40, Topical Talk. 8.0, Concert by the Station Orchestra, conducted by Oziminski. Soloist: Salecki (Tenor); Ukrainian Overture, Marie (Grossmann); Barcarolle for Strings (Dlutovsky); Mazurka (Noszkowski-Kondracki); Liebeswalzer (Moszkowski); Spanish Dance (Sarasate); Songs: (a) Aria from La Juive (Halévy), (b) Aria from The Haunted Castle (Aloniuski); Suite, Goliardica (Anadei); Songs: (a) Aria from Janek (Zelenki), (b) Aria from The Pearl Fishers (Bizet), (c) The Bagpipe Player (Paderevsky); Der Erkonig (Schubert-Liszt); Dream on the Vistula (Helmsberger); Mazurka (Noszkowski). In the interval, Radio Journal and Agricultural Notes. 10.0, Dance Music from the Gastronomia Café. In the intervals at 10.25, Sports Notes, and at 10.35, News, Weather and Police Notes.

ZURICH.—See Schweizerischer Landessender.



KINGS  
OF THE  
AIR

# Improve the volume of those "whispering" stations



Those stations that you can only just hear—the ones that are mere whispers in the distance—they too can give you entertainment. Fit a Cossor Screened Grid Valve. You'll be surprised at

the difference it will make—longer range, and a general all-round improvement. Your dealer will gladly advise you on the most suitable type for your receiver. Ask him to-day.

Cossor 2-volt Screened Grid Valves

Type	Fila-ment Amps.	Anode Volts	Imped.	Amp. Factor	Mutual Conduc-tance m.a./v.	Price
*215 S.G.	-15	120-150	390,000	337	1-10	15/6
*220 S.G.	-2	120-150	200,000	320	1-60	15/6
*220 V.S.G.	-2	120-150	110,000	—	1-60	15/6
*220 V.S.	-2	120-150	400,000	—	1-60	15/6

Cossor A.C. Mains Screened Grid Valves

Type	Purpose	Imped.	Amp. Factor	Mutual Conduc-tance m.a./v.	Price
**MSG-HA	Super H.F. Amp'n.	500,000	1,000	2.0	17/6
*41 MSG	Super H.F. Amp'n.	400,000	1,000	2.5	17/6
**MSG-LA	Super H.F. Amp'n.	200,000	750	3.75	17/6
**MMSG	Variable-Mu	200,000	—	2.5	17/6
**MS PEN-A	H.F. Pentode	—	—	4.0	17/6
*†MS PEN	H.F. Pentode	—	—	2.8	17/6
*†MVS PEN	Variable-Mu H.F. Pentode	—	—	2.2	17/6

The above Valves have Indirectly Heated Cathode, 4 Volts, 1 Amp.

Cossor D.C. Mains Screened Grid Valve

*DVSG	Variable-Mu	—	—	2.5	17/6
-------	-------------	---	---	-----	------

The above Valve has Indirectly Heated Cathode, 16 Volts, 0.25 Amp.

\*These Valves available with or without Metallised Bulbs.

† Characteristics measured at 175 grid volts.

\* \* Stocked with Metallised Bulb only

# COSSOR SCREENED GRID VALVES

To A. C. COSSOR LTD., Melody Dept., Highbury Grove, London, N.5.

Please send me, free of charge, a copy of the 64-page Cossor Valve Catalogue B.14.

Name.....

Address.....

W.W. 15.111.....



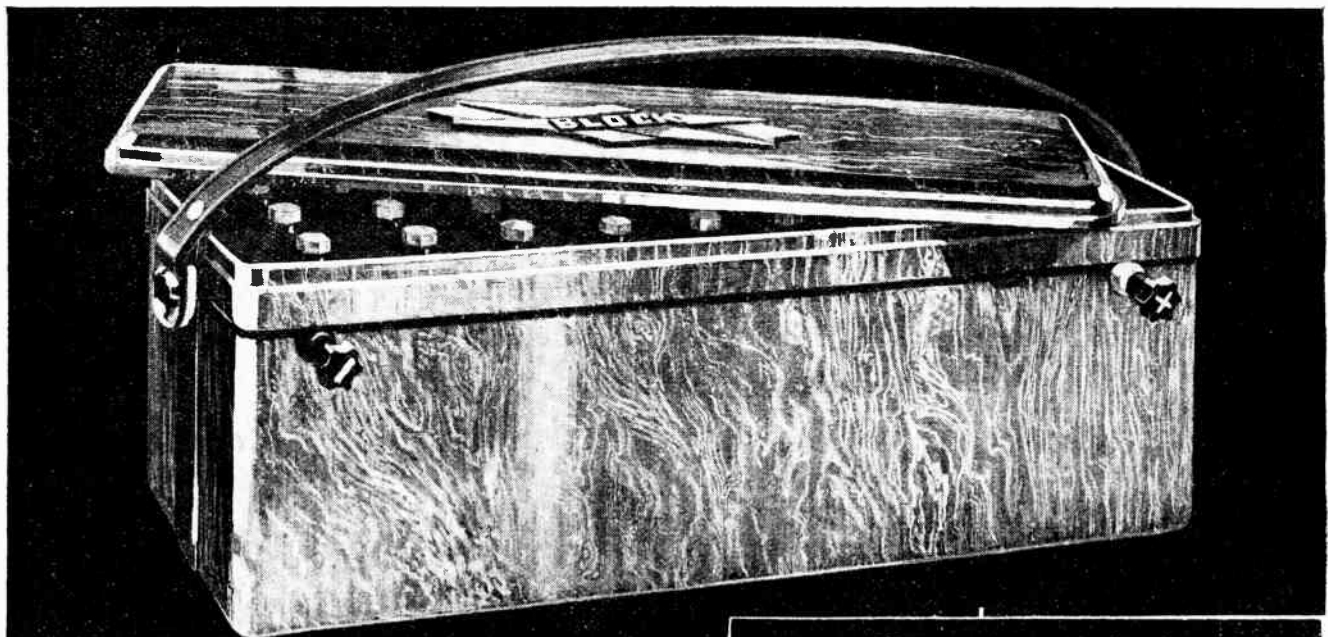

**Now H.T.**

*Imagine it!*  
**60** v. 5000 m.a.h.  $14\frac{1}{2} \times 4\frac{3}{8} \times 5\frac{1}{2}$ " high 16 lbs. **37/6**  
**30** v. 5000 m.a.h.  $8\frac{3}{8} \times 4\frac{3}{8} \times 5\frac{1}{2}$ " high 8 lbs. **21/-**

*accumulators*

*half the size!*

**NO NEED NOW FOR DRY BATTERY EXPENSE**

● A new era opens. Gone are the costly dry batteries. Gone are the bulky H.T. accumulators. To-day comes a new kind of H.T. source—a plate-less accumulator hardly bigger than the old dry battery itself. ● Startlingly low in first cost, it costs you nothing after except for occasional re-charging. The secret is the Block plate-less cell, that does away with the old weight, space and weakness of accumulator plates. ● Non-fragile. Elegant (the case is coloured bakelite). More durable than the plate type; inexpensive. Demand is overwhelming—order at once for early delivery.

**DOUBLE CAPACITY L.T.**

**MANCHESTER  
STAND  
54**

**BLOCK**

**PLATE-LESS ACCUMULATORS**

*Block Batteries Ltd, Abbey Road, Barking, Essex.*

*What a boon!*

Cut away view of Block cell. — First the coloured bakelite that covers the L.T. type; next a lead cylinder (both the 'negative' and the cell's container.) Inside it, active paste. Last is the central 'positive' column and separator.

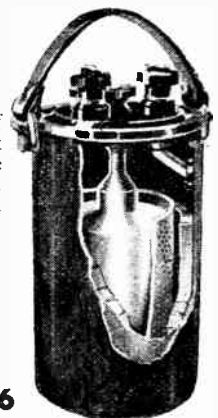

Price of **80** a.h. **11/6**  
 L.T. **2.v.**

*Tel: Grangewood 3346/7*

# THE ADVANTAGES OF SUPERINDUCTANCE ARE PROVED BY THESE 6 FEATURES

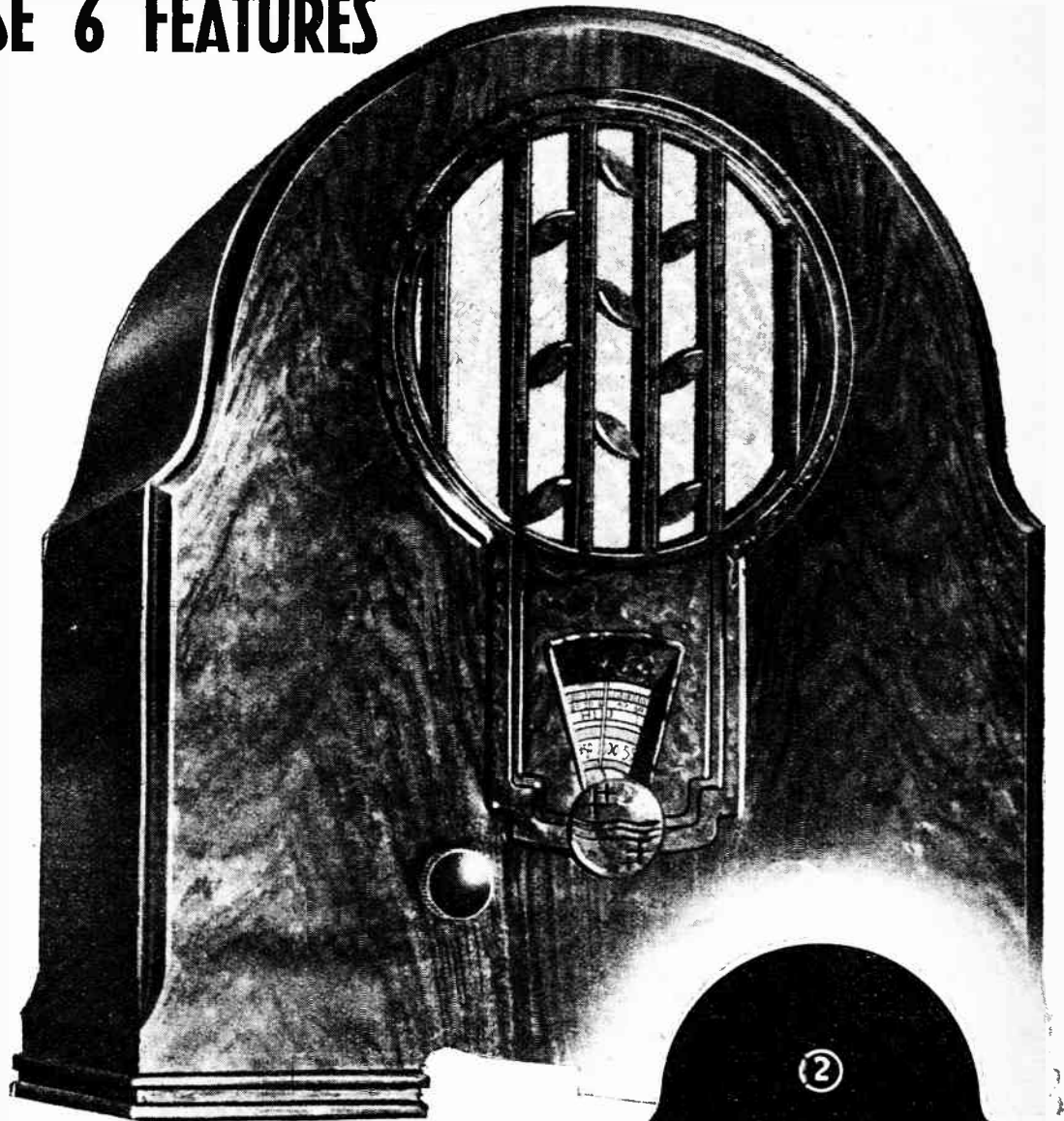

- 1** Amazing sensitivity and selectivity. Four Super-inductance tuned circuits. Precision methods of construction applied throughout the design.
- 2** Magnificent reproduction ensured by moving coil loudspeaker, carefully designed output stage and 3-position tone filter.
- 3** Simple 2-knob control. Absence of any oscillating circuit gives complete freedom from second channel and similar types of heterodyne whistles.

- 4** Automatic fading compensation and special selector control for quickly selecting the worthwhile programmes, and eliminating those spoiled by mush and background noise.
- 5** Easy station identification. Comprehensive station chart in conjunction with micrometer dial indicates the positions of nearly 100 stations with extreme accuracy.
- 6** The micrometer dial will not become obsolete when stations change their wavelengths. Revised charts will be supplied when necessary.

The 634 is another striking example of the success achieved by Superinductance. By means of this original method of set construction, developed exclusively by Philips for the reception of dual waveband broadcasting, the highest selectivity is ensured with complete freedom from heterodyne interference, absolute simplicity of operation and easy and accurate station identification.

For A.C. Mains. Type 634A.

100/260 volts, 40/100 cycles. 2 S.G.H.F.-Diode detector with S.G.L.F. Output Pentode. Valve Rectifier.

PRICE **16** GNS. or by 12 monthly payments of £1.16 each.

For D.C. Mains. Type 634C.

110, 150, 200/260 volts. 2 S.G.H.F.-Diode detector with S.G.L.F. 2 parallel Output Pentodes. Current regulator lamp.

PRICE **17** GNS. or by 12 monthly payments of £1.36 each.

We claim that model 634C is the finest receiver ever produced for operation on D.C. mains regardless of cost.

# PHILIPS SUPERINDUCTANCE RADIO-RECEIVERS



## OLYMPIA SUCCESS REPEATED AT GLASGOW

### KITS for

The Wireless World

### NEW MONODIAL SUPER

**KIT "A" RECEIVER UNIT:** Comprising the specified components (less Chassis, Panel, Valves and Cabinet) **£10-19-6**

**KIT "B" POWER UNIT:** Comprising the Designer's first specified components (less Chassis and Valves) **£8-13-6**

*Detailed Price List Free on Application.*

**ALUMINIUM CHASSIS** correctly drilled with side members, finished in French-grey cellulose. Receiver Chassis, **10-**; Power Unit Chassis, **7 6**. "C.A.C." Panel, 14" x 10", in Polished Oak, Walnut or Mahogany, 2/-; Valves: Receiver (5), **£4-4-6**. Power Unit (1), **£3-0-6**.

### FERROCART CLASS "B"

**KIT "A."** Complete (less Valves, Batteries, Cabinet and Loud Speaker) **£7-11-0**

**KIT "B."** Complete with Valves (less Batteries, Cabinet and Loud Speaker) **£9-17-3**

**KIT "C."** Complete with Valves, Cabinet and Loud Speaker (less Batteries) **£13-9-3**

**CABINET** beautifully finished in Figured Walnut exclusively specified by the designer and manufactured in our own factory **£1-12-6**

*(Front drilled, if desired, without extra charge.)*  
Continuous Demonstrations Daily.

#### CONSTRUCTION

We shall be pleased to undertake the construction of the above Receivers to customers' own requirements. Only highly skilled technicians, under the personal supervision of Mr. W. I. G. Page, B.Sc., are entrusted with this work. This ensures that the results obtained by the designer will be duplicated.

Sole Agents for Scotland:—

**WILKINSON RADIO AND MUSICAL LTD.,**  
176, INGRAM STREET, GLASGOW.

Telephone: Bell 2167.

Trade Enquiries Invited.

As at Olympia, every article on our Stand at Kelvin Hall was sold within two hours of the opening of the Exhibition and orders have poured in since. We still keep our definite promise, however, of

#### DELIVERY BY RETURN

Our 1933-4 Catalogue is now ready and we invite every "Wireless World" reader to send for free copy.

### THE "C.A.C." PENTAGRID SUPERHET

A four-valve A.C. Superhet of highly specialised technique using a Pentagrid Converter as a single-valve frequency changer, which performs the dual functions of oscillator and first Detector in the most efficient manner known. In the I.F. stage a variable-mu Pentode is used, which adds its contribution to A.V.C. The third valve is one of the new double Diode Pentodes, which gives almost perfect automatic volume control, and the fourth valve is a Catkin Pentode. The output is in the order of 2½ watts, whilst the sensitivity of this Receiver is a revelation. The four special valves give an overall performance equal to that of any six-valve superhet on the market.

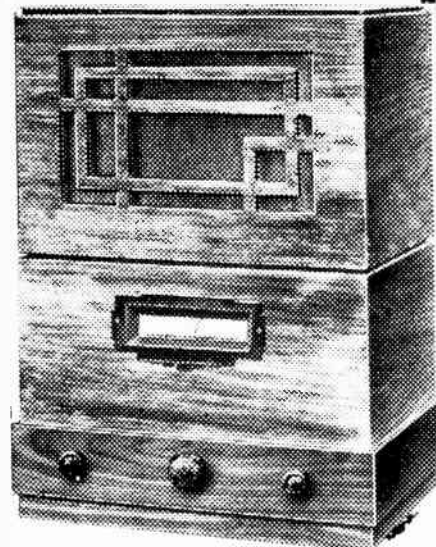

Price 14 GUINEAS

### CITY ACCUMULATOR Co. Ltd.

18-20, NORMAN'S BUILDINGS (off Central Street), LONDON, E.C.1  
Telephones: Radio Dept.—Clerkenwell 6206. Telegrams: Cabinet Dept. "1038 "Cityacco, Barb, London."

WE ARE EXHIBITING AT THE MANCHESTER AND EDINBURGH RADIO EXHIBITIONS.

## Transformers specified by WESTINGHOUSE for use with their METAL RECTIFIERS in TROPICAL COUNTRIES

Transformer Type.	Price.		Transformer Output.		D.C. Output.		Rectifier Type	Capacity in Mfds.
	M.	S.	Volts.	Amps.	Volts.	m Amps.		
W.T.1	16 -	20 -	150 110 80	0.040 0.075 0.060	150 175 120	25 25 20	H.T.13 H.T.12 H.T.5	8 4 : 4 4 : 4
W.T.2	20 -	24 -	175 4 C.T. 4 C.T.	0.150 2 3 1	200	50	H.T.8	4 : 4 — —
W.T.3	26 -	30 -	200 4 C.T. 4 C.T.	0.180 3 5 1	250	60	H.T.9	4 : 4 — —
W.T.4	35 -	39 -	250 4 C.T. 4 C.T.	0.300 3 5 2	400	100	H.T.11	6 : 6 — —
W.T.5	17 -	21 -	22 11 11	0.9 0.9 0.3	12 6 6	0.75 0.75 0.25	L.T.5 L.T.4 L.T.2	— — —
W.T.6	18 -	22 -	14 11	1.3 1.8	9 6	1.5 1.5	A.4 L.T.6	— —
W.T.7	17 6	21 -	9	2.4	6	2	A.6	—

M—Manufacturer's type without terminals.  
S—Standard type with terminals.

NOTE: All the above transformers are impregnated against HEAT and DAMP.

## W. BRYAN SAVAGE

56/58, CLERKENWELL ROAD, LONDON, E.C.1.

TELEPHONE - - - CLERKENWELL 3068 9.



... is not a catch phrase designed to persuade the public to buy a component of doubtful value, but adequately describes the effect produced by fitting the 'NOVOTONE' Compensator to a Gramophone amplifier. These extracts from users' letters fully bear out this statement.

"I recently purchased a Type 'J' 'Novotone' Compensator for use in conjunction with a B.T.H. Pick-up and a Hartley-Turner Loudspeaker, and I am very pleased to say that results have exceeded all my expectations. I did not know that such results were possible in the electrical reproduction of records. . . . I would like to take this opportunity of congratulating you on your excellent products.

"Upon fitting the 'Novotone' the results were most surprising. Moving Coil Speakers that we thought were the last word in purity on Radio Gramophone work, were improved beyond measure."

"I am more than delighted with it. It has brought notes out from my records that I had no idea were there."

Write now for free descriptive booklet, "Realism from Records," which fully explains the application to your Radio Gramophone of this remarkable instrument.

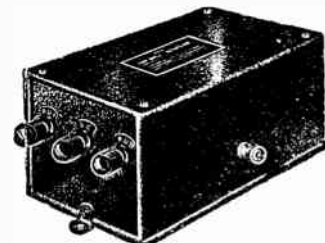

## THE 'NOVOTONE' COMPENSATOR

GAMBRELL BROS. & CO. LTD., MERTON ROAD, SOUTHFIELDS, S.W.18.  
Telephone: Putney 3641.

Mention of "The Wireless World," when writing to advertisers, will ensure prompt attention.

**NOW RELEASED**

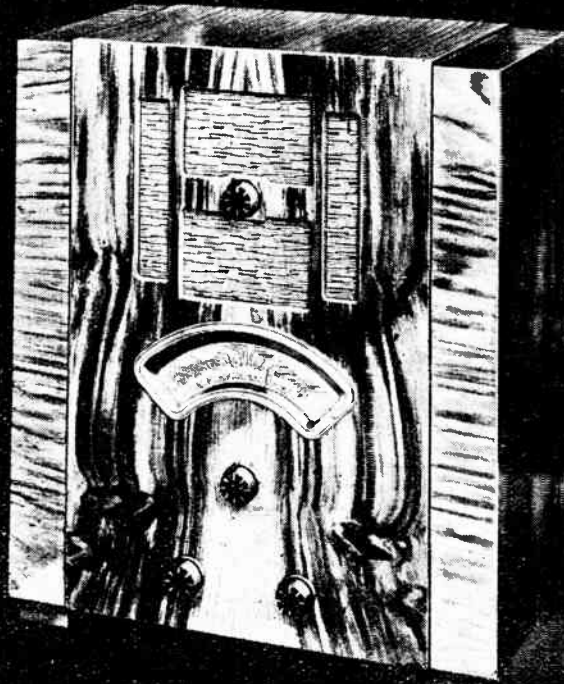

# G.E.C. Superhet 5

**FOR A.C. OR D.C. MAINS**

The most outstanding Superhet of its class, available now for D.C. Mains as well as A.C. in separate models. Tuning by station names. Complete station separation and true, uncoloured reproduction. Energised moving coil speaker, tone control, speaker silencing key, internal aerial for local stations, pick-up jack, provision for external speaker. Richly figured walnut cabinet.

**HIRE PURCHASE TERMS:** Deposit £1 5 0 and 12 monthly payments of £1 5 0

**WRITE FOR FOLDER BC.6671**

**14 GNS**

MADE IN ENGLAND  
Sold by all Radio Dealers

**The sets with the big name behind them**

**G.E.C.  
RADIO**

*Advt. of The General Electric Co. Ltd., Magnet House, Kingsway, London, W.C.2*



# An Olympic Triumph!



## Model 74. New 7-Stage Superhet.

OUTSTANDING FEATURES. British and Continental stations can be received at full programme strength and unsurpassed fidelity—DELAYED Automatic Volume Control in All-Electric Models ensuring desired volume from both distant and local stations—One Knob Tuning—CLASS "B" OUTPUT in Battery Models permits "All-Electric" performance—Magnificent Bakelite Cabinet available in two finishes, figured walnut, and black with chromium-plated fittings—detachable fret; an exclusive feature permitting speaker silk to be changed to match any furnishing scheme—New Station scale with names and wavelengths—Seven-stage superhet circuit with band-pass tuning—Light-beam station selector—Combined on-off switch and volume control for radio and gramophone—Moving coil speaker—Gramophone pick-up sockets controlled by switch—External speaker connection.

## Model 74

Battery and All-Electric  
Black and Chromium.

**14 GNS.**

or 12 monthly payments of  
£1.7.0

Walnut Finish

**13 GNS.**

or 12 monthly payments of  
£1.5.0

# EKCO RADIO

To E. K. COLE Ltd., Dept. W.25, EKCO Works, Southend-on-Sea.

NAME .....

ADDRESS .....

A full-coloured folder will be sent to you free on receipt of this coupon.

Mention of "The Wireless World," when writing to advertisers, will ensure prompt attention.

# The Wireless World

THE  
PRACTICAL RADIO  
JOURNAL  
23<sup>rd</sup> Year of Publication

No. 733.

FRIDAY, SEPTEMBER 15TH, 1933.

VOL. XXXIII. No. 11.

Proprietors: ILIFFE & SONS LTD.

Editor:  
HUGH S. POCOCK.

Editorial,  
Advertising and Publishing Offices:  
DORSET HOUSE, STAMFORD STREET,  
LONDON, S.E.1.

Telephone: Hop 3333 (50 lines).  
Telegram: "Ethaworld, Watloo, London."

COVENTRY: Herford Street.

Telegrams: "Cyclist, Coventry."  
Telephone: 5210 Coventry.

BIRMINGHAM:

Guildhall Buildings, Navigation Street, 2.

Telegrams: "Autopress, Birmingham."  
Telephone: 2970 Midland (3 lines).

MANCHESTER: 260, Deansgate, 3.

Telegrams: "Iliffe, Manchester."  
Telephone: Blackfriars 4412 (4 lines).

GLASGOW: 26B, Renfield Street, C.2.

Telegrams: "Iliffe, Glasgow." Telephone: Central 4857.

PUBLISHED WEEKLY. ENTERED AS SECOND  
CLASS MATTER AT NEW YORK, N.Y.

Subscription Rates:

Home, £1 1s. 8d.; Canada, £1 1s. 8d.; other  
countries abroad, £1 3s. 10d. per annum.

As many of the circuits and apparatus described in these  
pages are covered by patents, readers are advised, before  
making use of them, to satisfy themselves that they would  
not be infringing patents.

## CONTENTS

	Page
<b>PROGRAMMES FROM</b>	
<b>ABROAD, pp. I-XXIV</b>	
Editorial Comment .. .. .	225
The Electrostatic Loud Speaker ..	226
Practical Hints and Tips .. .. .	228
Design of the Detector-Oscillator ..	229
Why Kalundborg is Loud .. .. .	231
News of the Week .. .. .	233
Television at the Berlin Show .. ..	234
Unbiased .. .. .	236
Bush Radio Television Receiver ..	237
Broadcast Brevities .. .. .	239
Laboratory Tests .. .. .	240
Varley "Square Peak" 4 Receiver	241
Readers' Problems .. .. .	242

## EDITORIAL COMMENT

### Aerials and Earths

#### Importance of an Overhaul

**A**LL of us have a natural desire to improve the standard of reception and are prepared to devote a large amount of time, and money according to our means, in doing all that we can to perfect our receivers. In the early days of wireless reception, when the simplicity of the crystal set left comparatively little scope for improving the efficiency of the receiver beyond a certain point, we paid the greatest attention to the aerial and earth because it was on this end of the outfit that we depended for any real improvement in reception.

#### Why Aerials Are Neglected

To-day, with the amazing amplification which the modern valve can give, and the efficiency of our receivers, we are inclined to think that the aerial and earth do not matter. A year or so ago, when the increase in the number and power of transmitters overtook the standard of selectivity in receivers, it was common practice to shorten the aerial, reducing its efficiency as a collector, as a means of improving selectivity of the set. Now, with set selectivity vastly improved, we would be prepared to wager that there are thousands of aerials which have been left precisely as they were, in spite of the fact that a new and up-to-date selective receiver has been installed in the meantime in place of the unselective one.

Wherever circumstances and space permit, a return to a long and efficient aerial would be found worth while to-day if a selective set is in use, and an indoor aerial, or any compromise of this nature, should only be entertained as an alternative if a good outside aerial is a physical impossibility.

In three weeks Summer Time will be

at an end and very probably a wet spell will set in, so that the opportunity should be taken now for a thorough overhaul of the outside aerial and earth. From every point of view it will be found well worth the time spent.

#### Do It Well

Whilst on the job, put up the best aerial possible in the space available and then see how much difference it is going to make to reception. The earth, too, requires the same sort of overhaul, and, above all, watch for any rubbing contacts which may give rise to crackles which we may have hitherto regarded as inevitable atmospherics. Whilst the fine weather is still with us it is an opportunity, also, to consider whether it is advisable to install a screened down lead or other refinements. It is a job easily tackled whilst the fine weather lasts, but one to be shunned on a cold and wet day.

We should take the opportunity to discourage our friends from resorting to the use of "aerial substitutes" of pocket size, which, even in these enlightened days, are still being sold in a variety of types, in spite of the fact that their very dimensions are sufficient to preclude the possibility that they could act as efficient collectors. On the other hand, indoor aerials of good type and others of special design for outdoor use, will often be found to be the next-best-thing if outside aerial facilities are restricted.

On this question of aerials we should not be selfish, that is to say, we should, in our common interest of raising the standard of reception, encourage our friends, particularly those who are not technical, to take this opportunity to overhaul the aerial system or fit an outside aerial, if possible. We shall have the satisfaction of our friends' appreciation later of the value of the advice we give them now.

# The Electrostatic Loud Speaker

## 1. How It Works

By M. G. SCROGGIE, B.Sc., A.M.I.E.E.

If a sufficiently high voltage were applied between the plates of a variable condenser, and the moving plates were sufficiently freely suspended, they would rotate into the maximum capacity position. In practice there is no great likelihood of our tuning dials moving round in this way when an extra powerful "atmospheric" arrives, because the friction at the bearings is so great that the voltage would spark across between the vanes long before being enough to shift them round. But the electrostatic voltmeter, which is simply a very tiny and lightly suspended variable condenser fitted with a pointer, demonstrates the truth of this principle every time it is used.

The principle, of course, is that a difference of potential or voltage between any two conductors causes them to attract one another, and, where they are free to move, to approach one another.

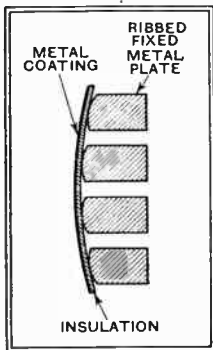

Fig. 1.—Section of the "Kyle" electrostatic loud speaker.

on being connected across the A.C. mains or other source of high alternating voltage. But generally the manufacturer has taken good care that the two strips of foil that make up the condenser are too tightly sandwiched between the waxed paper dielectric strips to vibrate at all.

### Practical Considerations

If a condenser is to be any good as a sound reproducer it should be exposed to the open air, and one at least of its two conducting elements should be reasonably free to move to and from the other. This could be done by suspending it a little distance away, with a layer of air in between. There are several disadvantages in this. The layer of air acts as a cushion, tending to damp out the motion, just as a pneumatic stop prevents a door from being slammed, however hard it is pushed. Then the force set up by a given voltage falls off very rapidly as the plates are separated even slightly. And to keep them separated at a fixed distance without solid material in between it is necessary to im-

pede their free motion still further, either by making the plates very thick and stiff or by stretching them tightly.

The result is that the simple condenser loud speaker tends to be very inefficient and insensitive, and the object of design is to remove these objections. An example

*THE amount of information which has been published about the electrostatic or condenser loud speaker is almost negligible. Being such an unknown quantity it has not yet come into general use, although it has been on the way for over fifty years. This neglect is not altogether deserved, for in some respects, particularly reproduction of the higher frequencies, it is unrivalled. Being fundamentally different from other types of loud speaker it is unfair simply to substitute it and expect the best results. The purpose of the author of this contribution will be to explain how the electrostatic loud speaker works and to give advice on its use.*

of the stretched diaphragm type is that by Hans Vogt, of Ferrocart fame. He used an extremely thin moving diaphragm, stretched so tightly, close to a perforated fixed plate, that the natural frequency was above the usual audio frequency range—about 15,000 cycles per second, in fact. The perforations were intended, of course, to remove the air damping.

The Kyle loud speaker—of American

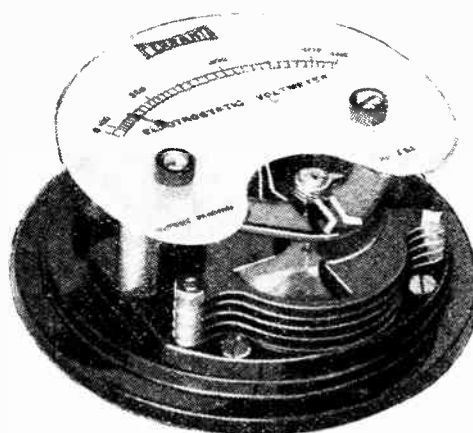

The Ferranti electrostatic voltmeter illustrates the principle of electrostatic attraction.

origin—has the effect of splitting up the total surface into a vast number of tiny diaphragms, by stretching the moving element directly on the fixed one, separated only by a thin layer of flexible insulation. Fig. 1 shows in section a small por-

tion of this arrangement. The fixed plate is slotted and ribbed, and so shaped where it makes contact with the composite moving plate that an increase in voltage between them causes the latter to cling closer to the fixed plate and squeeze some of the air out through the slots. The reverse action takes place when the voltage relaxes.

A still closer approach to unrestricted motion is obtained in the "Primustatic" speaker, which, as it is one readily obtainable in this country, will be principally considered. Fig. 2 shows an enlarged section of it, in which the fixed plate, of perforated aluminium, is slightly curved. Behind it is a tinfoil-coated sheet of waxed paper, folded so as to form tiny triangular-sectioned air spaces behind the perforations. At the "dead" lines, in between the rows of perforations, where there is no motion, the foil paper is held in position by a special sort of hairy thread which makes very light, but adequate, contact everywhere. It is possible to use graphite-coated paper instead of metal, as a fairly high resistance does not interfere with the operation.

It will be clear that when a voltage is set up between the plates a sort of rolling action takes place, causing the line contact to spread out into a strip, as shown dotted, and air to be expelled through the perforations.

### Possibilities of Distortion

As the attractive force takes place whenever a difference of voltage exists between the plates, it is obvious that they will move together during both positive and negative halves of an alternating wave. Thus, in Fig. 3, if (a) represents two complete periods of a 50-cycle supply, (b) represents the corresponding attractive force set up, and it will be seen that there are *four* complete waves. So instead of a 50-cycle note we get a 100-cycle note.

Reproduction in which every frequency is double what it ought to be is not likely to be considered satisfactory. It is interesting to note that precisely the same result is obtained in a moving-iron loud speaker or headphones in which no permanent magnetism is provided, the only

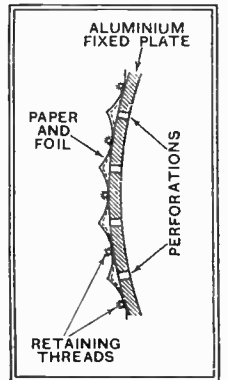

Fig. 2.—Section of the "Primustatic" loud speaker. The dotted line shows the position of the diaphragm under the force of attraction.

**The Electrostatic Loud Speaker—**

attractive force being due to the signal current. The remedy in the latter case gives us the clue to that for the electrostatic speaker defect—the provision of a steady initial force considerably larger than any due to the signal.

Fig. 3 (c) shows the combination of the high steady voltage and the alternating signal voltage, and one important feature is that it never reverses—the initial voltage being relatively large keeps it on one side of the base line throughout. Consequently the frequency-doubling effect is absent, and the attractive force closely follows the outline of the voltage, Fig. 3 (d).

**The Polarising Voltage**

It can be shown mathematically that not only is the distortion reduced to an unimportant quantity, but also the sensitivity is considerably increased. In practice it is not advantageous to increase the initial polarising voltage indefinitely, even if it were convenient. There would be the danger of breaking down the insulation—air or solid according to the type of construction—between the plates. Also the freedom of motion would be impaired by an excessive displacement in one direction. So the actual voltage is something of a compromise, and one is not far wrong in imposing the voltage used at the anode of the output valve. The signal voltage at this point is, of course, always substantially less. If the latter is stepped up, however, it may be necessary to increase the polarising voltage also, to make sure that it is in the correct proportion.

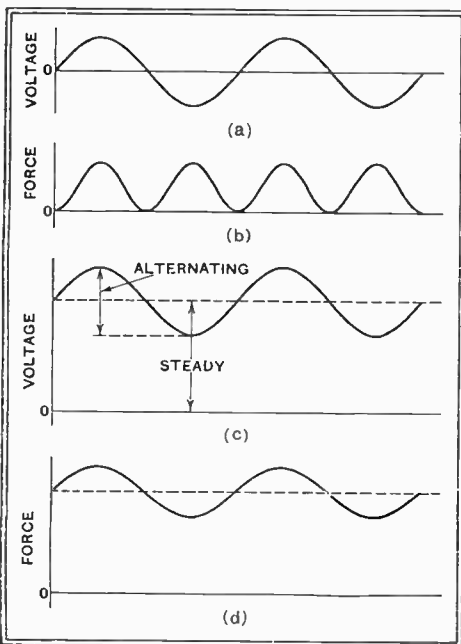

Fig. 3.—Without a polarising voltage, frequency doubling would occur in an electrostatic loud speaker.

A polarising voltage of 1,000 used to be necessary for the earlier types, which is sufficient to explain the disfavour with which they were regarded for general use, and an advantage of the Primustatic type is that about 250 volts is usually enough.

So what used to be a serious drawback now seldom presents much difficulty. The loud speaker being in effect a condenser draws no current from the polarising source.

A rather more serious criticism is that the amplitude of motion is not very great, and that there is therefore difficulty in obtaining strong reproduction of the lowest frequencies. This can be got over to some extent by increasing the area of the diaphragm, which can be done as much as one pleases by adding more units in parallel.

in speech, string tone, and sounds involving transients, such as clapping, tapping, paper rustling, and cymbals.

The construction is much simpler than that of any other type. There are no coils, magnets, or field excitation. For the same reason it is extraordinarily light, and as regards compactness it can be made into panels of very little depth—an inch or so, for example, or even less if necessary.

An electrostatic loud speaker, used alone, is far superior in naturalness and clarity of speech to a moving coil speaker,

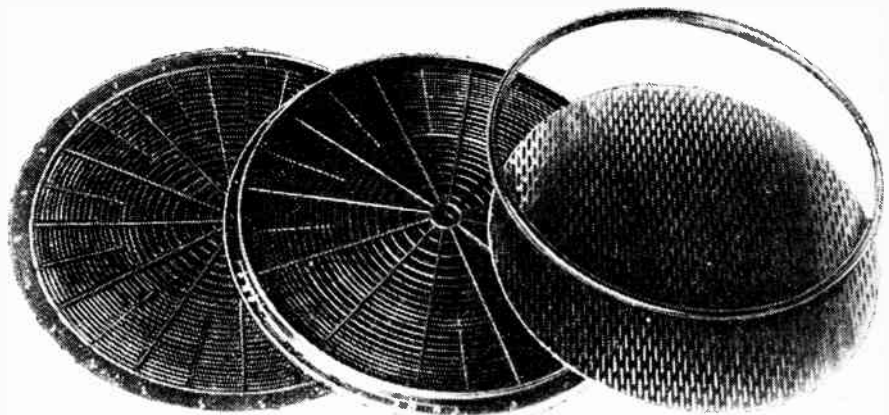

Component parts of the Vogt stretched diaphragm loud speaker.

Lastly, on the debit side of the account there is a problem in efficiently coupling the speaker to the output valve. This matter will be gone into in detail later.

**High-frequency Response**

Now for the credit side. It has already been pointed out that the high note reproduction is a strong feature. There are several reasons for this. Instead of the relatively heavy and complex moving system of any of the magnetic types of speaker, which renders it difficult to get upper frequency reproduction except in the form of resonances, there is a light uniform moving diaphragm, with extremely low inertia. Moreover, this is actuated all over its surface instead of at one part, as in other types, thus avoiding the complicated modes of vibration with resulting resonances and irregularities that distinguish the latter. Further, the area of the diaphragm can be made as large as one pleases, and the focusing and "interference" effects of a small cone are avoided. It is a better sound radiator, in other words. There is practically no upper frequency limit, and therefore it is in advance of present day microphones and transmitting systems, and advantage can be taken of any improvements in the latter. But even with existing standards of transmission, so long as local interference does not impose a severe limit, it is possible to appreciate a very greatly increased clarity and faithfulness of reproduction. It is significant that for special experiments in America, where substantially uniform output of sound was required up to 14,000 cycles, a condenser reproducer was employed.

The advantage is particularly marked

particularly of the cheap sort now almost universal. But unless very large there is not enough depth to music to please most listeners, although even this deficiency can be made considerably more tolerable by the delightful distinctiveness of the instruments in the upper registers, which is variously described as brilliance, "life," and crispness. It is a great relief to get away from the thumpy whoofy reproduction that is so common, or the still commoner apology for "brilliant" tone produced by a fierce high note resonance.

The best overall reproduction is therefore given by a combination of moving coil and electrostatic speakers. To obtain a satisfactory distribution of labour between the two, or even to run an electrostatic on its own, we must consider how it behaves as a load in the valve circuit. Unless attention is given to this the results can be very bad indeed. So it will form the subject of the next part of this article.

**Northern National  
Radio Exhibition**

The Manchester Wireless Show will be held in the City Hall, Deansgate, from Wednesday, September 27th, to Saturday, October 7th, 1933.

Next week's issue will contain a plan and guide to all the Stands at the Show.



# Practical HINTS and TIPS

IN a few cases it may be found that the special frequency-changing valve in the New Monodial receiver fails to oscillate over the whole of the medium wave-band. Assuming that the circuits are correctly wired and that the working voltages are normal, this effect must generally be ascribed to the fact that the particular specimen of valve in use has a somewhat lower mutual conductance than usual.

## The Pentagrid Oscillator.

Although there are several ways of correcting this trouble, probably the simplest and most satisfactory cure can be effected by shunting the reaction section of the oscillator coil assembly with a fixed condenser of 0.0001 mfd. The coil terminals across which the condenser should go are numbered 1 and 2 in the diagrams published with the description of the set.

IT is probable that many readers have not noticed that, in the A.V.C. version of the original Monodial, a "free" supply of anode voltage for the control valve is obtained by the expedient of inserting the loud speaker field in the negative high-tension lead. This is a plan that might often be adopted when fitting a similar system of A.V.C. to existing receivers of the superheterodyne type; it is not suitable for "straight" sets, for the reason that a sufficiently high H.F. voltage is not available on the anode of the detector at the higher frequencies. The system of control is, however, useful when

## Free Volts for A.V.C.

receivers of the superheterodyne type; it is not suitable for "straight" sets, for the reason that a sufficiently high H.F. voltage is not available on the anode of the detector at the higher frequencies. The system of control is, however, useful when

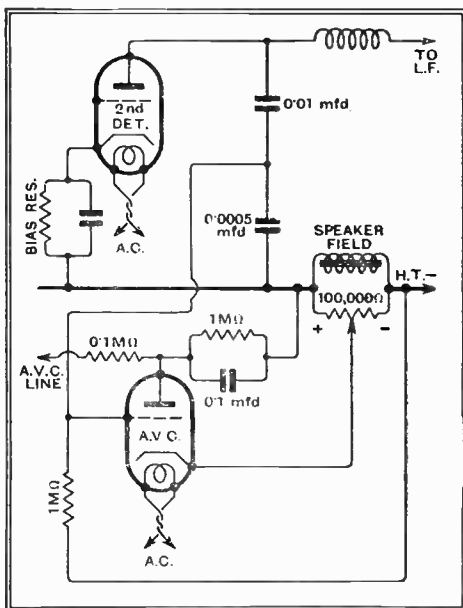

Fig. 1.—The voltage developed across the speaker field winding in the negative H.T. lead supplies the anode circuit of an A.V.C. valve; adjustment of grid voltage is made by means of a potentiometer.

## AIDS TO BETTER RECEPTION

a straight set is employed in conjunction with a superheterodyne converter for short-wave work.

The essentials of the control system are shown in Fig. 1. By adopting this form of connection, correct working voltages will be obtained for the A.V.C. valve; its anode will be positive with respect to the cathode, and its grid will be negative with respect to the same point by an extent depending on the position of the potentiometer slider. This slider is provided in order that the working voltage of the A.V.C. grid may be set to a value which gives the correct amount of "delay" action; in practice it is easily adjusted by tuning in a very weak signal and then moving the slider gradually from the positive towards the negative end until a point is reached where signal strength begins to decrease. The slider is then moved back slightly towards the positive end; this will be the final working position.

The actual voltage existing across the speaker field is comparatively unimportant; 60 volts will give results, but a higher voltage is desirable.

FOR amateur use there is no more convenient method of coupling together two H.F. circuits than the "top-end capacity" system. As compared with methods which require adjustment of the relative positions of the coils, it presents no mechanical difficulties, and is therefore especially suitable for extemporising two-circuit tuners or filters when existing apparatus not specially designed for the purpose is to be used. Practically speaking, the only difficulties that are likely to arise are those brought about by imperfect screening and excessive minimum coupling; both have the same effect. It is therefore necessary to make sure that the coils used are properly screened, and that the coupling condenser which is joined between the high-potential ends of the circuit has a suitably low minimum capacity.

Although this system of coupling is largely used in signal-frequency circuits, it does not appear to be generally realised that it is equally applicable to the I.F. couplings of superheterodynes—this in spite of the fact that it has been so used in several well-known receivers. As compared with arrangements in which the relative positions of primary and secondary coils may be changed, the capacity-coupled filter is probably easier to adjust and is certainly more suitable for those who, in spite of limited workshop facilities, are in the habit of making their own coils.

A capacity-coupled I.F. filter is shown diagrammatically in Fig. 2. For the coupling condenser CC, a semi-variable component of 50 micro-mfds. will be amply large enough; a condenser of 0.0001 mfd. may be used, but it is sometimes desirable to reduce its minimum capacity by cut-

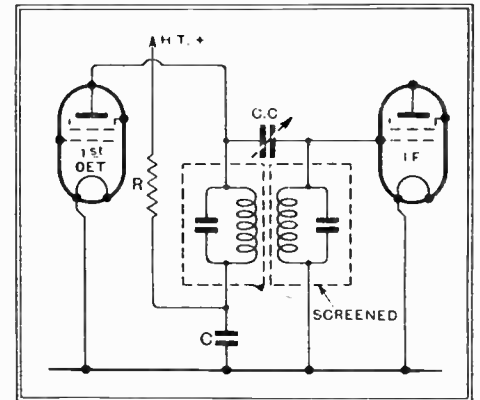

Fig. 2.—"Top-end" capacity coupling is as suitable for I.F. as for H.F. circuits.

ting off a part of one of the plates. The decoupling resistance R and the associated condenser C may have normal values.

THE main reason for the universal dislike to a background of mains hum is that it impairs the artistic value of the programme, gives a constant reminder that we are hearing an artificial reproduction, and is distinctly unpleasant to listen to for long periods.

## Another Aspect of Mains Hum.

In addition to this, the existence of hum may actually have a prejudicial effect on the behaviour of the receiver. An output valve, or even a detector, which is partially loaded by hum potentials will not accept so large an input as one working under more ideal conditions.

It might be thought that if the intensity of hum be sufficiently great to load the valve to an appreciable extent the noise would be unbearably loud, but this is not always so in practice; if the hum frequency be above or below the normal band of frequencies reproduced at good strength by the loud speaker it is quite possible that it may not be audible at anything approaching its proper relative strength.

Similar remarks apply to interfering voltages produced by certain forms of man-made static, and in one case which was recently investigated it was found that the fittings of a proper mains filter, in addition to providing a quieter background, made a very obvious improvement to the sensitivity of the set. Admittedly, the detector used in this particular case was of the screen grid type, and able to deal with but a very small input without overloading, but the average detector has quite a small margin of safety.

# DESIGN OF THE Detector-Oscillator

## Precautions to Observe When a Single Valve is Employed to Serve the Dual Purpose

By F. R. W. STRAFFORD

THE frequency-changing device employed in all superheterodyne receivers generally presents the designer with his most difficult problem. Practically every case of failure to work or violent instability can be traced to this stage, particularly when a single valve is made to perform the dual function of providing the local oscillation, mixing it with the incoming preselected signal, and rectifying the resultant wave form to give the desired beat frequency or intermediate frequency.

The use of a separate valve for each function is often the most straightforward method of securing the optimum conditions for maximum heterodyne conversion, but the tendency of the manufacturer, as distinct from the builder of an individual set, towards reducing costs of construction and subsequent maintenance is a paramount factor in these days; and if the commercial designer can kill two scientific birds with one stone it is the course to adopt.

Bearing this in mind, the writer will

able to rectify these combined wave forms, although less efficiently than a separate detector, and the resultant intermediate frequency appears in the plate current components and sets up a resonant voltage across the intermediate frequency transformer. The apparent simplicity of the action, however, loses some of its appeal when the circuit is tried out unless great care is exercised in selecting the circuit constants.

### Undesired Oscillations

It can easily be seen that, since there are two tuned circuits in the anode lead, there is every possibility of the circuit oscillating at an undesired frequency in the neighbourhood of the intermediate frequency. This often occurs—particularly when the dynamic impedance of the oscillator circuit is less than that of the intermediate frequency circuit. The condition may be cured by tapping the anode lead down the primary of the intermediate frequency transformer, thereby reducing its effective dynamic impedances as reflected into the anode circuit. Such an operation will naturally reduce the intermediate magnification, but in general practice this method of eliminating intermediate frequency oscillation will give the necessary suppression before much loss of magnification has occurred.

The desirability of employing an oscillator circuit with a high magnification has now been established from the viewpoint of stabilising the oscillation over the working frequency range. Another advantage is the reduction of oscillator harmonics transferred to the grid circuit; for it is known that when the preselection is not exceedingly high the small out-of-tune signals from a local transmitter produce a complex series of chirps by beating with these harmonics as the tuning condenser is rotated in search of stations.

Theoretically, the amplitude of the intermediate frequency is directly proportional to the product of oscillator and signal voltage, and it would therefore appear that

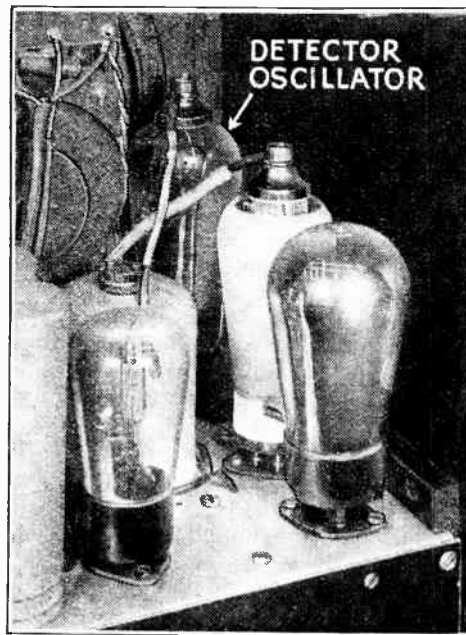

An H.F. pentode valve, the Mullard S.P.4, is employed in the detector-oscillator stage of the Varley "Square Peak" 4 Superhet.

the best operating conditions implied strong local oscillation. The assumption is, however, only true while the rectification continuously occurs on the parabolic portion of the anode current grid volts characteristic; when the valve has to perform the dual function of simultaneously oscillating and rectifying the conditions are altered, and the assumption no longer implies.

### Effect of Strong Oscillations

If the oscillations are too strong, first the violent grid current will damp the preselector circuit and increase also the re-radiation of oscillator voltage via the grid cathode impedance, and, secondly, the rectification efficiency will fall, since the weak signal is, in a way, demodulated by the stronger oscillation.

Fig. 2 shows the approximate relationship between oscillator voltage and intermediate frequency output for a small input signal assumed to be constant.

It can be seen that a linear action does exist until a certain strength of oscillation

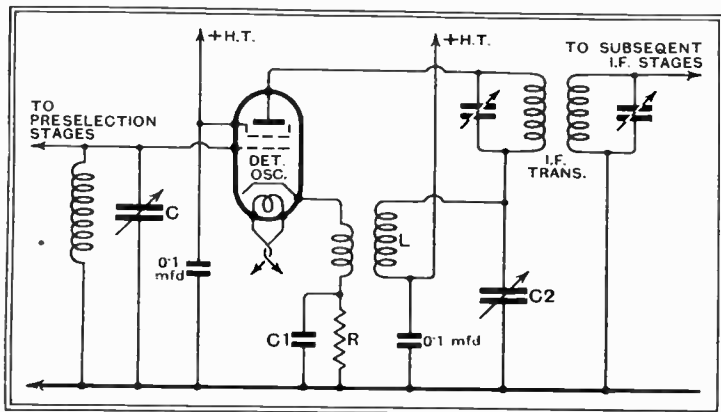

Fig. 1. A typical detector-oscillator circuit. Condensers C, C2, are normally ganged.

attempt to elucidate the action of the detector-oscillator and describe how a single screened grid or H.F. pentode valve may successfully perform the requisite dual function if certain circuit precautions are observed.

Schematically, the simple detector-oscillator circuit is depicted in Fig. 1. Oscillations, the frequency of which are fixed by the LC circuit, are produced via the coupling coil in the cathode circuit, and the oscillating difference of potential set up between cathode and earth is applied to the grid, together with the signal from the preselector stage or stages.

Even though oscillating, the valve is

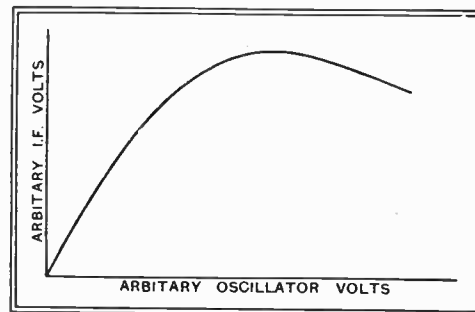

Fig. 2.—Relation between oscillator and I.F. voltage.

**Design of the Detector-Oscillator—**

is reached, and thereafter the rate of change rapidly decreases and finally reverses.

Experience has indicated that the best value for initial bias voltage (obtained via the cathode resistance  $R$ ) and oscillator voltage between cathode and earth should be experimentally determined.

Using typical British A.C. screened grid valves or H.F. pentodes, at their normal voltage ratings, the bias resistance should be between 3,000 and 8,000 ohms, and the r.m.s. oscillator voltage across the cathode coil from 2 to 5 volts, and certainly not greater.

**Effect of Coupling**

The strength of oscillation is chiefly determined, for a given anode voltage, by the tightness of coupling between the reaction and oscillator coils, and the selection of suitable reaction conditions is very important. Tight coupling with few turns is better by far than loose coupling with many turns, although the mutual inductance may be the same in each case. For when the reaction turns are excessive the inductance of the winding may resonate with associated capacities and produce either spurious oscillations or "blind spots" over certain portions of the desired waveband, resulting in partial or complete loss of sensitivity. Even when few turns are used it is a good plan to wind the coil with resistance wire so that the reaction circuit losses effectively damp out any such tendencies.

In normal practice, a rough guide to the number of reaction turns required when tight coupling is used is as follows: For ordinary screen-grid valves operating at normal voltage ratings, approximately one-tenth of the oscillator coil turns, and for H.F. pentodes about one-twentieth.

When the oscillator-detector is directly connected to the aerial preselection circuits a certain amount of re-radiation of oscillator frequencies is unavoidable due to the

grid cathode impedance, which is normally a capacity resistance. Great care should therefore be taken to keep any stray capacities, effectively in parallel with grid and cathode, at a minimum. Where the valve is metallised it is useful to remove the coating by scraping; or, better still, to employ the equivalent unmetallised version.

In most cases the clear valve is the better to employ, since the cathode is at H.F. potential above earth, and the metallising, which is connected to the cathode pin, will often produce queer "blind spot" effects by resonating with the reaction coil inductance.

There is still one very important function of the detector-oscillator with which it is proposed to deal. The intermediate frequency component passes through the reaction coil during its circuit from anode to cathode, and thereby sets up potentials across the grid-cathode circuit. These potentials are therefore amplified to some extent by the oscillating valve, and unless the phase is suitably adjusted the net result developed across the intermediate frequency transformer may show an appreciable loss in magnification.

By a judicious adjustment of phase, which may be carried out to a considerable degree by varying the capacity  $C_1$  across the cathode bias resistance  $R$ , the intermediate frequency may be reintroduced so that the anode circuit components are brought very nearly into phase. By this method the magnification or conversion factor of the detector oscillator stage may be increased several times. If the adjustment is carried out too far the inevitable occurs, and the stage flops into violent oscillation or squegging.

**Summary**

The important points in detector-oscillator design may be summarised as follows:—

(1) The use of a high magnification oscillator circuit reduces the tendency for unstable oscillation or sudden transference

of oscillations to intermediate frequency.

(2) For normal screened grid or H.F. pentode valves the oscillating voltage across the cathode coil should lie between 2.0 and 5.0 volts r.m.s.

(3) The bias resistances should lie between 4,000 and 8,000 ohms, and the capacity between 0.001 and 0.005  $\mu\text{F}$ . It is best to commence with some low limit of both resistance and capacity and finally adjust both for maximum stable magnification when the other circuit conditions are correct.

**NEW BOOKS**

**Experimental Television.** by A. Frederick Collins, F.R.A.S. Sir Isaac Pitman and Sons, Ltd. 313+xxii and 185 diagrams. Price 10s. 6d.

The title of this book would lead one to believe that it deals with the experimental side of television transmission or reception, but a glance at the chapter headings soon shows that it is concerned at least as much with optics and radio technique. Although they both play an important part in television they are themselves specialised subjects, and elementary descriptions of experiments with reflection, refraction, crystal detectors, and simple amplifiers are out of place in a book on television. A thorough knowledge of these subjects is undoubtedly necessary for a complete understanding of the problems of television, but there are many good text-books available which deal with them in a scientific manner.

Apart from matters of this nature, the book is by no means free from errors. On page 2 it is stated that "a molecule consists of two or more atoms," whereas, of course, molecules consisting of no more than a single atom are quite common. The errors in the circuit diagrams are too numerous to be listed here, but it should be noted that they consist chiefly of the omission of grid leaks and the connection of H.T. batteries in such a manner that they are short-circuited.

The author possesses a happy air of infallibility, and it is interesting to know that he has settled the vexed question of the exact composition of the ether! The book assumes no knowledge whatever on the part of the reader beyond the ability to read, and while this in itself may be a good point, in this case it results in a style which is reminiscent of a book for the very young.

The book is of American origin, but the English edition under review, which is well printed and bound, and free from typographical errors, is published by Sir Isaac Pitman and Sons, Ltd. W. T. C.

**The Radio Trade Annual of Australia, 1933** (First Edition), compiled by the staff of "Radio Retailer of Australia" and containing a quantity of useful information concerning the progress and present position of wireless in Australia, including the general history of the industry during the past twenty years, the laws, regulations, and agreements now in force in the Commonwealth, list of national and private broadcasting stations, servicing, and technical data and other useful information. Pp. 247. Published by Australian Radio Publications, Ltd., Sydney. Price 10s. post free in Australia, or 12s. 6d. overseas.

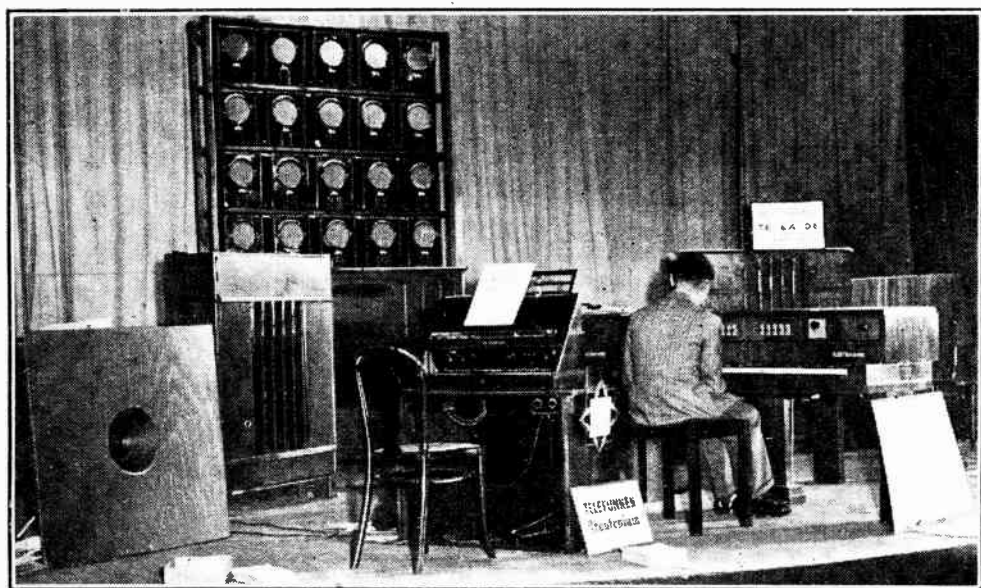

The Trautonium and other electrical musical instruments shown at the Berlin Exhibition. The Telefunken Company now manufactures the Trautonium to an improved design.

**YOU BE THE JUDGE**

*"I present to you*  
**INCONTESTABLE EVIDENCE**



... I place before you the actual EVIDENCE of where your set is right or wrong. I am giving you conclusive and all-inclusive evidence of radio faults and efficiency. I give you—not just the circumstantial evidence of amperes, volts and ohms, no mere hypothesis, but proved and tested ACCURACY. I present the precision of the AvoMinor, a younger brother of the famous Avometer, the instrument that is so accurate and efficient that it is preferred and insisted upon by the world's foremost technical experts and service engineers. This in itself is evidence enough that nothing less than the AvoMinor is dependable enough for you.

*The* **AVOMINOR** TRADE MARK

**TELLS THE WHOLE TRUTH**

Now YOU can test YOUR set—examine it, locate the faults, get first-class results from it—with the ease and precision of the technical expert. You can test ACCURATELY with the AvoMinor—test circuits, valves, components, batteries and power units. There is no test you need that you cannot make with the AvoMinor. It gives **TEN different** ranges of readings in milliamps, volts and ohms. It is a moving-coil combination testing instrument with a total resistance of 100,000 ohms. Full scale deflection is obtained with only 3 milliamps. No other instrument in the world gives you, at such a convenient price, so many tests with such dependable accuracy.

*Ask your radio dealer to show you the AvoMinor. Be satisfied with nothing less. Remember, it's accuracy that is all-important. In case of difficulty, write for fully descriptive folder.*

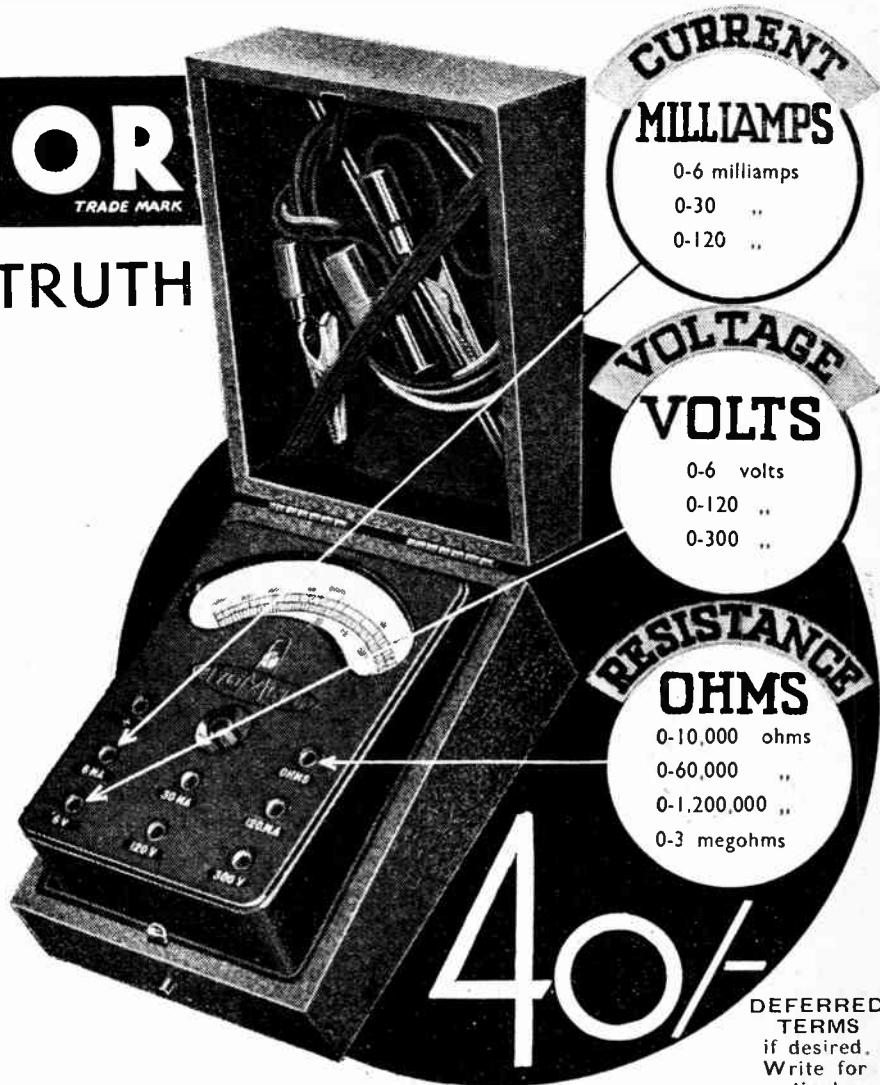

**CURRENT**  
**MILLIAMPS**

0-6 milliamps  
 0-30 ..  
 0-120 ..

**VOLTAGE**  
**VOLTS**

0-6 volts  
 0-120 ..  
 0-300 ..

**RESISTANCE**  
**OHMS**

0-10,000 ohms  
 0-60,000 ..  
 0-1,200,000 ..  
 0-3 megohms

**40/-**

DEFERRED  
 TERMS  
 if desired.  
 Write for  
 particulars.

THE AUTOMATIC COIL WINDER & ELECTRICAL EQUIPMENT CO. LTD.  
 Winder House, Douglas Street, London, S.W.1. Telephone: Victoria 3105 7.

*Complete in handsome case with pair of leads and interchangeable crocodile clips and testing prods.*



# 9,000 "HANDS"—MORE THAN EIGHTY ACRES OF FLOOR-SPACE... THE GREAT HIVE OF INDUSTRY WHERE COLUMBIA SETS ARE BORN!

● Huge, towering buildings of concrete, glass, and steel . . . as eloquent in their clean severity of line, as in their materials, keen, relentless modern efficiency . . .

What you see illustrated here is only a part of the great factory where Columbia sets are made—only a part of the largest and most up-to-date radio factory in the world. It is capable of

turning out with ease a thousand sets a day—six thousand a week. And yet with this tremendous production there is coupled the *most exact microscopic accuracy* in a thousand tiny details of each set, to give you the performance and finish the world expects from

Columbia, at Columbia prices. Ask to hear any of the four Columbia models listed below at the nearest Columbia dealer.

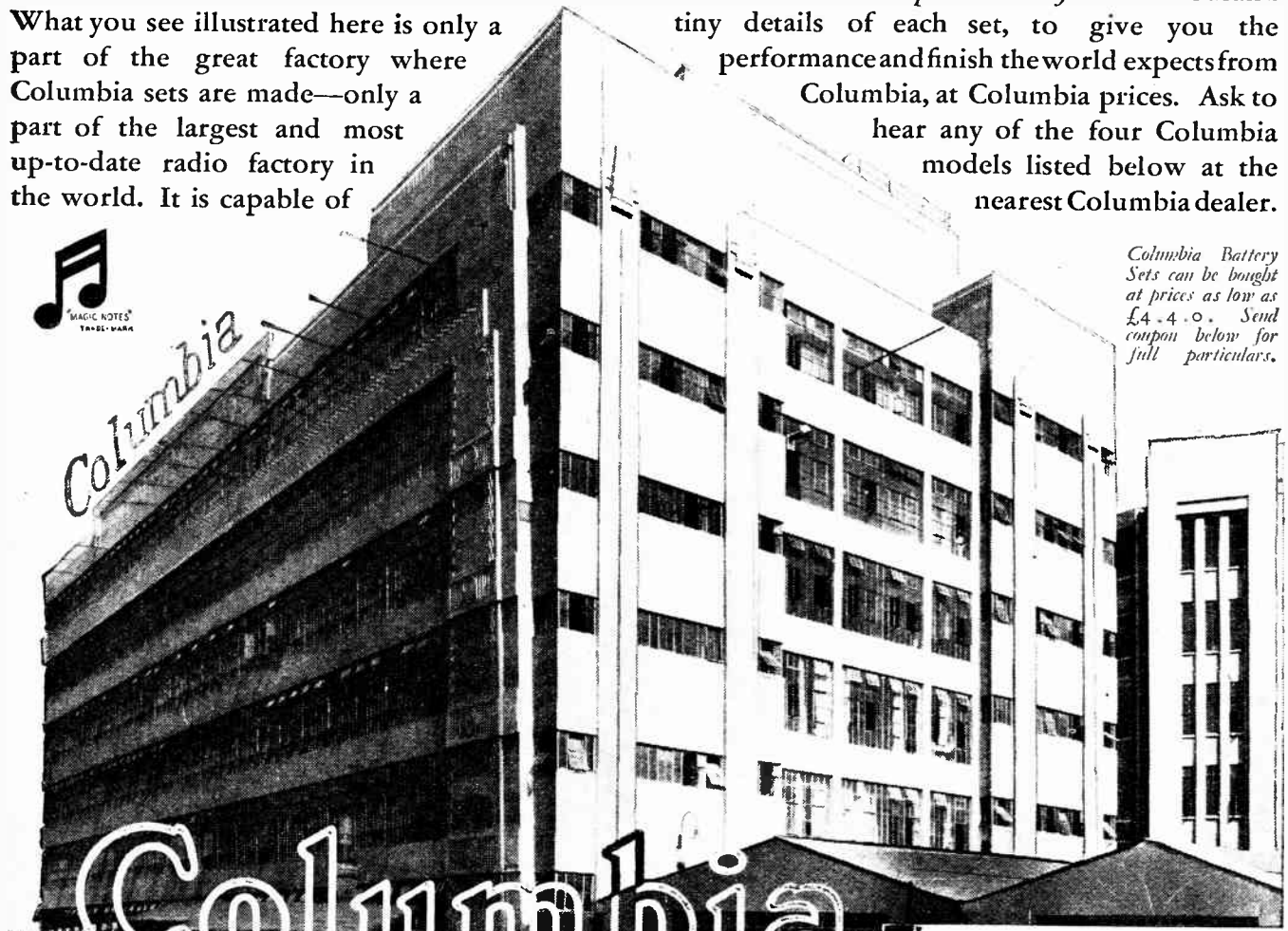

*Columbia Battery Sets can be bought at prices as low as £4-4-0. Send coupon below for full particulars.*

## Columbia RADIO AND RADIO-GRAPHOPHONES

**THE C.Q.A. BATTERY RADIOGRAPH FOUR, Model 1003**—the battery Radiogram with an all-mains performance: three-stage band-pass receiver. Columbia Constant Quality Amplification. 65 amp. hour L.T. battery. 175 v. H.T. battery including 9 v. G.B. Automatic flood-lighting of scales from switch M.W.-L.V.-Gram. Permanent magnet moving coil speaker. Marconi valves. Walnut cabinet of fine workmanship. **20 Gns.**  
(Prices not valid in I.F.S.)

**THE C.Q.A. BATTERY FOUR, Model 1001**—an entirely new standard of performance and economy from a battery set. Columbia Constant Quality Amplification. Triple action volume control. 60 amp. hour accumulator. 175 v. coded H.T. battery, including 9 v. G.B. battery. Marconi valves. Alternative Aerial tappings and pick-up connection. **11 Gns.**

**3-VALVE BATTERY SET, Model 1005.** A highly selective set with band-pass tuning, at an unusually low price. Inductively coupled band-pass aerial circuit. Screen grid, high-frequency amplifier. Permanent-magnet moving coil speaker. Single tuning knob for three gang condenser. Marconi valves. **£8. 15. 0**

**ALL-ELECTRIC RADIO-GRAPH FOUR, Model 620**—a low-priced all-mains radiogram, embodying every modern development. Band-pass aerial circuit. Screen-grid high frequency amplifier. Energised moving-coil speaker. Wave range, 200-550 med. and 1000-2,000 metres. Single knob tuning for three gang condenser. Volume control operating on radio and gramophone. Marconi valves. Fine walnut cabinet. **23 Gns.**

**COUPON :**

To The Columbia Graphophone Co. Ltd.,  
98 Clerkenwell Road, London, E.C.1.

Please send me particulars of the new Columbia models without obligation.

NAME .....

ADDRESS .....

W. W.

# Why Kalundborg is Loud

## Novel Features in New 60 kW.

### Transmitter

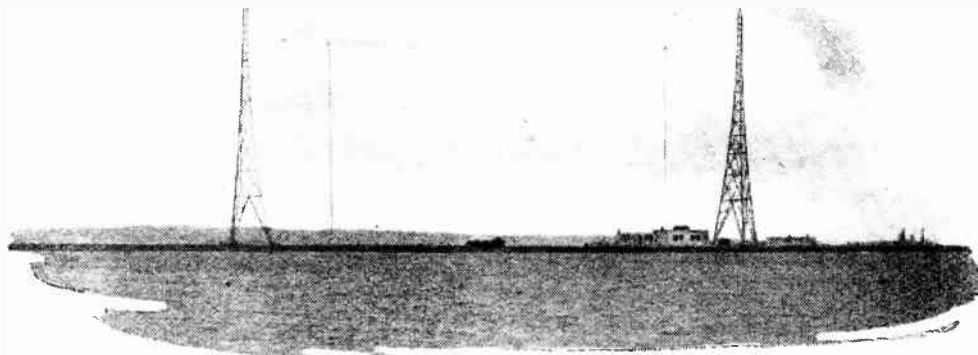

*Denmark's famous station at Kalundborg occupies a dominating site on a narrow peninsula.*

**A**PART from the remarkable strength at which it is received in this country, the new 60 kW. broadcasting station at Kalundborg is notable in several ways, not least in the method of high power assembly. It has been usual in the past to build transmitters in factory-made units. With increase in power and consequently in size of components, this unit system may tend towards a certain mechanical clumsiness, seriously modifying the layout as compared with what would be desirable from an electrical point of view. This consideration led the manufacturers, Standard Telephones and Cables, of Hendon, London, working in collaboration with the Danish Posts and Telegraphs Administration, to adopt a "cellular" system of construction, the high-power amplifying valves and inter-stage circuits being mounted in a line of cubicles forming part of the building.

Each cubicle, which is inset into the walls, consists of two screened cells in which are mounted the two halves of a balanced push-pull amplifier or output circuit. As a consequence, the transmitter room presents a remarkably simple appearance, in which all that can be seen of the apparatus is the front panels with their indicating dials and switches.

From the circuit standpoint, probably the most prominent feature is the use made of push-pull in the high-frequency stages. Only the Master Oscillator and First Separator are single valve circuits; the Second Separator, the Modulated Amplifier and the three Power Amplifiers are all of the push-pull type. Besides giving an exceptional degree of stability, the use of such balanced circuits aids in the reduction of harmonic

content at the output stage, thus reducing the possibilities of interference.

A plate supply of no less than 20,000 volts operates the two high-power stages. This handling of high power at high voltage levels means greater economy and efficiency; the valves used in the last stage are each capable of an output of 200 kilowatts with a plate supply of 25,000 volts.

### The Valves

These valves, being of the double-ended type, are designed with the idea of reducing internal capacity. The filament is a system of Tungsten wires kept in tension by means of a spring, and the terminals are fitted with cooling pins so that, despite the large current to be handled—225 amps. at 25 volts—there is no necessity for air blast cooling of the filament seals. The grid terminal at the top end is also fitted with cooling pins. The water jacket, which is a fixture on the anode, is made with flexing ribs, whereby the mechanical stress of contraction and expansion, corresponding to changes in load and temperature of the water, can be taken up safely.

The anode supply for the high-power stages comes from a 20,000-volt rectifier embodying hot cathode mercury vapour

valves. It was during laboratory tests with these particular valves that the interesting discovery was made of a former cause of the unreliability which has been a drawback with this type. As a consequence, it is now possible to make satisfactory rectifiers embodying this form of valve, with its extraordinarily high efficiency of the order of 99 per cent. The Kalundborg rectifier is of the three-phase, full-wave type, and is made in two units, each using six valves and giving an output of 10,000 volts, the total output of the two units in series being 20,000 volts, 12 amps. It is believed to be the largest rectifier of its type at present in regular commercial service.

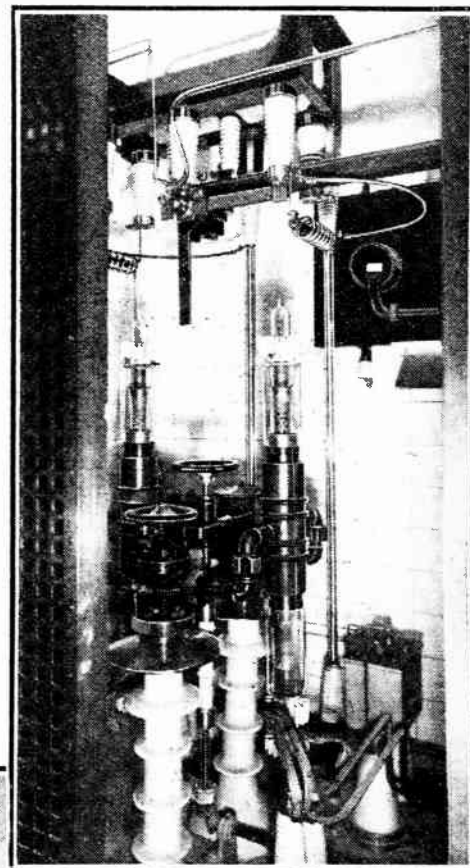

(Above) Two output valves of the double-ended type, each capable of an output of 200 kilowatts at a plate voltage of 20,000. Note the cooling fins and central water jackets.

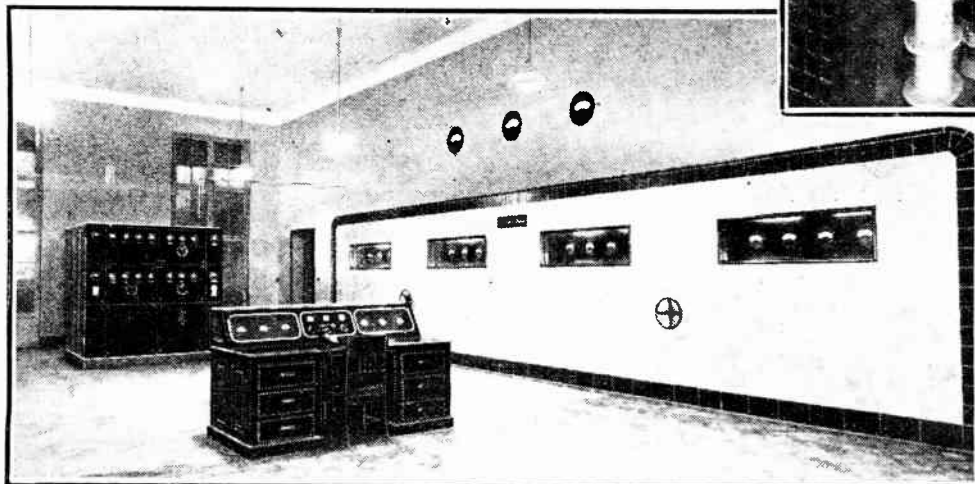

(Left) This view of the transmitting room, with its control desk, shows the unique "cellular" layout adopted by the manufacturers, Standard Telephones and Cables.

**Why Kalundborg is Loud—**

The Kalundborg aerial system is of the "multiple-tuned" type, and good radiation efficiency is obtained while using masts lower than the long wavelength would otherwise necessitate. Slung between the two 330ft. masts, the horizontal length of the aerial is nearly 400ft. At each end is a tuned down-lead, one of which is coupled to the transmitter through a short transmission line.

As the station receives most of its programmes from Copenhagen, an elaborate line amplifier system equipment has been

necessary with all power supply taken from the station lighting mains. Mercury vapour valves are used for the H.T. supplies and copper oxide rectifiers in conjunction with ballast lamps for the filaments.

While it cannot be claimed that Kalundborg is Europe's most powerful station, it certainly earns distinction on the score of novelty, and it will be interesting to observe whether the new ideas incorporated in the design, particularly in regard to the "cellular" form of construction, become popular in the case of other and more powerful transmitters.

## DISTANT RECEPTION NOTES

### France's Broadcasting Problems

**I**NTERFERENCE by heterodynes or actual jamming has been rather serious on both the medium and the long wavebands of late. Much of it is due to wavelength wandering, though some of it is caused by illicit stations or by authorised stations working on unauthorised wavelengths. This state of affairs does not augur very well for the success of the Lucerne Plan, for one might have expected that station engineers would now be doing their best to ensure correct wavelength keeping to prepare for it. Some of them will require a good deal of practice in this matter if they are to comply with the stringent rules of the Plan! Governments, too, should be setting their houses in order. It is not to be expected that a miracle will happen on January 15th, and if any country permits illicit stations within its borders to continue broadcasting at the present time there is undoubtedly trouble in the offing.

The French Government is making every effort to obtain the necessary powers to deal with the extraordinary wireless situation that exists within its borders. Bill after Bill to give the Government the power that it needs has been brought before the Chamber, but none of them so far has ever passed into an Act.

### The Ferrié Plan

The Ferrié Plan is going forward, though it has been to some extent revised. In its original form it contemplated the erection of fourteen stations, mostly with output ratings of 60 kilowatts, though two or three were rated at 30 kilowatts only. In its present form the scheme allows for ten main stations, one on the long waves and nine on the medium band. The long-wave station will be Radio-Paris, whose power will soon be raised from 75 to 100 kilowatts. In addition to the Poste-Parisien, it is expected that three other high-power French stations on the medium waveband will be at work before Christmas.

The Russian interference with Huizen's transmissions (Hilversum programmes) has ceased for the moment, and it is to be hoped that no more will be heard of it. A good deal of trouble has been caused on the lower part of the medium waveband by spark signals which frequently mar transmissions on wavelengths from about 250 metres downwards. Some of the transmitters responsible are very broadly tuned, and one of them was "double-humping" badly a few evenings ago. It seems a most curious thing that

spark transmissions should be allowed to take place during programme hours within the limits of the waveband dedicated to broadcasting.

The number of well-received stations has increased considerably during the last week or two. The improvement is particularly noticeable at the top of the medium waveband, where stations are usually the first to suffer from summer-time conditions and the last to return to their winter strength. Budapest is now well heard on most evenings. Vienna is improving, and will, no doubt, come in well as soon as the aerial mast is in full use. Munich is now strong, and Riga has been coming in at good loud-speaker strength.

Recommended stations on the long waveband are Motala, Luxembourg, Kalundborg, Radio-Paris, and Huizen. On the medium band the choice is very large, and the following list gives those which have been found completely reliable night after night during the week preceding the writing of

## FOREIGN BROADCAST GUIDE

### BUDAPEST

(Hungary).

Geographical position: 47° 30' N.; 19° 3' E.  
Approximate air line from London: 903 miles.

Wavelength: 550 m. Frequency: 545 kc/s. Power: 18.5 kW.

Standard time: Central European (coincides with B.S.T.).

#### Standard Daily Transmissions.

06.45 B.S.T., Physical exercises; 08.45 (Sun.), 09.45 (weekdays), news; 10.00, sacred service (Sun.); 12.00, carillon; then continuous broadcast until 18.30, concert; talks; 19.30, relay of opera or concert; 23.30, Cigány orchestra or dance music.

Announcers: Man and woman.

Call: *Hallo! Radio Budapest* (followed by names of relays). Details of programmes are frequently given in the French and German languages; also in English on International evenings.

Interval signal:



When plays are broadcast a gong is used at the beginning and end of each act.

Closes down with good-night greetings in several languages, occasionally followed by the Hungarian Anthem.

Relays: Miskolc, Magyarovar, Pecs—on 209.8 m. (1,429 kc/s), 1.25 kW. Budapest—Csepel, 840 m. (357.1 kc/s), 3 kW., and Nyiregyhaza, 267.4 m. (1,022 kc/s), 6.25 kW.

these notes. Here they are: Brussels No. 1 and No. 2, Prague, Langenberg, Rome, Toulouse, Leipzig, Strasbourg, Breslau, Hilversum, Heilsberg, and Trieste. Many others were good on most nights, but just fail to obtain places in the list owing to occasional heterodyne interference.

D. EXER.

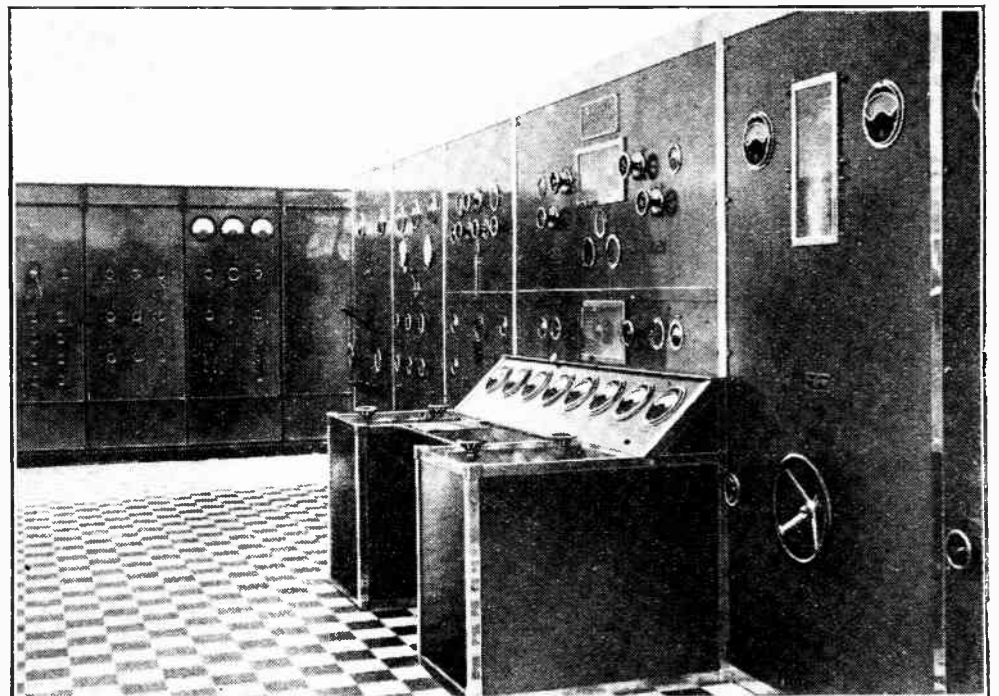

**MARCONI BROADCAST EQUIPMENT IN FINLAND.** The control desk and main transmitter of the Finnish Broadcasting station at Viipuri (Viborg), in the background can be seen the switchboard. This station broadcasts on a wavelength of 291 metres and the power is given as 13.2 kW.

# News of the Week

## Current Events in Brief Review

### Test for Ether Searchers

ANY listener with a good receiver has an opportunity to beat the world in an interesting competition which opens on October 1st to discover the set user who can tune in the greatest number of broadcasting stations on the medium waveband between 180 and 500 metres. The stations in question must be situated at a distance of not less than 2,000 miles from the receiving point and on a separate continent.

The contest is being organised by the International DX'ers Alliance, Brighton Grove, Newcastle-upon-Tyne. The competition remains open until April 1st, 1934.

### The Sultan's Own

IT is rumoured that the Sultan of Morocco will soon possess a private broadcasting station. On his recent visit to France, the Sultan ordered several receivers, including a short-wave set, and it is understood that special enquiries were made regarding transmission gear.

### First Aid by Radio

ALTHOUGH car radio, so far as we are aware, has made no progress in Soviet Russia, motorists are being helped by a new system of short-wave transmitters installed at strategical points on certain main roads. These wireless "posts" are of the fool-proof type, so that any car driver in need of mechanical or medical help can get into immediate radio touch with the nearest regional listening centre to which the transmitter is permanently tuned.

### Believe it or Not

THE latest radio story from Paris concerns a small boy whose schoolmaster considered that he deserved corporal punishment. The father, however, refused to take action, and on being questioned by the schoolmaster declared: "I dare not punish the lad; he is the only one in the family able to work the new wireless set."

### Polytechnic Wireless Classes

THE London Polytechnic courses in Wireless and High-Frequency Engineering commence on September 25th next, enrolment dates being from September 18th to the 22nd. The courses, which are given in the evenings from 6.30 onwards, are arranged to provide a thorough training in the principles and technique of H.F. engineering, and should appeal specially to those engaged or interested in wireless, gramophone, or talking film work.

The wireless laboratory includes a complete commercial installation for telegraphy and telephony (G6RA).

Fuller particulars can be obtained on application to the Polytechnic, 307-311, Regent Street, London, W.1.

### The Tell-Tale Badge

SWISS licence holders are now required to affix an official badge on their receivers to indicate payment of the necessary fee.

### Kite as Aerial

A KITE flying at the height of 1,500 feet was used to support a 30-ft. aerial for ultra-short wave experiments carried out by the London chapter of the International Short-Wave Club on September 3rd. The tests were carried out on Parliament Hill, London, with a "Wireless World" Ultra Short Wave Two, and several stations were heard.

### Programme Souvenirs

"EVAR," the Italian Broadcasting Company, has now begun the production and sale of gramophone records.

### Anti-Static Laws for Germany

GERMANY is considering legislation to stop electrical interference with radio reception. We understand that a Committee is being formed to investigate all causes of man-made static and to report to the Government at the earliest possible moment.

### Ban on Interference?

A TYPE of French listener who hopes to escape the new wireless tax is the man who is troubled by man-made static. Many claims have been sent in by individuals who claim exemption because the "parasites" are produced by the Postal Administration itself. The Post Office has bluntly replied in the negative, adding that a decree will be issued within six months on the subject of responsibility for interference with radio reception.



H.Q. CALLING. Battlefield instructions being communicated by a mobile field equipment during recent Italian Army manoeuvres.

### Boy Scouts Calling

A NEW sub-division of the American "ham" fraternity is the Boy Scouts' network, which now includes about fifty stations, the prime mover of which is H. W. Yalinell, of Helinetta, New Jersey, operator of station W2SN.

### Still They Come

THAT kilowatts spell wireless licences is once more revealed in Switzerland, where, since the opening of the high-power transmitters at Sötens and Beromünster, the number of licences has increased by leaps and bounds. Last year the licence figure was 187,080. On June 1st, 1933, the figure had increased to 261,361.

### The Gramophone Quota

POSTE PARISIEN has signed an agreement with the gramophone manufacturers limiting gramophone recitals to sixty hours per month, and forbidding a second broadcast of the same record without a special permit. The other French stations are expected to follow suit in the near future.

### More Encouragement for German Amateurs

GERMAN short-wave amateurs are about to be granted much more liberty in their experiments. Formerly there were not more than thirty to forty German short-wave transmitters. At least 150 licences are about to be issued.

### Super Pigmies in Paris

MINIATURE or "Gulliver" sets are to be a leading feature of the coming Paris Radio Salon; indeed, according to our Paris correspondent, many of the superhets will be "super pigmies." The average weight of the miniature set will not exceed ten pounds.

The main difference between the London and the Paris show will be the almost complete absence at the latter of the battery set. France is "all electric."

### Trying Again

BELGIAN architects are to have another opportunity to design a "Broadcasting House" worthy of their country. It will be remembered that the recent competition failed to evoke any effort of the required standard, though the first eight of the competitors have since been awarded consolation prizes of 1,000 francs each. The closing date for the new competition is November 10th.

### World Beater Set for Geneva

FACILITIES for hearing the world's broadcasting stations are considered essential for the new Palace of the League of Nations now being built at Geneva. In the Secretary-General's room a wireless receiver is to be installed operating on all wavelengths and capable of picking up any foreign station.

### At the Brussels Show

OVER 100 exhibitors, occupying 275 stands, provided Brussels with its fifth annual radio show last week. According to our Brussels correspondent, the event was a triumph for the superhet. Nearly all manufacturers displayed at least one superheterodyne receiver, and all the latest features, such as automatic volume control and silent tuning, were very much in evidence.

Short wave reception has not yet captured the public imagination in Belgium, but this year several short-wave receivers were shown, and it is hoped that this heralds the popularity of this form of reception.

German sets were displayed in large numbers, notably the new People's Receiver. American receivers were also well represented, and considerable interest centred on a 16-valve example which included A.V.C., silent tuning, a Class "B" low-frequency output stage, rectifier and twin speakers, and a tuning range of 14 to 2,500 metres. British sets were well in evidence, but it is a notable fact that the Belgians are most attracted by British components and accessories, which are always assured of a good market.

### Slander on the Air

THE Vienna police are still seeking the whereabouts of a mystery station at Oradea, which nightly broadcasts slanderous statements concerning well-known citizens. The transmission begins at exactly nine o'clock each evening, and a regrettable feature of the affair is that nearly all the citizens of Oradea forget the Vienna programmes in their anxiety not to miss the secret transmissions.



# Television at the Berlin Show

## A Review of the Year's Progress in Germany

*With a regular television transmission on ultra-short waves, Germany is at present taking a lead in television development in Europe. Apparatus for the reception of these transmissions is being developed by a number of manufacturers*

**D**URING the past year, and particularly in recent months, there has been great activity in the field of television in Germany. The German Government is anxious to encourage television. Even so, the only prospect of television at present seems to be on ultra-short waves. German investigators all use twenty-five picture changes and 180 lines, with 40,000 picture elements, and thus obtain pictures far in advance of the current Post Office transmissions.

Some examples of the progress made and shown at the Berlin Exhibition will be briefly mentioned.

### The Principal Exhibits

The Fernseh A.G. has been able to improve to a remarkable extent its well-known "intermediate film" process. In this system the object to be transmitted is first filmed, and the film still wet (in fact, five to ten seconds after exposure) is passed through the televisor and scanned. Formerly it was necessary to use a new film for every record; now, this is no longer necessary. A blank film in an endless band is now used. A sensitised layer is deposited on this by a special apparatus. After passing through a drying chamber the film arrives in the recording camera, where it is exposed, developed, fixed, and led to the

accomplishment of the Fernseh A.G. this year is the projection of television pictures to a size of 3 x 4 metres, by the following method. An endless band of blank film is provided with a sensitive layer in a special apparatus and is then dried. From the drying chamber the film passes to a window at which the received television picture is recorded as a negative by means of a perforated disc and a source of light modulated as to brightness. Although every separate picture element can only be illuminated for about a millionth of a second, the illumination is sufficient. The recorded picture is immediately developed and fixed and then projected as a positive picture in much the same way as an ordinary film, by a special cine projector. After passing through this projector the photographic layer is removed from the film and replaced by a new one so that the process continues without intermission.

Another exhibit of the Fernseh A.G. is a new light ray scanner for the direct scanning of subjects. The novelty in this process is that the scene and persons to be transmitted are in a closed room whose inner walls are as white as possible and thus possess a high power of diffuse reflection; in this way three dimensional scenes can be transmitted without interfering shadows and with great efficiency.

The Fernseh A.G. were also showing a cathode ray television receiver and a mirror

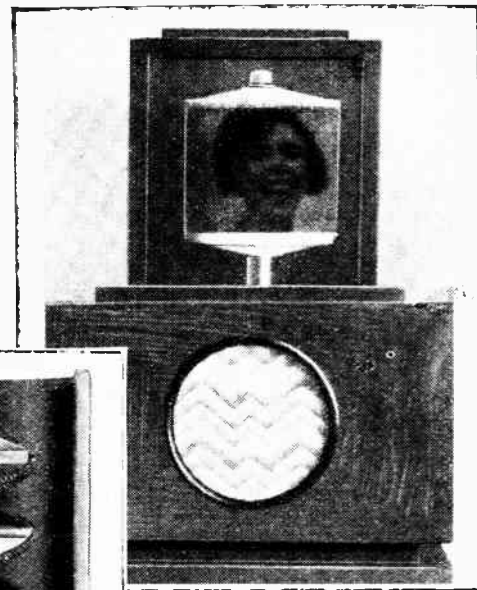

The Te-ka-de mirror screw television receiver and an enlarged view of the mirror screw and motor.

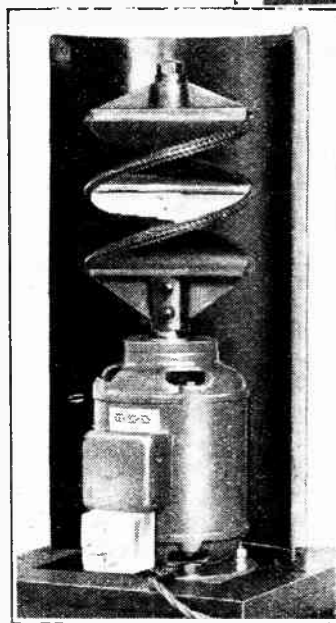

screw receiver, as developed by Te-ka-de.

As in former years, the Te-ka-de exhibited a mirror screw television receiver which is on sale and which this year also reproduces sound. A Te-ka-de novelty is a new type of Kerr cell for the control of the light ray. This Kerr cell does not consist, as

usual, of a small condenser in nitro-benzole, but of a crystal through which the light passes. The crystal plate is coated on both sides with metal foil to which the modulating voltage is applied. Under the influence of this voltage the transparency is altered, linearly.

The firm of Loewe exhibited a cathode ray television receiver. The length of this cathode ray tube is 60 cm., the diameter of the fluorescent screen being about 25 cm. The lower portion of the apparatus contains the ultra-short wave receiver, the "Kipp" apparatus for controlling the tube, and a mains unit for providing the necessary voltages. The knobs on the left-hand side of the front regulate the volume for the loud speaker and the tuning of the short-wave receiver, the knobs on the right control the sharpness, and also the switching on and off of the mains

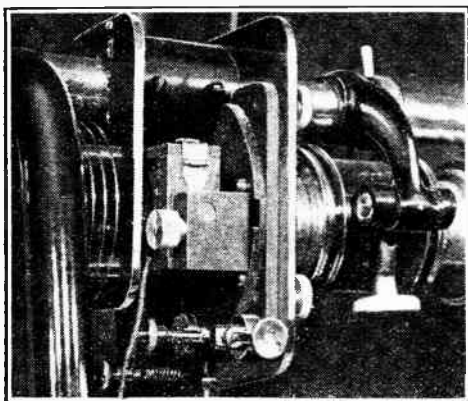

The Fernseh A.G. continuous "intermediate film" television projection receiver, with (inset) a close-up view of the Kerr cell unit which modulates the light.

television transmitting apparatus. Once the picture has been scanned, it is wiped out from the film by another process: a new sensitive layer is deposited on it, and the whole circle repeated. Another

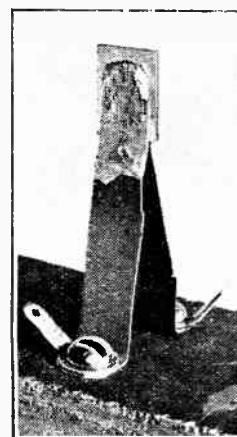
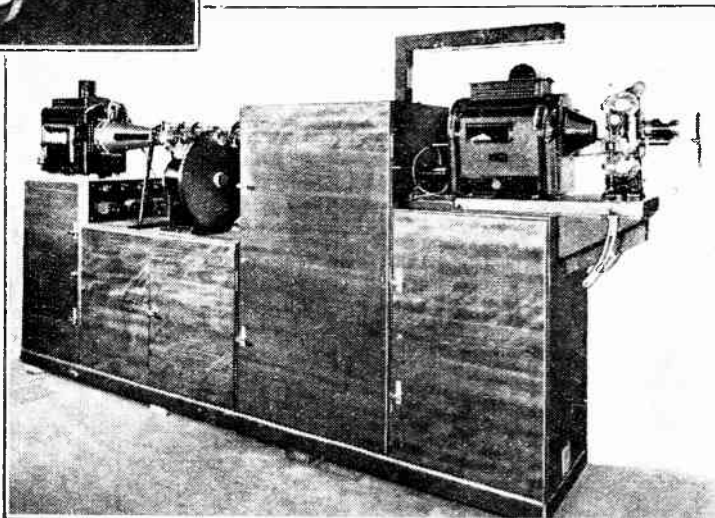

A crystal substitute for the Kerr cell. The crystal transparency varies, depending upon the potential applied across it.

**Television at the Berlin Show—**

current. The pictures demonstrated were extremely good. In the Loewe apparatus both sound and picture are received on the same receiver, but are then separated by two detector valves.

Telefunken also exhibited a television receiver with cathode ray tube. This, like the Loewe apparatus, has an ultra-short wave superheterodyne receiver.

M. von Ardenne was showing his new cathode ray tube equipment, distinguished by the remarkable brightness of the light spot, so that the images can be observed on the screen in daylight or can be projected. The method used is that of "line control" (speed modulation, in which a constantly bright spot of light travels over the field of view with varying velocity).

Apart from the Post Office exhibits, which also made use of cathode ray tubes, the new mirror wheel process of Mihaly should be mentioned. This employs a Weiller mirror wheel, in which, however, the mirrors are on the inner side. The mirror wheel W (see diagram) does not itself move, but inside it on its axis there is a small rotating plane mirror M, which is very light. This is driven by a small motor and kept in synchrony with the picture-changing frequency; a ray of light from a very strong source S is thrown on to this mirror, which reflects it on to the mirrors of the wheel. From here the ray is again led back to the little mirror which then projects it through a lens system on to the screen.

This extremely simple system would

The new Mihaly mirror wheel apparatus. The diagram indicates the principle of operation. With the complete receiver, which is enclosed in a cabinet, an external screen on a stand is provided and the picture is projected onto this screen from the receiver.

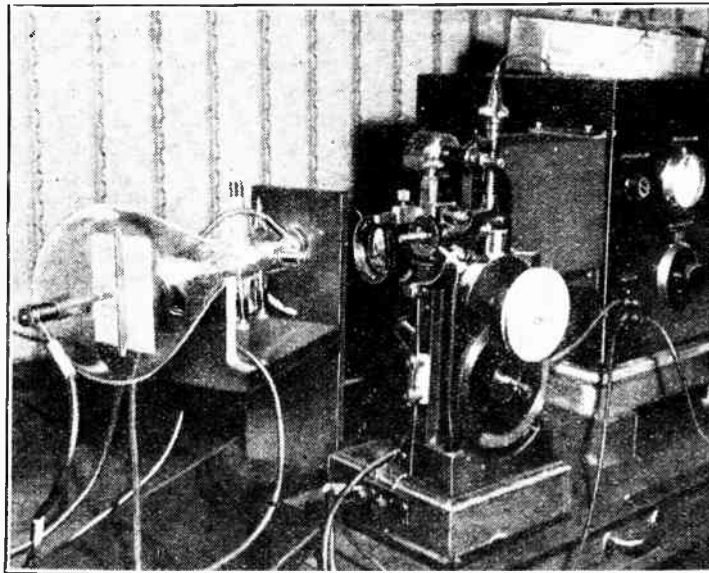

The new cathode ray tube equipment of von Ardenne, employing the principle of speed modulation.

a fraction of a watt in the case of the latter. The energy can, therefore, be taken from the receiver itself, and thus the television transmitter controls the synchronism of the receiver.

As already mentioned, the mirror drum is stationary and its different mirrors, when

once adjusted in the factory, need no further attention. The images thrown on the screen are sufficiently big to be viewed by a number of people from almost any position of the room. Apart from the technical advantages are the constructional ones, as the manufacturing price of this receiver is low.

At the Berlin Radio Exhibition this receiver was shown working off the 7-metre television transmitter. The image consisted of 90 lines (10,000 elements), there being 90 mirrors on the drum. In this receiver the small rotating mirror was silvered on both sides, so that the rotating speed need only be half of the picture speed, i.e., 750 r.p.m., according to the British standard. The results on the 90-line receiver were pleasing, the detail being about equal to a 9 mm. home cinema outfit. The image size was about 6 by 8 inches. Synchronism was perfect, the picture being rock steady. The internal construction of the receiver can be clearly seen in the illustrations. The complete set contains the actual television portion, together with a 3-valve ultra-short wave receiver for A.C. mains.

A receiver for the new German standard of 180 lines will shortly be put into production. This model will probably employ a Kerr cell as a light source, thus giving brighter and black-and-white images.

It is interesting to note that the regular television transmission service of the German Post Office employs ultra-short waves, the picture being horizontally scanned twenty-five times a second in ninety strips, the total number of picture elements or points being 10,000.

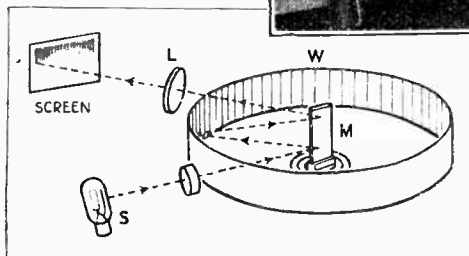
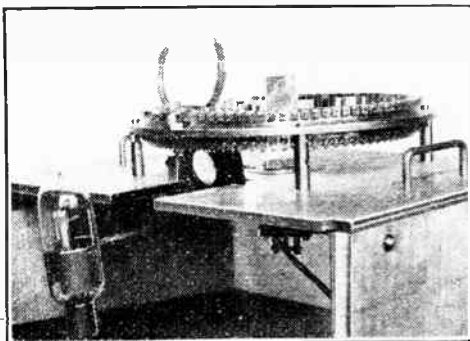

appear to have obvious advantages. The tiny rotating mirror only needs a very small and weak motor, which is no bigger than those used in synchronous electric clocks. As a result of this the driving and synchronising energy is extremely small, being only

**Singleton-Brown Test Oscillator**

**A Mains-Energised Source of Modulated H.F. for Receiver Servicing**

RECENT improvements in the design and performance of receivers have called for a corresponding advance in the skill and equipment of the service man, and a test oscillator is now as essential and important an item on the test bench as the soldering iron or the multi-range meter.

The S.B. Model 2 Modulated Oscillator consists of a screen-grid dynatron R.F. oscillator with three ranges (1,500-545, 375-136, and 148-96 kc/s) modulated to a depth of approximately 70 per cent. by a triode giving three alternative frequencies of approximately 70, 500 and 4,000 cycles. The H.F. ranges and modulation frequencies are controlled by switches on the front panel, and an extra contact on the L.F. switch brings into circuit pick-up sockets which may be used to modulate the oscillator by music or standard frequency records.

The illuminated horizontal tuning scale is divided into 100 divisions and a calibration chart is screwed to the top of the metal cabinet. An attenuator resistance is also incorporated and a calibration curve of the

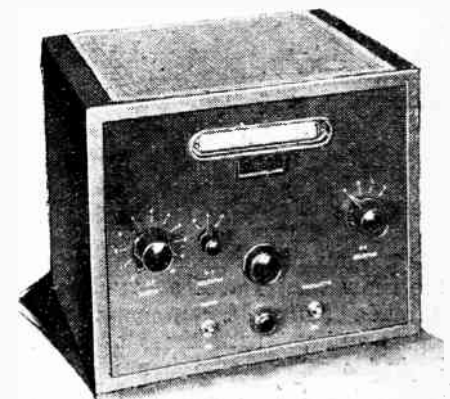

S.B. modulated oscillator in which the A.C. power pack may be used for external testing.

voltage output is given. The range is from 50 microvolts to 2.5 volts R.M.S., and the output is taken from a plug and jack through a pair of screened leads. A second jack supplies a source of audio-frequency voltage for testing U.F. amplifiers.

The oscillator runs entirely from A.C. mains and the output from the power pack may be used for energising mains receivers in which a fault in the power supply is suspected. Plugs and sockets are provided at the back of the cabinet for this purpose and are rated as follows: L.F. 4 volts 6 amps., H.T.1 200 volts 13 mA., H.T.2 100 volts 7 mA.

The cabinet is constructed of steel and is neatly finished in brown crystalline enamel, the overall dimensions being 12in. x 10in. x 10in.

The price of the Model No. 2 illustrated is £18, and supplies may be obtained from The Singleton-Brown Radio Instrument Co., Singleton House, Compton Road, Wolverhampton. A simplified model omitting the I.F. range and with only one modulating frequency (500 cycles) is also available at £15.

# UNBIASED

## BY FREE GRID

### Glasgolympia

YOU will no doubt be surprised to learn that, although the Scottish Radio Exhibition has been all over for a week now, I am still sojourning in the city of rivets and Red Biddy. I have, in fact, become so imbued with the spirit of Burns and Haig that I can scarcely tear myself away from the place; and at the conclusion of the show instead of returning with the caravan I risked being carted away forcibly.

The language difficulty at Glasgow has proved to be not nearly so bad as I had been led to believe. In any case, forewarned is forearmed; and I had come fully prepared to meet all difficulties in this respect, as my dentist had produced a special denture which was so arranged that it dealt automatically with the Scottish accent, and I flatter myself that my speech was indistinguishable from that of an inhabitant of the Broomielaw. I may mention that my dentist, a Cavendish Square man of considerable repute, specialises in this sort of thing, and has a considerable clientele among the London announcers, many of whom are actually Highlanders who, by the simple expedient of donning trousers and one of his special dental plates, have succeeded in passing the Oxford accent examination at Broadcasting House with flying colours.

One curious case which I encountered at the show was that of a manufacturer who made and sold automatic record changers and yet used those of another make in his radio-gramophones.

Tackling the first salesman I saw, I asked him to lead me gently by the hand and explain. I was, of course, referred to the elusive Mr. Blank, who, as at other radio shows, had gone to his interminable



At Glasgolympia.

lunch. I said I would wait, and did, and after an hour or so the people on the stand evidently realised that they had got to do something about it, with the result that a scientific-looking youth with bulging

forehead and horn-rimmed glasses presented himself and proceeded to try on the old dodge inherited from the motoring industry and which is, I believe, known among the fraternity as "blinding the customer with technicalities."

Eventually he retired baffled and gave place to another young man resplendent in gent's autumn suiting whom I took to be the leading salesman. His arguments were long, wordy and unconvincing, and I was getting very impatient when sud-



Blinding him with technicalities.

dently a brilliant idea struck him. "To tell you the truth, Sir," he said, "our own record changers are so much better than those of other makers that we decided to let the public have the benefit of them as our present factory output is not sufficiently large to fulfil the needs of the public and supply our own radio-gramophones as well."

Happily I was glad to see a fine collection of chairs, making it possible to sit down at intervals and reflect upon the frailty of human nature. According to all reports, things were not so comfortable at Olympia.

The dance floor was exceedingly well patronised, and I was glad to see that the authorities had followed the lead of Olympia last year by providing dancing partners. Of these there were so many that I felt quite embarrassed with their attentions.

### Arguing with the Blinkers On

AN ophthalmic surgeon, writing quite seriously to the Editor of a well-known daily, states that the cathode ray system of television reception is definitely harmful to the eyesight. Now I am more of an optimist than an optician, but, at the same time, I cannot give any credence to a medical man, however eminent in his own sphere, who supports his asser-

tions by arguments that totter like a superannuated cab horse.

He alleges that the cathode ray system is harmful because, in his view, the picture it gives is as unsteady and as full of flicker as the early movies of thirty years ago, and causes similar eye strain.

I am not going to deny that flickering pictures tire the eyes, no matter whether they emanate from cathode ray radiosopes or early cinema projectors, but what about the pictures given by alternative methods such as the scanning disc receiver?

It seems scarcely credible that an eminent oculist should have sat in judgment upon one type of machine without seeing the results from the other; if he had seen the other he would have realised that the older type was not one whit less flickery.

### To What Base Uses . . .

A WELL-KNOWN cabinet supplier was discussing with me the other day the relative merits of modernistic bakelite as against wood cabinets, to which latter substance he remains as faithful as the glue which he uses in his products.

I pointed out that one well-known firm was turning its attention to the production of bakelite tables and other major articles of furniture. "In fact," I added, "it is fairly certain that you and I will be buried in bakelite coffins if we live many years longer." "Not for me!" he said. "I am off at once to see my solicitor to guard against such a paradox in my will."

Frankly speaking, I cannot see any reason for retracting my prophecy except that in my own case, of course, not quite



Not all of me will be buried.

all of me will be buried, as I am at present considering several attractive offers from various hospitals and medical schools who want my scalp.

# BUSH RADIO BAIRD Television Receiver

## An Efficient Mirror-drum Televisor

TELEVISION transmission and reception has not yet achieved the degree of perfection which is now found in sound broadcasting, but in spite of this, the possession of a televisor is not without interest. Comparisons between vision and sound are difficult, but it is probable that the results now obtainable from good television apparatus are comparable with those given by sound equipment in the days when the weekly broadcast transmissions from Writtle were an outstanding event.

Unlike sound broadcasting, television receivers must be designed to operate with a given system of transmission, and the transmitter and the receiver are far more closely interlinked. The present B.B.C. broadcasting is carried out on the 30-line, 12½-picture system, which means that 12½ complete pictures are transmitted each second, and that each picture is analysed by scanning it vertically 30 times. With

the definition obtainable in this way it is probable that a receiver employing a mirror-drum is as satisfactory as any.

The apparatus under review is contained in a strongly built cabinet, which is similar in shape to that of a miniature grandfather clock; the lower portion contains the receiver proper, the power amplifier, and the mains equipment, while the upper part houses the purely television apparatus. The receiver is of conventional type, including H.F. amplification and resistance-capacity coupled L.F. circuits, and unusual care has been taken to avoid any loss of the upper modulation frequencies. Used for sound reproduction, therefore, the apparatus is capable of giving an exceptionally high standard of quality. Tuning coils are included for the medium

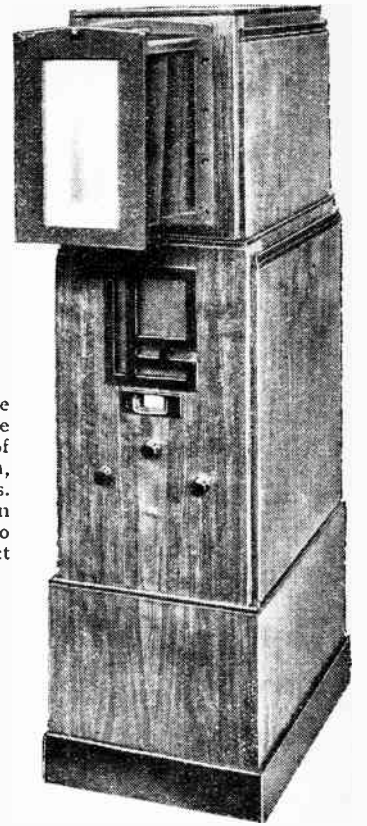

The picture covers the full area of the screen, 9×4 inches. The screen draws out to the correct position.

waveband only, since there are no television transmissions on the long waveband. A loud speaker is fitted in order to facilitate tuning, and when the station has been found a switch permits a change over to the television equipment.

The output valve is of the 25-watt type and feeds a Baird Grid Cell which acts to convert current, or, more strictly speaking, potential variations, into variations of light intensity. An additional valve of similar type is provided for synchronising, and it is doubtless largely due to the considerable power which it supplies that such a good performance is obtainable.

### The Television Equipment

The Baird Grid Cell acts, as a loud speaker in sound reception, to convert the electrical impulses into a form in which they can be detected by the senses. It consists essentially of a type of Kerr cell mounted between Nicol Prisms. A 100-watt lamp is mounted at one end of the assembly, and in its passage through the prisms and cell the light is modulated by the varying electrical potentials on the plates of the Kerr cell. The cell itself is a voltage-operated device, so that at first it seems that a large power valve is unnecessary for its control. Owing to its high self-capacity, however, it must be shunted by a fairly low resistance if frequency and phase distortion are to be kept at a low value. In order to obtain the necessary voltage variations across this resistance quite a large amount of power is required.

The modulated light output of the cell falls upon the mirror drum from which it is reflected on to the viewing screen. The drum contains thirty flat mirrors, each set

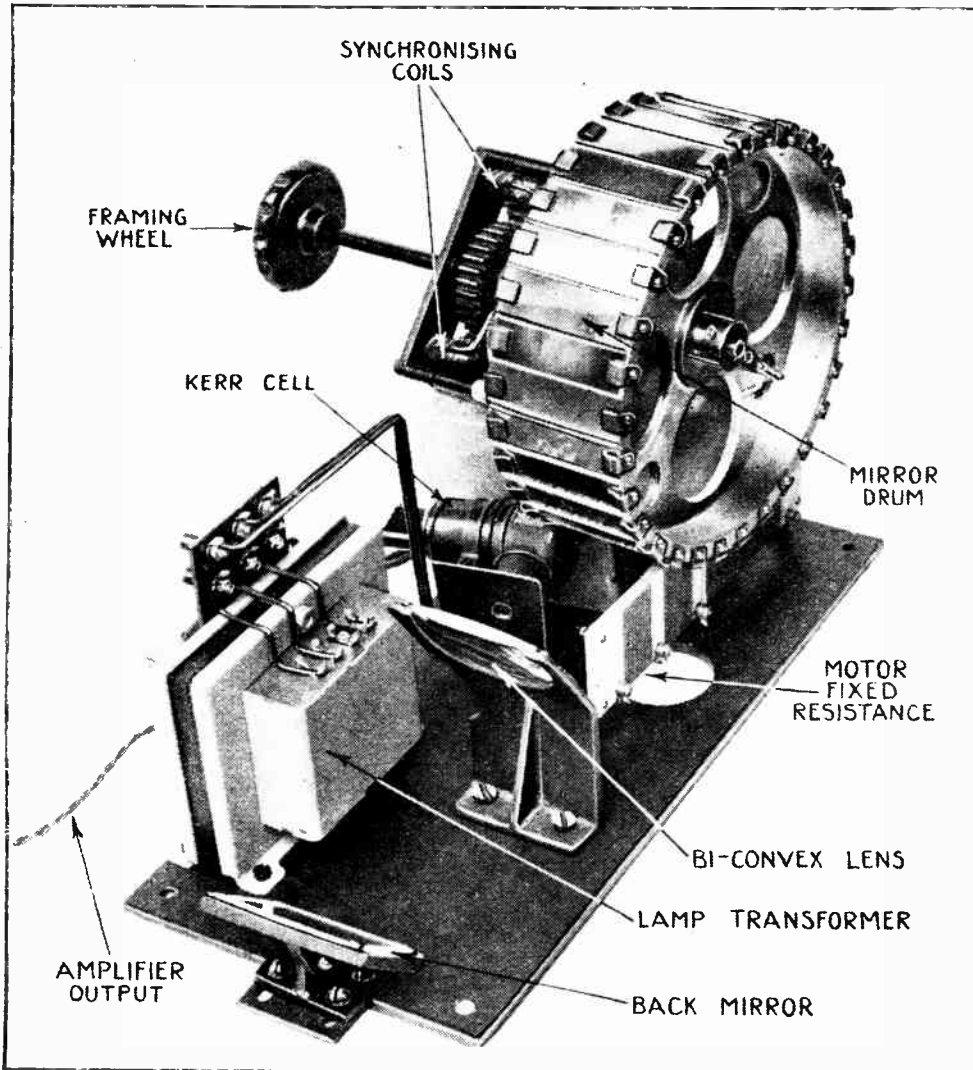

The important parts of the Baird projector. The rotary mirror drum works in conjunction with an optical system of adjustable lenses and mirrors.



**Bush Radio Baird Television Receiver—**

at a slightly different angle so that with the drum rotating at the correct speed and in the absence of a signal thirty vertical, parallel, and equi-spaced lines appear on the screen. This screen must be at some considerable distance from the mirror, so that to obtain a compact assembly it is arranged with bellows to pull out of the cabinet when reception is required.

The drum is driven by an electric motor, the speed of which is controlled by a variable resistance mounted on the left-hand side of the cabinet with the motor switch and the framing control. To assist in obtaining the correct speed it is fitted with a stroboscopic indicator which is viewed by the light of a neon tube operated by the 50 cycles lighting supply. With the aid of this it is a simple matter to adjust the motor speed. When the motor gathers speed the lines of the stroboscope can be seen slowly rotating, and as the correct speed is approached the apparent rotation is reduced. When the correct speed is found the stroboscope lines appear stationary.

Synchronising is carried out in the usual way. The black edging provided at the transmitter gives a series of pulses, one at the top of each scanning line. Since there are thirty lines per picture and  $12\frac{1}{2}$  pictures a second, there are 375 synchronising impulses a second, and in the receiver these are applied to what is virtually a small motor mounted on the main drum driving shaft. If the main driving motor increases or decreases its speed, the synchronising control operates to give a braking or accelerating effect and to maintain constant speed.

The controls comprise the normal tuning and volume adjustments, and an on-off switch mounted on the front of the cabinet, together with a control which acts to bias the Grid Cell and so regulate the average illumination of the picture. At the side of the cabinet are the purely television controls; the motor speed regulator, the framing handle, and the motor on-off switch, together with a viewing hole for the stroboscope.

**Adjusting the Apparatus**

In operation, the station is tuned in using the loud speaker as an indicator. The motor is started up and adjusted to its correct speed by the rheostat while watching the stroboscope. A change over from the speaker to the vision equipment is then made, and if perfect synchronism has been obtained the picture will be visible. A "flashing rain" effect indicates that the motor speed is incorrect, and an appropriate adjustment to the controlling resistance effects the necessary alteration.

When the picture appears, however, it may not be in frame; that is, it may be divided horizontally or vertically. This indicates incorrect phasing, and is adjusted by the framing control. This control operates to rotate the carcass of the motor and so moves the picture in a vertical direction. A small movement of this control, therefore, is sufficient to correct for any degree of vertical mis-framing. With most apparatus, horizontal mis-framing is more difficult to correct, and it is usually necessary to slow-up the motor momentarily so that a few pictures are slipped. The operation, therefore, requires some little skill for its successful accomplishment.

In this particular apparatus, however,

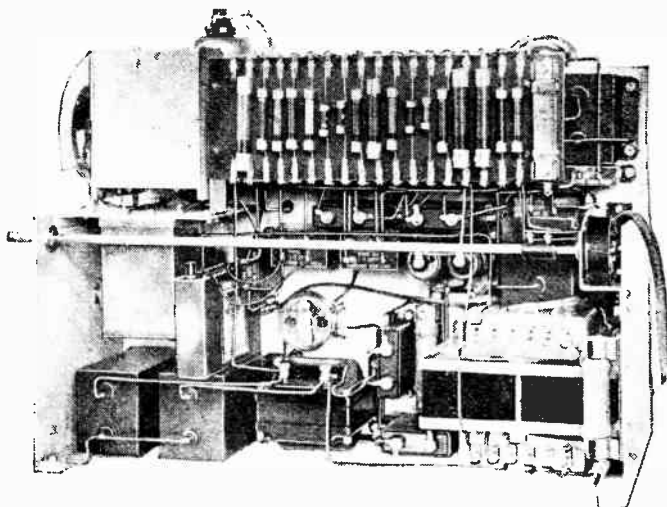

The amplifier and radio receiver unit.

the difficulty is avoided by a clever arrangement of the vertical framing control. The picture is arranged to be very slightly out of the vertical, so that rotating the carcass of the motor to produce a vertical displacement of the picture causes also a very slight sideways motion. To correct for horizontal displacement, therefore, it is necessary only to turn the framing control to a much greater degree than is necessary to compensate for vertical mis-framing. As the control is turned, the visual effect is of a number of pictures slowly moving vertically and gradually gliding sideways.

**Performance**

The operation, therefore, is quite simple, and the performance obtainable probably represents the best that can be achieved with the present 30-line transmissions. The detail obtainable is not high, and dark objects of different degrees of illumination tend to merge together. Thus, a man's chin is quite distinct as long as his head is held upright, but it merges into his tie when he looks downwards and his chin falls into the shadow. The scanning lines are quite obvious, and give a vertical striped appearance to any white object, such as a shirt front.

In spite of these drawbacks, which are unavoidable with the present transmissions, the programme can be followed with ease provided that it does not contain too rapidly moving objects. The degree of

definition is such that it is easily possible to recognise a well-known face.

The synchronising is really good, and during the half an hour's transmissions the apparatus often carries through without going out of synchronism even once. Occasional readjustment of the framing is necessary, since there is an occasional slow drift of the picture. The lapses from synchronism are apparently due more to the transmitter than to the receiver, for they invariably occur at the end of an item, when the curtain falls in the studio. Apparently this interrupts the synchronising impulses.

The apparatus is solidly built, and should give long and satisfactory service, and its adjustment does not call for any special degree of skill. The makers are Bush Radio, Ltd., of Woodger Road, Shepherd's Bush, London, W.12, and the apparatus is priced at 50 guineas complete.

**The Radio Industry**

WE are informed by Messrs. J. J. Eastick and Sons, of Ecelex House, 118, Bunhill Row, London, E.C.1, that they are able to supply a dual-range "Hartley" coil for the pentode oscillator described in the issue of August 25th. Complete with a suitable D.P.D.T. switch, the coil assembly costs 9s. 6d., or 7s. 6d. without switch.

An attractively written brochure, entitled "A City of Sound," by E. P. Leigh-Bennett, has just been issued by the Marconiphone Company. It describes Marconi activities from the earliest experiments of Marchese Marconi to the present-day work of the factory at Hayes. Free copies will be sent to interested readers.

In our "Show Guide" number it was stated that Fuller "Sparta" batteries are intended for Q.P.P. and Class "B" receivers. The Fuller Accumulator Co. now point out that, although the "Sparta" Batteries may be used for this form of set, their "Triple Capacity" types are especially recommended for the purpose.

The Hawley Products Company of America have now established a European factory and office at 101, Walmer Road, North Kensington, London, W.10. The new firm, under the name of Hawley Products, Ltd., will manufacture loud speaker diaphragms under the original patents; diaphragms can be made in all sizes, and with different response characteristics to meet various specifications and requirements.

**1933/1934 Catalogues Received.**

Colvern, Ltd., Mawneys Road, Romford, Essex.—Radio List No. 12 dealing with principles, design and application of Ferrocart components. A particularly informative booklet which is obtainable free on application to Colvern, Ltd.

Varley (Oliver Pell Control, Ltd.), Kingsway House, 103, Kingsway, London, W.C.2.—A 28-page booklet illustrating and describing the new season's components, also leaflet dealing with the latest receivers and radio-gramophones.

Igranic Electric Co., Ltd., 119, Queen Victoria Street, London, E.C.4.—New season's catalogue of Igranic devices, containing 48 pages of descriptive matter, technical data and illustrations.

Ward & Goldstone, Ltd.; Frederick Road (Pendleton), Salford, 6, Lancs.—1933-1934 Radio Catalogue R/130, containing 55 pages of descriptive matter and illustrations dealing with "Goldtone" components and accessories. Full technical details are given wherever warranted for all components.

# Broadcast Brevities

By Our Special Correspondent

## Television and the Film Industry

LEST any novelist should be preparing a saga on the decline and fall of the film industry consequent upon the advent of television, it is worth while remarking that the film folk are losing no time in "tying up" with television in this country.

## The Coming Tests

It is common knowledge, I suppose, that the new 120-line transmission tests from Broadcasting House, on the Baird and H.M.V. systems, will employ film almost exclusively.

The question arises as to whether the B.B.C. will ultimately rely entirely on celluloid entertainment in preference to the flesh-and-blood variety in the studio.

## Complications

Complications are likely to occur. For instance, it is improbable that the film companies will be willing to permit their best efforts to be broadcast—a practice which will eventually mean that a costly film will dissipate half its value in the course of one evening. Again, the film companies are not likely to follow the present practice of the gramophone firms in permitting their products to be put over the ether in expectation that bigger sales will ensue.

No listener or "looker" will feel impelled to dash out and purchase a seat for the film he has just witnessed on his television.

By way of self-preservation, the film industry in this country will make a big effort while there is still time to link up with broadcasting.

## Sir John Reith's Journey

Very shortly Sir John Reith will be crossing the Atlantic to attend the inaugural ceremony of Radio City, New York, which represents the world's greatest conglomeration of entertainment industries, banded together for mutual support and protection.

It will be interesting to note whether the



Mr. Melville Dinwiddie, D.S.O., O.B.E., M.C., who has been appointed the Scottish Regional Director.

Director-General, on his return, envisages a similar Palace of the Entertainment Arts in London, with Broadcasting House as the nucleus!

## Another Conflict of Interests?

This, perhaps, is sheer speculation. But those who sense the growing importance of television cannot but see that the present independence of broadcasting and the film cannot endure when television develops.

For example, television may be restricted in the early stages to brief comedies and short items of news interest; ultimately, however, the film industry may find itself in conflict with the B.B.C.

## "Effects" in Gramophone Programmes

I HAVE a fancy that "Free Grid" will relish the authentic news that the B.B.C. is adding "effects" to the broadcast of full-length operas on gramophone records. When "Pagliacci" was broadcast with the full gramophone version a short time ago, the Effects Department assisted with a special Columbia record of sounds in a theatre, the tuning-up of the orchestra, and the applause of the audience.

## And Why Not?

Surely this practice could be developed, particularly in relation to talks, which are so badly in need of a little tonic treatment?

Let the B.B.C. engineers take some Blattnerphone records of noises in Hyde Park so that the well-blended murmur of approval and disapproval can form a misty background to the pontifical utterances of some of our more solemn speakers. After all, the speaker himself need not be aware of this background to his remarks. Better not, perhaps, for the hoots and cat-calls which would go down very well with the army of listeners might play havoc with the composure of the professor in the studio.

At any rate, the B.B.C. should be prepared to try anything *once*.

## The Saturday "News Reel"

THE only striking innovation in the autumn talks programme is the introduction of the Saturday "news reel" after the second general news bulletin. This news reel will be based on the successful experiment of Saturday, July 1st, when news, topical talks, and relays from abroad were grouped in one continuous programme.

## Blattnerphone Flashes

Beginning on October 14th, the news and talks, starting at 9 o'clock, will be incorporated in a single programme, and the first three or four minutes will be devoted to a summary of the outstanding events of the day. This will be followed by a more elaborate presentation of the details of these events, possibly by the aid of gramophone and Blattnerphone records, brief interviews with people "on the spot," and a more vivid Sports Bulletin than has been given in the past.

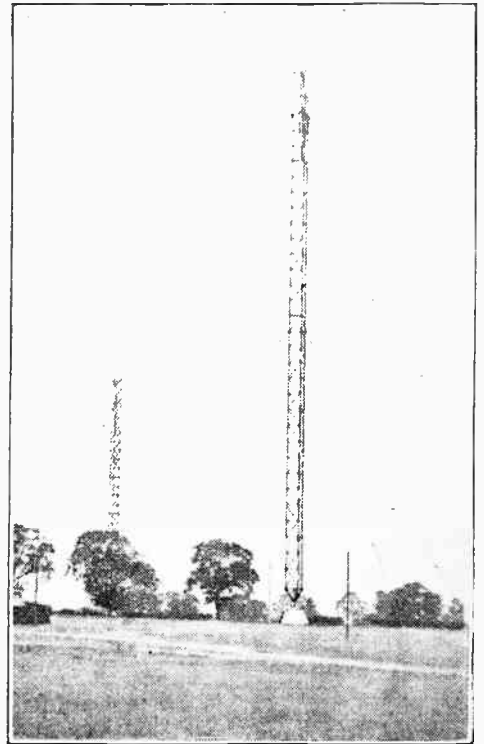

A DROITWICH LANDMARK IN THE MAKING. The first 250 feet of the giant masts of the new B.B.C. National transmitter in course of erection. When finished they will be over 700 feet high.

## An Aside

In regard to this last, the B.B.C. remarks rather patronisingly that a number of listeners appear to be interested in no other aspect of human activities.

## Big Names in the Making?

In the main the speakers are familiar names: Vernon Bartlett, Desmond MacCarthy, G. K. Chesterton, S. P. B. Mais, and Sir Walford Davies. There are, however, some new speakers, and we may legitimately hope that some hitherto mute and inglorious Miltons are about to burst upon our aspiring ears.

## Symphony Concerts

THE detailed programmes for the series of symphony concerts, which begin on Wednesday, October 18th, have now been issued by the B.B.C. They will, as usual, be conducted mainly by Dr. Adrian Boult, but several famous guest conductors will also do their share.

## Handel Modernised

AMONG the numbers to be performed for the first time in England are Bartok's Concerto No. 2 for pianoforte and orchestra, in which the composer will play the solo instrument; Alban Berg's "Wozzeck" and an arrangement by Arnold Schönberg of Handel's Concerto Grosso for string quartet and strings. It will be interesting to hear how Handel stands modernising, though it is difficult to imagine our old friend George Frederick in the dress of one of the ultra-moderns.

## Political Talks

PERHAPS the greatest novelty in the coming season's talks will be the political addresses to be given on Thursdays at 9.20 p.m., in which the speeches will not be subject to preliminary censorship.

# LABORATORY TESTS

## NEW RADIO PRODUCTS REVIEWED

### PARTRIDGE MONODIAL MAINS TRANSFORMER

PROSPECTIVE constructors of *The Wireless World* New Monodial Super may be interested to learn that a mains transformer for this set is now obtainable from N. Partridge, King's Buildings, Dean Stanley Street, London, S.W.1. The component is designed on very generous lines, for it measures 6 $\frac{3}{4}$ in. x 4 $\frac{3}{4}$ in. x 4 $\frac{1}{2}$ in. high overall, and, in view of these dimensions, it would seem desirable that slight alterations be made in the size of the baseboard for the power pack. An increase of  $\frac{3}{4}$ in. in the length and of  $\frac{1}{2}$ in. in the width would provide the additional space required. Increase in the latter direction may be avoided, however, by bending one of the fixing lugs at right angles and screwing it to the side of the baseboard, but the extension in the length is far preferable to a rearrangement of the components.

The various leads are brought out through the lower cheek of the bobbin, and thus fall convenient for passing through to the underside of the baseboard and thence to their respective anchorage points. The primary winding is screened, and a separate earth lead brought out. Small tags are tied on the wires for identification. Tappings are provided on the primary for supply mains of 200, 230, and 250 volts 50 cycles A.C.

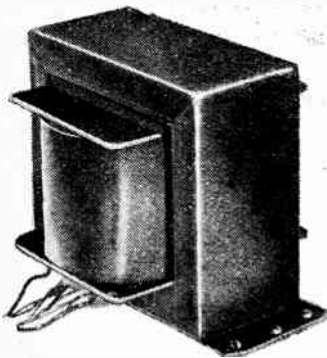

Partridge mains transformer for the New Monodial Super.

With all windings giving the specified output currents, the various voltages when measured were found to be correct for the satisfactory operation of the set. After smoothing, the H.T. supply measured 430 volts with 120 mA. flowing; the two one-amp. L.T. windings showed 4.01 volts, while the rectifier filament and the six-amp. windings were each giving 3.98 volts.

The transformer runs perfectly cool; there is no trace of mechanical hum due to looseness in the core or in the assembly; and, altogether, the component is a sound electrical job, which, at 36s., represents very good value.

### NEW POLAR DIALS

THE Polar range of condenser dials now includes six models; three are full-vision type, two are disc drives, and one is a drum pattern. The four latest additions, described respectively as the Horizontal, the Arcuate, the Semi-Circular, and the Moving Scale Disc drives are calibrated in wavelengths for Polar condensers, assuming a minimum capacity of the order of

70 m-mfds., and coils of 157 microhenrys and 1,900 microhenrys for medium- and long-wave pre-selector circuits. For super-heterodyne sets the oscillator coils should have inductances of 126.5 and 925 microhenrys respectively. But a plain graduated scale is provided as well, which in the Hori-

rapidly. The price of the de Luxe energised model is 35s., and of the permanent magnet model 65s., or 67s. 6d. with Class "B" output transformer.

The new Sonochorde Midget has been designed for portable sets and car radio, and has a cone diameter of 4 $\frac{1}{2}$ in. In spite

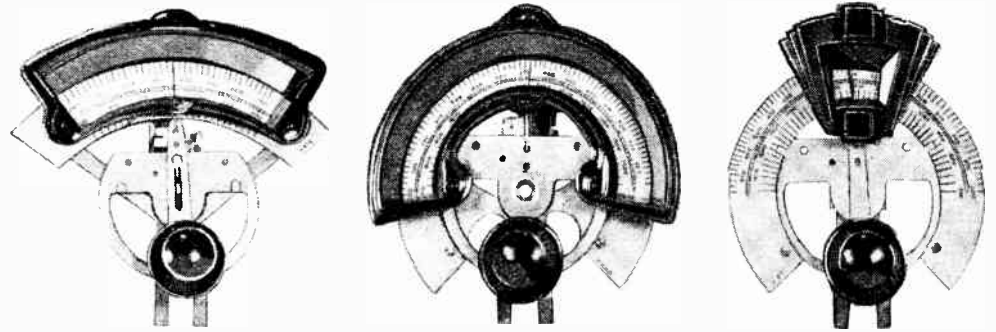

Polar condenser drives; illustrating the Arcuate, Semi-Circular and the Moving Scale Disc Models.

zontal and Arcuate models is divided in 100 divisions, and in the remainder into 180 degrees. These drives are very robust, well finished, and quite free from slip or backlash. The reduction ratio is about 8 to 1, and the knob drives the pointer in the same direction as its rotation.

The new models can be supplied fitted with a small air-dielectric trimmer condenser giving a variation of about 50 m-mfds., its control being mounted concentric with the tuning knob. Dual lamp-holders mounted on a removable clip are fitted, and the prices are 5s. 9d. each for the three full-vision types, 4s. 6d. for the new disc model, 5s. for the plain disc pattern, and 7s. 6d. for the drum drive. Escutcheon plates of appropriate design for each model in brown bakelite, also knobs to match, are included, together with fixing screws. The trimmer condenser adds 2s. to the price of each model.

### TWO SONOCHORDE REPRODUCERS

IN producing the Sonochorde de Luxe models the makers have set out to provide a chassis unit of better finish and external appearance than the average "set builder's" loud speaker. It is finished in a very attractive two-tone cellulose enamel, and the transformer is enclosed in a detachable metal cover with a rubber bush for the connecting leads.

In the mains-energised model tested the field terminals and those of the input to the transformer were, in our opinion, spaced rather too closely, but there is no reason why trouble should arise in this quarter if it is realised that special care must be taken to avoid short circuits due to stray strands of wire.

As regards sensitivity, few loud speakers we have tested in this class have given better results. The quality is well balanced and the output is exceptionally uniform from 150 to 2,000 cycles. There is a bass resonance at 130 cycles, and the output falls gradually to a cut-off at 75 cycles. Between 2,500 and 4,000 cycles the output is five or six decibels above the average level, and above 5,000 cycles it falls off

of its small size (the depth is 2 $\frac{3}{8}$ in. in the energised and 2 $\frac{1}{4}$ in. in the P.M. type), the performance is remarkably good, and the quality is to be preferred to many moving-iron units of comparable price. The middle and top register reproduction is very similar to that of the average medium-sized moving-coil loud speaker except that the increased output in the upper middle register is somewhat higher in frequency—approximately 3,800 cycles. There is not much output below 150 cycles, but the "bass" resonance at 260 cycles serves to prevent the reproduction becoming too high pitched. On both speech and music the balance is really rather surprising, having regard to the small size of the diaphragm. Naturally the efficiency is not so high as that of units employing larger magnets and diaphragms, and for a given sound output an increase of about 4 db. in the power input is necessary above that required by the average 7in. diaphragm unit. On the other hand, the power handling capacity is good, and over one watt was applied before chattering made itself heard. The price of

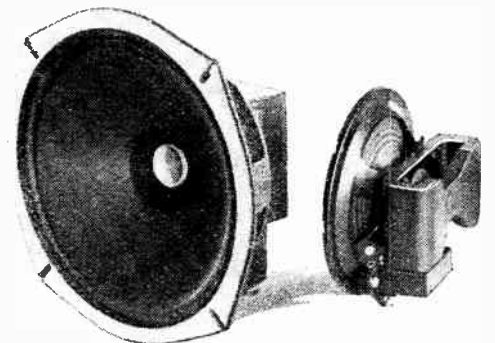

Sonochorde de luxe D.C. and Midget P.M. moving-coil loud speakers.

the permanent magnet model is 21s., and of the D.C. model 17s. 6d. The latter is available with 2,500- or 6,500-ohm field, and both types may be supplied with transformers for power or pentode valves.

The makers are Sonochorde Reproducers, Ltd., 1, Willesden Lane, London, N.W.6.

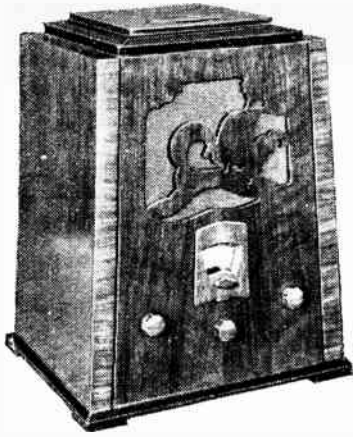

# Varley "SQUARE PEAK" 4 Model A.P.46

## High Selectivity with an Unconventional Circuit

**FEATURES.** *Type.*—Four-stage table model superheterodyne for A.C. mains. *Internal moving-coil loud speaker.* *Provision for pick-up and external loud speaker.* **Circuit.**—Signal frequency amplifier—oscillating detector with I.F. transformer—second detector—pentode output valve. *Full-wave valve rectifier.* **Controls.**—(1) Main tuning. (2) Waverange operated by sliding escutcheon. (3) Volume. (4) Reaction in I.F. circuit. **Price.**—15 guineas. **Makers.**—Messrs. Varley, 103, Kingsway, London, W.C.2.

**T**HE four-valve superheterodyne receiver, on account of its superior selectivity, is gradually ousting the three-valve straight set from its position as the "standard" receiver of the day. The number and variety of sets of the former type shown at Olympia were sufficient indication of the trend of events in this direction.

In the Varley Model A.P.46, however, we have something more than "just another 4-valve superhet," for there are many points both in the circuit and the structural design which indicate original thought rather than mere repetition of current practice.

Probably the most interesting innovation is the omission of valve amplification in the I.F. stage. There is, of course, an I.F. transformer in which both windings are tuned, so that the full advantage of the superheterodyne principle from the point of view of selectivity is retained. This is further enhanced by reaction applied to the I.F. transformer from the second detector stage.

The first valve, which is usually the detector-oscillator in a 4-valve superhet, in this case is used purely as an H.F. amplifier. It is of the variable-mu pentode type, and volume is controlled in this stage by simultaneous variation of the bias and screen grid voltages. Incidentally, it is the primary of the H.F. transformer which is tuned, and this circuit is ganged with the tuned aerial circuit and with the oscillator circuit associated with the second valve. This, again, is of the H.F. pentode type and combines the functions of oscillator and first detector. It is coupled to the second detector—a triode—through the band-pass I.F. transformer. Transformer coupling is employed between the detector and the pentode output valve,

and tone correction is applied across the primary of the output transformer to the moving-coil loud speaker. The external loud speaker is connected through a condenser across the output transformer primary, and is therefore suitable for high impedance loud speakers as well as moving-coils fitted with a suitable transformer.

The controls consist of main tuning, volume, reaction on the I.F. circuits and waverange. The latter is controlled by switch mechanism attached to the moulded escutcheon plate which slides up or down, thus exposing the appropriate scale and station calibrations. It is interesting to note that the makers are already supplying tuning dials with stations distributed according to the Lucerne agreement, which comes into force in January next.

At the back of the chassis, in addition to the usual sockets for aerial and earth, pick-up, mains aerial and external loud speaker, there are two tumbler switches. One is connected in the mains supply circuit and the other disconnects the loud speaker in the set when it is desired to use the exterior loud speaker only.

The performance of this set amply justifies the deviation from convention in the circuit arrangement. Whistles due to second channel interference are considerably reduced by the signal frequency stage, and the four tuned circuits in conjunction with the reaction in the I.F. circuits give a high degree of selectivity. Zeesen on long waves is easily tuned in free from

Daventry and Radio Paris, while, in Central London, on medium waves, only two channels are lost, on either side of the Brookmans Park National and Regional stations. The performance as regards selectivity seems to be equal to that of the average four-stage superhet, without having to resort to the use of reaction, which may be kept in reserve for exceptional receiving conditions.

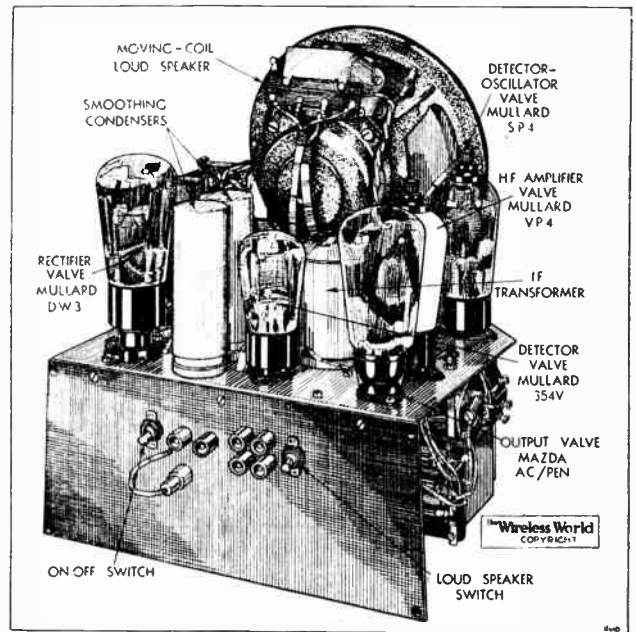

The moving-coil loud speaker and chassis form a single unit in the Varley A.P.46 receiver.

Quality of reproduction is bright, with an adequate foundation of bass, and transients are noticeably good. Mains hum is negligible.

To summarise, in the Varley A.P.46 we have a receiver at a reasonable price which is original in design and capable of a performance in range and selectivity which is above the average for a superheterodyne of four stages. The only criticism we have to make is that there is room for improvement in the mechanical rigidity of the chassis; but this is of concern more to the service engineer than the user.

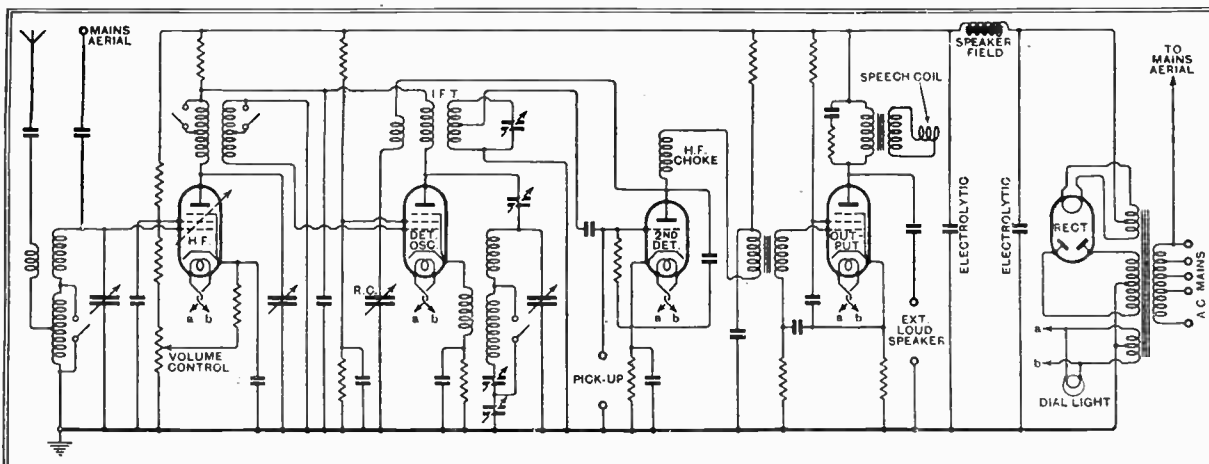

An unconventional feature of the circuit is the omission of valve amplification in the I.F. stage. The selectivity of the I.F. circuits is supplemented by reaction from the second detector.

Next Week's Set Review  
H.M.V. SUPERHET  
CONCERT SEVEN  
Model 467



# READERS' PROBLEMS

## Condensers in H.F. Circuits

EVER since non-inductive by-pass condensers appeared, it has been consistently advocated that they should be employed in all H.F. circuits in preference to those of the older type. To ensure that by-pass and decoupling condensers shall be entirely effective in such circuits, it is strongly recommended that attention should be paid to this point.

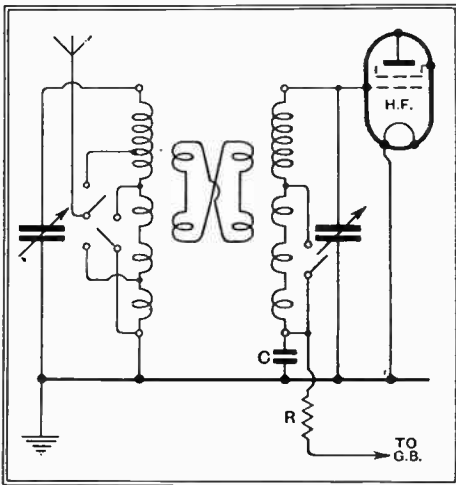

Fig. 1.—The by-pass condenser C is effectively in series with the secondary tuned circuit, and if this condenser has appreciable inductance, the matching of the secondary coil will be affected.

A correspondent, who realises that it would be fatal to employ an inductive condenser in such a position that it would be common to the two component circuits of a band-pass filter, nevertheless seems to think that an old type of condenser might be used satisfactorily for decoupling the H.F. grid circuit of the Modern Battery Four (*Wireless World*, August 11th). This condenser is not common to both filter circuits, and so it is argued that, even if it be slightly inductive, filter coupling will not be affected.

All this is true enough, but our correspondent has overlooked the fact that the condenser in question is in series with the second tuned circuit, and therefore, if it happens to have an appreciable inductance, it will upset the matching of the two coils. Any inductance in the condenser will be additive to that of the secondary winding; this is made clear in Fig. 1.

## Gilding the Lily

IT has been asked whether it would be worth while going to the trouble of fitting a band-pass input circuit for the New Monodial superheterodyne; a second reader words his question rather differently by asking whether the quality of the receiver would be improved by such an addition.

Although it cannot be denied that an additional tuned circuit is bound to lead to increased immunity from second-channel interference, the benefits to be derived from such an addition are not considered to be sufficient to warrant the extra complication and cost involved. So far as quality is con-

cerned, no improvement would result from this addition, as the loss of side bands which inevitably takes place in a single-tuned input circuit was taken into account in the design of the tone-correction system.

## Car Sets Afloat

IT has occurred to a reader that one of the recently introduced motor car sets would be almost ideal for installation on board his cabin cruiser, where space is at a premium. The engine is fitted with 12-volt electrical system and a large battery. We are asked to say whether any unsuspected difficulties are likely to arise in operating the set, and, indeed, to criticise the proposal in general.

Although we have not yet had any personal experience of the use of car sets for this purpose, we can see no reason why they should not be entirely satisfactory for motor boats or motor yachts, provided that a suitable converter or battery be fitted. It is understood that these specialised receivers are installed on board many motor cruisers in America.

## Limitations of Multiple Valves

THE user of a "straight" H.F.-det.-L.F. three-valve set asks whether it would be satisfactory to replace the present detector valve by a double-diode-triode, and, with the help of this valve, to obtain automatic volume control without loss of sensitivity and without adding to the number of valves in the receiver.

Although these new valves provide an excellent solution of the problem of adding A.V.C. to a "2-H.F." set, we fear that our present querist may be dissatisfied if he makes the proposed alterations. All "1-H.F." sets depend largely on reaction for their sensitivity, but this invaluable aid to long-distance reception must be forfeited if one of the new valves be fitted.

## A.V.C. Without Alteration

ANOTHER query dealing with the addition of A.V.C. to an existing receiver comes from a reader who wishes to fit an "amplified and delayed" automatic control to his "2-H.F." A.C. receiver without making any internal alterations. It is stipulated that the control valve shall be entirely mains-operated.

Were it not for this latter stipulation, we would suggest the A.V.C. unit described in *The Wireless World* of March 31st. The

## The Wireless World

### INFORMATION BUREAU

THE service is intended primarily for readers meeting with difficulties in the construction, adjustment, operation, or maintenance of wireless receivers described in *The Wireless World*, or those of commercial design which from time to time are reviewed in the pages of *The Wireless World*. Every endeavour will be made to deal with queries on all wireless matters, provided that they are of such a nature that they can be dealt with satisfactorily in a letter.

Communications should be addressed to *The Wireless World* Information Bureau, Dorset House, Stamford Street, London, S.E.1, and must be accompanied by a remittance of 5s. to cover the cost of the service. The enquirer's name and address should be written in block letters at the top of all communications.

THESE columns are reserved for the publication of matter of general interest arising out of problems submitted by our readers. Readers requiring an individual reply to their technical questions by post are referred to "The Wireless World" Information Bureau, of which brief particulars, with the fee charged, are to be found at the foot of this page.

threshold value of signal strength at which the control exercised by this unit comes into operation may be adjusted to any desired extent; further, the system is an "amplified" one, as the control valve acts as a D.C. amplifier of voltage changes appearing on the anode of the detector valve. Although not impossible, it would be difficult to arrange the unit for "all-mains" feed, but our correspondent might like to effect a compromise by supplying the anode of the valve from the mains through a separate rectifier, a battery being used for grid bias purposes.

## True Selectivity

PROBABLY the most common question propounded to the Information Department deals with the improvement of selectivity of existing receivers. In replying to such questions, it is comparatively easy to suggest methods whereby the signal input from the aerial, or the H.F. magnification of the set, may be reduced, and thus an apparent improvement in selectivity be obtained. But this improvement will always be at the expense of sensitivity; none of the popular "losser" methods can do anything towards improving the true selectivity of a receiver.

This can only be done by improving the "goodness" of the tuned circuits in the set or by adding to their number. The first alternative is generally impracticable, but the second can generally be put into effect by adding an external tuned aerial circuit to receivers which do not already include a band-pass input.

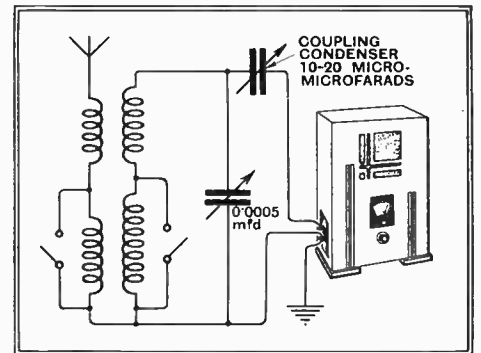
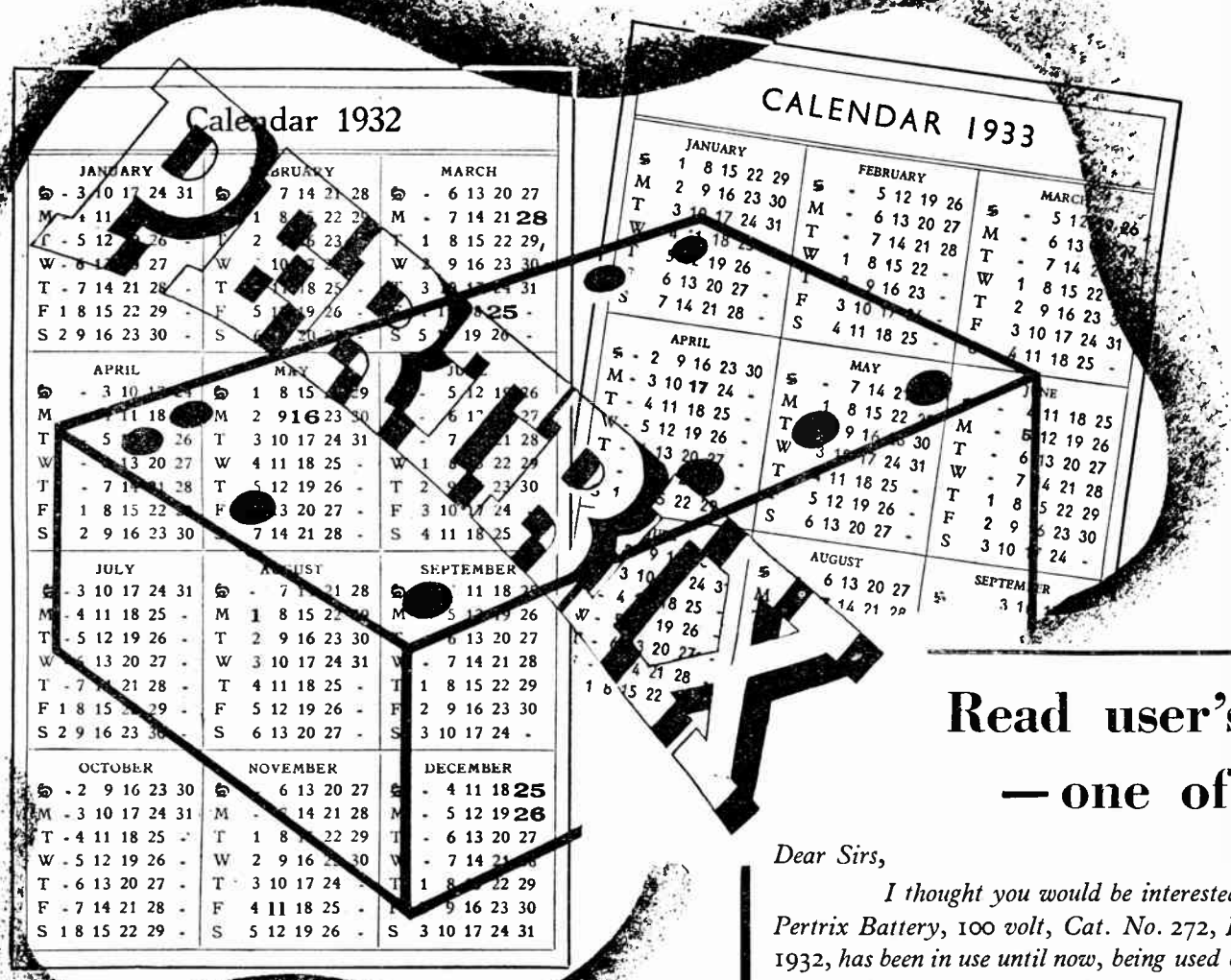

Fig. 2.—The most practical method of adding an extra tuned circuit, and thereby improving true selectivity.

Accordingly, this is the plan that is usually recommended, and for the benefit of several readers who have written on the subject, the circuit diagram of a satisfactory arrangement is reproduced in Fig. 2. The necessary apparatus is, of course, mounted externally to the receiver, and may be accommodated in a small box. Any reasonably effective standard coil assembly may be used, and particular care should be taken to see that the coupling condenser has a really small minimum capacity. It is worth while mentioning that the new iron-cored tuning coils are suitable for this purpose, and also that the addition of a separate aerial tuner may necessitate the need for "reganging" the original input circuit of the receiver.

# His PERTRIX Battery lasted *EIGHTEEN MONTHS!*



**E**ighteen months use—an amazing record of active service and therefore of money saved. Yet this is no unusual feat for a Pertrix—almost every post brings a letter from some member of the public whose Pertrix has lasted a year or more! Only a Pertrix High Tension

Battery could give such service, because Pertrix is the only battery that uses a patent *neutral* electrolyte. There is no constant corro-

sive process going on inside any Pertrix. Its power is not turned against itself. There is no "shorting" between the zinc cells. A Pertrix will give the same number of hours' service, whether you use your set every day or intermittently. These amazing batteries recover power overnight—preparing for the next day's programme. H.T., L.T., or G.B.—*there is a Pertrix that fits your set.*



## *FIT PERTRIX FOR GOOD*

MADE BY BRITANNIA BATTERIES LTD., REDDITCH, WORCESTERSHIRE

### Read user's letter — one of scores

Dear Sirs, July 29th, 1933

*I thought you would be interested to know that a Pertrix Battery, 100 volt, Cat. No. 272, I purchased Feb. 1932, has been in use until now, being used on an average of about 3 hours per day, which I think excellent. I have today purchased another one, G.B. & H.T. combined.*

*Yours faithfully,*  
F. M. U., Bellingham

The above letter can be inspected at the offices of Britannia Batteries Ltd.,  
233 Shaftesbury Avenue, London, W.C.2.

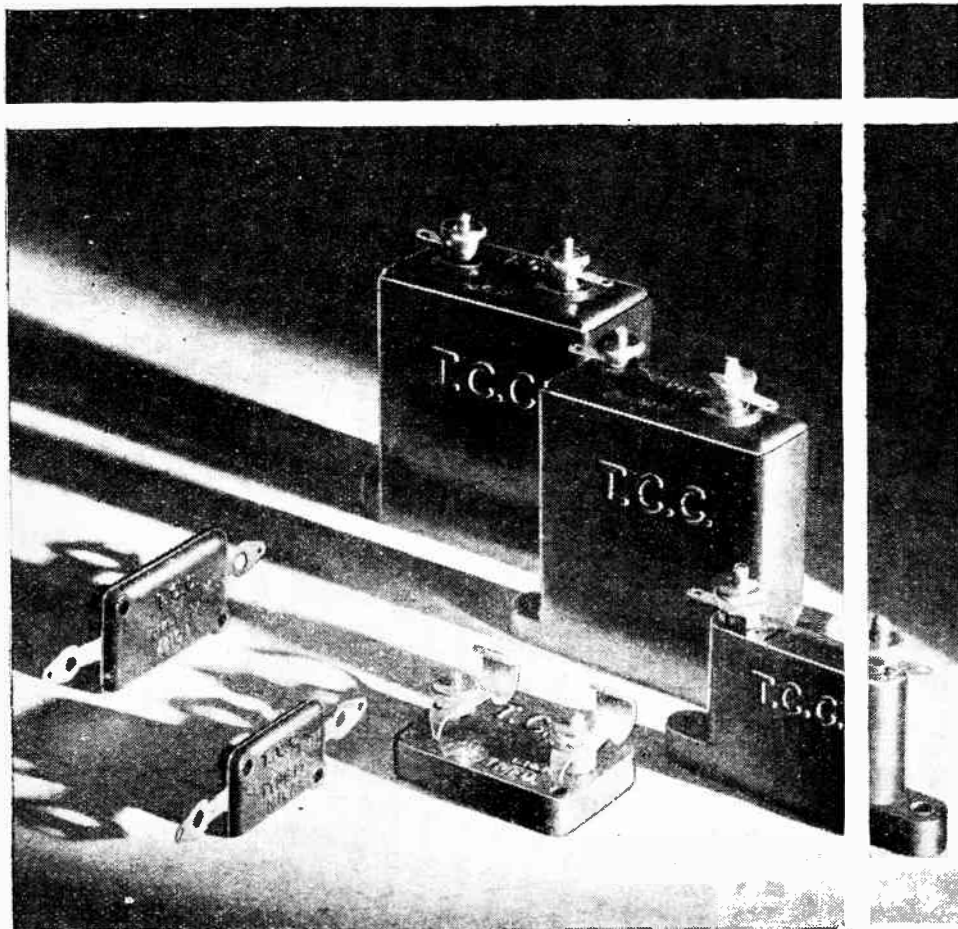

T.C.C. means  
SAFETY . . . .  
ALWAYS



Research — intensive concentrated research—Creating the means to solve the ever present problems of Radio — Rejecting all but what experience has found 100% right. That is the job of the vast T.C.C. organisation—that is why none but the perfect product finds its way to the storeroom. But even more, that is why T.C.C. spells SAFETY at all times. Throughout the world the “condenser in the green case” is synonymous with condenser efficiency—whatever the need there is a T.C.C. to fulfil it—adequately—the reason for the choice of T.C.C. by all the leading set designers.

**T.C.C.**  
ALL-BRITISH  
**CONDENSERS**

The Telegraph Condenser Co. Ltd.  
Wales Farm Road, N. Acton, London, W.3

♥ 3478

**For PERFECT VOLUME CONTROL — WATMEL POTENTIOMETERS**

Our Policy this year is to specialise in Potentiometers. You can therefore be certain when purchasing a Watmel Potentiometer that you are obtaining the very best from a firm that is concentrating on this type of component. This resistance meets with the requirements for a volume control which will have an equal variation of volume for the rotation of the knob. This is specially important for the control of the grid bias of the new variable-Mu valves.

Here is illustrated the Watmel Type 2 Potentiometer with mains switch.

Price.  
Square Law Winding 8/6  
Without Mains Switch 6/3  
Type 1.  
Standard Winding 5/6

Please write for the interesting Watmel book on volume control! Free

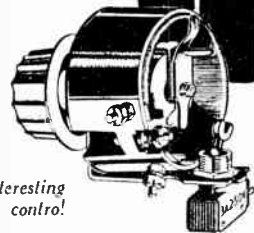

WATMEL WIRELESS Co. Ltd., Imperial Works, High Street, EDGWARE. Telephone: Edgware 0323

M.C.92

*Efficiency depends on Perfect Contact*

To ensure perfect, reliable contact and the highest possible efficiency from any receiver, follow experienced designers — always use Clix.

“ A MATTER OF CONNECTION.”

Clix New Folder “ W ” gives details of over 30 Perfect Contact Components. Write for a copy now.

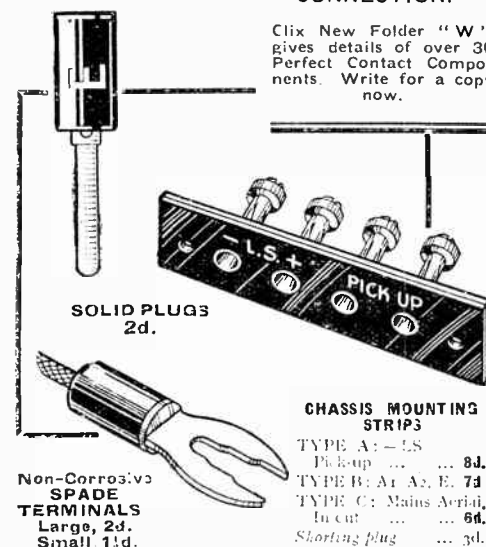

LECTRO LINX, LTD., 79a Rochester Row, S.W.1

Mention of “The Wireless World,” when writing to advertisers, will ensure prompt attention.

# MISCELLANEOUS ADVERTISEMENTS

## NOTICES.

**THE CHARGE FOR ADVERTISEMENTS** in these columns is

12 words or less, 3- and 3d. for every additional word.

Each paragraph is charged separately and name and address must be counted.

**SERIES DISCOUNTS** are allowed to Trade Advertisers as follows on orders for consecutive insertions, provided a contract is placed in advance, and in the absence of fresh instructions the entire "copy" is repeated from the previous issue: 13 consecutive insertions 5%; 26 consecutive, 10%; 52 consecutive, 15%.

**ADVERTISEMENTS** for these columns are accepted up to **FIRST POST** on **MONDAY MORNING** (previous to date of issue) at the Head Offices of "The Wireless World," Dorset House, Stamford Street, London, S.E.1, or on **SATURDAY MORNING** at the Branch Offices, 19, Hertford Street, Coventry; Guildhall Buildings, Navigation Street, Birmingham, 2; 260, Deansgate, Manchester, 3; 26, Renfield Street, Glasgow, C.2.

Advertisements that arrive too late for a particular issue will automatically be inserted in the following issue unless accompanied by instructions to the contrary. All advertisements in this section must be strictly prepaid.

The proprietors retain the right to refuse or withdraw advertisements at their discretion.

Postal Orders and Cheques sent in payment for advertisements should be made payable to **ILIFFE & SONS Ltd.**, and crossed & Co. Notes being untraceable if lost in transit should not be sent as remittances.

All letters relating to advertisements should quote the number which is printed at the end of each advertisement and the date of the issue in which it appeared.

The proprietors are not responsible for clerical or printers' errors, although every care is taken to avoid mistakes.

## NUMBERED ADDRESSES.

For the convenience of private advertisers, letters may be addressed to numbers at "The Wireless World" Office. When this is desired, the sum of 6d. to defray the cost of registration and to cover postage on replies must be added to the advertisement charge, which must include the words "Box no., c/o 'The Wireless World,' Dorset House, Stamford Street, London, S.E.1. Readers who reply to Box No. advertisements are warned against sending remittance through the post except in registered envelopes; in all such cases the use of the Deposit System is recommended, and the envelope should be clearly marked "Deposit Department."

## DEPOSIT SYSTEM.

Readers who hesitate to send money to advertisers in these columns may deal in perfect safety by availing themselves of our Deposit System. If the money be deposited with "The Wireless World," both parties are advised of its receipt.

The time allowed for decision is three days, counting from receipt of goods, after which period, if buyer decides not to retain goods, they must be returned to sender. If a sale is effected, buyer instructs us to remit amount to seller, but if not, seller instructs us to return amount to depositor. Carriage is paid by the buyer, but in the event of no sale, and subject to there being no different arrangement between buyer and seller, each pays carriage one way. The seller takes the risk of loss or damage in transit, for which we take no responsibility. For all transactions up to £10, a deposit fee of 1/- is charged; on transactions over £10 and under £50, the fee is 2/6; over £50, 5/-. All deposit matters are dealt with at Dorset House, Stamford Street, London, S.E.1, and cheques and money orders should be made payable to Iliffe & Sons Limited.

**SPECIAL NOTE.**—Readers who reply to advertisements and receive no answer to their enquiries are requested to regard the silence as an indication that the goods advertised have already been disposed of. Advertisers often receive so many enquiries that it is quite impossible to reply to each one by post. When sending remittances direct to an advertiser, stamp for return should also be included for use in the event of the application proving unsuccessful.

# PILOT AUTHOR KITS

*Exact to Specification*

AS FOUNDERS OF CONSTRUCTORS' SETS IN 1910, we have established a world-wide reputation for the supply of Complete Kits and Part Kits for all "Wireless World" Set designs. An essential feature of this Expert Service to the Home Constructor is **IMMEDIATE DELIVERY FROM STOCK CASH or C.O.D.** of any exclusively specified or difficult to obtain components. Rely on **PETO-SCOTT**, he always gives fullest satisfaction to every customer.

## NEW MONODIAL

**RECEIVER KIT**  
Author's Kit of FIRST SPECIFIED PARTS for RECEIVER PORTION ONLY, less Plymax Chassis, Panel, Cabinet and Valves  
Cash or C.O.D. Carriage Paid **£10-19-6**  
Extra for Peto-Scott Plymax Chassis as used by the Author, 14" x 12" Ready Drilled and Assembled with Runners 10 6  
Peto-Scott Oak faced Ply Panel, 10 Drilled, 14" x 10" 2 6

**RECEIVER KIT "A"** as above but with PETO-SCOTT READY-DRILLED AND ASSEMBLED PLYMAX CHASSIS WITH RUNNERS AND PANEL, less Valves and Cabinet, Cash or C.O.D., Carriage Paid, £11-12-0 or Deposit £1-12-0. Balance in 11 monthly payments of 20/-.

**POWER UNIT KIT**  
Author's Kit of FIRST SPECIFIED PARTS for POWER UNIT ONLY but less Plymax Chassis and Valves  
Cash or C.O.D. Carriage Paid **£8-13-6**  
Extra for Peto-Scott Ready-Drilled Plymax Chassis with Runners, 18" x 6" x 12" 7 6  
**POWER UNIT KIT** as above but with READY-DRILLED AND ASSEMBLED PLYMAX CHASSIS, Cash or C.O.D., Carriage Paid, £9-0-0 or 12 monthly payments of 16 6.

**BUILD your "Wireless World" Set on the PETO-SCOTT PLYMAX CHASSIS used and specified by the Author.**

**COMBINED KIT**  
Comprising Receiver and Power Unit Kits with 2 Peto-Scott Ready-drilled Plymax Chassis with Runners and Peto-Scott Ready-drilled Oak Panel, less Valves and Cabinet, Cash or C.O.D. Carriage Paid **£20-12-0**  
or £3-12-0 Deposit and 11 monthly payments of 35/-.

**COMPLETE KIT**  
Comprising Receiver and Power Unit Kits as Combined Kit but with Valves, less Cabinet, Cash **£27-17-0**  
or £5-17-0 Deposit, Balance in 11 monthly payments of £2-4-0.

**FINISHED INSTRUMENTS.**—Peto-Scott supply all "Wireless World" Sets as finished receivers, Aerial tested. Cash, C.O.D. or H.P. Send for quotation, no obligation. Peto-Scott have specialised in "Wireless World" Kits and finished instruments for 14 years.

**MODERN BATTERY FOUR KIT 'A'** Author's Kit of FIRST SPECIFIED COMPONENTS including ready-drilled ply-panel and Peto-Scott assembled and drilled PLYMAX CHASSIS, excluding Valves, Cabinet and Speaker. Cash or C.O.D. **£8-6-9**  
or 12 monthly payments of 15 3.

**PETO-SCOTT PLYMAX CHASSIS SOLELY SPECIFIED.** Plymax Chassis as specified by the Author, drilled and assembled, 10" x 10". Cash or C.O.D. Post **7/6** and Packing 1 3 extra.

## IMMEDIATE DELIVERY CASH - C.O.D. - H.P.

**FOREIGN ORDERS.** Send one-third value of goods with order. Balance (including forwarding charges) payable to our forwarding agents on delivery. Insurance effected if desired. All orders carefully executed and expertly packed by special export staff.

**PETO-SCOTT CO. LTD.**  
77, CITY ROAD, LONDON, E.C.1.  
West End Showrooms: 62, High Holborn, London, W.C.1

## RECEIVERS FOR SALE.

- M**ILDMAY RADIO Exchange Offers the following, Sound and Perfect. [3451]
- M**ICHAEL, 1932 3-valve A.C. Mains Set, with built-in moving coil speaker and valves, listed £25 4, C9.
- M**URPHY B.5 5-valve Superhet Receiver with moving coil speaker and valves, 1933 model, £8.
- W**IRELESS WORLD Baby Superhet, built to specification, complete with Bakers P.M. speaker and mains unit, £6.
- P**HILIPS 3-valve A.C. Set, with built-in speaker and valves, £5.
- T**HE Above Carriage Paid.
- C**LOSED Saturday, open Thursday all day.
- P**HONE: Clissold 5601
- 24**, Mildmay Grove, London, N.1. [3451]
- O**RIGINAL Monodial Units, as specified, with valves and spares, 2½ watt output; £10, or near offer. - Everett, 222, Great Portland St. W.1. [3447]
- 40/-**—Ediswan D.C. all electric, S.G., det. and pentode, without valves, worth more to break up; transformers output choke, 2,0005, with drum drives, coils, smoothing unit, resistances and condensers, etc.
- £3/19/6**—Miles Radio 2-valve, A.C. with Ultra speaker, complete with valves unopened; list £8/10.—Kay, 167 City Rd., London, E.C.1. [3352]
- A**RMSTRONG Latest Universal A.C./D.C. Chassis, specially efficient, S.G. circuit, pentode output, incorporating 3-ranophone amplifier, splendid reproduction, fully guaranteed; 75 w. with 5 valves, 114 w. approval. Armstrong Co. 100, King's Rd., N.W.1. [3469]
- C**IBEL D.C. 2-valve Sets, detector, pentode, Magnavox M.C. Osram valves, packed in makers' unopened carton; at £3/19/6, c.o.d., carriage paid; also Mayco D.C. 2-valve detector, power, Sonochord M.C., £3/12/6. W. Burns and Co., 287, City Rd., London, E.C.1. [3374]
- 19** 33 New Century Super Battery Six, Ring valves, less cabinet, Headlamp eliminator, 250v. 60ma., 6 tap plugs, 3 variable, 4v. 6 amp. L.T., adjustable 25-50 cycles, cost £8 fifteen months ago. Pico Radio-Set, cost £2 2; sell separately if desired; offers—Box 8074, c/o The Wireless World [3471]

## MAINS EQUIPMENT

- S**ERADEN Products.
- S**ERADEN V.R.328-B Battery Charger, will charge up to 200 cells per week, maximum output 1.5 amps.; price complete, £3 5; photographs, and lists of others for stamp.
- S**ERADEN Eliminators, Westinghouse rectified, housed in perforated metal containers, special smoothing circuit, ensures dead silent reception, and immunity from modulation hum, 4 decoupled tapping.
- S**ERADEN M.5 Eliminator, output 120v. 50ma., £2 17/6; T.M.5 auto, with trickle charger, 2, 4, 6 vab. at 0.5 amps., £3 16 6.
- S**ERADEN M.6 Eliminator, gives maximum output of 150v. 25ma., £3 1; or with trickle charger, £4.
- S**ERADEN Mains Transformers, now list available shortly. Have you reserved your copy? If not, send stamp.—Trevor Pepper, 575d, Moseley Rd., Birmingham, 12. [2465]

## Mains Equipment.—Contd.

- N.P.** Chargers for A.C. mains. Trade list free.
- N.P.** Have Most Efficient Chargers from £2 6, complete ready for use.
- N.P.** Have one or two Chargers Slightly Soiled at Bargain Prices. List.
- N.P.** Chargers, 3 circuits to charge 12 x 2 volt batteries on each 6-4 amps., variable resistances, from £9; chargers to six 36 x 2 volt cells in series up to 2 amps., £5; 75 volts 3 circuits 6 amps., total £13 15; trade list.
- N.P.** Have a Special Bargain This Week for Large Station; 150 volt 10 amps. A.C. charging plant, may be seen working; cost £35, sacrifice £15, or offer.—Nash Products, Ltd., Stechford, Birmingham 9.
- N.P.** Will Send You Full Details of Small or Large Battery Charging Plants with Photographs; no wiring necessary, plug into your mains and switch on; now is the time to merge your business.—Nash Products, Ltd., Stechford, Birmingham 9. [3480]
- V**ORTEXION, Wimbledon, for 99.9% reliable transformers.
- I**f You Haven't Tried Them Yet Ask Someone who has, or call and inspect complimentary letters.
- A**ll Standard Models Delivery by Return; all secondaries centre tapped.
- G**UARANTEED 12 Months, and within 5% normal and 2½% super models, neat shrouding, with detachable feet, as used by Government Departments, etc., etc.
- V**ORTEXION, New monodial transformer, 200-250, 50 cycles, 425-0-425, 120 ma., 4v. C.T. 5a., 4v. C.T. 1a., 4v. C.T. 1a., 4v. C.T. 6a., screw primary, open type, 2v. shrouded, 22; super shrouded, 26; 10 henry choke, 5 6; 20 henry choke, 8 6.
- V**ORTEXION, Ferrarist III, 350-0-350, 60 ma., 4v. 2.5, C.T. 4v. 3.5, C.T.; open type 13 6, shrouded 16; post 9d.
- V**ORTEXION -250 0-250, 4v. 1 to 2a., 4v. 2 to 4a.; open type 10 6, shrouded 12 6; post 9d.
- V**ORTEXION.—Super model for H.T. or 9 or 10 4v. 1 to 2, 4v. 2 to 4; open type 14 6, shrouded 16 4; post 12.
- V**ORTEXION.—2½ watt Monodial A.V.C. model; open type 14 6; shrouded 16 6; post 12.
- V**ORTEXION, 5-watt Monodial A.V.C. model, 400 0-400, 120 ma., 4v. 6a., 4v. 7½a., 4v. 2, 4v. 1a., super screened; 250-0-250, shrouded 24 6.
- V**ORTEXION.—350-0-350, 120 ma., 4v. 2 to 5a., 4v. 2 to 4a., 4v. 2.5a.; open type 14 6, shrouded 16 6.
- V**ORTEXION.—400 or 450 or 500v., 120 ma., 4v. 2 to 5, 4v. 2 to 5, 4v. 2 to 5; open type 19 6, shrouded 23 6.
- V**ORTEXION.—400 or 450 or 500, 150 ma., 4v. 4a., 4v. 2.5, 4v. 2, 4v. 2, 4v. 2, core size 2½ in. x 1½ in., a superb job, 2% regulation; 35; shrouded with terminals, less terminals, 30; open type 26 4; post 1 3.
- V**ORTEXION, Auto Transformers to B.E.S.A. Specification, 100, 110, or 120v. to 200, 220 or 240 volts, 60 watts, 7 3; post 9d.; 120 watts, shrouded 12 6, open type 10 6, post 1; 200 watts, open 14 6, shrouded 16 6, post 1; 500 watt, 30; 2,000 watts £4 10.
- V**ORTEXION 600-watt Transformers; £4 10, carriage free.
- V**ORTEXION 30h. at 60 ma. Chokes, 5 6; 40h. at 60 ma., 8 6; 30h. at 150 ma., 200 ohm., 10 6 open type, 12 6 shrouded.
- V**ORTEXION 200v. 30 ma. Eliminators, 110 or 220 ma. with 4v. 4a. winding; 37 6.
- V**ORTEXION.—Transformers made to your specification. All standards in stock. Phone all hours.
- V**ORTEXION (S. A. Brown), 182, The Broadway, Wimbledon, Tel: Liberty 2814. [3117]



## These "New Notes"?

Some of our correspondents take us to task for not shouting down fantastic claims made for certain speakers, and ask us to come forward and say more about the HARTLEY TURNER Loud-speaker. A refined voice does not indulge in brawling and, according to those who have bought them, the voice of the HARTLEY TURNER is refined.

"NEW NOTES IN RADIO" sent for a 1½d. stamp does tell you all about the

### Hartley Turner Loudspeakers

D.C. MODEL £7.7.0

A.C. MODEL £8.8.0

Demonstrations any time by appointment.

**HARTLEY TURNER RADIO LTD.,**

Thornbury Road, Isleworth, Middlesex.

Tel.: Hounslow 1854.

### THE HARTLEY TURNER LOUDSPEAKER

We are demonstrating this remarkable new moving coil loudspeaker daily between 12 and 3 p.m., and 4 and 6 p.m. Other times by appointment.

**Easy Payment Terms** for the Hartley Turner Moving Coil Unit, complete with special transformer, carriage paid, are as follows:—

**D.C. Model, cash price £7.7.0 or 20/- with order and 11 monthly payments of 12.9.**

**A.C. Model, cash price £8.8.0 or 26/- with order and 11 monthly payments of 14/-**

We supply all other high-grade radio apparatus on convenient easy payment terms. Please send us your enquiries and a quotation will be sent by return.

**THE LONDON RADIO SUPPLY CO.**

(Established 1925)

11, Oat Lane, Noble Street, London, E.C.2

(off Gresham Street)

Phone: National 1977.

## EVERY TEST WITH ONE INSTRUMENT ONLY

D.C.  
AND  
A.C.

The Avometer is indispensable to the Service men of leading radio manufacturers as the only instrument which adequately meets their needs. It is the only complete testing instrument giving direct readings in amps, volts and ohms without the necessity for mathematical calculations.

Two models: One for D.C. only, 8 Gals., and the Universal Avometer giving both D.C. and A.C. readings (40 cycles 12 Gals.). Detailed Terms desired.

Fully descriptive pamphlets free on application.

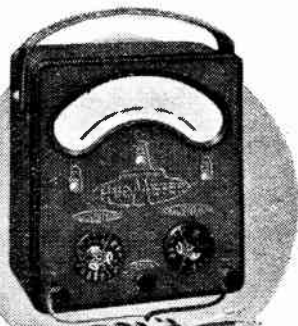

The AVOMETER

REGD. TRADE MARK

THE AUTOMATIC COIL WINDER AND ELECTRICAL EQUIPMENT CO., LTD.,

Winder House, Douglas Street, London, S.W.1.

Phone: Victoria 3400-7.

BRITISH MADE

### Mains Equipment.—Contd.

**HOYNE'S** Transformers and Chokes the Best Obtainable perfect insulation, regulation and reliability.

**HOYNE'S** Transformers used by many well-known set manufacturers after testing all others

**HOYNE'S** Transformers fitted with taped and screened primaries, filaments all centre tapped, stout cast aluminium chaps and clearly marked terminal strips are fitted to all models.

**HOYNE'S** Components are guaranteed for one year; built to your own specification at very competitive prices.

**HOYNE'S** Components. The components you will eventually use, start right; a dud cannot pass the Hoyne test.

**HOYNE'S** New Monodial Super, aluminium chassis, drilled for components, complete with Power Transformer, two chokes, push-pull intervalve transformer and valve holders 51/- carriage paid.

**HOYNE'S** New Monodial Transformer, 425-0-425v. 120 m.a., 4v. 2a., 4v. 1a., 4v. 1a., 4v. 6a., 24v., post 1/3; weight 10lb., 10 henry choke, 6/-, post 6d.; 20 henry choke, 7/6, post 6d.

**HOYNE'S**—250-0-250v. 60 m.a., 4v. 1-2a., 4v. 2-4a., 10/-, post 9d.; with extra 4v. 1-2a. winding, 12/6, post 1/-.

**HOYNE'S** Ferrocart Model, 350-0-350v. 60-70 m.a., 4v. 2-3a., 4v. 2-4a., 12/6, post 1/-; with extra 4v. 1-2a. winding, 13/6, post 1/-.

**HOYNE'S**—350-0-350v. 120 m.a., 4v. 2-2a., 4v. 4-6a., 4v. 1a., 4v. 1a., 16/-, post 1/-.

**HOYNE'S**—500-450-0-450-500v. 140 m.a., 4v. 2-4a., 4v. 4-6a., 4v. 2a., 4v. 2a., 27/6, post 1/3; weight 11lb.

**HOYNE'S**—0-110-135v. 50 m.a., suitable for H.T. 6 or 7. 7/6, post 9d.; with 4v. 2-4a. winding, 9/6, post 9d.

**HOYNE'S**—200v. 260 m.a., 4v. 2-4a., 4v. 1-2a., for H.T. 8, 13/6, post 1/-.

**HOYNE'S** Auto Transformers, Chokes and Filament Transformers always in stock.

**HOYNE'S** Components still have no equal.

**M. J. HOYNE**, Offices and Works, 8a., Gladstone Rd., Wimbledon, S.W.19. Tel.: Liberty 3303. [3455]

**TANTALUM** for A.C. Chargers, H.T. and I.T.—Blackwell's Metallurgical Works, Ltd., Garston, Liverpool. [3448]

**A.C. Charging Plant**, unused, cost £18 18, for £6 18 6; write for makers' specification.—Jersey, Cummor Hill, Oxford. [3424]

**POWERITE** Mains Transformers, a real engineer's job with 3 years' guarantee, competitive prices; lists free; trade enquiries invited.—Nasco, Wireless Products, Pittville Works, Tower Rd., Aston, Birmingham. [3506]

**100** Accumulator Chargers, ½ amp., 26v., in ventilated metal case (Arden, 1932), incorporating Westinghouse rectifier, 10/8; 1½ amp., 21/-; 7 days' trial.—Aiden Agency, Wollaston, Wellingborough. [3400]

### CABINETS.

**RADIO-GRAM** Cabinets; fully illustrated list free; remarkable values.—Gilbert, Cabinet Maker, Swindon. [1696]

**MANUFACTURER'S** Clearance Lines of Cabinets for Radiograms, loud-speakers and radio sets; hundreds to select from; sent postpaid for list; special cabinets for Skyscraper and S.T.400.—H. I. Smith and Co., Ltd., 289, Edgware Rd., London, W.2. [3469]

### DYNAMOS, ETC.

**CLASS "B"** Converter, multi ratio, with P.D.220 and battery; 30/- Box 8065, c/o *The Wireless World*. [3462]

**ROTARY** Converters, E.D.C. Co.'s manufacture, as new, D.C. to A.C., with output of 220 watts.—Apply Electricity Works, Newquay, Cornwall. [3335]

**ROTARY** Converters, 220 volts D.C. to 200 volts A.C., capacities up to 0.44 K.V.A., cheap.—Milo Engineering Works, Milo Rd., East Dulwich, S.E.22, Sydenham 4422. [3450]

### GRAMOPHONES, PICK-UPS, ETC.

**GARRARD** Induction Motor, A.C. four, 32/-; Auto record changer, £7 10, sealed cartons; Bowyer-Lowe Pickups, Mark 3, 22/6.—K. Treen, Coleshill, Birmingham. [3477]

### LOUD-SPEAKERS.

**P.M. Speakers** Bargain

**LARGE** Quantities, 8½ in. P.M.M.C. Speakers, made by well-known manufacturer for set maker; highly sensitive, work off any set; 3-ratio transformer; 19/6, post free; money returned if not satisfactory.—Milton Manufacturing Co., Milton St., Coventry. [3415]

**B.T.H. RK** Moving Coil Speakers, guaranteed new, unused, manufacturers' surplus, original price.

**6** Guineas, highly sensitive and wonderful tone response, will handle up to 10 watts output, available for 6v., 100v., 200v. D.C., 30/-, also A.C. models

£2 10; carriage paid, c.o.d. or cash with order; the best value in speakers obtainable today.—O. H. Seekamp, First Avenue House, High Holborn, London, W.C.1. Phone No.: Holborn 6609. [1425]

**EPOCH** 99K, £3 10; N. and K., dynamic, 25/-; both new, May, 51, Graham Mansions, Hackney, E.8. [3474]

**10/-**—Lamplugh Silver Ghost, 2,200 ohms, with output transformer, unopened; list 47/6; c.o.d., carriage paid.—Kay, 167, City Rd., London, E.C.1. [3351]

**ARMSTRONG** 1934 Permanent Magnet Moving Coil Speaker, better than ever this year, transformer matched to your requirements; technical advice willingly given; full size speaker, remarkable performance, 21/-; guaranteed; approval.—Armstrong Co., 100, King's Rd., N.W.1. [3468]

# RADIO DATA CHARTS

## A SERIES OF ABACS

providing most of the essential Data required in Receiver Design

By

**R. T. BEATTY, M.A., B.E., D.Sc.**

Reprinted from  
"The Wireless World"

(1930)

"Radio Data Charts" provide designers of wireless apparatus with a ready and convenient means of solving problems without having recourse to complicated formulæ and mathematics.

By the use of the charts it is possible to tackle all the more familiar problems in radio receiver design, such as, for example, finding the relationship between inductance capacity and frequency, and working out the design of high frequency transformers. All keen amateurs will appreciate this helpful book.

(39 CHARTS and more than 50 Diagrams)

Price 4/6 net

By post 4/10

Published from the Offices of  
"THE WIRELESS WORLD"

From all leading booksellers or direct from the Publishers

**ILIFFE & SONS LTD.**

Dorset House,

Stamford St., London, S.E.1

W.W.93

**Loud-Speakers.—Contd.**

**30/-**!!!—B.T.H., R.K. moving coil speakers, 6in. cone, new and unused, guaranteed; these speakers are the type as used in cinema sound equipment; suitable for public address work; weight 30lb., and are vastly superior to the cheap speakers now on the market, 100 volts, 150 volts, and 200 volts D.C.

**27/6**!!!—6-volt D.C. speakers, as above; £2 7 6 speaker as above for 100-250 volts A.C., complete with field rectifier.

**CARRIAGE** Paid, cash with order, or e.o.d.; send for list.—Ward, 12, Trolegar Rd., Bow, E.3. Tel.: Advance 3668. [3459]

**CHAL. ELECTRIC** Offer New Boxed Set Manufacturers' Surplus Rola Speakers, all fitted hum buckers, state if Power or Pentode Transformer F6 110-175v. D.C. (2,000 ohms); 90-130v. D.C. (2,500 ohms); 150-200v. D.C. (4,700 ohms); 200-250 D.C. (6,500 ohms), listed at 35/-, at 18/-; F7 voltages as above list, 47 6, at 25/- each; permanent magnets F6P.M., listed at 49 6, at 28/-; F7P.M., listed £3, at 33/-; Ultra 95P.M., a real hefty job with Power-Pentode transformer, listed 44/15, at 47/6; Rola Dual Compensated (2) F6, list £3/10, at £2; (1) F6 and (1) F7, list £4 5, at 47/-; all goods Carriage Paid, Cash with order, or C.O.D.—Chal Electric, 6, Conduit St., London, W.1. [3221]

**VALVES.**

**ALL** Classes of Valves in Stock, including American and non-ing valves; send for price list.—R. Newman, 309, Roman Rd., London, E.3. [3446]

**ALL** Types of Valves in Stock, including the following brand new American valves, first-class makes: 247s, 235s, 224s, 236s, 237s, 235s, 245s, 244s, 12 : 227s, 226s, 280s, 245s, 9 6; 242s, 232s, 11 : U.X.210s, 15 : U.X.250s, 7 watts output, 16 : 281s, 14 6; post paid, cash with order or e.o.d. Send for valve list, Ward, 12, Trolegar Rd., Bow, E.3. Tel.: Advance 3668. [3488]

**COMPONENTS, ETC., FOR SALE.**

**R.** **SELECTED** Parts for Sale, as new; e.o.d. or "Wireless World" deposit system, which we recommend if in doubt as to the splendid value offered; we take risk of damage in transit to our customers; goods tested for callers and guaranteed.

**NEW** Output Transformers similar to R. and A., ratio 18 23 32, 6 : Telsen 0.05 mica condensers, 2/3; T.C.C. 0.01 mica type M, 1 : new Paxodin formers, 1in. slotted, with guides, 8d.; T.C.C. 2 mf., 350v. working, 1/6; ditto, 1 mf., 1 3, new; T.C.C. 4-4, 250v. working, 4 9.

**VARLEY** P.P. Input Transformer, 15/-; pairs new Polar twin S.M. thumb drive, 0.0005, complete, 12 6; Telsen 100h. chokes, 3 : Westinghouse H.T.4 and A4 rectifiers, with Varley transformer, £2; Clyden 0.0005 double thumb twin extender, 15 6; Clyden single 0.0005 extender, 7 6; Ready Radio 0.0005 extender condensers, new, 3 6; Sound Sales 10h. choke, 9 6; Ormond 65-type P.M. speaker complete, 37 6.

**RADIOPHONE** Pots with Switch, 5,000, 10,000, 100,000, 25,000, new, 2 6 each; new type Magna-speaker, 2,500 ohm and 5,000 ohm, 42 6 each complete; Sonocord Senior D.C. with 10-watt field, 30 : complete.

**FERRANTI** Resistances, with holder, 3,000, 5,000, 15,000, 20,000, 30,000, 50,000, 100,000, 2 6 each; Varley Power, 500, 1,000, 5,000, 10,000, 40,000, 50,000, 3/- each.

**TRANSFORMERS**, Ferranti A.F.4 8 1/2, A.F.3 12/6, A.F.5 18 6, A.F.5c 21 6, O.P.M. 16 6, O.P.M.2 13 : O.P.M.4 16 6; B1 choke, new, 13/-; A.F.6 18/6, A.F.7c 22 6.

**EDISON BELL** 10,000 Eureka, wire wound, with holders, 1 : Edison Bell 0.0005 universal lg all metal condensers, 1 6, new.

**AMPLION** Public Address Microphone, £3; Ready Radio A Senior Inflatam matching transformers, new, 10 25/-; 15 9; G.E.C. Senior induction motor, 47/6; set Colvern battery Super Five coils, 10 : set Colvern single dial super battery coils, 15 : Mullard H.T. eliminator, complete, 150v. 30 m.a., 240v. input, 30/-; Six-Sixty eliminator, 200v. 25 m.a., and G.B., 32 6; Ekco A.C.25, 47 6; Atlas A.C.244, 39 6.

**PAIR** Varley Q.P.P. Input and Output, 19/-; Wearite and Leveco Superhet. coils, 5 : 3-range oscillators, 7 6; 8-way bases, 4 6; T.C.C. 2,000 mf. electrolytic, 9/-; T.C.C. dipo, 250 mf., 100v., 8 6; Navotone J., 30 : Igranite L.F. choke coupling units, 3 9; Lotus new 4-gangs, 15 9.

**RYALLS** Mains Condensers, 4 mf., 250v. working, 2/6; 4 mf., 500v. working, 4 6; 4 mf., 750v., 6 6; 2,000v., 17 6; Ryalls condenser blocks, 2 4 mf., 2/2 mf., 500v. working, 8 6; Dubilier 2-2, 560v. working, 2 6.

**RYALLS** Mains Transformers, 250v. 60 m.a., 4v. 1 amp., 4v. 3 amp., 10 6; 350v., 12 9; H.T.7, with 4v. 4 amp., 10 6; 4v. 3 amp. only, 6 9; chokes, 25h. at 60 m.a., resistance 260 ohms, 6 9; 20h. at 100 m.a., 8 9; 10h., 8 9, for Monodial; 40h. at 100 m.a., 10 6.

**RYALLS** RADIO Offer Reliable Resistances, 1 watt, suitable for all "Wireless World" sets where a 1 watt resistance is specified, in values 100, 500, 1,000, 2,000, 5,000, 6,000, 10,000, 25,000, 30,000, 75,000, 150,000, 250,000, 20,000, all values stated in ohms, 6d. each, guaranteed one year, wire ends, new goods.

**WE** Hold a Large Stock of First Class Radio Apparatus, meters, resistances, condensers, heavy chokes, and all set requirements, at bargain prices, all modern goods.

**RYALLS** RADIO, 33, Chancery Lane, Lond. W.C.2 (nearest Tube Chancery Lane); bus 67 passes door, or tram 1 Savoy St., Holborn 3529. Open Saturday afternoon. Close 7 p.m., Thursdays 1 o'clock, Saturday 6 p.m.

**R.** [3456]

**A.** **SURPLUS** RADIO, Ponders End, offers the following genuine manufacturers' stocks:  
**DOUBLE** Smoothing Choke, mounted, sound, robust job, 120m.a., 14 28 henrys each, usual price 35/-, our price 6 6 each, 9d. postage; single ditto, 4 6 each.  
**CHOKES**, small, iron-covered, 2,000 ohms, for output or choke coupling, 1 6 each, 3d. postage.

(This advertisement continued in third column.)

**QUALITY CLASS B... Are you a Battery Set Owner**

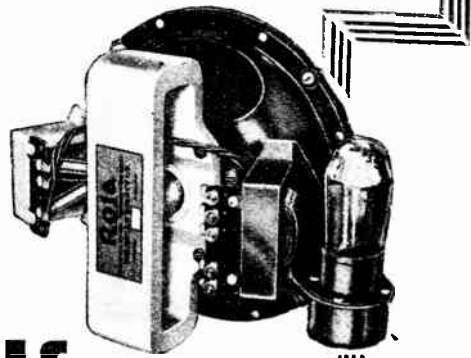

**If so...**

do you know that it takes only 5 seconds to fit a

**ROLA CLASS B SPEAKER AMPLIFIER Unit**

to any battery receiver and increase the volume 5 times.

Rola speakers are used by the large majority of British radio manufacturers and by nearly "all" constructor set designers. For realistic reproduction and impressive volume maintained year after year they occupy a position of unchallengeable supremacy. Write to-day for the Rola folder.

**Model A—** for MULLARD P.M.2B, B.T.H. P.D220, COSSOR 220B, STANDARD 13B1, HIVAC B220, MARCONIPHONE B21, G.E.C. B.21, CLARION B22.

**Model B—** for COSSOR 240, FERRANTI HP2, CLARION B24.

PRICE (Both Models) **57/-** without valve Price with Valve 71/-



THE BRITISH ROLA CO., LTD.,

Minerva Rd., Park Royal, N.W.10. Phone: Willesden 4322-3/4-5.

**ROLA SPEAKERS** for better Radio Reception

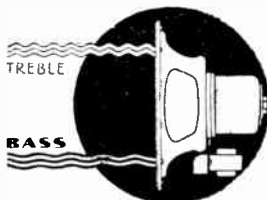

**Components, etc., for Sale.—Contd.**

(This advertisement continued from first column.)

**A.C. H.T. Eliminator**, 220v. to 240, with 4 tappings, total output 150v. at 25m.a., for use with D.W.2 or Phillips 1821 valve, or Westinghouse H.T.6 rectifier; full instructions given.

**MAINS** Transformer for Eliminators, output 250-0-250 at 60m.a., 4v. at 1 amp.; state input when ordering; price 6 6 each, postage 9d.

**14** mfd. Block Condensers, 250v. working, 6-4-2-1-1: 4/- each, postage 6d.

**RESISTANCES**, wire-wound, finest quality at ridiculous prices:—3,000, 5,000, 8,000, 40,000, 65,000 ohms, all 5 watt, worth 3 6 each; 6d. each, post 3d.

**WIRE-WOUND** Potential Dividers, 60 watt, wound 3 sections, 4,500 ohms, 3,000 ohms, and 2,000 ohms, 1 6 each, postage 4d.; 5 watt ditto, 20,000 ohms, 20,000 ohms, 20,000 ohms, 1/- each, postage 3d.

**POTENTIAL** Dividers, wound 2 sections, 5 watt, 40,000 and 23,000 ohms, 40,000 and 80,000 ohms, 40,000 and 100,000 ohms, 30,000 and 50,000 ohms; at 1/- each, postage 3d.

**POTENTIAL** Dividers, wound 5 sections, 5 watt, 250, 165, 100, 100, 100 ohms; 1 6 postage 3d.

**TWO** Separate Resistances, 60 watt, on one tube, 2,500 ohms and 500 ohms; 1 6 each, postage 4d.

**THREE** Separate Resistances on One Tube, 2,500 ohms, 1,000 ohms, 80 ohms; 1 - each, postage 3d.

**100,000, 200,000, and 300,000** ohms 1 watt type resistances at 4 6 per dozen, postage 3d.

**2** Meg., 0.1 meg., 0.5 meg. leaks, 0.001, 0.0001, 0.015 fixed condensers; all 3/- per dozen, postage 3d.

**R.C. Coupling** Units; 1/- each, postage 3d.

**1** mfd. Condensers, 250 volt working, 6d. each, postage 2d.; 4 mfd. condensers, 250 volt working, 1/6 each, postage 4d.

**GOODS** Order Value 20/- Carriage free

**EACH** Article is Tested Before Despatch and Guaranteed First Class Manufacture.

**CASH** With Order: all goods despatched the same day.—Surplus Radio, 32, Queensway, Ponders End, Middlesex. [3461]

**PREMIER**

**PREMIER SUPPLY STORES** Offer the following Set Manufacturers' Surplus New Goods at a fraction of the Original Cost, all goods guaranteed perfect, carriage paid over 5/-, under 5/- postage 6d. extra (Ireland, carriage forward).

**ELIMINATOR** Kits, including transformer, choke, Westinghouse metal rectifier, T.C.C. condensers, resistances and diagram, 120v. 20 m.a., 20 : trickle charger 8 - extra; 150v. 30 milliamperes, with 4v. 2-4 amps. C.T., L.T. 25/-; trickle charger 6/6 extra; 250v. 60 milliamperes, with 4v. 3-5 amps. C.T., L.T. 30/-; 200v. 100 milliamperes, with 4v. 3-5 amps. C.T., L.T. 49/6; 300v. 60 milliamperes, with 4v. 3-5 amps. C.T., L.T., 37 6.

**ELLIOTT** First Grade Moving Coil Meters in the Following Ranges:—0-10, 0-30, 0-50, 0-100, 0-150 milliamperes, also 250v. flush type, 17/6, projecting 15/-.

**ROLA** Moving Coil Speakers, complete with humbucking coils and output transformer; please state whether power or pentode required; F6, 2,000 or 6,500 ohm, listed 35/-, at 17 6; F7, 2,000 or 6,500 ohm, listed 47/6, at 23 6; A.C. conversion kit for any of above, 10/-.

**SPECIAL** Offer.—Reisz type microphone with transformer, a really professional job, listed at £12; our price 52 6.

**HEAVY** Duty Variable Resistances, wound on porcelain, 2,000 ohms 1-4 amp., 5,000 ohms 1-2 amp., 120 ohms 1 amp., all the above values, 3 6 each.

**T.C.C. Condensers** 750v. working, 2 mf. 3/6, 4 mf. 6/-, 4 mf. 400v. working 4/-, 250v. working 1 mf. 1/-, 2 mf. 1/9, 4 mf. 2/6, 1,500v. working Standoff insulators 5 mfd. 1/6, 2 mfd. 6/-, aqueous electrolytic 440v. working, 4 mf. 3/-, 8 mf. 3/6.

**DUBILIER** Condensers.—.01 mica 6d., .01 mica 1,000v. working 1/-.

**ALL** the Following Lines 6d. each or 5/- per dozen; 4 and 5 pin chassis mounting valve holders; shielded screen grid or pentode leads 1-watt wire end resistances, any value; T.C.C. .1 condensers; hum dingers; on-off switches pushpull; polar ganging devices.

**FERRANTI** Condenser Blocks 300v. working 4-4-2-2, all separate, 5/-.

**POLAR** 3-gang 0.0005 Condensers, split end vanes, totally screened, disc drive; 6/11.

**AMSCO** Triple-gang 0.0005 Condensers, with trimmers 4/11.

**ORMOND** 0.0005 Condensers, 1/3: 2-gang semi shielded, 2/6.

**WESTERN ELECTRIC** Mains Transformers, input 200-250 volt, output 500-0-500 volt, at 150 milliamperes, 4v. 4a., 4v. 2.5a., 4v. 2a., 4v. 1a., 4v. 1a., massive job; 19/6.

**T.C.C. Electrolytic** Condensers, 10 mfd., 100 volts working, 1/-; 15 mfd. 1/3.

**SPECIAL** Offer of Mains Transformers manufactured by Phillips, input 100-150v. or 200-250v., output 180-0-180 volts, 40 m.a., 4v. 1a., and 4v. 3a., 4 6; 200-0-200v., 4v. 1a., 4v. 3a., 4/6.

**ALL** Premier Guaranteed Mains Transformers have engraved terminal strips with terminal connections, input 20-250 volts, 40-100 cycles, all windings paper interleaved.

**PREMIER** H.T.8 Transformer, 250v. 60 m.a., rectified, with 4v. 3.5a. c.t. L.T., and screened primary, 15/-; with Westinghouse rectifier, 25/-.

(This advertisement continued on next page.)

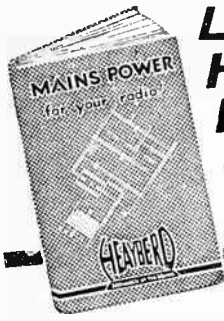

# Let this Handbook help you on Mains Problems

Containing many circuit diagrams for the construction of mains units, battery chargers and a unit for energising the field-coil of M.C. speakers, the latest version of the Heyberd Handbook "Mains Power for Your Radio" will prove valuable to all keen experimenters or set-builders. It also contains pages of technical hints and data; details of Mains Units, Kits, Battery Chargers, Amplifiers, Mains Transformers, Chokes and Condensers. If you are interested in the Mains—you will be interested in this Handbook. Fill in the coupon and post to-day with 3d. stamps—a copy will be sent you by return.

Mr. ....  
Address ..... W.W.

F. C. HEYBERD & CO., 10, FINSBURY STREET, E.C.2



One minute from Moorgate Und. Station.

## EPOCH

**MOVING COIL SPEAKERS**  
The Finest in The World in Each of Their Price-classes.

Ask your dealer or call for a demonstration at Exmouth House.  
Send for New Booklet W.S.5a. It is free.  
EPOCH RADIO MANUFACTURING Co. Ltd., Exmouth House, Exmouth St., London E.C.1  
At the junction of Rosebery Avenue and Farringdon Road.  
Phone: Clerkenwell 6096 (4 lines)

## What is ENGINEERING OPPORTUNITIES

250 pages

"ENGINEERING OPPORTUNITIES" is a 250-page Hand-book that has been prepared after years of patient search into the possibilities of various Engineering careers. It shows clearly and definitely the way in which you may carve out a successful career in your chosen branch of Engineering irrespective of your age, education or experience. Among a host of other things, it outlines Home-Study Courses in all branches of Civil, Mech., Elec., Motor, Aero., Wireless and "Table" Engineering and shows the way to pass A.M.I.C.E., A.M.I.Mech.E., I.E.E., A.M.I.A.E., M.I.M.T., G.P.O., Matriculation, Civil Service and other Examinations.  
"ENGINEERING OPPORTUNITIES" is a unique Hand-book that you should not certainly re-l. Send for your copy to-day—FREE of any cost.  
BRITISH INSTITUTE OF ENGINEERING TECHNOLOGY, 387, SHAKESPEARE HOUSE, 20 St. OXFORD STREET, LONDON, W.1.

## ELECTRADIX BARGAINS

Write for New Sale List "W"  
ELECTRADIX RADIOS,  
218, Upper Thames Street, E.C.4.

### Components, etc., for Sale.—Contd.

(This advertisement continued from previous page.)  
PREMIER H.T.9 Transformer, 300v. 60 m.a., rectified, with 4v. 3-5a. c.t. L.T., and screened primary, 15/-; with Westinghouse rectifier, 26/-.  
PREMIER H.T.10 Transformer, 200v. 100 m.a., rectified, with 4v. 3-5a. c.t. L.T., and screened primary, 15/-; with Westinghouse rectifier, 26/-.  
PREMIER Mains Transformer, output 135v. 80 m.a., for voltage doubling, 8/6; 4v. 3-4a. c.t. L.T. 2/- extra; Westinghouse rectifier for above, giving 180v. 30 m.a., 8/6.  
PREMIER Mains Transformers, output 250-0-250 volts, 60 m.a., 4v. 1-2a., 4v. 2-3a. 4v. 3-4a. (all c.t.), with screened primary; 15/-.  
PREMIER Mains Transformers, output 350-0-350 volts, 90 m.a., 4v. 3-5a., 4v. 2-3a. (both c.t.), with screened primary; 15/-.  
PREMIER Mains Transformers, output 400-0-400 volts, 100 m.a., 4v. 4-5a., 4v. 2-3a., with screened primary; 15/-.  
PREMIER Auto Transformers, 100-110/200-250 volts or vice versa. 60-watt, 7/9; 100-watt, 10/-.  
SPECIAL Offer of Manufacturers' Type Transformers, any input, output 250-0-250 volts, 60 m.a., 4v. 1a., 4v. 3a. (both c.t.), 8/6; H.T.8 transformer, with 4v. 3-4a. (c.t.), 8/6; with rectifier, 18/6.  
AMPLION Mains Transformers, input 100-250 volts, output 350-0-350 volts, 120 m.a., 4v. 5a., 4v. 2a., 6v. 1a. (all c.t.); 17/6.  
FILAMENT Transformers, polished and engraved terminal boards, N.P. terminals: 4v. 3-4a., 5/-; 10v. 3a., 6/6; 12v. 1a., 5/-; 4v. 4-6a., 6/6; 14v. 4a., 6/6; 22v. 1a., 6/-; 6v. 2a., 5/-; 9v. 1a., 5/-; 35v. 3a., 15/-.  
PREMIER Chokes, 40 m.a., 25 hys., 4/-; 65 m.a., 30 hys., 6/-; 150 m.a., 30 hys., 10/6.  
PYE Chokes, 20 or 32 hys., 4/-; Premier multi-ratio output transformers, giving 15 different ratios 7/6.  
PREMIER Eliminators, input 200-250 volts, 40-100 cycles, A.C., incorporating Westinghouse metal rectifiers, output 250v. 60 m.a., S.G., and 120v. taps, 42/6; with 4v. 4a. c.t. L.T., 7/6 extra.  
BRITISH RADIOPHONE Wire Wound Potentiometers, with mains switch incorporated, 5,000 ohms, 10,000 ohms, 50,000 ohms, 100,000 ohms, 250,000 ohms, any value; 3/6.  
PREMIER Eliminators, output 150v. at 30 m.a., S.G., and 100v. taps, with 4v. 3-4a. c.t. L.T., 37/6; or with trickle charger, 42/6.  
PREMIER Eliminators, output 120v. at 20 m.a., S.G., and 100v. taps, 27/6; with L.T. trickle charger incorporated, 35/-.  
PREMIER D.C. Eliminators, output 120v. at 20 m.a., S.G. and 100v. taps; 15/-.  
ACCUMULATOR Chargers, 200-250 volts A.C., all incorporating Westinghouse metal rectifiers; 2, 4, and 6v. at 1/2 amp., 12/6; 2, 4, and 6v. at 1 amp., 17/6; 12v. 1a., 27/6; 6v. 2a., 35/-; 12v. 2a., 35/-; 12v. 1.5a., 50/-; 6v. 3a., 39/6; 30v. 3a., 42/6.  
AMPLION High Inductance Chokes, resistance 2,500 ohms, 80 henries 60 m.a.; 5/6.  
WESTINGHOUSE Metal Rectifiers: 120v. at 20 m.a., 5/6; 180v. at 30 m.a., 8/6; 8v. at 1/2 amp., 6/6; 6v. at 1 amp., 9/6.  
KOLSTER BRAADES Electric Gramophone Motors, complete with turntables and automatic stop, 100-250v., A.C. and D.C.; list price £5, to clear £2.  
B.T.H. Induction Type (A.C. only) Electric Gramophone Motors, 100-250v.; 30/- complete.  
AMPLION Moving Coil Speakers, type E.M.644, dual fields, 2,500 and 5,000 ohms (100 and 200v.), with output transformer, 12/6; A.C. conversion kit for this speaker, 10/- extra.  
WESTERN ELECTRIC Condensers, 250v. working, 1 mfd. 6d., 2 mfd 1/-; 500v. working, 1 mfd., 1/-.  
T.C.C. Condensers, 250v. working, 4x4x1 mfd., 3/6; 300v. working, 4x4x2x2 mfd., 6/-; 6x4x2x2x2 mfd., 37/5v. working, 6/11; 4x4x1, 6/-.  
SPECIAL Offer of Wire Wound Resistances.—4 watts, any value up to 10,000 ohms, 1/-; 8 watts, any value up to 15,000 ohms, 1/6; 15 watts, any value up to 50,000 ohms, 2/-; 25 watts, any value up to 50,000 ohms, 2/6; 50 watts, any value up to 50,000 ohms, 3/6.  
WIRE Wound Potentiometers, 15,000 ohms, 1/6; Centralab Potentiometer volume controls, 50,000 ohms, 2/-; wire wound Clarostat Potentiometer, 50,000 ohms, 2/6; Colverstats, logarithmically wound Potentiometers, 6,000 ohms, 1/9.  
FOR Callers only.—The following valves, guaranteed new:—  
THE Last Few Western Electric 3211-D Valves, 10v. 3a. filament, 750-1,000v. plate, 50-65 m.a., impedance 3,500 ohms, amplification factor 12; cost £5; to clear at 15/-.  
PHILIPS 328 Valves for L.T. Charging, 5/6; 329 Barretter lamps, 2/-.  
HARLEY Pick-ups with arm and volume control; 12/6.  
PREMIER SUPPLY STORES, 20-22, High St., Clapham S.W.4. Macaulay 2188. Closed 1 o'clock Wednesdays, open to 9 o'clock Saturdays. Nearest Station, Clapham North Underground.  
PREMIER. [3487]

GILBERT INDUSTRIES' Parcels.  
"A," "B," "D," and Condenser Parcels, as advertised in issues August 4th and August 11th, still available by return of post.  
GILBERT INDUSTRIES, Ltd., 519, London Rd., West-cliff-on-Sea. [3283]

## "UNIVERSAL" HIGH-VOLTAGE VALVES

THE ONLY ones which operate direct from FULL MAINS VOLTAGE, either A.C. or D.C., without the use of transformers or resistances, and greatly reduce the cost of running your set. Do not confuse these with valves which can only be wired in series.

S100. S.G. valve for H.F. stages, L.T. couplings. Very high slope. Great amplification. Impedance over 1 million ohms	18/0
S25. S.G. valve for Det.—Audio and H.F. stages. High slope. Impedance 250,000 ohms	18/0
MS18. S.G. Vari-tun, with variable slope	18/0
MS70. S.G. Vari-tun. Excellent for A.V. control	18/0
D130. Outstanding characteristics: High-imp. Triode valve. Impedance 40,000. Amp. factor 100	17/6
PT 3. Multi-grid valve. Very remarkable slope and high internal resistance	19/0
K3580. Output stage amplifying valve. Dissipation 15 watts. Amplification factor 3. Impedance 500 ohms. Remarkable scale of 6mA. V.	25/6

Other types and rectifiers as previously listed all in stock. Details on request. Free Blueprint with first order.

## OSTAREGANZ

'UNIVERSAL' HIGH-VOLTAGE MAINS VALVES  
Kits and Special model Sets supplied.  
Ask for details.

Sole Agent for Great Britain:  
EUGEN FORBAT, 28-29, Southampton Street, Strand, W.C.2  
Telephone: Temple Bar 8608.

## NOW READY

The completely revised 1934 EDITION of RICH & BUNDY.

### 24-Page CATALOGUE

OVER 100 Models of Mains Transformers and Power Chokes fully described.

Valuable information.

### FREE

Ask for 1934 Catalogue "W." Free by return of post.

## RICH & BUNDY LTD.,

Transformer Manufacturers,  
New Road, Ponders End, Middlesex.

Phone: Eufield 0777.  
Sole Distributors, I.P.S.: KELLY & SHELL LTD., 17, Fleet St., Dublin, C.4.

## AN INSIDE AERIAL THAT'S AS GOOD AS AN OUTSIDE AERIAL—

OF EQUAL LENGTH.  
JUST PRESS IT UP AND IT STICKS.  
Run it round the room and up the stairs and you'll be amazed at the result. From all Wireless Shops or from British Pix Co., Ltd. (Dept. 588), 118, Southwark St., London, S.E.1  
2/- DOUBLE LENGTH 3/6. IDEAL FOR FLATS

See  
**COLVERN**  
FERROCART  
COILS  
ON  
STAND 32  
MANCHESTER SHOW  
Sept. 27—Oct. 7

Components, etc., for Sale.—Contd.

MILDMAY RADIO Exchange Offers the following Sound and Perfect. LOUDSPEAKERS.—Bakers Super D.C. 50/-; Epoch 99K De Luxe, £3; Epoch 661P.M., 40/-; B.T.H. Senior P.M., 50/-; Rola P6 S.T.400, 20/-; Farrard Inductor, 50/-; Veight Speaker Unit only £6.10, 200 or 400 volts D.C. A.C. MOTORS. Garrard, Collaro, etc., from 20/-. ALL Post Paid. CLOSED Saturday, open Thursday all day. PHONE: Chis-01 5001. 24, Midway Grove, London, N.1. [3452

SOUTHERN RADIO Wireless Bargains. Set manufacturers' guaranteed surplus: VARIABLE Condensers.—British Radiophone 4-gang superhet type, fully screened and trimmers, 0.0005/8/9 (list 45/-). Same type, complete with dial knob and (s. each), 12/9 (list 50/-). India black condensers, new, 16 mfd., 2-2 8-2-1-1, 1,000 volt test (made for Canadian Gramophone Co.), 7/-; 4 mfd., 2-6; 2 mfd., 1-5; 1 mfd., 1-; all 750 volt. Polar 3-gang condensers, 0.0005, fully screened, complete trimmers, dial, knob, escutcheon; 11/6 (list 55/-).

SPEAKERS. Celestion Soundex permanent magnet, 16/- (list 27/6); Rola P6 permanent magnet, 28/- (list 49/6); D.C. mains energized, 2,000 to 6,500 ohms, complete with loud-speaking coils and transformers, 16/6 (list 39/6); Peter Grassman dynamic speakers and chassis, 10/6 each (list 35/-); G.E.C. Stork speakers, complete in magnificent cabinet, 19/6 (list £3 15/-); Diamond speakers, complete in cabinet, 10/- (list 25/-); Dr. Nesper "Tang" speakers, 11/6 (list 55/-).

CONSTRUCTION KITS. Ready Radio "303" battery 3-valve kits, less valves, 18/- each; complete with 3 Mullard valve (P.M., H.T., P.M.2, 21D.X.), 33/- each (list 70/-); Ready Radio Meteor screen grid 3-valve kit, less valves, 26/-; with 3 Mullard valves (P.M.12a, P.M.21D.X., P.M.2a), 29/- (list 45/7/6); Universal Radio 3-valve kits, ready assembled on chassis, 12/6 (list 45/-); 4-valve, metal chassis only, 11in. x 9in. x 3in. (deep), 2/6 each, brand new.

READY RADIO S.T.400 Kits, as specified by Scott Taggart; £2 10/6 each (list £4 17/6).

MULLARD RADIO for Million 3-valve A.C. Kit, complete with 3 Mullard A.C. valves (Pen. 4V, 354V, 84V), £3 10 (list 46/10); Mullard Radio for Million 3-valve battery kit, complete with 3 Mullard valves, £3 3 (list 46/2/6); all kit brand new, in original sealed cartons.

BRITISH General Tuning Units.—Band Pass, 10 kecs., aeral or aerial; 5 (list 14/6); Metro-Vick and other resistances, all capacities, 3/9 per doz., assorted; B.M.V. tone controls, 1/6 each (list 12/6).

ALL Goods Guaranteed New and Perfect, and sent carriage paid. PLEASE Note, We have opened branches at 271-275, High Rd., Willesden Green, N.W.10, and at 46, Lisle St., W.12, where callers are cordially invited to inspect our large stocks of wireless bargains. Please send all post orders to 323, Euston Rd., N.W.1.

SOUTHERN RADIO, 323, Euston Rd., London, N.W.1 (near Warren St. Rd.). Phone: Muscum 6324. [3481

M.R.D. C's Guaranteed Surplus; carriage paid or coll; 10/2 discount on orders over 10/-. DUBILIER and Givette High-Watt Resistors, as last week, 4d. each, 1/9 half-dozen; Benjamin 5-pin chassis voltmeters, 1/3 half-dozen.

POLYMET Mica Foil Condensers, all sizes, 0.0001 to 0.01, 3d. each, 1/3 half-dozen; 1 mfd., 400v., working, 10/6d.

T.C.C. 2 mfd. Electrolytics, 100v., working, 9d.; T.C.C. 4 x 4 mfd., 250v., working, 3/3; T.C.C. 4x4-1-1 x 5 mfd., 250v., working, 3/11.

FORMO 0.0013 reactin, 81; Varley 250,000 pots, 1/7; Pye L.F. chokes, 32h., 60 m.a., 1/6; Mains Radio Development Co., 4-6, Muswell Hill Rd., London, N.6. [3483

PEPPER offers the following Under Usual Money back Guarantee; carriage paid, over £2. BAKERS 1935 S.P.A. speakers (list £2 6/-), complete, £2 15/-; ditto, 1941 model, £2 5/-; Magnavox Magna, D4-142, 2,500 field, boxed, £2 5/-; Amplion EM.644, 14/6; Farnet, 2,500 field, 15/-.

JUNET Baby Super Transformer (for H.T.9), 19/6; Westinghouse H.T.9, H.T.10, H.T.1 rectifiers, as new, 10/6 each; H.T.4, H.T.6, 7/5.

ACTUATOR Chargers, by Supremus, etc.; 6 volts 1 amp., 17/6; 12 volts 1 amp., 26/-; 24 volts 1 amp., 34/6; 6 volts 1/2 amp., 12/6; 15v., 2 amps., 59/6; above Westinghouse rectified; 23 volts 1.5 amps., complete with meter and valve, £1 19/6.

MARCONI 63/- Pick-ups, as new, 25/6; Limit pick-up heads, 7/11; L'ecume Phonovox pick-ups, with arms, 8/11; Bulgin ditto, 12/6; Garrard H.A. motors, with tunable, etc., less, 14/6.

ELIMINATOR KITS (A.C.), smoothed output 500v., 120m.a., Westinghouse rectified, including B.T.H. transformer, etc., £3 11/-; similar kit, valve rectified, £2 10/-.

QUANTITY of Low's, Weatite, Igranite, etc., volume controls at half list. THEVOR PEPPER, 575 1/2, Moseley Rd., Birmingham, 12 [3464

CAMBRIDGE Unipivot Galvanometer, test certificate, brand new; list £9 10/-, price £5 10/-. FOLLOWING Ferranti's Half List Price: J.T.1, volts 0-10-100-500, milliamps. 0-10-100, in case, list £6.10; 0-10-250 v.d.t., 100 milliamps, list £3 10/-; both above moving coil instruments; 0.600 volts Electrostatic, list £3 5/-; R.T.5 resistance tester, 0-5,000-50,000 ohms, list £4 15/-. NO.1040 Converter, 200-250 D.C. to 200-250 A.C., 90 watts, work 2-valve to 9-valve set; £3 10/-, 20, Albion Terrace, Blackwood, Mon. [3458

CHAL. ELECTRIC Offers New Set Manufacturer's Surplus, all carriage paid; cash with order or e.o.d. VARIABLE Condensers.—J.B.Nu Gang (3-gang), complete with disc drive, covers, trimmers, escutcheon, light knob, etc., 17/6; 2-gang, fitted as above, 9/6; Polar Star (3-gang 1933), complete, fitted as above, list 30/6, at 18/-; Uniknob 2-gang, fitted as above, complete, 10/-; Utility 2-gang, fitted as above, 8/6. COILS (6 sets each only).—Colverson Ferrocart, F1, F2, F3, C-ganged, 32/-; Varley Nicore (1), B.P.30 and 2B.P.31, 28/-; Varley sets, B.P., 19-ganged, 25/6. (This advertisement continued in third column.)

Components, etc., for Sale.—Contd.

(This advertisement continued from first column.)

SMOOTHING Condensers.—C.F.C. Murphy, etc., 800 test 250 A.C. working, 1 mfd. 1/1, 2 mfd. 1/9, 4 mfd. 2/6; all the following 1,500 D.C., test 500 A.C., working 800 peak, 1 mfd. 1/9, 2 mid. 2/4, 4 mfd. 4/-; Multiple Banksall, separate tappings, 20 mfd., 4+4+2+2+2+2+1 at 11/-, 31 mfd., 4+2+2+2+1, at 6/9. CHOKES.—30 henry 30 m.a. (500 ohms), 6/-; 30 henry 50 m.a. (450 ohms), 6/3; 30 henry 60 m.a. (600 ohms), 6/6; another (300 ohms), 6/9; 30 henry 75 m.a. (300 ohms), 6/9; 50 henry 60 m.a. (850 ohms), 8/6; 20 henry 120 m.a. (325 ohms), 10/6.

MAINS Transformers.—All tapped and screened primary series, I.T. windings C.T.: 500-0-500, at 120 m.a., 4v. 2.5a., 4v. 5a., 4v. 2a., 21/-; 350-0-350 at 120 m.a., 4v. 2.5a., 4v. 4a., 4v. 1a., 19/-; 250-0-250 at 75 m.a., 4v. 1a., 4v. 5a., 12/6; 250-0-250, 60 m.a., 4v. 1a., 4v. 3a., 4v. 1a., at 12/-. Note.—All transformers, chokes and condensers guaranteed against breakdown for 12 months.

RADIO Gramophone Cabinets, Marconiphone 535, walnut, 40/-, 19/-, 16, take chassis up to 39 1/2 x 18 1/2 x 14 1/2, 9/4 to make £8, at £2 12/6. ASK for Special Quotation for Anything You May Need.—Chal. Electric, No. 6, Conduit St., London, W.1. [3442

EBURY BRIDGE RADIO Co. Offer the following Stupendous Bankrupt and Set Manufacturers' Surplus Bargains: A.C. H.T. Eliminators, 200 250v. input, 150v. 50 m.a. output, 2 pos. tappings, one fixed, one variable, Westinghouse rectified, best components, guaranteed, special summer price, 25/-; 3 pos. tappings, for S.G., 23/6, post 1/3; also in 100, 110v.

D.C. Mains High Tension Eliminators, 200 250v. input, output 150 volts 30 m.a., 2 pos. tappings, one variable, 10/-; 3 positive tappings, for S.G., 12/6; post 9d. GENUINE Reiss P.A. Microphones for all Amplifiers up to 60 Watts, straight line response, 52/6; transformer, 5/-; nickel plated stand, with rubber suspension, oxy. lase, 12/6; post 1/-. ELKO Mains Transformers, suitable Ferrocart III, tapped input 200 250v., 50m., outputs 350-0-350v., 70 m.a., 4v. 2.5a., 4v. 3.4a., C.T.; 9/6, post 9d., a real bargain; low only.

ELKO Ekev Smoothing Chokes, 50h. 50 m.a., C.T.; 5/6; post 6d.; few only left. PHILLIPS Mains Transformers, at ridiculously prices, input 200 250v., outputs 200 0 200v. 40 m.a., 4v. 1a., 4v. 3.4a.; 4/6; post 9d. PHILLIPS Heavy Duty Smoothing Chokes, 50h. 75 m.a.; 4/6; post 9d.

SPECIAL Summer Offer of Ebury Electric Chal. Movers, 200 250v., 50 cycles; special slow speed motor; write for full details; 16/6; post 6d.; this offer soon closing.

CONDENSERS.—T.C.C.'s 3 M.F., 800v. working, 5/-, post 6d.; 2 M.F., 500v., 2/3, post 3d.; 15 M.F., 100v. working, for auto G.B., 1/3, post 3d.; 9 M.F., (4+4+1) 500v., 5/-, post 6d.; Wago's 9 M.F., (4+1+2+1) 500v. 3/6, post 6d.; 2 M.F., 1,000v. 2/-, post 3d.; in perfect condition.

CHASSIS Mounting Valve Holders, 4- and 5-pin, 3d. each, 2/6 doz., post 1/6d. and 2d.; Dubilier resistances, vacuum, 5 watt, 50,000 and 100,000 ohms, 1/- each, post 1/6d.; Pye 1/2 watt wire wound 10,000, 7,500 ohms, 4d.; Globar metallized 500 ohm, 2 watt, 6d., post 1/6d.

ROLA P6 Moving Coil Speakers, 6,500 ohms, pentode, 14/6; A.C. mains, 24/-; post 1/3. MARCONI 531 Radio Gram Cabinets, low only, 44/4; Atlas Concolite cabinets, take set, batteries, and speaker, 9/11; post 1/3.

COVEREIGN 3-valve Battery Set, complete with speaker, 3 valves, 3rd batteries, complete, £2 3/-. FERRANTI 7-valve superhet, station indicated; list 25 guineas; 10 guineas; in perfect order; send for our bargain list; all goods 3 days approx. against cash or credit. Your safeguard.

EBURY BRIDGE RADIO Co., 33, Ebury Bridge Rd., E.8.W.1 near Victoria Station, No. 11 bus to Ebury Bridge). Open Saturday all day, Shorne 8407. [3485

EPTON Leads Again!—Polar 3-gang 0.0005 tub condensers, fully screened, dust covers, trimmers, split end vases; 9/6. RESISTORS, cabinets, potentiometers, condensers, coils, transformers, etc.; complete list in EPTON'S RADIO BULLETIN, Epton, 93, New Rd., Chingford, E.4. (Phone: Silverthorn 1427.) [3490

G.E.C. New 60 watt Battery Operated P.A. Amplifiers, in teak cabinets; actual list price £45 each, to clear, £2 15 each. FERRANTI Double Channel Push-Pull Amplifiers, each amplifier 60 watts output, in splendid metal racks, using 2 D.O.25 valves in each last stage, bargain, £25, for 110 250v. A.C. mains; 4 Siemens Halke new 50-watt A.C. amplifiers, complete with valves, 66/10 each.

D.C. to A.C. Converters by Crypto, M.L. and Lang Electrical, ranging from 40 to 440 watts; prices on application. 3,000 Siemens Halke Condensers, 0.1 to 10 mfd., from 500 to 3,500v., test; prices on application.

WESTON 0-600v. Moving Coil Voltmeters, model 506, 500 ohms per volt, ditto Tumers, price 25/- each; Weston 0-20 amps., model 506, price 7/6 each; Zenith sliding resistance, 6 chms 5 amps., 7/6 each.

G.E.C. Smoothing Equipment, comprising of 20h. 200 m.a. choke, ditto 50h. 50 m.a., four 3 mfd. and two 1 mfd., 800v. working condensers; 22/6 each. LAST Few Driven and Pull Through Sound Heads by B.T.A., Mihaly, B.T.P., some with Taylor Hobson optical systems; prices on application.

H. FRANKS, 42a, St. George St., Commercial Rd., London, E.1. (Phone: Royal 8546. [3467

POLAR .0005, 2/6; A.F.3, 10/6; Weatite Oscillator, 4/-; exchange willingly.—Haynes, 29, Lee St., King-Land Rd., E.8. [3449

# Now the Show is over . . .

and reflection is the order of the day, there is no doubt that the "W.W."

## NEW MONODIAL

will be the choice of the radio connoisseur.

IN response to many queries last month, we are again offering our Monodial constructional and servicing facilities to readers in all parts of Great Britain. Consult us NOW! You will benefit by our condensed experience gained in building and servicing sets for "W.W." readers during the last 7 years.

Our Workshops test apparatus has been considerably augmented and we are ready to build for you a de-luxe NEW MONODIAL and if necessary to fit it in a period cabinet, and to supply and instal all necessary associated components. If desired, any apparatus can be supplied for a first deposit of 12 1/2% with the balance over 1 year.

This extract from a letter entirely unsolicited regarding the original Monodial, is illuminating.

"I should like to place on record my appreciation of the excellent job you have made of the Monodial Superhet set which I recently ordered from you. Results have been most pleasing and I am highly satisfied with the whole outfit . . . I shall have great pleasure in recommending your Firm to any of my friends . . ."



# SCOTT SESSIONS & CO.,

Radio Engineers and Consultants, MUSWELL HILL, LONDON, N.10

Cables: "Tropiset, London." Contractors to H.M. Government Depts., &c.



There is a model to suit every output.

Prices from 2/- to 70/- Your dealer will demonstrate. REPRODUCERS & AMPLIFIERS, LTD., WOLVERHAMPTON.



# SEND FOR OUR NEW SEASON'S CATALOGUE

**BIGGER & BETTER THAN EVER**

**269 ILLUSTRATIONS**

More Radio Components than ever are included in this New Season's Catalogue. The Guide to Home Constructors.

**ASK FOR CATALOGUE No. 153 "W"**

*Enclose 2d. Postage.*

Enclose 2<sup>d</sup> Postage.

**A. F. BULGIN & CO., ABBEY RD., BARKING, ESSEX.**

London Showrooms: 9, 10, 11, Cursitor Street, Chancery Lane, E.C.1. Telephone: Grangewood 3266 & 7. Telephone: Holborn 2072.

## Belling-Lee Pick-ups

LET YOUR EAR BE THE JUDGE!

**Model "C"**

Constructed of metal, this new pick-up follows modern design in appearance and technique. Octagon in form, self-contained Volume Control, Ball Bearing Swivel. The whole arm rotates 180° to facilitate needle changing and simultaneously lifts to swing clear over the record. Complete with template. List No. 1117

35/-

**Model "A"**

Adjustable arm allows distance between needle point and centre of base to be varied from 7½" to 9½". The arm should be as long as cabinet space permits. Head angle is also adjustable to obtain minimum tracking error for different arm lengths. List No. 1098

27/6

**Special Features.**—Perfectly natural frequency response... minimises needle scratch while retaining high notes and brilliancy of reproduction. Minimum record wear... Copper screened flex.

**BELLING & LEE LTD**  
CAMBRIDGE ARTERIAL ROAD, ENFIELD, MIDD.

**FOR HIRE**  
FULLY EQUIPPED VAN  
PUBLIC ADDRESS VAN  
Sent anywhere in British Isles, also  
RADIO, MICROPHONE, &  
GRAMOPHONE AMPLIFIERS  
giving exceptional quality and  
volume, suitable for Dances, Sports  
Meetings, Fetes, etc., from 15/-  
per day.  
McMichael Portable Sets 15/- a  
week; £2-12-6 a month.

**ALEXANDER BLACK, LTD**  
WIRELESS CONSULTANTS  
55, EDURY STREET, LONDON, S.W.1.  
ESTABLISHED IN 1925. SLOANE 1655.  
Trade Inquiries Invited.

**SERVICE**  
SETS OF ALL TYPES.  
Supplied, Serviced and  
Visited in any district, or  
may be sent for Full Test  
and Report, at 2/- per valve-  
holder; portables 1/6 per  
valve-holder.

SEND FOR LITERATURE OF

**Silver Ghost**

Lamplugh Radio Ltd. Coventry.  
Silver Ghost Reproducers MASTERS OF SOUND

Famous Maker's Offer!

**£5 Radio-Gram CABINET for 65/-**  
**7 DAYS' FREE TRIAL**  
(OR 10/- MONTHLY).  
Piano built (Pat. 8123), the acoustic  
tone brings a fine thrill (Piano Talk).  
(Radio-Press, B.B.C., 3,000 clients.)  
Models from 35/- to £15. List  
FREE.  
Send for photographs, detail drawings,  
Picketts Piano-Tone Cabinets, Albion  
Rd. (w.w.) Bexleyheath, Kent.

**Components, etc., for Sale.—Contd.**

**8/9**—3-gang 0.0005, on die-cast chassis, trimmers, with illuminated drum drive, made for H.M.V.—Kay, 167, City Rd., London E.C.1. [3353]

**SPECIAL Clearance Bargains.**—Projectors (9, 16 and 35 mm.), 30/-; Cameras, from 20/-; everything for Movies, Walkies and Talkies; inspection invited.

**ILLUSTRATED ENTERPRISES**, 159, Wardour St. (facing Film House), London, W.1. Phone: Gerrard 6889. [3004]

**EPOCH 99 Speaker**, 2,500 ohms, 20 -; Hyper-core, 50m.a. -; 10 -; Chassis transformer, for Monodial, 20/-; Amp Lion, 10/-; A.F.5, 18 -; A.F.5c, 18 -; A.F.6, 18 -; O.P.9c, 7/6-14/-, Brunswick Rd., E.14. [3466]

**MOVING Coil Milli-Ammeters**, 0-50, 10/6 each; 2 milliamps and 120v., 47.6 each; other ranges in stock; alterations, repairs of every description.—The Victoria Electrical Co., 47, High St., Battersea, S.W.11. [0355]

**SULLIVANS Universal Galvanometer**, £3; extra slide, 20/-; carriage for sale; very large spark coils, A.C. 100 volt, Marconi's, 25 -; carriage forward; resistances, sliding, 4 amp., 2/-; potentiometer, sliding, 2/-, both Marconi's; postage 3d.—Beaton, Chalk Farm Rd., N.W. [3473]

**NOVOTONE J**, 28 6; Simpsons motor, 15/-; Paillard in mahogany case, 28 -; Daptonon Senior pick-up, 11/-; Harlie on Kuba arm, 11/-; Jensen Auditorium M.C. unit, D.C., 22 -; Magnavox 144, D.C., 11/-; Igranie G.3, 6 to 1, 10/-; Shaul, 20, Thurlestone Rd., West Norwood. [3457]

**FERRANTI A.F.4**, 7/9; A.F.5, 18 6; O.P.M.2c, O.P.M.5c, O.P.M.2, 14 -; O.P.1, O.P.3c, O.P.6c, 7/6; B.1 choke, 10/-; Varley "Rectatone", 9 -; set 4 Lewcos Century Super coils, 18/-; single coils, 4/-; Varley push-pull transformers, input and output, 13 6 each; Weirite I.F. transformers, 4/-; B.T.H. Minor pick-up, 16 6; Mullard H.T. A.C. unit, with valves, £1 17 6.—Bostock and Stennill, 1, Westbourne Terrace, S.E.23. [3467]

**H.D. RADIO ELECTRICAL SERVICE** Offers Surplus of a Set Manufacturer, every article guaranteed new. Moving coil speakers; Magnavox, type D.C.144, 2,500 or 7,500 ohms, with Multi Ratio transformer, at 18/-; type D.C.142, same voltages, at 25/-, complete with universal transformer; Sonochor, all voltages, F.S. type (state requirements), list 25 -; at 17 6, with Universal transformer, Pick-ups, G.E.C., complete, list 27/6, at 15/-; variable condensers, J.B. No-gang, complete in every detail, disc drives, 2-gang 10 -; 3-gang 17/6; chassis constructed to specification and sprayed; radio repair specialists to the trade and public; send S.A.E. for quotation; all goods carriage paid; cash with order or credit; orders only between 1 and 6 p.m.—H.D. Radio Electrical Service, 31, George St., Hanover Sq., London, W.1. [3459]

**CLASS "B" COMPONENTS.**

**SOUND SALES, Ltd.**, for Class "B" Components, List "B.B." on request, Tremlett Grove, Highgate, N.19 [0401]

**MISCELLANEOUS.**

**EASY Payments.**—We supply, by easy payments, components, accessories, and sets, any make; 10% down, balance spread over 11 months.—Send list of requirements to London Radio Supply Co., 11, Oat Lane, London, E.C.2. [0337]

**ENGINEERS and Technical Workers of All Kinds.**—A proper training by post in your spare time will take you through your right examination, the employment is waiting. Our advice on all careers free.—Dept. 92, The Bennett College, Ltd., Sheffield. [0392]

**AMBITIOUS Men.**—Qualify for a well-paid post by studying at home with the T.I.G.B. Write to-day for "The Engineer's Guide to Success," 144 pages, free, which contains the widest selection of engineering and wireless courses in the world, and shows you how to become A.M.I.E.E., A.M.I.Mech.E., A.Rad.A., etc. State branch, post or qualification that interests you.—The Technological Institute of Great Britain, 82, Temple Bar House, London, E.C.4. (Founded 1917, 19,000 successes.) [3398]

**PATENT AGENTS.**

**PATENTS and Trade Marks**, British and foreign.—Gee and Co. (H. T. P. Gee, Member R.S.G.B. and A.M.I.E.E.), 51-52, Chancery Lane, London, W.C.2. Phone: Holborn 1525. [0001]

**REPAIRS.**

**SEND Us your Receiver** for free quotation; overhauling, rebuilding, repairing or conversion to Class B.—Unit Radio, 12, Pallenny Street, Barnsbury, London, N.1. [3454]

**REPAIRS.**—Rebuilding to any set; highest quality work only; lowest charges; estimates given free; distance no object.—L. Eastwood, Radio Manufacturers' Consultant, Late of His Master's Voice and Marconi Wireless Telegraph Co. Telephone: Clerkenwell 4520. Address: 60, Herder Rd., Fulham, S.W.6. [3342]

**GUARANTEED Repairs by Experts;** specialists for repairs to S. G. Brown and Amplion radio apparatus, also loud-speakers, headphones, pick-ups, Blue Spots, any type re-wound, remagnetised and adjusted; 4/-; post free; mains transformer repairs; terms to trade.—Howell, 91, Morley Hill, Enfield, Middlesex. [9716]

**REPAIRS to Loud-speakers, transformers and headphones, 4/-; Blue Spots or Wufas, 5/-, post free; moving coils a speciality, new cones fitted; eliminators and mains transformers quoted for; prompt service; satisfaction guaranteed; discount to trade.—Loud Speaker Repair Works, 5, Ballham Grove, London, Battersea 1321. [0394]**

**TUITION.**

**R.T.I. Training Methods** are Recognised; write for particulars of home study, for radio appointments; secure "Certificate of Proficiency" and become "A.M.R.T.I."—Radio Training Institute, 85, New Oxford St., London, W.C.1. [2947]

**QUALIFIED Radio Engineers** are Always in Demand, and our Home Study Course will enable you to qualify for a good post; many students already placed this season; prospectus free.—Northern Counties Wireless School, Preston [0399]

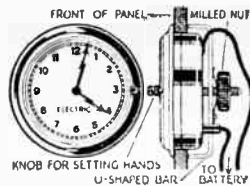

### FIT THIS ELECTRIC CLOCK TO YOUR SET!

NO MAINS NEEDED!  
KEEPS CORRECT TIME!  
NO WINDING!

Works off small battery lasting 12 months, or can be plugged into G.B. Battery without affecting reception. Uses practically no current. Fits into hole 3 1/2" dia. in any panel up to 1/4" thick. Easy to fix—no screws required. Only 1 1/2" from front of panel to back of case. Swiss movement. Hands set from front. Nickel plated bezel. Useful addition to any set.



RIVERSIDE MFG. CO., LTD.,  
Dept. 29, 41-43 Rd., Hammer Smith, W.6  
Telephone: Riverside 6392.  
POSTAGE 6D

## HARKEN !!

### CHANGE OF ADDRESS

We have removed to larger premises and increased our equipment in order to cope with the growing demand for special apparatus.

May we quote you for Power Amplifiers, Transformers, Coil Winding by automatic machines, Photo-Electric Cell Amplifiers, and all types of special radio and electrical sound apparatus?

TROPICAL APPARATUS A SPECIALITY.

All our work is backed by 25 years' Communications Engineering experience.

### THE HARKEN ELECTRICAL CO. LTD.,

Manufacturers of High-Grade Radio & Electrical Apparatus.

18a, SOUTH END, CROYDON

Telephone: Fairfield 4772. Telegrams: HARKEN, Croydon.



are simple and economical to install and avoid unsightly poles. Write for leaflet to:—

PARTRIDGE WILSON & CO.,  
Dept. 29, Davenset Works, Leicester.

## MODULA

### ARMCHAIR CONTROL.

In last week's advertisement, page 14, we stated that with armchair control the price was 4/-. This should have read with armchair STRAP, 4/-.  
The MODULA CONTROL without strap is 2/11.

From all Wireless Dealers or

BRITISH PIX CO., LTD.,  
118, Southwark Street, London, S.E.1.

### EXCHANGE.

HIGH Allowances Made on Second-hand Goods in Part Payment for New Sets or Components; easy payments available; we have tremendous stocks tested second-hand goods; send list of your requirements for quotation.—Bostock and Stonnill, 1, Westbourne Terrace, S.E.23. [3466]

### WANTED.

A.C. Eliminator, with charger, Atlas preferred; cheap.—A. Williams, 11, Bedford St., Plymouth. [3479]

SPOT Cash for Modern Components, etc.—Economic Radio Co., 96-98, South Lambeth Rd., S.W.8. [3231]

NEW or Second-hand Sets, kits, and parts bought, sold, exchanged; best prices allowed.—R. Wigfield, Farning Rd., Goldthorpe, Yorks. [3470]

HIGH-Class Radio Parts and Sets Wanted for cash, new or second-hand, any quantity; send yours stating reasonable price cash by return; retailers' stocks purchased.—Midway Radio Exchange, 24, Midway Grove, London, N.1. Phone: Chisold 5001. [3453]

### SITUATIONS VACANT.

IF You Wish to Enter the Wireless Profession with a Thorough Training, or if you wish to improve your present position, you will need the certificate issued by Britain's leading wireless college. This is not a correspondence college. Apparatus of all leading makes installed for instructional purposes. Boarders accepted. Training fees can be paid after appointment. Prospectus free.—Wireless College, Colwyn Bay. [0583]

SMART Lads Wanted, 14-16.—Apply M. A. Mason and Sons, Ltd., W.T. Works, Collingwood Rd., Sutton, Surrey. [3475]

OPPORTUNITY Opens for Bright Young Man of Pleasant Disposition, with some knowledge accumulator charging and radio, to fill junior post in service dept.; preferably owning motor cycle.—Melody Shop, Maidenhead. [3476]

JUNIOR Technical Assistant Required for Experimental Work in Connection with Radi Valve Experiment; applicants should have passed the London Intermediate B.S.C. or higher school examination with physics as one subject. Apply by letter, stating qualifications, experience and age, to Easen, Ltd., Worpole Rd., Isleworth, Middlesex. [3484]

### SITUATIONS WANTED.

PUBLIC Schoolboy, 22, physics degree, musical diploma, at present in Government service, desires change of occupation.—Box 8075, c/o The Wireless World. [3472]

BOY, 18, just left school, desirous of starting in radio firm; will take evening institute study in radio technology, etc., in conjunction with same.—Wilson, "Wakefield," Chatsworth Rd., S.E.27. [3478]

### BOOKS, INSTRUCTIONS, ETC.

300 Clean Issues "Wireless World," to date; 15/—Pinner, 15, Albert Rd., Mitcham. [3485]

## THE POLYTECHNIC, REGENT STREET, W.1.

ELECTRICAL ENGINEERING DEPARTMENT.  
WIRELESS AND HIGH FREQUENCY SECTION.  
Evening Session, 1933-34.

Courses and Classes, including laboratory work, in WIRELESS AND HIGH FREQUENCY ENGINEERING extending over a period of FIVE YEARS and suitable for those engaged in, or desirous of entering, the Radio, Gramophone, or Talking Film Industries.

Courses prepare for the Graduateship Examination of the I.E.E. and City and Guilds Grouped Course Certificates.

Session commences September 25th, 1933.  
Enrolments: September 18th to 22nd, from 6 to 9 p.m.  
Full particulars and prospectus from the Director of Education.



- AMPLIFIERS
- SPEAKERS
- MICROPHONES
- RADIOGRAMS

'SOUND' EQUIPMENT FOR ALL PURPOSES. INDIVIDUALLY BUILT, NOT MASS PRODUCED

## TANNOY

GUY R. FOUNTAIN Ltd.,  
CANTERBURY GROVE,  
WEST NORWOOD,  
LONDON, S.E.27

## TURN YOUR D.C. TO A.C. THIS SIMPLE WAY...

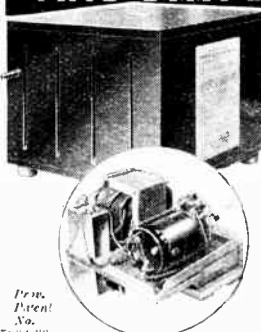

All the best Receivers are made for A.C. Power. The "NO-RO-CO" (non-rotary) Converter enables you to run A.C. sets from D.C. Power mains immediately. Works on voltages from 200-250. Operates sets from 2-valve to 9-valve. Fitted with specially made ball-bearing motor with automatic switch and cut-out. Noiseless and safe. Fully guaranteed. Can be installed by a novice in a few minutes. Revolutionary in practice and revolutionary in price. Send for fully descriptive leaflet.

## THE "NO-RO-CO" CONVERTER

Price: 35.19.6  
THE WILROSE CO (BHAM) LTD  
47-CORNWALL ST. BIRMINGHAM

Cash with order. Money refunded if not satisfactory. Trade enquiries invited, invaluable to dealers on D.C. mains.

## DON'T LEAVE MONEY IN THE DUSTBIN

LET us take your old Set or components in PART EXCHANGE for New Season's Radio—NEW KITS, MONODIAL, ETC., ETC., NEW ACCESSORIES, or PART KITS—in fact, any RADIO APPARATUS. Best quotations and fullest allowance given. Balance payable by Cash or H.P. Send us your enquiry for quotation by return, stating apparatus you wish to dispose of and NEW KIT, SET or Miscellaneous Components required.

### WE GIVE YOU MORE.

PARTEX RADIO, VULCAN HOUSE, Ludgate Hill, LONDON, E.C.4.

## INDEX TO ADVERTISEMENTS.

	PAGE
Automatic Coil Winder & Elec. Equipment Co., Ltd.	7 and 12
Belling & Lee, Ltd.	16
Birmingham Sound Reproducers, Ltd.	Inside Back Cover
Black, Alexander, Ltd.	16
Black Batteries, Ltd.	2
Britannia Batteries, Ltd.	9
British Institute of Engineering Technology	14
British Pix Co., Ltd.	14 & 17
British Rola Co., Ltd.	15
British Thomson-Houston Co., Ltd.	18
Bulgin, A. F., & Co., Ltd.	16
Carrington Manf. Co., Ltd.	18
City Accumulator Co., Ltd.	4
Cole, E. K., Ltd.	6
Cole, E. K., Ltd.	14
Colvern, Ltd.	8
Columbia Gramophone Co., Ltd.	8
Fosser, A. C., Ltd.	1
Dubilier Condenser Co. (1925), Ltd.	Front Cover

	PAGE
Edison Swan Electric Co., Ltd.	Inside Back Cover
Electradix Radios	14
Epoch Radio Manf. Co., Ltd.	14
Gambrell Bros., Ltd.	4
General Electric Co., Ltd.	5
Gossvener Electric Batteries, Ltd.	18
Hartley Turner Radio, Ltd.	12
Harken Electrical Co., Ltd.	17
Hayberd, F. C., & Co.	14
Ignac Electric Co., Ltd.	Inside Front Cover
Lamphugh Radio, Ltd.	16
Leetro Linx, Ltd.	10
Ostar Ganz (Eugen Forbat)	14
Partex Radio	17
Partridge & Mee, Ltd.	18
Partridge, Wilson & Co.	17
Peto-Scott Co., Ltd.	11
Philips Radio-Receivers	3

	PAGE
Picketts	16
Pifco, Ltd.	5
Polytechnic, The	17
Radio-Gramophone Development Co.	Back Cover
Reproducers & Amplifiers, Ltd.	15
Rich & Bundy, Ltd.	14
Riverside Manf. Co., Ltd.	17
Rotax, Ltd. (M.I. Equipment)	Front Cover
Savage, W. Bryan	4
Scott Sessions & Co.	15
Somehorde Reproducers, Ltd.	Front Cover
Tannoy Products	17
Telegraph Condenser Co., Ltd.	10
Telsen Electric Co., Ltd.	Front Cover
Watmel Wireless Co., Ltd.	10
Westinghouse Brake & Saxby Signal Co., Ltd.	Inside Back Cover
Wilrose Co. (B'ham) Ltd.	17

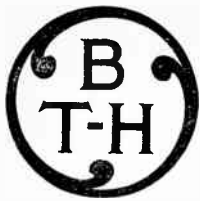

# ELECTRIC GRAMOPHONE MOTORS

**TRUSPEED-DC**

100 125 Volt.  
200 250 Volt.

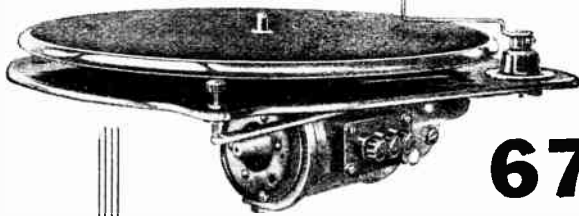

**67/6**

**T**HE only gramophone motor on the market built exclusively for D.C. circuits.

- Totally enclosed motor
- Self-aligning bearings
- Automatic stop switch

Other models include:—

TRUSPEED-AC for A.C. circuits price 49 6  
GOLDEN-DISC for A.C. circuits price 67 6  
UNIVERSAL for A.C. & D.C. circuits „ 110.-  
All fitted with automatic stop switches.

Write for  
Free Booklet  
A.G. 455

**BTH RUGBY**  
THE BRITISH THOMSON-HOUSTON COMPANY LIMITED, RUGBY, ENGLAND  
A1547N

# CRAMMED WITH EXTRA CHEMICALS !

—and  
**MERCURY**  
means  
enormously  
increased  
**LIFE !**

**T**HE life of a battery is the life of its cells. That is where the Grosvenor MERCURY process works such wonders. It guards the cells against corrosion —makes them last so long that they are crammed by hydraulic pressure with extra chemicals to use them up.

Next time you buy a battery, remember the amazingly long life, the extra reserves of power that are packed into Grosvenor. Insist on Grosvenor—and get the most for your money!

Grosvenor Mercury Batteries are made in three grades for every Radio need:

- Grosvenor Red Line ..... 5 6 to 11.-
- Grosvenor Brown Line ..... 6 - to 15 6
- Grosvenor Blue Line ..... 7 - to 20 -



GROSVENOR ELECTRIC BATTERIES Ltd., 2-3, White St., London, E.C.2  
Phone: METropolitan 2261 (3 lines). Works: Watford, Herts.

**IF YOU CAN AFFORD TO BUY**



**THE SATISFACTION OBTAINED WILL WELL REPAY YOU**

PARTRIDGE & MEE, LTD.  
LEICESTER AND LONDON.

SPECIALISTS IN HIGH QUALITY TRANSFORMERS, CHOKES, SPEAKERS, AMPLIFIERS

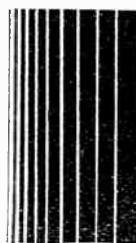

Mention of "The Wireless World," when writing to advertisers, will ensure prompt attention.

# TO NE....

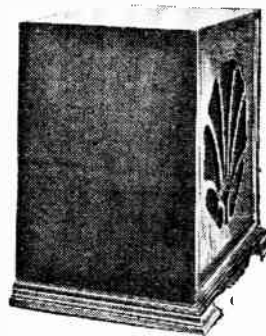

To get the best out of a speaker, it is essential to have sufficient depth in the cabinet—that's where the Camco No. 2 "Melodee" scores. It measures 12in. from back to front and gives the same effect as a large baffleboard but without booming. Supplied in Oak, 30-. Mahogany and Walnut, 33/-. Complete with baffleboard having hole cut to requirements. See it at our Showrooms and send for a copy of the new Camco Cabinet Catalogue containing particulars of complete range.

CARRINGTON MANUFACTURING CO. LTD.  
Showrooms: - - 24, Hatton Garden, E.C.1  
Holborn B202. Wks. S. Croydon.

# THE WIRELESS ENGINEER

AND  
EXPERIMENTAL WIRELESS  
The Journal for Professional Engineers  
and Advanced Wireless Experimenters

Monthly  
2/6 net

Annual Subscription  
32/- post free

ILIFFE & SONS LTD., Dorset House, Stamford Street, London, S.E.1 W.W.2

# WEDNESDAY

## SEPTEMBER THE TWENTIETH

### PRINCIPAL EVENTS OF THE DAY:

#### AT HOME

- NATIONAL** Promenade concert from Queen's Hall.
- LONDON REGIONAL** Chardot's Hour.
- MIDLAND REGIONAL** Gwen Lewis's Entertainers, relayed from Cheltenham Spa.
- NORTH REGIONAL** Relay from the Hippodrome, Manchester.
- WEST REGIONAL** "Tomos Bartley and those College Boys," from the novel "Rhys Lewis" (Daniel Owen).
- SCOTTISH REGIONAL** Orchestral concert.
- BELFAST** Variety programme.

#### ABROAD

- BARCELONA** 7.0 p.m. Trio concert.
- BRUSSELS (No. 1)** 6.15 p.m. Baritone song recital, by Daniel Harris.
- BRUSSELS (No. 2)** 8.0 p.m. The Station Symphony Orchestra, conducted by Meulmans.
- COPENHAGEN** 10.15 p.m. The Station Orchestra, conducted by Lanny Gröndahl.
- EIFFEL TOWER** 8.30 p.m. Symphony concert, conducted by Flamant.
- HILVERSUM** 9.25 p.m. Organ recital, by Bouwmeester.
- HUIZEN** 7.55 p.m. The Station Orchestra, conducted by De Groot.
- ROME** 8.45 p.m. Opera: "Ruy Blas," by Marchetti.
- STOCKHOLM** 8.0 p.m. Brahms concert.
- STRASBOURG** 8.30 p.m. Operetta: "A Waltz Dream," by Oscar Straus.

### BUDAPEST

545 kc/s, 550.5 metres; 18.5 kW. Also relayed on 840 metres from 8.15 p.m. till Close Down.—5.30 p.m., Radio Concert. 6.0, Italian Lesson. 6.30, Concert by the Opera House Orchestra, conducted by Fridl. 7.45, Humorous Programme. 8.15, Light Music by the Mocsanyi-Lakos Band. 8.45, Review of Foreign Affairs. 9.0, Viktor Lanyi and Hugo Kellen Song Recital by Maria Basilides and Andreas Rösler. 10.0, News. 10.15, Concert by the Arpad Toll Gypsy Band, relayed from the Patria Café. 11.0, Talk in German: The Tragic Lot of Man. 11.20, Dance Music by the Bachmann Band, relayed from the Café Bodo.

CASSEL.—See Frankfurt.

### COPENHAGEN

1,067 kc/s, 281 metres; 0.75 kW. Relay by Kalundborg. 260 kc/s, 1,153.8 metres.—12 Noon, Time Signal and Chimes from the Town Hall. 12.2 p.m., Concert by the Harald Andersen String Ensemble, relayed from the Bellevue Strandhotel. 1.15, Broadcast for Schools. 1.35, Interval. 3.0, Gramophone Concert of Variety Music. 3.30, Concert by the Mogens Hansen's Instrumental Ensemble: Romanian Festival Overture (Kéler Béla); Two Melodies (Dohnányi); Waltz, Le retour du printemps (Waldteufel); Song (Chavarriz); Selection from The Mikado (Sullivan); Overture, Le carnaval de Venise (Thomas); Ballet Music from The Cid (Massenet); Lullaby (Henriques); Overture, La sirène (Auber). In an interval at 4.15 (approx.), Talk for Women. 5.30, Exchange and Fish Market Prices. 5.45, Talk. 6.15, French Lesson. 6.45, Weather. 6.54, Announcements. 7.0, News. 7.15, Time Signal. 7.33, Agricultural Talk. 8.0, Time Signal from the Town Hall. 8.1, The Orchestra and its Instruments—Talk with Musical Illustrations. 9.10, Pianoforte Recital of French Music by Folmer Jensen: Chanson triste (Duparc); Song (Lalo); Les différences (Leparra); Corsican Song, Ninina (Romassi); Poème d'un jour (Faure). 9.30, Religious Address. 10.0, News. 10.15, Concert by the Station Orchestra, conducted by Lanny Gröndahl: Overture, Le roi Pa dit (Delibes); Two Swedish Folk Melodies (Svensden); Slav Dance in C (Dvorák); Slav Dance in F (Dvorák); Waltz from Faust (Gounod); Ballet Music from Aida (Verdi); Homage March from Sigurd Jorsalfar (Grieg). 11.0, Dance Music, conducted by Jens Warny, relayed from the Nimb Restaurant. In an interval at 12 Midnight, Time Signal and Chimes from the Town Hall. 12.30 a.m. (Thursday), Close Down.

CORK.—See Athlone.

DANZIG.—See Heilsberg.

DRESDEN.—See Leipzig.

### FECAMP

1,328 kc/s, 225.9 metres; 10 kW.—11.0 to 12.0 Noon, Programme in English by the I.B.C. 11.0, The Happy Hour, Part I—Request Half-Hour: Signature Tune, Cupid's Army (Sievier); The Match Parade (Whele); Poème (Fibich); Her Name is Mary (Sievier); Aloma (Bowers); After the Ball (Harris); Liebesbraun (Liszt); Blaze Away (Holzmann). Part 2—Dance Music: Stay out of my Dreams (Washington); I can't remember (Irving); Sweetheart Darlin' (Kahn); When Gimble hits the Cymbal (Gordon); There's a Cabin in the Pines (Hill); Maybe I love you too much (Berlin); Seven Years with the Wrong Woman (Muller); At the Old Pig and Whistle (Butler); Signature Tune. 12.0 Noon, Programme in French. 4.30 to 6.0 p.m., Programme in English by the I.B.C. 4.30, Programme for Children. 5.0, Concert for Port-mouth and Southsea Listeners. Members' Request Half-Hour: Signature Tune, The Night by the Sea; Woodland Peace (Favilla); Love's Old Sweet Song (Melloy); Bells across the Meadow (Ketelbey); Songs that are old live for ever (Warich); Poor Man's Garden (Russell); The Old Rustic Bridge by the Mill (arr. Wood); Trees (Kaschaeb); Moonlight on the Alster (Fetras). 5.30, Organ Recital for Isle of Wight Listeners: (Glow Worm Idyll (Lincke); Indian Love Call (Friml); The Kiss Waltz (Burke); Horses carry Tails (Redmond); Somewhere a Voice is calling (Tate); Bonnie Ball (Wark); Thompson's Old Grey Mule (Pickard); Popular Melodies on a Wurlitzer; Signature Tune. 6.0, French Programme. 10.0 till Close Down, Programme in English by the I.B.C. 10.0, Dance Music: Signature Tune, Bells of Normandy; Get Happy (Arben); Look what I've got; The Shadow Waltz (Warren); Hold me (Little); I'm getting sentimental over you (Baffmann); I've got to sing a Torch Song (Warren); Rock-a-bye (Lang); Let's all be happy together (Thomas); Land of Love and Laughter (Gottler); Picanniny; Smilin' through (Penn); Sing a New Song (Wever); Bugle Call Rag (Schoebel); Meet me in the Gloaming (Goodhart); My Love Song (Burnaby); That's what life is made of (Soble); Signature Tune. 11.0, Sound Film Music: Signature Tune; Sitin' in the Dark; Selection from The King of Jazz (Whiteman); Live, Laugh and Love (Heymann); Blonde Women (Hollander); There's Magic in the Air; The Moment I say you (Gay); The Birth of the Blues (Henderson); But for you

### ATHLONE

725 kc/s, 413 metres; 60 kW. Relay by Cork. 1,337 kc/s, 224.4 metres.—1.30 to 2.30 p.m., Time Signal, Weather Report, Stock Report, and Gramophone Music. 4.0, Concert by the Savoy Instrumental Quartet. Soloist, W. J. Lemass (Songs). 6.0, Programme for Children. 6.45, News. 7.0, Gaelic Talk. 7.15, German Lesson. 7.30, Time Signal. 7.31, Music by the Station Orchestra. 8.0, Concert by the Caledonian Male Voice Choir. 8.30, Traditional Fiddle Solos. 8.45, Anglo-Irish Songs by Edie O'Dwyer (Soprano). 9.0, Irish Music by the Station String Orchestra. 9.10, Recital of Songs by Irish Composers, by J. O'Neill (Tenor). 9.30 to 10.30, Programme by the I.B.C. (Ireland), Ltd. 9.30, Concert of Light Music: The Frog King's Parade (Marriot); Dance of the Tea Dolls (Schmidt-Hagen); Xylophone Solo, The Blue Danube (Strauss); Shepherd's Boy (Grainger); Cheery Song Memories; Highland Schottische; A Shower of Notes (Steele); Autumn Leaves (Vogelme). 10.0, Concert arranged by the International Broadcasting Company (Ireland), Ltd., on behalf of the Hospitals Trust, Ltd.; Signature Tune, Come Back to Erin; Selection from The Gipsy Baron (Strauss); La flûse (Raff); Gavotte in B Flat (St. Denis); Black Eyes (Ferraris); Violin Solo, Sonvenir (Orfila); Selection from Lilac Time (Schubert-Berté); March (France); Signature Tune. 10.29, I.B.C. Goodnight Melody. 10.45, News and Weather Report.

### BARCELONA

EAJ1, 860 kc/s, 348.8 metres; 8 kW. 7.0 p.m., Trio Concert: Selection from Don Giovanni (Mozart); Serenade (Van den Eynde); Romantic Piece and Gavotte (Chaminade); Aria from Louise (Charpentier); Love Song from The Valkyrie (Wagner); Selection from A Masked Ball (Verdi). 8.0, Request Gramophone Music. 8.30, Exchange. 9.0, Gramophone Music and News. 10.0, Chimes from the Cathedral, Weather, Exchange and Market Prices. 10.5, Dance Music, followed by Concert by the Station Orchestra and Relay from the Guibllid. 12 Midnight (approx.), News.

### BARI

1,112 kc/s, 269.8 metres; 20 kW. See Rome.

BASLE.—See Schweizerischer Landessender.

### BERLIN

**DEUTSCHLANDSENDER (REICHSENDER),** 183.5 kc/s, 1,635 metres; 60 kW.—12 (Noon), Weather. 12.5 p.m. (approx.), Gramophone Concert. 12.55, Time Signal. 1.45, News. 2.0, Gramophone Concert: Overture, Rosamund (Schubert); Aitria's Dance (Grieg); Arabian Dance (Grieg); Carnival roman (Berlioz); Melodies from The Cousin from Nowhere (Künneke); Selection from Wiener Blut (Strauss); Waltz, Die Weber (Lammer); Waltz, Hofballtänze (Lammer); Tanz der Selbsteinsefeger (Glake); English Hornpipe; Song from Die Fledermaus (Joh. Strauss). 3.0, Concert of Light Music. In the interval at 3.30, Weather and Exchange. 4.0, Reading from Fortunatus. 4.15, Concert from Hamburg. 5.0, In a Fashion Studio. 5.20, Chopin Song and Pianoforte Recital: Else Krauss (Pianoforte) and Margarete Vogt-Gebhardt (Soprano); Pianoforte Solos: (a) Two Preludes, (b) Nocturne in C Minor, (c) Two Mazurkas, (d) Songs; Six Songs from the Polish Songs, Op. 74; Pianoforte Solos: (a) Scherzo in C Sharp Minor, (b) Waltz in A flat. 6.0, Pocus. 6.5, Religious Address. 6.35, Wireless Technical Talk. 6.50, Weather and Announcements. 7.0, Transmission for all German Stations relayed from Stuttgart. 8.0, Today's Motto. 8.5 (approx.), Wein der Träne—a Radio Play (Else Kraft-Stramm). 9.10, See Heilsberg. In the intervals at 10.15, Weather and News, and 10.45, Weather. 12 Midnight, Close Down.

### BERLIN

**FUNKSTUNDE,** 715 kc/s, 419.5 metres; 15 kW. 4.30 p.m., Military Band Concert, relayed from the Spreegarten, Treptow; Conductor: Paul Müller; March, Hoch Rheinland (Anzer); Overture, The Gallop of Baghdad (Bohldien); Waltz on Airs from Zeller's Operettas (Thiele); Potpourri, Rheinischer Song (Hannemann); Scottish Caprice, Echo des Bastions (Kling); Tannenberg-Marsch (Wachlin); March, Erinnerung an Dänemark (Janssen); Waltz, O Frühling wie bist du so schön (Lincke). 5.25, Talk: Education under the New Régime. 5.45, Partita in E for Violin (Bach), by Grete Eweler. 6.5, See Berlin (Deutschlandsender). 6.40, The Funkstunde informs its Listeners. 6.45, Topical Talk. 7.0, Transmission for all German Stations, relayed from Stuttgart. 8.5, Programme from Munich. 9.0, Community Singing. 9.30, Radio Report from A Watchmakers' Work Shop. 10.0, Weather and News. 10.10 (approx.), Dance Music by the Kernbach Band, relayed from the Spreegarten, Treptow. In an interval at 11.0, Talk. 12 Midnight (approx.), Close Down.

BERNE.—See Schweizerischer Landessender.

BEROMÜNSTER.—See Schweizerischer Landessender.

BODEN.—See Stockholm.

BODO.—See Oslo.

### BORDEAUX-LAFAYETTE

986 kc/s, 304 metres; 13 kW.—6.15 p.m., Radio Journal. 7.45, News. 8.0, Concert of Gramophone Music. 9.0 Symphony Concert.

### BRATISLAVA

1,076 kc/s, 279 metres; 14 kW.—6.25 p.m., Gramophone Concert. 7.0, See Prague. 10.50 (approx.), Close Down.

BREMEN.—See Hamburg.

### BRESLAU

923 kc/s, 325 metres; 60 kW. Relay by Gleiwitz. 1,184 kc/s, 253 metres.—2.5 p.m. (from Gleiwitz), Song Recital by Margarete Franz (Soprano). 2.35, Dance Music on Gramophone Records. 3.0, Market Prices. 3.15, Talk: A German Student in Prague. 3.35, Talk for Parents. 3.55, Talk: M. Etna. 4.15, Schubert Pianoforte Recital by Margarete Slawik; Wanderer-Fantasia, Op. 142, No. 2; Moment Musical, Op. 94, No. 5. 5.5, Zither and Lute Recital. 5.45, Market Prices. 5.50 (approx.), Review of the September Number of Der Oberschlesier. 6.5, German Songs of Freedom by the Upper Silesian Choral Society. 6.50, Meat Market Prices. 7.0, Transmission for all German Stations, relayed from Stuttgart. 8.0, News. 8.10, Topical Talk. 8.25, Pianoforte Concerto in A (Mozart), by Georg Dohrn and the Silesian Philharmonic Orchestra, conducted by Hoesslin. 9.5, Talk: Why are we organising Folk Dancing Lessons? 9.20, The Fourth Symphony in E flat (Bruckner), by the Silesian Philharmonic Orchestra, conducted by Hoesslin. 10.10 (approx.), Programme relayed from Munich. 10.20, Time and News. 10.45, Light Music and Dance Music from the Café Vaterland. 12 Midnight, Close Down.

### BRNO

878 kc/s, 342 metres; 35 kW.—2.50 to 10.50 p.m., See Prague.

### BRUSSELS (No. 1)

I.N.R., 590 kc/s, 509 metres; 15 kW.—12 Noon, Gramophone Music: Acts II and III of La Bohème (Puccini); Potpourri, What's next? (Finck). 1.0 p.m., Le Journal Parlé. 1.10, Concert by the Lullin Orchestra. 5.0, Concert by the Station Symphony Orchestra, conducted by Meulmans. Soloist: Théo Belyenne (Violin); Ronde wallonne (Jongen); Divertissement on Transylvanian Airs (Scaumel); Elegy for Violin and Orchestra (Beernaert); Suite printanière (Dane); La lune et les peupliers (Rogister); Orchestral Suite (Kalmán). 12 Noon, Talk: Confessions of a Globe-Trotter. 6.15, Baritone Song Recital by Daniel Harris; Serenade from Don Giovanni (Mozart); Prologue to I Pagliacci (Leoncavallo); Le secret (Fauré); Les br-

ceux (Fauré); D'une prison (Hahn); Nègre Spirituals (Burleigh); (a) Every Time, (b) Didn't it rain? (c) Go down Moses, (d) The Gospel Train, (e) Swing low, sweet Chariot. 6.45, Le billet de l'interie Sketch (Lauville). 7.0, Gramophone Concert: Hungaria (Dancó); Schün Rosmarin (Kreislere); La cragotte (Clorice); Polka rondo, L'ou-can tapagan (Balleron); The Clock is playing (Blouw). 7.15, Talk for Housewives. 7.30, Talk on Hygiene. 8.0, Extracts from Lilac Time—Operetta (Schubert-Berté), by the Radio Orchestra, conducted by André, and Soloists. 8.45 (approx.), Dramatic Programme: (a) Les médecins spécialistes—Monologue (Tristan Bernard), (b) Un mari qui chasse—Farce (Eugène Chavette).

### BRUSSELS (No. 2)

N.I.R., 887 kc/s, 338.2 metres; 15 kW.—Programme in Flemish. 12 Noon, Orchestral Concert. 1.0 p.m., Le Journal Parlé. 1.10, Gramophone Concert. In a Monastery Garden (Ketelbey); Gascon Song, L'Arrenoulat (Bonery); Andalusian Airs (Gomez); Ombrà Jeggiera (Meyerbeer); Melodies from Auvergne (Debrons); Villanella from the Sonata in G (Pianelli-Salmon); You are my Heart's Delight from The Land of Smiles (Lohár); Two Airs from Sylvia (Delibes). 5.0, Dance Music relayed from the St. Sanyver Palais de Danse. 6.15, Talk. 6.30, Grieg Song Recital by Franz Schell. 6.50, Gramophone Music, Toccatina (Scuratiotti); Pastorale with Variations (Mozart); Sonata in F (Händel-Tertis); Scherzo from a Quartet (Rimsky-Korsakov); Iberian Dance (Nin). 7.15, Protestant Address. 7.30, Horticultural Talk. 8.0, Symphony (Tchaikovsky) by the Station Symphony Orchestra, conducted by Meulmans. 8.45, Gramophone Music, Quartet No. 3 (Dalyayre); Nocturne (Schelling). 9.0, Brigade Exchange—Play (Johannsen arr. Bevershuis). 10.0, Le Journal Parlé.

### BUCHAREST

761 kc/s, 394 metres; 12 kW.—5.0 p.m., Concert by the Station Orchestra, March (Dieker); Wiener Bonbons (Strauss); Intermezzo from Tiedland (d'Albert); Spinning Chorus and Ballad from The Flying Dutchman (Wagner); Selection from La Bohème (Puccini). 6.0, Radio Journal. 6.15, Concert (cont'd), Potpourri, Fortissimo (Kalmán); Characteristic Piece (Manfeld); Intermezzo (Teller). 7.0, Educational Programme. In the interval at 7.20, Gramophone Music. 8.0, Violin Recital by L. Mendelssohn, Suite (Alfred Mendelssohn); Arioso and Presto in Romanian Style (Golestan). 8.30, Talk. 8.45, Carnival Suite (Schumann) by Edward Stein (Pianoforte). 9.15, Orlo Solos. 9.45, Radio Journal. 10.0, Light Music relayed from a Restaurant.



SEPT. 20th

**WEDNESDAY**

continued

(Hollander); Maurice Chevalier Potpourri; Signature Tune. 11.30, Club Concert for Workop Listeners. Part 1—Military Band Music; Signature Tune: The Chum Song; The Gladiator March (Sousa); Le rêve passe (Krier); Fire Star; Xylophone Solo: The Huntsman (Nelson); En promenade; Shenandoah (arr. Terry); Loin du bal (Gillet); Ben Hur March. 12.5 a.m. (Thursday), I.B.C. Late News Bulletin in English. 12.10 (approx.). Club Concert. Part 2—Oh, I wish I could sing a Love Song; I lost my Girl from Memphis; I'm yours; The Japanese Sandman; Shoo the Hoodoo away; Signature Tune. 12.30, Dance Music by the Blue Mountaineers (Electrical Transcriptions); Fit as a Fiddle; Taboo, Taboo; All over Italy; When my little Pomeranian; You've got me crying again; Two Buck Tim from Tinbuc-too; When it's Lamp-lightin' time; The Language of Love; Won't you stay to Tea?; There's a Tiny little Hair upon your shoulder. 1.0, Dance Music; Signature Tune; Bells of Normandy; Twenty Million People; Sweetheart; Moon Song; Can't we meet again; Rose Mia; My Heart's to let; Seven Years with the Wrong Woman; Well! Well! Well!; I cover the Waterfront; The Lady I love; Jack-in-the-Box; Honeysuckle Rose; Adorable; Letting in the Sunshine; Down the Old Ox Road (Coslow); Signature Tune. 2.0, I.B.C. Good-night Melody and Close Down.

FLENSBURG.—See Hamburg.

FLORENCE.—See Turin.

**FRANKFURT**

1,157 kc/s, 259.3 metres; 17 kW. Relayed by Cassel, 1,200 kc/s, 245.9 metres; and Trier, 1,157 kc/s, 259.3 metres.—6.0 p.m., Talk. 6.25, Topical Talk. 6.45, Today's News. 6.50, Time and Announcements. 7.0, Transmission for all German Stations, relayed from Stuttgart. 8.0, See Munich. 9.0, A German Motor Factory brings out a New Car—Radio Report from the Works. 9.50, Unfamiliar Music by Schumann—Song and Pianoforte Recital by Hans Rosband and Reinhold Merten, with Commentary by Dr. Karl Geiringer: Three Songs; (a) Sehnsucht, (b) Gesanges Erwachen, (c) An Anna; Pianoforte Duet; Polonaise; Songs: (a) Die Weinende, (b) Kurzes Erwachen, (c) Erinnerung. 10.30, Time and News. 11.0, Dance Music from Heilsberg. 12 Midnight (approx.), Close Down.

FREDRIKSSTAD.—See Oslo.

FREIBURG.—See Stuttgart.

GENEVA.—See Radio-Suisse Romande.

GENOA.—See Turin.

GLEIWITZ.—See Breslau.

GOTEBORG.—See Stockholm.

GRAZ.—See Vienna.

HAMAR.—See Oslo.

**HAMBURG**

806 kc/s, 372 metres; 1.5 kW. Relayed by Bremen, 1,112 kc/s, 269.8 metres; Flensburg, 1,319 kc/s, 227.4 metres; Hanover, 530 kc/s, 566 metres; and Kiel, 1,292 kc/s, 232.2 metres.—4.0 p.m., Concert by the Hamburg Philharmonic Orchestra, conducted by José Eibenschütz. Overture, William Tell (Rossini); Polkina (Reesen); Idyll (Kamm); Ballet Music from Czar and Carpenter (Lortzing); Selection from Don Cesar (Delinger); Wonneträum (Meyer-Helmund); Waltz from Der Feldprediger (Müllöcker). 5.0, Old Calendars—Some Amusing Extracts. 5.30, Hamburg, Bremen and Lübeck—Report on Events in the Senates and Houses of Burgesses of the Hanseatic Free Cities. 6.0, Reading (Lulu von Strauss and Torney). 6.30, Talk and Reading (Konradin Kreuzer). 6.45, Frankfurt Exchange. 6.50, Weather. 7.0, Transmission for all German Stations, relayed from Stuttgart. 8.0, See Munich. 9.0, Announcements. 9.10 (from Hanover), The Poetry of the Romantic Period in Settings by Max Peters. The Composer (Pianoforte), Curt Huxdorf (Songs) and Harry Moss (Recitations). Poems of Delmud, Claudius, Lilioceron and Sturm. 10.0, News. 10.10, Topical Talk. 10.20, Dance Music from Berlin (Funkstunde).

HANOVER.—See Hamburg.

**HEILSBERG**

1,085 kc/s, 276.5 metres; 60 kW. Relayed by Danzig, 662 kc/s, 453.2 metres.—1.5 p.m., Gramophone Concert. In the intervals at 1.20 and 2.0, News. 2.30, Programme arranged by the Post Office, with Gramophone Records. 3.0, Agricultural Prices and Exchange. 3.20, Hints for the Housewife. 3.30, Programme for Children. 3.55, Programme for Parents. 4.20, Concert by the Small Station Orchestra, conducted by Eugen Wilcken; Overture, Die Matrosen (Flotow); Suite, Poems of May (Monton); Waltz, Grillenbauer (Strauss); Second Italian Suite (Beethoven); Selection from Der Nachtlager von Granada (Kreutzer). In the interval at 5.0 (approx.), Book Review. 5.50, Talk: Tyrolean Peasant Plays. 6.15, Agricultural Prices. 6.25, Pianoforte Recital by Elisabeth Szage;

Fantasia in C minor (Bach); Symphonic Studies (Schumann); Etude in A minor (Chopin). 6.50, Weather. 7.0, Programme for all German Stations, relayed from Stuttgart. 8.0, Programme of Munich Humour, relayed from the Platzl, Munich. 9.0, Weather and News. 9.10, Light Music and Dance Music by the Small Station Orchestra, conducted by Wilcken and the Börschel Dance Band. In the interval at 10.15, Weather, News, and Sports Notes. 12 Midnight, Close Down.

**HILVERSUM**

Announced HUIZEN, 1,013 kc/s, 296.1 metres; 7 kW. (until 5.40 p.m.), and 20 kW. from 5.40 p.m., Programme of the Christian Radio Society (N.C.R.V.). 11.40 a.m., Police Notes. 11.55, Gramophone Music. 12.10, Quartet Concert; Overture, The Tales of Hoffmann (Offenbach); La villanella rapita (Mozart); Dolores (Ondshorn); Overture, Martha (Flotow); Mädchenenamen (André); Gramophone Music: March, El Capitan (Sousa); Overture, Oberon (Weber); Melody (Hoffmann); Ländler, Alpenveilchen (André); Selection from Die Fledermans (Joh. Strauss). 1.40, Interval. 2.10, Gramophone Music. 2.40, Bible Reading. 3.10, Concert by the Kunst en Genoezen Girls' Choir, conducted by Eerdman, with Gramophone Interludes. 4.40, Programme for Children. 5.40, Agricultural Talk. 6.10, Talk. 6.40, Police Report. 6.55, Ecclesiastical Notes. 7.10, Talk. 7.40, Concert by the Salvation Army Band, with the Station Orchestra and Choir. 9.10, Gramophone Music. 9.25, Organ Recital by Bouwmeester. In the interval at 9.40, News. 10.25, Gramophone Music. 11.10 (approx.), Close Down.

HORBY.—See Stockholm.

**HUIZEN**

Announced HILVERSUM, 160 kc/s, 1,875 metres; 7 kW. (until 3.40 p.m.). Transmitted from Kootwijk on 30 kW. from 3.40 p.m.—11.40 till Close Down. Programme of the Workers' Radio Society (V.A.R.A.). 11.40, Organ Recital by Jong. 12.10 p.m., Concert by De Fiedrebluters. In the interval, Gramophone Music. 1.40, Concert by the Small Station Orchestra, conducted by de Groot; Selection from A Nous la Liberté (Auric); Brise de mer (Leonecavallo); Poème (Fibich); Waltz from Die geschiedene Frau (Fall); Ridonami la calma (Tosti); Serenade (Hayken); Servus Wien (Stolz); Flirtation (Steck); Little Viennese March (Kreiser); Gramophone Records; Overture, Gri-Gri (Lincke); Mattinata (Leonecavallo); La toupie (Gillert); White Negroes (Berger); Vorrei morire (Tosti); Chinese Tambourine (Kreiser); Wien wird bei Nacht erst schön (Stolz). 2.40, Programme for Children. 5.10, Organ Recital by Steyn. 5.40, Recitation. 5.55, Gramophone Concert. 6.40, Talk. 6.55, Concert by the Small Station Orchestra, conducted by de Groot. Soloist: Jong (Organ). 7.40, S.O.S. Messages. 7.42, News. 7.55, Concert by the Station Orchestra, conducted by de Groot; Overture, Mignon (Thomas); Waltz from The Prophet (Meyerbeer); Prelude to Werther (Massenet); Bacchanal from Samson and Delila (Saint-Saëns); Berceuse from Jocelyn (Godard); March from The Queen of Sheba (Gounod). 8.25, Songs by Lisette Stevens. 8.40, Orchestral Concert (cont'd.); Selection from Maximilian Robespierre (Litolff); The Secret of the Adige (Carena); The Student passes by (Dancze); Melody (Gungl); Selection from Hansel and Gretel (Humperdinck). 8.25, Song Recital. 9.30, Song Recital (cont'd.). 9.40, Gramophone Music. 10.10, Concert by De Fiedrebluters, conducted by Ray Forest. 10.55, Talk. 11.10, Gramophone Music. 11.40 (approx.), Close Down.

INNSBRUCK.—See Vienna.

KALUNDBORG.—See Copenhagen.

**KATOWICE**

734 kc/s, 408 metres; 16 kW.—7.5 p.m., Talk: Italy. 7.25, Announcements and Gramophone Music. 7.40, See Warsaw. 10.40, Dance Music. 11.0, The Letter Box in French.

KIEL.—See Hamburg.

KLAGENFURT.—See Vienna.

KOSICE.—See Prague.

**LANGENBERG**

635 kc/s, 473 metres; 60 kW.—12 Noon, Songs, Choral and Instrumental Music (on Gramophone Records). 1.15 p.m., News. 1.30, Concert by the Station Orchestra, conducted by Werner Göhre; Waltz, Künstlerleben (Strauss); Liebeslied (Schütt); Canzonetta (Schütt); Suite, Aus aller Herren Länder (Moszkowsky); Viennese Dances (Friedman-Gärtner); Potpourri, Pikante Blätter (Kouzak). In the interval at 2.0, News. 3.0, Handicrafts Lesson. 3.30, Exchange and

Time Signal. 3.50, Programme for Young People: Ten Cologne Boys travel through East Prussia. 4.30, Topical Talk. 4.40, Talk on Insurance. 5.0, Light Music on Gramophone Records. 5.30, Chamber Music by the Station String Quartet: Quartet in A (Dittersdorf); Divertissement (Michael Haydn); Italian Serenade (Wolf). 6.15, Radio Report from the Fair. 6.35, A Westphalian Legend. 6.45, News. 7.0, Transmission for all German Stations, relayed from Stuttgart. 8.0, General News. 8.5, Concert by the Münster Municipal Orchestra, conducted by Jochem. Soloists: Hilde Göhre (Harpssichord) and Karl Spiegel (Bassoon); Symphony in B Flat (Bach); Concerto for Harpssichord and Orchestra (Haydn); Concerto for Bassoon and Orchestra (Mozart); Entr'acte and Ballet Music from Rosamunde (Schubert); Overture, Die Fledermans (Joh. Strauss). In the interval, Talk on Lulu von Strauss and Torney. 10.0, News. 10.20, A Flying Visit. 10.35, Dance Music from Heilsberg. 12 Midnight, Close Down.

LAUSANNE.—See Radio-Suisse Romande.

**LEIPZIG**

769.9 kc/s, 389.6 metres; 120 kW. Relayed by Dresden, 941 kc/s, 319 metres.—12 Noon, Weather and Time. 12.5 p.m., Concert by the Leipzig Symphony Orchestra, conducted by Alfred Schröter, relayed from the Capitol. Soloist: Erich Neumann (Organ). In the interval at 1.0, News. 2.0, News. 2.30, Talk: Motors and Drivers. 3.0, Book Review. 3.20, Swabian Stories on Gramophone Records. 3.35, Market Prices. 4.0, Peter the Cabin-Boy—Radio Play for Young People (Dieffenbach), with Music by Fritzsche. 4.50, Choral Concert relayed from Halle. 5.30, Reading of Animal Stories. 5.50, Weather and Time. 6.0, Talk: The Peasants in Thuringia. 6.20, Modern German Songs by the Eintracht Male Voice Choral Society: Wach auf, du deutsches Land (Walther-Knab); Das neue Lied (Lürmann); Deutscher Frühling naht (Lürmann); Von Freiheit und Vaterland (Goepfert); Heimat, liebe Heimat (Pohl); Ich kenn' ein' hellen Edelstein. 6.50, Today's News. 7.0, Transmission for all German Stations, relayed from Stuttgart. 8.0, See Munich. 9.0, Concert of Scandinavian Music. The Leipzig Symphony Orchestra, conducted by Theodor Blumer. Soloists: Lena Eiehler (Soprano), Fritz Weitzmann (Pianoforte) and Friedbert Sammler (Cello). Norwegian Suite (Seljelderup). Songs (Seljelderup): (a) Ein Blumenstrauß. (b) Verräter der Liebe. (c) Wiegenlied. Pianoforte Concerto No. 2 (Op. 33, The River (Palangren). 10.5, News. 10.30, Serenades on Gramophone Records. 11.0, Dance Music, relayed from Heilsberg. 12 Midnight, Close Down.

LINZ.—See Vienna.

**LJUBLJANA**

522 kc/s, 574.7 metres; 7 kW.—10.30 to 11.0 p.m., Programme in English by the I.B.C. 10.30, International Broadcasting Club Concert: You loving me; Little Yvonne; Flower of Spain; Ziganette; Why be so unkind to me; We all wanna know why; Selection from The Count of Luxembourg (Lelair).

**LUXEMBOURG**

252 kc/s, 1,191 metres; 200 kW.—12.30 p.m., Concert by the Station Orchestra, conducted by Henri Pénis; Overture, Die Felsenmühle (Reissiger); Selection from Faust (Gounod); Lullaby (Roger); Serenade (Tarenghi); Suite, Greenland (Frederiksen); Sur le lac (Godard-Salabert); Selection from Casanova (Lincke). 1.30, Gramophone Concert. 7.30 till Close Down, Luxembourg Programme. 7.30, Concert by School Children. 8.20, Concert by the Station Orchestra; Overture, Mignon (Thomas); Selection from Samson and Delila (Saint-Saëns); Selection from La Bohème (Puccini). 8.50, News in French. 9.0, Song Recital by Nicholas Schult; Songs from: (a) Carmen (Bizet), (b) Herodiade (Massenet), and (c) Mignon (Thomas); Enfant, si j'étais roi (Liszt); Cavatina from La dame blanche (Boieldieu). 9.30, Variety Concert by the Station Orchestra; Prince Jean (Merletens); Dieksiana (Kahnt). 9.50, News in German. 10.0, Variety Concert (cont'd.); Suite, Il menestrello (Amadei); In the Steppes of Central Asia (Borodin); Ballet Egyptian (Luigini). 10.30, Dance Music on Gramophone Records.

**LYONS**

LA DOUA, 644 kc/s, 465.8 metres; 1.5 kW.—7.30 p.m., Radio Gazette for Lyons and the South East. 8.30, Concert Version of The Barber of Seville—Opera (Rossini). After the Programme, News Bulletin.

**MADRID**

ARANJUEZ, EAQ, 10,000 kc/s, 30 metres; 20 kW.—11.30 p.m., Popular Concert. In the interval at 11.45, Radio Chronicle. 12.40 a.m. (Thursday), Light Music. 1.0 (approx.), Close Down.

**MADRID**

EAJ7, 707 kc/s, 424.3 metres; 2 kW.—8.0 p.m., Chimes, Exchange, Radio Journal, Programme for Women, Gramophone Records, and Dance Music. 9.15, Topical Review. 9.30 to 11.0, Interval. 11.0, Chimes, Time Signal, and Topical Review. 11.20 (approx.), La leandriera—Play (Goldoni), arranged for Radio. 1.15 a.m. (Thursday), Topical Review and News. 1.30, Chimes and Close Down.

MALMO.—See Stockholm.

MILAN.—See Turin.

**MORAVSKA-OSTRAVA**

1,137 kc/s, 263.8 metres; 11 kW.—2.50 to 10.50 p.m., See Prague.

MOTALA.—See Stockholm.

MUHLACKER.—See Stuttgart.

**MUNICH**

563 kc/s, 533 metres; 60 kW. Relayed by Augsburg and Kaiserslautern, 536 kc/s, 560 metres and Nürnberg, 1,256 kc/s, 239 metres.—4.30 p.m., Orchestral Concert, conducted by Karl List: Soloist: Walter Heinze (Oboe); Hungarian March (Fucik); Comedy Overture (Scheimpflug); Oboe Concerto (Haydn); Selection (Maasz); Serenade in D (Draesecke); Chromatischer Galopp (Liszt). 5.45, A Discussion with Two Workmen—Mechanics in a Motor Factory. 6.5, Sonata in B minor for Cello and Piano-forte (Kuhli), by Willy Esterl and Thea Bischoff. 6.25, Talk: On the Volga. 6.45, Time, Weather and Agricultural Report. 7.0, Transmission for all German Stations, relayed from Stuttgart. 8.0, Humorous Munich Programme, relayed from the Platzl. 9.0, Concert of Folk Music. 10.0, Austria. 10.20, Time and News. 11.0, Dance Music relayed from Stuttgart. 12 Midnight, Close Down.

NAPLES.—See Rome.

NOTODDEN.—See Oslo.

**OSLO**

277 kc/s, 1,083 metres; 60 kW. Relayed by Fredriksstad, 820 kc/s, 365.8 metres; Hamar, 522 kc/s, 574.7 metres; Notodden, 671 kc/s, 447.1 metres; Porsgrund, 662 kc/s, 453.2 metres; and Rjukan, 671 kc/s, 447.1 metres.—5.30 p.m., Concert by the Station Ensemble, relayed from Bergen, 824 kc/s, 364 metres; Overture, Orpheus in the Underworld (Offenbach); Waltz, Künstlerleben (Joh. Strauss); Russian Dance, Livonie (Bartel); Ritoria (Carosio); Selection from The Czarevitch (Lelair); Goodbye (Tosti); Norwegian Dances (Grieg). 6.30, Programme for Girls. 7.0, News. 7.30, Talk on the Norwegian Language. 8.0, Time Signal. 8.1, Concert by the Station Orchestra, conducted by Hugo Kramm; Elegiac Suite for Strings (Rangström); Pianoforte Concerto in G minor, Op. 22 (Saint-Saëns); Andante from Symphony No. 5 (Beethoven); Suite erotique (Hurnum); Largo from the Symphony, From the New World (Dvorak); Spanish Rhapsody (Chabrier); Overture, Patrie (Bizet). 9.30, Market Prices. 9.40, News. 10.0, Topical Talk. 10.15, Programme to be announced. 10.45, Dance Music on Gramophone Records. 11.30 (approx.), Close Down.

OSTERSUND.—See Stockholm.

**PALERMO**

558 kc/s, 537.6 metres; 3 kW.—8.0 p.m., Dopplavoro Announcements, Tourist Talk, Agricultural Notes and Giornale Radio. 8.20, Gramophone Music. In the interval at 8.30, Time and Announcements. 8.45, Concert: Slav Dance (Dvorak); Nocturne (Martucci); Introduction and Wedding Procession (Rimsky-Korsakov); Violin Solos: Two Caprices (Paganini); Soprano solos: (a) Aria from Ero e Leandro (Bottesini), (b) Aria from Riccardo (Goverale); Pianoforte Solos: Two Preludes (Bach); Violin and Pianoforte Duets: (a) Prelude and Allegro (Pugnani-Kreiser), (b) Paravento giapponese (Arno), (c) Scene infantile (Napoli); Allegro (Schubert); Tambourin (Rameau); Minuet (Debussy); Hungarian Dance No. 5 (Brahms). In the interval, Talk. 10.0 (approx.), Gramophone Music. 11.0 Giornale Radio.

**PARIS**

EIFFEL TOWER, Call FLE, 207.5 kc/s, 1,445.7 metres; 13 kW. Time Signals (on 2,650 metres) at 10.26 a.m. and 11.26 p.m. (Preliminary and 6-dot Signals)—6.45 p.m., Theatre Talk. 7.0, Le Journal Parlé. 8.30, Symphony Concert, conducted by Flamant; Overture, Fingal's Cave (Mendelssohn); Minuet from Orpheus (Gluck); Melody (Stack); Overture and Minuet; Serenade for Strings (Périllon); Pagode an ercénacule (Flamant); Selection from The Barber of Seville (Rossini); Siegfried Idyll (Wagner); Sevilla (Albeniz); Selection from Il Seraglio (Mozart). 10.0 (approx.), Close Down.

SEPT. 20th **WEDNESDAY** continued

**PARIS**

**POSTE PARISIEN**, 914 kc/s, 328.2 metres; 60 kW.—7.0 p.m., Impression d'Italie (Charpentier) on Gramophone Records. 7.15, Le Journal Parle. 7.30, Musical and Literary Programme by Derival and Mayen of the Comédie Française. L'éventail, Words and Music by Frédéric de Fayez-Jozin; Poem, Jean Renard (Gérard de Nerval); with Music by Gustave Sandré; L'étoile du soir (Alfred de Musset); with Music by Luile Dous. 8.0, Economic Talk. 8.5, Gramophone Music. 8.30, Le Message Play in Three Acts (Juliette Mylo). 10.30, Dance Music, relayed from the Lido. 11.0, News.

**PARIS**

**RADIO-PARIS**, Call CFR, 174 kc/s, 1,725 metres; 75 kW.—7.30 a.m., Weather and Physical Culture. 7.45, Gramophone Music: Les pupilles de la marine (Chic); Flots d'or (Salabert); Stephanie Gavotte (Zibulka); Indian March (Sellenick). 8.0, Weather and Press Review. 12 Noon, Educational Talk. 12.15, Gramophone Music: Toujours on jamaïs (Waldteufel); Aria from Die Fledermaus (Strauss); Ein' Nacht in Venedig (Strauss); Serenade (Curtis-Matray). 12.30, Art Notes, followed by Organ Recital from the Gaumont Palace. 1.0 p.m., Market Prices, Weather and News. 1.5, Gramophone Music: Jota aragonesa (Saracate); Marche militaire (Schubert); Andante Pastorale (Taffanel); Chant d'expresso (Cuvillier); Simple ayeu (Thomé); Le cœur de ma mie (Dalerose); Chant sans paroles (Tchaikovsky); Penn d'âne (Borel); Pandanguillo (Turina); Lament (Dvorak); Larghetto (Weber-Kreiser); Les myrtes sont fleuries (Fauré); La source (Zabel); Matin d'Octobre (Gautier); Mazurka (Chopin); Ronde de nuit (Glinka); Souvenir des bois d'Avron. 2.0, Exchange, News and Weather. 3.45, Exchange. 7.0, Agricultural Notes. 7.10, Gramophone Music: My Ideal (Whiting-Well-Chase); Saxophobia (Wiedorf); Les baraquons (Mondex-Gallego); Toccata Dance (Wiener); Messager d'amour (Witmann); La serenata (Braga); Popular Venetian Airs for Harpsichord. Two Guitars. Ballade des gros Dindons (Chabrier). Glockenspiel Solo: Le père nue, Cavatina (Raff). 7.50, Exchange and News. 8.0, Songs and Gramophone Records: The Skaters' Waltz (Waldteufel); Petite grand-mère; Selection from The Queen of Spades (Tchaikovsky). Songs: (a) Quand je suis loin de toi (Weber-Sylviano). (b) Sans qu'on le veuille (Boyer-Sileau). (c) Little Grey Home in the West (Löhr). (d) Tango from White Horse Inn (Benatsky). 8.30, News and Weather. 8.40, Fashion Review by Mlle. José. 8.45, Pianoforte Recital by Pierre Fontaine. 9.15, Press Review and News. 9.30, Gramophone Music: La vie gaie à Kieff (Wetchemitz); Rondo brillant (Weber); Aria (Caldara); Legend (Coppola); Two Arab Poems (Coppola); Chanson (Friml); Valencianas (Cristobal); Scherzo-Valse (Chabrier); Overture, Anacron (Chernini); Impressions of Damascus (Konguelt-Desportes); Waltz (Durand).

**PITTSBURGH**

**KDKA**, 980 kc/s, 306 metres; 50 kW. Relayed by **W8XK** on 48.85 metres and 25.27 metres.—7.30 p.m., Pontiac and Home Forum. 8.0 to 9.30, **New York** Relay. 8.0, Betty and Bob. 8.15, Utility Hall. 8.30, Contest and Dixie Days. 9.0, Southern Symphonies. 9.30, Frances Ingram. 9.45, News and Market Report. 10.0, Uncle Tom and Betty. 10.15, Tolan of the Apes. 10.30, The Singing Lady, from **New York**. 10.45, Orphan Annie, from **New York**. 11.0, News and Talk. 11.15, Sports Notes and a Song. 11.30, Pittsburgh Spotlights. 11.45, Lowell Thomas. 12 Midnight, Amos 'n' Andy, from **New York**. 12.15 a.m. (Thursday), Rhythm Kings. 12.30, Popular Programme. 1.0, Nomads. 1.30 to 3.0, **New York** Relay. 1.30, Potash and Perlmuter. 1.45, The King's Jesters. 2.0, History American Legion. 2.30, Ortiz Tirado, Mexican Tenor. 3.0, Quest of Perfect Women.

**PORSGRUND**.—See Oslo.

**PRAGUE**

614 kc/s, 488.6 metres; 120 kW.—2.50 p.m., Concert. 3.50, Aviation Weather Report. 3.55, Exchange. 4.0 to 6.5, Programme relayed from **Pilsen**. 4.0, Talk: Gymnastics. 4.10, Talk: Excursions in the Pilsen District. 4.20, A Scene from Student Life at Pilsen. 4.50, Concert. 5.20, Programme for Children. 5.50, Reading. 6.5, Agricultural Programme. 6.15, Talk for Workers. 6.25, News in German. 6.30, German Transmission; Programme for Workers; Talk and Labour Market Report. 7.0, Chimes and News. 7.10, Reading. 7.25, Talk. 7.35, Relay from the Municipal Theatre. 9.45, Soloist Concert. 10.0, Time Signal, News, and Sports Notes. 10.15, Variety Programme from **Pilsen**. 10.35, News in French. 10.50, Close Down.

**RADIO-SUISSE ROMANDE**

**SOTTENS**, 743 kc/s, 403 metres; 25 kW.; and **Geneva**, 395 kc/s, 760 metres.—6.15 to 6.30 a.m., Gymnastics Lesson. 12.28 p.m., Time

Signal from Neuchâtel Observatory. 12.30, News and Weather. 12.40 (from **Geneva**), Gramophone Music. 1.0 (from **Geneva**), Financial Notes. 1.10 (from **Geneva**), Gramophone Concert. 2.0 to 3.28, Interval. 3.28, Time Signal from Neuchâtel Observatory. 3.30 (from **Lausanne**), Concert by the Radio Lausanne Orchestra, conducted by Moser. 5.0 to 6.0, Interval. 6.0 (from **Lausanne**), Programme for Children. 7.0 (from **Lausanne**), Talk: Natural Silk. 7.25 (from **Lausanne**), Agricultural Report, News and Announcements. 7.30 (from **Lausanne**), Tourist Talk. 7.45 (from **Lausanne**), Talk: The 1933 Walking Tour round Lake Geneva. 8.0 (from **Geneva**), Talk: Montaigne, His Work and Personality. 8.25, Concert by the Radio-Suisse Romande Orchestra, conducted by Echenard. Soloist: Mme. Nicolai (Songs). Orchestral Suite (Puccini); Songs with Orchestral Accompaniment; Concerto for Three Violins (Vivaldi); Song from Castor et Pollux (Jolly); Symphony in E Flat, No. 3 (Haydn). 9.50, News and Weather. 10.0 (from **Geneva**), Dance Music. 11.0 (approx.), Close Down.

**REYKJAVIK**

1,200 metres; 21 kW.—9.5 p.m., Musical Programme. 9.30, Weather. 9.40, Musical Programme and Announcements. 10.0, Chimes and News. 10.30, Reading. 11.0, Violin Solos by Thorarinn Gudmundsson, followed by Icelandic Songs on Gramophone Records.

**RIGA**

572 kc/s, 525 metres; 15 kW. 6.0 p.m., English Lesson. 6.30, Agricultural Talk. 7.0, Weather Report. 7.5, Programme of Operetta Music, Sketches and Songs. In the intervals at 8.0 and 9.0, News and Weather. 9.30, Grand Symphony (Beethoven), on Gramophone Records.

**RJKUKAN**.—See Oslo.

**ROME**

Call **1R0**, 680 kc/s, 441 metres; 50 kW. Relayed by **Naples**, 941 kc/s, 319 metres; and **2R0**, 11,810 kc/s, 25.4 metres, from 5.15 p.m., and **Milan** (Vigentino), 662 kc/s, 453.2 metres, from 8.45 p.m.—12.30 p.m., Gramophone Music. 1.0, Orchestral Concert. In the interval from 1.30-1.45, Giornale Radio and Exchange. 2.0, Time and Announcements. 4.30, Giornale Radio, Exchange and Report of the Royal Geographical Society. 4.45, Children's Radio Review. 5.10, Weather. 5.15-6.0, Orchestral Concert. 6.40 (Naples), Shipping and Sports Notes. 6.45, Dopulavoro Notes and Tourist Report. 6.57, Report of the International Institute of Agriculture (in Italian and English). 7.10, Agricultural Report. 7.20, News in Foreign Languages. 7.40, Giornale Radio. 8.0, Time, Announcements and Gramophone Music. 8.15, Medical Talk. 8.30, Giornale Radio and Sports Notes. 8.45, Rny Blas-Opera in Three Acts (Marchetti). In the intervals, Talk and Theatre Notes. Giornale Radio after the Programme.

**SALZBURG**.—See Vienna.

**SCHENECTADY**

**WGY**, 790 kc/s, 379.5 metres; 50 kW. Relayed at intervals by **W2XAF** on 31.48 metres and by **W2XAD** on 19.56 metres.—9.0 to 10.0 p.m. (approx.), **New York** Relay. 9.0, Pop Concert. 9.30, The Mind Age. 9.35, Lady Next Door. 12.45 a.m. (Thursday), Stock Reports and Baseball Scores. 1.0, Standard Brands, from **New York**. 1.30, Popular Programme. 1.45, Musical Programme. 2.0, Ferde Grofe's Orchestra, from **New York**. 2.15, Outdoor Girl. 2.30, Popular Programme. 3.0, Variety Programme from **New York**. 3.30, Ship of Joy, from **New York**, followed by Programme Resume.

**SCHWEIZERISCHER LANDESENDER**

**BEROMUNSTER**, 653 kc/s, 459 metres; 60 kW.; **Basle**, 1,229 kc/s, 244.1 metres; and **Berne**, 1,220 kc/s, 245.9 metres.—6.15 a.m. (from **Basle**), Gymnastics. 6.35 to 11.59, Interval. 11.59, Time Signal from Neuchâtel Observatory, and Weather. 12 Noon (from **Berne**), Concert of Chamber Music on Gramophone Records. 12.30 p.m., Time, Weather and News. 12.40 (from **Berne**), Gramophone Concert of Music by Offenbach, Millöcker, O. Straus, Egler and Lehár. 1.25 (from **Berne**), Time, Weather and Exchange. 1.30 to 5.0, Interval. 5.0 (from **Berne**), Programme for Children. 5.30 (from **Berne**), Gramophone Music. 6.0 (from **Berne**), Concert of Chamber Music on Gramophone Records. 6.30 (from **Zürich**), Talk on Astronomy. 7.0 (from **Zürich**), Time, Weather and Market Prices. 7.10 (from **Zürich**), Gramophone Concert. 7.30 (from **Zürich**), English Lesson. 8.0 (from

**Zürich**), Maurice Ravel Pianoforte Recital. 8.30, Talk: Travelling Experiences. 9.0, Weather and News. 9.10 (from **Zürich**), Haydn's Symphonies—a Lecture Recital. 10.15 (approx.), Close Down.

**SOTTENS**.—See Radio-Suisse Romande.

**STOCKHOLM**

689 kc/s, 436 metres; 55 kW. Relayed by **Boden**, 244 kc/s, 1,229.6 metres; **Göteborg**, 932 kc/s, 322 metres; **Hörby**, 1,166 kc/s, 257 metres; **Motala**, 221.5 kc/s, 1,354.4 metres; **Ostersund**, 389 kc/s, 770 metres; and **Sundsvall**, 554 kc/s, 542 metres.—5.5 p.m., Musical Programme. 5.35, Reading. 6.0, Gramophone Music. 7.0, Talk: The Practical Corner. 7.15, Weather and News. 7.30, Talk: Finland under the Czars, relayed from **Malmö**, 1,301 kc/s, 231 metres. 8.0, Brahms Concert, conducted by Vazhay Talich. Soloist, Olof Wiberg (Pianoforte). Academic Festival Overture, Pianoforte Concerto in D Minor; Symphony No. 1 in C. 9.45, Weather and News. 10.0, Dance Music by Enders' Band, relayed from the Bern Hall. 11.0 (approx.), Close Down.

**STRASBOURG**

£69 kc/s, 345 metres; 11.5 kW.—11.30 a.m., Classical Music on Gramophone Records. 12.45 p.m., News. 1.0, Time and Exchange. 1.5, Light Music on Gramophone Records. 2.0, Interval. 5.0, Talk in German: Street Lighting by Electricity. 5.15, Orchestral Concert, conducted by Roskam; Overture, The Gipsy Baron (Joh. Strauss); Selection from Martha (Flotow); Pianoforte Solo: Plaisir d'amour (Martini); Waltz, Tales of the Vienna Woods (Joh. Strauss); Selection from The Cunning Peasant (Fall); Petite suite, sur le mode mineur (Gabriel-Marie); En relisant vos lettres (Masson-Kieck); March from Casanova (Lincke). 6.0, Concert by the Station Trio, relayed from **Lille**, 1,130 kc/s, 265.4 metres. 7.0, Talk: Insurance against Hunting Risks. 7.15, Talk in German: The Skilled Trades in the Middle Ages. 7.30, Time and News. 7.45, Gramophone Music. 8.0, Press Review in German, Lottery Results and Announcements. 8.30, A Waltz Dream, Operetta in Three Acts (O. Straus). In the interval, Press Review. 10.30, Orchestral Concert, conducted by Jennie, relayed from the Grand Kießer Tavern; Waltz, Trés jolie (Waldteufel); Ständchen (Schubert); Selection from Rose Marie (Friml); Die Spieluhr (Blaw); Selection from Le petit Duc (Lecocq); Hungarian Dances, Nos. 5 and 6 (Brahms); Vienna, City of my Dreams (Siczynski); Soldiers' Songs (Salabert). 11.30 (approx.), Close Down.

**STUTTGART**

**MUHLACKER**; 832 kc/s, 360.5 metres; 60 kW. Relayed by **Freiburg**, 527 kc/s, 570 metres.—12 Noon, Concert by the Station Orchestra, conducted by Gustav Görlich; Overture, Nordische Seemannsfahrt (Gade); Weyland's Lament (Fini Benjamins); Lyric Suite (Grieg); Saltarella (Amadei); Farandole (Bizet); Overture, A Night in Venice (Joh. Strauss); Waltz, Herbststimmung (Lincke); Alter Jägermarsch, 1813; Rakoczy Overture (Keler-Bela). 1.15 p.m., Time and News. 1.30, See **Langenberg**. 2.0, News from **Frankfurt**. 2.10 to 2.40, Concert arranged by the Post Office, with Gramophone Records. 3.30, Programme for Children. 4.30, See **Munich**. 5.45, Nature Talk: When the leaves fall... 6.0, Talk: A Flight from Stuttgart to Lake Constance. 6.30, Time and News. 7.0, Transmission for all German Stations: Ferdinand Count Zeppelin—a Radio Play in Ten Scenes (Karl Köstlin and Arthur Georg Richter). 8.0, See **Munich**. 9.0, Talk: What Everybody Should Know... 9.10, Dance Music and Light Music from Greiner's Restaurant. 10.0, See **Munich**. 10.20, Time and News. 10.40, Dance Music (contd.). 12 Midnight, Close Down.

**SUNDSVALL**.—See Stockholm.

**TOULOUSE**

779 kc/s, 385 metres; 8 kW.—6.0 p.m., News. 6.15, Accordion Music. 6.30, Popular Orchestral Music. 6.45, Sponsored Programme. 7.15, News, Racing Results, and Market Prices. 7.30, Leonora Overture (Beethoven), by a Symphony Orchestra. 7.45, Operetta Music: Selection from Une nuit au Louvre (Urgel); Les Saltimbanques (Ganne); and Elle est à vous (Yvain). 8.0, Light Orchestral Music. 8.15, Opera Music: Arias from: Sappho (Massenet); Le roi de Lahore (Massenet); and Rigoberto (Verdi). 8.30, Jazz Music. 9.0, Concert by a Marmelade Orchestra: Two-Step (Maciejochi); Prelude in F (Maciejochi); Waltz, Espoirs perdus (Morotti); Selection from La Traviata (Verdi); Barcarolle (Maciejochi); Overture, Tancered (Rossini); Intermzzo (Salvetti); Two-Step, Mercedes (David del Castillo). In the interval, Songs. 10.15, North African News and Local News. 10.30, Concert for Listeners in Morocco: Prelude to Act III of Louise (Charpentier); Songs from Les Noces de Jeannette

(Massé); Selection from Les millions d'Arlequin (Drigo); Chez le tailleur (Bach and Laverne); The Sleeping Beauty (Baker). 11.0, Dance Music. 11.45, Popular Music, Liebessträume (Liszt); Minnet in G (Paderevsky); Selection from Maritima (Wallace). 12 Midnight, News, Weather, and Announcements. 12.5 a.m. (Thursday), Music by a Viennese Orchestra. 12.15, Music by an Argentine Orchestra. 12.30 (approx.), Close Down.

**TRIESTE**

1,211 kc/s, 247.7 metres; 10 kW.—5.10 p.m., Concert: Attilio Poluzzi (Flute), Ettore Sizon (Cello), Enrico Martucci (Pianoforte), and Valeria de Poltieri (Soprano); Sonata, Op. 48 (Pierne); Three Songs with Flute, Cello and Pianoforte Accompaniment (Ravel). 6.0 till Close Down, See **Turin**.

**TRONDHEIM**.—See Oslo.

**TURIN**

1,096 kc/s, 273.7 metres; 7 kW. Relayed by **Milan**, 905 kc/s, 331.5 metres; and **Florence**, 599 kc/s, 500.8 metres.—5.10 p.m., Song Recital. 6.0-6.5, Weather. 6.40, Giornale Radio, Dopulavoro Announcements and Gramophone Music. 7.0, Time, Tourist Report and Gramophone Music. 7.10, Agricultural Notes and Market Prices. 7.20, News in Foreign Languages. 7.40, Gramophone Music. 8.0, Announcements, Giornale Radio, Sports Notes and Weather. 8.15, Medical Talk. 8.30, A Comedy in Three Acts, followed by Concert. 11.0, Giornale Radio.

**VATICAN CITY**

15,120 kc/s, 19.84 metres (Morning), and 5,969 kc/s, 50.26 metres (Evening); 10 kW.—11.0 to 11.15 a.m., Religious Information in Spanish. 8.0 to 8.15 p.m., Religious Information in Italian.

**VIENNA**

581 kc/s, 517 metres; 100 kW. Relayed by **Graz**, 852 kc/s, 352.1 metres; **Innsbruck**, 1,058 kc/s, 283 metres; **Klagenfurt**, 662 kc/s, 453.2 metres; **Linz**, 1,220 kc/s, 245.9 metres; and **Salzburg**, 1,373 kc/s, 218.5 metres.—12 Noon, Concert by the Wiener Symphoniker, conducted by Josef Holzer: March, Jetzt geht's los (Lehár); Overture, Der Bettelstudent (Müllöcker); Violin Solos: (a) Waltz (Hummel). (b) Die Biene (Schubert); Waltz Morgenblätter (Joh. Strauss); Song, Lass dir Zeit; (Zeller); Prelude and Serenade from Der Schneemann (Korngold); Symphonic Polonaise (Bass); Selection from Madame Butterfly (Puccini); March, Wiener Hausfrauen (Jurek); Strauss-Müllöcker-Suppé Potpourri (Ziehrer); Song, Am Sommerheideberg (Silying); Aufzug der Stadtwache (Jessel); Song, Gruss mir mein Wien (Kalmán); Waltz, Rindgesänge (Hellmesberger); Potpourri, Hört und staunt (Dostal). In the interval at 1.0 p.m., Time and News. 3.0, Time and Announcements. 3.20, Talk: The Röntgen Rays. 3.45, Songs on Gramophone Records. 4.15, Talk: Travelling by Raft on Austrian Rivers. 4.40, Educational Talk. 5.5, Concert of Music by Arnold Röhrling, with the Composer at the Pianoforte; Wind Instrument Quintet in E flat minor; Last Movement of the String Quartet arranged for Pianoforte Quintet. 5.55, Talk: The Semmering Race, 1933. 6.10, Talk on the Broadcasts for Schools. 6.35, Talk. 7.0, The Town—Concert by the Wiener Symphoniker, conducted by Bernhard Paumgartner. In the interval at 7.15, Time and Announcements. 8.30, Topical Talk. 8.45, Der wilde Grabbe—Radio Sequence. 9.45, Announcements. 10.0, Gramophone Music, followed by Announcements.

**WARSAW**

212.5 kc/s, 1,411 metres; 120 kW.—11.57 a.m., Time Signal and Fanfare from St. Mary's Church, Cracow. 12.5 p.m., Gramophone Music. In the intervals at 12.25, Press Review and at 12.33, Weather. 12.55, Radio Journal. 1.0, Interval. 2.55, Gramophone Music. In the intervals at 3.5, News, at 3.25, Economic Notes, and at 3.45, News. 5.0, Topical Talk. 5.15, Light Music from the Gastronomica Café. 6.15, Talk: Stefan Gorezynski, Soldier and Poet, on the Centenary of his Death. 6.35, Song Recital by Emma Szabranska. Je voudrais avec toi (Szopski); Spring (Joteyko); The Wind (Wielhorski); La Malédiction (Niewiadomski); Brunette (Zelenski); Tu ne t'en iras pas (Maklakiewicz); Prayer from La Favorita (Donizetti); Aria from The Queen of Sheba (Goldmark); Aria from The Queen of Spades (Tchaikovsky). 7.0, Gramophone Music. 7.20, Miscellaneous Items. 7.35, Programme Announcements. 7.40, Reading. 8.0, Ludomir Roszycki Chamber Music by the Polish Quartet, with the Composer at the Pianoforte. Pianoforte Quintet; Rhapsody for Trio. 8.50, Radio Journal. 9.0, Agricultural Notes. 9.10, Light Music. 10.0, Dance Music from the Oaza Dance Hall. In the intervals at 10.25, Sports Notes, and at 10.35, News, Weather and Police Notes.

**ZÜRICH**.—See Schweizerischer Landessender.

## ATHLONE

725 kc/s, 413 metres; 60 kW. Relayed by Cork, 1,337 kc/s, 224.4 metres.—1.30 to 2.30 p.m., Time, Weather, Stock Report and Gramophone Concert. 4.0, Police Band Concert. Soloist: K. McCully (Soprano). 6.0, Programme for Children. 6.40, News. 7.0, French Lesson. 7.15, Readings. 7.30, Time Signal. 7.32, Pianoforte Recital by Claud Biggs. 8.0, Soprano Solos by Letitia Ennis. 8.20, Traditional Fiddle Solos by Michael O'Maolain. 8.30, The Station Orchestra. 9.0, Programme by the Emer Comedy Company. 9.30 to 10.30, Programme arranged by the I.B.C. (Ireland). Ltd. 9.30, Concert: The Watermelon Fête (Thomson); Slippery Fingers (Steele); The Humble Bee's Wedding (Clare); The Clock and the Dresden Figures (Kotelnikoff). 9.45, Organ Recital: Nola (Arnold); In a Persian Market (Griffiths); Bird Songs at Eventide (Coates); A Palace of Dreams (Waller). 10.0, Concert arranged by the International Broadcasting Company (Ireland), Ltd., on behalf of Hospitals Trust, Ltd.: Signature Tune, Come back to Erin; I like Mountain Music (Weldon); Farewell to Arms (Wrubel); What more can I ask? (Noble); Play, Fiddle, Play; Good Morning, Mr. Sun; You've got me crying again; I've got the World on a String; Signature Tune. 10.29, I.B.C. Good-night Melody.

## BARCELONA

EAJI; 560 kc/s, 348.8 metres; 8 kW.—7.0 p.m., Trio Concert. 8.0, Request Gramophone Records. 8.30, Exchange. 9.0, Gramophone Music and News. 10.0, Chimes from the Cathedral. Weather, Exchange, Quotations, and Market Prices. 10.5, Concert by the Station Orchestra: March (Raymond); Jota, El andarin (Coto); La Letra de Manon (Gillet); Polonaise from Boris Godunov (Mussorgsky); Selection from Ghismonda (Février); Overture, Euryanthe (Weber). 11.0, La Fonta del Boté—Play in Three Acts (Pilar Millán Astray). In the interval at 12 Midnight, News. 1.0 a.m. (Friday), Close Down.

## BARI

1,112 kc/s, 269.8 metres; 20 kW.—See Rome.

BASLE.—See Schweizerischer Landessender.

## BELGRADE

697 kc/s, 430.4 metres; 2.8 kW.—5.0 p.m., Gramophone Music. 6.55, Time and Programme Announcements. 7.0, Gramophone Music. 7.20, Address. 7.50, Violin Recital. 8.30, Arias from Opera. 9.15, Dramatic Programme. 9.30, Symphony Concert. 11.0, Time and News.

## BERLIN

DEUTSCHLANDSENDER (Reichssender), 183.5 kc/s, 1,635 metres; 60 kW.—1.45 p.m., News. 2.0, Gramophone Concert. 3.10, Programme for Young People. 3.30, Weather and Exchange. 3.45, Reading. 4.0, See Heilsberg. 5.0, Discussion for Women. 5.20, The German Forests—Literary and Musical Sequence (arr. Gertrud Sonntag). 6.0, Poems. 6.5, Humorous Programme. 6.30, Agricultural Programme. 6.50, Weather and News. 7.0, Transmission for all German Stations, relayed from Langenberg. 8.0, Today's Motto. 8.5, Mammot—a Peasant Comedy. (Unger). 9.15, Musical Programme. 10.0, Weather and News. 10.15 (approx.), Talk: Gymnastics for the Nation. 10.45, Weather for Shipping. 11.0, Dance Music from Hamburg. 12.30 a.m. (Friday), Close Down.

## BERLIN

FUNKSTUNDE, 715 kc/s, 419.5 metres; 1.5 kW.—4.15 p.m., Talk: A Journey to Rome. 4.30, Orchestral Concert. Soloist: Walter Drzewski (Organ). Organ Concerto in D minor (Handel); Four Sonatas in B flat, Op. 68, E flat, Op. 67, F, Op. 145, and B flat, Op. 212 (Mozart); for Orchestra and Organ; Tocata and Fugue in G Op. 69 for Organ (Bach); Variations and Fugue on a Theme for Organ, from Op. 7 (Drzewski). 5.30, Reading (Rudolf G. Binding). 5.50, Contemporary Song Recital by Fred Drissen (Bartone). An die Nacht (Schankal); Herbstabend (Schellberg); Herbst (Enderling); Der Beichtiger (Wetz); Songs (Rasch): (a) Zu guter Letzt, (b) Man wünschte sich herzlich gute Nacht, (c) Wenn ich dereinst, (d) Es flog einmal ein munteres Fliegl. 6.10, Talk on Peasant Customs. 6.30, Talk on Pomerania. 6.40, The Funksstunde informs its Listeners. . . . 6.45, Topical Talk. 7.0, Transmission for all German Stations, relayed from Langenberg. 8.5, Eine Stunde Lexikon—Dream Play (Günther Eich). 9.0, Light Music and Dance Music. In an interval at 10.0 (approx.), Weather and News. 1.0 a.m. (Friday), Close Down.

BERNE.—See Schweizerischer Landessender.

BEROMUNSTER. — See Schweizerischer Landessender.

BODEN.—See Stockholm.

BODO.—See Oslo.

## BORDEAUX-LAFAYETTE

986 kc/s, 304 metres; 13 kW.—6.15 p.m., Radio Journal. 7.40, Talk arranged by the International Labour Bureau. 7.55, Lottery Results and Charades. 8.0, Talk on Wine. 8.15, News. 8.30, La Gamine—Comedy in Four Acts (P. Véber).

THURSDAY  
SEPTEMBER THE TWENTY-FIRST

## PRINCIPAL EVENTS OF THE DAY:

## AT HOME

**NATIONAL LONDON** Organ recital.  
Three plays: "The Safe," "The Proposal," and "The Human Horse."  
**REGIONAL MIOLAND** Variety: a gramophone recital.  
**REGIONAL NORTH** Orchestral and choral concert.  
**REGIONAL WEST** Police Band concert.  
**REGIONAL SCOTTISH** Rosslyn Chapel: Patronal and Dedication Festival.  
**REGIONAL BELFAST** Music of Dutch composers, orchestral concert.

## ABROAD

**BRNO** 7.30 p.m. Opera: "Khovanshchina," by Mussorgsky.  
**BUCHAREST** 8.20 p.m. Symphony concert, by the Station Orchestra, conducted by Rogalski.  
**COPENHAGEN** 8.10 p.m. The Station Symphony Orchestra, conducted by Nicolai Malko.  
**HAMBURG** 8.10 p.m. Operetta: "Der Bettelstudent," by Millocker.  
**HUIZEN** 7.45 p.m. The Wireless Orchestra, conducted by A. van Raalte.  
**RADIO PARIS STRASBOURG** 9.30 p.m. Popular music.  
6.30 p.m. Orchestral concert, conducted by M. de Villers.  
**STUTTGART** 8.30 p.m. Serenades: Concert by the Station Orchestra, conducted by Paul Sixt.  
8.30 p.m. Opera: "Il Pirata," by Bellini.  
6.35 p.m. Chamber music.

## BRATISLAVA

1,076 kc/s, 279 metres; 14 kW.—2.50 p.m., Concert by the Station Orchestra: Overture, The Cunning Peasant (Dvorak); Melody (Polprecht); Festive Polonaise (Marsik); Suite from L'Arlesienne (Bizet); Homage March from Sigurd Jorsalfar (Grieg). 3.50 to 4.0, See Prague. 5.25, See Brno. 5.45, See Prague. 6.25, Pianoforte Recital by Sylvia Maendzinska: Valse impromptu, Op. 16 (Blumenfeld); Gavotte No. 3 Op. 49 (Glazunov); Paraphrase on Themes from Eugene Onegin (Tchaikovsky-Pabst). 6.55, Talk for Housewives, 7.0, See Prague. 7.25, See Brno. 10.15, See Prague. 11.0 (approx.), Close Down.

BREMEN.—See Hamburg.

## BRESLAU

923 kc/s, 325 metres; 60 kW. Relayed by Gleiwitz, 1,184 kc/s, 253 metres.—12.2 p.m. (approx.), Concert by the Silesian Philharmonic Orchestra, conducted by Topitz, 1.45 p.m., Time and News. 2.45, Light Music on Gramophone Records. 2.45, Market Prices. 3.0, Concert by the Station Orchestra, conducted by Rischka: Overture, The Magic Flute (Mozart); Serenade in D minor (Götze); Von Glück bis Wagner (Schreiner); Cradle Song (Jännefeld); Selection from Der Freischütz (Weber); Waltz, Roses from the South (Joh. Strauss); Military March (Schubert). 4.0, Review of Books. 4.20, Talk: Excursions to the Moorland. 4.30, Concert by the Station Orchestra, conducted by Ernst Topitz: Ballet Overture (Ganglbauer); Waltz, Die Romantiker (Lammer); Fröschkönigs Fackelzug (Kronberger-Marriott); Rumpelstilzchen (Hartenbauer); Amen-Polka (Joh. Strauss, Sen.); Komödianten-Marsch (Smetana); Kaiserwalzer (Joh. Strauss); Selection from The Count of Luxembourg (Lehár). 5.40, Weather for Farmers. 5.45 (approx.), Programme for Children. 6.10, Programme to be announced. 6.30, Talks by Workers and their Leaders. 7.0, Transmission for all German Stations, relayed from Langenberg. 8.0, News. 8.10, Public Demonstration of Folk Dancing from the Konzerthausaal. 9.10 (from Gleiwitz), Poems and Songs of the Miners' Life. 10.0, News. 10.25, Dance Music from Berlin (Funkstunde). 12 Midnight, Close Down.

## BRNO

878 kc/s, 342 metres; 35 kW.—5.25 p.m., Programme for Children. 5.45, Gramophone Music. 6.25, German Transmission: News and Gramophone Music. 7.0, See Prague. 7.25, Introductory Talk to the following Transmission. 7.30, Khovanshchina—Opera (Mussorgsky), relayed from the National Theatre. 10.15, See Prague. 11.0 (approx.), Close Down.

## BRUSSELS (No. 1)

I.N.R.; 590 kc/s, 509 metres; 15 kW.—12 Noon, Gramophone Concert of Light Music. 1.0 p.m., Le Journal Parlé. 1.10, Concert by

the Small Station Orchestra, conducted by Leemans: Two-Step, Contrabandista valiente (Laestella); Prelude (Beaume); Strauss Potpourri (Hilmar-Weber); Londonderry Air for Violin (Kreisler); Selection from Déje (Christiné); Serenade (Padilla); Waltz, Mais quand le cœur dit oui (Sylvain); The Swanee River (Myddleton). 5.0, Concert by the Radio Orchestra, conducted by André; Paeanade from The Seasons (Glazunov); Selection from Surcouf (Planquette); Fête chez Thérèse (Hahn); Aubade (Caludi); Chant érepsculaire (Brusselmann); Un rêve, for Violin and Cello (Cammis); Ballet Music from Callirhoë (Chaminade); Carnival (Ring). 5.30, Musical Programme. 6.0, Cookery Talk. 6.15, Gramophone Music. 6.30, Concert by the Small Station Orchestra, conducted by Leemans; Turkish March (Mussorgsky); Venetian Barcarolles (Leemans); Bellmaniana—Suite of Popular Swedish Songs (Malin); Andante and Scherzo for Violin and Flute (Radand); Spanish Serenade (Glazunov); Norwegian Dances (Grieg). 7.15, Talk for Workers. 7.30, Sports Notes. 8.0, Act I and Finale from Act III of Carmen—Opera (Bizet) on Gramophone Records. 8.45, Talk. 9.0, Concert by the Radio Orchestra, conducted by Franz André: March (Fauly); Cello Solos: (a) Menuet printanier (Desprez), (b) Remembrance (Desprez); Waltz, Tournesol (Michiel); Elvès' Serenade (Rayners); Selection from Teresina (O. Strauss); Nachtigall im Fliederbusch (Kromer); Aubade à Fémin (Denard); Invitation to the Waltz (Weber); Viva Palma (Brocker). 10.0, Le Journal Parlé.

## BRUSSELS (No. 2)

N.I.R., 887 kc/s, 338.2 metres; 15 kW. Programme in Flemish.—12.0 Noon, Concert by the Small Station Orchestra, conducted by Leemans. 1.0 p.m., Le Journal Parlé. 1.10, Waltzes and Marches on Gramophone Records. 5.0, Gramophone Records: Overture, The Italian Girl in Algiers (Rossini); Dance of the Hours, from La Gioconda (Ponchielli); Selection from I Pagliacci (Leoncavallo); Mattinata (Leoncavallo); Selection from Madame Butterfly (Puccini); Overture, Gwendoline (Cherrier). 5.45, Programme for Children. 6.25, Gramophone Records: Waltz, Tres Jolie (Waldteufel); Waltz, Les Palmiers (Waldteufel). 6.33, Programme arranged by the J.V.K.A. 7.12, News. 7.15, Talk: Carnations. 7.30, Programme for Women. 8.0, Concert by the Radio Orchestra, conducted by André; Soloist, Tontenel (Baritone); Waltz, Frühlingstimmchen (Strauss); Overture, The Gipsy Baron (Strauss); Three Songs (Brahms): (a) Liebestreu, (b) Wiegenlied, (c) Meine Liebe ist grün; Selection from Il Trovatore (Verdi); Songs (Brahms): (a) Wie ich die meine Königin, (b) Miennelied, (c) Ich hab' dich, Semper Fidelis (Sonsa). 8.45, Talk. 9.0, Gramophone Concert with songs by the Schola Cantorum Choir; Overture, Il Maschere (Mascagni); Seven Popular Irish

Songs: (a) The Lark in the clear air, (b) The Shan Van Voght, (c) Kathleen O'Mory, (d) Kate Kearney, (e) Long, long ago, (f) The little red lark, (g) Arrammore Boat Song; Concerto for Bassoon (Mozart); Pianoforte Solos: (a) Perpetuum Mobile (Weber), (b) Pastorale Capriccio (Scazzati); Five Flemish Songs; March from The Prophet (Meyerbeer). 9.55, Evening Prayer. 10.0, Le Journal Parlé.

## BUCHAREST

761 kc/s, 394 metres; 12 kW.—5.0 p.m., Light Music and Romanian Music by the Dinco Orchestra. In the interval at 6.0, Radio Journal. 7.0, Educational Programme. In the interval from 7.20 to 7.40, Light Music on Gramophone Records. 8.0, Song Recital by Mme. Olga Solomoncau. 8.20, Symphony Concert by the Station Orchestra, conducted by Rogalski; Concerto grosso No. 1 in B flat (Handel); Violin Concerto in C (Vivaldi); Concerto for Wind Instrument Quintet and Orchestra (Rietti). In the interval at 9.0, Talk. 9.45, Radio Journal.

## BUDAPEST

545 kc/s, 550.5 metres; 18.5 kW. Also relayed on 840 metres from 8.0 p.m. till Close Down.—5.30 p.m., Concert by the Lajos Veres Cigány Band. 7.0, Radio Concert. 7.30, English Lesson. 8.0, An Operetta. 10.30, News, followed by Gramophone Music.

CASSEL.—See Frankfurt.

## COPENHAGEN

1,067 kc/s, 281 metres; 0.75 kW. Relayed by Kalundborg, 260 kc/s, 1,153.8 metres. 12 Noon, Time and Chimes from the Town Hall. 12.5 p.m., String Ensemble Concert, relayed from the Hotel d'Angleterre. 2.0, Interval. 2.45, Dance Music by Otto Lington and his Band. In the interval at 3.30 (approx.), Recitation. 4.45, Programme for Boys. 5.30, Exchange and Fish Market Prices. 5.45, Talk in French: Alexandre Dumas (Pérel). 6.15, Elementary English Lesson. 6.45, Weather and Announcements. 7.0, News. 7.15, Time Signal. 7.16, Talk: Democracy or Dictatorship? 7.45, Danish Lesson. 8.10, Concert, relayed from the State Broadcasting Building; The Station Symphony Orchestra, conducted by Nicolai Malko. Soloist: Margherita Flor (Songs); Concert Overture, The Hebrides (Mendelssohn); Symphonic concertante for Violin, Cello, Oboe and Bassoon (Haydn); Selection from The Loves of the Three Oranges (Prokofiev); Ten Minutes' Interval; Symphonic Poem; Manfred (Tchaikovsky); Songs: (a) Aria from Aida (Verdi), (b) Aria from Mephistopheles (Boltó); Polovtsian Dances from Prince Igor (Borodin). 10.15, News. 10.30, Reading. 10.50, Dance Music, relayed from the National Scala. In the interval at 12 Midnight, Time and Chimes from the Town Hall. 12.30 a.m. (Friday), Close Down.

CORK.—See Athlone.

DANZIG.—See Heilsberg.

DRESDEN.—See Leipzig.

## FECAMP

1,328 kc/s, 225.9 metres; 10 kW.—10.30 to 11.30 a.m., Programme in English by the I.B.C. 10.30 a.m., Happy Hour. Part I: Orchestral Concert. Signature Tune: I do like to be beside the Seaside (Glover); Marching through Georgia; When the Convent Bell is ringing (Trevor); Ke-sa-ko (Chapman); Beautiful (Gillespie); Old Folks at Home (Foster); Once on the Rhine (Ostermann); Valse Septembre (Godin). Part II: Dance Music. Smilin' through; Dancing Butterly; Rosa Mia; In the Valley of the Moon; My, oh My; A Woman should stick to her Man; Learn to croon; Let's all be happy together; Signature Tune. 11.30 a.m., Programme in French. 4.30 to 6.0 p.m., Programme in English by the I.B.C. 4.30, Programme for Children. 5.0, Concert of Gramophone Records for Worthing and Littlehampton Listeners. Signature Tune: The Night by the Sea; The Turning of the Tide, by Layton and Johnston; To-day I feel so happy, by Renate Muller; Somebody's waiting for me (Sir Harry Lauber); Stars and Stripes (Sonsa); The Fly be on the Turnouts (arr. Wheatley); The Match Parade (Weble); Selection from He wanted Adventure (Waller). 5.30, Trio Concert for Brighton and Hove Listeners. Pearl of Mine (Fletcher); Friend o' Mine (Sanderson); Cello Solo, Harlequinade (Squire); Evening (Ea-sthope Martin); Cavatina (Radl); Cello Solo, Salut d'amour (Elgar); Pizzicato from Sylvia (Delibes); Love's Old Sweet Song (Molloy); Signature Tune. 6.0 p.m., French Programme. 10.0 till Close Down, Programme in English by the I.B.C. 10.0, Dance Music. Signature Tune, Bells of Normandy; Hot Feet; Fiddlin' Joe; My Wishing Song; You did Everything for me; Chansonnette; In the Valley of the Moon; Hold me; At the Old Pig and Whistle; Lover; A Woman should stick to her Man; Castles in the Sand; The Dirty Glide; Whispring; Drifting Down the Shalimar; I've got the World on a String; One Tiny Tear; My Darling; Put a Little Spring-Time; Her Name is Mary; Peter, Peter; In the Park in Parade; Signature Tune. 11.0, Talkie Time. Times from Talkies; Signature Tune, Sitin' in the Dark; Come out Vienna; Song: Sweetheart Darlin'; Piano-



SEPT. 21st

THURSDAY

continued

forte Solo: Everyone Says I Love You; The Little Company; Selection from The Big Pond (Fain); Happy Ending; Puttin' on the Ritz; Selection from The Kid from Spain; Signature Tune. 11.30, Concert arranged by the International Broadcasting Company (Ireland), Ltd., on behalf of Hospitals Trust, Ltd. Signature Tune. Come Back to Erin; What's next? (arr. Finck); The Nightingale in the Linn Bush (Krone); Selection from The Student Prince (Roverberg); The Irish Emigrant; Love in Cloverland (Peter); Terence's Farewell to Katherine (Lady Duffin); Mon réve (Waldteufel). 12.5 a.m. (Friday), Late News Bulletin. 12.10, Club Concert for Retford Listeners. Signature Tune. The Chum Song; Wherever you are; Steamboat Bill; Aint Misbehavin'; Beautiful Lady; Hold my Hand; I wanna count sheep; Sylvia; You're telling Me; I sigh for you, Rio Rita; The Village Band; Thank Heaven for You; Smilin' through; All over Italy; Signature Tune. 1.0, Dance Music. Signature Tune. Bells of Normandy; Any time, any day, anywhere; Nine Little Miles from Ten-Tennessee; Stay out of my Dreams; Dancing Butterfly; Learn to Croon; In Santa Lucia; The Gidd-diggers' Song; I raised my Hat; Contented; Dance, Pretty Lady; Seven Years with the Wrong Woman; Down the Old Ox Road; Twelfth Street Rag; Rosa Mia; Sweetheart Darlin'; Signature Tune. 2.0, I.B.C. Good-night Melody and Close Down.

FLENSBURG.—See Hamburg. FLORENCE.—See Turin.

FRANKFURT

1,157 kc s, 259.3 metres; 17 kW. Relayed by Cassel, 1,220 kc s, 245.9 metres; and Trier, 1,157 kc s, 259.3 metres. 12 Noon, Concert of Light Music on Gramophone Records: Folk Songs of Germany: Wohltaut noch getrunken (Schumann); Wiegenlied (Brahms); My Homeland (Obermayer); An der Weser (Pressel); Ich hab dich lieb, weil du ein deutsches Mädchen bist (Seubach); Im Rolandshagen (Beimes); O Schwarzwald, o Heimat (Alt); Ich hatte einst ein schönes Vaterland (Lassen); Deutschland, du darfst nicht untergehen (Höser); Deutschland blühe neu und (Meyer-Helmann); Orchestral Selections: Overture, Hans Heiling (Marschner); Air and Rigodon from The Flute of Samsonei (Graener); Overture, Bozzacchi (Suppé); Hungarian Rhapsody No. 6 (Liszt). 1.15 p.m., News and Weather. 1.30, Concert on Gramophone Records: Quintet in A major (Mozart), played by the Lener String Quartet and C. Draper (Clarinet). 2.0, News Bulletin. 2.20, Listen, everybody. 3.0, Weather Reports. 3.10, Time and Economic Notes. 3.30 (from Mannheim), Talk: With a Nautibus through the Ocean Depths. 4.25, Economic Notes. 4.30, Programme from Stuttgart. 5.45, Economic Notes. 6.0, Talk: Free Competition. 6.25, Topical Talk. 6.45, Today's News. 6.50, Time and Announcements. 7.0, Transmission for all German Stations, relayed from Langenberg. 8.0, Lowke Ballad Recital by Kurt Wielmann (Baritone); Der alte Hesseger; Das Erkennt; Graf Eberstein; Agnes; Wer ist Bär; Der Blumen Raue; Zauberschleier; Die wandelnde Glocke; Totentanz. 9.0, Baden-Baden—Radio Sequence (Hans Kulms). 9.45, Programme to be announced. 10.15, Time and News. 10.45, (approx.), Close Down.

FREDRIKSSTAD.—See Oslo. FREIBURG.—See Stuttgart. GENEVA.—See Radio-Suisse Romande. GENOA.—See Turin. GLEIWITZ.—See Breslau. GÖTEBORG.—See Stockholm. GRAZ.—See Vienna. HAMAR.—See Oslo.

HAMBURG

806 kc/s, 372 metres; 1.5 kW. Relayed by Bremen, 1,112 kc/s, 269.8 metres; Flensburg, 1,319 kc/s, 227.4 metres; Hannover, 530 kc/s, 566 metres; and Kiel, 1,292 kc/s, 232.2 metres. —5.30 p.m., Variety Programme. 6.25, Book Review. 6.45, Frankfurt Exchange. 6.50, Weather. 7.0, Transmission for all German Stations, relayed from Langenberg. 8.0, Topical Talk. 8.10, Der Bettelstudent—Opera in Three Acts (Müllacker). In the interval, Announcements. 10.0, News. 10.20, Topical Talk. 10.30, Dance Music by the Small Station Orchestra, conducted by Gerhard Maasz; Soloist, Richard Beckmann (Pianoforte).

HANOVER.—See Hamburg.

HEILSBURG

1,085 kc/s, 276.5 metres; 60 kW. Relayed by Danzig, 662 kc/s, 453.2 metres.—1.5 p.m., Gramophone Music. In the intervals at 1.20 and 2.0, News. 2.30 (from Danzig), Danzig Exchange. 3.0, Agricultural Prices and Exchange. 3.30 (from Danzig), Programme for Children. 4.0, Concert by the Small Station Orchestra, conducted by Eugen Wilken; Overture (Verdi); Extracts from the Suite for Small Orchestra (Wilken); Selection from Undine (Lortzing); Seberzo and Intermezzo (Mussorgsky); Violin Solo; Ballet Scene (Berlioz); Selection from Der Teufel

der Herzogin (Künneke); Overture, Gasparone (Müllacker). In the interval at 5.0 (approx.), Book Review. 5.45, Folk Songs and Dances by a Wind Instrument Quintet; Das deutsche Lied (Kalliwoda); Wanderlied (Schumann); Stolzelsens am Rhein (Müssler); Waltz, Schön ist die Jugend (Radke); Polka-Mazurka, Deutsche Frau (Kiesler); Balka-Polka (Röder); Flotte Burschen (Stärke); Bayerian Ländler (Huber). 6.15, Agricultural prices. 6.25, Agricultural Talk. 6.50, Weather. 7.0, Transmission for all German Stations, relayed from Langenberg. 8.0, Weather and News. 8.10, Concert by the Small Station Orchestra, conducted by Eugen Wilken. In the intervals, Humorous Programme by Paul Schuch. 9.20, Violin Recital by Hugo Kolberg; La follia (Corelli); Romance (Wagner); Sierra Morena (de Monasterio); La Capriciosa (Ries); Bulgarian Rhapsody (Waldteufel). 9.50, Elementary English Lesson. 10.15, Weather and News.

HILVERSUM

Announced HUIZEN, 1,013 kc/s, 296.1 metres; 7 kW (until 5.40 p.m.) and 20 kW from 5.40 p.m.—11.55 a.m. to 1.40 p.m., Programme of the Catholic Radio Society (K.R.O.). 11.55, Concert by the K.R.O. Orchestra, conducted by van 't Woud; La Féria (Lacombé); Malaguena (Moszkowsky); La boutique fantasque (Rossini-Respighi); Danse des marionettes (Gillet); Caravane (Scarlatti); March, Regimentkinder (Fueik); Gramophone Records; Modern Ballet Suite (Armandada); Souvenir of Lucern (Blon); My Old Kentucky Home (Busch); Potpourri, Fortissimo (Kalmán). 1.40 till Close Down. Programme of the Christian Radio Society (N.C.R.V.). 1.40, Book-keeping Lesson. 2.40, Programme for Women. 3.10 to 3.40, Interval. 3.40, Bible Reading and Sacred Songs. 4.40, Handicraft Lesson for Young People. 5.10, Song Recital by Bogtman (Baritone); Gramophone Records in the intervals. 6.10, Gramophone Music. 6.25, Dressmaking Lesson. 6.40, Police Notes. 6.55, Religious News. 7.10, Talk. 7.25, Gramophone Music. 7.40, Concert by the Arnhem Orchestra, conducted by Mank; Overture, A Mid-summer Night's Dream (Thomas); Selection from Sigurd-Jorsdalf (Grieg); Four Paraphrases; Tasso Lamento e Trionfo (Liszt). 8.40, Talk. 9.10, Concert (cont'd); Overture, Amneron (Cherubini); Les petits riens (Mozart); Symphony No. 1 (Beethoven). In the interval at 9.40, News. 10.10, Gramophone Music. 11.10 (approx.), Close Down.

HOBBY.—See Stockholm.

HUIZEN

Announced HILVERSUM, 160 kc s, 1,875 metres; 7 kW (until 3.40 p.m.). Transmitted from Kootwijk, on 50 kW, from 3.40 p.m. Programme of the Algemeene Vereuigend Radio Omroep (A.V.R.O.). 11.10 a.m., Violin Recital by van Gelderen. 11.40, Time Signal. 11.41, Gramophone Music. 11.55, Concert by the Rentmeester Orchestra. 1.55, Recitations. 2.25, Concert, Piet van Egmont (Organ); Hendrik van Oort (Songs), and Jan Felderhof (Violin); Tocatta and Fugue in D minor (Bach); Aria from Cantata No. 13—Meine Sinfzer (Bach); Aria from Cantata No. 150—Seliet wir gehen hinauf (Bach); Largo (Händel); Andante cantabile (Tchaikovsky); Gebet (Wolf); Schlafendes Jesukind (Wolf); Calvary (Oort). 3.25, Interval. 3.40, Programme for Hospitals. 4.10, Gramophone Music. 4.40, Play for Children. 5.20, Concert by Kovacs Lajos and his Orchestra. In the interval at 6.10, Sports Talk. 7.10, Dressmaking Lesson. 7.40, Time and News. 7.45, Concert by the Wireless Orchestra, conducted by Albert van Raalte; Suite from Sylvia (Debussy); Songs; (a) Herzwunden (Grieg). (b) Letzter Frühling (Grieg); Selection from Mors et vita (Gounod); Overture, Maritima (Wallace). In the interval, Talk. 8.40, Radio Play. 9.20, Orchestral Concert (cont'd); Pianoforte Concerto in F minor (Chopin); Danse macabre (Saint-Saëns); Overture, Les Saltimbanques (Ganne); Valse triste (Sibelius); Waltz, Künstlerleben (Joh. Strauss); French Military March (Saint-Saëns). In the interval at 10.0, Gramophone Records. 10.40, News. 10.50, Gramophone Music. 11.40 (approx.), Close Down.

INNSBRUCK.—See Vienna.

KALUNDBORG.—See Copenhagen.

KATOWICE

734 kc s, 408 metres; 16 kW. 7.10 p.m., Sports Talk. 7.25, Announcements and Gramophone Music. 7.40 till Close Down, See Warsaw.

KIEL.—See Hamburg.

KLAGENFURT.—See Vienna.

KOSICE.—See Prague.

LANGENBERG

635 kc/s, 473 metres; 60 kW.—1.30 p.m., Orchestral Concert, conducted by Werner

Göhre; Overture, Jean de Paris (Boieldien); Waltz, Die Werber (Lammer); Finale from Undine (Lortzing); Two Pieces from the Suite, Old China (Niemann); Selection from Wo die Lerche singt (Lehar); Mussinau Marsch (Carl). In the interval at 2.0 (approx.), News. 3.0, Programme for Children. 3.30, Market Prices and Time. 3.50, Reports on Scientific Research, with Musical Interludes. 4.20, Political Announcements. 4.30, Joseph von Lauff Memorial Programme. 5.0, Concert by the Fröhliche Fünf. 5.30, Operetta and Sound Film Music on Gramophone Records. 6.15, Recitation. 6.25, Talk: The Technique of Speech. 6.45, Weather, Sports Notes and Market Prices. 7.0, Transmission for all German Stations; Das Deutsche Vatermser (The German Lord's Prayer)—Cantata (Kneip), for Soloists, Choirs and Orchestra. 8.0, News. 8.5, Gramophone Music: Rhapsody on Goethe's Harzreise (Brahms); Overture, Egmont (Beethoven). 8.30, The Battle of the Marne—Play (Paul Josef Creuers), arr. for the Radio by Gerd Fricke. 10.0, News. 10.20, Concert. 12 Mid-night, Close Down.

LAUSANNE.—See Radio-Suisse Romande.

LEIPZIG

769.9 kc s, 389.6 metres; 120 kW. Relayed by Dresden, 941 kc s, 319 metres.—12 Noon, See Munich. 1.15 p.m., News and Programme Announcements. 1.30, Grieg Concert by a Male Voice Choir, Elizabeth Meinel (Soprano), Richard Schmidt (Bass) and Dr. Alf Nestmann (Pianoforte). Choir: (a) Waldwanderung, (b) Zwei braune Augen, (c) Hoffnung; Allegro and Andante molto from the Pianoforte Concerto in E Minor, Op. 7; Five Songs for Soprano: (a) Margareten's Wiegenlied, (b) Die Hütte, (c) Erstes Begegnung, (d) Am schönsten Sommerabend war es, (e) Solveig's Song; Scandinavian Dances and Folk Melodies for Pianoforte; Choir: (a) Im Kahne, (b) Die Prinzessin, (c) Ich liebe dich. 2.15, News. 2.30, Art and Film Review. 2.40, The Forest—Gramophone Music: Wer hat dich, du schöner Wald (Mendelssohn); Waldezauber (Kollmann); Waldensamkeit (Reger); Bird Song Trio; Ich lag am Waldessaume (Bradenberg); Nachtgesang im Walde (Schubert). 3.0, Handwork for Children. 3.35, Market Prices. 4.0, Songs and Lyrics of Autumn. 4.30, Review of Books from the Hitler Youth. 5.0, Radio Report from the Sonneberg Toy Show. 5.30, Concert by the Leipzig Symphony Orchestra, conducted by Blumer; Ritornella and Rondo capriccio (Mrazek); Selection from Der Kulturgen (Kienzl); Selection from the Antique Suite (Schroeder); Comedy Overture (Fischer-Frank); Waltz, Aquarellen (Joh. Straus); Overture, The Bartered Bride (Smetana); Lotti-Walzer (Beck); Operetta Revue (Petras); Movement from the First Little Suite (Michele). In an interval at 5.50, Exchange, Weather and Time after the Concert. 6.50, Today's News. 7.0, Transmission for all German Stations, relayed from Langenberg. 8.0, Readings from the Letters of Hebel, Hölderlin, Nietzsche, Novalis, Stifter and Others. 9.30, Beethoven Pianoforte Recital by Wilhelm Kempff; Sonata in E Flat, Op. 27, No. 1—Quasi una fantasia; The Moonlight Sonata in C Sharp Minor, Op. 27, No. 2. 10.15, News.

LINZ.—See Vienna.

LUXEMBOURG

252 kc s, 1,191 metres; 200 kW.—12.30 p.m., Variety Concert by the Station Orchestra, conducted by Henri Ponsis; Overture, Der Wildschütz (Lortzing); Waltz, Erinnerungen an Baden (Kozak); Love Song (Königsberger); Selection from Lakme (Debussy); Ballad (de Michele); Selection from The Geisha (Jones).—1.30, Gramophone Music. 7.30 till Close Down, German Programme. 7.30, Symphony No. 6 in B Minor—the Pathetic (Tchaikovsky). 8.20, Concert of German Music by the Station Orchestra, conducted by Henri Ponsis; Leonora Overture No. 3 (Beethoven); Reigen (Spies); Der sterbende Schwan (Spies); Bilder aus dem Orient (Unger). 8.50, News in French. 9.0, Concert by the Station Orchestra, conducted by Henri Ponsis; Overture, Oberon (Weber); Slav Dance No. 4 (Dvorak); Meditation (Glazunov); Selection from The Queen of Spades (Tchaikovsky); Redzi (Caldi); Selection from The Maid of the Black Forest (Jesse). 9.50, News in German. 10.0, Gramophone Records of Kreisler, Menuhin, Tibaud, and Casals. 10.30, Dance Music on Gramophone Records.

LYONS

LA DOUA, 644 kc s, 465.8 metres; 1.5 kW.—7.30 p.m., Radio Gazette for Lyons and the South-East. 8.30, Concert by Georges Rabinand (Tenor), Mme. Blane Dauphin and a String Quintet; Marche parisienne (Ganne); Rustic Waltz (Krone); Tenor Aria from Griseididis (Massenet); Extracts from Tosca (Puccini); Tenor Aria from Tosca (Puccini); Piece (Rosen); Pieces (Lecocq); Bar-

carolle (Offenbach); Selection from La Fille de Madame Angot (Lecocq); Selection from La vie parisienne (Offenbach). After the Concert, News Bulletin.

MADRID

ARANJUEZ; EAQ; 10,000 kc s, 50 metres; 20 kW.—11.30 p.m. to 1.0 a.m. (Friday), Programme relayed from Madrid (EAJ7).

MADRID

EAJ7, 707 kc s, 424.3 metres; 2 kW.—8.0 p.m., Chimes, Exchange, Radio Journal, and Programme for Children. 9.15, Topical Review. 9.30 to 11.0, Interval. 11.0, Chimes, Time Signal, and Topical Review. 11.20 (approx.), Song Recital by Roman Zorano (Baritone). 11.30, Municipal Band Concert, conducted by Villa, relayed from Rosales. 1.15 a.m. (Friday), Topical Review and News. 1.30, Chimes and Close Down.

MALMO.—See Stockholm.

MILAN.—See Turin.

MORAVSKA-OSTRAVA

1,137 kc/s, 263.8 metres; 11 kW.—6.30 p.m., German Transmission: Talk on Modern Music. 7.0, See Prague. 7.25, See Brno. 10.15, See Prague. 11.0 (approx.), Close Down.

MOSCOW

TRADES UNION; 300 kc s, 1,000 metres; 100 kW.—11.45 a.m., Weather. 2.45 p.m., Weather. 3.0, Glazunov, Grieg and Cooperin Concert. 3.55, Time. 4.0, Topical Talk. 4.30, Radio Play (Selatunovsky). 5.30, Educational Talk. 6.30, Concert relayed from the Radio Theatre. 9.0, News. 9.30, Programme Announcements. 9.55, Chimes from the Red Square. 10.5, Press Review.

MOTALA.—See Stockholm.

MUHLACKER.—See Stuttgart.

MUNICH

563 kc s, 533 metres; 60 kW. Relayed by Augsburg and Kaiserslautern, 536 kc s, 560 metres; and Nürnberg, 1,256 kc s, 239 metres. 4.30 p.m., See Stuttgart. 5.45, Agricultural Talk. 6.5, Pianoforte Sonata. 6.25, A Dialogue. 6.45, Time, Weather, and Agricultural Report. 7.0, Transmission for all German Stations, relayed from Langenberg. 8.0 (from Nürnberg), Orchestral Concert: Florentine March (Fueik); Overture, The Thieving Magpie (Rossini); Waltz, Estudiantina (Waldteufel); Selection from Undine (Lortzing); Frühling am Rhein (Bren); Intermezzo, Rosen und Fäitler (Kockert); March (Souza). 9.0, Talk. 9.30, Vienna—Literary Programme (Frauz Weichenmayr). 10.20, Time and News.

NAPLES.—See Rome.

NOTODDEN.—See Oslo.

OSLO

277 kc s, 1,083 metres; 60 kW. Relayed by Fredriksstad, 820 kc/s, 365.8 metres; Hamar, 522 kc/s, 574.7 metres; Notodden, 671 kc/s, 447.1 metres; Porsgrund, 662 kc/s, 453.2 metres; and Rjukan, 671 kc/s, 447.1 metres.—5.0 p.m., Orchestral Concert, conducted by Erling Nielsen. 6.0, Political Talk. 6.30, Studio Service. 7.0, News. 7.30, Recital. 8.0, Time Signal. 8.1, Agricultural Talk. 8.30, Tenor Song Recital by Bjarne Bmtz, relayed from Bergen, 824 kc/s, 364 metres. 8.50, Recitations. 9.20, Sponsored Programme. 9.40, News. 10.0, Topical Talk. 10.15, Concert by the Trinder Choir, relayed from Trondheim, 605 kc/s, 495.8 metres. 10.45 (approx.), Close Down.

OSTERSUND.—See Stockholm.

PALERMO

558 kc s, 537.6 metres; 3 kW.—8.0 p.m., Dopolarvo Announcements, Agricultural Notes and Giornale Radio. 8.20, Gramophone Music. In the interval at 8.30, Time and Announcements. 8.45, Popular Music. 9.0, Rosalia—Comedy in One Act (Murey). 9.30, Popular Music. 10.0, Cedoni personaggi Comedy in One Act (Rimini). 10.30, Light Music. 11.0, Giornale Radio.

PARIS

EIFFEL TOWER. Call FLE, 207.5 kc s, 1,445.7 metres; 13 kW. Time Signals (on 2,650 metres) at 10.26 a.m. and 11.26 p.m. (Preliminary and 6-dot Signals)—6.45 p.m., Theatre Talk. 7.0, Le Journal Parle. 8.30, Gramophone Concert. Part I: Music by Mozart. Part II: Variety Music. 10.0 (approx.), Close Down.

PARIS

POSTE PARISIEN, 914 kc/s, 328.2 metres; 60 kW.—6.45 p.m., Programme for Children. 7.15, Le Journal Parle. 7.30, English and Spanish Duets by Anny Reyna and Stenio Tsas-si. 8.0, Sponsored Talk. 8.5, Symphonic Poem, Placéon (Saint-Saëns), on Gramophone Records. 8.30, Sponsored Concert. 9.15, Concert: Overture, Sous la Régence (Brusselmann); La sérénade à ma mie (Casard); Grand Guignol Suite (Gabriel-Marie); Danse d'Orient (Mathé); Ode à Terpsichore



(de Taeye); Pensée élégiaque (Ancel); Oriental Suite. Le joyeux postillon, Aziyadé (Ruyssens); Andalusian Nocturne (Infante); Ballad, Saphantou (Brunel); Quand j'étais jeune (Février); March of the Nutcrackers (Ranzato). 13.10, News.

## PARIS

**RADIO-PARIS**, Call CFR, 174 kc/s, 1,725 metres; 75 kW.—7.30 a.m., Weather and Physical Culture. 7.45, Gramophone Music. 8.0, Weather and News. 12.0 Noon, Protestant Address. 12.30 p.m., Gramophone Concert: Symphony in G (Haydn); Song from The Seasons (Haydn); Serenade from Eine kleine Nachtmusik (Mozart); To Chloe (Mozart); Minuet and Song from Orpheus (Glück); Overture, Egmont (Beethoven); In questa tomba oscura (Beethoven); Perpetuum mobile (Weber); Cavatina from Norma (Bellini); Allegro molto from the Sonata for Organ, No. 6 (Mendelssohn); On Wings of Song (Mendelssohn); Le carnaval des animaux (Saint-Saëns). In the interval at 1.3, Exchange, Announcements and Weather, and at 1.30, Exchange. 2.0, Exchange. 3.45, Exchange and Market Prices. 7.0, Agricultural Report 7.10, Songs and Instrumental Music on Gramophone Records: Minuet chrétien (Adam); Noveletta (d'Ambrósio); Charité (Faure); Slav Dance (Dvorak-Kreisler); Melody (Busser); Schön Rosmarin (Kreisler); Aïmon-nous (Gounod); Jota (Falla); Air (Hahn); Dance (Koenig); Two Melodies (Patroni-Casadesu); Valse binette (Drigo-Aner). 7.50, Commercial Notes and News. 8.0, Gramophone Concert: Overture, La classe du jeune Henri (Méhul); Violin Solo, Rigaudon (Monsigny); Pianoforte Solos: (a) Prelude in A Minor (Bach), (b) Valse brillante (Chopin); Guitar Solo, Gavotte (Bach); Sonata for Flute and Strings (Scriabin). 8.30, News, Weather and Sports Notes. 8.45, Modern Music: Chanson intime (de la Presse); Lament and Tarantella for Clarinet (Grovelez); Songs: Piece in C Sharp Minor (Boulangier); Chorus of the Nymphs from La naissance de la lyre (Roussel). 9.15, Press Review and News. 9.20, Gramophone Music: Kunstlerleben (Joh. Strauss); Selection from La Mascotte (Andran); Serenade (Toselli); Selection from La Fille de Madame Angot (Lecocq); Extracts from Les Millions d'Arlequin (Drigo); Bonsoir Madame la Lune (Marinier); Overture, The Drum-Major's Daughter (Offenbach); Selection from Monsieur Beaucaire (Messager); Madame Favart (Offenbach); and Pagamini (Lohéar); Melody (Heymann); Selection from Maître Pathelin (Bazin); Les Brigands (Offenbach); and Harlequin Doll (Darcy); Moineau (Beydt); España (Chabrier).

## PITTSBURGH

**KDKA**, 980 kc/s, 306 metres; 50 kW. Relayed by W2XK on 48.85 metres and 25.27 metres.—8.30, Words and Music from New York. 8.45, Federation Pennsylvania Women. 9.0, Thursday Special from New York. 9.30, News and Market Report. 9.45, Thursday Special. 10.0, Casino Orchestra, from New York. 10.15, Tarzan of the Apes. 10.30, The Singing Lady, from New York. 10.45, Orphan Annie, from New York. 11.0, News and Piano Classique. 11.15, Sports Notes and a Song. 11.30, Political Talk. 11.45, Lowell Thomas. 12 Midnight, Amos 'n' Andy, from New York. 12.15 a.m. (Friday), Silver Toppers. 12.30, Concert Footlights, from New York. 12.45, Pathé News of the Air. 1.0 to 2.30, New York Relay. 1.10, Captain Diamond. 1.30, John Fogarty, Tenor. 1.45, The Roll-lickers. 2.0, Death Valley Days. 2.30, Programme to be announced. 3.0, Hands across the Border, from New York.

**PORSGRUND**.—See Oslo.

## PRAGUE

614 kc/s, 488.6 metres; 120 kW.—2.50 p.m., See Bratislava. 3.50, Aviation Weather Report. 3.55, Exchange. 4.0, Interval. 5.25, See Brno. 5.45, Talk. 5.55, Talk. 6.5, Agricultural Programme. 6.15, Talk for Workers. 6.25, News in German. 6.30, German Transmission: Review of New Publications and Agricultural Programme. 7.0, Chimes and News. 7.10, Talk: Water Divination. 7.25, See Brno. 10.15, News and Sports Notes. 10.30, Concert by the Skalický Orchestra: Waltz (Rehór); Cradle Song (Kostal); Selection from La Bohème (Puccini); Fox Trot (Tichý); Romance (Tchaikovsky). 11.0, Close Down.

## RADIO-SUISSE ROMANDE

**SOTTENS**, 743 kc/s, 403 metres; 25 kW. and Geneva, 395 kc/s, 760 metres.—6.15-6.30 a.m., Gymnastics. 12.28 p.m., Time Signal from Neuchâtel Observatory. 12.30, News and Weather. 12.45 (from Geneva), Variety Items. 1.0, Financial News. 1.10 (from Geneva), Gramophone Concert. 2.0-3.28, Interval. 3.28, Time Signal from Neuchâtel Observatory. 3.30 (from Geneva), Gramophone Concert. 4.15 (from Geneva), An Interlude. . . . 4.40 (from Geneva), Gramophone Concert (contd.). 5.30-7.0, Interval. 7.0 (from Geneva), Programme for Children. 7.15 (from Geneva), Talk for Mountaineering Enthusiasts. 7.30 (from Geneva), Radio Chronicle. 7.50 (from Geneva), Esperanto Talk. 8.0, Concert by the Radio Suisse Romande Orchestra, conducted by Echemard: Orchestral Suite (Bach-Hönniger);

SEPT. 21st

THURSDAY

continued

Serenade (Rozsa); Symphony No. 5 (Schubert). 9.0 (from Lausanne), Organ Recital by Charles Fallier, relayed from Lausanne Cathedral: Passacaglia (Buxtehude); Prelude (Zachon); Benedictus and Trio (Conperin); Choral in A minor, No. 3 (César Franck). 9.35, News and Weather. 9.46 (from Lausanne), Offenbach Song Recital. 10.30 (approx.), Close Down.

## REYKJAVIK

250 kc/s, 1,200 metres; 21 kW.—9.5 p.m., Musical Programme. 9.30, Weather. 9.40, Musical Programme and Announcements. 10.0, Chimes and News. 10.30, Reading. 11.0, Concert by the Station Trio, followed by Arias on Gramophone Records.

## RIGA

572 kc/s, 525 metres; 15 kW.—6.30 p.m., English Lesson. 7.0, Weather Report. 7.5, Concert of Arensky Music: Silhouettes; Trio in D Minor for Pianoforte, Violin, and Cello; Variations on a Theme of Tchaikovsky. 8.0, News. 8.20, Soprano Solos. 8.40, Orchestral Concert: Overture, Lysistrata (Lincke); Waltz, España (Waldteufel); Melody (Meyer-Hellmund); Musical Telegrams (Rubach). 9.0, Weather and News. 9.30, Saxophone Solos: Intermezzo (Mascagni); Waltz (Wiedoeff); Liebestraume (Liszt); Air (Bach); Savena (Wiedoeff).

**RJUKAN**.—See Oslo.

## ROME

Call 1RO, 680 kc/s, 441 metres; 50 kW. Relayed by Naples, 941 kc/s, 319 metres, and 2RO, 11,810 kc/s, 25.4 metres, from 5.15 p.m., and Milan (Vigentino), 662 kc/s, 453.2 metres from 8.45 p.m. 12.30 p.m., Gramophone Music. 1.0, Humorous Items. 1.5 (approx.) to 2.0, Concert of Variety Music, relayed from Turin. In the interval from 1.30 to 1.45, Giornale Radio and Exchange. 2.0, Time and Announcements. 4.30, Giornale Radio and Exchange. 4.45, Children's Radio Review. 5.0, Announcements. 5.10, Weather. 5.15 to 6.0, Concert by Maria Flori (Violin), Guadalupe Caputo (Soprano) and Bianca Colombo (Cello); Violin Solos: (a) Andante from the Spanish Symphony (Lalo), (b) Scherzo-Tarantella (Maria Flori); Soprano Solos: (a) Rispetto (Benedetti), (b) Aria from Il carnevale di Venezia (Petrella); Pieces for Violin, Cello and Pianoforte (Lacietto), with the Composer at the Pianoforte: (a) Contemplazione, (b) Secna villerecia; Soprano Solos: (a) Le luciole (Broggi), (b) Aria from Sicilian Vespers (Verdi). 6.40 (Naples), Shipping and Sports Notes. 6.45, Dopolavoro Announcements and Tourist Talk. 7.10, Agricultural Notes and Market Prices. 7.20, News in Foreign Languages. 7.40, Giornale Radio. 8.0, Time and Announcements. 8.15, Soprano Song Recital. 8.45, Concert of Light Music. In the interval, Talk. 11.0, Giornale Radio.

**SALZBURG**.—See Vienna.

## SCHENECTADY

**WGY**, 790 kc/s, 379.5 metres; 50 kW. Relayed at intervals by W2XAF on 31.48 metres and by W2XAD on 19.56 metres.—12.45 a.m. (Friday), Stock Reports and Baseball Scores. 1.0, Popular Programme from New York. 2.0, Captain Henry's Show Boat, from New York. 3.0, Variety Programme

## SCHWEIZERISCHER

## LANDESENDER

**BEROMUNSTER**, 653 kc/s, 459 metres; 60 kW.; Basle, 1,229 kc/s, 244.1 metres; and Berne, 1,220 kc/s, 245.9 metres.—6.15 a.m. (from Basle), Gymnastics. 6.35-11.59, Interval. 11.59, Time Signal from Neuchâtel Observatory and Weather. 12 Noon (from Basle), Vocal Duets on Gramophone Records. 12.30 p.m., Time, Weather and News. 12.40 (from Basle), Concert of Viennese Music by the Krems Orchestra. 1.25 (from Basle), Time, Weather and Exchange. 1.30-5.0, Interval. 5.0 (from Zürich), Concert by the Small Station Orchestra. 6.0 (from Berne), Schubert Song Recital on Gramophone Records. 6.30 (from Basle), Talk: Across the Mediterranean in a Collapsible Boat. 7.0 (from Basle), Time, Weather and Announcements. 7.10 (from Basle), Variety Concert on Gramophone Records. 7.45 (from Basle), Italian Lesson. 8.30 (from Basle), Orchestral Concert of Italian Music of the Eighteenth Century. In an interval at 9.5 (approx.), Weather and News. 10.0 (approx.), (from Basle), A Farce in Dialect (E. Bloch). 10.20 (approx.), Close Down.

**SOTTENS**.—See Radio-Suisse Romande.

## STOCKHOLM

689 kc/s, 436 metres; 55 kW. Relayed by Boden, 244 kc/s, 1,229.5 metres; Göteborg, 932 kc/s, 322 metres; Hörby, 1,166 kc/s, 257 metres; Motala, 221.5 kc/s, 1,354.4 metres;

Ostersund, 369 kc/s, 770 metres, and Sundsvall, 554 kc/s, 542 metres.—5.5 p.m., Talk. 5.30, Programme for Children. 5.45, Gramophone Music. 6.45, Elementary English Lesson, relayed from Jönköping, 1,490 kc/s, 201.3 metres. 7.15, Weather and News. 7.30, Bröllopsvinsten (The Wedding Prize)—Comedy (Thunberg). 9.0, Choral Concert, conducted by Karl Söderberg. 9.30, Radio Report. 9.45, Weather and News. 10.0, Orchestral Concert: Waltz, Seid umsiedlungen Millionen (Strauss); Variations on Carnival in Venice (Strauss-Ritzau); Four Sketches (Björkander); Pa fjället i sol (Peterson-Berger); Selection from Die Fledermaus (Joh. Strauss). 11.0 (approx.), Close Down.

## STRASBOURG

869 kc/s, 345 metres; 11.5 kW.—11.30 a.m., Gramophone Concert of Classical Music. 12.45 p.m., News. 1.0, Time and Exchange. 1.5, Orchestral Concert, conducted by Maurice de Villers: Les préludes (Liszt); Orchestral Suite No. 5 (Ginraind); A Night on the Bare Mountain (Mussorgsky); Four Sketches. 2.0, Programme for Children. 3.0, Interval. 4.0, Popular Music on Gramophone Records. 5.0, French Elocution Lesson. 5.15, Orchestral Concert, conducted by Rismak. 6.0, Talk in German: Romantique Architecture in Alsace. 6.15, Talk for Women. 6.30, Orchestral Concert, conducted by Maurice de Villers: Overture, Le postillon de Longjumeau (Adam); Valse des brunes (Ganne); Selection from Véronique (Messager); Czardas (Hubay); Orchestral Suite, Bouton d'or (Pierné); Ballet Music, Les papillons (Pugno-Lippacher). 7.30, Time and News. 7.45, Gramophone Music. 8.0, Press Review in German, Lottery Results, and Announcements. 8.30, Military Band Concert, relayed from Colmar: Alsace-Lorraine (Tayon); March-Intermezzo (Gilbert); Selection from The Girl in the Taxi (Gilbert); Masquerade (Lacôme); Waltz, Künstlerleben (Joh. Strauss); Ballet Music from Coppélia (Delibes); Le joyeux trompette (Allier). 1.30 (approx.), Press Review.

## STUTTGART

**MUHLACKER**, 832 kc/s, 360.5 metres; 60 kW. Relayed by Freiburg, 527 kc/s, 570 metres.—1.15 p.m., Time and News. 1.30, Suite in B Minor, No. 2 (Bach), by the Concertgebouw Orchestra, conducted by Willem Mengelberg (on Gramophone Records). 2.0, Concert arranged by the Post Office, with Gramophone Music. 2.30, Spanish Lesson. 3.0, Elementary English Lesson. 3.30, Programme for Children from Frankfurt. 4.20, Concert by the Station Orchestra, conducted by Gustav Görlich: Overture, Berlin wie es weint und lacht (Conradi); Schlager und Schlager—Berlin Melodies of the Year 1910 (Lincke); Overture, Berliner Luft (Lincke); March, Wien-Berlin (Schramm); Flieder-Marsch (Reidhardt); Two Old Viennese Dances; Waltz, Wiener Extrablätter (Translatent); Selection from Libae Time (Schubert-Berté); March, Wien bleibt Wien (Schramm). 5.45, Talk: Animals. 6.10, Famous Lovers of Opera—A Talk with Gramophone Record Illustrations. 6.35, Time and News. 7.0, Transmission for all German Stations, relayed from Langenberg. 8.0 (from Karlsruhe), Discussion: The Labour Service. 8.30, Serenades—Concert by the Station Orchestra, conducted by Paul Sixt: Hafner Serenade (Mozart); Serenade in D (Brahms); Serenade for Wind Instruments (Richard Strauss); Italian Serenade (Hugo Wolf). 9.45, Pianoforte Recital by Helene Renate Lang: Fugue on the Magnificat (Pachelbel); Sonata in B flat (Schubert). 10.30, Time and News. 10.50 to 1.0 a.m. (Friday), Interval. 1.0, Also on Zeesen, 31.38 metres, Concert of Swabian Folk Music. 1.30, Close Down.

**SUNDSVALL**.—See Stockholm.

## TOULOUSE

779 kc/s, 385 metres; 8 kW.—6.0 p.m., News. 6.15, Concert by a Viennese Orchestra. 6.45, Chansonnettes. 7.0, Les Préludes (Liszt), by a Symphony Orchestra. 7.15, News, Racing Results and Market Prices. 7.30, Operetta Music: Songs from The Drum Major's Daughter (Offenbach); Elle est à vous (Yvain); Une nuit au Louvre (Urgel). 7.45, Light Orchestral Music. 8.0, Orchestral Concert: Poème (Fibich); Potpourri; Napoletana (Popeski); Gavotte from Mignon (Thomas); Czardas; Valse de Souvenir (Mélé). 8.30, Sound Film Music. 8.45, Accordion Music. 9.0, Programme relayed from Clermont Ferrand. In the intervals, Popular Concert and Light Music. 10.15, North African News Bulletin and Local News. 10.30, Concert for Listeners in Morocco: Operetta Potpourri (Misraki); Melody (Tagliaferré); Waltz caprice (Wieniawsky); Lullaby from Mignon (Thomas); Invitation to the Waltz (Weber). 11.0, Dance Music. 11.45, Popular Music: Au den Frühling (Grieg); Wien bleibt Wien (Schrammel); La dédaigneuse. 12.0 Midnight, News Bulletin, Weather Forecast and

Announcements. 12.5 a.m. (Friday), Popular Music. 12.15, Orchestral Music: Extracts from Alessandro Stradella (Plotow) and The Secret Marriage (Cimarosa). 12.30 (approx.), Close Down.

## TRIESTE

1,211 kc/s, 247.7 metres; 10 kW.—5.10 p.m. till Close Down, See Turin.

**TRONDHEIM**.—See Oslo.

## TURIN

1,096 kc/s, 273.7 metres; 7 kW. Relayed by Milan, 905 kc/s, 331.5 metres; Genoa, 959 kc/s, 312.8 metres, and Florence, 599 kc/s, 500.8 metres.—5.10 p.m., Concert. 6.0 to 6.5, Weather. 6.40, Giorna e Radio, Dopolavoro Announcements and Gramophone Music. 7.0, Time, Tourist Report and Gramophone Music. 7.10, Agricultural Notes and Market Prices. 7.20, News in Foreign Languages. 7.40, Gramophone Music. 8.0, Announcements, Giornale Radio, Sports Notes, Weather and Gramophone Music. 8.20, Talk on the following Transmission. 8.30, Il Pirata—Opera (Bellini). After the Opera, Giornale Radio.

## VATICAN CITY

15,120 kc/s, 19.84 metres (Morning), and 5,969 kc/s, 50.26 metres (Evening); 10 kW.—11.0 to 11.15 a.m., Religious Information in French. 8.0 to 8.15 p.m., Religious Information in Italian.

## VIENNA

581 kc/s, 517 metres; 100 kW. Relayed by Graz, 852 kc/s, 352.1 metres; Innsbruck, 1,058 kc/s, 283 metres; Klagenfurt, 662 kc/s, 453.2 metres; Linz, 1,220 kc/s, 245.9 metres; and Salzburg, 1,373 kc/s, 218.6 metres.—12 Noon, Concert by the Wiener Symphoniker, conducted by Josef Holzer: Overture, Des Wanderers Ziel (Suppé); Suite from Les millions d'Arlequin (Drigo); Duet for Two Trumpets, Ich wollt' mein Lieb' (Mendelssohn); Two Polish Folk Dances (Scharwenka); Waltz, Genrebilder (Lanner); Serenade pizzicato (Ganne); Musikalische Vexierbilder (Schreiner); Liedermarsch (Lehár); Slow Waltz, Heures Elysées (Fueik); Polka, Wiener Leben (Jos. Strauss); Waltz, Weana Frühling (Czibulka); Idyll for String Quintet (Blasser); Eysler Potpourri (Hrubý). In an interval at 1.0 p.m., Time and News. 3.0, Time and Announcements. 3.35, Programme for Children. 3.45, German Opera Music on Gramophone Records. 4.25, Talk: Painting and Photography. 4.40, Talk for Women. 5.5, Sarasate Recital by Ludwig Wittels (Violin); Andalusian Romance; Habanera; Carmen Fantasia; Zapatero; Zigeunerweisen. 5.45, Theatre Notes. 5.55, Talk on Ferdinand Avenarius. 6.10, Talk: Autumn in the Eastern Tyrol. 6.35, Talk: Ourselves and Primitive Races. 7.0, Concert by the Tautenhayn Quartet: Minuet (Haydn); Ecosaises (Schubert); Andante (Mozart); Gavotte (Méhul); Humoresque (Fibich); Wiegendorf und Ständchen (Heller); Viennese Suite (Tautenhayn); Schön Rosmarin (Kreisler); Folk Song (Komzak); Waltz, Les deux chats (Varney). In the interval at 7.35, Time and Announcements. 8.0, Undine—Opera in Four Acts (Lortzing). In an interval at 9.20 (approx.), News. 10.20, Descriptive Piece on Gramophone Records, and Announcements.

## WARSAW

212.5 kc/s, 1,411 metres; 120 kW.—11.57 a.m., Time Signal and Fanfare from Turin, for the 700th Anniversary of the Town. 12.5 p.m., Gramophone Music. In the intervals at 12.25, Press Review; and at 12.33, Weather. 12.55, Radio Journal. 1.0, Interval. 2.55, News. 3.0, Gramophone Music. In the intervals at 3.5, News; at 3.25, Economic Notes; at 3.45, Programme for Boy Scouts; and at 4.0, Programme for Children. 5.0, Dialogue. 5.15, Song Recital by Halfreich (Soprano) and Hermes (Tenor). 6.15, Talk. 6.35, Chamber Music: Pianoforte Trio in D Minor, Op. 9 (Mendelssohn); Second Part of Pianoforte Trio in G Minor (Chopin). 7.20, Miscellaneous Items. 7.35, Programme Announcements. 7.40, Reading. 8.0, Concert by the Station Orchestra. Soloist, Eugene Mai (Baritone). Overture, Der Operndahl (Heuberger); Intermezzo from Naïfa (Delibes); An Evening in Hawaii (Filipponi); Songs: (a) Aria from The Queen of Spades (Tchaikovsky), (b) Monologue from Rigoleto (Verdi); Russian Dance (Tchaikovsky); Chanson sans paroles (Tchaikovsky); Invitation to the Waltz (Weber-Berlioz); Fantastic Dance (Weber-Berlioz). 8.50, Radio Journal. 9.0, Agricultural Notes. 9.10, Concert (contd.): Selection from Madame Butterfly (Puccini); Songs: (a) Aria from Verbum Mobile (Moniuszko); Serenade from Don Juan (Sapranik); Ballet Music from Coppélia (Delibes); Melody (Lodwigowsky). 10.0, Dance Music from the Adria Dance Hall. In the intervals at 10.25, Sports Notes; and at 10.35, Weather and Police Notes.

**ZURICH**.—See Schweizerischer Landessender.

**ATHLONE**

725 kc s, 413 metres; 60 kW. Relayed by Cork, 1,337 kc s, 224.4 metres.—1.30 to 2.0 p.m., Time, Weather, Stock Report, and Gramophone Concert. 4.0, Orchestral Concert. Soloist, John Lysney (Baritone). 6.0, Programme for Children. 6.45, News, 7.0, Gardening Talk. 7.15, Talk: The New Psychology. 7.30, Time Signal. 7.32, The Station Orchestra. 8.0, Baritone Solos by Robert Irwin. 8.15, Violin Solos by Jennie Ballantine. 8.30, The Station Orchestra. 8.50, Contralto Solos by Jean Roper. 9.5, The Station Orchestra. 9.20, Illustrated Lecture Recital: Songs of Wicklow. 9.30 to 10.30, Programme arranged by the I.B.C. (Ireland). Ltd. 9.30, Concert: Humorous Fantasy, Wedded Whimsies (Alford); In a Chinese Temple Garden (Kettelbey); Xylophone Solo, The Blue Danube (Strauss); Light of Foot (Latan); A Life on the Ocean (Binding); Xylophone Solo, The Skaters' Waltz (Waldteufel); Quand Madeon (Bousquet); Old Comrades March (Teike). 10.0, Concert arranged by the International Broadcasting Company (Ireland). Ltd., on behalf of the Hospitals Trust, Ltd.; Signature Tune, Come Back to Erin; Waltz from The Gipsy Princess (Kálmán); Intermezzo, Liebesfreund (Kreisler); Xylophone Solo; Overture, Light Cavalry (Suppe); By the Swanee River (Myddleton); Serenade (Moszkowsky); Banjo Solo; Minuet (Bocherini); Waltz from Der Rosenkavalier (R. Strauss). 10.45, News and Weather.

**BARCELONA**

EAJ1; 860 kc s, 348.8 metres; 8 kW. 7.0 p.m., Trio Concert: Selection from Sappho (Massenet); Der Erkönig (Schubert); Song (d'Azzurro); Selection from the Rheingold (Wagner); L'amour printanier (Kálmán); Dance (d'Ambrosio); Selection from Hamlet (Thomas). 8.0, Request Gramophone Music. 8.30, Exchange. 9.0, Gramophone Music and News. 10.0, Chimes from the Cathedral, Weather, Messages to Seamen, Exchange, and Market Prices. 10.10, Concert by the Station Orchestra. 11.15, Literary Talk. 11.30, An Opera on Gramophone Records. In the interval at 12 Midnight, News. 1.0 a.m. (Saturday), Close Down.

**BARI**

1,112 kc s, 269.8 metres; 20 kW. See Rome. BASLE.—See Schweizerischer Landessender.

**BERLIN**

**DEUTSCHLANDSENDER (Reichssender)**, 183.5 kc/s, 1,635 metres; 60 kW.—12 Noon, Weather. 12.5 p.m. (approx.), Gramophone Concert. After the Concert, Weather, 12.55, Time Signal. 1.45, News, 2.0, Gramophone Concert. 3.0, Talk: Books for Girls. 3.15, Talk for Women. 3.30, Weather and Exchange. 3.54, Reading. 4.0, Concert from Leipzig. 5.0, Stags—a Radio Report. 5.20, Concert. Part I, Block Music: Four Serenades by the Station Chamber Orchestra: (a) Festliches Ständchen, (b) Geburtstagsständchen, (c) Frühlingsständchen, (d) Abendständchen. Part II: Music by Buncke: Saxophone and Piano-forte Duets by Emil Manz and Heinz Lamann: Romance in G flat; Intermezzos in G; Intermezzo in A flat; Concert Waltz. 6.0, A Poem. 6.5, The Merceis Microphone—A Discussion between Heinrich Romer and Dr. Friedrich Bohndey. 6.30, Gramophone Music. 6.50, Weather and Announcements. 7.0, Transmission for all German Stations, relayed from Heilsberg. 8.0, To-day's Motto. 8.5, See Heilsberg. 9.20, Der Klippdachs—a Radio Picture of the South West. 10.0, News, followed by a Dialogue between Christian Sen and Triugard von Bork on the Italian Atlantic Flight. 10.45, Weather. 11.0, Concert. 12 Midnight, Close Down.

**BERLIN**

**FUNKSTUNDE**, 715 kc s, 419.5 metres; 1.5 kW.—4.0 p.m., A Discussion on the German Theatre. 4.15, Talk: The Care of a Motor Bicycle. 4.30, Military Band Concert, relayed from the Zoo. Conductor: Walter Harmens. 5.10, Aria Recital by Alfred Schäfer (Baritone): Aria from (a) Così fan tutte (Mozart), (b) Ernani (Verdi), (c) The Pearl Fishers (Bizet), (d) The Battle of Legnano (Verdi). 5.30, Autumn Songs—Radio Sequence (Karl Privat). 6.0, Talk: Horst Wessel's Father—a Model German. 6.15, Review of Sound Films. 6.40, The Funkstunde informs its listeners... 6.45, Topical Talk. 7.0, Transmission for all German Stations, relayed from Heilsberg. 8.5, The History of the Berlin Suburb Friedrichstadt—Musical and Literary Programme. 9.0, The Third Symphony in D Minor (Bruckner), by the Station Orchestra, conducted by Eugen Joachim. 10.0, Weather and News. 10.25 (approx.), Light Music by the Wilfried Krüger Orchestra, relayed from the Traube Restaurant. In the interval at 11.0 (approx.), Theatre and Film Review. 12 Midnight (approx.), Close Down.

**BERNE**.—See Schweizerischer Landessender. **BEROMUNSTER**.—See Schweizerischer Landessender.

**BODEN**. See Stockholm.

**BODO**. See Oslo.

**BORDEAUX-LAFAYETTE**

986 kc s, 304 metres; 13 kW. 6.15 p.m., Radio Journal. 7.40, News. 7.50, Romeo

# FRIDAY

## SEPTEMBER THE TWENTY-SECOND

### PRINCIPAL EVENTS OF THE DAY:

**AT HOME**

**NATIONAL LONDON REGIONAL MIDLAND REGIONAL NORTH REGIONAL WEST REGIONAL SCOTTISH REGIONAL BELFAST** Music hall programme. Promenade concert from Queen's Hall.

**BRUSSELS (No. 2) BUDAPEST** Band programme. A Coleridge-Taylor Orchestral programme. Choral concert.

**COPENHAGEN** "Fishers' Howff," a gathering of musical and loquacious anglers, relayed from Newhaven. Orchestral concert.

**ABROAD**

**BRUSSELS (No. 2) BUDAPEST** 8.0 p.m. The Station Symphony Orchestra, 10.15 p.m. The Opera House Orchestra, conducted by Komor.

**COPENHAGEN** 10.10 p.m. Contemporary Danish music, by the Station Symphony Orchestra.

**EIFFEL TOWER HEILSBURG** 7.50 p.m. Opera: "Romeo and Juliet," by Gounod, relayed from the Opera.

**HILVERSUM** 8.5 p.m. The Königsberg Opera House Orchestra, conducted by Bruckner.

**LANGENBERG** 8.40 p.m. The Station Orchestra, conducted by Gerritsen.

**POSTE PARISIEN TURIN** 5.30 p.m. Symphonic dances, by the Station Orchestra, conducted by Kulm. 8.30 p.m. Two operas: "Bousoin, Voisin," by F. Poisa, and "Paille d'Avoine," by Planquette. 8.15 p.m. Symphony concert, conducted by Daniele Amfitheatrof.

and Juliet—Opera (Gounod), relayed from the Opera, Paris.

**BRATISLAVA**

1,076 kc s, 279 metres; 11 kW. 5.45 p.m., Dramatic Programme. 6.45, Sports Talk. 6.55, Talk for Housewives. 7.0, See Prague. 7.10, Reading. 7.25, See Prague. 10.15 (approx.), Close Down.

**BREMEN**.—See Hamburg.

**BRESLAU**

923 kc/s, 325 metres; 60 kW. Relayed by Gleiwitz, 1,184 kc/s, 253 metres.—1.5 p.m., Gramophone Concert. 1.45, Time and News. 2.5, Piano-forte Recital by Hanna Born: Sonata in E (Brahms); Three Pieces (Graener); Sonata No. 2 in A Minor from the Scarlattianna (Niemann). 2.30, Gramophone Music. 3.0, Agricultural Prices. 3.15, Programme for Young People. 3.40, Reading. 4.0, Concert by the Station Orchestra, conducted by Topitz: Overture, Maritana (Wallace); Suite from Coppélia (Delibes); Im Reiche der Venus (Gröschel); Second Rhapsody (Liszt); Trambilder (Joh. Strauss); March (Schicke); Alt Heidelberg—Potpourri of Students' Songs (Klose). 5.30, Market Prices. 5.45 (approx.), Reading. 6.0, Programme to be announced. 6.30, Germans outside the Reich—German Settlements in South-East Europe. 6.50, Market Prices. 7.0, Transmission for all German Stations, relayed from Heilsberg. 8.0, News. 8.10, Choral Concert. In the intervals, Duets by Käthe Heßbig (Soprano) and Herbert Heidrich (Tenor). 9.10, A Monkey on Board—Radio Play (Geyer). 10.10, Time and News. 10.35, Talk: Artillery Fighting around Jezz. 10.55 (from Gleiwitz), Light Music and Dance Music by the Kulmert Orchestra. 12 Midnight, Close Down.

**BRNO**

878 kc s, 342 metres; 35 kW. 6.5 p.m., Gramophone Music. 6.15, Talk for Workers. 6.25, German Transmission: News and Talks. 7.0, See Prague. 7.10, Reading. 7.25, See Prague. 10.15 (approx.), Close Down.

**BRUSSELS (No. 1)**

I.N.R., 590 kc s, 509 metres; 15 kW.—12 Noon, Autumn—Gramophone Concert: Pensée d'Antoine (Massenet); Feuilles d'Antoine (Reuig); Le cor (Flegier); Shepherd-Hey (Grainger); Le chasseur maudit (César Franck); Melody (Humbly); Chrysanthèmes (Gombier); Extracts from the Ballet, The Sea-sons (Glazunov); Autumn Mist (Krottinghberger); Foytrot; Autumn Winds (Packay); Mazurka (Paradis); Die Jagd im Schwarzwald (Voelker); Brilliant chassés (Contade). 1.0 p.m. Le Journal Parlé. 1.10, Concert by the Small Station Orchestra, conducted by Leemans, and a Vocal Quartet: Overture, Les Hirondelles

(Hirshman); Suite, Jeux d'enfants (Bizet); Songs; Violin Solo; Minuet (Mozart); Selection from Le Jour et la nuit (Lecocq). 5.0, Concert by the Radio Orchestra, conducted by André, Soloist: Mison (Violin); Overture, Cousin de Poperinghe (van Oost); Valse en sourdine (Aekermans); Esquisses flamandes (Brussels); Andante from the Third Violin Concerto (Saint-Saëns); Suite (Andaya); Mozartiana (Tchaikovsky); Italian Songs (de Michel); Old French Songs (Broustet). 6.0, Talk by the Director of the Prison Schools. 6.15, Request Gramophone Records. 6.30, Song Recital. 7.15, Talk: Journal. 7.30, Legal Talk and Literary Review. 8.0, Military Programme—Addresses, Military Band Music and Songs. After the Programme: Announcements for Ex-Servicemen. 8.45, Educational Talk: Our World Tour. 9.0, Popular Concert by the Radio Orchestra, conducted by Franz André. 10.0, Le Journal Parlé.

**BRUSSELS (No. 2)**

N.I.R.; 887 kc s, 338.2 metres; 15 kW.—Programme in Flemish. 12 Noon, Concert by the Small Station Orchestra, conducted by Leemans: Overture, Nordische Seinfahrt (Gade); Serenade (Saint-Saëns); Spanish Music from Terpsichore (Ganne); Ballet Dance No. 8 (Sarasté); Selection from the Carnival Fairy (Kálmán); Cello Solo, La Cinquantine (Gabriel Marie); Waltz (Abraham); Ein Tango macht verliebt (Komjati); Potpourri of American Melodies (Nicholls). 1.0 p.m., Le Journal Parlé. 1.10, Gramophone Music. 5.0, Concert by the Station Symphony Orchestra, conducted by Kump: Overture, Tambhäuser (Wagner); Le Tombeau de Couperin (Ravel); Cortège (Rocis); Arabesque (Absid); Dance (Absid); Entr'acte Music from Jean Michel (Dupuis). 6.0, Sonata for Piano-forte and Violin (Lekou). 6.30, Concert by the Small Station Orchestra, conducted by Leemans: Prelude and Cortège from Dejanire (Saint-Saëns); Petite Suite No. 2 (Gilsou); Chant sans paroles (Tchaikovsky); Mirologue (Marsick); Parade of the Tin Soldiers. 7.0, Talk, with Gramophone Illustrations: East European Folklore. 7.30, Le Journal Parlé. 8.0, Concert by the Station Symphony Orchestra, conducted by Kump; Symphony No. 2 (Beethoven); Sigfried Idyll (Wagner); Overture, Oberon (Weber). 9.0, Daan Sternefeld Concert by the Station Symphony Orchestra, conducted by Kump. Soloists: Ina Wasserman and Doris Diels. Extracts from Twelfth Night; Minuet from Les Precieuses ridicules; Selection from Antigone; Three Popular Flemish Songs from Wonderdoktoor; Selection from As You Like It; Prelude and Bacchanal from Mary Magdalene and the Nazarenes. 10.0, Le Journal Parlé. 10.10 (approx.), Close Down.

**BUCHAREST**

761 kc s, 394 metres; 12 kW.—5.0 p.m., Concert of Variety Music by the Jean Marco

Orchestra. 6.0, Radio Journal. 6.15, Concert (contd.). 7.0, Educational Programme. In the intervals from 7.20 to 7.40, Light Music on Gramophone Records. 8.0, The Pearl Fishers—Opera in Three Acts (Bizet). In the intervals, Radio Journal and Talk.

**BUDAPEST**

545 kc s, 550.5 metres; 18.5 kW. Also relayed on 840 metres from 7.40 till Close Down. 5.30 p.m., Light Music by the Szervanszky Orchestra. 6.30, Talk. 7.0, Concert by a Workers' Choir. 7.40, Talk: The Author, Francis Hertzeg. 8.0, The Black Rider—Play (Hertzeg). 10.0, News. 10.15, Concert by the Opera House Orchestra, conducted by Komor: Overture, Der Vampyr (Marschner); Indian Suite (Lüling); España (Waldteufel); Operetta Potpourri (Kont); Extract from Gipsy Love (Lebár); March, Vivat Hungaria (Kálmán). 11.0, Light Music by the Lajos Kiss Gágyú Band, relayed from the Café Baross.

**CASSEL**.—See Frankfurt.

**COPENHAGEN**

1,067 kc s, 281 metres; 0.75 kW. Relayed by Kalundborg, 260 kc s, 1,153.8 metres.—12 Noon, Time and Chimes from the Town Hall. 12.5 p.m., String Ensemble Concert, relayed from the Bellevue Strandhotel. 2.0, Interval. 3.0, Concert by the Radio Orchestra, conducted by Launy Gröndahl. Soloist, Oda Petersen (Songs). Overture, Titus (Mozart); Waltz Suite (Schubert); Selection from Masaniello (Auber); Three Pieces from the Indian Suite (Macedoweld); Six Songs (Heise); Concert Overture, Hamlet (Gade); Waltz, Cecile (Lumbye); Movement from the Symphony in B Flat (Mozart); Berceuse (Respighi); Selection from La Poupée (Andran); March, Uncle Teddy (Fueik). 5.0, Programme for Children. 5.30, Exchange and Fish Market Prices. 5.45, Talk: King Ferdinand of Bulgaria. 6.15, Elementary German Lesson. 6.45, Weather and Announcements. 7.0, News. 7.15, Time Signal. 7.16, Talk on Unemployment, relayed from the University. 8.0, Chimes from the Town Hall. 8.5, Programme by Per Knutzen. 8.10, Harpsichord Recital: Canzone (Poglietti); Sonata in C Minor (Galuppi). 8.25, The Violin King—Radio Play (Hetsch). 9.25, Gramophone Music. 9.45, Humorous Recitation. 9.55, News. 10.10, Concert of Contemporary Danish Music, by the Station Symphony Orchestra, conducted by Emil Ressen. Soloists: Holger Jespersen (Flute), Knud Lassen (Bassoon), Thorvald Nielsen (Violin), and Sverre Forchhammer (Viola). Symphony No. 2, Op. 11 (Emborg); Flute Concertino, Op. 5 (Sensstins); Sonata for Bassoon, Violin, and Viola (Brentano). 11.10, Dance Music, relayed from the Wivey Restaurant. In the interval at 12 Midnight, Time and Chimes from the Town Hall. 12.30 a.m. (Saturday), Close Down.

**CORK**.—See Athlone.

**DANZIG**.—See Heilsberg.

**DRESDEN**.—See Leipzig.

**FECAMP**

1,328 kc s, 225.9 metres; 10 kW.—11.0 a.m. to 12 Noon, Programme in English by the I.B.C. 11.0, Happy Hour. Part I, Orchestra Music: Signature Tune; Old Music Hal Memories. Piano-forte Solo: The Squirrel, Dance (Smith); Dance of the Raindrops (Reeves); The Devil Dance (Petersen); Crazy Pionette (Frisk). Piano-forte Solo: Melody from Viktoria and her Hussar (Abraham); The Wedding of the Birds (Petersen); Sari Waltz (Kálmán). Part II, Request Music: Hawaiian Hotel (Traditional); In the Valley of the Moon (Burke); Lullaby of the Leaves (Petker); Kiliama (Traditional); La Paloma (Yradier); Peter, Peter (Connolly); Silvery Moon (Frazzini); Pukiko Blues (Hackforth); Signature Tune. 12 Noon, Programme in French. 4.30 to 6.0, Programme in English by the I.B.C. 4.30, Programme for Children. 5.0, Concert for Southampton and Winchester Listeners. I.B.C. Members' Request Half Hour: Signature Tune, The Night by the Sea; Veterans of Variety; Air from The Belle of New York (Kerker); The Skaters' Waltz (Waldteufel); Marta (Simons); The Sanctuary of the Heart (Kettelbey); Glow-Worm Idyll (Lincke); The Old Rustic Bridge by the Mill (arr. Wood); Black Eyes (Ferraris). 5.30, Concert of Light Music for Bournemouth and Weymouth Listeners: Rhapsody in Blue (Gershwin); Xylophone Solo: Air from Carmen (Bizet); A Letter to my Mother (Gilbert); Jungle Brums (Kettelbey); The Ghost Walk; A Boy and Girl were Dancing (Revel); Xylophonia (Green); Song of the Islands (Kerg); Signature Tune. 6.0, Programme in French. 10.0 (approx.), till Close Down, Programme in English by the I.B.C. 10.0, Dance Music: Signature Tune, The Pells of Normandy; At the Old Pig and Whistle; In the Valley of the Moon; You're mine, you; Under my Umbrella; When the Morning rolls around again; Thank Heaven for you; In a Second-hand Store; When Gimble hits the Cymbal. 10.30, Dance Music: A Woman should stick to her Man; The Old Spinning Wheel; Wanderer; Pop Gun; Melody from Forty-Second Street; Maybe I love you too much; Waiters on Parade; My, Oh My; Hyde Park Corner; Signature Tune. 11.0, Music from Sound Films: Signature Tune, Sittin' in the Dark;

SEPT. 22nd

FRIDAY

continued

Talkie Gems: Heaven will protect an Honest Girl; Melody from Congress Dances; Sergeant Flagg and Sergeant Quirt; I want to cling to Ivy; Sweep; In the Park in Parce; Selection from The Love Parade; Signature Tune. 11.50, Club Concert for Newark Listeners; Signature Tune. The Chum Song; Morning, Noon and Night (Suppe); Down Vauxhall Way (Oliver); Piano Solo; Butterfly in the Rain (Myers); The Song of Songs (Moya); Selection from The Mikado (Sullivan); Song, The Temple Bells (Woodford-Finden); Around the Volga (Borchert). 12.5 a.m., News Bulletin in English. 12.10 (approx.), Club Concert, Part II: I don't know why (Ahlert); My Silent Love (Suess); In Sunny Monterey (Nicholls); Bahama Mama (Gilbert); When Work is through (Shermann); Signature Tune. 12.50, Dance Music: I cover the Waterfront; Waltzing in a Dream; They all do the Rumba; That's my Home; I've told every Little Star; Something came and got me in the Spring; Dance, Pretty Lady; Fit as a Fiddle. 1.0, Dance Music: Signature Tune, Bells of Normandy; My Bluebird's singing the Blues; Lover; Peter, Peter; Waltzing in a Dream; That's my Home; Come out Vienna; Letting in the Sunshine; Let's all be happy together; Learn to croon; There's a Cabin in the Pines; He was only a Poor Musician; Somebody stole my Gal; In Old Vienna; The Girl in the Little Green Hat; Sweetheart darlin'; Signature Tune. 2.0, I.B.C. Goodnight Melody and Close Down.

FLENSBURG.—See Hamburg.

FLORENCE.—See Turin.

FRANKFURT

1,157 kc/s, 259.3 metres; 17 kW. Relayed by Cassel, 1,220 kc/s, 245.9 metres; and Trier, 1,157 kc/s, 259.3 metres.—4.30 p.m. (from Cassel). Concert by the Cassel Kamphund Orchestra, conducted by Ludwig Maurick: Overture, Der Wildschütz (Lortzing); Ballet Music from Rosamund (Schubert); Overture, La dame Blanche (Boieldieu); Piccolonte Dances Nos. 1 and 2 (Sinigaglia); Waltz from Faust (Gounod); Lehár Potpourri; Waltz, Frühlingsstimmen (Joh. Strauss). 5.45, Economic Notes. 6.0, Medical Talk. 6.20 (from Trier), Talk: The Economic Relationship between the Saar District and Germany. 6.45, Today's News. 6.50, Time and Announcements. 7.0, Transmission for all German Stations, relayed from Heilsberg. 8.0, Lotzar Wimperger Concert by the Station Orchestra, conducted by Hans Rosband. Soloist: Max Strub (Violin). Concert Overture in G, Op. 17; Violin Concerto, Op. 39. 8.50, Programme in Memory of the Baden Poet, Samuel Friedrich Sauter. 9.50, Talk with Gramophone Illustrations: The Automatic Organ. 10.20, Time and News. 10.45, Serenade. 12 Midnight (approx.), Close Down.

FREDRIKSSTAD.—See Oslo.

FREIBURG.—See Stuttgart.

GENEVA.—See Radio-Suisse Romande.

GENOA.—See Turin.

GLEIWITZ.—See Breslau.

GOTEBORG.—See Stockholm.

GRAZ.—See Vienna.

HAMAR.—See Oslo.

HAMBURG

806 kc/s, 372 metres; 1.5 kW. Relayed by Bremen, 1,112 kc/s, 269.8 metres; Flensburg, 1,319 kc/s, 227.4 metres; Hanover, 530 kc/s, 566 metres; and Kiel, 1,292 kc/s, 232.2 metres.—6.0 p.m., Variety Programme. 6.25, Talk: German Heroes of the Great War—Wedding of the U Boats. 6.45, Exchange and Market Prices. 6.50, Weather. 7.0, Transmission for all German Stations, relayed from Heilsberg. 8.0, From the Weststein to the Porta-Verfalia—Landscape Pictures (Robert Walter). 10.0, Time and News. 10.20, Topical Talk. 10.30 (from Bremen), The Weather in Music—Orchestral Concert, conducted by Reinhold Krug; Waltz, Zephyr Breezes (Gungl); Brise de mer (Leoncavallo); Overture, A Summer Night in Madrid (Glinka); Waltz, Meeresschleichen (Ziehrer); Murneludes (Lüttchen Jensen); Prelude, The Rain Drop (Chopin); Waltz, Winterstürme (Fucik); Adagio from the Moonlight Sonata (Beethoven); Storm (H. Wolf); Regenacht (Niemann); Strandwellen (Lülling); Lockende Dämmerung (Leuschner); Schneeflocken (Thiele).

HANOVER.—See Hamburg.

HEILSBURG

1,085 kc/s, 276.5 metres; 60 kW. Relayed by Danzig, 662 kc/s, 453.2 metres.—1.5 p.m., Gramophone Concert. In the intervals at 1.20 and 2.0, News. 2.30, Programme arranged by the Post Office, with Gramophone Records. 3.0, Agricultural Prices and Exchange. 3.30, Programme for Children. 4.0, Talk for Women. 4.30 (from Danzig), Concert by a Nazi Band. 5.45 (from Danzig), Rocco Suite (Ziehrer) for Voice, Pianoforte, Violin and Cello. 6.15, Agricultural Prices. 6.20, Concert by a Zither Trio: Leopold March (Obermaier); Prelude (Swoboda); Waltz (Bauer);

Polka, La Bohème (Würzinger); Royal March (Wormsbacher). 6.50, Weather. 7.0, Transmission for all German Stations: Fishermen of the Kurisches Hafl—Radio Sequence (Burchard-Gerhard-Kaestner). 8.0, Weather and News. 8.5, Concert by the Königsberg Opera House Orchestra, conducted by Bruckner. Introductory Talk by Prof. Dr. Müller-Blattau: Symphony for Chamber Orchestra No. 2 (Schello); Concerto for Flute, Clarinet, Bassoon Trumpet, Drums and Strings, Op. 106 (Weismann). 9.20, Humorous Tales from the Argentine. 9.40, News. 9.45, Extracts from Ernani—Opera (Verdi) by the Orchestra and Choir of the Milan Scala (on Gramophone Records). 10.30, Weather, News and Sports Report.

HILVERSUM

Announced HUIZEN, 1,013 kc/s, 296.1 metres; 7 kW. (until 5.40 p.m.), and 20 kW. from 5.40 p.m. Programme of the Catholic Radio Society (K.R.O.).—11.40 a.m., Police Notes. 11.55, Concert by the Station Sextet. 1.25-1.40 p.m., Interval. 1.40, Song and Pianoforte Recital. 3.40, Organ Recital by Dreissen. 4.20, Gramophone Music. 5.10, Agricultural Talk. 5.40, Concert by the K.R.O. Boys: The London Fire Brigade (Nicholls); Einmal kommt einer (Guttman); Selection from The Flower of Hawaii (Abraham); Black-Eyed Susan Brown; Ich kann Dir gar nicht sagen (Grün); Délices Potpourri (Urbach); Please handle with care (Stride); Malaga (Sautis); Finale. 6.40, Police Report. 6.55, Talk. 7.15, Gramophone Music. 7.25, Concert by the K.R.O. Orchestra, conducted by Gerritsen: Overture, Ruy Blas (Mendelssohn); Lyric Suite No. 1 (Grieg); Piedmontese Dance (Sinigaglia); Glinka Potpourri (Urbach). 8.10, News. 8.15, Violin Recital by Grootegoed: Ave Maria (Schubert-Wilhelmy); Rondino (Beethoven-Kreisler). 8.25, Gramophone Music. 8.40, Concert by the K.R.O. Orchestra, conducted by Gerritsen: Soloist: Grootegoed (Violin); Selection from L'enfant prodige (Debussy); Concertino (Weill); Spanish Serenade (Chaminade-Kreisler); Spanish Dance (Falla-Kreisler). In an interval at 9.10, The Letter—Radio Play in One Act. 9.40, A Radio Play. 9.50, Orchestral Concert (cont.): The Wedding of the Rose (Jessel); Entr'acte Gavotte (Gilbert); Weaner Madlen (Ziehrer); March (Blankenburg). 10.10, News. 10.15, Concert by the K.R.O. Boys, conducted by Lustenhouwer. 11.40 (approx.), Close Down.

HORBY.—See Stockholm.

HUIZEN

Announced HILVERSUM, 160 kc/s, 1,875 metres; 7 kW. (until 3.40 p.m.). Transmitted from Kootwijk, on 50 kW. from 3.40 p.m.—11.40 a.m. to 3.40 p.m., Programme of the Algemeene Vereeniging Radio Omroep (A.V.R.O.).—11.40, Time Signal. 11.41, Concert of Light Music. In the interval, Gramophone Music. 1.40, Gramophone Records. 2.10, Recitations. 2.40, Gramophone Music. 3.40, Interval. 3.55-7.40, Programme of the Workers' Radio Society (V.A.R.A.). 3.55, Concert by the Small V.A.R.A. Orchestra, conducted by de Groot. 4.30, Programme for Children. 5.10, Concert by De Notenkrakers Orchestra, conducted by Wins; Czardas (Lebert). 5.40, Gramophone Music. 5.55, Concert by De Fliedruiters Orchestra, conducted by Forest. 6.20, Talk. 6.40, Concert by the V.A.R.A. Orchestra, conducted by De Groot: Soloist: Jo Heekert van Eysden (Songs); Hungarian Comedy Overture (Köler-Bela); Waltz, Accelerationen (Strauss); Song, Wer ungetraut (Strauss); Spielmannslied (Nicolai); Carnival Suite (Thomé); Waltz, Seid umschlungen Millionen (Strauss); Song (Olmann); Song, Houdt medel (Cyttenbogaardt); March (Carstens). 7.40-10.40, Programme of the Liberal Protestant Radio Society. 7.40, Talk. 8.10, Cello and Pianoforte Recital, by v.d. Stad and Mlle. Bosmans: Suite in D minor, Op. 13, No. 2 (Reger); Calm Night (Bosmans); Conchita's Dance (Veermolen); Fantasie-stueck, Op. 8, No. 2 (Hindemith); Sonata (Andriessen). In the interval at 8.40, Religious Address. 9.40, Religious Notes and Press Review. 9.55, Talk. 10.25, Gramophone Music. 10.40 till Close Down, V.A.R.A. Programme. 10.40, Organ Recital by J. Jong: I love a little Cottage (O'Hara); Turkish March (Mozart); Selection from Madame Butterfly (Puccini); Stormy Weather (Arlen); Selection from Die schöne Galathee (Suppé-Gross). 11.10, Gramophone Music. 11.40 (approx.), Close Down.

INNSBRUCK.—See Vienna.

KALUNDBORG.—See Copenhagen.

KATOWICE

734 kc/s, 408 metres; 16 kW.—7.20 p.m., Announcements and Gramophone Music. 7.35, Sports Talk. 7.40, See Warsaw. 10.40, The Letter Box in French.

KIEL.—See Hamburg.

KLAGENFURT.—See Vienna.

KOSICE.—See Prague.

LANGENBERG

635 kc/s, 473 metres; 60 kW.—12 Noon, Concert by the Fröhliche Fünf. 1.15 p.m., News. 1.30, Orchestral Concert, conducted by Eysoldt: Overture, The Gipsy Baron (Joh. Strauss); Selection from Martha (Flotow); Verbotener Gesang (Gastaldini); Für dich allein (Geibel); Wanderer-Suite (Kuhmann); Four Indian Love Lyrics (Woodford-Finden); Waltz, Donauweibchen (Strauss); Intermezzo, Silver Moon (Darewsky); From the Far West (Denneke); Overture, Bique Dame (Suppé). In an interval at 2.0 (approx.), News. 3.0, Topical Talk. 3.10, Talk for Workers. 3.30, Economic Notes and Time. 3.50, Programme for Young People. 4.30, Famous Voices on Gramophone Records. 4.40, Reading of a War Story (Paul Alverdes). 5.0, Concert: Erdmüthe Fiebiger (Contralto), Edelrot Grape (Pianoforte), and Walter Schneiderher (Violin); Pianoforte Solo: (a) Hindu Song (Rimski-Korsakov), (b) Doubt (Glinka), (c) Maiglöckchen (Arenski); Variations on a German Song (Chopin); 5.30, Symphonic Dances by the Station Orchestra, conducted by Kühn: Minuet from the Symphony in E flat (Haydn); Minuet from the Symphony in E flat (Mozart); Second Movement from the Symphonic fantasia-tique (Berlioz); Waltz from the Fifth Symphony (Tchaikovsky). 6.15, To the Fatherland—Reading of Poems by Uhland, Delmeil, Geibel, and Klopstock. 6.25, English Conversation. 6.45, Announcements. 7.0, Transmission for all German Stations, relayed from Heilsberg. 8.0, Announcements. 8.5, Poems which became Folk Songs, Concert by the Station Choir, the Children's Choir, and the Station Wind Instrument Orchestra; Soloists, Rolf Prarr (Baritone) and Wilhelm Strienz (Bass). 9.0, Ferdinand Avenarius Memorial Programme. 10.15, News. 10.40, Forthcoming Events. 10.50, Serenade and Dance Music, conducted by Eysoldt. 11.30 (approx.), Close Down.

LAUSANNE.—See Radio-Suisse Romande.

LEIPZIG

769.9 kc/s, 389.6 metres; 120 kW. Relayed by Dresden, 941 kc/s, 319 metres.—12 Noon, Concert by the Endé Orchestra: March (Schneider); Overture (Doppler); Waltz (Jos. Strauss); Suite, At the Circus (Armandola); Boston Waltz (Milde); Song without Words (Tchaikovsky); Intermezzo (Schmalstieg); Melodies from Frau Luna (Linke); Waltz Intermezzo (Mielich); Lied (Krome); Descriptive Piece (Klose); Waltz (Döring); Visione lirica (Mascagni); Selection from Das süsse Müdel (Reinhardt); Florentine Intermezzo (Waghalter); Paraphrase (Rhode); Bedouin Marsch (Oscheit). In an interval at 1.15 p.m., News and Programme Announcements. 2.15 News. 2.30, Art Review. 2.45, Notes for Tax-Payers. 3.0, Concert by the Leipzig Symphony Orchestra, conducted by Hilmar Weber: Overture, Im Walde (Brüll); Rossiniana Suite (Rossini-Respighi); Selection from Die toten augen (d'Albert); Three Pieces for Strings (Kranz); Slav Rhapsody in G Minor (Dvorak); Waltz from Der Rosenkavalier (Richard Strauss). In an interval at 3.35, Market Prices. 5.0, Reading of Lyrics (Ernst Droem). 5.20, Lute Recital by Hans Neemann: Sarabande in C Minor (Bach); Polonaise (Weiss); Suite (Viscé); Legend (Nowowiecki); Romance (Neemann); Melody (Czarnusheka). 6.0, Italian Lesson. 6.25, Talk: Salma Lagerlöf's Native Region. 6.45, Gramophone Records: Selection from the Peer Gynt Suite (Grieg); Im Kabiné (Grieg); Rustle of Spring (Sinding). 7.0, Transmission for all German Stations, relayed from Heilsberg. 8.0, Der alte Dessauer Operetta (Otto Findeisen), after Henschel's Play, Die Anna-Liese. 10.15, News. 10.45, See Frankfurt.

LINZ.—See Vienna.

LUXEMBOURG

252 kc/s, 1,191 metres; 200 kW.—12.30 p.m., Variety Music on Gramophone Records. 7.30 till Close Down, Dutch Evening. 7.30, The Fourth Symphony (Tchaikovsky), by the Concertgebouw Orchestra, conducted by Willem Mengelberg (on Gramophone Records). 8.15, Song Recital by Laure Lamb-Tronet: Air from Amdaig (Handel); Four Songs (Schubert); (a) An die Musik, (b) Wanderers Nachtlied, (c) An die Nachtligall, (d) Sölgkelt; Ingeborg's Lament from Prithhof-Szenen (Max Bruch); Maria Wiegand (Reger). 8.50, News in French. 9.0, Violin Recital by Jean Dörner: Sonata in A (Vivaldi); Variations on a Theme of Corelli (Tartini-Kreisler); Andante and Finale from the Concerto in C (Vivaldi-Kreisler). 9.45, News in German. 9.55, Concert from the Brasserie of the Pôle du Nord.

LWOW

788 kc/s, 381 metres; 16 kW.—7.20 p.m., Announcements and Gramophone Music. 7.35, Programme Announcements. 7.40, See Warsaw. 10.40, Gramophone Music. 11.0 (approx.), Close Down.

LYONS

LA DOUA, 644 kc/s, 465.8 metres; 1.5 kW.—7.30 p.m., Radio Gazette for Lyons and the

South-East. 7.40, Romeo and Juliet—Opera (Gounod), relayed from the Opera, Paris. After the Relay, News.

MADRID

ARANJUEZ, EAQ, 10,000 kc/s, 30 metres; 20 kW.—11.30 p.m., Popular Concert. In the interval at 11.45, Radio Chronicle. 12.35 a.m. (Saturday), Answers to Correspondents. 12.40, Spanish-American Programme. 1.0 (approx.), Close Down.

MADRID

EAJ7, 707 kc/s, 424.3 metres; 2 kW.—8.0 p.m., Chimes, Exchange, Radio Journal and Request Gramophone Records. 9.15, Topical Review. 9.30-11.0, Interval. 11.0, Chimes, Time Signal and Topical Review. 11.20 (approx.), Symphony Music on Gramophone Records: Overture, Figaro (Mozart); Selection from Goyescas (Granados); Le Chasseur maudit (César Franck); Symphony No. 2 in A (Brahms); Pianoforte Concerto (Chopin). 1.15 a.m. (Saturday), Topical Review, News and Programme Announcements for Listeners Abroad. 1.30, Chimes and Close Down.

MALMO.—See Stockholm.

MILAN.—See Turin.

MORAVSKA-OSTRAVA

1,137 kc/s, 263.8 metres; 11 kW.—2.50 p.m., Orchestral Concert, conducted by Plichta: Overture, La Princesse jaune (Saint-Saëns); Jeux d'enfants (Bizet); Ballad (Ondricek); Selection from Little Ida's Flowers (Klema); Waltz Intermezzo (Nedbal); Slovak Dance (Smatek); March (Kostal). 3.50 to 4.0, See Prague. 5.45, Gramophone Music. 5.55, Talk for Scouts. 6.5, Tourist Report. 6.15, See Prague. 7.10, Gramophone Music. 7.25 to 10.15, See Prague. 10.15 (approx.), Close Down.

MOSCOW

(TRADES UNION), 300 kc/s, 1,000 metres; 100 kW.—11.45 a.m., Weather. 2.45 p.m., Weather. 3.0, Ballakirev, Glinka and Rimsky-Korsakov Concert. 3.55, Time. 4.0, Topical Talk. 4.30, Talk: Foreign Revolutions in Literature and Music—The Nazi Revolution in Germany. 5.30, Programme for Children. 6.30, Mussorgsky and Glazunov Concert, relayed from the Radio Theatre. 9.0, News. 9.30, Programme Announcements. 9.55, Chimes from the Red Square. 10.5, Press Review.

MOTALA.—See Stockholm.

MUHLACKER.—See Stuttgart.

MUNICH

563 kc/s, 533 metres; 60 kW. Relayed by Augsburg and Kaiserslautern, 536 kc/s, 560 metres; and Nürnberg, 1,256 kc/s, 239 metres.—4.30 p.m. (from Nürnberg), Orchestral Concert, conducted by Willi Böhm: March, Weidmanns Heil (Beekling); Die Felsenmühle (Reissiger); Waltz, Dorfschwalben aus Oesterreich (Joh. Strauss); Flute Serenade (Roland); Potpourri, The Tyrol in Song and Dance (Fehrs); Paraphrase on the Song, Teure Heimat (Ach); Slawische Wachtparade (Linke); Gallop, Im D-Zug (Blon). 5.40, Talk: The Young People of Germany. 6.0, Quartet Concert: Overture, Flotte Bursche (Suppé); Potpourri, Soligo-Wiener Zeiten (Morena); Autumn Song (Beece); Im Märchenwald (Ganglberger); Waltz, Süsse Mädln (Rheinhardt); Spiel der Wellen (Rot-recht). 6.45, Time, Weather and Agricultural Report. 7.0, Transmission for all German Stations relayed from Heilsberg. 8.0, Symphony Concert by the Station Orchestra, conducted by Hans Winter. Soloist: Walter von Hoeszlin (Pianoforte). Pianoforte Concerto in D minor (Bach); Jugend-Symphonie (Beethoven). 8.50, Topical Talk. 9.10, Concert by the Small Station Orchestra, conducted by Erich Klosz: Overture, Le Brasseur de Preston (Adam); Three Pieces (Rachmaninov): (a) Elgie, (b) Serenade, (c) Prelude; Selection from Tannhäuser (Wagner); Münchener Kindl-Walzer (Komzak); Modern Dance Suite (Lautenschläger); Meditation (Scarsola); Träume der Nacht (Schmalstieg); March Intermezzo, Die kleinen Soldaten (Marks). 10.20, Time and News.

NAPLES.—See Rome.

NOTODDEN.—See Oslo.

OSLO

277 kc/s, 1,063 metres; 60 kW. Relayed by Fredrikstad, 820 kc/s, 365.8 metres; Hamar, 522 kc/s, 574.7 metres; Notodden, 671 kc/s, 447.1 metres; Porsgründ, 662 kc/s, 453.2 metres; and Rjukan, 671 kc/s, 447.1 metres.—5.0 p.m., Gramophone Music. In an interval at 5.40, Programme for Schools. 6.30, Political Talk. 7.0, News. 7.20, Introductory Talk on the following Relay. 7.50, See Paris (Eiffel Tower). In the interval at 8.30, Agricultural Notes. 9.20, News. 9.30, Johan Svendsen Programme. In the interval at 10.10, News. 11.0 (approx.), Close Down.

OSTERSUND.—See Stockholm.

PALERMO

558 kc/s, 537.6 metres; 3 kW.—3.0 p.m., Dopplavoro Announcements, Tourist Talk,



SEPT. 22nd

FRIDAY

continued

Agricultural Notes, Report of the Royal Geographical Society, and Giornale Radio. 8.20, Gramophone Music. In the interval at 8.30, Time and Announcements. 8.45, Concert of Opera Music, conducted by Russo. In the interval, Talk. 11.0, Giornale Radio.

PARIS

EIFFEL TOWER, Call FLE, 207.5 kc/s, 1,445.7 metres; 13 kW. Time Signals (on 2,650 metres) at 10.26 a.m. and 11.26 p.m. (Preliminary and 6-dot Signals). 6.45 p.m., Theatre Talk. 7.0, Le Journal Parle. 7.50, Romeo and Juliet Opera (Gounod) relayed from the Opera. 10.0 (approx.), Close Down.

PARIS

POST PARISIEN; 914 kc/s, 328.2 metres; 60 kW.—7.0 p.m., Gramophone Music. 7.5, Sponsored Talk. 7.15, Le Journal Parle. 7.30, Concert. 8.0, Agricultural Talk. 8.5, Songs on Gramophone Records; Aria from Prince Igor (Borodin); Lullaby from Sadko (Rimsky-Korsakov); Mexican Serenade (Ponce). 8.30, Two One-Act Operas: (a) Ronsard, Voisin (Ferdinand Poise); (b) Paille d'Avoine (Planquette). 10.15, News.

PARIS

RADIO PARIS, Call CFR, 174 kc/s, 1,725 metres; 75 kW. 7.30 a.m., Weather and Physical Culture. 7.45, Gramophone Music. 8.0, Weather and News. 12 Noon, Jewish Programme; Talk, Songs, and Sacred Music. 12.30 p.m., Military Music on Gramophone Records; Overture, Semiramis (Rossini); Selection from Maseurade (Lacome); Quadrille from La Mascotte (Audran); Two-Step, Espana (Bianco); Melody (Wittmann); Selection from Les deux pigeons (Messager); The Ride of the Valkyries, from The Valkyries (Wagner); Waltz (Andolf); Triana (Albioniz); Rondo (Weber); Dionysiaques (Schmitt). In the intervals at 1.0, Exchange, Announcements, and Weather, and at 1.30, Exchange. 2.0, Exchange and Announcements. 3.45, Exchange and Market Prices. 7.0, Agricultural Report. 7.10, Assurance Societies Reports. 7.20, Gramophone Music; Rhapsody in Blue (Gershwin); Melody (Spencer); Selection from A Waltz Dream (O. Strauss); Pluie de roses (Avignon); Melody (Dani); Nocturne (van Hoorebeke). 7.50, Romeo and Juliet—Opera (Gounod), relayed from the Opera. In the intervals, News and Talks.

PITTSBURGH

KDKA, 980 kc/s, 306 metres; 50 kW. Relay by W8XK on 48.86 metres and 25.27 metres.—8.15 p.m., Utility Hall. 8.30 to 9.30, New York Relay. 8.30, Words and Music. 8.45, Morin Sisters. 9.0, Gene Quaw Orchestra. 9.30, News and Markets Report. 9.45, Arcadius, from New York. 10.0, Uncle Tom and Betty. 10.15, Tarzan of the Apes. 10.30, The Singing Lady, from New York. 10.45, Orphan Annie, from New York. 11.0, News-Reeler. 11.15, Sport Notes and a Song. 11.30, Pittsburgh Spotlights. 11.45, Lowell Thomas, from New York. 12 Midnight, Amos 'n' Andy, from New York. 12.15 a.m. (Saturday), Silver Toppers. 12.30 to 1.45, New York Relay. 12.30, Lexington Hotel Orchestra. 1.0, Popular Programme. 1.30, Potash and Perlmutter. 1.45, Rocking Chair Memories. 2.0 to 3.30, New York Relay. 2.0, Let's Listen to Harris. 2.30, Variety Programme. 3.0, First Nighters.

PORSGRUND.—See Oslo.

PRAGUE

614 kc/s, 488.6 metres; 120 kW.—2.50 p.m., See Moravská-Ostrava. 3.50, Aviation Weather Report. 3.55, Exchange. 4.0 to 5.45, Interval. 5.45, Gramophone Music. 5.55, Talk: New Developments in Town-Planning. 6.5, Agricultural Programme and Market Prices. 6.15, Talk for Workers. 6.25, News in German. 6.30, German Transmission; Talk for Women and Talk on German-Jewish Humour. 7.0, Chimes and News. 7.10, Talk. 7.25, Tales of Czechoslovak Soldiers in Blatna (Garr-Menger). 8.25, Quartet in B flat, No. 9 (Mozart), by the Andriek Quartet. 9.0, Rozkosny Centenary Concert by the Station Orchestra. 10.0, Time, News, and Sports Notes. 10.15, News in Russian. 10.30, Close Down.

RADIO-SUISSE ROMANDE

SOTTENS, 743 kc/s, 403 metres; 25 kW.; and Geneva, 395 kc/s, 760 metres.—6.15 to 6.30 a.m., from Lausanne. Gymnastics. 12.28 p.m., Time Signal from Neuchâtel Observatory. 12.30, News and Weather. 12.40 (from Geneva), Gramophone Concert. 1.0 (from Geneva), Financial News. 1.10 (from Geneva), Gramophone Concert. 2.0 to 3.28, Interval. 3.28, Time Signal from Neuchâtel Observatory. 3.30 (from Geneva), Gramophone Concert. 4.30 (from Geneva), Programme for Women. 5.30 to 7.0, Interval. 7.0 (from Lausanne), Talk. 7.30 (from Lausanne), Announcements and News. 7.35 (from Lausanne), Answers to Correspondents. 8.0, Military Band Concert, relayed from London. 8.40 (from Lausanne), 'Cello Recital by Gasparini; Sonata in D (Locatelli); Lament (Magrini); Abendlied (Schumann); Spanish Dance (Popper). 9.15 (from Lausanne), Wine Festival Songs—a Lecture-Recital. 9.50, News and Weather. 10.0 (from Lausanne), Jazz Music, relayed

from the Hotel Splendide. 10.30 (approx.), Close Down.

REYKJAVIK

250 kc/s, 1,200 metres; 21 kW. 9.5 p.m., Musical Programme. 9.30, Weather. 9.40, Musical Programme and Announcements. 10.0, Chimes and News. 10.30, Reading. 11.0, Wind Instrument Quintet (Mozart) on Gramophone Records.

RIGA

572 kc/s, 525 metres; 15 kW. 6.0 p.m., Old Dance Music by the Y.M.C.A. Orchestra. 6.30, Medical Talk. 7.0, Weather Report. 7.5, Concert by the Station Orchestra, conducted by Medius; Prelude to Le Déluge (Saint-Saëns); Symphony in D minor (C. Franck); Overture, Coriolanus (Beethoven); Piano-forte Concerto in E flat (Beethoven); La Tragedie de Salomé (F.L. Schmitt). In the intervals at 8.0 and 9.0, News and Weather. 9.30, Dance Music. 10.30 (approx.), Close Down.

RJUKAN.—See Oslo.

ROME

Call IRO; 680 kc/s, 441 metres; 50 kW. Relay by Naples, 941 kc/s, 319 metres, and 2RO, 11,810 kc/s, 25.4 metres, from 5.15 p.m.; and Milan (Vigentino), 662 kc/s, 453.2 metres, from 8.15 p.m. (approx.).—12.30 p.m., Gramophone Music. 1.0 to 2.0 p.m., Concert by the Radio Orchestra. In the intervals from 1.30 to 1.45, Giornale Radio and Exchange. 2.0, Time and Announcements. 4.30, Giornale Radio and Exchange. 4.45, Children's Radio Review. 5.10, Weather. 5.15 to 6.0, Piano-forte and Song Recital by Bario Banca (Piano-forte), Guglielmo Bandini (Bass), and Margherita de Aentis (Soprano). Piano-forte Solo, The Harmonious Blacksmith (Handel); Bass Solos: (a) Morgen (Richard Strauss), (b) Ballad from Mephistopheles (Baito); Soprano Solos: (a) Toglietemi la vita (Scarlatto), (b) E tanto è il periodo che io si lasci (Wolf-Ferrari), (c) Aria from The Thieving Magpie (Rossini); Piano-forte Solos: (a) Prelude (Bajardi); Vagotte (Scambati); Etude in F (Chopin). 6.40 (Naples), Shipping and Sports Notes. 6.54, Dopolavoro Announcements and Tourist Talk. 6.57, Report of the International Institute of Agriculture (in Spanish, German, and French). 7.10, Agricultural Notes and Market Prices. 7.20, News in Foreign Languages. 7.40, Giornale Radio. 8.0, Time, Announcements, and Sports Notes. 8.15, Sponsored Concert. 9.15, Variety Concert. In the interval, Talk. 11.0, Giornale Radio.

SALZBURG.—See Vienna.

SCHENECTADY

WGY, 790 kc/s, 379.5 metres; 50 kW. Relay at intervals by W2XAF on 31.48 metres and by W2XAD on 19.56 metres.—9.0 p.m., Duets by Haber and Curtis. 9.15, May we present, from New York. 9.30, Talk: The Mind Age. 9.35 to 10.0 (approx.), South Sea Islanders, from New York. 12.45 a.m. (Saturday), Stock Reports and Baseball scores. 1.0, Concert, from New York. 1.30, WGY Farm Forum. 2.0, Musical Programme, from New York. 2.30, Popular Programme, from New York. 3.0, WGY Players. 3.30, Friday Night Sociable, from New York, followed by Programme Résumé.

SCHWEIZERISCHER LANDESENDER

BEROMUNSTER, 653 kc/s 459 metres; 60 kW.; Basle, 1,229 kc/s, 244.1 metres; and Berne, 1,220 kc/s, 245.9 metres.—6.15 a.m. (from Basle), Gymnastics. 6.35 to 11.59, Interval. 11.59, Time signal from Neuchâtel Observatory, and Weather. 12 noon (from Zürich), Orchestral Concert. In an interval at 12.30 p.m., Time, Weather and News. 1.25 (from Zürich), Time, Weather and Exchange. 1.30 to 5.0, Interval. 5.0 (from Zürich), Programme for Children. 5.30 (from Zürich), Concert by the Small Station Orchestra. 6.30 (from Berne), Talk: Changes in Education during the last Century. 7.0 (from Berne), Time, Weather, Market Prices, Tourist Report and Sports. Talk. 7.20 (from Berne), Gramophone Concert. 7.20 (from Berne), Gramophone Concert. 7.20, Concert by the Wireless Military Band, relayed from London. 8.40 (approx.) (from Berne), The Pathfinder—Radio Sequence, Rudolf Benard. 9.0, Weather and News. 9.10 (from Berne), Concert of Folk Music by the Löffler Quartet. 10.15 (approx.), Close Down.

SOTTENS.—See Radio-Suisse Romande.

STOCKHOLM

689 kc/s, 436 metres; 55 kW. Relay by Boden, 244 kc/s, 1,229.5 metres; Göteborg, 932 kc/s, 322 metres; Hörby, 1,166 kc/s, 257 metres; Motala, 221.5 kc/s, 1,354.4 metres; Östersund, 389 kc/s, 770 metres; and Sundsvall, 554 kc/s, 542 metres.—5.5 p.m., Programme for Children. 5.25, Provincial Programme, relayed from Eskilstuna, 1,220 kc/s, 245.9 metres. 6.0, Gramophone Music.

6.45, Talk on Swedish Literature, relayed from Uppsala, 662 kc/s, 453.2 metres. 7.15, Weather and News. 7.30, Talk on Foreign Politics. 7.50, See Paris (Eiffel Tower). 9.30, A Visit with the Microphone. 10.0, Concert by the Septiman String Ensemble: March (Peterson-Berger); Overture, The Magic Flute (Mozart); Waltz, Roses from the South (Joh. Strauss); Minnet and Serenade (Skold); Intermezzo (Ek); Angelus (Wenner-Beuter); Prayer and Temple Dance from Olav Trygvason (Grieg); Spanish Tango (Wenning). 11.0 (approx.), Close Down.

STRASBOURG

869 kc/s, 345 metres; 11.5 kW.—11.30 a.m., Gramophone Concert of Classical Music. 12.45 p.m., News. 1.0, Time and Exchange. 1.5, Orchestral Concert, conducted by Roskam; One-step, C'est la fille du moulin (Gavé); Potpourri of Viennese Waltzes (Morena); Intermezzo (Petras); Foxtrot, Man trägt rot wenn man verliebt ist; Idylle passionelle (Razigade); Tango, The Old Musical Box; Marta (Sitons); Potpourri, Von Wien durch die Welt (Hrbny); Slow Foxtrot, Let's try again (Newman and Jones); Foxtrot, My Sweet Virginia; One-step, I beg your Pardon. 2.0, Interval. 5.0, Literary Talk. 5.15, Orchestral Concert, conducted by Roskam; March (Lincke); Waltz, Deux à deux (Waldteufel); Dance of the Merry Mascoets (Kettelby); Overture, Czar and Carpenter (Lortzing); Selection from La fille de Madame Angot (Lecocq); Intermezzo, Patsy (Myddleton); Ballet Music, Excelsior (Maenno). 6.0, Concert by the Station Trio, relayed from Lille, 1,130 kc/s, 265.4 metres. 6.45, Topical Talk in German. 7.0, Lottery Results and Announcements. 7.30, Time and News. 7.45, Announcements. 7.50, Romeo and Juliet—Opera (Gounod), relayed from Paris. 11.0 (approx.), Press Review.

STUTT GART

MUHLACKER, 832 kc/s, 360.5 metres; 60 kW. Relay by Freiburg, 527 kc/s, 570 metres.—12 Noon, Song Recital by the Don Cossack Choir, on Gramophone Records. 12.30 p.m., Extracts from Othello—Opera (Verdi), on Gramophone Records. 1.15, Time and News. 1.30, Concert from Langenberg. 2.0, Concert arranged by the Post Office. 2.30, Advanced English Lesson. 3.0, Interval. 3.45, Talk: Sunday Excursions. 4.0, Interval. 4.30 (from Badenweiler), Orchestral Concert, conducted by Albert Hitzig; Overture, The Magic Flute (Mozart); Treasure Waltz from The Gipsy Baron (Joh. Strauss); Ballet Music from Rosamund (Schubert); Selection from The Mastersingers (Wagner); Serenade d'Amalfi (Beere); Two Scottish Dances (Langey); Potpourri, Hungaria (Leopold); March (Blankenburg). 5.45, Dialogue: Swabians To-day. 6.10, Legal Talk. 6.35, Time and News. 7.0, Transmission for all German Stations, relayed from Heilsberg. 8.0, See Frankfurt. 8.50, Reading from Johannes (Kortum). 9.20, Georg Schmitzke Literary Programme: Dialogue from Engel Hiltensperger; Reading from Das Duell; Recitations. 10.0, Time and News. 10.45, See Frankfurt. 12 Midnight, Close Down.

SUNDSVALL.—See Stockholm.

TOULOUSE

RADIOPHONIE DU MIDI, 779 kc/s, 385 metres; 8 kW.—6.0 p.m., News. 6.15, Light Music. 6.30, Operetta Music: Selections from (a) The Chocolate Soldier (O. Straus), (b) The Merry Widow (Lehár), (c) The Land of Smiles (Lehár). 6.45, Accordion Music. 7.0, Psyche Symphonie Poem (Franck), by the Symphony Orchestra. 7.15, News, Racing Results, Commercial Notes and Market News. 7.30, Opera Music: Arias from (a) Samson and Delilah (Saint-Saëns), (b) The Valkyrie (Wagner), (c) Il Trovatore (Verdi). 7.45, Music by a Viennese Orchestra: Serenade (Moszkovskya); Selection from The Arabian Nights (Strauss); Waltz (Amadei); Melody (Plessow); Anne Marie (Bochmann); Ballet Waltz (Zoubov); La nostra Serenata (Monti). 8.15, Chansonnettes. 8.30, Military Music. 8.45, Opera Music: Arias from (a) Lakmé (Delibes), (b) Cavalleria rusticana (Mascagni), (c) Tosca (Puccini). 9.0, Symphony Concert by the Casino Orchestra, conducted by Bathon, relayed from the Casino, Biarritz. In the intervals, Operetta Music: Arias from (a) Elle est à vous (Vvain), (b) Déshabillez-vous (Merleier), (c) Paganini (Lehár), (d) Le grand Mogol (Aulman). 10.0, Medical Talk. 10.15, North African News and Local News. 10.30, Programme for Listeners in Morocco: Sphärenklänge (Strauss); Waltz (Rosler); Sous les toits de Paris (Moretti); In a Clock Shop (Ortlb); Selection from Carmen (Bizet); March (Farrington). 11.0, Music by an Argentine Orchestra. 11.15, Dance Music. 12 Midnight, News, Weather and Announcements. 12.5 a.m. (Saturday), Orchestral Music: Old Spanish Song (Aubert); The Moldau (Smetana); La poupée d'Arlequin (Darcy); Selection from Sicilian Vespers (Verdi); Bourrée fantasque (Chabrier). 12.30, Close Down.

TRIESTE

1,211 kc/s, 247.7 metres; 10 kW.—5.10 p.m. till Close Down, See Turin.

TRONDHEIM.—See Oslo.

TURIN

1,096 kc/s, 273.7 metres; 7 kW. Relay by Milan, 905 kc/s, 331.5 metres; Genoa, 959 kc/s, 312.8 metres; and Florence, 599 kc/s, 500.8 metres.—5.10 p.m., Chamber Music. 6.0 to 6.5, Weather. 6.40, Giornale Radio, Dopolavoro Notes, and Gramophone Music. 7.0, Time, Report of the Royal Geographical Society, and Gramophone Music. 7.10, Agricultural Notes and Market Prices. 7.20, News in Foreign Languages. 7.40, Gramophone Music. 8.0, Announcements, Giornale Radio, Sports Notes, and Weather. 8.15, Symphony Concert, conducted by Daniele Amfitheatrof. In the interval, Talk. 10.0, Concert. 11.0, Giornale Radio.

VATICAN CITY

15,120 kc/s, 19.84 metres (Morning) and 5,969 kc/s, 50.26 metres (Evening); 10 kW.—11.0 to 11.15 a.m., Religious Information in German. 8.0 to 8.15 p.m., Religious Information in Italian.

VIENNA

581 kc/s, 517 metres; 100 kW. Relay by Graz, 852 kc/s, 352.1 metres; Innsbruck, 1,058 kc/s, 283 metres; Klagenfurt, 662 kc/s, 453.2 metres; Linz, 1,220 kc/s, 245.9 metres; and Salzburg, 1,373 kc/s, 218.5 metres.—12 Noon, Concert by the Wiener Symphoniker, conducted by Josef Holzner; March, Tschinn, Tschinn (Morawetz); Overture, Si j'étais Roi (Adam); Waltz from Bruder Lustig (Siegfried Wagner); Selection from Les Cloches de Corneville (Planquette); Waltz, Donaupeilen (Vollstedt); Spanish Barcarolle, Küss mich (Lehar); Polka, Die Libelle (Jos. Strauss); Thors Brautfahrt (Frederiksen); Suite: In the Circus (Armandola); Waltz, Regentropfen (Zichner); Gern geh' ich durch Wien (Flemming); Scenes from the Czardas (Hubay); Potpourri, Aus der Zeit der jungen Liebe (Komzak); Galop, Boboli (Gundel); in the interval at 1.0 p.m., Time and News. 2.0, Interval. 3.0, Time, Weather, Market Prices and Exchange. 3.20, Talk: The Mushroom and Fungi Exhibition in Vienna. 3.30, Talk: Eva Lessing. 3.55, Sound Film Music on Gramophone Records. 4.25, Talk: Russian Turkestan—The Country and People. 4.50, Talk: Neu-Waldsee. 5.15, Song and Piano-forte Recital by Hertz Glatz (Contralto), and Elvira Jung; Songs (Brahms); (a), Immer leiser wird mein Schlummer; (b), Von ewiger Liebe; (c), O liebliche Wangen; Songs (Wolf); (a), Auf einer Wanderung; (b), In der Frühe; (c), Verborgenheit; Songs (R. Strauss); (a), Georginen; (b), Traum durch die Dämmerung; Plantase-Etude (Georg Schumann); Sillhouette (Rege); Elegance (Vladigerov); Cake-Walk (Debusse); Negro Dance (Cyril Scott). 5.55, Tourist Report. 6.10, Talk: The European Championship of the Workers' Football Clubs. 6.25, Weekly Sports Report. 6.35, Talk: Prince Eugen. 7.15, Concert by the Wiener Symphoniker, conducted by Max Schönherr, Soloist, Jan Kiveron (Tenor); Miniatur Overture (Tchakovsky); Ländliche Suite (Kormann); Suite from The Taming of the Shrew (Zichner); Waltz, Vienna—Madrid (Klein). In the interval at 7.45, Time, Weather and Programme Announcements. 8.30, Autumn—Concert by the Wiener Symphoniker, conducted by Anton Konrath, the Opera House Choir, a Viennese Boys' Choir and Soloists; Erika Rokyta (Soprano), Hermann Galos (Tenor), and Karl Ettl (Bass); Overture, Im Herbst (Grieg); Herbstchor an Pau (Mars); Der geigende Eremit (Reger); Herbststurm (Unger); Autumn, from The Seasons (Haydn). 10.0, News. 10.15, Dance Music on Gramophone Records. After the Dance Music, News.

WARSAW

212.5 kc/s, 1,411 metres; 120 kW.—11.57 a.m., Time Signal and Fanfare from St. Mary's Church, Cracow. 12.5 p.m., Gramophone Music. In the intervals at 12.25, Press Review, and at 12.33, Weather. 12.55, Radio Journal. 1.0, Interval. 2.55, Gramophone Music. In the intervals at 3.5, News, at 3.25, Economic Notes, at 3.45, Aviation Report and Anti-Gas Drill, and at 3.55, Maritime and Colonial Report. 4.0, Concert by the Poznan Opera House Orchestra, conducted by Tylja, relayed from Ciechocinek. Overture, Der Geist des Wojewoden (Grossman); Waltz from Die Puppenfee (Bayer); Selection from Cavalleria rusticana (Mascagni); Hungarian Dances, Nos. 5 and 6 (Brahms); Selection from Polenlied (Neubal). 5.0, Book Review. 5.15, Gramophone Music. 6.15, Talk: Poland To-day. 6.35, Soprano and 'Cello Recital by Olga Lada (Soprano) and Altenberg ('Cello). Plaisir d'Amour (Martini); A quelli begli occhi (Mozart); Scotch Songs (Beethoven); Largo (Handel); Lullaby (Reger); Georgian Song (Rachmaninov); Ave Maria (Symbalinski). 7.30, Miscellaneous Items. 7.35, Programme Announcements. 7.40, Topical Talk. 8.0, Concert by the Station Symphony Orchestra. Soloist: Krongold (Violin). 8.50, Radio Journal. 9.0, Hints for the Week-end. 9.10, Concert (contd.). 10.0, Dance Music from the Ziemianska Café. In the intervals at 10.25, Sports Notes, and at 10.35, Weather and Police Notes. ZURICH.—See Schweizerischer Landessender.



**ATHLONE**

725 kc/s, 413 metres; 60 kW. Relayed by Cork, 1,337 kc/s, 224.4 metres.—1.30 to 2.30 p.m., Time, Weather, Stock Report, and Gramophone Records. 4.0, Artistic Band concert; Soloist, J. C. Doyle (Baritone). 6.0, Gramophone Music. 6.45, News. 7.0, Talk. 7.15, Gaelic Talk. 7.30, Time. Signal. 7.32, The Station Orchestra. 8.5, Traditional Fiddle Solos by T. J. Small. 8.20, Tenor Solos by F. Walsh. 8.30, Flute Solos by MacNamara. 8.45, Original Sketches and Songs by John McDonagh and Company. 9.30 to 10.30, Programme by the I.B.C. (Ireland), Ltd. 9.30, Dance Music: What a Perfect Combination; The Village Band; The Song of the Slave; Hyde Park Corner; Song of the Harp; Tony's Wife; No More Love; Da dar, Da dar. 10.0, Concert arranged by the International Broadcasting Company (Ireland), Ltd., on behalf of Hospitals' Trust, Ltd.: Signature Tune, Come back to Erin; Waltz, Acclamations (Waldteufel); Ich liebe dich (Grieg); Bells across the Meadows (Kettelbey); Violin Solo, Caprice viennois (Kreisler); Devotion (Kettelbey); Golliwog's Cake Walk (Debussy); Moonlight on the Alster (Petras); Signature Tune. 10.19, I.B.C. Goodnight Melody.

**BARCELONA**

EAJ1, 860 kc/s, 348.8 metres; 8 kW.—7.0 p.m., Trio Concert: Rocco Minuet (Haydn); Song (Filipucci); Selection from Siegfried (Wagner); Pastorale (Lovreglio); A Wedding Day on Troldhaugen (Grieg); Larghetto (Delmas); Selection from Cavalleria rusticana (Mascagni). 8.0, Request Gramophone Records. 8.20, Exchange. 9.0, Gramophone Music. 9.15, Anti-War Talk. Gramophone Music and News. 10.0, Chimes from the Cathedral. Weather, Exchange and Market Prices. 9.15, Concert by the Station Orchestra. 11.0, Pianoforte Recital by Rosaura Coma. 11.30, Dance Music, relayed from the Casa Libre. In the interval at 12.0 Midnight, News. 1.0 a.m. (Sunday), Close Down.

**BARI**

1,112 kc/s, 269.8 metres; 20 kW.—See Rome.

**BASLE**.—See Schweizerischer Landessender.

**BELGRADE**

697 kc/s, 430.4 metres; 2.8 kW.—4.0 p.m., Gramophone Music. 4.45, Orchestral Concert. 6.55, Time Signal and Programme Announcements. 7.0, Address. 7.30, Recital of Yugoslav Songs. 8.0, Dramatic Programme. 8.30, Concert. 10.30, Time and News. 10.40 (approx.). Dance Music on Gramophone Records.

**BERLIN**

**DEUTSCHLANDSENDER (REICHSSENDER)**, 183.5 kc/s, 1,635 metres; 60 kW. 1.45 p.m., News. 2.0 Gramophone Music. 3.0, Hand-work for Children. 3.30, Weather and Exchange. 3.45, Reading. 4.0, See Hamburg. 5.0, Review of the Week's Sport. 5.20, Dance Music by Ralph Siegel and his Soloists. 6.0, Poems. 6.5, Dance Music (contd.). 6.15, Topical Talk. 6.30, Week-end Salad—Radio Play. 6.50, Weather and News. 7.0, Transmission for all German Stations, relayed from Munich. 8.0, To-day's Motto. 8.15 (approx.), Film Magic—Cinema Programme. 10.0, Weather and News. 10.45, Weather for Shipping. 11.0, Dance Music from Leipzig. 12 Midnight, Close Down.

**BERLIN**

**FUNKSTUNDE**, 715 kc/s, 419.5 metres; 1.5 kW.—4.0 p.m., Light Music and Dance Music by a Military Band, relayed from the Krollgarten. In an interval, Talk: Sailing as a Sport. 5.20, Schneidehül—Radio Report on a Frontier Town. 5.50, Community Singing from Schneidehül (on Gramophone Records). 6.0, Extracts from the Sonata in G minor—Op. 13—the Pathetic (Beethoven) by Else Kraus. 6.20, Talk: Folk Customs. 6.40, The Funkstunde informs its Listeners. 6.45, Topical Talk. 7.0, Transmission for all German Stations, relayed from Munich. 8.5, Bunter Abend. In the interval at 10.0 (approx.), Weather and News. 1.0 a.m. (Sunday), Close Down.

**BERNE**.—See Schweizerischer Landessender.

**BEROMUNSTER**.—See Schweizerischer Landessender.

**BODEN**.—See Stockholm.

**BODO**.—See Oslo.

**BORDEAUX-LAFAYETTE**

386 kc/s, 304 metres; 13 kW.—6.15 p.m., Radio Journal. 7.40, Sports Talk. 7.45, News and Market Prices. 8.0, Symphony Concert, relayed from London. 9.30, Gramophone Concert.

**BRATISLAVA**

1,076 kc/s, 279 metres; 11 kW.—7.0 p.m., See Prague. 7.30, A Sketch in Dialect, relayed from Kosice, 1,022 kc/s, 293 metres. 7.55, See Brno. 8.45, See Prague. 9.20, See Moravská-Ostrava. 10.0, See Prague. 10.15, Concert by the Station Orchestra. 11.30 (approx.), Close Down.

**BREMEN**.—See Hamburg.

**SATURDAY**

SEPTEMBER THE TWENTY-THIRD

**PRINCIPAL EVENTS OF THE DAY:**

**AT HOME**

- NATIONAL LONDON REGIONAL** Promenade concert from Queen's Hall. New Songs for Old, a programme of comparisons.
- MIDLAND REGIONAL NORTH REGIONAL WEST REGIONAL SCOTTISH REGIONAL BELFAST** Choral concert from the Ulster Hall.
- ATHLONE** 10.0 p.m. Concert on behalf of Hospitals' Trust Ltd.
- BARCELONA** 7.0 p.m. Trio concert.
- HAMBURG** 8.10 p.m. Gala concert, by the Philharmonic Orchestra.
- HEILSBURG** 4.0 p.m. The Small Station Orchestra, conducted by Eugen Wilcken.
- LANGENBERG** 5.30 p.m. Violin and Pianoforte recital.
- PALERMO** 8.45 p.m. Operetta: "The Merry Widow," by Lehár.
- ROME** 8.45 p.m. Opera: "Il Pirata," by Bellini.
- STRASBOURG** 5.0 p.m. Orchestral concert, conducted by M. de Villers.
- WARSAW** 9.30 p.m. Chopin recital.

**ABROAD**

by the Station Symphony Orchestra, conducted by Meulemans: Fantasia on a Wallon Theme (Ysaye); Piece (Donizetti); Extract from Masaniello (Auber); Wedding March (Quintet); Patrie (Paladilhe); Goodbye (Tosti). 8.45, Talk. 9.0, Concert (contd.): Extracts from Le Maître à danser (Rasse); Wallonia (Guillaume); Scene and March from L'Apothéose de la Wallonie; Finale from Jean Michel (Dupuis). 10.0, Le Journal Parlé.

**BRUSSELS (No. 2)**

**N.I.R.**, 887 kc/s, 338.2 metres; 15 kW.—Programme in Flemish. 12 Noon, Concert by the Small Station Orchestra, conducted by Leemans: March soennelle (Tchaikovsky); Waltz Suite from Eva (Lehár); Little Grey Home in the West (Lohr); Selection from Hans the Flute Player (Ganne); Pianoforte Solo: Polonaise (Chopin); Scènes napolitaines (Massenet); Printemps d'amour (Kalkman); Selection from Sunny. 1.0 p.m., Le Journal Parlé. 1.10, Gramophone Concert. 5.0, Dance Music, relayed from the Saint-Sauveur Palais de Danse. 6.0, Gramophone Records, with Commentary: Le Chasseur Mandit (Frank); L'apprenti sorcier (Dukas). 6.45, Request Gramophone Concert. 7.30, Agricultural Notes. 8.0, Gramophone Records: Baba Yaga (Liadov); Plainte (d'Hervelois); Prelude and Napolitaine (d'Hervelois); Scherzo from the Irish Symphony (Hamilton Harty); Londonderry Air (arr. Hamilton Harty). 8.20, Quintet for Wind Instruments (Khughart). 8.45, Recitations. 9.0, Concert of Sixteenth Century Dutch Songs by the Schola Cantorum, conducted by Eugène van der Velde. 9.20, Wind Instrument Quintet (d'Haeyer). 9.40, Choral Concert (contd.). 10.0, Le Journal Parlé.

**BUCHAREST**

761 kc/s, 394 metres; 12 kW.—5.0 p.m., Concert of Variety Music by the Sibiceanu Orchestra. 6.0, Radio Journal. 6.15, Concert (contd.). 7.0, Educational Programme. In the interval from 7.20 to 7.40, Instrumental Music on Gramophone Records. 8.0, Zither Duets. 8.30, Song Recital by Emilie Gatiannu. 9.0, Talk. 9.15, Concert of Popular Romanian Music by the Fania Orchestra. 9.45, Radio Journal.

**BUDAPEST**

545 kc/s, 550.5 metres; 18.5 kW. Also relayed on 840 metres from 7.45 till Close Down.—5.0 p.m., Chopin Pianoforte Recital by Mile. Marik: Nocturne in F sharp; Etude in B minor; Etude in C sharp; Sonata in B minor. 5.30, Answers to Correspondence. 6.0, Hungarian Folk Song Recital by Nany, accompanied by the Inre Magyar Cigány Band. 7.15, Talk. 7.45, Concert by the Budapest Concert Orchestra, conducted by Fridl; Overture, Mignon (Thomas); Waltz, Dolores (Waldteufel); Potpourri (Huszka);

Ballet Suite (Goldmark); Potpourri (Szabados). 9.0, News and Sports Report. 9.15, Variety Concert. 10.15 (in an interval), Weather. 11.0, Concert by the Karl Bura Cigány Band, relayed from the Ketter Restaurant.

**CASSEL**.—See Frankfurt.

**COPENHAGEN**

1,067 kc/s, 281 metres; 0.75 kW. Relayed by Kalundborg, 260 kc/s, 1,153.8 metres.—12 Noon, Time and Chimes from the Town Hall. 12.5 p.m., String Ensemble Concert, relayed from the Wivex Restaurant. 2.0, Interval. 2.30, Gramophone Music. 3.0, Programme for Children. 3.20, Concert by the Radio Orchestra, conducted by Emil Reesen. Soloist: Karl Poulsen (Songs). March, Entry of the Boyards (Halvorsen); Overture, Alessandro Stradella (Flotow); Waltz, Soir d'été (Waldteufel); Miniature Suite (Rosenberg); Dances from The Bartered Bride (Smetana); French Military March (arr. Reesen); Five Danish Songs; Overture, Romeo and Juliet (Bellini); Fantasia on Jutland Melodies (arr. Reesen); Two Hungarian Dances (Brahms); (a) No. 5 in G Minor, (b) No. 6 in D; Norwegian Bridal Procession (Grieg); Melody from Scènes alsaciennes (Massenet). 5.20, Exchange and Fish Market Prices. 5.45, Talk. 6.15, French Lesson. 6.45, Weather and Announcements. 7.0, News. 7.15, Time Signal. 7.20, Talk: Lord Kitchener. 8.0, Chimes from the Town Hall. 8.5, Modern Music by Louis Preil's Instrumental Ensemble. In the intervals at 8.20 and 9.0, Readings. 9.35, Songs by Fritz Berger. 9.50, Modern Music by Louis Preil's Instrumental Ensemble. 10.10, News. 10.25, Modern Music (contd.). 10.40, Humorous Monologues on Gramophone Records. 10.55, Modern Music (contd.). In the interval at 11.15, The Five Syncopators. 12 Midnight, Time and Chimes from the Town Hall.

**CORK**.—See Athlone.

**DANZIG**.—See Heilsberg.

**DRESDEN**.—See Leipzig.

**FECAMP**

1,328 kc/s, 225.9 metres; 10 kW.—11.0 a.m. to 12 Noon, Programme arranged by the I.B.C. 11.0, Happy Hour: Part I. Orchestral Concert: Signature Tune; Snacks in Bars (Agner); Chinatown, my Chinatown (Schwartz); When the Lilac blooms again (Rotter); Xylophone Solo, Gold Fishes (Kroeger); In the Night (Tate); Vienna, Vienna (Foss); Pianoforte Solo, Butterflies in the Rain (Myers); Valencia (Padilla); Part II. Dance Music: Meet me in the gloaming; My Love Song; Hold Me; Talking to you about me; You're mine, you; In a Second Hand Store; The Shadow Waltz; Peter, Peter; Signature Tune. 12 Noon, French Programme. 4.30 to 6.30, Programme arranged by the I.B.C. 4.30, Programme for Children. 5.0, Concert for Tunbridge Wells and Thanet Listeners: Members Request Half Hour: Signature Tune, The Night by the Sea; Overture, Zampa (Hérold); Hawaiian Love (Gaston); Song, The Mountains of Mourne (French); Sleepy Valley (Hanley); Song, O dem Golden Slippers (Bland); Waltz from Bitter Sweet (Noel Coward); Song, Father O'Flynn (Trad.); Barcarolle (Offenbach). 5.30, Concert for Dover and Folkestone Listeners: Military Band Music: The Mad Major (Alford); Song, If I were King (Coslow); Carry on (Dundas); Cupid's Army (Sievier); Signature Tune. 5.45, Concert, Special Requests: Liebestrend (Kreisler); Réve angélique (Godard); Liebesleid (Kreisler). 6.0, French Programme. 11.0 till Close Down, Programme arranged by the I.B.C. 11.0, Talkie Time: Signature Tune, Sittin' in the Dark; Monte Carlo Medley (Robin); Paris, stay the same; City Lights; You are my Heart's delight (Lehar); There's something about a soldier (Gay); Whoopie Medley (Kahn); Love Songs of the Nile; Selection from the Show Boat (Kern); Signature Tune. 11.30, Concert arranged by the International Broadcasting Company (Ireland), Ltd., on behalf of Hospitals' Trust, Ltd.: Signature Tune, Come back to Erin; Rakey March (Berlioz); The Last Rose of Summer (Moore); Prelude and Mazurka from Coppélia (Delibes); Violin Solo, Chanson bohémienne (Baldy); Hungarian Dance No. 6 (Brahms); Morning from Peer Gynt (Grieg); My little Irish Cottage (Summers); Old Spanish Song (Albert); Signature Tune. 12.5 a.m. (Sunday), Late News Bulletin. 12.50 (approx.), Club Concert for Sutton-in-Ashfield Listeners: Signature Tune, The Chum Song; How are you (Pola); The Lady I Love (Young); Balloons (Magine); My heart's to let (Waller); Roll along Kentucky Moon (Halley); This is the Rhythm for me (Monkman); Hiawatha's Lullaby (Donaldson); Little Miss Muffett (Perritt); Adorable (Marion); Goodnight but not Goodbye (Michael); Just an Echo in the Valley (Woods); Any time, any day, anywhere (Young); Dancing Butterfly (Young); Signature Tune. 1.0, Dance Music: Signature Tune, Bells of Normandy; My Bluebird singing the Blues (Robin); Let's all be happy together (Thomas); Hold Me (Schuster); Stay out of my dreams (Washington); Peter, Peter (Connelly); The Old Spinning-Wheel (Hill); Farewell to Arms (Wrubel); Spanish Eyes (Kester); Letting in

SEPT. 23rd

SATURDAY

continued

le Sunshine; Drifting Down the Shalimar; A woman should stick to her man; Twelfth Street Rag; Smilin' through; I wish I had Wings (Woods); Meet me in the Gloaming (Goodhart); Signature Tune. 2.0, Good-night Melody and Close Down.

LENSBURG.—See Hamburg.

LORENCE.—See Turin.

FRANKFURT

1,157 kc/s, 259.3 metres; 17 kW. Relayed by Jassel, 1,220 kc/s, 245.9 metres; and Trier, 1,157 kc/s, 259.3 metres.—12 Noon, Concert on Gramophone Records: Selection from Iagoletto (Verdi); Death of Mimi from La Bohème (Puccini); Aria from I Pagliacci (Leoncavallo); Air from Cavalleria rusticana (Mascagni); Selection from Don Carlos (Verdi); Aria from Der Evangelinam (Kienzl); Aria from La Traviata (Verdi); Ballad from The Flying Dutchman (Wagner); Elizabeth's Prayer from Tannhäuser (Wagner); Air from Madame Butterfly (Puccini). 1.15 p.m., News and Weather. 3.30, Concert, relayed from Langenberg. In an interval at 2.0, News. 3.30, Variety Programme. 3.10, Time and Economic Notes. 3.30, Programme for Young People. 4.30, Concert by the Station Orchestra: Programme of Light Music. 5.0, Talk by Carl Cornelius for the Hundred and Fiftieth Anniversary of the Birth of Peter von Cornelius. 5.25, Time and Announcements. 6.30, Review of the Week. 6.50, Today's News. 7.0, Transmission for all German Stations, relayed from Munich. 8.0, Talk on Albrecht Dürer. 8.30, See Stuttgart. 10.0, Topical Talk. 10.20, Time and News. 11.0, Concert from Leipzig.

FREDRIKSSTAD.—See Oslo.

FREIBURG.—See Stuttgart.

GENEVA.—See Radio-Suisse Romande.

GENOA.—See Turin.

GLEIWITZ.—See Breslau.

GOTEBORG.—See Stockholm.

GRAZ.—See Vienna.

HAMAR.—See Oslo.

HAMBURG

306 kc/s, 372 metres; 1.5 kW. Relayed by Brauen, 1,112 kc/s, 269.8 metres; Flensburg, 1,310 kc/s, 227.4 metres; Hanover, 530 kc/s, 566 metres; and Kiel, 1,292 kc/s, 232.2 metres.—4.0 p.m., Concert by the Hamburg Philharmonic Orchestra, conducted by Gerard Maassz: Overture, Abu Hassan (Weber); Ballet Music from Undine (Lortzing); Selection from The Merry Wives of Windsor (Nicolaï); March from Le Cid (Cornelius); Overture, The Taming of the Shrew (Goetz); Scherzo, Und wenn die Welt voll Teufel wär (S. Wagner); Overture, Gaudemann (Humperdinck). 5.0, Exciting Stories. 5.20, Variety Programme. 6.30, (from Kiel), Religious Address. 6.50, Weather. 7.0, Transmission for all German Stations, relayed from Munich. 8.0, Political Address. 8.10, Gala Concert by the Hamburg Philharmonic Orchestra, the Male Voice and the Women's Quartet, and Soloists; Introductory Talk by Fritz Pauli. 9.50, Topical Talk. 10.0, Time and News. 10.20, Concert from Berlin (Funkstunde). 1.0 a.m. (Sunday), Close Down.

HANOVER.—See Hamburg.

HEILSBURG

1,085 kc/s, 276.5 metres; 60 kW. Relayed by Danzig, 662 kc/s, 453.2 metres.—11.30 a.m., Concert by the Königsberg Opera House Orchestra, conducted by Georg Wöllner; Auf treue Kameradschaft (Blankenburg); Selection from Zigeunerprimas (Kálmán); Valse chromatique (Kockert); Overture, Gri-Gri (Lincke); On the Banks of the Nile (Platen); Waltz from Faust (Gounod); Potpourri, From A to Z (Geiger); Florentine March (Fueik). 1.5 p.m., Gramophone Concert. In the intervals at 1.20 and 2.0, News. 2.30, Programme arranged by the Post Office with Gramophone Records. 3.0, Agricultural Prices and Exchange Rates. 3.30, Handicrafts for Children. 4.0, Concert by the Small Station Orchestra, conducted by Eugen Wilcken; March, Deutschland voran (Rust); Overture, Carnival in Rome (Joh. Strauss); Suite, From Southern Spheres (Fresco); Berceuse (Dvorak); Dance (Dvorak); Selection from The Little Dutch Girl (Kálmán); Czardas, Rosza (Hubay); Serenade (Schubert); Waltz, Etincelles (Waldteufel); Dulcissima (Schirmer). In the interval at 4.50 (approx.), A.D.A.C. Road Report. 5.45, Monthly Report of Sports in East Prussia. 6.5, Programme Announcements. 6.15, Agricultural Prices. 6.20, Organ Recital by Walter Hanft, relayed from a Church in Danzig. 6.50, Weather. 7.0, Transmission for all German Stations, relayed from Munich. 8.0, News. 8.10, Variety Programme. 10.10, News. 10.30 (approx.), Dance Music relayed from Berlin (Funkstunde). 12.30 a.m. (Sunday), Close Down.

HILVERSUM

Announced HUIZEN, 1,013 kc/s, 296.1 metres; 7 kW. (until 5.40 p.m.) and 20 kW. from 5.40 p.m. Programme of the Catholic Radio Society (K.R.O.).—11.55 a.m., Concert by the K.R.O. Sextet: 'Heut' bin ich so vergnügt (Lettow); Aubade d'amour (Monti); Waltz, Frühlingsstimmen (Joh. Strauss); Ballet Air (Massenet);

Blumengeflüster (Blon); Song of Spring (Stabel); Gramophone Music; Kaveewarmarhe (Maas); Overture, Light Cavalry (Suppé); Puppenwalzer (Bayer); Melody (Ackermans); Finale. 1.25, Interval. 1.40, Programme for Young People. 2.10, Programme for Children. 3.40, Gramophone Music. 4.10, Concert by the K.R.O. Orchestra, conducted by J. Wond; Overture, Karnival im Rom (Strauss); Three Elfing Dances (Waldo-Warner); Andaluca (Popy); Lortzing Potpourri (Lortzing); Overture, Paragraph 3 (Suppé); Nachklänge aus Ossian (Gade); Selection from Madame Butterfly (Puccini); Puppenwalzer (Bayer); Suite, The Three Bears (Coates); In a Fairy Realm (Kettelbey); Waltz, Potpourri (Robrecht). In the intervals at 4.55, News in Esperanto, at 6.0, Press Review, and 6.40, Police Report. 7.5, Talk. 7.25, Gramophone Music. 7.30, Talk on the Esperanto Course. 7.40, Gramophone Music. 7.65, Talk. 7.55, Concert by the K.R.O. Boys, conducted by Lustenbower; After To-night we say Goodbye (Towers); Selection from Der Geist des Wajwodin (Grossman); Wir sind ja so fidel (Strasky). 8.10, News. 8.15, Concert (cont'd.): Süssliches Feuer (Grosslay); In Grinzang (Sieczynski); Die Mühle im Tale (Rhode). 7.30, Recitations. 8.40, Gramophone Music. 8.55, Concert (cont'd.): Edelweiss (Raymond); Potpourri (Clere); Shadow Waltz (Warren); Melody (Chapuis). 9.25, Recitations. 9.35, Concert (cont'd.): Potpourri of Sound Film and Operetta Music (Dostal). 9.50, Gramophone Music. 10.0, Recitations. 10.10, News. 10.15, Concert (cont'd.): Ein jeder hat mal Glück (Schubert); Waltz, Lotosblumen (Ohlsen); Ich suche Liebe (Buder); So tanze schon der Groszpa (Krome); Finale. 10.40, Gramophone Music. 11.40 (approx.), Close Down.

HORBY.—See Stockholm.

HUIZEN

Announced HILVERSUM, 160 kc/s, 1,875 metres; 7 kW. (until 5.40 p.m.). Transmitted from Kootwijk on 50 kW. from 3.40 p.m. Programme of the Workers' Radio Society (V.A.R.A.).—11.40 a.m., Concert by De Notenkrans Orchestra, conducted by Wins, Vindobona (Schrammel); Schafwalzer (Strauss); Non tamo pin (Tosti); Réve (Leoncavallo); A petits pas (Sudess); Hallo, hier Wien (Morena); Gramophone Music; Zaragossa (Grosos); Ich hab' einen Mann, der mich liebt (Abraham); Du bist so wunderschön, Dolores (Valerio); Selection from The Czaryvitch (Lehár); Gramophone Music; Nocturne (Tchaikovsky); Nur wer die Sehnsucht kennt (Tchaikovsky); Polish Dance (Scharwenka); Two Guitars (Horlick); Gramophone Music; Was die Donna erzählt (Morena). 1.40, Gramophone Music. 2.10, Concert by De Eliefluiters, conducted by Ray Forest. Soloist: Esther Philijse (Song-S). 2.40, Mouth Organ Recital. 2.55, Orchestral Concert (cont'd.). 3.25, Interval. 3.40, Organ and Song Recital by Steyn and Chamon. 3.55, Concert by the V.A.R.A. Mandoline Orchestra, conducted by Kok. 4.10, Organ and Song Recital (cont'd.). 4.25, Concert by a Mandoline Orchestra (cont'd.). 4.40, Programme for Children. 5.0, Literary Talk. 5.40, Concert by the V.A.R.A. Young People's Choir, conducted by Tiggers. 6.10, Concert by Pirotigbas Orchestra, conducted by Carlquist. In the interval at 6.40, Gramophone Music. 7.10, Gramophone Music. 7.40, S.O.S. Announcements. 7.42, News and Announcements. 7.55, Concert by the V.A.R.A. Orchestra, conducted by de Groot; Overture, Flotte Bursche (Suppé); Die eine Frau (Kornegold); Chant sans paroles (Tchaikovsky); Dorfkindewalzer (Kálmán); Een vroedijge baal (Clere); Dreams on the Ocean (Gungl); Chinesische Strassenseenade (Siede); A petits pas (Sudess); Selection from Lilac Time (Schubert-Berté). In the interval at 8.25, Gramophone Music. 9.40, Dramatic Programme. 9.55, Concert by the V.A.R.A. Orchestra, conducted by de Groot. In the interval at 10.20, Gramophone Music. 10.55, Gramophone Music. 11.10, Organ Recital by Jong. 11.40 (approx.), Close Down.

INNSBRUCK.—See Vienna.

KALUNDBORG.—See Copenhagen.

KATOWICE

734 kc/s, 408 metres; 16 kW.—7.25 p.m., Announcements and Gramophone Music. 7.40, See Warsaw. 9.15, Press Review, relayed from Wilno, 533 kc/s, 553 metres. 9.30, See Warsaw. 11.30, Dance Music.

KIEL.—See Hamburg.

KLAGENFURT.—See Vienna.

KOSICE.—See Prague.

LANGENBERG

635 kc/s, 473 metres; 60 kW.—12 Noon, Broadcast for Schools. 12.30 p.m., Concert by the Fröliche Fünf. 1.15, News. 1.30, Concert by the Station Orchestra, conducted by Kühn; March, Einig und tren (Stahl); Overture, Czar and Carpenter (Lortzing);

Hungarian Dances (Brahms); Waltz, Nordseebilder (Joh. Strauss); Polonaise from Eugene Onegin (Tchaikovsky); Selection from Eine Nacht in Venedig (Joh. Strauss); March, Junges Deutschland (Bachmann). In the interval at 2.0 (approx.), News. 2.30, Gramophone Concert. 3.30, Economic Notes and Time. 3.50, Talk on Gardening. 4.10, Talk; Excursions in the Rhineland and Westphalia. 4.30, Talk; Is Not Necessary to a People? 5.0, Concert of Folk Songs by the Station Choir and Heinz Schleichel (Tenor); Conductor, Josef Brener. 5.30, Violin and Pianoforte Recital by Therese Sarata-Kuermann and Egbert Graepel (Sarasate); Garmen Waltzes and Ländler (Schubert); Mazurka in A flat (Chopin); Minuet (Mozart); Ländler and Waltz (Weber); Improvmtu in E flat (Schubert); Mazurka in A flat (Chopin); Die Biene (Schubert); Suite, My Country (Smetana); Minute Waltz (Chopin); Piano-forte Solo: Wiener Blut (Strauss-Schyllt-Gröpe). 6.15, German for Germans. 6.25, Talk on The Racial Question. 6.45, Announcements. 7.0, Transmission for all German Stations, relayed from Munich. 8.0, Announcements. 8.5, Dance Music, conducted by Eysoldt. 8.45, Variety Concert relayed from the Municipal Concert Hall, Düsseldorf. 10.15, News. 12 Midnight (approx.), Close Down.

LAUSANNE.—See Radio-Suisse Romande.

LEIPZIG

769.9 kc/s, 389.6 metres; 120 kW. Relayed by Dresden, 941 kc/s, 319 metres.—12.55 p.m., Concert by the Station Orchestra, conducted by Blumer. 1.15, News and Programme Announcements. 1.30, Gramophone Concert: Der Zirkus kommt (Rust); Tales from the Vienna Woods (Strauss); Roses from the South (Strauss); Puppe and Kolofid (Armandola); Melody (Valentin); Foxtrot (Steele); Parody, Ans Schlagschlagwerkstatt; Tyrolse Ländler; Tango (Sorge); Tango (Böhmlert); Potpourri of Student Songs; Humorous Piece (Lommel); Fensterpromenade (Mohr); Der Radfahrer (Mapp); Tyrolse Folk Songs; Gallop, Bahn frei (Ed. Strauss). 2.45, Programme for Children. 3.30, Music Review. 3.45, Economic Notes. 4.0, See Hamburg. 5.0, Talk: Animal Pictures. 5.20, Talk; Curious Names and their Meaning. 5.40, Choral Music on Gramophone Records; Chorus from Iphigenia in Aulis (Glück); Drei Sterne (Weber); Three Choral Pieces (Schein); (a) Je länger, je lieber. (b) Vergissmichnicht. (c) Die Macht der Phyllis; Bleib deutsch, du herrlich Land am Rhein (Hausen); Rüdelsheimer Wein (Hausen); Scheiden (Wohlgemuth). 6.0, A Modern Dictionary. 6.20, String Quartet in C, Op. 76 (Haydn), by the Reitz Quartet, relayed from Weimar. 6.50, Today's News. 7.0, Transmission for all German Stations, relayed from Munich. 8.0, See Munich. 10.5, News. 10.30 (approx.), Dance Music by the Emde Orchestra. 12 Midnight, Close Down.

LINZ.—See Vienna.

LUXEMBOURG

252 kc/s, 1,191 metres; 200 kW.—12.30 p.m., Concert by the Station Orchestra, conducted by Henri Pénis; Overture, Boccaccio (Suppé); Selection from The Tales of Hoffmann (Offenbach); Waltz, Roses from the South (Joh. Strauss); Egyptian Serenade, Amiba (Lüeke); Intermezzo from Cavalleria Rusticana (Mascagni); Selection from Die Fledermaus (Joh. Strauss); Circus March (Maassz). 1.30, Gramophone Concert. 7.30 till Close Down, French Programme. 7.30, Gramophone Concert of Variety Music. 8.10, Talk on Saint-Saëns. 8.20, Tenor Song Recital by Schœckel, La profession (France); Aria from Le roi d'Ys (Lalo); Aria from Manon (Massenet); Si vous l'aviez compris (Denza); Flower Aria from Carmen (Bizet). 8.50, News in French. 9.0, Concert of French Music by the Station Orchestra, conducted by Henri Pénis. Soloist, Jean Dax (Pianoforte). Pianoforte Concerto No. 3 (Saint-Saëns); Suite No. 2 from L'Arlesienne (Bizet). 9.45, News in German. 9.55, Concert by the Station Orchestra, conducted by Henri Pénis; Waltz, Morgenblätter (Joh. Strauss); Moment musical (Schubert); Hexentanz (MacDowell); The Flight of the Bumble Bee (Rimsky-Korsakov); Selection from White Horse Inn (Stolz-Benatzky). 10.30, Songs on Gramophone Records. 11.0, Dance Music by the Station Jazz Band, conducted by Ferry Jusa.

LWOW

788 kc/s, 381 metres; 16 kW. 7.25 p.m., Programme Announcements. 7.30, Announcements and Gramophone Music. 7.45, See Warsaw. 8.0, Gramophone Music. 8.15, Military Programme. 8.45, Programme relayed from Warsaw. 12.0 Midnight (approx.), Close Down.

LYONS

LA DOUA, 644 kc/s, 465.8 metres; 1.5 kW.—7.30 p.m., Radio Gazette for Lyons and the South-East. 8.30, Programme relayed from Paris (Ecole Supérieure), 671 kc/s (447.1 metres). After the Relay, News Bulletin.

MADRID

ARANJUEZ; EAQ; 10,000 kc/s, 30 metres; 20 kW.—7.0 to 9.0 p.m., Programme for Listeners in the Canary Islands, Guinea, and Europe. 7.0, Concert of Popular Music. 8.15, Talk. 8.30, Light Music. 9.0 to 11.30, Interval. 11.30, Popular Concert. In the interval at 11.45, Radio Chronicle. 12.45 a.m. (Sunday), Light Music. 1.0 (approx.), Close Down.

MADRID

EAJ7, 707 kc/s, 424.3 metres; 2 kW.—8.0 p.m., Chimes, Exchange, Radio Journal and Request Gramophone Records. 9.15, Topical Review. 9.30 to 11.0, Interval. 11.0, Chimes, Time Signal and Topical Review. 11.20 (approx.), El rey que Mabilo—Musical Comedy (Chapi). In the interval, Literary Talk. 1.15 a.m. (Sunday), Topical Review and News. 1.30, Chimes and Close Down.

MALMO.—See Stockholm.

MILAN.—See Turin.

MORAVSKA-OSTRAVA

1,137 kc/s, 263.8 metres; 11 kW.—2.50 p.m., Police Band Concert: March (Hervert); Polka (Poncar); Waltz (Fueik); March (Leopold); Waltz, The Sailor's Return (Petrzilka); National Guards' March (Pellik); Czech Potpourri (Taborsky); My Girl, where are you going? (Voldan). 5.45, Gramophone Music. 5.55, Talk. 6.5, Trio Concert, relayed from Opava. 6.25, Talk: The Care of the Teeth. 6.35, Light Music. 7.0, See Prague. 7.30, A Sketch in Dialect, relayed from Kosice, 1,022 kc/s, 293 metres. 7.55, See Brno. 8.45, See Prague. 9.20, Literary Programme. 10.0, See Prague. 10.15, See Bratislava. 11.30 (approx.), Close Down.

MOSCOW

(TRADES UNION), 300 kc/s, 1,000 metres; 100 kW.—11.45 a.m., Weather. 2.45 p.m., Weather. 3.0, Extracts from Carmen—Opera (Bizet). 3.55, Time. 4.0, Topical Talk. 4.30, Literary Programme. 5.30, Musical Programme by Amateurs. 6.30, Concert of Ballet Music. 9.0, News. 9.30, Programme Announcements. 9.55, Chimes from the Red Square. 10.5, Press Review.

MOTALA.—See Stockholm.

MUHLACKER.—See Stuttgart.

MUNICH

563 kc/s, 533 metres; 60 kW. Relayed by Augsburg and Kaiserlautern, 536 kc/s, 560 metres, and Nürnberg, 1,756 kc/s, 239 metres.—4.30 p.m., Concert by the Station Orchestra, conducted by Karl List. Soloist: Josef Machoi (Xylophone). Overture, Si j'étais roi (Adam); The Skaters' Waltz (Wahlteufel); Xylophone Solo; Stelldichein (Aelter); Piece for Trombone and Piccolo; Elefant und Mücke (Kling); Waltz, Moonlight on the Aster (Fetras); Xylophone Solo; Huttenleben auf den Alpen (Kling); Famous Marches. 5.45 (from Nürnberg), Franconia—a Radio Sequence for Young People (Artur Kuhnert). 6.15, Trio (Klaas), for Pianoforte, Violin and Cello. 6.45, Wireless Talk. 7.0, Transmission for all German Stations. Berechtigungsspenden in the Bavarian Alps—Programme relayed from Adolf Hitler's Sommer Residence (arr. Kühne-Helmsens). 8.0, Part-Relay from the Munich Autumn Festival. 10.0, Austria. 10.26, Time and News. 11.0, Concert from Leipzig. 12 Midnight (approx.), Close Down.

NAPLES.—See Rome.

NOTODDEN.—See Oslo.

OSLO

277 kc/s, 1,083 metres; 60 kW. Relayed by Fredrikstad, 820 kc/s, 365.8 metres; Hamar, 522 kc/s, 574.7 metres; Notodden, 671 kc/s, 447.1 metres; Porsgrund, 662 kc/s, 453.2 metres; and Rjukan, 671 kc/s, 447.1 metres.—4.15 p.m., Concert by the Station Orchestra, conducted by Hugo Kramm; Invitation to the Waltz (Weber); Overture, Die schöne Galathee (Suppé); Rocco Suite (Raif); Romance (Svendsen); Crescendo (Lasson); Waltz (Mackeben); Salut d'amour (Elgar); Carnival March (Friml). 5.15, Programme for Children. 6.15, Norwegian Melodies by Erling Krogh (Tenor), and Eivind Groven (Hardanger Fiddle). 6.45, Talk on Economic News. 7.0, News. 7.30, Interview with a Librarian: What the Public Reads. 8.0, Time Signal. 8.1, Revue, relayed from the Black Cat Theatre. In the intervals, News and Topical Talk. 10.45, Dance Music on Gramophone Records. 12 Midnight (approx.), Close Down.

OSTERSUND.—See Stockholm.

PALERMO

558 kc/s, 537.6 metres; 3 kW.—8.0 p.m., Dopolarovo Announcements, Tourist Talk, Agricultural Notes and Giornale Radio. 8.20, Sports Talk. 8.25, Gramophone Music. 8.30, Time and Announcements. 8.45, The Merry Widow—Operetta in Three Acts (Lehár). In the intervals: Book Review and Announcements. After the Operetta: Giornale Radio.

PARIS

EIFFEL TOWER, Call FLE. 207.5 kc/s, 1,445.7 metres; 13 kW. Time Signals (on 2,650 metres) at 10.26 a.m. and 11.26 p.m.

SEPT. 23rd

SATURDAY

continued

(Preliminary and 6-dot Signals).—6.45 p.m., Theatre Talk. 7.0, Le Journal Parlé. 8.0, Promenade Concert, relayed from London. 9.30, Les pieds nickelés—Comedy in One Act (Tristan Bernard). 10.0 (approx.), Close Down.

PARIS

POSTE PARISIEN, 914 kc/s, 328.2 metres; 60 kW.—7.0 p.m., Gramophone Music: Aria from Don Giovanni (Mozart); Melody (Musorgsky); Hopak (Musorgsky). 7.15, Le Journal Parlé. 7.30, Film Review. 8.0, Talk: The Event of the Week. 8.30, Concert. 9.10, Dance Music by the Sonora Radio Band, conducted by Fred Hoffmann. 11.0, News.

PARIS

RADIO-PARIS, Call CFR, 174 kc/s, 1,725 metres; 75 kW.—7.30 a.m., Weather and Physical Culture. 7.45, Gramophone Music. 8.0, Weather and News. 12.0 Noon, Gramophone Concert: Pluie d'or (Waldteufel), Marquita (Schertzinger); Fascination (Marchetti); Funiculi, Funicula (Denza); ça c'est Paris (Padilla); Sans rien dire (Legay-Moselle); La Violettera (Padilla); Place blanche (Mele-Graven); Melody (Boyer); Contantimpe (Carlton); Singing in the Rain (Herb-Brown); Parlez-moi d'amour (Lénoir); Je sais que vous êtes jolie (Christine); Rose mounse (Bose); It's you (Richman); Ay! Ay! Ay! (Freire); El Relicario (Padilla); La Czarine (Ganne); Scherherazade (Sternmann); Joution (Fischer); Dinah! (Aks); Dance of the Hours (Priva); Sérénade (Toselli); Ramona (Wayne); Valencia (Padilla). In the interval at 1.0, Exchange, Announcements and Weather, and at 1.30, Exchange. 2.0, Exchange. 3.45, Exchange and Market Prices. 7.0, Agricultural Report. 7.10, Gramophone Concert: March from Sigurd Jönsdóttir (Grieg); Donauwälder (Janovici); Rigodon (Lacome); Honolulu (Yvain); Etincelles (Waldteufel); Melody (Valente); Etude in G Flat (Zubalov); Melody (Feret); Blonde amie (Carcel); Autour du Moulin (Feret); Pastel (Paradis); Lullaby from Mignon (Thomas); Melody (Rubinstein); La valeur française. 7.50, Commercial Notes and News. 8.0, Gramophone Concert: Vieux airs limousins (Ronchand); Chinese serenade (Siede); Campana a terra (Bili); Santiago (Cubier); Selection from Le Jour et la nuit (Lecocq); Spring Song (Mendelssohn); Hopak (Musorgsky). 8.30, News, Weather and Sports Notes. 8.40, Le Petit Duc—Opérette (Audran) relayed from the Théâtre de la Porte Saint-Martin. In the interval, News and Announcements.

PITTSBURGH

KDKA, 980 kc/s, 306 metres; 50 kW. Relayed by WXXK on 48.86 metres and 25.27 metres.—7.30 to 11.0 p.m., New York Relay. 7.30, Concert Echoes. 8.0, Words and Music. 8.30, Wealth of Harmony. 9.0, Dance Masters. 9.30, Concert Favorites. 10.0, Casino Orchestra. 10.30, Neil Sisters. 10.45, Orphan Annie. 11.0, News and Piano Classics. 11.15, Sports Notes and a Song. 11.30, A Recreo by Bill and Alex. 11.45 to 12.30 a.m. (Sunday), New York Relay. 11.45, A Century of Progress. 12 Midnight, Ross Pearson, Baritone. 12.15, Ethel Waters. 12.30, Huston Ray's Orchestra. 1.0 to 3.15, New York Relay. 1.0, Jack Denny's Orchestra. 1.30, Brown and Lewellyn. 1.45, Annie, Judy, and Zeke. 2.0, Tales of the Titans. 2.30, Jamboree. 3.15, Behind the Law.

PORSGRUND.—See Oslo.

PRAGUE

614 kc/s, 488.6 metres; 120 kW.—2.50 p.m., See Moravská-Ostrava. 3.55, Aviation Weather Report. 4.0, Interval. 5.45, Talk. 5.55, Talk. 6.5, Agricultural Programme. 6.15, Talk for Workers. 6.25, News in German. 6.30, German Transmission: Concert for Young People. 7.0, Chimes and News. 7.10, Medical Talk. 7.30, A Sketch in Dialect relayed from Kosice. 1.022 kc/s, 293 metres. 7.55, See Brno. 8.45, Dialogue: An Adventurous Tour (Rossler). 9.20, See Moravská-Ostrava. 10.0, Time Signal, News and Sports Notes. 10.15, See Bratislava. 11.30, Close Down.

RADIO-SUISSE ROMANDE

SOTTENS, 743 kc/s, 403 metres; 25 kW.; and Geneva, 395 kc/s, 760 metres.—6.15 to 6.30 a.m. (from Lausanne), Gymnastics. 11.45, Report on the Start of the Walking Tour round Lake Geneva. 12.28 p.m., Time Signal from Neuchâtel Observatory. 12.30, News and Weather. 12.40 (from Geneva), Gramophone Music. 1.0 (from Geneva), Financial News. 1.10 (from Geneva), Gramophone Concert. 2.0, Report on the Walking Tour, relayed from Morges. 3.28, Time Signal from Neuchâtel Observatory. 3.30 (from Geneva), Gramophone Music. 5.0, Report on the Walking Tour, relayed from

Nyon. 5.50 to 7.0, Interval. 7.0 (from Lausanne), Talk: The Blind. 7.30 (from Geneva), Talk: A Walking Tour round Lake Geneva. 8.0, Concert of Light Music by the Radio Suisse Romande Orchestra, conducted by Echemard. 9.0 (from Lausanne), Opera Arias by Gustave Dutoit (Bass). 9.20 (from Lausanne), Saxophone Solos. 9.50, News and Weather. 10.0 (from Lausanne), Dance Music, relayed from the Hotel Splendide. 10.50 (approx.), Close Down.

REYKJAVIK

1,200 metres; 21 kW.—9.5 p.m., Musical Programme. 9.30, Weather. 9.40, Musical Programme and Announcements. 10.0, Chimes and News. 10.30, Reading. 11.0, Concert by the Station Quartet, followed by Choral Music on Gramophone Records. After the Programme, Dance Music. 2.0 a.m. (Sunday), Close Down.

RIGA

572 kc/s, 525 metres; 15 kW.—4.40 p.m., Faust, Opera (Gounod). In the intervals at 6.10, French Lesson. 6.40, Agricultural Talk and 7.10, Weather Report. 8.0, News. 8.20, Italian Guitar Duets. 8.45, Recital of Latvian Songs by Irma Kalhins. 9.0, Weather and News. 9.15, Humorous Programme. 9.40, Dance Music. 11.0 (approx.), Close Down.

RJUKAH.—See Oslo.

ROME

Call 1R0, 680 kc/s, 441 metres; 50 kW. Relayed by Naples, 941 kc/s, 319 metres; and 2R0, 11,810 kc/s, 25.4 metres, from 5.15 p.m. (approx.), and Milan (Vigentino), 662 kc/s, 453.2 metres, from 8.45 p.m.—12.20 p.m., Gramophone Records. 1.0, Gramophone Concert. In the interval from 1.30 to 1.45, Giornale Radio and Exchange. 2.0, Time and Announcements. 4.30, Giornale Radio and Report of the Royal Geographical Society. 4.45, Children's Radio Review. 5.10, Weather. 5.15 to 6.0, Orchestral Concert. 6.40 (Naples), Shipping and Sports Notes. 6.45, Lesson in Morse and Dopplavoro Notes. 7.0, Tourist Report. 7.10, Agricultural Report. 7.20, News in Foreign Languages. 7.40, Giornale Radio. 8.0, Time and Announcements. 8.15, Violin Recital. 8.30, Giornale Radio and Sports Notes. 8.45, Il Pirata—Opera in Two Acts (Bellini). In the interval, Humorous Talk and Announcements. Giornale Radio after the Programme.

SALZBURG.—See Vienna.

SCHENECTADY

WGY, 790 kc/s, 379.5 metres; 50 kW. Relayed at intervals by WZXF on 31.48 metres, and by WZXD on 19.56 metres.—12.45 a.m. (Sunday), Stock Reports and Baseball Scores. 1.0 to 4.0, New York Relay. 1.0, Soloist. 1.15, The Rollickers. 1.30, Sous les ponts de Paris. 2.0, Autobal's Cubans. 2.30, K-7 Secret Service Spy Story. 3.0, Saturday Night Dancing Party with B. A. Rolfe and his Orchestra. 4.0, Programme Resumé.

SCHWEIZERISCHER LANDESENDER

BEROMUNSTER, 653 kc/s, 459 metres; 60 kW.; Basle, 1,229 kc/s, 244.1 metres; and Berne, 1,220 kc/s, 245.9 metres.—11.59 a.m., Time Signal from Neuchâtel Observatory and Weather. 12 Noon (from Berne), Slav Music on Gramophone Records. 12.30 p.m., Time, Weather and News. 12.40 (from Berne), Recital of Yodels on Gramophone Records. 1.25, Time, Weather and Exchange. 1.30 (from Basle), The Letter Box. 1.45 (from Basle), Review of Books on Music. 2.15 (from Basle), Folk Songs by a Schoolgirls' Choir. 2.45 (from Basle), Programme of Alsatian Music and Poetry. 3.30 to 5.0, Interval. 5.0 (from Basle), Accordion Concert. 5.30 (from Basle), Wind Instrument Concert on Gramophone Records. 6.0 (from Basle), Talk by a Blind Man: From Darkness to Light. 6.30 (from Basle), Programme for Women. 7.0, Chimes from Zürich Churches. 7.15 (from Basle), Time, Weather and Announcements. 7.20 (from Basle), Opera and Opérette Music on Gramophone Records. 7.40 (from Basle), Vocal Duets. 8.10 (from Basle), Talk on Wireless. 8.40 (from Basle), Light Music on Gramophone Records. 9.0, Weather and News. 9.10 (from Basle), Amors Guekkä-ten Opérette in One Act (J. B. Michaelis). 10.15 (from Basle), Dance Music on Gramophone Records. 11.0 (approx.), Close Down.

SOTTENS.—See Radio-Suisse Romande.

STOCKHOLM

689 kc/s, 436 metres; 55 kW. Relayed by Boden, 244 kc/s, 1,229.5 metres; Göteborg, 932 kc/s, 222 metres; Hörby, 1,166 kc/s, 257 metres; Motala, 221.5 kc/s, 1,354.4 metres; Östersund, 389 kc/s, 770 metres; and Sundsvall, 554 kc/s, 542 metres.—4.0 p.m. (from Göteborg), Orchestral Concert: Overture, Fingal's Cave (Mendelssohn); Waltz from Der Rosenkavalier (R. Strauss); Violin Solo: Sérénade, Bimba Mia (Coda); Selection from A Waltz Dream (O. Strauss); Slav Dance No. 10 (Dvorák); Waltz, Tanzrausch (Schmalstieg); Tango, Heut' nacht hab ich geträumt von dir (Kálmán). 5.55, Programme for Children. 5.30, Accordion Music from Eskilstuna, 1,220 kc/s, 453.2 metres. 6.0, Diakogue. 6.15, Gramophone Music. 7.15, Weather and News. 7.30, Old Dance Music. 8.15, Talk. 8.45, Musical Programme. 9.45, Weather and News. 10.0, Dance Music. 11.0 (approx.), Close Down.

STRASBOURG

869 kc/s, 345 metres; 11.5 kW.—11.30 a.m., Variety Music on Gramophone Records. 12.45 p.m., News. 1.0, Time. 1.1, Popular Music on Gramophone Records. 2.0, Legal Talk in German. 2.15, Opera Music on Gramophone Records. 2.45, Talk, Chabrier's Piano-forte Music. 3.0, Interval. 4.0, Opérette Music on Gramophone Records: Selection from Ciboulette (Halévy); Two Airs from La Basoche (Messager); Selection from Les mousquetaires au Convent (Varney); Two Airs from Le petit Duc (Lecocq); Air from Les Saltimbanques (Ganne); Selection from Véronique (Messager); Selection from Rip (Planquette); Two Airs from Ciboulette (Halévy); Selection from Miss Decima (Andran). 5.0, Orchestral Concert, conducted by Maurice de Villers: Entr'acte from Messidor (Bruncan); Scandinavian Symphony (Casadesu); Symphony for Viola and Orchestra, Harold en Italie (Berlioz); Overture, The Mastersingers (Wagner). 6.15, French Elocution Lesson. 6.30, Gramophone Music. 6.45, Talk on Aviation. 7.0, Agricultural Talk in German. 7.15, Lottery Results and Announcements. 7.30, Time and News. 7.45, Press Review in German and Gramophone Music. 8.0, Promenade Concert, relayed from London. 9.45, Press Review. 9.55, Dance Music on Gramophone Records. 10.30, Dance Music, relayed from the Savoy. 12 Midnight (approx.), Close Down.

STUTTGART

MUHLACKER, 832 kc/s, 360.5 metres; 60 kW. Relayed by Freiburg, 527 kc/s, 573 metres.—12.20 p.m., A Non-Stop Flight round the World—Gramophone Concert. 2.30, Time and News. 2.50, Talk. 3.0, Concert of Swiss Songs: Schweizerpsalm (Zwysig); An das Vaterland (Baumgartner); Schweizer Heimwehtraum (Walser-Rossov); Potpourri of Swiss Alpine Songs, Grässe aus den Schweizeralpen (Ruh). 3.30 (from Mannheim), Programme for Young People. 4.30, Concert from Munich. 5.45, Talk: A Walk in Transylvania. 6.35, Time and News. 7.0, Transmission for all German Stations, relayed from Munich. 8.0, Concert. 8.30, Robert and Bertina—Humorous Radio Play with Songs (Raeder). 10.0, See Munich. 10.20, Time and News. 10.30 (approx.), Gramophone Music. 11.0, Dance Music, relayed from Leipzig. 12 Midnight, Close Down.

SUNDSVALL.—See Stockholm.

TOULOUSE

RADIOPHONIE DU MIDI, 779 kc/s, 385 metres; 8 kW.—6.0 p.m., News. 6.15, Light Orchestral Music. 6.30, Music from Sound Films. 6.45, Opera Music: Hungarian March from The Danubian of Mendelssohn (Wagner); Wedding Scene from Lohengrin (Wagner); Polonaise from Boris Godunov (Musorgsky). 7.0, Accordion Music. 7.15, News, Racing Results, Market Prices and Exchange. 7.30, Fete du Couronnement de la Muse (Charpentier), by the Symphony Orchestra. 7.45, Music by a Viennese Orchestra. 8.15, Light Music. 8.30, Military Music. 8.45, Opera Music: Arias from (a) Griseldis (Massenet), (b) The Valkyrie (Wagner), (c) Faust (Gounod). 9.0, Mendelssohn Concert: Overture, A Midsummer Night's Dream; Wedding March from A Midsummer Night's Dream; Overture, Fingal's Cave; Spring Song; Song without Words; Scherzo; On Wings of Song; Trio in D Minor; Rondo capriccioso. After the Concert, Tango Songs. 10.0, Organ Music. 10.15, North-African News and Local News. 10.30, Concert for Listeners in Morocco; Souvenirs classiques; Aria from

Louise (Charpentier); Selection from Morning, Noon and Night (Suppé); Ils étaient en pyjama (Borel Clerc); American March (Souza). 11.0, Music from Sound Films. 11.15, Dance Music. 12 Midnight, News Weather and Announcements. 12.15 a.m. (Sunday), Orchestral Concert: Selection from The Desert Song (Romberg); The Distant Sound of Bagpipes (Weinberger); Spins (Poppy); Selection from La princesse jaune (Saint-Saëns); Ronde villageoise (Chabrier). 12.30, Close Down.

TRIESTE

1,211 kc/s, 247.7 metres; 10 kW.—5.20 p.m. till Close Down, See Turin.

TRONDHEIM.—See Oslo.

TURIN

1,096 kc/s, 273.7 metres; 7 kW. Relayed by Milan, 905 kc/s, 331.5 metres; Cenoa, 956 kc/s, 312.8 metres; and Florence, 599 kc/s, 500.8 metres.—5.20 p.m., Gramophone Music. 6.0 to 6.5, Weather. 6.40, Giornale Radio Talk, Gramophone Music and Dopplavoro Announcements. 7.0, Time, Tourist Report and Gramophone Music. 7.10, Agricoltura Notes and Market Prices. 7.20, News in Foreign Languages. 7.40, Gramophone Music. 8.0, Announcements, Giornale Radio, Sports Notes, Weather and Gramophone Music. 8.25, Talk: Events and Problems. 8.40, Variety Programme. In the interval, Book Review. 11.0, Giornale Radio.

VATICAN CITY

15,120 kc/s, 19.84 metres (Morning), and 5,969 kc/s, 50.26 metres (Evening); 10 kW.—11.0 to 11.15 a.m., Religious Announcement in Various Languages. 8.0 to 8.15 p.m., Religious Information in Italian.

VIENNA

581 kc/s, 517 metres; 100 kW. Relayed by Graz, 852 kc/s, 352.1 metres; Innsbruck, 1,057 kc/s, 283 metres; Klagenfurt, 662 kc/s, 453.2 metres; Linz, 1,220 kc/s, 245.9 metres; and Salzburg, 1,373 kc/s, 218.5 metres.—11.30 a.m. Gramophone Concert. Gesang Weylas (Wolf); Valentine's Aria from Faust (Gounod); Aria from Eugene Onegin (Tchaikovsky); Aria from Tosca (Puccini); Waltz, Op. 42 (Chopin); Aria from The Peat Fishers (Bizet). 11.55, Weather. 12 Noon Wind Instrument Concert. 1.0 p.m., Time and News. 1.10, Concert (contd.). 2.0 to 3.0 Interval. 3.0, Time, Weather and Exchange. 3.15, The Liberation of Vienna—A Prize Winning Radio Play (Dessey and Strobl) with Musical Interludes. 5.45, Talk, with Gramophone Illustrations: A Lett Festival. 6.15, Technical Wireless Talk. 6.30, Topical Talk. 7.0, To-day's Motto. 7.5, Piano-forte Recital by Dr. Paul Weingarten. 7.50, Time, Weather, Sports Notes and Programme Announcements. 8.0, The Immortal Franz—Four Pictures (Bittner and Dessey), with Music by Schubert: (a) Per aspera, (b) An Brunnen vor dem Tore, (c) Die schöne Müllerin, (d) Ad Astra. 10.0, News. 10.15, Dance Music, relayed from the Oase. After the Programme, Announcements.

WARSAW

212.5 kc/s, 1,411 metres; 120 kW.—11.57 a.m., Time Signal and Fanfare from Torun for the 700th Anniversary of the Town. 12.5 p.m., Gramophone Music. In the interval at 12.25, Press Review, and at 12.33, Weather. 12.55, Radio Journal. 1.0, Interval. 2.55, Gramophone Music. In the intervals at 3.5, News, and at 3.25, Economic Notes. 4.0, Programme for Invalids, relayed from Lwow, 788 kc/s (381 metres). 4.30, Gramophone Records. 5.0, Topical Talk. 5.15, Light Music from the Gastronomia Café. 6.10, Talk: Sobieski and the Castle of Olesk, relayed from Lwow. 6.30, Violin Recital by Lidia Kmita: Reverie (Mozusko-Meleer); Slav Dance in C Minor (Dvorák); Valse joyeuse (Prozanski); Two Pieces (Kreisler); (a) Liebeslied, (b) Schön Rosmarin. 7.0, Miscellaneous Items 7.15, The Retreat and the Last Post, relayed from a Regimental Celebration at Gheln. 7.40, Programme Announcements. 7.45, Reading from Lord Jim (Conrad). 8.0, Concert by the Station Orchestra: Soloist: Mme. Makowska (Song); Comedy Overture (Keler Bela); Stephanie Gavotte (Czibulka); Gorkis (Namyslowski); Songs: Overture, Dames of Hussards (Jonota); Boston from Schön ist die Welt (Lehár); Song; Waltz, Frühlingsstimmen (Strauss); Cardas, from Countess Maritza (Kálmán); Pavane (Majottti); Mazurka (Namyslowski). 9.5, Radio Journal. 10.15, Press Review, relayed from Wilno, 533 kc/s (563 metres). 9.30, Chopin Recital: Sonata in B Minor; Nocturne in G, Op. 15; Waltz in E Minor. 10.0, Dance Music from the Oza Dance Hall. In the intervals at 10.25, Sports Notes, and at 10.35, Weather and Police Notes.

ZURICH.—See Schweizerischer Landessender.

Printed for the Publishers, ILIFFE & SONS LTD., Dorset House, Stamford Street, London, S.E.1, by The Cornwall Press Ltd., Paris Garden, Stamford Street, London, S.E.1.

UNITED STATES—The International News Co., 131, Varick Street, New York. FRANCE—W. H. Smith & Son, 248, Rue Rivoli, Paris; Hachette et Cie., Rue Réaumur, Paris. BELGIUM—W. H. Smith and Son, 71-75, Boulevard Adolphe Max, Brussels. INDIA—A. H. Wheeler & Co., Bombay, Allahabad and Calcutta. SOUTH AFRICA—Central News Agency, Ltd., AUSTRALIA—Gordon & Gotch, Ltd., Melbourne (Victoria), Sydney (N.S.W.), Brisbane (Queensland), Adelaide (S.A.), Perth (W.A.), and Launceston (Tasmania). CANADA—The American News Co., Ltd., Toronto, Winnipeg, Vancouver, Montreal, Ottawa, St. John, Halifax, Hamilton; Gordon & Gotch, Ltd., Toronto; Imperial News Co., Toronto, Montreal, Winnipeg, Vancouver, Victoria. NEW ZEALAND—Gordon & Gotch, Ltd., Wellington, Auckland, Christchurch and Dunedin.





**The ALL-METAL WAY 1934**

**3<sup>d</sup>**

brings you that essential guide to A.C. mains working..

**"THE ALL-METAL WAY"**

Send to Dept. W.W.

**The WESTINGHOUSE**

**BRAKE & SAXBY SIGNAL CO<sup>LD</sup>**

82, YORK ROAD, LONDON, N.1



**This B.S.R. 60 Watt Amplifier**  
gives an undistorted output of

**15 Watts**



B.S.R. Amplifiers are supplied in standard types from 25 to 120 Watts, and special models are manufactured for individual needs. We specialise in P.A. Equipment of every description for the indoor and outdoor operation of any number of loud speakers, us'2 microphone, gram, and radio as desired. Workmanship and performance of the highest order, and prices keenly competitive. Special treatment for export without extra cost.

Write for Lists, sent post free.  
**BIRMINGHAM SOUND REPRODUCERS LTD.,**  
CLAREMONT WORKS, OLD HILL, STAFFS.

Phone: Cradley Heath 6370.  
Grams: "Electronic, Old Hill."

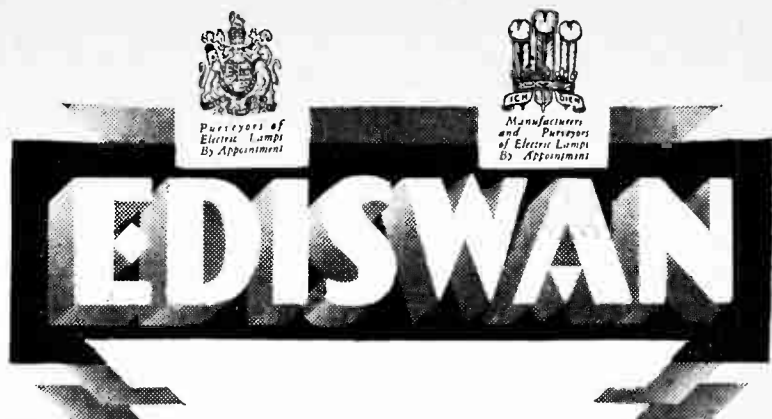

This Ediswan H.T. Battery cell reveals the secrets of extra H.T. service

A brass cap tightly affixed to the carbon rod forms the positive connection.

The cell is sealed by means of a waxed washer over which paraffin wax is poured. This washer assists in centralising the sac in the cell.

An air space is left between the top of the sac and the washer to allow for the expansion of the electrolyte during discharge.

A substantial zinc container which forms the negative pole of the cell.

The sac consists of a highly efficient depolariser, tightly compressed round the carbon rod, the whole being securely wrapped and tied.

Electrolytic paste of a special chemical composition which fills the space between sac and zinc container and activates the cell.

A waxed paper disc which insulates the sac from the bottom of the zinc container.

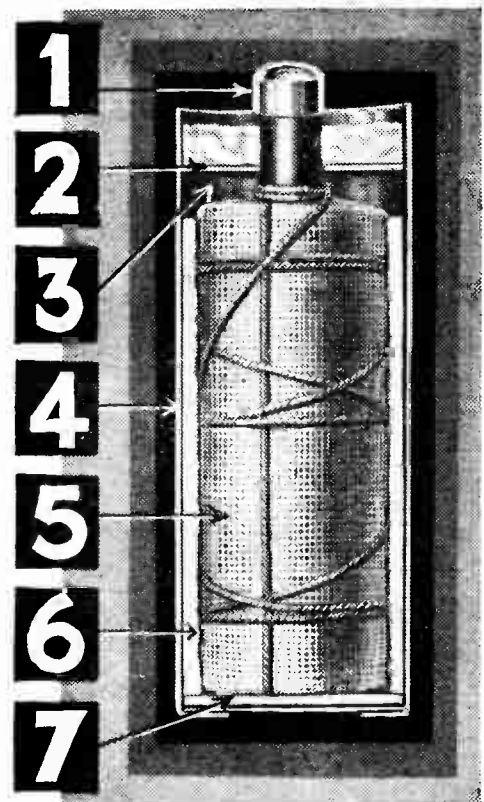

Don't risk wasting your money on inferior batteries. Insist on Ediswan. You can get them in all standard sizes including portable types—Standard or Super Capacity—at the usual prices.

**EDISWAN**  
**H.T. BATTERIES**



THE EDISON SWAN ELECTRIC CO. LTD.  
PONDERS END, MIDDLESEX

**EDISWAN—the Better Service Batteries**

B.254



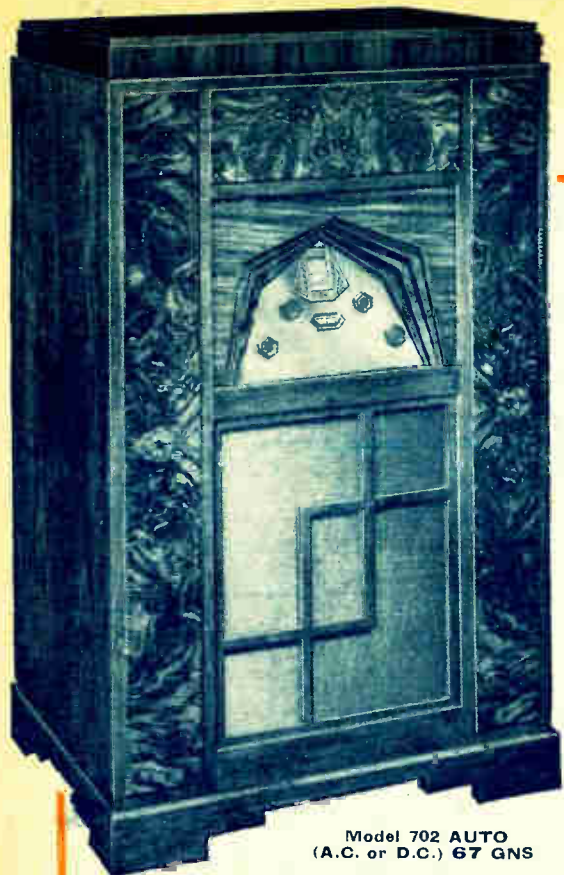

Model 702 AUTO  
(A.C. or D.C.) 67 GNS

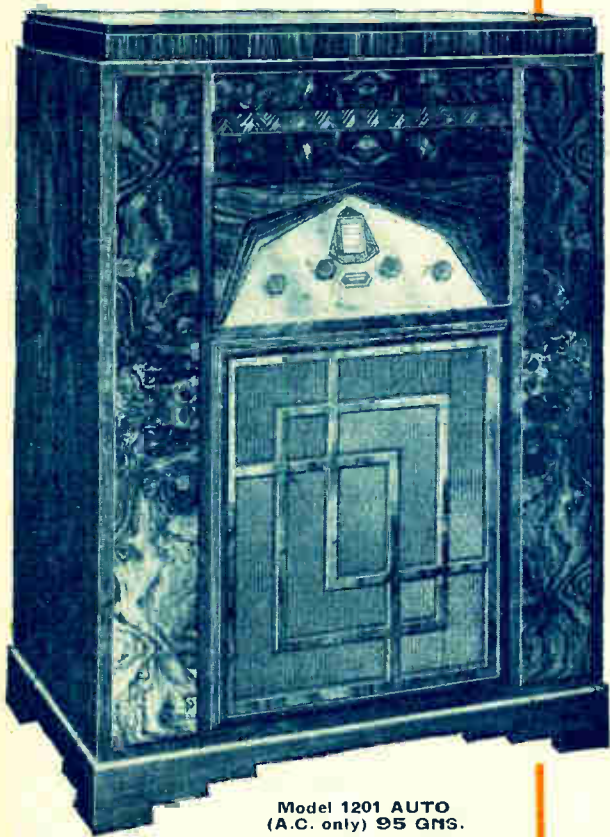

Model 1201 AUTO  
(A.C. only) 95 GNS.



# Harmony

*An elusive, subtle quality is Harmony; a tranquil backwater in the upper reaches of the mind; a blending of things beautiful with things practical.*

*One finds it in R.G.D. Radio Gramophones, wherein the beautiful is wedded with the practical.*

*Here the traditions of fine craftsmanship find full expression in superb cabinetwork, and mechanical design and ingenuity contrive to produce the ideal means for reproducing speech and music.*

*The R.G.D. is a thing of beauty and utility; a treasured possession in a thousand homes; the instrument you cannot fail to admire, and to eventually possess.*

Ten models comprise the R.G.D. range of Radio Gramophones, and prices are from 48 to 105 Guineas. They have been aptly described by the "Daily Mail" as the "Aristocrats of the radio world."

The leading radio stores and piano salons display R.G.D. Radio Gramophones and will gladly demonstrate.

Write for fully descriptive Catalogue of the complete range of R.G.D. Radio Gramophones and Extension Loud Speakers.

# R.G.D.

## The World's Finest Radiogramophones

RADIO GRAMOPHONE DEVELOPMENT CO. LTD.  
17-20, FREDERICK STREET BIRMINGHAM  
Manchester—17, Bridge St. London—40, Doughty St., W.C.1



# The Wireless World

4<sup>D</sup>

THE PRACTICAL RADIO JOURNAL

with Complete Foreign Programmes

Friday, September 22nd, 1933.

MODEL

SEVEN STAGE SUPER-HET

74

Black and Chromium 14 Gns. or 12 monthly payments of £1-7-0. Battery and All-Electric, Walnut Finish, 13 Gns. or 12 monthly payments of £1-5-0.

EKCO RADIO

Write for illustrated folder to E. K. COLE Ltd., Dept. W.26, Ekco Works, Southend-on-Sea.

## AN INTERESTING GIFT



RESISTORS

To prove the superiority of our "B.A.T." (Best-After-Test) BRITISH-MADE FIXED RESISTANCES (1, 1.1, 2, 3, and 5-WATTS) we will send Free and Post-Free to applicants mentioning this Journal, our 2-Colour Art Booklet, 2nd, ENLARGED EDITION 16pp., entitled:

"OHMS LAW WITHOUT TEARS"

A Complete Treatise, with Circuits, Simple Formulae, Voltage-Dropping and Current-Carrying Charts, "ABAC," worked examples, etc. It tells you all you ought to know about the "mysteries" of Volts, Amps, Resistance, Values and Watts-Dissipation as applied to the use of Resistors for Radio purposes. The edition is limited.

CLAUDE LYONS, LIMITED, 76, OLDHALL STREET, LIVERPOOL. 40, BUCKINGHAM GATE, LONDON, S.W.1.

THE LATEST DEVELOPMENT IN P.M.M.C. DESIGN AND CONSTRUCTION

"WIRELESS WORLD," 25-8-33, states: "a distinct advance in the reliability of M.C. Units."

"DAILY MAIL," 24-8-33, states: "another outstanding success."

Write for 1934 Leaflet of the complete range of R & A Reproducers.

R & A "ALPHA" 52/6

REPRODUCERS & AMPLIFIERS LTD., WOLVERHAMPTON



## TELSEN Intermediate Frequency TRANSFORMER COILS

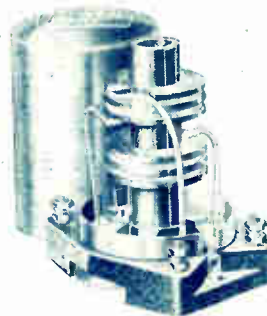

Specified by the designer of the "Wireless World" NEW MONODIAL SUPER. Ideal for every superhet where lasting efficiency is the first essential. Totally screened. The world's finest value at the new reduced price of 7'6

TELSEN FOR EVERYTHING IN RADIO

Announcement of the Telsen Electric Co., Ltd., Aston, Birmingham.

**PERFECT  
POWER  
PUREST  
TONE**

*if an*



**WIRELESS  
BATTERY**  
*is in your set!*

DO YOU RUN A COLUMBIA 380?

If so, the Ever Ready Batteries made specially for this set are : H.T./W 1180; G.B./9 v. Winner; L.T./2130. If not, simply ask your dealer for the Ever Ready List, showing all popular makes with their special Ever Ready batteries. Your set will be powered perfectly by its appropriate Ever Ready batteries.

THE EVER READY CO. (GREAT BRITAIN) LTD.,  
HERCULES PLACE, HOLLOWAY, LONDON, N.7.

The Best Low-Priced  
L.F. Transformer  
on the Market

**BRITISH GENERAL**

"VICTORY"

Beautifully made ;  
superb performance.  
Ratio 3½-1. Suitable  
for single or double  
staging.

4/6

From all dealers or  
direct from the  
manufacturers.

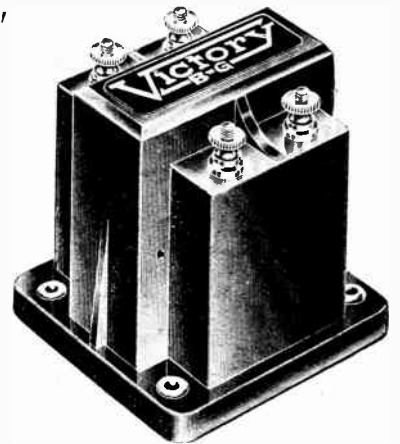

BRITISH GENERAL MANUFACTURING CO., LTD.  
Brockley Works, London, S.E.4

*Player's  
please  
Everyone*



NCC 176

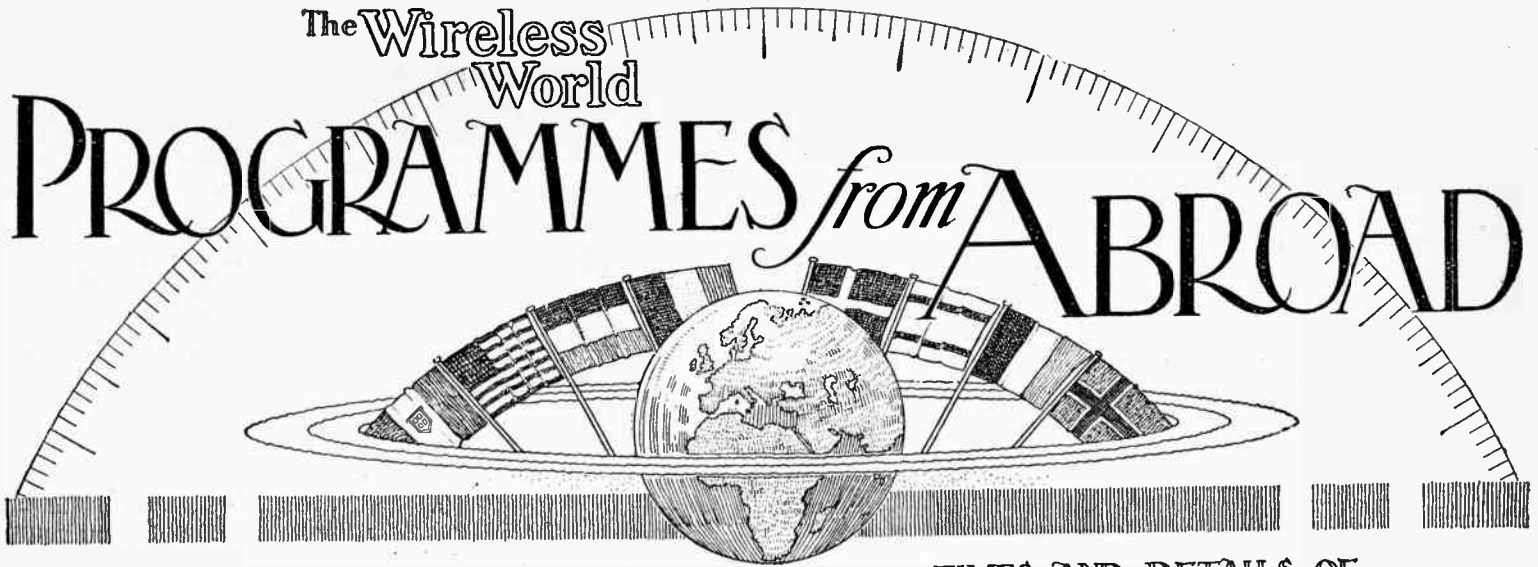

**BROADCASTING STATIONS  
ARRANGED IN ORDER  
OF WAVELENGTH**

**TIMES AND DETAILS OF  
FULL WEEK'S FOREIGN  
TRANSMISSIONS**

Metres.	kc's.	kW.	Station.	Tuning Positions.	Metres.	kc's.	kW.	Station.	Tuning Positions.
1935	155	7	Kaunas (Kovno) (Lithuania) .. .. .		453.2	662	0.25	Agen (France) .. .. .	
1875	160	8.5	Hilversum (Holland) ( <i>Kootuyk</i> , 50kW., after 3.10 p.m.) ( <i>V.A.R.A.</i> , <i>A.F.R.O.</i> und <i>V.P.R.O.</i> programmes.)		453.2	662	4	Milan (Vigentino) (Italy). ( <i>Relays Rome</i> ) .. .. .	
1796	167	40	Lahti (Finland) .. .. .		450.3	666	20	Madona (Latvia). ( <i>Relays Riga</i> ) .. .. .	
1725	174	75	Radio Paris, C.F.R. .. .. .		447.1	671		Paris, Ecole Supérieure, PTT (7.0 kW.); Rjukan (0.15 kW.); Notodden (0.08 kW.); Alesund (0.35 kW.) (Norway) ( <i>relays Oslo</i> ); Rome, I.R.O. ( <i>S.-W. Station</i> , 2RO on 25.4 m.) .. .. .	
1635	183.5	60	Berlin. ( <i>Deutschlandsender</i> ) (Germany). ( <i>S.-W. Stn. DJI</i> on 31.38 m., <i>DJB</i> on 19.73 m., <i>DJC</i> on 19.83 m., <i>DJD</i> on 25.51 m., <i>DJE</i> on 16.86 m.)		441.2	680	50	Stockholm, SASA (Sweden) .. .. .	
1554.4	193	30	Daventry National .. .. .		435.4	689	55	Belgrade (Yugoslavia) .. .. .	
1538	195	7	Ankara (Angora) (Turkey) .. .. .		430.4	697	2.5	Madrid, EAJ7 (Union Radio) .. .. .	
1481	202.5	500	Moscov, RV1 (Old Komintern) (Russia) .. .. .		424.3	707	2	Moscow, Imini Stalina (Russia) .. .. .	
1446	207.5	13	Eiffel Tower, FL, Paris .. .. .		419.5	715	1.5	Berlin, Funkstunde (Germany) .. .. .	
1412	212.5	120	Warsaw I (Poland) .. .. .		418.4	720.5	5	Rabat (Morocco) .. .. .	
1380	217.5	100	Novosibirsk, RV76 I (Russia) .. .. .		413	725	60	Athlone (Irish Free State) .. .. .	
1354.4	221.5	30	Motala (Sweden). ( <i>Relays Stockholm</i> ) .. .. .		408.7	734	16	Katowitz (Poland) .. .. .	
1350	222	0.5	Tunis-Kasbah (Tunisia) .. .. .		403.8	743	25	Sottens (Radio Suisse Romande) ( <i>Switzerland</i> ) .. .. .	
1304	230	100	Moscov, WZSPS (Trade Union) (Russia) .. .. .		398.9	752	25	Midland Regional (Daventry) .. .. .	
1230	244	0.6	Boden (Sweden). ( <i>Relays Stockholm</i> ) .. .. .		394.2	761	12	Bucharest (Roumania) .. .. .	
1200	250	5	Stamboul (Turkey) .. .. .		389.6	770	120	Leipzig (Germany) .. .. .	
1200	250	21	Reykjavik (Iceland) .. .. .		385.1	779	8	Toulouse (Radiophonie du Midi) (France) .. .. .	
1190	252	200	Luxembourg .. .. .		385.1	779	10	Stalino, RV26 (Russia) .. .. .	
1170	256	25	Tashkent, RV11 (Russia) .. .. .		381	788	16	Lwow (Lemberg) (Poland) .. .. .	
1154	260	75	Kalundborg (Denmark). ( <i>Relays Copenhagen</i> ) .. .. .		376.4	797	50	Scottish Regional (Falkirk) .. .. .	
1154	260	20	Monte Ceneri (Switzerland). ( <i>Temporarily Closed</i> ) .. .. .		372.2	806	1.5	Hamburg (Germany) .. .. .	
1117	268.5	40	Moscov, Popoff RV58 (Russia) .. .. .		370.1	810.5	0.8	Radio, I.L, Paris .. .. .	
1083	277	60	Oslo (Norway) .. .. .		368.1	815		Seville, EAJ5 (Union Radio) (1.0 kW.); Galieta EAJ4 (0.2 kW.) (Spain); Bolzano (1.0 kW.) (Italy); Helsinki (10 kW.) (Finland) ( <i>relays Lahti</i> ); Kharkov, RV20 (10kW.) (Russia) .. .. .	
1071	280	35	Tiflis, RV7 (Russia) .. .. .		368.1	815	0.7	Fredriksstad (Norway). ( <i>Relays Oslo</i> ) .. .. .	
1035	290	36	Kiev, RV9 (Russia) .. .. .		364.1	824	1	Bergen (Norway) .. .. .	
1000	300	100	Moscov RV39 (Russia) ( <i>S.-W. Stn. on 50 m.</i> ) .. .. .		363.6	825	13	Algiers (Algeria) .. .. .	
938	320	20	Kharkov, RV4 (Russia) .. .. .		360.6	832	60	Mühlacker (Stuttgart) (Germany) .. .. .	
857	350	100	Leningrad (Russia) .. .. .		355.9	843	50	London Regional (Brookmans Park) .. .. .	
840	357	18.5	Budapest (Hungary) .. .. .		352.1	852	7	Graz (Austria). ( <i>Relays Vienna</i> ) .. .. .	
825	363.6	50	Sverdlovsk, RV5 (Russia) .. .. .		348.8	860	7.6	Barcelona, EAJ1 (Spain) .. .. .	
760	395	1.3	Geneva (Switzerland). ( <i>Relays Sottens</i> ) .. .. .		348.8	860	10	Leningrad, RV70 (Russia) .. .. .	
720	416.6	20	Moscov, RV2 (Experimental) (Russia) .. .. .		345.2	869	11.5	Strasbourg, PTT (France) .. .. .	
690	434.6	1.5	Oulu (Uleaborg) (Finland) .. .. .		341.7	878	35	Brno (Brunn) (Czechoslovakia) .. .. .	
680	441.2	0.6	Lausanne (Switzerland). ( <i>Relays Sottens</i> ) .. .. .		338.2	887	15	Brussels II, Velthem (Belgium). ( <i>In Flemish</i> ) .. .. .	
574.7	522	7	Ljubljana (Yugoslavia) .. .. .		335	896	5	Cadiz (Spain) .. .. .	
569	527	0.25	Freiburg-im-Breisgau (Germany). ( <i>Relay Stn.</i> ) .. .. .		334.4	897	1.9	Poznan (Poland) .. .. .	
588.1	528	2	Grenoble (France) .. .. .		331.5	905	50	Milan (Italy). ( <i>Relays Turin</i> ) .. .. .	
563	533	16	Wilno (Poland). ( <i>Relay Station</i> ) .. .. .		328.2	914	60	Poste Parisien (France) .. .. .	
560	536	0.25	Augsburg (Germany). ( <i>Relays Munich</i> ) .. .. .		325	923	60	Breslau (Germany) .. .. .	
560	536	1.5	Kaiserslautern (Germany). ( <i>Relays Munich</i> ) .. .. .		321.9	932	10	Göteborg (Sweden). ( <i>Relays Stockholm</i> ) .. .. .	
550	545	18.5	Budapest No. 1 Lakihegy (Hungary) .. .. .		318.8	941	0.25	Dresden (Germany). ( <i>Relays Leipzig</i> ) .. .. .	
542	554	10	Sundsvall (Sweden). ( <i>Relays Stockholm</i> ) .. .. .		318.8	941	1.5	Naples, INA (Italy). ( <i>Relays Rome</i> ) .. .. .	
537.6	558	3	Palermo (Italy) .. .. .		315.8	950	1.6	Marseilles, PTT (France) .. .. .	
533	563	60	Munich (Germany) .. .. .		312.8	959	0.7	Radio Vitus (Paris). ( <i>S.-W. Stn. on 43.75 m.</i> ) .. .. .	
525	571	15	Riga (Latvia) .. .. .		312.8	959	1.7	Cracow (Poland) .. .. .	
517.2	580	100	Vienna (Bisamberg) (Austria) .. .. .		312.8	959	10	Genoa, IGE (Italy). ( <i>Relays Turin</i> ) .. .. .	
509	589	15	Brussels No. 1, Velthem (Belgium). ( <i>In French</i> ) .. .. .		309.9	968	50	West Regional (Washford Cross) .. .. .	
500.8	599	20	Florence, IF1 (Italy). ( <i>Relays Turin</i> ) .. .. .		307	977	0.75	Zagreb (Yugoslavia) .. .. .	
495.8	605	1.2	Tröndelag (Norway) .. .. .		304	986	13	Bordeaux Lafayette, PTT (France) .. .. .	
488.6	614	120	Prague (Czechoslovakia) .. .. .		301.5	995	50	North National (Manchester) .. .. .	
480	625	50	North Regional (Manchester) .. .. .		298.8	1004	11	Tallinn (Esthonia) .. .. .	
472.4	635	60	Langenberg (Germany) .. .. .		296.1	1013	20	Huizen (Holland). ( <i>7 kW. before 4.40 p.m.</i> ) .. .. .	
465.8	644	1.5	Lyons la Doua, PTT (France) .. .. .		293.5	1022	0.7	Limoges, PTT (France) .. .. .	
459.4	653	60	Beromünster (Schweizerischer Landessender) (Switzerland) .. .. .		293.5	1022	2.6	Kosice (Czechoslovakia) .. .. .	
453.2	662		San Sebastian, EAJ8 (0.6 kW.); Pori (1.0 kW.) (Finland); Danzig (0.5 kW.) ( <i>relays Heilsberg</i> ); Klagenfurt (0.5 kW.) (Austria) ( <i>relays Vienna</i> ); Porsgrunn (0.7 kW.) ( <i>relays Oslo</i> ); Tromsø (0.1 kW.) Bodö (0.5 kW.) (Norway); Uppsala (0.15 kW.) (Sweden) ( <i>relays Stockholm</i> ) .. .. .		291	1031	13.2	Viipuri (Viborg) (Finland). ( <i>Relays Helsinki</i> ) .. .. .	
					288.3	1040	50	Scottish National (Falkirk) .. .. .	
					288.3	1040	1	Bournemouth. ( <i>Relay Station</i> ) .. .. .	



BROADCASTING STATIONS ABROAD (In Order of Wavelength)

Table with columns: Metres, kc/s, kW, Station, Tuning Positions. Lists various international broadcasting stations and their technical specifications.

PRINCIPAL SHORT-WAVE STATIONS

(N.B.—Times of Transmission, given in parentheses, are approximate only and represent B.S.T.)

Table with columns: Metres, kc/s, Call Sign, Station, Tuning Positions. Lists principal short-wave stations with call signs and transmission times.

# FOREIGN SUNDAY PROGRAMMES

SEPTEMBER THE TWENTY-FOURTH

## PRINCIPAL EVENTS OF THE DAY:

### AT HOME

- NATIONAL** Harvest Festival service from Cranleigh Parish Church.
- LONDON REGIONAL** Guards Band concert.
- MIDLAND REGIONAL** Orchestral concert from the Winter Gardens, Droitwich Spa.
- NORTH REGIONAL** A programme of glees.
- WEST REGIONAL** A nocturne; orchestral concert.
- SCOTTISH REGIONAL** Service from St. Mungo's Church, Alloa.

### ABROAD

- BRUSSELS (No. 2)** 9.0 p.m. The Symphony Orchestra, conducted by Kumps.
- BUCHAREST** 8.20 p.m. Concert by the Station Orchestra.
- BUDAPEST** 7.45 p.m. Concert of operetta music.
- COPENHAGEN** 8.5 p.m. L har operetta concert. 10.15 p.m., French opera music, by the Station Orchestra.
- HEILSBURG** 8.0 p.m. The K nigsberg Opera House Orchestra.
- LEIPZIG** 8.0 p.m. The Symphony Orchestra.
- OSLO** 8.0 p.m. Concert by the Budapest Trio.
- PITTSBURGH** 8.0 p.m. National opera concert.
- PRAGUE** 7.0 p.m. Opera: "Libusa," by Smetana, from the National Theatre.
- TURIN** 8.30 p.m. Opera: "Ruy Blas," by Marchetti.

## COPENHAGEN

1,067 kc/s, 281 metres; 0.75 kW. Relayed by Kalundborg, 260 kc/s, 1,163.8 metres.—8.0 a.m., Gymnastics for Women. 8.15, Gymnastics. 9.0 to 9.30, Talk. 10.0, Divine Service from the Cathedral. 11.30, Weather and News. 12 Noon, Time and Chimes from the Town Hall. 12.5 p.m., Concert by Lotis Prell's Instrumental Ensemble. 1.30, Talk in English: The Grand Tour of Scotland. 1.50, German Lesson. 2.10, Reading in French. 2.30, Gramophone Concert. 3.0, Programme for Children. 3.30, Concert by the Radio Orchestra, conducted by Launy Gr ndahl. Soloist: Edel Wamberg (Songs). 5.0 (also relayed by Skamlebaek on 31.51 metres), Divine Service, relayed from the Holmens-Kirke. 6.20, Talk. 6.50, Weather, News and Sports Results. 7.15, Time Signal. 7.30, Talk. 8.0, Chimes from the Town Hall. 8.5, L har Operetta Concert by the Station Orchestra, conducted by Emil Reesen: Prelude to Eva; Selection from The Czarevitch; Waltz from Der G ttergatte; Selection from Sch n ist die Welt; Overture, Gipsy Love. 8.50, The Hansen Family—Sketch (Locher). 9.5, Folk Songs of the Nations by a Male Voice Choir—Denmark, Norway, Iceland, Sweden, Finland, the Netherlands, England, Scotland, Ireland, Switzerland, Germany and Austria. In the interval, Readings. 10.5, News. 10.15, Concert of French Opera Music by the Station Orchestra, conducted by Emil Reesen: Overture, Jean de Paris (Boieldieu); Rondo from Les Deux Avaros (Gr try); Overture and Tarentella from Masaniello (Auber); Prelude to Djamilah (Bizet); Selection from Carmen (Bizet); Overture, La Princesse Jaune (Saint-Sa ns); Baccanale from Sanson and Delliak (Saint-Sa ns). 11.0, Dance Music, relayed from the Wivex Restaurant. In the interval at 12 Midnight, Time and Chimes from the Town Hall. 12.30 (Monday), Close Down.

CORK.—See Athlone.

DANZIG.—See Heilsburg.

DRESDEN.—See Leipzig.

## FECAMP

1,328 kc/s, 225.9 metres; 10 kW.—11.0 a.m. till 12 Noon, Programme in English by the I.B.C. 11.0, Happy Hour. Part I, Orchestral Concert: Signature Tune; Classical Selection (arr. Ewing); Invitation to the Waltz (Weber); Selection from Die Fledermaus (Joh. Strauss); Anitra's Dance from the Peer Gynt Suite (Grieg); Scarf Dance (Chaminade); Ich liebe Dich (Grieg); Hungarian Dance No. 6 (Brahms); Waltz from The Sleeping Beauty (Tchaikovsky). Part II, Organ Recital: Selection from Indian Love Lyrics (Woodforde-Finden); Berceuse de Jocelyn (Godard); Les millions d'Arlequin (Drigo); Melody in F (Rubinstein); The Lounderry Air; Suite, Ballet  gyptien (Luigini); Cathedral Chimes (Lindahl); Chant sans paroles (Tchaikovsky); Signature Tune. 12 Noon, Programme in French. 2.0 to 7.30 p.m., Programme in English by the I.B.C. 2.0, Variety Concert: Ah, Sweet Mystery of Life; The Song of Songs (Moya); Selection from Orpheus in the Underworld (Offenbach). 2.15, Concert for Blind Club Members: Signature Tune, The Night by the Sea; Overture, William Tell (Rossini); Rhapsody on Alice, where art thou? (Ascher); Liebestraum (Liszt); Valse brune (Krier); Melody in F (Rubinstein); Dance of the Hours (Ponchielli); Barcarolle from The Tales of Hoffmann (Offenbach); Summer Days Suite (Coates). 3.0, Light Music: Selection from Music in the Air; Ding, Dong, Ding (Evans); Jealousy (Gade); I've found the right girl (Gay); The Song of the Rose (McAlough); Down in the Valley (Harrington); Animal Antics (Wark); Roll up the Carpet (Goodhart). 3.30, Light Orchestral Music: What's next? (arr. Finck); Chinatown, my Chinatown (Schwartz); Handsaw Solo, The Rosary (Nevin); Selection from Somerset (Coates); Violin Solo, Indian Love Call from Rose Marie (Friml); Old Music-Hall Memories; Last night I dreamed of you (Kalnan). 4.0, Judge Rutherford's Address. 4.15, Programme for Children. 4.30, Descriptive Adventure Story. 5.0, Charles Stevens' Orchestral Concert: Southern Rhapsody (Hosmer); In a Country Lane, from the Summer Days Suite (Coates); Violin Solo, Valse bluette (Drigo); Selection from The Flower of Hawaii (Abraham); 'Cello Solo, Harlequinade (Squire); My Lady Dainty (Hesse); Ay, Ay, Ay (Freire); Fr hlingstimmen (Strauss). 5.30, Concert: Popular Music of Today; Signature Tune; Jolly good Company; A Medley of British Songs; Selection from Verds and Music (Coward); Serenade (Heykens); Selection from The Cat and the Fiddle (Kern); Jack-in-the-Box (Shand); Violin Solo, The Song of Songs (Moya); Xylophone Solo, Snappy Sticks (Robbins); Selection from Congress Dances (Heymann). 6.0, Club Concert for Dumfries Listeners. Part I—Orchestral Music. Signature Tune, The Chum Song; Mrs. Ferguson of Raith's Delight; Scarf Dance (Chaminade); The Wedding of the Rose (Jessel);

## ATHLONE

725 kc/s, 413 metres; 60 kW. Relayed by Cork, 1,337 kc/s, 224.4 metres.—8.30 p.m., Time Signal. 8.31, Concert by Lucy Lee nane's Instrumental Trio. The Glasgow Orpheus Choir, conducted by Sir Hugh S. Robertson, The Mystics in a Drama, and Soprano Solos by Gertrude Mortimer. 11.0, Time Signal, News, Weather Report, and Close Down.

## BARCELONA

EAJ1, 363 kc/s, 348.8 metres; 8 kW.—12 Noon, Chimes from the Cathedral and Weather. 2.0, Gramophone Music. In the interval at 2.30, Theatre Notes. 3.0, Sextet Concert. 4.0, Programme for Hospitals and other Benevolent Institutions, with Gramophone Records. 5.0 to 6.30, Interval. 6.30, Agricultural Talk in Catalan and Gramophone Music. 7.0, Concert by the Station Orchestra. 7.30, Song Recital by Pepita Paulet. 8.0, Concert by the Station Orchestra. Soloists: Paquita Gilbert (Songs) and Josefa Tomas (Pianoforte). 9.0, Dance Music relayed from The Hollywood Bar. 10.0, Musical Comedy on Gramophone Records. 11.45, Chess Lesson. 12 Midnight (approx.), Close Down.

BASLE.—See Schweizerischer Landessender.

## BERLIN

DEUTSCHLANDSENDER (REICHSENDER), 183.5 kc/s, 1,635 metres; 60 kW.—6.0 a.m., Gymnastics from Berlin (Funkstunde). 6.15, News, followed by the Day's Motto, Morning Hymn and Harbour Concert from Hamburg. 8.0, Two Agricultural Talks. 8.55, Morning Recital from Nikolskoe. 10.5, Weather from Berlin (Funkstunde). 11.0, Reading (Paul Ernst). 11.15, Weather. 11.30, See Leipzig. 12 Noon, See Stuttgart. 12.55 p.m., Time Signal. 1.0, Concert from Hamburg. 2.0, The German Harvest—Radio Sequence (Patzold). 3.0, Hans Hermann Wilhelm reads from his own Works. 3.30, Song Recital by a Girls' Choir. 4.0, Reading. 4.30, Concert from Breslau. 5.30, Reading: The Philosophy of a Churl (J. Hanns R sler). 5.50, Orchestral Concert. 6.50, Sports Notes. 7.0, Great Actors—Programme on Gramophone Records with Commentary. 8.0, Concert by the Station Orchestra, conducted by Hanns Udo M ller; Soloists, Adelheid Arnold (Soprano), Konrad Hansen (Pianoforte), and Max Bleiss (Cello). In the interval at 8.40, Radio Report of the German Cyclists' Club. 10.0, News. 10.45, Weather. 11.0, Concert from Langenberg. 12 Midnight, Close Down.

## BERLIN

FUNKSTUNDE, 715 kc/s, 419.5 metres; 1.5 kW.—11.30 a.m., See Leipzig. 12 Noon, See Heilsberg. 2.0, Talks for Garden City Dwellers. 3.0, Dr. Johannes G nther speaks with Three Artists. 3.30, Concert by an Orchestra of Unemployed Musicians. In the interval at 5.10 (approx.), Running Commentary on the Second Half of the Rugby Match Hanover v. Berlin. 5.40, Siegfried Burgstaller Song Recital by Tiny Deb ser (Soprano). 6.0, A Working Day in the Life of a German Peasant—a Radio Picture. 7.0, Opera Songs on Gramophone Records. 7.50, Sports Notes. 8.5, Autumn from The Seasons—Oratorio (Haydn) by the Station Orchestra, the Oratorio Society and Soloists. 8.40, Orchestral Concert, conducted by Willi Hahn. 10.0, News. 10.15 (approx.), Dance Music, relayed from the Delphi-Palast. In the interval at 11.0 (approx.), A Visit to Paris (on Gramophone Records). 1.0 a.m. (Monday), Close Down.

BERNE.—See Schweizerischer Landessender.

BEROMUNSTER.—See Schweizerischer Landessender.

BODEN.—See Stockholm.

BODO.—See Oslo.

## BRATISLAVA

1,076 kc/s, 279 metres; 14 kW.—12.15 p.m., Military Band Concert. 1.30, See Prague. 1.45 to 1.50, Hydrographic Report. 3.45, Variety Programme relayed from Skalica. 5.30, See Prague. 5.45, Reading. 6.0, Piano Recital by Rudolf Mauczinsky. 6.30, Talk: The Work of the Slovak League. 6.45, Gramophone Music. 6.55, Talk for Housewives. 7.0 till Close Down, See Prague. 10.50 (approx.), Close Down.

BREMEN.—See Hamburg.

## BRESLAU

923 kc/s, 325 metres; 60 kW. Relayed by Gleiwitz, 1,184 kc/s, 253 metres.—11.30 a.m., See Leipzig. 12 Noon, Concert by the Silesian Symphony Orchestra, conducted by Mundry. 2.0, Talk: Amateur Films. 2.20, Talk for Stamp Collectors. 2.45, Talk: Women in Early German History. 3.0, A Play for Children. 3.30, Orchestral Concert conducted by Gerhard Rischka. In the interval at 4.30, The New Organ at Lichten-

waldau—a Radio Report, relayed from Lichtenwaldau. 6.0, Reading (Sch ke). 6.25, Talk: The Victims of Mont Blanc. 6.45, Divertimento in E Flat (Mozart), by Hanns Schmack-Urbach (Violin), Rudolf Vormeng (Viola), and Fritz Binnowsky (Cello). 7.30, Weather and Sports Notes. 8.0, A German Evening—Literary and Musical Programme. In the interval at 9.0, News. 10.0, Time and News. 10.30, Dance Music from Berlin (Funkstunde). 12 Midnight, Close Down.

## BRNO

878 kc/s, 342 metres; 35 kW.—5.30 p.m., Song Recital by Milada Sklenarov . 5.45, Talk: Early Slovak Poetry. 6.0, German Transmission: Song Recital with Guitar Accompaniment. 7.0 till Close Down, See Prague. 10.50 (approx.), Close Down.

## BRUSSELS (No. 1)

1.N.R., 590 kc/s, 509 metres; 15 kW.—9.45 a.m., Culinary Talk. 10.0, Gramophone Records: Violin Concerto No. 5 in A (Mozart); Symphonic Study, Falstaff (Elgar). 11.0, Concert by the Small Station Orchestra, conducted by Leemans. 12 Noon, Concert by the Station Symphony Orchestra, conducted by Kumps. 1.0 p.m., Le Journal Parl . 1.10, Concert, conducted by Felleman, relayed from the Grand Hotel, Antwerp. In the interval at 1.40, Monologues. 5.0, Concert by the Radio Orchestra, conducted by Andr . 5.30, Football Results. 6.0, Gramophone Records: Concerto in E Flat (Liszt); Overture, Le Roi d'Ys (Lalo). 6.30, Song Recital by Lina Pollard; Song Cycle, Frauen-Liebe und-Leben (Schumann); Barcarolle (Schubert); Der Erlk nig (Schubert). 7.0, Gramophone Music: Sonata in A (Mozart-Tertis); Teccata from Symphony No. 5 (Widor). 7.15, Religious Address. 7.30, Wireless Notes and Musical Review. 8.0, Concert by the Station Symphony Orchestra, conducted by Kumps; Soloist: Henry Wagenmans (Violin); Fantasia on a Walloon Theme (Th o Ysa e); Romantic Concerto for Violin and Orchestra (Godard); Marche Cort ge (Vreulx). 8.45, Readings of Walloon Poetry. 9.0, Concert by the Radio Orchestra, conducted by Franz Andr ; Soloist: Thom  (Teuor); Hallelujah (Youmans); Polonaise in D for Violin (Wieniawsky); Selection from Paganini (Leh r); Three Songs from The Land of Smiles (Leh r); Morocco (Marangue); Russian Dances (Bareh). 10.0, Le Journal Parl .

## BRUSSELS (No. 2)

1.N.R., 887 kc/s, 338.2 metres; 15 kW.—Programme in Flemish. 10.0 a.m., Concert

by the Small Station Orchestra, conducted by Leemans. 11.0, Gramophone Concert. 12.0 Noon, Concert, relayed from the Grand Hotel, Antwerp. 1.0 p.m., Le Journal Parl . 1.10, Concert by the Station Symphony Orchestra, conducted by Kumps. 5.0, Dance Music, relayed from the St. Sauveur Palais de Danse. 5.30, Sports Notes. 6.15, Movements from the Quartet in A Minor (Schumann) on Gramophone Records. 6.30, Concert by the Small Station Orchestra, conducted by Leemans. 7.15, Religious Address. 7.30, Review of Music. 8.0, Concert by the Radio Orchestra, conducted by Franz Andr ; Soloist: Mme. Marie-Rose (Soprano); Overture, The Bohemian Girl (Balfe); Three Pieces (Fletcher); Finale from the Violin Concerto in E (Vieuxtemps); Songs; Romanian Airs (Dauber); Melody (Offenbach); Fantasia appassionata for Pianoforte (Saint-Sa ns); At the Circus (Armandola). 8.45, Reading Egypt (R mer). 9.0, Concert by the Symphony Orchestra, conducted by Kumps; Soloist: Henry Wagenmans (Violin); Overture, Euryanthe (Weber); Caprice for Violin and Orchestra (Gairaud); Three Romantic Waltzes (Chabrier); Gipsy Suite (Wormser); Feestklanken (Verheyden). 10.0, Le Journal Parl .

## BUCHAREST

761 kc/s, 394 metres; 12 kW.—5.0 p.m., Dance Music by the Seidmann Jazz Band. In an interval at 6.0, Radio Journal. 7.0, Educational Talk. 7.20, Gramophone Music. 7.40, Talk. 8.0, Song Recital by Gabriel Popescu. 8.20, Concert by the Station Orchestra: Overture, The Bohemian Girl (Balfe); The Nut-Cracker Suite (Tchaikovsky); Elegy (Ernst); Selection from The Flower of Hawaii (Abraham); Spanish Dance (Fallas). In an interval at 9.0, Talk. 9.45, Radio Journal.

## BUDAPEST

545 kc/s, 550.5 metres; 18.5 kW.—Also relayed on 840 metres from 7.45 p.m. till 12 Midnight. 9.15 a.m., News. 10.0, Divine Service. 11.0, Catholic Service from a Church. 12.30 (approx.), Concert by the Opera House Orchestra, conducted by Otto Berg. 2.0, Gramophone Music. 3.45, Talk. 4.30, Military Band Concert. 5.30, Reading. 6.0, Concert by Eugen Farka's Gipsy Band. 7.15, Talk. 7.45, Concert of Operetta Music by the Budapest Concert Orchestra, conducted by Fridl; Soloists: Gabrielle Belle and Johann Halmos. 9.30, Pianoforte Recital. 10.15, Concert from the Caf  Ostende; Soloist, Paul Kalmur in his Repertoire. 12 Midnight, Close Down.

CASSEL.—See Frankfurt.

SEPT. 24th

SUNDAY

continued

## HAMBURG

806 kc/s, 372 metres; 1.5 kW. Relayed by Bremen, 1,112 kc/s, 269.8 metres; Flensburg, 1,319 kc/s, 227.4 metres; Hanover, 530 kc/s, 566 metres; and Kiel, 1,292 kc/s, 232.2 metres.—10.55 a.m. (from Kiel). Divine Service relayed from the University Church. 12.15 p.m., Concert by the Hamburg Philharmonic Orchestra, conducted by Gerhard Maasz. In an interval at 12.55, Time and Weather. 2.0, Programme for the Hitler Youth. 3.0, Concert of Chamber Music by the Small Station Orchestra. 3.45 (from Hanover), Der Dilldapp-Puppel Play, after the Fairy Story by Brentano. 4.40 (from Kiel), Variety Programme. 6.0, Concert by the Small Station Orchestra, conducted by Gerhard Maasz. 7.10, Reading (Max Treu), for the Author's Seventieth Birthday. 7.40, Sports Notes and Weather. 8.0, Concert of Italian Music by the Philharmonic Orchestra, conducted by Richard Richter. Soloist: Otto Stadelmaier (Tenor). In an interval, News. 10.0, Time and News and 10.10, Hamburg, Bremen and Lübeck—Weekly Review of the Hanseatic Free Cities. 10.25, Light Music and Dance Music from Berlin (Funkstunde).

HANOVER.—See Hamburg.

## HEILSBURG

1,085 kc/s, 276.5 metres; 60 kW. Relayed by Danzig, 662 kc/s, 453.2 metres.—11.30 a.m., See Leipzig. 12 Noon, Concert by the Small Station Orchestra, conducted by Eugen Wilcken. 2.0, Chess Lesson. 2.30, Talk. 3.0, Das Lied von Andreas Hofer—Radio Play for Young People (Herbert Maruschak). 3.40, Concert by the Small Station Orchestra, conducted by Eugen Wilcken. In the interval at 4.20, Report of the East Prussian Gynastic Festival, relayed from Trakehnen. 5.25, Horse-racing Results. 5.35, Talk: Richard Wagner, the Pioneer of German Opera. 6.0, Bandonion Concert. 6.45, Reading (Lorenz). 7.15, Choral Concert of New Patriotic Songs. 7.50, Sports Report. 8.0, Concert by the Königsberg Opera House Orchestra, conducted by Brückner; Overture, William Tell (Rossini); Scènes pittoresques (Massenet); Oriental Ballet Suite (Krieger); Waltz, Les Sirènes (Waldteufel); Selection from Der lustige Krieg (Joh. Strauss); Overture, Die schöne Galathee (Suppé); Ordensritter-Marsch (Blankenburg). In the interval at 9.0 (approx.). Talk: The Heilsberg Musical Programmes for the Coming Winter. 10.0, News. 10.30 (approx.). Dance Music relayed from Berlin (Funkstunde). 12 Midnight, Close Down.

## HILVERSUM

Announced HUIZEN, 1,013 kc/s, 296.1 metres; 7 kW. (until 5.40 p.m.) and 20 kW. from 5.40 p.m.—8.10 a.m., Religious Programme of the Catholic Radio Society (K.R.O.). 9.10 to 11.55, Programme of the Christian Radio Society (N.C.R.V.). 9.10, Sacred Music on Gramophone Records. 9.40, Organ Recital by Bos. 10.10, Divine Service relayed from the Cathedral, Utrecht. After the Service, Sacred Music on Gramophone Records. 11.55 to 4.40 p.m., K.R.O. Programme. 11.55, Orchestral Concert. 12.40 p.m., Talk. 1.0 Concert (contd.). 1.50, Literary Talk. 2.10, Gramophone Music. 2.40, Farewell Ceremony to the Missionaries to Africa, relayed from the Mission House, Cadier en Keer. 4.10, Programme for Invalids. 4.40 to 7.25, N.C.R.V. Programme. 4.40, Sacred Music on Gramophone Records. 4.55, Divine Service and Choral Concert, relayed from Ermelo. 7.25 till Close Down, K.R.O. Programme. 7.25, Football Results. 7.30, Talk. 7.55, Orchestral Concert. Soloist: Bril (Cello). Overture, Russian and Luduilla (Glinka); Variations (Tchaikovsky); The Enchanted Lake (Liadov); Cello Solos: (a) Intrada (Desplains-Lier), (b) Allegro spiritoso (Scaillé), (c) Minuet (Ravel); La jeunesse d'Iheremie (Saint-Saëns); Canzonetta (Pierné); Selection from Tosca (Puccini); Cello Solos: (a) Serenade (Cassado), (b) Prayer (Bloch), (c) Czardas (Fischer); Overture, Der Waffenschmid (Lortzing); Two Noletteles (Coleridge-Taylor); Invitation to the Dance (Weber). In the intervals at 8.30, Recitation, at 8.45 and 10.5 (approx.). News. 10.20, Epilogue by the Small Choir. 10.40 (approx.), Close Down.

HORBY.—See Stockholm.

## HUIZEN

(Announced HILVERSUM), 160 kc/s, 1,875 metres; 7 kW. (until 3.40 p.m.). Transmitted from Kootwijk on 50 kW. from 3.40 p.m.—8.40 to 11.40 a.m., Programme of the Workers' Radio Society (V.A.R.A.). 8.40, Pigeon Flying Report and Football Notes. 8.43, Gardening Talk. 9.10, Concert by the V.A.R.A. Orchestra, conducted by De Groot. 9.40, Recitations and Gramophone Music. 10.0, Orchestral Concert (contd.). 10.40, Song Recital by Emejanov. 10.55, Orchestral Concert (contd.). 11.40 to 4.40, Programme of the Algemeene Vereeniging Radio Omroep (A.V.R.O.). 11.40, Time Signal. 11.41, Gramophone Music. 12.40 p.m., Concert by the Rentmeester Orchestra. 1.40, Book Re-

view. 2.10, Concert by the Station Orchestra, conducted by Albert van Raalte. Soloist: Emile de Vlieger (Cello). 3.40, Gramophone Music. 4.25, News and Gramophone Music. 4.40, V.A.R.A. Programme; Programme for Children. 5.40 to 7.40, Programme of the Liberal Protestant Radio Society (V.P.R.O.). 5.40, Book Review. 6.10, Organ Recital by Provily. 6.25, Divine Service relayed from Purmerend. 7.40 till Close Down, A.V.R.O. Programme. 7.40, Time Signal and News. 7.55, Concert by the Wireless Orchestra, conducted by Nico Treep. Soloist: Henk Viskil (Tenor). Overture, Morning, Noon and Night (Suppé); So tanz man nur in Wien (Weizel); Alter Refrain (Kreisl); Ah Sweet Mystery of Love (Herbert); Lasciati Amore (Leonavallo); Viennese Musical Comedy Potpourri (Robrecht); Because (d'Hardelet); Dream Waltz (Müllacker). Two Fairy Eyes (Kálmán); Max and Moritz (Zimmer); Patsy (Myddleton); Splendour and Victory (Finck). 8.40, Part II of Escape—Radio Play after the Novel by Galsworthy. 9.40, Concert of Light Music by Kovacs Lajos and his Orchestra. 10.40, Gramophone Music. 11.40 (approx.), Close Down.

INNSBRUCK.—See Vienna.

## JUAN-LES-PINS

1,205 kc/s, 249 metres; 0.8 kW.—8.0 p.m., Amusement Guide and Sports Notes. 8.15, Radio Concert. 9.0, News. 9.15, Musical Programme. 10.0, The Listeners' Half Hour. 10.30 till Close Down, Programme in English by the I.B.C. 10.30, Gramophone Concert: Saschinka, Pt. I (Schermann); Sleep on (Offenbach); Organ Solo: La Paloma (Yradier); In a Monastery Garden (Kettelbey); Violin Solo: Waltz, Dolores (Waldteufel); I Give my Heart, from The Dubarry (Müllacker); Saschinka, Pt. II (Schermann). 11.0, Military Band Concert: Distant Greeting March (Loring); Gaiety Echoes; Quand Madelon (Bonsquet); Fire Star (Carter); El Abasco (Javaloyes); Variation and Dance, Circassienne from La Source (Delibes); Wood Nymphs (Coates); Naval Patrol (Williams). 11.30, Light Music: Waltz, Frühlingsstimmen (Joh. Strauss); Gavotte, The Fairies (Kohn); Selection from Mother of Pearl (O. Straus); Adios (Fernandez); You are my Heart's Delight (Lehár); The Skaters' Waltz (Waldteufel); Serenata No. 2 (Toselli); Play, Fiddle, Play (Lawrence). 12 Midnight, Music by a Tango Band: El Estardarte (Pizarro); Mariette (Linda Flor); Mama, yo quiero un novio (Collazo); A medi a Luz (Donato) (Collazo); A mede stolen my Heart (Schwabach); Goodbye Argentina (Rodriguez); Farelito de mi Barrio (Traditional); Rose Colour (Polito). 12.30, Dance Music: The King's Navee; Love will find a Way; Don't be late in the Morning; The Old Spinning Wheel; In the Valley of the Moon; Hold me; Barlon Fuss; When you've fallen in love. 12.57, I.B.C. Good-night Melody. 1.0 (approx.), Close Down.

KALUNDBORG.—See Copenhagen.

KIEL.—See Hamburg.

KLAGENFURT.—See Vienna.

KOSICE.—See Prague.

## LANGENBERG

635 kc/s, 473 metres; 60 kW.—10.0 a.m., Protestant Service, relayed from the Christuskirche, Aachen. 11.30, See Leipzig. 12 Noon, Musical Interlude. 1.0 p.m., Concert by the Münster Municipal Orchestra, conducted by Werner Göhre. 2.30, Chess Lesson. 3.0, A Report with Gramophone Records: Adventures in North Africa. 3.30, Concert by the Münster Municipal Orchestra, conducted by Georg Ludwig Jochum. In the interval, Talk on Fritz Wienke. 4.30, Concert by the Fröhliche Fünf, Accordion and Gramophone Music. 5.40, Talk: The West German Cycling Club. 5.45, Sports Report. 6.0, The Merry Wives of Windsor—Opera (Nicolaï) (Concert Version on Gramophone Records). 6.40, Talk: The International Air Pageant at Cologne. 7.0, Talk: The Pilgrimage to Trier, 1933. 7.30, Programme to be announced. 7.45, Sports Report. 8.0, A Harvest Festival relayed from Odenthal. 9.30, Symphony No. 6—the Pastoral (Beethoven), by the Station Orchestra, conducted by Buschköttler. 10.10, News. 10.35, Light Music and Dance Music. 12 Midnight, Close Down.

LAUSANNE.—See Radio-Suisse Romande.

## LEIPZIG

769.9 kc/s, 389.6 metres; 120 kW. Relayed by Dresden, 941 kc/s, 319 metres.—11.15 a.m., Talk on the following Transmission. 11.30, Was Gott tut, das ist wohlgetan—Cantata (Bach), by the Municipal and Gewandhaus Orchestras, the Choir of St. Thomas, and Soloists. 12 Noon, Concert by the Emde Orchestra. 2.0 p.m., Weather and Time. 2.5, Programme Announcements. 2.25, Agricultural Notes. 2.30, Sun over Thüringia—Literary Programme. 3.0, Gramophone Music. 3.40, Programme for Young People. 4.30, See Stuttgart. 6.0, Talk: Burgenland—an old German Province. 6.20,

Talk: Autumn Days in the Garden City. 6.45, Programme to be announced. 7.5 Two One Act Comedies: (a) Der Schwarrsänger (Prell), (b) Rösige Zukunft (Klotz). 8.0, Concert by the Symphony Orchestra, conducted by Blumer; Soloist, Charlotte Böner (Soprano); Concert Overture (Cherubini); Soprano Solos: (a) Wenn ich für dich sterbe (Alary), (b) Das Seemannsständchen (Mercadente); Italian Capriccio (Tchaikovsky); Aria from La Traviata (Verdi); Hungarian Rhapsody No. 6 (Liszt); Aria from Tarandot (Puccini); Selection from The Jewels of the Madonna (Wolf-Ferrari); Aria from Madame Butterfly (Puccini); Overture, Der Bärenhäuter (Wagner); Syrian Dances (Kienzl); Waltz, Wo die Citronen blühen (Strauss); Extract from the Peer Gynt Suite No. 1 (Grieg). 10.5, News. 10.15 (approx.), Dance Music from Berlin (Funkstunde). 12 Midnight, Close Down.

LINZ.—See Vienna.

## LUXEMBOURG

252 kc/s, 1,191 metres; 200 kW.—12.30 p.m., Concert by the Station Orchestra, conducted by Henri Pensis. 1.30, Gramophone Concert of Variety Music. 7.30 till Close Down, English Programme. 7.30, Gramophone Music: Variations, Enigma (Elgar); Spanish Caprice (Rimsky-Korsakov). 8.20, Concert by the Station Orchestra, conducted by Henri Pensis: Overture, Fra Diavolo (Auber); Waltz, Tales from the Vienna Woods (Joh. Strauss); Selection from Cavalleria rusticana (Mascagni); Scheherazade (Rimsky-Korsakov); Indian Canzonetta (Dvorák); Spanish Dances (Mozzkovsky); Kisses in the Dark (Mielich); Selection from Viktoria and her Hussar (Abraham); The Caress (Byford); Grandmama (Lange); Anbade (Caludi); March, Liberia (Lincke). In the interval at 8.50, News in French, and at 9.50, News in German. 10.20, Dance Music on Gramophone Records.

## MADRID

EAJ7, 707 kc/s, 424.3 metres; 2 kW.—9.0 to 10.0 a.m., Topical Review. 3.0 p.m., Chimes, Time, Theatre Notes and Popular Concert. 5.0 to 8.0, Interval. 8.0, Chimes, Radio Journal and Dance Music. 9.30 to 11.0, Interval. 11.0, Chimes, Time Signal and Science Talk. 11.20 (approx.), Variety Programme. 1.0 a.m. (Monday), Dance Music relayed from the Alkazar Dance Hall. 1.30, Chimes and Close Down.

MALMO.—See Stockholm.

MILAN.—See Turin.

## MORAVSKA-OSTRAVA

1,137 kc/s, 263.8 metres; 11 kW.—6.0 to 10.50 p.m., See Prague.

MOTALA.—See Stockholm.

MUHLACKER.—See Stuttgart.

## MUNICH

563 kc/s, 533 metres; 60 kW. Relayed by Augsburg and Kaiserslautern, 536 kc/s, 560 metres; and Nürnberg, 1,256 kc/s, 239 metres.—11.0 a.m., Concert of Sixteenth Century Music and Modern Music. 11.30, See Leipzig. 1.0 p.m., Time and News. 1.10, Agricultural Talk. 1.30, Gramophone Concert of Light Music. 2.30, Talk: The Landscape Painter on his Travels. 2.50, Extracts from the German Folk Song Play, Op. 32 (Zilcher). In the interval, Polonaise Fantasia, Op. 61, for Pianoforte (Chopin). 3.30, Programme for Children. 4.0, Hups of Mischief—Humorous Programme (Schröder Justin) with Music by Ludwig Kusche. 4.40, Programme to be announced. 5.10, Concert by the Augsburg Concert Orchestra, conducted by Schmidt-Breston. 6.25, Talk or the following Transmission. 6.35, Patsy (Pfitzner)—Musical Legend in Three Acts (Pfitzner), relayed from the National Theatre. Conductor: The Composer. In the interval, Weather and Sports Notes. 10.30 (approx.), Time and News. 11.0, Dance Music from Berlin (Funkstunde). 12 (Midnight), Close Down.

NAPLES.—See Rome.

NOTODDEN.—See Oslo.

## OSLO

277 kc/s, 1,083 metres; 60 kW. Relayed by Fredrikstad, 815 kc/s, 368.1 metres; Hamar, 522 kc/s, 574.7 metres; Notodden, 671 kc/s, 447.1 metres; Porsgrund, 662 kc/s, 453.1 metres; and Rjukan, 671 kc/s, 447.1 metres.—5.15 p.m., Concert by the Bergen Radio Orchestra. 6.15, Talk and Recitation. 6.45, Song Recital. 7.15, Weather Report and News. 7.30, Talk. 8.0, Time Signal. 8.1, Concert by the Budapest Trio: Trio (Beethoven); Trio in B Minor, Op. 99 (Schubert). 9.0, Recitations. 9.30, Announcements. 9.40, Weather and News. 10.0, Topical Talk. 10.15, Concert of Eighteenth Century Music by the Station Orchestra, conducted by Hugo Kramm; Concerto grosso in F Minor (Pietro Locatelli); Amphitryon (Purcell); Air (Lully); Minuet (Bocherini); Soeur Monica (Cooperin); Serenade for String Orchestra, Eine kleine Nachtmusik (Mozart). 11.0 (approx.), Close Down.

OSTERSUND.—See Stockholm.

## PALERMO

558 kc/s, 537.6 metres; 3 kW.—10.25 a.m., Bible Reading. 10.40, Sacred Music. 11.5,



SEPT. 24th

SUNDAY

continued

Agricultural Talk. 12.45 p.m., Giornale Radio. 1.0 to 2.0, Concert of Light Music. In the interval at 1.30, Time, Announcements and Weather. 5.30 to 6.30, Gramophone Music. 8.0, Dopolavoro Announcements and Giornale Radio. 8.20, Sports Notes. 8.25, Gramophone Music. In the interval at 8.30, Time and Announcements. 8.45, Orchestral Concert, conducted by La Rosa Parodi. In the interval, Talk. After the Concert, Gramophone Music. 11.0 (approx.), Close Down.

PARIS

EIFFEL TOWER, Call FLE, 207.5 kc/s, 1,445.7 metres; 13 kW. Time Signals (on 2,650 metres) at 10.26 a.m. and 11.26 p.m. (Preliminary and 6-dot Signals)—1.0 p.m., News. 1.15, Weather. 1.30 to 2.30, Concert by the Ibos Orchestra. 6.45, Le Journal Parlé. 8.30, Gramophone Concert: Part I: Italian Music; Part II: Variety Music. 10.0 (approx.), Close Down.

PARIS

POSTE PARISIEN, 914 kc/s, 328.2 metres; 60 kW.—10.0 a.m., Gramophone Music. 10.20, Press Review. 10.30, Sponsored Concert. 11.0, Orchestral Concert. 12.15 p.m., Sponsored Concert of Sound Film Music. 12.45, Sponsored Programme. 12.50, Half an Hour of Fantasy by Paul Weill. 1.30, Sponsored Programme. 2.0, Interval. 7.0, Le Journal Parlé. 7.5, Sports Notes. 7.15, Gramophone Music. 7.30, Catholic Review. 8.0, Classical Music on Gramophone Records. 8.30, Sponsored Concert. 9.15, Literary Programme. 9.54, Concert. 10.15, News.

PARIS

RADIO-PARIS, 174 kc/s, 1,725 metres; 75 kW.—7.45 a.m., Gramophone Music. 8.0, Press Review and Weather. 8.30, Physical Culture. 12.0 Noon, Religious Address. 12.20 p.m., Sacred Music: Prelude in E Minor (Bach); Pastorale (Pachelbel); In dulce jubilo (Buxtehude). 12.30, Gramophone Concert. 1.30 to 3.0, Programme in English by the I.B.C. 1.30, Gramophone Concert: L'Heure douce (Eslavly); Selection from Lilac Time (Schubert-Berté); Song from Les noces de Jeannette (Massé); Sérénade badine (Gabriel Marie); Arlequin (Lalo); Concert Polonaise (Vidal). 2.0, Concert of Dance Music: Signature Tune, Happy Feet; From me to you; Just making conversation; Learn to croon; If I had somebody to love; Roll up the Carpet; Moonstruck; Sandown in a little green hollow; It's a nice day to-day; Signature Tune. 2.30, Orchestral Concert: March, Stars and Stripes (Souza);

Dixieland (Stoddon); Barcarolle from The Tales of Hoffmann (Offenbach); Selection from The Gipsy Princess (Kálmán); Selection from Bitter Sweet (Coward). 3.0, Variety Music. 5.30, Gramophone Music: Au moulin (Gillet); La valse bleue (Margiz); Chant d'après-midi (Cavillier); La Mousmée (Ganne); Honolulu (Yvain); Sous les ponts de Paris (Scott); Selection from Scaramouche (Messager-Yatove); March des petits pierrots (Bose). 6.0, Popular Concert. 7.0, Variety Music. 8.0, Gramophone Music. 8.30, News, Sports Notes and Weather. 8.45, Gramophone Music (cont'd). In the interval at 9.15, Press Review and News.

PITTSBURGH

KDKA, 980 kc/s, 306 metres; 50 kW. Relayed by W8XK on 48.86 metres and 25.27 metres.—5.30 to 6.30 p.m., Radio City Concert, from New York. 7.0, Boys of Wynnecastle. 7.15 to 11.0, New York Relay. 7.15, Summer Idylls. 7.30, Popular Programme. 8.0, National Opera Concert. 9.0, Gould and Shefter. 9.15, Ennio Bolonini. 9.30, Organ Recital. 10.0, Vesper Services. 11.0, News, Among Masters. 11.15, Weather, Sports. 11.30, Huston Ray's Orchestra. 12 Midnight, Variety Programme. 12.30 to 2.45 a.m. (Sunday), New York Relay. 12.30, Desert Guns. 1.0, Light Opera Nights. 2.0, Gulf Headliners. 2.30, Walter Winchell. 2.45, Programme to be announced. 3.0, Mountain Music, from New York.

PORSGRUND.—See Oslo.

PRAGUE

614 kc/s, 488.6 metres; 120 kW.—11.0 a.m., Orchestral Concert of Czech Music. Conductor: Pataky Jeremias. Soloist: Ada Nordenova (Soprano). 12 Noon, Chimes. 12.5 p.m., News. 12.15, See Bratislava. 1.30, Agricultural Talk. 1.45 to 1.55, Announcements. 3.45, See Bratislava. 5.30, A Blind Actor's Reminiscences. 5.45, Gramophone Music. 6.0, German Transmission: Programme Review. An Operaletta in One Act (Pisarowitz), with the Station Orchestra, conducted by the Composer. News. 6.55, Talk on the following Transmission. 7.0, Libusa—Opera (Smetana), relayed from the National Theatre. 10.30, News. 10.50 (approx.), Close Down.

RADIO-SUISSE ROMANDE

SOTTENS, 743 kc/s, 403 metres; 25 kW.; and GENEVA, 395 kc/s, 760 metres.—9.15 a.m. (from Aigle), Radio Report of the Walking Tour round Lake Geneva. 10.0 (from Lausanne), Protestant Service. 10.45 (from Lugano), Radio Report of the International Motor Car Race at Mont Ceneri. 12 Noon (from Vevey), Radio Report of the Walking Tour. 12.30 p.m., News and Weather. 12.40 (from Lausanne), Gramophone Concert. 2.0 (from Lausanne), Sports Relay from the Stadium. Walking Tours, Rugby and Football Matches. 5.30, Interval. 7.0, Religious Address. 7.40, Sports Notes. 8.0, Concert by the Radio-Suisse Romande Orchestra. Soloist: Henri Honegger (Cello). Selection from H Seraglio (Mozart); The Unfinished Symphony (Schubert); Cello Concerto (Lalo); Overture, Penelope (Fauré); Petite Suite (Debussy). 9.0 (from Lausanne), Readings. 9.15 (from Lausanne), Cello Recital by André Levy: Sonata in B Flat (Händel); Suite in C (Bocherini); Spanish Dance (Fallá); Tarantella (Casella); Two Pieces (Ibert). 9.50, News. 10.0 (from Lausanne), Pianoforte Recital by Irène Hertzig: Sonata in D (Mozart); Prelude (Prokofiev); Jugend Erinnerung (Iserlis); Tarantella (Blanchet); The Blue Danube (Strauss-Schultz-Evler). 10.30 (approx.), Close Down.

RJUKAN.—See Oslo.

ROME

Call 1R0, 680 kc/s, 441 metres; 50 kW. Relayed by 2R0, 11,810 kc/s, 25.4 metres, from 5.15 p.m.; Bari, 1,112 kc/s, 269.8 metres; Milan (Vigentino), 662 kc/s, 453.2 metres, from 8.45 p.m., and Naples, 941 kc/s, 319 metres.—10.0 a.m., News, Sports Notes and Amusement Guide. 10.30, Agricultural Notes. 10.45, Bible Reading. 11.0, See Turin. 2.0, Time and Announcements. 5.0 (from Naples), Programme for Children. Weather, and Sports Notes. 5.15 to 6.30, Vocal and Instrumental Concert. In the interval at 5.30, Sports Notes. 6.30, Weather. 7.30, Sports Notes, Dopolavoro Report and News. 7.45, Mezzo-Soprano Solos by Bianca Bianchi. 8.0, Time and Announcements. 8.30, Sports Notes. 8.45, Variety Concert: Ornella Pulitanti (Pianoforte); Maria Senes (soprano) and Emilio Livi (Tenor); Pianoforte Solos; (a) Capriccio (Dohnanyi), (b)

Per una vecchia beona (Rocca), (c) Per un guerriero (Rocca); Gramophone Records: (a) Suite, The Good-humoured Ladies (Scarlatti-Tommasini). (b) Waltz Intermezzo (R. Strauss). (c) Second Entr'acte from The Jewels of the Madonna (Wolf-Ferrari). (d) Dance of the Tumblers from The Snow Maiden (Rimsky-Korsakov); Soprano Solos: (a) Two Arias from Figaro (Mozart). (b) Maria Wiegandil (Reger). (c) Donde estas corazon (Sorrano); Tenor Solos: (a) Almaviva's Serenade from The Barber of Seville (Rossini). (b) Arias from Rigoletto (Verdi); Questa o quella and La donna è mobile, (c) Aria from Martha (Flotow). (d) Princesita (Padilla); Dance Music. 11.0, News.

SALZBURG.—See Vienna.

SCHENECTADY

WGY, 790 kc/s, 379.5 metres; 50 kW. Relayed at intervals by W2XAF on 31.48 metres, and by W2XAD on 19.56 metres.—8.0 to 10.0 (approx.), New York Relay. 8.0 p.m., Gene Arnold and the Commodores. 8.15, Pop Concert. 9.0, Wayne King's Orchestra. 9.30 to 10.0, Radio Pulpit. 1.45 to 4.45 a.m. (Monday), New York Relay. 1.45, Popular Programme. 2.0, Variety Programme. 3.0, Manhattan Merry-Go-Round. 3.30, American Album of Familiar Music. 4.0, Musical Programme. 4.15, Impressions of Italy. 4.45, Sunday at Seth Parker's, from New York, followed by Programme Resumé.

SCHWEIZERISCHER LANDESENDER

BEROMUNSTER, 653 kc/s, 459 metres; 60 kW.; Basle, 1,229 kc/s, 244.1 metres; and Berne, 1,220 kc/s, 245.9 metres.—10.0 a.m. (from Zürich), Protestant Service. 10.45, See Radio-Suisse Romande (Sottens). 12.0 Noon (approx.) (from Zürich), Gramophone Concert. 12.30 p.m., Time, Weather, and News. 12.40 (from Zürich), Concert by the Station Orchestra, conducted by Neppach. 1.30 (from Zürich), Agricultural Programme. 2.30 to 5.0, Interval. 5.0 (from Zürich), Gramophone Concert. 5.30 (from Zürich), Talk: The Care of the Aged. 6.0 (from Zürich), Talk: Ping-pong, etc. 6.30 (from Zürich), Readings. 7.0 (from Zürich), Sports Results. 7.10 (from Zürich), Organ Recital by Peter Stüssi. 8.0 (from Zürich), Songs in Dialect. 9.0, News. 9.10 (from Zürich), Dance Music. 10.15 (from Zürich), Sports Notes.

SOTTENS.—See Radio-Suisse Romande.

"My dear Watson . . . !  
 . . . IT IS OBVIOUS THE VALVE HAS GONE . . ."

"It took me only a very short time to discover that—thanks to the 'All-in-One' Radiometer. With this invaluable instrument to help me I'll guarantee to track down any trouble in a few minutes."

The "All-in-One" Radiometer is essential to every radio user. It tests everything, locates faults instantly, and helps to keep any set in 100% condition.

Ask your radio dealer about it,  
 or write direct to  
 PIFCO LTD., High Street,  
 MANCHESTER, or  
 150, Charing Cross Road,  
 London, W.C.2.

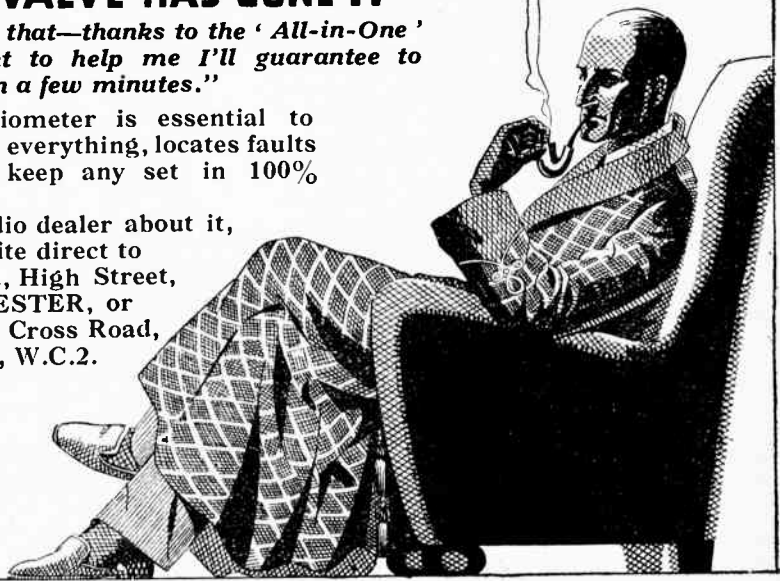

PIFCO  
**ALL IN ONE**  
 RADIOMETER

Standard Model "All-in-One" Radiometer, for Battery Sets only, as shown here. Price **12'6**

De Luxe Model, for Battery Sets, Electric Receivers and Mains Units. Price - - - **£2:2**



SEPT. 24th

**SUNDAY**

continued

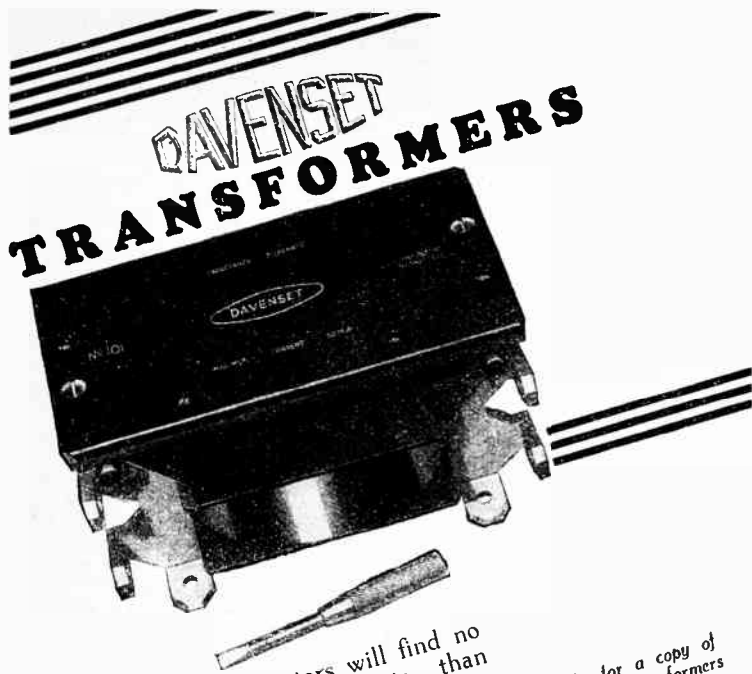

# DAVENSET TRANSFORMERS

Home set constructors will find no more reliable components than DAVENSET Transformers. Their recurring specification in many well-known sets is evidence of their high standing in the opinion of the acknowledged radio experts.

Write for a copy of "Mains Transformers and Power Smoothing Chokes for Radio and Industrial Purposes."

**PARTRIDGE, WILSON & CO.**  
Dept. 29, Davenset Works, Leicester.  
Scottish Branch: 200, St. Vincent Street, Glasgow, C.2.

## TONE....

The responsibility of reproducing music and speech, clear and sharp without distortion, rests not with the speaker alone but with the cabinet it is housed in. To get the best out of a speaker it is essential to have depth in the cabinet—that's where the Camco No. 2 "Melodee" scores. It measures 12in. from back to front and gives the same effect as a large baffleboard but without booming.

Supplied in Oak, 30/-, Mahogany and Walnut, 33/- complete with baffleboard, having hole cut to suit requirements.

See it at our Showrooms and send for a copy of the new Camco Cabinet Catalogue containing particulars of complete range. **CARRINGTON MFG. CO. LTD.** Showrooms: 24, Hatton Garden, E.C.1.

Phone: Holborn 8202.  
Works: S. Croydon.

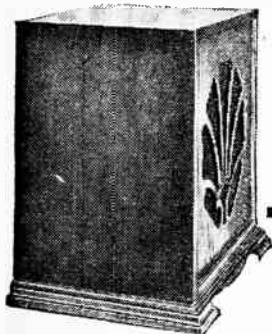

### STOCKHOLM

689 kc/s, 436 metres; 55 kW. Relayed by Boden, 244 kc/s, 1,229.5 metres; Göteborg, 932 kc/s, 322 metres; Hörby, 1,166 kc/s, 257 metres; Motala, 221.5 kc/s, 1,354.4 metres; Östersund, 389 kc/s, 770 metres; and Sundsvall, 554 kc/s, 542 metres.—9.0 a.m., Rural Programme. 9.30, Gramophone Music. 10.10, Talk for Workers. 11.0 (from Göteborg), Divine Service. 12.45 p.m., Weather. 3.0, Provincial Programme. 3.30, Reading. 4.0, Gramophone Music. 5.5, Programme for Children. 5.30, Pianoforte Recital by Mary Barratt-Due. 6.0, Divine Service. 7.15, Weather and News. 7.35, Master Olof—Play (August Strindberg). 9.15, Concert by the Station Orchestra; Soloist, Stefan Frenkel (Violin). In the interval at 9.45, Weather and News. 11.0 (approx.), Close Down.

### STRASBOURG

869 kc/s, 345 metres; 11.5 kW.—9.30 a.m., Orchestral Concert, conducted by Maurice de Villers. 10.45, Protestant Service in German. 11.30, Catholic Service. 12 Noon, Classical Music on Gramophone Records. 12.45 p.m., News. 1.0, Time. 1.1, Light Music on Gramophone Records. 2.0, Popular Music on Gramophone Records. 3.0, Interval. 4.0, Chamber Music, relayed from Radio Coleniale (Paris), 15,243 kc/s, 19.68 metres. 5.0, Orchestral Concert, conducted by Roskam; March, Salut à l'Alsace (Sali); Waltz, Wood Violets (Fétras); Waltz from The Nuremberg Doll (Adam); Three Melodies (Brahms); Liszt Potpourri (Glazunov); Selection from La Bohème (Puccini); Orchestra Suite, Mascarade (Lacôme). 6.0, Medical Talk in German. 6.15, Sports Talk. 6.30, Orchestral Concert, conducted by Maurice de Villers; Overture, Le Caid (Thomas); Selection from La pâtisserie de la Reine Pédouque (Lévy); Suite from The Sleeping Beauty (Tchaikovsky); Ballet Music from Lakmé (Delibes); Mandi, Pomp and Circumstance (Elgar). 7.30, Time and News. 7.45, Gramophone Music. 8.0, Press Review in German, Lottery Results and Announcements. 8.30, Dramatic Programme: (a) Le Legs—One-Act Play (Marivaux). (b) Les folies amoureuses—Play in Three Acts in Verse (Marivaux). 9.30 (approx.), Press Review. 10.30, Dance Music, relayed from the Savoy. 12 Midnight (approx.), Close Down.

### STUTTGART

MUHLACKER, 832 kc/s, 360.5 metres; 60 kW. Relayed by Freiburg, 527 kc/s, 570 metres.—11.30 a.m., See Leipzig. 12 Noon, Orchestral Concert relayed from Glottersbad. 1.0 p.m., Topical Talk. 1.15, Aureliano Pertile Song Recital on Gramophone Records. 1.30, The Jupiter Symphony in C, No. 41 (Mozart), on Gramophone Records. 2.0, Agricultural Talks. 2.30, Songs of the Nations by Gina Concert. 3.0, Choral Concert. 3.30, Tempo-Tempo—Play for Children (Else Holle-Hellmund), with Music by Gustav Görlich. 4.30 (from Mannheim), Concert by the Philharmonic Orchestra, conducted by Ludwig Becker. 5.30, Reading of a Swabian Story (Gaupp). 6.0, Pianoforte Sonata in F minor, Op. 57—the Appassionata (Beethoven) by Hans Brehme. 6.30, Sports Report. 6.50, A Swabian Musical Instrument—Radio Picture relayed from Trossingen. 7.20, Nazi Band Concert. 8.0, See Frankfurt. 10.20, Time and News. 10.45, Dance Music relayed from Berlin (Funkstunde). 12 Midnight, Close Down.

SUNDSVALL.—See Stockholm.

### TOULOUSE

RADIOPHONIE DU MIDI, 779 kc/s, 385 metres; 8 kW.—11.0 a.m., Dance Music. 11.30, Military Music. 11.45, Music from Sound Films. 12 Noon, Organ Solos. 12.15 p.m., Operetta Music. 12.30, Viennese Music. 12.45, Accordion Music. 1.0, Amusement Guide. 1.5, Opera Music. Bacchanal from Tannhäuser (Wagner); Triumphant March from Aida (Verdi). 1.15, Chansonnettes. 1.30, Orchestral Music. 1.45, Opera Music. Duet from Act I of Mignon (Masseuet); Air from Mirella (Gounod); Clair de lune from Werther (Masseuet); Air from Fortunio (Messager). 2.0, Orchestral Music. 2.30, Popular Melodies. 2.45, Agricultural Notes. 3.0, Lakmé—Opera (Delibes) (Concert Version). 4.15, Military Music. 4.30, Music from Sound Films. 4.45, Music by an Argentine Orchestra. 5.0, Dance Music. 5.45, Accordion Music. 6.0, News. 6.15, Popular Melodies. 6.30, Opera Music. Ballad from L'Africaine (Meyerbeer); Air from William Tell (Rossini); Prelude to Faust (Gounod). 6.45, Overture, Le roi d'Ys (Lalo), by a Symphony Orchestra. 7.0, Chansonnettes. 7.15, News. 7.30, Operetta Music. 7.45, Opera Music. 8.0, Songs. 8.15, Military Music. 8.30, Opera Music. 8.45, Accordion Music. 9.0, Concerto No. 5 in A (Mozart), followed by Songs from Sound Film and Orchestral Music. 10.0, Chansonnettes. 10.15, News. 10.30, Concert for Listeners in Morocco. Ballet Music from Les deux pigeons (Messager); The Death of Siegfried and Air from The Dusk of the Gods (Wagner); The Emperor Waltz

(Joh. Strauss); La Rigolomanie (Picolini); Encore une Java (Maye). 11.0, Music by a Viennese Orchestra. 11.30, Orchestral Music. 11.45, Military Music. 12 Midnight, News. 12.5 a.m. (Monday), Dance Music. 12.30 (approx.), Close Down.

### TRIESTE

1,211 kc/s, 247.7 metres; 10 kW.—9.40 to 9.55 a.m., See Turin. 9.55, Mass from the Cathedral of San Giusto. 11.0, Religious Address. 11.20, Agricultural Talk. 12 Noon till Close Down, See Turin.

TRONDHEIM.—See Oslo.

### TURIN

273.7 metres; 7 kW. Relayed by Milan, 331.5 metres, Genoa, 312.8 metres, and Florence, 509.5 metres.—9.40 to 9.55 a.m., News. 10.40, Agricultural Talk. 11.0, Mass from the Church of the Annunciation. Florence. 12 Noon, Bible Reading. 12.30 p.m., Gramophone Music. In the interval at 1.0, Time and Announcements. 1.30 (approx) to 2.0, Orchestral Concert. 1.45 to 2.0, Gramophone Music. 4.30, Concert. In the intervals, Sports Notes and Football Results. 6.15, Weather and Gramophone Music. 6.30, Sports Notes, Football Results and Announcements. 7.0, Time and Popolayoro Notes. 7.10, Gramophone Music. 8.0, Announcement, News, and Sports Notes. 8.20, Talk on the following Transmission. 8.30, Ruy Blas—Opera (Marchetti). In the intervals, Talk and Theatre Notes. After the Opera, Giornate Radio.

### VIENNA

581 kc/s, 517 metres; 100 kW. Relayed by Graz, 852 kc/s, 352.1 metres; Innsbruck, 1,058 kc/s, 283 metres; Klagenfurt, 652 kc/s, 453.2 metres; Linz, 1,220 kc/s, 245.9 metres; and Salzburg, 1,373 kc/s, 216.5 metres.—11.30 a.m., Radio Report of the International Hill Climbing Races on the Semmering. 11.50, Reading (Max Hayek). 12.5 p.m., Concert by the Vienna Chamber Orchestra, conducted by Karl Auerlieth. Soloist: Karl Baltz (Violin). Glees (Telemann). Violin Concerto in A minor (Spohr); Suite for Strings (Janacek); Violin Pieces; Fantasia on Two Russian Folk Songs, Karaminskaya (Glinka); Serenade, Op. 15 (Fiedler); Overture to a Comedy (Reznicek). In the intervals, Relay of the International Hill Climbing Race on the Semmering. 2.40, Time and Announcements. 3.0, Agricultural Talk. 2.20, Book Review: Reminiscences of Pre-War Austria. 3.45, Concert by the Anita Ast Quartet; String Quartet in A (Bittner); String Quartet in F minor, Op. 95 (Beethoven). 4.45, Talk: The Mighty Danube. 5.10, Concert by the Wiener Symphoniker, conducted by Josef Holzner. 6.30, Recital of Arias and Ballads by Franz Höbbling (Bartone); Archibald Douglas (Löwe); Aria from Figaro (Mozart); Bitterolf (Wolf); Gerard's Monologue from Andrea Chénier (Giordano); Bolero from Don Quixote (Kienzl); Nilakantha's Aria from Lakmé (Delibes); The Two Grenadiers (Schumann); Hans Sachs' Monologue from The Mastersingers (Wagner). 7.20, Bruno Wolfgang reads from his own works. 7.50, Time and Announcements. 8.0, Minna von Barnhelm—Comedy in Five Acts (Lessing). 10.0, Announcements. 10.15, Military Band Concert. After the Concert, Announcements.

### WARSAW

212.5 kc/s, 1,411 metres; 120 kW.—10.50 a.m., Programme Announcements. 11.0, Divine Service and Unveiling of the War Memorial to the Fallen of the Seventh Legionary Regiment, relayed from Chelm Lubelski. In an interval at 11.57, Time Signal, and Fanfare from St. Mary's Church, Cracow. 12.50 p.m., Weather Report. 12.55, Concert by the Station Orchestra conducted by Oziminski. Soloist Mile. Perenson (Soprano). 2.0, Agricultural Programme and Weather Report. 2.20, Choral Music. 2.45, Talk on the Corn Trade. In the interval, News. 4.0, Topical Talk. 4.15, Talk on Denmark. 4.30, Gramophone Music. 5.0, Talk. 5.15, Polish Dance Music by the Adam Stromberg Orchestra. 6.0, Song Recital by Wronski. Aria from The Haunted Castle (Moniuszko); Aria from Martha (Flotow); Aria from the First Act of Don Pasquale (Donizetti); Aria from the Third Act of André Chénier (Giordano); Don Juan's Serenade (Tchaikovsky); Two songs (Buzzi-Peccati): (a) Non una ferita, (b) Nina Querida. 6.35, Programme Announcements. 6.40, Miscellaneous Items. 7.0, Talk. 7.40, Answers to Technical Correspondence. 8.0, Szymanowski Concert for the Composer's Fiftieth Birthday. The Station Orchestra, conducted by Fiteberg. Soloists: Szymanowski (Pianoforte), Korwin-Szymanowska (Songs) and Umńska (Violin). Introductory Talk by Prof. Z. Jachimecki, relayed from Cracow. 9.59 kc/s, 312.8 metres. In the interval, Radio Journal. 10.0, Sports Talk. 10.15, Aviation Weather Report and Police Notes. 10.20, Programme relayed from Lwów, 788 kc/s, 381 metres.

ZURICH.—See Schweizerischer Landessender.

# MONDAY

## SEPTEMBER THE TWENTY-FIFTH

### PRINCIPAL EVENTS OF THE DAY:

#### AT HOME

<p><b>NATIONAL LONDON REGIONAL</b></p> <p><b>MIDLAND REGIONAL</b></p> <p><b>NORTH REGIONAL</b></p> <p><b>WEST REGIONAL</b></p> <p><b>SCOTTISH REGIONAL</b></p> <p><b>BELFAST</b></p>	<p>Crazy Variety programme.</p> <p>Promenade concert from Queen's Hall.</p> <p>Orchestral concert.</p> <p>Orchestral concert.</p> <p>From Famous Trios, instrumental recital.</p> <p>"The Pigeon," a play, by Ian Priestley Mitchell.</p> <p>Excerpts from opera: "Orpheus," by Gluck.</p>
<b>ABROAD</b>	
<p><b>ATHLONE</b></p> <p><b>BRUSSELS</b></p> <p style="text-align: center;">(No. 1)</p> <p><b>COPENHAGEN</b></p> <p><b>EIFFEL TOWER</b></p> <p><b>HEILSBURG</b></p> <p><b>HUIZEN</b></p> <p><b>LUXEMBOURG</b></p> <p><b>SOTTENS</b></p> <p><b>STRASBOURG</b></p> <p><b>VIENNA</b></p>	<p>10.0 p.m. Concert on behalf of Hospitals Trust Ltd.</p> <p>8.0 p.m. The Station Symphony Orchestra, conducted by Jean Kumps.</p> <p>8.30 p.m. Mozart concert, by the Radio Orchestra.</p> <p>8.30 p.m. Concert of operetta and light music.</p> <p>8.5 p.m. Brahms concert.</p> <p>5.10 p.m. The Station Orchestra.</p> <p>8.20 p.m. Austrian concert, by the Station Orchestra.</p> <p>8.0 p.m. Rameau concert from Geneva.</p> <p>8.30 p.m. Light opera: "Monsieur de la Palisse," by Terrasse.</p> <p>6.55 p.m. Opera: "Tannhäuser" (Wagner), from the State Opera House.</p>

**ATHLONE**  
 25 kc/s, 413 metres; 60 kW. Relayed by York, 1,337 kc/s, 224.4 metres.—1.30 to 2.30 p.m., Time Signal, Weather Report, Stock Exchange Quotations, and Gramophone Music. 6.0, Programme for Children. 6.45, News. 7.0, Gaelic Talk. 7.15, Reading of James Stephens' Poems by Mrs. E. V. Fleming-Moran. 7.30, Time Signal. 7.31, Concert by the Station Orchestra. 8.0, Dramatic sketch by Elizabeth Young and Company. 8.30, Soprano Solos by May Doyle. 8.45, Lecture Recital by H. R. White. 9.15, The Station Orchestra. 9.30 to 10.30, Programme by the I.R.C. (Ireland), Ltd. 9.30, Dance Music: The Tapper; I'll be good because of you; Harlequinade; Lucky. Xylophone: There's a Cabin in the Pines; Jog along; In the Valley of the Moon; When the wild, wild Roses bloom. 10.0, Concert arranged by the International Broadcasting Company (Ireland), Ltd., on behalf of Hospitals' Trust, Ltd.: Selection from The Desert Song (Romberg); Pianoforte Solo, Rangoon Rice Carriers (Hollbrook); A Bachelor Gay (Harris); Souvenir de Capri (Becc); If I were King (Robin); Gavotte (St. Denis); Waltz from The Gipsy Baron (Strauss). 10.30, I.R.C. Goodnight Melody, followed by News, Weather Report, and Time Signal. 10.40, Pipe and Fiddle Recital by Liam and Maurice Condon. 11.0 (approx.), Close Down.

**BARCELONA**  
 EAJI, 860 kc/s, 348.8 metres; 8 kW.—7.0 a.m., Trio Concert; Selection from Lohengrin (Wagner); The Musical Snuff-box (Ljadov); Adoration (Philippi); Alt Wien (Drdla); Intermezzo (Haugregard); Love Song and Serenade (Vallany and J. Weber); Selection from The Pearl Fishers (Bizet). 8.0, Request Gramophone Music. 8.20, Sports Notes. 8.30, Exchange and Talk in Catalan. 9.0, Gramophone Music and News. 10.0, Chimes from the Cathedral, Weather, Exchange and Market Prices. 10.5, Humorous Review of the Week in Verse. 10.15, Concert by the Station Orchestra: Heroic March (Blokland); Selection from Boris Godunov (Mussorgsky); Gopak (Mussorgsky); Overture, Mignon (Thomas). 10.45, Trio Concert. 11.30, Popular Orchestral Music, relayed from the San Sebastian Casino. In the interval at 12 Midnight, News. 1.0 a.m. Tuesday), Close Down.

**BASLE**.—See Schweizerischer Landessender.

**BERLIN**  
**DEUTSCHLANDSENDER (REICHSENDER)**, 193.5 kc/s, 1,635 metres; 60 kW.—1.45 p.m., News. 2.0, Gramophone Concert; Dorfschwalben aus Oesterreich (Strauss); Overture, Poet and Peasant (Suppe); Czardas and Mazurka, from Coppelia (Delibes); Overture, Der Opernball (Heuberger); The Last Rose, from Martha (Flotow); Knowest thou the Land from Mignon (Thomas); Overture, Zampa (Hérold); Marche joyeuse (Chabrier-Hirrich); Slav Dance (Chabrier); España (Chabrier); Selection from Tiefland (G. Albert); Marienkönige (Strauss). 3.0, Talk: Books for Women. 3.15, Talk: The German Autumn Fashions. 3.30, Weather and Exchange. 3.45, Book Review. 4.0, Concert from Breslau. 5.0, Talk: The Cinema. 5.20, Pianoforte Recital by Eva Elmer-Robert: Ecosaisnes (Beethoven); Aufschwung (Schumann); (b) Grillen (Schumann); Der Lindenbaum (Schubert-Liszt); Ständchen (Schubert-Liszt); Gnomenszene (Liszt). 5.40, Violin and Pianoforte Recital by Erich Rohm and Bertha Düring: Andalusian Romance (Sarasate); Andalusian Serenade (Sarasate); Danza delle streghe (Paganiini). 6.0, A Poem. 6.5, Orchestral Concert; Soloists: Erwin Hartung (Songs). 6.50, Weather and Announcements. 7.0, Transmission for all German Stations: Where is Germany?—Programme arranged by Edwin Erich Dwinger. 8.0, Today's Motto. 8.5 (approx.), Concert from Frankfurt. 9.0, Ingeborg Comedy (Götz). 10.0, News. 10.45, Weather. 11.0, Concert from Leipzig. 12 Midnight, Close Down.

**BERLIN**  
**FUNKSTUNDE**, 715 kc/s, 419.5 metres; 1.5 kW.—4.0 p.m., Orchestral Concert, relayed from the Moka Effi; Intermezzo, Eine kleine Liebeli (Lautenschlager); Serenade, Starry Night (Michele); Czardas (Monty); Draussen in Schönbrunn (Benatzky); Cello Solo: The Rose (Spilkr-Kummer); Selection from Plauen und Elfenreigen (Kark); Rubin und Smaragd (Kick-Schmidt); Verdi Potpourri (Weninger). 5.5, Ernst Eduard Taubert—Song and Pianoforte Recital by Elisabeth Ohloff (Soprano) and Karl Heinz Taubert: Songs: (a) Sarella, (b) Auftrag, (c) Sonnet; Pianoforte Solos: Prelude, Intermezzo and Scherzo from Fantasietücke, Op. 42. 5.30, The Twilight Hour—a Radio Sequence in Verse and Song. 6.0, Talk: The Petroleum Fields of the Californian Desert. 6.15, Book Review. 6.40, The Funkstunde informs its Listeners. . . . 6.45, Topical Talk. 7.0, Transmission for all German Stations, relayed from Berlin (Deutschlandsender). 8.5, A Visit to a Tobacco and Cigarette Factory. 8.55, Unfamiliar Music of German Composers—Concert by the Station Orchestra, conducted by Waldemar von Yültze, the Station Choir, conducted by Heinzkarl Weigel, and Soloists: Rio Kube (Tenor) and Burchard Kaiser (Baritone).

Commentary by Heinrich Burkard. 9.50, Topical Talk. 10.0, News. 10.15 (approx.), Dance Music, relayed from the Roof Garden of the Eden Hotel. In the interval at 11.0, Police Notes. 12 Midnight, Close Down.

**BERNE**.—See Schweizerischer Landessender.

**BEROMUNSTER**. — See Schweizerischer Landessender.

**BODEN**.—See Stockholm.

**BODO**.—See Oslo.

**BRATISLAVA**  
 1,076 kc/s, 279 metres; 14 kW.—6.5 p.m., Trio Concert. Actardieff (Violin), Beza (Flute), and Lily Kratochilova (Viola); Trio, Op. 32 (Marteau); Serenade, Op. 77 (Reger). 6.55, Talk for Housewives. 7.0, See Prague. 7.10, See Brno. 7.40, See Moravská-Ostrava. 8.50, See Prague. 9.5, See Brno. 10.0, See Prague. 10.15 (approx.), Close Down.

**BREMEN**.—See Hamburg.

**BRESLAU**  
 923 kc/s, 325 metres; 60 kW. Relayed by Gleiwitz, 1,184 kc/s, 253 metres.—1.0 p.m., Weather. 1.5, Sound Film and Operetta Music on Gramophone Records. 1.45, Time Music on Gramophone Song Recital by Hans Hantke. 2.40, Gramophone Music. 3.0, Agricultural Prices. 3.15, Book Review: Agricultural Period. 3.35, Legal Talk. 4.0, Orchestral Concert, conducted by Gerhard Rischka: Little Suite (No. 2) (Schumann-Rischka); Selection from Der Freischütz (Weber); Waltz, Hofballtanz (Lammer); Serenade (Grig); Overture, Die Frau Meisterin (Suppe); Funkgeister-Potpourri (Noack); American Intermezzo (Recktenwald); Waltz, Badener Grüsse (Kauler); Weidmanns Juchel-Quadrille (Herrmann). 5.30, Agricultural Prices. 5.35, Talk: German Culture. 5.50, Programme to be announced. 6.10, Italian Duets for Mandoline and Guitar by Walter Fabig and Alfons Anlauf: Mareh, Amore e Concordia (Agos-Tini); Capricciotto (Sartori); Neapolitan Folk Song, O sole mio (di Capua); Scherzettino, Cicalciole di Rondini (Delbas); Waltz, Sguardi Provoocanti (Marinelli). 6.30, A Discussion: German Youth in the National Movement. 6.50, Meat Market Prices. 7.0, Transmission for all German Stations, relayed from Berlin (Deutschlandsender). 8.0, News. 8.10, Symphony Concert, relayed from the Concert Hall: The Silesian Philharmonic Orchestra, conducted by Hermann Behr, Soloist: Sigmund Bleier (Violin); Overture, Der Beherrscher der Geister (Weber); Violin Concerto in D (Mozart); The Unfinished Symphony in B minor (Schubert); Overture, Christophher Columbus (Wagner); Les Prehudes (Liszt). In the interval at 9.30, Theatre Talk. 10.15, Time and News. 10.45, Wireless Technical Talk. 10.55, Reading. 11.10 (approx.), Close Down.

**BRNO**  
 878 kc/s, 342 metres; 35 kW.—5.55 p.m., Programme for Scouts. 6.5, Gramophone Music. 6.25, German Transmission: News and Talks. 7.0, See Prague. 7.10, Concert of Russian Music. 7.40, See Moravská-Ostrava. 8.50, Home from the Holidays—Radio Scene (Kozik). 9.5, The Countryside—Concert by the Station Orchestra, conducted by Bretislav Bakala: Sommertag auf dem Laude, Op. 55 (Gade); From the Fields and Groves of Bohemia (Smetana); Rural Impressions (Fuchs). In the interval, Poetry Recital. 10.0, See Prague. 10.30 (approx.), Close Down.

**BRUSSELS (No. 1)**  
 I.N.R., 590 kc/s, 509 metres; 15 kW.—12 Noon, Gramophone Concert. 1.0 p.m., Le Journal Parlé. 1.10, Concert by the Small Station Orchestra, conducted by Pierre Leemans: Overture (Rogister); Petite Suite (Jongen); Aubadinette (Gaillard); Selection from Hérodiade (Massenet); Humorous Pieces for Violin (Leonard); Jonjou d'amour (Denard); Cramignon (Gibson). 5.0, Concert by the Radio Orchestra, conducted by Walpot: Hungarian March (Berlioz); Overture, Merry Wives of Windsor (Nicholai); Selection from Werther (Massenet); Waltz (Paradis); Overture, La belle Hélène (Offenbach); Musical Poem, April in the Woods (Grieg); Scenes brabantiques (Sarli). 6.0, Talk: September, 1830. 6.15, Gramophone Music. 6.30, Concert by the Small Station Orchestra, conducted by Leemans: Overture, Jean de Paris (Boieldieu); Symphonic Poem, Apaisement (Chadi); Amabilité (Lagarde); Pianoforte Solo: Ballad (Dupuis); Selection from La Pompe (Audran); Dream of Love (Marsick); Rag Time (Gollin). 7.30, Film and Theatre Review. 8.0, Concert by the Station Symphony Orchestra, conducted by Jean Kumps. Soloists: Borgers (Tenor) and Heistrank (Bass); Extracts from Faust (Gounod); Selection from La Vie du Poète (de Boeck); Bass Solo: Hopsasa (De Greef); Springdans (De Greef); Tenor Solos: Milenka (Block). In the interval at 8.45, Talk on the coming Musical Programmes. 10.0, Le Journal Parlé.

**BRUSSELS (No. 2)**  
 N.I.R., 987 kc/s, 338.2 metres; 15 kW.—Programme in Flemish.—12 Noon, Concert by the Small Station Orchestra, conducted by Leemans: Overture, Tancred (Rossini); Waltz Suite, Fedora (Kálmán); Geburtstag Ständchen (Lincke); Selection from Hansel and Gretel (Humperdinck); Violin Solo: La Gitana (Kreisler); The Song of Songs (Moya); Lehar Potpourri (Hrub); Two-step (Gordon). 1.0 p.m., Le Journal Parlé. 1.10, Gramophone Concert. 5.0, Concert by the Station Symphony Orchestra, conducted by

Kumps: The Unfinished Symphony (Schubert); Intermezzo for Horn and Orchestra (Jehin); Meurtri est mon coeur (De Greef); Dance (De Greef); Marche cortège (Delcroix). 5.45, Programme for Children. 6.30, Septet (Beethoven) on Gramophone Records. 7.12, Announcements. 7.15, Talk. 7.30, Le Journal Parlé. 8.0, Concert by the Radio Orchestra, conducted by Walpot: March of the Marionettes (Hullobroek); Waltz, Wiener Blut (Joh. Strauss); Overture, Lysistrata (Lincke); On the Bosphorus (Bayer); Gramophone Record: Air from The Gipsy Baron (Joh. Strauss); Fantasia on Flemish Songs (Walpot). 8.45, The Man in the Street's Views. 9.0, Concert (contd.): Suppé-Illusionen (Michadov); Rhapsody in B (Hartung); Gramophone Records: (a) Prayer from Rienzi (Wagner); (b) Air from Aida (Verdi); Selection from La Bohème (Puccini); Waltz Potpourri (Robrecht). 10.0, Le Journal Parlé.

**BUCHAREST**  
 761 kc/s, 394 metres; 12 kW.—5.0 p.m., Concert by the Station Orchestra: March (Blaukenburg); Waltz, The Blue Danube (Joh. Strauss); Overture, Peter Schmolli (Weber); Selection from La Traviata (Verdi); Selection from Clo-Clo (Lehar); Potpourri, Für alle (Dostal); Two Hungarian Dances (Brahms); Humoresque and Mazurka (Dvorak). In an interval at 6.0, Radio Journal. 7.0, Educational Talk. 7.20, Symphony Music on Gramophone Records. 7.40, Talk. 8.0, Quartet in F (Rogalski), by the Sarvas Quartet. 8.30, Talk. 8.45, Modern Music on Two Pianofortes. 9.15, Light Music, relayed from a Restaurant. 9.45, Radio Journal.

**BUDAPEST**  
 545 kc/s, 550.5 metres; 18.5 kW. Also relayed on 840 metres from 8.15 p.m. till Close Down.—5.0 p.m., Legal Talk. 5.30, Zither Concert. 6.15, German Conversation. 6.45, Gramophone Music. 7.45, Talk for Workers. 8.15, String Quartet Concert: Quartet in F (Ravel); String Quartet in D (Haydn). 9.15, News. 9.30, Concert from the Café Baross. 10.45, Song Recital. 11.15, Dance Music from the Café Bodo.

**CASSEL**.—See Frankfurt.

**COPENHAGEN**  
 1,067 kc/s, 281 metres; 0.75 kW. Relayed by Kalundborg, 260 kc/s, 1,153.8 metres.—12 Noon, Time and Chimes from the Town Hall. 12.5 p.m., String Ensemble Concert relayed from the Wivex Restaurant. 2.0, Interval. 3.20, Talk for Housewives. 3.30, Concert by Karl Rydahl's Instrumental Ensemble: Overture, Berlin, wie es weint und lacht (Conradi); Waltz (Ivanovitch); Selection from Meeste (Glick); Romance (Debussy); Prelude (Danning); Waltz (Brahms); Selection from Der Obersteiger (Zeller); Russian March (Ganne); Rapsodietta (Gade); Melody from Maskerade (Nielsen); Spring Song (Mendelssohn); Intimité (Moszkowsky); Serenade (Rachmaninov); Overture, Casanova (Lincke). In the interval at 4.15, Readings. 5.30, Exchange and Fish Market Prices. 5.45, Talk. 6.15, Elementary English Lesson. 6.45, Weather and News. 7.15, Time Signal. 7.30, Talk. 8.0, Chimes from the Town Hall. 8.5, Reading for Girls. 8.10 (approx.), Pianoforte Solos by Elisabeth Mollgaard: Nocturne in F sharp (Chopin); Scherzo (Schumann); Introduction and Presto in D (Haydn). 8.30, Mozart Concert: The Radio Orchestra, conducted by Fritz Mahler: Soloists: Sylvia Schierbeck (Songs), and Carl Bloch (Bassoon); Overture, Il Seraglio; Allegro from the Bassoon Concerto in B flat; Song; Serenade for strings, Eine kleine Nachtmusik. 9.10, A Visit with the Microphone to Copenhagen Harbour. 9.40, Gramophone Music. 9.56, Harp Recital of Music by Marcel Tournier: Les anesses grises sur la route d'El-Azib; Berceuse russe; Ses enfants à la crèche de Noël. 10.10, News. 10.25, Concert of Opera Music by the Radio Orchestra, conducted by Fritz Mahler: Soloist: Sylvia Schierbeck (Soprano); Salome's Dance from Salome (R. Strauss); Extracts from Wozzeck (Berg). 11.0 (approx.), Close Down.

**CORK**.—See Athlone.

**DANZIG**.—See Heilsberg.

**DRESDEN**.—See Leipzig.

**FECAMP**  
 1,328 kc/s, 225.9 metres; 10 kW.—11.0 a.m. to 12 Noon, Programme in English by the I.B.C. 11.0, Happy Hour. Part I—Maudeline Band Concert; Signature Tune; In Old Seville (Ege and Rosen); Capriccio Mazurka (Arienzo); Napolitana (Hay and Meisel); Loin du bal (Gillet); Mandoline (Thomé); Tesoro mio (Benedi); Czardas (Monti); La Czarine (Ganne). Part II—Dance Music: My! oh my!; I can't remember; I cover the Waterfront; I lay me down to sleep; In the Valley of the Moon; Stay out of my Dreams; Peter, Peter, Sweetheart Darlin'; Signature Tune. 12 Noon, French Programme. 4.30 to 6.0, Programme in English by the I.B.C. 4.30, Programme for Children. 5.0, Orchestral Concert for Chichester and

SEPT. 25th

MONDAY

continued

**Bogor Listeners:** Signature Tune; The Night by the Sea; The Wedding of the Birds; Love sends a Little Gift of Roses (Openshaw); Out of Breath; Pianoforte Solo: Selection from He Wanted Adventure (Waller); Southern Rhapsody (Hosmer); It seems to me; Pianoforte Solo: That Futuristic Rag (Bloom); Selection from No. No. Nannette (Youmans). 6.30, Orchestral and Choral Concert for Hastings and Eastbourne Listeners: Roses from the South (Strauss); Selection from Waltzes from Vienna (Strauss); Love everlasting (Friml); Mighty lak' a Rose (Clutsam); Goodbye (Tosti); Come to the Fair (Easthope-Martin); The Drums; Selection from The Quaker Girl (Monckton); Signature Tune. 6.0, French Programme. 10.0 to Close Down. Programme in English by to I.B.C. 10.0, Dance Music: Signature Tune; Bells of Normandy; From me to you; Wear a great big Smile; Love Songs of the Nile; I've told every little Smile; My Darling; Rosa Mia; Maybe I love you too much; Smilin' Through; The Old Spinning Wheel; Twelfth Street Rag; In the Valley of the Moon; I raised my Hat; I gotta right to sing the Blues; Seven years with the wrong Woman; You are too beautiful; Let's all be happy together; Signature Tune. 11.0, Sound Film Music: Signature Tune; Sittin' in the Dark; I want to be happy; But for you (Hollander); You are too beautiful (Rodgers); You are my Heart's Delight (Lehar); There's Magic in the Air (Bytown); Sweetheart Darlin' (Stodhart); In the Park in Parce (Woods); Waltz from Bitter Sweet (Coward); Signature Tune. 11.30, Club Concert for Annon Listeners. Part I—Wagner Music: Signature Tune; March from Tannhäuser; Walter's Song from The Mastersingers; Pilgrims' Chorus from Tannhäuser; Träume; Swan Song from Lohengrin; Overture, Kienzi; March, Nibelungen. 12.5 a.m. (Tuesday), I.B.C. News Bulletin in English. 12.10 (approx.), Club Concert. Part II: Hello (Redman); My pretty Girl (Fulcher); Hello, you can't ride this Train (Armstrong); The Diety Glide (Ellington); I hate to leave you now (Armstrong); Signature Tune; There's a Cabin in the Pines (Hill); Sweetheart Darlin' (Kahn); Hold me (Schuster); Dancing Butterfly (Young); You're mine, you (Green); I can't remember (Berlin); Drifting down the Shalimar (Moll); In the Park in Parce (Rainger). 1.0, Dance Music: Signature Tune; Bells of Normandy; Lover; Look what I've got; Stay out of my Dreams; I lay me down to sleep; The Shadow Waltz; Old Man Harlem; I've got to sing a Torch Song; Here is my Heart; I cover the Water-front; That's what life is made of; In Santa Lucia; Somebody stole my Girl; He was only a Poor Musician; Pink Elephants; When Gimble hits the Cymbal; Under my Umbrella; Signature Tune. 2.0, I.B.C. Good-night Melody and Close Down.

FLENSBURG.—See Hamburg.

FLORENCE.—See Turin.

## FRANKFURT

1,157 kc/s, 259.3 metres; 17 kW. Relayed by Cassel, 1,220 kc/s, 245.9 metres; and Trier, 1,157 kc/s, 259.3 metres.—4.30 p.m. (from Trier), Orchestral Concert, conducted by Otto Degen; Soloist, Otto Degen (Clarinet); Overture, Im Reiche des Indra (Lincke); Selection from Der Evangelium (Kienz); Waltz from Die Landstreicher (Zielner); Swedish Wedding March (Södermann); First Movement from the Concerto in F Minor (Weber); Waltz, Accelerationen (Jos. Strauss); Potpourri, Klänge aus Arkadien (Morena); Serenade, Gartenständchen (Meyer-Helmund). 5.45, Exchange. 6.0, A German Almanac. 6.10, Programme to be announced. 6.25, Lulu von Strauss-Torney discusses her new Book, Vom Biedermeier zur Bismarckzeit. 6.45, Review of the Day's News. 6.50, Time and News. 7.0, Transmission for all German Stations, relayed from Berlin (Deutschlandsender). 8.0, Concert by the Frankfurt Mandoline Orchestra and a Male Voice Quartet; Soloist, Hermann Uhticke (Accordion); Mandoline Orchestra: Overture, Die Heimreise (Wölki); Male Voice Quartet: Folk Songs; Mandoline Orchestra: Paraphrase on Aennchen von Tharau (Schanno); Accordion Solo: Folk Dances; Mandoline Orchestra: Dance of the Butterflies (Wormsbacher, arr. Wölki); Male Voice Quartet: Folk Songs; Accordion Solo: Folk Dances; Mandoline Orchestra: Romantic Concert Piece (Wölki). 9.0, Part-Relay of a Rehearsal of Schiller's Drama, Die Räuber, from the Playhouse. 9.30, Chamber Music by the Riele-Queling Quartet: Quartet in E flat, Op. 74 (Beethoven); Italian Serenade (Hugo Wolf). 10.20, Time and News. 10.45, Programme from Leipzig. 12 Midnight, Close Down.

FREDRIKSSTAD.—See Oslo.

FREIBURG.—See Stuttgart.

GENEVA.—See Radio-Suisse Romande.

GENOA.—See Turin.

GLEIWITZ.—See Breslau.

GÖTEBORG.—See Stockholm.

GRAZ.—See Vienna.

HAMAR.—See Oslo.

## HAMBURG

806 kc/s, 372 metres; 1.5 kW. Relayed by Bremen, 1,112 kc/s, 269.8 metres; Flensburg, 1,319 kc/s, 227.4 metres; Hannover, 530 kc/s, 566 metres; and Kiel, 1,292 kc/s, 232.2 metres.—6.0 p.m., Variety Programme. 6.40, Frankfurt Exchange and Hamburg Market Prices. 6.50, Weather. 7.0, Transmission for all German Stations, relayed from Berlin (Deutschlandsender). 8.0, Concert by the Wohlklang Quartet, the Small Station Orchestra, and Soloists. Conductor: Gerhard Manz. Folk Song; Waltz Potpourri (Egg); Zither Solo: Münchener Schützen-Marsch (Baader); Old Styrian Light Music and Dance Music (Pachernegg); Quartet; Violette von Avignon (arr. Baussern); Accordion: Foxtrot Intermezzo, Glow-worm (Nicholls); Quartet: Brautfahrt in Hardanger (Kjerulf); Accordion: Tango, La Comparsita (Rodriguez); Zither Solo: Erinnerung aus den Alpen (Baader); Klavierstück (Lindemann). 9.0, See Berlin (Deutschlandsender). 9.50, Topical Talk. 10.10, Time and News. 10.30 (from Kiel), Concert by the Kiel Orchestra of Unemployed Musicians, conducted by Hans Döring: March Von Welle zu Welle (Senzer); Romantic Overture (Kler-Bela); Waltz, Liebe und Leben (Kossov); Gavotte (Gossec); Selection from Don Pasquale (Donizetti); Intermezzo, Hanneles Himmelfahrt (Graener); Ungarischer Steppemarsch (Siede); Song (Sullivan); Concert Polka No. 3 (Grünfeld); Selection from Fatinitza (Suppé); Serenade, Pierrette (Brase); March, Unterm Freiheitsstern (Blankenburg).

HANOVER.—See Hamburg.

## HEILSBURG

1,085 kc/s, 276.5 metres; 60 kW. Relayed by Danzig, 662 kc/s, 453.2 metres.—1.5 p.m., Gramophone Concert: Overture, Pique Dame (Suppé); Selection from Mirella (Gomoul); Aria from The Magic Flute (Mozart); Selection from Maritana (Wallace); Trio Selections (Nevin); (a) Song of Thanksgiving, (b) The Rosary; Balgelisten (Meyer-Helmund); Blumenlied (Lange); Honour March (Wagner); Children's Symphony (Haydn); Concerto in E Flat (Liszt). In the intervals at 1.20 and 2.0, News. 2.30, Interval. 3.0, Agricultural Prices and Exchange. 3.30, Children read their own Magazines. 4.0 (from Danzig), Concert by a Nazi Band: March, Märkische Heide (Lincke); Overture, Norma (Bellini); Siegestrophäen (Friedemann); Kreuzritter-Fantase (Henrion); Fehrbelliner Reitermarsch (Henrion); Two Alsatian Peasant Dances (Merkling); Paraphrase on the Song, Volk ans Gewehr (Kutsch); Nazi Song Potpourri (Seidel); Marching Song Potpourri, Die Wache zieht auf (Kochmann); March, Wiener Jungarbeiter (Schroder-Nadelmayer). In the interval at 4.50 (approx.), Talk. 5.45, Wireless Technical Talk. 6.15, Agricultural Prices. 6.25 (from Danzig), Talk: Danzig Works of Art in the Danzig Municipal Museum. 6.50, Weather. 7.0, Transmission from all German Stations, relayed from Berlin (Deutschlandsender). 8.0, Weather and News. 8.5, Brahms Concert by the Station Choir, conducted by Paul Firschow, Margarethe Selchmann and Maria Fischer (Pianoforte). Five Songs, Op. 104, Liebeslieder-Walzer, Op. 52, for Soprano, Contralto, Tenor, Bass and Pianoforte. 8.50, Kleinpaul discovers a Titian—Radio Play (Franke). 9.50, Elementary English Lesson. 10.15, News.

## HILVERSUM

Announced HUIZEN, 1,013 kc/s, 296.1 metres; 7 kW. (until 5.40 p.m.) and 20 kW. from 5.40 p.m.—Programme of the Christian Radio Society (N.C.R.V.). 11.40 a.m., Police Notes. 11.55, Gramophone Music. 12.10 p.m., Organ Recital by Jan Zwart. Potpourri (Zwart); Vor und Nachspiele (Rinek); Choral Prelude (Bach); Extracts from Sonatas (Mendelssohn); Trios (Bach); Extracts from Concertos (Handel); Potpourri (arr. Zwart). 1.40, Broadcast for Schools. 2.15, Gramophone Music. 2.25, Talk on Cookery. 2.55, Gramophone Music. 3.10, Interval. 3.40 Bible Reading, Baritone Solos and Organ Recital. 4.40, Concert, Mne. Knecht-Haar (Songs), Mlle. Beute (Pianoforte), and Oostdram (Flute). Two Airs (Bach); (a) Höchstler, was ich habe, from Cantata No. 39, (b) Ich will auf den Herrn schauen, from Cantata No. 33; Two Choral Preludes for Pianoforte (Bach-Buson); Sonata in G for Flute and Pianoforte (Haydn); Waltz in A Flat for Pianoforte (Chopin); Five Songs: Le rossignol en amour (Couperin); Sonata No. 8 (Mattheson); Les bais de Sologne (Rameau); La Poule (Rameau); Four Songs (Wolf); (a) Verborgenheit, (b) Jägerlied, (c) Fussesreise, (d) Er ist's; D'mm matin de Printemps (Boulanger). 6.10, Answers to Correspondence. 6.40, Police Notes. 6.55, Ecclesiastical Notes. 7.10, Answers to Correspondence. 7.40, Orchestral Concert, relayed from Krommenie. In the interval, Gramophone Records. 8.40, Talk.

9.10, Organ Recital by Kloek. In the interval at 9.40, News. 10.10, Gramophone Concert. 11.10 (approx.), Close Down.

HORBY.—See Stockholm.

## HUIZEN

Announced HILVERSUM, 160 kc/s, 1,875 metres; 7 kW. (up to 3.40 p.m.). Transmitted from Kootwijk on 50 kW. from 3.40 p.m. Programme of the Algemeene Vereeniging Radio Omroep (A.V.R.O.).—11.40 a.m., Concert by the Kovacs Lajos Orchestra, with Gramophone Interlude. 1.40 p.m., Pictures from an Exhibition (Musserowsky-Ravel), on Gramophone Records. 2.10, Violin and Pianoforte Recital by Jan Felderhof and Egbert; Sonata (Beger); Hyan (Diepenbroek). 2.40, Gramophone Music. 3.25, Interval. 3.40, Song Recital by Herman Sweers. 4.10, Talk, with Gramophone Illustrations: Old Viennese Operas. 5.10, Concert by the Station Orchestra, conducted by Nico Treep: March, The Diplomat (Sousa); Overture, Queen for a Day (Adam); Concert Waltz (Robrecht); Selection from Martha (Flotow-Holmar); Gavotte (Gossec); Minuet (Beethoven); Spanish Dances 1 and 2 (Beethoven); Nuptial Dance from Feramos (Rubinstein); Potpourri of Hungarian Folk Songs (Padouk); Selection from La vie parisienne (Offenbach). In the intervals, Recitations. 6.40, Book Review. 7.10, Serenade in D (Beethoven), by the Helmann Trio. 7.40, News. 7.45, Concert by Pierre Palla (Organ), Boris Lenssy (Violin), and Eddie Karelsen (Saxophone). 8.50, Concert by a Male Voice Choir. 9.10, Gramophone Music. 9.25, Concert by the Station Orchestra, conducted by Nico Treep. 9.55, Gramophone Music. 10.10, Concert by the Station Orchestra, conducted by Nico Treep: Overture, Zampa (Herold); Flirtation (Steck); Diamonds and Pearls (Dostal); Hoch Heidecksburg (Herzer). 10.40, News. 10.50, Gramophone Music. 11.40, Close Down.

INNSBRUCK.—See Vienna.

## JUAN LES PINS

1,205 kc/s, 249 metres; 0.8 kW.—8.0 p.m., Amusement Guide, Exchange, Racing Results, and News. 8.10, Sports Notes. 8.25, Light Music. 8.45, News and Weather. 9.0, Literary and Musical Programme.

KALUNDBORG.—See Copenhagen.

KIEL.—See Hamburg.

KLAGENFURT.—See Vienna.

KOSICE.—See Prague.

## LANGENBERG

635 kc/s, 473 metres; 60 kW.—12.10 p.m., Weather. 12.12, Concert by the Münster Municipal Orchestra, conducted by Werner Gähre. Overture, The Bohemian Girl (Balfe); Suite from La Source (Delibes); Spanish Serenade (Bizet); Dance from The Pearl Fishers (Bizet); German Dances (Schubert); Scherzo, Sonnenkind und Wolkenkamm (Clemens); Potpourri, Klänge aus Rinnäen (Dauber); Waltz, Francheliebe und Leben (Blon). 1.15, News. 1.30, Concert by the Station Orchestra, conducted by Kühn. Deutschlands Erhebung (Machts); March, Mein Kamerad (Ewers); Two Marching Songs; Waltz, Bei uns z'haus (Strauss); Mussian-Marsch (Carl); Erinnerung aus dem Militärlieben (Reckling); March, Heil der Zukunft (Frantzen); March, Mit Standarten (Blon). In the interval at 2.0 (approx.), News. 2.30, Meat Market Prices. 3.0, Talk. Paper Manufacture. 3.15, Dialect Reading. 3.30, Market Prices and Time. 3.50, Programme for Young People. 4.30, The Cologne Zoological Gardens—a Radio Picture. 5.0, Dance Music. 5.30, Concert: Kläre Hansen (Soprano), Hubert Kirsch (Baritone), Egbert Grape (Pianoforte), Robert Grote (Cello), Rudi Rhein (Violin), and Kurt Wessel (Harp). Romance for Violin, Cello and Pianoforte (Marschner); Soprano Solos: Two Songs (Franz); Melody (Gluck); Violin Solo: Gipsy Dance (Naché); Serenade for Harp, Violin and Cello (Oelschlegel); Baritone Solos: (a) Was ich hab' (Bohm), (b) Der Wagen rollt (Fürst); Baritone (Sokolov); Cello Solo: Mazurka (Werkmeister); Harp Solo: Concert Waltz (Gillmann); Novelletten (Gade). 6.15, Political Announcement. 6.25, Talk for Parents. 6.45, Weather, Sports Notes and Market Prices. 7.0, Transmission for all German Stations, relayed from Berlin (Deutschlandsender). 8.0, News. 8.5, Extracts from La Traviata—Opera (Verdi) by Soloists, Choir and Orchestra of the Scala Milan (on Gramophone Records). 9.0, Fritz in Westphalia—Radio Play (Josef Weinkler). 10.0, News. 10.30, Concert, relayed from Leipzig.

LAUSANNE.—See Radio-Suisse Romande.

## LEIPZIG

769.9 kc/s, 389.6 metres; 120 kW. Relayed by Dresden, 941 kc/s, 319 metres.—12 Noon, Weather and Time. 12.5 p.m., Concert from Munich. 1.15, News and Programme Announcements. 1.30, Bavarian Folk Music.

(on Gramophone Records). 2.45, News. 3.0, Art and Film Review. 3.10, Programme for Women. 3.35, Economic Notes. 4.0, Concert. 5.0, Talk by Hans Helfritz. 5.20, Reading. 5.50, Economic Notes, Weather and Time. 6.0, Italian Lesson. 6.25 (from Dresden), Recital of Romantic Pianoforte Music by Franz Wagner. 6.50, Review of the Day's Events. 7.0, Transmission for all German Stations, relayed from Berlin (Deutschlandsender). 8.5 to 9.50, See Berlin (Funkstunde). 9.50, Review of Sunday's Events. 10.5, News and Sports Notes. 10.15 (from Dresden), Concert by the Dresden Philharmonic Orchestra, conducted by Hilmar Weber. Overture, The Gipsy Baron (Strauss); Ave Verum and Theme with Variations from the Suite, Mozartiana (Tchaikovsky); German Dances, Op. 10 (Reger); Songs from the Erzgebirge (Körke); Selection from Martha (Flotow); Waltz, Gartenlaube (Strauss); Waldstille und Eifenreigen (Rhode). 12 Midnight, Close Down.

LINZ.—See Vienna.

## LUXEMBOURG

252 kc/s, 1,191 metres; 200 kW.—12.30 p.m., Concert by the Station Orchestra, conducted by Henri Pénis: Overture, The Caliph of Bagdad (Boïeldien); Carnival Suite (Schmalstich); The Skaters' Waltz (Waldteufel); Sur le lac (Godard); Selection from Rose-Marie (Friml). 1.30, Gramophone Music. 7.30 till Close Down, Austrian Programme. 7.30, Merry Schubert—Musical Radio Sequence. 8.20, Austrian Concert by the Station Orchestra, conducted by Henri Pénis: Overture, Don Giovanni (Mozart); Verklärte Nacht (Schönberg). 8.50, News in French. 9.0, Viennese Concert by the Station Orchestra, conducted by Henri Pénis: Overture, Morning, Noon and Night (Suppé); Waltz, Wiener Kinder (Jos. Strauss); Kleiner Wiener Marsch (Kreisl); Potpourri, Servus Wien! (Dostal); Overture, Die Fledermas (Joh. Strauss). 9.50, News in German. 10.0, Viennese Waltzes on Gramophone Records. 10.30, Dance Music on Gramophone Records.

## LYONS

LA DOUA, 644 kc/s, 465.8 metres; 1.5 kW.—6.30 p.m., Radio Journal. 7.30, Radio Gazette for Lyons and the South-East. 8.30, See Strasbourg. After the Programme, News.

## MADRID

EAJ7, 707 kc/s, 424.3 metres; 2 kW.—8.0 p.m., Chimes, Exchange, Radio Journal, Sports Notes, and Dance Music, relayed from the Alkazar Dance Hall. 9.15, Topical Review. 9.30 (approx.), Close Down.

MALMO.—See Stockholm.

MILAN.—See Turin.

## MORAVSKA-OSTRAVA

1,137 kc/s, 263.8 metres; 11 kW.—6.15 p.m., See Prague. 6.30, German Transmission; Talks: (a) Adalbert Stifter as a Painter, and (b) Modern German Poetry. 7.0, See Prague. 7.10, See Brno. 7.40, Talk: 7.55, Village Band Concert. 8.50, See Prague. 9.5, See Brno. 10.0 See Prague. 10.15 (approx.), Close Down.

MOTALA.—See Stockholm.

MULLACKER.—See Stuttgart.

## MUNICH

563 kc/s, 533 metres; 60 kW. Relayed by Augsburg and Kaiserlautern, 536 kc/s, 560 metres; and Nürnberg, 1,256 kc/s, 239 metres.—12 Noon, Orchestral Concert, conducted by Erich Kloss: Overture, Die drei Pintos (Weber); Two Pieces (Wagner); (a) Traume, (b) Albumblatt; Rondo (Mozart); Suite from Der Rosenkavalier (R. Strauss); Extracts from Der Zauberberg (Grimm); Selection from Das Dorf ohne Glocke (Künneke); Two Pieces (Schebeck); (a) Puppenballlet, (b) Spieluhr; Spinetta (Larsen). 1.15 p.m., Time, Weather and News. 1.30, Gramophone Music. 2.0, Time, Weather and Announcements. 2.20, Programme arranged by the Post Office with Gramophone Records. 2.50, Song Recital by Elisabeth Voigt (Soprano), and Fritz Schleiter (Baritone); Two Soprano Songs (Schumann); Three Baritone Songs (Schumann); (a) In der Ferne, (b) Sonntags am Rhein, (c) Ich wandere nicht; Three Songs (Cornelius); (a) In der Ferne, (b) Botschaft, (c) Am Rhein; Daheim (Kaun). 3.15, Programme for Children. 3.30 (from Nürnberg), Reading. 4.5, War Reminiscences by Major Reitzenstein. 4.30, See Frankfurt. 5.45, Youth at Work: Talk by a Junior Teacher. 6.51, Chiemseebilder for Pianoforte (Nieman), played by Richard Staab. 6.25, Book Review. 6.45, Time, Weather and Agricultural Notes. 7.0, Transmission for all German Stations, relayed from Berlin (Deutschlandsender). 8.0, Concert by the Station Orchestra, conducted by Hans Winter. 9.20, Programme to be announced. 9.40, Chamber Music by Ludwig Hölscher (Cello) and Ely Ney (Pianoforte); Sonata in A Op. 69 (Beethoven); Adagio and Allegro (Schumann). 10.20, Time, Weather and News. 11.0, Serenade by the Small Station Orchestra, conducted by Erich Kloss. Solo-



SEPT. 25th

MONDAY

continued

ist: Rose Kugler (Soprano). 12 Midnight, Close Down.

NAPLES.—See Rome.

NOTODDEN.—See Oslo.

OSLO

277 kc/s, 1,083 metres; 60 kW. Relayed by Fredrikstad, 815 kc/s, 368.1 metres; Mamar, 522 kc/s, 574.7 metres; Notodden, 671 kc/s, 447.1 metres; Porsgrund, 662 kc/s, 453.2 metres; and Rjukan, 671 kc/s, 447.1 metres.—5.30 p.m., Orchestral Concert by the Radio Ensemble, 6.30, Recitations, 7.0, Advertising Notes, Weather, and News. 7.30, Agricultural Talk, 8.0, Time Signal, 8.1, Song Recital, 8.30, The Codeman—a Tableau of Germany in the Rococo Period (Stefan Zweig), 9.10, Talk on Politics, 9.40, Weather and News, 10.0, Topical Talk.

OSTERSUND.—See Stockholm.

PALERMO

558 kc/s, 537.6 metres; 3 kW.—8.0 p.m., Dopplavoro Announcements, Tourist Talk, Agricultural Notes, Report of the Royal Geographical Society and Giornale Radio, 8.20, Gramophone Music. In the interval at 8.30, Time and Announcements, 8.45, Concert of Chamber Music: Two Piano-forte Sonatas (Scarlati); Soprano Solos: (a) Se tu m'ami (Pergolesi), (b) Mamma, non m'ama; Cello Solos: (a) Nocturne (Casella), (b) Lament (Cruce); Two Movements from the Viola Sonata (Rubinstein); Cello Solos: (a) Aria in D (Bach), (b) Capriccio (Piaatti); Piano-forte Solos: Three Pieces (Piek-Mangiagalli); Soprano Solos: (a) Song (Firmidelli), (b) Solveig's Song (Grieg); Violin Solos: (a) Romance (Brahms), (b) Gavotte (Pritter); Piano-forte Solo: Scherzo in B minor (Mendelssohn). After the Concert, Gramophone Music, 11.0, Giornale Radio.

PARIS

EIFFEL TOWER, Call FLE, 207.5 kc/s, 1,445.7 metres; 13 kW. Time Signals (on 2,650 metres) at 10.26 a.m. and 11.26 p.m. (Preliminary and 6-dot Signals).—6.45 p.m., Theatre Notes, 7.0, Le Journal Parlé, 8.30, Concert of Operetta Music and Light Music by the Station Orchestra, conducted by Flamant: Prelude to an Operetta (Casadesu); Selection from Die geschiedene Frau (Fall); Sons un balcon fleuri (Noelty); Selection from Der Orloy (Graham-Smith); Waltz from The Count of Luxembourg (Lehár); Selection from La Maison grise (Messager) and Ciboulette (Hahn); Overture, La petite mariée (Lecocq); Le gai Postillon (Flamant); Andante from Lucas et Lucette (Missa); Guitare (Thomé); Promenade en forêt (Christiné); Selection from Miss Decima (Audran); Danse mystique (Ganne); Klatsch-Galop (Strauss), 10.0 (approx.), Close Down.

PARIS

POSTE PARISIEN, 914 kc/s, 328.2 metres; 60 kW.—7.0 p.m., Gramophone Concert of Classical Music, 7.15, Le Journal Parlé, 7.30, Hot Jazz, 8.0, Chabrier Song Recital by Paul Pavay; Romance from Le roi malgré lui; Villanelle des petits canards; Toutes les fleurs; Ballade des gros dindons; Pastorale des coquelons roses, 8.30, Song Recital by Max Régner, 9.15, Sponsored Gramophone Concert, 10.15, News.

PARIS

RADIO PARIS, Call CFR, 174 kc/s, 1,725 metres; 75 kW.—7.30 a.m., Weather and Physical Culture, 7.45, Gramophone Music, 8.0, Weather and Press Review, 12 Noon, Massenet Concert on Gramophone Records, Extracts from: Le roi de Lahore, Hérodiade, Le Cid, Eschardonne, Thais and Thérèse. In the interval at 1.0, Exchange, News and Weather, and at 1.30, Exchange, 2.0, Exchange, 3.45, Exchange and Market Prices, 7.0, Agricultural Report, 7.10, Gramophone Concert: Selection from Bitter Sweet (Coward); Melodies from Love's Dream after the Ball (Zibulka); Torna a Sorrenta (Delustri); Monte Christo (Istvan Kotlar); Hungarian Serenade (Jancieres); Songs from La danseuse de Tanagra (Hirschmann); Potpourri, Fortissimo (Kalmán), 7.50, Commercial Notes and News, 8.0, Variety Programme. Part I—Recitation of Love Poems, Part II—Song Recital, Part III—L'école des mères—Sketch (Marius), Part IV—L'anglais on le fou raisonnable—Play (Patrat). In the interval at 8.30, News, Sports Notes and Weather, at 8.40, Review by Paul Reboux, and at 9.15, Press Review and News.

PITTSBURGH

KDKA, 980 kc/s, 306 metres; 50 kW. Relayed by W8XK on 48.86 metres and 25.27 metres.—7.30 p.m., Huston Ray's Orchestra, 8.0, Betty and Bob, from New York, 8.15, Words and Music, from New York, 8.45, Human Values, 9.0, Radio Guild, from New York, 10.0, Uncle Tom and Betty, 10.15, KDKA Kiddies' Club, 10.50, The Singing Lady, from New York, 10.45, Orphan Annie, from New York, 11.0, Press News-Reeler, 11.15, Sports, A Song, 11.30, Pittsburgh Spotlights, 11.45 to 3.0 a.m. (Tuesday), New York

Relay, 11.45, Lowell Thomas, 12 Midnight, Anos 'n' Andy, 12.15, Baby Rose Marie, 12.30, Popular Programme, 1.0, The Nomads, 1.30, Potash and Perlmutter, 1.45, Red Davis, 2.0, Simclair Minstrels, 2.30, Melody Moments, 3.0, Silver Toppers.

PORSGRUND.—See Oslo.

PRAGUE

614 kc/s, 488.6 metres; 120 kW.—2.50 p.m., Gramophone Music, 3.50, Aviation Weather Report, 3.55 to 4.0, Exchange, 5.45, Hints for the Housewife, 5.55, Talk for Office Workers, 6.5, Agricultural Talk, 6.15, Talk for Workers, 6.25, News in German, 6.30, German Transmission: Review of Foreign Affairs, 7.0, Chimes, 7.5, News, 7.10, See Brno, 7.40, See Moravská-Ostrava, 8.50, Reading, 9.5, See Brno, 10.0, Time and News, 10.15, Art Report, 10.30 (approx.), Close Down.

RADIO-SUISSE ROMANDE

SOTTENS, 743 kc/s, 403 metres; 25 kW.; and Geneva, 395 kc/s, 760 metres.—6.15 a.m. to 6.30 (from Lausanne), Gymnastics Lesson, 6.30 to 12.28 p.m., Interval, 12.28, Time Signal from Neuchâtel Observatory, 12.30, News and Weather, 12.40 (from Lausanne), Italian Opera Music on Gramophone Records, 1.0 (from Lausanne), Financial Notes, 1.10 (from Lausanne), Gramophone Music, 2.0, Interval, 3.28, Time Signal from Neuchâtel Observatory, 3.30 (from Lausanne), Concert by the Station Orchestra, conducted by Moser, 5.0 (from Lausanne), Programme for Children, 5.30, Interval, 7.0 (from Lausanne), Talk on Maxime Raymond's History of Switzerland, 7.25 (from Lausanne), Weather, Announcements, and News, 7.30 (from Lausanne), Talk, The Swiss Lakes, 8.0 (from Geneva), Rameau Concert for the 150th Anniversary of the Composer's Birth; Introductory Talk; Dance Suite arranged for Orchestra; Suite in E for Harpsichord; Aria from Les Gêtes d'Hébé; Three Pieces for Harpsichord: (a) Dauphine, (b) Les savages, (c) La Poule; Aria from Castor and Pollux; Concerto for Flute, Viola da Gamba and Harpsichord, 9.0 (from Lausanne), Popular Concert by the Station Orchestra, conducted by Moser; Soloist, Paul Sandoz (Baritone), 9.50, News, 10.0, Pelléas et Melisande—Lyric Drama (Debussy), on Gramophone Records, 10.30 (approx.), Close Down.

RJUKAN.—See Oslo.

ROME

Call 1R0, 680 kc/s, 441 metres; 50 kW. Relayed by 2R0, 11,810 kc/s, 25.4 metres, from 5.15 p.m.; Bari, 1,112 kc/s, 269.8 metres; Milan (Yigentino), 662 kc/s, 463.2 metres, from 8.45 p.m.; and Naples, 941 kc/s, 319 metres.—12.30 p.m., Gramophone Music, 1.0 to 2.15, Popular Gramophone Music. In an interval at 1.30, Giornale Radio and Exchange, and at 2.0, Time and Announcements, 4.30, Children's Radio Review, 4.55, Giornale Radio and Exchange, 5.10, Weather, 5.15, Vocal and Instrumental Concert: Alberico Guidi (Violin); Guglielmina Ricci (Soprano) and Alfredo Sernicoli (Tenor); Violin Solos: (a) Chaconne (Veracini-Franzoni), (b) Cantabile and Waltz (Paganini); Soprano Solos: (a) Arietta (Mazzaferrata), (b) Concert Mazurka (Chopin-Viardot); Tenor Solos: (a) Un verde praticello (Marelli), (b) Aria from The Signor Bruschino (Rossini), (c) Aria from The Queen of Sheba (Goldmark); Violin Solos: (a) Sirentese (Piek-Mangiagalli), (b) Introduction and Humoresque (D'Ambrosio); Soprano Solo: Ogni sabato avrete il lume acceso (Gordigiani), 6.40 (from Naples), Shipping and Sports Notes, 6.45, Dopplavoro Report and Tourist Notes, 7.10, Agricultural Report, 7.20, News in Foreign Languages, 7.40, Giornale Radio, 8.0, Time and Announcements, 8.5, Gramophone Music, 8.30, Giornale Radio and Sports Notes, 8.45 (from Naples), Concert of Light Music. In the intervals, Talk, 11.0, Giornale Radio.

SALZBURG.—See Vienna.

SCHENECTADY

WGY, 790 kc/s, 379.5 metres; 50 kW. Relayed at intervals by W2XAF on 31.48 metres and by W2XAD on 19.56 metres.—8.30 p.m., Revolving Stage, from New York, 9.0, Health Hunters, 9.15 to 9.30 (approx.), Soloist, 1.45 a.m. (Tuesday), Stock Reports, 2.0 to 4.30, New York Relay, 2.0, Socynland Sketch, 2.30, Variety Programme, 3.0, A and P, Gypsies, 3.30, Popular Programme, 4.0, Contended Programme, 4.30, Musical Programme, from New York, followed by Programme Restiné.

SCHWEIZERISCHER LANDESENDER

BEROMUNSTER, 653 kc/s, 459 metres; 60 kW.; Basle, 1,229 kc/s, 244.1 metres; and Berne, 1,220 kc/s, 245.9 metres.—6.15 to 6.35 a.m. (from Basle), Gymnastics, 11.59, Time Signal from Neuchâtel Observatory and

Weather, 12 Noon (from Basle), Choral Music on Gramophone Records, 12.30 p.m., Time, Weather, and News, 12.40 (from Basle), Folk Music on Gramophone Records, 1.25 (from Basle), Time, Weather, and Exchange, 1.30 (approx.) to 5.0, Interval, 5.0 (from Zürich), Programme for Women, 5.30 (from Berne), Gramophone Music, 6.30 (from Zürich), Talk: Swiss Statesmen in Times of Crisis, 7.0, Time and Weather, 7.5 (from Zürich), Gramophone Music, 7.30 (from Zürich), Elementary English Lesson, 8.0 (from Zürich), Reading of Poems, 9.0, Weather and News, 9.10 (from Zürich), Dvorák Concert by the Augmented Station Orchestra; Soloist: Frédéric Mottier (Cello); Conductor, Hofmann, 10.15 (approx.), Close Down.

SOTTENS.—See Radio-Suisse Romande.

STOCKHOLM

689 kc/s, 436 metres; 55 kW. Relayed by Boden, 244 kc/s, 1,229.5 metres; Göteborg, 932 kc/s, 322 metres; Hörby, 1,166 kc/s, 257 metres; Motala, 221.5 kc/s, 1,354.4 metres; Östersund, 389 kc/s, 770 metres; and Sundsvall, 554 kc/s, 542 metres.—5.5 p.m. (from Boden), Violin Recital: Sérénade mélancolique (Tchaikovsky); Hungarian Dance No. 4 (Brahms-Jochim); Canzonetta (Poder Gram); Der Vogel als Prophet (Schumann-Auer); Scherzo-Tarantella (Wieniawsky), 5.30, Reading, 5.45, Gramophone Music, 6.45, German Lesson, 7.15, Weather and News, 7.30, A Dialogue, 7.45, Spanish Song Recital by Karin Juel, 8.15, Talk, 8.45, Military Band Concert, conducted by Ivar Widner, Viktoriamarsch (Korsgren); Overture, I promessi sposi (Ponchielli); Indian Sérénade (Burgmüller); Dance of the Sultanas (Florida); Selection from Aida (Verdi); Clarinet Solo: Waltz (Schreiner); Carnival de Paris (Svendsen); Lindbergh March (Austin), 9.45, Weather and News, 10.0, Organ and Violin Recital, Organ Solos: Theme with Variations (Raasted); Violin and Organ Sonata, Op. 45 (Raasted); Organ Sonata, Op. 16, No. 1 (Raasted); Prelude, Fugue and Chaconne in C (Buxtehude), 11.0 (approx.), Close Down.

STRASBOURG

869 kc/s, 345 metres; 11.5 kW.—11.30 a.m., Variety Music on Gramophone Records, 12.45 p.m., News, 1.0, Time and Exchange, 1.5, Popular Music on Gramophone Records, 2.0, Interval, 5.0, Orchestral Concert, conducted by Roskam: March, Sabre et Lance (Starke); Overture, Casanova (Lincke); Sérénade in B flat (Widor); Selection from Le Chemineau (Leroux); Spanish Rhapsody (Richardy); Piano-forte Solo, Cantabile (Spöck); Suite, Summer Days (Coates), 6.0, Film Review, 6.15, Review of the Week in German, 6.30, Boehlmann Concert: Sonata for Cello and Piano-forte; Trio for Violin, Cello and Piano-forte, 7.30, Time and News, 7.45, Gramophone Music, 8.0, Press Review in German, Lottery Results and Announcements, 8.30, Monsieur de la Palisse—Opéra-Bouffe in Three Acts (Terrasse). In an interval at 9.30 (approx.), Press Review, 10.30 (approx.), Close Down.

STUTT GART

MUHLACKER, 832 kc/s, 360.5 metres; 60 kW. Relayed by Freiburg, 527 kc/s, 570 metres.—1.30 p.m., Concert by the Berlin Philharmonic Orchestra on Gramophone Records: Overture, The Thieving Magpie (Rossini); Suite from L'Arlesienne (Bizet), 2.0, Concert arranged by the Post Office, 2.30, Spanish Conversation, 3.0, Elementary English Lesson, 3.30, Interval, 4.30, See Frankfurt, 5.45, German Chamber Music, 6.10, Talk: Gardening in the Autumn, 6.35, Time and News, 7.0, Transmission for all German Stations, relayed from Berlin (Deutschlandsender), 8.0, Piano-forte Quintet in F minor Op. 34 (Brahms) by the Wendling Quartet and Prof. Walter Reiberg, 8.40, War-time Stories, 9.0 (from Karlsruhe), Wireless Cabaret, 10.0, Time and News, 10.20, Concert from Leipzig, 12 Midnight, Close Down.

SUNDSVALL.—See Stockholm.

TOULOUSE

RADIOPHONE DU MIDI, 779 kc/s, 385 metres; 8 kW.—6.0 p.m., News, 6.15, Music by an Argentine Orchestra, 6.30, Operetta Music: Selection from Rip van Winkle (Planquette); Léon à la bouche (Parès et van Parys); Tip-Toes (Gershwin), 6.45, Accordion Music, 7.0, Symphonic Poem, Mazepa (Liszt), 7.15, News, Racing Results and Market Prices, 7.30, Opera Music: Extracts from: Pénélope (Faure); Mignon (Thomas); and Resurrection (Alfano), 7.45, Orchestral Music, 8.0, Balalaika Music and Russian Songs, 8.15, Military Music, 8.30, Concert by a Viennese Orchestra: Selection from Les millions d'Arlequin (Drigo); Melody (Ehlinger); Waltz (Lincke); Sourire d'avril (Depret); The Kiss Waltz (Joh. Strauss); Waltz, Frühlingsstimmen (Joh. Strauss); Serenade (Toselli), 9.0, Extracts from The Road to Paradise—Sound Film (Heymann), 9.20, Light Orchestral Music, 9.30, Concert: Wedding March (Mendelssohn); La housarde (Ganne); Selection from Les cent vierges

(Lecocq); Wedding Waltz (Lincke); Selection from La Habanera (Laparra); Marche héroïque (Saint-Saëns), 10.0, Opera Music: Selection from: Siegfried (Wagner), Hérodiade (Massenet), and Sigurd (Reyer), 10.15, North African News and Local News, 10.30, Concert for Listeners in Morocco: Torero y torerao (Dorantes); Melody (Coslow); O, Frühling wie bist du so schön (Lehár); Flower Song from Carmen (Bizet); Selection from Masaniello (Auber); Künstlerleben (Strauss); Les grenadiers du Caucase, 11.0, Popular Music, 11.15, Dance Music, 12 Midnight, News, Weather and Announcements, 12.5 a.m. (Tuesday), Chansonnets, 12.15, Military Music, 12.30 (approx.), Close Down.

TRIESTE

1,211 kc/s, 247.7 metres; 10 kW.—5.10 p.m. till Close Down, See Turin.

TRONDHEIM.—See Oslo.

TURIN

273.7 metres; 7 kW. Relayed by Milan, 331.5 metres; Gnoa, 312.8 metres; and Florence, 500.8 metres.—5.10 p.m., Mandoline Concert, 6.0 to 6.5, Weather, 6.40, Giornale Radio, Dopplavoro Announcements and Gramophone Music, 7.0, Time, Tourist Report and Gramophone Music, 7.10, Agricultural Notes and Market Prices, 7.20, News in Foreign Languages, 7.40, Gramophone Music, 8.0, Announcements, Giornale Radio and Weather, 8.15, Sponsored Concert, 9.15, Chamber Music, Virgilio Brugi (Violin), Giuseppe Tabarelli (Double Bass) and Luigi Gallino (Piano-forte), Violin Solos: (a) Minuet (Corelli-Kreisler), (b) Gavotte (Bach-Kreisler); Elegia for Double Bass (Bottesini); Violin Solos (Albeniz): (a) Catalan Song, (b) Tango; Tarantella for Double Bass (Bottesini), 9.45, A Comedy in One Act, 10.15, Orchestral Concert, conducted by Etnio Arlandi: Selection from San' Elena al Calvario (Leo); Träume, for Violin and Orchestra (Wagner); Mother Goose Suite (Ravel); Symphony in D No. 35 (Mozart), 11.0, Giornale Radio.

VATICAN CITY

15,120 kc/s, 19.84 metres (Morning), and 5,969 kc/s, 50.26 metres (Evening); 10 kW.—11.0 to 11.15 a.m., Religious Information in Italian, 8.0 to 8.15 p.m., Religious Information in Italian.

VIENNA

581 kc/s, 517 metres; 100 kW. Relayed by Graz, 852 kc/s, 352.1 metres; Innsbruck, 1,058 kc/s, 283 metres; Klagenfurt, 662 kc/s, 453.2 metres; Linz, 1,220 kc/s, 245.9 metres; and Salzburg, 1,373 kc/s, 218.5 metres.—12 Noon, Concert by the Wiener Symphoniker, conducted by Holzer. In the interval at 1.0 p.m., News and Announcements, 2.0, Interval, 3.0, Time, Weather and Market Report, 3.20, Talk: The Foreign Competitors at the October Riding Tournament, 3.30, Talk: Feigins, the Epic Poet of the Turkish Siege, 3.55, Song Recital by Lucie Ritter and Sybille Krumpolz: Aria from Il Seraglio (Mozart); Aria from The Barber of Seville (Rossini); Kinderlieder (Blech); Lullabies of the Nations (Krumpolz), 4.35, Programme for Young People, 5.0, Talk: The Place of the Chorus in Opera, 5.25, Review of the Theatre, 5.45, Books and Works of Reference in Connection with the Week's Talks, 5.50, Talk: Weinwurm, the Architect of the Stephansdom, 6.15, Topical Talk, 6.40, Time, Weather and Announcements, 6.55, Tannhäuser—Opera in Three Acts (Wagner), relayed from the State Opera House. In the interval at 9.45 (approx.), News, Weather and Market Report, 10.50, Gramophone Music. After the Programme, Exchange.

WARSAW

212.5 kc/s, 1,411 metres; 120 kW.—11.57 a.m., Time Signal and Fanfare from Torun Cathedral, 12.5 p.m., Gramophone Music, 12.25, Polish Press Review, 12.33, Weather Report, 12.35, Gramophone Music, 12.55, Radio Journal, 1.0 to 2.55, Interval, 2.55, News, 3.0, Gramophone Music, 3.5, Announcements, 3.15, Gramophone Music, 3.25, Economic Notes, 3.35, Gramophone Music, 3.45, Traffic Report, 3.50, Gramophone Music, 4.0, Gramophone Music, 5.0, Talk in French, 5.15, Soprano and Violin Recital by Walcska and Sznajderman: Violin Solo: Rondo capriccioso (Saint-Saëns); Three Songs (Zalenski): (a) La Princesse enchantée, (b) Mes chansons, (c) Petit rossignol; Song, Le rêve (Noskowski); Violin Solos: (a) The Flight of the Bumble Bee (Rimsky-Korsakov-Kreisler), (b) Roxane's Aria from Le roi Roger (Szymanowski), (c) Capric (Paganini-Szymanowski), (d) Motto perpetuo (Paganini), (e) Melody (Rozycycki); Two Songs (Troszel); Song (Zarzycki); Hymn: Veni Creator (Niewiadomski), 6.15, Talk, 6.35, Light Music, relayed from the Gastronomica Café, 7.20, Miscellaneous Items, 7.35, Programme Announcements, 7.40, Reading, 8.0, La Gioconda—Opera (Ponchielli), on Gramophone Records. In the intervals, Answers to Agricultural Correspondence and Radio Journal, 10.30, Sports Notes, 10.40, Aviation Weather Report and Police Notes, 10.45, Dance Music.

ZURICH.—See Schweizerischer Landessender



**TUESDAY**

SEPTEMBER THE TWENTY-SIXTH

## PRINCIPAL EVENTS OF THE DAY:

## AT HOME

NATIONAL  
LONDON"The Use of Man," a play by Lord Dunsany.  
Crazy Variety programme.

## REGIONAL

## MIDLAND

## REGIONAL

Choral programme.

## NORTH

## REGIONAL

Episodes and songs from "Alice in Wonderland," by  
Lewis Carroll.

## WEST

## REGIONAL

"Simple Faith and Norman Blood, or the Secret of  
Biggwig Towers," a burlesque, by Diana Morgan  
and Michael Sayer.  
Orchestral concert.

## SCOTTISH

## REGIONAL

## BELFAST

Variety programme.

## ABROAD

## BRUSSELS

(No. 2)

## COPENHAGEN

## HAMBURG

## HEILSBURG

## HUIZEN

## EIFFEL

## TOWER

## PALERMO

## TOULOUSE

## TURIN

9.15 p.m. Wagner concert, by the Station Orchestra,  
conducted by Meulemans.8.1 p.m. Concert by the Ringsted Orchestral Society.  
10.40 p.m. The Philharmonic Orchestra, conducted  
by J. Eibenschütz.8.5 p.m. Mozart, Weber and Wagner concert, by the  
Danzig State Theatre Orchestra.7.55 p.m. The Concertgebouw Orchestra, conducted  
by Blech.

8.30 p.m. Concert, relayed from the Conservatoire.

8.30 p.m. Opera: "Andrea Chénier," by Giordano.

9.30 p.m. Orchestral concert.

8.30 p.m. Operetta: "The Merry Peasant," by Fall.

Talk: Stage and Films. 12 Midnight, Close  
Down.

BERNE.—See Schweizerischer Landessender.

BEROMUNSTER.—See Schweizerischer  
Landessender.

BODEN.—See Stockholm.

BODO.—See Oslo.

## BRATISLAVA

1,076 kc/s, 279 metres; 14 kW.—6.5 p.m.,  
Concert by the Station Band, conducted by  
Nagl. 6.40, Talk. 6.55, Talk for House-  
wives. 7.0, See Prague. 7.10, Gramophone  
Music. 7.30, An Opera relayed from the  
National Theatre. 10.0, See Prague. 11.0  
(approx.), Close Down.

BREMEN.—See Hamburg.

## BRESLAU

923 kc/s, 325 metres; 60 kW. Relayd by  
Gleiwitz, 1,184 kc/s, 253 metres.—1.0 p.m.,  
Weather. 1.5, Caruso on Gramophone  
Records. 1.45, Time and News. 2.10, Brahms  
Song Recital by Käthe Mann (Soprano);  
Mairacht; Wir wandelten Unbewegte laue  
Luft; Wie bist du, meine Königin; Ruhe  
süss, Liebchen; Wehe, so willst du mich  
wieder; Heimweh; Du blaues Auge; Bots-  
chaft. 2.40, Spanish Caprice (Rimsky-Kor-  
sakov) on Gramophone Records. 3.0, Agri-  
cultural Prices. 3.15, Programme for Chil-  
dren. 3.40, Book Review. 4.0, Orchestral  
concert, conducted by Gerhard Riechka:  
Festival Overture (Leutner); Two Pieces  
from the Lyric Suite No. 1 (Grieg); (a)  
Hirtenknabe, (b) Norwegian Peasant March;  
Two Pieces from the Lyric Suite No. 2  
(Grieg); (a) Nocturne, (b) March of the  
Dwarfs; Nachruf an Franz Schubert  
(Petras); Invitation to the Dance (Weber);  
A la Gavotte (Schott); Homage March  
(Liszt). In the interval, Readings. 5.35,  
Agricultural Prices. 5.40, Talk: German  
Socialism. 6.0, Orchestral concert, con-  
ducted by Riechka: Russian Suite (Bul-  
lerian); Harlequin's Serenade (Schmitt);  
Liebeswalzer (Frank); Selection from Das  
Pensionat (Suppé); Waltz, Liebespiele  
(Rust); Im Märchenwald (Ganglberger);  
Musikalische Neckereien (Worel); Nazi  
Parade March (Marquart). 6.50, Meat Market  
Prices. 7.0, Transmission for all German  
Stations, relayed from Leipzig. 8.0, News.  
8.10, Chamber Music, relayed from the Con-  
cert House. 9.10, Indian Summer—Wireless  
Cantata (Sezuka). 10.0, Time and News.  
10.25, Concert relayed from the Haus Ober-  
schlesien, Gleiwitz. 12 Midnight, Close  
Down.

## BRNO

878 kc/s, 342 metres; 35 kW.—6.25 p.m.,  
German Transmission: News, followed by  
Vintage in Moravia, Programme with Music,  
and Agricultural Report. 7.0, See Prague.  
7.10, Gramophone Music. 7.20, Humorous  
Song Recital. 7.45, See Prague. 8.20, Read-(Balfé); Bohemian Songs (Dvorák); Slav  
Dances (Dvorák); Hungarian March (Liszt).  
After the Concert, Dramatic Programme. 9.15,  
Wagner Concert by the Station Symphony  
Orchestra, conducted by Meulemans. Solo-  
ist: Frans Schell (Tenor). March of the  
Nobles from Tannhäuser; Songs: (a) Air  
from Lohengrin, (b) Walter's Prize Song from  
The Mastersingers; Gramophone Record:  
The Ride of the Valkyries; Songs: (a) Song  
of the Forge from Siegfried, (b) Siegfried's  
Death and Funeral March. 10.0, Le Journal  
Parlé.

## BUCHAREST

761 kc/s, 394 metres; 12 kW.—5.0 p.m.,  
Variety Music by the Motoi Orchestra. In  
an interval at 6.0, Radio Journal. 7.0, Edu-  
cational Talk. 7.20, Instrumental Music on  
Gramophone Records. 7.40, Talk. 8.0, Italian  
Song Recital (Bassani, Fasolo, Scarlatti, and  
Rossini). 8.20, Concert by the Station Or-  
chestra: Persian March (Joh. Strauss);  
Waltz, Erinnerung an Baden (Komzak);  
Suppé Potpourri (Michaelov); Suite, La  
farandole (Dubois); Slav Dances, Nos. 12  
and 13 (Dvorák); La cascade (Bergé). In  
an interval at 9.0, Talk. 9.45, Radio Journal.

## BUDAPEST

545 kc/s, 550.5 metres; 18.5 kW. Also relayed  
on 840 metres from 7.30 p.m. till Close Down.  
—5.30 p.m., Orchestral Concert. 6.30, Talk.  
7.0, Harp Recital. 7.30, A Comedy. 9.30,  
News. 9.45, Gramophone Music. 11.0, Con-  
cert from the Café Enke. Soloist: Imre  
Laszlo sings Folk Songs.

CASSEL.—See Frankfurt.

## COPENHAGEN

1,067 kc/s, 281 metres; 0.75 kW. Relayd by  
Kalundborg, 260 kc/s, 1,153.8 metres.—12  
Noon, Time Signal and Chimes from the  
Town Hall. 12.2 p.m., Concert by Harald  
Andersen's String Ensemble, relayed from  
the Bellevue Strandhotel. 2.0, Interval. 3.0,  
Concert by the Station Orchestra, conducted  
by Emil Reesen. Soloist: Augusta Haugsted  
(Pianoforte). 5.0, Programme for Children.  
5.30, Exchange and Fish Market Prices. 5.45,  
Talk: English as a World Language. 6.15,  
Elementary German Lesson. 6.45, Weather.  
7.0, News. 7.15, Time Signal. 7.30, Talk.  
8.0, Time Signal from the Town Hall. 8.1,  
Concert by the Ringsted Orchestral Society,  
relayed from Ringsted: Overture, Rienzi  
(Wagner); Finale from Act II of Aida  
(Verdi); Danmarks-mærchen (Höberg);  
Finale from Act III of Et Folkesagn  
(Gade); Julex from Mors et vita (Gounod);  
Three Danish Songs; March royal (Hansson);  
Overture, Tamer (Rossini); Helmsmann's  
Song and Sailors' Chorus from The Flying  
Dutchman (Wagner). 9.0, Rameau Harpsi-  
chord Recital by Folner Jensen. 9.15, En  
Satyrisk spiller paa Fløjte—Radio Dialogue  
(Christen Möller). 9.30, Pianoforte Solos by  
Viktor Fischer: Sweet Pepper (Löhner); Le  
jongleur (Grotzschke); Chopsticks (Mayer).  
9.45, Lokkedu—Radio Play (Ernst Wei-  
gand). 10.0, News. 10.15, Oletet in F, Op. 166  
(Schubert), for Two Violins, Viola, Cello,  
Double Bass, Clarinet, Horn and Bassoon.  
11.10, Dance Music, conducted by Jens  
Warny, relayed from the Nimb Restaurant.  
In an interval at 12 Midnight, Time Signal  
and Chimes from the Town Hall. 12.30 a.m.  
(Wednesday), Close Down.

CORK.—See Athlone.

DANZIG.—See Heilsberg.

DRESDEN.—See Leipzig.

## FECAMP

1,328 kc/s, 225.9 metres; 10 kW.—11.0 a.m.  
to 12 Noon, Programme in English by the  
I.B.C. 11.0, Happy Hour. Part I: Orchestral  
Concert: Signature Tune; Selection from  
He wanted Adventure (Waller); Coal Black  
Manny (Cliff); The Busy Bee (Bendix);  
Idylle bretonne (Gennin); The way to the  
heart (Lincke); Fluttering Birds (Gennin);  
Liebesserenade (von Blon); Swanee (Gersh-  
win). Part II: Dance Music: When Gimble  
hits the Cymbal; All over Italy; Maybe  
I love you too much; Chewing Gum; He was  
only a poor Musician; Down the Old Ox  
Road; In Santa Lucia; Learn to Croon;  
Signature Tune. 12 Noon, Programme in  
French. 4.30 to 6.0, Programme in English  
by the I.B.C. 4.30, Programme for Chil-  
dren. 5.0, Military Band Concert for Tor-  
quay and Exeter Listeners: Signature Tune,  
The Night by the Sea; The Changing of the  
Guard (Flotsam and Jetsam); In a Monas-  
tery Garden (Kettelbey); Bradazon (Dunn);  
On the Quarter Deck (Alford); Fighting  
Mac; Squirrel Dance (Elliott Smith); Jungle  
Drums (Kettelbey); Selection from The  
Vagabond King (Friml). 5.30, Orchestral  
Concert for Plymouth and Devonport  
Listeners: Nautical Moments (arr. Winter);  
Song; In a Sheltered Vale (Clarke);  
Spanish Serenade (Herbert); Chinese Sere-  
nade (Herbert); Song, Le Reve passe (Krier);  
Under Heaven's Blue (Payan); Song, The  
Company Sergeant Major (Sanderson); By  
the Sleepy Lagoon (Coates); Selection from  
Wiener Blut (Strauss); Signature Tune.  
6.0, Programme in French. 10.0, Dance  
Music: Signature Tune, Bells of Normandy;  
All over Italy; My Lucky Day; Chewing  
Gum; Happy Ending; It was a Night in  
June; When your little Pomeranian; It's  
Sunday down in Caroline; Moon Song;  
Hyde Park Corner; My Bluebird's singing  
the Blues; What a Lady Josephine mustALGIERS  
824 kc/s, 364 metres; 18 kW.—8.10 p.m.,  
Shipping Notes. 8.15, Agricultural Report  
and Weather Forecast. 8.20, Gramophone  
Music. 8.40, Lottery Results. 8.55, News.  
9.0, Time. 9.2, The Trout Quintet (Schu-  
bert). 9.35, News. 9.40, Dance Refrains.  
10.0, Concert of Oriental Music.

## ATHLONE

725 kc/s, 413 metres; 60 kW. Relayd by  
Cork, 1,337 kc/s, 224.4 metres.—1.30 to 2.30  
p.m., Time Signal, Weather Report, Stock  
Exchange Quotations, and Gramophone  
Music. 6.0, Programme for Children. 6.40,  
News. 7.0, Gaelic Reading. 7.15, Talk. 7.30,  
Time Signal. 7.31, Concert of Irish Music  
by the Station Orchestra. 8.0, Traditional  
Fiddle Solos by Betty Burke. 8.15, Weber  
Music by the Station Orchestra. 8.50, Weber  
Pianoforte Recital by Fred Stone. 9.10,  
Variety Programme by Messrs. Earls and  
Thornton. 9.30 to 10.30, Programme by the  
I.B.C. (Ireland), Ltd. 9.30, Variety Concert:  
Waltz, Tales from the Vienna Woods  
(Strauss); Love in Cloverland (Peter);  
Violin Solo, Au mois d'avril (Adlington);  
The Phantom Brigade (Myddleton). 9.45,  
Light Music: Accordion Duet, Talkie Film  
Favourites; Impressions of Bird Life; Cuban  
Love Song (Stohart); Accordion Duet, Festi-  
val March (Michael). 10.0, Concert  
arranged by the International Broadcasting  
Company (Ireland), Ltd., on behalf of Hos-  
pitals Trust, Ltd. Military Band Music:  
The Elephant March (Ord Hume); The  
Whistler and his Dog (Pryor); Glow-Worm  
Idyll (Lincke); Coronation Bells (Partridge);  
A Gipsy Impression, from Wayside Sketches  
(Scott Minchin); Jolly Fellows (Vollstedt);  
Step Lightly (Anderson). 10.30, I.B.C. Good-  
night Melody, followed by News, Weather  
Report, and Time Signal. 10.40, Irish Bal-  
lads by Betty Byrne (Contralto). 11.0 (ap-  
prox.), Close Down.

## BARCELONA

EAJ1, 860 kc/s, 348.8 metres; 8 kW.—7.0  
p.m., Trio Concert: Extase (Gauguin); May  
Song (Daudois); Selection from Don Quixote  
(Massenet); Les cloches (Debussy); Sym-  
phonic Intermezzo (Desprez); Romance from  
the Violin Concerto (Lalo); Overture, Der  
Freischütz (Weber). 8.0, Request Gramo-  
phone Records. 8.30, Exchange. 9.0, Gramo-  
phone Music and News. 10.0, Chimes from  
the Cathedral, Weather, Messages to Sea-  
men, Exchange and Market Prices. 10.5,  
Sponsored Programme. 10.30, Concert of  
Spanish Music by the Station Orchestra.  
11.30, Band Concert, relayed from the Café  
Español. In the interval at 12 Midnight,  
News. 1.0 a.m. (Wednesday), Close Down.

BASLE.—See Schweizerischer Landessender.

## BELGRADE

697 kc/s, 430.4 metres; 2.8 kW.—6.55 p.m.,  
Time and Announcements. 7.0, Popular  
Songs. 7.30, Concert by the Station Orches-  
tra. 8.30, See Paris (Eiffel Tower). In an  
interval, Time and News. After the pro-  
gramme, Čigány Music from the Potrosacka  
Zadruga Restaurant.

## BERLIN

DEUTSCHLANDSENDER (REICHSEN-  
DER), 183.5 kc/s, 1,635 metres; 60 kW.—2.0,  
Gramophone Concert: Extracts from (a) Aida  
(Verdi), (b) La Bohème (Puccini), and (c)  
Carmen (Bizet); Concert Paraphrase on  
Johann Strauss' Waltzes (Rehberg); Festival  
Overture (Lassen); Matrosenstreich  
(Rathke); Polka; Wir marschieren (Woit-  
schach). 3.0, Concert by the Rasselbande  
Children's Orchestra. 3.30, Weather and  
Exchange. 3.45, Reading (Plato). 4.0, Con-  
cert from Leipzig. 5.0, Violin and Song Re-  
cital by Robert Zeiler and Margarete Wach-  
smuth. Suite for Violin and Pianoforte  
(Schitt) Songs (Rasch); (a) Der schöne  
Sommer ging von ihnen, (b) Ich ging zur  
Bahn, (c) Die Liebe war nicht geringe, (d)  
Es sass in meiner Knabenzeit, (e) Man  
wünschte sich herzlich, Gute Nacht, (f) Es  
flog einmal ein muntres Fliegelein, (g) Wenn  
ich dreinst. 5.0, Talk for the Country  
Woman. 6.0, A Poem. 6.5, Behind the  
Scenes—An Actor and a Playwright exchange  
reminiscences. 6.30, Talk: Sports for Young  
People. 6.50, Weather and Announcements.  
7.0, Transmission for all German Stations,  
relayed from Leipzig. 8.0, To-day's Motto.  
8.5, Man the Boats!—Programme by Ralph  
Siegel and his Company. 9.0, Dance Music.  
10.0, News. 10.20, Max Schmelling discusses  
his Experiences in America with Erwin  
Thoma. 10.45, Weather. 11.0, Concert from  
Hamburg. 12 Midnight, Close Down.

## BERLIN

FUNKSTUNDE, 715 kc/s, 419.5 metres; 1.5  
kW.—6.0 p.m., Three Castles: Küstrin—  
Rheinsberg—Sans-souci. 6.40, The Funk-  
stunde informs its Listeners. . . . 6.45,  
Topical Talk. 7.0, Transmission for all Ger-  
man Stations, relayed from Leipzig. 8.5,  
The Second Day—Prussian Comedy (Hans  
Rehberg). 9.35, Concerto in C for Three  
Pianofortes and Orchestra (Bach), by  
Richard Laugs, Helmut Hildeguth, Walter  
Thiele and The Station Orchestra, conducted  
by Hans von Bendt. 10.0, News. 10.25  
(approx.), Report of the Fair at Schneide-  
mühl. 10.40 (approx.), Concert from Ham-  
burg. In the interval at 11.0 (approx.),

SEPT. 26th

TUESDAY

continued

Weather. 7.0, Transmission for all German Stations, relayed from Leipzig. 8.0, Weather. 8.5 (from Danzig), Mozart—Weber—Wagner—Concert of German Opera Music by the Danzig State Theatre Orchestra, conducted by Ernst Senff; Soloists, Reina Backhaus, Hella Goebel, Karl Kahler, and Fritz Kurt Wehner; Extracts from Don Giovanni (Mozart); Prelude and Lohengrin's Narrative from Lohengrin (Wagner); Aria from Der Freischütz (Weber); Aria and Overture from Oberon (Weber). In the interval, News. 9.30, News. 9.35, Pianoforte Quartet in E flat, Op. 87 (Dvorak), by Kurt Dombrowski (Violin), Kurt Bluhm (Violin), Erich Hämpler (Cello), and Karl Nike (Pianoforte). 10.0, News. 10.20, See Berlin (Deutschlandsender).

HILVERSUM

Announced HUIZEN, 1,013 kc/s, 296.1 metres; 7 kW. (until 5.40 p.m.) and 20 kW. from 5.40 p.m.—Programme of the Catholic Radio Society (K.R.O.). 11.40 a.m., Police Report. 11.55, Concert by the K.R.O. Boys, conducted by Lustenhouwer. 1.25, Interval. 1.40, Programme for Women. 2.40, Gramophone Music. 3.10, Recitations. 3.25, Pianoforte Recital by de Jager: Toccata and Fugue in D minor (Bach-Bausig); Rhapsody in E flat (Brahms). 3.40, Gramophone Music. 4.10, Recitations. 4.25, Pianoforte Recital (cont'd.): Nocturne in G (Schubert); (Chopin); Improviser in G (Schubert); Dutch Rhapsody (de Jager). 4.40, Gramophone Music. 5.10, Concert by the K.R.O. Sextet: Dutch Peasant Dances (Siep); Panis Angelicus (Frank); Was die Domus erzählt (Morena); Berceuse (Järnefeld); Intermezzo (Schneider); March: Strauss Waltz Potpourri (Weber); Godard Potpourri (Urbach); Serenade (Siede); Finale. In an interval at 5.40, Talk. 6.40, Police Report. 6.55, Medical Talk. 7.15, Gramophone Music. 7.25, Talk. 7.40, Concert by the K.R.O. Orchestra, conducted by Gerritsen: Overture: Amerçon (Cherubini); Concerto grosso No. 1 (Lazari); Pavane pour une infante défunte (Ravel). 8.10, News. 8.15, Recitations. 8.40, Concert by the K.R.O. Orchestra, conducted by van 't Woud. In the intervals at 8.10, De Oudjes—Radio Play in Three Acts (Hank), at 9.55, Recitations, and at 10.15, News. 10.40, Gramophone Music. 10.55, Concert by the K.R.O. Boys, conducted by P. Lustenhouwer. 12 Midnight (approx.), Close Down.

HORBY.—See Stockholm.

HUIZEN

Announced HILVERSUM, 160 kc/s, 1,875 metres; 7 kW. (up to 3.40 p.m.). Transmitted from Kootwijk on 50 kW. from 3.40 p.m.—Programme of the Algemeene Vereniging Radio Omroep (A.V.R.O.). 11.40 a.m., Concert by the Wireless Orchestra, conducted by Nico Tremp; March, Der Tausendkünstler (Blankenburgh); Overture, Poet and Peasant (Suppe); Lyric Suite (Grieg); Waltz, Estudiantina (Waldteufel); Melody (Tosti); Serenade (Tosti); Selection from Faust (Gounod); Pumpernickel (Siede); Dellhus Potpourri (Urbach); Dream Waltz (Müllhölzer); Selection from Das Süsses Madel (Reinhardt); Anbade (Poppy); Patrouille enfantine (Gillel); Martial Moments (Winter). In the intervals, Items by the Three Synopators. 2.10, Concert by the Haaxsch Trio: Sonata in A minor (Buxtehude); Trio in F (Haydn). 3.25, Interval. 3.40, Beethoven and Schubert Song Recital by Toby v. d. Brink. 4.10, Concert by a Children's Choir, conducted by Hamel. 4.40, Programme for Children. 5.10, Light Music by the Kovacs Lajos Orchestra. In the interval at 6.10, Talk. 7.10, News. 7.45, Talk. 7.55, Concert by the Concertgebouw Orchestra, conducted by Blech. Soloist: Lotte Schöne (Soprano): Eine kleine Nacht-musik (Mozart); Aria from La finta Giardiniera (Mozart); Aria from The Magic Flute (Mozart); Symphony in C, No. 97 (Haydn); Les préludes (Liszt); Two Songs: (a) Der Hirt auf dem Felsen (Schubert); (b) Tales from the Vienna Woods (Strauss); Overture, Oberon (Weber). 10.10, Gramophone Music. 10.40, News. 10.50, Dance Music. 11.40 (approx.), Close Down.

INNSBRUCK.—See Vienna.

JUAN LES PINS

1,205 kc/s, 249 metres; 0.8 kW.—8.0 p.m., Amusement Guide, Exchange, Racing Results and News. 8.10, Agricultural Notes. 8.25, Musical Programme. 8.45, News and Weather. 9.0, Concert by the Casino Orchestra, relayed from Monte Carlo.

KALUNDBORG.—See Copenhagen.

KIEL.—See Hamburg.

KLAGENFURT.—See Vienna.

KOSICE.—See Prague.

LAHTI

167 kc/s, 1,796 metres; 40 kW. Relayd by Helsinki, 615 kc/s, 368.1 metres.—6.15 p.m., Talk. 6.40, Orchestral Concert. 7.10, Recitation. 7.35, Song Recital. 8.0, Talk. 8.15, Concert by the Station Orchestra: Overture,

La moglie rapita (Drigo); Valse des fleurs (Tchaikovsky); Melody from Coppélia (Delibes). 8.45, News in Finnish. 9.0, News in Swedish.

LANGENBERG

635 kc/s, 473 metres; 60 kW.—12 Noon, Concert by the Münster Municipal Orchestra, conducted by Göhre. 1.15 p.m., News. 1.30, Popular Concert by the Fröhliche Fünf. In the interval at 2.0, News. 3.0, Programme for Children. 3.30, Economic Notes and Time. 3.50, Talk with Music: War Experiences. 4.20, Schubert Lieder by Elisabeth Schumann (on Gramophone Records). 4.30, Reading. 4.50, Topical Talk. 5.0, Concert by the Small Station Choir. 5.30, Concert of Chamber Music, Fiebiger (Contralto), Rummel (Pianoforte), Müller (Violin), Mantels (Oboe), and Schreiber (Cello). Trio in D (Handel); Andante cantabile (Sganabati); Violin Solo, Romance (Smigajka); Three Songs from the Lyric Diary (Haas); Sur le lac (Godard); Cello Solo, Gipsy Song (Dvorak); Oboe Solo, Romance in A (Schumann). 6.20, Reading (Wilhelm Kohl). 6.30, Italian Lesson. 6.45, News. 7.0, Transmission for all German Stations, relayed from Leipzig. 8.0, News. 8.5, Hermann Löns Programme for the 19th Anniversary of his Death; Peasants and Werewolves—Radio Sequence (Castelle). 9.0, Concert conducted by Eysoldt, relayed from the Municipal Theatre, Düren. 10.0, News. 10.20, See Berlin (Deutschlandsender). 10.40, Review of the Week's Events.

LAUSANNE.—See Radio-Suisse Romande.

LEIPZIG

769.9 kc/s, 389.6 metres; 120 kW. Relayd by Dresden, 941 kc/s, 319 metres.—12 Noon, Weather and Time. 12.15 p.m., Concert by the Pletsch-Marko Orchestra. In the interval at 1.15, News and Programme Announcements. 2.10, News. 2.30, Tests for Steel and Iron—Radio Report from the Technical School at Dresden. 3.0, Orchestral Concert, conducted by Wünschmann: Concert Overture, In Autumn (Grieg); Baroque Suite No. 5, Op. 23 (Atterberg); Overture, Der Waldmeister (Strauss); Waltz, Frau-Frau (Blumer); Overture, The Corsair (Berlioz); Ballet Music from Rienzi (Wagner); Basque Rhapsody (Piercé); Waltz, Der Himmel voller Geigen (Ziehrer); Norwegian Artists' Carnival (Svendsen); Dudelsack (Nielsen). In the intervals at 4.0, Market Prices, and at 4.15, Reading (Gottlieb). 5.30, Dialogue on the Game Laws. 5.50, Economic Notes, Weather and Time. 6.0, Review of Books for Young Hitlerites. 6.25, Brahms Lieder on Gramophone Records. 6.50, Review of the Day's Events. 7.0, Transmission for all German Stations: Soldiers' Songs—Concert by the Symphony Orchestra, conducted by Weissbach: Soloist: Johannes Willy (Bari-tone); Ballads (Loewe): (a) General Schwerin, (b) Odins Meeresritt, (c) Trommetständerchen; Orchestra: Wellington's Victory or the Battle of Vittoria, for Orchestra, Op. 92 (Beethoven); Ballads (Loewe): (a) Prince Eugene, (b) Nächtliche Heerschau, (c) Graf Eberstein, (d) Fridericus Rex; War March from Rienzi (Wagner). 8.0, Walter and Hildegund—Radio Play after the German Legend (Lehmann). 8.40, Court Singer—Sketch (Brink). 9.0, Concert by the Symphony Orchestra, conducted by Weissbach. 10.5, News and Sports Notes. 10.30, Talk: Infra-Red Rays. 10.40, See Hamburg. 12 Midnight, Close Down.

LINZ.—See Vienna.

LUXEMBOURG

252 kc/s, 1,191 metres; 200 kW.—12.30 p.m., Concert by the Station Orchestra, conducted by Henri Pensis: Florentine March (Fucik); Dynamiden-Walzer (Jos. Strauss); Selection from The Flying Dutchman (Wagner); Prelude (Albeniz-Salabert); Humoresque (De Taeye); Norwegian Dances (Grieg); Selection from Die Fledermaus (Joh. Strauss). 1.30, Variety Music on Gramophone Records. 7.30, Sonata (Frauck) for Violin and Pianoforte (on Gramophone Records). 8.10, Concert by the Station Orchestra, conducted by Henri Pensis: Overture, Manfred (Schumann); A Night on the Bare Mountain (Mussorgsky); Concert Waltz (Moszkovsky); Interlude (Vreulst); Overture, The Thieving Magpie (Rossini); Granada (Albéniz); Spanish Dance No. 5 (Granados); Caprice (Brusselmanns); Suite from Sylvia (Delibes); Berceuse (Krieka); Selection from Countess Maritza (Kálmán). In the interval at 8.50, News in French, and at 9.45, News in German. 10.20, Dance Music on Gramophone Records.

LWOW

788 kc/s, 381 metres; 16 kW.—7.20 p.m., Announcements and Gramophone Music. 7.35, Programme Announcements. 7.40, See Warsaw. 9.0, Gramophone Music. 9.10, See Warsaw. 10.40, Gramophone Music. 11.0 (approx.), Close Down.

LYONS

LA DOUA, 644 kc/s, 465.8 metres; 1.5 kW.—6.30 p.m., Radio Journal. 7.30, Radio Gazette for Lyons and the South-East. 8.30, See Paris (Eiffel Tower). After the Programme, News.

MADRID

EAJ7, 707 kc/s, 424.3 metres; 2 kW.—8.0 p.m., Chimes, Exchange, Radio Journal and Request Gramophone Records. 8.30, Talk by Joaquin España Cantos and Request Gramophone Records (cont'd.). 9.15, Topical Review. 9.30 to 11.0, Interval. 11.0, Chimes, Time and Topical Review. 11.20 (approx.), La Bohème—Opera (Puccini) on Gramophone Records. 1.15 a.m. (Wednesday), Topical Review. 1.30, Chimes and Close Down.

MALMO.—See Stockholm.

MILAN.—See Turin.

MORAVSKA-OSTRAVA

1,137 kc/s, 263.8 metres; 11 kW.—2.50 p.m., Concert by the Station Orchestra, conducted by Plichta: Overture, Wanda (Dvorák); Suite from Falstaff (Verdi); Medieval Suite from The Minnesingers (Amadei); Savanna Waltz (Balling); The Blue Pavilion (Armandola); Andalusian Serenade (Armandola); Mazurka (Marsik); March (Tichy). 3.50 to 4.0, See Prague. 5.45, Gramophone Records. 5.55, Talk: Science and Art in Italian Switzerland. 6.5, Talk: Travelling by River and Lake. 6.15, Programme from Brno. 7.0, See Prague. 7.10, Concert by the Station Orchestra, conducted by Musil: Melody (Maly); Aquarellenwalzer (Job. Strauss); Gallon (Leopold); Polka (Moore); Dance (Heykens); March (Fucik). 7.45, See Prague. 8.20, See Brno. 9.0, See Prague. 11.0 (approx.), Close Down.

MOSCOW

(TRADES UNION), 300 kc/s, 1,000 metres; 100 kW.—11.45 a.m., Weather. 2.45 p.m., Weather. 3.0, Copernic and Beethoven Concert. 4.0, Topical Talk. 4.30, Boris Godunov—Play (Pshiklin). 5.30, The Immovable Mountain—Operetta for Children. 6.30, Liszt Concert by the Symphony Orchestra conducted by Orlov. Soloist: Ginsburg (Pianoforte). Symphonic Concerto Overture to Dante's Divina Commedia; Mephisto-Walzer; Concerto in A; Overture, Hamlet. 9.0, News. 9.30, Programme Announcements. 9.55, Chimes. 10.5, Press Review.

MOTALA.—See Stockholm.

MUHLACKER.—See Stuttgart.

MUNICH

563 kc/s, 533 metres; 60 kW. Relayd by Augsburg and Kaiserslautern, 536 kc/s, 560 metres; and Nürnberg, 1,256 kc/s, 239 metres.—12 Noon, Gramophone Concert. 1.0 p.m., Concert, conducted by Erich Kloss. In the interval from 1.15 to 1.30, Time and News. 2.0, Time and News. 2.20, Song and Pianoforte Recital. 3.0, Programme for the Housewife. 3.55, Weather and Market Prices. 4.5, Talk: The Village Dramatic Society. 4.25, Concert by the Station Orchestra, conducted by Karl List. Soloist: Karlheinz Grono (Baritone); Hauptmann-Göring March (Taube); Waltz, Im schönen Tal der Isar (Löffl); Overture, Roccaccio (Suppe); Prologue to I Pagliacci (Leoncavallo); Ballet Music from Udine (Lortzing); Turkish Serenade (Zimmer); Funk-walzer (Powolny); March, Rambambuli (Larsen). 5.40, A Dialogue. 6.5, Sonata in A minor for Violin and Pianoforte (Noren). 6.25, Talk: Three German Authors who died recently—Hermann Löns, Gorch Fock and Walter Flex. 6.45, Time and News. 7.0, Transmission for German Stations, relayed from Leipzig. 8.0 (from Nürnberg), Würzburg, the Jewel of Franconia—Some Radio Pictures of an Old Bavarian City (Hans Meder). 9.0, Request Concert on Gramophone Records. 10.0, Time and News. 10.20, See Berlin (Deutschlandsender). 10.40, News.

NAPLES.—See Rome.

NOTODDEN.—See Oslo.

OSLO

277 kc/s, 1,083 metres; 60 kW. Relayd by Fredriksstad, 815 kc/s, 368.1 metres; Hamar, 522 kc/s, 574.7 metres; Notodden, 671 kc/s, 447.1 metres; Porsgrund, 662 kc/s, 453.2 metres; and Rjukan, 671 kc/s, 447.1 metres.—5.0 p.m., Concert by the Grand Café Orchestra. 6.0, Programme for Women. 6.45, Banjo Recital by Norman Olsen. 7.0, Advertising Notes, Weather and News. 7.30, Theatre Review. 8.0, Time Signal. 8.1, Concert by the Station Orchestra, conducted by Hugo Kramm: Soloist: Nancy Naess (Songs); Introduction to The Mastersingers (Wagner); Air from Iphigenia in Aulis (Gluck); Elizabeth's Prayer from Tannhäuser (Wagner); Selection from Hansel and Gretel (Humperdinck); Two Arias (Verdi) from (a) The Force of Destiny, (b) Il Trovatore; Selection from Hanneles Himmelfahrt (Graener); Overture, Russian and Ludmilla (Glinka); Suite ancienne (Halvorsen). In an interval at 9.0, Talk

FRANKFURT

1,157 kc/s, 259.3 metres; 17 kW. Relayd by Cassel, 1,220 kc/s, 245.9 metres; and Trier, 1,157 kc/s, 259.3 metres.—4.30 p.m., See Stuttgart. 5.45, Exchange. 6.0, Reading. 6.25, Talk: Adventurers in German Literature. 6.45, Review of the Day's News. 6.50, Time and News. 7.0, Transmission for all German Stations, relayed from Leipzig. 8.0, Suor Angelica—Opera in One Act (Puccini). 9.0, Gott erhalte—A Radio Sequence about Haydn (arr. Ferdinand Drost and Karl Köstlin). 10.0, Time and News. 10.20, See Berlin (Deutschlandsender). 10.40, See Hamburg. 12 Midnight, Close Down.

FREIDRIKSSTAD.—See Oslo.

FREIBURG.—See Stuttgart.

GENEVA.—See Radio-Suisse Romande.

GENOA.—See Turin.

GLEIWITZ.—See Breslau.

GOTEBORG.—See Stockholm.

GRAZ.—See Vienna.

HAMAR.—See Oslo.

HAMBURG

806 kc/s, 372 metres; 1.5 kW. Relayd by Bremen, 1,112 kc/s, 269.9 metres; Flensburg, 1,319 kc/s, 227.4 metres; Hanover, 530 kc/s, 566 metres; and Kiel, 1,292 kc/s, 232.2 metres.—6.15 p.m. (from Hanover), Hermann Löns Memorial Programme—Concert by the Hanover Male Voice Double Quartet, with Commentary by Harry Moss. 6.45, Frankfurt Exchange and Hamburg Market Prices. 6.50, Weather. 7.0, Transmission for all German Stations, relayed from Leipzig. 8.0, Talk: Hermann Löns. 8.10, Richard Strauss and Franz Liszt Concert by the Hamburg Philharmonic Orchestra, conducted by José Eibenschütz. Soloist: Herbert Heinemann (Pianoforte). Dance Suite (Comperin-Strauss); Pianoforte and Orchestra: Burlesque (Strauss); Symphonic Poem, Les Préludes (Liszt). 9.25, Der verlorene Pudel vor dem Antzergericht (The Case of the Lost Poodle)—Radio Play (Kieffisch). 10.0, Time and News. 10.20, See Berlin (Deutschlandsender). 10.40, Concert by the Hamburg Philharmonic Orchestra, conducted by José Eibenschütz: Overture, Rienzi (Wagner); Italian Caprice (Tchaikovsky); Hungarian Dances Nos. 5 and 6 (Brahms); Invitation to the Dance (Weber); Selection from The Gipsy Baron (Joh. Strauss); Waltz, Wiener Bürger (Ziehrer).

HANOVER.—See Hamburg.

HEILSBURG

1,085 kc/s, 276.5 metres; 60 kW. Relayd by Danzig, 662 kc/s, 453.2 metres.—1.5 p.m., Gramophone Concert. In the intervals at 1.20 and 2.0, News. 2.30, Programme arranged by the Post Office with Gramophone Records. 3.0, Agricultural Prices and Exchange Rates. 3.30, Musical Improvisation for Children. 4.0, Concert by the Small Station Orchestra, conducted by Eugen Wilcken: Overture, The Puritans (Bellini); Little Suite No. 1 (de Micheli); Selection from La Gena della beffe (Giordano); Ballet Music from Otello (Verdi); Waltz, The Secret of the Adige (Carena); Overture, Bruchlino (Rossini). In the interval at 4.50 (approx.), Talk: What the German Woman can do for the Fatherland. 5.45, Review of Periodicals. 6.15, Agricultural Prices. 6.25, Talk for Workers. 6.50,

on Politics. 9.40, Weather and News. 10.0, Topical Talk. 10.15, Concert by a Male Voice Choir. OSTERSUND.—See Stockholm.

PALERMO

558 kc/s, 537.6 metres; 3 kW.—8.0 p.m., Dopplavoro Announcements. Tourist Talk. Agricultural Notes, and Giornale Radio. 8.20, Gramophone Music. In the interval at 8.30, Time and Announcements. 8.45, Andrea Chenier—Opera in Three Acts (Giordano). In the intervals, Talk and Announcements. After the Opera, Giornale Radio.

PARIS

EIFFEL TOWER, Call FLE, 207.5 kc/s, 1,445.7 metres; 13 kW. Time Signals (on 2,650 metres) at 10.26 a.m. and 11.26 p.m. (Preliminary and G-dot Signals).—6.45 p.m., Theatre Notes. 7.0, Le Journal Parle. 8.30, Concert relayed from the Conservatoire: The Opéra-Comique Orchestra, conducted by Inghelbrecht, and Soloists; Overture, Phèdre (Massenet); Septet for Trumpet, Two Violins, Viola, Cello, Double Bass and Piano (Saint-Saëns); Lyric Scene for Women's Choir and Soloists; La Sulamite (Chabrier); Prelude and Finale from Le Diable dans le Beffroy (Inghelbrecht); Piano Concerto (Cras); Suite for Strings, Two Harps and Piano, from Le bal de Béatrice d'Este (Hahn); Incidental Music to Caligula (Faure); Norwegian Rhapsody (Lalo). 10.45 (approx.). Close Down.

PARIS

POSTE PARISIEN, 914 kc/s, 328.2 metres; 60 kW.—7.0 p.m., Concerto in D minor (Bach), by Yehudi Menuhin (on Gramophone Records). 7.15, Le Journal Parle. 7.30, Le Voyage à Fontaines—One-Act Comedy. 8.0, Song Recital: Si vous l'aviez compris (Denza); Enchantment (Massenet); Paysage (Hahn); Novembre (Trémissot); Temps perdu (Vidal); Air from The Desert Song (Romberg). 8.35, Concert. 10.30, News.

PARIS

RADIO PARIS, Call CFR, 174 kc/s, 1,725 metres; 75 kW.—7.30 a.m., Weather and Physical Culture. 7.45, Gramophone Music. 8.0, Weather and Press Review. 12 Noon, Opera Music on Gramophone Records: Overture, Si j'étais roi (Adam); Songs from Le Châlet (Adam); Overture, Fra Diavolo (Auber); Songs from Masaniello (Auber); Songs from La Dame blanche (Boieldieu); Selection from Carmen (Bizet); Song from The Fair Maid of Perth (Bizet); Cavatina from The Pearl Fishers (Bizet); Overture, Le roi d'Ys (Lalo); Songs from Grisélidis (Massenet); Nocturne from La Navarraise (Massenet); La sange fleurie from Le jongleur de Notre Dame (Massenet); Overture, La princesse jaune (Saint-Saëns). In the interval at 1.0, Exchange, News and Weather, and at 1.30, Exchange. 2.0, Exchange and Announcements. 3.45, Exchange and Market Prices. 7.0, Agricultural Report. 7.10, Gramophone Concert: March, King Cotton (Sousa); Selection from The Czardasvitch (Lehár); Bells across the Meadows (Ketyelbey); Granada (Garcia); Berceuse (Gretchaninov); Songs from Paganini (Lehár); Melody (Prietystal); Marche tarare (Ganne). 7.50, Commercial Notes and News. 8.0, Gramophone Music: Danse sacrée et Danse profane (Debussy); Habanera (Aubert). 8.25, Review by Pierre Seize. 8.30, See Paris (Eiffel Tower).

PITTSBURGH

KDKA, 980 kc/s, 306 metres; 50 kW. Relayed by W8XK on 48.86 metres and 25.27 metres.—7.30 p.m., KDKA Home Forum. 8.0, Betty and Bob, from New York. 8.15, Words and Music, from New York. 8.45, Congress of Clubs. 9.0, Meredith Wilson's Orchestra, from New York. 9.15, Jack Walton's Orchestra, from New York. 9.30, News, Markets. 10.0, Casino Orchestra, from New York. 10.15, KDKA Kiddies' Klub. 10.30, Singing Lady, from New York. 10.45, Orphan Annie, from New York. 11.0, News, Piano Classique. 11.15, Sports. A Song. 11.30, Pittsburgh Spotlights. 11.45 to 4.0 a.m. (Wednesday), New York Relay. 11.45, Lowell Thomas. 12 Midnight, Amos 'n' Andy. 12.15, Radio in Education. 12.45, Carney's Dog Chats. 1.0, Crime Clues. 1.30, Adventures in Health. 1.45, The Rollickers. 2.0, Miniature Theatre. 2.30, Pastoral. 3.0, Musical Memories. PORSGRUND.—See Oslo.

PRAGUE

614 kc/s, 488.6 metres; 120 kW.—2.50 p.m., See Moravská-Ostrava. 3.50, Aviation Weather Report. 3.55 to 4.0, Exchange. 5.45, Legal Talk. 5.55, Talk on Commerce. 6.5, Agricultural Prices. 6.15, Talk for Workers. 6.25, News in German. 6.30, German Transmission: Popular Sound Film Songs. 7.0, Chimes and News. 7.10, See Moravská-Ostrava. 7.45, Talk: Water Divining. 8.0, Concert by the Prague Piano-forte Quartet: From Sumava to Verchovina (Tihnak); Tango; In your little Hands; Fox-trot; March (Mach). 8.20, See Brno. 9.0, Concert by the Station Orchestra, conducted by Dolzycki. 10.0, Time and News. 10.15, Piano-forte Duets of Czech Dance Music. 11.0 (approx.). Close Down.

SEPT. 26th

TUESDAY

continued

RADIO-SUISSE ROMANDE

SOTTENS, 743 kc/s, 403 metres; 25 kW.; and Geneva, 395 kc/s, 760 metres.—6.15 a.m. to 6.30 (from Lausanne), Gymnastics. 12.28 p.m., Time Signal from the Neuchâtel Observatory. 12.30, News and Weather. 12.40 (from Lausanne), Gramophone Music. 1.0 (from Lausanne), Financial Notes. 1.10 (from Lausanne), Gramophone Music. 2.0, Interval. 3.28, Time Signal from Neuchâtel Observatory. 3.30 (from Lausanne), Concert by the Station Orchestra, conducted by Moser. 5.0, Programme for Women. 5.30, Interval. 7.0 (from Geneva), Talk: Lute-Playing in Bologna in the 15th and 16th Centuries. 7.30 (from Geneva), Weather and News. 8.0 (from Lausanne), Lapointe et Ropiteau—Play in One Act (Dubamel). 8.30, See Paris (Eiffel Tower). 10.15, News and Weather. 10.30 (approx.). Close Down.

RJUKAN.—See Oslo.

ROME

Call 1RQ; 680 kc/s, 441 metres; 50 kW. Relayed by 2RQ, 11,810 kc/s, 25.4 metres, from 5.15 p.m.; Bari, 1,112 kc/s, 269.8 metres; Milan (Vigentino), 662 kc/s, 453.2 metres, from 8.45 p.m.; and Naples, 941 kc/s, 319 metres.—12.30 p.m., Gramophone Music. 1.0 p.m., Orchestral Concert. In the interval at 1.30, Giornale Radio and Exchange. 2.0, Time and Announcements. 4.30, Children's Radio Review. 4.55, Giornale Radio and Exchange. 5.10, Weather. 5.15 to 6.0, Concert by the Station Orchestra. 6.40, Shipping and Sports Notes. 6.45, Lesson in Morse and Dopplavoro Notes. 7.0, Tourist Report. 7.10, Agricultural Notes. 7.20, News in Foreign Languages. 7.40, Giornale Radio. 8.0, Time and Announcements. 8.15, Request Gramophone Music. 8.30, Sports Notes. 8.45, Symphony Concert, conducted by Zinno: Overture, La baruffa chiozzotta (Sinigaglia); Extracts from the Symphony in D Minor (Franck); Overture (Zinno); Intermezzo from Le Confese (Mile); Canto di zolfara (Gibilaro); Overture, Tannhäuser (Wagner). In the interval, Talk on Literature and Art. 11.0, Giornale Radio.

SALZBURG.—See Vienna.

SCHENECTADY

WGY, 790 kc/s, 379.5 metres; 50 kW. Relayed at intervals by W2XAF on 31.48 metres and by W2XAD on 19.56 metres.—1.45 a.m. (Wednesday), Stock Reports. 2.0 to 4.45, New York Relay. 2.0, Blackstone Plantation. 2.30, Wayne King's Orchestra. 3.0, Variety Programme. 3.30, Ben Bernie's Orchestra. 4.0, Lives at Stake. 4.30, Popular Programme. 4.45, National Radio Forum, from New York, followed by Programme Resumé.

SCHWEIZERISCHER LANDESENDER

BEROMUNSTER, 653 kc/s, 459 metres; 60 kW.; Basle, 1,229 kc/s, 244.1 metres; and Berne, 1,220 kc/s, 245.9 metres.—6.15 to 6.35 a.m. (from Basle), Gymnastics. 11.59, Time from Neuchâtel Observatory and Weather. 12 Noon (from Berne), Sound Film Music on Gramophone Records. 12.30 p.m., Time, Weather and News. 12.40 (from Berne), Extracts from Faust—Opera (Gounod) on Gramophone Records. 1.0 (from Berne), A Microphone Report. 1.15 (from Berne), Folk Music on Gramophone Records. 1.25 (from Berne), Time, Weather, and Exchange. 1.30 (approx.) to 5.0, Interval. 5.0 (from Zürich), Light Orchestral Concert. 5.30 (from Basle), Review of New Gramophone Records. 6.30 (from Berne), Talk: The Holy Waters of Valais. 7.0, Time and Weather. 7.1 (from Berne), Talk: Excursions for Sunday. 7.10 (from Berne), Extracts from Kinderszenen (Schumann) on Gramophone Records. 7.15 (from Berne), A Scene (Brawand). 7.35 (from Berne), Gramophone Records: Nocturne in E Flat (Chopin); Waltz in A Flat (Chopin). 7.45 (from Berne), Introductory Talk to the following Transmission. 8.0, The Queen of Spades—Opera in Three Acts (Tchaikovsky). In the interval at 9.0 (approx.), Weather and News. 10.15 (approx.). Close Down.

SOTTENS.—See Radio-Suisse Romande.

STOCKHOLM

689 kc/s, 436 metres; 55 kW.; Relayed by Boden, 244 kc/s, 1,229.5 metres; Göteborg, 932 kc/s, 322 metres; Hörby, 1,166 kc/s, 257 metres; Motala, 2215 kc/s, 1,354.4 metres; Ostersund, 389 kc/s, 770 metres; and Sundsvall, 554 kc/s, 542 metres.—5.5 p.m., Accordion Music, relayed from Falun. 9.7 kc/s, 307 metres. 5.30, The Practical Corner. 5.45, Gramophone Music. 6.45, French Lesson. 7.15, Weather and News. 7.30, Talk, relayed from Malmö, 1,301 kc/s, 231 metres. 8.0, Song Recital by Margit Rosengren. 8.30, Piano-forte Recital. 8.45, Literary Review, relayed from Malmö. 9.15, Concert by the Station Orchestra. Soloist: Charles Barkel

(Violin). 9.45, Weather and News. 10.0, Popular Music by the Station Orchestra: Cavalry March (Schubert-Liszt); Suite, Joyous Youth (Coates); Prelude and Lullaby (Järnefeldt); Valse triste (Sibelius); Melody (Akerberg); Slav Dance (Dvorak). 11.0 (approx.), Close Down.

STRASBOURG

869 kc/s, 345 metres; 11.5 kW.—11.30 a.m., Classical Music on Gramophone Records. 12 Noon, Orchestral Concert, conducted by Maurice de Villers: Ballet Music from Faust (Gounod); Symphonic Poem, Helvetia (Scasola); Arab Suite (Dyck); Overture, Phèdre (Massenet); Symphonic Poem, Phaëton (Saint-Saëns); Orchestral Suite, L'enfant prodigue (Debussy); Hungarian Rhapsody No. 11 (Liszt). In the intervals at 12.45 p.m., News, and 1.0, Time and Exchange. 2.0, Interval. 4.45, Talk on Tunisia. 5.0, Orchestral Concert, conducted by Roskam: March, Marching along together (Steininger); Waltz, Liebe kommt von einnal irgendwo her (Künneke); Dancing Moon (Aubry); Lies (Soringer and Barris); Tango (Stauch); Minuet (Bocherini); Schotzwalzer (Joh. Strauss); Selection from No No Nanette (Yonnans); Auf Wiedersehen, my dear (Hoffmann-Nelson); Down South (Myddelle); Two Step (Heymann). 6.0, History Talk. 6.15, Topical Talk. 6.30, Song Recital by Jeanine Wild (Soprano) and Jean Hazart (Bass): Bass Solos: (a) Triolets (Larmanjat); (b) Chant du semeur (Brunant); Soprano Solos: (a) Gazoillies enfant (Jean Hazart); (b) Six Children's Songs: Duets (Berlioz); (a) Prière du Matin, (b) Sata la Baiguisse; Bass Solos: (a) L'Angelus (Foudrain); (b) Lever du soleil (Erlanger); Soprano Solos: (a) En Sour-dine (Hahn); (b) Le thé. (c) Si tu le veux (Kochlin); Duets: (a) Cueilions les bouquets (Goudard); (b) D'un cœur qui t'aime (Gounod). 7.30, Time and News. 7.45, Gramophone Music. 8.0, Press Review in German, Lottery Results and Announcements. 8.30, See Paris (Eiffel Tower). 10.45 (approx.), Press Review.

STUTTART

MUHLACKER, 832 kc/s, 360.5 metres; 60 kW. Relayed by Freiburg, 527 kc/s, 570 metres.—1.30 p.m., Concert from Munich. 2.0, Concert arranged by the Post Office. 2.30, Advanced English Conversation. 3.0, Interval. 3.30, Talk on Flowers. 4.0, Reading and Songs (Theodor Storm). 4.30, Orchestral Concert, conducted by Gustav Görlich: Overture, Idomeneo (Mozart); Minuet from the Divertimento (Mozart); Little Suite (Michele); Waltz, Gold and Silver (Lehár); Selection from The Mikado (Sullivan); Spanische Wachtparade (Lincke). 5.45, Light Music. 6.10, Talk: Modern Art. 6.35, Time and News. 7.0, Transmission for all German Stations, relayed from Leipzig. 8.0, See Frankfurt. 9.0, Joseph Haydn—a Biographical Radio Sequence (Drost and Köstlin) with Music by the Württemberg Symphony Orchestra. 10.0, Time and News. 10.20, See Berlin (Deutschlandsender). 10.40 from Freiburg, Theatre Talk. 11.0, Concert from Hamburg. 12 Midnight, Close Down. SUNDSVALL.—See Stockholm.

TOULOUSE

779 kc/s, 385 metres; 8 kW.—6.15 p.m., Opera Music: Airs from: (a) Carmen (Bizet), (b) Romeo and Juliet (Gounod), and (c) I Pagliacci (Leoncavallo). 6.30, Light Music by a Viennese Orchestra. 7.0, Accordion Solos. 7.15, News. 7.30, Till Eulenspiegel's Merry Pranks (R. Strauss). 7.45, Opera Music: Cavatina from Norma (Bellini); Barcarolle from The Tales of Hoffmann (Offenbach); Air from Così fan tutte (Mozart); Aria from Le Jongleur de Notre Dame (Massenet). 8.0, Music by an Argentine Band. 8.15, Chansonnettes. 8.30, Military Music. 8.45, Hawaiian Guitar Solos. 9.0, Concert Version of Hamlet—Opera (Thomas). 9.30, Orchestral Concert: The Flight of the Bumble Bee (Rimsky-Korsakov); Marche joyeuse (Chabrier); Selection from Der Bettelstudent (Millöcker); Eglogue (Rabaud); Italian Serenade (Wolf); Selection from The Queen of Spades (Tchaikovsky). 10.0, Sound Film Music. 10.15, News. 10.30, Concert for Listeners in Morocco: Overture, The Flying Dutchman (Wagner); Air from Figaro (Mozart); Schotzwalzer (Strauss); Jambais (Cazes); Jolly Fellows (Vollstedt); La montmartroise (Peyronnin); Tina (Romero). 11.0, Operetta Music: Selection from: (a) Le Train Bleu (Pares and Van Parys), and (b) Les Cloches de Corneville (Planquette). 11.15, Dance Music. 12 Midnight, News. 12.5 a.m. (Wednesday), Chansonnettes. 12.15, Music by a Viennese Orchestra. 12.30 (approx.), Close Down.

TRIESTE

1,211 kc/s, 247.7 metres; 10 kW.—5.10 p.m. till Close Down. See Turin.

TRONDHEIM.—See Oslo.

TURIN

273.7 metres; 7 kW. Relayed by Milan, 331.5 metres; Genoa, 312.8 metres; and Florence, 500.8 metres.—5.10 p.m., Dance Music, relayed from the Savoia. 6.0 to 6.5, Weather. 6.40, Giornale Radio, Dopplavoro Announcements, and Gramophone Music. 7.0, Time, Report of the Royal Geographical Society, and Gramophone Music. 7.10, Agricultural Notes and Market Prices. 7.20, News in Foreign Languages. 7.40, Gramophone Music. 8.0, Announcements, Giornale Radio, Sports Notes, and Weather. 8.25, Talk on the following Transmission. 8.30, The Merry Peasant—Operetta in Three Acts (Fall). In the intervals, Talk and Literary Notes. After the Operetta, Giornale Radio.

VATICAN CITY

15,120 kc/s, 19.84 metres (Morning) and 5,969 kc/s, 50.26 metres (Evening); 10 kW.—11.0 to 11.15 a.m., Religious Information in English. 8.0 to 8.15 p.m., Religious Information in Italian.

VIENNA

581 kc/s, 517 metres; 15 kW. Relayed by Graz, 852 kc/s, 352.1 metres; Innsbruck, 1,058 kc/s, 283 metres; Klagenfurt, 662 kc/s, 453.2 metres; Linz, 1,220 kc/s, 245.9 metres; and Salzburg, 1,373 kc/s, 218.5 metres.—12 Noon, Concert by the Wiener Symphoniker, conducted by Holzer: Overture, Le roi Fa dit (Delibes); Extract from Carmen (Bizet); Lullaby (Smetana); Waltz, Illustrationen (Strauss); Rheinleugeudehen (Mahler); Selection from The Merry Wives of Windsor (Nicolaï); Waltz from Der Rosenkavalier (R. Strauss); March (Rochlitzer); Violin Solo: Nocturne (Pausperti); Waltz, In den Sternien stehst's gescrieben (Fetras); Poeme d'extase (Bullerian); Viennese Song (Goetz); Indian Intermezzo (Ketyelbey); Waltz (Lehár); Potpourri (Komzak). In the interval at 1.0 p.m., Time, Weather and Announcements. 2.0, Interval. 3.0, Time, Weather and Market Prices. 3.20, Talk: Cellulose Spraying Plants. 3.35, Overtures on Gramophone Records. 4.30, Talk: Stories of Famous Conductors. 4.55, Talk on Autumn Flowers. 5.20, Song and Violin Recital by Hanna Lorenz (Contralto) and Ferdinand Adler: Songs: (a) My Homeland (Gretchaninov), (b) Trepat (Mussorgsky), (c) The Nightingale (Alabiev), (d) Three Russian Folk Songs; Violin Solos: (a) Faust Fantasia (Wieniawski), (b) The Lilac Bush (Hulay), (c) Serenade in E (Bass), (d) Perpetuum mobile (Novacek). 5.55, Report on Gramophone Records of the Children's Session of the German Catholic Congress, 1933. 6.30, A Psychological Criticism of the Theory of Reincarnation. 6.55, Hunting Songs and Hunting Music—Concert by the German Folk Song Society, conducted by Kotek, with an Introductory Talk by Karl Klier. 7.40, Time, Weather and Announcements. 7.50, Talk on Music. 8.5, Memorial Programme. 8.30, A Flight round the World—Potpourri (Hrabý) by the Chorus of the Volksoper, the Wiener Symphoniker, the Pfleger Wind Band, the Mathé Dance Band, and Soloists. 10.0, News, Weather and Exchange. 10.15, Concert by the Haupt Orchestra, relayed from the Hotel Krautz-Ambassador, followed by Schrammel Music and Songs. After the Programme, Announcements.

WARSAW

212.5 kc/s, 1,411 metres; 120 kW.—11.57 a.m., Time Signal, and Fanfare from St. Mary's Church, Cracow. 12.5 p.m., Gramophone Music. 12.25, Polish Press Review. 12.33, Weather Report. 12.35, Gramophone Music. 12.55, Radio Journal. 1.0 to 2.55, Interval. 3.5, News. 3.10, Announcements. 3.15, Gramophone Music. 3.25, Economic Notes. 3.35, Gramophone Music. 3.45, Aviation Report and Anti-Gas Drill. 3.50, Gramophone Music. 3.55, Announcements. 4.0, Light Music and Dance Music by the Goryzski Quartet. 5.0, Answers to Correspondence. 5.15, Soprano and Piano-forte Recital by Laniewska and Wysocka-Ochlewska. Piano-forte Solos: (a) Chromatic Fantasia and Fugue (Bach), (b) Andante cantabile (E. Bach), (c) Allegro (Schubert). Song: (a) Barcarolle (Szopski), (b) L'Oiseau dans la forêt (Faubert), (c) L'Onidine (Glière). Piano-forte Solos: (a) Rhapsody in G minor (Brahms), (b) Variations in F minor on a Theme of Clara Wieck (Schumann). Songs: (a) Aria from Lakmé (Delibes), (b) Variations (Proch), (c) Aria from The Magic Flute (Mozart). 6.15, Talk: Poland Today. 6.35, Concert of Polish Music by the Station Orchestra, conducted by Oziminski: Polonaise (Cymbalinski); Suite (Pachulski); Concert Waltz (Dworakowski); Mazurka (Mlynarski). 7.20, Miscellaneous Items. 7.35, Programme Announcements. 7.40, Topical Talk. 8.0, Concert of Light Music. 8.50, Radio Journal. 9.0, Agricultural Notes. 9.10, Piano-forte Recital by Henri Sztompka: Variations in F minor (Haydn); Sonata appassionata (Beethoven); Nocturne and Cracovienne fantastique (Paderewski); Melody (Chopin-Liszt); Spinning Chorus from The Flying Dutchman (Wagner-Liszt). 10.0, Dance Music. 10.25, Sports Notes. 10.35, Aviation Weather Report and Police Notes. 10.40, Dance Music (contd.). ZURICH.—See Schweizerischer Landessender.





**In positions of trust,** where reliability may be a matter of life and death the Exide battery is chosen. It is found in the Wireless Cabins of 9 out of 10 British ships, ready to radiate or receive the signal of distress.



# Exide

BATTERIES

**EXIDE "D" TYPE  
L.T. BATTERIES**

TYPE DTG	20 amp. hours	4/6
TYPE DFG	45 amp. hours	8/6
TYPE DMG	70 amp. hours	11/-
TYPE DHG	100 amp. hours	14/6

*For wireless H.T. get Drydex — the dry battery by Exide*

Obtainable from Exide Service Stations and all reputable dealers. Exide Batteries, Exide Works, Clifton Junction, near Manchester  
Branches: London, Manchester, Birmingham, Bristol, Glasgow, Dublin, Belfast



Silent in  
operation



Individually tested  
and packed. *Plus*  
*unrivalled quality*

## DUBILIER RESISTANCES

These new Dubilier Resistances are the outcome of an improved process of manufacture which ensures an even better resistance than the popular Dubilier Type of 1932. Consistency of characteristics under prolonged load is a most noteworthy feature, and you are always assured of long life and silence in operation. Undoubtedly the finest resistances selling to-day.

*Write for your copy of the new Dubilier Catalogue!*

DUBILIER CONDENSER CO. (1925) LTD., DUCON  
WORKS, VICTORIA ROAD, NORTH ACTON, W.3

# 10th NORTHERN NATIONAL RADIO EXHIBITION CITY HALL, DEANSGATE MANCHESTER

★ Sept. 27th—Oct. 7th, 1933 ★

The Exhibition will open officially  
on Wednesday, September 27th,  
and afterwards

**DAILY FROM 11 A.M. to 10 P.M.**

The opportunity provided by this Exhibition to see and hear the latest in Radio has been eagerly awaited by thousands of enthusiasts.

Second only in size and importance to Olympia, this exhibition has made a greater appeal than ever to the Trade, the leading Manufacturers and Distributors having secured stand accommodation.

This Exhibition offers an opportunity to see, under one roof, all that is new in the world of radio.

### CHEAP RAILWAY FACILITIES

Arrangements have been made with the Railway Companies for the issue of reduced Railway Vouchers for distances within 60 miles radius of Manchester. This Voucher entitles the holder to travel at single fare for the return journey, and is available on the day of issue only. Applications to be made to Provincial Exhibitions, Ltd., City Hall, Deansgate, Manchester, and accompanied by stamped, addressed envelope.

**ADMISSION 1/3 (INCLUDING TAX)**

Organised by the  
**RADIO MANUFACTURERS' ASSOCIATION  
AND PROVINCIAL EXHIBITIONS LIMITED**



45.P.M.

# There's NOTHING to equal BLUE SPOT MOVING COILS

Only by insisting on a Blue Spot moving coil speaker are you absolutely sure of satisfaction. Blue Spot Speakers are the best in the world. They have the highest reputation for quality and reliability. They incorporate the most advanced ideas in the best and most convenient way. They give the most lifelike reproduction and so bring out the full values of the broadcast programmes. It is a good investment to buy extra Blue Spot Speakers and use them throughout the house from your present set. There are Blue Spot Speakers for every purpose.

Write for Catalogue No. W.W.81.S.

## Some Reasons for Blue Spot Superiority

- 1 POSITIVELY NO FOULING IN THE GAP.**  
Blue Spot moisture proof Cones and Speech Coils absolutely eliminate all possibility of warping or fouling in the gap.
- 2 EXCLUSIVE MAGNETS.**  
Specially designed high quality magnets ensure powerful and permanent energy and complete reliability.
- 3 UNIVERSAL TRANSFORMERS FOR ALL OUTPUT STAGES.**  
Terminals or plugs and sockets in place of solder tags for ease in valve matching. No danger of damaging windings with soldering iron. No troublesome switch contacts. All output stages including Class B. Matched in a moment. Q.P.P. Pentode 2,6 extra.
- 4 DUST PROOF SIDE PLATES.**  
Special dust proof side plates preventing dust and magnetic particles being attracted into powerful gap.

MANCHESTER EXHIBITION: STAND 50.

### MOVING COIL LOUDSPEAKERS

27/- to 87/6

Moving Iron Speakers 12/6 to 42/-

THE BRITISH BLUE SPOT COMPANY LTD.

94, 96, Rosoman Street, Rosebery Avenue, London, E.C.1.

Distributors for N. England, Scotland and Wales:

H. C. RAWSON (Sheffield and London), Ltd., 100, London Road, Sheffield.



# MILNES H.T. SUPPLY UNIT

gives

## 65-70% WATT - HOUR Efficiency

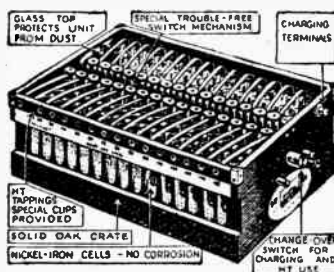

No other form of H.T. Supply of any type can show so high a degree of efficiency. The charge and discharge curves reproduced are illuminating and are typical of every Milnes Unit. Furthermore, this efficiency is maintained indefinitely. Year after year—for

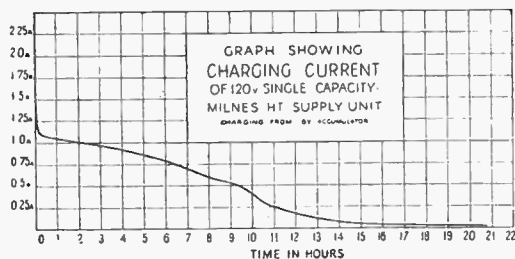

twenty years and more, the Milnes Unit will function with unflinching regularity and perfect consistency.

The Milnes Unit will serve the largest set. It will stand almost any rate of discharge. (Even dead shorting will not harm the nickel-cadmium plates). Overnight the Milnes Unit regains its fully charged condition by drawing current from the L.T. accumulator—automatically, without need for watching or timing and without wasting a milliamp of current. The constant voltage, steady flow and dead silent background make the Milnes Unit ideal for quality reproduction and short-wave work. It gives punch and dependability equal to the mains with the purity of a brand-new dry battery. The Milnes Unit is a sound engineering production—proved by 15,000 users over 5 years. It stands for a definite and permanent solution of all H.T. problems. Ask your radio dealer to demonstrate, or send the coupon to-day for free descriptive book.

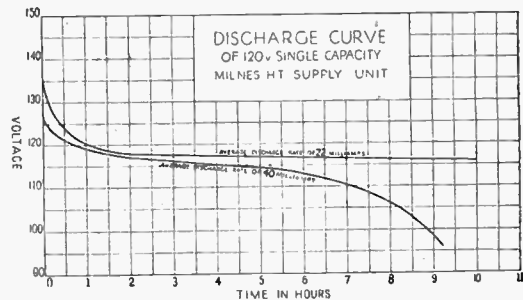

SEE THE MILNES UNIT AT STAND 108  
Gallery Bridge, MANCHESTER RADIO EXHIBITION.

PRICES IN GT. BRITAIN  
90 v. £3.3.0  
100 v. £3.9.5  
120 v. £4.2.3  
150 v. £5.1.6  
Hire Purchase Terms from 8/- monthly.

MILNES RADIO CO. LTD. BINGLEY, YORKS.  
Please send FREE Book describing the Milnes H.T. Supply Unit. No obligation.  
Name .....  
Address .....  
B9

SAVAGE SOUND REPRODUCTION EQUIPMENT

# A NEW SAVAGE Amplifier

The Panel Type Cabinet  
**320**

Backed by the world-wide Savage reputation for reliability comes this New Savage Amplifier. It is constructed on a vertical Metal Panel with Valves and Controls in front and all other components behind. One of the principal advantages of this method of construction is that all components are extremely accessible. No cost has been spared to make this a luxury outfit of sturdy build. It is extremely compact and readily transportable. The Strong Oak Cabinet includes Panel 320, Volume and Tone Controls, Micro-Gram Switch, Microphone Transformer and Battery, Two Microphone positions with switching, Single Turntable and Pick-up as illustrated £34. Can be supplied without Turntable and Pick-up £27.10.0 or with double Turntable and two Pick-ups £41. Tropical models £1 extra. Undistorted Sp each Output—20 watts approx. Write for complete details and full price list.



**W. BRYAN SAVAGE**

56, 58, Clerkenwell Rd., London, E.C.1.

# Write for this new guide to Class 'B'

Write to-day for a free copy of this new Complete Guide to Class "B," which has just been published. It describes fully the theoretical and practical sides of Class "B" amplification and tells you all about the Multitone True Tone-Control transformers, which save an extra 30% H.T. besides ensuring the best quality under all conditions.

**TOCO TONE CONTROL TRANSFORMER**

	Price
ratio 1/4 (saves an EXTRA 30% H.T.)	17 6
Graded Potentiometer	3 6

**BEPU DRIVER TRANSFORMER**

ratios 1, 1.5, 2, 1. High Power	
Efficiency over 85%. Very low overall	
secondary resistance 100 ohms.	9 6

**PUCHOKE CENTRE-TAPPED CHOKE**

For matching any speaker to Class "B" output	9 6
--	-----

**CLASS "B" CONVERTER UNIT**

Those who do not wish to interfere with the wiring of their present set can buy this simple unit. Just plug in adaptor to last valve stage and enjoy Class "B" advantages

	37 6
(less valve)	27 6

**OR IN KIT FORM**

If you do not know who is your nearest Multitone dealer, please let us know



Write to Dept. D. (72)

**MULTITONE**  
ELECTRIC COMPANY LIMITED  
95-98, White Lion Street, London, N.1. Terminus 5063



# Low Impedance Volume Control



Just another unique feature of Earl Speakers the only speakers with the fully Floating Cone

PRICES from:-  
25/- energised  
32 1/2 P.M.

**EARL** MANUFACTURING COY. LTD.  
'AVENUE WORKS'  
HANOVER PARK, S.E. 15  
NEW CROSS O422

# NICORE TUNING COILS

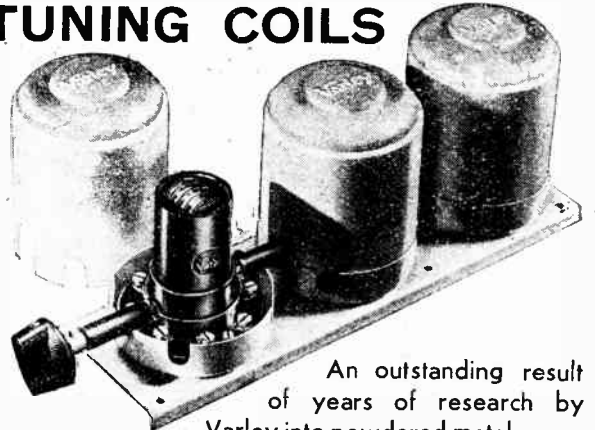

An outstanding result of years of research by Varley into powdered metal cores. Incidentally, the remarkable consistency of the NICORE core material and its high efficiency have been largely instrumental in enabling Varley to produce the first ganged and working Permeability Tuner—Varley first again. Coils 10/6 each (also supplied in 3 or 4-gang on base).

Write for FREE literature.

Messrs. Varley Ltd., Kingsway House, 103, Kingsway, W.C.

**Varley**  
PROPRIETORS OLIVER PELL CONTROL LTD.

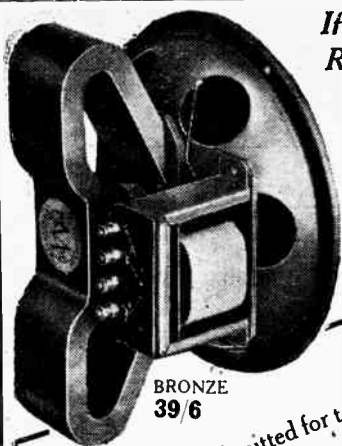

BRONZE  
39/6

If "The Wireless World" approves—it is O.K.  
Read what "The Wireless World" says about the

# WHARFEDAILE MOVING COIL SPEAKER

(Sept. 8th, 1933  
issue)

STAND  
**101**  
MANCHESTER  
RADIO  
EXHIBITION

"The Units submitted for test were the 'Bronze' and 'Golden' models. Both are notable for their rugged construction and the generous dimensions of the magnet systems. A notable feature is the method which has been adopted to ensure the exclusion of foreign matter from the air gap, falling in towards the apex of the cone are stopped by a fine mesh gauze behind the centre spider, while the back of the gap is sealed by a sponge rubber ring surrounding the centre pole-piece. As regards frequency response

the 'Golden' model has a better output in the bass below 100 cycles on account of its larger diaphragm and in the extreme top its higher price is again justified. In both models there is an appreciable response at 8,000 cycles, but whereas the 'Bronze' model commences to fall off at 4,000 cycles, the output of the 'Golden' model is fully maintained up to 5,000 cycles. The bass resonance occurs in the 'Bronze' model at 145 cycles and in the 'Golden' at 120 cycles, but in neither case is it sufficiently prominent to colour

the quality of reproduction. Apart from a slight increase in output in the region of 2,500—3,000 cycles the response in the middle and upper middle registers is in both cases sensibly uniform. The prevailing impression of the quality is one of brightness without too heavy a bass response. Reproduction of speech is exceptionally good. The output transformers have interleaved and impregnated windings and are of more than usually generous design. Tappings are provided for matching to all types of output stages, including Class B.

- BLUE WHARFEDAILE  
2 watts input - 32/6
- BRONZE WHARFEDAILE  
4 watts input - 39/6
- GOLDEN WHARFEDAILE  
6 watts input - 55/-

All fitted with Universal Transformers suitable for Power, Pentode, Q.P.P. and Class B valves.

**WHARFEDAILE EXTENSION SPEAKERS**  
Now fitted with combined Volume Control and On-Off Switch. Enables volume to be adjusted to suit room, increased for music and reduced for speech, varied to suit the listener and to match that of speaker in set. Unwanted items can be cut out. All without need for visiting the set. Perfect match Guaranteed to all well-known makes of sets. Prices from 36/- complete.

**Send the Coupon TO-DAY for Catalogue.**  
Please send Catalogue of Wharfedale Speakers. No obligation.

Name ..... Address ..... C.2.

# MODERN RADIO

HEAD OFFICE:

25, YORK TERRACE, CLAPHAM, S.W.4

Phone: MACAULAY 3409.

Nearest Tube: CLAPHAM NORTH.

37, LISLE STREET, W.C.1

Phone: GERRARD 2969.

Nearest Tube: LEICESTER SQUARE.

A LARGE CLEARANCE OF SURPLUS GOODS BY WELL-KNOWN SET MANUFACTURERS.  
ALL GOODS ADVERTISED ARE POST FREE. WE SEND BY RETURN.

A LARGE SELECTION of Phillips surplus components, all in perfect condition. Do not hesitate to send us your order, as owing to the ridiculously low prices we are offering, stocks will be quickly cleared. 1 watt resistances, 400 ohms, 640, 2,000, 8,000, 10,000, 16,000, 20,000, 32,000, 40,000, 100,000 and 200,000 ohms, 6d. each, 5/6 per dozen. Mains transformers, 210-220 volts input, 200-0-200 volts 30 m.a., 4 volt 3 amp., 4 volt 1 amp., 3/6. Ditto, all C.T. with screened primary, 4/6. 330-0-330 volts 60 m.a., 4 volts 4 amps., 4 volts 2 amps., 7/6. Eliminator transformer, output 200-0-200 30 m.a., 4 volts 1 amp., 2/6. Input, 100-240 volts, 250-0-250 60 m.a., 4 volts 4 amps., 4 volts 1 amp., 5/-. Smoothing chokes, 1,000 ohm., 40 m.a., 20 henries, 2/-. 1,200 ohm., tapped at 800, 2/6. Special high quality choke, as used in Phillips' receivers, nickel iron core, with special high inductance winding 30 henry, 2/9 each, easily fixed, improved results. A large assortment of 100 volt transformers at 1/6 each, stampings alone worth double. Block condensers, 300 volt working, a real high quality job. 0.5 x 0.5 x 0.5, 1/6; 3 x 2.5 x 1 x 0.5 x 0.5 x 0.1, 3/6; 4 x 3 x 1.5 x 0.5 x 0.5 x 0.2, 4/6. All the above represent the finest value of their type in London. Do not be disappointed by sending too late. DUBILIER 650 volt test block condensers, 8 x 4 x 2 x 0.25, 6/-. 500 volt test, 2 x 2 x 1 x 1 x 1, 4/-. POCKET type 0-15 amp. meters, in polished nickel case, 2/6. SWIFT LEVICK high-grade permanent magnets, for moving coil speakers, weight over 10 lb., 1 1/2 in. pole, gap 60 thousandths, 17/6. WATES polyscope set testers, 6d.; split anode adapters, 6d., worth 1/6 each. TUMBLER switches, 10 amp., 6d. WATES 4-valve A.C. chassis, 25/-, cabinet free with every one. SUPERIOR earthing switch, always safe, spark gap and fuse constantly in circuit, enclosed in porcelain case, 1/6. Zonophone pick-ups, brand new and boxed, 8/6. COLLARO double spring motors, on unit-plate with automatic stop, beautiful condition, complete 17/6. VIR cable, 100-yard coils, 1/44, 4/6. TRANSFORMERS for HT8 and 4 volts 2 amps. C.T., 4 volts 1 amp. C.T. with screened primary for 200-240 volts input, 9/6. BRITISH RADIOPHONE, 3-gang, 0.0005 condensers, 1/4 in. spindle, 7/6. LARGE DISPOSAL stock of KOLSTER BRANDES loud speakers, in solid oak cabinet, all new and boxed, list number 287, 10/11, easily worth treble. PAXOLIN PANELS, 18 x 7 1/2, 1/-; 14 x 7 1/2, 9d. MARGONI IDEAL transformers, 2.7-1, 4-1, 6-1, 5/- each. MAINS TRANSFORMERS, input 200-240, output 300 volts 90 m.a., 4 volts 3 amps. C.T., 5/-. ERIE 1 WATT resistors, 350, 4,000, 10,000, 15,000, 20,000, 250,000 ohms, 6d. each. KOLSTER BRANDES Kobra cabinets, ready drilled to take chassis, 10/-. PUP cabinets, 2/6 each. COLLARO INDUCTION GRAMO-

PHONE motors, bronze finish with unit-plate and auto stop, 100-250 volts, boxed and unused 37/6. H.M.V. A.C. POWER AMPLIFIERS, will handle 5 watts undistorted. For 100-250 volts input, components are honestly worth £10 for dismantling. £3 10s., less valves. ECKERSLEY TROUTON loud speaker unit complete on chassis with 12in. cone, the most advanced type of balanced armature made, originally listed at 37/6. 7/6 each, all boxed. LOEWE vacuum-type resistances, 2 watt, rating 25,000, 50,000 and 100,000 ohms, 1/- each, 10/6 per dozen. EDISON BELL upright type fixed condensers, capacities up to 0.002, 4d. each, 3/- per dozen, up to 0.006, 6d. each, 5/- per dozen. 0.01, 9d. each; 7/6 per dozen. SWIFT LEVICK 1 watt resistors, with wire ends, 1,000, 20,000 ohms, 6d. each, 5/- per dozen. SWIFT LEVICK high-grade permanent magnets, for moving coils, weight of magnet over 10 lb., diameter of pole 1 1/2 in., gap distance 60 thousandths, 17/6. A.C. VOLTMETER.—Two-range model by high-class manufacturer, 5.5 and 27.5 volts, boxed, brand new, 12/6. Centralab twin volume controls, as used in many modern receivers, 10,000 and 20,000 or 10,000 and 100,000 ohms, listed at 12/6 each, our price 2/6. PHILLIPS high-voltage condensers, 0.5 mfd., 6,000 volt working, and 1 mfd. 3,000 volt working, 10/- each. ENERGISED moving coil speaker, for power and pentode, output 2,000 ohm field, 10/6. SMOOTHING chokes, 750 ohm 40 m.a., 20 henry, 3/-; 1,400 ohm 60 m.a. 30 henry, 4/8; 640 ohm 30 m.a. 50 henry, 4/-; shrouded type, 590 ohms 20 m.a. 70 henry, 3/6. LOEWE vacuum-type resistances, with wire ends, 3,000, 10,000, 15,000, 25,000, 50,000, 100,000, 250,000, 1 meg and 0.005 condensers, 3d. each, 2/- per dozen. LOEWE vacuum-type resistances, with screw ends, 25,000, 50,000 ohms, 4d. each, 3/- per dozen. MARGONI short wave sets, a real snip, complete in sloping mahogany cabinet, with coils to cover, 16-20 metres, 29-52 metres, 27/6. MARGONI 4-valve battery receiver, 2 S.G. DET and POWER, in sloping mahogany cabinet, at 27/6. Book yours early, we cannot repeat at this price. MARGONI 5-valve A.C. receiver for 200-250 volts, a first-class class job, parts alone worth 4 times as much as we are offering the set for, 52/6, less valves. COLUMBIA set cabinets, a real solid job, 15 x 15 x 10 1/2, in good condition, 8/6. UTILITY 3-gang 0.0005 condensers, fully screened, complete with disc drive and escutcheon brown knobs, 11/6. HIGH-GRADE REISZ type microphone, in heavy polished aluminium case with suspension rings, 52/6. Transformer for above 5/6, stand 12/6 extra. MARGONI HORN type speakers, Model 45, all brand new and boxed, 9/6. PHILLIPS 6,000 ohm volume, with mains switch, 3/6. SEND US YOUR ORDER WITHOUT DELAY. WE WILL DESPATCH BY RETURN. AT THE ABOVE PRICES YOU CANNOT AFFORD TO HESITATE AS STOCKS WILL BE QUICKLY CLEARED.

Advertisements for "The Wireless World" are only accepted from firms we believe to be thoroughly reliable.



# a GIANT in performance and output

## A DWARF IN ACTUAL SIZE

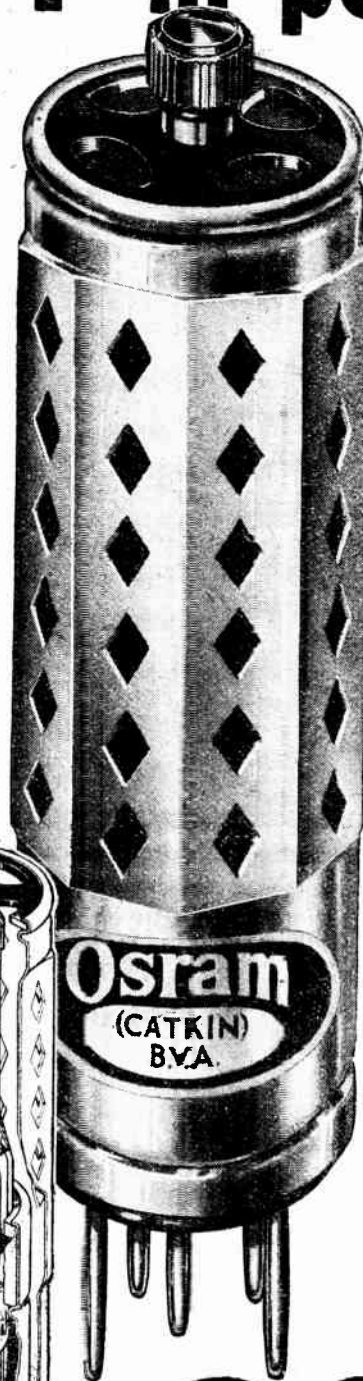

A small valve is an asset in to-day's space-saving wireless sets. The OSRAM "CATKIN" VALVE is a small valve with a stout heart. It is conceived and built to give a higher standard of performance. Highest uniformity is made possible by metal construction. A 'picked' valve becomes a thing of the past—every OSRAM "CATKIN" VALVE is made with absolute accuracy and uniformity of characteristics.

WRITE for the OSRAM VALVE GUIDE (1933 Edition) sent post free.

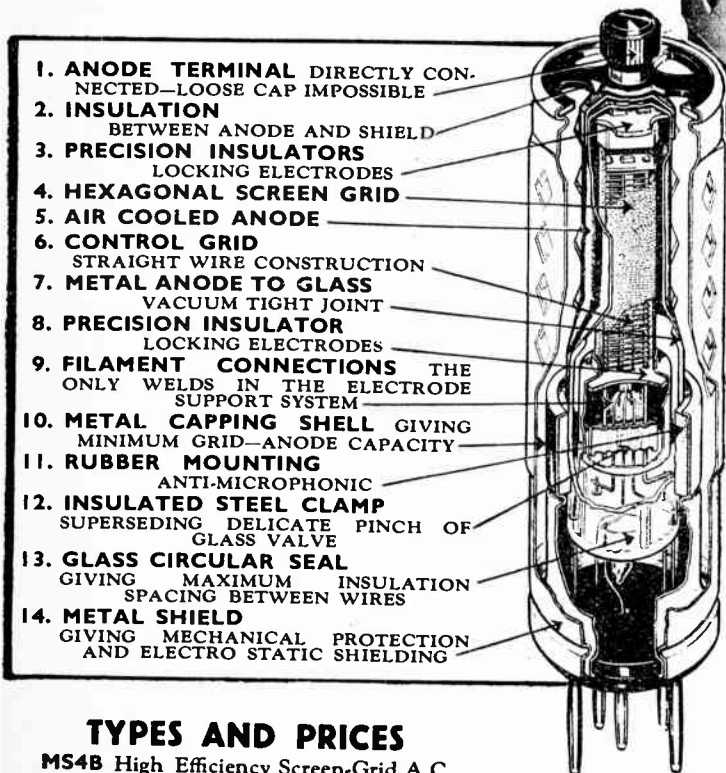

1. ANODE TERMINAL DIRECTLY CONNECTED—LOOSE CAP IMPOSSIBLE
2. INSULATION BETWEEN ANODE AND SHIELD
3. PRECISION INSULATORS LOCKING ELECTRODES
4. HEXAGONAL SCREEN GRID
5. AIR COOLED ANODE
6. CONTROL GRID STRAIGHT WIRE CONSTRUCTION
7. METAL ANODE TO GLASS VACUUM TIGHT JOINT
8. PRECISION INSULATOR LOCKING ELECTRODES
9. FILAMENT CONNECTIONS THE ONLY WELDS IN THE ELECTRODE SUPPORT SYSTEM
10. METAL CAPPING SHELL GIVING MINIMUM GRID-ANODE CAPACITY
11. RUBBER MOUNTING ANTI-MICROPHONIC
12. INSULATED STEEL CLAMP SUPERSADING DELICATE PINCH OF GLASS VALVE
13. GLASS CIRCULAR SEAL GIVING MAXIMUM INSULATION SPACING BETWEEN WIRES
14. METAL SHIELD GIVING MECHANICAL PROTECTION AND ELECTRO STATIC SHIELDING

### TYPES AND PRICES

MS4B High Efficiency Screen-Grid A.C. Mains Valve	17/6
VMS4 Improved Variable Mu Screen-Grid A.C. Mains Valve	17/6
MH4 High Magnification Detector A.C. Mains Valve	13/6
MPT4 Power Pentode A.C. Mains Valve	18/6

(OTHER TYPES TO FOLLOW)  
Sold by all Wireless Dealers.

Made in  
England

Covered by  
World Patents

"CATKIN" is the Trade Mark of The M.O. Valve Co. Ltd., manufacturers and patentees.

FOR A.C. MAINS RECEIVERS.

**METAL INSTEAD OF GLASS**

# Osram (CATKIN) Valves

Adv. of The General Electric Co. Ltd., Magnet House, London, W.C.2.

Mention of "The Wireless World," when writing to advertisers, will ensure prompt attention.

# The Wireless World

THE  
PRACTICAL RADIO  
JOURNAL  
23<sup>rd</sup> Year of Publication

No. 734.

FRIDAY, SEPTEMBER 22ND, 1933.

VOL. XXXIII. No. 12.

Proprietors: ILIFFE & SONS LTD.

Editor:  
HUGH S. POCOCK.

Editorial,  
Advertising and Publishing Offices:  
DORSET HOUSE, STAMFORD STREET,  
LONDON, S.E.1.

Telephone: Hop 3333 (50 lines).  
Telegrams: "Ethaworld, Watloo, London."

COVENTRY: Hertford Street.  
Telegrams: "Cyclist, Coventry." Telephone: 5210 Coventry.

BIRMINGHAM:  
Guildhall Buildings, Navigation Street, 2.  
Telegrams: "Autopress, Birmingham." Telephone: 2970 Midland (3 lines).

MANCHESTER: 260, Deansgate, 3.  
Telegrams: "Iliffe, Manchester." Telephone: Blackfriars 4412 (4 lines).

GLASGOW: 26B, Renfield Street, C.2.  
Telegrams: "Iliffe, Glasgow." Telephone: Central 4857.

PUBLISHED WEEKLY. ENTERED AS SECOND  
CLASS MATTER AT NEW YORK, N.Y.

#### Subscription Rates:

Home, £1 1s. 8d.; Canada, £1 1s. 8d.; other  
countries abroad, £1 3s. 10d. per annum.

*As many of the circuits and apparatus described in these  
pages are covered by patents, readers are advised, before  
making use of them, to satisfy themselves that they would  
not be infringing patents.*

## CONTENTS

	Page
<b>PROGRAMMES FROM ABROAD, pp. I—XXIV</b>	
Editorial Comment .. ..	243
Delayed Amplified A.V.C. ..	244
Unbiased .. ..	247
The Electrostatic Loud Speaker II	248
How the Signal Reaches Your Set	250
News of the Week .. ..	253
Manchester Radio Show. Plan and Guide .. ..	254
G.E.C. Six-watt Power Amplifier	256
Broadcast Brevities .. ..	257
Practical Hints and Tips .. ..	258
H.M.V. "Superhet Concert Seven"	259
Laboratory Tests on New Appa- ratus .. ..	260

## EDITORIAL COMMENT

### Car Radio

#### The Rumours of Official Restrictions

**I**NTEREST in car radio is undoubtedly increasing in this country and it looks as if, in the course of the next few months, a large number of sets will be fitted both on new models of cars and existing types. All sorts of rumours have been current as to what may be the official attitude towards car radio, and it has been suggested that the Ministry of Transport or the Home Secretary will prohibit the use of wireless whilst cars are travelling on the road.

It is not unnatural that some alarm should be felt by those wireless manufacturers who are at present interesting themselves in the development of car radio at the idea of restrictions of this kind, because the public are not likely to spend money if there is any likelihood of a ban being put on the use of the sets at an early date.

Wireless on motor cars is not by any means a new idea; portable sets have been carried for years past, and sets built in as permanent fittings on a car have also been known in this country almost since the days that broadcasting started. It is only recently, however, that the possibilities of a really compact and efficient set have made the idea generally attractive for privately owned cars.

The officials of the Ministry of Transport and the Home Office have, naturally, had to look into the question of car radio from the point of view of accident risks on the road, and consider whether special regulations ought to be issued governing the use of car wireless. Consultations have certainly taken place, but, as yet, no statement has been made by these authorities

as to what their attitude will be. On the face of it, the possibility of a prohibition of wireless on cars seems impossible. It is at present not illegal to carry and use wireless on a car, and the only action that the police might take would be on the grounds that, because the driver's attention was distracted by wireless, the car was being driven negligently or dangerously. We hope that if the Home Office and the Ministry of Transport have any recommendations to put forward, or if they contemplate regulations affecting the use of wireless on cars, they will lose no time in making these known. It would be unfortunate if car radio were developed on lines which subsequently had to be revised because of new regulations.

Regulations, if any, should be with the object of ensuring simple control of the set so as to cause the least possible distraction from the attention of the driver. For this reason it seems particularly desirable that tuning should be by touch rather than visual in order to avoid any necessity for the driver to take his eye off the road in order to adjust the set.

### End of Summer Time

#### Prepare for Winter Reception

**S**UMMER TIME ends in the first week of October and the change will revive intense interest in foreign station reception. Let us make the most of our opportunity now during fine weather to overhaul aerials and earths and put up the best outside aerial which space will permit. With automatic volume control there are now dozens of foreign stations which can be received as well and consistently as many locals. A good aerial will make the average set a super set from the point of view of distant reception.

# Delayed Amplified A.V.C.

## Designing the System—Some Practical Considerations

By W. T. COCKING

A SIMPLE method of selecting the correct delay voltage for a delayed diode automatic volume control circuit was recently described<sup>1</sup> and it is intended in the present article to extend the treatment to cover the case of delayed amplified A.V.C., for this is a system which better fits the average receiver in which a moderate degree of H.F. amplification and a fairly large amount of L.F. amplification are employed. With amplified A.V.C., the bias voltages developed by the detector are amplified before being applied to the H.F. valves, and this results in the detector being operated at a smaller input than in the simpler case.

The first step in design is to calculate the delay voltage required, and as before, we shall assume that two H.F. stages with Mullard V.P.4 variable-mu H.F. pentodes are used, and that for a signal input varying in the ratio of 5,000-1 the L.F. output must not change by more than 2-1, or 6 DB. The input ratio is equivalent to a change of 74 DB, so that the amplification of the H.F. stages must change by  $74 - 6 = 68$  DB between a weak and a strong signal. The bias voltage change on the H.F. valves for this can be read off from the curve B of Fig. 2, which is repeated from the previous article. Curve A of this figure shows the variation of amplification, with bias voltage for a single H.F. stage, and curve B for two such stages.

### The Action of the Circuit

We see immediately that if the initial bias of 1.5 volts remains constant we require 16 volts A.V.C. bias for a strong signal, but that if the initial bias drops with increasing A.V.C. bias, as with cathode type biasing, we require nearly 17.5 volts. In the previous article we assumed that the initial bias was maintained, as when it is derived from a potentiometer across the H.T. supply; this time let us assume that cathode biasing is used, and we shall then need 17.5 volts A.V.C. bias for a strong signal.

Fig. 1 shows the fundamental circuit of the amplified A.V.C. system using transformer coupling to the succeeding valve.

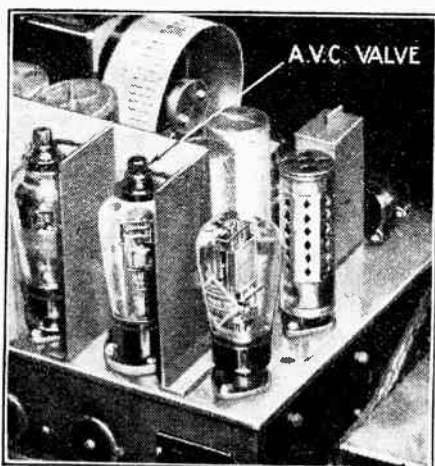

A duo-diode-triode provides amplified A.V.C. in the R.G.D. Superheterodyne.

A duo-diode-triode type valve is used to provide signal rectification, delayed amplified A.V.C., and the first stage of L.F. amplification. Signal rectification occurs in the diode circuit A1, and the D.C. potential consequent upon rectification is developed across the load resistance R1; the L.F. voltages also appear across this resistance, and these are applied to the grid of the triode portion of the valve through the condenser C1, the resistance R1 acting as a manual volume control. The full D.C. potential across R1, however, is applied to the grid through the resistance R2.

In the absence of a signal, the grid of the triode assumes a potential which is about 0.7 volt negative with respect to the cathode in the case of the MHD4 valve, owing to the triode grid current

anode A2 is returned to the earth line through R5, the anode A2 is negative with respect to the cathode, and there is no current flow. The bias on the H.F. valves is then only that provided by their own individual biasing resistances.

### The Delay Operation

When a signal is applied to the diode A1, rectification occurs, and the diode anode, and consequently the triode grid both assume a potential negative with respect to the cathode, and of a value which is dependent upon the signal strength. As a result, the anode current of the triode falls, and the voltage drop across R4 is reduced. The cathode, therefore, becomes less positive with respect to the earth line. In the diode A2 circuit nothing happens until the cathode becomes negative with respect to the earth line; when the signal is strong enough for this to occur the anode A2 becomes positive with respect to the cathode, and this diode becomes conductive. Since the internal resistance of the diode is low compared with R5, the internal voltage drop can be ignored, and the diode anode assumes practically the same D.C. potential as the cathode. As the cathode moves increasingly negative with respect to the earth

*AMPLIFIED A.V.C. has the advantage over simpler forms in that it operates with a modest detector input and so throws less strain on the H.F. amplifier. In this article, the design of amplified A.V.C. circuits is considered in a practical manner.*

flow, and the steady anode current of the triode is then determined by the value of the resistances R3 and R4 and by the H.T. voltage applied. Normally the circuit values are selected so that with no signal the cathode is positive with respect to the earth line by the amount of the delay voltage required. The grids of the controlled valves are returned to earth through the filter resistance R6 and the delay-diode load resistance R5,

which normally has a value of some 0.5 meg. Since the cathode is positive with respect to the earth line, and the diode

line with increasing signal strength, therefore, so the potential of the diode anode A2 and the A.V.C. line follow it.

To return to the design problem, it will

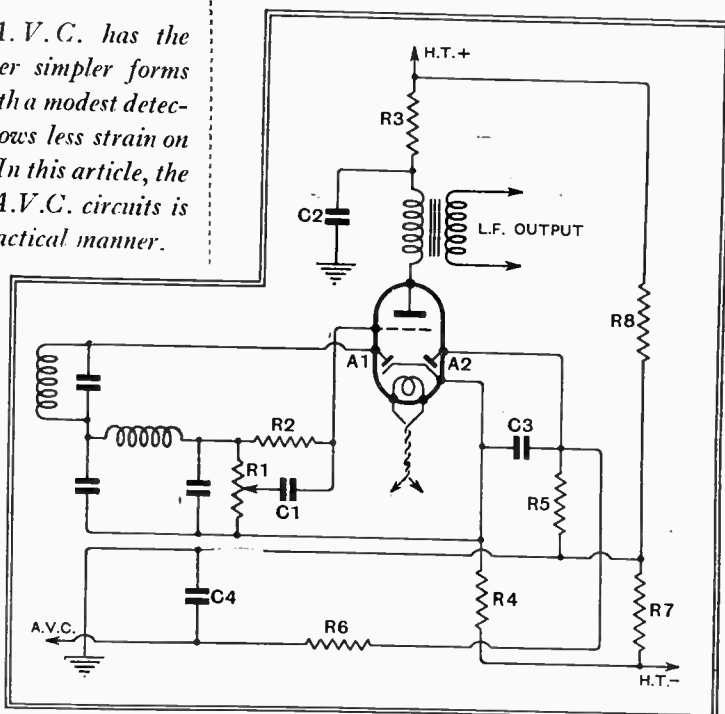

Fig. 1.—The duo-diode-triode can be connected to give delayed amplified A.V.C. The anode A2 is negatively biased in the absence of a signal and is non-conductive. With a strong signal the anode-cathode path becomes conductive and the anode assumes practically the same potential as the cathode.

<sup>1</sup> The Wireless World, Sept. 8th, 1933.

**Delayed Amplified A.V.C.—**

be seen that our first problem is to assign circuit values such that with no applied signal the cathode potential is positive with respect to the earth line by the delay voltage required, in this case 17.5 volts. Let us assume that we have a total H.T. supply of 270 volts, and that we need a total of 200 volts for the H.F. stages. The drop across R8 will be 200 volts (in practice this resistance may be replaced by the other valves in the set) and that across R7 will be 70 volts. The cathodes of the

former primary has zero D.C. resistance, which is untrue. The actual value used for R3, therefore, should be the calculated figure less the resistance of the transformer primary. One well-known transformer has a primary resistance of 2,400 ohms, and in this case the actual value of R3 would become 8,000 ohms.

The next step is to draw a load line on the valve curves with a slope corresponding to the total anode and cathode resistance, and from the full H.T. point of 270 volts. The total resistance is 28,650 ohms, and is represented by the line AB of Fig. 3. This permits the anode current of the valve for any grid potential to be read off, and by multiplying the current by the cathode resistance R4 we can obtain the voltage drop across this for any grid potential. This is shown by the curve of Fig. 4, and represents the cathode potential with respect to negative H.T. We are interested, however, in the cathode potential only during that time when it is negative with respect to the earth line, for this represents the A.V.C. bias. The figures in question can be obtained from Fig. 4 by deducting the potentials less than 70 volts (the difference between the earth and negative H.T. lines) from 70 and ignoring the potentials greater than 70, for the diode A2 is then non-conductive. We thus obtain the curve of Fig. 5.

Now for the strongest signal we need a bias of 17.5 volts, and Fig. 5 shows the grid potential necessary to give this bias, and it will be seen to be 2.95 volts, or, say, 3 volts. With this bias there will be no grid current flow in the triode, so the diode A1 must provide 3 volts bias as a consequence of rectification. Curves for

the rectification efficiency of a diode show that this D.C. potential is developed when the H.F. input is about 3 volts R.M.S., or 4.2 volts peak.

It is immediately obvious that no type of variable-mu valve at any high bias would give distortion on such a small output, even when the peak value is 7.56 volts as with deep modulation. Even with a band-pass coupling preceding the detector, the output of the last H.F. or I.F. valve will only be about 15-16 volts peak, and this should raise little difficulty. The stage immediately preceding the detector can thus be fully controlled.

The L.F. voltage developed across the diode load R1 for 80 per cent. modulation will be  $3 \times 0.8 = 2.4$  volts peak, so that at maximum input the L.F. grid voltage of the triode will swing between -0.6 volt and -5.4 volts if the manual volume control be set at maximum. The load impedance to L.F. currents is not the D.C. resistance of the circuit, but the transformer primary impedance, and on the curves of Fig. 3 this can be represented by a horizontal straight line drawn through the intersection of the -3 volts curve with the D.C. load line. This is shown by the line CD, the points E and F representing the limits of the L.F. grid swing. These points are nearly equidistant from the -3 volts line, so that amplification will be practically distortionless.

The L.F. amplification obtained will be equal to the valve amplification factor, and at the working point this is about 34. The L.F. output on the transformer primary for maximum signal, therefore, will be  $34 \times 2.4 = 81.6$  volts peak with 80 per cent. modulation. With minimum signal, of course, at which A.V.C. just commences to operate, the output will be one-half, or 40.8 volts. With a transformer having a ratio of 3.5-1, therefore, an output stage capable of handling an input of 142.5 volts can be fully loaded.

In the majority of cases, of course, the output stage requires a much smaller input, so that the manual volume control would normally be turned down to give a smaller proportion of the available L.F. potential on the triode grid. This means, of course, that the L.F. amplification is

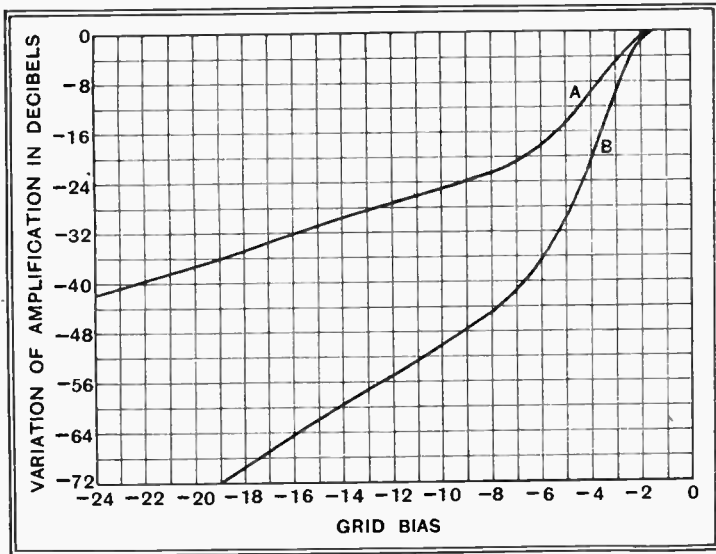

Fig. 2.—The variation of amplification with bias for one (A) and two (B) H.F. stages is shown here.

controlled valves are returned to the earth line, so that the initial cathode potential of the duo-diode-triode must be  $70 + 17.5 = 87.5$  volts positive with respect to negative H.T. The drop across R4, therefore, must be 87.5 volts.

**Calculating Circuit Constants**

The problem of selecting the value of R4 is complicated by the presence of the decoupling resistance R3, but as this will usually be necessary we cannot afford to neglect it. Let us assume that we shall lose 50 volts across R3 with no signal. The voltage available across the valve and the cathode resistance R4 will then be the total H.T. voltage less the drop in R3 or  $270 - 50 = 220$  volts. Fig. 3 shows the anode volts-anode current curves for the triode portion of the MHD4, and from this we can immediately derive the values of R4 and R3. We have a total of 220 volts across the valve and R4, and we know that the drop across R4 must be 87.5 volts, so that the difference, or 132.5 volts, must be the actual anode voltage of the valve. With no-signal, the triode grid potential will be about -0.7 volt, so that we can immediately read off the no-signal anode current of the valve, and this is equal to 4.8 mA.

We have, therefore, to drop 87.5 volts at 4.8 mA. in R4, which must thus have a value of 18,250 ohms, and 50 volts at the same current in R3, which must be 10,400 ohms. It should be noted that we have assumed that the L.F. trans-

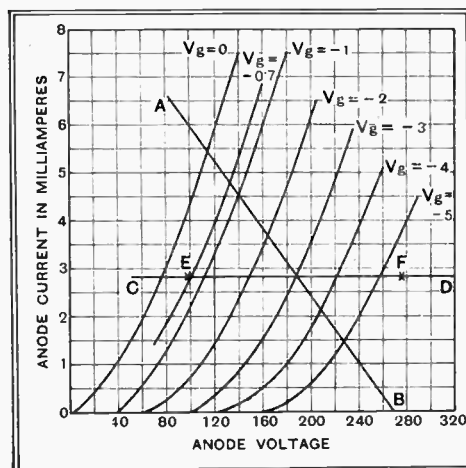

Fig. 3.—Anode-volts-anode-current curves of the MHD4 duo-diode-triode used in determining the operating conditions.

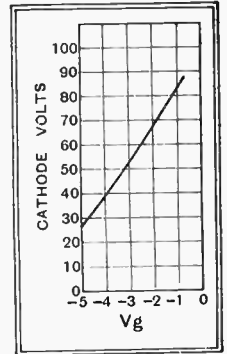

Fig. 4.—The variation in cathode potential for various grid bias voltages is shown here.

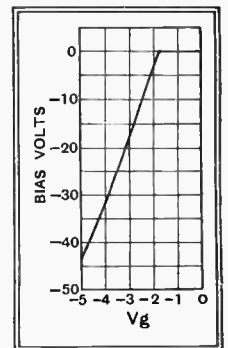

Fig. 5.—This curve shows the A.V.C. bias voltage available for various grid voltages on the MHD4



**Delayed Amplified A.V.C.—**

really excessive, but it can be turned to good account when it is desired to receive really weak signals which do not provide sufficient output at the normal setting of the control.

Now, in the previous article describing delayed diode A.V.C., it was assumed that the maximum input to the first H.F. valve would be 5 volts R.M.S. and the minimum 1 millivolt, and it was shown that the stage gain required from each H.F. valve to fulfil the conditions led to a figure difficult to attain in practice owing to instability troubles. Let us, therefore, calculate the gain required in this case for the same input figures. The detector input for A.V.C. threshold is 1.5 volts R.M.S., and the first H.F. valve input 1 millivolt, so that the amplification must be 1,500 times, or 38.7 times per stage. This is a very reasonable figure, and quite in accordance with modern practice for two H.F. stages.

It will thus be seen that amplified A.V.C. offers considerable advantages over the simpler diode circuit, for the D.C. amplification of the bias potentials which is obtained reduces the amount of H.F. amplification necessary for good automatic volume control. Its sole disadvantages are the greater circuit complication and the need for providing a steady potential which is negative with respect to the earth line.

**The Choice of Circuit**

Although it has been shown that amplified A.V.C. is superior to diode A.V.C. for the particular case which we have considered, it must not be thought that it is always so. The type of receiver taken as an example is a common one, and, therefore, it is true to say that amplified A.V.C. is usually better than the simpler diode controls. Much depends on the total pre-detector amplification, however, and in the case of a superheterodyne, where three stages can often be controlled, amplified A.V.C. may indeed prove disadvantageous and the difficulties of the delayed diode control are reduced. Moreover, in these two articles neither delayed diode A.V.C. with L.F. control nor delayed square law A.V.C. has been considered. The whole question as to the choice of an A.V.C. circuit may be summed up by saying that no one method is generally the best, and the best system for any particular receiver will depend upon the design of that set.

**DISTANT RECEPTION NOTES****More Power Increases on the Continent**

**P**LANS for increasing the power of the Paris PTT station from 7 kilowatts to 120 have recently been approved. The new transmitter is to be situated at Villejuste, twelve miles outside the city, though the studios will remain in Paris itself. Under the Lucerne Plan the wavelength of the station will be 431.7 metres, and it will

A correspondent tells me that he received an American station recently at very great strength on 348.6 metres. This is WAHC, the 50-kilowatt station of the Columbia broadcasting chain situated in New York City.

Is Berlin Witzleben's new transmitter now in use from about 10.30 p.m. onwards? I find the station quite weak, if indeed it is audible at all, during the early part of the evening; but later on it comes in with fine strength. Any reader who has not recently received Witzleben should certainly try for it now.

**Recommended Transmissions**

There is intermittent interference still with Huizen from a Russian station, though I have not often found it troublesome of late.

The long-wave stations are all in good form. Oslo in particular is showing remarkable strength.

The stations at the top of the medium waveband have now definitely returned to good strength, good reception being obtainable from Budapest, Munich and Vienna. On one recent evening, however, Vienna had a strong background which appeared to come from Riga. If so, the Latvian station must be working rather below its normal wavelength. Florence is still heterodyned on many evenings, and Turin suffers badly in the same way.

Beromünster, Prague, Rome, Toulouse, Strasbourg, Breslau, Hilversum, Heilsberg, and Trieste are outstanding medium-wave stations, though there are many others from which first-rate reception is regularly obtainable.

D. EXER.

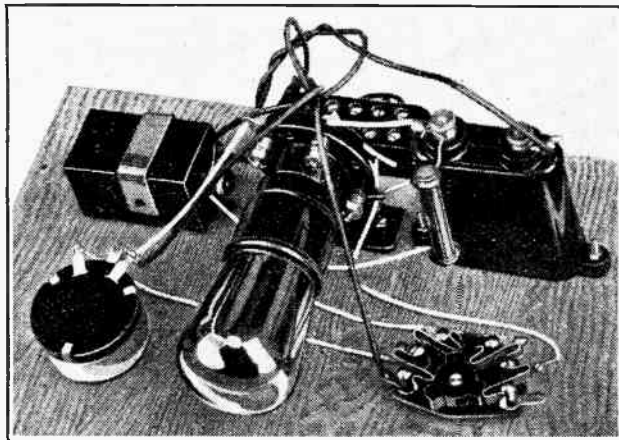

Fig. 6.—The Wireless World A.V.C. Unit is an example of one form of amplified automatic volume control.

have Belgrade on one side and Stockholm on the other as next door neighbours.

Extensive alterations will be required at the Muhlacker station of Stuttgart to increase the output power to 100 kilowatts and the wavelength to 522.6 metres. For this reason the station is now silent until 4 p.m., and it will be closed down entirely from the middle of October until the beginning of December, the old 1.5 kilowatt transmitter taking on the service.

A correspondent writes to ask why I so frequently mention Katowice as a good station since in his area "it has not been worth two minutes' attention since the winter before last." Curiously enough he lives not more than thirty miles from me, and I find Katowice one of the strongest and most reliable of Continental stations from about 8 p.m. onwards. His trouble, I think, is that lack of selectivity prevents him from separating Katowice from Athlone and Söttens.

**American Stations**

In a recent note I suggested that we ought soon to be hearing more of American stations with wavelengths above 300 metres. Up to the end of last month very few transatlantic stations with wavelengths higher than this were at all well heard, though several of them could be received rather feebly. I can now report excellent reception of WGY on 379.5 metres and WJZ on 394.5 metres.

**FOREIGN BROADCAST GUIDE****BUCHAREST**

(Roumania).

Geographical position: 44° 25' N.; 26° 2' E.

Approximate air line from London: 1,300 miles.

**Wavelength: 394.2 m. Frequency: 761 kc/s. Power: 12 kW.**

Standard time: Eastern European (G.M.T. plus 2 hours) (Roumania adopts Summer Time.)

**Standard Daily Transmissions.**

10.00 B.S.T., Sacred service (Sun.); 13.00, gramophone records, news; 17.00, concert, news, weather; 20.00, main evening entertainment; 22.15, dance music, news, weather.

Announcer: Woman.

Call: (Phon.) *Atent-see-oon-aye ah-eetch-ee rah-dee-owe Book-oo-recht-ee*. Announcements are all made in the Roumanian language, but occasionally also in French, German and Italian.

Interval signal: The following bars of a Roumanian Folk Song, *Hai Lelitzo* repeated *ad lib*.



Closes down with good-night greetings (in Roumanian), *Buna seara tuturor*, repeated in different languages and followed by *Traiasca Regele* (National Anthem) played on a gramophone record.

\* A high-power transmitter is under construction.

**HINTS AND TIPS BOOKLET**

With the issue of October 6th, a special supplement will be included in the form of a 32-page Booklet of practical *Hints and Tips*, specially compiled by the staff of THE WIRELESS WORLD.

# UNBIASED

By  
FREE GRID



which the whole machine was electrically driven, had been superseded, because members of the so-called fair sex had been in the habit of forgetting to switch off when stopping to chat with a neighbour over the fence, with the result that the machine had run amok, lopping off flowers, bushes, babies, dogs, and other impedimenta in its mad career.

I find that the losses due to this arrangement are extraordinarily small, and, of course, the lead coming from the wall plug to the set is no more conspicuous than the mains lead running from the neighbouring wall plug. As for my earth lead, this is plaited in with the mains flex, and, since I naturally use a three-point plug and socket, all difficulties of connection are completely overcome.

I find that there are very little losses even if I plait the aerial lead with the others; and so I am now waiting for an enterprising manufacturer to produce a four-point plug and socket for use in order to make the job a really neat one. Judging from my knowledge of manufacturers, however, I fear that I shall have to wait for a confoundedly long time.

## My New Down Lead

**A Snake in the Grass**  
RECENTLY, when I happened to be staying at the home of a rather unpleasant sister-in-law, I was rudely awakened one afternoon, while taking a siesta in the garden, by a demand to "come and see what's wrong with the wireless." With many muttered imprecations I bestirred myself and went into the house, where I found that electrical interference of a particularly objectionable type was drowning everything.

All my efforts to stop the trouble failed, and after spending many days experimenting with various forms of interference suppressors and a goodly portion of my sister-in-law's money in purchasing the necessary gear, I dropped everything and took to detective work. After a fruitless search of the neighbourhood I had almost given the job up as hopeless when I observed that the trouble seemed to coincide with the mechanical rattle of a mowing machine a few gardens away. Naturally I immediately suspected radiation from the ignition system of a motor mower, and I hastily went upstairs to make closer observation from a bedroom window.

To my surprise nothing was in view save a perspiring little man pushing a heavy-looking mower of a more or less conventional type under the direction of an imperious-looking female of amazonian proportions. I was about to turn away when the servile little serf took advantage of a momentary disappearance of his chain-gang overseer to stop and mop his brow. To my utter amazement the mower, though standing still, continued to mow. Hastily calling for a telescope I took a further observation, and noticed a snake in the grass in the form of a cable running from the machine to the house.

I immediately consulted a large firm of mowing machine makers on the 'phone concerning this strange phenomenon, and was told that this was a new type of machine which was rapidly becoming universal; only the knives were driven by the electric motor. The older type, in

IN spite of all the progress that has been made in radio, we are still faced with the incongruous sight of a set housed in a beautiful piece of cabinet work connected up to the aerial by a straggling wire which meanders through the house till it finally connects with the down lead. The reason for this state of affairs is that the average urban and suburban house has its garden, and, therefore, its aerial, at the back, whereas the listeners themselves, with that peculiar cussedness which endears them so much to the hearts of the B.B.C. programme staff, insist on sticking their receivers in a room in the front of the house.

It is true that there are plenty of patented indoor aerials on the market, but no matter how sensitive the set is, a lofty outdoor aerial is always to be preferred on account of the improved signal-strength-to-noise ratio which it gives. The same argument holds good against a set which employs a frame aerial or a "mains" aerial.

I flatter myself that I have solved the problem in a manner which greatly redounds to my credit. The arrangement I have fixed up is really very simple. All that I have done is to fix a length of screened aerial down lead under the floorboards so that one end terminates at a



A straggling wire.

wall plug, the other end, of course, carrying on outside the house until it gives place to the ordinary down lead.

## Can One Steal Electrons?

NOTICE that quite a large number of people have been prosecuted lately for stealing electrical energy from the wires of radio relay companies. In my



Carefully put back by her.

opinion none of the defendants are deserving of any sympathy save one good lady who, according to a newspaper report, has parted with the sum of £1 for "fraudulently extracting a quantity of electricity."

If the good dame will take a spot of advice from me she will appeal and, if need be, carry the case right up to the House of Lords. It may certainly have been wrong to tap the wires of the relay company and steal entertainment therefrom, but that was not the subject of the charge. I entirely fail to see how anybody can "extract" a quantity of electricity from the relay company's wires, and she could, I think, successfully plead that the electrons which she took out were carefully put back by her, as they merely flowed out of one wire, trotted round her loud-speaker windings, and then went back to the company by the other wire. If the lady cares to take action she is assured of my full moral support.

# The Electrostatic Loud Speaker

## II. Matching Loud Speaker and Output Valve

By M. G. SCROGGIE, B.Sc., A.M.I.E.E.

WE have seen the fundamental difference between the electrostatic loud speaker and all other types. Before it can be effectively used it is necessary to consider it as a load in a valve circuit.

A moving-iron speaker can be considered approximately as an inductance. A moving-coil speaker is conveniently (but not very accurately) assumed to be a resistance. An electrostatic speaker may be represented as a capacity, perhaps not quite so pure (i.e., free from resistance) as the very best condensers, but one does not go far wrong in neglecting the impurity.

It has already been explained that the effect of a voltage between the two plates is to draw them closer together. Therefore, one would expect the capacity to be increased thereby, and this is exactly what happens. Fig. 1 shows the measured capacity of a "Primustatic" loud speaker with an 18in. by 20in. diaphragm. The capacity averages about 0.008 mfd. per square foot, or a reactance of about 20 megohms divided by the frequency in cycles per second.

### The Load Diagram

In drawing load curves on a valve diagram the loud speaker is usually represented by a straight line, which means a resistance, constant at all frequencies. No loud speaker ever does act just like that, but a moving-coil type is near enough to it over the middle range of frequencies for

one to get at least a hazy idea of how to match it to the valve. Our condenser speaker has this advantage at least, that it is very closely a capacity load, but, unfortunately, it is therefore not a straight line at all, but an ellipse, and one of a different size at every frequency. So it is rather an exasperating business trying to fit it comfortably into the valve diagram.

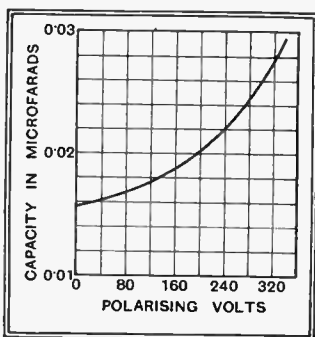

Fig. 1.—Variation of capacity with polarising voltage in the "Primustatic" 18in. x 20in. loud speaker.

There are two ways in which these figures can be altered to suit the valve: first, by selecting a diaphragm of different area, and, secondly, by using a

step-up or step-down transformer, which has the effect, looked at from the primary side, of multiplying the reactance by the square of the transformer ratio. A step-up is equivalent to an increase in capacity. But it is inevitable that with any one arrangement the reactance must vary over the same range as the frequency.

The result of this characteristic is that the behaviour is strikingly different according to whether a triode or a pentode is used. Fig. 2 shows a diagram for a triode with an internal resistance (impedance) of about 2,500 ohms, and the three reactance ellipses have been drawn in to show what happens at the lowest, middle, and highest frequencies. The ellipses in each case are the largest that can go in without running into grid current on the left, or bottom-bend rectification at the foot.

At 80 cycles the full grid excitation is possible; that is to say, the grid voltage can be swung right from zero on one side to double the bias voltage on the other, without any possible risk of overloading due to rectification. The voltage

THE electrostatic loud speaker is unique in presenting a capacitive load to the output valve, and the conditions necessary to prevent distortion and overloading are essentially different from those of moving-iron or moving-coil types.

developed across the loud speaker is the maximum possible.

### Permissible Grid Volts

At 800 cycles it is just possible to give it the full grid, but the ellipse has opened out so much that it is approaching the danger zone along the foot. Still, it is working quite happily and developing practically the full voltage. At any higher frequency, however, the lower half would be flattened out, unless the whole ellipse were reduced in size by reducing the grid input. This is well shown at the upper extreme of 8,000 cycles, where the grid excitation must be reduced to less than a half in order to avoid rectification distortion, and the anode voltage developed across the loud speaker dwindles to about a tenth.

These features are illustrated rather more concisely in Fig. 3. Curve A shows the maximum peak volts that can be applied to the grid without overloading, and curve B shows the voltage developed across the loud speaker with maximum grid volts as given. In each case the voltage is level up to a certain critical frequency, in this case 800 cycles, after which it rapidly falls.

It must not be hastily concluded that the response suddenly falls off above 800 cycles, for it must be emphasised that curve B is strictly dependent on A, and shows the maximum output short of overloading the valve.

P. P. Eckersley has shown experimentally that in normal broadcasting the amplitudes to be expected at the upper frequencies are considerably lower, and would come well below curve A. In addition, by-pass condensers, H.F. tuning characteristics, and other factors are almost certain to prevent the grid voltage from breaking the allotted bounds. So if the grid excitation is kept at a level six volts throughout, as it can be without fear of overloading (curve A'), the output is as shown by B'.

Another point is that it is the falling part of curve B', rather than the level part, that is correct. The amplitude of diaphragm required to give a constant

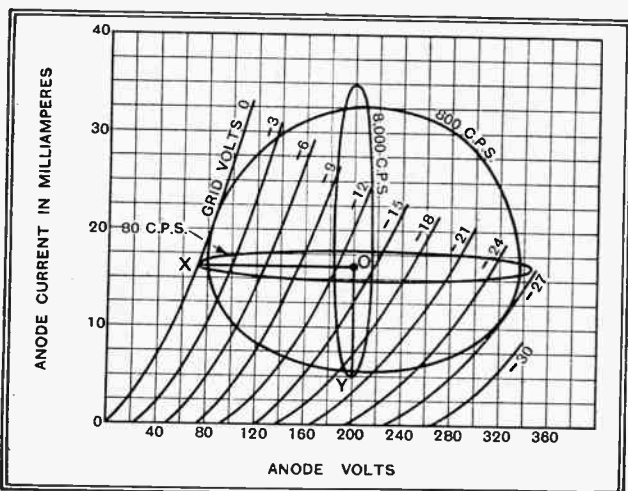

Fig. 2.—The load ellipse of an electrostatic loud speaker varies in shape and inclination as the frequency changes.

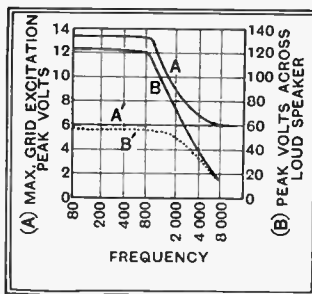

Fig. 3.—Curves showing maximum permissible grid volts with capacity load.

**The Electrostatic Loud Speaker—**

output of sound gets steadily less as the frequency rises. It is not possible to state exactly what is the ideal characteristic

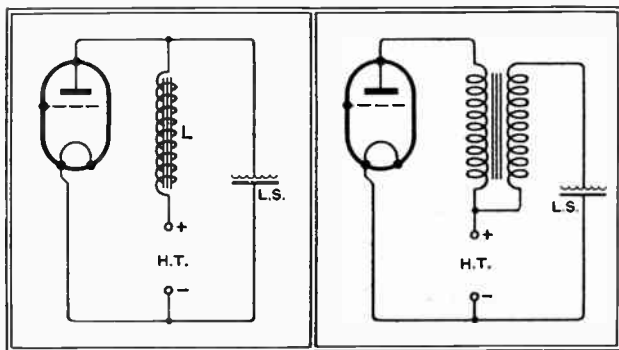

Fig. 4.—Choke coupling provides the simplest connection between valve and loud speaker.

Fig. 5.—Connections for applying polarising voltage with transformer coupling.

without knowing exactly how the particular type of diaphragm behaves at various frequencies; but a listening test with a constant-amplitude pure tone shows a satisfactory response down to about 800 cycles, and a falling response below that.

**The Critical Frequency**

We can calculate this critical frequency by measuring the distance in anode volts horizontally from the initial working point O on the valve diagram to the zero grid voltage point X, and dividing this by the vertical distance, in anode milliamps, from O to Y, the minimum current consistent with avoiding severe curvature. This gives the reactance in thousands of ohms, which is also equal to  $\frac{1,000}{2\pi fC}$ , where f is the frequency and C is the capacity in microfarads; so it is easy, knowing C, to calculate f. By altering C in either of the two ways already described it is possible to shift the critical frequency f, thus extending either the level or the falling part of the curve.

As it has just been stated that it is the falling part that is correct, it would seem that the sensible thing to do would be to make the critical frequency as low as possible. That means making either the actual capacity or the step-up ratio as large as possible. An additional allure-ment is that an increase in capacity means an increase in sound-radiating surface, and an increase in step-up means an increase in signal voltage, and in either case it looks as if the volume would be increased without any greater expenditure of power. But, while it is true that there is improved uniformity of response, the improved efficiency fails to materialise; for curve A is shifted to the left too, and necessitates severely cutting down the input. And, as the lower tones are less audible than the upper, there is an apparent falling-off in volume, and in endeavouring to restore it by the volume control the only result is rattling and distortion. If, on the other hand, the capacity is too small, the volume again drops, and what output there is consists almost entirely of extreme top.

Hence a compromise is necessary, giving a reasonable efficiency at the upper fre-

quencies, the lower being augmented, if necessary, by a bass moving coil unit.

To descend for a moment from these theoretical reasonings to consider how the connection is made in practice, the simplest circuit is that of Fig. 4, where L is a choke of high inductance capable of carrying the valve anode current. In this way the loud speaker receives both the output voltage from the valve and the steady polarising voltage from the H.T. source. The choke behaves as a 1:1 transformer, and if its inductance is sufficiently high it by-passes a negligible proportion of the "signal," and so the whole arrangement conforms very closely to the preceding theory. It may be of interest to realise that at one particular frequency the imped-

the anode current rising much above normal.

If a transformer is used to alter the ratio it is essential to allow for the polarising voltage (Fig. 5), and if it is a step-up ratio it may be desirable to add some auxiliary voltage, but only if the H.T. voltage itself is rather low. An old dry battery can be used, as no current is drawn. If the secondary is linked to the anode end of the primary the sum or difference of the voltages across both windings is obtained, giving a choice of three ratios altogether.

**Push-pull Connections**

A push-pull stage is much to be recommended, and Fig. 6 shows one method of connection. If there is no secondary winding, or if it is being used for another loud speaker, the connection of Fig. 7 is another of the many schemes. Although this looks a one-sided arrangement, it actually loads the whole transformer, which acts as a 2:1 step-down.

Summarising: the larger the area of diaphragm, or the higher the step-up, the lower is the frequency below which response falls off. But the lower also is the efficiency and the tendency to rattle. So only when there is plenty of power available in the last stage is it possible to arrange these matters so as to go low down the scale. The smaller the number of milli-watts available the higher must be the critical frequency. A dual speaker combination is in any case the best for effective reproduction over the whole audible scale.

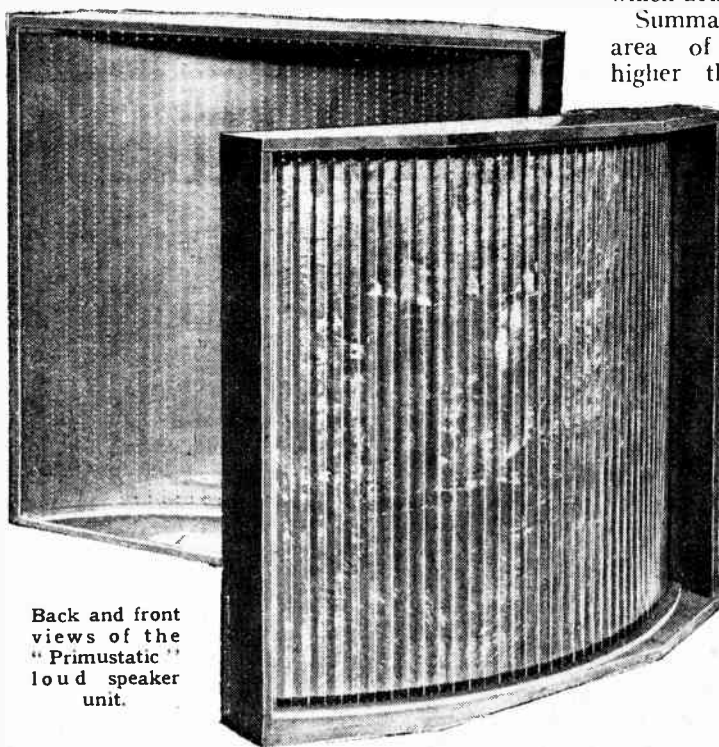

Back and front views of the "Primustatic" loud speaker unit.

ance of the anode load is almost infinite, due to the resonance of choke and loud speaker, and is also a pure resistance, and hence a nearly horizontal straight line instead of an ellipse. With normal components this frequency is about two or three hundred cycles, but the phenomenon does not appreciably modify the performance as already described. The whole action is very beautifully confirmed by cathode ray oscillograph tests, using a variable-frequency oscillator. Beginning at the lowest frequencies, we see the "lengthwise" ellipse become a straight line, and then open out into an "upright" ellipse, which, unless the input is reduced, causes terrible overloading.

Methods of obtaining this, together with tone control, and the conditions for pentode operation, will next be considered.

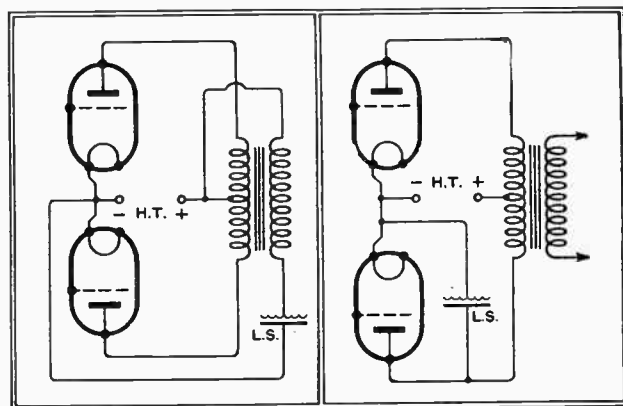
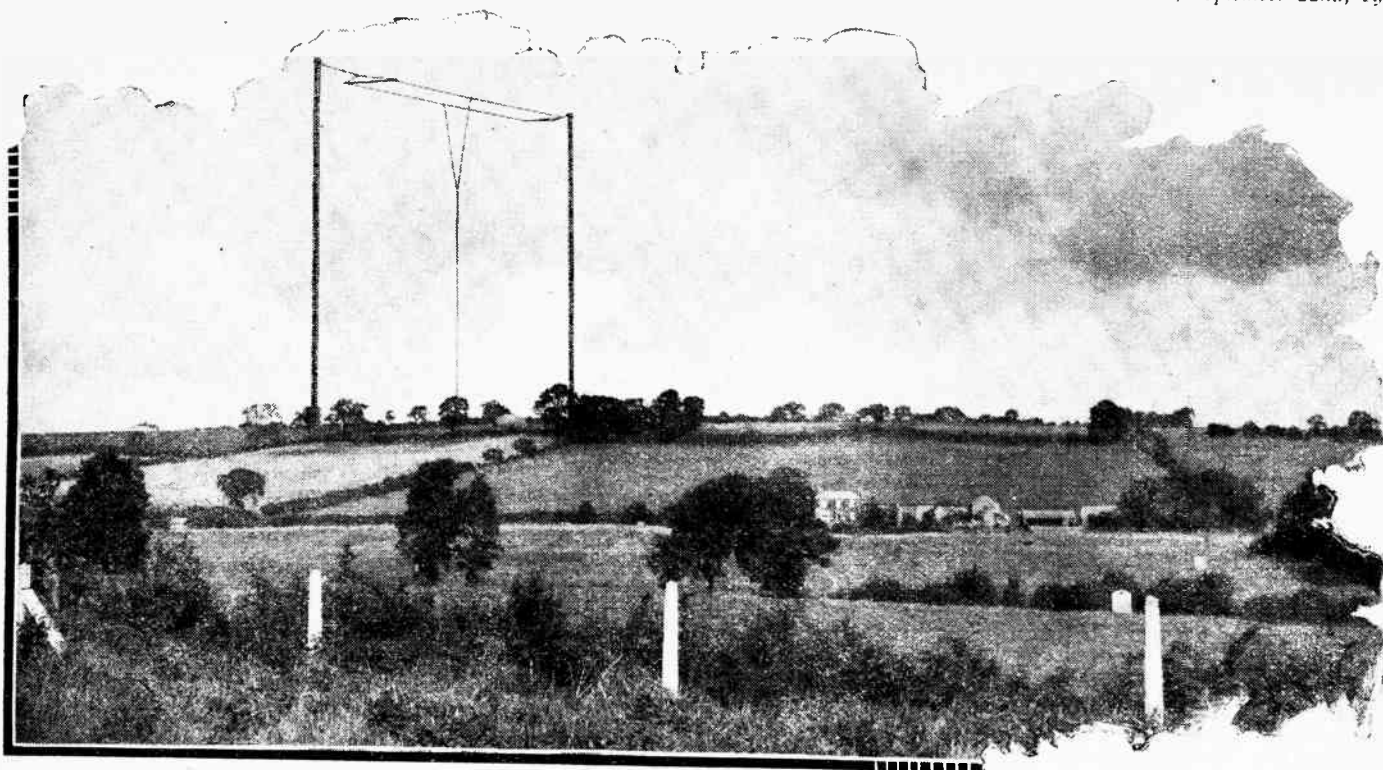

Fig. 6.—Push-pull output using transformer secondary winding to energise the loud speaker.

Fig. 7.—This circuit gives a 2:1 step-down and leaves secondary free for an additional loud speaker.





# How the Signal Reaches Your Set

Modulation and the Purpose of the Carrier Wave Explained

By S. O. PEARSON, B.Sc., A.M.I.E.E.

AS one listens to an item in a broadcast programme one can readily appreciate that the sound waves emanating from the diaphragm of the loud speaker must bear a very close resemblance in form to those actuating the microphone at the broadcasting station. If this were not so the sounds received would be unpleasantly distorted, if not unintelligible, for the smaller the degree of wave-shape distortion in the sending and receiving systems the more realistic and true to life is the reproduction.

The air vibrations, or waves of rarefaction and compression representing sound, extend over a considerable range of frequencies. The upper and lower limits of this range, however, are not very sharply defined, depending to a very large extent on the intensity of the sound and to some extent on the individual listener. In general, audible frequencies may be considered to extend from about 16 cycles per second at the lower end of the scale to perhaps 10,000 cycles per second or more for the highest notes. In the case of orchestral music practically the whole of this range of frequencies is involved, the highest frequencies representing the overtones of violins, etc. Ordinary speech involves a frequency range from about 100 cycles per second to 5,000 cycles per second or so. Intelligible speech can be transmitted on a much narrower band of frequencies, but when this is done the speaker loses the essential characteristics of his voice, which convey to some extent an impression of his personality. So to obtain realistic reproduction at the receiver all frequencies must

*THE most vital principle of wireless communication is that of modulation of the carrier wave. The purpose of the carrier wave is often not properly understood, yet no real conception of what happens in a receiver can be gained without a grasp of this fundamental principle.*

be delivered by the loud speaker in their correct relative amplitudes.

## Need for the Carrier Wave.

At the transmitting station the microphone converts the sound waves impinging on its diaphragm into electrical variations of the same wave form, and consequently these electrical variations are represented by frequencies which all lie within the audible range. These frequencies are usually referred to as "low frequencies" or "audio-frequencies," to distinguish them from the very much higher frequency of the oscillations in the aerial system. The necessity for high-frequency oscillations will now be briefly explained.

A little thought will make it quite clear that the audible frequencies cannot be directly transmitted through the ether because, for one reason, every station would have to operate over the same range of frequencies and selection would be impossible; the transmitting station must

send out from its aerial system a train of ether waves of fixed frequency in order that distant receivers may be accurately tuned to it. And, further, the frequency must have a very high value compared with the frequencies within the audible range, the main reason for this being that the efficiency of an aerial as a radiator of energy falls off very rapidly as the frequency is lowered. The efficiency of radiation is proportional to the square of the frequency. The lowest frequency used for ordinary broadcasting purposes is about 155,000 cycles per second, corresponding to 1,935 metres wavelength; and the shortest wavelength stations operate with a frequency in the neighbourhood of twenty million cycles per second!

The constant-frequency waves emanating from the transmitting aerial are made to serve as the means of conveying the low-frequency or speech-frequency variations, representing the matter to be broadcast, from the transmitting station to the various receiving aerials. For this reason the train of high-frequency waves, upon which the low-frequency variations are to be superimposed, is known as the "carrier wave," and we are mainly concerned here with the manner in which the audio-frequencies are combined with the carrier frequency and separated out again in the circuits of the receiving set.

Now in the first place it must be remembered that the carrier frequency is far above the highest audible frequency, and could not possibly produce any sound on its own account. During an interval between two items in a programme silence

**How the Signal Reaches Your Set—**

reigns (or should), although the carrier wave is being received at full strength the whole of the time. In order to convey an audible note from transmitting aerial to receiving aerial the intensity or amplitude of the carrier wave must be made to vary at the audible frequency in accordance with the wave-shape representing the note in question, and this process is referred to as "amplitude modulation." The amplitude of an oscillation is the maximum or peak value reached in each direction, and the low-frequency variation of the amplitude of the high-frequency carrier wave enables the audible note to be carried across.

A numerical example will be helpful in explaining the principle of amplitude modulation and in giving a sense of proportion as regards relative values. Suppose, for instance, that the frequency of the oscillations in a transmitting aerial is 1,000,000 cycles (1,000 kilocycles) per second, being the frequency of a station working on 300 metres. Currents of the same frequency are set up in the tuned circuits of a distant receiver, but when these currents have constant amplitude no sound would be given out by the loud speaker, a million cycles per second being far outside the audible range of frequencies.

Now suppose that the 1,000 kilocycle carrier wave is to convey between the transmitting station and the receiving aerial a single pure note of 500 cycles per second, being represented by a sine wave of this frequency. Then, by some suitable means, the high-frequency oscillations in the transmitting aerial are made to vary in amplitude, about the mean value, at a frequency of 500 cycles per second. Since the carrier frequency is one million cycles per second, it follows that for each cycle of the low-frequency variation (called the modulation frequency) there will be 2,000 high-frequency oscillations.

The constant-amplitude sine wave of Fig. 1 (a) represents the unmodulated

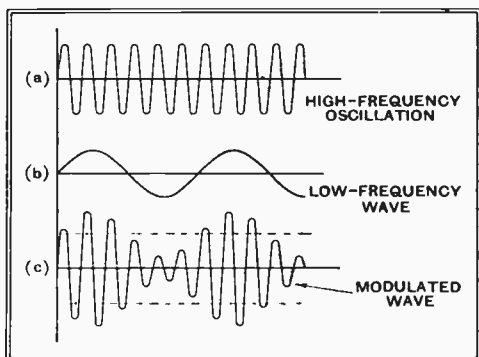

Fig. 1.—Diagram showing how the amplitude of a high-frequency oscillation is varied at an audible frequency.

high-frequency oscillations or carrier wave referred to, the frequency being 1,000 kilocycles per second. The sine wave at (b) represents the low-frequency variation corresponding to the pure tone of 500 cycles per second. By the action of the

modulating system in the transmitting circuits these two waves are combined in such a way as to give the modulated wave of Fig. 1 (c). The lines passing through the positive and negative peak values respectively of the resultant high-frequency wave have exactly the same shape and frequency of variation as the low-frequency curve shown at (b). Of course, during each low-frequency cycle there will be 2,000 high-frequency oscillations, but for convenience in drawing only a few H.F. oscillations per low-frequency cycle are shown.

It will be observed that the number of complete reversals per second is the same for the modulated wave (c) as for the unmodulated wave (a), and so it is usual to state that the modulated wave is one of constant frequency but varying amplitude. This statement is, however, not strictly correct, because the term "frequency," as ordinarily defined, only applies to a wave which repeats itself exactly cycle by cycle, and similarly as regards the term "amplitude." So it must be understood that the frequency of a modulated wave means the number of complete or double reversals per second.

**Percentage Modulation**

When the amplitude of a high-frequency oscillation is varying periodically above and below the mean or normal value, the degree of modulation, or depth of modulation, is expressed as a percentage of the normal amplitude of the unmodulated wave. For instance, when the modulation is 20 per cent. the amplitude of the high-frequency oscillation varies between limits 20 per cent. above and 20 per cent. below the mean value. It is possible to modulate to a depth of 100 per cent., that is to say, to vary the amplitude of the high-frequency oscillations between zero and twice the normal value, but for practical reasons connected with the quality of reproduction at the receiver it is not usual to modulate to a greater depth than about 50 per cent.

It has been assumed that the unmodulated carrier wave represented by the curve of Fig. 1 (a) is a pure sine wave, and, this being the case, the modulated wave of Fig. 1 (c) is very frequently referred to as a high-frequency *sine wave* whose amplitude is varying periodically at the low, or modulation, frequency. This description, however, as already pointed out, is not strictly correct, for it is quite evident that the change in peak value, cycle by cycle, is brought about by changing the *shape* of each H.F. wave, the number of reversals per second being unaltered. But in the case under consideration there are 2,000 high-frequency oscillations to a low-frequency cycle, and so the difference in the amplitudes of two successive H.F. oscillations is very small indeed, their ratio being practically unity. Consequently, the extent to which the high-frequency oscillations depart from the true sine shape is extremely small, and the statement referred to above as being inaccurate may be employed in a

descriptive sense. The idea of a sine wave gradually varying in amplitude is easy to understand; but such a statement would not be—indeed it could not be—tolerated by a mathematician working out the detailed theory of modulation.

**Conditions at the Receiving End**

The modulated ether waves reaching a receiving aerial set up in the latter high-frequency electromotive forces which vary in exactly the same way as the currents in the transmitting aerial. So when the H.F. oscillations in the sending system are modulated in any particular way, the resulting high-frequency electromotive forces in the receiving aerial are similarly

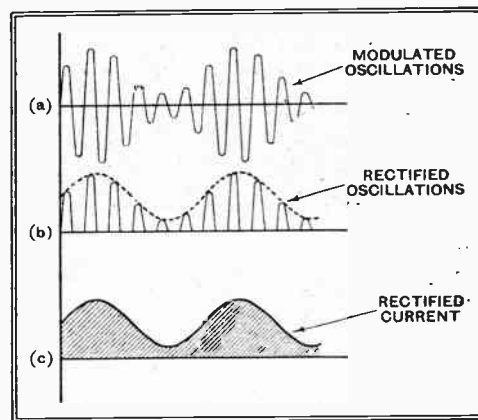

Fig. 2.—The curves show the process of separating out the low-frequency component from a modulated wave by means of a rectifier or detector.

modulated. Now if the receiving aerial circuit behaved like a simple resistance the currents set up in it would be at all times proportional to the voltage, and the resulting H.F. currents would be an exact replica of the currents in the transmitting aerial.

This would be a most desirable state of affairs, because the object is to obtain in the loud speaker an audio-frequency current which is as nearly as possible a true copy of that in the microphone circuit at the transmitting station. But it is a well-known fact that a sharply tuned receiving circuit has a modifying effect on a modulated high-frequency oscillation, the effect being to lessen or attenuate the degree of modulation.

The reason for this demodulating effect is that a certain amount of energy is stored in the tuned circuit when oscillations are present; this stored energy oscillates between the magnetic field of the coil and the electrostatic field of the condenser. The result is that any change in the amplitude of the high-frequency oscillation involves a change in stored energy, which is proportional to the square of the amplitude. Now it is a fundamental law of physics that energy cannot be accumulated or expended instantaneously, the result being that the high-frequency oscillations tend to resist any change in their amplitude, in the same way that a moving body, which possesses inertia, resists any change in its motion.

### How the Signal Reaches Your Set—

The weakening effect is greatest at the highest modulation frequencies, so that the high notes tend to be reduced in greater proportion than the low ones. However, when the tuning is not too sharp, or when special filter circuits are employed, the quality of reproduction is not seriously affected on this score.

### Function of the Detector

The modulated H.F. potential difference set up across the last of the tuned circuits in a receiver cannot be made to operate a loud speaker directly because, referring to curve (a) of Fig. 2, it will be seen that the zero line is symmetrically placed about the zero line. Consequently, although the H.F. oscillations are modulated at low frequency, there would be no low-frequency current set up in the loud speaker coil. For this reason the low-frequency component or modulation frequency must be separated from the carrier wave again at the receiver, and this is the function of the detector stage.

The detector almost invariably takes the form of a rectifier, that is, a device which completely or partially cuts off all the negative half waves of the modulated oscillation by the property of possessing one-way or unilateral conductivity, in the manner shown by curve (b) of Fig. 2. A perfect rectifier could be defined as one which offers a constant resistance to current flowing in one direction, irrespective of the value of the current, but which allows no current whatever to flow in the opposite direction when the applied voltage is reversed. The static characteristic curve of a perfect rectifier is shown in Fig. 3 (a); the current is proportional to positive values of applied voltage and zero for negative values.

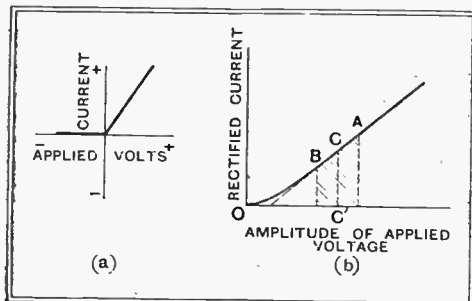
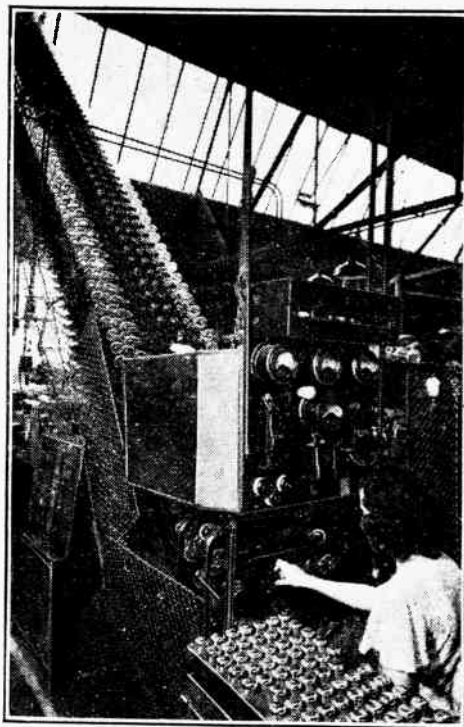

Fig. 3.—(a) The voltage/current or static characteristic curve of an imaginary perfect rectifier. (b) Representative rectification characteristic curve of a valve detector, such, for instance, as a diode.

With such an arrangement the resulting unidirectional current produced when an alternating voltage is applied will have a mean value proportional to the amplitude of the applied voltage. If the applied voltage has constant amplitude the successive current pulsations will all be equal, but when a modulated high-frequency voltage is applied to a perfect rectifier the unidirectional current pulsations will vary in amplitude in accordance with the audio-frequency variations as shown at (b) in Fig. 2. By smoothing out the radio-fre-



On this equipment at the Cossor valve works valves are carried on a continuously moving band. After first being gettered, the valves are run under operating conditions to stabilise their characteristics before testing.

quency variations with the aid of a suitable condenser filter the resulting rectified current fluctuates at the low frequency, being at all times proportional to the amplitude of the high-frequency oscillation as indicated by the dotted-line curve. Consequently, with a perfect rectifier, proportionality is fully maintained and no distortion of the audio-frequency wave-shape is introduced.

In practice it is usual to employ a thermionic valve of some kind as "detector," but, although there are several possible systems, there is not one which gives theoretically perfect rectification, because the relationship between the amplitude or R.M.S. value of the applied high-frequency voltage and the resulting rectified current is never represented by a straight line; they are not truly proportional to each other. This, of course, means that the effective resistance of the rectifier depends to some extent on the value of the applied voltage oscillation. Fig. 3 (b) gives a dynamic characteristic curve of a typical valve detector; although the curve is practically straight over a considerable portion of its length it is more or less curved at the lower end, and if the straight part is produced back it does not pass through the origin O.

Now if a high-frequency voltage, modulated to a depth of 100 per cent., were applied to a rectifier with such a characteristic, the rectified current would obviously not conform strictly to the variations in amplitude of the applied voltage, and distortion would result. But, as stated previously, in practice 100 per cent. modulation is rarely ever encountered and with a lower percentage modulation, distortionless rectification can be attained even though the rectification

characteristic is curved at the bottom. This will be the case if the modulation is sufficiently shallow to ensure that the oscillation voltage amplitude fluctuates between upper and lower limits represented by two points such as A and B on the straight part of the curve, the wave, when unmodulated, having an amplitude OC' represented by C midway between A and B. In these circumstances the change of rectified current is proportional to the change of applied voltage, being the necessary condition for distortionless rectification.

It should be realised that this condition can only be realised if the mean amplitude OC' of the applied high-frequency voltage is sufficiently large to ensure that the upper and lower limits A and B, with the maximum degree of modulation, fall on the straight part of the curve. If the signal voltage were too low rectification would take place round the bend of the curve, with accompanying distortion. Consequently, for the reception of all but the strongest local transmissions it is essential to employ one or more stages of high-frequency amplification before the detector.

### HIGH-VOLTAGE VALVES

SEVERAL interesting developments have taken place in the design of Ostar-Ganz high-voltage valves, which, as most of our readers are aware, have heating elements designed for direct connection to either D.C. or A.C. mains of standard voltages without the intermediary of resistances or transformers.

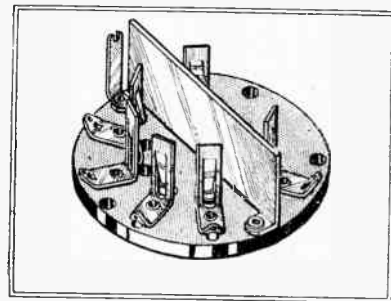

Under-side of the new Ostar-Ganz valve-holder, showing screening plate.

Hitherto it has been impossible to obtain really high anode voltages from the indirectly heated rectifiers of the series; this difficulty is now overcome by the introduction of a voltage-doubling rectifier, which costs 22s. 9d. With a 220-volt supply a rectified output of about 440 volts is obtainable at 40 milliamps. Another new rectifier provides full-wave rectification.

The K.3560 three-electrode output valve is another interesting innovation; it has an A.C. resistance of only 500 ohms and a mutual conductance of 6 mA/V. The maximum D.C. anode dissipation is 15 watts, and the valve is specially designed to give a large output with normal supply voltages.

It has previously been necessary to employ double smoothing chokes in circuits employing Ostar-Ganz valves. The need for this special smoothing system has now been avoided by alterations in the arrangement of the pins and by the introduction of a special valve holder, in which the heater connections are effectively screened.

The agent for Ostar-Ganz valves in Great Britain is Mr. Eugen Forbat, of 28-29, Southampton St., Strand, London, W.C.2.

# News of the Week

## Current Events in Brief Review

### The Passing of a Giant

WE understand that one result arising out of the Lucerne Conference is that the famous Eiffel Tower Broadcasting Station will cease its transmission on January 1st, 1935.

### Marking Foreign Valves

THE Board of Trade's Standing Council recommends that certain imported wireless and rectifying valves should be plainly marked with the country of origin. The valves specified are thermionic valves having an anode dissipation that does not exceed 50 watts, and rectifying valves not exceeding a capacity of 60 volt-amperes or passing a current of more than one ampere. Such valves to carry a durable mark in a contrasting colour on the bulb or cap and a corresponding indication to be printed or stamped on the carton or container in which they are exposed for sale.

### Guided by Music

AEROPLANE pilots in America find the broadcast programmes a pleasant means of whiling away the monotony of long flights, tuning back and forth from the special wavelengths carrying weather reports, direction signals, and landing instructions to their favourite broadcasting station along the route. The use of the direction-finding aerial makes it possible for a pilot while listening to a programme from WOR, for example, to know that he is heading in the right direction for the Newark airport.

### The Obsolescent Crystal Set

IT is stated that one of the advantages to be gained by the new P.T.T. high-power station is that owners of crystal sets in Paris and its suburbs will be able to receive the programmes throughout the day, but the result of the return of the sets made in accordance with the new licence regulations would show that the declaration of crystal sets is negligible, those possessing these relics of the past are no longer using them. Strictly speaking, they are bound to declare them, but it is unlikely that the administration will go to the trouble of prosecuting them for their neglect.

### Dr. Giesecke Returns Home

AMONG the various broadcasting chiefs who were recently compulsorily retired and sent to the internment camp at Oranienburg was the former Vice-President of the Broadcasting Union and Director of the Reichs-Rundfunk-Gesellschaft. We are glad to learn from our foreign correspondent that he, Dr. Giesecke, has been liberated, and that he returned home on August 23rd, though we understand that no mention of this fact appeared in the German Press.

### Ultra Shorts at Sing Sing

SING SING is seeking permission to use ultra short waves to guard its prisoners. According to a Washington correspondent, the idea is that the warders would carry light-weight transmitters and receivers strapped on their backs, enabling them to converse across the prison grounds while on their beats.

### Unlucky Tunis

TUNISIAN listeners want to hear French, and are loudly lamenting that they are doomed to absorb German, Italian, and other foreign comedies and lectures. Apparently the only French stations that are audible, viz., Radio Paris, Poste Parisien, Toulouse, and Algiers, are so "pursued by parasites" that five to ten minutes of listening is the utmost that can be borne.

### Feeling the Economic Strain

THE Belgian Government has just decided to reduce the grant for 1933 to the National Broadcasting Institute from over

### Another Arctic Station

THE 10 kW. Norwegian station now being erected at Vadsø in Finnmark claims to be the most northerly station in the world, latitude 70° 4' N. When completed it will relay the programme from Oslo.

### Storms in Hungary

LOCAL thunderstorms frequently interrupt broadcast transmission in Hungary and the relay stations often have to shut down for "storm pauses." From Budapest now comes the assurance that listeners will be warned, at such times, which stations are affected and which are still continuing their transmissions, in order that they may tune in to the active station and continue to follow the programme.

### Belgian Political Talks

IN view of the correspondence which has recently appeared in the English papers between three distinguished statesmen and the B.B.C. concerning the selection of speakers for the forthcoming political addresses, it is interest-

### German Anti-Static Campaign

IN view of the forthcoming anti-interference law, the National Socialist Funkkammer has decided to clear the town of Baden-Baden of all man-made statics. Work has already begun under the direction of a Post Office engineer and the second burgomaster of the town, and it is hoped that by the middle of October all such interference will have ceased. The authorities have inferred that the law against man-made interference will be based on the technical requirements of the Volksempfänger (the new People's Receiver), so that every owner of this set will have clear reception without the necessity of providing shielded aerial down-leads.

### Forthcoming Lectures

A NEW session of the British Radio Institution opens to-day (September 22nd), when a lecture will be given by Dr. L. E. C. Hughes on "The Reproduction of Sound via Radio." The meeting is to be held at 7.30 p.m. at King's College, Strand, W.C.2, and the chair will be taken by Prof. C. L. Fortescue. The Hon. General Secretary asks us to state that any of our readers who wish to attend what promises to be an interesting lecture will be welcomed. Invitation cards are available, but are not necessary for admission. The headquarters of the B.R.I. are at 36, Gordon Square, W.C.1.

### R.S.G.B. Meetings

THE secretary of the Incorporated Radio Society of Great Britain has kindly sent us a preliminary list of the series of lectures which will be given on Friday evenings at 6.15 p.m. at the Institute of Electrical Engineers. The dates and subjects are:—

September 20th.—"Experiments with Portable 56 mc. Apparatus," by R. H. Hamman, G2IG.

October 20th.—"Technique in Valve Manufacture," by Stephen de Laszlo, B.A. (Director, High Vacuum Valve Co., Ltd.).

November 24th.—"The Magnatron Oscillator for very High Frequencies," by Eric Megaw, B.Sc. (Research Laboratories, General Electric Co.).

December 20th.—Annual General Meeting followed by a lecture, "Transmitting Valves for Amateur Needs," by L. Grinstead (Transmitting Division, Mullard Wireless Service Co.).

### New German Relay Station

A NEW relay station from Coblenz will shortly be erected and further stations are projected for Würzburg, in Bavaria, and somewhere not yet settled in Pomerania.

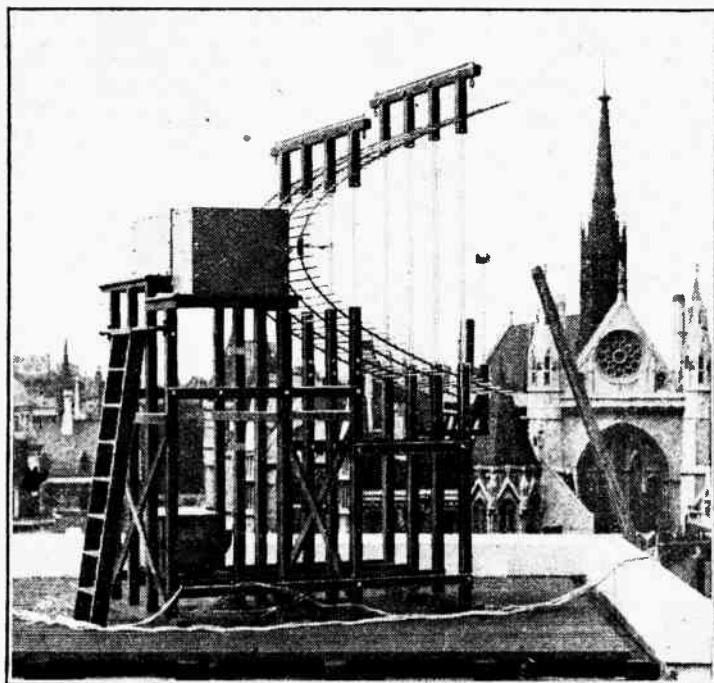

**MICRO-WAVES AT ELECTRA HOUSE.** The Research Department of Marconi's Wireless Telegraph Co., Ltd., has now settled down in its new quarters facing the Embankment, and one sign of the move is the erection of the parabolic aerial for the ultra-short wave beam on the roof of Electra House.

22 million francs to about 17 million. In consequence of this the I.N.R. (as it is generally known) has felt compelled to reduce both the talks and musical programmes. The broadcasting hours have been shortened to 12 noon to 2.0 p.m. and 5.0 to 10.0 p.m. on week-days. The Sunday transmission will start two hours earlier than this, but will otherwise be the same. It is hoped that when times improve the old hours may be restored or even extended.

ing to hear from our correspondent that the Belgian Government has issued a decree according to which "every one of its members has the right to use the broadcasting station for speeches up to a maximum of ten hours per month." If this is the case, Belgium stands in danger of being inundated with political addresses, and the prospect of an ardent politician insisting on his right to take the whole of his allotted time in "one fell swoop" must be rather disconcerting to listeners.



# MANCHESTER SHOW GUIDE

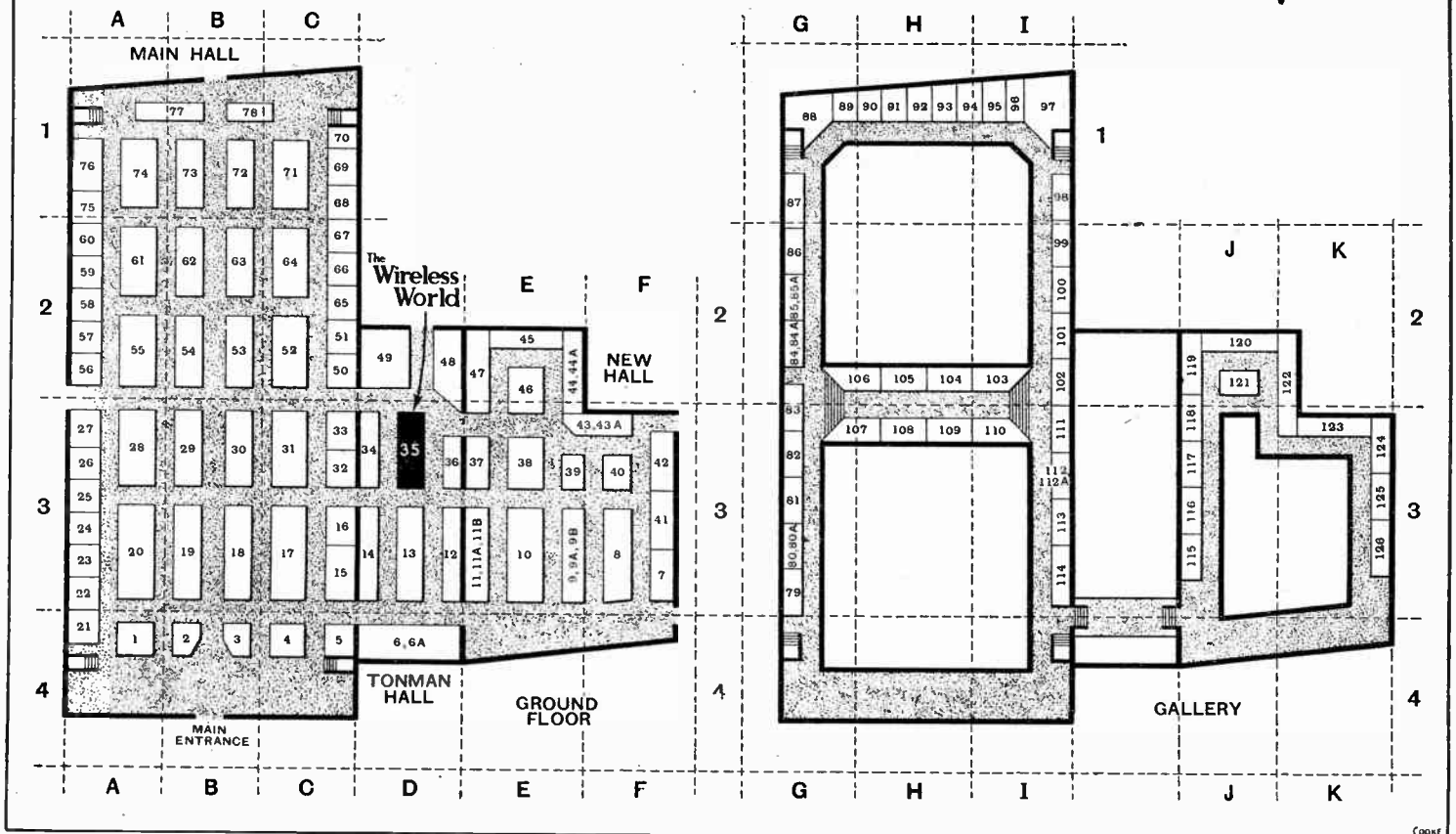

The Manchester Radio Show will be held in the City Hall, Deansgate, from Wednesday, September 27th to Saturday, October 7th, 1933

In the following list we give the names and addresses of exhibitors, with Stand numbers, and a reference (in heavier type) to be used in conjunction with the above plan for locating individual stands

## FULL LIST OF EXHIBITORS

EXHIBITOR.	STAND.	REF. SQS.	EXHIBITOR.	STAND.	REF. SQS.	EXHIBITOR.	STAND.	REF. SQS.
<b>AERIALITE</b> , Ltd. ...	77	G 2	City Accumulator Co., Ltd. ...	79	G 3	<b>GENERAL ELECTRIC</b> Co., Ltd. ...	19	B 3
Aerialite House, Amber St., Manchester.	78	A 4, A 3	18-20, Norman's Bldgs., Central St., London, E.C.1.	29	B 3	Magnet House, Victoria Bridge, Manchester.	103	I 2
Allied Newspapers, Ltd. ...	21-2	A 4, A 3	Clarke & Co. (A)C., Ltd., II. Atlas Wks., Patricroft, Nr. Manchester.	16	C 3	Goodmans, Ltd. ...	69	E 1
Withy Grove, Manchester.	31	D 3	Climax Radio Electric, Ltd. Haverstock Wks., 59, Parkhill Rd., Hampstead, N.W.3.	18	B 3	69, St. John St., Clerkenwell, London, E.C.1.	23-6	A 3
Amplion (1932), Ltd. ...	11B	E 3	Colc. Ltd., E. K. Ekco Wks., Southend-on-Sea. Colvern, Ltd. Mawneys Rd., Romford, Essex. Cosmocond, Ltd. Cambridge Arterial Rd., Enfield, Mddx. Cossor, Ltd., A. C. Cossor House, Highbury Grove, London, N.5.	32	C 3	Graham Farish Ltd. 153, Massons Hill, Bromley, Kent. Granophone Co., Ltd. 98-108, Clerkenwell Rd., London, E.C.1. Gramphon Reproducers, Ltd. Station Ave., Kew Gardens, Surrey. Gresley Radio, Ltd. Ordsall Lane, Salford Lanes.	52	C 2
Automatic Coil Winder & Elec. Equipment Co., Ltd. Winder House, Douglas St., London, S.W.1.	6, 6A	T 3	Crownwell (Southampton), Ltd. 32, Brinton's Terr., Southampton.	61	A 2	Hackler & Sons, II. Ray Lea Rd., Maidenhead, Berks. Hayberd & Co., F. C. 10, Finsbury St., London, E.C.2.	92-3	H 1
<b>BALCOMBE</b> , Ltd., A. J. ...	73	B 1	<b>DAWES</b> , F. London Rd., Manchester. Dent, R. H. 309, Oxford St., London, W.1. Diggle & Co., A. Jane St., Rochdale, Lanes. Dyson & Co., Ltd., J. Godwin St., Bradford.	30	B 3	Hellesens, Ltd. Hellesen Wks., Morden Rd., South Wimbledon, London, S.W.19.	39	E 3
52-58, Tabernacle St., London, E.C.2.	27	A 3	<b>ECONASIGN</b> Co., Ltd. 92, Victoria St., London, S.W.1.	107	G 3	High Vacuum Valve Co., Ltd. 113-117, Farringdon Rd., London, E.C.1.	6A	D 4
Belling & Lee, Ltd. ...	27	A 3	Edge Radio, Ltd. Bolton, Lanes. Edison Swan Electric Co., Ltd. 155, Charing Cross Rd., London, W.C.2.	9A	E 3	Hobday Bros., Ltd. 11-20, Turner St., Manchester. Hollingsdrake & Sons, Ltd., II. Princess St., Stockport. Hustler, Simpson & Webb, Ltd. Acrodyne Wks., Hoe St., Walthamstow, London, E.17.	80	G 3
Cambridge Arterial Rd., Enfield, Mddx.	76	A 1	Electro-Dynamic Construction Co., Ltd. Devonshire Grove, London, S.E.15.	81A	G 2	IGRANIC Electric Co., Ltd. 117, Queen Victoria St., London, E.C.4.	56-9	A 2
Bernard Jones Publications, Ltd. 58, Fetter Lane, London, E.C.4.	76	A 1	Epoch Radio Mfr. Co., Ltd. Exmouth House, Exmouth St., London, E.C.1.	36	D 3	Iliffe & Sons Ltd. Dorset House, Stamford St., London, S.E.1.	91	H 1
Berry & Wilson, Ltd. Mansion Wks., Gt. Horton, Bradford. Block Batteries, Ltd. Abbey Rd., Barking, Essex. Britannia Batteries, Ltd. 233, Shaftesbury Ave., London, W.C.2.	79	G 3	<b>FERRANTI</b> , Ltd. Hollinwood, Lanes.	20	A 3	Lissen, Ltd. Lissenium Wks., Worple Rd., Isleworth, Middx.	33	C 3
British Blue Spot Co., Ltd. 91-96, Rosoman St., London, E.C.1.	79	G 3	Ever Ready Co. (Gt. Britain), Ltd. Hercules Place, Holloway, London, N.7.	53	B 2	McMICHAEL Radio, Ltd. Slough, Bucks.	106	G 2
British Broadcasting Corporation. Portland Place, London, W.1.	91-7	I 1	Express Radio Factors, Ltd. 25, Gt. Eastern St., London, E.C.2.	6	D 4	Marlborough Radio Co., Ltd. Priarose Bank, Ashton Rd., Oldham.	120	J 2
British Pix Co., Ltd. 118, Southwark St., London, S.E.1.	86	G 2				121	J 2	
British Radiophong, Ltd. Aldwych House, Aldwych, London, W.C.2.	11	D 3				122	J 2	
British Rola Co., Ltd. Minerva Rd., Park Royal, London, N.W.10.	75	A 1				123	J 2	
Brown Bros., Ltd. Gt. Eastern St., London, E.C.2.	48	D 2				124	J 2	
Bulgin & Co., Ltd., A.F. Abbey Rd., Barking, Essex.	69	C 1				125	J 2	
<b>CARRINGTON</b> Mfg. Co., Ltd. Camco Wks. Sanderstead Rd., S. Croydon.	41	E 2				126	J 2	
Celestion, Ltd. London Rd., Kingston-on-Thames. Cifel Products, Ltd. 131, Pentouville Rd., London, N.1.	1	A 4						

Manchester Show Guide—

EXHIBITOR.	STAND.	REF. NOS.
Milnes Radio Co. ... Bingley, Yorks.	108	H 3
Mullard Wireless Service Co., Ltd. Mullard House, Charing Cross Rd., London, W.C.2.	17	C 3
NEW London Electron Works, Ltd. East Ham, London, E.6.	3	B 4
Newnes Ltd., G. 8-11, Southampton St., Strand, London, W.C.2.	11	E 3
ODHAMS Press, Ltd. 68, Long Acre, London, W.C.2.	82	G 3
Ormond Engineering Co., Ltd. Ormond House, Rosebery Ave., London, E.C.1.	67-8	C 2, C 1
Orr Radio, Ltd. 63, Lincoln's Inn Fields, London, W.C.2.	46	E 2
Osborn, C. A. Regent Wks., Arlington St., London, N.1.	78	B 1
Oslur Manufacturing Co. 26, Adam St., London, W.1.	11A	E 3
PARTRIDGE, Wilson & Co. Davenset Wks., Evington Valley Rd., Leicester.	4	C 4
Portadyne Radio, Ltd. Gorse Rd., North Acton, London, N.W.10.	66	C 2
Practical Radio, Ltd. Stal House, Judd St., London, W.C.1.	9	E 3
Pressland Sales, Ltd. 84, Eden St., Kingston-on-Thames.	9b	E 3
Priestley & Ford. 3-11, Carrs Lane, Birmingham.	98	I 1
Provincial Incandescent Fittings Co., Ltd. High St., Manchester.	45	E 2
Pye Radio, Ltd. Africa House, Kingsway, London, W.C.2.	55	A 2
QUICKSIGN, Ltd. 106, Queen Victoria St., London, E.C.1.	112	I 3
RADIALADDIN, Ltd. 16, Brewer St., London, W.1.	47	E 2
Radio Instruments, Ltd. Purley Way, Croydon, Surrey.	65	C 2
Radiomes, Ltd. 129-131, Bridge St., Warrington.	113	I 3
Rawplug Co., Ltd. Rawplug House, Cromwell Rd., London, S.W.7.	44A	E 2
Reproducers & Amplifiers, Ltd. Frederick St., Wolverhampton.	5	C 4
Richardsons (R.M.L.), Ltd. 21, St. John St., Manchester.	49	D 2
Ridings Reliance, Ltd. 331, Stockport Rd., Manchester.	13	D 3
Roberts, J. Bridgewater Viaduct, Knott Mill, Manchester.	112A	I 3
SIEMENS Electric Lamps & Supplies, Ltd. 38, Upper Thames St., London, E.C.1.	15	C 3
Small Power Dynamo & Motor Co., Ltd. Old Lane, Hr. Openshaw, Manchester.	99	I 2
Sovereign Products, Ltd. 52-1, Rosebery Ave., Clerkenwell, London, E.C.1.	100	I 2
Standard Telephones & Cables, Ltd. 361, Gray's Inn Rd., London, W.C.2.	38	E 3
Star Radio Products, Ltd. 11, Sugar Lane, Manchester.	102	I 2
TANNOY Products, Ltd. Dalton St., West Norwood, London, S.E.27.	87	G 1
The 362 Radio Valve Co., Ltd. Stoneham Wks., Stoneham Rd., London, E.5.	111	I 3
Thomas & Bishop, Ltd. 37, Tabernacle St., London, E.C.2.	90	H 1
Trade Chronicles, Ltd. 6, Carmelite St., London, E.C.1.	85A	G 2
ULTRA Electric, Ltd. Erskine Road, Chalk Farm, London, N.W.3.	31	C 3
Universal Electric Supply Co., Ltd. 4, Brown St., Manchester.	110	I 3
VARLEY (Oliver Pell Control, Ltd.) 103, Kingsway, London, W.C.2.	77	B 1
Vince's Dry Batteries, Ltd. Garford Wks., Garford St., London, E.14.	74	A 1
WELLWORTH Wireless Co. 8, Withy Grove, Manchester.	81	G 2
Westinghouse Brake & Saxby Signal Co., Ltd. 82, York Rd., King's Cross, London, N.1.	63	B 2
Wharfedale Wireless Works, Ltd. 62, Leeds Rd., Bradford.	101	I 2
Whiteley Electrical Radio Co., Ltd. Victoria St., Mansfield.	62	B 2
Wingrove & Rogers, Ltd. Polar Wks., Old Swan, Liverpool.	51	C 2
Wireless & Gramophone Trader Dorset House, Stamford St., London, S.E.1.	60	A 2
Wireless Retailers' Assoc. of Gt. Britain and N. Ireland. 1, Mitre Court, Fleet St., London, E.C.4.	89	G 1
Wireless World. Dorset House, Stamford St., London, S.E.1.	35	D 3
Wright & Weaire, Ltd. 740, High Rd., London, N.17.	80A	G 3

In Next Week's Issue:—

"The Wireless World"

# D.C. Superhet

## Incorporating A.V.C., Westectors and Pentagrid Frequency Changer

THE new receiver has only four valves, but is capable of a performance equal to, if not surpassing, that of a five- or six-valve set of only a few months ago. The reduction in the number of valves has been made possible by recent valve development and by the introduction of metal rectifiers for signal rectification.

A signal frequency H.F. stage with two tuned preselector circuits for second channel rejection precedes the Pentagrid frequency changer, and the single I.F. stage is coupled by means of iron-core type I.F. transformers. This stage feeds two Westectors, giving signal rectification and delayed A.V.C. on the H.F. frequency changer and I.F. variable-mu valves, and feeds the output pentode through a resistance coupling.

Due largely to this important feature, the A.V.C. system functions unusually well and maintains constant apparent loud speaker volume for large variations in signal input. In addition, the low value of L.F. amplification employed has far-reaching effects on the question of hum. A minimum of smoothing is needed, and yet the hum level is exceptionally low, even with a positive earth, while electrostatic hum pick-up is negligible.

The quality of the reproduction reaches a high level, while the selectivity and sensitivity are adequate for most purposes. The tuning dial is wavelength calibrated, and owing to the use of a special barretter for regulating the heater current of the valves, alterations to the set for different mains voltages between 200 and 250 volts become unnecessary.

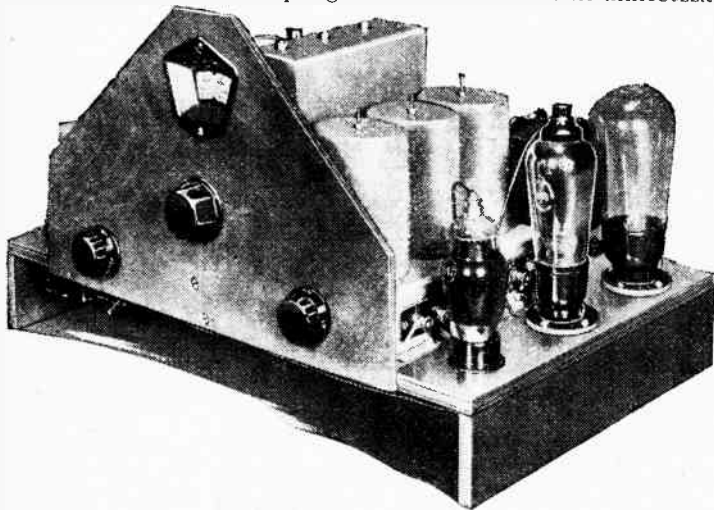

New Superheterodyne Circuit Employing Four Valves Only.

Full size blue prints of the wiring connections will be available.

LIST OF PARTS

After the particular make of component used in the original model, suitable alternative products are given in some instances.

- 1 Super R.F. Radiopak, without volume control **British Radiophone**
- 2 Ferracart Colverdynes, 110 kc/s **Colvern**
- 1 Tapered volume control, 0.25 megohm, and knob **Claude Lyons Type 250 M-T** (Magnum, Rothermel, Varley.)
- 1 Potentiometer, 5,000 ohms **Claude Lyons Type P.58** (Haynes Radio, Rothermel, Watmel.)
- 1 Screened H.F. choke **Goltone Type SHF** (Klavya, Varley, Wearite.)
- 2 Mains H.F. chokes **Goltone Type PHF**
- 1 L.F. choke **Hayberd No. 752** (Davenset, Ferranti, Parmeko, R.I., Sound Sales, Varley, Vortexion.)
- 5 5-pin valve holders **Clix Chassis Mounting Type** (Preh.)
- 1 7-pin valve holder **Philco 27/6005**
- 1 Grid clip, for 6A7 valve **Philco 4897** (Claude Lyons.)
- 1 Fixed condenser, 4 mfd., 250 v. D.C. working **T.C.C. Type 65**
- 2 Fixed condensers, 2 mfd., 200v. D.C. working **T.C.C. Type 50**
- 3 Fixed condensers, tubular, 0.1 mfd. 350v. D.C. working **T.C.C. Type 250**
- 1 Fixed condenser, 0.01 mfd. **Igranic Type FF.12**
- 1 Fixed condenser, 0.001 mfd. **Igranic Type FF.12**
- 1 Fixed condenser, 0.002 mfd. **Igranic Type FF.12**
- 4 Fixed condensers, 0.0001 mfd. **Igranic Type FF.12**
- 2 Fixed condensers, 0.0002 mfd. **Igranic Type FF.12** (Dubilier, Peak, Telsen.)
- 1 Dry electrolytic condenser, 50 mfd. **T.C.C. Type 521** (Dubilier, Telsen.)
- 1 Make-and-break switch **Claude Lyons B.A.T.728**

- 1 Double-pole single-throw switch **Claude Lyons B.A.T.2728** (British Radiophone, Belgm.)
- 2 Ebonite shrouded terminals, A.F. **Belling-Lee Type "B"** (Igranic.)
- 2 Westectors **Westinghouse W.6**
- 1 Resistor, 25 ohms **Claude Lyons Type FW.25**
- 1 Resistance, 100 ohms 1/2 watts **Seradex Type M.150**
- 1 Resistance, 250 ohms 1/2 watts **Seradex Type M.150**
- 1 Resistance, 20,000 ohms 1/2 watts **Seradex Type M.150**
- 1 Resistance, 0.1 megohm 1/2 watts **Seradex Type M.150**
- 2 Resistances, 0.25 megohms 1/2 watts **Seradex Type M.150**
- 1 Resistance, 0.5 megohm 1/2 watts **Seradex Type M.150**
- 1 Resistance, 1 megohm 1/2 watts **Seradex Type M.150**
- 1 Resistance, 2 megohms 1/2 watts **Seradex Type M.150**
- 2 Resistances, 10,000 ohms 2 1/2 watts **Seradex Type G.250** (Dubilier, Erie, Claude Lyons, Varley, Watmel.)
- 1 5-pin plug **British Radio Gramophone Co.** (Belgim.)
- 1 Bulb, 6 volts 0.15 amp. **Bulgim Type "OB"**
- 1 Twin safety fuse holder, with 1 amp. fuses **Belling-Lee Type 1033** (Belgim.)
- 1 Length Screened Sleeve **Harbros**
- 1 Plymax baseboard, 10in. x 16in. x 1/2in. **Peto-Scott** (Overall dimensions of assembled chassis, 16in. length x 10in. width x 9 1/2in. height.)
- 1 Voltage regulator **Osram Barretter No. 251** 4 oz. No. 20 tinned copper wire, 10 lengths Systo-flex, wire, wood, etc.
- Screws:—  
 25 1/2in. No. 4 R/hd. 10 1/2in. No. 4 R/hd.  
 4 1/2in. No. 4 R/hd. 10 3/4in. No. 4 R/hd.  
 7 1/2in. No. 4 C/sk. 4 6BA. with nuts and washers.
- Valves:—2 Marconi or Osram VDS. 1 Marconi or Osram DPT. 1 Philco or Claude Lyons 6A7.

# G.E.C. Six-watt Power Amplifier

## Two-stage A.C.-operated Power Unit in Compact Form



Model B.C.S.1562

THE B.C.S.1562 power amplifier made by the General Electric Co., Ltd., Magnet House, Kingsway, London, W.C.2, is an A.C.-operated two-stage unit giving a maximum undistorted power output of six watts. An output of this order is sufficient to fill a small- or medium-sized hall, and with suitable disposition of loud speakers will answer for many purposes out of doors, such as at sports meetings, garden fêtes, and the like. Yet on first acquaintance few would include it in the category of public address equipment in view of its exceptionally small size, for the overall dimensions are but 13in. x 6½in. x 10¼in. high. Despite its compactness, there is no undue crowding of the components, nor has the safety factor in a single instance been pared down to the border line to achieve this end; indeed, the components are very generously rated.

in a wireless unit, and, furthermore, enables separate volume controls, or fading devices, to be used where two gramophone turntables or a combination of these and a microphone unit are connected to the amplifier.

Three degrees of tone control are available, but not for compensation of the amplifier's characteristic, which is entirely satisfactory without this artificial aid. They are included in order to meet any particular contingency that may arise in connection with the acoustic properties of the hall or the loud speakers. The high-tension supply is derived from a full-wave rectifying valve (Osram U.14), the output being smoothed by a single choke and the customary array of condensers.

Anode and grid decoupling is applied where necessary, with the result that entire freedom from interstage coupling is achieved, and the amplifier is perfectly stable under all conditions of working.

The only precautions we found necessary, and this applies also to all high gain amplifiers, was to shield the gramophone pick-up leads and earth the outer covering as well as the metal parts of the tone arm.

the relative level with the switch in the low gain position.

Curve A is the normal characteristic of the amplifier. For curve B tone control switch No. 1 was depressed; curve C shows the characteristic of the amplifier with the next degree of tone control, while with the full measure available curve D resulted. With the input switch set to "Low Gain" and without tone compensation we obtained the broken line curve, marked E on the graph.

Provision is made to take the necessary operating voltages for a microphone unit from the amplifier. At the back of the chassis is a sunk five-pin valve holder at the filament sockets of which is available a four-volt A.C. supply, while the anode and grid sockets give access to the smoothed D.C. line.

To sum up, the G.E.C. model B.C.S.1562 amplifier satisfactorily fulfils the various functions for which it is intended. It is of sound electrical design without frills or unnecessary complications likely to introduce annoying troubles, and, finally, the workmanship and finish are quite above criticism. Its compactness makes it readily portable and easily stowed away when not in use, and

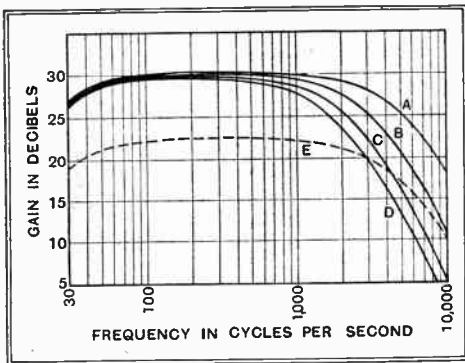

Overall response curves of G.E.C. six-watt amplifier taken across the 15-ohm tapping of output transformer. A, normal characteristic, B, C and D with three degrees of tone control, and E, low gain characteristic.

### Good Characteristic

The performance of the amplifier gives no grounds for adverse criticism; gramophone recordings are reproduced faithfully, all of which is in keeping with expectations, having regard to the very satisfactory response curve. A brief explanation of this is necessary, for it may be thought at first that it represents the total gain of the unit. In order to ascertain the overall response, including the output transformer, our measurements were made by joining a 15-ohm non-inductive resistance across the 15-ohm impedance tapping. The decibel scale should

The circuit employed is quite straightforward, and consists of an Osram MS4B S.G. valve resistance-capacity coupled to a PX25 power valve. The A.C. output from this is fed through a choke-capacity filter to an output transformer having windings to give correct matching for loud speakers of 2.5, 5, 7.5, and 15 ohms impedance. Alternatively, if two or more loud speakers are employed the wide choice of output ratios renders it comparatively easy to arrange their connections so that the total impedance of the line amounts to one of these four values. The provision for low impedance transmission lines is a wise one, for with the loud speakers located at a distance little or no loss occurs of the higher frequencies due to capacity effects.

### Alternative Input

Control of volume is effected by a 500,000-ohm potentiometer in the grid circuit of the first valve, but, in addition, provision is made to reduce the input to about one-half should the need arise. A switch, marked "High Gain" and "Low Gain," is fitted, and in the former position an input of about 0.22 volt suffices to fully load the amplifier, while 0.56 volt approximately is required under low-gain conditions. A volume control of one-half megohm may seem unduly high, but it allows the amplifier to be employed following the detector valve

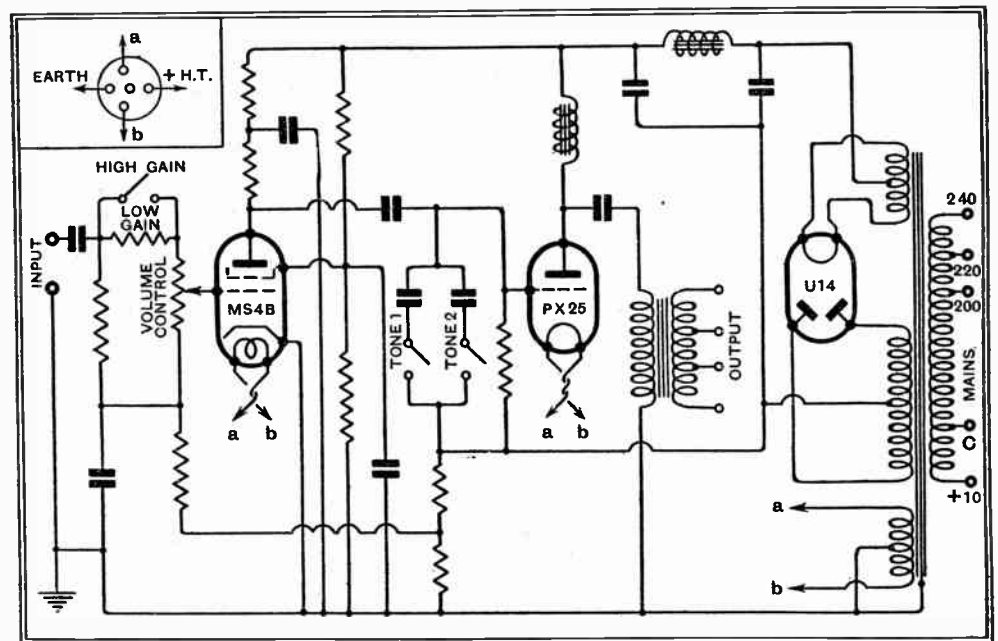

Theoretical circuit of G.E.C. B.C.S.1562 six-watt power amplifier.

be used for relative computation of the output only at different frequencies with and without tone compensation. It also shows

at the attractive price of £18 15s., complete with valves, represents very good value for money.

# BROADCAST BREVITIES

## Time Signals

THE B.B.C. has long been anxious to arrange a fixed schedule for the hours at which the Greenwich time signals are transmitted to avoid the annoyance caused when the "six pips" are superimposed on an interesting programme or when the expected signal is postponed. They hope now to arrange that the time signals in future will always be heard at fixed times, and that they will not interfere with musical or other programmes.

## North Regional Dramatic Producer

THE organisation of the staff for the North Regional area proceeds apace. I understand that Mr. Robin Whitworth has been appointed the dramatic producer, working under Mr. E. F. R. Harding, the recently appointed director of programmes.

## The Children's Hour

I UNDERSTAND that no decision has yet been made to omit the customary birthday greetings from the Children's Hour, but that the matter is receiving serious consideration. The B.B.C. recognises that the omission may cause acute disappointment to many children, but with the development of the Children's Hour from the informal entertainment of a gathering of "Uncles and Aunts" to its present more serious forty-five minutes, the birthday lists have grown to such a length that it is felt that they now occupy too much of the time and may have to be reluctantly abandoned.

## Empire Broadcasting

THE change in the announcements of the different programmes transmitted on the Daventry short-wave sets is merely one of nomenclature. After October 8th the various Empire programmes will be known as No. 1, No. 2, and so on. Thus instead of announcing a programme for "The Canadian Zone," it will in future be known as "Programme No. 5." It has been found that there was so much overlapping of the formal zones that, in practice, the attempt to allot a certain programme to any certain zone was impossible.

## Mr. Roger Eckersley's New Title

THE announcement that Mr. Roger Eckersley is now the "Director of Entertainments" only indicates a change in the name of his official post. It was found that some confusion arose occasionally between the respective posts of "Director of Programmes" and "Director of Talks," it was therefore decided to make it clear that the Director of Entertainments and the Director of Talks are two separate and hard-worked individuals, who together are responsible for the entertainment and instructional sides of the programmes.

## Transatlantic Relays

THE interchange of programmes between Europe and America appears likely to receive a fresh impetus from the formation of an International Committee to organise the broadcasting of talks, debates and discussions by prominent speakers in Europe, Asia and America. Dr. Nicholas Butler, president of Columbia University, is chair-

## By Our Special Correspondent

man, and the committee includes distinguished representatives from England, and practically all European countries, together with China and Japan. The scheme is under the auspices of the Columbia Broadcasting System, and may be regarded as their answer to the National Broadcasting Company of America, whose interchange of programmes, following the visit of Mr. F. Bate to this country, first brought to public notice the possibilities of transoceanic broadcasting.

## Prospective "General Post"

ON the completion of the new National station at Droitwich it is possible that the existing medium wave National transmitters at Brookmans Park, Moorside Edge

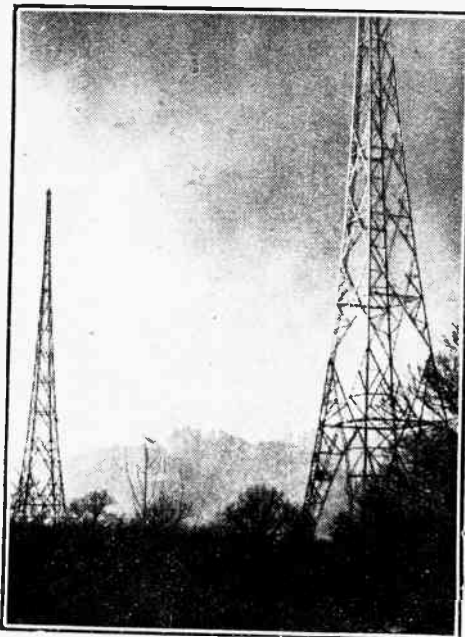

SILENT FOR A TIME. The splendidly situated masts of the Italian-speaking station at Monte Ceneri and the studio in Lugano. This station is at present closed down while the transmitters are adjusted to the new wavelength.

and Watchet may become redundant, but in that case it is probable that two of the transmitters will be transferred to the projected North-East of England and North of Scotland Regional stations, while the third may be re-erected at Droitwich as the new Midland Regional transmitter.

## The Disgruntled Statesmen

THE recent correspondence between three eminent statesmen and the chairman of the B.B.C. with regard to their non-inclusion in the list of speakers to broadcast forthcoming political addresses has aroused considerable interest. Many listeners, myself included, would welcome the opportunity of hearing addresses by Sir Austen Chamberlain, Mr. Lloyd George and Mr. Winston Churchill, also by Mr. Maxton and many

other prominent politicians, but those in authority at the B.B.C. wisely set a limit to the time allotted to political speeches, fearing that a plethora of such addresses would only weary listeners and thereby defeat their own object. They therefore decided, for the coming season at all events, to limit the speakers to those chosen by the leaders of the three main parliamentary parties. In the good old days when "every little boy or gal . . . was either a little Liberal or else a little Conservative," the task of selection would have been simplified, but now that there are so many shades of political thought it becomes complicated and necessarily leads to some dissatisfaction.

## The New Aberdeen Studios

IT is right that Aberdeen, the home-town of Scotland's New Regional Director, Mr. Dinwiddie, should be equipped with the most up-to-date studios, but I must confess to surprise when I dropped in at the newly designed studios in Belmont Street last week.

## Broadcasting House in Miniature

There will be a Press view soon, and meantime those in authority have decreed that no detailed account must appear, so I am debarred from describing the new talks studio, rigged up with the now familiar "traffic signal" system of lights for communicating between the control engineer and the speaker, of the twin gramophone turntables and the modernistic fittings and furniture, the whole giving the appearance of having been lifted lock, stock, and barrel from Broadcasting House, London, while the concert studio will certainly be Scotland's finest.

## Mr. Dinwiddie's Slogan

I can, however, say this: Mr. Dinwiddie

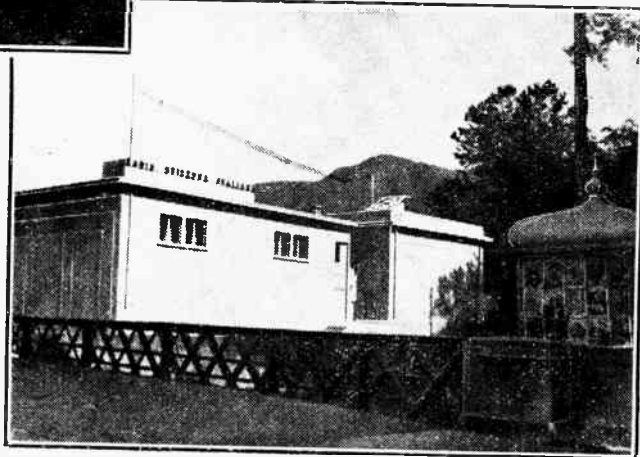

is already on the warpath with the slogan, "A fair chance for every town in Scotland," and the probability is that broadcasting studios will be erected in other Scottish centres, and a start can be expected in the region of Inverness.

## "The White Château" Again

LISTENERS will welcome the opportunity of again hearing that popular broadcast play, "The White Château," which will be revived on October 9th and 10th with incidental music specially composed by Norman O'Neill.



# Practical HINTS and TIPS

SO far as the "one H.F." receiver is concerned, it is generally best to carry out the operation of adjusting the trimming condensers while the reaction control is advanced towards its limit. Although the best form of reaction control does not introduce much change in tuning, there is always the possibility of some slight disturbance

## Reaction and Ganging.

being introduced, and so it is desirable that the circuits should be in most accurate alignment when the set is in the most sensitive condition—that is, with reaction fully advanced.

IN the "Hints and Tips" section of *The Wireless World* of September 1st a note was published on the advantages of inserting an anti-interference filter in the mains supply leads at the point where they enter the building. The purpose of such a filter is, of course, to dispose of interference of a high-frequency nature, which may have been superimposed on the mains current by electrical machinery, etc., connected to the same mains supply system, but perhaps at a considerable distance.

## Filtering and Electrical Supply.

It is, of course, to dispose of interference of a high-frequency nature, which may have been superimposed on the mains current by electrical machinery, etc., connected to the same mains supply system, but perhaps at a considerable distance.

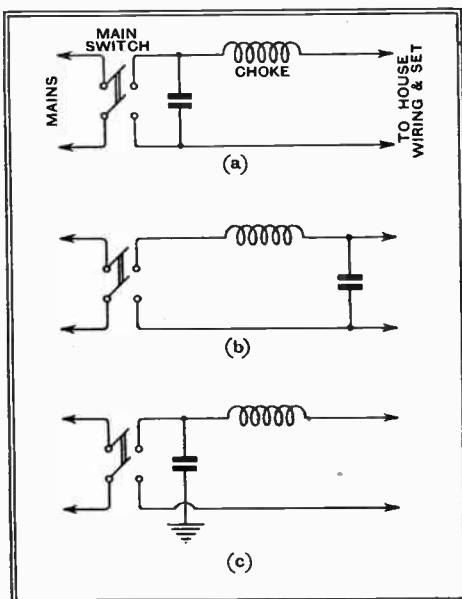

Fig. 1.—Simplified mains filters with a single choke.

As a footnote to what has already been said on the subject, it should perhaps be pointed out that in some cases the filter may be simplified and cheapened by using a single choke instead of a pair of chokes. It is therefore suggested that one or other of the arrangements shown in Fig. 1 should be tried, if only for the reason that the use of a single choke introduces less loss of voltage; looked on in another way,

## AIDS TO BETTER RECEPTION

it becomes less important to use a choke of extremely low D.C. resistance.

Referring to the diagram, it will be seen that the various arrangements suggested differ only with regard to the position of the by-pass condenser. In circuits (a) and (b) this condenser is respectively connected on the "input" and "output" sides of the filter, while in diagram (c) one side of it is connected directly to earth. It can only be determined by trial which arrangement will give best results, and, above all, it must be remembered that it will depend on circumstances in which mains lead the choke should be inserted.

THE practice of fitting some form of tone control whereby heterodyne interference may be minimised by reducing the high-note response of the receiver is now fairly common. Unfortunately, most of the methods adopted are somewhat crude and extremely drastic in their action. True, many of them are effective enough in suppressing certain forms of interference from stations working in adjacent channels, but music is quite lifeless, and speech has lost much of its intelligibility.

## The Best Whistle Suppressor.

This is mainly due to the fact that the filters fitted have a "tailing characteristic"; they begin to attenuate at frequencies of the order of 2,000 cycles per second to an appreciable extent. The heterodyne whistle between adjacent stations, if it is worth while trying to remove it, is of considerably higher frequency than this, and it is not hard to see that the ideal arrangement should only come into operation at a suitably chosen point in the spectrum (actually about 3,500 kc/s), leaving the upper middle register at full strength.

In the New Monodial receiver a scientifically designed low-pass filter of this nature is fitted and is so arranged that it may be thrown into circuit when heterodyne interference is present. At other times full advantage is taken of the wide frequency response of the receiver.

To hear a filter of this type in operation is a revelation of what can be done. With the receiver tuned to a station suffering from interference, and while the filter is out of operation, one hears a distressing background of whistle, mixed with side-band "splash," which may be so bad that the transmission has no entertainment value. Then, at a turn of the switch, the interference disappears as if the unwanted station had suddenly shut down.

The purpose of this note is to point out that the same type of low-pass filter is

also applicable to other receivers, more especially to those which have an intermediate L.F. stage. The main requirements are that the filter should work with input and output impedances of roughly 10,000 ohms; this means that the preceding valve and the succeeding coupling device should have roughly that impedance value. If transformer coupling be employed, it will be necessary to reduce impedance artificially by shunting the primary with a 10,000-ohm resistance.

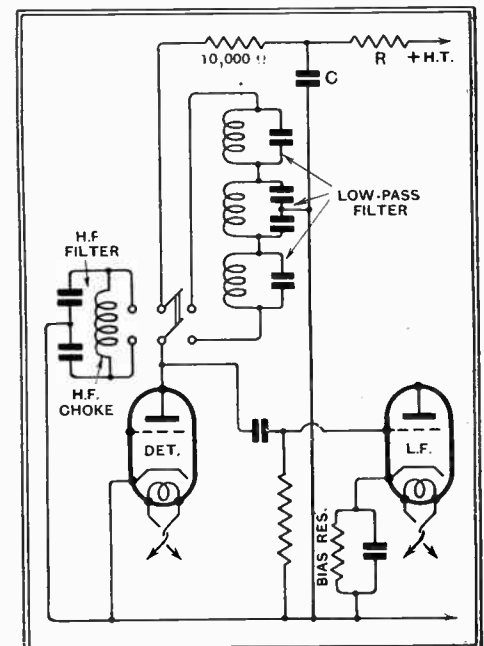

Fig. 2.—An advanced type of heterodyne whistle filter which may be thrown into circuit at will. The ordinary decoupling components are marked R. and C.

The connections of the low-pass filter unit are shown in Fig. 2. With the switch in the right-hand position the filter is in circuit, while in the other position the ordinary H.F. stopping devices become operative.

LOW-FREQUENCY transformer ratio is often a matter of considerable importance, especially in view of the fact that, in most modern sets, the detector is arranged to feed directly into the output valve without an intermediate L.F. stage.

## An Important Link.

It is seldom that the typical grid detector provides a large surplus of undistorted output, and so the result of using an insufficiently high step-up ratio is likely to be serious.

It should be remembered that the detector output required for loading the output stage is directly proportional to the voltage step-up provided by the transformer. If, for example, a ratio of 1:2.5 were employed in a set where 1:5 was specified, twice the detector output would be needed for correct operation.

# H.M.V. "Superhet Concert Seven"

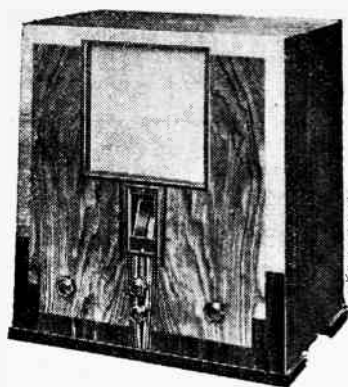

**FEATURES. Type.**—Seven-stage table-model super-heterodyne receiver with automatic volume control. Moving-coil loud speaker and provision for pick-up and external loud speaker. **Circuit.**—Signal frequency H.F.—oscillator—first detector—I.F. amplifier—metal oxide second detector—first L.F. with tone control—triode output valve. Full-wave valve rectifier. **Controls.**—(1) Main tuning with optically magnified illuminated scale. (2) Volume control and "Static Suppressor." (3) Duplex tone control. (5) Waverange, gramophone and on-off switch. **Price.**—22 gns. **Makers.**—The Gramophone Co., Ltd., 98-108, Clerkenwell Road, London, E.C.1.

MODEL 467

from seven stages, and there is an ample reserve of magnification for use when conditions permit. There is not the least doubt that this set will receive any station above the prevailing noise level, and will do so, moreover, without calling for special skill on the part of the operator. At no time during the course of our tests did we find it necessary to make anything like full use of the overall amplification of which the set is capable.

## A Receiver of High Performance on All Points

THE specification of this table-model receiver, having regard to its compact design, is remarkably full, and the numerous detail refinements in the circuits and controls indicate that no pains have been spared to secure the highest possible performance under modern receiving conditions. The cabinet is very similar in size and general design to that of the Model 438 reviewed in our issue of June 16th, 1933, but instead of dual vertical tuning scales there is a single illuminated drum dial which is viewed through a magnifying glass prism.

There are seven valves and seven stages in the circuit, excluding the power rectifier, the reason being that a metal oxide rectifier is used in the second detector stage. Selectivity at signal frequency is provided by the first stage, which is preceded by a band-pass tuner. Separated valves are employed for the oscillator and first detector, and two band-pass filters tuned to 117 kc/s are associated with the single I.F. stage. The metal oxide second detector is tapped across a portion of the secondary of the output I.F. transformer, while a second metal oxide rectifier for automatic volume control derives its input from the primary winding. Both the first H.F. valve and the first detector are controlled, and a delay voltage is supplied by a potential divider resistance across the H.T. supply.

In addition to the A.V.C. bias on the first valve there is a variable cathode bias resistor which is fitted at the back of the chassis, and may be pre-set to give a volume level suited to local conditions of background noise. The full magnification of the set is obtained at any time by pushing inwards the main volume control spindle. This actuates a shorting switch connected across

the "Static Suppressor" control resistance.

The manual volume control follows the second detector and functions both on radio and gramophone. There are two L.F. stages—both triodes—the output valve giving 2½ watts undistorted. The coupling between these stages is of the parallel-fed transformer type, and incorporates a tone control circuit which is worthy of the name. It controls both high- and low-note response, and is operated by two variable resistances coupled together. There is a mid-position which can be felt by a notch in the control, and movement to the left increases the low and to the right the high notes.

The power transformer is of unusually generous proportions, and is protected by a fuse in the centre connection to the H.T. winding and a "heat coil" in series with the primary winding. The latter is a special type of thermally delayed fuse which breaks down for steady currents in excess of 0.6 amp., but stands up to brief surges which may occur while the set is warming up.

The range is all that might be expected

The makers claim adjacent channel selectivity, and in Central London on a 50ft. outdoor aerial the set could be tuned to Mühlacker without any trace of modulation interference from London Regional. Few receivers we have tested have equalled this performance in the matter of selec-

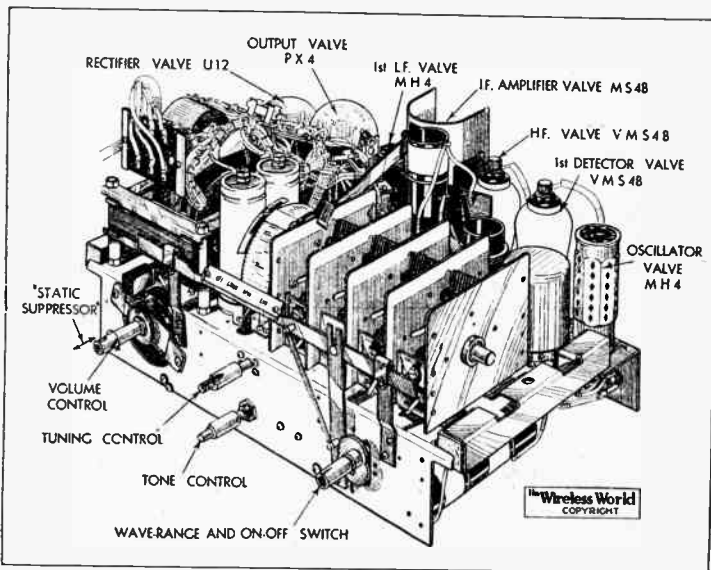

For a seven-stage circuit the chassis is remarkably compact.

tivity. On long waves the range and selectivity are equally good.

The high selectivity has not been gained at the expense of quality, however, and the tonal balance with the set properly tuned and the tone control in the mid-position is, in our opinion, just right when listening to the B.B.C. stations. The move-

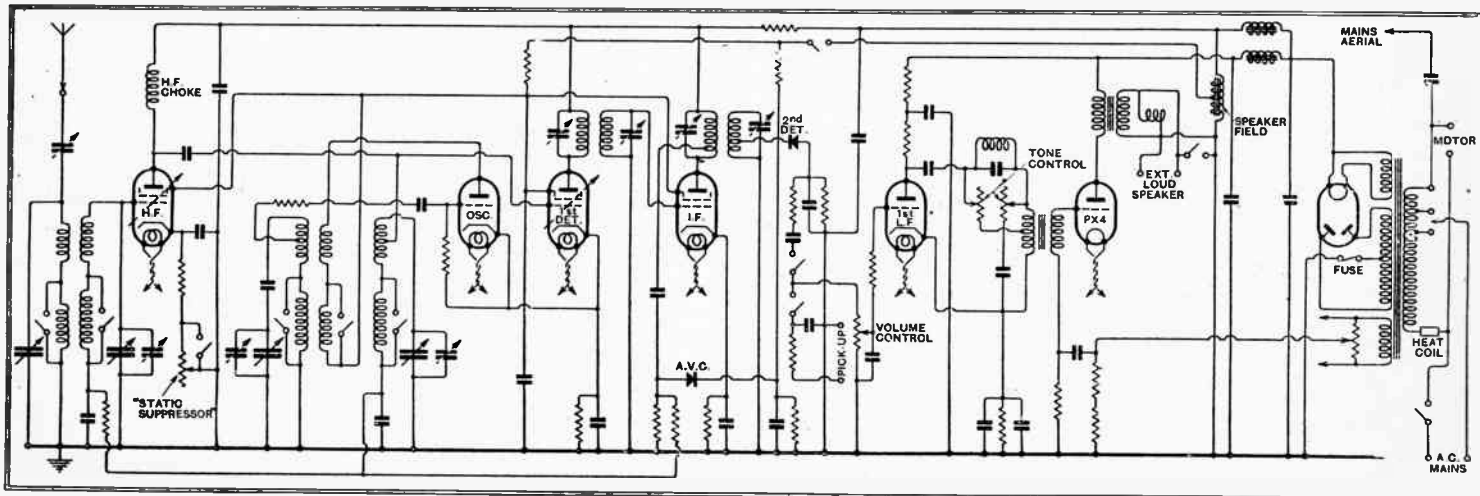

Schematic circuit diagram. Separate metal oxide rectifiers are used for final detection and A.V.C.

**H.M.V. "Superhet Concert Seven"**

ment of the silk covering the loud speaker fret affords proof of the amplitudes which are developed in the bass, but the set is free from the slight over-emphasis of low tones which we have noticed in some earlier H.M.V. sets. One's personal predilections in the matter of quality are easily satisfied by the tone control, which is one of the most satisfactory we have so far handled.

A careful search of the medium waveband failed to reveal any whistles due to second channel interference, and as no special circuits have been included to suppress these

the success achieved must be attributed to the high selectivity at signal frequency.

It is indicative of the satisfactory working of the A.V.C. that with the manual volume control once set for the local station no further adjustment is required when turning to the principal European stations.

**Next Week's Set Review :**

**PHILIPS 634A  
SUPERINDUCTANCE RECEIVER**

# LABORATORY TESTS

## A Review of Manufacturers' New Products

### PENTAGRID VALVES

**A** NUMBER of American Pentagrid valves, intended for use as combined oscillator and first detector valves for super-heterodyne frequency changing purposes, has been submitted for test. The valves are listed as the 6A7 type, and have a heater rated to consume 0.3 ampere at 6.3 volts; they are designed expressly for use in car radio sets where the 6-volts accumulator may rise to a considerably higher voltage when on charge, hence the peculiar voltage rating. It is stated by the makers that considerable latitude in the heater potential is permissible.

The valve is of the indirectly heated type, and contains five grids and an anode. The two inner grids form the control grid and anode of the oscillator, while the next is a screen grid arranged to screen the oscillator electrodes from the others. The remaining electrodes form the control grid, screen grid, and anode of a variable-mu tetrode which is used as the first detector. No external mixing circuit is required, and the oscillator coupling is obtained internally through electronic action.

On test, the valve gave an entirely satisfactory performance, and proved superior from every point of view to the conventional two-valve frequency changer.

Although the valve is primarily intended for battery operation in a car set, it can also be used in a D.C. mains set, and tests indicated that it would give a satisfactory performance when used in this manner. It may also be operated from A.C.

Another Pentagrid with similar characteristics, the 2A7, but with a heater rated to consume 0.8 ampere at 2.5 volts is available, and this is suitable for use in the New Mono-



6A7 Pentagrid with a heater rated at 6.3 volts 0.3 ampere.

dial Super. The makers are the Philco Radio and Television Corp. of Great Britain, Ltd., Aintree Road, Perivale, and the price is 16s.

### W.B. TYPE PM4A SPEAKER

**A**S in most of the W.B. range of loud speaker units this year, the model tested was fitted with the "Microlode" output transformer and switching device. There are two switch arms controlling tappings on

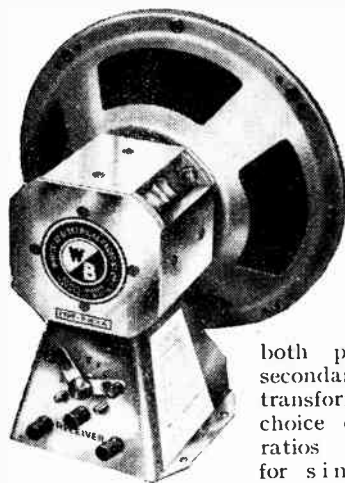

W.B. type PM4A permanent magnet loudspeaker incorporating the "Microlode" matching device.

both primary and secondary of the transformer, and a choice of seventeen ratios is available for single output valves and four

ratios for push-pull stages requiring a centre tap. The change, both in volume and quality, on varying the step-down ratio is most marked, and the load can be rapidly adjusted to give the best results.

Tested with the load adjusted to the calculated value, the efficiency was found to be exceptionally good for a permanent-magnet unit. Above 100 cycles it was equal to that of our standard 10in. energised unit.

The PM4A is also remarkable for the excellent response at the extreme top. Between 7,000 and 9,000 cycles it has a better output than any small commercial unit so far tested. There is a small resonance at 4,500 cycles, a more pronounced one at 2,500 cycles, and the bass resonance occurs at 130 cycles, below which the output falls steadily to a cut off at about 75 cycles.

The price of the new PM4A, which is made by Whiteley Electrical Radio Co., Ltd., Victoria Street, Mansfield, Notts, is 42s.

### GOLTONE H.F. CHOKES

**T**HE type P.H.F. heavy-duty H.F. choke has been designed especially for use in circuits passing currents of a greater magnitude than can be dealt with safely by the normal H.F. choke. It is particularly suitable for including in the heater supply circuits of a D.C. mains receiver and for certain types of interference suppressor devices where the current flowing does not exceed 0.35 amp.

Measured at a frequency of 1,000 c/s its inductance was 10,000 microhenrys approximately, yet its D.C. resistance is only 17.6 ohms. The choke is wound on a 10-section former and measures 4½in. high, the base being 2½in. x 1¼in. overall, and the price is 7s. 6d.

The standard model for use in H.T. smoothing circuits is made in two styles: the type S.H.F. and the type S.S.H.F.

Goltone heavy-duty and screened-type H.F. chokes.

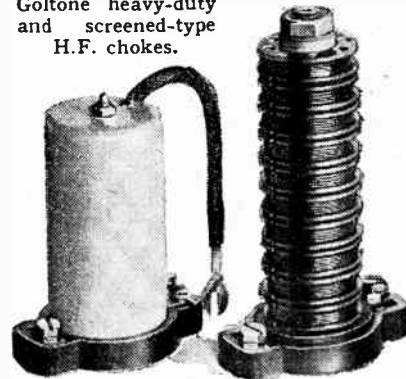

Both models are screened, the principal difference being that the type S.S.H.F. is provided with a screened lead for joining to the anode terminal of S.G. valves. The specimen tested showed an inductance of approximately 200,000 microhenrys at a frequency of 1,000 c/s, its D.C. resistance being 490 ohms. This choke will carry up to 50 mA. with safety, and the price is 4s. 6d.

The makers are Ward and Goldstone, Ltd., Frederick Road (Pendleton), Salford 6, Lancs.

### FIX-A-FLEX WIRE CLIP

**A**N ingenious clip for fixing flexible wires such as loud speaker extensions, earth lead, etc., to skirting boards, picture mouldings and other woodwork in the room, has been introduced by N. Johnson, Fix-a-Flex Works, 35a, South Park Road, Wimbledon, London, S.W.19.

It consists of a stout brass strip, bent at one end into a loop for the wire, the other being slightly pointed and having a tongue-piece stamped out. It is fixed in position by inserting the pointed end between the woodwork and the wall; if the gap between these is too wide to afford a secure grip the tongue-piece can be opened out until a secure fixing is obtained.

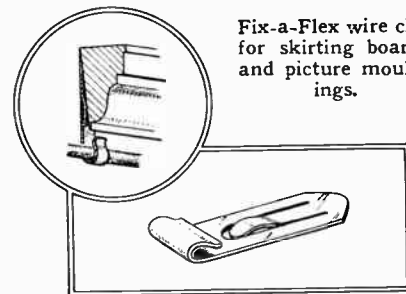

Fix-a-Flex wire clip for skirting boards and picture mouldings.

They are distributed through Houghton (Ensign, Ltd.), High Holborn, London, W.C.1, and cost 1s. 6d. a box containing one dozen.

### WHARFEDALE LOUD SPEAKERS

**I**N connection with our review of these units on page 220 of our September 8th issue, we are asked by the makers to state that the price of the "Golden" model has now been reduced from 63s. to 55s.



**ACCURATE  
MATCHING  
AT LAST!**



*"Did you notice one of the radio journals says the 'Microlode' was probably the high spot at Radiolympia?"*  
*"I can quite believe it. Perfect matching has certainly made a difference to MY set!"*

● 17 transformer ratios for really accurate matching to ANY power valve or pentode and 4 ratios for Class B or QPP *all available on one speaker* by a simple switch adjustment!  
● Added sensitivity due to the 'Mansfield' magnetic system! Better balance through really accurate matching! The difference in performance must be heard to be believed.

**'MICROLODE'**

(Regd. Trade Mark)

Type PM4a-42/- Type PM6-32/6  
**MOVING-COIL SPEAKERS'**  
With the new Microlode feature and the famous 'MANSFIELD' magnetic system.

Write for the MICROLODE folder.

*We are exhibiting at the Manchester Radio Exhibition Sept. 27 to Oct. 7.*

Whiteley Electrical Radio Co. Ltd., Dept. W, Radio Works, Mansfield, Notts.



SEND FOR  
NEW POLAR  
CATALOGUE

**POLAR**

for **SOUND DESIGN!**

FAMOUS  
SINCE  
1922

HIGHEST quality workmanship, accuracy and dependability have contributed to the unique position Polar hold to-day. The ever-increasing popularity has been further enhanced by the recent additions to the Polar Range.

≡≡≡ **POLAR FULL-VISION & MOVING SCALE DRIVES** ≡≡≡

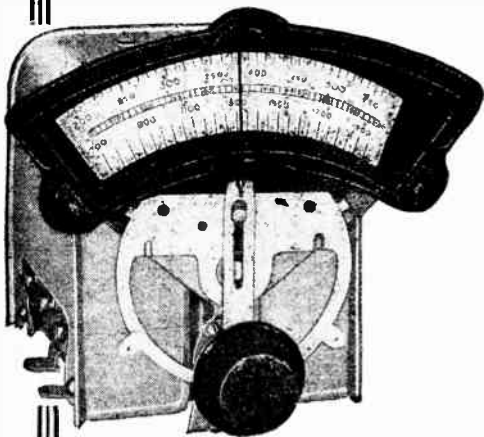

**POLAR STAR MINOR THREE  
FOUR AND SUPER HET TYPES**

Steel frame with cover. Trimmers operated from top. Sections matched within 1/2 per cent. or 1 mmfd. (whichever is the greater).

3 x '0005 and Superhet - - - - **18/9**  
4 x '0005 and Superhet - - - - **25/-**

With full-vision "arcuate" (as shown), "horizontal" or "semi-circular" drive, 5/9 extra, and for a further 2 - the drive can be fitted with air dielectric trimmer as "Uniknob" design.

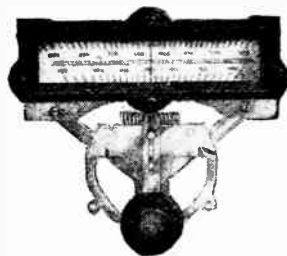

**POLAR FULL-VISION  
"HORIZONTAL" DRIVE**

Slow-motion drive. Scale in wavelengths and 0-100 degrees. Moulded escutcheon. Lampholder. Price **5/9**

Fitted with air dielectric trimmer, as "Uniknob" design, 7/9.

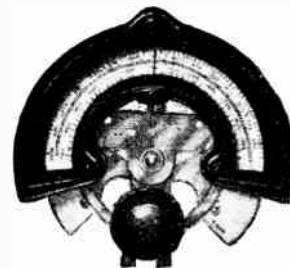

**POLAR "SEMI-CIRCULAR"  
DRIVE.**

Slow-motion drive. Bevelled scale in wavelengths and 0-180 degrees. Moulded escutcheon. Lampholder. Price **5/9**

Fitted with air dielectric trimmer, as "Uniknob" design, 7/9.

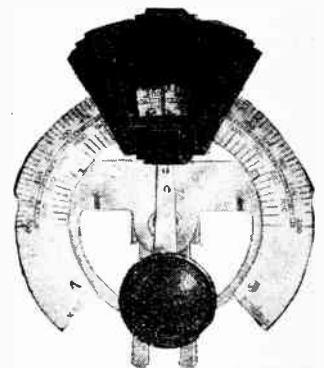

**POLAR "MOVING-SCALE" DRIVE**

Slow-motion drive. Bevelled scale in wavelengths and degrees 0-180. Moulded escutcheon. Lampholder.

Fitted with air-dielectric trimmer, as "Uniknob" design, 6/6. **4/6**

||| **WINGROVE & ROGERS, LTD.** |||  
**188-9, STRAND, LONDON, W.C.2.**  
Phone: Temple Bar 2244 5 6. Polar Works: Old Swan, Liverpool.



# MISCELLANEOUS ADVERTISEMENTS

## NOTICES.

**THE CHARGE FOR ADVERTISEMENTS** in these columns is

12 words or less, 3/- and 3d. for every additional word.

Each paragraph is charged separately and name and address must be counted.

**SERIES DISCOUNTS** are allowed to Trade Advertisers as follows on orders for consecutive insertions, provided a contract is placed in advance, and in the absence of fresh instructions the entire "copy" is repeated from the previous issue: 13 consecutive insertions 5%; 26 consecutive, 10%; 52 consecutive, 15%.

**ADVERTISEMENTS** for these columns are accepted up to **FIRST POST ON MONDAY MORNING** (previous to date of issue) at the Head Offices of "The Wireless World," Dorset House, Stamford Street, London, S.E.1, or on **SATURDAY MORNING** at the Branch Offices, 19, Hertford Street, Coventry; Guildhall Buildings, Navigation Street, Birmingham, 2; 280, Deansgate, Manchester, 3; 28a, Renfield Street, Glasgow, C.2.

Advertisements that arrive too late for a particular issue will automatically be inserted in the following issue unless accompanied by instructions to the contrary. All advertisements in this section must be strictly prepaid.

The proprietors retain the right to refuse or withdraw advertisements at their discretion.

Postal Orders and Cheques sent in payment for advertisements should be made payable to **LILFIE & SONS Ltd., and crossed** Notes being untraceable if lost in transit should not be sent as remittances.

All letters relating to advertisements should quote the number which is printed at the end of each advertisement and the date of the issue in which it appeared.

The proprietors are not responsible for clerical or printers' errors, although every care is taken to avoid mistakes.

## RECEIVERS FOR SALE.

**WEBSTER** Amplifier, A.C. 8 watts undistorted output, complete 6 valves; £10. Smallridge, 38, Farnham Rd., Guildford. [3513]

**"W.W."** Single Dial Super (battery), including valves; £3/10. Steele, 33, Burleigh Rd., West Southbourne, Bournemouth. [3520]

**CAMBRELL** Halford 7-stage A.C. Superhet. Chassis, valves, speaker; cost £28, accept £14.-15, Ballant Rd., W.3. Acorn 1212. [3510]

**8** Guineas.—Eithatrop 200-240 A.C., 2 S.G. det. and pentode, automatic tuning, in walnut cabinet, with valves and moving coil speaker; listed 23 guineas, unopened; c.o.d., carriage paid.—Kay, 167, City Rd., London, E.C.1. [3506]

**ARMSTRONG**—Latest Universal A.C. D.C. chassis, specially efficient S.G. circuit, Pentode output, incorporating gramophone amplifier, splendid reproduction, fully guaranteed, 75/-; with 5 valves, 114/-; approval.—Armstrong Co., 100, King's Rd., N.W.1. [3517]

## ACCUMULATORS—BATTERIES.

**MATERIALS**—Cans, 15/-; carbons, 5/9; muslins, 1/6 1,000.—Batteries, 310, Markhouse, Walthamstow. [3524]

## MAINS EQUIPMENT

**N.P.** Battery Chargers for A.C. Mains; trade list free; special offer for 7 days only.

**N.P.** Have a Few Slightly Soiled Instruments; bargains; list; from 35/- to £15.

**N.P.**—Trade lists make a very special offer in prices for 7 days only.

**N.P.**—30 volts variable 1/2 to 2 amps. will charge up to 50x2 volt batteries at once; cost 3d. in current.

**N.P.** Have 3 Circuit Chargers that Will Do Up to 120x2 volt batteries for 2/6 cost; for £7/12/6; offer open for 7 days only.

**N.P.**—Send full list with photographs of battery chargers. 2 years' guarantee; lowest price on market.—Nash Products, Ltd., Stechford, Birmingham, 9 [3508]

**HOYNE'S** Transformers and Chokes the Best Obtainable perfect insulation, regulation and reliability.

**HOYNE'S** Transformers used by many well-known set manufacturers after testing all others.

**HOYNE'S** Transformers fitted with tapped and screened primaries, filaments all centre tapped, stout cast aluminium clamps and clearly marked terminal strips are fitted to all models.

**HOYNE'S** Components are guaranteed for one year; built to your own specification at very competitive prices.

**HOYNE'S** Components.—The components you will eventually use, start right; a dud cannot pass the Hoyne test.

**HOYNE'S** New Monodial Super, aluminium chassis, drilled for components, complete with Power Transformer, two chokes, push-pull intervalve transformer and valve holders, 51/-, carriage paid.

**HOYNE'S** New Monodial Transformer, 425-0-425v. 120 m.a., 4v. 3a, 4v. 1a., 4v. 1a., 4v. 6a., 24/-, post 1/3; weight 10lb. 10 henry choke, 6/-, post 6d.; 20 henry choke, 7/6, post 6d.

**HOYNE'S**—250-0-250v. 60 m.a., 4v. 1-2a., 4v. 2-4a., 10/-, post 9d.; with extra 4v. 1-2a. winding, 12/6, post 1/-.

(This advertisement continued in third column.)

# PILOT AUTHOR KITS

Exact to Specification

Peto-Scott are pioneers in Radio and Television. Our service to the British public was introduced in 1919, and during fourteen years of Solid Service and Satisfaction we have established a reputation for fair delivery that defies competition. Sets, Kits of all descriptions, Part Kits, Miscellaneous Components, Speakers, Eliminators, and Accessories. Purchases can be made for Cash, C.O.D., or on Easy Payments. Send list of your requirements for quotation by return.

## NEW MONODIAL

### RECEIVER KIT

Author's Kit of **FIRST SPECIFIED PARTS FOR RECEIVER PORTION ONLY**, less Plymax Chassis, Panel, Cabinet and Valves  
**Cash or C.O.D. £10-19-6**  
 Carriage Paid

Extra for Peto-Scott Plymax Chassis as used by the Author, 14" x 12" x 3". Ready Drilled and Assembled with Runners ... 10 6  
 Peto-Scott Oak faced Ply Panel, Ready Drilled, 14" x 10" ... 2 6

**RECEIVER KIT "A"** as above but with **PETO-SCOTT READY-DRILLED AND ASSEMBLED PLYMAX CHASSIS WITH RUNNERS AND PANEL**, less Valves and Cabinet, Cash or C.O.D., Carriage Paid, £11-12-0 or Deposit, £1-12-0, Balance in 11 monthly payments of 20/-.

### POWER UNIT KIT

Author's Kit of **FIRST SPECIFIED PARTS FOR POWER UNIT ONLY** but less Plymax Chassis and Valves  
**Cash or C.O.D. £8-13-6**  
 Carriage Paid

Extra for Peto-Scott Ready-Drilled Plymax Chassis with Runners, 18" x 6" x 3" ... 7 6

**POWER UNIT KIT** as above but with **READY-DRILLED AND ASSEMBLED PLYMAX CHASSIS**, Cash or C.O.D., Carriage Paid, £9-0-0 or 12 monthly payments of 16/6.

**BUILD your "Wireless World" Set on the PETO-SCOTT PLYMAX CHASSIS used and specified by the "Wireless World."**

### COMBINED KIT

Comprising Receiver and Power Unit Kits with 2 Peto-Scott Ready-drilled Plymax Chassis with Runners and Peto-Scott Ready-drilled Oak Panel, less Valves and Cabinet, Cash or C.O.D. Carriage Paid **£20-12-0** or £3-12-0 Deposit and 11 monthly payments of 35/-.

### COMPLETE KIT

Comprising Receiver and Power Unit Kits as Combined Kit but with Valves, less Cabinet, Cash **£27-17-0** or C.O.D. Carriage Paid ... or £5-17-0 Deposit. Balance in 11 monthly payments of £2-4-0.

## FINISHED INSTRUMENTS

Peto-Scott supply all "Wireless World" Sets as finished receivers, Aerial tested. Cash, C.O.D. or H.P. Send for quotation, no obligation. Peto-Scott have specialised in "Wireless World" Kits and finished instruments for 14 years.

## MODERN BATTERY FOUR

**KIT 'A'** Author's Kit of **FIRST SPECIFIED COMPONENTS** including ready-drilled ply-panel and Peto-Scott assembled and drilled **PLYMAX CHASSIS**, excluding Valves, Cabinet and Speaker. Cash or C.O.D. **£8-6-9** Carriage Paid ... or 12 monthly payments of 15/3.

**PETO-SCOTT PLYMAX CHASSIS SOLELY SPECIFIED.** Plymax Chassis as specified by the Author, drilled and assembled, 10" x 10". Cash or C.O.D. Post **7/6** and Packing 1/3 extra.

## IMMEDIATE DELIVERY CASH - C.O.D. - H.P.

## PETO-SCOTT CO. LTD.

77, CITY ROAD, LONDON, E.C.1.  
 West End Showrooms: 62, High Holborn, London, W.C.1

## NUMBERED ADDRESSES.

For the convenience of private advertisers, letters may be addressed to numbers at "The Wireless World" Office. When this is desired, the sum of 6d. to defray the cost of registration and to cover postage on replies must be added to the advertisement charge, which must include the words Box 000, c/o "The Wireless World." All replies should be addressed to the Box number shown in the advertisement, c/o "The Wireless World," Dorset House, Stamford Street, London, S.E.1. Readers who reply to Box No. advertisements are warned against sending remittance through the post except in registered envelopes; in all such cases the use of the Deposit System is recommended, and the envelope should be clearly marked "Deposit Department."

## DEPOSIT SYSTEM.

Readers who hesitate to send money to advertisers in these columns may deal in perfect safety by availing themselves of our Deposit System. If the money be deposited with "The Wireless World," both parties are advised of its receipt.

The time allowed for decision is three days, counting from receipt of goods, after which period, if buyer decides not to retain goods, they must be returned to sender. If a sale is effected, buyer instructs us to remit amount to seller, but if not, seller instructs us to return amount to depositor. Carriage is paid by the buyer, but in the event of no sale, and subject to there being no different arrangement between buyer and seller, each pays carriage one way. The seller takes the risk of loss or damage in transit, for which we take no responsibility. For all transactions up to £10, a deposit fee of 1/- is charged; on transactions over £10 and under £50, the fee is 2/6; over £50, 5/-. All deposit matters are dealt with at Dorset House, Stamford Street, London, S.E.1. and cheques and money orders should be made payable to Lilfie & Sons Limited.

**SPECIAL NOTE.**—Readers who reply to advertisements and receive no answer to their enquiries are requested to regard the silence as an indication that the goods advertised have already been disposed of. Advertisers often receive so many enquiries that it is quite impossible to reply to each one by post. When sending remittances direct to an advertiser, stamp for return should also be included for use in the event of the application proving unsuccessful.

## Mains Equipment.—Contd.

(This advertisement continued from first column.)

**HOYNE'S** Ferrocarril Model.—350-0-350v. 60-70 m.a., 4v. 2-3a., 4v. 2-4a., 12/6, post 1/-; with extra 4v. 1-2a. winding, 15/6, post 1/-.

**HOYNE'S**—350-0-350v. 120 m.a., 4v. 2-3a., 4v. 4-6a., 4v. 1a., 4v. 1a., 16/-, post 1/3.

**HOYNE'S**—500-450-0-450-500v. 140 m.a., 4v. 2-4a., 4v. 4-6a., 4v. 2a., 4v. 2a., 27/6, post 1/3; weight 11lb.

**HOYNE'S**—0-110-135v. 90 m.a., suitable for H.T. 6 or 7, 7/6, post 9d.; with 4v. 2-4a. winding, 9/6, post 9d.

**HOYNE'S**—200v. 200 m.a., 4v. 2-4a., 4v. 1-2a., for H.T. 8, 13/6, post 1/-.

**HOYNE'S**—Auto Transformers, Chokes and Filament Transformers always in stock.

**HOYNE'S** Components still have no equal.

**M. J. HOYNE**, Offices and Works, 8a., Gladstone Rd., Wimbledon, S.W.19. Tel.: Liberty 3303. [3455]

**VORTEXION**, Wimbledon, for 99.9% reliable transformers.

**I**f You Haven't Tried Them Yet Ask Someone who has, or call and inspect complimentary letters.

**A**ll Standard Models Delivery by Return; all secondaries centre tapped.

**G**UARANTEED 12 Months, and within 5% normal and 2 1/2% super models, neat shrouding, with detachable feet, as used by Government Departments, etc., etc.

**VORTEXION**—New monodial transformer, 200-250, 50 cycles, 425-0-425, 120 m.a., 4v. C.T. 3a., 4v. C.T. 1a., 4v. C.T. 1a., 4v. C.T. 6a., screen primary, open type, 20/-; shrouded, 22/-; super shrouded, 26/-; 10 henry choke, 5/6; 20 henry choke, 8/6.

**VORTEXION**—Ferrocarril 111, 350-0-350, 60 m.a., 4v. 2.5, C.T., 4v. 3.5, C.T.; open type 13/6, shrouded 16/-; post 9d.

**VORTEXION**—250-0-250, 4v. 1 to 2a., 4v. 2 to 4a.; open type 10/6, shrouded 12/6; post 9d.

**VORTEXION**—Super model for H.T. 8 or 9 or 10, 4v. 1 to 2, 4v. 2 to 4; open type 14/6, shrouded 16/6; post 9d.

**VORTEXION**—21/- watt Monodial A.V.C. model; open type 14/6, shrouded 16/6; post 1/-.

**VORTEXION**—5-watt Monodial A.V.C. model, 400-0-400, 120 m.a., 4v. 6a., 4v. 2 1/2a., 4v. 2, 4v. 1a., super screened; 20/-, shrouded 24/-.

**VORTEXION**—350-0-350, 120 m.a., 4v. 2 to 5a., 4v. 2 to 4a., 4v. 2.5a.; open type 14/6, shrouded 16/6.

**VORTEXION**—400 or 450 or 500v., 120 m.a., 4v. 2 to 5, 4v. 2 to 5, 4v. 2 to 5; open type 19/6, shrouded 23/-.

**VORTEXION**—400 or 450 or 500, 150 m.a., 4v. 4a., 4v. 2.5, 4v. 2, 4v. 2, 4v. 2, core size 2 1/4 in. x 1 1/4 in., a superb job, 2% regulation; 35/- shrouded with terminals, less terminals, 30/-, open type 26/-; post 1/3.

**VORTEXION** Auto Transformers to B.E.S.A. Specification, 100, 110, or 120v. to 200, 220 or 240 volts, 60 watts, 7/3, post 9d.; 120 watts, shrouded 12/6, open type 10/6, post 1/-; 200 watts, open 14/6, shrouded 16/6, post 1/-; 500 watts 30/-, 2,000 watts £4/10.

**VORTEXION** 600-watt Transformers; £4/10, carriage free.

**VORTEXION** 30h. at 60 m.a. Chokes, 5/6; 40h. at 60 m.a., 8/6; 30h. at 150 m.a., 200 ohms, 10/6 open type, 12/6 shrouded.

**VORTEXION** 200v. 30 m.a. Eliminators, 110 or 220 input with 4v. 4a. winding; 37/6.

**VORTEXION**—Transformers made to your specification. All standards in stock. Phone all hours.

**VORTEXION** (S. A. Brown), 182, The Broadway, Wimbledon. Tel.: Liberty 2814. [3117]

**Mains Equipment.—Contd.**

**TANTALUM** for A.C. Chargers, H.T. and L.T.—Blackwell's Metallurgical Works, Ltd., Garston, Liverpool. [3448]

**A.C. Charging Plant**, unused, cost £18 18, for £6/18/6; write for makers' specification.—Jersey, Cumnor Hill, Oxford. [3424]

**SERADIX** Products, specified for "New Monodial Super," "Modern Battery Four," "Kelvin A.C. Three," "Exhibition Three," etc.

**SERADIX** Resistances Are Used by the Leading Set Manufacturers; let us quote you for any type of resistance; illustrated lists for stamp.

**SERADIX** Transformers, as supplied to Lloyds Bank, Ltd., and to the largest British manufacturers of mains equipment; new catalogue available soon.

**SERADIX** V.T.7 Transformer for the New Monodial primary terminals, heavy aluminium clamps and colour-coded leads, as specified; £1 17 6.

**SERADIX** Battery Chargers; new illustrated catalogue and real photographs for stamp.

**SERADIX** V.R.1326a Charger, will charge up to 400 cells per week at very low cost; price, complete, £4/4.

**TREVOR PEPPER**, 575d, Moseley Rd., Birmingham, 12. Telephone: Calthorpe 1618. Telegrams: Seradix, Birmingham. [3532]

**A.C. or D.C. Chargers** for 2 to 200 Cells at Low Prices; state requirements; dynamo and rotaries in stock, all sizes; Brown's Generometer, battery super-sellers for H.T. for 2v. or 6v. input, 37 6 and 52 6; television and sewing machine universal motors, 25 -; lists.—Electradix Radio, 218, Upper Thames St., E.C.4. [10398]

**CABINETS.**

**RADIO-GRAM** Cabinets; fully illustrated list free; remarkable values.—Gilbert, Cabinet Maker, Swindon. [1686]

**H.M.V.** Radiogram Cabinet, model 522, in walnut, felt lined lid, handsome piece of furniture; sacrifice, 70 -; first cash secures.—Fine, 81, Park Avenue, Willesden. [3501]

**MANUFACTURER'S** Clearance Lines of Cabinets for Radiograms, loud-speakers, and radio sets; hundreds to select from; send postcard for list; special: cabinets for Skyscraper and S.P.400.—H. L. Smith and Co., Ltd., 289, Edgware Rd., London, W.2. [3409]

**DYNAMOS, ETC.**

**ROTARY** Converters, 220 volts D.C. to 200 volts A.C., capacities up to 0.44 K.V.A., cheap.—Milo Engineering Works, Milo Rd., East Dulwich, S.E.22. Sydenham 4422. [3450]

**GRAMOPHONES, PICK-UPS, ETC.**

**PAILLARD** A.C. Induction Motor, 12in. turntable, automatic brake, perfect condition; cost £2/5, accept 27/6.—Pinchbeck, 91, Sandy Lane, Chesham. [3500]

**D.C. or A.C. 100-250v.** Universal New K-B Gramophone Motors, complete, turntable, autostop, etc.; list £6/15, 30/- cash, post free, or c.o.d.—5, Hillside Crescent, N.10. [3514]

**LOUD-SPEAKERS.**

**P.M. Speakers** Bargain.

**LARGE** quantity 8 1/2 in. P.M.C. Speakers, made by well known manufacturer for set maker, highly sensitive, work off any set, 3-ratio transformer; 19/6, post free; money returned if not satisfactory.—Milton Manufacturing Co., Milton St., Coventry. [3415]

**B.T.H. RK** Moving Coil Speakers, guaranteed new, unused, manufacturers' surplus, original price.

**6** Guineas, highly sensitive and wonderful tone response, will handle up to 10 watts output, available for 6v., 100v., 200v. D.C., 30 -; also A.C. models.

**£2/10;** carriage paid, c.o.d. or cash with order; the best value in speakers obtainable to-day. O. H. Seekamp, First Avenue House, High Holborn, London, W.C.1. Phone No.: Holborn 6609. [1425]

**10/-**—Lampugh Silver Ghost, 2,200 ohms, with output transformer, unopened; list 47/6; c.o.d., carriage paid. Kay, 167, City Rd., London, E.C.1. [3351]

**ARMSTRONG**—1934 permanent magnet moving coil speaker, better than ever this year, transformer matched to requirements—full size speaker, remarkable performance; 21/-; guaranteed; approval.—Armstrong Co., 100, King's Rd., N.W.1. [3518]

**30/-**—B.T.H., R.K. moving coil speakers, 6in. cone, new and unused, guaranteed; these speakers are the type as used in cinema sound equipment; suitable for public address work; weight 30lb., and are vastly superior to the cheap speakers now on the market, 100 volts, 150 volts, and 200 volts D.C.

**27/6**—6-volt D.C. speakers, as above; £2/7/6 speaker as above for 100-250 volts A.C., complete with field rectifier.

**CARRIAGE** Paid, cash with order, or c.o.d.; send for list.—Ward, 12, Tredgar Rd., Bow, E.3. Tel.: Advance 3668. [3489]

**CHAL-ELECTRIC** Offer New Boxed Set Manufacturers' Surplus Rola Speakers, all fitted hump buckers, state for power or pentode: F6, 110-175v. (2,000 ohms), 90-130v. (2,500 ohms), 150-200v. (4,700 ohms), 200-250v. (6,500 ohms), list 35/-, at 18 - each; F7, voltages as above, list 47/6, at 25/-; permanent magnets, F6, P.M., list 49/6, at 28 -; F7, P.M., list £3, at 33/-; dual compensated (2) F6, list £3 10, at £2, or (1) F6 and (1) F7, list £4 5, at 47 -; few Class B; state requirements; all goods carriage paid; cash with order, or c.o.d.—Chal-Electric, 6, Conduit St., London, W.1. [3524]

**VALVES.**

**VALVES**—All types American screen grids, etc., in stock; send for quote.—Mildmay Radio Exchange, 24, Mildmay Grove, London, N.1. [3531a]

**ALL** Classes of Valves in Stock, including American and non-ringing valves; send for price list.—R. Newman, 309, Roman Rd., London, E.3. [3446]

**M.R.D. Co.'s** Own Super British Valves, brand new, guaranteed 6 months, 2-volt types, V.M.S. 7/6; S.G.S. 7/6; det., L.F., H.F., R.C., 3/6; power, 4 -; super power, 4/6; Class B 9 -; also other types and full A.C. range; any details on request.—Mains Radio Development Co., 4-6, Muswell Hill Rd., London, N.6. [3482]



the Speakers that Put the "Class" in Class B Amplification

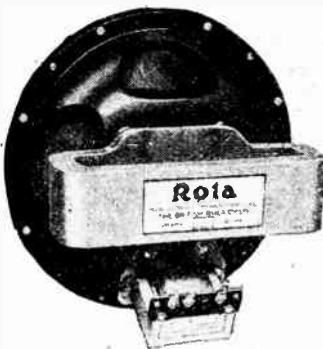

High class radio reproduction in its highest form has always been associated with Rola reproducers. Now, this comprehensive range of Class B units ensures your getting quality Class B Amplification.

For MULLARD P.M. 2B, B.T.H. PD220, COSSOR 220B, STANDARD 13 B1, HIVAC B220, MARCONIPHONE B21, G.E.C. B21, CLARION B22.

ROLA FR5	—PM	33	Class B	...	29/6
ROLA FR6	—PM	23	Class B	...	39/6
ROLA F6	—PM	23	Class B	...	49/6
ROLA F7	—PM	23	Class B	...	60/-

For COSSOR 240, FERRANTI HP2, CLARION B24.

ROLA FR5	—PM	32	Class B	...	29/6
ROLA FR6	—PM	22	Class B	...	39/6
ROLA F6	—PM	22	Class B	...	49/6
ROLA F7	—PM	22	Class B	...	60/-

All Prices include Transformer.

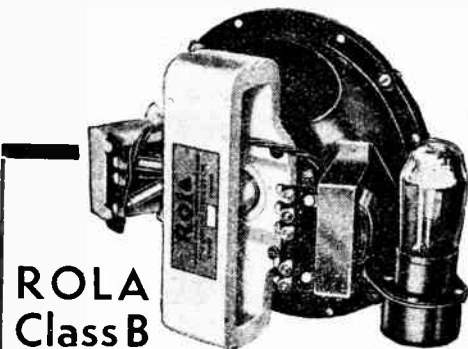

**ROLA Class B Speaker Amplifier Unit**

Without alteration to his set any battery set owner can increase its volume about 5 times in 5 seconds by connecting this outstanding Rola unit.

Model A—For Mullard P.M. 2B, B.T.H. PD220, Cossor 220B, Standard 13B1, Hivac B220, Marconiphone B21, G.E.C. B21, Clarion B22.  
Model B—For Cossor 240, Ferranti HP2, Clarion B24.

**PRICE (Both Models less Valve) 57/-**

**THE BRITISH ROLA CO., LTD.**  
MINERVA ROAD, PARK ROYAL, N.W.10  
Phone: Willesden 4322-3-4-5.

**ROLA SPEAKERS** for better Radio Reception

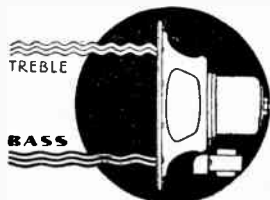

**Valves.—Contd.**

**SPECIAL** Offer.—Valves by world famous Continental manufacturers, fully guaranteed, screen grid, variable Mu screen grid, high magnification screen grid, low magnification screen grid, H, H.L., L, R.C. power, super power, pentode, Bi-grid, directly heated pentode, 300v. 60 millamp, rectified, 350v. 150 millamp, rectifier, all the above standard mains type; 4 6 each.—Premier Supply Stores, 20-22, High St., Clapham, S.W.4. Macaulay 2188. [3535a]

**ALL** Types of Valves in Stock, including the following brand new American valves, first-class makes: 247s, 235s, 224s, 236s, 237s, 233s, 245s, 244s, 12 -; 227s, 226s, 280s, 245s, 9 6; 242s, 232s, 11 -; U.X.210s, 15 -; U.X.250s, 7 watts output, 16 -; 281s, 14/6; post paid, cash with order or c.o.d. Send for valve list.—Ward, 12, Tredgar Rd., Bow, E.3. Tel.: Advance 3668. [3488]

**COMPONENTS, ETC., FOR SALE.**

**R. SELECTED** Parts for Sale, as new, any c.o.d. or "Wireless World" deposit system, which we recommend if in doubt as to the splendid value offered; we take risk of damage in transit to customers; goods tested for callers and guaranteed.

**M.** Anole Converter, 6v. to 200v. 40 m.a., perfect, new in February, £3 10; Gumbrell senior Novotone, perfect, a new, 50 -; Philips 6 amp. charger, complete 70/-; Morrison 6 amp. charger, 2 line and H.T., £5 10; B.T.H. senior P.M., with transformer, £3 10; P.A. set, with radio, 10v. A.C., entirely complete, modern, £20; Ferranti portable meter, 250v. 10v. 100 m.a., 200 ohm. per volt, 45/-; Lotus 2v. A.C. set, modern, 90/-; D.C. ditto.

**HARTLEY TURNER** Speaker, 200/250v. D.C. with transformer, £3/15; Westinghouse H.T.1 with R.I. transformer, 25/-; Heavybird 250v. A.C. meter, large commercial type, 20 -; Weston portable A.C. voltmeter, multi range, £3; Ediswan 1 1/2 amp. charger, 17/6; Vertexion 250v. 120 m.a., 4v. 2 amp., 4v. 7 amp., 6v. 15/-; Ferranti 84V transformer, 15/-; Ferranti E.M.1 H.T. eliminator, 200v. 100 m.a., 90/-.

**METERS**, moving coil, made for Ryall's Radio, guaranteed one year, and to B.E.S. first grade specification, all panel flush type, bakelite case, 0-1 m.a., 25/-; 0-5 m.a., 0-20 m.a., 0-50 m.a., 0-150 m.a., 21/- each; 0-250v., 32/6; 0-300v., 35/-; 1,000-ohm per volt, zero adjuster, size 3 1/2 in.

**METERS**, as above, moving iron, first grade, air damped, zero adjuster, 0-250v. A.C., 18/-; 0-50 m.a. A.C. and D.C., 15/-; non damped, without zero, 0-12v., 10/-; 0-250v., 12 -; 0-3 amps., 10/-; 0-20 m.a. A.C. and D.C., 10 -; 0-50 m.a., ditto.

**SUITCASE** Type Cases, in best crocodile leather, 14x14 x8, ample room for 12in. turntable and pick-up, 15/-; set cabinets for 3v. A.C. sets, room for speaker, good appearance, 15 -.

**B.T.H. Junior** A.C. Speaker, with corrugated cone, separate rectifier, 67/6; Enoch 991, 6v., 47/6.

**T.C.C.** 2 mf., 350v. working, 1/6; T.C.C. 1 mf. type, 84, 1/3; T.C.C. 0.01 mica, type M, 1/-; T.C.C. 250v. working, 4/4, 4/9; ditto, 4x4x1 1/2 in., 5/9; T.C.C. 15 mf., 100v. working, electrolytic, 1/3.

**B.T.H. Universal** Senior Gramophone Motors, A.C. D.C., new, complete with auto stop and all fittings 55/-.

**RYALL'S** Mains Transformers, 250v. 60 m.a. 4v. 1 amp., 4v. 3 amp. 10 6, 350v. 12 9, H.T.7 10 6, H.T.8 12/9, 4v. 3-5a. L.T. 8 9; chokes, 20H. 120 m.a. 8/9, 25H. at 60 m.a. 6 9, resistance 260 ohms, 40H. at 100 m.a. 600 ohms 10 6; all other models available.

**WE** hold a Large Stock of First Class Radio Apparatus, meters, resistances, condensers, heavy chokes, in addition to the goods advertised.

**POLAR** Star 3-gang Condensers, 15/-; with drive, 17/6; Polar Uniknob 2-gangs, with cover and drive, new, 10/6; Radiophone 4-gangs, 12/6; with cover and drive, 17/6; Radiophone 4-gang superb, type, screened, with trimmers, Radiopack type, 9 -, post 9d.; Lotus new 4 gangs, 15/-.

**RYALL'S RADIO**, 33, Chancery Lane, London, W.C.2 (nearest Tube, Chancery Lane; bus 67 passes door, or tram to Sway St.), Holborn 3529. Open Saturday afternoon. Close 7 p.m., Saturday 6 p.m. Thursday closed all day.

**R.** 13503

**PREMIER.**

**PREMIER SUPPLY STORES** Offer the following Set Manufacturers' Surplus New Goods at a fraction of the Original Cost, all goods guaranteed perfect, carriage paid over 5 -; under 5 - postage 6d. extra (Ireland, carriage forward).

**ELIMINATOR** Kits, including transformer, choke, Westinghouse metal rectifier, T.C.C. condensers, resistances and diagram, 120v. 20 m.a., 20 -; trickle charger 8 - extra; 150v. 30 millamps with 4v. 2-4 amps. C.T., L.T. 25 -; trickle charger, 6 6 extra; 250v. 60 millamps with 4v. 3-5 amps. C.T., L.T. 30/-; 200v. 100 millamps with 4v. 3-5 amps. C.T., L.T. 49/6; 300v. 60 millamps with 4v. 3-5 amps C.T., L.T., 37 6.

**ROLA** Moving Coil Speakers, complete with hump bucking coils and output transformer; please state whether power or pentode required; F6, 2,000 or 6,500 ohm, listed 35 -; at 17/6; F7, 2,000 or 6,500 ohm, listed 47/6, at 23/6; A.C. conversion kit for any of above, 10/-.

**SPECIAL** Offer.—Reisz type microphone with transformer, a really professional job, listed at £12; our price 52 6.

**HEAVY** Duty Variable Resistances, wound on porcelain, 2,000 ohms 1-4 amp., 500 ohms 1-2 amp., 120 ohms 1 amp., all the above values, 3 6 each.

**T.C.C.** Condensers, 750v. working, 2 mf. 3/6, 4 mf. 6/-, 4 mf. 400v. working 4/-, 250v. working 1 mf. 1/-, 2 mf. 1/9, 4 mf. 2 6, 1,500v. working Standoff insulators .5 mid, 1/6, 2 mid, 6 -, aqueous electrolytic 440v. working, 4 mf. 3 -, 8 mf. 3 6.

**DUBILIER** Condensers,—.01 mica 6d., .01 mica 1,000v. working 1 -.

**ALL** the Following Lines 6d. each or 5/- per dozen; 4 and 5 pin chassis mounting valve holders; shielded screen grid or pentode leads 1-watt wire end resistances, any value; T.C.C. 1 condensers; hum dingers; on-off switches pushpull; polar ganging devices.

**POLAR** 3-gang 0.0005 Condensers, split end vanes, totally screened, disc drive; 6/11.

**AMSCO** Triple-gang 0.0005 Condensers, with trimmers, 4/11.

(This advertisement continued on next page.)

# Did you hear those organ notes?

That's what Filson Young asked, after Mr. Taylor had played down to 32 cycles and up to 8,000 on the B.B.C. Organ.

## Our customers did

If you didn't, send a 1½d. stamp for "NEW NOTES IN RADIO."

## Hartley Turner Loudspeakers

D.C. Model £7.7.0  
A.C. Model £8.8.0

Demonstrations any time by appointment.

**HARTLEY TURNER RADIO LTD.,**  
Thornbury Road, Isleworth, Middlesex.  
Tel.: Hounslow 1854.

We are demonstrating this remarkable new

**HARTLEY TURNER**  
moving coil loudspeaker daily between 12 and 3 p.m., and 4 and 6 p.m. Other times by appointment.

**Easy Payment Terms** for the Hartley Turner Moving Coil Unit, complete with special transformer, carriage paid, are as follows:—

D.C. Model, cash price £7.7.0 or 20/- with order and 11 monthly payments of 12 9.

A.C. Model, cash price £8.8.0 or 26/- with order and 11 monthly payments of 14.-.

We supply all other high-grade radio apparatus on convenient easy payment terms. Please send us your enquiries and a quotation will be sent by return.

## THE LONDON RADIO SUPPLY CO.

(Established 1925)

11, Oat Lane, Noble Street, London, E.C.2  
(off Gresham Street)  
Phone: National 1977.

# THE WORLD from your FIRESIDE



## WITH YOUR PRESENT SET!

Here is a wonderful instrument that will give you tremendous range with your receiver.

Short wave stations can be tuned in with most receivers when fitted with an "EELIX" Short Wave Converter. Programmes from Australia, America and other distant countries are brought in without trouble even by those with little or no experience of Short wave reception. You can spend many thrilling hours tuning in distant countries and your friends will be amazed at the remarkable increase in the range of your set.

Price 52s. 6d. (less valves). Send for Booklet No. C.46.

J. J. EASTICK & SONS, 118, Bunhill Row, London, E.C.1. Phones: Met. 0314 (6 lines).

## Components, etc., for Sale.—Contd.

(This advertisement continued from previous page.)

**ORMOND** Condensers, 2-gang semi shielded, 2/6.  
**WESTERN ELECTRIC** Mains Transformers, input 200-250 volt, output 500-500 volt, at 150 milliamps., 4v. 4a., 4v. 2.5a., 4v. 2a., 4v. 1a., 4v. 1a. massive job; 19/6.  
**T.C.C.** Electrolytic Condensers, 100 volts working, 15 mfd.; 1/3.  
**SPECIAL** Offer of Mains Transformers, manufactured by Philips, input 100-115v. or 200-250 v., output 180-0-180 volts, 40 m.a., 4v. 1a., and 4v. 3a., 4/6; 200-0-200v., 4v. 1a., 4v. 3a., 4/6.  
**ALL** Premier Guaranteed Mains Transformers have engraved terminal strips with terminal connections, input 20-250 volts, 40-100 cycles, all windings paper interleaved.  
**PREMIER** H.T.8 Transformer, 250v. 60 m.a., rectified, with 4v. 3.5a. c.t. L.T., and screened primary, 15/-; with Westinghouse rectifier, 25/-.  
**T.C.C.** 2,000+2,000 Electrolytic, 12 volts working; listed 27/6, at 10.-.  
**ROLA** P5 P.M., 18/6; Rola F6 P.M., 22/6; Rola F7 P.M., 32/-; please state whether power or pentode transformer.  
**PREMIER** H.T.9 Transformer, 300v. 60 m.a., rectified, with 4v. 3.5a. c.t. L.T., and screened primary, 15/-; with Westinghouse rectifier, 26/-.  
**PREMIER** H.T.10 Transformer, 200v. 100 m.a., rectified, with 4v. 3.5a. c.t. L.T., and screened primary, 15/-; with Westinghouse rectifier, 26/-.  
**PREMIER** Mains Transformer, output 135v. 80 m.a., for voltage doubling, 8/6; 4v. 3.4a. c.t. L.T., 2/- extra; Westinghouse rectifier for above, giving 180v. 30 m.a., 8/6.  
**PREMIER** Mains Transformers, output 250-0-250 volts, 60 m.a., 4v. 1-2a., 4v. 2-3a., 4v. 3-4a. (all c.t.), with screened primary; 15/-.  
**PREMIER** Mains Transformers, output 350-0-350 volts, 50 m.a., 4v. 3-5a., 4v. 2-3a. (both c.t.), with screened primary; 15/-.  
**PREMIER** Mains Transformers, output 400-0-400 volts, 100 m.a., 4v. 4-5a., 4v. 2-3a., with screened primary; 15/-.  
**PREMIER** Auto Transformers, 100-110/200-250 volts or vice versa, 60-watt, 7/9; 100-watt, 10/-.  
**SPECIAL** Offer of Manufacturers' Type Transformers, any input, output 250-0-250 volts, 60 m.a., 4v. 1a., 4v. 3a. (both c.t.), 8/6; H.T.8 transformer, with 4v. 3-4a. (c.t.), 8/6; with rectifier, 18/6.  
**AMPLION** Mains Transformers, input 100-250 volts, output 350-0-350 volts, 120 m.a., 4v. 5a., 4v. 2a., 6v. 1a. (all c.t.); 17/6.  
**FLUAMENT** Transformers, polished and engraved terminal boards, N.P. terminals, 4v. 3-4a., 5/-; 10v. 3a., 6/6; 12v. 1a., 5/-; 4v. 4-6a., 6/6; 14v. 4a., 6/6; 22v. 1a., 6/-; 6v. 2a., 5/-; 9v. 1a., 5/-; 35v. 3a., 15/-.  
**PREMIER** Chokes, 40 m.a., 25 hys., 4/-; 65 m.a., 30 hys., 6/-; 150 m.a., 30 hys., 10/6.  
**PYE** Chokes, 20 or 32 hys., 4/-; Premier multi-ratio output transformers, giving 15 different ratios, 7/6.  
**PREMIER** Eliminators, input 200-250 volts, 40-100 cycles, A.C. incorporating Westinghouse metal rectifiers, output 250v. 60 m.a., S.G. and 120v taps, 42/6; with 4v. 4a. c.t. L.T., 7/6 extra.  
**BRITISH** RADIOPHONE Wire Wound Potentiometers, with mains switch incorporated, 5,000 ohms, 10,000 ohms, 50,000 ohms, 100,000 ohms, 250,000 ohms, any value; 3/6.  
**PREMIER** Eliminators, output 150v. at 30 m.a., S.G., and 100v. taps, with 4v. 3-4a. c.t. L.T., 37/6; or with trickle charger, 42/6.  
**PREMIER** Eliminators, output 120v. at 20 m.a., S.G., and 100v. taps, 27/6; with L.T. trickle charger incorporated, 35/-.  
**PREMIER** D.C. Eliminators, output 120v. at 20 m.a., S.G. and 100v. taps; 15/-.  
**ACCUMULATOR** Chargers, 200-250 volts A.C., all incorporating Westinghouse metal rectifiers, 2, 4, and 6v. at 1/2 amp., 12/6; 2, 4, and 6v. at 1 amp., 17/6; 12v. 1a., 27/6; 6v. 2a., 35/-; 12v. 2a., 35/-; 12v. 1.5a., 30/-; 6v. 3a., 39/6; 30v. 1a., 42/6.  
**AMPLION** High Inductance Chokes, resistance 2,500 ohms, 80 henries 60 m.a.; 5/6.  
**WESTINGHOUSE** Metal Rectifiers: 120v. at 20 m.a., 6/6; 180v. at 30 m.a., 8/6; 8v. at 1/2 amp., 6/6; 6v. at 1 amp., 9/6.  
**KOLSTER** BRANDES Electric Gramophone Motors, complete with turntables and automatic stop, 100-250v., A.C. and D.C.; list price £5, to clear £2.  
**B.T.H.** Induction Type (A.C. only) Electric Gramophone Motors, 100-250v.; 30.- complete.  
**AMPLION** Moving Coil Speakers, type E.M.644, dual fields, 2,500 and 5,000 ohms (100 and 200v.), with output transformer, 12/6; A.C. conversion kit for this speaker, 10/- extra.  
**WESTERN ELECTRIC** Condensers, 250v. working, 1 mfd. 6d., 2 mfd. 1/-; 500v. working, 1 mfd., 1/-.  
**T.C.C.** Condensers, 250v. working, 4x4x1 mfd., 3/6; 6x4x2x2 mfd., 375v. working, 6/11; 4x4x1, 6/-.  
**SPECIAL** Offer of Wire Wound Resistances—4 watts, any value up to 10,000 ohms, 1/-; 8 watts, any value up to 15,000 ohms, 1/6; 15 watts, any value up to 50,000 ohms, 2/-; 25 watts, any value up to 50,000 ohms, 2/6; 50 watts, any value up to 50,000 ohms, 3/6.  
**WIRE** Wound Potentiometers, 15,000 ohms, 1/6; Centralab Potentiometer volume controls, 50,000 ohms, 2/-; Colverstats, logarithmically wound Potentiometers, 6,000 ohms, 1/9.  
**FOR** Callers only.—The following valves, guaranteed new:—  
**THE** Last Few Western Electric 3211-D Valves, 10v. 3a. filament, 750-1,000v. plate, 50-65 m.a., impedance 3,500 ohm., amplification factor 12; cost £5, to clear at 15/-.  
**PHILIPS** 328 Valves for L.T. Charging, 5/6; 329 Barretter lamps, 2/-.  
**HARLEY** Pick-ups, with arm and volume control; 12/6.  
**PREMIER** SUPPLY STORES, 20-22, High St., Clapham, S.W.4. Macaulay 2188. Closed 1 o'clock Wednesdays, open to 9 o'clock Saturdays. Nearest Station, Clapham North Underground.  
**PREMIER.**

# NOW READY

The completely revised  
1934 EDITION of  
**RICH & BUNDY.**

## 24-Page CATALOGUE

OVER 100 Models of Mains Transformers and Power Chokes fully described.

Valuable information.

## FREE

Ask for 1934 Catalogue "W." Free by return of post.

## RICH & BUNDY LTD.,

Transformer Manufacturers,  
New Road, Ponders End, Middlesex.

Phone: Enfield 0777.

Sole Distributors: I.F.S.: KILLY & SHIEL LTD., 47, Fleet St., Dublin, C.4.

# HAVE YOU HAD?

particulars of the famous "Magnum" Short Wave Adaptor, which is now available for every type of receiver? Full particulars, with a list of short wave stations and free trial offer, on request.

**BURNE-JONES & CO. LTD.**  
296, Borough High St., London, S.E.1

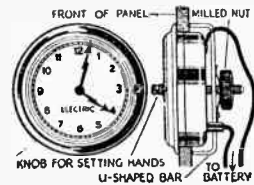

**FIT THIS ELECTRIC CLOCK TO YOUR SET!**  
NO MAINS NEEDED!  
KEEPS CORRECT TIME!  
NO WINDING!

Works off small battery lasting 12 months, or can be plugged into G.B. Battery without affecting reception. Uses practically no current. Fits into hole 3 1/2" dia. in any panel up to 1 1/2" thick. Easy to fix—no screws required. Only 1/4" from front of panel to back of case. Swiss movement. Hands set from front. Nickel plated bezel. Useful addition to any set.  
**RIVERSIDE MFG. CO., LTD.,**  
Dept. 20, Crisp Rd., Hammersmith, W.6  
Telephone: Riverside 6392.

**12/6**  
COMPLETE WITH BATTERY  
POSTAGE 6D



"ENGINEERING OPPORTUNITIES" is a 250-page Hand-book that has been prepared after years of patient search into the possibilities of various Engineering careers. It shows clearly and definitely the way in which you may carve out a successful career in your chosen branch of Engineering irrespective of your age, education or experience. Among a host of other things, it outlines Home-study Courses in all branches of Civl, Mech., Elec., Motor, Aero., Wireless and "Talkie" Engineering and shows the way to pass A.M.I.C.E., A.M.I.Mech.E., I.E.E., A.M.I.A.E., M.I.M.T., G.P.O., Matriculation, Civil Service and other Examinations. "ENGINEERING OPPORTUNITIES" is a unique Hand-book that you should most certainly read. Send for your copy to-day—FREE of any cost.  
**BRITISH INSTITUTE OF ENGINEERING TECHNOLOGY, 387, SHAKESPEARE HOUSE, 29/31, OXFORD STREET, LONDON, W.1.**

## The full range of catalogues describing SERADIX PRODUCTS

will be sent on receipt of completed form:—

To **TREVOR PEPPER, 575d Moseley Road, Birmingham, 12.**

Please place the following on your regular mailing list.

Name.....

Address.....

W.W.22933

Components, etc., for Sale.—Contd.

**GILBERT INDUSTRIES' Parcels.**  
 "A," "B," "D," and Condenser Parcels, as advertised in issues August 4th and August 11th, still available by return of post.  
**GILBERT INDUSTRIES, Ltd.,** 519, London Rd., West-cliff-on-Sea. (3285)  
**SEND Stamp for List Amateur Surplus.—M.,** 139, Beach Rd., Shoreham-by-Sea. (3502)  
**MILDMAY RADIO EXCHANGE** Offers the Following Sound and Perfect:—  
**FERRANTI A.F.5, 17**; A.F.5C, 19/6; A.F.3, 11/—; A.F.6, 17/—; B5 chokes, 17/—; O.P.M.1, 10/—; O.P.1, 1-1, 7/6; O.P.M.1C, 14/—; O.P.M.2C, 14/—; O.P.M.3C, 14/—  
**R.J. Driver** m. 9/—; output choke, 7/—; R.J. Q.P.P., input, output, 17/6; Nuore 1, 9/6; Hypermu, 8/6, second-hand; Varley Rectatone, 7/6; Hypercore chokes, 30-20 H. 50 m.a., 8/6; Pyc tapped output transformers, 5/6; Lotus mains chokes, 5/6.  
**MARCONI P.M. Sneaker Magnets, 15**; Senior Synchron D.C. speaker, 2,500, 25/—; Senior Novotone, standard model, 35/—.  
**GARRARD A.C. Motors, fully automatic stop and start, 35**; Collaro A.C. motors, fully automatic, complete with combined pick-up and volume control 59/6, less pick-up 37/6; Wates A.C. motor, complete, 25/—; Undy ditto, 20/—.  
**ALL Post Paid; e.o.d. extra.**  
**CLOSED Saturday, open Thursday all day.**  
**PHONE Clissold 5001.**  
**24, Mildmay Grove, London, N.1.** (3551)  
**SOUTHERN RADIO'S** Wireless Bargains.—Set manufacturers' guaranteed surplus.  
**VARIABLE Condensers.**—British Radiophone 4-gang superhet. type 0.0005, 8/9 (list 45/—); same with dial, knob and esutchcon, 12/9 (list 50/—); Polar 3-gang 0.0005, complete with dial, knob, esutchcon, 11/— (list 35/—); Lotus 2-gang 0.0005, complete with dial, knob, esutchcon, 8/6; all ganged condensers are fully screened, with trimmers and boxes; Hydra black condensers, new, 16 mfd., 2+2; 8+2+1+1, 1,000 volt test, 7/— each; 4 mfd., 2/6; 2 mfd., 1/9; 1 mfd., 1/—.  
**SPEAKERS.**—Celestion Soundex permanent magnet, 16/— (list 27/6); Rola F6 permanent magnet, 28/— (list 49/6); D.C. mains energised, 2,500 to 6,500 ohms, complete with humbucking coils and transformers, 16/6 (list 39/6); G.E.C. Stork speakers, complete in magnificent cabinet, 19/6 (list £3/15); Ormond speakers, complete in cabinets, 10/— (list 25/—); Utah D.C. mains energised pentode or power, 9in. cone 21/—; 5in. cone 13/6; ultra-permanent magnet speakers, 95 P.M., 35/— each, a really hefty job (list £4/15).  
**CONSTRUCTORS' Kits.** Ready Radio "303" battery 3-valve kits, less valves, 18/— each; complete with 3 Mullard valves (P.M.11.E., P.M.2, 21.A.), 33/— each (list 70/—); Ready Radio Meteor screen grid 3-valve kit, less valves, 26/—; with 3 Mullard valves (P.M.12a, P.M.2D.X., P.M.2a), 49/— (list £5/7/6); Universal Radio 3-valve kits, ready assembled on chassis, 12/6 (list 45/—).  
**READY RADIO S.T.400 Kits,** as specified by Scott Taggart, £2/19/6 each (list £4/17/6); Mullard Radio for Million 3-valve A.C. kit, complete with 3 Mullard A.C. valves (Pen.4V, 354V, 84V), £3/10 (list £6/10); Mullard Radio for Million 3-valve battery kits, complete with 3 Mullard valves, £3/3/— (list £6/2/6), all kit brand new, in original sealed cartons.  
**PISCO.** All-in-One latest type bakelite case, 8/9 (list 12/6), 6 only, B.T.H. Junior pick-ups, 17/6 (list 25/—); British General Band Pass tuning units, 10-K.C. aerial or anode, 5/— each (list 14/6); Lotus triple coil Band Pass units with universal switching, 18/6 per set.  
**RECEIVERS.** Lotus A.C. mains 3-valve (actual), with Magnavox M.C. speaker, complete with valves, in magnificent cabinet, £6/19/6 (list £21).  
**ALL Goods Guaranteed New and Perfect and Sent Carriage Paid.**  
**PLEASE Note.**—We have opened branches at 271-275, High Rd., Willesden Green, N.W.10, and at 46, Lisle St., W.C.2, where callers are cordially invited to inspect our large stocks of wireless bargains. Please send all post orders to 323, Euston Rd., N.W.1.  
**SOUTHERN RADIO, 323, Euston Rd., London, N.W.1** (near Warren St. Tube). Phone: Museum 6324. (3529)  
**M.R.D. Co's** Guaranteed Surplus.—Carriage paid, or call; 12/— discount on orders over 10/—.  
**T.C.C.** 4x2 mfd., 250v., working, 3/3; ditto 4x4 c.1.1 >0.5 mfd., 3/11; T.C.C. 2 mfd., electrolytic, 100v. working, 9d.  
**FORMO** 0.0003 Reaction, 8d., 3/— half dozen; resistors, as last week; L-watt, 4d.; Polymet condensers, 0.0001 to 0.01, 3d., or 1/3 half dozen.  
**VARLEY** 250,000 pots., 1/7; Radiophone 10,000 pots., mains switch, 2/6; Benjamin chassis 5-in valveholders, 3d., 3 lb.; genuine assorted components, 2/6.—Mains Radio Development Co., 4-6, Muswell Hill Rd., London, N.6. (3527)  
**CHAL-ELECTRIC** Offers New Set Manufacturers' Surplus, all carriage paid; cash with order, or e.o.d.  
**VARIABLE Condensers.**—J.B.Nu Gang (3-gang), complete with disc drive, covers, trimmers, esutchcon, light knob, etc., 17/6; 2-gang, fitted as above, 9/6; Polar Star (3-gang 1933), complete, fitted as above, list 30/6, at 18/—; Uniknob 2-gang, fitted as above, complete, 10/—; Utility 2-gang, fitted as above, 8/6.  
**COILS** (6 sets each only). Colvern Ferrocart, F1, F2, £3, ganged, 32/—; Varley Nuore (1), B.P.30 and 2B.P.31, 28/—; Varley sets, B.P., 19 ganged, 25/6.  
**SMOOTHING Condensers.**—C.E.C. Murphy, etc., 800 test 250 A.C. working, 1 mfd., 1/1, 2 mfd., 1/9, 4 mfd., 2/6; all the following 1,500 D.C. test 500 A.C. working 800 peak, 1 mfd., 1/9, 2 mfd., 2/4, 4 mfd., 4/—; Multiple Banksall, separate tappings, 20 mfd., 4+4+2+2+2+2+2+1+1 at 11/—, 11 mfd., 4+2+2+2+1, at 6/9.  
**MAINS Transformers and Chokes.**—Philips 250-0-250 at 75 m.a., 4 volts 1 amp., 4 volts 5 amps., 11/—; chokes for same, 30 hours, 75 m.a. (300 ohms), 6/9.  
**M.V. Cabinet, type M.H.10,** with doors as incorporated in 120-guinea job, cost to make £12, take chassis up to 22x19, overall 27x24x42; at £5; packing and carriage 8/— extra.  
**RADIO Gramophone Cabinets, Marconiphone 535,** walnut, 40x19x16, take chassis up to 39x18x12x14, cost to make £8, at £2/12/6.  
**ASK for Special Quotation for Anything You May Need.**—Chal-Electric, No. 6, Conduit St., London, W.1. (3525)

# SECRETS OF CELESTION SUPREMACY

## No. 2 Accurately Proportioned Magnets!

The cobalt steel magnets fitted to Celestion Speakers are *accurately* proportioned. The proportions are such that wasteful magnetic leakage is reduced to a minimum and the whole of the cobalt steel used to its fullest advantage. As a result, Celestion Speakers are much more efficient—are much more sensitive—than other speakers fitted with far larger magnets less accurately designed. It is such *attention to detail* that puts Celestion in the forefront of modern loudspeaker design. The name Celestion stands for high-quality reproduction combined with unfailing efficiency. Celestion speakers can be supplied to match any set or type or output. Ask your dealer to demonstrate, or write for illustrated details.

PPM9	Chassis Model	£1-15-0
PPM19	Chassis Model	£2- 7-6
PPM29	Chassis Model	£3-17-6

Celestion Ltd., London Road, Kingston-on-Thames.

### MODEL P.P.M.9



# CELESTION

The Very Soul of Music

## THE FOREMOST NAME IN SOUND REPRODUCTION

Components, etc., for Sale.—Contd.

**BIRMINGHAM RADIO MART'S** Weekly Selection Guaranteed Manufacturers' and Bankrupt Stocks, all perfect.  
**RESISTANCES.**—Erie, H.M.V., etc., 100 to 100,000 Ohms, our assortment; 3/— doz.; various values.  
**POTENTIOMETERS.**—Wire wound Radiophone, 5,000, 15,000, 50,000, 100,000; Magnum, 25,000; Colvern, 2,500, 5,000, 6,000; all 2/3.  
**TRANSFORMERS,** standard, not stripped.—Wearite, 500/500v., 60 m.a., 4v., 2 1/2 m.a., 4v., 3-4a., 9/6; H.T. 8v., 2a., 4v., 4a., 9/6; Philips stripped, 200/200, 4v., 3a., 4v., 11s., 4/—.  
**CONDENSERS.** Polar 3-gang, 10/6; 2-gang, 5/6; screened and trimmers, standard, not faked.  
**DUAL Faders.**—Magnum, 2/9; A.E.D., 3/3; Electrolytic, T.C.C., 15 mfd., 100v., 1/—; 8 mfd., 440v., Aqueous, 3/11; Hellesens, 8-4 mfd., 500v., 3/11; all post 3d. extra.  
**METERS.**—Raymart's famous 2 1/2 in. nickel flush, any reading above 25 m.a.; 5/9; full list stamp.  
**CALLERS Only.**—2 H.M.V. Super-power amplifiers, £8, less valves; Decca ditto, with valves, gram, etc., £10 to £15.  
**LARGEST Stocks** in Midlands of H.M.V. Marconi Set and Radiogram Cabinets, and other quality radio gear; trade invited; we can save you money.  
**THE Square Dealers,** "Raymart," 19, John Bright St., and 44, Holloway Head, Birmingham. (3491)  
**NOVOTONE,** standard £5 model, 37/6; Varley constant inductance choke, 8/6.—Atkin, 13, Clapham Park Rd., S.W.4. (3528)  
**HOUSE Telephones,** magneto ringing, 12/6; with magneto, 17/6; battery ringing, 15/—; table telephones, magneto ringing, 15/—.—Below.  
**PEDESTAL Phones, 7/6;** handphones, 4/6; magnetos, 4/6; microphones, 1/—, 2/6 and 4/6; transformers, 2/6; phone bells, 3/—; loud ringing, 6/—.—Below.  
**TALKIE Reduction Gears,** 2 flexible shafts, 40 to 1, 9/—; dimmer rheostats, 110v., 15/—; motor driven pumps, for water, etc., 110v. or 220v. D.C., 35/—.—Below.  
**A.C. Induction Motors,** fractional, 220v., 50 cycles, single phase, synchronous type in new condition; 7/6 each. Below.  
**X-RAY Coils,** 10-inch, complete, £3; ditto, no interrupter, £2; also 1 1/2 in. coils, 10/—; 1 in. coil, 6/6; ignition coils, 5/—; 7 lbs. useful scrap (no iron), 5/—, post free.—Below.  
**ROTARY Converters,** 6-12v., D.C. input, 30v.-1a., A.C. output, 15/—; also 220v. D.C. input, with 500-700v. 150 m.a. D.C. output, £3 10/—.—Below.  
**CHARGING** Dynamoes to Requirements; also meters, rheostats, regulators, D.C. motors, switches, transformers, etc.; please state requirements.—Below.  
**GALPIN, 51, Bowfield Rd., Lewisham, London, S.E.13.**—All goods guaranteed; cash with order or e.o.d. Works and stores, 14, Loampit Hill, S.E.13. All correspondence to private address. (3512)  
**T. W. THOMPSON and Co., 17, Stratton Ground, Westminster, S.W.1.** Telephone: Franklin 6355. Nearest station St. James's Park (Underground).  
**ALL Goods on 3 Days' Approval Against Cash or C.o.d.** (I.F.S. excepted).  
**OPEN Every Day Until 7.30 p.m.** (Sundays excepted).  
**THE Firm to Give Satisfaction.** Established 40 years. To deal with the fountain's head of surplus materials saves pounds.  
**INDOOR and Office Telephones.**—Sterling, wall type, magneto ringing, 12/6 each; table type, 10/6, complete and working, all having high grade microphone.  
**HIGH Grade Transmitting Microphones,** brand new and complete with breast fixing attachment; cost 50/—, to clear 6/— each, post 9d.  
**ELECTRIC Driven Morse Recording Tape Machines,** in good order; cost £35, to clear 70/—.  
**H.M.V. Balanced Armature Loud-speakers,** complete with high grade volume control and resistance, in beautiful oak cabinet; ridiculous clearance, 7/6 each, post 1/—.  
**FILMOPHONE Unbreakable Gramophone Records,** all the latest dance records and selections, were listed at 1/6; to clear 5/— per dozen, post 9d.  
**A FEW of the Remaining Goods** left from Our Last Display, Advertisement of September 8th issue "Wireless World," and from which we obtained hundreds of highly satisfied customers: Electric light and power check meters, for A.C. mains, 6/— each, post 9d.; Philips latest type chokes, 20/30 henries, 2/—; Crypto D.C. to A.C. converters, £4/15; Centralab volume controls, 2/6; British Radiophone controls, with switch, 2/— each, post 3d.; A.C. eliminators, 28/6; D.C. eliminators, 12/6.  
**EKCO Mains Transformers,** 9/6, post 1/—; Wego condensers, in bakelite cases, 700 volt test, 1 mfd., 1/— each, post 3d.; 2 mfd., 1/9, post 3d.; 4 mfd., 2/8, post 4d., all new and guaranteed; Heisz pattern microphones, 52/6; dropping resistances, 200/250 volts, dropping to 15 volt 1/2 amp., 2/— each; small fixed condensers, mixed 36 condensers, 1/— box, post 3d.  
**WE Hold a Large Selection of Everything in Surplus Materials;** enquiries are invited.  
**T. W. THOMPSON and Co., 17, Stratton Ground, Westminster, S.W.1.** Telephone: Franklin 6355. As above. (3535)  
**SPECIAL Clearance Bargains.**—Projectors (9, 16 and 35 mm.), 30/—; Cameras, from 20/—; everything for Movies, Walkies and Talkies; inspection invited.  
**ILLUSTRATED ENTERPRISES, 159, Wardour St. (facing Film House), London, W.1.** Phone: Gerrard 6889. (3004)  
**EPTON Leads Again!**—Polar 2-gang Uniknob condensers, screened, trimmers, disc drive, dial, etc., 8/11; Polar Tub 3-gang, as advertised last week, 9/6; many other bargain in.—  
**EPTON'S RADIO BARGAIN BULLETIN, 93, New Rd., Chingford, E.4.** Phone: Silverthorn 1427. (3536)  
**WHEATSTONE Bridges, 17 plngs, 15/—;** condensers, mica, 0.01, 20,000 volts, Dubilier, 10/—; radiation meters 0-18, brass case, 7in., 6/6; postage 1/— each.—Beaton, Chalk Farm Rd., N.W. (3511)  
**ONE Watt Carbon Type Resistances,** all values, from 500 ohms to 1 megohm, 1/4d. each, or 1/— per dozen, plus postage; special prices for large quantities.—Box 8128, c/o The Wireless World. (3504)  
**FERRANTI A.F.5, 18/—;** A.F.6, 16/—; O.P.3(C), 1-1 push-pull, 9/6; R & A. Challenger, 19/6; B.T.H. synchro-blue motor, 18/6, all as new.—Hulbert, 24, Paragon Rd., Warley, Birmingham. (3522)



**HIGH IN QUALITY**

**EXHIBITION SETS . . . . .**

The following **HIVAC** Valves are recommended: For "Wireless World"

**MODERN BATTERY FOUR**

SG210	.. ..	10/6
H210	.. ..	4/6
D210	.. ..	5/6
B220	.. ..	10/6

**THE HIVAC VALVE GUIDE "W"**

gives our complete range of 2-volt high efficiency, low cost valves together with a comparative table of other makes and their Hivac equivalents.

WRITE NOW FOR A FREE COPY

HIVAC Valves are British Made in our own Factory. From all dealers.

If any difficulty, send us P.O. and address of nearest dealer.

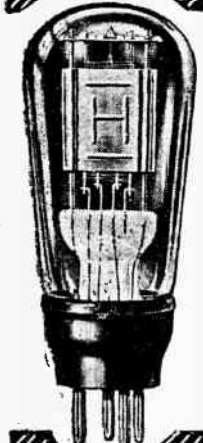

**LOW IN PRICE**

**HIVAC THE SCIENTIFIC VALVE**

**HIGH VACUUM VALVE CO. LTD.,**  
113-117, FARRINGTON ROAD, E.C.1.

**Components, etc., for Sale.—Contd.**

**EPOCH 99** Speaker, 2,500 ohms, 20/-; Hyper-core, 50m.a., 10/-; Challis transformer, for Monodial, 20/-; Amplicon Lion, 10/-; A.P.5, 18/-; A.F.5c, 18/-; A.P.6, 18/-; O.P.9c, 7/6.—148, Brunswick Rd., E.14. [3460]

**MOVING COIL** Milli-Ammeters, 0-50, 10/6 each; 2 milliamps and 120v., 17/6 each; other ranges in stock; alterations, repairs of every description.—The Victoria Electrical Co., 47, High St., Battersea, S.W.11. [0355]

**RADIOPHONE** Superhet. Radiopak, perfect, 50/-; B.T.H. Minor P.M., with Ferranti O.P.M.4, 32/-; Amplicon, Class B, 30/-; wanted, mains transformer, about 425 volts output, cheap.—Aldridge, 29, Chatterton Rd., London, N.4. [3492]

**LIQUIDATING** Edison Bell Gramophone and Radio Stocks; bargains; 20 amplifiers up to 40 watt, 30 field supply rectifiers, 5 exciter lamp supplies, 12 Photo-cell 2-valve amplifiers, 80 voltage regulators, 80 Plessey 3-gang condensers, 40 pick-ups with arms, copper coil winding wire, radio sets and gramophones; all at bargain prices; ask for list.—Engineer, Edison Bell Works, Gall Rd., London, S.E.15. [3497]

**ALL** New Goods, boxed. The famous (N. and K.) Farad. brand inductor loud-speaker, listed £3 10, our price 22/6, suitable (Class B). Permanent magnet, moving coil speakers, 17/6; (Class B) permanent magnet moving coil speakers, 21/-; eliminators, with trickle charger, 200 to 250 input, 42/-, without charger 30/-; (Class B) transformers, 7/6; Philips mains transformers, 5/6; Wearite mains transformers, 10/-; Edison Bell mains transformers, 6/6; variable condensers, 0.0003, Pyc, Dubilier, Invincible, Ormond, 1/- each; 5,000 cabinets to choose from 1/-; variable 0.0005 Burndopt condensers, with drum dial, 2/-, postage free on 5 - orders.—Radio Supplies, 131, Lee Rd., Blackheath, London, S.E.3. [3507]

**H.D. RADIO ELECTRICAL SERVICE** Offers Surplus of a Set Manufacturer, every article guaranteed new. Moving coil speakers; Magnavox, type D.C.144, 2,500 or 7,500 ohms, with Multi Ratio transformer, at 18/-; type D.C.142, same voltages, at 25/-, complete with universal transformer; Sonochord, all voltages, P.S. type (state requirements), list 25/-, at 17/6, with Universal transformer. Pick-ups, G.P.C., complete, list 27/6, at 15/-; variable condensers, J.B. Nu-gang, complete in every detail, disc drives, 2-gang 10/-, 3-gang 17/6; all goods carriage paid; cash with order or c.o.d.; callers only between 1 and 6 p.m.—H.D. Radio Electrical Service, 31, George St., Hanover Sq., London, W.1. [3459]

**CLASS "B" COMPONENTS.**

**SOUND SALES, Ltd.**, for Class "B" Components. List "B.B." on request.—Trenlett Grove, Highgate, N.19 [0401]

**MISCELLANEOUS.**

**EASY** Payments.—We supply, by easy payments, components, accessories, and sets, any make; 10% down, balance spread over 11 months.—Send list of requirements to London Radio Supply Co., 11, Oat Lane, London, E.C.2. [0337]

**ENGINEERS** and Technical Workers of All Kinds.—A proper training, by post in your spare time will take you through your right examination, the employment is waiting. Our advice on all careers free.—Dept. 92, The Bennett College, Ltd., Sheffield. [0395]

**AMBITIOUS** Men.—Quality for a well-paid post by studying at home with the T.I.G.B. Write to-day for "The Engineer's Guide to Success," 144 pages, free, which contains the widest selection of engineering and wireless courses in the world, and shows you how to become A.M.I.E.E., A.M.I.Mech.E., A.Rad.A., etc. State branch, post, or qualification that interests you.—The Technological Institute of Great Britain, 82, Temple Bar House, London, E.C.4. (Founded 1917. 19,000 successes.) [3398]

**PATENT AGENTS.**

**A. MATHISEN, B.Sc.**, Patent Agent and Consulting A. Electrical Engineer, First Avenue House, High Holborn, London, W.C.1. Holborn 8950. [3496]

**PATENTS** and Trade Marks, British and Foreign.—Gee and Co. (H. T. P. Gee, Member R.S.G.B. and A.M.I.E.E.), 51-52, Chancery Lane, London, W.C.2. Phone: Holborn 1525. [0001]

**PATENTS.**

**THE** Proprietor of British Patent No. 244139 is prepared to sell the patent or to license British manufacturers to work thereunder; it relates to improvements in wireless distant control apparatus.—Address Boulton, Wade and Tennant, 112, Hatton Garden, London, E.C.1. [3499]

**REPAIRS.**

**R** only; lowest charges; estimates given free; distance no object.—L. Eastwood, Radio Manufacturers' Consultant, late of His Master's Voice and Marconi Wireless Telegraph Co. Telephone: Clerkenwell 4520. Address: 70, Pitfield St., Hoxton, N.1. [3345]

**GUARANTEED** Repairs by Experts; specialists for repairs to S. G. Brown and Amplicon radio apparatus, also loud-speakers, headphones, pick-ups, Blue Spots, any type rewound, remagnetised and adjusted; 4/-; post free; mains transformer repairs; terms to trade.—Howell, 91, Morley Hill, Enfield Middlesex. [9716]

**R** epairs to Loud-speakers, transformers and headphones, 4/-; Blue Spots or Wufas, 5/-, post free; moving coils a speciality, new cones fitted; eliminators and mains transformers quoted for; prompt service; satisfaction guaranteed; discount to trade.—Loud Speaker Repair Works, 5, Balham Grove, London, Battersea 1321. [0394]

**EXCHANGE.**

**R** OTARY Transformer, 220 D.C. to 1,200 at 150 milliamps; sell or exchange for Rotary transformer, 12 or 24 volts input.—G. Hodgkinson, 114a, Highgate, Kentd. [3495]



**MOVING COIL SPEAKERS**

The Finest in The World in Each of Their Price-classes.

Ask your dealer or call for a demonstration at Exmouth House.

Send for New Booklet W.S.5a. It is free.

**EPOCH RADIO MANUFACTURING Co. Ltd.** Exmouth House, Exmouth St., London E.C.1

At the junction of Rosebery Avenue and Farringdon Road. Phone: Clerkenwell 6666 (4 lines).



**GOOD RECEPTION MEANS RECEPTION**

**RECEPTION**

**INSULATED AERIAL CABLE**

in the **ORANGE & BLUE CARTON**

"Reception" can be used either as an indoor or outdoor aerial or as an earth. It is a seven-strand insulated aerial cable drawn from pure electrolytic copper and protected with a weatherproof covering, and is definitely non-corrosive. The conductivity of the aerial is, of course, extremely high, so that when "Reception" is fitted perfect satisfaction is assured. Obtainable from all Wireless dealers, or if in difficulty apply direct to the manufacturers.

**THE CONCORDIA ELECTRIC WIRE CO. LTD.** New Sawley Nr. Nottingham

**TRIX QUALITY AMPLIFIERS**  
for P.A. with a Punch!

Send for illustrated lists and free estimate for any public address installation, whether permanent or for hire.

**E. J. Lever (TRIX) Ltd.**, 8/9, Clerkenwell Green, London, E.C.1. Contractors to H.M. Government.

SEND FOR LITERATURE OF **Silver Ghost**



**Lamplugh Radio Ltd. Coventry.** Silver Ghost Reproducers MASTERS OF SOUND



**SELL LIGHT**  
Very competitive Prices.

FOR THE TRADER

Cycle & Flash Lamp Bulbs. Batteries & Cases. **DOMESTIC HOUSE LAMPB.** Fillings, Firms etc. Radio Sundries. **SUPERHET RECEIVERS** 29-17-8 & other special lines. All W.W. Kits and other Kits supplied. Quick despatch. Catalogue 6d. Personal attention of the Proprietor. **PERSEUS Co., w.w. Burton-on-Trent.**



The weekly journal for all who keep Canaries, British Hybrids or Foreign Pet Birds.

EVERY FRIDAY 2d. W.W.98

Specimen copy of recent issue free on request from The Publisher (W.W.), Dorset House, Stamford St., London, S.E.1

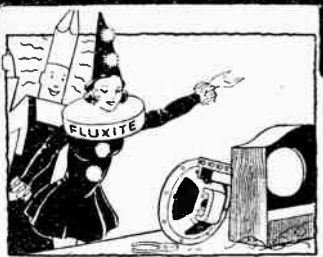

"We're Fluxite and Solder—the reliable pair; Famous for Soldering—known everywhere!"

Allow us to help you—when making that Set; The job will be 'super'—PERFECTION you'll get!"

See that Fluxite and Solder are always by you—in the house—garage—workshop—anywhere where simple speedy soldering is needed.

**ALL MECHANICS WILL HAVE FLUXITE**  
IT SIMPLIFIES ALL SOLDERING

All Ironmongers sell Fluxite in tins: 4d., 8s., 1s. 4d., and 2s. 8d. Ask to see the **FLUXITE POCKET SOLDERING SET**—complete with full instructions—7s. 6d. Ask also for our leaflet on **HARDENING STEEL** with Fluxite.

**FLUXITE LTD.,**  
(Dept. W.W.) **ROTHERHITHE, S.E.15**

**FOR ALL REPAIRS!**



# WATMEL POTENTIOMETERS GIVE THE BEST CONTROL

It is obvious that if a firm concentrates on one type of component it is going to turn out a better job than a firm that dabbles in many. This year we are concentrating on potentiometers, and you may rest assured that when you purchase a Watmel potentiometer you are obtaining the very best from a firm that specialises in this type of component.

Here is illustrated the Watmel Type 1 Potentiometer.

Any resistance up to 50,000 ohms (Standard Wiring).

Price 5/6

With quick break Switch

Price 7/6

Please write for free fully illustrated catalogue that will give you interesting information on Volume Control.

Special models made for manufacturers and for the Export Market. Please write for further particulars.



## Watmel POTENTIOMETERS GIVE THE BEST CONTROL

WATMEL WIRELESS CO. LTD., Imperial Works, High Street, Edgware.

Telephone: Edgware 0823. (G.L.C.21)

### BAKER

WRITE NOW FOR OUR NEW BOOKLET & LEAFLETS

75-77 SUSSEX ROAD, CROYDON, SURREY

FOR QUALITY MOVING-COIL SPEAKERS.

### CHARGE YOUR OWN ACCUMULATOR

at less than a penny. The Arden Unit suitable for 2 or 4 volts, at 14/6 post free. Output 1 amp. Particulars on application. Traders supplied.

THE ARDEN AGENCY, Wollaston, WELLINGBOROUGH.

### ALUMINIUM COIL COVERS

Manufactured by WHITE BROS. & JACOBS LTD., CHALK FARM ROAD, N.W.1.

TRADE ONLY Telephone: GULLIVER 5148.

### Exchange.—Contd.

HIGH Allowances Made on Second-hand Goods in Part Payment for New Sets or Components; easy payments available; we have tremendous stocks tested second-hand goods; send list of your requirements for quotation.—Bostock and Stonhill, 1, Westbourne Terrace, S.E.23. [3509]

### TUITION.

R.T.I. Training Methods are Recognised; write for particulars of home study for radio appointments; secure "Certificate of Proficiency" and become "A.M.R.T.I."—Radio Training Institute, 85, New Oxford St., London, W.C.1. [2947]

QUALIFIED Radio Engineers are Always in Demand, and our Home Study Course will enable you to qualify for a good post; many students already placed this season; prospectus free.—Northern Counties Wireless School, Preston [0399]

IF You Wish to Enter the Wireless Profession with a Thorough Training, or if you wish to improve your present position, you will need the certificate issued by Britain's leading wireless college. This is not a correspondence college. Apparatus of all leading makes installed for instructional purposes. Boarders accepted. Training fees can be paid after appointment. Prospectus free.—Wireless College, Colwyn Bay. [0388]

### ELECTRIC CLOCKS.

SPECIAL Offer.—Superior A.C. mains electric clock movements, rotor only 127 revs., drive up to 10-inch hands; 16/6, post 6d.—Write details, Ebury Bridge Radio Co., 33, Ebury Bridge Rd., Soane 8407. [3519]

### WANTED.

SPOT Cash for Modern Components, etc.—Economic Radio Co., 96-98, South Lambeth Rd., S.W.8. [3291]

WIRELESS Wanted, suitable market stall; must be cheap. Haigh, 146, Southwark Park Rd., S.E.16. [3494]

CORRESPONDENCE with Constructors of Sarver's "Treasure Finder" (Radio Craft, July).—BM/ZL.M.E, W.C.1. [3526]

NEW or Second-hand Sets, kits or parts bought, sold, exchanged; best prices allowed.—R. Wigfield, Furlong Rd., Goldthorpe, Yorks. [3516]

SURPLUS and Second-hand Goods, any quantity, for cash urgently; also rotary converter.—Woburn Radio Co., 7, Woburn Buildings, W.C.1. [3534]

HIGH-class Radio Parts and Sets Wanted for cash, new or second-hand, any quantity; send yours stating reasonable price cash by return; retailers' stocks purchasing.—Mildmay Radio Exchange, 24, Mildmay Grove, London, N.1. Phone: Clissold 5001. [3453]

### SITUATIONS VACANT.

SMART Lads Wanted, 14-16.—Apply M. A. Mason and Co., Ltd., W/T Works, Collingwood Rd., Sipton, Surrey. [3475]

WANTED, by radio valve manufacturers in North London, young man with experience of radio valve manufacture and electrical engineering.—Write Box 8131, c/o The Wireless World. [3522]

WANTED, radio engineer by retail firm, Liverpool area, experience all reputable makes essential; state salary required, details experience.—Box 8118, c/o The Wireless World. [3498]

AMATEURS Wanted in all Districts to act as Salesmen.—Engineers to old-established company selling direct to public; good commission for spare time occupation.—Box 8152, c/o The Wireless World. [3523]

### SITUATIONS WANTED.

WIRELESS Engineer (33), qualified, 14 years' all round experience.—Cromin, 28, Framfield Rd., London, N.5. [3515]

YOUNG Man, single, seeks situation in retail, experienced sales and repairs, car driver.—Box 8129, c/o The Wireless World. [3505]

RADIO Engineer, M.I.R.E., seeks position, research and development; experienced in receiver and transmitter measurement, short wave work; technical correspondence.—Box 8108, c/o The Wireless World. [3493]

## ALEXANDER BLACK, LTD

WIRELESS CONSULTANTS

55, EBURY STREET, LONDON, S.W.1.

ESTABLISHED IN 1925.

SLOANE 1655.

Trade Inquiries Invited.

FOR HIRE FULLY EQUIPPED PUBLIC ADDRESS VAN Sent anywhere in British Isles, also RADIO, MICROPHONE, GRAMOPHONE AMPLIFIERS giving exceptional quality and volume, suitable for Dances, Sports Meetings, Parties, etc. from 15/- per day. McMichael Portable Sets 15/- a week; £2-12/6 a month.

SERVICE SETS OF ALL TYPES. Supplied, Serviced and Visited in any district, or may be sent for Full Test and Report, at 2/- per valve-holder; portables 1/6 per valve-holder.

## ELECTRADIX BARGAINS

DIXMIPANTA, A.C. or D.C. A small A.C. Test Meter that is really a VEST POCKET TESTER. A wonderfully versatile moving-iron, multi-range meter for service on A.C. jobs. No projecting terminals. THREE ranges of volts: 0-7.5 0-153, 0-300. Used for MILLIAMPS. reads 0-12; m.a. and 0-75 m.a.



From Test Reports on the DIXMIPANTA: Wireless World: "The accuracy with which voltage measurements can be made is surprisingly high, indeed, it could not be improved in view of the limitations imposed by the scale." Popular Wireless: "... one of the most attractive devices of its kind I have ever had come into my way."

SELENIUM CELLS. Light sensitive resistance, gold grids, moisture-proof. L to D ratio 5 to 1 5 - each. Mounted in Bakelite. 7/6. Super Model in Oxy-brass body with window. 10/- PHOTO CELLS. £5 Photo Cells for Talkies, Light Tests, Timing Controls, etc., at bargain prices. Response to light 50 microamps. per lumen 40 watt lamp, 75 c.m. King B.T.P., 15/-; R.C.A., 25/-; Holders, 1/-; Beck Prisms, 5/6; Focus Lens, 3/6. TELESCOPES. Cooke monocular prism R.F., with 9-mile distance scale, 7 1/2 in. long, weight 3 1/2 lb., sale 17/6. Naval Gun-Sighting Telescopes, internal focus ring, 2 1/2 in. long, 2 in. dia., weight 6 lb., magnification 6, for short and long range. Cost £25. Sale, 17/6. Spotting Telescopes, 17 in. x 1 1/2 in., by Watson 25/-, 120 lb. Pressure Gauges, 2/6. Watch movements, 1/6



### S. G. BROWN'S BATTERY SUPERSEDER

REPLACES H.T. from your L.T. 2-volt battery, rectified and smoothed. 3 tappings. A boon to those who are not on the mains. Reduced from £3 15/- to New and Guaranteed 37/6

MICROPHONE BUTTONS for all purposes. 1 - Volume Controls, 6d. Announcers No. 11 Mikes, 5/6; Pedestal type, 18/6. Microphone Carbon Granules. In glass capsule, enough for four buttons. Grade No. 1, 8d.; No. 2, Medium, 1/-; No. 3, Fine, 1/6; Carbon, solid back, blocks, 3d. Mouthpieces, curved or straight, 10d. Carbon diaphragm, 55 m.m., 4d. Panel Brackets, pivoted, 5/-, Reed Receiver Unit for Amplifier making, 3/-, Headphones, 2/9 pair. Veeder 10 000 Counters, 1/-, Leaflet with diagrams free if stamped envelope sent.

PARCELS of experimental odd coils, magnets, wire, chokes, condensers, switches, terminals, etc., post free. 10 lbs. 7/-, 7 lbs. 5/-, 1,000 other Bargains in New Sale List W.

ELECTRADIX RADIOS, 218, UPPER THAMES STREET, LONDON, E.C.4

## FIRST CLASS REPRODUCTION

AN UNREPEATABLE OPPORTUNITY TO SECURE A REAL B.T.H.

### R. K. LOUDSPEAKER

GUARANTEED NEW AT BARGAIN PRICES

Specification:—6in. diameter cone Moving Coil Loudspeaker giving full bass response and handling the output from the heaviest power valve. Far superior to many small modern moving coil speakers. Weight 30 lbs. Field winding to suit 6, 100, or 200 volts D.C. Send cash with order or C.O.D. Telephone: Holborn 6999.

O. H. SEEKAMP, FIRST AVENUE HOUSE, HIGH HOLBORN, LONDON, W.C.1. 4th Floor, Office No. 382a.

R. K. SPEAKER Originally listed at £6. 6. 0 Now offered for 30/- A.C. MODEL S £2. 10. 0

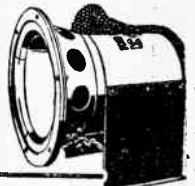

## INDEX TO ADVERTISEMENTS.

Advertisement	PAGE	Advertisement	PAGE	Advertisement	PAGE
Apollo Gramophone Co., Ltd.	14	Epoch Radio Manf. Co., Ltd.	12	Pifco, Ltd.	9
Arden Agency	14	Exlike	1	Players	Inside Front Cover
Baker's "Sellurst" Radio	13	Fluxite, Ltd.	12	Rawwood Electrical Co.	14
Black, Alexander, Ltd.	13	General Electric Co., Ltd.	6 & Back Cover	Reproducers & Amplifiers, Ltd.	Front Cover
British Blue Spot Co., Ltd.	3	Hartley-Turner Radio, Ltd.	10	Rich & Bundy, Ltd.	10
British General Manfg. Co., Ltd.	Inside Front Cover	High Vacuum Valve Co., Ltd.	12	Riverside Manf. Co., Ltd.	10
British Institute of Engineering Technology	10	Langhugh Radio, Ltd.	12	Savage, W. Bryan	10
British Rola Co., Ltd.	9	Lever, Eric J. (Prix), Ltd.	12	Seekamp, O.	13
Burne-Jones & Co., Ltd. (Magnum)	9	Lyons, Claude, Ltd.	Front Cover	Telsen Electric Co., Ltd.	Front Cover
Carrington Manf. Co., Ltd.	11	Milnes Radio Co., Ltd.	3	Varley (Oliver Pell Control, Ltd.)	4
Celestion, Ltd.	VI	Modern Radio (A. Hyams)	5	V.G. Mfg. Co., Ltd.	Inside Back Cover
Cole, E. K., Ltd.	Front Cover	Multitone Electric Co., Ltd.	4	Watmel Wireless Co., Ltd.	13
Concordia Electric Wire Co., Ltd.	12	Northern National Radio Exhibition	2	Westinghouse Brake & Saxby Signal Co., Ltd.	Inside Back Cover
Dubilier Condenser Co. (1925), Ltd.	2	Osborn, Chas. A.	14	White Bros. & Jacobs, Ltd.	13
Earl Manfg. Co., Ltd.	4	Partridge, Wilson & Co.	11	Whitely Electrical Radio Co., Ltd.	7
Eastick, J. J., & Sons	10	Pepper, Trevor (Seradex)	10	Wharfedale Wireless Works	7
Edison Swan Electric Co., Ltd.	Inside Back Cover	Perseus Co.	12	Wingrove & Rogers, Ltd. (Polar)	7
Ever Ready Co. (Great Britain), Ltd.	Inside Front Cover	Peto-Scott, Ltd.	8		
Electradix Radios	13				

# Your set here equals a fine Radio-Gram

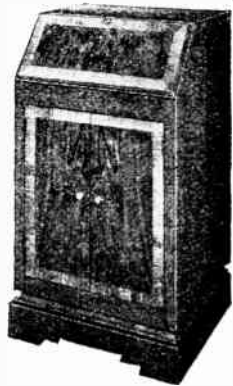

An Apollo Playing Desk will double the value and usefulness of your Wireless Set, as well as converting it into a handsome piece of furniture. You simply place the set on the Desk and connect Pickup leads.

**IN LIGHT, MEDIUM or DARK WALNUT TO MATCH VARIOUS WIRELESS SETS**

Size of top 18" x 11 1/2"

**CASH PRICE 8 GNS.**

or 15/6 deposit and 11 payments of 15/6.

As illustrated, with Collaro Induction Motor and Pickup, automatic current stop, volume control, record cupboard, etc. Also supplied fitted with GARRARD AUTOMATIC RECORD CHANGER and volume control complete for £15-5-0 cash, or 30/- deposit and 11 payments of 30/-.

## APOLLO PLAYING DESKS

Ask your Radio Shop, or write to

**APOLLO GRAMOPHONE CO., LTD.**  
4, Bunhill Row, London, E.C.1.

Make your set a part of your home

## Get an OSBORN CABINET

MODEL No. 258. Queen Ann radio-gram cabinet. 2' 2" high, 1' 10" wide, 1' 4" deep. Height between motor-board and baseboard 12 1/2". Height for pick-up 4". Accommodates baseboard 18" x 14" or smaller. Ample room for any type speaker and batteries. Silk fabric baffleboard and baseboard included. Panel above fret cut to your specification. Takes any gramophone motor, fitted free if purchased from us.



WRITE FOR CATALOGUE

NORTHERN NATIONAL RADIO EXHIBITION Manchester, Sept. 27-Oct. 7. Stand 78—Main Hall.

Sole Manufacturers of the Osborn Baffle Box. 18" x 18" - £1.0.0. 24" x 24" - £2.0.0.

CHAS. A. OSBORN (Dept. W.W.), Regent Works, Arlington St., New North Rd., London, N.1. Tel.: Clerkenwell 5095. Showrooms, 21, Essex Rd., Islington, N.1. Tel.: Clerkenwell 5634.

## The ELEMENTARY PRINCIPLES of WIRELESS TELEGRAPHY and TELEPHONY

Third Edition (1930) Revised by O.F. Brown, B.Sc.

**PRICE 7/6 by post 8/-**

From all leading Booksellers or direct from the Publishers:

**ILIFFE & SONS LTD., Dorset House, Stamford St., London, S.E.1**

Mention of "The Wireless World," when writing to advertisers, will ensure prompt attention.

NO HUM NO HEATING

12 Months Guarantee

## RAWSWOOD MAINS TRANSFORMERS & CHOKES (shrouded)

Designed with one end in view—Efficiency, yet the question of price has never been lost sight of. You will look a long way before you find components that combine such high qualities with such moderate prices—and they are BRITISH.

Illustrated Catalogue on request.

Prices 12/6 to 60/-

TESTED TO THE HILT—

both on No-Load and Full Load, 3,000 volts A.C. between Windings and Core. Megohm Test—750 megohms. No Heating. No Hum. Excellent Regulation. Test Chart supplied with each Component.

**RAWSWOOD ELECTRICAL CO.,**

Preston New Road, BLACKPOOL, Lancs.

Telephone: Marton 183.



SPECIAL TERMS TO TRADE

## DICTIONARY of WIRELESS TECHNICAL TERMS

Compiled by S. O. Pearson, B.Sc., A.M.I.E.E., and issued in conjunction with "THE WIRELESS WORLD"

SECOND EDITION

Revised and brought up to date

THIS handy volume is very much more than a Dictionary. It not only takes the technical terms of wireless and explains their meaning, but in doing so it concentrates into a small space a large amount of information on wireless subjects. It has become, in fact, a compendium of current wireless knowledge, and an invaluable handbook for all who are interested in wireless transmission and reception. Diagrams and illustrations are freely interspersed throughout the book to amplify the explanations of the text.

272 pp., bound in cloth boards  
Size 5 by 3 inches

Price 2/- net. By post 2/2

From all leading booksellers or direct from the Publishers

ILIFFE AND SONS LTD.  
Dorset House, Stamford Street, London, S.E.1

W.W.48.

WEDNESDAY SEPTEMBER THE TWENTY-SEVENTH

PRINCIPAL EVENTS OF THE DAY:

AT HOME

- NATIONAL LONDON REGIONAL MIDLAND REGIONAL NORTH REGIONAL WEST REGIONAL SCOTTISH REGIONAL BELFAST

Promenade concert from Queen's Hall. "The Use of Man," a play, by Lord Dunsany. Military Band programme. Concert Party programme from the Spa Theatre, Scarborough. A Children's Evening: Welsh choral programme. Excerpt from "Sunny Days," relayed from the Barrfields Pavilion, Largs. "The Bishop's Candlesticks," a play, by Norman McKinnell.

ABROAD

- BARCELONA BRUSSELS (No. 1) BUDAPEST COPENHAGEN HAMBURG LUXEMBOURG PRAGUE STRASBOURG TURIN WARSAW

7.0 p.m. Trio concert. 8.0 p.m. The Station Orchestra, conducted by D. Dufauw. 8.0 p.m. Orchestral concert, conducted by E. Dolmányi. 10.30 p.m. Concert of Danish opera music, by the Station Orchestra. 8.0 p.m. Concert of opera music, relayed from Kiel. 9.20 p.m. The Station Orchestra, conducted by H. Pensis. 9.30 p.m. Mendelssohn's String Quartet in E Minor (Op. 44, No. 2), played by the Ondrecek Quartet. 8.30 p.m. Three operettas: "La Chouanne," by Missa, "Les deux Pêcheurs" and "Le violoneux," by Offenbach. 8.30 p.m. Opera: "Il Pirata," by Bellini. 8.15 p.m. Orchestral concert from the Conservatoire.

Sonata No. 5 in E flat (Mozart); Sonata, Op. 13 (Fauré). 7.15, Reading. 7.30, Book Review. 8.0, Concert by the Radio Orchestra, conducted by Walpot. Soloists: Mme. Lauwers-Vanhomerich (Soprano) and Rik Willense (Baritone); Overture, Die Fledermans (Joh. Strauß); Waltz, Dolores (Waldteufel); Bells across the Meadow (Kettelby). Soprano Solos: Selection from The Tales of Hoffmann (Offenbach). Baritone Solos: Parade of the Tin Soldiers (Jessel). Piano-forte and Orchestra: Rhapsody in Blue (Gershwin). Soprano Solos: Selection from Viktoria and her Hussar (Abraham). Baritone Solos: Love's Dream after the Ball (Czibulka); 1933 Jazz Fantasia (Candrix). In an interval at 8.45, Readings. 10.0, Le Journal Parlé.

BUCHAREST

761 kc/s, 394 metres; 12 kW.—5.0 p.m., Concert by the Station Orchestra: March (Translatour); Waltz (Lincke); Overture, Raymond (Thomas); Selection from The Tales of Hoffmann (Offenbach); Potpourri of Popular Melodies (Morena); Fantasy on a Theme of Tchaikovsky (Urbach); Garofita (Dinico); Violin Solo, Leggenda d'amore (Bece); Grotesque (Siede). In an interval at 6.0, Radio Journal. 7.0, Educational Talk. 7.20, Symphony Music (on Gramophone Records). 7.40, Talk. 8.0, Pianoforte Recital by Nicolas Radulesco: Two Sonatas (Scarlatti); Variations (Beethoven). 8.30, Talk. 8.45, Flute Recital of Romanian Music. 9.15, Violin Recital. 9.45, Radio Journal.

BUDAPEST

545 kc/s, 550.5 metres; 18.5 kW. Also relayed on 840 metres from 8.0 p.m. till Close Down.—5.30 p.m., Dance Music from the Café Ostende. 5.45, Italian Conversation. 6.45, Concert by Jenő Perti's Gypsy Band. 8.0, Recitations. 8.30, Orchestral Concert conducted by Ernst Dohnányi: Symphony No. 3 in F (Brahms); Suite, Scheherazade (Rimsky-Korsakov). 10.0, News. 10.15, Relay of a Sound Film. 10.40, Trio Concert, relayed from the Café Simplon.

CASSEL.—See Frankfurt.

COPENHAGEN

1,067 kc/s, 281 metres; 0.75 kW. Relayed by Kalundborg, 260 kc/s, 1,153.8 metres.—12 Noon, Time Signal and Chimes from the Town Hall. 12.2 p.m. Concert by the Bendix String Ensemble, relayed from the Wivex Restaurant. 2.0, Interval. 3.0, Gramophone Concert of Variety Music. 3.30, Danish Music by Sid Merrymann's Soft Band, with Songs by Einar Jensen and Rose Mari. In an interval at 4.15 (approx.), Talk for Women. 5.30, Exchange and Fish Market Prices. 5.45, Agricultural Prices. 6.15, French Lesson. 6.45, Weather. 6.54, Announcements. 7.0, News. 7.15, Time Signal. 7.30, Talk. 8.0, Time Signal with Musical Illustrations: The Orchestra and its Instruments. 9.0, Swedish Song Recital by Lisa Nilsson. 9.20, Topical Talk. 10.5, News. 10.20, Concert of Danish Opera Music by the Station Orchestra, conducted by Launy Gröndahl: Overture and Dance from Little Christie (Hartmann); Suite from King and Marshal (Heise); Prelude to Act II of Saul and David (Nielsen); Overture, Vifandaka (Toft). 11.5, Dance Music, conducted by Otto Lington, relayed from the Ritz Restaurant. In an interval at 12 Midnight, Time Signal and Chimes from the Town Hall. 12.30 a.m. (Thursday), Close Down.

CORK.—See Athlone.

DANZIG.—See Heilsberg.

DRESDEN.—See Leipzig.

FECAMP

1,328 kc/s, 225.9 metres; 10 kW.—11.0 to 12 Noon, Programme in English by the I.B.C. 11.0 a.m., Happy Hour: Part I, Request Half Hour; Signature Tune, Let me explain (Tower); Farewell to Arms (Wrubel); Hold me (Schuster); My Darling (Heymann); The Old Spinning-Wheel (Hill); The Girl in the Little Green Hat (Rich); Auf Wiedersehen, my Dear (Ager); Stormy Weather (Arlen); Part II, Dance Music: It's Sunday down in Caroline; From me to you; It was a Night in June; Love Songs of the Nile; My Lucky Day; Picannunny Happy ending; When my little Pomeranian (Schuster); Signature Tune, 12 Noon, French Programme. 4.30 to 6.0, Programme in English by the I.B.C. 4.30, Programme for Children. 5.0, Octet Concert for Portsmouth and Southsea Listeners: Signature Tune, The Night by the Sea; Valse bluette (Drigo); Song, My ain folk (Lemon); Narcissus (Nevin); Hungarian Dance in D (Brahms); Blunengeflüster (von Blon); Romance (Rubinstein); Song, Over the Dark Still Silence (Rizza); Rose mousse (Bosc). 5.30, Gramophone Concert for Isle of Wight Listeners: Selection from The Belle of New York (Kerker); Ocarina Solo, Under the Double Eagle (Tapiero); My Old Kentucky Moon (Foster); Friends once more united (Spoliansky); Veterans of Variety; Still I love her (Gaskill); A little idea of my own (Robins); Xylophone Solo, Snappy Sticks (Robins); Signature Tune. 6.0, French Programme. 10.0 till Close Down, Programme in English by the I.B.C. 10.0, Dance

ALGIERS 824 kc/s, 364 metres; 13 kW.—8.10 p.m., Shipping Notes. 8.15, Agricultural Report and Weather Forecast. 8.20, Operetta Music. 8.55, News. 9.0, Time. 9.2, Lottery Results. 9.10, One-Act Comedy. 9.35, News. 9.45, Open-Air Concert.

ATHLONE 725 kc/s, 413 metres; 60 kW. Relayed by Cork, 1,337 kc/s, 224.4 metres.—1.30 to 2.30 p.m., Time Signal, Weather Report, Stock Exchange Quotations, and Gramophone Music. 6.0, Programme for Children. 6.45, News. 7.0, Gaelic Talk. 7.15, German Lesson. 7.30, Time Signal. 7.31, Violin and Pianoforte Recital by Amy Ellard and Mrs. Boxwell. 7.55, Tenor Solos by N. O'C. Redmond. 8.5, Concert by the Station Orchestra. 8.35, Tenor Solos (contd.). 8.45, Orchestral Concert (contd.). 9.15, Gaelic Song Recital by Brigid O'Cleirigh. 9.30 to 10.30, Programme by the I.B.C. (Ireland), Ltd. 9.30, Dance Music: When it's lamp-lightin' time; The Language of Love; Peter, Peter; There's a Light in your window; You've got me cryin' again; I've got the World on a String; One tiny Tear; The Girl in the little green Hat; My Darling. 10.0, Concert arranged by the International Broadcasting Company (Ireland), Ltd., on behalf of Hospitals Trust, Ltd.: Angero March (Franco); Pizzicato from Sylvia (Delibes); Valse caprice (Rubinstein); Autumn (Chaminade); Violin Solo, Fandango (Gadowsky); Liebeslied (Kreisler); Golliwog's Cakewalk (Debussy). 10.30, I.B.C. Goodnight Melody, followed by News, Weather Report, and Time Signal. 10.40, Pipe and Fiddle Solos by S. MacAonghusa and F. O'Higgins. 11.0 (approx.), Close Down.

BARCELONA EAJI, 860 kc/s, 348.8 metres; 8 kW.—7.0 p.m., Trio Concert: Selection from The Mastersingers (Wagner); Serenade (Dvorák); Le concou (Daquin); Reverie (Tchaikovsky); Selection from Mirella (Gounod); The Shepherd's Song (Elgar); Carnaval japonais (de Basque). 8.0, Request Gramophone Records. 8.30, Exchange. 9.0, Gramophone Music and News. 10.0, Chimes from the Cathedral. Weather, Exchange and Market Prices. 10.5, Concert by the Station Orchestra. 10.45, Trio Concert. 11.30, Dance Music, relayed from the Casa Libre. In the interval at 12 Midnight, News. 1.0 a.m. (Thursday), Close Down.

BASEL.—See Schweizerischer Landessender.

BELGRADE 697 kc/s, 430.4 metres; 2.8 kW.—6.55 p.m., Time and Announcements. 7.0, Talk. 7.30, Song and Cello Recital. 8.30, Part Relay of an Opera from Ljubljana, 522 kc/s (574.7 metres). 10.30, Time and News. 10.45 (approx.), Dance Music on Gramophone Records.

BERLIN DEUTSCHLANDSENDER (REICHSENDER), 183.5 kc/s, 1,635 metres; 60 kW.—2.0 p.m., Gramophone Concert: Walter Rehberg (Pianoforte): (a) Spanish Rhapsody (Liszt), (b) Impromptu in G (Schubert); Vasa Prihoda (Violin); (c) Humoresque (Dvorák), (d) Chant d'automne (Tchaikovsky); Heinrich Schliemann (Baritone); (e) Die beiden Grenadiere, (f) Der Hidalgo (Schumann); Willi Dongrat-Fassbender (Baritone); (g) Monologue from Rigoletto (Verdi); (h) Cavatina from The Barber of Seville (Rossini); Egon Petri (Pianoforte): (a) Auf dem Wasser zu singen (Schubert-Liszt); (b) Die Forelle (Schubert-Liszt); Pablo Casals (Cello): (a) Songs my Mother taught me (Dvorák), (b) Prelude (Chopin-Sievking); Franz Völker (Tenor): (a) Home land (Gretchaninov), (b) Matmata (Leoncavallo). 3.0, Programme for Children. 3.30, Weather and Exchange. 3.45, Love—Reading from the Letters of German Mystics. 4.0, See Hamburg. 5.0, Programme in commemoration of Hermann Löns. 5.30, Concert of Light Music. 6.0, Poems. 6.5, Religious Address. 6.55, Wireless Technical Talk. 6.50, Weather and Announcements. 7.0, Transmission for all German Stations, relayed from Frankfurt. 8.0, To-day's Motto. 8.2 (approx.), Cavalleria rusticana—Opera in One Act (Mascagni), followed by I Pagliacci—Opera in Two Acts (Leoncavallo), relayed from the Municipal Opera House. 10.15, News. 10.45, Weather. 11.0, Programme from Breslau. 12 Midnight, Close Down.

BERLIN FUNKSTUNDE, 715 kc/s, 419.5 metres; 1.5 kW.—4.30 p.m., Dance Music relayed from the Moka Efti. 5.25, A Discussion on Labour Service between Hans Wilhelm Scheidt and Dr. Will Decker. 5.45, Arthur Hartmann Song Recital by Susanne Haym (Soprano) with the Composer accompanying. Daheim, Songs from Des Knaben Wunderhorn: (a) Morzenglied, (b) Ich hab' die Nacht geträumt, (c) Wer sehen will zweien lebendige Bräunen, (d) Altdäntseher Spruch, (e) Ich wandre meine Strassen, (f) Ach, wenn ich so wär, (g) Es wollt' ein Mägdlein Wasser holen. 6.5, See Berlin (Deutschlandsender). 6.40, The Funkstunde informs its Listeners... 6.45, Topical Talk. 7.0, Transmission for all German Stations relayed from Frankfurt. 8.5, Recital of Folk Songs. 8.40, Fare-

well to Summer—a Radio Report of the River Traube. 9.0, Schumann Concert by the Station Orchestra, conducted by Eugen Jochem and Prof. Walter Rehberg (Pianoforte). Pianoforte Concerto in A minor Op. 51; Fourth Symphony in D minor Op. 120. 10.0, News. 10.15 (approx.), Dance Music relayed from the Sprengarten, Treptow. In the interval at 11.0, Radio Report from Moabit. 12 Midnight, Close Down. BERNE.—See Schweizerischer Landessender. BEROMUNSTER.—See Schweizerischer Landessender. BODEN.—See Stockholm. BODO.—See Oslo.

BRATISLAVA 1,076 kc/s, 279 metres; 14 kW.—5.55 p.m., Hungarian Programme: From the Carpathians to the Mediterranean—Radio Sequence with Gramophone Records. 6.55, Talk for Housewives. 7.0 till Close Down, See Prague. 10.30 (approx.), Close Down.

BRESLAU 923 kc/s, 325 metres; 60 kW. Relayed by Gleiwitz, 1,184 kc/s, 253 metres.—12 Noon, Weather. 12.6 p.m., See Leipzig. 1.45, Time and News. 2.10 (from Gleiwitz), Soprano Song Recital by Ami Bernert. 2.40, Gramophone Music. 3.0, Agricultural Market Prices. 3.15, Talk: The Gold Fields of New Guinea. 3.35, Talk: The Original Home of the Gipsy. 4.0, Pianoforte Recital by Helmut Korbella: Twelve Variations on Ein Mädchen (Beethoven); Impromptu in B flat (Schubert); Bolero in C (Chopin). 4.30, Talk. 4.50, Violin Recital by Otto v. Wilpert: Sonata in E minor (Biber); Sonata, Op. 1 (Thunille). 5.20, Agricultural Prices. 5.25, Talk: The Bolshevik Regime in Russia. 5.40, Concert by the Bethuen Choir. 6.35, Talk: The German Revolution. 6.50, Meat Market Prices. 7.0, Transmission for all German Stations relayed from Frankfurt. 8.0, News. 8.10, Chamber Music. 8.40, Goethe Song Recital by Gertrude Pitzinger (Mezzo-Soprano): Wechseltend zum Tanze (Reichardt); Das Veilchen (Mozart); Maliedi (Beethoven); Talismane (Schumann); An den Mond (Schubert); Der Musensohn (Schubert); Songs (H. Wolf): (a) Anakreons Grab, (b) Frühling übers Jakt, (c) Der Schäfer, (d) Epiphanius. 9.10, The Great Chance—Comedy (Möller and Lorenz). 10.15, Time and News. 10.40, Wireless Notes. 10.50, Concert from the Café Vaterland. 12 Midnight, Close Down.

BRNO 878 kc/s, 342 metres; 35 kW.—6.25 p.m., German Transmission: News, Talk. Broadcast for Workmen and Educational Talk. 7.0. See Prague. 7.25, Music by a Bagpipe

Trio. 7.50 till Close Down, See Prague. 10.30 (approx.), Close Down.

BRUSSELS (No. 1) I.N.R., 590 kc/s, 509 metres; 15 kW.—12 Noon, Concert by the Station Orchestra, conducted by Leemans: March (Ross); Waltz, Tres jolie (Waldteufel); Serenade, El mi amor (Margutti); Selection from Madame Butterfly (Puccini); Violin Solo: Serenade (Bass); Intermzzo, Bird of Love Divine (Haydn Wood); Waltz, Paradise of my Heart (Novvo); Piece for Two Pianofortes: Kitten on the Keys (Confrey); Selection from Un bon Garçon (Yvain). 1.0 p.m., Le Journal Parlé. 1.10, Concert, relayed from the Grand Hotel, Antwerp. 5.0, Concert by the Radio Orchestra, conducted by Walpot: Wedding March, Francia (Paradis); Overture, Maximilien Robespierre (Litolff); Bruissement sous Bois (Razigade); Danse macabre (Saint-Saëns); Selection from Carmen (Bizet). Violin Solo: Meditation from Thais (Massenet); Vers la Cité lindoue (Delmas); Marche lorraine (Ganne). 6.0, Talk. 6.15, Petite Suite (Jongjen) on Gramophone Records. 6.30, Concert by the Small Station Orchestra, conducted by Leemans: Overture, Fra Diavolo (Auber); Suite, Summer Days (Coates); Barcarolle (Gallard); Rondo for Pianoforte (Guillaume); Selection from H.M.S. Pinafore (Sullivan); Dance (Roels); Oriental March (Gibson). 7.30, Talk on Hygiene. 8.0, Concert by the Station Orchestra, conducted by Desiré Dufauw. Soloist: Maurice Bambois (Cello); Overture, Euryanthe (Weber); Concerto for Cello and Orchestra (Dvorak); Symphonie Poem, Werther (Vreulds); Elegiac Song for Cello and Orchestra (Florent Schmitt); Dance of the sylphs, Minuet and Hungarian Dance from The Damnation of Faust (Berlioz). In the interval at 8.45, Reading of Poems by Belgian Authors. 10.0, Le Journal Parlé.

BRUSSELS (No. 2) N.I.R., 887 kc/s, 338.2 metres; 15 kW. Programme in Flemish.—12 Noon, Concert, conducted by André Felleman, relayed from the Grand Hotel, Antwerp: March, Blaze away (Holzmann); Overture to a Spanish Comedy (Köler-Bela); Gypsy Song Potpourri, Play Gypsy (Geiger-Huber); Tango, Gy zwarte zigeuner (Vecek); Selection from The Tales of Hoffmann (Offenbach); Foxtrot, One Tiny Tear (Woods); Peter-Peter (Woods). 1.0 p.m., Le Journal Parlé. 1.10, Concert by the Small Station Orchestra, conducted by Leemans: Overture, The Italian Girl in Algiers (Rossini); Pesther-Walzer (Lammer); Love in Arcady (Wood); Selection from Eugene Onegin (Tchaikovsky). Violin Solo: Humoresque (Wigy); Serenade (Moszkowsky); Selection from Die geschiedene Frau (Fall); Slav Dances (Dvorák). 5.0, Dance Music, relayed from the St. Sauveur Palais de Danses. 6.15, Talk. 6.30, Sonata Recital by Lien Van Eyck and Jean Laurent;



SEPT. 27th

WEDNESDAY

continued

Music: Signature Tune, Bells of Normandy; Learn to Croon; That's my Home; Down the Old Ox Road; Sittin' in the Dark; Waltzing in a Dream; He was only a Poor Musician; Pop Gun; In Santa Lucia; Nine Little Miles from Ten, Ten, Tennessee; Kerie Moon; It's a glory; Anytime, any day, anywhere; My Darling; Happy Ending; One little Word led to another; My Lucky Day; Signature Tune. 11.0, Sound Film Music: Signature Tune, Sittin' in the Dark; Smilin' through; The Kiss Waltz; Happy Ending (Davies); Oh! I wish I could sing a Love Song; Learn to Croon; Song of the West; My Lucky Day; Shuffle off to Buffalo; Signature Tune. 11.30, Club Concert for Moffat Listeners: Part I, Orchestral Music: Signature Tune, The Chum Song; The Thistle (Myddleton); Barcarolle from The Tales of Hoffman (Offenbach); Violin Solo, Selection from Heire Kati (Hubay); Three Fishers went sailing (Kingsley); Selection from The Yeomen of the Guard (Sullivan); I kiss your lips (Rudolphe); The Foola Reel (Traditional). 12.5 a.m. (Thursday), I.B.C. News Bulletin in English. 12.10 (approx.), Club Concert, Part II: Jericho (Myers); Loving them all (Coningsby); I faw down and go "Boom" (Stevens); Deep Night (Vallee); The Bogie Wail (Myers); Signature Tune. 12.30, Dance Music: There's a Cabin in the Pines; Jog along; Waiters on Parade; The Old Spinning-Wheel; It was a Night in June; At the Old Pig and Whistle; It's Sunday down in Caroline; A Woman should stick to her man; I cover the Waterfront. 1.0, Dance Music: Signature Tune, Bells of Normandy; Sweetheart Darling; When it's Lamp lightin' time in the Valley; The Language of love; Put a little Springtime; Her Name is Mary; Let's All be Happy Together; Stay out of my Dreams; Adorable; Rosa mia; Love Songs of the Nile; That's my Home; From me to you, Rio Rita; Someone to care for; They all do the Rumba; Won't you stay to Tea?; Signature Tune. 2.0, I.B.C. Goodnight Melody and Close Down.

FLENSBURG.—See Hamburg.

FLORENCE.—See Turin.

## FRANKFURT

1,157 kc/s, 259.3 metres; 17 kW. Relayed by Cassel, 1,220 kc/s, 245.9 metres; and Trier, 1,157 kc/s, 259.3 metres.—4.30 p.m., Concert from the Kurhaus, Wiesbaden. 5.45, Exchange. 6.0, Talk in commemoration of Hermann Löns. 6.25, Topical Talk. 6.45, Review of the Day's News. 6.50, Time and News. 7.0, Transmission for all German Stations: The Hum of Engines—a Radio Play (Paul Ehrhardt and Dr. Paul Laven). 8.0, Concert of Operetta Music, with Sketches in the intervals. 10.0, Pianoforte Sonata, Op. 1 (Rudolf Racky), played by the Composer. 10.15, Time and News. 10.45, Programme from Leipzig. 12 Midnight, Close Down.

FREDRIKSSTAD.—See Oslo.

FREIBURG.—See Stuttgart.

GENEVA.—See Radio-Suisse Romande.

GENOA.—See Turin.

GLEIWITZ.—See Breslau.

GOTEBORG.—See Stockholm.

GRAZ.—See Vienna.

HAMAR.—See Oslo.

## HAMBURG

806 kc/s, 372 metres; 1.5 kW. Relayed by Bremen, 1,112 kc/s, 269.8 metres; Flensburg, 1,319 kc/s, 227.4 metres; Hanover, 530 kc/s, 566 metres; and Kiel, 1,292 kc/s, 232.2 metres.—4.0 p.m., Autumn—Concert by the Hamburg Philharmonic Orchestra, conducted by Gerhard Maasz: Concert Overture, Im Herbst (Grieg); Minuet and Dance from The Seasons (Palmgren); Elegies (Niemann); Finale from Symphony No. 75 in D—La Chasse (Haydn); Waltz, Herbstrosen (Jos. Strauss); Overture, St. Hubertus (Fueki). 5.0, Dialogue: A Trip to the Frisian Islands. 5.30, Hamburg, Bremen and Lübeck—Report on Events in the Senates and Houses of Burgesses of the Hanseatic Free Cities. 6.0, Variety Programme. 6.40, Frankfurt Exchange and Hamburg Market Prices. 6.50, Weather. 7.0, Transmission for all German Stations, relayed from Frankfurt. 8.0 (from Kiel), Concert of Opera Music. The Kiel Orchestra of Unemployed Musicians, conducted by Hans Böhring. Soloist: Helene Sommerfeld (Soprano); Entry of the Guests into the Wartburg from Tannhäuser (Wagner); Ballad from The Flying Dutchman (Wagner); Overture, Der Wildschütz (Lortzing); Selection from The Merry Wives of Windsor (Nicolai); Aria from Rienzi (Wagner); Duet from Der Rosenkavalier (R. Strauss). 9.0, See Berlin (Funkstunde). 10.0, Time and News. 10.20, Topical Talk. 10.30, Dance Music, relayed from the Haus Siegtor. HANOVER.—See Hamburg.

## HEILSBURG

1,085 kc/s, 276.5 metres; 60 kW. Relayed by Danzig, 662 kc/s, 453.2 metres.—1.5 p.m., Gramophone Music. In the intervals at 1.20, and 2.0, News. 2.30, Programme arranged by the Post Office with Gramophone Records. 3.0, Agricultural Prices and Exchange. 3.20, Hints for the Housewife. 3.30,

Programme for Children. 4.0, Talk for Teachers—New Books for German Youth. 4.30, Concert by the Small Station Orchestra, conducted by Wilcken. Overture, Othello (Verdi); Pastoral Suite (Arnold); Selection from La dame blanche (Boieldieu); Extase (Bizet); Mazurka (Debussy); Scandinavian Suite (Frederiksen); On the Riviera (Fassunge); Legends of the Pusztá (Lindsay-Theimer); Selection from Der Obersteiger (Zeller); Moonlight on the Alster (Fetras). In the interval at 5.0 (approx.), Book Review. 6.15, Agricultural Prices. 6.20, Illustrated Talk: The Art of Pianoforte Playing—Fantasiestücke (Schumann). 6.50, Weather. 7.0, Transmission for all German Stations, relayed from Frankfurt. 8.0, News. 8.10, Dance Music by the Small Station Orchestra and the Börschel Dance Band. 10.10, Weather and News. 10.15, Concert by the Königsberg Opera House Orchestra, conducted by Brückner. Overture, Le Maçon (Auber); Little Suite (Bizet); Lagunen-Walzer (Strauss); Selection from The Carnival Fairy (Kálmán); Overture, Morning, Noon and Night (Suppé); March (Blatkenburg). 11.30, Close Down.

## HILVERSUM

Announced HUIZEN, 1,013 kc/s, 296.1 metres; 7 kW. (until 5.40 p.m.) and 20 kW. from 5.40 p.m.—Programme of the Christian Radio Society (N.C.R.V.). 11.40 a.m., Police Report. 11.55, Gramophone Music. 12.10 p.m., Concert by the Van der Horst Ensemble. Selection from The Messiah (Händel); Sonata (Händel); Sacred Songs arranged for Two Violins and Cello; Sonata (Pugnani); Songs from De Nieuwe Leidsche Kruithof; Old Dutch Songs arranged for Two Violins and Cello; Das ist der Tag des Herrn (Kreutzer); Air from Die Königs-kinder (Humperdinck); Mendelssohn Potpourri (Fetras). 1.40, Talks and Orchestral Music. 2.40, Concert. Driel (Violin), Brink-Prakken (Flute), de Nobel (Cello) and Mlle. Leenwen (Pianoforte); Flute and Pianoforte: Sonata in F (Loeillet); Cello Solo: Sonata in D minor (Corelli); Flute, Violin and Pianoforte: Sonata in G minor (Loeillet); Gramophone Music. Andante from the Violin Concerto in D (Mozart); Sonata in D (Mozart); Trio in G (Mozart); Gramophone Music; Madrigal (Albéniz); Flute and Pianoforte: Spring (Turina); Sicilienne and Pastorale (Bonis). 4.40, Programme for Children. 5.40, Agricultural Talk. 6.10, Programme to be announced. 6.40, Police Report. 6.55, Ecclesiastical Notes. 7.10, Gramophone Music. 7.40, Gramophone Music. 8.40, Talk. 9.10, Concert by the N.C.R.V. choir. In the interval at 9.25, News. 10.10, Gramophone Music. 11.10 (approx.), Close Down.

HORBY.—See Stockholm.

## HUIZEN

Announced HILVERSUM, 160 kc/s, 1,875 metres; 7 kW. (until 3.40 p.m.). Transmitted from Kootwijk on 50 kW. from 3.40 p.m.—11.40 a.m. till Close Down, Programme of the Workers' Radio Society (V.A.R.A.). 11.40, Gramophone Music. 11.55, Concert by the Small Station Orchestra, conducted by de Groot: Overture, The Secret Marriage (Cimarosa); Peasant Suite (Albott); Reve (d'Amhrosio); Marionetten auf der Spieluhr (Arimandola). 12.25 p.m., Concert by De Flierefuiters. 12.55, Concert by the Small Station Orchestra (cont'd.): The Skaters' Waltz (Waldteufel); Lullaby (Bizet); Duet (Bizet); Grieg Potpourri (Urbach). 1.25, Concert by De Flierefuiters (cont'd.). 1.55, Gramophone Music. 2.10, Organ Recital by Steyn. 2.40, Programme for Children. 5.10, Concert by De Notenkrakers: Gipsy Csardas (Michiels); Hungarian Dances Nos. 1 and 7 (Brahms); Melody (Dvorák); Nuit d'étoiles (Debussy); Suite (Dvorák); Gramophone Records: Two Spanish Dances (Moskovsky); Spanish Charm (Mezcapo); Spanish Rhapsody (Richardy); El torero (Lucchesi); Habanera (Barbot); Sautiango (Corbin-Normann); Nino de la Palma (Lucchesi). 6.10, Concert of Light Music. 6.40, Topical Talk for Workers. 6.55, Concert by de Flierefuiters, with Esther Ephraim (Songs). 7.25, Gramophone Music. 7.35, S.O.S. Messages. 7.40, Talk. 8.10, Concert by the Station Orchestra, conducted by de Groot. Soloist: Leydensdorff (Violin): Overture, Prometheus (Beethoven); Violin Concerto in G (Bruch); Selection from Boahdill (Moskovski); Hungarian March (Liszt). 9.10, News. 9.25, Song Recital by Ankele Tosnerova and Tummers. 9.40, Concert (cont'd.): Overture, La Dame blanche (Boieldieu); Scènes pittoresques (Massenet); Waltz from the Serenade, Op. 48 (Tchaikovsky); Mon rève (Waldteufel); Maxim March (Lehar). 10.25, Song Recital (cont'd.). 10.40, Gramophone Music. 11.40 (approx.), Close Down.

INNSBRUCK.—See Vienna.

## JUAN-LES-PINS

1,205 kc/s, 249 metres; 0.8 kW.—8.0 p.m., Amusement Guide, Exchange, Racing Results and News. 8.5, Oceanographic Report.

8.15, Tourist Talk. 8.30, Radio Concert. In an interval at 9.0, News and Weather.

KALUNDBORG.—See Copenhagen.

KIEL.—See Hamburg.

KLAGENFURT.—See Vienna.

KOSICE.—See Prague.

## LANGENBERG

635 kc/s, 473 metres; 60 kW.—12 Noon, Variety Concert. 1.15 p.m., Announcements. 1.30, Concert by the Remscheid Municipal Orchestra, relayed from Remscheid. Conductor: Felix Oberboeck. Schlageter-Nationalmarsch (Klein); Overture, Don Pasquale (Donizetti); Waltz, Die Dynamiden (Strauss); Concertino (Mozart); Selection from Preciosa (Weber); Extracts from The Seven Words from the Cross (Haydn); Unter dem Grillenbanner (Lindemann). In an interval at 2.0 (approx.), Announcements. 3.0, Handwork Lesson. 3.30, Economic Notes and Time. 3.50, Programme for Young People. 4.30, Talk: The Lower Rhine. 4.45, Programme for Women. 5.5, Dance Music, conducted by Eysoldt. 6.15, Authors' Voices on Gramophone Records. 6.45, Weather and Sports Notes. 7.0, Transmission for all German Stations, relayed from Frankfurt. 8.0, Announcements. 8.5, Bunte Stunde. 9.5, Concert by the Station Orchestra, conducted by Kuhn. Soloists: Walter Schneiderhan (Violin) and Robert Grote (Cello). Military March in E flat (Schubert); Czardas, Heire Kati (Hubay); Potpourri, Wiener Spaziergange (Komzak); Flower Dance from Naila (Delibes); Cello Solo: Allegro and Andante (Goltermann); Austrian Folk Dances (Pachernegg); Persian March (Strauss). 10.5, News. 10.30, A Flying Visit. 10.45, Chamber Music by the Cologne Viola Society, the Station String Quartet and Soloists: Suite in G, Op. 17, for Five Violas (Schein); Dances for Viola da Gamba and Harpsichord (Schenk); Suite, Lustige Feldmusik (Krieger) for Four Violas, Two Oboes, cor anglais and Bassoon; Waltz for Guitar and Flute; Five Country Dances (Mozart); Pianoforte Quintet (Dvorák). In an interval, Bass Songs and Ballads by Strienz. LAUSANNE.—See Radio-Suisse Romande.

## LEIPZIG

769.9 kc/s, 389.6 metres; 120 kW. Relayed by Dresden, 941 kc/s, 319 metres.—12 Noon, Weather and Time. 12.5 p.m., Concert by the Chemnitz Orchestra, conducted by Werner. In the interval at 1.15, News and Programme Announcements. 2.0, News. 2.30, Talk: Motor-Car and Driver 3.0, Concert by Young Musicians—Thilde Sammet (Contralto) and Irene Pretsch (Pianoforte). 3.35, Market Prices and Weather. 4.0, Programme for Young People. 5.50, Economic Notes, Weather and Time. 6.0, Book Review. 6.20, An Opera on Gramophone Records. 6.50, Review of the Day's Events. 7.0, Transmission for all German Stations, relayed from Frankfurt. 8.0, Concert by the Station Orchestra. Conductor: Blumer (Pianoforte). Soloist: Ilana Kuz (Baritone). Overture, Undine (Lortzing); Two Songs (Schubert): (a) An die Musik, (b) Der Lindenbaum. Pianoforte Solos: Valse sentimentales Op. 50 (Schubert); Hungarian Dances Nos. 5 and 6 (Brahms); Two Songs (Brahms): (a) Wiegenlied, (b) Mein Mädle hat einen Rosenmund; Overtüre, Die Fledermaus (Strauss); Ballad, Tom der Reimer (Loewe); Selection from Hansel and Gretel (Humperdinck). 9.0, Opportunity—Radio Play (Loder). 10.15, News and Sports Notes. 10.20, Concert by the Ende Orchestra. Teuton March (Lilling); Overture, Eine Vision (Lehar); Intermezzo, Elfengeflüster (Rhode); Tyrolese Potpourri (Fetras); Intermezzo (Grothe); Waltz Nordsee-stürme (Döring); Folk Songs and Fairy Tales (Komzak); Selection from Der Vagabund (Zeller); Tango, Edith (Krüger); Bavarian Waltz (Hinterstübl); Foxtrot, Heimat am Rhein (Doelle); Potpourri, Aus der Zeit der junge Liebe (Komzak); March, Frohsinn (Blankenburg). 12 Midnight, Close Down.

LINZ.—See Vienna.

## LJUBLJANA

522 kc/s, 574.7 metres; 7 kW.—6.0 p.m., Concert of Chamber Music by a String Quartet. 7.0, Talk: Religions of the World. 7.30, Literary Talk. 8.0, Programme from the Opera House. 10.0, Weather and News. 10.30 to 11.0, Programme in English by the I.B.C. Concert: For you, Rio Rita; Sweet Amanda; In Santa Lucia; Rosa Mia; Flower of Spain; Zingarette; Someone to care for; This is no Dream. 11.0 (approx.), Close Down.

## LUXEMBOURG

252 kc/s, 1,191 metres; 200 kW.—12.30 p.m., Concert by the Station Orchestra, conducted by Henri Pensis: Overture, Oberon (Weber); Salut d'Amour (Elgar); Lyric Suite (Grieg); Waltz, The Blue Danube (Joh. Strauss); Selection from La Bohème (Puccini). 1.30, Gramophone Concert of Variety Music. 7.30,

till Close Down, Luxembourg Programme. 7.30, Concert by the Station Orchestra, conducted by Henri Pensis. Soloist: Alexandre Zakia (Pianoforte). Pianoforte Concerto in E flat (Gebhardt); One Day (Pakay); Overture, Maritana (Wallace); Selection from The Merry Widow (Lehar). 8.20, Recital of Luxembourg Songs by Auguste Donnen. 8.50, News in French. 9.0, Viola Recital by Marie Braum: Sonata in C minor (Bach); Elégie (Vicuxtemp). 9.20, Concert by the Station Orchestra, conducted by Henri Pensis: The Nutcracker Suite (Tchaikovsky); Minuet (Paderewsky); Boxe (Schoenmaker). 9.50, News in German. 10.0, Variety Music on Gramophone Records. 10.30, Dance Music by the Station Jazz Band, conducted by Ferry Jusa.

## LYONS

LA DOUA, 644 kc/s, 465.8 metres; 1.5 kW.—6.30 p.m., Radio Journal. 7.30, Radio Gazette for Lyons and the South-East. 8.30, Orchestral Concert. After the Concert, News.

## MADRID

EAJ7, 707 kc/s, 424.3 metres; 2 kW.—8.0 p.m., Chimes, Exchange, Radio Journal, Programme for Women, Gramophone Records, and Dance Music relayed from the Alkazar Dance Hall. 9.15, Topical Review. 9.30 to 11.0, Interval. 11.0, Chimes, Time Signal and Topical Review. 11.20 (approx.), La Verdad Sospechosa—Play (Alarcón), with an Introductory Talk. 1.15 a.m. (Thursday), Topical Review. 1.30, Chimes and Close Down.

MALMO.—See Stockholm.

MILAN.—See Turin.

## MORAVSKA-OSTRAVA

1,137 kc/s, 263.8 metres; 11 kW.—6.20 p.m., Gramophone Music. 6.25, Tenor Solos by Otakar Macha. 7.0, See Prague. 10.15 (approx.), Close Down.

## MOSCOW

(TRADES UNION), 300 kc/s, 1,000 metres; 100 kW.—11.45 a.m., Weather. 2.45 p.m., Weather. 3.0, Literary and Musical Programme with Gramophone Records. 4.0, Topical Talk. 4.30, Literary Programme. 5.30, Technical Talk. 6.30, Music Hall Programme. 9.0, News. 9.30, Programme Announcements. 9.55, Chimes. 10.5, Press Review.

MOTALA.—See Stockholm.

MUHLACKER.—See Stuttgart.

## MUNICH

563 kc/s, 533 metres; 60 kW. Relayed by Augsburg and Kaiserslautern, 536 kc/s, 560 metres; and Nürnberg, 1,256 kc/s, 239 metres.—12 Noon, Concert conducted by Erich Kloss. 1.15 p.m., Time and News. 1.30, Zither Recital by Bachofner. 2.0, Time and News. 2.20, Programme arranged by the Post Office with Gramophone Records. 3.0, Concert by the Munich Chamber Orchestra, conducted by Friedrich Rein. 4.0, Weather and Agricultural Report. 4.10, Programme for Children. 4.40, Orchestral Concert, conducted by Willy Ehrmann: Overture, Oberon (Weber); Kaiserwalzer (Joh. Strauss); Erzhoj-Johann Lied (Trauer); 's Rösler vom Wörthersee (Koschat); Extracts from the Peer Gynt Suite (Grieg); Crescendo (Lasehen); Potpourri (Rhode); Waltz, Die ersten Gedanken (Lanner); Bayerischer Oberland Marsch (Wanker). 5.45 (from Nürnberg), Nature Talk. 6.5 (from Nürnberg), Pianoforte Sonata in B minor, Op. 12 (Roselius), played by the Composer. 6.25, Reading: The Victoria Falls (Paul Lohrbach). 6.45, Time, Weather and Agricultural Report. 7.0, Transmission for all German Stations, relayed from Frankfurt. 8.0, Begone dull care!—Musical Radio Potpourri by the Wireless Orchestra, conducted by Karl List, the Little Radio Orchestra, conducted by Erich Kloss, the Radio Choir, Lilly Preisig (Soprano), Karl Groll (Tenor), and Franz Baumann (Tenor). 10.20, Time and News. 11.0, Concert from Leipzig. 12 Midnight, Close Down.

NAPLES.—See Rome.

NOTODDEN.—See Oslo.

## OSLO

277 kc/s, 1,083 metres; 60 kW. Relayed by Fredrikstad, 815 kc/s, 368.1 metres; Hamar, 522 kc/s, 574.7 metres; Notodden, 671 kc/s, 447.1 metres; Porsgrund, 662 kc/s, 453.2 metres; and Rjukan, 671 kc/s, 447.1 metres.—5.30 p.m., Song; Violin and Pianoforte Recital: Melody (Hensent); Granada (Albeniz); Scherzo and Caprice for Pianoforte (Mendelssohn); Anderssen and Alnaes Songs; Violin Solo: Souvenir de Moscou (Wieniawski). 6.30, Programme for Boys. 7.0, Advertising Notes, Weather and News. 7.30, Talk on Science. 8.0, Time Signal. 8.1, Concert by the Station Orchestra, conducted by Ingo Kraun: Overture, Patrie (Bizet); The Crown of India (Elgar); Largo from the Fifth Symphony (Dvorak); Bacchanale (Saint-Saëns); Romantic Suite (Niemann). 9.0, Talk on Politics. 9.20, Gramophone

SEPT. 27th **WEDNESDAY** continued

Music. 9.30, Agricultural Report. 9.40, Weather Report and News. 10.0, Topical Talk. 10.15, Popular Concert.

**OSTERSUND.**—See Stockholm.  
**PALERMO**

558 kc/s, 537.6 metres; 3 kW.—8.0 p.m., Dopplavoro Announcements, Tourist Talk, Agricultural Notes, and Giornale Radio. 8.20, Gramophone Music. In the interval at 8.30, Time and Announcements. 8.45, A Midsummer Night's Dream—Play in Four Acts (Shakespeare). In the intervals, Gramophone Music. 11.0, Giornale Radio.

**PARIS**  
**EIFFEL TOWER, Call FLE, 207.5 kc/s, 1,445.7 metres; 13 kW.** Time Signals (on 2,650 metres) at 10.26 a.m. and 11.26 p.m. (Preliminary and 6-dot Signals).—6.45 p.m., Theatre Talk. 7.0, Le Journal Parle. 8.30, Symphony Concert, conducted by Flamant: Soloist: Georges Gabor (Pianoforte); Suite for Three Violins, Viola, Cello and Double-Bass (Lindsay Seymour); Pianoforte Concerto in C Minor (Beethoven); Radio Symphony (Flamant); Pianoforte Solo: Allegro Barbare (Bartok); Symphonic Variations from Le festin de l'araignée (Roussel); Overture, La dame blanche (Boieldieu). 10.0 (approx.), Close Down.

**PARIS**  
**POSTE PARISIEN, 914 kc/s, 328.2 metres; 60 kW.—7.0 p.m., Galli-Curci Song Recital on Gramophone Records: Arias from (a) The Barber of Seville (Rossini), (b) Rigoleto (Verdi), (c) Philémon et Baucis (Gounod); Cantata (Scazzati). 7.15, Le Journal Parle. 7.30, Poetry and Music—Recital by Rosine Morzate, M. Dorival and M. Lehmann; Le parlon (Chaumet); Un Evangile (François Coppée—Thomé); La petite Margot (Louis Bourry-Saudré); The Dairymaid and the Milk Jug (La Fontaine). 8.0, Talk on Wireless Interference. 8.5, Assurance Societies' Report. 8.35, Une danseuse est morte—Play (Le Bary). 10.30, Dance Music relayed from the Lido. 11.0, News.**

**PARIS**  
**RADIO PARIS, Call CFR, 174 kc/s, 1,725 metres; 75 kW.—7.30 a.m., Weather and Physical Culture. 7.45, Gramophone Music. 8.0, Weather and Press Review. 12.0 Educational Programme. 12.15 p.m., Gramophone Music: Alleluia d'amour (Fauré); Charité (Fauré); Le crucifix (Fauré); Berceuse from Jocelyn (Godard); Sérénade printanière (Holmes). 12.30 p.m., Art Notes followed by Organ Recital, relayed from the Gaumont Palace. 1.0, Exchange, News and Weather. 1.5, Gramophone Music (cont'd.): Part 1: Florent Schmitt Programme: La Tragedie de Salomé; Dionysiaques; Rapsodie viennoise. Part II: Ewig Liebe (Brahms); Vergiliches Ständchen (Brahms); La procession (César Franck); Die Lorelei (Liszt); Liebeslied (Liszt). In the interval at 1.30, Exchange. 2.0, Exchange. 3.45, Exchange and Market Prices. 7.0, Agricultural Report. 7.10, Gramophone Concert: Selection from Le jour et la nuit (Lecocq); Funiculi, Funicula (Denza); Quand referira le lilas blanc; Hoheitzzug in Liliput (Translaten); Les sapins (Dupont); Selection from The Girl in the Taxi (Gilbert); Marche lorraine (Ganne). 7.50, Commercial Notes and News. 8.0, Recitation of Poems on Gramophone Records. 8.30, News and Weather. 8.40, Fashion Talk. 8.45, Vocal Quartet Concert. 9.15, Press Review and News. 9.30, Gramophone Concert: Symphonic Poem, Psyche (César Franck); Songs: (a) Aria from The Magic Flute (Mozart), (b) Pyramus and Thisbe (Trémisot), (c) Moi (Hahn); Symphonic Poem, Steinka Razin (Glazunov); Ballet, La ronde des saisons (Blusser); Marche écossaise (Debussy).**

**PITTSBURGH**  
**KDKA, 980 kc/s, 306 metres; 50 kW.** Relay by W8XK on 48.86 metres and 25.27 metres.—7.30 p.m., Pontiac, Home Forum. 8.0 to 9.30, New York Relay. 8.0, Betty and Bob. 8.15, Utility Hall. 8.30, Dixie Days. 9.0, Southern Symphonies. 9.30, Frances Ingram. 9.45, News, Markets. 10.0, Uncle Tom and Betty. 10.15, KDKA Kiddies' Klub. 10.30, The Singing Lady, from New York. 10.45, Orphan Annie, from New York. 11.0, News and Talk. 11.15, Sports. A Song. 11.30, Pittsburgh Spotlights. 11.45, Lowell Thomas, from New York. 12 Midnight, Amos 'n' Andy, from New York. 12.15 a.m. (Thursday), Rhythm Kings. 12.30 to 3.30, New York Relay. 12.30, Richard Himber's Orchestra. 1.0, Crime Chases. 1.30, Potash and Perlmutter. 1.45, Red Davis. 2.0, American Legion. 2.30, Ortiz Tirado. 3.0, Quest of Perfect Woman.

**PORSGRUND.**—See Oslo.

**PRAGUE**  
614 kc/s, 488.6 metres; 120 kW.—2.50 p.m., Concert by the Station Orchestra: Foxtrot, from Son of the Think (Miro Mosay); Overture, Raymond (Gabriel Marie); Italian Suite, in the Bay of Naples (Ellenberg); Mazurka from Polen Blut (Nedbal); Potpourri of Hunting Songs (Vackar); Waltz, Reminiscence (Kozak). 3.50, Aviation Weather Report. 3.55 to 4.0, Exchange. 5.45, Gramophone Music. 5.55, Talk: With a Yacht

through the Egean Sea. 6.5, Agricultural Report. 6.15, Talk for Workers. 6.25, News in German. 6.30, German Transmission: Programme for Children and Talk for Workers. 7.0, Chimes and News. 7.10, Topical Talk. 7.25, Round the World on Gramophone Records—Africa. 7.50, Nannette's Wedding—Play in Three Acts (Podhorska, after the Book by Herrmann). 9.30, String Quartet in E minor, Op. 41, No. 2 (Mendelssohn), by the Ondricek Quartet. 10.0, Time and News. 10.15, News in French. 10.30 (approx.), Close Down.

**RADIO-SUISSE ROMANDE**  
**SOTTENS, 743 kc/s, 403 metres; 25 kW.; and Geneva, 395 kc/s, 760 metres.—6.15 a.m. to 6.30 (from Lausanne), Gymnastics. 12.28 p.m., Time Signal from the Neuchâtel Observatory. 12.30, News and Weather. 12.40 (from Lausanne), Gramophone Music. 1.0 (from Lausanne), Financial Notes. 1.10 (from Lausanne), Gramophone Music. 2.0, Interval. 3.28, Time Signal from Neuchâtel Observatory. 3.30 (from Geneva), Gramophone Concert. 5.0, Interval. 6.0, Programme for Children. 7.0 (from Lausanne), Talk: The Part Played by Portugal in the History of Civilisation. 7.25 (from Lausanne), Announcements and Weather. 7.30, Agricultural Talk. 8.0, Concert by the Radio-Suisse Romande Orchestra, conducted by Echenard: Overture and Ballet Music from Prometheus (Beethoven); The Italian Symphony (Mendelssohn); Light Music. 9.0 (from Lausanne), Readings. 9.20, Concert of Light Music. 9.50, News and Weather. 10.0 (from Lausanne), Dance Music by the Station Orchestra. 10.30 (approx.), Close Down.**

**RJUKAN.**—See Oslo.

**ROME**  
**Call IRO, 680 kc/s, 441 metres; 50 kW.** Relay by 2RO, 11,810 kc/s, 25.4 metres from 5.0 p.m.; Bari, 1,112 kc/s, 269.8 metres; Milan (Vigentino), 662 kc/s, 453.2 metres from 8.45 p.m.; and Naples, 941 kc/s, 319 metres.—12.30 p.m., Gramophone Music. 1.2 to 2.15, Orchestral Concert. In the intervals at 1.30, Giornale Radio and Exchange, and 2.0, Time and Announcements. 4.30, Children's Radio Review. 4.55, Giornale Radio, Exchange and Report of the Royal Geographical Society. 5.10, Weather. 5.15 to 6.0, Orchestral Concert: Rumba (Clarey-D'Anzi); Soleika (Chesi); Chorus and Wedding March from Lohengrin (Wagner); Lungi tu sei (Gardel-Ciollotta); Sérénade (Manno-Gauwin); Selection from La Bohème (Puccini); Melody (Porter); Bachalana (Azzoni). 6.40 (from Naples), Shipping and Sports Notes. 6.45, Dopplavoro Report and Tourist Notes. 6.57, Report of the International Institute of Agriculture (in Italian and English). 7.10, Agricultural Notes. 7.20, News in Foreign Languages. 7.40, Giornale Radio. 8.0, Time, Announcements and Gramophone Music. 8.15, Medical Talk. 8.30, Giornale Radio and Sports Notes. 8.45, Fantasia—One Act Comedy (Luca d'Ambra), with incidental Music. 9.15, Soprano Solos by Maria Sones: Aria from The Wily Widow (Wolff-Ferrari); Il grillo del Natale (Zanella); Aria from I Puritani (Bellini). 9.50, Gramophone Concert: Symphonic classique in D, Op. 25 (Prokofiev); Barcarolle from Cleopatra (Mancinelli); Fugue from the Suite Scene veneziane (Mancinelli); Introduction and Wedding Procession from The Golden Cockerel (Rimsky-Korsakov); Ballet Music from Le botticelle fantasque (Rossini-Respighi). 10.30, Dance Music. 11.0, Giornale Radio.

**SALZBURG.**—See Vienna.

**SCHENECTADY**  
**WGY, 790 kc/s, 379.5 metres; 50 kW.** Relay at intervals by W2XAF on 31.48 metres and by W2XAD on 19.56 metres.—8.20 p.m., Two Seats in the Balcony, from New York. 9.0, Grande Trio, from New York. 1.45 a.m. (Thursday), Stock Reports. 2.0 to 3.30, New York Relay. 2.0, Popular Programme. 2.30, Variety Programme. 3.0, Ferde Grofe's Orchestra. 3.15, Regimentalists. 3.30, Popular Programme. 4.0, Variety Programme, from New York. 4.30, Ship of Joy, from New York, followed by Programme Résumé.

**SCHWEIZERISCHER LANDESENDER**  
653 kc/s, 459 metres; 60 kW.; Basle, 1,229 kc/s, 244.1 metres; and Berne, 1,220 kc/s, 245.9 metres.—6.15 to 6.35 a.m. (from Basle), Gymnastics. 11.59, Time from Neuchâtel Observatory and Weather. 12 Noon, (from Zürich), Light Orchestral Concert. 12.30 p.m., Time, Weather and News. 12.40 (from Zürich), Orchestral Concert (cont'd.). 1.25 (from Zürich), Time, Weather and Exchange. 1.30 to 5.0, Interval. 5.0 (from Basle), Programme for Children. 5.30 (from Basle), Light Music on Gramophone Records. 6.30 (from Zürich), Programme for Women. 7.0 (from Zürich), Time, Weather and Market Prices. 7.10 (from Zürich), Gramophone Concert. 7.30, Elementary English Lesson. 8.0

(from Zürich), The Swiss Psalm—(Concert. 9.0, Weather and News. 9.10 (from Zürich), Concert by the Station Orchestra, conducted by Neppach. 10.15 (approx.), Close Down.

**SOTTENS.**—See Radio-Suisse Romande.

**STOCKHOLM**  
689 kc/s, 436 metres; 55 kW. Relay by Boden, 244 kc/s, 1,229.5 metres; Göteborg, 932 kc/s, 322 metres; Hörby, 1,166 kc/s, 257 metres; Motala, 221.5 kc/s, 1,354.4 metres; Östersund, 389 kc/s, 770 metres; and Sundsvall, 554 kc/s, 542 metres.—5.5 p.m., Sextet Concert of Light Music: March (Costa); Romantic Overture (Kéler Béla); Waltz, Donauwellen (Yvanovitch); Potpourri (Sjöberg); Romance (Kuntze); Mazurka (Sjöberg); Intermezzo (Macheth); Melody (arr. Willners); Piece (Peter). 5.45, Reading. 6.15, Gramophone Music. 7.15, Weather and News. 7.30, Cabaret Programme. 8.30, Talk, relayed from Malmö, 1,301 kc/s, 231 metres. 9.0, Symphony No. 3 in E Flat, Op. 55 (Beethoven), relayed from the Concert Hall. Conductor: Václav Talich. 9.45, Weather and News. 10.0, Dance Music. 11.0 (approx.), Close Down.

**STRASBOURG**  
869 kc/s, 345 metres; 11.5 kW.—11.30 a.m., Classical Music on Gramophone Records. 12.45 p.m., News. 1.0, Time and Exchange. 1.5, Light Music on Gramophone Records. 2.0, Interval. 4.45, Talk in German on Electricity. 5.0, Orchestral Concert, conducted by Roskam: Waltz, Winterstürme (Fueki); Overture, Die schöne Galathee (Suppe); Träume (Wagner); Selection from La Favorita (Donizetti); La chanson des boilles (Filipucci); Minuet, Gracienx page (Delannaye); Selection from Lilac Time (Schubert-Berté); March, Salut à la France (Scassola). 6.0, Trio Concert, relayed from Lille, 1,130 kc/s, 265.4 metres. 7.0, Talk: French Wines. 7.15, Talk in German on Handicrafts. 7.30, Time and News. 7.45, Gramophone Music. 8.0, Press Review in German, Lottery Results and Announcements. 8.30, Three One-Act Operettas: (a) La chanson (Missa), (b) Les deux Pêcheurs (Offenbach), (c) Le violonux (Offenbach). In the interval at 9.30 (approx.), Press Review. 10.30, Orchestral Concert, relayed from the Grand Kléber Tavern: March, Lille (Lettellier); Waltz from Gipsy Love (Lelair); Overture, La belle Hélène (Offenbach); Selection from Countess Maritza (Kálmán); Fantasia, Les airs de Christine (Salabert); Potpourri, Freut euch des Lebens (Lincke); Vibrations Solo; March, Folles Bergère (Lincke). 11.0 (approx.), Close Down.

**STUTTGART**  
**MUHLACKER, 832 kc/s, 360.5 metres; 60 kW.** Relay by Freiburg, 527 kc/s, 570 metres.—1.30 p.m., Song Recital on Gramophone Records: Guten Abend, gut' Nacht (Brahms); Maria sitzt am Rosengang (Reger); Wie sich der Aenglein kindlicher Himmel (Schubert); Tom der Reimer (Loewe); Wedding Song; Traum durch die Dämmerung (R. Strauss); Ich schwebte (R. Strauss); Mondnacht (Schumann). 2.0, Concert arranged by the Post Office. 2.30, Interval. 3.30, Programme for Children. 4.40, See Munich. 5.45, Humorous Dialogue. 6.0, Talk: Joy in Work or Enslavement by Machinery? 6.20, Gramophone Music. 6.35, Time and News. 7.0, Transmission for all German Stations relayed from Frankfurt. 8.0, Talk: What everyone should know. . . . 8.5, Concert by the Station Orchestra, conducted by Gustav Grölich. 9.30, Bavarian Humour on Gramophone Records. 10.10, Time and News. 10.45, Concert from Leipzig. 12 Midnight, Close Down.

**SUNDSVALL.**—See Stockholm.

**TOULOUSE**  
**RADIOPHONIE DU MIDI, 779 kc/s, 385 metres; 8 kW.—6.0 p.m., News. 6.15, Music by an Argentine Band. 6.30, Orchestral Music: Andante from the Quartet in G Minor (Debussy); Cheriza (Breton); Moment musical (Schubert); Overture, Poet and Peasant (Suppe); Air from the Suite in D (Bach); March (Stravinsky). In the interval at 6.50, Talk. 7.15, News, Racing Results, Market Prices and Exchange. 7.30, Overture, Tannhäuser (Wagner). 7.45, Songs. 8.0, Military Music. 8.15, Operetta Music: Songs from (a) Ciboulette (Hahn), (b) Les mousquetaires au couvent (Varney), (c) Veronique (Messager), (d) Paganini (Lelair). 8.30, Orchestral Music. 8.45, Opera Music: Arias from (a) The Tales of Hoffmann (Offenbach), (b) Figaro (Mozart), (c) Il Trovatore (Verdi), (d) Tannhäuser (Wagner). 9.0, Old-Time Dance Music. 9.30, Light Music. 9.45, Concert by a Viennese Orchestra. 10.15, North African News and Local News. 10.30, Concert for Listeners in Morocco. 11.0, Opera Music: Arias from (a) Werther (Massenet), (b) The Fair Maid of Perth (Bizet), (c) Sappho (Massenet); Duet from Le châtelet (Adam). 11.15, Dance Music.**

12 Midnight, News, Weather and Announcements. 12.5 a.m. (Thursday), Orchestral Music: Danse macabre (Saint-Saëns); Jubel-Önvertüre (Brahms); Selection from Schwanda the Piper (Weinberger). 12.30 (approx.), Close Down.

**TRIESTE**  
1,211 kc/s, 247.7 metres; 10 kW.—5.10 p.m., Concert: Bruno Degraasi (Pianoforte), Ettore Sigon (Cello), and Enrico Martucci (Pianoforte): English Suite in A Minor for Pianoforte (Bach); Cello and Pianoforte Duets: (a) Adagio from the Toccata in C (Bach-Stutschewsky), (b) Minuet from the Haffner Serenade (Mozart-Stutschewsky), (c) Gavotte (Francoeur-Stutschewsky); Pianoforte Solos: (a) Nocturne (Respighi), (b) Moto perpetuo (Weber); Cello and Pianoforte Duets: (a) Two Melodies (Tausman), (b) Exotic Dance (Jeral). 6.0 till Close Down, See Turin.

**TRONDHEIM.**—See Oslo.

**TURIN**  
1,096 kc/s, 273.7 metres; 7 kW. Relay by Milan, 905 kc/s, 331.5 metres; Genoa, 959 kc/s, 312.8 metres; and Florence, 589 kc/s, 500.8 metres.—5.10 p.m., See Trieste. 6.0 to 6.5, Weather. 6.35, Giornale Radio, Dopplavoro Announcements and Gramophone Music. 7.0, Time, Tourist Report and Gramophone Music. 7.40, Agricultural Notes and Market Prices. 7.50, News in Foreign Languages. 7.40, Gramophone Music. 8.0, Announcements, Giornale Radio and Weather. 8.20, Talk on the following Transmission. 8.30, Il Pirata—Opera in Two Acts (Bellini). In the intervals, Talk, Art Notes and Giornale Radio.

**VATICAN CITY**  
15,120 kc/s, 19.84 metres (Morning) and 5,969 kc/s, 50.26 metres (Evening); 10 kW.—11.0 to 11.15 a.m., Religious Information in Spanish. 8.0 to 8.15 p.m., Religious Information in Italian.

**VIENNA**  
581 kc/s, 517 metres; 100 kW. Relay by Graz, 852 kc/s, 352.1 metres; Innsbruck, 1,058 kc/s, 283 metres; Klagenfurt, 662 kc/s, 453.2 metres; Linz, 1,220 kc/s, 245.9 metres; and Salzburg, 1,373 kc/s, 218.5 metres.—12 Noon, Concert by the Wiener Symphoniker conducted by Holzner. In the interval at 1.0 p.m., Time, Weather and Announcements. 2.0, Interval. 3.0, Time, Weather and Exchange. 3.20, Talk: Poultry-keeping in the Suburbs. 3.30, Talk: Animals' Homes. 3.55, Music from Sound Films on Gramophone Records. 4.20, Programme for Young People. 4.45, Talk for Parents. 5.10, Concert of Contemporary Music by Austrian Composers—Josef Lechtlialer, The Sedlak-Winkler Quartet and Erika Rokyta (Soprano). Three Songs: (a) Bitte, (b) Maria mein, im Rosenlag, (c) Der Herr ist mit dir; String Quartet, Op. 20. 5.55, Talk: Labour and Industry in the Mountains. 6.20, Wine-growing and Vintages 2,000 Years ago. 6.45, Pachernegg Concert by the Wiener Symphoniker, conducted by the Composer: Styrian Dances, Op. 35; German Baroque Suite: Hunting Music; Three Bavarian Dances; Austrian Peasant Dances; Old Styrian Dance; Waltz, Stories from the Enns Valley; Fantasia of Alpine Songs. In the interval at 7.25, Time, Weather and Announcements. 7.55, Reading: In Praise of Autumn. 8.20, See Turin. In the interval at 9.20 (approx.), News, Weather and Exchange. After the Programme, Exchange.

**WARSAW**  
212.5 kc/s, 1,411 metres; 120 kW.—11.57 a.m., Time Signal and Fanfare from Torun Cathedral. 12.5 p.m., Gramophone Music. 12.25, Polish Press Review. 12.33, Weather Report. 12.35, Gramophone Music. 12.55, Radio Journal. 1.0-2.55, Interval. 3.5, News. 3.10, Announcements. 3.15, Gramophone Music. 3.25, Economic Notes. 3.35, Gramophone Music. 3.45, Announcements. 4.0, Gramophone Music. 5.0, Topical Talk. 5.15, Song and Cello Recital by Mmes. Korf and Adamska: Cello Solos: Aria from (a) I Capuletti ed i Montecchi (Bellini), (b) Don Pasquale (Donizetti), (c) Tarantol (Puccini); Cello Songs: (a) Potpourri dois-je t'aimer (Rybiicki), (b) Mes chansons (Zelenki), (c) Two Songs (Rachmaninov). 6.15, Talk relayed from Lwów 788 kc/s, 381 metres. 6.40, Light Music relayed from the Gastronomica Café. 7.20, Miscellaneous Items. 7.35, Programme Announcements. 7.40, Reading. 8.0, Answers to Agricultural Correspondence. 8.15, Orchestral Concert, relayed from the Conservatoire: Fantasia for String Orchestra and Organ (Zelenki); Concerto in D minor for Violin, Oboe and Orchestra (Bach); Concerto in A minor for Organs (Vivaldi-Bach); Concerto in A for Violin and Orchestra (Vivaldi); Concerto grosso in G minor for Oboe and String Orchestra (Händel). In the interval, Radio Journal. 10.0, Dance Music. 10.25, Sports Notes. 10.35, Aviation Weather Report and Police Notes. 10.40, Dance Music (cont'd.).

**ZURICH.**—See Schweizerischer Landessender.

# THURSDAY

## SEPTEMBER THE TWENTY-EIGHTH

### PRINCIPAL EVENTS OF THE DAY:

#### AT HOME

**NATIONAL LONDON REGIONAL** "The Desert Song," a musical comedy, by Romberg. Promenade concert from Queen's Hall.

**MIDLAND REGIONAL** Orchestral programme from Leamington Spa.

**NORTH REGIONAL** "The Silent Witness," a play, by Whittie Kerr.

**WEST REGIONAL** A Nautical Medley: orchestral and choral programme.

**SCOTTISH REGIONAL** "Ceilidh," a gathering of some of the singers and story tellers attending the Glasgow Mod.

**BELFAST** In Lighter Vein, orchestral concert.

#### ABROAD

**BRUSSELS (No. 2)** 8.0 p.m. The Station Symphony Orchestra and the St. Dominique Choir, conducted by Kumps.

**BUDAPEST COPENHAGEN** 8.50 p.m. Cigany Band concert.

**HAMBURG** 8.10 p.m. The Radio Symphony Orchestra, conducted by Nicolai Malko.

**LUXEMBOURG POSTE** 7.0 p.m. Brahms concert; the Philharmonic Orchestra, conducted by J. Eibeuschütz.

**PARISIEN PRAGUE** 9.0 p.m. German music, by the Station Orchestra.

**ROME WARSAW** 9.15 p.m. Orchestral concert.

8.0 p.m. Dvorak concert from the Smetana Hall.

8.45 p.m. Opera: "Ruy Blas," by Marchetti.

8.0 p.m. The Station Orchestra, conducted by Nawrot.

#### BRNO

878 kc/s, 342 metres; 35 kW.—6.0 p.m. till Close Down, See Prague. 11.0 (approx.), Close Down.

#### BRUSSELS (No. 1)

I.N.R.; 590 kc/s, 509 metres; 15 kW.—12 Noon, Concert by the Small Station Orchestra, conducted by Leemans: Overture, Mari-tana (Wallace); Suite, La Cigale (Masse-net); Violin Solo, Minuet (Porpora-Kreisler); Divertissement on Popular Songs (Leemans); Spring Song (Mendelssohn); Selection from The Grand Mogul (Audran); Fantasia on Russian Airs (Douliez). 1.0 p.m., Le Journal Parlé. 1.10, Gramophone Music. 5.0, Concert by the Station Symphony Orchestra, conducted by Kumps: Overture, Mignon (Thomas); Selection from Lakmé; Selection from Aida (Verdi). 5.30, Programme for Children. 6.0, Talk: Art in the Home. 6.15, Gramophone Concert. Part I, Opera Music: Overture, The Crown Diamonds (Auber); Song from Mirella (Gounod); Aria from The Pearl Fishers (Bizet); Song from Louise (Charpentier). Part II, Operetta Music: Overture, Les Cloches de Corneville (Planquette); Two Airs from Die Fledermaus (Strauss); Duet from Miss Decima (Audran); Air from The Great Mogul (Audran); Chorus from Les Brigands (Offenbach). Part III: Five Comic Monologues. 7.15, Report for Workers. 7.30, Sports Notes. 8.0, Extracts from Lohengrin—Opera (Wagner), on Gramophone Records. 8.45, Talk. 9.0, Waltz Music by the Station Orchestra, conducted by Kumps: Künstlerleben (Strauss); Waltz from The Count of Luxembourg (Léhar); Invitation to the Waltz (Weber); Waltz from Mirella (Gounod), on Gramophone Records; Unter den Lindenbaum (Strauss); Waltzes from Gipsy Love (Léhar); Waltz from Romeo and Juliet (Gounod) on Gramophone Records; Waltz from The Chocolate Soldier (O. Straus); Waltz from The Merry Widow (Léhar). 10.0, Le Journal Parlé.

#### BRUSSELS (No. 2)

N.I.R.; 897 kc/s, 338.2 metres; 15 kW. Programme in Flemish. 12 Noon, Variety Music on Gramophone Records. 1.0 p.m., Le Journal Parlé. 1.10, Concert by the Small Station Orchestra, conducted by Leemans: Overture, Raymond (Thomas); Waltz, The Belles of Valencia (Moreno); Serenade (Malato); Selection from La Favorita (Donizetti); Knave of Diamonds (Steele); Selection from A Kiss in Spring (Kálmán); Gallop (Eilen-berg). 5.0, Gramophone Concert: Spanish Caprice (Rimsky-Korsakov); Italian Caprice (Tchaikovsky); Waltz, España (Chabrier); Joyeuse marche (Chabrier). 5.45, Programme for Children. 6.30, Concert by the Small Station Orchestra, conducted by Leemans. Soloist, Gilson (Flute). Overture, Phédre (Massenet); Waltz, The Blue Danube (Joh. Strauss); Serenade (Saint-Saëns); Concertino for Flute (Chaminade); Three Flemish Songs; Waltzes (Waldteufel). 7.12, News.

**ALGIERS**  
824 kc/s, 364 metres; 13 kW.—8.10 p.m., Shipping Notes. 8.15, Agricultural Report and Weather Forecast. 8.20, Opera Arias. 8.40, Lottery Results. 8.55, News. 9.0, Time. 9.2, Instrumental Concert. 9.45, News. 9.50, Talk: Strange Facts and Hobbies. 10.5, Song Recital. 10.35, News. 10.40, Music by an Argentine Orchestra. 10.55, News. 11.0, Concert of Oriental Music (on Gramophone Records).

#### ATHLONE

725 kc/s, 413 metres; 60 kW. Relayed by Cork, 1,337 kc/s, 224.4 metres.—1.30 to 2.30 p.m., Time Signal, Weather Report, Stock Exchange Quotations, and Gramophone Music. 6.0, Programme for Children. 6.40, News. 7.0, French Lesson. 7.15, Talk by Mab Hickman: Dublin Statues—Daniel O'Connell. 7.30, Time Signal. 7.31, Concert by the Station Orchestra. 8.0, The Studio Players. 8.30, Soprano Solos by Mollie Phillips. 8.45, Lecture Recital by Grace O'Brien. 9.15, The Station Orchestra. 9.30 to 10.30, Programme by the I.B.C. (Ireland), Ltd. 9.30, Balalaika Orchestra: Le Réve (Andrayef); The Red Saraphan (Leontieff); By the Riverside (Leontieff); The Song of the Volga Boatmen (Leontieff). 9.45, Vocal Concert: Jewel Song from Faust (Gounod); Two Arias from I Pagliacci (Leoncavallo); Aria from Rigoletto (Verdi). 10.0, Concert arranged by the International Broadcasting Company (Ireland), Ltd., on behalf of Hospitals Trust, Ltd.: The Mighty Deep (Guy); Xylophone Solo, The Blue Danube (Strauss); Jingle Drums (Ketelbey); Live, Laugh and Love (Heymann); Pianoforte Solo, Roumanian Piece (Hollbrooke); The Frog King's Parade (Marriot); The Tiger's Tale and When Melody Sings, from the Suite americana (Thurban). 10.30, I.B.C. Goodnight Melody, followed by Time Signal, News, and Weather Report. 10.40, Band Music. 11.0 (approx.), Close Down.

#### BARCELONA

EAJI, 860 kc/s, 348.8 metres; 8 kW.—7.0 p.m., Trio Concert. 8.0, Request Gramophone Records. 8.30, Exchange Quotations. 9.0, Gramophone Music. 9.20, Topical Talk, Gramophone Music and News. 10.0, Chimes from the Cathedral, Weather, Exchange Quotations and Market Prices. 10.5, Concert by the Station Orchestra: Oriental March (Ailbont); Waltz, Bluets et coquelets (Waldteufel); Melody (Cools); Overture, King Stephen (Beethoven). 10.30, Two One-Act Musical Plays: Agua, Azucarillos y Aguardiente (Chueca) and La Marcha de Cadix (Valverde). In the interval at 12 Midnight, News.

BASEL.—See Schweizerischer Landessender.

#### BELGRADE

697 kc/s, 430.4 metres; 2.8 kW.—6.55 p.m., Time and Announcements. 7.0, Talk. 7.30, Sonata for Clarinet and Pianoforte (Reger). 8.0, Gramophone Music. 8.30, Concert of Polish Music. 10.0, A Radio Play, followed by Cigany Music from the Zanatski Dom Restaurant.

#### BERLIN

DEUTSCHLANDSENDER (REICHSENDER), 183.5 kc/s, 1,635 metres; 60 kW.—2.0 p.m., Gramophone Concert of Popular Music. 2.45, A Dialogue between Mother and Child; The Sun, Moon and Stars. 3.10, Talk for Young People: Experiences with Germans in North Africa. 3.30, Weather and Exchange. 3.45, Reading (Justus Möser). 4.0, See Heilsberg. 5.0, Talk: The German Woman as Wife, Mother and Citizen. 5.20, Musicians as Humorists. Vocal and Instrumental Concert: Songs, (a) Schade, and (b) Phyllis (Teleman), (c) Anselmuccio and (d) Romaner (Schulz), (e) Eine sehr gewöhnliche Geschichte (Haydn), (f) Die alte and (g) Warnung (Mozart), (h) Der Kuss and (i) Flohelied (Beethoven); Ein musikalischer Spass, for two Violins, Viola, Bass and two Horns (Mozart); Country Dances, for two Violins and Bass (Beethoven). 6.0, Poems, 6.5, Reading (Gustav Jacobi). 6.30, Agricultural Programme. 6.50, Weather and Announcements. 7.0, Transmission for all German Stations, relayed from Hamburg. 8.0, Today's Motto. 8.5, Upstairs and Downstairs, Humorous Programme arranged by Hanns Dekner. 9.15, Septet (Beethoven), by the Berlin State Opera House Chamber Music Society, conducted by George Knielstädt. 10.0, News. 10.45, Weather. 11.0, Programme from Hamburg. 12 Midnight, Close Down.

#### BERLIN

FUNKSTUNDE, 715 kc/s, 419.5 metres; 1.5 kW.—5.50 p.m., Pianoforte Recital by Ferruccio Busoni, with commentary by Heinrich Burkard. Polonaise in A flat (Chopin); Rigoletto Paraphrase (Liszt); La Campanella (Liszt); Norma-Fantasia (Liszt). 6.30, A Call from Magdeburg. 6.40, The Funkstunde informs its Listeners. 6.45, Topical Talk. 7.0, Transmission for all German Stations, relayed from Hamburg. 8.0, Lottery Announcements. 8.5, Programme to be announced. 9.0, Programme of Dance Music by Ferdj Kaufmann and his Orchestra and the Julius Tausen Dance Band, with Soloists. In the interval: Music of the Streets. In an in-

7.15, Talk. 7.30, Talk for Housewives. 8.0, Concert by the Station Symphony Orchestra and the St. Dominique Choir. Conductor: Kumps; De Vlaamsche Leeuw (Miry); Benediction from La Baccée de la mer (Boeck); Choir: (a) Extracts from Cantata No. 4 (Bach), (b) Final Chorus from De Génies des Vaderlands (Benoit); Fantasia on Two Flemish Songs (De Boeck); Choir: (a) Er waren twee koningskinderen (De Boeck), (b) Zeg kwezelke wilde gij dansen? (De Boeck); Commemorative March (De Boeck). 8.45, Talk. 9.0, Gramophone Concert: March of the Nobles, from Tannhäuser (Wagner); Selection from Die tote Stadt (Korngold); Selection from The Jewels of the Madonna (Wolf-Ferrari); Overture, Le carnaval romain (Berlioz); Prelude to Act III of Lohengrin (Wagner); Overture, Tannhäuser (Wagner). In the intervals, Songs by Sterken. 9.55, Evening Prayer. 10.0, Le Journal Parlé.

#### BUCHAREST

761 kc/s, 394 metres; 12 kW.—5.0 p.m., Variety Music by the Dinco Orchestra. In an interval at 6.0, Radio Journal. 7.0, Educational Talk. 7.20, Light Music on Gramophone Records. 7.40, Talk. 8.0, Song Recital. 8.20, Symphony Concert by the Station Orchestra, conducted by Rogalski; Soloist, Maria Potino (Pianoforte); Overture, Im Herbst (Grieg); Concerto for Piano-forte and Orchestra (Mozart); Verklärte Nacht (Schönberg). In an interval at 9.0, Talk. 9.45, Radio Journal.

#### BUDAPEST

545 kc/s, 550.5 metres; 18.5 kW.—Also relayed on 840 metres from 8.0 p.m. till Close Down. 5.30 p.m., Song Recital by Tibor Weygand. 6.0, English Conversation. 6.30, Talk with Gramophone Illustrations: Harlem, the Negro Quarter of New York. 7.20, Pianoforte Duets by Josef Osby and Peter Solyomos; Sonata in D (Mozart); Fantasia in F Minor (Schubert); Cortège (Debussy); Waltz in F Sharp Minor (Johannany). 8.0, Review of Foreign Politics. 8.20, Talk. 8.50, Cigany Band Concert from the Keltler Restaurant. 10.15, Orchestral Concert, conducted by Fridl. March (Weinberger); Waltz, Paysage d'autonne (Waldteufel); Overture (Tid); Strauss-Millocker-Suppe Potpourri (Ziehrer); Die Lerehe und der Frosch (Eilenberg); Parade of the Tin Soldiers (Jessel); Potpourri (Pecsi); The Phantom Brigade (Mydleton); Selection from Die Prinzessin (Léhar). 11.0, Talk in French: Aquatic Sports in Hungary.

CASSEL.—See Frankfurt.

#### COPENHAGEN

1,067 kc/s, 281 metres; 0.75 kW. Relayed by København, 260 kc/s, 1,153.8 metres.—12 Noon, Time Signal and Chimes from the Town Hall. 12.2 p.m., Concert by Harald Andersen's String Ensemble, relayed from the Bellevue Strandhotel. 2.0, Interval. 3.10, Scandinavian Song Recital by Sonja Heyman. 3.30, Concert by Teddy Petersen's Orchestra, relayed from the Wivex Restaurant. 4.45, Programme for Boys. 5.30, Exchange and Fish Market Prices. 5.45, Talk: Reminiscences of a Danish Parson. 6.15, Elementary English Lesson. 6.45, Weather. 7.0, News. 7.15, Time Signal. 7.16, Talk. 7.45, Danish Lesson. 8.10, Concert by the Radio Symphony Orchestra, conducted by Nicolai Malko, relayed from the State Broadcasting Building. Soloist: Nathan Milstein (Violin). Symphonie classique (Prokofiev); Allegro Moderato from the Violin Concerto in D, Op. 35 (Tchaikovsky); Canzonetta (Tchaikovsky); Bolero (Ravel); Chaconne in D Minor (Bach); Caprice No. 17 in E Flat (Paganini); Caprice No. 5 in A Minor (Paganini); L'apprenti sorcier (Dukas). 10.15, News. 10.30, Reading. 10.50, Dance Music, conducted by Ange Juhl-Thomsen, relayed from the National Scala. In the interval at 12 Midnight, Time Signal and Chimes from the Town Hall. 12.30 a.m. (Friday), Close Down.

CORK.—See Athlone.

DANZIG.—See Heilsberg.

DRESDEN.—See Leipzig.

#### FECAMP

1,328 kc/s, 225.9 metres; 10 kW.—10.30 to 11.30 a.m., Programme in English by the I.B.C. 10.30, Happy Hour: Part I—Orchestral Concert: Signature Tune; Overture Medley (arr. Peter); Liebesfreund (Kreisler); 'Cello Solo, The Nightingale and the Rose (Rimsky-Korsakov); Minuet; Violin Solo, La Bohème (Puccini); Minuet; Violin Solo, Le Cygne (Saint-Saëns); Coeur Brisé (Gilbert); Pizzicato from Sylvia (Delibes); Part II—Dance Music: I've told every little Star: Maybe I love you too much; The Song is up to Heaven that way; Smilin' through; Tiger Rag; Rosa Mia; Signature Tune. 11.30, Programme in French. 4.30 to 6.0, Programme in English by the I.B.C. 4.30, Programme for Children. 5.0, Concert of Sea Shanties for Worthing and Littlehampton Listeners: Signature Tune, The Night by the Sea; Nautical Moments (arr. Winter); One Dollar Fifty a Day; Rio Grande (arr. Harris); The Middy (Alford); A Rovin' (arr. Terry); Shenandoah; The Drunken Sailor (arr. Terry); A Life on the Ocean (Binding). 5.30, Concert for Brighton and Hove Listeners: Demande et Réponse (Coleridge-



SEPT. 28th

THURSDAY

continued

Taylor): A Birthday Serenade (Lincke); Cloze Props (Charles); Selection from Wild Violets (Stolz); The Valley of the Poppies (Ancliffe); Night aboard the Sancy Sue; The Warbler's Serenade (Perry); Vienna, City of my Dreams (Reeve); Signature Tune. 6.0, Programme in French. 10.0 Till Close Down, Programme in English by the I.B.C. 10.0, Dance Music: Signature Tune, Bells of Normandy; You're getting to be a Habit with me; I wake up smiling; You're beautiful to-night, my dear; Sylvia; The Wind-mill Waltz; Piccauniny; The Village Baud; When my little Pomeranian; Hold me; Smilin' through; You're mine, you; Rosa Mia; I cover the Waterfront; I'll see you in the morning; I Raised my Hat; Drifting down the Shalimar; Signature Tune. 11.0, Tunes from the Talkies: Signature Tune, Sittin' in the Dark; I got Rhythm (Gershwin); Sweep (Ellis); The Whip (Hammerstein); Moonstruck; Love Songs of the Nile (Brown); There's Something about a Soldier (Gay); Selection of Old Talkie Gems; There's a Crowd (Warren); Signature Tune. 11.30, Concert by the I.B.C. (Ireland), Ltd., on behalf of Hospitals' Trust, Ltd.; Signature Tune, Come back to Erin; Selection from Naula (Delibes); Rose of Tralee (Spencer); Modern Conception of Russian Melodies (de Filippi); Pan and the Wood Goblins (Ratlike); Acushlee Maehree (Brown); Humoresque (Dvorak); In Tulip Time beside the Water Mill (Ailbhou); Signature Tune. 12.5 a.m. (Friday), News Bulletin in English. 12.10 (approx.), Club Concert for Kelso Listeners; Signature Tune, The Chum Song; It's no use, I'm in love (Rice); Southern Serenade (Norman); Sweethearts of Yesterday; P.C. 123 (Munro); Mad Moments (Hoekins); You've got me crying again (Newman); Something came and got me in the Spring; Stormy Weather; Castles in the Sand; Come out Vienna; That's what Life is made of; Dance Pretty Lady; Spanish Eyes; Signature Tune. 1.0, Dance Music: Signature Tune, Bells of Normandy; Fit as a Fiddle; Taboo, Taboo; Balloons; Roll along Kentucky Moon; In a Second-Hand Store; My first Love to last; Lover; The Gold-Digger's Song; Have you had a good day, today?; In Santa Lucia; There's a Cabin in the Pines; He was only a Poor Musician; Seven years with the Wrong Woman; At the Old Pig and Whistle; It was a Night in June; A Woman should stick to her Man; It's Sunday down in Caroline; Signature Tune. 2.0, I.B.C. Good-night Melody and Close Down.

FLensburg.—See Hamburg.

FLORENCE.—See Turin.

FRANKFURT

1,157 kc/s, 259.3 metres; 17 kW. Relayed by Cassel, 1,220 kc/s, 245.9 metres, and Trier, 1,157 kc/s, 259.5 metres.—4.30 p.m., See Munich. 5.45, Exchange. 6.0, Talk: The German National Spirit. 6.25, Talk: Sardinia, the Land of the Nurags. 6.45, Review of the Day's News. 6.50, Time and News. 7.0, Transmission for all German Stations, relayed from Hamburg. 8.0, Topical Programme. 8.15, Three Short Radio Plays of Real Life. 9.0, Respihig Concert by the Station Orchestra, conducted by the Composer: Overture, Bellagor; Suite for Little Orchestra, Gli Uccelli; Suite, Impressioni Brasiliane. 10.0, Time and News. 10.15 (approx.), Close Down.

FREDRIKSSTAD.—See Oslo.

FREIBURG.—See Stuttgart.

GENEVA.—See Radio-Suisse Romande.

GENOA.—See Turin.

GLEIWITZ.—See Breslau.

GOTEBORG.—See Stockholm.

GRAZ.—See Vienna.

HAMAR.—See Oslo.

HAMBURG

806 kc/s, 372 metres; 1.5 kW. Relayed by Bremen, 1,112 kc/s, 269.8 metres; Flensburg, 1,319 kc/s, 227.4 metres; Hanover, 530 kc/s, 566 metres; and Kiel, 1,292 kc/s, 232.2 metres.—5.30 p.m., Variety Programme. 6.0, Concert by the Hamburg Philharmonic Orchestra, conducted by Gerhard Maasz; Overture, Djamilah (Bizet); Ballet Suite, A Thousand and One Nights (Bortkiewicz); Waltz, Märchen aus dem Orient (Joh. Strauss); Sang und Klang aus dem Osten (Eberle). 6.45, Frankfurt Exchange. 6.50, Weather. 7.0, Transmission for all German Stations: Brahms Concert: The Hamburg Philharmonic Orchestra, conducted by José Eibenschütz, and Soloists: Georg Kulenkampff (Violin), Max Baldner (Cello), and Gerhard Organ (Organ); Concerto in A minor, Op. 102, for Violin and Cello: (a) Allegro, (b) Andante, (c) Vivace non troppo; Symphony No. 3 in F, Op. 90: (a) Allegro con brio, (b) Andante, (c) Poco Allegretto, and (d) Allegro. 8.0, Krist—Tragedy (Hans Heyck). 9.30, Freedom—Recitations. 10.0, Time and News. 10.20, Topical Talk. 10.30, Old and New Dance Music by the Small Station Orchestra, conducted by Gerhard Maasz.

HANOVER.—See Hamburg.

HEILSBURG

1,085 kc/s, 276.5 metres; 60 kW. Relayed by Danzig, 662 kc/s, 453.2 metres.—1.5 p.m., Gramophone Music. In the intervals at

1.20 and 2.0, News. 2.30 (from Danzig). Exchange and Market Prices. 3.0, Agricultural Prices and Exchange. 3.30, Harvest Festival Programme for Young People. 4.0, Concert by the Small Station Orchestra, conducted by Wilcken; Overture, Medea (Cherubini); Lyric Suite (d'Albert-Recco); Selection from The Bartered Bride (Smetana); Boston Waltz and Tango (Niemann); Czardas from Der Geist des Wajewoden (Grossmann); Sphärenklänge (Jos. Strauss); Selection from Gri-Gri (Lincke). In the interval at 5.0 (approx.), Book Review. 5.45, Eichendorff Lyrics to the Lute by Aenne and Walther Pudselko; Heimweh (Knab); Reise-lied (Hensel); Der frohe Wandersmann (Hensel); Liebe in der Fremde (Knab); Lockung (Hensel); Freude (Hensel); Der alte Garten (Knab); Die Nachtlilie (Knab). 6.15, Agricultural Prices. 6.25, Talk: State Diplomas for Farmers. 6.50, Weather. 7.0, Transmission for all German Stations, relayed from Hamburg. 8.0, Weather. 8.5, Variety Programme. 9.15, Part Relay of the Municipal Festival Programme from Instenburg, for the Town's 350th Anniversary. Readings from East Prussian Authors. A German Comedy Overture (Wiener), played by the Orchestral Society and a Military Band, conducted by the Composer. 9.50, Elementary English Lesson. 10.15, Weather, News and Sports Report.

HILVERSUM

Announced HUIZEN, 1,013 kc/s, 296.1 metres; 7 kW. (until 5.50 p.m.) and 20 kW. from 5.40 p.m.—11.55 a.m. to 1.40 p.m., Programme of the Catholic Radio Society (K.R.O.). 11.55, Concert by the K.R.O. Orchestra, conducted by van 't Woud. 1.40 till Close Down. Programme of the Christian Radio Society (N.C.R.V.). 1.40, Book-keeping Lesson. 2.40, Talk for Women. 3.10, Interval. 3.40, Programme for Sailors. Mlle. de Jager (Songs) and Gorter (Organ). 4.40, Handwork Lesson for Children. 5.10, Oboe and Pianoforte Recital by de Vries and Tump; Oboe and Pianoforte Sonata No. 15 (Locillet); Oboe and Pianoforte Concerto (Marcell); Oboe and Pianoforte Concerto in F minor (Telemann). In the intervals, Gramophone Music. 6.10, Gramophone Music. 6.25, Dressmaking Lesson. 6.40, Police Notes. 6.55, Gramophone Music. 7.10, Recitations. 7.40, Concert by the Small N.C.R.V. Orchestra, conducted by Van de Hark; Overture, Raymond (Thomas); Violin Solo: Rondo capriccioso (Saint-Saens); March, Blaze Away (Holzmann); Piccolo Solo: Cleopatra (Damaré); La Housarde (Ganne); Xylophone Solo: Herzklopfen (Riedel); Gallon (Strauss); Saxophone Solo: Caprice and Variations (Arban); March, Holdenparade (Blankenburg); Trumpet Solo: Melody from Der Trompeter von Sakkingen (Nessler); Clarinet Duet: Duo concertante (Bärmann); Czardas (Grossmann); 'Cello Solo: Minuet (Valensin); The Match Parade (Wehle); Trombone Solo: Plaisir d'amour (Martini); Extravaganzen (Morena); March, Semper Fidelis ( Sousa). In the interval at 8.40, Talk, and at 9.40 (approx.), News. 10.25, Gramophone Music. 11.10 (approx.), Close Down.

HORBY.—See Stockholm.

HUIZEN

Announced HILVERSUM, 160 kc/s, 1,875 metres; 7 kW. (up to 3.40 p.m.). Transmitted from Kootwijk on 50 kW. from 3.40 p.m. Programme of the Algemeene Vereniging Radio Omroep (A.V.R.O.).—11.40 a.m., Gramophone Music. 11.55, Light Music by the Otto Hendriks Ensemble, with Gramophone Interhudes. 1.55 p.m., Concert by the Wireless Orchestra, conducted by Nico Treep. Soloist: Geysel-Gestman (Songs); Celtic Overture (Foulds); Suite, Four Ways (Coates); Songs with Pianoforte Accompaniment: (a) Ave Maria (Ettéma), (b) Anarilli (Accini), (c) Caro mio ben (Giordano), (d) Per la Gloria (Bononcini); Selection from Andrea Chénier (Giordano); Syn-copation (Kreisler); Three Songs (Geysel); Three Songs (R. Strauss); (a) Morgen, (b) Du meine Herzens Kronelein, (c) Zueignung; Lagunenwälder (Strauss); The Rose Beetle goes a-walking (Armandola); Overture, Les dragons de Villars (Maillart). 3.25, Interval. 3.40, Programme for Hospitals. 4.10, Gramophone Music. 4.40, Programme for Children. 5.10, Gramophone Music. 6.10, Sports Talk. 6.40, Light Music by the Kovacs Lojos Orchestra. In the interval at 7.10, Talk. 7.40, Time, Weather, and News, followed by Gramophone Music. 7.55, Light Music (cont'd). 8.40, Talk. 8.50, Concert by the Wireless Orchestra, conducted by Gerharz. Soloist: Julie de Staers (Soprano); Selection from Coppélia (Delibes); Song, Marins d'Islande (Fouadain); Solveig's Song from Peer Gynt (Grieg); Three Love Songs (Wegener-Kopman); Wagner Potpourri (Ur-bach); Gramophone Records: Selection from Carmen (Bizet); Tchaikovsky Potpourri (Ur-bach). 10.40, News. 10.50, Gramophone Music. 11.40, Close Down.

INNSBRUCK.—See Vienna.

JUAN-LES-PINS

1,025 kc/s, 249 metres; 0.8 kW.—8.0 p.m., Amusement Guide, Exchange, Racing Re-

sults and News. 8.5, Talk on Science. 8.15, Radio Concert. 9.0, News and Weather. 9.30, Concert by Thomas and his Merry Boys, relayed from the Casiuo.

KALUNDBORG.—See Copenhagen.

KATOWICE

734 kc/s, 408 metres; 16 kW.—7.10 p.m., Sports Notes. 7.25, Announcements and Gramophone Music. 7.40 till Close Down, See Warsaw.

KIEL.—See Hamburg.

KLAGENFURT.—See Vienna.

KOSICE.—See Prague.

LAHTI

167 kc/s, 1,796 metres; 40 kW. Relayed by Helsinki, 815 kc/s, 368.1 metres.—6.15 p.m., Talk. 6.40, Recitations. 7.0, Flute Recital by Michele Orlando. 7.25, Talk. 7.50, Dance Music. 8.10, A Revue (Kafael Jura). 8.45, News in Finnish. 9.0, News in Swedish.

LANGENBERG

635 kc/s, 473 metres; 6 kW.—12 Noon, Concert by the Münster Orchestra, conducted by Werner Göhre: Telefunkn-Marsch (Evert); Waltz, Straudwille (Lüling); Overture, Russian and Ludmilla (Glinka); Selection from The Merry Wives of Windsor (Nicolaï); Auf stillem Waldespfad (Strauss); Scherzo (Strauss); Selection from Coppélia (Delibes); Serenade (Reznicek); Selection from Das Pensionat (Suppé). 1.15 p.m., News. 1.30, Orchestral Concert, conducted by Eysoldt; Overture, Gri-Gri (Lincke); Humorous Variations on Was kommt dort von der Höh (Suppé); Tango, Jealousy (Gade); Potpourri, Jung Deutschland (Weninger). In an interval at 2.0 (approx.), News. 3.0, Programme for Children. 3.30, Economic Notes and Time. 3.50, Talk, with Gramophone Illustrations; National Hymns all over the World. 4.15, Legal Talk. 4.35, Reading (Wilhelm Schmied-bonn). 5.0, Recital on Two Pianofortes by Hermann Fasshender and Egbert Grape; Sonata in D (Mozart); Sonata in B Flat (Clementi). 5.30, Vocal and Instrumental Concert: Violin Solo, My Country (Smetana); Contralto Solos, Kinderlieder (Tillmann-Strater); Harpischord and Guitar, Sonata (Diabelli); Contralto Solos, Kinderlieder (Tillmann-Strater); Violin Solo, Sonata (Schubert). 6.15, Talk: Wilhelm Leibl, a German Artist. 6.30, Talk: German Pronunciation. 6.45, Announcements. 7.0, Transmission for German Stations, relayed from Hamburg. 8.0, Announcements. 8.5, Autumn, Radio Sequence (Else Pfaff). 8.50, Topical Talk. 9.30, Programme from Frankfurt. 10.0, News. 10.25, Dance Music, conducted by Eysoldt. 12 Midnight (approx.), Close Down.

LAUSANNE.—See Radio-Suisse Romande.

LEIPZIG

769.9 kc/s, 389.6 metres; 120 kW. Relayed by Dresden, 941 kc/s, 319 metres.—12 Noon, Weather and Time. 12.5 p.m., Folk Music. 1.15, News. 1.30, Gramophone Concert. 2.15, News. 2.30, Film Report. 3.0, Talk for Young People: Mathematical Problems. 3.35, Market Prices and Weather. 4.0 to 5.30, Concert by the Station Orchestra, conducted by Hilmar Weber: Overture, The Caliph of Bagdad (Boieldien); Musikalisches Bilderbuch (Volkmann); Hungarian March (Berlioz); Intermezzo from Notre Dame (Schmidt); Selection from Der arme Jonathan (Müllcker); Waltz, Uhlenhorster Kinder (Petras); Scherzo, Ein elensisches Fest (Ambrosius); Four Little Pieces (César Franck); Wilhelm-Linzer-Walzer (Joh. Strauss); Two Military Marches in D and G (Schubert). 5.50, Market Prices, Weather and Time. 6.0, Italian Lesson. 6.25, Medical Talk. 6.50, To-day's News. 7.0, Transmission for all German Stations, relayed from Hamburg. 8.0, Cellar, Threshing-Floor and Wine-Press—An Autumn Play, with Music by the Endé Orchestra. 10.5, News, followed by Talk: Mankind and the Cosmos. 10.50 (approx.), Close Down.

LJUBLJANA

522 kc/s, 574.7 metres; 7 kW.—6.0 p.m., Talk for Country Women. 6.30, The Letter Box. 7.0, Serbo-Croatian Lesson. 7.30, Gramophone Concert. 8.0, Programme from Belgrade, 697 kc/s (430.4 metres). 10.0, Weather and News. 10.30, Dance Music. 11.0 (approx.), Close Down.

LUXEMBOURG

252 kc/s, 1,191 metres; 200 kW.—12.30 p.m., Concert by the Station Orchestra, conducted by Henri Pensis; Overture, Sakuntala (Gold-mark); Waltz, Hofballtanz (Zihrer); Selection from Hérodiade (Massenet); Selmsicht (Beyer); Gavotte caprice (Bertkiewicz); S'kommt ein Vogel geflogen (Ochs). 1.30, Gramophone Music. 7.30 till Close Down, German Programme. 7.30, Concert by the Station Orchestra: Violin Concerto (Bruch); Overture, Prometheus (Beethoven). 8.15, Talk in German: Indoor Games. 8.25, Song Recital by Elisabeth Corty: Ueber Nacht (Hugo Wolf); Er ists (Hugo Wolf); Aria

from The Seasons (Haydn); Cherubino's Song from Figaro (Mozart); Song from Carmen (Bizet); Aria from Figaro (Mozart). 8.50, News in French. 9.0, German Music by the Station Orchestra: Overture, Der Freischütz (Weber); Invitation to the Dance (Wéber); Ballet Music from Undine (Lortzing); Wiegienied (Reger); Ständchen (R. Strauss). 9.45, News in German. 9.55, The Station Orchestra: Serenade (Tarenghi); Prairie Lily (Mills); Jalousie (Gade); Czardas from Coppélia (Delibes). 10.20, Dance Music on Gramophone Records.

LYONS

1 A DOUA, 644 kc/s, 465.8 metres; 1.5 kW.—6.30 p.m., Radio Journal. 7.30, Radio Gazette for Lyons and the South-East. 8.30, Quintet Concert. 9.0, Violin and Harp Recital. 9.30, Quintet Concert (cont'd.). After the Concert, News.

MADRID

EAJ7, 707 kc/s, 424.3 metres; 2 kW.—8.0 p.m., Chimes, Exchange, Radio Journal, and Programme for Children. 9.15, Topical Review. 9.30 to 11.0, Interval. 11.0, Chimes, Time Signal and Topical Review. 11.20 (approx.), Variety Programme. 1.15 a.m. (Friday), Topical Review. 1.30, Chimes and Close Down.

MALMO.—See Stockholm.

MILAN.—See Turin.

MORAVSKA-OSTRAVA

1,137 kc/s, 263.8 metres; 11 kW.—4.0 p.m., Concert by the Station Orchestra, conducted by Plichta: Pieces (Smetana); (a) Selection from The Bartered Bride, (b) Waltzes, (c) Polka, (Czech Suite, Op. 39 (Dvorak)). 5.30, Dance Music by the Station Orchestra. 5.50, See Prague. 5.45, Gramophone Records. 6.30, German Transmission: Recital of Heine's Lyrics. 7.0, See Prague. 11.0 (approx.), Close Down.

MOSCOW

(TRADES UNION), 300 kc/s, 1,000 metres; 100 kW.—11.45 a.m., Weather. 2.45 p.m., Weather. 3.0, Request Concert. 4.0, Topical Talk. 4.30, Golden Childhood—Play (Schaumovsky), Music by Kabalevsky. 5.30, Programme for Young People. 6.30, Concert from the Radio Theatre. 9.0, News. 9.30, Programme Announcements. 9.55, Chimes. 10.5, Press Review.

MOTALA.—See Stockholm.

MUHLACKER.—See Stuttgart.

MUNICH

563 kc/s, 533 metres; 60 kW. Relayed by Augsburg and Kaiserslautern, 536 kc/s, 560 metres; and Nürnberg, 1,256 kc/s, 239 metres.—12 Noon, Gramophone Concert of Light Music. 1.0 p.m., Concert by the Radio Orchestra, conducted by Josef Suder. 1.15, Time and News. 1.30, Gramophone Concert. 2.0, Time and News. 2.20, Variety Concert. 3.5, Talk: A Palatinate Musician. 3.25, Reading. 3.55, Weather and Agricultural Report. 4.5, Talk with Gramophone Illustrations: Korean Music. 4.30, Concert conducted by Erich Kloss: Overture, The Mikado (Sullivan); Vogel als Prophet (Schumann); Winterzeit (Schumann); Scene from Carmen (Bizet); Tango, Expression (Brude); Hungarian Potpourri (Leopold); Langsamer Tanz (Franck); Hymn to the Sun from The Golden Cockerel (Rimsky-Korsakov); March, Lachendes Leben (Blankenburg). 5.45, Agricultural Talk. 6.5, Pianoforte Sonata in C minor, Op. 27 (Beuss); by Karl Rinn. 6.25 (from Nürnberg), Talk. 6.45, Time, Weather and Agricultural Report. 7.0, Transmission for all German Stations, relayed from Hamburg. 8.0, Die arme Margaret—Radio Play (Ruhbau), after the Story by Enrica Handel-Mazetti. 9.0 (from Nürnberg), Orchestral Concert, conducted by Willy Böhm; Hungarian March (Berlioz); Comedy Overture (Böhm); German Dances (Pagel); Ballad, Ton der Reimer (Loewe); Selection from Der Obersteiger (Zeller); Rocooco Love Song (Mayer-Heilmund); Waltz, Die Werber (Lauer). 10.0, Austria. 10.20, Time and News.

NAPLES.—See Rome.

NOTODDEN.—See Oslo.

OSLO

277 kc/s, 1,083 metres; 60 kW. Relayed by Fredriksstad, 815 kc/s, 368.1 metres; Hamar, 522 kc/s, 574.7 metres; Notodden, 671 kc/s, 447.1 metres; Porsgrund, 662 kc/s, 453.2 metres; and Rjukan, 671 kc/s, 447.1 metres.—5.0 p.m., Concert by the Station Orchestra, conducted by Hugo Kramm. 6.0, Talk. 6.30, Divine Service. 7.0, Advertising Notes, Weather and News. 7.30, Plantation Songs by a Male Voice Quartet. 8.0, Time Signal. 8.1, Agricultural Talk. 8.30, 'Cello Recital. 9.0, Talk on Politics. 9.20, Recital of German Folk Songs (arr. Brahms) by Margrit Franke. 9.40, Weather and News. 10.0, Topical Talk. 10.15, Recitation.

OSTERSUND.—See Stockholm.

PALERMO

558 kc/s, 537.6 metres; 3 kW.—8.0 p.m., Dopolaro Announcements, Tourist Talk, Agricultural Talk, and Giornale Radio. 8.20, Gramophone Music. In the interval at 8.30, Time and Announcements. 8.50, Gaetano va al mercato—Musical Play in One Act (Mortari). 9.30, Popular Music. 11.0, Giornale Radio.



## PARIS

**EIFFEL TOWER**, Call **FLE**, 207.5 kc/s, 1,445.7 metres; 13 kW. Time Signals (on 2,650 metres) at 10.26 a.m. and 11.26 p.m. (Preliminary and 6-dot Signals).—6.45 p.m., Theatre Notes. 7.0, Le Journal Parlé. 8.30, Gramophone Concert. Part I: Extracts from Tannhäuser—Opera (Wagner). Part II: Popular Music. 10.0 (approx.), Close Down.

## PARIS

**POSTE PARISIEN**, 914 kc/s, 328.2 metres; 60 kW.—6.45 p.m., Programme for Children. 7.15, Le Journal Parlé. 7.30, Concert. 8.30, Sponsored Concert. 9.15, Orchestral Concert: Introduction and Procession from The Golden Cockerel (Rimsky-Korsakov); Waltz, Estudiantina (Waldteufel); Selection from Le Chemineau (Leroux); Meditation (Glazunov); Parade galante (Ganne); Ballet Music from Veronique (Messager); Ronde française (Boëllmann); Violin and Orchestra: Romance in G (Beethoven); Rhapsody on Oriental Airs (Lacôme); Tarantella (Chopin); Trianon (Lachmaire); Selection from Cavalleria rusticana (Mascagni). In the interval at 9.0, Talk on Fashions. 10.15, News.

## PARIS

**RADIO PARIS**, Call **CFR**, 174 kc/s, 1,725 metres; 75 kW.—7.30 a.m., Weather and Physical Culture. 7.45, Gramophone Music. 8.0, Weather and Press Review. 12.0 Noon, Protestant Address. 12.30 p.m., Concert for Young People: Piano-forte Solo: Polichinelle (Rachmaninov); Old Popular Songs: (a) L'enfant dormira bientôt, (b) Ne pleure pas, Jeanette; Songs: (a) La toute petite maison, (b) Le petit qui ne mange pas sa soupe, (c) L'omelette au chocolat. Gramophone Records: (a) Le Parisien (Dorin), (b) Les années sont courtes (Dorin); Selection from Cinderella (Zimmermann); Recitations: (a) Il faut bien se refaire une santé (Cheffer), (b) La bonne hôtesses; Gramophone Records: (a) Les trois petits oiseaux (Piercé), (b) La Franc-Comtoise; Bilboquet; Beassine dit ses bêtises (Dandelin-Bol); Les Fratellini. In the interval at 1.0, Exchange, News and Weather, and at 1.30, Exchange. 2.0, Exchange. 3.45, Exchange and Market Prices. 7.0, Agricultural Report. 7.10, Gramophone Music: Selection from Schön ist die Welt (Lehár); In a Chinese Temple Garden (Ketelbey); Song (Blangy); Melody (Fian); Christmas Evening (Gavel-Rodor); Grieg Potpourri; Slav Dances (Dvorak). 7.50, Commercial Notes and News. 8.0, Humorous Programme on Gramophone Records. 8.30, News, Weather and Sports Notes. 8.45, Gramophone Music. 9.15, Press Review and News. 9.30, Modern Music on Gramophone Records: Rugby (Honegger); Three Poems (Jacob); Two Symphonic Dances (Coppola); Septet Suite (Hoerece); Five Poems (Ferroud); Marine (Delannoy); Piano-forte Concerto (Gershwin).

## PITTSBURGH

**KDKA**, 980 kc/s, 306 metres; 50 kW. Relayed by **W8XK** on 48.86 metres and 25.27 metres.—7.0 p.m., Programme to be announced. 7.30, Pioneers. **KDKA** to New York. 7.45, **KDKA** Home Forum. 8.0, Betty and Bob from New York. 8.15, Quitting Party. 8.30, Words and Music from New York. 8.45, Federation of Pennsylvania Women. 9.0, Thursday Special from New York. 9.30, News and Markets. 9.45, Thursday Special from New York. 10.0, Federation of Women's Clubs. 10.15, **KDKA** Kiddies' Klub. 10.30, The Singing Lady from New York. 10.45, Orphan Annie from New York. 11.0, News, Piano Classique. 11.15, Sports, A Song. 11.30, Pittsburgh Spotlights. 11.45, Lowell Thomas from New York. 12 Midnight, Amos 'n' Andy from New York. 12.15 a.m. (Friday), Programme to be announced. 12.30, Concert Footlights from New York. 12.45, Pathé News of the Air. 1.0 to 3.30, New York Relay. 1.0, Captain Diamond. 1.30, Adventures in Health. 1.45, The Rollickers. 2.0, Death Valley Days. 2.30, Jules Lande. Violinist. 3.0, Hands across the Border.

**PORSGRUND**.—See Oslo.

## PRAGUE

614 kc/s, 488.6 metres; 120 kW.—12.15 p.m., Military Band Concert, conducted by Pesta: Sokol March (Fiala); Overture, The Calliph of Bagdad (Boieldieu); Selection from Der Freischütz (Weber); Czech Fantasy (Händel); Intermezzo (Pesta); Czech Military March (Oberthor); Love Song (Suk); Potpourri (Pelhik). 1.30 to 1.45, Agricultural Talk. 4.0, Choral Concert, relayed from Hermann Mestec. 5.0, See **Moravská-Ostrava**. 5.30, Talk. 5.45, Gramophone Music. 6.0, German Transmission: The Man Hunt—Play in Five Acts (Kolbenheyer), followed by News in German. 7.0, News. 7.5, Variety Programme. 7.50, Evening Bells; Radio Report. 8.0, Dvorak Concert, relayed from the Smetana Hall: Slavonic Dances by the Czech Philharmonic Orchestra, conducted by Otakar Jeremias. 10.0, Time, News and Sports Notes. 10.15, Concert by Jaroslav Skalický and his Small Chamber Orchestra. 11.0 (approx.), Close Down.

SEPT. 28th

THURSDAY

continued

## RADIO-SUISSE ROMANDE

**SOTTENS**, 743 kc/s, 403 metres; 25 kW.; and **Geneva**, 395 kc/s, 760 metres.—6.15 a.m. to 6.30 (from Lausanne), Gymnastics. 12.28 p.m., Time Signal from Neuchâtel Observatory. 12.30, News and Weather. 12.40 (from Geneva), Humorous Programme. 1.0 (from Lausanne), Financial Notes. 1.10 (from Lausanne), Gramophone Music. 2.0, Interval. 3.28, Time Signal from Neuchâtel Observatory. 3.30 (from Geneva), Gramophone Music. 4.15 (from Geneva), Talk. 4.40 (from Geneva), Gramophone Concert (cont'd). 5.30, Interval. 7.0, Talk for Mountaineering Enthusiasts. 7.30 (from Geneva), Radio Chronicle. 7.50, Esperanto Talk. 8.0, Jazz Music for Piano-forte. 8.20, Readings. 8.35 (from Geneva), Concert of Light Music by the Radio Suisse Romande Orchestra, conducted by Echenard. Soloist: Mme. Pigeon-Fancher (Songs). 9.50, News. 10.0 (from Geneva), Gramophone Music. 10.30 (approx.), Close Down.

## RIGA

572 kc/s, 525 metres; 15 kW.—5.30 p.m., Kreisler Gramophone Records. 6.0, Programme to be announced. 6.30, English Lesson. 7.0, Weather. 7.5, Countess Mariliza—Operetta in Three Acts (Kálmán), followed by Concert. 10.30 (approx.), Close Down.

**RJUKAN**.—See Oslo.

## ROME

Call **1R0**, 680 kc/s, 441 metres; 50 kW. Relayed by **2R0**, 11,810 kc/s, 25.4 metres; from 5.15 p.m.; **Bari**, 1,112 kc/s, 269.8 metres; **Milan (Vigentino)**, 662 kc/s, 453.2 metres from 8.45 p.m.; and **Naples**, 941 kc/s, 319 metres.—12.30 p.m., Gramophone Music. 1.0 p.m., Sponsored Programme. 1.10 to 2.15, Orchestral Concert. In an interval at 1.30, Giornale Radio and Exchange, and at 2.0, Time and Announcements. 4.30, Children's Radio Review. 4.55, Giornale Radio and Exchange. 5.0, Reading. 5.10, Weather. 5.15 to 6.0, Vocal and Instrumental Concert: Luisa Carlevarini (Violin), Maria Zilia (Soprano), and Gino Conti (Bass); Violin Solos: (a) Nocturne (Sibelius), (b) Russian Dance (Faure); Soprano Solos: (a) Ich trage meine Minne (R. Strauss), (b) Aria from Falstaff (Verdi), (c) Aria from Manon (Massenet); Bass Solos: (a) Aria from Simone Boccanegra (Verdi), (b) Aria from L'Ebrea (Apolloni); Violin Solos: (a) Lotus Land (Scott), (b) Air and Trepak (Sasonov-Dushkin); Soprano Solo: Elsa's Dream from Lohengrin (Wagner). 6.40 (Naples), Shipping and Sports Notes. 6.45, Dopolavoro Notes and Tourist Report. 7.10, Agricultural Notes. 7.20, News in Foreign Languages. 7.40, Giornale Radio. 8.0, Time and Announcements. 8.15, Gramophone Music. 8.45, Ruy Blas—Opera in Three Acts (Marchetti).

**SALZBURG**.—See Vienna.

## SCHENECTADY

**WGY**, 790 kc/s, 379.5 metres; 50 kW. Relayed at intervals by **W2XAF** on 31.48 metres and by **W2XAD** on 19.56 metres.—1.45 a.m. (Friday), Stock Reports. 2.0 to 5.0, New York Relay. 2.0, Variety Programme. 3.0, Captain Henry's Show Boat. 4.0, Popular Programme. 5.0, Programme Résumé.

## SCHWEIZERISCHER

## LANDESENDER

**BEROMUNSTER**, 653 kc/s, 459 metres; 60 kW; **Basle**, 1,229 kc/s, 244.1 metres; and **Berne**, 1,220 kc/s, 245.9 metres.—6.15 to 6.35 a.m. (from Basle), Gymnastics. 11.59, Time from Neuchâtel Observatory and Weather. 12 Noon (from Basle), Gramophone Concert. 12.30 p.m., Time, Weather and News. 12.40 (from Basle), Gramophone Concert (cont'd). 1.25 (from Basle), Time, Weather and Exchange. 1.30 (approx.), to 5.0, Interval. 5.0 (from Zürich), Concert by the Small Station Orchestra, conducted by Max Scherbaum. 6.0 (from Berne), Gramophone Concert. 6.30 (from Basle), Talk: Animals in Art. 7.0 (from Basle), Time, Weather and Traffic Report. 7.10 (from Basle), Italian Arias and Songs (on Gramophone Records). 7.30 (from Basle), Elementary Italian Lesson. 8.15 (from Basle), Concert of Chamber Music, relayed from the Conservatoire. Soloist: Ada Schwaender (Piano-forte). 9.30 (approx.), Weather and News. 9.40 (approx.) (from Basle), A Radio Play. 10.15 (approx.), Close Down.

**SOTTENS**.—See Radio-Suisse Romande.

## STOCKHOLM

689 kc/s, 436 metres; 55 kW. Relayed by **Boden**, 244 kc/s, 1,229.5 metres; **Göteborg**, 932 kc/s, 322 metres; **Hörby**, 1,166 kc/s, 257 metres; **Motala**, 221.5 kc/s, 1,354.4 metres; **Ostersund**, 389 kc/s, 770 metres; and **Sundsvall**, 554 kc/s, 542 metres.—5.5 p.m., Divine Service. 5.30, Programme for Children. 5.45, Gramophone Music. 6.45, Elementary

English Lesson, relayed from Jönköping, 1,490 kc/s, 201.3 metres. 7.15, Weather and News. 7.30, Talk. 8.0, 'Cello Recital by Roman Dukstulsky: Toccata (Frescobaldi-Cassado); Two Fantasiestücke (Schumann); Dance of the Green Devil (Cassado). 8.15, A Play in Three Acts (Heiberg). 9.45, Weather and News. 10.0, Concert of Light Music: Ballet Music from La Gioconda (Ponchielli); Selection from The Tales of Hoffmann (Offenbach); Valse triste (de Vecsey); Minuet in G (Beethoven); Waltz Intermezzo. Die reizende Wenerin (Kahrman); Extase (Ganne); Serenade (Widor); Tango (O. Strauss). In the Valley of the Moon (Tobias-Burker); Potpourri (Lincke). 11.0 (approx.), Close Down.

## STRASBOURG

869 kc/s, 345 metres; 11.5 kW.—11.30 a.m., Variety Music on Gramophone Records. 12.45 p.m., News. 1.0, Time and Exchange. 1.5, Orchestral Concert, conducted by Maurice de Villers: Ballet Music from Henry VIII (Saint-Saëns); Overture, La roi La dit (Delibes); Spanish Dances (Granados); Violin Solo: Meditation from Thaïs (Massenet); Suite of Dances (Godard). 2.0, Programme for Children. 3.0, Interval. 3.45, Gramophone Concert. 4.45, French Elocution Lesson. 5.0, Orchestral Concert, conducted by Roskam: Overture, Les cent vierges (Lecocq); Serenade (Padilla); Wedding Waltz (Lincke); Ideale (Tosti); Jo penso (Tosti); Selection from La belle Hélène (Offenbach); Melody (Rubinstein); Dance of the Flowers, from La Gioconda (Ponchielli); Hymn to the Sun (Rimsky-Korsakov); Marche Tartare (Ganne). 6.0, Talk in German: The Barbizon School of Artists. 6.15, Talk for Women. 6.30, Song and Saxophone Recital by Inès Manjeun (Soprano) and Jean Weber: Saxophone Solo: Fantasia on an Original Theme (Demeersman); Airs from (a) Judas Maccabaeus (Händel), (b) Rodelinda; Legend for Saxophone (Sporek); Song (Sporek); Saxophone Solo: Orientale (Sporek); Song from Les Adieux de l'hotesse Arabe (Bizet); Songs (Chabrier); (a) Invitation au voyage, (b) Tes yeux bleus; Saxophone Solos: (a) Czardas (Gurewicht), (b) Oriental (Gurewicht); Songs: (a) Colombe (Busser), (b) Coeur solitaire (Busser). Time and News. 7.45, Gramophone Music. 8.0, Press Review in German, Lottery Results and Announcements. 8.30, Symphony Concert from Lyons (La Doua). 10.30 (approx.), Press Review in French.

## STUTTGART

**MUHLACKER**, 832 kc/s, 360.5 metres; 60 kW. Relayed by **Freiburg**, 527 kc/s, 570 metres.—1.15 p.m., Time and News. 1.30, Concert from Langenberg. 2.0, Concert arranged by the Post Office. 2.30, Spanish Conversation. 3.0, Elementary English Lesson. 3.30, Programme for Young People. 4.30, See Munich. 5.45, Talk: The Art of Story-telling. 6.10, A Basque Festival Day (on Gramophone Records). 6.35, Time and News. 7.0, Transmission for all German Stations, relayed from Hamburg. 8.0, Dietrich-Eckardt Programme. 9.0, See Frankfurt. 10.0, Dance Music, relayed from Berlin (Funkstunde). 12.15 a.m. (Friday), Modern Light Music and Dance Music, by Henry Kassbon: Fox-trot, Wenn die roten Rosen blühen (Kassbon); Waltz, Es gibt eine Frau, die mich lieb hat (Bachem-Schlenkermann); Tango, Ich kam dich nie vergessen (Friedemann-Pfau); Fox-trot (Winston); Fantasia on Der Lenz (Hildach); Waltz, The Blue Danube (Joh. Strauss); Tango, So wie's früher war (Meisel); Violin Solos: (a) Czardas, Hulanzo Ballata (Hubay), (b) Spanish Serenade (Chaminade); Guten Abend, Gute Nacht (Brahms-Schlenkermann); Kaiser-Walzer (Joh. Strauss). 1.0 a.m. (Friday), Close Down.

**SUNDSVALL**.—See Stockholm.

## TOULOUSE

**RADIOPHONIE DU MIDI**, 779 kc/s, 385 metres; 8 kW.—6.0 p.m., News. 6.15, Jazz Music. 6.45, Music by a Viennese Orchestra. 7.15, News. 7.30, Ballet Music from Faust (Gounod). 7.45, Popular Melodies. 8.0, Operetta Music: Selection from La fille de Madame Angot (Lecocq); Die Fledermaus (Joh. Strauss); The Dollar Princess (Fall). 8.15, Opera Music: Arias from: L'Attaque du moulin (Bruneau); Werther (Massenet); Les Brigands (Offenbach); Tosca (Puccini). 8.30, Military Music. 8.45, Music from Sound Films. 9.0, Maurice Yvain Operetta Concert. 9.30, Accordion Music. 9.45, Orchestral Concert: Fireworks (Stravinsky); Turkish March from El amor brujo (Fall); Selection from Robert the Pirate (Romberg); Air from Veronique (Messager). 10.15, News. 10.20, Concert for Listeners in Morocco: Overture, Barbe-Jeune (Offenbach); Air from Prince Igor (Borodin); Sérénade des fleurs (Cazes); Simplement pat amour (Hilinger); Parade of the Marionettes (Bühni). 11.0, Chansonnettes. 11.15, Dance

Music. 12 Midnight, News. 12.5 a.m. (Friday), Music by an Argentine Orchestra. 12.15, Accordion Music. 12.30 (approx.), Close Down.

## TRIESTE

1,211 kc/s, 247.7 metres; 10 kW.—5.10 p.m. till Close Down, See Turin.

**TRONDHEIM**.—See Oslo.

## TURIN

1,096 kc/s, 273.7 metres; 7 kW. Relayed by **Milan**, 905 kc/s, 331.5 metres; **Genoa** 959 kc/s, 312.8 metres; and **Florence**, 599 kc/s, 500.8 metres.—5.10 p.m., Gramophone Music. 6.0 to 6.5, Weather. 6.40, Giornale Radio, Dopolavoro Announcements and Gramophone Music. 7.0, Time, Tourist Report and Gramophone Music. 7.10, Agricultural Notes and Market Prices. 7.20, News in Foreign Languages. 7.40, Gramophone Music. 8.0, Announcements, Giornale Radio, Weather, and Gramophone Music. 8.30, A Comedy in Three Acts. After the Comedy, Gramophone Music. 11.0, Giornale Radio.

## VATICAN CITY

15,120 kc/s, 19.84 metres (Morning); and 5,969 kc/s, 50.26 metres (Evening); 10 kW.—11.0 to 11.15 a.m., Religious Information in French. 8.0 to 8.15 p.m., Religious Information in Italian.

## VIENNA

581 kc/s, 517 metres; 100 kW. Relayed by **Craz**, 852 kc/s, 352.1 metres; **Innsbruck**, 1,058 kc/s, 283 metres; **Klagenfurt**, 662 kc/s, 453.2 metres; **Linz**, 1,220 kc/s, 245.9 metres; and **Salzburg**, 1,373 kc/s, 218.5 metres.—12 Noon, Concert by the Wiener Symphoniker, conducted by Holzer. In the interval at 1.0, p.m., Time, Weather and Announcements. 2.0, Interval. 3.0, Time, Weather and Market Report. 3.20, Talk: The Roman Fortified Town of Carnuntum and the Gateway to Hungary. 3.35, Readings for Children. 4.0, Mendelssohn Concert on Gramophone Records. 4.40, Talk: Life in the Malayan Archipelago. 5.0, Talk for Women. 5.25, Song and Violin Recital by Lily Ulanowsky (Soprano) and Balda Grassler. 6.5, Talk: Errors in Speech. 6.30, Talk: Old Austrian Places of Pilgrimage. 7.0, Concert by the Wiener Symphoniker, conducted by Holzer: Soloists, Dely Pevler (Soprano) and Otto Glaser (Tenor): Overture, Venus auf Erden (Lincke); Soprano Song from Paganini (Lehár); Tenor Song from Freut Euch des Lebens (Strauss-Grün); Waltz, Singen, lachen, tanzen (Ziehrer); Soprano Song from The Cinema Star (Gilbert); Overture, Gipsy Love (Lehár); Soprano Song from Der Orlov (Granichstaedten); Intermezzo, Lachende Welt (Stede); Tenor Song (Granichstaedten); Potpourri (Komzak); Duet from Madame Pompadour (Kálmán); March, Mit Lust und Lieb- (Ertl). In the interval at 7.35, Time and Weather. 8.10, Talk: String Instruments. 8.20, Radio Sequence for the Centenary of the Birth of Ferdinand von Saar. 9.20, News, Weather and Exchange. 9.35, Concert by the Wiener Symphoniker, conducted by Webern: Soloists, Hans Kolisch (Violin), Jascha Heifitz (Cello), and Eduard Steuermann (Piano-forte): Concerto in C, Op. 56, for Piano-forte, Violin and Cello (Brahms); Symphony No. 4 in E Minor, Op. 98 (Brahms). 10.55, Dance Music on Gramophone Records. After the Programme, Exchange.

## WARSAW

212.5 kc/s, 1,411 metres; 120 kW.—11.57 a.m., Time Signal and Fanfare from St. Mary's Church, Cracow. 12.5 p.m., Gramophone Music. 12.25, Polish Press Review. 12.33, Weather Report. 12.35, Gramophone Music. 12.55, Radio Journal. 1.0 to 2.55, Interval. 2.55, Announcements. 3.15, Gramophone Music. 3.25, Economic Notes. 3.35, Gramophone Music. 3.45, Review for Scouts. 3.50, Gramophone Music. 4.0, Programme for Children. 4.30, Gramophone Music. 5.0, Talk for Women. 5.15, Latvian and Polish Songs. 5.55, Gramophone Music. 6.15, Talk. 6.35, Michalowski Piano-forte Recital: Prelude in E flat; Prelude in F sharp minor; Bagatelle in G; Valse brillante; Berceuse; Gavotte in B flat minor; Improptu; Mazurka in E minor; Mazurka in B minor; Polonaise. 7.20, Miscellaneous Items. 7.35, Programme Announcements. 7.40, Reading: From Bulgaria to Constantinople. 8.0, Concert by the Station Orchestra, conducted by Nawrot: Soloist, Karowska (Soprano): The Nutcracker Suite (Tchaikovsky); Songs: (a) Aria from I Pagliacci (Leoncavallo); Villanella (Dell'Acqua); Overture (Lortzing); Spanish Suite (Leoncavallo); Albumblatt (Gyldmark); Waldmärchen from Der Berggeist (Meyer-Heimund); Waltz, Tales from the Vienna Woods (Joh. Strauss); Three Songs; Romance (Rencé); Fête à Séville (Favay); Waltz-Fantasia (Grossmann); Florentine March (Fucik). In an interval at 8.50, Radio Journal and Agricultural Notes. 10.0, Dance Music. 10.25, Sports Notes. 10.35, Aviation Weather Report and Police Notes. 10.40, Dance Music (cont'd).

## WILNO

533 kc/s, 563 metres; 16 kW.—7.20 p.m., Answers to Correspondence. 7.40, See Warsaw. 9.0, Talk. 9.10, Concert relayed from Warsaw.

**ZÜRICH**.—See Schweizerischer Landessender.

# FRIDAY

SEPTEMBER THE TWENTY-NINTH

## PRINCIPAL EVENTS OF THE DAY:

### AT HOME

- NATIONAL** Promenade concert from Queen's Hall.
- LONDON REGIONAL** "The Desert Song," a musical comedy, by Romberg.
- NORTH REGIONAL** Orchestral concert.
- WEST REGIONAL** Ballad concert.
- SCOTTISH REGIONAL** Excerpt from the Glasgow Mod, 1933, from St. Andrew's Hall, Glasgow.
- BELFAST** Organ recital.

### ABROAD

- BRUSSELS (No. 1)** 5.0 p.m. Mendelssohn concert, by the Station Symphony Orchestra. 6.30 p.m. Pianoforte recital, by Raoul Seitels.
- BRUSSELS (No. 2)** 8.0 p.m. Lalo concert, by the Station Symphony Orchestra, conducted by A. Meulemans.
- COPENHAGEN** 8.10 p.m. Haydn recital, music for flute, violin and cello.
- HEILSBURG** 9.10 p.m. The Königsberg Opera House Orchestra, conducted by Brückner.
- HUIZEN** 8.10 p.m. Concert by the Haydn String Quartet.
- LEIPZIG** 8.0 p.m. Opera: "Alceste," by Gluck, from Dresden.
- POSTE PARISIEN** 9.15 p.m. Comic opera: "Le Toréador," by Adam.
- ROME** 8.30 p.m. Opera: "La Sonnambula," by Bellini.
- TURIN** 8.30 p.m. Orchestral concert, conducted by D. Amfitheatri.
- WARSAW** 8.0 p.m. Symphony concert, conducted by Fitelberg.

## BRUSSELS (No. 2)

N.I.R.; 887 kc/s, 338.2 metres; 15 kW.—Programme in Flemish. 12 Noon, Concert by the Primas Sylva Orchestra. In the interval at 1.0 p.m., Le Journal Parlé. 5.0, Concert by the Radio Orchestra, conducted by Charles Walpot; Unie-marche (Walpot); Waltz, Josef Strauss Erinnerung (Fahrbach); Overture, The Black Domino (Anber); Suite from Maia (Leonevallo); Negro Lullaby (Clutsam); Selection from The Count of Luxembourg (Lelaër); Flemish Dances (Blockx). 6.0, Finale from The Valkyrie—Opera (Wagner), on Gramophone Records. 6.15, Reading. 6.30, Sonata in F Sharp Minor, Op. 46, for Cello and Piano-forte (Pierci). 7.0, Tone Poem, Tamar (Balakirev), on Gramophone Records. 7.15, Talk: Family Names. 7.30, Wireless Talk. 8.0, Lalo Concert by the Station Symphony Orchestra, conducted by Arthur Meulemans. Soloist, Theo Delvenne (Violin). Overture, Le roi d'Ys; Violin Concerto; Scherzo; Norwegian Rhapsody; Selection from Namouna. 9.0, Reimaert de Vos—Play, adapted for Radio by Hubert Molis, with Incidental Music by Paul Doulez. 9.45, Three Fanciful Etchings (Kettelbey), on Gramophone Records. 10.0, Le Journal Parlé.

## BUCHAREST

761 kc/s, 394 metres; 12 kW.—5.0 p.m., Concert by the Station Orchestra: March, Manhattan (Sousa); Waltz Intermezzo (Translator); Rocooco Suite (Alboub); Selection from The Circus Princess (Kálmán); Melody (De Micheli); Potpourri, Extravaaganza (Morena); Souvenir (Hebert); Trot de cavalerie (Rubinstein); Rigandon (Hartog). In an interval at 6.0, Radio Journal. 7.0, Educational Talk. 7.20, Talk. 7.40, La Boléme—Opera in Three Acts (Puccini), on Gramophone Records. In the intervals, Reading and Radio Journal. After the Opera, Light Music relayed from a Restaurant.

## BUDAPEST

545 kc/s, 550.5 metres; 18.5 kW. Also relayed on 840 metres from 7.15 p.m. till Close Down.—5.0 p.m., Cigány Band Concert. 6.0, Talk. 6.30, Song Recital. 7.15, Two One-Act Plays. 8.0, Extracts from The Barber of Seville—Opera (Rossini) on Gramophone Records. 8.45, News. 9.0, Dance Music from the Hotel Royal. 10.15, Orchestral Concert: Overture (Cimarosa); Sonata da Camera (Marefello); Allegro alla militare (Bocherini); Suite antique (Couperin-Kreisler); Suite, In modo popolare (Cui); Lieder (Layotta). 11.15, Cigány Band Concert from the Restaurant Kovacscevs.

CASSEL.—See Frankfurt.

## COPENHAGEN

1,067 kc/s, 281 metres; 0.75 kW. Relayed by Kalundborg, 260 kc/s, 1,153.8 metres.—12 Noon, Time Signal and Chimes from the Town Hall. 12.2 p.m., Concert by the Bendix String Ensemble, relayed from the Wivex Restaurant. 2.0, Interval. 2.30, Concert by Louis Prell's Instrumental Ensemble: Nurra March (Andy); Suite of Viennese Waltzes (Gilsen); Humoresque (de Tave); Sylvia (Speaks); Rogue Song Fantasy (Stothart); Potpourri, Von Wien durch die Welt (Hrub); Melody (Broner); Zazra (Bowen); Die Spieluhr der Poppydour (Noack); Valse dolore (Gyldmark); Selection from Wonder Bar (Katscher); Indigo from Three Shades of Blue (Grofé); Foxtrot, Turf (Demaret); Canzonetta (Friml); Foxtrot, Business in Q (Bleyer). In an interval at 3.15 (approx.), Reading. 4.30, Programme for Children. 5.30, Exchange and Fish Market Prices. 5.45, Talk: The Masterpieces of Danish Literature. 6.15, Elementary German Lesson. 6.45, Weather. 6.54, Announcements. 7.0, News. 7.15, Time Signal. 7.16, Talk: Unemployment and the Wages Question. 8.0, Time Signal from the Town Hall. 8.1, Programme by Per Knutson. 8.10, Haydn Recital by Holger Gilbert-Jespersen (Flute), Johan Henriques (Violin), and Torben Anton Svedsen (Cello); Divertimento in C for Flute, Violin and Cello; First Movement from the Trio in D for Flute, Violin and Cello. 8.30, Nathan the Wise—Dramatic Poem (Lessing). 10.15, News. 10.30, Concert of Light Music by the Venetian Trio and Aase Wallenström (Songs). 11.0, Dance Music by Kai Julian and his Band, relayed from the Valencia. 12 Midnight (approx.), Close Down.

CORK.—See Athlone.

DANZIG.—See Heilsberg.

DRESDEN.—See Leipzig.

## FECAMP

1,328 kc/s, 225.9 metres; 10 kW.—11.0 a.m. to 2 Noon, Programme in English by the I.B.C. 11.0, Happy Hour. Part I: Orchestral Concert: Signature Tune; Overture, Die Fledermaus (Strauss); Fleurette (Fletcher); Violin Solo, The Song of Songs (Moya); Wedding of the Rose (Jessel); Bells across the Meadows (Kettelbey); Xylophone Solo, Danse d'Heola (Abbey); Columbine (Gardland); Souvenir de Capri (Beece). Part II: Dance Music: Merry-go-round; Saratoga Swing; Sophisticated Lady; Balloons; Junk Man Blues; My Wishing Song; You did everything for me; My woman; Sadie the Skater; Signature Tune. 12 Noon, Pro-

## ALGIERS

824 kc/s, 364 metres; 13 kW.—8.10 p.m., Shipping Notes. 8.15, Agricultural Report and Weather Forecast. 8.20, Agricultural Talk. 8.35, Wind Instrument Solos. 8.55, News. 9.0, Time. 9.2, Lottery Results. 9.10, Instrumental and Vocal Concert. 9.45, News. 9.50, Concert (cont'd.). 10.30, News. 10.35, Instrumental Concert.

## ATHLONE

725 kc/s, 413 metres; 60 kW. Relayed by Cork, 1,337 kc/s, 224.4 metres.—1.30-2.30 p.m., Time Signal, Weather Report, Stock Exchange Quotations and Gramophone Music. 6.0, Programme for Children. 6.45, News. 7.0, Gardening Talk by G. O. Sherrard. 7.15, Literary and Dramatic Talk by Aodh de Blacain. 7.30, Time Signal. 7.31, Songs by The Good Companions. 7.45, Concert by the Station Orchestra. 8.15, The Good Companions (cont'd.). 8.30, Tenor Solos by Sean O'Carroll. 8.45, Music by the Station String Orchestra. 9.10, Soprano Solos by Nellie Ryan. 9.30-10.30, Programme by the I.B.C. (Ireland), Ltd. 9.30, Concert: Huslin' and Bustlin': Till tomorrow; My Darling; What more can I ask?; The Lord Mayor's Show; Play, Fiddle, play; Rock-a-bye Moon; Jack Payne's Memories. 10.0, Concert arranged by the International Broadcasting Company (Ireland), Ltd., on behalf of Hospitals' Trust, Ltd.: Overture, Figaro (Mozart); Hungarian Dance in G minor (Brahms); Autumn Leaves (Voglein); Shepherd's Hey (Grainger); Violin Solo, Caprice viennois (Kreisler); Slav Dances (Dvorak); Waltz, Acclamation (Waldteufel). 10.30, I.B.C. Goodnight Melody, followed by Time Signal, News, and Weather Report. 10.40, Accordion and Fiddle Solos by John Haugh and J. Carroll. 11.0 (approx.), Close Down.

## BARCELONA

EAJ1, 860 kc/s, 348.8 metres; 8 kW.—7.0 p.m., Trio Concert: Overture, Zampa (Hérold); Fenille d'Albion (Chabrier); Melody (Leopold); Intermezzo (Percy); Sallor's Song (Mendelssohn); Romance (Rubinstein); Selection from Hérodias (Massenet). 8.0, Request Gramophone Records. 8.30, Exchange. 9.0, Gramophone Music and News. 10.0, Chimes from the Cathedral, Weather, Messages to Seamen, Exchange and Market Prices. 10.10, Concert by the Station Orchestra. 11.15, Vicente Diez de Tejada reads from his own Works. 11.30, An Opera on Gramophone Records. In the interval at 12 Midnight, News. 1.0 a.m. (Saturday), Close Down.

BASEL.—See Schweizerischer Landessender.

## BELGRADE

697 kc/s, 430.4 metres; 2.8 kW.—5.55 p.m., Time and Programme Announcements. 7.0, Concert by the Station Orchestra. 8.30, Concert relayed from Zagreb, 977 kc/s (307 metres). 10.30, Time and News. 10.45 (approximate), Dance Music from the Ratnički Dom Restaurant.

## BERLIN

DEUTSCHLANDSENDER (REICHSENDER) 183.5 kc/s, 1,623 metres; 40 kW.—12 Noon, Weather. 12.2 p.m., Gramophone Concert: Morning (Grieg); Oriental Suite (Popy); Moonlight on the Danube (Gay); Wedding Day on Troldhaugen (Grieg); O kounm' im Traum (Liszt); None but the lonely heart (Tchaikovsky); Suite campestre (Amadei); Slav Dance No. 8 (Dvorak); The Flight of the Bumble Bee (Rimsky-Korsakov); Japanese Cherry Blossom Festival (Yoshitomo); Procession of the Gnomes (Blon); Waltz, Mia Bella (Sommerfeld). 12.55, Time Signal. 1.45, News. 2.0, Gramophone Concert: Balakika Orchestra: (a) Piece from Caucasian Sketches (Ippolitov-Ivanov). (b) Ukrainian Sketches (Sibirsky); Cigány Band: (a) Folk Song, Chrysanthemum, (b) Puszta-Grüsse (Kiss-Bela); Hawaiian Band (a) Melody (Payne-Wallace-Herbert). (b) Waltz, Tesoro mio (Becucci); Bandonion Solos: (a) Intermezzo, Koketterie (Mahr). (b) Russian Waltz (Mahr); Cigány Band: (a) Abschied von der Puszta (Jeno). (b) Strahlende Augen (Falussy); The Wurflitzer Organ: (a) Weist Du noch, (b) Butterflies in the Rain (Myers). 3.0, Programme for Girls. 3.30, Weather and Exchange. 3.45, Reading from Lucinde (Schlegel). 4.0, See Leipzig. 5.0, Reminiscences by Alwin Dressler. 5.15, Songs by Children. 5.45, Topical Talk. 6.0, Poems. 6.5, Modern Music by the Karl Ristenpart Chamber Orchestra: Serenade for String Orchestra (Richard Trunk); Kleine Serenade (Reznicek). 6.40, Talk by Dr. Schlange: The Prussian-South German State Lottery. 7.0, Transmission for all German Stations: Wilhelm Busch—Radio Sequence (Hilz Schwitzke). Music by Hans Joachim Sobanski. 8.0, To-day's Motto. 8.2, Concert from Munich. 8.30, Der ewige Bauer—Radio Play (Josef Martin Bauer). 10.0, News. 10.45, Weather. 11.0, Concert of Light Music. 12.30 a.m. (Saturday), Close Down.

## BERLIN

FUNKSTUNDE, 715 kc/s, 419.5 metres; 1.5 kW.—4.30 p.m., Concert from the Zoological Gardens. 5.0, Second String Quartet (Curt Protze). 5.30, Programme in Commemoration of Ferdinand von Saar on the Centenary of his Birth. 6.0, Fifteen minutes in front of a Picture—Talk on Caspar David Friedrich's Der einsame Baum. 6.15, Radio Week End

Report. 6.40, See Berlin (Deutschlandsender). 7.0, Transmission for all German Stations, relayed from Berlin (Deutschlandsender). 8.0, Lottery Announcements. 8.5, Programme to be announced. 8.35, Concert by the Berlin Station Orchestra, conducted by Dr. Helmuth Thierfelder. Prelude for Orchestra, An mein deutsches Land Op. 48 (Hermann Zieher); Variations on Ach, wie ist's möglich dann, Op. 29a (Rössler); Märchen—Symphonic Pictures (August Ema); Peer Gynt Suite No. 2 (Grieg); Polovtsian Dances (Borodin). In the interval at 8.40, Radio Report of the Chimes from the Potsdam Garrison Church. 10.0, News. 10.15, (approx.), Dance Music from the Hotel Alhambra. In the interval from 11.0 to 11.5, Talk: Stage and Cinema. 12 Midnight, Close Down.

BERNE.—See Schweizerischer Landessender.

BEROMUNSTER.—See Schweizerischer Landessender.

BODEN.—See Stockholm.

BODO.—See Oslo.

## BRATISLAVA

1,076 kc/s, 279 metres; 4 kW.—6.25 p.m., Gramophone Music. 6.40, Sports Talk. 6.55, Talk for Housewives. 7.0, See Prague. 7.25, See Brno. 7.55 till Close Down, See Prague. 10.15 (approx.), Close Down.

BREMEN.—See Hamburg.

## BRESLAU

923 kc/s, 325 metres; 60 kW. Relayed by Gleiwitz, 1,184 kc/s, 253 metres.—1.5 p.m., Gramophone Music. 1.45, Time and News. 2.10, Schubert Lieder Recital by Else Schütze (Soprano). 2.40, Gramophone Concert. 3.0, Agricultural Prices. 3.15, Programme for Young People. 3.45, Tales of the Pioneers of Gliding. 4.0, Concert by the Station Orchestra, conducted by Topitz: Overture, The Daughter of the Regiment (Donizetti); Waltz, Wiener Bürger (Ziehrer); Polka, Bitte schön (Strauss); Selection from La Traviata (Verdi); Ballet Overture (Kremer); Selection from Ihre Höheit die Kaiserin (Goetze); Waltz, O du Himmelhäuler See (Müllicker); March (Ziehrer). 5.20, Agricultural Prices, followed by Reading. 5.45, Talk: Germans outside the Reich—German Settlements in the Baltic Lands and Russia. 6.10 (from Gleiwitz), Industry on the Frontier—Radio Report from a Blast Furnace. 6.40, See Berlin (Deutschlandsender). 6.50, Meat Market Prices. 7.0, Transmission for all German Stations relayed from Berlin (Deutschlandsender). 8.0, News. 8.10, Concert by the Silesian Philharmonic Orchestra, conducted by Hoffmann, Soloist: Charlotte Boerner (Soprano). The London Symphony in D (Haydn); Aria from Il Seraglio (Mozart); Overture, Così fan tutte (Mozart); Aria from Figaro (Mozart); Overture, Euryanthe (Weber); Minuet, Dance of

the Sylphs and Hungarian March from The Danonation of Faust (Berlioz); Two Slav Dances (Dvorak); Carnival Overture (Dvorak); Overture and Aria from The Merry Wives of Windsor (Nicolai); Waltz, Frühlingsstimmen (Strauss). In the interval at 9.0, Programme to be announced. 10.15, Time, Weather and News. 10.40, Talk: German Wrought Iron Work in the Great Days of Prussia. 11.0, Light Music and Dance Music from the Admiralspalast. 12 Midnight, Close Down.

## BRNO

878 kc/s, 342 metres; 35 kW.—2.50 p.m., Concert by the Station Orchestra, conducted by Bakala: Overture, Figaro (Mozart); Mendelssohn Potpourri (Fonds); Waltz from Der Rosenkavalier (R. Strauss); Serenade for Strings (Hrimaly); Baccanale (Dvorak). 3.50-4.0, See Prague. 5.45, Gramophone Music. 5.55, Talk for Women: Rhythmic. 6.5, Gramophone Music. 6.15, Talk for Workers. 6.25, German Transmission: News, Sports Notes, Topical Talk and Readings. 7.0, See Prague. 7.25, Haydn Chamber Music: Four Pieces for Flute; Quartet in D for Lute, Violin, Viola and Cello. 7.55, See Prague. 9.30, Pianoforte Recital by Norbert Matzek. 10.0, See Prague. 10.15 (approx.), Close Down.

## BRUSSELS (No. 1)

I.N.R.; 590 kc/s, 509 metres; 15 kW.—12 Noon, Acts II and III of Lucia di Lammermoor (Donizetti), on Gramophone Records. 1.0 p.m., Le Journal Parlé. 1.10, Modes of Travelling—Gramophone Concert. 5.0, Mendelssohn Concert by the Station Symphony Orchestra, conducted by Meulemans; Overture, Ruy Blas; Spring Song; Spinning Song; Symphony in A Minor—The Scottish. 6.0, Talk: Wireless Reception and its Development in Belgium and Abroad. 6.15, Request Gramophone Music. 6.30, Pianoforte Recital by Raoul Spitaels: Spanish Suite (Albeniz); Waltz (Chopin); Dances (Debussy); Rondeau brillant (Weber). 6.45, Symphony No. 1 (Beethoven), on Gramophone Records. 7.15, Talk. 7.30, Legal Talk and Literary Talk. 8.0, Concert by the Radio Orchestra, conducted by Walpot. Soloist, Mlle. De Troch (Soprano). Overture and Air de Ballet from Pan's Flute (Van Oost); Waltz, Les sirènes (Waldteufel); Selection from Paganini (Lehár); Songs: (a) Aria from Alceste (Gluck), (b) Aria from Cavalliera rusticana (Mascagni); Selection from White Horse Inn (Stolz-Benatzky). 8.45, Talk: Ghent and its People. 9.0, Concert by the Station Symphony Orchestra, conducted by Meulemans; Overture, Amarcion (Cherubini); Petite suite (Busser); Scherzo-Valse (Guillaume); Two Symphonic Pieces (Bernart); Scenes alsaciennes (Massenet); March héroïque (Saint-Saëns). 10.0, Le Journal Parlé. 10.10, La Brabançonne.

SEPT. 29th

FRIDAY

continued

gramme in French. 4.30 to 6.0, Programme in English by the I.B.C. 4.30, Programme for Children. 5.0, Hawaiian Band Concert for Southampton and Winchester Listeners: Signature Tune, The Night by the Sea; Tomi, Tomi; My Waikiki Mermaid; Aloha (Bowers); Mami Girl (Liborau); Palukko Blues; Makin' wicky wacky down in Waikiki (Hoffmann); Reef of Stars (Watts); My South Sea Home (Camillio). 5.30, Concert for Bournemouth and Weymouth Listeners: Waltz, Künstlerleben (Strauss); Mignonette (Friml); Xylophone Solo, Clatter of the Clogs (Flynn); Selection from The Merry Widow (Lehár); Dance of the Clowns (Smetana); Air de ballet (Herbert); Xylophone Duet, Dance of the Nymphs (Birch); Love everlasting (Friml); Signature Tune. 6.0, Programme in French. 10.0 till Close Down, Programme in English by the I.B.C. 10.0, Dance Music: Signature Tune, Bells of Normandy; Look what I've got; The Old Spinning Wheel; In the Park in Páree; In the Valley of the Moon; Falling Star; This is the Rhythm for me; Where are you tonight?; It's the Band; Won't you stay to Tea?; There's a tiny little Hair; There's a Cabin in the Pines; Jog along; Rhapsody in Blue; Here is my Heart; Lover; Old Man Harlem; My Wishing Song; Signature Tune. 11.0, Tunes from Talkies; Signature Tune, Sittin' in the Dark; Selection from Music in the Air; To-day I feel so Happy (Carter); Making a Talkie (Clapham and Dwyer); I lost my Girl from Memphis; Sergeant Flagg and Sergeant Quirt (Moll); Falling in love again (Hollander); One little Drink (Akt); The Good Companions; Signature Tune. 11.30, Club Concert for Jedburgh Listeners. Part I: Gramophone Records: Signature Tune, The Chum Song; Ginger Snaps (Bourdon); Marching through Georgia (Wark); Coeur brisé (Gillet); Bella, the Belle o' Dumoon (Lauder); Selection from The Student Prince (Romberg); March, Stars and Stripes (Souza); And wouldst thou thus have sullied (Verdi); Sans-Souci (von Blon). 12.5 a.m. (Saturday), News Bulletin in English. 12.10 (approx.), Club Concert. Part II: It's Glory (Serman); Sophisticated Lady (Ellington); Any Time, any Day, anywhere (Young); Sadie the Skater (Miller); Bass Drum Dan (Trumbauer); Signature Tune. 12.30, Dance Music: Peter, Peter; There's a Light in your Window; I've got the World on a String; One Tiny Tear; Stay out of my Dreams; I can't remember; Sweetheart Darlin'; Hold me; Let's all be happy together. 1.0, Dance Music: Bells of Normandy; Learn to croon; Maybe I love you too much; Down the Old Ox Road; When Gimble hits the Cymbal; Smilin' through; My lucky Day; At the Old Pig and Whistle; Happy ending; Somebody stole my Gal; Roll along, Kentucky Moon; Bugle Call Rag; Pink Elephants; Castles in the Sand; Love Songs of the Nile; Maria, my own; From me to you; Signature Tune. 2.0, I.B.C. Good-night Melody and Close Down.

FLENSBURG.—See Hamburg.

FLORENCE.—See Turin.

## FRANKFURT

1,157 kc/s, 259.3 metres; 17 kW. Relayed by Cassel, 1,220 kc/s, 245.9 metres; and Trier, 1,157 kc/s, 259.3 metres.—1.30 p.m., Gramophone Concert. The Squire String Orchestra: On Wings of Song (Mendelssohn); Ria Ginstler (Songs); (a) Guten Abend, gute Nacht (Brahms); (b) Maria sitzt im Rosenhag (Reger); (c) Wie sich der Aenglein kindlicher Himmel (Schubert); Frida Leider (Songs); (a) Träume, (b) Schmerzen (Wagner); Elizabeth Schumann (a) Mondnacht (Schumann), (b) Traum durch die Dämmerung, and (c) Ich schwebe (Richard Strauss); Le Cygne (Saint-Saëns). 2.0, News. 2.20, Talk. 3.0, Weather. 3.10, Time and Exchange. 3.20, Musical Programme. 4.25, Exchange. 4.30, Orchestral Concert. 5.45, Exchange. 6.0, Talk on the Industrial Crisis in Australia. 6.30, The Day's News. 6.40, See Berlin (Deutschlandsender). 7.0, Transmission for all German Stations, relayed from Berlin (Deutschlandsender). 8.0, Six Pieces from the Augsburgers' Tafelkonzert (Johannes Günther, arr. Wolfgang Jacobi). 8.45, Max von Schillings Memorial Programme. 10.0, Topical Talk. 10.15, Time and News. 10.44, Programme from Stuttgart. 12 Midnight, Close Down.

FREDRIKSTAD.—See Oslo.

FREIBURG.—See Stuttgart.

GENEVA.—See Radio-Suisse Romand.

GENOA.—See Turin.

GLEIWITZ.—See Breslau.

GOTEBORG.—See Stockholm.

GRAZ.—See Vienna.

HAMAR.—See Oslo.

## HAMBURG

806 kc/s, 372 metres; 1.5 kW. Relayed by Bremen, 1,112 kc/s, 269.8 metres; Flensburg, 1,319 kc/s, 227.4 metres; Hanover, 530 kc/s, 566 metres; and Kiel, 1,292 kc/s, 232.2 metres.—6.0 p.m. (from Hanover), Concert by the Hanover Station Orchestra, conducted by Otto Ebel von Sosen; Ilse Huhn-Irnscher (Soprano), Heinz Schütz (Tenor), and Wily Lantelme (Songs to the Lute). 6.25, Frankfurt Exchange and Hamburg Market Prices. 6.30, Weather. 6.40, See Berlin (Deutschlandsender). 7.0, Transmission for all German Stations, relayed from Berlin (Deutschlandsender). 8.0, Concert by the Station Choir,

conducted by Gerhard Gregor: Der Sommerkanon; Das Jahr (Stürmer); A Song of Summer (Delius); Nippon (Lendvai). 8.25 (from Bremen), Wenn die Halm kreicht—Peasant Comedy in North German Dialect (Hilfrichs). 10.0, Time and News. 10.20, Topical Talk. 10.30, Music by Arnold Ebel—Violin and Pianoforte Recital for the Composer's Fiftieth Birthday. 11.0, Cabaret on Gramophone Records.

HANOVER.—See Hamburg.

## HEILSBURG

1,085 kc/s, 276.5 metres; 60 kW. Relayed by Danzig, 662 kc/s, 453.2 metres.—1.5 p.m., Gramophone Concert. In the intervals at 1.20 and 2.0, News. 2.30, Programme arranged by the Post Office with Gramophone Records. 2.45, Agricultural Prices and Exchange. 3.0, Concert by the Small Station Orchestra, conducted by Wilcken: Selection from Alceste (Gluck); Suite, Op. 98 (Dvorák); Intermezzo from I quattro rusteghi (Wolf-Ferrari); Extracts from A Carnival Wedding (Poljini); Suite from Coppélia (Delibes). 4.0, Talk for Women: Animals' Toilet Secrets. 4.30, Concert by the Small Station Orchestra, conducted by Wilcken: Overture, Waldmeister (Strauss); Waltz, Gruss aus Wien (Strauss); Selection from Frühlingstut (Jos. Strauss); Polka and Galop (Jos. Strauss); Waltz, Sorgenbrecher (Strauss); Radetzky March (Strauss); Selection from The Arabian Nights (Strauss). 5.40, Recital of Flute Sonatas of the Time of Frederick the Great by Hans Jürgen Walter: Sonata in C (P. E. Bach); Sonata in B Minor (Frederick the Great); Sonata No. 6 in C (Bach). 6.15, Agricultural Prices. 6.20, Talk: The Care and Choice of Gloves. 6.40, See Berlin (Deutschlandsender). 7.0, Transmission for all German Stations, relayed from Berlin (Deutschlandsender). 8.0, Weather and News. 8.10, The East Prussian Landscape—Musical and Literary Sequence (Words, arr. Bornmann, Music arr. Besch). The Königsberg Opera House Orchestra, conducted by Erich Siedler. 9.0, News. 9.10, Concert by the Königsberg Opera House Orchestra, conducted by Brückner. Soloist: Siegfried Schultze (Pianoforte). Symphony No. 8 (Haydn); Pianoforte Concerto in B Flat (Mozart); Ballet Music from Prometheus (Beethoven). 10.10, Weather, News and Sports Report.

## HILVERSUM

Announced HUIZEN, 1,013 kc/s, 296.1 metres; 7 kW. (until 5.40 p.m.) and 20 kW. from 5.40 p.m. Programme of the Christian Radio Society (N.C.R.V.).—11.40 a.m., Police Notes. 11.55, Gramophone Music. 12.10 p.m., Concert by the Horst Ensemble: Overture, La part du diable (Auber); Frühlingsschaer (Translatour); Selection from La Juive (Halévy); Styrian Dance (Gillet); Gramophone Records: Naeklinge aus Ossian (Gade); Loreley-Rheinklänge (Strauss); Selection from Rip (Planquette); Dubinischka (Schirrmann). 1.40, Interval. 2.10, Religious Address. 2.40, Organ Recital: March from Athalie (Mendelssohn); Chorus from The Creation (Haydn); Paraphrase (Blaauw); Three Dutch Songs; Meditation (Faulkes); Serenade (Widor); Woodland Rest (Oelme); Sabbath Eve (Elliott); Hymn. 3.40, Concert by the Duteli Harp Quartet: Prelude for Harp (Mozart-Schaefer); Ballet Music from Orpheus (Gluck); Sonata in B Flat (Mozart); Souvenir de Pergolesi (Hartogh); Pastorale (Nieland); Air (Huré); Gramophone Music; Schubert Potpourri (Trneck); Fantasia (Lewin); Trio (Ropartz); Gramophone Music; Pavane (Ravcl); Serenade (Pierné); Pantomime (Friml); Serenade (Widor). 5.40, Gramophone Music. 6.10, Gardening Talk. 6.40, Police Notes. 6.55, Religious Notes. 7.10, Talk on Literature. 7.40, Concert by the Apollo Male Voice Choir. Soloist: Zwart (Organ). Prelude and Fugue in C Minor (Bach); Choral-Partita, Jesu meine Freude (Walther); Ecce quomodo moritur (Händel); Concerto in C (Händel); Choir: (a) Magyar Hymn (Ferenz), (b) Hullaizo Balaton (Jenö), (c) Trüber Samstag (Dobrown); Organ Solos: (a) Andante from the First Sonata (Borowsky), (b) Toccata from Suite No. 1 (Borowsky), (c) Toccata (Zwart), (d) Pastorale (Zwart); Three Songs for Choir; March (Roese); Finale (Zwart). In the intervals at 8.40, Recitation, and at 9.40, News. 10.10, Gramophone Music. 11.10 (approx.), Close Down.

HORBY.—See Stockholm.

## HUIZEN

Announced HILVERSUM, 160 kc/s, 1,875 metres; 7 kW. (until 3.40 p.m.). Transmitted from Kootwijk on 50 kW. from 3.40 p.m.—11.40 a.m. to 3.40 p.m., Programme of the Algemeene Vereeniging Radio Omroep (A.V.R.O.). 11.40, Popular Music by the Rentmeester Ensemble. In the intervals, Gramophone Music. 1.55 p.m., Gramophone Music. 2.10, Talk. 2.40, Gramophone Music. 3.55-7.40, Programme of the Workers' Radio Society (V.A.R.A.). 3.55, Organ Recital by Jong: Cockney Suite (Kettelbey); Letzter Frühling (Grieg); Melody from Wild Violets

(Stolz). 4.30, Programme for Children. 5.10, Orchestral Concert, conducted by de Groot: V.A.R.A. March (de Groot); Estudiantina (Waldteufel); Irrlichter (Calubley); Tounjours vivement (Kunth); Dureli Webers Zauberswald (Urbach); Meditation from Thaïs (Massenet); Kol Nidrei (Bruch); Gramophone Records: Bells across the Meadows (Kettelbey); Selection from Der Teufelsreiter (Kálmán). 6.20, Talk. 6.40, S O S Announcements. 6.42, Concert (continued): Comedy Overture (Kéler-Béla); Caucasian Sketches (Ippolitov-Ivanov); Am Ziehbrunne (Rust); Wiener Praterleben (Translatour); Glöckchen im Tale (Sackur); Die Spiellose (Eichhorn); A-B-C Potpourri (Komzak). 7.40-10.40, Programme of the Liberal Protestant Radio Society (V.P.R.O.). 7.40, Talk. 8.10, Concert by the Haydn String Quartet: String Quartet in A minor, Op. 51 (Brahms); String Quartet No. 2 (Piper); String Quartet in C, Op. 54, No. 2 (Haydn). In the interval at 8.40, Talk. 9.40, Religious Information. 9.45, News. 9.55, Talk. 10.25, Gramophone Music. 10.40, V.A.R.A. Programme: Organ Recital by Steyn, followed by Gramophone Music. 11.40 (approx.), Close Down.

INNSBRUCK.—See Vienna.

## JUAN LES PINS

1,205 kc/s, 249 metres; 0.8 kW.—12.30 p.m., Amusement Guide and Variety Items. 1.0, News. 1.15, Radio Concert. 8.0, Amusement Guide, Exchange, Racing Results and News. 8.10, Esperanto Lesson. 8.30, Radio Concert. In an interval at 9.0, News and Weather.

KALUNDBORG.—See Copenhagen.

## KATOWICE

734 kc/s, 408 metres; 16 kW.—4.0 p.m., Concert by the Moniusko Mandoline Orchestra: March (Miller); Overture, Martha (Flotow); Wiener-Walzer (Strauss); Selection from The Bird-Fancier (Zeller); Liebesfreud (Kreisl); Moment musical (Schubert); Chanson d'automne (Tchaikovsky); Fantasia (de Lada); Waltz from Casanova (Rozycky); March from Aida (Verdi). 5.0, See Warsaw. 7.5, Talk: Colonel Lawrence, the Uncrowned King of the Arabs. 7.20, Gramophone Music and Announcements. 7.35, Sports Talk. 7.40, See Warsaw. 10.40, Dance Music. 11.0, The Letter Box in French.

KIEL.—See Hamburg.

KLAGENFURT.—See Vienna.

KOSICE.—See Prague.

## LANGENBERG

635 kc/s, 473 metres; 60 kW.—12 Noon, Concert of Folk Music. 1.15 p.m., News. 1.30, Concert by the Münster Municipal Orchestra, conducted by Göhre: Overture, Der Erlenhügel (Kuhlan); Norwegian Wedding Procession (Grieg); Selection from Mignon (Thomas); Waltz, from Gipsy Love (Lehár); Rhapsodic Fantasia (Urban). In the interval at 2.0, News. 3.0, Talk: German Deep Sea Fisheries. 3.20, Political Announcement. 3.30, Economic Notes and Time. 3.50, Programme for Young People. 4.30, Talk: Experiences among the Cannibals and Headhunters of German New Guinea. 5.0, Clarinet Quintet in A (Mozart), by Philipp Dreisbach and the Wending Quartet (on Gramophone Records). 5.30, Concert by the Fröhliche Fünf and Soloists. 6.15, Talk. 6.30, News. 6.40, See Berlin (Deutschlandsender). 7.0, Transmission for all German Stations, relayed from Berlin (Deutschlandsender). 8.0, News. 8.5, Operetta Programme: (a) Das Liebespfand (The Love Pledge) (Hermann Bredehoff—Music Kneip); (b) Das grosse Los (The Great Gamble) (Hermann Bredehoff—Music Kneip); (c) Operetta Medley (arr. Görtitz and Kneip). 10.15, News. 10.30, Talk: Coming Events in West Germany. 10.45, Popular Concert. 11.30 (approx.), Close Down.

LAUSANNE.—See Radio-Suisse Romande.

## LEIPZIG

769.9 kc/s, 389.6 metres; 120 kW. Relayed by Dresden, 941 kc/s, 319 metres.—12 Noon, Weather and Time. 12.5 p.m., Concert by the Leipzig Symphony Orchestra, conducted by Theodor Blumer. Soloist: Kurt Günther (Flute); Overture, Um Deutschland (Stadler); Selection from Der Widschütz (Lortzing); Flute Concerto in D (Mozart); Elegy and Waltz from the Serenade for Strings (Tchaikovsky); Die Jagd nach dem Glück (Nicoed); Overture, Prince Methusalem (Joh. Strauss); Polka, Leichtes Blut (Joh. Strauss). 1.15, News. 1.30, German Dances and Marches on Gramophone Records. 2.5, News. 2.20, Lyrics by Johannes Linke. 2.30, Art Report. 2.40, Talk: Motor Traffic Regulations. 3.15, Talk: Harvest Festivals in Germany. 3.35, Market Prices and Weather. 4.0, Concert by the Station Orchestra, conducted by Hilmar Weber: Overture, Fra Diavolo (Auber); Orientale Suite (Popy); Selection from Fatinitza (Suppé); Rhapsody in B Minor, Op. 25 (Hartung); Waltz, Unter der blühenden Linde (Gellert); Overture in Italian Style (Schubert). 5.0, Talk: Mia Munier-Wroblewska. 5.20, Talk on Architecture: Modernising Houses. 5.50, Market

Prices, Weather and Time. 6.20, Music by the Station Orchestra, with Introductory Talk. 6.40, See Berlin (Deutschlandsender). 7.0, Transmission for all German Stations, relayed from Berlin (Deutschlandsender). 8.0 (from Dresden), Alceste—Opera (Glück). 10.15, News. 11.0, Programme from Stuttgart. 12 Midnight, Close Down.

LINZ.—See Vienna.

## LUXEMBOURG

252 kc/s, 1,191 metres; 200 kW.—12.30 p.m., Gramophone Music. 7.30 till Close Down, Dutch Programme. 7.50, Symphony No. 3 in E Flat, Op. 55—the Eroica (Beethoven), on Gramophone Records. 8.35, Strauss Potpourri (arr. Marek Weber) on Gramophone Records. 8.50, News in French. 9.0, Song Recital by Alice Peffer. La cloche (Saint-Saëns); La Brise (Saint-Saëns); The Harpsichord (Dell'Acqua); La maison grise from Fortuno (Messager); Elegie (Duparc); Chanson triste (Duparc). 9.30, Gramophone Records. 9.45, News in German. 9.55, Gramophone Music. Potpourri, Rund um die Wolga; Waltz, The Blue Danube (Joh. Strauss); Selection from the Dollar Princess (Fall). 10.20, Dance Music on Gramophone Records.

## LYONS

LA DOUA, 644 kc/s, 465.8 metres; 1.5 kW.—6.30 p.m., Radio Journal. 7.30, Radio Gazette for Lyons and the South-East. 8.30, Pédère—Drama (Racine). After the Programme, News.

## MADRID

EAJ7, 707 kc/s, 424.3 metres; 2 kW.—9.0 p.m., Chimes, Exchange, Radio Journal and Request Gramophone Records. 9.15, Topical Review. 9.30 to 11.0, Interval. 11.0, Chimes, Time and Topical Review. 11.50 (approx.), Symphony Music on Gramophone Records. Prelude to Lohengrin (Wagner); Serenade (Volkman); Selection from The Damnation of Faust (Berlioz); Symphony No. 7 (Beethoven); Pianoforte Concerto in E minor (Chopin). 1.15 a.m. (Saturday), Topical Review and Programme Announcement for Listeners Abroad. 1.30, Chimes and Close Down.

MALMO.—See Stockholm.

MILAN.—See Turin.

## MORAVSKA-OSTRAVA

1,137 kc/s, 263.8 metres; 11 kW.—6.15 p.m., See Prague. 7.25, See Brno. 7.55, See Prague. 10.15 (approx.), Close Down.

MOTALA.—See Stockholm.

MÜHLACKER.—See Stuttgart.

## MUNICH

563 kc/s, 533 metres; 60 kW. Relayed by Augsburg and Kaiserslautern, 536 kc/s, 560 metres; and Nürnberg, 1,256 kc/s, 235 metres.—12.5 p.m., See Leipzig. 1.15, Time, Weather and News. 1.30, German Opera Music on Gramophone Records. 2.0, Time, Weather and Announcements. 2.20 (Nürnberg), Programme arranged by the Post Office, with Gramophone Records. 3.0, Programme for Women. 3.55, Weather and Agricultural Notes. 4.5, Reading for Young People. 4.30, Orchestral Concert, conducted by Erich Kloss: Overture, Le Maçon (Auber); Selection from Faust (Gounod); Waltz, Künstlerblut (Waldschütz); Carnival Suite (Schmalstich); Sons ton balcon (Lacombe); Dance of the Merry Mascots (Kettelbey); Zardas from Ritter Pasman (Strauss). 5.45, Talk for Young People: The Universities under the New Regime. 6.5, Recital of Eichendorff's Lyrics to Settings by Annin Knab. 6.20, Talk: The Renaissance of the German Lyric. 6.40, See Berlin (Deutschlandsender). 7.0, Transmission for all German Stations, relayed from Berlin (Deutschlandsender). 8.0, Orchestral Concert, conducted by Erich Kloss: Overture, The Magic Moon (Humphries); Slow Movement for Violin and Viola from the Sinfonia Concertante (Mozart); Selection from Czar and Carpenter (Lortzing); Waltz, Gross-Wien (Strauss); Ballet Suite from Sylvia (Delibes-Rhode); Sword Dance (Poldini); Romance, Gipsy Longing (Nicklas-Kemper); The Merry Postilion (Pesse). 9.20, Symphony Concert by the Station Orchestra, conducted by Hans Winter. Soloist: Viktoria Wolfram-Schröfl (Pianoforte); Overture to a Comic Opera (Huber); Pianoforte Concerto in D (Haydn); Swabian Music, Op. 73 (Rüdinger). 10.20, Time, Weather and News.

NAPLES.—See Rome.

NOTODDEN.—See Oslo.

## OSLO

277 kc/s, 1,083 metres; 60 kW. Relayed by Fredrikstad, 815 kc/s, 368.1 metres; Hamar, 522 kc/s, 574.7 metres; Notodden, 671 kc/s, 447.1 metres; Forgrund, 662 kc/s, 453.2 metres; and Rjukan, 671 kc/s, 447.1 metres.—5.0 p.m., Gramophone Concert. 6.0, Talk. 6.30, Recital of Neapolitan and Italian Songs by Alessandro Tiesio and Odette Landauer. 7.0, Advertising Notes, Weather and News. 7.30, Programme from Romerike. In the interval at 8.0, Time Signal. 8.45, Concert by the Budapest Quartet and Anton Meyer (Pianoforte). 9.30, Agricultural Report. 9.40, Weather and News. 10.0, Topical Talk. 10.15, Concert of Operetta Music



by the Radio Ensemble. Soloists: Huida Frisk Gran (Soprano), and Bjarne Buntz (Tenor).

OSTERSUND.—See Stockholm.

PALERMO

558 kc/s, 537.6 metres; 3 kW.—8.0 p.m., Dopplavoro Announcements, Tourist Talk, Agricultural Notes, Report of the Royal Geographical Society and Giornale Radio. 8.20, Gramophone Music. In the interval at 8.30, Time and Announcements. 8.45, Concert of Opera Music, conducted by Russo. In the interval, Literary Talk and Announcements. 11.0, Giornale Radio.

PARIS

EIFFEL TOWER, Call FLE, 207.5 kc/s, 1,445.7 metres; 13 kW. Time Signals (on 2,650 metres) at 10.26 a.m. and 11.26 p.m. (Preliminary and 6-dot Signals).—6.45 p.m. Theatre Talk. 7.0, Le Journal Parle. 8.30, Literary and Musical Programme. 9.0, Orchestral Concert, conducted by Flamant; Agnès dame galante (Février); Overture and Minuet from L'accordée du village (Steck); Romance in F minor (Tchaikovsky); Violin Solo; Pieces (d'Amoroso): (a) Rêve. (b) En badinant. (c) Cazonetta; Le pas des fleurs (Delibes); Cello Solo; Selection from La Bohème (Puccini); Overture, Le Pré aux clères (Hérold. 10.0 (approx.). Close Down.

PARIS

POSTE PARISIEN, 914 kc/s, 328.2 metres; 60 kW.—7.0 p.m., Gramophone Music. 7.15, Le Journal Parle. 7.30, Concert. 8.0, Agricultural Talk. 8.30, Concert. 9.15, Le Toréador—Comic Opera in Two Acts (Adam). 10.30, News.

PARIS

RADIO-PARIS, Call CFR, 174 kc/s, 1,725 metres; 75 kW.—7.30 a.m., Weather and Physical Culture. 7.45, Gramophone Music. 8.0, Weather and News. 12 Noon, Programme for Hebrews. 12.30 p.m., Concert of old and New Italian Music: Madrigal (Monteverde), by the Choir of the Scala, Milan; Aria from Ezechias (Carissimi); Harpsichord Solo, Toccata (Pasquini); Two Songs (Cavalli); Sonata for Flute and Strings (Searlatti); Aria (Caldara); Amarilli (Caccini); Violin Solo (Tartini); Two Arias from Iris (Mascagni); Song from Resurrección (Alfano); Le fontane di roma (Respighi). In the interval at 1.0, Exchange, News, and Weather, and at 1.30, Exchange. 2.0, Exchange and Announcements. 3.45, Exchange and Market Prices. 7.0, Agricultural Report. 7.10, Assurance Societies' Reports. 7.20, Gramophone Music: Selection from The Dollar Princess (Fall); Song from Moineau (Beydts); L'Auvergnate (Ganne); La Touppie (Gillet); Song, Villanelle (dell'Acqua); Reminiscences (Koek). 7.50, Commercial Notes and News. 8.0, Suite, L'Arlesienne (Bizet), on Gramophone Records. 8.30, News and Weather. 8.40, Talk. 8.45, Hors du nid—Play (Charles Etienne). 9.15, Press Review and News. 9.30, Gramophone Concert: Children's Symphony (Haydn); Chanson de la Puce (Berlioz); Soir (Faure); Les Roses d'Isphahan (Faure); Les bereaux (Faure); The Fire-Bird (Stravinsky).

PITTSBURGH

KDKA, 980 kc/s, 306 metres; 50 kW. Relayed by W8XK on 48.86 metres and 25.27 metres.—4.15 to 5.0 p.m., U.S. Marine Band, from New York. 7.30, Home Forum. 8.0, Betty and Bob, from New York. 8.15, Utility Hall. 8.30 to 9.30, New York Relay. 8.30, Words and Music. 8.45, Morn Sisters. 9.0, Gene Quaw's Orchestra. 9.30, News and Markets. 9.45, Areadians, from New York. 10.0, Uncle Tom and Betty. 10.15, KDKA Kiddies' Klub. 10.30, The Singing Lady, from New York. 10.45, Orphan Annie, from New York. 11.0, Press News-Reeler. 11.15, Sports, A Song. 11.30, Pittsburgh Spotlights. 11.45, Lowell Thomas, from New York. 12 Midnight, Amos 'n' Andy, from New York. 12.15 a.m. (Saturday), Silver Toppers. 12.30, Lexington Hotel Orchestra, from New York. 12.45, Rhythm Kings. 1.0 to 3.30, New York Relay. 1.0, Popular Programme. 1.30, Potash and Perlmutter. 1.45, Red Davis. 2.0, Let's Listen to Harris. 2.30, Variety Programme. 3.0, First Nighter. PORSGRUND.—See Oslo.

PRAGUE

614 kc/s, 488.6 metres; 120 kW.—2.50 p.m., See Brno. 3.50, Weather. 3.55 to 4.0, Exchange. 5.45, Readings. 6.5, Agricultural Talk. 6.15, Talk for Workers. 6.25, News in German. 6.30, German Transmission: Talk on Krumlov and Topical Talk. 7.0, Chimes and News. 7.10, Talk on Economics. 7.25, See Brno. 7.55, Reading. 8.10, The Goats on Olympus—a Burlesque by Jurist with Kredba at the Piano. 9.30, Sonatas for Two Violins and Piano. (Händel): (a) in B. (b) in G minor. 10.0, Time, News and Sports Notes. 10.15 (approx.), Close Down.

RADIO-SUISSE ROMANDE

SOTTENS, 743 kc/s, 403 metres; 25 kW.; and Geneva, 395 kc/s, 760 metres.—6.15 to 6.30 a.m. (from Lausanne). Gymnastics. 12.28 p.m., Time Signal from Neuchâtel Observatory. 12.30, News and Weather. 12.40 (from Lausanne), Concert by the Radio-Lausanne Orchestra. 1.0 (from Lausanne), Financial Notes. 1.10 (from Lausanne), Concert

SEPT. 29th

FRIDAY

continued

(cont'd.). 2.0, Interval. 3.28, Time Signal from Neuchâtel Observatory. 3.30 (from Geneva), Gramophone Concert. 4.30 (from Geneva), Programme for Women. 5.30, Interval. 7.0 (from Lausanne), Talk: Perseus. 7.25 (from Lausanne), Weather and Announcements and Answers to Correspondence. 8.0, Talk: Modern Chinaware. 8.25, (from Geneva), Variety Programme. 9.20, News and Weather. 9.30 (from Lugano), Music and Wine, Concert by the Station Orchestra, the St. Cécile Choir and Soloists: Allegri beivium from Ernani (Verdi) Orchestra: Wine, Woman and Song (Joh. Strauss); Baritone Solo, Tuscan Song. Le Vendemmia bevi, bevi, camerata (Ferrari); Orchestra, Brindisi allegri; Tuscan Folk Songs for Soprano; Vintage Chorus from la Nostra vita. 10.50, News and Weather. 11.0 (approx.). Close Down.

RIGA

572 kc/s, 525 metres; 15 kW.—6.0 p.m., Popular Songs. 6.30, Talk: Cancer. 7.0, Weather. 7.5, Symphony Concert: Impressions d'Italie (Charpentier); Concert Piece in D for Violin and Orchestra (Dohnanyi); Symphony in D (Dohnanyi). In the interval at 9.0, Weather and News. 9.15, Old and Modern Dances.

RJUKAN.—See Oslo.

ROME

Call IRO, 680 kc/s, 441 metres; 50 kW. Relayed by 2RO, 11,810 kc/s, 25.4 metres, from 5.15 p.m.; Bari, 1,112 kc/s, 269.8 metres; Milan (Vigentino), 662 kc/s, 453.2 metres from 8.45 p.m., and Naples, 941 kc/s, 319 metres.—12.30 p.m., Gramophone Music. 1.0 to 2.15, Orchestral Concert. In the interval at 1.30, Giornale Radio and Exchange, and at 2.0, Time and Announcements. 4.30, Children's Radio Review. 4.55, Giornale Radio and Exchange. 5.10, Weather. 5.15 to 6.0, Concert: Luigi Chiarappa (Cello), Margherita Cossa (Soprano), and Carlo Platania (Baritone). Cello Solos: (a) Largo (Veracini-Chiarappa). (b) Intermezzo from Goyescas (Granados). Soprano Solos: Castelnuovo-Telesco: (a) Ninna-Nanna. (b) Serenata indiana. (c) Girotondo dei golosi. Baritone Solos: (a) Aria from Le Roi de Lahore (Massenet). (b) Aria from Don Carlos (Verdi). Cello Solos: (a) Greek Song (Seligmann). (b) Tarantella (Popper). Soprano Solos: (a) Su per l'argenteo ciel (Zandonai). (b) Giorno per giorno (Alfano). 6.40 (Naples), Shipping and Sports Notes. 6.45, Dopplavoro Announcements and Tourist Report. 6.57, Report of the International Institute of Agriculture (in Spanish, German and French). 7.10, Agricultural Notes and Market Prices. 7.20, News in Foreign Languages. 7.40, Giornale Radio. 8.0, Time, Announcements and Sports Notes. 8.30, La Soubambula—Opera in Three Acts (Bellini). In the intervals, Humorous Talk and Theatre Notes. After the Opera, Giornale Radio.

SALZBURG.—See Vienna.

SCHENECTADY

WGY, 790 kc/s, 379.5 metres; 50 kW. Relayed at intervals by W2XAF on 31.48 metres; and by W2XAD on 19.56 metres.—8.30 to 9.30 p.m. (approx.). New York Relay. 8.30, The Romancers. 8.45, Three Shades of Blue. 9.0, Sonata Recital. 9.15 to 9.30, Soloist. 1.45 a.m. (Saturday), Stock Reports. 2.0, Popular Programme, from New York. 2.30, Concert. 3.0 to 4.30, New York Relay. 3.0, Variety Programme. 3.30, Popular Programme. 4.0, First Nighters. 4.30, Friday Night Sociable, from New York, followed by Programme Resumé.

SCHWEIZERISCHER

LANDESENDER

BEROMUNSTER, 653 kc/s, 459 metres; 60 kW.—Basle, 1,229 kc/s, 244.1 metres; and Berne, 1,220 kc/s, 245.9 metres.—6.15 to 6.35 a.m. (from Basle), Gymnastics. 11.59, Time Signal from Neuchâtel Observatory, and Weather. 12 Noon (from Zurich), Concert of Operetta Music by the Station Orchestra, conducted by Neppach. In the interval at 12.30 p.m., Time, Weather and News. 1.25 p.m. (from Zurich), Time, Weather and Exchange. 1.30 (approx.) to 5.0, Interval. 5.0 (from Zurich), Programme for Children. 5.30 (from Zurich), Concert by the Small Station Orchestra, conducted by Scheubaum. 6.30 (from Berne), Programme for Women. 7.0 (from Berne), Time, Weather, Market Prices, Tourist Talk and Sports Notes. 7.20 (from Berne), Hugo Wolf Song Recital. 8.0, Concert by the Station Orchestra. 8.30, A Request—Sketch (Eugen Robert). 9.0, Weather and News. 9.10 (from Berne), Albert Moeschlinger Song Recital by Traute Börner (Contralto), with the Composer at the Piano. 9.30, Italian-Swiss Programme, relayed from Lugano. 10.30 (approx.), Close Down.

SOTTENS.—See Radio-Suisse Romande.

STOCKHOLM

689 kc/s, 436 metres; 55 kW. Relayed by Boden, 244 kc/s, 1,229.5 metres; Göteborg, 932 kc/s, 322 metres; Hörby, 1,166 kc/s, 257 metres; Motala, 221.5 kc/s, 1,354.4

metres; Ostersond, 389 kc/s, 770 metres; and Sundsvall, 554 kc/s, 542 metres.—5.5 p.m., (from Sundsvall), Rural Programme. 5.30, Reading. 6.0, Gramophone Music. 6.45, Legal Talk. 7.15, Weather and News. 7.30, Talk, relayed from Malmö, 1,301 kc/s, 231 metres. 8.0, Concert by the Station Orchestra: Soloist, Nancy Naess (Songs); Overture, Idomeneo (Mozart); Aria from Alceste (Gluck); Chaconne and Rigaudon for Strings (Montigny); Three Songs with Orchestral Accompaniment (Jordan); Suite (Björkander); Aria from The Force of Destiny (Verdi); Piece for Flute, Oboe, Clarinet, Horn and Bassoon (Grainger); Norwegian Rhapsody No. 3 (Svendsen). 9.15, Talk. 9.45, Weather and News. 10.0, Microphone Report. 10.15, Light Orchestral Concert: Petite suite de Concert (Coleridge Taylor); Aria from Eugene Onegin (Tchaikovsky); Romance (Svendsen); Selection from Wonder Bar (Katscher). 11.0 (approx.), Close Down.

STRASBOURG

869 kc/s, 345 metres; 11.5 kW.—11.30 a.m., Gramophone Concert of Popular Music. 12.45 p.m., News. 1.0, Time and Exchange. 1.5, Sphonic Suite, Scheherazade, Op. 35 (Rimsky-Korsakov), by the Philadelphia Orchestra (on Gramophone Records). 2.0, Interval. 4.45, Literary Talk. 5.0, Orchestral Concert, conducted by Roskam: Selection from Pas sur la bouche (Vivanti); Slow Waltz, In the Valley of the Moon (Tobias and Burke); Selection from White Horse Inn (Stolz-Benatzky); Waltz Potpourri No. 3 (Robrecht); Violin Solo: Canzonetta (d'Amoroso); Love is the Sweetest Thing (Noble); Salut d'Amour (Elgar); Two Step, Caranula (de Bizi). 6.0, Trio Concert, relayed from Lille, 1,130 kc/s, 265.4 metres. 7.0, Topical Talk in German. 7.15, Gramophone Music. 7.30, Time and News. 7.45, Gramophone Music. 8.0, Press Review in German, Lottery Results and Announcements. 8.30, See Lyons-la-Doua. 10.30 (approx.), Press Review.

STUTT GART

MUHLACKER, 832 kc/s, 360.5 metres; 60 kW. Relayed by Freiburg, 527 kc/s, 570 metres.—1.15 p.m., Time and News. 1.30, Military Symphony in G, No. 100 (Haydn), on Gramophone Records. 2.0, Programme arranged by the Post Office, with Gramophone Records. 2.30 to 3.0, Advanced English Lesson. 4.15, Talk: Sunday Excursions. 4.30, See Munich. 5.45, Talk: Experiences of a Country Doctor. 6.10, Time and News. 6.40, See Berlin (Deutschlandsender). 7.0, Transmission for all German Stations, relayed from Berlin (Deutschlandsender). 8.0, Der Waifenfriedhof—Opera Comique (Lortzing). 10.0, Time and News. 10.20, Dance Music and Light Music from Greiner's Restaurant. 12 Midnight, Close Down.

SUNDSVALL.—See Stockholm.

TOULOUSE

RADIOPHONIE DU MIDI, 779 kc/s, 385 metres; 8 kW.—6.0 p.m., News. 6.15, Chansonnettes. 6.30, Accordion Music. 6.45, Extracts from Prince Igor—Opera (Borodin). 7.0, Military Music. 7.45, News, Racing Results, Market Prices and Exchange. 7.30, Opera Music: Selection from Il Trovatore (Verdi); Manon (Massenet); Carmen (Bizet); and Tosca (Puccini). 7.45, Orchestral Music: Invitation to the Waltz (Weber); Radetzky March (Strauss); La boutique fantasque (Rossini); Two Melodies (Lincke). 8.15, Die Felsenmühle. (b) Verschämte Liebe. (c) Opera Music: Selection from Othello (Verdi); The Magic Flute (Mozart); and The Prophet (Meyerbeer). 8.30, Music by a Viennese Orchestra. 9.0, Extracts from Ciboletta—Operetta (Lohr). 9.30, Opera Music: Selection from Le roi malgré lui (Chabrier); Madame Butterfly (Puccini) and Carmen (Bizet). 9.45, Chansonnettes. 10.0, Medical Talk. 10.5, Chamber Music: Hungarian Fantasia (Logzter); Chant sans paroles (Tchaikovsky); Ständchen (Schubert); Meditation from Thaïs (Massenet). 10.15, North-African News and Local News. 10.30, Concert for Listeners in Morocco. 11.0, Humorous Items. 11.15, Dance Music. 12 Midnight, News. 12.5 a.m. (Saturday), Balalaika Music and Russian Songs. 12.15, Light Orchestral Music. 12.30 (approx.), Close Down.

TRIESTE

1,211 kc/s, 247.7 metres; 10 kW.—5.10 till Close Down. See Turin.

TRONDHEIM.—See Oslo.

TURIN

273.7 metres; 7 kW. Relayed by Milan, 331.5 metres; Genoa, 312.8 metres; and Florence, 500.8 metres.—5.10 p.m. (from Florence), Soprano and Tenor Song Recital by Evy Santonieto and Ezio Badii; Vittoria, vittoria (Carissimi). Songs (Bellini): (a) Abbandono. (b) Melanconia. (c) Per pietà dell'Idolo mio. Aria from Manon (Massetet); Serenata d'inverno (Bettinelli); Rusticella (Santoneito); La Paloma (Yradier); Serenata (Bracco); Addio del

Sagno (de Curtis); Canzone dell'uccellino (Bili). 6.0 to 6.5, Weather. 6.40, Giornale Radio, Dopplavoro Announcements and Gramophone Music. 7.0, Time, Report of the Royal Geographical Society and Gramophone Music. 7.10, Agricultural Notes and Market Prices. 7.20, News in Foreign Languages. 7.40, Gramophone Music. 8.0, Announcements, Giornale Radio and Weather. 8.15, Sponsored Music. 8.30, Orchestral Concert, conducted by Daniele Amfitheatrof. In the interval, Talk. 10.0, Gramophone Music. 11.0, Giornale Radio.

VATICAN CITY

15,120 kc/s, 19.84 metres (Morning) and 5,969 kc/s, 50.26 metres (Evening); 10 kW.—11.0 to 11.15 a.m., Religious Information in German. 8.0 to 8.15 p.m., Religious Information in Italian.

VIENNA

581 kc/s, 517 metres; 100 kW. Relayed by Graz, 852 kc/s, 352.1 metres; Innsbruck, 1,058 kc/s, 283 metres; Klagenfurt, 662 kc/s, 453.2 metres; Linz, 1,220 kc/s, 245.9 metres; and Salzburg, 1,373 kc/s, 218.5 metres.—12 Noon, Concert by the Volksoper Orchestra, conducted by Dostal: Overture, Alessandro Stradella (Flotow); Suite from The Sleeping Beauty (Tchaikovsky); Adagio (Bizet); Selection from Tosca (Puccini); Overture, Isabella (Suppé); Selection from La belle Hélène (Offenbach); Fata Morgana (Lehár); Italian Waltz (Strauss); Romance and Waltz intermezzo (Hiess); Gipsy Festival (Lehár). In the interval at 1.0 p.m., Time, Weather and Announcements. 2.0, Interval. 3.0, Time, Weather and Exchange. 3.20, Talk: Safety First Films. 3.35, Reading for Women. 4.0, The Paul Godwin Orchestra, on Gramophone Records. 5.0, Wireless Talk: Modern Methods of Combating Fading. 5.25, Sonata in F Minor, Op. 120, No. 1 (Brahms) for Clarinet and Piano. 5.55, Tourist and Traffic Report. 6.10, Talk: The Sailing Championship. 6.25, Sports Review of the Week. 6.35, Talk, by Minister Dr. Eugen Lauske: A Topical Problem—The Austrian Weekly Review. 7.0, Violin and Piano Recital by Wolfgang Schneiderhan and Karl Frotzler. 7.45, Talks on Music with Song and Piano Recital Illustrations. 8.5, Time, Weather and Announcements. 8.15, Topical Talk. 8.30, Concert by the Wiener Symphoniker, conducted by Schönherr; Soloists, Maria Gerhart (Soprano) and Dario Medina (Tenor); Overture to a Puppet Play (Wienberger); In the Hall of the Mountain King (Grieg); Soprano Aria from The Tales of Hoffman (Offenbach); In the Poultry-Yard (Bortkiewicz); Dance (Mussorgski); Tenor Serenade from I Pagliacci (Leoncavallo); Potpourri from Die Puppenfee (Bayer); Extracts from La Poupée (Audran); Extracts from the Music to Much Ado about Nothing (Kornegodt); Extracts from The Magic Flute (Mozart); Suite from Coppelia (Delibes); Tenor Song and Soprano and Tenor Duet from Der Humpelmann (Stolz); Dance from the Music to A Midsummer Night's Dream (Mendelssohn); Soprano Aria from The Nuremberg Doll (Adam); Dance from the Ballet Andersen (Nedbal); Duet from Bnh oder Mädel (Granichstedten); Duet from A Waltz Dream (O. Straus); Burlesque, In an Oriental Café (Vollstedt). 10.10, News, Weather and Announcements. 10.25, Concert by The Four Funny Fellows, relayed from the Oase. After the programme, Exchange.

WARSAW

212.5 kc/s, 1,411 metres; 120 kW.—11.57 a.m., Time Signal and Fanfare from Torun Cathedral. 12.5 p.m., Gramophone Music. 12.25, Polish Press Review. 12.33, Weather Report. 12.35, Gramophone Music. 12.55, Radio Journal. 1.0 to 2.55, Interval. 2.55, Gramophone Music. 3.5, News. 3.10, Announcements. 3.15, Gramophone Music. 3.25, Economic Notes. 3.35, Gramophone Music. 3.45, Aviation Report and Anti-Gas Drill. 3.50, Gramophone Music. 3.55, Naval and Colonial Report. 4.0, Gramophone Music. 5.0, Book Review. 5.15, Violin and Song Recital by Bacewicz and Roginska; Violin Solos: (a) Spanish Songs (Nim), (b) Slav Dance in E minor (Dvorak-Kreislér), (c) Caprice No. 2 (Bacewicz); Songs; Violin Solos: (a) Suite (Szalowski), (b) Berceuse from The Fire-Bird (Stravinsky), (c) The Fountain of Arcthusa, from Myths (Szymanowski); Songs. 6.15, Talk: Poland To-day. 6.35, Light Music from the Gastro-nomia Café. 7.20, Miscellaneous Items. 7.35, Programme Announcements. 7.40, Topical Talk. 8.0, Symphony Concert by the Station Orchestra, conducted by Fitelberg; Soloist, Woytowicz (Piano): Second Symphony (Beethoven); Polish Fantasia for Piano and Orchestra (Paderewsky); Symphony Suite, Scheherazade (Rimsky-Korsakov). In the interval at 8.30, Radio Journal and Hints for the Week-end. 10.0, Dance Music. 10.25, Sports Notes. 10.35, Aviation Weather Report and Police Notes. 10.40, Dance Music (cont'd.).

WILNO

533 kc/s, 563 metres; 16 kW.—7.35 p.m., Programme Announcements. 7.40, See Warsaw. 9.0, Talk: The Latest Developments in Aviation. 9.10, Symphony Concert relayed from Warsaw.

ZURICH.—See Schweizerischer Landessender.



## ALGIERS

824 kc/s, 364 metres; 13 kW.—8.10 p.m., Shipping Notes. 8.15, Agricultural Report and Weather Forecast. 8.20, Jazz Music. 8.55, News. 9.0, Time. 9.2, Request Gramophone Concert. 9.40, News. 9.45, Open Air Concert.

## ATHLONE

725 kc/s, 413 metres; 60 kW. Relayed by Cork, 1,337 kc/s, 224.4 metres.—1.30 to 2.30 p.m., Time Signal, Weather Report, Stock Exchange Quotations and Gramophone Music. 6.0, Programme for Children. 6.45, News. 7.0, Poetry Recital by Cathleen Murphy. 7.15, Gaelic Talk by Seamus O'Duinn. 7.30, Time Signal. 7.31, Concert by the Station Orchestra. In an interval at 7.50, Contralto Solos by Nora Finn. 8.25, Readings from Tristram Shandy by Rev. A. H. Macpherson. 8.45, Baritone Solos by Frank Gallagher. 9.0, The Station Orchestra. 9.15, Uilleann Pipe Solos by Liam Breathnach. 9.30 to 10.30, Programme by the I.B.C. (Ireland) Ltd. 9.30, Light Music. Just once for all time (Heymann); Bertina Waltz (Baptiste); Song, Don't be late in the Morning (Le Clerq); Volante March (Baptiste); Swanee (Gershwin); Song, Me and mine are doing fine (Connelly); Ninon (Charlier); Coal Black Manmy (St. Helier). 10.0, Concert arranged by the International Broadcasting Company (Ireland) Ltd. on behalf of Hospitals' Trust Ltd. The Lord Mayor's Show (Sarony); Farewell to Arms (Wrubel); The Grandfather Clock (Alwyn); You're the Cream in my Coffee (de Sylva); Butterflies in the Rain (Myers); Rock-a-bye Moon (Lang); Let's all be happy together (Leslie). 10.30, I.B.C. Good-night Melody, followed by News and Weather Report. 10.40, Pianoforte Recital by Sydney Green. 11.0 (approx.), Close Down.

## BARCELONA

EAJ1; 860 kc/s, 348.8 metres; 8 kW.—7.0 p.m., Trio Concert: March (Hume); Prelude in F, No. 23 (Chopin); Minuet from the Symphony No. 3 (Mozart); Selection from La Bohème (Puccini); The Clock and the Dresden Figures (Kettelbey); Noletta No. 1 (d'Ambrosio); Selection from The Snow Maiden (Rimsky-Korsakov). 8.0, Request Gramophone Records. 8.30, Exchange. 9.0, Gramophone Music. 9.15, Anti-War Talk, Gramophone Music, and News. 10.0, Chimes from the Cathedral, Weather, Exchange, and Market Prices. 10.5, Concert by the Station Orchestra. 11.15, Literary Review. 11.30, Dance Music, relayed from the Casa Libre. In the interval at 12 Midnight, News. 1.0 a.m. (Sunday), Close Down.

BASLE.—See Schweizerischer Landessender.

## BELGRADE

697 kc/s, 430.4 metres; 2.8 kW.—6.55 p.m., Time and Announcements. 7.0, Talk. 7.30, Gramophone Music. 8.0, Kostana-Opera (Peter Krstic). In an interval at 9.30, Time and News. 10.30, Cigány Music from the Dva Jelena Restaurant. 11.0, Dance Music on Gramophone Records.

## BERLIN

DEUTSCHLANDSENDER (Reichssender), 183.5 kc/s, 1,635 metres; 60 kW.—2.0 p.m., Gramophone Concert. 3.0, Concert of Old and Modern German Music: Gavotte-Musette (Gluck); Manchurian Sketches Nos. 1 and 2 (Gian); Country Dances (Mozart); Serenade for Violin and Orchestra (Kreighauer); Serenade (Haydn); Concert Waltz (Winkler); Hungarian Dances Nos. 5 and 6 (Brahms); Intermezzo, The Awakening of the Spring Flowers (Löhrl); Balgelfüster (Meyer-Helmund); Klosterglocken (Derksen); Glow-worm Idyll (Lincke); March (Franz). 3.30, Weather and Exchange. 3.35 (approx.), Programme of Light Music. 4.0, See Hamburg. 5.0, Sports Review. 5.20, Concert of Light Music. 6.0, Poems. 6.5, Reading: Ein Feldpostbrief (Rudolf Huch). 6.20, Programme of Light Music. 6.50, Weather and Announcements. 7.0, Transmission for all German Stations, relayed from Berlin (Funkstunde). 8.0, To-day's Motto. 8.5, Variety Programme. 10.0, News. 10.45, Weather. 11.0, Dance Music from Leipzig. 12 Midnight, Close Down.

## BERLIN

FUNKSTUNDE, 715 kc/s, 419.5 metres; 1.5 kW.—4.0 p.m., Concert from the Stadthalle, Magdeburg: March, Deutsche Wacht (Gauss); Overture, Maritima (Wallace); Kaiser-Walzer (Joh. Strauss); Paraphrase on the Song, Ich hatte einst ein schönes Vaterland (Heyer); Czardas from Der Geist des Wajewoden (Grossmann); Overture, Die schöne Galathee (Suppé); March, Deutschland erwache; March, Hoeh Magdeburg (Coors); Selection from Die Fledermaus (Joh. Strauss). In the interval at 5.0, Sports Report. 5.30, Radio Report from the Kreimnen Dam. 6.0, Recital of Songs by Ilete Mex (Soprano). Songs (Reger) (a) Dein Auge, (b) Und hab' so grosse Sehnsucht doch, (c) Allein, (d) Ach, Liebster, in Gedanken. Songs from Geistliche Lieder op. 27 (Walter Courvoisier). 6.20, Talk: Wall and Windows—Furniture and People. 6.40, The Funkstunde informs its Listeners. . . . 6.45, Topical Talk. 7.0, Transmission for all German Stations: Wallenstein—Radio Play (Wulf Bley). Music by Ernst Roters. 8.0,

## SATURDAY

SEPTEMBER THE THIRTIETH

## PRINCIPAL EVENTS OF THE DAY:

## AT HOME

## NATIONAL

"My American Tour," impression of famous bands and new numbers from the U.S.A., by Henry Hall. Promenade concert from Queen's Hall.

## LONDON

## REGIONAL

## MIDLAND

## REGIONAL

## NORTH

## REGIONAL

## WEST

## REGIONAL

## BELFAST

Programme of incidental music to Shakespeare's plays. History in music, orchestral programme.

## ABROAD

## BRATISLAVA

7.30 p.m. Operetta: "The Vintager's Bride," by Nedbal.

## BRUSSELS

## (No. 1)

8.5 p.m. Operetta: "The Merry Widow," by Lehár, from the Royal Theatre, Liège.

## HILVERSUM

## HUIZEN

6.20 p.m. The K.R.O. Orchestra.

## PALERMO

4.40 p.m. The Amsterdam Orchestral Society, conducted by Diepenbeek.

## POSTE

## PARISIEN

## STRASBOURG

## TOULOUSE

## WARSAW

8.45 p.m. Operetta: "La reginetta delle rose," by Leoncavallo.

8.30 p.m. Brahms concert.

8.30 p.m. Military Band concert from Verdun.

9.0 p.m. Concert of opera music.

9.30 p.m. Chopin pianoforte recital, by Mme. Jaroszewicz.

Lottery Announcements. 8.5, Orchestral Concert, conducted by Etti Zimmer. Soloist: Mareel Wittrisch (Songs). March in D (Mozart); Overture, Il Seraglio (Mozart); Aria from Don Giovanni (Mozart); Entr'acte Music from Die drei Pintos (Weber); Piedmontese Dances (Sinigaglia); Tarantella, Venezia e Napoli (Liszt). Songs: (a) Aria from Turandot (Puccini), (b) Aria from Cavalleria rusticana (Mascagni); Dance of the Hours from La Gioconda (Ponchielli); Overture, Boecaccio (Suppé); Two Songs (Joh. Strauss): (a) Gondellied, (b) Song from A Night in Venice; Ballet Music from Sylvia (Delibes); Song from Wiener Blut (Joh. Strauss); Waltz, Fideles Wien (Kouzak). 10.0, News. 10.15 (approx.), Dance Music from the Wilhelmshalle of the Zoological Gardens. 1.0 a.m. (Sunday), Close Down.

BERNE.—See Schweizerischer Landessender.

BEROMUNSTER. — See Schweizerischer Landessender.

BODEN.—See Stockholm.

BODO.—See Oslo.

## BRATISLAVA

1,076 kc/s, 279 metres; 14 kW.—5.55 p.m., A Marionette Play. 6.55, Talk for Housewives. 7.0, See Prague. 7.30, The Vintager's Bride—Operetta in Three Acts (Nedbal). 10.0, See Prague. 10.15, See Moravská-Ostrava. 11.30 (approx.), Close Down.

BREMEN.—See Hamburg.

## BRESLAU

923 kc/s, 325 metres; 60 kW. Relayed by Gleiwitz, 1,184 kc/s, 253 metres.—1.5 p.m., Gramophone Concert. 1.45, Time and News. 2.10, Gramophone Concert. 3.0, Agricultural Prices. 3.15, Book Review. 3.35, Talk: The Early German Colonists in Silesia. 3.50, Film Review. 4.5, Concert by the Station Orchestra, conducted by Rischka: Jubel-Ouverture (Weber); An Evening with Schubert in Old Vienna (Raif); Extracts from the Album for the Young (Tchaikovsky); Waltz from Faust (Gounod); Ballet Music from Rienzi (Wagner); Overture, Irrfahrt ums Glück (Suppé); Andalusian Serenade (Eilenberg); To Mignonne (Schütt); Prayer and Temple Dance (Grieg); Romance (Kalm); Waltz, Märgelmeister (Staub); March, Immer höher (Gangleberger). 6.0, Programme Announcements. 6.10, Programme to be announced. 6.35, Reading. 7.0, Transmission for all German Stations, relayed from Berlin (Deutschlandsender). 8.0, News. 8.10, Concert by the Station Orchestra, conducted by Topitz: Wiener Jubel-Ouverture (Suppé); Mein Lebenslauf ist Lieb und Lust (Jos. Strauss); March Flott durchs Leben (Haupt); Melody (Geisler); The Merry Clown (Strauss); Waltz, Freut euch des Lebens (Strauss); Polka, Frohsinn (Strauss); Potpourri, Fur lustige Leut

(Kouzak); Intermezzo, Weindusel (Taitenhayn); Overture, Lachendes Leben (Russ); Potpourri, Freut euch des Lebens (Lincke); Galop, Leben heisst geniessen (Zielner); 10.0, Austria. 10.20, Time and News. 10.50, Dance Music by a Nazi Band, relayed from the Restaurant at the Zoological Gardens. 12 Midnight, Close Down.

## BRNO

878 kc/s, 342 metres; 35 kW.—6.25 p.m., German Transmission: News, and Moravian Folk Song Recital by a Small Mixed Choir. 7.0, See Prague. 7.30, See Bratislava. 10.0, See Prague. 10.15, See Moravská-Ostrava. 1.30 (approx.), Close Down.

## BRUSSELS (No. 1)

I.N.R., 590 kc/s, 509 metres; 15 kW.—12 Noon, Concert by the Small Station Orchestra, conducted by Lecmans: Overture, The Barber of Seville (Rossini); Liebestraum (Liszt); Scene and Waltz from Gretia (Green (Ginraud); Selection from Samson and Delilah (Saint-Saëns); Serenade (Löhrl); Violin Solo: Fantasia on Faust (Gounod-Sarasate); Dances from Tom Jones (German). 1.0, Le Journal Parlé. 1.10, Gramophone Concert. Christmas Overture (Coleridge-Taylor); Serenade mélancolique (Tchaikovsky); Rapsodiana (arr. Debroy-Somers); Serenade (Metra); Selection from Frederica (Lehár); Aria (Verdi); Selection from Princess Charming (Waller). 5.0, Concert by the Radio Orchestra, conducted by Franz André. Soloist: Lombard (Xylophone). 6.0, Talk on the Walloon Country and People. 6.15, Andante and Allegretto from the Concerto in G No. 17 (Mozart). 6.30, Concert by the Small Station Orchestra, conducted by Pierre Leenans. Overture, Peter Schmolli (Weber); Suite, At the Circus (Arnandola); Serenade (Samazeuilh); Strauss Potpourri (Winter); Träume (Wagner); Scène enfantine (Bruselmans); Le caravane passe (Letorey). 7.30, Wireless Notes. 8.5, The Merry Widow—Operetta (Lehár), relayed from the Royal Theatre, Liège. In the intervals at 9.4, Recitations, and 10.24, Le Journal Parlé. 11.10 (approx.), Close Down.

## BRUSSELS (No. 2)

N.I.R., 887 kc/s, 338.2 metres; 15 kW.—Programme in Flemish. 12 Noon, Gramophone Concert of Variety Music. 1.0 p.m., Le Journal Parlé. 1.10, Concert by the Small Station Orchestra, conducted by Leemans. Soloist: Paul Doniez (Pianoforte). Kleiner Wienermarsch (Kreisl); Waltz from The Count of Luxembourg (Lehár); Serenade, (Dearly-Leslie); Air from Dinorah (Meyerbeer); Pianoforte Solos: Three Waltzes (Van Hoof); Ballet Music from Hérodias (Massenet); Slav Dances (Dvorák). 5.0, Dance Music, relayed from the Saint Sauveur Palais de Danse. 6.0, Jazz Music, with Commentary. 7.0, Gramophone Music. Norwegian Dances

(Grieg); Ballet Music from Isoline (Messager). 7.30, Film Review. 8.0, Concert by the Radio Orchestra, conducted by Franz André. Soloists: Locufer (Tenor) and Steurs (Accordion). Overture, Fra Diavolo (Auber); An Evening in Petrograd (Meyer-Helmund); Give her a Kiss (Rodgers); Waltz, Un sourire (Ducarne); Tenor and Accordion Music; Slovak Dances (Felber); Suite belgienne (Coleridge-Taylor). 8.45, Recitations. 9.0, Orchestral Concert (contd.). Hungarian Overture (Kéler Bela); Rhapsody in A (Dvorák); Selection from Hansel and Gretel (Humperdinck); Melodies; Le train bleu (Milhaud); Pastorale Suite (Vreuls); Final from the 'Cello Concerto (Haydn); Contes et fantaisies (Chavarril). 10.0, Le Journal Parlé.

## BUCHAREST

761 kc/s, 394 metres; 12 kW.—5.0 p.m., Concert of Variety Music by the Sibiceano Orchestra. In an interval at 6.0, Radio Journal. 7.0, Educational Talk. 7.20, Gramophone Music. 7.40, Talk. 8.0, Romanian Songs. 8.20, Dance Music by the Seidmann Jazz Band. In an interval at 9.0, Talk. 9.45, Radio Journal.

## BUDAPEST

545 kc/s, 550.5 metres; 18.5 kW. Also relayed on 840 metres from 5.30 p.m. till Close Down.—5.0 p.m., The Letter Box. 5.30, Military Band Concert. 6.45, Talk. 7.15, Concert. 8.0, Radio Play. 10.0, News. 10.15 (approx.), Gramophone Concert. 11.30, Cigány Band Concert, from the Hotel Metropole.

CASSEL.—See Frankfurt.

## COPENHAGEN

1,067 kc/s, 281 metres; 0.75 kW. Relayed by Kalundborg, 260 kc/s, 1,153.8 metres.—12 Noon, Time Signal and Chimes from the Town Hall. 12.15 p.m., Broadcast for Schools. 12.45, Concert by the Harald Andersen String Ensemble. 2.0, Interval. 3.0, Gramophone Concert of Variety Music. 3.30, Concert by Mogens Hansen's Instrumental Ensemble; Soloist, Helge Sehested Larsen (Songs); Overture, The Italian Girl in Algiers (Rossini); Chanson Louis XIII and Pavane (Couperin); Selection from Lilac Time (Schubert-Berté); Pieces (Mozzkovsky): (a) Serenade, (b) Spanish Dance No. 1 in C, (c) Spanish Dance No. 2 in G Minor; Song from The Merry Widow (Lehár); Six Danish Songs; Comedy Overture (Kéler-Béla); Selection from The Duchess of Chicago (Káimán); Melody (Gabriel-Marie); Songs (Grieg): (a) Herzwunden, (b) Au den Frühling; Waltz, Inmertellen (Gungl); MacMahon March (Lunbye). 5.30, Exchange and Fish Market Prices. 5.45, Talk on St. Michael's Church at Slagelse. 6.15, French Lesson. 6.45, Weather. 6.54, Announcements. 7.0, News. 7.30, Talk. 8.0, Time Signal from the Town Hall. 8.1, Talk: Danish Dramatic Literature. 8.45 to 12 Midnight, Radio Ball for the Older Generation; The Station Orchestra and Soloists; Conductor, Launy Grøndahl. In an interval at 11.0, News. 12 Midnight, Time Signal and Chimes from the Town Hall.

CORK.—See Athlone.

DANZIG.—See Heilsberg.

DRESDEN.—See Leipzig.

## FECAMP

1,328 kc/s, 225.9 metres; 10 kW.—11.0 a.m. till 12 Noon, Programme in English by the I.B.C. 11.0, Happy Hour. Part I: Orchestral Concert: Signature Tune; Musical Comedy Switch (arr. Hall); Cheer up, good times are coming; By the Swanee River (Myddleton); Memories of Paris (Christine); Valencia (Padilla); Waltz from Bitter Sweet (Coward); When the Lilac blooms again (Rotter); Gipsy Moon (Borganov). Part II: Dance Music; Put on your Old Grey Bonnet; Somebody stole my Gal; Whispering; That's what Life is made of; The Shadow Waltz; You're mine, you; I've got to sing a Torch Song; One tiny Tear; Signature Tune. 12 Noon, Programme in French. 4.30 to 6.0, Programme in English by the I.B.C. 4.30, Programme for Children. 5.0, Military Band Concert for Tunbridge Wells and Isle of Thanet Listeners: Signature Tune, The Night by the Sea; Naval Patrol (Williams); Hohomoko (Jessel); Amoretentanz (Gungl); Xylophone Solo, Fairy Tiptoe (Fredericks); Loin du Bal (Gillet); Praeludium (Järnefeld); Xylophone Solo, Fiddlesticks (Robbins); Ca c'est Parée (Padilla). 5.30, Concert for Dover and Folkestone Listeners: Tango Band; Todavía (Pizarro); La Camparsita; Maman, yo quiero un novio? (Collazo); Madrid (Rotter); Signature Tune. 5.45, Concert: If I am dreaming (Müllcker); Caro Nome, from Rigoletto (Verdi); Serenade (Toselli); A Brown Bird singing (Haydu Wood). 6.0, Programme in French. 11.0 till Close Down, Programme in English by the I.B.C. 11.0, Talkie Time; Times from the Talkies; Signature Tune, Sittin' in the Dark; Selection from Show Boat, Part 2 (Kern); Learn to croon (Johnston); Dreuna Lover; Louise; My lucky Day (Davies); The moment I saw you (Gay); Why has a Cow got Four Legs? (Ellis); Selection from The Three Musketeers (Friml); Signature Tune. 11.30, Concert by the I.B.C. (Ireland), Ltd., on behalf of Hospitals' Trust, Ltd.: Signature Tune, Come back to Erin; Beautiful

SEPT. 30th **SATURDAY** continued

Spring (Lincke); She is far from the Land (Moore); Reconciliation (Drigo); Maire my Girl (Casey); Babes in Toyland (Herbert); The Grasshopper's Dance (Bucalossi); The Whistler and his Dog (Pryor); Signature Tune. 12.5 a.m. (Sunday), News Bulletin in English. 12.10 (approx.), Club Concert for Hawick. Listeners: Signature Tune, The Chum Song; Tea for Two (Youmans); Lower come back to me (Romberg); Kansas (City Kitty (Leslie); Alice Blue Gown (Tierney); My Coquette (Andrew); And so I married the Girl (Magidson); Dancing Butterfly (Young); It's the Band (Steininger); I can't remember (Berlin); This is the Rhythm for me (Monkman); Let's all be happy together (Thomas Leslie); The Old Spinning Wheel (Hill); Sweetheart Darlin' (Kühne); Signature Tune. 1.0, Dance Music: Signature Tune, Bells of Normandy; Hiawatha's Lullaby; There's a Cabin in the Pines; In a Second-Hand Store; Seven Years with the Wrong Woman; I cover the Waterfront; You don't understand; I raised my Hat; Sweep; Look what I've got; Lover Waltz in the Park in Paris; Rhapsody in Blue; The Shadow Waltz; My, oh my; I've got to sing a Torch Song; It was a Night in June; Signature Tune. 2.0, I.B.C. Goodnight Melody and Close Down.

**FLENSBURG.**—See Hamburg.  
**FLORENCE.**—See Turin.

**FRANKFURT**

1,157 kc/s, 259.3 metres; 17 kW. Relayed by Cassel, 1,220 kc/s, 245.9 metres; and Trier, 1,157 kc/s, 259.3 metres.—12 (Noon), Gramophone Concert; Potpourri, Fabelhaft; Was nützt dem Soldaten Schinken und Braten Bin kein Hauptmann, bin kein grosses Tier; Potpourri, Alt-Berliner Leierkasten (Leuschner); Xylophone Quartet; Die lustigen Vier; Radlerpech; Potpourri, Münchner Bilderbogen (Gaiden); Foxtrot, Dorothee Dorothee; Polka, Pique As (Pärschmann); Potpourri, Hoch das Bein; Intermezzo, Der verliebte Hampelmann (Kunst); The Whistler and his Dog (Pryor); Potpourri, Wir kurbeln an (Dostal); Saxophone Solo, Sax-o Trix (Widoft); Musical Jests at the Week End; Dem Semlitz sing Frau ess durchgebrannt (Ostermann); Näi, ich mag dich nit mie (Ostermann); He gefällt et uns (Ebeler); Loss mer noch e Gläsele schlupppe (Ebeler). 1.15 p.m., News and Weather. 1.30, See Langenberg. In the interval at 2.0, News. 2.30, Week end Programme. 3.20, Weather. 3.25, Time and Exchange. 3.30, Programme for Young People. 4.30, See Munich. 5.45, Exchange. 6.0, Talk: The Limits of Rationalisation. 6.25, Time and News. 6.30, Weekly Review. 6.50, Review of the Day's News. 7.0, Transmission for all German Stations relayed from Berlin (Funkstunde). 8.5-1.0 a.m. (Sunday). Langenberg-Frankfurt-Stuttgart Exchange Programme. In the interval at 10.0, Time and News. 1.0 a.m. (Sunday), Close Down.

**FREDRIKSSTAD.**—See Oslo.  
**FREIBURG.**—See Stuttgart.  
**GENEVA.**—See Radio-Suisse Romande.  
**GENOA.**—See Turin.  
**GLEIWITZ.**—See Breslau.  
**GÖTEBORG.**—See Stockholm.  
**GRAZ.**—See Vienna.  
**HAMAR.**—See Oslo.

**HAMBURG**

806 kc/s, 372 metres; 1.5 kW. Relayed by Bremen, 1,112 kc/s, 269.8 metres; Flensburg, 1,319 kc/s, 227.4 metres; Hanover, 530 kc/s, 566 metres; and Kiel, 1,292 kc/s, 232.2 metres.—4.0 p.m., The Cousin from Nowhere—Operetta (Künneke) (Concert Version). 5.0, Thrilling Stories. 5.20, Variety Programme. 6.30 (from Kiel), Religious Address. 6.50, Weather. 7.0, Transmission for all German Stations, relayed from Berlin (Funkstunde). 8.0 to 10.0, See Berlin (Deutschlandsender). 10.0, Time and News. 10.20, Topical Talk. 10.30, Music from Berlin (Funkstunde).

**HANOVER.**—See Hamburg.

**HEILSBURG**

1,085 kc/s, 276.5 metres; 60 kW. Relayed by Danzig, 662 kc/s, 453.2 metres.—11.30 a.m., Concert by the Königsberg Opera House Orchestra, conducted by Brückner: Overture, King Stephan (Beethoven); Divertimento No. 10 (Mozart); Ballet Suite from Macbeth (Verdi); Suite from Die Todestarentella (Bittner); Waltz, Herz-tone (Strauss); Overture, The Golden Cross (Brüll); Einzug schneidiger Truppen (Blankenburg). 1.5 p.m., Gramophone Concert of Variety Music. In the intervals at 1.20 and 2.0, News. 2.30, Programme arranged by the Post Office with Gramophone Records. 3.0, Agricultural Prices and Exchange. 3.30 (from Danzig), Handicrafts for Children. 4.0, Concert by the Small Station Orchestra, conducted by Eugen Wileken: Overture, Romeo and Juliet (Bellini); Berceuse (Cui); Rêve d'amour (Cui); Selection from Le Villi (Puccini); Waltz, Nordseebilder (Strauss); Japanese Suite (Yoshitomo); Water Sprites (Ketel-bay); Dance of the Merry Mascots (Ketel-

bey); Alt-Wien in Lied und Tanz (Pacher-negg); Selection from The Dubarry (Müllbeker-Mackeben); Overture, An mein Vaterland (Alibout). In an interval at 4.50, A.D.A.C. Traffic Report. 5.40, Talk: Catching Wild Animals in the Primeval Forests of Liberia. 6.5, Programme Announcements. 6.15, Agricultural Prices. 6.25, Armin Knab Song Recital by Mia Nensitzer-Thoenissen. 6.50, Weather. 7.0, Transmission for all German Stations, relayed from Berlin (Deutschlandsender). 8.5, Military Programme for East Prussia. 9.5, News. 9.10, Bunter Abend. In an interval at 10.10 (approx.), News. 11.0, Dance Music relayed from Berlin (Funkstunde). 12.30 a.m. (Sunday), Close Down.

**HILVERSUM**

Announced HUIZEN, 1,013 kc/s, 296.1 metres; 7 kW. (until 5.40 p.m.) and 20 kW. from 5.40 p.m. Programme of the Catholic Radio Society (K.R.O.).—11.40 a.m., Police Notes. 1.25 p.m., Interval. 1.40, Programme for Young People. 2.10, Programme for Children. 3.40, Concert by the K.R.O. Boys. 4.10, Talk. 4.20, Concert (cont'd). 4.55, Sports Talk. 5.10, Gramophone Music. 5.35, Wireless Talk. 5.50, Gramophone Music. 6.0, Press Review. 6.20, Concert by the K.R.O. Orchestra, conducted by Gerritsen: Two Pieces, Op. 32 (Nicode); Selection from Die Königskinder (Humperdinck); Selection from Tannhäuser (Wagner). In the interval at 6.40, Police Notes. 7.30, Talk on the Esperanto Lessons. 7.40, Concert by the K.R.O. Orchestra, conducted by van't Woud: Potpourri, Bei Lied und Wein (Armandola); Waltz Potpourri No. 2 (Robrecht); Selection from Die Puppenfee (Bayer); Alte Kameraden (Teike); Berlin, wie es weint und lacht (Conradi); The Skaters' Waltz (Waldteufel); Hurrah, die Musik kommt (Zimmer). In the interval at 8.10 (approx.), Press Review. 8.40, Concert by the Three Keddys Ensemble. 9.0, Van den dood die bijna stierf—Faree in Five Scenes (Ghelderode). 9.40, Concert by the K.R.O. Boys. 10.10, News. 10.15, Music by the Three Keddys. 10.35, Gramophone Music. 10.55, Concert by the K.R.O. Boys (cont'd). 11.40 (approx.), Close Down.

**HORBY.**—See Stockholm.

**HUIZEN**

Announced HILVERSUM, 160 kc/s, 1,875 metres; 7 kW. (until 3.40 p.m.). Transmitted from Kootwijk on 50 kW. from 3.40 p.m.—Programme of the Workers' Radio Society (V.A.R.A.). 11.40 a.m., Concert by the Small V.A.R.A. Orchestra, conducted by de Groot. 1.40, Gramophone Music. 2.25, Accordion Music. 2.40, Film Review. 3.0, Concert by De Fliedersuiters, conducted by Ray Forest. 3.40, Interval. 3.55, Organ Recital by Jong: Selection from Martha (Flotow); Dance of the Dervishes (Bendix); Same Old Moon (Baskette); Under my Umbrella (Plyn-Myers). 4.20, Literary Talk. 4.40, Concert by the Amsterdam Orchestral Society, conducted by Diepenbeek: Freieitsjubel (Blankenburg); Overture, The Italian Girl in Algiers (Rossini); Selection from Rosamund (Schubert); Weaner Madln (Ziehrer). Gramophone Music: Selection from Aida (Verdi); Selection from La fille de Madame Angot (Lecocq). 5.40, Talk. 6.0, Orchestral Concert (cont'd). Husaren-Vedette (Fucik); Ballet Music from Faust (Gounod). 6.45, Accordion and Pianoforte Recital by Steyn and Jong. 6.40, Orchestral Concert (cont'd): Overture, Banditenstreichle (Suppé); Vive la danse (Waldteufel); Selection from La vie parisienne (Offenbach); Russian March (Ganne). 7.10, Gramophone Music. 7.40, S.O.S. Announcements. 7.42, News. 7.50, Concert by the V.A.R.A. Orchestra, conducted by Gehert. Soloist: Rose Walter (Soprano). Allemande (Beethoven); Old Dutch Dances (Röntgen); Old Melodies; Slav Dances (Dvorák); Russian Dance (Tchaikovsky); Spanish Caprice (Granados); Romanian Folk Dance (Bartok); Polka (Weinberger); Waltz, The Blue Danube (Joh. Strauss). In an interval at 8.25, Part III of De Zee roept—Radio Play (Busch-Beversluis). 9.50, Soprano Song Recital by Rosa Walter. 10.5, Talk. 10.15, Dance Music by De Fliedersuiters, conducted by Ray Forest. 10.55, Dance Music on Gramophone Records. 11.40 (approx.), Close Down.

**INNSBRUCK.**—See Vienna.

**JUAN-LES-PINS**

1,205 kc/s, 249 metres; 0.8 kW.—12.30 p.m., Amusement Guide and Variety Items. 1.0, News. 1.15, Radio Concert. 8.0, Amusement Guide, Exchange, Racing Results and News. 8.5, Film Review. 8.20, Radio Concert. 9.0, News and Weather.

**KALUNDBORG.**—See Copenhagen.

**KIEL.**—See Hamburg.

**KLAGENFURT.**—See Vienna.

**KOSICE.**—See Prague.

**LAHTI**

167 kc/s, 1,796 metres; 40 kW. Relayed by Helsinki, 815 kc/s, 368.1 metres.—4.0 p.m., Concert by the Station Orchestra, conducted by Erkki Linko: Heinzelmächens Wachtparade (Noack); Arc en ciel (Waldteufel); Melody from Paganini (Lehár); Merikanto Potpourri (Kauppi); Waltz, Wienerblut (Strauss); Offenbach Potpourri (Conradi). 5.0, Dramatic Programme. 5.30, Song Recital. 5.50, News in Finnish. 5.59, Time and Weather. 6.10, News in Swedish. 6.15, Sports Talk. 6.35, Xylophone Solos. 6.55, Talk. 7.15, Popular Concert. 8.45, News in Finnish. 9.0, News in Swedish. 9.15, Dance Music relayed from the Pörsi Restaurant. 11.0 (approx.), Close Down.

**LANGENBERG**

635 kc/s, 473 metres; 60 kW.—12 Noon, Broadcast for Schools. 12.30 p.m., Concert by the Münster Municipal Orchestra, conducted by Gähre: March, Gruss am Münster (Lange); Die Felsenmühle (Reisiger); Suite, The Merchant of Venice (Sullivan); Dance of the Tumblers (Rimsky-Korsakov); Flight of the Bumble Bee (Rimsky-Korsakov); Selection from Ernani (Verdi); Four Indian Love Songs (Woodford-Finden); Potpourri, Westfalenklänge (Ritter). 1.15, News. 1.30, Concert by the Station Orchestra, conducted by Kühn: Overture, The Queen's Kerchief (Strauss); Norwegian Artists' Carnival (Svendsen); Selection from Tosca (Puccini); Three Pieces from Prometheus (Béethoven); Selection from Othello (Verdi); March in C (Mozart). In the interval at 2.0 (approx.), News. 2.30, Gramophone Music. 3.30, News and Time. 3.35, Sports Report on Gramophone Records. 3.50, Talk: The Old Sea Rovers and the Hitler Youth. 4.10, Reading. 4.30, The Rhineland and Westphalia—Hünxe—Radio Sequence of Verse and Song (Bockemühl). 5.0, Pianoforte Recital by Hans Jasso: Romance No. 2 (Schumann); Burla (Grieg); Jeux d'eau (Ravel); Mazurka (Granados); Mephisto-Walzer (Liszt). 5.30, Concert by the Station Orchestra, conducted by Eysoldt: Selection from The Geisha (Jones); Overture, Isabella (Suppé); Negro Lullaby (Clubsam); Paraphrase on the Song Rose-Marie (Blume-Weninger); Waltz, Hereinspaziert (Ziehrer); Potpourri, Mosaic (Zimmer). In the interval, Topical Talk. 6.15, A Blind Passenger on a Sailing-boat narrates his Experiences. 6.45, News. 7.0, Transmission for all German Stations, relayed from Berlin (Funkstunde). 8.0, News. 8.5, West German Stations Calling—Langenberg-Frankfurt-Stuttgart Exchange Programme. In the interval at 10.5, News. 1.0 a.m. (Sunday), Close Down.

**LAUSANNE.**—See Radio-Suisse Romande.

**LEIPZIG**

769.9 kc/s, 389.6 metres; 120 kW. Relayed by Dresden, 941 kc/s, 319 metres.—12 Noon, Weather and Time. 12.5 p.m., Gramophone Concert. 1.15, News. 1.30, Concert from Langenberg. 2.30, News. 2.35 (approx.), Programme for Children. 3.15, Talk on Music. 3.45, Market Prices. 4.0, Reading (Rudolf Binding). 4.30, Concert from Munich. 5.45, Talk: The German Language. 6.5, A Modern Dictionary. 6.20, Robert Franz Song Recital by Eva Graf (Soprano) and Erich Wagner (Tenor): Soprano Solos: (a) Ein Stündlein wold vor Tag, (b) Die helle Sonne leuchtet; Tenor Solos: (a) Waldfahrt, (b) Willkommen, mein Wald, (c) Jagdlied, (d) Auf gehehnen Waldespfad; Soprano Solos: (a) Das macht das dunkelgrüne Laub, (b) Rosmarin, (c) Er ist gekommen; Tenor Solos: (a) Weiss du noch, (b) Umsonst; Soprano Solos: (a) Lieber Schatz, sei wieder gut zu mir, (b) Ständchen, (c) Mein schatz ist auf der Wänderchaft; Tenor Solos: (a) Ave Maria, (b) Abends, (c) Gute Nacht; Duet, Mutter, o sing mich zur Ruh'. 6.50, To-day's News. 7.0, Transmission for all German Stations, relayed from Berlin (Funkstunde). 8.0, Orchestral Concert from Berlin (Funkstunde). 10.5, News. 10.15 (approx.), Dance Music by the Endé Orchestra. 12 Midnight, Close Down.

**LINZ.**—See Vienna.

**LUXEMBOURG**

252 kc/s, 1,191 metres; 200 kW.—12.30 p.m., Concert by the Station Orchestra, conducted by Henri Pénis: Overture, The Daughter of the Regiment (Donizetti); Waltz, Les fleurs (Waldteufel); Selection from The Barber of Seville (Rossini); Serenade (Toselli); Rocooco Gavotte (Translatour); The Torch Dance of the Brides of Kashmir (Rubinstein); Selection from The Blue Mazurka (Lehár). 1.30, Gramophone Music. 7.30 till Close Down, French Programme. 7.30, Violin Concerto No. 3 (Saint-Saëns) on Gramophone Records. 8.10, Talk in French: Anne Beffort, a Luxembourg Authoress. 8.20, Pianoforte Concerto (Grieg) by Jeanne Jaspas and the Station Orchestra. 8.50, News in French. 9.0, Song Recital by Gustave Simon, with Music by the Station Orchestra: La vague et la cloche (Duparc);

Balls de gros dinons (Chabrier); Villanelle des petits canards (Chabrier); Le dormeur du val (Bachelet); Tendresse (Bachelet); Orchestra: Danse macabre (Saint-Saëns); Le bachelier de Salamauque (Roussel); Jazz dans la nuit (Roussel); Beau soir (Debussy); Maudoline (Debussy); Orchestra: Military March (Saint-Saëns). 9.50, News in German. 10.0, Gramophone Music. 10.50, Dance Music by the Station Jazz Band.

**LYONS**

LA DOUA, 644 kc/s, 465.8 metres; 1.5 kW.—5.0 p.m., Dance Music. 7.0, Gramophone Music. 7.15, Musical Programme. 7.30, Radio Gazette for Lyons and the South-East. 8.30, Concert. After the Concert, News.

**MADRID**

EAJ7, 707 kc/s, 424.3 metres; 2 kW.—8.0 p.m., Chimes, Exchange, Radio Journal and Dance Music, relayed from the Sikazar Dance Hall. 9.15, Topical Review. 9.30 to 11.0, Interval. 11.0, Chimes, Time and Topical Review. 11.20 (approx.), Musical Comedy on Gramophone Records; Selection from La Alegria de la Huerta (Cluena), and La Verbena de la Paloma (Breton). 1.15 a.m. (Sunday), Topical Review. 1.30, Chimes and Close Down.

**MALMO.**—See Stockholm.

**MILAN.**—See Turin

**MORAVSKA-OSTRAVA**

1,137 kc/s, 263.8 metres; 11 kW.—2.50 p.m., Concert by the Station Orchestra, conducted by Plichta: Introduction to the Third Act of The Devil and Kate (Dvorák); Rhapsody (Lalo); Selection of Slovak Folk Songs (Piskacek); Waltz, Paysage d'autonime (Waldteufel); Intermezzo (Pretsch); March (Cerny). 3.55 to 4.0, See Prague. 5.45, Gramophone Records. 5.55, Reading. 6.5, Gramophone Records. 6.15, Talk for Workers. 6.25, Brahms Song Recital. 7.0, See Prague. 7.30, See Bratislava. 10.0, See Prague. 10.15, Concert of Light Music by the Station Orchestra. 11.30 (approx.), Close Down.

**MOSCOW**

TRADES UNION, 300 kc/s, 1,000 metres; 100 kW.—11.45 a.m., Weather. 2.45 p.m., Weather. 3.0, Gramophone Music. 4.0, Topical Talk. 4.30, Talk on Dramatic Art by a Celebrated Actor. 5.30, Programme for Young People. 6.30, Romeo and Juliet—Opera (Berlioz) from the Radio Theatre. 9.0, News. 9.30, Programme Announcements. 9.55, Chimes. 10.5, Press Review.

**MOTALA.**—See Stockholm.

**MUHLACKER.**—See Stuttgart.

**MUNICH**

563 kc/s, 533 metres; 60 kW. Relayed by Augsburg and Kaiserslautern, 536 kc/s, 560 metres; and Nürnberg, 1,256 kc/s, 233 metres.—12 Noon, Gramophone Music. 1.0 p.m., Orchestral Concert, conducted by Herr Kloss: Little Overture (Beccer); Suite Bergamasque (Debussy); Selection from Jossendo (Spohr); Two Pieces (Michele); (a) Almbumblatt, (b) Cecilia; March, Die Husaren kommen (Eilenberg). In the interval at 1.15, Time, Weather and News. 2.0, Time, Weather and News. 2.30, The Reimicker Family at the October Festival—a Radio Sequence of the Year 1899 (Brunner). 3.25, Reading. 3.45, Weather and Agricultural Notes. 4.0, Labour Market Report. 4.10, Theodore Anzinger reads from his Reminiscences. 4.30, Orchestral Concert, conducted by Karl List. Soloist: Elisabeth Hallstein (Coloratura Soprano). Overture, Pique Dame (Suppé); Parla-Concert Waltz for Soprano and Orchestra (Arditi); The Emperor Variations (Haydn); Selection from Rigoletto (Verdi-Tavau); Arietta for Soprano and Orchestra from Mirella (Gounod); Selection from Der Evangelinann (Kienzl); Perpetuum mobile (Gungl); March Song Potpourri, Jungdeutschland (Wenninger). 5.45, Programme for Young People. 6.30, Songs to the Lute with Violin Obligato by Robert and Lies Rothe and Adolf Bruno Winkler. 6.45, Wireless Notes. 7.0, Transmission for all German Stations, relayed from Berlin (Funkstunde). 8.0, Variety Programme (arr. Lipp). 10.0, Austria. . . . 10.20, Time, Weather and News. 11.0, Serenade. 12 Midnight, Close Down.

**NAPLES.**—See Rome.

**NOTODDEN.**—See Oslo.

**OSLO**

277 kc/s, 1,083 metres; 60 kW. Relayed by Fredriksstad, 815 kc/s, 368.1 metres; Hamar, 522 kc/s, 574.7 metres; Notodden, 671 kc/s, 447.1 metres; Porsgrund, 662 kc/s, 453.2 metres; and Rjukan, 671 kc/s, 447.1 metres.—4.30 p.m., Gramophone Concert of Norwegian Music. 5.15, Programme for Children. 6.15, Concert of Norwegian Music. 6.45, Talk on Economics. 7.0, Advertising Notes, News and Weather Report. 7.30, Talk. 8.0, Concert by the Station Orchestra, conducted by Hugo Kramm. Soloists: Leif Halvorsen (Violin) and Sigurd Hoff (Songs). 9.20, Advertising Notes, Weather and News. 10.0, Topical Talk. 10.15, Popular Concert.

**OSTERSUND.**—See Stockholm.

**PALERMO**

558 kc/s, 537.6 metres; 3 kW.—8.0 p.m., Dopplavoro Announcements, Tourist Talk, Agricultural Notes and Giornale Radio. 8.20, Sports Notes. 8.25, Gramophone Music. In the interval at 8.30, Time and Announcements. 8.45, La reginetta delle rose—Operetta in Three Acts (Leoncavallo). In the intervals Talk and Announcements. After the Operetta, Giornale Radio.

**PARIS**

**EIFFEL TOWER.** Call FLE, 207.5 kc/s, 1,445.7 metres; 13 kW. Time Signals (ou 2,650 metres) at 10.26 a.m. and 11.26 p.m. (Preliminary and 6-dot Signals).—6.45 p.m. Theatre Notes. 7.0, Le Journal Parlé. 8.30, Antony—Play (Alexandre Dumas). 10.0 (approx.), Close Down.

**PARIS**

**POSTE PARISIEN,** 914 kc/s, 382.2 metres; 60 kW.—7.0 p.m., Trio in G (Haydn) on Gramophone Records. 7.15, Le Journal Parlé. 7.30, Sponsored Gramophone Concert. 8.0, Talk: The Event of the Week. 8.30, Brahms Concert. 9.10, Dance Music by the Sonora Radio Band, conducted by Fred Hoffman. 11.0, News.

**PARIS**

**RADIO-PARIS:** Call CFR; 174 kc/s, 1,725 metres; 75 kW.—7.30 a.m., Weather and Physical Culture. 7.45, Gramophone Music. 8.0, Weather and Press Review. 12 Noon, Gramophone Concert: Selection from La vie parisienne (Offenbach); Adios Muchachos (Sauder); Melody (Robrecht); Melody (Daniederf); Gouttes d'eau (Petit); Chante, chemineau (Persiani-Jourdan); Melody (Lincke); Entr'acte (Hirschmann-Yatove); Chante pierrot (Bixio); Rondes enfantines françaises; Mon fétiche (Vacher); Des femmes, des Roses (Grothe); Pinsonnette et pinsonnet (Saint-Servan); Mon seul Paris (Labor); Liebesglocken (Benatzky); Gardemol (Yvain); J'ai compris (Lenoir); Cou et poules (Paradis); C'est peu de chose (Verdun); Chante de berger (Servanti-Bergeret); Aubade d'amour (Mintzi); Poupées de Paris (Loyraux). In the interval at 1.0, Exchange, News, and Weather; and at 1.30, Exchange. 2.0, Exchange. 3.45, Exchange and Market Prices. 7.0, Agricultural Report. 7.10, Popular Music on Gramophone Records. 7.50, Commercial Notes and News. 8.0, Gramophone Records: March écossaise (Debussy); Ballet Music from The Cid (Massenet); Menuet antique (Ravel). 8.30, News, Weather, and Sports Notes. 8.45, Musical and Literary Programme. Songs by Mme. Suzanne Nivette and Recitations by Georges Saillard. In the interval at 9.15, Press Review and News. 10.0, Gramophone Records: Bulgarian Suite (Wiadigerov); Coronation March (Saint-Saëns).

**PITTSBURGH**

**KDKA,** 980 kc/s, 306 metres; 50 kW. Relayed by W8XK on 48.86 metres and 25.27 metres.—7.0 p.m., Programme to be announced. 7.30 to 11.0, New York Relay. 7.30, Concert Echoes. 8.0, Words and Music. 8.30, Wealth of Harmony. 9.0, Dance Masters. 9.30, Concert Favourites. 10.0, Casino Orchestra. 10.30, Neil Sisters. 10.45, Orphan Annie. 11.0, News, Piano Classique. 11.15, Sports. A Song. 11.30, A Recreo by Bill and Alex. 11.45 to 12.30 a.m., (Sunday), New York Relay. 11.45, A Century of Progress. 12.15, Ethel Waters. 12.30, Ilustone. Ray's Orchestra. 1.0 to 3.15, New York Relay. 1.0, Jack Denny's Orchestra. 1.30, Brown and Llewellyn. 1.45, Annie, Judy and Zeke. 2.0, Tales of the Titans. 2.30, Jamboree. 3.15, Behind the Law.

**PORSGRUND.**—See Oslo.

**PRAGUE**

614 kc/s, 488.6 metres; 120 kW.—2.50 p.m., See Moravská-Ostrava. 3.55 to 4.0, Weather. 5.45, Talk. 5.55, Commercial News. 6.5, Agricultural Report. 6.15, Talk for Workers: Evening Schools and Sunday Schools. 6.25, News in German. 6.30, German Transmission: Talk on Rome. 7.0, Chimes and News. 7.10, Reading. 7.30, See Bratislava. 10.0, Time, News and Sports Notes. 10.15, See Moravská-Ostrava. 11.30 (approx.), Close Down.

**RADIO-SUISSE ROMANDE**

SOTTENS, 743 kc/s, 403 metres; 25 kW.; and Geneva, 395 kc/s, 760 metres.—6.15 a.m. to 6.30 (from Lausanne), Gymnastics Lesson. 12.28 p.m., Time Signal from the Neuchâtel Observatory. 12.30, News and Weather. 12.40 (from Lausanne), Light Music on Gramophone Records. 1.0 (from Lausanne), Financial Notes. 1.10 (from Lausanne), Gramophone Music. 2.0, Interval. 3.25, Time Signal from Neuchâtel Observatory. 3.30 (from Lausanne), Concert by the

SEPT. 30th

**SATURDAY**

continued

Station Orchestra, conducted by Moser. 4.15 (from Lausanne), Song Recital by France Legaudy. 4.30, Concert (contd.). 5.0 (from Lausanne), Dance Music on Gramophone Records. 5.30, Interval. 7.0 (from Geneva), Talk. 7.30 (from Geneva), Radio Chronique. 8.0 (from Geneva), Russian Music by the Ilorwood Orchestra. 8.25 (from Geneva), Humorous Talk. 9.0, Concert by the Radio Suisse Romande Orchestra, conducted by Echenard: Overture, Der Freischütz (Weber); Music to Ramuntcho (Piernu); Serenade for String Orchestra Op. 48 (Tchaikovsky); Danse macabre (Saint-Saëns); In the Crimea (Mussorgsky). 9.50, News and Weather. 10.0 (from Geneva), Dance Music. 11.30 (approx.), Close Down.

**RJUKAN.**—See Oslo.

**ROME**

Call IRO, 680 kc/s, 441 metres; 50 kW. Relayed by Naples, 941 kc/s, 319 metres; and 2RO, 11,810 kc/s, 25.4 metres from 5.15 p.m.; Bari, 1,112 kc/s, 269.8 metres; Milan (Vigentino), 662 kc/s, 453.2 metres from 8.45 p.m., and Naples, 941 kc/s, 319 metres.—12.30 p.m., Gramophone Music. 1.0 to 2.15, Orchestral Concert. In the interval at 1.30, Giornale Radio. 4.30, Children's Radio Review. 4.55, Giornale Radio and Report of the Royal Geographical Society. 5.10, Weather. 5.15, Orchestral Concert of Light Music. 6.40 (Naples), Shipping and Sports Notes. 6.45, Lesson in Morse and Dopplavoro Announcements. 7.0, Tourist Report. 7.10, Agricultural Notes and Market Prices. 7.20, News in Foreign Languages. 7.40, Giornale Radio. 8.0, Time and News. 8.15, Sponsored Concert. 9.15, Military Band Concert: March, Viva il Duce (Marchesini); Selection from Rigoletto (Verdi); Overture, Le Roi de Lahore (Massenet); Good Friday Magic from Parsifal (Wagner); Selection from the Suite siciliana (Marinuzzi): (a) Valzer canpestre, (b) Leggenda di Natali; Selection from Semiramide (Rossini). In the intervals, Monologue: The Human Voice, and Literary Notes. 11.0, Giornale Radio.

**SALZBURG.**—See Vienna.

**SCHENECTADY**

WGY, 790 kc/s, 379.5 metres; 50 kW. Relayed at intervals by W2XAF on 31.48 metres and by W2XAD on 19.56 metres.—1.45 a.m. (Sunday), Stock Reports. 2.0 to 5.0, New York Relay. 2.0, Soloist. 2.15, The Sizzlers. 2.30, Sons les Ponts de Paris. 3.0, One Man's Family. 3.30, K-7, Secret Service Spy Story. 4.0, Saturday Night Dancing Party. 5.0, Programme Résumé.

**SCHWEIZERISCHER**

**LANDESENDER**

**BEROMUNSTER,** 653 kc/s, 459 metres; 60 kW.; Basle, 1,229 kc/s, 244.1 metres; and Berne, 1,220 kc/s, 245.9 metres.—6.15 to 6.35 a.m. (from Basle), Gymnastics. 11.59, Time Signal from Neuchâtel Observatory, and Weather. 12.0 Noon (from Berne), Chamber Music on Gramophone Records. 12.30 p.m., Time, Weather and News. 12.40 (from Berne), Light Music on Gramophone Records. 1.25 (from Berne), Time, Weather and Exchange. 1.30 (from Berne), The Listeners' Quarter of an Hour. 1.45 (from Berne), Talk on Appenzell. 2.15 (from Berne), Book Review. 2.45 (from Berne), Folk Music by a Village Band. 3.0 (from Berne), Talk: Consumption. 3.30 to 5.0, Interval. 5.0 (from Berne), Accordion Band Concert. 5.30 (from Berne), Talk with Illustrations: Swiss Songs. 6.30 (from Berne), Recital by Richard Sturzenegger (Viola da Gamba) and Zulauf (Harpisichord). 7.0, Chimes from Zürich (Churches). 7.15 (from Berne), Time, Weather and Market Prices. 7.20 (from Berne), Cabaret Programme. 8.15 (from Berne), Concert of Music by Swiss Composers. 9.5 (approx.), Weather and News. 9.20 (approx.), (from Berne), Concert. 10.20 (from Berne), Dance Music by the Maxim Band. 11.0 (approx.), Close Down.

**SOTTENS.**—See Radio-Suisse Romande.

**STOCKHOLM**

689 kc/s, 436 metres; 55 kW. Relayed by Boden, 244 kc/s, 1,229.5 metres; Göteborg, 932 kc/s, 322 metres; Hörby, 1,166 kc/s, 257 metres; Motala, 221.5 kc/s, 1,354.4 metres; Östersund, 389 kc/s, 770 metres; and Sundsvall, 554 kc/s, 542 metres.—4.0 p.m. (from Göteborg), Light Orchestral Concert. 5.5, Programme for Children. 5.30, Songs to the Lute by Vilhelm Julinder. 5.45, Gramophone Music. 6.45, Talk: Table d'hôte or à la carte—relayed from Norrköping, 1,292

kc/s (232.2 metres). 7.15, Weather and News. 7.30, Cabaret Programme. 8.30, Cigany Band Music, relayed from a Concert Hall: Slav Dance No. 10 (Dorák); Taragato Solos: Old Hungarian Songs; Arias from Carmen (Bizet); Improvisations on Hungarian Folk Songs and Dances; Waltz, The Blue Danube (Joh. Strauss). 9.15, One-Act Play (Oljelund). 9.45, Weather and News. 10.0, Dance Music, relayed from the Savoy. 11.0 (approx.), Close Down.

**STRASBOURG**

869 kc/s, 345 metres; 11.5 kW.—11.30 a.m., Variety Music on Gramophone Records. 12.45 p.m., News. 1.0, Time and Exchange. 1.5, Variety Music on Gramophone Records. 2.0, Legal Talk. 2.15, Light Music on Gramophone Records. 2.45, Music Talk: Chabrier's España. 3.0, Interval. 4.0, Orchestral Concert, conducted by Maurice de Villers: Symphony No. 16 (Haydn); Bassoon Concerto (Mozart); Overture, Leonora (Beethoven); Impressions d'Italie (Charpentier); Images d'Epinal (Dupérier); Suite No. 2, The Nursery (Inghelbrecht); Fresques (Gaubert). 6.0, Gramophone Music. 6.15, French Lesson. 6.30, Popular Music on Gramophone Records. 7.0, Tourist Talk. 7.15, Gardening Talk. 7.30, Time and News. 7.45, Gramophone Music. 8.0, Press Review. 8.30, Military Band Concert, conducted by Guiraud, relayed from Verdun: Introductory Talk; The Temeraire (Mougeot); Sublime Belgique (Balay); Overture, William Tell (Rossini); Suite, Impressions d'Italie (Charpentier); Norwegian Rhapsody (Lalo); Ballet Music from Isoline (Messager); Selection from La Bohème (Puccini); Cornet Solo: Polka, Gracieuse (Koch); Regimental March (Guiraud). In the interval, Talk. 10.30 (approx.), Press Review. 10.45, Dance Music, relayed from the Savoy. 12 Midnight (approx.), Close Down.

**STUTTGART**

**MUHLACKER,** 832 kc/s, 360.5 metres; 60 kW. Relayed by Freiburg, 527 kc/s, 570 metres.—12.20 p.m., Gramophone Concert: Overture, The Barber of Bagdad (Cornelius); Two Pieces (Grieg): (a) Solveig's Song, (b) Cradle Song; Symphonic Poem, The Swan of Tuonela (Sibelius); Symphony No. 4 in F Minor, Op. 36 (Tchaikovsky). 1.30, See Langenberg. 2.30, Time and News. 2.50, Concert by the Schulrahe Balalaika Orchestra: Night (Glinka); Polka, Marianna (Bébe); The Nightingale (Alabiev); Balalaika Quartet: Waltz, Ferne Heimat (Schulrahe); Potpourri No. 3, Apfelfchen (Schulrahe). 3.30, See Frankfurt. 4.30, See Munich. 5.20 (from Pforzheim), Choral Music by Fritz Neuert—Concert in Memory of the Composer, with Introductory Talk. 5.45, Talk with Musical Illustrations: Max Reger in Light and Serious Mood. 6.35, Time and News. 7.0, Transmission for all German Stations, relayed from Berlin (Funkstunde). 8.5 to 12 Midnight, Langenberg-Frankfurt-Stuttgart Exchange Programme. In the intervals at 10.0, Talk from Munich, and from 10.20 to 10.40, Time and News. 12 Midnight (approx.), Close Down.

**SUNDSVALL.**—See Stockholm.

**TOULOUSE**

**RADIOPHONIE DU MIDI,** 779 kc/s, 385 metres; 8 kW.—6.15 p.m., Music by an Argentine Band. 6.30, Opera Music. 6.45, Military Music. 7.0, Overture, Patrie (Bizet). 7.15, News. 7.30, Accordion Solos. 7.45, Opera Music: Arias from (a) William Tell (Rossini), (b) The Tales of Hoffmann (Offenbach), (c) The Huguenots (Meyerbeer), and (d) Faust (Gounod). 8.0, Orchestral Music. 8.30, Operetta Music: Airs from (a) Le Comte Obligado (Moretti), (b) Les Cloches de Corneville (Planquette), and (c) Le Coup de roulis (Messager). 8.45, Music by an Argentine Band. 9.0, Concert of Opera Music: Selection from (a) Faust (Gounod), (b) Madame Butterfly (Puccini), (c) Tosca (Puccini), (d) Lakmé (Delibes), (e) Carmen (Bizet), (f) Mignon (Thomas), (g) Mirella (Gounod), (h) Si j'étais Roi (Adam), (i) Les Dragons de Villars (Maillart), (j) Fortunio (Messager), (k) La Traviata (Verdi), (l) Sigurd (Reyer), and (m) Thäis (Massenet). After the Concert, Programme by a Viennese Orchestra. 10.0 Chansonnettes. 10.15, News. 10.30, Concert for Listeners in Morocco. 11.0, Light Music. 11.15, Dance Music. 12 Midnight, News. 12.5 a.m. (Sunday), Orchestral Music. 12.30 (approx.), Close Down.

**TRIESTE**

1,211 kc/s, 247.7 metres; 10 kW.—5.20 p.m., till Close Down, See Turin.

**TRONDHEIM.**—See Oslo.

**TURIN**

273.7 metres; 7 kW. Relayed by Milan, 331.1 metres; Genoa, 312.8 metres; and Florence, 500.8 metres.—5.20 p.m., Gramophone Music. 6.0 to 6.5, Weather. 6.40, Giornale Radio, Talk, Dopplavoro Announcements and Gramophone Music. 7.0, Time, Tourist Report and Gramophone Music. 7.10, Agricultural Notes and Market Prices. 7.20, News in Foreign Languages. 7.40, Gramophone Music. 8.0, Announcements, Giornale Radio and Weather. 8.25, Talk: Events and Problems. 8.40, Variety Programme. In the interval, Book Review. 10.0, Orchestral Concert. 11.0, Giornale Radio.

**VATICAN CITY**

15,120 kc/s, 19.84 metres (Morning) and 5,969 kc/s, 50.26 metres (Evening); 10 kW.—11.0 to 11.15 a.m., Religious Announcements in Various Languages. 8.0 to 8.15 p.m., Religious Information in Italian.

**VIENNA**

581 kc/s, 517 metres; 15 kW. Relayed by Graz, 852 kc/s, 352.1 metres; Innsbruck, 1,058 kc/s, 283 metres; Klagenfurt, 662 kc/s, 453.2 metres; Linz, 1,220 kc/s, 245.9 metres; and Salzburg, 1,373 kc/s, 218.5 metres.—12 Noon, Concert by the Wiener Symphoniker, conducted by Josef Holzer. 1 p.m., Time and News. 1.10, Concert (contd.). 3.0, Time, Weather and Market Prices. 3.15, Italian Lesson. 3.40, Zither Recital. 4.20, Talk by Dr. Hugo Adolf Bernatzki: My Expedition to the South Seas. 4.45, Gramophone Records by Famous People. 5.30, Talk: A Meeting in Erfurt. 6.0, Dance Music. 6.35, To-day's Axion. 6.40, Time, Weather and Sports Notes. 6.50, Talk on Music. 7.0, Topical Talk. 7.35, Concert of Opera Music by the Wiener Symphoniker, conducted by Hugo Reichenberger. Soloists: Eva Hadravova (Soprano), Armand Tokatyán (Tenor), and Josef Manowarda (Bass). Overture, The Merry Wives of Windsor (Nicolai). Bass Solos: (a) Aria from Figaro (Mozart), (b) Aria from Der Waffenschmied (Lortzing), (c) Soprano Solos: Prelude, and Cavatina, from Faust (Gounod). Soprano Solo: Aria from Rusaalka (Dvořák); Intermezzo from Cavalleria rusticana (Mascagni). Tenor Solo: Aria from Tosca (Puccini). Bass Solo: Aria from Madam Butterfly (Puccini). Waltz from Der Rosenkavalier (R. Strauss). 9.35, News. 9.50, Concert by the Wiener Symphoniker, conducted by Josef Holzer. After the Concert, Announcements.

**WARSAW**

212.5 kc/s, 1,411 metres; 120 kW.—11.57 a.m., Time Signal and Fanfare from St. Mary's Church, Cracow. 12.5 p.m., Gramophone Music. 12.25, Polish Press Review. 12.33, Weather Report. 12.35, Gramophone Music. 12.55, Radio Journal. 1.0 to 2.55, Interval. 2.55, Gramophone Music. 3.5, News. 3.10, Announcements. 3.15, Gramophone Music. 3.25, Economic Notes. 3.35, Gramophone Music. 4.0, Programme for Invalids, relayed from Lwów, 788 kc/s, 381 metres. 4.30, Gramophone Music. 5.0, Topical Talk. 5.15, Piano-forte and Cello Recital by Marie and Casimir Wilkomirski: Sonata in G Minor, Op. 19, for Piano-forte and Cello (Rachmaninov); Impromptu (Scriabin); Prelude in E, Op. 15 (Scriabin); Jardins sous la pluie (Debussy); Two Etudes, Op. 33 and Op. 39 (Rachmaninov); Hindoo Song (Rimsky-Korsakov); The Flight of the Bumble Bee (Rimsky-Korsakov); Orientale (Cui); Scherzo (Godard); Tambourin chinois (Kreisler). 6.15, Talk. 6.35, Gramophone Music. 7.20, Miscellaneous Items. 7.35, Programme Announcements. 7.40, Humorous Reading. 8.0, Concert by the Station Orchestra, conducted by Nawrot. Soloist, Konarek-Korska (Songs). Spanish Overture (Keler-Bela); Hochzeitung in Lilliput (Trauslatur); Waltz-Intermezzo, Was blumen träumen (Trauslatur); Three Songs; Gavotte (Lewak); Waltz, Manoha (Waldteufel); Intermezzo, Bih et Bob (Demaret); Three Songs; Berceuse (Fucik); Potpourri (Namyrowski). 9.5, Radio Journal. 9.15, Agricultural Press Review, relayed from Wilno, 533 kc/s, 563 metres. 9.30, Chopin Piano-forte Recital by Mme. Jaroszewicz: Etude No. 1, Op. 25, in A Flat; Etude No. 2, Op. 25, in F Minor; Etude No. 1 in F Minor; Etude No. 2 in A Flat; Nocturne in C Sharp Minor, Op. 27; Mazurka in F Sharp Minor, Op. 6; Ballad in A Flat. 10.0, Dance Music. 10.25, Sports Notes. 10.35, Aviation Weather Report and Police Notes. 10.40, Dance Music (contd.).

**ZURICH.**—See Schweizerischer Landessender.



**The ALL-METAL WAY 1934**

**3<sup>d</sup>**

brings you that essential guide to A.C. mains working..

**"THE ALL-METAL WAY"**

Send to Dept. W.W.

**The WESTINGHOUSE**  
BRAKE & SAXBY SIGNAL CO. LTD.  
82, YORK ROAD, LONDON, N.1

**EDISWAN**

*The name that means 'EXCELLENCE'*

**LONGER LIFE  
LESS CHARGING**

EDISWAN ACCUMULATORS

**... the secret is  
BALANCED CAPACITY**

An accumulator with unbalanced plates is like a set with worn-out valves—just as inefficient. Ediswan accumulators are *balanced*. The positive and negative plates are designed to function in exact electrical balance, so that it is possible to charge them quicker and discharge them longer without the slightest risk of damage. A host of minor improvements, too, are incorporated in these Ediswan cells. Better from every point of view than ordinary cells, and no more expensive. Get an Ediswan to-day.

E.L.M.2. 20 a.h. . . . . 4 3	E.L.S.8. 40 a.h. . . . . 11 -	E.L.7. 60 a.h. . . . . 10 3
E.L.M.4. 45 a.h. . . . . 8 -	E.L.S.7. 60 a.h. . . . . 12 6	E.L.9. 80 a.h. . . . . 12 3
	E.L.S.6. 80 a.h. . . . . 15 6	

**EDISWAN**

**EXTRA LIFE**

**ACCUMULATORS**



THE EDISON SWAN ELECTRIC CO. LTD.  
PONDERS END, MIDDLESEX

**EDISWAN - the Better Service Batteries**

**SCRUIT**

MIDGET AND NORMAL CONNECTORS

SCRUIT NORMAL

FITTED WITH

**'A TWIST OF THE WRIST'**  
SIMPLE • SAFE • SPEEDY

The Mark of the finest made Electrical Wire Connector.

USE THEM TO-DAY to save Time, Temper and Money. Designed for Speed, Simplicity and Absolute Perfect Insulation.

Stocked by the Principal Wholesalers and Factors throughout the Country.

Made by:  
**V.G. MFG. CO., LTD.,**  
Gorst Road, Park Royal  
LONDON, N.W.10.  
Willesden 1632.



# G.E.C. H.T.

## A new range of Wireless Batteries

### TESTED AT EVERY STAGE OF MANUFACTURE

**GUARANTEED CAPACITY • 120 volt • 144000 milliwatt hours**



**PRICES :**

60V. . . . .	5/6
99V. . . . .	9/-
108V. . . . .	10/-
120V. . . . .	11/-
150V. . . . .	14/-
60V. Triple Capacity	12/-

MADE IN ENGLAND

Sold by all Wireless Dealers

## A TRIAL MEANS YOU'LL ALWAYS USE GEC HT

*Advt. of The General Electric Co. Ltd., Magnet House, Kingsway, London, W.C.2*



4<sup>D</sup>

# The Wireless World

THE PRACTICAL RADIO JOURNAL

with Complete Foreign Programmes

Friday, September 29th, 1933.

## BURTON CLASS "B" CONVERSION UNIT

This unit is intended to be added to existing battery sets in order that moving coil reproduction may be obtained. It contains a specially designed driver and output transformer, and the whole unit is housed in a highly polished brown bakelite case. The unit takes an average current of 6 m.a. and is capable of delivering 2 watts output without distortion.

Made by C. F. & H. BURTON, Progress Works, WALSALL.



35/-

## TELSEN Intermediate Frequency TRANSFORMER COILS

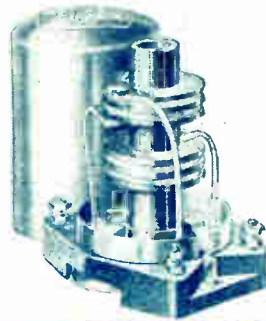

Specified by the designer of the "Wireless World" NEW MONODIAL SUPER. Ideal for every superhet where lasting efficiency is the first essential. Totally screened. The world's finest value at the new reduced price of **7/6**

TELSEN FOR EVERYTHING IN RADIO

Announcement of the Telsen Electric Co., Ltd., Aston, Birmingham.

D.C. AND A.C. AMPS VOLTS OHMS

## EVERY TEST WITH ONE COMPLETE INSTRUMENT



The Avometer is the only complete testing instrument which gives direct readings in amps, volts and ohms without the necessity for mathematical calculations. It is indispensable to the Service men of leading radio manufacturers as the only instrument that adequately meets their needs.

Two models, one for D.C. only, 8 GNS. and the Universal Avometer giving both D.C. and A.C. readings (50 cycles) 12 GNS. Deferred Terms if desired.

Illustrated Pamphlet post free.

## One AVOMETER

BRITISH MADE

AUTOMATIC COIL WINDER & ELECTRICAL EQUIPMENT CO., LTD., Winder House, Douglas Street, London, S.W.1 Telephone: Victoria 3408-7.

## COLVERN FERROCART COILS

There is now a Ferrocart Coil for practically every modern radio receiver... We have written a booklet explaining the advantages of Ferrocart coils and containing suitable circuit diagrams...

May we send you a copy? It's free!

MANCHESTER RADIO EXHIBITION STAND No. 32.

COLVERN LIMITED, ROMFORD, ESSEX.

London Wholesale Depot: 150, King's Cross Road, W.C.1.

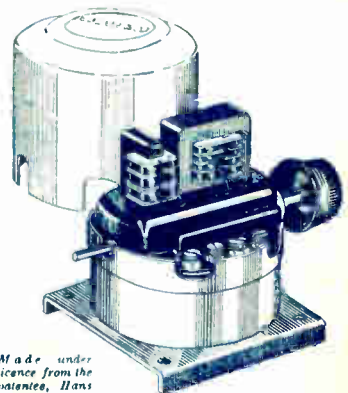

Made under licence from the patentee, Hans Vogt.



**HIS PERTRIX BATTERY LASTED TWO YEARS**

Dear Sirs, 11th February, 1933.  
 It may interest you to learn that I have at present in use on a 3 valve wireless set a 120 volt Pertrix H.T. Battery, which I purchased in September, 1930. This battery has now been in daily use for 2 years 5 months and still registers 65 volts. Is this a record life for a H.T. Battery?  
 Yours faithfully, G. F., Lanark.

The above letter can be inspected at the offices of Britannia Batteries Ltd., 233 Shaftesbury Avenue, London, W.C.2

**SAVE BY BUYING A PERTRIX**

It's hard to say which is the record-holder. Scores of Pertrix users write to ask if theirs is the oldest working H.T. battery.

The reason for this Pertrix long life isn't an open secret—it's inside the battery. The only batteries in the world using a patent *neutral* electrolyte, Pertrix Batteries don't fall victims to corrosion. They don't eat their own insides out—and so there is no "shorting" between the cells, no clogging crystals. Your set can run morning, noon and night or be idle for weeks: it will make no difference to the long life of your Pertrix Battery. Pertrix Power does not leak away when the set is idle, it is stored up for the next time you want to listen. There's a Pertrix H.T. or G.B. to fit every set; the right battery in the right space. Pertrix also make Low Tension Accumulators that stand second to none.

**FIT PERTRIX**  
TRADE MARK  
**FOR GOOD**

British Made by BRITANNIA BATTERIES LTD., REDDITCH, WORCESTERSHIRE.

*Mention of "The Wireless World," when writing to advertisers, will ensure prompt attention.*

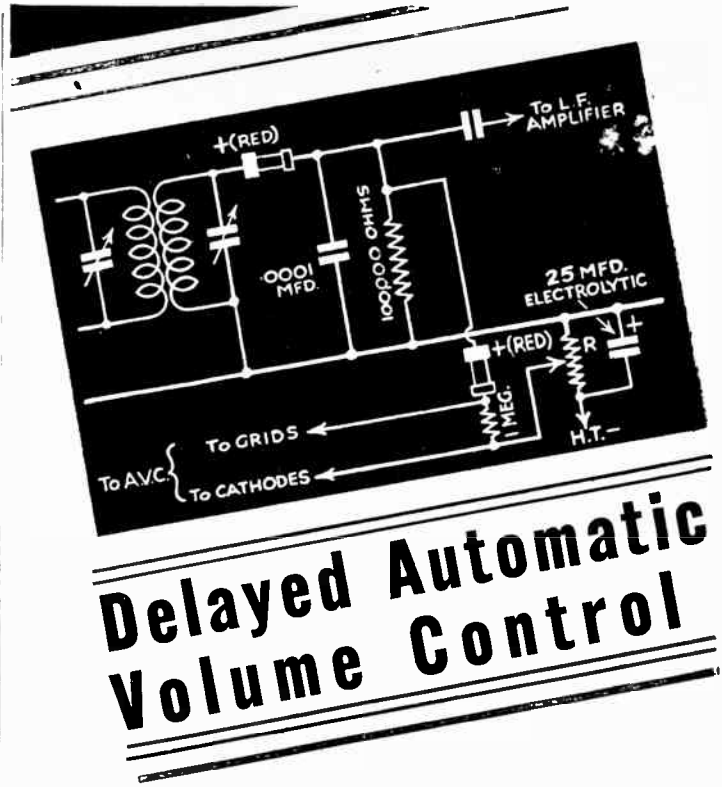

**Delayed Automatic Volume Control**

Up to the present, the introduction of Automatic Volume Control to receivers has necessitated complicated and costly alterations.

But by using a Westector, even Delayed Automatic Volume Control may be achieved in a simple and efficient manner.

By using the circuit shewn above, the Automatic Volume Control is inoperative on moderately weak signals, and only begins to function on signals of more than a certain pre-set value.

The particular value at which the control becomes operative is set by means of the potentiometer R.

Full details of A.V.C. and D.A.V.C. are given in "The All Metal Way, 1934."

The attached coupon and 3d. in stamps will bring you a copy.

**COUPON**

Please send me "The All Metal Way, 1934" for which I enclose 3d. in stamps.

Name .....

Address .....

W.W. 30933

THE WESTINGHOUSE BRAKE & SAXBY SIGNAL CO. LTD.,  
 82, YORK ROAD, KING'S CROSS, LONDON, N.1.

**Westinghouse**  
 metal rectifiers

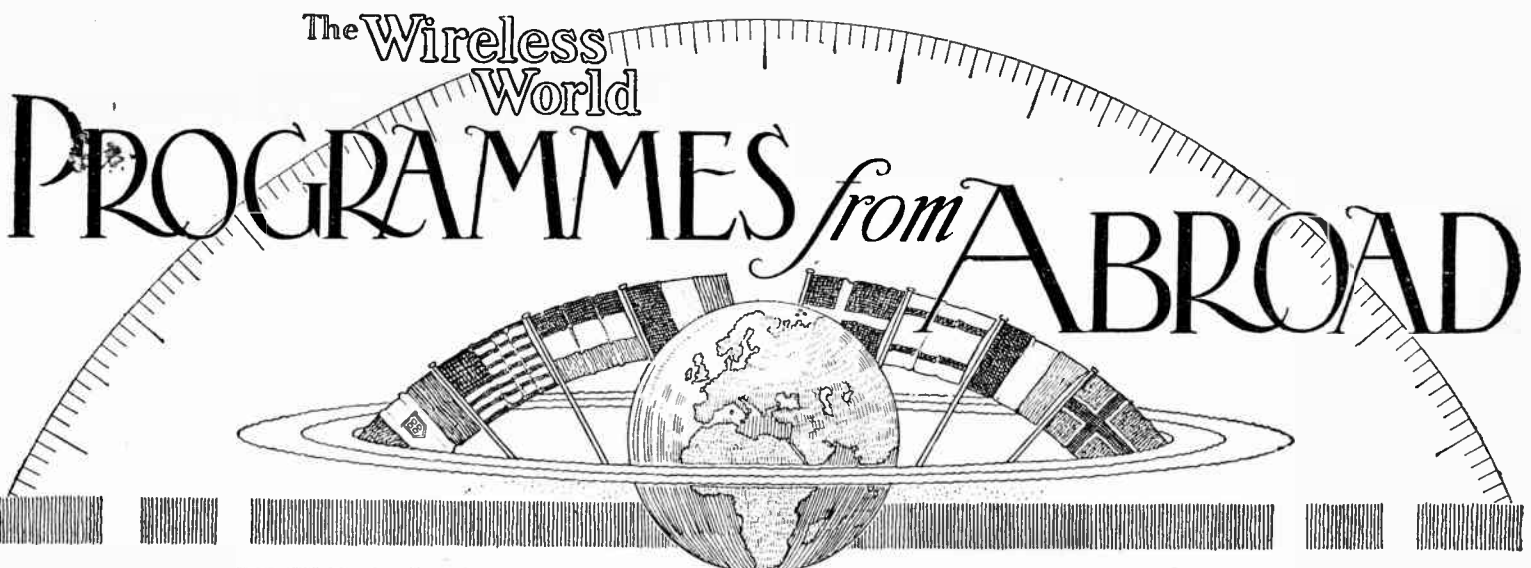

**BROADCASTING STATIONS  
ARRANGED IN ORDER  
OF WAVELENGTH**

**TIMES AND DETAILS OF  
FULL WEEK'S FOREIGN  
TRANSMISSIONS**

Metres.	kc s.	kW.	Station.	Tuning Positions.	Metres.	kc s.	kW.	Station.	Tuning Positions.
1935	155	7	Kaunas (Kovno) (Lithuania) ..	.....	453.2	662	0.25	Agen (France) ..	.....
1875	160	8.5	Hilversum (Holland) ( <i>Kootuyk</i> , 50kW.. after 3.10 p.m.) ( <i>F.A.R.A.</i> , <i>A.F.R.O.</i> and <i>F.P.R.O.</i> programmes.)	.....	453.2	662	4	Milan (Vigentino) (Italy). ( <i>Relays Rome</i> ) ..	.....
1796	167	40	Lahti (Finland) ..	.....	450.3	666	20	Madona (Latvia). ( <i>Relays Riga</i> ) ..	.....
1725	174	75	Radio Paris, C.F.R. ..	.....	447.1	671		Paris, Ecole Supérieure, PTT (7.0 kW.); Rjukan (0.15 kW.), Notodden (0.08 kW.), Alesund (0.35 kW.) (Norway) ( <i>relays Oslo</i> ).	.....
1635	183.5	60	Berlin. (Deutschlandsender) (Germany). ( <i>S.-W. Stn. DJA on 31.38 m., DJB on 19.73 m., DJC on 19.83 m., DJD on 23.51 m., DJE on 16.86 m.</i> )	.....	441.2	680	50	Rome, IRO. ( <i>S.-W. Station, 2RO on 25.4 m.</i> )	.....
1554.4	193	30	Daventry National ..	.....	435.4	689	55	Stockholm, SASA (Sweden) ..	.....
1538	195	7	Ankara (Angora) (Turkey) ..	.....	430.4	697	2.5	Belgrade (Yugoslavia) ..	.....
1481	202.5	500	Moscow, RV1 (Old Komintern) (Russia)	.....	424.3	707	2	Madrid, EAJ7 (Union Radio)	.....
1446	207.5	13	Eiffel Tower, FL, Paris ..	.....	424.3	707	100	Moscow, Imini Stalina (Russia) ..	.....
1412	212.5	120	Warsaw 1 (Poland) ..	.....	419.5	715	1.5	Berlin, Funkstunde (Germany)	.....
1380	217.5	100	Novosibirsk, RV76 1 (Russia) ..	.....	416.4	720.5	5	Rabat (Morocco)	.....
1354.4	221.5	30	Motala (Sweden). ( <i>Relays Stockholm</i> )	.....	413	725	60	Athlone (Irish Free State)	.....
1350	222	0.5	Tunis-Kashah (Tunisia)	.....	408.7	734	16	Katowitz (Poland)	.....
1304	230	100	Moscow, WZSPS (Trade Union) (Russia)	.....	403.8	743	25	Sottens (Radio Suisse Romande) ( <i>Switzerland</i> )	.....
1230	244	0.6	Boden (Sweden). ( <i>Relays Stockholm</i> )	.....	398.9	752	25	Midland Regional (Daventry)	.....
1200	250	5	Stamboul (Turkey) ..	.....	394.2	761	12	Bucharest (Roumania)	.....
1200	250	21	Reykjavik (Iceland) ..	.....	389.6	770	120	Leipzig (Germany)	.....
1190	252	200	Luxembourg ..	.....	385.1	779	8	Toulouse (Radiophonie du Midi) (France)	.....
1170	256	25	Tashkent, RV11 (Russia)	.....	385.1	779	10	Stalino, RV26 (Russia) ..	.....
1154	260	75	Kalundborg (Denmark). ( <i>Relays Copenhagen</i> )	.....	381	788	16	Lwow (Lemberg) (Poland) ..	.....
1154	260	20	Monte Ceneri (Switzerland). ( <i>Temporarily Closed</i> ).	.....	376.4	797	50	Scottish Regional (Falkirk)	.....
1117	268.5	40	Moscow, Popoff RV58 (Russia)	.....	372.2	806	1.5	Hamburg (Germany) ..	.....
1083	277	60	Oslo (Norway) ..	.....	370.1	810.5	0.8	Radio, L.L. Paris	.....
1071	280	35	Tiflis, RV7 (Russia) ..	.....	368.1	815		Seville, EAJ5 (Union Radio) (1.0 kW.); Galicia EAJ1 (0.2 kW.) (Spain); Bolzano (1.0 kW.) (Italy); Helsinki (10 kW.) (Finland) ( <i>relays Lahti</i> ); Kharkov, RV20 (10kW.) (Russia).	.....
1035	290	36	Kiev, RV9 (Russia)	.....	368.1	815	0.7	Fredriksstad (Norway). ( <i>Relays Oslo</i> )	.....
1000	300	100	Moscow RV39 (Russia) ( <i>S.-W. Stn. on 50 m.</i> )	.....	364.1	824	1	Bergen (Norway)	.....
938	320	20	Kharkov, RV4 (Russia)	.....	363.6	825	13	Algiers (Algeria)	.....
857	350	100	Leningrad (Russia)	.....	360.6	832	60	Mühlacker (Stuttgart) (Germany)	.....
840	357	18.5	Budapest (Hungary) ..	.....	355.9	843	50	London Regional (Brookmans Park)	.....
825	363.6	50	Sverdlovsk, RV5 (Russia)	.....	352.1	852	7	Graz (Austria). ( <i>Relays Vienna</i> )	.....
760	395	1.3	Geneva (Switzerland). ( <i>Relays Sottens</i> )	.....	348.8	860	7.6	Barcelona, EAJ1 (Spain)	.....
720	416.6	20	Moscow, RV2 (Experimental) (Russia)	.....	348.8	860	10	Leningrad, RV70 (Russia)	.....
690	434.6	1.5	Oulu (Uleaborg) (Finland)	.....	345.2	869	11.5	Strasbourg, PTT (France)	.....
680	441.2	0.6	Lausanne (Switzerland). ( <i>Relays Sottens</i> )	.....	341.7	878	35	Brno (Brunn) (Czechoslovakia)	.....
574.7	522	7	Ljubljana (Yugoslavia)	.....	338.2	887	15	Brussels 11, Velthem (Belgium). ( <i>In Flemish</i> )	.....
569	527	0.25	Freiburg-im-Breisgau (Germany). ( <i>Relay Stn.</i> )	.....	335	896	5	Cadiz (Spain)	.....
568.1	528	2	Grenoble (France)	.....	334.4	897	1.9	Poznan (Poland)	.....
563	533	16	Wilno (Poland). ( <i>Relay Station</i> )	.....	331.5	905	50	Milan (Italy). ( <i>Relays Turin</i> )	.....
560	536	0.25	Augsburg (Germany). ( <i>Relays Munich</i> )	.....	328.2	914	60	Poste Parisien (France)	.....
560	536	1.5	Kaiserslautern (Germany). ( <i>Relays Munich</i> )	.....	325	923	60	Breslau (Germany)	.....
550	545	18.5	Budapest No. 1 Lakihegy (Hungary)	.....	321.9	932	10	Göteborg (Sweden). ( <i>Relays Stockholm</i> )	.....
542	554	10	Sundsvall (Sweden). ( <i>Relays Stockholm</i> )	.....	318.8	941	0.25	Dresden (Germany). ( <i>Relays Leipzig</i> )	.....
537.6	558	3	Palermo (Italy) ..	.....	318.8	941	1.5	Naples, INA (Italy). ( <i>Relays Rome</i> ) ..	.....
533	563	60	Munich (Germany) ..	.....	315.8	950	1.6	Marseilles, PTT (France)	.....
525	571	15	Riga (Latvia)	.....	312.8	959	0.7	Radio Vitus (Paris). ( <i>S.-W. Stn. on 43.75 m.</i> )	.....
517.2	580	100	Vienna (Bisamberg) (Austria) ..	.....	312.8	959	1.7	Cracow (Poland)	.....
509	589	15	Brussels No. 1, Velthem (Belgium). ( <i>In French</i> )	.....	309.9	968	50	Genoa, IGE (Italy). ( <i>Relays Turin</i> ) ..	.....
500.8	599	20	Florence, IF1 (Italy). ( <i>Relays Turin</i> )	.....	307	977	0.75	West Regional (Washford Cross)	.....
495.8	605	1.2	Tröndelag (Norway) ..	.....	304	986	13	Zagreb (Yugoslavia)	.....
488.6	614	120	Prague (Czechoslovakia)	.....	301.5	995	50	Bordeaux Lafayette, PTT (France)	.....
480	625	50	North Regional (Manchester) ..	.....	298.8	1004	11	North National (Manchester)	.....
472.4	635	60	Langenberg (Germany)	.....	296.1	1013	20	Tallinn (Esthonia)	.....
465.8	644	1.5	Lyons la Doua, PTT (France) ..	.....	293.5	1022	0.7	Huizen (Holland). ( <i>7 kW. before 4.40 p.m.</i> ) ..	.....
459.4	653	60	Beromünster (Schweizerischer Landessender) (Switzerland).	.....	293.5	1022	2.6	( <i>K.R.O. and N.C.R.V. programmes</i> ).	.....
453.2	662		San Sebastian, EAJ8 (0.6 kW.); Pori (1.0 kW.) (Finland); Danzig (0.5 kW.) ( <i>relays Heilsberg</i> ); Klagenfurt (0.5 kW.) (Austria) ( <i>relays Vienna</i> ); Porsgrunn (0.7 kW.) ( <i>relays Oslo</i> ); Tromsø (0.1 kW.) Bodö (0.5 kW.) (Norway); Uppsala (0.15 kW.) (Sweden) ( <i>relays Stockholm</i> ).	.....	291	1031	13.2	Limoges, PTT (France)	.....
				.....	288.3	1040	50	Kosice (Czechoslovakia)	.....
				.....	288.3	1040	1	Viipuri (Viborg) (Finland). ( <i>Relays Helsinki</i> )	.....
				.....				Scottish National (Falkirk)	.....
				.....				Bournemouth. ( <i>Relay Station</i> )	.....



BROADCASTING STATIONS ABROAD (In Order of Wavelength)

Table with columns: Metres, kc's, kW, Station, Tuning Positions, Metres, kc/s, kW, Station, Tuning Positions. Lists various international broadcasting stations and their technical specifications.

PRINCIPAL SHORT-WAVE STATIONS

(N.B.—Times of Transmission, given in parentheses, are approximate only and represent B.S.T.)

Table with columns: Metres, kc/s, Call Sign, Station, Tuning Positions, Metres, kc/s, Call Sign, Station, Tuning Positions. Lists principal short-wave stations with call signs and transmission times.

# FOREIGN SUNDAY PROGRAMMES

OCTOBER THE FIRST

## PRINCIPAL EVENTS OF THE DAY:

### AT HOME

- NATIONAL LONDON REGIONAL** —Orchestral concert from Bournemouth.
- MIDLAND REGIONAL** —Military Band programme.
- NORTH REGIONAL** —Light orchestral concert from Leamington Spa.
- WEST REGIONAL** —Service from the Parish Church, Leeds.
- SCOTTISH REGIONAL** —Carolare from the Central Hall, Swansea.
- BELFAST** —Evening service from St. Culbert's Church, Edinburgh.
- BELFAST** —Service from St. Patrick's Protestant Cathedral, Armagh.

### ABROAD

- BARCELONA** —8.0 p.m. Grieg concert, by the Station Orchestra.
- COPENHAGEN** —10.0 p.m. Johann Strauss concert, by the Radio Orchestra.
- HUIZEN** —8.45 p.m. The K.R.O. Orchestra, conducted by Gerritsen.
- RADIO PARIS** —8.40 p.m. Operetta: "White Horse Inn," by Benatzky, from the Théâtre Mogador.
- ROME** —8.45 p.m. Operetta: "Countess Maritza," by Kalman.
- SOTTENS** —8.0 p.m. Opera: "Susanna's Secret," by Wolf-Ferrari, relayed from Lugano.
- TURIN VIENNA** —8.30 p.m. Opera: "La Wally," by Catalani.
- VIENNA** —12.0 noon. The Viennese Chamber Orchestra, conducted by Karl Auerieth.
- WARSAW** —12.15 p.m. The Station Symphony Orchestra, conducted by Oziminsky.

co). 8.45, Recitations. 9.0, Concert by the Radio Orchestra, conducted by Walpot: Soloist, Rubenau (Tenor); Overture, Light Cavalry (Suppé); Waltz, Dolorès (Waldteufel); Selection from The Merry Widow (Lehar); Songs, (a) Recitative from Lohengrin (Wagner), (b) Ein Traum (Grieg), (c) Pedro (Morvan); Fantasia on Flemish Songs; Selection from White Horse Inn (Benatzky). 10.0, Le Journal Parlé.

### BUCHAREST

761 kc/s, 394 metres; 12 kW.—5.0 p.m., Light Music and Romanian Music by the Marco Orchestra. In an interval at 6.0, Radio Journal. 7.0, Educational Programme. In an interval at 7.20, Dance Music on Gramophone Records. 8.0, Operetta Programme. In the intervals, Radio Journal.

### BUDAPEST

545 kc/s, 550.5 metres; 18.5 kW. Also relayed on 8.40 metres from 6.30 p.m. till Close Down.—2.0 p.m., Gramophone Music. 3.0, Agricultural Programme. 3.50, Radio Report of the Athletic Championship, Sweden v. Hungary. 4.50, Talk. 5.0, Concert by the Budapest Concert Orchestra. 6.0, Talk with Gramophone Records. 6.30, Hungarian Folk Song Recital with Csányi Band Accompaniment. 7.45, Talk. 8.30, Concert by the Budapest Concert Orchestra, conducted by Polgar. 10.0, News. 10.15, Dance Music. 11.15, Concert by Béla Bodrie's Csányi Band.

CASSEL.—See Frankfurt.

### COPENHAGEN

1,667 kc/s, 281 metres; 0.75 kW. Relayed by Kalundborg, 250 kc/s, 1,153.8 metres.—9.0 a.m., Gymnastics for Women. 8.15, Gymnastics. 9.0, Talk from the Randers Studio. 10.0, Divine Service Relay. 11.30, Weather and News. 12 Noon, Town Hall Chimes. 12.2 p.m., Gramophone Music. 12.30, Concert and Addresses from the Nicolai Hus: The Orchestra conducted by Joh. Bentzen, Aage Thygesen (Songs) and Ellen Thygesen (Pianoforte). 2.0 (Also relayed on Skamlebaek, 31.51 metres), Divine Service Relay. 3.25, Symphony Concert from the Oddfellows' Hall: The Symphony Orchestra conducted by Nikolai Malko; Soloist, France Ellegard (Pianoforte). 5.20, Talk in English: Lord Grey of Fallodon. 5.40, Talk in German: The German Pre-War Novel. 6.0, Literary Talk in French. 6.20, Talk on Flowers. 6.50, Weather and News. 7.15, Time Signal. 7.30, Talk: American Politics. 8.0, Town Hall Chimes. 8.2, Concert of Seventeenth and Eighteenth Century Dances. 8.35, Reading. 9.0, Recital of Danish Hunting Choruses and Melodies. 9.20, Saxophone solos. 9.35, The Hansen Family, Humorous Episode (Jens Locher). 9.50, News. 10.0, Johann Strauss Concert by the Radio Orchestra, conducted by Fritz Mahler: Overture, Imago und die vierzig Räuber; Kaiserwalzer; Ballet Music from Ritter Pasman; Overture, A Night in Venice; Deutschmeister Jubiläumsmarsch. 10.45, Dance Music from the Ritz Restaurant. In the interval at 12 Midnight, Town Hall Chimes. 12.30 a.m. (Monday), Close Down.

CORK.—See Athlone.

DANZIG.—See Heilsberg.

DRESDEN.—See Leipzig.

### FECAMP

1,328 kc/s, 225.9 metres; 10 kW.—11.0 a.m. to 12 Noon, Programme in English by the I.B.C. 11.0, Happy Hour, Part I: Orchestral Concert: Signature Tune; Overture, A Midsummer Night's Dream (Mendelssohn); The Witches' Ride, from Hansel and Gretel (Humperdinck); Air de Ballet (Drigo); Spring Song (Mendelssohn); The Gingerbread Waltz from Hansel and Gretel (Humperdinck); Ballet Egyptien (Luigini); Hungarian Dance No. 6 (Brahms). Part II: Organ Recital: Potted Overtures (Englemann); Schön Rosmarin (Kreisl); Sylvan Scenes (Fletcher); (Chanson (Friml); Love's Old Sweet Song (Molloy); A Brown Bird Singing (Haydn Wood); Old Minuet (Walding); Ca c'est Madrid (O'Henry); Signature Tune. 12 Noon, French Programme. 2.0 to 7.30, Programme in English by the I.B.C. 2.0, Light Music: Signature Tune; The Night by the Sea; Rosa Mia; Ding Dong Ding (Hargreaves); My Heart stood still (Rodgers); Rhapsody in Blue (Gershwin). 2.15, Classical Music: Dance of the Hours, from La Gioconda (Ponchielli); Ave Maria (Bach-Gounod); Angels guard thee (Godard). 2.30, Orchestral Concert: The Valley of the Poppies (Ancliffe); My Lady Dainty (Hesse); Song, That's my Home (Rosing); Violin Solo, Oh, could I but express in Song; When the Convent Bell is ringing (Trevor); The Song of the Rose (McCullough); Piano-forte Solo, He wanted Adventure (Waller); Spring Blossoms awaken (Lühr). 3.0, Special Request Programme, Marta; Serenade (Heykens); Smilin' through (Penn); Farewell to Arms (Wrubel); A Fine Old English Gentle-

### ATHLONE

725 kc/s, 413 metres; 60 kW. Relayed by Cork, 1,337 kc/s, 224.4 metres.—1.0 to 2.0 p.m., Programme by the I.B.C. (Ireland). Ltd. 1.0, Special Variety Concert with the Well-known Comedian, Mr. Stanley Holloway, supported by Tony Roddin and his Band. Announcement by Mr. Stanley Holloway; Orchestra: Memories of Leshie Stuart introducing Dolly Daydream, Lily of Laguna, Little Octoroon; Interlude by Mr. Stanley Holloway; Orchestra: Sanderson's Songs Selection; Interlude by Mr. Stanley Holloway; Announcement by Mr. Stanley Holloway; Orchestra: Some Newer Ones, introducing "Nightfall, Stormy Weather, Sweetheart Parim", In the Valley of the Moon, Gipsy Rhapsody; Orchestra: Good Old Songs, introducing Waiting at the Church, A Little Bit of the Top, Miner's Dream of Home; Orchestra: Waltzes Divine Introducing Vocalists, including "Pink Lady, Blue Danube, Bonanwellen, Merry Widow; Interlude by Stanley Holloway; Orchestra: March of the Grenadiers; Announcement by Mr. Stanley Holloway. 1.30, Time Signal. 8.31, Scenes from The Merchant of Venice (Shakespeare), by John Stephenson and Company and the Station Orchestra. 10.0, Anglo-Irish Songs by Atwood (Baritone). 10.10, Pipe Solos by Jam Breathnach. 10.25, Baritone Solos by Atwood. 10.35, Irish Music by the Station Orchestra. 11.0, Time, News, Weather and Close Down.

### BARCELONA

AJ1, 860 kc/s, 348.8 metres; 8 kW.—2.0 p.m., Gramophone Music. 2.30 (in an interval), Theatre Notes. 3.0, Sextet Concert. 4.0, Programme for Hospitals and other benevolent Institutions, with Gramophone music. 5.0, Interval. 6.0, Agricultural talk in Catalan, followed by Gramophone music. 7.0, Orchestral Concert. 7.30, Song recital by Julian Ortego (Baritone). 8.0, Recital Concert, by the Station Orchestra and Concepcion Callao (Songs). 9.0, Dance music, relayed from the Hollywood Bar. 10.0, Selection from Musical Plays on Gramophone Records. 11.45, Chess Lesson. 12 Midnight, Close Down.

ASLE.—See Schweizerischer Landessender.

### BERLIN

DEUTSCHLANDSENDER (REICHSENDER), 3.5 kc/s, 1,635 metres; 60 kW.—Harvest Thanksgiving Programme. 6.30 a.m., See Ingelberg. 7.45 to 8.15 (approx.). See Hamburg. 9.0, Harvest Festival Service on Zeesen. 10.5, Weather from Berlin (Funkstunde). 10.45 to 1.45 p.m., See Berlin (Funkstunde). 1.45, Harvest Thanksgiving Play (Hans Friedrich Blumek). 2.30, Ue Weser to Bodenwerder—Radio Play (Verner Fleskes). 2.45, See Frankfurt. 3.5 3.45, See Hamburg. 3.45, Der Segen der uernerschaft—(Choral Harvest Play (Hans regn Nierentz). 4.20, Programme from Breslau. 5.0 to 7.15, See Hamburg. 7.15, Autumn ings and Dances. 7.45, Talk on Gymnastics. 1.0 to 3.0 a.m. (Monday), Harvest Festival programme — Heilsberg — Munich — Leipzig — Stuttgart — Berlin (Deutschlandsender) d Berlin (Funkstunde) Inter-Relay. 8.0, e Heilsberg. 9.0, See Munich. 10.0, News. 30, See Leipzig. 12 Midnight, See Stuttgart. 1.0 a.m. (Monday), Musical Programme to be announced. 2.0, See Berlin unktunde). 3.0 (approx.), Close Down.

### BERLIN

INKSTUNDE, 715 kc/s, 419.5 metres; 1.5 kW.—National Harvest Thanksgiving Day. 5 a.m., See Hamburg. 8.0, Address. 8.5, k: Between Country and Town. 8.10, amophone Music. 9.0, See Berlin utschlandsender). 10.5, Weather. 10.45, dio Report from the Tempelhof Aerome. 11.0, Relay from the Reichskanzlei The Reception of the Peasants' Leaders Adolf Hitler. 12 Noon, Military Band ncert, conducted by Hans Krüger-Burg- d: Hymn of Praise (Prätorians); Jubel- vertüre (Plotow); Selection from Madame uerfly (Puccini); Waltz, Bei uns z Haus ranns); Two Pieces (Rissman); (a) itschland erwache, dein grosser Tag ist i; (b) Das Lied der deutschen Arbeit; rühling Song, Deutschland, glaub' an ck (Rasza); Märeling Song, Der neschauer (Majefevski). 1.0, Concert by Radio Orchestra, conducted by Otto khoeffer: Harvest Festival from Moloch u Schillings); Tone Poem, Till Euleng- efs Merry Pranks (R. Strauss); Peasant ices. 1.45 to 2.45, See Berlin (Deut- landsender). 2.45, See Frankfurt. 3.5 to 4.45, See Hamburg. 3.45, See Berlin utschlandsender). 4.20, See Breslau. 4.20 to 8.0, See Hamburg. 8.0 to 3.0 a.m. (Monday), Harvest Festival Programme — Heilsberg — Munich — Leipzig — Stuttgart — Berlin (Deutschlandsender) and Berlin unktunde) Inter-Relay. 8.0, See Heils- berg. 9.0, See Munich. 10.0, News. 10.30, Leipzig. 12 Midnight, See Stuttgart.

1.0 a.m. (Monday), See Berlin (Deutschland- sender). 2.0, Musical Programme (to be announced). 3.0 (approx.), Close Down.

BERNE.—See Schweizerischer Landessender.

BEROMUNSTER.—See Schweizerischer Landessender.

BODEN.—See Stockholm.

BODO.—See Oslo.

### BRATISLAVA

1,076 kc/s, 279 metres; 14 kW.—10.30 a.m., Talk: Humour in Slovak Literature. 11.0, See Prague. 2.0 p.m., Agricultural Talk: Wine growing. 2.15 Hydrographic Report. 2.20, Interval. 4.0, See Moravská-Ostrava. 5.30, Reading. 5.55, Harmonica Recital of Slovak Songs. 6.25, Mandoline Concert by the Orpheus Club. 6.55, Hints for Housewives. 7.0, See Prague. 7.5, See Brno. 7.55, See Prague. 11.0 (approx.), Close Down.

BREMEN.—See Hamburg.

### BRESLAU

923 kc/s, 325 metres; 60 kW.—Relayed by Gleiwitz, 1,184 kc/s, 253 metres.—7.45 a.m., See Hamburg. 8.10, Talk. 8.20, Concert by a Marine Band. 9.40, Chimes. 9.45, Protestant Service. 10.45, See Berlin (Funkstunde). 12 Noon, Organ and Choral Recital from St. Christopher's Church. 1.0 p.m., See Berlin (Funkstunde). 1.45, See Berlin (Deutschlandsender). 2.45, See Frankfurt. 3.5, See Hamburg. 3.45, See Berlin (Deutschlandsender). 4.20, A Silesian Fair (Ernst Selenko) with Music by Karl Sczuka. 5.0, See Hamburg. 6.45, Old German Folk Music (on Gramophone Records). 7.30, The East German Festival—Radio Reports of Athletic Championships. 8.0 to 3.0 a.m. (Monday), Harvest Festival Programme—Heilsberg-Munich-Leipzig-Stuttgart-Berlin (Deutschlandsender), and Berlin (Funkstunde) Inter-Relay. 8.0, See Heilsberg. 9.0, See Munich. 10.0, News. 10.30, See Leipzig. 12 Midnight, See Stuttgart. 1.0 a.m. (Monday), See Berlin (Deutschlandsender). 2.0, See Berlin (Funkstunde). 3.0 (approx.), Close Down.

### BRNO

878 kc/s, 342 metres; 35 kW.—5.45 p.m., Gramophone Music. 6.0, German Trans- mission: Recital on Two Pianofortes: Hungarian Dances (Brahms); Spanish Dances (Moszkowsky). 7.0, See Prague. 7.5, Concert by a Brass Band. 7.55, See Prague. 11.0 (approx.), Close Down.

### BRUSSELS (No. 1)

1,181 kc/s, 590 kc/s, 509 metres; 15 kW.—9.45 a.m., Agricultural Talk. 10.0, Concert by the Small Station Orchestra, conducted by Leemans. 11.0, Gramophone Concert. 12 Noon, Concert by the Radio Orchestra, conducted by Walpot. Soloist: Mlle. Paillot (Songs). 1.0 p.m., Le Journal Parlé. 1.10, Concert, relayed from the Grand Hotel, Antwerp. In the interval at 1.30, A Monologue, followed by Two Dialogues, on Gramophone Records. 5.0, Dance Music, relayed from the Saint Saviour Dance Hall. 5.30, Football Results. 6.15, Symphony No. 1 in C (Beethoven) on Gramophone Records. 6.45, Harp Recital by Mme. Guéry-Fanerie. 7.15, Religious Address. 7.30, Music Talk. 8.0, Concert by the Radio Orchestra, conducted by Walpot: Marche lorraine (Ganne); Waltz Potpourri (Robrecht); Overture, Zampa (Hérold). Tenor Solos: (a) Aria from Werther (Massenet), (b) Chevauchée à l'Anle (Brenta). Ballet Music from Faust (Gounod). 8.40, Nounouche—One-Act Comedy (Duvvernois). 9.0, Concert by the Station Symphony Orchestra, conducted by Meulemans. Soloists: Mme. Farrère (Soprano) and Letroye (Tenor). Overture, Alessandro Stradella (Flotow); Selection from La Bohème (Puccini); Orchestral Suite (Ducasse); Melody (Poof); Invocation (Massenet); Waltz (Lauweryns); March from Jean de Nivelles (Delibes). 10.0, Le Journal Parlé.

### BRUSSELS (No. 2)

N.I.R., 887 kc/s, 338.2 metres; 15 kW. Programme in Flemish.—10.0 a.m., Gramophone Concert. 11.0, Concert by the Small Station Orchestra, conducted by Leemans. 12 Noon, Concert relayed from the Grand Hotel, Antwerp 1.0 p.m., Le Journal Parlé. 1.10, Concert by the Radio Orchestra, conducted by Walpot. Soloist, Mme. Van den Eynde (Songs). 5.0, Concert by the Station Symphony Orchestra, conducted by Meulemans: Leonora Overture, No. 3 (Beethoven); Pastorale lyrique for Horn and Orchestra (Mortelmans); Suite from Tsar Sultan (Rimsky-Korsakov); Prelude to Le Dénge (Saint-Saëns); Trio for Trumpet, Horn and Trombone (Poulenc); Valses romantiques (Chabrier). 5.30, Sports Talk. 6.0, Gramophone Music. 6.30, Popular Music by the Small Station Orchestra. 7.15, Religious Address. 7.30, Le Journal Parlé. 7.55, Music Talk by Paul Gilson. 8.0, Concert by the Station Symphony Orchestra, conducted by Meulemans: Pomp and Circumstance (Elgar); Overture, Gwendoline (Chabrier); Andante from the Symphonic Suite (van der Heyden); Dance from the Suite in G (de Greef); Songs, Romanian Rhapsody (Enes-

OCT. 1st

**SUNDAY**

continued

man (arr. Wheatley); Grand March from Aida (Verdi); In the Valley of the Moon (Burke); Dance of the Cuckoos (Stenberg). 3.30, Military Music: Selection from The Pirates of Penzance (Sullivan); Valse des Alouettes (Drigo); Old Panama (Aldford); Amorettenzänze (Gungl); Wood Symphs (Coats); Naval Patrol (Williams); Holomoko (Reeves); Regimental March; Signature Tune. 4.0, Judge Rutherford's Address. 4.15, The Nursery Corner. 5.0, Orchestral Concert: Once on the Rhine (Ostermann); Xylophone Solo, Spanish Dance (Moszkowsky); Woodland Peace (Favilla); Cœur brisé (Gillet); Xylophone Solo, Selection from Carmen (Bizet); My Dream (Waldteufel); Goodbye (Tosti); Valse Septembre (Godin). 5.30, Concert; Signature Tune. Jolly Good Company; Love is the sweetest thing (Noble); Kashmiri Love Song (Woodford-Finden); At Dawning (Caldman); Barcarolle from The Tales of Hoffmann (Offenbach); Love will find a way (Fraser-Simson); Liebestraum (Liszt); Auf Wiedersehen, my dear (Ager); My Hero, from The Chocolate Soldier (O. Straus); Signature Tune. 6.0, Members' Request Hour: Invitation to the Waltz (Weber); Song of the Volga Boatmen; The Broken Melody (van Bienen); Peg Leg Jack (Robison); Barcarolle from The Tales of Hoffmann (Offenbach); Lily of Laguna (Stuart); My Darling (Heymann); Waltz, The Blue Danube (Joh. Strauss). 6.30, Dance Music: Somebody stole my gal; I cover the waterfront; That's what life is made of; I raised my hat; Maria my own; Night after night; Castles in the sand; Always in my heart. 7.0, Orchestral Concert: Selection from Princess Pat (Herbert); Pulemelo (Alberty); Serenata Toselli; Serenade (Herbert); Ay, Ay, Ay! (Proire); The Song of Songs (Moya); Singing a Song to the Stars (Meyer); Beautiful (Gillespie). 7.30, French Programme. 9.0 till Close Down. Programme in English by the I.B.C. 9.0, Concert of Dance Music: Signature Tune, Happy Feet; It was a Night in June; From me to you; Twelfth Street Rag; It's Sunday down in Caroline; Learn to croon; A Woman should stick to her man; Down the old Ox Road; Meet me in the Gloaming; Signature Tune. 9.30, Times from the Talkies; Signature Tune, Sittin' in the Dark; Adorable; There'll still be love; But for you; My Bluebird's singing the Blues. 9.45, Concert: The Little Company (Ganglberger); Song, In the Moonlight (Rubby); Look what you've done, from The Kid from Spain (Kalmár-Akst). 10.0, Gramophone Concert: Johann Strauss Potpourri (Weber); Marigold (Mayerl); I stopped, I looked, I listened; Clapham and Dwyer on Photography; St. Louis Blues; Bonnie Mary of Argyll; Scherzo from the Trio in D Minor (Arensky); Selection from The Belle of New York (Kerker). 10.30, Concert of Dance Music: Let's call it a day; Down in the Valley; Avalone; Nobody's Sweetheart; Love is the Thing; Under a Blanket of Blue; My Gipsy Rhapsody; Reflections in the Water; Isn't it heavenly. 11.0, Concert: Signature Tune, Oh, Maiden, my Maiden (Lehár); Hello; How are you; Put on your old grey Bonnet; Tea for two; Dancing Time; Manhattan; What more can I ask; Good-night, but not good-bye; Signature Tune. 11.30, Concert by the I.B.C. (Ireland) Ltd., on behalf of Hospitals Trust, Ltd. Signature Tune, Come back to Erin. Overture, Mignon (Thomas); The Moon and I from The Mikado (Sullivan); The dear little Shamrock; Selection from The Student Prince (Romberg); Violin Solo, Valse bluette (Drigo); Autumn (Chaminade); Around the Volga (Borchert); Signature Tune, Come back to Erin. 12.5 a.m. (Monday), News Bulletin in English. 12.10 (approx.), Club Concert for Pembroke Listeners. Signature Tune, The Chum Song. There's a Cabin in the Pines; In Santa Lucia; All over Italy; Maybe I love you too much; Cheving Gum; Let's all be happy together; Lover; I wish I had Wings; Meet me in the Gloaming; Have you had a good day to-day; Talking to you about me; Dancing Butterflies; My Love Song; Signature Tune. 1.0, Dance Music, Signature Tune, Bells of Normandy; Somebody stole my Gal; In a little Second-hand Store; That's what life is made of; I cover the waterfront; This lovely Rose; Sweep; Hiawatha's Lullaby; You don't understand; Peter, Peter; I've got to sing a torch song; One Tiny Tear; Stay out of my dreams; My, oh My; The Old Spinning Wheel; In the Valley of the Moon; I lay me down to sleep; Signature Tune. 2.0, I.B.C. Good-night Melody and Close Down.

FLENSBURG.—See Hamburg.

FLORENCE.—See Turin.

**FRANKFURT**

1,157 kc/s, 259.3 metres; 17 kW. Relayed by Cassel, 1,220 kc/s, 245.9 metres; and Trier, 1,157 kc/s, 259.3 metres.—National Harvest Thanksgiving Day.—7.45 a.m., See Hamburg. 8.0, Time, Weather and News. 8.10, Gymnastics. 8.45, See Stuttgart. 9.30, Concert by the Station Orchestra, conducted by Hans Rosband. Pastorale from The Messiah (Handel); Recitations: Autumn from The Seasons (Haydn). 10.0, See Langenberg. 10.45, See Berlin (Funkstunde). 12 Noon, See Stuttgart. 1.0 p.m., See Berlin (Funk-

stunde). 1.45, See Berlin (Deutschlandsender). 2.10, Rural Programme. 2.30, See Berlin (Deutschlandsender). 2.45, Vintage Festival Songs. 3.5 to 3.45, See Hamburg. 3.45, See Berlin (Deutschlandsender). 4.20, See Breslau. 5.0, See Hamburg. 6.45, See Stuttgart. 7.0, See Langenberg. 7.45, Sports Notes. 8.0 to 3.0 a.m. (Monday), Harvest Festival Programme.—Heilsberg-Munich-Leipzig-Stuttgart-Berlin (Deutschlandsender), and Berlin (Funkstunde) Inter-Relay. 8.0, See Heilsberg. 9.0, See Munich. 10.0, News. 10.30, See Leipzig. 12 Midnight, See Stuttgart. 1.0 a.m. (Monday), See Berlin (Deutschlandsender). 2.0, See Berlin (Funkstunde). 3.0 (approx.), Close Down.

FREDRIKSSTAD.—See Oslo.

FREIBURG.—See Stuttgart.

GENEVA.—See Radio-Suisse Romande.

GENOA.—See Turin.

GLEIWITZ.—See Breslau.

GÖTEBORG.—See Stockholm.

GRAZ.—See Vienna.

HAMAR.—See Oslo.

**HAMBURG**

Call ha, 806 kc/s, 372 metres; 1.5 kW. Relayed by Bremen, 1,112 kc/s, 269.8 metres; Freiburg, 1,319 kc/s, 227.4 metres; Hanover, 530 kc/s, 566 metres; and Kiel, 1,292 kc/s, 232.2 metres.—National Harvest Thanksgiving Day. 7.45 a.m. (from Hanover), Opening of the National Harvest Thanksgiving Day. Address by Dr. Goebbels. 8.15, Time, Weather and News. 8.30, Gymnastics. 8.45, Talk: The North German Theatre. 9.0 (from Kiel), Schleswig-Holstein Programme.—Orchestral Concert, conducted by Hans Döring. 9.30 (from Kiel), Harvest Thanksgiving Service at Eutin. 10.45, See Berlin (Funkstunde). 12 Noon, Concert by the Small Station Orchestra, conducted by Gerhard Maasz. 12.50 p.m., Time and Weather. 1.0, See Berlin (Funkstunde). 1.45, See Berlin (Deutschlandsender). 2.45, See Frankfurt. 3.5, Harvest Festival Programme.—Lüns Lieder. 3.25 (from Hanover), Harvest Festival Programme.—Radio Report of the Arrival of Adolf Hitler at the Aerodrome. 3.45, See Berlin (Deutschlandsender). 4.20 to 5.0, Programme from Breslau. 5.0 (from Hanover), National Harvest Thanksgiving, relayed from the Bückeberg, Hameln. Report of the Arrival of Adolf Hitler—Farefare-Salvo and Community Singing of the Hymn: Now thank we all our God. 5.40, Address by Reich-minister Darré. 6.0, Address by Adolf Hitler. 6.45 (from Hanover), Grand Tattoo, followed by Report on the Close of the Demonstration. 8.0 to 3.0 a.m. (Monday), Harvest Festival Programme Heilsberg - Munich - Leipzig - Stuttgart - Berlin (Deutschlandsender), and Berlin (Funkstunde) Inter-Relay. 8.0, See Heilsberg. 9.0, See Munich. 10.0 (approx.), News. 10.30, See Leipzig. 12 Midnight, See Stuttgart. 1.0 a.m. (Monday), See Berlin (Deutschlandsender). 2.0, See Berlin (Funkstunde). 3.0 (approx.), Close Down.

HANOVER.—See Hamburg.

**HEILSBURG**

1,085 kc/s, 276.5 metres; 60 kW. Relayed by Danzig, 662 kc/s, 453.2 metres. National Harvest Thanksgiving Day.—7.45 a.m., See Hamburg. 8.0, Catholic Service. 10.0, Protestant Service from St. Mary's Church, Danzig. 10.45, See Berlin (Funkstunde). 12 Noon, Concert by the Small Station Orchestra, conducted by Eugen Wilcken. 1.0 p.m., See Berlin (Funkstunde). 1.45 (approx.), See Berlin (Deutschlandsender). 2.45, See Frankfurt. 3.5, See Hamburg. 3.45, See Berlin (Deutschlandsender). 4.20, Programme from Breslau. 5.0, See Hamburg. 6.45, Chamber Music of Old Königsberg—Violin, Harpsichord, and Song Recital of Music by Johann Friedrich Reichardt. 7.45, Sports Notes. 8.0 to 3.0 a.m. (Monday), Harvest Festival Programme.—Heilsberg, Munich, Leipzig, Stuttgart, Berlin (Deutschlandsender), and Berlin (Funkstunde) Inter-Relay. 8.0 (from Königsberg), Concert by the Small Station Orchestra, conducted by Eugen Wilcken; March, Ins blühende Land (Schmidt-Hagen); Bauern-Suite (Albouth); Peasant Dances (Paehnerge); Two East Prussian Peasant Dances (Schultze-Stolle); Swabian Peasant Waltz (Hermann Krome); Suite caempstre (Scassola). 9.0, See Munich. 10.0 (approx.), News. 10.30, See Leipzig. 12 Midnight, See Stuttgart. 1.0 a.m. (Monday), See Berlin (Deutschlandsender). 2.0, See Berlin (Funkstunde). 3.0 (approx.), Close Down.

**HILVERSUM**

1,013 kc/s, 296.1 metres; 7 kW up to 5.40 p.m., and 20 kW from 5.40 p.m.—8.10 to 9.40 a.m., Programme of the Workers' Radio Society (V.A.R.A.). 8.10, Pigeon Flying and Football Report. 8.12, Horticultural Talk. 8.40, Organ Recital. 9.0, Gramophone Music. 9.20, Song and Organ Recital. 10.10 to 11.40, Programme of the Liberal Protestant Radio

Society (V.P.R.O.); Divine Service from Bussan. 11.40 to 3.40 p.m., Programme of the Allgemeine Vereinigung Radio Omroep (A.V.R.O.). 11.40, Concert of Light Music. Gramophone Music in the intervals. 12.55 p.m., Talk. 1.10, Concert by the Wireless Orchestra, conducted by Nico Treep. 1.40, Weekly Book Talk. 2.10, Concert by the Wireless Orchestra, conducted by Nico Treep. Soloist: Max Rodriguez (Cello). 3.40, Gramophone Music. 4.25, Sports Notes and Gramophone Music. 4.40 to 7.40, Programme of the V.A.R.A. 4.40, Programme for Children. 5.40, Orchestral Concert, conducted by de Groot. 6.30, The Adventures of Wakker and Tropicund. 6.50, Concert (contd.). 7.40 till Close Down, Programme of the A.V.R.O. 7.40, Time and News. 7.55, Concert by the Wireless Orchestra, conducted by Nico Treep. Soloist: Herbert Ernst Groll (Tenor). Overture, Preciosa (Weber); Songs: (a) Aria from The Merry Wives of Windsor (Nicolaï), (b) Aria from Carmen (Bizet), (c) Air from Le Postillon de Longjumeau (Adam); Second Hungarian Rhapsody (Liszt); Aria from Tosca (Puccini); Aria from Rigoletto (Verdi); Im schönen Tal der Isar (Lähr); Songs: (a) Song from The Circus Princess (Kálmán), (b) Song from Paganini (Lehár), (c) Song from The Rose of Stamboul (Fahl); Potpourri of Marches (Ciere). 9.10, Escape—Play from the Story by John Galsworthy. 9.40, Music Hall Programme on Gramophone Records. 10.40, Concert of Light Music. 11.40 (approx.), Close Down.

HORBY.—See Stockholm.

**HUIZEN**

160 kc/s, 1,875 metres; 7 kW (until 3.40 p.m.). (Transmitted from Kootwijk on 50 kW from 3.40 p.m.).—8.10 to 9.10 a.m., Programme of the Christian Radio Society (N.C.R.V.). 9.10 to 4.40, Programme of the Catholic Radio Society (K.R.O.). 9.10, Gramophone Music. 10.10, High Mass, relayed from the Church of St. Lambertus, Hengelo. 11.40, Gramophone Music. 11.55, Concert by the K.R.O. Orchestra, conducted by van 't Woud. In an interval at 12.40 p.m., Theatre Talk. 1.40, Religious Address. 2.10, Concert by the Koninklijke Harmonie, relayed from Bois-le-Duc. Conductor: Wiertz. 2.40, Gramophone Music. 3.40, Programme for Invalids. 4.40 to 7.25, N.C.R.V. Programme. 4.40, Concert by the Jerusalem Church Choir, conducted by Laar. 5.30, Divine Service, relayed from a Church in Amsterdam. 7.10, Organ Recital by Kloppeburg. 7.25 till Close Down, K.R.O. Programme. 7.25, Sports Notes. 7.30, Educational Talk. 7.55, Concert by the K.R.O. Boys, conducted by Lustenhouwer. 8.40, News. 8.45, Concert by the K.R.O. Orchestra, conducted by Gerritsen. Soloist: Sydney de Vries (Song).—Part I. Verdi Music. Overture, The Force of Destiny. Air from (a) Rigoletto, (b) A Masked Ball, (c) La Traviata; Selection from A Masked Ball. 9.30, Song Recital by Sydney de Vries; Ständchen (Mozart); Oh! Star of Eve (Wagner); Aria from Faust (Gounod); Visions fugitives (Massenet). 9.40, Orchestral Concert (contd.). Part II. Selection from I Pagliacci (Leoncavallo); Overture, The Black Domino (Auber); Selection from Carmen (Bizet). In the interval at 9.55, News. 10.20, Epilogue by the Small Choir, conducted by Piekkers. 10.40 (approx.), Close Down.

INNSBRUCK.—See Vienna.

**JUAN LES PINS**

1,205 kc/s, 249 metres; 0.8 kW.—8.0 p.m., Amusement Guide and Sports Notes. 8.15, Popular Concert. 9.0, News. 9.15, Popular Concert (contd.). 10.0, The Listeners' Half-Hour. 10.30 till Close Down, Programme in English by the I.B.C. 10.30, Orchestral Concert: Molly on the Shore (Grainger); Song: Room for the Faetotum, from The Barber of Seville (Rossini); Shepherd's Hey (Grainger); Mazurka from Coppélia (Delibes); Violin Solo: Le Balcon (St. Denis); Liebestraum (Liszt); Song: False Phyllis (arr. Lane Wilson); Ride of the Valkyries from the Valkyries (Wagner). 11.0, Gramophone Concert: Dreams on the Ocean (Gungl); Negro Nothings (Bennett); Look what you've done (Kalmár); Selection from The King of Jazz (Whiteman); Just once for all time (Heymann); In the Valley of the Moon (Burke); When we're alone (Jason); Tres jolie (Waldteufel). 11.30, Military Music; Quand Madelon (Bousquet); Wood Symphs (Coates); Song: The Lincolnshire Poacher (Barrett); On the Quarter Deck (Alford); Xylophone Solo; Overture, Raymond (Thomas); The Thunderer (Souza); Medley of British Songs; Distant Greeting (Loring). 12 Midnight, Dance Music: Piccaninies' Heaven; Hold me; Moon Song; Harlem Fuzz; Drifting down the Shalimar; The Minor Drag; I'll see you in the morning; The Old Spinning Wheel; Waltzing in a Dream; Don't be late in the Morning; Shout 'em, Aunt Tillie; When my Little Pomeranian; I'm so in love with you; It's within your power; The Lady I love; Maybe I love you too much. 1.0 a.m.

(Monday), I.B.C. Good-night Melody and Close Down.

KALUNDBORG.—See Copenhagen.

KIEL.—See Hamburg.

KLAGENFURT.—See Vienna.

KOSICE.—See Prague.

**LANGENBERG**

635 kc/s, 473 metres; 60 kW. National Harvest Thanksgiving Day.—6.30 a.m., Reveille 6.32 (approx.), Concert. 7.45 to 8.0, See Hamburg. 8.15, Time and Weather. 8.3 Gymnastics. 8.45, See Stuttgart. 9.30, St. Frankfurt. 10.0, Catholic Service from St. Cathedral, Münster. 10.45, See Berlin (Funkstunde). 12 Noon, See Stuttgart. 1.0 p.m., See Berlin (Funkstunde). 1.4 See Berlin (Deutschlandsender). 2.45, St. Frankfurt. 3.5, See Hamburg. 3.45, St. Berlin (Deutschlandsender). 4.20, Programme from Breslau. 5.0, See Hamburg. 7.0, Programme Grave and Gay. 7.3 Report of the Walking Races from Duisburg. 7.45, Sports Notes. 8.0 to 3.0 a.m. (Monday), Harvest Festival Programme Heilsberg, Munich, Leipzig, Stuttgart, Berlin (Deutschlandsender), and Berlin (Funkstunde) Inter-Relay. 8.0, See Heilsberg. 9.0, See Munich. 10.0 (approx.), News. 10.30, See Leipzig. 12 Midnight, See Stuttgart. 1.0 a.m. (Monday), See Berlin (Deutschlandsender). 2.0, See Berlin (Funkstunde). 3.0 (approx.), Close Down.

LAUSANNE.—See Radio-Suisse Romande.

**LEIPZIG**

769.9 kc/s, 389.6 metres; 120 kW. Relay by Dresden, 941 kc/s, 319 metres.—National Harvest Thanksgiving Day. 7.45 a.m., See Hamburg. 8.0, Religious Address. 10.45 12 Noon, See Berlin (Funkstunde). 12 Noon Popular Concert. 1.0 p.m., See Berlin (Funkstunde). 1.45 to 2.45, See Berlin (Deutschlandsender). 2.45, See Frankfurt. 3.5 to 3.45, See Hamburg. 3.45, See Berlin (Deutschlandsender). 4.20 to 5.0, See Breslau. 5.0 to 6.45, See Hamburg. 6.5 Gramophone Records. 8.0 to 3.0 a.m. (Monday), Harvest Festival Programme—Heilsberg, Munich, Leipzig, Stuttgart, Berlin (Deutschlandsender), and Berlin (Funkstunde) Inter-Relay. 8.0, See Heilsberg. 9.0, See Munich. 10.0, News. 10.30, Musical Programme (to be announced). 12 Midnight, See Stuttgart. 1.0 a.m. (Monday), See Berlin (Deutschlandsender). 2.0, See Berlin (Funkstunde). 3.0 (approx.), Close Down.

LINZ.—See Vienna.

**LJUBLJANA**

522 kc/s, 574.7 metres; 7 kW.—8.0 p.m., Programme relayed from the Opera House, an interval at 9.30, Weather and News. 11.0 (approx.), Close Down.

**LUXEMBOURG**

252 kc/s, 1,191 metres; 200 kW.—12.30 p.m. Concert by the Radio Orchestra. 1 Gramophone Music. 7.30 till Close Down English Programme. 7.30, Symphony, I in C Minor, Op. 68 (Brahms), by the London Symphony Orchestra (on Gramophone Records). 8.15, Concert by the Radio Orchestra, conducted by Henri Pénis. 8 News in French. 9.0, Symphony Concert. 9.50, News in German. 10.0, Variety Concert. 10.20, Gramophone Dance Music.

**MADRID**

ARANJUEZ (EAQ), 10,000 kc/s, 30 metr 20 kW.—11.30 p.m., Popular Concert, the interval at 11.45, Humorous T. 12.45 a.m., Light Music. 1.0 to 1.30, I gramme in English by the I.B.C. 1.0, Concert by the I.B.C. (Ireland) on behalf Hospitals Trust, Ltd.; Humming to mys Bidin' my Time; Soft Lights and Sw Music; Oh, Sailor Behave; Whistle; blow your cares away; Please; Blue Danu Butterflies in the Rain. 1.30, I.B.C. Go night Melody.

**MADRID**

EAJ7, 707 kc/s, 424.3 metres; 2 kW.—9.0 10.0 a.m., Topical Review. 3.0 p.m., (Chin Time, Theatre Notes, and Popular Concert 5.0 to 8.0, Interval. 8.0, Chimes. Ra Journal and Dance Music. 9.30 to 11.0, terval. 11.0, Chimes and Times. 11.5 (prox.), Band Concert of Spanish Mu Song) by an Argentine Trio and Cello Solo by Galvez Bellino. After the Program Dance Music relayed from the Alka Dance Hall. 1.30 a.m. (Monday), (Chin 2.0 to 3.0, Programme in English by I.B.C. 3.0 (approx.), Close Down.

MALMO.—See Stockholm.

MILAN.—See Turin.

**MORAVSKA-OSTRAVA**

1,137 kc/s, 263.8 metres; 11 kW.—4.0 p.m. Concert by the Station Orchestra, conducted by Plichta. 5.30, See Prague. 7.5, See Bi (approx.), Close Down.

MOTALA.—See Stockholm.

MÜHLACKER.—See Stuttgart.

OCT. 1st **SUNDAY** continued

**MUNICH**

563 kc/s, 523 metres; 60 kW. Relayed by Augsburg and Kaiserslautern, 536 kc/s, 560 metres; and Nürnberg, 1,256 kc/s, 239 metres.—National Harvest Thanksgiving Day, 7.45 a.m., See Hamburg, 8.5, Chamber Music, 8.50, Reading from the Works of Eminent Men, 9.10, Concert by the Munich Schwabing Male Voice Choir, 10.0, Protestant Service, 10.45 to 12 Noon. See Berlin (Funkstunde). 12 Noon, Concert from the Feldherrnhalle, 12.50 p.m., Time, Weather, and Programme Announcements, 1.0, See Berlin (Funkstunde), 1.45 to 2.45, See Berlin (Deutschlandsender), 2.45, See Frankfurt, 3.5 to 3.45, See Hamburg, 3.45, See Berlin (Deutschlandsender), 4.20 to 5.0, Program from Breslau, 5.0 to 6.45, See Hamburg, 6.45, Serenades—Concert by the Small Station Orchestra, conducted by Erich Klöss, Soloists: Otto Hillerbrand (Tenor), Hugo Reker (Violin), Georg Troiber (Cello), Walter Holten (Speaker), 7.45, Weather and Sports Notes, 8.0 to 3.0 a.m. (Monday), Harvest Festival Programme—Heilsberg, Munich, Leipzig, Stuttgart, Berlin (Deutschlandsender) and Berlin (Funkstunde), Inter-Relay, 8.0, See Heilsberg, 9.0, Peasant Plays (Hans Sachs), 10.20, News, 10.30, See Leipzig, 12 Midnight, See Stuttgart, 1.0 a.m. (Monday), See Berlin (Deutschlandsender), 2.0, See Berlin (Funkstunde), 3.0 (approx.), Close Down.

**NAPLES.** See Rome.

**NOTODDEN.** See Oslo.

**OSLO**

277 kc/s, 1,063 metres; 60 kW. Relayed by Fredrikstad, 315 kc/s, 368.1 metres; Hamar, 522 kc/s, 574.7 metres; Notodden, 671 kc/s, 447.1 metres; Porsgrund, 662 kc/s, 453.2 metres; and Rjukan, 671 kc/s, 447.1 metres.—1.0 p.m., Swedish Concert, relayed from the National Theatre, 5.0, Concert by the Station Orchestra, conducted by Hugo Kræmmer; Overture, Prince Igor (Borodin); Selection from Faust (Gounod); Prelude (Scriabin); Piece (Grieg); Capriccio Viennois (Kreisler); Der letzte Gedanke (Weber); Suite, Cinderella (Coates); Turkish March (Mozart), 6.0, Talk, 6.20, Programme relayed from Selbu, 7.15, Weather and News, 7.30, Relay from Selbu (contd.), 8.0, Time, 8.1, Recitations, 8.30, Variety Programme.

**OSTERSUND.** See Stockholm.

**PALERMO**

558 kc/s, 537.6 metres; 3 kW, 10.25 a.m., Bible Reading, 10.40, Sacred Music, 11.5,

Agricultural Talk, 12.45 p.m., Giornale Radio, 1.0 to 2.0, Jazz Music, In the interval at 1.30, Time, Announcements and Weather, 5.30 to 6.30, Gramophone Concert, 8.0, Dopolavoro Announcements and Radio Giornale, 8.20, Gramophone Music, In the intervals at 8.25, Sports Notes, and at 8.30, Time and Announcements, 8.45, Symphony Concert, conducted by La Rosa Parodi, Soloist: Vincenzo Mammio (Pianoforte); Comedy Overture (Parodi); Pianoforte Concerto (Poulenc); Symphony No. 2 in D (Brahms). In the interval, Reading, After the Concert, Gramophone Music, 11.0, Giornale Radio.

**PARIS**

**EIFFEL TOWER,** Call FLE, 207.5 kc/s, 1,445.7 metres; 14 kW, Time Signals (on 2,650 metres) at 10.26 a.m. and 11.26 p.m. (Preliminary and 6-dot Signals)—1.0 p.m., News, 1.15, Weather, 1.30 to 2.30, Concert by the Jean Ines Orchestra; Soloist: Deva Bassy (Singer), 6.45, Le Journal Parlé, 8.30, Gramophone Concert; Part I—Music from Coppelia and Lakmé (Delibes); Part II—Variety Music, 10.0 (approx.), Close Down.

**PARIS**

**POSTE PARISIEN,** 914 kc/s, 328.2 metres; 60 kW.—10.0 a.m., Gramophone Music, 10.20, Press Review, 10.30, Sponsored Gramophone Concert, 11.0, Concert by the Station Quartet; Overture, The Grand Duchess of Gerolstein (Offenbach); Waltz, La Vagite (Métra); Suite d'inspiration (Messager); Canzonetta (Doncetti); Selection from The Crown Diamonds (Auber); Second Spanish Dance (Fallá); Amorettenänze (Ganne), 12.15 p.m., Sponsored Concert of Sound Film Music, 12.45, Sponsored Programme, 12.50, Half-an-hour of Fantasy, by Paul Weill, 1.30, Sponsored Programme, 2.0, Interval, 7.0, Le Journal Parlé, 7.5, Sports Notes, 7.15, Duets from Opera on Gramophone Records, 7.20, Catholic Review, 8.0, Spanish Music on Gramophone Records, 8.30, Sponsored Concert, 9.15, L'Innocente, One-act Play (Lecormand), 9.45, Concert by the Valses viciniques Orchestra, 10.30, News.

**PARIS**

**RADIO-PARIS,** Call CFR, 174 kc/s, 1,725 metres; 75 kW—7.45 a.m., Gramophone Music, 8.30, Physical Culture, 12 Noon, Re-

ligious Address by the Reverend Father Dixon, 12.20 p.m., Sacred Music: Cantate Domine (Alain); Dialogue (Clérambault); Fantasia No. 3 (Tonnerre), 12.30, Gramophone Concert, 1.30 to 3.30, Programme in English by the I.B.C., 1.30, Concert of Gramophone Records; Duet from La Faussette du temple (Messager); Invitation to the Waltz (Weber); Erwin (Meister); Diver-tissement on Russian Songs (Rabaud), 2.0, Concert of Dance Music; Signature Tune, Happy Feet; Peter, Peter, We'll have a Honeymoon some day; Sweetheart Darling; When the Sun bids the Moon Good-night; It's time to sing Sweet Adeline again; Gipsy Fiddles; Dancing Butterly; When the King goes by; Signature Tune, 2.30, Variety Programme, 3.0 to 3.30, Orchestral Concert; Vimy Ridge March (Biddgood); Waltz, Live, Love and Laugh, from Congress Danes (Heymann); Selection from The Lily of Killarney (Beardiet); One-Step, Valencia (Padilla); Selection from Betty in Mayfair (Fraser-Simson), 5.30, Light Music on Gramophone Records, 6.0, Variety Concert, 7.0, Popular Concert, 8.0, Light Music on Gramophone Records, 8.30, News, 8.40, White Horse Inn—Operetta (Benastzky), relayed from the Théâtre Mogador, In the interval at 9.15, News.

**PORSGRUND.** See Oslo.

**PRAGUE**

614 kc/s, 488.6 metres; 120 kW.—11.0, Concert, conducted by Jeremias; Pan—Sym-phonie Poem in Five Parts (Sovak), 12 Noon, Chimes, 12.5 p.m., News, 12.15, Military Band Concert, 1.30, A Sketch, 2.0, Agricultural Talk, 2.15 to 2.25, Social News, 4.0, See Moravsko-Ostrava, 5.30, Talk: Experiences during an Earthquake, 5.45, Gramophone Music, 6.0, German Trans-mission—A Review of the Station Musical Programme, followed by a Part Relay of a Revue from the Municipal Theatre, Liberec; News after the Programme, 7.0, Time and News, 7.5, See Brno, 7.55, Gramophone Records of Emmy Destinn, 8.20, Laughter—Humorous Programme by the Bajo Trio and the Smiling Boys Dance Band, In the interval at 9.0, Time Signal, 9.15, String Quartet in C, Op. 163 (Schubert), by the Ondriek Quartet, 10.0, Time and News, 10.20, Czech Dance Songs (arranged for two Pianofortes) by the Prague Pianoforte Duo, 11.0 (approx.), Close Down.

**RADIO-SUISSE ROMANDE**

**SOTTENS,** 743 kc/s, 403 metres; 25 kW.; and Geneva, 395 kc/s, 760 metres.—9.55 a.m. (from Geneva), Chimes, 10.0 (from Geneva), Protestant Service, relayed from the Oratory, 11.0 (from Geneva), Gramophone Music, 12.30 p. m., News and Weather, 12.40 (from Geneva), Gramophone Music, 2.0 to 3.30, Interval, 3.30 (from Geneva), Popular Concert, 5.0 to 7.0, Interval, 7.0 (from Geneva), Religious Address, 7.30 (from Geneva), Sports Notes, News, and Announcements, 8.0, Susanna's Secret—Opera in One Act (Wolf-Ferrari), relayed from Lugano, 8.50 (from Geneva), The Week's Review, 9.0, Concert by the Radio-Suisse romande Orchestra, 9.50, News and Weather, 10.0 (from Geneva), Gramophone Concert, 10.30 (approx.), Close Down.

**RJUKAN.** See Oslo.

**ROME**

Call 1RO, 680 kc/s, 441 metres; 50 kW. Relayed by Naples, 941 kc/s, 319 metres; Bari, 1,112 kc/s, 269.8 metres; Milan (Vigentino), 662 kc/s, 453.2 metres, from 8.45 p.m. and 2RO, 11,810 kc/s, 25.4 metres from 5.15 p.m.—10.0 a.m., News, Sports Notes and Announce-ment Guide, 10.30, Agricultural Notes, 10.45, Bible Reading, 11.0 to 12 Noon, See Turin, 12.30 p.m., Gramophone Music, 12.45, Sponsored Music, 1.0, Orchestral Concert, 2.0, Time and Announcements, 5.0 (Naples), Programme for Children, Weather and Sports Notes, 5.15, Vocal and Instrumental Concert: Sports Notes during the intervals, 6.30, Weather, 7.30, Sports Notes and News, 8.0, Time and Announcements, 8.30, Sports Notes, 8.45, Contessa Maritza—Operetta in Three Acts (Kálmán), In the intervals, Theatre Talk and Reading of Poems, 11.0, Giornale Radio.

**SALZBURG.** See Vienna.

**SCHWEIZERISCHER LANDESENDER**

**BEROMUNSTER,** 653 kc/s, 459 metres; 60 kW.; Basle, 1,229 kc/s, 244.1 metres; and Berne, 1,220 kc/s, 245.9 metres.—10.0 a.m. (from Basle), Catholic Service, 10.45 (from Basle), Chamber Music by the Basle Brass Band, 11.30 (from Basle), Readings from Swiss Authors, 12 Noon (from Basle), Gramophone Concert, 12.30 p.m., Time, Weather and News, 12.40 (from Zürich), Concert of Italian Music by the Station Orchestra, 1.30 (from Basle), Agricultural Programme, 2.0 (from Basle), Music by the Stemmer Zither Trio, 2.30 to 5.0, Interval,

**INSTRUMENTS OF PRECISION**

The illustration shows a group of highly sensitive yet moderately priced instruments which should appeal to the discriminating wireless enthusiast.

Ammeters, Milli-ammeters and Voltmeters supplied for flush mounting 1½", 2", 2½" and 3½" diameter, or Projecting type in the 2½" and 3½" sizes.

Send for descriptive literature.

**METROPOLITAN Vickers**  
SUBSIDIARY OF ASSOCIATED ELECTRICAL INDUSTRIES LTD.

ELECTRICAL CO., LTD.  
TRAFFORD PARK, MANCHESTER, 17



The **NEW**"CLARKE'S  
**ATLAS**"  
MAINS UNITS

**NEW DESIGNS •  
INCREASED OUTPUTS •  
FOR "Q.P.P." & "CLASS B" •  
NO INCREASE IN PRICE**

See them at **MANCHESTER EXHIBITION. Stand No. 29.**

**ONLY "ATLAS" can improve on "ATLAS."** It seems incredible that these world's finest Mains Units, the only Units to win the Olympia Ballots for two years in succession, could possibly be improved. But they have been—and without any increase in price!

New Cases—Re-designed Panels—Increased Outputs—Better smoothing and improved regulation. All the 25 m/A models are now suitable for "Q.P.P." and "Class B" amplification.

No wonder the new "ATLAS" Units are being specified by all the leading designers for their new season's Receivers. Follow the expert's advice and *insist* on "ATLAS." Ask for a demonstration to-day.

**H. CLARKE & CO. (M/CR.) LTD.,**  
PATRICROFT, MANCHESTER. LONDON: BUSH HOUSE, W.C.2.  
GLASGOW: G.E.S. CO., LTD., 38, OSWALD STREET.

Messrs. H. CLARKE & CO. (M/CR.) LTD.,  
Atlas Works, Patricroft, Manchester.

Please send full details of the new "ATLAS" Mains Units.

NAME.....  
ADDRESS.....  
31/29 '9.

OCT. 1st

**SUNDAY**

continued

5.0 (from Basle), Brass Band Concert. 6.0 (from Basle), Talk: The Vienna Philatelic Exhibition. 6.30 (from Basle), Talk in English: The Life and Works of Lord Byron. 7.0 (from Basle), Time and Sports Results. 7.5, Bach and Schumann Recital on Two Pianofortes. 7.35 (from Basle), Talk: The Sabbath as a Benefit to Mankind. 9.0, News. 9.5 (from Basle), Schubert Song Recital by Joseph Cron (Tenor). 9.10, Concert by the Station Orchestra, with Commentary by Hermann Vallentin. 10.15 (from Basle), Sports Notes and Close Down.

**SOTTENS.**—See Radio-Suisse Romande.

**STOCKHOLM**

689 kc/s, 436 metres; 55 kW. Relayed by Boden, 244 kc/s, 1,229.5 metres; Göteborg, 932 kc/s, 322 metres; Hörby, 1,166 kc/s, 257 metres; Motala, 221.5 kc/s, 1,354.4 metres; Östersund, 389 kc/s, 770 metres; and Sundsvall, 554 kc/s, 542 metres.—4.30, Song and Pianoforte Recital by Astrid Axelsson and Henrik Munthe (Songs) and Werner Ekström (Pianoforte), relayed from Borås, 1,450 kc/s (207 metres). 5.5, Programme for Children. 5.30, Concert of Swedish Folk Songs by the Station Choir. 6.0, Evensong. 7.15, Weather and News. 7.35, The Geisha—Operetta (Jones) (Swedish Translation by Ernst Wallmark). 9.45, Weather and News. 10.0, Violin and Pianoforte Recital by Johan Henriques (Violin) and Esther Vagnung, relayed from Malmö, 1,301 kc/s (231 metres). 11.0 (approx.), Close Down.

**STRASBOURG**

869 kc/s, 345 metres; 11.5 kW.—9.45 a.m., Protestant Service, relayed from the Temple Neuf. 10.45, Orchestral Concert conducted by Maurice de Villers. 11.30, Catholic Service in German. 12 Noon, Gramophone Concert of Classical Music. 12.45 p.m., News. 1.0, Time. 1.1, Light Music on Gramophone Records. 2.0, Relay of Addresses from a Non-Commissioned Officers' Banquet at Mulhouse. 3.0, Interval. 3.45, Talk on Agriculture. 4.0, Light Music on Gramophone Records. 5.0, Orchestral Concert, conducted by Roskam. 6.0, Medical Talk. 6.15, Sports Notes. 6.30, Orchestral Concert, conducted by Maurice de Villers: Festival Overture (Lortzing); Waltz, Brune ou Blonde (Waldteufel); Baccanale from Sanson and Delilah (Saint-Saëns); Orchestral Suite, Illys (Ganne); Selection from The Tales of Hoffmann (Offenbach); Carnival (Gouraud). 7.30, Time and News. 7.45, Gramophone Music. 8.0, Press Review in German, Lottery Results and Announcements. 8.30, Alsatian Programme: Three Poems (Voelzel); D'r daab Nazi, Humorous Scene (Schott); Four Poems (Voelzel); Wurscht wider Wurscht, Humorous Scene (Deck); E Serenädel, One-Act Comedy (Ferdinand Bastian). After the Programme, News. 10.30, Dance Music, relayed from the Savoy. 12 Midnight (approx.), Close Down.

**STUTTGART**

**MUHLACKER;** 832 kc/s, 360.5 metres; 60 kW. Relayed by Freiburg, 527 kc/s, 570 metres.—National Harvest Thanksgiving Day. 7.45 a.m., See Hamburg. 8.0, See Frankfurt. 8.10, Gymnastics. 8.45, Protestant Harvest Festival Service. 9.30, See Frankfurt. 10.0, See Langenberg. 10.45 to 12 Noon, See Berlin (Funkstunde). 12 Noon, Promenade Concert from the Schlossplatz. 1.0 p.m., See Berlin (Funkstunde). 1.45 to 2.45, See Berlin (Deutschlandsender). 2.45, See Frankfurt. 3.5 to 3.45, See Hamburg. 3.45, See Berlin (Deutschlandsender). 4.20 to 5.0, Programme from Breslau. 5.0 to 6.45, See Hamburg. 6.45, Orchestral Concert, conducted by Ferdinand Drost, Soloist: Willi Dongraf-Fasshaender (Baritone). 8.0 to 3.0 a.m. (Monday), Harvest Festival Programme—Heilsberg, Munich, Leipzig, Stuttgart, Berlin (Deutschlandsender), and Berlin (Funkstunde). Inter-Relay. 8.0, See Heilsberg. 9.0, See Munich. 10.0, See Frankfurt. 10.30, See Leipzig. 12 Midnight, Banckerkibe—Swabian Peasant Programme in Dialect. 1.0 a.m. (Monday), See Berlin (Deutschlandsender). 2.0, See Berlin (Funkstunde). 3.0 (approx.), Close Down.

**SUNDSVALL.**—See Stockholm.

**TOULOUSE**

**RADIOPHONIE DU MIDI,** 779 kc/s, 385 metres; 8 kW.—11.0 a.m., Dance Music. 11.30, Viennese Music. 12 Noon, Chanson-Lettes. 12.15 p.m., Organ Solos. 12.30, Catholic Service. 12.35, Music by a Symphony Orchestra. 12.45, Airs from Operetta. 1.0, Accordion Music. 1.15, Light Orchestral Music. 1.30, Songs. 1.45, Military Music. 2.0, Opera Music. 2.15, Agricultural Notes. 2.30, Romeo and Juliet—Opéra-Comique (Gounod) (Concert Version). 3.15, Music by a Symphony Orchestra. 3.45, Music from Sound Films. 4.0, Opera Music. 4.15, Chansonnets. 4.30, Symphony No. 5 in C minor (Beethoven) by a Symphony Orchestra. 5.0, Dance Music. 5.45, Airs from Operetta. 6.0, News. 6.15, Military Music. 6.30, Orchestral Music. 6.45, Choral Music: La Fête des Vignerons—Festival Play (Doret). 7.0, Orchestral Music. 7.15, News. 7.30, Music by a Viennese Orchestra. 8.0, Airs from Opéra-Comique. 8.15, Dance Music. 9.30, Chau-

sonnets. 9.0, Organ Recital. 9.30, Opera Music. 9.45, Orchestral Music. 10.15, News. 10.30, Concert for Listeners in Monaco: Dances from Saccin (R. Strauss); Aria from Mignon (Thomas); Empereur, Waltz (John Strauss); French Serenade (Leoncavallo); Montmartre (Alexander). 11.0, Russian Songs and Balalaika Music. 11.15, Jazz Music. 12 Midnight, News. 12.5 a.m. (Monday), Orchestral Music. 12.15, Military Music. 12.30 (approx.), Close Down.

**TRIESTE**

1,211 kc/s, 247.7 metres; 10 kW.—9.40 a.m., Giornale Radio. 9.55, Mass from the Cathedral of San Giusto. 11.0, Religious Address. 11.20, Agricultural Talk. 12.30 p.m. till Close Down, See Turin.

**TRONDHEIM.**—See Oslo.

**TURIN**

1,096 kc/s, 273.7 metres; 7 kW. Relayed by Milan, 905 kc/s, 331.5 metres; Genoa, 959 kc/s, 312.3 metres; and Florence, 599 kc/s, 500.8 metres.—9.40 to 9.55 a.m., Giornale Radio. 10.40, Agricultural Talk. 11.0, Mass from the Church of the Annunciation, Florence. 12 Noon to 12.15 p.m., Religious Address. 12.30, Concert of Variety Music. In the interval at 1.0, Time and Announcements. 1.30, Sponsored Music. 1.45 to 2.0, Gramophone Music. 4.30, Concert of Variety Music: Sports Notes in the interval. 6.15, Weather and Gramophone Music. 6.30, Sports Results. 7.0, Time, Popolavoro Report and Gramophone Music. 7.10, Gramophone Music. 8.0, Announcements and Sports Notes. 8.20, Talk on the following Transmission. 8.30, La Wally—Opera in Four Acts (Catalani). Talk and News in the intervals.

**VIENNA**

581 kc/s, 517 metres; 100 kW. Relayed by Graz, 852 kc/s, 352.1 metres; Innsbruck, 1,058 kc/s, 283 metres; Klagenfurt, 662 kc/s, 453.2 metres; Linz, 1,220 kc/s, 245.9 metres; and Salzburg, 1,373 kc/s, 218.5 metres.—10.0 a.m., Organ Recital. 10.30, Recitation. 10.50, Song Recital by Hedda Kuy (Soprano). 11.20, Sacred Programme. 12 Noon, Concert by the Vienna Chamber Orchestra, conducted by Karl Audieth; Sobist, Otto Schulhoff (Pianoforte); Italian Overture (Schubert); Serenade in D (Mozart); Pianoforte Solo; Suite after Unknown Masters of the 16th Century (Franck); Sinfonietta (Graener); Pianoforte Solos: (a) Etude in A flat (Chopin), (b) Valse impromptu (Wilm), (c) Dance of the Elves (Joakim); Air and Dance (Delius); Oberon romanero (Brandt-Bays); Overture to a Puppet Play (Gál). 2.20, Time and Announcements. 2.40, Agricultural Talk. 3.0, Radio Report of the International Light Athletic Championship, Italy v. Austria relayed from the Stadium. 3.25, String Quartet in A Flat, Op. 105 (Dvorak), played by the Weiss Quartet. 4.15, Radio Report of the International Football Match, Austria v. Hungary, relayed from the Stadium. 5.10, Review of Books. 5.35, Mandoline Recital. 6.15, Heinrich Suso Waldeck reads from his own Works. 6.45, Concert of Waltzes and Ballet Music, by the Wiener Symphoniker, conducted by Martin Spörr; Le petits riens (Mozart); Waltz, Die Schöne Brunner (Lanner); Suite from Sylvia (Delibes); Kaiserwalzer (John Strauss); Selection from Lazy John (Nedbal). In the interval at 7.25, Time, Sports Notes and Programme Announcements. 8.0, Siegfried Liebe, Play (Richard Reich). 9.50, News. 10.5, Concert of Light Music, by the Wiener Symphoniker, conducted by Josef Holzer. After the Programme, Market Prices.

**WARSAW**

212.5 kc/s, 1,411 metres; 120 kW.—11.57 a.m. Time Signal and Fanfare from St. Mary Church, Cracow. 12.5 p.m., Programme Announcements. 12.10, Weather. 12.1 p.m., Concert by the Station Symphony Orchestra, conducted by Oziminsky; Soloist Mme. Raheewicz (Pianoforte); Overture Russian and Ludmilla (Glinka); Pianoforte Concerto in D Minor (Rubinstein); Symphony No. 6, The Pastoral (Beethoven). In the interval at 1.0, Talk for Workers. 2, Agricultural Talk. 2.15, Agricultural Report. 2.20, Dances, Sketches and Monologues on Gramophone Records. 3.0, Agricultural Talk. 3.20, Chamber Music by the Wilkosz Orchestra. 4.0, Talk for Children. 4.15, Recitations for Children. 4.30, 'Ciel Solos on Gramophone Records. 4.45, Literary Programme. 5.0, Programme for Mother. 5.15, Choral Concert of Popular Polish Song Soloist, Mme. Szlenimska (Soprano). 6. Radio Play. 6.40, Light Orchestral Music on Gramophone Records. 7.5, Miscellaneous Items. 7.30, Talk for Young People. 7.4 Programme Announcements. 7.50, Rad Journal. 8.0, Light Music by the Station Orchestra, conducted by Navrot; Soloist: Fogg (Songs). 9.0, Topical Talk. 9.1 Humorous Programme relayed from Lwow. 788 kc/s, 381 metres. 10.15, Sports Talk. 10.25, Dance Music relayed from the Adri. 11.0, Aviation Weather Report and Police Notes. 11.5, Dance Music (contd.).

**ZURICH.**—See Schweizerischer Landessender

# MONDAY

## OCTOBER THE SECOND

### PRINCIPAL EVENTS OF THE DAY:

#### AT HOME

- NATIONAL** Promenade concert from Queen's Hall.
- LONDON REGIONAL** "Taking you Over" for an hour with Billy Merson.
- MIDLAND REGIONAL** Midland composers: Eric Coates, orchestral concert.
- NORTH REGIONAL** Brass Band concert.
- WEST REGIONAL** Welsh instrumental and vocal programme.
- SCOTTISH REGIONAL** Excerpt from a rehearsal of the Glasgow Orpheus Choir.
- BELFAST** Old Masters, orchestral programme.

#### ABROAD

- BARCELONA** 7.0 p.m. Trio concert.
- BERLIN (Deutschlandsender)** 8.5 p.m. Beethoven concert, by the Station Orchestra
- BUDAPEST** 6.45 p.m. Pianoforte recital, by Ludwig Heimlich.
- COPENHAGEN** 8.30 p.m. Danish music, by the Symphony Orchestra 10.30 p.m. Modern French music.
- EIFFEL TOWER** 8.30 p.m. Symphony concert, conducted by E. Flament.
- HAMBURG** 8.0 p.m. Max von Schilling's concert, by the Municipal Orchestra, from Bremen
- OSLO** 8.1 p.m. Chamber music, by the Budapest Trio.
- RADIO PARIS** 8.0 p.m. Pianoforte recital, by Mary Regnard Weingartner.
- ROME** 8.45 p.m. Opera: "La Sonnambula," by Bellini.

#### BERLIN

**FUNKSTUNDE, 715 kc/s, 419.5 metres; 1.5 kW.—5.50 p.m.**, Walter Schlageter Song Recital by Mia Neussitzer-Thömmissen (Soprano). 6.15, Talk on Photography. 6.30, The Funkstunde informs its listeners. . . . 6.45, Topical Talk. 7.0, See Berlin (Deutschlandsender). 8.5, This is Berlin—Radio Sequence. 9.0, Variations on a Theme of Bach, Op. 81 (Regor), by Richard Kössler (Pianoforte). 9.30, The Beginning of the Winter Season—Discussion between a Theatre Critic, a Literary Critic, an Art Critic, a Film Critic and a Wireless Critic. 10.0, News. 10.15 (approx.), Dance Music by the Oscar Joost Band, relayed from the Eden-Pavillon. In an interval at 11.0, Police Notes. 12 Midnight (approx.), Close Down.

**BERNE.**—See Schweizerischer Landessender.

**BEROMUNSTER.** — See Schweizerischer Landessender.

**EGDEN.** See Stockholm.

**BODO.** See Oslo.

#### BRATISLAVA

1,076 kc/s, 279 metres; 14 kW.—5.5 p.m., Kreisleriana, Op. 16 (Schumann), for Pianoforte. 5.40, Talk: The Slovak League. 5.55, Schrammel Concert. 6.25, Recital of Flute Duets, by Beza and Bilek; Duet, Op. 75 (Mozart); Duet, Op. 2 (Quantz). 6.55, Hints for Housewives. 7.0, See Prague. 7.10, See Brno. 7.55, Talk relayed from Kosice, 1,022 kc/s, 293 metres. 8.10, See Prague. 8.45, Concert by the Station Orchestra, conducted by Schimpel. 9.20, Concert by the Station Orchestra, conducted by Dyk; Overture, Figaro (Mozart); Intermezzo from In the Well (Blodek); Introduction to Act IV of Carmen (Bizet); Song from Jacobin (Dvorak); Mimet and Barcarolle from The Tales of Hoffmann (Offenbach); Polka from Schwanda the Piper (Weinberger); Intermezzo from Cavalleria rusticana (Mascagni); Dance from The Bartered Bride (Smetana); Coronation March from The Prophet (Meyerbeer). 10.0, See Prague. 10.15 (approx.), Close Down.

**BREMEN.**—See Hamburg.

#### BRESLAU

923 kc/s, 325 metres; 60 kW. Relayed by Gleiwitz, 1,184 kc/s, 253 metres.—2.10 p.m., Recital of Brahms Songs. 2.40, Suite from El amor brujo (Falla) on Gramophone Records. 3.0, Market Prices. 3.15, Review of Books. 3.35, Talk. 4.0, Orchestral Concert, conducted by Ewald Rischka; Overture, Rienzi (Wagner); Selection from Faust

(Gounod); Norwegian Dances (Grieg); Grottesque March (Sinding); A Wedding Trip through Scandinavia (Juel-Fredrikson); Waltz, Rindolphsklänge (Jos. Strauss). 5.30, Market Prices. 5.32 (approx.), Talk: German Culture. 5.50, Topical Talk. 6.10, Violin Recital. 6.30, Talk: What does the Younger Generation expect from the New Legal Code? 6.50, Meat Market Prices. 7.0, See Berlin (Deutschlandsender). 8.0, News. 8.10, Lulu von Strauss und Torney—a Radio Sequence (Elizabeth Darge). 9.0, Recital of East Prussian Folk Songs. 10.0, See Munich. 10.20, Time and News. 10.45, Wireless Technical Talk. 10.55, Concert of Light Music, conducted by Topitz. 12 Midnight, Close Down.

#### BRNO

878 kc/s, 342 metres; 35 kW.—6.25 p.m., German Transmission: News and Programme for children. 7.0, See Prague. 7.10, Jazz Music with Vocal Refrains. 7.55, Talk relayed from Kosice, 1,022 kc/s, 293 metres. 8.10, See Prague. 8.45, Reading. 9.5, Concert by the Station Orchestra, conducted by Bakala; Soloist, Karel Zavrel (Baritone). 10.0, See Prague. 10.30 (approx.), Close Down.

#### BRUSSELS (No. 1)

I.N.R., 590 kc/s, 509 metres; 15 kW.—12.0 Noon. Extracts from Falstaff—Opera (Verdi) on Gramophone Records. 1.0 p.m., Le Journal Parlé. 1.10, Concert by the Small Station Orchestra, conducted by Pierre Leemans. 5.0, Concert by the Station Symphony Orchestra, conducted by Jean Kumps; Carnaval de Paris (Svendsen); Two Oriental Dances (Kumps); Selection from Manon (Massenet); Dance (de Boeck); Le due d'Albe (de Greef); Ballet Music from Faust (Gounod). 6.0, Agricultural Talk. 6.15, Violin and Pianoforte Sonatas: (a) Sonata (Haydn), (b) The Kreuzer Sonata (Beethoven). 6.45, Concert by the Small Station Orchestra, conducted by Pierre Leemans. 7.30, Film Review and Theatre Notes. 8.0, Quintet for Strings and Pianoforte (Ysaye). 8.35, Gramophone Music: Suite in D (Bach); Overture, Idomeo (Mozart). 9.0, A Tennis Party—Sketch (Gaston Rey). 9.20, Popular Concert by the Radio Orchestra, conducted by Franz André. 10.0, Le Journal Parlé.

#### BRUSSELS (No. 2)

I.N.R., 887 kc/s, 328.2 metres; 15 kW. Programme in Flemish.—12 Noon, Concert by the Small Station Orchestra, conducted by Leemans. 1.0 p.m., Le Journal Parlé. 1.10, Autumn—Gramophone Concert. 5.0, Concert by the Radio Orchestra, conducted by André; Marche lorraine; Overture, The Gipsy Baron (Joh. Strauss); Ballet Music from The Cid (Massenet); Intermezzo, Mureurs des bois (Razigade); Bosphorus

(Baeyens); March of the Marionnettes (Hulbroeck); Aubade à Kiki (de Boeck); Selection from Mirella (Gounod). 5.45, Programme for Children. 6.30, Gramophone Concert. 7.12, News. 7.15, Talk: Henri Conscience and the Flemish Theatre. 7.30, Le Journal Parlé. 8.0, Concert by the Station Symphony Orchestra, conducted by Kumps; Soloists, P. Hellinek (Songs) and Mlle. Legrain (Songs); Feestklanken (Verheyden); Overture, Rienzi (Wagner); Song, Consummatum est (Baeyens); Le jeune berger (Marsick); Canadian Fantasy (Giltson); Songs: (a) Schilder Herfst (Baeyens), (b) Herfstlied (de Mol); Waltz, The Blue Danube (Joh. Strauss); Overture, Der Freischütz (Weber); Joyeuse Marche (Chabrier). 8.42, News. 8.45, Recitations. 9.0, Concert by the Station Symphony Orchestra (cont.): Overture, Don Giovanni (Mozart); Selection from Nannouka (Lalo); Slav Dances (Dvorak); Selection from Charlotte Corday (Benoit). 10.0, Le Journal Parlé.

#### BUCHAREST

761 kc/s, 394 metres; 12 kW.—5.0 p.m., Concert by the Station Orchestra: Cadet March (Souza); Spanish Waltz (Lincke); Overture, Le fils du mandarin (Cui); Selection from Manon Lescaut (Puccini); Potpourri of Russian Songs and Dances (Lindemann); Suite from The Queen of Spades (Tchaikovsky); Albumblatt (Gyldenmark); Gavotte in D Minor (Bach); Crépuscule oriental (de Michel); Rêve angélique (Rubinstein). In an interval at 6.0, Radio Journal. 7.0, Educational Programme. In an interval at 7.20, Gramophone Music. 8.0, Saxophone Solos. 8.30, Talk. 8.45, Song Recital. 9.15, Quartet No. 1 in C Minor, Op. 51 (Brahms), by the Theodoroseo Quartet. 9.45, Radio Journal. 10.0, Programme relayed from a Restaurant.

#### BUDAPEST

545 kc/s, 553.5 metres; 18.5 kW. Also relayed on 840 metres from 8.30 till Close Down.—5.0 p.m., Military Band Concert. 6.15, German Lesson. 6.45, Pianoforte Recital by Ludwig Heimlich: Three Pieces (Chopin): (a) Etude in C, (b) Scherzo in B Minor, (c) Berceuse; Pastorale (Dohnanyi); Serenade (Strauss-Giesecking); Old Vienna (Godowsky); Etude in G Sharp (Friedemann). 7.30, Talk. 7.50, Talk with Gramophone Interludes: Memories of Summer in Naples. 8.30, Dramatic Programme. 10.30, News. 10.45, Concert by the Emil Roos Orchestra from the Café New York; Overture, Die schöne Galathee (Suppé); Romance (Svendsen); Italian Serenade (Mielich); Selection from The Land of Smiles (Lehár); Tango Song (Szenkar); Ninon (Jurmann); Selection from The Drabary (Müllbacher-Mackeben); Selection from White Horse Inn (Benatzky); Waltz Song (Eisemann).

**CASSEL.** See Frankfurt.

#### COPENHAGEN

1,057 kc/s, 281 metres; 0.75 kW. Relayed by Kalundborg, 260 kc/s, 1,153.8 metres.—12 Noon, Town Hall Chimes. 12.2 to 2.0 p.m., Concert from the Hotel d'Angleterre. 2.50, Talk for the Housewife. 3.0, Orchestral Concert, conducted by Emil Reesen. Overture, Aladdin (Hornemann); Cradle Song for Orchestra (Andersen); Scenes pittoresques (Massenet); Selection from the Music to On the Bosphorus (Lange-Müller); Waltz, La Housarde (Ganne); Serenade (Rachmaninov); Old Suite for Orchestra (Roseberg); Habanera (Chabrier); Overture, Le Roi d'Ys (Lalo). In the interval at 3.45, Reading. 5.0, Programme for Children. 5.30, Exchange and Market Prices. 5.45, Talk. 6.15, English Lesson. 6.45, Weather and News. 7.15, Time Signal. 7.30, Discussion: The Decline of the Race and the Danger to Culture. 8.30, Concert of Danish Music. The Symphony Orchestra, conducted by Lanny Gröndahl. Soloist: Marius Jacobsen, Overture, Hugo and Adelheid (Kuhlau); Aria from Röverborgen (Kuhlau); Symphony No. 6 in G Minor Op. 42 (Gade); Song from Aladdin (Hornemann); Romance from Tornerose (Heise); Two Pieces from the Music to Aladdin (Nielsen). 9.40, Reading. 10.0, News. 10.15, Ernst Rolf on Gramophone Records. 10.30, Concert of Modern French Music. Terzetto for Flute, Viola and Harp (Dubois); Serenade for Flute, Violin, Viola, Cello and Harp Op. 80 (Roussel). 11.0 (approx.), Close Down.

**CORK.**—See L'hlone.

#### CRACOW

959 kc/s, 312.8 metres; 1.5 kW.—6.45 p.m., Gramophone Music. 7.0, Talk: The Centenary of Two Polish Painters, Szermentowski and Gryglowski. 7.15, Miscellaneous Items and News. 7.25, See Warsaw. 7.40, Programme Announcements. 7.45, See Warsaw. 11.5, Gramophone Music. 11.30 (approx.), Close Down.

**DANZIG.**—See Heilsberg.

**DRESDEN.**—See Leipzig.

#### ALGIERS

824 kc/s, 364 metres; 13 kW.—8.20 p.m., Instrumental Solos on Gramophone Records. 8.55, News. 9.0, Time and Lottery Results. 9.10, Orchestral Concert. Overture, Semiramis (Rossini); Le bûcher (Durand); Waltz, La plus belle (Waldteufel); Les larmes de Pierrot (Bizet); Selection from Le roi d'Ys (Lalo). 9.45, News. 9.50, Concert (cont.). Selection from Mirella (Gounod); Aria from La Traviata (Verdi); Dance from La vida breve (Fallá - Kreisler); El Relicario (Padilla); Song (Graničstaedten); Birthday Serenade (Lincke); Trois jours de vengeance (Hahn); Krakowiak (Körke). 10.30, News. 10.35, Dance Music. 10.55, News.

#### ATHLONE

725 kc/s, 413 metres; 60 kW. Relayed by Cork, 1,337 kc/s, 224.4 metres.—1.30 to 2.30 p.m., Time, Stock Report, Weather and Gramophone Concert. 6.0, Programme for Children. 6.45, News. 7.0, Gaelic Talk. 7.15, Talk on Poultry. 7.30, Time. 7.31, The No. 1 Army Band, conducted by Colonel Fritz Brase. 8.30, Tenor Solos by Peter Dunn. 8.45, Cello Solos by Pollaky. 9.0, Soprano Solos by Eileen Clancy. 9.15, Harp Solos by Annie Fagan. 9.30 to 10.30, Programme by the I.B.C. (Ireland), Ltd. 9.30, Dance Music: Please (Robin); Lullaby of the Leaves (Potkers); Here lies love (Robin); When work is through (Sherman). 9.45, Pianoforte Concert; Pianist, Mr. Fred Stone. 10.0, Concert arranged by the International Broadcasting Company (Ireland), Ltd., on behalf of Hospitals Trust, Ltd.: Poeme (Fibich); Song, Under Heaven's Blue (Pola); The Dancing Doll (Poldini); Smilin' through; Song, Love's Pleading (Pecia); Rosa Mia (Guzar); Columbine (Garland). 10.30, I.B.C. Goodnight Melody. 10.33, News and Weather. 10.40, The Belhaven Traditional Trio. 11.0 (approx.), Close Down.

#### BARCELONA

EAJ1, 860 kc/s, 348.8 metres; 8 kW.—7.0 p.m., Trio Concert: Selection from The Rheingold (Wagner); Aubade (Pierini); Minuet No. 2 in G (Beethoven); Intermezzo (Moumaert); Scherzo Waltz (Ljadov); Romance (Reektonwald); Selection from La Traviata (Verdi). 8.0, Request Gramophone Records. 8.20, Sports Notes. 8.30, Exchange Quotations and Talk in Catalan. 9.0, Gramophone Music and News. 10.0, Chimes from the Cathedral, Weather and Exchange. 10.5, Humorous Review of the Week's Events in Verse. 10.15, Concert of Sardanas. 11.0, Orchestral Concert. 11.30, Topical Talk. 12 Midnight, News, followed by Dance Music from the Casa Llibre. 1.0 a.m. (Tuesday), Close Down.

**BASLE.** See Schweizerischer Landessender.

#### BELGRADE

697 kc/s, 430.4 metres; 2.8 kW.—5.0 p.m., Dance Music on Gramophone Records. 6.55, Time Signal and Programme Announcements. 7.0, Concert by the Station Orchestra. 8.30, Relay of an Opera from the National Theatre. In the interval at 9.30, Time and News.

#### BERLIN

**DEUTSCHLANDSENDER (REICHSENDER), 193.5 kc/s, 1,635 metres; 60 kW.—12.2 p.m.**, Gramophone Concert: Jubel-Ouverture (Weber); Toccata and Fugue in D Minor (Bach); Serenade (Schubert-Liszt); Tom der Reimer (Loewe); Traummensuren (Schumann); Adagio in E (Mozart); Star of Eve—Aria from Tannhäuser (Wagner); Ständchen (Richard Strauss); Cécilie (Richard Strauss); Schäfers Sonntagslied (Kreutzer). 12.55, Time Signal. 1.45, News. 2.0, Concert by a Reichswehr Band. 3.0, Talks for Women. 3.30, Weather and Exchange. 3.45, Review of Books on Animals. 4.0, See Leipzig. 5.0, Dialogue: The New Vocational Training School and its Teachers. 5.25, Concert of Operetta Arias and Duets by Ellen Althorn (Soprano) and Günter Stenzel (Tenor): Soprano Solo from The Cousin from Nowhere (Künneke); Es war einmal (Lincke); Tenor Solo from A Night in Venice (Joh. Strauss); Duet from The Gipsy Baron (Strauss); Duet from Wiener Blut (Strauss); Soprano Solo: Im Chambre séparée, from Der Opernhall (Heuberger); Tenor Solos: (a) Patiently smiling, from The Land of Smiles (Lehár), (b) Song from The Bird Fancier (Zeller); Melody from The Bird Fancier (Zeller); Selection from The Maid of the Black Forest (Gesslel). 6.0, Poems. 6.5, Talk on Sport. 6.25, Reading of Poems by Hans Friedrich Blunck. 6.45, Weather and News. 7.0, Programme for Hindenburg's Birthday. Ewiges Deutschland—Radio Sequence (Otto Heinz Jahn). 8.0, An Axiom. 8.5, Beethoven Concert by the Station Orchestra, conducted by Buschhöfner. Overture, Egmont; Pianoforte Concerto in C; Overture, Die Weihe des Hauses. 9.15, And the Stars are Shining—Radio Sequence (Kurt Kissbauer). 10.0, Weather and News. 10.15 (approx.), Talk: Physical Culture under the New Régime. 10.45, Weather. 11.0, Concert from Breslau. 12 Midnight, Close Down.

## FECAMP

1,328 kc/s, 225.9 metres; 10 kW.—11.0 a.m. till 12 Noon, Programme in English by the I.B.C. Happy Hour. Part I: Orchestral Music; Signature Tune; March from Sylvia (Delibes); Poor Butterfly (de Fillippi); Violin Solo: Chanson Bohémienne (Boldi); The Fortune Teller (Herbert); Selection from Sari (Kálmán); Serenade (Herbert); Waltzes from A Waltz Dream (O. Strauss); Evolution of Dixie (Lake). Part II: Dance Music: Let's call it a Day; My Lucky Day; Down in the Valley; Happy Ending; There's a Cabin in the Pines; Meet me in the Gloaming; Seven Years with the Wrong Woman; Lover; Signature Tune. 12 Noon to 4.30 p.m., Programme in French. 4.30 to 6.0, Programme in English by the I.B.C. 4.30, Programme for Children. 5.0, Concert for Chichester and Bognor. Signature Tune, The Night by the Sea. Overture, Die Fledermaus (Joh. Strauss); Love will find a Way (Graham); Selection from The Merry Widow (Lehár); Tea for Two (Youmans); The Night was made for Love (Kern); Violin Solo: Indian Love Call (Priml); Selection from The Dubarry (Millöcker-Mackeben); Selection from No, No, Nanette (Youmans). 5.30, Concert of Military Music for Hastings and Eastbourne. Old Panama (Alford); Jolly Fellows (Vollstedt); Cornet Solo: Carnival of Venice (Briccialdi); Præledium (Järnefelt); Parade of the Tin Soldiers; Cornet Solo: Il Bacio (Arditi); Wood Nymphs (Coates); The Bullfighter's March (Kottann); Signature Tune. 6.0, Programme in French. 10.0 (approx.) till Close Down, Programme in English by the I.B.C. 10.0, Dance Music. Signature Tune, Bells of Normandy; The Old Spinning Wheel; Hold me; Waltzing in a Dream; I can't remember; Maybe I love you too much; My Lucky Day; It's within your Power; Happy Ending; Come out Vienna; In a Second-hand Store; Dance Pretty Lady; I cover the Waterfront; I gotta right to sing the Blues; Drifting down the Shalimar; You are too beautiful; Castles in the Sand; Signature Tune. 11.0, Tunes from the Talkies. Signature Tune, Sittin' in the Dark; I want to be Happy; To-day I feel so happy (Abraham); Your Lips say No (Rossen); L'Edera (Sehor); There'll still be Love (Marvel); The Whip (Harbach); The Big Pond Medley (Fain); Mrs. Bartholomew (Ellis); Selection from Forty-Second Street (Warren); Signature Tune. 11.30, Club Concert for Milford Haven Listeners. Part I: Orchestral Music. Signature Tune, The Chum Song; Overture, Figaro (Mozart); In the Hall of the Mountain King (Grieg); Violin Solo: La capricieuse (Elgar); Weaner Madn (Ziehrer); Violin Solo: Old Viennese Dance (Vogelin); Waltz, Spährenklänge (Jos. Strauss); Prelude to Carmen (Bizet); Liebestraum (Liszt). 12.5 a.m. (Tuesday), News in English. 12.10 (approx.). Club Concert (cont'd). Part II: Swanee Rhapsody (Ellington); The Voodoo; Blue Tune (Ellington); As long as you're there (Monaco); Heat Waves (Leslie); Signature Tune. 12.30, Dance Music by Jack Payne and his Band (Electrical Transcriptions). Sweetheart Darlin'; In the Valley of the Moon; Stormy Weather; Hiawatha's Lullaby; There's a Cabin in the Pines; When the Wild, Wild Roses bloom; Seven Years with the Wrong Woman; Let's all be Happy together. 1.0, Dance Music. Signature Tune, Bells of Normandy; That's what life is made of; Rhapsody in Blue; Spanish Eyes; Lover; Look what I've got; Stay out of my Dreams; In the Park in Paree; I've got to sing a Torch Song; A Shadow Waltz; T.C.123 (The Policeman's Song); Moon Song; Two Buck Tim from Timbuctoo; Pickaninies Heaven; From me to you; I've told every little Star; Love Song of the Nile; Signature Tune. 2.0, I.B.C. Good-night Melody and Close Down.

FLENSBURG.—See Hamburg.

FLORENCE.—See Turin.

## FRANKFURT

1,157 kc/s, 259.3 metres; 17 kW. Relayed by Cassel, 1,220 kc/s, 245.9 metres; and Trier, 1,157 kc/s, 259.3 metres.—6.0 p.m., See Stuttgart. 6.35, Astronomical Talk: The Heavens in October. 6.50, News. 7.0, The Wines of Germany. 8.0, Topical Talk. 8.10, Concert of Folk Music. 8.50, Personalities of the Supreme Army Command—Radio Sequence. 9.30, Pianoforte Recital by Max Paur. 10.0, Time and News. 10.20, Local News. 10.30, Light Music on Gramophone Records. 12 Midnight, See Stuttgart. 1.0 a.m. (Tuesday), Close Down.

FREDRIKSSTAD.—See Oslo.

FREIBURG.—See Stuttgart.

GENEVA.—See Radio-Suisse Romande.

GENOA.—See Turin.

GLEIWITZ.—See Breslau.

GÖTEBORG.—See Stockholm.

GRAZ.—See Vienna.

HAMAR.—See Oslo.

## HAMBURG

806 kc/s, 372 metres; 1.5 kW. Relayed by Bremen, 1,112 kc/s, 269.8 metres; Flensburg, 1,419 kc/s, 227.4 metres; Hanover, 530 kc/s, 566 metres; and Kiel, 1,292 kc/s, 232.2

OCT. 2nd

MONDAY

continued

metres.—6.0 p.m., Variety Programme. 6.40, Frankfurt Exchange and Hamburg Market Prices. 6.50, Weather. 7.0, See Frankfurt. 8.0 (from Bremen), Max von Schillings Concert by the Municipal Orchestra, conducted by Siegmund von Hausegger; Soloist: Rudolf Watzke (Baritone); Symphonic Fantasia, Meergruss; Four Baritone Solos from the Ertelieder; Aria from Moia Lisa; Erste-Regien from Der Moloch. 9.0, Dreemal Kinddöp—Radio Sequence (Heinrich Andresen). 10.0, News. 10.20, Sports Notes. 10.35 (from Kiel), Concert by the Kiel Orchestra of Unemployed Musicians; Overture, Sicilian Vespers (Verdi); Selection from Der Freischütz (Weber); Siziliana (Schmalstieg); Ballet égyptien (Luigin); Paraphrase on the Song, La Paloma (Vradier-Weninger); Waltz Rhapsody, Pusztalegenden (Lindsay-Thiemer); Römische Suite (Zimmer); Flute Serenade from Fridericus Rex (Holand); Symphonic Foxtrot, Phantom (Robrecht); March, Fürs Vaterland (Millöcker).

HANOVER.—See Hamburg.

## HEILSBURG

1,085 kc/s, 276.5 metres; 60 kW. Relayed by Danzig, 662 kc/s, 453.2 metres.—1.5 to 2.30 p.m., Gramophone Concert: Army March, No. 126; March, Duke of Brunswick; Deutschland im Lied (Snagra); Selection from A Masked Ball (Verdi); Invitation to the Dance (Weber); Polonaise (Tchaikovsky); Still wie die Nacht (Bohm); Eine Jagd im Schwarzwald (Völker); Liebessehnen (Michaelis); Tonerna (Sjöberg); Evening Chimes (Marzian); Selection from Fraquinia (Lehár); March, Frei weg (Latann). In the intervals at 1.20 and 2.0, News. 3.0, Market Prices. 3.30, Programme for Children. 4.0 (from Danzig), Concert conducted by Bruno Bukolt; March, Semper Talis (Richard Knoch); Hungarian Comedy Overture (Keler-Bela); Lima-Walzer (Lincke); Mein Schlieslerland (Mittmann); Waldmanns Liebblingslied (Lössner); Zigeunerständchen (Nehl); Maryn, Geschlossene Front (Kurtze); Selection from Das Pensionat (Suppé). In the interval at 5.0, Review of Books. 5.30, Talk on Sport. 5.45, Violin and Harp Recital; Adagio from the Sonata in G Minor (Handel); Bourrée (Bach); Sonata in C Minor (Spohr). 6.15, Market Prices. 6.25 (from Danzig), Talk on Music. 6.50, Weather. 7.0, See Frankfurt. 8.0, Weather and News. 8.10, Programme for the Birthday of General Field Marshal von Hindenburg. 8.45, News. 8.50 (from Danzig), Concert. 9.50, Elementary English Lesson, followed by Report on the Insterburg Tournament Week. 10.15, Weather and News.

## HILVERSUM

1,013 kc/s, 296.1 metres; 7 kW up to 5.40 p.m., and 20 kW from 5.40 p.m. Programme of the Workers' Radio Society (V.A.R.A.).—11.40 a.m., Concert by the Small V.A.R.A. Orchestra, conducted by de Groot. 1.40, Interval. 2.10, Concert by De Flierefluiters, conducted by Horst. 3.10, Recitations. 3.40, Pianoforte Recital by Nel Bijkes; Sonata in D (Mozart); Evening in the Country (Bartok); Chaconne and Variations (Castella); Spanish Dance (Granados). 4.10, Programme for Children. 4.40, Gramophone Music. 5.10, Organ Recital by Jong. 5.42, Concert by De Notenkrakers, conducted by Wims. 6.10, Talk on Music. 6.50, Concert by the V.A.R.A. Orchestra, conducted by de Groot: Children's Symphony (Haydn); Jeux d'enfants (Bizet); Dance from The Sleeping Beauty (Tchaikovsky); Dance of the Sugar Plum Fairy (Tchaikovsky); Sérénade de la poupée (Debussy); Golliwog's Cakewalk (Debussy); Ein Puppenhaus (Engelman). 7.40, S.O.S. Announcements. 7.42, News. 7.55, Concert by the V.A.R.A. Orchestra, conducted by de Groot: Granados (Garcia); Jour de fête (Lacôme); Spanish Dances (Palla); Spanish Suite (Albeniz); Vive le Toréador (Poppy); March, Picador (Oseheit). 8.40, Recitations. 9.0, Concert by De Flierefluiters, conducted by Horst. 9.40, Concert relayed from the Queen's Hall, London. 10.30, Organ Recital by Steyn. 10.55, Gramophone Music. 11.40 (approx.), Close Down.

HORBY.—See Stockholm.

## HUIZEN

160 kc/s, 1,875 metres; 7 kW. (until 3.40 p.m.). (Transmitted from Kootwijk on 50 kW; from 3.40 p.m.). Programme of the Christian Radio Society (N.C.R.V.). 11.40 a.m., Police Notes. 11.55, Gramophone Music. 12.10 p.m., Organ Recital by Zwart. Two Overtures (Zwart); Variations on Mein junges Leben hat ein End (Sweelinck); Fantasia and Fugue in G Minor (Bach); Three Choral Melodies (Zwart); Sonata No. 7 (Gulmiant); Finales (Zwart). 1.40, Programme for Schools. 2.15, Talk on Gardening. 2.55, Dressmaking Lesson. 3.25, Interval. 3.40, Bible Reading, Song Recital and Organ Music. 4.40, Organ Recital by Mlle Lauberoth; Das ist der Tag des Herrn (Kreutzer); Four Songs (Zundel); Im Wald steht a Hügel (Rosen); Idyll (Stutzer); March (Duhols); Psalm, Nos. 48 and 38; Allegro and Andante (Krusy); Psalm 58, Verses 1, 5 and

7. 5.40, Talk. 6.10, Answers to Correspondence. 6.40, Police Notes. 6.55, Religious Notes. 7.10, Answers to Correspondence. 7.40, Programme to commemorate the Raising of the Siege of Leyden (October 3, 1574). 8.40, News and Gramophone Music. 8.55, Talk. 9.25, Recital by Welman (Bass-Baritone) and Visser (Organ). 10.10, Gramophone Music. 11.10 (approx.), Close Down.

INNSBRUCK.—See Vienna.

## JUAN LES PINS

1,205 kc/s, 249 metres; 0.8 kW.—8.0 p.m., Amusement Guide, News, Exchange and Racing Results. 8.10, Sports Notes. 8.25, Light Music. 8.45, News and Weather. 9.0, Literary Programme.

KALUNDBORG.—See Copenhagen.

KIEL.—See Hamburg.

KLAGENFURT.—See Vienna.

KOSICE.—See Prague.

## LAHTI

167 kc/s, 1,796 metres; 40 kW. Relayed by Helsinki, 815 kc/s, 368.1 metres.—6.15 p.m., English Lesson. 6.40, Song Recital by Temo Viromi. 7.0, Two Talks. 7.40, Concert by the Station Orchestra, conducted by Erkki Linko; Overture, Fra Diavolo (Auber); Intermezzo from Cavalleria Rusticana (Mascagni); Intermezzo from L'amico Fritz (Puccini); Selection from Tosca (Puccini). 8.15, Scene (Stefan Zweig). 8.45 p.m., News in Finnish and Swedish.

## LANGENBERG

635 kc/s, 473 metres; 60 kW.—12 Noon, Concert by the Station Orchestra, conducted by Kühn; Overture, Le Roi d'Ys (Lalo); Norwegian Rhapsody No. 3 (Svendson); Two Pieces (Grieg); (a) Letzter Frühling, (b) Herzwunden; Suit, Swan Lake (Tchaikovsky); Transaktionen-Walzer (Strauss); Selection from The Trumpeter of Säckingen (Nessler). 1.15, News from Frankfurt. 1.25, News and Weather. 1.35, Orchestral and Choral Concert. Conductors: Kühn and Breuer. Coronation March from Die Folkinger (Kretschmer); Waltz Entr'acte and Ballet Music from Donna Diana (Reznicek). Choir: (a) Die Lore am Tore (Folk Song); (b) In einem kühlen Grunde (Folk Song); A Capella Choir: (a) Heideröschchen, (b) Waldvöglein, (c) Aennechen von Tharau; Prelude to Corregidor (Hugo Wolf); Prelude to The Third Act of Kunitih (Kistler); Prelude to Die Marktentenderin (Humpelnick). 2.30, Meat Market Prices. 3.0, Talk: Young Office Workers. 3.20, Talk: Röhmi, the Soldier. 3.30, Exchange. 3.50, Topical Talk. 4.0, Concert from Stuttgart. 6.0, See Stuttgart. 6.20, Talk: Ushering in October. 6.50, News. 7.0, See Frankfurt. 10.20, See Stuttgart. 10.30, News, Weather and Sports Notes. 10.40, See Stuttgart. 11.0, Programme from Leipzig. 12 Midnight, Concert from Stuttgart. 1.0 a.m. (Tuesday), Close Down.

LAUSANNE.—See Radio-Suisse Romande.

## LEIPZIG

769.0 kc/s, 389.6 metres; 120 kW. Relayed by Dresden, 941 kc/s, 319 metres.—12 Noon, Concert from Munich. 1.15 p.m., News. 1.30, Gramophone Music. 2.15, News. 2.30, Art and Film Notes. 2.40, Notes on Taxation. 3.0, Talk for Women; Clothes from German Material. 3.15, Reading. 3.35, Exchange and Market Prices. 4.0, Concert Relay. 5.0, Talk: Why Peoples Perish. 5.20, Organ Recital by Friedrich Högner; Sonatina (Ritter); Prelude and Fugue in D (Buxtehude); Partita on the Choral Es ist das Heil uns kommen her (Nepomuk David); Prelude and Fugue in E (Nepomuk David); Introduction and Passacaglia in F Minor (Reger). 5.50, Exchange, Weather and Time. 6.0, Italian Lesson. 6.30, A Visit with the Microphone to the Gliding Contests at Laveha-Domsdorf in Thuringia. 6.50, A Review of the Day's News. 7.0, See Berlin (Deutschlandsender). 8.0, Concert of Folk Music for Zither. 8.30, A Hunting Programme. 10.15, News. 10.15 (approx.), Concert Relay. 12 Midnight, Close Down.

LINZ.—See Vienna.

## LJUBLJANA

522 kc/s, 574.7 metres; 7 kW.—6.0 p.m., Programme for Women. 6.30, Talk on Science. 7.0, Gramophone Music. 7.30, Foreign Press Review. 8.0, Programme relayed from the Opera House, Belgrade, 697 kc/s, 430.4 metres. In an interval at 9.30, Weather and News. 11.0 (approx.), Close Down.

## LUXEMBOURG

252 kc/s, 1,191 metres; 200 kW.—Italian Evening. 7.30 p.m., Orchestral Concert. Overture, Amarcion (Cherubini); Selection from A Masked Ball (Verdi); Gondoliera (Bossi); Falling Leaves (Carena); Angelus (Michele). 8.25, Symphony in D, The Clock

(Haydn), on Gramophone Records. 8.50, News in French. 9.0, Gramophone Music. 9.30, Orchestral Concert. In the interval at 9.45, News in German. 10.30, Gramophone Dance Music.

## LWOW

788 kc/s, 381 metres; 16 kW.—7.5 p.m., Announcements and Gramophone Music. 7.25, See Warsaw. In the interval at 7.40, Programme Announcements. 10.40, Gramophone Music. 11.30 (approx.), Close Down.

## LYONS

LA DOUA, 644 kc/s, 465.8 metres; 1.5 kW.—6.30 p.m., Radio Journal. 7.30, Radio Gazette for Lyons and the South-East. 8.30, Programme relayed from Paris (Ecole Supérieure), 671 kc/s, 447.1 metres. After the Programme, News.

## MADRID

ARANJUEZ (EAQ), 10,000 kc/s, 30 metres; 20 kW.—11.30 p.m., Concert of Popular Music. In the interval at 11.45, Radio Chronicle. 12.35 a.m. (Tuesday), Sports and Bull-Fighting Notes. 12.40, Light Music. 1.0 to 1.30, Programme in English by the I.B.C. 1.0, I.B.C. Concert: Smile, darn yer, smile; Beautiful Spring; Song of the Islands; Waltz Dream; Secret; The Wave; Kissing is no sin; Once I was in love. 1.30, I.B.C. Goodnight Melody.

## MADRID

EAJ7, 707 kc/s, 424.3 metres; 2 kW. 8.0 p.m., Chimes, Exchange and Radio Journal. 8.20 (approx.), Baritone Song Recital by Guillermo Garcemartin, followed by Dance Music. 9.15, Topical Review. 9.30 (approx.), Close Down.

MALMO.—See Stockholm.

MILAN.—See Turin.

## MORAVSKA-OSTRAVA

1,137 kc/s, 263.8 metres; 11 kW.—4.0 p.m., Popular Concert by the Station Orchestra, conducted by Plichta. 4.50, See Prague. 5.5, Gramophone Music. 5.15, Sports Talk. 5.25, Gramophone Music. 5.35, See Prague. 5.50, Song Recital by Vera Borská. 6.15, See Prague. 6.30, German Transmission: Mikasiovic reads from his own Poems; Theatre and Film Review. 7.0, See Prague. 7.10, See Brno. 7.55, Talk relayed from Kosice. 1,022 kc/s, 293 metres. 8.10, See Prague. 8.55, Pianoforte Recital of Music by Josef Suk. 9.20, See Bratislava. 10.0, See Prague. 10.15 (approx.), Close Down.

## MOSCOW

TRADES UNION, 300 kc/s, 1,000 metres; 100 kW.—2.45 p.m., Weather. 3.0, Musorgsky, Borodin and Rimsky-Korsakov Concert. In the intervals: Readings. 3.55, Time. 4.0, Foreign Language Lesson. 4.30, The Narrow Pass—Comedy (Ordinsky), with Music by Osermanov. 5.30, Programme for Children. 6.30, Extracts from Romeo and Juliet—Opera (Berlioz), by the Symphony Orchestra and Soloists. Conductor: Orlov. 9.0, News. 9.30, Programme Announcements. 9.55, Chimes from the Red Square. 10.5, Press Review.

MOTALA.—See Stockholm.

MUHLACKER.—See Stuttgart.

## MUNICH

563 kc/s, 533 metres; 60 kW. Relayed by Augsburg and Kaiserslautern, 536 kc/s, 560 metres; and Nürnberg, 1,256 kc/s, 239 metres.—4.30 p.m., Concert by the Station Orchestra, conducted by Liszt. Soloists: Hanna Rodetzg (Soprano), Erich Wirl (Tenor). 5.45, Book Review for Young People. 6.5, Sonata in A for Violin and Pianoforte (Reger). 6.25, Book Review. 6.45, Time, Weather and Agricultural Notes. 7.0, See Frankfurt. 8.0, Concert by the Small Station Orchestra and the Station Choir, conducted by Kloss: Overture, Post and Peasant (Suppé); Humoresque, O du lieber Augustin (Homann-Wehau); Humorous Interlude; Waltz, Wine, Woman and Song (Strauss); Die Post im Walde (Schäffer); Humorous Interlude; Old Russian Melodies, Eishlunen (Lenschner); Gallop, Zirkus Renz. 9.20, Chamber Music of the Time of Frederick the Great by the Munich Flute Trio: Trio Sonata in D for Flute, Violin and Harpsichord (Quantz); Sonata in E Minor for Flute and Harpsichord (Frederick the Great); Grave Cantabile from Concerto No. 2 in G for Flute and Harpsichord (Frederick the Great); Trio in E Flat for Flute, Violin and Harpsichord (Telemann). 10.0, Austria. 10.20, Time, Weather, News and Sports Notes. 11.0, Serenade from Leipzig.

NAPLES.—See Rome.

NOTODDEN.—See Oslo.

## OSLO

277 kc/s, 1,083 metres; 60 kW. Relayed by Fredrikstad, 815 kc/s, 368.1 metres; Hamar 427 kc/s, 574.7 metres; Notodden, 671 kc/s, 566 metres; and Rjukan, 671 kc/s, 447.1 metres



OCT. 2nd

**MONDAY**

continued

5.0 p.m., Concert by the Radio Orchestra. 6.30, German Lesson. 6.30, Hungarian Song recital by Mme. Astri Kalseth Szerenyi. 6.45, Advertising Notes. 7.15, Weather and News. 7.30, Talk. 8.0, Time. 8.1, Chamber Music by the Budapest Trio. Nicholas Roth Violin, Frantz Isborn (Pianoforte), and Tibor di Machula (Cello). Trio No. 7 in E Minor (Haydn); Trio, Op. 49, in D Minor (Mendelssohn). 9.10, Political Talk. 9.40, Weather and News. 10.0, Topical Talk. 10.15, Concert by a Male Voice Choir and Soloists.

STERSUND.—See Stockholm.

**PALERMO**

53 kc/s, 537.6 metres; 3 kW.—8.0 p.m., Popolavoro Announcements, Tourist Talk, Agricultural Notes, Report of the Royal Geographical Society, and Giornale Radio. 10.0, Gramophone Music. In the interval at 10.30, Time and Announcements. 8.45, Chamber Music by the Station Quartet and Vincenzo Mammio (Pianoforte); Quartet in C (Mozart); Violin Sonata in G minor (Tartini); Trio in G for Pianoforte, Violin and Cello (Castellonovo-Tedesco). After the concert, Gramophone Music. 11.0, Giornale Radio.

**PARIS**

IFFEL TOWER; Call FLE; 207.5 kc/s, 445.7 metres; 13 kW. Time Signals (on 650 metres) at 10.26 a.m. and 11.26 p.m. Preliminary and 6-dot signals.—6.45 p.m., Theatre Talk. 7.0, Le Journal Parlé. 8.30, Symphony Concert, conducted by Eduard Lamont; Chaconne and Rigaudon (Monty); Entr'acte from Rosamunde (Schubert); Idyll (Chabrier); Nocturne (Rossini); Cloudy and Humorous (Tchaikovsky); Conclation (Liszt); Ballet Music from Antar Dupont); Divertissement (Lalo); Overture and Waltz from Die Fledermaus (Strauss). 10.0 (approx.), Close Down.

**PARIS**

OSTE PARISIEN, 914 kc/s, 328.2 metres; 1 kW.—7.0 p.m., Gramophone Concert; ergo expressivo (Pugnani); Hymn to the In (Rimsky-Korsakov); En bateau (Debussy); Pavane pour une Infante défunte (Chopin); 7.15, Le Journal Parlé. 7.30, Hot jazz on Gramophone Records. 8.0, Talk on aviation. 8.30, Humorous Songs by Max Guiler. 9.15, Sponsored Gramophone Concert. 10.15, News.

**PARIS**

ADIO PARIS, Call CFR, 174 kc/s, 1,725 metres; 75 kW.—7.30 a.m., Weather and Musical Concert. 7.45, Light Gramophone Music. 8.0, News. 12 Noon, Choral Concert. Gramophone Records: La bataille de Arignan (Jannquin); Au joly feu du usse-avant (Jannquin); Fuyons tous amour le jeu (de Lassus); Il est bel et n (Expert); La belle aronde (Le Jeune); adrigals (Monteverde): (a) Ecco mormorar nde, (b) Cor mio mentre vi miro; Kyrie on the Pontifical Mass (Palestrina); Magieat (Bach); Extracts from Idomeno (ozart); Seigneur écoute ma priere (Arehgelsky); Quartet from A Life for the Czar (linka); Extracts from Boris Godunov (ussorgsky); Extracts from La fête des zernons (Doret); Extracts from Aeschylus (ilhand); Two Popular Melodies (Sarony). In the interval at 1.0, Exchange, News and eather, and at 1.30 and 2.0, Exchange, 3.45, change and Market Prices. 6.30, Agricultural Talk. 6.50, Film Review. 7.0, Book view: La conversion de Chateaubriand (oreau). 7.20, Gramophone Concert: Waltz, diantina (Waldteufel); Rondo brilliant (eber); Le passe qui file (Beytes); Songs on Véronique (Messager); L'auvergnate aune). 7.45, Commercial Prices and News. Pianoforte Recital by Mary Regnard singartner: Les barrières mystérieuses (aperin); Courante in G (Handel); Prele in C Sharp Minor (Chopin); Etude in E (t Minor (Chopin); Improrompt in A Flat (hubert); Albumblätter (Grieg); Taraula (Cuvellart); Gopak (Mussorgsky); onaise in A Flat, Op. 53 (Chopin). 8.30, ws. 8.40, Review by Rehoux. 8.45, ont of Chamber Music: Raymond Belinkoff iola), Margelle Soulage (Pianoforte) and eleine Barbreau (Songs). Concerto in B nor for Viola and Pianoforte (Handel); gs; Viola Solos: (a) Jis-Roel (Soulage), (b) Litany (Schubert), (c) Chanson et boîte usique (Tausman-Belinkoff), (d) Dance of yllphis (Jenkunson-Belinkoff), (e) Astuna y Granadina (Nin); The Calvet Quartet ramophone Records: String Quartet (ebussy). In the interval at 9.15, News.

RSGRUND.—See Oslo.

**POZNAN**

kc/s, 335 metres; 1.9 kW.—7.0 p.m., ical Talk. 7.5, Miscellaneous Items and ws. 7.25, See Warsaw. 7.40, Theatre Notes l Programme Announcements. 7.45, Programme from Warsaw. 10.30, Time Signal, rts and Police Notes. 10.45 (approx.), se Down.

**PRAGUE**

kc/s, 488.6 metres; 120 kW.—4.0 p.m., Moravská-Ostrava. 4.50, Programme for idren. 5.5, Gramophone Music. 5.15, k. 5.25, Gramophone Music. 5.35, English

Lesson. 5.50, Gramophone Music. 6.5, Agricultural Report. 6.15, Talk for Workers. 6.25, News in German. 6.30, German Transmission: Dialogue on the Theatre. 7.0, Time and News. 7.10, See Brno. 7.55, Talk relayed from Kosice, 1,022 kc/s, 293 metres. 8.10, Violin Sonata in E, Op. 57 (Dvorák), by Stanislav Novak. 8.45, In Praise of Radio—Verses by Listeners. 8.55, Dutch Folk Song Recital by Marta Harlasova. 9.20, See Bratislava. 10.0, Time and News. 10.15, Talk in German: Art and Culture in 1933. 10.30 (approx.), Close Down.

**RADIO-SUISSE ROMANDE**

SOTTENS; 743 kc/s, 403 metres; 25 kW.; and Geneva, 395 kc/s, 760 metres.—7.0 to 7.15 a.m., Gymnastics. 12.28 p.m., Time Signal from Neuchâtel Observatory. 12.30, News and Weather. 12.40 (from Geneva), Gramophone Music. 1.0 (from Geneva), Financial News. 1.10 (from Geneva), Gramophone Music. 2.0 to 3.28, Interval. 3.28, Time Signal from Neuchâtel Observatory. 3.30 (from Lausanne), Concert by the Radio Lausanne Orchestra, conducted by Moser. 5.0 (from Lausanne), Programme for Children. 5.30 to 7.0, Interval. 7.0, Talk on the Forthcoming Production of the Berlioz Opera, The Damnation of Faust, at La Chaux-de-Fonds. 7.30 (from Lausanne), Weather, News, and Report of the Swiss Peasants' Union. 7.35 (from Lausanne), Talk: The Sanitation of the Canton of Vaud and the Town of Lausanne. 8.0 (from Lausanne), Extracts from Hamlet—Play (Shakespeare), on Gramophone Records. 9.0 (from Geneva), Talk: A Stradivarius Epic. 9.15, Concert of Romanian Music, with Introductory Talk by Vamareco. Soloists, Mme. Pia Igy (of the Royal Opera House, Bucharest) and Nicola Vamareco (Guitar).

**REYKJAVIK**

250 kc/s, 1,200 metres; 21 kW.—9.5 p.m., Musical Programme. 9.30, Weather Report. 9.40, Musical Programme and Announcements. 10.0, Chimes and News. 10.30, Reading. 11.0, Popular Music by the Radio Quartet, with Songs.

**RIGA**

572 kc/s, 525 metres; 15 kW.—6.30 p.m., English Lesson. 7.0, Weather. 7.3, Talk: The Life and Work of Anna Brigades. 7.30, Latvian Songs. 8.0, News. 8.25, Raudpiete—Play in Three Acts (Brigades). In the interval at 9.0, News. 10.0 (approx.), Close Down.

RJUKAN.—See Oslo.

**ROME**

Call IRO, 680 kc/s, 441 metres; 50 kW. Relayed by Naples. 941 kc/s, 319 metres; Bari, 1,112 kc/s, 269.8 metres; Milan (Vigentino), 662 kc/s, 453.2 metres from 8.45 p.m., and 2R0, 11,810 kc/s, 25.4 metres from 5.15 p.m.—12.30 p.m., Variety Music on Gramophone Records. 1.0, Gramophone Concert of Opera and Variety Music. In the interval from 1.30 to 1.45, Giornale Radio and Exchange. 2.0, Time and Announcements. 4.30, Children's Radio Review. 4.55, Giornale Radio and Exchange. 5.10, Weather. 5.15, Vocal and Instrumental Concert. Soloists: Dina Fiumana (Soprano) and Germano Arnaldi (Pianoforte); Trio, Op. 12, for two Violins and Viola (Kodaly); Soprano Solos: (a) Aria from The Secret Marriage (Cimarosa), (b) Caro nome, from Rigoletto (Verdi), (c) Cavatina from Don Pasquale (Donizetti); Syncopated Music for Pianoforte. 6.40 (Naples), Shipping and Sports Notes. 6.45, Popolavoro Report and Tourist Notes. 7.10, Agricultural Report. 7.20, News in Foreign Languages. 7.40, Giornale Radio. 8.0, Time, Announcements and Gramophone Music. 8.30, Giornale Radio and Sports Notes. 8.45, La sonnambula—Opera in Three Acts (Bellini). In the intervals, Talk and Theatre Notes. Giornale Radio after the Opera.

SALZBURG.—See Vienna.

**SCHWEIZERISCHER LANDESENDER**

BEROMUNSTER, 653 kc/s, 459 metres; 60 kW.; Basle, 1,229 kc/s, 244.1 metres; and Berne, 1,220 kc/s, 245.9 metres.—11.59 a.m., Time Signal from Neuchâtel Observatory and Weather. 12 Noon (from Basle), Organ Music on Gramophone Records. 12.30 p.m., Time, Weather and News. 12.40 (from Basle), Talk: The International Animal Protection Day (4th October). 12.45 (from Basle), Light Music on Gramophone Records. 1.25 (from Basle), Time, Weather and Exchange. 1.30 (approx.) to 5.0, Interval. 5.0 (from Basle), Talk: The Musical Education of Children. 5.30 (from Basle), Operetta Music on Gramophone Records. 6.30 (from Zürich), Talk with Gramophone Illustrations; Two Thousand Years of Japanese and Chinese Music. 7.0, Time and Weather. 7.5 (from Zürich), Gramophone Music. 7.30 (from Zürich), Elementary English Lesson. 8.0 (from Zürich), Concert by

the Station Orchestra, conducted by Gilbert. 8.30 (from Zürich), Talk: Travels in Greece. 9.0, Weather and News. 9.10 (from Zürich), The Development of the Symphony—Mozart Concert by the Station Orchestra, with Commentary by Hermann Odermatt. 10.15 (approx.), Close Down.

SOTTENS.—See Radio-Suisse Romande.

**STOCKHOLM**

689 kc/s, 436 metres; 55 kW. Relayed by Boden, 244 kc/s, 1,229.5 metres; Göteborg, 932 kc/s, 322 metres; Hörby, 1,166 kc/s, 257 metres; Motala, 221.5 kc/s, 1,354.4 metres; Östersund, 389 kc/s, 770 metres; and Sundsvall, 554 kc/s, 542 metres.—1.0 to 1.30 p.m., Broadcast for Schools, relayed from Malmö, 1,301 kc/s, 231 metres. 5.5 (from Sundsvall), Accordion Music. 5.30, Talk, relayed from Norrköping, 1,292 kc/s, 232.2 metres. 5.50, Gramophone Music. 6.45, Elementary German Lesson. 7.15, Weather and News. 7.30, Dialogue on Economies. 8.30, Song Recital by Isabel Ghasal-Othman: La Partida (Alvarez); Two Songs (Giannini): (a) Zoupa Ileri Ileri! (b) Manella nia; Les filles de Cadix (Delibes); Two Persian Folk Songs. 8.50, Cello Recital by Karl Bjarnhof, relayed from Malmö, 1,301 kc/s, 231 metres. Suite No. 1 in A (Chou d'Hervelois); Au Soir (Blasy); Sicilienne (Faure); Scherzo (Grieg). 9.15, Talk. 9.45, Weather and News. 10.0, Musical Cabaret. 11.0 (approx.), Close Down.

**STRASBOURG**

869 kc/s, 345 metres; 11.5 kW.—11.30 a.m., Variety Music on Gramophone Records. 12.45 p.m., News. 1.0, Time and Exchange. 1.5, Dance Music on Gramophone Records. 2.0, Interval. 5.0, Orchestral Concert, conducted by Roskam. March (Heymann); Waltz Pagan Moon; Extase (Ganne); Air from Das Lied der Liebe (Joh. Strauss-Korngold); Selection from Les Saltimbanques (Ganne); Tango, Pour toi; Foxrott, Just a Night for Meditation; Waltz, Luna (Lineke); Violin Solo: Humoresque (Dvorák-Kreisler); Pour dire adieu; Tango, Alma Herida; Two Step, Vizzavona (Bozi). 6.0, Literary Review. 6.15, Review of the Week in German. 6.30, Chamber Music. Sextet (Brahms); Affettuoso (Bach); Violin and Pianoforte: Gavotte and Burlesque (Scriabini); Two Cellos: Sonata No. 6 (Leclair); Quartet (Loelliet). 7.30, Time and News. 7.45, Gramophone Music. 8.0, Press Review in German, Lottery Results and Announcements. 8.30, Concert by the Station Orchestra and Soloists. Conductor: Maurice de Villers. Part I Gounod Music. Overture dramatique; Spanish Dance and Italian Dance from Le tribut de Zamora; Ballet Music and Air from The Queen of Sheba; Prayer from The Messe à Jeanne d'Arc; Entr'acte from The Pet Dove. Part II, Ballad from The Earl King's Daughter (Gade); Melodies from Elverskud (Gade); Melodies from Aucassin and Nicolette (Eina); L'enfant prodigue (Debussy). In an interval at 9.30 (approx.), Press Review. 10.30 (approx.), Close Down.

**STUTTIGART**

MUHLACKER, 832 kc/s, 360.5 metres; 60 kW. Relayed by Freiburg, 527 kc/s, 570 metres.—1.35 p.m., See Langenberg. 2.30 to 3.30, Interval. 3.30, Talk: Germany's Lost Territory—Alsace. 4.0, Concert by the Station Orchestra, conducted by Gustav Gährlich. Wiener Heurigen-Marsch (Römi-sch); Selection from Der Obersteiger (Zeller); Waltz from The Gipsy Baron (Joh. Strauss); Overture, Poet and Peasant (Suppé); Selection from Eva (Lehar); Waltz from Das Fürstentum (Lehar); Selection from A Night in Venice (Joh. Strauss); Polka Mazurka from Die seltsame Poln (Müllbacher); Potpourri of Marches (Komzak). 6.0, French Lesson. 6.20, Talk: Georg von Frundsberg, the Organizer of the German Infantry. 6.35, Talk: The Italian Popolavoro Movement. 6.50, Time and Market Prices. 7.0, See Frankfurt. 10.0, See Munich. 10.20, Talk: You must know... 10.30, Time and News. 10.45, Local Announcements. 11.0, Programme from Leipzig. 12 Midnight, Serenade. 1.0 a.m. (Tuesday), Close Down.

SUNDSVALL.—See Stockholm.

**TOULOUSE**

RADIOPHONIE DU MIDI, 779 kc/s, 385 metres; 8 kW.—6.0 p.m., News. 6.15, Viennese Music. 6.45, Popular Melodies. 7.0, La Boite à Jouxoux (Debussy), by a Symphony Orchestra. 7.15, News. 7.30, Orchestral Music. 7.45, Opera Music. Airs from (a) Romeo and Juliet (Gounod), (b) Manon (Massenet), (c) The Fair Maid of Perth (Bizet); Quartet from Rigoletto (Verdi). 8.0, Military Music. 8.15, Operetta Music. Selection from Eva (Lehar); Waltz from Die Teresina (O. Strauss); Selection from Les noces de Jeannette (Massé). 8.30, Accordion Music. 8.45, L'Africaine—Opera (Meyerbeer) (Concert Version). 9.15, Orchestral Music. 9.45, Opera Music: Airs from Lohengrin (Wagner), Don Giovanni (Mozart), Sigurd (Reyer), and The Tales

of Hoffman (Offenbach). 10.0, Hunting-Horn Music. 10.15, News. 10.30, Concert for Listeners in Morocco (Clavelitos (Valverde); Petite chose (Charlys); Suite orientale (Popy); Duet from Werther (Massenet); Selection from H est charmant (Moretti); Cardas (Kaisz). 11.0, Request Music. Seduction (Cazes); Overture, Poet and Peasant (Suppé); Song of the Volga Boatmen; Si petite; March of the Foreign Legion. 11.15, Dance Music. 12 Midnight, News. 12.5 a.m. (Tuesday), Chansonnettes. 12.15, Music by a Viennese Orchestra. 12.30 (approx.), Close Down.

**TRIESTE**

1,211 kc/s, 247.7 metres; 10 kW.—5.10 p.m. till Close Down, See Turin.

TRONDHEIM.—See Oslo.

**TURIN**

1,096 kc/s, 273.7 metres; 7 kW. Relayed by Milan, 905 kc/s, 331.5 metres; Genoa, 959 kc/s, 312.8 metres; and Florence, 599 kc/s, 500.8 metres.—5.10 p.m., Mandoline Concert. 6.0 to 6.5, Giornale Radio, Popolavoro Report and Gramophone Music. 7.0, Time, Tourist Report and Gramophone Music. 7.10, Wheat Market Report. 7.20, News in Foreign Languages. 7.40, Gramophone Music. 8.0, News and Weather. 8.15, Sponsored Concert. 9.15, A Comedy. 9.45, Trio Op. 99 for Pianoforte, Violin and Cello (Schubert). 10.30, Orchestral Concert, conducted by Tito Petralia. Melody (Dax); Moonlight on the River (Gilbert); Sanguie gitano (Mattani); Pastoral Suite (Scassola); My beloved (Myers); Melody (Pascal-Bastia). 11.0, Giornale Radio.

**VATICAN CITY**

15,120 kc/s, 19.84 metres (Morning) and 5,969 kc/s, 50.26 metres (Evening); 10 kW.—11.0 to 11.15 a.m., Religious Information in Italian. 8.0 to 8.15 p.m., Religious Information in Italian.

**VIENNA**

581 kc/s, 517 metres; 100 kW. Relayed by Graz, 852 kc/s, 352.1 metres; Innsbruck, 1,058 kc/s, 283 metres; Klagenfurt, 662 kc/s, 453.2 metres; Linz, 1,220 kc/s, 245.9 metres; and Salzburg, 1,373 kc/s, 218.5 metres.—1.10 p.m., Gramophone Concert. 2.0, Interval. 3.0, Time, Weather and Market Report. 3.20, Talk: The Dutch Oven. 3.30, Programme for Children. 3.55, Choral Music on Gramophone Records. 4.35, Programme for Young People.—Reading of Ballads. 5.0, Talk on Brahms. 5.25, Lieder Recital by Jella Braun-Fernwald (Contralto). 6.5, Talk: Weinwurm, the Architect of the Stephansurm. 6.25, Books of Reference in connection with the Week's Talks. 6.30, Elementary English Lesson. 7.0, Concert by the Wiener Symphoniker conducted by Holzer. Soloist: Ernst Arnold (Tenor). Viennese Festival Overture (Suppé); Tenor Solo: Lachendes, klingendes, singendes Wien (Arnold); Waltz, Wiener Madln (Ziehrer). Tenor Solos: (a) Das Lied vom Zusehauer (Granietchaeden), (b) Ja wer ist schuld (Götz); March, Weaner Drahrer (Kronegger); Tenor Solos: (a) Ein Wiener Lied, ein Wiener Madel (Flemming), (b) Im Prater blühen wieder die Bäume (Stolz); Overture, Wiener Franen (Lehar); Tenor Solos: (a) Du grüde Märchenwelt (Arnold), (b) Song from Der Rastelbinder (Lehar); Potpourri, Wien bei Nacht (Komzak); Tenor Solo: Kinder san ma, froh das ma g'sund san (Arnold); Waltz, Wiener Blut (Strauss); March, Wien bleibt Wien (Schrammel). In the interval at 7.45, Time and Weather. 8.30, Topical Talk. 8.45, Chamber Music by the Kolisch Quartet. String Quartet in C Sharp Minor, Op. 131 (Beethoven); Variations (Krenek). 9.45, News, Weather and Exchange. 10.0, Gramophone Concert. After the Programme, Exchange.

**WARSAW**

212.5 kc/s, 1,411 metres; 120 kW.—11.57 a.m., Time Signal and Fanfare from St. Mary's Church, Cracow. 12.5 p.m., Gramophone Music. 12.30, Radio Journal. 12.35, Gramophone Music. 1.0 to 3.30, Interval. 3.30, Economic Notes. 3.40, Answers to Correspondence. 3.45, Aviation Report and Anti-Gas Drill. 3.55, Light Orchestral Concert, relayed from Lwów, 788 kc/s, 381 metres. 4.40, Elementary French Lesson. 4.55, Recital by Rössler-Stowska (Soprano) and Czaplinsky (Violin), relayed from Lwów. 5.50, Agricultural Report. 6.0, Talk on Economic Problems. 6.20, Programme for Soldiers. 6.45, Gramophone Music. 7.5, Miscellaneous Items. 7.25, Talk: Adam Wieniawsky. 7.40, Programme Announcements. 7.45, Radio Journal. 8.0, Wieniawsky Concert by the Station Symphony Orchestra, conducted by Wolfstal. Soloists: Hliewicka (Pianoforte) and Lipowska (Soprano). Extracts from Lidita; Pianoforte Solos; Soprano Solos; Songs in Popular Style; Magae—Japanese Lyric Legend in Two Acts, for Male Voice Choir, Women's Choir, Soloists and Orchestra. 10.40, Topical Talk and Sports Notes. 11.0, Aviation, Weather Report and Police Notes. 11.5, Dance Music on Gramophone Records.

ZÜRICH.—See Schweizerischer Landessender.



## ATHLONE

725 kc/s, 413 metres; 60 kW. Relayed by Cork, 1,337 kc/s, 224.4 metres.—1.30 to 2.30 p.m., Time, Weather, Stock Report and Gramophone Music. 6.0, Programme for Children. 6.40, News. 7.0, Gaelic Programme. 7.15, Readings. 7.30, Time Signal. 7.31, The Station Orchestra. 8.0, Piano-forte Solos by Marie Muleahy. 8.15, Tenor Solos by Harrison. 8.30, The Station Orchestra. 8.50, Soprano Solos by Kathleen Grennon. 9.0, The Emer Comedy Company. 9.30-10.30 p.m., Programme by the I.B.C. (Ireland) Ltd. 9.30 p.m., Concert: What have we got to lose? (Kent); The Moment I saw you (Gay); The Whisper Waltz (Burke); Home-made Heaven (Rainger). 9.45, Tango Band Music: Argentine Moon (Elkins); To-night (Lesso); The Night is gone (Castello); Zigeuner, you have stolen my heart (Egen). 10.0, Concert arranged by the International Broadcasting Company (Ireland) Ltd., on behalf of Hospitals Trust, Ltd.: Bandmaster March; Glow Worm Idyll (Lincke); Regiment-kinder (Fueck); Waltz, Jolly Fellows (Vollstedt); March, Stars and Stripes (Souza); A Gipsy Impression (Scott); Minchin); Waldmere March (Losey). 10.30, I.B.C. Goodnight Melody. 10.33, News and Weather. 10.40, Piano-Accordion Solos by Joe Carey. 11.0 (approx.), Close Down.

## BARCELONA

EAJ1, 850 kc/s, 348.8 metres; 8 kW.—7.0 p.m., Trio Concert: Selection from Mephistopheles (Boito); Venetian Barcarolle (Mendelssohn); Intermezzo (Delmas); Alt-Wien (Drda); Sérénade d'amour (Doubiez); Canto apasionado (Malvezzi); Selection from Le Cid (Massenet). 8.0, Request Gramophone Records. 8.30, Exchange Quotations and Talk in Catalan. 9.0, Request Gramophone Records and News. 10.0, Chimes, Weather, Messages for Seamen and Exchange. 10.5, Sponsored Programme. 10.30, Concert by the Station Orchestra: Sérénade, Granada (Albeniz); Russian Festival (Frigola); Dance (Furina); Overture, Oberon (Weber). 11.0, Concert of Light Music. 12 Midnight (in an interval), News. After the Concert, Dance Music on Gramophone Records. 1.0 a.m. (Wednesday), Close Down.

BASEL.—See Schweizerischer Landessender.

## BELGRADE

697 kc/s, 430.4 metres; 2.8 kW.—6.55 p.m., Time and Programme Announcements. 7.0, Talk. 7.30, Popular Music on Gramophone Records. 8.0, Saxophone Solos by Alexander Nikolic. 8.30, European Concert, relayed from Bucharest. In the interval at 10.0, Time and News. 10.40, Dance Music on Gramophone Records.

## BERLIN

DEUTSCHLANDSENDER (Reichssender), 133.5 kc/s, 1,635 metres; 60 kW.—12 Noon, Weather. 12.2 p.m., Gramophone Concert: Concerto grosso in D (Handel); Six German Dances (Mozart); Tarantella from the Suite, Venezia e Napoli (Liszt); Overture, The Barber of Bagdad (Cornelius); Waltz from the Ballet Suite (Reger); Tocata in C Sharp Minor (Debussy); Waltz in E Minor (Chopin); Dreams on the Ocean (Gungl); Die Welle (Metra); Liebesmarchen Walzer (Oscheit); Der Liebe Freund und Leid (Lindsay-Thiemer). 12.55, Time. 1.45, News. 2.0, Gramophone Concert of Operetta Music: Overture, Bereccio (Suppé); Melody from Der Obersteiger (Zeller); Das Lied vom süßen Mädel (Reinhardt); Second Waltz Potpourri (Robrecht); Selection from Die Landstreicher (Ziehrer); Selection from Eva (Lehár); Czardas from Die Fledermans (Joh. Strauss); Selection from The Maid of the Black Forest (Jesse); You are my heart's delight, from The Land of Smiles (Lehár); Selection from The Gipsy Baron (Joh. Strauss); Ach, ich hab' sie ja mir auf die Schulter geküsst. (Millöcker). 3.0, Programme for Young People: How to Construct Model Aeroplanes and Gliders. 3.30, Weather and Exchange. 3.45, Reading from Gewalt über das Feuer (Hans Friedrich Blunck). 4.0, See Breslau. 5.0, An Interview with Agnes Blum, a distinguished Authority on Heredity. 5.20, Concert of Music by Contemporary Munich Composers. Irgard Pröhland M. Hartmann (Songs) and Paul Gerhard Scholz (Piano-forte). Songs from The Chinese Flute (Frankenstein); Five Songs from the Rilke-kreis (Karl Marx); Three Pieces from Sechs Stimmungsbildern (von Westermann); Two Pieces from Heibel Gesänge (Pottgiesser). 6.0, Poems. 6.5, Talk by a Publisher: Books have their Ups and Downs. 6.25, Political Press Review. 6.45, Weather and Announcements. 7.0, Transmission for all German Stations, relayed from Berlin (Funkstunde). 8.0, An Axiom. 8.5, Concert, conducted by the Japanese Conductor, Konoye, relayed from the Philharmonic. 9.0, Weddings—a Topical Programme. 10.0, News. 10.45, Weather. 11.0, Concert from Hamburg. 12 Midnight, Close Down.

## BERLIN

FUNKSTUNDE, 715 kc/s, 419.5 metres; 1.5 kW.—6.0 p.m., Book Review. 6.30, The Funkstunde informs its Listeners. . . . 6.45, Topical Talk. 7.0, Transmission for all German Stations: Brahms Concert by the

# TUESDAY

## OCTOBER THE THIRD

### PRINCIPAL EVENTS OF THE DAY:

**AT HOME**

**NATIONAL LONDON REGIONAL** Burlesque programme by the Brothers Melhuish. Promenade concert from Queen's Hall.

**NORTH REGIONAL** Instrumental concert.

**WEST REGIONAL** "The Fire-Lighters," a dialogue, by Laurence Houseman.

**SCOTTISH REGIONAL** Band concert.

**BELFAST** Orchestral concert.

**ABROAD**

**BERLIN (Deutschlandsender)** 8.5 p.m. Concert from the Philharmonic, conducted by the Japanese conductor, Konoye.

**BUCHAREST** 8.30 p.m. European concert, by the Philharmonic and Radio Orchestras, conducted by Georgesco, relayed by Warsaw.

**COPENHAGEN** 8.50 p.m. English suites, by the Station Orchestra, conducted by Emil Reesen.

**HAMBURG** 8.0 p.m. Acts I and II of Opera "Die Königskinder," by Hamperdinck. 10.20 p.m. The Philharmonic Orchestra.

**HILVERSUM** 8.0 p.m. The Concertgebouw Orchestra and the Scala Choir of Milan, relayed from Amsterdam.

**LANGENBERG** 10.40 p.m. Tchaikovsky's Symphony No. 5, in E Minor, by the Station Orchestra, conducted by Buschkötter.

**MUNICH STUTTGART** 8.0 p.m. Operetta: "Das Modell," by Suppé. 8.10 p.m. Johann Strauss concert, by the Station Orchestra.

Berlin Station Orchestra, conducted by Otto Frickhoeffer and the Berlin Station Choir, conducted by Heinz Karl Weigel. Soloists: Agnes Leydhecker (Contralto). Rhapsody for Contralto Solo, Male Chorus—Fragments from Goethe's Harzreise, and Orchestra, Op. 53; Symphony No. 2 in D, Op. 73. 8.0, See Berlin (Deutschlandsender). 8.15, Der grosse Topf—Sketch (Heinrich Schmidt Schmiedebach). 9.5, Concert of Handel Opera Music by the Station Orchestra, conducted by Georg Gühler. Soloist: Agnes Leydhecker (Contralto). Overture, Alcina; Irene's Aria from Tamerlano; Overture, Berenice; Two Arias from Partenope; Air from Alcina. 10.0, News. 10.20, See Hamburg. In an interval at 11.0, Theatre and Film Review. 12 Midnight (approx.), Close Down.

BERNE.—See Schweizerischer Landessender.

BEROMUNSTER.—See Schweizerischer Landessender.

BODEN.—See Stockholm.

BODO.—See Oslo.

## BRATISLAVA

1,076 kc/s, 279 metres; 11 kW.—5.50 p.m., Violin Recital. 6.40, Talk on Telegraphy. 6.55, Hints for Housewives. 7.0, See Prague. 8.30, European Concert relayed from Bucharest. 10.40, See Prague.

BREMEN.—See Hamburg.

## BRESLAU

923 kc/s, 325 metres; 60 kW. Relayed by Gleiwitz, 1,184 kc/s, 253 metres.—1.0 p.m., Weather. 1.5, Famous Singers on Gramophone Records. 1.45, Time, Weather, News, and Exchange. 2.10, Piano-forte Recital by Vally Schmidt. 2.35, Gramophone Concert. 3.35, Agricultural Prices. 3.45, Book Review. 3.55, Programme for Children. 4.0, Concert by the Silesian Philharmonic Orchestra, conducted by Fricke. 5.30, Agricultural Prices. 5.45, Reading (Nielsen). 6.0, Programme to be announced. 6.25, Talk: Luther's Inner Conflicts. 6.50, Market Prices. 7.0, Transmission for all German Stations, relayed from Berlin (Funkstunde). 8.0, News. 8.10, Concert of Folk Dances relayed from the Great Hall of the Concert House. 9.10, Talk: The Cultivation of the Heart. 9.30, String Quartet in D, Op. 61, No. 5 (Haydn). 10.0, Time, Weather and News. 10.25, Political Press Review. 10.45, Dance Music and Light Music by the Sparmann Orchestra, relayed from the Vaterland Café. 12 Midnight, Close Down.

## BRNO

878 kc/s, 342 metres; 35 kW.—5.50 p.m., Gramophone Music. 6.0, Review of Music.

Strauss); Songs: (a) Theme with Variations (Proch), (b) Aria from The Barber of Seville (Rossini); Ballet Music from Hérodiate (Massenet). 10.0, Le Journal Parlé.

## BUCHAREST

761 kc/s, 394 metres; 12 kW.—5.0 p.m., Light Music and Romanian Music by the Motoi Orchestra. In an interval at 6.0, Radio Journal. 7.0, Educational Programme. In an interval at 7.20, Gramophone Music. 8.30 to 10.40, European Concert, by the Philharmonic Orchestra and the Radio Orchestra, conducted by Georgesco. 8.30, Symphony Concert: Romanian Rhapsody (Stau Golestan); Country Festival (Enacovici); Kermesse (Nottara), conducted by the Composer. 8.55, Popular Romanian Songs by Georges Foleseo (Bass); Plänge-ma mama cu dor (Juga); Lung e drumul (Anjului (Juga); Bate murgul din picior (Brailoiu); Jos pe Mures (Borgovan); Inghetata! Dumarea (Kiriac); Unde-ai ecul cantand (Kiriac); Duce m'asi si m'asi tot duce (Montia). 9.20, Symphony Concert (contd.): Finale from The Serenade (Andric); Two Sketches (Rogalski), conducted by the Composer; Two Dances from Del a Matei cetire (Nona Ottesco), conducted by the Composer; Rhapsody in A (Enesco). 10.0, Interval. 10.10, Programme by the Carmen Choral Society, conducted by Professor Chiresco. 10.45, Radio Journal.

## BUDAPEST

545 kc/s, 550.5 metres; 18.5 kW. Also relayed on 840 metres from 8.0 till Close Down.—5.0 p.m., Concert by the Csorba Cigany Orchestra. 5.40, Talk with Song Illustrations: The Music of Szentimay. 6.10, Violin Recital. 6.50, French Lesson. 7.20, Concert by a Blind Choir. 8.0, Reading. 8.30, Operetta Music by the Concert Orchestra, conducted by Vaszy, and Soloists. 10.0, News. 10.15 (approx.), Jazz Music and Cigany Music from the Café Ostende, with Hungarian Folk Song Refrains by Kalmar Pal.

CASSEL.—See Frankfurt.

## COPENHAGEN

1,037 kc/s, 281 metres; 0.75 kW. Relayed by Kalundborg, 260 kc/s, 1,153.8 metres.—12 Noon, Time and Chimes from the Town Hall. 12.5 p.m., String Ensemble Concert from the Bellevue Strandhotel. 2.0, Interval. 3.0, Concert by Mogens Hansens' Instrumental Ensemble; Soloist, Karl Paulsen (Songs); March from Der fliegende Rittmeister (Dostal); Waltz, Pomona (Waldeufel); Selection from The Barber of Seville (Rossini); Theme with Variations from the Kaiser Quartet (Haydn); Serenade (Jorgensen); Salute to Spring (Jorgensen); Torch Dance (Jorgensen); Danish Songs; Ballet Suite (Gyldmark); Pavane pour une Infante défunte (Ravel); Wedding Scenes (Smetana); Overture, Le Cheval de Bronze (Anber). 5.0, Programme for Children. 5.30, Exchange and Fish Market Prices. 5.45, Talk. 6.15, Elementary German Lesson. 6.45, Weather and News. 7.15, Time Signal. 7.30, Talk: The Chinese Mind. 8.0, Chimes from Folk Town Hall. 8.5, Choral Recital of Folk Music, with Commentary. 8.50, English Suites by the Station Orchestra, conducted by Emil Reesen: Three Pieces from The Egyptian Suite (Haydn Wood); Suite, The Four Ways (Eric Coates). 9.15, Radio Play in Three Acts (Sörensen). 10.0, News. 10.15, Concert by the Station Orchestra, conducted by Emil Reesen. 11.0, Dance Music relayed from Nim's Restaurant. In the interval at 12 Midnight, Time and Chimes from the Town Hall. 12.30 a.m. (Wednesday), Close Down.

CORK.—See Athlone.

## CRACOW

959 kc/s, 312.8 metres; 1.5 kW.—7.0 p.m., Talk: Old Cracow. 7.15, Miscellaneous Items and News. 7.25, See Warsaw. 7.40, Programme Announcements. 7.45, See Warsaw. 8.30, European Concert, relayed from Bucharest. 10.40, See Warsaw. 11.30 (approx.), Close Down.

DANZIG.—See Heilsberg.

DRESDEN.—See Leipzig.

## FECAMP

1,328 kc/s, 225.9 metres; 10 kW.—11.0 a.m. to 12 Noon, Programme in English by the I.B.C. 11.0, Happy Hour. Part I: Orchestral Concert. Signature Tune; Selection from The Flower of Hawaii (Abramson); A Birthday Serenade (Lincke); Sweetheart, I'm dreaming of You (Desmond); The Valley of the Poppies (Ancliffe); I kiss your Lip (Rudolph); When day is done (de Sylva); Serenade (Blon); The Old Spinning Wheel (Hill). Part II: Dance Music. I wish had wings; All over Italy; Have you had good day to-day; Chewing Gum; Twelfth Street Rag; It's Sunday down in Caroline. I raised my Hat; It was a Night in June. Signature Tune. 12 Noon, French Programme. 4.30 to 6.0, Programme in English; by the I.B.C. 4.30, Programme for Children

## BRUSSELS (No. 1)

I.N.R., 590 kc/s, 509 metres; 15 kW.—12 Noon, Concert by the Small Station Orchestra, conducted by Leemans. 1.0 p.m., Le Journal Parlé. 1.10, Extracts from The Cid—Opera (Massenet) on Gramophone Records. In the interval at 1.25, Recital on Two Piano-fortes: Invitation to the Waltz (Weber-Sammel); Allegro de concert (Wehle). 5.0, Concert by the Radio Orchestra, conducted by André: Concert Waltz (Albeniz); Valse lente (Chopin); Valse triste (Sibelius); Le pas des fleurs (Tchaikovsky); Waltz Op. 10 (Rachmaninov); Two Waltzes (Dvorak). 5.30, Programme for Children. 6.5, Literary Talk. 6.15, Piano-forte Recital by Mlle. Bulens. 6.30, Concert by the Small Station Orchestra, conducted by Leemans: Suite (Chaminade); Flute Solos: (a) Romance (Saint-Saëns), (b) Melody (Gaubert); Suite, Harlequinade (Casavecue); Selection from Les fantoccini (Lecocq). 7.15, Film Review. 7.30, Art Notes and Talk for Women. 8.0, Albéniz Concert by the Radio Orchestra, conducted by André: Recuerdos de viaje; Spanish Suite; Mallorca; Oriental Dance, Zambra grandina. 8.45, Talk: The Campaign against Dishonest Financiers. 9.0, Gramophone Concert of Popular Songs of Many Lands. 9.55, Christus Vincit (Liszt). 10.0, Le Journal Parlé.

## BRUSSELS (No. 2)

I.N.R., 887 kc/s, 339.2 metres; 15 kW.—Programme in Flemish. 12 Noon, Gramophone Concert. 1.0 p.m., Le Journal Parlé. 1.10, Concert by the Small Station Orchestra, conducted by Leemans. 5.0, Gramophone Concert. 5.45, Programme for Children. 6.30, Viennese Music on Gramophone Records: Overture, Die Fledermans (Joh. Strauss); Selection from The Count of Luxembourg (Lehár); The Merry Widow (Lehár); The Last Waltz (O. Strauss). 7.0, Gramophone Music: Rhapsody for Orchestra and Saxophone (Debussy); Schön Rosmarin (Kreisler); Gollwog's Cake-Walk (Debussy). 7.15, Talk. 7.30, Le Journal Parlé. 8.0, Het Verraad der Intellectuelen—Radio Play (Bas van Doilen). 9.0, Concert by the Radio Orchestra, conducted by Franz André. Soloist, Mme. Van den Rydt (Songs). Melody (Brecht-Eisler); Overture, Tancred (Rossini); Songs: (a) Scene and Rondo from Bilet de Loterie (Lionard), (b) Chanson provençale (Dell'Acqua); Hindu Song (Rimsky-Korsakov); Waltz, Tales from the Vienna Woods (Joh.

OCT. 3rd

TUESDAY

continued

5.0, Accordion Concert for Torquay and Export Listeners. Signature Tune, The Night by the Sea; Comedy Overture (Keler-Sela); Javanette; Accordion Solo, La Tourerelle (Damare); Volante; The Lullaby of the Leaves; Accordion Solo, Petit Jean (Cavelier); Accordion Nights; Bertino. 5.30, Concert of Light Music for Plymouth and Devonport Listeners. Rosa mia (Guzar); The Busy Bee (Bendix); Down in the Valley (Harrington); My lady dainty (Hesse); Roll up the Carpet (Klages); I shall remember you; Ding, Dong, Ding (Hargreaves); Jack Payne's Memories; Signature Tune. 6.0, French Programme. 10.0 till Close Down, Programme in English by the I.B.C. 10.0, Dance Music. Signature Tune, Bells of Norway; Peter, Peter; There's a Light in our Window; I'm one of the Lads of Valencia; Look what you've done; Waltzing in a dream; Dancing Butterfly; Pop Gun; You're mine you; Hyde Park Corner; Good-night but not Good-bye; That's my Home; Us the Band; Chewing Gum; Sittin' in the Park; All over Italy; This is the Rhythm or me; And so I married the girl; Signature tune. 11.0, Sound Film Music. Signature tune, Sittin' in the Dark; Selection from The Id from Spain; Selection from The King of Jazz (Whiteman); I've found the right girl; Selection from Sunny; Let the World go drifting by; Selection from Love me tonight; Why has a cow got four legs?; I see an echo in the valley; Signature Tune. 1.30, Concert arranged by the International Roadcasting Company (Ireland), Ltd., on behalf of Hospitals' Trust, Ltd. Signature tune, Come back to Erin; Donanwellen (vanovic); Ireland, Mother Ireland (Loughrough); The Phantom Brigade (Myddle); Selection from Chu Chin Chow (Norton); My Old Irish Cottage (Kavanagh); ylophone Solo: Liebesfreund (Kreiser); eight Bells (Lindeman); Waltz, Acclamations (Waldteufel); Signature Tune, Come back to Erin. 12.5 a.m. (Wednesday), I.B.C. ws Bulletin in English. 12.10 (approx.), ub Concert for Tenby Listeners. Signature Tune, The Chum Song; Alabama Song; ger Rag; Moon over Dixie; Arm in Arm; evenly Night. 12.30, Dance Music by mbrose and his Orchestra (Electrical anscriptions); Down the Old Ox Road; aybe I love you too much; Sylvia; When imble hits the Cymbal; I wake up smiling; nder my Umbrella; Sweetheart Darlin'; arm to croon. 1.0, Hot Jazz. Signature ume, Bells of Normandy; Eric Moon; ery-ground; Blues I love to sing; ulti-plicated Lady; Hot Feet; Saratoga ving; Moon over Dixie; The Dirty Glide.

ENSBURG.—See Hamburg.

ORENCE.—See Turin.

FRANKFURT

57 kc/s, 259.3 metres; 17 kW. Relayed by 57 kc/s, 259.3 metres; 17 kW. Relayed by 57 kc/s, 259.3 metres.—1.35 p.m., Concert by the Station Orchestra, conducted by inhold Merten; Introduction and Chorus us Der Schwur (Merkadante); Soldiers' orus and Waltz from Faust (Gounod); lection from Der Wildschütz (Lortzing); dtz, Fesche Geister (E. Strauss); Dumka d Cracoviak (Neubal); Waltz, Singen, hen, tanzen (Ziehrer); Kinderlieder- rtsch (Fetras). 3.30, Weather. 3.40, Time d Economic Notes. 4.0, See Langenberg. , Italian Lesson. 6.20, Radio Report from Emergency Czech. 6.35, Talk: The anges in Germany from 1929 to 1933, as n by an Englishman. 6.50, News. 7.0, nmission for all German Stations, red from Berlin (Funkstunde). 8.0, pical Talk. 8.10, See Stuttgart. 10.0, ws. 10.20, See Stuttgart. 10.30, News. 45, See Langenberg. 12 Midnight, Ser- le. 1.0 a.m. (Wednesday), Close Down.

EDRIKSSTAD.—See Oslo.

EIBURG.—See Stuttgart.

NEVA.—See Radio-Suisse Romande.

NOA.—See Turin.

EIWITZ.—See Breslau.

TEBORG.—See Stockholm.

AZ.—See Vienna.

MAR.—See Oslo.

HAMBURG

kc/s, 372 metres; 1.5 kW. Relayed by 19 kc/s, 227.4 metres; Flensburg, 19 kc/s, 227.4 metres; Hanover, 530 kc/s, metres; and Kiel, 1,292 kc/s, 232.2 tres.—6.0 p.m., Variety Programme. 6.45, ukfurt Exchange and Hamburg Market ces. 6.50, Weather. 7.0, Transmission all German Stations, relayed from Berlin (Funkstunde). 8.0, Acts I and II of Die nig-kinder—Opera in Three Acts (Humper- ck), relayed from the Municipal Theatre, an interval at 9.0, Announcements. 10.0, ws. 10.10, Topical Talk. 10.20, Concert the Hamburg Philharmonic Orchestra, ducted by José Eibenschütz; Overture, un Von U'recht (Grimpe); Abendlied; htliches Präludium (Bose); itlicher Zug (Kaum); Selection from illens (Bruch); Prelude to Act V of

King Manfred (Reinecke); Theme and Variations from Suite No. 3 (Tchaikovsky); Filr- tation (Steck); Suite from Sylvia (Debüss); Waltz, Paysage d'automne (Waldteufel).

HANOVER.—See Hamburg.

HEILSBURG

1,085 kc/s, 276.5 metres; 80 kW. Relayed by Danzig, 662 kc/s, 453.2 metres.—1.5 p.m., Gramophone Concert. In the intervals at 1.20 and 2.0, News. 2.30, Programme arranged by the Post Office with Gramophone Records. 3.0, Agricultural Prices and Exchange Rates. 3.30, Musical Improvisations for Children. 4.0, Concert by the Small Station Orchestra, conducted by Wilcken; Overture, Tancered (Rossini); Suite, A Mediterranean Trip (Jalowiec); Waltz, Jugendträume (Strauss); Potpourri, Rumania (Geiger); Intermezzo from Si (Mascagni); Selection from Der arme Jonathan (Müllöcker); Florentine Serenade (Seybold); Overture, Die beiden Husaren (Doppler). In the interval at 4.50 (approx.), Fashion Review. 5.45, Talk: The German Language. 6.15, Agricultural Prices. 6.25, Talk: Physical Training in the East Prussian Reichswehr. 6.50, Weather. 7.0, Transmission for all German Stations, relayed from Berlin (Funkstunde). 8.0, See Berlin (Deutschlandsender). 8.10, Johann Strauss Concert, relayed from the Saalbau, Ulm. The Orchestra conducted by Knappertsbusch, the Tentonia Choral Society conducted by Füssinger, and Soloists; Overture, Die Fledermaus; Song from Der Waldmeister; Lagunenwalzer from Eine Nacht in Venedig; Kusswalzer; Song, Frühlingstimmen-Walzer; Polka, Tritsch-Tratsch; Choir; Waltz, The Blue Danube; Overture, The Gipsy Baron; Waltz, Bei uns z'Haus; Duet from Cagliostro; Duet from Der lustige Krieg; Waltz, Freut euch des Lebens; Polka, Leichtes Blut. In the interval, Weather and News. 9.50, Weather and News. 10.10, Part Relay of the European Concert from Bucharest. 10.40 (approx.), Close Down.

HILVERSUM

1,013 kc/s, 296.1 metres; 7 kW up to 5.40 p.m., and 20 kW from 5.40 p.m. Programme of the Algemeene Vereeniging Radio Omroep (A.V.R.O.). 10.10 a.m., Chopin Pianoforte Recital by Betsy van Praag; Ballad in A flat; Impromptu in A flat; Waltz in A flat; Berceuse in D flat; Scherzo in B flat minor. 10.40, Talk: Cookery. 11.10, Concert by the Wireless Orchestra, conducted by Nico Treep; Auto March (Translatenr); Ballet (Popy); Selection from La Juive (Halévy); Gramophone Music; Overture, Masaniello (Auber); Waltz (Ganne); Selection from White Horse Inn (Benatzky-Krome); My Lady Brocade (Keleibey); Elfengelüster (Rhode); Walzerflut (Petras); Le regiment de Sambre et Meuse (Turlet). 1.10, Gramophone Music. 2.10, Harpsichord Recital. 2.40, Recitations. 3.10, Gramophone Music. 3.40, Song Recital by Ré Koster; Part I—Schubert Programme: Who is Sylvia; Goldelmnis; Suleika; Wiegenlied; Die Fellelle. Part II—Brahms Programme: Mädchenlied; Von ewiger Liebe; Immer leiser wird mein Sehnen; Ständchen; Der Schmelz. 4.10, Concert by a Children's Choir, conducted by Jacob Hamel. 4.40, Programme for Children. 5.10, Talk. 5.40, Concert of Light Music. 6.10, Talk. 6.40, Concert (contd.). 6.50, Talk. 7.0, Concert. 7.10, Talk. 7.25, Concert (contd.). 7.40, The Signal. 7.41, News. 7.45, Programme for the Unemployed. 7.45, March (Ganne). 7.50, Address by S. van Citters. 8.0, Concert by the Concertgebouw Orchestra, conducted by Albert van Raalte, and the Scala Choir, Milan, relayed from the Concertgebouw, Amsterdam; Overture, The Barber of Seville (Rossini); Chorus from Cavalleria rusticana (Mascagni); Chorus from Don Pasquale (Donizetti). 8.25, Address by Baron van Heemstra. 8.35, Concert (contd.): Gipsy Chorus from Il Trovatore (Verdi). 8.45, Address by E. Menten. 8.50, Vocal and Instrumental Concert—Soprano, Organ and Violin, Hélène Cals (Soprano), Pierre Palla (Organ), and Boris Lensky (Violin); Papa (Arditi); Il bacio (Arditi). 9.10, Address by H.R.H. Princess Juliana of Holland. 9.15, Concert (contd.): Soprano Aria from Lakmé (Delibes). 9.25, A Radio Play featuring Kees Koen. 9.45, Concert of Light Music by Kovacs Lajos and his Orchestra, with Interludes by the Fidelio Singers. 10.25, Gramophone Music. 11.40 (approx.), Close Down.

HORBY.—See Stockholm.

HUIZEN

160 kc/s, 1,875 metres; 7 kW. (until 3.40 p.m.). Transmitted from Kootwijk on 50 kW from 3.40 p.m.). Programme of the Catholic Radio Society (K.R.O.).—11.40 a.m., Police Notes. 11.55, Concert by the Vienna Station Orctel: Overture, Raymond (Thomas); Im Reiche der Venus (Groschal); Serenade (Tarengli); Serenata de Baci (de Micheli); Potpourri, Von Wien durch die Welt (Hrubý); Zigeunersehnsucht (Kempner); Selection from Der Geist des Woej- woden (Grossmann); Selection from The

Merry Widow (Lehár); Finale. In the interval at 12.40 p.m., Gramophone Music. 1.25, Interval. 1.40, Programme for Women. 2.40, Pianoforte Recital by Leni Costerman. 2.55, Contralto Song Recital by Agathe Reigers. 3.10, Gramophone Music. 3.25, Pianoforte Recital (contd.). 3.40, Song Recital (contd.). Ruhe, meine Seele (Strauss); Zueignung (R. Strauss); Gesang Weylas (Wolf); Wo ich dich Traust (Wolf). 3.55, Gramophone Music. 4.10, Concert by the Station Orchestra, conducted by Gerritsen. Scenes from the Scottish Highlands (Granville-Bantock); Overture, The Barber of Bagdad (Cornelius); Overture, Ali Baba (Cherubini); Petite suite (Debussy); Marche militaire française (Saint-Saëns); Indian Ballet (Debüss); Le cygne (Saint-Saëns); Suite, Scènes napolitaines (Massenet). In the intervals at 4.40, Talk on the Protection of Animals, and at 5.30, Gramophone Music. 6.20, Esperanto Lesson. 6.40, Police Report. 6.55, Talk on Theology. 7.15, Gramophone Music. In an interval at 7.25, Talk. 7.55, News. 8.0, Promenade Concert, relayed from London. In an interval at 9.30, Recitations. 10.30, News. 10.35, Orctel Concert. 11.40 (approx.), Close Down.

INNSBRUCK.—See Vienna.

JUAN LES PINS

1,205 kc/s, 249 metres; 0.8 kW.—8.0 p.m., Amusement Guide, Exchange, Racing Results and News. 8.10, Agricultural Report. 8.25, Radio Concert. In an interval at 8.45, News and Weather.

KALUNDBORG.—See Copenhagen.

KIEL.—See Hamburg.

KLAGENFURT.—See Vienna.

KOSICE.—See Prague.

LAHTI

167 kc/s, 1,796 metres; 40 kW. Relayed by Helsinki, 815 kc/s, 368.1 metres.—6.40 p.m., Negro Song Recital, with Commentary. 7.5, Talk. 7.30, Concert by the Station Orchestra, conducted by Toivo Haapanen. Soloist: Merete Söderhjelm (Pianoforte); Overture, Rosamunde (Schubert); Pieces for Chamber Orchestra (Maasz); Pianoforte Concerto in A (Mozart); Karelian Rhapsody (Klami). 8.45, News in Finnish and Swedish.

LANGENBERG

635 kc/s, 473 metres; 60 kW.—12 Noon, Concert by the Small Münster Orchestra, conducted by Göhre. Overture, Der Waldmeister (Strauss); Suite, Dances of the Nations (Mannfred); Waltz, Abendsterne (Lammer); Intermezzo, Ein Schäferstündchen (Siede); Intermezzo, Elfengelüster (Rhode); Selection from Casanova (Lincke); Rhapsody in B minor (Hartung). 1.15 p.m., See Frankfurt. 1.25, News and Weather. 1.35, Concert from Frankfurt. 2.45, In Honour of Labour—Discussion with Readings. 3.10, Talk: Cultural Influences in Western Germany. 3.30, Economic Notes. 3.50, Political Talk. 4.0, Concert by the Station Small Choir, with Gramophone Records in the interval. Choir: Three Folk Songs: (a) Zwei Königskinder, (b) Spielmann und Mägdlein, (c) Die schwarzbarme Hexe. Violin Solo: Sonatina (Dvorák). Harp Solos: (a) Waltz (René), (b) Song without Words (Dubey), (c) Spelthose (Poentz). Contralto Solos: (a) Es muss ein wunderbares sein (Liszt), (b) Waldweinsauigkeit (Reger), (c) Cretel (Pritznert). Duet for Flute and Oboe: Tarantella (Gaubert). Pianoforte Solos: (a) Tarantella (Palmgren), (b) Mazurka (Chopin). Contralto Solos: (a) Georgine (Strauss), (b) Für fünfzehn Pfennige (Strauss), (c) In den Schatten meiner Locken (Wolf). Sonata No. 1 for Harpsichord and Guitar (Carulli); Romance for Four Cellos (Grützmacher). Choir: Three Folk Songs: (a) Die Henne, (b) Schneiders Höllefahrt, (c) Vetter Michel; Quintet in C (Bocherlini). Gramophone Records. 6.0 See Frankfurt. 6.35, Talk on the Rhenish Museum in Cologne (opened October 1st, 1933). 6.50, News. 7.0, Transmission for all German Stations, relayed from Berlin (Funkstunde). 8.0, See Berlin (Deutschlandsender). 8.10, See Stuttgart. 10.0, News from Frankfurt. 10.20, See Stuttgart. 10.30, News and Weather. 10.40, Symphony No. 5 in E minor (Tchaikovsky), by the Station Orchestra, conducted by Buschkötter. 11.0, Light Music and Dance Music by the Orchestra and the Dance Band, conducted by Kühn. 12 Midnight, See Frankfurt. 1.0 a.m. (Wednesday), Close Down.

LAUSANNE.—See Radio-Suisse Romande.

LEIPZIG

769.9 kc/s, 389.6 metres; 120 kW. Relayed by Dresden, 941 kc/s, 319 metres.—1.15 p.m., News and Programme Announcements. 1.30, Concert of Chamber Music by Gertie Flor (Violin), Werner Weigelt (Cello), and Alf Nestmann (Pianoforte); Violin Sonata in E Minor (Haydn); Trio (Haydn); Pianoforte

Sonata with Variations in A (Mozart). 2.15, News. 2.30, Reading (Ferdinand von Saars). 3.0, Programme for Young People. 3.20, Review of Economic Policy. 3.35, Economic Notes. 4.0, Concert by the Landmann Orchestra: March, Unter dem Sachsenstern (Landmann); Rakoczy Overture (Keler Bela); Waltz, Walzerträume (Vollstedt); Selection from Tosca (Puccini); Chapelle de Guillaume Tell (Liszt); Waltz from Die Försterheime (Jarno); Hitler-Fahnen (Dorrbauer); Overture, Die Frau Meisterin (Suppe); Waltz, Herbststimmung (Lincke); Hungarian Rhapsody No. 1 in F Minor (Liszt); March Potpourri (Landmann); March Song, Deutschland Glaub ans Glück (Raszat). 5.30, Poetry Reading (Leifhelm). 5.50, Economic Notes, News, Weather and Time. 6.0, Review of Books for the Hitler Jugend. 6.20, Talk: With the Zeppelin to South America. 6.50, Review of the Day's Events. 7.0, Transmission for all German Stations, relayed from Berlin (Funkstunde). 8.0, Concert by the Jena Choral Society. 8.30, Reading (Mark Twain). 9.0, Concert by the Symphony Orchestra, conducted by Weisbach. 10.0, News. 10.30, Talk: The Race History of Mankind. 10.50, Concert from Hamburg. 12 Midnight, Close Down.

LINZ.—See Vienna.

LJUBLJANA

522 kc/s, 574.7 metres; 7 kW.—6.0 p.m., Programme for Children. 6.30, Gramophone Music. 7.0, French Lesson. 7.30, Talk. 8.30, European Concert, relayed from Bucharest. In an interval at 10.0, Weather and News. 10.40, Gramophone Music. 11.0 (approx.), Close Down.

LUXEMBOURG

252 kc/s, 1,191 metres; 200 kW.—Belgian Evening.—7.30 p.m., Violin Concert, No. 5, in A Minor (Vieuxtemps). 8.0, Concert by the Radio Orchestra; Spanish Caprice (Rimsky-Korsakov); Berceuse (Vrenlis); Danse orientale (Douliez); Une nuit de solitude (Clemens); Wedding Procession from Feramors (Rubinstein). 8.50, News in French. 9.0, Concert (contd.): Overture, Tannhäuser (Wagner). 9.10, Talk: Why don't we eat more Fish? 9.20, Song Recital by Grosfilé-Cuyper. Ave Maria (Schubert); Two Songs from Mirella (Gomodo); Elegy (Delage-Prat); Nuit d'étoiles (Delage-Prat); Song (Massenet). 9.50, News in German. 10.0, Cabaret Programme on Gramophone Records. 10.25, Dance Music.

LWOW

788 kc/s, 381 metres; 16 kW.—7.15 p.m., Announcements and Gramophone Music. 7.25, See Warsaw. In the interval at 7.40, Programme Announcements. 8.30, European Concert, relayed from Bucharest. 10.40, See Warsaw. 11.5, Gramophone Music. 11.30 (approx.), Close Down.

LYONS

LA DOUA, 644 kc/s, 465.8 metres; 1.5 kW.—6.30 p.m., Radio Journal. 7.30, Radio Gazette for Lyons and the South-East. 8.30, Le Chapeau de paille d'Italie—a Farce (Labiche).

MADRID

ARANJUEZ (EAQ), 10,000 kc/s, 30 metres; 20 kW.—11.30 p.m., Concert of Popular Music. In the interval at 11.45, Radio Chronicle. 12.35 a.m. (Wednesday), Spanish American Talk. 12.45, Light Music. 1.0-1.30, Programme in English by the I.B.C. 1.0, I.B.C. Concert of Hawaiian Music: Hawaiian Sunset; Hawaiian Waltz Medley; Sweet Hawaiian Dreams; Kilina Waltz; On a Little Street in Honolulu; All through the Night; The Rosary; Aloha Oe! 1.30, I.B.C. Good-night Melody.

MADRID

EAJ7, 707 kc/s, 424.3 metres; 2 kW.—8.0 p.m., Chimes, Exchange, Radio Journal and Request Gramophone Music. 8.30, Talk by Joaquin España (Cantos and Gramophone Music (contd.)). 9.15, Topical Review. 9.30 to 11.0, Interval. 11.0, Chimes, Time and Topical Review. 11.20 (approx.), Falstaff—Opera (Verdi) on Gramophone Music. 1.15 a.m. (Wednesday), Topical Review. 1.30, Chimes. 2.0 to 3.0, Programme in English by the I.B.C. 3.0 (approx.), Close Down.

MALMO.—See Stockholm.

MILAN.—See Turin.

MORAVSKA-OSTRAVA

1,137 kc/s, 263.8 metres; 11 kW.—5.25 p.m., Gramophone Music. 5.30, See Prague. 5.50, Gramophone Music. 6.15, See Brno. 7.8, See Prague. 8.30, European Concert relayed from Bucharest. 10.40, See Prague.

MOSCOW

TRADES UNION, 300 kc/s, 1,000 metres; 100 kW.—2.45 p.m., Weather. 3.0, Humour and Satire in Music—Concert. 3.55, Time. 4.0, Foreign Language Lesson. 4.30, Literary

OCT. 3rd

TUESDAY

continued

TOULOUSE

RADIOPHONIE DU MIDI, 779 kc/s, 385 metres; 8 kW.—6.0 p.m., News, 6.15, Music by an Argentine Orchestra. 6.30, Opera Music: Duet from Act II of Rigoletto (Verdi); Air from Manon (Massenet); Air from Le Châlet (Adam). 6.45, Military Music. 7.0, Chansonnettes. 7.15, News. 7.30, Extracts from Parsifal (Wagner), by a Symphony Orchestra. 7.45, Songs from Sound Films. 8.0, Accordion Music. 8.15, Orchestral Music. 8.30, Operetta Music: Airs from Miss Decima (Andran); La Basoche (Messager); Vêronique (Messager); La Mascotte (Andran). 8.45, Hawaiian Guitar Music. 9.0, At Carcassonne—A Radio Report. 9.30, Orchestral Music: Selection from Die Fledermaus (Joh. Strauss); Prélude à l'après-midi un faune (Debussy); A Hunt in the Black Forest (Voelcker); Three Pieces (Satie); Selection from The Italian Girl in Algiers (Rossini); Overture, Rosamund (Schuberl). 10.0, Popular Songs. 10.15, News. 10.30, Concert for Listeners in Morocco. 11.0, Organ Solos. 11.15, Dance Music. 12 Midnight, News. 12.5 a.m. (Wednesday), Music by a Viennese Orchestra. 12.15, Music by an Argentine Orchestra. 12.30, Close Down.

TRIESTE

1,211 kc/s, 247.7 metres; 10 kW.—5.10 p.m. till Close Down, See Turin.

TRONDHEIM.—See Oslo.

TURIN

1,096 kc/s, 273.7 metres; 7 kW. Relayed by Milan, 905 kc/s, 331.5 metres; Genoa, 559 kc/s, 312.8 metres; and Florence, 599 kc/s, 500.8 metres.—5.10 p.m., Dance Music from the Savoia Dance Hall. 6.0 to 6.5, Weather. 6.40, Giornale Radio, Dopolavoro Report and Gramophone Music. 7.0, Time, Report of the Royal Geographical Society and Gramophone Music. 7.30, Wheat Market Report. 7.20, News in Foreign Languages. 7.40, Gramophone Music. 8.0, News and Weather. 8.25, Talk on the following transmission. 8.30, Operetta in Three Acts. In the intervals: Talk and Notes on Art. Giornale Radio after the Operetta.

VATICAN CITY

15,120 kc/s, 19.84 metres (Morning), and 5,969 kc/s, 50.26 metres (Evening); 10 kW.—11.0 to 11.15 a.m., Religious Information in English. 8.0 to 8.15 p.m., Religious Information in Italian.

VIENNA

581 kc/s, 517 metres; 100 kW. Relayed by Graz, 552 kc/s, 352.1 metres; Innsbruck, 1,058 kc/s, 283 metres; Klagenfurt, 662 kc/s, 453.2 metres; Linz, 1,220 kc/s, 245.9 metres; and Salzburg, 1,373 kc/s, 218.5 metres.—12 Noon, Concert by the Wiener Symphoniker, conducted by Holzner. In the interval at 1.0 p.m., Time, Weather and Announcements. 2.0, Interval. 3.0, Time, Weather and Market Prices. 3.20, Talk: Photography by Artificial Light. 3.35, Gramophone Concert. 4.35, Handwork Lesson. 5.10, Talk: Games, Sport and Recreation for City Dwellers. 5.25, Song Recital by Jenny Jungbauer (Soprano) and Wilhelm Tisch (Bass). 6.5, Talk by Prof. Sauter: The Modern Trend in Biology. 6.35, French Lesson. 7.0, Concert by the Wiener Symphoniker, conducted by Schönherr: Overture, Die kaiserliche Barbara (Nedbal); Geisterwalzer (Bayer); From the Fields and Groves of Bohemia (Dvorák); Overture to the Fairy Tale, Dwarf Nase (Uray); Three Pieces (Salmhofer); (a) Schneeflockentanz, (b) Der Wald, (c) Kälzertanz; Little Serenade (Grabner). In the interval at 7.35, Time, Weather and Announcements. 8.15, Topical Talk. 8.30, European concert relayed from Bucharest. 10.40, News, Weather and Exchange. 10.55, Dance Music on Gramophone Records. After the Programme, Announcements.

WARSAW

212.5 kc/s, 1,411 metres; 120 kW.—11.57 a.m., Time Signal and Fanfare from St. Mary's Church, Cracow. 12.5 p.m., Gramophone Music. 12.30, Radio Journal. 12.35, Gramophone Music. 1.0 to 3.30, Interval. 3.30, Economic Notes. 3.40, Light Music by the Gorzyzky Orchestra. 4.25, Announcement. 4.40, Wireless Notes. 4.55, Pianoforte Recital by Marie Jonas: Gavotte and Polonaise (Zaremsky); Legend and Two Preludes (Rozyzky); Love Song, Waltz-Caprice and Nocturne (Paderevsky). 5.30, Song Recital by Gruszczyński. 5.50, Agricultural Correspondence. 6.0, Talk on Art. 6.20, Light Orchestral Concert, relayed from the Café Adria. 7.5, Miscellaneous Items. 7.25, Topical Talk. 7.40, Programme Announcements. 7.45, Radio Journal. 8.0, Book Review. 8.15, Gramophone Music. 8.30, European Concert, relayed from Bucharest. 10.40, Sports Notes. 10.50, Dance Music, relayed from the Oaza. 11.0, Aviation Weather Report and Police Notes. 11.5, Dance Music (contd.). 12.0 Midnight (approx.), Close Down.

ZURICH.—See Schweizerischer Landessender.

Programme. 5.30, Educational Talk: The Earth. 5.30, Concert of Italian Songs and Dances. 9.0, News. 9.30, Programme Announcements. 9.55, Chimes from the Red Square. 10.5, Press Review.

MOTALA.—See Stockholm.

MUHLACKER.—See Stuttgart.

MUNICH

563 kc/s, 533 metres; 60 kW. Relayed by Augsburg and Kaiserslautern, 536 kc/s, 560 metres; and Nürnberg, 1,256 kc/s, 239 metres.—4.30 p.m., Concert from Langenberg. 5.45 (from Nürnberg), Talk. 6.0, Concert by the Reithmeier Orchestra: Potpourri, Viennese Operetta Revue (Robrecht); Song from The Land of Smiles (Lehár); Waltz, Die Werber (Lanner); Nocturne No. 3 (Liszt); Arabesque (Debussy). 6.45, Time, Weather and Agricultural Notes. 7.0, Transmission for all German Stations, relayed from Berlin (Funkstunde). 8.0, Das Modell—Operetta in Three Acts (Suppé), arranged for Radio by Hartung. After the Operetta, Dance Music by the Station Band. 10.20, Time, Weather, News and Sports Notes.

NAPLES.—See Rome.

NOTODDEN.—See Oslo.

OSLO

277 kc/s, 1,083 metres; 60 kW. Relayed by Fredrikstad, 815 kc/s, 368.1 metres; Hamar, 522 kc/s, 574.7 metres; Notodden, 671 kc/s, 447.1 metres; Porsgrund, 662 kc/s, 453.2 metres; and Rjukan, 671 kc/s, 447.1 metres.—5.0 p.m., Gramophone Concert. 6.0, Programme for Women. 6.45, Recital of Jazz Music on Two Pianofortes. 7.0, Advertising Notes. 7.15, Weather and News. 7.30, English lesson. 8.0, Time. 8.1, Concert by the Station Orchestra, conducted by Hugo Kramm: Petite Suite for Strings (Nielsen); Scherzo and Finale from the Symphony No. 4 (Tchaikovsky); Suite, Aphrodite (Jebe); 4 (Tchaikovsky); (Rimsky-Korsakov). 9.0, Political Talk. 9.20, Carl Nielsen Recital by Fanny Elsta (Songs) and Ingrid Salvanes (Pianoforte). 9.40, Weather and News. 10.0, Topical Talk. 10.15, Recitations.

OSTERSUND.—See Stockholm.

PALERMO

558 kc/s, 537.6 metres; 3 kW.—8.0 p.m., Dopolavoro Announcements, Tourist Talk, Agricultural Notes and Giornale Radio. 8.20, Gramophone Music. In the interval at 8.30, Time and Announcements. 8.45, Turandot—Opera in Three Acts (Puccini). In the intervals: Talk and Announcements. After the Opera, Giornale Radio.

PARIS

EIFFEL TOWER, Call FLE, 207.5 kc/s, 1,445.7 metres; 13 kW. Time Signals (on 2,650 metres) at 10.26 a.m. and 11.26 p.m. (Preliminary and 6-dot Signals)—6.45 p.m., Theatre Talk. 7.0, Le Journal Parlé. 8.30, Un chapeau de paille d'Italie—Comedy in Five Acts (Labiche and Michel); Music by Ibert.

PARIS

POSTE PARISIEN, 914 kc/s, 328.2 metres; 60 kW.—7.0 p.m., Recital of Opera Arias on Gramophone Records. 7.15, Le Journal Parlé. 7.30, Sponsored Gramophone Concert. 8.0, Talk on the Music Hall. 8.5, Film Review. 8.35, Orchestral Concert, conducted by Théodore Mathieu: Overture (Weingartner); Waltz from The Arabian Nights (Joh. Strauss); Cello Solo: Kol Nidrei (Bruch); Symphonie Poem, La jeunesse d'Hercule (Saint-Saëns); Dance (Reinecke); Music for Radio (Lazar); Intermezzo (Lacombe); Suite from Izeyl (Pierné); Nocturne (Boëllmann); Intermezzo (Mussorgsky); Marche provençale (Nicodé). 10.30, News.

PARIS

RADIO-PARIS, Call CFR, 174 kc/s, 1,725 metres; 75 kW.—7.30 a.m., Weather and Physical Culture. 7.45, Gramophone Music. 8.0, Weather and News. 12 Noon, Round the World in Eighty Minutes—Gramophone Concert. The Retreat; Herbstlied (Mendelssohn); Old Panama (Alford); Two Choral Etudes (de Vocht); Trink, trink, Brüderlein trink; O sole mio; Waltz, Wiener Blut (Joh. Strauss); Ozi Kozsa (Lorand); Slav Dances (Dvorák); Greek Song, Kalanattianos; Russia under the Snow; Indian Song; Thou art a drop of Gold (Tagore); Japanese Lantern Dance (Yoshitomo); Songs and Dances of Tahiti; Cannibal Songs of the Marquesas; Na lei o Hawaii; Cahmet and Buffalo Dances; Old Man River; Saudades do Brazil (Milhand); Argentine Tangos: (a) Adios muchachos, (b) Yira, Yira; Moroccan Song, Rais Mohamed ben Iahsen; Algerian Song; Portuguese Song; Menina e moça; San Juan; Potpourri of Old French Songs, Part II; La Paloma (Yradier); Selection from The Chocolate Soldier (O. Strauss); Vision from The Passing of Salomé (Joyce); Claveltos (Valverde); Douce tendresse (Paradis); My little brown Mandoline (Mayk); Al Fresco (Her-

bert); Melody (Green-St. Granier). In the interval at 1.0 p.m., Exchange, News, and Weather; and at 1.30 and 2.0, Exchange, 3.45, Exchange and Market Prices. 6.30, Agricultural Talk. 6.50, Gramophone Records: Menuet antique (Ravel); Spanish Dance (Fallá). 7.0, Theatre Talk. 7.20, Gramophone Records: Overture, Romeo and Juliet (Tchaikovsky); Kikimora (Lidov). 7.45, English Press Review. 8.0, Gramophone Music. 8.30, See Paris (Eiffel Tower).

PORSGRUND.—See Oslo.

POZNAN

896 kc/s, 335 metres; 1.0 kW.—7.5 p.m., Miscellaneous Items and News. 7.25, See Warsaw. 7.40, Theatre Notes and Programme Announcements. 7.45, See Warsaw. 7.58, Time Signal. 8.0, See Warsaw. 8.15, Gramophone Music. 8.30, European Concert, relayed from Bucharest. 10.40, Time Signal, Sports and Police Notes. 10.55, Dance Music from The Esplanade Café. 11.30 (approx.), Close Down.

PRAGUE

614 kc/s, 488.6 metres; 120 kW.—4.0 p.m., Bulgarian Suite, Op. 21 (Vladigerov), by the Station Orchestra, conducted by Parik, in Celebration of the Bulgarian National Festival. 4.55, Programme for Children. 5.15, Talk on Economics. 5.25, Gramophone Music. 5.35, German Lesson. 5.50, Gramophone Music. 6.5, Agricultural Talk. 6.15, Talk for Workers. 6.25, News in German. 6.30, German Transmission: Das Hexentli (Schillings). 7.0, Time and News. 7.10, Talk. 7.25, Folk Songs by a Vocal Quartet. 8.0, Gramophone Music. 8.30, European Concert relayed from Bucharest. 10.40, News. 10.55 (approx.), Close Down.

RADIO-SUISSE ROMANDE

SOTTENS, 743 kc/s, 403 metres; 25 kW.; and Geneva, 395 kc/s, 760 metres.—7.0 to 7.15 a.m. (from Lausanne), Gymnastics. 12.28 p.m., Time Signal from Neuchâtel Observatory. 12.30, News and Weather. 12.40 (from Geneva), Gramophone Concert. 1.0 (from Geneva), Financial News. 1.10 (from Geneva), Gramophone Concert. 2.0 to 3.28, Interval. 3.28, Time Signal from Neuchâtel Observatory. 3.30 (from Lausanne), Concert by the Radio Lausanne Orchestra, conducted by Moser. 5.0 (from Lausanne), Programme for Women. 5.20 to 7.0, Interval. 7.0 (from Geneva), Gramophone Records. 7.30 (from Geneva), News, Announcements and Weather. 7.45 (from Geneva), Answers to Correspondence. 8.0 (from Geneva), Debussy Recital by Hugues Chenod and Mme. Marroussia Orloff (Pianoforte). 8.30, See Paris (Eiffel Tower). 9.50, News and Weather. 10.0 (from Geneva), Talk: The Work of the League of Nations. 10.30 (approx.), Close Down.

REYKJAVIK

250 kc/s, 1,200 metres; 21 kW.—9.5 p.m., Musical Programme. 9.30, Weather Report. 9.40, Musical Programme and Announcements. 10.0, Chimes and News. 10.30, Reading. 11.0, Cello Solo by Thorballur Arnason, followed by Pianoforte Concerto in A minor (Grieg), relayed by Tgnacy Friedman, on Gramophone Records.

RIGA

572 kc/s, 525 metres; 15 kW.—7.3 p.m., Concert of American Music. 8.0, News. 8.15, Pianoforte Recital. 8.40, Orchestral Music. 9.0, Weather and News. 9.20, Part Relay of the European Concert from Bucharest.

RJUKAN.—See Oslo.

ROME

Call IRO, 680 kc/s, 441 metres; 50 kW. Relayed by Naples, 941 kc/s, 319 metres; Bari, 1,112 kc/s, 269.8 metres; Milan (Vigentino), 662 kc/s, 453.2 metres from 8.45 p.m. and 2RO, 11,810 kc/s, 25.4 metres from 5.15 p.m.—12.30 p.m., Gramophone Music. 1.0, Trio Concert from Turin. In the interval from 1.30 to 1.45, Giornale Radio and Exchange. 2.0, Time and Announcements. 4.30, Children's Radio Review. 4.55, Giornale Radio and Exchange. 5.10, Weather. 5.15 to 6.0, Orchestral Concert. 6.40 (Naples), Shipping and Sport Notes. 6.45, Morse Signals and Dopolavoro Report. 7.0, Tourist Report. 7.10, Agricultural Report. 7.20, News in Foreign Languages. 7.40, Giornale Radio. 8.0, Time, Announcements and Gramophone Music. 8.15, Sponsored Music. 8.30, Sports Notes. 8.45, Concert of Light Orchestral Music. Conductor: Illuminato Calotta. Part I. Variety Music. Part II. Operetta Music. Talk in the interval. 11.0, Giornale Radio.

SALZBURG.—See Vienna.

SCHWEIZERISCHER LANDESENDER

BEROMUNSTER, 653 kc/s, 459 metres; 60 kW.; Basle, 1,229 kc/s, 244.1 metres; and Berne, 1,220 kc/s, 245.9 metres.—11.59 a.m.,

Time Signal from Neuchâtel Observatory and Weather. 12 Noon (from Zürich), Light Music by the Station Orchestra, conducted by Neppach. 12.30 p.m., Time, Weather and News. 12.40 (from Zürich), Light Music (contd.). 1.25 (from Zürich), Time, Weather and Exchange. 1.30 (approx.) to 5.0, Interval. 5.0 (from Zürich), Concert by the Small Station Orchestra, conducted by Max Scherbaum. 5.30 (from Basle), Light Music on Gramophone Records. 6.30 (from Berne), Legal Talk: Collective Responsibility. 7.0 (from Berne), Time, Weather and Announcements for Schools. 7.10 (from Berne), Excursions for Sunday. 7.15 (from Berne), Concert of Light Music. 7.55 (from Berne), A Dialect Play (Karl Grandor). 9.10, Weather and News. 9.20, Part Relay of the European Concert from Bucharest. 10.0 (from Berne), Talk: Romania and her Folk Music. 10.10, European Concert from Bucharest (contd.). 10.40 (approx.), Close Down.

SOTTENS.—See Radio-Suisse Romande.

STOCKHOLM

689 kc/s, 436 metres; 55 kW. Relayed by Boden, 244 kc/s, 1,229.5 metres; Göteborg, 532 kc/s, 322 metres; Hörby, 1,166 kc/s, 257 metres; Motala, 221.5 kc/s, 1,354.4 metres; Östersund, 389 kc/s, 770 metres; and Sundsvall, 554 kc/s, 542 metres.—2.45 to 3.10 p.m., Broadcast for Schools. 5.5, Programme for Children, relayed from Norrköping, 1,292 kc/s, 232.2 metres. 5.30, Guitar Recital by Bo Peters. 5.45, Gramophone Music. 6.45, Elementary French Lesson. 7.15, Weather and News. 7.30, Talks for Listeners: (a) Speech by Professor Sven Tamberg, (b) Swedish Self Government. 8.5, Violin Recital by Gösta Rybrant; Romance and Orientale (Vladigerov); Caprice No. 13 in B (Paganini-Kreisler); Caprice No. 20 in D (Paganini-Kreisler). 8.20, Talk: International Economics. 8.45, Concert by the Station Orchestra; Soloist, Doris Bergman-Ryner (Pianoforte); Overture, Anacron (Cherubini); Pianoforte Concerto in D Minor (Bach); Symphony in G Minor, No. 40 (Mozart). 9.45, Weather and News. 10.0, The Primeval Forest—Play (Fred von Hoerschelmann), translated by Olov Molander. 11.0 (approx.), Close Down.

STRASBOURG

869 kc/s, 345 metres; 11.5 kW.—11.30 a.m., Gramophone Music. 12 Noon, Orchestral Concert, conducted by Maurice de Villers. In the interval at 12.45 p.m., News, and at 1.0, Time and Exchange. 2.0, Interval. 4.45, Talk on the French Colony Laos. 5.0, Orchestral Concert, conducted by Roskam: Overture, The Golden Cross (Brüll); Waltz from Das Fürstentum (Lehár); Selection from La Navarraise (Massenet); Cello Solo, Andante from the Concerto No. 14 (Gölkermann); Ballet Music from Cim-Mars (Gounod); Selection from Monsieur Beaucaire (Messager); March, Lisbona (Candido). 6.0, History Talk. 6.15, Topical Talk. 6.30, Song and Pianoforte Recital by Hilmar Biöhe (Tenor) and Jeanne Wolfenstädter; Pianoforte Solos: Andantino and Variations (Schubert-Tausig); Five Danish Songs; Pianoforte Solo: The children's Corner (Debussy); Tenor Solos: (a) La fontaine de Croquott (Letortrey), (b) Les Différences (Laparra), (c) La chanson des marins halés (Laparra); Pianoforte Solos (Moreau): (a) Dans la nuit, (b) Valse brillante. 7.30, Time and News. 7.45, Gramophone Music. 8.0, Press Review in German. Lottery Results and Announcements. 8.30, See Paris (Eiffel Tower). 10.30 (approx.), Press Review.

STUTTGART

MUHLACKER, 832 kc/s, 360.5 metres; 60 kW. Relayed by Freiburg, 527 kc/s, 570 metres.—12 Noon, See Langenberg. 1.15 p.m., News relayed from Frankfurt. 1.25, News. 1.35, See Frankfurt. 2.30, Interval. 4.0, See Langenberg. 6.0, See Frankfurt. 6.35, An Ex-Soldier's War Reminiscences. 6.50, Time and Economic Notes. 7.0, Transmission for all German Stations, relayed from Berlin (Funkstunde). 8.0, See Berlin (Deutschlandsender). 8.10, Johann Strauss Concert by the Station Orchestra, conducted by Knappertsbusch and the Teutonia Choir conducted by Füssinger, relayed from Ulm; Soloists, Elisabeth Feuge (Songs) and Julius Patzak (Songs); Overture, Die Fledermaus; Songs: (a) Song from Waldmeister, (b) Lagunenwalzer; Kusswalzer; Song, Frühlingsstimmengewalt; Polka, Tritscheltratsch; Male Voice Choir: The Blue Danube. Overture, The Gipsy Baron; Waltz, Bei uns z' Haus; Duet from (a) Cagliostro, (b) Der lustige Krieg; Waltz, Freut euch des Lebens; Polka, Leichtes Blut. 10.0, See Frankfurt. 10.20, Things you should know... 10.30, Local News. 10.45 to 12 Midnight, Light Music from Langenberg. 12 Midnight, See Frankfurt. 1.0 a.m. (Wednesday), Close Down.

SUNDSVALL.—See Stockholm.



# SEE THESE WORKS OF ART ON STAND 37 MANCHESTER RADIO EXHIBITION.

"All Radio Dealers have customers who wish for something different, something better, and there is profitable business to be obtained by using the Cabinets sold by C.A.C."

*Scottish Radio Dealer, September, 1933.*

"But for really ornate work, commend me to the C.A.C., whose cabinets touch the foremark of class."

*The Nottingham Journal, 26th August, 1933.*

Visitors to the Manchester Exhibition should not fail to inspect these beautiful models. The stand decorations include a magnificent

## LANDSCAPE BY GAINSBOROUGH

valued at

# £6,500

and considered to be one of the most outstanding examples of his work.

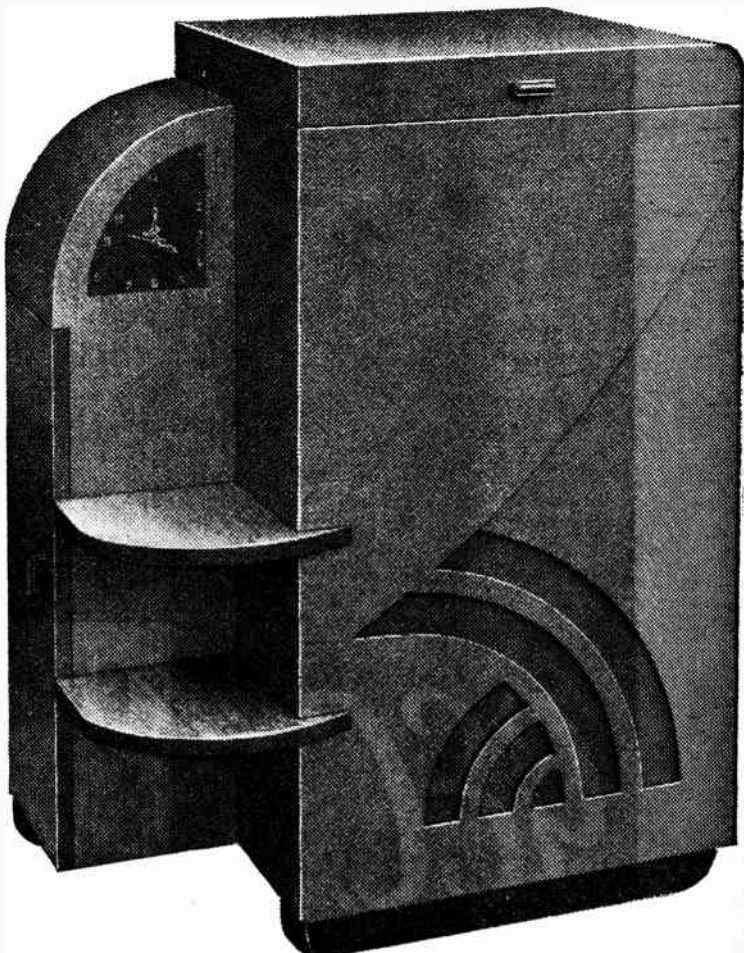
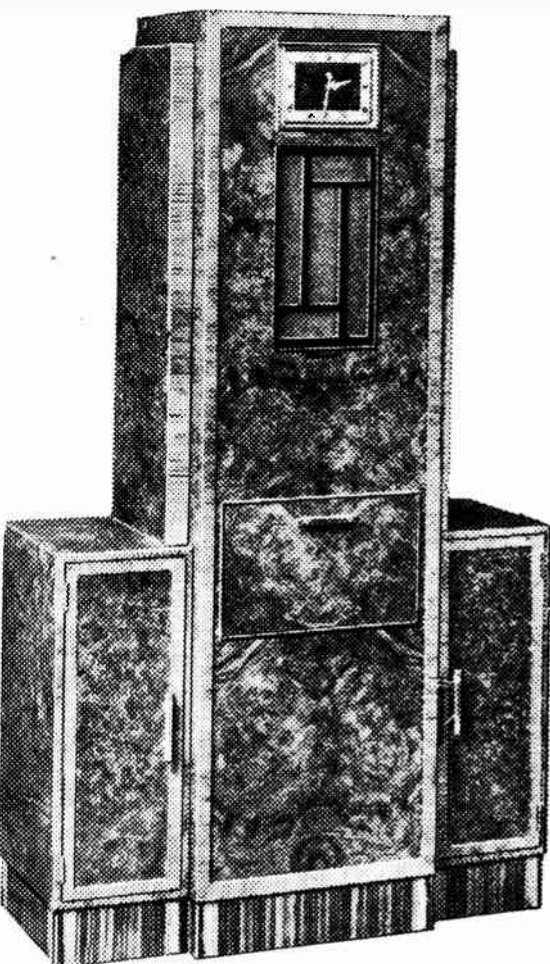

The "C.A.C." GRANDFATHER CLOCK  
RADIO-GRAM CABINET.

This handsome and original piece of furniture represents the very last word in Radio-Gramophone Cabinet design. Intended to house an electric clock movement, it has provision for fitting, if desired, a pair of dual compensated Loud Speakers. Ample provision is given below the Speaker Grille to accommodate almost any type of Receiver, whilst the electric Gramophone Motor and Pick-up fit into the sliding drawer below. The two side compartments allow for the storage of a very large number of records.

In Burr Walnut, Mahogany or Oak, 16 Guineas.

SEND TO-DAY FOR OUR 1933-34  
**ILLUSTRATED CATALOGUE**

OF RECEIVERS, RADIO-GRAMS AND CABINETS.

Also PRICE LISTS OF "WIRELESS WORLD" KITS including

The Ferrocart Class "B" Receiver  
and the

**NEW MONODIAL SUPER.**



18-20, NORMAN'S BUILDINGS,  
CENTRAL STREET, LONDON, E.C.1.

Phones: Clerkenwell 1038,  
" 6206,  
" 6207.

Telegrams:  
"Cityacco, Barb, London."

The "C.A.C." COCKTAIL RADIO-GRAM CABINET.

This ultra-modern piece of furniture created immense interest at Radiolympia, where it was shown for the first time, and obtained for itself more press publicity than any other exhibit in the show. Provision is made for the accommodation of Combined Radio-Gramophone equipment, whilst on the left is fitted a spacious enclosed cupboard, admirably suited for a Cocktail Cabinet. Alternatively, it can be used as a storage compartment for Gramophone Records.

In Burr Walnut, Mahogany or Oak, 16 Guineas.

Complete with "MONODIAL SUPER," Electric Clock, Garrard Automatic Record Changer, "Rola" Loud Speaker, Aerial tested and fully guaranteed,  
Quotations for alternative  
Receivers on request.

**64 Guineas.**

ANNOUNCEMENT OF THE CITY ACCUMULATOR CO., LTD., LONDON.

Advertisements for "The Wireless World" are only accepted from firms we believe to be thoroughly reliable.



# NOW RELEASED



# G.E.C. RADIO

## G.E.C. Radiogram Superhet 5

FOR A.C. MAINS

The G.E.C. Radiogram Superhet 5 provides superlative radio and gramophone reproduction — and at an unrivalled price. Powerful modern superheterodyne circuit, tuning by station names, oversize energised moving coil speaker on inclined baffle with tone control.  $2\frac{1}{2}$  watts A.C. output, speaker silencing key, interna aerial for local stations. Induction type gramophone motor with automatic stop and start. Modern cabinet in richly figured walnut.

### 25 GNS.

Including OSRAM VALVES.

**HIRE PURCHASE TERMS:** Deposit £2 5 0 and 12 monthly payments of £2 5 0

**WRITE FOR FOLDER BC.6671.**

**MADE IN ENGLAND**  
Sold by all Radio Dealers.

### The sets with the big name behind them

Advt. of The General Electric Co. Ltd., Magnet House, Kingsway, London, W.C.2



# MEET THE GREAT RADIO DETECTIVE...!

Radio's greatest boon! The Pifco ROTAMETER tracks down every radio trouble instantly. The octagonal knob on the Pifco ROTAMETER, with its eight different dials—"The Sign of Eight"—is the key to the instrument's simplicity and accuracy. The eight dials are shown here.

## EIGHT SEPARATE METERS IN ONE

Radio testing is amazingly simple with the Pifco ROTAMETER. Just turn the octagonal knob according to the test desired and then connect the suspected component to the instrument. The needle gives its reading instantly on the dial. What could be simpler?

## A BRITISH INVENTION—MADE IN ENGLAND

Ask your radio dealer to demonstrate the Pifco ROTAMETER to-day. If any difficulty, write direct to PIFCO LTD., High Street, MANCHESTER, or 150, Charing Cross Road, London, W.C.2.

*No instrument in the world makes all tests more easily than the Pifco Rotameter. Any component or circuit can be tested quickly and surely. Makes 100 tests.*

### RANGES :

1. 0-8 Volts. For low-tension voltage test.
2. 0-30 Volts. For Grid-bias voltage test.
3. 0-250 Volts For high-tension voltage test.
4. BATTERY TEST.
5. 0-20 M.A. For individual valve test.
6. 0-100 M.A. For testing current taken by total valves in set.
7. 0-250 M.A.
8. FILAMENT AND RESISTANCE TEST (4,000 ohms), for D.C. and rectified A.C.

*Finished in black bakelite case, complete with two 22-in. rubber-covered cables.*

*Dimensions: Height 4 1/2 in., width 3 1/2 in., depth 1 1/2 in., weight 12 ozs.*

Price

**29/6**

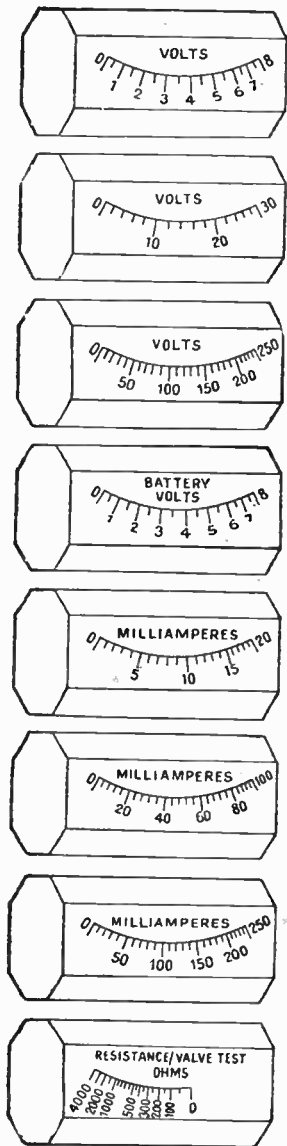
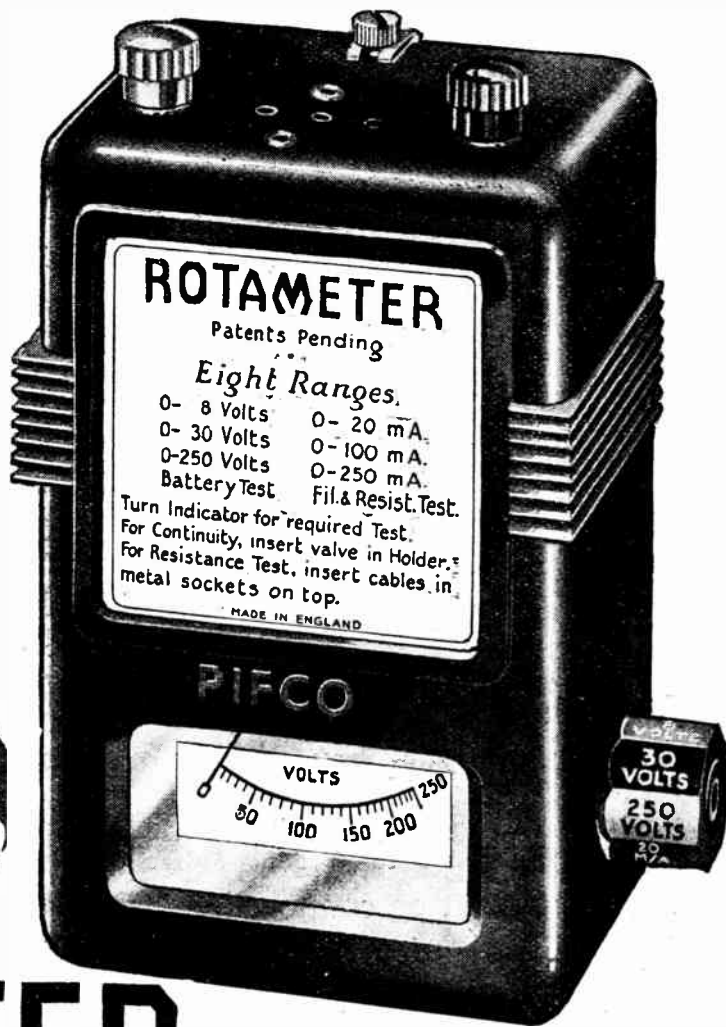

# PIFCO ROTAMETER

Φ 01.

PURVEYORS OF  
ELECTRIC LAMPS  
BY APPOINTMENT



**EDISWAN**

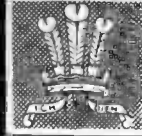

MANUFACTURERS  
& PURVEYORS OF  
ELECTRIC LAMPS  
BY APPOINTMENT



**some  
take  
chances  
...**

**others  
buy**

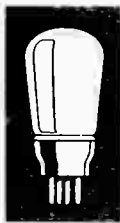

Research goes on all the while in every radio valve laboratory, and every once in a while (but not nearly as often as you might suppose!), there is a real step forward in valve design or construction. But the real all-day and every-day problem of the valve maker is to achieve reliability! It is reliability that has brought Mazda right up to the top in the last three or four years. And it is because of reliability that Mazda will remain there.

**MAZDA**  
THE  
**SAFETY  
VALVE**



*Mazda Radio Valves are manufactured in Gt. Britain for The British Thomson-Houston Co. Ltd., London & Rugby*

THE EDISON SWAN ELECTRIC CO. LTD., 155, CHARING CROSS ROAD, W.C.2.

*Mention of "The Wireless World," when writing to advertisers, will ensure prompt attention.*

# Superhet Efficiency by Merely Changing Coils

# MICRION

## THE ONLY DUST IRON COIL With Adjustable Inductance



SUPERHET  
PERFORMANCE  
FOR  
**12 1/6**

List No.  
B. Y. 36.  
Actual size  
2 1/2 in. dia-  
meter, 3 in.  
high.

STAND No. 65  
MANCHESTER  
EXHIBITION



### "MICRION" Points of Superiority :

1. "MICRION" is the only dust iron cored coil with a micrometer adjustment on both medium and long waves.
2. It can be used in any existing set without alteration of dial calibration.
3. It is the only coil of its type that gives such striking improvement of range and selectivity without demanding difficult structural alterations to the set.

**ASK YOUR DEALER FOR FOLDER**

**I**MPEDANCE TUNING IS AN ENTIRELY NEW SYSTEM which makes the advent of the "MICRION" Coil a milestone in the progress of radio development; it is the outstanding achievement of 1933/34.

By substituting the "MICRION" Coil (or coils) for existing coils, your old set may be brought right up to date and given an almost unbelievable increase in selectivity & range.

**PARTICULARLY DOES THIS APPLY TO CONSTRUCTORS WHO HAVE BUILT SETS WITH THE FAMOUS & POPULAR DUAL RANGE COIL**

which although in its day giving truly remarkable results, is now superseded by the "MICRION" Coil, that is designed for modern broadcasting conditions which now render older coils obsolete.

The "MICRION" Coil replaces all existing coils without alteration of the circuit, and thus renders old sets modern without costly and difficult alteration to the circuit and calibration.

The point to remember is that this coil is being used by R.I. in all their mains and "Class B" sets. It is the secret of the success of the 1933/34 "Madrigal" Receivers, which have already won such unstinted praise from the Wireless Press throughout this country.

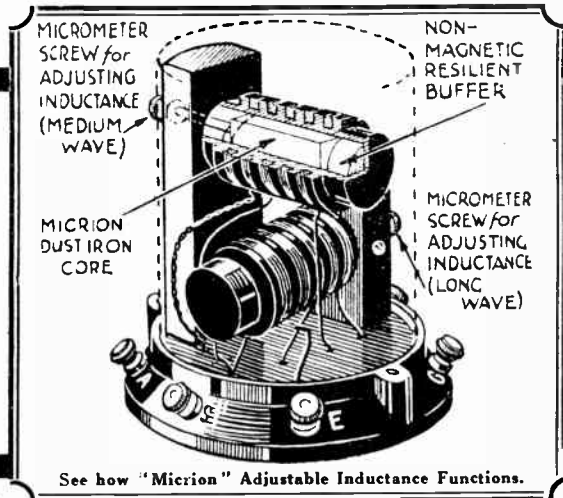

See how "Micrion" Adjustable Inductance Functions.

The Advertisement of Radio Instruments Ltd., Croydon, Surrey. Telephone: Thornton Heath 3211.



# Bakelite Condensers

Last season Utility bakelite condensers were the best available, this year the new models are better still. They are sturdier, they are more accurate and we have improved on the previous low H.F. losses figure.

So whenever you require a bakelite condenser insist on a Utility model, the range includes all values from .00075 to .0001 and differentials from .0003 to .0001, a model for every purpose. The ordinary type can be supplied fitted with a standard

Utility dial complete with baseboard mounting panel and escutcheon, as illustrated, for 4/6 complete. This combination gives you a complete tuning unit at an exceedingly low price.

Prices, including knobs:

W307	.00075	2/6 each
W297/8/9	.0005/3/2	2/- each
W300	.001	1/6 each

Write for a copy of our new catalogue, it contains full details of our complete range of condensers, dials, and switches.

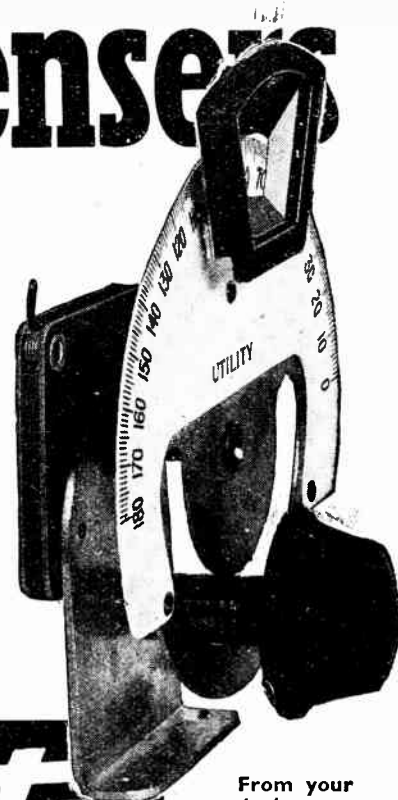

**WILKINS AND WRIGHT, LTD.**

Utility Works,  
Holyhead Rd., Birmingham

London Agent: E.R. Morton, 22, Bartlett's Buildings, Holborn Circus, E. C.4.



From your dealer or post free from the makers.

Belmont

# COLVERN FERROCART COILS

Made under licence from the patentee, Hans Vogt.

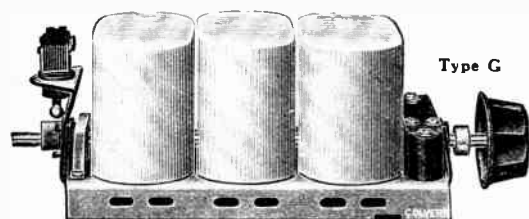

Type G

## SPECIAL G Type GANGED COILS

Complete with gramophone and wave change switch

Two Gang ..	..	25/-
Three Gang ..	..	37/6
Four Gang ..	..	50/-

On and off Switch if required 1/6 extra. State if required for battery or mains receivers.

## COLPAK Type H

Comprising Ferrocart G type Coils, Tuning Condenser, Gramophone and on and off Switch (state if required for battery or mains receivers).

Coils can be supplied for 1 SGHF stage receivers with Band Pass filter or Band Pass filter and Oscillator Coil for Superheterodyne receivers.

Price 57/6

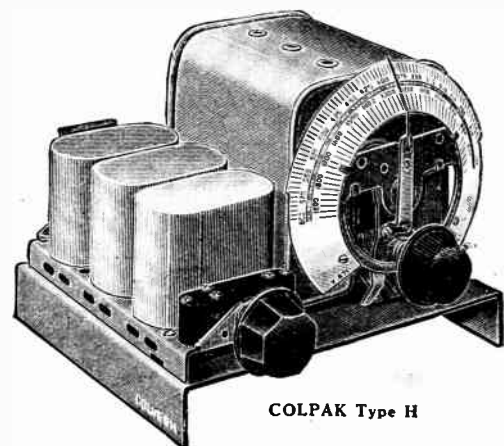

COLPAK Type H

## STANDARD Type F GANGED COILS

Two Gang ..	..	..	25/-
Three Gang ..	..	..	37/6
Four Gang ..	..	..	50/-
Single Coils ..	..	..	12/6

## COLVERDYNE FERROCART INTERMEDIATES

Type F C 115 } 12/6 each  
Type F C 150 }

With universal mounting bracket, limited capacity adjustment and band pass coupling controlled externally.

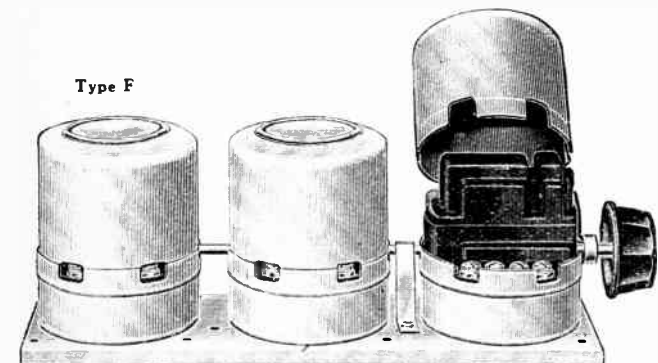
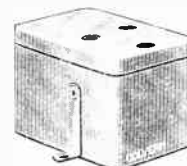

Type F

Send for the Colvern Ferrocart Booklet.

**COLVERN LIMITED, MAWNEYS ROAD, ROMFORD, ESSEX**

London Wholesale Depot: 150, King's Cross Road, London, W.C.1

Mention of "The Wireless World," when writing to advertisers, will ensure prompt attention.

# G.E.C. H.T.

## THE NEW H.T. BATTERY WITH THE STABILISED ELECTROLYTE

### 120 Volt... 144,000 Milliwatt Hours GUARANTEED

PRICES:  
60v: 5/6. 99v: 9/-. 108v: 10/-. 120v: 11/-.  
150v: 14/-. 60v. Triple Capacity: 12/-.



ASK FOR  
**G.E.C. H.T.**  
TO-DAY

Sold by all Wireless Dealers

## A TRIAL MEANS YOU'LL ALWAYS USE G.E.C. H.T.

Advt. of The General Electric Co. Ltd., Magnet House, Kingsway, London, W.C.2

*Advertisements for "The Wireless World" are only accepted from firms we believe to be thoroughly reliable.*

# Sh-h stop all that noise!

The  
**RADIOFORMER**  
DEALS STERNLY WITH  
MAN-MADE STATIC

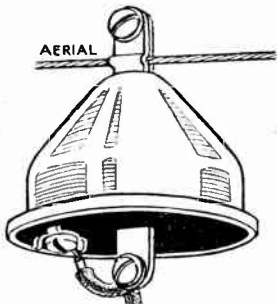

The greatest bugbear encountered in the quest for perfect wireless reception lies in the interference caused by neighbouring electrical apparatus. Prior to the appearance of the "RADIOFORMER" this nuisance could be cured only by action on the part of the owners of interfering appliances, but with the advent of the "RADIOFORMER" a new prospect opens before the set owner. Consisting of the Aerial and Set Radioformers, with 50 feet of shielded down lead, the kit will make a world of difference to the reception of any set on

The RADIOFORMER eliminates "static" when the set is tuned to a station. Many sets fitted with A.V.C. become extremely sensitive between stations, and pick up a great deal of noise. The so-called interference suppressors are fitted to reduce this noise between stations whereas the RADIOFORMER reduces the noise which interferes with pure reception of a station.

wavelengths from 15 to 550 metres, and with only the slightest weakening of the less powerful signals on the long waves.

**17'6**

COMPLETE  
POST FREE

**SINGLE UNITS**

Aerial Transformer Type A.	7 6
Set Transformer Type S.	7 6
Shielded Cable, 50 ft.	4 6
Ditto 100 ft.	8 6

Pat. applied for.

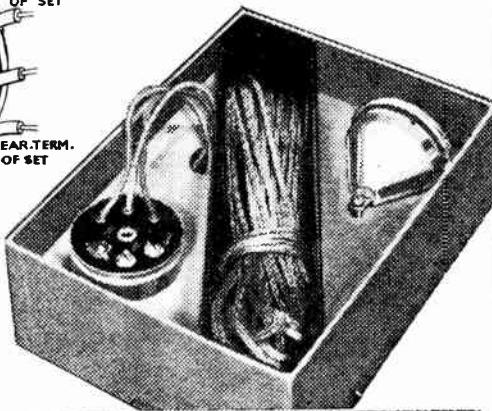
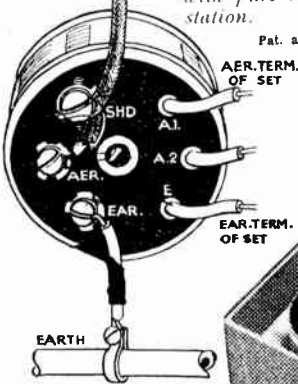

# The RADIOFORMER

BRITISH MADE

Terms to the trade supplied on application to the Sole Manufacturers:—

**RADIOFORMER LTD.**  
31 FELDAY ROAD  
LONDON S.E.13

# REFINEMENTS WHICH ARE OUTSTANDING IN THE DESIGN AND MANUFACTURE OF—

*Darwin*

## PERMANENT MAGNETS FOR MOVING COIL SPEAKERS

No. 1  
FOUR CLAW  
TYPE

**A** Uniform distribution of flux in air-gap.

**B** Magnet economically designed to avoid wastage of material.

**C** Patent dust cover to prevent entry of foreign matter into air-gap.

**D** Patent fixing of centre pole ensuring mechanical accuracy of air-gap.

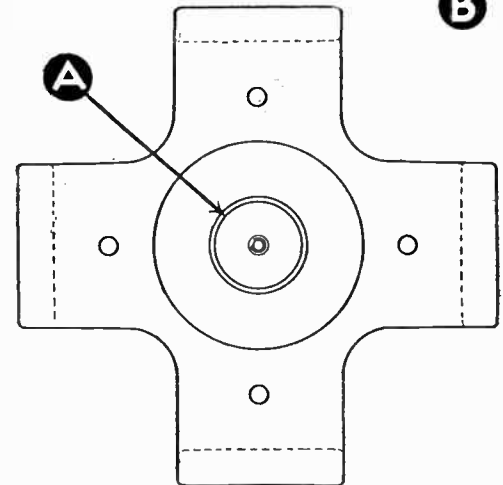
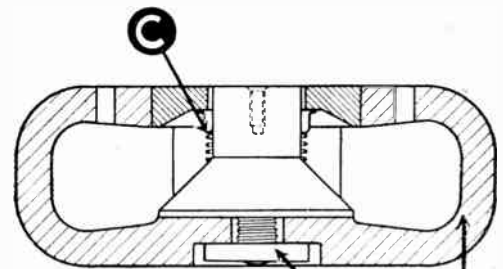

The details above are given in order that manufacturers and designers of Speakers and Radio Receivers may be aware of the refinements which are essential features in the design and manufacture of Darwin Magnets. Each month a different type of Magnet will be illustrated.

Our Technical Staff is always available to assist in solving any magnet problem. They can materially assist in economies in magnet steel for a given output and performance.

*Darwins Ltd*  
**CORRECT MAGNET DESIGN**

Head Office: Fitzwilliam Works, SHEFFIELD.  
London Office: 29/31, Regent St., S.W.1.



PRECISELY!

Knowledge of the working conditions of every part of a Radio circuit is essential to true Radio reproduction.

Such knowledge is useless unless based upon the findings of a reliable instrument; but every wireless man knows that the basis provided by a Ferranti meter is precise and reliable beyond all argument.

Here is the range of Ferranti Testers. There is a model for each and every requirement. They are the essential equipment of the Radio Engineer and Service Agent, and vital to the work of every serious experimenter.

British Standard Specification, First Grade Accuracy and Performance. No better instruments are available at any price.

**UNIVERSAL VALVE TESTER**

Resistance 1,000 ohms per volt.  
 0-150-300 volts H.T.  
 0-6 Volts L.T.  
 0-1.5 Amps. Heater Current.  
 0-3-15-60 m.A. Anode Current.  
 0-15-60 Volts Grid Bias. Price - £7.7.0  
 Complete with 3 adaptors for testing all kinds of valves.

**D.C. TEST SET (Multi-range)**

250-Volt Range. 1,000 ohms per volt.  
 Ranges: 2½" dial 110° scale.  

Volts	Amperes	Also available in
0-0.1	0-10	0-0.01
0-0.5	0-50	0-0.05
0-1	0-100	0-0.1
0-5	0-250	0-0.5
		0-10
		0-25

Tester only - £8. 5.0  
 500-volt model - £9.15.0  
 Case, with leads, extra - £1.15.0

**A.C. TEST SET (Multi-range)**

Volts	Ranges	Volts	Amperes
0-7.5	10 ohms per volt 2½" dial 110° scale.	0-150	0-0.5
0-15		0-300	0-0.5
0-30		0-600	0-0.5

Price - £6 6.0

**RADIO SERVICE TESTER**

Comprises an A.C. and a D.C. element mounted alongside in one case, permitting the taking of instantaneous A.C. and D.C. measurements. The Ranges are:-  
 A.C. 0-10 volts - 10 ohms per volt.  
 0-400 volts - 133 ohms per volt.  
 D.C. 0-5-10-100-500 volts 1000 ohms per volt.  
 0-1-10-100-500 milliamperes.  
 Price - £6.6.0

**FERRANTI**  
**TESTING INSTRUMENTS**

Ask for List Wh526.

FERRANTI LTD., HOLLINWOOD, LANCS. London: Bush House, Aldwych, W.C.2.

Advertisements for "The Wireless World" are only accepted from firms we believe to be thoroughly reliable.



# MILNES H.T. SUPPLY UNIT

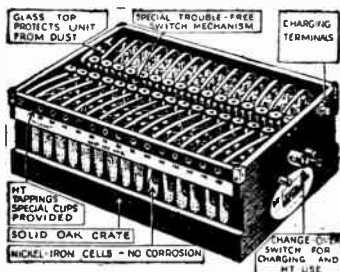

gives  
**65-70%  
WATT - HOUR  
Efficiency**

No other form of H.T. Supply of any type can show so high a degree of efficiency. The charge and discharge curves reproduced are illuminating and are typical of every Milnes Unit. Furthermore, this efficiency is maintained indefinitely. Year after year—for

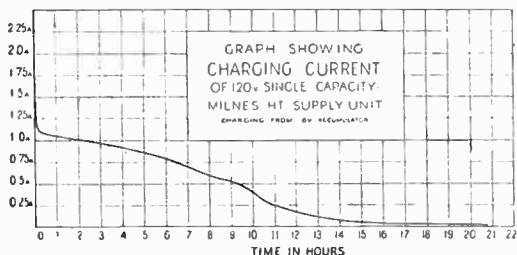

twenty years and more, the Milnes Unit will function with unflinching regularity and perfect consistency.

The Milnes Unit will serve the largest set. It will stand almost at any rate of discharge. (Even dead shorting will not harm the nickel-cadmium plates). Overnight the Milnes Unit regains its fully charged condition by drawing current from the L.T. accumulator—automatically, without need for watching or timing and without wasting a milliamp of current. The constant voltage, steady flow and dead silent background make the Milnes Unit ideal for quality reproduction and short-wave work. It gives punch and dependability equal to the mains with the purity of a brand-new dry battery. The Milnes Unit is a sound engineering production—proved by 15,000 users over 5 years. It stands for a definite and permanent solution of all H.T. problems. Ask your radio dealer to demonstrate, or send the coupon to-day for free descriptive book.

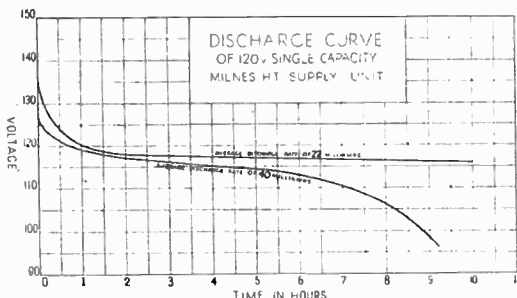

SEE THE  
MILNES UNIT  
AT  
STAND  
**108**  
Gallery Bridge,  
MANCHESTER  
RADIO EXHIBITION.

PRICES IN  
GT. BRITAIN  
80 v. £3.3.0  
100 v. £3.9.5  
120 v. £4.2.3  
150 v. £5.1.6

Hire Purchase  
Terms from 6/-  
monthly.

MILNES RADIO CO. LTD., BINGLEY, YORKS.  
Please send FREE Book describing the Milnes H.T. Supply Unit. No obligation.

Name: .....

Address: .....

B 10

## From every point of view



## the 'Alpha' leads

The R. & A. 'Alpha' Reproducer, to quote "The Wireless World," "is a distinct advance in the reliability of M.C. Units."

With ordinary speakers, chassis distortion or damage affects the diaphragm, and may cause the speech coil to foul the gap.

In the 'Alpha,' the unique and patented method of mounting the diaphragm independently of the chassis ensures complete freedom from the effects of chassis distortion.

Diaphragm and speech coil are mounted to a pressed steel member which is secured to the centre pole piece of the magnet by a single nut. Accurate centring of the speech coil in the gap is thus assured, resulting in permanent and trouble-free operation.

The 'Alpha' has a flux density of 9,000 lines per sq. cm. in the gap. This high sensitivity results in maximum power output with minimum input and the 6 ratio transformer permits accurate matching with the impedance of any super power or pentode valve.

**2**  
Models

Two models are available, viz., STANDARD, with 6 ratio Transformer, and MODEL "B," with Universal Transformer for Class B operation.

**52/6**

Ask your dealer to demonstrate, and write us for new 1934 Leaflet.

# R. & A. 'ALPHA'

P.M. MOVING COIL REPRODUCER DE-LUXE

REPRODUCERS & AMPLIFIERS LTD. WOLVERHAMPTON

Holdens

Mention of "The Wireless World," when writing to advertisers, will ensure prompt attention

# IGRANIC

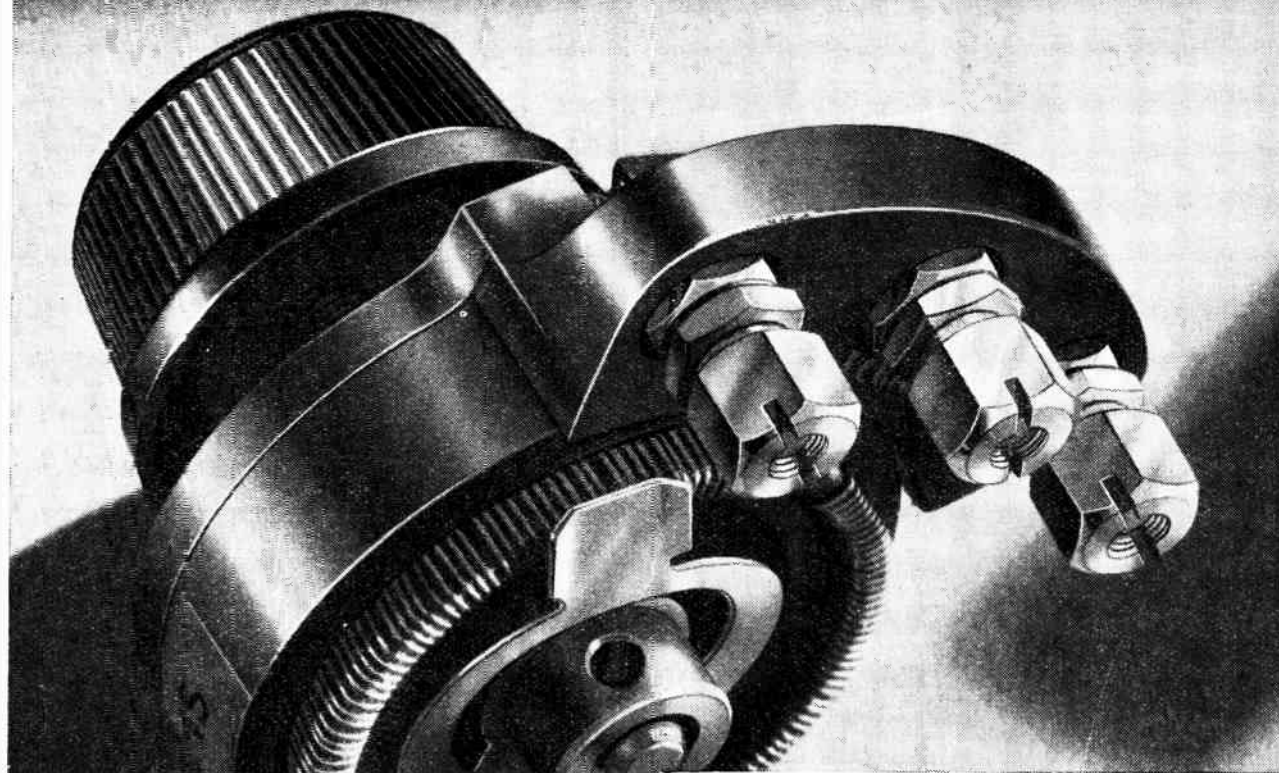

The Igranic Variable "Megostat" High Resistance. Designed and constructed to the highest standards of radio engineering—finish in keeping with the reputation of Igranic—special contact preventing wear and ensuring constant resistance value—can be used as a volume or tone control, as a variable grid leak or as stabilising resistance, etc., in single-hole fixing—at the reduced price of 3/6 in four sizes—another example of that efficiency of performance and reasonableness in price which are typical of every item in the Igranic range. Let Igranic Components be the making of your set.

Send for fully illustrated Catalogue No. U.355.

If you cannot obtain Igranic Components, write to us direct and include the name of your local dealer



Igranic Electric Co., Ltd.,  
149, Queen Victoria Street, E.C.4

CVS-93

# R.F. SUPER-HET RADIOPAK



**The only complete  
FACTORY MATCHED  
Super-Het Tuning Unit**

THE unit comprises CONSTANT AERIAL COUPLING coil, R.F. inter-valve coil and oscillator coil, special super-het 3 ganged condenser, the oscillator tuning section having "shaped" tracking vanes ensuring matching over the whole wave-band. The R.F. Super Radiopak is matched within  $\frac{1}{2}$  of 1 per cent. before despatch. One has only to balance out the stray circuit capacities with the aid of the trimmers conveniently provided at the top of the Unit to ensure permanent MATCHED PERFECTION.

A PADDING CONDENSER is incorporated to balance the tuning on the LONG WAVE-BAND. PRICE SUITABLE FOR I.F. of 110 K.C. The scale is calibrated in Wave-lengths. 200-550 m. 800-2,000 m. Type 535 c/w

**75/-**

**SPECIFIED EXCLUSIVELY for the**

**W.W.D.C. Super-het**



# RADIOPHONE

MATCHED PERFECTION

BRITISH RADIOPHONE LTD., ALDWYCH HOUSE, ALDWYCH, LONDON, W.C.2  
Telephone: Holborn 6744



**SPECIFIED for the  
"D.C." SUPERHET**

**LYONS-SYLVANIA  
TYPE 6A7  
PENTAGRID-CONVERTER**

Price 16/-

COMPLETE WITH HOLDER AND GRID-CLIP

ALSO SPECIFIED:

- 1 Tapered Volume Control .25 megohm .. 6/6
- 1 P58, wire-wound Potentiometer, 5,000 ohms 6/6
- 1 No. 728, "Q-M-B" Switch .. .. . 1/6
- 1 No. 2,728, Double-Pole "Q-M-B" Switch 3/3
- 1 F.W.-25, 25 ohms Resistor .. .. . 1/6

**CLAUDE LYONS LTD.**

76, OLD HALL STREET, LIVERPOOL, 3  
40, BUCKINGHAM GATE, WESTMINSTER, S.W.1

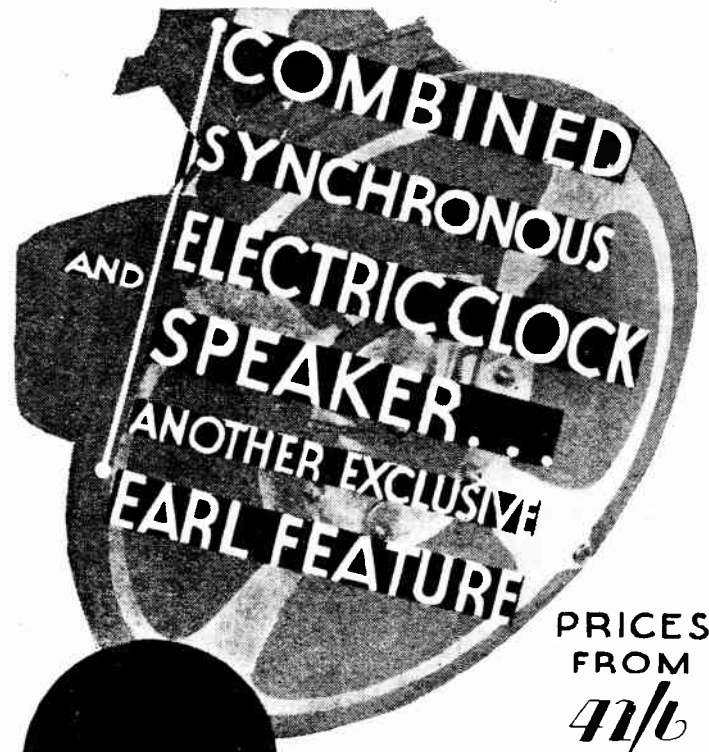

PRICES FROM **4/6**



**MANUFACTURING COY. LTD.**  
'AVENUE WORKS'  
**HANOVER PARK, S.E. 15**  
NEW CROSS O422

# SUPERINDUCTANCE ALONE OFFERS ALL THESE FEATURES AT THIS LOW PRICE

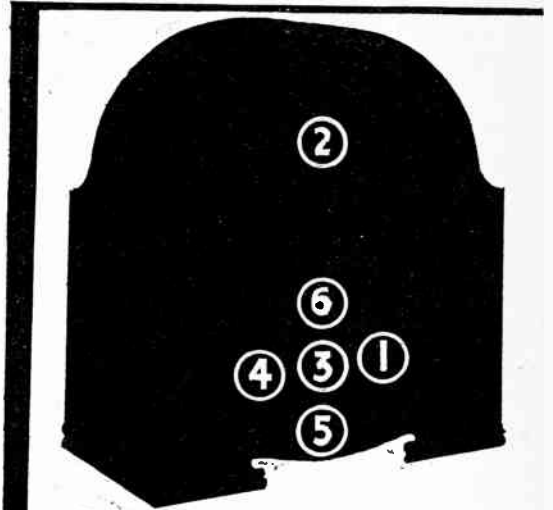
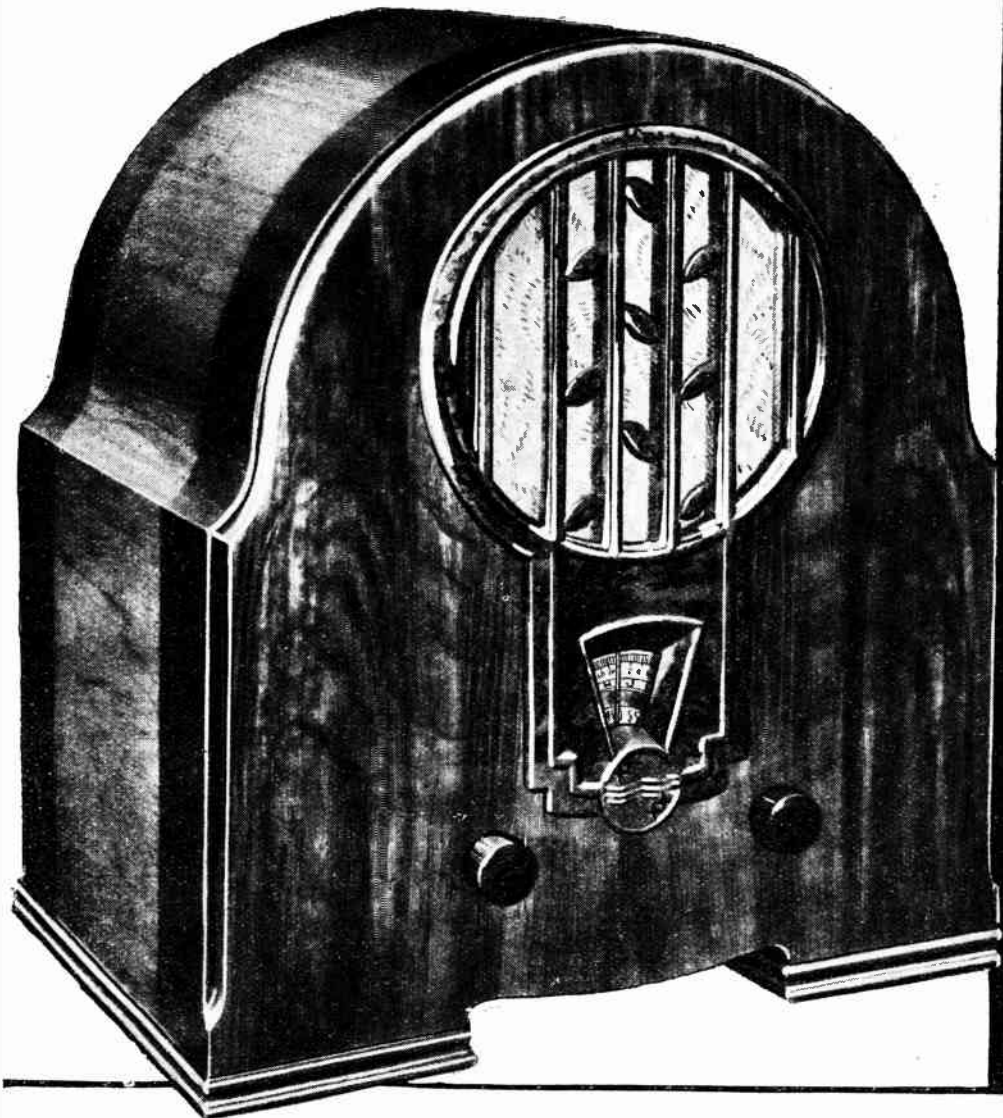

- 1** Amazing sensitivity and selectivity. Four Super-inductance tuned circuits. Precision methods of construction applied throughout the design.
- 2** Magnificent reproduction ensured by moving coil loudspeaker, carefully designed output stage and 3-position tone filter.
- 3** Simple 2-knob control. Absence of any oscillating circuit gives complete freedom from second channel and similar types of heterodyne whistles.
- 4** Automatic fading compensation and special selector control for quickly selecting the worthwhile programmes, and eliminating those spoilt by mush and background noise.
- 5** Easy station identification. Comprehensive station chart in conjunction with micrometer dial indicates the positions of nearly 100 stations with extreme accuracy.
- 6** The micrometer dial will not become obsolete when stations change their wavelengths. Revised charts will be supplied when necessary.

The Superinductance principle, designed by Philips for the reception of dual waveband broadcasting, has achieved its peak success in the new 634. The perfection of its all round performance, the simplicity of operation and the quality of its reproduction reach a standard hitherto unequalled by 7 or 8-valve sets of more conventional design.

For A.C. Mains. Type 634A.  
100/260 volts 40/100 cycles. 2 S.G.H.F.-Diode Detector with S.G.L.F. Output Pentode. Valve Rectifier.

**PRICE : 16 GNS.**

or by 12 monthly payments of £1/11/- each.

For D.C. Mains. Type 634C.  
110, 150, 200/260 volts. 2 S.G.H.F.-Diode Detector with S.G.L.F. 2 parallel Output Pentodes. Current regulator lamp.

**PRICE : 17 GNS.**

or by 12 monthly payments of £1/13/- each.

We claim that model 634C is the finest receiver ever produced for operation on D.C. mains regardless of cost.

# PHILIPS SUPERINDUCTANCE RADIO - RECEIVERS



**OF ECONOMY plus RELIABILITY**

**NEW PAPER CONDENSER TUBULAR TYPE**

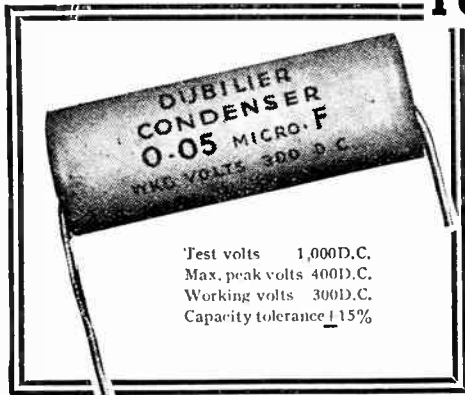

Economical, compact, reliable, moisture-proof, these new Dubilier Tubular Paper Condensers give complete satisfaction.

Suitable for use in circuits where the peak voltage does not exceed 400 v. D.C., or in H.F., I.F., L.F., amplifier and detector circuits and capacity coupled band pass circuits.

You are safe in using these new Dubilier Condensers

—they carry Dubilier's established guarantee of satisfaction.

Write for free catalogue  
**DUBILIER**  
PAPER CONDENSERS

PRICES			Price
Capacity $\mu$ F	Length	Diameter	
.001	1 1/8"	7/16"	1/-
.002	1 1/8"	7/16"	1/-
.005	1 1/8"	7/16"	1/3
.015	1 1/8"	7/16"	1/3
.02	1 1/8"	7/16"	1/4
.04	1-9/16"	7/16"	1/4
.05	1-9/16"	9/16"	1/4
.1	1-9/16"	9/16"	1/4
.15	2-1/16"	9/16"	1/6
.2	2-1/16"	1 1/16"	1/9
.25	2-1/16"	1"	1/9
.5	2-1/16"	1"	2/-

DUBILIER CONDENSER CO. (1925) LTD., DUCON WORKS, VICTORIA RD., N. ACTON, W.3

Mention of "The Wireless World," when writing to advertisers, will ensure prompt attention.



**"KINVA"**  
RADIO SPECIALITIES

THE VERY LATEST IN H.F. CHOKES

"Kinva" laboratories have produced the ideal Screened H.F. Choke for the exacting requirements of H.F. Anodes. Use of the Kinvalloy iron-dust core has enabled the high figure of 200,000 micro-H. to be obtained with the exceptionally low self-capacity of 3 m-mfds. Specify type I.D.C., maximum stage-gain assured.

PRICE **4/6** (Postage 4d. extra)

Type A.3  
Two Coil Filter

The zenith of perfection in Heterodyne-whistle and side-band splash filters. Reception of your favourite long-distance stations improved beyond measure. Easily fitted to all sets.

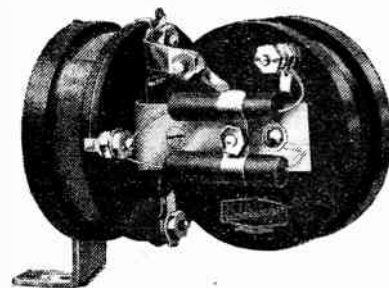

PRICE **13/6**

A postcard brings you full details, curves, etc., of these and other "Kinva" Products. Manufactured by

**POSTLETHWAITE BROS.**  
Dept. B, Established 1922  
Church Hill, KINVER, near Stourbridge

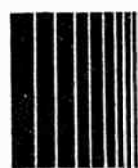

**IF YOU CAN AFFORD TO**

**BUY**



**THE SATISFACTION OBTAINED WILL WELL REPAY YOU**

PARTRIDGE & MEE, LTD.  
LEICESTER AND LONDON.

SPECIALISTS IN HIGH QUALITY TRANSFORMERS, CHOKES, SPEAKERS, AMPLIFIERS



# With any Circuit... ORMOND LOUDSPEAKERS

## 38'6



## Give best results

### The ORMOND Permanent Magnet MOVING COIL CHASSIS

(Illustrated below)

A Moving Coil Speaker at a price which all can afford, yet which gives performance of the very highest merit.

Fitted with a pressed steel chassis and moulded cone with large permanent magnet to give reliability with long life. Overall size: diameter 8", depth 5 1/8".

**Supplied with specially designed output transformer to meet each required circuit condition.**

For Normal Outputs. Cat. No. R/494.

For use with high efficiency Pentodes.

Cat. No. R/494Z.

For Class 'B' and Q.P.P. Cat. No. R/494C.T.

### The ORMOND Permanent Magnet MOVING COIL CHASSIS

(illustrated above)

The performance of this wonderful Speaker can only be compared with that of much higher-priced products. Its unflinching faithfulness throughout the frequency range—with neither shrillness in the treble or booming in the bass—is truly delightful. Overall size: diameter 8", depth 4 1/4".

**Supplied with specially designed output transformer to meet each required circuit condition.**

For Normal Outputs. Cat. No. R/475.

For use with high efficiency Pentodes.

Cat. No. R/475Z.

For Class 'B' and Q.P.P. Cat. No. R/475C.T.

## 26'



THE ORMOND  
ENGINEERING CO. LTD.,

Ormond House,  
Rosebery Avenue,  
London, E.C.1.



Telephone:  
Clerkenwell 5334-5-6 & 9344-5-6.

Telegrams:  
Ormondengi, Isling.

## for PUNCH, POWER & PURITY !!

# An Olympic Triumph!



## Model 74. New 7-Stage Superhet.

**OUTSTANDING FEATURES.** British and Continental stations can be received at full programme strength and unsurpassed fidelity—**DELAYED AUTOMATIC VOLUME CONTROL** in All-Electric Models ensuring desired volume from both distant and local stations—**One Knob Tuning**—**CLASS "B" OUTPUT** in Battery Models permits "All-Electric" performance—Magnificent Bakelite Cabinet available in two finishes, figured walnut, and black with chromium-plated fittings—Detachable fret, an exclusive feature permitting speaker silk to be changed to match any furnishing scheme—New Station scale with names and wavelengths—Seven-stage superhet circuit with band-pass tuning—Light-beam station selector—Combined on-off switch and volume control for radio and gramophone—Moving coil speaker—Gramophone pick-up sockets controlled by switch—External speaker connection.

## Model 74

Battery and All-Electric  
Black and Chromium.

**14 GNS.**

or 12 monthly payments of  
£1.7.0

Walnut Finish

**13 GNS.**

or 12 monthly payments of  
£1.5.0

# EKCO RADIO

To E. K. COLE Ltd., Dept. W.27, EKCO Works, Southend-on-Sea.

NAME .....

ADDRESS .....

A full-coloured folder will be sent to you free on receipt of this coupon.

*Mention of "The Wireless World," when writing to advertisers, will ensure prompt attention.*

# The Wireless World

THE  
PRACTICAL RADIO  
JOURNAL  
23<sup>rd</sup> Year of Publication

No. 735.

FRIDAY, SEPTEMBER 29<sup>TH</sup>, 1933.

VOL. XXXIII. No. 13.

Proprietors: ILIFFE & SONS LTD.

Editor:  
HUGH S. POCOCK.

Editorial,  
Advertising and Publishing Offices:  
DORSET HOUSE, STAMFORD STREET,  
LONDON, S.E.1.

Telephone: Hop 3333 (50 lines).  
Telegrams: "Ethaworld, Watloo, London."

COVENTRY: Hertford Street.  
Telegrams: "Cyclist, Coventry." Telephone: 5210 Coventry.

BIRMINGHAM:  
Guildhall Buildings, Navigation Street, 2.  
Telegrams: "Autopress, Birmingham." Telephone: 2970 Midland (3 lines).

MANCHESTER: 260, Deansgate, 3.  
Telegrams: "Iliffe, Manchester." Telephone: Blackfriars 4412 (4 lines).

GLASGOW: 268, Renfield Street, C.2.  
Telegrams: "Iliffe, Glasgow." Telephone: Central 4857.

PUBLISHED WEEKLY. ENTERED AS SECOND  
CLASS MATTER AT NEW YORK, N.Y.

Subscription Rates:  
Home, £1 1s. 8d.; Canada, £1 1s. 8d.; other  
countries abroad, £1 3s. 10d. per annum.

As many of the circuits and apparatus described in these pages are covered by patents, readers are advised, before making use of them, to satisfy themselves that they would not be infringing patents.

## CONTENTS

	Page
<b>PROGRAMMES FROM ABROAD, pp. I—XXIV</b>	
Editorial Comment .. ..	261
D.C. Superhet .. ..	262
By-Pass Condensers for 5-metre Work .. ..	266
The Manchester Show Report ..	268
Unbiased .. ..	270
News of the Week .. ..	271
The Electrostatic Loud Speaker III	272
Philips "Superinductance" Re- ceiver 631A .. ..	275
Letters to the Editor .. ..	276
Broadcast Brevities .. ..	277
Readers' Problems .. ..	278

## EDITORIAL COMMENT

### Station Identification

#### Why Not Call Signs?

**A** CORRESPONDENT, whose letter appears elsewhere in this issue, raises once more the question of station identification and suggests that, when the new wavelength changes come into operation in January of next year, an excellent opportunity presents itself to remedy the present inadequate methods of announcing the identity of stations. Our correspondent recommends the system of individual station calls, as adopted by the leading networks in America.

It has always been a matter of disappointment to us that our own stations, as well as those on the Continent, do not give satisfactory indications of their identity during transmissions. It is all very well to suggest, as has so often been done, that the wavelength of the transmissions should be a sufficient guide, but it is by no means easy to identify all the stations of Europe, and when the general reshuffle of wavelengths takes place under the recommendations of the Lucerne Plan, it will be some time before listeners are able to regain confidence in the exact identity of many of the transmitters. If this change of wavelengths were made the occasion for adopting call-signs to be given out at frequent intervals during the transmissions, identification troubles would be overcome. Individual countries could be allotted call-signs commencing with a particular letter to designate the country of origin as is done when general wireless communication call signs are allotted.

There are only two complications which we foresee might arise in connection with a call-sign for the purposes of identification; the first is that in many instances in Europe a number of

stations broadcast the same programme and are controlled from a common microphone, and secondly, pronunciation of letter call-signs in different countries might be difficult to interpret. The difficulty in the case of relaying the same programme might be overcome by announcing the call-signs of all the various stations taking a common programme, and in the matter of pronunciation of call letters it would probably take very little time to recognise the differences.

If a system of call-signs of this nature is to be adopted, it should be considered without delay, in order that the system could be introduced throughout Europe at the time the reshuffle of wavelengths takes place.

### Double - channel Transmission

#### Opportunity for an Experiment

**T**HE suggestion has been put forward through our correspondence columns recently that the B.B.C. might consider the possibility of conducting double-channel transmissions from two separate broadcasting stations at times when these stations are both taking the same programme. This would necessitate, of course, a duplication of microphones in the studio and of the amplifiers and connecting links to the transmitting stations, and at the receiving end listeners would have to employ two independent receiving sets and loud speakers.

Reception under present conditions is, of course, only "one-eared," and it is not possible to obtain a stereophonic effect without a duplication of equipment. We believe that an enormous number of listeners would be prepared to set up two receivers for the purpose of testing out this experiment if the B.B.C. were prepared to do their part.



The Wireless World

# D.C. SUPERHET

## A Highly Selective Four-valve Receiver with A.V.C.

By W. T. COCKING

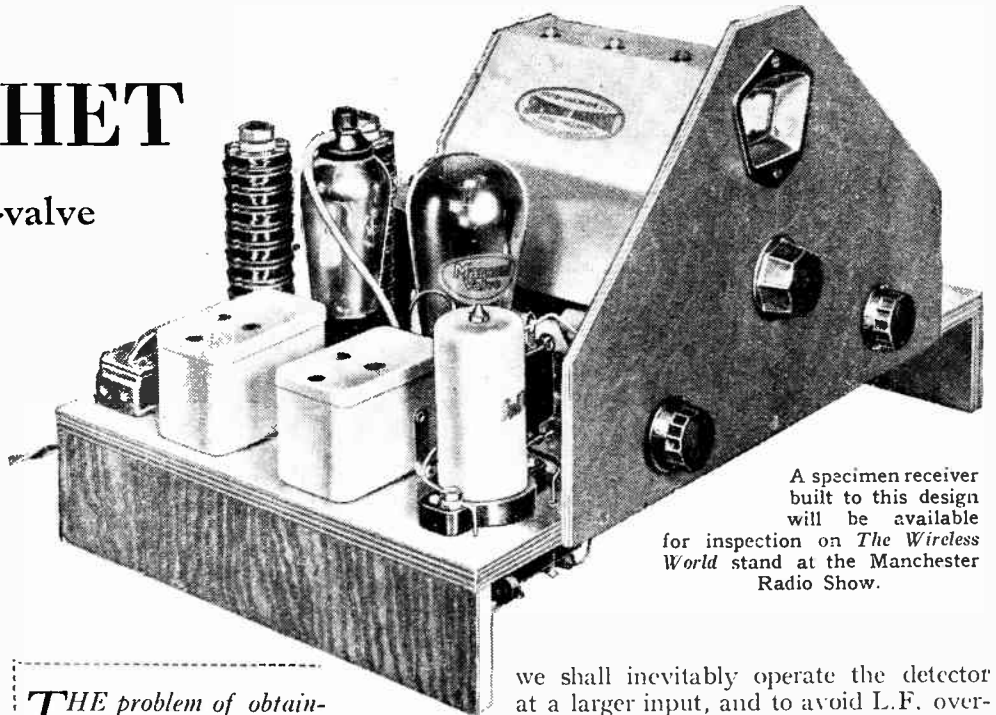

A specimen receiver built to this design will be available for inspection on *The Wireless World* stand at the Manchester Radio Show.

THE difficulties attendant upon the design of a D.C. mains receiver are considerably greater than those attached to the production of a set for alternating current supplies for two reasons: first, the voltage available is limited to that of the mains, and, secondly, complete isolation of the receiver circuits from the mains is not possible. The first of these is reflected in the choice of the output equipment and the A.V.C. system, while the second necessitates greater care in mechanical construction.

Practically speaking, we are limited to pentode type output valves with D.C. working, for the high bias voltage usually prohibits the use of triodes. Of the satisfactory automatic volume control systems we must usually choose the delayed diode type, for practically all others require a source of voltage additional to the H.T. supply. It was shown in a recent article<sup>1</sup> that the delayed diode A.V.C. circuit can only give satisfactory results if the delay voltage is large and the detector is operated at a correspondingly large signal input. At first sight there appears to be no alternative to using a duo-diode-triode type of second detector to give signal rectification, delayed A.V.C., and first-stage L.F. amplification. Even if the triode be resistance coupled to the output pentode, however, its amplification will not normally be less than about twenty times, and as a pentode only requires an input

*THE problem of obtaining hum-free operation and good automatic volume control is considerably greater in a receiver operated from D.C. mains than in one designed for working from an A.C. supply. These difficulties have been completely overcome in "The Wireless World" D.C. Superhet, and the receiver gives exceptionally good quality of reproduction with an entire absence of hum, while the A.V.C. system employed holds all stations at approximately constant volume and largely counteracts fading.*

of the order of 10 volts, the triode input could not be greater than 0.5 volt if overloading were to be avoided. A delay of only 0.5 volt on the A.V.C. system, however, would not permit good control to be obtained, for the bias on the early stages has to be at least 10 volts on a strong signal. If we use a larger delay voltage,

we shall inevitably operate the detector at a larger input, and to avoid L.F. overloading we shall have to throw away most of the amplification provided by the L.F. stage.

This is obviously uneconomical, and to avoid these difficulties in the present receiver no L.F. amplification is used between the detector and the output valve. The output pentode is operated with a grid bias of about 9 volts, and so requires a signal input of this value for maximum output. A duo-diode type of delayed A.V.C. system is used, the delay voltage being 9 volts, and being actually derived from the output valve bias. A.V.C., therefore, does not act until the detector input exceeds 9 volts, with which an L.F. output of very nearly 9 volts is obtained on deep modulation. With such a large detector input, rectification is truly linear and distortionless, and the A.V.C. action is extremely good.

The disadvantages of operating with such a large detector input are two: the pre-detector amplification must be unusually high for a given overall sensi-

<sup>1</sup> *The Wireless World*, September 8th, 1933.

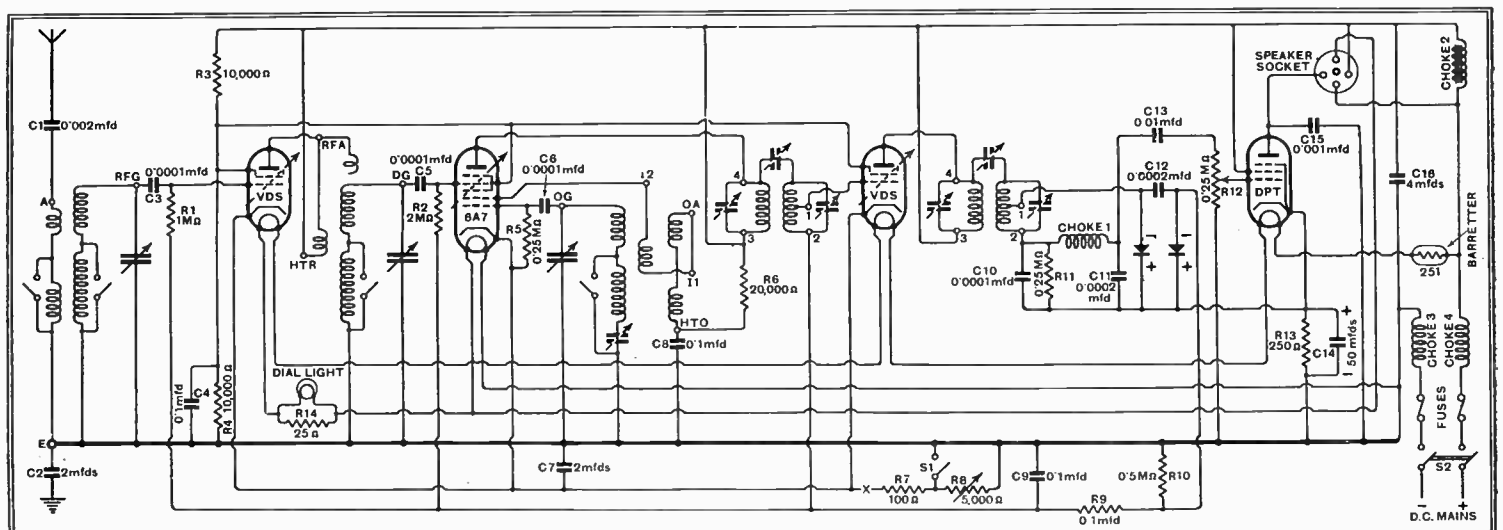

Fig. 1.—The complete circuit diagram of the new superheterodyne. The field winding of the speaker is connected across the "grid" and "plate" pins of the speaker socket and so provides additional heater current for the 6A7 valve.

**"The Wireless World" D.C. Superhet—**

tivity, and it is not possible to use the receiver with a gramophone pick-up, since the L.F. amplification is insufficient for adequate volume even with a sensitive pick-up. These points, however, are far outweighed by the advantages, for apart from the unusual freedom from detector distortion and the good A.V.C. system, there is a complete absence of hum under normal conditions owing to the small amount of L.F. amplification incorporated. To anyone with experience of the difficulties often encountered in the elimination of hum in a D.C. mains receiver, this alone would offer sufficient justification for the arrangement employed.

the tests, even with positive earthed mains.

After smoothing, the total H.T. supply is about 180 volts with 220 volts mains, and the full voltage is applied to the anode and screen of the output pentode, which is self-biased by the drop in the 250 ohms resistance R13, which is shunted by the 50 mfd. electrolytic condenser C14, the positive terminal of which is connected to the valve cathode.

**The Use of Westectors**

The duo-diode second detector actually consists of two Westectors. They are both fed from a tapping point on the secondary of the second I.F. transformer, one

with respect to the earth line. The Westector anode, therefore, is biased 9 volts negatively, and rectification does not occur until the signal input exceeds 9 volts. The potential set up across R10 as the result of rectification is applied to the grids of the controlled valves through the filter R9 of 100,000 ohms and C9 of 0.1 mfd.

The I.F. stage employs a variable-mu valve coupled to the second detector through an iron-core type transformer, thus giving high selectivity and amplification. The component is of the band-pass type, permitting the retention of high audible frequencies, and the adjustment of the circuit coupling is carried out by a

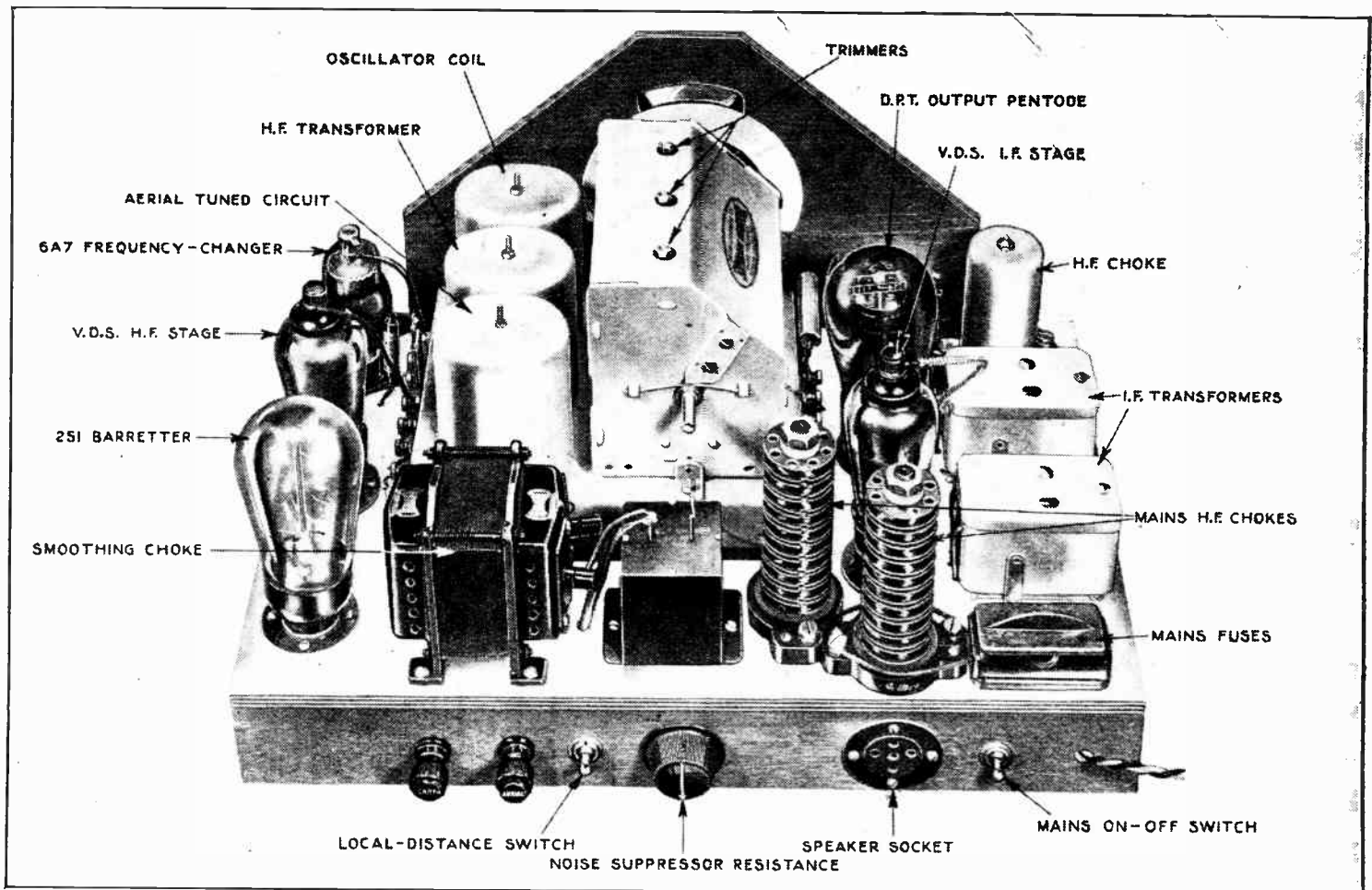

A general view of the D.C. Superhet showing the chief components. The local-distance and mains switches are fitted at the rear as they require only occasional operation.

The circuit diagram of the complete receiver is shown in Fig. 1; a double-pole mains switch S2 is fitted to permit complete isolation of the chassis from the mains when the set is switched off. A fuse in each mains lead offers protection against short-circuits, and 10,000 mH. chokes Ch3 and Ch4 tend to isolate the receiver circuits from the mains so far as H.F. currents are concerned, and also tend to reduce L.F. interference from the supply. The current for the series-connected heaters is then tapped off, and that for the H.T. line passes through a single smoothing choke Ch2, which is followed by a 4 mfd. condenser C16. Tests showed that this modest equipment was sufficient to reduce hum to inaudibility during all

directly and the other through the 0.0002 mfd. condenser C12. The first provides signal rectification, and its circuit is completed through the load resistance R11 shunted by the 0.0001 mfd. condenser C10. The L.F. potentials developed across this load are applied through the filter circuit Ch1 and C11 of 0.0002 mfd. to the output valve, the grid condenser of which is given a value of 0.01 mfd. The 250,000 ohms tapered potentiometer R12 acts as the pentode grid leak and the manual volume control.

The 500,000 ohms load resistance R10 of the second rectifier is returned to the earth line, whereas the Westector itself is returned to the pentode cathode, which is 9 volts positive

small variable condenser. As the detector input impedance is fairly low, the secondary is tapped to give a step-down ratio, thus reducing detector damping.

The input to the I.F. stage is taken from the frequency changer through another identical transformer, also used with a tapped secondary, this time, however, to maintain stability. It is the usual practice to tap the primary of a transformer in cases where the coil efficiency is so high that stability cannot be maintained with the full winding in circuit. In the case of a transformer following a frequency changer, however, this practice is inadvisable, for the efficiency will suffer unless a low impedance load be placed on the frequency changer at the signal and

"The Wireless World" D.C. Superhet - oscillator frequencies, and H.F. instability may occur if this load be inductive. A tapped primary leads to a fairly high load impedance at high frequencies, and gives an inductive load; it is, therefore, to be avoided. With modern high-resistance screen-grid valves the amplification obtainable is the same whether the tapping point be in the primary or secondary, and in this receiver, therefore, a tapped secondary has been adopted.

For the frequency changer the Pentagrid type valve has been chosen on account of its marked superiority over the conventional two-valve arrangement. The oscillator grid is self-biased by the grid current flow along the 250,000 ohms grid leak R5, the tuned circuit being fed

coupling coil, therefore, is used in series with the reaction coil proper to give increased feed-back, and experiment shows it to be entirely satisfactory in this respect. The oscillator anode circuit is fed through the 20,000 ohms resistance R6 with a 0.1 mfd. condenser C8 as a by-pass to earth.

The H.F. Transformer

The variable-mu H.F. valve is coupled to the variable-mu tetrode section of the Pentagrid through an H.F. transformer of a type specially designed to maintain high efficiency at the low-frequency end of the medium waveband. The H.F. stage is preceded by a further tuned circuit, thus giving two signal frequency circuits to guard against second channel interference.

mfd. condenser C7, which provides the minimum bias. With the switch open, a variable resistance R8 of 5,000 ohms is connected in circuit for two purposes—to act as a noise suppressor and to assist the A.V.C. system in dealing with a very strong local station.

For use as a noise suppressor, the switch is opened, and with the set tuned to no signal the resistance is adjusted until the background of atmospherics and local interference is not excessive. Nothing louder than this pre-determined level will then be heard, and the process of tuning will be quiet. When a station has been tuned in the switch can be closed and the maximum sensitivity of the set is then available to counteract fading. For local reception it may be found that with the

PRACTICAL WIRING DIAGRAM.

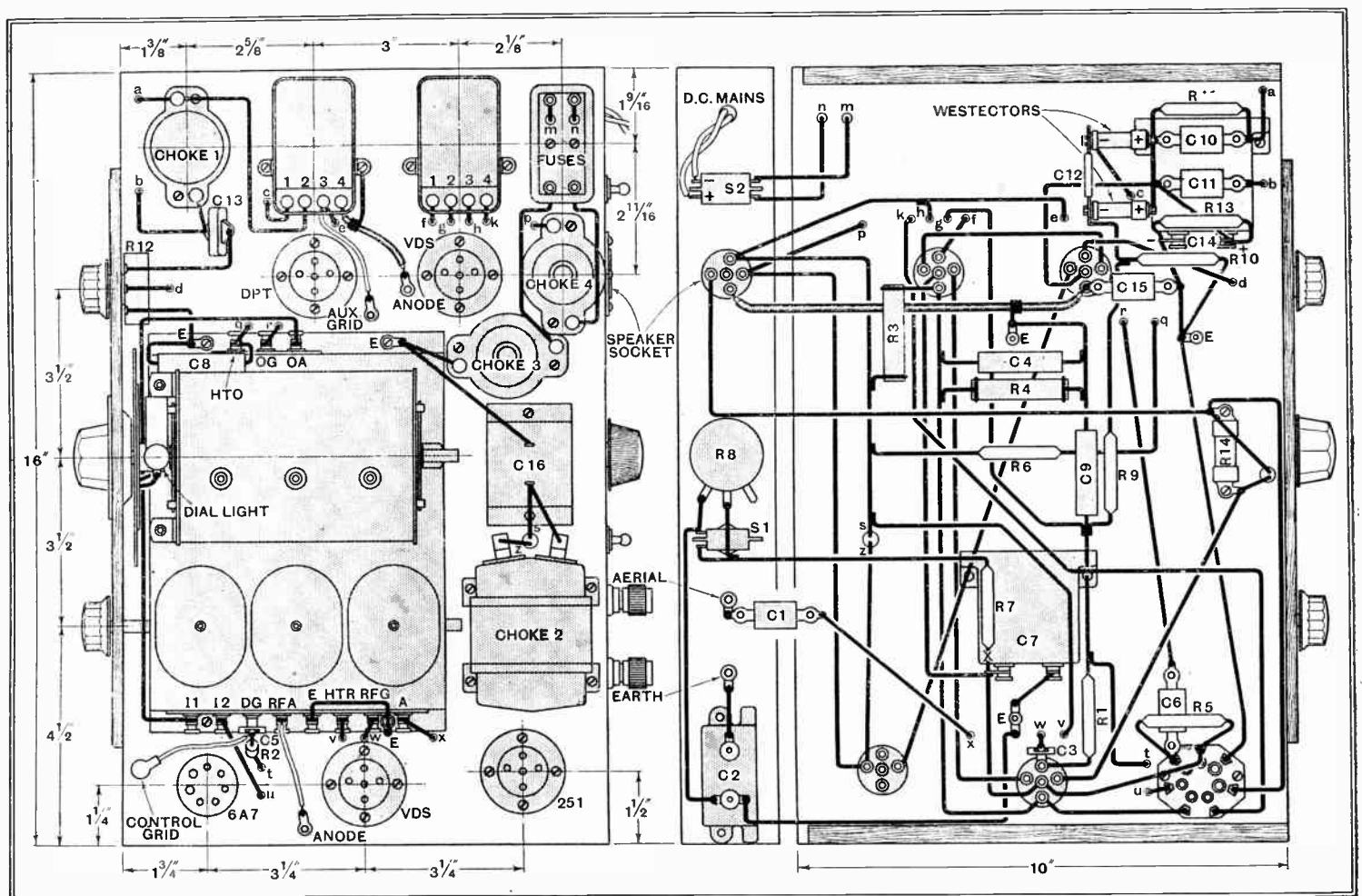

The clean layout and simplicity of the wiring are readily seen from these drawings.

through the 0.0001 mfd. condenser C6. The tuning condenser, which is of the shaped plate type, and coils employed in this set are obtained as a complete unit, which was designed originally for a two-valve frequency changer with cathode injection. A coupling coil is provided, therefore, in the oscillator section which is not required with the Pentagrid valve, since coupling then takes place by electronic action. The normal reaction turns, however, are insufficient to maintain reliable oscillation with the Pentagrid, since the unit is designed for an oscillator valve of higher mutual conductance. The spare

A 0.002 mfd. condenser C1 and a 2-mfd. condenser C2 in the aerial and earth leads respectively are used as a protection against short-circuits.

The screen grids of the H.F., frequency changer, and I.F. stages are all fed from a common line derived from the junction of two 10,000 ohms resistances R3 and R4 across the H.T. supply; a by-pass condenser C4 of 0.1 mfd. maintains the screens effectively at earth potential to H.F. currents. The cathodes of these stages are also commoned, and, with the switch S1 closed, are taken to earth through the 100 ohms resistance R7, shunted by the 2-

switch closed there is a certain amount of distortion, for the I.F. valve may be unable to provide the detector with sufficient input to give the requisite bias without being overloaded. The switch is opened for local reception, therefore, and the resistance adjusted nearly to the point at which a perceptible change in volume can be heard.

The H.F., I.F., and output valves are all of the type requiring 16 volts at 0.25 ampere for their heaters. No British D.C. mains type Pentagrid is yet available, however, and here an American valve, the 6A7, has been used. This is rated for 6.3

"The Wireless World" D.C. Superhet—volts at 0.3 ampere, so that the heater connections are slightly more complicated than usual. The heaters of all valves and the 25 ohms resistance R14 shunting the

advised, therefore, that the receiver be always operated in a cabinet, and that the grub screws in the control knobs be well countersunk. The switches mounted on the rear of the set are not connected to the chassis, so that there is no fear of a shock on touching these.

(To be concluded.)

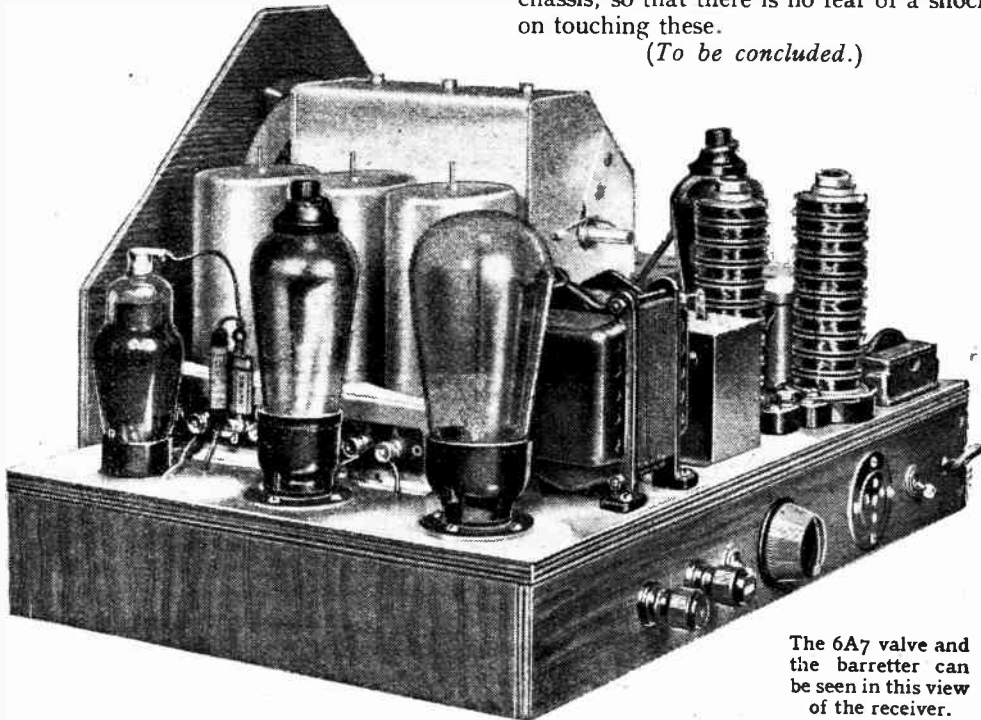

The 6A7 valve and the barretter can be seen in this view of the receiver.

dial light are all wired in series, with the 6A7 valve at the negative end of the chain. The positive end is then connected to the supply through the Osram 251 barretter, which maintains a constant current of 0.25 ampere through the whole circuit, irrespective of mains voltage variations between the usual limits of 200-250 volts. The British valves then all have their correct current, but the 6A7 current is low by 50 mA. This additional current, therefore, is passed through its heater by means of a 5,000 ohms resistance connected between the positive line and the positive side of the 6A7 heater. The Pentagrid thus receives its correct current of 0.3 ampere on 250 volts supplies, and about 0.29 ampere on 200 volts; since the lower current is sufficient to maintain an entirely satisfactory performance, the arrangement is simple and satisfactory.

The 5,000 ohms resistance used for this purpose will not be found as such on the circuit diagram, for the field of a moving-coil speaker is there shown as serving this purpose. In cases where a 5,000 ohms speaker field is not available, an alternative arrangement must be used, and the connections then required will be given in next week's issue.

The receiver is exceptionally easy to build, and no difficulty should be experienced, since the chassis is obtainable with the large holes ready drilled. When connecting up, care should be taken to preserve the correct polarity of the electrolytic condenser and of the Westectors. When using the set it must be remembered that the chassis of the set and all metal parts are in direct connection with the supply mains; if the positive of the mains be earthed, therefore, there is a risk of a shock on touching any metal part. It is

- |  |   |
|--|---|
| 5 5-pin valve holders  | Clix Chassis Mounting Type                      |
| 1 7-pin valve holder   | Philco 27/6005                                  |
| 1 Grid clip, for 6A7 valve   | Philco 4897                                     |
|  | (Claude Lyons.)                                 |
| 1 Fixed condenser, 4 mfd. 250v. D.C. working, C16  | T.C.C. Type 65                                  |
| 2 Fixed condensers, 2 mfd. 200v. D.C. working, C2, C7                                    | T.C.C. Type 59                                  |
| 3 Fixed condensers, tubular, 0.1 mfd. 350v. D.C. working, C4, C8, C9, T.C.C. Type 250    | T.C.C. Type M                                   |
| 1 Fixed condenser, 0.01 mfd., C13  | Igranic Type FF.12                              |
| 1 Fixed condenser, 0.001 mfd., C15   | Igranic Type FF.12                              |
| 1 Fixed condenser, 0.002 mfd., C1  | Igranic Type FF.12                              |
| 4 Fixed condensers, 0.0001 mfd., C3, C5, C6, C10   | Igranic Type FF.12                              |
| 2 Fixed condensers, 0.0002 mfd., C11, C12  | Igranic Type FF.12                              |
|  | (Dubilier, Peak, T.C.C., Telsen.)               |
| 1 Dry electrolytic condenser, 50 mfd., C14   | T.C.C. Type 521                                 |
|  | (Dubilier, Telsen.)                             |
| 1 Make-and-break switch, S1  | Claude Lyons B.A.T.728                          |
| 1 Double-pole single-throw switch, S2  | Claude Lyons B.A.T.2728                         |
|  | (British Radiophone, Belgin.)                   |
| 2 Ebonite shrouded terminals, A.E.   | Belling-Lee Type "B"                            |
|  | (Igranic.)                                      |
| 2 Westectors   | Westinghouse W.6                                |
| 1 Resistor, 25 ohms, R14   | Claude Lyons Type FW.25                         |
| 1 Resistance, 100 ohms 1/2 watts, R7   | Seradex Type M.150                              |
| 1 Resistance, 250 ohms 1/2 watts, R13  | Seradex Type M.150                              |
| 1 Resistance, 20,000 ohms 1/2 watts, R6  | Seradex Type M.160                              |
| 1 Resistance, 0.1 megohm 1/2 watts, R9   | Seradex Type M.150                              |
| 2 Resistances, 0.25 megohms 1/2 watts, R5, R11   | Seradex Type M.150                              |
| 1 Resistance, 0.5 megohm 1/2 watts, R10  | Seradex Type M.150                              |
| 1 Resistance, 1 megohm 1/2 watts, R1   | Seradex Type M.150                              |
| 1 Resistance, 2 megohms 1/2 watts, R2  | Seradex Type M.150                              |
| 2 Resistances, 10,000 ohms 2 1/2 watts, R3, R4   | Seradex Type G.250                              |
|  | (Dubilier, Erie, Claude Lyons, Varley, Watmel.) |
| 1 5-pin plug   | British Radio Gramophone Co.                    |
|  | (Belgin.)                                       |
| 1 Bulb, 6 volts 0.15 amp.  | Bulgin Type "OB"                                |
| 1 Twin safety fuse holder, with 1 amp. fuses   | Belling-Lee Type 1033                           |
|  | (Belgin.)                                       |
| 1 Length Screened Sleeve   | Harbros   |
| Plymax baseboard, 10in. x 16in. x 3/8in.   | Peto-Scott                                      |
| (Overall dimensions of assembled chassis, 16in. length x 10in. width x 9 1/2in. height.) |   |

LIST OF PARTS

After the particular make of component used in the original model, suitable alternative products are given in some instances.

- |   |                    |
|---|--------------------|
| 1 Super R.F. Radiopak, without volume control | British Radiophone |
| 2 Ferrocart Colverdynes, 110 kc/s             | Colvern            |

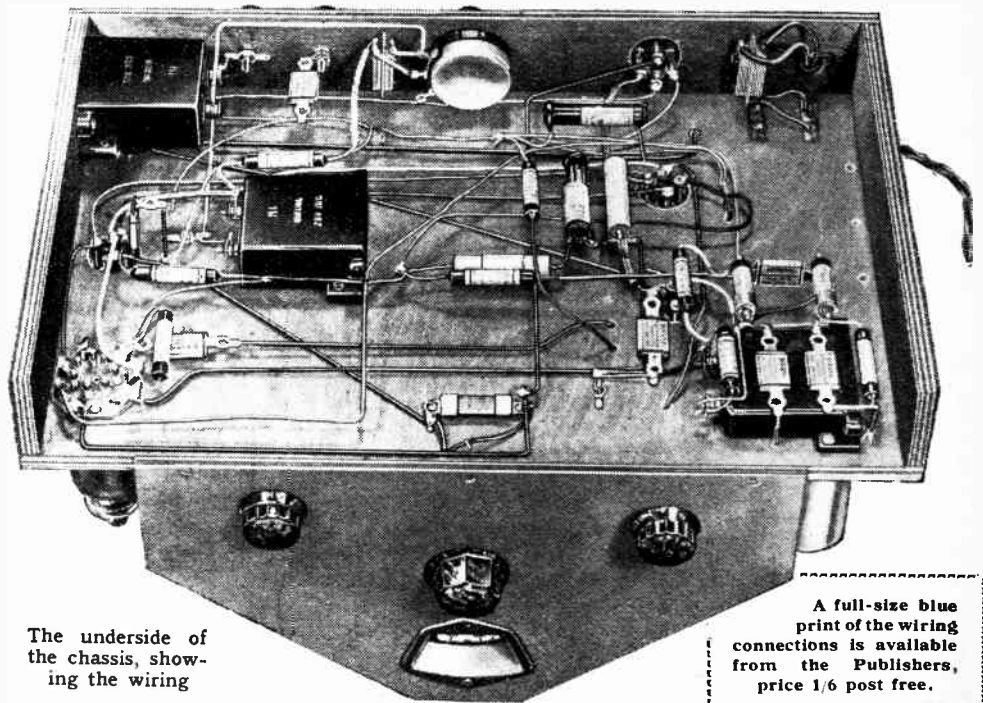

The underside of the chassis, showing the wiring

A full-size blue print of the wiring connections is available from the Publishers, price 1/6 post free.

- |   |  |
|---|--|
| 1 Tapered volume control, 0.25 megohm, and knob R12                                   | Claude Lyons Type 250 M-T  |
|   | (Magnum, Rothermel, Varley.)   |
| 1 Potentiometer, 5,000 ohms R8  | Claude Lyons Type P.58   |
|   | (Haynes Radio, Rothermel, Watmel.)                                   |
| 1 Screened H.F. choke, Ch1  | Goltone Type SHF   |
|   | (Kinva, Varley, Wearite.)  |
| 2 Mains H.F. chokes, Ch3, Ch4   | Goltone Type PHF   |
| 1 L.F. choke, Ch2   | Heyberd No. 752  |
|   | (Davenset, Ferranti, Parmeko, R.I., Sound Sales, Varley, Vortexion.) |
| 1 Voltage regulator   | Osram Barretter No. 251  |
| 4 oz. No. 20 tinned copper wire, 10 lengths Systoflex, wire, wood, etc.               |  |
| Screws:—  |  |
| 25 1/8in. No. 4 R/hd.   | 10 5/8in. No. 4 R/hd.  |
| 4 1/2in. No. 4 R/hd.  | 4 6BA, with nuts and washers.  |
| 7 3/4in. No. 4 C/sk.  |  |
| 10 3/4in. No. 4 R/hd.   |  |
| Valves:—2 Marconi or Osram VDS. 1 Marconi or Osram DPT. 1 Philco or Claude Lyons 6A7, |  |



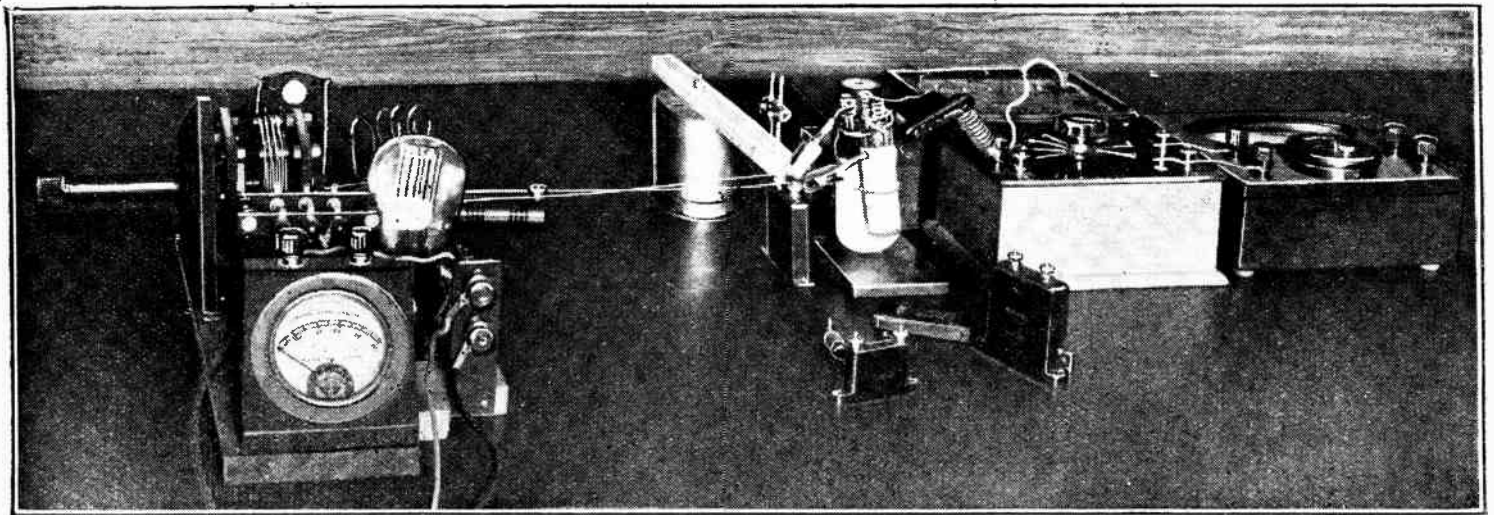

# By-pass Condensers for 5-metre Work

## Experimental Equipment Required for Comparative Measurements

**W**HEN is a condenser not a condenser? The answer, "On 5 metres!" is more likely than not to be true. In fact, most things are quite different from what they are supposed to be at these short wavelengths. Which is the secret of their fascination, no doubt. It is splendid to be able to signal 200 miles on wavelengths that can't possibly travel more than about fifty.

But that is not our subject at this moment. Some time ago<sup>1</sup> Mr. Sowerby wrote an article showing how the inductance of a fixed condenser is important. The object of a fixed condenser—in the larger sizes, at any rate—is to provide a path of as low impedance as possible, in cases where an actual short-circuit is not permissible because of D.C. voltages. The greater the capacity of the condenser, the lower the impedance. But one cannot go

<sup>1</sup> The Wireless World, July 15th, 1932.

*THE performance of H.F. by-pass condensers on the ultra-short wavelengths has not hitherto received much attention, but as these very high frequencies are now coming more to the fore the results of some actual measurements made with several different sizes and types of condenser should prove of more than usual interest.*

on improving things by using larger and larger condensers, because beyond a certain point the inductance of the condenser, small though it is, sets a limit. The shorter the wavelength, the more serious is this restriction. Mr. Sowerby showed how the older type of 1 mfd. condenser reaches its minimum impedance at about 850 metres; below that it increases again. The "non-inductive" type, with a residual inductance of only about 0.02 microhenry, is better; its minimum is at about 270 metres, and it is still quite low at 100 metres, which was the lowest wavelength shown.

If even a "non-inductive" condenser is inductive below 270 metres, what about

5 metres! The condenser makers having done their best in reducing inductance to a minimum, we cannot turn to them for further help. With a view to providing some definite guidance on selection of condensers for 5-metre work, the following results are put forward. This particular wavelength has been singled out for attention because a good deal of interest has been devoted to it by amateurs. The

*The title illustration shows the apparatus used for measuring impedance of condensers at 5 metres. The oscillator on the left is coupled through a one-turn coil, tuning condenser and fuse lamp to the "goal-post" inductance and condenser under test, the voltages across which are measured by the skeleton valve voltmeter on the right.*

figures to be given may, however, provide food for thought on ultra-short waves generally.

Before getting to the actual results, the method of obtaining them may be of some interest, as the problems met in devising it illustrate some of the delightful difficulties of 5-metre work.

If the same current is passed through two components, one known and the other unknown, the voltage across each is proportional to their impedances, so this provides a method for comparing them. The 5-metre current is easily obtained from an oscillator. The known impedance and the voltmeter are not quite so easy. As even an inch of wire has a large inductive impedance at this wavelength, there is not much hope of getting a standard resistance. And a condenser—well, that is our "unknown." So the only possible standard is an inductance. Fortunately, one

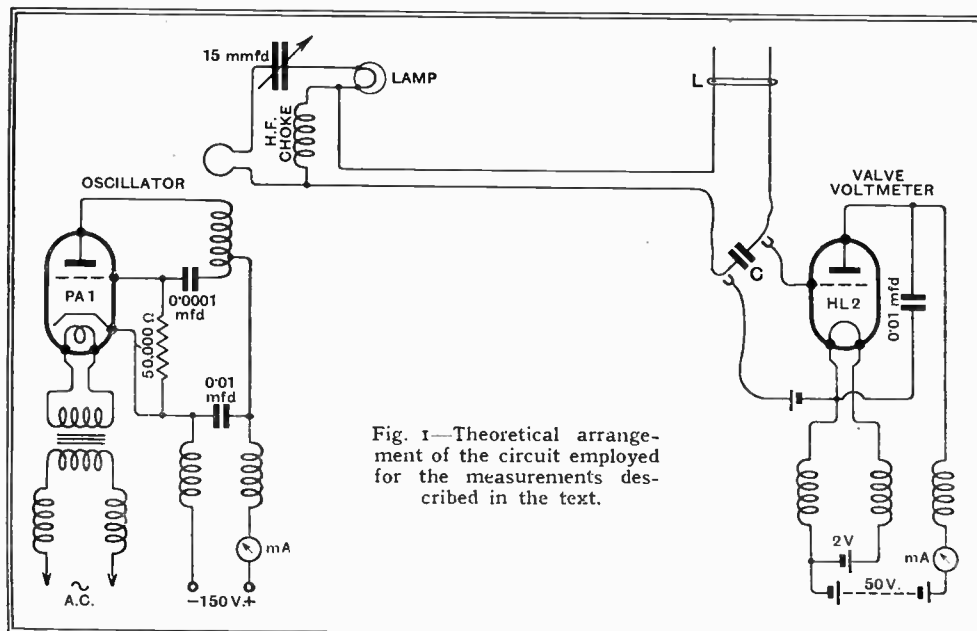

Fig. 1—Theoretical arrangement of the circuit employed for the measurements described in the text.

**By-pass Condensers for 5-metre Work—**

can calculate the inductance of regular geometrical circuits quite easily. The type found most convenient is like a miniature Rugby goal—two uprights and a cross-bar. The inductance is varied by moving the cross-bar up or down.

The voltmeter—obviously a valve voltmeter is the only hope—gave more trouble. However short the leads were made to it, some H.F. current would stray along them and produce almost as large a deflection with the grid-filament input short-circuited as when applied across an impedance in the intended circuit! Ultimately, sensible results were obtained with a specially rigged voltmeter as illustrated. The valve itself, a Mazda HL2, was suspended in mid-air, with no holder, and input clip leads cut down to about two inches, including a small grid cell picked for low resistance and wrenched out of its battery. The anode path was completed as shortly as possible by a 0.01 mfd. condenser.

**Circuit Described**

This little assembly was isolated, so far as H.F. was concerned, by chokes in all the battery and meter leads—40 turns on a ½-inch former gives 7.5 microhenrys, which, assuming a self-capacity of 1 mmfd., forms a circuit roughly tuned to 5 metres, and therefore a very effective rejector. The grid-filament path was investigated and found to introduce negligible shunt loss on the components, viz., the goal-post inductance L, and the unknown condenser C (Fig. 1). Actually, L was about 1½ in. high by ½ in. apart, 18 S.W.G. wire. The rest of the circuit was separated about a foot by close parallel wires, to avoid direct pick-up from the oscillator. The H.F. choke was to provide a conducting path for the voltmeter when measuring C, and the tuning condenser to adjust the current, which is

maintained constant by getting the little fuse lamp just visibly glowing. This is quite a sound and sensitive method when all others fail.

There is nothing very special about the

0.024 microhenry, which agrees very well with the figure given for "non-inductive" condensers.

But, you may say, surely the 1 mfd. condenser, with scores of turns of foil, should have a very much larger inductance? Well, it would have if the current took the trouble to go along all its tortuous convolutions. But it is much too rapidly oscillating for that, and finds the capacity of the first fold quite a good enough path, and the rest is just ignored. So the route taken, as the measurements show, is only about double the minimum distance between the terminals.

Thus a large condenser is in no case very bad. But, seeing that the inductive reactance cannot possibly be got lower than about 9 ohms, the only chance of improving matters is to choose such a capacity as just wipes it out—in other words, to employ a tuned acceptor circuit. The required capacity is 0.0003 mfd., and that this works out in practice is shown by the nearest example measured—the 0.00027 mfd., with only 1½ ohms.

Fig. 2 (curve A) shows how the impedance of condensers depends on the

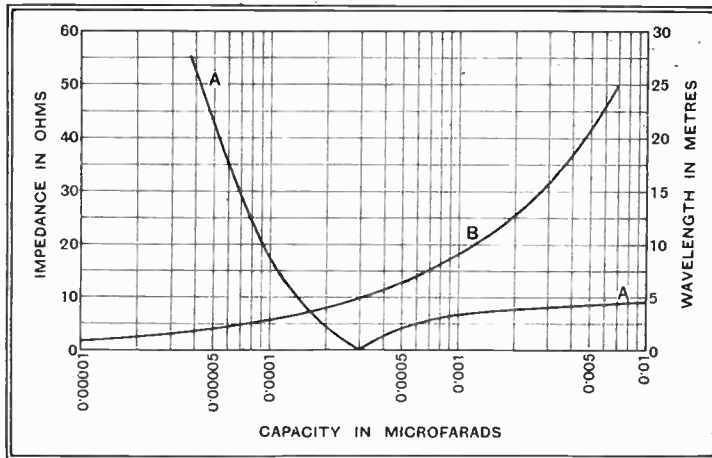

Fig. 2.—Curves showing how impedance of condensers varies with capacity and frequency. The optimum value for 5 metres can be obtained from curve A.

oscillator. A high-slope PA1 valve was used because of its easy oscillation. Less than one turn was required for grid coupling.

The goal-posts were calculated to give an inductance of 0.034 microhenry—not very much, but 13 ohms at this wavelength!

The various types of condensers tested gave impedances as shown in the table.

The condenser consists of a capacity in series with a small unavoidable inductance, and what is measured is the resultant of both. The two work in opposite directions, and, as the capacity effect can be calculated, it is easy to arrive at the inductive contribution, which is shown in the last column.

It will be noticed that there is a fairly considerable uniformity about these last figures. The two old inductive types are higher, but not enormously so. The others average about 9 ohms. Now 9 ohms is the inductive reactance of a piece of wire a little over an inch long. This is equal to the minimum distance from one terminal to the other, and therefore confirms the measurements. Incidentally, the inductance is

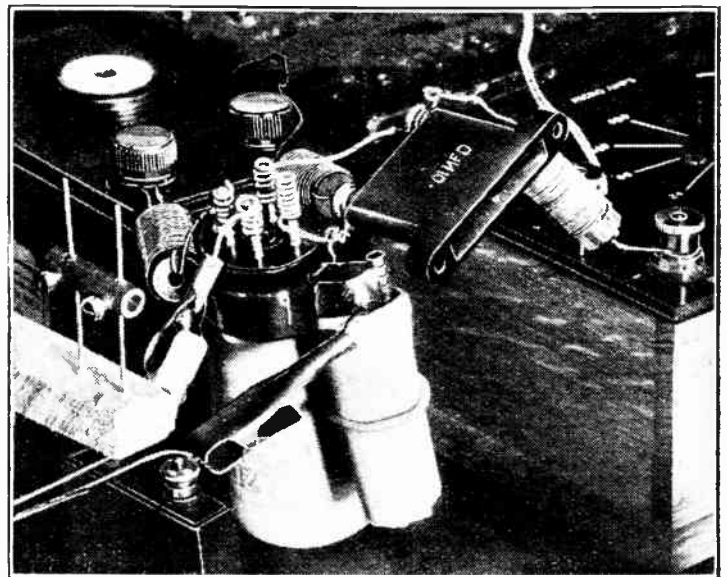

Specially rigged valve voltmeter for condenser measurements at 5 metres. The goalpost inductance is seen on the left.

capacity, assuming 0.024 microhenry inductance in each case. The conclusion, then, is that the best value to choose for by-pass condensers in 5-metre circuits is 0.0003 mfd., assuming normal construction, which gives the inductance stated. Of course, the best value for other wavelengths is different; Fig. 2 (curve B) shows this.

It is not quite so important to get such a low-impedance path as would be necessary for a by-pass in sensitive medium or long-wave receivers, with amplification running into thousands, because such amplification is not attempted by direct means using ultra-short waves (and no wonder!). Nevertheless, it is useful to know definitely the best value instead of blindly thinking of a number; and so to reduce the many uncertainties of this work.

**IMPEDANCES OF VARIOUS TYPES OF CONDENSERS TESTED.**

Condenser.	Actual capacity	A. Measured impedance; ohms.	B. Calculated capacitive reactance; ohms.	Inductive reactance derived from (A) and (B).
1 mfd. Paper; old type ..	1.0 mfd.	18	Negligible	18
1 mfd. Paper; non-inductive ..	1.1	7.7	..	7.7
0.1 mfd. Paper; old type ..	0.10	13.8	..	13.8
0.1 mfd. Paper; non-inductive ..	0.095	7.3	..	7.3
0.01 mfd. Mica ..	0.010	9.1	..	9.1
0.01 mfd. Paper; tubular, 1in. long ..	0.010	7.1	..	7.1
0.0005 Mica ..	0.00053	4.1	5	9.1
0.00025 Mica ..	0.00027	1.5	10	8.5
0.00025 Mica ..	0.00020	4.2	13	8.8
0.0001 Mica ..	0.000090	18	30	12



# MANCHESTER

Sept. 27th to Oct. 7th.

11 a.m. to 10 p.m. Daily

# RADIO SHOW

*THE tenth northern national Radio Show opened at the City Hall, Deansgate, Manchester, on September 27th, and promises to create records both in size and in public attendance. Manchester has been a radio centre since the very earliest days of broadcasting, and even before that was the home of an enthusiastic body of amateurs who played a considerable part in hastening the development of broadcasting in the early days.*

## Importance of the Northern Exhibition

THE Manchester Exhibition was in former years really a local show mainly supported by Northern manufacturers, but with the growth of broadcasting the position has changed somewhat, and to-day it is really in the

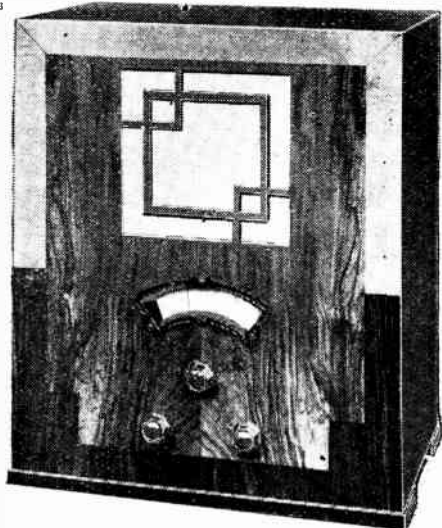

B.W. Distavox receiver (Berry and Wilson).

nature of a duplicate of the Olympia Show held in London in August.

On this account our three special numbers dealing with the exhibits at Olympia, and dated August 11th, 18th and 25th, can really be taken as a guide to Manchester, since the majority of the stands are exhibiting the same sets and components. In fact, our Olympia Show numbers comprise a review not of any particular exhibition but of the new season's products in general.

In the present article we propose, therefore, to confine our attention principally to the exhibits of those firms at Manchester which were not showing at Olympia, and to new products of other firms which have made their appearance since.

Visitors to Manchester will notice two outstanding features of this year's sets. First, sensitivity and selectivity have been greatly increased and the superheterodyne type of receiver is more in evidence than ever before. Interest in foreign-station reception must be taken to be the cause of this change. Secondly, the price of sets has reached a very low figure indeed, and yet without any apparent sacrifice in efficiency and quality. Undoubtedly sets and components of this season are an invest-

ment, for with the sets selectivity has been attained of an order which precludes the possibility of their becoming obsolete on this score. The number of foreign stations and their power already have reached a point when the problem of selectivity cannot become greater, so that as this season's sets are adequate in selectivity for present-day requirements they should remain equally serviceable in the future. Prices, we believe, could not be further reduced without a compromise with quality of reproduction, and since it would be suicidal for the manufacturers to cheapen sets at the expense of quality, no further reduction can be anticipated, but rather may we expect an increase in price in the future.

### What the North is Doing

The local firm of Garnetts (Gresley) Radio did not exhibit at Olympia, and are now showing a series of sets manufactured in Salford. It will probably be agreed that their most interesting production is a five-valve (plus rectifier) mains-operated superheterodyne which embodies delayed amplified A.V.C. and has a total of seven tuned circuits. The chassis may be mounted either in a console or in a radio-gramophone cabinet. Other models include a Class "B" receiver and a similar radio-gramophone.

Berry & Wilson, another Northern firm, are showing a complete range of sets, both for battery and mains operation. Their "Distavox" model is a seven-stage set with two screened-grid H.F. pentodes and a

Amplifiers for cinema, church and public-address purposes are produced in addition to the well-known deaf-aid devices. It is:

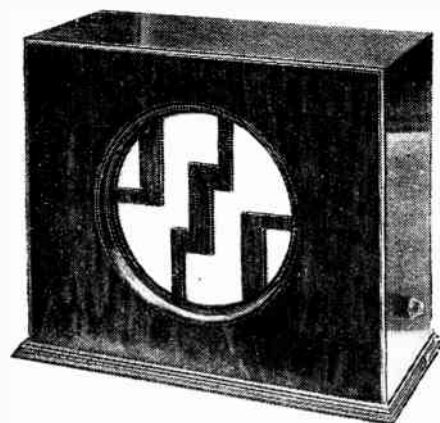

Wharfedale extension loud speaker with independent volume control.

interesting to note that an exceptionally compact deaf-aid amplifier which, complete with battery, microphone and earphone, weighs under 4 lb. is one of the latest models to be produced.

Measuring instruments shown by Pifco have many points of novelty; probably the most attractive of the new products is the "Rotameter" Universal Meter, which covers eight separate ranges. The appropriate scale for each range is brought into position automatically by operation of the multiple change-over switch, and so the instrument should be simpler to read than one employing a fixed scale.

Aerial equipment of various kinds, including lightning arrestors and earthing devices, forms a prominent part of the exhibit of Clifford Pressland, Ltd., of Kingston-on-Thames, who is also showing an extremely low-priced dual-range-screened tuning coil.

The series of permanent magnet moving-coil loud speakers made by Wharfedale Wireless Works, Bradford, has recently been supplemented by an extension model intended for

adding to an existing receiver. This instrument is, of course, mounted in a cabinet and has the valuable feature of an independent volume control and on-off switch.



Ardent microphone and amplifier.

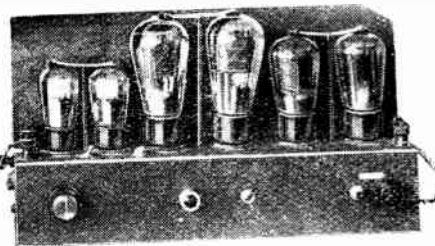

double-diode-triode giving delayed A.V.C. Iron-cored tuning coils are employed in this receiver.

The firm of R. H. Dent, showing at Manchester, did not exhibit at Olympia.

**Manchester Radio Show—**

The Star H.F.-Det. L.F. set employs pentode valves in all stages, and is offered at an extremely moderate price. The makers are also showing valves, batteries, and other components and accessories.

Although high-tension batteries form the principal "Universal" exhibit, several components, including dual-range coils and fixed condensers, are shown.

Battery charging equipment, which is mainly of interest to dealers and garages, is manufactured by Diggle, John Roberts, and the Small Power Dynamo Co.

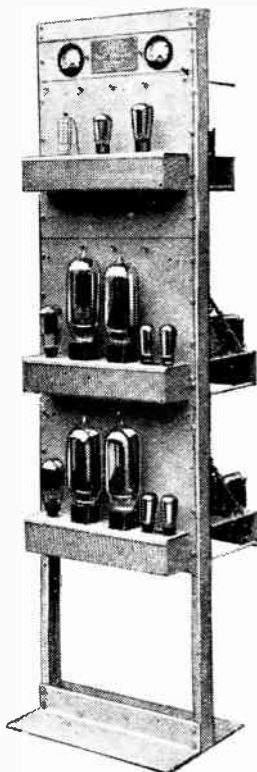

Rack-built receiver-amplifier by Tannoy.

Although their programmes for the present season were described at length in our Olympia Show numbers, it is opportune to remind readers of the activities of several well-known local firms which are also exhibiting at Manchester. Of course, L.F. transformers of all conceivable types, including the latest designs for battery-economy circuits, figure prominently on the Ferranti stand. The new range of superheterodyne receivers makes a spectacular exhibit; space does not permit of a full description of these sets, but, as they include all the latest and most desirable features, such as automatic volume control, visual tuning, etc., the visitor should not miss an opportunity of examining them.

Clarke's Atlas have a very up-to-date range of sets for the present season, including an A.C. three-valve model with pentodes in all positions. Class "B" battery sets are also made, and the series of Atlas eliminators has now been suppl-

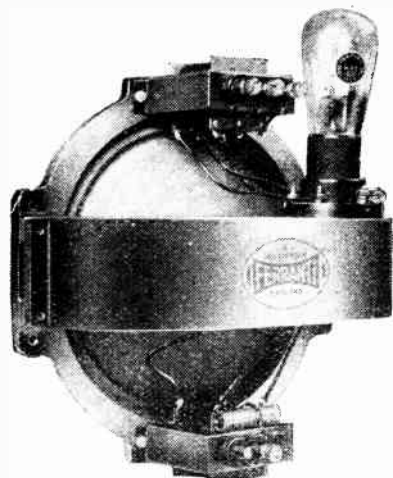

Ferranti Class "B" loud speaker unit.

mented by a new model intended for sets having Class "B" or similar output stages; the regulation of voltage output has been

made specially constant for this purpose. Northern listeners now have an opportunity of examining the extremely attractive range of "Drummer" receivers made by the new firm of Edge Radio, Ltd., of Bolton. All types are represented, but as an example we may take the five-valve superheterodyne chassis, which is available in various forms of cabinet work, including a radio-gramophone with such refinements as automatic record changing and dual loud speakers. Adequate selectivity is assured by the provision of a total of seven tuned circuits, and delayed A.V.C. is included. An interesting new tendency brought about by the introduction of efficient battery economy circuits is illustrated by the production of an extremely ambitious battery-operated radio-gramophone with Class "B" amplification.

As already stated, there have been few changes or additions in the programmes of the principal firms which exhibited at Olympia, but a few alterations are announced; for instance, the Ekco Model 74 superheterodyne chassis has been made available in a console model since the opening of the London Show. This chassis is well worth examining, as it includes many interesting circuit details, and is extremely well made in spite of its low price. It will be interesting to see how the North reacts to the modernistic black bakelite case, relieved with chromium insets, in which one of the models is housed.

The Dynatron "Ether Lord" radio-gramophone is now shown as a battery-fed set with Q.P.P. amplification. Here we have an-

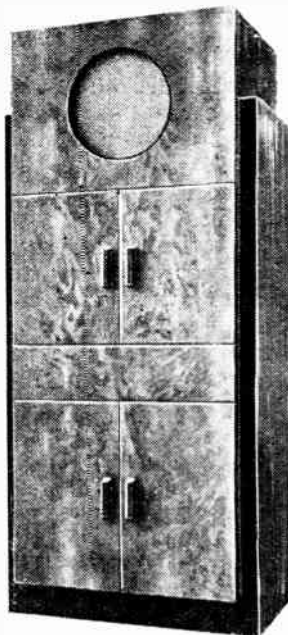

An example of modern cabinet work; the Dynatron receiver.

other illustration of the tendency to provide those who are forced to use batteries with the most ambitious and refined types of receiver. Improved "battery economy" circuits are, of course, responsible for this.

With regard to components, there have been few changes, but the firm of Graham Farish are now manufacturing a gauged version of the Zelos variable condenser, and a complete range of non-inductive fixed condensers as well.

Belling & Lee are making a feature of their Mains Disturbance Suppressor, which is designed in accordance with Post Office recommendations.

A few reminders as to other exhibits that should not be missed will not be out of place, in spite of the fact that they were described in our Olympia Show numbers. The larger G.E.C. superheterodyne merits attention, if only for the reason that it is one of the few to include a fully automatic system of "quiet" A.V.C.

Each one of the many H.M.V. sets have points of interest, but attention will

probably be focused on the "de luxe" model—the Superhet 10 Autoradiogram. McMichael are concentrating on "straight"

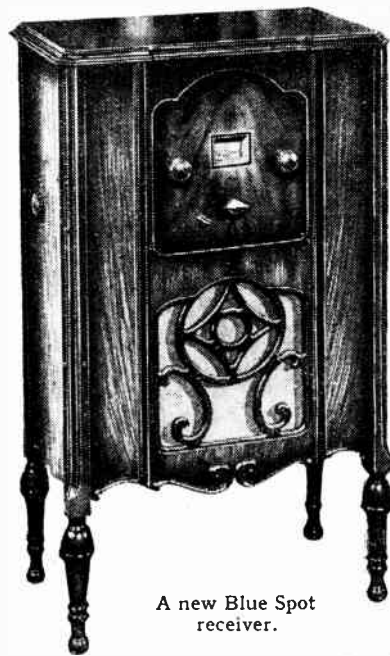

A new Blue Spot receiver.

sets as opposed to superheterodynes, and have several very interesting models, including one with built-in dual speakers.

Unconventional cabinet work and radically new ideas in the housing of receivers are much in evidence this season. For example, the Climax "Casket" in which the loud speaker aperture is cut through the base, gives no visible indication that an up-to-date superheterodyne is mounted in the cabinet. A still more novel style of mounting is adopted by Ferranti for one of the superheterodyne sets, which is mounted in a low "bookcase" type of cabinet, with the controls most conveniently arranged so that the user can operate them while reclining in an armchair. Just the thing for the "tired business man" of whom we hear so much, and, seriously, an excellent idea.

The City Accumulator Company are also showing some highly original cabinet work, and, incidentally, are specialising in kits of parts for *Wireless World* receivers, in addition to sets of their own design. While on the subject of kits, it should be pointed out that the Cossor Melody Maker, on view in its latest form, is an extremely workmanlike job, and is available in several forms for both battery and mains operation. Lissen is also specialising in kits; one of the most interesting productions is an

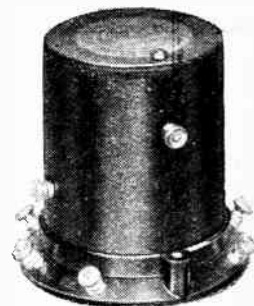

R.I. "Micrion" iron-cored tuning coil.

"all-wave" model (12-2,000 metres).

Among the new components, iron-cored coils as shown by Colvern, R.I., Varley, and Igranic will be examined with special interest, as will the new "plateless" Block batteries and the extraordinarily comprehensive range produced by Bulgin. In addition to the well-known Avometer multi-range measuring instrument, there is now a smaller model, with plug-and-socket change-over, known as the Avominor, which is sold at an extremely attractive price.



# UNBIASED

## BY FREE GRID

### At the Bar

**K**ING SOLOMON is reported to have said once in a burst of confidence that there were two things in life that got him down, and while I do not presume to attain to his eminence, either in the matter of wisdom or women, I must confess that to me one of the greatest mysteries of life is the manner in which the great superstition persists that Christmas and no other season is the proper time to buy a new wireless set. I mention this here since, in spite of my recent remarks upon the matter, this fact was forcibly brought home once more by an incident which—emulating the example set by Sir John Reith—I intend to inflict on you whether you like it or not.

A friend of mine who is well known at the bar—not the alcoholic variety—recently approached me with the statement that as a result of a recent action in the high court concerning a wireless set, during which he had an opportunity of hearing it demonstrated, he had been so delighted with the musical reproduction that he had definitely decided to join the ever-growing ranks of the radiophiles. He wanted to know if, in my opinion, it was the most suitable instrument for him, and, if not, what did I advise? I told him that while the instrument was undoubtedly good, I thought he ought to hear one or two others before finally making up his mind, and volunteered to accompany him there and then to the showroom of a dealer who, I knew, always carried a varied stock, and who, moreover, possessed premises wherein customers could make their choice in real comfort.



Borrowing his own weapon of cross-examination.

To my amazement he demurred, saying that this was no time to buy a set, and he intended to wait until Christmas, which he alleged was the proper time to do it. Borrowing his own weapon of cross-examination, I soon elicited the fact that his opinion was solely based on hearsay

from people as ill-informed in the matter as he himself proved to be. As a lawyer he should, of course, have known that what the soldier said is not evidence; but, seriously speaking, it occurred to me that if a man in his position, with a mind trained to form a sane and level-headed opinion upon almost anything under the sun, can fall into such an error, how much more so is the man in the street likely to go wrong. By dint of threats and cajolings I eventually got him along to the dealer's, and with my assistance he eventually chose a particular set which I'll warrant is not likely to be surpassed in performance for a long time to come.

### Dropping a Brick

**I**T has caused me much pain and sorrow to read an ebullition from the pen of a well-known star who always twinkles brightly in the firmament of an old-established wireless company.

The cause of my distress and bewilderment is a statement to the effect that in one of their sets this old and honourable firm use a valve, to wit, a second detector, in which there are "three anode-to-cathode electron streams." Now it is not the number of the electron streams in this valve about which I am quibbling, but their nature.

Being born at the very peak of Victorian respectability, I was always very strictly brought up in the belief that no self-respecting valve ever allowed any electrons to chase each other along from the plate to the grid. It is painfully obvious to me, however, that I must be a back number from the point of view of valve technique, for I feel sure that the alternative theory, namely, that the writer in question has made an error, or to quote the language of the vulgar—dropped a brick—is quite untenable.

### The Radio Roundabout

**O**NE feels almost dizzy at times at the number of revolutionary improvements that nowadays follow so hard on each other's heels in radio matters. "Revolutionary" is, I think, certainly the correct word to use with regard to some of them. I have in mind one in particular which a certain newspaper has just announced with great gusto. The "revolutionary" invention is a set which is operated by remote control. It struck me as somewhat strange, since a local firm put one on the market some years ago; what is stranger still, however, is that the firm which has just "invented" the set is the *same* one which marketed it several years ago. This "revolutionary" business is certainly designed to make your head whirl.

### Caveat Emptor

**A**LTHOUGH I have been threatened with dire penalties, including that of being put on the spot, I intend here and now to draw attention to what I consider is a very great scandal, and that is the reprehensible practice of the B.B.C. giving free advertisements in the Press to all the butchers and bakers and candlestick makers whom they patronise; this is apt to be extremely misleading to the general public, who are accustomed to look up to the B.B.C. as the fountain of all knowledge.

Some years ago the B.B.C. adopted a certain make of gramophone pick-up which was peculiarly suited to their particular needs. Half-hearted attempts were made to conceal its identity, with the result



Half-hearted attempt to conceal its identity.

that the public's curiosity was piqued and eventually the secret was discovered. The upshot of the matter was that Mr. Everyman bought it, and found to his dismay that the volume obtained was far less on his set than that given him by the pick-up which he had discarded. The result was that the manufacturers of the device were unjustly blamed by the general public for selling them something which was not equal in every respect to that supplied to the B.B.C.

The above is, perhaps, an extreme case which I have deliberately chosen to illustrate what evils can result from the half-hearted concealment adopted by the B.B.C. All trouble could have been averted if they had taken thorough measures to conceal the identity of this particular component or, better still, have come out into the open and issued a frank statement explaining just why this particular pick-up, although suitable for their particular needs, was not necessarily suitable for attachment to the *average* set.

Since that date we have been regaled with the names of gramophone motors, pianos, furniture, and all manner of things chosen by the B.B.C. which very unfairly leads people to think that those of any other make are not worth considering.

# Better

## 'CLASS B' WITH . . .

# MARCONI



PRICE **14/-**

★ Send a card to the

MARCONIPHONE CO. LTD.,  
RADIO HOUSE,  
210-212 TOTTENHAM COURT ROAD,  
LONDON, N.W.1,  
for your copy of an interesting folder  
describing all the new Marconi Valves

Marconi B21 brings better class B performance to all battery sets.

B21 differs from previous valves in several respects, the most important being that it operates with grid bias. This feature gives these important advantages:

- ① **Better quality, because the anode current cut-off is less sharp and the currents in the two halves overlap. This reduces spurious oscillation and gives less distortion at low output levels.**
- ② **Greater sensitivity, because the input impedance is higher and less power is needed from the driver valve.**
- ③ **Greater overall magnification, because it is possible to use driver transformers having higher ratio than those allowable with the zero bias type of valve.**

In addition, Marconi B21 is built on exceptionally robust lines, the bulb being shaped to give a firm support to the top of the electrode system. Greater uniformity and stability are assured.

### MARCONI DRIVER VALVES FOR USE WITH B21

**Marconi L21** A new high-efficiency Class B driver incorporating mica bonded construction. And gives ample output to load B21 up to good home volume **7/-**

**Marconi LP2** Used when maximum output is required **8/9**

### MARCONI 2-VOLT VALVES

S23	Screen Grid	15/6	L21 Triode	7/-
S24	Screen Grid	15/6	LP2 Power Valve	8/9
VS24	V. Mu. S. Grid	15/6	P2 Super Power	12/-
VP21	V. Mu. H.F. Pen.	15/6	B21 Class B	14/-
HL2	Triode	7/-	PT2 Pentode	16/6

The choice **MARCONI VALVES** of the experts

# FINE.



# 40/-

**NOTHING LESS WILL DO**

**MILLIAMPS**  
 0-6 milliamps.  
 0-30 "  
 0-120 "

**VOLTS**  
 0-6 volts.  
 0-120 "  
 0-300 "

**OHMS**  
 0-10,000 ohms.  
 0-60,000 "  
 0-1,200,000 "  
 0-3 megohms.



BRITISH MADE

**TEN**  
 TESTING INSTRUMENTS  
 in **ONE**

**T**HERE could be no surer conviction than that! . . . that the AvoMinor, priced at only 40/-, is supremely **ACCURATE!** It means more than mere fault-finding, more than mere testing. It gives precisely measured evidence of radio faults and efficiency.

It measures **TEN different** ranges of milliamps, volts and ohms—affording testing facilities combined with positive accuracy which no other instrument at anywhere near its price can give. The AvoMinor is a self-contained moving coil combination measuring instrument with a total resistance of 100,000 ohms. Full scale deflection is obtained with a consumption of only 3 milliamps.

Make any comparison you like. This little brother of the world-famous Avometer does more, and more accurately, than any other combination testing instrument priced so modestly. Ask your radio dealer . . . he knows!

DEFERRED  
 TERMS  
 if desired. Write  
 for particulars.

*Be satisfied with nothing less. You will prefer the precision of the AvoMinor. Fully descriptive pamphlet post free.*

*The* **AVOMINOR** TRADE MARK  
**TELLS THE WHOLE TRUTH!**

*Dimensions, 4" x 3" x 1 1/2". Complete in handsome case, with pair of leads and interchangeable crocodile clips and testing prods.*

*The Automatic Coil Winder & Electrical Equipment Co. Ltd., Winder House, Douglas St., London, S.W.1 ● Telephone: Victoria 3405-7*

## MORE FOR YOUR MONEY

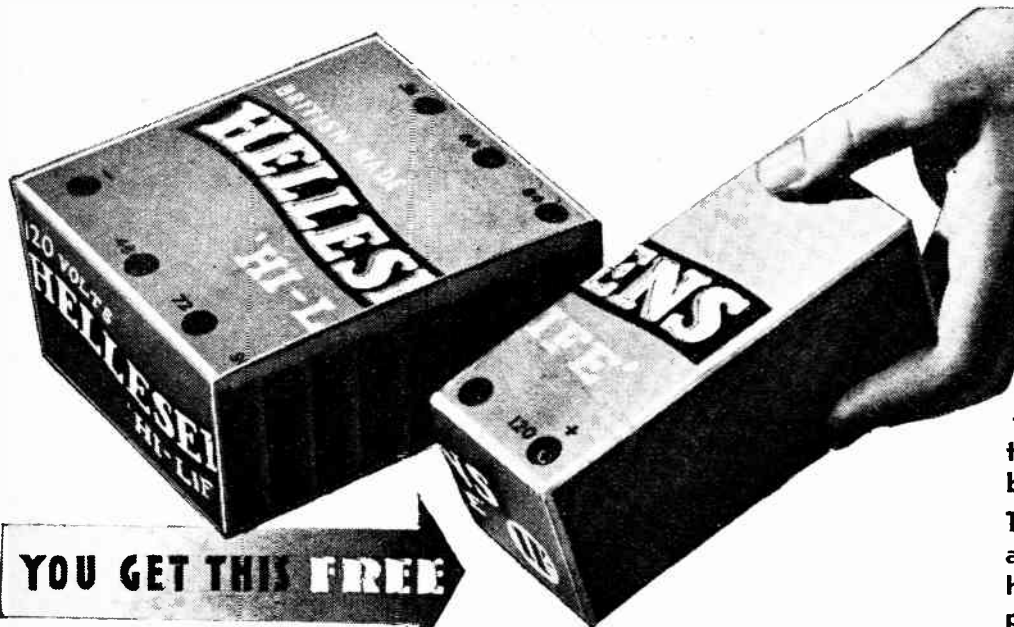

# 50.2% LONGER LIFE

For every eleven shillings you pay for a Hi-Life battery you get 4/6 worth free—50.2% longer life. This figure is the result of an impartial test by a famous British set-maker, a test that has proved that only the Hi-Life battery can give you this extra life. No other battery can equal this performance, no other manufacturer has the experience of more than 40 years battery manufacture.

The new Hi-Life batteries are the latest addition to the Hellesens range. They have set a new standard of battery performance and they sell at a price competitive with any other quality battery.

Stand No. 6A Manchester Radio Exhibition. Sept. 27—Oct. 7

**YOU GET THIS FREE**

**BRITISH MADE BY BRITISH LABOUR**

**11/-**  
 120 VOLTS

# HELLESENS

## HI-LIFE BATTERY

Hellesens Limited, Morden Road, South Wimbledon, S.W.19.

*Mention of "The Wireless World," when writing to advertisers, will ensure prompt attention.*

Arks

# News of the Week

## Current Events in Brief Review

### Meeting of the U.I.R.

THE Union Internationale de Radiodiffusion will hold its next meeting from October 4th to October 13th in Amsterdam. A certain amount of importance will be attributed to this meeting as, no doubt, attempts will be made in Amsterdam to obtain the adhesion to the Lucerne Plan of the eight non-signatory countries. On the other hand it must be stressed that the U.I.R. is only an expert body and its decisions are by no means binding. But it may be easier to discuss matters in a semi-official manner than directly between postal administrations.

### Bari Links Up With Rome

THE big telephone cable connecting Naples to Bari in the south of Italy has been completed, and as a result Bari has been connected with the South Italian group of stations since September 18th, receiving most of its programmes from Rome. The completion of this cable has been eagerly awaited by Italian broadcasters as, owing to the lack of suitable lines, most of the day's programme has hitherto to be provided in Bari itself, and this has proved very expensive.

### Evening Lectures at the Borough Polytechnic

A SPECIAL course of twelve lectures and demonstrations on Loud Speakers and Acoustic Problems will be given by Dr. N. W. McLachlan, who is well known both as an authority on this subject and as a frequent contributor to our pages. The lectures, which range from loud speaker mechanism to transients and the general acoustic problems associated with speakers, are to be given on Mondays, at 6 p.m., at the Borough Polytechnic, Borough Road, S.E.1, beginning on October 2nd. The fee for the whole course is only 10s., and applications for particulars should be made to the Principal.

### High Power Station in France

IN addition to the new P.T.T. station now in course of erection at Villebon-sur-Yvette, about 18 miles from Paris, work has begun on the 120 kW station at Thourie, 37 miles distant from Nantes, and it is expected that this station also will be transmitting in 1934.

### Police Sets at Brighton

THE issue to the Brighton Police of pocket receivers with a calling device, such as were described in our issue for September 6th, 1932, has been the subject of a number of paragraphs in the provincial Press, and several writers to the lay papers appear to regard it as the precursor of two-way communication which, as we stated last week, is proposed for the warders at Sing Sing. It is doubtful, however, if such two-way working would be of much practi-

cal use. The system being tried at Brighton seems mainly applicable to urban areas where, presumably, any police officer receiving a call from headquarters can readily get on the telephone.

### American Amateurs

ULTRA-SHORT wave working has taken a great hold on American amateurs, as is shown by the rapid increase in the number of amateur transmitting stations. In 1931 licensed amateur stations in the United States totalled 22,000. The figure now is 40,000, and, despite the depression, the Federal Radio Commission is receiving new applications for amateur stations at the rate of about 200 a week.

new aerial in a fifty-mile gale was no easy matter, but eventually the little band of enthusiasts, standing ankle deep in water, managed to get into contact with W9CVW, Mr. J. Haggan, at Louisville, Kentucky. Emergency pleas for relief, Press messages, personal and official traffic flowed from the transmitter from the small hours of one morning till 5 p.m. on the following day, when normal telegraphic communication was resumed.

### Japan Goes Ahead

ACCORDING to Tokio reports, Japan has made astounding radio progress in the last eighteen months. The total number of listeners now exceeds a million and

correspondent states that one object is to counteract, in the "Polish Corridor," the influence of the propaganda transmitted from the neighbouring station at Königsberg in Eastern Prussia.

### Future Prospects in Ulster

THE Vice-Chairman of the Radio Manufacturers' Association, Mr. S. W. Cole, anticipates a very considerable expansion of the wireless industry in Northern Ireland when the new station for Belfast has been opened. At present it is estimated that only ten per cent. of the homes in the six counties possess a wireless set, but he envisages a time in the near future when there will be a radio in every other house and wireless manufacturers establishing works and helping to absorb local labour.

### Swiss Broadcasting House

THE French-speaking cantons of Switzerland are to be provided with a new "radio house," the existing studios at Lausanne being inadequate for their present needs. A site has been purchased at La Salla, a suburb of Lausanne, where work on the building will soon start, and when opened, as is anticipated, in July, 1934, it will contain one large and two smaller studios with two rooms for talks.

### New York Radio Exhibition

THE Wireless Exhibition which, until last year had been held annually since 1923 in Madison Square Garden, New York, has been revived this year, and forms a part of the National Electrical Exposition now being held in New York under the auspices of the National Electrical Manufacturers' Association.

### Powerful South American Station

A NEW 37.5 kW. broadcasting station is projected for Buenos Aires, and the transmitter is now being constructed by the Telefunken Company. When complete this station will be the most powerful in South America.

### Licence Expectations in France

IN a recent speech the French P.M.G., M. Laurent-Eynac, after outlining the progress of the new broadcasting service according to the "Ferrié plan" mentioned that, contrary to the expectations of sceptics, 1,400,000 declarations of sets had already been received, and it was hoped that the 1½ million mark would be passed before the end of the year. A minimum of 60 million francs would be brought in by the new taxes this year and the Government counted on 100 million next year.

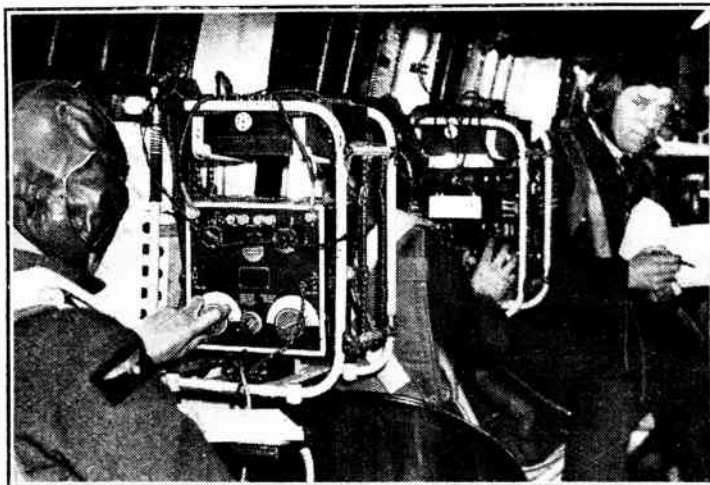

"HIGH-CLASS" RECEPTION. An aircraft cabin fitted as a classroom for the wireless instruction of R.A.F. pupils at the Electrical and Wireless School at Cranwell.

### American Amateurs Again to the Rescue

DURING the violent hurricane which raged along the Atlantic Coastline of the United States at the end of August, amateur transmitters had a busy time re-establishing communication links with stricken areas in Maryland, Delaware, Virginia, Florida and Texas. In the neighbourhood of Salisbury, Maryland, power lines, telegraph and telephone lines were down, no trains or buses were running, and motor traffic was impossible.

A group of amateurs held a hurried conference and decided to move the station of Mr. E. L. Thompson (W3CQS) to the small section of the city where power was available. The erection of a

half, the Tokio region alone supplying more than 636,000. No fewer than nineteen broadcasting stations are in service, including the famous Joak, Tokio, and other high-power stations at Osaka, Nagoya, Hiroshima, Kumamoto, Sendai and Sapporo, each of which is well up to Western standards in technical design and studio construction.

In the meantime, the amateur transmitters are gaining strength and the Ministry of Communications has had to formulate new regulations to cope with them.

### New Station for Poland

THE Polish authorities are contemplating the erection of a relatively high power station in the port of Gdynia. Our Berlin

### Next Week's Special Number

#### HINTS AND TIPS BOOKLET

With next week's issue dated October 6th a special Supplement will be included in the form of a 32-page Booklet of practical HINTS AND TIPS specially compiled by the staff of *The Wireless World*. The full week's Foreign Programme Supplement will appear in a new form. A new Three-valve A.C. receiver with automatic volume control will also be announced in this issue.



# The Electrostatic Loud Speaker

## III.—Circuits for Operation with a Moving-coil Unit

By M. G. SCROGGIE, B.Sc., A.M.I.E.E.

IT has been shown that when an electrostatic loud speaker is connected to a triode output valve there is a certain critical frequency below which the response falls off. The critical frequency is that which makes the reactance of the loud speaker (which being in effect a condenser is dependent on frequency) equal to  $OX$  (volts) divided by  $OY$  (amps) (Fig. 1) where  $Y$  is the lowest permissible anode current without serious bottom-bend rectification.

It is convenient to remember that this reactance is roughly equal to the optimum load for the valve. The critical frequency can be pushed lower to widen the effective response, but only at the expense of efficiency. So unless a very large output is available and used rather waste-

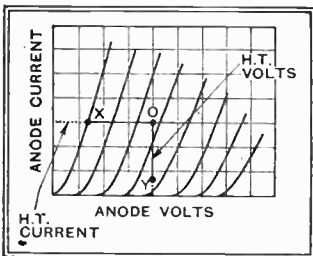

Fig. 1.—Critical reactance is given by  $OX$  in volts divided by  $OY$  in amps.

the transformer, or even excessive self-capacity, or there will be a series resonance and a worse state of affairs than ever. Another improvement is a variable

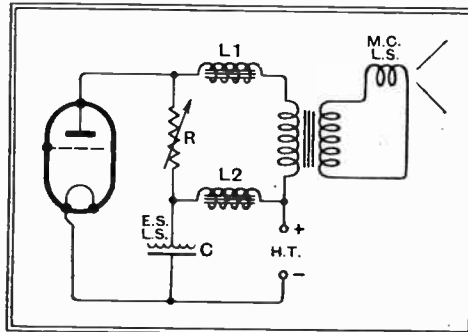

Fig. 2.—Practical circuit for combining the electrostatic with a moving-coil loud speaker following a triode output valve.

resistance  $R$  of about 10,000 ohms, which can be used to prevent the high-note overloading described last week. A further refinement, with the object of preventing large low-frequency voltages reaching the electrostatic speaker and causing it to rattle, is the choke  $L2$ , also tapped, with values up to 2 or 3 henrys.

### The Pentode Valve

If  $R$  is in, the parallel resonance due to  $C$  and  $L2$  may undesirably emphasise one frequency; if it is out, there may be both high- and low-note overloading. But as  $L2$  is of value mainly in high-power stages, the overloading point is not likely to be reached; and, in any case, the danger of overloading can be minimised by stepping down, as shown in Fig. 3. Remember that stepping down tends to reduce the electrostatic low-note response, and vice versa, while excessively wrong ratio causes loss of volume too.

The case of the pentode is considerably different from that of the triode, and the situation is best explained while looking again at a valve load diagram (Fig. 4). Again we take the extreme and middle frequencies of 80, 800, and 8,000, giving

*IN this article the author concludes his review of the electrostatic loud speaker with an analysis of the operating conditions when using pentode output valves and gives practical hints on the best method of combining electrostatic and moving-coil units.*

with a loud speaker capacity of 0.02 mfd. reactances of 100,000, 10,000, and 1,000 ohms. Neglecting for the moment any complications due to the necessary coupling arrangement, these three conditions are again represented by the three ellipses. Here the lowest frequency ellipse develops across itself the maximum possible anode voltage, but unlike the triode it does so with a very small grid swing. Any larger grid swing would result in excessive voltages being developed, besides severe distortion.

The medium-frequency condition is similar to that of the triode in so far as the full grid swing results in full output voltage with just tolerable distortion. The load ellipse only just succeeds in fitting in. The highest frequency condition is also similar in that the anode voltage developed is very low, but full grid swing is possible at all the upper frequencies. Transferring these results to Fig. 5, it is seen that curve B, which shows the maximum voltage that can be developed across the speaker without overloading the valve, is practically the same as that for a triode. But the actual state of affairs is very

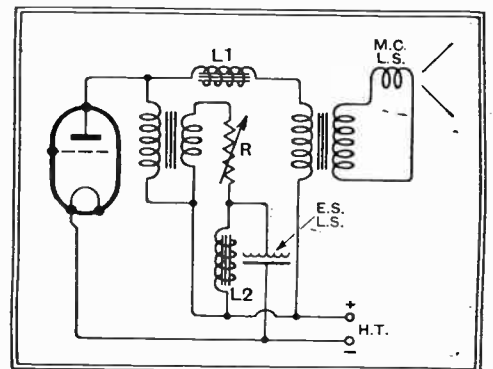

Fig. 3.—Modified arrangement of Fig. 2, with step-down transformer to minimise overloading.

fully, it is better to obtain the bass response by means of a moving-coil loud speaker and to make the critical frequency quite high, say about 1,000 cycles per second. The table below may be useful.

The capacity of the loud speaker is the actual capacity multiplied by the square of the output transformer ratio; a step-up giving a larger capacity and vice versa.

Fig. 2 shows a method of adding an electrostatic speaker to an existing triode and moving-coil (or inductor) speaker. The latter is likely to have a resonance somewhere about 2,000 or 3,000 cycles; and as this comes within the province of the electrostatic it is desirable to cut it out by inserting a choke  $L1$ , with an inductance of about one henry, preferably variable to allow of adjustment to suit the working conditions. If  $L1$  is used, it is important to avoid any capacity across

Critical frequency.	Critical reactance of loud speaker in ohms.					0.004 cap. mfd. 0.5 sq. ft. approx.
	0.064 8	0.040 5	0.024 3	0.016 2	0.008 1	
250	10,000	16,000	26,500	40,000		
400	6,200	10,000	16,500	25,000		
600	4,100	6,600	11,000	16,500		
1,000	2,500	4,000	6,600	10,000	33,000	
1,500	1,650	2,600	4,400	6,600	20,000	40,000
2,000	1,250	2,000	3,300	5,000	13,000	26,000
3,000	830	1,300	2,200	3,300	10,000	20,000
					6,600	13,000

different, for the output shown is on the assumption of maximum allowable grid swing, which as indicated by curve A is just the opposite to that of the triode. Moreover as in average broadcasting the actual distribution of grid swing over the frequency scale is very different from curve A, being greatest at low frequencies, curve B must be interpreted accordingly. If the grid swing were distributed according to the intensity given at the various frequencies during normal broadcasting,

**The Electrostatic Loud Speaker—**

the resulting curve B would slope off at the high frequency end very steeply indeed. A listening test confirms this by giving the rather surprising result that this type of loud speaker, noted for high-

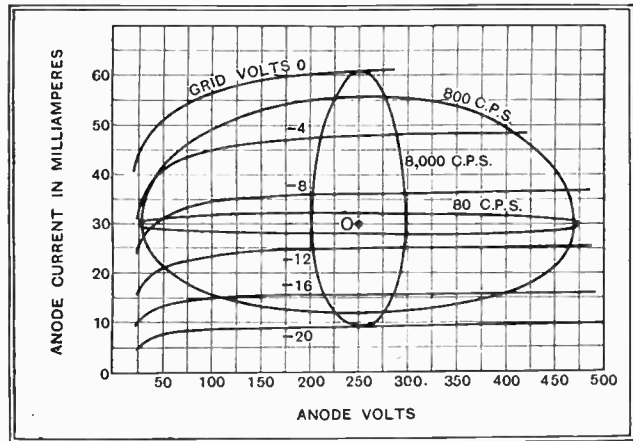

Fig. 4.—Load diagram for the electrostatic loud speaker in conjunction with a pentode output valve.

note response, is deficient in the same when run from a pentode.

At the lowest frequencies, however, there is a considerable divergence between theory and practice. It was explained in connection with the triode that some sort of coupling device is essential, and if this takes the form of a choke or a transformer, the loud speaker resonates with the inductance at some moderately low frequency. That causes little concern in the triode, for as long as the impedance in the anode circuit is *greater* than several times the valve impedance it makes little difference, and it is a *series* resonance, which causes the load impedance to become very small, which is to be guarded against. But in the pentode the output voltage increases almost without limit as the load impedance is raised, and the effect of a parallel resonance is to cause excessive emphasis of the resonant frequency, accompanied by severe overloading unless the volume is reduced so that all other frequencies are very feebly reproduced.

**Practical Schemes**

This serious objection can be counteracted by connecting a resistance in parallel with choke and loud speaker. If, for example, the resistance is 20,000 ohms, it

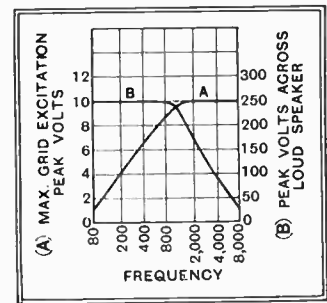
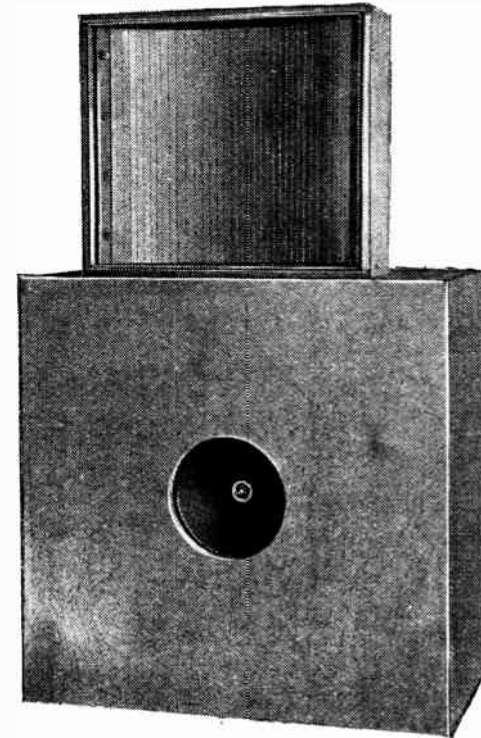

Fig. 5.—Operating conditions for a pentode derived from the curves of Fig. 4.

is obvious that the load can never *exceed* this figure, and so a limit is set to the voltage that can be developed, and a much more uniform response obtained, but somewhat at the expense of efficiency.

Fortunately, the efficiency of the pentode drive starts off at a considerably higher maximum than that of the triode.

But the desirability of a dual loud speaker system is even more marked with the pentode, and so is the desirability of preventing the low-frequency voltages from being set up across the electrostatic loud speaker. This object can be achieved by shunting it with a relatively low inductance and also a resistance to prevent a sharp resonance. A fairly large condenser shunt across the moving-coil loud speaker completes the division of labour, and a resistance is necessary here also. All this sounds very complicated, but Fig. 6 shows how a single variable resistance can be made to serve not only as both shunting resistances but also as an effective tone control.



The combination of moving-coil and electrostatic units gives full bass response with unusually good reproduction of high frequencies and transients.

1.5 henrys on the primary side, and a secondary inductance to suit the size of loud speaker. The Varley 3H choke provides a variety of taps for obtaining the best balance. A 1:1 ratio is about right for a 0.01 mfd. speaker.

The tone-control potentiometer gives every tone from extreme low to extreme high preponderance.

Although any standard moving-coil loud speaker can be successfully used in a cir-

cuit of this type, it is, of course, preferable to use one specially intended for low-note reproduction. If there is no neces-

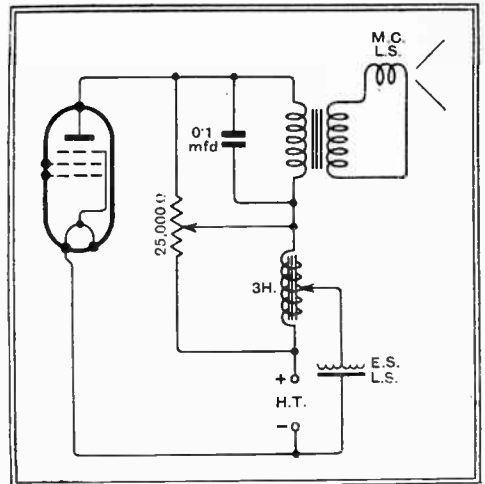

Fig. 6.—Dual loud speaker connections for a pentode output valve. The variable resistance provides tone control.

sity to look after the high volts, it is possible to do better justice to the bass by selection of suitable cone material and dimensions, and in other ways.

A simpler and less satisfactory circuit, but one which is more convenient to add to an existing receiver, and also gives some degree of tone control, is given in Fig. 7. It will be seen that in this the electrostatic loud speaker takes the place of the usual tone-compensating condenser, but, of course, it is essential that the H.T. voltage should come across it.

When applying to existing sets, it is important to see that any tone-compensating system that may be left in circuit is not preventing the electrostatic loud speaker from pulling its weight. In fact, the whole receiver, whether with triode or pentode output, must obviously be capable of passing the higher audible frequencies to the loud speaker if it is to reproduce them. This point needs to be stressed, because it is customary to cut high frequencies down fairly drastically in the interests of selectivity and freedom from mush, scratch,

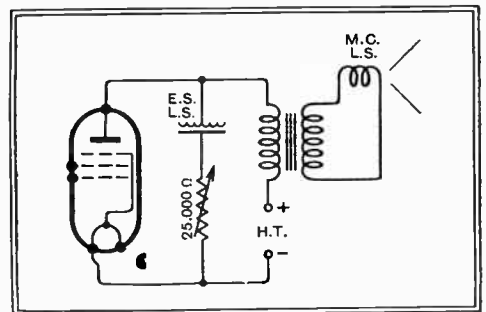

Fig. 7.—Simplified circuit for adding the electrostatic loud speaker to existing receivers. The loud speaker takes the place of the tone-correction condenser.

and hiss. The best plan is to restrict such limitation to one particular part of the circuit, where it can be controlled.

Where conditions permit—as when a station is being received at short range in relation to its power—the “top cut” can be removed and the advantages of the elec-

**The Electrostatic Loud Speaker—**

trostatic principle realised to the full. Attention should therefore be paid to by-pass condenser, anode filter chokes, grid "stopper" resistors, and other devices which tend to side-track the high tones.

It is a disputed point whether phase distortion is an important imperfection in reproduced sound. It is generally agreed that the ear is not sensitive to displacement of phase, such as occurs whenever a transformer coupling is used, in the case of sustained sounds like those of the flute or organ. This matter, being so extremely difficult to handle either theoretically or experimentally, seldom goes beyond vague references to "attack," yet it is undoubtedly of importance.

There seems little doubt that the electrostatic type of loud speaker is superior to any other in the reproduction of transients, but it hardly has a chance if there is considerable phase distortion in the preceding stages. The substitution of well-designed resistance coupling for transformers helps, but even if transformers are eliminated from the receiver there are likely to be several in circuit before ever the wave strikes the receiving aerial. Careful test has established, however, that the removal of even one transformer of several can be detected by a sensitive ear. So the point is one worth considering, and the electrostatic loud speaker is the most useful with which to consider it.

**Distant Reception Notes**

**D**ETAILED of France's revised Ferrié Plan announced by M. Eynac in his speech at the Paris Wireless Exhibition are interesting, for they show that the Government has no intention of taking over any of the large privately owned stations which are already in existence. These stations will have apparently to come down to a maximum power output of 5 kilowatts and to work on common-wave channels. It seems rather a curious business, for some Government high-powered stations are being built quite close to the private ones.

One correspondent enquires why there is now nothing to be heard on the short waves before the time when reasonable men go to bed. I am afraid that I cannot say why he hears nothing, for there is certainly a great deal going on on most evenings. Zeesen, for instance, has five different transmissions, DJA, DJB, DJC, DJD, DJE, three of which are generally well received before midnight. DJC is a small hours station on 49.83 metres, but DJA on 31.38 metres starts operations at 11 p.m. DJD on 25.51 metres transmits from 4 p.m. until midnight, and DJB on 19.73 metres from 2 to 10.30 p.m. DJE on 16.89 metres has no regular times at present.

Other European short-wave transmissions worth attention are Rome, 2RO, on 25.4 metres, usually to be heard at good strength at any time during the evening. Radio Nations, Switzerland, HBP, on 38.47 metres, to be heard on Saturdays after 11 p.m., Madrid, EAQ, on 30 metres at work from 11 p.m., and Skamlebaek, Denmark, OXP, on 49.4 metres from 7 p.m.

Of American short-wave stations, W2XAD of Schenectady, works on 19.6 metres on Mondays, Wednesdays and Fridays from 9 to 10 p.m., W8XK, of Pittsburgh, transmits

on 25.27 metres from 10.30 p.m. onwards, and W3XAL, of Boundbrook, is to be heard on 49.18 metres on Saturdays after 9.30 p.m. W2XAF, of Schenectady, on 31.48 metres does not come into operation until 1 a.m.

There is still occasional interference with Huizen (Hilversum programmes) from a Russian transmitter. Radio-Paris, Luxembourg, Kalundborg and Oslo are excellent on the long waves, and Motala is showing considerable improvement. Zeesen has been particularly good lately.

Lyons Doua has returned to splendid strength on the medium waveband, and Beromünster is coming in so well that it is frequently receivable in daylight. First-rate reception has also been obtained during the past week from Budapest, Munich, Vienna, the two Brussels stations, Prague, Langenberg, Rome, Katowice, Leipzig, Toulouse, Hamburg, Strasbourg, Milan, the Poste Parisien, Breslau, Bordeaux, Hilversum, Bratislava, Heilsburg, Turin, Hörby, Trieste and Nürnberg.

D. EXER.

**VOIGT LOUD SPEAKERS****Moving-coil Units of High Electro-Acoustic Efficiency**

**T**HE driving unit is of the moving-coil type with a 6in. cone diaphragm, and is remarkable for its exceptionally high efficiency. To obtain some estimate of the relative efficiency, the unit was first tested on a plane baffle, and it was found that for a given input the sound output was fully 5 db. above that of any unit we have so far tested. With the 4ft. horn a further increase of 3 db. was obtained.

The efficiency is largely attributable to the high flux density—according to N.P.L. tests, about 17,000 lines under working conditions. This has important consequences in other directions, for not only is the diaphragm damping increased, with consequent improvement in transient response and freedom to overloading due to excessive diaphragm displacement, but the usual rise in the impedance of the coil at high frequencies is prevented. Actually, the average impedance is between 30 and 35 ohms, and the impedance at 8,000 cycles is of the order of 50 ohms. Much better matching with the power valve is thus obtained over the frequency range.

The unit has been designed to work in conjunction with the Voigt "Tractrix" horns rather than in a plane baffle. The rate of expansion of these

indoor use, and a smaller horn of the same type with a 2ft. mouth is available for use where space is limited. Naturally, the bass

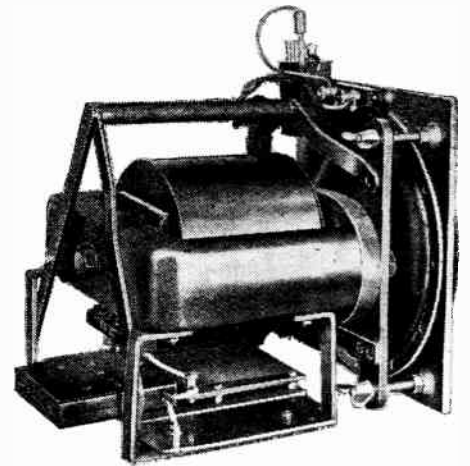

The Voigt moving-coil unit is provided with a field magnet giving 17,000 lines per sq. cm.

cut-off in the latter is higher, and was estimated aurally to be in the region of 110 cycles; the larger horn goes comfortably down to 75 cycles. For outdoor work a spun metal horn has been developed in conjunction with a cast aluminium housing for the moving-coil unit.

The frequency response with the standard 4ft. horn is aurally uniform from 75 to 6,000 cycles with the exception of a just perceptible resonance between 3,500 and 4,000 cycles. It was interesting to note that the increase of output in this region was much less marked with the horn loading than on a plane baffle. Above 6,000 cycles the response tails off relative to the general level, but the response at 8,000 cycles is nevertheless higher than that of the majority of high-grade moving-coil loud speakers. The performance in general sets a very high standard of quality, both as regards balance and the reproduction of transients.

The makers are Voigt Patents, Ltd., The Courts, Silverdale, London, S.E.26, and the prices are as follow:

Moving-coil unit, £14 10s.; 4ft. horn, £8; 2ft. horn, £4; all-metal horn and unit housing, £12 (provisional).

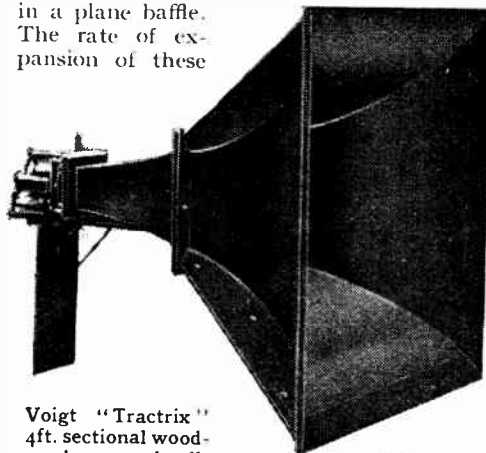

Voigt "Tractrix" 4ft. sectional wooden horn and all-weather metal horn.

horns is calculated for a spherical wave front, and it is claimed that the loading of the diaphragm is more uniform and efficient than in the case of the logarithmic or exponential types. The standard horn has a 4ft. square mouth and is built up of wood sections which are readily dismantled for transport. It is intended for

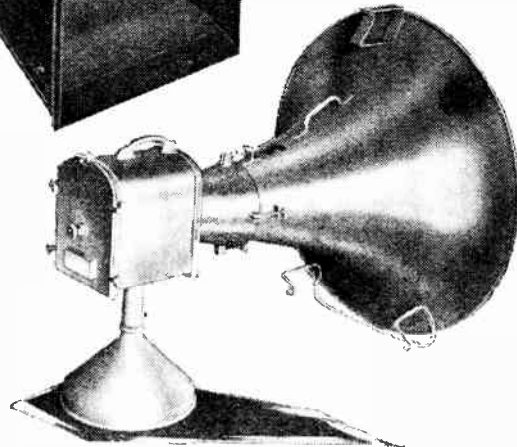

# Philips "Superinductance" Receiver

MODEL 634A

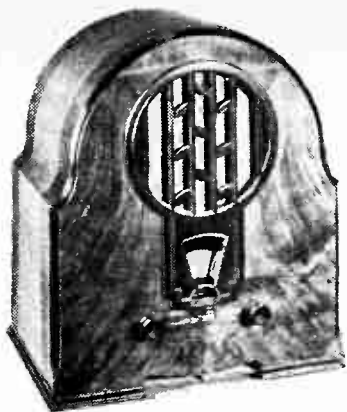

**FEATURES.** *Type.*—Five-stage "straight" set with two tuned H.F. stages: designed for external aerial. *Automatic volume control.* Permanent magnet moving-coil loud speaker. *Circuit.*—Two tuned variable-mu H.F. stages preceded by band-pass filter—single diode tetrode detector-amplifier—pentode output valve. *Full-wave valve rectifier.* **Controls.**—(1) Combined tuning and waverange. (2) Combined volume control and sensitivity selector and mains switch. **Price.**—16 guineas. **Makers.**—Philips Lamps, Ltd., 145, Charing Cross Road, London, W.C.2.

## A "Straight" Set of High Selectivity and Long Range

THOSE responsible for the design of Philips receivers have always been consistent supporters of the "straight" set in which the amplification prior to detection is carried out at the frequency of the incoming signal. To meet modern requirements as regards range and selectivity in a receiver of this type calls for considerable knowledge in design and skill in construction, and the makers are to be congratulated on having solved the problem in a manner which has won unstinted praise from the adherents of rival systems of reception.

The success of the design is largely attributable to the efficiency of the tuning coils, which are Litz-wound on glass formers, and to the accuracy of alignment of the tuning condensers. There are four tuned circuits—two in the band-pass input circuit and one in each of the coupling transformers associated with the high-frequency amplifying valves. Detection is carried out by a single-diode S.G. valve which supplies the bias for automatic fading compensation to the first H.F. valve, and amplifies the L.F. component of the output before passing it through resistance coupling to the power valve.

To compensate for the variation in sensitivity between the top and bottom of the wavelength scale, the bias of both H.F. stages is varied by a wire-wound potentiometer ganged to the main tuning control. A further step in the sensitivity of the set as a whole is introduced by switching in or out a section of the bias resistance network. The manual volume control is situated between the diode and amplifier sections of the detector valve, and operates

both on radio and gramophone reproduction.

It is interesting to observe that the smoothing of the H.T. supply is accom-

open scale, and the accurate station calibration chart provided, offset any difficulties that might otherwise arise from the high selectivity of the H.F. circuits. There are only two knobs on the front of the cabinet, and both are arranged to combine a push-pull switching action with the usual rotary motion. Thus the right-hand knob takes care of waverange switching as well as tuning, and the left-hand control combines volume control with a sensitivity or "local-distance" switch and the main on-off switch. At the back of the set there is a three-position tone control for use when background noise is troublesome.

The set is a very pleasant one to handle and the automatic fading compensation reduces background noise to a negligible level on all worthwhile stations. The range is at least as good as that of the average superheterodyne with an equal number of stages. The long-wave performance is particularly good and the selectivity on this range has not been bettered by any set so far tested. On medium waves, adjacent channel separation was possible on all stations other than those lying immediately on either side of the local stations. Under identical conditions, more channels are lost with

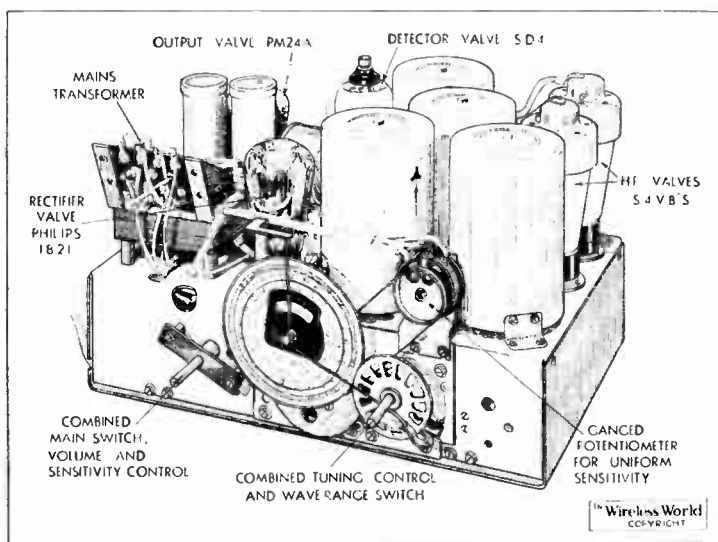

General view of chassis showing micrometer dial gearing.

plished by resistance-capacity circuits, without the aid of iron-cored chokes or even of a loud speaker field winding. The method is successful, as the mains hum is inaudible under normal working conditions.

It might be thought that in a highly developed set of this type the handling of the controls would call for a corresponding degree of skill. This is far from being the case, as the geared micrometer dial with its

many superheterodynes.

The permanent magnet moving-coil loud speaker is free from objectionable bass resonance, and the general character of the response is crisp and bright. This is probably due to accentuation of the upper middle register, as the high-frequency response above 3,500 to 4,000 cycles has been cut to reduce background hiss. Output is sufficient, but not exceptional.

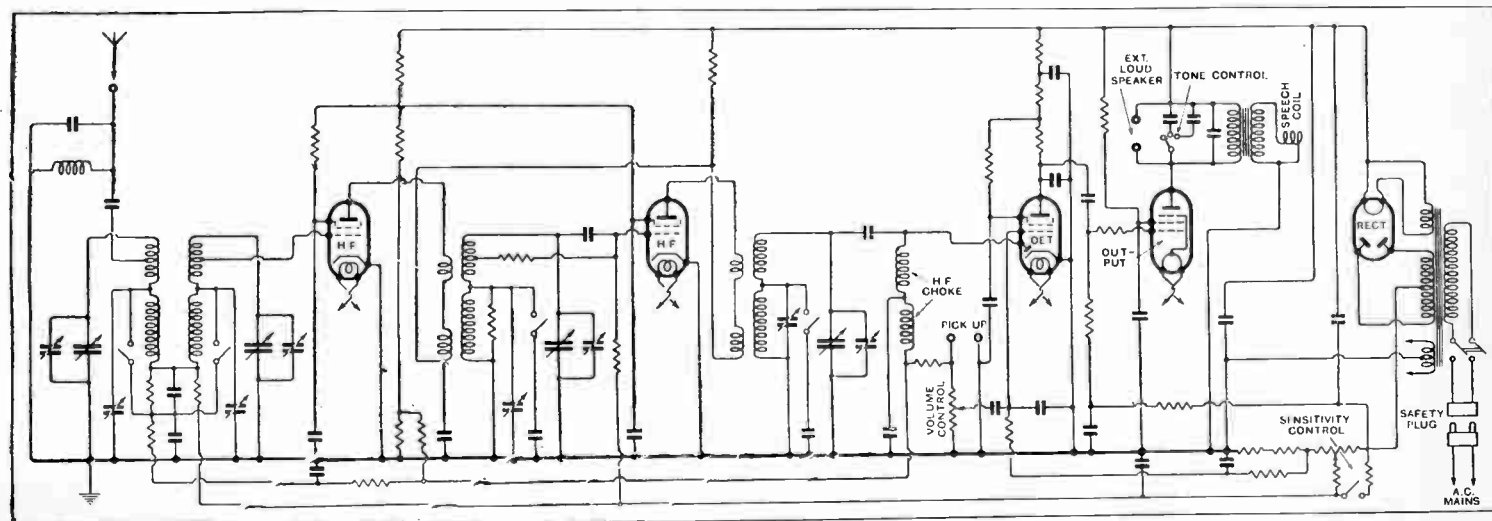

Complete circuit diagram, showing bias resistance network. No chokes are included for H.T. smoothing.



# Correspondence

The Editor does not hold himself responsible for the opinions of his correspondents.

Correspondence should be addressed to the Editor, "The Wireless World," Dorset House, Stamford Street, S.E.1, and must be accompanied by the writer's name and address.

## Station Announcements

JANUARY, 1934, when the wavelength changes come into operation, presents the B.B.C. with an unique opportunity to remedy the confusing methods now employed in connection with "Station" call sign announcements. Let the B.B.C. scrap the grossly misleading "National" and "Regional" announcements in favour of the highly organised system of individual station "call signs" as adopted by the leading "networks" in America.

Wallasey.

L. DAVIES.

## Double Channel Transmission

MAY I endorse the suggestions made by Mr. Moor concerning double channel transmissions, in your issue of September 8th?

I suggest that the reason why electrically reproduced music sounds unnatural is that each instrument is fixed only by a system of "mono-focal" co-ordinates.

The use of a single channel for it with one or more microphones enables the mind to fix the position of the performers in one way only, namely, the distance from the microphone.

Now, if double-channel transmission were used, feeding into loud speakers placed at the same distance apart as the microphones, we have a system of bi-focal co-ordinates; each instrument is now definitely fixed by its distance from the two microphones separately.

The two receivers necessary could be built into the same cabinet with a loud speaker on each side, the two receivers having a common power unit.

I believe that by this means a high standard of reproduction could be attained, even with the receivers available commercially to-day.

R. B. RANSOME.

Ipswich.

## Wireless Set and Electricity Charges

YOUR reproduction of the notice issued by the Electricity Department of the Mexborough U.D.C. restricting the use of radio receivers to lighting circuits must have been read with very mixed feelings by those of your readers who, like myself, are, or have been, connected with the supply of electricity.

Until my resignation in 1933 I was for over eight years managing director of an electricity supply company, whilst I have owned radio receivers ever since 1921, so perhaps I am not unqualified to see both sides of the picture.

Let me say at the outset that I regard such a restriction as most short-sighted and extremely detrimental to the interests of the electricity department concerned. My personal experience is that the advent of the H.T. eliminator and then of the all-mains set led to the ousting of gas, at least for lighting purposes, in thousands of houses, and made a definite contribution towards making up the losses which the introduction of "Summer Time" inflicted on the supply industry. Furthermore, the rela-

tively late hour to which broadcasting continues has undoubtedly led to a greater consumption of current in houses where there is a receiver. I have always done my best to foster the use of radio sets from the mains because I am convinced that radio is one of the quickest ways of getting electricity into a house and ensuring its developed use when there, but I frankly feel that the righteousness of your indignation led you to adopt a singularly unfortunate line of attack.

Nowhere in any of the Electricity Acts will you find any support whatsoever for your statement that the lighting rate can only be exacted where electricity is used for purposes of illumination.

There is, in law, no obligation whatsoever on a supply authority to sell its current at a rate below the maximum rate laid down in its Statutory Order, which in the case of the Mexborough Order is 8d. per unit, whereas the rate charged in that area for heating is 1d. per unit.

If, for the purpose of increasing its sales of current and levelling up its load, an undertaking concedes special rates for specific purposes, it is at liberty to lay down certain conditions, and consequently may dictate the type of apparatus which may be connected to circuits metered at these special rates.

Finally, I would point out that the prohibition contained in Section 27 of the Electric Lighting (Clauses) Act, 1899, of any control or interference by the supply authority with the consumers' manner of using electricity supplied to him has been held to apply only to cases where the maximum rate, permitted under the Order, is being paid by the consumer.

D. N. W.  
London, W.1.

## Valves or Stages?

THE letter of Mr. J. Baggs, of Messrs. Ferranti, Ltd., in *The Wireless World* of September 1st calls for a reply in support of the new description applied to multiple-valve receivers. Your leader of August 4th stated that a well-known firm of manufacturers, Messrs. E. K. Cole, Ltd., had adopted the principle of designating their receivers according to the number of stages—a stage being an anode-to-cathode electron stream. I agree with Mr. Baggs that to describe a receiver which incorporates even one multiple-purpose valve by the number of its valves would be misleading and unfair to the manufacturer of such a set, as it would be understating its capabilities. Clearly, then, some other description is necessary, and the new system appears to be the only sensible alternative, which after a short time has elapsed for its general adoption, cannot possibly lead to confusion.

In support of his criticism, Mr. Baggs states that in *The Wireless World* review of the Ferranti "Gloria" Consolette, in the issue of August 4th, it was wrongly described as a six-stage receiver. I agree with him that it has seven stages. Possibly *The Wireless World* omitted to take into account the A.V.C. diode, which does, of course, ful-

fil the condition of an anode-to-cathode electron stream. However, the system is quite new, and one cannot condemn it and strangle it at its birth.

The public must know what it is buying, and here again I must differ from Mr. Baggs. My experience is that the man in the street does know what he wants, and has, up to now, been guided in his choice very considerably by taking into account the number of valves employed in a receiver. When his neighbour becomes the plutocratic possessor of a four-valve set, against his three-valve, pride will not be satisfied until he himself purchases a five-valve. This is good for trade, Mr. Baggs, of the sales department, and you at least will be the last person to deny that the public should not be deprived of some reliable measure to guide its purchases. I contend that the "stage" description meets the case admirably.

Finally, I cannot congratulate Mr. Baggs on his solution of the problem. He states that his firm have "gone still farther than any of the foregoing proposals," by the simple process of not mentioning the number of valves or the number of stages at all! This, surely, is an Irishman's advance. It certainly does not help one iota.

Sheffield.

G. A. TAYLOR.

IN your issue of September 1st we notice a letter criticising our new policy of describing sets by stages instead of valves. This suggestion is that a better method would be to make no mention either of stages or valves other than to list the valves in the specification.

The problem of how best to give a description of the capabilities of a receiver is admittedly difficult, but we do frankly believe that a "stage" is the best descriptive unit available at the present time.

The alternative suggested by your correspondent to our view will not only maintain the use of "valves" but will also introduce once again our old friend the rectifier. The average member of the public has been brought up on "three-valve sets" and "six-valve sets," and similar terms. When he buys a new set he naturally wants to know something about it, and if it is not described as having "so many valves" he will count them either in the set or in their printed description. In both cases the rectifying valve is there to mislead him or to involve him in a lengthy argument.

The ideal method of description, no doubt, would be a term metaphorically equivalent to the use of "horse-power" in rating cars. Whether "stages" provides this equivalent or whether it has yet to be found must remain in question until future inventions and developments decide.

In conclusion, we regret that your correspondent should suggest that our new description will "open up the paths for misrepresentation." It was solely with the object of lessening this risk that we adopted it. Support for the method has been unanimous from Press, trade and public, the only note of dissension being from your correspondent.

BARRY KAY,  
Sales Promotion Manager, E. K. Cole, Ltd.  
Southend-on-Sea.

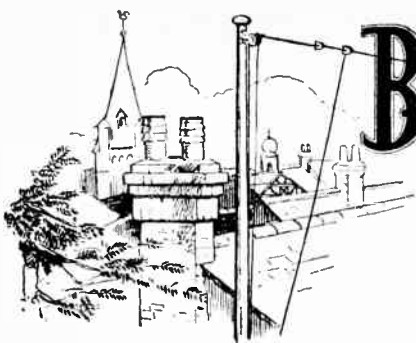

# Broadcast Brevities

By Our Special  
Correspondent



is still unsettled, but the legal advisers of the B.B.C. are hopeful of a speedy solution of the difficulty. It is not intended that this station shall have twin transmitters as at Brookmans Park, but a single transmitter as at the projected Midland Regional station.

## Provincial Progress

THE alterations in the studios and offices of the Midland Regional station are practically completed, and within a short time the staff will enter into full possession of the new and up-to-date studios, offices, and technical apparatus, all of which, following the experience gained at Broadcasting House and elsewhere, are devised to facilitate the task of programme production.

## Personnel of the Midland Regional Station

The Station Director at Birmingham is Mr. Percy Edgar, well known to all Midland listeners as he has been in charge of the station for eleven years. With him will be Mr. H. G. Dunkerly as Programme Director, Mr. Victor Hely-Hutchinson as Musical Director, and Mr. Mostyn Webster as Director of Productions. Mr. Dunkerly has had a wide experience at the Liverpool and Manchester stations of the B.B.C., and has for the last month or so been in sole charge of the North Regional, while Mr. Mostyn Webster has for some time been engaged in the production of some of the revues and lighter programmes at Broadcasting House. Mr. Hely-Hutchinson is too well known to all listeners to need any introduction.

## Midland Regional for the Midlands

When writing last week about the Aberdeen studio I gave Mr. Dinwiddie's slogan as "A fair chance for every town in Scotland," and Mr. Edgar holds strong views that the Midland Regional programmes should be, as far as possible, contributed by Midland artists. At present those of local origin constitute only 40 per cent. of the whole.

## Cardiff Studios

THE large single-deck studio at Cardiff has been reconstructed to make it double-height. The architect, Mr. Edward Maufe, who decorated the religious studio at Broadcasting House, has been responsible for the decorations as well as for those of a smaller studio.

## New Premises at Bristol

At Bristol, new premises have been taken over by the B.B.C., and the Corporation has carried out certain alterations, while Mr. J. C. Proctor, the architect who decorated the studio in Leeds, is preparing designs for the decoration of a studio in Bristol which will be used for dramatic performances and talks. Mr. Proctor will also carry out the decoration of a new large studio to be constructed in the garden at the back of these premises.

## Belfast Station

I UNDERSTAND that the question of the mineral rights of the site chosen for the new High-power Station for Northern Ireland

## A Fair Warning

LISTENERS in Newcastle, Sunderland, Gateshead, South Shields, and the surrounding areas should make a note that the G.P.O. is arranging a "comb-out" of that district next month in order to trace unlicensed receiving apparatus. The investigation will probably start on October 2nd, so any listener whose conscience convicts him of working a wireless receiver without a licence and reads this note will have a day or two in which to repair this unfortunate omission.

## The Wanderer's Return

TURNING to lighter and more pleasant subjects, I hear that when Mr. Henry Hall stepped off the "Berengaria" at Southampton last week he looked the picture of health and evidently was suffering no ill-effects from the overwhelming welcome he had received in America. He came back with considerably more luggage than he took

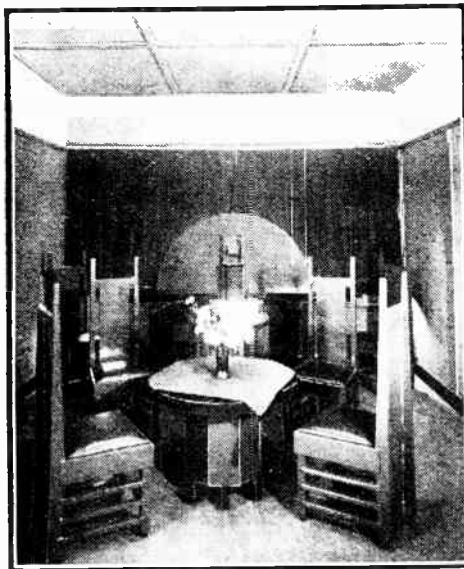

NOT THE "SALLE À MANGER." An emergency studio at the Huizen transmitting station for use in case of a breakdown in the normal lines connecting to the main studios.

out, and this increase included the scores of some of the American music which he intends to introduce to our notice.

## No Time Wasted

In the short space of a fortnight Mr. Hall met practically everybody of note in his particular sphere on the other side of the Atlantic, including Vincent Lopez, Wayne King, Emil Coleman, Johnny Morris, and Ben Bernie, who, I understand, delight all the "radio fans" of the United States. Their music, as interpreted by them, will be introduced to British listeners by Henry Hall during the winter months, so jazz enthusiasts may expect many a treat.

## Talks on Sport

THE Talks Department of the B.B.C. has been busily engaged on the lighter side of its work, and is arranging an attractive series of sports talks by record-holders and other leading lights. In addition to Mr. H. W. Austin's discourse on Lawn Tennis to-morrow, Mr. W. C. Lyle on "Sport in other Countries" on October 7th, Mr. C. Buchan on "Association Football" on October 21st, and General Critchey on "Greyhound Racing" on October 25th, we are promised a talk by Larry Gains, the British Empire Boxing Champion, and by Colonel Peel on "Tunny Fishing," while, in all probability, listeners will also have an opportunity of hearing Sir Malcolm Campbell on "Motor Racing," Mr. and Mrs. Mollison on "Long Distance Flying," Stan. Woods on "Motor Cycle Records," Miss M. Foster on "Rifle Shooting at Bisley," and the veteran, Mr. J. H. Taylor, will give us an account of fifty years' experience in Golf.

## The West Regional Director of Programmes

THE appointment of Mr. J. T. S. Suthery as director of programmes for the West Regional station has, as usual, aroused some protest from Wales on account of his not being Welsh. The objectors do not seem to realise that the West Regional station serves the enthusiastic listeners in Devon, Somerset, Cornwall, Gloucestershire and Hereford, and should not, therefore, be considered as belonging exclusively to the Principality. I understand, also, that Mr. Suthery spent a considerable part of his boyhood at Llandaff, so that he is not altogether a stranger to Wales.

## Anti-Interference Campaign

THE special committee of the I.E.E., formed at the instigation of *The Wireless World*, which is considering the best means of overcoming "man-made static," will get into its stride at the general meeting summoned for October 5th. Meantime its members are busy collecting more evidence for discussion in detail, and it is expected that the committee will have a busy time during the winter months.

## Possible Legislation

The possibility of introducing some form of legislation under the Wireless Telegraphy Act will probably have to be considered. Even though experience shows that in a great number of cases it is not difficult to persuade parties responsible for various forms of interference to adopt ameliorative measures without having to resort to compulsion, yet legislation would remove the risk of unfairness. All manufacturers should be on the same basis, and imported apparatus, too, must be controlled. In the meantime the B.B.C. and the Post Office are handling an average of 150 complaints about interference each week.

# READERS' PROBLEMS

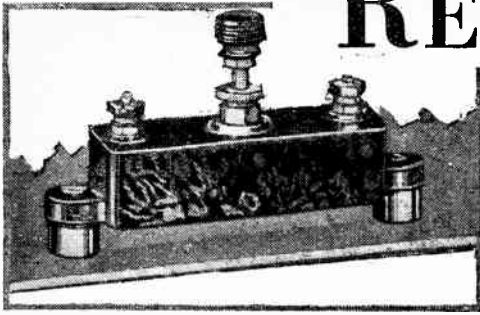

Reducing stray capacity by mounting a compression type of condenser above a metal base.

## Alternative Components

PROVIDED that a certain amount of discrimination be exercised, it is not essential that all the components used in building the New Monodial should be of the same makes as those employed in the original model; in many instances substitutions may be made without impairing performance.

But, with regard to the 0.002-mfd. compression condenser in the oscillator circuit, it should be pointed out that the particular make of component specified has a low residual capacity to earth when mounted in the normal manner on a metal base-plate. The substitution of other makes of condenser will in some cases add an excessive amount of stray capacity across the oscillator circuit, unless the precaution be taken of mounting the condenser some  $\frac{1}{4}$  in. above the metal base, as shown in the above illustration.

In order that the full range of capacity variation may be available, it will sometimes be necessary to place a rigid backing-plate of insulating material under the condenser.

## Peaked Tuning

THE observant visitor to the recent Olympia exhibition may have noticed that a new expression has crept into the language of radio. This is "peaked

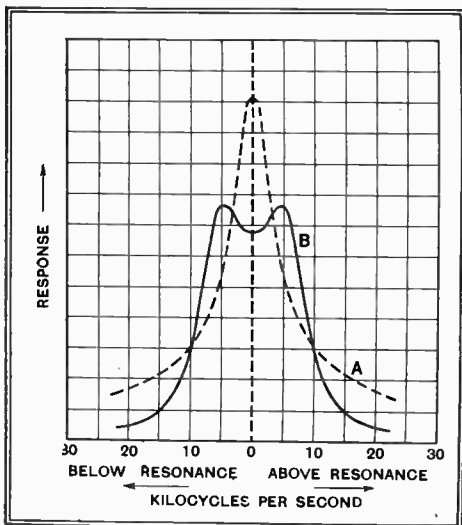

Fig. 1.—The double-humped resonance curve is that of a band-pass filter: the other is that of a similar pair of circuits, but coupled more loosely to give "peaked tuning."

tuning," which is now sometimes applied to circuit arrangements which differ in no obvious way from the band-pass filter with which we are all familiar.

A reader's request for information on

this point may be satisfied by saying that peaked tuning differs from band-pass tuning only in that the coupling between the component circuits is made just close enough to give maximum transference of energy, but no "double hump." This is illustrated diagrammatically in Fig. 1.

This method of adjusting a two-circuit tuner is sometimes referred to as "peaked band-pass," which seems to be a contradiction of terms, as no attempt is made to pass on a definite band of frequencies at full strength. Of course, peaked tuning confers no immunity from sideband cutting, and so, when it is employed, suitable compensation must be made in the L.F. circuits by providing tone correction.

*THESE columns are reserved for the publication of matter of general interest arising out of problems submitted by our readers.*

*Readers requiring an individual reply to their technical questions by post are referred to "The Wireless World" Information Bureau, of which brief particulars, with the fee charged, are to be found at the foot of this page.*

## H.F. on Short Waves

SEVERAL readers seem to be uncertain as to the benefits likely to result from adding an aperiodic H.F. stage to their short-wave converters.

It should be made clear that no appreciable amount of true H.F. amplification is to be expected from such a stage, but, paradoxical as it may seem, the addition is one that can be thoroughly recommended. In the first place, radiation from the aerial and consequent interference with other listeners will be minimised, and also the interposition of the H.F. valve between the aerial and the tuned circuit will remove the damping effect of the former and make operation very much easier and more certain. In particular, the reaction adjustment will work more consistently, and "dead spots" should be absent.

## Is the A.V.C. Working?

IT is far from easy to form a definite opinion as to whether an automatic volume control system is working properly. From its very nature, A.V.C. should function unobtrusively by maintaining volume at the required level irrespective of fluctuations in the strength of incoming signals.

Unless it is possible to make comparative tests during periods of fading against a receiver which is not fitted with A.V.C., it is almost impossible to check the functioning of the control system without the use of a milliammeter. This instrument should be connected in series with the anode circuit of one or of all the controlled valves, and a strong transmission should then be tuned in. If everything is working well, a considerable increase in anode current should take place as a result of touching the high potential end of one of the tuned circuits of the receiver. This will show that sensitivity is being automatically increased to make good the loss of volume which would otherwise arise through artificial detuning of one of the circuits. A still more convincing test may be made after darkness has set in by tuning in a short-wave station known to be subject to fading; violent fluctuations of controlled anode current will probably take place every half-minute or so.

## The Low-pass Filter

THERE is no reason why the low-pass filter included in the New Monodial superheterodyne should not be adapted to almost any type of receiver, arrangements being made to place it in circuit when heterodyne interference is present. But it should be pointed out to a correspondent who raises this query that a filter of this kind is of little benefit in eliminating whistles due to second-channel and similar forms of interference.

## Taken Too Literally

CERTAIN expressions used in the radio art are admittedly rather confusing to the newcomer, who is particularly likely to be misled by the terms "earth" and "earthy." One of our newer readers has been misled by the expression "earthed end of the tuning coil," as used by a more knowledgeable friend, and, by taking him literally at his word, has imposed an accidental short-circuit across his H.T. battery.

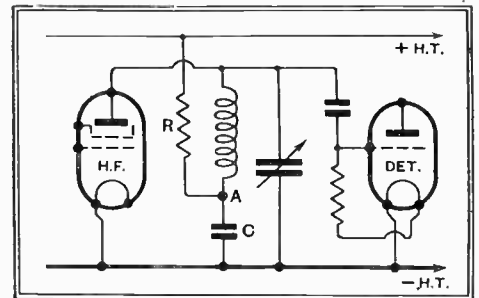

Fig. 2. Although point A may be positive with respect to earth by the full voltage of the H.T. battery, it is "earthy" so far as H.F. voltages are concerned.

It must not be assumed that the earthed or low-potential end of a circuit is always joined directly to the earth line, or chassis, of a receiver. The expression as generally used relates to the part of the circuit or component which is at low-potential with regard to signal-frequency voltages, whether H.F. or L.F. For instance, in Fig. 2, point A would be spoken of as the earthed end of the tuned anode coupling coil, although, so far as D.C. is concerned, it may be at a potential of a couple of hundred volts above earth. But there should be no appreciable signal-frequency difference of potential between point A and earth, as it is "tied down" by the combined action of the decoupling resistance R and the by-pass condenser C.

## The Wireless World INFORMATION BUREAU

THE service is intended primarily for readers meeting with difficulties in the construction, adjustment, operation, or maintenance of wireless receivers described in *The Wireless World*, or those of commercial design which from time to time are reviewed in the pages of *The Wireless World*. Every endeavour will be made to deal with queries on all wireless matters, provided that they are of such a nature that they can be dealt with satisfactorily in a letter.

Communications should be addressed to *The Wireless World* Information Bureau, Dorset House Stamford Street, London, S.E.1, and must be accompanied by a remittance of 5s. to cover the cost of the service. The enquirer's name and address should be written in block letters at the top of all communications.

# EFFICIENCY

# UNIFORMITY

# LONG LIFE



KINGS OF THE AIR

You can appreciably improve the performance of your All-Electric Receiver, especially if it is two or three years old, by fitting the correct types of Cossor Mains Valves. Due to their advanced design and their famous Mica Bridge Construction, Cossor Mains Valves possess remarkable efficiency, uniformity and long life. Your dealer will tell you the types you need to make your Set like new again.



# COSSOR

## A.C. and D.C. MAINS VALVES

COSSOR A.C. MAINS VALVES (4 Volt Indirectly Heated Cathodes)

Type	Purpose	Impedance	Amp. Factor	Mut. Con. m.a.v.	Price
**M.S.G.-H.A.	Super H.F. Amp'n	500,000	1,000	2.0	17/6
*41 M.S.G.	Super H.F. Amp'n	400,000	1,000	2.5	17/6
**M.S.G.-L.A.	Super H.F. Amp'n	200,000	750	3.75	17/6
†M.V.S.G.	Variable Mu -	200,000	-	2.5	17/6
**M.S./PEN.-A	H.F. Pentode -	-	-	4.0	17/6
**M.S./PEN.	H.F. Pentode -	-	-	2.8	17/6
†M.V.S./PEN.	Variable Mu -	-	-	-	-
	H.F. Pentode	-	-	2.2	17/6
*41 M.D.G.	Bigrid -	40,000	10	.25	19/-
*D.D. PEN.	A.V.C. (Detector and I.F. Amp.)	-	-	-	-
	A.V.C. (do.)	-	-	2.7	20/-
**D.D.T.	A.V.C. (do.)	17,000	41	2.4	15/6
41 M.R.G.	R.C.C. or Det.	19,500	50	2.0	14/-
41 M.H.	Detector -	18,000	72	4.0	13/6
41 M.H.F.	H.F. or Det.	14,500	41	2.8	14/-
41 M.H.L.	Det. or H.F.	11,500	52	4.5	13/6
41 M.L.F.	Low Frequency	7,000	15	1.9	14/-
41 M.P.	Normal Power	2,500	18.7	7.5	14/-
41 M.X.P.	Extra Power	1,500	11.2	7.5	16/6
M.P./PEN.	Pen. Power Output	-	-	3.5	18/6
‡P.T. 41B	Pen. Power Output	-	-	2.25	22/6
‡P.T. 41	Pen. Power Output	-	-	3.0	18/6

\* Supplied with Plain or Metallised Bulbs. \*\* Stocked with Metallised Bulb only. † Characteristics measured at -1.5 Grid Volts. ‡ Directly heated filaments.

COSSOR D.C. MAINS VALVES (16 Volt 0.25 amp. Indirectly Heated Cathodes)

Type	Purpose	Impedance	Amp. Factor	Mut. Con. in a.v.	Price
†D.V.S.G.	Super H.F. Amp.	-	-	2.5	17/6
*D.H.L.	Detector -	13,000	58	4.5	13/6
D.P.	Power Output -	2,800	17	6.0	15/-
D.P./PEN.	Power Pentode -	-	-	3.5	18/6

\* Supplied with plain or metallised bulbs. † Characteristics measured at -1.5 grid volts. Prices in this List do not apply in I.F.S.

To A. C. COSSOR LTD., M:loody Dept., Highbury Grove, London, N.5.  
Please send me free of charge, a copy of the 64-page Cossor Valve Catalogue B14.

Name .....

Address .....

W-W.29.9.33.





# MISCELLANEOUS ADVERTISEMENTS

## NOTICES.

**THE CHARGE FOR ADVERTISEMENTS** in these columns is

12 words or less, 3- and 3d. for every additional word.

Each paragraph is charged separately and name and address must be counted.

**SERIES DISCOUNTS** are allowed to Trade Advertisers as follows on orders for consecutive insertions, provided a contract is placed in advance, and in the absence of fresh instructions the entire "copy" is repeated from the previous issue: 13 consecutive insertions 5%; 26 consecutive, 10%; 52 consecutive, 15%.

**ADVERTISEMENTS** for these columns are accepted up to **FIRST POST ON MONDAY MORNING** (previous to date of issue) at the Head Offices of "The Wireless World," Dorset House, Stamford Street, London, S.E.1, or on **SATURDAY MORNING** at the Branch Offices, 19, Hertford Street, Coventry; Guildhall Buildings, Navigation Street, Birmingham, 2; 280, Deansgate, Manchester, 3; 28a, Renfield Street, Glasgow, C.2.

Advertisements that arrive too late for a particular issue will automatically be inserted in the following issue unless accompanied by instructions to the contrary. All advertisements in this section must be strictly prepaid.

The proprietors retain the right to refuse or withdraw advertisements at their discretion.

Postal Orders and Cheques sent in payment for advertisements should be made payable to **ILLIFFE & SONS Ltd., and crossed & Co. Notes** being untraceable if lost in transit should not be sent as remittances.

All letters relating to advertisements should quote the number which is printed at the end of each advertisement and the date of the issue in which it appeared.

The proprietors are not responsible for clerical or printers' errors, although every care is taken to avoid mistakes.

## NUMBERED ADDRESSES.

For the convenience of private advertisers, letters may be addressed to numbers at "The Wireless World" Office. When this is desired, the sum of 6d. to defray the cost of registration and to cover postage on replies must be added to the advertisement charge, which must include the words "Box 000/0" "The Wireless World." All replies should be addressed to the Box number shown in the advertisement, c/o "The Wireless World," Dorset House, Stamford Street, London, S.E.1. Readers who reply to Box No. advertisements are warned against sending remittances through the post except in registered envelopes; in all such cases the use of the Deposit System is recommended, and the envelope should be clearly marked "Deposit Department."

## DEPOSIT SYSTEM.

Readers who hesitate to send money to advertisers in these columns may deal in perfect safety by availing themselves of our Deposit System. If the money be deposited with "The Wireless World," both parties are advised of its receipt.

The time allowed for decision is three days, counting from receipt of goods, after which period, if buyer decides not to retain goods, they must be returned to sender. If a sale is effected, buyer instructs us to remit amount to seller, but if not, seller instructs us to return amount to depositor. Carriage is paid by the buyer, but in the event of no sale, and subject to there being no different arrangement between buyer and seller, each pays carriage one way. The seller takes the risk of loss or damage in transit, for which we take no responsibility. For all transactions up to £10, a deposit fee of 1/- is charged; on transactions over £10 and under £50, the fee is 2/6; over £50, 5/-. All deposit matters are dealt with at Dorset House, Stamford Street, London, S.E.1, and cheques and money orders should be made payable to Illiffe & Sons Limited.

**SPECIAL NOTE.**—Readers who reply to advertisements and receive no answer to their enquiries are requested to regard the silence as an indication that the goods advertised have already been disposed of. Advertisers often receive so many enquiries that it is quite impossible to reply to each one by post. When sending remittances direct to an advertiser, stamp for return should also be included for use in the event of the application proving unsuccessful.

# PILOT AUTHOR KITS

Exact to Specification

AS FOUNDERS OF CONSTRUCTORS' SETS IN 1919, we have established a world-wide reputation for the supply of Complete Kits and Part Kits for all "Wireless World" Set designs. An essential feature of this Expert Service to the Home Constructor is **IMMEDIATE DELIVERY FROM STOCK CASH or C.O.D.** of any exclusively specified or difficult to obtain components. Rely on **PETO-SCOTT**, he always gives fullest satisfaction to every customer.

## D.C. SUPER-HET

**KIT 'A'—Author's Kit of First Specified Parts, including Peto-Scott Plymax Chassis and Ply Panel, assembled and drilled, less valves and cabinet.**

Cash or C.O.D. Carriage Paid. **£12**

or £2 Deposit and 11 monthly payments of 20/-.

Set of Specified Values..... £3-9-6.

THESE ARE THE PARTS THE AUTHOR USED:

1	PETO-SCOTT Plymax chassis 16in. x 10in. x 2 1/2in. with Ply Panel, 250 ohm, 20,000 ohm, 1 meg. 5 meg. 1 meg. 2 meg. 25 meg.	12	6
1	BRITISH RADIOPHONE Super H.F. Radiopak, without volume control	3	15
2	COLVERN Ferrarot Galvalynes, 110 k.c.	1	5
1	CLAUDE LYONS Type P.58 5,000 ohm potentiometer	1	5
1	CLAUDE LYONS Type 250 tapered volume control, 0.25 megohm	6	6
1	GOLDFINE Type SHF screened H.F. choke	4	0
2	GOLDFINE Type PHF mains H.F. chokes	15	0
1	HEABERD No. 752 L.F. choke	12	6
5	CLIX chassis type Type 5-pin valveholders	3	9
1	T.C.C. Type 65 4 mfd. fixed condenser, 250 v. D.C. working	5	0
2	T.C.C. Type 60 2 mfd. fixed condensers, 200 v. D.C. working	7	0
1	T.C.C. Type 250 tubular type, oil mfd., 550 v. D.C. working	4	0
1	T.C.C. Type M 901 mfd. fixed condenser	2	0
8	IGRANIC Type PE.12, one each 0.001 mfd., 0.002 mfd., four 0.001 mfd., two 0.002 mfd. fixed condensers	4	8
1	T.C.C. Type 621 dry electrolytic condenser, 50 mfd., 250 v. D.C. working	1	6
1	CLAUDE LYONS R.A.T. 275 double-throw single-throw switch	1	3
2	BELLING LEE Type "B" porcelain-broiled terminals, A & E	1	0
2	WESTINGHOUSE W.6 Westectors	15	0
1	CLAUDE LYONS Type PL.25 25-ohm resistor	1	6
9	SERADEX Type M.50 12-watt resistances, one each 100 ohm, 250 ohm, 20,000 ohm, 1 meg., 5 meg., 1 meg., 2 meg., two 25 meg.	6	0
2	SERADEX Type 6250 10,000 ohm 21-watt resistances	3	0
1	BULGIN Type "OR" bulb, 6 volts 0.15 amp.	3	0
1	BELLING LEE Type 1033 twin safety fuseholder, with 1 amp. fuses	2	6
1	LENATH HARBROE screened-leaving transformer	2	9
1	OSRAM Barretter No. 253 voltage regulator	12	6
4 or 2	No. 20 tinned copper wire; 10 lengths Systodex wire wood screws, etc.	5	0
1	PHILCO Type No. 27 6005 7-pin valveholder	1	0
1	PHILCO Type 1897 grid ohm for 6A7 valve	1	0
1	BRITISH RADIO GRAMOPHONE 7-pin plug	2	3

**KIT 'A' CASH OR C.O.D. £12 0 0**

**PETO-SCOTT PLYMAX CHASSIS AND PLY PANEL SOLELY SPECIFIED. Plymax Chassis as specified by the Author, drilled and assembled, 16" x 10" x 2 1/2". 11/6**  
Cash or C.O.D. Post and Packing 13 extra.

**COMPLETE KIT** As Kit 'A' but with Specified Valves and Peto-Scott Walnut D.C. Super-het Cabinet. Cash or C.O.D. Carriage Paid **£16-12-0**  
or £3-12-0 Deposit and 11 monthly payments of 26/-.

**FINISHED INSTRUMENT**  
D.C. SUPER-HET—Ready Assembled exact to Author's Specification with Valves. Aerial Tested. Cash or C.O.D. Carriage Paid **£21**  
or £5 Deposit and 11 monthly payments of 32/-.

**RECOMMENDED**  
**PETO-SCOTT WALNUT D.C. SUPER-HET CABINET**

A Handsome figured Walnut Cabinet specially recommended for the D.C. Super. Constructed throughout with well-seasoned timber by London's leading piano craftsmen. Front ready drilled for panel controls. Cash or C.O.D. Carriage Paid. Size 16" x 10" x 2 1/2"



**22/6**

SEND FOR 1934 CABINET CATALOGUE

**IMMEDIATE DELIVERY CASH - C.O.D. - H.P.**

**FOREIGN ORDERS.** Send one-third value of goods with order. Balance (including forwarding charges) payable to our forwarding agents on delivery. Insurance effected if desired. All orders carefully executed and expertly packed by special export staff.

**NOUS DONNONS D'ATTENTION SPECIALE AUX INSTRUCTIONS ÉTRANGERES.**

**PETO-SCOTT CO. LTD.**  
77, CITY ROAD, LONDON, E.C.1.  
West End Showrooms: 62, High Holborn, London, W.C.1

## RECEIVERS FOR SALE.

**H.M.V.** Seven Valve Superhet, Lowboy, 3 months old; first £16 10. Box 8154, c/o The Wireless World. [3561]

**BURNEPT** Universal S.G. Mains 5-valve; list 42 guineas, offers, c/o Ely Lodge, St. Faith's Rd., S.E.21. 3538

**D.C.** Super Hetrodyne 200 250 volts, latest design, 6-valve single dial chassis; removing A.C. district; £10. - Phone: Whitehall 1522. [3562]

**A.C.** and Battery Receivers, built for laboratory experimental work, to clear cheap; high class apparatus. - Write Engineer, 56, Hazel Rd., Kensal Rise, N.W.10. [3575]

**8** Guineas.—Ethartre 200-240 A.C., 2 S.G. det. and pentode, automatic tuning, in walnut cabinet, with valves and moving coil speaker; listed 23 guineas, unopened; c.o.d., carriage paid.—Kay 167, City Rd., London, E.C.1. [3506]

**ARMSTRONG** Latest 1934 Universal 4 A.C. D.C. chassis, 3 tuned circuits, giving approximately 9 kilocycles separation, incorporating gramophone amplifier, 12 watts output, massive chassis with practically superhet performance, fully guaranteed; 75/- with 5 valves, 114/-; approved willingly. Armstrong Co., 100, King's Rd., N.W.1. [3563]

## MAINS EQUIPMENT

**HOYNE'S** Transformers and Chokes the Best Obtainable perfect insulation, regulation and reliability. HOYNE'S Transformers used by many well-known set manufacturers after testing all others.

**HOYNE'S** Transformers fitted with tapped and screened primaries, filaments all centre tapped, stout cast aluminium clamps and clearly marked terminal strips are fitted to all models.

**HOYNE'S** Components are guaranteed for one year; built to your own specification at very competitive prices.

**HOYNE'S** Components.—The components you will eventually use, start right; a dud cannot pass the Hoyne test.

**HOYNE'S** New Monodial Super, aluminium chassis, drilled for components, complete with Power Transformer, two chokes, push-pull intervalve transformer and valve holders 51/-, carriage paid.

**HOYNE'S** New Monodial Transformer, 425-0-425v. 120 m.a., 4v. 3a. 4v. 1a., 4v. 1a., 4v. 6a., 24/-, post 1/3; weight 16lb., 10 henry choke, 6/-, post 6d.; 20 henry choke, 7/6, post 6d.

**HOYNE'S**,—250-0-250v. 60 m.a., 4v. 1-2a., 4v. 2-4a., 10/-, post 9d.; with extra 4v. 1-2a. winding, 12/6, post 1/-.

**HOYNE'S** Ferrarot Model.—350-0-350v. 60-70 m.a., 4v. 2-5a., 4v. 2-4a., 12/6, post 1/-; with extra 4v. 1-2a. winding, 13/6, post 1/-.

**HOYNE'S**—350-0-350v. 120 m.a., 4v. 2-7a., 4v. 4-6a., 4v. 1a., 4v. 1a., 16/-, post 1/3.

**HOYNE'S**—500-450-0-450-500v. 140 m.a., 4v. 2-4a., 4v. 4-6a., 4v. 2a., 4v. 2a., 27/6, post 1/3; weight 11lb.

**HOYNE'S**—0-110-135v. 90 m.a., suitable for H.T. 6 or 7, 7/6, post 9d.; with 4v. 2-4a. winding, 9/6, post 9d.

**HOYNE'S**—200v. 200 m.a., 4v. 2-4a., 4v. 1-2a., for H.T. 8, 13/6, post 1/-.

**HOYNE'S** Auto Transformers, Chokes and Filament Transformers always in stock.

**HOYNE'S** Components still have no equal.

**J. HOYNE**, Offices and Works, 8a., Gladstone Rd., Wimbledon, S.W.19. Tel.: Liberty 3303. [3455]

## Mains Equipment.—Contd.

**VORTEXION**, Wimbledon, for 99.9% reliable transformers.

**IF** You Haven't Tried Them Yet Ask Someone who has or call and inspect complimentary letters.

**ALL** Standard Models Delivery by Return; all secondaries centre tapped.

**GUARANTEED** 12 Months, and within 5% normal and 2 1/2% super models, neat shrouding, with detachable feet, as used by Government Departments, etc., etc.

**VORTEXION** D.C.4 Choke, specified for D.C. superhet; 8/6.

**VORTEXION** Transformers, tested with 2,000 volts between windings.

**VORTEXION**—New monodial transformer, 200 250. 50 cycles, 425-0-425, 120 m.a., 4v. C.T. 3a, 4v. C.T. 1a., 4v. C.T. 1a., 4v. C.T. 6a., screen primary, open type, 20/- shrouded, 22/- super shrouded, 26/-; weight 14 lb., carriage 2/- extra; 10 henry choke, 5/6, post 9d.; 20 henry, 8/6.

**VORTEXION**—Ferrarot III, 350-0-350, 60 m.a., 4v. 2.5, C.T. 4v. 3.5, C.T.; open type 13/6, shrouded 16/-; post 9d.

**VORTEXION**—250-0-250, 4v. 1 to 2a., 4v. 2 to 4a.; open type 10/6, shrouded 12/6; post 9d.

**VORTEXION**—Super model for H.T. 8 or 9 or 10, 4v. 1 to 2, 4v. 2 to 4; open type 14/6, shrouded 16/6; post 1/-.

**VORTEXION**, 2 1/2-watt Monodial A.V.C. model; open type 14/6, shrouded 16/6; post 1/-.

**VORTEXION**—5-watt Monodial A.V.C. model, 400-0-400, 1-0 m.a., 4v. 6a., 4v. 5 1/2a., 4v. 2, 4v. 1a., super screened; 20/-, shrouded 24/-.

**VORTEXION**—350-0-350, 120 m.a., 4v. 2 to 5a., 4v. 2 to 4a., 4v. 2.5a.; open type 14/6, shrouded 16/6.

**VORTEXION**—400 or 450 or 500v., 120 m.a., 4v. 2 to 5, 4v. 2 to 5, 4v. 2 to 5; open type 19/-, shrouded 23/-.

**VORTEXION**—400 or 450 or 500, 150 m.a., 4v. 4a., 4v. 2.5, 4v. 2, 4v. 2, 4v. 2, core type 2 1/2 in. x 1 1/2 in.; a superb job, 2/- regulation, 35/-; shrouded with terminals, less terminals, 30/-, open type 26/-; post 1/3.

**VORTEXION** Auto Transformers to B.E.S.A. Specification, 100, 110, or 120v. to 200, 220 or 240 volts, 60 watts, 7/3, post 9d.; 120 watts, shrouded 12/6, open type 10/6, post 1/-; 200 watts, open 14/6, shrouded 16/6, post 1/-; 500 watts 30/-, 2,000 watts £4 10.

**VORTEXION** 600-watt Transformers; £4 10, carriage free.

**VORTEXION** 30h. at 60 m.a. Chokes, 5/6; 40h. at 60 m.a., 8/6; 30h. at 150 m.a., 200 ohms, 10/6 open type, 12/6 shrouded.

**VORTEXION** Transformers Made to Your Specification; price according to wattage, 6v. filaments same price unless wattage grossly exceeded; special quotations by return.

**VORTEXION** (S. A. BROWN), 182, The Broadway, Wimbledon, S.W.19. Tel.: Liberty 2814. [3572]

**TANTALUM** for A.C. Chargers, H.T. and I.T.—Blackwell's Metallurgical Works, Ltd., Garston, Liverpool. [3448]

**A.C.** Charging Plant, unused, cost £18/18, for £6/18/6; write for makers specification.—Jersey, Cumnor Hill, Oxford. [3424]

## HARTLEY-TURNER IS AT THE MANCHESTER SHOW

We invite the public to see, hear and discuss this celebrated speaker at Messrs. Radiomes' stand, No. 113; the trade to Messrs. Henry Hollingdrake & Son Ltd., Stand No. 91 and demonstration room No. 115.

If you cannot come to the Show, send a 1d. stamp for our 32-page technical booklet

"New Notes in Radio."

**HARTLEY TURNER RADIO LTD.,**  
Thornbury Road, Isleworth, Middlesex.

Tei.: Hounslow 1854.

We are demonstrating this remarkable new

**HARTLEY TURNER**  
moving coil loudspeaker daily between 12 and 3 p.m., and 4 and 6 p.m. Other times by appointment.

**Easy Payment Terms** for the Hartley Turner Moving Coil Unit, complete with special transformer, carriage paid, are as follows:—

**D.C. Model, cash price £7.7.0**  
or 20/- with order and 11 monthly payments of 12.9.

**A.C. Model, cash price £8.8.0**  
or 25/- with order and 11 monthly payments of 14.-.

We supply all other high-grade radio apparatus on convenient easy payment terms. Please send us your enquiries and a quotation will be sent by return.

**THE LONDON RADIO SUPPLY CO.**

(Established 1925)

11, Oat Lane, Noble Street, London, E.C.2

(off Gresham Street)

Phone: National 1977.

### The Opinion of Experts

"The Choice of a suitable Output Transformer is a matter requiring no less care than the selection of an intervalve coupling if the best reproduction is to be obtained."—See "Wireless World" article on "Push-Pull Output Transformers."

## The MONODIAL

is a wonderful receiver in which SOUND SALES 10 henry Chokes have always been EXCLUSIVELY SPECIFIED.

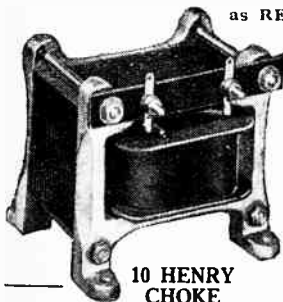

10 HENRY  
CHOKE

as RECOMMENDED in  
"The Wireless  
World," Sept. 8.

Types to suit  
all speakers.

YOU MUST HAVE  
OUR LATEST  
LIST OF MAINS  
TRANSFORMERS,  
CHOKES, CLASS B  
COMPONENTS,  
SPEAKERS, ETC.

WRITE NOW.

It also needs  
and deserves a

**SOUND SALES  
OUTPUT TRANSFORMER**

Specified by  the Experts

**SOUND SALES**

Telephone:  Archway 1661-2.

SOUND SALES LTD., Tremlett Grove Wks, Junction Rd., N.19.

### Mains Equipment.—Contd.

N.P. for all Sizes of Battery Chargers, A.C. mains; trade list.

N.P. Allow 7 Days in which to Test the Efficiency of their instruments.

N.P. Have a Special Charger, 75 volts, 1/2 to 2 amps., will charge up to 80 batteries at one time; cost 6 hours full load per unit, £6 6.

N.P.3 Circuit Chargers, will do 250 batteries for 2 6 current; lowest prices in the trade; 2 years' guarantee.

N.P. Send Full Trade Lists and Photographs; state your requirements; now is the time to get busy.—Nash Products, Ltd., Stechford, Birmingham, 9. [3567]

SERADEX Products.—First specification for "D.C. Superhet."

THE Following Seradex Products are also suitable for the above receiver.

SERADEX C.256 Choke, 25H. at 60 m.a. constant inductance; 12 6.

SERADEX Glasswound Resistor, type G.125, 25 ohms; price 9d.; illustrated lists of other types for stamp.

SERADEX Type B Condensers, 400v. working; 2 mfd. 2 3 each, 4 mfd. 4 5.

SERADEX Tubular Condensers, 400v. working, sizes from 0.01 to 0.1 mfd.; 8d. each.

SERADEX Mains Equipment Catalogue, ready next week; reserve your copy.

TREVOR PEPPER, 575d, Moseley Rd., Birmingham, 12 [3555]

DAVENSET Automatic Charging Board, model A.C.6, little used, condition practically as new; retail list price £49 10, £28, or near offer; deferred terms arranged.—Apply Trewin Bros., Ltd., Queen's Rd., Watford. [3560]

100 Accumulator Chargers, 1/2 amp., 2-6v., in ventilated metal case (Arden 1932), incorporating Westinghouse rectifier, 10 6, postage 6d.; 1 1/2 amp., 21/-; 7 days' trial.—Arden Agency, Wollaston, Wellesborough. [3548]

FOR Sale, as new, £25 Crypto charger, 200-250 A.C., cost £50, output 50 volts 25 amps., automatic cut-out, 3 boards, complete with meters, etc.—Apply Lemmon, Battery Charging Station, 198, Harwoods Rd., Watford, Herts. [3559]

### CABINETS.

RADIO-GRAM Cabinets; fully illustrated list free; remarkable values.—Gilbert, Cabinet Maker, Swindon. [1686]

H.M.V. Radiogram Cabinet, model 522, in walnut, lined lid, handsome piece of furniture; sacrifice, 70%, first cash secures.—Fine, 81, Park Avenue, Willesden. [3501]

EPTON First Again! Just arrived, Table Console cabinets, polished and handsome; Clarke's Atlas, 11 9; Regentone, 12 6; Aerodyne, 13 6; Alba, 14/-; send for [3578]

EPTON'S Radio Bargain Bulletin, 93, New Rd., Chingford, E.4. Phone: Silverthorn 1427. [3578]

MANUFACTURER'S Clearance Lines of Cabinets for Radiograms, loud-speakers, and radio sets; hundreds to select from; send postcard for list; special cabinets for Skyscraper and S.T.400.—H. L. Smith and Co., Ltd., 289, Edgware Rd., London, W.2. [3409]

### DYNAMOS, ETC.

ROTARY Converters, 220 volts D.C. to 260 volts A.C., capacities up to 0.44 K.V.A., cheap.—Milo Engineering Works, Milo Rd., East Dulwich, S.E.22, Sydenham 4422 [3450]

E.D.C. Rotary Converter, 230v. D.C. input 230v., 50-230 watts A.C. output, in soundproof cabinet, as new, with filter unit; £10.—Apply Knights Radio Stores, Leigh Rd., Leigh-on-Sea [3550]

ROTARY Converter, 200-250 D.C. to 260-250 A.C., 180 watts, brand new, with 12 months' guarantee, £6 5, or complete unit with Auto-Starter and silence cabinet (G.E.C. manufacture), £7 15.—Johnson Engineering Co., 86, Great Portland St., W.1. [3551]

D.C. to A.C. Non Rotary Converters; inputs 100/110 and 200 250 D.C.; outputs 200/250 A.C. 50 cycles, 80 watts; £5 19 6; no rotating parts; silent, efficient; other voltages at slightly increased cost; trade enquiries invited.—"Desak" Electrical Products, 2, County Rd., Swindon. [3541]

### GRAMOPHONES, PICK-UPS, ETC.

D.C. or A.C. 100-250v. Universal New K-B Gramophone Motors, complete, turntable, autostop, etc.; list £6 15, 30/- cash, post free, or c.o.d.—5, Hillside Crescent, N.10. [3557]

### LOUD-SPEAKERS.

B.T.H. RK Moving Coil Speakers, guaranteed new, unused, manufacturers' surplus, original price, 6 Guineas, highly sensitive and wonderful tone response, will handle up to 10 watts output, available for 6v., 100v., 200v. D.C., 30/-, also A.C. models

£2/10; carriage paid, c.o.d. or cash with order; the best value in speakers obtainable to-day.—O. H. Seckamp, First Avenue House, High Holborn, London, W.C.1. Phone No.: Holborn 609. [1425]

10/-—Lamplugh Silver Ghost, 2,200 ohms, with output transformer, unopened; list 47/6; c.o.d., carriage paid. Kay, 167, City Rd., London, E.C.1. [3351]

PERMANENT Magnet Speakers; P.M.5 T, made by W.B., 3 ratio transformer, very sensitive, unopened; reduced to 18 6 post free or c.o.d., satisfaction or refund.—Burrows Radio, 92, Park Rd., Prestwich, Manchester. [3568]

ARMSTRONG Permanent Magnet Moving Coil Speakers, 1934 model, better than ever this year, transformer matched to requirements, massive full size speaker, beautiful tone; 21/-, approval.—Armstrong Co., 100, King's Rd., N.W.1. [3564]

# RADIO DATA CHARTS

## A SERIES OF ABACS

providing most of the essential  
Data required in Receiver Design

By

**R. T. BEATTY, M.A., B.E., D.Sc.**

Reprinted from  
"The Wireless World"

(1930)

"Radio Data Charts" provide designers of wireless apparatus with a ready and convenient means of solving problems without having recourse to complicated formulæ and mathematics.

By the use of the charts it is possible to tackle all the more familiar problems in radio receiver design, such as, for example, finding the relationship between inductance capacity and frequency, and working out the design of high frequency transformers. All keen amateurs will appreciate this helpful book.

(39 CHARTS and more than  
50 Diagrams)

Price 4/6 net

By post 4/10

Published from the Offices of  
"THE WIRELESS WORLD"

From all leading booksellers or direct  
from the Publishers

**ILIFFE & SONS LTD.**

Dorset House,

Stamford St., London, S.E.1

W.W.93

Loud-Speakers.—Contd.

30/-!!! B.T.H., R.K. moving coil speakers, 6in. cone, new and unused, guaranteed; these speakers are the type as used in cinema sound equipment; suitable for public address work; weight 30lb., and are vastly superior to the cheap speakers now on the market, 100 volts, 150 volts, and 200 volts D.C.

27/6!!! 6-volt D.C. speakers, as above; £2 7 6 speaker as above for 100-250 volts A.C., complete with field rectifier.

B.T.H. Transformers, brand new, ratios 1-1, 2-1, 20-1, and 30-1 microphone; 7 - each.

CARRIAGE Paid, cash with order, or cash; send for list.—Ward, 12, Tredegar Rd., Bow, E.3. Tel.: Advance 3668. [3552]

CHAL. ELECTRIC Offer New Boxed Set Manufacturers' Surplus Rola Speakers, all fitted hum buckers, state for power or pentode; F6, 110-175v. (2,000 ohms), 90-130v. (2,500 ohms), 150-200v. (4,700 ohms), 200-250v. (6,500 ohms), list 35/-; at 18 - each; F7, voltages as above, list 47 6, at 25/-; permanent magnets, F6, P.M., list 49 6, at 28 -; F7, P.M., list £3, at 33/-; dual compensated (2) F6, list £3 10, at £2, or (1) F6 and (1) F7, list £4 5, at 47 -; low Class B; state requirements; all goods carriage paid; cash with order, or cash.—Chal. Electric, 6, Conduit St., London, W.1. [3524]

PICTURE RECEIVER APPARATUS.

TELEVISION Constructors, disc receiver, 1/3; mirror receiver, 2 6; illustrated catalogue free.—Ancel Television Co., 230, High St., Camden Town. [3566]

VALVES.

EPTON Leads Again! Latest types of battery and mains valves in stock. Send for list. Epton, 93, New Rd., Chingford, E.4. [3581]

THE M.R.D. Co. Invite You to Test any of their New Range of British Made Valves. All valves guaranteed six months; carriage paid.

TWO-VOLT Range.—VM SG 7 6; SG 2 7 6; L.F.2, Det.2, HF.2, RC.2, 3 6; Driver, 4 -; Power, 4 6; PEN.2, 10 -; Class B, 1 1/2 watts, 9 -; Class B, 3 watts, 9 6.

A.C. Range, VM SGA, 12 6; SGA, 12 6; DET AC, 7 6; LF AC, 7 6; P AC, 8 6; PEN AC, 15 -. Details and characteristics on request.—Mains Radio Development Co., 4-6, Muswell Hill Rd., London, N.6. [3583]

VALVES. All types American screen grids, etc., in stock; send for quote, Midway Radio Exchange, 24, Midway Grove, London, N.1. [3531a]

ALL Classes of Valves in Stock, including American and non-ring valves; send for price list.—R. Newman, 309, Roman Rd., London, E.3. [3446]

ALL Types of Valves in Stock, including the following brand new American valves, first class makes: 247s, 235s, 224s, 236s, 237s, 235s, 245s, 244s, 12 -; 227s, 226s, 280s, 245s, 9 6; 242s, 232s, 11 -; U.X.210s, 15 -; U.X.250s, 7 watts output, 16 -; 281s, 14/6; post paid, cash with order or cash. Send for valve list.—Ward, 12, Tredegar Rd., Bow, E.3. Tel.: Advance 3668. [3488]

SPECIAL Offer.—Valves by world-famous Continental manufacturers, fully guaranteed, screen grid, variable mu screen grid, high magnification screen grid, low magnification screen grid, H, H.L., L, RC, power, super power, directly heated pentode, directly heated power pentode; all the above standard mains type, 4 6 each; 300v. 60 milliamp. rectifier 5 6, 350v. 120 ma. 6 6, 500v. 125 ma. 7 6; the following 4 volt battery valves at 2 - each, H, H.L., L, power, screen grid, Premier Supply Stores, 20-22, High St., Clapham, S.W.4. Macaulay 2188. [3582]

COMPONENTS, ETC., FOR SALE.

R. SELECTED Parts for Sale, as new, good, or "Wireless World" deposit system, which we recommend if in doubt as to the splendid value offered; we take risk of damage in transit to our customers; goods tested for callers and guaranteed.

"WIRELESS World" Quality Amplifier, to specification, with valves, March 25th, 1931, £7; Baker's super 6v. speaker, cone repaired, 20 -; Magnavox D.C.144, 2,500 ohm speakers, new, Pentode transformer, 22 6; British Radiophone 3-gang condensers, new, with primer cover, disc drive and all fittings, 15 9; Tritron 8 mf. electrolytic, 3 6; Polar 2-gang tubs, 6 6; Polar 3-gang tubs, 10 -.

NEW Output Transformers Similar to R. and A., ratio 18 23 32, 6 -; Telen 0.05 mica condensers, 2 3; T.C.C. 0.01 mica type M, 1 -; new Paxolin formers, 1in., slotted, with guides, 8d.; T.C.C. 2 mf., 350v. working, 1 6; ditto, 1 mf., 1 3, new; T.C.C. 4x4, 250v. working, 4 9.

PAIRS New Polar Twin S.M. Thumb Drive, 0.0005, complete, 12 6; Telen 100h. chokes, 3 -; Westinghouse H.T.4 and A4 rectifiers, with Varley transformers, £2; Clynbon 0.0005 double thumb twin extensr, 15 6; Clynbon single 0.0005 extensr, 7 6; Ready Radio 0.0005 extensr condensers, new, 3 6; Ormond 65 - type P.M. speaker, complete, 37 6.

RADIOPHONE Pats with Switch, 5,000, 10,000, 100,000, 25,000, new, 2 6 each; new type Magna speaker, 2,500 ohm and 5,000 ohm, 42 6 each complete.

FERRANTI Resistances with holder, 3,000, 15,000, 20,000, 2 6 each; Varley Power, 500, 5,000, 10,000, 40,000 2/6 each.

TRANSFORMERS.—Ferranti A.F.4 8 -, A.F.3 12 6, A.F.5 18 6, A.F.5w 21 6, O.P.M.1e 16 6, O.P.M.2 13 -, O.P.M.4e 16 6; B1 choke, new, 13 -; A.F.6 18 6.

EDISON BELL 10,000 Eureka, wire wound, with holders, 1 -; Edison Bell 0.0005 universal log all metal condensers, 1 6, new.

AMPLION Public Address Microphone, £3; Ready Radio Senior Instamat matching transformers, new, 10 25-1, 15 9; G.E.C. Senior induction motor, 47 6; set Colvern battery Super Five coils, 10 - set Colvern single dial super battery coils, 15 -; Mullard H.T. eliminator, complete, 150v. 30 m.a., 240v. input 30 -; Six-Sixty eliminator, 200v. 25 m.a., and G.H., 32 6; Ekco A.C.25, 47/6; Atlas A.C.244, 39/6.

(This advertisement continued in third column.)

ROLA the World's Finest Reproducers

QUALITY Class B for Every Battery Set Owner

No battery set owner need be without the advantages of Class B Amplification. By using a Rola Class B Speaker Amplifier Unit which takes only 5 seconds to connect, the volume of the set is instantly increased about 5 times.

Model A—For MULLARD P.M. 2B, B.T.H. PD 220, COSSOR 220 B, STANDARD 13 B.1, HIVAC B220, MARCONIPHONE B21, G.E.C. B21, CLARION B22. Model B—For COSSOR 240, FERRANTI HP 2, CLARION B 24.

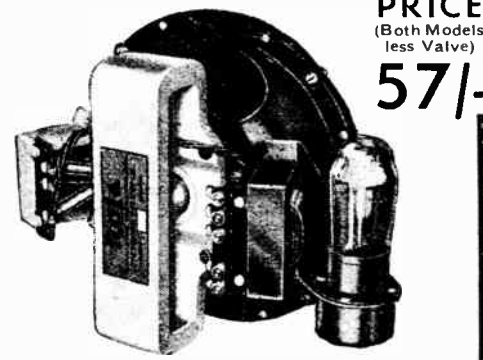

PRICE (Both Models less Valve) 57/-



ROLA CLASS B SPEAKERS

No matter what Class B Valve you are using there is a Rola Class B Speaker to match its characteristics. Like all Rola speakers these Class B Units are unrivalled for realistic reproduction.

For MULLARD P.M. 2B, B.T.H. PD220, COSSOR 220B, STANDARD 13B1, HIVAC B220, MARCONIPHONE B21, G.E.C. B21, CLARION B22.

Table listing Rola speaker models and prices: ROLA FR5-PM-33-Class B ..... 29 6, ROLA FR6-PM-23-Class B ..... 39 6, ROLA F6-PM-23-Class B ..... 49 6, ROLA F7-PM-23-Class B ..... 60 -

For COSSOR 240, FERRANTI HP2, CLARION B24.

Table listing Rola speaker models and prices: ROLA FR5-PM-32-Class B ..... 29 6, ROLA FR6-PM-22-Class B ..... 39 6, ROLA F6-PM-22-Class B ..... 49 6, ROLA F7-PM-22-Class B ..... 60 -

All Prices include Transformer.

THE BRITISH ROLA CO. LTD., Minerva Road, PARK ROYAL, N.W.10.

Phone: Willesden 4322-3-4-5.



ROLA SPEAKERS for better Radio Reception

Components, etc., for Sale.—Contd.

(This advertisement continued from first column.)

PAIR Varley Q.P.P. Input and Output, 19/-; Wearile and Lewcos superhet. coils, 5 -; 3-range oscillators, 7/6; T.C.C. 2,000 mf. electrolytic, 9 -; T.C.C. ditto, 250 mf., 100v., 8 6; Igranic L.F. choke coupling units, 3/9; Lotus new 4-gangs, 15 9.

RYALLS Mains Condensers, 4 mf., 250v. working, 2 6; 4 mf., 500v. working, 4 6; 4 mf., 750v., 6/6; 2,000v., 17 6; Ryalls condenser blocks, 2-4 mf., 2-2 mf., 500v. working, 8 6; Dubilier 2x2, 500v. working, 2 6.

RYALLS Mains Transformers, 250v. 60 m.a., 4v. 1 amp., 4v. 3 amp., 10 6; 350v., 12 9; H.T.7, with 4v. 4 amp., 10 6; 4v. 3 amp. only, 6 9; chokes, 25h. at 60 m.a., resistance 260 ohms, 6 9; 20h. at 100 m.a., 8/9; 10h., 8 9, for Monodial; 40h. at 100 m.a., 10/6.

RYALLS RADIO Offer Reliable Resistances, 1 watt, suitable for all "Wireless World" sets where a 1 watt resistance is specified, in values 100, 500, 1,000, 2,000, 5,000, 6,000, 10,000, 25,000, 30,000, 75,000, 150,000, 250,000, 20,000, all values stated in ohms, 6d. each, guaranteed one year, wire ends, new goods.

WE Hold a Large Stock of First Class Radio Apparatus, meters, resistances, condensers, heavy chokes, and all set requirements, at bargain prices, all modern goods.

RYALLS RADIO, 33, Chancery Lane, London, W.C.2 (nearest Tube Chancery Lane; bus 67 passes door, or tram to Savoy St.), Holborn 3529. Open Saturday afternoon. Close 7 p.m., Thursdays 1 o'clock, Saturday 6 p.m.

R. [3545]

PREMIER.

PREMIER SUPPLY STORES Offer the following Set Manufacturers' Surplus New Goods at a fraction of the Original Cost, all goods guaranteed perfect, carriage paid over 5 - under 5 - postage 6d. extra (Ireland, carriage forward).

ELIMINATOR Kits, including transformer, choke, Westinghouse metal rectifier, T.C.C. condensers, resistances and diagram, 120v. 20 m.a., 20 -; trickle charger 8 - extra; 150v. 30 milliamps with 4v. 2-4 amps. C.T., L.T. 25 -; trickle charger, 6 6 extra; 250v. 60 milliamps with 4v. 3-5 amps. C.T., L.T., 30 -; 200v. 100 milliamps with 4v. 3-5 amps. C.T., L.T., 49 6; 300v. 60 milliamps with 4v. 3-5 amps. C.T., L.T., 37 6.

ROLA Moving Coil Speakers, complete with humbucking coils and output transformer; please state whether power or pentode required; F6, 2,000 or 6,500 ohm, listed 35 -; at 17 6; F7, 2,000 or 6,500 ohm, listed 47 6, at 23 6; A.C. conversion kit for any of above, 10 -.

SPECIAL Offer.—Reisz type microphone with transformer, a really professional job, listed at £12; our price 52 6.

HEAVY Duty Variable Resistances, wound on porcelain, 2,000 ohms 1/2 amp., 500 ohms 1/2 amp., 120 ohms 1 amp., all the above values, 3 6 each.

T.C.C. Condensers, 750v. working, 2 mf. 3 6, 4 mf. 6 -, 4 mf. 400v. working 4 -, 250v. working 1 mf. 1/-, 2 mf. 1 9, 4 mf. 2 6, 1,500v. working Standoff insulators 0.5 mf. 1 6, 2 mf. 6 -, aqueous electrolytic 440v. working, 4 mf. 3 -, 8 mf. 3 6.

DUBILIER Condensers, 0.01 mica, 6d.; 1 mf. 1,000v. working, 1 6.

ALL the Following Lines 6d. each or 5 - per dozen; 4- and 5-pin chassis mounting valve holders; shielded screen grid or pentode leads 1-watt wire end resistances, any value; T.C.C. 0.1 condensers; hum dingers; on-off switches push-pull; polar gauging devices.

POLAR 3-gang 0.0005 Condensers, split end vanes, totally screened disc drive; 6 11.

AMSCO Triple-gang 0.0005 Condensers, with trimmers, 4 11.

KOLSTER BRANDES Gramophone Motors, dual type, can be worked by clockwork or mains, No. 1 induction type 100-250 volts, 27/6; No. 2, A.U. and P.C., 100-250 volts, 27 6; both the above complete with all fittings and turntable.

SPECIAL Offer.—Microphones by prominent manufacturer, high sensitivity, uniform response, complete with stand, transformer and battery; listed £3 15, our price 18 6.

DUBILIER Condenser 300v working, 4+4+2+2+2+0.1 0.1+0.1; 6 -

PREMIER British Made Meters, moving iron, flush mounting, accurate: 0-15, 0-50, 0-100, 0-250 milliamps, 0-1, 0-5 amps., all at 6 -.

ORMOND Condensers, 2-gang semi shielded, 2 6.

WESTERN ELECTRIC Mains Transformers, input 200-250 volt, output 500-560 volt, at 150 milliamps., 4v. 4a., 4v. 2.5a., 4v. 2a., 4v. 1a., 4v. 1a., massive job; 19 6.

T.C.C. Electrolytic Condensers, 100 volts working, 15 mf.; 1 3.

SPECIAL Offer of Mains Transformers, manufactured by Philips, input 100-115v. or 200-250v., output 180-0-180 volts, 40 m.a., 4v. 1a., and 4v. 3a., 4/6; 200-0-200v., 4v. 1a., 4v. 3a., 4/6.

ALL Premier Guaranteed Mains Transformers have engraved terminal strips with terminal connections, input 20-250 volts, 40-100 cycles, all windings paper interleaved.

PREMIER H.T.8 Transformer, 250v. 60 m.a., rectified, with 4v. 3.5a. c.t. L.T. and screened primary, 15 -; with Westinghouse rectifier, 25 -.

T.C.C. 2,000-2,000 Electrolytic, 12 volts working; listed 27 6, at 10 -.

ROLA F5 P.M., 18 6; Rola F6 P.M., 22 6; Rola F7 P.M., 32 -; please state whether power or pentode transformer.

PREMIER H.T.9 Transformer, 300v. 60 m.a., rectified, with 4v. 3.5a. c.t. L.T. and screened primary, 15/-; with Westinghouse rectifier, 26 -.

(This advertisement continued on next page.)



# T. W. THOMPSON & CO.

**SURPLUS CLEARANCE DEPOT**  
17, Strutton Ground, WESTMINSTER, S.W.1.  
Telephone: Franklin 6355.

Nearest Station, St. James's Park (Underground).  
**ALL GOODS ON THREE DAYS' APPROVAL AGAINST CASH OR C.O.D. (L.F.S. EXCEPTED).**

Open Week-days 9 o'clock until 7.30 p.m.  
Another Great Purchase of Surplus Materials, including Manufacturers' Stocks of H.M.V., Yagerphone, Fay Home Recorders, etc.

**FAY "ACOUSTIC" MODEL HOME RECORDERS.**—Comprising tracking device, needle sharpener, fibre needles, and recording diamond stylus, acoustic soundbox and horn, brand new in box. Great amusement for anybody making their own records. Listed 30% to clear 5/- each, post 6d. **ALUMINIUM DISCS READY FOR RECORDING.**—To suit above, 6in. dia., 5/- dozen; 12in. dia., 8/- dozen, post 6d. **FAY RECORD ALBUMS.**—To carry 10in. records, very neat and beautifully covered, 1/- each. **OUR GREATEST BARGAIN** of the Fay Radiogram model, special sensitive microphone, complete with stand and spring suspension, perfect for public address. Large quantity, to clear 10/6, each, new and boxed, post 1/-.

Impossible to repeat at the price. Equal to the Reisz-pattern microphone. On our terms we ask you to try before you buy. **ELECTRIC SOLDERING IRONS.**—200/250 v., best makers, 5/- each. **UNIVERSAL MOTORS.**—1 1/2 h.p. A.C. or D.C. 200/250 volts, 15/6, post 9d. **WEGO CONDENSERS.**—With tappings 3.6 m.f., 500 v., new, 1/6, post 3d.; 8 m.f. Hydra Condensers, 1,000 v., test, 2/6, post 3d. **U.100.**—Balanced armature loud speakers, complete with cone and chassis, 15/6, new and boxed, post 9d. **PRIVATE HOUSE AND OFFICE TELEPHONES.**—Complete units, consisting of pedestal telephone with Receiver, magneto, ringing and battery. All types highly useful for extensions, sick rooms, etc., 12/6 each, post 1/-.

**ELECTRIC LIGHT AND POWER CHECK METERS.**—For A.C. mains, 200-250 volts 50 periods. No more wondering as to the amount this or that article is using. Here is the check on same. Useful for checking consumption of sub-let flats, charging plants motors, wireless apparatus, or anything using electricity. Makers: Westinghouse and other well-known makers. Jewelled pivots. Cost £1.18. We are clearing these at 6/- each, post 1/3. **ONLY 10 OF THESE LEFT OUT OF A TOTAL OF 600**, which we advertised 2 weeks ago. **SECURE ONE BEFORE TOO LATE. ONE OF OUR BEST BARGAINS FOR YEARS. ECKERSLEY TROUGHTON BALANCED ARMATURE SPEAKERS.**—Complete with 12in. chassis and cone, beautiful reproduction, new and boxed, listed 27/6, to clear, 6/11, post 9d. **LAMPLUGH MOVING-COIL SPEAKERS.**—SILVER GHOST, 200-250 volts D.C., listed 27/6, to clear 10/- each, perfect. A.C. model, 22/6, post 1/-.

**PHILIPS CHOKES.**—As used in Philips All Mains receivers. Highest grade nickel iron stamping, special winding. Highly impregnated manufacturers' type, 20, 25 and 30 henrys. Out of many thousands of these, only a few hundred remain. A wonderful offer, far too good to be missed. Many pleasing testimonials received from highly satisfied customers. **ELIMINATOR VOLTAGE CONTROLS.**—Listed 5/6, to clear 1/-, post 3d. **TRANSFORMERS, EKCO.**—All for 200-250 volt input, tapped outputs 350, 0.350 volt 80 m.a., 1 v. 1 amp, and 4 v. 2 amp., 10/6, post 1/-.

**CRYPTO CONVERTERS.**—Input 200-220 volt D.C., output 200 volts A.C., 100 watt, complete with starter and hum-proof smoother. Price £4.15, worth double the amount. **REGENTONE ALL-MAINS TABLE CONSOLE CABINETS.**—Polished walnut, size 19in. x 16in. x 10in., beautifully designed, complete with felt-lined baffle, 10/6, post 1/-.

Owing to the exceptionally heavy demand for these, we would advise an early ordering to avoid disappointment. **D.C. ELIMINATORS.**—200-250 volts input, output 150 volts 30 m.a., 2 pos. tappings, 1 var., all new and guaranteed, 10/6, post 9d.; 3 positive tappings, and variable, 15/-, post 9d. **THESE ALL A POSITIVE SNIFF FOR THE MONEY. BUY ONE WHILEST THEY LAST. COLLARO INDUCTION GRAM MOTORS.**—Latest type, complete with automatic stop and all fittings, boxed and unused, £1 17/6, post 1/-.

**WEGO MOULDED BAKELITE CONDENSERS.**—With terminals, 700 volt test 1 m.f. 1/-, post 3d.; per dozen 10/-; 2 m.f. 1/9, post 3d., per dozen 18/-; 1 m.f. 2/8 each, per dozen 2/3 each. **CONDENSER BANKS, ETC.**—8.25 m.f. T.C.C. tapped 500 v., 2/9, post 3d.; 10.5 m.f. T.C.C. tapped, 3/-, post 4d.; 8.5 m.f. H.M.V. tapped, 2/6, post 1/-; 3.6 m.f. Wego 500 volt tapped, 1/9, post 3d.; 8 m.f. Siemens 700 volt working, 2/6, post 3d.; 4 m.f. Siemens 500 volt, 2/-, post 3d. **FARADIX INTER-VALVE TRANSFORMERS.**—2/6, post 4d. **FARADIX Mains Chokes.**—2/-, post 3d. **CENTRALAB DOUBLE VOLUME CONTROLS.**—Listed 10/6, to clear 2/6, post free. **British Radiophone Controls**, with combined switch, 2/-, post 3d. **PHILIPS 1-WATT RESISTANCES.**—Pull range from 400 ohms up to 100,000, 6d. each, post free. **TO BE CLEARED CHEAP.**—10,000 manufacturers' type Edison Bell small fixed Condensers, sample box, 36 in box, 1/- each, post 3d. **DUR AMESCO 3-GANG VARIABLE CONDENSERS.**—As used in H.M.V. sets with trimmers. Can be dismantled and used as 2-gang, brand new, 9/6, post 6d.

(See Classified Advt. on page 27).

## Components, etc., for Sale.—Contd.

(This advertisement continued from previous page.)

**PREMIER H.T.10 Transformer**, 200v. 100 m.a., rectified, with 4v. 3-5a. c.t. L.T., and screened primary, 15/-; with Westinghouse rectifier, 26/-.  
**PREMIER Mains Transformer**, output 135v. 80 m.a., for voltage doubling, 8/6; 4v. 3-4a. c.t. L.T., 2/- extra; Westinghouse rectifier for above, giving 180v. 30 m.a., 8/6.

**PREMIER Mains Transformers**, output 250-0-250 volts 60 m.a., 4v. 1-2a., 4v. 2-3a., 4v. 3-4a. (all c.t.), with screened primary, 15/-.

**PREMIER Mains Transformers**, output 350-0-350 volts, 90 m.a., 4v. 3-5a., 4v. 2-3a. (both c.t.), with screened primary; 15/-.

**PREMIER Mains Transformers**, output 400-0-400 volts, 100m.a., 4v. 4-5a., 4v. 2-3a., with screened primary; 15/-.

**PREMIER Auto Transformers**, 100-110/200-250 volts or vice versa, 60-watt, 7/9; 100-watt, 10/-.

**SPECIAL Offer of Manufacturers' Type Transformers**, any input, output 250-0-250 volts, 60 m.a., 4v. 1a., 4v. 3a. (both c.t.), 8/6; H.T.8 transformer, with 4v. 3-4a. (c.t.), 8/6; with rectifier, 18/6.

**AMPLION Mains Transformers**, input 100-250 volts, output 350-0-350 volts, 120 m.a., 4v. 5a., 4v. 2a., 6v. 1a. (all c.t.); 17/6.

**FILAMENT Transformers**, polished and engraved terminal boards, N.P. terminals, 4v. 3-4a., 5/-; 10v. 3a., 6/6; 12v. 1a., 5/-; 4v. 4-6a., 6/6; 14v. 4a., 6/6; 22v. 1a., 6/-; 6v. 2a., 5/-; 9v. 1a., 5/-; 35v. 3a., 15/-.

**PREMIER Chokes**, 40 m.a., 25 hys., 4/-; 65 m.a., 30 hys., 6/-; 150 m.a., 30 hys., 10/6.

**PYE Chokes**, 20 or 32 hys., 4/-; Premier multi-ratio output transformers, giving 15 different ratios, 7/6.

**PREMIER Eliminators**, input 200-250 volts, 40-100 cycles, A.C., incorporating Westinghouse metal rectifiers, output 250v. 60 m.a., S.G. and 120v. taps, 42/6; with 4v. 4a. c.t. L.T., 7/6 extra.

**BRITISH RADIOPHONE Wire Wound Potentiometers**, with mains switch incorporated, 5,000 ohms, 10,000 ohms, 50,000 ohms, 100,000 ohms., 250,000 ohms, any value; 3/6.

**PREMIER Eliminators**, output 150v. at 30 m.a., S.G., and 100v. taps, with 4v. 3-4a. c.t. L.T., 37/6; or with trickle charger, 42/6.

**PREMIER Eliminators**, output 120v. at 20 m.a., S.G. and 100v. taps, 27/6; with L.I. trickle charger incorporated, 35/-.

**PREMIER D.C. Eliminators**, output 120v. at 20 m.a., S.G. and 100v. taps; 15/-.

**ACCUMULATOR Chargers**, 200-250 volts A.C., all incorporating Westinghouse metal rectifiers; 2, 4, and 6v. at 1/2 amp., 12/6; 2, 4, and 6v. at 1 amp., 17/6; 12v. 1a., 27/6; 6v. 2a., 35/-; 12v. 2a., 35/-; 12v. 1.5a., 30/-; 6v. 3a., 39/6; 30v. 1a., 42/6; 50v. 1a., 62/6.

**AMPLION High Inductance Chokes**, resistance 2,500 ohms, 80 henries, 60 m.a.; 5/6.

**WESTINGHOUSE Metal Rectifiers**: 120v. at 20 m.a., 6/6; 180v. at 30 m.a., 8/6; 8v. at 1/2 amp., 6/6; 6v. at 1 amp., 9/6.

**B.T.H. Induction Type (A.C. only) Electric Gramophone Motors**, 100-250v.; 30/- complete.

**AMPLION Moving Coil Speakers**, type E.M.644, dual fields, 2,500 and 5,000 ohms (100 and 200v.), with output transformer, 12/6; A.C. conversion kit for this speaker, 10/- extra.

**WESTERN ELECTRIC Condensers**, 250v. working, 1 mid. 6d., 2 mid 1/-; 500v. working, 1 mid., 1/-.

**T.C.C. Condensers**, 250v. working, 4x4x1 mid., 3/6; 6x4x2x2-2 mid., 375v. working, 6/11; 4x4x1, 6/-.

**SPECIAL Offer of Wire Wound Resistances**—4 watts, any value up to 10,000 ohms, 1/-; 8 watts, any value up to 15,000 ohms, 1/6; 15 watts, any value up to 50,000 ohms, 2/-; 25 watts, any value up to 50,000 ohms, 2/6; 50 watts, any value up to 50,000 ohms, 3/6.

**WIRE Wound Potentiometers**, 15,000 ohms, 1/6; Centralab Potentiometer volume controls, 50,000 ohms, 2/-; Colvostats, logarithmically wound Potentiometers, 6,000 ohms, 1/9.

**FOR Callers Only.**—The following valves, guaranteed new:—

**THE Last Few Western Electric 3211-D Valves**, 10v. 3a. filament, 750-1,000v. plate, 50-65 m.a., impedance 3,500 ohms, amplification factor 12; cost £5, to clear at 15/-.

**PHILIPS 328 Valves** for L.T. Charging, 5/6; 329 Barretter lamps, 2/-.

**HARLEY Pick-ups**, with arm and volume control; 12/6.

**PREMIER SUPPLY STORES**, 20-22, High St., Clapham, S.W.4, Macaulay 2188. Closed 1 o'clock Wednesdays, open to 9 o'clock Saturdays. Nearest Station, Clapham North Underground.

**PREMIER**, [3576]

**GILBERT INDUSTRIES, Ltd.**—Latest offer of parcels and components:—

**COMPLETE Kit** for 30 m.a., 150-180 volt A.C. Eliminator, comprising the "B" paired as under, together with handsome cellulose finished steel case, engraved panel, plugs, wire, sleeving, solder, nuts and bolts, flex, plug, etc., and constructor's blue print all components specially colour-coded to facilitate assembly; a 25 S eliminator for only 30/-, post paid.

**A** Parcel, containing 1 steel chassis with valve holders, 1 heavy mains transformer 350v.-0-350v. at 60 m.a., 4v. 6a., c.t., 4v. 2a., 1 Amesco 2-gang with trimmers, and two coils, 1 8 mfd. condenser, 1 screened H.F. choke, 1 volume control 1 smoothing choke 50h.50 m.a.; complete parcel, post paid, £1.

(This advertisement continued on next page.)

"Amazing Success" says the critics of the H.S.P.

Radiogram. **H.S.P.**

# RADIOGRAM

**25 GNS.**

WITH GARRARD AUTO RECORD CHANGER

As Illustrated.

A product of outstanding performance and merit.

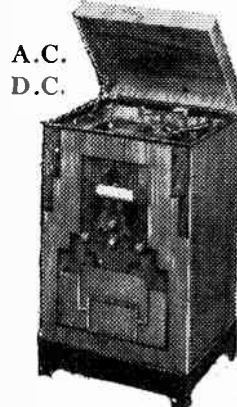

Send for Illustrated Lists.

Name

Address

We are Actual Makers. Handsome Cabinet, Radiogram plays eight tunes, Coil Speaker. Agencies vacant.

**H.S.P. WIRELESS CO. LTD.**  
Langford Works, Weston-Super-Mare.

## TURN YOUR D.C. TO A.C. THIS SIMPLE WAY...

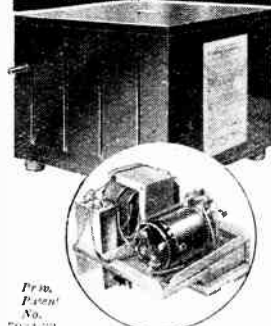

All the best Receivers are made for A.C. Power. The "NO-RO-CO" (non-rotary) Converter enables you to run A.C. sets from D.C. Power mains immediately. Works on voltages from 200-250. Operates sets from 2-valve to 9-valve. Fitted with specially made ball-bearing motor with automatic switch and cut-out. Noiseless and safe. Fully guaranteed. Can be installed by a novice in a few minutes. Revolutionary in practice and revolutionary in price. Send for fully descriptive leaflet.

### THE "NO-RO-CO" CONVERTER

Phone: Central 3813.

**THE WILROSE CO (BHAM) LTD**  
47-CORNWALL ST. BIRMINGHAM

£5.19.6

Cash with order. Money refunded if not satisfactory. Trade enquiries invited, invaluable to dealers on D.C. mains.

**BAKER** WRITE NOW FOR OUR NEW BOOKLET & SPEAKERS.  
75-77 SUSSEX ROAD, CROYDON SURREY  
Phone: Croydon 2441-2  
FOR QUALITY MOVING-COIL SPEAKERS.

## STOP PRESS

The Heyberd 752 Choke has been specially selected and specified for the "W.W." D.C. SUPERHET—for perfect smoothing! It costs only 12/6 with case and terminals. Immediate delivery from stock.  
**F. C. HEYBERD & CO., Mains Specialists,**  
10, FINSBURY STREET, LONDON, E.C.2

Mention of "The Wireless World," when writing to advertisers, will ensure prompt attention.

# FELIX

CHEAPEST PERFECT CONTACT

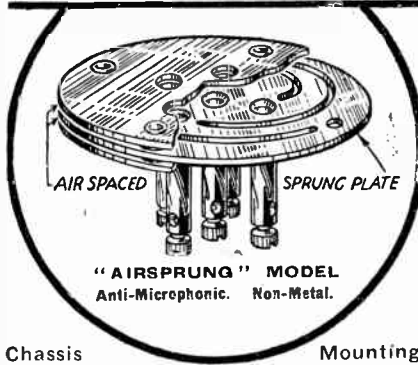

"AIRSPRUNG" MODEL  
Anti-Microphonic. Non-Metal.

Chassis Mounting

## VALVEHOLDERS Specified for the D.C. SUPERHET

Clix New "Airsprung" Anti-microphonic Valveholder is designed to—

- Damp out actual physical shocks to the valve.
- Insulate the valve from consistent vibration set up by the transformer on the chassis.
- Counteract and absorb the air pulsations set up by the increased acoustic output of modern receivers.

ANTI-MICROPHONIC	
4-pin	12
5-pin	13
STANDARD TYPE	
4-pin	8d.
5-pin	9d.
FLOATING TYPE	
7-pin	1-

"A MATTER OF CONNECTION."  
Clix New Folder "W" gives details of over 30 Perfect Contact Components. Write for a copy now.

Lectro Linx, Ltd., 79a, Rochester Row, S.W.1

## For PERFECT VOLUME CONTROL — WATMEL POTENTIOMETERS

Our Policy this year is to specialise in Potentiometers. You can therefore be certain when purchasing a Watmel Potentiometer that you are obtaining the very best from a firm that is concentrating on this type of component.

This resistance meets with the requirements for a volume control which will have an equal variation of volume for the rotation of the knob. This is specially important for the control of the grid bias of the new variable-Mu valves.

Here is illustrated the Watmel Type 2 Potentiometer with mains switch.

Price.  
Square Law Winding 8/6  
Without Mains Switch 6/6  
Type 1.

Standard Winding 5/6  
Special models made for manufacturers and for the Export Market.

Please write for the interesting Watmel book on volume control! Free

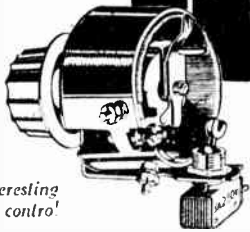

WATMEL WIRELESS Co. Ltd., Imperial Works, High Street, EDGWARE. Telephone: Edgware 0323

### Components, etc., for Sale.—Contd.

(This advertisement continued from previous page.)

"B" Parcels, suitable for building Class B or straight 30 m.a., 150-180 volt A.C. eliminators; containing 1 Westinghouse rectifier, voltage doubler, 1 choke 50h-50 m.a., 4 resistances (please state mains voltage); complete parcel, post paid, £1.

"D" Parcels, containing 1 steel chassis, with valve holders, 1 heavy mains transformer 350v.0 350v. at 60 m.a., 4v-6a. e.t., 4v-2a., 1 Amso 2-gang with trimmers, 1 15-mfd. T.C.C. electrolytic, 1 4x4 mfd. H.M.V. block condenser, 1 volume control, 4 assorted resistances, 6 small assorted condensers, 1 Paxson strip (10m. x 4in.), 1 packet of Varox skewing, 6yds. heavy flex; complete parcel, post paid, £1.

R.S.3 Mains Transformers, as in "A" parcel, 12 6; heavy pattern P.M. nice speakers 25 -; full volume and tone; B.P.H. minor pick-ups, latest pattern, 25 -; Pathfall type 1504 electric gramophone motors, 100-150 volts, with turntable, 25 -.

ONE "A," "B," or "D" parcels and any one 25/- article for £2, post paid.

TRADEPS.—Do you realise that these parcels, when split up, will realise £3 to £4 in the shop?

GILBERT INDUSTRIES, Ltd., 519, London Rd., West-chilton-sea.—We are open to callers Sunday mornings. —Phone: Southend 492071. [3537

M.R.D. Co. Offer Guaranteed Surplus as Last Week; 10% discount on orders over 10 -; also the following:

CABINETS. Exceptionally handsome upright polished walnut, to take set speaker, and chrome clock, with beautiful clock; 19 6.

ELECTROLYTICS. Dubilier 8 mf. 450v., 3 8. Mains Radio Development Co., 4-6, Muswell Hill Rd., London, N.6. [3577

SOUTHERN RADIO'S Wireless Bargains.—Set manufacturers' guaranteed surplus.

MAINS Transformers.—250.0-250 volts 60 m.a., 4v. 1a., 2-3a., 4v. 1a., 12 -; 250.0-350 volts 60 m.a., 4v. 2-2 1/2 a., 4v. 2 1/2 a., 13 6; 350.0-350 volts 120 m.a., 4v. 2-2 1/2 a., 4v. 3-5a., 4v. 1a., 16 -; 500.0-500 100 m.a., 4v. 2 1/2 a., 4v. 3-5a., 4v. 2a., 19 -; step-up or step-down transformers, 0, 100, 110, 200, 250 and 250 volts, 60 watt output 12 6, 100 watt output 14 9.

SMOOTHING Chokes, 20 henrys, 120 m.a., 320 ohms, 12 9; 50 henrys, 60 m.a., 500 ohms, 7 8; 40 henrys, 40 m.a., 700 ohms, 6 6.

A.L. Mains Transformers and Chokes Guaranteed for 12 Months—specials quoted for and delivery given within 3 days of order.

VARIABLE Condensers.—British Radiophone 4-gang superhet, type 0.0005, 8 9 (list 45 -); same with dial knob and escutcheon, 12 9 (list 50 -); Polar 3-gang 0.0005, complete with dial, knob, escutcheon, 11 - (list 25 -); Lotus 2-gang 0.0005, complete with dial, knob, escutcheon, 8 6; all ganged condensers are fully screened, with trimmers and boxed; Hydra block condensers, new, 16 mfd., 2-2-8-2-1-1, 1,000 volt test, 7 - each; 4 mfd., 2 6; 2 mfd., 1 9; 1 mfd., 1 -.

SPEAKERS. Celestion Soundex permanent magnet, 16 - (list 27 6); Rola F6 permanent magnet, 28 - (listed 49 6); D.C. mains energised, 2,500 to 6,500 ohms, complete with humbucking coil and transformers, 16 6 (list 39 6); G. E. C. Stork speakers, complete in magnificent cabinet, 19 6 (listed £3 15); Ormond speakers, complete in cabinets, 10 - (listed 25 -); Utah D.C. mains energised pentode or power, 9in. cone 21 -; 5in. cone 13 6; ultra-permanent magnet speakers, 95 P.M., 35 -, each, a really hefty job (listed £4 15).

CONSTRUCTORS' Kits.—Ready Radio "303" battery 3-valve kits, less valves, 18 - each; complete with 3 Mullard valves (P.M.11.F., P.M.2, 21X.1), 33 - each (list 70 -); Ready Radio Meteor screen grid 3-valve kit, less valves, 26 -, with 3 Mullard valves (P.M.12a, P.M.20.X., P.M.2a), 49 - (list 45 7 6); Universal Radio 3-valve kit, ready assembled on chassis, 12 6 (list 45 -).

READY RADIO S.T.400 Kits, as specified by Scott Taggart, £2 19 6 each (list £4 17 6); Mullard Radio for Million 3-valve A.C. kit, complete with 3 Mullard A.C. valves (Pen.4V, 354V, 84V), £3 10 (list £6 10); Mullard Radio for Million 3-valve battery kits, complete with 3 Mullard valves, £3 3 (list £6 2 6), all kit brand new in original sealed cartons.

B.P.H. Senior Pick-ups, 1934 model with volume control 28 - each (list 37 6); 6 only, B.P.H. Junior pick-ups, 17 5 (list 25 -); British General Band Pass tuning units, 10-K.C. aerial or anode, 5 - each (list 14 6); Lotus triple coil Band Pass units with universal switching, 18 6 per set.

RECEIVERS. Lotus A.C. mains 3-valve (actual), with Magnavox, M.C. speaker, complete with valves, in magnificent cabinet; £6 19 6 (list £21).

A.L. Goods Guaranteed New and Perfect and Sent Carriage Paid.

PLEASE Note.—We have opened branches at 271-275, High Rd., Willesden Green, N.W.10, and at 46, Lisle St., W.C.2, where callers are cordially invited to inspect our large stock of wireless bargains. Please send all post orders to 323, Euston Rd., N.W.1.

SOUTHERN RADIO, 323, Euston Rd., London, N.W.1 (near Warren St. Tube). —Phone: Museum 6324. [3571

WEST END RADIO STORES.—A few more genuine bankrupt stock bargains:—

"FAY" Home Recorders, complete with diamond cutting stylus, etc., 5 6. list price 31 6; Fay microphones with stand, transformer, complete, 25 -; list price £5 3.

BLANK Aluminium Records for "Fay" Recorders, 6 inch 30, 9 inch 64; all "Fay" goods are new and boxed.

BRITISH Transformer for I.L.T.8, 200v. 120 m.a., 4v. 3a., and 4v. 1a., 6 6; Heybird 350.0 350v. 60 m.a., 4v. 4a., 4v. 2a., 6 6.

T.C.C. Type 80 4 mfd. bands, 400v. working terminals, 3 6; ditto, 250v. working, 2 6.

(This advertisement continued on next page.)

# SCOTT SESSIONS for

"WIRELESS WORLD" SETS

completely constructed with fine workmanship.

## OVERHAULS RE-BUILDING

## OR MODERNISATION

TO ANY EXISTING SET

Many thousands of "W.W." readers have profited from our specialised experience during the last seven years.

Write to us now and tell us about your requirements or your radio troubles.

Our advice and estimate is free of charge.



Monodial Construction and Servicing Experts.

# SCOTT SESSIONS & CO.,

Radio Engineers and Consultants, MUSWELL HILL, LONDON, N.10

Cables: "Tropiset, London."

Contractors to H.M. Government, Depts., &c.

## "SHAKEPROOF" LOCK WASHERS

AND LOCKING TERMINALS. Used by all the Leading Set Manufacturers—

The twisted teeth bite into the metal and prevent "slacking off." The more the vibration, the tighter they grip.

ASK YOUR DEALER FOR "SHAKEPROOF."



Manufactured by BARBER & COLMAN LTD., Brooklands, MANCHESTER.

Dealers and factors enquires to Wm. CLARK (Spare Parts) Ltd., 5, Marshalsea Road, London S.E.1.

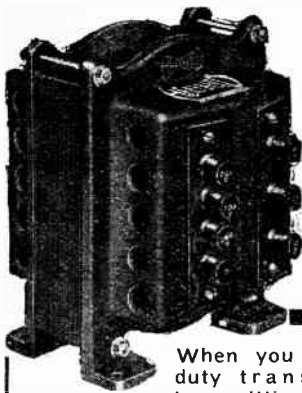

**Do you want a big output ?**

When you require heavy duty transformers for transmitting, for amplifier power units or for battery charging—let Heyberd the Mains Specialists help you. There are many large-power models in the Heyberd range and any model can be made to specification. Here is a popular transformer suitable for a Power Amplifier.

**HEYBERD 806 TRANSFORMER (Valve Rectification). Secondary Output: 500 500v. 120 ma. L.T. 2-2v. 2! 3! amps. 2! 2v. 5 6 amps. and 2! 2v. 2 amps. Price 65/-**

(A special circuit diagram, and kit of parts, incorporating this Transformer, is given in the Handbook.)

**STAND 39 MANCHESTER**

Enclose 3d. stamps. By return please send me the Heyberd Handbook. Packed with diagrams, hints and details of mains apparatus.

M. \_\_\_\_\_  
Address \_\_\_\_\_ W.W.

**F. C. HEYBERD & CO.,**  
10, FINSBURY ST., LONDON, E.C.2



One minute from Moorgate Stn.

## NOW READY

### The "D" Model

# PRIMUSTATIC

## ELECTROSTATIC SPEAKER

Size 14" x 16", designed for use as a Dual Speaker to work in combination with a moving Coil.

**PRICE 25/-**  
Complete in Chassis Case

**STANDARD MODEL**  
Size 18" x 20", supplied in Cabinet only. **PRICE 40/-**

The world's greatest authorities describe the Primustatic as indispensable for perfect reproduction.

Send P.O. or Money Order to **PRIMUSTATIC SALES**  
Primus House, Willow Street, London, E.C.2.

### Components, etc., for Sale.—Contd.

(This advertisement continued from previous page.)

**MARCONI** 555 Walnut Radio-gram Cabinets, perfect condition, 35/-; carriage fwd.; also large models at £3.

**GENUINE N. & K. Inductor Junior**, list price 55/-, 19 6 new; Psychon 3 valve A.C. set with energised moving coil, valves, complete, £5/15.

**EDISON BELL R.C. Units**, 1 6; Eureka wire wound resistances, with holders, 9d. each.

**AFEW** Only 4- and 5-valve Midget Super-het Sets for 100-250v. A.C. or D.C.; from £5.

**T.C.C.** 8.25 Tapped Condenser Banks, 250v. working, 2 6; Wates 2 watt resistances, 20,000 ohms to 5 meg., 3d. each.

**HUNDREDS** of Special Bargains for Callers, carriage extra on all orders.—West End Radio Stores, 14, Lisle St., Leicester Sq., and at 382, Coldharbour Lane, Brixton. [3553]

**B.T.H.** Senior P.M.M.C., 50/-; Ferranti AF.5C., 20/-; OPM.A.C., 12/-; 227, Chamber Rd., Oldham. [3543]

**CHAL-ELECTRIC** Offers New Set Manufacturers' Surplus, all carriage paid; cash with order, or c.o.d.

**VARIABLE** Condensers.—J.B.Nu Gang (3-gang), complete with disc drive, covers, trimmers, escutcheon, light knob, etc., 17 6; 2-gang, fitted as above, 9 6; Polar Star (3-gang 1933), complete, fitted as above, list 30 6, at 18/-; Uniknob 2-gang, fitted as above, complete, 10/-; Utility 2-gang, fitted as above, 8 6.

**COILS** (6 sets each only).—Colvern Ferrocart, F1, F2, F3, ganged, 32/-; Varley Ni-core (1), B.P.30 and 2B.P.31, 28/-; Varley sets, B.P., 19 ganged, 25 6.

**SMOOTHING** Condensers.—C.E.C. Murphy, etc., 800 test 250 A.C. working, 1 mfd. 1 1, 2 mfd. 1 9, 4 mfd. 2 6; all the following 1,500 D.C., test 500 A.C., working 800 peak, 1 mfd. 1 9, 2 mfd. 2 4, 4 mfd. 4/-; Multiple Banks all, separate tappings, 20 mfd., 4+4+2+2+2+2+1+1 at 11/-, 11 mfd., 4+2+2+2+1, at 6 9.

**MAINS** Transformers and Chokes.—Philips 250-0-250 at 75 ma., 4 volts 1 amp., 4 volts 5 amps., 11/-; chokes for same, 30 henry, 75 ma. (300 ohms), 6 9.

**ASK** for Special Quotation for Anything You May Need.—Chal-Electric, No. 6, Conduit St., London, W.1. [3525]

**EBURY BRIDGE RADIO** Offer the Following Stupendous Bankrupt and Set Manufacturers' Surplus Bargains:

**A.C. Eliminators**, 200-250v., output 150v. 30 ma., 3 pos. tappings, Westinghouse rectified, guaranteed, 28 6; 2 pos. taps, 25/-; post 1 3; also 100-110v.

**D.C. Eliminators**, 200-250v., output 150v. 30 ma., 3 pos. taps, 12 6; 2 pos. taps, 10/-; post 9d.

**GENUINE** Reisz P.A. Microphone, 52 6; transformer 5/-; nickel plated stand, rubber suspension with oxidised base, 12 6, post 1/-.

**SPECIAL** Offer of Ebury Electric Clock Movements, 200-250v., 50v., write full detail: 16 6, post 6d.

**ROLA** F.6 Moving Coil Speakers, 6,500 ohms, 14/-, post 1/-; 200-250v. A.C., 24/-, post 1 3.

**H.M.V.** 5-watt 2-valve A.C. Amplifier, complete, less valves; wonderful bargain, 60/-.

**EX** Ekco Mains Transformers, suitable for rowant III, tapped 200-250v. input, outputs 350-0-350v., 70 ma., 4v. 2a., 4v. 3-4a., r.t., 9 6, post 9d.

**EX** Ekco Heavy Duty Smoothing Chokes 50 henry at 50 ma., C.I., 5 6, post 6d.

**PYE** Mains Transformers, 200-250v. input, 135v. 80 ma., 4v. 4a., r.t., 5 6, post 9d.; smoothing chokes, 30h., at 30 ma., C.I., 3 9, post 9d.; 600 ohms

**UTILITY** 0.0005 Var. Condenser, with S.M. drum dial and Escutcheon plate, new, boxed; 5 6, post 6d.

**CONDENSER** Bargains.—T.C.C. 3 mfd. 800 v. working, as new, 5/-; T.C.C., 9 mfd. (4+4+1) 250v. working, as new, 3 6, post 6d.; Siemens 4 mfd. 250v. working, 2 7; Hydra 2 mfd., 250v., working, 1 6; Wego 2 mfd., 1,000v., working, 1 9; Wego 2 mfd., tapped for auto G.B., 1 3, postage 4d.

**CHASSIS** Mounting Valve Holders, 4 5 pin, 3d. each, 2 6 dozen post 2d.; Loewe 4-watt vacuum resistances, 50,000 and 100,000 ohms, 9d. each, post 1 1/2d.

**EBURY BRIDGE RADIO** Co., 33, Ebury Bridge Rd., S.W.1, Near Victoria Station, (No. 11 Bus to Ebury Bridge.) Sloane 8407. [3578]

**UNIT** RADIO.—Universal short wave adapter on metal chassis, in cabinet; price 37 6; send for particulars, Unit Radio, 12, Pulteney St., London, N.1. [3547]

**SPECIAL** Clearance Bargains.—Projectors (9, 16 and 35 mm.), 30/-; Cameras, from 20/-; everything for Movies, Walkies and Talkies; inspection invited.

**ILLUSTRATED** ENTERPRISES, 159, Warburton St. (facing Film House), London, W.1. Phone: Gerrard 6889. [3094]

**FERRANTI** "Minimax" 3 kit valve and cabinet, 45/-; A.F. 6, 15/-; parcel components, 4/-; A.C. Pen., 9/-; Bryant, 2, Smith Ridgway Place, Wimbledon, S.W.19. [3554]

**EPTON** Leads Again!—R. and A. multi-ratio output transformers, power or pentode (32-1, 23-1, 18-1), centre tapped; 6 6; see also "Cabinets" section, and send for

**EPTON'S** Radio Bargain Bulletin, 93, New Rd., Chingford, E.4. Phone: Silverthorn 1427. [3579]

**ONE** Watt Carbon Type Resistances, all values, from 500 ohms to 1 megohm, 1 1/2d. each, or 1/- per dozen, plus postage; special prices for large quantities.—Box 8128, c/o The Wireless World. [3504]

**MILLIAMMETERS** moving coil, 60-0-60, Siemens, 7 6; telephone handcombs, second-hand, 2 7, postage 6d.; terminals, new 6B.A., nuts, washers, 8 1/2 doz., postage 3 1/2.—Beaton, Chalk Farm Rd., N.W. [3558]

**MOVING** Coil Milli-Ammeters, 0-50, 10 6 each; 2 milliamps and 120v., 17 6 each; other ranges in stock; alterations, repairs of every description.—The Victa Electrical Co., 47, High St., Battersea, S.W.11. [0355]

**CONSTRUCTORS**.—Latest kits, components and accessories, sent carriage paid; three valve kits from 25/-, six valve super-het kits from 95/-, enquiries invited, prompt, personal attention.—Aldridge, 29, Chatterton Rd., London, N.4. [3570]

## 3,000 MILES WITHOUT A HITCH

Over 3,000 miles of good and bad roads without giving the slightest trouble. That is the record of the Amplifying equipment fitted to the "Daily Mirror" Coach for the recent tour. The Amplifiers were standard in all respects, and show that the Tanno Slogan "INDIVIDUALLY BUILT—NOT MASS PRODUCED" means utmost reliability. For sound equipment for all purposes—



**GUY R. FOUNTAIN, LTD.,**  
Canterbury Grove, West Norwood,  
LONDON, S.E.27. Phone: Streatham 6730.

**Gripshell Aerial Brackets** are simple and economical to install and avoid unsightly poles. Write for leaflet to:—  
**PARRIDGE WILSON & CO.,**  
Dept. 29, Davenset Works, Leicester.

## HOW to HALVE YOUR H.T. BILL

Many thousands of listeners in all parts of the country have banished the bugbear of costly H.T. by installing the wonderful Sac Leclanche Wet H.T., the permanent battery that lasts for years. The Sac Leclanche Battery consists of a number of high-capacity cells in neat glass containers. The cells are self-regenerative and any slight current drop is made up when not in use. Popular Battery, 120 volts, No. 3 cell, 12,500 milliamps. Price, complete with chemical, etc., £2, carriage paid. Send for full particulars. All spares for Standard Batteries supplied. **THE WET H.T. BATTERY CO.,** 26 Lisle St., London, W.C.2. Phone: Gerrard 6121

SEND FOR LITERATURE OF

**Lamplugh Radio Ltd. Coventry.**  
**Silver Ghost Reproducers MASTERS OF SOUND**

## ELECTRADIX BARGAINS

Write for New Sale List "W"  
**ELECTRADIX RADIOS,**  
218, Upper Thames Street, E.C.4.

**TRANSFORMER AND CHOKE STAMPINGS, INSTRUMENT AND RESISTANCE WIRES.**  
Lists Free  
**LUMEN ELECTRIC CO.**  
9, SCARISBRICK AVE., LITHERLAND, LIVERPOOL, 21

**Components, etc., for Sale.—Contd.**

**T. W. THOMPSON and Co.,** 14-17, Stratton Ground, Westminster, S.W.1.  
**ELECTRIC** Clocks for A.C. mains—11in. dial, 27/6; 5in. dial, Boudoir type, 25/-. Movements only, 17/6, post 9d. Large condensers, half microfarads—10,000 volt, 10/6 each.  
**BROWN'S** Metal Eliminator Cases.—Size 10 1/2 in. x 6 in. x 5 in., 9d each, post 6d. Out of many thousands only a few hundreds remain. Secure one whilst they last.  
**MAINS** dropping resistances.—592 ohms 40 watts, reducing from 200/250 volts to 15 volts 1/2 amp, 2/- each, post free.  
**BOXES** of Assorted Screws—1 gross in each. Always useful, 6d. per box, post 3d.  
**DARIO** Intervalve Transformers, ratio 3-1, 4-1 and 5-1, 1/6 each, post 3d.  
**HUNDREDS** of Other Items in Oddsments Too Numerous to Advertise. Enquiries promptly dealt with. An early visit to our shop is advised. Promptness and courtesy our motto.  
**T. W. THOMPSON and Co.,** 14-17, Stratton Ground, Westminster, S.W.1. (See Bargain advertisement on page 24.) [3583a]

**COSMIC RADIO SERVICE,** 23, Water St., Liverpool.—J.B. 3-gang screened, 11/-; Nugang 2, 8/-; Nugang A1, 9/-; ultra pickup, £1; O.T.2 coils, 5/-; Varley Square Peak coils, 5/-; Ferranti A.F.50, 14/-; A.F.3, A.F.4, 9/-; O.P.M.10, O.P.M.30, O.P.M.6, 8/-; B7, 8/-; postage extra. [3542]

**LIQUIDATING** Edison Bell Gramophone and Radio Stocks; bargains; 20 amplifiers up to 40 watt, 30 field supply rectifiers, 5 exciter lamp supplies, 12 Photo-cell 2 valve amplifiers, 80 voltage regulators, 80 Pkassy 5-gang condensers, 40 pickups with arms, copper coil winding wire, radio sets and gramophones; all at bargain prices; ask for list.—Engineer, Edison Bell Works, Glen-gall Rd., London, S.E.15. [3497]

**MODERN RADIO.** Refer to last week's half-page advert. on page 5 for some of the most outstanding bargains yet offered! Swift Levick permanent magnets, 1in. pole piece, cap about 40 thousandths, 3/6; 1 1/2 in. magnet 6/-; 5/1, 1 1/2 in. 9/6, 5/1, 10/6; a large stock still available of Philips resistances, transformers, block condensers, chokes, etc. Modern Radio, 25, York Terrace, London, S.W.4 (near Clapham North Tube). [3574]

**H.D. RADIO ELECTRICAL SERVICE** Offers Surplus of a Set Manufacturer, every article guaranteed new. Moving coil speakers; Magnavox, type D.C.144, 2,500 or 7,500 ohms, with Multi Ratio transformer, at 18/-; type D.C.142, same voltages, at 25/-, complete with universal transformer; Sonoherd, all voltages, F.S. type (state requirements), list 25/-, at 17/6, with Universal transformer. Pick-ups, G.E.C., complete, list 27/6, at 15/-; variable condensers, J.B. Nu-gang, complete in every detail, disc drives, 2-gang 10/5, 3-gang 17/6; all goods carriage paid; cash with order or C.O.D.; orders only between 1 and 6 p.m.—H.D. Radio Electrical Service, 31, George St., Banover Sq., London, W.1. [3459]

**CLASS "B" COMPONENTS.**

**SOUND SALES, Ltd.,** for Class "B" Components. List "B.B." on request.—Trenlett Grove, Highgate, N.19. [0401]

**MISCELLANEOUS.**

**EASY** Payments.—We supply, by easy payments, components, accessories, and sets, any make; 10% down, Balance spread over 11 months.—Send list of requirements to London Radio Supply Co., 11, Oct Lane, London, E.C.2. [0237]

**ENGINEERS** and Technical Workers of All Kinds.—A proper training by post in your spare time will take you through your right examination, the employment is waiting. Our advice on all careers free.—Dept. 92, The Bennett College, Ltd., Sheffield. [0395]

**AMBITIOUS** Men.—Qualify for a well-paid post by studying at home with the T.I.G.B. Write to-day for "The Engineer's Guide to Success," 144 pages, free, which contains the wisest selection of engineering and wireless courses in the world, and shows you how to become A.M.I.E.E., A.M.I.Mech.E., A.Rad.A., etc. State branch, post, or qualification that interests you.—The Technological Institute of Great Britain, 82, Temple Bar House, London, E.C.4. (Founded 1917, 19,000 successes.) [3398]

**PATENT AGENTS.**

**A. MATHISEN, B.Sc.,** Patent Agent and Consulting Electrical Engineer, First Avenue House, High Holborn, London, W.C.1. Holborn 8950. [3496]

**PATENTS** and Trade Marks, British and Foreign.—Gee and Co. (H. E. P. Gee, Member R.S.G.B. and A.M.I.R.E.), 51-52, Chancery Lane, London, W.C.2. 'Phone: Holborn 1525. [0601]

**REPAIRS.**

**REPAIRS.**—Rebuilding to any set; highest quality work only; lowest charges; estimates given free; distance no object.—L. Eastwood, Radio Manufacturers' Consultant, late of His Master's Voice and Marconi Wireless Telegraph Co. Telephone: Clerkenwell 4520. Address: 70, Pittfield St., Hoxton, N.1. [3544]

**GUARANTEED** Repairs by Experts; specialists for repairs to S. G. Brown and Amplion radio apparatus, also loud-speakers, headphones, pick-ups, Blue Spots, any type rewound, remagnetised and adjusted; 4/-; post free; mains transformer repairs; terms to trade.—Howell, 91, Morley Hill, Enfield, Middlesex. [9716]

**REPAIRS** to Loud-speakers, transformers and headphones, 4/-; Blue Spots or Wufas, 5/-, post free; moving coils a speciality, new cones fitted; eliminators and mains transformers quoted for; prompt service; satisfaction guaranteed; discount to trade.—Lond Speaker Repair Works, 5, Balham Grove, London, Battersea 1321. [0394]

**TUITION.**

**QUALIFIED** Radio Engineers are Always in Demand, and our Home Study Course will enable you to qualify for a good post; many students already placed this season; prospectus free.—Northern Counties Wireless School, Preston. [0399]

**EXCHANGE.**

**EXCHANGE** Your Set or Components for New; best allowance.—Radio Exchanges, 114, Ritzway Drive, West Histon, Sec. [3556]

**HIGH** Allowances Made on Second-hand Goods in Part Payment for New Sets or Components; easy payments available; we have tremendous stocks tested second-hand goods; send list of your requirements for quotation.—Bostock and Stonnill, 1, Westbourne Terrace, S.E.23. [3509]

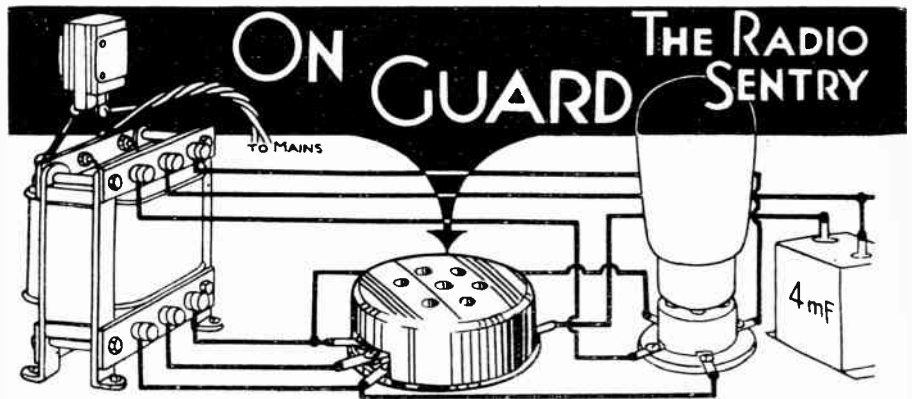

**LETTERS PATENT**  
No. 371,018.

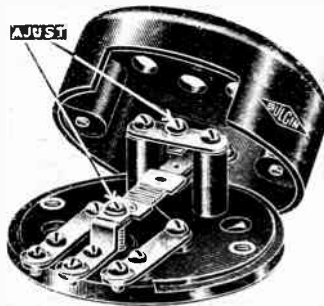

**BULGIN THERMAL DELAY SWITCH**

Delays the application of H.T. to valves, until full emission is attained. Prevents production of peak voltages and damage to condensers, etc. New Seasons models fitted with adjustable contacts for any time period. The types listed cover every A.C. and D.C. requirement and will switch H.T. up to 500 Volts.

LIST No.	RATING OF HEATER
S.100	4 volts 0.1 amp.
S.101	7.5 volts 0.5 amp.
S.111	16 volts 0.25 amp.

**6/-**  
EACH

SEND FOR 80 PAGE CATALOGUE No. 153 W. ENCLOSE 2d. POSTAGE

**A. F. BULGIN & CO., LTD.,** ABBEY RD., BARKING, ESSEX

Telephones: Grangewood 3266 & 3267. London Showrooms: 9, 10, 11, Curstow Street, Chancery Lane, E.C.4

**IMPROVE YOUR SHORT WAVE RESULTS**

SHORT-WAVE ENTHUSIASTS will welcome this "EDDYSTONE" high efficiency lead-in device. It makes sure that weak short-wave signals from thousands of miles away are carried safely to the set without loss at the point of lead-in—usually the weakest link of any aerial system.

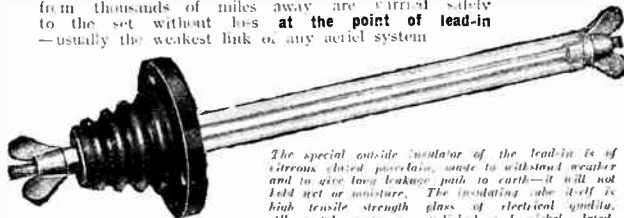

The special outside insulator of the lead-in is of vitreous glazed porcelain, made to withstand weather and to give long leakage path to earth—it will not get wet or oxidise. The insulating tube itself is high tensile strength glass, of electrical quality. All metal parts are polished and nickel plated. Also suitable for use with transmitters.

STRATTON & CO., LTD., BROMSGROVE ST., BIRMINGHAM. LONDON SERVICE DEPOT—WEBB'S RADIO STORES, 164, Charing Cross Rd., W.C.2

"EDDYSTONE" LOW LOSS LEAD IN CAT. No. 946, PRICE 2/6.

Latest list of "EDDYSTONE" short wave parts now ready, free on request.

**EDDYSTONE**  
LOW LOSS LEAD IN

**FOR HIRE**  
FULLY EQUIPPED PUBLIC ADDRESS VAN Sent anywhere in British Isles, also RADIO, MICROPHONE, & GRAMOPHONE AMPLIFIERS giving exceptional quality and volume, suitable for Dances, Sports Meetings, Parties, etc. from 15/- per day. McMichael Portable Sets 15/- a week: £2-12-6 a month.

**ALEXANDER BLACK, LTD**

WIRELESS CONSULTANTS  
55, EBURY STREET, LONDON, S.W.1.

ESTABLISHED IN 1925.

SLOANE 1655.

Trade Inquiries Invited.

**SERVICE**

SETS OF ALL TYPES.

Supplied, Serviced and Visited in any district, or may be sent for Full Test and Report, at 2/- per valve-holder; portables 1/6 per valve-holder.

**OPENINGS for ENGINEERS!**

Never before has engineering offered such magnificent chances. With the rise of the depression, the industry is literally teeming with first-class opportunities. Our 250-page Hand-book "ENGINEERING OPPORTUNITIES," shows where the opportunities lie, and the easiest way prepare for them. The Hand-book gives details of A.M.I.Mech.E., A.M.I.E.E., A.M.I.C.E., G.P.O., etc. Exams., outlines Home-Study Courses in all branches of Civil Mech., Elec., Motor, Radio & "Talkie," Engineering, Building, etc., and explains our unique Employment Dept. Send for this valuable Hand-book to-day—FREE! BRITISH INSTITUTE OF ENGINEERING TECHNOLOGY, 387, SHAKESPEARE HOUSE, 29, OXFORD STREET, LONDON

**FREE!**  
**250**  
**PAGES**

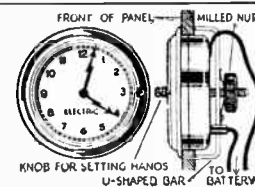

**FIT THIS ELECTRIC CLOCK TO YOUR SET!**

NO MAINS NEEDED! KEEPS CORRECT TIME! NO WINDING!

Works off small battery lasting 12 months, or can be plugged into G.B. Battery without affecting reception. Uses practically no current. Fits into hole 3 1/2" dia. in any panel up to 1/2" thick. Easy to fix—no screws required. Only 2" from front of panel to back of case. Swiss movement. Hands set from front. Nickel plated bezel. Useful addition to any set.

**12/6**  
COMPLETE WITH BATTERY  
POSTAGE 6D

RIVERSIDE MFG. CO., LTD., Dept. 29, Crisp Rd., Hammer-smith, W.6 Telephone: W7 6322



# 3 SAVAGE STANDARDISED SPECIFICATIONS

## TYPE A

250-0-250, 60 m.A., 4 v. C.T. 1-2 amp., 4 v. C.T. 2-4 amp. With electrostatically screened primary. Mnfrs.' type:—Price 20/-. Standard type with terminals:—Price 25/-.

## TYPE B

350-0-350, 120 m.A., 4 v. C.T. 2-3 amp., 4 v. C.T. 6 amp., 4 v. C.T. 2 amp. With electrostatically screened primary. Mnfrs.' type:—Price 30/-. Standard type with terminals:—Price 35/-.

## TYPE C

500-0-500, 120 m.A., tapped at 465 v. each side. 4 v. C.T. 2-3 amp. Twice 4 v. C.T. 2amp., 4 v. C.T. 3-4 amp. Mnfrs.' type:—Price 43/-. Standard type with terminals:—Price 49/-.

# SAVAGE

## MAINS TRANSFORMERS

56/58, CLERKENWELL ROAD, E.C.1

Phone: Clerkenwell 3068/9.

# EPOCH

## MOVING COIL SPEAKERS

The Finest in The World in Each of Their Price-classes.

Ask your dealer or call for a demonstration at Exmouth House.

Send for New Booklet W.S.5a. It is free.

EPOCH RADIO MANUFACTURING Co. Ltd.  
Exmouth House, Exmouth St., London, E.C.1

At the junction of Rosebery Avenue and Farringdon Road.  
Phone: Clerkenwell 6666 (4 lines).

### WANTED.

**S**ONORHORDE Senior D.C. 6,500.—Particulars to F. Green, 40, Conliffe St., Burnley. [3565]  
**C**OIL Winding Machine, price and particulars.—Kenward, 109, High St., Ryde, Isle of Wight. [3546]  
**S**POT Cash for Modern Components, etc.—Economic Radio Co., 96-98, South Lambeth Rd., S.W.8. [3291]  
**P**ARTS for Televisor Wanted. Particulars to "D-I-bruck," Alcester Rd., Studley, Warwickshire [3549]  
**W**ANTED, January, February, March, 1931, "Experimental Wireless."—78, Osmaston Rd., Preston, Birkenhead. [3539]  
**S**URPLUS and Second-hand Goods, any quantity; for cash.—Woburn Radio Co., 7, Woburn Buildings, W.C.1. Euston 1571. [3569]  
**H**IGH-Class Radio Parts and Sets Wanted for cash, new or second-hand, any quantity; send yours stating reasonable price cash by return; retailers' stocks purchased.—Mildmay Radio Exchange, 24, Mildmay Grove, London, N.1. Phone: Clissold 5001. [3455]

### SITUATIONS VACANT.

**S**MART Lads Wanted, 14-16.—Apply M. A. Mason and Co., Ltd., W/T Works, Collingwood Rd., Sutton, Surrey. [3475]

**I**F You Wish to Enter the Wireless Profession with a Thorough Training, or if you wish to improve your present position, you will need the certificate issued by Britain's leading wireless college. This is not a correspondence college. Apparatus of all leading makes installed for instructional purposes. Boarders accepted. Training fees can be paid after appointment. Prospectus free.—Wireless College, Colwyn Bay. [3388]

### AUCTION SALES.

AUCTION SALES  
OF RADIO AND ELECTRICAL GOODS.

### GODDARD & SMITH

will hold their regular Monthly Sales on  
OCTOBER 18th and 19th.  
NOVEMBER 15th and 16th.  
DECEMBER 13th and 14th.

Entries now accepted. Goods can be stored awaiting sale. Collection made. Payment immediately after realisation. Entry forms from  
70, SEYMOUR PLACE, W.1.  
Paddington 0277-8.

## NOW READY

The completely revised  
1934 EDITION of  
RICH & BUNDY.

### 24-Page CATALOGUE

OVER 100 Models of Mains Transformers and Power Chokes fully described.

Valuable information.

### FREE

Ask for 1934 Catalogue "W." Free by return of post.

### RICH & BUNDY LTD.,

Transformer Manufacturers,  
New Road, Ponders End, Middlesex.

Phone: Enfield 0777.

Sole Distributors J.F.S.: KELLY & SHIEL LTD., 47, Fleet St., Dublin, C.1

PRICE, complete, in sealed dust-proof bag,

# 42/-

including O.-P. Transformer suitable for Class B. Super Power, Power and Mains Pentode & Battery Pentode.

FOUR  
SQUARE



Sept. 27th to Oct. 7th  
Manchester Radio Exhibition.  
STAND No. 103.

## "GRILLE"

## P.M.M.C. SPEAKER

A de luxe instrument embodying an entirely new development in Loudspeaker design. This consists of a unique suspension method for the diaphragm, consisting of resilient pads between which the periphery of the diaphragm is cushioned. These pads are held by the outer edge of the grille, thus eliminating all edge resonance and much of the usual suspension resonance. The design of the grille protects the diaphragm from damage by careless handling.

High Cobalt content Magnet of generous cross section. Lacquered bronze finish. Highly finished Chromium-plated Grille. Specially impregnated cone. Chassis. Rust and Scratch proof finish.

WRITE NOW FOR ILLUSTRATED FOLDER



(CLERKENWELL) Ltd.

Broad Yard Works, Turnmill Street, Clerkenwell, London, E.C.1. (Late of 69 97, St. John Street.)

Phones: Clerkenwell 3838 3839.

## THE MACHINE THAT MAKES MONEY

Start a profitable business Printing for local Tradesmen, Cinema Proprietors, etc. There is a Huge Weekly Demand for Printed Material in your District which you could easily produce.

My wonderful all steel 'Adana' Machine prints anything from a Chemist's label to an Illustrated Magazine.

# 45/-

**Special Easy Payment Terms.**  
Send for Free Details and Samples of actual work produced.  
D. A. ADANA (W.W.1),  
17, Church St., Twickenham.  
London: Ludgate House,  
Fleet-street,  
Manchester: 60,  
Oldham-st.

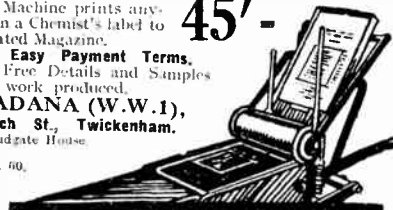

D.C.  
TO  
A.C.

# ELECTRO DYNAMIC

AND ANODE TYPE

## CONVERTERS

THE D.C./A.C. TYPE converts direct current to alternating current up to a capacity of 600 watts. A small size (approx. 40 watts) is produced at a low price for use with 2 to 5-valve sets. Prices from £6 10s.

THE ANODE (H.T.) CONVERTER provides a high-efficiency H.T. supply from the L.T. accumulator. Input, 2 to 110 volts; output 150-250 volts, 15-40 m.A. Prices from £7.

STAND 109  
RADIO SHOW, City Hall, MANCHESTER  
Sept. 29th—Oct. 7th.

ELECTRO DYNAMIC CONSTRUCTION CO., LTD.,  
Devonshire Grove, London, S.E.15  
Telephone: New Cross 4972 (4 lines).

## The ELEMENTARY PRINCIPLES of WIRELESS TELEGRAPHY and TELEPHONY

Third Edition  
(1930) Revised by  
O.F. Brown, B.Sc.

by R. D. BANGAY

The standard book of instruction for wireless students. Deals thoroughly with modern developments. Leaflet with full particulars and synopsis of chapters sent on request.

PRICE  
7/6 by post 8/-

From all leading Booksellers or direct from the Publishers:

LIFFE & SONS LTD., Dorset House, Stamford St., London, S.E.1

W.W. 97



# products are in a class apart

*Design, construction and performance unequalled.*

AMPLIFIERS, P.A. EQUIPMENT, TRANSFORMERS and CHOKES for all requirements.

5.9 watts (U.D.O.) Amplifiers for domestic use, other models up to 120 watts.

**BIRMINGHAM SOUND REPRODUCERS LTD., CLAREMONT WORKS, OLD HILL, STAFFS.**

Write for complete Lists.

60 WATT AMPLIFIER.

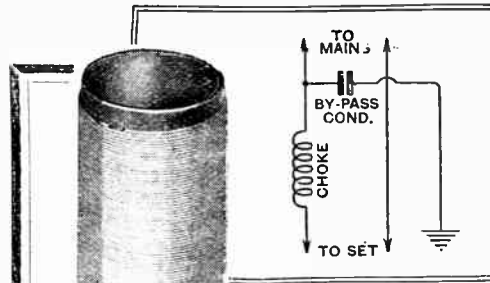
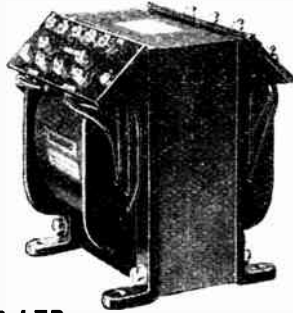
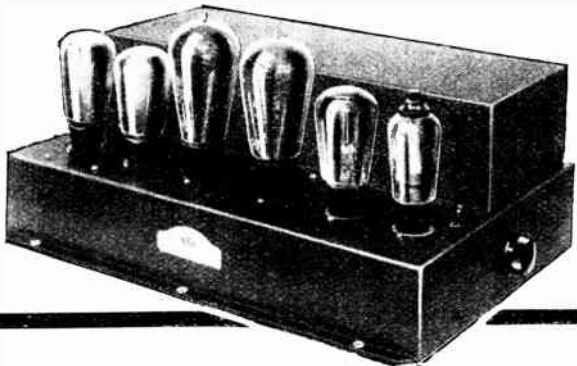

**STOP THOSE NOISES!**

UNPLEASANT NOISES, SUCH AS CRACKLING, HUMMING AND OTHER EQUALLY ANNOYING INTERFERENCES, DEPRIVE THE LISTENER OF THE ENJOYMENT HE WOULD OTHERWISE RECEIVE.

## "GOLSTONE" INTERFERENCE SUPPRESSING DEVICES

"GOLSTONE" MAINS H.F. CHOKES (For A.C. and D.C. supplies) as illustrated, W.H.F., 36 INTERFERENCE COMPENSATORS, HIGH VOLTAGE CONDENSERS, SCREENED AERIAL DOWN LEADS, IMPEDANCE MATCHING DEVICES, SCREENED TRANSMISSION LINES, SCREENED TUBINGS are some of the wide range manufactured. Obtainable from all first-class radio stores. See the name "GOLSTONE" on each component before purchasing and refuse substitutes. If any difficulty write direct. Let "GOLSTONE" Technical Department solve your Interference Problems. Send Postcard for "Interference Elimination" Form and descriptive Folders.

Use "GOLSTONE" Components, as specified, for your "Wireless World" D.C. Superhet. "GOLSTONE" Screened H.F. Choke Type S.H.F.4 - each. "GOLSTONE" Heavy-Duty Mains H.F. Choke Type P.H.F. 7 6 each.

**- FREE -**  
Large 56 - page 1933-34 RADIO CATALOGUE sent FREE on request.



## YOUR DISCARDED SET IS WORTH REAL MONEY

LET us take your old Set or Components in PART EXCHANGE for New Season's Radio—NEW KITS, NEW ACCESSORIES, or PART KITS—in fact any RADIO APPARATUS. Best quotations and fullest allowance given. Balance payable by Cash or H.P. Send us your enquiry for quotation by return, stating apparatus you wish to dispose of and NEW KIT, SETS or MISCELLANEOUS COMPONENTS REQUIRED. WE GIVE YOU MORE.

**PARTEX RADIO, VULCAN HOUSE, Ludgate Hill, LONDON, E.C.4**

# OSTAR-GANZ

"UNIVERSAL" HIGH VOLTAGE MAINS VALVES  
Model SETS—KITS and AMPLIFIERS also supplied *Write for full Details*

**Complete range for all purposes!**

These are the valves for building "UNIVERSAL" A.C.-D.C. sets. No Transformers or Resistances required. Convert Battery sets to All-Mains, or make Mains sets suitable for ANY Mains supply.

*Write for full list to*  
**EUGEN FORBAT**  
(Sole Agent for Gt. Britain)  
28-29, SOUTHAMPTON STREET STRAND, LONDON, W.C.2  
Telephone: Temple Bar 8608

## INDEX TO ADVERTISEMENTS.

Adana, D. A. ....	PAGE 28	Electro Dynamic Construction Co., Ltd. ....	PAGE 28	Pepper, Trevor (Scradox) .....	PAGE 20
Automatic Coil Winder & Elec. Equipment Co., Ltd. ....	28	Epoch Radio Manf. Co., Ltd. ....	28	Pelo-Scott Co., Ltd. ....	21
Front Cover & .....	15	Ferranti, Ltd. ....	9 & 30	Philips Radio-Receiver .....	13
Baker's "Selhurst" Radio .....	24	General Electric Co., Ltd. ....	2, 7, & Back Cover	Primustatic Sales .....	26
Barber & Colman, Ltd. ....	25	Goobard & Smith .....	28	Pifo, Ltd. ....	3
Birmingham Sound Reproducers Ltd. ....	29	Goodmans .....	28	Pestlethwaite Bros. ....	14
Black, Alexander, Ltd. ....	27	Hacker, H. & Sons .....	20	Radio Instruments, Ltd. ....	5
Britannia Batteries, Ltd. ....	Inside Front Cover	Hartley Turner Radio, Ltd. ....	22	Radioformer, Ltd. ....	10
British Institute of Engineering Technology .....	27	Hayberd, P. C. & Co. ....	24 & 26	Reproducers & Amplifiers, Ltd. ....	28
British Radiophone Co., Ltd. ....	12	Hollesens, Ltd. ....	18	Rich & Bunby .....	27
British Rola Co., Ltd. ....	23	H.S.P. Wireless Co., Ltd. ....	24	Riverside Manf. Co., Ltd. ....	28
British Thomson-Houston Co., Ltd. ....	20	Igranite Electric Co., Ltd. ....	26	R.I., Ltd. ....	5
Bruce, W. Andrew, & Co. ....	20	Lanphugh Radio, Ltd. ....	26	Savage, W. Bryan .....	28
Bulgin, A. E. & Co., Ltd. ....	27	Lectro Lux, Ltd. ....	25	Scott, Sessions & Co. ....	25
Burton, C. F. & H. ....	Front Cover	Lumen Electric Co. ....	26	Sound Sales, Ltd. ....	22
City Accumulator Co., Ltd. ....	1	Lyons, Claude Ltd. ....	12	Stratton & Co., Ltd. ....	27
Clarke, H. & Co. (Mer.), Ltd. ....	vi	Maticophone Co., Ltd. ....	17	Tannoy Products .....	26
Cole, E. K., Ltd. ....	16	Metropolitan-Vickers Electrical Co., Ltd. ....	v	Telsen Electric Co., Ltd. ....	Front Cover
Colvern, Ltd. ....	Front Cover & 6	Miles Radio Co. ....	10	Thompson, T. W. & Co. ....	24
Cosser, A. G., Ltd. ....	19	New London Electron Works, Ltd. ....	Inside Back Cover	Ward & Goldstone, Ltd. ....	29
Darwins, Ltd. ....	8	Ormond Engineering Co., Ltd. ....	15	Watnet Wireless Co., Ltd. ....	29
Dubilier Condenser Co. (1925), Ltd. ....	14	Osborn, Chas. A. ....	20	Westinghouse Brake & Saxby Signal Co., Ltd. ....	26
Earl Manfg. Co., Ltd. ....	12	Ostar-Ganz (Eugene Forbat) .....	29	Inside Front Cover	29
Edison Swan Electric Co., Ltd. ....	3	Partex Radio .....	29	Wet H.T. Battery Co. ....	6
Electradix Radios .....	26	Partridge & Mee, Ltd. ....	14	Wilkins & Wright, Ltd. ....	26
		Partridge, Wilson & Co. ....	26	Witrose Co. (Bham), Ltd. ....	24

Exactly the same skill and care needed in the construction of a £15,000 Ferranti transformer are lavished on the building of a Ferranti Superhet costing 15 guineas. Ferranti radio will never fail you, never let you down. But that isn't all.

This year, Ferranti engineers have made radio very much simpler for you. First by means of Automatic Volume Control. This prevents "fading" on distant stations and maintains a steady volume for all programmes you tune in. Further, by Electric Tuning, which enables you to see when a station is accurately tuned in: an important advantage, since the human ear cannot always correctly tune in a highly sensitive Superhet. The Ferranti Radio Book fully describes these new technical advances and the Ferranti range of Superhets. Get a copy from your dealer, or send to ★ Ferranti Ltd., Hollinwood, Lancs, or Bush House, London.

# FERRANTI

ELECTRICAL ENGINEERS  
TO THE 20th CENTURY

## radio

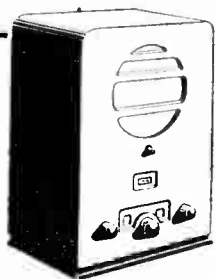
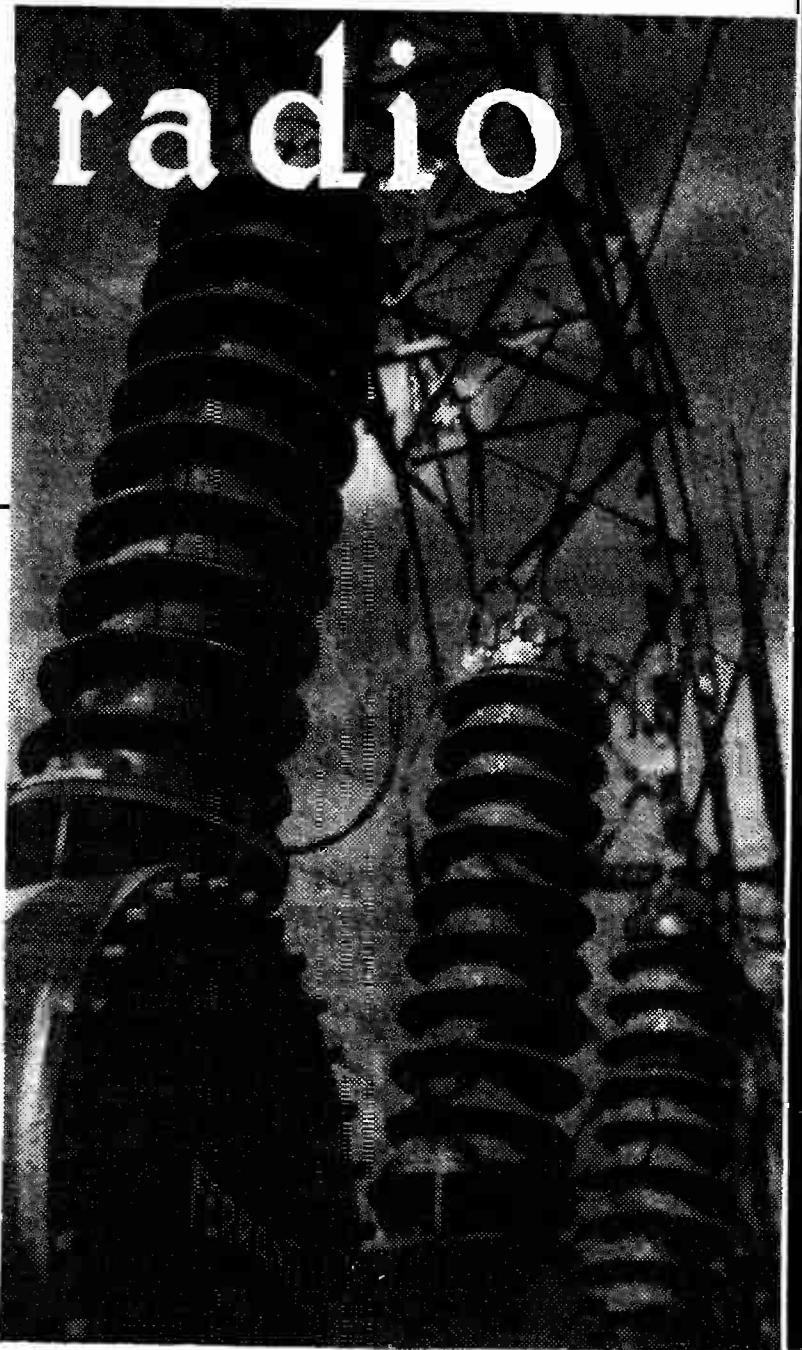

### FERRANTI RANGE

ARCADIA  
CONSOLETTA **18** GNS

#### ARCADIA (illustrated)

A truly modern Superhet, small in size (the modern trend) but very powerful, having 7 tuned circuits, Ferranti Heptode oscillator-modulator valve and Double-diode-triode valve for full A.V.C. and improved undistorted detection. 2½ watt triode undistorted Output. Electric Tuning. Image Rejector to reduce second channel interference. Illuminated Station Name and Wavelength indicators. Energised moving coil speaker. Gramophone sockets. Manual volume control for both radio and gramophone. Continuously variable tone control.

COMPANIONETTE 20 GNS.

CONSOLE 23 GNS.

#### LANCASTRIA

A Superhet similar in size and appearance to the Arcadia. Has all the new Ferranti valves, but one or two refinements are omitted for the sake of a remarkably low price.

CONSOLETTA **15** GNS

#### GLORIA

A larger cabinet than the Arcadia. Has all the new Ferranti features.  
CONSOLETTA 24 GNS.  
(CONSOLETTA with Ferranti synchronous clock built into speaker 26 gns.)  
COMPANION 35 gns.

CONSOLE 29 gns.

FERRANTI LTD. HOLLINWOOD LANCs

Mention of "The Wireless World," when writing to advertisers, will ensure prompt attention.

# WEDNESDAY

## OCTOBER THE FOURTH

### PRINCIPAL EVENTS OF THE DAY:

#### AT HOME

- NATIONAL** Two plays: "Danger," by Richard Hughes, and "The Wrong Bus," by Martin Hussingtree.  
 "Times of the Twenties," instrumental concert.
- LONDON REGIONAL MIDLAND REGIONAL NORTH REGIONAL SCOTTISH REGIONAL BELFAST** Orchestral concert from the Municipal Museum.

#### ABROAD

- BARCELONA** 7.0 p.m. Trio concert.
- BRESLAU** 8.10 p.m. Request concert by the Silesian Philharmonic Orchestra. 11.45 p.m. Organ recital, by Prof. Stein.
- BRUSSELS (No. 2)** 8.0 p.m. The Station Symphony Orchestra, conducted by J. Ehrlich.
- BUDAPEST** 7.45 p.m. Opera: "Aunt Simona," by Dohnanyi.
- MORAVSKA-OSTRAVA** 6.25 p.m. Recital for Two Pianofortes.
- PALERMO** 8.45 p.m. Orchestral concert.
- PRAGUE** 8.30 p.m. The Czech Philharmonic Orchestra, conducted by Prik.
- ROME** 8.30 p.m. Opera: "La Wally," by Catalani.
- STOCKHOLM** 8.0 p.m. Concert by the Budapest Trio.
- WARSAW** 8.0 p.m. Concert of chamber music.

1.10, Concert by the Max Alexys Orchestra. 5.0, Dance Music relayed from the Saint Sauveur Palais de Danse. 6.0, Protestant Address. 6.30, Gramophone Concert: Offenbachiana (Finck); Alter Refrain (Kreisler); Overture, Show Boat (Kern); Gipsy Serenade (Borganov); Melody (Suk); Dance from Othello (Verdi); Melody (Laparra); Ballet Music from Hamlet (Thomas). 7.15, Talk: The Famine in the Carpathians. 7.30, Horticultural Report. 8.0, Concert by the Station Symphony Orchestra, conducted by Julius Ehrlich: Symphony No. 3 (Steinberg); Ballet Suite (Schosta-kowitsch); Piece (Mossolow). In the interval at 8.45, Reading. 10.0, Le Journal Parlé.

#### BUCHAREST

761 kc/s, 394 metres; 12 kW.—5.0 p.m., Concert by the Station Orchestra: March (Blankenburg); Waltz from Gipsy Love (Lehar); Overture, Cavalleria rusticana (Mascagni); Selection from Mephistopheles (Boito); Hindoo Ballet from Lakmé (Delibes); Fantasia on Themes of Haydn (F. Bach); Prayer and Temple Dance (Grieg); Kinderszenen (Schumann). In an interval at 6.0, Radio Journal. 7.0, Educational Programme. In an interval at 7.20, Romanian Music on Gramophone Records. 8.0, Pianoforte Recital. 8.30, Talk. 8.45, Recital of Operetta Arias. 9.15, Violin Recital. 9.45, Radio Journal. 10.0, Programme relayed from a Restaurant.

#### BUDAPEST

545 kc/s, 550.5 metres; 18.5 kW. Also relayed on 840 metres from 7.45 p.m. till Close Down.—5.0 p.m., Gramophone Concert. 6.0, Italian Lesson. 6.30, Pianoforte Recital by Bela Nagy: Sonata in A Minor (Schubert); Intermezzo in C Flat (Brahms); Two Mazurkas in C Sharp Minor and B Minor (Chopin); Dance (Kodaly). 7.10, Talk: Professor Picard's Researches in the Stratosphere. 7.45, Aunt Simona—Operetta in One Act (Dohnanyi), produced by the Composer. After the Operetta, Song Recital. 9.45, News. 10.0, Concert by the Magyar Cigany Band, relayed from the Hungaria Hotel. 11.0, Talk in Italian.

CASSEL.—See Frankfurt.

#### COPENHAGEN

1,067 kc/s, 281 metres; 0.75 kW. Relayd by Kalundborg, 260 kc/s, 1,153.8 metres.—12 Noon, Time and Chimes from the Town Hall. 12.5 p.m., String Ensemble Concert, relayed from the Wivex Restaurant. 2.0, Interval. 3.0, Gramophone Concert. 3.30, Concert by the Station Orchestra, conducted by Launy Gröndahl: Prelude to the Second Act of Saul and David (Nielsen); First Movement from the Symphony in E (von Dittersdorf); Arabesque in E (Debussy); Selection from Madame Sans-Gêne (Giordano); Minuet for Strings (Boccherini); Mars and Venus (Ganne); Overture, Lulu (Kuhlan); Sover sovit i hellig Fred (Nielsen); Selection from Le Petit Duc (Lecoeq); Strophe élégiaque (Poszy); Caucasian Folk Song, Kazbek; Norwegian Artists' Carnival (Svendsen). In the interval at 4.15 (approx.), Talk for Women. 5.30, Exchange and Fish Market Prices. 5.45, Talk: The New York of To-day. 6.15, French Lesson. 6.45, Weather and News. 7.15, Time Signal. 7.30, Agricultural Talk. 8.0, Chimes from the Town Hall. 8.5, Talks arranged by the Society for Cancer Research, relayed from the Odd Fellows' Hall. 9.15 to 2.0 a.m. (Thursday), Radio Hall. 9.15, Dance Music by Louis Preil's Band. In the interval at 10.5, News. 11.15, Dance Music by the Valencia Band. 12 Midnight, Time and Chimes from the Town Hall. 12.5 a.m. (Thursday), Dance Music from the Ritz Restaurant. 1.0, Dance Music from Nim's Restaurant. 2.0 (approx.), Close down.

CORK.—See Athlone.

DANZIG.—See Heilsberg.

DRESDEN.—See Leipzig.

#### FECAMP

1,328 kc/s, 225.9 metres; 10 kW.—11.0 to 12 Noon, Programme in English by the I.B.C. 11.0 a.m., Happy Hour. Part I: Request Half-hour. Signature Tune; Waltz Favourites (arr. Ancliffe); My Hero, from The Chocolate Soldier (O. Strauss); No more Love (Friend); Selection from The Desert Song (Romberg); Song, Sweetheart Berlin (Stodhar); Tired Hands (Sander-son); When the Lilac blooms again (Rotter); Waltz, The Blue Danube (Strauss). Part II: Request Dance Programme. My Darling; In the Valley of the Moon; Letting in the Sunshine; Drifting down the Shalimar; I can't remember; Dance, pretty Lady; Wanderer; Come out Vienna; Philco Signature Tune. 12 Noon, Programme in French. 4.30 to 6.0 p.m., Programme in English by the I.B.C. 4.30, Programme for Children. 5.0, Concert of Light Music for Isle of Wight Listeners. Signature Tune, The Night by the Sea; Dreams on the Ocean (Gungl); I do like to be beside the Seaside (Glover); Song, I raised my Hat (Polka); When the Convent Bell is ringing (Trevor); Song, Lettin' in the Sunshine (Gay); In the Valley where the Bluebirds sing (Salman); Guitar Solo, Feeling my Way (Lang-Kress); Romance (Lühr). 5.30, Gramophone Con-

**ALGIERS**  
 824 kc/s, 364 metres; 13 kW.—8.20 p.m., Songs and Dance Music. 8.55, News. 9.0, Time and Lottery Results. 9.10, Orchestral Concert: Overture, Poet and Peasant (Suppe); Aubade mignone (Stanb); Waltz, Etincelles (Waldteufel); Selection from The Damnation of Faust (Berlioz); Cavatina (Saint-Saëns). 9.45, News. 9.50, Songs from Ma tante d'Honfleur (Lemoir) on Gramophone Records. 10.0, Orchestral Concert (cont.). Siamesische Wachtparade (Lincke); Narcissus (Nevin); Zingaresca (Monti); Sérénade des Pygmées (Rizgarede); Maria (Simons). 10.30, News. 10.35, Sketches: (a) Kito se soigne (Kito), (b) Le duel de Kito (Kito), (c) L'accident (Bach and Laverne), (d) Chez le contrôleur des contributions (Bach and Laverne), (e) Un immeuble tranquille (Warms), (f) Le mistingo (Gérin Junior). 10.55, News.

**ATHLONE**  
 725 kc/s, 413 metres; 60 kW. Relayd by Cork, 1,337 kc/s, 224.4 metres.—1.30 to 2.30 p.m., Time Weather, Stock Report and Gramophone Concert. 6.0, Programme for Children. 6.45, News. 7.0, Gaelic Programme. 7.15, German Lesson. 7.30, Time Signal. 7.31, Pianoforte Solos by Dina Copeman. 7.50, The Station Orchestra. 8.15, Gaelic Songs. 8.30, A Play by J. Priestly Mitchell and Company. 9.0, Violin Solos by Kieran. 9.15, Talk: The Sacred Places of Ireland. 9.30 to 10.30, Programme by the I.B.C. (Ireland), Ltd. 9.30, Light Music: On the Beach at Waikiki (Traditional); Ke-sa-ko (Chapuni); Musical Saw Solo: I love you (Inns); Song: Going Home (Eyton); Tomi Tomi (Traditional); Crazy Promette (Frisk); Song: A Beggar can sing the Song of a King (Kiehl); Waltz, Lorentina (arr. Macari). 10.0, Concert, arranged by the International Broadcasting Company (Ireland), Ltd., on behalf of Hospitals Trust, Ltd.: Little Sunshine (Krausz); Me and Mr. Sunshine (Gilbert); Merry Me (Krausz); Pink Elephants (Woods); Jealousy (Gade); I'm forgetting myself for you (Meyer); In Santa Lucia (Strausky). 10.30, I.B.C. Goodnight Melody. 10.33, News and Weather. 10.40, The Traditional Quartet. 11.0 (approx.), Close Down.

**BARCELONA**  
 EAJ1, 860 kc/s, 348.8 metres; 8 kW.—7.0 p.m., Trio Concert: Polonaise in F (Schubert); Gavotte-Caprice (Bortkiewicz); A Summer Evening (Grieg); Entr'acte (Chillemont); Selection from Lucia di Lammermoor (Donizetti); The Musical Box (Mannfred); Selection from Der Freischütz (Weber). 8.0, Request Gramophone Records. 8.30 (in an interval), Exchange. 9.0, Gramophone Music and News. 10.0, Chimes, Weather, and Exchange. 10.5, Concert by the Station Orchestra. 11.0, Song Recital, followed by Concert relayed from the Ayuntamiento.

BASLE.—See Schweizerischer Landessender.

**BELGRADE**  
 697 kc/s, 430.4 metres; 2.8 kW.—6.55 p.m., Time and Programme Announcements. 7.0, Concert by the Radio Orchestra. 8.0, See Ljubljana. 10.0, Time and News, followed by Dance Music relayed from the Ratnicki Dom Restaurant.

**BERLIN**  
**DEUTSCHLANDSENDER (Reichssender),** 183.5 kc/s, 1,635 metres; 60 kW.—12 Noon, Weather. 12.5 p.m., Gramophone Concert. 12.55, Time. 1.0, Interval. 1.45, News. 2.0, Famous Artists on Gramophone Records: Selhmsus: Aria from Sicilian Vespers (Verdi) and The Queen of Spades (Tchaikovsky); Fildesly: Two Cello Solos: (a) Spinnlied (Popper), (b) Chanson (Blanc); Cortot: Three Pianoforte Solos: (a) Concert Fantasia on Rigoletto (Verdi-Liszt), (b) Malagena (Albeniz), (c) Minstrels (Debussy); Caruso: Three Tenor Songs: (a) In Granada (Alvarez), (b) Komm auf's Meer (Tchaikovsky), (c) Aria from Faust (Gounod); Marteau: Two Violin Solos: (a) Concert Fantasia on Themes from Carmen (Bizet), (b) Hungarian Dance No. 6 (Brahms); Mildner: Two Pianoforte Solos: (a) Etude in C minor (Chopin), (b) Arabesques on The Blue Danube. 2.45, Programme for Children. 3.30, Weather and Exchange. 3.45, Reading of Ballads (Hans Friedrich-Bühne). 4.0, See Hamburg. 5.0, A Political A.B.C. 5.20, Recital of Chamber Music by Willi Steck (Pianoforte), Bruno Stehlmann (Violin), and Max Bleiss (Cello); Pianoforte Solos (Brahms): (a) Ballad in G minor, (b) Intermezzo in E flat minor, (c) Rhapsody in B minor; Pianoforte Trio in B flat, Op. 11 (Beethoven). 6.0, Poems. 6.5, Address and Organ Music. 6.55, Wireless Notes. 6.50, Weather. 7.0, Transmission for all German Stations, relayed from Breslau. 8.0, To-day's Motto, followed by Talk. 8.10, A Musical Medley by Willi Glahe and his Band. 9.0, A German Calendar—October. 10.0, Weather and News. 10.15, Dialogue: The National Association of Gymnastics Teachers. 10.45, Weather. 11.0, Concert from Heilsberg. 12 Midnight, Close Down.

**BERLIN**  
**FUNKSTUNDE,** 715 kc/s, 419.5 metres; 1.5 kW.—5.45 p.m., Pianoforte Sonata in D, Op. 10, No. 3 (Beethoven), by Erich Winkler. 6.5, See Berlin (Deutschlandsender). 6.40, The Funkstunde informs its Listeners. . . . 6.45, Topical Talk. 7.0, Transmission for all German Stations, relayed from Breslau. 8.5, Songs. 8.35, May God bless Honest Handwork!—Radio Report. 9.0, German Handicrafts in Music—Concert by the Station Orchestra, conducted by Otto Frickhoff, and the Station Choir, conducted by Heinzkarl Weigel. Soloist: Rudolf Watzke (Baritone). Old Guild Songs; Procession of the Guilds, Melody and Hans Sachs' Monologue from The Mastersingers (Wagner). 9.30, Sailors' Yarns. 10.0, News. 10.15 (approx.), Dance Music by the Waldemar Haas Band, relayed from the Spreegarten, Treptow. In an interval at 11.0, Radio Report from Moabit. 12 Midnight (approx.), Close Down.

BERNE.—See Schweizerischer Landessender.

BEROMUNSTER.—See Schweizerischer Landessender.

BODEN.—See Stockholm.

BODO.—See Oslo.

**BRATISLAVA**  
 1,076 kc/s, 279 metres; 14 kW.—4.0 p.m., Concert by the Station Orchestra, conducted by Zdenek Folprecht; Suite from The Sleeping Beauty (Tchaikovsky); Selection from Jenufa (Janacek); Symphonic Picture (Chilip). 4.50, See Prague. 5.35, Programme for Children. 5.55, Hungarian Transmission: Talk and Recitation, followed by Violin Recital: Largo (Veracini-Corti); Rondo (Schubert-Friedmann); La Gitana (Kreisler); Capricciosa (Ries); Hebrew Melody (Achorn); Madrigal (Simonetti); Tambourine (Gosse-Bourmeister). 6.55, Hints for Housewives. 7.0, See Prague. 7.25, A Comedy (Serbojev). 8.5, See Prague. 10.30 (approx.), Close Down.

BREMEN.—See Hamburg.

**BRESLAU**  
 923 kc/s, 325 metres; 60 kW. Relayd by Gleiwitz, 1,184 kc/s, 253 metres.—1.45 p.m., Time and News. 2.10 (from Gleiwitz), Brahms Duet Recital by Käthe Prochaska (Soprano) and Adelheid Prochaska (Contralto). 2.40, Petite Suite (Debussy) on Gramophone Records. 3.0, Agricultural Prices. 3.15, Reading. 3.35, Talk: Silesian History as portrayed by Silesian Village Names. 4.0, Orchestral concert: Weddigen-Marsch (Büttner); Overture, The Bohemian Girl (Balfe); Air for Oboe (Herzog); Waltzes on Themes from Zeller's Operettas (Thiele); Serenade, Wenn die Rosen blüh'n. (Siede); Selection from

Wiener Blut (Joh. Strauss); Fantasia on the Song, Ach, wie ist's möglich dann (Esterl); Waltz, Kroll's Balkklänge (Lunbye); Am Lagerfeuer; Heimatlieder und Volkslieder (Urbach); March, Grenzmarkklänge (Schmidt). 5.30, Agricultural Prices. 5.35, Talk on Smuggling. 5.50, Reading (Hermann Falk). 6.10, Talk: A Journalist or Publisher? 6.25 (from Gleiwitz), Concert by the Benthon French Horn Quartet; Selection from Iphigenia in Aulis (Glück); Larghetto (Schulze); Stilles Tal (Wohlgemuth); Frisch gestungen (Sileher). 6.50, Meat Market Prices. 7.0, Transmission for all German Stations. A Ship under Steam—Radio Play for Workers (Lüttjohann). 8.0, News. 8.10, Request Concert by the Silesian Philharmonic Orchestra, conducted by Ernst J. Topitz. In the interval at 9.0, Five Answers to Romain Rolland—German Men of Letters Confess their Faith in Hitler Dritte Reich. 10.0, See Munich. 10.20, Time and News. 10.45, Concert relayed from the Hans Oberschlesien. Gleiwitz. 11.45, Organ Recital by Prof. Franz Stein, relayed from the Sand-Kirche; Prelude in G minor (Bach); Three Choral Preludes (Bach): (a) Auf meinen lieben Gott, (b) Ich ruf zu dir, Herr Jesu Christ, (c) Kyrie, Gott heiliger Geist; Fantasia in F minor (Brosig). 12.15 a.m. (Thursday), Close Down.

**BRNO**  
 878 kc/s, 342 metres; 35 kW.—5.55 p.m., Esperanto Lesson. 6.5, Journalistic Review. 6.15, Talk for Workers. 6.25, German Transmission: News, Biological Notes and Talk: Workers as Poets. 7.0, See Prague. 10.30 (approx.), Close Down.

#### BRUSSELS (No. 1)

I.N.R., 590 kc/s, 509 metres; 15 kW.—12 Noon, Concert by the Max Alexys Orchestra. 1.0 p.m., Le Journal Parlé. 1.10, Gramophone Concert: Two-Step, Me l'aman coqueta (Sarno); Hungarian Rhapsody No. 14 (Liszt-Doppler); Ballet Suite (Popy); Foxtrot (Packay); Il tango delle capinere (Bixio); Strauss Waltz Potpourri (arr. F. Weber). 5.0, Extracts from Les Cloches de Corneville—Operetta (Planquette), on Gramophone Records. 6.0, Talk: The Battle of the Yser. 6.15, Chamber Music: Dyckhof (Pianoforte), de Herdt (Violin), Distelmans (Viola), and Celemans (Cello): Quartet for Pianoforte and Strings (Mozart); Quartet for Pianoforte and Strings, Op. 23 (Jongen). 7.15, Protestant Address. 7.30, Medical Talk. 8.0, Overture, Le roi malgré lui (Chabrier), on Gramophone Records. 8.5, La Rabouilleuse—Play in Four Acts (Emile Fabre), after a Story by Balzac. 10.5, Le Journal Parlé.

#### BRUSSELS (No. 2)

I.N.R., 887 kc/s, 338.2 metres; 15 kW. Programme in Flemish.—12 Noon, Gramophone Concert. 1.0 p.m., Le Journal Parlé.



OCT. 4th

WEDNESDAY

continued

cert for Portsmouth and Southsea Listeners. Selection from He wanted Adventure; El Dia que me Quieras (Donato); Selection of War Marching Songs; Hand me down my Walking Cane (Franklin); My Heart stood still (Rodgers); You're still in my heart (Dougherty); El Amor hace fruncir (Cupello); My ain Folk (Lemon); Signature Tune. 6.0, Programme in French. 10.0 (approx.) till Close Down. Programme in English by the I.B.C. 10.0, Dance Music. Signature Tune, Bells of Normandy; In Santa Lucia; Out in the Open; He was only a poor Musician; Little Miss Muffet; The Old Spinning Wheel; It was a Night in June; In the Valley of the Moon; It's Sunday down in Caroline; Wear a great, big Smile; My Darling; Rock-a-Bye; A Ghost of a Chance; When my little Pomeranian; I wake up smiling; We belong together; The Song is you; Signature Tune. 11.0, Tunes from the Talkies. Signature Tune, Sittin' in the Dark; My Lucky Day; Selection from Congress Dances (Heymann); Everyone says I love you; They's Magic in the Air (Eyton); Popular Melodies on the Piano; In the Park in Patee (Rainger); I got Rhythm (Gershwyn); Signature Tune. 11.30, Club Concert for Haverfordwest Listeners. Part I: Gramophone Concert. Signature Tune, The Chum Song; Dance of the Nymphs (Birch); Whispering Flowers (von Blom); The Birth of the Blues (Henderson); He's been on the Bottle since a Baby (Bell and Fyffe); Homing (del Riego); A Radio Roundabout (arr. Noack); The Blue Bird (Bordin); Sweethearts of Yesterday. 12.5 a.m. (Thursday), News Bulletin in English. 12.10 (approx.), Club Concert. Part II: Someone stole Gabriel's Horn (Mills); Beautiful Lady (Caryl); Let's call it a Day (Brown); Dixiana (Caldwell); We've got the Moon and Sixpence (Grey); Signature Tune. 12.30, Dance Music by Jack Hylton and his Orchestra. (Electrical Transcriptions.) Hold me; That's my Home; You're mine, you; What a Lady Josephine must have been; I can't remember; Waltzing in a Dream; Dancing Butterfly; It's the Band; This is my Love Song; Don't be Late in the Morning; I've told every little Star; Lover come back to me; Rockin' Chair; ToyMaker's Dream; I wanna count Sheep; P123, The Policeman's Song; Seven Years with the Wrong Woman; There's a Cabin in the Pines; I raised my Hat; I'll see you in the Morning; Twelfth Street Rag; Drifting down the Shalimar; Old Man Harlem; Here is my Heart; Signature Tune. 2.0 a.m., I.B.C. Good-night Melody and Close Down.

FLENSBURG.—See Hamburg.

FLORENCE.—See Turin.

## FRANKFURT

1,157 kc/s, 259.3 metres; 17 kW. Relayed by Cassel, 1,220 kc/s, 245.9 metres; and Trier, 1,157 kc/s, 259.3 metres.—4.0 p.m., See Stuttgart. 6.0 to 6.55, See Langenberg. 6.55, Topical Talk. 6.50, Weather, News and Announcements. 7.0, Transmission for all German Stations, relayed from Breslau. 8.0, Topical Talk. 8.10 to 10.0, See Langenberg. 10.0, Local News and Weather. 10.20, See Stuttgart. 10.30, Time and News. 10.45, Concert of Light Music. 12 Midnight, See Langenberg. 1.0 a.m. (Thursday), Interval. 1.45 (relayed by Zezen, 9,560 kc/s, 31.28 metres). The Everlasting Flame—A Call to German Youth. 2.45, Close Down.

FREDRIKSSTAD.—See Oslo.

FREIBURG.—See Stuttgart.

GENEVA.—See Radio-Suisse Romande.

GENOA.—See Turin.

GLEIWITZ.—See Breslau.

GOTEBORG.—See Stockholm.

GRAZ.—See Vienna.

HAMAR.—See Oslo.

## HAMBURG

806 kc/s, 372 metres; 1.5 kW. Relayed by Bremen, 1,112 kc/s, 269.8 metres; Flensburg, 1,319 kc/s, 227.4 metres; Hanover, 530 kc/s, 566 metres; and Kiel, 1,292 kc/s, 232.2 metres.—4.0 p.m., Concert by the Small Station Orchestra, conducted by Gerhard Maasz: Festival Overture (Brusselmann); Wiener Carneval (Schuster); Hexentanz (MacDowell); Bauern-Suite (Alhont); Selection from Die schwarze Orchidee (d'Albert); Frei-Korps-Marsch (Millocker). 5.0, Programme for Young People. 5.30, Topical Talk. 6.0 (from Bremen), Concert of Italian Music by the Emberger Mandoline Quartet: March, Un saluto a Trieste (Coppetti); Capriccio (Burgstaller); Fantasia, Impressioni musicali (Sartori); Memories of Florence (Bellaghi). 6.30, Report on the Year's Regattas. 6.40, Frankfurt Exchange and Hamburg Market Prices. 6.50, Weather. 7.0, Transmission for all German Stations, relayed from Breslau. 8.0, Topical Talk. 8.10, Concert by the Small Station Orchestra, conducted by Gerhard Maasz. Soloist: Bernhard Jakschtat (Songs). 8.55, Animals

among themselves—Concert by the Small Station Orchestra with Recitations and Commentary. Conductor: Gerhard Maasz. 10.10, News. 10.30 (from Kiel), Choral Concert by the Germania Glee Society. 11.0 (from Hanover), Concert relayed from the Georgspalast.

HANOVER.—See Hamburg.

## HEILSBURG

1,085 kc/s, 276.5 metres; 60 kW. Relayed by Danzig, 662 kc/s, 453.2 metres.—1.5 p.m., Gramophone Concert. In the intervals at 1.20 and 2.0, News. 2.30, Programme arranged by the Post Office with Gramophone Records. 3.0, Agricultural Prices and Exchange. 3.20, Hints for the Housewife. 3.30, Reading for Children. 4.0, Concert Relay. 5.0, Talk arranged by the Society for the Prevention of Cruelty to Animals. 5.10, Harpsichord Recital by Anna Specker: Passacaglia in D minor (Krieger); Toccata (Bach-Vivaldi); Harpsichord Concerto in C (Bach). 5.35, Talk for Parents. 6.0, Concert by the Small Station Orchestra, conducted by Eugen Wilcke: Florentine March (Fucik); Festival Overture (Lortzing); Scénade pittoresque (Graener); Waltz from Ritter Pasman (Joh. Strauss); Potpourri, Fir Herz und G'müt (Komzak). In the interval at 6.15 (approx.), Agricultural Prices. 6.50, Weather. 7.0, Transmission for all German Stations, relayed from Breslau. 8.0, News. 8.10, Dance Music by the Small Station Orchestra and the Erich Börschel Dance Band. 10.10, News. 10.30, Orchestral Concert, conducted by Hans Othorst: March, Adlerflag (Blankenburg); Jubel-Ouverture (Bach); Dorf-schwalben aus Oesterreich (Jos. Strauss); Alle mit uns (Rohrleit); Lieder Potpourri, Wandervogel (Meister); Steinmetz-Marsch (Bratfisch); March, Duppel-Schanzen (Pferke); Waltz, Grubenlichter (Zeller); An der Weser (Pressel). 12 Midnight, Close Down.

## HILVERSUM

1,013 kc/s, 296.1 metres; 7 kW up to 5.40 p.m., and 20 kW from 5.40 p.m.—11.40 a.m., till Close Down. Programme of the Workers' Radio Society (V.A.R.A.). 11.40 a.m., Concert by De Notenkraakers, conducted by Wims; Zaragossa (de Gredos); The Wedding of the Winds (Hall); Invano (Costi); Es war einmal ein Zigeuner (Einez); Red Pepper (Lodge); Vienneuse Overture; Revue (Robrecht); Gramophone Music; Soljanka (Wilke); Slav Dance No. 10 (Dvorák); Nocturne (Borodin); Hungarian Dance No. 2 (Brahms); Gramophone Music; Czardas (Mielichs); A Cigarette (Lucchesi); Dir sing ich mein Lied (Lohár); Marionetten Brautjung (Rathke). 1.40, Interval. 1.55, Gramophone Music. 2.40, Programme for Children. 5.10, Concert by De Pliercollaters, conducted by v. d. Horst: Stampede (Hederson); Romantische Tangen (Luchini); Vielleicht bist du das grosse Glück (Erwin); Whispering (Schönberger); Some of these Days (Brooks); Jodelied (Steininger); Dayfish; Sing-Song in Waltz Time (Goslyn); Gramophone Music; Schön ist das Leben (Heymann); Hiawatha's Lullaby (Donaldson); Say it isn't so (Berlin); Moon Song (Johnston); That's what Life is made of (Noble). 5.55, Organ Recital by John Jong: Play, Piddle, Play (Deutsch); Whistling Dance (Jong); Melody (Martin); The Old Kitchen Kettle (Wood-Campbell). 6.10, Gramophone Music. 6.40, Talk. 7.0, Gramophone Music. 7.20, Talk. 7.40, S.O.S. Messages. 7.55, Orchestral Concert, conducted by Hugo de Groot: Overture, La Princesse jaune (Saint-Saëns); Ballet Music from Les deux pigeons (Messager); Intermezzo (Beußmann); Symphonic Poem, Phaeton (Saint-Saëns). 8.40, The Child—Radio Play (Heymans-van Din). 9.30, Concert (cont'd.): Attila (Fucik); Selection from Tannhäuser (Wagner); Mitternachts-glocken (Heubergner); I love my little Cottage (O'Hara); Waltz from The Sleeping Beauty (Tchaikovsky); Ballet égyptien (Luigini). 10.10, Song Recital by Henry Marchand. 10.25, Concert (cont'd.): Overture, Zampa (Hérold); Waltz, Estudiantina (Waldteufel); Die Reise durch Europa (Conrad). 10.55, Gramophone Music. 11.40 (approx.), Close Down.

HORBY.—See Stockholm.

## HUIZEN

160 kc/s, 1,875 metres; 7 kW. (until 3.40 p.m.). (Transmitted from Kootwijk on 50 kW. from 3.40 p.m.). Programme of the Christian Radio Society (N.C.R.V.).—10.40 a.m., Cello Recital by L. Smitzer. 11.40, Police Notes. 11.55, Gramophone Music. 12.10 p.m., Concert by the v.d. Horst Trio. Soloist: Mnc. v. Ravenzwaay-Möllenkamp (Songs); Selection from The Seasons (Haydn); Four Songs; Pastorale (Vivaldi); Romance and Minuet (Mozart); Songs: (a) An die Musik (Schubert), (b) Ungeduld (Schubert), (c) Liebst du um Schönheit (Mahler), (d) Verborgtheit (Wolf), (e)

Ueber Nacht (Wolf); Selection from Henry VIII (Saint-Saëns); Die Uhr (Loewe); Die drei Liebes (Speier); Selection from The Prophet (Meyerbeer); 1.40, Interval. 2.10, Gramophone Music. 2.40, Religious Address. 3.10, Concert by the Sunsum Corda Women's Choir, conducted by Egbert Vos, with Gramophone Interludes. 4.40, Programme for Children. 5.40, Symphony No. 4—The Jupiter (Mozart). 6.10, Programme to be announced. 6.40, Police Notes. 6.55, Religious Reports. 7.10, Talk. 7.40, S.O.S. Messages. 7.45, Concert for the Fortieth Birthday of Jan Zwart, Organist of the Lutherse Kerk, Amsterdam. Address: Cantique de fête (Wiehard); Music by Zwart; Organ Solos by Zwart; Hymn (Zwart); Choral (Zwart); Toccata and Fugue in D Minor (Bach); Andante from the Sonata No. 4 (Bach); Fantasia on the Hymn Ein feste Burg (Zwart); Fantasia on the Hymn, Ich bete dich an, O Macht der Liebe (Zwart); Toccata (Zwart); Achter Hem aan (v. Drieënhuizen-Zwart); Finale and Pastorale from the First Symphony (Guilmant); Finale on Psalm 72 (Zwart). 8.55, News. 9.40, Concert by the Apollo Double Male Voice Quartet. 10.10, Gramophone Music. 11.40 (approx.), Close Down.

INNSBRUCK.—See Vienna.

## JUAN LES PINS

1,205 kc/s, 249 metres; 0.8 kW.—8.0 p.m., Amusement Guide, Exchange, Racing Results and News. 8.5, Oceanographic Report. 8.15, Radio Concert. 9.0, News and Weather.

KALUNDBORG.—See Copenhagen.

KIEL.—See Hamburg.

KLAGENFURT.—See Vienna.

KOSICE.—See Prague.

## LAHTI

167 kc/s, 1,796 metres; 40 kW. Relayed by Helsinki, 815 kc/s, 368.1 metres.—6.15 p.m., Talk. 6.40, Song Recital. 7.5, Talk. 7.30, Dance Music by the Dallapé Band. 7.50, Humorous Items. 8.10, Dance Music (cont'd.). 8.45, News in Finnish and Swedish.

## LANGENBERG

635 kc/s, 473 metres; 60 kW.—1.35 p.m., Orchestral Concert, conducted by Werner Göhre: Homage March (Grieg); Concert Waltz in E (Moszkovsky); Overture, Eury-anthe (Weber); Autumn Song from The Months (Tchaikovsky); Suite from Der Rosenkavalier (R. Strauss); Märchen-Ouverture (Rust); Selection from Lilac Time (Schubert-Berté). 2.30, See Stuttgart. 3.30, Market Prices. 3.50, Political Announcement. 4.0, See Stuttgart. 6.0, German for Germans. 6.20, Talk. 6.35, Talk: Modern German Architecture. 6.50, News. 7.0, Transmission for all German Stations, relayed from Breslau. 8.0, See Frankfurt. 8.10, Around the World—Gramophone Concert, with Commentaries by Stefan Adres, Franz Johannes Weinrich and Walter Bauer. 9.10, Ciocanna Gofica (Dopper) by the Station Orchestra, conducted by Otto Julius Kühn. 9.30, Programme arranged by the Society for the Protection of Animals. 10.0, See Frankfurt. 10.20, See Stuttgart. 10.30, News. 10.45, See Frankfurt. 12 Midnight, Serenade on Gramophone Records. 1.0 a.m. (Thursday), Close Down.

LAUSANNE.—See Radio-Suisse Romande.

## LEIPZIG

769.9 kc/s, 389.6 metres; 120 kW. Relayed by Dresden, 941 kc/s, 319 metres.—12 Noon, Weather and Time. 12.5 p.m., Concert by the Emde Orchestra: March, Reiter-Attacke (Döring); Scandinavian Suite (Juel-Fredrik-son); Florentine Serenade (Seybold); Potpourri, Von Bühne zu Bühne (Fetras); Eine kleine Liebeli (Lautenschläger); Zwei dunkle Augen (Heins); Waltz, Am schönen Rhein gedenk' ich dein (Kéler-Béla); Suite, Dances of the Nations (Manfred); A Spring Dream (Lilling); Intermezzo, Flamingo Parade (Teller); Potpourri, Wiener Leben (Konzak); Kirchweih in Tirol (Krome); Matrosen-Marsch (Christian). In the interval at 1.15 p.m., News. 2.0, Second News. 2.15, Talk for Motorists: Women at the Wheel. 3.0, Gramophone Music. 3.35, Market Prices. 4.0, Annelies dreams—Radio Play for Children (Göcking). 4.45, Choral Concert. In the interval, Reading. 5.50, Market Prices, Weather and Time. 6.0, Book Review. 6.20, Talk on Burgenland. 6.40, Spanish Caprice (Rimsky-Korsakov), played by the Hallé Orchestra on Gramophone Records. 7.0, Transmission for all German Stations, relayed from Breslau. 8.0, Musical Programme. 9.0, Johnny and his Conscience—Radio Play (Peter Steinbach). 10.0, News. 10.30 (from Dresden) (approx.), Dance Music by the Kauffmann Band. 12 Midnight, Close Down.

LINZ.—See Vienna.

## LJUBLJANA

522 kc/s, 574.7 metres; 7 kW.—8.0 p.m., Concert. In an interval at 10.0, Weather and News. 10.30 to 11.0, Programme in English by the I.B.C. Concert: He's got a Wife and Family at Home; Will you dance through life with me?; Ich Liebe Dich, my dear; Bon Voyage; How are you?; When they're on the Love Parade; Why be so unkind to me?; We all wanna know why. 11.0 (approx.), Close Down.

## LUXEMBOURG

252 kc/s, 1,191 metres; 200 kW.—Luxembourg Evening.—7.30 p.m., Concerto in G Minor, Op. 22 (Saint-Saëns), by Arthur de Greef and the New Symphony Orchestra, conducted by Landon Ronald (on Gramophone Records). 8.0, Recitations. 8.20, Concert by the Station Orchestra, conducted by Henri Pénis. Overture, The Bartered Bride (Smetana); Largo (Handel); Mephisto-Walzer (Liszt). 8.50, News in French. 9.0, Concert (cont'd.), Coquette (Danjann); The Dying Swan (Spies); The Witch (MacDowell). 9.15, Recital of Old Luxembourg Songs. 9.45, News in German. 9.55, Concert, Waltz (Koster); Potpourri, Dixiana (Kahnt); Prince Felix (Albrecht). 10.25, Gramophone Records of Dance Music.

## LWOW

788 kc/s, 381 metres; 16 kW.—7.5 p.m., Announcements and Gramophone Music. 7.25, See Warsaw. 7.40, Programme Announcements. 8.0, See Warsaw. 9.15, Warsaw and Lwow Exchange Programme: Pianoforte and Song Recital by Mme. Familier-Hepner (Pianoforte) and Dolnicki (Baritone). 10.0, See Warsaw. 11.5, Gramophone Music. 11.30 (approx.), Close Down.

## LYONS

LA DOUA, 644 kc/s, 465.8 metres; 1.5 kW.—6.30 p.m., Radio Journal. 7.30, Radio Gazette for Lyons and the South-East. 8.30, An Operetta, relayed from Paris (Ecole Supérieure, 671 kc/s, 447.1 metres. After the Operetta, News.

## MADRID

ARANJUEZ (EAQ), 10,000 kc/s, 30 metres; 20 kW.—11.30 p.m., Popular Concert. In the interval at 11.45, Radio Chronicle. 12.00 a.m. (Thursday), Light Music. 1.0 to 1.30, Programme in English by the I.B.C. 1.0, Concert by the I.B.C. (Ireland) Ltd., on behalf of Hospitals Trust, Ltd.: After Love; Selection from Viktoria and her Hussar; Beautiful Nice; The Russian Princess; Black Eyes; The Skaters' Waltz; Rosa de Rio; Selection from The Land of Smiles. 1.30, I.B.C. Goodnight Melody.

## MADRID

EAJ7, 707 kc/s, 424.3 metres; 2 kW.—8.6 p.m., Chimes, Exchange, Programme for Women, Guitar Solos by Soledad Ceca, and Dance Music. 9.15, Topical Review. 9.30 to 11.0, Interval. 11.0, Chimes, Time and Topical Review. 11.20 (approx.), Dramatic Programme. 1.15 a.m. (Thursday), Topical Review. 1.30, Chimes and Close Down.

MALMO.—See Stockholm.

MILAN.—See Turin.

## MORAVSKA-OSTRAVA

1,137 kc/s, 263.8 metres; 11 kW.—6.25 p.m., Recital on Two Pianofortes: Variations and Fugue on a Theme of Beethoven (Saint-Saëns); Suite No. 2 (Rachmaninov). 7.0, See Prague. 7.25, Russian Gipsy Music. 10.15 (approx.), Close Down.

MOTALA.—See Stockholm.

MUHLACKER.—See Stuttgart.

## MUNICH

563 kc/s, 533 metres; 60 kW. Relayed by Augsburg and Kaiserslautern, 536 kc/s, 560 metres; and Nürnberg, 1,256 kc/s, 239 metres.—4.35 p.m., Orchestral Concert, conducted by Erich Kloss: Overture, Franz Schubert (Kéler-Béla); Canzonetta and Minuet (Bocherini); Selection from The Masteringers (Wagner); Invitation to the Dance (Weber); Ballet Music, Ueber allen Zauber Liebe (Lassen); The Peer Gynt Suite (Grieg); Nocturne from Junker Satan (Homani-Wehau); Gavotte (Gossec). 5.45 (from Nürnberg), Talk: German Soldiers in North America. 6.5, Sonata in E Flat for Violin and Pianoforte (Richard Strauss), played by Sigmund Bleier and Karl Kottermeier. 6.25, Talk on the Protection of Animals. 6.45, Time, Weather and Agricultural Notes. 7.0, Transmission for all German Stations, relayed from Breslau. 8.0, Concert of Folk Songs and Folk Music, relayed from Frankenthal. 8.40, Concert of Folk Music by the Mangfalltal Musical Society, the Bad Tölz Zither Club and Boldi

OCT. 4th

WEDNESDAY

continued

(Accordion). 9.10 (from Nürnberg). Bunter Abend. 10.0, Austria. 10.20, Time, Weather, News and Sports Notes. 11.0, Serenade by the Small Station Orchestra, conducted by Erich Kloss. 12 Midnight, Close Down.

NAPLES. See Rome.  
NOTODDEN. See Oslo.

OSLO

277 kc/s, 1,083 metres; 60 kW. Relayed by Fredrikstad, 820 kc/s, 365.8 metres; Hamar, 522 kc/s, 574.7 metres; Notodden, 671 kc/s, 447.1 metres; Porsgrund, 662 kc/s, 453.2 metres; and Rjukan, 671 kc/s, 447.1 metres.—5.0 p.m., Popular Concert by Trygve Christiansen and his Orchestra. 6.0, French Lesson. 6.30, Programme for Children. 7.0, Advertising Notes. 7.15, Weather and News. 7.30, Educational Talk. 8.0, Time. 8.1, Concert of Famous Marches and Waltzes by the Station Orchestra. 9.0, Political Talk. 9.30, Agricultural Talk. 9.40, Weather and News. 10.0, Topical Talk. 10.15, Popular Song Recital. 10.45, Dance Music on Gramophone Records.

DSTERSUND.—See Stockholm.

PALERMO

558 kc/s, 537.6 metres; 3 kW.—8.0 p.m., Dopplavoro Announcements, Tourist Talk, Agricultural Notes and Giornale Radio. 8.20, Gramophone Music. In the interval at 8.30, Time and Announcements. 8.45, Orchestral Concert. Soloists: Della Helt di Gregorio (Soprano), and Miezzi (Clarinet). Scenes pittoresques (Massenet); Soprano Solos: (a) Opina (Cimarosa); (b) Frühlingsraum (Reinhardt); Intermezzo from I quattro rusteghi (Wolf-Ferrari); Allegro from the Clarinet Concerto (Mozart Baerman); Soprano Solos: (a) Stormelli (Cimarosa); (b) The Nightingale (Albini); In the Steppes of Central Asia (Borofin); Clarinet Solo: Caprice (Gaharo); Danse macabre (Saint-Saëns). In the interval: Talk on Witchcraft. After the Concert, Gramophone Music. 11.0, Giornale Radio.

PARIS

EIFFEL TOWER, Call FLE, 207.5 kc/s, 1,445.7 metres; 13 kW. Time Signals (on 2,650 metres) at 10.26 a.m. and 11.26 p.m. (Preliminary and End Signals)—6.45 p.m., Theatre Talk. 7.0, Le Journal Parlé. 8.30, Symphony Concert, conducted by Flamant; Suite No. 1 (Tchaikovsky); Interlude from Polyphème (Ciaes); Selection from Pepita Jimenez (Albeniz); Valse triste (Sibelius); Sicilian Rhapsody (Silber); Suite, Agnus domine glauca (Périer). 10.0 (approx.), Close Down.

PARIS

POSTE PARISIEN, 914 kc/s, 328.2 metres; 60 kW.—7.0 p.m., Ballet Music from Marouf (Rabaud), on Gramophone Records. 7.15, Le Journal Parlé. 7.30, Dance Music by Olga Petroff and his Orchestra: Tango, Rosa de amor (Canaro); Tango, Inspiration (Paulos); Waltz, El jardin del amor (Canaro); Tango, Quien hubiera dicho? (Sciamarella); Tango, Lonjatos (Domeneck); Tango, Volvé (Domato); Waltz, Noche de Tormento (Aenna); Tango, Te quiero (Canaro). 8.0, Talk on Economics. 8.30, Bastos le Hardi—Play in Four Acts (Léon Régis and François de Veynes). 10.30, Dance Music, relayed from the Lido. 11.0, News.

PARIS

RADIO-PARIS, Call CFR, 174 kc/s, 1,725 metres; 75 kW.—7.30 a.m., Weather and Physical Culture. 7.45, Light Music on Gramophone Records. 8.0, Weather and News. 12 Noon, Educational Talk. 12.15 p.m., Gramophone Music: Overture, Zampa (Hérold); Duet from Le pré aux clercs (Hérold); Chorus from Mirella (Gounod). 12.30, Organ Recital from the Gammont Palace. 1.0, Exchange, News, and Weather. 1.5, Gramophone Concert: Overture, Mignon (Thomas); Two Songs from La Basoche (Messager); Melodies from Lakmé (Delibes); Song from Les dragons de Villars (Maillart); Extracts from Carmen (Bizet); Selection from Le Grand Mogol (Audran); Song from Le jour et la nuit (Lecocq); Song from The Grand Duchesse of Gérolstein (Offenbach); Song from The Merry Widow (Lehar); Selection from Les moussquetaires au convent (Vanevy); Quadrille from Orpheus in the Underworld (Offenbach); Song from Les Saltimbanques (Ganne); Selection from Mamezelle Nitouche (Hervé). In the interval at 1.30, Exchange. 2.0, Exchange. 3.45, Market Prices and Weather. 6.30, Talk: The 1933 Vintage. 6.50, Gramophone Records: Overture, Oberon (Weber); Canzonetta (Piaçné); March from Tannhäuser (Wagner). 7.0, Medical Talk. 7.20, Gramophone Records. 8.0, Reading from the Works of Prosper Mérimée. 8.30, News. 8.40, Fashion Review. 8.45, Symphony Concert of French Music. Soloists: Georges Jonatte (Songs). In the interval at 9.15, News.

PORSGRUND.—See Oslo.

PRAGUE

614 kc/s, 488.6 metres; 120 kW.—4.0 p.m., See Bratislava. 4.50, The Mayor of Kozlovice

—Marionette Comedy (Vesely); Music by Prochaska. 5.35, Gramophone Music. 5.45, Talk. 5.55, Gramophone Music. 6.5, Agricultural Report. 6.15, Talk for Workers. 6.25, News in German. 6.30, German Transmission: Sports Talk for Workers and Labour Market Report. 7.0, Time and News. 7.10, Talk. 7.25, Humorous Poetry Recital. 8.5, Concert by the Prague Mandoline and Guitar Club. 8.30, Concert by the Czech Philharmonic Orchestra, conducted by Parik: Three Nocturnes (Debussy); Spanish Caprice (Rimsky-Korsakov). 10.0, Time and News. 10.15, News in French. 10.30 (approx.), Close Down.

RADIO-SUISSE ROMANDE

SOTTENS, 743 kc/s, 403 metres; 25 kW.; and Geneva, 395 kc/s, 760 metres.—7.0 to 7.15 a.m. (from Lausanne), Gymnastics. 12.28 p.m., Time Signal from Neuchâtel Observatory. 12.30, News and Weather. 12.40 (from Geneva), Gramophone Concert. 1.0 (from Geneva), Financial News. 1.10 (from Geneva), Gramophone Concert. 2.0 to 3.28, Interval. 3.28, Time Signal from Neuchâtel Observatory. 3.30 (from Lausanne), Concert by the Radio Lausanne Orchestra, conducted by Musser. 5.0 to 6.0, Interval. 6.0 (from Lausanne), Programme for Children. 7.0 (from Lausanne), Talk: The Tenth Anniversary of the Société Romande de Radio-diffusion. 7.25 (from Lausanne), Agricultural Report, News, and Weather. 7.30 (from Lausanne), Talk on Anthrax. 8.0, Concert by the Radio-suisse Romande Orchestra, conducted by Echonard; Part I: Symphony in D (Haydn); Suite événuelle (Aubert); Part II: Six Pieces (Turina); (a) Jugos, (b) Habanera, (c) The Road to the Alhambra, (d) In the Gardens of Murcia, (e) Cordova, (f) Mirambur. 8.50 (from Geneva), Cabaret Programme. 9.50, News and Weather. 10.0 (from Geneva), Talk: The Work of the League of Nations. 10.30 (from Geneva), Dance Music. 11.0 (approx.), Close Down.

REYKJAVIK

259 kc/s, 1,200 metres; 21 kW.—9.5 p.m., Musical Programme. 9.30, Weather Report. 9.40, Musical Programme and Announcements. 10.0, Chimes and News. 10.30, Reading. 11.0, Violin Solo by Thorarinn Gudmundsson, followed by Icelandic Songs on Gramophone Records.

RIGA

572 kc/s, 525 metres; 15 kW.—6.0 p.m., English Lesson. 6.30, Agricultural Programme. 7.0, Weather. 7.5, Concert of Latvian Music. 8.0, News. 8.5, Concert (contd.). 9.0, Weather and News. 9.10, Concert (contd.). 9.30, Marches by a Mandoline Orchestra. 10.30 (approx.), Close Down.

RJUKAN.—See Oslo.

ROME

Call IRO, 680 kc/s, 441 metres; 50 kW. Relayed by Naples, 941 kc/s, 319 metres; Bari, 1,112 kc/s, 269.8 metres; Milan (Vigenino), 662 kc/s, 453.2 metres from 8.30 p.m. (approx.). and 2RO, 11,810 kc/s, 25.4 metres, from 5.15 p.m.—12.30 p.m., Gramophone Music. 1.2, Orchestral Concert of Light Music. In the interval from 1.30 to 1.45, Giornale Radio and Exchange. 2.0, Time and Announcements. 4.30, Children's Radio Report. 4.55, Giornale Radio, Exchange and Review of the Royal Geographical Society. 5.10, Weather. 5.15 to 6.0, Concert of Light Orchestral Music. 6.40 (Naples), Shipping and Sports Notes. 6.45, Dopplavoro Notes and Tourist Report. 6.57, Report of the International Institute of Agriculture (in Italian and English). 7.10, Agricultural Report. 7.20, News in Foreign Languages. 7.40, Giornale Radio. 8.0, Time, Announcements and Gramophone Music. 8.15, Medical Talk. 8.25, Giornale Radio and Sports Notes. 8.30, La Wally—Opera in Four Acts (Catalani). In the intervals, Talk—St. Francis of Assisi, News, and Giornale Radio.

SALZBURG.—See Vienna.

SCHWEIZERISCHER LANDESENDER

BEROMUNSTER, 653 kc/s, 459 metres; 60 kW.; Basle, 1,229 kc/s, 244.1 metres; and Berne, 1,220 kc/s, 245.9 metres.—11.59 a.m., Time Signal from Neuchâtel Observatory and Weather. 12.0 Noon, (from Berne), Gramophone Music. 12.30 p.m., Time, Weather and News. 12.40 (from Berne), Richard Strauss Gramophone Concert. 1.25 (from Berne), Time, Weather and Exchange. 1.39 (approx.) to 5.0, Interval. 5.0 from Berne), Programme for Children. 5.50 (from Berne), Gramophone Music. 5.59 (from Berne), Extracts from Madame Butterfly—Opera (Puccini), on Gramophone Records. 6.30 (from Zürich), Talk with Gramophone Illustrations: Two Thousand Years of Japanese and Chinese Music. 7.0 (from Zürich), Time, Weather and Market Prices.

7.10 (from Zürich), Gramophone Concert. 7.30 (from Zürich), Elementary English Lesson. 8.0 (from Zürich), Concert of Russian Music by the Station Orchestra. 8.30 (from Zürich), Talk: Baroque Architecture. 9.0, Weather and News. 9.10 (from Zürich), Organ Recital. 10.15 (approx.), Close Down.

SOTTENS.—See Radio-Suisse Romande.

STOCKHOLM

689 kc/s, 436 metres; 55 kW. Relayed by Boden, 244 kc/s, 1,229.5 metres; Göteborg, 932 kc/s, 322 metres; Hörby, 1,166 kc/s, 257 metres; Motala, 221.5 kc/s, 1,354.4 metres; Östersund, 389 kc/s, 770 metres; and Sundsvall, 554 kc/s, 542 metres.—1.0 to 1.30 p.m., Broadcast for Schools, relayed from Malmö, 1,301 kc/s, 231 metres. 5.5, Organ Recital of Light Music. 5.30, Report relayed from Svalöv. 5.55, Gramophone Music. 6.45, Medical Talk. 7.15, Weather and News. 7.30, Talk on Finland, relayed from Malmö. 8.0, Concert by the Budapest Trio; Piano-forte Trio No. 5 in D (Beethoven); Sicilienne and Etrusque (Casella). 8.45, Reading (Katherine Mansfield). 9.15, Song Recital by Gréthe Schöen. 9.45, Weather and News. 10.0, Dance Music by Ender's Orchestra, relayed from the Bern Hall. 11.0 (approx.), Close Down.

STRASBOURG

869 kc/s, 345 metres; 11.5 kW.—11.30 a.m., Gramophone Concert of Variety Music. 12.45 p.m., News. 1.0, Time and Exchange. 1.5, Orchestral Concert, conducted by Maurice de Villers. 2.0, Interval. 4.45, Talk on Electricity. 5.0, Orchestral Concert, conducted by Roskam. 6.0, Trio Concert, relayed from Lille, 1,130 kc/s, 265.4 metres. 7.0, Talk: Rest Cures and Convalescence. 7.15, Talk in German: Review of the World Economic Conference. 7.30, Time and News. 7.45, Gramophone Music. 8.0, Press Review in German, Lottery Results and Announcements. 8.30, Concert for the Feast of St. Francis of Assisi with an Introductory Talk on Kindness to Animals: Ballet Music from Les deux pigeons (Messager); Marriage du pinson; Airade d'oiseaux; Le Gora (Courteline); The Trout Quintet (Schubert); The Flight of the Bumble Bee (Rimsky-Korsakov). 9.30, Orchestral Concert, conducted by Jennine, relayed from the Grand Kelder Tavern; March, Régiments-kinder (Fueik); Waltz, Donauwellen (Ivanovici); The Parade of the Tin Soldiers (Jessel); En parcourant mon album à musique (Baillon); Potpourri of Popular American Melodies, Fox-Cocktail (Sabbert); Potpourri, Old Alsace (Meyer). 10.30, Dance Music, relayed from the Savoy. 12 Midnight (approx.), Close Down.

STUTTGART

MUHLACKER, 832 kc/s, 360.5 metres; 60 kW. Relayed by Freiburg, 527 kc/s, 570 metres.—1.35 p.m., See Langenberg. 2.30, Programme for Young People. 3.30, Swabian Folk Music on Gramophone Records. 4.0, Concert by the Station Orchestra, conducted by Gorieli; March from The Bartered Bride (Smetana); Overture, Peter Schmuell (Weber); Scandinavian Suite (Friedrikson); Marionetten-Hoelzel (Koeferl); Selection from Madame Butterfly (Puccini); Russian March (Ohlson); Fantasia, Wolgalklänge (Lindemann); Gallop, Die Hasenjaed (Eilenberg); Waltz, Der Himmel voller Geigen (Ziehrer); Ballet Music (Lautenschläger); March Art and Nature (Schrammel). 6.0, See Langenberg. 6.35, Talk: The Protection of Animals. 6.50, Time and Agricultural Notes. 7.0, Transmission for all German Stations, relayed from Breslau. 8.0, See Frankfurt. 8.10, See Langenberg. 10.0, See Munich. 10.20, Things one should know. 10.30, See Frankfurt. 10.45, News. 11.0, Concert from Frankfurt. 12 Midnight, See Langenberg. 1.0 a.m. (Thursday), Close Down.

SUNDSVALL.—See Stockholm.

TOULOUSE

RADIOPHONIE DU MIDI, 779 kc/s, 385 metres; 8 kW.—6.0 p.m., News. 6.15, Light Orchestral Music. 6.45, Extracts from Sound Films. 6.50, Sponsored Programme. 7.15, News, Racing Results and Market Prices. 7.30, French Military Music. 7.45, Opera Music: Selection from: L'attaque du moulin (Bruneau); L'émant prodigue (Debussy); Aida (Verdi); and Le jongleur de Notre-Dame (Massenet). 8.0, Orchestral Concert. 8.30, Popular Music. 9.0, Brass Band Concert: Overture, Raymond (Thomas); Jovense carillon de Livray; The Skaters' Waltz (Waldteufel); Selection from Faust (Gounod); Gais échos; March from Athalia (Mendelssohn). 9.30, Operetta Music. Songs from: The Divine Lady (Schikret); Encore cinquante centimes (Yvain); The Desert Song (Romberg) and The Land of Smiles (Lehar). 9.45, Concert by a Viennese Orchestra. 10.15, North African News and Local News. 10.30, Concert for Listeners in Morocco. 11.45, Military Music.

12 Midnight, News, Weather and Announcements. 12.5 a.m. (Thursday), Accordion Music. 12.15, Popular Melodies. 12.50 a.m. (Thursday), Close Down.

TRIESTE

1,211 kc/s, 247.7 metres; 10 kW.—5.10 p.m., Chamber Music: Graziella Bezecchi (Piano-forte), Laura Piazza-Bezecchi (Violin) and Antonietta Merli (Soprano). Piano-forte Solos: (a) Le rossignol (Liszt), (b) Scherzo in E minor (Mendelssohn). Soprano Solos: (a) Nocturne (Trindelli), (b) Catargole (Bianchini), (c) Aria from Louise (Chapelier). Violin Solos: (a) Malaguena (Albeniz), (b) Danse diabolique (Hubay). Soprano Solos: (a) Berceuse (Godard), (b) Aria from Otello (Rossini). 6.0 till Close Down, See Turin.

TRONDHEIM.—See Oslo.

TURIN

1,096 kc/s, 273.7 metres; 7 kW. Relayed by Milan, 905 kc/s, 331.5 metres; Genoa, 599 kc/s, 312.8 metres; and Florence, 599 kc/s, 500.8 metres.—5.10 p.m., Song Recital. 6.0 to 6.5, Weather. 6.45, Giornale Radio, Dopplavoro Notes and Gramophone Music. 7.0, Time, Tourist Report and Gramophone Music. 7.10, What at Market Report. 7.20, News in Foreign Languages. 7.40, Gramophone Music. 8.0, News and Weather. 8.15, Medical Talk. 8.30, Comedy in Three Acts. 9.45, Dance Music. 11.0, Giornale Radio.

VATICAN CITY

15,120 kc/s, 19.84 metres (Morning), and 5,969 kc/s, 50.26 metres (Evening); 10 kW.—11.0 to 11.15 a.m., Religious Information in Spanish. 8.0 to 8.15 p.m., Religious Information in Italian.

VIENNA

581 kc/s, 517 metres; 100 kW.—Relayed by Graz, 852 kc/s, 352.1 metres; Innsbruck, 1,058 kc/s, 283 metres; Klagenfurt, 662 kc/s, 453.2 metres; Linz, 1,220 kc/s, 245.9 metres; and Salzburg, 1,373 kc/s, 218.5 metres.—11.30 a.m., Concert by the Wiener Symphoniker, conducted by Bolzer. In the interval at 11.55, Weather. 1.0 p.m., Time, Weather and Announcements. 1.10, Gramophone Concert. 2.45, Time, Weather and Market Prices. 3.0, Programme for Young People. 3.35, Talk: The Earth Gas Fire at Mediasch in Transylvania. 3.50, Music from Sound Films on Gramophone Records. 4.25, Talk: New Fashions in Men's Hats. 4.35, Talk: Preparation for Life and a Career. 5.10, Talk: The Spanish Hiding School. 5.20, Concert of Contemporary Austrian Music—Alfred Uhl; Sonata for Cello and Piano-forte; Three Sketches for Piano-forte, Bilder aus Wangerouge; Septet for Three Violins, Two Violas, Cello and Clarinet. 6.10, Talk: The Modern Woman's Cosmetics. 6.35, Legal Talk for Workers. 7.0, Italy in German and Italian Music: Concert by the Wiener Symphoniker, conducted by Kabasta. Soloist: Angelo Kessiosoglou (Piano-forte); Symphonic Fantasia in G, Op. 16, Aus Italien (R. Strauss); Castelli romani (Mars); Rhapsody, Italia (Casella). In the interval at 7.45, Time, Programme Announcements and Exchange. 8.45, Topical Talk. 9.0, Talk: Protection of Animals' Day. 9.25, Two Plays: (a) The Little Relations—Comedy in One Act (Thoma), (b) A Peaceful Home (Courteline). 10.40, News, Weather and Exchange. 10.55, Serenade by the Karl Haupt Orchestra, a Schrammel Trio and Singers. After the Programme, Announcements.

WARSAW

212.5 kc/s, 1,411 metres; 120 kW.—11.57 a.m., Time Signal and Fanfare from St. Mary's Church, Cracow. 12.5 p.m., Orchestral Concert: Waltz (Lassota); Aria from Eugene Onegin (Tchaikovsky); Ballad (Wilkosz); Elegy (Rachmaninoff); Violin Solo: Poème (Fibich); Song (Freire); Piece (Orzechowski); Tango (Wilkosz); Tango (Gay). 12.30, Radio Journal. 12.35, Orchestral Concert (contd.). 1.0 to 3.30, Interval. 3.30, Economic Notes. 3.40, Gramophone Music. 4.10, Programme for Children. 4.40, Talk on the Polish Language. 4.55, French Songs on Gramophone Records, relayed from Wilno, 533 kc/s, 563 metres. 5.50, Agricultural Correspondence. 6.0, Talk: Polish Discoveries. 6.20, Programme of Songs and Recitations. 7.5, Miscellaneous Items. 7.25, Literary Talk. 7.40, Programme Announcements. 7.45, Radio Journal. 8.0, Concert of Chamber Music; Mme. Dubiska (Violin), Fiedlerbaum (Violin), Szalesky (Viola), and Adanska (Cello); Quartet in G (Haydn); Quartet in F (Mozart); Duet for Viola and Cello (Beethoven). 9.0, Talk. 9.15, Warsaw and Lwow Exchange Programme—Piano-forte and Song Recital by Mme. Fanciller-Hepner (Piano-forte) and Dolniczy (Baritone); Baritone Solos; Piano-forte Solos: (a) Andante with Variations in F Minor (Haydn), (b) Pastoral and Caprice (Scarlatti); Baritone Solos; Piano-forte Solos: (a) L'Amouresse (Rachmaninoff), (b) Cordoba (Albeniz), (c) Caprice (Bortkiewicz). 10.0, Sports Notes. 10.10, Dance Music. 11.0, Aviation Weather Report and Police Notes. 11.5, Dance Music (contd.).

ZURICH.—See Schweizerischer Landessender.

# THURSDAY

## OCTOBER THE FIFTH

### PRINCIPAL EVENTS OF THE DAY:

#### AT HOME

<b>NATIONAL</b>	Promenade concert from Queen's Hall.
<b>LONDON</b>	Acts I and II of "Snow Maiden" (Rimsky-Korsakov), from Sadlers' Wells.
<b>REGIONAL</b>	"Vignettes of Variety," feature programme.
<b>MIDLAND</b>	
<b>REGIONAL</b>	
<b>NORTH</b>	Relay from the Shakespeare Theatre, Liverpool.
<b>REGIONAL</b>	
<b>WEST</b>	Police Band concert.
<b>REGIONAL</b>	
<b>SCOTTISH</b>	Organ recital by Mr. Robert Head, from St. Mary's Cathedral, Edinburgh.
<b>REGIONAL</b>	
<b>BELFAST</b>	Programme by Street Entertainers.
<b>ABROAD</b>	
<b>BERLIN</b>	5.20 p.m. Bach and his Contemporaries—Concert on Old Instruments.
<b>(Deutschland-sender)</b>	
<b>BRESLAU</b>	8.0 p.m. Oratorio: "The Seasons," by Haydn.
<b>COPENHAGEN</b>	8.10 p.m. The Station Symphony Orchestra.
<b>HEILSBURG</b>	8.10 p.m. Act I of "Rienzi," by Wagner, from the Königsberg Opera House.
<b>HILVERSUM</b>	9.15 p.m. The Utrecht Municipal Orchestra and the Scala Choir of Milan, relayed from Utrecht.
<b>MORAVSKA-OSTRAVA</b>	7.10 p.m. Opera: "Prince Igor," by Borodin, from the National Theatre.
<b>POSTE</b>	8.35 p.m. Recital on the Martenot "Ether Wave" Organ, by the Inventor, accompaniment by the Station Orchestra.
<b>PARISIEN</b>	
<b>TURIN</b>	8.30 p.m. Opera: "William Ratcliff," by Mascagni.

**ALGIERS**  
824 kc/s, 364 metres; 13 kW.—8.20 p.m., Arias from Opera: Elsa's Dream from Lohengrin (Wagner); Elizabeth's Prayer from Tannhäuser (Wagner); Athanaël's Aria from Thaïs (Massenet); Aria from William Tell (Rossini). 8.40, Lottery Results. 9.0, Time. 9.2, Soloist Concert: Violin Solo, Habanera (Sarasate); Pianoforte Solo, Waltz in E Minor (Chopin); Cello Solo, Grave (Corelli); Oboe Solo, Melody No. 3 (Schumann); Violin Solo, Tambourin (Leclair); Pianoforte Solo, Malaguena (Albéniz); Cello Solo, Mazurka (Borodin); English Horn Solo, Le cygne (Saint-Saëns). 9.40, News. 9.45, Professor Cosinus Programme. 10.0, Songs from Sound Films. 10.30, News. 10.35, Military Music. 10.55, News. 11.0, Concert of Oriental Music.

#### ATHLONE

725 kc/s, 413 metres; 60 kW. Relayed by Cork, 1,337 kc/s, 224.4 metres.—1.30 to 2.30 p.m., Time, Weather, Stock Report and Gramophone Concert. 6.0, Programme for Children. 6.40, News. 7.0, French Lesson. 7.15, Val Vonsden (Entertainer). 7.30, Time Signal. 7.31, The Station Orchestra. 7.50, Violin Solos by Editha Braham. 8.5, Comedy by E. Fleming Moran and Company. 8.35, Soprano Solos by Violet Pearson. 8.45, The Station Orchestra. 9.5, Soprano Solos. 9.15, Baritone Solos by Sam Joy. 9.30 to 10.30 p.m., Programme by the I.B.C. (Ireland), Ltd. 9.30, Dance Music: Don't be late in the Morning (Le Clerq); Let Bygones be Bygones (Gilbert); My Love Song (Burnaby); Sunny Madeira (Gilbert). 9.45, Concert: Barcarolle from The Tales of Hoffmann (Offenbach); Intermezzo from Cavalleria rusticana (Mascagni); O Star of Eve, from Tannhäuser (Wagner); Selection from La Bohème (Puccini). 10.0, Concert arranged by the International Broadcasting Company (Ireland), Ltd., on behalf of Hospitals Trust, Ltd. Over the Waves (Rosas); Molly on the Shore (Grainger); Song: Silver Threads along the Gold (Rexford); Handsaw Solo: Roses of Picardy (Haydn Wood); Song: Love's Old Sweet Song (Molloy); Soldatenlieder (Gungl); Cherry Ripe (Frank Bridge). 10.30, I.B.C. Goodnight Melody. 10.33, News and Weather. 10.40, Traditional Fiddle Music by K. Cahalane. 10.50, Pipe Solos by Liam Andrews. 11.0 (approx.), Close Down.

#### BARCELONA

EAJ1, 860 kc/s, 348.8 metres; 8 kW.—7.0 p.m., Trio Concert. In the interval, Talk. 8.0, Request Gramophone Records, followed by News. 10.0, Chimes, Weather and Exchange. 10.5, Concert by the Station Orchestra: March (Kostal); Selection from Déjanire (Saint-Saëns); Czardas (Monti); Cancion canaria (Alonso); Gavotte (Heumenberg); Overture, Prince Igor (Borodin). 11.0, L'Amour Médecin—Comedy (Molière). 12 Midnight (in an interval), News. 1.0 a.m. (Friday), Close Down.

**BASLE.**—See Schweizerischer Landessender.

#### BELGRADE

697 kc/s, 430.4 metres; 2.8 kW.—6.55 p.m., Time and Programme Announcements. 7.0, Talk. 7.30, Popular Music on Gramophone Records. 8.0, Vocal Trios. 8.40, Violin Recital. 9.20, Concert of Operetta Music by the Radio Orchestra. Soloist: Mme. Evka Mikulic. 10.0, Time and News, followed by Dance Music on Gramophone Records.

#### BERLIN

**DEUTSCHLANDSENDER**, 183.5 kc/s, 1,635 metres; 60 kW.—12 Noon, Weather. 12.5 p.m., Gramophone Concert. 12.55, Time. 1.0, Interval. 2.0, Gramophone Concert (cont'd.). 2.45, Talk: The Wonders of Nature. 3.10, Talk for Young People: Impressions of Central America. 3.30, Weather and Exchange. 3.45, Reading from the Novel, Stelling Rotkirson (Blunck). 4.0, See Langenberg. 5.0, Talk for Women: Women in Fascist Italy. 5.20, Bach and his Contemporaries—Concert on Old Instruments; Eta Harich-Schneider (Harpischord), Hans Fieguth (Flute), and Friedhelm Wilksh (Viola da Gamba): Sonata for Flute and Harpischord (Bach); Sonata for Viola da Gamba and Harpischord (Händel); Harpischord Solo, Extracts from Biblische Historie (Kuhnau); Sonata in E Flat for Flute and Harpischord (Bach). 6.0, Poems. 6.5, From North and South—Orchestral Concert, conducted by Sonntag; Swedish Wedding March (Södermann); Spanish Dance No. 4 (Granados); Ballet Suite (Gyldmark); Romance (Turina); Wedding Day on Trollhaugen (Grieg); Spanish Caprice, Moraima (Espinoza); Prelude (Jarnefelt); Cadiz (Albeniz); Three Pieces (Frederiksen): (a) Norwegian Idyll, (b) Scandinavian Peasant Dance, (c) Troll Dance. 6.50, Weather and News. 7.0, Transmission for all German Stations, relayed from Hamburg. 8.0, To-day's Motto. 8.5, Lovers and Fools—Scenes from Shakespeare's Plays, arranged by Hans Rothie to Music by Purcell. 9.20, Concert from Munich. 10.0, Weather, News, and Sports Notes. 10.45, Weather. 11.0, Concert by a Nazi Band, relayed from the Nationalen Gaststätten. 12 Midnight, Close Down.

**BRATISLAVA**  
1,076 kc/s, 279 metres; 14 kW.—5.30 p.m., Russian Song Recital by Arthur Gofman (Baritone). 5.55, Gramophone Music. 6.0, Violin Recital by Rudolf Dbl. 6.25, Concert of Light Music by the Station Band, conducted by Karel Nagl. 6.55, Hints for Housewives. 7.0, See Prague. 8.10, Talk. 8.25, See Prague. 9.15, See Brno. 10.0, See Prague. 11.0 (approx.), Close Down.

**BREMEN.**—See Hamburg.

#### BRESLAU

923 kc/s, 325 metres; 60 kW. Relayed by Gleiwitz, 1,184 kc/s, 253 metres.—12 Noon, Concert by the Silesian Philharmonic Orchestra, conducted by Rischka: Overture, Die Weihe des Hauses (Beethoven); Selection from Boris Godunov (Mussorgsky); Ballet Music from Rosamund (Schubert); Waltz, Op. 59, No. 2 (Schütt); Russian Dance No. 5 (Bullerian); Overture to a Revue (Lincke); Strauss, Milfäcker, and Suppé Potpourri (Ziehrer); Waltz, Am schnee Rhein gedank ich dein (Keler Bela);

March, Hoch Deutschlands Ruhm (Schröder). 1.45 p.m., Time, Weather and News. 2.10, Recital of Max Reger Lieder by Claire Frühling. 2.40, Request Gramophone Records. 3.0, Agricultural Prices. 3.15, Review of Books about Transylvania. 3.35, Talk: The Beauties of Silesia's Valleys. 3.45, Programme for Children. 4.15, Concert by the Station Orchestra, conducted by Topitz; Overture, The Italian Girl in Algiers (Rossini); Selection from Il Trovatore (Verdi); Adagio (Sardini); Minuet (Mozart); Selection from Eugene Onegin (Tchaikovsky); Selection from Im Reiche des Indra (Lincke); In a Persian Market (Ketelbey); Waltz, Weaner Madln (Ziehrer); Gallop (Dittrich). 5.50, Agricultural Prices. 6.0, Programme to be announced. 6.15, Talk: Everyday Secrets. 6.25, Talks by Workers and their Leaders. 7.0, Transmission for all German Stations relayed from Hamburg. 8.0, The Seasons—Oratorio (Haydn). In the interval at 9.0, News. 10.0, Time, Weather and News. 10.25, Dance Music from Sound Films, relayed from Berlin (Funkstunde). 1.0 a.m. (Friday), Close Down.

#### BRNO

878 kc/s, 342 metres; 35 kW.—4.0 p.m., Concert by the Station Orchestra, conducted by Janota. Overture, The Secret (Dvorak); Suite, Op. 39 (Dvorak); Hindu Song (Prozavnik); Waltz and Polka (Moor); March (Nedbal). 4.50, See Prague. 5.15, News for Young People. 5.25, Gramophone Music. 5.35, See Prague. 5.50, Gramophone Music. 6.0, Theatre and Film Review. 6.15, See Prague. 6.25, German Transmission: News and Dramatic Programme. 7.0, See Prague. 8.10, See Bratislava. 8.25, See Prague. 9.15, Summer Nights—Trio Concert with Recitations. 10.0, See Prague. 11.0 (approx.), Close Down.

#### BRUSSELS (No. 1)

I.N.R., 590 kc/s, 509 metres; 15 kW.—12 Noon, Concert by the Small Station Orchestra, conducted by Leemans: Overture, Solidarité (Weyts); Waltzes (Gillon); Serenade (de Boeck); Selection from I Pagliacci (Leoncavallo); Pense a te (To-ti); Violin Solo: The Canary (Polliakin); Selection from Sunny (Kern); Spanish Dances (Mozzkovsky). 1.0 p.m., Le Journal Parlé. 1.10, Gramophone Concert. 5.0, Concert by the Station Symphony Orchestra, conducted by Kumps. Overture, Si j'étais roi (Adam); Hungarian March (Berlioz); Fête à Aranjuez (Demersseman); Valse des violettes (Waldteufel). 5.30, Programme for Children. 6.0, Theatre Talk. 6.15, Popular Gramophone Concert. 7.15, Talk for Workers. 7.30, Sports Talk. 8.0, Concert by the Station Symphony Orchestra, conducted by Kumps: Overture, The daughter of the Regiment (Donizetti); Offenbachiana

(Conrardi); Selection from A Masked Ball (Verdi); Polish Dances (Scharwenka). In the interval, Variety Items. 8.45, Talk. 9.0, Concert by the Radio Orchestra, conducted by Walpot: Florentine March (Fueick); Waltz, Wine, Woman and Song (Joh. Strauss); Prelude and Intermezzo from Cavalleria rusticana (Mascagni); Selection from Phi-Phi (Christine); Ballet Music from Le Cid (Massenet). Variety Items or Gramophone Records in the interval. 10.0, Le Journal Parlé.

#### BRUSSELS (No. 2)

N.I.R., 887 kc/s, 338.2 metres; 15 kW. Programme in Flemish.—12 Noon, Strauss and Lehár Gramophone Concert. 1.0 p.m., Le Journal Parlé. 1.10, Concert by the Small Station Orchestra, conducted by Leemans: March, Sambre et Meuse (Planquette); Overture, Poet and Peasant (Suppé); Selection from Lilac Time (Schubert-Berté); Fantasia on Songs of Hullebroeck (Wigy); Serenade, Les trésors de Colombine (Drigo); Serenade (Toselli); Meditation from Thaïs (Massenet); Spanish Dances (Mozzkovsky). 5.0, Gramophone Music: Coronation March (Saint-Saëns); Le carnaval des animaux (Korsakov). 5.45, Programme for Children. 6.30, Programme for Young People. 7.12, News. 7.15, Film and Book Review. 7.30, Programme for Housewives. 8.0, Concert by the Radio Orchestra, conducted by Charles Walpot: Waltz from La Houssarde (Ganne); Marche lorraine (Ganne); Selection from Viktoria and her Hussar (Abraham); Extracts from White Horse Inn (Benatzky); Phantom Brigade (Myddleton); Down South (Myddleton); March, Stars and Stripes (Souza). 8.45, Talk. 9.0, Concert by the Station Symphony Orchestra, conducted by Jean Kumps. Soloist De Becker (Bass): Overture, Le Roi d'Ys (Lalo); L'apprenti-sorcier (Dukas). Bass Solos: (a) Serenade (Schubert). (b) Aria from The Barber of Seville (Rossini); Le chasseur maudit (César Franck). Bass Solos: (a) Song (Mussorgsky). (b) Aria from The Magic Flute (Mozart); Overture, The Flying Dutchman (Wagner). 9.55, Evening Prayer. 10.0, Le Journal Parlé.

#### BUCHAREST

761 kc/s, 394 metres; 12 kW.—5.0 p.m., Light Music and Romanian Music by the Dinico Orchestra. In an interval at 6.0, Radio Journal. 7.0, Educational Programme. In an interval at 7.20, Gramophone Music. 8.0, Songs. 8.20, Concert by the Station Orchestra: Egyptian Dance (Niemann); Bourrée and Gavotte (Bach); Sarabande, Pavane and Passepied (Foullès); Minuet from Orpheus (Gluck); Waltz, Accelerationen (Strauss); Boston Waltz, Tango, Negro Dance and Charleston (Niemann); Russian Dance (Bullerian); Spanish Dance (Falla); Slav Dance No. 10 (Dvorak); Hungarian Dance No. 8 (Brahms); Polonaise (Chopin); Tarentella (Castaldi); Two Romanian Dances (Silvestri). In an interval at 9.0, Talk. 9.45, Radio Journal.

#### BUDAPEST

545 kc/s, 550.5 metres; 18.5 kW.—Also relayed on 840 metres from 8.0 p.m. till Close Down.—5.0 p.m., Agricultural Programme. 5.30, Concert by the Bertha Orchestra. 6.30, Talk. 7.0, Cello Recital by Buttala: Sonata in C Minor (Marelli); Hungarian Rhapsody (Popper); Melody (Godard); Sehnetwärtling (Popper). 7.30, Talk on St. Stephen's Cathedral, Vienna. 8.0, Pianoforte and Song Recital. 9.15, Talk. 9.40, Extracts from The Tragedy of Mankind (Madaeh). 10.30, News. 10.45, Hungarian Music on Gramophone Records.

**CASSEL.**—See Frankfurt.

#### COPENHAGEN

1,067 kc/s, 281 metres; 0.75 kW. Relayed by Kalundborg, 260 kc/s, 1,153.8 metres.—12 Noon, Time and Chimes from the Town Hall. 12.5 p.m., String Ensemble Concert, relayed from the Hotel d'Angleterre. 2.0, Interval. 3.10, Danish Song Recital by Anna Mundt-Thuner. Songs (Fini Henriques): (a) Nocturne, (b) Blomsterbud; Alle Klokker bringer hjem (Kjerulf). Songs (Thuner): (a) Vuggesang, (b) Serenade, (c) Roser, (d) Du som Freden mig forkynder. 3.30, Orchestral Concert, relayed from the Wivex Restaurant. 4.45, Programme for Boys. 5.30, Exchange and Fish Market Prices. 5.45, Talk. 6.15, Elementary English Lesson. 6.45, Weather and News. 7.15, Time Signal. 7.16, Talk: Democracy and Dictatorship. 7.45, Danish Lesson. 8.10, Concert by the Station Symphony Orchestra, relayed from the State Broadcasting Building. Conductor: Nicolai Malko. Soloist: Vladimir Horowitz (Pianoforte). Overture, The Maid of Pskov (Rimsky-Korsakov). Pianoforte Concerto No. 3 in D minor (Rachmaninov). Ten Minutes Interval. Variations for Strings (Arensky). Pianoforte Solos: (a) Funerailles (Liszt), (b) Sérénade à la Pouppée (Debussy), (c) Russian Dance from Petruschka (Stravinsky); Introduction and Wedding March from The Golden Cockerel (Rimsky-Korsakov). 10.15, News. 10.30, Readings from The Works of Daudet. 10.55, Dance Music, re-



OCT. 5th **THURSDAY** continued

played from the National Scala. In the interval at 12 Midnight, Time and Chimes from the Town Hall. 12.30 a.m. (Friday), Close Down.

**CORK.**—See Athlone.  
**DANZIG.**—See Heilsberg.  
**DRESDEN.**—See Leipzig.

**FECAMP**

1,328 kc/s, 225.9 metres; 10 kW.—11.0 a.m. to 12 Noon, Programme in English by the I.B.C. 11.0, Happy Hour: Part I—Orchestral Concert: Gipsy Moon (Borghano); Fairy Tale (Heykens); Pianoforte Solo, The Squirrel Dance (Elliot-Smith); Barcarolle (Waldteufel); The Dwarf's Patrol (Rathke); Pianoforte Solo, Selection from Words and Music (Coward); Pan and the Wood Goblins (Rathke); Wiener Blut (Joh. Strauss). Part II—Dance Music: From me to you; Reflections in the Water; Love Songs of the Nile; My Gipsy Rhapsody; A Woman should stick to her Man; In Santa Lucia; At the Old Pig and Whistle; He was only a poor Musician; Signature Tune. 12 Noon, Programme in French. 4.30 to 6.0, Programme in English by the I.B.C. 4.30, The Nursery Corner. 5.0, Concert for Worthing and Littlehampton Listeners—Light Music: Signature Tune, Night by the Sea; Dream Girl of Yesterday; Tango de Pâques; The Wedding of the Painted Doll; I can't write the Words; What aloha Means; Flappette; The Return of Johnnie; The Old Folks at Home. 5.30, Concert for Brighton and Hove Listeners—Orchestral Concert: Rakoczy March (Berlioz); Searf Dance (Chaminade); Hungarian Dance, No. 5 (Brahms); Violin Solo, Caprice Basque (Sarasate); Selection from I Pagliacci (Leoncavallo); Cello Solo, The Nightingale and the Rose (Rimsky-Korsakov); Slav Dance, No. 10 (Dvorak); Sleeping Beauty Waltz (Tchaikovsky); Signature Tune. 6.0, Programme in French. 10.0 till Close Down, Programme in English by the I.B.C. 10.0 (approx.). Dance Music: Signature Tune, Bells of Normandy; I wanna count Sheep; Balloons; Roll along Kentucky Moon; My Darling; One little Word led to another; P.C. 123; Somebody stole my Gal; The Shadow Waltz; I lay me down to sleep; Maria my own; Shuffle off to Buffalo; Castles in the Sand; I'll do my best to make you happy; Just an Echo in the Valley; Love is the Sweetest Thing; By the Fireside; Pink Elephants; Signature Tune. 11.0, Times from the Talks: Signature Tune, Sittin' in the Dark; You are my Heart's Delight, from The Land of Smiles (Lehár); But for you; One little Brick; There's Something about a Soldier (Gay); Selection from The Crooner; Sweetheart Darlin'; The Rozone Song; Twentieth Century Blues; Signature Tune. 11.30, Concert by the International Broadcasting Company (Ireland), Ltd., on behalf of Hospitals' Trust, Ltd.: Signature Tune, Come back to Erin; Potpourri Overture (arr. Leggett); Harp Solo, Irish Melodies; Serenade (Pierné); Selection from Wonder Bar (Katscher); Song, Inisfallen (Aitken); The Nightingale in the Lilac Bush (Krome); Stéphanie Gavotte (Czibulka); The Mill in the Black Forest (Eilenberg); Signature Tune, Come back to Erin. 12.5 a.m. (Friday), News Bulletin in English. 12.10 (approx.), Club Concert for Cadrigan and Newport Listeners: Signature Tune, The Chum Song; Red Devil (Perkins); Melancholy (Bloom); Just an Echo in the Valley; Black and Tan Fantasy; Room 1411. Part II—Dance Music by Jay Wilbur and his Band (Electrical Transcriptions): I've got the World on a String; One Tiny Tear; Stormy Weather; I shall still keep smiling along; Good-night but not good-bye; And so I married the Girl; Put a little Spring-time; Her Name is Mary; This is no Dream; Hyde Park Corner; Signature Tune. 1.0, Dance Music: Signature Tune, Bells of Normandy; Stay out of my Dreams; Rhapsody in Blue (Gershwin); Sweetheart Darlin'; Look what I've got; Lover; In the Park in Parade; Down the Old Ox Road; Learn to croon; My Lucky Day; From me to you; Happy Ending; Love Songs of the Nile; I've told every little Star; No more Love; Two Buck Tim from Timbuctoo; I cover the Waterfront; Signature Tune. 2.0, I.B.C. Good-night Melody and Close Down.

**FLENSBURG.**—See Hamburg.  
**FLORENCE.**—See Turin.

**FRANKFURT**

1,157 kc/s, 259.3 metres; 17 kW. Relayed by Cassel, 1,220 kc/s, 245.9 metres; and Trier, 1,157 kc/s, 259.3 metres.—4.0 p.m., See Langenberg. 6.0, See Stuttgart. 6.35, Talk: The Doctor and Sport. 6.50, Weather Announcements and Time. 7.0, Transmission for all German Stations, relayed from Hamburg. 8.0, Topical Talk. 8.10, See Langenberg. 10.0, Time and News. 10.20, See Stuttgart. 10.30, Local News and Weather. 10.45 to 1.0 a.m. (Friday), See Stuttgart.  
**FREDRIKSSTAD.**—See Oslo.  
**FREIBURG.**—See Stuttgart.  
**GENEVA.**—See Radio-Suisse Romande.  
**GENOA.**—See Turin.  
**GLEIWITZ.**—See Breslau.  
**GOTEBORG.**—See Stockholm.  
**GRAZ.**—See Vienna.  
**HAMAR.**—See Oslo.

**HAMBURG**

806 kc/s, 372 metres; 1.5 kW. Relayed by Bremen, 1,112 kc/s, 269.8 metres; Flensburg, 1,319 kc/s, 227.4 metres; Manover, 530 kc/s, 566 metres; and Kiel, 1,292 kc/s, 232.2 metres.—6.10 p.m., Variety Programme. 6.25, Book Review. 6.45, Frankfurt Exchange. 6.50, Weather. 7.0, Transmission for all German Stations: Symphonic Dances by North German Composers. The Hamburg Philharmonic Orchestra, conducted by José Ethonshütz. Minuet from Symphony No. 4 (Woysech); Scherzo capriccioso (Scheffer); Two German Dances (Günats); Extracts from the Carnival Suite Op. 15 (Grimpe); Exotische Tanz-Szene (Udall). 8.0, Agricultural Talk. 8.15, Geld—Comedy in Dialect (Heinrich Dieckmann). 9.15, Concert of Max Trapp Music by the Philharmonic Orchestra, conducted by the Composer. 10.5, News. 10.25, Topical Talk. 10.35, Dance Music by the Small Station Orchestra, conducted by Gerhard Maasz.

**HANOVER.**—See Hamburg.

**HEILSBURG**

1,085 kc/s, 276.5 metres; 60 kW. Relayed by Danzig, 662 kc/s, 453.2 metres.—1.5 p.m., Concert by the Small Station Orchestra, conducted by Wileken. Overture, Prince Methusalem (Strauss); Moonlight in Venice (Armandola); Waltz-Serenade (Reznicek); Selection from L'amico Fritz (Mascagni); Waltz, In Zentrum (Strauss); Three Fanciful Etchings (Kettelbey); Andalusian Serenade (Armandola); Overture, Le dieu et la Bayadère (Auber). In the intervals at 1.20 and at 2.0, News. 3.0, Agricultural Prices and Exchange. 3.15, Programme for Young People. 4.0, Concert by the Small Station Orchestra, conducted by Wileken. Overture, Le maschere (Mascagni); Two Old Russian Dances (Clemens); Serenade from Don Juan's Last Adventure (Graener); Intermezzo from Tiefland (d'Albert); Marienwälder (Lanner); Suite, Erinnerungen an Kairo (Armandola); Two Old Dutch Dances (Heykens); Gipsy Festival (Heykens); March, Mit vereinten Kräften (Strauss). In the interval at 5.0, Book Review. 5.35, Talk: "Children are an Heritage of the Lord." 5.50, Gipsy Songs (Dvorak), sung by Hans Koelsing (Baritone). 6.15, Agricultural Prices. 6.25, Agricultural Programme. 6.50, Weather. 7.0, Transmission for all German Stations, relayed from Hamburg. 8.0, Weather and News. 8.10, Act I of Rienzi—Opera (Wagner), relayed from the Königsgberg Opera House. 8.50, Pianoforte Recital by Franz Rupp, Sonata in A Minor, Op. 142 (Schubert); Capriccio in F Sharp Minor, Op. 76 (Brahms); Rhapsody in E Flat, Op. 119 (Brahms). 9.24, South Sea Flight—Radio Play (Steimbach). 10.20, Weather, News and Sports Notes.

**HILVERSUM**

1,013 kc/s, 296.1 metres; 7 kW. up to 5.40 p.m., and 20 kW. from 5.40 p.m. Programme of the Allgemeine Vereinging Radio Omroep (A.V.R.O.).—10.10 a.m., Organ Recital by Egbert Vos, with songs by Annie Veenbos (Contraalto); Prelude and Fugue in E Minor (Bach); Songs: (a) Letzter Frühling (Grieg); (b) Die Prinzessin (Grieg); (c) Ich liebe dich (Grieg); (d) Wiegenlied (Brahms); Pastorale (Franck); Benedicteus (Max Reger); Songs: (a) Im wunderschönen Monat Mai (Schumann); (b) Aus meinem Tränen spriessen (Schumann); (c) Two Songs (Hammers); Pastoral, Recitative and Choral (Elert). In the interval at 10.40, Recitations. 11.40, Time. 11.41, Concert by the Octophonikers. In the intervals, Gramophone Music. 1.55 to 2.10, Interval. 2.10, Concert by the Wireless Orchestra, conducted by Nico Treep. Overture, The Bartered Bride (Smetana); Selection from Turandot (Puccini); Granada (Albeniz); Tarantella (Saint-Saëns); Three Dances from Henry VIII (German); Valse des fleurs (Tchaikovsky); The Birthday Greeting (Kettelbey); Forget-me-not (Macbeth); Selection from The Mikado (Sullivan). In the intervals, Gramophone Music. 3.40, Programme for Hospitals. 4.10, Gramophone Music. 4.25, Programme for Children. 5.10, Concert by the Wireless Orchestra. Knights of the King (Kettelbey); Byzock (Bullerian); Copak (Bullerian); Waltz, Over the Waves (Rosas); Kimmsterlaune (Fetras); Clog Dance (Fetras); Florentine Serenade (Godard); Selection from The Gipsy Baron (Joh. Strauss). 6.10, Sports Talk. 6.40, Concert by the Octophonikers. 7.10, Talk. 7.20, Concert (cont'd.). 7.40, Time. 7.41, News. 7.45, Concert by the Concertgebouw Orchestra, relayed from the Concertgebouw, Amsterdam. Conductor, William Mengelberg. Soloist: José Iturbi (Pianoforte). The Halfner Serenade (Mozart); Pianoforte Concerto in A Minor (Schumann). 8.55, Gramophone Music. 9.15, Concert, relayed from the Tivoli, Utrecht. The Utrecht Municipal Orchestra, conducted by Albert van Raalte, and the Scala Choir of Milan, conducted by Veneziani. Chorus from Nebuchadnezzar (Verdi); Symphonic Intermezzo from L'Amico Fritz (Mascagni);

Chorus from Aida (Verdi); Triumphant March and Ensemble from Act II of Aida (Verdi). 10.10, Gramophone Music. 10.40, News. 10.50, Light Music by Tom van der Stap and his Orchestra, relayed from the Grand Hotel Central, The Hague. 11.40, Time and Close Down.

**HORBY.**—See Stockholm.

**HUIZEN**

160 kc/s, 1,875 metres; 8.5 kW. 7 kW. until 3.40 p.m. (Transmitted from Kootwijk on 50 kW. from 3.40 p.m.)—11.55 a.m. to 1.40 p.m., Programme of the Catholic Radio Society (K.R.O.). 11.55, Concert by the K.R.O. Orchestra, conducted by van 't Woud; March, Victoria (Blon); Overture, La belle Hélène (Offenbach); Vive la danse (Waldteufel); Ballet Suite (Popy); Slav Rhapsody No. 1 (Friedemann); Gramophone Records; Overture, Norma (Bellini); Selection from The Love Parade (Scherzinger); Melody (Rubinstein); Gitana (Bucalossi); Love's Dream after the Ball (Czibulka); Prelude (Rachmaninov); The Diplomat (Souza). 1.40 till Close Down, Programme of the Christian Radio Society (N.C.R.V.). 1.40, Book-keeping Lesson. 2.40, Gramophone Music. 3.20, Interval. 3.40, Bible Reading and Sacred Songs. 4.40, Handwork Lesson for Young People. 5.10, Song and Organ Recital by Alie, Hagenbeek (Soprano) and Klock (Organ); Prelude in C (Bach); Soprano Solos (Bach): (a) Dem Ende zu, (b) Gott lobet mich, (c) Quia exposit; Concerto No. 1 in G (Handel); Soprano Solos: (a) Angels ever bright and fair (Handel); (b) When I am laid in Earth (Purcell); Cantabile (Messner); Soprano Solos: (a) Schlafendes Jesuskind (Wolf); (b) Gebet (Wolf). 6.10, Talk. 6.25, Gramophone Music. 6.40, Police Messages. 6.55, Religious News. 7.10, Press Review. 7.40, Public Meeting of the Union of the Youth of the Reformed Church, relayed from Rotterdam. 9.40, News, followed by Gramophone Music. 11.0 (approx.), Close Down.

**INNSBRUCK.**—See Vienna.

**JUAN LES PINS**

1,205 kc/s, 249 metres; 0.8 kW.—8.0 p.m., Amusement Guide, Exchange, Racing Results and News. 8.10, Fashion Review. 8.20, Radio Concert. In an interval at 9.0, News and Weather.

**KALUNDBORG.**—See Copenhagen.

**KIEL.**—See Hamburg.

**KLAGENFURT.**—See Vienna.

**KOSICE.**—See Prague.

**LAHTI**

167 kc/s, 1,796 metres; 40 kW. Relayed by Helsinki, 815 kc/s, 368.1 metres.—6.15 p.m., Talk. 6.40, Pianoforte Recital by Kerstin Karsten; Sicilienne (Bach-Galston); Passacaglia (Händel-Halvorsen-Ekman); Réverie (Debussy); Ballad in G Minor (Chopin); Etude in C Sharp Minor (Chopin). 7.5, Talk. 7.30, Concert by the Station Orchestra, conducted by Erkki Linko. 8.10, Talk. 8.25, Gramophone Music. 8.45, News in Finnish and Swedish.

**LANGENBERG**

635 kc/s, 473 metres; 60 kW.—12 Noon, Concert by the Fröhliche Fünf, Willi Jansen (Accordion), and Fassbender (Pianoforte). 1.15 p.m., Time and News from Frankfurt. 1.25, News. 1.35, Concert from Stuttgart. 3.0, Reading of a Legend: How Eve died. 3.30, Market Prices. 3.50, Topical Talk. 4.0, Concert by the Station Orchestra and String Quartet, conducted by Kuhn: Italian Caprice (Tchaikovsky); Theme and Variations for String Quartet (Glière); Ballet Music from Les petits riens (Mozart); Slav Dances (Dvorak); Pieces for String Quartet: (a) Minuet (Mozart); (b) Scherzo (Beethoven). (c) Adagio (Schumann). (d) Rondo (Haydn); Second Suite from L'Arlesienne (Bizet). 6.0, See Stuttgart. 6.35, Talk on the Nazi Salute. 6.40, Talk on Carinthia. 6.50, News. 7.0, Transmission for all German Stations, relayed from Hamburg. 8.0, See Frankfurt. 8.10, Wibbel's Resurrection—Comedy in Four Acts (Müller-Schlösser). 10.0, Time and News from Frankfurt. 10.20, See Stuttgart. 10.30, News. 10.40 to 1.0 a.m. (Friday), See Stuttgart. 1.0 a.m., Close Down.

**LAUSANNE.**—See Radio-Suisse Romande.

**LEIPZIG**

769.9 kc/s, 386.6 metres; 120 kW. Relayed by Dresden, 941 kc/s, 319 metres.—12 Noon, Concert relayed from Breslau. 1.15 p.m., News. 1.30, German Classical Music on Gramophone Records; Overture, Coriolanus (Beethoven); Romances Nos. 1 and 2 (Schumann); Extracts from Act 3 of Lohengrin

(Wagner); Two Movements from the Piano-forte Trio Op. 87 (Brahms). 6.30, Harpsichord Recital by Anna Barbara Specker; Passamezzo Variations (Scheidt); Dance from the 1523 Lute Tablature; Flötenhrstücke (Haydn). 7.0, Transmission for all German Stations, relayed from Hamburg. 8.0, Programme to be announced. 10.0, News. 10.30 (approx.), Close Down.  
**LINZ.**—See Vienna.

**LJUBLJANA**

522 kc/s, 574.7 metres; 7 kW.—6.0 p.m., Programme for Children. 6.30, The Letter Box. 7.0, Serbo-Croatian Lesson. 7.30, Gramophone Music. 8.0, Talk on Music, with Illustrations by the Station Orchestra. 8.45, Choral Concert. 9.30, Weather and News. 9.45, Concert by the Station Orchestra. 10.30, Dance Music. 11.0 (approx.), Close Down.

**LUXEMBOURG**

252 kc/s, 1,191 metres; 200 kW.—German Evening. 7.30 p.m., Symphony No. 3—the Scottish Mendelssohn, by the Royal Philharmonic Orchestra, conducted by Felix Weingartner (on Gramophone Records). 8.5, Talk: Superstition. 8.20, Song Recital by Johannes Kressen; Songs (Schumann): (a) Der Nussbaum, (b) Du bist wie eine Blume. (c) Aus den östlichen Rosen. (d) Zum Schluss, (e) Widmung; Songs (Schubert): (a) Der Tod und das Mädchen, (b) Der Doppelgänger, (c) An die Musik. 8.50, News in French. 9.0, Concert of German Music by the Station Orchestra, conducted by Henri Pénis. Soloist: René Delporte (Pianoforte); Eine kleine Nachtmusik (Mozart); Pianoforte (Concerto (Delporte). 9.45, News in German. 9.55, Concert by the Station Orchestra: Ode to Terpsichore (de Taeye); Selection from Nala (Delibes); Selection from Viktoria and her Hussar (Abraham). 10.25, Dance Music on Gramophone Records.

**LOWO**

788 kc/s, 381 metres; 16 kW.—7.5 p.m., Gramophone Music. 7.10, Announcements and Gramophone Music. 7.25, See Warsaw. 7.40, Programme Announcements. 7.45, See Warsaw. 11.5, Gramophone Music. 11.30 (approx.), Close Down.

**LYONS**

LA DOUA, 644 kc/s, 465.8 metres; 1.5 kW.—6.30 p.m., Radio Journal. 7.30, Radio Gazette for Lyons and the South-East. 8.30 (approx.), Concert followed by Poste à l'air—Opérette in One Act (Cavel and Cools). After the Programme, News.

**MADRID**

ARANJUEZ (EAQ), 10,000 kc/s, 30 metres; 20 kW.—11.30 a.m., Concert, relayed from Madrid (EAJ7). 1.0 to 1.30 a.m. (Friday), Programme in English by the I.B.C. 1.0, I.B.C. Concert: Montana Moon; Yes, Mr. Brown; Montana Call; Only a Rose; The Old Blind Man; My Beautiful; The Russian Princess; Selection from The Count of Luxembourg. 1.30, I.B.C. Goodnight Melody.

**MADRID**

EAJ7, 707 kc/s, 424.3 metres; 2 kW.—8.0 p.m., Chimes, Exchange, and Programme for Children. 9.15, Topical Review. 9.30 to 11.0, Interval. 11.0, Chimes, Time and Topical Review. 11.20 (approx.), Concert. Part I: Opérette Music. Selection from The Gipsy Princess (Kálmán); A Waltz Dream (O. Straus); Paganini (Lehár), and Rose Marie (Friml). Part II: Song Recital by Trini Carreras. Part III: Guitar Solos by Trinidad García Aguado. 1.15 a.m. (Friday), Topical Review. 1.30, Chimes. 2.0 to 3.0, Programme in English by the I.B.C. 3.0 (approx.), Close Down.

**MALMO.**—See Stockholm.

**MILAN.**—See Turin.

**MORAVSKA-OSTRAVA**

1,137 kc/s, 263.8 metres; 11 kW.—6.30 p.m., German Transmission: Pianoforte Recital by Jelez; Suite, The Circus; Suite Op. 14 Bela-Bartok); Melody (Pierné). 7.0, See Prague. 7.10, Prince Igor—Opera (Borodin), relayed from the National Theatre. 10.0, See Prague. 11.0 (approx.), Close Down.

**MOSCOW**

TRADES UNION, 300 kc/s, 1,000 metres; 100 kW.—3.0 p.m., Soprano Song Recital. 3.55, Time. 4.00, Foreign Language Lesson. 4.30, Play (Gorky), followed by Reading. 5.30, Orchestral and Choral Concert by the Workers' Amateur Musical Society. In the intervals, Recitations. 6.30, Dance Music and Talk. 9.0, News. 9.30, Programme Announcements. 9.55, Chimes from the Red Square. 10.5, Press Review.

**MOTALA.**—See Stockholm.

**MUHLACKER.**—See Stuttgart.



MUNICH

563 kc/s, 533 metres; 80 kW. Relayed by Augsburg and Kaiserslautern 636 kc/s, 660 metres; and Nürnberg, 1,266 kc/s, 239 metres.—4.30 p.m. (from Kaiserslautern), Orchestral Concert, relayed from the Fruchthalde. 5.46 (from Nürnberg), Agricultural Talk. 6.5, Songs to the Lute by Oscar Besenfelder. 6.26, Graf Yorck von Wartenburg—Memorial Talk. 6.45, Time, Weather, Agricultural Notes. 7.0, Transmission for all German Stations, relayed from Hamburg. 8.0, Einer ohne alle—Radio Play in Three Acts (Querin Engasser). 9.0, Concert by the Station Orchestra, conducted by List: Galop (Bizet); Overture, The Gipsy Baron (Strauss); Violin Solo: The Canary (Schütt); Waltz, Estudiantina (Waldfenfel); Hungarian Fantasia for Pianoforte and Orchestra (Liszt); Romance for Cello and Orchestra (Bruch); Slav Dance (Dvorak). 10.0, Time, Weather, News and Sports Notes.

NAPLES.—See Rome.

NOTODDEN.—See Oslo.

OSLO

277 kc/s, 1,083 metres; 60 kW. Relayed by Fredricksstad, 815 kc/s, 368.1 metres; Hamar, 522 kc/s, 574.7 metres; Notodden, 671 kc/s, 447.1 metres; Porsgrund, 662 kc/s, 453.2 metres; and Rjukan, 671 kc/s, 447.1 metres.—5.0 p.m., Popular Orchestral Concert. 6.0, German Lesson. 6.30, Divine Service. 7.0, Advertising Notes. 7.15, Weather and News. 7.30, Violin Recital by Trygve Christiansen. 8.0, Time. 8.1, Agricultural Talk. 8.30, Reading from Kurt Hamsun's Latest Novel. 9.0, Political Talk. 9.20, Advertising Notes. 9.40, Weather and News. 10.0, Topical Talk. 10.15, Variety Programme.

OSTERSUND.—See Stockholm.

PALERMO

558 kc/s, 537.6 metres; 3 kW.—8.0 p.m., Dopolavoro Announcements, Agricultural Notes, and Giornale Radio. 8.20, Gramophone Music. In the interval at 8.30, Time Signal and Announcements. 8.45, Concert of Operetta Music: Extracts from: Eva (Lehár), Le tre Lune (Lombardo), Frasquita (Lehár) and Paseino azzurro. In the interval at 9.30, Cedoni's personaggi—One-Act Play (Rimini). 11.0, Giornale Radio.

PARIS

EIFFEL TOWER. Call FLE, 207.5 kc/s, 1,465.7 metres; 13 kW. Time Signals (on 2,650 metres) at 10.26 a.m. and 11.26 p.m. (Preliminary and 6-dot Signals).—6.45 p.m., Theatre Talk. 7.0, Le Journal Parlé. 8.30, Gramophone Concert. Part I: Classical Music; Part II: Variety Music. 10.0 (approx.), Close Down.

PARIS

POSTE PARISIEN, 914 kc/s, 328.2 metres; 60 kW.—7.0 p.m., Songs on Gramophone Records. 7.15, Le Journal Parlé. 7.30, Programme for Children. 8.0, Sponsored Talk. 8.5, Talk for Workers. 8.35, Recital on the Martenot Ether Wave Organ by the Inventor with Accompaniment by the Orchestra, conducted by Théodore Mathien; Overture, The Mazie Flute (Mozart); Organ and Pianoforte: Prelude, Minuet and Plainte Napolitaine (d'Herveyols); Air from Arinida (Gluck); Arietta (Mozart); Organ and Orchestra: (a) Musette (Bach), (b) Chants russes (Lalo); Le tombeau de Couperin (Ravel); Largo (Vivaldi); Organ and Orchestra: Two Chorals (Bach); Air from L'enfance du Christ (Berlioz); Gavotte (Gossec); Pur dieesti (Lotti); Organ and Pianoforte: Scintillement (Fl. Schmitt); Elegy and Serenade from the Suite for Organ (Milhaud); Pieces (Debussy): (a) Clair de lune, (b) L'échelonnement des haies, (c) The Little Shepherd; Organ and Pianoforte: Popular Hawaiian Melody; Organ and Orchestra: Bourrée (Cantalube); Carnival (Guirand). 10.30, News.

PARIS

RADIO PARIS, Call CFR, 174 kc/s, 1,725 metres; 75 kW.—7.30 a.m., Weather and Physical Culture. 7.45, Gramophone Music. 8.0, Weather and News. 12 Noon, Protestant Address. 12.30 p.m., Gramophone Concert for Young People. In the interval at 1.0, Exchange, News and Weather, and at 1.30, Exchange. 2.0, Exchange. 3.45, Exchange and Market Prices. 6.30, Agricultural Talk. 6.45, Legal Talk. 7.0, Talk: Rabat. 7.20, Overture, Il Guarany (Gomez); Rondel de l'adieu (de Lara); Song and Waltz from The Desert Song (Romberg); Granada (Garcia). 7.45, Review of the German Press. 8.0, Le fils de Giboyer—Play (Augier). In the interval at 8.30, News and Weather, at 8.40, Review by Christophe, and at 9.15, Press Review and News. PORSGRUND.—See Oslo.

PRAGUE

514 kc/s, 488.6 metres; 120 kW.—4.0 p.m., See Brno. 4.50, Programme for Children. 5.15, Talk on Economics. 5.25, Gramophone Music. 5.35, French Lesson. 5.50, Gramophone Music. 6.5, Agricultural Talk. 6.15, Talk for Workers. 6.25, News in German.

OCT. 5th

THURSDAY

continued

6.30, German Transmission: Topical Talk and Agricultural Report. 7.0, Time and News. 7.10, Talk: Magazines for Children. 7.20, Brass Band Concert. 8.10, See Bratislava. 8.25, Funeral March—Radio Fantasy (Stoklas), based on Scenes from the Life of Svihlikova; Polka in A Minor (Smetana); Polka in F (Smetana); Il sospiro (Liszt); Paraphrase on Rigoletto (Liszt-Verdi). 9.15, See Brno. 10.0, Time and News. 10.15, Concert by the Hermann Schramm Ensemble. 11.0 (approx.), Close Down.

RADIO-SUISSE ROMANDE

SOTTENS, 743 kc/s, 403 metres; 25 kW. and Geneva, 395 kc/s, 760 metres.—7.0 to 7.15 a.m. (from Lausanne), Gymnastics. 12.28 p.m. Time Signal from Neuchâtel Observatory. 12.30, News and Weather. 12.40 (from Geneva), Variety Items. 1.0 (from Geneva), Financial News. 1.10 (from Geneva), Gramophone Concert. 2.0 to 3.28, Interval. 3.28, Time Signal from Neuchâtel Observatory. 3.30 (from Geneva), Gramophone Concert. 4.15 (from Geneva), Interlude by Edouard Combe. 4.40 (from Geneva), Gramophone Concert. 5.30 to 7.0, Interval. 7.0 (from Geneva), Programme for Children. 7.20 (from Geneva), News, Announcements and Weather. 7.50 (from Geneva), Esperanto Programme. 8.0, Concert by the Radio-Suisse Romande Orchestra, conducted by Eichenard. 9.0 (from Lausanne), Brahms Recital by Mme. Rumbely-Trokay (Songs) and Jean Koella (Pianoforte). 9.30 (from Lausanne), Recitation of Poems. 9.50, News and Weather. 10.0 (from Geneva), Talk: The Work of the League of Nations. 10.30 (approx.), Close Down.

REYKJAVIK

250 kc/s, 1,200 metres; 21 kW.—9.5 p.m., Musical Programme. 9.30, Weather Report. 9.40, Musical Programme and Announcements. 10.0, Chimes and News. 10.30, Reading. 11.0, Concert by the Radio Trio, followed by Gramophone Music.

RIGA

572 kc/s, 525 metres; 15 kW.—6.30 p.m., English Lesson. 7.0, Weather. 7.5, Concert of Waltzes. 8.0, News. 8.20, Songs and Airs. 8.40, Popular Concert. 9.0, Weather and News. 9.30, Dance Music.

RJUKAN.—See Oslo.

ROME

Call IRO, 680 kc/s, 441 metres; 50 kW. Relayed by Naples, 941 kc/s, 319 metres; Bari, 1,112 kc/s, 269.8 metres; Milan (Vigentino), 662 kc/s, 453.2 metres; from 8.45 p.m. and 2R0, 11,810 kc/s, 25.4 metres, from 5.0 p.m.—12.20 p.m., Gramophone Music. 1.8, Sponsored Programme—Humorous Talk. 1.10, Orchestral Concert from Turin. In the interval from 1.30 to 1.45, Giornale Radio and Exchange. 2.0, Time and Announcements. 4.20, Children's Radio Review. 4.55, Giornale Radio and Exchange. 5.0, Reading. 5.10, Weather. 5.15 to 6.0, Song and Pianoforte Recital by Margherita Cossa (Soprano) and Cecilia Cesi: Pianoforte Solos (Napoleone Cesi): (a) Scintillio del mare, (b) Pensiero drammatico; Soprano Solos: (a) Manoline (Debussy), (b) La piccola strega (Mortari); Pianoforte Solo: Twelfth Hungarian Rhapsody (Liszt); Soprano Solos: Pianoforte Solo: Etude brillante (Chopin). 6.40 (Naples): Shipping and Sports Notes. 6.45, Dopolavoro and Tourist Report. 7.10, Agricultural Report. 7.20, News in Foreign Languages. 7.40, Giornale Radio. 8.0, Time, Announcements, and Gramophone Music. 8.45, Talk on Literature and Art. 9.0, Gramophone Concert: Overture, Coriolanus (Beethoven); The Unfinished Symphony (Schubert); Intermezzo from Il carillon magico (Piek-Mangiagalli); Waltz of the Flowers from Loreley (Catalani); Tarantella and Dance from La Giarra (Casella). 10.0 (approx.), L'Osteria della Posta—Comedy in One Act (Gondoni). 10.30 (approx.), Variety Concert: Duets for two Sopranos: (a) Song (Mendelssohn), (b) Duet from Figaro (Mozart), (c) Duet from Le Cid (Massenet); March from Tannhäuser (Wagner). 11.0, Giornale Radio.

SALZBURG.—See Vienna.

SCHWEIZERISCHER LANDESENDER

BEROMUNSTER, 653 kc/s, 459 metres; 60 kW.; Basle, 1,229 kc/s, 244.1 metres; and Berne, 1,220 kc/s, 245.9 metres.—11.59 a.m., Time Signal from Neuchâtel Observatory and Weather. 12.0 Noon (from Basle), String Instrument Concert on Gramophone Records. 12.30 p.m., Time, Weather and News. 12.40 (from Basle), In the Wine-Cellar, Music by a Jazz Band, conducted by Carl Thomas. 1.25 (from Basle), Time, Weather and Exchange. 1.30 (approx.) to 5.0, Interval. 5.0 (from Zürich), Concert by the Small Station Orchestra. 6.0, (from Zürich), Gramophone Concert. 6.30 (from Basle), Talk: Aphorisms on Life. 7.0 (from

Basle), Time, Weather and Traffic Report. 7.15 (from Basle), Italian Lesson. 8.0, Orchestral Concert, conducted by Othman Schloek, relayed from St. Gall. Soloist: Louis Caluzae (Clarinet). 10.0 (approx.) from Basle), Reading of Poems. 10.15 (approx.), Close Down.

SOTTENS.—See Radio-Suisse Romande.

STOCKHOLM

689 kc/s, 436 metres; 55 kW. Relayed by Boden, 244 kc/s, 1,229.5 metres; Göteborg, 932 kc/s, 322 metres; Hörby, 1,166 kc/s, 257 metres; Motala, 221.5 kc/s, 1,354.4 metres; Östersund, 389 kc/s, 770 metres; and Sundsvall, 554 kc/s, 542 metres.—2.45 to 3.10 p.m., Broadcast for Schools, relayed from Malmö, 1,301 kc/s, 231 metres. 5.5, Talk, relayed from Uppsala, 662 kc/s, 453.2 metres. 5.30, Programme for Children. 5.45, Gramophone Music. 6.45, Elementary English Lesson, relayed from Jönköping, 1,490 kc/s, 201.3 metres. 7.15, Weather and News. 7.30, Light Music. 8.15, Talk. 8.45, Song Recital by Romana Hambrink: Schäfers Klage-lied (Schubert). Songs (Mozart): (a) Alle-luja, (b) Das Veilchen, Songs (Debussy): (a) Ariettes oubliées, (b) Green; The Nightingale (Alabiev); Waltz, Parla (Arditi). 9.15, Reading (Hjalmar Bergman). 9.45, Weather and News. 10.0, Military Band Concert. Conductor: Viktor Fritzell. Selection from Faust (Gounod-Dacé); Offenbachiana (Finck); Melody in Waltz Time (Golwyn); A Jazz Fantasia (Rolrecht); Pot-pourri, Servus Wien (Dostal). 11.0 (approx.), Close Down.

STRASBOURG

859 kc/s, 345 metres; 11.5 kW.—11.30 a.m., Gramophone Concert of Variety Music. 12.45 p.m., News. 1.0, Time and Exchange. 1.5, Orchestral Concert, conducted by Maurice de Villers. 2.0, Programme for Children. 3.0, Interval. 4.45, French Elocution Lesson. 5.0, Gramophone Music. 6.0, Talk in German: Jean François Millet—the Man and the Artist. 6.15, Talk for Women. 6.30, Light Music on Gramophone Records. 7.30, Time and News. 7.45, Gramophone Music. 8.0, Press Review in German, Lottery Results and Announcements. 8.30, Concert by the Station Orchestra and Soloists. Conductor: Maurice de Villers. Flute Solo: Suite in B minor (Bach); Violin Concerto (Beethoven); Pianoforte and Orchestra: Symphonic Poem (Pierné); Song and Pianoforte: Histoires naturelles (Ravel); Flute and Orchestra: La forêt enchantée (Moraux); Orchestral Suite No. 1 (Guirand). In an interval at 9.30 (approx.), Press Review. 10.30 (approx.), Close Down.

STUTTGART

MUHLACKER, 832 kc/s, 360.5 metres; 60 kW. Relayed by Freiburg, 527 kc/s, 570 metres.—1.15 p.m., News from Frankfurt. 1.25, News and Programme Announcements. 1.35, Concert by the Station Orchestra, conducted by Görlich. March Parody, Uncle Teddy (Fenek); Overture, Venus auf Eridon (Lincke); Polka for Piccolo Solo, Ein Tag in Wiener Wald (Kreuzberger); Bisson Solo: My Teddy Bear (Ganglberger); Waltz, Wedding Song (E. Strauss); Volksliedchen und Märchen (Kozak); March Potpourri, Jungdeutschland (Weninger). 3.0, Programme for Children. 4.0, See Langenberg. 6.0, Spanish Lesson. 6.20, Educational Talk. 6.35, Talk: Friedrich von der Trenck as portrayed by his own Memoirs and Writings. 6.50, Time and Agricultural Notes. 7.0, Transmission for all German Stations, relayed from Hamburg. 8.0, See Frankfurt. 8.10, See Langenberg. 10.0, See Frankfurt. 10.20, Things one should know. . . . 10.30, News. 10.45, Concert by the Württemberg Symphony Orchestra, conducted by Drost. Soloist: Reichardt (Cello); Capriccio (Piehler); 'Cello Concerto, Op. 104 (Dvorak); Verdi variations (Heger). 12 Midnight, Serenade. 1.0 a.m. (Friday), Close Down.

SUNDSVALL.—See Stockholm.

TOULOUSE

RADIOPHONIE DU MIDI, 779 kc/s, 385 metres; 8 kW.—6.0 p.m., News. 6.15 p.m., Popular Melodies. 6.30, Light Orchestral Music. 6.45, Concert: Part I—Military Music: La sidi-Brabim (Porot); Le tram (Mougnot); Castaldo (Novarek); La divette (Sali); Part II—Opera Music: Selection from Le roi malgré lui (Chabrier), I Pagliacci (Leoncavallo), Werther (Massenet), and Le jongleur de Notre Dame (Massenet). 7.15, News, Racing Results, and Market Prices. 7.30, Overture, William Tell—Opera (Rossini). 7.45, Chansonnettes. 8.0, Operetta and Opera Music: Selection from The Land of Smiles (Lehár), The Drum Major's Daughter (Offenbach), Le voyage en Chine (Hérold), Philémon et Baucis (Gounod), Sigurd (Reyer), and Faust (Gounod). 8.30, Orchestral Music: Waltz (Thomé); Allegro and Minuet (Heydu); Two Pieces in Symphonic Style (Franck); Waltz (Lincke);

Danse des sylphes (Berlioz); Erotica (Grieg) 9.0, Extracts from White Horse Inn—Operetta (Benatzky). 9.45, Concert: Part I: Orchestral Music; Part II—Chansonnettes. 10.15, North African News and Local News. 10.30, Concert for Listeners in Morocco: Introduction and Wedding Procession from The Golden Cockerel (Rimsky-Korsakov); Chorus from Act I of Cavalleria rusticana (Mascagni); The Canary (Poliakou); Selection from Griseldis (Massenet); Melody (Fischer); Le père la victoire (Ganne). 11.0, Sound Film Music. 11.15, Dance Music. 12 Midnight, News, Weather, and Announcements. 12.5 a.m. (Friday), Hawaiian Guitar Music. 12.15, Music by an Argentine Orchestra. 12.30 (approx.), Close Down.

TRIESTE

1,211 kc/s, 247.7 metres; 10 kW.—5.10 p.m., till Close Down. See Turin.

TRONDHEIM.—See Oslo.

TURIN

1,096 kc/s, 273.7 metres; 7 kW. Relayed by Milan, 905 kc/s, 331.5 metres; Genoa, 959 kc/s, 312.8 metres; and Florence, 599 kc/s, 500.8 metres.—5.10 p.m., Gramophone Music. 6.0 to 6.5, Weather. 6.40, Giornale Radio, Dopolavoro Report and Gramophone Music. 7.0, Time, Tourist Report, and Gramophone Music. 7.10, Wheat Market Prices. 7.20, News in Foreign Languages. 7.40, Gramophone Music. 8.0, News, Weather, and Gramophone Music. 8.25, Talk on the following transmission. 8.30, William Ratcliff—Opera in Three Acts (Mascagni). Talk and News in the intervals. Giornale Radio after the Opera.

VATICAN CITY

15,120 kc/s, 19.84 metres (Morning), and 5,969 kc/s, 50.26 metres (Evening); 10 kW.—11.0 to 11.15 a.m., Religious Information in French. 8.0 to 8.15, Religious Information in Italian.

VIENNA

581 kc/s, 517 metres; 100 kW. Relayed by Graz, 852 kc/s, 352.1 metres; Innsbruck, 1,059 kc/s, 283 metres; Klagenfurt, 662 kc/s, 453.2 metres; Linz, 1,220 kc/s, 245.9 metres; and Salzburg, 1,373 kc/s, 218.5 metres.—12 Noon, Concert by the Wiener Symphoniker, conducted by Holzer. In the interval at 1.0 p.m., Time, Weather and Announcements. 2.0, Interval. 3.0, Time, Weather and Market Prices. 3.20, Hints for the Housewife. 3.30, Programme for Children: Hans Andersen's Fairy Tales. 3.55, Gramophone Records of the Bohemian Orchestra. 4.45, Talk: The Construction of Modern Radio Apparatus. 5.0, Talk for Women. 5.25, Recital of Lieder and Arias by Clarissa Stukart (Soprano); Five Lieder (Grieg); (a) Erstes Begegnung, (b) Verborgene Liebe, (c) Hoffnung, (d) Margarethein, (e) Ein Traum; Arietta from Floridaia (Handel); Cavatina from Der Freischütz (Weber); Aria from Der Kuhreigen (Kienzl); Waltz Song from The Iron Saviour (Oberbithener). 5.55, Talk for Workers. 6.20, Talk. 6.50, Reading (Rieger). 7.15, Time, Weather and Announcements. 7.25, La Juive—Opera (Halévy), relayed from the State Opera House. In the interval at 9.20, News and Weather. 10.20, Announcements. 10.30, Gramophone Concert. After the Programme, Announcements.

WARSAW

212.5 Kcs, 1,411 metres; 120 kW.—11.57 a.m., Time Signal and Fanfare from St. Mary's Church, Cracow. 12.5 p.m., Gramophone Music. 12.30, Radio Journal. 12.35, Gramophone Music. 1.0 to 3.30, Interval. 3.30, Economic Notes. 3.40, Chamber Music: Fliederbaum (Violin), Günsburg (Cello), and Rosenbaum (Pianoforte); Trio in G minor (Schumann); Trio in G, Op. 1, No. 2 (Beethoven). 4.40, Talk for Women. 1.55, Soprano Song Recital by Olga Szumaska; Arias from: Madame Butterfly (Puccini); Manon Lescaut (Puccini); and The Queen of Spades (Tchaikovsky); Little Star (Glier); Song (Karlowicz); Fragment (Wielhorsky); L'ombra di Carmen (Tirindelli). In the intervals: Pianoforte Solos by Mme. Berkwie, relayed from Cracow, 959 kc/s, 312.8 metres. 6.0, Agricultural Report. 6.0, Talk on a Museum in Stockholm. 6.20, Radio Play. 7.5, Miscellaneous Items. 7.25, Topical Talk. 7.40, Programme Announcements. 7.45, Radio Journal. 8.0, Concert by the Station Orchestra, conducted by Navrot. Soloist: Messal (Songs). Overture, Morning, Noon and Night (Suppé); Traumland-walzer (Fueik); Parade des Einhornpoin-tis (Aubert); Russian Dances (Bullerian) Three Songs: Piece (Meyer-Helmund); Evening on the Banks of the Neva (Meyer-Helmund); Polka from Der Frauenfresser (Eysler); Waltz from Polenbit (Nedbal); In Sunny Spain (Elliot). Three Songs: Selection from Frasquita (Lehár); Fox-trot (Kalmán); Melody (Bancker); Tango (Michaelov); March, the Globetrotter (Leopold). 9.0, Answers to Correspondence. 9.15, Concert (contd.). 10.0, Sports Notes. 10.10, Dance Music. 11.0, Aviation Weather Report and Police Notes. 11.5, Dance Music (contd.). 11.30 (approx.), Close Down. ZURICH.—See Schweizerischer Landessender.

**ATHLONE**

725 kc/s, 413 metres; 60 kW. Relayed by Cork, 1,337 kc/s, 224.4 metres.—1.30 to 2.30 p.m., Time, Weather, Stock Report and Gramophone Records, 6.0, Programme for Children, 6.45, News, 7.0, Gardening Talk, 7.15, Literary and Dramatic Talk, 7.30, Time Signal, 7.31, The Station Orchestra, 8.0, Bass Baritone Solos by Mervyn Bell, 8.15, 'Cello and Violin Music by R. and D. Conlan, 8.35, Soprano Solos by McGough, 8.50, The Station String Orchestra, 9.0, Illustrated Lecture Recital by C. Ni Dhuibhghail, 9.30 to 10.30, Programme by the I.B.C. (Ireland), Ltd., 9.30, Concert: Valse amoureuse (Berger); Harlequinade (Squire); Song, Myself when young (Lehmann); Pianoforte Solo, Dance from The Wizard (Holbrook); Play Gipsies, dance Gipsies (Kalmán); Love in Cleveland (Leo Peter); A Banjo Song (Homer); La fleuse (Raf), 10.0, Concert arranged by the International Broadcasting Company (Ireland), Ltd., on behalf of Hospitals Trust, Ltd., What have we got to lose?; My Wishful Song; Maybe I love you too much; Shuddle off to Buffalo; You've got me cryin' again; Butterflies in the Rain; Hustlin' and bustlin' for Baby, 10.30, I.B.C. Good-night Melody, 10.33, News, and Weather, 10.40, Accordion Solos by Michael Grogan, 11.0 (approx.), Close Down.

**BARCELONA**

EAJ1, 860 kc/s, 348.8 metres; 8 kW.—7.0 p.m., Trio Concert: Selection from Fidelio (Beethoven); Larghetto (Mozart); Oriental Romance (Halmes); Ballet (Pessier); Chanson d'Arlette (de Taeye); Selection from Robert le Diable (Meyerbeer); Selection from Boris Godunov (Mussorgsky), 8.0, Request Gramophone Records, In the interval at 8.30, Exchange, 9.0, Gramophone Music, followed by News, 10.0, Chimes, Weather, Messages for Seamen and Exchange, 10.10, Orchestral Concert, 11.15, Vicente Diez de Tejada reads from his own Works, 11.30, Extracts from an Opera, on Gramophone Records, 12 Midnight (in an interval), News, 1.0 a.m. (Saturday), Close Down.

**BASLE**.—See *Schweizerischer Landessender*.

**BELGRADE**

697 kc/s, 430.4 metres; 2.8 kW.—6.55 p.m., Time and Programme Announcements, 7.0, Concert by the Radio Orchestra, 8.0, Programme relayed from Zagreb, 977 kc/s, 307 metres.—10.0, Time and News, followed by Cigany Music, relayed from the Zanatski Dom Restaurant.

**BERLIN**

**DEUTSCHLANDSENDER (REICHSENDER)**, 183.5 kc/s, 1,635 metres; 10 kW.—12 Noon, Weather, 12.2 p.m., Gramophone Concert: Dein gedenk ich, Margaretha (Meyer-Helmund); Elegy (Massenet); Liebste glaub' an mich (Lehár); Heut' bin ich gut aufgelegt (Jummann); Under a Texas Moon (Perkins); When Love is dead (Cremieux); Sternschuppen (Kauler); Der letzte Münchener Flaker (Hilber); Rheinländer, Ach Herr Schmidt (Carlos); Liebe kommt einmal von irgendwoher (Künneke); Dragoners Abschied (Heilborn); Der Entenstrom (Valentin); Musmann-Marsch (Carl), 12.55, Time, 1.0, Interval, 1.45, News, 2.0, Gramophone Concert: March from Carmen (Bizet); Hungarian March No. 2 (Liszt); Mamma mia (Nuttile); Ay-ay-ay (Perez); Song from The Trumpeter of Säckingen (Nessler); Glow-Worm Idyll (Lincke); Ave Maria (Schubert); La Serenata (Braga); Hindu Song (Rimsky-Korsakov); March, The Star-spangled Banner (Souza); Sei gegrüsst, du mein schönes Sorrent (Waldmann); Zauberspiel (Meyer-Helmund), 3.0, Discussion on Careers for Girls who have left School, 3.30, Weather and Exchange, 3.45, Reading of Fairy Tales (Blunck), 4.5, See *Breslau*, 5.0, Talk: Elementary School Teachers and National Socialism, 5.25, Recital of Contemporary Music by Inge Brodersen (Songs) and Margerete Ansoerge (Pianoforte); Songs (Hanns Naumann), accompanied by the Composer: (a) Wer glaubt, braucht nicht zu eilen, (b) Gott schließ in meiner Seele, (c) Langsam fließt wie Wein aus goldener Schale, (d) Morgenrot, Deutschland; Pianoforte Solos (Ansoerge): (a) Adagio and Agitato from the Sonata in E minor, (b) Three Dream Pictures, (c) Valse Impromptu, 6.0, Poems, 6.5, Talk: The Saar Territory in German History, 6.25, Country Programme, 6.45, Weather and News, 7.0, Transmission for all German Stations: Hugo Kaun Programme by the Berlin Liedertafel, with the Berlin Liedertafel Augmented Orchestra, conducted by Teichmann, and Soloists: Maria Pesckben (Contralto) and Helmut Hanning (Organ); Orchestral Prelude; Five Choral Songs: (a) Feuerspnech, (b) Carfreitag, (c) Nacht am Rhein, (d) Deutsche Wacht, (e) Lebenslied; Chorus and Orchestra with Contralto Solo: Der Glückchen; Chorus and Orchestra: Volk aus Gesehr, 8.0, Today's Motto, 8.5, Nazi Programme, 9.10, See *Heilsberg*, 10.0, Weather and News, 10.30, Discussion: The Physical Training of the Nazi Storm Troops, 10.45, Weather, 11.0, Dance Music from Langenberg, 12 Midnight, Close Down.

**BERLIN**

**FUNKSTUNDE**, 715 kc/s, 419.5 metres; 1.5 kW.—6.0 p.m., German Pressant Customs—Report by Heinrich Schöreyer, 6.15, Es gibt nur eine Liebe—Radio Report from a Sound Film Studio, 6.30, The Funkstunde informs

**FRIDAY**  
OCTOBER THE SIXTH

**PRINCIPAL EVENTS OF THE DAY:**

**AT HOME**

**NATIONAL LONDON** Music hall programme. Promenade concert from Queen's Hall.  
**REGIONAL MIDLAND REGIONAL** Band concert.  
**NORTH REGIONAL** Tom Vernon's Royal Follies, from the Central Pier, Blackpool.  
**WEST REGIONAL** Choral programme.  
**SCOTTISH REGIONAL** Excerpt from the Theatre Royal, Edinburgh.  
**BELFAST** Organ recital from the Grosvenor Hall.

**ABROAD**

**BRESLAU** 9.0 p.m. The Station Orchestra, conducted by E. Topitz.  
**BRUSSELS (No. 1)** 5.0 p.m. Mozart concert, by the Station Symphony Orchestra.  
**BUDAPEST** 10.30 p.m. The Opera House Orchestra.  
**EIFFEL TOWER** 9.0 p.m. Symphony concert, conducted by E. Flament.  
**HAMBURG** 10.30 p.m. Chamber music.  
**HILVERSUM** 8.10 p.m. Pianoforte recital.  
**LEIPZIG** 10.50 p.m. The Symphony Orchestra, conducted by W. Steffen.  
**POSTE PARISIEN** 8.30 p.m. Light opera: "La petite Mariée," by Lécocq.  
**ROME** 9.45 p.m. Song and violin recital.  
**STOCKHOLM** 10.0 p.m. Orchestral concert from Goteborg.  
**WARSAW** 8.15 p.m. Polish music, by the Philharmonic Orchestra, conducted by Fitelberg.

its Listeners. . . 6.45, Topical Talk, 7.0, Transmission for all German Stations, relayed from *Berlin (Deutschlandsender)*, 8.5, Gramophone Concert of Classical Music, 8.25, Radio Report of the Harvest Festival in Tellow, 8.45, Bach and his Sons—Musical Radio Play (Herbert Just), 10.0, News, 10.15 (approx.), Concert by the Station Orchestra, conducted by Karl Rockstroh; Overture, The Water Carrier (Chernobin); Overture, Semiramis (Rossini); Overture, Le cheval de bronze (Auber); Overture, Abu Hassan (Weber); Scandinavian Suite (Juel-Frederiksen); Suite, Aus dem Morgenlande (Heuberger); Suite from The Bartered Bride (Smetana); Waltz, Hoffnungsstrahlen (Lanner); Waltz, Aus den Bergen (Joh. Strauss); Walt, Flattergeister (Jos. Strauss), In an interval at 11.0, Theatre and Film Review, 12 Midnight (approx.), Close Down.

**BERNE**.—See *Schweizerischer Landessender*.

**BEROMUNSTER**.—See *Schweizerischer Landessender*.

**BODEN**.—See *Stockholm*.

**BODO**.—See *Oslo*.

**BRATISLAVA**

1,076 kc/s, 279 metres; 11 kW.—6.20 p.m., Pianoforte Recital by Vilem Pistelak: Prelude (Ravel); Minuet on the Name, Havdn (Ravel); Air (Ravel); Two Arabesques (Debussy); Serenade (Debussy), 6.40, Talk: Telegraphy, 6.55, Hints for Housewives, 7.0, See *Prague*, 7.10, See *Moravská-Ostrava*, 8.0, See *Prague*, 8.15, See *Brno*, 8.50, See *Prague*, 10.30 (approx.), Close Down.

**BREMEN**.—See *Hamburg*.

**BRESLAU**

923 kc/s, 325 metres; 60 kW. Relayed by *Gleiwitz*, 1,184 kc/s, 253 metres.—1.5 p.m., Gramophone Concert of Popular Music, 1.45, News, 2.10, Pianoforte Suite: Pictures from an Exhibition (Mussorgsky), 2.40, Gramophone Music, 3.0, Agricultural Prices, 3.15, Talk for Young People: My Escape from a Prisoners of War Internment Camp in England (Heribert Glodny), 3.45, Talk: The Greatest Political Writers of Today, 4.5, Concert by the Station Orchestra, conducted by Gerhard Ewald Rischka; Scandinavian Suite (Juel-Frederiksen); Selection from Das Nachtlager in Granada (Kreutzer); Waltz from the Second Serenade (Volkmann); Serenade (Graener); Potpourri, Major and Minor (Schreiner), 5.10, Agricultural Prices, 5.15 (approx.), Reading (Gerhard Menzel), 5.40, Talk: Silesia's Geographical Unity, 6.0, Concert by the Station Orchestra, conducted by Gerhard Ewald Rischka; Overture, Gri-Gri (Lincke); Wilde Rosen (Ganglbauer); Kleine Gratulanten (Schicke); Song Potpourri, Das neue deutsche Herz (Wenger), 6.50, Cattle Market Prices, 7.0, Transmission for all German Stations, re-

layed from *Berlin (Deutschlandsender)*, 8.0, News, 8.10, Durch Kampf zum Sieg—Radio Play (Erich Komitzny), 9.0, Concert by the Station Orchestra, conducted by Ernst Topitz, Soloists: Herbert Heidrich (Tenor) and Gerhard Bertermann (Baritone); Overture, Morning, Noon, and Night (Suppé); Suite, Aus dem Morgenlande (Heuberger); Duet from (a) Iphigenia in Tauris (Gluck), (b) La Favorita (Donizetti), (c) The Force of Destiny (Verdi); Waltz, Estudiantina (Waldteufel); Xylophone Solos: (a) Polka Mazurka (Dittlich), (b) Maiglöckchen (Dittlich), 10.10, News, 10.30, Reading (Margarete Nitsche), 10.50, Concert by the Station Orchestra, conducted by Topitz, Soloists: Herbert Heidrich (Tenor) and Gerhard Bertermann (Baritone); Overture (Cooper); Intermezzo from The Arabian Nights (Joh. Strauss); Air from Il Seraglio (Mozart); Duet from Alessandro Stradella (Plotow); Piccolo Solo; Polonaise, Till Eulenspiegel (Rudolph); Selection from Eva (Lehár), 12 Midnight (approx.), Close Down.

**BRNO**

878 kc/s, 342 metres; 35 kW.—6.5 p.m., Talk: Creative Art, 6.15, Talk for Workers, 6.25, German Transmission: News, Sports Notes, Topical Talk and Talk for Women, 7.0, See *Prague*, 7.10, See *Moravská-Ostrava*, 8.0, See *Prague*, 8.15, The Romance of Ondras—Play (Martinek), 8.50, See *Prague*, 10.30 (approx.), Close Down.

**BRUSSELS (No. 1)**

**I.N.R.**, 590 kc/s, 509 metres; 15 kW.—12 Noon, Concert by the Small Station Orchestra, conducted by Lecmans, 1.0 p.m., Le Journal Parlé, 1.10, The Forest—Gramophone Concert, 5.0, Mozart Concert by the Station Symphony Orchestra, conducted by Meulemans, Soloist: Lion (Flute), Symphony in G; Flute Concerto in D; Ballet Music from Les petits riens; Overture, Don Giovanni, 6.0, Talk: Old Age Pensions, 6.15, Request Gramophone Records, 6.30, Home from the Holidays—Sketch, 6.45, Heller Pianoforte Recital by Oscar Delvigne, 7.15, Talk: Is Liberalism Doomed? 7.30, Legal Talk and Literary Review, 8.0, Concert by the Station Symphony Orchestra, conducted by Meulemans, Soloist: Mme. Lambertini (Songs), Extract from the Suite, Scheherazade (Rimsky-Korsakov); Suite printanière (van Doren); Songs: (a) Aria from Sappho (Massenet), (b) Tounjous (Fauré), (c) Three Songs of April (Roels); Spanish Dances (Fallá), 8.45, Educational Talk: Our Wonderful World Cruise, 9.0, Concert by the Radio Orchestra, conducted by Walpot, March, Semper fidelis (Souza); Overture, Masaniello (Auber); Selection from Paganini (Lehár); Une fête à Aranjuez (Demesserman); Waltz Potpourri, Was die Doman erzählt (Morena); Fantastie Suite (Gabriel Marie), 10.0, Le Journal Parlé, 10.10, La Brabançonne.

**BRUSSELS (No. 2)**

**N.I.R.**, 887 kc/s, 338.2 metres; 15 kW.—Programme in Flemish.—12 Noon, Gramophone Music, 12.15 p.m., Request Gramophone Records: Overture, Lohengrin (Wagner); Spring Song from Samson and Delilah (Saint-Saëns); Aria from La Bohème (Puccini), 12.30, Gramophone Music (contd.), 1.0, Le Journal Parlé, 1.10, Concert by the Small Station Orchestra, 5.0, Concert by the Radio Orchestra, conducted by Charles Walpot; Overture, Hansel and Gretel (Humperdinck); Selection from The Bayadere (Kalmán); Selection from Les Dragons de Villars (Maillart); Fantasia on Hungarian Melodies (Aanfred); Waltz, Autumn (Albéniz); March, Morgenrot (Jessel), 5.45, Pallieter Programme, 6.30, Concert by the Small Station Orchestra, conducted by Pierre Lecmans, Le carillonneur (Gauvin); Selection from White Horse Inn (Benatzky); Gipsy Songs and Dances (Petras); Mendelssohn Potpourri (Foulds); Russian Minuet (Akkimenko); Waltz, Pour toujours (Delmas); March, The Gloebrotter (Leopold), 7.15, Talk: The Flemish Football League, 7.30, Wireless Notes, 8.0, Concert by the Radio Orchestra, conducted by Charles Walpot, Huldigungsarsch (Grieg); Spiegelgavotte (Lincke); Serenade and Waltz (d'Indy); Gramophone Records: (a) Danse des elfes (Popper), (b) Aria from Martha (Plotow), (c) Soiree de Vienne (Schubert-Liszt); Selection from Viktoria and her Hussar (Abraham); On the Banks of the Neva (Eilenberg), 8.45, Announcements, 8.50, Talk, 9.5, Concert by the Station Symphony Orchestra, conducted by Arthur Meulemans: Marche jubilaire (de Bosck); Festklagen (Verheyden); Symphonie Poem, De Morgen (Duxosel); Gramophone Records: (a) Si vous l'avez compris (Denza), (b) Gipsy Song on the G. String, (c) Salut d'Amour (Elgar); Fantasia on Canadian Melodies (Gilson); Brautmarsch (Tinel). In the interval: Talk and Announcements, 10.0, Le Journal Parlé.

**BUCHAREST**

761 kc/s, 394 metres; 12 kW.—5.0 p.m., Concert by the Station Orchestra: Retraite montmartroise (Bosc); Waltz (Lumby); Overture, La dame blanche (Boieldieu); Selection from Adrienne Lecouvreur (Gilea); Selection from The Bayadere (Kalmán); Ballet Suite from Sylvia (Delibes); Pizzicati (Helmund); Oriental Piece (Lundemann); Fox trot on Themes from The Bird-Fancier (Zeller-Kochmann), In an interval at 6.0, Radio Journal, 7.0, Educational Talk, 7.40, Opera Music on Gramophone Records, In the intervals, Radio Journal, After the Programme, Concert relayed from a Restaurant.

**BUDAPEST**

545 kc/s, 550.5 metres; 18.5 kW.—Also relayed on 840 metres from 7.45 p.m. till Close Down.—5.0 p.m., Concert by the Post Office Orchestra, 6.0, Review of Publications, 6.30, Harpsichord Recital, 7.30, Sports Talk, 7.45, Gramophone Records, 9.0, Review of Foreign Politics, 9.15, Concert by the Bura Cigany Band, 10.0, News, 10.30, Concert by the Opera House Orchestra, conducted by Ferenicz; Melody (Weiner); Hungarian Tone Pictures (Bartok); Variations on a Hungarian Song (Butykal); Suite, Mosaic (Radnai); Old Hungarian Dance Suite (Szabados); Hungarian Rhapsody, No. 1 (Liszt).

**CASSEL**.—See *Frankfurt*

**COPENHAGEN**

1,067 kc/s, 281 metres; 0.75 kW. Relayed by *Kalundborg*, 260 kc/s, 1,153.8 metres.—12 Noon, Time and Chimes from the Town Hall, 12.5 p.m., String Ensemble Concert, relayed from the Wiyex Restaurant, 2.0, Interval, 3.0, Orchestral Concert, conducted by Launy Grøndahl, Soloist: Henry Jensen (Violin); Cavalry March (R. Strauss); Overture, Le lac des fées (Auber); Military Waltz (Waldteufel); Venetian Serenade (Svendsen); Irish Folk Song, Molly on the Shore (Grainger); Overture, Elverhøj (Kublan); Violin Solos: (a) Andantino (Martini-Kreisler), (b) Waltz (Field-Burmeister), (c) Canto amoroso (Sammartini-Elman), (d) Gavotte (Rameau-Burmeister), (e) Lullaby (Fini Henriques), (f) Allegretto (Boechner-Kreisler); Homage March (Dahl); Overture, Light Cavalry (Suppé); Air from The Mastersingers (Wagner); Waltz, La Hussarde (Ganne); Aftensang (Stockmarr); Polka and Gallop (Lumby), 5.0, Reading, 5.30, Exchange and Fish Market Prices, 5.55, Talk: Danish Literature, 6.15, Elementary German Lesson, 6.45, Weather and News, 7.15, Time, 7.16, Talk on Unemployment, relayed from the University, 8.0, Chimes from the Town Hall, 8.5, Programme by Per Knutzon, 8.10, Concert of Chamber Music by Erik Thomsen (Flute), Leo Hansen (Violin), and Folmer Jensen (Harpsichord); Sonata for Flute and Harpsichord (Freihoff); Harpsichord Sonata (Scheibe); Folia con Variationi for Violin and Harpsichord (Corelli), 8.40, Sorcery—Comedy in Five Acts (Holberg), 10.10, News, 10.25, String Quartet, Op. 20 (Borresen), 11.5, Dance Music, relayed from the Valencia, In the interval at 12 Midnight, Time and Chimes from the Town Hall, 12.30 a.m. (Saturday), Close down.

**CORK**.—See *Athlone*.

**DANZIG**.—See *Heilsberg*.

**BREMEN**.—See *Leipzig*.

FECAMP

1,328 kc/s, 225.9 metres; 10 kW.—11.0 a.m., to 12 Noon, Programme in English by the I.B.C. 11.0, Happy Hour. Part I, Military Band Music: Signature Tune; On the Quarter Deck (Alford); In a Chinese Temple Garden (Kettelbey); Selection from Cavalcade (Coward); Lancashire Rumble; Tally Ho (Barrot); The Passing of the Regiment (arr. Winter); March, Sambre et Meuse (Ganne); Popular Medley. Part II, Dance Music: Thank Heaven for You; Learn to Croon; My Bluebird's singing the Blues; Down the old Ox Road; Tick-Tock; Under a Blanket of Blue; Out in the Open; Love is the Thing; Signature Tune. 12 Noon, French Programme. 4.30 to 6.0, Programme in English by the I.B.C. 4.30, Programme for Children. 5.0, Choral Concert for Southampton and Winchester Listeners: Signature Tune, The Night by the Sea; Southern Rhapsody (Hosmer); Come where my Love lies dreaming (Foster); When the Dew is falling; Lady Chloë; Love and War (Cook); In a Monastery Garden (Kettelbey); When you and I were young, Maggie; Pretty Flowers (Perkins); The Warbler's Serenade (Perry). 5.30, Orchestral Concert for Bournemouth and Weymouth Listeners: Minuet from the Pötte Suite (Debussy); In a Country Lane (Coates); The Clatter of the Clogs (Flynn); Entrance of the Little Fauns (Pierné); On the Edge of the Lake (Coates); Idylle bretonne (Gemin); Fairy Tale (Heykens); Dance of the Sylphs (Berlioz); Signature Tune. 6.0, French Programme. 10.0 till Close Down, Programme in English by the I.B.C. 10.0, Dance Music: Signature Tune, Bells of Normandy; Good-night but not Goodbye; I cover the Waterfront; I can't remember; Out in the Open; Sittin' in the Dark; Sweetheart Darlin'; Little Miss Muffet; It's Sunday down in Caroline; Dancing Butterfly; It's the Band; Hold Me; This is the Rhythm for me; Seven Years with the Wrong Woman; You're mine you (Green); In the Valley of the Moon; Let's all be happy together; Signature Tune. 11.0, Sound Film Music: Signature Tune; Sittin' in the Dark; Melody from Sous les toits de Paris (Mort); Just because I lost my heart (Gilbert); I want to cling to Ivy; Monte Carlo Medley; Lover of my Dreams; Song, I'll stay with you (Woods); Just once for all time (Leigh); The flies crawled up the Window (Ellis); Signature Tune. 11.50, Club Concert for Aberystwyth Listeners. Part I, Orchestral Music: Signature Tune, The Chum Song; Künstlerleben (Strauss); The Butterfly (Nevin); Selection from Fredericka (Lehar); Kisses in the Dark (Michele); March of the Men of Harlech; When I'm dreaming (Inns); The Capricious Music Box (Fresco); Savoy Medley (arr. Somers). 12.5 a.m. (Saturday), I.B.C. News Bulletin in English. 12.10 (approx.). Club Concert. Part II: Adios Juventud; Piezaria (Bianco); Mama, lo quiero un novio (Collazo); Madrid (Potter); Todavía (Pizarro). 12.30, Dance Music by the Mountaineers (Electrical Transcriptions); There's a Cabin in the Pines; Jog along; Fit as a Fiddle; Taboo, Taboo; When its lamplightin' time in the Valley; The Language of Love; Won't you stay to tea?; There's a Tiny little hair upon your Shoulder; All over Italy; When my Little Pomeranian. 1.0, Dance Music: Signature Tune, Bells of Normandy; Farewell to Arms; Come out, Vienna; Let bygones be bygones; In a Second-hand Store; Dance, Pretty Lady; Hiawatha's Lullaby; Sweep; This Lovely Rose; You don't understand; I raised my Hat; The Old Spinning Wheel; Falling Star; Spanish Eyes; Twelfth Street Rag; I've got to sing a Torch Song; In Santa Lucia; Signature Tune. 2.0, I.B.C. Goodnight Melody and Close Down.

FLENSBURG.—See Hamburg.

FLORENCE.—See Turin.

FRANKFURT

1,157 kc/s, 259.3 metres; 17 kW. Relayed by Cassel, 1,220 kc/s, 245.9 metres, and Trier, 1,157 kc/s, 259.3 metres.—4.0 to 6.35 p.m., See Langenberg. 6.35, Talk: The Student Guild Houses. 6.50, Weather, News and Announcements. 7.0, Transmission for all German Stations, relayed from Berlin (Deutschlandsender). 8.0, Topical Talk. 8.30, Recital of Songs of the Rhine, Mosel, Lahn and Nahe by Carlos Llach: A Song from the Rhine (Frantzen); Mädal komu wir wollen wandern (Ritzel); Bei einer Flasche Mosel; In Marburg an der Lahn, dem schönen Städchen (Gabriel); Mein Nahetal (George); Komm trink und lach am Rhein (Raymond). 8.30, The Language of the German Soldier—Radio Sequence (Trinius). 9.0, Concert of Hungarian Music by the Station Orchestra, conducted by Rosbald; Soloist: Dolnanyi (Pianoforte); Hungarian Pictures (Bela Bartok); Pianoforte Concerto, Op. 5 (Dohnanyi); A Summer Evening (Kodaly); Transylvanian Dances (Bela Bartok). 10.0, Time and News. 10.20, See Stuttgart. 10.30, News and Weather. 10.40, See Langenberg. 12 Midnight, Interval. 12.15 a.m. (Saturday) (relayed by Zeesen, 9,560 kc/s, 31.38 metres). Talk: The German Spirit. 1.0, Close Down.

FREDRIKSTAD.—See Oslo.

FREIBURG.—See Stuttgart.

GENEVA.—See Radio-Suisse Romande.

GENOA.—See Turin.

GLEIWITZ.—See Breslau.

ROTEBORG.—See Stockholm.

GRAZ.—See Vienna.

HAMAR.—See Oslo.

OCT. 6th

FRIDAY

continued

HAMBURG

Call ha (in Morse), 806 kc/s, 372 metres; 1.5 kW. Relayed by Bremen, 1,112 kc/s, 269.8 metres; Flensburg, 1,319 kc/s, 227.4 metres; Hanover, 530 kc/s, 566 metres; and Kiel, 1,292 kc/s, 232.2 metres.—6.0 p.m., Gramophone Music. Military March (Schubert); Liebestraum (Liszt); Zigeunerweisen (Sarasate); March from The Bartered Bride (Smetana). 6.20, German Naval Heroes of the Great War—Captain Hans Rose of U-Boat 53 describes his Raid on Newport Harbour, Rhode Island. 6.40, Frankfurt Exchange and Hamburg Market Prices. 6.50, Weather. 7.0, Transmission for all German Stations, relayed from Berlin (Deutschlandsender). 8.0, Variety Concert by the Altona-Wandsbek Police Band and the Spitzendorf-Schulauer Male Voice Choir. 9.30, Topical Talk. 9.40, Peter Dörfler reads from his own Works. 10.10, News. 10.30, Chamber Music. The London Trio No. 2 for Two Flutes and Cello (Haydn); Divertimento for Two Violins, Viola and Bass (M. Haydn). 11.0 (from Bremen), Serenade Concert by the Bremen Municipal Musicians, conducted by Reinhold Krug. Abendmusik (Forster); Canzone amorosa (Carosio); Evening Dream (Ray); Bridal Serenade (Gibson); Abendstimmung (Kaun); Ständchen (Schubert); Adagio from the Moonlight Sonata (Beethoven); Trauenspiel-Suite (Reznicek); Melody (Debussy); Wiegieden (Mozart).

HANOVER.—See Hamburg.

HEILSBURG

1,685 kc/s, 276.5 metres; 60 kW. Relayed by Danzig, 602 kc/s, 483.2 metres.—1.5 p.m., Variety Concert on Gramophone Records. In the intervals at 1.0 and 2.0, News. 2.30, Programme arranged by the Post Office, with Gramophone Records. 3.0, Agricultural Prices and Exchange. 3.15, Programme for Children. 3.40, Programme for Women. 4.0, Concert by the Small Station Orchestra, conducted by Eugen Wilken; Overture, The Nuremberg Doll (Adam); Venetian Serenade (Helmeberger); Mephistowalzer No. 1 (Liszt); Selection from Preciosa (Weber); Overture, Albin (Flotow); Poetic Suite (Dvorak); Waltz, Diesen Kuss der ganzen Welt (Ziehrer); Overture to a Comedy (Lincke); In an interval at 4.50 (approx.). Book Review. 5.45, Talk on Country Continuation Schools. 6.15, Agricultural Prices. 6.25, Talk: Germans in North America. 6.50, Weather. 7.0, Transmission for all German Stations, relayed from Berlin (Deutschlandsender). 8.0, Weather and News. 8.10, Concert by the Königsberg Mandoline and Guitar Society, with Humorous Talks in East Prussian Dialect by Kurt Wernick. 9.10, Concert by the Small Station Orchestra, conducted by Eugen Wilken. 10.0, Weather and News. 10.20, Modern German Dances.

HILVERSUM

1,013 kc/s, 296.1 metres; 7 kW. up to 5.40 p.m. and 20 kW. from 5.40 p.m.—11.40 a.m. to 3.40 p.m., Programme of the Algemeene Vereeniging Radio Omroep (A.V.R.O.). 11.40, Concert of Light Music. Gramophone Music in the intervals. 1.40 p.m., Gramophone Music. 2.10, Recitations. 2.40, Gramophone Music. 3.40 to 7.40, Programme of the Workers' Radio Society (V.A.R.A.). 3.40, Gramophone Music. 4.30, Programme for Children. 5.10, Orchestral Concert, conducted by de Groot; Overture, Gri-Gri (Lincke); Melody (Rubinstein); Polish National Dance (Scharwenka); From the Old and New World (Dvorak-Leopold). 5.40, Pianoforte and Accordion Recital: Valse des Fleurs (Tchaikovsky); Czardas (Michele). 5.50, Concert (contd.): Le Jongleur (Rosny); Cigány Melody (Baldy); Lolita (Buzzi-Peccia); Algerian Suite (Saint-Saëns). 6.20, Talk on Fascism. 6.40, Concert (cont.): Per aspera ad astra (Ulbrach); Serenade, Mandoline (Eilenberg); Pikanterien (Lehar); Wiener-Operetten-Revue (Robrecht). 7.10, Accordion and Pianoforte Recital (contd.): Russian Rag (Cobb); Waltz (Berger); Red Pepper (Lodge). 7.20, Concert (contd.): Ballet Music from Coppélia (Delibes). 7.40 to 10.40, Programme of the Liberal Protestant Radio Society (V.P.R.O.). 7.40, Talk. 8.10, Pianoforte Recital: Extracts from Das Waldtemperierte Klavier (Bach); Sonata in D (Haydn); Minuet with Variations (Mozart). 8.40, Talk. 9.10, Pianoforte Recital (contd.): Prelude in C Minor (Chopin); Prelude in F (Chopin); Polonaise in E Minor, Op. 26 (Chopin); Mazurka in B Minor, Op. 33, No. 4 (Chopin); Prelude in G Minor (Rachmaninov); Prelude autumnali (Malipiero); La Danza d'Olaf (Piek-Mangiagalli). 9.40, Religious Notes and News. 9.55, Talk. 10.25, Gramophone Music. 10.40 till Close Down, Programme of the V.A.R.A.: Gramophone Music. 11.40 (approx.), Close Down.

HORBY.—See Stockholm.

HUIZEN

160 kc/s, 1,875 metres; 7 kW. (until 3.40 p.m.). (Transmitted from Kootwijk on 50 kW. from 3.40 p.m.).—Programme of the Catholic Radio Society (K.R.O.). 11.40 a.m., Police Notes. 11.55, Concert by the K.R.O. Orchestra, conducted by van t'Woud; March, Auf treue Kameradschaft (Blendenburg); Overture, The Nuremberg Doll

(Adam); Die Schöner von Valencia (Morana); Selection from The Bird-Fancier (Zeller); Netherland Peasant Dances (Step); March from Carmen (Bizet); Gramophone Records; Overture, Casanova (Lincke); Eternelle ivresse (Ganne); Meditation (Massenet); Aubade printanière (Lacombe); March; Hispana (Dreyer). 1.25 p.m., Interval. 1.40, Concert by the Vienna Station Octet; Overture, Si j'étais roi (Adam); Selection from The Count of Luxembourg (Lehar); Baci al buio (de Micheli); Selection from Countess Maritza (Kálmán); Delibes Potpourri (Ulbrach); Zwei Märchenbungen (Kálmán); 2.25, Violin Recital by Trom; Romance (Beethoven); Berceuse (Aulin); Slav Dance (Dvorak-Kreisler). 2.40, Song Recital by Perlot (Baritone). 2.55, Octet Concert (contd.); Selection from Die Puppenfee (Bayer). 3.10, Violin Recital (contd.): Chanson Louis III (Coperin-Kreisler); Pavane (Coperin-Kreisler); Serenade (Drlla); Introduction and Rondo capriccioso (Saint-Saëns). 3.25, Song Recital (contd.). 3.40, Concert by the K.R.O. Orchestra, conducted by Gerritsen; Overture, Le roi d'Ys (Lalo); Valse triste (Sibelius); Selection from the Ballet Raymond (Glazounov); Selection from The Pearl Fishers (Bizet); Selection from A Midsummer's Night's Dream (Mendelssohn); Overture in B flat (Schubert); The Holberg Suite (Grieg). In the interval at 4.25, Gramophone Records, at 5.10, Talk on Agriculture, and at 6.10, Gramophone Records. 6.40, Police Notes. 6.55, Talk. 7.15, Gramophone Records. 7.25, Talk. 7.40, Gramophone Records. 7.55, Concert by the Maastriicht Municipal Orchestra, conducted by Hermans. In the interval at 8.10, News. 8.50, Recitation. 9.10, Concert (contd.). 9.55, Talk. 10.30, News. 10.15, Concert by the Vienna Station Octet. 11.40 (approx.), Close Down.

INNSBRUCK.—See Vienna.

JUAN LES PINS

1,205 kc/s, 249 metres; 0.8 kW. 8.0 p.m., Amusement Guide, Exchange, Racing Results and News. 8.10, Esperanto Lesson. 8.30, Radio Concert. In an interval at 8.45, News and Weather.

KALUNDBORG.—See Copenhagen.

KIEL.—See Hamburg.

KLAGENFURT.—See Vienna.

KOSICE.—See Prague.

LAHTI

167 kc/s, 1,796 metres; 10 kW. Relayed by Helsinki, 815 kc/s, 368.1 metres.—6.15 p.m., Two Talks in Swedish. 6.40, Talk. 7.5 (from Helsinki), Concert of French Music by the Helsinki Municipal Orchestra, relayed from the University. Conductor, Georg Schneivoigt. Soloist, Jacques Thibaud (Violin). Symphonie fantastique (Berlioz); Violin Solo, Spanish Symphony (Lalo); Ballet Music from Daphnis et Chloë (Ravel). 8.45, News in Finnish and Swedish.

LANGENBERG

635 kc/s, 473 metres; 60 kW.—12 Noon, Concert by the Münster Municipal Orchestra, conducted by Georg Jochem. 1.15, News, relayed from Frankfurt. 1.25, News. 1.35, Variety Concert by the Fröhliche Film und Soloists. 3.0, A Visit with the Microphone to the Klutert Caves at Milspe, Westphalia. 3.30, Economic Notes. 3.50, Political Announcements. 4.0, Concert by the Station Orchestra, conducted by Kühn; Soloist, Wilhelm Strienz (Bass); Part I: Italian Opera Music: Overture, Norma (Bellini); Ballet Music from William Tell (Rossini); Bass Aria from Simone Boccanegra (Verdi); Selection from Othello (Verdi); Aria, Vecchia zinnarra, from La Bohème (Puccini); Selection from Manon Lescaut (Puccini); Part II: German Music: Tragic Overture (Brahms); Selection from Ariadne auf Naxos (R. Strauss); Bass Solo, Fire Magic from The Valkyrie (Wagner); Jubel-Ouverture (Weber). 6.0, English Lesson. 6.20, Talk. 6.35, The Stallion Parade at Warendorf (on Gramophone Records). 6.50, Announcements. 7.0, Transmission for all German Stations, relayed from Berlin (Deutschlandsender). 8.10, See Frankfurt. 10.20, See Stuttgart. 10.30, News. 10.40, Dance Music by the Station Dance Band, conducted by Kühn. 12 Midnight, Dance Music Relay. 1.0 a.m. (Saturday), Close Down.

LAUSANNE.—See Radio-Suisse Romande.

LEIPZIG

769.9 kc/s, 389.6 metres; 120 kW. Relayed by Dresden, 941 kc/s, 319 metres.—12 Noon, See Langenberg. 1.15 p.m., News. 1.30, Folk Music. 2.15, News. 2.30, Art Notes. 2.45, Talk for the Country Woman. 3.0, Concert by the Leipzig Symphony Orchestra, conducted by Theodor Blumer; Soloist, Karl Meissner (Viola); Part I: Orchestral Suite, Vasantasana (Halvorsen); Viola Concerto in D (Stamitz); Hungarian Dances Nos. 1, 3 and 10 (Brahms); Humoresque (Humperdinck); Part II: Marches and Waltzes; March, Mit Standarden (Blon); Waltz, Moonlight on the Alster (Fétras); March, Waidmannshell (Reckling); Waltz from Gipsy Love (Lehar); March, The Star Spangled Banner (Souza); Waltz, Edelweiss

(Blumer); Helenenmarsch (Lübbert); Waltz from Gasparone (Müllöcker). In an interval at 4.0, Market Prices. 5.0, Book Review. 5.20, Military Notes. 5.50, Economic Notes, Weather and Time. 6.0, Hermann Zaube Music for the Flute, played by the Composer; Suite Op. 7, Two Impressions; Op. 6a, Caprice; Op. 6c. 6.30, A Picture of Life in Central German Towns, Villages and Markets. 6.50, Today's News. 7.0, Transmission for all German Stations, relayed from Berlin (Deutschlandsender). 8.0, Humorous Programme. 9.0, See Frankfurt. 10.0, News. 10.30, Talk: Great German Achievements in Scientific Research. 10.15, Concert by the Leipzig Symphony Orchestra, conducted by Willy Steffeu; Soloist, Dorothea Schröder (Contralto); Overture in Italian Style (Schubert); Pastorale, Op. 29 (Bose); Stimmen der Nacht from Impressionen (Karg-Elert); Divertimento in F for Two Horns, Two English Horns, Two Violins and Two Bassoons (Haydn); Contralto Songs (Wolf): (a) Anakreons Grab, (b) Deuk es, oh Seele, (c) Ueber Nacht; Suite, In Sunny Spain (Elliot). 12 Midnight (approx.), Close Down.

LINZ.—See Vienna.

LJUBLJANA

522 kc/s, 574.7 metres; 7 kW.—6.0 p.m., Gramophone Music. 6.30, Russian Lesson. 7.0, Programme for Sokols. 7.30, Tourist Talk. 8.0, Programme relayed from Zagreb. 9.77 kc/s, 307 metres. 10.0, Weather and News. 10.20, Dance Music by the Radio Jazz Band. 11.0 (approx.), Close Down.

LUXEMBOURG

252 kc/s, 1,191 metres; 300 kW. Dutch Evening. 7.30 p.m., Symphony No. 1 in C, Op. 21 (Beethoven) by the New York Philharmonic Orchestra, conducted by Mengelberg (on Gramophone Records). 8.15, Gramophone Concert. 8.50, News in French. 9.0, Violin Recital by Jeanne Vogelsang; Dutch Piece (Heliandahl); Potpourri of Airs and Dances (Röntgen). In the interval, Talk on Art. 9.45, News in German. 9.55, Concert relayed from the Polo-Nood Brasserie.

LWOW

789 kc/s, 331 metres; 16 kW.—7.5 p.m., Announcements and Gramophone Music. 7.25, See Warsaw. 7.40, Programme Announcements. 7.45, See Warsaw. 11.5, Gramophone Music. 11.30 (approx.), Close Down.

LYONS

LA DOUA, 644 kc/s, 465.8 metres; 1.5 kW.—6.30 p.m., Radio Journal. 7.30, Radio Gazette for Lyons and the South-East. 8.30, Concert by the Pierre Lorraine Quintet; Soloist, Ly-siane Doriani (Soprano); Overture, Les Dragons de Villars (Maillart); Waltz, Amour bohème (Poppy); Czardas (Marie); Song, Solyog's Song (Grieg); Waltz Suite (Kálmán); Overture, Giróff-Girólla (Leocop); Hungarian March (Berlioz); Song, Chanson gothique (Berlioz); March (Rubinstein); Song, Romance de Marguerite (Berlioz); Soir à Rio (Callenier); Ballet Music from Les Saltimbanques (Ganne); Chöre felice (Cubota); Cavatina from The Pearl Fishers (Bizet); Waltz Suite, A toi (Waldteufel); Selection from The Huguenots (Meyerbeer). After the Concert, News.

MADRID

ARANJUEZ (EAO), 10,000 kc/s, 80 metres; 20 kW.—11.30 p.m., Concert of Popular Music. In the interval at 11.45, Radio Chronicle. 12.35 a.m. (Saturday), Answers to Correspondence. 12.40, Spanish-American Talk. 12.45, Light Music. 1.0 to 1.30, Programme in English by the I.B.C. 1.0, I.B.C. Concert: Song of the Vagabonds; The Love Lieutenant; The Regiment of Peace; The Siege of Monte Carlo; Waltz Dream; Kissing is no Sin; Song of the Islands; Dreams on the Ocean. 1.30, I.B.C. Good-night Melody.

MADRID

EAJZ, 707 kc/s, 424.3 metres; 2 kW.—8.0 p.m., Chimes, Exchange and Request Gramophone Records. 9.15, Topical Review. 9.20 to 11.0, Interval. 11.0, Chimes, Time, and Topical Review. 11.20 (approx.), Symphony Music on Gramophone Records; Overture, The Secret Marriage (Cimarosa); Scherzo from A Midsummer Night's Dream (Mendelssohn); El Albaicin (Albéniz); Symphony No. 5 (Tchaikovsky); Pianoforte Concerto in E flat (Liszt). 1.15 a.m. (Saturday), Topical Review and Programme Announcements for Listeners Abroad. 1.30, Chimes and Close Down.

MALMO.—See Stockholm.

MILAN.—See Turin.

MORAVSKA-OSTRAVA

1,137 kc/s, 263.8 metres; 11 kW.—4.0 p.m., Concert by the Station Orchestra, conducted by Plichta; Overture, La Princesse Jaune (Saint-Saëns); Scènes alsaciennes (Massenet); Souvenir (Sestak); Waltz, Wienerblut (Joh. Strauss); Krakoviak (Czajnek); Neapolitan Serenade (Bayer); March of the Aviators (Polprecht). 4.55, Educational Talk. 5.5, See Prague. 6.5, Tourist Talk. 6.15, See Prague. 7.10, Dance Music. 8.0, See Prague. 8.15, See Brno. 8.50, See Prague. 10.30 (approx.), Close Down.

MOTALA.—See Stockholm.

MUHLACKER.—See Stuttgart.



OCT. 6th

FRIDAY

continued

MUNICH

563 kc/s, 533 metres; 60 kW. Relayed by Augsburg and Kaiserslautern, 536 kc/s, 560 metres; and Nürnberg, 1,256 kc/s, 239 metres. — 4.30 p.m. (from Kaiserslautern), Orchestral Concert. 5.45, Talk for the Younger Generation. 6.5, Violin Recital. 6.30, Report of the Palatinate Society for Scientific Research, relayed from Bad Dürkheim. 6.45, Time, Weather and Agricultural Notes. 7.0, Transmission for all German Stations relayed from Berlin (Deutschlandsender). 8.0, Talk: Industrial Development in the Soviet Union. 8.20, Concert by the Small Station Orchestra, conducted by Kloss, with Emmy Lemberger (Soprano) and Hans Schindler (Tenor). 9.10, Political Talk. 9.20, Concert by the Station Orchestra, conducted by Winter; Soloists: Elizabeth Woldeman (Alto) and Walter von Hoesslin (Pianoforte); Pianoforte Concerto in D minor (Bach); Rhapsody (Brahms); The Jena Symphony (Beethoven). 10.0, Time, Weather and News.

NAPLES.—See Rome.

NOTODDEN.—See Oslo.

OSLO

577 kc/s, 1,083 metres; 60 kW. Relayed by Fredrikstad, 815 kc/s, 368.1 metres; Hamar, 522 kc/s, 574.7 metres; Notodden, 671 kc/s, 447.1 metres; Porsgrund, 662 kc/s, 453.2 metres; and Rjukan, 671 kc/s, 447.1 metres. — 5.0 p.m., Concert by the Mincus Orchestra. 6.0, French Lesson. 6.30, Pianoforte Recital by Elisabeth Hads Andersen; Theme with Variations (Handel); Sonata Op. 31, No. 3 (Beethoven). 7.0, Advertising Notes. 7.15, Weather and News. 8.0, Time. 8.1, Talk. 8.15, Chamber Music by the Budapest Quartet. 9.15, Recitations. 9.40, Weather and News. 10.0, Topical Talk. 10.15, Song Recital by Einar Eldgen.

OSTERSUND.—See Stockholm.

PALERMO

558 kc/s, 537.6 metres; 3 kW. 8.0 p.m., Dopplavoro Announcements, Tourist Talk, Agricultural Notes, Report of the Royal Geographical Society, and Giornale Radio. 8.20, Gramophone Music. In the interval at 8.30, Time and Announcements. 8.45, Concert of Opera Music, conducted by Russo. In the interval, Talk. 11.0, Giornale Radio.

PARIS

EFFEL TOWER, Call FLE, 207.5 kc/s, 1,445.7 metres; 13 kW. Time Signals (on 2,650 metres) at 10.26 a.m. and 11.26 p.m. (Preliminary and 6-dot Signals).—6.45 p.m., Theatre Talk. 7.0, Le Journal Parlé. 8.30, Pianoforte Recital by Marie-Antoinette Pradier, with Commentary by André Delacour; Moments musicaux (Schubert); Impromptus (Schubert). 9.0, Symphony Concert, conducted by Flamant; Soloists: René Bas (Violin), Ladurie (Viola), and Krabanski (Cello); Selection from Maroni (Raband); Violin Solo; Menuet rose (Ganne); Viola Solo; Cello Solo; Extempore pastorale (Flamant); Farandole (Pierne); Au der schönen grünen Narenta (Komzak). 10.0 (approx.). Close Down.

PARIS

POSTE PARISIEN, 914 kc/s, 328.2 metres; 60 kW.—7.0 p.m., Gramophone Music. 7.5, Sponsored Talk. 7.15, Le Journal Parlé. 7.30, Gramophone Concert: Overture, Le Carnaval de Venise (Thomas); España (Chabrier); Festival Polonoise from Le roi malgré lui (Chabrier). 7.55, Agricultural Talk. 8.0, Talk on Music. 8.30, La petite mariée—Opéra-Bouffe in Three Acts (Lecocq). 10.30, News.

PARIS

RADIO-PARIS, Call CFR, 174 kc/s, 1,725 metres; 75 kW.—7.30 a.m., Weather and Physical Culture. 7.45, Gramophone Music. 8.0, Weather and News. 12 Noon, Jewish Talk. 12.30 p.m., Symphony Concert on Gramophone Records: The Braudenberg Concerto in F (Bach); Aria from The Magic Flute (Mozart); Aria from Don Giovanni (Mozart); Concerto in E Minor (Mendelssohn); Nocturne (Franck); Mater Dolorosa (Franck); Second Suite from Daphnis et Chloé (Ravel); Bourré fantasque (Chabrier). In the interval at 1.0, Exchange, News and Weather, and at 1.30, Exchange. 2.0, Exchange. 3.45, Exchange and Market Prices. 6.30, Agricultural Talk. 6.50, Gramophone Music: Military March (Schubert); Songs: (a) Le beau séjour, (b) Dans notre village; (c) Old Spanish Song (Aubert). 7.0, Talk: The Foreign Legion. 7.10, Assurance Societies Report. 7.20, Gramophone Music: El miró de la Palma (Celder-Lefler); Spanish Echoes (Marquina); Melody in F (Rubinstein); Songs from La danseuse de Tanagra (Hirschmann); Arab March (Ganne). 7.45, Commercial Prices and News. 8.0, Literary Talk. 8.30, News and Weather. 8.40, Gastronomic Review. 8.45, Aria and Duet Recital by Renée Legendre and Germaine Champell; Song from Les Cloches de Corneville (Planquette); Waltz from La cocarde de Mimi Pinson (Goublier); Duet and Rondo from Le petit duc (Lecocq); Song from La Poupée (Audran); Duet from La fille de Madame Angot (Lecocq); Song from The Merry Widow (Lehár); Air from Les Saltimbanques (Ganne); La cigale et la fourmi (Audran). 9.15, News. 9.30, American Concert on Gramophone Records: March (Souza); Good Girl (Ash); Baby come on! (de Sylva); A Certain Feeling (Ira and Gershwin); Negro

Spiritual; Song; Two Melodies; Mi trumbao (Castellanos); Teclote (Ponce); Mexican Serenade (Ponce); Estrellita (Ponce); Pegandole al emarron (Alonso); Engrupido (Enriotti); Quano Liora la Milonga (Mario); Gracia y sal (Lucchesi).

PORSGRUND.—See Oslo.

PRAGUE

614 kc/s, 488.6 metres; 120 kW.—4.0 p.m., See Moravská-Ostrava. 4.55, Legal Talk. 5.5, Concert of the Ondrick Quartet; String Quartet in A (Mozart); String Quartet, Op. 17 (Prochazka). 6.5, Agricultural Report. 6.15, Talk for Workers. 6.25, News in German. 6.30, German Transmission; Talk. 7.0, Time and News. 7.10, See Moravská-Ostrava. 8.0, Topical Talk. 8.15, See Brno. 8.50, Talk on the following Transmission. 9.0, Ogari—Operetta for Children (Krieka). 10.0, Time and News. 10.15, News in Russian.

RADIO-SUISSE ROMANDE

SOTTENS, 743 kc/s, 403 metres; 25 kW.; and Geneva, 395 kc/s, 760 metres.—7.0 to 7.15 a.m. (from Lausanne), Gymnastics. 12.28 p.m., Time Signal from Neuchâtel Observatory. 12.30, News and Weather. 12.40 (from Geneva), Gramophone Concert. 1.0 (from Geneva), Financial News. 1.10 (from Geneva), Gramophone Concert. 2.0 to 3.28, Interval. 3.28, Time Signal from Neuchâtel Observatory. 3.30 (from Geneva), Gramophone Music. 4.30 (from Geneva), Programme for Women. 5.30 to 7.0, Interval. 7.0, German Lesson. 7.30 (from Lausanne), Weather, Announcements and News. 7.35 (from Lausanne), Answers to Correspondence. 8.0 (from Lausanne), Concert by the Radio Lausanne Orchestra, conducted by Moser; Soloist: Romano Rasponi (Baritone); Invicidiro (Cotogni); Venetian Vision (Broggi); Sogno (Ricci); Ideale (Tosti); Ave Maria (Lamo); Tango, Gitana (Padilla). 8.50 (from Lausanne), Cabaret Programme. 9.50, News and Weather. 10.0 (from Geneva), Talk: The Work of the League of Nations. 10.30 (approx.). Close Down.

RIGA

572 kc/s, 525 metres; 15 kW.—7.0 p.m., Symphony Concert, conducted by Medine; Extracts from Tristan and Isolde (Wagner); Scottish Fantasia for Violin (Bruch); Symphony No. 1 in G Minor (Kalimikov). In the interval at 8.0, News. 9.0, Weather and News. 9.15, Old and Modern Dance Music. 10.0 (approx.). Close Down.

RJUKAN.—See Rome.

ROME

Call IRO, 680 kc/s, 441 metres; 50 kW. Relayed by Naples, 941 kc/s, 319 metres; Bari, 1,112 kc/s, 269.8 metres; Milan (Vigentino), 662 kc/s, 453.2 metres, from 8.15 p.m. (approx.), and 2RO, 11,810 kc/s, 25.4 metres, from 5.15 p.m.—12.30 p.m., Gramophone Music. 1.0, Orchestral Concert of Light Music. In the interval from 1.30 to 1.45, Giornale Radio and Exchange. 2.0, Time and Announcements. 4.30, Children's Radio Review. 4.55, Giornale Radio and Exchange. 5.10, Weather. 5.15 to 6.0, Song and Pianoforte Recital by Maria Grimaldi (Soprano), Romano Rasponi (Baritone), and Silvano de Francesco. 6.40 (Naples), Shipping and Sports Notes. 6.45, Dopplavoro and Tourist Report. 6.57, Report of the International Institute of Agriculture (in Spanish, German, and French). 7.10, Agricultural Report. 7.20, News in Foreign Languages. 7.40, Giornale Radio. 8.0, Time, Announcements, and Sports Notes. 8.15, Sponsored Concert. 9.15, L'Arlecine—Comedy in One Act (Clarice Tartufari). 9.45, Song and Violin Recital by Emilio Livi (Tenor), Gianna Perea Labia (Soprano), and Bruna Franchi (Violin). Tenor Solos: (a) Aria from Werther (Massenet), (b) Aria from Martha (Flotow), (c) La Paloma (Yradier), (d) A vucchella (Tosti); Violin Solo, La Campanella (Paganini); Cavatina from The Barber of Seville (Rossini); Duet from Rigoletto (Verdi); Announcements in the interval. Dance Music after the Concert. In the interval at 11.0, Giornale Radio. 11.30 (approx.). Close Down.

SALZBURG.—See Vienna.

SCHWEIZERISCHER

LANDESENDER

BEROMUNSTER, 653 kc/s, 459 metres; 60 kW.; Basle, 1,229 kc/s, 244.1 metres; and Berne, 1,220 kc/s, 245.9 metres.—11.57 a.m., Time Signal from Neuchâtel Observatory and Weather. 12.0 Noon (from Zürich), Light Orchestral Concert. 12.30 p.m., Time, Weather and News. 12.40 (from Zürich), Light Orchestral Concert (cont'd.). 1.25 (from Zürich), Time, Weather and Exchange. 1.30 (approx.) to 5.0, Interval. 5.0, from Basle), Programme for Children on Gramophone Music. 6.30 (from Berne), A Dialogue; Elementary School Teaching. 7.0 (from Berne), Time, Weather, Market Prices, Tourist Talk and Sports Notes. 7.20 (from Berne), Talk with Illustrations; Swiss Folk Songs. 8.20, Concert of Light Music by the Station Orchestra. 9.0, Weather and News. 9.10 (from Berne), Biel (Bienne)—Radio Sequence. 10.30 (approx.). Close Down.

SOTTENS.—See Radio-Suisse Romande.

STOCKHOLM

699 kc/s, 436 metres; 55 kW. Relayed by Boden, 244 kc/s, 1,229.5 metres; Göteborg, 932 kc/s, 322 metres; Hörby, 1,166 kc/s, 257 metres; Motala, 2,215 kc/s, 1,354.4 metres; Östersund, 389 kc/s, 770 metres; and Sundsvall, 554 kc/s, 542 metres.—1.0 to 1.30 p.m., Broadcasts for Schools. 5.5, Programme for Children. 5.25, Light Music. 5.45, Talk, relayed from Malmö, 1,301 kc/s (231 metres). 6.15, Gramophone Music. 6.55, Review of Foreign Affairs. 7.15, Weather and News. 7.30, Talk, relayed from Malmö. 8.0, Pianoforte Solos by Vladimir Horowitz (Gramophone Records). 8.15, (cont'd.) Comedy (E. W. Olson). 10.0 (from Göteborg), Orchestral Concert: Overture, The Bohemian Girl (Balle); Emperor Waltz (Joh. Strauss); Selection from Die toten Augen (d'Albert); Melody (Peterson-Berger); Hungarian Rhapsody No. 2 (Liszt); Matilda (Leoncavallo); March Potpourri, Im Tempo der Zeit (Robrecht). 11.0 (approx.). Close Down.

STRASBOURG

869 kc/s, 345 metres; 11.5 kW.—11.30 a.m., Variety Music on Gramophone Records. 12.45 p.m., News, 1.0, Time and Exchange. 1.5, Orchestral Concert, conducted by Roskam; Mareil, Hollywood (Leopold); Waltz, Barcarolle (Waldteufel); Cello and Pianoforte, Berceuse (Roskam); Overture, Jean de Paris (Boieldien); Selection from Die Fledermaus (Joh. Strauss); Violin and Pianoforte, Liebesfreud (Kreisler); Spanish Dances Nos. 2 and 5 (Moszkovsky); A Wedding Day on Troldhaugen (Grieg). 2.0, Interval. 4.45, Literary Talk on Molière's Sonnets. 5.0, Orchestral Concert, conducted by Roskam; Two-Step, Micella (Bozi); Waltz, Künstlerleben (Joh. Strauss); Serenade (Moszkovsky); Foxtrot, Ein kleiner Vorschuss (Kollo); Tango, Cikanka (Azak); Selection from The Love Parade (Schertzingler); Serenade, Bella Venezia (Schulenburg); Gavotte from Der Weg zum Herzen (Lincke); Foxtrot, You're telling me (Kahn-Donaldson); Tango, Wir tanzen ein und sehen aus (Heymann); Waltz, Tout Paris (Waldteufel); March, This is a Day of Days (Woods-Dixon). 6.0, Trio Concert, relayed from Lille, 1,130 kc/s, 265.4 metres. 7.0, Topical Talk in German. 7.15, Talk: The Archeological Riches of the Meuse. 7.30, Time and News. 7.45, Gramophone Music. 8.0, Press Review in German, Lottery Results, and Announcements. 8.30, Concert by the Esperance Musical Society, conducted by Emile Schmit, relayed from Hagondange: Concert Allegro, Eavant (Menzel); Overture, Sous la fenille (Strawen); Amoretteintänze (Gungl); Tarass Boulba (George); Egyptian Serenade, Amina (Lincke); Waltz, The Blue Danube (Joh. Strauss); March of the Tin Soldiers (Pierre); Russian Mazurka, La Czarine (Ganne); Gavotte des baisers (Popy); Marche Lorraine (Ganne). Talk in an interval. 10.30 (approx.). Close Down.

STUTTART

MUHLACKER, 832 kc/s, 360.5 metres; 60 kW. Relayed by Freiburg, 527 kc/s, 575 metres.—12 Noon, See Langenberg. 1.15 p.m., News from Frankfurt. 1.25, News. 1.35, See Langenberg. 2.30, Vocal and Instrumental Concert: Hilde Kefer-Bluthardt (Soprano), Schummacher (Violin), and Leo Hantz (Lute); Songs (Pflster) to Poems of Hermann Löwis: (a) Das Wahrzeichen, (b) Der Tausch, (c) Das Irrlicht, (d) Die Nachtigall, (e) Der Kuckuck; Violin and Guitar; Serenade (Giuliani); Airs (Pflster): (a) Wiegeliend im Chiemgau zur Kriegszeit, (b) Wenn die Blümchen schlafen ein, (c) Blaue Ackerle, (d) Zwei Spielent, (e) Tänzchen im Freien. 4.0, See Langenberg. 6.35 Legal Talk. 7.0, Transmission for all German Stations, relayed from Berlin (Deutschlandsender). 8.0 to 10.20, See Frankfurt. 10.20, Things you should know. 10.30, Local News. 10.45, Dance Music from Langenberg. 12 Midnight, Dance Music Relay.

SUNDSVALL.—See Stockholm.

TOULOUSE

779 kc/s, 385 metres; 8 kW.—6.0 p.m., News. 6.15, Music by an Argentine Orchestra. 6.30, Sound Film Music. 6.45, Opera Music, Dance of the Fireflies, from The Damnation of Faust (Berlioz); Prelude to Act I of Lohengrin (Wagner); March from The Valkyrie (Wagner). 7.0, Operetta Music. Selection from Deshabillez-vous (Mercier), La Mascotte (Audran), La petite mariée (Lecocq), and Suzanna (Paladillle). 7.15, News, Racing Results, and Market Prices. 7.30, Extracts from Hansel and Gretel—Operetta (Hamperdinck). 7.45, Accordion Music. 8.0, Opera Music. Selections from: Mignon (Thomas); Manon (Massenet), and Così fan tutti (Mozart). 8.15, Orchestral Concert. 8.45, Military Music. 9.0, Music Hall Programme. 9.30, Music by a Viennese Orchestra; Tonjours on jamais (Waldteufel); Amour et printemps (Waldteufel); Chanson triste (Tchaikovsky); Selection from The Merry Widow (Lehár). 9.45, Opera Music. Arias from: Faust (Gounod), Prince Igor (Borodin), Sigurd (Reyer), and Samson and Delilah (Saint-Saëns). 10.0, Medical Talk. 10.10, Operetta Music. Selections from: Le jour et la nuit (Lecocq), Viktoria and her Hussar (Abraham). 10.15, North African

News and Local News. 10.30, Concert for Listeners in Morocco: Overture, Raymond (Thomas); Arias from The Barber of Seville (Rossini); L'horloge à grand mère (Smet); Les rêves sont des bulles de savon (Hermitte); Sons les ponts de Paris; Melody (Raiter). 11.0, Popular News. 11.15, Dance Music. 12.0 Midnight, News, Weather, and Announcements. 12.5 a.m. (Saturday), Music by an Argentine Orchestra. 12.15, Military Band Music. 12.30 (approx.). Close Down.

TRIESTE

1,211 kc/s, 247.7 metres; 10 kW.—5.10 p.m., till Close Down. See Turin.

TRONDHEIM.—See Oslo.

TURIN

1,096 kc/s, 273.7 metres; 7 kW. Relayed by Milan, 905 kc/s, 331.5 metres; Genoa, 959 kc/s, 312.8 metres; and Florence, 599 kc/s, 500.8 metres.—5.10 p.m., Chamber Music. 6.0 to 6.5, Weather. 6.40, Giornale Radio, Dopplavoro Report, and Gramophone Music. 7.0, Time, Report of the Royal Geographical Society, and Gramophone Music. 7.10, Wheat Market Report. 7.20, News in Foreign Languages. 7.40, Gramophone Music. 8.0, News and Weather. 8.15, Sponsored Music. 8.30, Symphony Concert. Talk in the interval. 10.0, Concert of Variety Music. 11.0, Giornale Radio.

VATICAN CITY

15,120 kc/s, 19.84 metres (Morning); and 5,969 kc/s, 50.26 metres (Evening); 10 kW.—11.0 to 11.15 a.m., Religious Information in German. 8.0 to 8.15 p.m., Religious Information in Italian.

VIENNA

581 kc/s, 517 metres; 100 kW. Relayed by Graz, 852 kc/s, 352.1 metres; Innsbruck, 1,058 kc/s, 283 metres; Klagenfurt, 662 kc/s, 453.2 metres; Linz, 1,220 kc/s, 245.9 metres; and Salzburg, 1,373 kc/s, 218.5 metres.—11.30 a.m., Concert by the Wiener Symphoniker, conducted by Holzer. In the interval at 11.55, Weather. 1.0 p.m., Time, Weather and Announcements. 1.10, Gramophone Concert. 2.0, Interval. 3.0, Time, Weather and Market Prices. 3.20, Talk: Water-Supply Systems. 3.35, Talk for Women: Gottfried Keller's Sister, Ragula. 4.0, Gramophone Concert. 4.50, Schubert Pianoforte Recital. 5.15, Concert of Chamber Music: Quintet in E flat, Op. 16, for Oboe, Clarinet, Bassoon, Horn and Pianoforte (Beethoven); Suite for Flute, Oboe, Clarinet, Bassoon and Pianoforte (Klein). 5.55, Tourist and Traffic Report. 6.10, Talk. 6.25, Weekly Sports Report. 6.35, Talk: An Archeological Tour. 7.0, Concert by the Wiener Symphoniker, conducted by Alwin; Overture, William Tell (Rossini); Ballet Music from Othello (Verdi); Three Pieces from the Music to Sigurd Jossalfar (Grieg); Waltz, Sphärenklänge (Strauss); Overture, Orpheus in the Underworld (Offenbach). In the interval at 7.35, Time, Weather and Announcements. 8.15, A Spy in the Hangar—Radio Play after the Novel by Kussak-Raytenau. 10.0, News, Weather and Announcements. 10.15, Music by the Four Funny Fellows, relayed from the Oasis Café. After the Programme, Announcements.

WARSAW

212.5 kc/s, 1,411 metres; 120 kW.—11.57 a.m., Time Signal and Fanfare from St. Mary's Church, Cracow. 12.5 p.m., Gramophone Music. 12.30, Radio Journal. 12.35, Quartet (Beethoven) on Gramophone Records. 1.0 to 3.30, Interval. 3.30, Economic Notes. 3.40, Announcements. 3.45, Boy Scouts' Report. 3.50, Talk: Maritime and Colonial Affairs. 3.55, Pianoforte and Tenor Recital by Trombini Kazuro (Pianoforte) and Umberto Maenez (Tenor). (Pianoforte Solo: Variations in C minor (Beethoven). Tenor Solos: (a) Barcarolle (Rossini), (b) Two Songs (Rachmaninov). Pianoforte Solos: (a) Impromptu in G. Op. 90, No. 3 (Schubert), (b) Novelette in D. Op. 21, No. 4 (Schumann). Tenor Solos: (a) Aria from Halka (Moniuszko), (b) Aria from Lohengrin (Wagner). 4.40, Review of Books. 4.55, Soprano and Cello Recital by Mme. Krzywiec and Casimir Wilkomirsky; Cello Concerto in B (Bocherini). Soprano Arias from: La Sonnambula (Bellini), Il Trovatore (Verdi), Mephistopheles (Boito) and Wanda (Doppler). Cello Solos: (a) Le Cygne (Saint-Saëns), (b) Arabesque (Debussy) and Requiebras (Cassado). Soprano Solos: (a) Divertissement (Chopin), (b) Fillette (Friedman), (c) Nimon (Tosti). 5.50, Agricultural Notes. 6.0, Talk in German: The Battle of Vienna. 6.20, Light Music. Soprano Solos by Mme. Olga Iada and Recital on Two Pianofortes by Altenberg and Rybczynsky. 7.5, Miscellaneous Items. 7.20, Talk: Where to go on Holidays. 7.25, Talk: Contemporary Romanian Literature. 7.40, Programme Announcements. 7.45, Radio Journal. 8.0, Music Talk. 8.15, Concert of Polish Music by the Warsaw Philharmonic Orchestra, conducted by Fiteberg. Soloist: Paul Kochansky (Violin); Symphony (Guzawsky); Violin Concerto in D minor (Wieniawsky); Violin Concerto No. 2 (Szymanovsky); Short Pieces for Violin. In the interval, Talk: The Future of Polish Literature. 10.40, Sports Notes. 10.50, Dance Music. 11.0, Aviation Weather Report and Police Notes. 11.5, Dance Music (cont'd.). 11.30 (approx.). Close Down.

ZURICH.—See Schweizerischer Landessender.



## ATHLONE

725 kc/s, 413 metres; 60 kW. Relayed by Cork, 1,337 kc/s, 224.4 metres.—1.30 to 2.30 p.m., Time Signal, Weather, Stock Report and Gramophone Concert. 6.0, Gramophone Concert. 6.45, News. 7.0, Poetry Recital. 7.15, Gaelic Programme. 7.30, Time Signal. 7.31, The Station Orchestra. 8.0, Variety Items by Messrs. Millard and Jones. 8.15, Pianoforte Duets by Ellen Buckley and Jennie Russell. 8.40, Soprano Solos by Gladys MacNevin. 8.55, The Station Orchestra. 9.30 to 10.30, Programme by the I.B.C. (Ireland), Ltd. 9.30, Dance Music: Play, fiddle play; Darkness on the Delta; Take me in your Arms; No more Love; Moon Song; Street of Dreams; Twenty Million People; Waltzing in a Dream. 10.0, Concert arranged by the International Broadcasting Company (Ireland), Ltd., on behalf of Hospitals' Trust, Ltd.: Angero (Pruanco); The Mighty Deep (Guy); Violin Solo, Au mois d'avril (Adlington); Jungle Drums (Kettelhey); Just once for all time (Heymann); Violin Solo, Fandango (Godowsky); Live, laugh and love (Heymann). 10.30, I.B.C. Good-night Melody. 10.33, News and Weather. 10.40, Traditional Fiddle Music by Frank O'Higgins. 11.0 (approx.), Close Down.

## BARCELONA

EADJ, 863 kc/s, 348.8 metres; 8 kW.—7.0 p.m., Tri. Concert. Selection from The Dusk of the Gods (Wagner); Russian Song, Moscow (Decker); Réverie (Luigini); Selection from Intermezzo (Richard Strauss); Gavotte and Musette (d'Ambrosio); Selection from Le Roi de Lahore (Massenet); Minuet Op. 81 (Drdla). 8.0, Request Gramophone Records. In the interval at 8.30, Exchange. 9.0, Gramophone Music. 9.15 (in the interval), Talk: No more War. After the Programme, News. 10.0, Chimes, Weather and Exchange. 10.5, Concert by the Radio Orchestra. 11.15, Song Recital by Carmen Palazon (Soprano). 11.45, Dance Music relayed from the Casa Llibre. 12 Midnight, (in the interval), News. 1.0 a.m. (Sunday), Close Down.

BASLE.—See Schweizerischer Landessender.

## BELGRADE

697 kc/s, 430.4 metres; 2.8 kW.—6.55 p.m., Time and Programme Announcements. 7.0, Talk. 7.30, Cello Recital by Jovan Mokranjac. 8.0, Radio Play. 8.30, Concert by the Radio Orchestra. 9.30, Recital of Popular Songs by Mile Mihulovic with orchestral accompaniment. 10.10, Time, News and Gramophone Music. 10.40, Cigány Music relayed from the Dva Jeleni Restaurant. 11.10, Dance Music on Gramophone Records.

## BERLIN

DEUTSCHLANDSENDER (REICHSEN-  
DER), 183.5 kc/s, 1,635 metres; 60 kW.—12 Noon, Weather. 12.5 p.m., Broadcast for Schools. 12.55, Time Signal. 1.0, Interval. 1.45, News. 2.0, Gramophone Concert. 3.0, Drawing Lesson for Children. 3.30, Weather and Exchange. 3.45, Reading from the Novel, Volkswende (Blumck). 4.0, See Hamburg. 5.0, Sports Review of the Week. 5.20, Dance Music by Ralph Siegel and his Soloists. 6.0, Poems. 6.5, Ferdinand von Saar—Radio Sequence for the Centenary of the Austrian Poet's Birth (Meckel). 6.30, Topical Talk. 6.45, Weather and News. 7.0, Transmission for all German Stations relayed from Langenberg. 8.0, To-day's Motto. 8.10 (approx.), Dance Music by Robert Gaden and his Band. 10.0, Weather and News. 10.45, Weather for Shipping. 11.0, Dance Music (contd.). In the interval at 12 Midnight, Ten Minutes' Ghost Stories. 12.30 a.m. (Sunday), Close Down.

## BERLIN

FUNKSTUNDE, 715 kc/s, 419.5 metres; 1.5 kW.—4.0 p.m., Concert by the Alfred Brox Orchestra, relayed from the Zoological Gardens; Hungarian Song Potpourri (Taubert); Waltz, Lustiges Wien (Meisel); Nur wer die Sehnsucht kennt (Tchaikovsky); Heimweh (Kick-Schmidt); Minnet (Bolzon); Zwei Temperamente (Kark); Two Movements from the Russian Suite (Bulcrian); Serenade, Marie-Luis (Meisel); Overture, The Thieving Magpie (Rossini); Pensiero nostalgico (Wassili); Aria from Madame Butterfly (Puccini); Waltz, Come to me (Sgrizzi). In an interval at 5.0 (approx.), Talk: German Sport under the New Régime. 5.30, Wireless Notes. 5.55, Brahms Song Recital by Kurt Ingo Rieger (Baritone); Sehnsucht; Nachtigall; In meiner Nächte sehnen; Leibstreu; Unbewegte laue Luft; Die Schale der Vergessenheit. 6.15, Talk by Joseph Witting: Little Joys. 6.30, The Funkstunde informs its Listeners. . . . 6.45, Topical Talk. 7.0, Transmission for all German Stations, relayed from Langenberg. 8.5, Variety Concert by the Station Orchestra, conducted by Karl Knauer, the Station Choir conducted by Heinz Karl Weigel, the French Horn Society conducted by Georg Schumann, and Anton Goronezy and his Dance Band. In the interval at 10.0, News, and

## SATURDAY

OCTOBER THE SEVENTH

## PRINCIPAL EVENTS OF THE DAY:

## AT HOME

- NATIONAL** Promenade concert (last of the season) from Queen's Hall.
- LONDON REGIONAL** Variety programme.
- MIDLAND REGIONAL** Current Midland Theatre music, orchestral programme.
- NORTH REGIONAL** Running commentary on the Rugby League Football Match from Belle Vue, Manchester.
- WEST REGIONAL** "Going West," feature programme.
- SCOTTISH REGIONAL** "Tea for Ten," a comedy, by A. P. Wilson.
- BELFAST** "Costigan's Courtship," a farce, by F. Julia Bolton.
- ABROAD**
- BRESLAU** 8.10 p.m. Opera music, by the Silesian Philharmonic Orchestra.
- COPENHAGEN** 10.20 p.m. Kálmán operetta concert, by the Station Orchestra.
- HAMBURG** 8.30 p.m. Operetta: "Der Page des Königs," by Goetze.
- HILVERSUM** 9.40 p.m. The V.A.R.A. Orchestra, conducted by de Groot.
- OSLO** 10.15 p.m. Norwegian music, by the Station Orchestra.
- PALERMO** 8.45 p.m. Operetta: "Casa mia, casa mia," by Pietri.
- POSTE PARISIEN** 8.30 p.m. Sponsored concert.
- ROME** 8.30 p.m. Opera: "William Ratcliff," by Mascagni.
- WARSAW** 9.20 p.m. Chopin pianoforte recital, by Turczynski.

11.0, Topical Talk. 1.0 a.m. (Sunday), Close Down.

BERNE.—See Schweizerischer Landessender.

BEROMUNSTER.—See Schweizerischer Landessender.

BODEN.—See Stockholm.

BODO.—See Oslo.

## BRATISLAVA

1,076 kc/s, 279 metres; 14 kW.—6.30 p.m., Gramophone Music. 6.45, Topical Talk. 6.55, Hints for Housewives. 7.0, See Prague. 7.10, See Brno. 8.0, See Prague. 8.15, See Moravská-Ostrava. 9.0, Programme to be announced. 10.0, See Prague. 10.15, See Moravská-Ostrava. 11.30 (approx.), Close Down.

BREMEN.—See Hamburg.

## BRESLAU

923 kc/s, 325 metres; 60 kW. Relayed by Gleiwitz, 1,184 kc/s, 253 metres.—1.5 p.m., Gramophone Concert. 1.45, News. 2.10, Gramophone Concert. 3.0, Agricultural Prices. 3.15, Review of Books on Music. 3.35, Talk on Fernand Avenarius. 3.55, Film Review. 4.10, Concert by the Station Orchestra, conducted by Gerhard Ewald Rischka: Overture, Die Matrosen (Flotow); Ballet Suite from The Sleeping Beauty (Tchaikovsky); Waltz, Donauwellen (Ivanovic); Selection from The Merry Widow (Lehar); Mazurka in B flat (Godard); Gavotte in D (Gossec); Amorettdanze (Gungl); Overture, Paragraph 3 (Suppé). 5.50, Reading (Kurt Eggers). 6.0, Programme to be announced. 6.30, Programme Announcements for the coming week. 6.40, Handicrafts of To-day—Report from a Work-Shop. 7.0, Transmission for all German Stations, relayed from Langenberg. 8.0, News. 8.10, Concert of Opera and Operetta Music by the Silesian Philharmonic Orchestra, conducted by Ernst Topitz: Soloists: Anny Kunze (Soprano) and Jost Bergmann (Tenor); Overture, Der Freischütz (Weber); Belmont's Aria from H. Seraglio (Mozart); Romance from Mignon (Thomas); Turiddu's Aria from Cavalleria rusticana (Mascagni); Entr'acte and Entry of the Kings, from Dalibor (Smetana); Selection from Der Rosenkavalier (R. Strauss); Waltz from Der Rosenkavalier (R. Strauss); Overture, Ein tolles Mädel (Ziehrer); Gavotte from Der Gasconeur (Suppé); Song from Das Musikantenmädel (Jarno); Song from The Czarevitch (Lehar); Song from Don Cesar (Bellinger); Waltz from Das Fürstkind (Lehar); Overture, Die Fledermaus (Joh. Strauss). 10.0, See Munich. 10.20, News. 10.50, Programme from Berlin (Funkstunde). 1.0 a.m. (Sunday), Close Down.

## BRNO

873 kc/s, 342 metres; 35 kW.—6.25 p.m., German Transmission: News, Cabaret Programme of Ballet Music with Songs. 7.0, See Prague. 7.10, Concert by the Station Orchestra, conducted by Janota. Soloist: Karel Hanousek (Violin): Ballet Music from Le roi s'amuse (Delibes); Scène de ballet (Bériot); Ballet Music from Rosamunde (Schubert); Ballet Music from Lazy John (Nedbal). 8.0, Report on the Society of Moravian Artists. 8.15, See Moravská-Ostrava. 9.0, Programme to be announced. 10.15, See Moravská-Ostrava. 11.30 (approx.), Close Down.

## BRUSSELS (No. 1)

I.N.R., 590 kc/s, 509 metres; 15 kW.—12 Noon, Gramophone Concert. 1.0 p.m., Le Journal Parlé. 1.10, Concert by the Small Station Orchestra, conducted by Leemans. March chevaleresque (Popy); Slav Rhapsody (Volpatti); Gavotte and Minuet from Manon (Massenet); Violin Solo: Guitar (Moszkowsky-Sarasate); Selection from La Bohème (Puccini); Water Sprites (Kettelhey); Waltz, Dolly (Langlois); One-Step, La boulangère de Seville (Langlois). 4.45, Talk: The Prevention of Cruelty to Animals. 5.0, Concert by Robert de Kers and his Cabaret Kings, relayed from the Century Hotel, Antwerp. 6.0, Walks in Belgium—Belgian Luxembourg. 6.15, Gramophone Music. 6.30, Concert by the Small Station Orchestra, conducted by Pierre Leemans. Overture, Sous la Régence (Brusselsmans); Oriental Song (Guillemin); Algerian Song (Guillemin); Trémignon (Gilson); Violin Solo: Petite suite (Frénolle); Elan (Douliet); Aurore (Leemans); Je voudrais (Lagarde); Chevauchée fantastique (Brenta); Flute Solo: Danse lente (Jongen); Andalous (de Teye); Extracts from Milenka (Blockx). 7.30 Le Journal Parlé. 8.0, Concert by the Radio Orchestra, conducted by Franz André. Overture, Die seltsame Galathée (Suppé); Fantasia on L'Imouine Airs (Rouchaux); Marche baroque (Goeyens); Selection from The Sleeping Beauty (Tchaikovsky); Dances from Tom Jones (German). 8.45, Talk on Georges Vandereynden with Readings from his Works. 9.0, La Clarinette—Operetta in One Act (Hubans). After the Operetta, Le Journal Parlé.

## BRUSSELS (No. 2)

I.N.R., 887 kc/s, 338.2 metres; 15 kW. Programme in Flemish. 12 Noon, Concert by the Small Station Orchestra, conducted by Pierre Leemans. Overture, La Preciosa (Weber); Printemps d'amour (Kalkman); Seville (Albéniz); Selection from Paganini (Lehar); Pianoforte Solo: Polonaise in C Sharp minor (Chopin); Chant sans paroles (Tchaikovsky); Padilla Pot-

pourri (Salabert); Waltz (Samek); Babies on Parade (Ellis). 1.0 p.m., Le Journal Parlé. 1.10, Gramophone Concert. 4.45, Reading. 5.0, Concert by the Radio Orchestra, conducted by Franz André. Overture, The Bird Fancier (Zeller); Selection from Die geschiedene Frau (Fall); Two Symphonic Rhapsodies (Coates); Intermezzo, Sag mir wer du bist (Grothe); Lullaby (Goeyens); Melodies (Albéniz): (a) Castilla, (b) Granada, (c) España; Schubert Potpourri (Raff); Popular Medley (Noack); Tango, Hélène (Mevensen); Two-Step, Canta guitarra (Villajos). 6.0, Gramophone Music. Potpourri Karnevalsklänge (Hannemann); Selection from Véronique (Messager). 6.15, Talk on Canaries. 6.30, Violin Concerto in C (Haydn) by Mme. Buysse-Rolin. 6.55, Gramophone Music. 7.15, Talk: University Life in the Middle Ages. 7.30, Agricultural Report. 8.0, Promenade Concert, relayed from London. In the interval at 9.35, Reading from Three Men in a Boat (Jerome K. Jerome). 10.30, Le Journal Parlé.

## BUCHAREST

761 kc/s, 394 metres; 12 kW.—5.0 p.m., Variety Concert by the Sibiccano Orchestra. In an interval at 6.0, Radio Journal. 7.0, Educational Programme. In an interval at 7.20, Gramophone Music. 8.0, Dance Music by the Seldmann Jazz Band. In an interval at 9.0, Talk. 9.45, Radio Journal.

## BUDAPEST

545 kc/s, 550.5 metres; 18.5 kW. Also relayed on 840 metres from 6.20 p.m. till Close Down.—5.30 p.m., Concert by the Budapest Concert Orchestra, conducted by Fridl. 6.30, Answers to Correspondence. 7.0, Recital by Edith Dioso and Polgar. 7.30, A Radio Play. 9.15, News. 9.30, Jazz Music by the Bachmann Band, relayed from the Bodo Café. 10.45, Concert by the Farkas Gypsy Band.

CASSEL.—See Frankfurt.

## COPENHAGEN

1,067 kc/s, 281 metres; 0.75 kW. Relayed by Kalundborg 260 kc/s, 1,153.8 metres.—12 Noon, Time and Chimes from the Town Hall. 12.5 p.m., String Ensemble Concert, relayed from the Bellevue Strandhotel. 2.0, Interval. 2.30, Gramophone Music. 3.0, Programme for Children. 3.30, Concert by Louis Prof's Instrumental Ensemble. In the interval at 4.15 (approx.), Reading in Danish. 5.30, Exchange and Fish Market Prices. 5.45, Talk: Theatre Directors—Skæbner. 6.15, French Lesson. 6.45, Weather and News. 7.15, Time Signal. 7.30, Talk: Youth and Democracy. 8.0, Chimes from the Town Hall. 8.5, Concert of Danish Music by the Station Orchestra, conducted by Emil Reesen. Soloist: Hertha Björvig (Songs). Pieces (Lumbye): (a) King Frederick VII Hommage March, (b) Mazurka, Columbine, (c) Waltz, Nordlys, (d) Gallop, Salut for August Bonnonville; Three Songs (Weyse); Two Songs (Gade); Overture, Et Eventyr i Rosenborg Have (Weyse); Ballet Music from Elverhøj (Kullian); Tarantella from Napoli (Pavilli). 9.0, A Visit with the Microphone to Copenhagen Harbour. 9.30, Mozart Pianoforte Duets by Folmer Jensen and Ove Peters: Fantasia No. 2 in F minor; Sonata No. 3 in E. 9.50, The Comedian Harmonists on Gramophone Records. 10.5, News. 10.20, Kálmán Opera Concert by the Station Orchestra, conducted by Emil Reesen: Shimmy from Countess Maritza; Waltz from The Gipsy Princess; Selection from Zigeuner primas. Viennese Music from The Duchess of Chicago; Selection from Die Bayadere. 11.10, Folk Songs on Gramophone Records. 11.30, Dramatic Programme relayed from the New Theatre. 2.0 a.m. (Sunday), Close Down.

GORK.—See Athlone.

DANZIG.—See Heilsberg.

DRESDEN.—See Leipzig.

## FECAMP

1,328 kc/s, 225.9 metres; 10 kW.—11.0 a.m. till 12 Noon, Programme in English by the I.B.C. 11.0, Happy Hour. Part I, Orchestral Music: Signature Tune; By the Swanee River (Myddleton); Waltz, Gipsy Moon (Borganov); Selection from La belle Hélène (Offenbach); Last night I dreamed of you (Kálmán); Play of the Butterflies (Heykens); The Musical Clock of Madame Pompadour (Noack); Waltz from The Gipsy Princess (Kálmán); The Song of the Nightingale (Ailbout). Part II, Dance Music: P.C. 123; Nobody's Sweetheart; Two Buck Tim from Timbuctoo; Avalon; I cover the Waterfront; The Gold-digger's Song; Maybe I love you too much; Someone stole Gabriel's Horn; Signature Tune. 12 Noon, Programme in French. 4.30 to 6.0 p.m., Programme in English by the I.B.C. 4.30, Programme for Children. 5.0, Organ Recital for Tunbridge Wells and Isle of Thanet. Signature Tune, The Night by the Sea; A Life on the Ocean (Binding); Nola (Arndt). Weymouth Chimes (Lindahl); Indian Love (all Friml); Butterflies in the Rain (Myers); The Wooden Soldier and the China Doll (Jones); Serenade (Drigo); Waltzland Selection (arr. Scodden). 5.30, Orchestral Concert for Dover and Folketone: The Enchanted Forest (Ganglberger); Egyptian Serenade, Amina (Lincke); There's Something in your Eyes (Grothe); Animal Antics

OCT. 7th

SATURDAY

continued

(Kark); The Match Parade (Wehle); Marching through Georgia (Wark); Heartaches (Klemmer); Selection from Music in the Air; Signature Tune. 6.0, Programme in French. 11.0 (H) Close Down. Programme in English by the I.B.C. 11.0, Music from Sound Films: Signature Tune, Sittin' in the Dark; How do you do, Mr. Brown? (Abraham); March of the Musketeers (Friml); Sweep (Ellis); Selection from Love me To-night; Love Songs of the Nile (Brown); Selection from The Good Companions; The Moment I saw you (Gay); Heaven will protect an Honest Girl (Weston); Signature Tune. 11.30, Concert by the International Broadcasting Company (Ireland), Ltd., on Behalf of Hospital's Trust, Ltd.; Signature Tune, Come back to Erin; Waldteufel Memories (arr. Finck); Pizzicato from Sylvia (Delibes); Aria from Madame Butterfly (Puccini); The Londonderry Air (Traditional); Fleur-de-Lis (Fletcher); Savourneen Berish (Traditional); Waltz Song from La Bohème (Puccini); Selection from Die Fledermaus (Joh. Strauss); Signature Tune, Come back to Erin. 12.5 a.m. (Sunday), News Bulletin in English. 12.10 (approx.), Club Concert for Lampeter Listeners: Signature Tune, The Chum Song; I lost my Girl from Memphis; Adios Muchachos; O Ya Ya; Mia Cara; The Japanese Sandman; He was only a Poor Musician (Schwartz); P.C. 123 (The Policeman's Song) (Butler); St. Louis Blues (Hardy); My Darling (Myers); One Little Word led to Another (Jones); My Wishing Song (Burke); You did Everything for me (Hoffmann); Balloons (Magine); Roll along Kentucky Moon (Halley); Signature Tune. 1.0, Dance Music by the Rhythm Rascals (Electrical Transcriptions); Maybe I love you too much; Waiters on Parade; No more Love; Da, Da, Da, Da; I'm one of the Lads from Valencia; Look what you've done; Peter, Peter; There's a Light in your Window; Stranger; Sing a New Song. 1.30, Dance Music; Signature Tune, Bells of Normandy; Whispering; It was a Night in June; Put on your Old Grey Bonnet; When it's Sunday down in the Tegen Sea; Happy Ending; We belong Together; Signature Tune; I.B.C. Good-night Melody and Close Down.

FLensburg.—See Hamburg.

Florence.—See Turin.

FRANKFURT

1,157 kc/s, 259.3 metres; 17 kW. Relayed by Cassel, 1,220 kc/s, 245.9 metres; and Trier, 1,157 kc/s, 259.3 metres.—12 Noon, See Langenberg. 1.15 p.m., Time, Weather and News. 1.25, News. 1.35-3.15, See Langenberg. 3.30, Weather. 3.40, Time and Economic Notes. 4.0, Concert by the Unemployed Musicians' Orchestra; Overture, Der Waffenschmied (Lortzing); Scandinavian Suite (Frederiksen); Legend and Serenade (Glan); Waltz, Wiener Bürger (Ziehrer); Czardas from Der Geist des Wojewoden (Grossmann); Oriental Ballet Suite (Krüger); At the Circus (Armandola). 6.0, Talk: The State and the Artisan in Modern Italy and Germany. 6.20, Talk: Graf Yorek vom Wartenberg. 6.35, Review of the Day's Events. 6.50, Weather and News. 7.0, Transmission for all German Stations relayed from Langenberg. 8.0, Topical Talk. 8.10-10.0, See Stuttgart. 10.0, Time, News and Weather. 10.20, See Stuttgart. 10.30, News. 10.45, Light Music and Dance Music. 2.0 a.m. (Sunday), Close Down.

FREDRIKSSTAD.—See Oslo.

Freiburg.—See Stuttgart.

Geneva.—See Radio-Suisse Romande.

Genoa.—See Turin.

Gleiwitz.—See Breslau.

Göteborg.—See Stockholm.

Graz.—See Vienna.

Hamar.—See Oslo.

HAMBURG

806 kc/s, 372 metres; 1.5 kW. Relayed by Bremen, 1,112 kc/s, 269.8 metres; Flensburg, 1,319 kc/s, 227.4 metres; Hanover, 530 kc/s, 566 metres; and Kiel, 1,292 kc/s, 232.2 metres.—4.0 p.m., Concert by the Small Station Orchestra, conducted by Adolf Secker; Overture, Nacklänge von Ossian (Gade); Romantic Suite (Lantenschläger); Prelude to Aufruf der Ideale (Girattis); Scherzo um Mitternacht (Girattis); Valse triste (Sibelius); Selection from The Geisha (Jones). 5.0, Topical Talk. 5.30, (from Bremen), Lieder Duets and Instrumental Music. Käthe Tenen (Soprano), Edmont Koch (Baritone), Heinz Bärries (Violin), Werner Riecke (Cello) and Reinhold Krug (Piano-forte). Extract from the Dumky Trio (Dvorák); Soprano Solos: (a) Song (Tchaikovsky); (b) Du kleines blitzendes Sternlein (Aht); Violin Solo: Cansometta (Boecherini); Soprano and Baritone Duets: (a) Abschied der Vögel (Hildach), (b) Ach, dass ewig hier die Liebe (Sinding), (c) Deine Liebe hat mich beschließen (Sinding); Cello Solo: Preghiera (Schubert); Baritone Solos: (a) Moeresleuchten (Löwe), (b) Lacerime Christi (Bohm); Elegia from the Trio in D minor (Arensky). 6.30, Religious Address. 6.50, Weather. 7.0, Transmission for all German Stations, relayed from Langenberg. 8.0,

Talk on Winter Relief Works. 8.30, Der Page des Königs—Operetta in Six Scenes (Goetze). 10.0, News. 10.30, Dance Music relayed from the Eilbecker Bürgersalen.

HANOVER.—See Hamburg.

HEILSBURG

1,085 kc/s, 276.5 metres; 60 kW. Relayed by Danzig, 662 kc/s, 453.2 metres.—1.5 p.m., Gramophone Concert of Old and New Dances. In the intervals at 1.20 and 2.0, News. 2.30, Programme arranged by the Post Office with Gramophone Records. 3.0, Agricultural Prices and Exchange. 3.30, Handwork Lesson. 4.0, Concert by the Small Station Orchestra, conducted by Eugen Wilken; Italian Comedy Overture (Kéler Béla); Flute Solos: Nocturne and Mazurka (Doppler); Waltz, Scheiden und Meiden (Fetras); Catalan Capriccio (Albeniz); Malaguena (Albeniz); Triumph-Ouverture (Suppé); In the Harbour of Port Said (Armandola); Potpourri of Drinking Songs (Rhode); Egyptian March (Joh. Strauss). In the interval at 4.50 (approx.), A.D.A.C. Traffic Report. 5.50, Sports Programme. 6.5, Programme Announcements for the Coming Weeks. 6.15, Agricultural Market Prices. 6.25, Gello Recital by Günther Schulz-Firstenberg; Sonata in B flat minor (Händel); Arioso (Bach); Capriccio (Schmal-tiel). 6.25 (from Danzig), Duet Recital by Elvira Hausdörffer (Soprano) and Hilma Schmidt-Opitz (Contralto); Duets (Schumann): (a) Ländliches Lied, (b) Schön Blümelein, (c) An den Abendstern, Duets (Cornelius): (a) Verrätene Liebe, (b) In Sternennacht, (c) Ich und Du; Six Moravian Duets (Dvorák). 6.50, Weather. 7.0, Transmission for all German Stations, relayed from Langenberg. 8.0, News. 8.5, Programme from Berlin (Funkstunde). 12.30 a.m. (Sunday), Close Down.

HILVERSUM

1,013 kc/s, 296.1 metres; 7 kW. up to 5.40 p.m.; and 20 kW. (from 5.40 p.m.).—Programme of the Workers' Radio Society (V.A.R.A.). 11.40 a.m., Concert by the Small V.A.R.A. Orchestra, conducted by de Groot; Neu Wien (Strauss); Song from The Bird Fancier (Zeller); Waltz from Rose-Marie (Friml); Tyrol in Lied und Tanz (Fetras); Glockenserenade (Koecker); Selection from The Dollar Princess (Fall); Gramophone Records; Pieces (d'Ambrosio): (a) Andantino, (b) Paysanne, (c) Ronde des latins; Hungarian Dance (Brahms); Andantino (Martini); Grieg Potpourri (Urbach); Gramophone Records; Come Gipsy (Kahnann). 1.25 to 1.40 p.m., Interval. 1.40, Gramophone Music. 2.25, Talk. 2.40, Accordion Band Music. 2.55, Talk. 3.0, Gramophone Music. 3.40, Literary Talk. 4.0, Concert by the V.A.R.A. Mandoline Orchestra, conducted by Kok; Freiheitsspiel (Blankenburg); Rose moinse (Bose); Mattinata (Leoncavallo); Gramophone Records; Gavotte (Gossec); Melody (l'Enfant); Siamesische Wachtparade (Lincke). 4.25, Film Review. 4.55, Concert by De Fler-fluiters, conducted by van de Horst, Soloist: Mlle. Philippe (Songs). 5.42, Choral Concert and Talk. 6.10, Viola d'amore and Piano-forte Duets; Sonata in A (Ariosti); Preludes (Casadesu). 6.40, V.R.O. Programme. 7.40, Announcements. 7.55, S.O.S. Messages. 7.57, Song Recital by Collin. 8.10, Concert by the V.A.R.A. Orchestra, conducted by de Groot; Friendship March (Sousa); Overture, Raymond (Thomas); Schatzwälder (Strauss); Andantino for Strings (Gade); Four Ballet Airs (Drigo); Russian Rhapsody (Mielchli). 8.55, Reading. 9.40, Concert (cont'd.); Hydropathen (Gungl); Valse lente (Popy); Melody (Coates); Gipsy Waltz (Kotelnik); Selection from A Waltz Dream (O. Strauss). 10.10, Songs by Collin (cont'd.). 10.25, Concert (cont'd.); Selection from Fatinitza (Suppé); Zwei dunkle Augen (Henns); La Mateliche (Chera); O Sole mio (di Capua); Quand les papillons (Verceiler); O, Susanne (Hinsch); Puppenwälder (Bayer); Boïsoir, Madame la lune (Chapelier); Aïsta (Lind-say); Püppchen (Gilbert); Are you from Dixie? (Vellam-Cobb). 11.10, Gramophone Records. 11.40 (approx.), Close Down.

HORBY.—See Stockholm.

HUIZEN

160 kc/s, 1,875 metres; 7 kW. (until 3.40 p.m.). (Transmitted from Kootwijk on 50 kW. from 3.40 p.m.).—Programme of the Catholic Radio Society (K.R.O.). 11.40 a.m., Police Notes. 11.55, Concert by the Vienna Station Orct., led by Mme. Ditta Schmetterling; Florentine March (Fueik); Tales from the Vienna Woods (Strauss); Overture, Die schöne Galathee (Suppé); Lüg' mich nicht an (Strauss-Weiss); Für dich, Rio Rita (Santungi); Ballet Music from La Gioconda (Ponchielli). Gramophone Records; Fortissimo (Kálmán-Fejöld); Souvenir de Capri (Beere); Finale. 1.25, Interval. 1.40, Programme for Young People. 2.10, Programme for Children. 3.40, H.I.R.O. Programme. 4.40, Talk. 5.10, Orchestral Concert, conducted by van't Woudt; Overture, Der Wildschütz (Lortzing). The Three Bears (Coates); Valses d'Amour (Moszkovsky); Selection from Polenbut (Nedbal); Overture, Das Modell (Suppé). 6.0, Press Re-

view. 6.20, Concert (continued); Selection from The Bartered Bride (Smetana); Sailors' Dance (Edonet); In a Turkish Bazaar; March, Wien bleibt Wien (Schrammel). In the interval at 6.40, Police Announcements and Topical Talk. 7.25, Talk. 7.40, A Winter Programme with the K.R.O. Boys. In the intervals, Recitation and News.

INNSBRUCK.—See Vienna.

JUAN LES PINS

1,205 kc/s, 249 metres; 0.8 kW.—8.0 p.m., Amusement Guide, Exchange, Racing Results and News. 8.5, Film Review. 8.20, Radio Concert. In the interval at 9.0, News and Weather.

KALUNDBORG.—See Copenhagen.

KIEL.—See Hamburg.

KLagenfurt.—See Vienna.

KOSICE.—See Prague.

LAHTI

167 kc/s, 1,796 metres; 40 kW. Relayed by Helsinki, 815 kc/s, 368.1 metres.—6.15 p.m., Sponsored Programme. 8.45, News in Finnish and Swedish. 9.15, Dance Music relayed from the Restaurant Porssi. 11.0 (approx.), Close Down.

LANGENBERG

625 kc/s, 473 metres; 60 kW.—12 Noon, Concert by the Münster Orchestra, conducted by Werner Göhre; Overture, Turandot (Lachner); Waltz, Morgenblätter (Joh. Strauss); Selection from The Czarevitch (Lehar); Réverie (Vieuxtemps); Old Russian Dance Pictures (Chernus); Vergleichliches Ständchen (de Taeye); Waltz Serenade, An dieh (Czibulka); Czardas No. 8 (Mielchli). 1.15 p.m., News, relayed from Frankfurt. 1.25, News. 1.35, Concert by the Station String Quartet, with Gramophone Interludes. 2.30, Programme for Young People. 3.15, Morse Lesson. 3.30, Talk on Economics. 3.40, Talk: Excursions in the Rhineland and Westphalia. 3.55, Hints for Photographers. 4.0, See Frankfurt. 6.35, Poems in Dialect (Franz Peter Kürten). 6.50, Announcements. 7.0, Transmission for all German Stations; The Twentieth Bach Festival, relayed from the Carthusian Church; The Bach Choral Society, the String Orchestra of the Academy of Music, and Soloists; Conductor, Heinrich Boell; Organ Choral, Herr Gott, nun sei gepreiset; Cantata No. 169, Gott soll allein mein Herze haben; for Contralto, Choir, Organ and Orchestra; Organ Choral, Kyrie, Gott Vater in Ewigkeit; Mass in A, for Solo Voices, Choir and Orchestra. 8.0, See Frankfurt. 8.10, See Stuttgart. 10.0, See Frankfurt. 10.20, See Stuttgart. 10.30, News. 10.45, Light Music and Dance Music, relayed from Frankfurt. 2.0 a.m. (Sunday), Close Down.

LAUSANNE.—See Radio-Suisse Romande.

LEIPZIG

769.9 kc/s, 389.6 metres; 120 kW. Relayed by Dresden, 941 kc/s, 319 metres.—12 Noon, Concert by the Station Orchestra, conducted by Hilmar Weber; Overture, Lisola disabitata (Haydn); Suite from H Seraglio (Mozart); Scherzo from the Sixth Symphony in C (Schubert); Music from A Winter's Tale (Humperdinck); Slav Rhapsody in C Minor (Friedemann); Prelude and Extracts from Carmen (Bizet). 1.15 p.m., News. 1.30, Gramophone Music. 2.0, Economic Review of the Week. 2.30, Programme for Children. 3.15, Gramophone Records of the Don Cossack Choir and the Balalaika Orchestra. 3.45, Economic Notes. 4.0, See Hamburg. 5.0, Talk: The Meaning of German Names. 5.20, Book Review. 5.40, Gramophone Concert. 6.0, Reading (Kleist). 6.20, A Modern Dictionary. 6.35, Agricultural Review of the Week. 6.50, Today's News. 7.0, Transmission for all German Stations, relayed from Langenberg. 8.30, See Hamburg. 10.0, News. 10.30 (approx.), Dance Music Relay. 12 Midnight (approx.), Close Down.

LINZ.—See Vienna.

LJUBLJANA

522 kc/s, 574.7 metres; 7 kW.—6.0 p.m., Gramophone Music. 6.30, Humorous Programme and Road Report. 7.0, Talk. 7.30, Review of Foreign Affairs. 8.0, Concert. 10.0, Weather and News. 10.20, Dance Music by the Radio Jazz Band. 11.0 (approx.), Close Down.

LUXEMBOURG

252 kc/s, 1,191 metres; 200 kW.—French Evening. 7.30 p.m., Concert of French Music by the Station Orchestra, conducted by Henri Pensis; Suite pour mes petits amis (Piermé); Cello Concerto (Lalo). 8.10, Topical Talk in French. 8.25, Concert (cont'd.). Cant du Mulctier (Pesse); Phaeton (Saint-Saëns); Marche militaire (Saint-Saëns). 8.50, News in French. 9.0, Gramophone Records of French Music; Symphony No. 3 in C minor with Organ (Saint-Saëns); Ballet Music from Faust (Gounod). 9.50, News

in German. 10.0, Trio Concert; Syncopation (Kreisler); Schön Rosmarin (Kreisler); Lament (de Taeye); Comme meurent les feuilles (de Taeye); Barcarolle (de Taeye); Kleiner Wiener Marsch (Kreisler). 10.25, Saxophone and Accordion Music. 10.50, Dance Music by the Station Jazz Band.

LWOW

788 kc/s, 381 metres; 16 kW.—7.5 p.m., Miscellaneous Items. 7.25, See Warsaw. 7.40, Programme Announcements. 7.45, See Warsaw. 10.25, Talk on Music with Gramophone Illustrations. In the interval at 11.0 See Warsaw. 12.0 Midnight (approx.), Close Down.

LYONS

LA DOUA, 644 kc/s, 465.8 metres; 1.5 kW.—7.0 p.m., Gramophone Music. 7.15, Musical Programme. 7.30, Radio Gazette for Lyons and the South-East. 8.10, Report in Esperanto. 8.30, Operetta Music relayed from Paris (Ecole Supérieure), 671 kc/s, 447.1 metres. After the Concert, News.

MADRID

ARANJUEZ (EAQ), 10,000 kc/s, 30 metres; 29 kW.—7.0 to 9.0 p.m., Programme for Listeners in the Canary Islands, Guinea and Europe. 7.0, Popular Music. 8.15, Talk. 8.30, Light Music. 9.0 to 11.30, Interval. 11.30, Musical Comedy Programme, relayed from Madrid (EAJ7). 1.0 to 1.30 a.m. (Sunday), Programme in English by the I.B.C. 1.0, I.B.C. Concert: Oh, Sailor Behave; Butterflies in the Rain; Soft Lights and Sweet Music; The Wave; Fiesta; Black Eyes; Only a Rose; Beautiful Nice. 1.30, I.B.C. Good-night Melody.

MADRID

EAJ7, 707 kc/s, 424.3 metres; 2 kW.—8.0 p.m., Chimes, Exchange, Radio Journal and Dance Music. 9.15, Topical Review. 9.30 to 11.0, Interval. 11.0, Chimes, Time and Topical Review. 11.20 (approx.), Musical Comedy Programme; Concert Versions of: (a) La Viejejeita (Caballero), (b) La Rosa del Azafrañ (Guerrero). 1.15 a.m. (Sunday), Topical Review. 1.30, Chimes and Close Down.

MALMO.—See Stockholm.

MILAN.—See Turin.

MORAVSKA-OSTRAVA

1,137 kc/s, 263.8 metres; 11 kW.—7.0 p.m., See Prague. 7.10, See Brno. 8.0, See Prague. 8.15, Music by a Country Band. 9.0, Programme to be announced. 10.0, See Prague. 10.15, Concert of Light Music by the Station Orchestra, conducted by Jan Plichta. Humorous Recitations in the intervals. 11.30 (approx.), Close Down.

MOTALA.—See Stockholm.

MUHLACKER.—See Stuttgart.

MUNICH

563 kc/s, 533 metres; 60 kW. Relayed by Augsburg and Kaiserslautern, 536 kc/s, 560 metres; and Nürnberg, 1,256 kc/s, 239 metres.—4.30 p.m., Concert from Frankfurt. 5.45, Programme for Young People. 6.15, Concert by the Augsburg Bandionin Club, conducted by Sieder; March, Adlerflug (Blankenburg); Overture, Light Cavalry (Suppé); Waltz, Ma bien aimée (Waldtenfel); Descriptive Piece, Marionetten-Wachtparade (Kuhn); March, Frühlingskinder (Blankenburg). 6.40, Wireless Notes. 7.0, Transmission for all German Stations relayed from Langenberg. 8.0, Bunter Abend, relayed from the the Kurhaus. Bad Dürkheim: Musical and Literary Programme by the Palatinate Orchestra, Members of the Palatinate Opera Company and Well-known Poets and Writers. 9.50, Talk in connection with German Art Day. 10.0, Time, Weather and News. 11.0, Dance Music by the Station Band. 12 Midnight, Close Down.

NAPLES.—See Rome.

NOTODDEN.—See Oslo.

OSLO

277 kc/s, 1,083 metres; 60 kW. Relayed by Fredrikstad, 815 kc/s, 368.1 metres; Hamar, 522 kc/s, 574.7 metres; Notodden, 671 kc/s, 447.1 metres; Porsgrund, 662 kc/s, 453.2 metres; and Rjukan, 671 kc/s, 447.1 metres.—4.30 p.m., Gramophone Concert: Andalusian Romance (Sarasate); Spanish Dance No. 3 (Sarasate); Butterflies (Harty); Prelude and Allegro (Pugnani-Tertis); La Campanella (Paganini); At the Fountain (Davidov); Passacaglia (Händel-Halvorsen); Scherzo Tarantella (Wieniawsky); First Movement from the Quartet in C, Op. 26 (Brahms). 5.15, Programme for Children. 6.15, Concert of Norwegian Music. 6.45, Economic Notes. 7.0, Advertising Notes. 7.15, Weather and News. 7.30, Programme to be announced. 8.0, Time. 8.1, Talk. 8.30, Choral Concert relayed from Nidaros Cathedral. 9.15, Recitations. 9.40, Weather and News. 10.0, Topical Talk. 10.15, Concert of Norwegian Music by the Station Orchestra, conducted by Hugo Kramm; Soloist: Henry Alf (Songs).

OSTERSUND.—See Stockholm.

PALERMO

558 kc/s, 537.6 metres; 3 kW.—8.0 p.m., Dopolavoro Announcements, Tourist Talk, Agricultural Notes, and Giornale Radio, 8.20, Gramophone Music. In the interval at 8.30, Time and Announcements. 8.45, Casa mia, casa mia—Operetta in Three Acts (Pietri). In the intervals, Book Review and Announcements. After the Operetta, Giornale Radio.

PARIS

EIFFEL TOWER, Call FLE, 207.5 kc/s, 1,445.7 metres; 13 kW. Time Signals (on 2,650 metres) at 10.26 a.m. and 11.26 p.m. (Preliminary and 6-dot Signals).—6.45 p.m., Theatre Talk. 7.0, Le Journal Parle, 8.30, Antony—Melodrama (Dumas Pèrèh) played in the style of 1830. 10.0 (approx.), Close Down.

PARIS

POSTE PARISIEN, 914 kc/s, 328.2 metres; 60 kW.—7.0 p.m., Gramophone Music. 7.15, Le Journal Parle, 7.30, Gramophone Music: Aria from La Traviata (Verdi); Aria from Thais (Massenet); Duet from La Source (Delibes). 7.50, Talk: The Event of the Week. 8.0, Theatre Review. 8.30, Sponsored Programme. 9.10, Dance Music by the Sonora Radio Band, conducted by Fred Hoffmann. 11.0, News.

PARIS

RADIO-PARIS, Call GFR, 174 kc/s, 1,725 metres; 75 kW.—7.30 a.m., Weather and Physical Culture. 7.45, Gramophone Music. 8.0, Weather and News. 12 Noon, Gramophone Concert: Caucasian Sketches (Ivanov-Ippolitov); Melody (Hasselmann); Dawn in the Country; Sous les toits de Paris (Moretti); Ne m'écoutez plus (Lénoir); Effileurement (Ganne); Rôses of Picardy (Haydn Wood); Selection from The Geisha (Joncs); Je ne t'aime plus (Cazes); The Phantom Brigade (Myddleton); Tes roses (Stroeva); Nocturne from Cocorico (Ganne); Melody (Chamfleury); Adoration (Filippucci); Le chien du berger (Marceau); Romanian Dance (Bartok); Piccolo (Dasmare); Autour du moulin (Feret); Dans la fumée (Bos); Selection from Schön ist die Welt (Lehar); Bells across the Meadow (Kettelbey); C'est pour toi (Verdun); Bilboquet and his Pig; Magic Lantern (Godard); Voici mon coeur (Cremieux); Two Songs (Whiting); Castilian Nights (Duronio); Villanelle (Dell'acqua); Song (Haydn Wood); Le sonnet d'arvers à Feviers (Bonmay); Amorettenzänze (Gungl); Siempre (Bianco); Mon coeur est à vous (Valaire); Pierrot galant (Chillemont); Greek March (Ganne). In the intervals at 1.0 p.m., Exchange, News and Weather, and at 1.30, Exchange. 2.0, Exchange. 3.0, Programme for Children. 3.45, Exchange and Market Prices. 6.30, Agricultural Talk. 6.50, Gramophone Concert. In the interval at 7.0, Scientific Talk. 7.45, Commercial Prices and News. 8.0, Gramophone Concert: Improvment in A Flat (Schubert); Mazurka (Zarsycki); Canzonetta (Tchaikovsky); Theme with Variations (Sor); Prelude in C (Prokofiev); The Fountains of Arethusa (Szymanovsky); Aria from The Seasons (Haydn); Pastoral (Léto (Honegger). 8.30, News and Weather. 8.40, Review. 8.45, Concert of Light Music and Popular Songs by the Melody Artist and Alice Nanssen. 9.15, Press Review and News. 9.30, Gramophone Music and Songs. Songs: Habanera (Aubert); Symphonie, from the New World (Dvorák).

PORSGRUND.—See Oslo.

PRAGUE

614 kc/s, 488.6 metres; 120 kW.—3.55 p.m., Gramophone Concert. 4.50, Programme for Young People. 5.15, Talk on Economics. 5.25, Gramophone Music. 5.35, German Lesson. 5.50, Gramophone Music. 6.5, Agricultural Talk. 6.15, Talk for Workers. 6.25, News in German. 6.30, The Nightingale—Radio Play after the Story by Hans Andersen. 7.0, Time and News. 7.10, See Brno. 8.0, Talk on America. 8.15, See Moravská-Ostrava. 9.0, Programme to be announced. 10.0, Time and News. 10.15, See Moravská-Ostrava. 11.30 (approx.), Close Down.

RADIO-SUISSE ROMANDE

SOTTENS, 743 kc/s, 403 metres; 25 kW.; and Geneva, 395 kc/s, 760 metres.—7.0 to 7.15 a.m. (from Lausanne), Gymnastics. 12.28 p.m., Time Signal from Neuchâtel Observatory. 12.30, News and Weather. 12.40 (from Geneva), Gramophone Concert. 1.0 (from Geneva), Financial News. 1.10 (from Geneva), Gramophone Concert. 2.0-3.28, Interval. 3.28, Time from Neuchâtel Observatory. 3.30 (from Geneva), Gramophone Concert. 5.0 (from Geneva), Gramophone Music. 5.30-7.0, Interval. 7.0 (from Geneva), Film Review. 7.30 (from Geneva), Weather, News and Announcements. 8.0, Concert by

OCT. 7th

SATURDAY

continued

the Radio-Suisse Romande Orchestra, relayed from the Radio Exhibition at the Kursaal, Geneva: Soloists: Mme. Marguerite de Reding. 9.0 (from Lausanne), Concert by a Peasant Orchestra and Soloists. 9.50, News and Weather. 10.0 (from Geneva), Talk: The Work of the League of Nations. 10.15 (from Lausanne), Dance Music relayed from the Hotel Splendide. 11.0 (approx.), Close Down.

RIGA

572 kc/s, 525 metres; 15 kW.—7.5 p.m., Abraham Operetta Concert: Selection from The Flower of Hawaii; Two Songs from Ball at the Savoy; Do, do, from Viktoria and her Hussar; Good Night, from Viktoria and her Hussar; March from The Flower of Hawaii; Waltz from Ball at the Savoy; Three Songs from Viktoria and her Hussar. 8.0, News. 8.20, Concert of Operetta Music: Overture, La belle Hélène (Offenbach); Three Songs from Les Cloches de Corneville (Plauquette); Selection from Eine Nacht in Venedig (Joh. Strauss); Waltz from Der Obersteiger (Zeller); Selection from Girofle-Girofla (Lecocq). 9.0, News. 9.30, Dance Music.

RJUKAN.—See Oslo.

ROME

Call 1R0, 680 kc/s, 441 metres; 50 kW. Relay by Naples, 941 kc/s, 319 metres; Bari, 1,112 kc/s, 269.8 metres; Milan (Vigentino), 662 kc/s, 453.2 metres, from 8.15 p.m. (approx.). and 2R0, 11,810 kc/s, 25.4 metres, from 5.15 p.m.—12.30 p.m., Gramophone Music. 1.0 to 2.0, Concert of Light Orchestral Music. In the interval from 1.30 to 1.45, Giornale Radio and Exchange. 4.30, Children's Radio Review. 4.55, Giornale Radio and Report of the Royal Geographical Society. 5.10, Weather. 5.15 to 6.0, Orchestral Concert: Mari, Mari (Roland); Waltz, Bella (Moresca); Humoresque (Dvorák); Barcarolle, Canto d'Imera (Mullé); Melody (Vescey); Selection from Carnasciali (Lacetti); (riddle Song (Centola); Happy Jazz (Borgato). 6.40 (Naples), Shipping and Sports Notes. 6.45, Morse Signals and Dopplavoro Report. 7.0, Tourist Report. 7.10, Agricultural Report. 7.20, News in Foreign Languages. 7.40, Giornale Radio. 8.0, Time and Announcements. 8.15, Gramophone Music. 8.25, Giornale Radio and Sports Notes. 8.30, William Kattelife—Opera in Four Acts (Maseagni). In the intervals, Talk and News. Giornale Radio after the Opera.

SALZBURG.—See Vienna.

SCHWEIZERISCHER LANDESENDER

BEROMUNSTER, 653 kc/s, 459 metres; 60 kW.; Basle, 1,229 kc/s, 244.1 metres; and Berne, 1,220 kc/s, 245.9 metres.—11.59 a.m., Time Signal from Neuchâtel Observatory and Weather. 12 Noon (from Berne), Gramophone Concert. 12.30 p.m., Weather and News. 12.40 (from Berne), Gramophone Concert (contd.). 1.25 (from Berne), Time, Weather and Exchange. 1.30 (from Zürich), The Listeners' Quarter of an Hour. 1.45, Readings. 2.15 (from Zürich), Gramophone Music. 2.45 (from Zürich), Talk: The Employment Problem. 3.30 to 5.0, Interval. 5.0 (from Zürich), Song Recital by Ernst Frey-Berthardgrütter and Mary Frey-Berthardgrütter with Music by an Accordion Band. 5.30 (from Zürich), Light Music on Gramophone Records. 6.0, (from Zürich), Talk: The Choice of a Profession. 6.30 (from Basle), Reading. 7.0, Chimes from Zürich Churches. 7.15 (from Basle), Time, Weather and Market Prices. 7.20 (from Basle), Opera and Operetta Music on Gramophone Records. 8.0 (from Basle), Talk with Readings: The Poet Manfred Kyber. 8.30 (from Basle), Concert of Old Music. 9.0, Weather and News. 9.10 (from Basle), Concert by the Concordia Male Voice Choir, conducted by Müller von Kuhn. 10.10 (from Basle), Dance Music on Gramophone Records. 11.0 (approx.), Close Down.

SOTTENS.—See Radio-Suisse Romande.

STOCKHOLM

689 kc/s, 436 metres; 55 kW. Relay by Boden, 244 kc/s, 1,229.5 metres; Göteborg, 932 kc/s, 322 metres; Hörby, 1,166 kc/s, 257 metres; Motala, 221.5 kc/s, 1,354.4 metres; Östersund, 389 kc/s, 770 metres; and Sundsvall, 554 kc/s, 542 metres.—4.0 p.m., Technical Talk. 4.20, Orchestral Concert of Light Music: Soloist: Walburg Beer (Songs). 5.20, Programme for Children. 6.0, Gramophone Music. 7.0, The Practical Corner. 7.15,

Weather and News. 7.30, Reading (Albert Engström). 7.55, Old Dance Music. 8.30, Dialogue on Sea Animals. 9.0, Concert: Judit Malmquist (Pianoforte), Ursula Lénrodt-Burger (Harp), and Carl Schylling and Olle Wahlström (Songs); Pianoforte Solos (Chopin): (a) Scherzo in E, (b) Berceuse; Two Song Duets; Harp Solos: (a) Impromptu (Pierne), (b) Fantasia (Saint-Saëns); Two Song Duets. 9.45, Weather and News. 10.0, Dance Music. 11.0 (approx.), Close Down.

STRASBOURG

869 kc/s, 345 metres; 11.5 kW.—11.30 a.m., Gramophone Concert of Light Music. 12.45 p.m., News. 1.0, Time and Exchange. 1.5, Gramophone Concert of Variety Music. 2.0, Legal Talk in German. 2.15, Dance Music on Gramophone Records. 3.0 to 3.15, Talk in French on Modern Music. 4.0, Orchestral Concert, conducted by Maurice de Villers: Overture, Benvenuto Cellini (Berlioz); Symphonie légendaire (Godard); African Suite (Lacombe); Selection from Salammbô (Reyer); Marche héroïque (Saint-Saëns); Japanese Variations (Vidal); Ballet Music from Le Roi de Lahore (Massenet); Musiques intimes (Florent Schmitt). 6.0, Talk in German: Unemployment in Germany. 6.15, French Lesson. 6.30, Gramophone Music: Potpourri. Mosaic (Zimmer); Viennese Melody (Strauss); Selection from La vie Parisienne (Offenbach); Potpourri (Dostal); Selection from The Rose of Stamboul (Fall). 7.0, Talk in French: Travelling in the Vosges Mountains. 7.15, Horticultural Talk. 7.30, Time and News. 7.45, Gramophone Music. 8.0, Press Review in German. 8.30, Variety Programme. The Station Company and Orchestra, conducted by Maurice de Villers: Ballet, Music Hall (Biancheri); En attendant le coche (Waiting for the Coach)—Opéra-Comique in One Act (Flament); Suite, Le Train bleu (Darius Milhaud); Si l'amour passe (If love should end)—Opéra-comique in One Act (Chadal). In the interval at 9.30 (approx.), Press Review in French. 10.30, Dance Music from the Savoy. 12 Midnight, Close Down.

STUTTGART

MUHLACKER, 832 kc/s, 360.5 metres; 60 kW. Relay by Freiburg, 527 kc/s, 570 metres.—1.35 to 3.15 p.m., See Langenberg. 3.15, Morse Lesson. 3.30, Julius Wengert Concert by the Freundschaft Male Voice Quartet: Sonntagstfeier; Morgenruf; Der Fremdenlegionär; Der Diamant; Gute Nacht und süsse Ruh. 4.0-6.35, See Frankfurt. 6.35, Talk: The Aims of the German Christian Movement. 6.50, Time and Agricultural Notes. 7.0, Transmission for all German Stations, relayed from Langenberg. 8.0, See Frankfurt. 8.10, The Better Half—Variety Programme. 9.10, Variety Concert by the Station Orchestra, conducted by Gustav Göhrlich, and the Station Choir. 10.20, Things you should know. 10.30, News. 10.45, Light Music from Frankfurt. 2.0 a.m. (Sunday), Close Down.

SUNDSVALL.—See Stockholm.

TOULOUSE

RADIOPHONIE DU MIDI, 779 kc/s, 385 metres; 8 kW.—6.0 p.m., News. 6.15, Music by an Argentine Orchestra. 6.30, Operatic Music. 6.45, Strauss Operetta Potpourri by a Symphony Orchestra. 7.0, Songs. 7.15, News. 7.30, Concert of Instrumental Music. 8.0, Arias from Opera: Sa voix tombe comme la foudre, from Hérodiade (Massenet); O beau pays de la Touraine, from Les Huguenots (Meyerbeer); Song to Venus, from Tannhäuser (Wagner); Salut nous est promis, from Le roi d'Ys (Lalo). 8.15, Orchestral Concert: Selection from Masaniello (Auber); Melody (Manfred); A Wedding Waltz (Lincke); Clair de lune (Kettelbey); Dornröschens Brautfahrt (Rhode); Im Walzerrausch (Lincke). 8.45, Accordion Solos. 9.0, Orchestral Concert. 10.0, Songs from Sound-Films. 10.15, News. 10.30, Concert for Listeners in Morocco: Slav Fantasia in B Minor (Dvorák); Petite dinde, from Véronique (Messager); Selection from La Gioconda (Ponchielli); Tout le pays l'a su (Borel Clerc); Selection from Viktoria and her Hussar (Abraham); Si j'étais petit serpent, from Le grand Mogol (Audran). 11.0, Light Music. 11.15, Dance Music. 12 Midnight, News. 12.5 a.m. (Sunday), Light Music. 12.15, Light Music by a Viennese Orchestra. 12.30 (approx.), Close Down.

TRIESTE

1,211 kc/s, 247.7 metres; 10 kW.—5.20 p.m., till Close Down, See Turin. TRONDHEIM.—See Oslo.

TURIN

1,096 kc/s, 273.7 metres; 7 kW. Relay by Milan, 905 kc/s, 331.5 metres; Genoa, 959 kc/s, 312.8 metres; and Florence, 599 kc/s, 500.8 metres.—5.20 p.m., Gramophone Music. 6.0 to 6.5, Weather. 6.40, Giornale Radio. Dopolavoro Report and Gramophone Music. 7.0, Time, Tourist Report and Gramophone Music. 7.10, Wheat Market Report. 7.20, News in Foreign Languages. 7.40, Gramophone Music. 8.0, News and Weather. 8.30, Talk: Events and Problems. 8.45, Variety Programme. 9.45, Dance Music. 11.0, Giornale Radio.

VATICAN CITY

15,120 kc/s, 19.84 metres (Morning) and 5,969 kc/s, 50.26 metres (Evening); 10 kW.—11.0 to 11.15 a.m., Religious Announcements in Various Languages. 8.0 to 8.15 p.m., Religious Information in Italian.

VIENNA

581 kc/s, 517 metres 100 kW. Relay by Graz, 852 kc/s, 352.1 metres; Innsbruck, 1,058 kc/s, 283 metres; Klagenfurt, 662 kc/s, 453.2 metres; Linz, 1,220 kc/s, 245.9 metres; and Salzburg, 1,373 kc/s, 218.5 metres.—12 Noon, Concert by the Wiener Symphoniker, conducted by Christoph: Overture, Raymond (Thomas); Petite Suite (Debussy); Selection from Romeo and Juliet (Gounod); Scènes napolitaines (Massenet); Viennese Suite (Dité); Waltz, An der schönen grünen Narenta (Komzak); Selection from Countess Maritza (Kálmán); Overture, The Land of Smiles (Lehář). In the interval at 1.0 p.m., Time, Weather and Announcements. 2.0, Interval. 3.0, Time, Weather and Exchange. 3.15, A Play for Young People: The Bottle Imp (R. L. Stevenson). 4.0, Italian Lesson. 4.30, Concert by the Döbling Workers' Choral Society, conducted by Schager. Soloists: Ninni Human-Seluz (Soprano) and Leopold Schramek (Pianoforte); Three Songs (Mozart): (a) Brüder, reich die Hand zum Bunde, (b) Dir, Seele des Weltalls (c) Hörst die Fanfare; The Journey of the Jews to Babylon (Vaechi); Heil'ge Freiheit (Sücher-Küchel). 5.10, Variety Programme. 5.35, Well-known Arias on Gramophone Records: Arias from Lucia di Lammermoor (Donizetti). The Barber of Seville (Rossini), Tannhäuser (Wagner), Fidelio (Beethoven), Der Rosenkavalier (R. Strauss), Carmen (Bizet), Rigoletto (Verdi), La Bohème (Puccini), The Prophet (Meyerbeer), and Faust (Gounod). 6.30, Topical Talk. 7.0, Pianoforte Recital with Commentary. 7.45, To-day's Motto. 7.50, Time, Weather and Announcements. 8.0, Prince Methusalem—Operetta in Three Acts (Strauss). In the interval at 9.30, News and Weather. 10.20, Announcements. 10.30, Concert by Claire Hagedüs and her Band, relayed from the Café Palmhof. After the Programme, Announcements.

WARSAW

212.5 kc/s, 1,411 metres; 120 kW.—11.57 a.m., Time Signal and Fanfare from St. Mary's Church, Cracow. 12.5 p.m., Dance Music by the Gorzyski Orchestra. In an interval at 12.30, Radio Journal. 1.0, Interval. 3.30, Economic Notes. 3.40, Announcements. 3.55, Aviation Report and Anti-Gas Drill. 4.0, Gramophone Music. 4.20, Talk, relayed from Lwow. 4.40, French Lesson. 4.55, Concert by the Station Orchestra, conducted by Nawrot. Soloist: Selecki (Tenor). Overture, Gri-Gri (Lincke); Airs from Les Cloches de Corneville (Plauquette); Selection from The Queen's Kerechif (Joh. Strauss); Air from Schön ist die Welt (Lehar); Gavotte from Lysistrata (Lincke); Air from The Merry Widow (Lehar); March (von Blon). 5.45, Programme for Invalids relayed from Lwow. 6.0, Divine Service relayed from the Ostro Brama, Wilno, 533 kc/s, 563 metres. 7.5, Miscellaneous Items. 7.25, Reading. 7.40, Programme Announcements. 7.45, Radio Journal. 8.0, Concert by the Station Orchestra, conducted by Oziminski. Soloist: Eve Bandrowska-Turska (Soprano). Overture, The Merry Wives of Windsor (Nicolaï); Selection from Eugene Onegin (Tchaikovsky); Songs; Ballet Music from Dia Puppenfee (Bayer); Songs; Mazurka from The Haunted Castle (Moniuszko). 9.0, Answers to Technical Correspondence. 9.20, Chopin Pianoforte Recital by Turczynski; Prelude in C sharp minor, Op. 45; Polonaise in E flat minor, Op. 26; Impromptu in A flat, Op. 29; Ballade in F, Op. 38; Waltz No. 2 in A minor, Op. 34; Ecossaises; Tarantella. Op. 43. 10.0, Talk in a Foreign Language. 10.15, Sports Notes. 10.25, Dance Music. 11.0, Aviation Weather Report and Police Notes. 11.5, Dance Music (contd.).

ZURICH.—See Schweizerischer Landessender.

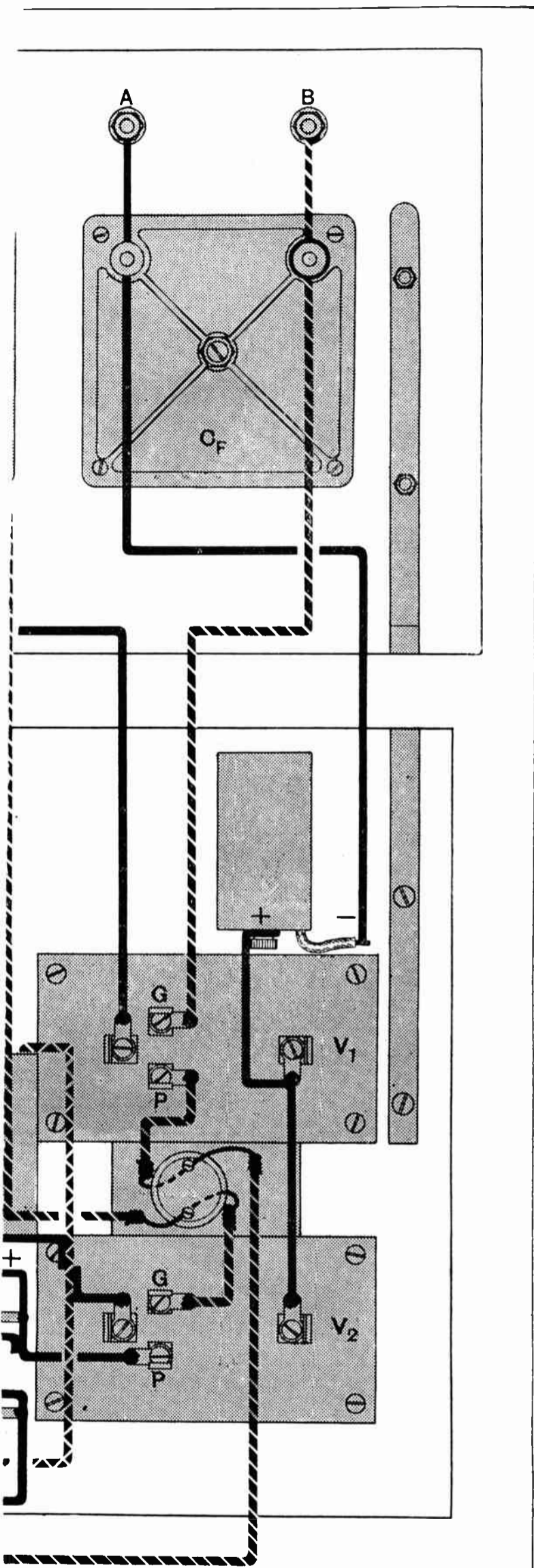

The  
**Wireless**  
 AND  
 RADIO REVIEW  
**World**





# HETERODYNE RECEIVER

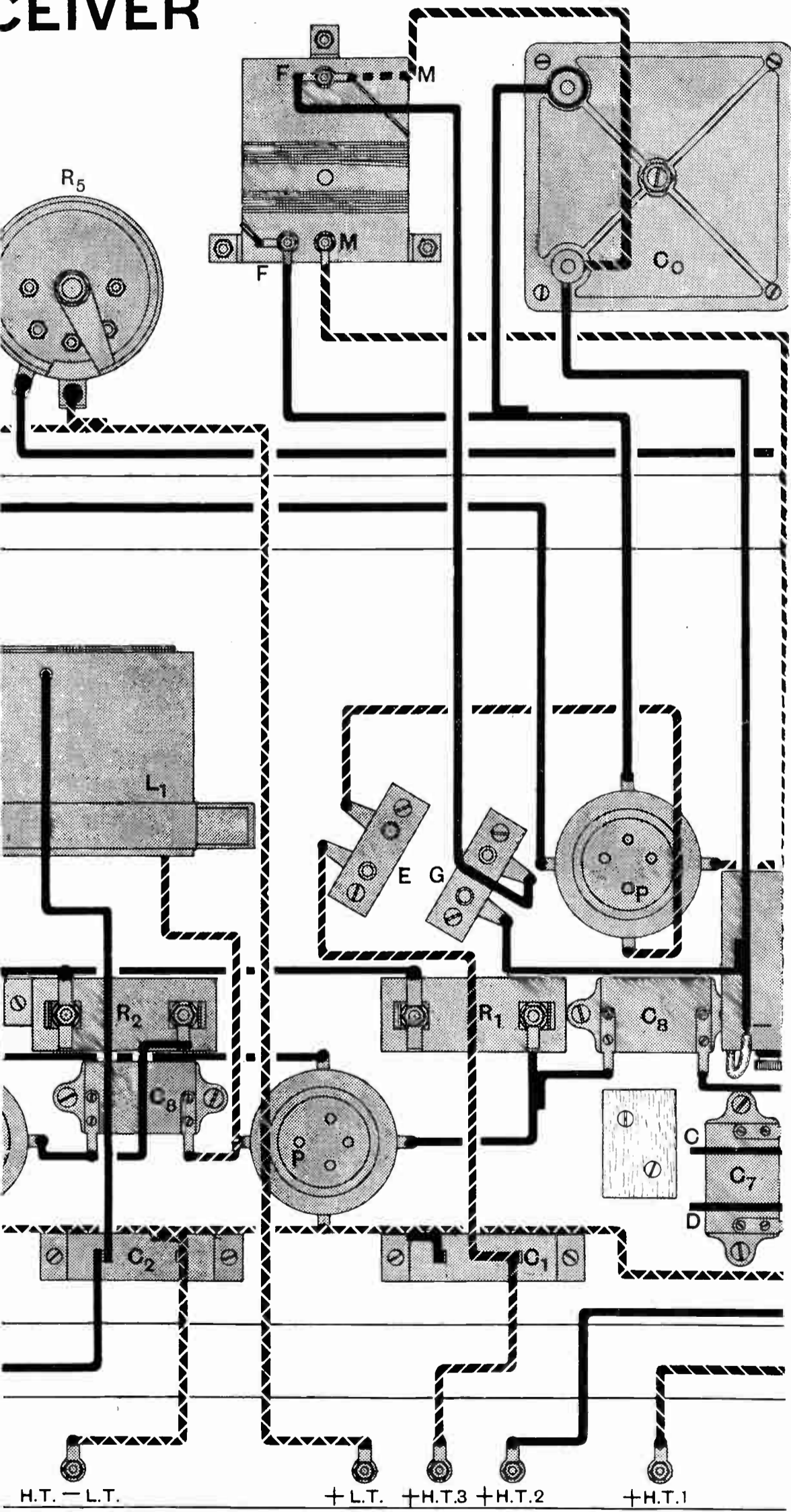



# SUPERH REC

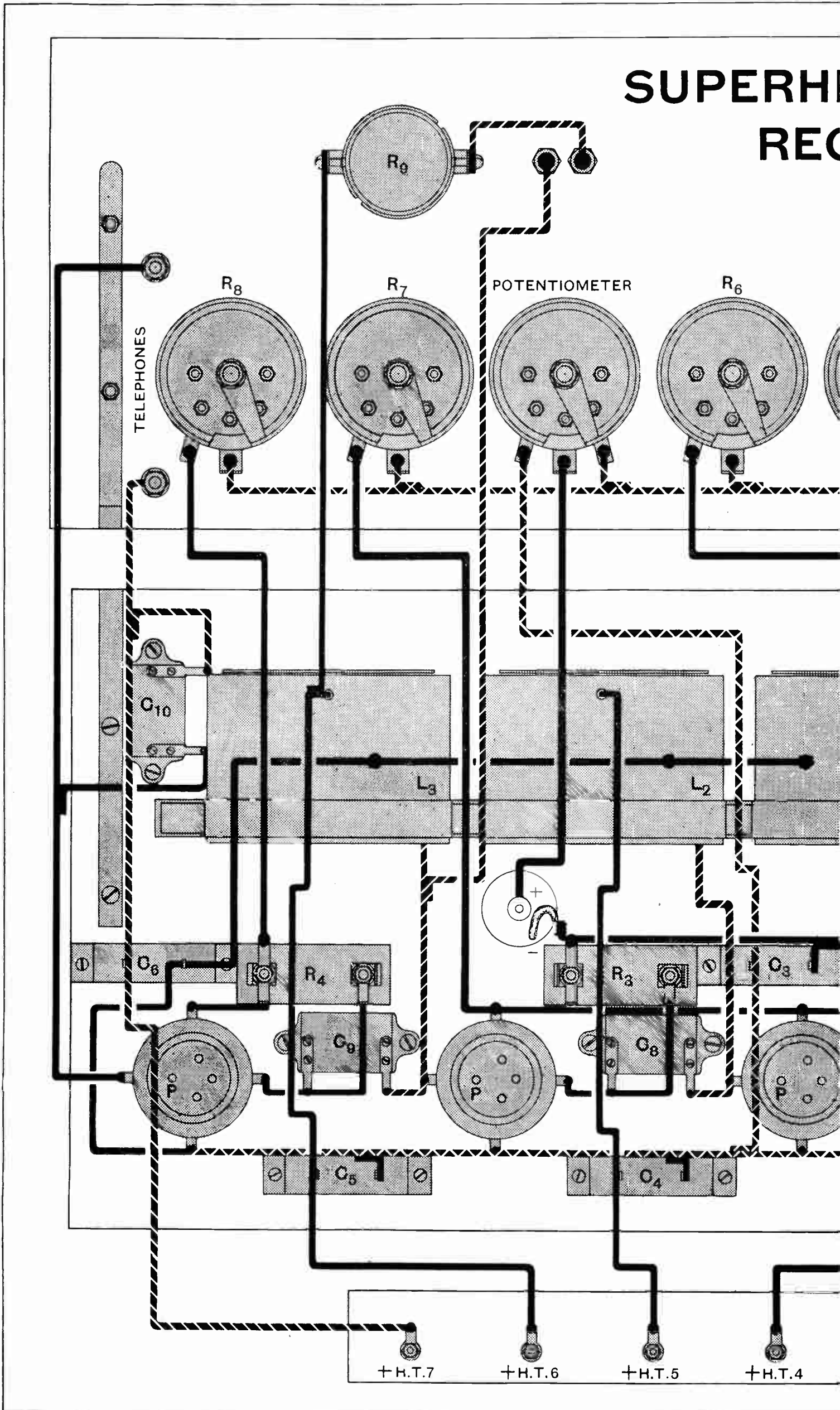





# PUBLIC WARNING

Magnified portion of **SUPERIAL** showing the only correct method of Insulation.



Some "covered" wires are being boxed and made to look like **SUPERIAL**. Imitators know that the way to sell you another wire is to make it seem like **SUPERIAL**.

They imitate the box and the name, but they cannot imitate its vulcanized rubber insulation or the scientific combination of ferrous and non-ferrous metals (including copper). They offer you a stranded wire of one metal only which has a cheap and ineffective cotton "covering." This is not insulation and will not protect the aerial after a little exposure to weather. Some dealers try to deceive you. Avoid deception. **DON'T BUY ANOTHER WIRE** made to look like **SUPERIAL**. **That cheats you of something you prize.**

### LOOK AT THE NAME AND THE BOX.

**SUPERIAL** is more than just an aerial—it is a very particular kind of aerial. It is a properly insulated aerial. It brings envied results, and does for your reception what every enthusiast wants—**SELECTIVITY, VOLUME, BEAUTIFUL TONE**. Imitations do not bring what you seek. They are **NOT SUPERIAL**.

**TRY IT at our Expense** and then you will know why it is so efficient. Ask your dealer for **SUPERIAL**— But you must agree to return it if it does not "prove up" to every claim made for it. We guarantee to refund your money unconditionally if **SUPERIAL** disappoints you. If your dealer does not stock **SUPERIAL** he can get it for you, or we will send it direct to you upon receipt of your remittance.

Good reception is worth any price you pay. Ask your dealer for **SUPERIAL**. You will get perfect reception and a £500 Free Lightning Insurance for two years from a Company which is in a position to meet all its obligations.

**SUPERIAL**  
THE AERIAL WHICH MADE BROADCASTING POPULAR  
**ELECTRON'S SUPER-AERIAL**

100 FT.	75 FT.	50 FT.	25 FT.
3 6	2 6	1 9	1 -

From dealers everywhere or write to:

**The NEW LONDON ELECTRON WORKS Ltd.**  
**92 EAST HAM LONDON. E.6**

Telephones:—  
Grange Road 1408-9—1363

Telegrams:—  
"Stannum, London."

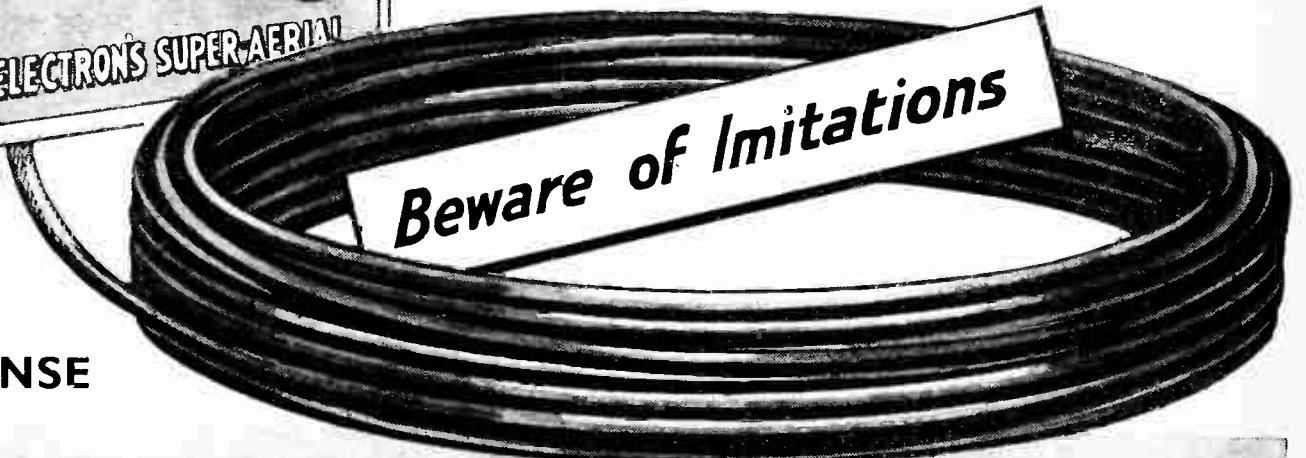

Try it at  
**OUR EXPENSE**

**NEW**

**CLASS "A" QUALITY**  
with  
**CLASS "B"**  
**VOLUME**

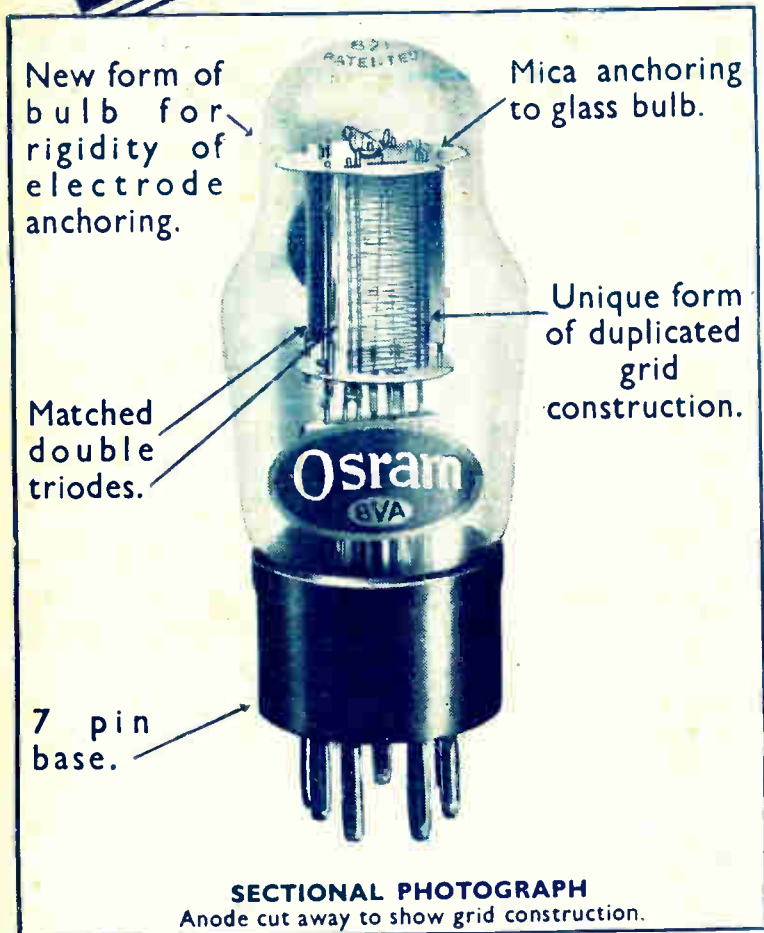

**OSRAM**  
**VALVE**  
**TYPE B.21**  
(For use in 2-volt Battery "Class B" Sets)  
**PRICE 14/- each**

The Osram B21 double triode "Class B" valve sets a new standard of quality in "Class B" amplification.

**NOTE THESE POINTS.**

1. New and unique duplicated grid construction in each half of the double valve — giving a higher power output to input efficiency.
2. Characteristics — a combination of QPP and positive grid drive "Class B", giving freedom from distortion or spurious oscillation. This involves the use of negative grid bias.
3. Total filament consumption only 0.2 ampere.
4. Low H.T. current consumption.
5. New form of bulb for complete rigidity of electrode anchoring — small size and neat appearance.

**OSRAM 2-VOLT BATTERY VALVES**  
*For use with type B21.*

**NEW OSRAM S23**  
Screen-grid Price 15/6

**NEW OSRAM S24**  
Screen-grid (high slope) Price 15/6

**NEW OSRAM VS24**  
Variable mu Price 15/6

**OSRAM HL2** Detector Price 7/-

**NEW OSRAM L21** Driver for moderate power Price 7/-

**OSRAM LP2** Driver for large power Price 8/9

**Osram**  
**2 VOLT BATTERY**  
**Valves**  
**MADE IN ENGLAND**

WRITE for the OSRAM VALVE GUIDE (1933 Edition) sent post free.

SOLD BY ALL WIRELESS DEALERS