

LABORATORY TESTS ON CONE SPEAKER UNITS

The Wireless World

AND RADIO REVIEW

The Paper for Every Wireless Amateur

Wednesday, February 5th, 1930.

4^D



RADIOGRAND
12/6

TELSEN
L.F. TRANSFORMERS

Radio's Choice

Have acquired a world-wide reputation for Quality and Value.

Built by Specialists in Transformer construction, they have set a Quality of Performance above reproach. Your Set will work better with a Telsen Transformer - - - Fit one now!

TELSEN ELECTRIC CO. LTD.,
Miller Street,
Birmingham.

CLAROSTAT



This authoritative 36-Page Book, compiled by Experts, with 47 Illustrations (27 circuits - 3 scale drawings), describes clearly and simply the home construction of all types of Eliminator, etc.

FREE AND POST FREE to "W. W." Readers on receipt of a postcard. The complete range of "Clarostat" variable Resistances, and their uses, is also described.

CLAUDE LYONS Ltd.,
76, OLDHALL ST., LIVERPOOL.

HYDRA CONDENSERS

THE STRONG POINT IN ANY MAINS UNIT!

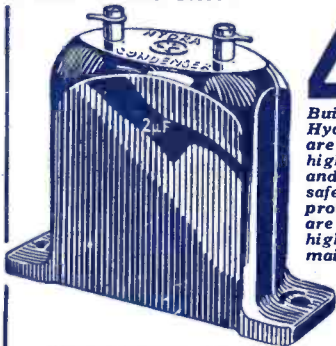

LOUIS HOLZMAN, 37 Newman Street, London, W.1.

for
SAFETY

Build an eliminator with Hydra Condensers and you are putting between the high voltage of your mains and your set the surest safeguard that science can provide. Hydra Condensers are built to stand up to higher pressures than your mains supply - and every one is tested before it leaves the factory - tested far beyond its stated working voltage. Fit HYDRA for safety.

BurTON

SELF-LOCATING VALVE HOLDER



1/- each

Pentode-Valve-Holders
1/6 each

Patent No. 318708

MANUFACTURED BY
C. F. & H. BurTon

PROGRESS WORKS
WALSALL, ENG.

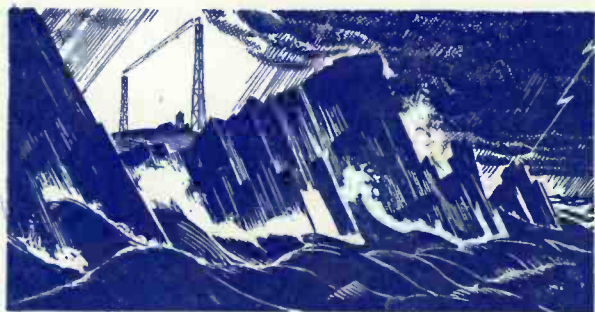

IN THE WILD NIGHT
THE URGENT CALL FOR HELP
COMES BY THE AID
OF THE EXIDE BATTERY

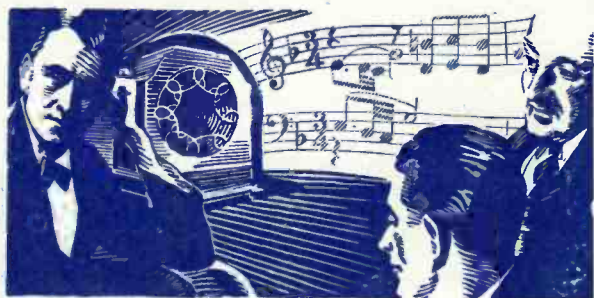

AND THE TWIN
OF THIS BATTERY MAY BE
IN YOUR OWN WIRELESS SET
GIVING PURE AND POWERFUL
THE FLOW OF
REASON AND OF SOUL

Exide

THE LONG LIFE
BATTERY

Obtainable from Exide Service Stations and all reputable dealers.
Exide Service Stations give service on every make of battery.

EXIDE BATTERIES

(London Sales & Service Depot) 215-229 Shaftesbury Avenue, W.C.2

Mention of "The Wireless World," when writing to advertisers, will ensure prompt attention.

DUBILIER FOR DURABILITY

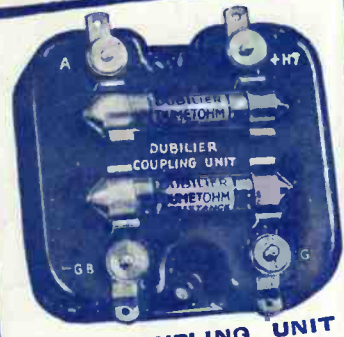

R.C. COUPLING UNIT
With or without Valve Holder. 7/-
Complete with Dumetohms ..



DUCON AERIAL
Does away with outdoor aerial, as it has simply to be plugged into any standard electric lamp socket. Tested at 2,300 volts. Absolutely safe. 5/-



H.F. CHOKE
Four types to meet all uses. All types 4/6

Ask your dealer for the Dubilier Booklet—"A Bit about a Battery"—it's free.

If you have any difficulty in obtaining Dubilier products write to us direct giving the name and address of your dealer.

DUBILIER RADIO PRODUCTS

Dubilier Condenser Co. (1925) Ltd., Ducan Works, Victoria Road North Acton, London W.3

RC 289/C

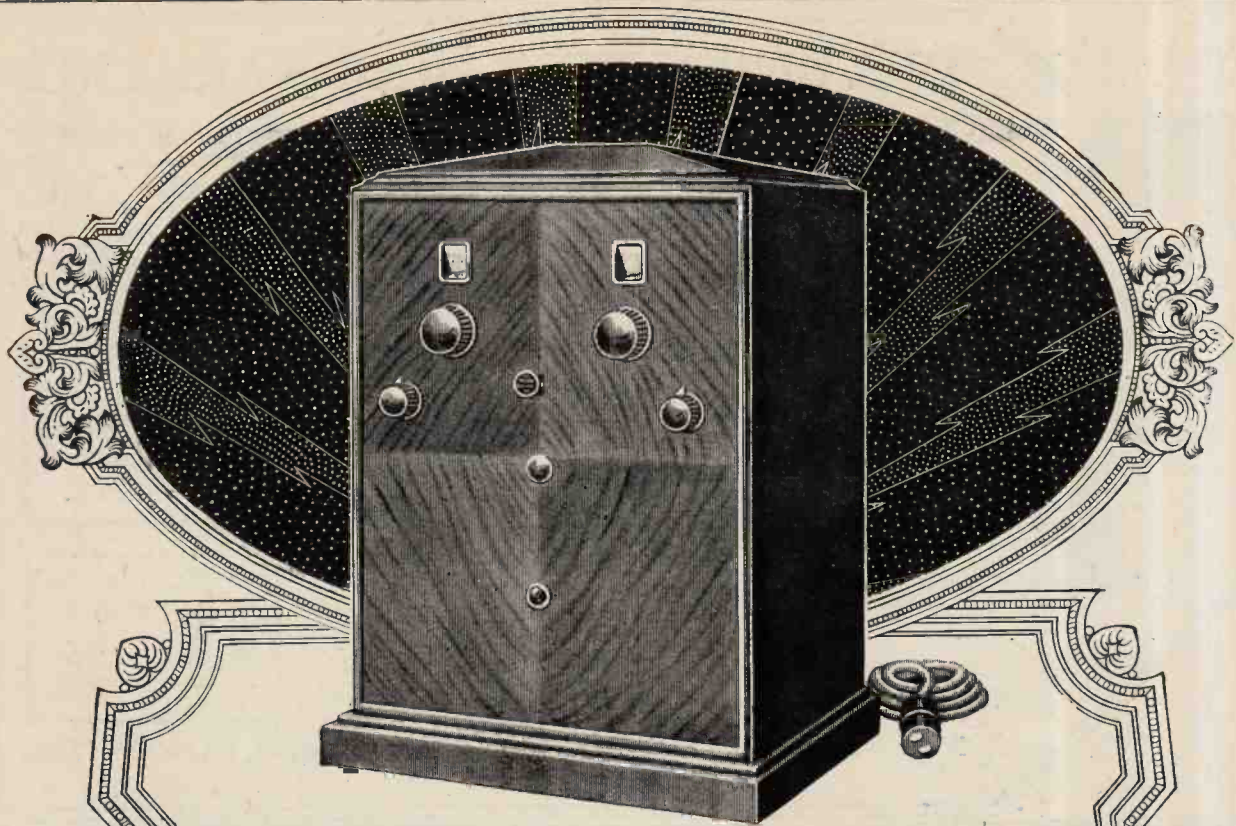

The outstanding feature of the FERRANTI A.C. Mains Receiver is the reproduction, which is very nearly true to life. The volume and richness of tone satisfy the critical listener.

This quality is attained by the use of the finest audio frequency components available and the close attention to detail which is expected from FERRANTI. Every component has been designed or chosen for the purpose it has to fulfil.

We have considered quality before price. Quality tells in the long run, and the first cost is the last cost when the best is bought.

The Set is handsome, too. You have the choice of three woods to tone with any scheme of furnishing.

Available for Alternating Current only, voltages 200 to 250; 40 cycles or over.

Any high-class dealer will demonstrate this Set to you and many will supply it on H.P. terms, if desired.

Price, including valves:

In Oak £25; In Mahogany £26; In Walnut £26

Royalty £1 extra.

FERRANTI

A.C. MAINS RECEIVER

FERRANTI LTD.

HOLLINWOOD

LANCASHIRE

FERRANTI



IF YOUR SUPPLY MAINS ARE D.C.

You can use an A.C. All Electric Receiver
By Employing The M.L.—D.C. to A.C.
ROTARY TRANSFORMER

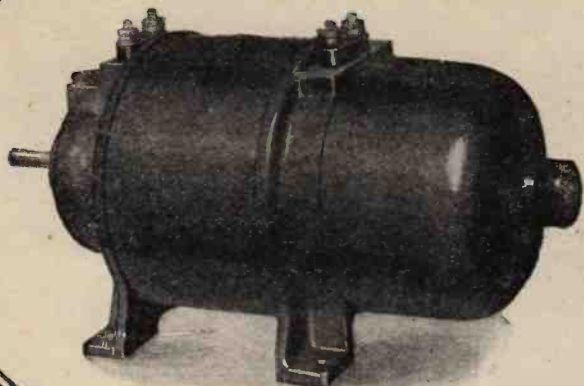

Can be supplied to run from any Voltage 12-250 V.D.C.

Recommended and used by
Philips Radio, Marconiphone, Burndept, Kolster-Brandes, Etc., Etc.

ON VIEW
British Industries Fair
STAND D.7
OLYMPIA.

40 WATT Model £13-0-0
85 WATT Model £19-0-0

M-L MAGNETO SYND. Ltd., Radio Dept., COVENTRY.
Telephone: 5001.

LOW FREQUENCY PURITY

PRICE
17'6

Type "J" Transformer

PRICE
17'6

Small, neat and handsome, but with a straight line performance and a purity and constancy of amplification far above any transformer in its price or class. Use it and enjoy truly magnificent magnification.

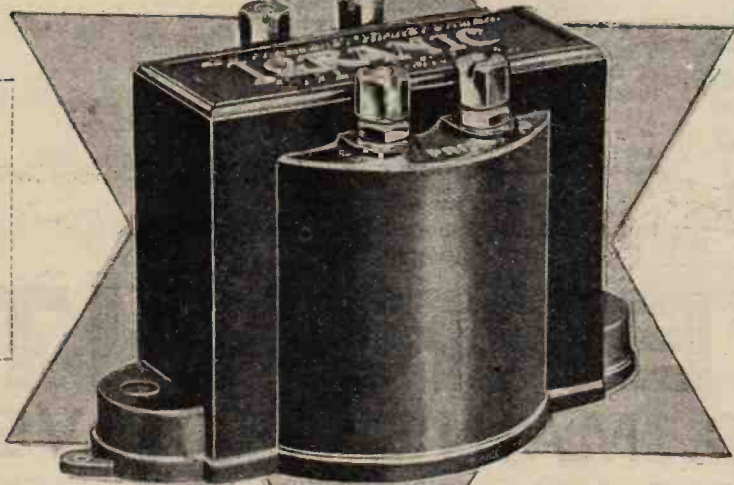

Obtainable in two ratios 3-1 and 6-1. Ratio 3-1 for valves with impedances of 10,000 - 20,000 ohms. Ratio 6-1 for valves with impedances of 5,000 - 10,000 ohms. Apply to your dealer. If he cannot supply you, please write at once to Dept. U306.



IGRANIC ELECTRIC Co., Ltd.,

149, Queen Victoria St., London.

Mention of "The Wireless World," when writing to advertisers, will ensure prompt attention.

The SUPER-POTENT "PERTRIX" PAIR



"PERTRIX"
SUPER-LIFE
H.T. BATTERIES

EVERY day brings home to more and more wireless users the knowledge that "Pertrix" stands supreme—unchallenged and unchallengeable—among H.T. Batteries.

The one battery that engenders potent and steady voltage without sal-ammoniac, and therefore without that "crackle" which every sal-ammoniac unit must develop after being in use for some time.

Next time you need a new battery, plug into "Pertrix," and you will use none but "Pertrix" ever after.

STANDARD TYPE "PERTRIX"
H.T. BATTERY.

60 volts - - - 8s. 0d.
100 volts - - - 13s. 0d.
120 volts - - - 15s. 6d.

"PERTRIX" GRID BIAS
BATTERY.

9 volts - - - 1s. 6d.
12 volts - - - 2s. 3d.
15 volts - - - 2s. 9d.



"PERTRIX" PATENT ACCUMULATORS

And now for low tension current comes the "Pertrix" Patent Accumulator, in its field as efficient and dependable as "Pertrix" H.T. Batteries. Glass boxes obviate frothing, cell-discharge and all risk of fire.

| TWO VOLT. | | | FOUR VOLT. | | |
|-----------|-----------------|-------|------------|-----------------|-------|
| Type | Actual Capacity | Price | Type | Actual Capacity | Price |
| LE1 | 15 | 8- | DLE1 | 15 | 14/- |
| LE2 | 30 | 11/6 | DLE2 | 30 | 19/6 |
| LE3 | 50 | 17/6 | | | |

Send for catalogue of all "Pertrix" Products.

PERTRIX SUPER-LIFE BATTERIES

Pertrix Limited, Britannia House, Shaftesbury Avenue,
London.

Factory: Britannia Works, Redditch, Worcs.

A3 Advertisements for "The Wireless World" are only accepted from firms we believe to be thoroughly reliable.

Radio's Supreme Power



ARE YOU PROUD
OF YOUR NEW SET?
DO IT JUSTICE
AND FIT THE BEST
POSSIBLE BATTERY

Grosvenor Batteries give continuous and satisfactory service because they incorporate a new vitalising element which is unique to Grosvenor.



| | | |
|----------------|-------------------------------------|------------|
| 66 v. from 7/6 | Super Capacity for Multi-Valve Sets | 66 v. 20/- |
| 99 v. " 11/6 | | 99 v. 32/6 |

The Grosvenor Battery

BRITISH MANUFACTURE

GROSVENOR BATTERY CO., LTD., 2-3, White St., MOORGATE, LONDON, E.C.2. Phone Met. 6365

Weston sets the world's standard

MODEL 506 Panel Voltmeter ensures permanent accuracy on your radio receivers. Experimenters and radio enthusiasts find it necessary for checking the electrical operation of their sets.

Having a high internal resistance of 125 ohms per volt, it makes practically no load on the batteries. It is compact and neat in appearance.

The Weston booklet "Radio Control," which explains the uses of this and other Weston Radio Instruments, is free. Write for your copy now.

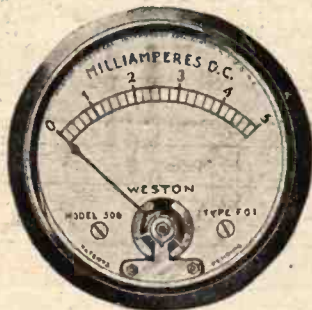

MODEL 506
PANEL VOLTMETER.

Prices: £1-15-0—£2-15-0

WESTON

STANDARD THE WORLD OVER

Pioneers since 1888
WESTON ELECTRICAL INSTRUMENT CO., LTD.,
15, Great Saffron Hill, London, E.C.1.

THE FINEST VERNIER DIAL OBTAINABLE

MECHANICALLY PERFECT, POSITIVE BRASS CONTACT drive on SOLID BRASS SCALE ensuring smooth movement, with absolutely NO BACK-LASH. ROBUST in Construction and Trouble Free. SMALL, EXTREMELY ELEGANT, EFFICIENT

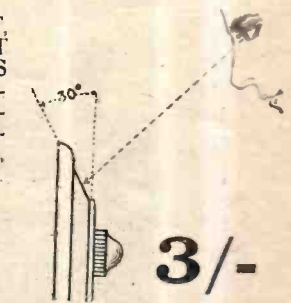

TUNING WITHOUT IRRITATING UNCOMFORTABLE CROUCH OR STOOP.

As pictorially shown, the scale and aperture are inclined at an angle of 30° from perpendicular, thereby permitting convenient unobstructed view of scale without need to crouch or stoop.

Full Catalogue sent post free on receipt of post card.

THE FORMO CO., CROWN WORKS,
CRICKLEWOOD LANE, LONDON, N.W.2

Mention of "The Wireless World," when writing to advertisers, will ensure prompt attention.

SEND 2d. STAMP FOR THIS INTERESTING PAMPHLET:
“HOW TO BUILD AN ALL-MAINS RADIO-GRAMOPHONE”
FREE TO ALL W.W. READERS ON REQUEST.
GET YOUR COPY NOW.

MR. W. H. SQUIRE,
 the World-famous Violoncellist
 and Composer, writes:—

“I have always felt that one day something would give us just that difference in quality which would make it hard to distinguish between Loud Speaker reproduction and the actual renderings of the music or speech. **YOUR COUPLER HAS UNDOUBTEDLY ACCOMPLISHED THIS.**

During the Military Band programme last evening I was able FOR THE FIRST TIME to identify not only every individual instrument, BUT ALSO TO HEAR DISTINCTLY THE WHOLE RANGE OF SOUNDS FROM THE VERY LOWEST NOTES OF THE BASSES TO THE HIGHEST NOTE OF THE PICCOLO. I consider this a very great achievement. The quality was uncannily faithful as was also the perfect fidelity of the pianoforte tone in the accompaniments to the songs.”

(The original of this letter may be seen on request).

We claim that never in the history of Wireless Reception has such perfect quality of reproduction been possible until the advent of the

C.A.C. LOW-FREQUENCY COUPLER.

This revolutionary and unorthodox method of amplification, employed under our own exclusive patents, should be heard by everyone who is desirous of obtaining that perfection of quality which is absolutely indistinguishable from the original—either from Record or Radio.

Eminent musicians and music lovers are daily testifying to the marvellous results they have achieved by the use of this Coupler. Read these two testimonials—one from no less an authority than Mr. W. H. Squire, the world-renowned violoncellist, and the other, chosen from hundreds of others in our possession, from a music lover. Such glowing tributes have never before been paid to any instrument—positive proof that the C.A.C. Coupler is the only method of Low-Frequency amplification which will satisfy those whose first consideration is a perfection of quality which cannot be improved upon.

The reason why the C.A.C. Coupler can reproduce FAITHFULLY every note of the whole accoustical range is simple to understand. It consists of two or three succeeding stages of AIR-core Transformers with highly inductive primary and secondary windings, having a minimum of self-capacity. Between the ends of the primary and secondary windings is connected a condenser of relatively small capacity, so proportioned as to provide a leakage path for any peak voltages which may develop in either winding.

This, together with the absence of an iron core, avoids electrical resonance and back-ground noises, whilst the high resistance of the primary limits the anode current of the first valve, and thus avoids parasitic low-frequency oscillation.

“A MUSIC LOVER”

writes:—

CORRINGHAM ROAD,
 GOLDERS GREEN,
 N.W.11.

January 17th, 1930.

“I should like to compliment you on being the first to convert a wireless set into a beautiful musical instrument. After testing most of the sets on the market from the music lover’s standpoint, I can say that none of them equals your instrument.”

(Signed) R.P.H.

(The original of this letter may be seen on request).

Our Free Pamphlet fully describes the construction of the complete combined instrument, and contains full-size point-to-point wiring diagrams of receiver and L.T. and H.T. Eliminator.



A SECTION OF THE PUBLIC OUTSIDE OUR PREMISES LISTENING TO THE ALL-MAINS COMBINED RADIO-GRAMOPHONE DESCRIBED IN OUR FREE PAMPHLET.

The C.A.C. Coupler, when used in conjunction with the valves and eliminator as described in our pamphlet, is capable of giving sufficient volume to fill the average dance hall. Using 400-500 volts and with suitable valves, it will fill a hall of 1,000 seating capacity. One cinema owner wired us:—“Your apparatus equal to anything ever heard. Business trebled. Apparatus everything you claim. Congratulations and thanks.” Special quotations for complete amplifiers for Dance Halls, Talking Film apparatus or any special purpose supplied immediately on request.

GRAMO-RADIO AMPLIFIERS LTD., 1a, New London Street, E.C.3
(Foot of steps facing Fenchurch Street Station). Phone: ROYAL 4300.

Continuous demonstrations daily at our address.

North London residents can hear this instrument in the Lounge of “The Angel and Crown” Hotel, 235, Upper Street, Islington, N.1.

PRICES:—

Battery or H.T.
 Eliminator model
 2 stage - 35/-
 3 stage - 52/6

All-mains A.C. model
 (Five pin valve holders)
 2 stage - 45/-
 3 stage - 60 -

Tudor

H.T. UNITS FOR MODERN SETS

For modern sets, with power valves, pentodes and moving coil loudspeakers, the Tudor Monobloc High Tension Unit has no superior.

It is a 10-volt Unit sold in three capacities, each more than ample for ordinary requirements, yet not too heavy to make awkward handling—a unit that will stand for months between charges without a drop in voltage, because of its absolutely non-current-leaking construction. It is a unit which has sold in thousands since its introduction, not one single unit having been returned because of unsatisfactory performance. A unit made by a company with 35 years' battery experience—whose huge stationary batteries, weighing hundreds of tons each, are used by the majority of power stations in this country.



M.C.45.

ESTABLISHED IN PUBLIC SERVICE 10 VOLT HIGH TENSION UNITS.

COUPON.
Please send me full particulars of Tudor Wireless Batteries.
Name
Address

Tudor Accumulator Co., Ltd., 2, Norfolk Street,
Strand, London, W.C.2.

| | Capacity. | Price. |
|------------|-----------------|--------|
| 5 H.T.1 .. | 2,750 milliamps | 6/9 |
| 5 H.T.2 .. | 5,500 | 10/- |
| 5 H.T.4 .. | 12,500 | 17/6 |

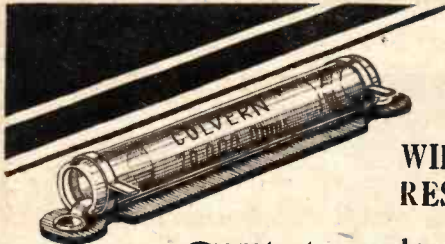

COLVERN WIRE-WOUND RESISTANCE.

Constant under working conditions.
Ohmie values as required.
Liberally spaced wire winding on glass.
Valves get correct voltages.
Easily fitted.
Rating 10 watts.
Never fail.

COLVERN RADIO

2 6 in values up to 50,000 ohms, 3/6 above 50,000 up to 100,000 ohms, tapping points 1/-

LONDON DEPOT:
150, KING'S CROSS
ROAD, W.C.1.

Phone: Clerkenwell 5362.

MAWNEYS RD.,
ROMFORD
ESSEX.

PANEL LOGIC

Trolitax popularity is the logical outcome of producing a panel giving perfect insulation and absolute reliability. There is a splendid range of handsome designs—and the new screened panel—Trolitax with a metal back *sprayed on!*

TROLITAX

F. A. HUGHES & CO., LIMITED
204-6, Great Portland Street, London, W.1

Phone: Museum 8630 (4 lines).

Distributors for Northern England, Scotland and North Wales:
H. C. Ratson (Sheffield and London), Ltd., 100, London Road,
Sheffield. Phone: Sheffield 26006. 22, St. Mary's Parsonage,
Manchester. Phone: Manchester City 3329.

Mention of "The Wireless World," when writing to advertisers, will ensure prompt attention.

BAYLISS ROTARY CONVERTER

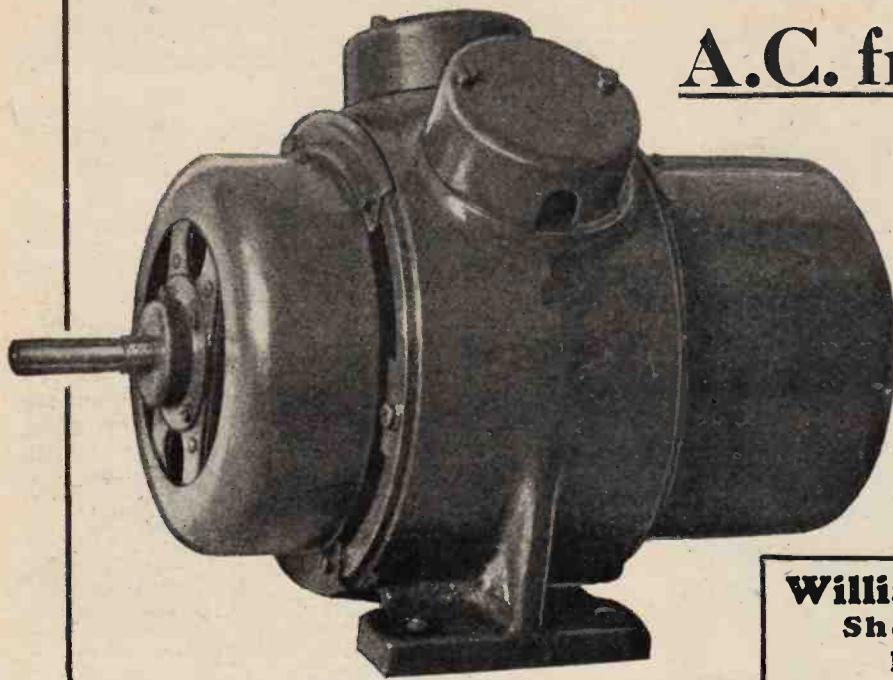

A.C. from D.C.

Load 400 Watts.

ANY Input.
ANY Output.

PRICE

£12. 10. 0

Delivery
from Stock.

William Bayliss Ltd.
Sheepcote Street
BIRMINGHAM

Telephone :
Mid 1409.

Telegrams :
"Drawbench, B'ham."

**A Pick-Up
of
Distinction.**

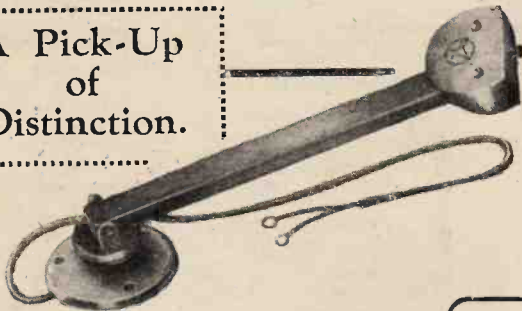

Read what January 29th
"Wireless World" says
OF THE
R.G.D. Pick-Up

The external appearance is PARTICULARLY NEAT AND BUSINESS-LIKE, and the over-all height is only 1½ ins., so that it can be accommodated under the shallowest cabinet lid.

The Pick-Up unit is attached at such an angle that TRACKING ERRORS ARE REDUCED TO A MINIMUM.

THE PICK-UP MOVEMENT IS SOUND IN PRINCIPLE. The armature is kept down to the smallest possible dimensions and is mounted between the pole pieces in such a manner as to give different variations of the flux surrounding the pick-up coil. ADEQUATE CONTROL OF THE MOVEMENT IS OBTAINED by

As used by
**Lozells Picture
House,
Birmingham**
which Broadcasts
from
5GB
regularly

clamping the knife-edge pivot between rubber packing. The needle set-screw passes through the axis of the pivot and its moment of inertia is therefore negligible.

The characteristic shows THESE PRINCIPLES OF DESIGN TO BE JUSTIFIED, for the output is practically constant from 250 to 1,500 cycles. No objectionable resonance could be detected by ear when playing ordinary records.

However, taking a general view, this pick-up is well above the average in performance and in use possesses a noticeable freedom from producing record wear.

Extracts from "Wireless World," Jan. 29, 1930.

Place your order now to ensure delivery and we shall be pleased to supply literature on application.

The Radiogramophone Development Co.,
St. Peter's Place, Broad Street, Birmingham.

Rid yourself of
yourself of
accumulator
worries!



Buy an EDISWAN ACCUMULATOR

The demand for Ediswan L.T. Batteries and the increased manufacturing facilities have enabled Ediswan to produce a range of long discharge batteries to sell at amazingly low prices. Here is your opportunity to end your battery worries and save money. Less charging—longer service—wonderful value.

B.W.G.2. 24 Ampere Hours ... 8/9
 B.W.G.3. 36 Ampere Hours ... 11/9
 B.W.G.4. 48 Ampere Hours ... 13/9

Midget Loten. 12 Amp. Hrs. 2/9
 Little Loten. 20 Amp. Hrs. 4/3
 Minor Loten. 45 Amp. Hrs. 8/-
 Major Loten. 70 Amp. Hrs. 11/-



THE EDISON SWAN ELECTRIC CO., LTD.,
 123/5, QUEEN VICTORIA STREET, LONDON, E.C.4.

Branches in all the Principal Towns.

B.55.



For Every Wireless Man

BE HE EXPERIMENTER, MANUFACTURER, FACTOR OR RETAILER.

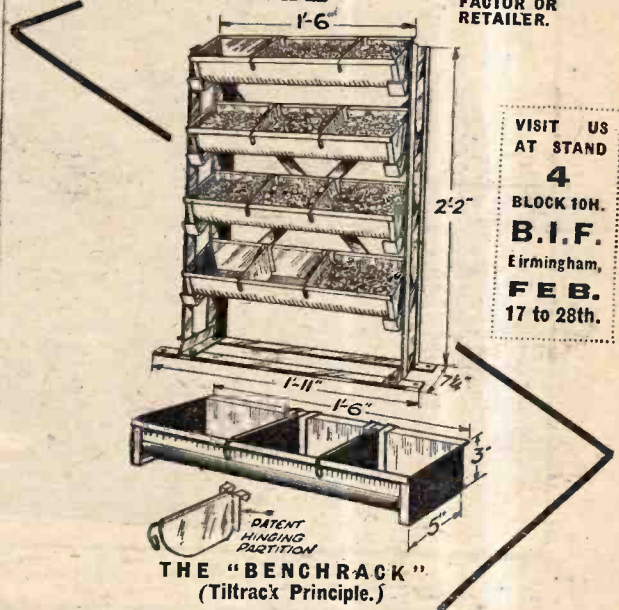

VISIT US AT STAND 4 BLOCK 10H. B.I.F. Birmingham, FEB. 17 to 28th.

THE "BENCHCRACK" (Tiltrack Principle.)

A real help for storing small parts such as Terrinals, Nuts, Washers, Insulators, etc. Made to stand on the work bench, it enables all small parts needed for the job in progress to be stored where they are immediately to hand. All the trays are tilted so that the parts stored can be seen at a glance, and the front faces of the trays are rounded so that the smallest parts can be swept up the slope with the fingers of one hand. Each tray is provided with patent hinging partitions which can be moved quickly to make larger or smaller compartments. Being so accessible these racks greatly facilitate stocktaking, and being all-steel there is no danger of fire. The Experimenter will do his jobs much quicker and with greater pleasure, and the Factory will save many pounds per year by installing this Benchcrack.



30/- Carr. Extra.

TILTRACK JUNIOR.

A splendid rack for storing small components. A most popular rack that quickly pays for itself.

30/- Post Free.

TILTRACK TWEENIE.

Somewhat bigger than the "Junior," very compact. Great storage capacity.

70/- F.O.R.

Particulars from Manufacturer & Patentee: — **BERTRAM THOMAS,** Worsley Street, Hulme, MANCHESTER.
 London Office & Showroom: — 28, Victoria Street, S.W.1.

Mention of "The Wireless World," when writing to advertisers, will ensure prompt attention.



Behind the perfect tone of radio that lives *and will live*—VARLEY radio—you will find VARLEY Components—every one an answer to the modern radio problem. The Varley H.F. Choke gives you results unequalled by any other H.F. Choke. It has an impedance frequency curve free from peaks—no minor resonances. It offers higher impedance over the lower broadcast band than any other H.F. Choke designed to cover both upper and lower bands.

It is a choke of VARLEY quality. You cannot expect—nor will you get—a better H.F. Choke. Write for Sections B and C of the Varley Catalogue. MULTI-CELLULAR H.F. CHOKE

9/6



Advertisement of Oliver Pell Control Ltd., Kingsway House, 103, Kingsway, London W.C.2. Telephone: Holborn 5303.

KUKOO

The **SUPER SPEAKER UNIT**

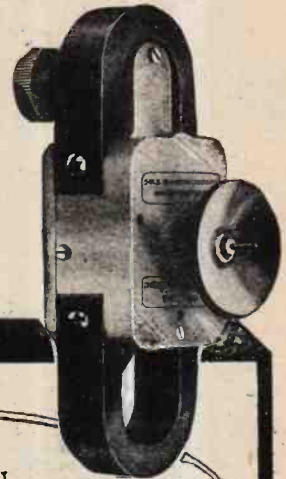

Plases once again

ROBERT NEWTON.
263, Stockport Road.
LEVENSHULME.

· MANCHESTER ·

Jan. 2nd. 1930.

Messrs Sheffield Magnet Co.
116/126 Broad Lane,
Sheffield.

Dear Sirs,

I have purchased several "Kukoo" Units in Manchester through one of your factors and am highly satisfied with same as the range both on the upper and lower frequencies is most exceptional.

Your spontaneous offer to replace free of charge one that was damaged in transit causes me not only to write thanking you for your liberal treatment but if you wish you may make use of this letter.

Yours faithfully,

R Newton.

S 25/- NETT

Sole Patentees & Manufacturers :—
THE SHEFFIELD MAGNET CO.,
BROAD LANE, SHEFFIELD.
Phone :—20866.
Grams :—Magnet 20866 Sheffield.

FAMOUS RADIO CORRESPONDENT writes

The Morning Post.

Mains units of all descriptions are so useful and trouble-free that I can not understand any wireless user not preferring them to batteries.

W. James in *The Morning Post*

Plug-in — That's all!

Read the extract above—it speaks for itself. Why not use an "EKCO" Power Supply Unit with your set—from the smallest to the largest receiver there is a model that will give you easier, simpler and cheaper radio. "EKCO" Power Supply Units can be fitted in two minutes—they are British Made for D.C. as well as A.C. Mains, with Westinghouse Valveless Rectification in A.C. Models, and they are guaranteed for one year.

"EKCO" H.T. Unit (illustrated) Model 3F.20 for A.C. Mains. Tapping for S.G. Valve and at 60 and 120/150 volts. Up to 20 m/a. (size 7½ in. by 6½ in. by 4½ in.) £3 . 19 . 6 .
D.C. Model (size 5½ in. by 3 in. by 2½ in.) £1 . 17 . 6 .

EKCO

POWER SUPPLY UNITS

There are "EKCO" Power Supply Units to suit any type of set and eliminating either batteries or accumulators, or both. Write for details of Easy Payments and Free Book'ies on "All-Electric Radio," containing full particulars of these Units and "EK O-ELECTRIC" Radio Receivers. Radio's supreme two and three valve sets—No batteries or accumulators!

E. K. Cole Ltd., Dept. W, "EKCO" Works, Leigh-on-Sea.

Centralab

Control is everything



Your radio or electrical gramophone must carry on every time you snap on the switch. Your volume control must function smoothly, easily—consistently if you wish to be rewarded with perfect reproduction. No radio is perfect unless it is Centralab equipped. Centralab Modulators and Potentiometers are used as standard by all the leading manufacturers—this is an insurance of supreme quality.

Our 1930 4th Edition of the "Great Voice" booklet tells you all about Centralab Volume Controls and their uses. This 68-page booklet contains numerous diagrams and information of paramount importance to all constructors of radio sets, gramophones, etc. Send 6d. in stamps for postage.

| POTENTIOMETERS. | | |
|-----------------|--------|-------------|
| Type P. | 109 | 0-200 ohms. |
| " | P. 110 | 0-400 " |
| " | P. 111 | 0-2,000 " |
| " | P. 112 | 0-10,000 " |
| " | P. 050 | 0-50,000 " |
| " | P. 100 | 0-100,000 " |
| MODULATORS. | | |
| " | M. 250 | 0-250,000 " |
| " | M. 500 | 0-500,000 " |

All 10/6 each.

THE ROTHERMEL CORPORATION LTD.,
24, Maddox Street, London, W.1.
Phone : MAYFAIR 0578/9.

HERE IS THE OAK WIRELESS CABINET YOU ARE LOOKING FOR

Do not put a fine piece of work into a fourth-rate box
Install a "LANGMORE"
and be proud of your set.

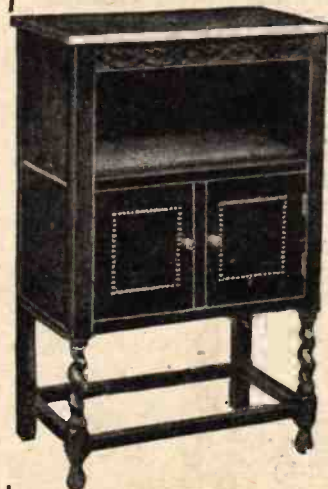

These cabinets are made in the following sizes:—

| | |
|---|-----------------------------------|
| No. 1. Panel, 16 in. x 7 in. Cabinet, 2 ft. 6 in. high, 1 ft. 8 in. wide, 12 in. deep. | Nos. 1 & 2 37/6 Each |
| No. 2. Panel, 18 in. x 7 in. Cabinet, 2 ft. 6 in. high, 1 ft. 10 in. wide, 12 in. deep. | |
| No. 3. Panel, 21 in. x 7 in. Cabinet, 2 ft. 6 in. high, 2 ft. 1 in. wide, 12 in. deep. | Nos. 3 & 4 42/6 Each |
| No. 4. Panel, 18 in. x 8 in. Cabinet, 3 ft. high, 1 ft. 10 in. wide, 12 in. deep. | |

These Cabinets can also be supplied with battery compartment open (Tray only). Price 10/- less.

PACKED and SENT CARRIAGE PAID to ANY ADDRESS in G.T. BRITAIN. All are fitted with hinged top, heavy baseboard, etc., and the cupboard underneath gives accommodation for batteries. London made. Highly finished in Jacobean style. Please note this price does not include Panel. Other sizes and styles, prices on application. Trade enquiries invited.

THE MISCELLANEOUS TRADING CO. LTD.,
Phone : Hol. 4894. 143 High Holborn London, W.C.1.

Mention of "The Wireless World," when writing to advertisers, will ensure prompt attention.

GET THEM TOGETHER

Put them together!

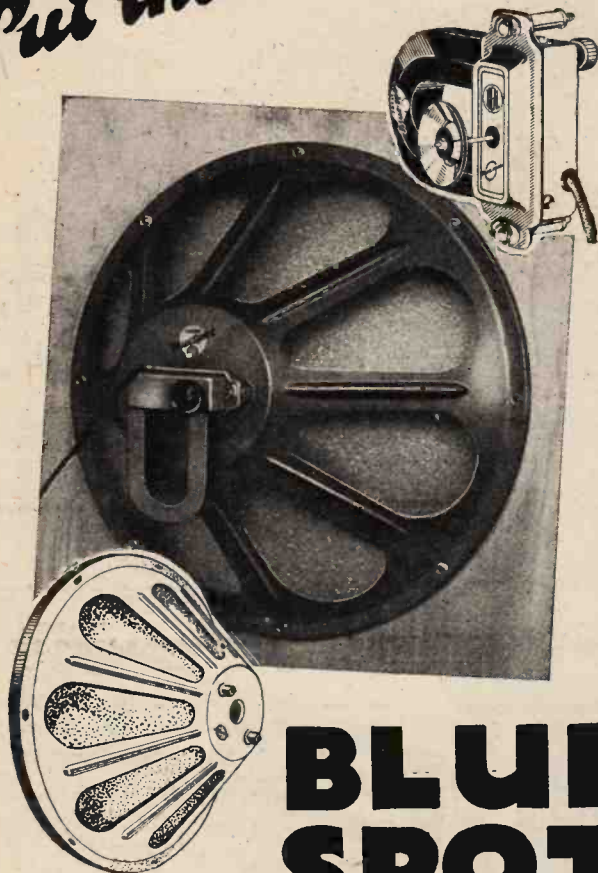

BLUE SPOT

UNIT & CHASSIS

When getting your 66K Unit, hear it on the Blue Spot Chassis specially designed for it.

It is a simple matter to bolt the chassis to the unit—and the result is a complete speaker ready to play.

We are not exaggerating when we say you will be astounded at the purity of reproduction that your Blue Spot assembly will give—even the trade was, when it first heard it.

Look for the "Blue Spot" on all genuine Blue Spot products.

The 66K Unit is 25/-, sold under guarantee in special carton. The Chassis is made in two sizes, the "Major" (as illustrated) with 13" cone, price 15/-, and the "Minor" with 9½" cone, price 12/6.

F. A. HUGHES & CO., LIMITED

204-6 Great Portland Street, London, W.1

Phone: Museum 8630 (4 lines).

Distributors for Northern England, Scotland and North Wales: H. C. RAWSON (Sheffield and London), Ltd., 100 London Road, Sheffield (Phone: Sheffield 26006), and 22 St. Mary's Parsonage, Manchester (Phone: Manchester City 3329).

**BETTER THAN
A 2-VOLT
PENTODE**



**...AND
CHEAPER**

THE
**MAZDA
P.240**

Here is a valve that will, by reason of its high amplification factor and very low impedance, give you a power output that is equal to that of a pentode, while at the same time giving a far better reproduction of the bass notes. The Mazda P.240 is more robust and more economical, too, the H.T. current being only about two-thirds of that consumed by a pentode, whilst its cost price is considerably lower.

**PRICE
15/-**

Write for Catalogue. Sold by all reputable dealers.



THE EDISON SWAN ELECTRIC CO., LTD.

Radio Division,

1a, Newman Street, Oxford Street, W.1.

Showrooms in all the Principal Towns.

EDISWAN

V.23.

All Advertisements for "The Wireless World" are only accepted from firms we believe to be thoroughly reliable.

**WELDED
JOINTS!**



STRENGTH!

POWER!

LONG LIFE!

Because every joint is electrically welded, the elements of the *NEW* Cossor Screened Grid Valve have exceptional strength. And because they are built under the exclusive Cossor Interlocked Construction system, they are absolutely rigid. Even the hardest blow cannot mar their perfect alignment. For strength, for uniformity and for long life use the *NEW* Cossor in your Screened Grid Receiver. No other Screened Grid Valve has Interlocked Construction.

**2-volt type
now available.**

The *NEW* Cossor 220
S.G. (2 volts, .2 amp.)
Max. Anode Volts 150,
Impedance 200,000,
Amplification
factor 200. **22/6**
Price

Cossor 4 and 6 volt Screened
Grid Valves are also available
with similar characteristics at
the same price.

The **NEW**
COSSOR
Screened Grid
Valve

A. C. Cossor Ltd., Highbury Grove, London, N.5

3500



Mention of "The Wireless World," when writing to advertisers, will ensure prompt attention.

A12

The Wireless World

AND
RADIO REVIEW
(17th Year of Publication)

No. 545.

WEDNESDAY, FEBRUARY 5TH, 1930

VOL. XXVI. No 6.

Editor: HUGH S. POCKOCK.

Assistant Editor: F. H. HAYNES.

Editorial Offices: 116-117, FLEET STREET, LONDON, E.C.4

Editorial Telephone: City 9472 (5 lines).

Advertising and Publishing Offices:

DORSET HOUSE, TUDOR STREET, LONDON, E.C.4.
Telephone: City 2847 (13 lines). Telegrams: "Ethaworld, Fleet, London."

COVENTRY: Hertford Street.

Telegrams: "Cyclist, Coventry." Telephone: 8210 Coventry.

BIRMINGHAM: Guildhall Buildings, Navigation Street.

Telegrams: "Autopr ss, Birmingham." Telephone: 2970 and 2971 Midland.

MANCHESTER: 260, Deansgate.

Telegrams: "Hilife, Manchester." Telephone: 8970 City (3 lines).

GLASGOW: 101, St. Vincent Street, C2.

Telegrams: "Hilife, Glasgow." Telephone: Centra 4857.

PUBLISHED WEEKLY.

Subscription Rates: Home, £1 1s. 8d.; Canada, £1 1s. 8d.;
other countries abroad, £1 3s. 10d. per annum.

Entered as Second Class Matter at New York, N.Y.

As many of the circuits and apparatus described in these pages are covered by patents, readers are advised, before making use of them, to satisfy themselves that they would not be infringing patents.

CONTENTS OF THIS ISSUE.

| | PAGE |
|--|------|
| EDITORIAL VIEWS | 131 |
| RADIO SELF-STARTER. BY H. F. SMITH | 132 |
| TESTS ON CONE UNITS | 135 |
| CURRENT TOPICS | 141 |
| WIRELESS THEORY SIMPLIFIED.—PART XIX. BY S. O. PEARSON | 143 |
| NEW APPARATUS REVIEWED | 146 |
| ACCURATE WAVEMETER DESIGN (CONCLUDED). BY W. H. F. GRIFFITHS | 148 |
| CORRESPONDENCE | 150 |
| BROADCAST BREVITIES | 152 |
| READERS' PROBLEMS | 153 |

SIR JOHN REITH AND B.B.C. POLICY.

THOSE who are in the public eye as representative heads of organisations of national importance must expect that every statement which they may make disclosing their personal views tending to influence the policy of their organisations will be ruthlessly scrutinised and mercilessly criticised at the slightest provocation. We are not in the least surprised, therefore, that recent utterances of Sir John Reith regarding the administration and policy of the B.B.C. should have called forth a storm of criticism.

In the course of a paper to the Institute of Public Administration, Sir John Reith made the statement: "One rather hesitates to use the word 'idealism' as it is so often subjected to ridicule and contempt. But I am as certain as of anything that to set out to 'give the public what it wants,' as the saying is, is a dangerous and fallacious policy, involving almost always an underestimate of the public's intelligence and a continual lowering of standards."

Commentators have lifted this illusion to broadcasting

policy without reference to the context, but this, in our opinion, does not affect the issue to any appreciable extent, for whatever the context, the statement remains a direct challenge to those who consider that the B.B.C. policy should be to provide the public with programmes which are in keeping with the taste of the majority.

Let us analyse the statement and see what it really means. Does it not indicate that although the B.B.C. is financed by the listeners Sir John does not permit that fact to influence him unduly in his policy with regard to the supply of programme matter? Let us take a somewhat parallel case. The present Government or, in fact, any elected Government, does not, immediately that it gets into power, proceed to introduce legislation to meet the wishes of the majority of the electors who have put it into office. What actually happens is that the electors vote for those candidates in whom they have confidence, and, once in power, those representatives settle down as level-headed and competent individuals to act as they think is best for the good of the country. If we were in the fortunate position that every individual citizen had an adequate education and sufficient natural ability to fit him for the responsibility of Government, then, and only then, could we expect to arrive at a state of affairs where the votes of the majority of the electors would dominate the policy of the Government.

Disillusioning the Listener.

Sir John Reith has, in our opinion, always erred on the side of being too frank, and his recent utterance would never have been made by an administrator less outspoken than himself. But this very frankness is likely to have done harm to the cause of broadcasting. The public have liked to believe that the B.B.C. was at least trying to meet the wishes of the majority, but now those hopes have been shattered and the insinuation has come home to many that if we have been displeased with the programmes it is because, in the opinion of the B.B.C., we, as individuals, are not sufficiently educated or intelligent to merit our views being allowed to influence the programme policy. We have a great deal of sympathy with the attitude of Sir John Reith if his endeavour has been to give us, in programme matter, something a little higher in standard than that which we would choose for ourselves. This policy, carried out very gradually and with the utmost caution, would be to our benefit. The mistake which has been made is in the unstatesmanlike action of disclosing so publicly that the considered policy of the B.B.C. is to ignore the tastes of the majority, instead of carrying through that policy, whilst at the same time retaining the confidence of the public.

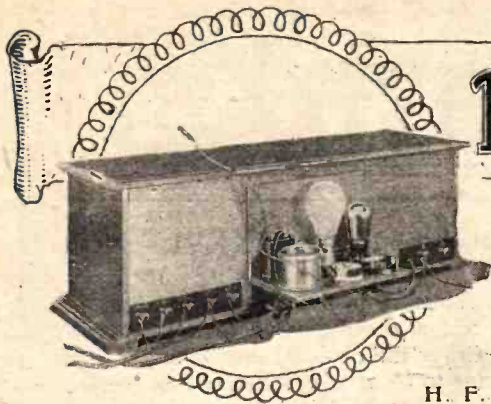

RADIO SELF-STARTER

Switching-on the Set by the Carrier Wave.

By
H. F. SMITH.

THIS piece of apparatus is intended for connection to an existing detector-L.F. receiver, which is normally tuned to the transmission of a local station. Its function is to switch on the filament current when the station begins to emit its carrier wave, and to

pressed into service. These beautifully made instruments are not now readily obtainable—at any rate, at the same price—but thanks to the economy of present-days valves and to the commercial production of relays for picture reception, it is possible to devise a practical and inexpensive alternative arrangement that is far more reliable than anything depending on a crystal.

The unit described in this article derives its current supply from D.C. mains (voltage 200-240), and as it consumes but one unit in fifty hours it cannot be considered as unduly extravagant. Except in unusual circumstances, it is hardly likely that it will be called upon to operate continuously; its real task is to switch on the receiver during “extra” broadcasts, and it will be likely to interest the listener whose local station puts on intermittent programmes rather than those

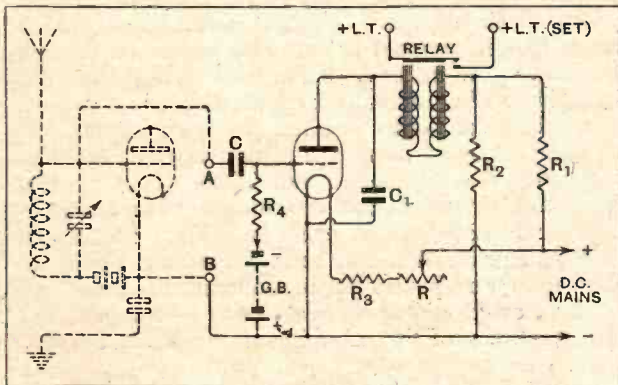

Fig. 1.—Circuit diagram of the relay unit, connected to the grid circuit of a receiver (shown in dotted lines). C, 0.0002 mfd.; C₁, 2 mfd.; R, variable resistance, 400 ohms; R₁, 25,000 ohms; R₂, 50,000 ohms; R₃, lamp resistance, 2,000 ohms; R₄, 2 megohms.

keep this circuit closed until the station finishes operations, when the set will be automatically switched off. The self-starter will not operate unless the signal voltage applied to it is considerable—which implies that it is only suitable for use at short range—and it is not intended for connection to receivers having an H.F. amplifying valve (or valves).

Devices of this sort have been in use for some time; in fact, a “gadget” with identical functions was described in *The Wireless World* in 1925. This was designed for operation by the rectified current output of a crystal, and consequently it demanded the use of a highly sensitive relay; actually, an ex-Government “Weston” instrument, then obtainable for a few shillings, was



The complete unit. The anode feed resistances are clamped together, and secured to one of the variable resistance terminals.

Radio Self-Starter.—

who are favoured by almost continuous transmissions. For operation of the relay which controls filament switching, advantage is taken of the fact that the standing anode current of a valve biased to act as a bottom bend detector is extremely low, amounting actually to something in the neighbourhood of 0.2 milliamp. When passed through the relay magnet windings, this value of current is insufficient to close its contacts. The grid circuit of the control valve is joined in parallel with the receiver input, and so the application of signal voltages from the aerial will bring about a rise of current through the relay windings which are in series with the anode. Provided that this anode current reaches a value of some 0.75 milliamp. or more, the relay contacts will close and the L.T. connections of the receiver will be completed.

To reduce filament voltage of the control valve to a suitable value, a 20-watt lamp, in series with a 400-ohm potentiometer (used as a variable resistance) is in-

serted in series with the mains. A lamp is the least expensive form of resistance obtainable, but it may be replaced by a wire-wound element of suitable value and current-carrying capacity (2,000 ohms and, in this case, 100 milliamps.).

Anode voltage, derived from the same source, is reduced to a suitable value by a potential divider made up of two fixed resistances, of which the values are given in the inscription under Fig. 1. This diagram shows the complete circuit, and also indicates how the input terminals A and B of the unit are joined across the tuned grid coil of an existing receiver. Grid voltage for the control valve is fed through a leak resistance, a condenser being interposed

so that the parallel grids may be unaffected by D.C. potentials. One of the control terminals (L.T.+) is joined to the positive side of the L.T. battery, while the other L.T.+SET) is joined to the positive L.T. terminal of the receiver.

There is considerable latitude in the method of construction, and it may be preferred to build the self-starter

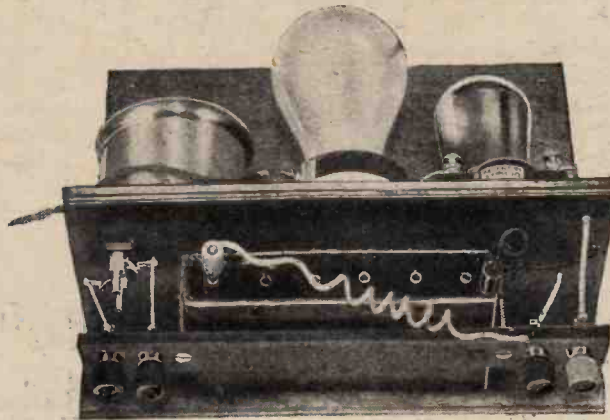

Components on the under-side of baseboard.

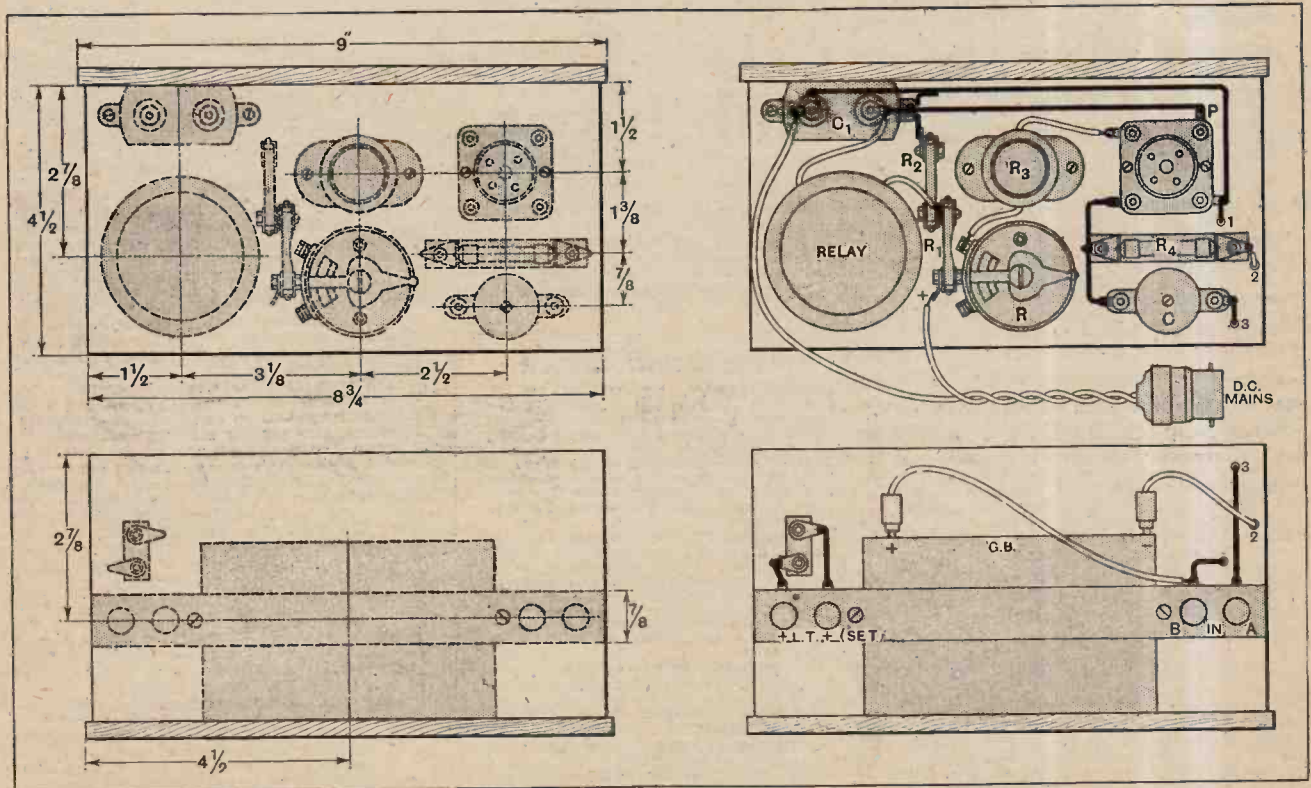

Fig. 2.—(On left) Layout of components on upper and lower surfaces of baseboard. (On right) Practical wiring plan: wires passing through the baseboard bear corresponding numbers. The bias battery is held in position by the paxolin terminal strip.

Radio Self-Starter.

in a small box, instead of mounting the components in the manner shown. This plan is, however, convenient enough, as the resulting unit may readily be secured to the back of an American type cabinet, as clearly indicated in the title illustration of this article.

As a refinement, two switches may be fitted; one of these should be inserted in the filament circuit, while the other would be joined across the relay contacts in order to put the unit out of action without the need for taking off both the L.T. leads and the connection to the mains.

A 2 volt 0.1 amp. valve with a fairly low impedance—in the order of 10,000 ohms—is suitable; a Mazda L.210 was used for tests, but any other valve of somewhat similar type will be satisfactory. If a valve of different current consumption is substituted, an appropriate change in the value of the series resistance R_3 must obviously be made.

In order to avoid "earthing" the mains, it is essential that a condenser should be inserted in the receiver earth lead.

Adjustment of the relay calls for a certain amount of care and some practice, but the instrument is usually "set" by its manufacturers, so there should be no

need to interfere with its contacts. Sensitivity is controlled, to some extent, by the tension of the small spring working against the pull of the magnets on the armature. To avoid the possibility of sticking, it is as well to work with as large a clearance as possible between the working contacts, but it must be remembered that a wide gap calls for a heavier current to close the contacts.

A relay of the type included in the unit described will easily handle the filament-heating current taken by the average set, but in exceptional cases (and particularly where a mains-operated receiver is to be controlled) it is recommended that a second, and less sensitive, relay should be interposed.

A sensitive milliammeter is most useful while making any initial adjustments; in fact, where there is any doubt as to whether incoming signals are sufficiently strong to bring about the necessary increase in anode current, it is recommended that one of these instruments should be used in making a preliminary measure-

ment of rectified current, after having set up the necessary valve circuit across the receiver input coil. This procedure will avoid the possibility of buying apparatus that may be useless unless the self-starter is complicated by adding an H.F. amplifying valve.

LIST OF PARTS

- 1 Relay (Goodmans).
- 1 Condenser, 2 mfd.
- 1 " 0.0002 mfd.
- 1 Resistance, 25,000 ohms (Met-Vick).
- 1 " 50,000 " "
- 1 Potentiometer, 400 ohms.
- 1 Grid leak, 2 megohms.
- 1 " " holder.
- 1 Valve holder.
- 1 Lamp holder.
- 4 Terminals, L.T.+, L.T.+, red, black.
- 1 Grid bias battery, 9 volts.
- 2 Wander plugs.
- 1 Lighting socket adaptor.

Wood, paxolin strip, wire, screws, etc.
(Approximate cost £3.)

The Photo-Electric Cell.

Interesting facts regarding the photo-electric cell were dealt with by Mr. Walker, of the General Electric Co., Ltd., at the annual general meeting of the Kensington Radio Society on Thursday, January 9th. The lecturer pointed out that the photo cell might be regarded as a two-electrode valve; in the case of the thermionic valve, the heating of the cathode results in the emission of electrons, whereas in the photo cell the mere falling of the sun's rays on the cathode produces an electron emission, and in both cases a potential applied to the anode produces a current. In the case of the photo cell the flow of current depends on the intensity of the light and on the element or combination of elements of which the cathode is composed.

Hon. Secretary, Mr. G. T. Hoyes, 71a, Elsham Road, W.14.

Selectivity.

Mr. A. J. Webb, M.A., B.Sc., gave a talk on "Selectivity" at the last meeting of the Croydon Wireless and Physical Society. The speaker drew attention to the necessity for effecting compromise between theory and practice in the design of a really selective set, and dealt lucidly with the effects of screening, electro-static and electro-magnetic coupling, wave-traps, etc.

Particulars regarding membership may be obtained from the hon. secretary, Mr. H. T. P. Gee, of Staple House, 51-2, Chancery Lane, London, W.C.2.

All About Metal Rectifiers.

Metal Rectifiers formed the subject of a very interesting lecture, illustrated by slides and films, given recently before the Tottenham Wireless Society by Mr. S. A. Stevens, B.Sc., A.C.G.I., of the Westinghouse Brake Co. Mr. Stevens first reviewed all the known methods of changing alternating current into direct current suitable for either battery charging or for operating a radio receiver. The working principles of these were clearly illustrated by slides. He then passed to a more detailed description of the now familiar metal rectifier and explained

Club News.

very lucidly how it worked. One of the great advantages of this type of rectifier is that when properly used its life is apparently indefinite; metal rectifiers had been in use for signal operation for many years without failure. Suitable circuits for use were shown and discussed. The

FORTHCOMING EVENTS.**WEDNESDAY, FEBRUARY 5th.**

Institution of Electrical Engineers, Wireless Section.—Visit to the Laboratory of the City and Guilds Engineering College, South Kensington, S.W.

Muswell Hill and District Radio Society.—Special meeting at a member's residence. Edinburgh and District Radio Society.—At 8 p.m. At 16, Royal Terrace. Lectures.

THURSDAY, FEBRUARY 6th.

Golders Green and Hendon Radio Society.—At 8 p.m. At the Club House, Willifield Way. Direction Finding Lecture. Slade Radio (Birmingham)—At the Parochial Hall, Broomfield Road, Erdington. Lecture: "Valves," by a representative of the Mullard Wireless Service Co., Ltd.

FRIDAY, FEBRUARY 7th.

Bristol and District Radio Society.—At 7.30 p.m. In the Geographical Lecture Theatre, University of Bristol. Lecture: "Tinned Music," by Mr. Higginson.

MONDAY, FEBRUARY 10th.

Newcastle-upon-Tyne Radio Society.—At 7.30 p.m. In the English Lecture Room, Armstrong College. Lecture: "Short-wave Transmission from Amateurs," by Mr. W. G. Dixon.

lively discussion which followed was indicative of the great interest which the lecturer had aroused.

Hon. Secretary, Mr. W. B. Bodemeaid, 10, Bruce Grove, Tottenham, N.17.

Loud Speakers Compared.

"Members' Night," celebrated at a recent meeting of Slade Radio (Birmingham), was the occasion of an interesting test of members' loud speakers. The set used was an "Ecko" all-mains, and each speaker was connected in turn. As a result of the voting, which was carried out on both speech and music, the winner proved to be a home-assembled loud speaker using a chassis of well-known make. The second in the order of merit was a loud speaker with double linen diaphragm.

Such tests as these give an opportunity for comparisons which are almost impossible for the individual amateur to carry out, and they are, therefore, very popular with the members.

Anyone interested in wireless is invited to attend the Society's meetings, which are held at the Parochial Hall, Broomfield Road, Erdington, Birmingham, every Thursday at 8 o'clock. Full details can be obtained on application to the Hon. Secretary, 110, Hillaries Road, Gravelly Hill, Birmingham.

Woodwork in the Wireless Set.

Woodworking in relation to wireless was discussed by Mr. J. H. A. Meadowcroft in a lecture before the Radio Experimental Society of Manchester on January 17th. After giving general information as regards the source of certain types of wood, the lecturer supplied some valuable hints on how, by studying the end section, it is possible to choose wood that will not warp.

The different kinds of planes and saws in use and their application came in for full consideration, and many members no doubt left the meeting with increased enthusiasm for the cabinet side of wireless construction.

Hon. Secretary, Mr. L. Fox, 23, Yew Tree Avenue, Alexandra Park, Manchester, 8.

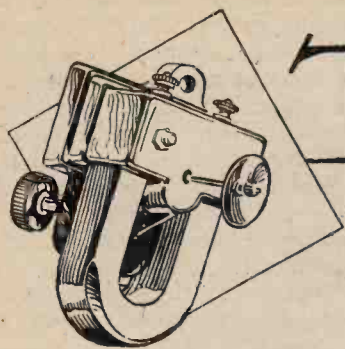

Tests on CONE UNITS

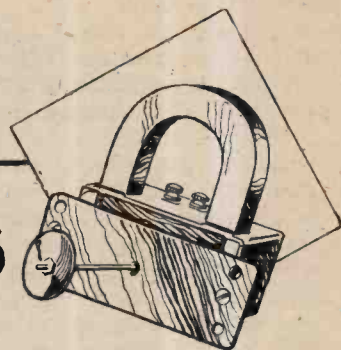

Constructional Details and Electrical Characteristics of Some Representative Commercial Types.

IN view of the increasing interest in the construction of cone loud speakers with commercial reed and balanced-armature movements, the following data relative to the majority of units now on the market have been prepared.

During the past year the number of units available to the public has considerably increased and much ingenuity has been displayed in evolving new types of magnet systems. In examining any new unit, therefore, one of the first points to receive attention is the principle of operation. Schematic diagrams are used to show the method of mounting the vibrating armature, the disposition of the magnet poles, etc., and these are supplemented by perspective details of construction points of interest.

Where possible the units were tested with the cone chassis for which they were designed; in all other cases the Baker Universal chassis was used. Preliminary experiments showed the performance of this diaphragm to be entirely satisfactory; it was also proved that the frequency characteristic of a loud speaker is governed almost entirely by the movement, and is dependent only to a secondary degree by the diaphragm. In all cases a baffle 3ft. square was used to prevent the short-circuiting

of acoustic energy at the lowest audio frequencies.

A super-power valve with an impedance of approximately 2,000 ohms was used to drive the units through a filter feed circuit. This valve was preceded by a high-quality two-stage amplifier and supplied with energy from selected gramophone records through a needle-armature Burndept pick-up.

For the purpose of preliminary adjustments three ordinary records were played through. These were specially chosen and included passages containing very high and very low frequencies as well as a useful variety of transients. From these records a very fair estimate of the frequency characteristics and sensitivity could be obtained, the conclusions arrived at being subsequently confirmed by more precise tests.

The first test was made with Parlophone record No. P9794-II which gives a continuously falling tone from 6,000 to 150 cycles with rapid 50-cycle variations superimposed to prevent the formation of standing waves. Throughout each test comparison was made with a good moving-coil loud speaker and a note was made of the relative outputs at regular frequency intervals. A supplementary test was made at 50 cycles and while all units were able to reproduce this note, few could equal

| Unit. | Diaphragm. | IMPEDANCE (OHMS). | | | | | | | | D.C. Resistance (ohms). |
|--------------------------|------------|-------------------|-------|-------|-------|--------|--------|--------|--------|-------------------------------|
| | | 50~ | 100~ | 200~ | 400~ | 800~ | 1,600~ | 3,200~ | 6,400~ | |
| Amplion Type B.A.2 | Baker | 577 | 717 | 1,198 | 1,720 | 3,510 | 5,430 | 9,740 | 11,000 | 495 (650) and (1,145) |
| Blue Spot Type 66K | Blue Spot | | | | | | | | | |
| | Major | 1,480 | 2,135 | 3,590 | 4,775 | 8,560 | 11,460 | 6,750 | 3,500 | 950 |
| Brown "Vee" Unit | Baker | 1,770 | 2,350 | 3,040 | 4,410 | 7,800 | 11,950 | 23,650 | — | 1,470 |
| Dynomag | Baker | 1,945 | 1,945 | 2,030 | 2,230 | 3,135 | 4,750 | 7,430 | 15,550 | 1,940 |
| Edison Bell | Baker | 2,130 | 2,620 | 2,435 | 5,520 | 9,400 | 14,300 | 22,900 | 16,200 | 1,800 |
| Ediswan | Baker | 2,550 | 4,370 | 4,950 | 8,150 | 11,950 | 14,550 | 19,400 | 30,500 | 1,250 |
| G.E.C. "Stork" | Baker | 668 | 757 | 995 | 1,510 | 2,610 | 4,620 | 8,100 | 9,930 | 410 |
| Goodman's "Twin Magnet" | Baker | 2,320 | 3,710 | 4,730 | 7,040 | 9,690 | 11,950 | 14,300 | 24,900 | 1,620 |
| Grawor Single Magnet | Baker | 2,300 | 2,580 | 3,420 | 5,760 | 11,200 | 18,700 | 8,870 | 4,580 | 2,100 |
| Grawor Balanced Armature | Baker | 1,790 | 1,990 | 2,440 | 3,290 | 4,670 | 7,600 | 7,500 | 4,280 | 1,600 |
| Hegra | Hegra | 1,110 | 1,720 | 2,930 | 4,040 | 6,880 | 11,200 | 18,000 | 21,100 | 510 |
| Iso Mona | Baker | 950 | 1,670 | 2,730 | 4,230 | 8,260 | 13,100 | 23,700 | 9,930 | 475 |
| Kukoo | Baker | 1,120 | 1,365 | 1,890 | 2,770 | 4,430 | 6,280 | 11,000 | 8,350 | 810 |
| Lissen | Lissen | 1,130 | 1,510 | 2,245 | 4,220 | 7,070 | 11,700 | 19,500 | 21,650 | 960 |

Tests on Cone Units.—

the moving coil. At frequencies below 500 cycles the moving-iron movements also showed a tendency to produce harmonics, notably the first harmonic, when the input was increased above a certain threshold value. In this respect the moving-coil loud speaker is fundamentally superior to the moving-iron unit, but in other respects the best moving-iron units are within challenging distance of the moving coil. This frequency-doubling would not be without its effect on the loud speaker impedance; accordingly the input was kept below the threshold value during these measurements.

The impedance was obtained by reading off the volts developed across the windings with a valve voltmeter simultaneously with the current as indicated by a thermo-junction in series with the windings. In order that the motional impedance of the armature might attain a normal value, the output was maintained at a good average volume while taking readings. The frequency range covered by these measurements is seven octaves, and much useful information is to be gained by plotting the impedance against frequency. For instance, a decrease of impedance at the higher frequencies almost always indicates the presence of considerable self-capacity in the windings if not the deliberate

insertion of a small fixed condenser in shunt with the coils. As a rough-and-ready guide to sensitivity a note was made of the relative voltage input to the amplifier required to produce the same volume of sound in the standard moving coil and in the loud speaker under test. In interpreting the results obtained the average impedance of the loud speaker relative to that of the output valve was taken into account in order to allow for possible inefficiency due to poor matching between valve and loud speaker. For this test an organ record covering a wide range of frequencies was used.

In cases where a tendency to chattering was observed, the power in milliwatts required to overload the movement was measured. It was estimated that the majority of units

would handle 750 to 1,000 milliwatts—more than enough for domestic requirements—without rattling. Where rattling occurred it was due generally to resonance in the lower register, and where possible the overload measurement was taken at a frequency in the vicinity of the resonance responsible.

Finally, the D.C. resistance of the windings was measured. This quantity, though in itself unimportant, must be taken into account when studying the impedance figures given in the table.

The units reviewed in the present article represent approximately one half of the total number tested. Considerations of space necessitate the holding over of the remaining units to a later issue.

AMPLION, TYPE B.A.2.

This unit functions on the differential principle, the relatively massive armature vibrating between laminated pole pieces mounted at right angles to the permanent magnet. The reed is not damped, but control springs for varying the adjustment are situated at each side near the middle. The winding is divided between two bobbins, and terminals, which incidentally are rather too close together, are provided, giving three alternative imped-

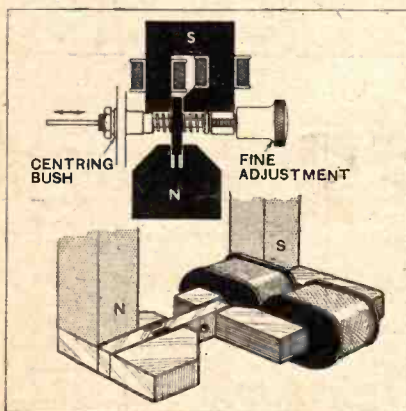

Amplion, Type B.A.2.

ance values suitable for use with pentode, power or super-power output valves. The impedance values in the table relate to the "Low" impedance terminals. The

movement is free and will develop considerable amplitudes at low frequencies. An adjustment is provided for moving the mean position of the reed, whereby the amplitude may be increased at the expense of sensitivity when desired.

The reproduction of frequencies below 400 cycles is excellent, and, with the possible exception of frequencies of about 50 cycles, equals the average moving coil. From 400 to 2,000 cycles the output is practically constant and of average value, with a slight increase at 1,000-1,200 cycles. There is then a steady fall to nearly zero at 4,000 cycles with a good recovery at 5,000 cycles and a further slight drop at 6,000 cycles, which is nevertheless definitely reproduced. With the standard setting for sensitivity, chattering occurs at 200 cycles with 154 milliwatts; this can be adjusted as explained above. With the makers' setting the sensitivity is exceeded only by one other make.

Price, 21s.

Graham Amplion Ltd., 26, Savile Row, London, W.1.

BLUE SPOT, TYPE 66K.

A first examination of the arrangement of the pole pieces suggests a balanced armature movement, but this is not the case, as the small armature moves bodily up and down in the gap. The movement is transmitted through a stirrup to the driving rod, the latter being centred by a flexible flat spring which also serves as a medium for adjustment. Damping is supplied by sponge rubber blocks under

each end of the armature. A small fixed condenser is connected in parallel with the windings.

This unit is remarkable for the wide range of frequencies covered, and is not excelled for reproduction in the upper register. From 4,000 cycles there is actually an increase of output up to 6,000 cycles, the highest frequency measured. At the other end of the scale the reproduction is also good, and a considerable output is given at 50 cycles. Resonance

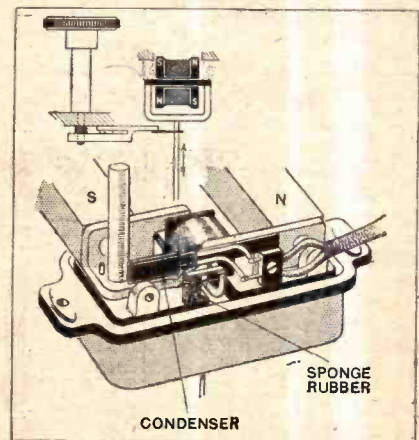

Blue Spot, Type 66K.

in the vicinity of 400-500 cycles—a common fault—is absent, and from 150 to 2,000 cycles the output is practically constant. A slight but nevertheless definite increase

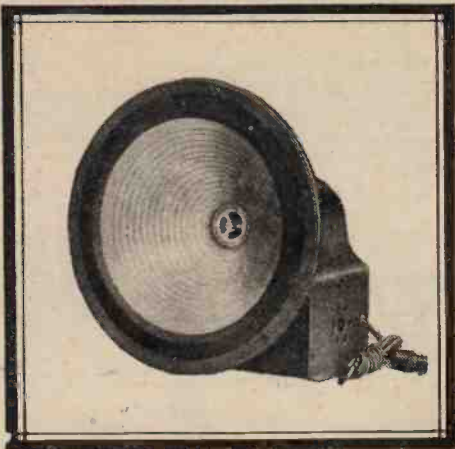

Senior "R.K." Unit with A.C. Field Excitation. This "R.K." Unit has a 10in. corrugated cone with moving coil, having an impedance of 10-15 ohms at 50/4,000 cycles. The pot magnet is mounted in a pressed metal base, which also contains a mains transformer, Mazda U.U. 60/250 rectifier valve, and smoothing condenser for the supply of field current. Price £ 11/10/0.

The B.T.H. "R.K."—justly described as the world's finest reproducer—first appeared in 1926 and its advent created a new standard of reproduction.

Four years have elapsed since then, but still the "R.K." maintains its leadership.

The new range of models includes the 10in. cone "Senior," with or without built-in rectifier for use with A.C. mains supply, and the "Junior" with 6in. cone.

Fidelity

—in Tone & Performance

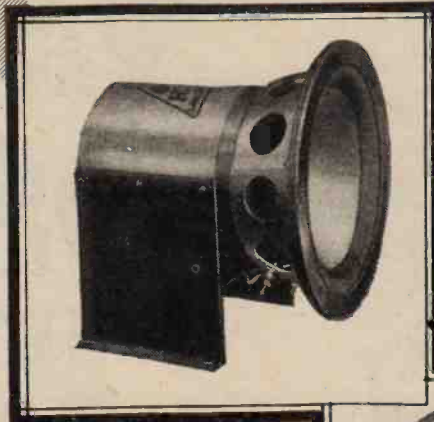

The Senior "R.K." Unit incorporates a 10in. corrugated cone with moving coil, having an impedance of 10-15 ohms at 50/4,000 cycles. Copper damping rings are fitted to reduce the impedance at higher frequencies. Price £ 7/7/0.

The Junior "R.K." Unit has a 6 in. straight-sided cone with moving coil, having an impedance of 10-15 ohms at 50/4,000 cycles. Copper damping rings are fitted to reduce the impedance at the higher frequencies. Price £ 6/6/0.

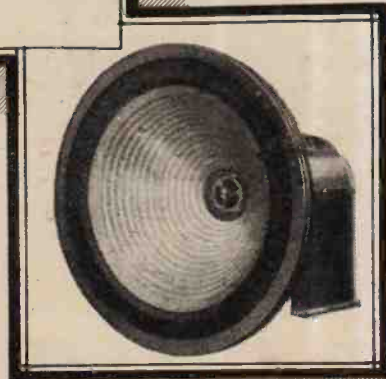

REPRODUCERS



THE EDISON SWAN ELECTRIC CO., LTD.,
Radio Division,
1, Newman Street, Oxford Street, W.1.
Branches in all Principal Towns.

EDISWAN

W66



An Entirely **NEW** Valve! **OSRAM** **PX.4**



A 4-VOLT VALVE giving ENORMOUS POWER to A.C. Mains Sets using indirectly heated valves, and to sets operating from 4-Volt Accumulators.

SUPER POWER

Osram Valves

MADE IN ENGLAND

Sold by all Wireless Dealers

This valve is the greatest advance yet in power amplification, possessing all the inherent qualities of the famous range of OSRAM Power Valves. It is the only valve in its class for loud speaker work, operating from 4 volts. Study the characteristics given below.

The OSRAM PX.4 requires only 200 volts H.T. to provide enormous power with perfect quality. It has been specially designed for radio gramophones.

| | | | |
|----------------------|-----|------------------|---------------|
| Filament Volts | ... | ... | 4.0 |
| Filament Current | ... | 0.6 amp. approx. | |
| Amplification Factor | ... | ... | 3.8 |
| Impedance | ... | ... | 1,450 ohms. |
| Anode volts | ... | ... | 200 max. |
| Anode dissipation | ... | ... | 10 watts max. |

PRICE 25/-

Adv. of The General Electric Co., Ltd., Magnet House, Kingsway, London, W.C.2.

Mention of "The Wireless World," when writing to advertisers, will ensure prompt attention.

Tests on Cone Units.— occurs between 2,000 and 2,500 cycles, and is followed by a sudden drop between 2,500 and 3,500 cycles. This is the only serious blemish in an otherwise excellent characteristic. Two specimens were tested on different diaphragms, and both showed the same general characteristic. As regards sensitivity, the Blue Spot is included in the best three, while no trace of chattering could be produced with the unit correctly adjusted, even at a volume level at which the low frequencies could be felt through the floor boards. The general performance of this unit is comparable to that of a moving coil.

Price, 25s.
F. A. Hughes and Co., Ltd., 204-206, Gt. Port and Street, London, W.1.

BROWN "VEE" UNIT.

The pole pieces are inclined so that their faces form approximately a right-angle. Into this space fits the "Vee" armature which is mounted on a skeleton bridge piece designed to give the requisite elasticity. Adjustment is effected by rocking the magnet system as a whole on a knife edge under the permanent magnet. No damping is employed.

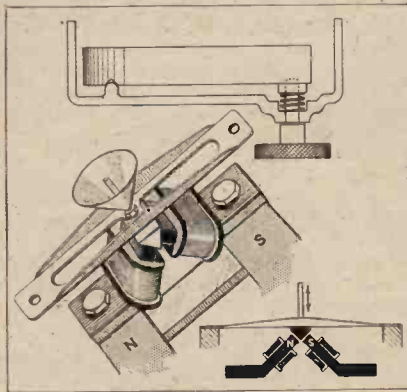

Brown "Vee" unit.

An estimate of the performance on ordinary musical records suggested that the bulk of the acoustic output was located in the middle register. Frequency tests confirmed this and revealed resonances at 700 and 1,400 cycles. The lower register is fair, but there is a steady decrease of output from 400 cycles downwards. A similar falling off takes place from 2,000 to 4,500 cycles, and for all practical purposes the latter frequency may be regarded as the cut-off for high notes. The sensitivity is slightly above the average, and the range of adjustment provided effectively prevents overloading.

Price, 25s.
S. G. Brown, Ltd., Western Avenue, North Acton, London, W.3.

DYNAMAG.

This unit employs an original method of mounting the armature, which consists of a rectangular stalloy plate suspended vertically inside the windings. The permanent magnet flux is introduced to the

armature through stalloy pole pieces placed above and below the ends of the armature plate. Adjustment is provided by a flat spring soldered to the mid-point of the armature, and the energy is transmitted to the drive rod through two thin vertical wires attached to a brass spring bridge piece. There is no damping.

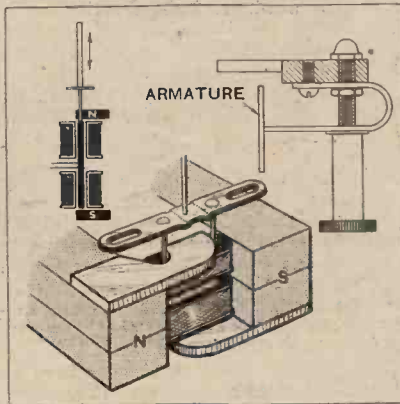

Dynamag.

With the exception of a resonance at 1,000 cycles the output is fairly constant from 500 to 4,000 cycles. Above and below these limits there is a steady falling off. The upper register cut-off is at 5,000 cycles. There is a tendency to produce parasitic frequencies (not harmonics of the fundamental) when the volume is pushed to maximum, which suggest subsidiary resonances in the suspension. The principal criticisms are concerned with the sensitivity, which is considerably below the average, and the reproduction of low frequencies, which might be improved. The makers are to be congratulated, however, on the originality of the armature mounting, which shows considerable promise.

Price 25s.
A. M. F. Sherwood, 150, King's Cross Road, London, W.C.1.

EDISON BELL.

The movement is differential with a simple magnet system employing two laminated pole pieces. The reed is tapered and is cut from the solid, adjustment being provided by rocking the mounting pillar. No damping is pro-

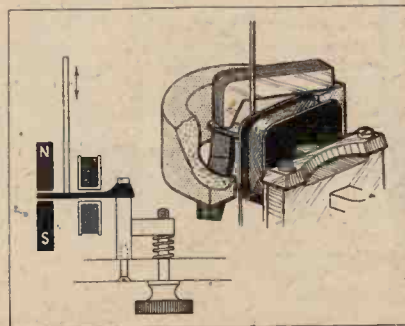

Edison Bell.

vided, and the winding surrounds the base of the reed out of the main magnetic flux. Mention should also be made of the substantial moulded base and the cone mountings which are turned from the solid.

The movement is below the average in sensitivity, but the reproduction of the bass, say, below 150 cycles, is very good indeed. It is in the middle and upper registers that the general level of output is low, but this region is nevertheless free from major resonances and depressions. There is a minor resonance at 4,500 cycles and the cut-off is at about 5,500.

Price 15s. 6d.
Edison Bell, Ltd., Glengall Road, London, S.E.15.

EDISWAN.

Constructed on the balanced armature principle, this unit at once creates a favourable impression by the massiveness of the magnet and pole pieces. The armature is mounted on a flexible strip passing at right angles through the centre point. No damping or adjustment of the gap is provided, but each unit is sent out with a paper spacing strip to keep the armature central during transit. This spacer must, of course, be removed before the unit is put into use.

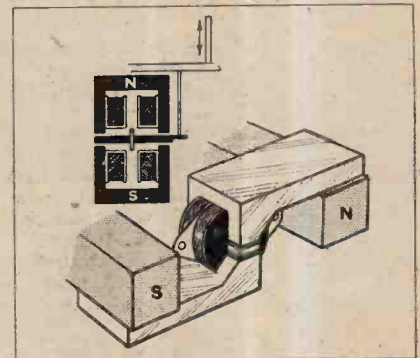

Ediswan.

The performance of this unit is characterised by a large output in the base. From 50 to 200 cycles the output was quite equal to that of the moving coil used for comparison. At 400 cycles, however, the output falls considerably and remains at this level with a slight resonance near 1,750 cycles until 2,500 cycles is reached. From this frequency it falls still further and cuts off at slightly over 4,000 cycles. The exaggerated bass is useful when reproducing gramophone records, but might prove troublesome with a sharply tuned radio receiver. It is, however, worthy of comment that there is no trace of frequency doubling in the bass even at maximum volume, and in this respect the Ediswan is among the best units tested. The sensitivity is below the average owing to the absence of any adjustment, but no trace of chattering could be provoked.

Price 15s.
The Edison Swan Electric Co., Ltd., 123-125, Queen Victoria Street, London, E.C.4.

Tests on Cone Units.—

G.E.C. "STORK."

Although simple in principle, this unit is extremely well designed and constructed from a mechanical point of view. The single-acting reed is firmly supported, and the laminated poles are secured to the permanent magnet by means of ingenious clamps. No damping is employed, and adjustment is made by a simple tension spring.

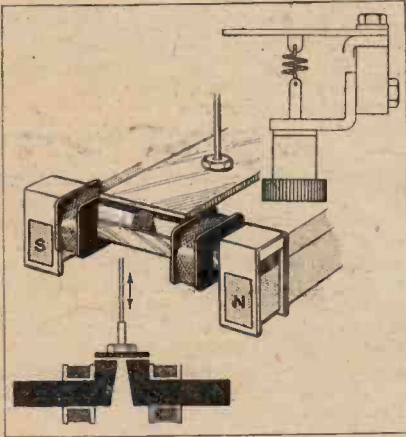

G.E.C. "Stork."

There is a small but definite response at 6,000 cycles and a normal output from 5,000 down to 500 cycles, with minor resonances at 3,200 and 900 cycles. Between 500 and 300 cycles there is a marked resonance, and in this region frequency doubling is noticeable. The bass is fair, but there is a distinct falling off below 200 cycles. The unit is sensitive and the adjustment sufficient to prevent rattling. Price 21s.

The General Electric Co., Ltd., Magnet House, Kingsway, London, W.C.2.

GOODMANS "TWIN MAGNET."

The balanced armature movement is of small dimensions and is detachable from the twin magnet system as a unit. The laminated poles are clamped together by two die-cast blocks, which also carry the reed suspension strip. The latter terminates in two plain brass plugs which may be turned to adjust the armature setting and fixed with the set-screws provided.

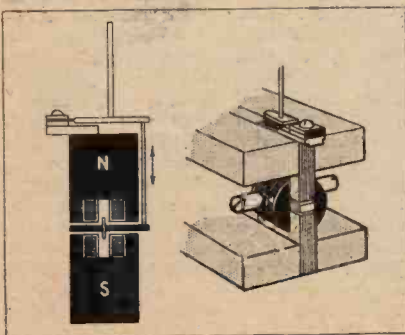

Goodman's "Twin-Magnet."

The bass reproduction is very good, and the output between 300 and 3,000 cycles, although on a lower level, is free from resonances. There is a slight rise at 3,500 cycles, after which the output falls rapidly up to 4,000 cycles, the cut-off point. The sensitivity is below the average, and the movement rattles at 100 cycles with an input of 285 milliwatts. Taken as a whole, however, the results are pleasing to listen to, and the bass reproduction should prove an advantage when playing gramophone records.

Price 29s. 6d.

Goodmans, 27, Farringdon Street, London, E.C.4.

GRAWOR SINGLE MAGNET.

A single-acting skeleton reed is actuated by double laminated pole pieces, adjustment being effected by raising or lowering the magnet system as a whole. The movement is mounted on a circular die-cast base, and a small by-pass condenser is connected across the input terminals. No damping is provided.

The output energy is concentrated in the middle register with a marked resonance at 1,500 cycles. From this peak the output falls on either side to a high note cut-off at 4,000 cycles and a low note cut-off at about 150 cycles. In spite

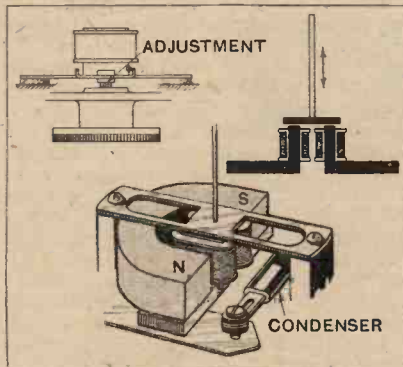

Grawor single magnet.

of the provision of an adjustment the sensitivity is below the average, but no evidence of chattering was observed.

Price 18s.

Henry Joseph, 11, Red Lion Square, London, W.C.1.

GRAWOR BALANCED ARMATURE.

A massive permanent magnet, a small armature and accurate workmanship and alignment contribute to the success of this unit. As with most balanced armatures there is no adjustment, neither is damping provided.

This unit has a remarkably good characteristic, and, apart from a tendency to frequency doubling between 100 and 400 cycles, is comparable in performance to a moving coil. The output is practically constant from 100 to 6,000 cycles. There is, however, a useful increase near 5,000 cycles, and a not so useful resonance at 1,500 cycles, the latter constituting the only serious flaw in the characteristic. The bass is good,

and there is only a small reduction from 100 cycles downwards. There was no sign of chattering, and the sensitivity is above the average. This unit is definitely among the best three as regards

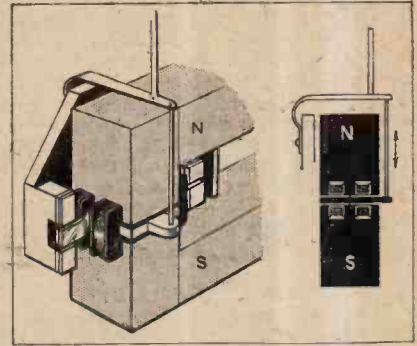

Grawor balanced armature.

quality of reproduction and will handle considerable power. Price 21s.

Henry Joseph, 11, Red Lion Square, London, W.C.1.

HEGRA.

A substantial permanent magnet and laminated pole pieces ensure that the balanced armature works in a concentrated flux. Adjustment is provided by rocking one end of the flat strip supporting the armature, and this is effected by sliding a pin upon which the suspension strip rides under the pressure of two coil springs. No damping is provided.

The sensitivity is good and the movement will handle considerable volume without chatter. The reproduction of both very high and very low notes is distinctly above the average, the output at 100 and 6,000 cycles being equal to the general level in the middle register. Resonances occur at 450 and 4,800 cycles, the latter being useful in giving brilliance to the reproduction. Apart from the resonance at 450 cycles the output from 100 to 4,000 cycles is absolutely constant. Taken as a whole this unit falls definitely into the highest class. Price 19s.

Geo. Becker, Ltd., 39, Grafton Street, London, W.1.

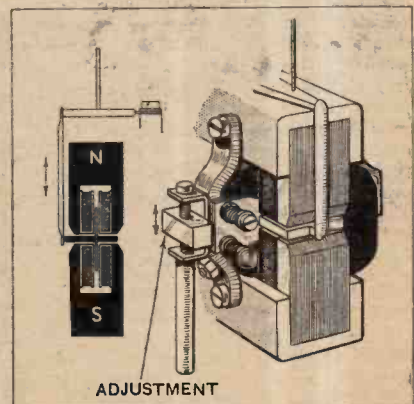

Hegra.

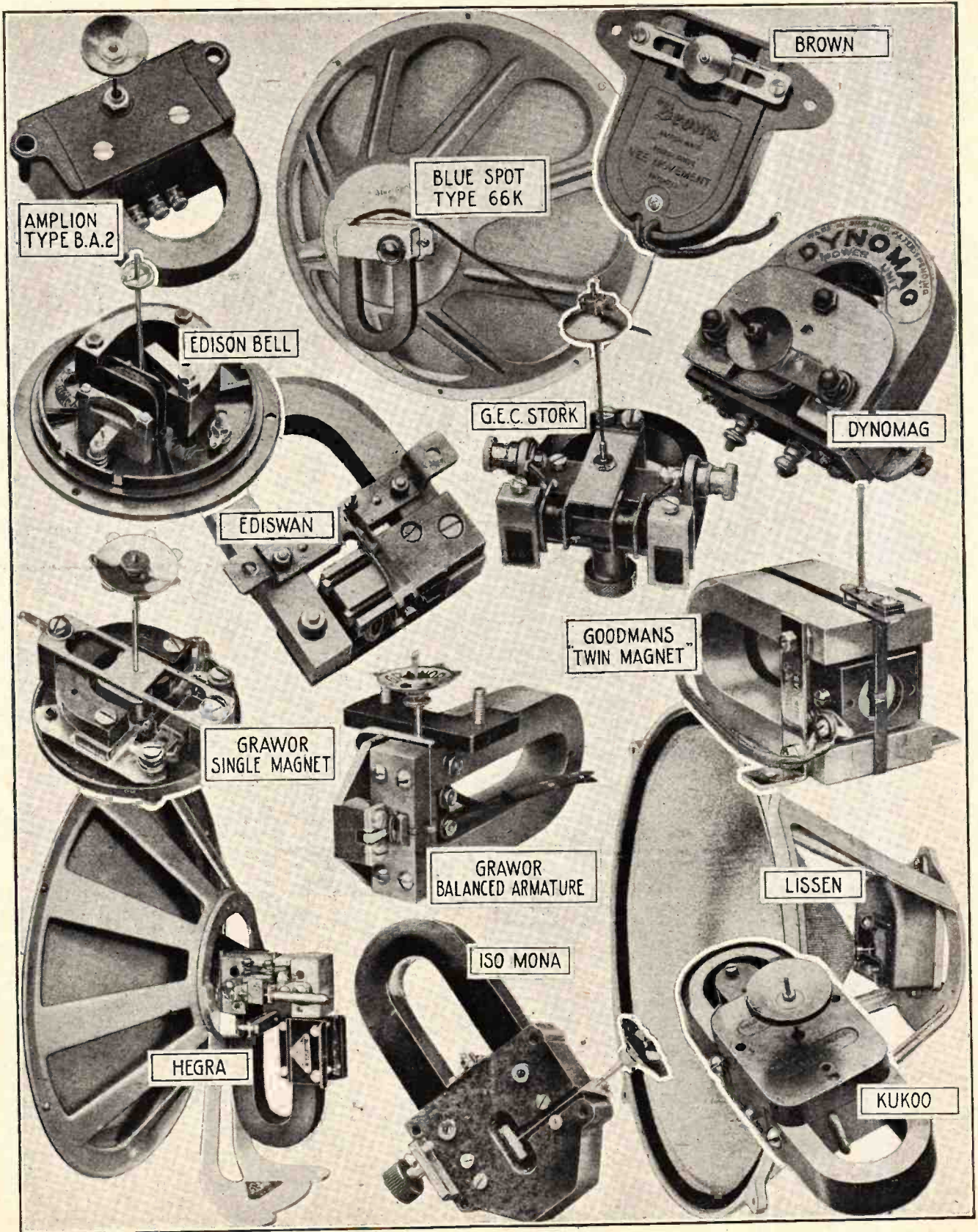

Tests on Cone Units.—

ISO MONA.

The balanced armature movement is encased in a die-cast housing. The permanent magnet is of generous dimensions, and both the pole pieces and the armature are laminated. The screw adjustment rocks one end of the armature suspension strip as shown in the drawing. No damping is provided.

The reproduction is very pleasing, in spite of resonances at 450, 1,200, and 3,500 cycles. The bass is very good, particularly below 100 cycles, and at 5,500 cycles

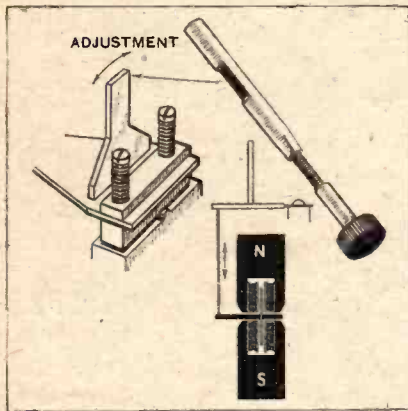

Iso Mona.

the output is above the general level of the rest of the characteristic. Above 5,500 there is a distinct cut-off and nothing is reproduced at 6,000 cycles. Nevertheless, brilliance is a noticeable feature of the general effect. The sensitivity is excellent, and is in fact unequalled. Chattering commences at 400 cycles when the input passes 412 milliwatts. Price 23s.

Haw and Co., Ltd., 20, Cheapside, London, E.C.2

KUKOO.

Constructionally, the movement of this unit resembles the Blue Spot in that the armature moves as a whole parallel to the pole pieces, the movement being transmitted to the drive rod through a stirrup. No damping is provided, however, and the flux is increased by using two permanent magnets. One set of magnets and pole pieces is fixed, while the other is pivoted, spring-loaded, and capable of being rocked by the adjusting screw. Incidentally, considerable lateral movement of the drive rod is caused by the form of adjustment adopted, and it would seem advisable to adjust the movement roughly before centring and fixing the diaphragm.

The reproduction of this movement is very pleasing. The upper register is definitely present, the bass very good indeed, while the characteristic from end to end is free from resonances. There is, however, a perceptible dip between 2,500

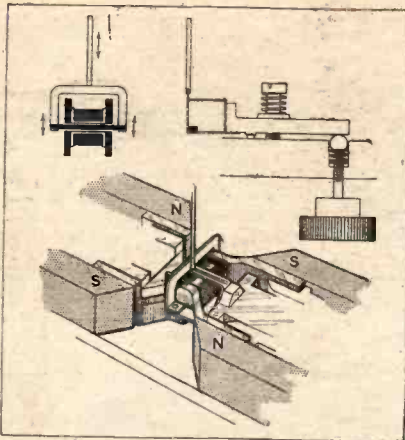

Kukoo.

and 3,500, with the minimum at 3,000 cycles. The unit will handle considerable volume and the sensitivity is satisfactory. A first-class job. Price 25s.

The Sheffield Magnet Company, Broad Lane, Sheffield.

LISSEN.

Although the shape of the pole pieces suggests a balanced armature, the movement is, strictly speaking, differential, as the arrangement of the four poles produces movement in the same direction under each pair of poles. The fact that the reed is clamped only at one end means that a portion of the energy is lost in bending the reed. Add to this

the fact that the driving rod is fixed rather near the point of fixing the reed, and one is forced to the conclusion that the movement finally reaching the cone must be small.

In actual fact the sensitivity proved to be considerably below the average, and as a necessary corollary no trace of chattering could be detected. The maximum output occurs at 500 cycles. Below this frequency there is a falling off, but the output is still appreciable at 50 cycles. From 500 upwards the output falls to normal at 1,000 cycles, continues to 2,000

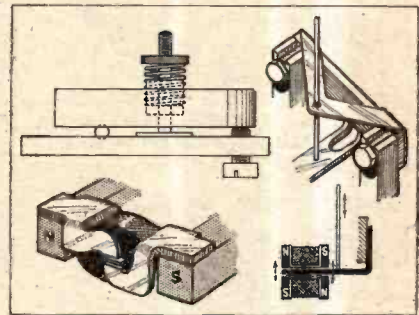

Lissen.

cycles, and then falls steadily to the cut-off at 4,000 cycles. Price 22s. 6d.

Lissen, Ltd., Frjars Lane, Richmond, Surrey.

(To be concluded.)

o o o o

AN AID FOR THE DEAF.

DR. GUSTAV EICHHORN, the inventor of the device which was described under the above title in the issue of *The Wireless World* for January 15th, has asked us to point out that the diaphragm which he uses consists of a semi-conductor of material known as "cellophane," a material of sufficient strength to withstand any incidental damage and metallised on one side only. The diaphragm is not metallised on both sides, as might have been inferred from the wording of our article, and the device is, therefore, entirely shock-proof, although, as the modulated alternating currents do not exceed 70-100 volts supplied by a small dry battery, the possibility of trouble from this source would not in any case arise in practice.

Also, a later investigation by Dr. Eichhorn showed that there is no polarity in the device, as was originally assumed by him and quoted in our correspondent's description.

o o o o

TRADE NOTE.

We are advised by Gramo-Radio, Ltd., Commercial Works, Church, near Accrington, Lancs, that some concern is felt regarding the liquidation of a firm trading under a somewhat similar name. Attention is drawn to the fact that Gramo-Radio, Ltd., of the above address has no connection with any other firm.

IN FEBRUARY NUMBER

EXPERIMENTAL WIRELESS.

Alignment Diagrams—the reactance of single and combined capacities and inductances.

By W. A. Barclay, M.A.

Braun Tube for the direct photography of waveform at audio and radio frequency.

By Manfred von Ardenne.

The Problem of Distortion in Sound Film Reproduction.

By C. O. Browne, B.Sc. (Gramophone Company, Ltd.)

Measuring the Overall Performance of Radio Receivers.

By H. A. Thomas, M.Sc. (I.E.E. Paper).

Measurement of Capacity and Inductance by the Absorption Method.

By A. P. Castellain, B.Sc.

The Physical Society's Exhibition. Recent Patents. Abstracts and References.

CURRENT TOPICS



Events of the Week in Brief Review.

IRELAND'S RADIO WEEK.
A "Radio Week" will probably be held in the Irish Free State before the end of February. The organisers are the Irish Radio Traders' Association.

HIGH POWER BROADCASTING IN IRELAND.
Listeners in the Irish Free State are rejoicing over the Government decision to sanction plans for the erection of a high power broadcasting station at a cost between £60,000 and £70,000. Although the site of the station has not been definitely chosen, it is believed that the choice will be a spot near Athlone, which is situated in the centre of the country.

FL TO TRY AGAIN.
Disappointment has been expressed in France over the comparative failure of the preliminary short-wave tests from the Eiffel Tower in preparation for the proposed Colonial service. Different types of aerial have been employed, and more encouraging results are now being obtained with a short aerial placed at the summit of the Tower. A more powerful transmitter is to be installed.

TOURISTS' WIRELESS IN FRANCE.
The Automobile Association is officially informed that tourists may take wireless sets to France, either mounted on motor cars or in their personal luggage, but duties and taxes must be paid. No refund will be granted on re-exportation. The Customs duty on British sets (minimum tariff) is 22 per cent. *ad valorem*. In addition, there is a luxury tax on sets valued at more than 700 francs and on loud speakers valued at more than 200 francs. The visitor must take out a licence at a post office before using his set.

ANGLO-JAPANESE BEAM SERVICE.
The Anglo-Japanese beam wireless link is now completed by the opening of the Japanese Wireless Telegraphy Company's station at Yokkaichi, permitting messages to be sent from Japan to England. The service in the reverse direction was opened last year by Imperial and International Communications, Ltd. The transmitting and receiving stations in England are at Dorchester and Somerton respectively.

A WIRELESS WHARF?
A writer in the *City Press* suggests that a certain wharf now vacant in

Thames Street would be valuable to the wireless trade. When the British radio industry is exporting in bulk to the four corners of the globe a Thames-side wharf may be a necessity.

STATE'S DUTY TO THE LISTENER.
"As the State intends to impose a tax on wireless receivers, its duty is to ensure that the owners thereof enjoy



THE COMPLETE MOTORIST. A tea service and Marconiphone portable set are incorporated in the coachwork of a saloon car which appeared at the Monte Carlo Rally last week. The wireless set is covered in green leather to match the upholstery.

good reception," is the concluding sentence in a proposed amendment to the French Broadcasting Bill, now awaiting the sanction of the House of Deputies. The two deputies who are proposing the amendment are ardent wireless enthusiasts who consider that interference from electrical machinery, sky signs, etc., is ruining reception in urban districts

NOT A W.W. SUBSCRIBER.
"I simply refuse to have a wireless set in my house."—Kubelik, the violinist.

THE "1930 EVERYMAN FOUR."
Our Birmingham readers will be interested to know that the "1930 Everyman Four," described in *The Wireless World* of October 16th last, is now on view at our offices in Guildhall Buildings, Navigation Street.

WEEK-DAY WIRELESS IN CHURCH.
The installation of a wireless set in the Argyle Congregational Church, Bath, referred to in a recent issue, has aroused widespread interest among churches in different parts of the country. The receiver at Bath is tuned-in daily to the Daventry morning religious service, and passers-by are invited to "Come in and Listen."

ONE SET: TWO LICENCES.
Several distressing cases are reported (from south of the Tweed) of husbands taking out a wireless licence in the city in ignorance of the fact that their wives had secured a licence from the local Post Office. We understand that the Postmaster-General is prepared to refund payment in such cases.

RADIO ON THE ROAD.
Tea with musical accompaniment can be enjoyed *en route* in a Talbot car which took part in the recent Monte Carlo Rally. The front seat has an unusually deep frame providing two large compartments at the rear. In one of these is a complete outfit for making and serving dainty teas. In the other recess is a Marconiphone Portable Model "55" receiver.

The set rests on a sprung platform, and is retained in position by a flap closing down over the handle, leaving the controls and loud speaker exposed. Passengers are thus able to tune in stations while the car is in motion.

America is already leading the way with radio-equipped cars. Will the wireless Talbot set a new fashion over here?

MORSE RECEPTION AT 45 W.P.M.
An "all-round" radio operating contest, organised by the Radio Corporation of America, has been won by Mr. R. C. Macpherson, who scored the following reception speeds:—Audio reception, 45 words per minute; recorder tape tran-

scription, 67 w.p.m.; sounder reception, 40 w.p.m.; keyboard perforating, 75 w.p.m. Ten letter code words were used.

o o o o

TRAIN WIRELESS INAUGURATION.

Saturday next, February 8th, is the provisional date for the inauguration of regular wireless reception on the French State Railways, writes our Paris correspondent. This decision is the outcome of a series of experiments recently conducted by the "Radio Fer" Company on expresses between Paris and Le Havre, with the approval of the French Postmaster-General. The official report describes the tests as thoroughly satisfactory, continuous communication being maintained with an experimental transmitter throughout each journey.

The first radio-equipped train will be available for public use on Sunday, February 9th. Individual headphones are fitted.

o o o o

"CONSCIENCE MONEY."

Messrs. Ferranti, Ltd., are anxious to trace the identity of a correspondent who has been moved to forward them 4s. as "conscience money." His letter runs:—"In the course of building a wireless set I obtained from a wholesaler one of your AF4 transformers. He charged me 13s. 6d. for the instrument; when I read the conditions of sale I felt that he was not justified in selling below 17s. 6d. So I am forwarding 4s., which I feel is an owing balance of account."

The letter bears neither address nor signature, but the manufacturers are hopeful that this note will induce the writer to disclose his identity so that he can be rewarded in some way for his honesty.

o o o o

CAIRO MAKES WIRELESS HISTORY.

The first wireless exhibition in Cairo was held at the Royal School of Engineering on January 9th and 10th. British wireless gear predominated.

THE "GAOL CONSTRUCTOR."

Prison conditions in the United States are far more lax than those prevailing in European prisons. From time to time

accounts are published in the Press purporting to give realistic descriptions of the royal time enjoyed by American gaol-birds.

As supporting evidence of these reports the PCJ station director has received a reception report from the Missouri State Penitentiary. One of the prisoners, who

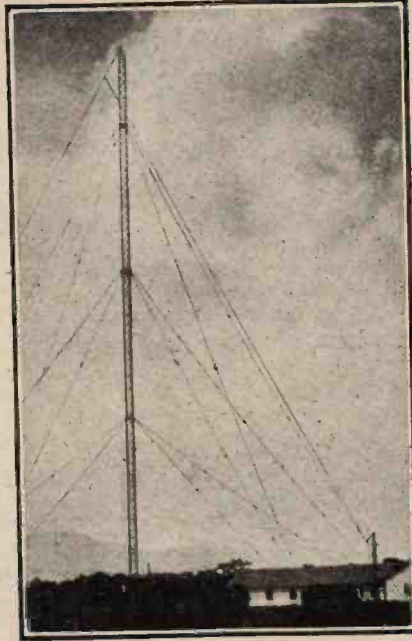

BROADCASTING IN BRAZIL. A glimpse of FQAA, the 2 kw. station at Rio de Janeiro, which operates at 400 metres.

gives his identity as No. 32,500, states that he regularly listens to PCJ with a four-valve receiver, which he has designed and built himself.

o o o o

BRITISH TRANSMITTER'S SUCCESS.

Mr. H. L. O'Heffernan (G5BY) has been awarded a cup presented by the American Radio Relay League for the best amateur transmitting station de-

scribed during 1929 in their magazine, "QST." Mr. O'Heffernan is a Philips Public Address engineer.

o o o o

WIRELESS POSTER DESIGNS.

Prizes for designs for posters to advertise loud speakers, all-electric wireless sets and mains units are to be awarded in the Seventh Annual Competition of Industrial Designs organised by the Royal Society of Arts.

Messrs. E. K. Cole, Ltd., offer a prize of £25 for a design for a double-crown poster in not more than seven colours to advertise their "Ekco" All-Electric Sets, while a prize of £30 is offered by Celebration, Ltd., for a double-crown poster design advertising the company's loud speakers.

The competitions will be held at the Imperial Institute, South Kensington, London, S.W., in June, 1930, and intending competitors must apply for entry forms to the Secretary of the Society, John Street, Adelphi, London, W.C.2, between May 1st and May 10th. The last day for receiving entries is May 26th.

WIRELESS AT WESTMINSTER.

(From Our Parliamentary Correspondent.)

The "Home-Fast" Listener.

In the House of Commons last week Mr. P. Oliver asked the Postmaster-General whether he was prepared to extend to persons who are permanently bedridden or home-fast the same exemption from fees in respect of wireless licences as was at present extended to blind persons; and if legislation was required for this purpose, was he prepared to introduce a Bill.

Mr. Lees-Smith (Postmaster-General) replied that the Broadcasting Committee of 1925 considered the question of the grant of free wireless licences, and recommended that this concession be made to blind persons only. Effect was given to the Committee's recommendation by the Wireless Telegraphy (Blind Persons' Facilities) Act, 1926. He did not consider that he would be justified in asking Parliament to extend the concession to other classes of the community.

MUSIC AND TRAVEL.

Loud Speaker Test on the L.N.E.R.

Several lessons could be learnt from the enterprising experiment carried out last week by the London and North-Eastern Railway. A special train of Pullman cars was run from King's Cross to Hatfield and back, and during the journey the passengers were invited to judge whether loud speaker music from a radio-gramophone set formed an agreeable accompaniment to modern railway travel.

Without discrediting the performance of the radio-gramophone, it can be said that the experiment went a long way towards proving that headphones would be a better medium for providing the train traveller with music. Headphones largely exclude extraneous noises, and they also exclude

the music from the ears of those who do not wish to hear it.

Few noises are more distracting than the half-heard loud speaker, yet on the smoothest-running railway coach the incidental noises deaden the finer shades of musical reproduction and listening becomes an effort. This was the experience on the run between London and Hatfield, though it is only fair to remark that this particular piece of line abounds in tunnels, which create a most unmusical roar!

The receiver—a self-contained "Super-tone Talkie" of the screened-grid H.F., detector and resistance-coupled L.F. type—gave excellent reproduction of the Regional transmission from Brookmans

Park, and volume was not appreciably affected when the train was burrowing through tunnels.

The L.N.E.R. has already distinguished itself among British railways for the interest it has shown in wireless. As long ago as May, 1924, the company co-operated with the Radio Society of Great Britain in transmission tests from the East Coast Express between King's Cross and Newcastle. Again in 1925, the celebration of the Railway Centenary was observed with a broadcast relay from the footplate of an engine on a night express. The reception of the Derby running commentary is now an annual event on the "Flying Scotsman."



Part XIX.—Radiated Energy and Wavelength.

By S. O. PEARSON, B.Sc., A.M.I.E.E.

(Continued from page 124 of the issue dated January 29th, 1930.)

NOW that the general properties of alternating current circuits have been dealt with for different arrangements of the three constants, inductance, capacity and resistance, the way has been paved for a more detailed consideration of the application of the principles involved to actual receiving circuits. Attention will first be directed to the high-frequency portions of receivers, then later to the detector, low-frequency and output sections.

In dealing with high-frequency circuits it is first essential to know the exact nature of the high-frequency currents and voltages which we require to pick up and amplify in the receiver, and how the electrical vibrations are picked up by the aerial. The receiving aerial is energised by ether waves emitted by the transmitting aerial of the broadcasting station and so a brief outline will be given of the general properties of an open-type aerial.

The commonest type of aerial used for receiving purposes consists of a wire or system of wires elevated at some distance above the ground and well insulated from its supports. The elevated portion is usually more or less horizontal, and there is a down-lead from one end or from the centre, making connection with the earth. In series with this down-lead is an inductance coil for the purpose of transferring the received signal voltages to the receiver.

The Aerial as a Tuned Circuit.

It is very important to realise at the outset that a simple aerial consisting of an elevated wire with one end connected to earth, even though there is no inductance coil in series with the down-lead, possesses resistance, inductance and capacity, and will therefore have a natural frequency of electrical oscillation if the resistance is not excessive. Resistance is present in the wire itself, in the connection to earth and due to other incidental causes mentioned subsequently; inductance is present because any current passed along the wire will cause a magnetic field to be

set up around it; and capacity exists because, if the voltage of the elevated portion is raised above that of the earth, lines of electrostatic force will extend from the wire to the earth, so that the elevated wire and the earth are really equivalent to the two plates of a condenser of large dimensions, with the intervening air acting as the dielectric. And so the open aerial circuit corresponds in many respects to the closed tuned circuits already considered, and can be made to respond to any desired frequency.

Let us consider a simple aerial of the inverted "L" type, as shown in Fig. 1, without any added inductance in the down-lead. Unlike the closed tuned circuit, the open aerial circuit has its capacity and inductance distributed along the whole length of the wire. But if the horizontal portion is fairly long, compared with the vertical down-lead, the major part of the capacity will exist between the elevated horizontal wire and the earth. Thus, if an alternating voltage is applied in series with the down-lead, a charging current of the same frequency will flow up and down the vertical wire, and the greatest magnetic effects will therefore be set up around the down-lead. This is of fundamental importance.

For our simple theory then, we shall assume that the whole of the capacity of the aerial is situated in the horizontal part, and that the whole of the inductance is in the vertical part. When an inductance coil is included in the down-lead, the latter assumption is even more nearly correct, and the equivalent circuit can be represented in the manner shown by Fig. 2 (a) where

the total inductance L is assumed to be concentrated at one point in the down-lead, and the capacity C is distributed along the horizontal portion only of the aerial. The effective capacity C can further be considered as being concentrated at one point in order to give a simplified equivalent circuit as shown in Fig. 2 (b), where R_e is the effective resistance due to all causes. This last circuit shows that the open aerial is the same

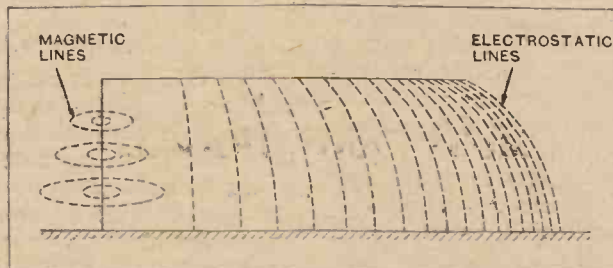

Fig. 1.—Simple inverted "L" aerial showing how the electrostatic and magnetic lines of force are disposed when an oscillating current is flowing. The fields are alternating and one is passing through zero when the other is at maximum.

Wireless Theory Simplified.—

as the ordinary closed circuit in all respects except that the lines of magnetic force and of electrostatic force are not confined to small spaces.

Long lines of electrostatic force stretch from the elevated part of the aerial to the ground, and large circles of magnetic force spread outwards from the vertical wire as the ripples on a pond do when a stone is thrown into the water. It is this fact which gives an open aerial its very special properties of being able to set up powerful electromagnetic waves in the ether in the case of a transmitting aerial, and of responding to ether waves in the case of a receiving aerial.

The Transmitting Aerial.

The functioning of a receiving aerial can be much more simply explained if we have first an elementary knowledge of the action of an aerial as a transmitter of radio signals. As we shall be primarily concerned with the amount of energy radiated into space by such an aerial, we must necessarily view it as a resonant circuit with particular reference to the energy stored in the oscillating circuit.

It has already been explained how, in a closed circuit tuned to resonance, energy is oscillated backwards and forwards between the coil and condenser, due to the fact that the current and voltage are out of step by exactly 90° , for the ordinary series circuit, so that when the current in the coil is a maximum, the voltage across the condenser is zero, and *vice versa*.

When the circuit possesses resistance a certain amount of energy is lost in the form of heat every half cycle, but if the same amount of energy is drawn per half-cycle from the source of supply the oscillations in the circuit will be maintained at constant amplitude, just as a clock pendulum is kept swinging through a constant arc due to the small impulses given every half-swing of the escapement wheel.

The aerial circuit behaves in exactly the same way as the closed circuit when oscillations are maintained in it by the generating apparatus. If an alternating E.M.F., whose R.M.S. value is E volts, is induced into the inductance coil L in the down-lead, and if the aerial circuit is accurately tuned to resonance with the frequency of this voltage, the inductive and condensive reactances will neutralise each other, and the aerial current in the vertical lead will be $I = \frac{E}{R_e}$ amperes,

where R_e is the *effective* resistance of the aerial, accounting for the total power consumed. The power input to the aerial is thus given by $P = I^2 R_e$ watts.

Now the open aerial circuit differs from the closed circuit only so far as the total effective or equivalent

series resistance is concerned. In the case of the aerial the whole of the energy put into the circuit is not converted into heat in the circuit itself as in the closed circuit; a certain proportion is actually radiated away into space in the form of electromagnetic ether waves, and is never recovered by the circuit. In exactly the same way, when a violin string is plucked *some* of the energy of the vibration is radiated in the form of sound waves. The radiated energy is the only useful part of the energy put into the aerial; the remainder is merely converted into heat and lost in the aerial circuit, and the efficiency of the aerial is the ratio of the power actually radiated away to the total power put in.

Why High Frequencies are Used.

The radiated power depends on the strength of the aerial current, the effective height of the aerial and the frequency of the oscillations being proportional to the *square* of each. It is because the radiated energy is proportional to the square of the frequency that such high frequencies have to be used for wireless communication. If high frequencies were not chosen the aerial currents would have to be so large and the aerial itself so immense as to be quite impracticable. The frequencies used range from about 20 kilocycles per second for the longest wave stations to about 30,000 kilocycles per second for the shortest wave stations. For telephony the audio-frequencies to be transmitted range from about 32 cycles per second to 8,000 cycles per second only, so that these frequencies, being too low to transmit by themselves, have to be superimposed on a higher radio frequency which acts as a "carrier," as will be described later.

Velocity of Radiated Waves.

It is definitely known that the electromagnetic ether waves set up by the oscillations in the transmitting aerial travel outwards from the aerial with exactly the same velocity as light travels through space. In fact, it has been conclusively proved that light waves are also electromagnetic waves of the same kind as radio waves, but having a frequency many times greater than the highest radio frequency used. The physical effects of ether waves depend entirely on the frequency, but the velocity of propagation through so-called empty space is the same for all frequencies. In the same way sound vibrations in air all travel with exactly the same velocity whatever their pitch or frequency. The velocity is determined alone by the density and elasticity of the medium in which the waves or ripples are produced.

The velocity of radio waves and light through space is 3×10^{10} centimetres per second, or about 186,000 miles per second. This is a stupendous speed, as will

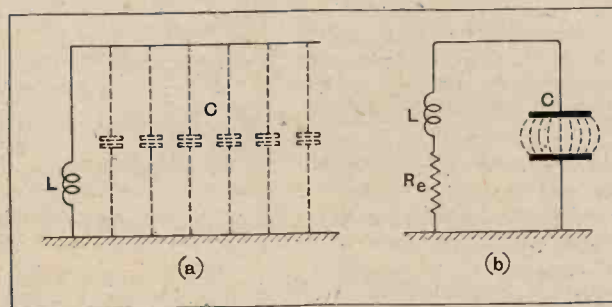

Fig. 2.—Diagrams showing how an open aerial circuit can be likened to a closed resonant circuit. The wire itself possesses inductance, and capacity exists between the elevated portion and the earth.

Wireless Theory Simplified.

be realised when one considers that anything moving at such a speed would travel nearly seven and a half times round the earth at the equator in one second. Radio signals emanating from Australia take about one-fourteenth part of a second to reach this country.

Connection Between Frequency and Wavelength.

Knowing the velocity of the waves radiated from an aerial and the frequency of the oscillations producing them, we are in a position to state definitely the length of each wave in the ether and to give a definition of wavelength.

Let the frequency of the electrical oscillations in the aerial be f cycles per second; that is to say, there will be f complete oscillations in the aerial in one second, and during this time f complete ether waves will have left the aerial on their outward journey at a velocity of 3×10^{10} centimetres per second. Therefore, the first wave which left the aerial at the beginning of the second under consideration will be just 3×10^{10} centimetres away when the last wave leaves at the end of that second.

It is thus clear that the f waves which left the aerial during one second will be spread out over a distance of 3×10^{10} cms., or 3×10^8 metres, as shown by Fig. 3 (a), and therefore one complete wave will occupy a space of 3×10^8 metres. The length of one wave in the ether is called the *wavelength*, and is usually expressed in metres and denoted by the Greek letter λ (lambda). One wavelength is shown at (b) in Fig. 3. Thus, when the frequency is f cycles per second the wavelength is given by $\lambda = \frac{3 \times 10^{10}}{f}$ metres.

This shows that the wavelength is inversely proportional to the frequency—the higher the frequency of the electrical oscillations the shorter the wavelength of the ether waves produced. Suppose, for instance,

that the frequency is one million cycles per second or 1,000 kilocycles per second; then the corresponding wavelength will be $\lambda = \frac{3 \times 10^8}{10^6} = 300$ metres. This is a useful relationship to memorise, namely, that 1,000 kc. per second corresponds to 300 metres, for we can use

it to find the frequency at any other wavelength by the rule of inverse proportion. For instance, London's Regional wavelength of 356.3 metres corresponds to a frequency

$$\text{of } 1,000 \times \frac{300}{356.3} = 842 \text{ kc.}$$

per second. So all we have to do to find the frequency of a station is to divide 3×10^5 by the wavelength in metres, or given the frequency, the wavelength is found by dividing 3×10^5 by the frequency in kilocycles per second.

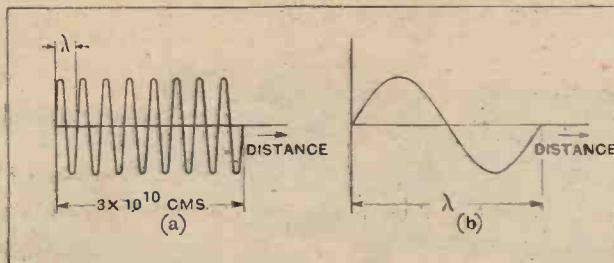

Fig. 3.—(a) Radio waves travel with a speed of 3×10^{10} cms. per sec. When the frequency is f cycles per sec. f waves occupy a space of 3×10^8 cms. (b) One wavelength $\lambda = \frac{3 \times 10^8}{f}$ metres.

wavelength is found by dividing 3×10^5 by the frequency in kilocycles per second.

Wavelength and Circuit Constants.

Although the term "wavelength" can, strictly speaking, only be applied to ether waves it is often used in connection with tuned circuits. Fortunately, however, this practice is dying out, but until the change-over from wavelength values to frequency values for circuit calculations is universal, it is necessary to be able to express the wavelength to which a circuit is tuned in terms of inductance and capacity.

The formula required is very easily found from the fundamental expression for the resonant frequency of

the circuit, namely, $f = \frac{1}{2\pi\sqrt{LC}}$. Substituting this value

for the frequency in the expression for wavelength above we get $\lambda = 3 \times 10^8 \times 2\pi\sqrt{LC}$ metres where L is in henrys and C is in farads. If L is expressed in *microhenrys* and C in *microfarads*, the formula reduces to

$$\lambda = 1885\sqrt{LC} \text{ metres.}$$

This is the wavelength to which the resonant frequency corresponds.

(To be continued.)

Transmissions from Philippine Islands.

A correspondent sends us particulars of the transmitters at present broadcasting from Manila Heights, about seven miles distant from the studio in the Manila Hotel, Philippine Islands.

The short-wave set operates on a frequency of 6,130 kC. (48.9 metres), and puts 1 kilowatt of energy into a special tuned aerial of the double type. The set is crystal controlled, using a 50-watt valve in its first stage, from which the output is taken through the following stages, either doubling or amplifying: one 75-watt, two 75-watt, and finally two 750-watt valves working through inductive coupling to the aerial circuit.

TRANSMITTERS' NOTES.

The medium-wave set has also an output of 1 kW., but is not crystal-controlled. It works on a frequency of 613.5 kC. (485 metres), and this is maintained accurately with little swinging. The aerial is suspended from two steel towers about 300ft. high.

Telephony from G 2GN.

We have had several enquiries about the identity of G 2GN, which is an experimental short-wave telephony set on

s.s. *Olympic*, somewhat like that on s.s. *Leviathan* described in our issue of January 1st.

G 2GN has been heard in Cape Town, calling WJOO—which is understood to be the U.S. s.s. *West Madaket*—and a correspondent in Reading reports hearing the station on January 25th, from 2000 to 2025 G.M.T., on 35 metres, speech and modulation good and quite clear on a loud speaker using three valves, the signal strength being QSA 3 to 5, with the carrier at a steady R8. It was calling G 2AA (Slough), WOO (Deal, NJ), and F 8PZ, and evidently testing.

We understand that it is intended to install a similar set in s.s. *Majestic*.

WIRELESS WORLD LABORATORY TESTS

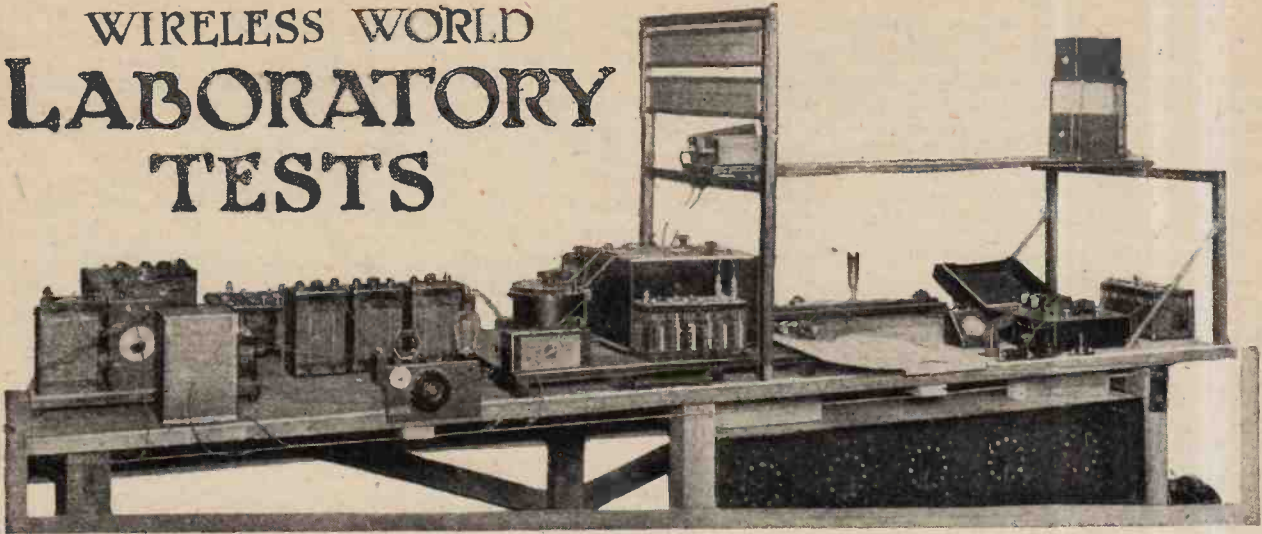

A Review of Manufacturers' Recent Products.

"UNLIMITEX" H.T. BATTERY.

A dry-cell H.T. battery that will survive seven months of real hard work, assuming the set is used on an average of twenty-five hours a week, is something of a rarity. This, however, is the result of a test carried out recently on a 60-volt "Unlimitex" H.T. battery. The sample



"Unlimitex" 60-volt dry cell H.T. battery. Tappings are provided in 1½-volt steps up to 12 volts and thence in 6-volt steps.

submitted was stated to be of "standard" capacity, so consequently the discharge was commenced at 8.8 mA, a fixed resistance of suitable value being employed. The battery was not discharged continuously, but given four hours of work with similar periods to recuperate. This was continued without break until the battery was exhausted.

In the discharge curve these rest periods have been omitted, only the working hours being shown. At first the voltage fell rapidly, but later this became more gradual, and eventually—after 240 hours' work—reached a comparatively steady state which was maintained for a further 500 hours. At the end of this period a rapid decline followed. The useful life of the battery can be assumed as 740 working hours.

Each cell is very carefully insulated from its neighbours by eight thicknesses of bakelised insulating material. Opening

up one cell revealed a further interesting fact. The whole of the zinc container had disappeared. The ingredients seem to have been so well proportioned that the electrolytic just outlives the zinc.

These batteries, which appear to be of foreign origin, are obtainable from the Wireless Supplies Unlimited, 278, High Street, Stratford, London, E.15, and the price is 5s. 3d. for the 60-volt size and 9s. 3d. for a 100-volt size. Grid bias batteries are available also at 1s. for a 9-volt size.

o o o o

CLIMAX AUTO-BAT TRANSFORMERS.

These transformers have been designed especially for use with the Westinghouse metal rectifiers style H.T.3 and H.T.4.

Two models are available. The type H.50 is a small component giving 135 volts R.M.S. output, and provided with a tapped primary winding to suit various supply voltages at frequencies of from 40 to 100 cycles. Some measurements were made with this transformer using as a rectifier the Westinghouse H.T.4 full-wave model and adopting the voltage doubling arrangement. The rectified voltage regulation curve is shown at C on the graph. The broken-line curve D is the secondary voltage regulation. For convenience this was plotted against the rectified current and not the A.C. current through the winding. It will be noticed that on full load the secondary voltage falls to 85 per cent. of the value at very small load.

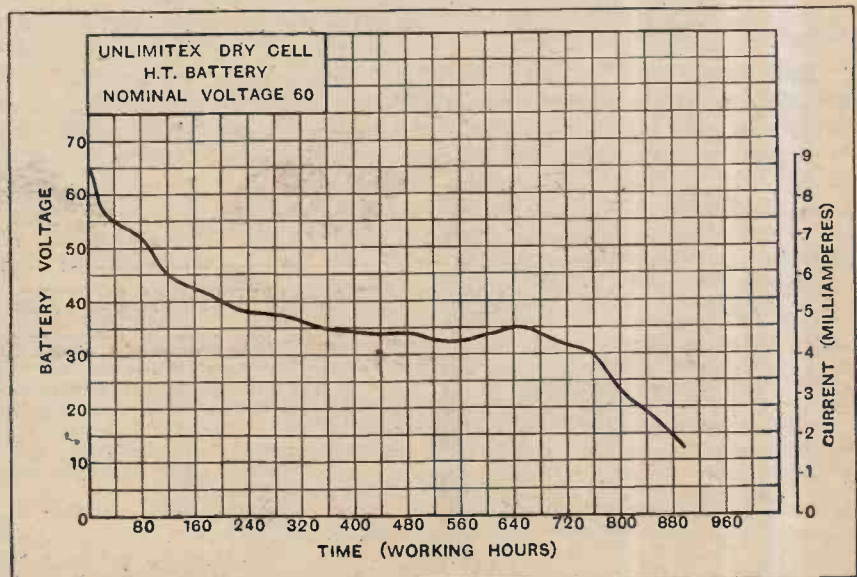

Discharge curve of the "Unlimitex" 60-volt battery.

This order of regulation may be regarded as satisfactory, having regard to the size of the transformer and its price, which is 17s. 6d.

The type H.L.G.4 transformer is a considerably larger model, as will be seen from the illustration, and provides three separate output voltages. There is one H.T. secondary wound to give 135 volts A.C., a 4-volt winding to give 4 amps., to supply the heaters of four indirectly heated valves and a winding, rated to give 40 volts, for use with a Westinghouse unit G.B.1. The function of this is to provide grid bias for the valves.

Regulation curves were taken of the output voltages in the same manner as described in the former case. These curves are given at A and B respectively. In this case the secondary regulation was found to be considerably better than on the smaller model. On full load the R.M.S. voltage was 90 per cent. of that at very small load.

The grid bias winding gave 45 volts R.M.S. on voltmeter load only. Since the current drawn from this coil will be

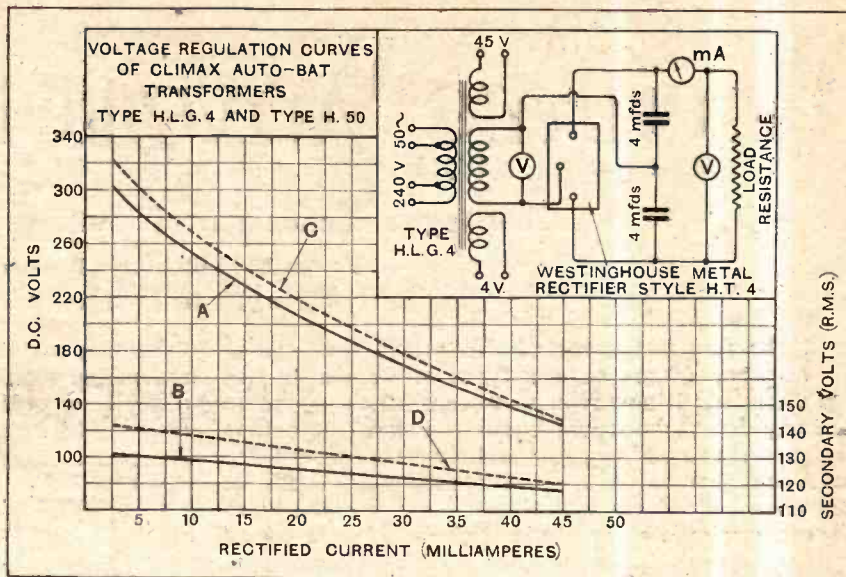

Voltage regulation curves of Climax Auto-Bat transformers using a Westinghouse H.T.4 rectifier. A, the rectified output and B, the secondary voltage regulation of H.L.G.4 model. Curves C and D are the rectified and A.C. outputs from the H.50 model.

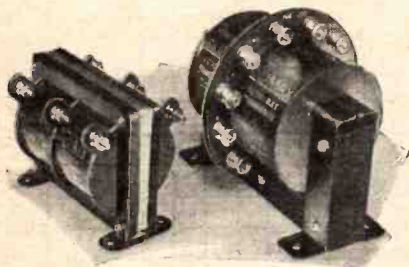

Climax Auto-Bat mains transformers for use with Westinghouse metal rectifiers. The larger component is the type H.L.G.4.

so very small—a few milliamps. only—it was not considered necessary to take a regulation curve. The output from the 4-volt winding was measured at various loads. The results are tabulated below.

OUTPUT FROM 4-VOLT WINDING.

| A.C. Current. | A.C. Voltage. |
|---------------|---------------|
| 1 Amp. | 4.3 volts |
| 2 Amps | 4.2 " |
| 3 " | 4.1 " |
| 4 " | 4.0 " |

It was noticed that loading the 4-volt winding had no appreciable effect on the output from the other secondary coils, showing that the primary winding is fully capable of carrying the full load for which the component was designed. The H.L.G.4 model is offered at the attractive price of 32s. 6d.

The makers are the Climax Radio Electric Co., Ltd., Haverstock Works, Parkhill Road, Hampstead, London, N.W.3.

o o o o

"OMNIVOX" CONDENSERS.

Some samples of variable condensers in which the usual air dielectric is replaced by a material described as "Acetoloid" have been submitted for test by the

A 31

makers, Omnivox Products, 20, Brook Street, Holborn, London, E.C.4.

One advantage arising out of the use of this material is that, for a given capacity, the physical size of the component can be considerably reduced. The first model tested was a differential condenser consisting of one moving vane and two sets of fixed vanes each of two plates. The measured minimum capacity between the rotor and each set of fixed plates was found to be 2.5 micro-microfarads. The maximum capacity was 0.0000665 mfd. in each case.

A reaction condenser rated at 0.0001 mfd., in which a single vane forms the rotor, the stator, consisting of two plates, was found to have a minimum capacity of 2.5 micro-microfarads, also a maximum capacity of 0.000102 mfd. A capacity of 0.0005 mfd. (nominal) has been condensed

num value was 0.0004 mfd. only, or 20 per cent. lower than the marked value.

The exceedingly low minimum capacities exhibited in these models can be attributed in the first case to the shape of the vanes, and, secondly, to the use of ebonite end plates. A single bearing suffices to support the moving vanes. This serves also as a fixing bush of the single-hole type. A standard 1/4 in. spindle is fitted.

Owing to the presence of the solid dielectric the movement of the vanes is not so free as in the air type, and when used for tuning purposes a slow-motion dial will be required generally for accurate tuning. The losses introduced by the particular dielectric used limits the application of these condensers, yet for the purpose of reaction control the dielectric loss may be of little consequence

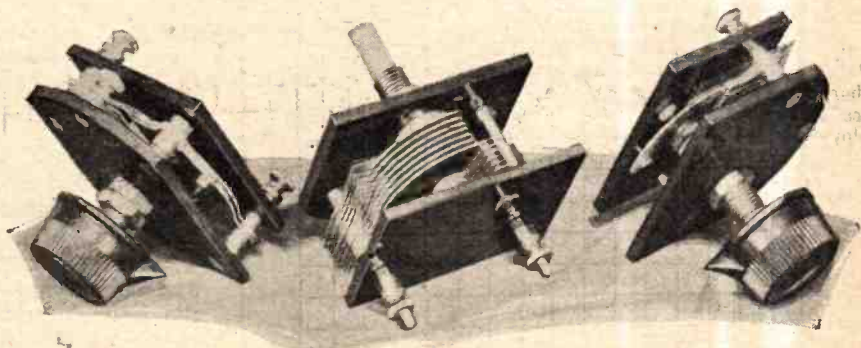

"Omnivox" variable condenser with "Acetoloid" solid dielectric.

into the exceedingly small space of 2in. x 2 1/4 in. x 2in. deep over terminals. This is made possible, of course, by the use of solid dielectric. The minimum capacity was 5.5 micro-microfarads, but the maxi-

and is offset by the advantage of compactness.

The price of the differential condenser is 2s. 9d.; the 0.0001 mfd. reaction model is 2s. 6d., and the 0.0005 mfd. size 3s. 6d.

Accurate Wavemeter Design

Choosing a Condenser of Suitable Capacity.

By W. H. F. GRIFFITHS, F.Inst.P., A.M.I.E.E.

(Concluded from page 115 of previous issue.)

IN the first instalment of this article the relative accuracy of the various types of wavemeter was discussed; it now remains to consider the optimum capacity for the resonant circuit. Before the outline design curves of Fig. 3 can usefully be employed one must be able to fix the value of capacity for the variable condenser for the wavemeter under consideration. Since the capacity ratio of the condenser is fixed by the curves it only remains to know the value of its maximum capacity. As has already been stated, somewhat persistently perhaps, this value must be made as high as possible in order to reduce the tendency to appreciable capacity uncertainty, but there is obviously a limit above which it must not be raised. One reason for this is the impossibility of constructing, economically, a variable air condenser of very large capacity having a reasonable degree of accuracy. This is, however, not the chief reason for the limitation of maximum resonant circuit capacity.

Taking, first, the case of a heterodyne wavemeter of reasonably good quality, the reason is to be found in the difficulty of production of oscillation (without excessive coupling between anode and grid circuits), as the value

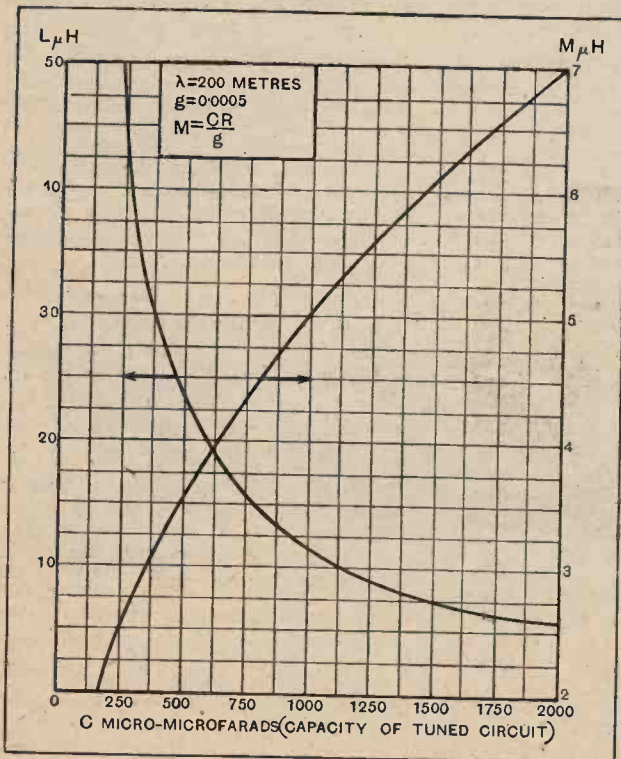

Fig. 5.—Curves to illustrate the limitation of capacity in heterodyne wavemeters.

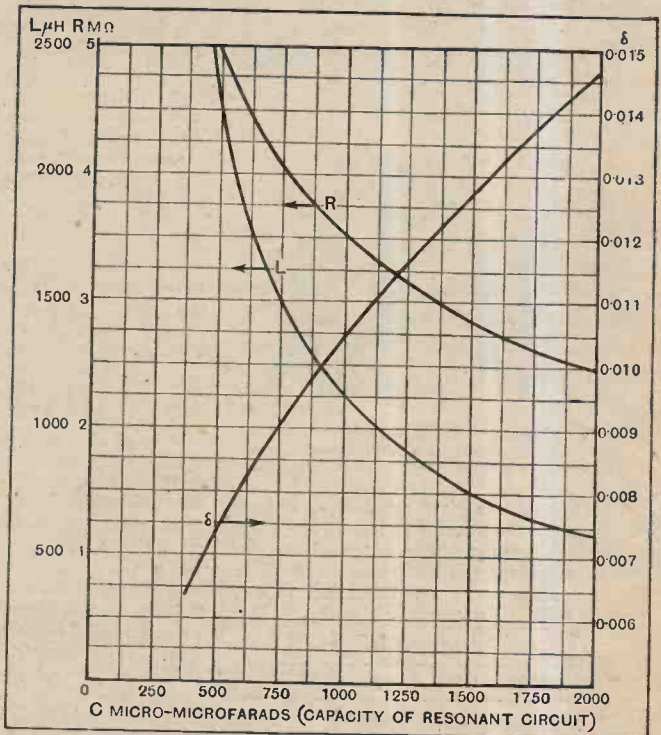

Fig. 6.—The limitation of capacity in an absorption wavemeter.

of C/L of the resonant circuit is increased beyond a certain limit. This is, of course, due to the fact that the effective negative resistance of the whole circuit as governed by the mutual inductance between the grid and anode coils¹ must, for the condition of self-oscillation, be greater than the effective positive resistance of the circuit. Upon equating these two resistances and simplifying the expression obtained we find that the mutual inductance of the reaction coupling must be greater than $\frac{CR}{g}$ where C is the capacity of the tuned circuit, R is the resistance of the circuit, and g is the grid-anode mutual conductance of the valve. This latter factor is constant for any particular valve, and the

¹ In the case of a simple three-electrode valve oscillator with tuned grid circuit and anode reaction coil.

Accurate Wavemeter Design.—

mutual inductance necessary to maintain oscillation merely depends upon the product of the capacity and resistance of the oscillatory circuit.

For a given wavelength, as the capacity is increased the inductance has to be decreased in the same proportion in order to keep the product LC constant. The resistance of the circuit² is not, however, decreased in the same proportion as the inductance, but more nearly as the root of the inductance, and so, for a given wavelength, as the capacity is increased the product CR increases, and an increase of mutual inductance is, in consequence, required to produce oscillation, *although the self-inductance available for this coupling has been reduced.* This state soon determines the limit to circuit capacity, as will be seen from the typical curves of Fig. 5, which show, for a constant wavelength, the simultaneous decrease of inductance and corresponding increase of mutual inductance, which must necessarily accompany an increase of capacity.

Thus it is seen that the maximum capacity of the variable condenser of a heterodyne wavemeter should be as great as possible provided that it does not demand too high a value of mutual inductance to produce oscillation—extremely high values of grid-anode coupling are not desirable for a variety of reasons.

Similarly, the maximum capacity permissible in the variable condenser of a substandard wavemeter of the simple resonant circuit (absorption) type is limited because, for a given frequency, the resistance of a range

² If the variable condenser is of moderately good design, the resistance of the oscillatory circuit may be assumed to reside almost entirely in the inductance.

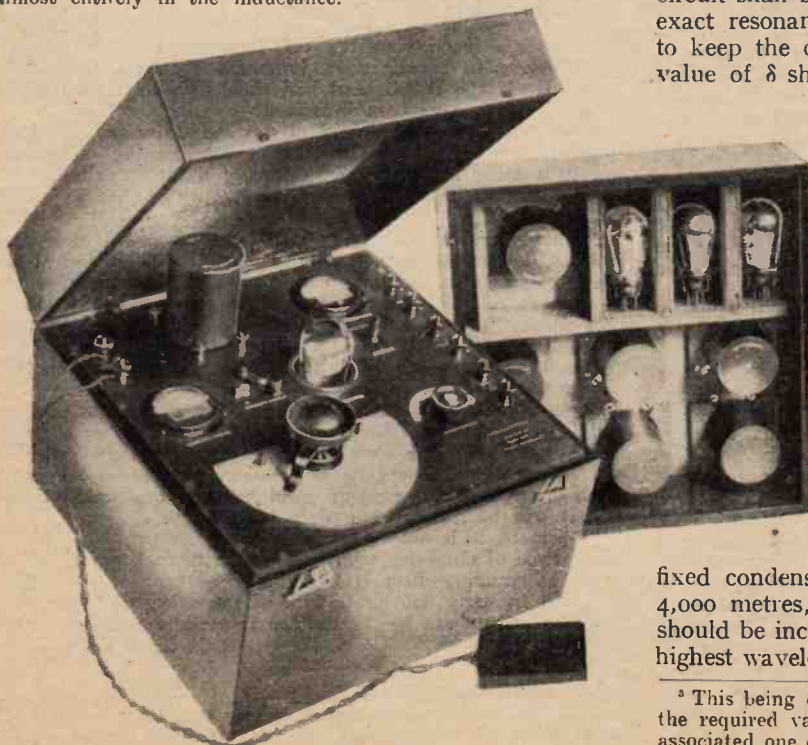

A modern commercial heterodyne wavemeter. Note the cylindrical interchangeable coils.

coil, as a first approximation, varies as the root of its inductance. The curves of Fig. 6 make this quite clear, showing R decreasing at a slower rate than L as the circuit capacity is increased. This results in an increase of circuit decrement, since

$$\delta = \frac{R}{2fL}$$

and a curve indicating this increase is also included in Fig. 6.

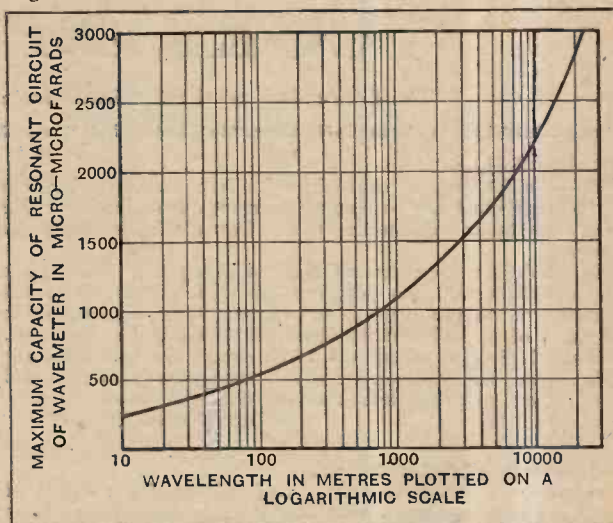

Fig. 7.—Curve from which to find the maximum circuit capacity permissible for a wavemeter of any given order of wavelength.

In order that the resonance curve of the resonant circuit shall be sharp enough to enable the detection of exact resonance to be sharply defined, it is necessary to keep the circuit decrement as low as possible. The value of δ should not be greater than 0.01 for really accurate substandard wavemeters, and this immediately fixes the maximum capacity permissible.

Thus it is seen that the maximum capacity of the resonant circuit of any wavemeter is, in effect, limited by considerations of efficiency. In all classes of wavemeters, therefore, it is well to limit the maximum capacity to the same value—the extent of limitation being governed somewhat by the type of variable condenser available.

A good average value for medium wavelengths is 1,200 micro-microfarads, since this value is usually available in ordinary variable air condensers without the complication of range extension by the addition of fixed condensers. For wavelengths higher than, say, 4,000 metres, however, the maximum circuit capacity should be increased beyond this value, until at the very highest wavelengths a value of 3,000 micro-microfarads³

³ This being obtained either by a large variable condenser of the required value or by one of smaller value with which are associated one or more range-extending fixed condensers. This latter method is especially to be advised if the wavemeter is to cover, in addition, wavelengths of a much lower order.

Accurate Wavemeter Design.—

is not excessive. Below 300 metres a value somewhat lower than 1,000 micro-microfarads should be employed, so that at 25 metres the maximum permissible capacity is usually of the order 350 micro-microfarads.

As a guide to the selection of a suitable value of maximum circuit capacity the curve of Fig. 7 has been plotted.

In conclusion it should be stated that care must be taken to see that the accuracy of the wavemeter is not impaired by inaccuracy of scale reading. For instance, interpolation readings become difficult if the scale divisions are too small. In order to avoid this an article is being prepared in which will be given the size and type of condenser scale which should be used for any accuracy of wavemeter.

CORRESPONDENCE.

The Editor does not hold himself responsible for the opinions of his correspondents.

Correspondence should be addressed to the Editor, "The Wireless World," Dorset House, Tudor Street, E.C.4, and must be accompanied by the writer's name and address.

BIG BEN BELLS.

Sir,—We note in your issue of the 8th inst., under the heading of "Things We Want to Know," reference to a crack in "Big Ben," the tenor bell in the Clock Tower of the House of Commons.

We would like to point out that no change has taken place in the condition of this bell, and the surface flaw which has been referred to as a crack is not a crack, as it only extends to the depth of one-third of the thickness of the bell at this spot. This small piece of metal was taken out of the bell when the surface flaw was discovered many years ago and has remained in its present condition from that day until the present time.

London, S.W.1.

E. DENT AND CO., LTD.

THE MAC CALLUM SCHEME.

Sir,—Major MacCallum's suggested scheme for a chain of low-power broadcasting stations radiating national programmes on four common waves is a very welcome and refreshing one, but I think the following objections can be raised against it:—

(1) The transmitters, though designated low-powered, must be capable of serving a considerable area each, and, in consequence, a bad "interference pattern," with its accompanying distortion, will be produced over a large region lying between two neighbouring transmitters.

(2) It follows from (1) that the transmitter must be situated where the population is densest; and this, coupled with the fact that there are four programmes of comparable strength to be received and separated, would seem to call for extreme selectivity. And, as yet, the Robinson Radiostat is only a promise, not a guaranteed cure for interference.

(3) The land lines, by which the transmitters are linked, are notorious for their mutilation of the material sent along them.

(4) If other countries followed our lead—and they might do!—the reception of foreign stations would be a thing of the past, the deleterious effect of this being obvious to all familiar with the B.B.C.'s motto.

And, anyway, the regional scheme is already under way and has begun to cast its shadow.

Hove.

A. J. BLAKE.

Sir,—I heartily agree with Mr. K. McCormack that the system of low-power transmitters radiating on one common frequency is entirely unsatisfactory. Since the Edinburgh relay station was put on this national common frequency its transmission, at two miles from the transmitter, has been intolerably heterodyned after dark by its fellow-transmitters. This heterodyne is of very low pitch, and forms a most distressing loud rumble, which goes on continuously, with a most unpleasant beat effect. At one mile from the station this is hardly audible, but at two miles it is so bad as to make it much preferable to take Glasgow on its individual frequency, although it is forty-five miles away. From this experience I am convinced that the MacCallum scheme would be a certain failure. I cannot, however, agree with the contention, held by several of your correspondents, that a land line of necessity causes audible distortion. When Glasgow radiates a Queen's Hall concert, *via* land line, the quality is, as a rule, in every respect as perfect as when a Scottish orchestra concert is being

broadcast, although in that case only a mile or so of line is involved. Again, in the recent S.B. relay from Cologne and Brussels the quality was exceedingly good. These observations were made on a moving-coil speaker fed by a screen-grid, reactionless receiver with paralleled L.S.5A.s.

No, sir, I contend that a first-rate programme over a good land line is vastly to be preferred to a second-rate programme of local origin.

I consider that the projected regional scheme with its great power gives the greatest hope of good quality. Great power is, in my opinion, essential to overcome interference. If foreign transmissions are wiped out they are little loss. I have yet to enjoy a foreign transmission—the inevitable accompaniment of atmospherics, morse and oscillation makes them a veritable cats' concert!

In my experience the usual fault in land-line transmissions is an attenuation of the bass, not of the higher frequencies. This is presumably due to over-correction, by the B.B.C., of the high note loss which one would expect to result from a long land line.

W. CRICHTON FOTHERGILL.

Edinburgh.

PICTURE RECEPTION.

Sir,—Concerning Mr. H. W. Howlett's plaint: Wireless pictures were doomed from the very commencement. This fact was obvious to anyone with judgment concerning broadcast material. If the B.B.C. had had their own way, they would certainly never have been broadcast.

Wireless pictures are devoid of any entertainment or educational value, which is the essence of broadcasting. They are merely a scientific novelty with a very limited application to certain useful purposes unconnected with ordinary broadcasting.

So that your readers may not again be misguided in similar matters, I venture the following comments: Television at the present time is in the same category as wireless pictures. It is a waste of good ether to broadcast them and a waste of good money for the ordinary listener to buy any sort of television receiver.

These conditions are likely to prevail for at least another ten years, if not much longer.

When a perfect system of television is evolved the position will be somewhat as follows: It will be operated on a wavelength much below 5 metres; the expense connected with it will be considerable and its entertainment value in the home much lower than the present aural material broadcast; therefore it will be mainly utilised in the cinemas.

At present it is not *remotely* in sight.

The hope of obtaining true television with such crude instruments as scanning discs is ludicrous.

It will be early enough to talk of television, when a single complete picture can be transmitted instantaneously.

Norbury, S.W.16.

B. S. T. WALLACE.

IN SEARCH OF QUALITY.

Sir,—The horn loud speaker struggles to maintain its existence! But it is doomed. No amount of development can eliminate its fundamental defects. Those who are striving to perfect the moving-coil system can at least feel that they are

striving in the right direction. The idea of connecting a horn to a diaphragm is radically unsound. After thirty years' study of horns of all shapes and lengths I have sorrowfully come to the conclusion that they were never intended by Nature for more than one note at a time. Even then, the horn is not capable of transmitting to the outside air an exact replica of the sound-wave produced at the diaphragm. Take the most perfectly designed and constructed exponential horn in the world and sing a note through it. The note produced at the narrow end is *not* the same in quality as that received at the wide end. When more than one note is sounded simultaneously the aberration is increased. Instead of spreading out in all directions in a comparatively wide space, the sound-waves are confined to an air column of definite shape and are profoundly influenced by it before debouching on to the open air. No amount of ingenuity on the designer's part can alter this characteristic condition. It does not matter whether the horn is one foot or a hundred feet long, it is bound to distort any complex wave-forms passing through it. As a *collector* of sounds the reversed horn is an excellent device. As a *radiator* it is radically deficient. But even if the horn could function as a perfect sound-radiator (it is an admirable *resonator*, as organ builders will testify), it makes futile all attempts at faithful reproduction. The reason for this is the comparatively small diaphragm necessitated by the system. It is impossible, apparently, to arrange the shape, mass, stiffness and movement of this diaphragm so that the lower, middle and upper registers of the musical scale can be uniformly reproduced. Further, a very distressing feature of the horn is its tendency to retain the sound after production has ceased. In long horns this is a heart-breaking phenomenon. The result is that transients are good in attack and slow in release. In the reproduction of rapid piano passages or of staccato chords this defect is very noticeable.

The moving-coil system operating a comparatively large diaphragm with a free, non-resonant suspension has brought the goal of faithful reproduction within measurable distance of attainment. The possession of a "moving-coil speaker" does not *ipso facto* entitle its owner to claim our congratulations. There are many specimens which are full of horrid resonances even apart from any bad effect the associated baffle may have upon them. Mr. Bertram Munn is doing us good service in condemning such monstrosities. But the moving-coil speaker as a *system* is the only contribution so far handed in that can satisfy the highest musical critics.

Hampstead, N.W.6.

NOEL BONAVIA-HUNT.

BRITISH BROADCAST TRANSMISSION.

Sir,—Ever since the war I have been interested in the wireless industry, and for a number of years it has been my sole business.

My house is on the outskirts of Edinburgh away from electrical disturbances and my aerial is in no way blanketed by buildings or trees.

British broadcasting in Scotland has for a very long time been an absolute farce and a disgrace to the British Broadcasting Corporation, and we are compelled to use wireless sets capable of giving long-distance reception from Germany, Norway, Italy, France, etc., to derive any real pleasure from our receivers. Complaints without number have been made to the B.B.C. about their rotten service in Scotland, but they are usually put aside by foolish answers or unfulfilled promises.

In the early days before many stations were erected we could get 2LO direct without fading—also Bournemouth, Cardiff, Birmingham and Manchester. The power of Bournemouth and Cardiff has now been cut down, so we cannot expect to get them, but, on the other hand, Manchester is as strong as ever, and 5GB has taken the place of Birmingham. Manchester we seldom hear, and 5GB with all its extra power fades so badly that it is not worth listening to. The two transmissions from Brookmans Park now replace the old 2LO. The transmission from both aeriels is received here for a few minutes at full loud speaker strength and then it fades completely out to return at regular intervals to full strength. When one writes for an explanation as to the reason for this fading on British stations in contrast to foreign stations the same old "tosh" of the Heaviside layer is served out. How is it, might I ask, that the Heaviside layer only affects British Broadcasting?

With a straight three-valve set, using ordinary valves, we can

get any night we wish the new Oslo station perfectly without the slightest fade or "mush" at greater strength than we get Glasgow 40 miles away. We also get Hamburg, Toulouse, Milan, Vienna, and many other Continental stations of less power than the British ones without fade or "mush." The high-powered Continental stations also come in without fade and no background of "mush."

Can anyone explain the reason for this peculiarity between British broadcasting and Continental broadcasting?

A lot of nonsense is written about the foreign transmission being messed up with Morse, etc. The only time we hear Morse on transmissions from abroad is on Sunday during the Hilversum concert or when using excessive reaction.

I feel confident there is some other reason for fading than the Heaviside layer. Part of it is, without doubt, due to the various waves acting like concentric rings formed in still water when stones are thrown in. What is the true reason? Can no one in this country explain it?

"EDINBURGH."

Sir,—I have followed with great interest the recent correspondence regarding the quality of the B.B.C. transmissions, as a result of which I have arrived at certain definite conclusions.

All the writers state that although some transmissions are well reproduced by their receiving apparatus, other transmissions of similar type appear to be of a decidedly inferior quality. Likewise, all are agreed that any appreciable length of land-line generally leads to a serious loss of quality. On further analysis of the correspondence, however, it is seen that while the majority of writers favour performances broadcast from concert halls, as giving more realistic reproduction from their receivers, there are others who assert that the only good transmissions are those emanating from a well-draped studio. Finally, there are writers who complain of the bad quality of certain items in a studio performance which is otherwise beyond reproach, although other equally critical listeners have failed to detect anything amiss.

It seems evident, therefore, that there are certain subtle differences in transmissions which affect different types of receiver in different ways. My lack of knowledge of transmitting technique prevents my going into details, but a possible line of investigation is suggested to me by a statement in a recent article on the Stenode Radiostat, where it was said that a certain amount of *frequency modulation* is present in ordinary transmissions in addition to the normal *amplitude modulation*. May not variations in the relative amounts of these two types of modulation be responsible for some of the hitherto unexplained variations in quality? Probably some of our technical contributors could enlighten us on this matter, and a series of articles on the relationship between modulation and receiver characteristics might enable us to remove *one* of the sources of complaint regarding the B.B.C.

E. F. FIGG.

Liverpool.

OUTSIDE BROADCASTS.

Sir,—I was very interested in "Frame Aerial's" remarks in this week's issue *re* Outside Broadcasts. Surely he does not intend us to take his letter seriously?

He talks about "real music, real singers, and real modulation." I wonder if he has ever listened to Albert Sandler's concerts from Park Lane, or Tom Jones' from Eastbourne, and if, after hearing them, he still maintains the same attitude towards Sunday evening relays?

Surely one cannot denounce the splendid performance that Sandler gives us as "second-hand rubbish." I think that the majority of listeners prefer to hear the Sunday evening church service relayed from some church or cathedral rather than from the studio. The whole atmosphere is entirely different. What better relay could one wish for than that of the service from St. Martin-in-the-Fields?

If "Frame Aerial's" plea for *studio broadcasts only* was carried out, we listeners would be the poorer, by missing some of the best orchestras, the best choirs, and the best preachers in the country; for it is hardly to be expected that a clergyman could deliver as inspiring an address to a microphone as he would to a living congregation.

It would be interesting to have other readers' views on this subject.

K. H. RANDALL.

Croydon.

Broadcast Brevities

By Our Special Correspondent.

Daventry's Power Increase.—Glasgow's Dilemma.—Those Talks.

More Power from 5XX.

Daventry 5XX is likely to increase its power in the next month or two, and there is a strong probability that it may be pushed up to its maximum of 50kW. This should be good news for the scattered army of unfortunates who are outside their nearest station's service area. One can only wonder why 5XX has curbed itself for so long. ○○○○

Joy on the Continent.

There will be less enthusiasm among those British listeners who favour the Continental long-wave stations. All these are inclined to spread themselves, and 5XX itself is no exception. With its power doubled it may cause still more interference with Eiffel Tower and Königswusterhausen. On the other hand, French and German listeners will be rubbing their hands with delight, 5XX being one of the most popular stations in Europe. ○○○○

Power Increase at Brookmans Park.

The 261-metre transmitter at Brookmans Park is still gradually increasing

its power, but I am authoritatively informed that the maximum is still a long way off, and that it will not be used even when the two stations have completed all tests. ○○○○

Prolonged Tests.

Tests on the present scale are to be continued throughout February. This means that on two or three evenings a week the "National" (shorter wave twin) will broadcast the published London programme while the Regional transmits the programme of 5GB. ○○○○

A Surprise.

A listener who has ceased to be thrilled by the "Surprise Items" has suggested that the B.B.C. should give us a surprise in the form of fifteen minutes' silence. ○○○○

Glasgow's Dilemma.

This reminds me of a reply recently sent by the Glasgow station to Savoy Hill in answer to an instruction that silence was to be observed during a certain interval in a forthcoming S.B. programme.

"Righto," said Glasgow, "and shall we use our silence or yours?" ○○○○

The Economy Question.

If economy in land-line expenses had been possible, Glasgow would not have asked the question, but the lines had to remain in circuit during the interval, and Glasgow naturally considered it rather a waste not to use them.

Savoy Hill retorted that Glasgow could use whichever silence was thought to be more artistic. ○○○○

Getting the Bird.

A provincial station director, who prefers to remain anonymous, reports that a hawk perches on the station aerial every evening just as the Children's Hour is beginning and flies away immediately the feature is concluded. The other night it dropped a dead bird on the station building, and the staff are wondering whether this was a tribute or a criticism. ○○○○

Talks.

In ten years' time I suppose eminent people will still be travelling to the B.B.C. studios to read aloud little articles which are to appear in print a day or two later. And yet, I wonder! Will the time come when the little articles will be read by qualified elocutionists? Shall we even see a time when the little articles are superseded altogether by vigorous extempore lectures given by people who can be trusted with a mere synopsis of what they intend to say? ○○○○

Those Sunday Programmes.

The Midlands have been engaged in a furious newspaper controversy over the question of the Sunday programmes, which are alleged by many to be exceeding the public demand for religious broadcasting. To judge from some of the letters one would gather that the country was on the verge of a civil war over this question, but reference to Savoy Hill indicates that letters on the Sunday transmissions are few and generally favourable. ○○○○

A "S.B." Play.

Naomi Jacobs' one-act play, "The Dawn," which is to be broadcast from all stations on February 12, will have the Glasgow studio as its stage. The play pictures an entirely mythical return of Bonnie Prince Charlie. Elliot Mason, of the Scottish National Players, will produce it.

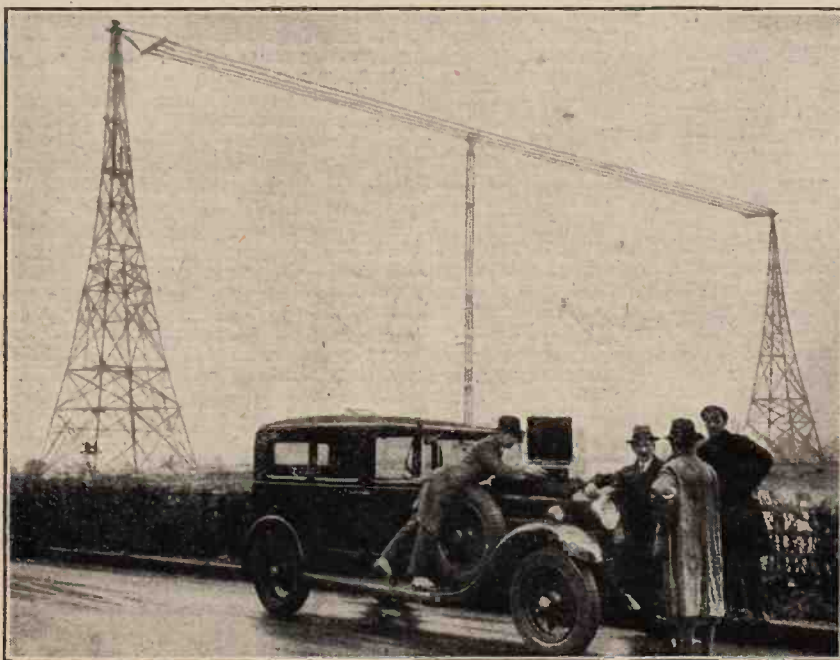

THE ACID TEST. An audacious experiment in separating the twin transmissions was recently conducted in the shadow of the Brookmans Park masts, the receiver being a McMichael Standard Portable. The photograph shows the receiver in use. Several Continental stations were well received while the B.B.C. transmitters were in action.

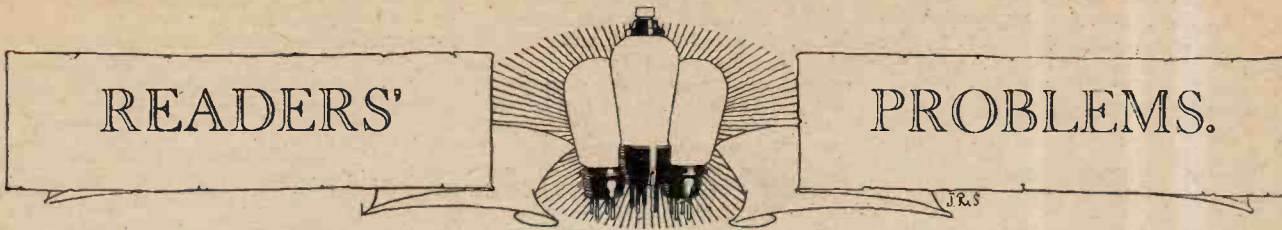

"The Wireless World" Supplies a Free Service of Technical Information.

The Service is subject to the rules of the Department, which are printed below; these must be strictly enforced, in the interest of readers themselves. A selection of queries of general interest is dealt with below, in some cases at greater length than would be possible in a letter.

Situation and Set.

My receiver comprises an S.G. high-frequency amplifier coupled by a transformer to an anode bend detector (without reaction), which is in turn transformer-coupled to the output valve. In broad principles the set is similar to arrangements that have been discussed on several occasions in your journal; in particular, the L.F. coupling transformer was carefully chosen, and has a very high primary inductance, while the valve preceding it is of low impedance.

Unfortunately, quality is far from good, although signal strength from several stations is adequate enough. Can you suggest a likely reason for this poor reproduction? H. A. C.

The circuit arrangement of your receiver is capable of giving good quality reproduction only when the detector is supplied with an H.F. voltage of considerable magnitude—approaching to its full capacity. We see that you live in Cornwall, and we cannot think that you are likely to get sufficient signal strength from any station (except, perhaps, at night under freak conditions) with the set as described. In particular, the H.F. transformer you are using is intended primarily for operation in conjunction with a grid detector and reaction; it is entirely unsuitable for your own arrangement, and cannot provide a very high degree of amplification.

Probably the best advice we can give you is that you change your system of rectification to the alternative method.

o o o o

Utilising the By-products.

Will you please examine my circuit diagram and let me know if the method of connection shown will provide a "free" positive bias of 2 volts on the grid of the detector? It should be explained that 4-volt valves are used throughout in the set, with the exception of the screen-grid H.F. amplifier, of which the filament is rated at 2 volts; the resistance R is of a suitable value for absorbing the surplus voltage. C. T. N.

The filament and grid return connections shown in your diagram (which is reproduced in Fig. 1) are quite correct for the required purpose. The junction of the detector grid return lead

(in your case the low-potential end of the grid leak) is made to a point which is 2 volts positive with respect to the negative end of the valve filament.

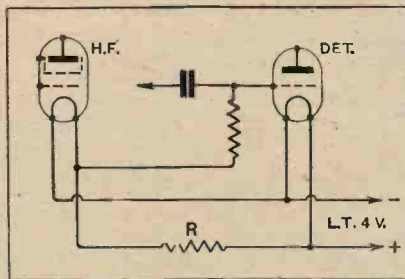

Fig. 1.—A 2-volt H.F. valve with 4-volt valves elsewhere: a form of connection giving 2 volts positive bias for grid detection.

o o o o

Foreign Listener's Four.

Will a volume control by variation of screen-grid voltage on the two H.F. valves be satisfactory? D. F. B.

You are not recommended to provide a variation of screen voltage as a means of volume control. Such a method will undoubtedly modify the performance of the H.F. stages by producing an adjustment far removed from a condition where the valve capacity is producing beneficial reaction effects. A more important con-

RULES.

- (1.) Only one question (which must deal with a single specific point) can be answered. Letters must be concisely worded and headed "Information Department."
- (2.) Queries must be written on one side of the paper, and diagrams drawn on a separate sheet. A self-addressed stamped envelope must be enclosed for postal reply.
- (3.) Designs or circuit diagrams for complete receivers cannot be given; under present-day conditions justice cannot be done to questions of this kind in the course of a letter.
- (4.) Practical wiring plans cannot be supplied or considered.
- (5.) Designs for components such as L.F. chokes, power transformers, etc., cannot be supplied.
- (6.) Queries arising from the construction or operation of receivers must be confined to constructional sets described in "The Wireless World" or to standard manufacturers' receivers. Readers desiring information on matters beyond the scope of the Information Department are invited to submit suggestions regarding subjects to be treated in future articles or paragraphs.

sideration is that change of screen voltage would, in the case of a battery-operated set, bring about an appreciable change in anode current. When fed from an eliminator through voltage regulating resistances this change in anode current will be accompanied by a considerable change in anode voltage as a result of the alteration in the voltage now dropped through the feed resistances.

o o o o

Unnecessary Precautions.

In the interests of safety, is there any need to earth a frame aerial during a thunderstorm? S. W. D.

It is entirely unnecessary to observe any safety precautions of this sort with a frame aerial, unless it is mounted external to the building—a very unusual procedure, of course.

o o o o

An Over-ambitious H.F. Amplifier.

I propose to make up a four-valve set with two H.F. stages of the type included in the "Record III" receiver. The extra H.F. stage is being added because the set is to be operated with a comparatively small frame aerial. Do you consider that any serious difficulty is likely to be encountered in getting a set of this sort into a state of satisfactory operation? S. W. S.

We would strongly dissuade you from proceeding with this project, as experience shows that it is an extraordinarily difficult matter to get two H.F. stages, each giving such an exceptionally high degree of magnification as to work without instability.

Difficulties will be accentuated by the use of a frame, which will tend to link up with other tuned circuits in spite of the most careful screening and the observation of the usual precautions towards complete isolation of individual circuits.

o o o o

An Anode Bend Rectifier.

Will you please tell me if a Mazda L.210 valve should be suitable for an anode bend rectifier followed by transformer coupling to the succeeding L.F. amplifier? R. W.

This valve has a rated impedance of 10,000 ohms, and a high mutual conductance; it will, therefore, be suitable for this purpose.

A.C. Kit Set Rectifier.

Will you please tell me if it is possible to use a Westinghouse Style H.T.4 rectifier in the construction of The Wireless World A.C. Kit Set? If so, a diagram showing the necessary alterations would be greatly appreciated.

A. T. V.

This type of rectifier can certainly be used. It should be connected in the manner shown in Fig. 2.

As the voltage output of the particular type of rectifier you specify will be only slightly in excess of that provided by the valve-transformer combination included in the original model, there is no real need to make any alteration in the values of the various voltage-absorbing resistances in the receiver itself. If preferred, however, you could bring about a slight reduction in the rectified output voltage by replacing the 4-mfd. condensers shown in the diagram as being connected across the rectifier by capacities of 3 mfd.

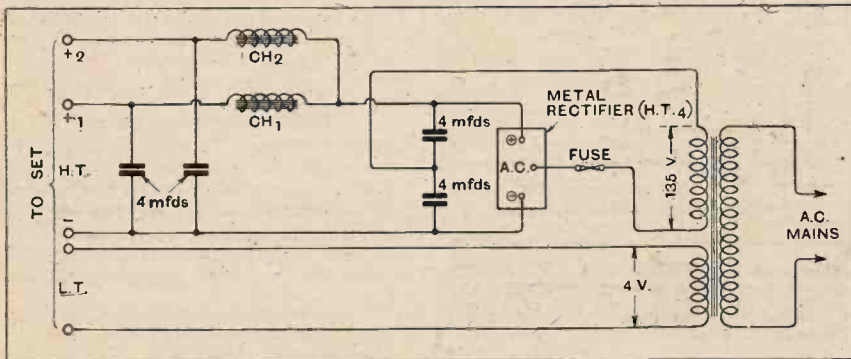

Fig. 2.—Circuit details of a metal rectifier using the voltage-doubling bridge scheme.

A Misconnection.

The tuning of the detector grid circuit of my recently completed "New Kilo-Mag Four" receiver does not seem to be operating properly. One or two stations towards the upper end of the medium broadcast waveband are received quite well, but only with the condenser set at minimum.

Apparently the second H.F. transformer is in perfect order, and is wound strictly in accordance with the published specification. Further, a test has been made by interchanging this transformer with the other one without any noticeable effect.

The following symptoms may, perhaps, convey something to you: the temporary disconnection of the detector anode by-pass condenser C_0 makes a very great difference to the strength of the few stations that are receivable—sometimes signal strength is increased and sometimes decreased by making this alteration. Any suggestions you can make as to the probable cause of the erratic behaviour of the circuit will be appreciated. B. J.

The test you describe would seem to preclude the possibility of any serious fault in the H.F. transformer, and it is likely that the trouble lies in the presence of an excessively high stray capacity across the grid circuit of the detector. In

all probability, the anode by-pass condenser to which you refer, instead of being connected between anode and negative filament of the valve, is actually joined between grid and filament. This would account for your troubles, and we advise that this point should be carefully checked; but it would be as well, at the same time, to assure yourself that the contacts of the wave-changing switch of the circuit in question are closing properly.

Gramophone Stroboscope.

Is the gramophone speed tester given in the issue of January 8th suitable for use with a 25-cycle supply?

H. H. M.

The number of black lines required for use with a 25-cycle supply, assuming 80 revolutions per minute, is $37\frac{1}{2}$. As obviously this cannot be produced, the figure of $37\frac{1}{2}$ is multiplied by 2, so that speed tester given in respect of 50-cycle supply and which consists of 75 bars

addition of a suitable potentiometer for this purpose.

It is just possible that the voltage applied to your grid circuit detector is not altogether suitable, but we doubt if this is likely to be responsible.

An Inexpensive Portable.

Can you refer me to the published description of a very small two-valve portable receiver which is easy and inexpensive to make, and which would be capable of receiving the 2LO and 5XX transmissions in London? Reception will be with headphones. W. R. F.

We think that the compact self-contained receiver described in our issue of April 18th, 1928, should be suitable for you, but it should be pointed out that a very small "loaded" frame aerial, as used in this receiver, is not particularly effective on the long wavelengths, and consequently signals from 5XX may not be obtainable if your receiving conditions are bad, unless a short aerial be added.

This is a common disability with det.-L.F. portables, and is difficult to overcome. Possibly it would be better to use an aperiodic H.F. stage, which will make up for the poor pick-up of the frame.

FOREIGN BROADCAST GUIDE.**HILVERSUM**

(Holland).

Geographical Position: $52^{\circ} 13' N. 5^{\circ} 11' E.$
Approximate air line from London: 226 miles.

Wavelength: 1,071 m. Frequency: 280 Kc.

(Before 17.40 G.M.T. transmissions are made on 298 m. 1,004 Kc. except Sundays.)

Power: 6.5 kW.

Time: Amsterdam (twenty minutes in advance of G.M.T.).

Standard Daily Transmissions.

8.40-9.05 G.M.T. Gramophone records (Sundays). 9.40, time signal (chimes); 9.40-9.55, morning service; 11.55, midday music; 17.10-18.10, dinner music; 18.25 or 18.55 (ex. Saturdays and Sundays), language lesson; 19.40, time, and main evening concert (Sundays, 19.55). Closes down at 23.40, preceded by short concert of gramophone records.

Programmes transmitted by A.V.R.O. (Algemeene Vereeniging Radio Omroep) and V.A.R.A. (Vereeniging Arbeiders Radio).

Interval Signal for V.A.R.A. only: a musical box; nine chords repeated every 5 seconds.

On alternate Sundays special transmission given for English listeners at 17.40 G.M.T. (Sponsored by Kolster Brandes Ltd.). On these occasions announcements are made in Dutch and English.

Male Announcer. Call: *Hier Hilversum, Holland, or Hier...* (and initials of Society giving transmission).

Closes down with a few bars of the Dutch National Anthem: *Wilhelmus van Nassau.*

can be used on 25 cycles. Synchrony between the movement of the bars and the supply frequency will now occur at half the correct r.p.m. as well as the 80 r.p.m. adjustment.

Eliminators: A Weak Point.

I have recently obtained an eliminator for my 1-v-1 set, of which I am sending you a circuit diagram. Although there is no instability, and quality is better than with a battery feed, I am disappointed to find that the range of the receiver is very seriously reduced; stations that were originally audible in daylight are now not heard until after dark.

Will you please say if the set is of a type that lends itself for use with an eliminator, and also point out the most likely causes for this falling-off in sensitivity?

H. E.

Your receiver is quite conventional, and as its H.F. stage is coupled to the detector by means of a double-wound transformer, and there is a choke filter output, it should be possible to feed it even from the most "brutal" type of eliminator.

We think it likely that your trouble is due to the fact that your eliminator includes no provision for critical adjustment of screening grid voltage. If this assumption is correct, we recommend the

ALBERT COATES

tests the tone!

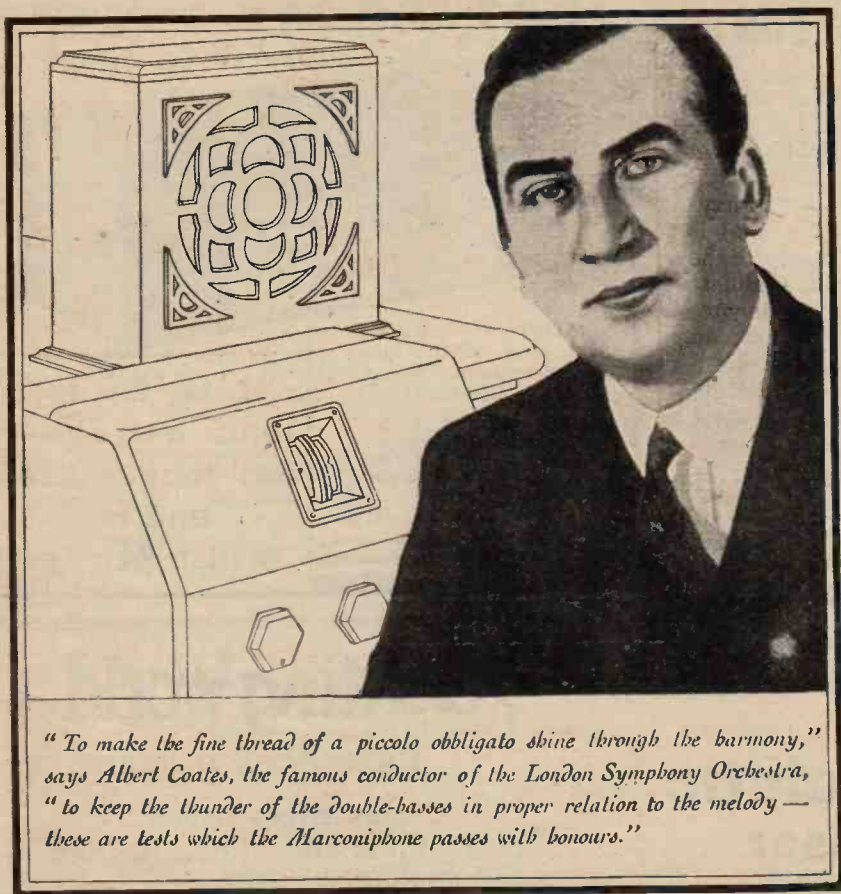

MODEL 60 CABINETCONE (shown on left). Obtainable at the very moderate price of £3, the Model 60 is a highly efficient "all-purpose" speaker. Made on the latest lines and embodying the Marconiphone reed system, its tone is outstandingly good.

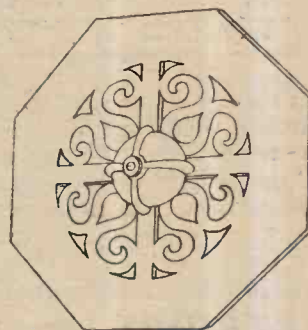

FOR 30/-... THIS FIRST-CLASS CONE SPEAKER. Giving excellent reproduction from a 2- or a 5-valve receiver, the Octagon Cone is a very popular speaker. It is made in two different and attractive designs, and can be placed on the table or hung from the wall.

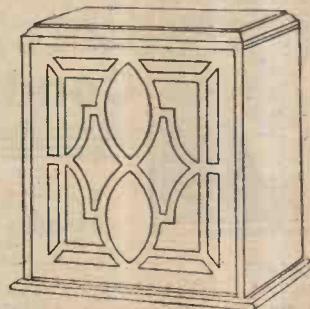

MARCONIPHONE MOVING COIL SPEAKER. Its sensitivity unrivalled by any speaker today, the Marconiphone Moving Coil responds fully, evenly to all tone-frequencies. Volume great enough for a ballroom! Works equally well with a 2- or a multi-valve receiver. Units from £4.10.0. Cabinet models: for 6-volt accumulator, £7; for D.C. mains, £7.10.0; for A.C. mains, £12.12.0.

WHAT is it to be? Dance band, a famous orchestra, an entertainer? Your surroundings fade away. You are in the audience itself—as you listen with the Marconiphone loud speaker! Every note in the musical scale, every modulation of the voice comes through marvellously clear, absolutely life-like.

Marconiphone engineers make these speakers. Thirty years of leadership, of tireless research are in their design and construction. Famous musicians, Sir Edward Elgar, Chaliapine, Peter Dawson, many others, are enthusiastic in praise of their tone, their volume. Ask any dealer to demonstrate the Marconiphone Speakers to you. The Marconiphone Company Limited, 210-212, Tottenham Court Road, London, W.1.



THE FIRST AND GREATEST NAME IN WIRELESS

Listen with a **MARCONIPHONE LOUD SPEAKER**

▲39 Advertisements for "The Wireless World" are only accepted from firms we believe to be thoroughly reliable.

PARMEKO



ON AN ELIMINATOR, CHOKE OR TRANSFORMER

denotes a product that is technically correct, made by skilled workmen, and the finest materials. PARMEKO components are always used where the best is required. In spite of the

Write for price-list of Wireless Mains Apparatus.

great variety of our stock range, which is almost unrivalled, we are specialists in apparatus to your own specification. No longer need you put up with the nearest if you want a component for a particular job. Let us know your requirements and we will quote you by return for the exact thing you need.

See the name PARMEKO before you buy.

PARTRIDGE & MEE LTD.
26, DOVER STREET, LEICESTER. 74, NEW OXFORD STREET, LONDON, W.C.1.

MERSHON Electrolytic Condenser

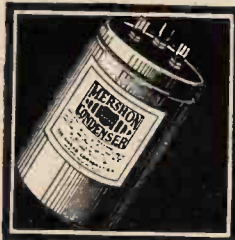

Engineered into your circuit the MERSHON Electrolytic Condenser

modernises its construction and insures its efficiency.

It saves weight, space, cost, trouble and replacements! It gives you capacity far beyond your fondest dreams!

For instance, 72 microfarads in 32 cubic inches.

It gives you a new low hum-level; and a new high standard of tone quality. And because it's self-healing, it gives life-time, wear-proof trouble-free service that makes its low first-cost its last cost as well.

One of the most important features of the Mershon Condenser is the low value of leakage current; this being 1 1/2 to 2 milliamperes per 10 mfd. Another surprising factor is the breakdown voltage at 400 volts D.C. and the fact that the condensers will stand surges up to 1,000 volts without damage. Types are available with single, double, triple and quadruple anodes with capacities from 18 to 72 mfd.

Write for complete data.

THE ROTHERMEL CORPORATION Ltd.
24, Maddox St., London, W.1.

'Phone: Mayfair 0578/9.

Fit the DUBILIER BATTERY

Fitted with the long-life Dubilier Battery, your Set will give better quality performance over 66 volts a longer period. **7/9** And it costs less! Other Voltages Available.

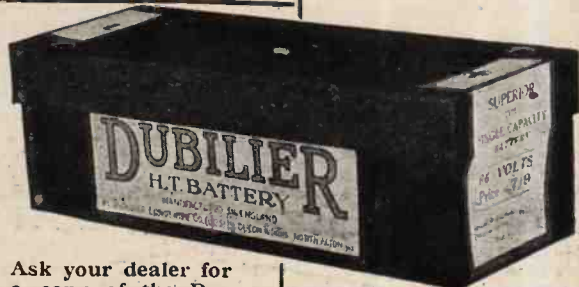

Ask your dealer for a copy of the Dubilier Booklet—"A Bit about a Battery."

DUBILIER CONDENSER CO. (1925), LTD., Ducon Works, Victoria Road, North Acton, London, W.3.

—it is Cheaper than others—has longer life, and is British Made.

Cleaver B22

The Yachting World and Motor Boating Journal

Covers Every Aspect of Yachting and Motor Boating
FOUNDED 1894

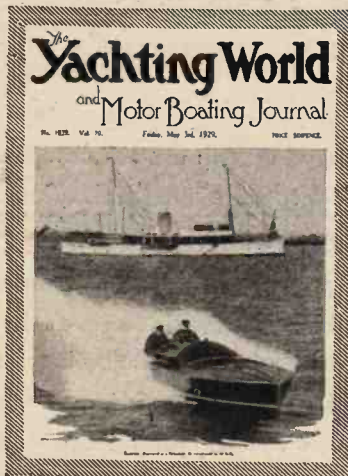

All who are interested in power-craft, whether cruisers, speed-boats or outboards, will enjoy reading "THE YACHTING WORLD and MOTOR BOATING JOURNAL."

It is a well-produced and attractive paper dealing with yachts and boats of all types and tonnages on sea and inland waters.

Racing, cruising, deep-sea sailing, practical seamanship and the construction of small craft are among the chief subjects of interest.

SUBSCRIPTIONS: Home and Canada, £1.10.4, other countries abroad £1.12.6, per annum, post free.

Every Friday 6^D.

ILIFFE & SONS LTD., Dorset House, Tudor Street, London, E.C.4.

W.W.8:

Mention of "The Wireless World," when writing to advertisers, will ensure prompt attention.

MISCELLANEOUS ADVERTISEMENTS.

NOTICES.

THE CHARGE FOR ADVERTISEMENTS in these columns is:

12 words or less, 2/- and 2d. for every additional word.

Each paragraph is charged separately and name and address must be counted.

SERIES DISCOUNTS are allowed to Trade Advertisers as follows on orders for consecutive insertions, provided a contract is placed in advance, and in the absence of fresh instructions the entire "copy" is repeated from the previous issue: 13 consecutive insertions 5%; 20 consecutive, 10%; 52 consecutive, 15%.

ADVERTISEMENTS for these columns are accepted up to FIRST POST on THURSDAY MORNING (previous to date of issue) at the Head Offices of "The Wireless World," Dorset House, Tudor Street, London, E.C.4, or on WEDNESDAY MORNING at the Branch Offices 19, Hertford Street, Coventry; Guildhall Buildings, Navigation Street, Birmingham; 260, Deansgate, Manchester; 101, St. Vincent Street, Glasgow, G.2.

Advertisements that arrive too late for a particular issue will automatically be inserted in the following issue unless accompanied by instructions to the contrary. All advertisements in this section must be strictly prepaid.

The proprietors retain the right to refuse or withdraw advertisements at their discretion.

Postal Orders and Cheques sent in payment for advertisements should be made payable to ILLIFFE & SONS Ltd., and crossed & Co. Notes being untraceable if lost in transit should not be sent as remittances.

All letters relating to advertisements should quote the number which is printed at the end of each advertisement, and the date of the issue in which it appeared.

The proprietors are not responsible for clerical or printers' errors, although every care is taken to avoid mistakes.

NUMBERED ADDRESSES.

For the convenience of private advertisers, letters may be addressed to numbers at "The Wireless World" Office. When this is desired, the sum of 6d. to defray the cost of registration and to cover postage on replies must be added to the advertisement charge, which must include the words Box 000, c/o "The Wireless World." Only the number will appear in the advertisement. All replies should be addressed No. 000, c/o "The Wireless World," Dorset House, Tudor Street, London, E.C.4. Readers who reply to Box No. advertisements are warned against sending remittance through the post except in registered envelopes; in all such cases the use of the Deposit System is recommended, and the envelope should be clearly marked "Deposit Department."

DEPOSIT SYSTEM.

Readers who hesitate to send money to unknown persons may deal in perfect safety by availing themselves of our Deposit System. If the money be deposited with "The Wireless World," both parties are advised of its receipt.

The time allowed for decision is three days, counting from receipt of goods, after which period, if buyer decides not to retain goods, they must be returned to sender. If a sale is effected, buyer instructs us to remit amount to seller, but if not, seller instructs us to return amount to depositor. Carriage is paid by the buyer, but in the event of no sale, and subject to there being no different arrangement between buyer and seller, each pays carriage one way. The seller takes the risk of loss or damage in transit, for which we take no responsibility. For all transactions over £10 and under £50, the fee is 2/6; over £50, 5/-. All deposit matters are dealt with at Dorset House, Tudor Street, London, E.C.4, and cheques and money orders should be made payable to Illiffe & Sons Limited.

THE SALE OF HOME-CONSTRUCTED UNLICENSED APPARATUS.

A Service to our Readers.

We have made an arrangement with the Patentees whereby readers who wish to dispose of a home-constructed receiver not licensed under the patents made use of, can license the set by means of the Deposit System referred to above.

The person desiring to sell, in sending us particulars for his advertisement, will in every case make use of a Box No., and should add to the price which he requires the amount of royalty customarily paid by manufacturers.

If the purchaser is satisfied with his purchase, the sum realised will be forwarded to the seller, less the amount due in respect of royalties, which amount will be paid by "The Wireless World" to the owners of the patents concerned, and a certificate will be handed on to the purchaser of the set.

SPECIAL NOTE.—Readers who reply to advertisements and receive no answer to their enquiries are requested to regard the silence as an indication that the goods advertised have already been disposed of. Advertisers often receive so many enquiries that it is quite impossible to reply to each one by post.

B&J

ALL WIRELESS WORLD COILS
1930 EVERYMAN
FOUR

| | |
|------------------------------------|--------------|
| KH SET, Coils with Switches | 47/6 set |
| NEW KILOMAG | 45/- set |
| RECORD III | 45/- set |
| FOREIGN LISTENERS 4 B.B.C. | 30/- set |
| METAL CABINETS | 5XX 37/0 set |
| 5 1/2" DRUM DIALS with Escutcheons | 38/6 to 46/6 |
| | 5/6 |

B&J. Wireless Co
2, 3, & 4, Athelstane Mews, Stroud Green Rd., N.4
Archway 2695

"END OF YEAR CLEARING."

APPLEBY'S

FOR BARGAINS WATCH Phone: Paddington
THE MISCELLANEOUS COLUMNS THIS MONTH. 8838 (3 lines)

For Modern High-grade Material Only.
CHAPEL ST., LONDON, N.W.1
OPEN TILL 7 P.M. SAT. 1 P.M.

A PICK-UP ARM WHICH IS ADJUSTABLE

IN ANGLE AND LENGTH TO ENSURE BEST TRACKING UNDER ALL CONDITIONS—AND THE PRICE IS REASONABLE.

12/6
(Bushed bearings 1/- extra).
Length 10 1/2 ins.
Height 3 1/2 ins.
British throughout



KUSHA PICK-UP ARM

"Swivel" Continental fitting (as illustrated) allows turn of Pick-up for easy insertion of needle from the top whilst maintaining the advantage of the long fall section. Vibrationless, weight-relieving, adjustable.
Of all Dealers, through G.E.C. and all main Factors, or direct from

R. H. GLASSCOE & CO.,
71, MOORGATE, LONDON, E.C.2.
Phone: London Wall 1176.

ROTOR-OHMS

If a volume control is specified in any given circuit, order a ROTOR-OHM. Because Rotor-ohms are smooth, silent, superbly finished and reasonably priced.



Send for a list of the famous European set manufacturers, who standardise Rotor-Ohms in their instruments. YOU WILL THEN REFUSE ALL SUBSTITUTES.

| | |
|---|--|
| <p style="text-align: center;">Ohms</p> <p>2,000, 5,000, 10,000, 25,000, 50,000, 70,000, 100,000, 200,000, 500,000, 1 Megohm, 2 Megohms 7 Megohms</p> | <p style="text-align: center;">2 TERMINAL TYPE 5/9 each.</p> <p style="text-align: center;">POTENTIOMETER TYPE 6/6 each.</p> <p style="text-align: center;">Rotor Electric Ltd. (Dept. W/W) 2-3, Upper Bathbone Place, LONDON, W.1. Telephone: MUSEUM 2841-2842.</p> |
|---|--|

RECEIVERS FOR SALE.

SCOTT SESSIONS and Co., Great Britain's Radio Doctors.—Read advertisement under Miscellaneous. [0264]

FERRANTI 5-valve, push-pull amplifier, twin turntables, Magnavox speaker on 3ft. baffle, all new; cost £56, accept £30; delivered within 100 miles.—Bradford, Entertainer, Whitchurch, Bristol. [7943]

WIRELESS Portable Sets, with 5 Cosor new process valves, for 9 guineas; less than components cost, comparable with any set double this price, Royalty paid; seen between 1 and 2 p.m., or particulars sent on receipt of stamped addressed envelope.—G. Hodgson, 53, Windsor House, Victoria St., Westminster. [7971]

GRAMOPHONE Amplifiers and McMichael Portable Sets Lent on Hire; sets modernised, installed and maintained.—Alexander Black, The Wireless Doctor, 55, Ebury St., S.W.1. Sloane 1655. [0322]

BOWYER-LOWE 1929 Short Wave, with valves 10, 5,000 metres; £5.—Burleigh House, West Heath Rd., N.W.3. [8135]

MARCONI Straight Eight Valve (chassis only), complete with valves and long wave coils; exchange portable or cash offer.—Mansell, 64, Baxtry Rd., Sheffield. [8166]

READ and MORRIS, Ltd., the mains pioneers, who in 1925 equipped the hospital with mains sets, still supreme in all-mains receivers and units.

LOW Tension A.C. Eliminators, permanently replacing batteries, now only £5/15; electrolyte condensers, 2,000 m.f., as used in above, 13/-; including postage. [8134]

BARGAINS.—Second-hand sets, units, meters, speakers.—Read and Morris, Ltd., 31, Eastcastle St. (facing back of Warings), Oxford St., W. [8156]

ELSTREE Six Receiver for Sale, complete with all coils and valves, or components separately; what offers?—Box 4691, c/o The Wireless World. [1444]

P.W. Magic 3 valves, cabinet, H.T., and B.T.H. speaker, complete; £6.—E.F., 30, Alperston St., Queen's Park, W.10. [8141]

MARCONIPHONE Model 35 3-valve Screened Grid Receiver, cost £12, accept £6; B.T.H. 45/-; pick-up, 29/6.—Robinson, Draper, Lowestoft South. [8134]

G.E.C. Portable S.G., cost £27/10, sell for £12/10; excellent condition, new valves, etc., in use 4 months; no reasonable offer refused.—H. Sindell, 53, Oxford Av., Merton Park, S.W. [8131]

A.J.S. 3-valve Receiver, nearly new, with valves, H.T. batteries, and 2 6-volt accumulators, in perfect condition; £13/10.—Hopewell, 78, Charles St., Newark, Notts. [8128]

5-VALVE Suitcase Portable, Pembroke Zenic type, used once, in perfect order, not scratched; £9.—Wallis, 49, High St., Saffron Walden. Phone: 45. [8125]

BRAND New Pye 3-valve Screen Grid Receiver, model 360, cabinet takes all batteries; £9.—Wallis, 49, High St., Saffron Walden. Phone: 45. [8126]

3-VALVE All Electric Eko Receiver, with valves, detector, 2 I.F.s, perfect, for D.C. mains; listed £16/10, accept £10.—Wallis, 49, High St., Saffron Walden. Phone: 45. [8127]

WE Offer You the Following Inducements to Purchase Your New Receiver or Other Apparatus from us.

FIRSTLY.—Unbiased advice. The principal of the firm has twenty years' professional wireless experience, having been at Government Experimental Stations in 1910. He has been Manager for the Sterling Telephone Co., radio expert to the G.E.C. and Chairman of the Technical Committee of the National Association of Radio Manufacturers. His advice has saved our clients many thousands of pounds, for, as everybody knows, there is no hobby on which more money is wasted on useless apparatus by the uninitiated.

SECONDLY.—We take your old apparatus in part exchange for new. Send us a list of your old apparatus, or, better still, send us the apparatus and state your new requirement. We will then make our offer for your goods, and if you do not approve, which is unlikely, we will return the parcel, carriage paid.

IF You are in Doubt as to the Make of Receiver or other Apparatus you should Purchase, write to us, and we will advise you; we have no leaning towards any particular maker, and will tell you the particular instrument you should buy for your purpose.

SCIENTIFIC DEVELOPMENT Co., 51, Fishergate, Preston Tel.: 1364. [0226]

SIMMONDS BROS.—Receivers constructed to your own or any published design; also repairs, reconstructions, and modernisations at moderate charges; best materials and workmanship guaranteed; numerous testimonials; quotations free.—Address, Shireland Rd., Smethwick. [5882]

BRANDES 3-valve A.C. Set, as brand new, with speaker; £13/10; demonstration.—Box 9694, c/o The Wireless World. [8151]

3-VALVE Set, all waves; with coils and valves, working order; £9.—Box 4715, c/o The Wireless World. [8210]

Receivers for Sale.—Contd.

ALL Mains (A.C.) 3-valve Set, unused; cheap.—Details, 6, Hauberk Rd., S.W.11. [8179]

5-VALVE Solodyne, large oak cabinet, one high and four low tension accumulators, excellent condition; cost £60, will accept £20.—Box 4714, c/o *The Wireless World*. [8209]

1930 Ether Searcher, complete kit specified components, valves, H.T., loud speaker; £11, or wired £12.—School House, Church Hill, Winchmore Hill. [8200]

1930 Marconiphone 4-valve A.C. 100-250, ideal reception, £17; Marconiphone moving coil speaker, 45/-; Ever-Ready accumulator, ebonite, 6-volt, 85 actual, 42/-, cost £4; all had two weeks' use only.—H. H., 39, Gloucester Gardens, W.2. Paddington 3268. [8195]

MUST Be Cleared.—The famous Royal Air Force 3-valve receivers, absolutely perfect reception on the loud speaker, a wonderful set; cost £18, we are sacrificing at 32/6, brand new, guaranteed.—J. B. Humphreys and Co., 23, College Hill, Cannon St., London, E.C.4. [8193]

MARCONI T2 5-valve Screened Grid, oak cabinet, valves, Ecko, H.T. eliminator, A.C. 210-240, perfect; lot £10.—1, The Drive, Northwood, Middlesex. [8191]

MARCONI Model 44, 2 screen grid, detector and pentode, set complete as new, complete with valves, £12; Lion Senior chassis, £3/10; Philips pick-up, £1; Meltrope tone arm, 7/-; also various components for sale cheap; lists.—1, Hamilton Drive, Giffnock, Renfrewshire. [8181]

ACCUMULATOR HIRE.

DON'T Buy Accumulators or Dry Batteries, join our G.A.V. low- and high-tension accumulator hire service, the largest and best in London; better and cheaper reception with no trouble; regular deliveries within 12 miles of Charing Cross; no deposit, payment on each delivery or by quarterly subscription; over 10,000 satisfied users; explanatory folder post free; phone or write to-day.—Radio Service (London), Ltd., 105, Torrionia Av., N.W.5. Phone: North 0623-4-5. [7596]

C.D.E.S. Accumulator Hire and Maintenance Service (5 mile radius).—98, Cherry Orchard Rd., Groydon. [6374]

BATTERIES.

WET H.T. Replacements.—Snacs (capped or uncapped), highest grade, No. 1, 10d. per doz.; No. 2, 1/9 per doz.—See below.

ZINCS.—Best quality (wired), No. 1, 8d. per doz.; No. 2, 9d. per doz.; orders valued 5/- carriage paid, otherwise 6d. for postage.—British Battery Co., Clarendon Rd., Watford, Herts. [0258]

WATES Wet H.T. Battery, No. 3 size, 120 volts, complete with wooden box; £1 only.—225, Ardgowan Rd., Catford, S.E.6. [8133]

CHARGERS AND ELIMINATORS.

TANTALUM and Lonium for A.C. Rectifiers; make up your own inexpensive chargers; blue prints for H.T. and L.T., 1/- each; Lonium electrodes fitted with terminals, 2-3 amps. and 5-8 amps.—Blackwell's Metallurgical Works, Ltd., Speke Rd. Works, Garston, Liverpool. Phone: Garston 980 (2 lines). [6282]

PHILIPSON'S Safety High Tension Battery Eliminators.

10/- Down and the Balance in Easy Monthly payments secures the finest high tension supply available.

PHILIPSON'S Safety Eliminators are Guaranteed for 12 Months.

PHILIPSON'S Safety Eliminators are the Cheapest to Install and the Cheapest to Run; prices: Model A.O.5 £4/17/6, A.O.7 £3/17/6, complete with full wave, rectifiers; D.C.4 37/6, D.C.5 45/-.

ALL Models Obtained for 10/- Deposit; take advantage of this and get constant high tension immediately.

WRITE for Our Booklet, "Radio Power" to Philipson and Co., Ltd., Radio Engineers, Astley Bridge, Bolton. Phone: 2038. Grams: Safety, Bolton. Est. over 50 years. [0318]

CHEBROS.—Chebros for all types of transformers and chokes, high grade instruments at a very moderate price; enquiries invited.—Chester Bros., 244, Dalston Lane, London, E.8. [5290]

TRANSFORMERS and Chokes for Battery Eliminators and for all wireless purposes, receiving or transmitting; enquiries invited.—Chester Bros., 244, Dalston Lane, London, E.8. [7587]

ATLAS Eliminator, D.C., 200-250 volts, 15 milliamps, quite new 6 weeks ago; reason for sale, supply now A.C.; cost 37/6, sacrifice, 25/-; tappings at 60 and 120 volts.—F. J. Lineton, 2, Trench Lane, Wellington, Shropshire. [8149]

EKCO A.O. Eliminator, metal rectifier, 120 volts 25 milliamps, £3/10, cost £6/10, almost new; Ferranti trickle charger, new, £2/5.—Saint, Derby Rd., Swanwick, Derbyshire. [8146]

EKCO Eliminator, A.C., cost £5/8, hardly used, 75/-; A.R.23 mahogany horn, 35/-; A.R.65, 15/-, both splendid condition.—Butler, "The Mums," Durants Hill, Hemel Hempstead. [8118]

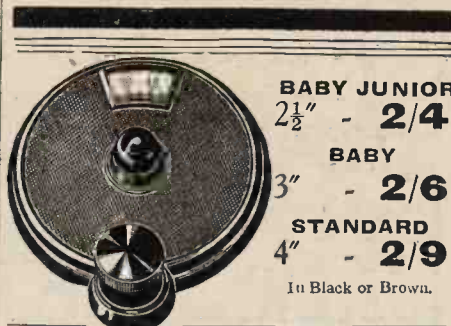

"ISO" DIALS

"Iso" Dials have a definite grip. They do not slip.

ISOMONA 70 PRECISION
SIZE PRICE
3" 4/-

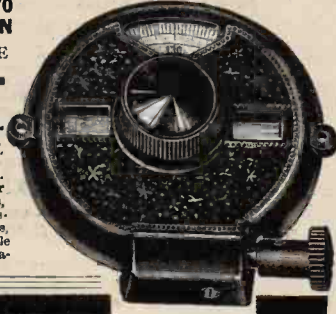

HAW & Co. Ltd.
20, CHEAPSIDE, London, E.C.2.
Tele: CITY 110.
Sole Distributor for "Iso" Products, Cone Units, Transformers, Chokes, Condensers, Trickle Chargers, Eliminators, etc.

TANNOY

HAVE YOU A GOOD SET?

Incorporated in place of your present H.T. and L.T. batteries, Tannoy mains units make your present set "all electric." they are "trouble free" with no expensive renewals.

Switch on like the electric light.

Combined H.T. and L.T. ... £5-12-6 (complete)

H.T. only £2-17-6. L.T. £2-12-6

TULSEMERE MANFG. CO.,
1-7, Dalton St. West Norwood, S.E.27.
Tel.: Streatham 6731.

Mains Units

TWIN CONE KIT OF PARTS

For a Double Linen Diaphragm Speaker

Steel chassis built, adjustable damping attachment. Size 20" square. Takes any popular movement.

GREEN & FAULCONBRIDGE, LTD.,
11, QUEENS ROAD, COVENTRY

Chargers and Eliminators.—Contd.

BRITISH Made Transformers for Westinghouse Rectifiers, universal primary 200-250 volts 50 cycles, outputs 135v. 70 m.a., 2-0-2v. 3 amps, 17/6; chokes, 40 henries 35 m.a., 11/-; 50 henries 100 m.a., 18/6, post free; list on request.—C. F. Gibbs, Pennygate, Spalding. [8116]

SAVAGE'S Specialise in Wireless Power from the Mains, reliable apparatus at reasonable prices.

SAVAGE'S.—Transformer laminations and bakelite bobbins; intending home constructors should write for list.

SAVAGE'S.—Reliable smoothing condensers, 1,000 volt D.O. test, 1 mfd., 2/-; 2 mfd., 3/-; 4 mfd., 5/3; 500 volt D.O. test, 1 mfd., 1/6; 2 mfd., 2/3; 4 mfd., 3/9.

SAVAGE'S.—Super smoothing and output chokes, many types available; write for list.

SAVAGE'S.—Mains transformers for Westinghouse H.T.4 unit, 18/6; A3, 17/-; A4, 20/-.

SAVAGE'S.—Mains transformers for Westinghouse H.T.4, with additional winding, 4 volts 3 amps, 23s.

SAVAGE'S.—Mains transformers V.T.31, 200-0-200 volts 60 m/amps, 2+2 volts 2 amps, 2+2 volts 3 amps, 28/-.

SAVAGE'S.—Mains transformers V.T.35, 250-0-250 volts 60 m/amps, 2+2 volts 1 amp., 2+2 volts 3 amp., and, for automatically biased super power valve, 3+3 volts 5 amp., 33/-.

SAVAGE'S.—Mains transformer B.T.3, 500-0-500 volts 120 m/amps, 3.75+3.75 volts 3 amps, 3+3 volts 3 amps, 2+2 volts 3 amps, 51/-.

SAVAGE'S.—Mains transformers and power chokes are carefully and individually constructed from first class materials with an exceptionally generous margin of safety.

SAVAGE'S, 146, Bishopsgate, London, E.C.2. Phone: Bishopsgate 6998. [7976]

RECTIFIER H.T. Eliminator Kit, comprising rectifying unit incorporating Westinghouse H.T.3, necessary condensers, choke, etc., output 120 volts at 20 m.a., complete; 45/-; money willingly refunded if not satisfied; state voltage.—Mic Wireless Co., Market St., Wellingtonburgh. [8205]

RADIELLE D.C. Eliminator, output 200v. 100m.a., and 2 variable outputs; cost £7/10, sell £2; brand new.—B. O. Priestley, 46, Glasslyn Rd., Crouch End, N.8. [8152]

CABINETS.

ARTCRAFT Radio Cabinets are Britain's Best Value. [0313]

DIGBY'S Cabinets.—Table models in solid oak and mahogany; from 11/6 to 71/-.

DIGBY'S Cabinets, fitted with Radion or Resiston ebonite if required.

DIGBY'S Cabinets.—Pedestal model, with separate battery components; from 56/- to £12.

DIGBY'S Cabinets Made to Customer's Own Designs.

DIGBY'S Cabinets.—Write for new 16-page art catalogue.—F. Digby, 9, The Oval, Hackney Rd., E.2. Phone: Bishopsgate 6458. [0128]

ARTCRAFT Radio Cabinets; Britain's best value; lowest prices consistent with highest quality; illustrated list free from actual manufacturers.—Artercraft Co., 156, Cherry Orchard Rd., Croydon. Phone: Croydon 1981. [0040]

KAY'S Cabinets, the greatest range of pedestal cabinets in the kingdom; original creative designs at prices 50% lower than elsewhere; quotations for specials by return; delivery at short notice guaranteed; moving coil, portable, baffle, vignette, radiogram, electric pick-up, television, etc.; illustrated lists free.—H. Kay, Wireless Cabinet Manufacturer, Mount Pleasant Rd., London, N.17. Phone: Walthamstow 1626. [7745]

ARTCRAFT Radio Cabinets are Britain's Best Value. [0311]

CABINETS for All Requirements.—F. W. Ramsey, 63, Shaftesbury St., London, N.1. Clerkenwell 7139. [8155]

ARTCRAFT Radio Cabinets are Britain's Best Value. [0309]

RADIO-GRAMOPHONE Cabinets, speaker and pedestal cabinets, sideboard radio-gramophone; write or call for catalogue.—Baker, 407, Hackney Rd., E.2. [8203]

ARTCRAFT Radio Cabinets are Britain's Best Value. [0310]

COILS, TRANSFORMERS, ETC.

1,000-OHM Decoupling Resistances for "Wireless World" Circuits; 1/6 each, post free.—Groves Bros., St. Mary's Place, Shrewsbury. [7833]

RADIOGRAPH.—V.W. coils, Record III, 35/-; new Kilo-Mag Four, 33/-; S.G. Regional, 37/6; foreign listeners' Four, 37/6 set; Europa Portable, 21/-; Europa III, 18/6; S.G. multi-valve portable, 22/6; new Everyman Four, 42/6.

RADIOGRAPH.—Litz wire, 9/40, 1/6; 27/42, 2/6 dozen yards, Redfern's deep ribbed or Beool tube, 5d. per inch, slotting 1/6 extra.—Station Rd., Handsworth, Birmingham. [7914]

NEW Kilo-Mag Four Coils, 37/6 set; ebonite formers (slotted), for winding, 12/6 set of 3; all post free; trade supplied.—Groves Bros., St. Mary's Place, Shrewsbury. [7975]

Mention of "The Wireless World," when writing to advertisers, will ensure prompt attention.

Coils, Transformers, Etc.—Contd.

600-OHM Decoupling Resistances for New Kilmag Four, foreign listeners' four, and all "Wireless World" circuits, hand made and tested in our own workshops; improved model, 1/6 each, post free.—Groves Bros., St. Mary's Place, Shrewsbury. [7832]

PUSH-PULL Transformers, world famous make, none better, absolute satisfaction or money refunded; 25/- per pair; will send c.o.d.—Sutton, 37, Belfield Rd., Rochdale. [8172]

SIMMONDS BROS.—Berolif coils, Record Three, 50/- pair; new kilo-mag, four, 50/- set; foreign listeners four, low, 30/-; long wave, 37/-; screened grid Regional, 40/-; Mullard S.G.P. dual range coils, 30/- pair; Berolif standard coils, for new all-wave four, standard four, A.C. three, Everyman four, etc., 63/6 set of 4, with bases; the same coils for the Lodestone series ("Wireless Magazine"), 65/9 set of 4, with bases; Titan unit, 15/-; decoupling resistances, 600 ohm, 1/6; 1,000 ohm, 2/-; all "Wireless World" and similar coils in regular production by the leading specialists; list free; trade supplied.—Simmonds Bros., Shireland Rd., Smethwick, Tek.: Smethwick 751. [6314]

GRAMOPHONES, PICK-UPS, ETC.

CROSSLEY-MEROLA Pick-up, with tone arm and volume control, 25/-; National filter, 10/-.—Shelley, Meadowcroft, Trentham, Staffs. [8188]

COLLARO Double Spring Motor, unused, perfect; 25/-.—6, Hauberk Rd., London, S.W.11. [8180]

PANATROPE Electrical Gramophone, made by B.T.H., moving coil speaker, two B12s output stage, contained in beautiful mahogany cabinet, A.O. 25 cycles and up; cost £80, perfect condition, £25.—1, Hamilton Drive, Giffnock, Renfrewshire. [8182]

DYNAMOS, ETC.

D.C. Generator by Lancashire Dynamo Co., 600 volts 0.1 amp. at 1,400 revs., this high class machine only had few hours running, perfect! What offers?—Green, "Staveleigh," Knott End, near Fleetwood. [8143]

M-L Rotary Transformer, type E, input 200 D.C., output 600 D.C. 200 m.a.s., as new, 20 hours' working only; £8/10, or offer.—Radio, 2, Ashburnham Gardens, Harrow. [8190]

LOUD-SPEAKERS.

BAKER'S SELHURST RADIO 36-page Booklet, "Sound Advice is Yours for the Asking"; write now for new edition; see displayed advertisement on page 21. [0231]

SELF-CENTRE, a device when fitted to your speaker will relieve driving rod of undue side stress, centering cone to driving rod thus improving results, ideal for linen speakers, easily fitted; price 2/6; c.o.d.; terms available.—Weedon, 80, Lonsdale Av., London, E.6. [8040]

PERARDUA Moving Coil Reproducers have a Pedigree, 7 years' experience designing and constructing high quality loud-speakers has preceded model S14, which is the most perfect instrument obtainable; 230-volt D.C. £3/3, 6-volt £3; handsome oak cabinet £2/2 extra.—R. Vevers, 4, York Rd., Maidenhead. [8170]

ZAMPA Double Cone Chassis, unused, 32/6 model, beautifully finished, 15/-; 7 days' approval against cash; also D.C. mains moving coil speaker, on 7 days' approval against cash, 29/6.—Fox, 115, Avondale Rd., Kettering. [8163]

PERMANENT Magnet Moving Coil Speaker, guaranteed not to lose magnetism, in perfect working order and splendid condition, cost £9/10; sent on 7 days' approval against cash; £3.—Brew, Pytchley, Kettering. [8162]

MOVING Coil Magnet Pots, ready machined, complete with coil former, 4/6; spiders for same, 2/6, ex stock; genuine bargain; 7 days' approval against cash.—Mic Wireless Co., Market St., Wellingborough. [8161]

£5/5 Amplion Horn Speaker, 14in. oak flare, perfect condition; £2/10.—Ross, 42, Lord Roberts Av., Leigh-on-Sea. [8160]

AMPLION Lion L14; £3/10.—Stockdale, 29, Towneley St., Burnley. [8159]

CONE Speaker, Blue Spot unit, floating cone, solid oak baffle, ornamental fret, fitting corner of room. £2; Ferranti O.P.3C, 19/-; Marconi phone Ideal M.C. output transformer (unused), 12/6; write, or call any evening.—89, Brooklands Rd., Hall Green, Birmingham. [8148]

EPOCH

Speakers by Deferred payments.

EPOCH

Speakers by Deferred payments.

EPOCH Famous Moving Coil Speakers, any type, may be obtained by any responsible householder, by easy payments; no interest, no references no red tape as simple, easy and quick as paying cash.

EPOCH

on the Easy.—Full particulars from Laser-son, Ltd., Gramol House, Farringdon Avenue, E.C.4. [7919]

EPOCH
Moving Coil Speakers
LEAD THE WORLD!

10 distinct models of Permanent Magnet Speakers. 9 distinct models of Electro Magnet Speakers, including the **New Model 101 (Domino)**, incorporating our **XX Magnet Pot** with a guaranteed flux density in the air gap of at least **15,300 lines per square C.M.** Full range comprises 60 models from 50/- to £30.

Send for Catalogue W.S.3 and particulars of the 7 days' approval offer.



Our Greatest Triumph!

Epoch
Super-Cinema Model

The most powerful speaker ever put on the market, and the most sensitive too! Many times as sensitive as an ordinary moving-coil speaker. Such superb quality has never been heard before. Delivers enormous volume and wonderful quality from the most modest of sets. The speaker for the home, public entertainments or Talkies!



EPOCH RADIO MANUFACTURING CO., LTD.,
Patentees and Manufacturers.
City Office & Service Station: 3, Farringdon Avenue
(Ludgate Circus end), E.C.4.

Loud-speakers.—Contd.

NIKOLA Cones; 3/-, 3/6, 4/-, 4/6; manufacturers' type, standardised, floating on leather.—Particulars from Knight and Co., 6, Chapel St., London, E.C.2. [8015]

LINEN Diaphragm Loud Speakers, front 22in., back 14in., with baffle, fit any type unit, £1; polished mahogany case and front fret, 27/6.—Melodist Radio, 57, Sparsholt Rd., Crouch Hill, N.19. [8186]

LATEST Marconi Moving Coil, 6-volt model, with baffle; 70/-; call evenings.—Potter, 2, St. Aidans Rd., London, S.E.22. [8202]

TRANSMITTERS.

CHEBROS. Chebros. Chebros transformers and chokes of all descriptions, special transformers for transmitting and modulation; chokes a speciality; enquiries invited.—Chester Bros., 244, Dalston Lane, London, E.8. [5240]

VALVES.

TWO P625A, 2 D.E.5A, 1 D.E.P.610, 2 D.E.5; 25/- the lot.—Box 4702, c/o The Wireless World. [8168]

TWO P625 Osram Valves; 7/6 each, 14/6 pair.—196, Farebrother St., Grimsby. [8122]

VALVES—D.E.5, D.E.5B, 4/- each; L.S.5A, L.S.5B, 15/- each; L.S.6A, £1; Celestion Woodroffe, £2; B.T.H. phones, 7/6; all brand new and guaranteed.—B. O. Priestley, 46, Glasslyn Rd., Crouch End, London, N.8. [8153]

AMPLIFIER Valve.—If you require power you cannot do better than one of these:—

FILAMENT Volts 6, plate volts 400 (maximum), grid bias 84 volts (approx.), impedance 800 ohms, amplification factor 3.8, mutual conductance 4.35 m.a./volts; price £5/10; see article "The Wireless World," 24th July, 1929, then send to North London Valve Co., Ltd., 22½, Cazcove Rd., Stoke Newington, London, N.16. [8177]

OSRAM P425, 5/6; Cossor 410 R.C., 4/-; full emission.—41, Finchley Rd., Southend-on-Sea. [8185]

COMPONENTS, ETC., FOR SALE.

BELLING-LEE Panel Fittings are designed to give an expert finish to any home-constructed set; catalogue post free.—Belling and Lee, Ltd., Queensway Works, Ponders End, Middlesex. [0018]

POWER Chokes, substantially built, for smoothing circuits in eliminators dealing with currents 100-300 milliampères, inductance 30 henries; 8/6 each; guaranteed 12 months.—Transformer Repair Co. (Dept. W), 214, High St., Colliers Wood, S.W.19. [0327]

WESTON Model 301, milliammeters, ammeters, and voltmeters, 21/- each; hot wire ammeters 0-1 amps., 4/-; 0-0.5 amp., 3/-; instrument repairs and alterations; send for list.—The Vieta Electrical Co., 47, High St., Battersea, S.W.11. Established 1910. [7563]

POTENTIAL Dividers 10,000, 15,000, 20,000, 25,000 and 30,000 ohms, 5 variable tappings; 2/- each.

POTENTIAL Dividers, heavy duty, wire wound, 15,000 and 20,000 ohms, 7 tappings, 5/6; 4 tappings, 3/9.

CONDENSERS, 2 mfd., 2/3; 4 mfd., 4/-; guaranteed; tested 500 volts.

CHOKES (L.F.)—Excellent for smoothing, up to 20 milliamps, 2/-; special heavy duty, 100 milliamps, 8/6.

ELIMINATORS, A.C., wired for half or full wave, complete with valve; £3/17/6.

H.F. Chokes; 3/-.

GRAMOPHONE Motors, well known make, double spring, silent, complete with fittings; 30/-.

SPECIAL Bargain.—B.T.H. 40 henry chokes; 9/6; any article on approval against cash.—Huggins, Radio Engineers, Clacton-on-Sea. [7398]

600-OHMS Decoupling Resistances; see advt. under Coils.—Groves Brothers, Manufacturers. [7751]

REMOTE Control Relays, new, not ex-W.D.; send 10/- P.O., stating accumulator voltage, to F. W. Hughes, 17, Blackheath Vale, London, S.E.3. [7944]

APPLEBY'S Bargains.

THE Following Slight Used Material is Offered Subject to Sale; every article will be severely tested before despatch, and guaranteed in workable condition; items are net cash and carriage paid in Great Britain.

RESIDUE of Transformers.—Ferranti A.F.5, 19/6 each; Ferranti A.F.3, Marconi Ideal, R.I. Straight Line, Mullard Permucore, Phillips, all one price, 14/- each limited number.

RESIDUE of Pick-ups.—Woodroffe, 45/-, 35/- and 25/- each; R.I. Varley, 25/-, 20/- each; Brown, best model 45/-, 30/- each, prices depending upon condition; smaller Brown, Igranic Phonovox, Amplion Vivavox, G.E.C., Burndep, all one price, 14/- each, limited number; Blue Spot and arm, 27/6; B.T.H. and arm (straight), 32/-; arms, Raytrak, 19/6; Watmel, 4/9.

NOW—Send now; many clients were disappointed when material having been sold previous to their application for goods lately.

APPLEBY'S, Number Forty-four, Chapel St., Marblebone, N.W.1 (4 minutes from Oxford St., London). [0316]

EPOCH

PERMANENT MAGNET MOVING COIL SPEAKERS.

Parts specified in "Wireless World," Jan. 15, 1930.

Obtainable from Stock.

Complete Speakers from £3 - 15 - 0

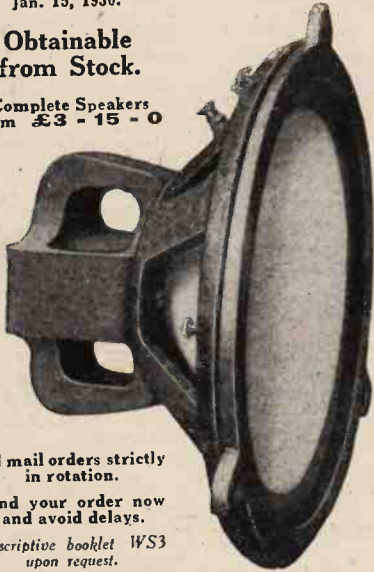

All mail orders strictly in rotation.

Send your order now and avoid delays.

Descriptive booklet WS3 upon request.

EPOCH RADIO MANUFACTURING CO. LTD.,
Farringdon Avenue, E.C.4.
*Phone: Central 1971 (2 lines). Private Branch Exchange.

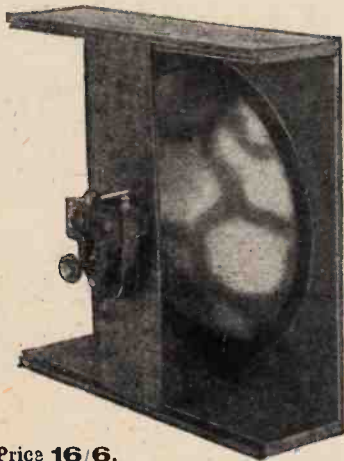

Price 16/6, complete with unit, including royalty.

Built up as a complete unit, fitted with a specially tested "Ormond" adjustable unit, the above chassis will find favour among all constructors of Radio-Grams, Portables, etc. Each chassis is thoroughly tested, and dispatched ready for playing. The artistic mosaic sprayed finish of the cone and baffle gives a pleasing effect, when chassis is placed behind a fretted grill.

Manufactured under licence, under patents owned by Messrs. Standard Telephones & Cables Ltd. Manufacturers' and dealers' inquiries invited.

WARRICK RADIO,
246, Romford Rd., Forest Gate, London.

Components, Etc., For Sale.—Contd.

COMPONENTS Lent on Hire; send for details.—Alexander Black, The Wireless Doctor, 55, Ebury St., S.W.1. Sicuna 1655. [0329]

RADIO HOUSE, Huddersfield, issues the Reliability Wireless Guide, which will be sent post free upon request by Messrs. J. H. Taylor and Co., 15, Macaulay St., Huddersfield. [7825]

YOUR Old Components Taken in Part Payment for Latest Type; see our advert. in column Receivers for Sale.—Scientific Development Co., 51, Fishergate, Preston. [0228]

CONTROL your Receiver from that Other Room by Means of the Foolproof and Inexpensive Yarg Relay, no maintenance or attention; model for battery operated sets, 10/6 post free: mains models, 17/6; 22/6, 25/-; stamp particulars.—Yarg, 1, Eccles Old Rd., Manchester. [7790]

EXPERIMENTER'S Surplus, some not used.—Ferranti A.F.5, 15/-; Ferranti A.F.5c P.P., 15/-; Marconi Ideal 2.7, 10/-; McMichael H.F. choke, 2/6; Varley volume control, 5/-; Watmel speaker unit, 5/-; Dubilier electrostatic pick-up, 6/-; Igranic pick-up, 5/-; Rich and Bundy transformer P.P., 10/- each; Sterling v. condenser 0.0005, 6/-; Igranic coils, 1,500, 650, 500, 400, 300, 60, 75, 2/- each; Lissen three, 200, 50, 60, 2/- each; Burndep 10, 15, 20, 30, 1/- each; various valves; National scratch filter, 5/-; O.A.V. dynamo, 12v. 8 amp.—Burleigh House, West Heath Rd., N.W.3. Carriage extra. [8136]

GAMBRELL Novotone, Bonaird-Hunt type C coupler; offers.—Box 4701, c/o The Wireless World. [8167]

R.I. Tuner and R.C. Coupler, 15/- and 8/-; new A.F.5C, 17/6; new valves, P.M.5B and P.M.5X, 7/-; D.U.2, 10/-.—2, Kingshill Rd., Knowle, Bristol. [8158]

HIGH-CLASS Apparatus and Components in new condition; list supplied on request.—1, Stapleford Rd., Wembley. [8157]

B.T.H. Pick-up (straight arm), with Bulgin scratch filter, 28/-; leather portable case, 15in. x 12in. x 8 1/2in., 15/-.—Rendall, 38, Caroline Place, Chelsea, S.W.5. [8150]

MAINS Transformer by Dearbeard, 220-240v. A.C., gives 300v. at 60 m.a., with 0.05 valve, 17/6; 6-volt 1/2-amp. pot for moving coil, Baker new coil to suit, P.625, 15/6; both genuine bargains.—R. Roach, 284, Hessle Rd., Hull. [8142]

SQUIRE Chassis, cone, and Blue Spot unit, 17/6; Brown Vee unit, 12/6; Marconiphone Popular horn loud-speaker, 15/-; all as new; set of components for Titan Three, best makes, including 3 Cossor valves, 45/-.—Box 4692, c/o The Wireless World. [8140]

OFFERS Wanted for D.E.5B (unused), P.M.5 and 6 (used), Clarostat volume control, Columbia Junior portable gramophone, 10 H.M.V. records, all as new.—Jones, Yatesfield, Nailsworth, Glos. [8138]

60V. Exide W.J., 14/-; Lissen gramophone unit, 4/-; Ormond 0.0005 and Jackson's 0.0003, friction geared, S. law; both for 9/-.—16, Manor Rd., Levenshulme, Manchester. [8132]

COMPONENTS, as new.—Transformers, chokes, coils, condensers (fixed and variable), valves, holders, speakers; stamp for list, must clear.—Inglis, Westgate Rd., Bury St. Edmund's. [8130]

PERFECT Condition, 32/-; Garrard double spring motor, 21/-; also O.P.3C, 12/6; and Cossor 2-volt R.C., 5/6, new.—Wilkinson, Golden Ball, Workson. [8129]

EXIDE 150-volt H.T. Accumulators, Oldham A.C. H.T. charger, new condition, 85/-; 2 D.E.5A, 10/-.—Watson, 23, Stangray Av., Nutley, Plymouth. [8125]

LOTUS Relay, Lissen Pick-up (15/-), several Igranic, Lissen and Lewcos coils; what offers?—Williams, 29, Briarfield Av., N.3. [8120]

NOVOTONE, unused, 85/-; P.625, P.M.256, S.625 valves, used test only, half price; Celestion-Woodruff, 84/-; pick-up, just overhauled by makers, 30/-; Philips, 55/-; trickle charger, 35/-, unused.—How, 252, Berkhamsted Rd., Chesham. [8119]

PHILIPS H.T. Eliminator, A.C., 205v.; also Philips trickle charger, Marconi 6v. valves, and all components for James Touchstone Receiver, everything guaranteed, brand new; all half list price.—Jackson, 77, Hopton Rd., Streatham, S.W.16. [8206]

A MATEUR'S Surplus, little used.—Ferranti resistance and holder, 20,000 ohm, 3/-; ditto, 5,000 ohm, 3/-; Centrolab 500,000 ohm potentiometer, 6/-; 2 Dubilier K.C. variable condensers, 0.0005 (slow motion), 6/6 each; drum dials for same, 2/6 each.—Ambrose, 21, Chapel Lane, Formby, Liverpool. [8197]

BROWN'S Microphone Amplifier Relay, in case, as new, cost £6, £3; meters, 0-3 volts, 0-160 volts, 0-32 milliamps, 7/- each.—Richmond, Victoria Rd., Mill Hill. [8194]

BLUE Spot 66K, unused, 20/-; Gilman adjustable chassis, new, 10/6; Cosmos R.C. unit, with valve holder, 5/6.—Morris, 27, Vernon Av., Carlton, Notts. [8192]

ONE Pair Matched L.S.6A Valves, £2; one pair matched L.S.5A valves, 25/-; Meltrope pick up arm, 10/-; specially tuned Phonovox pick up, cut for fibres, 20/-; R.I. H.F.C., 6/-.—Temple, Knockdolian, Comrie, Perthshire. [8187]

WE SPECIALISE IN MAKING PURCHASES FOR OVERSEAS READERS

Parts, Speakers, Eliminators, or complete Sets. We can buy them for you and what is more will see to it that your requirements are met in every way.

HOW TO ORDER

Enclose money order to the approximate amount of the purchase and add 5% to cover freight, Insurance, etc.

THE OVERSEAS TRADING CO.,
144, St. Vincent Street, Glasgow, Scotland.
Telegrams: "Tensity," Glasgow.

THE WANDER PLUG WITH THE POWERFUL GRIP

Look at its prongs of special spring-metal that grip the socket—its insulated holder—the neat engravings on the head—its finish. Replace your old wander plugs with Belling-Lee to-day and put an end to bad contacts and loose plugs.

Ask your dealer, or send to us for free Belling-Lee Handbook "Radio Connections."

4d.

P. Pat.

BELLING-LEE FOR EVERY RADIO CONNECTION

Advertisement of Belling and Lee, Ltd., Queensway Works, Ponders End, Middlesex.

"APTUS" LINEN DIAPHRAGM TRIPLE CHUCK ADAPTER FITS ALL UNITS

COMBINED BRASS AND CELLULOID WASHERS. PREVENTS RATTLE.

EXPERTS SAY:—"The most Successful Centre yet Devised."

PRICE 2/6 POST 3d.

"APTUS" DOPE .. 2/9
DOPE BRUSH .. 6d.
IRISH LINEN for 22in. 7/6
8 ANGLE BRACKETS with screws .. 1/6
RUBBER .. 6d. yard
SET (4) 2 B. A. RODS (6 NUTS and WASHERS) .. 1/6

ORDERS OVER 10/- POST FREE

Makers of "APTUS" specialities
MOORE & Co.
(Est. 50 YEARS)
101 & 103, Dale St., LIVERPOOL
Phone: Cen. 5284. Grams: "Solutions"

Mention of "The Wireless World," when writing to advertisers, will ensure prompt attention.

"Layerbilt"

Every inch of space is used in making the famous Columbia "Layerbilt" battery. The result—concentrated power from top to bottom and an electrical capacity half as great again as any other battery in the world of the same type and size. Not a single soldered connection.

25/-



Also
No. 4780.
60 Volts.
For multi-
valve sets.
20/-
No. 4763.
99 Volts.
Specially
recommended
for portables.
18/-

**by
Columbia
RADIO BATTERIES**

J. R. MORRIS, Imperial House, 15, Kingsway, London, W.C.
Scotland: J. T. Cartwright, 3, Cadogan Street, Glasgow.

POPULAR

The Brownie POPULAR Transformer is every bit as good as it looks. Its purity of amplification gives vivid clarity throughout the full musical range, while its sturdy British construction ensures that it will give this quality of reproduction not just now and then, but always. It costs only 9/6, and does the work of transformers at double its price.

BROWNIE WIRELESS CO. (G.B.) LTD.
Nelson Street Works, London, N.W.1



9/6

TRANSFORMER

BROWNIE

WIRELESS

A45 Advertisements for "The Wireless World" are only accepted from firms we believe to be thoroughly reliable.

Components, Etc., For Sale.—Contd.

SHORT Wave Variable Condensers: Cydon 0.00015, 8/6; J.B. 0.0001 reaction, 3/-; 2 Lewros coils, 20-90 metres, and base, 9/6; all new.—Geddes, Southbar, Rentrew. [8183]

STAR ENGINEERING 6-volt Moving Coil, H.R., perfect; 39/6, or exchange. Wanted, 230 A.C. moving coil, 1 amp., charger, pick up and arm.—46, Princes Boulevard, Bebington. [8173]

MARCONIPHONE Universal Transformers, 16/-; Cossor type slow motion dials, 2/3; Lotus type anti-microphonic valve holders, 3 for 2/6; S.L.F. condensers, 3/11; gramophone pick ups, 12/6.—Harris, 5, Martaban Rd., Stoke Newington, N.16. [8137]

MISCELLANEOUS.

ALEXANDER BLACK,
The Original Wireless Doctor, will call (London and Home Counties) and cure your set.
CONSULTATIONS by Appointment Without Obligation, sets installed, maintained, and brought up to date, gramophone pick-ups, eliminators, and Webson moving coil speakers demonstrated; purity reproduction specialist.
55 Ebury St., Victoria, S.W.1. Sloane 1655. [0277]

EASY Payments.—We supply, by easy payments, components, accessories, and sets, any make; 10% down, balance spread over 10 months.—Send list of requirements to London Radio Supply Co., 11, Oat Lane, London, E.C.2. [0097]

WIRELESS Notes.—A monthly service of information for all those who want the very best in wireless or gramophone reproduction; frank criticism of receivers and components; immediate postal help and advice in all difficulties; something new and unique; you must have it if you want to know the truth.—Full particulars free from Ernest H. Robinson, Langmead, Pirbright, Woking, Surrey. [7607]

SCOTT SESSIONS and Co., Great Britain's radio doctors, officially approved as wireless repairers by Radio Society of Great Britain and Wireless League; old sets of every type repaired, rebuilt, modernised; send set for immediate quotation.

SCOTT SESSIONS and Co.—New sets constructed with your or our components, guaranteed finest workmanship; we specialise in "The Wireless World" circuits; remember, we have satisfied customers throughout the British Isles and in three Continents; if you so desire, we will design and construct high grade apparatus to suit your special circumstances for quality, range and selectivity.—Tel.: Tudor 5326. Muswell Hill, London, N.10. [0262]

PATENT AGENTS.

PATENTS and Trade Marks, British and foreign.—Gee and Co (H. T. P. Gee, Member R.S.G.B. and A.M.I.R.E.), 51-52 Chancery Lane, London, W.C.2. 'Phone: Holborn 1525. [0001]

KING'S PATENT AGENCY, Ltd., 146a, Queen Victoria St. E.C.4.—Free advice and handbook on patenting inventions and registering trade marks by registered agent with 43 years' experience. [0002]

REPAIRS.

SCOTT SESSIONS and Co., Great Britain's radio doctors; read advertisement under Miscellaneous column. [0263]

TWELVE Months' Guarantee Accompanies all our Repairs; any make of L.F. transformer, headphones, or loud-speaker repaired and despatched within 48 hours; 4/- post free; don't discard if burnt out; terms to trade.—Transformer Repair Co. (Dept. W.), 214, High St., Colliers Wood, S.W.19. [0011]

REPAIRS Returned Post Free, and to ensure satisfaction send remittance after approval of same.—Leeds Wireless Repair Service.

LOUD-SPEAKERS, headphones, rewound to any resistance and remagnetised, 3/-; transformers rewound, 4/-; Blue Spots, Triotrons and 4-pole units, 4/6; work guaranteed.—Leeds Wireless Repair Service, 5, Boston Place, Green Rd., Leeds. [8101]

GUARANTEED Repairs by Experts.—Loud-speakers, headphones, cone units, pick-ups, any type, rewound, remagnetised, and adjusted, post free 4/-; transformers, from 4/-.—Howell, 91, Mofley Hill, Enfield, Middlesex. [7882]

LOOK!—Overhauls, repairs, maintenance; work carried out honestly and efficiently; moderate charges.—Bolton, 221, Cavendish Rd., Balham. [8199]

REPAIRS by Wireless Expert.—Loud speakers, 3/6; phones, 2/6; pick-ups, 3/6; rewound, returned O.K.; post free; terms to trade.—Cornwell, 15, Eastbrookend Rd., Romford. [8174]

WANTED.

WANTED for Experiment, dud valves, 6d. each; 1/- each S.G. and pentode.—Box 4706, c/o The Wireless World. [8171]



MARCONIPHONE Model K Transformer.—Fleming, Manor Cottage, Mill Lane, Rainhill, Lancs. [8124]

NEW PUBLIC ADDRESS and Broadcasting MICROPHONES

The Ideal Instruments for addressing an Audience through Loudspeakers (via Valve Amplifier or L.F. Stages of Wireless Set), and for relaying Speech and Musical Entertainment to any distance.
Powerful Loudspeaker Reproduction with perfect Purity.

Hand Type,
highly distance-sensitive, yet guaranteed entirely free from distortion or microphone noise, absolutely silent background; far superior to ordinary Microphone Transmitters; for use with Valve Amplifier or Valve Set (through leads of Gramophone Pick-up if desired) at Open-air Meetings, in Cinema, Theatre, or Concert Hall. Operates from 2 Volt tapping of L.T. Accumulator, through Microphone Transformer. Current consumption one-tenth Ampere. Provided with detachable Sound Collector, handle, hook for suspension, and a 9ft. silk connecting cord as illustration.

16/6

Pedestal Type
Highly Sensitive Microphone as above described, provided with detachable sound collector and a 9ft. silk connecting cord, but fixed by rubber-cord suspension in nickel-plated frame on pedestal 11in. high; for mounting on Speaker's Platform, in Pulpit, on top of Camera Stand, or for suspension from ceiling, as illustration.

25/-

The above Microphones are rendered Directional by attaching the Sound Collector.

Microphone Transformer,
special design to obtain best possible results from sensitive Microphones when connected to high-resistance phones, Loud Speaker, Valve Set, or Valve Amplifier; best Transformer made for clear speech with volume, modulation speech and music transmission, Public Address Microphones, etc.: Prim. and Sec. terminals fitted; full directions for use of Microphone and diagrams of connections free. Goals by return post.

6/-

FREDK. ADOLPH, Actual Maker,
27, Fitzroy Street, London, W.1. 'PHONE: Museum 8323

The Pilot Resistograd



For Volume and Oscillation Control, especially suitable for Eliminator Circuits.

Absolutely free from packing.
Four turns of the knob covers a range from 40 ohms to about 10 megohms.
Handles 20 watts.

RETAIL 5/- PRICE

Also all Lines manufactured by The Pilot Radio and Tube Corporation of New York.

Write for Catalogues to:—
THOMAS A. ROWLEY, Ltd.
59, Skinner Lane, Birmingham.
West of England Distributors:—
F. BURRIS & SONS, 7 to 16, Redcliffe Street, Bristol.

Receiver Sale

Electradix Clearance Bargains of Broadcast Receivers and Speakers at a fraction of cost. Cannot be sent on approval at these sacrifice prices. Valves and Batteries extra. Cannot be repeated when stock sold.

One-valve Sterling, steel-clad units with coil holders: 139/153, 15/-.

Marconiphone 1 Valve and Detector RB10 with valve, 17/6. 1 Valve TMC and Efesca, 17/6. 2 Valve Ditto, RB10 H.F. and L.F. enclosed in leatherette covered Cabinet, 35/-. Ditto, 2 L.F., 35/-.

3 Valve Sterling, Anode on Desk type, 50/-.

4 Valve Polar, H.F., Det., and 2 L.F., vertical polished Mahogany, 70/-. 5 Valve R.A.F.10, with valves, oak American type Cabinet, 80/-. Aircraft model, with valves, 60/-. Ditto, without remote control, 40/-. R.A.F.70 Receiver-Amplifier, 60/-. Marconi No. 55 7-valve H.F. screened, No. 39, 60/-.

Valve Bargains. 2 volt D.E., 4, 4 volt D.E., 3/6 AT 40, Power, 4/6.

Power Amplifiers for gramomotors and Western Electric 2-valve, mahogany case, 45/-. Sterling ditto, 45/-. W.D. M.K. IV, 40/-. Sterling 1-valve, 15/-. Panatrope for D.C. mains, 65/-.

Loud Speakers. Horn. Small NK, 5/-. Assorted, all sizes, 10/-. 15/-. and 20/-. Brown's H3 Loud Speakers, List £3; Sale 27/6. Brown's H30 Speakers, List £3 5s.; Sale 30/-. Brown's Disc Speakers, List £5 5s.; Sale 45/-. Brown's Cabinet Speakers, List £6 6s.; Sale 48/6. Western Electric, 12/-. Exponential curled in Tone Chamber, 10in. by 8in., Sale 28/-. Reed-diaphragm Balanced Units to match, 17/6.

300 CABINET LOUD SPEAKERS. The famous Violina, all mahogany, 2,000 ohms. Perfect reproduction high to bass. All new. List £5 5s.; Sale 22/6. Baker Texas Cone Speakers, plated frame, 17/6. Hegra, 14/-. Units, reed type for Portables, 5/-. Skinder, 5/6. Cones, 2/-. Powerful 4-pole Double Acting Magnetic Units, 8/6; usually 12/6.

ELECTRADIX RADIOS,

218, Upper Thames Street, E.C.

Blackfriars Sta., Met. Rly.

City 0191.

MUCH IMITATED

CLAROSTAT

NEVER EQUALLED

REDUCED PRICES!

STANDARD. WAS 10/6 NOW 9/6

VOLUME. " 8/6 " 7/6

POWERTYPES. WERE 15/6 " 13/6

FREE 40 Page Illustrated Booklet with Scale Drawings all types mains apparatus etc.

CLAUDE LYONS LTD.

76, OLDHALL ST., LIVERPOOL.

PAREX

Bakelite Drum Dials with Escutcheons

5/6

(from stock).

Cabinets, Coils, Valve Holders, etc., for New Kilo-Mag 4 and 1930 Everyman 4.

Order direct from

E. PAROUSSI,

10, Featherstone Buildings, High Holborn, W.C.1

Phone: Chancery 7010.

Mention of "The Wireless World," when writing to advertisers, will ensure prompt attention.

Wanted.—Contd.

WANTED, Mullard P.M. speaker, model E; must be cheap and efficient.—Oriebar, Crossways, Binstead. [8184]

DOUBLE Gang 0.0005 Condenser Drum Control; exchange S.625 and holder and D.E.P.610, almost new, or cash.—6a, Barnard Rd., S.W.11. [8189]

WANTED, mains transformers, valves, etc., to convert receiver to 200 A.C.; cheap.—H. Braithwaite, "Hillingdon," Brunstead Rd., Bournemouth. [8196]

EXCHANGE.

K NITTING Machine; exchange for portable wireless set.—Baker, 138, Church Rd., Battersea. [8147]

50/- Geophone Stork Cone Speaker, new; 30/-; exchange wireless components.—Hawkins, 11, Station Lane, Wombwell, near Barnsley. [8145]

PORTABLE Receiver Required in Exchange for "Wireless World" 3-valve Regional Receiver; cash adjustment.—Box 4654, c/o The Wireless World. [8139]

IGRANIC Pentofor and 6-volt Mullard Pentone Valve, both brand new; will exchange for other modern components.—Waine, Gayhurst, Streetly, Birmingham. [8115]

YOUR Old Apparatus Taken in Part Payment for Latest Type; see our advert. in column Receivers for Sale.—Scientific Development Co., 51, Fishergate, Preston. [8230]

EXCHANGE Ford Engine, converted, stationary, magnet, extension shaft, pulley, for single-cyl. water-cooled, or dynamo.—12, King Edward Rd., Coventry. [8176]

BUSINESSES & PROPERTY FOR SALE, TO BE LET, OR WANTED.

PROGRESSIVE Wireless Business, turnover over £2,000 per annum, South West England; living accommodation; low rent; £250.—Box 4607, c/o The Wireless World. [8059]

WIRELESS and Electrical Business for Sale, established 6 years, London, main road shop, accumulator charging, lease 19 years 7 rooms; £450, s.a.v., nearest offer.—Box 4716, c/o The Wireless World. [8211]

SITUATIONS VACANT.

RADIO Mechanic Required, must possess advanced practical and theoretical knowledge and be businesslike and efficient worker; state age, salary, and experience.—Box 4483, c/o The Wireless World. [7934]

SITUATIONS Guaranteed as Wireless Operators, age 15-50, day, evening, postal courses; boarding students fee payable after situation found.—School, 321, Mansfield Rd., Nottingham. [8038]

GOOD Opportunities for Progressive Men.—Several vacancies exist for men with practical experience in planning, installing and testing modern telephone equipment, permanent positions for men of proved ability.—Write, stating details of previous experience, to Box 4700, c/o The Wireless World. [8169]

WIRELESS Operating Appointments Assured; short qualifying course, day, evening; fees payable after appointment for boarding students; Morse classes.—Manager, Wireless School, 21, Manor Gardens, London, N.7. Archway 3694. [8121]

DRAUGHTSMAN, with good experience radio components and receivers.—Write full particulars, qualifications, age and salary, Box 725, Sells, Fleet St., E.C.4. [8164]

CAPABLE Man for Wireless Department for Repairs, sales, etc., must be efficient; state age, experience, salary, in writing.—Box 4634, c/o The Wireless World. [8117]

YOUNG Men (between 21 and 25 years), of good appearance and education required for high class installation and service work on electrical apparatus by firm near London, first class wireless knowledge essential and mechanical training an asset.—Write, stating age, experience and salary required, to Box W.W. 669, c/o C. Mitchell and Co., 1, Snow Hill, E.C.1. [8175]

GRAMOPHONE Company Requires Wireless Engineer for Recording, must have thorough up-to-date knowledge, previous experience, and, if musical, an advantage.—Give full particulars, with wages required, Box 12, W. H. Smith and Son, Ltd., Strand House, W.C.2. [8214]

CIVIL SERVICE COMMISSION.—Forthcoming examinations: Male Assistant Superintendent of Traffic (Class II) in the London Telephone Service, and Male Assistant Traffic Superintendent in the Provinces, General Post Office (18-23, with extension for service in H.M. Forces).—Regulations and particulars, together with the forms on which applications must be made, will be sent in response to requests (preferably by postcard) addressed to the Secretary, Civil Service Commission, Burlington Gardens, London, W.1. The latest date for the receipt of application forms is 6th March. [8204]

ASSISTANT Required, experienced in fault locating and repair work on radio receivers and mains apparatus; state experience and salary required; Central London district.—Write Box 4718, c/o The Wireless World. [8213]

CABINETS

KABILOK

OF DISTINCTION

A SET WORTH BUILDING IS WORTH BUILDING WELL

Put that new receiver in a Kabilok Cabinet of Distinction.

Illustrated Catalogue Free on request.

W. & T. LOCK LTD.

ST. PETER'S WORKS BATH

LONDON: 11, Red Lion St., W.C.1.

POLAR

0005

No. 3 & "IDEAL"

CONDENSERS GIVE

WIDE TUNING RANGE



Electrically sealed

METAL CABINETS

Complete with Base for 1930 Everyman Four, New Kilomag Four, and W.W. Record III. Jacobean Finish.

TERMS: CASH WITH ORDER Price 57/6.

RIGBY & WOOLFENDEN,

SHEET METAL WORKERS.

MILNROW RD., ROCHDALE.

REPAIRS

Any make of L.F. Transformer, Loudspeaker or headphones repaired and dispatched within 48 HOURS—TWELVE MONTHS GUARANTEE with each repair. 4/- Post Free.

Terms to Trade.

TRANSFORMER REPAIR CO.,

Dept. W.,

214, High Street, Colliers Wood, London, S.W.1

METAL CABINETS

for the 1930 Everyman Four, Kilo Mag 4 and Record III.

PRICE 27/6 with four Compartments.

Also for the WIRELESS WORLD KIT SET

PRICE 22/6 with two Compartments.

Trade enquiries invited.

W. H. PARKER,

Aircraft & Wireless Sheet Metal Worker,

BAOK AUTUMN TERRACE, LEEDS.

BONA FIDE TRADERS' GUIDE.

Send for our comprehensive Illustrated List. QUICK SERVICE. QUICK SERVICE.

THE QUALITY HOUSE.

PERSEUS MFG. CO., LTD. (Dept. W.W.),

BRANSTONE RD., BURTON-ON-TRENT.

THE

MOTORCYCLE

The Motor Cyclist's Newspaper

EVERY THURSDAY — 3d.

Publishers: ILIFFE & SONS LTD., Dorset House, Tudor Street, London, E.C.4. W.W.15

Situations Vacant.—Contd.

APLICATIONS are invited from Men, 18 to 21 years of age, to be trained for special work on short wave radio; former radio technical knowledge is necessary, and applicants must be willing to go to sea; all replies must give the following details in the order stated:—1. Name, age, brief description of appearance; 2. outline of general education, details of any technical training, and whether applicant has passed examination for P.M.G. certificate; 3. any further remarks.—Write, in confidence, to H., Box 4717, c/o *The Wireless World*. [8212]

SITUATIONS WANTED.

T.I.G.B. Student (Radio Engineering), 18, requires situation wireless; £1; salesman preferably, some experience.—96, Drakefield Rd., Balham. [8165]

AMATEUR Transmitter, 35, desires situation with radio, gramophone or talking picture firm, 7 years' experience all mains work, own car.—Box 4713, c/o *The Wireless World*. [8208]

OPERATOR, 26, new certificate, seagoing 7 years, C.W. short wave experience, seeks position.—Box 4712, c/o *The Wireless World*. [8207]

BOY, 17, public school, with knowledge of wireless, wishes further experience; will work in any branch.—Temple, Twyford, Berks. [8201]

DESIGNER of Six Famous Commercial Sets Requires New Contract from a Firm of Repute, all business in the strictest confidence, and early manufacturing stages supervised, patents and registered designs become property of employer; write appointment.—Box 4711, c/o *The Wireless World*. [8198]

WIRELESS Technician, sound technical, practical knowledge, wants situation at London, high standard of education (University), now at research laboratories on Continent, fluent English, Dutch, French, Flemish, German, Austrian.—Box 4695, c/o *The Wireless World*. [8154]

BOOKS, INSTRUCTION, ETC.

"THE Wireless Manual" (new 1930 edition), by Captain Frost, is an ideal non-technical book full of up-to-date facts about wireless development, choice of set, how to use your own set, etc.; illustrated; 5/- (post 5/4), of a bookseller, or Pitman's, Parker St., Kingsway, W.C.2. [8173]



THE IDEAL COMBINATION
Both engraved—no mistakes—easy connections. The handle of the Spade Terminal is fully insulated—the prongs are sprung—connecting up is a one-hand job—Entire flex—copper and covering—individually gripped without use of tools.

Belling Lee Terminal Type "B" 6d. Type "M" 4½d. Type "R" 3d. Belling Lee Spade Terminal, 4½d.

Ask your dealer, or send to us, for FREE Belling-Lee Handbook, "Radio Connections."

BELLING-LEE
FOR EVERY RADIO CONNECTION

Advertisement of Belling & Lee Ltd., Queensway Works, Ponders End, Middx.

WIRELESS WORLD METAL CABINETS
as described in "Wireless World," January 1st, 1930. Delivery from Stock.

Finished crystalline Brown, Black or Blue. (Prices on application). Trade Enquiries invited.

SAMUEL EATON & SONS,
66/72, Barr Street, Birmingham.

Books, Instruction, Etc.—Contd.

STEP by Step Wireless; a complete course of the theory of electricity in relation to the practical design of wireless apparatus, eliminators, circuits, etc., with extracts from a designer's notebook, giving up-to-date practical application; issued weekly; send 1/- p.o. for first 4 weeks.—Clifford Pressland, A.M.I.E.E. Engr., Dept. W.W., Hampton-on-Thames. [0195]

FREE: Inventor's Guide on Patents.—T. A. A., 253 (W), Gray's Inn Rd., London, W.C.1. [6373]

FOREIGN LISTENERS 4 Set of 6 Coils . . . 37/6
SCREENING BOXES 5/- each; 19/- set.
RECORD III Coils 35/- set. **KILO-MAG 4** Coils 33/- set.
1930 EVERYMAN Coils . 42/6 set. **METAL BOXES—**
4 Compartments. 32/6 **Complete Cabinets.** 45/-
W.W. KIT SET Coils and Switches, mounted . . . 37/6
Metal Boxes . . . 27/6 **Complete Cabinets** . . . 35/-
ALL TYPES OF SETS BUILT AT LOWEST PRICES.
SEND ALL YOUR ENQUIRIES. TRADE SUPPLIED.
A. T. STOTT, 1a, Duke St., ROCHDALE.
(Late 63, Syke Road.)

A CATALOGUE that Saves you Money!

EVERY RADIO ENTHUSIAST SHOULD SEND FOR IT!

Send 3d. in stamps for this 56-page Catalogue. Scores of Ready-to-assemble Wireless Cabinets and Special Osborn Offers.

CHAS. A. OSBORN (Dept. W.W.)
The Regent Works, Arlington Street, London, N.1.
Telephone: Clerkenwell 5095. Open to 7.30 p.m. Saturdays 4.30 p.m.
And at 21, ESSEX ROAD, ISLINGTON, N.1. Open until 9 p.m.
9 p.m. SATURDAYS. Phone: Clerkenwell 5634.

GILMAN THE LOUDSPEAKER CHASSIS

A completely assembled cone floated on felt in a highly polished aluminium casting. It incorporates our NEW adjustable unit fixing plate, ensuring the correct centering of the unit reed in cone. EXCLUSIVE TO GILMAN CHASSIS. Plates can be supplied to fit any make of unit in the World.

Power Model, 18" . . . 22/6

Ask for a GILMAN chassis! If your dealer cannot supply write direct to:
J. S. GILMAN & CO.,
63, Basinghall Street, London, E.C.2.
Phone: Metropolitan 9892.

The NEW adjustable back plate for perfect centering of any unit.

156 POST PAID COMPLETE

BE SURE OF YOUR PANEL

EBONITE IS GENUINE

Tested to 104,000 volts. USE THE PRIZE WINNING LOW LOSS FORMER.

LOOK FOR TRADE MARK.

Write for Handbook on Windings and Circuits, Post Free 4d.

THE BRITISH EBONITE CO., LTD., HANWELL, LONDON, W.7.

JUST PUBLISHED.

PHOTOELECTRIC CELLS

By Dr. N. R. Campbell and D. Ritchie, members of the Research Staff of the General Electric Company. A full and clear explanation of the theory, use and applications of photoelectric cells, for experimental wireless and television amateurs, etc. 15s. net.

Of a Bookseller, or
PITMAN'S, PARKER STREET, KINGSWAY, W.C.2.

LISENIN

POSITIVE GRIP TERMINALS
(Patent 245,586)

Maintain their lead established five years since, and are acclaimed by the keen Radio experimenter as the ideal terminal. There is one for all radio connections. Write for descriptive leaflet. It's sent free to all "W.W." readers.

Plugs and Rockets with 2 nuts . . . 4d.
Spade Ends . . . 3d.
Standard Wander Plugs . . . 2d.
Stubby Wander Plugs, for portable sets . . . 2d.
Pin Ends . . . 2d.
All Mains Socket and Plug . . . 6d.

Don't forget Pos. Grips overcome unsightly frayed ends to leads. What a boon!

THE LISENIN WIRELESS COMPANY, SLOUGH, BUCKS.

A47 Advertisements for "The Wireless World" are only accepted from firms we believe to be thoroughly reliable.

INDEX TO ADVERTISEMENTS.

| | | | | | |
|--|----------------|---|---------------|--|----------|
| Adolph, Fredk. | PAGE 21 | General Electric Co., Ltd. | PAGE 14 | Partridge & Mee, Ltd. | PAGE 16 |
| Appieby, E. Hetherington | 17 | Gilman, J. S., & Co. | 23 | Perseus Radio Manf. Co. | 22 |
| B. & J. Wireless Co. | 17 | Glasscoe, R. H., & Co. | 17 | Pertrix, Ltd. | 3 |
| Baker's "Selhurst" Radio | 24 | Gramo-Radio Amplifiers, Ltd. | 5 | Pitman, Sir Isaac, & Sons, Ltd. | 23 |
| Bayliss, Wm., Ltd. | 7 | Green & Faulconbridge, Ltd. | 18 | Radiogramophone Development Co. | 7 |
| Belling & Lee, Ltd. | 20 & 23 | Grosvenor Battery Co., Ltd. | 4 | Rigby & Woolfenden | 22 |
| British Ebonite Co., Ltd. | 23 | Haw & Co., Ltd. | 18 | Rothermel Corporation, Ltd. (Centralab) | 10 |
| British General Mfg. Co., Ltd. | Cover iii. | Holzman, L. | Cover i. | Rothermel Corporation, Ltd. (Mersham) | 16 |
| British Industries Fair | Cover iii. | Hughes, F. A., & Co., Ltd. | 6 & 11 | Rotor Electric, Ltd. | 17 |
| Brownie Wireless Co. (G. B.) Ltd. | 21 | Igranic Electric Co., Ltd. | 2 | Rowley, Thomas A., Ltd. | 21 |
| Burton, C. F. & H. | Cover i. | Lisenin Wireless Co. | 23 | Sheffield Magnet Co. | 9 |
| Carrington Mfg. Co., Ltd. | Cover iii. | Lock, W. & T., Ltd. | 22 | Stott, A. T. | 23 |
| Cole, E. K., Ltd. | 10 | Lyons, Claude, Ltd. | Cover i. & 22 | Telsen Electric Co., Ltd. | Cover i. |
| Covert, Ltd. | 6 | Marconiphone Co., Ltd. | 15 | Thomas, Bertram | 8 |
| Cossor, A. C., Ltd. | 12 | M-L Magneto Synd., Ltd. | 2 | Transformer Repair Co. | 22 |
| Dubilier Condenser Co. (1925), Ltd. | Cover ii. & 16 | Miscellaneous Trading Co., Ltd. | 10 | Tudor Accumulator Co., Ltd. | 6 |
| Eaton, S., & Sons | 23 | Moore & Co. | 20 | Tulsemere Manf. Co. | 18 |
| Edison Swan Electric Co., Ltd. | 8, 11 & 13 | Morris, J. E. | 21 | Varley (Oliver Pell Control), Ltd. | 9 |
| Electradix Radios | 22 | Mullard Wireless Service Co., Ltd. | Cover iv. | Warwick Radio | 20 |
| Epoch Radio Manf. Co., Ltd. | 19 & 20 | Osborn, Chas. A. | 23 | Westinghouse Brake & Saxby Signal Co., Ltd. | 24 |
| Exide | Cover ii. | Overseas Trading Co. | 20 | Weston Electrical Instrument Co., Ltd. | 4 |
| Ferranti, Ltd. | 1 | Parker, W. H. | 22 | Wingrove & Rogers, Ltd. | 22 |
| Forno Co. | 4 | Paroussi, E. | 22 | | |

Experts have chosen my voice for
THE LONDON HIPPODROME!

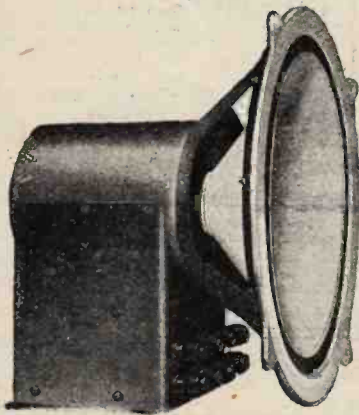

BAKER'S 1930 SUPER POWER LOUD SPEAKER.

The Pioneer manufacturers of Moving Coil Loud Speakers.

Head Office: 89, Selhurst Road, South Norwood, London, S.E.25

Works and Demonstration Room: 42, Cherry Orchard Road, East Croydon.

'Phone: 1618 Croydon.

I have again proved how far I am ahead of my competitors. The Thomassin Manufacturing Co. Ltd. tell me that I am THE IDEAL MOVING COIL SPEAKER FOR TALKIES.

I am now installed at the London Hippodrome, where my voice reproduces realistically at the Trade Shows to the most critical ears in the trade.

I have won the hearts of the keenest Cinema critics and am in demand everywhere.

I appeal to music lovers the world over. I give magnificent performances in the home as well as the Cinema.

I am supremely powerful. The National Physical Laboratory of Teddington say I have a flux density of 13050 lines per sq. cm.

I have no big ideas—a simple 2 Valve Receiver is all the help I need.

I am described fully in a new 36-pp. booklet. It is called "Sound Advice." It is yours free for the asking.

I am ALL BRITISH and speak the truth.

I am BAKER'S 1930 SUPER POWER MOVING COIL LOUD SPEAKER.

BAKER'S
'Selhurst'
RADIO

WRITE NOW FOR OUR
NEW EDITION — 36 - PAGE
BOOKLET: "SOUND ADVICE."

Just a postcard will do.

The type H.T.3

WESTINGHOUSE
METAL RECTIFIER

21/-

Output 120 volts. — 20 milliamps.

Suitable for incorporation in eliminators to work sets of the popular 3-valve types such as Cossor Melody Maker, Mullard Master Three, etc., etc.

The Westinghouse Brake & Saxby Signal Co., Ltd.,
82, York Road - King's Cross - London, N.1.



Our 32-page booklet "The All-Metal Way, 1930," shows how to make any type of eliminator or charger for A.C. Mains—Full description, circuits and components required.

Send 2d. stamp with your name and address for a copy.

Mention of "The Wireless World," when writing to advertisers, will ensure prompt attention.

The greatest display of British Goods ever assembled for Trade Buyers



The British Industries Fair is being held in London at the specially enlarged OLYMPIA, and in Birmingham at CASTLE BROMWICH. It will comprise the most comprehensive exhibit of British products ever brought together. Every aspect of modern wireless and its kindred trades will be represented.

OLYMPIA,
LONDON
and
CASTLE
BROMWICH,
BIRMINGHAM

FEBRUARY
17TH - 28TH

Visit the **BRITISH INDUSTRIES FAIR**

Free tickets entitling Trade Buyers to return fare on any train at reduced rates may be obtained from

THE DEPARTMENT OF OVERSEAS TRADE, 35, OLD QUEEN STREET, LONDON, S.W.1
or
THE SECRETARY, CHAMBER OF COMMERCE, BIRMINGHAM.

C.F.H.

Use



"MAJOR" Cabinet



Complete with
16 1/2" baseboard
and removable
baffle board.

for your
RADIOGRAM

This Cabinet provides ample space for your amplifier. It is soundly constructed and beautifully finished. Will take panels 18" 7" or 18" 8". Loud Speaker compartment is 18" 18" 16 1/2". Suitable for all popular circuits.

OAK - - £7:10:0
MAHOGANY £7:15:0

Call and see full range of
"Camco" cabinets at new
London showrooms.

CARRINGTON MANUFACTURING CO., Ltd.

New Showrooms, 24, Hatton Garden, Holborn, London, E.C.1
Telephone: Holborn 8202.  3503

MIDGET BRITISH GENERAL TRANSFORMER

The most
up-to-date
Transformer



A transformer of Giant Performance and perfect, distortionless reproduction—but small, compact and neat. The illustration is the actual size, and the complete job weighs only 4 ozs. The secret is in the Special Metal Alloy—a recent discovery which enables us to Guarantee performance the equal of a transformer of many times the weight or price.

From all dealers of repute or direct from the
manufacturers

The
**BRITISH GENERAL MANUFACTURING
CO., LTD.,**
Brockley Works, London, S.E.4.



Advertisements for "The Wireless World" are only accepted from firms we believe to be thoroughly reliable.

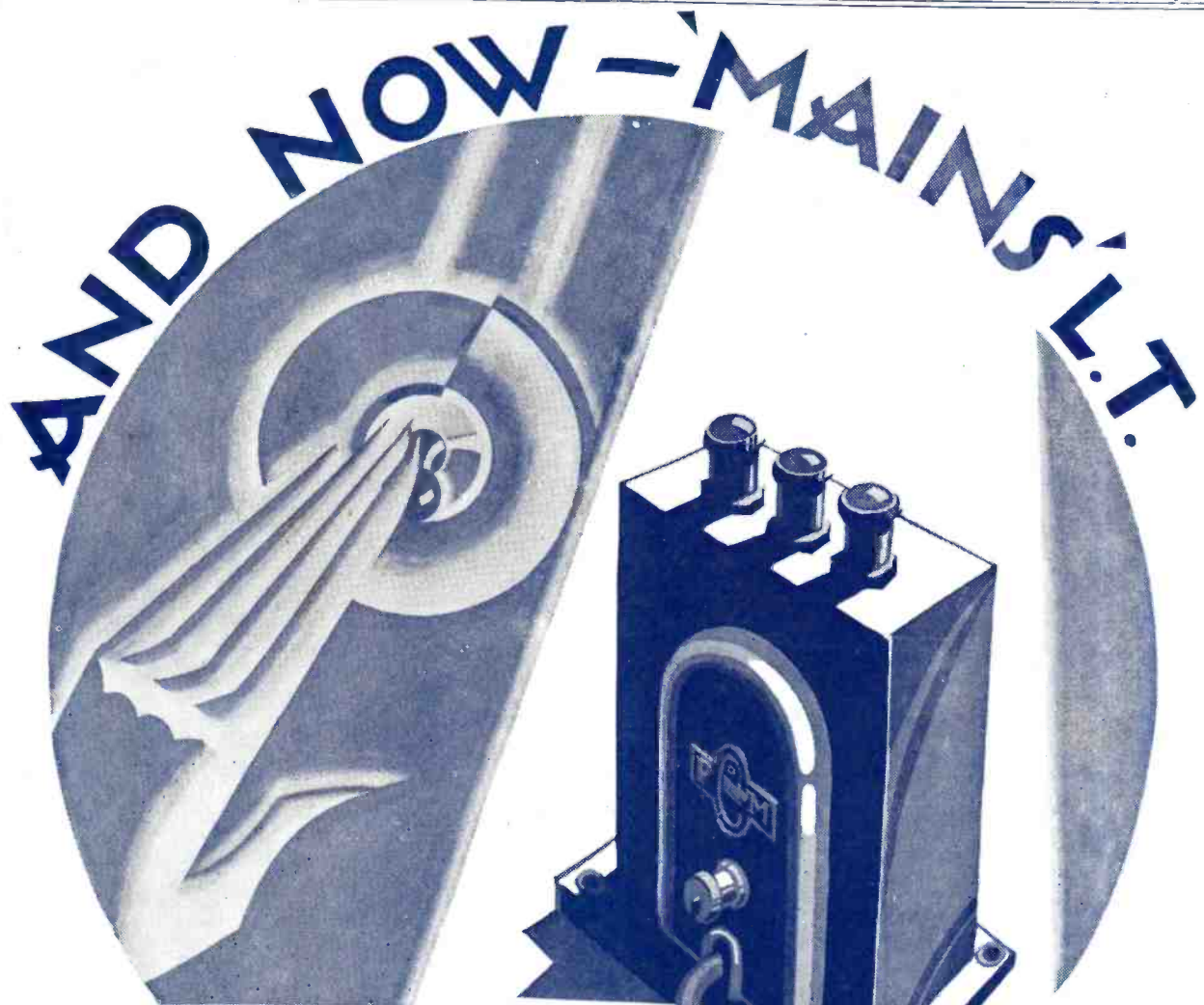

You've had High Tension Current from the mains for some considerable time. Now there is Low Tension from the same source with the Mullard Filament Heater Transformer. Three output terminals are provided, the two outer ones are for the 4 volt supply while the centre terminal is connected to the electrical centre of the secondary winding.

The transformer is designed for use primarily with Mullard A.C. valves and will normally supply five valves of this type.

Convert your radio to an all-electric set with this, one of the most recent 'mains' components. Price 32/6.

Mullard

MASTER · RADIO

Advt. of The Mullard Wireless Service Co., Ltd., Mullard House, Charing Cross Road, London, W.C.2.

Printed for the Publishers, LIPFE & SONS LTD., Dorset House, Tudor Street, London, E.C.4, by The Cornwall Press Ltd., Paris Garden, Stamford Street, London, S.E.1

Colonial and Foreign Agents:
 UNITED STATES—The International News Co., 131, Varick Street, New York. FRANCE—W. H. Smith & Son, 248, Rue Rivoli, Paris; Hacette et Cie, Rue Réaumur, Paris.
 BELGIUM—W. H. Smith & Son, 78, Marche aux Herbes, Brussels. INDIA—A. H. Wheeler & Co., Bombay, Allahabad and Calcutta. SOUTH AFRICA—Central News Agency, Ltd.
 AUSTRALIA—Gordon & Gotch, Ltd., Melbourne (Victoria), Sydney (N.S.W.), Brisbane (Queensland), Adelaide (S.A.), Perth (W.A.), and Launceston (Tasmania).
 CANADA—The American News Co., Ltd., Toronto, Winnipeg, Vancouver, Montreal, Ottawa, St. John, Halifax, Hamilton; Gordon & Gotch, Ltd., Toronto; Imperial News Co. Toronto, Montreal, Winnipeg, Vancouver, Victoria. NEW ZEALAND—Gordon & Gotch, Ltd., Wellington, Auckland, Christchurch and Dunedin.

NEW "FOREIGN LISTENER'S FOUR"

The Wireless World

4^D

AND
RADIO REVIEW

The Paper for Every Wireless Amateur

Wednesday, February 12th, 1930.

"Ekco-Lectrify"

your radio
with an

EKCO



Power Supply Unit

Write for Free Booklet on "All-Electric Radio" to:
E. K. COLE, Ltd., Dept. W, "EKCO" Works, Leigh-on-Sea.

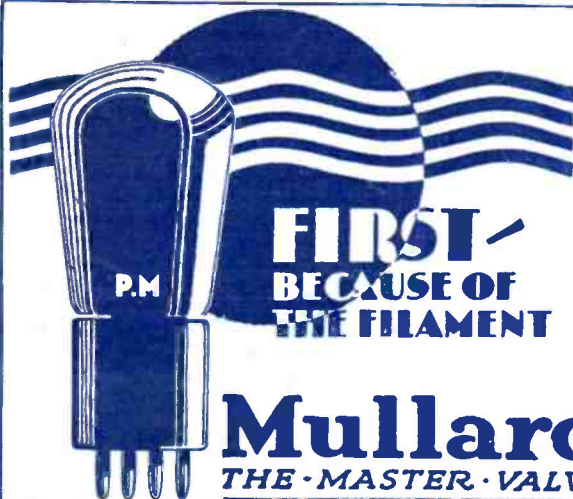

**FIRST-
BECAUSE OF
THE FILAMENT**

Mullard

THE MASTER VALVE

AWARDED THE CERTIFICATE OF
THE INSTITUTE OF HYGIENE
FOR QUALITY AND PURITY

Superfine Quality

Trelleborgs

GUARANTEED
FINE EBONITE

25% REDUCTION ON RETAIL PRICES

120000 VOLTS PER M.M.
National Physical Lab Report

TRELLEBORG EBONITE WORKS, LTD.,
Union Place, Wells Street, W.2

STILL ON TOP!

Blue Spot

BLUE
SPOT
66K
UNIT

25/-



A PERFORMANCE of HIGHEST MERIT

The greatest assurance of "success" possible for an artiste to receive is the public's demand for "more" and "more."

THE McMICHAEL SUPER RANGE PORTABLE FOUR

is an assured success and the most popular Portable with discriminating people. Judged on its own merits in regard to quality of design and construction, or judged from a high standard of convenience, portability and performance, this receiver is without doubt supreme. Fitted in a beautifully finished furniture hide suitcase, with patent locking clips, with all accessories ready for immediate use, it possesses the following noteworthy features:—

1. Screen Grid Amplification.
2. Single dial tuning and volume control.
3. High selectivity.
4. Low upkeep cost.

Owing to the high degree of selectivity in this, and our other Screened Grid Portable Receivers, we are able to guarantee complete selectivity between all main B.B.C. stations under the new scheme of wavelengths, as recently proved by an actual test under the twin aerials at Brookman's Park, when both programmes were received separately without interference, and in addition a number of other British and foreign stations.

This test was made on a standard "Super Range Four" receiver, under an independent Press observer, and was repeated at half-mile intervals with similar results.

CASH PRICE

22 GNS.

(Including all Equipment and Royalties).

Or by our special "Deferred Payments on Hire Purchase Terms" system, £5 down and 10 monthly payments of £2:1:0.



Ask for a demonstration of this set at any high-class radio store, or call at our London Showrooms.

L.M. MICHAEL LTD

Manufacturers of Wireless and Scientific Apparatus
WEXHAM ROAD, SLOUGH, BUCKS.

Telephone: SLOUGH 441-442. Telegrams: RADIETHER, SLOUGH.
London Showrooms: 179, STRAND, W.C.2. (Telephone: Holborn 2466.)



The McMICHAEL SUPER RANGE FOUR

(TABLE MODEL)

A handsome Walnut table model mounted on a turntable and with a self-contained frame aerial and earth. The McMichael Super Range Four (Table Model) offers the same perfection in performance as

the Portable model and contains an exactly similar circuit. This model is designed for home use where an outdoor aerial and earth are not convenient or desirable. An additional aerial and earth may be used, however, to add to the normal and truly remarkable range.



CASH PRICE **26 GNS.**

(Including all Equipment and Royalties).

Mention of "The Wireless World," when writing to advertisers, will ensure prompt attention.



NEW! A.C. Mains SCREEN GRID OSRAM M.S.4

(Indirectly Heated)

This valve has the lowest internal self-capacity of any screen grid valve — 0.0025 micro-microfarads when adequately screened. The characteristic "slope" is 1.1 ma/volt.

Small bulb. More magnification—easier to stabilize.

Characteristics

| | | | | |
|----------------------|-----|---------------|----------------------|----------|
| Filament Volts | ... | ... | ... | 4.0 |
| Filament Current | ... | 1.0 amp. | approx. | |
| Amplification Factor | ... | ... | ... | 550 |
| Impedance | ... | 500,000 ohms. | (at screen volts 70) | |
| Mutual Conductance | ... | ... | ... | 1.1 |
| Anode Volts | ... | ... | ... | 200 max. |

PRICE 25/-

Osram Valves

MADE IN ENGLAND

Sold by all Wireless Dealers.



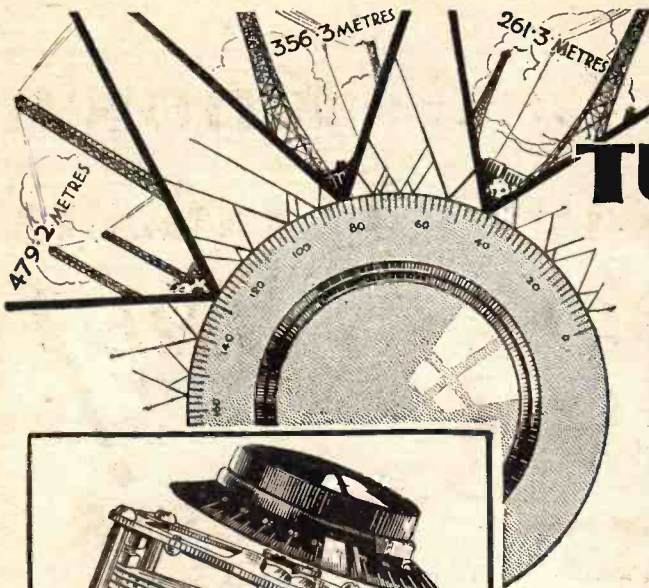

WIDE TUNING RANGE

Because Polar Condensers are scientifically designed—have accurately spaced vanes and low minimum self capacity—they give you a definitely wider range of tuning.

There is no need to sacrifice listening to 5GB (479 metres) because you want Brookman's Park (261 metres) transmission. The Polar "Ideal" or Polar "No. 3" Condenser of .0005 capacity will tune them all in on any standard circuit receiver.

Polar Condensers give velvet-smooth control, and the "Ideal" with both fast and slow motion gives knife-edge selectivity.

Both the Polar "Ideal" and "No. 3" will make a wonderful difference to your range of reception.

POLAR "IDEAL" .0005, 12/6. POLAR "No. 3" .0005, 5/9.
.0003, 12/- (as illustrated). .0003, 5/6 (Dial 1/- extra).

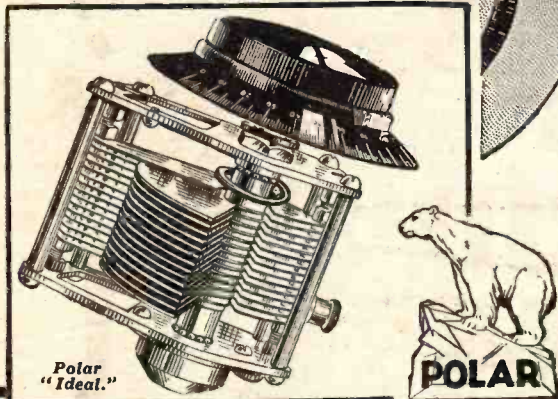

POLAR CONDENSERS

Obtainable from all dealers. Write for Free copy of "Polar" Catalogue (W).

WINGROVE & ROGERS, LTD.,
188-189, STRAND, LONDON, W.C.2.
Polar Works: Mill Lane, Old Swan, Liverpool.

IF YOUR SUPPLY MAINS ARE D.C.

You can use an A.C. All Electric Receiver
By Employing The M.L.—D.C. to A.C.

ROTARY TRANSFORMER

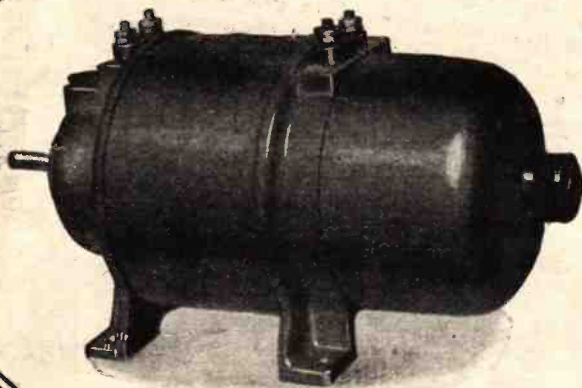

Can be supplied
to run from
any Voltage
12-250 V. D. C.

Recommended and
used by

Philips Radio,
Marconiphone,
Burndept,
Kolster-Brandes,
Etc., Etc.

ON VIEW
British Industries Fair
STAND D.7
OLYMPIA.

40 WATT Model
£13-0-0
85 WATT Model
£19-0-0

M-L MAGNETO SYND. Ltd., Radio Dept., COVENTRY.
Telephone: 5001.

|||||
 "Out of 22 Best Known
 British & Foreign Speakers
KUKOO BEATS THE
 LOT ——— " 99 !

High Praise
 Indeed for
 "KUKOO"

The **SUPER**
SPEAKER
UNIT

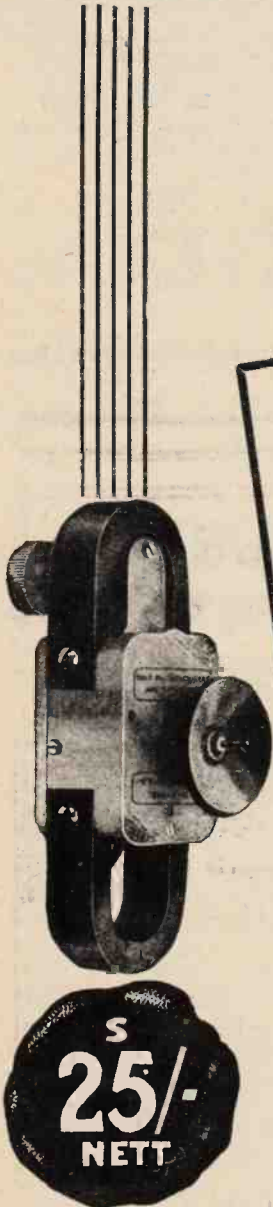

"Elmina,"
 Cross Roads,
 Newton by Frankby,
 Cheshire.

18th January, 1930.

Dear Sirs,
 I offer you my heartiest congratulations for placing on the market the finest Loud Speaker movement I have ever heard. Your Kukoo in conjunction with a double linen diaphragm gives results equal to the very best and far better than the cheaper Moving Coil Speakers offered to the public. Years ago I commenced experimenting with Cones, pleated diaphragms, etc., at a time when there was only a Brown earpiece or a home-made reed earpiece to choose from, and since then I have tested Units made by . . . (here follow the names of twenty-one of best-known English and Foreign Speaker Units) . . . and out of all these I have no hesitation in stating that the Kukoo easily beats the lot both in the quality of even response of all frequencies (high and low) and also in speech.

I do not know your firm neither do I know anyone connected with it but I do know that your Unit has not hitherto been equalled and is a boon to a lover of pure music.

Yours faithfully,
A. E. Hemley

Specially designed Kukoo Chassis and 10½" Cone, 15/6 post free.

From your Dealer or direct from Sole Patentees and Manufacturers:

Phone: Sheffield 20866.

THE SHEFFIELD MAGNET CO.,
Broad Lane, SHEFFIELD.

Grams: Magnet 20866 Sheffield

3 Advertisements for "The Wireless World" are only accepted from firms we believe to be thoroughly reliable.

A Complete receiver constructed in 15 MINUTES!

WITH THE LEWCOS 3 VALVE KIT

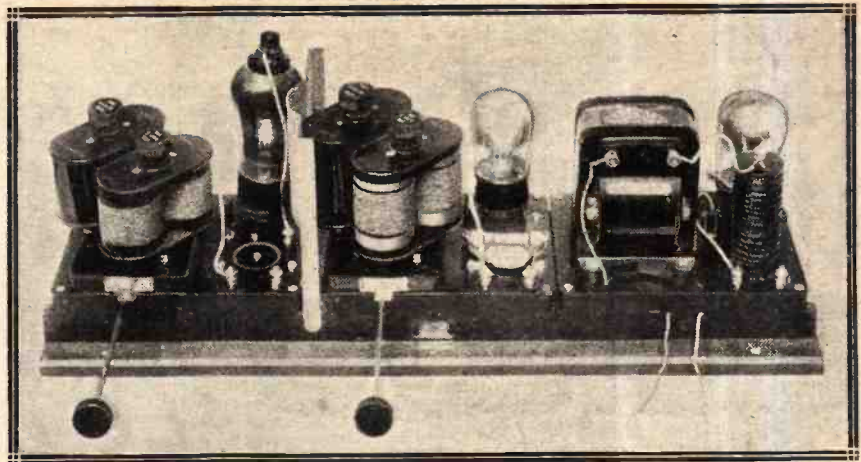

Eliminating troublesome complications, the Lewcos 3 Valve Kit, designed for use with either D.C. or A.C. Valves, enables a safe and satisfactory all-mains receiver to be built in fifteen minutes. Highly satisfactory results of quality and strength, combined with selectivity and sensitivity, are provided by this receiver.

"Valve," of the Nottingham Journal, says of the Lewcos 3 Valve Kit:—"The whole thing is strongly built and an extended trial HAS NOT FOUND A WEAK SPOT IN IT, using D.C. or A.C. Valves. Over fifty stations were logged by me the first week I used this unit, the quality and strength being far above normal."

SEND TO-DAY FOR BOOKLET R.58.

This free booklet fully describes the construction, assembly, working and performance of one of the most efficient circuits ever conceived.

Price, £7:0:0 without valves.



LEWCOS 3 VALVE KIT

REGD.

THE LONDON ELECTRIC WIRE COMPANY AND SMITHS, LIMITED,

CHURCH ROAD

LEYTON,

LONDON, E.10.

Playhouse Yard,

Trade Counter: Golden Lane,

London, E.10.

Fit the **DUBILIER** long-life **BATTERY**



66 Volts **7/9**

BRITISH MADE

and improve the quality of your reception

66 VOLTS PRICE 7/9

Ask your dealer for a copy of the Dubilier Booklet "A Bit about a Battery."

Other Voltages Available.

Dubilier Condenser Co. (1923), Ltd., Ducon Works, Victoria Road, North Acton, London, W.3.

Cleaver B21

NEW! ELECTRAD SUPER-TONATROLS



These new Electrad variable non-inductive high resistances will safely dissipate 6 watts at any position of the contact, with one-tenth or more of the resistance element in circuit. The all-metal construction with the graphite resistance element fused to an enamel base obviates the necessity of using either a low-current paper element or fine wire. The action is amazingly smooth, long lived and both mechanically and electrically perfect.

The Super-Tonatrol embodies new ideas of proved merit with generous factors of safety which more than fulfil all expectations. Super-Tonatrols are made in seven resistance ranges, taking care of all possible requirements.

| No. | Resistance | Control Type | List Price |
|----------|-------------|--|------------|
| No. 1 A. | 25,000-ohm | potentiometer | each 12/6 |
| 2 A. | 10,000-ohm | potentiometer | 12/6 |
| 3 A. | 50,000-ohm | rheostat | 12/6 |
| 4 A. | 10,000-ohm | rheostat | 12/6 |
| 5 A. | 100,000-ohm | potentiometer | 12/6 |
| 6 A. | 25,000-ohm | pick-up volume control | 12/6 |
| 7 A. | 50,000-ohm | fourth terminal pick-up fader volume control | 15/- |

Write for our 1930 catalogue and audio manual. It tells you all about Electrad resistances, volume controls, power amplifiers, etc. for electrical gramophones. Send 6d. in stamps for this 66-page booklet.

ROTHERMEL CORPORATION Ltd.
24, MADDUX ST., LONDON, W.1.

Phone: Mayfair 0578-9.

Mention of "The Wireless World," when writing to advertisers, will ensure prompt attention.

MAKE YOUR SET! A BETTER SET!



**BURTON
DIFFERENTIAL
CONDENSER.**

A new addition to the famous range of BurTon Condensers, scientifically designed, brass vanes, interleaved with Bakelite leaves, this condenser makes shorting an impossibility. It means easier tuning, better selectivity and better detection. The price is only 5/-

Every BurTon Component embodies every latest improvement! It is at BurTon's Progress Works where these improvements are first discovered, first experimented with and first utilised — others follow. Examine your set! Replace any defective part with a BurTon!

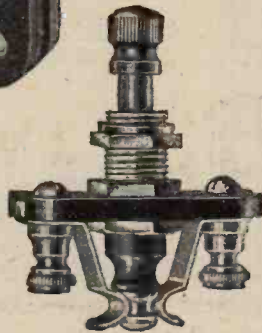

BURTON BATTERY SWITCH.

Super finish, with Ebonite Knob and Nickel Plated. Price 1/-
With metal knob. Price 9d.

BURTON BINOCULAR H.F. CHOKE.

Designed to avoid peaks and external magnetic field. Covers a waveband of 50-3,000 metres. Price 5/9

BurTon H.F. Choke covering waveband of 20-2,000 metres, ideal for any set. Price 3/9



BUY BURTON COMPONENTS

C. F. & H. BURTON, Progress Works, Walsall.

FERRANTI RADIO

The three essentials of radio reception—
Purity of tone, Volume, and Selectivity
— are well and truly balanced ★



MODEL 31.

THE FERRANTI "All Electric" Radio Receiver is designed by experts in the art, and built on sound engineering principles.

★ Whilst we make no extravagant claims we can definitely declare that our Set has been scientifically measured and compared with many others, and found equal to any and better than most in all the three essentials.

The price, including valves, is £25 in Oak Cabinet, and £26 in Walnut or Mahogany Cabinet. The Royalty is £1 extra.

This set is available for **Alternating Current mains only**, voltages 200/250, 40 cycles or over.

A special order from your dealer will ensure prompt delivery.

Write for illustrated book, and, if you are interested, we will arrange for a demonstration in your home.

FERRANTI LTD. HOLLINWOOD LANCASHIRE

STANDARDS

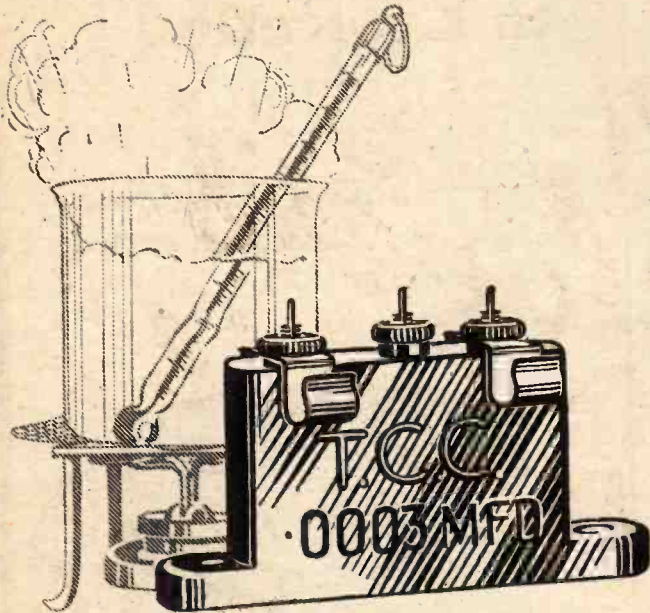

DEGREES and T.C.C.

A thermometerless boiler—a blast-furnace, or a locomotive without its pyrometer—a doctor without means of gauging temperature; all these things are unthinkable. Thermometers are a necessity, but they must have standardised marking. 60 degrees Fahrenheit on one thermometer should be 60 degrees Fahrenheit on another—and it will be if both thermometers are up to standard.

With condensers also a standard is essential—and that standard is fixed too—it is T.C.C. Wherever a condenser is indicated use the “condenser in the green case”—the condenser that possesses a degree of accuracy and reliability, unapproached by any other make. Remember this. T.C.C. have been making condensers—and nothing but condensers for nearly a quarter of a century.

Illustrated above is a .0003 mfd. T.C.C. Upright Mica Condenser (Series Parallel Type). Price 2/4 each. Other capacities are available from .0001 mfd. to .005 mfd. Prices 2/4 to 3/6.



A. J. V. Telegraph Condenser Co. Ltd., Wales Farm Road, N. Acton, London, W. 3.

3645

Mention of "The Wireless World," when writing to advertisers, will ensure prompt attention.

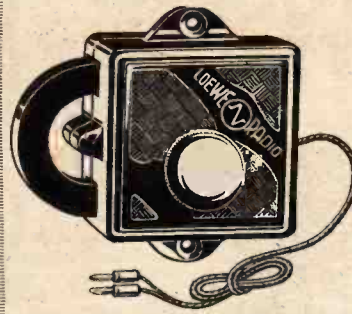

The NEW LOEWE RADIO CONE UNIT

gives Home Constructors an opportunity to build their own LOUD-SPEAKERS!

With the new LOEWE RADIO Cone Unit you can make in your own home a high-class cone loud-speaker. It will adapt itself to any type of cabinet, and whether it is simple or intricate in design is a matter for the builder to decide. With every Unit, complete instructions, working drawings, etc., are supplied for making the Cone Diagram and the Cabinet as recommended by LOEWE RADIO. Most of the Unit is enclosed in robust moulded casing. Plugs fitted to leads are also supplied. All enthusiastic home constructors should buy this pleasingly efficient unit without delay! All LOEWE RADIO products amounting to an aggregate sum of not less than £5 can be obtained on attractive H.P. terms. Full details from your dealer or from

PRICE 13/6



THE LOEWE-RADIO CO., LTD.
4, Fountayne Rd., Tottenham, N.15
Telephone: Tottenham 3911/2

A Few of the SPECIAL BARGAINS that can be obtained from

JOLLYS OF WITTON, BIRMINGHAM.

| | | |
|----------|---|---------|
| B.T.H. | Interval transformers, 2-1 and 4-1. Original price 15/- | 8/6 |
| B.T.H. | Secondhand | |
| B.T.H. | Output transformers, 15-1. Original price 15/- | 8/6 |
| B.T.H. | Secondhand | |
| B.T.H. | Power chokes, single winding to carry 100 m/a | 10/6 |
| B.T.H. | Power chokes, double winding to carry 300 m/a | 15/- |
| DUBILIER | Condensers, 8 mfd. Mansbridge type tested 600 volts | 10/6 |
| DUBILIER | Condensers, 6 mfd. Mansbridge type tested 1,500 volts. Original price 22/6. Secondhand | 15/- |
| B.T.H. | Two-stage coupler covering the 250/650 and 900/2,000 metre wave band | 10/- |
| MAZDA | Two-stage valve specially designed for above unit | 12/6 |
| B.T.H. | A.C. transformer, as used in R.K. and Panatrop | 35/- |
| B.T.H. | Pick-up amplifier, including B.T.H. transformer, scratch filter, 200,000 ohms, volume control. List price £3.7.6. Our price | 22/6 |
| ZENITH | Resistances, as used in Panatrop, set of eight complete | 15/- |
| B.T.H. | Senior and Junior R.K. Speakers for A.C. or D.C. Mains, complete with amplifier and eliminator, from £10.0.0. Also Panatropes for D.C. Mains, complete with motor generator, at bargain prices. | £10.0.0 |
| TERMS. | Cash with order. Any goods may be returned, carriage paid, within seven days of receipt, in which case your money will be refunded by return of post. | |

JOLLYS, 410-416, Aston Lane, WITTON, BIRMINGHAM.

A6

All who prefer Quality
in Cigarettes



Say
Player's
Please

5 for 3d. 10 for 6d.
20 for 11½d.



N.C.C. 722

Now watch

your set spring into life
the moment you fit

The
Grosvenor
Battery

INCORPORATING THE NEW
VITALISING ELEMENT.

BRITISH
MANUFACTURE

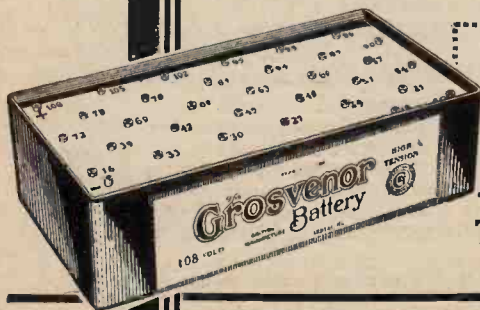

PRICES.

99 v.
11/6, 14/6, 30/- (SUPER)
66 v.
7/6, 9/6, 18/- (SUPER)

Notice the full volume, the long range obtainable, purity and clarity of tone you did not think possible—you have supplied the very life-blood your valves needed, life-blood that only GROSVENOR BATTERIES can give.

For satisfaction from first to last, use Grosvenor British Made H.T. Batteries.

THE GROSVENOR BATTERY Co., Ltd.,
2/3, White Street, Moorgate, LONDON, E.C.2.

Phone :
MET. 6866.

**Advertising in
"The Wireless World"
has a very
strong appeal!**

A regular advertiser in "THE WIRELESS WORLD" puts on record his opinion of the journal.

January 10th, 1930.

"On the opening of the New Year, I should like to take this opportunity of confirming my previous remarks, and it may be interesting for you to know that we hear regularly from many of our trade customers that our advertisements in your pages are very helpful to them in bringing business.

"Owing to the fact that we, ourselves, supply our Receiving Sets almost exclusively through the trade channels, we are not in a position actually to tabulate the response to any individual advertisement in its appeal to the general public, but our friends in the retail trade, who are in direct touch with the public, so frequently, in their correspondence to us, refer to 'The Wireless World' advertisements, that it is quite evident to us that the advertising has a very strong appeal.

"As some concrete evidence of our satisfaction, I may say that we have instructed our Advertising Agents to repeat the contract we had with you for last year, and to take additional space as well.

"Wishing your paper a still further measure of success in 1930."

(Signed) Leslie McMichael,
Managing Director,
L. McMichael, Ltd.,
Wexham Road, Slough, Bucks.

Particulars of advertising in "THE WIRELESS WORLD," together with Advertisement Tariff, will be sent on request to Iliffe & Sons Ltd., Dorset House, Tudor Street, London, E.C.4.

**Get the Experts to
Advise You:—
The R.G.D. Radiogramophone**



For the highest possible quality and tone for both radio and record, with ample volume, incorporating the latest developments in moving coil speaker; operates entirely from electric mains, A.C. any voltage, or D.C. 200 volts or over.

Mahogany Oak
£80 £75

Place your order now to ensure delivery and we shall be pleased to supply literature on application.

**The Radiogramophone Development Co.,
St. Peter's Place, Broad Street, Birmingham.**

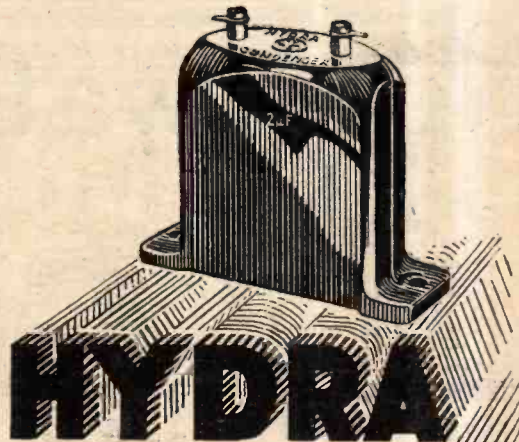

**THE STRONG POINT
IN ANY MAINS UNIT!**

The impregnable insulation of the paper dielectric in a Hydra Condenser is the "strong point" in any eliminator. When you put Hydra into the circuit, you cut out once and for all the risk of condenser-trouble—you safeguard your set and all who handle it.

The best eliminators you can buy contain Hydra Condensers—write for list of makers' names.

LOUIS HOLZMAN, 37, Newman Street, London, W.1.

Mention of "The Wireless World," when writing to advertisers, will ensure prompt attention.



**Certainly-
experiment
with your set**

**BUT NOT WITH
the COMPONENTS**

Always use the best—

BENJAMIN

VALVEHOLDERS.

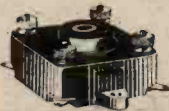

| | |
|--------------|-----|
| Clearer Tone | 2/- |
| Vibroder | 1/6 |
| 5-Pin Holder | 1/9 |
| Pentode | 2/3 |

SWITCHES.

| | |
|-----------|-----|
| Push-Pull | 1/3 |
| Rotary | 1/9 |



TURNTABLE.



Ball-bearing and equipped with hinged and folding legs . . . 7/6
Send P.C. for fully illustrated leaflet No. 2003.

THE BENJAMIN ELECTRIC LTD.
BRANTWOOD WORKS, LONDON, N.17

**DUBILIER
FOR
DURABILITY**



MICA CONDENSER. Type B775
01 4/-; 1 8/6; 5 37/6.
Intermediate capacities at proportionate prices.

PAPER CONDENSERS

| | | |
|----------|------|-----|
| Up to 1 | Each | 2/- |
| 25 and 3 | | 2/3 |
| 4 and 5 | | 2/5 |
| 10 | | 2/6 |
| | | 2/6 |
| | | 3/6 |

Prices of higher val. use on application

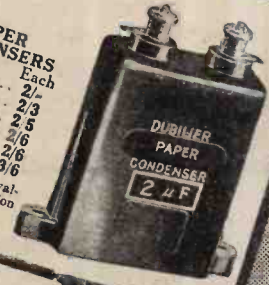

Type 620



MICA CONDENSERS

| | |
|-----------------|-----|
| '00005 to '0009 | 2/6 |
| '001 to '006 | 3/- |
| '007 to '009 | 3/6 |

Type 610



Free for the asking—“A Bit about a Battery.”

There's a copy for you at your dealers.

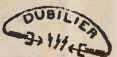

DUBILIER
FIXED CONDENSERS

If you have any difficulty in obtaining Dubilier Products, please write direct, giving your Dealer's name and address, to
DUBILIER CONDENSER CO. (1925) LTD., Ducon Works,
Victoria Road, N. Acton, London, W.3.

Cleaver

BC277F



205

THE NEW CELESTION LOUD-SPEAKER MODEL Z20

Designed specifically to give the finest possible results with any set from a Two-Valve to a Power Amplifier. Beautifully designed and hand polished cabinets in Oak £7.15.0. Mahogany £8.5.0. Walnut (to order) £9.0.0. Other models from £3.15.0.

"The very thing for constructors' receivers fill for the finest home in the land. "NOTIS EVG. POST."

WRITE FOR AN ABSORBING FREE BOOK ON "SOUND RE-CREATION" TO CELESTION LTD., DEPT. C, KINGSTON-ON-THAMES.

London Showrooms: 106, Victoria St, S.W.1.

CELESTION

The Very Soul of Music

AN INDOOR AERIAL



The neatest and quickest way to fix an indoor aerial is to use these

ELECTRON INSULATOR PINS

PRICE PER BOX 6^D POST FREE

Fixed in a moment to your picture rail, skirting or any convenient place, they hold the aerial so neatly that both the aerial and pins are practically invisible.

With Electron Indoor Aerial Insulator Pins a directional Aerial can be instantly removed and fixed at different angles at either end or across the room; simply pull out the Pins and fix in varying positions until the best results are obtained.

The NEW LONDON ELECTRON WORKS Ltd.
92, EAST HAM LONDON. E.6

For your Aerial use Electron, 25 ft. for 8d., 60 ft. for 1/- Superlat, 80 ft. for 1/6.
On Sale Everywhere or Direct.

149

WEARITE COMPONENTS

+ YOUR TIME
= BEST RESULTS
- TROUBLE

H.F. CHOKE

Iron cored. Can be supplied centre tapped for use in scratch filter.

Tuning range 10-2,000 metres.

Self-capacity 3.5 M.M.F. Inductance 300,000 M.H. Resistance 200 ohms.

Price 6/6.



RHEOSTATS

1/6 or 2/- each.

4, 7, 15, 30, 50 ohms. Potentiometers 2/- each. 300, 400 ohms. Volume controls 25, 5, 1 or 2 megohms. To pass 1 M.A. max. 4/- each. Baseboard mounting 3d extra.



Free illustrated lists by return post.

WRIGHT & WEAIRE LTD.
740, High Road, Tottenham, N.17.
Phone: Tottenham 3847/8.

471

Within the reach of every purse—

At your dealer **12' 6** or direct.

Another triumph of VOLTRON manufacturing skill. With Nickel Iron Alloy core and a coil aged in vacuo, to ensure long life.



VOLTRON PANASONIC TRANSFORMER

VOLTRON CO., Ltd., Queensway, Ponders End, MIDDLESEX.

Mention of "The Wireless World," when writing to advertisers, will ensure prompt attention. A10

CUT OUT THAT CRACKLE!



ALL SAL-AMMONIAC batteries develop "crackle" sooner or later. "Pertrix" cannot, for it contains no cell-corroding electrolyte—and in this respect "Pertrix" is unique. On every test, "Pertrix" shows 60% longer life, and no loss of power when out of circuit. Try "Pertrix" once, and you will never go back to the sal-ammoniac type again.

PERTRIX SUPER LIFE H.T. BATTERIES

Get also "Pertrix" Accumulators for filament current—the long service battery.

LONGER 60% LIFE

PERTRIX Ltd., Britannia House, Shaftesbury Avenue, London, W.C.2
Factory—Britannia Works, Redditch, Worcs.

CROSSWORD 12 PRIZES No Entrance Fee.

CLUES.

Your Name and Address

Name and Address of your Dealer

| | | | | | | | | | | | | | |
|----|---|---|----|----|---|----|---|---|----|----|----|----|----|
| 1 | 2 | | 3 | 4 | G | L | A | S | S | C | O | E | 6 |
| 7 | K | U | 8 | S | H | E | T | T | E | 10 | 11 | 12 | 13 |
| 14 | U | | 15 | C | | A | | | | | | | |
| 17 | S | | | 18 | | 19 | S | | | | | | |
| 20 | H | | 21 | | | 22 | Y | | 23 | | | | |
| 24 | A | | 25 | O | N | R | E | C | O | R | D | S | |

- | ACROSS. | DOWN. |
|--------------------------------|------------------------------------|
| 1. Capable. | 2. Food. |
| 4. Producer. | 3. Request to Repeat. |
| 7. A Popular Pick-up Arm. | 4. Distribute Kusha and Kushette. |
| 11. Tools. | 5. Must put this on. |
| 14. Rich in Mines and Mormons. | 6. Bars. |
| 16. An Order of Mammals. | 7. First and Foremost Pick-up Arm. |
| 17. Strip. | 8. Pavement. |
| 19. Mohammedan World. | 9. Purport. |
| 20. Bird. | 10. Gently! |
| 21. Lion. | 11. Village on Broads |
| 22. Grass. | 12. K u s h a and Kushette lessen. |
| 23. Material. | 13. Disabled. |
| 24. Holder. | 15. Luminous Circle. |
| 25. Proceed! | 18. Writer |
| 26. Flat Music. | |

PRIZES. First correct solution opened—£1 and one KUSHA Pick-up Arm (Turn Back Model). Next six correct—One KUSHETTE Pick-up Arm. Next five correct—One KUSHA Pick-up Arm (Standard Model).

CONDITIONS. All solutions must be sent to R. H. GLASSCOE & CO., 71, Moorgate, E.C.2, and received on or before 28th February, when they will be opened. Envelopes must be marked CROSSWORD. One solution only from each competitor. Our decision will be final. No correspondence. The result will be published in this journal under "Pick-ups" (small ads.) on March 12th. A sealed copy of the solution has been deposited with the Publishers of "The Wireless World."

The KUSHA Pick-up Arm (12/6) and the KUSHETTE (5/9) are highly satisfactory fittings at reasonable prices and consequently the most popular Arms on the market to-day. The KUSHA is weight-regulating and adjustable in angle and length to ensure best alignment under all conditions. The KUSHETTE is weight-regulating and correctly angled for best tracking. Both are "kind as a cushion" to the record and well worth competing for.

Obtainable everywhere through **R. H. GLASSCOE & CO., 71, Moorgate, E.C.2.**
G.E.C., any Factor, or

▲II Advertisements for "The Wireless World" are only accepted from firms we believe to be thoroughly reliable.

LOCKED *for* **SAFETY!**

LOCKED *for* **RIGIDITY!**

LOCKED *for* **LONG LIFE!**

—INTERLOCKED!



Individual movement of the elements is impossible in the *NEW* Cossor Screened Grid. They are rigidly locked in position, definitely eliminating all risk of internal short circuit. And because they are braced to a girder-like rigidity they are proof against even the hardest blow. As a result the *NEW* Cossor has an exceptionally long life. Nothing short of complete destruction can mar its extraordinary sensitivity and range. Demand the *NEW* Cossor for your Screened Grid Receiver. No other make has Interlocked Construction.

**2-volt type
now available.**

The *NEW* Cossor 220 S.G.
(2 volts, 2 amp.) Max.
Anode Volts 150, Im-
pedance 200,000, Ampli-
fication Factor **22/6**
200. Price - -

Cossor 4 and 6 volt Screened
Grid Valves are also available
with similar characteristics at
the same price.

The **NEW**
COSSOR
Screened Grid
Valve  3632

A. C. Cossor Ltd., Highbury Grove, London, N.5

Mention of "The Wireless World," when writing to advertisers, will ensure prompt attention.

AI2

The Wireless World

AND
RADIO REVIEW
(17th Year of Publication)

No. 546.

WEDNESDAY, FEBRUARY 12TH, 1930.

VOL. XXVI. No. 7.

Editor: HUGH S. POCOCK.

Assistant Editor: F. H. HAYNES.

Editorial Offices: 116-117, FLEET STREET, LONDON, E.C.4
Editorial Telephone: City 9472 (5 lines).

Advertising and Publishing Offices:
DORSET HOUSE, TUDOR STREET, LONDON, E.C.4.
Telephone: City 2847 (13 lines). Telegrams: "Ethaworld, Fleet, London."

COVENTRY: Hertford Street.
Telegrams: "Cyellst, Coventry." Telephone: 3210 Coventry.

BIRMINGHAM: Guildhall Buildings, Navigation Street.
Telegrams: "Autopress, Birmingham." Telephone: 2970 and 2971 Midland.

MANCHESTER: 260, Deansgate.
Telegrams: "Iliffe, Manchester." Telephone: 8970 City (4 lines).

GLASGOW: 101, St. Vincent Street, C.2.
Telegrams: "Iliffe, Glasgow." Telephone: Central 4857.

PUBLISHED WEEKLY.

Subscription Rates: Home, £1 1s. 8d.; Canada, £1 1s. 8d.;
other countries abroad, £1 3s. 10d. per annum.

Entered as Second Class Matter at New York, N.Y.

As many of the circuits and apparatus described in these pages are covered by
patents, readers are advised, before making use of them, to satisfy themselves
that they would not be infringing patents.

CONTENTS OF THIS ISSUE.

| | PAGE |
|---|------|
| EDITORIAL VIEWS | 155 |
| THE NEW "FOREIGN LISTENER'S FOUR." By F. H. HAYNES | 156 |
| TESTS ON CONE UNITS (CONCLUDED) | 182 |
| CURRENT TOPICS | 167 |
| RECENT INFLUENCES IN RECEIVER DESIGN. By A. G. WARREN | 168 |
| WIRELESS THEORY SIMPLIFIED, PART XX. By S. O. PEARSON | 172 |
| BROADCAST BREVITIES | 175 |
| CORRESPONDENCE | 176 |
| READERS' PROBLEMS | 177 |

POST OFFICE AND THE BEAM.

A GOOD deal has been published in the daily Press recently concerning the alleged obstructive policy of the Post Office in regard to telephony development, and, in particular, the neglect of the British beam stations in this connection. Before forming any hasty conclusions as to whether such an accusation against the Post Office is justified, it is necessary to trace briefly the history of the subject and see how the present friction has arisen.

As is well known, communications, both telegraphic and telephonic, in this country are a Post Office monopoly, and when the proposals for a fusion of the cable and wireless systems for communication beyond these islands was under discussion the Post Office was a definitely interested party, and no progress was possible without the agreement of the Post Office to cede to the Merger Company their rights in the matter of external communication. Eventually, on certain terms, the Post Office handed over to the Merger concern their rights in respect of external telegraphic communication, but

the Post Office at the same time retained their monopoly in external telephony communication. The Post Office has continued to run the Rugby short-wave telephony transmitter, which has been utilised for direct telephonic communication with America.

In the agreement under which the Merger Company was formed, a clause was inserted to the effect that, whilst retaining the right to conduct the external telephonic services of Great Britain, the Post Office would agree with the Merger Company the terms on which it would have the right to use the Merger Company's wireless stations for telephonic purposes.

The present trouble has arisen because the Merger Company believes that it has evidence that the Post Office, whilst being actively interested in the development of external telephony services, is ignoring the stations owned by the Merger Company and flirting with proposals for the establishment of independent telephony transmitters with the co-operation of foreign concerns.

The Merger Company, it would seem, reads into the clause regarding the use of their stations a statement of obligation on the part of the Post Office to utilise those stations for telephony on agreed terms, whereas the Post Office apparently does not consider the clause in any way binding to them, but leaving them with complete freedom to make other arrangements for their telephony services if they prefer to do so.

If the Merger Company has anticipated that the development of external telephony services from this country would be conducted through their stations, and that they would derive revenue therefrom, it must clearly have come as a severe blow to them to find that the Post Office interprets the position otherwise. It would seem that matters can only be cleared up when a proper legal interpretation has been given to the clause in dispute; but, even should it be decided that the Post Office has a free hand, one would expect that, in consideration of British interests, and also of the fact that the Merger Company must be classed as a public utility concern, the Post Office would not seek to utilise foreign apparatus and associations to satisfy its ambitions in developing telephony services, unless and until it had been definitely established that by so doing a better service than British resources could furnish would inevitably result.

We cannot believe that the Post Office would adopt so unpatriotic an attitude as to ignore the possibilities of stimulating British industry at a time when this country is so concerned with this particular problem, nor do we think that the Government would sanction such action even if it should be proved that Post Office officials have encouraged it.

The New "Foreign Listener's Four"

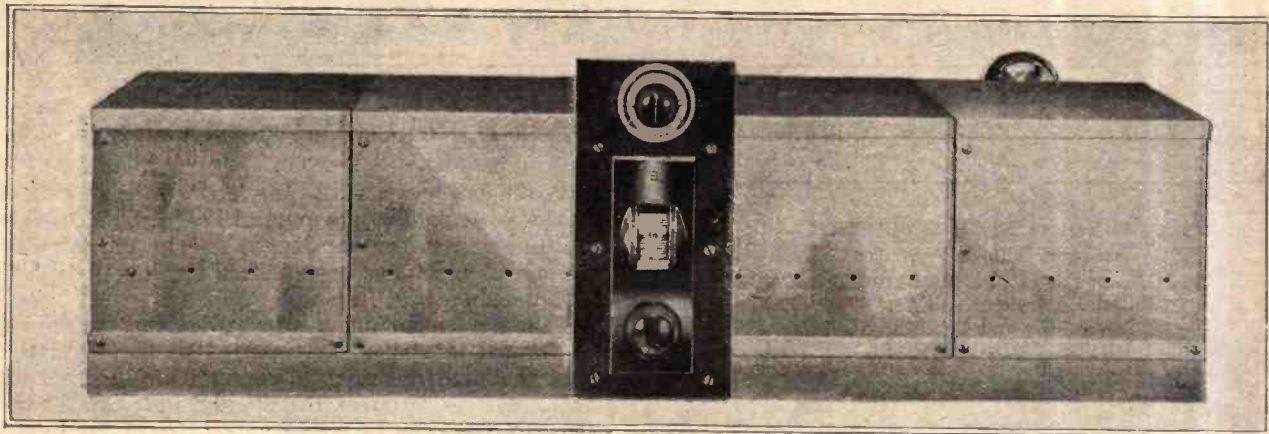

A Popular A.C. Mains Set Modified for Single Dial Control.

By F. H. HAYNES.

LOCAL station listening is the avowed policy of the B.B.C. It is dictated by its Director-General, endorsed by its late Chief Engineer, and revealed in its activities. Many of us largely agree with this view in that a set designed for local station reception and nothing more is capable of the most realistic results. On the other hand, a new class of receiving set is coming into vogue which, without whistles, howls, or complication, will give satisfactory reception of some thirty programmes, a property to be much appreciated when our local evening entertainment savours too much of education and dogmatism.

Switch Over for Two Wave Bands.

The Foreign Listener's Four¹ was the forerunner of a class of all-mains-operated sets to which considerable attention is being turned. The long-range A.C. receiver has already established itself in America to the exclusion almost of all others, and there is evidence that it will shortly be the foremost type of set in this country. In spite of the soundness of the argument for favouring a local station set, the merit of the future all-mains receiver is to be judged by the number of stations from which good-quality reception can be obtained. Correspondence has suggested the need for various modifications of the original design, such as the provision of a switch for wave changing, single-dial control, a higher degree of selectivity, and the adoption of the volume control and biasing methods to which reference has subsequently been made.²

Screen-grid H.F. stages in which the couplings have been designed to produce maximum amplification are comparatively flatly tuned, particularly when compared with the neutralised triode. It would be unsatisfactory,

for instance, to attempt to gang the tuning condensers of a multi-stage H.F. amplifier using triodes, as the tuned circuits would not remain sufficiently in step over the tuning range. Serious distortion would result, owing to lack of balance between the stages, together with poor range of reception. Logarithmic scale condensers were advocated in this journal as affording a solution to the ganging difficulty.³ Assuming that the coils to be tuned differ in their inductance values, it is only necessary, when using ganged logarithmic condensers, to shift the sets of moving plates on the common spindle to a point of resonance right through the receiver, and the relative tuning thus obtained would then be correct for all other setting positions. This method does not, however, compensate for differences in the stray capacities occurring in each stage, and these must be brought up, with the aid of trimming condensers, to the critical value adopted when designing the plate shape. It is better, however, to use carefully matched tuning coils in which the inductance values are all precisely the same in conjunction with tuning condensers following any convenient law and which all move off from zero together. In the one-dial-operated receiver to be described, the coils are machine wound and carefully matched by measurement. It is important to see that they are set up in their screening boxes at a sufficient distance from the metal so that small differences in their positions relative to the screening will not materially modify the matching. Differences of stray parallel capacity are unavoidable and arise chiefly in variations in the screen to grid and screen to anode capacities of the valves. These stray capacities are taken charge of by separate trimming condensers, though it might be mentioned that, by the use of the straight-line capacity tuning condensers of old, the trimming condensers become unnecessary. A correcting displace-

¹ Described in the issues of July 31st and August 7th, 1929.

² "Mains Sets and Grid Bias," December 4th, 1929.

³ "The Logarithmic Condenser," May 18th, 1927.

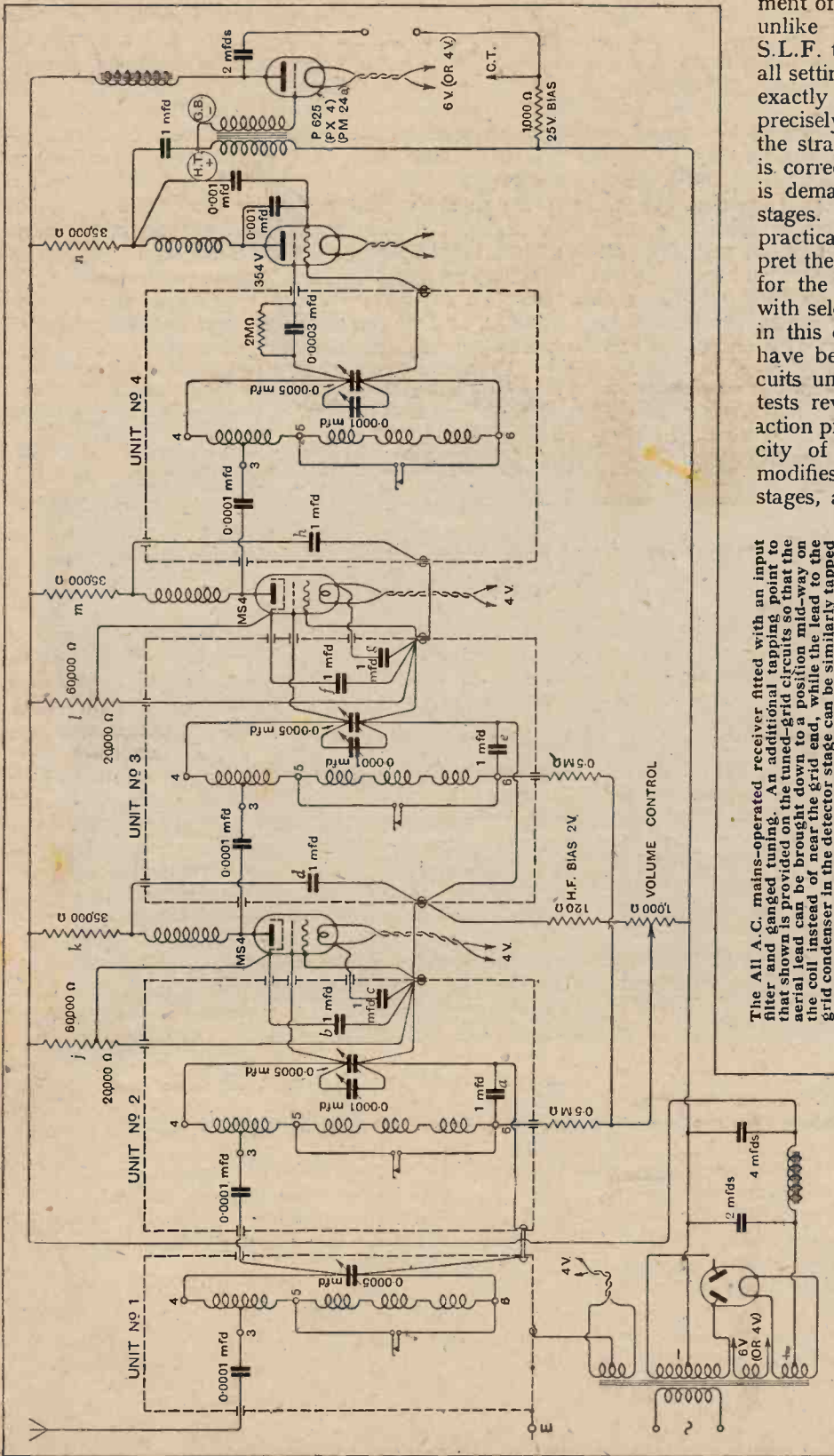

The All A.C. mains-operated receiver fitted with an input filter and ganged tuning. An additional tapping point to that shown is provided on the tuned-grid circuits so that the aerial lead can be brought down to a position midway on the coil instead of near the grid end while the tuned-grid condenser in the detector stage can be similarly tapped down when a higher degree of selectivity will result.

ment of the plates of such a condenser, unlike the square law, log scale of S.L.F. types, would remain constant at all settings. Thus, with the inductances exactly equal, the condensers following precisely the same capacity scales, and the stray capacities equalised, ganging is correct within far closer limits than is demanded by the screen-grid H.F. stages. It is not within the realms of practical application to readily interpret the principles of flat-topped tuning for the purpose of combining quality with selectivity. Tests have been made in this direction, and the H.F. volts have been taken across the tuned circuits under working conditions. Such tests reveal only too well that the reaction produced by the grid-anode capacity of the S.G. valves considerably modifies the resonance curves of the stages, an effect which is all-important and changes with the value of the tuning capacity.

In designing the H.F. intervalve coupling, the considerations involved are:—

- (1) Maximum amplification as dependent upon transformer ratio, valve impedance, and coil "goodness."⁴
- (2) Selectivity.
- (3) Maximum amplification as produced by a threshold adjustment of regeneration.

The best H.F. amplifier and the one which possesses the greatest range-getting properties is adjusted by trial and error, going right up to the point where oscillation occurs, and then slightly coming down on the transformer primary winding. An examination of such long-range commercial sets as are available reveals that the H.F. intervalve couplings are critically adjusted to a threshold condition of regeneration so that, while maintaining stability and without providing an actual reaction control, the range-getting properties are remarkable. On get-

⁴ "The Modern H.F. Valve," W. J. G. Page, July 24th and 31st, 1929.

The New "Foreign Listener's Four."—

ting down to the problem of arranging an H.F. intervalve coupling that would make use of valve reaction to the best advantage, one selects a valve with the smallest interelectrode capacity and investigates the three possible methods of coupling, viz., tuned anode, tuned transformer, tuned grid. The choke-fed tuned-grid system has been adopted in this receiver because, with the choke selected, it gave stable working and best amplification over the scale of the tuning capacity. A tuned transformer having the maximum permissible number of primary turns as determined near the maximum setting of the tuning condensers and without breaking into oscillation quickly reaches the oscillating condition as the tuning capacity is reduced. On reducing the turns to produce stability on the short-wave end of the scale

effected by short-circuiting an end section on each of the coils. Tests were made to determine the best distance that should be allowed between the short-wave section and the short-circuited turns. As soon as a distance of $\frac{1}{8}$ in. was exceeded with the particular former used, the presence of the short-circuited winding in no way reduced the H.F. potential developed across the remaining inductance or impaired the performance on the broadcast range. It might be mentioned here that if the short-circuited portion is brought closer to the remaining coil than about $\frac{1}{8}$ in., a ratio more nearly approaching unity can be tolerated as an intervalve coupling without oscillation trouble. The resulting amplification averaged over the entire scale is, however, reduced, and we see, therefore, that liberties cannot be taken by way of impairing the efficiency of the

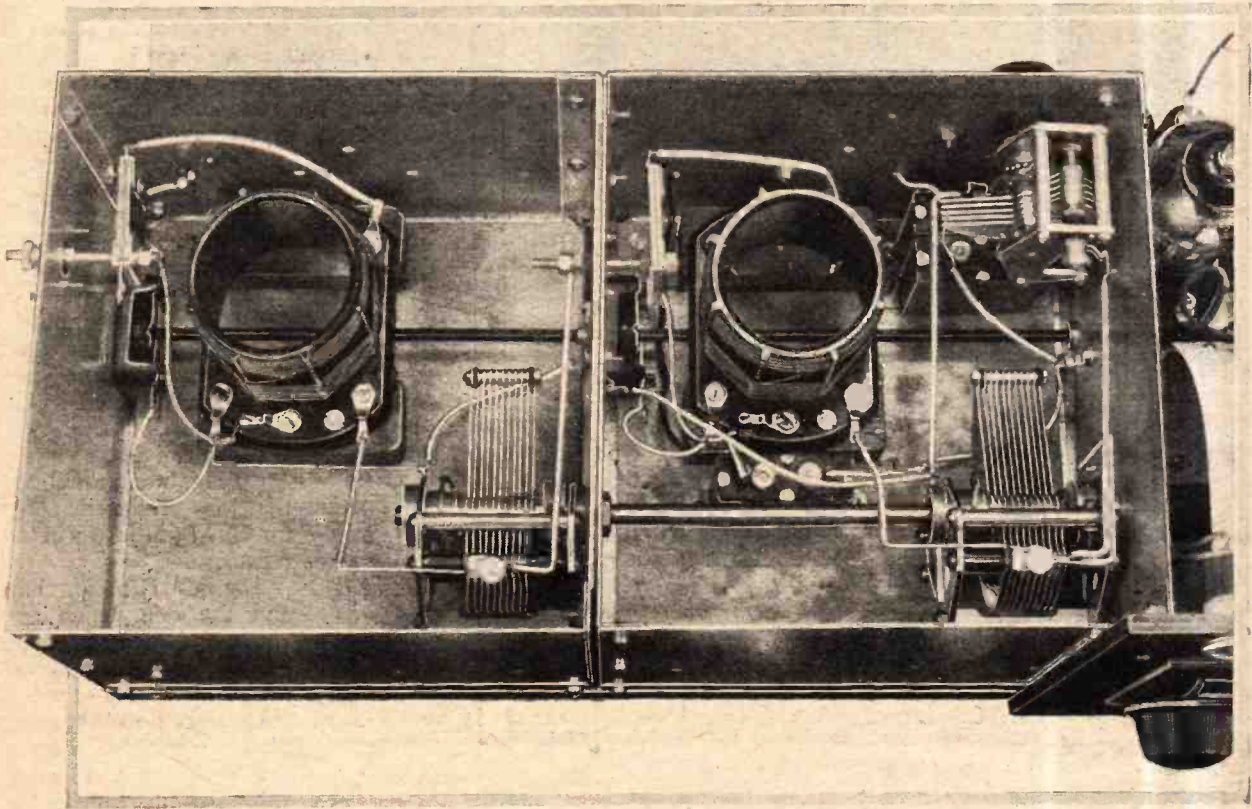

Units 1 and 2 housing the apparatus of the filter and first H.F. stage. The wiring is run in sleeving by the shortest route between terminals.

the amplification falls away swiftly as the wavelength advances and where the reaction becomes less effective.

Selectivity having been, so far, ignored in the interests of maximum stage gain, the inclusion of a filter stage is a desirable feature, a practice which has been adopted in several *Wireless World* receivers. There is no loss of signal strength by the use of the filter stage, and, while a special low-loss Litz wound coil would be a distinct advantage, successful ganging demands that this coil should be precisely similar to the coils associated with the screen-grid valves where the use of special low-loss coils would, in this instance, bestow little advantage.

Tuning to both long- and short-wave bands is

tuning coil. Conversely, the high efficiency of a Litz wound coil of large diameter may be of little advantage, owing to its close proximity to the screens and the fact that reaction is being effectively applied to increase the amplification.

Overloading of H.F. valves is an important factor in producing flatness of tuning, and it is obvious that stages should be graded in the same way as in an L.F. amplifier. Should the grid of an H.F. valve become positive as a result of a strong signal, there will be a flow of current between grid and filament, and the current path thus provided being similar to a shunt of comparatively low resistance across the tuned-grid circuit will create

The New "Foreign Listener's Four."—

damping. The M.S.4 valve, however, can be operated with treble the bias normally applied to an H.F. valve, and will therefore accommodate a strong signal without overloading. As the operating characteristic of the screen-grid valve is not straight, a strong signal produces harmonics and gives rise to rectification. The audio signal present by rectification will modulate the carrier of a transmission on an adjoining wavelength and bring about the symptoms of flat tuning. A step in the direction of removing this trouble is in the use of an H.F. valve that will operate with a generous value of grid bias so that the H.F. signal potentials can be accommodated.

As a further precaution, the volume control is arranged to cut down the signal by increasing the nega-

detector so as to produce a hum in the loud speaker, a carrier or signal when tuned in becomes modulated by the swinging L.F. oscillation, so that after detection the 50-cycle hum reaches the L.F. amplifier. Many readers have been puzzled by this hum trouble. It is avoided by the use of valves which allow of a generous grid potential swing and the adoption of the method of biasing now given. The steady anode current of the output stage is not used to produce the H.F. biasing potentials, as it is considered unwise to associate the heavy-speech currents with the earlier valves. By the use of a separate filament circuit for the output valve the anode current supply to the H.F. valves is localised so that the H.F. bias is in effect picked up across a potentiometer formed mainly by the D.C. current-carrying potential dividers supplying the screen voltages.

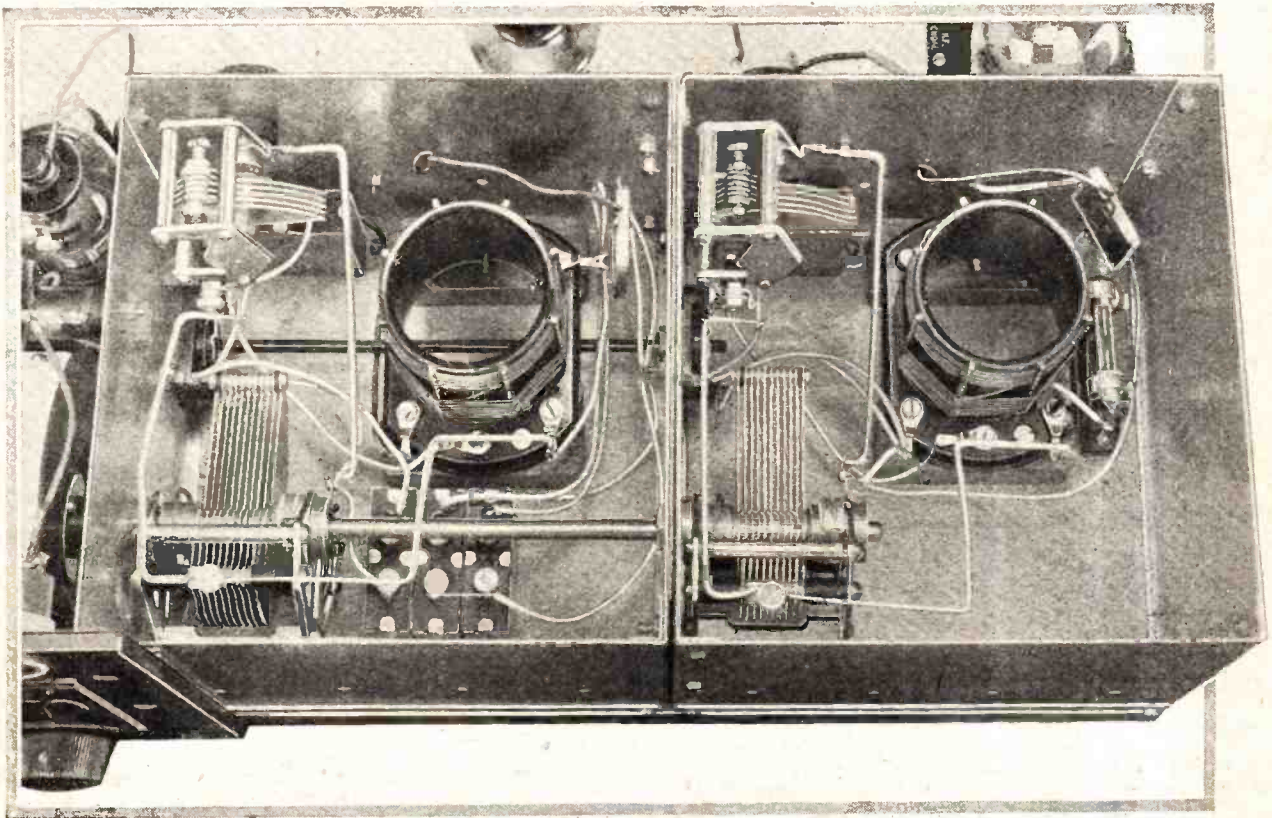

Units 3 and 4. By means of wooden blocks the tuning coils are elevated away from the metal base of the containers. The piece of 1/8in. square metal which gangs the switches is loosely mounted in the square holes provided so that no trouble is experienced due to errors in alignment.

tive bias so that the selectivity becomes improved, which is a desirable condition when dealing with a strong interfering signal. As the detector will overload before the H.F. valves, use of the volume control will ensure the avoidance of grid current damping in the H.F. amplifier. The importance of avoiding audio-frequency potentials in the grid circuit of a mains-operated H.F. stage has necessitated the removal of the biasing resistance from the cathode lead as first shown. Although a small 50-cycle A.C. potential on the grid of H.F. valve is scarcely passed on by the H.F. couplings and the

Orthodox practice is followed in the detector and L.F. amplifier. To provide maximum sensitiveness from the weakest signals, the usual leaky grid detector is adopted. Overloading is avoided by the use of the pre-detector volume control. To those readers who may consider the substitution of anode bend detection, it is pointed out that a highly selective detector stage will result. In fact, the selectivity will be sufficiently satisfactory to dispense with aerial filter. A 354V detector will still be adopted, but should be followed by resistance coupling. As the anode bend detector will, with

LIST OF PARTS.

- 1 Baseboard, wood, $28\frac{1}{2} \times 16 \times \frac{1}{8}$ in.
- 3 Battens, $2 \times 16 \times \frac{1}{8}$ in.
- 5 Valve holders 5-pin (W.B.).
- 3 H.F. chokes (McMichael Binocular Junior).
- 4 Tuning coils, type T.G.S./25 (Colvern).
- 4 Variable condensers, 0.0005 mfd. (J.B. Universal Log).
- 1 Drum Dial (J.B.).
- 1 Potentiometer, 1,000 ohms (Igranite type P59B).
- 4 Screening boxes (Bowyer-Lowe).
- 9 Fixed condensers, 1 mfd. 1,500 volts D.C. test ("Baugatz," A. M. E. Sherwood, 66, Hatton Garden, London, E.C.1).
- 2 Fixed condensers, 2 mfd. ("Baugatz," A. M. E. Sherwood, 66, Hatton Garden, London, E.C.1).
- 1 Fixed condenser, 4 mfd. ("Baugatz," A. M. E. Sherwood, 66, Hatton Garden, London, E.C.1).
- 3 Anode resistances, 35,000 ohms (Colvern).
- 2 Potentiometers, 80,000 ohms tapped 20,000 ohms (Colvern).
- 2 Grid leaks, 0.5 megohms (Loewe).
- 2 Porcelain grid-leak holders (Bulgin).
- 1 Grid leak, 2 megohms (Loewe).
- 2 Fixed condensers, 0.001 mfd. (Dubilier type 620).

- 1 Fixed condenser, 0.0002 mfd. with clips (Dubilier type 620).
- 4 Fixed condensers, 0.0001 mfd. (Polymet type F.C. 1101).
- 4 Range-wave switches (Colvern).
- 3 Condensers, 0.0001 mfd. (Polar "Volcon").
- 1 Mains transformer or 1 gross No. 4 stampings, 2 bobbins No. 4H. (W. B. Savage, 146, Bishopsgate, London, E.C.2).
- $\frac{1}{2}$ lb. No. 30 enamelled wire, $\frac{1}{2}$ lb. No. 36 enamelled wire.
- Small quantities Nos. 18, 22 and 24 D.S.C. wire. Brackets, screws and terminals.
- 1 Smoothing choke and
- 1 Output choke; or 1 $\frac{1}{2}$ gross stampings No. 4; 2 bobbins No. 4 (W. B. Savage), 1 lb. No. 32 enamelled wire, brackets, screws and terminals.
- 1 Interval transformer (Varley Nicore II).
- 2 Ebonite shrouded terminals (Belling Lee).
- Bakelite sheet, $4 \times 8\frac{1}{2} \times 3/16$ in.
- 2ft. $\frac{1}{8}$ in. square steel for switches.
- 2 \times 2ft. lengths $\frac{1}{8}$ in. round steel for condensers.
- Wood, Systoflex 1 mm., No. 22 tinned copper wire, 50 yards
- No. 42 D.S.C. Eureka wire, screws, tags, etc.
- Approximate cost, £14 10s.

In the "List of Parts" included in the descriptions of THE WIRELESS WORLD receivers are detailed the components actually used by the designer, and illustrated in the photographs of the instrument. Where the designer considers it necessary that particular components should be used in preference to others, these components are mentioned in the article itself. In all other cases the constructor can use his discretion as to the choice of components, provided they are of equal quality to those listed and that he takes into consideration in the dimensions and layout of the set any variations in the size of alternative components he may use.

weak stations, be underloaded, insufficient signal strength will result with the single-resistance L.F. stage. Contrary to a present tendency, therefore, this is an instance where a second L.F. stage might be used, and test has revealed that such an output amplifier follow-

ing anode bend detection brings the range-getting properties of the set up to those obtainable with the leaky grid detector. Precautions must be taken as regards decoupling the detector stage when attempting such a modification. An auto arrangement of connecting the

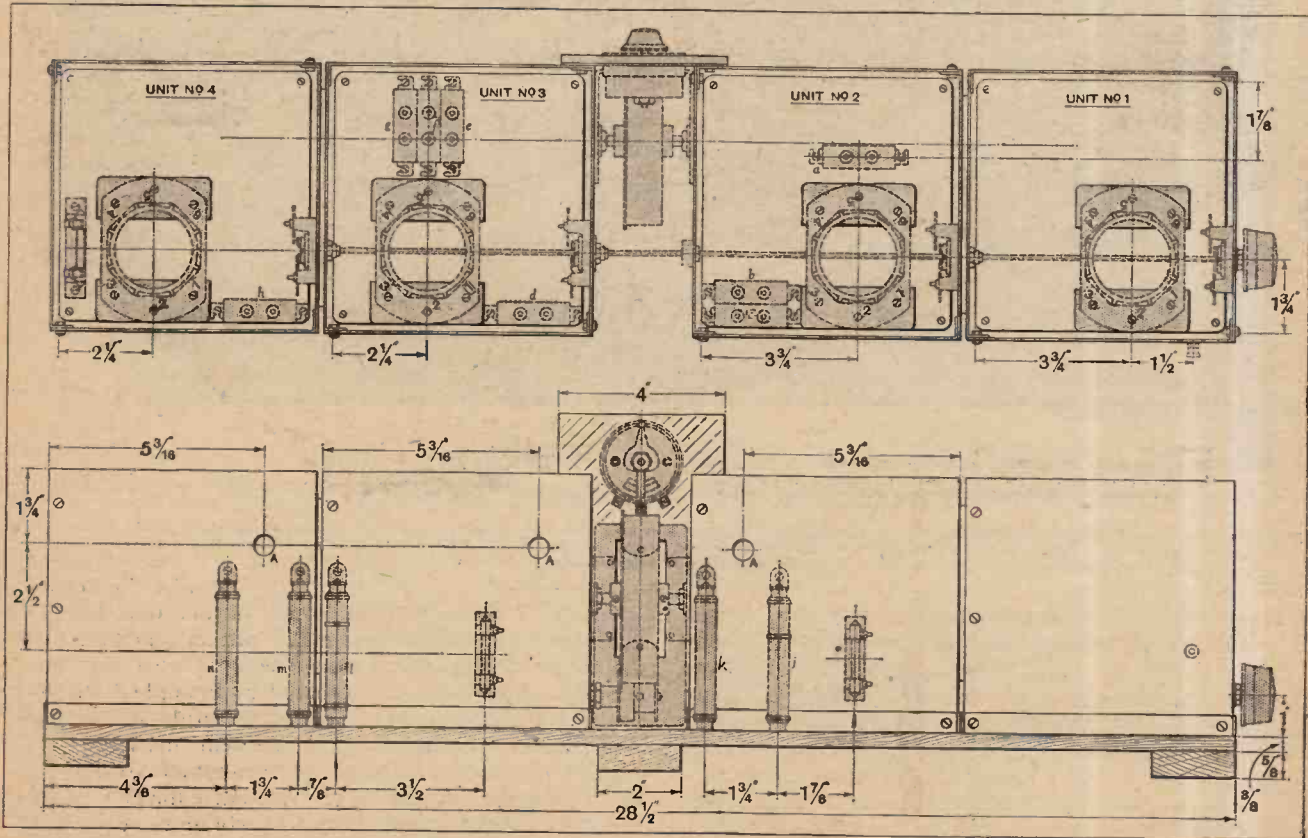

The layout of the components on the baseboard showing the assembly of the ganged switches. The boxes are clamped together by means of the bracket supplied with the drum dial and the one-hole fixing screws on the variable condensers. Small italic letters serve to identify the condensers and resistances by reference to the circuit diagram.

The New "Foreign Listener's Four."—

L.F. transformer is adopted⁵ in a manner indicated by the makers.

Before describing the mains equipment, it might be mentioned that quite a good battery-operated set can be built in accordance with the circuit given by introducing a single 1.5-volt grid biasing cell into each of the H.F. valve circuits, and omitting the 1-mfd. condenser associated with the free bias. Owing to the use of tuned-grid H.F. stages, the resistance-fed detector and filter-fed output stage, no decoupling apparatus need be introduced, while the negative of the filament circuit becomes earth connected in place of the heaters and cathodes. Separate H.F. feed leads will be needed to give the various potentials required by the four valves. The output valve is a P625. Substitution of the P.X.4 or P.M.24a will necessitate modification of transformer windings and the various voltage regulating resistances.

delivering 25 mA. R.M.S. or half the D.C. current required, which is, of course, the approximate anode current load. After rectification the D.C. voltage on load across the condenser is found to be 300 volts. The smoothing choke has a resistance of 300 ohms and an inductance of about 50 henrys when passing the load current of 42 mA., giving a drop of about 13 volts. A further 10 volts are dropped in the output choke, together with 25 volts across the biasing resistance, so that the potential at the anode of the P625 output valve is 250 volts. Potentials are tapped off from the negative side of the H.T. supply to bias all valves. Risk of L.F. oscillation is removed by avoiding a single common biasing resistance such as would result by the use of one transformer winding serving both the heaters and the filament of the output valve, as mentioned earlier.

Each H.F. valve draws 2 mA., and the screen voltage

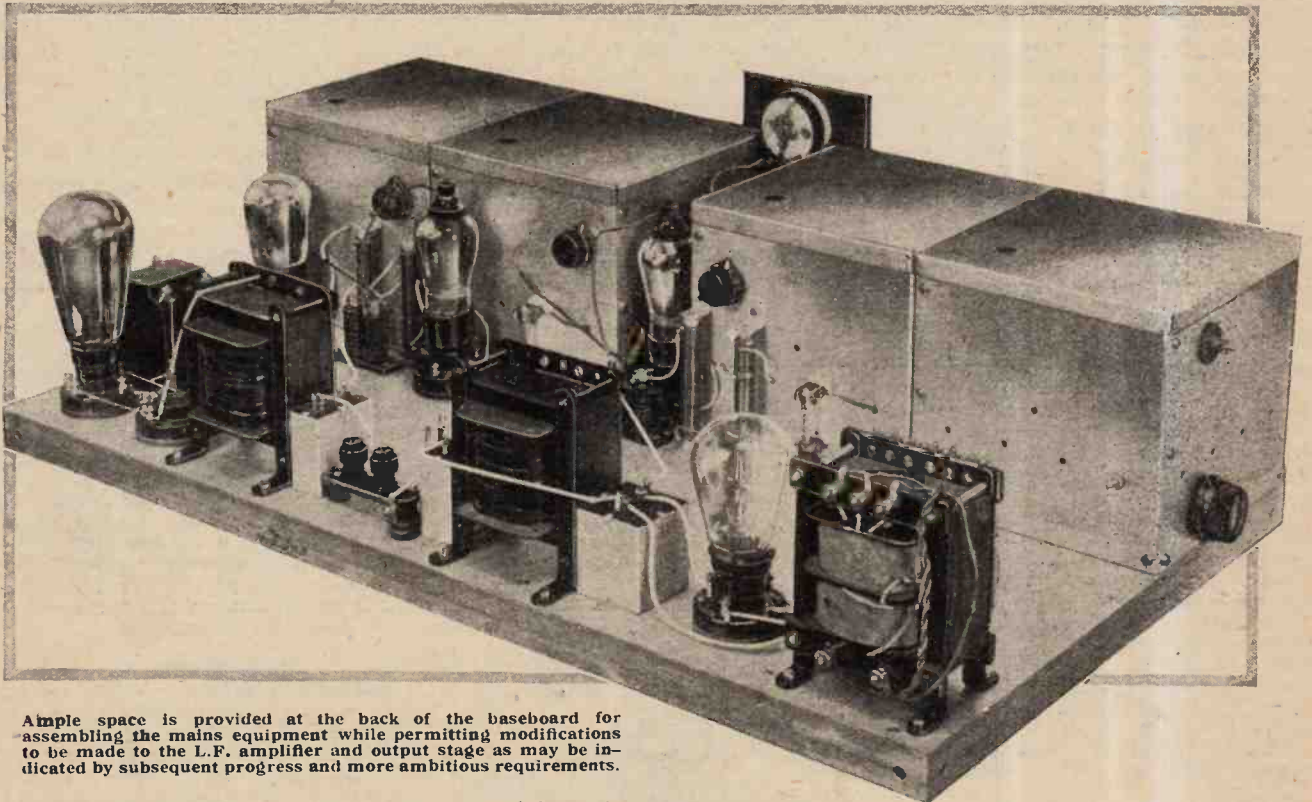

Ample space is provided at the back of the baseboard for assembling the mains equipment while permitting modifications to be made to the L.F. amplifier and output stage as may be indicated by subsequent progress and more ambitious requirements.

Details are given showing the construction of the mains transformer, partly because the home constructor can effect a saving by building this component himself, and more particularly to ensure the use of a transformer where the voltage outputs will precisely agree with those around which the voltage regulating resistances were determined. Practical details for making up such a transformer were given recently.⁶ With all windings loaded, an A.C. potential of 245 + 245 volts is obtained from the high-voltage terminals of the transformer when

potentiometers each 3.5 mA., with a screen current of 0.5 mA. Together with the 6 mA. taken by the detector valve, just over 18 mA. is passed in operating the three indirectly heated valves. A biasing potential of 2 volts is produced across a 120-ohm resistance connected in the earth lead, and this is applied through decoupling leak resistances to the grids of the two H.F. valves. A further 1,000 ohms in this H.T. negative lead renders available nearly another 10 volts, so that by coming back along this resistance the H.F. valves can be brought to an insensitive condition when it is required to cut down signal strength.

(To be concluded in the issue of February 26th, 1930.)

⁵ "The Parallel-fed L.F. Amplifier," F. Aughtie and W. F. Cope, December 11th, 1929.

⁶ "Mains Transformer Construction," H. B. Dent, January 22nd, 1930.

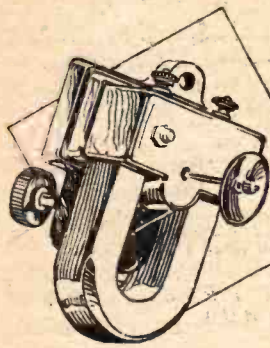

Tests on CONE UNITS

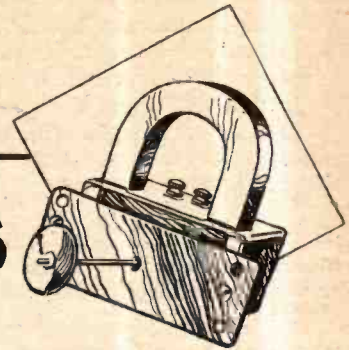

Further Notes on the Construction and Performance of Some Representative Commercial Types.

(Concluded from page 140 of the previous issue.)

IN estimating the performance of these units, gramophone records were used as a source of energy. Ordinary musical records specially chosen to represent all frequencies in the musical register were used for preliminary adjustments and to gain some idea of the general effect. A more accurate estimate of the frequency characteristic was then obtained by using a special continuously falling frequency record having a range of 6,000 to 150 cycles. This record was supplemented by further tests at fixed frequencies of 100 and 50 cycles. Measurements were also made of sensitivity, the power required to overload the unit and the impedance at eight different frequencies between 50 and 6,400 cycles. The results are given in the table on the opposite page. For further particulars of the tests applied to these units the reader is referred to page 135 of the previous issue.

LOEWE, TYPE L.S.71.

A single-acting reed movement is contained in the moulded bakelite shell. There is a single pole piece and bobbin which is attached to one leg of the permanent magnet about half-way from the end. This enables the reed to be increased in length, but at the cost of a certain amount of leakage flux. Tension spring adjustment is employed, and the windings are shunted by a Loewe vacuum condenser.

The sensitivity is below the average, and the greater part of the output is in the middle register, but the higher frequencies are unusually well reproduced for a unit of this type. Up to 400 cycles there is a gradual increase, and at this frequency the output is normal. Between 400 and 2,000 the volume is well above the average level, and resonances occur at 700 and 1,400 cycles. From 2,000 to 4,500 the output is again normal, and then there is a definite raising of the level between 4,500 and 5,500 cycles, after

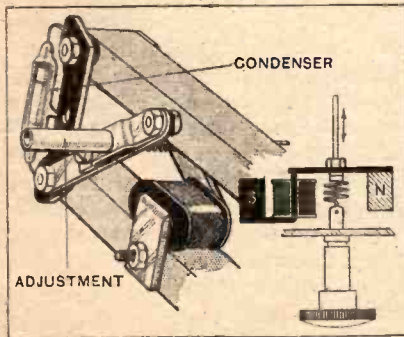

Loewe Type L.S.71.

which the output falls rapidly. Nevertheless, there is still a definite response at 6,000 cycles. Price 13s. 6d.

The Loewe Radio Co., Ltd., 4, Fountain Road, Tottenham, London, N.15.

LOEWE, L.S.130.

A balanced-armature movement in which the armature and speech coils are assembled in a self-contained die-cast unit.

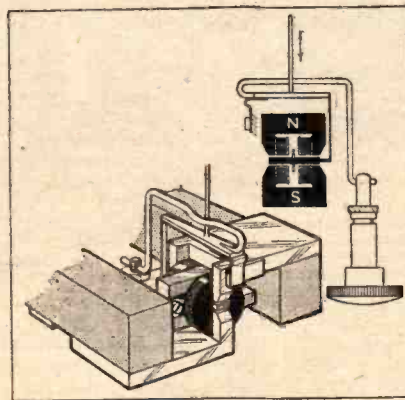

Loewe Type L.S.130.

The permanent magnet faces and pole pieces are accurately machined and assembled. No damping is provided, and the movement is free to develop large amplitudes at low frequencies. There is ample room in the pole piece gaps for the range of adjustment provided, which is applied through a stiff brass wire to the flexible bar supporting the cone driving rod.

The sensitivity of this unit is above

the average, and the reproduction pleasing. As might be expected in view of the freedom of movement of the armature, the bass reproduction is very good. The characteristic is free from violent resonances and depressions, and the reproduction at 6,000 was equal to that of the moving coil used for comparison. Depressions in the output of a minor character occurred at 2,800 and 5,000 cycles, while an increased output was noticed in the vicinity of 1,800 cycles and 3,200 cycles. The reproduction of transients such as drums and the triangle was sufficiently above the average to draw favourable comment. Price 23s. 6d.

The Loewe Radio Co., Ltd., 4, Fountain Road, Tottenham, London, N.15.

M.P.A. MARK VI.

Although of extremely simple design, this unit gives a remarkably good performance. The single-acting reed is supported on a lug projecting from the die-cast base of the unit, and is attracted by twin pole pieces and bobbins mounted

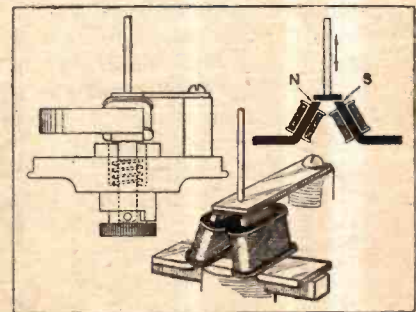

M.P.A. Mark VI Unit.

Tests on Cone Units.

at an angle to reduce leakage flux. The magnet system as a whole is mounted on a stout horizontal brass bar which is raised or lowered by a screw adjustment on the back. There is no provision for damping.

Apart from a noticeable increase near 500 cycles and a few minor local irregularities, the frequency characteristic does not deviate seriously from the normal at any point between 200 and 2,500 cycles. The reproduction in the middle and lower registers is consequently very good. The upper middle register is fair, and there is also definite evidence of reproduction at 6,000 cycles. The response between 2,500 and 6,000 cycles is, however, on a considerably lower level than from 2,500 downwards. The sensitivity is distinctly above the average, and the unit will handle considerable power without rattling. In view of the simplicity of the design this is a remarkably good overall performance. Price 12s. 6d.

M.P.A. Wireless Ltd., 62, Conduit Street, London, W.1.

ORMOND.

The arrangement of pole pieces gives the vibrating reed a differential movement. The reed is pivoted on two ball bearings, and is adjusted by a screw

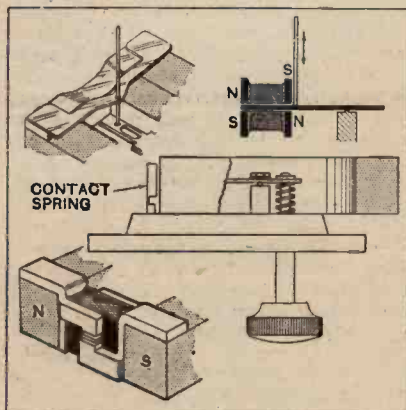

Ormond L.S. Movement.

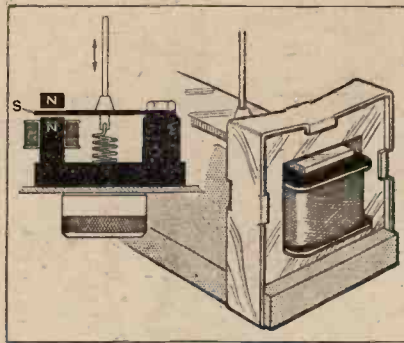

P.R. Cone Unit.

fitting into a tapped bush behind the pivot. The driving rod is attached to the reed close to the pole pieces, and is supported higher up by a flexible bridge piece. The terminals are mounted on a detachable moulded dust cover, and connection is made with the windings through a pair of spring contacts.

The reproduction of this unit in conjunction with the Ormond cone unit is very pleasing, and the only possible criticism is that the very top register is missing. Up to 2,800 cycles the output is normal and free from marked resonances, but above this frequency there is a steady decrease of 4,000 cycles, which is virtually the cut-off point. Nevertheless, this frequency is well above the top note of the piano. The lower middle register and bass are very good, and the response at 50 cycles above the average. The sensitivity is satisfactory, and taken as a whole the unit represents very good value for money.

Price, including cone chassis, 20s.
The Ormond Engineering Co., Ltd.,
Ormond House, Rosebery Avenue, London, E.C.1.

P.R. CONE UNIT.

The movement is of the differential type, in which the tip of the reed is of opposite polarity to the surrounding pole pieces. The permanent magnet is in the form of a flat bar which is drilled to pass the coil tension spring for adjustment. The lines of force pass to the reed

through an iron supporting pillar, and the surrounding pole pieces are laminated.

While the reproduction of the extremes of frequency in the useful musical range falls below the average, the middle and lower middle registers are good. The greatest output occurs between 500 and 1,000 cycles, and this is supplemented by distinct increases at 2,800 and 3,500 cycles, while depressions of the output occur at 2,500 and 3,000 cycles. The sensitivity is somewhat below the average, and the high-frequency cut-off is at 4,000 cycles.

Price 12s. 9d.
Peter Russell, P.R. House, Newgate Street, London, E.C.4.

R.C. CONE UNIT.

The single reed functions on the differential principle with laminated pole pieces and double windings. The permanent flux is derived from ring magnets placed above and below the reed, the flux being transmitted to the reed through the iron pillars between which it is clamped.

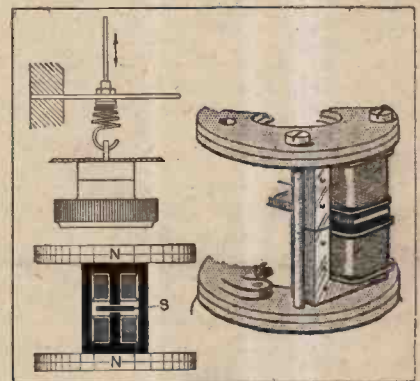

R.C. Loud Speaker Unit.

Adjustment is effected by a coil tension spring attached to the mid-point of the reed below the driving rod.

The sensitivity is below the average, but the unit shows no signs of rattling even at a volume level considerably in excess of that usually required for the average room. The bulk of the output is

| Unit. | Diaphragm. | IMPEDANCE (OHMS). | | | | | | | | D.C. Resistance (ohms). |
|---------------------|-------------|-------------------|-------|-------|--------|--------|--------|--------|--------|-------------------------|
| | | 50~ | 100~ | 200~ | 400~ | 800~ | 1,600~ | 3,200~ | 6,400~ | |
| Loewe, Type L.S.71 | Baker | 2,300 | 3,190 | 4,580 | 7,620 | 16,100 | 11,950 | 5,710 | 3,380 | 1,900 |
| Loewe, Type L.S.130 | Baker | 1,525 | 2,170 | 2,840 | 3,830 | 5,370 | 6,470 | 9,740 | 20,300 | 1,200 |
| M.P.A. Mark VI | M.P.A. | 2,065 | 2,340 | 3,100 | 4,740 | 7,430 | 12,100 | 19,100 | — | 2,000 |
| Ormond | Ormond | 2,180 | 2,670 | 3,760 | 4,680 | 7,550 | 12,100 | 19,700 | — | 1,950 |
| P.R. Cone Unit | Baker | 2,390 | 3,200 | 4,920 | 8,320 | 15,300 | 25,600 | 43,900 | 23,800 | 1,700 |
| R.C. Cone Unit | Baker | 2,820 | 4,300 | 6,900 | 12,550 | 20,200 | 30,000 | 58,600 | — | 2,000 |
| Six-Sixty | Baker | 1,655 | 2,555 | 2,740 | 7,240 | 14,100 | 23,600 | 41,000 | 21,800 | 1,060 |
| Tefag | Baker | 2,010 | 4,250 | 5,800 | 10,650 | 18,100 | 23,600 | 32,000 | 10,760 | 940 |
| Triotron | Baker | 1,125 | 1,550 | 2,275 | 3,650 | 5,700 | 7,890 | 13,500 | 11,920 | 750 |
| Tunewell | Baker | 1,375 | 1,660 | 2,530 | 4,110 | 7,980 | 15,000 | 9,900 | 4,730 | 1,050 |
| Wates "Star" | Wates | — | — | — | — | — | — | — | — | — |
| | Double Cone | — | 561 | 689 | 998 | 1,720 | 3,810 | 5,400 | 2,260 | 335 |
| Watmel | Watmel | 4,640 | 7,470 | 8,680 | 12,700 | 18,650 | 23,600 | 31,500 | — | 1,950 |
| W.B. | W.B. | 2,190 | 2,710 | 3,970 | 4,670 | 7,970 | 11,950 | 19,500 | — | 1,930 |

Tests on Cone Units.— between 400 and 1,500 cycles with a resonance at 900 cycles. The total range of useful frequencies reproduced is from 300 to 4,500 cycles, and beyond these points there is a definite cut-off. A ridged seamless fabric cone is supplied for use with this unit at a cost of 3s.

Price of unit 13s. 6d.
Ridged Cone Co., Ltd., York House, Southampton Row, London, W.C.1.

SIX-SIXTY.

Of unusually small dimensions this unit works on the differential principle, the tip of the reed being of opposite polarity to the surrounding poles, which are laminated. There are two curved bar magnets upon which the reed and pole pieces are built up. Adjustment is provided by a screw pressing on a U-shaped spring underneath the reed.

Although the reproduction of very high and very low notes is weak there is a good response between 150 and 3,500 cycles with a major resonance at 1,000 cycles, and another of less importance at 3,000 cycles. The sensitivity is somewhat below the average, but there were no signs of rattling.

Price 15s.
Six Sixty Radio Co., Ltd., 17-18, Rathbone Place, Oxford Street, London, W.1.

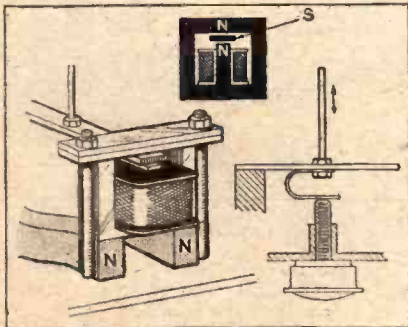

Six-Sixty L.S. Movement.

TEFAG.

This unit is assembled on a substantial die-cast base, and has a permanent magnet of generous dimensions. The reed is of unusual design and is over an inch in width near the supports. At the opposite extremity the reed is forked and each prong is surrounded by coils wound on a specially moulded former with an integral lug for screwing to the die-cast base. The laminated pole pieces are arranged to give a differential movement to the ends of the reed. No damping is provided and adjustment is effected by a screw pressing on the reed in the centre of the three-point suspension.

The reproduction between 400 and 4,500 cycles is good, but beyond these limits there is a distinct falling off. Noticeable resonances occur at 900 and 3,200 cycles. The sensitivity is somewhat below the average, but there is no evidence of any tendency to chatter.

Price 15s. 6d.
Telephone Berliner (London), Ltd., Colindale Avenue, London, N. W. 9.

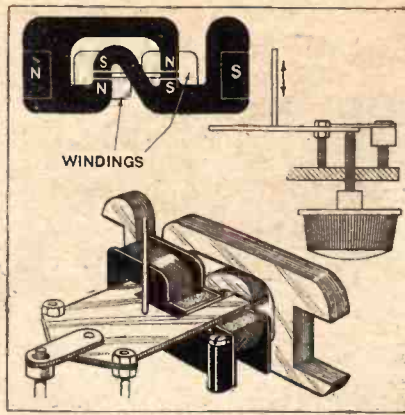

Tefag Cone Unit.

TRIOTRON.

The differential reed is supported on pivot points and adjusted under spring tension by a screw passing through a bush in the pressed metal base. A metal dust cover carries the insulated terminals to which contact is made by light brass springs attached to the speech coil bobbin. The pole pieces are arranged to give a differential movement to the reed.

The sensitivity of this unit is above the average and it has a very good frequency response. The high frequency reproduction is good up to 5,500 cycles, and the bass is also satisfactory. Between 200 and 5,000 the only serious departure from a normal output is a marked resonance at 1,200 cycles. No evidence of chattering was observed and, taken as a whole, the performance of this unit may be regarded as above the average.

Price 15s.
Electric Lamp Service Co., Ltd., 39 and 41, Parker Street, Kingsway, London, W.C.2.

TUNEWELL.

A horizontal skeleton reed is mounted between a pair of permanent magnets equipped with double laminated pole pieces and bobbins; the movement is therefore differential. A by-pass condenser is connected across the windings, and adjustment is effected by raising and lowering the lower set of magnets only.

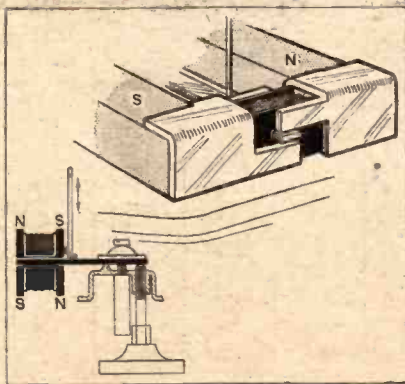

Trioatron L.S. Unit.

Apart from a slight resonance at 1,500 and a depression near 3,000 cycles, the response is remarkably uniform from 300 to 6,000 cycles. Below 300 there is a reduction, but there is a definite response down to 50 cycles. The general effect is very pleasing, and we have no hesitation

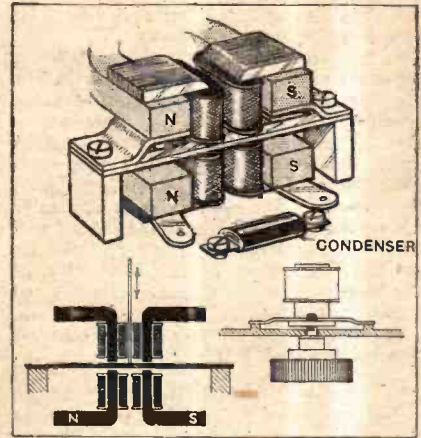

Tunewell Cone Movement.

in placing this unit in the highest class as regards quality of reproduction. The sensitivity is above the average, but chattering commences at 400 cycles with an input of 525 milliwatts.

Price 22s. 6d.
Turner and Co., 54, Station Road, New Southgate, London, N.11.

WATES "STAR."

The reed is provided with a three-point support and spring-loaded adjustment, and functions on the differential principle

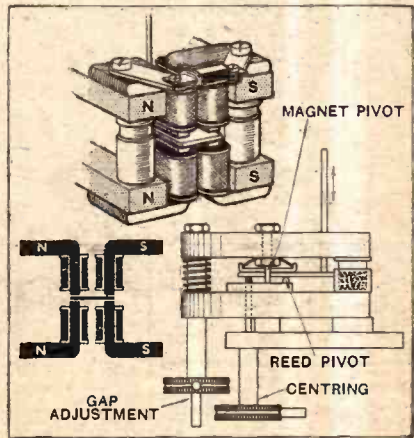

Wates "Star" Unit.

between pairs of laminated pole pieces and twin permanent magnets. An unusual feature of this unit is the provision of a separate adjustment for the gap between the pole pieces in addition to that for centring the reed. This enables an exact compromise to be effected between sensitivity and chattering for any input. The windings are shunted by a small condenser.

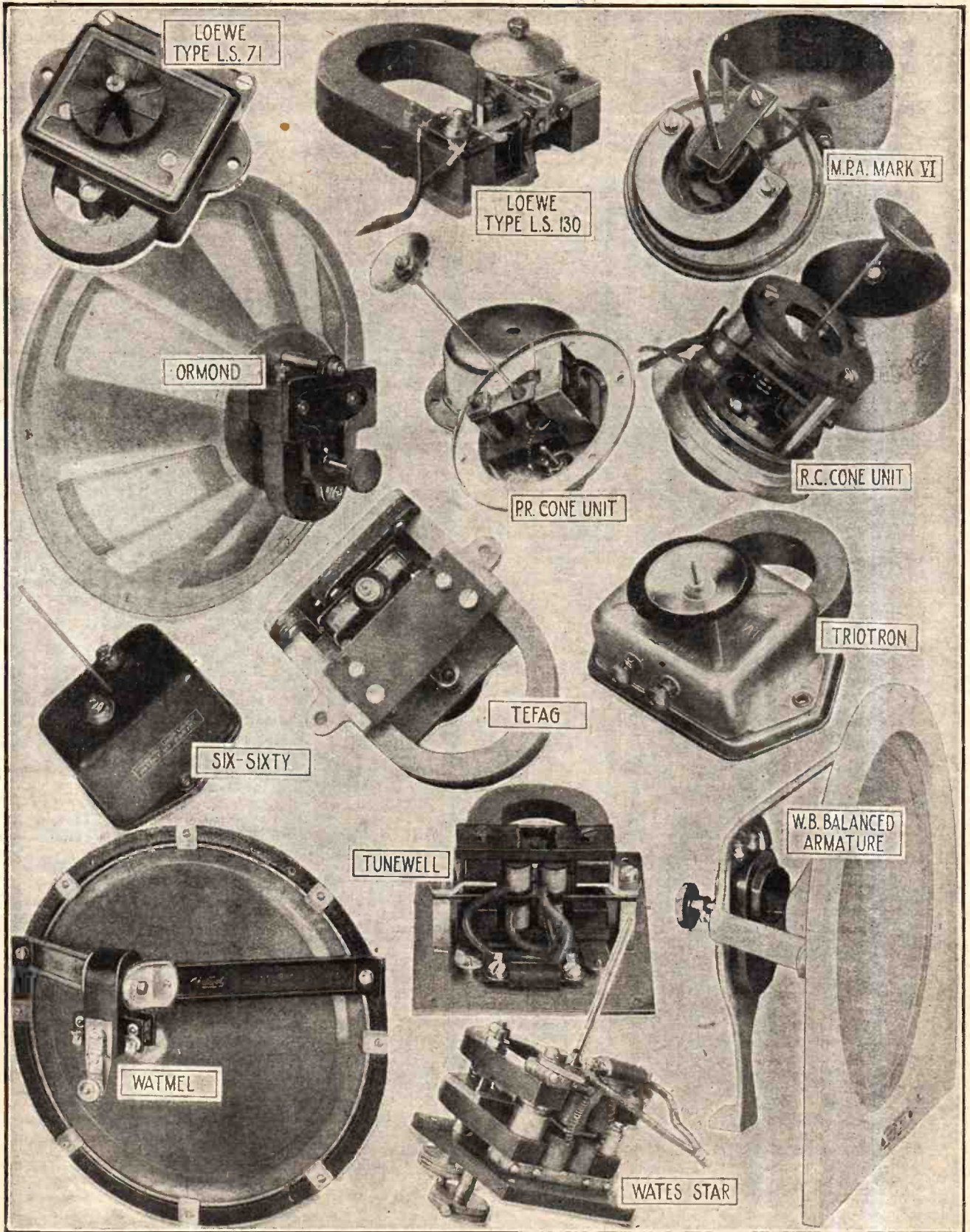

Tests on Cone Units.—

The bottom and middle register reproduction is good, the upper middle register fair and the top definitely present. The general effect is very pleasing, but a curious type of buzz, in which harmonics appeared to be present, was noticed at 1,200 and 4,500 cycles. This was probably due, however, to the particular diaphragm used in the test. As is only to be expected with the wide range of adjustment provided there is no trace of chattering and the sensitivity is above the average.

Price 36s.

Shaftesbury Radio Company, 184-188, Shaftesbury Avenue, London, W.C.2.

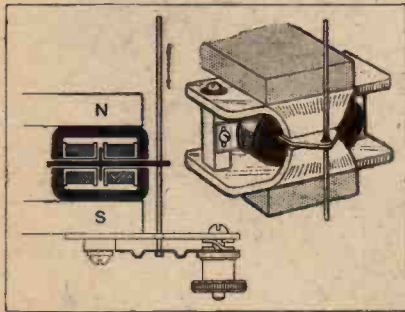

Watmel Cone Unit.

WATMEL.

This is a genuine balanced-armature unit which is characterised by considerable freedom of movement of the arma-

ture. Centring is effected by raising or lowering a flat brass spring, to the centre of which an extension of the driving rod is attached. Cast and machined aluminium brackets are provided for mounting the unit on the cone chassis.

As might be expected in view of the freedom of movement of the armature the bass reproduction is excellent and quite equal to the moving coil from 50 to 500 cycles. From 500 to 2,000 cycles the response is free from major irregularities, but at 2,750 there is a sharp cut-off. The general effect is, therefore, one of low pitch with a lack of brilliance in the upper register. The impedance of the unit is high, and while it would probably give good results with a pentode, the sensitivity with the 2,000-ohm output valve used was below the average. At 100 cycles chattering started with 135 milliwatts.

Price 18s. 6d.

Watmel Wireless Co., Ltd., Imperial Works, High Street, Edgware.

W.B.

Although described by the makers as a balanced armature, this unit functions actually on the differential principle, as the arrangement of pole pieces in the diagram indicates. The reed is attached to a lip raised in the brass base plate, and the adjustment depends upon the flexibility of this lip. The driving rod is centred by a thin German silver spring.

The quality given by this unit in conjunction with the W.B. cone chassis is very satisfying, the only criticism being

the absence of the very top register above 4,500 cycles. The sensitivity is distinctly above the average, and there was no evidence of any tendency to chatter.

Price 12s. 6d.

Whiteley, Boneham and Co., Ltd., Nottingham Road, Mansfield, Notts.

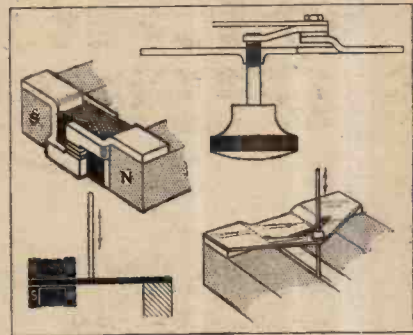

W.B. Loud Speaker Movement.

CORRECTION.

In the previous instalment of this article it was stated in error that the Baker diaphragm was used when testing the Goodmans "Twin Magnet" unit. Actually, the diaphragm used was the Goodmans Type 518, which is of a diameter considerably above the average. This factor no doubt contributed to the excellent reproduction of the bass, which was noted as a feature of the unit.

STROBOSCOPES. A Word in Self Defence.



The Stroboscope. Where the electric supply is alternating, a neon lamp can be used to check gramophone turntable speed. With a careful adjustment of the speed regulator the disc will appear to be stationary when illuminated by a neon lamp connected to alternating-current mains.

IN the February number of our contemporary, *The Gramophone*, we are taken to task for having published in our issue of January 8th an article prepared for us by Mr. H. Lloyd, M. Eng., A.M.I.E.E., describing a stroboscope gramophone speed tester.

The writer in *The Gramophone*, referring to this article, states: "I observe that *The Wireless World* has published a stroboscope similar to those published in *The Gramophone* by Mr. Ainger Hall last year—but, in my view, in not nearly so satisfactory a design, since the spokes are not so long and the placing of three sets in adjacent rings makes observation less easy." Later the writer continues: "It is unlike *The Wireless World* to publish what amounts to a paraphrase of an article in another journal without the courtesy of reference. No doubt, therefore, this was an oversight."

It is true that we were not aware of the publication of a stroboscope speed tester in *The Gramophone* last year; otherwise, perhaps we should have taken *The Gramophone* to task for having made use of an idea published in *The Wireless World* of December 7th, 1927, for in that issue we described a stroboscope, and the accompanying illustration is reprinted from the article, together with a description which appeared beneath the photograph. We certainly do not wish to suggest that we were entitled to "the courtesy of reference" in the article which appeared in *The Gramophone* last year because we had described the hoary principle in our issue of December 7th, 1927.

The Gramophone criticises the stroboscope which we published recently on the grounds that there are three adjacent rings, and also that the spokes are not long enough. If these are defects, then the defects were absent in the particular stroboscope which we described in 1927, but it is our view that the one published in our issue of January 8th, 1930, has very material points of advantage over the old type. Perhaps, in the view of our readers, the most noticeable difference between the stroboscope issued by *The Gramophone* and that which we have recently described is that the former sells for 1s., whereas *The Wireless World* supplies the stroboscope without charge to readers who forward a stamp for postage.—Ed.

The BETTER SERVICE BATTERIES



They're BRITISH

Super Quality Only

Get an Ediswan H.T. battery and note the silent background—the perfect reception. It will give you good service, too—your Ediswan battery—and it will still be going strong long after another battery would have been relegated to the dust bin.

- W.L. 204P. 66v. 9/6.
- W.L. 205P. 66v. 17/6.
- W.L. 208P. 103v. 15/6.

IF IT'S EDISWAN IT'S BETTER

THE EDISON SWAN ELECTRIC CO., LTD.,
123/5, Queen Victoria Street, London, E.C.4.
Showrooms in all the Principal Towns. B.54.

BETTER THAN A 2-VOLT PENTODE



AND CHEAPER

THE MAZDA P.240

Here is a valve that will, by reason of its high amplification factor and very low impedance, give you a power output that is equal to that of a pentode, while at the same time giving a far better reproduction of the bass notes. The Mazda P.240 is more robust and more economical, too, the H.T. current being only about two-thirds of that consumed by a pentode, whilst its cost price is considerably lower.

PRICE 15/-

Write for Catalogue. Sold by all reputable dealers.



THE EDISON SWAN ELECTRIC CO., LTD.,
Radio Division,
1a, Newman Street, Oxford Street, W.1.
Showrooms in all the Principal Towns.

EDISWAN

V.23.



Use an EVER READY
refill battery for your
Electric Hand Lamp.

EVER READY
REGD TRADE MARK

BRITAIN'S BEST BATTERIES

Mention of "The Wireless World," when writing to advertisers, will ensure prompt attention.



Events of the Week in Brief Review.

A LENIENT BENCH.

Nottingham is earning the reputation of being the wireless pirates' paradise. At the Nottingham Summons Court last week offenders were fined only 5s. each.

THE POPE AND MARCHESI MARCONI.

The Pope is reported to be showing great interest in the erection of the Vatican short-wave station, which is to have a world-wide audience. On February 2nd His Holiness received the Marchese Marconi in private audience.

CAPTAIN ECKERSLEY TO GIVE FARADAY LECTURE.

Captain P. P. Eckersley will deliver the Faraday Lecture at the meeting of the Institution of Electrical Engineers at Savoy Place, W.C.2, on February 27th. His subject will be "Broadcasting by Electric Waves."

ITALY'S RADIO FUTURE.

"Radio Roma," Italy's new broadcasting giant, is reported to be merely a jumping-off point for a larger broadcasting scheme with transmitters at Florence, Trieste, and Palermo. The plans also include a 15 kW. short-wave station at Rome for long-distance relays.

Wireless imports in 1929 were 400 per cent. in advance of previous figures.

WIRELESS AT INTERNATIONAL SHOW.

A large wireless section is to be included in the International Exhibition of Industry and Art, to be held at Liège in April next, in celebration of the centenary of Belgian independence.

PARIS RADIO RALLY.

A "grand reunion" of French wireless amateurs is to be held in the Sorbonne, Paris, during March, under the auspices of the Comité des Sociétés de T.S.F. The latest developments in wireless will be demonstrated.

MOON AS RADIO REFLECTOR.

To test the amount of absorption of electromagnetic waves in the earth's upper atmosphere, Dr. Hoyt Taylor, president of the American Institute of Radio Engineers, proposes to transmit short-wave signals to the moon. His intention is to measure the strength of the "echo," judging that this should be heard 2.8 secs. after transmission, as the waves, travelling at 186,000 miles per sec., must cover 500,000 miles.

RADIO RELICS IN CZECHOSLOVAKIA.

According to the *Central European Observer*, it is proposed to establish a wireless museum at Prague.

IRISH RADIO WEEK.

Radio Week is to be celebrated in the Irish Free State from February 24th to March 1st.

WIRELESS AT B.I.F.

Many wireless firms are exhibiting at the British Industries Fair, which opens at Olympia on Monday next, February 17th. Until 4 p.m. on the opening day admission is restricted to trade buyers.

JAPANESE RADIO SHOW.

A wireless exhibition is to be held in Tokyo from March 20th to April 18th.

BROADCASTING DANGERS IN INDIA.

The plucky fight of the Indian Broadcasting Company in the face of public indifference has won the sympathy of enthusiasts in all parts of the world, and the news that the company has decided to go into liquidation has caused widespread regret. The service was originally opened by the Viceroy early in 1927. Financial difficulties dogged the enter-

prise from the start, and when, in October, 1928, an appeal for a Government subsidy was refused, several European members of the staff resigned.

The absence of a responsible broadcasting authority in India may pave the way for wireless propaganda of an undesirable kind. The question warrants a Government enquiry.

U.S. RADIO TRADE "TERRORISED."

That the independent radio manufacturers of the U.S.A. are "terrorised" by the patent monopoly of the radio combines, which includes the Radio Corporation of America, is alleged by Mr. B. J. Grigsby, head of the Grigsby-Grunow Company. The radio combine, he states, has pooled its patents, good or bad. The result is that many firms are forced to pay royalties on patents which are valueless.

In evidence before the Interstate Commerce Committee it was reported that the independent firms had paid the combine \$5,302,879 in royalties in a year and a half.

THE KING'S RECORD.

At the suggestion of H.M. the King the proceeds from the sale of the gramophone record of the Royal Speech at the Naval Disarmament Conference are to be devoted to the "Wireless for the Blind Fund." This H.M.V. record, R.B.3290, bears a special decorative label of royal purple, gold and scarlet.

WIRELESS FOR THE BLIND.

At the twenty-first annual concert of the Motor and Cycle Trades' Benevolent Fund, held at the Temperance Hall, Birmingham, on Friday, January 31st, a collection was made for supplying wireless to the blind, and a sum of £9 5s. 9d. was obtained during the evening towards this fund. The Pandona Co. of Birmingham, also gave a 5-valve portable set.

MORE COMMUNAL WIRELESS.

The Bath Surveying Committee is considering an application from a company to establish a wireless distribution service in the town. Subscribers would obtain relayed programmes from a central receiver for 1s. 6d. a week.

CORRECTION.

A mistake, due to a printing error, occurred in the footnote to "Wireless Theory Simplified," on p. 124 of our issue of January 29th. The numerator in the fraction should be Z₁.

FORTHCOMING EVENTS.

WEDNESDAY, FEBRUARY 12th.
Edinburgh and District Radio Society. At 8 p.m. At 16, Royal Terrace. Lecture: "Eliminator Transformer Construction," by Messrs. G. N. Fordyce and J. L. Minto.
Muswell Hill and District Radio Society. At 8 p.m. At Tollington School, Tetherdown, N.10. Lecture and Demonstration: "Power Output and the Pentode Valve," by Mr. F. E. Henderson, A.M.I.E.E.
North Middlesex Radio Society. At 8 p.m. At St. Paul's Institute, Winchmore Hill, N.21. Lecture: "Progress in 1929," by Mr. L. C. Holton.

THURSDAY, FEBRUARY 13th.
Golders Green and Hendon Radio Society. The Annual Dinner. (At the Refectory Restaurant, Finchley Road, 7.30 p.m.)
Hford and District Radio Society. At the Westeyn Institute, High Road. Lecture: "Loud Speakers," by a representative of Messrs. S. G. Brown, Ltd.
Kensington Radio Society. At 20, Penywern Road, Earl's Court. Lecture: "Short-wave Transmission and Reception," by Mr. W. F. Floyd.
Slade Radio (Birmingham). At the Parochial Hall, Broomfield Road, Erdington. Demonstration of pick-ups and new loud speakers, by Mr. A. Freeman.

MONDAY, FEBRUARY 17th.
Newcastle-upon-Tyne Radio Society. At 7.30 p.m. In the English Lecture Room, Armstrong College. Lecture: "Valves—Their Manufacture and Use," by Mr. O. S. Pratt, B.A.

4^D

The Wireless World

AND RADIO REVIEW

The Paper for Every Wireless Amateur

Wednesday, February 19th, 1930.

BurTON

SELF-LOCATING

VALVE
HOLDER



1/- each

Pentode
-Valve-
Holders
1/6 each

Patent No.
316708

MANUFACTURED BY
C. F. & H. BurTON

PROGRESS WORKS
WALSALL, ENG.



TELSEN
L.F. TRANSFORMERS

Radio's Choice

Have acquired a world-
wide reputation for
Quality and Value.

Built by Specialists in
Transformer construction,
they have set a Quality of
Performance above re-
proach. Your Set will
work better with a Telsen
Transformer - - - - Fit
one now!

TELSEN ELECTRIC
CO. LTD.,
Miller Street,
Birmingham.

RADIOGRAND
12/6

VIVIDLY NATURAL RADIO WITH THIS SUPREME SPEAKER

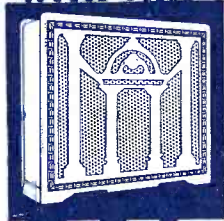

If your set is old or new, large or
small, the Ultra Air Chrome Speaker
will give you radio with atmosphere,
character, temperament and vital-
ity. Vividly natural, playing,
singing or talking, with perfect
acoustic balance over the full com-
pass of orchestra and voice. From
all dealers.

50%

ULTRA
AIR CHROME SPEAKER

WITH THE DOUBLE LINEN DIAPHRAGM

ULTRA ELECTRIC LIMITED, 661. HARROW ROAD, LONDON, N.W.10.

McMICHAEL PORTABLE RECEIVER

22 GNS.

Point No. 2.

QUALITY OF REPRODUCTION.

The McMichael Super Range Portable
Four reveals all the beauties of speech
and musical values to an unrivalled
degree.

Hear it at any high-class radio
store or our London showrooms.

L. McMICHAEL LTD.,
Wexham Road, Slough, Bucks.
179, Strand, London, W.C.2.



PHILIPS

BATTERY ELIMINATORS (H.T. UNITS)

Get the *best* out of your receiver—volume, tone quality, distance—by using a Philips Battery Eliminator and thus taking your H.T. current from the electric mains. Also it's *cheaper* than having to pay for new batteries every now and then. One of the three types of Philips Battery Eliminators meets your needs. Types 3009 and 3002 work off A.C. Mains, Type 3009 giving grid bias as well as H.T. For D.C. Mains there is Type 3005.



Type 3002
£5-10-0

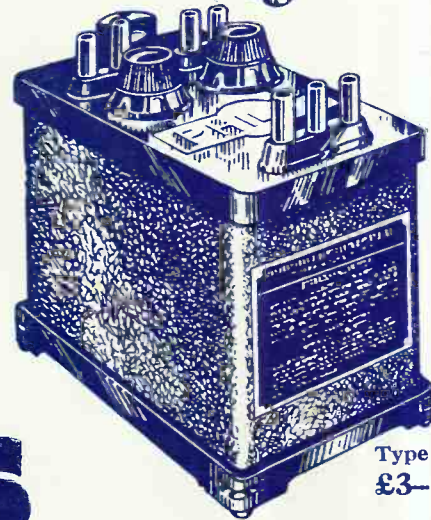

Type 3005
£3-17-6

PHILIPS

ALL-ELECTRIC RADIO

Made by the manufacturers of the famous Philips All-Electric Receivers and Argenta Electric Lamps.

For 10/- down you can have any of these on Philips' Easy Payment System.

Type 3009
£5-15-0

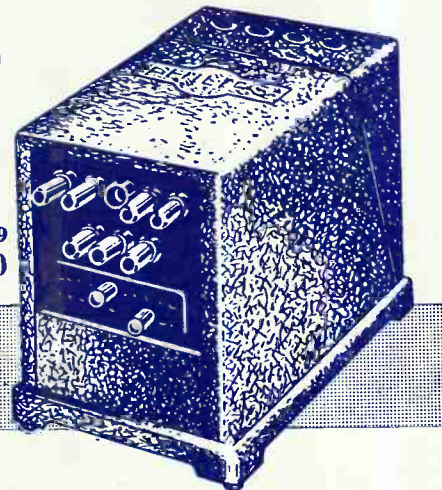

PHILIPS RADIO, PHILIPS HOUSE, 145, CHARING CROSS ROAD, LONDON, W.C.2.

Mention of "The Wireless World," when writing to advertisers, will ensure prompt attention.



The **NEW** A.C. Mains **DETECTOR VALVE**

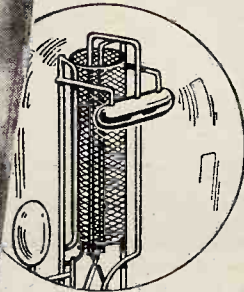

OSRAM **M.H.L.4** *(With Indirectly Heated Cathode)*

NOTE the gauze anode which assists in the ready dissipation of heat and maintains the initial efficiency of the valve throughout a long and use'ul life.

Recommended by leading wireless journals after exhaustive practical tests as a Detector Valve of the highest quality.

The OSRAM M.H.L.4 is designed with an adequate clearance between electrodes to ensure greater mechanical strength, absolute reliability and consistency of performance.

Osram **Valves**

Characteristics

| | | | |
|----------------------|----------|-------------|----------|
| Filament Volts | ... | ... | 4.0 |
| Filament Current | 1.0 amp. | approx. | |
| Amplification Factor | ... | ... | 16 |
| Impedance | ... | 8,000 ohms. | |
| Anode Volts | ... | ... | 200 max. |

MADE IN ENGLAND

Sold by all Wireless Dealers

PRICE 15/-

Let your 1930 battery

be a Tudor

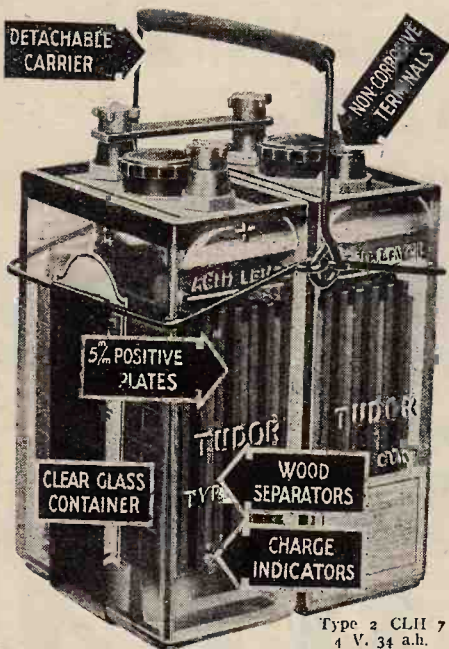

Type 2 CLII 7
4 V. 34 a.h.

In the field of good batteries Tudor, with its long life and reliability, always leads the way. The Tudor Monolt Unit is the ideal accumulator for your set. Every part has been carefully designed, and is the result of thirty years battery experience. With this accumulator you will obtain a definite refinement in reception, combined with a much longer life. Among its many characteristics are the charge indicators, which show you when the cells are running down. It has all the usual Tudor features, including non-corrosive terminals and 5 m/m positive plates. Despite these advantages, Tudor costs little more than ordinary accumulators, and in comparison with the excellent results obtained the slight extra cost is well worth while.

ESTABLISHED IN PUBLIC SERVICE.

27!

Complete

COUPON

Please send me full particulars of Tudor Wireless Batteries.

Name

Address

Tudor Accumulator Co., Ltd., 2, Norfolk St., Strand, London, W.C.2.

M.C. 47.

Superior A.C. POWER TRANSFORMERS

and **CHOKES** for the MAINS from 35/- each
for ALL INPUTS and OUTPUTS.

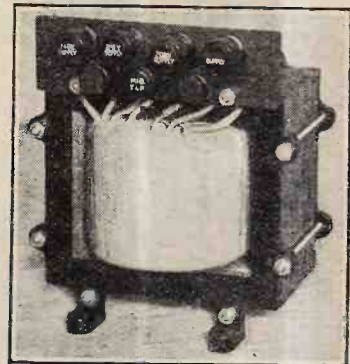
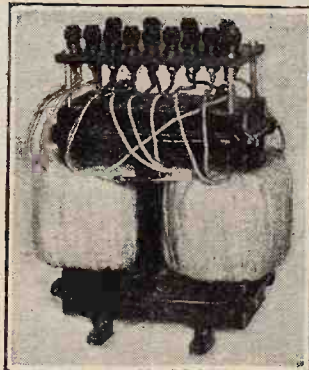
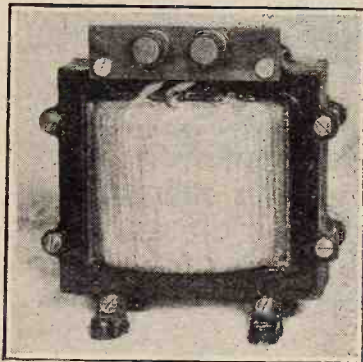

Special Audio-Frequency Chokes and Transformers, and Smoothing Chokes for all purposes.

WILLIAM BAYLISS LTD. Sheepcote Street, BIRMINGHAM.
Telephone: Mid. 1409. Telegrams: "Drawbench, B'ham."

Mention of "The Wireless World," when writing to advertisers, will ensure prompt attention.

FERRANTI RADIO



MODEL 31

*The three essentials
of satisfactory
radio reception—*

Purity
of tone;

Volume,
and

Selectivity

*—are well and
truly balanced. ★*

THE FERRANTI "All Electric" Radio Receiver is designed by experts in the art, and built on sound engineering principles.

★ Whilst we make no extravagant claims, we can definitely declare that our Set has been scientifically measured and compared with many others, and found equal to any and better than most in all the three essentials.

A special order from your dealer will ensure prompt delivery.

The price, including valves, is £25 in Oak Cabinet, and £26 in Walnut or Mahogany Cabinet. Royalty £1 extra. This set is available for **Alternating Current mains only**, voltages 200/250, 40 cycles or over.

FERRANTI LTD.
HOLLINWOOD
LANCASHIRE



13 ELECTRICAL INSTRUMENTS IN 1
The "AVOMETER"
 MEASURES
AMPS, VOLTS and OHMS
 without calculation of any kind.
NO EXTERNAL SHUNTS OR MULTIPLIERS.

The 13 ranges of the "AVOMETER" are as follows:

| | |
|------------------|------------|
| 0-12 Milliamps | } Amperes. |
| 0-120 Milliamps | |
| 0-12 Amperes | |
| 0-12 Amperes | |
| 0-120 Millivolts | } Volts. |
| 0-12 Volts | |
| 0-12 Volts | |
| 0-120 Volts | |
| 0-1200 Volts | |
| 0-1000 Ohms | } Ohms. |
| 0-10,000 Ohms | |
| 0-100,000 Ohms | |
| 0-1 Megohm | |

BRITISH THROUGHOUT.

No printing matter can possibly convey the numerous uses to which this Instrument can be put. One of the largest firms in the world informs us that "THE VALUE OF THE 'AVOMETER' CANNOT POSSIBLY BE APPRECIATED UNTIL IT IS IN ACTUAL USE." This concern has purchased over 80 "AVOMETERS" and is still ordering.

Price £8.8.0
DEFERRED PAYMENTS ARRANGED.

THE AUTOMATIC COIL WINDER & ELECTRICAL EQUIPMENT Co., Ltd.,
 WINDER HOUSE, ROCHESTER ROW,
 LONDON, S.W.1.
 Phone: VICTORIA 4350.

103

POWER RADIO-GRAMOPHONES

OUR SPECIALITY—These illustrations represent two of our standard instruments. Care is taken to obtain the highest possible quality and tone for both radio and record, with ample volume, incorporating the latest developments in moving coil speaker, operates entirely from electric mains, A.C. any voltage, or D.C. 200 volts or over.



The R.G.D.
complete, in Oak
£75 - 0 - 0

Mahogany
£80 - 0 - 0



We shall be pleased to send you full particulars and leaflets on application to:—

The RADIOGRAMPHONE DEVELOPMENT CO.,
ST. PETER'S PLACE, BROAD ST., BIRMINGHAM.

Mention of "The Wireless World," when writing to advertisers, will ensure prompt attention.

A4

YOU

will be interested to know that the apparatus used for the wireless transmission of photographs is operated by **EVER READY** dry Batteries.

Ever Ready Batteries again demonstrate their superiority by providing the pure steady current essential for the transmission of the wireless photograph in your newspaper.



They are more efficient and cheaper in the long run.



Write for list of sizes — suitable for every receiving set.

THE EVER READY CO. (G.B.) LTD., 29, Hercules Place, London, N.7

For All-Mains Units & Sets use

LISENIN POSITIVE GRIP

Safety Plugs and Sockets

(Registered Design)

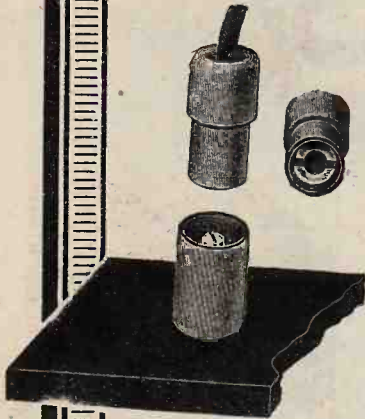

The Lisenin Mains Plug and Socket is totally insulated and is equally as valuable on sets working off batteries as those from the electric supply. The leads may be dropped with impunity and there is no chance of a short circuit. Instantly assembled with the aid of a screwdriver. **NOTE THE PRICE.**

6d each

Complete as illustrated.

WRITE to-day for our new descriptive folder, mentioning this paper.

THE LISENIN WIRELESS CO.,

5, Central Buildings, HIGH ST., SLOUGH, Bucks.

Phone: Slough 652. T. Address: POSGRIP, SLOUGH.

Positive Grip TERMINALS

(Patent 245,586)

Maintain their lead established five years since, and are acclaimed by the keen Radio experimenter as the ideal terminal. There is one for all radio connections. Write for descriptive leaflet. It's sent free to all "W.W." readers.

| | |
|--|-----|
| Plugs and Sockets with 2 nuts | 4d. |
| Spade Ends | 3d. |
| Standard Wander Plug | 2d. |
| Chubby Wander Plugs, for portable sets | 2d. |
| Pin Ends | 2d. |
| All Mains Socket and Plug | 6d. |

Don't forget Pos. Grips overcome unsightly frayed ends to leads. What a boon!

HYDRA



**RED ?
OR GREEN ?
OR WHITE ?**

The colour of a condenser is no indication of what is beneath—beauty is but skin deep. Buy condensers by name. Buy condensers with the finest name of all—buy Hydra.

LOUIS HOLZMAN

37, Newman Street,
London, W.1.

Telephone :
Museum 2641.

Weston sets the world's standard



Model 528, Pocket Size
A.C. Tester

A small and reliable instrument essential to maintain accuracy and efficiency in Voltage control. The sensitivity is remarkably high, 6 m.a. for 600 volts with self-contained resistance. The Scale is very legible and the damping excellent. This instrument is capable of continuous service at full load.

Prices from

£3 . 10 . 0 to £4 . 15 . 0

WESTON

ELECTRICAL INSTRUMENT
CO., LTD.

15, Great Saffron Hill, London, E.C.4

A.1

Write for your copy of "Radio Control," which explains simply the electrical operation of a radio set. Sent free on receipt of a postcard addressed to:—

Mention of "The Wireless World," when writing to advertisers, will ensure prompt attention.



ALL-MAINS RADIO

To the man who really knows—REGENTONE is the name in MAINS RADIO to-day. From small beginnings in the very early days of Broadcasting, REGENTONE has grown steadily and steadily, *always by sheer quality*, until to-day Regentone is looked up to by radio specialists, by the leading wireless publications, and by an ever-increasing section of the great radio public, as the authority in Great Britain on "Radio from the Mains." For Regentone products are good, they lead the way in quality and in up-to-date design and—they are fully GUARANTEED. There is a wide range of Regentone Mains Units—our latest model fits inside a Portable—Mains Components, and complete Mains Receivers. Our FREE ART BOOKLET gives full particulars: write for your copy to-day.



MODEL W.1.B.S.G.
130 Volts at 20 m.a.
£4 19 6

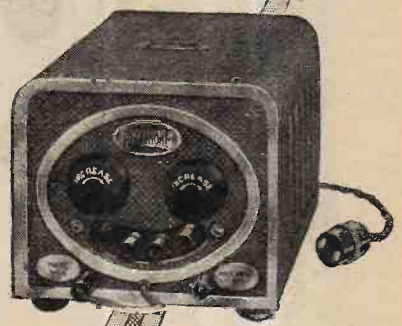

MODEL W.2a
160 volts at 50 m.a.
£7 15 0



"PORTABLE" MODEL.
Size 8½" x 4" x 4"
A.C. Model £4 5 0
D.C. Model £2 15 0
3 Tappings: 1 Variable,
1 Screened Grid, 1 Power.

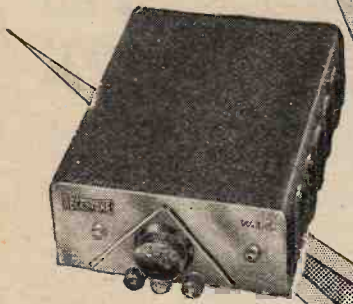

MODEL W.1.C.
120 Volts at 18 m.a.
£3 15 0



ONE-AMP. CHARGER
with L.T. Coupler.
£2 18 6
Also Half-Amp. Charger
with L.T. Coupler £2 7 6
without ,, ,, £2 2 6

EASY PAYMENTS

ALL REGENTONE products—listed at £2 and over—are now available on Hire Purchase Terms—write for full particulars.



For Radio from the Mains

REGENT RADIO SUPPLY CO. 21, Bartlett's Bldgs. Holbn. Circus London E.C.4. PHONE CENTRAL 9661

B3 Advertisements for "The Wireless World" are only accepted from firms we believe to be thoroughly reliable.

**This superb
"Ekco" Set
works entirely from
the Electric Supply**



**No Batteries!
No Accumulators!**

Model S.G.P. 3 (Three Valve). Has the power and range of an ordinary 4 or 5 valve set. For D.C. or A.C. Mains £21.
Model P. 2 (Two Valve). D.C. or A.C. £12.17.6
(Prices include valves and royalties).

Plug-in the "Ekco" adaptor to your electric light or power—switch on—and know what it means to receive radio in the modern way. No batteries to run down—no accumulators to recharge—no bother—no mess.

"Ekco-Lectric" Radio Receivers are in hand-polished Walnut cabinets—with volume and selectivity controls—sockets for gramophone pick-up—Westinghouse Valveless Rectification in A.C. models—and they are British made.

BRITISH INDUSTRIES FAIR, Olympia, Stand D28.



**Plug in—That's all!
"EKCO-LECTRIC"
RADIO RECEIVERS**

There are also "Ekco" Power Supply Units for electrifying or partly electrifying your present set. Write for Free Booklet giving full particulars, and details of Easy Payments, to—

E. K. Cole, Ltd., Dept. W.W., "EKCO" Works, Leigh-on-Sea.

188



**The
Summing up!**

Blue Spot Chassis are sold in two sizes, the "Major" with 13" cone, as illustrated, at 15/-, and the "Minor" with 9" cone at 12/6.

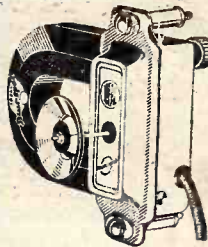

Blue Spot 66K Unit.
Price 25/-.

"After all is said and done, it is the Blue Spot 66K you want to buy, because really it is the best unit on the market.

And you'll get better results than ever with the Blue Spot Chassis because it has been designed to fit the 66K Unit so that it can work under the best conditions possible.

The Major or the Minor chassis, whichever you choose, can be bolted to the unit in a few moments, and it is hard to tell that it is not a moving-coil speaker playing to you. . . .

(So says the constructor who has experimented.)

**BLUE SPOT
CHASSIS**

F. A. HUGHES & CO., LIMITED
204-6, Great Portland Street, London, W.1

Phone: Museum 8630 (4 lines)

Distributors for Northern England, Scotland and North Wales: H. C. RAWSON (SHEFFIELD & LONDON) LTD., 100, London Road Sheffield (Phone: Sheffield 26006) 22, St. Mary's Parsonage, Manchester (Phone: Manchester City 3329).

Mention of "The Wireless World," when writing to advertisers, will ensure prompt attention.



**Look out for the
Special
Announcement
which will shortly be made**

Advertisement of
SIEMENS BROTHERS & CO., LTD., WOOLWICH, S.E.18.

Advertisements for "The Wireless World" are only accepted from firms we believe to be thoroughly reliable.

CUT OUT THAT CRACKLE!



ALL SAL-AMMONIAC batteries develop "crackle" sooner or later. "Pertrix" cannot, for it contains no cell-corroding electrolyte—and in this respect "Pertrix" is unique. On every test, "Pertrix" shows 60% longer life, and no loss of power when out of circuit. Try "Pertrix" once, and you will never go back to the sal-ammoniac type again.

PERTRIX

**SUPER LIFE
H.T. BATTERIES**

Get also "Pertrix" Accumulators for filament current—the long service battery.

LONGER 60% LIFE

PERTRIX Ltd., Britannia House, Shaftesbury Avenue, London, W.C.2
Factory—Britannia Works, Redditch, Worcs.

"TILTRACK"
Registered Trade Mark
Patent-STEEL STORES System

THE "BENCHRACK"
(Tiltrack Principle)

It stands on the bench and stores in the least space and most accessible fashion, all small parts. Trays tilt downwards with contents exposed to view, and the fronts of the trays are rounded to eliminate angles and to allow contents to be swept up the slope with one hand. Saves loss of parts, keeps benches tidy and is a tremendous time saver.

"TILTRACK" JUNIOR 30/-
Post Free.
A most popular rack for storing small components.

"TILTRACK" TWEENIE
Something between the "Junior" and the "Senior." Very compact with great storage capacity.
Price 70/- each f.o.r. M/cr.

"TILTRACK" SENIOR
The ideal stores for the Factory, Factor and Retailer.

STORES FOR WIRELESS PARTS

"Tiltracks" save Time, Money, Trouble, Labour. The Experimenter will do his jobs much quicker and with greater pleasure if all parts are to hand. The Factory, Factor and Retailer will save many pounds per year by cutting out the time now lost in looking for goods that are in stock but "nobody knows where." Far superior to old-fashioned wooden shelves.

Full Particulars from Manufacturer and Patentee:—
BERTRAM THOMAS,
Worsley Street, Hulme, MANCHESTER.
London Office and Showrooms:—28, Victoria Street, S.W.1.

VISIT US AT STAND 4 BLOCK 10H. B.I.F. Eirmingham, FEB. 17 to 28th.

Mention of "The Wireless World," when writing to advertisers, will ensure prompt attention.

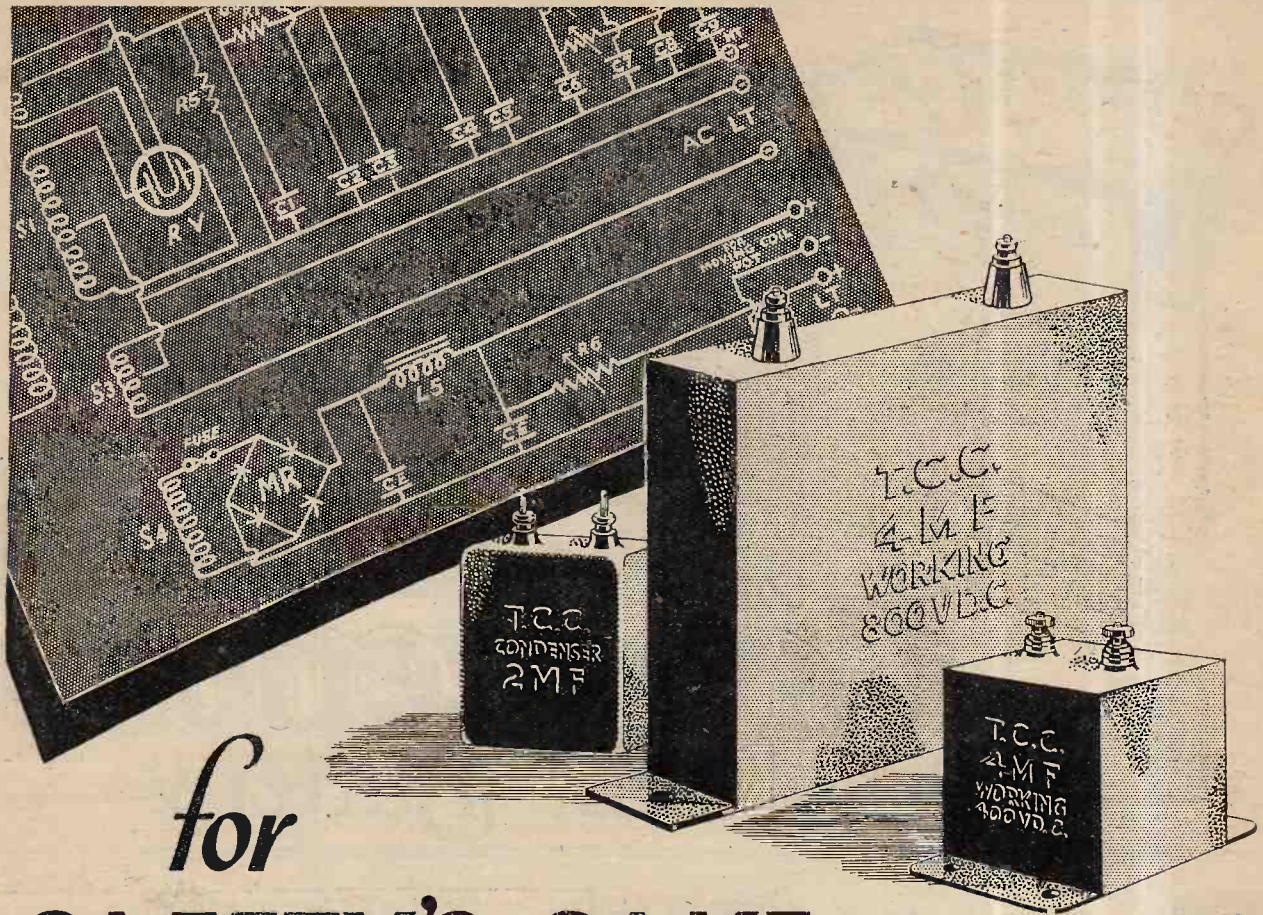

for
SAFETY'S SAKE —

WHETHER it's a mains drive set demanding 400 volts at 100 milliamps, or just a small unit to deliver 15 milliamps, use "the condenser in the green case" and be safe. Wherever a condenser is needed—for safety's sake use T.C.C. With over 40 years of condenser making—and condenser making only—the initials T.C.C. are an absolute guarantee of efficiency, accuracy and safety. No other condenser has such a factor of safety as T.C.C. Use T.C.C. always and be safe.

Above are illustrated three of the many types of T.C.C. condensers, a 4 mfd. 800 v. D.C. Test type, a 2 mfd. 400 v. D.C. paper type, and 4 mfd. High Voltage Condenser tested 1,500 v. D.C. Remember there is a T.C.C. for every purpose.



Advt. Telegraph Condenser Co., Ltd., Wales Farm Rd., North Acton, London, W.3

CA 3913

B7 Advertisements for "The Wireless World" are only accepted from firms we believe to be thoroughly reliable.

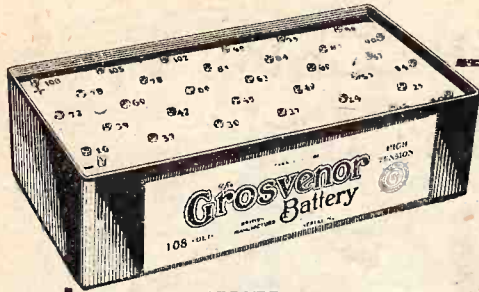

The Battery that puts new life into your set

A Reason why you should use a Grosvenor H.T. Battery. The Grosvenor Battery is fitted by most of the important Set manufacturers in the Radio World to-day.

The Set manufacturer depends for his reputation upon the efficiency of the Sets he sells—would he risk fitting an inferior battery?

Take your cue from those who *know* and follow *their* lead—let your next H.T. Battery be a *Grosvenor*. It will give you longer service with greater volume from your set *all the time*.

PRICES :

| | Standard | Super |
|-----------|----------|-------|
| 66v. from | 7/6 | 18/- |
| 99v. " " | 11/6 | 30/- |

Made in all voltages and capacities.

THE BATTERY WITH THE NEW VITALISING ELEMENT.

THE GROSVENOR BATTERY Co., Ltd.,
2/3, White Street, Moorgate, LONDON, E.C.2.

Phone: Met. 6866.

The Grosvenor Battery

BRITISH MANUFACTURE

MERSHON Electrolytic Condenser

The Mershon Electrolytic Condenser is self-healing, saves space, is light in weight and gives trouble-free service, making its low first cost its last cost as well. One of the most important features of the Mershon is its low value of leakage current, this being 1 1/2 to 2 milliamperes per 10 mfd. The breakdown voltage is 400 D.C., but the Mershon will stand surges of 1,000 D.C. without damage. It is the only self-healing condenser available.

"S" denotes single anode. "D" denotes double anode. "T" denotes triple anode and "Q" quadruple anode.

| | | | |
|---------|------------|------|-------|
| Type S. | 18 mfd. | 25/- | each. |
| " S. | 40 " " | 27/6 | " " |
| " S. | 72 " " | 32/- | " " |
| " D. | 18 " " | 31/- | " " |
| " T | { 2-18 " " | 39/6 | " " |
| | { 1-9 " " | | |
| " T | { 1-18 " " | 37/6 | " " |
| | { 2-9 " " | | |
| " Q. | 9 4-9 " " | 38/6 | " " |
| " Q | { 2-18 " " | 47/- | " " |
| | { 2-9 " " | | |

Write for full details of these new and revolutionary condensers.



THE ROTHERMEL CORPORATION LTD.,

24, Maddox Street, London, W.1.

Phone: MAYFAIR 0578/9.

MAKE TO SPECIFICATION

PARMEKO



Though the PARMEKO range is exceptionally wide, embracing Transformers and Chokes for every circuit featured in the technical Press, we recognise that occasionally a serious experimenter needs apparatus which he cannot buy from stock. We specialise in making apparatus to your own specification. Ask us to quote.

Transformers for all 4-volt indirectly heated valves, giving 5 amps. max. at 4 volts, centre tapped, made for all mains voltages.

30/- each.

The quality of PARMEKO apparatus is evident from the fact that some of the largest "Talkie" and Radio-gramophone companies use it.

Write for Price List of Wireless Mains Apparatus.

PARTRIDGE & MEE, Ltd.,

74, New Oxford Street, LONDON, W.C.1.

26, DOVER STREET, LEICESTER.

Mention of "The Wireless World," when writing to advertisers, will ensure prompt attention.

Here is the QUALITY RECEIVER You have been looking for!



A MOVING
COIL
SPEAKER
WITH A
LINEN
DIAPHRAGM
PLUS REAL
QUALITY
& FINISH.

A RECEIVER
WITH RESIS-
TANCE OR
TRANS-
FORMER
COUPLING
AT WILL
PLUS PURITY
& POWER.

This is BAKER'S 3-Valve All-Mains Receiver complete with Moving Coil Speaker as used at the LONDON HIPPODROME.

SPECIFICATION :

Receiver.
3-valves, A.C. Indirectly heated. 1 Rectifying Valve.
H.F. : Parallel Feed Grid Circuit. Detector : "Power Detection." L.F. : Resistance Coupling or Transformer Coupling by change-over switch. No reaction. H.T. : 300-v. 125 m.a. for Receiver and Field supply. L.T. : 4-v. 4 amps. 5-v. 2 amps.

This is the last word in ideal reception for the Radio-musician and the music lover who demands the *highest* quality reproduction of speech and music. An all-mains receiver quite 12 months ahead in improved design.

It has no external wires or knobs, but provision is made for electrical gramophone pick-up. This amazing receiver is the result of years of intensive research and specialised knowledge by the pioneers of Moving Coil Speakers in England. Again Bakers claim a high place by taking the lead in producing a first-class quality Receiver for realistic reproduction.

PRICE £36
for A.C. Mains.
Or in 10 month-
ly instalments.

SPECIFICATION :

Moving Coil Speaker.
Baker's Super Power (as in use at the London Hippodrome). Flux density 13,000 lines per sq. c.m. Floating Linen Diaphragm.

Cabinet.

Oak, 2' 6" x 2' x 9".
Correctly designed to avoid Box Resonance.

The Pioneer manufacturers of Moving Coil Loud Speakers.
Head Office :
89, Selhurst Road, South Norwood, London, S.E.25.

Works and Demonstration Room :
42, Cherry Orchard Road, East Croydon.
'Phone: 1618 Croydon.

BAKER'S
'Selhurst'
RADIO

WRITE NOW FOR OUR
NEW EDITION — 36 - PAGE
BOOKLET: "SOUND ADVICE."

Just a postcard will do.

ALL ELECTRIC - 2

A SET WORTH LISTENING TO

£13



£13

The Igranic All Mains 2 operates entirely from A.C. Mains. Compact design. One knob control. Dual wave switch to eliminate coil changing. Perfect reproduction.



Supplied in attractively designed oak or mahogany table cabinet. Price £13.0.0 complete with valves and royalties.

Please state exact mains voltage when ordering.

Write to Dept. U 307 for details.

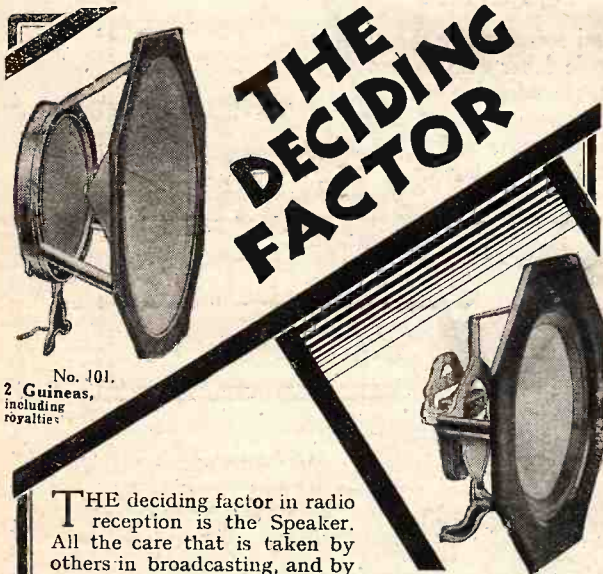

THE DECIDING FACTOR

No. 101.
2 Guineas, including royalties

THE deciding factor in radio reception is the Speaker. All the care that is taken by others in broadcasting, and by yourself in using a good circuit, will be wasted if your Speaker is a poor one. Therefore we ask you to take the first opportunity of hearing a Squire or Speaker with a good Unit. We definitely claim that the quality of reproduction afforded is equal to, if not better than, that of the most expensive Speaker on the market.

No. 97b. 15/-

The No. 97b, also shown here, with a cone of the latest climate-proof vellum type and constructed of solid cast aluminium, absolutely preventing chatter, will take any Unit at present on the market.

Frederick Squire Ltd., 10, Leswin Place, Stoke Newington, N.16.

Mention of "The Wireless World," when writing to advertisers, will ensure prompt attention.

DICTIONARY of WIRELESS TECHNICAL TERMS

(1926)

Compiled by S. O. PEARSON, B.Sc., A.M.I.E.E., and issued in conjunction with "THE WIRELESS WORLD."

THIS volume contains definitions of terms and expressions commonly used in wireless telephony and telegraphy and is intended to serve as a guide to all those interested in wireless who come across, from time to time, unfamiliar words in their reading. In such cases the DICTIONARY OF WIRELESS TECHNICAL TERMS proves of very great use and value. It is well illustrated, and cross-referenced to enable the required information to be rapidly obtained.

PRICE 2/- NET
By Post 2/2

From leading Booksellers or direct from the Publishers

ILIFFE & SONS LTD., Dorset House, Tudor Street, London, E.C.4. W.W.48

M-L MAGNETO SYND. LTD., COVENTRY.



SPECIALISTS IN THE EMPLOYMENT OF SUPPLY MAINS FOR OBTAINING ANODE AND FILAMENT CURRENT.

We manufacture equipment suitable for Radio Receiving and Transmitting Sets, Public Address and Band Repeater Systems, Gramophone Amplifiers, etc.

IF YOUR SUPPLY MAINS ARE D.C.

You can use an A.C. All Electric Receiver By Employing The M.L.—D.C. to A.C.

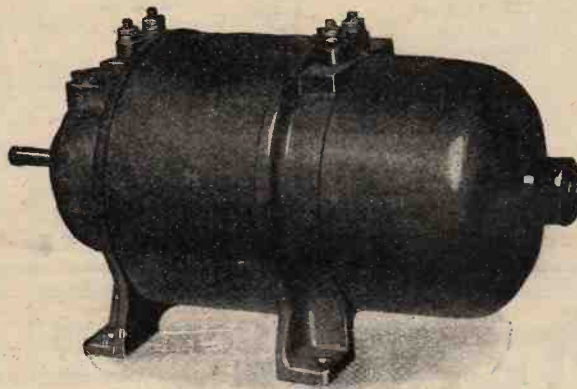

ROTARY TRANSFORMER

Can be supplied to run from any Voltage 12-250 V. D. C.

40 WATT Model £13-0-0

85 WATT Model £19-0-0

Recommended and used by
 Philips Radio,
 Marconiphone,
 Burndept,
 Kolster-Brandes,
 Etc., Etc.

EXHIBITING
 British Industries Fair
STAND D.7
OLYMPIA.

All machines have permanent magnetic fields which render them highly efficient and free from field troubles so often associated with H.T. machines having wound fields.



M-L MAGNETO SYND. Ltd., Radio Dept.
COVENTRY.
 Telephone 5001.

**The ADMIRALTY—
WAR OFFICE and AIR MINISTRY**
have for many years been supplied with
GAM-BRELL RADIO APPARATUS.

We are the acknowledged Pioneers
in this Country for
ALL-ELECTRIC RECEIVERS
for Direct Current and
Alternating Current.

| | | |
|---|---|--|
| GAM-BRELL All-electric Two. D.C. £13-15-0 A.C. £17-10-0 | GAM-BRELL All-electric Three. D.C. £22-0-0 A.C. £25-0-0 | GAM-BRELL All-electric Four. D.C. £33- 5-0 A.C. £39-15-0 |
|---|---|--|

The above prices include everything except Loudspeaker and Aerial.

GAM-BRELL
All-electric
TRANSPORTABLE.
D.C. £29-0-0
A.C. £32-0-0

*Complete and ready for use.
Celestion Loudspeaker
embodied.*

An entirely self-contained
receiver which may be carried
from room to room. Several
changes of programme are
Guaranteed.

GAM-BRELL
RADIO-GRAMOPHONE.
Novotone Model.
D.C. 69 Guineas
A.C. 80 Guineas

*Complete with
Moving Coil
Loudspeaker.*

Our full range is designed
to give perfect performances
of programmes.

Free on request: Illustrated Folder W
of our full range of Receivers.

GAMBRELL RADIO LTD.,
6, Buckingham St., Strand, London, W.C.2

Further Details, copies of "test"
reports N.W., free on request.

... practically inaudible...
then
BRILLIANCE!

"With the Novotone in circuit, the bass notes
are brought out with a healthy punch; this same
bass response was practically inaudible with the
Novotone out of circuit. Similarly, in circuit the
Novotone improved the upper register and gave us
brilliance."—*Talking Machine News.*

THE NOVOTONE
COMPENSATOR.

Puts in true bass without boom.
Causes an appreciable strengthening of the higher notes.
Improves reproduction beyond belief over the whole
musical scale.
Results in a brilliance of reproduction never before
obtained.

THE NOVOTONE
McLACHLAN TONE COMPENSATOR
(Patents Pending)

Price **£5 Complete.**

**"RITHO" METAL
CABINETS**

ALL MAINS MODEL



WRITE
TO-DAY.
*Eliminator Cases
and High Grade
Metal Cabinets of
every description
in various artistic
finishes. Screening
Boxes, Containers,
etc.*

£2 : 15 : 0 Plus 3/6 carriage and box.

Thoroughly Electrically Sealed.
Complete with Wood Base.
Beautifully finished in ROSE-
WOOD, WALNUT or
JACOBAN effects.

**RITHERDON
& CO., LTD.**
Metal Workers,
North Bridge Mills — BOLTON.
Phone: 1024.

COMPARE THESE PRICES

TROLITAX

| Size of Panel. | Black or Natural, polished one side. Black wavy, Black cube. | | Wood Finish. | |
|----------------|---|----------|--------------|----------|
| | 1/8-in. | 3/16-in. | 1 8-in. | 3/16-in. |
| 7-in. x 14-in. | 2/4 | 3/7 | 2/9 | 4/1 |
| 18-in. | 3/- | 4/7 | 3/6 | 5/3 |
| 21-in. | 3/6 | 5/5 | 4/1 | 6/2 |
| 8-in. x 16-in. | 3/1 | 4/8 | 3/7 | 5/4 |
| 9-in. x 18-in. | 3/11 | 5/11 | 4/6 | 6/9 |

As a result of its laminated structure Trolitax is
exceedingly strong. In most cases where pre-
viously material $\frac{3}{16}$ " thick was necessary a Trolitax
panel $\frac{1}{8}$ " thick will be found to suffice. This means
a great saving in price. Trolitax will not break and
may be relied upon for finish, quality and perform-
ance. Ask your wireless dealer to show it to you.

F. A. HUGHES & CO., LIMITED
204-6, Great Portland Street, London, W.1

Phone: Museum 8630 (4 lines).

Distributors for Northern England, Scotland and North Wales:
H. C. Rawson (Sheffield and London), Ltd., 100, London Road,
Sheffield. Phone: Sheffield 26006. 22, St. Mary's Parsonage,
Manchester. Phone: Manchester City 3329.

Mention of "The Wireless World," when writing to advertisers, will ensure prompt attention.

The Cheapest Radio Stores on Earth

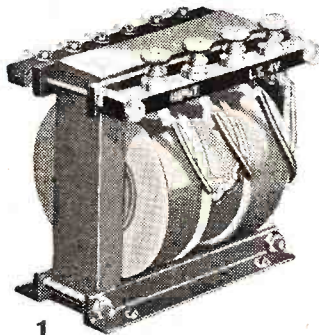

1.

- 1 **Marconi All Mains Transformer**
Former price 37/6
Our Price 21/-
- 2 **Marconi D.C.2 H.T. Unit**
Former price 35/-
Our Price 21/-
- 3 **Marconi H.T. Unit Type A.C.3**
200/250v.
Former price £3/10/-
Our Price £2/10/-



2.

If you are rebuilding or converting, here's the quality components that Save Your Pocket.

Just a few from the LIST

Marconi All Mains POWER UNIT.
Type D.C.4.
200/250v. giving H.T., L.T. & G.B. outputs. Former price £5/5/-
OUR PRICE 45/-
Type A.C.4.
giving H.T., L.T. and G.B. outputs.
Former price £4/15/-
OUR PRICE 63/-

Marconi All Mains Transformers
for H.T. and L.T. supply. Suitable for eliminators or all mains sets, types C, D, L, M, T, K.
Former price 37/6.
OUR PRICE 21/-

Marconi H.T. Supply Unit D.C.3
for 100-200v. mains.
Former price 35/-
OUR PRICE 21/-

Marconi H.T. Unit Model A.C.3.
200/250v.
Former price £3/10
OUR PRICE 50/-

Sterling Mansbridge Condensers.
For Set or Eliminator construction, tested 400v. D.C.
'05, '1, '2, '3, '4, '5.
Former prices 1/10 to 2/7.
OUR PRICE 1/6.

10 mf., former price 18/-
OUR PRICE 8/6.

Sterling Mansbridge Condensers,
tested 800v. D.C.
'5 mf., former price 3/3.
OUR PRICE 2/3.

1'0 mf., former price 3/9.
OUR PRICE 2/3.

2'0 mf., former price 6/-
OUR PRICE 3/3.

4'0 mf., former price 10/6.
OUR PRICE 5/9.

Marconi Sterling Loudspeakers,
Type 33.
Former price £4/4.
OUR PRICE 42/-

Ediswan R.C.C. Units.
Former price 9/6 each. **OUR PRICE 2/6** each. Ediswan Dual Range Inductance Coils.
Former price 17/6.
OUR PRICE 7/6.

"SILVER CHIMES"
4 pole balanced armature loudspeaker unit, acknowledged by all the leading experts of the country to be the best unit on the market.
PRICE 16/6.



3.



Be up to date. Enjoy the very best that Radio can give you—at almost half the cost. Here we offer you the highest quality components in the world. Can you find a better name than Marconi? Pioneers who dispelled the silence of the centuries to bring you the leading artists of the world around your evening fireside. You've fiddled with H.T. Batteries, despaired over low tension accumulators—now be up to the minute; turn your receiver to an all mains set by fitting these components, which come to you at less than wholesale prices.

But Hurry Up! the supply is not inexhaustible and the early bird gets the worm! Sit down now and write for what you need. And remember whenever you require anything in Radio—highest quality and lowest prices—send for our monster bargain list.

Send for the wonder Bargain List NOW!

SAMDON WIRELESS Co. Ltd.

102/104, SHUDEHILL, MANCHESTER.

When buying
 your A.C. Mains Receiver,
 battery eliminator, or
 battery charger
 see that it incorporates
A

WESTINGHOUSE
METAL RECTIFIER

which is one of the most important components in up-to-date radio equipment. There is nothing to wear out in this rectifier—no filaments, no chemicals nor moving parts. It is used in the majority of modern receivers and eliminators, designed and marketed by experts who are satisfied as to its reliability, and whose aim has been to provide TROUBLE-FREE RADIO EQUIPMENT.

For those who prefer to make up their own sets, our book "The All-Metal Way, 1930" will be invaluable. It contains 32 pages of circuits and instructions covering all types of A.C. Mains Units. Send a 2d stamp with your name and address.

The Westinghouse Brake & Saxby Signal Co. Ltd.,
 82, York Road, King's Cross, London, N.1.

**Still Further
 Testimony—**

The
**SUPER SPEAKER
 UNIT**

**K
 U
 K
 O
 O**

RAVENSCLIFFE AVENUE,
 ECCLESHILL,
 BRADFORD.
 16th Jan., 1930.

Dear Sirs,
 The Kukoo Unit you repaired for me came safely to hand, thanks for the prompt attention.

I have not replied earlier as I wanted to give the Unit a prolonged trial. I am pleased to report it is absolutely perfect. In my opinion it is wonderful, far better than the Moving Coil type; the bass is therein full strength; in fact, music and speech come through crisper and clearer than on any Moving Coil I have ever heard.

Yours truly,

W. H. Parker

**25/-
 NETT**

Post
 9d.
 extra.

Sole Patentees & Manufacturers:—
 THE SHEFFIELD MAGNET CO.,
 BROAD LANE, SHEFFIELD.

Phone:—20866.
 Grams:—Magnet 20866 Sheffield.

**The Unqualified Approval of
 The Press.**

**VOLTRON BABY
 CONDENSER**

3'9

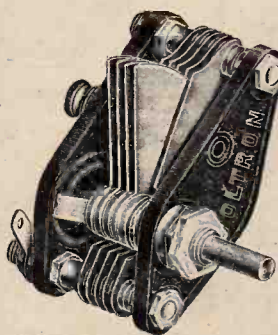

'00005 MFD.
 '0001 "
 '00015 "
 '0002 "



Free
 Illustrated
 Catalogue
 on request.

Modern Wireless:

"very reasonably priced. The design is good and its finish is of a high standard."

Wireless Constructor:

"The mechanical construction is strong... the whole component is well made and reasonable in price."

The keynote of all VOLTRON components is sound technical design, superb workmanship and reasonable price. That is why more and more set manufacturers are turning to VOLTRON for their components.

VOLTRON
 "years ahead in design"
COMPONENTS.

VOLTRON CO., LTD., QUEENSWAY, PONDERS END.

Mention of "The Wireless World," when writing to advertisers, will ensure prompt attention.

After all....
.... quality tells

Ask to hear
the DUBILIER
All-Electric RECEIVER

Compare its performance with that of any other Set—its perfect reception of British and Foreign programmes with what you have hitherto regarded as "good." There's no doubt you will prefer the Dubilier Receiver. It works entirely from the electric mains—without batteries or accumulators—on an outdoor or indoor aerial. In fact, it maintains the standard of excellence that is expected from Dubilier, who are pioneers in Wireless progress.

A.C. & D.C. Models.
£25
 Five Purchase terms through any Radio Dealer or Stores.
£3.17.0
DOWN SECURES



DUBILIER
ALL ELECTRIC
RADIO

If you have any difficulty in obtaining from your dealer, write direct to us, giving his name and address. Dubilier Condenser Co. (1925), Ltd., Ducon Works, Victoria Road, North Acton, London, W.3.

Cleaver S23



As machinery heralded the advent of the mechanical age, so the VARLEY ALL-ELECTRIC RECEIVERS are the consummation of a new era in radio—the all-electric age.

There never were such sets to give the quality of life to radio. Varley All-Electric Sets give you radio that lives—radio that will live—for they are years ahead in design of anything else on the market. They can handle the new Regional stations, too, tuning them in or out with amazing selectivity. And their long range—10 to 20 stations can be obtained from most places in the British Isles.

Up-to-date, handsome design reflects the quality of their performance—VARLEY quality. If you are to have the best that all-electric radio can give you—radio that lives, your set must be a VARLEY ALL-ELECTRIC 2- or 3-valve.

Section A of 1930 Catalogue gives full particulars.

ALL-ELECTRIC 2-VALVE RECEIVER. (A.C. or D.C.) 16 Gns. Marconi Royalty 15/- extra.

ALL-ELECTRIC 3-VALVE RECEIVER. (A.C. or D.C.) 25 Gns. Marconi Royalty 20/- extra.



Advertisement of Oliver Pell Control Ltd., Kingsway House, 103 Kingsway, London, W.C.2. Telephone: Holborn 5303



Fool Proof!

"Self-contained Simplicity" aptly describes the BurTon "Empire 3" All-Mains Set. This fine set works straight from the mains—any child can operate it. Its design is simple but exceedingly attractive, and the first-quality BurTon Components ensure remarkable performance in the true BurTon tradition. The aim has been achieved of providing an efficient but fool-proof set at a just price.

PRICE OF SET £11 : 5 : 0

Valves (Mullard AC) £3 : 10 : 0
Royalties Extra.

THE BURTON EMPIRE 3 All-Mains Set

C. F. & H. BURTON, Progress Works, Walsall.

Mention of "The Wireless World," when writing to advertisers, will ensure prompt attention.

EVERYTHING AN ALL-MAINS SET CAN GIVE YOU

VALUE "Saxon Radio" has meant sheer solid value and quality ever since we originated the "kit of parts" idea in 1922.

SELECTIVITY The Station Selector now incorporated in our All-Mains receivers **GUARANTEES** you selectivity on the 250-550 waveband. It is put in or out of action by a push-pull switch.

RANGE The range covers from 200 to over 1800 metres without a break.

EFFICIENCY The man who owns one will tell you. Secure convincing testimonials, circuit diagrams and free brochures

from

SAXON RADIO Co. (Dept. W.W.)
The Pioneer Firm,
Henry St. Works, BLACKPOOL, Lancs.

Kits of Parts Complete Receivers.

NO BATTERY WORRY!

ALL-MAINS SETS for A.C or D.C.

| | |
|--------------------------------|----------|
| 4 Valve Philips A.C. 200-2,000 | £37 10 0 |
| 3 " " " " " | £23 0 0 |
| 2 " " " " " | £12 10 0 |
| 3 " Dubilier A.C. or D.C. - | £25 0 0 |
| 3 " Marconi A.C. - | £21 0 0 |
| 3 " Lotus A.C. - | £21 0 0 |

SUPPLIED ON EASY TERMS. FULL DETAILS ON REQUEST. CATALOGUE FREE: by post 6d.

WILL DAY LTD.

19, LISLE STREET, W.C.2. Phone: Regent 0921-2.



1/9
POST FREE

WHAT STATION WAS THAT?

Why be limited in your choice of programme? Thousands of wireless sets are installed throughout the country which could bring boundless pleasure if their owners could use them to full advantage. With the B.G.L. RADIO STATION FINDER the choice of the world's finest programmes is yours.

IDENTIFY THE STATION CALLING—TUNE IN THE STATION YOU LIKE.

40 to 50

stations ought easily to be picked up by any modern set. The B.G.L. RADIO STATION FINDER enables you to identify any station calling or to tune in to any of the

WIRELESS STATIONS

you like. No technical knowledge necessary. Eliminates oscillation. Can be used with any valve set. The readings of every station within the range of your set are

GUARANTEED

by the manufacturers or your money refunded. The B.G.L. RADIO STATION FINDER attractively finished, complete with full instructions, 1/9, post free.

BRITISH GAMES Ltd. (Dept. W.W.),
19, CLERKENWELL CLOSE, LONDON, E.C.1.
Trade Enquiries Invited.

READ WHAT SATISFIED USERS SAY:

"I congratulate you on the great improvement you have made. It is surprisingly accurate."—H. B. Paignton.
"I am very pleased with the Station Finder you sent me and should like you to send one to a friend. . . please have one sent to—"—F.H., London.

Make your Set All-Electric without alterations of any kind by using an "Ekco" All-Power Unit

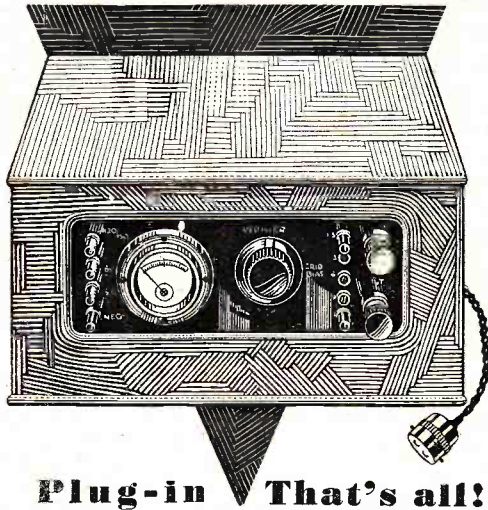

Plug-in That's all!

Disconnect batteries for ever - connect an "EKCO" Power Supply Unit to the same terminals—and your set is "All-Electric." No more mess—no more bother—no alterations to wiring—no new valves to buy—existing valves will work better and give better results. Simply plug the "EKCO" Adaptor in to the electric light or power socket and switch-on—That's all! Or you can partly electrify your set with an "EKCO" H.T. or L.T. Unit, eliminating H.T. or L.T. batteries, respectively.

"EKCO" products are British Made for D.C. as well as A.C. Mains, with Westinghouse Valveless Rectification in A.C. Models.

"EKCO" All-Power Unit, Model C.2.A. for A.C. Mains (as illustrated) H.T. tapping for S.G. Valve and at 60 and 120/150 volts. L.T. 2-6 volts. G.B. up to 12 volts. **£10:17:6.**

D.C. Model (exactly as above) **£5:17:6.**

|| We are exhibiting at the **Stand**
BRITISH INDUSTRIES FAIR, Olympia, **D28** **||**



Ask your dealer for details of Easy Payments and Free Booklet on "All-Electric Radio," including full particulars of "EKCO-LECTRIC" Radio Receivers, radio's supreme two and three valve sets.

E. K. COLE, LTD., DEPT. W, "EKCO" WORKS, LEIGH-ON-SEA.

187

B17

Advertisements for "The Wireless World" are only accepted from firms we believe to be thoroughly reliable.

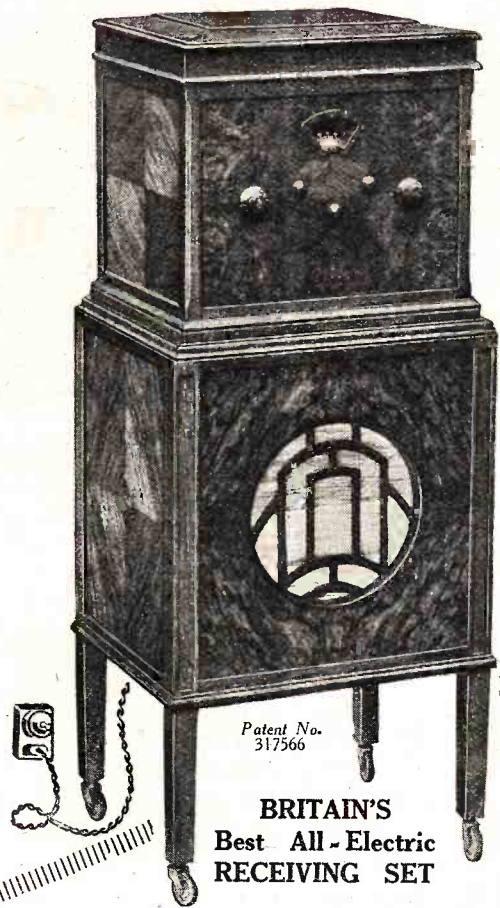

Patent No.
317566

**BRITAIN'S
Best All-Electric
RECEIVING SET**

The "MADRIGAL"

Designed with Musical Quality as the First Consideration, and with utility as the next feature of supreme modern importance, the "Madrigal" has attained the premier place in first-class Radio Production.

Musicians and Scientists agree that the "Madrigal" has reached degrees of reproduction and efficiency that will remain *Standard Radio for many years.*

It requires no Aerial, Frame-Aerial and Earth for local reception and its transportability is unique.

Selectivity and Reproduction via the remarkable coil-driven Loud Speaker are amazing—the "Madrigal" Booklet will enlighten you fully—please write for it.



"Madrigal" Receiver and Speaker Pedestal combined. In exquisitely figured Walnut or Mahogany as illustrated **£48-18-0**

A.C. Model **£45-15-0**

D.C. Model **£30**

"Madrigal" Receiver only without Pedestal Speaker, A.C. or D.C., Walnut or Mahogany **£30**

12, HYDE STREET, LONDON, W.C.1.



RIGID!

SECURE! LOCKED!

**THE ONLY
SCREENED
GRID VALVE
WITH
INTERLOCKED
CONSTRUCTION**

Because of the exceptional strength and rigidity of its elements due to its Interlocked Construction the *NEW* Cossor Screened Grid Valve has definitely established itself as the most robust and the most dependable Screened Valve made in Great Britain. Over and over again in actual service it has proved itself shock-proof, noise-proof and break-proof. In your Receiver use the New Cossor Screened Grid Valve. Every Dealer sells it.

**2-volt type
now available.**

The *NEW* Cossor 220 S.G.
(2 volts .2 amp.) Anode volts
120-150, Impedance 200,000
Amplification Factor **22/6**
200. Price - - -

Cossor 4 and 6 volt Screened
Grid Valves are also available
with similar characteristics at
the same price.

The **NEW**
COSSOR
Screened Grid
Valve

A. C. Cossor Ltd., Highbury Grove, London, N.5

 3456

Mention of "The Wireless World," when writing to advertisers, will ensure prompt attention.

RTS

The Wireless World

AND
RADIO REVIEW
(17th Year of Publication)

No. 547.

WEDNESDAY, FEBRUARY 19TH, 1930.

VOL. XXVI. No. 8.

Editor: HUGH S. POCOCK.
Assistant Editor: F. H. HAYNES.
Editorial Offices: 116-117, FLEET STREET, LONDON, E.C.4
Editorial Telephone: City 9472 (5 lines).
Advertising and Publishing Offices:
DORSET HOUSE, TUDOR STREET, LONDON, E.C.4.
Telephone: City 2847 (13 lines). Telegrams: "Ethaworld, Fleet, London."
COVENTRY: Hertford Street.
Telegrams: "Cyclist, Coventry." Telephone: 5210 Coventry.
BIRMINGHAM: Guildhall Buildings, Navigation Street.
Telegrams: "Autopress, Birmingham." Telephone: 2970 and 2971 Midland.
MANCHESTER: 260, Deansgate.
Telegrams: "Life, Manchester." Telephone: 8070 City (4 lines).
GLASGOW: 101, St. Vincent Street, C.2.
Telegrams: "Life, Glasgow." Telephone: Central 4857.
PUBLISHED WEEKLY.
Subscription Rates: Home, £1 1s. 8d.; Canada, £1 1s. 8d.;
other countries abroad, £1 3s. 10d. per annum.
Entered as Second Class Matter at New York, N.Y.
As many of the circuits and apparatus described in these pages are covered by patents, readers are advised, before making use of them, to satisfy themselves that they would not be infringing patents.

CONTENTS OF THIS ISSUE.

| | PAGE |
|---|------|
| EDITORIAL | 179 |
| ELECTRIC POWER DISTRIBUTION | 180 |
| FILAMENT CURRENT FROM D.C. MAINS. BY H. B. DENT | 183 |
| BUYERS' GUIDE TO ELIMINATORS | 188 |
| DISSECTING THE ELIMINATOR. BY H. F. SMITH | 192 |
| CURRENT TOPICS | 194 |
| SET SPECIFICATIONS: SIX TYPICAL MAINS RECEIVERS | 196 |
| MAINS TRANSFORMER CONSTRUCTION | 202 |
| BROADCAST BREVITIES | 205 |
| MAINS RECTIFIERS | 206 |
| CORRESPONDENCE | 209 |
| READERS' PROBLEMS | 211 |

ALL-ELECTRIC WIRELESS.

WE feel that no apology is necessary for devoting an issue of *The Wireless World* to the subject of mains-operated wireless, because to-day one may assume that there are comparatively few owners of wireless sets who do not operate their sets direct from the mains if electric light is available. By degrees, as electrification in this country is extended and voltages are standardised, mains operation of wireless sets will become a much simpler problem. At present progress is to a certain extent being held in check because of the multiplicity of voltages and the fact that both D.C. and A.C. supplies are approximately equally distributed. This state of affairs involves the manufacturer in the difficulty of having to supply a multiplicity of types of eliminators or sets, and, consequently, delays mass-production on a basis which would contribute towards reduction of cost to the user.

In this issue we give an outline of the various electricity schemes under which standardisation and extended distribution of electricity will eventually be

brought about in this country. So many of our readers have consulted us in the past on the choice of mains eliminators that we have arranged to include an index to such apparatus on the market, giving the essential information as to type, output and price, which, we think, will prove to be valuable for reference. In another article we deal with representative mains-operated complete receivers so as to give an indication of present practice in the design of the all-mains set. With the approval of the manufacturers circuit diagrams of these receivers are incorporated in the descriptions for the first time, so that a ready comparison can be made between the various methods adopted for mains operation.

Perhaps this is an occasion upon which a word might be said with regard to battery-operated sets. Electricity is still not available in the homes of an enormous number of the inhabitants of this country, so that primary or secondary batteries will still be in demand for many years to come, whilst for portable types of receiver batteries must always provide the source of current for valves.

The Cost of Batteries.

In the case of the dry battery, however, we are tempted to think that prevailing prices are higher than they should be. The popularity of the dry battery would, we believe, be enhanced to a very substantial extent if the cost to the purchaser could be reduced. There can be no case for contradicting the opinion that the last few years has shown ever-growing sales for dry batteries, as the popularity of valve-operated receivers has been extended. The cost to the user of general-purpose valves was substantially reduced after a plea had been made by *The Wireless World* a year or two back for a reduction. Some of our readers may think, with us, that a further reduction in valve prices will soon be due, but we do not feel that the public is entitled to stress this argument just at the present time because, whilst the standard and general-purpose valve is undoubtedly manufactured cheaply, yet the cost of development work in connection with the production of the many new special valves which have made their appearance during the past eighteen months has called for heavy expenditure on the part of the valve manufacturer. If, however, we consider the position with the dry battery, it must be admitted that the main cost here is in the raw materials and in manufacture, yet over a period of four years a comparison of figures for standard types of dry batteries shows but a small reduction, whilst in many instances no decrease in price has taken place.

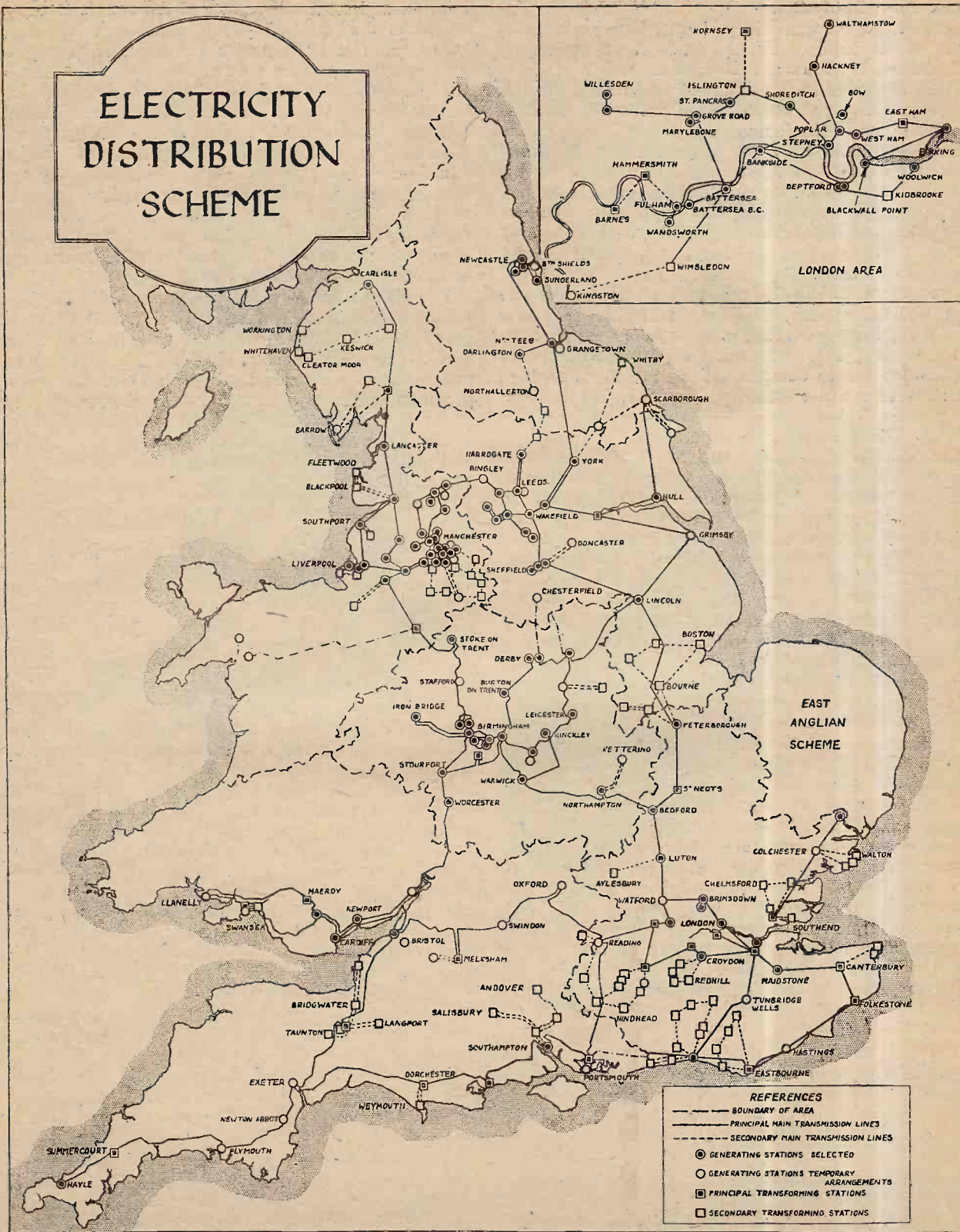

The "National Grid" which will eventually supply power at the standard frequency of 50 cycles to electrical undertakings, combining the various schemes drawn up by the Electricity Commissioners and approved by the Central Electricity Board. The East Anglian scheme still awaits the approval of the Board.

Electric Power Distribution.—

Middlesex, Essex, Cambridge, Herts, Huntingdon, and parts of Berkshire, Buckinghamshire, Bedfordshire, Oxfordshire, Hampshire, and Sussex.

There are, in all, 165 authorised undertakings in this area, including 93 which come within the district administration of the London and Home Counties Joint Electricity Authority. Many of these 165 undertakings take their supply in bulk from one or other of the big power companies, but the greater proportion have their own generating stations either to supply the whole of their individual requirements or to supplement the bulk supply. There were, in 1927, 135 public supply generating stations.

The scheme originally put forward in September, 1927, was subsequently modified. In its amended form 31 of the existing generating stations have been selected, and a further four, including the Battersea station of the London Power Company, Ltd., are to be erected, the remainder will eventually disappear. The scheme also provides for 49 main and about 20 secondary transforming stations as may be required.

The South-West England and South Wales Scheme covers a wide area, including the greater part of Oxfordshire, Berkshire, and Hampshire, and extending to Cornwall and South Wales. Six of the existing generating stations have been selected as permanent stations, viz., Cardiff, Hayle, Newport, Portishead, Southampton, and Upper Boat, South Wales, while new stations are projected on Southampton Water and in South Wales, and seventeen existing generating stations will be temporarily employed. There will be 21 main transforming stations and 11 secondary stations. The 25-cycle frequency employed in many of the present undertakings will be altered to 50 cycles at the earliest opportunity.

The Mid-East England Scheme comprises Lincolnshire, Rutland, and the southern part of Yorkshire, with 16 selected generating stations, 16 main and 10 secondary transforming stations, and 22 temporary generating stations. In this area there is, fortunately, no generating plant of non-standard frequency.

The Central England Scheme takes in Staffordshire, Leicestershire, Worcestershire, Northants, and parts of Notts and Bucks. There are 19 selected stations and a new generating station is to be erected at Ironbridge. Temporary arrangements are being made with 24 existing generating stations. There will be 20 main and 2 secondary transforming stations. The 25-cycle frequency prevalent in Birmingham, Halesowen, Kidder-

minster, and some other parts of the area is to be converted to the standard 50 cycles, though in parts of Birmingham and Smethwick the lower frequency will be permitted for some time to come.

The North-West England and North Wales Scheme includes North Wales, Cheshire, Lancashire, Westmorland and Cumberland, and provides for 27 selected generating stations and two new stations at Carrington, Manchester, and Clarence Dock, Liverpool, temporary arrangements being made with 35 existing generating stations. Provision is made for 29 main and 22 secondary transforming stations. The existing frequency of 40 cycles, which is somewhat prevalent in the North of England, is to be altered to 50 cycles.

The North-East England Scheme takes in the North Riding of Yorkshire, Northumberland and Durham, and provides for 6 selected generating stations, with 6 main and 8 secondary transforming stations. Temporary arrangements are being made with 11 of the existing generating stations in the area. The change over from 40 cycles to 50 cycles will be gradually accomplished.

The East Anglian Scheme, which includes Norfolk and Suffolk, has not yet been approved by the Central Electricity Board. The proposals submitted to the Electricity Commissioners comprise generating stations at Newmarket, Ipswich, Beccles, North Walsham and King's Lynn, with 18 main transformer stations.

The sketch map on the previous page will give some idea of the system of the standardised supply from which, when all the schemes are completed, the various electricity undertakings will draw. If all goes on smoothly, the next ten years should see a gradual standardisation of voltage and frequency, and a uniform supply of electricity throughout Great Britain which, besides cheapening the cost of electricity to the consumer, will considerably simplify the task of the manufacturer of wireless sets, as it is undoubtedly this lack of uniformity which is holding back the extended use of mains-operated receivers.

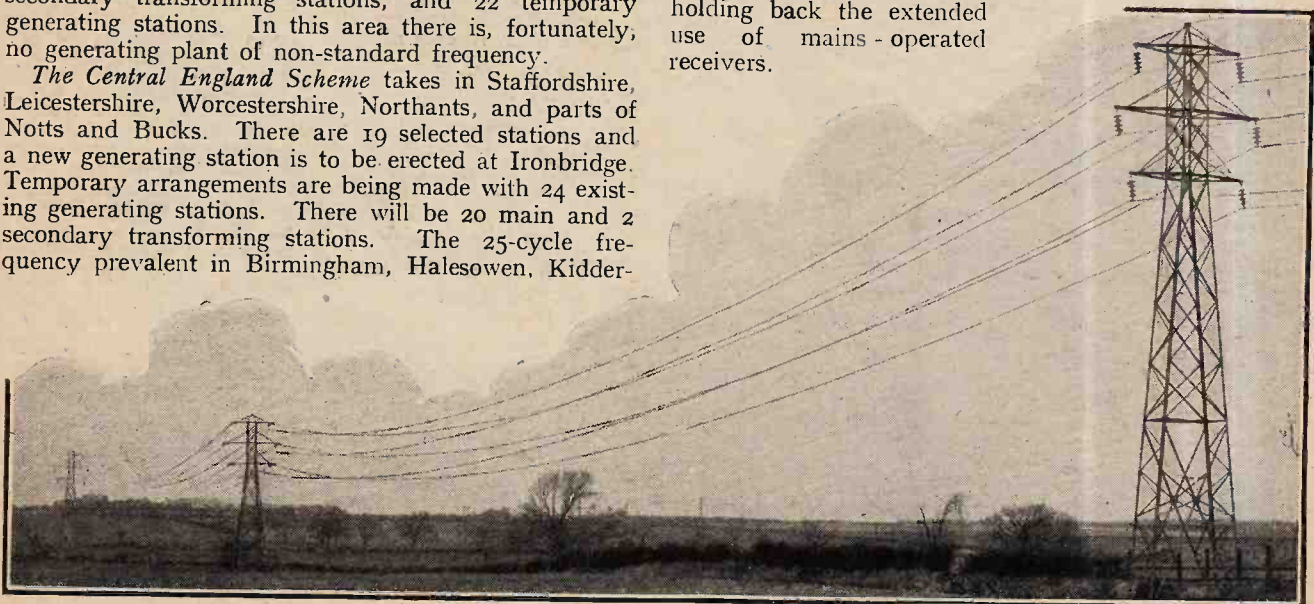

Typical high-voltage transmission line.

Rid yourself of accumulator worries!



Buy an EDISWAN ACCUMULATOR

The demand for Edison L.T. Batteries and the increased manufacturing facilities have enabled Edison to produce a range of long discharge batteries to sell at amazingly low prices. Here is your opportunity to end your battery worries and save money. Less charging—longer service—wonderful value.

- B.W.G.2. 24 Ampere Hours ... 8/9
 - B.W.G.3. 36 Ampere Hours ... 11/9
 - B.W.G.4. 48 Ampere Hours ... 13/9
- At the 20 hour rate of discharge.

- Midget Loten. 12 Amp. Hrs. 2/9
 - Little Loten. 20 Amp. Hrs. 4/3
 - Minor Loten. 45 Amp. Hrs. 8/-
 - Major Loten. 70 Amp. Hrs. 11/-
- At slow discharge rate.



THE EDISON SWAN ELECTRIC CO., LTD., 123/5, QUEEN VICTORIA STREET, LONDON, E.C.4.

Branches in all the Principal Towns.

B.55.

Heat Insulation Conserves Energy!

in the Mazda H.L. 210

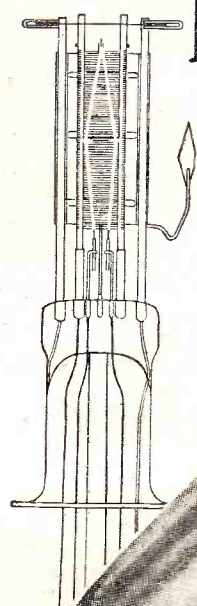

All filament supporting hooks in the Mazda H.L. 210 are coated with a heat insulating substance which retains the valuable heat in the places where it can do the most good instead of leaking away down the supports as is the case of most makes of valves. These filament supporting hooks render the valve sensibly non-microphonic and it is thus ideal for use in portable and similar receivers. For full details see catalogue—free on application.

MAZDA PRICE 10/6 RADIO VALVES



THE EDISON SWAN ELECTRIC CO., LTD., Radio Division, 1a, Newman Street, Oxford Street, W.1. Showrooms in all the Principal Towns.

EDISWAN

V.26

THE CONSTRUCTION OF A CONDENSER

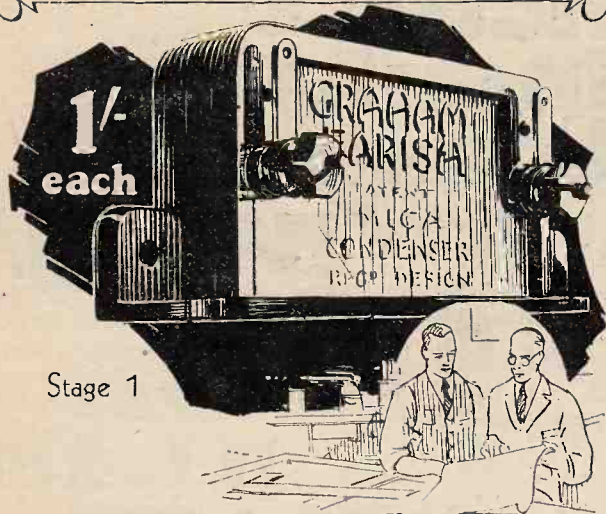

Stage 1

Scientific Designing



MICROFICIENT
Variable Condenser
Logmidline capacity. Brass vanes. Bakelite dielectric. Small but robust. .0005, 4/6. .0003 and .00015, 4/3.



ELECTROFICIENT
Eliminator Choke
Heavy design with large safety factor. Gives impedance of 30 Henries at 50 milliamperes 22/6



ELECTROFICIENT
Magnetic Pick up
Great sensitivity. No chatter. Free from resonance. Reduces record wear. Price, 27/6. With tone arm, 35/-.

SCIENTIFIC designing . . . means rather more than the designing of a product which, under certain conditions, will work efficiently. It means the first stage in the production of a component that will perform every desired function—that will be of robust construction—soundly made of good materials—and, finally, will sell at a competitive price.

Every Graham-Farish wireless component is "scientifically designed" by skilled radio engineers. No unnecessary feature is included—no vital point left out. It is this first stage—foremost in importance—that has made possible the production of a component such as the Fixed Mica Condenser.

The Graham-Farish Fixed Mica Condenser has the finest flawless Indian Ruby Mica as a dielectric. An exclusive feature is the alternative upright or flat mounting. Every condenser is tested three times and a written guarantee given with each.

Finest Indian ruby mica dielectric, bakelite case. Upright or flat mounting, terminals, soldering tags and series—parallel grid leak clips up to capacities .0005, .00005—.002, 1/-; .003—.006, 1/6; .007—.01, 2/6.

- "Ohmite" Anode Resistance . . . 2/3
- "Megite" New Process Grid Leak 2/-
- "Multiwave" H.F. Coupling Unit 7/6
- "Electroficient" Mains Transformer 39/6

GRAHAM FARISH

BROMLEY RADIO KENT

Look for this sign  in a dealer's shop.

THE FINEST MAINS UNIT FOR H.T. CURRENT YET PRODUCED AT THE PRICE absolutely safe, and guaranteed for 12 months.



Model A.C.16 for Alternating Current.

Suitable for any Set from one to five Valves.

All you require is Electric Light in the home and this "ATLAS" Super Eliminator, Model A.C.16, will provide all the H.T. Current necessary for your Set at practically no cost.

It has been specially produced to meet the demands of any Set from one to five valves and specially caters for Sets using Screen-Grid, Detector and Pentode Valves. Three Tappings are provided, one variable giving 0/100 Volts, and two fixed giving 120 Volts and 150 Volts respectively.

OUTPUT. 150 Volts at 25 m/A.

It is simple to adapt to your Set and there is no hum or motor-boating.

Yours for 10/- down, and nine monthly easy instalments, or

CASH PRICE £4 - 10 - 0.

Write for Folder No. 44, which gives full details of all

CLARKE'S "ATLAS" BATTERY ELIMINATORS

Ask your dealer about them or

POST THIS COUPON TO-DAY

in an unsealed &d. stamped envelope.

Messrs. H. Clarke & Co. (M/cr.) Ltd. (Dept. 3D), Atlas Works, Old Trafford, Manchester. Please forward Folder No. 44 with details of your easy payment system.

NAME
ADDRESS

Please use BLOCK LETTERS.

W.W.5

Mention of "The Wireless World," when writing to advertisers, will ensure prompt attention.

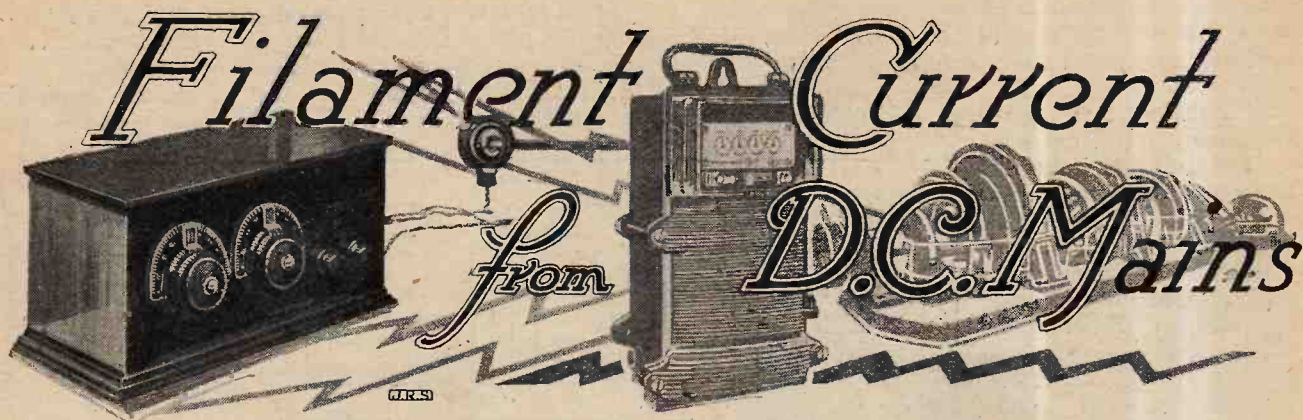

A Survey of the Most Economical Methods and Some Examples of Current Practice.

By H. B. DENT.

A LARGE percentage of broadcast listeners probably make use of the electric supply mains, either wholly or partially, as a means of obtaining the various voltages required to operate the receiver. So far as can be judged, those relying solely upon this source of power are in the minority, but there is evidence to show that this condition is not likely to obtain for long. Perhaps the present could be regarded as a transition period, and in the near future the all-electric broadcast receiver will figure largely in every display of wireless equipment. Sets deriving their power from the direct current mains are probably the scarcest of all, in spite of the fact that, of the authorities in the

ation of the supply voltages is largely responsible for the shortage of manufactured D.C. sets. Many of the antiquated systems will eventually disappear and be replaced by an A.C. supply at a standard voltage and frequency, but some considerable time must elapse before all D.C. systems die out.

Wasting Watts.

It is still worth while giving some thought to an all-electric set, particularly so if the design is such that a change can be made without too much difficulty, or the incurring of heavy expense when the system is eventually modernised. The subject bristles with difficulties, but they are surmountable.

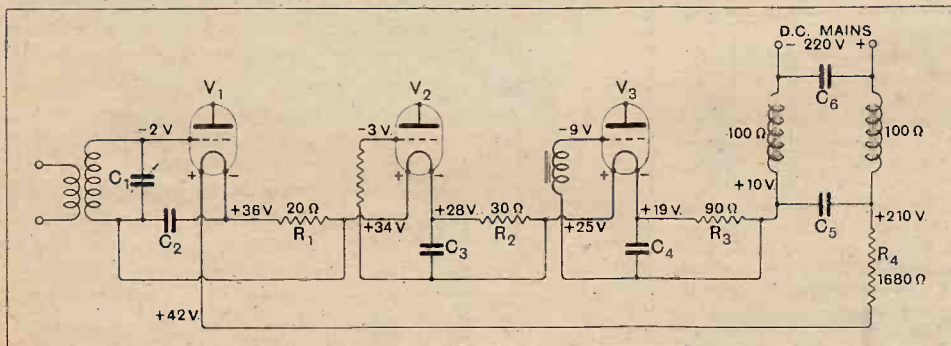

Fig. 1.—With valves series connected the difference in potential across resistances shown at R₁, R₂ and R₃ provides grid bias.

United Kingdom distributing electric current, approximately 37 per cent. provide continuous current. Of the remainder, 18 per cent. distribute both A.C. and D.C., although, of course, not necessarily to the same district. What percentage of the total users of electricity have D.C. available cannot be ascertained readily, but the above figures suffice to indicate that there is more than a passing interest in receivers capable of being connected to the D.C. mains and requiring little attention other than a periodic test of valves.

There can be no doubt that the lack of standardis-

employed to provide the filament and plate currents in an economical manner, but with continuous current rather wasteful methods have to be adopted. The filament of a valve requires current to bring it to the working temperature, and if it is rated to consume 0.25 amp. at 2 volts, this current must be passed through the filament even though the mains voltage is 240. Thus 60 watts are drawn from the supply to do the same work as 0.5 of a watt would do if an accumulator were used. Since the valve will suffer damage if more than two volts are applied across its filament, 238 volts will have

Filament Current from D.C. Mains.—

to be absorbed by a resistance. This resistance will dissipate 59.5 watts and perform no useful function whatsoever.

It is obvious that the valves used must all consume the same current, but their voltage rating is quite immaterial from the theoretical point of view. This qualification is included advisedly, since some designs make use of the difference in potential between the filaments of the valves to provide grid bias. It is, therefore, essential, in the majority of cases, to adhere strictly to the maker's, or designer's, recommendation regarding the type of valve to fit in each position.

In general, the receiving circuits show little deviation from those ordinarily employed. The filament connections and the grid bias arrangements are, of course, totally different, and it is with this portion of the set only that we will deal here. In Fig. 1 is shown a simple three-valve circuit with unimportant features omitted. A detector, followed by two low-frequency stages, constitute the arrangement. All valves are connected in series, but interposed between them is a resistance, the function of which is to provide negative grid bias for the preceding valve; considering the stages in the order V_1, V_2 and V_3 . The first stage is an anode bend detector, but the leaky grid method could be em-

ployed by fitting a grid condenser and leak and returning the grid leak to the slider of a potentiometer connected across the filament pins of the first valve.

In this case six-volt 0.1 amp. valves are assumed, and the voltages appearing at every point on the circuit

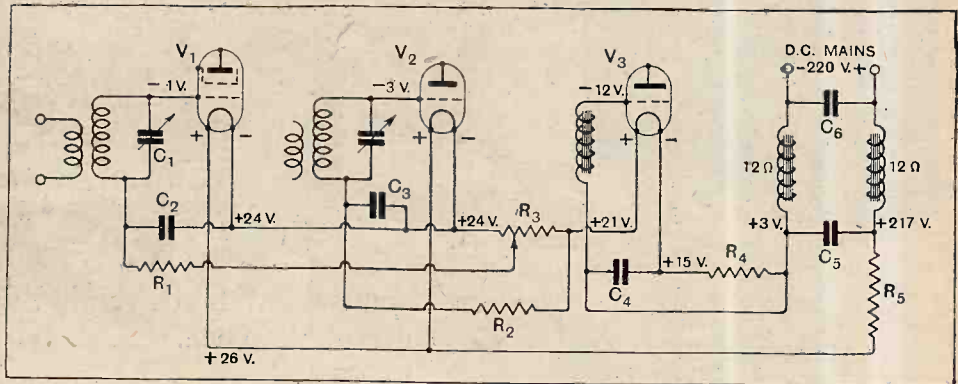

Fig. 2.—When a tapped resistance (R_3) provides grid bias for two or more valves, decoupling of the grid circuits is desirable. R_1 and C_2 decouple V_1 , and R_2 and C_3 perform this duty for V_2 .

are marked. The effective grid bias is the difference in potential between the negative leg of each valve and the point on the circuit to which its grid circuit is returned. For example, V_2 obtains grid bias from the end of a 30 ohms resistance connected between V_2 and V_3 , the bias being -3 volts ($30 \times 0.1 = 3$).

Series-parallel Connected Filaments.

The output from an arrangement on the lines shown will not be large, since a small power valve only can be employed, and if we wish to make provision for a larger output two courses are open. Either two 0.1

amp. valves may be used with their filaments in series but with the anodes and grids suitably connected in parallel; or, a super-power output valve fitted and the other valves chosen to have the same filament characteristics. There is another arrangement which at present is adopted by some manufacturers. It has been evolved particularly for sets embodying a screen-grid H.F. valve and a pentode. The essence of the arrangement is to connect the H.F. and detector filaments in parallel, as usual, but in series with the last valve. The first two valves would be chosen so that between them they take the same filament current as the last valve. To take a case in point. The H.F. valve

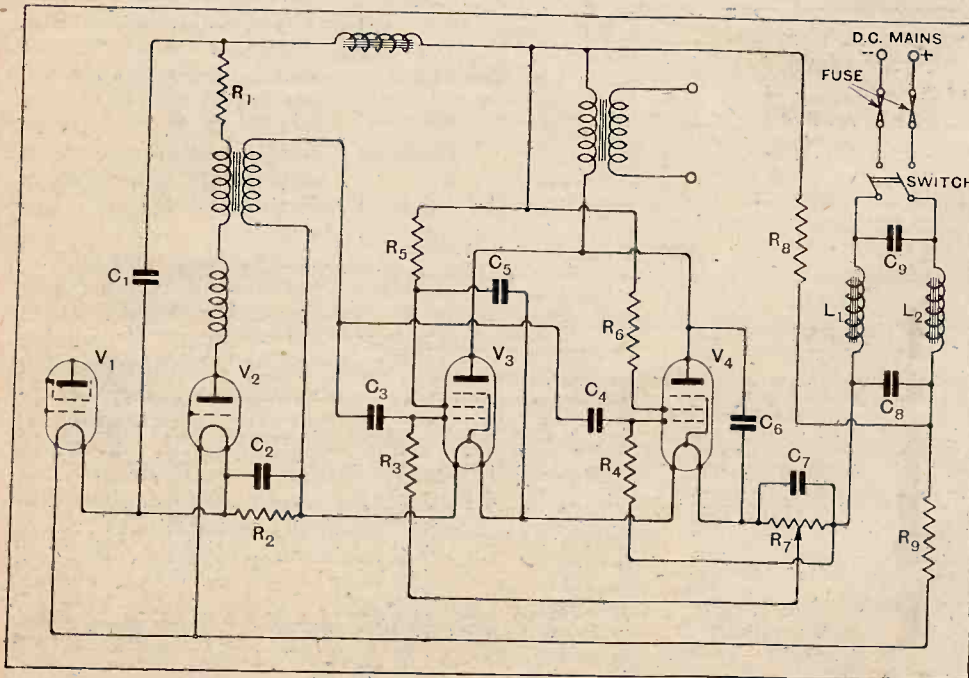

Fig. 3.—If the output stage consists of two pentodes, parallel-connected as regards their input and output circuits but with their filaments in series, grid bias can be taken from a tapped resistance, R_7 , in the manner shown.

Filament Current from D.C. Mains.—

two valves are sometimes fitted in the last stage. They can be operated with the grids and anodes suitably connected in parallel, but with the filaments in series. The current drawn from the mains will be increased only by the value of the anode current taken by the additional valve. This arrangement is shown in Fig. 3. A little thought will show that it is not practical to connect the working grids of the two pentodes together as in a straightforward parallel stage. As the filaments are in series, the negative leg of one valve will not have the same potential as the negative leg of the other, and if the grid bias was taken from one end of R_7 , which, for example, we will assume is 6 volts negative with reference to the negative leg of V_4 , the grid of V_3 would have the difference in potential across R_7 plus the difference across the filament of V_4 . If 4-volt valves were used this would amount to -10 volts. This can be corrected by an arrangement of condenser and grid leaks, shown at C_3 , C_4 , R_3 , and R_4 . The bias resistance R_7 is tapped so that the bias taken for V_3 is less, by the voltage rating of the valves, than that taken for V_4 .

Some Commercial All-mains D.C. Receivers.

The resistances R_5 and R_6 and condensers C_5 and C_6 serve to decouple the two valves and also reduce the voltage on the auxiliary grids to a more economical

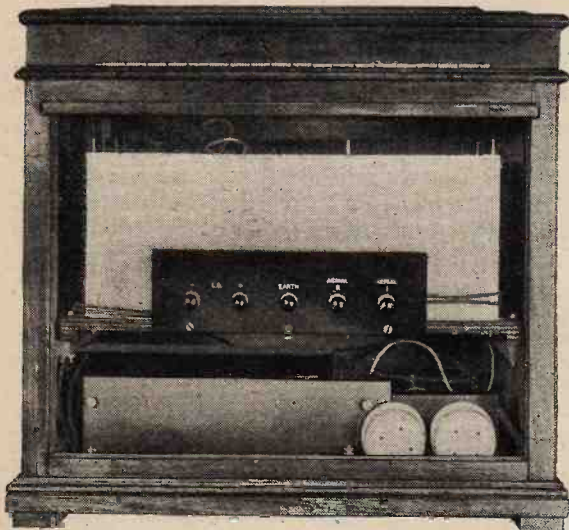

Back view of R.I. D.C. receiver. The smoothing equipment is housed in the base and screened from the receiver proper.

value. It is often advisable to give these less than the anode, particularly when dealing with rather high H.T. values.

The Gambrell S.P.4 D.C. all-electric receiver exhibits many of the features of Fig. 3. Two pentodes are used in the last stage, connected as shown, with the difference that R_3 and C_3 are omitted, but R_4 and C_4 are included. Grid bias is taken from a tapped resistance. In this receiver the tuned circuits are semi-ganged, edgewise drum control condensers being used with the operating drums mounted adjacent. Since each circuit can be tuned independently, there is no need for a "trim-

ming" condenser. This receiver is fitted with the four-volt type of valves. The H.F. and detector each take 0.075 amp., and the pentodes 0.15 amp. each. Reaction is incorporated.

The performance was well up to the standard of that expected from a three-stage receiver incorporating a screen-grid H.F. valve, and when opened full out the



Gambrell 4-valve all-mains D.C. set. Two pentodes are used in parallel as the output stage.

volume was uncomfortably large for a room of more than average size. No fault could be found with the background noises, and these were certainly no greater than with a set using battery-fed valves and an H.T. eliminator.

Screening plays an important part in mains receivers, and it is practically essential, in the interests of silent working, carefully and completely to screen all smoothing chokes and power resistances. The usual procedure is to accommodate these in a separate screened compartment. When an L.F. transformer is used care must be taken to keep this well away from the mains leads, and preference should be given to those components fitted in metal cases. If the metal case is "earthed" there will be little likelihood of induction taking place between the windings and the smoothing equipment.

Protecting Live Parts.

The filament chokes should be of fairly high inductance and as much capacity as can be conveniently incorporated used to smooth the supply. In general about 10 mfd. would appear to be required. This can be divided between C_5 and C_6 (Fig. 3), but with the bulk of the capacity at C_5 . Two mfd. should be ample for C_6 . A double-pole switch and a fuse in each supply lead should be included in the set. All exposed metal parts, such as panel fittings, condensers, dials, switches, etc., should be fully insulated from the mains. Drum control condensers and those with insulated spindles are the best to use, because in most tuning arrangements both sets of condenser vanes are electrically connected to the filament circuit. With D.C. mains that have the negative lead earthed no danger from shock should exist, but there is an equal number of house lighting circuits in which the

Filament Current from D.C. Mains.—

positive conductor is at earth potential. In these cases the filaments are practically at the mains potential above earth, hence the need for careful insulation of all metal parts in the filament circuit. This brings to light the interesting problem of how to tie down the screening containers. It is obviously unwise to join them direct to

the filament circuit in view of the foregoing, so it is suggested that 2-mfd. condensers should be interposed between the screens and the wiring. A theoretical sketch of a three-valve mains set, showing a suggested method of screening and embodying most of the features considered advisable and discussed in this article, is given in Fig. 4.

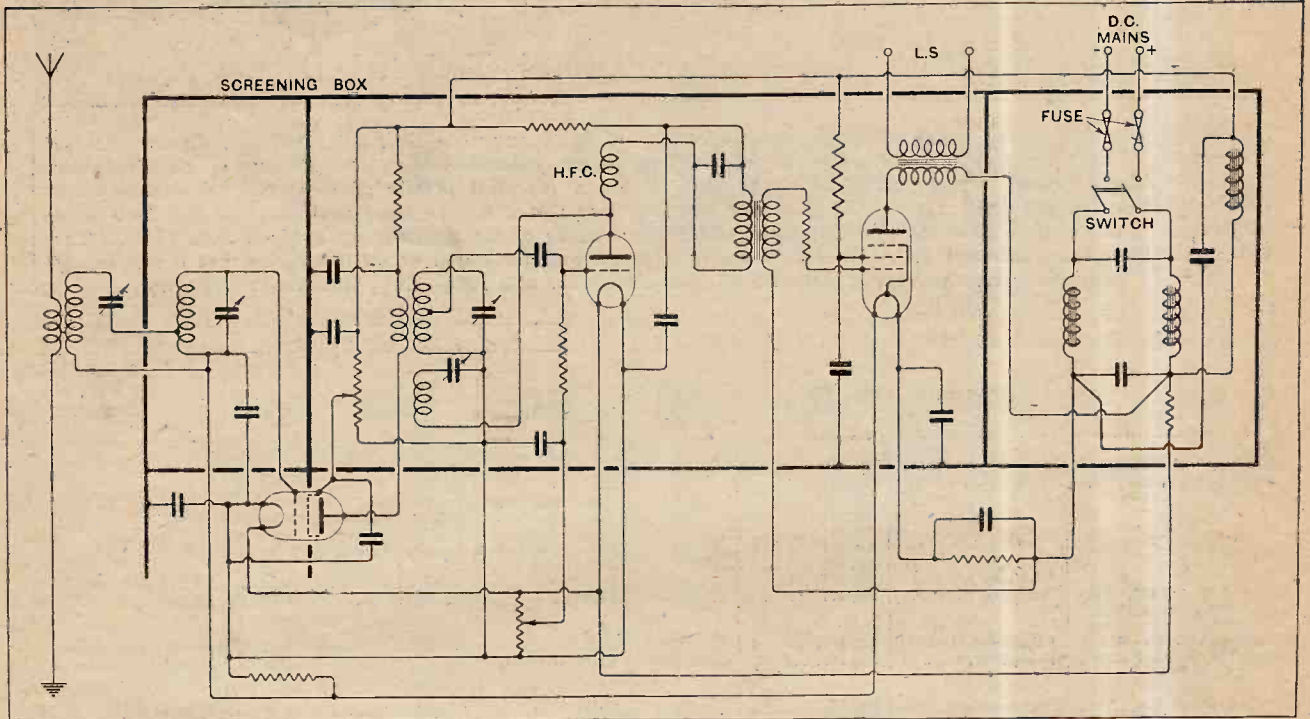

Fig. 4.—Suggested scheme for a 3-valve all-electric D.C. set. Complete screening of the eliminator is advocated, and an input filter, with aerial fully insulated, as shown. The H.F. and detector filaments are in parallel but in series with the pentode. The container is not "live," and may form the cabinet.

Eliminating Needle Scratch.

The lecture and demonstration before the Muswell Hill and District Radio Society on January 29th were given by Mr. F. N. G. Leavers, whose subject was "The Testing of a Modern Gramophone Pick-up." A large amount of useful information, both technical and practical, regarding the electrical reproduction of gramophone records was given by the lecturer, who also related many of his own experiences in this connection. In conclusion, a demonstration of a pick-up working through a four-valve amplifier was given, and the effect of a tone compensator shown, while the beneficial results of the use of a scratch filter were strikingly demonstrated.

Hon. Secretary, Mr. C. J. Witt, 30, Coniston Road, London, N.10.

o o o o

For Bristol Enthusiasts.

At the Bristol and District Radio and Television Society's annual general meeting, held recently, the secretary's report showed that the past year has been a very successful one.

The following officers were elected for 1930:—
Chairman, Mr. W. A. Andrews, B.Sc., A.I.C., M.I.Rad.E. Vice-Chairmen, Mr. W. C. Jennings, Mr. H. R. Beasant, A.M.I.E.E. Hon. Secretary, Mr. S. T. Jordan. Treasurer, Mr. C. H. Ashman, A.I.C.

An interesting programme has been arranged for the coming weeks, and the Society will be pleased to welcome new members. Anyone interested should apply for particulars to the Hon. Secretary, 1, Myrtle Road, Cotham, Bristol.

B 29

NEWS FROM
THE CLUBS.

How Dry Batteries Are Made.

The well-known Siemens films were shown and commented on by Mr. R. Ferguson at a combined meeting of the South Croydon, Thornton Heath, and Whitgift Middle School Radio Societies on January 28th. The films were three in number, namely, "The Siemens' Lamps," "The Siemens' Batteries," and "The Siemens' Cables," shown in that order.

In the battery construction film the first scenes showed the various crushers and grinders of the carbon slab at work. Zinc was found to be another highly important part in a battery, and its subsequent processes were keenly noted from sheet form until it finished as the familiarly shaped cylindrical vessel. By the modern process it was seen how the zinc containers were made seamless.

Mr. Ferguson laid stress on the fact that his firm's batteries were each made of a certain capacity, and it was useless to do otherwise than use one of a particular size for a required purpose. Much of the dissatisfaction with H.T. batteries was often due, he said, to using a battery of too small a capacity.

Hon. Secretary of Thornton Heath Society,

77, Torrridge Road, Thornton Heath. Hon. Secretary of South Croydon Society, 14, Campden Road, South Croydon.

o o o o

Junk Sale Brings New Members.

A large quantity of surplus apparatus was successfully disposed of during the "Junk Sale" held recently by Slade Radio (Birmingham). A number of new members joined at this meeting, but it is thought that there must still be a very large number of wireless enthusiasts in the district who are unaware of the Society's activities.

The Hon. Secretary, whose address is 110, Hillaries Road, Gravelly Hill, Birmingham, will be very pleased to forward particulars of membership on request.

o o o o

When Grid Bias Fails.

Several knotty problems were discussed at a recent meeting of the South Croydon and District Radio Society. Some amusement was caused when the valves in the club set were changed round to demonstrate the evils of overloading the last stage, which no amount of biasing would put right.

Much interest was shown in a member's valve-holder which had been made with two terminals in the plate connection, so that it was possible to connect up the milliammeter to that valve only and obtain a reading of its anode current apart from the other valves in the set.

Hon. Secretary, Mr. E. L. Cumbers, 14, Campden Road, South Croydon.

BUYERS GUIDE to ELIMINATORS

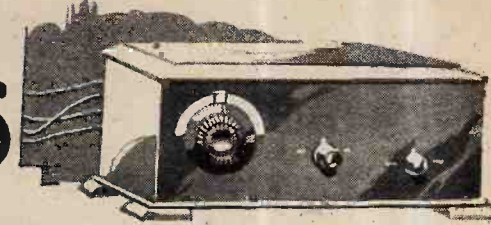

Reference List Giving Essential Technical Data.

To those contemplating the use of lighting mains for the supply of current to their sets, and who do not wish to dispose of their battery-operated receivers in favour of the modern all-mains equipment, the use of an eliminator will no doubt appeal. In the following pages will be found essential details of some 230 eliminators with tapping and output data. It can be generally assumed that where two or more variable tappings have been provided, one of these is suitable for supplying the critical needs of the screening grid of an S.G. valve. The mains transformers in the A.C. eliminators specified are wound for 40/60 or 40/100 cycles, but a number of manufacturers can supply a special 25-cycle eliminator at a 10%—20% increased selling price.

| Manufacturer. | Name of Eliminator. | Type. AC or DC, HT, LT, GB. | H.T. Output Current in mA. | Type of Rectifier. | HT Voltage Tappings. | Price. | Remarks. |
|--|-------------------------|-----------------------------|----------------------------|--------------------|----------------------|------------------------|--|
| Accessories (Birmingham), Weaman St., Birmingham. | — | DC, HT | 30 | — | 2 fixed | £ s. d. 1 8 0 | |
| | — | DC, HT | 30 | — | 3 fixed | 1 12 6 | |
| | — | AC, HT | 20 | Valve, half-wave | 2 fixed | 3 5 0 | |
| | — | AC, HT | 20 | Valve, half-wave | 2 fixed, 1 variable | 3 10 0 | |
| | — | AC, HT | 30 | Valve, full-wave | 1 fixed, 2 variable | 3 15 0 | |
| | — | AC, HT | 30 | Valve, half-wave | 2 fixed, 1 variable | 3 15 0 | |
| | — | AC, HT | 30 | Metal oxide | 2 fixed, 1 variable | 4 10 0 | |
| Ernest J. Baty, 157, Dunstable Rd., Luton, Beds. | All-Mains | AC, HT, LT | 30 | — | 2 fixed, 1 variable | 7 15 0 | |
| | Combined Unit | AC, HT, LT | 12 at 120 v. | Metal oxide | 3 variable | 9 0 0 | LT 2, 4 or 6 volts. Incorporates LT trickle charger. |
| Burndept Wireless (1928), Ltd., 15, Bedford Street, London, W.C.2. | Ethopower, Mark III | AC, HT, GB | 30 at 150 v. | Metal oxide | 3 fixed | 8 5 0 | One GB tapping. |
| | Ethopower, Mark II | AC, HT, GB | 25 at 150 v. | Valve, full-wave | — | 6 18 3 | Includes regulator tube and rectifying valve. |
| Chorlton Metal Co., Ltd., 18, Amber St., Shudehill, Manchester. | Supremus E25 | AC, HT | 25 | Valve | 3 fixed | 3 0 0 | Valve extra. |
| | Supremus E25A | AC, HT | 25 | Valve | 4 fixed | 3 7 6 | Valve extra. |
| | Supremus E25B | AC, HT | — | Valve | 5 fixed | 3 17 6 | Valve extra. |
| | Supremus F50A | AC, HT | 60 | Valve, full-wave | 9 tappings | 5 10 0 | Valve extra. |
| | Supremus F50B | AC, HT, GB | 60 | Valve, full-wave | 9 tappings | 6 0 0 | 4 GB tappings. Valve extra. |
| | Supremus 2C | DC, HT | 45 | — | 18 tappings | 2 5 0 | The AC models can be obtained with metal rectifiers at extra cost. |
| | Supremus 3C | DC, HT | 45 | — | 18 tappings | 2 10 0 | |
| | Supremus Power Model. | DC, HT | 150 | — | — | 2 12 6 | |
| | Supremus 2C de Luxe | DC, HT | 45 | — | 18 tappings | 3 0 0 | |
| | Supremus 3C de Luxe | DC, HT | 45 | — | 18 tappings | 3 5 0 | |
| | Supremus Power de Luxe. | DC, HT | 150 | — | — | 3 7 6 | |
| | Supremus B15 | DC, HT | 15 | — | 2 fixed | 1 1 0 | |
| | Supremus C25 | DC, HT | 25 | — | 3 fixed | 1 12 6 | |
| | Supremus D50 | DC, HT | 50 | — | 4 fixed | 1 19 6 | |
| Supremus D120 | DC, HT | 120 | — | 4 fixed | 2 2 6 | | |
| Supremus A8 | DC, HT | 8 at 60 v. | — | 1 fixed | 0 13 9 | Earth condenser extra. | |
| Supremus A12 | DC, HT | 12 at 100 v. | — | 1 fixed | 0 13 9 | Earth condenser extra. | |
| H. Clarke & Co. (Manchester), Ltd., Atlas Works, Old Trafford, Manchester. | Atlas AC38 | AC, HT | 50 | Valve | 1 fixed, 2 variable | 9 12 6 | |
| | Atlas AC50 | AC, HT | 50 | Metal oxide | 2 fixed, 2 variable | 12 17 6 | Output stage voltage = 200. |
| | Atlas AC56 | AC, HT | 50 | Metal oxide | 2 fixed, 1 variable | 8 15 0 | |
| | Atlas AC16 | AC, HT | 25 | Valve | 2 fixed, 1 variable | 4 10 0 | |
| | Atlas AC84X | AC, HT, LT | 15 | Metal oxide | 2 fixed, 1 variable | 6 17 6 | Incorporates LT trickle charger. |
| | Atlas DC6 | DC, HT | 20 | — | 4 fixed | 3 5 0 | |
| | Atlas DC16 | DC, HT | — | — | 2 fixed, 1 variable | 3 15 0 | |
| | Atlas DC18 | DC, HT | 15 | — | 2 fixed | 1 17 6 | |
| | Atlas DC50 | DC, HT | 50 | — | 2 fixed, 2 variable | 7 15 0 | Output stage voltage = 120. Output stage .40 mA. at 200 v. |
| | — | DC, HT | 50 | — | 1 fixed, 2 variable | 1 14 0 | |
| Climax Radio Electric Ltd., 59, Parkhill Rd., London, N.W.3. | U20 | AC, HT | 20 | — | 1 fixed, 2 variable | 4 5 0 | |
| | U50 | AC, HT | 50 at 150 v. | — | 1 fixed, 2 variable | 5 15 0 | |
| | — | DC, HT | 50 | — | — | — | |
| E. K. Cole, Ltd., London Rd., Leigh-on-Sea. | Ekco IF10 | DC, HT | 10 at 120 v. | — | 1 fixed | 0 17 6 | |
| | Ekco 2F10 | DC, HT | 10 | — | 2 fixed | 1 9 6 | |
| | Ekco 3F20 | DC, HT | 20 | — | 3 fixed | 1 17 6 | |
| | Ekco IV20 | DC, HT | 20 | — | 2 fixed, 1 variable | 2 10 0 | |
| | Ekco 4T60 | DC, HT | 60 | — | 2 fixed, 2 variable | 3 15 0 | |
| | Ekco 5T80 | DC, HT | 80 | — | 3 fixed, 2 variable | 4 15 0 | |
| | Ekco C1A | DC, HT, LT, GB | 60 | — | 4 tappings | 9 15 0 | LT current up to 0.6 amp. 7 GB tappings. |
| | Ekco C2A | DC, HT, LT, GB | 20 | — | 3 tappings | 5 17 6 | LT current up to 0.35 amp. 5 GB tappings. |
| | Ekco 2A10 | AC, HT | 10 | Metal oxide | 2 fixed | 3 10 0 | |

Buyers' Guide to Eliminators.—

| Manufacturer. | Name of Eliminator. | Type. AC or DC, HT, LT, or GB. | HT Output Current in mA. | Type of Rectifier. | HT Voltage Tappings. | Price. | Remarks. |
|--|---------------------|--------------------------------|--------------------------|-----------------------------------|----------------------|----------|---|
| E. K. Cole, Ltd. (continued). | Ekeo 1V20 | AC, HT | 20 | Metal oxide | 2 fixed, 1 variable | £ 4 12 6 | LT current up to 1.0 amp. 7 GB tappings. LT current up to 0.5 amp. 5 GB tappings. LT current up to 1.0 amp. Specially designed for Columbia portable receiver. |
| | Ekeo 3F20 | AC, HT | 20 | Metal oxide | 3 fixed | 3 19 6 | |
| | Ekeo 4T60 | AC, HT | 60 | Valve | 2 fixed, 2 variable | 7 5 0 | |
| | Ekeo 5T60 | AC, HT | 60 | Metal oxide | 3 fixed, 2 variable | 10 10 0 | |
| | Ekeo C1A | AC, HT, LT, GB | 60 | Metal oxide | 4 tappings | 17 15 0 | |
| | Ekeo C2A | AC, HT, LT, GB | 20 | Metal oxide | 3 tappings | 10 17 6 | |
| Columbia Graphophone Co., Ltd., 102-108, Clerkenwell Rd., London, E.C.1. | Ekeo LT1 | AC, LT | — | — | — | 8 15 0 | Specially designed for Columbia portable receiver. |
| | 305B and C | AC, HT, LT | 12 | Valve for HT, Metal oxide for LT. | 2 fixed | 10 10 0 | |
| | 305A | DC, HT, LT | 12 | — | 2 fixed | 10 10 0 | Specially designed for Columbia portable receiver. |
| Commercial Engineering Co., 15, Bedford St., Rhyd. | Standard Model | DC, HT | 20 | — | 2 fixed | 1 5 0 | |
| | Standard de Luxe | DC, HT | 50 | — | 10 tappings | 4 0 0 | |
| | De Luxe | AC, HT | 50 | Valve or metal oxide. | 4 fixed, 1 variable | 8 0 0 | |
| Condenser & Electric Co., Broadway House, South St., Romford. | Ceco No. 220 | AC, HT | 20 | Metal oxide | 2 fixed | 3 15 0 | LT current up to 1.0 amp. 7 GB tappings. |
| | Ceco No. 250 | AC, HT | 50 | Metal oxide | 3 fixed | 7 10 0 | |
| | Ceco No. 201 | AC, LT, GB | — | — | — | 8 17 6 | |
| Dubilier Condenser Co. (1925), Ltd., Ducon Works, Victoria Rd., North Acton, London, W.3 | A | DC, HT | 14 | — | 2 fixed | 1 8 6 | |
| | B | DC, HT | 40 at 180 v. | — | 1 fixed, 6 adj'table | 2 7 6 | |
| | C | DC, HT | 50 at 180 v. | — | 1 fixed, 6 adj'table | 3 12 6 | |
| | D | DC, HT | 50 at 180 v. | — | 1 fixed, 7 adj'table | 7 2 6 | |
| Dunhams, Ltd., New Wharf Rd., London, N.1. | — | AC, HT | 12 at 150 v. | Metal oxide | 2 variable | 5 5 0 | GB to 20 v.; LT 4 v. 3 amps. |
| | — | DC, HT | 12 at 150 v. | — | 1 fixed, 1 variable | 3 17 6 | |
| J. Dyson & Co., Ltd., 2, Coleman St., London, E.C.2. | All-Mains | AC, HT, LT, GB | 40 at 180 v. | Metal oxide | 1 fixed, 2 variable | 8 10 0 | Valve rectifier at same price. With valve rectifier, £7 7s. 6d. LT current up to 1.0 amp. |
| | DH | DC, HT | 20 at 150 v. | — | 2 fixed, 1 variable | 2 17 6 | |
| | DP | DC, HT | 50 at 200 v. | — | 3 fixed, 1 variable | 3 10 0 | |
| | AHW | AC, HT | 15 at 130 v. | Metal oxide | 2 fixed, 1 variable | 4 17 6 | |
| | AFW | AC, HT | 30 at 180 v. | Metal oxide | 2 fixed, 2 variable | 7 17 6 | |
| | APM | AC, HT, LT, GB | 50 at 200 v. | Valve | 2 fixed, 2 variable | 17 10 0 | |
| East Ham Wireless Supplies, 427 and 429, Barking Rd., East Ham, London, E.6. | Lassophone | DC, HT | 60 | — | 2 fixed, 2 variable | 2 12 6 | |
| | — | — | — | — | — | — | |
| The Edison Swan Electric Co., Ltd., 123-125, Queen Victoria St., London, E.C.4 | BS | AC, HT, LT, GB | 20 at 200 v. | Valve, half-wave | 4 fixed | 8 0 0 | 2 GB tappings. LT current of 5 amps. at 4 volts. 2 GB tappings. 1 GB tapping. LT current of 5 amps. at 4 volts. Provision for moving coil field, LT, and GB. 5 amps. at 4 volts. |
| | BS | DC, HT, GB | — | — | 4 fixed | 5 5 0 | |
| | C | AC, HT, LT, GB | 40 at 220 v. | Valve, full-wave | 4 fixed | 10 10 0 | |
| | D | AC, HT, LT, GB | 70 at 400 v. | Valves | 5 fixed | 21 0 0 | |
| | MV | DC, HT, GB | 50 | — | 6 fixed | 9 2 6 | |
| | MV | AC, LT | — | — | — | 2 10 0 | |
| The Ellison Mfg. Co., Ltd., Dragon Works, Harrogate. | P1 | AC, HT | 30 at 120 v. | Valve | 2 fixed | 6 0 0 | Price includes valve. Price includes valve. Price includes valve. 4 GB tappings. Provides current for 4 v. AC valves. 4 GB tappings. Interchangeable resistances in every feed. |
| | P1 | DC, HT | 30 | — | 2 fixed, 1 variable | 2 10 0 | |
| | P2 | AC, HT | 15 at 110 v. | Metal oxide | 2 fixed | 4 17 6 | |
| | AC1 | AC, HT | 20 at 110 v. | Valve, half-wave | 2 fixed | 3 15 0 | |
| | AC2 | AC, HT | 30 at 110 v. | Valve | 2 fixed, 1 variable | 4 10 0 | |
| Falk, Stadelmann & Co., Ltd., 83-93, Farringdon Rd., London, E.C.1. | Efesca Senior | AC, HT, GB | 50 | Valve, full-wave | 4 fixed | 6 6 0 | 4 GB tappings. |
| | Efesca Junior | AC, HT | 20 | Valve, half-wave | 3 fixed | 3 5 0 | |
| | All Mains | AC, HT, LT | 50 | Valve, full-wave | 4 fixed | 7 15 0 | |
| | — | — | — | — | — | — | |
| Ferranti, Ltd., Hollinwood, Lancashire. | Efesca Senior | DC, HT, GB | 60 | — | 4 fixed | 4 10 0 | 4 GB tappings. Interchangeable resistances in every feed. |
| | BEM1 | AC, HT | 100 at 200 v. | Metal oxide | 5 fixed | 13 10 0 | |
| Fonteyn & Co., Ltd., 2, 4, 5 and 6, Blandford Mews, Baker St., London, W.1. | Cifel Junior | AC, HT | 12 at 120 v. | Valve, full-wave | 1 fixed, 1 variable | 3 3 0 | Price includes valve. |
| Garnett Whiteley & Co., Ltd., Lotus Works, Mill Lane, Liverpool. | Lotus AM/10 | AC, HT, LT, GB | 50 at 200 v. | Valve, full-wave | 5 fixed | 7 7 0 | LT 4 volts 4 amps., adjustable GB. |
| The General Electric Co., Magnet House, Kingsway, London, W.C.2. | BC1400 | DC, HT | 25 at 140 v. | — | 1 fixed, 1 variable | 6 10 0 | With metal rectifier, £6. |
| | BC1520 | AC, HT | 20 | Valve, full-wave | 3 fixed | 5 5 0 | |
| | BC1530 | AC, HT | 40 | Valve, full-wave | 1 fixed, 2 variable | 9 0 0 | |
| Gollings & Ayres, 21, The Broadway, Bedford. | — | AC, HT | 30 at 150 v. | Valve | 2 fixed, 1 variable | 5 0 0 | |
| Haw & Co., Ltd., 20, Cheapside, London, E.C.2. | Isomona NG | AC, HT | 20 | Valve, half-wave | 1 fixed, 1 variable | 2 16 0 | 8 GB tappings. |
| | Isomona NV | AC, HT, GB | 50 | Valve, full-wave | 3 fixed, 1 variable | 5 5 0 | |
| W. J. Henderson & Co., Ltd., 351, Fulham Rd., London, S.W.10. | D1 | DC, HT | 15 at 120 v. | — | 2 fixed | 1 9 6 | To fit portable sets. To fit portable sets. |
| | D3 | DC, HT | 30 at 120 v. | — | 2 fixed, 1 variable | 2 10 0 | |
| | D5 | DC, HT | 60 at 180 v. | — | 3 fixed, 1 variable | 3 15 0 | |
| | D6 | DC, HT | 60 at 180 v. | — | 3 fixed, 2 variable | 4 15 0 | |
| | D7 | DC, HT | 30 at 120 v. | — | 1 fixed, 2 variable | 4 0 0 | |
| | D8 | DC, HT | 30 at 120 v. | — | 2 fixed, 2 variable | 4 10 0 | |
| | A4 | AC, HT | 20 at 120 v. | Metal oxide | 3 fixed | 4 10 0 | |
| | A5 | AC, HT | 20 at 120 v. | Metal oxide | 2 fixed, 1 variable | 5 5 0 | |
| Igranic Electric Co., Ltd., Bedford. | A6 | AC, HT | 30 at 180 v. | Metal oxide | 3 fixed, 2 variable | 7 10 0 | Provides LT current, 3 amps. at 4 volts. Valve extra. Suitable for receivers having up to 7 valves. |
| | V208 | AC, HT | 30 at 200 v. | Valve, full-wave | 3 fixed | 10 2 6 | |
| | A and B | AC, LT | — | Metal | — | 14 0 0 | |

Buyers' Guide to Eliminators.—

| Manufacturer. | Name of Eliminator. | Type. AC or DC, HT, LT, or GB. | HT Output Current in mA. | Type of Rectifier. | HT Voltage Tappings. | Price. | Remarks. | |
|--|--|--------------------------------|--------------------------|---------------------|----------------------|---------------------|--|---------------------------------------|
| Jones & Stewart, 247A, St. Vincent St., Glasgow, C.2. | Dynic A Junior | DC, HT | 10 | — | 2 fixed | £ s. d. 1 10 0 | | |
| | Dynic AL | DC, HT | 20 | — | 5 fixed | 2 10 0 | | |
| | Dynic MS8A | DC, HT | 40 | — | 10 tappings | 4 10 0 | | |
| | Dynic SPA | DC, HT | 120 | — | 7 fixed, 1 variable | 7 0 0 | | |
| | Dynic AR | DC, HT, LT | 40 at 140 v. | — | 5 fixed | 7 13 6 | 6-volt LT. | |
| | Dynic AL10 | AC, HT | 35 | Valve, full-wave | 5 fixed | 7 0 0 | Includes valve and Royalty. | |
| S. A. Lamplugh, Ltd., King's Rd., Tyseley, Birmingham. | — | DC, HT | 25 at 150 v. | Valve, full-wave | 10 tappings | 8 0 0 | " " " | |
| | — | AC, HT | 18 at 120 v. | Metal oxide | 2 fixed, 1 variable | — | " " " | |
| | — | AC, HT | 18 at 120 v. | Metal oxide | 1 fixed, 1 variable | — | " " " | |
| Eric J. Lever, Ltd., 9-9, Clerkenwell Green, London, E.C.1. | Trix | AC, HT | 15 at 120 v. | Valve, half-wave | 3 fixed | 3 17 6 | Includes valve. | |
| | Trix | DC, HT | 15 at 120 v. | — | 2 fixed | 1 17 6 | | |
| | Trix | AC, HT, LT | — | Metal oxide | 3 fixed | 6 10 0 | Includes 2-volt trickle charger. | |
| Lissen, Ltd., Worpole Rd., Isleworth, Middlesex. | A | DC, HT | 12 at 150 v. | — | 3 fixed | 1 7 6 | | |
| | B | DC, HT | 12 at 150 v. | — | 1 fixed, 2 variable | 1 19 6 | | |
| | A | AC, HT | 12 at 150 v. | Valve | 3 fixed | 3 0 0 | | |
| London Electrical Co., 1, Sherborne Lane, King William St., London, E.C.4 | B | AC, HT | 12 at 150 v. | Valve | 1 fixed, 2 variable | 3 15 0 | | |
| | DC4 | DC, HT | 30 | — | 4 fixed | 2 5 0 | | |
| | 2AC | AC, HT | 18 at 120 v. | Metal oxide | 1 fixed, 1 variable | 4 0 0 | | |
| | 3AC | AC, HT | 18 at 120 v. | Metal oxide | 1 fixed, 2 variable | 4 10 0 | | |
| | 4AC | AC, HT | 30 at 150 v. | Valve, full-wave | 1 fixed, 2 variable | 5 0 0 | | |
| H. Longton & Co., Josephs Rd., Guildford, Surrey. | — | AC, LT | — | Valve | — | 6 15 0 | LT current up to 1.2 amps. at 6 volts. | |
| Claude Lyons, Ltd., 76, Old Hall St., Liverpool. | 4V | DC, HT | 50 at 190 v. | — | 4 fixed | 6 10 0 | LT current up to 1 amp. at 6 volts. | |
| | HV3 | DC, HT | 50 at 190 v. | — | 1 fixed, 3 variable | 6 0 0 | Approximate volts drop per milliamp. load, 0.75. | |
| | 3V | DC, HT | 50 at 190 v. | — | 3 variable | 5 15 0 | " " " | |
| | H2V | DC, HT | 50 at 190 v. | — | 1 fixed, 2 variable | 5 0 0 | " " " | |
| | 2V | DC, HT | 50 at 190 v. | — | 2 variable | 4 12 6 | " " " | |
| | HV1 | DC, HT | 50 at 190 v. | — | 1 fixed, 1 variable | 4 10 0 | " " " | |
| | 4V | AC, HT, LT | 260 volts | Valve | 4 variable | 10 10 0 | Approximate volts drop per milliamp. load, 1.5. | |
| | HV3 | AC, HT, LT | 260 volts | Valve | 1 fixed, 3 variable | 10 0 0 | " " " | |
| | 3V | AC, HT, LT | 260 volts | Valve | 3 variable | 9 17 6 | " " " | |
| | HV2 | AC, HT, LT | 260 volts | Valve | 1 fixed, 2 variable | 9 7 6 | " " " | |
| | 2V | AC, HT, LT | 260 volts | Valve | 2 variable | 9 0 0 | " " " | |
| | HV1 | AC, HT, LT | 260 volts | Valve | 1 fixed, 1 variable | 8 10 0 | " " " | |
| | 2A | AC, LT | — | — | — | 10 10 0 | LT up to 2.0 amps. | |
| | M-L Magneto Syndicate, Ltd., Victoria Works, Coventry. | BX | HT | 15 at 150 v. | Rotary converter | 2 outputs | 12 0 0 | Input 6 volts. |
| | | C | HT | 40 at 400 v. | Rotary converter | — | 13 0 0 | Input 200 v. |
| E | | HT | 60 at 500 v. | Rotary converter | — | 20 15 0 | Input 12 v. | |
| M.P.A. Wireless, Ltd., 62, Conduit St., London, W.1. | Universal | AC, HT, LT, GB | 25 at 200 v. | Valve | 4 fixed | 12 10 0 | Excludes Marconi Royalties. | |
| | General Purpose | AC, HT, LT, GB | 25 at 200 v. | Valve | 4 fixed | 16 16 0 | | |
| The Mainten Mfg. Co., Ltd., 22, Gray's Inn Rd., London, W.C.1. | Power | AC, HT, LT, GB | 60 at 350 v. | Valve | 6 fixed | — | " " " | |
| | Portable | AC, HT | 20 at 120 v. | — | 2 fixed, 1 variable | 4 0 0 | | |
| | Portable | DC, HT | 20 at 120 v. | — | 2 fixed, 1 variable | 2 10 0 | | |
| | DC M1 | DC, HT | 12 at 120 v. | — | 2 fixed | 1 10 0 | | |
| | DC M2 | DC, HT | 15 at 120 v. | — | 2 fixed | 1 19 6 | | |
| | DC M3 | DC, HT | 16 at 120 v. | — | 3 fixed | 2 7 6 | | |
| | DC M4 | DC, HT | 50 | — | 2 fixed, 1 variable | 4 0 0 | | |
| | DC M5 | DC, HT | 50 | — | 2 fixed, 2 variable | 4 10 0 | | |
| | DC M6SG | DC, HT | 17 | — | 2 fixed, 1 variable | 2 7 6 | | |
| | AC M1 | AC, HT | 10 | Valve, half-wave | 3 fixed | 4 15 0 | | |
| | AC M2 | AC, HT | 13 | Valve, half-wave | 3 fixed | 5 0 0 | | |
| | AC M3 | AC, HT | 16 | Valve, full-wave | 3 fixed | 6 0 0 | | |
| | AC M4 | AC, HT | 17 | Valve, half-wave | 2 fixed, 1 variable | 5 10 0 | | |
| | AC M5 | AC, HT | 20 | Valve, full-wave | 2 fixed, 1 variable | 6 10 0 | | |
| | AC M6W | AC, HT | 10 | Metal oxide | 3 fixed | 6 0 0 | | |
| | The Marconiphone Co., Ltd., 210-212, Tottenham Court Rd., London, W.1. | DC7 | DC, HT | 50 | — | 8 tappings | 4 0 0 | |
| | | AC7 | AC, HT | 50 at 200 v. | Valve, full-wave | 8 tappings | 6 10 0 | |
| AM7 | | AC, HT, LT | 50 | Valve, full-wave | 8 tappings | 7 10 0 | LT 4 volts 3 amps. and 6 volts 1 amp., 4 amps. at 0.8 v. | |
| The Mullard Wireless Service Co., Ltd., Mullard House, Charing Cross Rd., London, W.C.2. | PM | AC, HT | 20 at 150 v. | Valve, full-wave | 4 fixed | 5 5 0 | | |
| | — | DC, HT | 35 | — | 7 fixed | 3 5 0 | | |
| Pandona, Ltd., 184, Aston Rd., Birmingham. | — | DC, HT | 35 | — | 7 fixed | 3 5 0 | | |
| | Partridge & Mee, Ltd., 74, New Oxford St., London, W.C.1. | Parmeko Junior | AC, HT | 20 at 120 v. | Valve, half-wave | 4 fixed | 4 15 0 | Royalty extra. |
| | | Parmeko Senior | AC, HT | 42 at 120 v. | Valve, full-wave | 1 fixed, 1 variable | 8 10 0 | " " " |
| | | Parmeko AC3 | AC, HT, LT | 50 at 400 v. | Valve, full-wave | 1 fixed, 2 variable | 13 10 0 | Royalty extra. LT 3 amps. at 5 volts. |
| | | Parmeko AC4 | AC, HT, LT | 100 at 500 v. | Valves, full-wave | 1 fixed, 2 variable | 16 10 0 | Royalty extra. LT 3 amps. at 5 volts. |
| | | Parmeko S2 HT, LT | AC, HT, LT | 40 at 140 v. | Valve, full-wave | 1 fixed, 2 variable | 9 10 0 | Royalty extra. LT 4 amps. at 4 volts. |
| | | Parmeko HT, LT | AC, HT, LT | 40 at 180 v. | Valve, full-wave | 1 fixed, 2 variable | 17 10 0 | Royalty extra. Rectified LT, 1 amp. |
| Parmeko LT Unit | | AC, LT | — | Metal oxide | — | — | 1 amp. at 2, 4 or 6 volts. | |
| Philips Lamps, Ltd., 145, Charing Cross Rd., London, W.C.2. | 3002 | AC, HT | 30 at 150 v. | Valve | 6 fixed | 5 10 0 | | |
| | 3009 | AC, HT, GB | 22 at 150 v. | Valve | 4 fixed | 5 15 0 | | |
| | 3005 | DC, HT | — | — | 2 variable | 3 17 6 | Variable GB tappings. | |
| Phillipson & Co., Ltd., Holland St., Astley Bridge, Bolton. | AC5 | AC, HT | 25 at 150 v. | Valve, full-wave | 1 fixed, 2 variable | 4 17 6 | | |
| | AC7(A) | AC, HT | 20 at 120 v. | Valve, full-wave | 2 fixed, 1 variable | 3 17 6 | Type B of this series gives 20 mA. at 150 v. | |
| | DC5 | DC, HT | 25 at 150 v. | — | 1 fixed, 2 variable | 2 5 0 | | |
| DC4 | DC, HT | 15 at 120 v. | — | 1 fixed, 1 variable | 1 17 6 | | | |

Buyers' Guide to Eliminators.—

| Manufacturer. | Name of Eliminator. | Type. AC or DC, HT, LT, or GB. | HT Output Current in mA. | Type of Rectifier. | HT Voltage Tappings. | Price. | Remarks. |
|---|---------------------|--------------------------------|--------------------------|-------------------------|-----------------------------|----------|---|
| C. Haddon Poupard & Co., Ltd., Thermion Works, Ilford, Essex. | Thermion F1 | DC, HT | — | — | 1 fixed, 1 variable | £ 2 19 6 | For low-power 2- or 3-valve sets. |
| | Thermion F2 | AC, HT | — | Valve | 1 fixed, 1 variable | 4 12 6 | " " " |
| | Thermion F3 | DC, HT | 60 at 180 v. | — | 2 fixed, 1 variable | 5 15 0 | " " " |
| | Thermion F4 | AC, HT | 60 at 180 v. | Valve | 2 fixed, 1 variable | 10 10 0 | " " " |
| | Thermion F5 | DC, HT | 120 at 200 v. | — | 2 fixed, 2 variable | 8 8 0 | " " " |
| | Thermion F6 | AC, HT | 120 at 400 v. | Valve | 2 fixed, 2 variable | 18 18 0 | " " " |
| | Thermion F7 | DC, LT | — | — | — | 7 7 0 | LT 0.35 amps. |
| | Thermion F8 | AC, LT | — | Metal oxide | — | 9 9 0 | " " " |
| | Thermion No. 13 | DC, HT, LT | 150 at 200 v. | — | 4 fixed | 16 10 0 | LT " 6 v. " 2 amps. and raw AC 0 v. 3 amps. |
| | Thermion No. 14 | AC, HT, LT | 150 at 400 v. | Metal oxide | 4 fixed | 28 10 0 | " " " |
| Power Equipment Co., Ltd., Kingsbury Works, The Hyde, London, N.W.9. | Powquip AS | AC, HT | 10 at 120 v. | Valve | 2 fixed | 2 10 0 | Valve extra. |
| | A | AC, HT | 20 at 150 v. | Valve | 5 fixed | 3 5 0 | " " " |
| | B | AC, HT | 45 | Valve | — | 5 5 0 | Valve extra. Voltage regulation by 2 selector switches |
| Pye Radio, Ltd., Radio Works, Cambridge. | D | DC, HT | — | — | 5 fixed | 2 15 0 | " " " |
| | 924 and 925 | AC, HT | 10 at 137 v. | — | 1 fixed, 1 variable | 5 0 0 | Specially designed for Pye Portable receiver 25/c. 4 GB tappings. |
| The Radielle Co., Ltd., 18A, Haverstock Hill Chalk Farm, London, N.W.3. | 933 | DC, HT, GB | 20 at 145 v. | — | 2 fixed, 1 variable | 5 10 0 | " " " |
| | 934 | AC, HT, GB | 17.5 at 138 v. | — | 2 fixed, 1 variable | 7 10 0 | " " " |
| | GP | AC, HT | 55 at 200 v. | Valve, full-wave | 1 fixed, 3 variable | 9 17 6 | " " " |
| | RK | AC, HT | 65 at 360 v. | Valves, full-wave | 1 fixed, 3 variable | 13 15 0 | LT 4 amps. at 4 volts, 15s. extra. |
| Radiovolt, Ltd., Kingston Rd., Staines, Middlesex. | Heavy Duty | AC, HT, LT | 200 at 400 v. | Valves, full-wave | 1 fixed | 25 0 0 | LT 5 amps. at 5.25 volts for bank of 1.55A valves. |
| | DC100 | DC, HT | 100 at 200 v. | — | 1 fixed, 3 variable | 7 10 0 | " " " |
| | De Luxe HL1 | AC, HT, LT | 500 at 200 v. | Metal oxide | 1 fixed, 1 variable | 14 0 0 | 1 amp. at 2, 4, and 6 volts. |
| Read & Morris, Ltd., 31, East Castle St., Oxford St., London, W.1. | LT1 | AC, LT | — | Metal oxide | — | 6 10 0 | " " " |
| | All-Mains | AC, HT, LT | 100 at 200 v. | Metal oxide | 1 fixed, 2 variable | 27 0 0 | LT 1 amp. by metal rectifier. |
| Regent Radio Supply Co., 21, Bartlett's Bldgs., Holborn Circus, London, E.C.4 | AC HT | AC, HT | 30 at 150 v. | Valve, full-wave | 1 fixed, 2 variable | 5 10 0 | " " " |
| | DC HT | DC, HT | 30 at 150 v. | — | 1 fixed, 2 variable | 3 0 0 | " " " |
| | AC LT Senior | AC, LT | — | Valve | — | 6 15 0 | LT 1.25 amps. |
| | DC1 | DC, HT | 25 at 120 v. | — | 1 fixed, 1 variable | 2 5 0 | " " " |
| | DC de Luxe | DC, HT | 50 at 160 v. | — | 1 fixed, 2 variable | 3 18 0 | " " " |
| | W1D | AC, HT | 15 at 120 v. | Metal oxide | 2 fixed | 3 5 0 | " " " |
| | W1C | AC, HT | 15 at 120 v. | Metal oxide | 1 fixed, 1 variable | 3 15 0 | " " " |
| | W1B SG | AC, HT | 20 at 130 v. | Metal oxide | 1 fixed, 2 variable | 4 19 6 | " " " |
| | W1A SG | AC, HT, LT | 30 at 160 v. | Metal oxide | 3 fixed, 1 variable | 6 18 6 | LT 4 amps. at 4 volts. |
| | W2A | AC, HT, LT | 50 at 160 v. | Metal oxide | 1 fixed, 2 variable | 7 15 0 | " " " |
| H. A. Riche, 20, Queen's Arcade, Leeds. | W2 | AC, HT, LT | 100 at 200 v. | Metal oxide | 1 fixed, 3 variable | 12 0 0 | " " " |
| | W4A | AC, HT, LT | 20 at 130 v. | Metal oxide | 1 fixed, 2 variable | 7 10 0 | Incorporates "LT" trickle charger. |
| | Portable | AC, HT | 18 at 120 v. | Metal oxide | 2 fixed, 1 variable | 4 5 0 | DC Model, £2 15s. |
| Rolls-Caydon Sales, 77, Rochester Row, London, S.W. | Richtone A | AC, HT | 130 volts | Valve | 4 fixed | 3 0 0 | " " " |
| | Richtone B | AC, HT | 150 volts | Valve | 1 fixed, 2 variable | 3 15 0 | " " " |
| Saxon Radio Co., Henry St. Works, South Shore, Blackpool, Lancs. | Portable | AC, HT | 50 | Valve, full-wave | 3 variable | 10 10 0 | " " " |
| Symphony Gramophone & Radio Co., Ltd., 23-24, Warwick St., London, W.1. | — | AC, HT | 35 | Valve | 1 fixed, 1 variable | 5 10 0 | " " " |
| | — | AC, HT, LT, GB | 20 at 180 v. | Metal oxide | 1 fixed | 20 0 0 | " " " |
| The Tulsemere Mfg. Co., 1-7, Dalton St., W. Norwood, London, S.E.27. | — | DC, HT, LT, GB | 20 at 180 v. | — | 1 fixed | 15 0 0 | " " " |
| | Tannoy 12C | AC, HT | 15 at 120 v. | Electrolytic full-wave. | Variable potential divider. | 2 17 6 | " " " |
| | 16CH | AC, HT | 25 at 150 v. | " " " | " " " | 3 15 0 | " " " |
| Ward & Goldstone, Ltd., Frederick Rd. (Pendleton), Manchester. | W8 | AC, HT | 50 at 200 v. | " " " | " " " | 5 15 0 | " " " |
| | Goltone CP | AC, HT | 12 | Valve | 3 fixed | 3 18 6 | " " " |
| | Goltone PA | AC, HT | 15 at 120 v. | Valve | 4 fixed | 5 0 0 | Valve extra. |
| | Goltone PX | AC, HT | 25 at 130 v. | Valve | 4 fixed | 5 15 0 | " " " |
| | Goltone DW | AC, HT | 80 at 200 v. | Valve, full-wave | 4 fixed | 6 17 6 | " " " |

Mullard Wireless Service Co., Ltd., Mullard House, Charing Cross Road, London, W.C.2.—Illustrated leaflet No. W.A.2S, dealing with P.M. paper dielectric condensers. The working voltage is 250 D.C., and they are tested at 500 volts D.C., standard capacities 1 to 4 mfd.

Tungram Electric Lamp Works (Great-Britain), Ltd., 72, Oxford Street, London, W.C.1.—Descriptive booklet of Tungram Barium Valves. A range of receiving valves with barium-coated filaments. Also leaflet dealing with Tungram Nava photo-electric cells.

Messrs. M. Stanley and Co., 174, London Road, Liverpool.—Illustrated cata-

Catalogues Received.

logue of Stanophone receivers and stock list of proprietary apparatus.

Messrs. Siemens Bros. and Co., Ltd., Woolwich, London, S.E.18.—1930 edition of illustrated catalogue No. 641 dealing with dry-cell H.T. batteries and sack-type wet cells. Also price list of H.T. and G.B. batteries for portable sets.

Messrs. Wingrove and Rogers, Ltd., Arundel Chambers, 188-189, Strand, London, W.C.2.—A 36-page book dealing

with the history of the condenser, a non-technical description of its function, and other matters of particular interest to the beginner. Copies will be sent free on receipt of a postcard.

Universal Gramophone and Radio Co., Ltd., Ryland Road, Kentish Town, London, N.W.5.—Descriptive literature dealing with "Truvox" electric gramophones, folded and straight exponential horns and electric pick-up. A moving-coil loud speaker unit for use with exponential horns should interest those concerned with public-address apparatus or equipment of a like nature. The field is wound for a 6-volt supply, and takes a current of 1 amp.

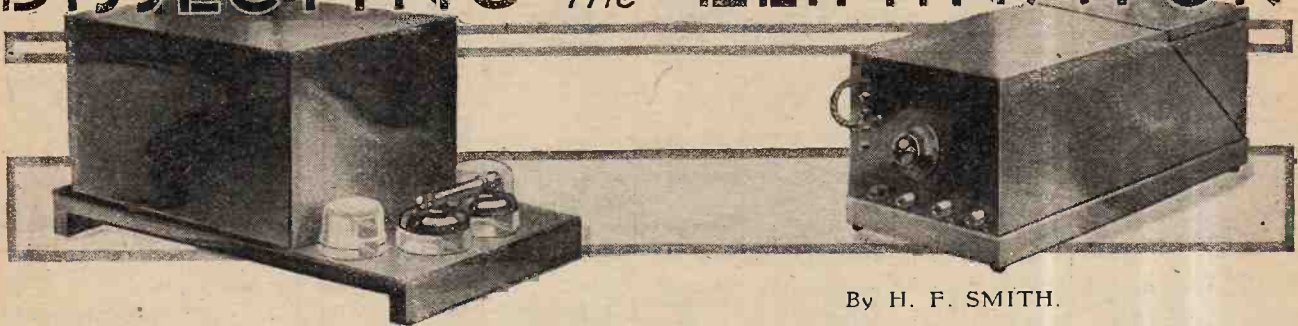
DISSECTING *the* ELIMINATOR

By H. F. SMITH.

Simplified Circuit Design and Calculation of Voltage-reducing Resistances.

A SURPRISINGLY large number of amateurs who cheerfully embark on the building of an ambitious multi-valve receiver show unmistakable signs of restiveness when it is suggested to them that their running costs might well be reduced by constructing an H.T. battery eliminator. They realise well that its initial cost may fairly be considered as a sound investment, and that danger only comes into the picture when excessively high voltages are to be handled, but seem to think that the whole question of obtaining anode current from the supply mains is too complex to be mastered by a merely superficial study of the subject.

This attitude is quite wrong. The most complicated eliminator is really a good deal simpler than the average three-valve set, and all its circuits are comparatively straightforward. Relative disposition of components is generally unimportant, and internal screening is quite unnecessary. Further, in cases of uncertainty, one can make a start with a bare minimum of components, adding refinements if they are found to be necessary. In this short article bare essentials will be discussed, and a mere nodding acquaintance with eliminator principles will be assumed. We will confine our attention to A.C. supplies, and, to simplify matters, mainly to metal rectifiers; having grasped the practical application of one system, it will be easy to understand others.

In the light of modern knowledge but few types of receivers may legitimately be fed from an eliminator with a single voltage output. Principal exceptions to this rule are 2-valve local-station receivers (generally with anode-bend detection) and H.F.-det.-L.F. 3-valve combinations with the same system of rectification and a neutralised triode H.F. amplifier with transformer-coupling—and, of course, similar sets with S.G. high-frequency valves in

which a device for regulating screen-grid voltage is included. Certain sets with built-in "decoupling" resistances may possibly be added to this list, but we need not consider them for the moment.

For these simple receivers an eliminator on the lines of that shown in Fig. 1 may be expected to yield satisfactory results; at the worst, it will serve as a nucleus round which to build something more elaborate. It makes use of a Westinghouse metal rectifier (H.T.4) connected in a voltage-doubling circuit, and is easily assembled from readily obtainable components, which include a power transformer delivering adequate current at 135 volts, several large condensers, and a smoothing choke having an inductance of some 30 henrys or more. R indicates the position of a resistance which, with the extra condenser shown in dotted lines, may not be required. If the "smoothed" output voltage existing across X and Y happens to be suitable, these terminals may be joined directly to the receiver. In practice this voltage seldom "happens to be suitable," and so we come to the problem that is responsible for half the amateur eliminator-builders' perplexities,

namely, that of voltage regulation.

It must be appreciated that output voltage is dependent on the current consumed, and that it is absolutely impossible to design a practical eliminator to give a pre-determined voltage (or voltages) unless we know precisely what this current is to be. In point of fact, we hardly ever do know

exactly, and cannot hope for more than an approximation. Fortunately there is seldom any need for real accuracy, and every eliminator is to some extent self-regulating. In any case, we have a loophole; a continuously variable control can be fitted, to be adjusted on the trial and error principle. Receivers requiring critical regulation of voltage throughout are now rare.

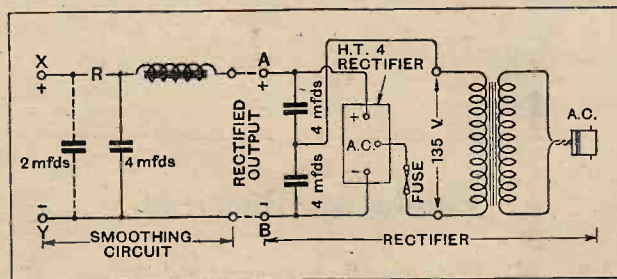
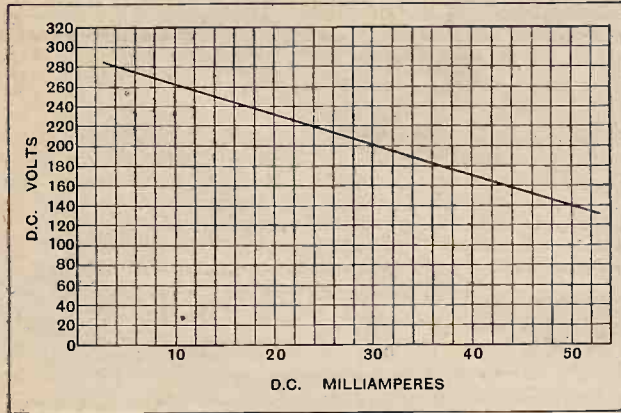

Fig. 1.—A nucleus eliminator, with single voltage output, divided into its main component parts.

Dissecting the Eliminator.—

The first task is to estimate the anode current to be taken by the set at the desired voltage, either with the help of the maker's literature or of *The Wireless World* Valve Data Sheet. Taking the case of the simple I-V-I receiver already mentioned, all valves might well have a maximum rating of 150 volts; the H.F. amplifier would consume, say, 2 mA., the detector 1 mA., and the power valve 12 mA., making a total of 15 mA. Next, the voltage delivered by the rectifier for this



(Courtesy Westinghouse Company.)
 Fig. 2.—Voltage output of the eliminator shown in Fig. 1 (without resistance R) under varying loads.

current must be ascertained. This is given by its manufacturers in the form of a graph (reproduced in Fig. 2), which shows the voltage for varying loads existing across the terminals X and Y of a smoothing circuit such as is shown in Fig. 1. It will be seen that the voltage corresponding to a drain of 15 mA. is nearly 250. Far too much; a resistance must be inserted at point R, Fig. 1, to absorb the surplus. Its value in ohms is easily ascertained by dividing "surplus volts" by "current passed," expressed as a fraction of an ampere. In this case, we want 150 volts and have 250 volts, so "surplus volts" are $250 - 150 = 100$ volts, and "current passed" is 0.015 amp. We get $100 \div 0.015 = 6666$ (approx). Thus a resistance of 6,666 ohms is required, and the nearest standard value will be chosen. The 2-mfd. condenser shown in dotted lines should be added unless the set includes a by-pass capacity.

If the three-valve H.F.-det.-L.F. set to be supplied includes a screen-grid valve, the "nucleus" eliminator must be complicated by adding a potentiometer across its output terminals for controlling screening-grid voltages (see Fig. 3). This potentiometer should consume several times the current (perhaps 0.5 mA.) taken by the valve, and, incidentally, its load must be added to that of the set before determining the value of R in Fig. 1. Wire-wound potentiometers of 50,000 ohms are now pro-

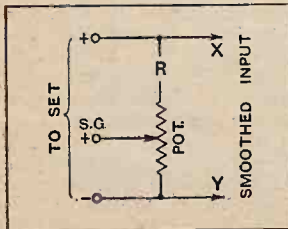

Fig. 3.—The first step; a screening grid feed added.

duced commercially; with 150 volts applied this resistance will pass 3 mA., and so is quite suitable. Where higher main terminal voltages are being dealt with an economy in current consumption is effected by inserting a fixed resistance R of from 10,000 to 30,000 ohms in series with the potentiometer.

Voltage Tappings.

Diagram No. 4 shows the voltage-distribution system that could be added to the nucleus eliminator (the latter without its series resistance) with the object of feeding, say, a I-V-I set with screen-grid H.F. valve coupled by tuned anode to a grid detector, which is followed by a rather greedy output valve. Procedure in estimating resistance values is similar to that followed in the example already given. First estimate consumption at desired voltage of each valve and of the potentiometer, and, having added these together, with the help of the regulation curve find the terminal voltage across X and Y. Then, using this as a basis, work out the values of the voltage-absorbing resistances R₁ and R₂ (and also of R, in the rather unlikely event of there being an excessive voltage available for the output valve). This calculation is made by applying the simplified formula discussed above: resistance required = "volts to be absorbed" ÷ "current taken." Another application of Ohm's Law is made when calculating the current consumed by a potentiometer; in this case we must divide the volts existing across its ends by its resistance (in ohms). The answer will be expressed as a fraction of an ampere.

In dealing with high-gain L.F. amplifiers liable to self-oscillation it is to be recommended, on safety-first grounds, that each feed circuit should be completely

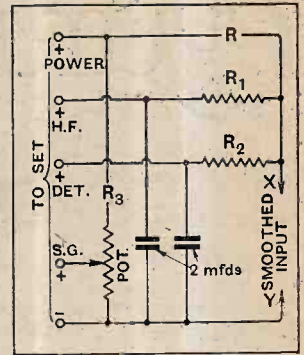

Fig. 4.—Parallel output feeds for connection to similarly lettered points on the nucleus eliminator.

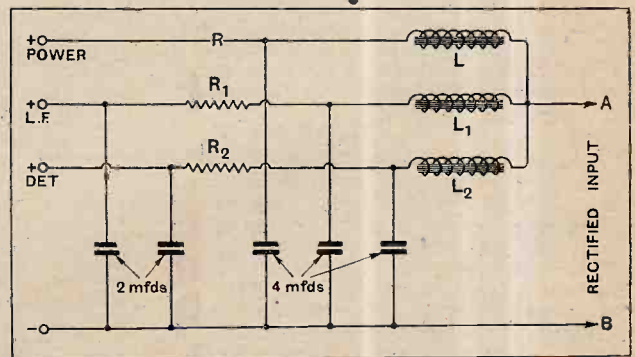
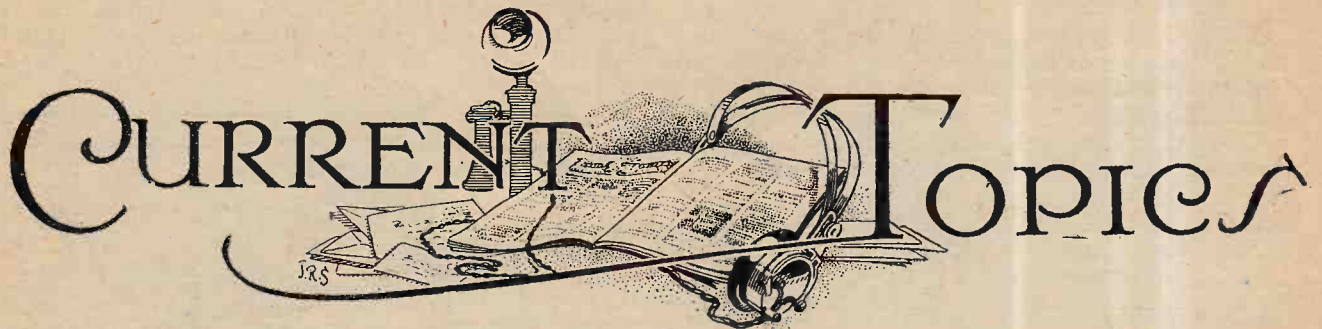

Fig. 5.—Individual voltage-regulating and smoothing circuits for connection direct to a rectifier.

separate, both as regards its smoothing and voltage-reducing devices. An arrangement on these lines, intended for connection to a rectifier, is given in Fig. 5. Any number of parallel-feed circuits can be added.



CURRENT TOPICS

Events of the Week in Brief Review.

"PETIT" NO LONGER.

"Petit Parisien," the famous Paris station owned by the newspaper of that name, is henceforth to be known as "Le Poste Parisien."

○○○○

THE FIRST "AERIAL"?

An interesting exhibit now on view at the Science Museum, South Kensington, is the original silk kite used by Benjamin Franklin in 1752 to prove that lightning is an electrical discharge. The kite has been on loan in the Museum for a number of years, but has not been on view since the galleries were re-arranged after the War.

○○○○

PRIZES FOR IRISH LISTENERS.

In connection with Irish Radio Week, to be held from February 24th to March 1st, a competition is being organised in which every Irish listener can participate, a sum of £50 being allotted in prizes. Listeners will be asked to select what they consider the three most popular items broadcast during the "Week."

This excellent scheme might well be adopted for future "Radio Weeks" in Great Britain.

○○○○

THEORY MADE EASY.

The articles in *The Wireless World* on "Wireless Theory Simplified" form a valuable source of inspiration for debate at radio society meetings. The Tottenham Wireless Society—one of the first to make this discovery—announces a further series of debates on these articles in the near future.

○○○○

A SAFETY INSULATOR.

An insulating substance which obligingly changes into a conductor when circumstances demand it was described by Karl B. McEachron, of the General Electric Company, at a meeting of the American Institute of Electrical Engineers on January 27th. Known as "Thyrite," the new compound functions as an insulator for ordinary low power purposes, being highly suitable for wireless aerials, but a sudden surge of high voltage electricity, such as a stroke of lightning, instantly converts it into a conductor, thus providing a path of escape.

In appearance "Thyrite" is stated to be a cross between black slate and porcelain.

TO STOP QUARRELS?

A correspondent in a daily newspaper calls upon inventors to devise a means whereby a single set can receive both programmes from Brookmans Park at the same time and pass each to a different loud speaker in different rooms.

○○○○

SETS FOR THE BEST PEOPLE.

"The newest (wireless) sets are far more superior than the suitcase portable sets, for they are made in one with a rather large-looking table lamp."—Daily Paper.

Why "superior"? Who would be seen carrying a table lamp on a field day?

○○○○

"RADIOFIED" FURNITURE.

A Massachusetts wireless firm has opened a new department specialising in the "radiofying" of home furniture. At a cost not exceeding \$125 the firm undertakes to incorporate a radio receiver in any article of furniture which will contain an instrument measuring 10×12×6 inches. Desks, bookcases, magazine racks, cupboards, and cabinets are included in the list of suitable articles.

FORTHCOMING EVENTS.

WEDNESDAY, FEBRUARY 19th.

Edinburgh and District Radio Society.—At 8 p.m. At 16, Royal Terrace. Lecture: "Aerials and Earths," by Mr. W. D. Oliphant, B.Sc.

Muswell Hill and District Radio Society.—At 8 p.m. At Tollington School, Tetherdown, N.10. Lecture and Demonstration: "Precision Instruments at All Frequencies," by Mr. F. L. Best, A.M.I.E.E.

THURSDAY, FEBRUARY 20th.

Slade Radio (Birmingham).—At the Parochial Hall, Broomfield Road, Erdington. Demonstration of Reception, by Mr. H. Clews.

FRIDAY, FEBRUARY 21st.

Bristol and District Radio Society.—At 7.30 p.m. In the Geographical Lecture Theatre, University of Bristol. Lecture: "Radio in Relation to Meteorology," by Mr. M. G. Bennett, M.Sc. (Department of Physics, University of Bristol).

MONDAY, FEBRUARY 24th.

Newcastle-upon-Tyne Radio Society.—At 7.30 p.m. In the English Lecture Room, Armstrong College. Lecture: "Woodwork, Staining and Polishing," by Messrs. W. M. Mackenzie and T. Heslop.

TUESDAY, FEBRUARY 25th.

South Croydon and District Wireless Society.—Joint meeting with the Thornton Heath Radio Society. At 8 p.m. at the Surrey Drovers' Hotel. Lecture and Demonstration: "Apparatus for High Quality Radio-Gramophone Reproduction," by Mr. P. K. Turner (of Graham Ampton, Ltd.).

A RELAY HITCH.

Radio By-Wire, Ltd., have been refused permission to carry wires across streets in Bromley (Kent) for the provision of a broadcast relay service.

○○○○

WATFORD'S LOUD SPEAKERS.

Watford Town Council has passed a bylaw making it an offence punishable by a fine of £5 for anyone to operate a loud speaker or gramophone to the annoyance of other people.

○○○○

15 KW. BROADCASTING FROM LILLE.

The listeners of Lille, who content themselves at present with a station of 0.7 kW., are to have a broadcaster of 12-15 kW. aerial power in the near future. The actual site will be at Camphin-en-Carenbault, ten miles from the city. The General Council of the *Département* has promised a contribution amounting to £800 towards construction expenses.

○○○○

BROADCAST CHESS.

Austria being a chess-playing nation, tremendous enthusiasm was aroused among listeners by the recent tournament staged by the Vienna and Linz broadcasting stations. Six games were played simultaneously, the players being seated in the studios at Vienna and Linz respectively. Listeners, who were provided with chessboard plans, were able to follow the course of the games from announcements at the microphone.

○○○○

FRENCH PRESIDENT'S WIRELESS COMEDY.

M. Gaston Doumergue, the French President, whose amateur wireless activities were mentioned in a recent issue, has recently permitted a Parisian journalist to inspect his collection of receivers. According to the journalist's report, the Presidential apartment in the Elysée contains four receivers *de grand luxe*, including a short-wave set with the latest in frame aerials. The President conducts his experiments alone when his entourage have departed in the evening.

Recently M. Doumergue startled the Foreign Minister with the announcement: "I have taken Moscow and Stamboul! (J'ai pris Moscou et Stamboul)" and some explanation was necessary before M. Briand realised that no new international complication had arisen.

STILL HOPE FOR INDIAN BROADCASTING.

We are glad to note that the broadcasting outlook in India may not be so black as first appeared. The Indian Broadcasting Company's decision to close down through lack of funds has attracted the attention of the Indian Legislative Assembly, and it is possible that the subsidy refused in 1928 may now be granted.

ELECTRICAL POWER DISTRIBUTION.

Readers who wish for detailed maps relating to electric supply will find them in the various electricity schemes published by H.M. Stationery Office. The map on page 181 is compiled, by permission of the Controller, from the particulars shown, in greater detail, in those with the individual schemes.

FRENCH RADIO TRAIN SUCCESS.

The first "radio train" on the Paris-Rouen route made a triumphant journey on February 8th, carrying among its 250 passengers the French Postmaster-General, M. Germain Martin, and the Minister of Public Works, M. Pernot. While the train was proceeding at 65 miles an hour not only were broadcast concerts received, but the special short-wave transmitter on the train was used for sending messages to President Doumergue and

the station works daily for sixteen hours on a wavelength of 175 metres.

GRADED LICENCE FEES IN IRELAND.

In view of the recent controversy as to whether listeners who plug into a central receiver serving a large building should pay a separate licence fee it is interesting to note that in the Irish Free State a graded scale of licence fees exists. The regulations, which came into force in January, 1927, stipulate the following fees:—

- (a) Ordinary licence for private use—10s. a year.
- (b) Schools and institutions, such as colleges, convents, hospitals, convalescent homes, boarding houses, etc.—£1 a year.
- (c) Hotels, restaurants, cafés, clubs, public-houses, etc.—£5 a year.
- (d) Public entertainments, such as public halls, cinemas, bazaars, etc., open to the public on payment of a charge—£1 a week.
- (e) Loud speaker stations for outside free public reception of broadcast matter as an advertisement or demonstration—£5 a year.

Owners of portable sets must secure an annual licence at 10s., and such licences are issued only to applicants who already hold an ordinary receiving licence.

32, Zurich, but those for unlicensed amateurs should be sent, under cover, via D.A.S.D., Blumenthalstrasse 19, Berlin, W.57. Unlicensed stations can be distinguished by having two letters following the figure 9 in their call-signs.

Rugby and Australia Tests.

Amateurs in Australia have been following, with interest, the tests between Rugby GBX and the Amalgamated Wireless Co.'s station VK 2ME, in Sydney, N.S.W. Signal strength between 6.0 and 7.0 p.m. in Sydney (0800-0900 G.M.T.) is stated to be strong, while after midnight in Australia (1400 G.M.T.) they are said to be at loud speaker strength.

Other Stations Heard in Australia.

G 5SW is heard at good strength between 10.0 and 11.30 p.m. (1500-1430 G.M.T.). PHI on 16.88 metres is at its best about the same time. PCJ is not so easily heard, but is generally audible in



BROADCASTING TO JAPAN. Over 7,000 miles were covered in the remarkable broadcast from the Marconi beam station at Dorchester on February 9th, when Mr. R. Wakatsuki, chief Japanese delegate at the Naval Conference, gave an address which was relayed throughout Japan. The right-hand photograph shows Mr. Wakatsuki at Dorchester in company with Mr. Ginman, the Marconi Co.'s Deputy Chief Engineer. On the left is a view of the main hall of the station.

Premier Tardieu, writes our Paris correspondent, who reports that all the *rapides* on this route are now to be radio-equipped. The novelty is also to be extended to other lines, including the Paris-Dieppe, Paris-Brest, Paris-Cherbourg, and St. Malo-Bordeaux.

The transmitter draws current from the train lighting system transformed up to 1,000 volts. Reception is by frame aerial. Each car is fitted with head-phone plugs, and headphones are available for each passenger at a cost of 5 francs for the journey.

POLICE WIRELESS IN U.S.

Undismayed by a Council decision to reject a \$40,000 Budget item for the establishment of a radio police force, the inhabitants of Indianapolis (Indiana) recently organised a subscription list. The outcome was the opening, on January 1st, of Station WMDZ, a police transmitter operating in conjunction with ten radio-equipped patrol cars.

According to reports from Indianapolis

TRANSMITTERS' NOTES AND QUERIES.

10-Metre Test with South Africa.

Mr. K. C. Wilkinson, of Herne Hill, owner of amateur transmitting station G-5WK, has recently succeeded in opening two-way communication with South Africa on a wavelength of 10 metres. Signals were exchanged with ZS4M, owned and operated by Mr. C. H. Hill, of Bloemfontein.

Mr. Wilkinson's transmitter is crystal-controlled, Marconi LS5B valves being used for frequency doubling. The main transmitting valve is one of the well-known Marconi DETISW valves specially designed for use on very high frequencies.

Forwarding Agents for Switzerland.

QSL cards intended for licensed stations in Switzerland may be sent via the Radio Club of Zurich, Spyrstrasse

the early mornings, and Australian reports speak highly of the transmissions from Manila, Philippine Islands.

Spanish Stations.

We give below the call-signs and addresses of some Spanish amateur stations which have been licensed since the list was prepared for the December issue of the Radio Amateur Call Book:—

- EAR 153 A. Vila, Pasea Chil 5, Las Palmas, Canary Islands.
- EAR 154 L. Benitez, Olivar 35, Arenys de Mar.
- EAR 155 I. Guitian, General Lacy 44, Madrid.
- EAR 156 Radio Club Tarrasa, Font Vella 62, Tarrasa.
- EAR 157 Asociacion Nacional de Radiodifusion, Fontanella 12, Barcelona.
- EAR 158 F. Calvera, Corcega 219, Barcelona.
- EAR 159 E. Sabater, Balmes 123, Barcelona.
- EAR 160 J. M. Borrogo Empedrada 7, Santa Cruz de la Zarza (Toledo).
- EAR 161 F. Gayo, Glorieta de Bilbao 4, Madrid.
- EAR 162 J. Forcades, Bonanova 35, Terreno, Palma de Mallorca.
- EAR 163 P. Arolas, Subida de la Iglesia 10, Figueras.
- EAR 164 M. Mata, Villanueva, Espolon 1, Burgos.
- EAR 165 J. V. Prat, Prat de la Riba 97, Badalona.

SET SPECIFICATIONS

Six Typical Mains Receivers.

While the performance of a receiver as revealed by a demonstration may be an important factor in judging its merits, comparisons cannot be made without a careful consideration of the arrangement of the valves and the general design of the set. In the absence of reliable performance data regarding selectivity, range getting properties and quality of reproduction, attention must be turned to the details of circuit and design. Circuits of commercial receivers are published for the first time in the following pages and will serve as a useful guide to readers in comparing the technical merits.

THREE indirectly heated valves are used, arranged as H.F., detector and L.F. stage. All are of the indirectly heated type, being the Mazda AC/SG, AC/HL and PEN/425. The rectifying valve also is of the indirectly heated type, being the UU60/250.

EDISWAN.

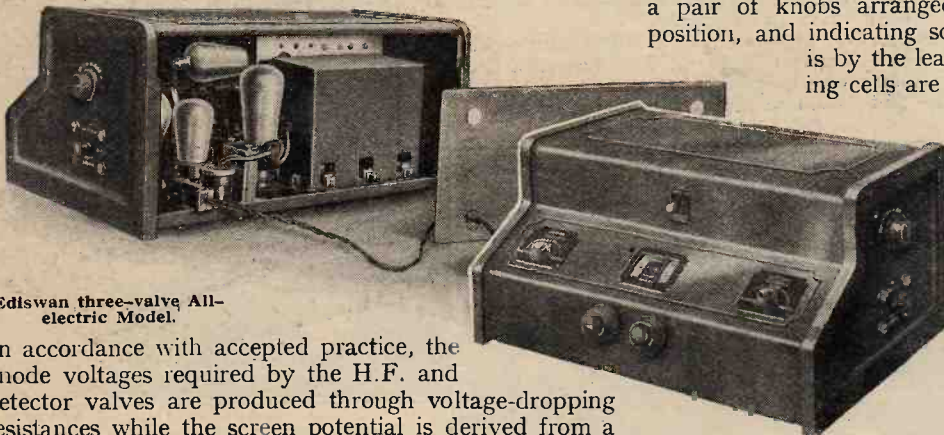

Ediswan three-valve All-electric Model.

In accordance with accepted practice, the anode voltages required by the H.F. and detector valves are produced through voltage-dropping resistances while the screen potential is derived from a potentiometer. A good feature is the provision of a loose-coupled aerial circuit combined with series and parallel

connected fixed condensers so that a high degree of selectivity is obtained. The wave-range switches which short-circuit a centre section on the astatic tuning coils carry contacts for introducing the aerial circuit condensers. The two-dial tuning is carried out with a pair of knobs arranged in a convenient operating position, and indicating scales are provided. Detection is by the leaky-grid method and grid biasing cells are provided to permit of the use of a gramophone pick-up. Reaction is applied to the tuned anode coil. Transformer coupling is used between detector and pentode. The anode circuit of the pentode includes a choke and condenser loud speaker feed, and it is interesting to note that the loud speaker circuit is tapped off along the choke so that only a portion of the winding is included. Practical points of construction follow modern ideas of receiver design.

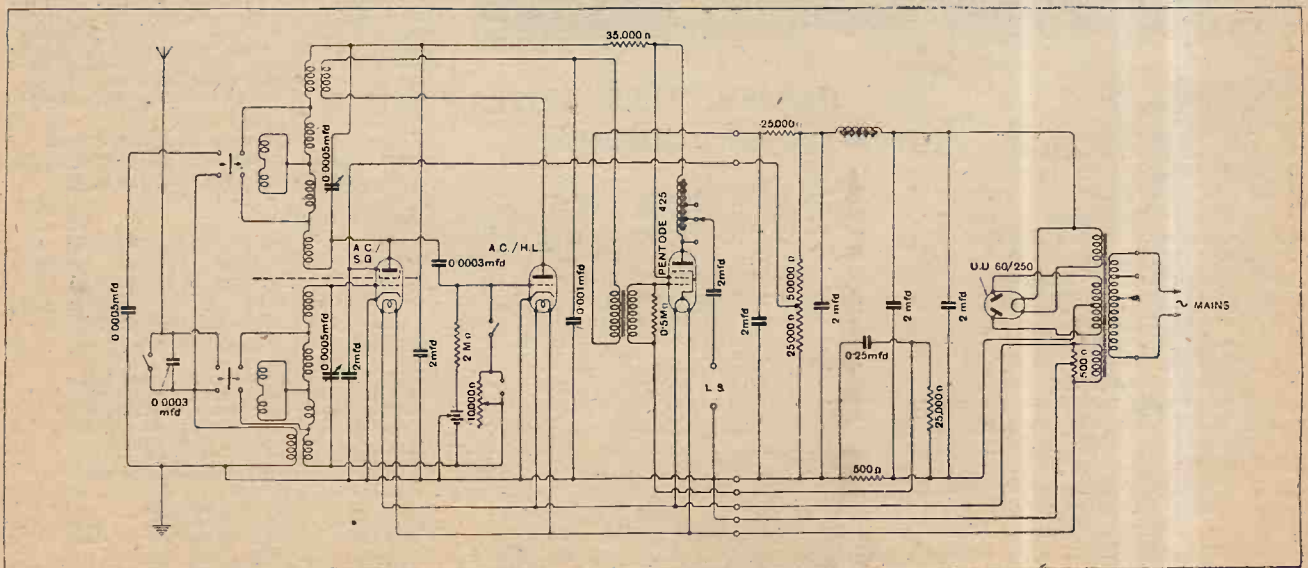

Circuit of the Ediswan A.C. mains-operated receiver.

Set Specifications.—

AN interesting departure from orthodox design is the use of battery-type valves in an A.C. mains receiver in conjunction with a low-voltage metal rectifier. This arrangement works without A.C. mains noise, while the receiver may be readily changed over for use with D.C. mains or batteries. Three H.F. stages, using screen-grid valves, are provided, so that the actual overall H.F. amplification is of a high order, without the need for producing a condition of threshold oscillation in the H.F. couplings. Owing to the high amplification an anode bend detector is used without impairing the range-getting properties. Negative bias is applied to the detector valve through a high resistance. Owing to the generous output given by an adequately loaded anode bend detector, a single stage of resistance coupling feeds the output valve, which may be a pentode or P.625. Grid biasing is produced by the use of grid cells throughout. Volume control is produced by regulation of the filament current of the first H.F. valve. The four tuning condensers are ganged as pairs and operated by calibrated drum dials. A U5 rectifying valve produces the H.T. supply. Output to the loud speaker is by transformer, a tapped secondary pro-

COLUMBIA.

viding for the use of high- or low-resistance windings. Screening is particularly complete; the entire equipment being enclosed in a sectioned metal container. By constructing the eliminator as a separate unit, changing over from D.C. to A.C. merely necessitates the inter-

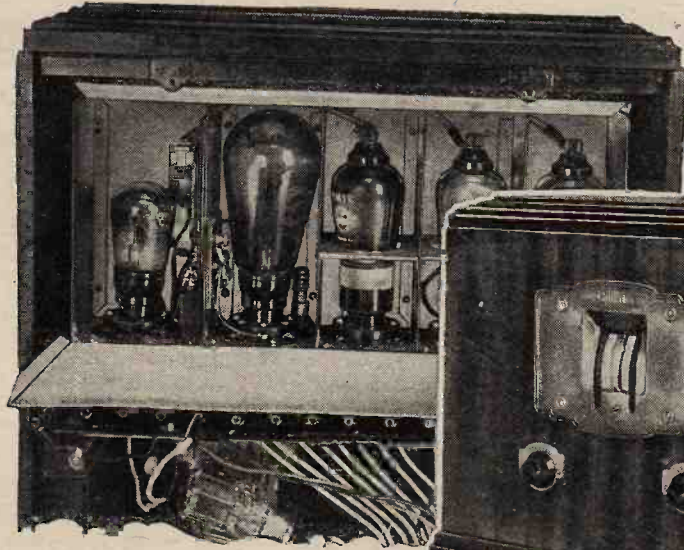

Columbia all-electric receiver, Model 304.

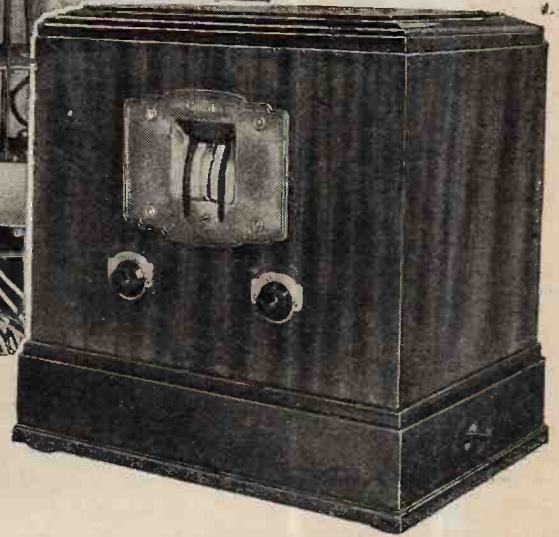

changing of the mains equipment. To suit various aerial conditions, a choice of three aerial condensers is provided.

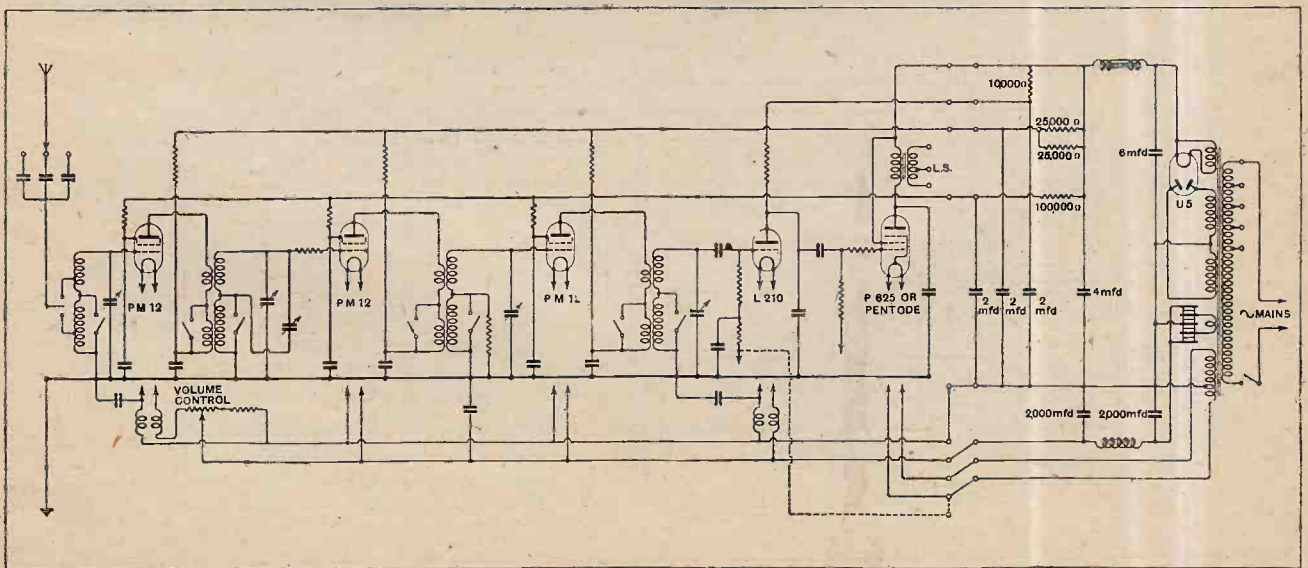

Circuit of Columbia Model 304 receiver with A.C. mains unit.

Set Specifications.—

McMICHAEL DIMIC THREE.

THE two-dial tuning is associated with the inputs to the screen-grid H.F. valve and the detector. Selectivity is controlled by the use of a tapped aerial coil and a low-capacity fixed condenser in the

in the detector stage through a winding which is coupled to the tuned-grid circuit. Tuning to the longer wavelengths results from the removal of a short circuiting contact connected across each tuning inductance. The leaky grid detector is followed by a transformer coupling and the output valve feeds the loud speaker through the usual choke-condenser arrangement. Volume control is effected by a series resistance connected in the A.C. filament leads of the S.G. valve. Indirectly heated valves are used in the detector and L.F. stages, the cathodes being earth connected. Dry cells are used for grid biasing, while provision is made for the use of a pentode valve in the output stage. A full-wave bridge-connected metal rectifier is used in conjunction with a potential divider for supplying the various H.T. voltages. Shunt-condensers are provided on each anode lead, the use of decoupling feed resistances being unnecessary with the circuit adopted in spite of the use of a potentiometer. While a double set of tuning coils provides reception on both wave ranges in connection with the switch provided on the front of the panel, this set can be readily adapted for short-wave reception by the substitution of short-wave Dimic coils.

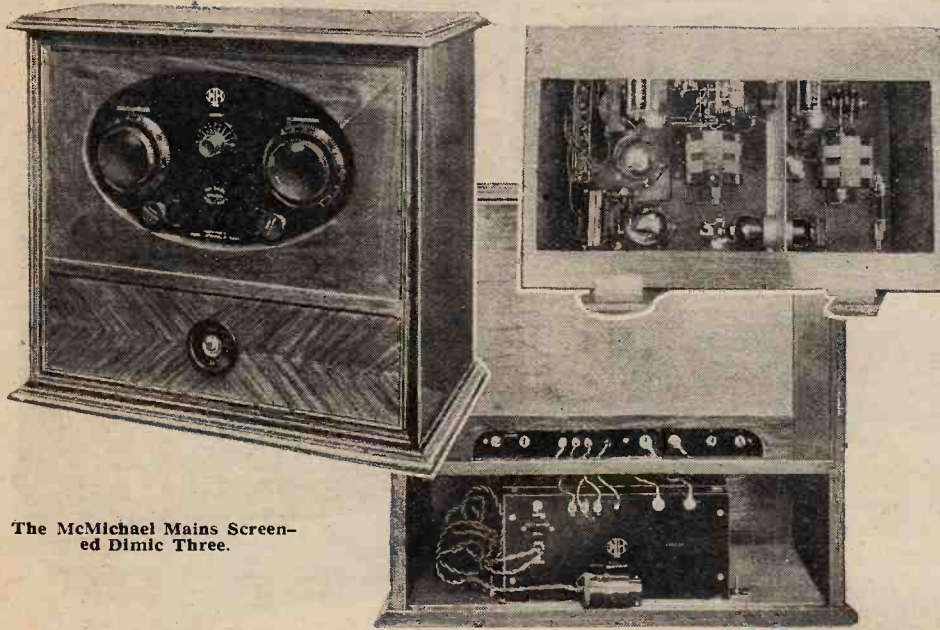

The McMichael Mains Screened Dimic Three.

aerial lead. The H.F. intervalve coupling consists of a tuned grid circuit and H.F. choke in the anode lead of the S.G. valve. Capacity reaction is applied

polished cabinet of walnut, oak or mahogany. The front panel is polished and engraved, and the tuning dials operate through reduction gearing.

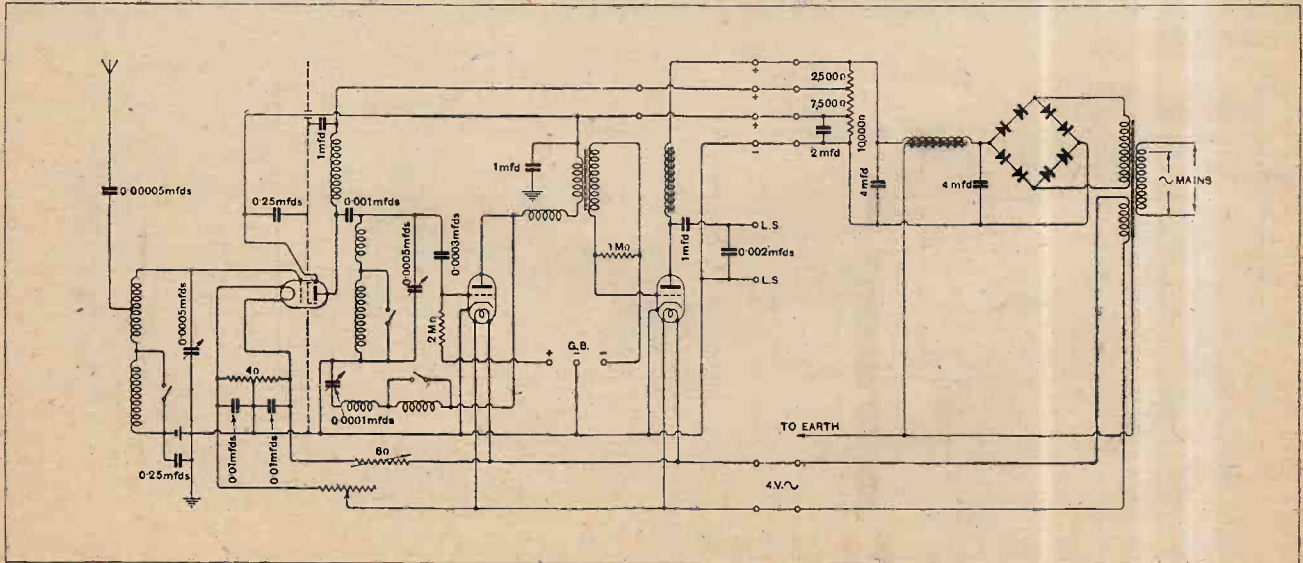

Circuit of McMichael A.C. Dimic receiver with A.C. mains unit.

Set Specifications.—

TWO screen-grid stages operated by a single control, followed by a leaky grid detector and power pentode output stage are the essentials of this receiver. The three sets of tuning coils are of the toroidal type, the long- and short-wave

PHILIPS. Type 2511.

are the coils and condensers totally enclosed, but the voltage-regulating circuits are also arranged in a manner to avoid stray couplings. Condensers and resistances are provided in the leads conveying the grid potentials so as to produce effective decoupling. A pair of windings permits of the use of high- or low-resistance loud speakers. Mullard S4V valves are used in the H.F. stages, and the detector is the 164V. The output is a high-voltage power-pentode valve, the Mullard P.M.24A. A container of pressed metal framing carrying bakelite panels gives the set a pleasing and durable finish.

Philips all-mains receiver, Type 2511.

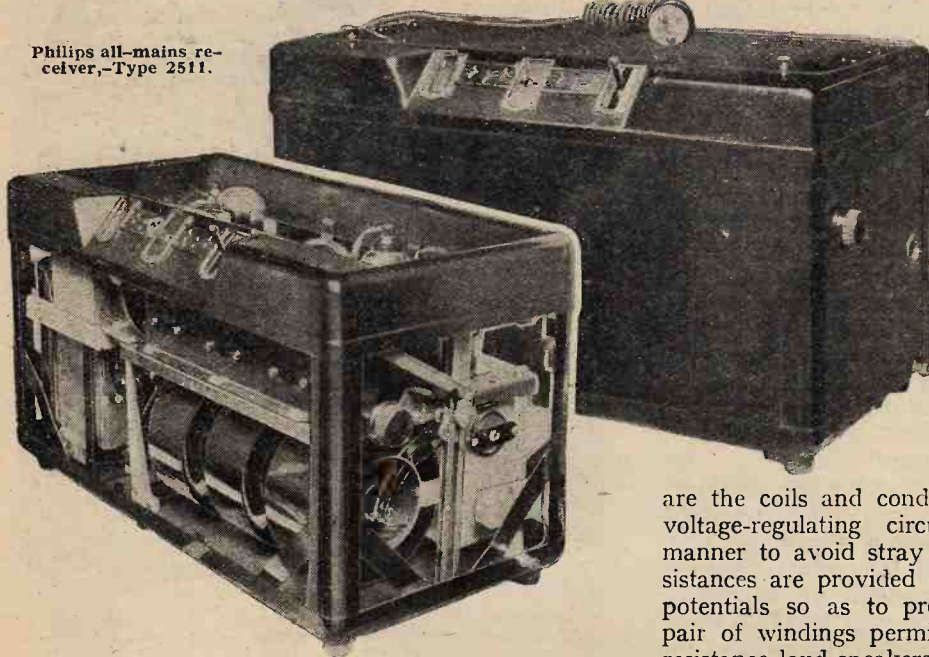

sections being arranged concentrically. Three pairs of short-circuiting blades are used for wave changing, and the metal arms with which these blades make contact are operated from a single lever, which also introduces the gramophone pick-up circuit into the grid of

the detector. The H.F. couplings are tuned anodes, and the ganged condensers are provided with trimmers. Anode voltages for the H.F. stages are regulated by voltage-dropping resistances, while a potentiometer formed by a number of series-connected resistances produces the screen voltage for the pentode, detector voltage and the screen-grid potentials for the two H.F. valves, these differing slightly in value. Grid-biasing potentials for pentode and H.F. valves are stepped off on the low-voltage side of the H.T. circuit. Volume control is by adjustment of bias of the H.F. valves. A 4-volt winding on the mains transformer is common to the heaters of the three indirectly heated valves and the filament of the pentode. All cathodes are earth-connected. Screening is particularly generous and complete, and not only

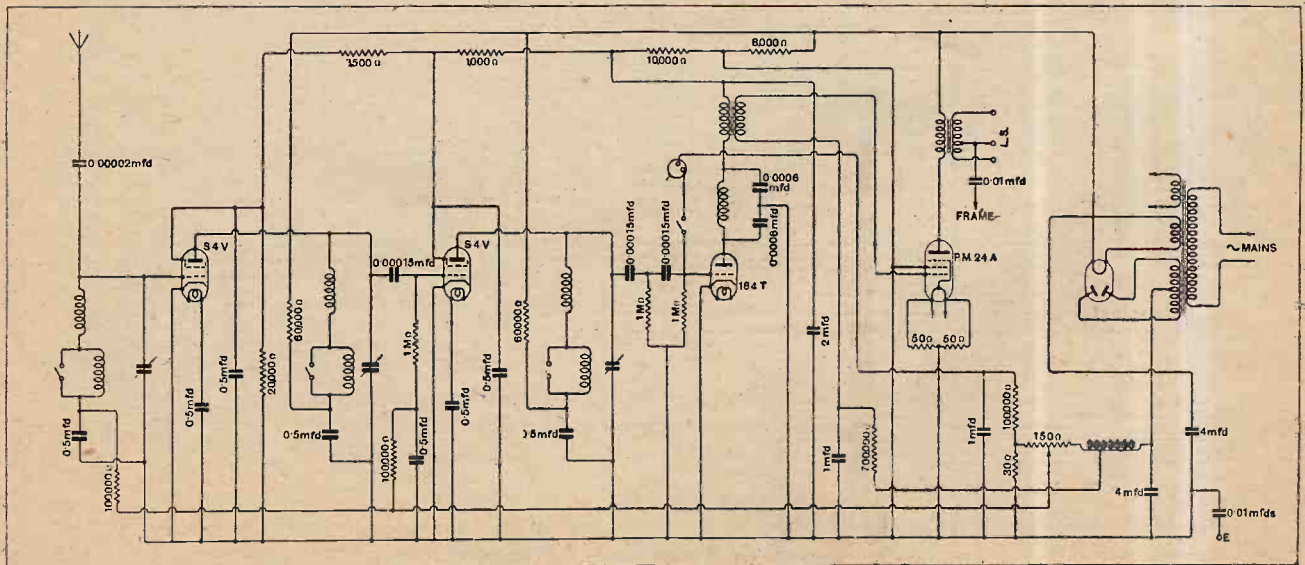

Circuit of Philips four-valve A.C. set.

(Not examined by the manufacturers.)

Set Specifications.—

R.I. Type AY3.

SERIES connected battery operated valves are employed and derive their current from the rectifier, which also produces the anode potentials. By this means suitable grid-biasing potentials are obtained as a result of the voltage drop produced across resistances interposed between successive valves. A single circuit-tuned aerial is followed by a screen-grid H.F. amplifier, the coupling between H.F. and detector valves being by transformer. Anode-bend detection is used, and capacity reaction is provided. The detector is followed by resistance coupling, and the first L.F. valve is transformer-coupled to the output valve. Resistances are connected in the grid leads of the two L.F. valves. A transformer output provides complete separation from the mains. An interesting feature is the cross connection of a loud speaker output terminal to the aerial, so that the loud speaker lead may itself serve as an aerial. Rectification following the mains transformer is by a bridge-connected metal rectifier. The smoothing circuit is generous. A metal container houses the receiver unit, which with internal barriers provides effective screening. Fuses are provided in the main leads. Both wave ranges are covered, the change-over being effected by an arrangement of switching, which is omitted from the circuit diagram given below. The ranges are given as 225 to 550 metres and 950 to 2,000 metres. The battery eliminator is built as a separate unit, so that the receiver can be readily changed over from D.C. to A.C. supply. In the A.C. model provision is made for the use of mains voltages of 100/120 and 200/250 at frequencies of 40 to 100 cycles. The D.C. model operates on 200 to 250 volts. Provision for gramophone pick up can be made if required. A loud speaker unit is available which carries the receiver so as to produce a complete outfit. The loud speaker is of the moving-coil type, and derives field current from a low-voltage metal rectifier.

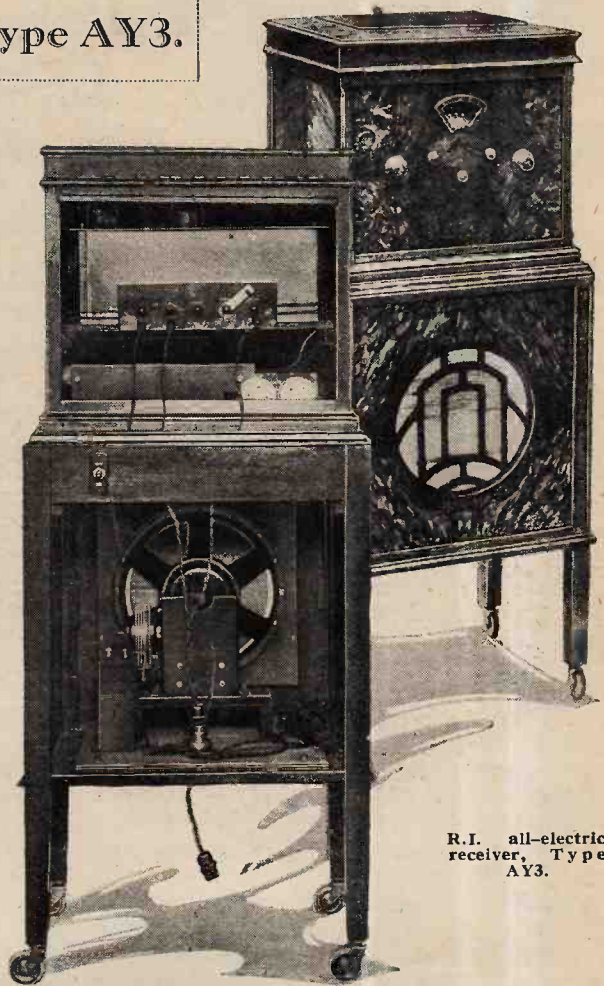

R.I. all-electric receiver, Type AY3.

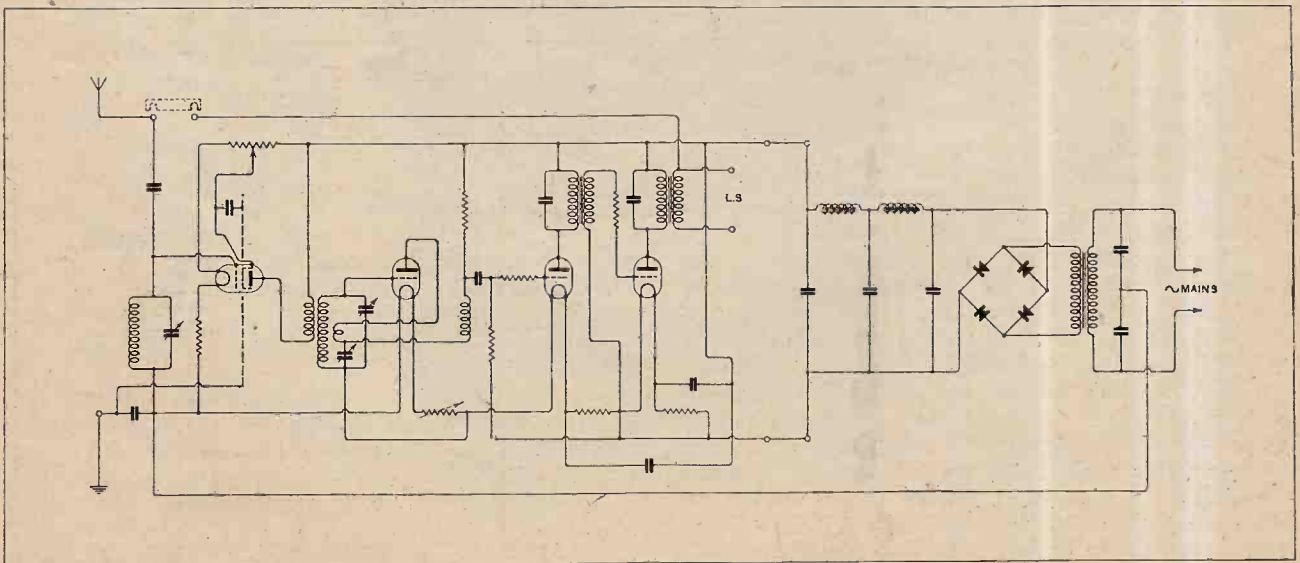

Simplified circuit of the R.I. mains-operated A.C. set.

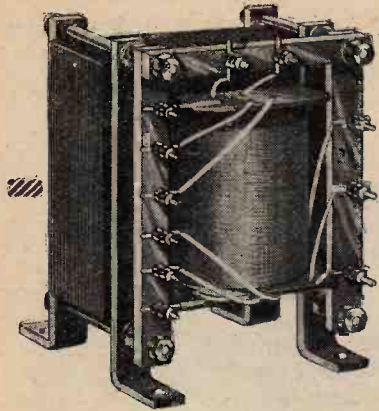

MAINS TRANSFORMER CONSTRUCTION.



Design No. II.—An Eliminator Transformer for 25-Cycle Supply Mains.

A TRANSFORMER designed to operate on a 50-cycle supply will function perfectly satisfactorily on any higher frequency, provided the supply voltage is the same. But if it is connected to a system where the frequency is considerably lower we find that certain unpleasant symptoms appear, overheating, accompanied by an excessive primary current being the most prominent features. Quite possibly there will be noticed, also, an all-round reduction in the output voltages. It can be shown by a simple calculation that the amount of iron, or perhaps it would be more accurate to say the cross-sectional area of the core, in a 50-cycle device, is insufficient to accommodate the extra flux circulating round the magnetic circuit.

The relationship between the frequency, number of turns, and the flux in every transformer, is given by the formula:

$$F = \frac{100,000,000 \times V}{4.44 \times f \times T}$$

where F is the total flux, V the supply voltage, f the frequency, and T the number of turns on the primary. It is at once obvious that if the frequency is halved the total flux will be doubled, provided the primary turns are kept constant. We

could, of course, wind on twice the number of turns and use a core of the same area, or increase, in suitable proportions, the size of the core and the number of turns. Having three lines of attack available, the only factor which need be considered is that of cost.

The largest bobbin available for the No. 4 size stampings does not allow for any increase in the core area, nor is it possible to accommodate many more turns without reducing the wire gauges throughout. The latter course is highly undesirable, and consequently it would be necessary to make up a special bobbin capable of accommodating an iron core 3in. in thickness. These factors weighed so heavily against the use of No. 4 stampings that it was decided to employ the next largest

size, and make the necessary adjustment in the windings. Actually the cross-sectional area of the core in this case is no greater than that in the 50-cycle component, but the winding space is so very much larger that extra turns can be wound on with ease.

The No. 25 size stampings supplied by W. Bryan Savage, 146, Bishopsgate, London, E.C.2, were found to meet the present requirements admirably, and it is fortunate, also, that a bakelite bobbin of just the correct size can be obtained from the same source. This is listed as bobbin No. 25 F.S., and gives a winding space of 3½ sq. in. With these dimensions as a basis on which to work, the design of the transformer described here was prepared. As a matter of interest the claims of the larger bobbin for this size of stamping were not dismissed without careful examination. This bobbin, the 25.F, will give a core area of 2½ sq. in. Its adoption would lead to about a 50 per cent. reduction in turns throughout, but the amount of wire would not be reduced in the same proportion, since the length of each turn will be approximately 40 per cent. greater. The ultimate result was a 100 per cent. increase in iron, but only a 25 per cent. decrease in the amount of wire. In spite of the fact that iron is cheaper than copper, the extra expenditure in one case is not

balanced by the saving in the other, and this design actually worked out much

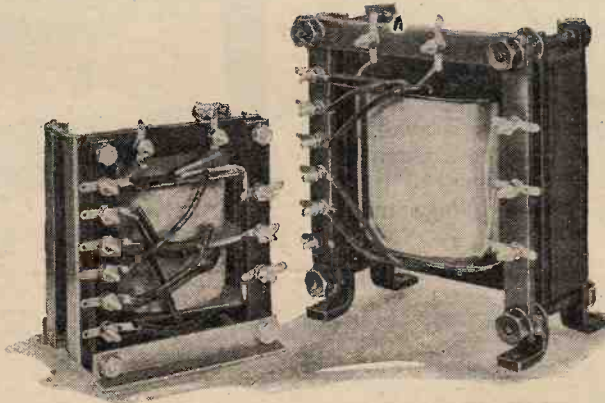

Both these transformers give similar output voltages and currents, but they have been designed for different supply frequencies. The larger is for 25 cycles, the smaller for 50 cycles.

more expensive than the one chosen first.

The No. 25 F.S. bobbin appears to have a square-shaped core tunnel, but if one of the "T"-shaped laminations is fitted in its centre it will be found that one side is slightly shorter than the other. The difference is only 1/16 in., but this is very important, and must be borne in mind when drilling the holes in the end cheeks to pass the beginning and finish of each winding. These holes must be passed through the face, not obscured by the iron when the core is assembled.

The method of winding is sensibly the same as that described for the first model, with this difference: that one bobbin only is used. The two-bobbin assembly

Mains Transformer Construction.—

facilitates bringing out the several centre taps, but by a little jugglery it can be done on the single bobbin without unduly complicating the winding. The size of wire, and the number of turns on the primary, are governed by the supply voltage, but it will be quite satisfactory to adopt, without modification, the winding data for the secondary coils for all primary voltages likely to be met with in practice.

The first step is to ascertain the supply voltage. This can be obtained from the cover on the meter, where will be found clearly marked both the voltage and the frequency. Reference to the following table will then give the number of turns and the gauge of wire for the primary coil.

Primary Windings for Various Mains Voltages.

| Supply Voltage (25 Cycles). | Number of Turns on Primary Coil. | Size of Wire S.W.G. |
|-----------------------------|----------------------------------|---------------------|
| 100 Volts A.C. | 1,000 Turns | 24 D.C.C. |
| 110 " " | 1,100 " | 24 " " |
| 120 " " | 1,200 " | 24 " " |
| 130 " " | 1,300 " | 24 D.S.C. |
| 140 " " | 1,400 " | 24 " " |
| 150 " " | 1,500 " | 24 " " |
| 200 " " | 2,000 " | 28 D.S.C. |
| 210 " " | 2,100 " | 28 " " |
| 220 " " | 2,200 " | 28 Enam. 1 |
| 230 " " | 2,300 " | 28 " " |
| 240 " " | 2,400 " | 28 " " |
| 250 " " | 2,500 " | 28 " " |

By adopting the wire coverings specified the space occupied by the primary will be approximately the same in all cases. Enamel-covered wire could be used in place of the D.C.C. and D.S.C. without affecting the performance if it is desired to save a shilling or two. In every case the quantity of wire will be about 1 lb. for the primary, irrespective of the size and nature of the covering.

A small hole, to pass the beginning of the primary, should be drilled through one end cheek on a level with the inside surface of the former; but be sure that the face chosen is not one of those covered by the core. The winding is put on with consecutive turns touching and a layer of thin paper run on between each layer of wire. The paper strips can be pre-

pared beforehand and cut a fraction of an inch wider than the width of the bobbin. The finishing end should be brought out through a small hole drilled in the same end cheek as the start of the winding. Owing to an oversight this was not done in the experimental model, and as a consequence the finish of the coil had to be carried round the outside of the former and brought up from the bottom (when assembled) to the top for connection to the terminal strip. If it is necessary to carry the finishing end along the surface of the winding a strip of thin paper or "Empire Cloth" should be used to insulate this lead from the turn it crosses *en route*.

As insulation between the primary and secondary, put on three layers of "Empire Cloth" cut as a strip a fraction of an inch wider than the

inside of the bobbin. Be sure that this completely covers the wire underneath and fits closely to the inside face of the cheeks. No cracks must be left down which the secondary turns can slip. This is followed by the high-voltage secondary coil having 5,260 turns of No. 36 enamel-covered wire. Although it is put on as a single coil, a tapping must be brought out at its centre; the centre in this case being the electrical centre which is at half the total number of turns. The holes for the beginning, centre-tap and finish of this coil should be drilled through the side of the former at the opposite end to that passing the primary. It is not possible to give the actual position of these holes, as they will be governed by the number of turns on the primary and also the manner of winding. Incidentally, the winding should be done as tightly as possible, keeping the wire at an even tension throughout. When drilling the holes take special care to see that the tip of the drill does not damage the primary wire or the inter-coil insulation.

The H.T. secondary winding need not necessarily be run on in absolute layer form; indeed, with such fine gauge wire this would be very tedious. The winding should be carried out as evenly as possible. An occasional layer of thin paper will be sufficient to maintain a flat winding surface.

With this method of winding, about 400 turns should carry the wire from one end of the former to the other, and then a layer of thin paper can be put on. When 2,630 turns have been completed, carefully solder on a length of

MATERIAL FOR TRANSFORMER.

7 doz. pairs No. 25 "Electra" stampings.
 1 No. 25 F.S. "Electra" bobbin for above.
 1 lb. No. 28 enamel wire.
 12 ozs. No. 36 enamel wire.
 8 ozs. No. 20 D.C.C. wire.
 1 doz. 3/4 in. 4 B.A. screws.
 2 doz. 4 B.A. lock nuts.
 2 ft. 1/2 in. x 3/16 in. iron strip.
 1 ft. 1/4 in. screwed iron rod.
 1 doz. nuts for above.
 Quantity of paxolin, insulating cloth and soldering tags.

Approximate cost, £1 1s.

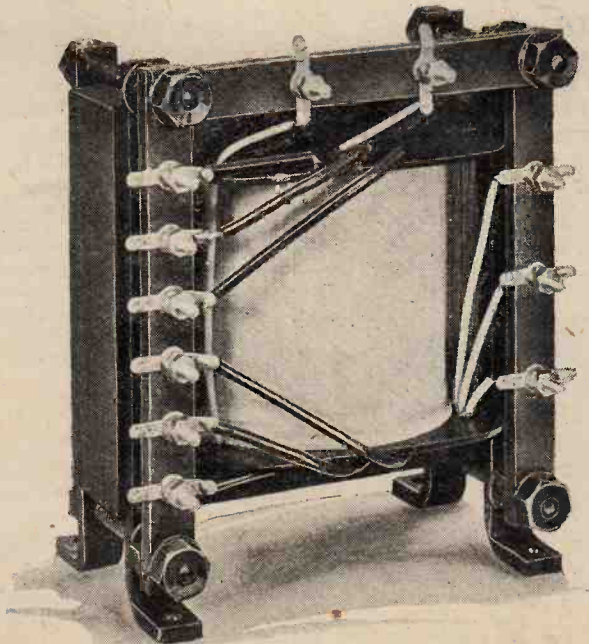

View of the finished 25-cycle transformer.

Mains Transformer Construction.—

stouter wire—No. 28 or any other convenient size will do—and bring this lead through a hole in the same face as the starting end. It would be well to use a thicker wire for the "lead-in" end, which could be soldered to the fine wire before starting to wind the coil. Where the join is made, cover the wire with a strip of paper bent double to protect the bare wire from neighbouring turns. A further 2,630 turns are required to complete this coil. A length of stouter wire can be used to finish the coil and lead out through the hole in the bobbin. Three layers of "Empire Cloth" wrapped carefully round the coil will afford adequate insulation.

The next winding supplies the filament of the rectifying valve, and the number of turns will depend on the type of valve to be used. For a 4-volt 1-amp. valve 42 turns of No. 20 D.C.C. wire will be required, but if a 5-volt valve is favoured, this coil should have 52 turns of the same gauge wire. For convenience the inlet and exit holes can be drilled through the same end of the former as the primary leads. Three holes are required, as this winding is centre-tapped. The tapping is made at the 21st turn in the case of a 4-volt winding, and at the 26th turn on the 5-volt coil. Three layers of insulating cloth should be used to protect this winding. Careful insulation is necessary, as the following winding will be at high potential to the one just finished. The gauge of wire, and number of turns, for the next coil depends on the voltage and current it will be required to give. If it is to be used to light the filament of a 6-volt output valve, taking up to 1 amp. of current, 62 turns, centre-tapped, of No. 20 D.C.C. wire will suffice. But if 4 volts at 4 amps. are required for some A.C. valves, the winding should consist of 42

turns of No. 16 D.C.C. wire. The three leads of this coil are brought out through the same cheek of the bobbin as the H.T. secondary wires.

This disposition divides the various leads fairly equally between the two ends of the former, and facilitates connecting to their respective terminal strips, also making for a neat finish. As a protection for the winding, a turn or two of insulating cloth can be put on and fixed, either by shellac or some other adhesive, such as Chatterton's compound.

The next job is to assemble the core, reversing the order of each pair of laminations, as explained fully in the first article. In all, 84 pairs are required, and these will build up to a thickness of $1\frac{3}{16}$ in. Clamps can be made out of $\frac{1}{4}$ in. angle iron, or $\frac{1}{2}$ in. \times $\frac{3}{16}$ in. strip iron will answer the purpose. For bolts, either 2BA. brass rod or $\frac{1}{4}$ in. Whitworth screwed iron rod may be used. Terminal strips can be cut from paxolin sheet $\frac{3}{16}$ in. thick, and as for terminals $\frac{3}{4}$ in. 4BA. screws, with nuts and soldering tags, form the cheapest arrangement. If the constructor does not wish to make the

clamps himself, they can be purchased from W. Bryan Savage at 2s. a set of four, with bolts and nuts to match.

A convenient method of connecting the coils to the terminal strips is to take the two primary leads to the top strip, the three H.T. secondaries to the right-hand strip, and the six wires, from the low-voltage secondaries, to the left-hand terminal strip. The three leads from the 4- or 5-volt winding come out through the top cheek, so that they can be connected to the top three terminals, and the 6-volt coil ends, which come through the bottom cheek, can go to the bottom three on the left-hand strip.

H. B. D.

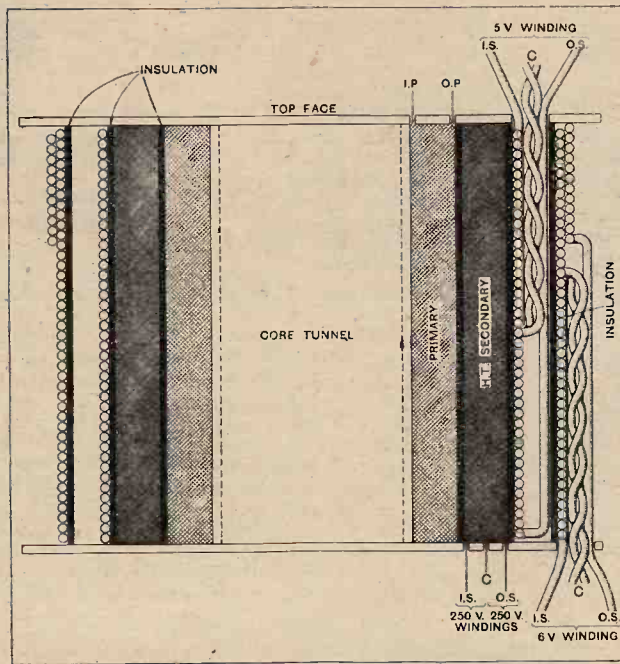

Disposition of the various windings on the bobbin. The space occupied by the low voltage coils has been exaggerated to show the method of bringing out the centre-tappings and end-connections.

Astra Schaltbuch.—Circuit diagrams and notes concerning upwards of eighty types of wireless receivers and subsidiary apparatus. Pp. 88+vii. Compiled by Emil Haslinger, Vienna. Price RM. 1.50.

o o o o

Electrical Wiring and Contracting. Vol. II. Edited by H. Marryat, M.I.E.E., M.I.Mech.E. — Comprising D.C. generators and motors, mathematics (as applied to wiring and con-

tracting), A.C. generators and motors, measuring instruments and testing, wires and cables. Pp. 512, with numerous illustrations and diagrams. Published by Sir Isaac Pitman and Sons, Ltd., London. Price 6s. net.

BOOKS RECEIVED.

The Wireless Manual (2nd edition), by Capt. Jack Frost.—A practical book for the ordinary broadcast listener, giving useful instruction in the erection of aerials, the installation and upkeep of receiving sets, with descriptions of the nature and use of various receivers, valves, and components supplied by wireless manufacturers. Pp. 164+viii, with 83 illustrations and diagrams. Published by Sir Isaac Pitman and Sons, Ltd., London. Price 5s. net.

Scotland Calling.

Scotland has suddenly become vocal in an appeal for a Scottish Broadcasting Board, the object of which would be to secure programmes of a national interest as distinct from those intended for the whole of Great Britain.

Many critics south of the Tweed will instantly see in this suggestion the influence of the "Kailyard" school, which has always aimed at tethering the Scot to his "ain fireside" to the exclusion of everything and everybody else.

o o o o

The Real Trouble.

The real cause of the present discontent can be summed up, I believe, in two words, viz., *land lines*. One grouse nourishes another. The atrocious quality which Scots have to endure in the transmissions from London has naturally set the Caledonian mind at work on schemes for a better service, and out of these has arisen the grandiose conception of a Scottish Broadcasting Board.

o o o o

B.B.C. Plans.

Savoy Hill is hurt by the very suggestion. But casting all thoughts of ingratitude on one side, the B.B.C. advances with a striking programme of Scottish national broadcasting which Scots might well consider closely before proceeding any farther with their new project.

o o o o

An Official Statement.

I quote from a statement given to me by a B.B.C. official:—"The policy is now to present a definitely national aspect of Scottish broadcasting more effectively under the Regional system than ever before. Under the old conditions a certain number of Scottish broadcasts were regarded as special programmes. These will in future be regarded as *normal* programmes, and the Regional staff will concentrate on securing distinctively national matter with a progressive development in quality."

o o o o

Mobilisation in Progress.

Plans are going ahead for mobilising Scotland's resources in drama, music and literature. Six dramatic clubs famous throughout Scotland are already busy preparing material. In the realm of music Scots are promised more broadcasts by the Scottish National Orchestra and the Reid Orchestra of Edinburgh, the two finest orchestral organisations in the country.

o o o o

A Word of Caution.

Further details of the B.B.C.'s plans for Scotland could easily fill a page, but space is precious. It is for Scots themselves to judge whether the B.B.C. is likely to fulfil its promises. That it has good intentions there can be no doubt, and bearing in mind that the present organisation is efficient and experienced, I think Scots would be well advised to "bide a wee" before setting up a new and untried broadcasting authority of their own.

B 47



By Our Special Correspondent.

British Methods for America.

Cecil Lewis, erstwhile "Uncle Caractacus" of Savoy Hill, is now blazing the trail in the U.S. and actually teaching the Americans something fresh about radio drama. And the Americans, realising that all is not well with their own methods of presentation, are eager to learn all about radio dramatic technique from the lips of a British pioneer.

o o o o

Lessons in Radio Drama.

The big lesson which Lewis is out to teach in a series of radio adaptations to be given through the National Broadcasting Company's stations is that no radio play with any pretensions to realism can be properly performed with the cast, musicians, and "effects" paraphernalia all crowded into the same studio. (America is still struggling with methods which the B.B.C. discarded as far back as 1926.)

o o o o

The Dramatic Control Board.

All this is to be changed, at any rate while Lewis is in charge, and tempera-

mental artistes will no longer have to rub shoulders with the pebble shakers, sand sifters, and manipulators of rattles. A dramatic control panel similar to that at Savoy Hill will be introduced with at least four separate studios in use for each play.

o o o o

Cup Tie Broadcast.

I hear that the Football Association has again refused permission to the B.B.C. to give a running commentary on the Cup Final this year. The B.B.C. is, therefore, searching around for another method of broadcasting the contest. Last year listeners heard scrappy versions from eyewitnesses who scrambled out of the Stadium at quarter-hour intervals and gave their descriptions through a microphone in a neighbouring building. This method is not to be repeated.

Why not a running commentary from a captive balloon?

o o o o

Portables at Aintree.

Portable sets are to be used by the two commentators on the Grand National, which takes place on March 28th. One commentator will describe as much as he can see from the Grand Stand, while his confrère, who will be waiting at the Canal turn, will listen to the account through 5XX, taking up the thread of the story when the first commentator stops.

o o o o

A New Chairman.

The appointment of the Earl of Clarendon as Governor-General of the Union of South Africa in succession to the Earl of Athlone will mean a vacancy in the Chair of the B.B.C. Board of Governors in January next. Can the vacancy be filled? The Chairman's salary is £3,000 per annum.

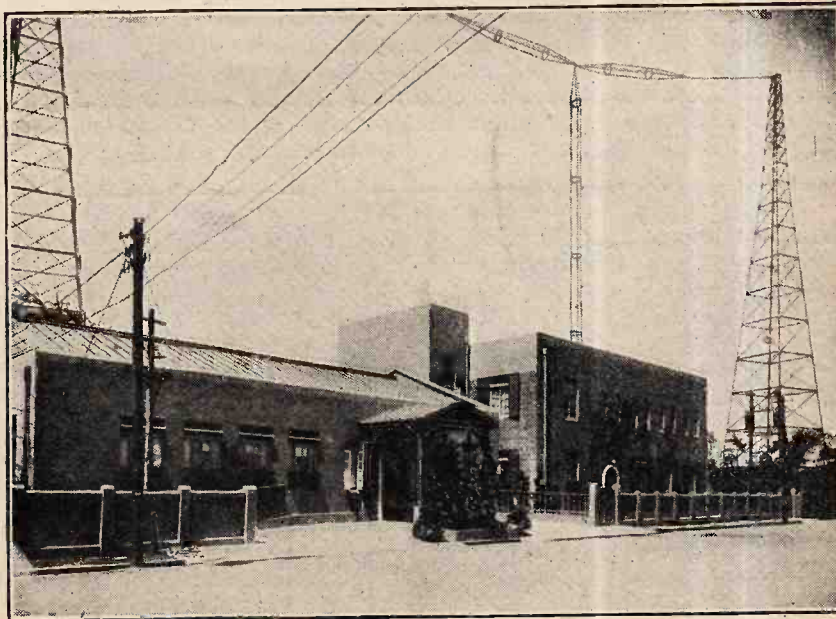

JAPANESE BROADCASTING. The 1 kw. station, JOCK, at Nagoya, which distributes programmes throughout central Japan on a wavelength of 370 metres. It was this station that relayed the speech of Mr. R. Wakatsuki, principal Japanese delegate to the Naval Conference, when he visited the Marconi beam station at Dorchester on Sunday, February 9th.

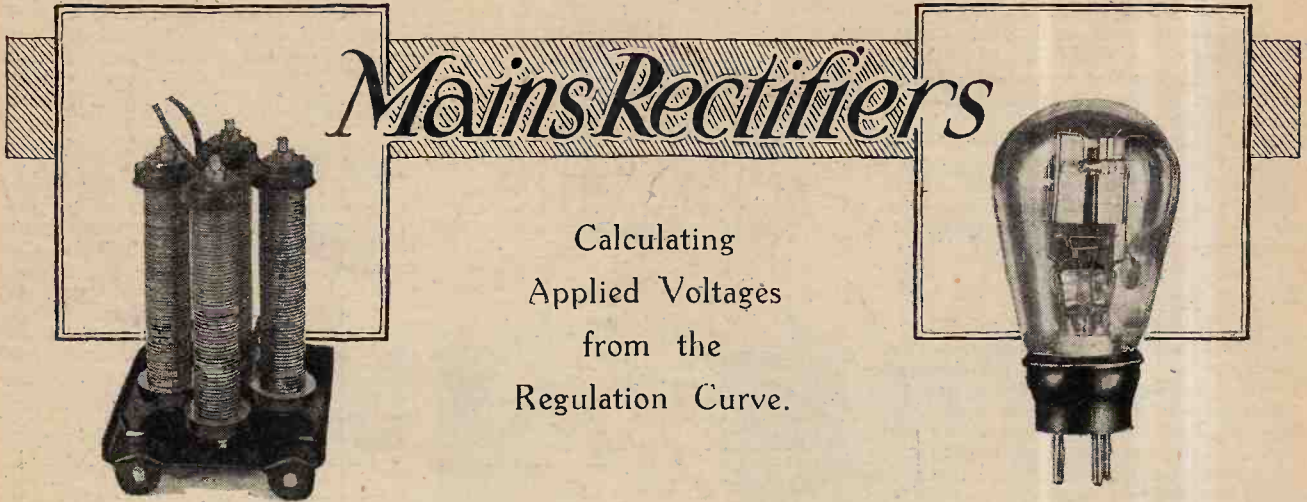

Calculating
Applied Voltages
from the
Regulation Curve.

TO those who are turning their attention for the first time to all-mains receivers deriving current from an A.C. supply, the problem of the change of applied voltage with varying loads, or "regulation," as it is called, may be a little bewildering. When a set is fed from a high-tension battery or accumulator, very little change occurs in the voltage applied to the valves for various currents taken, provided that the maximum discharge rating of the battery is not unduly exceeded. In such a source of supply there is a comparatively small internal resistance of perhaps 20 or 30 ohms, whereas that of an A.C. eliminator may well be many hundreds of ohms.

Of the various components necessary for the construction of an A.C. high-tension unit, the rectifier is the source of highest resistance, and it is the purpose of these notes to explain how the regulation curve supplied by the makers for rectifying equipment may be interpreted to the best advantage. Accompanying the text there are load characteristics for fifteen valves, and a table summarises the constants of the more important metal and gas-filled rectifiers. It will be seen that in no

case are any of the valve characteristics horizontal, so that a condition which brings about even a small change in the H.T. current taken by a valve is accompanied by a change in the D.C. volts applied to its anode.

When choosing a suitable rectifying valve it is necessary, therefore, that the total H.T. current (i.e., load) of the receiver should be known. The various anode currents can be obtained from the makers' curves or from *The Wireless World* Valve Data sheet issued on December 4th, 1929. To the aggregate of these must be added the screen currents of S.G. valves and pentodes, and any current wasted by potentiometers, such as those used for feeding the screening grids of S.G. valves or the plates of anode-bend detectors.

Having calculated the total load, it is necessary to know the unsmoothed voltage that the rectifier has to provide. It is important in this connection to point out that, apart from the effect of receiver load, the unsmoothed output is considerably influenced by the value of the condenser shunted directly across the rectifier. Valve manufacturers have agreed upon a standard of 4 mfd., which was the capacity used when plotting the

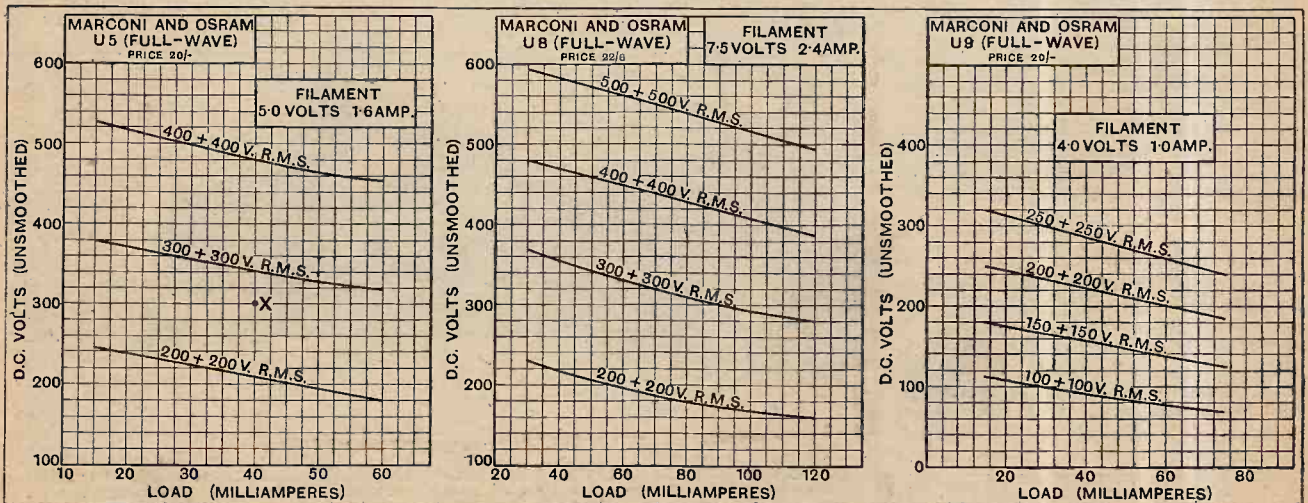

THE SELECTIVITY-QUALITY PROBLEM

The Wireless World

AND RADIO REVIEW

4^D

The Paper for Every Wireless Amateur

Wednesday, February 26th, 1930.



**FIRST-
BECAUSE OF
THE FILAMENT**

Mullard
THE MASTER VALVE

For Silent Power Always
'Ekco-Lectrify' your Radio

Write for Free Booklet on "All-Electric Radio" and details of Easy Payments, to:-

E. K. COLE, LTD.,
DEPT. W.,
"EKCO" WORKS,
LEIGH-ON-SEA.



**'EKCO' ALL-POWER UNITS
H.T. AND L.T. UNITS
RECTIFIER UNITS**

Utility DIFFERENTIAL CONDENSER

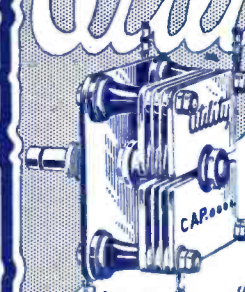

Stocked by all good dealers and the best value in a Condenser of this type that you can possibly obtain. The capacity is 0001 mfd. and the design provides smooth reaction at all points of the scale. Fully guaranteed for efficiency and finish by "Utility" — makers of the Dials, Condensers and switches that experienced constructors always choose. Illustrated list free for a p.c.

Other Prices:

| | | |
|--------|---------|-----|
| '00015 | | 7/- |
| '0002 | | 7/6 |
| '0003 | | 9/6 |

WILKINS & WRIGHT LTD.,
"Utility" Works,
Holyhead Road, BIRMINGHAM.

6/6

Green for Safety!



T.C.C. CONDENSERS

Adv. Telegraph Condenser Co. Ltd.,
Wales Farm Rd., N. Acton, London, W.3.

3396

Which make of
RESISTANCE
do you use?

MAKESHIFT

OR

"MAKE SURE"

DUBILIER
RESISTANCES
AND
MAKE SURE
FIT

With the Dumetohm you make sure of absolute constancy however much the voltage and temperature may vary. All Standard Values, each 2/6. Holder (Horizontal or vertical) 1/-.

| | |
|---------------------------------------|---------------|
| Filament Resister, any Standard Value | - 1/- |
| Holder | - 1/- |
| Duwirohm | - 5/- to 11/6 |
| Holder for Horizontal type | - 1/6 |

Call at your dealer's on the way home and get a copy of "A Bit about a Battery," Dubilier's free booklet.

DUBILIER
REGISTERED TRADE MARK
If unobtainable from your dealer write direct to us giving his name and address.
Dubilier Condenser Co. (1925) Ltd., Ducon Works, Victoria Road, N. Acton, London, W. 3.

ARE YOU BUILDING A RECEIVER?

BurTon Drum Control Single Condenser.

Fast and slow motion 12/6
Plain Drum Control 10/6

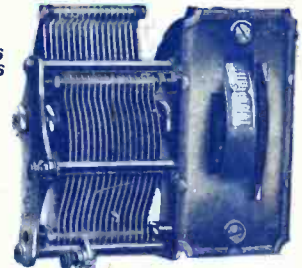

Then look at these components—each one a necessity in any set, each one tested and proved, each one the best of its kind. Use BurTon components throughout and feel the confidence of BurTons behind you. Remember that the success of the famous "Empire" 3 Valve set was due to its components—every one a BurTon!

BurTon Audio Transformer.

Completely wound to give correct ratios; a neat and compact instrument of the highest efficiency enclosed in a moulded case of high grade finish
Price 10/6



BurTon Differential Condenser.

Scientifically designed, brass vanes, interleaved with Bakelite leaves, this condenser makes shorting an impossibility. It means easier tuning, better selectivity and better detection. The price is 5/- only.



BurTon H.F. Choke.

Wave band of 20—2,000 metres. Price 3/9.
Binocular choke, wave band 50—3,000 metres. Price 5/9.

BUY BURTON COMPONENTS

C. F. & H. BURTON, Progress Works, Walsall.

Cleaver.

BU204/K

Mention of "The Wireless World," when writing to advertisers, will ensure prompt attention.



BRITANNIA WORKS,
REDDITCH, WORCS,
the up-to-date Factory where
the British Pertrix Battery
is made.

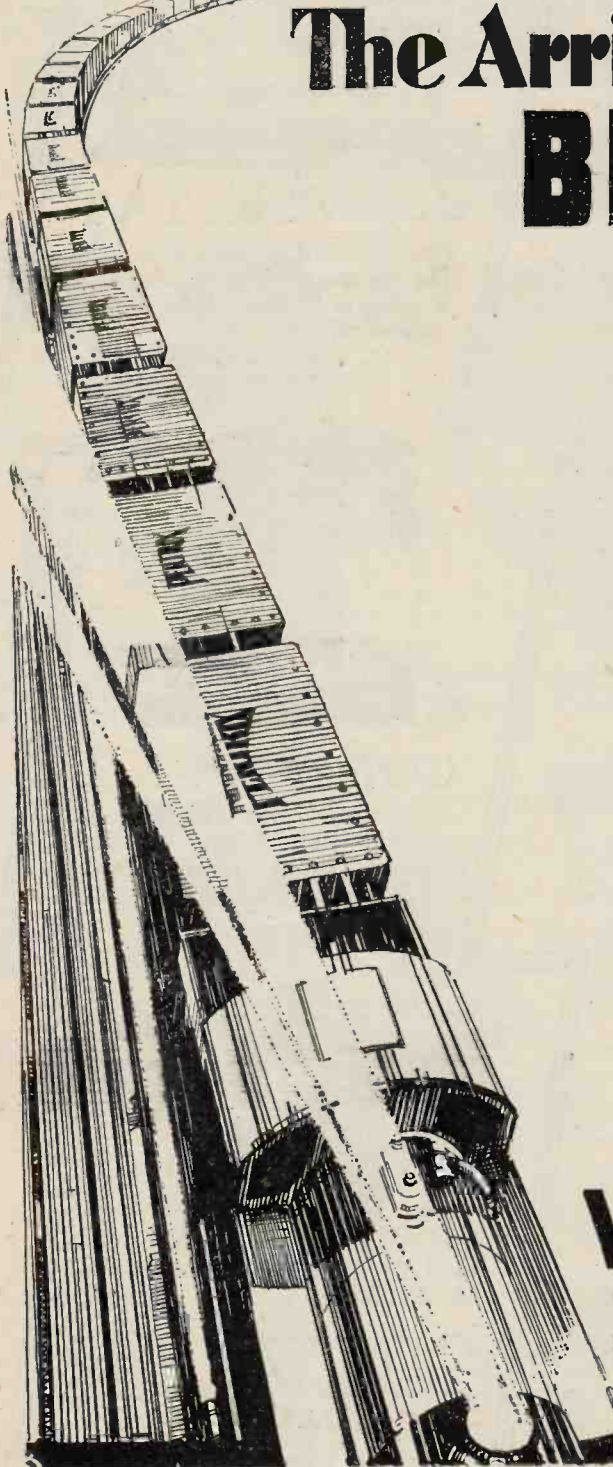

The Arrival of the BRITISH

PERTRIX PATENT DRY-BATTERY

THE British Pertrix is here!
It is here—supreme among dry batteries.
It starts with the greatest of all advantages over
other batteries—it has a **60% longer life**.
The reason is that in a Pertrix there is

NO SAL-AMMONIAC

to corrode the zinc cups.

This puts the British Pertrix far ahead of any other
dry battery on the market. There is no idle deteriora-
tion as in the ordinary sal-ammoniac battery, where
current losses occur even when the battery is not in
use. Ordinary batteries are choked by corrosion, but
in the Pertrix the powerful current flows freely
throughout the whole of its amazingly long life.

Buy a Pertrix battery for clear, silent and uniform
reception.

You can also obtain Pertrix batteries for your flash lamp.
Write for leaflet "B," which will give you full particulars
of all types.

PRICES.

| STANDARD (Discharge 12 milliamps.) | GRID BIAS. |
|---------------------------------------|------------------|
| 60 volt 8/- | 9 volt 1/6 |
| 100 13/- | 12 2/3 |
| 120 15/6 | 15 2/9 |

60%
LONGER LIFE

**What a
LIFE !!!**



EXIT SAL-AMMONIAC

PERTRIX, LTD., BRITANNIA HOUSE, SHAFTESBURY AVENUE, LONDON, W.C.2.

101.

Advertisements for "The Wireless World" are only accepted from firms we believe to be thoroughly reliable.

T.C.C.

**Condensers
cost no more
than ordinary
condensers
and are**

GUARANTEED

WHEN next you want a condenser be sure of its accuracy—be sure that it is dependable—that it will stand up to its job, in other words be sure it is a T.C.C. On this rests the efficient working of your Receiver. Remember that with the new prices you can now get a genuine T.C.C. condenser for the same cost as an ordinary condenser. Give your next Set a fair chance by fitting the "condenser in the green case"—made by the company that has made nothing but condensers for nearly a quarter of a century. Here is the upright mica type—one from the vast range of T.C.C. Condensers.

**T. C. C. MICA
CONDENSERS**
Upright Type

| mfd. | s. d. |
|----------------|-------|
| .0001 to .0009 | 1 6 |
| .001 to .004 | 1 10 |
| .005 & .006 | 2 6 |
| .01 | 3 0 |
| .02 | 3 6 |
| .05 | 5 6 |
| .1 | 8 0 |
| .2 | 14 6 |
| .25 | 18 0 |

*Tested to 500v. D.C.
to work at 250v. peak.*

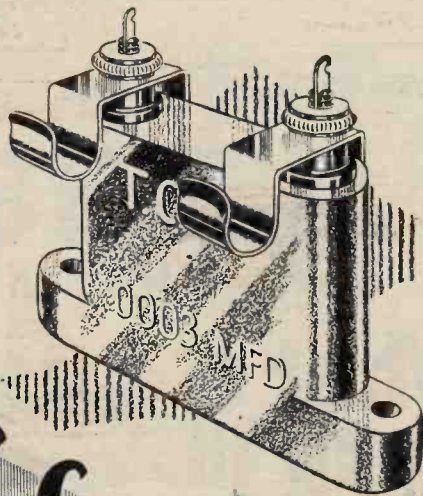

T.C.C.

CONDENSERS

Adv. Telegraph Condenser Co Ltd.
Wales Farm Road, N. Acton, London. W.3.

3897

Colvern products for Modern Radio circuits . . .



COLVERSTAT

For all voltage regulation—with liberally spaced wire, wound on glass, a rating of 10 watts, and a low end-to-end capacity.

Up to 45,000 ohms, 2/6 each.
50,000 to 100,000 ohms. 3/6 each.
Tapping points 1/-.

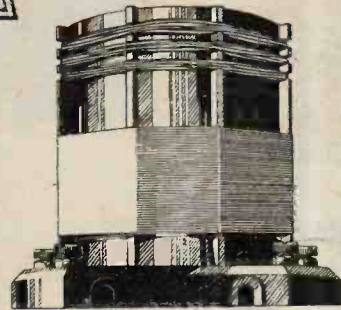

COILS

Accurately matched dual range—for use with gang condensers in H.F. circuits, Transformer-coupled, 12/6 each. Tuned grid 8/6 each.

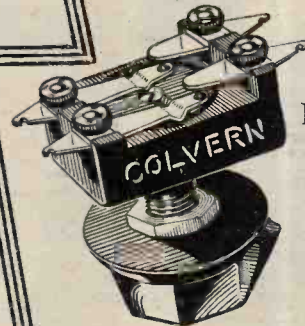

ROTARY DOUBLE POLE SWITCH

Adaptable for ganging and for changing wave-bands for coils. Price 2/6 each.

COLVERN RADIO

COLVERN LTD.
MAWNEYS ROAD,
ROMFORD.

London Depot:
150, King's Cross Rd.
W.C.1.

Phone: Clerkenwell 5362

Mention of "The Wireless World," when writing to advertisers, will ensure prompt attention.

THERE'S A PROUD REPUTATION BEHIND EVERY ORMOND PRODUCTION!

Designed to carry out their work faultlessly and smoothly, Ormond components reveal in every detail the highest standard in construction and design.



Four-Pole Adjustable Units, fitted large Cobalt Magnet and beautifully polished bakelite cover. Price 12/6.

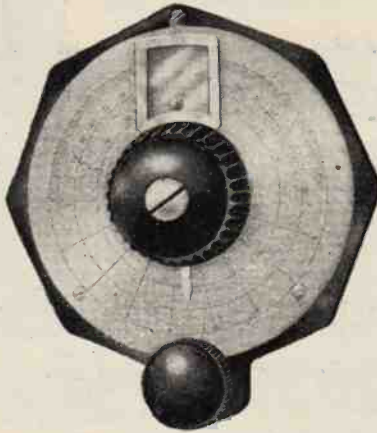

Duo Dual Indicator Dial. Operated either by direct drive from the central control knob or by the slow-motion drive. (Ratio 16-1). Price 6/-.

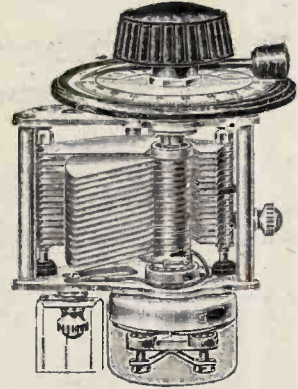

Small Logarithmic Condenser with Pointer Dial and slow-motion movement. Constructed mainly of Aluminium.

| Cap. | Price |
|--------|-------|
| ·00025 | 9/- |
| ·00035 | 9/3 |
| ·0005 | 9/6 |

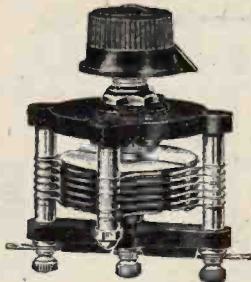

Differential Condenser. Insulation is provided between fixed and moving vanes, obviating all danger of short circuiting. One-hole fixing. Ideal for use as a reaction control. Price 4/-.

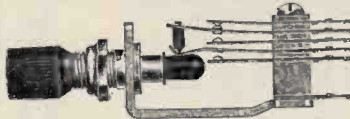

Jack Switch. Of entirely new design, brass frame, heavily nickel-plated, springs of nickel silver, the contacts being riveted in. The control contact is of the push-pull type. Prices from 2/9 to 4/6.

Three-Point Push-Pull Switch. May be mounted on a metal panel and insulated by means of the ebonite brush if necessary. Complete with knob terminals and soldering tags. "One-Hole" fixing. Price 1/6. Two-Point Type, Price 1/3.



Midget Condenser. Can be mounted on panel or baseboard. Minimum Capacity, ·0000015 Mfd. Maximum Capacity, ·0001 Mfd. Price 4/-.



Radio Frequency Choke. High Inductance. Low Self-Capacity. Impedance is constant up to 4,000 metres. Price 7/6.



Chassis and Cone. Produced for use with the loud-speaker unit. Constructed of aluminium, 2 1/4 ins. in diameter with a cone of specially selected material. Price 7/6.

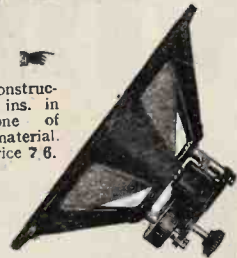

For Quality!

For Value!

THE ORMOND ENGINEERING CO., LIMITED,
ORMOND HOUSE, Rosebery Avenue, LONDON, E.C.1.
Phone: Clerkenwell 5334/5/6 & 9344/5/6. Telegrams: "Ormondengi, Smith."

Use a **NON-SPILLABLE** battery in your home ~

It is so fatally easy for a few drops of acid to spill when changing over ordinary low tension accumulators. You may already have experienced the vexation of discovering damage to carpet or furniture on which acid has dropped.

The C.A.V. Non-spillable accumulator contains acid—but in a jellied form. You cannot spill it, and it does not flow, so you can use it in any position. Because of its advantages over the free-acid type of non-spillable accumulator, its compactness, its safeness, it is the ideal battery for portable receivers. It is also the battery to relieve you of all anxiety. Why not use one with your home receiver?

Our latest Radio Battery catalogue No. T3 will gladly be forwarded upon application.

We have recently introduced an entirely new range of rechargeable high tension accumulators—built like car batteries. May we send you details?

CAVandervell & Co. Ltd.
ACTON, LONDON, W.3.



All Position-Non Spillable Batteries



The Original Jelly Acid Battery Perfect for Portables

NO ACCIDENTS

No accidents due to condenser failure can ever happen if you are using Hydra condensers. Every Hydra condenser is tested at a much higher voltage than it will ever have to deal with.

HYDRA

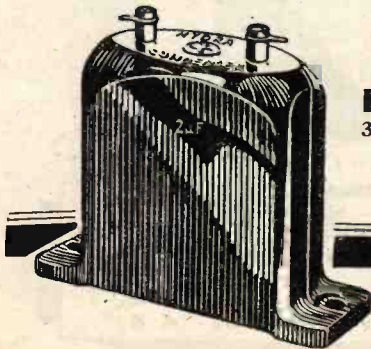

LOUIS HOLZMAN
37 Newman St., W.1
Telephone: Museum 2641

ELECTRAD ROYALTY RESISTANCES



The Royalty is the original non-inductive high resistance unit embodying features which are not to be found in cheap imitations. There is no possibility of mechanical binding, and the entire range of resistance can be covered by a single turn of the knob. The moulding and knob are of pure bakelite. Electrad Royalties are recommended by Ferranti and other prominent manufacturers.

Write for full data.

Our 1930 68-page Radio Catalogue and guide tells you all about the complete Electrad range of resistances. Send 6d. in stamps for postage.

| Type. | Resistance. | Price. |
|-------|---------------------------------|--------|
| A | 1/10 to 7 megs. | 7/- |
| B | 1,500 to 100,000 ohms | 7/- |
| C | 500 to 50,000 " | 7/- |
| D | 10,000 to 700,000 " | 7/- |
| E | 0 to 500,000 ohms | 7/- |
| F | 0 to 2,000 ohms (Potentiometer) | 8/3 |
| G | 0 to 10,000 " | 7/- |
| H | 0 to 25,000 " | 7/- |
| J | 0 to 200,000 " | 7/- |
| K | 0 to 5,000 " | 7/- |
| L | 0 to 500,000 " | 7/- |

THE ROTHERMEL CORPORATION Ltd.
24, Madd x Street, London, W.1.
Phone: MAYFAIR 0578/9.

Mention of "The Wireless World," when writing to advertisers, will ensure prompt attention.



Another **NEW** A.C. Mains
DETECTOR VALVE
OSRAM
M.H.4
(With Indirectly Heated Cathode)

Amplification Factor of 35, combined with moderate Impedance ensures high degree of magnification when used as a Detector or H.F. Amplifier in stabilized circuits.

The OSRAM M.H.4 is designed with an adequate clearance between electrodes to give greater mechanical strength, absolute reliability and consistency in performance.

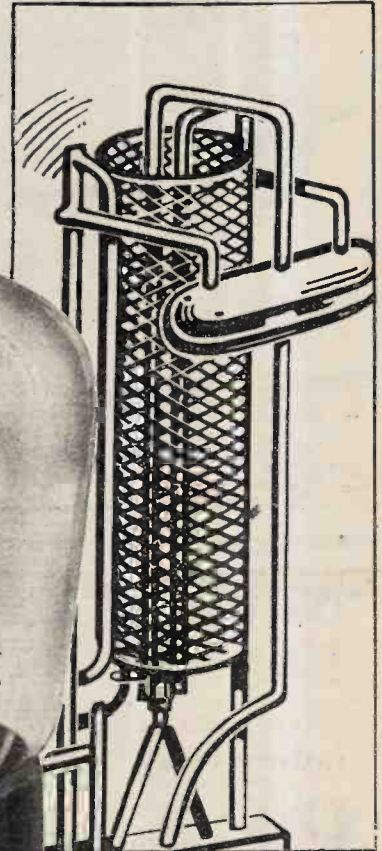
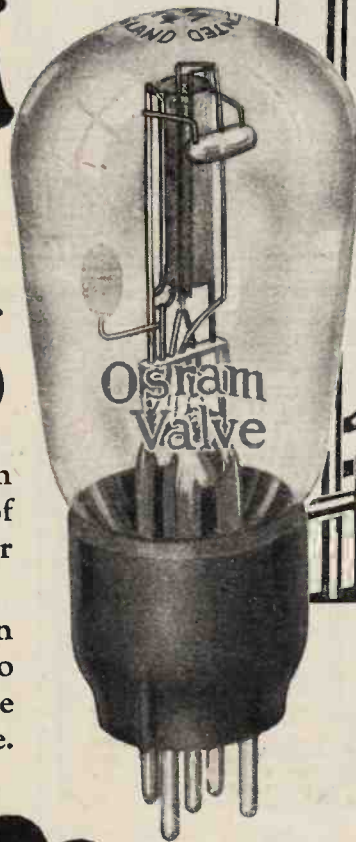

NOTE the gauze anode which assists in the ready dissipation of heat and maintains the initial efficiency of the valve throughout a long and useful life.

Osram
Valves

MADE IN ENGLAND

Sold by all Wireless Dealers

Characteristics

| | |
|-----------------------------------|--------------|
| Filament Volts | 4.0 |
| Filament Current 1.0 amp. approx. | |
| Amplification Factor | 35 |
| Impedance | 23,000 ohms. |
| Anode Volts | 200 max. |

PRICE 15/-



IF YOUR SUPPLY MAINS ARE D.C.

You can use an A.C. All Electric Receiver
By Employing The M.L.—D.C. to A.C.

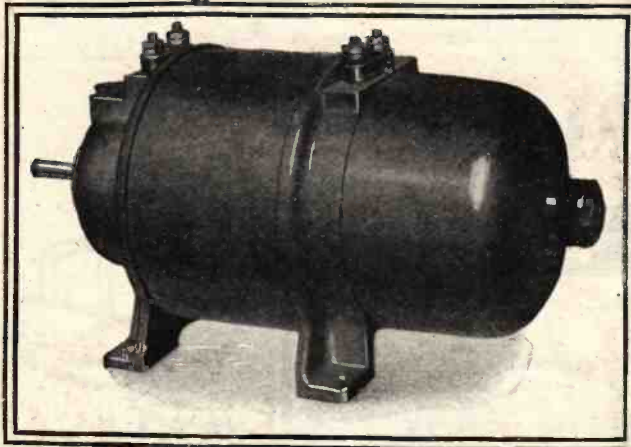

ROTARY TRANSFORMER

Exhibiting at the
British Industries Fair
STAND D.7,
Olympia.

Can be supplied
to run from
any Voltage
12-250 V.D.C.

Recommended and
used by

Philips Radio,
Marconiphone,
Kolster-Brandes,
Burndept, Etc.

40 WATT Model
£13-0-0
85 WATT Model
£19-0-0

M-L MAGNETO SYND. Ltd., Radio Dept., COVENTRY.
Telephone: 5001.

The Unqualified Approval of The Press.

VOLTRON BABY
CONDENSER

3'9

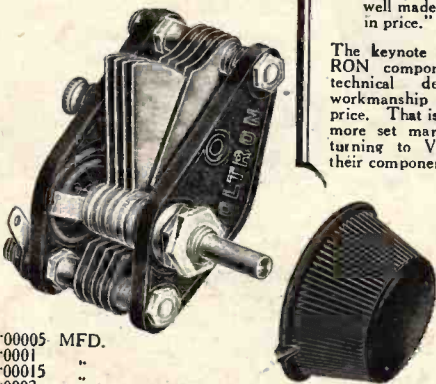

00005 MFD.
0001 ..
00015 ..
0002 ..

VOLTRON
"years ahead in design"
COMPONENTS.

VOLTRON CO., LTD., QUEENSWAY, PONDERS END.

Modern Wireless :

"very reasonably priced.
The design is good and
its finish is of a high
standard."

Wireless Constructor :

"The mechanical con-
struction is strong... the
whole component is
well made and reasonable
in price."

The keynote of all VOLT-
RON components is sound
technical design, superb
workmanship and reasonable
price. That is why more and
more set manufacturers are
turning to VOLTRON for
their components.

*Press
Illustrated
Catalogue
on request.*

NOW THE DEAF HEAR!

Brought
back into
touch with
the World



by PERFECT WIRELESS RECEPTION

Here at last is a unit that brings
pure colourful reproduction to all
but the stone deaf. Volume with-
out distortion. Real enjoyment
for those cut off from ordinary
conversation and music. You can
attach the SUPERVOX unit to
any loudspeaker set, or we supply
complete portable sets for the
deaf, illustrated above. Test before
buying. We demonstrate in your
own home or at our offices daily.
Write now for free brochure.



SUPERVOX
WIRELESS AID FOR THE DEAF

DIMSDALE BROS., 66, Victoria Street,
London, S.W.1 and 58-59, Timberbush, LEITH.

Mention of "The Wireless World," when writing to advertisers, will ensure prompt attention.

All who prefer Quality
in Cigarettes



Say
Player's
please

5 for 3d. 10 for 6d.
20 for 11½d.



N.C.C. 722

The
Grosvenor
Battery

BRITISH
MANUFACTURE

FULL VOLUME & LONG RANGE

These are impossible with any set unless the H.T. Battery is right—it is the life-blood of your valves. Try a Grosvenor Battery next time you replace your H.T. and note immediately it is connected how your set will jump into life with a volume the fullness of which you had not previously thought possible. Then search for that elusive foreign station that you never can quite hear and you will be surprised how near and clear it suddenly appears. Grosvenor Batteries will give you full satisfaction from first to last.

Incorporating the new
vitalising element.

The Grosvenor Battery Co., Ltd.,
2/3, White St., Moorgate, London, E.C.2.

Phone: MET. 6866.

PRICES

99 volts, 11/6, 14/6,
Super Capacity, 30/-
66 volts, 7/6, 9/6,
Super Capacity, 18/-

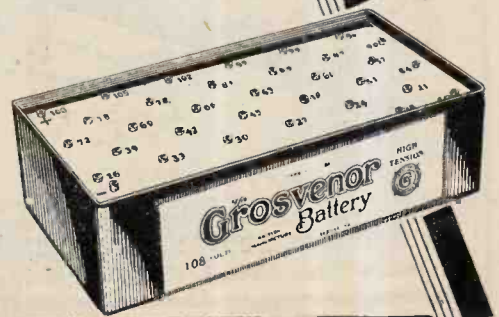



A GAP FILLED!



THE new Hegra "MAGNET - DYNAMIC" Loud Speaker fills the gap between the standard speaker and the moving coil type. An entirely new unit is used and unique principles of design are employed.

Quality of reproduction is equal to that of a moving coil and yet no field energising current is required. An input up to 4 watts can be handled with ease.

It costs no more than the standard type and yet it gives sufficient volume to fill a large hall.

Ask your dealer to demonstrate this new speaker; you will be astonished!

OBTAINABLE FROM ALL GOOD DEALERS.



Price in chassis form as illustrated £2.16.0
In polished Walnut Cabinet £5.10.0

Ideal for Radio-Gramophones and all-mains Receivers.



Perfect reproduction with small or powerful sets.

M.C.I.

"Wireless World" says OF THE R.G.D. Pick-Up

The external appearance is PARTICULARLY NEAT AND BUSINESSLIKE.

TRACKING ERRORS ARE REDUCED TO A MINIMUM.

THE PICK-UP MOVEMENT IS SOUND IN PRINCIPLE.

ADEQUATE CONTROL OF THE MOVEMENT IS OBTAINED.

The characteristic shows THESE PRINCIPLES OF DESIGN TO BE JUSTIFIED.

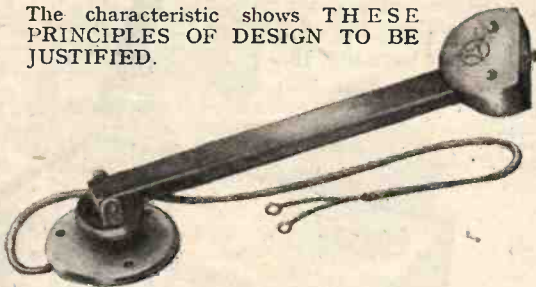

We shall be pleased to supply literature and prices on application.

The Radiogramophone Development Co.,
St. Peter's Place, Broad Street, Birmingham.

JOLLYS OF WITTON, BIRMINGHAM.

give a further list of their special bargains this week.

- | | | |
|----------|---|---------|
| B.T.H. | Interval transformers, 2-1 and 4-1. Output Transformers 10-1 and 15-1, original price 15/- | 8/6 |
| B.T.H. | Power chokes, single winding to carry 100 m/a | 10/6 |
| B.T.H. | Power chokes, double winding to carry 300 m/a | 15/- |
| DUBILIER | Condensers, 8 mfd. Mansbridge type tested 600 volts | 10/6 |
| DUBILIER | Condensers, 6 mfd. Mansbridge type tested 1,500 volts. Original price 22/6. Second-hand | 15/- |
| B.T.H. | Two-stage coupler, complete with valve covering the 250/650 and 900/2,060 metre wave band | 22/6 |
| B.T.H. | Pick-up amplifier, including B.T.H. transformer, scratch filter, 200,000 ohms, volume control. List price £3.7.6, Our price | 22/6 |
| ZENITE | Resistances, as used in Panatrope, set of eight complete | 15/- |
| B.T.H. | Senior and Junior R.K. Speakers for A.C. or D.C. Mains, complete with amplifier and eliminator, from Also Panatropes for D.C. Mains at bargain prices. | £10.0.0 |
| B.T.H. | A.C. transformer, secondary 200/250 volts, 50 cycle, Primary tapped 7.5 volts at 3 amps. Filament of Rectifying valves. Primary tapped 600 volt anodes. Primary tapped 7.5 at 3 amps. Filament output valves. Primary tapped 620 volts for anodes of output valves, and field coil current, etc. | 35/- |
| B.T.H. | D.C. Generators, 200/250 volts D.C. input, 475 volts at 2 amps output, in asbestos lined cases (second-hand) | £6.0.0 |

All components in stock for R.K. amplifiers and Panatrope. Let us quote you.

TERMS. Cash with order. Any goods may be returned, carriage paid, within seven days of receipt, in which case your money will be refunded by return of post.

All goods carriage paid within 150 miles.

JOLLYS, 410-416, Aston Lane,
WITTON, BIRMINGHAM.

Mention of "The Wireless World," when writing to advertisers, will ensure prompt attention.

FERRANTI

Radio Meters

are an invaluable aid to true reproduction.

Without an instrument you are operating your receiver by guesswork, thus getting poorer reproduction. Until the introduction of the FERRANTI Radio Meter, accuracy was impossible without excessive expenditure in elaborate instruments. The FERRANTI Radio Meter overcomes this difficulty.

Radio Meter No. 20SF permanently connected in your set will enable you, merely by turning the small switch, to read: The L.T. voltage applied to the filaments of the valves; the H.T. voltage applied to the anode of the output valve; the total anode current of the receiver. If you are desirous of getting the best out of your receiver, incorporate a FERRANTI Radio Meter.

Write for Pamphlet W2406.

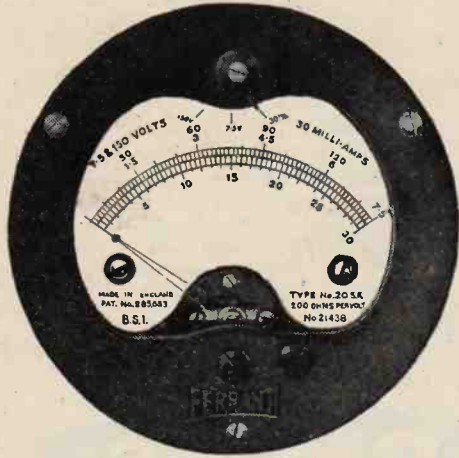

No. 20SF. Price £2 : 10 : 0

FERRANTI LTD. HOLLINWOOD LANCASHIRE

The LEWCOS 3 VALVE KIT

RECD.

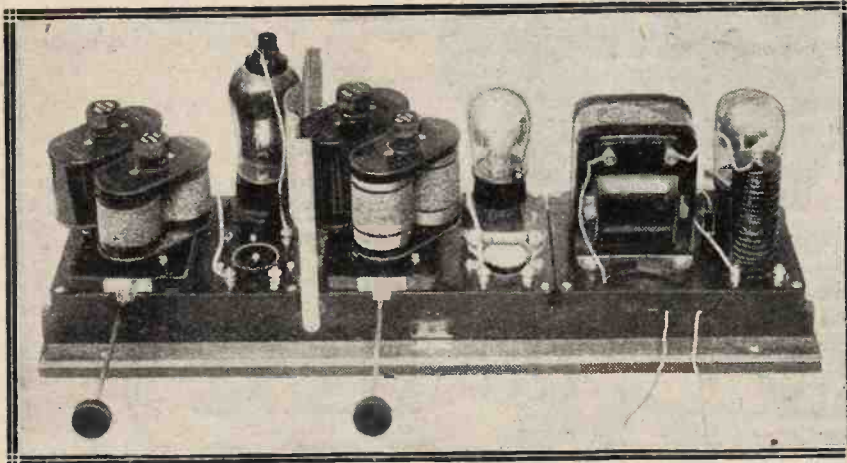

enables a complete receiver to be constructed in 15 MINUTES.

Eliminating troublesome complications, the Lewcos 3 Valve Kit, designed for use with either D.C. or A.C. Valves, enables a safe and satisfactory all-mains receiver to be built in fifteen minutes. Highly satisfactory results of quality and strength, combined with selectivity and sensitivity, are provided by this receiver.

"Valve," of the Nottingham Journal, says of the Lewcos 3 Valve Kit:—"The whole thing is strongly built and an extended trial HAS NOT FOUND A WEAK SPOT IN IT, using D.C. or A.C. Valves. Over fifty stations were logged by me the first week I used this unit, the quality and strength being far above normal."

SEND TO-DAY FOR BOOKLET R.58.

This free booklet fully describes the construction, assembly, working and performance of one of the most efficient circuits ever conceived.



LEWCOS Radio products for better reception

THE LONDON ELECTRIC WIRE COMPANY AND SMITHS, LIMITED,
CHURCH ROAD, LEYTON, LONDON, E.10.
Playhouse Yard, Trade Counter: Golden Lane, London, E.10.



BECAUSE of its Interlocked Construction the *NEW* Cossor Screened Grid has a degree of strength never before attained in any valve. Unit by unit its elements are assembled — each joint electrically welded — each unit reinforcing and locking the previous one until the whole structure assumes a girder-like rigidity. Even the hardest blow cannot disturb its perfect alignment. For strength, for power and for long life use the *NEW* Cossor Screened Valve in your Receiver, no other make has Interlocked Construction.

**2-volt type
now available.**

Cossor 220 S.G. (2 volts, .2 amp.) Anode volts 120-150, Impedance 200,000 Amplification Factor 200. Price **22/6**

Cossor 4 and 6 volt Screened Grid Valves are also available with similar characteristics at the same price.

The NEW COSSOR Screened Grid Valve

A. C. Cossor, Ltd., Highbury Grove, London, N.5.

3881. 

The Wireless World

AND
RADIO REVIEW
(17th Year of Publication)

No. 548.

WEDNESDAY, FEBRUARY 26TH, 1930.

VOL. XXVI. No 9.

Editor: HUGH S. POCOCK.
Assistant Editor: F. H. HAYNES.
Editorial Offices: 116-117, FLEET STREET, LONDON, E.C.4
Editorial Telephone: City 9472 (5 lines).
Advertising and Publishing Offices:
DORSET HOUSE, TUDOR STREET, LONDON, E.C.4.
Telephone: City 2847 (13 lines). Telegrams: "Ethaworld, Fleet, London."
COVENTRY: Hertford Street.
Telegrams: "Cyclist, Coventry." Telephone: 5210 Coventry.
BIRMINGHAM: Guildhall Buildings, Navigation Street.
Telegrams: "Autopress, Birmingham." Telephone: 2970 and 2971 Midland.
MANCHESTER: 260, Deansgate.
Telegrams: "Hiffe, Manchester." Telephone: 8970 City (4 lines).
GLASGOW: 101, St. Vincent Street, C.2.
Telegrams: "Hiffe, Glasgow." Telephone: Central 4857.

PUBLISHED WEEKLY.
Subscription Rates: Home, £1 1s. 8d.; Canada, £1 1s. 8d.;
other countries abroad, £1 3s. 10d. per annum.

Entered as Second Class Matter at New York, N.Y.
As many of the circuits and apparatus described in these pages are covered by
patents, readers are advised, before making use of them, to satisfy themselves
that they would not be infringing patents.

CONTENTS OF THIS ISSUE.

| | PAGE |
|--|------|
| EDITORIAL VIEWS | 213 |
| SELECTIVITY OF COUPLED COILS. BY A. L. M. SOWERBY | 214 |
| THE NEW "FOREIGN LISTENER'S FOUR" (CONCLUDED). BY F. H. HAYNES | 220 |
| CURRENT TOPICS | 225 |
| BROADCAST RECEIVERS. PYE FOUR-VALVE SET | 227 |
| BROADCAST BREVITIES | 229 |
| WIRELESS THEORY SIMPLIFIED. PART XXI. BY S. O. PEARSON | 230 |
| NEW APPARATUS REVIEWED | 233 |
| CORRESPONDENCE | 235 |
| READERS' PROBLEMS | 237 |

SHORTER BROADCASTING HOURS.

WE are told that one of the principal obstacles in the way of providing better broadcast programmes is the insufficiency of the funds at the disposal of the B.B.C. for expenditure on programme matter. At the same time, artistes complain of the absurdly meagre fees offered to them by the B.B.C. for their performances, and the public, in turn, criticises the programmes for their mediocrity.

It is probably useless to propose that the B.B.C. should receive a larger proportion of the revenue derived from licences; at the same time it would be neither just nor profitable that the best artistes should be prepared to broadcast for totally inadequate recompense.

What, then, is the remedy for the present state of affairs? We venture to suggest that some effort might usefully be made to ascertain how far the programme matter could be improved upon, at the same time retaining the alternative programmes of the regional scheme, if the number of broadcasting hours were curtailed so that all the available funds could be concen-

trated to provide programmes of first-class quality but restricted in quantity. Such an arrangement need not in any way interfere with the educational broadcasts and talks, for these are comparatively unimportant items in the arrangement of the B.B.C. programme budget.

The Limit of Broadcasting Hours.

The number of hours during which the B.B.C. broadcasts is a self-imposed maximum. In the B.B.C.'s licence from the Postmaster-General the limit of hours of transmissions is indicated, but there is no suggestion that the whole, or even a major proportion of the time available should be used.

It is not necessarily to the credit of the B.B.C. that at the end of each year they should be able to publish imposing figures indicating the total number of hours during which their stations have transmitted programme matter if the programmes have been of a poor average quality, for the public would, we believe, welcome a change which resulted in fewer hours of broadcasting but better programmes and better artistes as microphone performers.

The programme time might be more definitely divided into entertainment and educational hours. As an example, we might suggest that 8.30 to 10.30, or even shorter hours two or three times a week, should be an entertainment programme of good quality, when first-class artistes would be engaged so far as possible and the programme would be unbroken by talks and kindred matter.

The "My Programme" Idea.

Such an arrangement would also facilitate the development of the "My Programme" idea, when each entertainment programme would be of a particular type and character, instead of being a mixture only small items of which appeal to any particular group of individuals.

In our view the whole system of British broadcasting is to-day losing its position because too much is attempted in the way of filling every available minute with some sort of transmission, however poor in quality. The success of a book is not dependent upon its bulk but on the quality of its contents, and however much ability an author may show in individual chapters, the book as a whole will be condemned if the good in it is lost amongst pages of padding.

So it is with the programmes. Broadcasting would earn more respect and be more widely appreciated if the public were not satiated with mediocre entertainment matter.

SELECTIVITY OF COUPLED COILS

By A. L. M. SOWERBY, M.Sc.

Taking Account of the Effect of Coil Resistance.

As there have been a number of articles on band-pass filters—or coupled circuits—in recent issues of *The Wireless World*, we will not waste much time on preliminaries, though there must be just a word for those who have missed earlier articles.

If two tuned circuits are not coupled to one another, each has its own normal resonance curve, and the overall

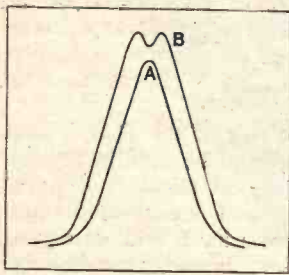

Fig. 1.—A is typical of the overall resonance curve of two tuned circuits that are not directly coupled to one another, but are separated by a valve. B shows the type of curve that arises when there is coupling between the two circuits. In each case, the curve shown is the joint curve of the two circuits taken together.

curve of the two circuits is given by the product of the two individual curves. The result is of the type illustrated at A in Fig. 1. Such a case arises when a valve is interposed between the two tuned circuits, as in a high-frequency amplifier of conventional design. But if, on the other hand, the two circuits are coupled together, their resonance curves are no longer independent, for each circuit can react on the other. In consequence a new type of resonance curve, of the kind illustrated at B in Fig. 1, makes its appearance.

If we compare these two curves we shall see why it is that band-pass filters are exciting so much interest. Both curves show good selectivity, for both have steeply falling sides. But in curve A the drop from the maximum begins practically at the wavelength to which the circuits are tuned, while curve B has a flat top, so that its selectivity does not become effective until reaching a wavelength a few metres away from the centre of the curve. This is exactly what is wanted in broadcast reception, for the transmissions from a telephony station occupy a small band extending for some five kilocycles on either side of the advertised frequency on which the station operates. If we use a receiver with a curve like that shown at A, we shall cut off, not only stations on neighbouring wavelengths, but also part of the transmission that we desire to hear. Curve B, on the other hand,

is hardly less effective in cutting off other stations, while allowing us to receive intact the programmes of the station to which we are listening. Since the outer frequencies of the band carry the high notes, it is these that we shall lose if our receiver has a response curve like curve A.

The rest of the present article will be devoted to a discussion of the means available for attaining a curve of the right shape, having a flat top of the right width to be a neat fit on the transmitter's frequency band.

The Effect of Coil Resistance.

The resistance of the tuned circuit is commonly omitted from consideration when discussing the correct coupling to use between the two coils of the filter. For the conditions arising in a receiving circuit, however, this is seldom justifiable, for the separation between the peaks is generally required to be small in comparison with the frequency of the received signal. Where this is the case, the coil resistance plays a very large part in determining the shape of the resonance curve.

In Fig. 2 are shown three calculated resonance curves. They refer to two coils, with the same coupling throughout, the difference between one curve and another being due to assuming different coil resistances for the calculation. It is to be observed that as the resistance of the coils is increased the two peaks that are so marked a feature of the curve R_1 flatten out and come together, until in the curve R_3 , which corresponds to a resistance

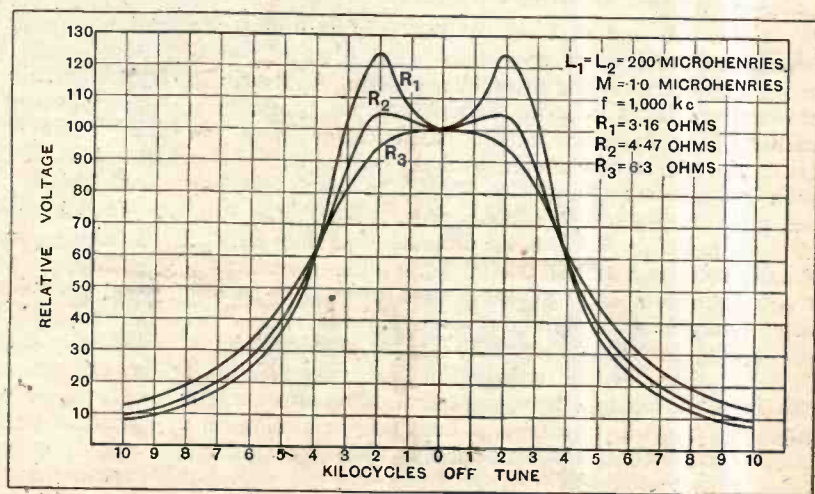

Fig. 2.—Effect of coil resistance on resonance curve of filter. As the resistance is increased the filter behaves more and more like a single tuned circuit.

Selectivity of Coupled Coils.—

only twice as great as that of curve R₁, they are replaced by a single peak, as the inmost curve shows.

It is interesting to notice that the behaviour of the filter, over the range of resistances considered, is exactly the opposite of that of ordinary tuned circuits. In the latter, an increase in resistance adds to the proportion of side-bands transmitted, and so tends to improve the reproduction of high notes. With the filter of Fig. 2 the exact opposite is the case. the increased resistance

the peaks in the resonance curve of a filter composed of two identical coils of inductance L, each separately tuned to resonance with the incoming signal, is given by:

$$d = \frac{\sqrt{39.5f^2M^2 - r^2}}{6.28L} \text{ cycles,}$$

where M = mutual inductance between coils
r = equivalent series resistance of each tuned circuit.

The theoretical circuit corresponding to the conditions is shown in Fig. 4 (a). For the circuit of Fig. 4 (b) the same expression holds, if M is now used to represent the small inductance common to the two tuned circuits, and if there is absolutely no coupling between the two main coils. (Which means, in practice, separating them by a screen.)

If the two circuits are coupled by a condenser C_m, as in Fig. 4 (c), the distance between the peaks of the resonance curve is given by the very similar expression:

$$d = \frac{\sqrt{0.0253 f^2 C_m^2 - r^2}}{6.28L} \text{ cycles.}$$

Using any of these three circuits, there is no difficulty in calculating, by the appropriate formula, a filter that will have any desired separation between its peaks at any one wavelength. It is clear, however, that as the peak separation d depends on f, the frequency of the received signal, and on r, the series resistance of the tuned circuit, the peaks will not remain at the same distance apart as we tune the coupled circuits to various frequencies within their range. The general behaviour of the filter can be seen, very roughly, in which case the peak separation is proportional to the frequency when inductive coupling is in use, and pro-

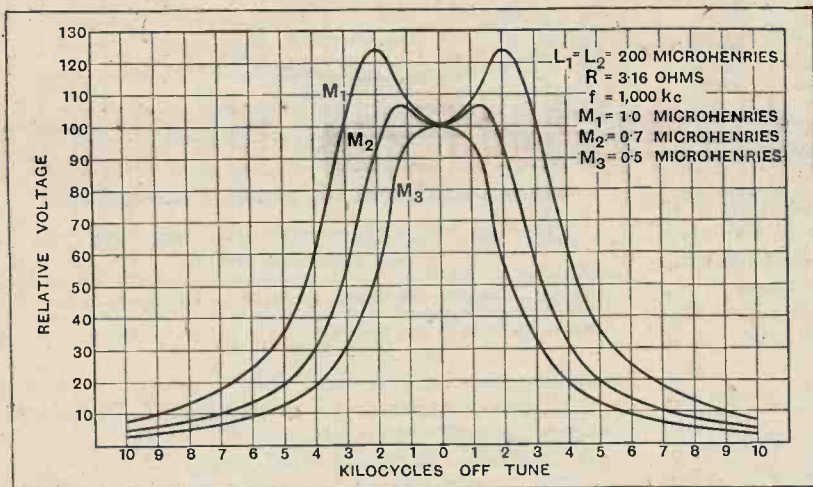

Fig. 3.—Effect of coupling on resonance curve of filter. As the coupling is loosened the filter behaves more and more like a single tuned circuit.

decreasing the proportion of side-bands transmitted by smoothing out the peaks of the curve.

Fig. 3 shows the variation in shape of the resonance curve of the same filter with change in coupling. The coils are the same as those of Fig. 2, the resistance being taken at the lowest of the three values, so that the outermost curve of both diagrams is the same. In this figure, starting with the same filter (M₁) the increase of resistance is replaced by a decrease in the coupling between the two coils, the mutual inductance required to produce the inmost curve being just half that for the outermost. The change in the shape of the curves due to this new cause is similar in kind, though different in degree, to that arising from increasing the resistance.

Comparison of the two figures will make it clear that closer coupling is required with coils of higher resistance, and that if the resistance of the coils is neglected in calculating the proper coupling, the resonance curves of the finished filter will have a shape very different from that intended.

It can be shown¹ that the distance in cycles between

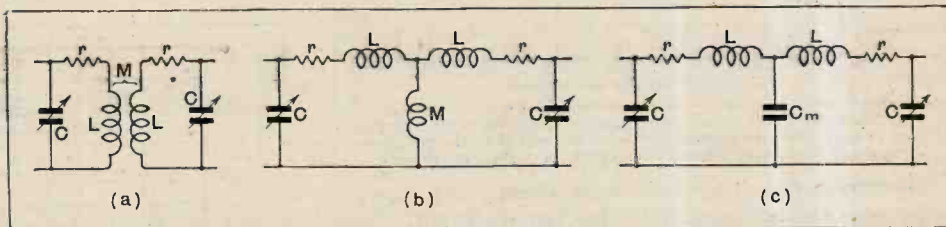

Fig. 4.—Three types of band-pass filter. In (a) the coils are coupled by being placed near to one another, M being their mutual inductance. In (b) the small inductance M, and in (c) the capacity C_m, are common to the two tuned circuits, and so serve to couple them together.

portional to the square of the wavelength when the circuits are coupled by a capacity.

In the case of inductive coupling, this implies that at the longer wavelengths the effective band of frequencies passed by the filter will be much less than at the lower wavelengths, thus increasing both selectivity and high-note loss towards the upper end of the tuning scale. If the filter is to be associated with

¹ E. A. Uehling, in "Proceedings of the Radio Club of America," November, 1929

Selectivity of Coupled Coils.—

ordinary tuned circuits in other parts of the receiver, this effect will be emphasised, for the single tuned cir-

TABLE I.

| Wavelength. (Metres.) | a | b | c | d |
|--------------------------|------|------|--------|--------|
| 200 | — | 2.90 | — | 0.0039 |
| 225 | 3.62 | 2.66 | 0.0039 | 0.0052 |
| 250 | 3.18 | 2.51 | 0.0055 | 0.0070 |
| 275 | 3.02 | 2.46 | 0.0070 | 0.0086 |
| 300 | 3.04 | 2.44 | 0.0083 | 0.0103 |
| 350 | 3.07 | 2.46 | 0.0112 | 0.014 |
| 400 | 3.19 | 2.59 | 0.0141 | 0.017 |
| 475 | 3.52 | 2.94 | 0.0180 | 0.022 |
| 550 | 4.00 | 3.32 | 0.0213 | 0.026 |

cuit is also more selective at the long-wave end of its range.

With capacitive coupling, the opposite effect is found, the filter tending to become more selective at the lower end of the scale. If ordinary tuned circuits, therefore, are associated with a capacity-coupled filter, we should be able to obtain a receiver in which the overall response is reasonably constant from 200 to 600 metres.

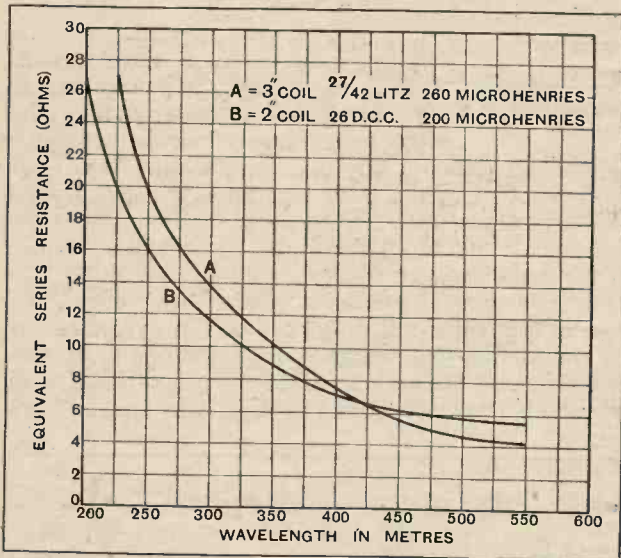

Fig. 5.—Equivalent series resistance of tuned circuits. In the case of both coils the resistances were measured in the presence of normal dielectric losses, the effect of which is included.

These remarks, it must be remembered, are based on neglecting the resistance of the tuned circuit. This, however, introduces a further complication; first, because it appears in the formula for band-width, and, secondly, because it does not remain constant over the tuning range of the coil.

In Fig. 5 is given the measured equivalent series resistance of two typical tuned circuits, one comprising a coil of "low-loss" construction (Litz), the other comprising a coil designed to be a compromise between compactness and efficiency. Using these results as a basis, the extent of coupling necessary to provide a resonance curve with an 8-kilocycle separation between

its peaks has been calculated at a number of wavelengths for each of the four possible cases. The results are given in Table I, in which the lettering of the columns identifies the following quantities:—

(a) Mutual (or common) inductance in microhenries for filters of circuit 4 (a) or 4 (b) using Litz coils.

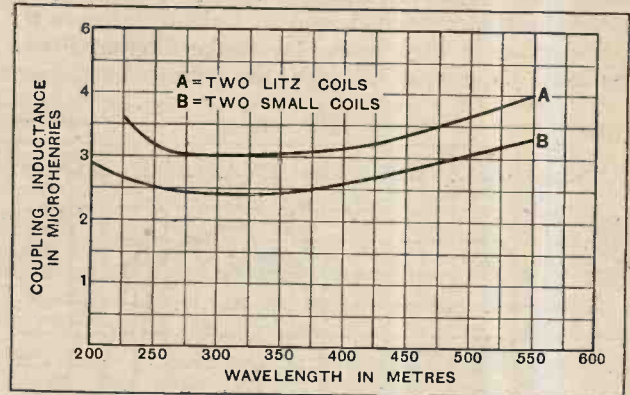

Fig. 6a.—Coupling inductance required for 8 kc. peak separation in filter composed of two Litz coils in the case of A, and two small coils in the case of B. The circuit is that of Fig. 4 (a) or 4 (b).

(b) The same, using small coils.

(c) Common capacity in microfarads for filters of circuit 4 (c) using Litz coils.

(d) The same, but using small coils.

In Fig. 6 these results are plotted. It is instantly apparent that if a capacity-coupled filter of the circuit of Fig. 4 (c) is to be used, it will be necessary to arrange for very extensive variations in the value of the coupling capacity if the waveband accepted by the filter is to be kept even reasonably constant. Our drooping hopes are revived again when we contemplate the pleasant flatness of the curves of Fig. 6a, where we see that the mutual or common inductance of circuit 4 (a) or 4 (b) requires to be varied by only some 25 per cent. to keep the waveband passed by the filter at a constant width over the whole range of wavelengths that the coils will cover. This means that the resistance of the coils, as measured under practical receiving conditions, changes

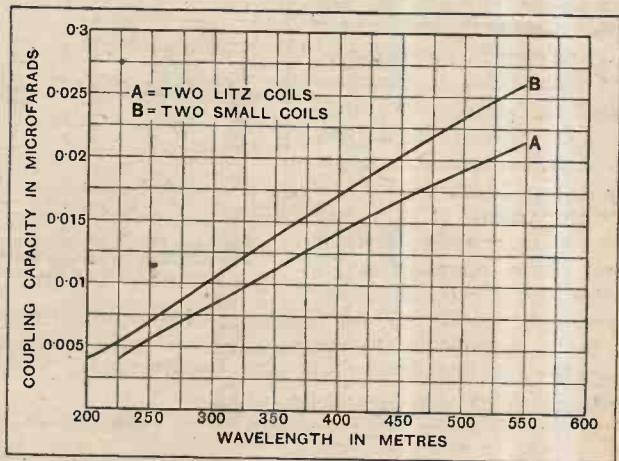

Fig. 6b.—Coupling capacity required for 8 kc. peak separation in filter composed of A two Litz coils, and B two small coils. The circuit is that of Fig. 4(c).

Selectivity of Coupled Coils.—

with wavelength in such a way as to compensate almost completely for the variation with wavelength of the impedance ($2\pi fM$) of a fixed coupling inductance M . It is purely an accident that this is so, but it is an accident of considerable importance from the point of view of the design of band-pass filters.

The next step, evidently, is to calculate the peak separation that we shall obtain at different wavelengths with a fixed coupling. On the assumption that it is better to accept a little loss of sidebands than a decrease in selectivity, the coupling inductance has been chosen on the low side, and is taken as 2.50 microhenries for the small solid-wire coils, and 3.25 microhenries for the larger Litz coils. On this basis, the separation of the peaks of the resonance curve of the complete filter works out as in Table II.

Filter Effect Not Needed for Lower Wavelengths.

The extraordinarily rapid disappearance of the two peaks at the lower end of the waveband covered by each coil is very clearly shown in Fig. 7, in which Table II is plotted as curves. This sudden drop is due to the rapid rise of circuit resistance at these wavelengths, and is caused by dielectric losses. It is particularly interesting to note that the contraction of the waveband passed by the filter at these wavelengths is, if coil resistance be neglected, the leading characteristic of the *capacity*-coupled filter. The fact that there are no actual peaks on the resonance curves at the lowest wavelengths must not be taken to mean that there will be any considerable loss of side-bands,

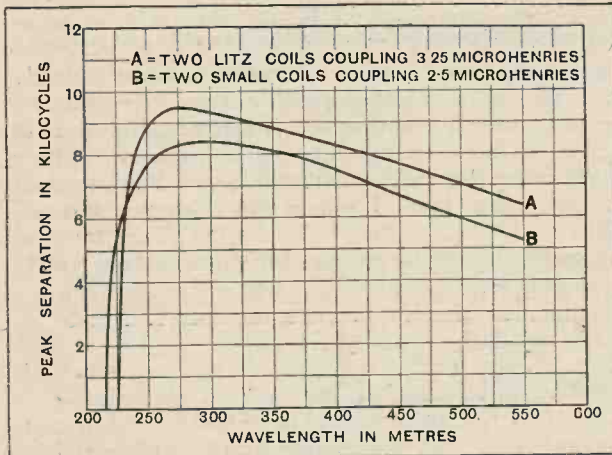

Fig. 7.—Variations of peak separation in inductively coupled filter incorporating:—A, two Litz coils, coupling 3.25 microhenries; and B, two small coils, coupling 2.50 microhenries.

because the tuning capacity is small enough and the resistance of the circuit high enough to ensure that the normal single-humped curve is reasonably flat. With normal circuit design, the filter effect is not needed at or below 250 metres, so that its disappearance need cause no regrets.

Fig. 8 shows the resonance curves, at 250 and at 550 metres, of two Litz coils *in cascade*—i.e., as successive tuned circuits, separated by an amplifying valve, and not giving the band-pass filter effect. At

550 metres, these two circuits pass a 5,000-cycle note (5 kc. off tune) at 6.1 per cent. of the strength of a low note, but at 250 metres a 5,000-cycle note is passed at 61 per cent. of the lowest. In practice, this means that reproduction at 550 metres would be bad, music being reproduced with so very "mellow" a tone that it would be quite impossible to recognise individual

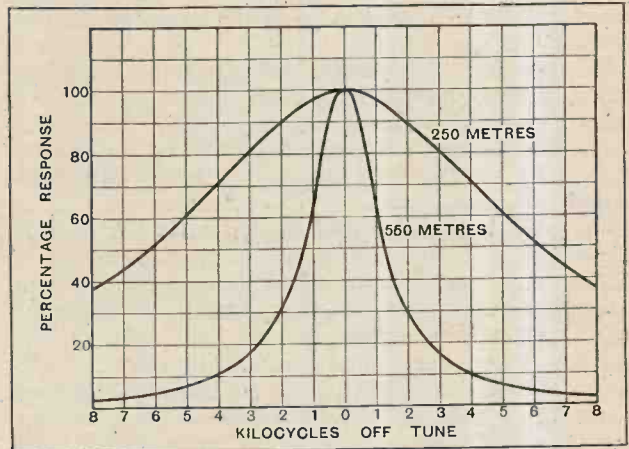

Fig. 8.—Resonance curves of two Litz circuits in cascade, at 250 and 550 metres.

instruments in an orchestra. At 250 metres, on the other hand, music would be near enough to perfection to please most people, so that a filter circuit in which the band-pass effect dies out at low wavelengths will nevertheless be perfectly satisfactory.

Fig. 9 shows, to a two-way logarithmic scale, the response curves of a filter of two Litz coils coupled by

TABLE II.

| Wavelength. (Metres.) | Peak Separation in Kilocycles. | |
|--------------------------|--------------------------------|-------------|
| | Small Coils. | Litz Coils. |
| 200 | 0 | — |
| 225 | 5.21 | 0 |
| 250 | 7.75 | 8.0 |
| 275 | 8.3 | 9.5 |
| 300 | 8.4 | 9.2 |
| 350 | 8.1 | 8.8 |
| 400 | 7.5 | 8.25 |
| 475 | 6.3 | 7.3 |
| 550 | 5.2 | 6.4 |

3.25 microhenries of mutual inductance. One curve relates to 250 metres, at which wavelength the double peaks hardly exist, and the other to 550 metres. At both wavelengths the side-bands are well retained, but it will be noticed that the selectivity at 250 metres is very poor, interfering stations 50 kilocycles away from that being received being heard at some 4 per cent. of their strength at resonance. At 550 metres the selectivity is better, stations removed 50 kilocycles from that to which the filter is tuned being received at only 0.55 per cent. of their full strength. This effect, however, has nothing to do with the filter as such, but is a result of the properties of the two simple tuned circuits from which it is built up.

Selectivity of Coupled Coils.—

Fig. 10 shows the resonance curves obtained at 225 and 550 metres with a filter consisting of two of the small solid-wire coils, coupled by 2.50 microhenries of mutual inductance. It is interesting to note that the formula for the separation of the peaks of the curve gives this as 5.2 kilocycles for each of these two wavelengths. The figure shows very clearly that this does not ensure that the selectivity is the same at the two wavelengths.

Although inductance-coupled filters with fixed coupling can be made to provide a peak separation that is nearly constant over the whole tuning range, they cannot give constant selectivity. A closer approach to this can be attained by employing a suitably designed filter with capacity coupling.

Since it is improbable that the one filter will provide all the tuning in the receiver, it becomes interesting to enquire how the filter performs in conjunction with ordinary tuned circuits used as intervalve couplings. Fig. 11 gives some information on this point, on the supposition that Litz-wound coils will be used throughout. Even in the worst case, where two coils are used as intervalve couplings in addition to the filter, making four tuned circuits in all (coupled aerial circuit, and two high-frequency amplifying stages each with a single tuned circuit), the loss of side-bands at 550 metres,

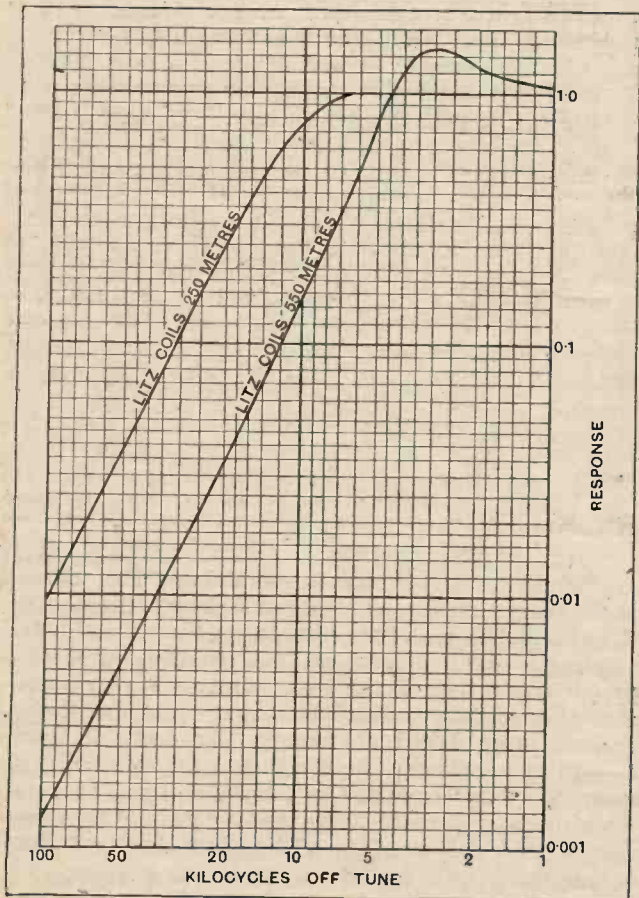

Fig. 9.—Resonance curves, at 250 and 550 metres, of filter consisting of two Litz coils, coupled by 3.25 microhenries.

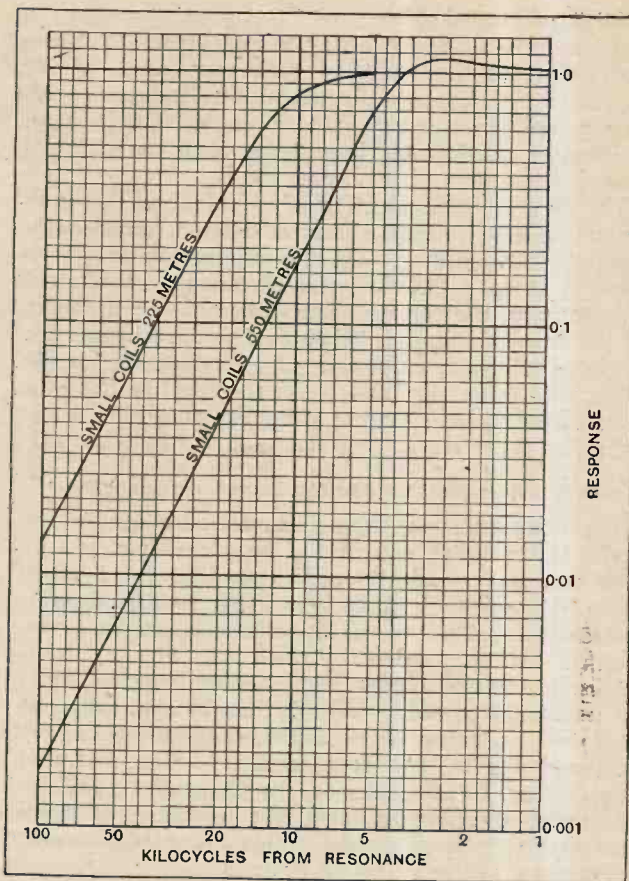

Fig. 10.—Resonance curves at 225 and 550 metres of filter consisting of two compact 2in. coils coupled by 2.50 microhenries.

though very considerable, is not prohibitive. Many simple sets, with only two tuned circuits, have a much greater side-band loss than this when a fair amount of reaction is used, while the selectivity is very poor indeed compared with that shown in Fig. 11. At 250 metres the loss of side-bands is completely negligible.

In preparing these curves, the effect of the valves in damping the intervalve coils was not taken into consideration, so that in practice the loss of side-bands will be decidedly less than is shown.

Fig. 12 gives similar resonance curves, with the same neglect of valve damping, for the case where Litz coils are used in the filter (where the filter action prevents side-band loss), but the smaller and less efficient coils are used as intervalve couplings.

Finally, the reader may very sensibly ask what use all these carefully calculated curves will be to him if he has not got the coils on whose measured resistance they are based, and if he has no means of ensuring that the coupling between the filter coils is that chosen for the calculation.

The Litz coil measured was a standard *Wireless World* coil, wound with 72 turns of 27/42 Litz on a six-ribbed ebonite former of nominal diameter three inches (3in. overall). The "compact coil"² was wound,

² For further details of this coil see "Size versus Efficiency of Small Coils," *The Wireless World*, Jan. 29th, 1930.

Selectivity of Coupled Coils.—

turns touching, with 80 turns of No. 26 S.W.G. d.c.c. wire on a two-inch paxolin former.

It is not easy to define exactly a means of providing a coupling between the coils that will give a mutual inductance of the right value; if correct relative positions of the coils were calculated, as they might be, it is more than probable that stray capacity couplings would step in and upset the adjustment. Instead, it

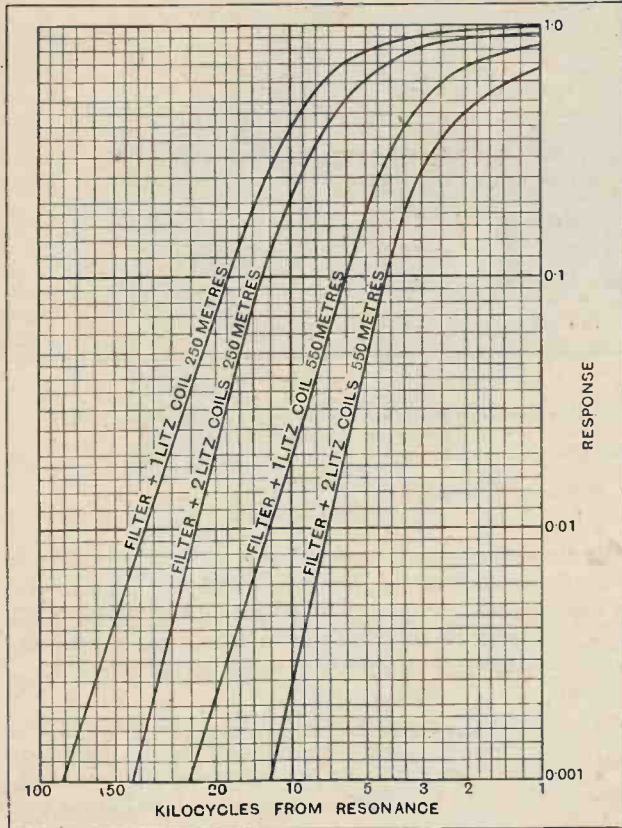

Fig. 11.—Resonance curves of filter using two Litz coils in conjunction with one or two Litz coils as single circuits.

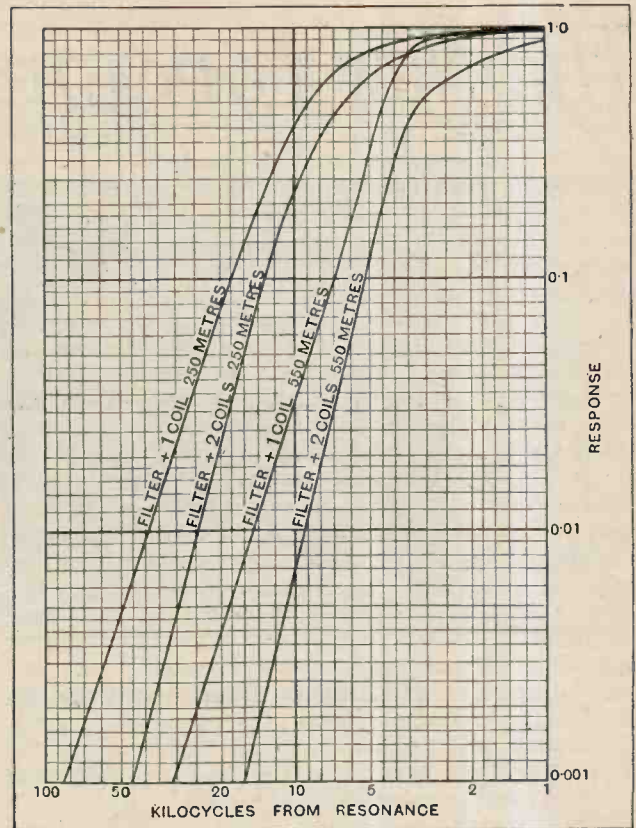

Fig. 12.—Resonance curves of filter using two Litz coils in conjunction with one or two small coils as single circuits.

is suggested that the circuit of Fig. 4 (b) be adopted, the coils being set with their axes at right-angles, and separated by a screen in the form of a metal sheet. The common inductance between the two circuits can then be provided by winding, on a one-inch former, 9 turns of No. 22 d.c.c. wire to couple the small coils, or 11 turns to couple the Litz coils. The coupling inductances so provided will be 2.55 and 3.49 microhenries respectively if they are wound with successive turns in contact.

Amateurs to the Rescue.

The winter gales in America caused unusual havoc among telegraph and telephone lines, especially in the western parts of the State of New York. The Niagara Falls Power Company found themselves cut off from Buffalo and Lockport, and enlisted the help of Mr. W. B. Russell, W8OA, who got into touch with Mr. H. T. Barker, W8ADE, and Mr. C. S. Taylor, W8PJ, at Buffalo, and with Mr. T. W. Connette, W8FM, at Lockport.

These four amateur stations, aided by others in their neighbourhoods, were not only able to keep up communication between their respective towns, but rendered invaluable help to the Lackawanna Railroad by keeping in touch with Binghamton and Scranton, without which it is probable that traffic on that section of the railway would practically have ceased.

A 17

TRANSMITTERS' NOTES.

Mr. H. D. Miller, W8DQP, at Glen Falls, kept up constant communication with Schenectady for seventy-two hours, with only four hours' sleep; he was doubly handicapped by the fact that the electric power supply had failed, and he was forced to work with an accumulator hastily rigged up, while the weight of ice several times brought down his aerial and added considerably to his labours.

Misuse of Call-Sign.

Mr. R. H. N. Johnston asks us to state that he has received several reports of transmissions from G2ZP, although he has

not used his station, of which that is the call-sign, since January 15th, and does not expect to return home until April 15th. Anyone, therefore, using the call-sign G2ZP between these dates must be a "pirate," and Mr. Johnston asks that the calls should be ignored by other transmitters.

Transatlantic Notes.

Five-metre signals from Hartford, Conn., have been successfully received at San Diego, California, a distance of 3,000 miles.

VRY is the call-sign of the Post Office Department, Engineering Branch, Georgetown, British Guiana. This station works on 43.86 metres between 24.00 and 02.00 G.M.T.

G2GN, the experimental telephony set on S.S. "Olympic," has been heard in Ohio, working on 17 metres with G2AA.

The New "Foreign Listener's Four"

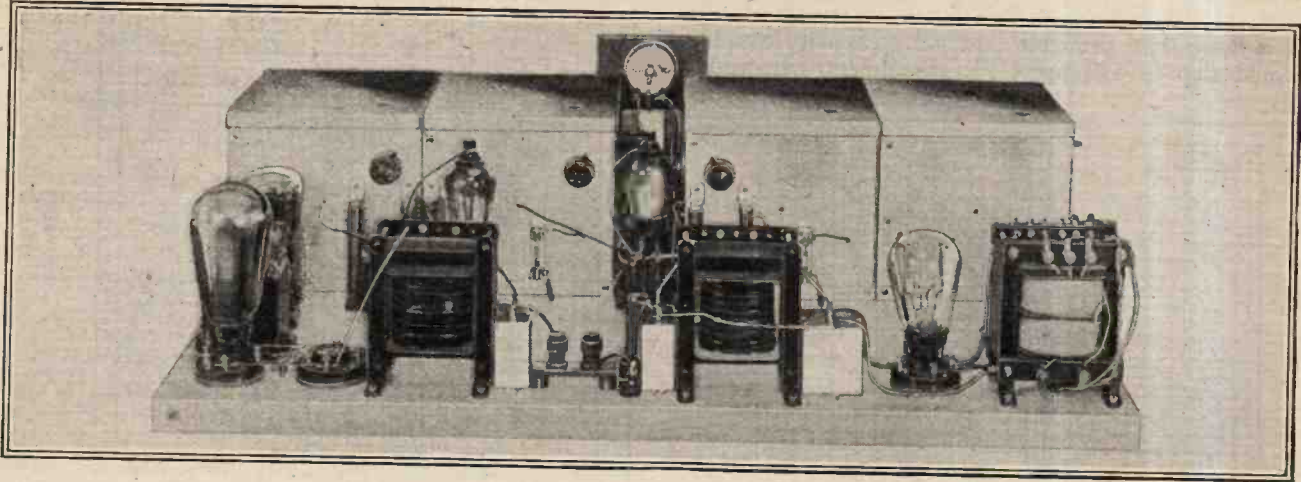

A Single Dial Long-range Receiver for A.C. Supply.

By F. H. HAYNES.

(Concluded from page 161 of February 12th issue.)

CONSTRUCTIONALLY the set takes the form of a chassis, and ample room is provided in the screening boxes to permit of easy wiring. The generous area left at the back of the baseboard allows of subsequent modification of the L.F. amplifier and output stage to suit more ambitious needs while giving liberal spacing from the A.C. carrying components. Apart from low cost the merit of the home-built set is that it can be readily altered as new ideas suggest themselves. After providing a good flat baseboard, the next step is that of rigging up the two centre boxes on to the brackets of the drum dial. Positions are not shown in the drawings for the condenser fixing holes, and instead of measuring up any given distance one arranges that the aluminium piece joining the two brackets has its lower edge as near to the base as possible and its front face flush with the screening boxes. This gives the approximate position of the spindle as $3\frac{1}{8}$ in. from the base and $1\frac{3}{8}$ in. from the front. Great care must be taken in correctly aligning the condensers, but no difficulty should be experienced if the positions are marked off on the assembled boxes with a pair of dividers measuring from both base and front edge. Two 10 in. lengths of $\frac{1}{4}$ in. silver steel link the condensers together and are clamped into the two sides of the drum dial by the pair of grub screws.

For a purely experimental type of receiver all condensers may be clamped on to the right-hand side of the boxes as viewed from the front, omitting the space between units 2 and 3, driving a $\frac{1}{4}$ in. spindle right through the four condensers and connecting a geared drum dial to a projecting end. The tuning panel can

thus be brought to the end of the set and the volume control transferred. A piece of cardboard about $\frac{1}{16}$ in. in thickness is clamped between adjoining boxes, while it is necessary to substitute countersunk screws for the raised headed type supplied in order to allow the boxes to come close together.

No difficulty will be met with in mounting the switches as small differences in aligning the holes can be tolerated. A piece of $\frac{1}{8}$ in. square steel is merely pushed through the square holes in the switches, and even a loose fit provides a positive drive, thus readily overcoming the mechanical difficulties of producing a good alignment. Negligible capacity is presented between the blades of these switches, an important detail when connected across part of a tuned circuit. A collar with grub screws is slipped on to the square rod to prevent its withdrawal, as shown in the drawing on page 160 of the issue of February 12th.

Hints on Assembly.

Pieces $2\frac{1}{2}$ in. long sawn from a $\frac{3}{4}$ in. square length of wood elevate the coils from the baseboard, allowing the $\frac{1}{4}$ in. square steel rod to run underneath. In addition to the holes required in the back of units 2, 3 and 4 for fixing the trimming condensers, $\frac{1}{2}$ in. holes are made in the two sides of unit 1 and the left-hand side of unit 2 at a distance of $1\frac{1}{2}$ in. from the top and 2 in. from the back in order that short 4 B.A. spindles may be passed through, carried on thin ebonite insulating pieces. These support the aerial and first coupling condensers. As an alternative these condensers may be soldered on to tags and supported vertically under the

The New "Foreign Listener's Four."

screws on the coil base, as is done in units 3 and 4. A $\frac{1}{8}$ in. hole is made in the left-hand side of unit No. 3 at a distance of $2\frac{1}{2}$ in. from the back and $1\frac{1}{2}$ in. from the top to support the H.F. grid biasing resistance. All other holes are at the back, and can therefore be made after assembly.

Before finally assembling the ganged condensers and switches the baseboards are dropped into position, all

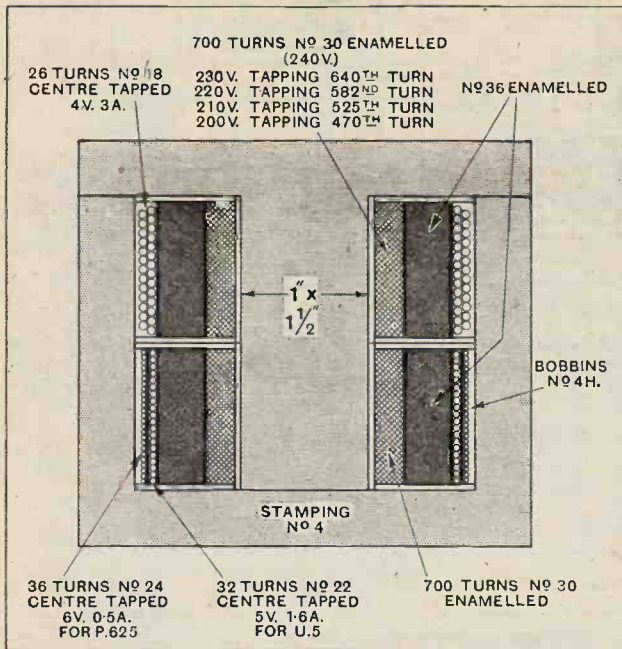

When used with the single P.625 output valve the 36 gauge winding consists of 1,500 + 1,500 turns. Practical hints on the making up of small transformers of this type have been given in recent articles.

bridging condensers, the blocks of wood and the grid condenser having been fixed. After completing the inside assembly it is an easy matter to attach the voltage regulating resistances, which are of a type consisting of fine wire windings on glass tubes, two of them being potentiometers and three voltage dropping resistances. Porcelain grid-leak holders are mounted on units 2 and 3. To provide adequate screening for the first H.F. valve it is dropped into the recess between units 2 and 3. More complete screening of these valves, as suggested by the manufacturers, was first used, but with the layout adopted no noticeable difference as regards oscillation was to be found. It is important that the valves be screened from the tuning apparatus, while in general the use of close-fitting tubular screens is advised.

Convenience of wiring accounts for the particular arrangement of the components of the detector and output stages and the H.T. eliminator. In spite of the use of screening boxes, wiring up, usually a difficult matter, will be found quite straightforward. The leads run from point to point in small gauge sleeving (1 mm.) without any attempt at shaping wires other than is required to avoid the swinging of condenser plates. When a rigid wire is needed, No. 18 tinned copper has been used, and in other cases, No. 22. As most people wire from a theoretical diagram, this has been repro-

duced on page 157 in a modified form so as to show the actual points of branching. By making the junctions to the points shown undesirable couplings, which might be produced by a lead being common to more than one circuit, have been avoided. A.C. carrying leads are run as twisted pairs beneath the baseboard. Likewise, the main H.T. positive and the grid biasing leads of the H.F. stages are best taken under the base.

Need for Testing the H.F. Stages.

In order to get the best out of the set, too much reliance must not be placed in the working of the eliminator without careful test. Not that the eliminator will fail to deliver its stated output, but rather that the H.F. valves vary in their requirements. Considerable variations have been found in the anode current taken by indirectly heated screen-grid valves, so that if the voltage regulating resistances possess the right value, assuming an anode current of 2 mA., they will be widely wrong with a current of 1.5 mA. It is a wise plan, therefore, by way of preliminary test, to run only the output stage from the rectifier providing the grid bias and anode potentials for the first three valves, from an H.T. battery. To do this, disconnect the leads from the biasing resistances and connect them to earth through a 1 1/2-volt cell so as to apply a negative bias. Earth the negative side of the H.T. battery and tap off 65 to 100 volts to the screen leads and 200 volts to the anodes. If a low-reading milliammeter is available, verify the current taken by the screens and anodes, which should be 2 mA. and 0.5 mA. respectively for each valve. As the screen voltage is increased the point of oscillation will be reached, probably occurring at about 100 volts on the broadcast range and a little earlier on the long-wave setting. Good valves will give

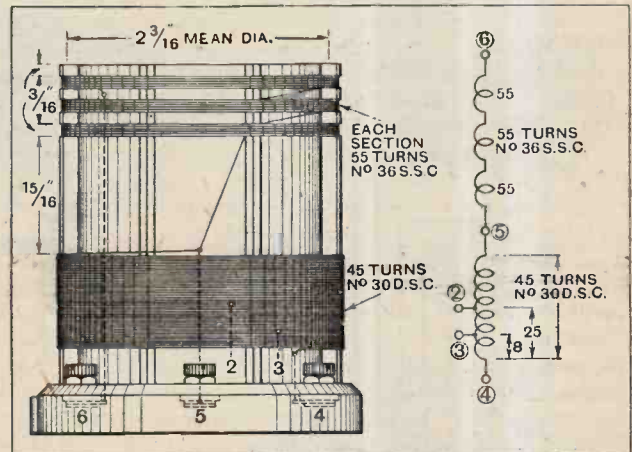

The coil windings. Greater selectivity will result by using terminal No. 2 instead of No. 3 in respect of the first and second coils and connecting the grid lead of the fourth coil to terminal No. 2 instead of No. 4, to which the condenser lead is run. When using an additional H.F. stage in place of the filter connect to terminal No. 2 instead of No. 3 throughout and join the grid lead of the anode bend detector to the top of the coil.

the correct anode current readings, assuming that the heater voltage is correct. This can be checked, in the absence of an A.C. voltmeter, by the temporary substitution of a 4-volt battery.

Correct ganging of the stages is arrived at in the course

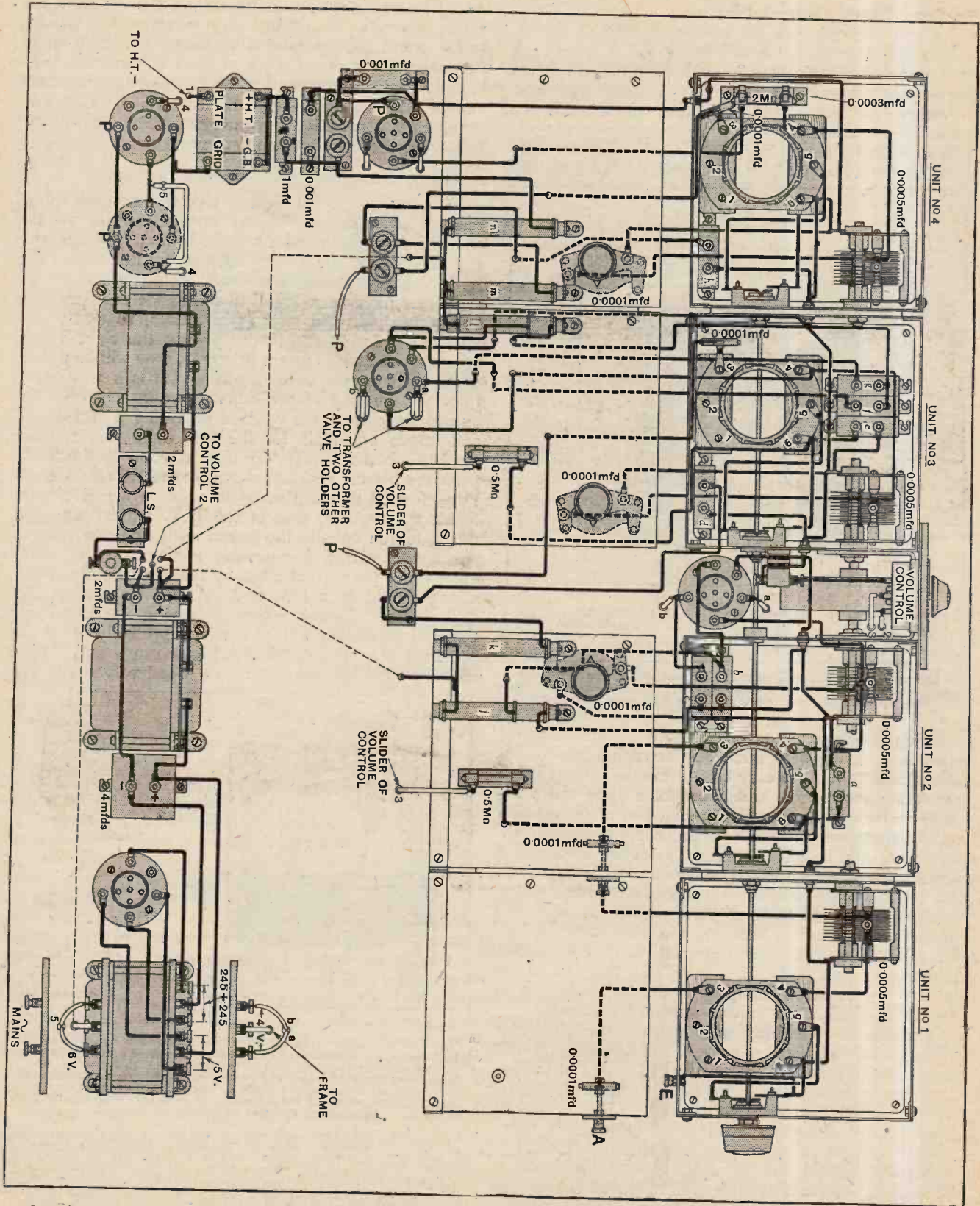

Practical wiring diagram. The actual points of connection agree with the theoretical circuit already given. The 120 and 1,000 ohm resistance spools consist of about 2 and 19 yards of No. 42 D.S.C. Eureka wire respectively.

The New "Foreign Listener's Four."—

of this preliminary test by setting all moving plates exactly in step and tuning in to a distant station when the trimming condensers are about three parts "in." Leaving the main tuning alone, a sharp setting may now be obtained on each of the trimmers. This adjustment is best made on a wavelength of 300 to 400 metres. Should a stage not be in tune when a trimming condenser has reached the limit of its adjustment, shift the main tuning and bring all the trimmers back by a corresponding amount. If there is no overpowering local station operating, preliminary tests can be made with the aerial connected to the stator of the first condenser,

the constant current passed in the potentiometers. As some confusion may be met with in connecting up the grid-biasing circuit it should be noted that the output stage is entirely separate from the others and is not earth connected, while the H.T. negative becomes earthed through the volume control and 120-ohm resistance. The breaking down, therefore, of any of the bridging condensers produces rather an obscure form of fault, and condensers of high test voltage have therefore been used.

Reference has already been made to the modification of substituting an anode bend detector, but it will be found that the range-getting properties will be slightly

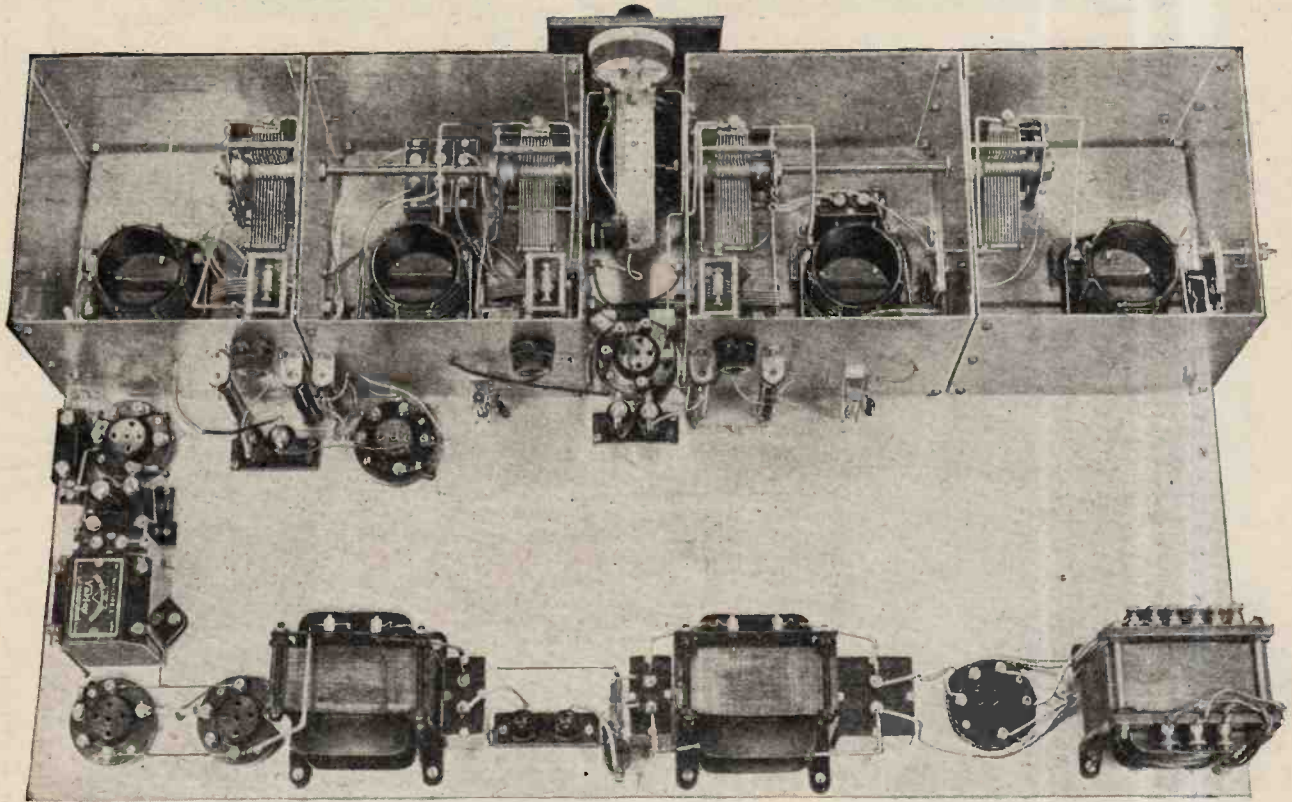

A merit of the home-built set is that it can be easily modified and for this reason a wide baseboard is used which provides space for the later inclusion of additional apparatus.

there being no need to throw off the connection to the tuned filter circuit.

Before changing over to the eliminator it is worth while noting the signal strength from a particular distant station, verifying the performance on this transmission as each change is made. Continue to feed the screens from the H.T. battery and connect up the anodes through the 35,000-ohm resistances, checking the working both as to range and correctness of anode current. Do not attempt to measure the anode volts, of course, with any ordinary voltmeter, as the reading will be rendered false as a result of the additional voltage dropped in the resistances by the meter current. Not until the potentiometers connected to the screens are in circuit can the free grid biasing of the H.F. valves be introduced, as this bias is mainly produced by

impaired. Fading, moreover, which is very little in evidence with a leaky grid detector, becomes apparent for the reason that as the signal voltage applied to an anode bend detector falls its sensitiveness decreases also whilst with a leaky grid detector the sensitiveness to a weak signal is more marked than to a stronger one. Considerations of cost have decided the use of two H.F. stages in preference to three, and comparative test shows that two stages followed by leaky grid detection gives reliable reception from distant stations. The overall amplification of the two H.F. stages may be less than 1,000, but this is considerably augmented by the effects of valve reaction. On the other hand, a third H.F. stage will give good results when the condenser tapping on the tuned-grid coils is brought down to terminal No. 2, indicating that the advantages of

The New "Foreign Listener's Four."

reaction are no longer present. Such a set proves highly selective when followed by anode-bend detection and the filter may be dispensed with. With this modification grid biasing will remain unaltered in spite of the small increase in anode current; the H.T. feed circuits of the additional valve being as shown for the other two. Grid bias for the anode-bend detector may be tapped off along the volume control resistance, the precise tapping point being found by experiment. The biasing lead may be soldered on to the side of the resistance winding.

These suggested modifications are merely mentioned as they have been tried and should not detract from

the original arrangement. Considerations of price have been a strong factor in designing this set, and the components are of standard type such as are used in many other connections. The home-built transformer can be readily adapted to suit varied requirements, while by building the windings in two sections in the manner shown the high voltage sections can be reduced or increased without the need for unwinding to the centre tap, as would be the case with the single spool. Tested in London, this set has on a single occasion given twenty-five transmissions on the broadcast band and five on the long-wave range. Used with a loud speaker possessing a good base response likely to accentuate hum, an entirely silent background is obtained.

"C.A.C." ALL-MAINS RADIO-GRAMOPHONE.

A Home Constructor's Kit Incorporating a Novel System of L.F. Coupling.

IN view of the increasing interest in cabinet radio-gramophones, it is surprising, having regard to the large number of radio "kit sets," that so few firms have catered for the home constructor who

transformer coupling, and the intention being to eliminate the shortcomings of both the recognised methods. There is no iron core, and both primary and secondary coils are wound with resistance wire.

Naturally, the absence of an iron core means that the primary inductance is low, but this is compensated for by the fact that the resistance is high. Nevertheless, for adequate amplification at low frequencies it is essential to use valves of low A.C. resistance and a generous H.T. supply is also desirable, in view of the volts dropped in the primary winding. These conditions are met in the radio-gramophone equipment, in which a H.T. voltage of 180 to 200 volts is available, the first two stages employing AC/P valves with an AC/PI in the output stage.

The design of the radio side is quite straightforward, and consists of a screen-grid H.F. amplifier followed by a leaky grid detector. The latter valve is also employed as a first stage L.F. amplifier when using the gramophone, the necessary change of grid bias being made automatically by the change-over switch. The pick-up is therefore followed by four stages of L.F. amplification with, of course, a volume control.

The kit of parts can be supplied with a variety of alternative pick-ups, loud speaker units, etc., to suit individual purses and tastes.

We have had an opportunity of testing the model illustrated equipped with a Magnavox moving-coil loud speaker and a B.T.H. pick-up. The volume obtained both on radio and gramophone is sufficient to work the AC/PI output valve

to capacity, while the quality of reproduction is very pleasing. We were particularly impressed with the brilliance of the upper frequencies, the highest notes of the piano being reproduced without any tendency to becoming wooden. There can be no doubt that the lower frequencies are also well reproduced, but without the booming effect which often spoils moving-coil reproduction.

A comprehensive wiring chart giving full constructional details and particulars of alternative sets of parts is obtainable from Messrs. Gramo-Radio Amplifiers, Ltd., 1a, New London Street, London, E.C.3.



The "C.A.C." low-frequency amplifier which incorporates a combination of resistance and transformer coupling.

wishes to build the more ambitious equipment. This demand is now met by the very complete set of parts produced by Messrs. Gramo-Radio Amplifiers, Ltd., the assembly of which is well within the scope of the amateur constructor.

The accompanying photograph shows the finished product to be an imposing piece of furniture, while the results obtained fully justify the makers' claims.

The most important component is the "C.A.C." low-frequency coupler unit, which is used for both radio and gramophone reproduction. Essentially, it is a three-stage amplifier with an unconventional combination of resistance and



Radio-gramophone for home construction, incorporating the "C.A.C." low-frequency coupler.

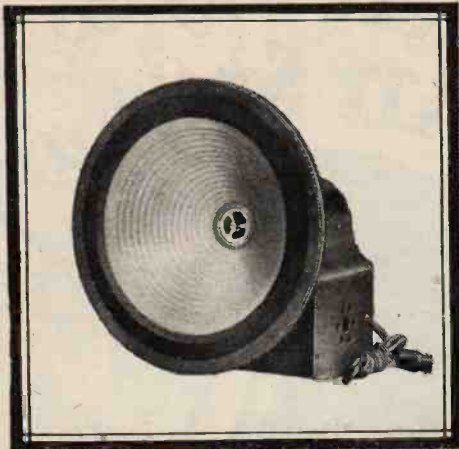

Senior "R.K." Unit with A.C. Field Excitation.
This "R.K." Unit has a 10in. corrugated cone with moving coil, having an impedance of 10-15 ohms at 50/4,000 cycles. The pot magnet is mounted in a pressed metal base, which also contains a mains transformer, Mazda U.U. 60/250 rectifier valve, and smoothing condenser for the supply of field current.
Price £ 11/10/0.

The B.T.H. "R.K."—justly described as the world's finest reproducer—first appeared in 1926 and its advent created a new standard of reproduction.

Four years have elapsed since then, but still the "R.K." maintains its leadership.

The new range of models includes the 10in. cone "Senior," with or without built-in rectifier for use with A.C. mains supply, and the "Junior" with 6in. cone.

Fidelity

—in Tone & Performance

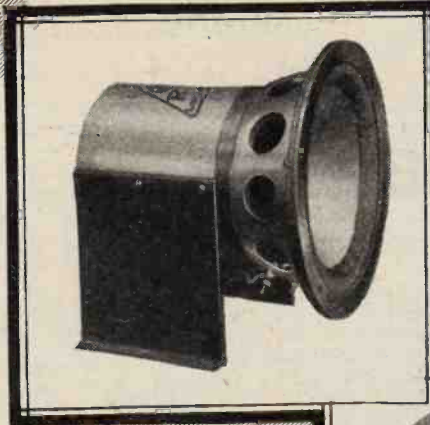

The Senior "R.K." Unit incorporates a 10in. corrugated cone with moving coil, having an impedance of 10-15 ohms at 50/4,000 cycles. Copper damping rings are fitted to reduce the impedance at higher frequencies.
Price £ 7/7/0.

The Junior "R.K." Unit has a 6 in. straight-sided cone with moving coil, having an impedance of 10-15 ohms at 50/4,000 cycles. Copper damping rings are fitted to reduce the impedance at the higher frequencies.
Price £ 6/6/0.

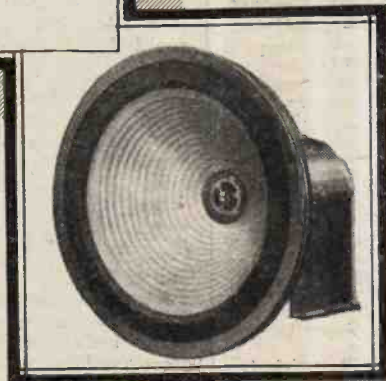

REPRODUCERS



THE EDISON SWAN ELECTRIC CO., LTD.,
Radio Division,
1, Newman Street, Oxford Street, W.1.
Branches in all Principal Towns.

EDISWAN

W68

THE CONSTRUCTION OF A CONDENSER

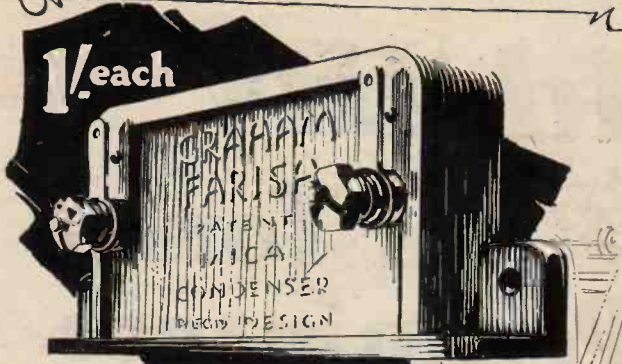

STAGE 2.

Toolmaking



MULTI-WAVE
H.F. Choke

Employs solenoid winding followed by sectional winding. High impedance. Low D.C. resistance. With base. 5/- each.



OHMITE
New Process
Anode Resistance

Hermetically sealed in Bakelite. Better than wirewound. Negligible self-capacity. All values, 1,000 to 500,000 ohms. 2/3 each.

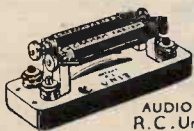

AUDION
R.C. Unit

Employs "Ohmite" and "Megite" Resistances. Even Amplification. Extremely Compact. 5/6.

TOOLMAKING is the second stage in the construction of a condenser. Only skilful workmanship could produce the necessary dies, mouldings and stampings accurate to a thousandth part of an inch. And only skilled engineers could design them.

All Graham-Farish wireless components are the result of scientific design and careful construction. Although Graham-Farish components are inexpensive, they are built up to a high standard—not down to a price.

The Graham-Farish Fixed Mica Condenser has the finest flawless Indian Ruby Mica as a dielectric. An exclusive feature is the alternative upright or flat mounting. Every condenser is tested three times and a written guarantee given with each.

Finest Indian Ruby Mica dielectric and bakelite case. Upright or flat mounting, terminals, soldering tags and series—parallel grid leak clips on all sizes up to capacities .0005. .00005—.002, 1/-; .003—.006, 1/6; .007—.01, 2/6.

- "Microficient" Variable Condenser ... 4/3, 4/6
- "Electroficient" Eliminator Choke ... 22/6
- "Multiwave" H.F. Choke 5/-
- "Megite" New Process Grid Leak ... 2/-
- "Electroficient" Mains Transformer ... 39/6

GRAHAM FARISH

BROMLEY

KENT

Look for this sign



in a dealer's shop.

Best way to All Stations



The new Dario Valves will improve your radio set at a lower price. Dario Valves have the New Coated Filament—the New Super Strength Grid and the New Large Size Anode—points that mean greater all-round efficiency—points that prove Dario supremacy.

SCREENODION

15⁶

2 v. .15 amps.
4 v. .075 amps.

SUPER POWER PENTODION

18⁶

2 v. .3 amps.
4 v. .15 amps.

| TWO VOLT | | Prices |
|----------------|-----------|--------|
| Universal | .1 amp | 5/6 |
| Resistron | .1 amp | 5/6 |
| Super H.F. | .15 amps | 5/6 |
| Super Detector | .15 amps | 6/6 |
| Super Power | .18 amps | 7/6 |
| Hyper Power | .3 amps | 9/6 |
| FOUR VOLT | | Prices |
| Universal | .075 amps | 5/6 |
| Resistron | .075 amps | 5/6 |
| Super H.F. | .075 amps | 5/6 |
| Super Detector | .075 amps | 6/6 |
| Super Power | .1 amp | 7/6 |
| Hyper Power | .15 amps | 9/6 |



Best way to all Stations

Ask your dealer for free Dario Folder or write direct to:
IMPEX ELECTRICAL, LTD.,
Dept. C, 538, High Road, Leytonstone, London, E.11.

Mention of "The Wireless World," when writing to advertisers, will ensure prompt attention.

Current Topics

EVENTS of the WEEK in BRIEF REVIEW

ALGERIA MEANS BUSINESS.

In Algeria's Centenary Budget two million francs will be set aside for broadcasting.

○○○○

GERMAN LICENCE ADVANCE.

Wireless licence holders in Germany on December 31st last numbered 3,066,682, marking an advance of nearly a quarter of a million in three months.

○○○○

SHORT WAVES FROM VIENNA.

UOR 2, Vienna, will probably transmit the Vienna studio broadcasts regularly on both 24.7 and 49.4 metres in the near future. Transmissions are already being made on a shorter wavelength.

○○○○

CAPTAIN ECKERSLEY'S LECTURE.

"Broadcasting by Electric Waves" is the title of the Faraday Lecture to be given by Captain P. P. Eckersley tomorrow evening (Thursday) at 6 p.m. at the Institution of Electrical Engineers, Savoy Place, W.C.2.

○○○○

WHO'LL PAY THE PIPER?

Considerable opposition is being encountered by the Irish Free State Government in their project for a high-power broadcasting station. The majority of complaints are based on the fear of increased taxation.

○○○○

SHORT-WAVERS, PLEASE NOTE.

The Trens Agency, of Mexico, announces that a daily news bulletin is transmitted at 9 p.m. (G.M.T.) on a wavelength of 16 metres. The transmission begins with QST in Morse for five minutes.

○○○○

2XAF TO WGY VIA AUSTRALIA.

A 20,000-mile short-wave relay was carried out successfully on February 4th by American and Australian short-wave stations.

A test programme transmitted by the G.E.C. short-wave station at Schenectady was picked up by VK 2ME, Sydney, relayed back to America, and rebroadcast on the normal broadcast band by WGY, Schenectady.

○○○○

TO CURE INSOMNIA?

During the past month several of the German broadcasting stations have transmitted special programmes between 12.30 a.m. and 1 a.m. for the benefit of "night walkers." Stations catering for the sleepless included Leipzig, Frankfurt, and Berlin. Stuttgart will oblige early to-morrow morning (Thursday), and Langenberg early on Saturday.

A 25

SURPRISE FOR THE POST OFFICE.

A supplementary estimate of funds required by the Post Office for the year ending March 31st next makes mention of £38,000 paid to the B.B.C. in consequence of the number of wireless licences in force last March being greater than was anticipated.

○○○○

HEART BEATS AMPLIFIED.

Although the amplification of heart beats is not new, it is interesting to note this laboratory experiment is being put to practical use at a maternity home attached to University College Hospital, London. This work is being carried out by the Marconiphone Co., Ltd., who have de-



JAPAN LISTENS TO 5SW. A picture from Tokyo showing Mrs. Shigeko Tawara, daughter of the Reijiro Wakatsuki, listening with her two children to her father's speech at the Naval Disarmament Conference in Westminster. Note the horn-type speaker, which is still popular in Japan.

veloped a special type of microphone and amplifier whereby doctors and nurses can listen to heart beats and other still fainter sounds without disturbing the patients.

The microphone, which is held in position on the patient by a broad elastic belt, is connected to the amplifiers, which may be used either in a room adjacent to the ward, or may be mounted on a small trolley and wheeled to the bedside.

The microphone output is taken first to a five-valve resistance-capacity-coupled amplifier, designed to cut off at 1,000 cycles. This is connected in turn to a two-valve transformer-coupled amplifier having low-gain stages. Loud speakers or headphones can be used as desired.

MADAGASCAR CALLING.

A broadcasting station with a minimum power of 15kW. is to be erected by the French Colonial Post Office at Antananarivo, in the Island of Madagascar (Indian Ocean).

○○○○

R.S.G.B. AT THE MICROPHONE.

Amateur radio work, particularly on the short-wave band, will be dealt with in a talk by Mr. J. B. Chisholm, representing the Radio Society of Great Britain, to be broadcast from B.B.C. stations at 6.35 p.m. on Friday next, February 28th.

○○○○

PHOTO-ELECTRIC CELLS.

A lecture entitled "Photo-electric Cells, their Characteristics and Applications," will be delivered by a representative of the General Electric Co., Ltd., at a meeting of the Radio Society of Great Britain to be held on Friday next, February 28th, at 6.15 p.m., at the Institution of Electrical Engineers.

○○○○

TELEPHONING TO MID-ATLANTIC.

A ship-to-shore telephony service was opened on the liner *Majestic* during its recent voyage from Southampton to New York, passengers being able to communicate with telephone subscribers in this country. It is hoped that on the next voyage the service will be extended to include messages originating on shore.

The Rugby wireless station is used for transmission to the ship, and the Baldock station for reception. These stations are connected with the London Trunk Exchange, where the service is controlled.

The service will be available for any ship on the North Atlantic route which is fitted with any suitable type of wireless telephony apparatus.

○○○○

5SW SHEDS JOY IN JAPAN.

The *Japan Advertiser*, Tokyo, tells a human story of how the speech of Mr. Reijiro Wakatsuki, Japan's chief delegate at the Naval Conference, was heard by his family in Tokyo. Considerable anxiety was felt by the engineers of Station JOAK as to whether Mr. Wakatsuki would be heard, particularly as the earlier speeches at the inaugural session, including that of King George, were almost inaudible owing to extraneous noises. As time went on, however, 5SW's power seemed to increase, and when Mr. Wakatsuki's turn came his speech was strong and clear. The chief delegate's family were grouped round a loud speaker in Tokyo and were overjoyed when they recognised his voice.

PCJ'S WAVELENGTH CHANGE.

In view of interference between PCJ, Eindhoven (Holland), and the Zeesen short-wave transmissions, the Dutch station has reduced its wavelength to 31.20 metres (9,620 kc).

MR. A. A. CAMPBELL SWINTON.

The death, on Wednesday last, of Mr. A. A. Campbell Swinton, F.R.S., at the age of sixty-six, will be deeply regretted by a very wide circle of wireless workers, both amateur and professional. Identified with wireless research from its early days,



MR. A. A. CAMPBELL SWINTON, F.R.S., one of the pioneers of the amateur radio movement, whose death occurred last week. He took a prominent part in the formation of the Wireless Society of London (now the Incorporated Radio Society of Great Britain) in 1913, and was its first President.

Mr. Campbell Swinton will always be remembered for his keen interest in the amateur movement, to which he gave much practical support, becoming the first president of the Wireless Society of London in 1913.

Born in 1863, Mr. Campbell Swinton was educated at Edinburgh and abroad. After a period in the Armstrong works he came to London in 1887, setting up in practice as a consulting electrical engineer. He was responsible for various electric lighting and traction schemes, and was also associated with Sir Charles Parsons in the development of the steam turbine.

Apart from work of this kind he followed with great interest the researches carried out in many phases of electrical physics, notably X-rays and the development of wireless telegraphy and telephony. The possibilities of television always attracted him; as early as 1908 he suggested that the problem might be solved by means of magnetically controlled cathode rays, his views being crystallised in a paper read before the Radio Society of Great Britain in March, 1924. At an early date he operated a two-way radiotelephone

system between his office in Victoria Street and his house in Chester Square.

Mr. Campbell Swinton was a Fellow of the Royal Society and a member of the Institutions of Civil, Electrical, and Mechanical Engineers. He was also a member of the general board of the National Physical Laboratory.

100 PER CENT MODULATION AT ROME.

Interesting technical details are now available regarding the new broadcasting station at Santa Palomba, Rome, which is becoming one of the most widely heard transmitters in Europe. The installation was carried out under the supervision of American engineers under contract with the Radio Corporation of America, manufacturers of the equipment.

While the station is rated at 50 kilowatts, a system of 100 per cent. modulation is employed whereby, it is stated, the transmitter is capable of a peak output of 200 kilowatts. Mercury vapour valves are used for high-voltage rectification. The transmitting valves are of the 100-kilowatt "Radiotron" type, and are the only specimens of their kind in Europe. Constant frequency regulation is maintained by crystal control.

The Ente Italiano Audizioni Radiofoniche, owners of the station, continue to receive eulogistic reports from listeners at distances up to 1,000 miles.

Club News.**Eliminating Waste in Valve Manufacture.**

"The Manufacture of Radio Valves" formed the subject of a fascinating lecture by Mr. G. Parr, of The Edison Swan Electric Co., Ltd., at the last meeting of the North Middlesex Radio Society.

The evolution of a valve was traced from the blowing of the bulb, stage by stage, up to the final testing of the finished article, each step being illustrated by interesting lantern slides. The lecturer pointed out that as the valve progressed through the various processes it increased in value proportionally to the amount of work put into it, and the manufacturers made every effort to discover defects as early as possible in the making in order that subsequent operations should not be wasted.

Mr. Parr has kindly promised to revisit the Society at a future date to give a talk on the power valve.

Hon. Secretary, Mr. E. H. Laister, "Windflowers," Church Hill, N.21.

The Thirst for Power.

"Power Output and the Pentode Valve" was the title of the lecture given before the Muswell Hill and District Radio Society on February 12th by Mr. F. E. Henderson, A.M.I.E.E., of the G.E.C., a member of the Society. The lecturer commented on the continual demand for power, and still more power, especially by the talkie concerns, whose latest requirement was for a 200-watt power valve! Some very interesting and illuminating data were given regarding the pentode valve, and the pitfalls awaiting the unwary user of pentodes were described. In conclusion, a series of demonstrations were given.

It may be of interest to note that the Muswell Hill Society is now running a Morse class for members, a facility of which several have availed themselves. Further details can be obtained from the Hon. Secretary, Mr. C. J. Witt, 39, Coniston Road, N.10.

The Modern Pick-up.

Modern pick-ups and loud speakers were demonstrated by Mr. A. Freeman at the last meeting of Slade Radio. In a talk on the

progress which has been made in the design of pick-ups, the lecturer gave interesting details regarding construction, and the effect of needle wear, and emphasised the necessity for the use of a volume control.

Membership of the Society is open to anyone interested in wireless, and full particulars may be obtained from the Hon. Secretary, 110, Hillaries Road, Gravelly Hill, Birmingham.

All About S.G. Valves.

The Marconiphone Company's illustrated lecture on screen grid valves was delivered by Mr. E. Remington at a recent meeting of the South Croydon and District Radio Society. The lecture described the ordinary three-electrode valve when used as an H.F. amplifier, and made it clear why this method of pre-detector amplification had its limitations. In the screen grid valve another grid, namely, one with a positive bias of 70 volts, was introduced which had the effect of reducing the internal capacity of the valve to an almost negligible figure.

Slides were also shown of the characteristic curves of some of the Marconi screen grid valves, and it was explained how greater selectivity could be obtained by reducing the plate voltage until a certain point on the curve was reached. Finally came slides showing the construction of Marconiphone "All-Mains" receivers. Two stages of screened H.F. amplification in such a receiver ensured enormous and stable amplification which far surpassed results hitherto regarded as excellent.

Hon. Secretary, Mr. E. L. Cumbers, 14, Campden Road, South Croydon.

Push-pull Hints.

A special band pass filter circuit by which various frequency bands were cut out at will was demonstrated by Mr. K. Higginson, of the Varley (Oliver Pell Control, Ltd.), at a recent meeting of the Bristol and District Radio and Television Society.

Mr. Higginson at the outset gave a few of the laws of sound which are not usually encountered by the student of acoustics, confirming them with demonstrations. By the aid of black-board diagrams and lantern slides the lecturer showed the conditions necessary for efficient working of push-pull low-frequency amplification, in particular stressing the importance of matching the two grid circuits.

Hon. Secretary, J. Myrtle Road, Cotham, Bristol.

FORTHCOMING EVENTS.**WEDNESDAY, FEBRUARY 26th.**

Edinburgh and District Radio Society.—At 8 p.m. At 16, Royal Terrace. Lecture by Mr. S. D. Forrester, Ph.D., A.I.C.

Golders Green and Hendon Radio Society.—

Informal Meeting at member's residence.

Muswell Hill and District Radio Society.—

At 8 p.m. At Tollington School, Tetherdown, N.10. Lecture: "Valve Manufacture," by Mr. C. A. Quarrington, of Messrs. A. C. Cossor, Ltd.

North Middlesex Radio Society.—At 8 p.m.

At St. Paul's Institute, N.21. Lecture: "Rectification," by the Westinghouse Company

THURSDAY, FEBRUARY 27th

Ilford and District Radio Society.—At the Wesleyan Institute, High Road. Demonstration of Gramophone Pick-ups.

Slade Radio (Birmingham).—At the Parochial Hall, Broomfield Road, Erdington.

Lecture: "Transformers," by Messrs. Ferranti, Ltd. To be followed by demonstration of a Ferranti A.C. receiver.

FRIDAY, FEBRUARY 28th.

Bristol and District Radio Society.—At 7.30 p.m. In the Geographical Theatre, University of Bristol. The Siemens Film: "How Batteries are Made."

Radio Society of Great Britain.—At 6.15 p.m. (Refreshments at 5.30). At the Institution of Electrical Engineers, Savoy Place, W.C.2. Lecture: "Photo-Electric Cells: Their Characteristics and Applications," by the General Electric Co., Ltd.

MONDAY, MARCH 3rd.

Newcastle-upon-Tyne Radio Society.—At 7.30 p.m. In the English Lecture Room, Armstrong College. Lecture: "Television Developments," by Mr. J. Denton (Secretary, The Television Society).

TUESDAY, MARCH 4th.

Bee Radio Society.—At 7.30 p.m. At Bee School, Beecherot Road, S.W.17. Lecture: "The Design of Modern L.F. Amplifiers," by Mr. Chas. H. Roddis, Assoc.I.E.E.

BROADCAST RECEIVERS

**FOUR-VALVE
No 406c**

An Up-to-date
Design with an
Efficient H.F.
Stage.

WHEN it fell to the writer's lot to conduct a distinguished foreign radio engineer round the last Olympia Exhibition, he made a bee-line for the Pye stand, explaining that the 3- and 4-valve receivers made by that firm were "typical of the best British practice." It was perhaps unfortunate that the word "typical" was chosen, but it will still serve: although the more ambitious Pye sets are very much in a class of their own, both as regards layout and circuit design, it will be freely admitted that in neither particular do they show any trace of American or Continental influence.

The receiver with which we are now dealing embodies those refinements that we in this country have become accustomed to look for nowadays. It is a straightforward four-valve combination, with an S.G. high-frequency amplifier, transformer-coupled to an anode-bend detector. This valve is followed by a resistance-coupled stage of fairly low gain, which, in its turn, feeds the output valve through a transformer. A choke-filter is provided for the loud speaker.

Turning back to the input end of the set, it is found that double-wound "aperiodic" aerial-grid transformers are used, and that there is no metallic junction between the open aerial circuit and the valve filaments. Further, there is no connection between filaments and metal-work, although the aluminium chassis is joined to the earth terminal. All this is arranged with a view to obtaining anode and grid-bias potentials from a D.C. mains supply with complete safety, although the set is primarily intended for battery feed. Incidentally, the makers do not encourage the use of D.C. mains for filament heating, and point out that the upkeep of a high-capacity single accumulator cell (2-volt valves are standardised) will give little trouble.

The aerial-grid and intervalve H.F. transformers are on lines that will be familiar to readers of this journal. Primaries of the medium-wave couplings are carried on spacing strips, this arrangement providing close magnetic linkage, with a minimum capacity between windings. The secondaries are single-layer windings. Sectionally wound coils, with primaries sandwiched between

secondary sections, are used for the long-wave assemblies.

Wave-changing is effected by a pair of switches mechanically linked together and controlled by a single lever on the front panel. As each point is changed by operation of the switch, the coupling unit for each wave-band, consisting of a primary, secondary, and reaction winding, is an independent unit.

There is no pre-detection volume control, but it is recommended in the instruction book that very strong signals should be reduced in intensity by setting the two edgewise tuning dials to opposite sides of the point of resonance. This plan is almost always satisfactory, particularly when it is applied in conjunction with the detector anode potentiometer, which controls input to the L.F. amplifier. One's aim should be to get a large, but not excessive, signal voltage on to the detector grid, and then to reduce L.F. magnification to the capabilities of the output valve. For the reception of distant stations, intensity is regulated by reaction control, which is on the differential principle.

Precautions Against Instability.

Anode circuits are completely "decoupled" by series resistances and parallel by-pass condensers, with the result that incidental battery resistance has no effect in marring quality or bringing about L.F. oscillation. By suitable choice of the resistance for the detector feed circuit, this valve is made to perform its function with the same bias as that of the first-stage L.F. amplifier, which is of similar type. H.F. energy is kept out of the L.F. amplifier by the combined action of a high-resistance in series with the grid of the third valve and of a detector anode by-pass condenser which is of rather higher capacity than usual—as it can be, without prejudice to high-note reproduction, in view of the fact that the anode resistance is of low value.

Although the set is compact, all components, with the possible exception of those associated with the output stage, are readily accessible for examination and test. All the wiring may be traced readily after removing the chassis from its wooden case by simply taking out two screws passing through the supporting battens and two

Broadcast Receivers—Pye Four-Valve No. 406/c.—

more behind the control panel. This must not be taken as implying that the set is particularly likely to stand in need of repair work: on the contrary, its construction is so sound that the evil but inevitable day when some part will stand in need of adjustment is likely to be deferred much longer than usual. At any rate, it is almost inconceivable that faulty wiring joints should develop, as all connections are "pinched" on to their tags before soldering.

One's impression that the H.F. stage should be more than usually effective is confirmed on testing the receiver, and it is clear that good use is being made of the exceptional properties of the Mazda 215 S.G. valve, which, together with suitable valves of the same make for other positions, is supplied with the set. Sensitivity is sufficient to satisfy all ordinary requirements, and except for the confirmed long-distance enthusiast, there will seldom be any point in going to the trouble of setting up a super-efficient aerial-earth system. Under fairly good conditions, it is possible to forget the existence of a reaction control knob, but where extreme range is needed this adjustment is more than useful: it works well and smoothly, but introduces a slight change in the

easier by the provision of direct wavelength calibration for the tuning dials. This calibration is accurate enough for practical purposes.

In the matter of selectivity, general performance is rather above the average, but on the long-wave side there is a good deal of "spreading" of local medium-wave signals. This trouble is always present to some extent in any receiver with "aperiodic" aerial coupling. In the case in question the trouble was readily overcome by adding a simple wavetrap. This form of interference will only be experienced in the vicinity of a high-power transmitter. It was observed that the interference was confined to the longer of the two London wavelengths. On the medium broadcast band there was no difficulty, in London, in separating the "Regional" stations, even with a longer aerial than that specified for the set.

Optional Power Outputs.

A choice of valves for the output position is allowed; where the extra anode current can be provided, it is recommended that a Mazda P.240 should be used, although, where battery economy must be exercised, a smaller power valve may be substituted.

Naturally enough, quality is at its best with the first-mentioned valve, and, with intelligent operation of the volume controls on the lines suggested in an earlier paragraph, is exceptionally good. Even the more economical P.220, in conjunction with a sensitive loud speaker (actually a 6ft. logarithmic horn was used), can afford more than ample volume for average requirements.

Arrangements are made for connection of a pick-up, which is thrown into the detector grid circuit by a switch mounted on the terminal strip at the rear. Volume of gramophone reproduction is controlled by the normal post-detection anode potentiometer, which proves entirely satisfactory in practice, as it can compensate for the widely differing sensitiveness of various pick-ups.

Mention has already been made of the excellence of the internal constructional work, which is in every way

worthy of a firm with a reputation as instrument makers. External finish is of an equally high standard, and the set is of pleasing appearance. Ample space is provided in the lower compartment for all batteries or for a D.C. mains unit.

The price of the set described is £19 10s., including valves and royalties, but exclusive of batteries.

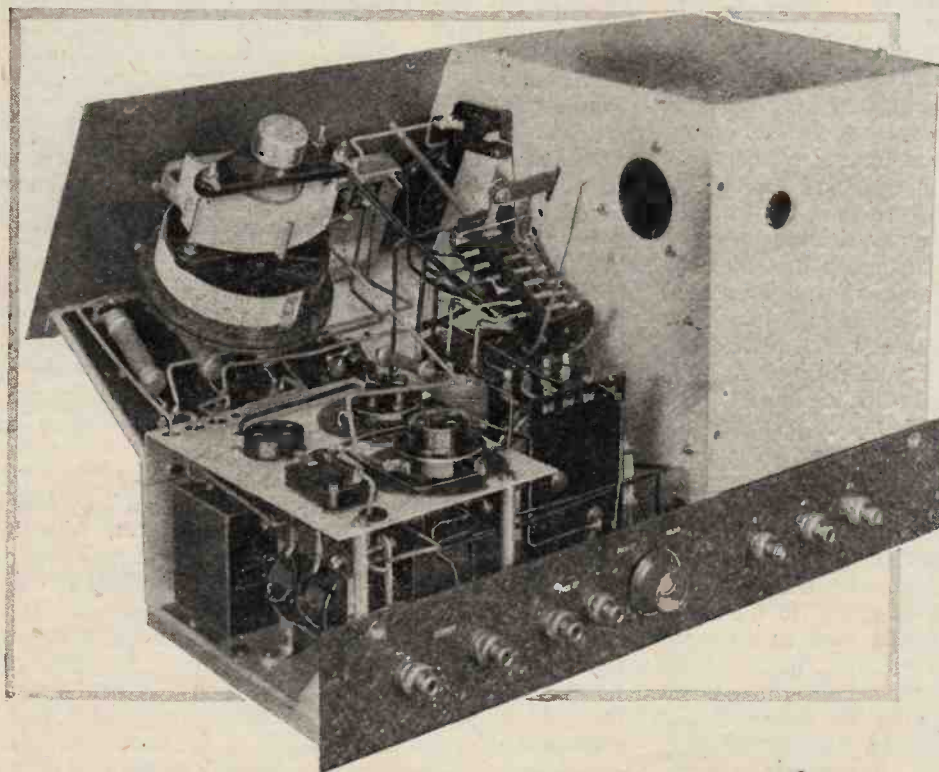

The complete chassis may readily be withdrawn from its containing cabinet.

setting of dial No. -2 (H.F. transformer tuning condenser).

H.F. amplification is particularly good on the longer of the two wavebands, and it was found possible, even under poor conditions, to get good signals from all the more popular high-power European stations. "Searching" for distant transmissions on either band is made

BROADCAST

BREVITIES



Lord Clarendon's Successor.

The announcement of Lord Clarendon's departure at the end of the year has naturally given rise to all sorts of wild rumours. The string of "probable starters" now rivals a Derby list.

How many of the prophets have noted that the B.B.C.'s Charter contains nothing which would preclude a single individual from assuming the double rôle of Chairman and Director-General?

o o o o

A Power in the Land.

If the offices were combined the holder would be Sir John Reith, whose personal power would then challenge comparison with that of the "great ones" of all ages.

There are ten months in which to discuss whether the appointment would be popular.

o o o o

Comforting Words for Birmingham.

The sympathies of London listeners will go out to their brethren in Birmingham, who are asking why the Midland Regional is to derive most of its programmes from London Regional. I imagine that they will gain little comfort from the B.B.C.'s explanation that the boot is on the other foot, i.e., that London Regional will be deriving its programmes from Midland Regional. This sounds rather "Irish."

o o o o

Programmes Under the Regional Scheme.

Actually, however, arrangements are being made to give Midland listeners at least 25 per cent. of their programmes from the Birmingham studio. Similarly the same amount of original programme material will be given by London Regional, so that at certain periods three different programmes will be going out simultaneously.

o o o o

A Sabbath Anomaly.

From the plans I have seen for the regular twin programmes from Brookmans Park beginning on March 9th, it seems that there will be a distressing waste of power on Sundays, both transmitters sending the same religious service.

o o o o

Silence Would be Golden.

While the B.B.C. definitely refuses an alternative to the religious broadcasts, it would surely be a graceful gesture to allow one of the transmitters to remain silent during the 8-8.45 period. This would prevent no one from listening to the service if they wished, and would enable others to tune in those Continental stations which are usually swamped by the local carrier wave.

A 29

send its waves at a slower speed, mentioning that his set was fitted with a slow-motion dial.

o o o o

Nocturnal Economy.

Now is the time to bombard the B.B.C. with letters if you wish to retain the light orchestral music given after 10.30 p.m. from London Regional. I am officially informed that this feature will cease with the conclusion of the present tests, and that only dance music will be available late at night.

As one of the reasons for this attitude, the B.B.C. state that the economical side of the question must be considered.

o o o o

A Hero.

Mr. Gerald Barry, who has temporarily relinquished his work at the microphone, must surely be regarded as the B.B.C.'s first official "debater." Other debaters have dazzled us for a brief hour and then retired more or less gloriously, but Mr. Barry has had the "nerve" to come back and has never disappointed. Some people could win a V.C. on the field more easily than face a debater and a microphone without a manuscript.

o o o o

A Relay to Germany.

On March 14th Frankfurt intends to regale its listeners with Arnold Bax's Third Symphony, relayed from the Queen's Hall, London. The programme will also go out from Cassel.

By Our Special Correspondent.

Hearing "B.P." at 2,380 Miles.

Among the reports received by the B.B.C. of distant reception of the programmes broadcast from Brookmans Park is one from the steamship *Davisian*.

The writer, a Liverpool seaman, says: "I am using a — three-valve 1928 model, and we are in lat. 53-51 N., long. 48-41 W., the actual distance from London being 2,380 miles. I have heard the Brookmans Park programmes ever since we left Liverpool, and up to the above distance I got good 'phone strength. Up to 1,800 miles I was using a loud speaker. I find that the 261-metre is the stronger, but both are very good and clear."

o o o o

Wanted: Slower Waves.

A contributor to the Savoy Hill post-bag last week urged the Corporation to

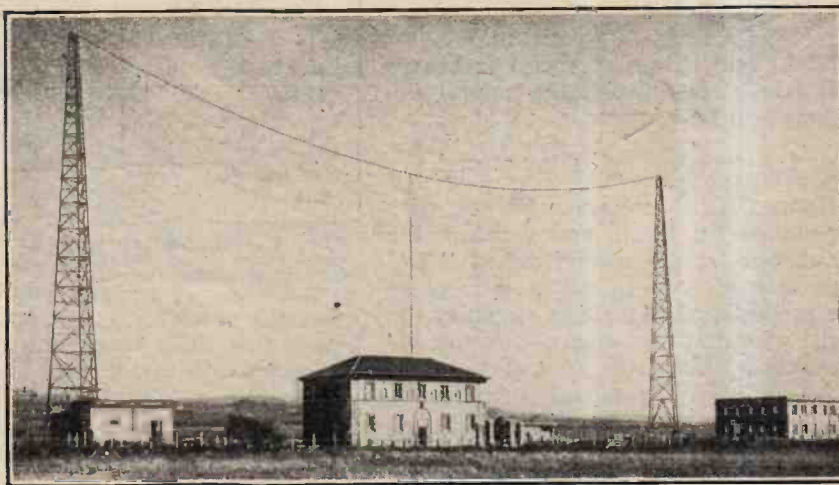

"RADIO ROMA." This photograph helps to explain why the new 50 kw. station at Rome is such an efficient radiator. The site appears to be ideal. The nightly transmissions on 441 metres can be heard without difficulty all over the British Isles.



Part XXI.—The Tuning of Aerial Circuits.

By S. O. PEARSON, B.Sc., A.M.I.E.E.

(Continued from page 174 of the issue dated February 12th.)

THE high-frequency voltage generated in a receiving aerial by the oncoming waves from a distant transmitting station causes an alternating current to be set up in the aerial, its frequency being the same as that in the transmitting aerial. The magnitude of this aerial current will depend on the value of the induced voltage E and the effective aerial impedance Z_a , being given by $I_a = E/Z_a$ ampere. By tuning the aerial circuit so that it is in resonance with the frequency of the induced voltage a comparatively large aerial current will be obtained because under these conditions the inductive and capacitive reactances balance out and the impedance of the aerial becomes equal to its effective resistance R_e , which may be a few ohms only. In this section we are mainly concerned with the methods available for effecting the necessary tuning.

Natural Wavelength of an Aerial.

The aerial alone, without any added inductance or capacity in the form of coils or condensers respectively, will respond to one definite wavelength or frequency because it has fixed inductance and capacity, as explained in the previous part. This particular wavelength of the untuned aerial is called its *natural wavelength*. If L_a is the inductance of the aerial in microhenrys and C_a the capacity in microfarads, the natural wavelength will be

$$\lambda_0 = 1,885 \sqrt{L_a C_a} \text{ metres,}$$

or if L_a and C_a are expressed in henrys and farads respectively, the natural frequency will be

$$f_0 = \frac{1}{2\pi \sqrt{L_a C_a}} \text{ cycles per second.}$$

Both the inductance and capacity depend on the length and shape of the aerial, but for the usual inverted "L" type each of these quantities is more or less proportional to the total length of the aerial wire measured from the remote end to the earth connection. Since the natural wavelength is proportional to $\sqrt{L_a C_a}$ it follows that its value is roughly proportional to the length of the aerial. For an ordinary type the natural wavelength in metres is approximately equal to 1.5 times the length measured in feet. Thus for an aerial 50ft. long the natural wavelength will be of the order of $1.5 \times 50 = 75$ metres.

It is necessary to be able to tune a receiving aerial circuit over a fairly wide range of wavelengths in order to select signals from any desired transmitting station. Some of the stations to be received will have wavelengths higher than the natural wavelength of the aerial and some lower, and this means that some device must be introduced for varying the product of inductance and capacity in the aerial circuit. The various methods of doing this and the principles involved are discussed below.

Increasing the Wavelength.

In the first place it is essential to include an inductance in the down-lead for the purpose of passing the received signal voltage on to the receiving apparatus. Sometimes this added inductance coil is directly connected to the receiver and sometimes coupled magnetically to a tuned circuit of the closed type. For the present we shall consider only those arrangements where the first valve of the receiver is connected directly across the inductance coil in the aerial circuit, and then later lead on to the discussion of more efficient arrangements.

When a coil of inductance L microhenrys is connected in the down-lead of an aerial whose inductance is L_a microhenrys and whose capacity is C_a mfd., as shown in Fig. 1 (a), the wavelength to which the aerial responds is increased above the natural value because the total inductance has been raised to $(L + L_a)$ microhenrys, the new wavelength being given by

$$\lambda = 1,885 \sqrt{(L + L_a) C_a} \text{ metres,}$$

assuming that the coil itself has no self-capacity. The frequency to which the aerial circuit is now tuned is given by

$$f = \frac{1}{2\pi \sqrt{(L + L_a) C_a}} \text{ cycles per second, the}$$

units used being henrys and farads. The equivalent tuned circuit corresponding to

this arrangement is shown in Fig. 1 (b).

Variometer Tuning.

If the added inductance L is continuously variable between two limits—for instance, if L is in the form of a variometer—it is possible to tune the aerial to respond to any wavelength between the limits imposed by the maximum and minimum inductance values of

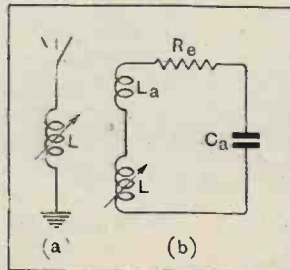

Fig. 1.—(a) Variometer tuned aerial circuit and (b) the equivalent closed circuit.

Wireless Theory Simplified.—

the variometer. Theoretically the variometer method of tuning for wavelengths above the natural wavelength of the aerial has some good points and some bad ones. It has been shown that for a circuit tuned to resonance the voltage developed across the whole of the inductance is greatest when the ratio of inductance to capacity is as high as possible, and the use of a variometer leads to this desired condition. But the receiver is connected across the added portion of the inductance only; the aerial itself possesses inductance L_a , and the voltage built up across this is not available for operating the receiver.

Thus, from the point of view of signal strength, the added inductance should be several times greater than the aerial inductance. But we have no choice of value—it is determined by the wavelength to be received and the constants of the aerial. For instance, when receiving a wavelength only slightly above the natural wavelength merely a small fraction of the reactive voltage due to the total inductance is passed on to the receiver. But this tendency to inefficiency is partly offset by the fact that the *receiving efficiency* of the aerial becomes greater as the natural wavelength is approached—a higher value of E.M.F. is induced into the aerial by oncoming waves whose wavelength is near the natural wavelength of the aerial than by waves of a widely differing length.

Apart from the theoretical considerations variometer tuning is not highly satisfactory. For practical reasons it is impossible to design a variometer with really low losses at high frequencies over the entire tuning range, because at the lower end, where the inductance value is small, the full length of wire is still in the circuit and the resistance is high compared with that of an ordinary coil of the same inductance value.

Parallel Condenser Tuning.

In view of the rather serious disadvantages of variometer tuning it is better to have a fixed inductance coil in the aerial circuit and to tune the combination with a variable condenser in parallel with the coil in the manner shown by Fig. 2 (a). This method, however, also has limitations, not so much as regards efficiency, but rather in regard to wavelength range. The added inductance first puts up the minimum wavelength to which the aerial will tune to a definite value above the natural wavelength. The added condenser in parallel with the coil then enables tuning to be effected over a certain range of wavelengths above the minimum value for the aerial and coil alone. The reason for this will be made clear by reference to Fig. 2 (b), which shows the circuit electrically equivalent to that of Fig. 2 (a), on the assumption that the whole of the inductance, including that of the aerial itself, is lumped

in the tuning coil. Actually the added capacity is shunted across part only of the total inductance, namely, that of the coil, but if the aerial inductance L_a is small compared with the coil inductance L , the wavelength to which the aerial is tuned will be approximately

$$\lambda = 1,885 \sqrt{L(C + C_a)} \text{ metres} \dots\dots (1)$$

On the other hand, if the aerial inductance is too large to be neglected, as is usually the case, the aerial circuit of Fig. 2 (a) approximates more closely to the equivalent of Fig. 2 (c), which is not a very straightforward circuit. However, sufficient accuracy will be obtained if we assume that the added capacity C is connected directly across the whole of the inductance $(L + L_a)$, giving us an approximate value of

$$\lambda = 1,885 \sqrt{(L + L_a)(C + C_a)} \text{ metres} \dots\dots (2)$$

for the wavelength. In practice it will be slightly less than this.

Limited Tuning Range.

An average aerial as used for broadcast reception might have a capacity of the order of 0.0002 microfarad and an inductance of about 10 microhenrys, these figures, of course, depending on the size and disposition of the aerial.

As an example, let us assume that we have an aerial with the constants mentioned and that we require to tune it over a band of wavelengths ranging from 250 metres upwards by means of a coil and parallel condenser. Suppose that the condenser is of the ordinary variable-capacity type having a maximum capacity of 0.0005 microfarad and a

minimum capacity of 0.0003 microfarad.

First of all we want to know the value of the coil inductance L to be used. Substituting the known values in equation (2) above we get

$$250 = 1,885 \sqrt{(L + 10)(0.0003 + 0.0002)},$$

from which $L = 66.5$ microhenrys.

Using a coil with this value of inductance the aerial circuit tunes to 250 metres with the condenser set to its minimum value. If now the condenser is set to its maximum value of 0.0005 microfarad, the maximum wavelength of the tuning range is obtained by again using equation (2); thus

$$\lambda = 1,885 \sqrt{(66.5 + 10)(0.0005 + 0.0002)} = 436 \text{ metres.}$$

This example has been given to show what a very limited range of wavelengths is afforded by plain aerial tuning with a parallel condenser. A condenser with a higher maximum capacity would certainly give an increased range, but its use is not advisable as it would reduce signal strength.

The reason for the narrow band of wavelengths covered is the presence of the fixed aerial capacity virtually in parallel with the tuning condenser. The ratio of maximum wavelength to minimum wavelength

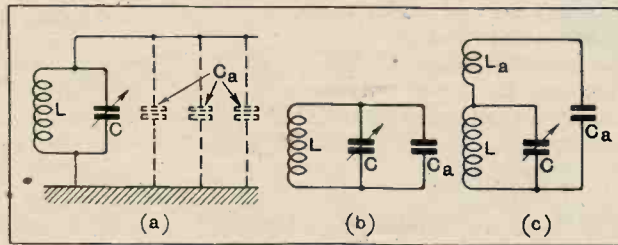

Fig. 2.—(a) Plain aerial tuning with fixed inductance and variable condenser in parallel; (b) represents the equivalent closed circuit if the aerial inductance is small enough to be neglected. The equivalent circuit at (c) is more accurate but rather complicated.

Wireless Theory Simplified.—

obtainable is equal to the square root of total capacity (including that of the aerial) with the condenser set to maximum to the total capacity with the condenser at minimum. The ratio of wavelengths in this case works out to only 1.74 to 1. If an ordinary coil with negligibly small self-capacity were tuned with this same condenser the ratio of wavelengths would be $\sqrt{\frac{0.0005}{0.00003}}$, or just over 4 to 1.

Series Condenser in Aerial.

It should be obvious from this that if we could reduce the influence of the aerial capacity of the tuning of the circuit a wider waveband could be covered with the same variable condenser as before, but a coil of higher inductance would be necessary. The effect of the aerial capacity can be reduced by connecting in series with the aerial a condenser whose capacity is considerably smaller than the aerial capacity itself. Tuning is then effected by means of the coil and parallel condenser as before, the connections being shown in Fig. 3 (a), where C is the tuning condenser and C_s the series aerial condenser. Fig. 3 (b) gives the equivalent closed circuit on the assumption that the effective aerial inductance L_a is lumped in with that of the coil.

It is clear that the series capacity C_s is truly in series with the aerial capacity. To be strictly accurate, the aerial inductance should come in the equivalent circuit between the condensers C_s and C_a when the tuning coil is at the foot of the aerial. However, since the aerial inductance is small compared with that of the tuning coil, its position in the circuit does not make much difference in the calculated wavelength.

The addition of the series condenser C_s in the aerial lead reduces the effective aerial capacity from C_a to a value C_a¹, given by $\frac{1}{C_a^1} = \frac{1}{C_a} + \frac{1}{C_s}$ or $C_a^1 = \frac{C_a C_s}{C_a + C_s}$. Thus, if we connect a 0.0001-microfarad condenser in series with the 0.0002-microfarad aerial considered previously, the effective capacity is reduced to

$$C_a^1 = \frac{0.0002 \times 0.0001}{0.0003} = 0.000067 \text{ mfd.},$$

that is, to one third of the actual aerial capacity.

Let us see now what value of inductance will be required to tune the aerial from 250 metres upwards, as before, with the same 0.0005-mfd. condenser whose minimum capacity was 0.00003. We have $\lambda_{min} = 1,885 \sqrt{(L + L_a)(C + C_a^1)}$ metres where L_a is 10 microhenrys, $C + C_a^1 = (0.00003 + 0.000067) = 0.000097$ mfd. Substituting these values in the equation in the manner explained before, we get L=171 microhenrys. For the case without the series condenser we required only 66.5 microhenrys for the same minimum wavelength of 250 metres.

With the tuning condenser set to the maximum value of 0.0005 microfarads the wavelength will be $\lambda_{max} = 1,885 \sqrt{(171 + 10)(0.0005 + 0.000067)}$ by substitution of the new values in the previous equation. This works out to $\lambda_{max} = 603$ metres. Without the series condenser in the aerial it was found only possible to tune from 250 to 436 metres, so that a considerable gain in wavelength range has been effected by its inclusion.

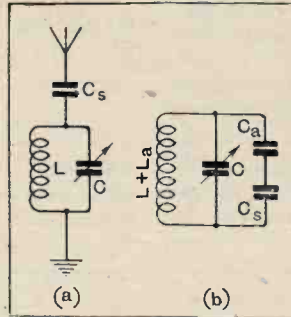

Fig. 3.— By connecting a series condenser in the aerial the tuning range and selectivity are improved but signal strength is lowered.

Signal Strength and Selectivity.

The series condenser C_s not only affects the tuning range, but also the selectivity and signal strength. The aerial resistance is considerable, and results in very flat tuning when no series condenser is used. The addition of the series condenser has the effect of partially isolating the aerial resistance from the closed portion LC of the tuned circuit, and results in a very much sharper resonance curve. The lower the value of the series capacity the greater will be the selectivity.

But, on the other hand, the series condenser restricts the aerial current and results in a reduction of signal strength. This condenser does not by itself produce resonance in conjunction with the inductances of the circuit, and must, therefore, be regarded as a high reactance or impedance in series with the aerial. Obviously, then, in a simple aerial circuit of this type a compromise must be struck between tuning range, selectivity and signal strength. The various values given in the foregoing numerical illustration are representative of an average case on the medium-wave broadcast band.

In the next instalment of this series, coupled aerial tuning will be given consideration. Our aim will be to eliminate the effects of aerial resistance.

(To be continued.)

General Physics and Its Application to Industry and Everyday Life (3rd Edition, revised), by Prof. Ervin S. Ferry. Published by John Wiley and Sons, Inc., New York, and Chapman and Hall, Ltd., London. Price 20s. net.

This book is intended for students requiring a co-ordinated elementary course in the fundamental principles, methods, and the industrial application of physics. Within the 652 pages of instructional matter the author has endeavoured to com-

BOOK REVIEW.

press the main facts relating to Dynamics, Sound, Heat, Electricity, and Light. No knowledge of mathematics is assumed, beyond the elements of algebra and trigonometry, and the evident intention of the author is to give the student a good general knowledge of the groundwork of

the various subjects and to demonstrate the practical application of the laws and discoveries of physics to matters of everyday life, and thereby encourage him to pursue one or more of these branches of science to a further stage.

At the end of the book are 1,634 practical problems based upon the information given, and each chapter concludes with a series of questions intended to develop the student's understanding and appreciation of the subjects with which it deals.

TRIPLE TEST SIFAMETER.

This is a three-range instrument of the moving-iron type which has been developed by the Sifam Electrical Instrument Co., Ltd., Bush House, Aldwych, London, W.C.2, to meet the demand for a moderately priced meter suitable for checking the voltages of the batteries used to operate a wireless receiver. It is not intended, neither is it suitable, for permanent connection in the circuit, since the current demands on the voltage ranges are somewhat on the heavy side. For a full scale deflection 50 mA. are required.

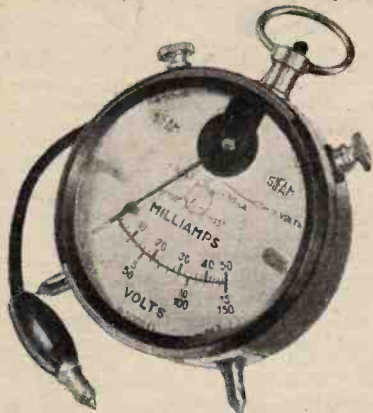

Sifam three-range measuring instrument with two voltage ranges and a 0-50 mA. scale.

Two voltage ranges and one milliamperes scale are provided. The two voltage scales read 0-150 and 0-15 respectively, and the current range is 0-50 mA. The measured D.C. resistance of the instrument on the 150-volt range was 5,200 ohms, and on the 15-volt range 270 ohms. The maximum error recorded on the two

NEW APPARATUS REVIEWED.

voltage scales did not exceed 5%, but on the mA. range this was found to be 10%. The rather short scales, and the thickness of the pointer, will not permit readings to be made with a much greater accuracy than this.

The application of the instrument is to check the voltages of the batteries from time to time, and the mA. scale may be used as an occasional check on the total H.T. current drawn from the battery. When used for this purpose it would be well to shunt the meter with a large-capacity condenser, as its rather high D.C. resistance—95 ohms—could cause L.F. instability if the receiver was none too stable under ordinary conditions.

The measurements made with this instrument will be sufficiently accurate for all practical purposes. Although the movement is magnetically controlled, gravity plays some part in positioning the pointer. The needle rests on the zero mark only when the face is vertical, so that all measurements should be made with the meter in this position.

It is an attractive instrument, and at the price of 10s. is good value for the money.

o o o o

FERRANTI ANODE FEED UNITS.

The function of these units is to prevent interstage coupling in a receiver, but they will serve, also, as voltage dropping resistances where a lower value than the maximum battery voltage is required.

The resistances, which are of the familiar cartridge pattern, are supported

in clips mounted on top of the condenser housing. In addition to the single units there is a triple model which consists of three resistances and three condensers. This model can be used as a three-stage decoupler, or the resistances can be connected so as to form a potentiometer device. This method of breaking down the output voltage from an eliminator for the screen grid in modern H.F. sets, or, for an anode bend detector, assures a constant voltage irrespective of small current changes.

The fact that these combined units require considerably less baseboard space is a further recommendation for their use.



Ferranti anode feed unit consisting of a bypass condenser and decoupling resistance.

The makers are Messrs. Ferranti, Ltd., Hollinwood, Lancs, and the prices have been fixed at 5s. for the single model, without resistance, and 7s. 6d. with a 20,000 ohms resistance. The triple unit costs 10s. 6d. plain and 17s. 6d. including one 20,000, one 15,000, and one 4,000 ohms resistance.

FURTHER TESTS ON CONE UNITS.

The Series Concluded from February 12th Issue.

MULLARD.

The Mullard "Pure Music" speaker unit consists of an acute-angle cone operated by a differential unit. The cone diameter is 6in. and the depth 3½in., while the unit is mounted on a bridge-piece inside the angle of the cone. This gives a compact construction and renders the unit suitable for incorporation in portable sets.

The armature is supported on spring strips at each end, and moves as a whole parallel to the four poles. There is no lateral movement, and the drive is transmitted to the cone through a built-up stirrup. The winding is provided with three alternative tappings.

The reproduction of this unit is characterised by crispness and a brilliant output in the upper register. The response be-

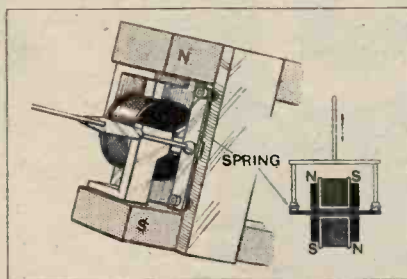

The Mullard movement.

tween 2,500 and 4,500 is well above the average, and there is a good output from 4,500 up to 6,000 cycles. From 4,000 cycles down to 150 cycles the output is free from major resonances, but on a lower level than the 2,500-4,500 band. Below 150 cycles the output falls rapidly, and there is little or no response at 50 cycles. The lack of bass is noticeable in orchestral music, but does not affect the reproduction of speech, which is excellent. In spite of the absence of any adjustment, the sensitivity is good and there is no evidence of chattering. Price 38s. 6d.

The Mullard Wireless Service Co. Ltd., Mullard House, Charing Cross Road, London, W.C.2.

| Unit. | Diaphragm. | IMPEDANCE (OHMS). | | | | | | | | D.C. Resistance (ohms). |
|-------------------|------------------|-------------------|-------|-------|-------|-------|--------|--------|--------|-------------------------|
| | | 50~ | 100~ | 200~ | 400~ | 800~ | 1,600~ | 3,200~ | 6,400~ | |
| Mullard | Mullard | — | 574 | 753 | 1,215 | 1,680 | 3,130 | 4,720 | 6,250 | 485 (1,345) and (1,830) |
| Rotor | Baker | 1,390 | 1,890 | 2,810 | 3,840 | 6,200 | 9,000 | 16,650 | 9,440 | 990 |
| Silver Chimes ... | Silver Chimes .. | 1,700 | 2,350 | 3,390 | 5,380 | 8,560 | 12,350 | 21,400 | 25,600 | 1,500 |

ROTOR.

The reed is fixed at two points to a cast-aluminium frame, while a spring extension at the back is used to give additional support and as a means of initial adjustment. The fine adjustment is provided by a screw passing on the reed in the centre of the three-point support.

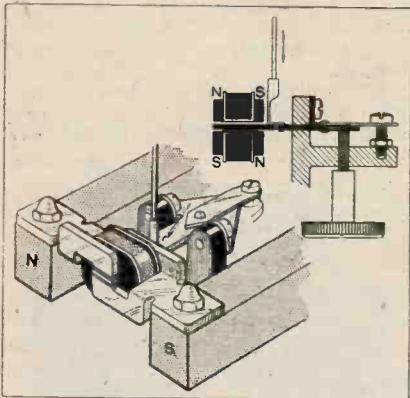

The Rotor unit.

The movement is free and capable of developing considerable amplitude.

As might be expected, the bass reproduction is good and the output is well maintained up to 1,500 cycles. At this

frequency the output falls and continues at a lower level up to a cut-off point at 5,500 cycles. There is a noticeable resonance at 1,300 cycles, and another of less importance at 3,900 cycles. Taken as a whole, however, the reproduction is pleasing, and, although the upper register is not prominent, it is nevertheless definitely present. The sensitivity is decidedly above the average, and no evidence of chattering was observed. Price 19s. 6d.

Rotor Electric Ltd., 2-3, Upper Rathbone Place, London, W.1.

o o o o

SILVER CHIMES.

This is a four-pole reed movement functioning on the differential principle. The reed is tapered and fixed at its broadest end to the die-cast base. An unusual feature is the employment of geared slow-motion adjustment for centring the reed.

The output is principally in the middle register with a maximum at 1,100 cycles. On either side of this frequency the output falls away steadily, and there is a high-frequency cut-off at 4,500 cycles.

The general effect is therefore lacking in balance in the very high and very low frequencies. Sensitivity is normal, and the unit will handle ample power without chattering. Price 16s. 6d.

L. Kremner, 49a, Shudehill, Manchester.

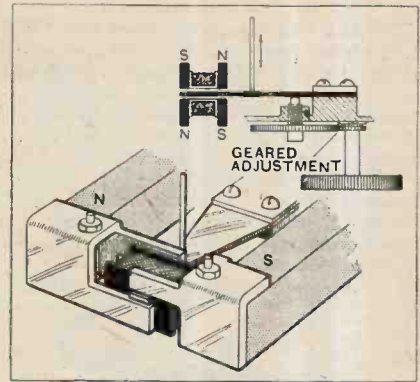

Silver chimes reed movement.

The KUKOO UNIT. A Correction.

In the description of this loud speaker unit on page 140 of the February 5th issue it was stated that adjustment was effected by rocking one pair of pole pieces. Actually, of course, both permanent magnets are fixed, and it is the die-cast plate carrying the armature suspension which is pivoted and capable of being raised or lowered by the adjusting screw. This point is quite clear from the original drawing, in which the die-casting supporting the armature assembly is shown unshaded.

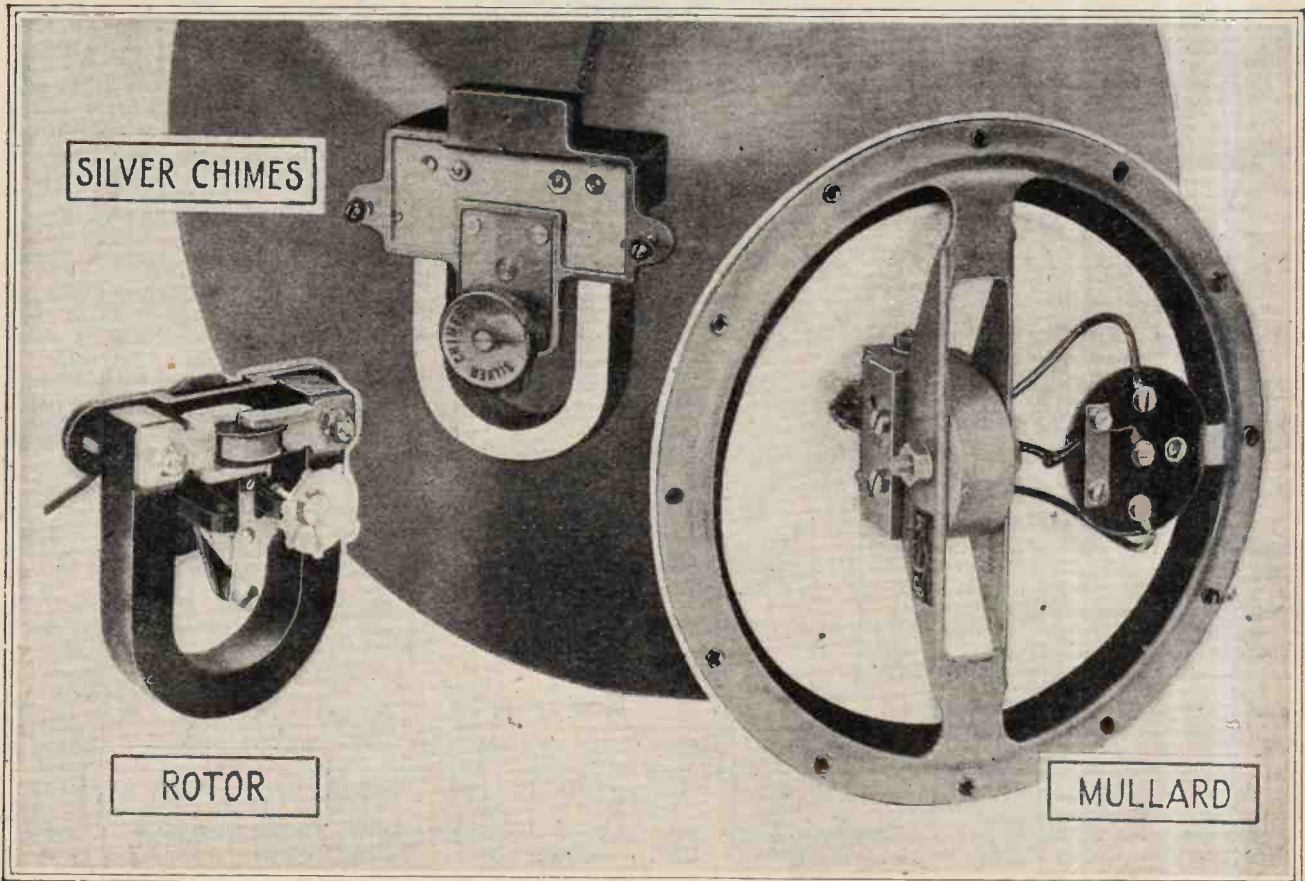



The Editor does not hold himself responsible for the opinions of his correspondents.

Correspondence should be addressed to the Editor, "The Wireless World," Dorset House, Tudor Street, E.C.4, and must be accompanied by the writer's name and address.

THOSE SUNDAY PROGRAMMES.

Sir,—Under the title "Broadcast Brevities" in the Feb. 5th issue you observe that the letters received at Savoy Hill in reference to the Sunday programmes are "few and generally favourable."

There is good reason for this. In the past three years I have visited, in the course of my business, every town in England and Wales. I am interested in the Sunday programme question and have taken the opportunity of making enquiries amongst all sorts of people, and I can assure you that the curses over the Sunday programmes are not loud but deep, and are widespread.

On my asking why those who complained did not write to the B.B.C., the answer was always the same. "What is the good? It will make no difference. It is only wasting time and stamps."

I myself received, in answer to a reasoned letter, the curt intimation that there was no intention of making any alteration in the policy governing Sunday programmes.

It would appear that the B.B.C. let it be known that no complaints on this head will have the slightest effect; and then when the public, knowing this, refrain from writing, the B.B.C. say that they "have very few complaints." Is it honest?

J. C. PRIOR.

SIR JOHN REITH AND B.B.C. POLICY.

Sir,—I have just read a statement in the Press in which Sir John Reith is credited with some amazing views.

He is reported as referring to "the dangerous and fallacious policy of giving the public what it wants."

Here, at last, we evidently have a statement of policy: the B.B.C. assumes a monopoly of wisdom as well as a monopoly of broadcasting, they know without asking what is good for the public.

The man who pays the piper may no longer call the tune—in fact, tunes are hardly allowed, and instead we have tedious readings of magazine articles under the guise of education and the discords of so-called modern music.

This is surely bureaucratic control at its worst, and I can only trust it may in some measure be checked by vigorous and persistent publicity.

There should be a more effective measure of public control, and the public should be allowed to decide by ballot or some method of election the general outline of policy.

The programme time allotted under various heads and the time of day for presentation should at least be open to discussion and revision if contrary to the wishes of the majority.

Heswall, Cheshire. J. B. WILSON.

Sir,—I was interested in your recent Editorial, and after carefully reading Sir John Reith's speech I cannot help feeling that you are misinterpreting him, and have missed his point completely.

He says that "to set out to give the public what it wants is a dangerous and fallacious policy involving almost always an under-estimate of the public intelligence, etc."

A 35

I read this as meaning that if you form an impression in your mind of what the public wants, and then give that to the public, you will find that you are wrong and that you have called down on your head the public's condemnation for giving them trash. The words "fallacious policy" which here mean "deceptive policy" surely give this meaning clearly.

Further, this fact is a common experience of authors, playwrights, film producers, painters, and in fact all classes of people whose work is produced for the public consumption. It is only when your rifle barrel points to a point considerably above the bull's eye that you stand some chance of hitting it from a distance.

Sir John Reith's mail bag must give him more information as to how to adjust his sights than you, Mr. Editor, or I, can possibly hope to obtain. After hearing programmes for the last six years I should say that notice is taken of the public's criticisms, and that any person, whatever his taste, who listens intelligently can find plenty in the programmes which will give him that interest or entertainment that he enjoys.

Wireless cannot be all things to all men as so many of us expect it to be. It cannot read our good books for us, it cannot see our best plays for us, and it cannot do our thinking for us—so it behoves us to use it as additional to, and *not* in substitution for, all the interests, occupations and enjoyments which people employed before the advent of listening-in.

Shrewsbury.

JOHN D. DAVIES.

[We cannot agree that we have misinterpreted Sir John Reith's meaning. The above letter suggests that we criticise Sir John's programme policy, whereas in point of fact our article supported that policy in principle.—Ed.]

BABY ALARM.

Sir,—Those parents possessed of an Everyman Four who wish to listen to the programmes and their offspring at the same time may be interested in the accompanying diagram.

Lead-covered "electric light" wire is used for the extension leads to a pair of phones used as the baby's microphone, the lead covering being earthed (to a separate earth).

This arrangement has given entire satisfaction for over a year. Strength, purity, and "distance" do not seem to be affected.

Plumstead, S.E.18.

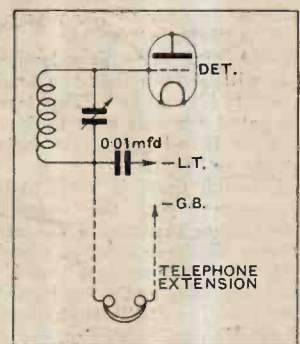

F. H. W. PETERS.

FREQUENCY MODULATION.

Sir,—Referring to Mr. John Harmon's article entitled "Frequency Modulation" in your issue for the 22nd January last, may I be permitted to point out that, contrary to Mr. Harmon's

statement, a carrier which is "wobbled" in frequency can be resolved into a carrier and side-bands occupying a "spectrum band" at least as wide as that found in the case of amplitude modulation?

The problem of waveband overcrowding is a very old one, and the classical, if somewhat highbrow, article on the subject is that by Dr. J. R. Carson in the *Proceedings of the Institute of Radio Engineers*, 1922, Vol. 10, pp. 57-64.

A physical explanation of the facts, proved mathematically in this paper, must be prefaced by pointing out that the words "frequency of a carrier-wave" have no meaning unless the wave is of periodic sine wave-form.

This is just the mathematician's way of saying that "frequency" has a meaning only when each wave composing the carrier is identical in every way (i.e., in amplitude and frequency) to the last, and each is of the special shape known as the sine wave. It is obvious that any way of modulating must prevent this from being the case.

Thus, any modulated carrier wave is of complex wave-form. Because the usual analysis of A.C. circuits is based on the assumption of a periodic sine wave only, it will be realised that it is necessary to treat a modulated carrier in just the same way as any other complex wave-form (e.g., in the same way as speech currents are treated).

A complex wave-form is usually treated as the sum of a series of periodic sine waves. In the case of a carrier wave these are usually referred to as the carrier and side-bands.

An analysis of phase modulation was given by Mr. N. E. Holmblad in *Experimental Wireless*, Vol. VI, May, 1929, p. 260. This applies to "frequency" modulation as well (as regards band-spread) and shows that, provided that the "frequency wobble" is small, the wave resolves into carrier ω and two side-bands ($\omega + p$) and ($\omega - p$). This is the same as amplitude modulation. If the "wobble" is large an even greater spread is found. Apart from this introduction of extra side-bands by large values of "wobble," the depth of "frequency" modulation has no effect on the spread.

I trust that this brief explanation of a subject which seems little understood may be of use to Mr. Harmon and to others. A fuller explanation will be found in a paper by the writer of this letter in *Television*, August, 1929, pp. 310-314.

Frinton-on-Sea.

J. H. OWEN-HARRIES.

IN SEARCH OF QUALITY.

Sir,—There was a time when I believed that men with scientifically inclined minds (such as the readers of your excellent paper) always avoided the personal element in discussions on loud speakers, chokes, grids, and other instruments of torture. And yet, in less than twelve short months, I have been inserted (in your correspondence columns) into complex personal equations and accused of being equal to:—

- (1) A member of the B.B.C. staff.
- (2) A second G.B.S.
- (3) A deceiver of the young.
- (4) A "comic" writer.
- (5) A grandad with a long, flowing white beard.

It will be seen that the brickbats (1) and (3) cancel out the bouquets (2) and (4). This leaves us with (5) only. The biscuit (or palm) for this goes to Mr. E. H. Palm, a gentleman who lives at Ilford (noted for its moving coils and lack of underground railways).

Although there is much to be said for big, bushy whiskers, as compared with the tender down which would make even a safety razor shudder, I am surprised at Mr. Palm's method of defence of the moving-coil loud speaker. He gives me a leaky grid detector, reaction, two L.F. transformers, no filter-choke, no decouplers, and a cardboard trumpet. Then he says, melodramatically: "I'll back my 16 lb. pot reproduction against yours any day." The proper place for a pot of such enormous dimensions is obviously not in the room of a respectable private house, but in the four-ale bar of an East End gin palace.

In his enthusiasm for these huge utensils, he even challenges me to a cracking-of-heads combat, with loud speakers as weapons. I regret that I cannot accept his challenge. It would be homicidal. What chance would his mere 16 lb. pot stand against my 56 lb. logarithmic, exponential, substantial, ten-foot horn?

His argument is the old, old argument of all M.-C. fanatics. "Ah! But you should hear one with a really properly designed set, hundreds of volts H.T., thousands of milliwatts output, a well-fed pot, and perfect transmission from 2LO." If you hear this amazing instrument and your eyes do not brighten with a new light, then its owner explains that the M.C. is not at its best owing to a little trouble with the eliminator, or the power station, or a wonky valve, or a throttled choke, or last (but not least) with the poor old B.B.C. It is much the same with the young mother and that very young baby with the wonderful laugh and the scintillating intelligence. But we grandads know better. We know that child; we have met it before. It has its moments, of course. But they occur in secret. Sh!

Therefore, in spite of Mr. Palm's hymn of praise to the M.C., I still adhere to my original contention that "in the ordinary room of an ordinary house" (which excludes gin palaces and public halls) my jolly little trumpet arrangement gives me just the de-thudded but full-bodied music suitable to the normal ear. I get all that Mr. Palm mentions with such pride. Transients (such as the horrid clash of cymbals) are magnificent; a violin is not a piccolo, a flute or a clarinet, but simply a violin; and a studio piano is so good that it comes through with just that "loose-keys" and broken strings effect, so dearly beloved by the B.B.C. As for the long land-line transmissions (such as "Huntingtower" from Glasgow via 2LO on January 30th), the distorted dialect is so perfectly terrible that one gasps for a breath of pure English. It may be that a small moving-coil unit would give me still better reproduction. I am not asserting, like M.-C. enthusiasts, that my loud speaker is the last word. It isn't. I should hate it to be. Even whiskers improve in luxuriousness and volume as time goes on.

It seems to me that the ideals to be aimed at in any loud speaker are: (1) Sensitivity, (2) proper loading of the vibratory mechanism, and (3) efficient coupling with the atmosphere. The comparatively small diaphragm (moving as a whole at the higher frequencies) and a large, properly designed horn come nearer to accomplishing these desirable aims than does the M.C. or reed-driven cone.

The conventional M.-C. cone is a compromise between too large and too small a cone, and the energy required to drive it is comparable with hiring an elephant to dust one's valuable china. Give me the feather duster, the light and sensitive feminine touch, and—the undamaged ornament. In other words, pass me the small cone with a horn conserving the air pressure near the diaphragm. If there is any compromising to be done between the theoretical and the practical, let the horn suffer and not the vibratory mechanism. In practice, a diminution in horn length and output area is not as vital as the scientists would have us believe. They try to terrify us into impossibly long horns, just as the modern doctor tries to terrify us into gorging ourselves with vitamins and sunlight.

Is there no manufacturer in this our England with sufficient enterprise and ability to design a small moving-coil unit (preferably with permanent magnet) for use with a horn—a sort of baby Vitaphone and Movietone type? Or must we all be driven to pots and baffle-boards, or the blurred discords of reed-driven cones? Will no one answer the trumpet call to action?

Twickenham.

BERTRAM MUNN.

LIGHT V. DANCE MUSIC.

Sir,—With reference to your paragraph under "Broadcast Brevities" in your issue dated February 12th, I certainly endorse your view relative to the light music provided by the Gershom Parkington Quintet. Surely it is time that the eternal jazz music which is ground out night after night from the British stations, and which seems to me to be an insult to the intelligence of the listening public, should be confined to one or the other of the stations.

We might well follow the example of some of the Continental stations, which give us light music up to midnight.

The Gershom Parkington Quintet and the Victor Olof's Sextette must have delighted many thousands of listeners, who, I am sure, will agree with me that with the twin transmitters going regularly we should be entitled to expect a little change.

London, E.C.3.

GERALD MARCUSE.

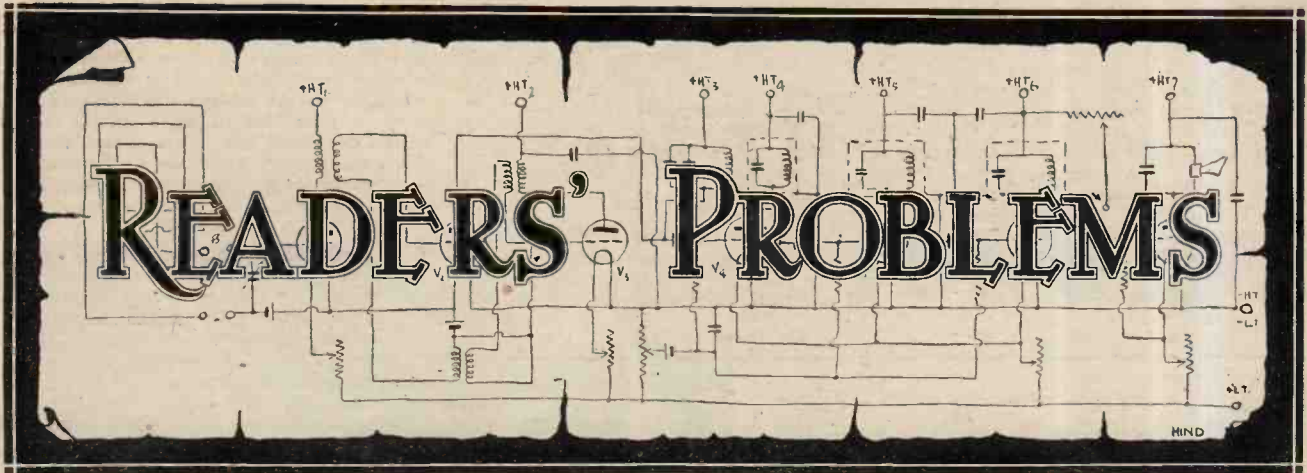

"The Wireless World" Supplies a Free Service of Technical Information.

The Service is subject to the rules of the Department, which are printed below; these must be strictly enforced, in the interest of readers themselves. A selection of queries of general interest is dealt with below, in some cases at greater length than would be possible in a letter.

Insufficient Inductance.

My "Wireless World Kit Set" is working well, but it is found that the upper limit of each wave range seems to be unduly low. On the medium band, in particular, it is impossible to tune to a wavelength much greater than that of 5GB. This applies to the H.F. transformer circuit.

Will you suggest a probable cause for this? The coils are commercial products, and are apparently very well made, and the components throughout are of the best class.

N. R. P.

Assuming that your tuning condensers have a maximum capacity not appreciably less than that at which they are rated—and few fall short in this respect—it is concluded that the trouble must be due to insufficient inductance of the H.F. transformer secondary. It has been observed that the slots in which the windings are

carried are sometimes made unnecessarily wide, and sometimes too deep, with the result that the mean diameter of each turn (and consequently the inductance of the coil) is much less than intended by the designer. If this is the cause of your trouble, it will be essential to wind on more secondary turns; this should not be a matter of any very great difficulty. Possibly ten extra turns will be necessary.

o o o

Testing Power Transformers.

I have reason to believe that the L.T. winding of my power transformer is defective, and actually gives a much lower voltage on load than its rated output. This winding is supposed to deliver up to 4 amps. at 4 volts for feeding indirectly heated valves. It seems rather difficult, without access to A.C. measuring instruments, to confirm this, but I believe it is possible to do so with the help of a milliammeter, if an accumulator is available for use in a comparative test. Will you please describe the procedure to be followed?

B. G. D.

Yes, it is quite a simple matter to determine whether your transformer is delivering approximately the correct low-tension voltage. The milliammeter should be put in the anode circuit of one of the valves, choosing one of them that normally passes an anode current well within the range of the instrument, and the current reading should be carefully noted while the heaters are being fed from the step-down transformer. The next step is to connect these heaters across a 4-volt accumulator of adequate capacity, and then to take a second reading of anode current under otherwise identical operating conditions. If anode current has now increased, you can take it that the voltage delivered by the transformer is less than that of the accumulator; if it has decreased, the converse will be true.

Anode or Grid Detection.

Will you please examine my circuit diagram, and say whether the simple method shown for changing over from anode bend to grid circuit detection has any real drawbacks? It seems to function quite satisfactorily, but I suppose that one has to pay for its simplicity, and that some losses will be introduced.

V. R. L.

By merely connecting a short-circuiting switch across the grid condenser it is possible in a circuit arrangement as shown in your diagram to provide for alternative methods of rectification. Of course, the switch is open when the valve is to operate as a grid detector.

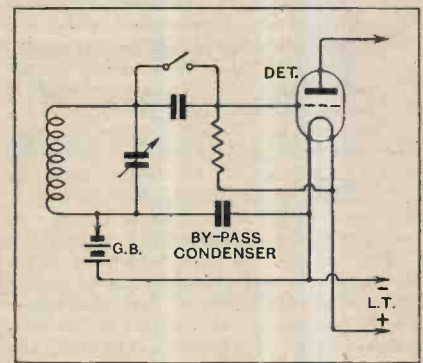

Fig. 1.—Anode bend or leaky grid. A simple switching scheme.

There is actually a theoretical loss when using the anode bend method, due to the fact that the tuned circuit is shunted by the grid leak, but unless you are using exceptionally good coils it is certain that the dynamic resistance of the tuned circuit will be very much less than the resistance of the grid leak, and so the loss will not be appreciable.

The circuit diagram is reproduced in Fig. 1.

RULES.

- (1.) Only one question (which must deal with a single specific point) can be answered. Letters must be concisely worded and headed "Information Department."
- (2.) Queries must be written on one side of the paper, and diagrams drawn on a separate sheet. A self-addressed stamped envelope must be enclosed for postal reply.
- (3.) Designs or circuit diagrams for complete receivers cannot be given; under present-day conditions justice cannot be done to questions of this kind in the course of a letter.
- (4.) Practical wiring plans cannot be supplied or considered.
- (5.) Designs for components such as L.F. chokes, power transformers, etc., cannot be supplied.
- (6.) Queries arising from the construction or operation of receivers must be confined to constructional sets described in "The Wireless World" or to standard manufacturers' receivers.

Readers desiring information on matters beyond the scope of the Information Department are invited to submit suggestions regarding subjects to be treated in future articles or paragraphs.

The Bigger the Better.

I am in course of building a receiver with three H.F. stages, which is to be operated with a frame aerial. Will you please suggest suitable dimensions for the frame? G. R.

We cannot give a definite answer to this query. The receptive power of a frame aerial depends on its size, and, from the point of view of signal pick-up, it cannot be too large. We suggest that you should construct the largest frame aerial possible, consistent with the space available for it.

Condenser Dial Discrepancies.

Tuning condensers C_2 and C_3 of my "Wireless World Kit Set" are almost exactly in step over the whole tuning range, but there is a wide divergence between the readings of these dials and that of the aerial tuning condenser C_1 . Will you please suggest a way of overcoming this minor drawback? F. D. L.

It is almost inevitable that a condenser used for tuning an open aerial circuit, in which there is a large parallel capacity of uncertain value that cannot be allowed

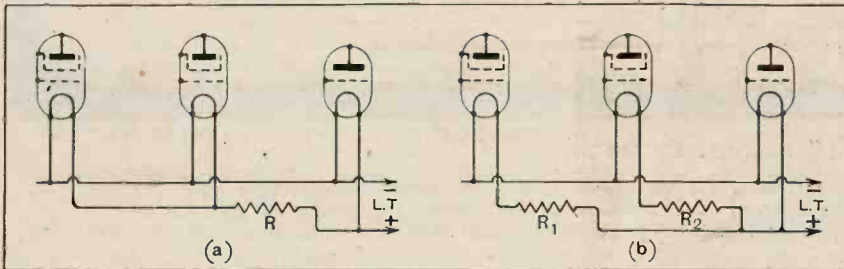

Fig. 2.—Using 2-volt S.G. valves in a set with 6-volt detector and L.F. amplifier. (a) One common rheostat, (b) separate rheostat for each H.F. valve.

Filament Wiring: Another Safety Precaution.

It is proposed to use two 2-volt screen-grid valves in a receiver in which 6-volt valves will be used for detection and L.F. magnification. If a resistance of the correct value is inserted in the positive L.T. lead the correct voltage would be applied to the filaments of the H.F. valves as long as they were both in position, but if one were removed, or if its filament were accidentally burnt out, I think I am right in saying that the voltage across the other would rise considerably, and that it would probably be damaged.

This risk might be obviated by fitting a fuse, but I imagine that it would be rather difficult to obtain a device that would "blow" before the current reached an excessive value, and at the same time be capable of carrying the normal amperage. Can you suggest a better way out of the difficulty? P. F.

This is rather an important point nowadays, as it is by no means unusual to find the valve combination you describe—partly because certain modern 2-volt S.G. valves have an exceptionally high efficiency.

The normal arrangement is shown in Fig. 2 (a); here the resistance R is common to the two high-frequency amplifiers, and an interruption of the filament circuit of one of the valves will be responsible for a considerable rise in voltage across the other, and damage will probably be done.

We suggest that the best and safest plan is to provide separate filament resistances—fixed, semi-fixed, or variable—for each valve, in the manner shown in Fig. 2 (b), in which these resistances are marked R_1 and R_2 .

for by the designer, will not keep "in step" with a condenser forming part of a closed circuit.

This is not generally considered to be a serious drawback, but if you are particularly desirous of obtaining synchrony we suggest that you should fit a variable series aerial condenser (C_1) and experiment with the relative values of this capacity and that of the aerial tuning inductances. o o o o

An Unfair Comparison.

I have been endeavouring to carry out a comparative test between my old "Everyman Four" and a new "2-H.F." receiver with screen-grid valves. In order to get a steady signal of not overpowering strength the tests were carried out on the local station with the aerial completely disconnected—this is a plan which was recommended in your columns some time ago. Both sets give loud signals from the near-by transmitter (seven miles away), but, much to my disappointment, the new receiver is distinctly inferior in the matter of volume when compared with the old one.

Obviously there is something wrong here, and I am not getting anything like the magnification that is to be expected from a two-stage high-frequency amplifier. Can you suggest a few probable causes for this poor performance? P. D. W.

We cannot be definite, but we are inclined to think that you have made your comparative tests under conditions that are unfair to the new set. In all probability this receiver, with its two high-frequency stages, is completely screened, whereas the old "Everyman Four" was fairly "open," and there was consider-

able pick-up of signals by its input grid coil and wiring.

We suggest that you should make another comparative test on signals from a more distant station—5GB should do well in your case—using a similar short aerial for each set. This aerial should be long enough to have a "pick-up" sufficiently large to overshadow the direct pick-up of either set. o o o o

Causes of Self-oscillation.

Will you please give me a brief summary of the possible causes of instability in a screen-grid H.F. amplifying stage? T. W. H.

Production of uncontrollable self-oscillation when plate and grid circuits are brought into resonance may be due to:—

- Inadequate screening between input and output circuit components.
- Inter-circuit coupling brought about by common resistances, or, incidentally, to ineffective decoupling devices, among which one may include high-resistance by-pass condensers.
- Incorrect operating conditions (anode and screen voltages) of the valve.
- The use of a valve with an exceptionally high residual capacity.
- Merely to the fact that the resistance of the tuned circuits is so low that stability is impossible; there is a definite upper limit to amplification in every case.

FOREIGN BROADCAST GUIDE.**LENINGRAD**

(Russia).

Approximate Geographical Position: 59° 42' N. 30° 27' E.

Approximate air line from London: 1,300 miles.

Wavelength 1,010 m. Frequency 300 kc. Power 20 kW.

Time: Eastern European (two hours in advance of G.M.T.).

Standard Daily Transmissions.

Weekdays: 4.30, 5 and 5.30. G.M.T. morning gymnastics (Sundays: 6 and 6.30 a.m.); 12.00 news; 12.45 gramophone concert. Sundays: 13.10; 13.30-15.30 app. talks; Mondays, Tuesdays and Wednesdays from 13.30-18.00 or 18.30; Daily: 18.00 or 18.30 main evening concert relayed from the Radio Theatre, or from one of the Russian stations.

Time signal given at 5 p.m. G.M.T.: one long hoot followed by two dashes and one dot (G).

Man and woman announcers. Call: *Hallo! Govorit Leningrad* (Here speaks Leningrad); or *Sloeschaitye Leningradskaya radio veschschatel'naya stancia na volnye tisatschia metrov*. (Attention! Here speaks Leningrad radio station on wavelength 1,000 metres). Abbreviated call: *Leningradski Radio Central*.

Occasional interval signal: the call of the cuckoo.

12 MONTHS IN THE

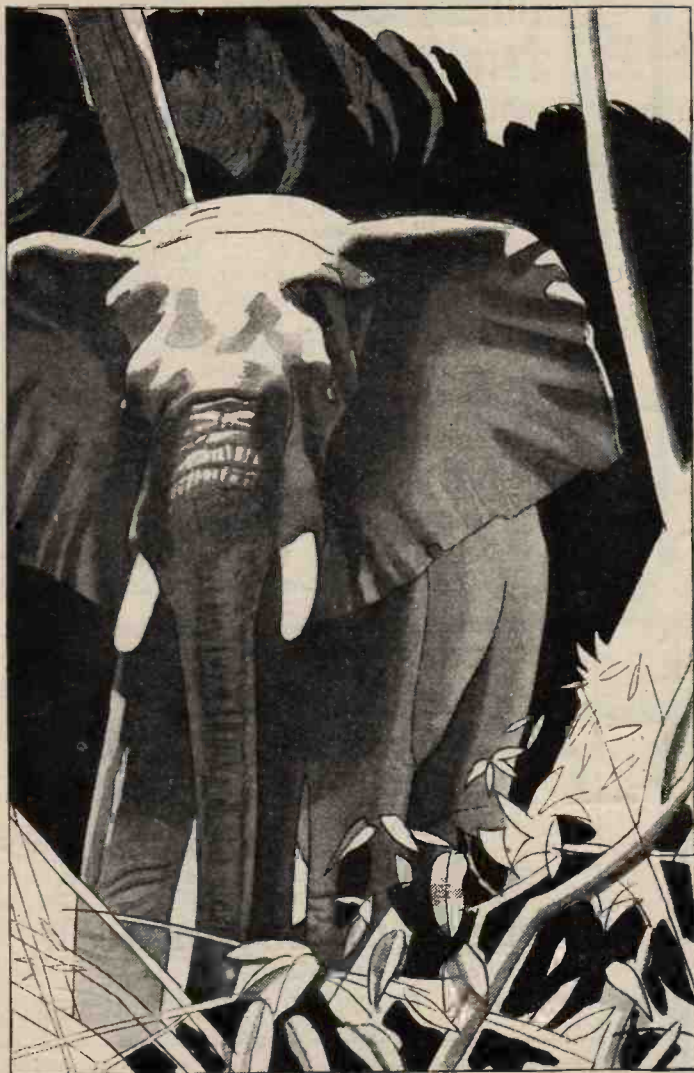

JUNGLE!

In wilds of Africa the Court-Treatt expedition makes great British film "Stampede." Hundreds of miles from nearest white men! Yet always in touch with London, *through Marconi Valves*. The expedition's messages, transmitted by Errol Hinds, were heard even in United States—5000 miles away! Marconi Valves were used in his portable wireless equipment. They are used by all British broadcasting stations . . . by all Imperial Airways machines . . . by all Trinity House lightships and beacon stations. For their wide range. For their long life. For their dependability. ● *In cases like these, when unfailing reliability is essential men insist on Marconi Valves.*

FIT MARCONI VALVES



THE FIRST AND
GREATEST NAME
IN WIRELESS

TO YOUR RADIO SET

Give you clearer tone, greater volume, longer range. Cost not a penny more. Fit any set.

For all technical information on valves write to THE MARCONIPHONE COMPANY LIMITED, 210-212 Tottenham Court Road, London, W.1

▲20 Advertisements for "The Wireless World" are only accepted from firms we believe to be thoroughly reliable.

WEARITE COMPONENTS

+ YOUR TIME
= BEST RESULTS
- TROUBLE

H.F. CHOKE

Iron cored. Can be supplied centre tapped for use in scratch filter. Tuning range 10-2,000 metres. Self-capacity 3.5 M.M.F. Inductance 300,000 M.H. Resistance 200 ohms.



Price 6/3.

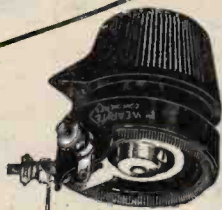

RHEOSTATS

1/6 or 2/- each.

4, 7, 15, 30, 50 ohms. Potentiometers 2/- each. 300, 400 ohms. Volume controls 25, 5, 1 or 2 megohms. To pass 1 M.A. max. 4/- each. Baseboard mounting 3d extra.

Free illustrated lists by return post.

WRIGHT & WEAIRE LTD.
140, High Road, Tottenham, N.17.
Phone: Tottenham 3847/8.

223

THE NEW CELESTION LOUD-SPEAKER MODEL Z20

Designed specifically to give the finest possible results with any set from a Two-Valve to a Power Amplifier. Beautifully designed and hand polished cabinets in Oak £7.15.0. Mahogany £8.5.0. Walnut (to order) £9.0.0 Other models from £3.15.0.

"The very thing for constructors' receivers . . . fit for the finest home in the land. "NOTIS EVG. POST."

WRITE FOR AN ABSORBING FREE BOOK ON "SOUND RE-CREATION" TO CELESTION LTD., DEPT. C, KINGSTON-ON-THAMES.

London Showrooms: 106, Victoria St, S.W.1.

CELESTION

The Very Soul of Music

KUKOO

And here's further proof

SUPER CONE SPEAKER UNIT

24, East Parade, Steeton, Nr. Keighley.

Dear Sirs, 20th January, 1930.

Some time ago I purchased one of your Kukoo Units, and having made up a 12" Cone was most disappointed with the results obtained. Naturally I condemned the Unit, but last week I had an opportunity of trying out this Kukoo Unit on a Philips All Mains 4, when I was astonished to find exactly what you claim, viz., Moving-Coil results. The gentleman who owns this Philips Set thought that it was actually a Moving Coil Speaker I had brought to him. He afterwards stated that your 25/- Kukoo Unit was greatly superior to the £5 12 6 . . . he was using. I have written this letter in fairness to you as I at one time thought I had a legitimate cause of complaint, whereas the trouble undoubtedly is in my set.

Yours faithfully,

W. Barker

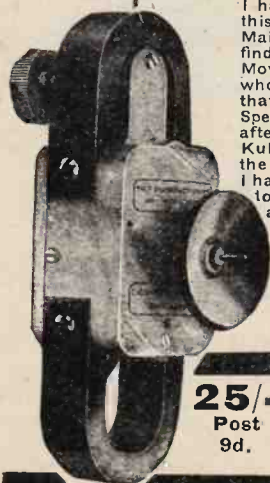

25/- from your Dealer or Direct—
Post 9d. The SHEFFIELD MAGNET CO.
Broad Lane, SHEFFIELD.

MONEY FOR YOU

Men or Women, you can earn a good weekly income in whole or spare time, no matter where you may live,

WRITING DISPLAY CARDS

The work is light and pleasant, without canvassing, and previous experience is not essential as we instruct you by post and provide the complete working outfit of tools and materials.

WE SUPPLY YOU WITH WORK

and pay cash weekly. Apply:—

GRANT & GRAY LTD., 498, ST. ALBANS.

GILMAN THE ALL BRITISH LOUDSPEAKER CHASSIS



A completely assembled cone floated on felt in a highly polished aluminium casting. It incorporates our NEW adjustable unit fixing plate, ensuring the correct centering of the unit reed in cone. EXCLUSIVE TO GILMAN CHASSIS. Plates can be supplied to fit any make of unit in the World. Power Model, 18" . . . 22/6

Ask for a GILMAN chassis!

If your dealer cannot supply write direct to:
J. S. GILMAN & CO.,
63, Basinghall Street,
London, E.C.2.

Phone: Metropolitan 9892.

The NEW adjustable back plate for perfect centering of any unit.



Mention of "The Wireless World," when writing to advertisers, will ensure prompt attention.

MISCELLANEOUS ADVERTISEMENTS.

NOTICES.

THE CHARGE FOR ADVERTISEMENTS in these columns is:

12 words or less, 2/- and 2d. for every additional word.

Each paragraph is charged separately and name and address must be counted.

SERIES DISCOUNTS are allowed to Trade Advertisers as follows on orders for consecutive insertions, provided a contract is placed in advance, and in the absence of fresh instructions the entire "copy" is repeated from the previous issue: 13 consecutive insertions 5%; 28 consecutive, 10%; 52 consecutive, 15%.

ADVERTISEMENTS for these columns are accepted up to **FIRST POST ON THURSDAY MORNING** (previous to date of issue) at the Head Offices of "The Wireless World," Dorset House, Tudor Street, London, E.C.4, or on **WEDNESDAY MORNING** at the Branch Offices, 19, Hertford Street, Coventry; Guildhall Buildings, Navigation Street, Birmingham; 260, Deansgate, Manchester; 101, St. Vincent Street, Glasgow, G.2.

Advertisements that arrive too late for a particular issue will automatically be inserted in the following issue unless accompanied by instructions to the contrary. All advertisements in this section must be strictly prepaid.

The proprietors retain the right to refuse or withdraw advertisements at their discretion.

Postal Orders and Cheques sent in payment for advertisements should be made **& Co.** payable to **LILIFE & SONS Ltd.**, and crossed **& Co.** Notes being untraceable if lost in transit should not be sent as remittances.

All letters relating to advertisements should quote the number which is printed at the end of each advertisement, and the date of the issue in which it appeared.

The proprietors are not responsible for clerical or printers' errors, although every care is taken to avoid mistakes.

NUMBERED ADDRESSES.

For the convenience of private advertisers, letters may be addressed to numbers at "The Wireless World" Office. When this is desired, the sum of 6d. to defray the cost of registration and to cover postage on replies must be added to the advertisement charge, which must include the words Box 000, c/o "The Wireless World." Only the number will appear in the advertisement. All replies should be addressed No. 000, c/o "The Wireless World," Dorset House, Tudor Street, London, E.C.4. *Readers who reply to Box No. advertisements are warned against sending remittance through the post except in registered envelopes; in all such cases the use of the Deposit System is recommended, and the envelope should be clearly marked "Deposit Department."*

DEPOSIT SYSTEM.

Readers who hesitate to send money to unknown persons may deal in perfect safety by availing themselves of our Deposit System. If the money be deposited with "The Wireless World," both parties are advised of its receipt.

The time allowed for decision is three days, counting from receipt of goods, after which period, if buyer decides not to retain goods, they must be returned to sender. If a sale is effected, buyer instructs us to remit amount to seller, but if not, seller instructs us to return amount to depositor. Carriage is paid by the buyer, but in the event of no sale, and subject to there being no different arrangement between buyer and seller, each pays carriage one way. The seller takes the risk of loss or damage in transit, for which we take no responsibility. For all transactions up to £10, a deposit fee of 1/- is charged; on transactions over £10 and under £50, the fee is 2/6; over £50, 5/-. All deposit matters are dealt with at Dorset House, Tudor Street, London, E.C.4, and cheques and money orders should be made payable to Lilife & Sons Limited.

SPECIAL NOTE.—Readers who reply to advertisements and receive no answer to their enquiries are requested to regard the silence as an indication that the goods advertised have already been disposed of. Advertisers often receive so many enquiries that it is quite impossible to reply to each one by post.

RECEIVERS FOR SALE.

SCOTT SESSIONS and Co., Great Britain's Radio Doctors.—Read advertisement under Miscellaneous. [0264]

HIRE a McMichael Portable Set by day or week from Alexander Black, the Wireless Doctor, 55, Ebury St., S.W.1. Sloane 1655 [0328]

Q- and 3-valve London Make Efescaphone Receivers, with valves and cone loud speaker, to be disposed of at great sacrifice; 2-valve outfit, 45/-; 3-valve outfit, 56/6; all brand new and guaranteed.—J. B. Humphreys and Co., 23, College Hill, Cannon St., London, E.C.4. [8413]

EVERYMAN Four, two range, perfect condition, set, 6-rod valves, spares, G.B. battery, booklet, Ethevmin dials; without cabinet, £5/10; handsome receiver.—Fergus, 13, Carshalton Rd., Mitcham. [8419]

B&J

ALL WIRELESS WORLD COILS

1930 EVERYMAN

| | |
|---------------------------------|--------------|
| FOUR | 47/6 set |
| KIT SET, Coils with Switches | 45/- set |
| NEW KILOMAG | 45/- set |
| RECORD KIT | 45/- set |
| FOREIGN LISTENERS 4 B.B.C. | 30/- set |
| | 52X 37/6 set |
| METAL CABINETS | 38/6 to 46/6 |
| 51' DRUM DIALS with Escutechons | 5/6 |

B&J. Wireless Co.

2, 3, & 4, Athelstane Mews, Stroud Green Rd., N.4

Archway 1695

"END OF YEAR CLEARING."

APPLEBY'S

FOR BARGAINS WATCH Phone: Paddington

THE MISCELLANEOUS COLUMNS THIS MONTH. 8828 (3 lines)

For Modern High-grade Material Only.

CHAPEL ST., LONDON, N.W.1

OPEN TILL 7 P.M. SAT. 1 P.M.



Have You Electric Light?

Tannoy Mains units act like the electric light, no moving parts or valves to break . . . simply connect to your present set and switch on.

They are always constant, providing more volume with FULL H.T. and L.T. ready at hand. Write for leaflets.

Tulsemere Mfg. Co.
1/7 Dalton St.
S.E.27

THE NEW KILO-MAG 4

AFTER careful comparison with the leading 1529-30 receivers, we can state definitely that the New Kilo-Mag 4 is the outstanding set of the season.

In view of its remarkable performance we are specialising in this receiver and guarantee entire satisfaction.

Complete Receiver, wired and carefully tested, including Mullard or Marconi Valves,

£21.0.0

or Deposit of £1.16.9 and 11 payments of 36/9.

Complete Kit of Parts exactly to "Wireless World" specification including Ritherdon Steel Cabinet and Valves,

£17.10.0

or Deposit of £1.12.0 and 11 payments of 30/6.

The London Radio Supply Co.,
11 Oat Lane, Noble St., London, E.C.2.

*Phone: National 1977.

Receivers for Sale.—Contd.

BARGAIN.—8-valve receiver, 30-2,000 metres, new valves, batteries and frame, and gramophone pick-up included, in mahogany polished cabinet 26in. long, 20in. high; cost over £30, will accept £15.—Box 4964, c/o *The Wireless World*. [8444]

YOUR OLD Receiver or Components Taken in Part elsewhere, and obtain expert advice from wireless engineer of 25 years professional wireless experience; send a list of components or the components themselves, and we will quote you by return post; thousands of satisfied clients.—Scientific Development Co., 57, Guildhall St., Preston. [0226]

SIMMONDS BROS.—Receivers constructed to your own or any published design; also repairs, reconstructions, and modernisations at moderate charges; best materials and workmanship guaranteed; numerous testimonials; quotations free.—Address, Shireland Rd., Smethwick. [5882]

PHILIPS 3-valve Mains Receiver, cost £23, accept £15, same, 2-valve, cost £12/10, accept £9; also other stock, including mains units; send for list.—Cooling, 37, Teanyson Av., New Malden, Surrey. [8504]

PUBLIC Hall Amplifiers, one only, Marconi Co., make excellent condition with 2 Browns power loud-speakers, the lot for quick sale £5; sterling power 2-valve amplifiers, brand new, £2, bargain.—J. H. Humphreys and Co., 23, College Hill, Cannon St., London, E.C.4. [8494]

McMICHAEL 5-valve Portable Wireless Set for Sale, as new; £10, or near offer—Apply Miss Doctors, c/o Newton and Sons, 20, Charles St., Hatton Garden, E.C.1. [8498]

LUFUS 3-valve S.G.P. Receiver, 6/6; all-electric receiver, 9/6 per week; particulars.—Frost, 54, Clerkenwell Rd., E.C.1. [8495]

SURPLUS Stock.—B.T.H. De Luxe receiver [200-260 A.C.]; list £110, £75.

B.T.H. Junior R.K. (200-250 A.C.); list £34, 4/8 each; all above complete with valves.

B.T.H. Pick-ups and Tone Arms (branded), list 45/-, 39/- each; 200,000 ohms. volume controls, list 11/3, 3/- each.

B.T.H. 1,600 Metre Crystal Loading Attachment; 2/- each.—F. H. H., 27a, Bridget St., Rugby. [8488]

ADVERTISING Offer for Limited Period.—Raco 3-valve pedestal model receivers, complete with cabinet cone speaker, Ever-ready and Exide batteries, valves, Royalty paid, powerful yet simple to handle, no coil changing; price £11/15; despatched upon receipt of cash; all orders in strict rotation.—Raven and Corks, 22, Walton St., Long Eaton, Nottingham. [8487]

IGRANIC 3-valve All Mains Set, for A.C., 210-240 volts, with Western Electric loud-speaker, new condition, what offers.—Box 4974, c/o *The Wireless World*. [8480]

BURNDIPT Screened Grid 4-valve Portable, leather cover, suitcase model, equal to new; owner must sell; £15, or nearest offer.—Mr. Arthur, 50, Sussex Av., Ashford, Kent. [8478]

A GIFT.—2v. Burndipt, guaranteed new, cost £10, complete with valves; first £4 secures.—435, Barkington Rd., E.13. [8477]

3-VALVE All-wave Set, complete with Marconi valves; cost £10, sell £3/10; brand new.—B. O. Priestley, 13, Canonbury Park North, London, N.1. [8476]

EDISON BELL 16 guinea 5-valve Portable, won in "Daily Express" competition, absolutely new.—Offers to Ramsay, Grendon House, Exeter. [8470]

WHAT Offers?—Lissen 5-valve portable, new condition, spare accumulator, Gecophone 2-valve amplifier with valves, Gecophone horn loud-speaker, Cydon triple 0.005 log condenser, 3 only 1928 music Magnet coils, 1 Cosmos S.210 valve, 3 Cosmos AC/S valves, 2 Cosmos AC/R valves, 1 Cosmos AC/G valve, Ormond cone unit and chassis, Ediswan cone unit, Igranic Elken E.H.B. rectifier and transformer to suit.—Hill, 5, Church Rd., Stainforth, Doncaster. [8467]

ROLLS Cayden 1929, 5 valves, complete, in walnut case only; £8.—Piggott, High St., Edgware. [8452]

TRUPHONIC 5-valve Portable Receivers, used for demonstration only, at present at the manufacturers for complete overhaul, without valves or batteries; at a bargain price of £6/15; reason for disposal not powerful enough at this distance on Daventry.—Fairbairn, 181, High St., Ayr. [8450]

NEW Kilo-Mag Four Polished Copper Cabinet and Mahogany Plinth, fitted with Mazda A.C. valves and filament transformer, perfect quality and great range and selectivity, new condition, will accept £20 lowest; also Ferranti H.T. eliminator, 200-240 volts, £10.—Benham, 8, Rostrevor Rd., Wimbledon, S.W.19. *Phone: Royal 3654. [8458]

1930 Demonstration Model National Portable, complete, fully charged batteries, as new, 10 guineas; also Rotax Rotola portable, £7/10.—Engineer, 105, Torriano Av., Camden Rd North 0623. [8484]

for **SMOOTH RECEPTION**
"Layerbilt"

The "Layerbilt" is unbeatable for smooth reception. It is crammed full of electricity and lasts half as long again as any other battery of the same size and weight in the world. This is assured by the Columbia patented process of building layer upon layer of flat cells. The "Layerbilt" Heavy Duty Battery is the best and most economical battery in the world. Use it always.



No. 4721. 60 volts. 10/6.
No. 4755. 99 volts. 15/-.
Layerbilt No. 4496. for 18 m/a. No. 4780. 25/- 60 volts. 20/-.

Columbia RADIO BATTERIES

J. R. MORRIS, Imperial House, 15, Kingsway, London, W.C.2.
Scotland: J. T. Cartwright, 3, Cadogan St., Glasgow.

BROWNIE SELECTIVITY UNIT

Mr. F. T. Collins, of East Barnet, writes: "Although I am within 6 miles of Brookman's Park, I find the Brownie Selectivity Unit enables me to separate either wave length without the least difficulty. I feel that your Unit is the only relief for listeners in this area." Screen-Grid selectivity with any set—

that's what you get with the Brownie Selectivity Unit, at a cost of only 10/6! Your dealer will tell you all about it.

10/6

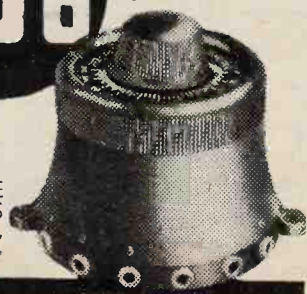

BROWNIE WIRELESS CO. (G.B.) LTD., Nelson St. Works, London, N.W.1.

ACCUMULATOR HIRE.

DON'T Buy Accumulators or Dry Batteries, join our C.A.V. low- and high-tension accumulator hire service, the largest and best in London; better and cheaper reception with no trouble; regular deliveries within 12 miles of Charing Cross; no deposit, payment on each delivery or by quarterly subscription; over 10,000 satisfied users; explanatory folder post free; 'phone or write to-day.—Radio Service (London), Ltd., 105, Torrington Av., N.W.5. 'Phone: North 0623-4-5.

C.D.E.S. Accumulator Hire and Maintenance Service (5 mile radius).—98, Cherry Orchard Rd., Croydon. [6374]

BATTERIES.

WET H.T. Replacements.—Sacs (capped or uncapped), highest grade, No. 1, 10d per doz.; No. 2, 1/9 per doz.—See below.

ZINCS.—Best quality (wired), No. 1, 6d per doz.; No. 2, 9d per doz.; orders valued 5/- carriage paid, otherwise 6d for postage.—British Battery Co., Clarendon Rd., Watford, Herts. [0258]

TWO 60v. Tinglestone De Luxe H.T. Accumulators, just overhauled by makers, £7, cost £11/10.—Paige, 242, Cowley Rd., Uxbridge, Middlesex. [8429]

CHARGERS AND ELIMINATORS.

CHEBROS.—Chebros for all types of transformers and chokes, high grade instruments at a very moderate price; enquiries invited.—Chester Bros., 244, Dalston Lane, London, E.8. [5290]

TRANSFORMERS and Chokes for Battery Eliminators and for all wireless purposes, receiving or transmitting; enquiries invited.—Chester Bros., 244, Dalston Lane, London, E.8. [7587]

TANTALUM and LITHIUM for A.C. Rectifiers; for inexpensive chargers; blue prints for H.T. and L.T., 1/- each; Lithium electrodes, 2-3 and 5-8 amps.—Blackwell's Metallurgical Works, Ltd., Garston, Liverpool. [8298]

ZAMPA H.T. Eliminator Kit, comprising: Rectifying unit (incorporating transformer, condensers, Westinghouse H.T.5), necessary condensers, choke, panel, terminals, flex baseboard, etc.; output 120 volts at 20 m.A.; complete, 45/-; 7 days' approval against cash; other Zampa kits and transformers on request.—Mic Wireless Co., Market St., Wellesborough. [8397]

FOR Sale, 50 mains transformers universal 200-250 volts, 40-100 cycles, delivering 4 volts 1 amp., 4 volts 1 amp., 6 volts 0.25 amps., and 300-300 volts, capable of supplying a Philips type 506 rectifier and an indirectly heated valve, and with any of the 6-volt superheated power class valves, all windings are centre tapped.—Box 4922, c/o The Wireless World. [8412]

NEW Foreign Listener's Four Transformer, exactly as specified by "Wireless World," 30/- post free, guaranteed 12 months, state mains, voltage and frequency; smoothing and output chokes, also as specified, 18/- each, post free, complete kit, 64/-.—Knight and Co., 6, Chapel St., London, E.C.2. [8355]

WESTINGHOUSE H.T.4 Rectifier, 25/-; Varley E.P.2 transformer, 15/-; 2 T.C.C. 4mfd. condensers, 5/- each; Igranite potential divider, 7/-; all as new.—Box 4976, c/o The Wireless World. [8482]

SAVAGE'S Specialise in Wireless Power from the Mains, reliable apparatus at reasonable prices.

SAVAGE'S Transformers Laminations and Bakelite Bobbins; intending home constructors should write for list.

SAVAGE'S Reliable Smoothing Condensers, 1,000 volt D.C. test, 1 mid., 2/-; 2 mid., 3/-; 4 mid., 5/3; 500 volts D.C. test, 1 mid., 1/6; 2 mid., 2/3; 4 mid., 3/9.

SAVAGE'S Super Smoothing and Output Chokes, many types available, write for list.

SAVAGE'S Mains Transformers for Westinghouse H.T. 4 Unit, 18/6; A.3, 17/-; A.4, 20/-.

SAVAGE'S Mains Transformers for Westinghouse H.T. 4, with additional winding, 4 volts, 3 amps.; 23/-.

SAVAGE'S Mains Transformer V.T.31 200-0-200-volts 60 milliamps 2+2 volts 2 amps., 2+2 volts 3 amps., 28/-.

SAVAGE'S Mains Equipment for New Foreign Listeners Four Transformer N.F.L.4, 33/-; smoothing choke C.32G, 20/-; output choke C.32/0, 20/-.

SAVAGE'S Mains Transformers and Power Chokes are Carefully and Individually Constructed from First Class Materials with an Exceptionally Generous Margin of Safety.

SAVAGE'S, 146, Bishopgate, London, E.C.2. 'Phone: Bishopgate 6998. [8474]

M.L. Anode Converter, 6 volt input, 120 volt output; 55/-; perfect condition.—Payne, 26, Earl St., Coventry. [8473]

THREE M.L. Anode Converters, Type C, input 12 volts, output 240-325-400 respectively, bargain, £5 each complete, as new; B.T.H. anode converters, input 6.5 volt, output 150-200 volt, 100 milliamps, £2/10.—E. B. Jeffrey, 25a, Strathville Rd., Southfields, S.W.18. 'Phone: Putney 6128. [8471]

REGENTONE A.C. Eliminator W.I.a, 200 volts, 100 milliamps, 200-500 input, never used; £6, or near offer.—25, Wallington Rd., Seven Kings. [8446]

LOTUS All-mains Unit (replaces all batteries); 3/6 per week; details.—Frost, 54, Clerkenwell Rd., E.C.1. [8497]

FERRANTI H.T. Eliminator, new; cost £13/10, accept £10.—Benham, 8, Rostrevor Rd., Wimbledon, S.W.19. [8459]

VIVIDLY NATURAL RADIO



WITH THIS SUPREME SPEAKER

If you are a "Double Diaphragm" fan, save time and trouble by using this commercially-made product. Available in chassis form from £2 0



The secret of the musical supremacy and the overwhelming technical merits of the Ultra Air Chrome Speaker lie in the fact that the two diaphragms are accurately balanced. The large diaphragm gives a true bass note response, while the small diaphragm reproduces the high notes in correct acoustic balance. This balance brings vividly natural radio. Hear it at your radio or music dealer's.

Models at £2:10:0 and £5:5:0

ULTRA AIR CHROME SPEAKER

"B.A.T." 750 Watt "Q.M.B." SWITCH.

This miniature switch comfortably breaks 3 Amperes at 250 Volts. For H.P., L.F., H.T., L.T. Circuits. For A.C. Sets, Eliminators, Gramo-Motors, and as Loud Speaker Field Switch, etc.



"WIRELESS WORLD" said (14.8.29) "functioned quite well on test and did not give any cause to justify doubt as to their ability to handle this wattage" (750 Watts!). "Ideal for use in portable sets and in all types of mains equipment."

"B.A.T." "Q.M.B." POWER SWITCH only 2/6 Each.

CLAUDE LYONS LTD., 76, OLDHALL STREET, LIVERPOOL.



E.ELEX MOISTURE RETAINING EARTH BOWL

Supplied with 9 ft. rubber-covered lead connector, price 5/6 each. Write for List X96.

J.J. EASTICK & SONS, Eelex House, 118 Bunhill Row, London, E.C.1

Mention of "The Wireless World," when writing to advertisers, will ensure prompt attention.

CABINETS.

ARTCRAFT Radio Cabinets are Britain's Best Value. [0313]

DIGBY'S Cabinets.—Table models in solid oak and mahogany; from 11/6 to 71/-.

DIGBY'S Cabinets, fitted with Radion or Resiston ebonite if required.

DIGBY'S Cabinets.—Pedestal model, with separate battery components; from 56/- to £12.

DIGBY'S Cabinets Made to Customers' Own Designs.

DIGBY'S Cabinets.—Write for new 16-page art catalogue.—F. Digby, 9, The Oval, Hackney Rd., E.2. Phone: Bishopsgate 6458. [0128]

ARTCRAFT Radio Cabinets are Britain's Best Value. [0311]

KAY'S Cabinets, the greatest range of pedestal cabinets in the kingdom; original creative designs at prices 50% lower than elsewhere; quotations for specials by return; delivery at short notice guaranteed, moving coil, portable, baffle, vignette, radiogram, electric pick-up, television etc.; illustrated lists free.—H. Kay, Wireless Cabinet Manufacturer, Mount Pleasant Rd., London, N.17. Phone: Walthamstow 1626. [7745]

ARTCRAFT Radio Cabinets are Britain's Best Value. [0309]

CABINETS for All Requirements.—F. W. Ramsey, 63, Shaftesbury St., London, N.1. Clerkenwell 7139. [8155]

ARTCRAFT Radio Cabinets are Britain's Best Value. [0310]

DOUBLE Chassis for 22in. x 22in. Fabric Speakers, strong oak, cut to exact size, 8 supporting brackets, tube liquid glue, drilled ready for assembling with screws provided, cannot possibly go out of shape when fabric is fixed; 6/-, complete assembly; c.o.d., carriage paid; trade inquiries solicited.—W. T. Tucker, 2, Vincent St., Moseley Rd., Birmingham. [8318]

ARTCRAFT Radio Cabinets; Britain's best value; lowest prices consistent with highest quality; illustrated list free from actual manufacturers.—Artraft Co., 156, Cherry Orchard Rd., Croydon. Phone: Croydon 1981. [0040]

RADIO Gramophone Cabinets, speaker and pedestal cabinets, sideboard radio gramophone; write or call for catalogue.—London Super Cabinet Co., 407, Hackney Rd., E.2. Bishopsgate 6324. [8500]

COILS, TRANSFORMERS, ETC.

W.W. Coils and Cabinets.—Kit coils, complete, 37/6; Kilo-mag. coils, 33/-; Record III, 35/-; 1930 Everyman, 42/6; metal cabinets, 45/- and 35/-; Foreign Listener's 4, set of 4 boxes, 19/-.—Stott. [8369]

BEST and Cheapest, trade supplied.—Stott, Townhead Radio Works, Duke St., Rochdale. [8369]

SIMMONDS BROS.—Bereliff coils, Record Three, 50/- pair; new kilo-mag. four, 50/- set; foreign listeners four, low, 30/-; long wave, 37/-; screened grid Regional, 40/-; Mullard S.G.P. dual range coils, 30/- pair; Bereliff standard coils, for new all-wave four, standard four, A.C. three, Everyman four, etc., 63/6 set of 4, with bases; the same coils for the Lodestone series ("Wireless Magazine"), 65/9 set of 4, with bases; Titan unit, 15/-; decoupling resistances, 600 ohm, 1/6; 1,000 ohm, 2/-; all "Wireless World" and similar coils in regular production by the leading specialists; list free; trade supplied.—Simmonds Bros., Shireland Rd., Smethwick. Tel.: Smethwick 751. [6314]

NEW Kilo-Mag Four Coils, 37/6 set; Kilo-Mag formers, 12/6 set; 1930 Everyman Four formers, 8/6 set of three; all post free.—Groves Brothers. [8472]

NEW Foreign Listeners Four Screening Boxes; 6/- each, post free.—Groves Brothers. [8472]

NEW Foreign Listeners Four, 125 and 1,000 ohms fixed resistances.—Groves Brothers. [8472]

NEW Foreign Listeners Four Jackson Log Condensers, .0005; 9/6 each, post free; trade supplied.—Groves Brothers, St. Mary's Place, Shrewsbury. [8472]

RADIOGRAPH.—"Wireless World" Coils, Record III, 35/-; New Kilomag Four, 33/-; S.G. Regional, 37/6; kit set, 45/-; 1930 Everyman Four, 42/6.

RADIOGRAPH.—Litz wire, 9/40, 1/6; 27/42, 2/6 dozen yards; Redfern's deep ribbed or Becol tube, 5d. per inch, slotting 1/6 extra.—Station Rd., Handsworth, Birmingham. [8490]

DYNAMOS, ETC.

M-L Motor Generator, consisting interchangeable motors, A.C. 110 or 200v. 50 cy. and D.C. 200v., coupled to generator, giving outputs 500v., 200 ma., and 12v., 5A, complete with L.T. and H.T. smoothing, automatic cut-out; cost £45, accept £35.—J. V. Mulholland, 73, Upper Richmond Rd., Putney, S.W. [8414]

GRAMOPHONES, PICK-UPS, ETC.

B.T.H., latest pattern, Woodruff, as new, never used, original packings; half list price.—S., 53, Princes Park Av., Golders Green. [8416]

RADIOGRAPH.—Pick-up, with valve adaptor, 18/- complete; approval.—Station Rd., Handsworth, Birmingham. [8491]

CELESTION-WOODRUFFE Pick-up, absolutely O.K., 30/-; also suitable Centralab potentiometer for control, 5/-.—Kemp, 297, Yarrow Rd., Welling. [8457]



"Why not hear the LOTUS in your own home?"

"Your dealer will gladly arrange it free, and without obligation to you." Ask him to demonstrate one of the following—that which fits your need and price: The Lotus 3-valve S.G.P. All-Electric Receiver at £21 cash. Very low in upkeep cost, no batteries required—worked from any A.C. Mains supply. Highly selective and covers a splendid range of stations. The Lotus 3-valve S.G.P. Battery Receiver at £13:15:0 cash. The Lotus 3-valve S.G.P. Battery Model Kit for home construction at £7:12:6 cash. All available on the generous Lotus Hire Purchase terms. Ask your dealer for particulars, or write for the Lotus Sets Catalogue and Hire Purchase terms.

LOTUS ALL ELECTRIC RECEIVER

Gets the Best Reception

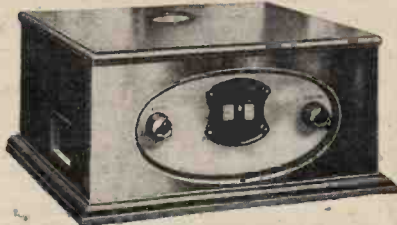

Made by the makers of the famous Lotus Components in one of the most modern radio factories in Great Britain

GARNETT, WHITELEY & CO., LTD., Dept. W.W.6, Lotus Works, Mill Lane, Liverpool.

Causton.

Gramophones, Pick-ups, etc.—Contd.

B.T.H. Pick-up and Arm, latest pattern, new, 35/-, cost 45/-; G.L.C. pick-up, 25/-; G.E.C. Universal gramophone motor, new, 4 guineas (gilt finish); clearing workshop; send for list.—Cooling, 37, Tennyson Av., New Malden, Surrey. [8501]

CLEARANCE.—The following new, guaranteed goods must go:—Igramic, McMichael filament rheostats, 1/3; McMichael potentiometers, 1/9; grid leaks, anode resistances, 8d.; condensers, 9d.; loud-speaker cords, 9d.; Highgrade 8-way battery leads, all labelled and fitted with plugs, original price 6/6, our price 2/9; well known make high tension accumulators, fitted in oak cabinets, with carrying handle, 40 volts 14/6, 80 volts 25/-; orders of 5/- post free; stamped envelope for replies.—J. B. Humphreys and Co., 23, College Hill, Cannon St., London, E.C.4. [8493]

LOUD-SPEAKERS.

BAKER'S SELHURST RADIO 36-page Booklet, "Sound Advice is Yours for the Asking"; write now for new edition; see displayed advertisement on page 19. [0231]

MOVING Coil Magnet Pots, ready machined, complete with coil former, 4/6; spiders for same, 2/6 and 6d. postage, ex stock; genuine bargain; 7 days' approval against cash.—Mic Wireless Co., Market St., Wellingborough. [8398]

PERMANENT Magnet Moving Coil Speaker, 1929 model, as new, cast cobalt steel magnet, guaranteed not to lose magnetism; cost £9/10, sent on 7 days' approval against cash, £3.—Brew, Pytchley, near Kettering. [8382]

DOUBLE Cone Chassis (new), in oxydised copper drum, with polished fretted front, circular seamed cones, only wants hearing; sent on 7 days' approval against cash; cost 32/6, sell 13/6.—Brew, Pytchley, near Kettering. [8383]

PERARDUA Moving Coil Reproducers.—These superlative instruments may be obtained for 15/- down, balance by 5 equal monthly payments; cash prices, 230-volt D.C., £3/3; 6-volt, £3.—R. Vevers, 4, York Rd., Maidenhead. [8437]

B.T.H. C.2 Speaker, perfect condition, 15/-; Amplion Lion L.C.41 speaker, Amplion oak cabinet, as new, £5/10; 2 P.M.256, 6/- each; 2 P.M.6, 5/- each.—Kitchen, Meriden, Coventry. [8435]

MODERN Cone, Blue Spot unit, solid oak baffle, real piece furniture, must sell; 30/-.—Williams, 89, Brooklands Rd., Hall Green, Birmingham. [8443]

CELESTION £7/10 Speaker, mahogany; £3/10.—Drinkwater, 3, St. Stephen's Sq., Bayswater, Park 0712. [8432]

HEXA Moving Coil Reproducers, best value on the market; from 58/6; purity of tone unequalled.—Hill, 154, Compton Rd., Wolverhampton. [8280]

TRIOTRON Loud-speaker Units, performance above the average; usually sold at 15/-, having purchased factors stock we can offer for 10/9; every unit tested and guaranteed, c.o.d. if desired.—Storrs, Ltd., 143-145, Eastbank St., Southport. [8426]

MARCONI £6/6 Moving Coil Chassis, 6-volt, £4/10; with Eye transformer, metal rectifier, electrolytic condenser, £7; perfect; 2 Webson speakers, very powerful, £5; separate, 55/-, offers, carriage forward; bought Radio-gram.—How, 252, Berkhamsted Rd., Chesham. [8442]

EPOCH. EPOCH Speakers by Deferred Payments. EPOCH. EPOCH Speakers by Deferred Payments. EPOCH Famous Moving Coil Speakers, any type, may be obtained by any responsible householder by easy payments; no interest, no references, no red tape, as simple, easy and quick as paying cash. EPOCH. EPOCH on the Easy.—Full particulars from Laser-son, Ltd., Gramol House, Farringdon Av., E.C.4. [8506]

MARCONI Moving Coil, in cabinet, D.C. mains, cost £10/10, accept 70/-; B.S.A. double cone, cost 6 guineas, accept 3 guineas; Ultra air column, in cabinet, new, cost £6, accept 50/-; same, but Lee cabinet, 30/-; also various other loud-speakers; send for list.—Cooling, 37, Tennyson Av., New Malden, Surrey. [8503]

TRIOTRON (new type) Unit, 9/6; chassis, 4/6; Hegra (new), 7/6; Ormond, 10/6; chassis, 6/6; surplus components galore! List free.—Frost (see Eliminators). [8496]

GOODMANS' Permanent Magnet Moving Coil Speaker, as described in "Wireless World," write for full particulars; odd size moving coil pots, from 12/6; special suspension material for cones or moving coils, 1/6 per square foot; tinsel fabric for loud speaker cabinets, 2/6 per 18in. square.—Goodmans, 27, Farringdon St., E.C.4. [8499]

BLUE Spot 66K and Chassis, £1; Amplion 49/6 cone, £1; 55/- linen double diaphragm speaker, beautifully finished, 29/-; c.o.d.—4, Brecon Rd., Handsworth, Birmingham. [8448]

**NEW
PUBLIC ADDRESS
and Broadcasting
MICROPHONES**

The Ideal Instruments for addressing an Audience through Loudspeaker (via Valve Amplifier or L.F. Stages of Wireless Set), and for relaying Speech and Musical Entertainment to any distance. Powerful Loudspeaker Reproduction with perfect Purity.

Hand Type,
highly distance-sensitive, yet guaranteed entirely free from distortion or microphonic noises, absolutely silent background; far superior to ordinary Microphone Transmitters; for use with Valve Amplifier or Valve Set (through leads of Gramophone Pick-up if desired) at Open-air Meetings, in Cinema, Theatre, or Concert Hall. Operates from 2 Volt tapping of L.T. Accumulator, through Microphone Transformer. Current consumption one-tenth Ampere. Provided with detachable Sound Collector, handle, hook for suspension, and a 9ft. silk connecting cord as illustration **16/6**

Pedestal Type
Highly Sensitive Microphone as above described, provided with detachable sound collector and a 9ft. silk connecting cord, built into rubber-cord suspension in nickel-plated frame on pedestal 11in. high; for mounting on Speaker's Platform, in Pulpit, on top of Camera Stand, or for suspension from ceiling, as illustration **25/-**

The above Microphones are rendered **Directional** by attaching the Sound Collector.

Microphone Transformer,
special design to obtain best possible results from sensitive Microphones when connected to high-resistance phones, Loud Speaker, Valve Set, or Valve Amplifier; best Transformer made for clear speech with volume, modulation speech and music transmission, Public Address Microphones, etc. Prim. and Sec. terminals fitted; full directions for use of Microphone and diagrams of connections free. Goods by return post **6/-**

FREDK. ADOLPH, Actual Maker, 27, Fitzroy Street, London, W.1. PHONE: Museum 8329

**BUILD THE
HEAYBERD
H.T.
ELIMINATOR**

The eternal cost of replacing H.T. batteries is the bugbear of Radio. And most eliminators on the market are too costly to be generally adopted. Realising this, Heayberd's have designed an H.T. unit so simple and inexpensive that everybody can purchase a kit of components incorporating Westinghouse metal rectifiers and construct it themselves!

59'6

buys the complete kit, together with assembling and working instructions. Running cost—6d. a year!

Write for explanatory Leaflet No. 928.

F.C. HEAYBERD & CO.
10, Finsbury St., E.C.2
Phone: Clerkenwell 7216.

Loud-speakers.—Contd.

EPOCH.—Moving coil speakers.
EPOCH.
EPOCH.—Master engineering throughout.
EPOCH.
EPOCH.—Ask any engineer who owns one.
EPOCH.
EPOCH.—Ask any musician who has heard one.
EPOCH.
EPOCH.—Ask any scientist who has tested one.
EPOCH.
EPOCH.—Ask any of the editors who are using them as their standard of comparison.
EPOCH.
EPOCH.—Ask some of the world's most famous laboratories.
EPOCH.
EPOCH.—When you hear good reproduction in a cinema ask if it's an Epoch.
EPOCH.
EPOCH.—Ask your wife.
EPOCH.
EPOCH.—Your brothers, sisters, father, mother, friends, enemies, baker, tailor, banker, or jailor.
EPOCH.
EPOCH.—Ask our competitors.
EPOCH.
EPOCH.—In fact, ask any of the thousands upon thousands who use them or who have heard them.
EPOCH.
EPOCH.—The answer will be the same; they are the masterpieces of moving coil speaker design.
EPOCH.
EPOCH.—Perhaps you do not know anyone who owns one.
EPOCH.
EPOCH.—Perhaps you have read the rival claims of other makers.
EPOCH.
EPOCH.—Perhaps you believe us; perhaps you do not.
EPOCH.
EPOCH.—Perhaps you think your umpteenth-pole balanced armature cone or lignin diaphragm speaker is the best that ever happened.
EPOCH.
EPOCH.—Perhaps you, in fact, think you have heard moving coil reproduction—of a kind.
EPOCH.
EPOCH.—Dear readers, here is our invitation, challenge or threat, whichever way you like to take it.
EPOCH.
EPOCH.—Get one of our booklets W.S.3 and select a model for your pocket, tastes, or requirements.
EPOCH.
EPOCH.—Send for one for 7 days' approval and test it freely on your set.
EPOCH.
EPOCH.—Compare it with any or every make you swear by or that swears at us behind our backs.
EPOCH.
EPOCH.—And if you do not receive the greatest surprise of your life in the marvel of perfect reproduction.
EPOCH.—If you do not feel like telegraphing, telephoning, or sending a car to bring your friends to help share your joy.
EPOCH.—Just pack up the speaker, bring it back and have your full cash refunded; no excuses will be asked.
EPOCH. RADIO MANUFACTURING Co., Ltd., are the manufacturers. City Office and Service Station, 3, Farringdon Av. (Ludgate Circus end), E.C.4. Phone: Central 1971 (2 lines). Private Branch Exchange. [8310]

STEEL MAST **SPECIAL GUARANTEE!**

This vastly improved model is made of best British Steel throughout (not iron) and is very easy to erect. We guarantee that if MAST becomes damaged from ANY cause **WHATEVER** within 6 months of purchase we will replace entirely **FREE** of CHARGE any damaged part caused through any accidents—gales—or mishap during erecting. No other MAST bears this guarantee.

26ft. STEEL MASTS, tapering 1 1/2" to 1". Carriage: London, 14/-
1/6; Midlands, 2/6; Elsewhere, 3/6; Weight 28 lbs.
30ft. Tapering 1 1/2" to 1". Carriage: London, 2/-; Midlands, 17/-
3/-; Elsewhere 4/-. Weight 36 lbs.
34ft. Tapering 1 1/2" to 1 1/4". Carriage: London, 2/6; Midlands, 20/-
3/-; Elsewhere, 4/-. Weight 40 lbs.

NOTE. Our Masts are stayed at 4 ground points (not 3) which ensures safety. Mast complete with Galv. Wire, Pulley, Cleat, Solid Metal Foot Rest and stay fasteners. ACCESSORIES—Manilla Halyards, 60ft. 1/6, 100ft. 2/6, Special Anti-Rust Paint, 1/6.

C. P. MAST CO., 48, HIGH ST., PENGE, S.E.20.

EXACT TUNERS

250 to 2,000 metres.

No further coils are required, tuning is as simple as A.B.C., see "Wireless World," January 25th: "We can strongly recommend these tuners." Send postcard for particulars and Circuits **FREE** to

THE EXACT MANUFACTURING CO.
Croft Works, Priory Place, COVENTRY.

TWIN CONE KIT OF PARTS **21/-**

For a Double Lined Diaphragm Speaker
Steel chassis built, adjustable damping attachment. Size 20" square. Takes any popular movement.

GREEN & FAULCONBRIDGE, LTD.,
11, QUEENS ROAD, COVENTRY

600 OHMS DECOUPLING RESISTANCES

SPECIFIED FOR "NEW KILOMAG" FOUR and "Foreign Listeners Four"

1/6 EACH POST FREE. Manufactured by **GROVES BROTHERS, ST. MARY'S PLACE, SHREWSBURY.** 1,000 ohms 1/6 each.

BONA FIDE TRADERS' GUIDE.

Send for our comprehensive Illustrated List. **QUICK SERVICE. QUICK SERVICE.**

THE QUALITY HOUSE.
PERSEUS MFG. CO., LTD. (Dept. W.W.), BRANSTONE RD., BURTON-ON-TRENT.

Have you got this Catalogue?

BULGIN **RADIO PRODUCTS**

56 PAGES **2/- POST FREE**

A. F. BULGIN & Co.,
9/11, Cannon St., Chancery Lane, London, E.C.4.

Mention of "The Wireless World," when writing to advertisers, will ensure prompt attention.

Loud-speakers.—Contd.

EPOCH.
EPOCH Moving Coil Speakers.
EPOCH.
EPOCH Lead the Speaker World.
EPOCH.
EPOCH Announces New, startling models again.
EPOCH.
EPOCH.—New energised model 101 (Domino), the most sensitive super moving coil speaker extant; flux density in air gap guaranteed over 15,300 lines per cm., with characteristic Epoch quality.
EPOCH.
EPOCH New Auditorium Model (energised), a speaker between our super moving coil types and the now world-famous super cinema model, for the home, theatre, or cinema.
EPOCH.
EPOCH New Permanent Magnet Moving Coil Speakers, model A1, for portables; weight 4lb.; price £3/15.
EPOCH.
EPOCH New Permanent Magnet Model, B2, for portable, and general requirements, £4/10; also the parts described in "The Wireless World," January 15th.
EPOCH.
EPOCH New Permanent Magnet Moving Coil Speaker, B3, and the parts described in "The Wireless World," January 15th.
EPOCH.
EPOCH Recent New Models are still the World's Greatest Leaders.
EPOCH.
EPOCH Super Cinema Model, the speaker of speakers. Nothing like it has ever been heard, or heard of, before.
EPOCH.
EPOCH Super Cinema Model is several times as Sensitive as any commercial super speaker.
EPOCH.
EPOCH Super Cinema is the Most Powerful Speaker made.
EPOCH.
EPOCH Super Cinema Model is being installed in the Principal Cinemas as fast as we can deliver them.
EPOCH.
EPOCH Super Cinema is the Personification of the Full-throated Voice or Brass Band.
EPOCH.
EPOCH Super Cinema.—The power of a lion, but the gentleness of a lamb when turned down with a volume control.
EPOCH.
EPOCH Super Cinema, the speaker that hypnotises its audience.
EPOCH.
EPOCH.—Hear it in our new demonstration room.
EPOCH Model 99 P.M. is the Most Sensitive Non-energised Speaker made.
EPOCH Model 99 P.M. Requires No Mains or Accumulators, but is more sensitive and powerful than most mains models.
EPOCH 99 P.M. (or energised models) give the Most Perfect Reproduction of any speakers made—a marvel of accuracy and clarity.
EPOCH 99 has the Suspensionless Diaphragm (patents pending), therefore no suspension resonance.
EPOCH.—Hear it in our new demonstration room, working from a 2-valve set.
EPOCH World Famous Model 66, the standard of comparison in the speaker world.
EPOCH Model 66.—With the exception of the model 99, no speaker has a look in against a model 66 for perfection.
EPOCH.—Dear Mr. Epoch (writes a customer), Why have you so many models? The answer is that we are the greatest moving coil specialists in the world, and provide different speakers for each requirement—not just one speaker for all the varied and opposed requirements.
EPOCH.—Let us advise you on your requirements.
EPOCH.—Send for our booklet W3, containing 16 pages of serious information, free from salesman's talk or puff.
EPOCH.—Call at our New Demonstration Room, and hear the speakers working from a 2-valve set.
EPOCH RADIO MANUFACTURING Co., Ltd., City Offices and Demonstration Room, 3, Farringdon Avenue, E.C.4. 'Phone: Central 1971 (2 lines). [8311]

The IDEAL RECEIVER for Music Lovers—

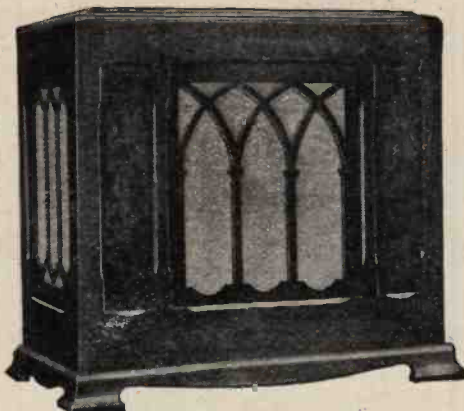

BAKER'S 3-Valve All-Electric quality receiver for A.C. Mains. Complete with Moving Coil Loud Speaker, as installed at the London Hippodrome. Price £36, or in 10 monthly instalments. All who are interested in realistic reproduction should write now for full particulars. & THE IDEAL SPEAKER

SEND TO-DAY FOR OUR FREE 36-PAGE BOOK-LET "SOUND ADVICE."



BAKER'S SUPER POWER MOVING COIL LOUD SPEAKER. ALL BRITISH. PRICE FROM £5.15.0. This Speaker was selected for one of the world's most famous theatres—the LONDON HIPPODROME—for Trade Show Talks, where perfect reception is imperative.

BAKER'S 'Selhurst' RADIO

Pioneer Manufacturers of Moving Coil Loud Speakers.

Offices: 89, Selhurst Road, S. Norwood, S.E.25
 Works and Demonstration Room:
 42, Cherry Orchard Road, E. Croydon
 Telephone: Croydon 1618

Loud-speakers.—Contd.

CELESTION C.12, mahogany, new condition; £4; approval.—Malkin, Madeley, near Crewe. [8463]
FINEST Suspension Leather, for fixing cones to principal makers; 2/- sq. ft., 1/6 10in. square; segments up to 12in. cone 9d. for 4; all post free, cash with order.—Dilley, 8, Ashby Rd., Essex Rd., N.1. Clis-sold 0736. [8454]
SPECIAL Offer of 1 Magnavox M.C. Speaker, model R.4, for 6-volt accumulator, used for few demonstrations; price 70/.—Engineer, 105, Torriano Av., Camden Rd. North 0623. [8495]

PICTURE RECEIVER APPARATUS.

FULTOGRAPH Picture Receiving Apparatus; experimenter selling; absolutely brand new and in perfect condition, complete; £4.—Mr. Arthur, 50, Sussex Av., Ashford, Kent. [8479]

TRANSMITTERS.

CHEBROS. Chebros. Chebros transformers and chokes of all descriptions, special transformers for transmitting and modulation; chokes a speciality; enquiries invited.—Chester Bros., 244, Dalston Lane, London, E.8. [5240]

VALVES.

MAZDA S.G.215, few hours' use; 17/6.—Darke, 41, North Rd., Wolverhampton. [8436]
MAZDA S.G.215, nearly new, 17/- Marconi Ideal. 4-1, 15/-—Cooper, 21, Marmora Rd., Honor Oak. [8464]

COMPONENTS, ETC., FOR SALE.

BELLING-LEE Panel Fittings are designed to give an expert finish to any home-constructed set; catalogue post free.—Belling and Lee, Ltd., Queensway Works, Ponders End, Middlesex. [0018]
POWER Chokes, substantially built, for smoothing circuits in eliminators dealing with currents 100-300 milliamperes, inductance 30 henries; 2/6 each; guaranteed 12 months.—Transformer Repair Co. (Dept. W), 214, High St., Colliers Wood, S.W.19. [0327]
POTENTIAL Dividers 10,000, 15,000, 20,000, 25,000 and 30,000 ohms, 5 variable tappings; 2/- each.
POTENTIAL Dividers, heavy duty, wire wound, 15,000 and 20,000 ohms, 7 tappings, 5/6; 4 tappings, 3/9.
CONDENSERS, 2 mfd, 2/3; 4 mfd, 4/-; guaranteed; tested 500 volts.
CHOKES (L.F.).—Excellent for smoothing, up to 20 milliamps, 2/-; special heavy duty, 100 milliamps, 3/6.
ELIMINATORS, A.C., wired for half or full wave complete with valve; £3/17/6.
H.F. Chokes; 3/-.
GRAMOPHONE Motors, well known make, double spring, silent, complete with fittings; 30/-.
SPECIAL Bargain.—B.T.H. 40 henry chokes; 9/6; any article on approval against cash.—Huggins, Radio Engineers, Clacton-on-Sea. [7398]

COMPONENTS Lent on Hire; send for details.—Alexander Black, The Wireless Doctor, 55, Ebury St., S.W.1. Sloane 1655. [0329]
WESTON Model 301, milliammeters, ammeters, and voltmeters, 21/- each; hot wire ammeters 0-1 amps, 4/-; 0-0.5 amp., 3/-; instrument repairs and alterations; send for list.—The Victra Electrical Co., 47, High St., Battersea, S.W.11. Established 1910. [7563]

REMOTE Control Relays, with full instructions, 10/- each; static accumulator voltage; stamp particulars.—F. W. Hughes, 17, Blackheath Vale, London, S.E.3. [8254]

CYLANITE, the latest artistic panel covering, offering infinite insulation; costs only 3/- per sq. ft.; generous terms to the trade; send 1/6d. postage for samples.—Marsh and Wright, 5, Royal Arcade, Weymouth. [8236]

TWO Cossor Pentodes, 2v., 2 Mullard Pentodes, 2v., D.U.2 rectifier, R.I. Pentanum transformer, as new, never used, original packings; half list price.—S., 53, Princes Park Av., Golders Green. [8417]

BLUE Spot 66 Unit; 10/-, or exchange for Hegra.—Wood, 30, High St., Kirkcudbright. [8415]

LEWCOS Tuned Anode Binocular, S.G. coils, B.A.C.5, B.A.C.20, B.A.R.5, B.A.R.20, with bases, 15/-; valves, S.625, 10/-; P.625, 7/-; H.610, D.E.L.610, 5/- each; all little used.—Kirkpatrick, 61, Ranelagh Rd., Southall. [8433]

ALL Sizes of Power Transformers and Smoothing Chokes Constructed to Specification, only first class units.—Hill, 154, Compton Rd., Wolverhampton. [8361]

RADIO HOUSE, HUDDERSFIELD, issues the Reliability Wireless Guide, which will be sent post free upon request by Messrs. J. H. Taylor and Co., 15, Macaulay St., Huddersfield. [7823]

PART Exchange.—See our advertisement under Receivers for Sale.—Scientific Developments Co., 57, Guildhall St., Preston. [0228]

Components, Etc., for Sale.—Contd.

APPLEBY'S Bargains.

THE Following Slight Used Material is offered subject to sale; every article will be severely tested before despatch, and guaranteed in workable condition; items are nett cash and carriage paid in Great Britain.

RESIDUE of Transformers.—Marconi Ideal, R.I. Straight Line, Ferranti O.P.1 and 2, all one price, 14/- each, limited number; Ferranti A.F.4 Royal (best model), Dymac, all one price, 10/- each, limited number; Marconi Popular, Pye, G.E.C., small Marconi Ideal, all one price, 5/6 each, limited number; Formo, Lissen, Eureka, Brandes, Igranic Shrouded, all one price, 5/6 each, limited number.

RESIDUE of R.C.C. Units.—Mullard, 9/- each; R.I. Varley, 7/6 each; Cosmos, Marconi, Dubilier, Carborundum, all one price, 4/- each; Cosmos, Dubilier, Magnum, with valve holder, all one price, 5/- each, limited number; Ediswan, 3/- each; Polar, 2/6 each, limited number.

RESIDUE of Pick-ups.—R.I. Varley, 25/-, 20/- each; Brown, best model, 45/-, 30/- each, prices depending upon condition; smaller Brown, Igranic Phonovox; Amplion Vivavox, G.E.C., all one price, 14/- each, limited number; Webster, with Melotrope arm, 50/-.

RESIDUE of Condensers.—Ormond No. 3 S.L.F. and log, 0.0005 and 0.00035, with dials, all one price, 3/9 each; Igranic control model, 7/6 each, postage 6d. extra on singles priced 3/9.

NOW Send Now; many clients were disappointed by material having been sold previous to their application for goods lately.

APPLEBY, Number Forty-four, Chapel St., Marylebone, N.W.1 (four minutes from Oxford St., London). [0316]

EXPERIMENTER'S Surplus.—Philips trans., 14/-, cost 25/-; Pilot single drum drive, 5/6; ex W.D. jacks, 6d. each; R.I. Varley S.L. trans., 14/-, cost 25/-; Cydon 0.0005 gang coils, solodyne type, 35/-; Keystone 0.0005 gang coils, solodyne type, 25/-; also various other goods; write for list.—Cooling, 37, Tennyson Av., New Malden, Surrey. [8502]

EDISON Bell Pick-up, 10/-; 2 frame aerials, 10/- and 15/-; R.I. reactance unit, 15/-; R.I.H.P. unit, 10/-; 150-volt Exide H.T., 20/-; Blue Spot 66A, 10/-; Garrard 11A double spring grammo motor 12in. T.T., new, 30/-; M.P.A. speaker, new, 5/-; 1 type G Igranic L.F. choke, 10/-.—W., 37, Beaufort Rd., Kingston-on-Thames. [8486]

FERRANTI Voltmeter, flush, 0-7½ volts, 12/6; 2 electrolytic condensers, T.C.C., 2,000 m.F., each 7/6; 2 L.T. chokes to carry 3 amps, R.I., 10/- each; 2 P.M.14, 10/- each; 2 P.M.24, 11/- each; one P.M.4D.X., 5/-; one Philips 506, 10/-; Brown No. 2 pick-up and Kusha arm, 10/-; or exchange any of above for anything useful.—C. O. Pattison, 548, Shields Rd., Newcastle-on-Tyne. [8483]

FERRANTI Rectifier Unit, 6-volt ½ amp. new, 14/6; copper oxide rectifier unit, 120v. 20 ma. new, 15/-; transformers for above, 15/-; moving coil speaker 230-250v. 50 cycles, complete, £5/5.—Box 4975, c/o The Wireless World. [8481]

CAMDEN SURPLUS MAR!—New Amplion horn speakers, cost £4/15, 16/6, guaranteed ex Government surplus, etc.; microphone buttons, 6d. each; Veeder counters, 1/-; Mark III 2-valvesets, 27/6; new X-ray valves, 7/6; new 1 kilowatt transformer, 25/-; aerial test sets, 10/-; Morse tappers, 5/6; new single phones, 1/6. plus carriage, no catalogues.—25, King St., Camden Town, N.W. Phone: 2920 North. [8475]

EPOCH 66 M.C. ½-amp. Speaker, A.F.5C. O.P.3C. 2 P.625A.s, 2 100,000 wire resistances, 2 weeks' use, various other parts, giving up; £6, or separate.—16, Eccleston Place, S.W.1. [8468]

IMPROVED H.F. Choke, incorporating spiral iron core, increasing inductance without raising D.C. resistance, 2,000 turns in air spaced segments; 2/6, post free.—Calton-Stewart, 28, St. Enoch Sq., Glasgow. [8466]

WESTERN ELECTRIC B.S.A. Kone Speaker, £2; Sterling horn type, £1; P.M.24, used few hours, 14/-; P.M.24, 12/6; 2 Stentor sixes, 5/- each; P.M.12, 12/6; P.M.2, 5/-; P.M.1, 5/-; P.M.4D.X., 5/-; 410S.G., 12/6; 410R.C., 5/-; several 2v. and 6v. G.P., 2/6; 60v. Exide W.H., 6/-.—Smith, 31, Legard Rd., Highbury, London. [8462]

1,000-ohm Wire Wound Spools, ¼in. x ¼in., can be screwed down, suspended from wiring, or threaded on wire, suitable for decoupling or making up potential dividers, 3½d. each, 2/- dozen, post free; second-hand condensers, 1 mfd. 9d., 2 mfd. 1/-, post free; second-hand slow motion dials, 4in., various makes, 2/-, post free.—Darke, Marakeb, Riverside, Staines. [8461]

ENGINEER'S Surplus.—Ferranti O.P.1. O.P.2. A.F.5. 1 each; Ferranti metal rectifier, 200v., 100 m.A., all perfectly new; 2 Cosmos A and B mains transformers, excellent condition, first genuine offers secure.—BM/NJH4, London, W.C.1. [8460]

EPOCH PERMANENT MAGNET MOVING COIL SPEAKERS.

(As described in "The Wireless World," Jan. 15th.)

When ordering specify "EPOCH" make.



A postcard will bring you, free, the valuable 16 pp. Epoch Booklet 53.

For further particulars see Epoch ads., pp. 18 and 19.

EPOCH RADIO MANUFACTURING CO. LTD., Farrington Avenue, E.C.4. Phone: Central 1971 (2 lines). Private Branch Exchange.

METAL CABINETS

for the 1930 Everyman Four, Kilo Mag 4 and Record III.

PRICE 27/6 with four Compartments.

Also for the WIRELESS WORLD KIT SET

PRICE 22/6 with two Compartments.

Trade enquiries invited.

W. H. PARKER, Aircraft & Wireless Sheet Metal Worker, BACK AUTUMN TERRACE, LEEDS.

POLAR "VOLCON"

for the "Wireless World"

"Foreign Listener's Four"

·0001 - 5/6



"TILTRACK"

Patent STEEL STORES System

For the Wireless Experimenter, Factory

Factor and Retailer,

Full Particulars from Sole Manufacturer and Patentee:—

BERTRAM THOMAS, Worsley Street, Hulme, MANCHESTER.

For the Best in Radio WILL-DAY LTD.

(THE BEST IN THE WEST)

10 LISLE STREET, LEICESTER SQUARE, LONDON, W.C.2.

Telephone: (Day) 4922, (Night) 4922. Telegrams: Willday, London.

OPEN TIL 7 P.M. WRITE FOR OUR CATALOGUE POSTAGE 6d. FREE TO CALLERS

Components, Etc., For Sale.—Contd.

ORGOLA Three Condenser Assembly, trimmer and reaction condensers, coils, panel, all new; 35/- lot.—1, Mannheim Rd., Bradford, Yorks. [8456]

WHAT Offers?—Set Bowyer-Lowe superhet. transformers and coupler, Marconi Ideal transformers, 4 to 1 and 2.7 to 1, Primus loud speaker, cost £7/10, all new and perfect.—H. Nunnerley, Fairlawn, Belgrave Rd., Bournemouth, W. [8451]

RADIELE Eliminator, model R.K., input 200-240 volts 50 cycles, output 400 volts 80 m.A., £6/10; Igranic induction type gramophone motor, 200-240 volts input, £4; Godman moving coil 200-240 volt pot, £2; Wearite coils and switches for Record III, unused, £2; coils, Kilomag Four, old type, 15/- set; high resistance panel mounting voltmeters, 0-7 volts, 0-15 volts, 15/- each; Squire double diaphragm cradle, £1; B.T.H. pick-up and arm, complete, 32/6; B.T.H. pick-up only, £1; R.I. Varley pick-up, £1; 2 Cydon twin thumb control condensers, 0.0005, £1 each; R.I. Varley tone arm, £1; 7 Marconi S.625 valves, complete with special valve holders, 5/- each.—Rogers, 21, New Rd., Brentwood. [8447]

P.M.12, P.M.22, P.M.14, P.M.3, D.E.L.410. Igranic Elkin rectifier, Amplion cone speaker, Q.S.G. coil, Ferranti aerial coil; wanted, M.C. speaker.—Scott, 10, East Parade, Ilkley. [8449]

MISCELLANEOUS.

ALEXANDER BLACK,

THE Original Wireless Doctor, will call (London and Home Counties) and cure your set.

CONSULTATIONS by Appointment Without Obligation, sets installed, maintained, and brought up to date, gramophone pick-ups, eliminators, and Webson moving coil speakers demonstrated; purity reproduction specialist.

55, Ebury St., Victoria, S.W.1. Sloane 1655. [0277]

EASY Payments.—We supply, by easy payments, components, accessories, and sets, any make; 10% down, balance spread over 10 months.—Send list of requirements to London Radio Supply Co., 11, Oct Lane, London, E.C.2. [0097]

WIRELESS Notes.—A monthly service of information for all those who want the very best in wireless or gramophone reproduction; frank criticism of receivers and components; immediate postal help and advice in all difficulties; something new and unique; you must have it if you want to know the truth.—Full particulars free from Ernest H. Robinson, Langmead, Pirbright, Woking, Surrey. [7607]

SCOTT SESSIONS and Co., Great Britain's radio doctors, officially approved as wireless repairers by Radio Society of Great Britain and Wireless League; old sets of every type repaired, rebuilt, modernised; send set for immediate quotation.

SCOTT SESSIONS and Co.—New sets constructed with your or our components, guaranteed finest workmanship; we specialise in "The Wireless World" circuits; remember, we have satisfied customers throughout the British Isles and in three Continents; if you so desire, we will design and construct high grade apparatus to suit your special circumstances for quality, range and selectivity.—Tel.: Tudor 5326. Muswell Hill, London, N.10. [0262]

ENGINEERS.—Can't we get together? All we ask is the chance to prove that you can earn £300, £400, £500 per year and more; other men are doing it, and you can do the same. We have an unrivalled and world-wide organisation waiting to help you, whether you be novice or expert; if you wish for something more than a bread and butter job you owe it to yourself to investigate our service; our handbook, "Engineering Opportunities," has pointed the way to better things to over 20,000 of your fellows; it contains details of A.M.I.Mech.E., A.M.I.O.E., A.M.I.E.E., A.M.I.A.E., A.M.I.Struct.E., O. and G., G.P.O., etc., exams., and outlines home study courses in all branches of electrical, mechanical, motor and wireless engineering; in a brilliant article Professor A. M. Low shows clearly the chances you are missing; the book and our advice are quite free; we guarantee No Pass—No Fee; don't miss this opportunity; send a postcard, now (state branch, post or exam.)—British Institute of Engineering Technology, 87, Shakespeare House, 29, Oxford St., London, W.1. [8233]

THE RADIELE Co., Ltd., in liquidation.—Plant and machinery, office furniture, and entire stock for sale by private treaty; M.A.X.E.I. and other winding machines, 1 kilo-watt converter set (220 v. d.c. input and A.C. output 240 v. 50 cycles), numerous testing instruments, etc., complete H.T. battery eliminators and battery chargers; may be viewed at Haverstock Hill, Chalk Farm, N.W.3, by appointment with the Receiver.—F. J. Parsons, A.C.A., 2, Austin Friars, E.C.2. [8492]

PATENTEES.—Small manufacturer desires to get in touch with several good ideas on royalty basis only; send specification.—Box 4977, c/o The Wireless World. [8489]

EFFICIENT Overhauls, repairs, maintenance; moderate charges; consultations free.—G. Bolton, 221, Cavendish Rd., Balham. [8465]

Mention of "The Wireless World," when writing to advertisers, will ensure prompt attention.

PATENT AGENTS.

PATENTS and Trade Marks, British and foreign.—Gee and Co. (H. T. P. Gee, Member R.S.G.B. and A.M.I.R.E.L.), 51-52, Chancery Lane, London, W.C.2. Phone: Holborn 1525. [0001]

REPAIRS.

SCOTT SESSIONS and Co., Great Britain's radio doctors; read advertisement under Miscellaneous column. [0263]

TWELVE Months' Guarantee Accompanies all our Repairs; any make of L.F. transformer, headphones, or loud-speaker repaired and despatched within 48 hours; 4/- post free; don't discard if burnt out; terms to trade.—Transformer Repair Co. (Dept. W.), 214, High St., Colliers Wood, S.W.19. [0011]

GUARANTEED Repairs by Experts.—Loud-speakers, headphones, cone units, pick-ups, any type, re-wound, remagnetised, and adjusted, post free 4/-; transformers, from 4/-.—Howell, 91, Morley Hill, Enderfield, Middlesex. [7882]

REPAIRS Returned Post Free, and to ensure satisfaction send remittance after approval of same.—Leeds Wireless Repair Service.

LOUD-SPEAKERS, headphones, re-wound to any resistance and remagnetised, 3/-; transformers re-wound, 4/-; Blue Spots, Triotrons and 4-pole units, 4/6; work guaranteed.—Leeds Wireless Repair Service, 5, Boston Place, Green Rd., Leeds. [8505]

WANTED.

EVERYMAN'S Pentode Two, or parts, perfect and to author's specification, with or without valves.—Hannam, Edgewood, Blossomfield, Birmingham. [8423]

WANTED, good L.F. transformer, V Lewcos, H.F. choke.—McPhee, Blackburn, Bathgate. [8424]

WANTED, cone unit, Blue Spot preferred; exchange switchboard, meters, etc.—Lines, "Cromleigh," Burcroft Rd., Wisbech. [8430]

WANTED, several condensers, 2, 4 and 6 mfd., also small loud-speaker, Benjamin valve holders, and A.F.3 and A.F.5 transformers.—Wynn, Balsall Common, Coventry. [8431]

WANTED, A.C. unit, 30 milliamps; exchange Ecko D.C. 60 milliamp, Amphon, Loewe and Triotron speakers; sell £4.—32, Richborough Rd., N.W.2 [8438]

SUPERHET Intermediate Transformers, G.R., Silver Marshall or Bowyer-Lowe.—Watts, 1, Elton Rd. (entrance Elmdale), Tyndall's Park, Bristol. [8440]

WANTED, Igranc Neutrosonic Seven Portable type receiver, with frame aerial and speaker.—Lownds, The Cottage, Old Lenton, Nottingham. [8469]

EXCHANGE.

UNWANTED Radio Parts Taken in Part Payment for New; state lowest price acceptable for your goods and new parts required; we guarantee to supply only brand new goods. (Goods bought for cash, lowest price by letter only).—Ryalls Radio, 182, Kennington Rd., London. [8524]

ULTRA Short Wave Adaptor (Stonehouse) value 18/-, for ultra short, short and long wave.—Box 4962, c/o The Wireless World. [8428]

WE Will Accept your Surplus Apparatus (making you a high allowance) in part payment for any new apparatus; your enquiry will be dealt with promptly.—Bostock and Stonnill, 1, Westbourne Terrace, S.E.23. [8434]

MATCHLESS Combination 8hp. H. Model, for anything wireless, electric, gramophone and/or cycle, cash.—26, Friars Rd., East Ham. [8453]

BUSINESSES & PROPERTY FOR SALE, TO BE LET, OR WANTED.

WIRELESS Business, main road, London suburb, 5 rooms, telephone, profits over £400 p.a., certified accountant's figures; price £400; stock at valuation, about £150-£200.—Write 71, Winchelsea Rd., Tottenham, N.17. [8422]

SITUATIONS VACANT.

WIRELESS Operating Appointments Assured; short qualifying course, day, evening; fees payable after appointment for boarding students; Morse classes.—Manager, Wireless School, 21, Manor Gardens, London, N.7. Archway 3694. [8121]

WIRELESS Engineer wanted, with good technical knowledge of mains apparatus and factory experience; good opportunity for first class man.—Write Box 4935, c/o The Wireless World. [8425]

ELECTRADIX

ACCUMULATORS, etc. Best British, celluloid cases: 2-volt 200 amp., 18/6; 2-volt 16/32 amp., 6/-; 4-volt 10/20 amp. linked as 2-volt 20/40 amp., 6/6; 4-volt 20/40 amp. linked as 2-volt 40/80 amp., 11/-; 4-volt 30/60 amp. linked as 2-volt 60/120 amp., 12/6; 4-volt 50/100 amp., 18/-; 6-volt 10/20 amp., 9/-.

New 12-volt P. & R. in case for running board, £3 5s. Glass, 2-volt 20 amp., 5/6. H.T. Accumulators, ebonite case, 1 amp. hr., 60-volt, 17/6. 90-volt, 27/6. 120-volt 35/-, 240-volt, 63/-. 3-volt Inert "Dura," 1/3. "Siemens S." 1 1/2-volt, 1/-. Large Inert 3-cell 4 1/2-volt in teak case, 4/6. High Capacity American 45-volts units 100 m/a., 17/6. Cell fillers. Hydrometers, 1/-. 2-volt cell inspection Bulbs, flat, 6d.

CONDENSER SNIPS. Bebe Cyldon, 8/6 model for 3/6. Atlas S.L.F., .0005 or .0003 mfd., 3/6. Polar Square, .0005 mfd., 3/-; .0003 mfd., 2/3. Drum Dials with bracket and plate, 4/-. Fixed Dubilier No. 577 list, 7/6; .01 mfd. for 1/8.

COILS. Titan, 6/11. Six-pin Mullard Orgola, 8/6. Lewcos 6-pin CSP5, 6/6; CAC20, 6/6. Binocular, 5/6. Lewcos Q coils with switch, 10/6. Cossor Short-wave 4-pin, 5/6. Ditto, long wave, 6/-. Faradex 6-pin Master 3, 4/6. Six-pin Bases, 1/-. Burnpdet 2-pin S1 and S2 for 260 or 400 metres, 1/6 each. Cossor Melody, 4/6.

GLAZITE. Four colours, 2ft. lengths, 6d. set; 10ft. coils, 7d. each. Inductance wire, 22 gauge, enamel and cotton covered, 1/3 lb.; all gauges stocked. Fine 5x3 Silk-covered wire, 12 yards, 9d. Heavy twin flex V.I.R., 35-40, 2/6 per doz. yards. Twin Red and Black Flex, 12 yards, 1/6. Phone extension, twin wire, 2-colour, 3/- per 100 yards. Single 1-044 Insulated V.I.R. Cable, 5/6 per 100 yard coil. Paxolin Tubes, under cost, 2 1/2 in. dia. by 2 1/2 in., 3d.; 3 1/2 in. by 2 1/2 in., 4d.; 3 1/2 in. by 1 1/2 in., 2d. Also rod and sheet. 7/22 enamelled Aerial, 40ft., 1/9. Indoor, 22 special, 100ft., 1/-. Frame Aerial Wire, 50ft., 1/-.

WAVE-TRAP KIT. .0005 variable Condenser, Knob and Dial, .001 mfd. fixed, 260 and 400-metre 2-pin Coils and Bases, Mahogany BBC/15 Cabinet, 5 1/2 in. by 4 1/2 in.—the Set, 10/-.

GRAMOPHONE PICK-UPS. Watmel Tonearms with Loewe or Acusticon Pick-up, 19/-. Panstrate Electric Mains Turntable Motors, £3 10s. Metal Cabinets, 17 by 8 by 9 in., reduced to 10/6. Colvern Aluminium S.G.B. Panel, drilled and cut, black finish, 4/- only. Magnet Earpiece Units, wound ready for making own Pick-up. 1/6. Brown "A" 750-ohm Phone, 7/6. Three-valve mains-operated Panstrate Amplifiers, 70/-. R.K. Cones, fitted B.T.H. Moving Coil, 100 surplus, at only 7/6 each. Marconi L.S. Magnet Poles, 6 v., for Moving Coil Cones, 20/-. Moving-coil Loud-speakers, £3 10s.

Ball Bearings Turntables for Portables, 3/- each. 3-Valve S.G.C., Det., and L.F. Lamp-lug with 3 Osrams, £4 15s. G.E.C. Victor 3, with valves, £4 2s. 6d. R.A.F. Aircraft semi-portable 3-v. receiver with valves, £1 17s. 6d. R.A.F. 10 Receiver 5-v. Set with valves in Polished Cabinet, £5 19s. Heliogen Underground Aerials, 1/6.

THE VIOLIN CABINET LOUD-SPEAKER DE LUXE. Wonderful reproduction, complete tonal range. Beautifully polished mahogany. List, £5. Sale price, 22/6.

BATTERY CHARGERS, etc. 2, 4, or 6-volt Trickle or Full Charge, Phillips, Ediswan, Ella, etc., 50/-. Kit, with Westinghouse 9-volt lamp Rectifier and 200/250-volt Transformer for charging or M.C. magnets off A.C. mains, 30/-. The DIX D.C. Mains Unit, Humless Filter, 3 taps, 30/-. De Luxe Model with Meter, 40/-. A.C. Unit with Control and 3 taps, two Valves and Special Filter, £4 10s.

VIBRO-MASSAGE SETS, with electric motor, for home use. Cost £4. New, in case, Sale, 25/6. X-Ray tubes, 35/-. Neon Lamps, 2/6. Helio or Television, 3 1/2 in. reflectors, 1/-.
ELECTRIC. 220-volt Blowers, 30/-. Flat Irons, small, 5/-. Medium, 10/-. Electric Two-plate Cooker, 12/-. Single Hotplates, 7/6. Immersion Heaters for 3/6, with plugs and cord. Electric Soldering Irons, all sizes, from 5/6. Glass Boring Outfits for lead-in holes in window, 10/6.

If you cannot call at our Showrooms, send addressed envelope for our illustrated list to

ELECTRADIX RADIOS,
218, UPPER THAMES STREET, E.C.4.
Phone: City 0191.

LOWEST NEW PRICES
FOREIGN LISTENERS IV
COILS, CONDENSERS, ETC.
MAINS CHOKES AND TRANSFORMERS.
BOXES 19/- for 4. TRADE SUPPLIED.
SWITCH BARS, 9d. CONDENSER BARS, 1/-. SEND FOR LISTS.
FULL KITS OF PARTS, ETC. A. T. STOTT, DUKE ST., TOWNHEAD RADIO WORKS, ROCHDALE.

Situations Vacant.—Contd.

ELECTRICAL Engineers Required, well educated, age 23-30, good knowledge of Audio frequency and amplification essential; commencing salary £260 p.a. and expenses.—Apply Arthur and Co., Employment Agents, 59, New Oxford St., W.C.1. No preliminary fee. [8455]

SITUATIONS WANTED.

WIRELESS Operator, 9 years' experience, all multi-valve, preferably talkies or recording; through practical and theoretical experience.—Box 4936, c/o The Wireless World. [8421]

WIRELESS Engineer Desires Change, as service engineer or shop assistant; good technical training; Glasgow district.—Box 4961, c/o The Wireless World. [8427]

T.I.G.B. Student (18), radio engineering, requires situation, wireless, salesman preferably; some experience.—96, Drakefield Rd., Ballham. [8439]

RADIO Mechanic, age 23, seeks situation, good practical and technical knowledge, 2 years repair work on own, diploma wireless engineer; salary £3; Plymouth or Exeter preferred.—Box 4968, c/o The Wireless World. [8445]

BOOKS, INSTRUCTION, ETC.

"**THE Wireless Manual**" (new 1930 edition), by Captain Frost, is an ideal non-technical book full of up-to-date facts about wireless development, choice of set, how to use your own set, etc.; illustrated; 5/- (post 5/4), of a bookseller, or Pitman's, Parker St., Kingsway, W.C.2. [8178]

STEP by Step Wireless; a complete course of the theory of electricity in relation to the practical design of wireless apparatus, eliminators, circuits, etc., with extracts from a designer's notebook, giving up-to-date practical application; issued weekly; send 1/- p.o. for first 4 weeks.—Clifford Pressland, A.M.I.E.E. Eng. Dept. W.W., Hampton-on-Thames. [0195]

FREE: Inventor's Guide on Patents.—T. A. A., 253 (W), Gray's Inn Rd., London, W.C.1. [6375]

WIRELESS Students—Morse key, books, lectures; lot £1.—Dwyer, 99, First Ave., Manor Park, E.12. [8507]

AUCTION SALES.

By Order of Trustees and Official Receivers in Bankruptcy: re Royal Radio, J. L. Goldsman, and Others.

AUCTION ROOMS, 34, CHANCERY LANE, W.C.2. Magnavox, Grassman, Harlie Moving Coil, and Philips, Celestion, Ormond and Blue Spot Cone Loud-speakers, H.T. Eliminators, B.T.H., Harlie, Brown Pick-ups and Tone Arms, Transformers, Stock of Mazda and other A.C. and Battery Valves, Dulcetto-Polyphon, Royal Radio and other Radio-Gramophones, Cabinet and Portable Gramophones, Records, Electric Gramophone Motors, Portable Radio Sets,

D.C. and A.C. All-mains Transportable Sets, Mahogany, Hide and other Cabinets and Portable Set Cases, partly made Sets and numerous Radio and Electrical Components, to be Sold by Auction by Messrs.

MILLER, PAXTON and FAIRMINE, on WEDNESDAY, MARCH 5th, at 12 o'clock. Auction Offices: 5 and 6, Clement's Inn, Strand, W.C.2.

REPAIRS
Any make of L.F. Transformer, Loudspeaker or headphones repaired and dispatched within 48 HOURS—TWELVE MONTHS' GUARANTEE with each repair. 4/- Post Free.
Terms to Trade.
TRANSFORMER REPAIR CO., Dept. W., 214, High Street, Colliers Wood, London, S.W.1

Electrically sealed
METAL CABINETS
Complete with Base for 1930 Everyman Four, New Kilomag Four, and W.W. Record III. Jacobean Finish.
TERMS: CASH WITH ORDER Price 57/6.
RIGBY & WOLFENDEN, SHEET METAL WORKERS, MILNROW RD., ROCHDALE.

INDEX TO ADVERTISEMENTS.

| | | | | | |
|--|------------|---|-----------|--|--------------|
| Adolph, Fredk. | 18 | Garnett, Whiteley & Co., Ltd. | 17 | Ormond Engineering Co., Ltd. | 3 |
| Appleby, E. Hetherington | 15 | General Electric Co., Ltd. | 5 | Overseas Trading Co. | 22 |
| B. & J. Wireless Co. | 15 | Gilman, J. S. & Co. | 14 | Parker, W. H. | 20 |
| Baker's "Selhurst" Radio | 19 | Graham Farish Radio | 12 | Perseus Manf. Co. | 18 |
| Bayliss, W., Ltd. | Cover iii. | Grant & Gray, Ltd. | 14 | Pertrix, Ltd. | 1 |
| British Games, Ltd. | 22 | Green & Faulconbridge, Ltd. | 18 | Pitman, Sir Isaac, & Sons, Ltd. | Cover iii. |
| Brownie Wireless Co. (G.B.), Ltd. | 16 | Grosvenor Battery Co., Ltd. | 7 | Player's | 7 |
| Bulgin, A. F., & Co. | 18 | Groves Bros. | 18 | Potter, H. B., & Co., Ltd. | Cover iii. |
| Burton, C. F. & H. | Cover ii. | Haybe'd, F. C., & Co. | 18 | Radiogramophone Development Co. | 8 |
| C.P. Mast Co. | 18 | Hegra | 8 | Rigby & Woolfenden | 21 |
| Celestion, Ltd. | 14 | Holzman, L. | 4 | Rothermel Corp'n., Ltd. (Electrad) | 4 |
| Cole, E. K., Ltd. | Cover i. | Impex Electrical, Ltd. | 12 | Sheffield Magnet Co. | 14 |
| Colvern, Ltd. | 2 | Jollys | 8 | Stott, A. T. | 21 |
| Coscor, A. C., Ltd. | 10 | Lectro Linx, Ltd. | 22 | Telegraph Condenser Co., Ltd. | Cover i. & 2 |
| Day, Will, Ltd. | 20 | Liverpool Radio Supplies | 22 | Thomas, Bertram | 20 |
| Dimsdale Bros. | 6 | London Electric Wire Co. & Smiths Ltd. | 9 | Transformer Repair Co. | 21 |
| Dubilier Condenser Co. (1925), Ltd. | Cover ii. | London Radio Supply Co. | 15 | Tulsemere Manf. Co. | 15 |
| Eastick, J. J., & Sons | 16 | Lyons, Claude, Ltd. | 16 | Ultra Electric, Ltd. | 16 |
| Edison Swan Electric Co., Ltd. | 11 | McMichael, L., Ltd. | Cover iv. | Vandervell, C. A., & Co., Ltd. | 6 |
| Electradix Radios | 21 | Marconiphone Co., Ltd. | 13 | Voltron Co., Ltd. | 6 |
| Epoch Radio Manf. Co., Ltd. | 20 | M-L Magneto Synd., Ltd. | 6 | Westinghouse Brake & Saxby Signal Co., Ltd. | Cover iii. |
| Exact Manf. Co. | 18 | Morris, J. R. | 16 | Wilkins & Wright, Ltd. | Cover i. |
| Ferranti, Ltd. | 9 | Mullard Wireless Service Co., Ltd. | Cover i. | Wingrove & Rogers, Ltd. | 20 |
| | | | | Wright & Weaire, Ltd. | 14 |

CLIX FOR CONTACT

No. 5 No. 15 No. 4

No. 5. CLIX RING TERMINAL 2d.
 No. 15. ALL-IN-PLUG & SOCKET 8d.
 No. 4. CLIX HOOK TERMINAL 2d.

Nos. 5 and 4 can be supplied with engraved insulators for 1d. extra. Wide range of markings.

Write for the Clix leaflet, "A Matter of Connection."

LECTRO LINX LTD.

254 Vauxhall Bridge Road, S.W.1.

WE SPECIALISE IN MAKING PURCHASES FOR OVERSEAS READERS

Parts, Speakers, Eliminators, or complete Sets. We can buy them for you and what is more will see to it that your requirements are met in every way

HOW TO ORDER

Enclose money order to the approximate amount of the purchase and add 5% to cover freight, Insurance, etc.

THE OVERSEAS TRADING CO.

144, St. Vincent Street, Glasgow, Scotland.
 Telegrams: "Tenacity," Glasgow.

TUNING COILS and METHODS of TUNING

By W. James. (1925)

Price 2/6 net. By post 2/10.

From ILIFFE & SONS LTD., Dorset House, Tudor Street, London, E.C.4, and leading booksellers. w.w.32

Uniflex

ELIMINATOR KIT

for 30/-

MADE IN 10 MINUTES

6d Per YEAR to Run

COMPLETE KIT

as shown mounted on baseboard and panel ready for wiring—for A.C. mains (100/110, 200/220, 230/250 volts).

AMAZING VALUE—

This well-designed Kit will run 3 to 4 valves, free from hum, giving an output of 120 volts at 15 mA, and 60 volt tapping. (Extra tapping if desired, 3/6.)

EVERY PART GUARANTEED. THOUSANDS SOLD. HUNDREDS OF TESTIMONIALS.

Sent complete with full instructions, C.O.D. Post paid **30/-** (Phillips rectifying valve 15/- extra.)

Just send a P.C. stating mains voltage and cycle, also if Phillips rectifying valve (15/- extra) is required.

LIVERPOOL RADIO SUPPLIES

UNIFLEX WORKS, MYRTLE STREET, LIVERPOOL L.

1/9 POST FREE

WHAT STATION WAS THAT?

Why be limited in your choice of programme? Thousands of wireless sets are installed throughout the country which could bring boundless pleasure if their owners could use them to full advantage. With the B.G.L. RADIO STATION FINDER the choice of the world's finest programmes is yours.

IDENTIFY THE STATION CALLING—TUNE IN THE STATION YOU LIKE.

40 to 50 stations ought easily to be picked up by any modern set. The B.G.L. RADIO STATION FINDER enables you to identify any station calling or to tune in to any of the

WIRELESS STATIONS

you like. No technical knowledge necessary. Eliminates oscillation. Can be used with any valve set. The readings of every station within the range of your set are

GUARANTEED

by the manufacturers or your money refunded.

The B.G.L. RADIO STATION FINDER attractively finished, complete with full instructions, 1/9, post free.

BRITISH GAMES Ltd. (Dept. W.W.),
 19, CLERKENWELL CLOSE, LONDON, E.C.1.
 Trade Enquiries Invited.

READ WHAT SATISFIED USERS SAY:

"I congratulate you on the great improvement you have made... it is surprisingly accurate."
 H. B. Falgouton.

"I am very pleased with the Station Finder you sent me and should like you to send one to a friend... please have one sent to—"
 F.H., London.

The Yachting World

and Motor Boating Journal

The Leading British Yachting Journal

"THE YACHTING WORLD" deals with yachts and boats of all types and tonnages, whether on the sea or inland waters. Every aspect of yachting and motor boating is covered in an attractive and interesting manner.

Every Friday 6D.

ILIFFE & SONSLtd., Dorset House, Tudor St., London, E.C.4

Mention of "The Wireless World," when writing to advertisers, will ensure prompt attention.

BAYLISS ROTARY CONVERTER

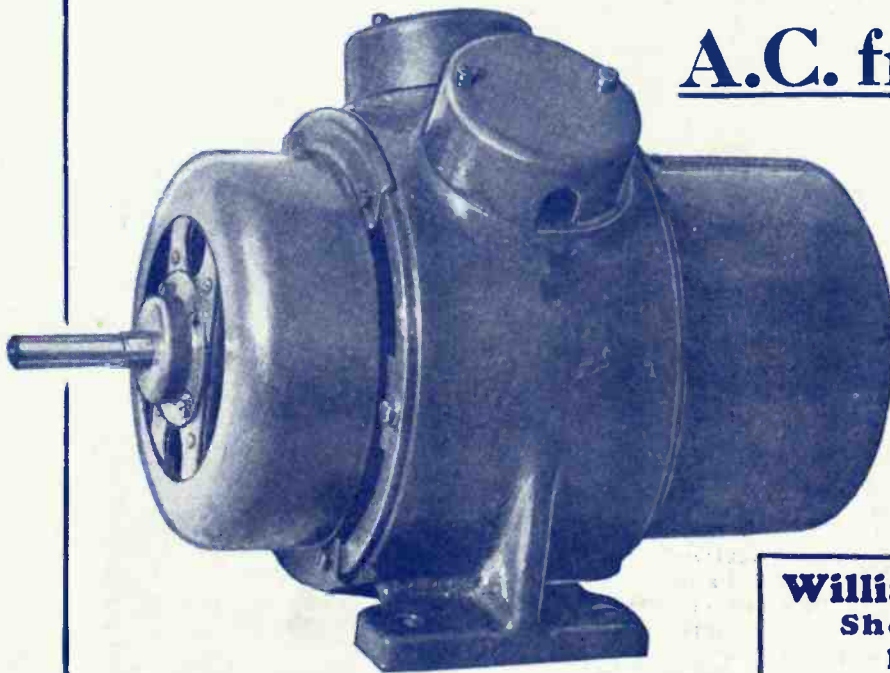

A.C. from D.C.

Load 400 Watts.

ANY Input.
ANY Output.

PRICE

£12 . 10 . 0

Delivery
from Stock.

William Bayliss Ltd.
Sheepcote Street
BIRMINGHAM

Telephone:
Mid 1409.

Telegrams:
"Drawbench, B'ham."

PARFAIT
THE PERFECT
EBONITE

SUPPLIED IN SIX FINISHES

Semi-Polished Black
Highly Polished Black
Matt

Semi-Polished Mahogany,
Highly Polished Mahogany
Cube Surface

Obtainable from most wireless dealers.

Advertisement of H. B. Potter & Co., Ltd., Station Buildings, ROCHDALE.



1930 EDITION

USE YOUR SET
INTELLIGENTLY
THIS YEAR.

THE WIRELESS
MANUAL is the
world's non-technical guide
to Wireless, choice of sets,
their use and care.

Of bookseller, or
Pitman's, Parker St.
Kingsway, W.C.2
(Postage 4d.).

5/-
Net.

WESTINGHOUSE

METAL RECTIFIERS

TYPE A

FOR LOW TENSION D.C.



A.3.

D.C. Output 9 volts. 1 amp.

23/6

Send 2d. Stamp for our 32-page book "The All Metal Way, 1930," giving full details of these and other units—high and low tension, and full instructions and circuits for making A.C. mains units of all types.

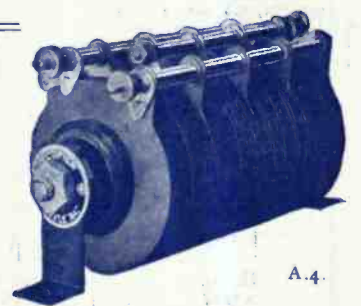

A.4.

D.C. Output 9 volts. 2 amps.

39/6

THE WESTINGHOUSE BRAKE & SAXBY SIGNAL CO., LTD.
82, YORK ROAD, KING'S CROSS, LONDON, N.1

Advertisements for "The Wireless World" are only accepted from firms we believe to be thoroughly reliable.

EXACTNESS THAT COUNTS...



Supreme precision in construction allied with outstanding genius makes McMichael Receivers without equal for results achieved.

Such perfection results in ideal selectivity, enabling the maximum number of stations to be obtained without interference, and with greater volume than usual.

THE McMICHAEL SUPER RANGE PORTABLE FOUR

Incorporating the latest Screened Grid Amplification—unsurpassed for power and high quality of tone. The most effective Receiver indoors or outdoors. Fitted in a beautifully finished furniture hide suit case with patent locking clips. Easy to tune—single dial. Exceptional volume and selectivity. Gives a wonderfully true reproduction of every note broadcasted. Superlative tonal quality. Low cost of upkeep. Special volume control.

Owing to the high degree of selectivity in this, and our other Screened Grid Portable Receivers, we are able to guarantee complete selectivity between all main B.B.C. stations under the new scheme of wavelengths, as recently proved by an actual test under the twin aerials at Brookman's Park, when both programmes were received separately without interference, and in addition a number of other British and foreign stations.

This test was made on a standard "Super Range Four" receiver, under an independent Press observer, and was repeated at half-mile intervals with similar results.

CASH PRICE **22** GNS.

(Including all equipment and Royalties).

Or by our special "Deferred Payments on Hire Purchase Terms" system, £5 down and 10 monthly payments of £2.1.0.



The ideal combination of the latest valves and the most advanced circuit for portable and self-contained receivers—hear the McMichael Super Range Four (either model) demonstrated at any high-class radio store, or call at our London Showrooms.

L.M^CMICHAEL^{LTD}

Manufacturers of Wireless and Scientific Apparatus
WEXHAM ROAD, SLOUGH, BUCKS.

Telephone: Slough 441-442. Telegrams: Radiether, Slough.

London Showrooms: 179, Strand, W.C.2. (Phone: Holborn 2466.)

The McMICHAEL SUPER RANGE FOUR (Table Model)

Containing a circuit of exactly similar design to that of the Portable Model, but fitted in a handsome Walnut Cabinet, mounted on a turntable. Designed with a self-contained frame aerial, this receiver is intended for use in the home where an outdoor aerial and earth are not necessary or desirable. An additional aerial and earth can be used to add to the normal and very remarkable range.

CASH PRICE

26 GNS.

(Including all equipment and Royalties).



Printed for the Publishers, LITTLE & SONS LTD., Dorset House, Tudor Street, London, E.C.4, by The Cornwall Press Ltd., Paris Garden, Stamford Street, London, S.E.1.

UNITED STATES—The International News Co., 131, Varick Street, New York. FRANCE—W. H. Smith & Son, 248, Rue Rivoli, Paris; Hachette et Cie, Rue Réaumur, Paris.
BELOUM—W. H. Smith & Son, 78, Marche aux Herbes, Brussels. JAPAN—A. H. Wheeler & Co., Bombay, Allahabad and Calcutta. SOUTH AFRICA—Central News Agency, Ltd.
AUSTRALIA—Gordon & Gotch, Ltd., Melbourne (Victoria), Sydney (N.S.W.), Brisbane (Queensland), Adelaide (S.A.), Perth (W.A.), and Launceston (Tasmania).
CANADA—The American News Co., Ltd., Toronto, Winnipeg, Vancouver, Montreal, Ottawa, St. John, Halifax, Hamilton; Gordon & Gotch, Ltd., Toronto; Imperial News Co., Toronto, Montreal, Winnipeg, Vancouver, Victoria. NEW ZEALAND—Gordon & Gotch, Ltd., Wellington, Auckland, Christchurch and Dunedin.