

3^D

The Wireless World

AND RADIO REVIEW

The Paper for Every Wireless Amateur

Wednesday, July 6th, 1927.

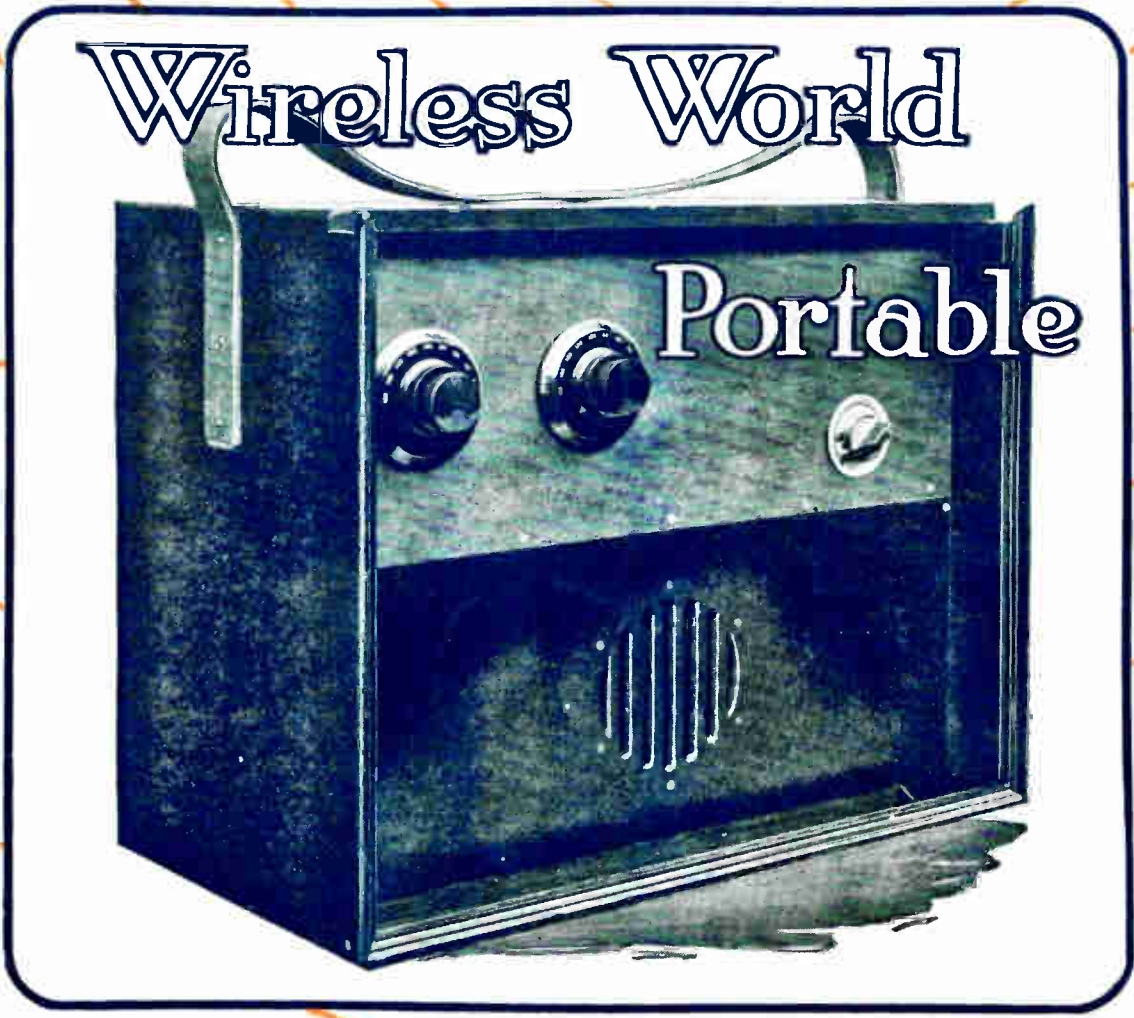

CONE AMPLION SPEAKER

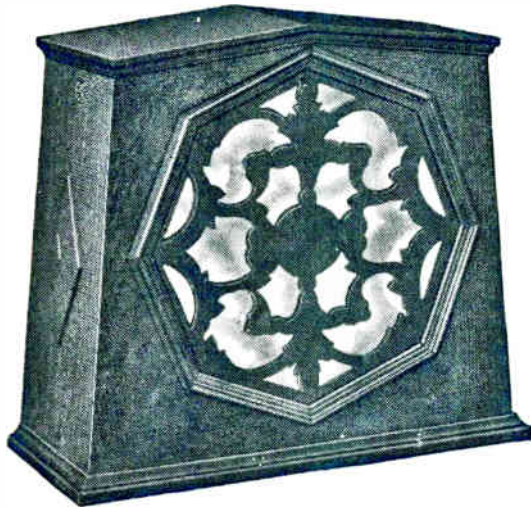

"Dark Oak" Model A.C.5. Price £6 : 0 : 0
Other Cone Models from £3 : 15 : 0

Shut your eyes and listen !

The artistes are there, each instrument is there, every word and every note is reproduced with fidelity—you might be in the studio! Try this for yourself and you will understand why the AMPLION Cone is known as

The Natural Tone Loud Speaker

Announcement of Graham Amplion Limited, 25, Savile Row, London, W.1.

Mention of "The Wireless World," when writing to advertisers, will ensure prompt attention.

G. F. Mansbridge himself



is behind Every Dubilier Mansbridge Condenser

There are many "Mansbridge Type" Condensers for you to choose from, some of them British, some of them Foreign, some of them good, others quite good.

Perhaps you find it difficult to make a choice.

Try the simple expedient of asking for, and seeing that you get, a condenser in a maroon coloured case with the words Mansbridge Condenser on the case as shown above.

Tested to 300 volts D.C., self sealing, high insulation resistance to case, bakelite bushes, screw terminals, soldering tags, and, most important of all, backed by the name of the inventor as well as by the Dubilier guarantee of complete satisfaction.

That is the condenser for you.

| | | | | | |
|----------------------|-----|-------------|-------------|---|------|
| 0.01 to 0.1 μ F | 2/6 | 1.0 μ F | - | - | 4- |
| 0.125 to 0.2 μ F | 2/8 | 2.0 μ F | - | - | 5- |
| 0.25 to 0.3 μ F | 3/- | 3.0 μ F | - | - | 8/- |
| 0.4 μ F | - | 3/3 | 4.0 μ F | - | 10/- |
| 0.5 μ F | - | 3/6 | 5.0 μ F | - | 12- |

Prices for special capacities and test voltages on request.



Advt. of the Dubilier Condenser Co. (1925) Ltd.,
Ducon Works, Victoria Road, North Acton, W.3.

Resistance Coupling IS the right way to true reproduction

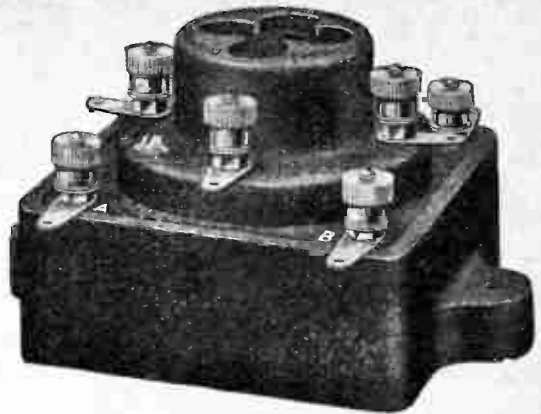

Quality of reproduction has no relationship to quantity of amplification, but only to the shape of the amplification—frequency curve.

Curves and statements have been published comparing a transformer with a resistance unit employing high anode resistances and a high impedance valve.

SUCH COMPARISONS SHOW—

For the TRANSFORMER :—

The Distortion on Low Notes (due to insufficient primary inductance).

The Distortion on High Notes (due to resonance in windings).

For the High Anode RESISTANCE UNIT :—

No Distortion on low notes.
Distortion on high notes (due to the relatively low impedance of the valve capacity shunting the high anode resistance).

Note—The “Cosmos” Resistance Unit *does not* use high anode resistances for this very reason.

The “Cosmos” Shortpath Low Impedance High Voltage Factor Valve does not need high anode resistances to obtain good amplification.

The “Cosmos” Resistance Unit has a high value coupling condenser and normal grid leak thereby bringing in those low notes which make music.

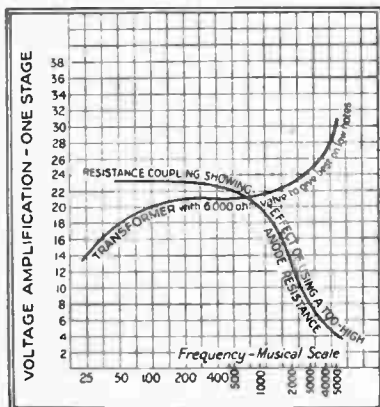

The Curves show the distortion effects in the amplification—frequency curves of a good transformer, a high anode resistance unit and the “Cosmos” Resistance Unit using low anode resistances and large coupling condenser.

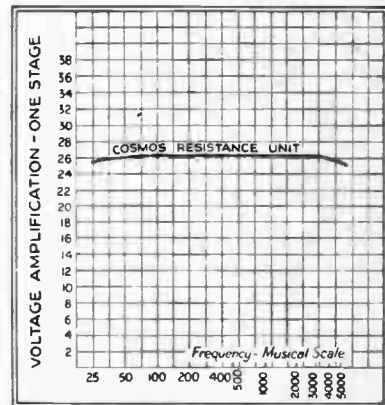

These are comparable

This is incomparable

Cosmos UNIT

FOR RESISTANCE CAPACITY COUPLING

Advt. of Metrovick Supplies Ltd., 155 Charing Cross Road, London, W.C.2

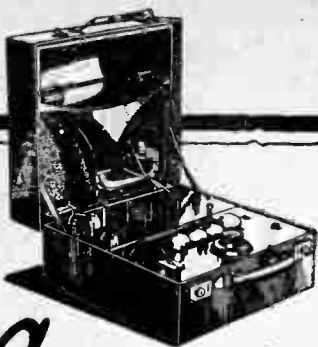

a true portable set

The Langham Portable (measuring only 15" x 15" x 8" when closed) is a 4-valve set having a special Langham circuit giving perfect loud speaker reproduction of British main stations up to 150 miles, and of Daventry and such continental stations as Radio Paris, Berlin, Madrid, Hilversum and many others up to at least 400 miles.

Aerial, earth, batteries and loud speaker are all included in the set, which is ready to work the moment you receive it.

There is only ONE tuning control!

You may try it yourself for a week: send us full price or initial deposit and we will let you have the set. If you don't like it, send it back and we will gladly refund in full.

Write to us direct for full particulars.

30 GNS.

Complete and absolutely ready for use.

DEFERRED TERMS.

Initial deposit of £5 and 12 monthly instalments of £2.7.6.

Langham Radio
Albion House
 59
NEW OXFORD STREET.
 LONDON W.C.1.

Telephone: Museum 2878 and 8293.

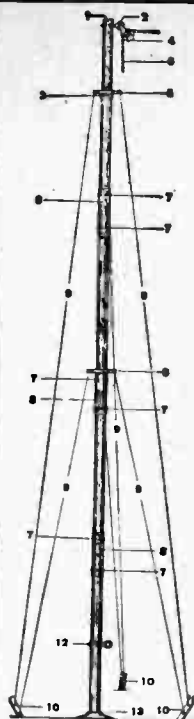

ARE YOU PROUD

OF YOUR

AERIAL MAST

or is it tottering beneath the burden of its responsibility? EFFICIENT, HANDSOME, and an Ornament to any Garden is a

"LAKER" STEEL MAST

30 ft. for 22/6

COMPLETE WITH ALL ACCESSORIES AS ILLUSTRATED.

Can be erected in a few minutes. Occupies only 4' 6" radius. Send 1/- extra for part carriage. We pay the rest.

Send cheque or postal order to

J. & J. LAKER CO.,
 Engineers, Beckenham, Kent.
 Contractors to H.M. Government, The B.B.C., etc.
 On the Admiralty List.

Money refunded if not completely satisfied.

THE MAST for the MILLION

SHORT-WAVE TRANSMISSION

AND

RECEPTION

(Described in last week's issue)

KEYSTONE TRANSMITTING COILS
 MADE EXACTLY TO MR. HAYNES' SPECIFICATION AND GUARANTEED PER SET

18/6

IMPORTANT. See that the name "Keystone" appears on every Coil. Accept no other.

CHOKE COILS—EXACTLY AS DESCRIBED, PER PAIR **5/-**

All other Parts in Stock for Mr. Haynes Transmitting Set. Write for List.

THE EMPIRE SHORT-WAVE RECEIVER.

WE CARRY IN STOCK ALL PARTS FOR THIS SET

Including: 2 Low Loss Variable Condensers '0002 mfd. with vernier dials £1.6.0, 1 Filament Rheostat 2s. 6d., 1 Potentiometer 2s. 6d., 1 Ferranti A.F.3 L.F. Transformer £1.5.0, 2 Fixed Condensers '0002 mfd., with bases 4s. 6d., 1 Fixed Condenser '001 mfd. with base 2s. 3d., 2 T.C.C. Fixed Condensers 2 mfd. 8s. 8d., 2 Valve Holders 2s. 0d., 1 Porcelain Grid Leak Base 6d., 1 Dubilier 3 megohm Grid Leak 2s. 6d., 1 Special ready-wound Coil 7s. 6d., 1 Special H.F. Choke 8s. 6d., 2 Spring Clips 1s. 0d., 3 3-way Porcelain Connectors 8d., 1 2-way Porcelain Connector 2d., Sundry Supports, Wire, Screws, Flex, etc., 2s. 6d.

Remember that our famous Pilot Service guarantees you good results. Our Technical and Service Dept. will advise and help you free of charge.

Do not fail to send for the latest edition of the Pilot Manual. Fully illustrated and containing much useful advice, this book should be in the hands of every enthusiast. Post free 3d.

PETO-SCOTT CO., Ltd.,

77, CITY ROAD, E.C.1 and
 62, HIGH HOLBORN, W.C.1

ALSO AT 4 MANCHESTER STREET, LIVERPOOL.

LEWCOS 6-PIN COILS

have been approved by engineers responsible for
MULLARD P.M. SETS | **B.T.H. RESISTOR SETS**

RODNEY

- 1 6-pin Centre Tapped Secondary Aerial Coil. Ref. SSTP .. 10/-
- 1 Magnetic Reaction H.F. Transformer. Ref. MRT .. 10/-
- 2 Rectangular 6-pin Bases 3/- each.

NELSON & COLUMBUS

- 1 6-pin Centre Tapped Secondary Aerial Coil. Ref. SSTP .. 10/-
- 1 Split Primary H.F. Transformer. Ref. SPT .. 10/-
- 2 Rectangular 6-pin Bases 3/- each.

RESISTOR 2

- 1 6-pin Aerial Coil. Ref. RTA 10/-
- 1 Rectangular 6-pin Base .. 3/-

RESISTOR 3

- 1 6-pin Aerial Coil. Ref. RTA 10/-
- 1 Rectangular 6-pin Base .. 3/-

To obtain the best results use

LEWCOS Coils

Regd. Trade Mark.

Full particulars on application to

The LONDON ELECTRIC WIRE COMPANY & SMITHS LTD.,
 7, Playhouse Yard, Golden Lane, London, E.C.1.

DO NOT SPEND MONEY ON EXPENSIVE & TROUBLESOME APPARATUS for H.T. SUPPLY.

This is an extract from a letter recently received:

"Much is written in the wireless Press on high-tension supply, accumulator, rectifiers and smoothers for main A.C. and D.C. current, and so on, but from my own experience it would be futile to try any other method than that of your high-tension batteries. It certainly is the 'no bother' source of energy, and the 'Ever Ready' servant of,

Yours faithfully,"

SAVE MONEY AND USE

(Regd. Trade Mark)

"EVERREADY"

BRITAIN'S BEST BATTERIES

Service Dept. D.L., Hercules Place, Holloway, London, N.7.

ARE SAFE, PUREST IN TONE, CLEANEST IN USE, FREE FROM TROUBLE, LESS IN COST than any other form of High-Tension supply.

The Set that received
AMERICAN Stations for 24 hours!

EDDYSTONE

2 valve SHORT-WAVE Receiver.

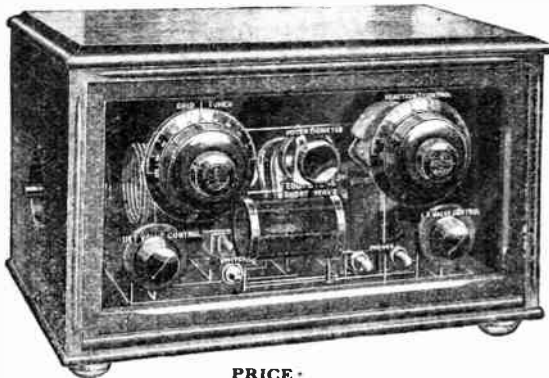

YOU can listen to the American short-wave stations any night on this set; reception at times being loud enough for a Speaker to be used. During the recent short-wave tests, the programmes from one or the other of the American stations 2XAF—32 metres and 2XAD—22 metres were received on a standard "EDDYSTONE" set during the whole of the 24 hours, this time including 18 hours of daylight. Every set is guaranteed to give equal performance, and in addition to the American Short-Wave stations, there is the new Dutch station PCJJ on 30 metres, which can be received easily, together with other Continental experimental stations, and a large number of amateur transmissions. The set is simple to operate, is contained in a first-class oak cabinet, with an instrument panel of glass. A short-wave receiver is ideal for reception in tropical countries where reception on the ordinary broadcast band is out of the question. If you are so situated, this set should receive your best consideration as it will bring hours of enjoyment to you.

PRICE:
S.W. Receiver £10.0.0
Plus Royalty £1.5.0

If you wish to construct your own S.W. receiver, send for Catalogue of "EDDYSTONE" guaranteed S.W. apparatus, with designs.

STRATTON & CO., LTD., Balmoral Works,
Bromsgrove Street, BIRMINGHAM.

LONDON SERVICE DEPOT:
WEBB'S RADIO ELECTRIC STORES,
164, Charing Cross Road.



JACOBAN OAK CABINET

THIS popular model has real twist legs. Top compartment for set, and bottom compartment for batteries. Fitted with lock and key. Size No. 1 takes any set or panel up to 24x8 in. Size No. 2, set or panel up to 30x9 in. Insets. In Mahogany with Cabriole legs, Size 1, £4.17.6. Size 2, £5.7.6

£4.7.6

Delivered Free in U.K. Special sizes to order.

Write for Illustrated Price List. Let us quote for your own designs.
F. DIGBY, 9, Banbury Road, South Hackney, E.9.

The TANNAY

A.C. MAINS
L.T. SUPPLY UNIT

Used in conjunction with a 2, 4 or 6 volt accumulator. Operates automatically with no fear of overcharging. Main consumption is negligible and there is no danger of shock, the unit being entirely insulated from Mains supply.

Charge and discharge Ammeter 10/- extra.

7 days free trial against cash. Guaranteed for 12 months.

THE TULSEMERE MANFG. CO.,
Tulsemere Road, West Norwood, S.E.27.

Phone: Streatham 6731.

Wholesale Distributors: H.T.C. Electrical Co., Ltd.,
2, Boundaries Rd., Balham, S.W.12.



39/6

GAMBRELL CENTRE TAPPED COILS

These are universal coils, their use not being limited to centre tapped circuits. They can be plugged into any standard coil socket. Baseboard space occupied is very small.

| SIZE. | PRICE. | Approx. No. of Turns. |
|-------|--------|-----------------------|
| a 2 | 4/10 | 13 |
| a | 4/10 | 25 |
| A | 5/- | 30 |
| B1 | 5/3 | 40 |
| B | 5/6 | 50 |
| C | 5/9 | 75 |
| D | 6/3 | 100 |
| E1 | 6/9 | 150 |
| E | 7/9 | 200 |
| F | 8/6 | 300 |
| G | 10/- | 500 |

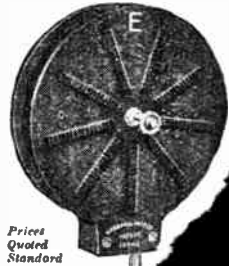

Prices Quoted Standard Coils, Centre Tapped 6d. Extra
Details of Gambrell Receivers on re

GAMBRELL BROS
76, Victoria St., London,

Chakophone

REGD

EVERYMAN FOUR COILS.

The Wireless World says: "The Chakophone coils can be recommended for building the 'Everyman Four' receiver. As well as being electrically correct, the coils are well finished, and with the green silk-covered Litzendraht wire, are of particularly good appearance."

Manufacturers:

EAGLE ENGINEERING CO., LTD., WARWICK.



31/- per pair with booklet sent post free if your Local Radio Dealer cannot supply.

THE NEW WALL

Designed for use with the "Tapa" Twin Plug for Phone or Loud Speaker extensions where a neat and efficient connection is required; will take all Standard Plugs.

W. J. CHARLESWORTH
88, ASTON STREET, BIRMINGHAM



BRITISH MADE.

TAPA JAC

Made in Two Patterns. No. 262, Parallel Pattern, 2/3 each. No. 264, Series Pattern, 2/9 each. "Tapa" Jacs are also made for panel & base-board mounting.

Mention of "The Wireless World," when writing to advertisers, will ensure prompt attention.



NEW! and Cheaper- and why!

For a moderate initial expenditure you get years of constant H.T. supply for an *annual* upkeep cost of from 2/2d. for a 2-valve set to 6/- for a 7-valve set. Compare this cost with your present H.T. expenditure! In addition you get constant voltage which permits your set always to operate at 100% efficiency.

The "GEEKO" H.T. Accumulator is self-charging, a simple operation needed about once a fortnight. You just switch on to the mains before retiring to bed, and the unit is ready for use again in the morning.

WRITE FOR FULL PARTICULARS.

Sold by all
WIRELESS DEALERS.

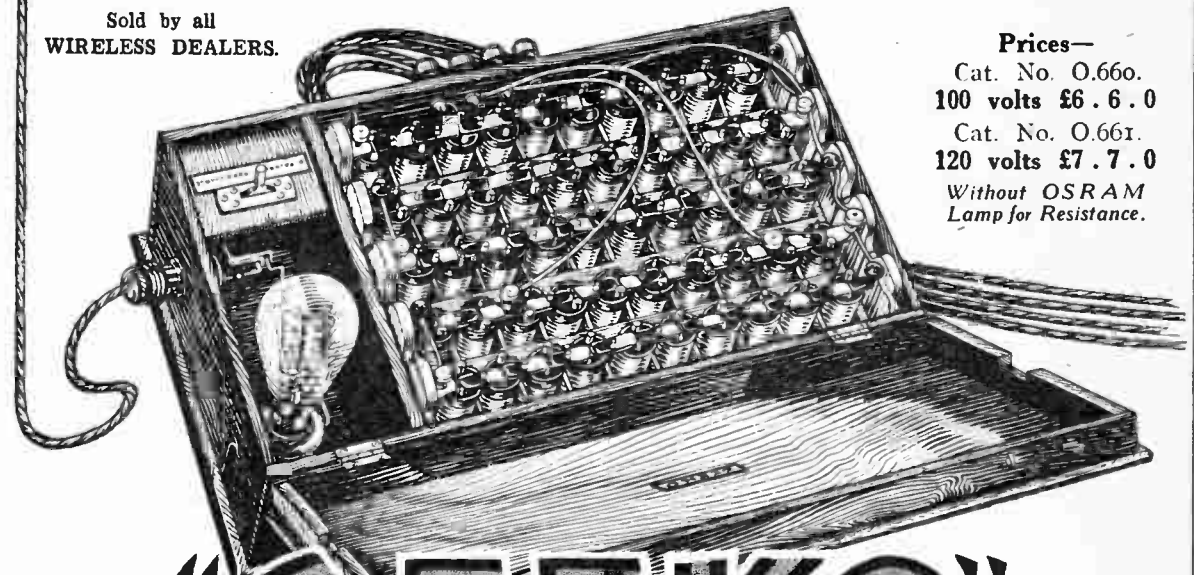

Prices—
Cat. No. O.660.
100 volts £6.6.0
Cat. No. O.661.
120 volts £7.7.0
*Without OSRAM
Lamp for Resistance.*

"GEEKO"

**H.T. ACCUMULATOR & CHARGER
FOR D.C. MAINS**

Advt. of The General Electric Co., Ltd., Magnet House, Kingsway, London, W.C.2.

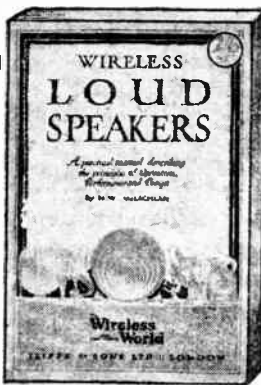

A Practical Manual
describing the Prin-
ciples of Operation,
Performance and
Design.

Price 2/6 net

By Post 2/8

WIRELESS LOUD SPEAKERS

By N. W. McLACHLAN, D.Sc.

THE purpose of this book is to describe in a simple manner the major principles of the design of modern loud-speakers—chiefly of the large diaphragm type—and some associated circuits. Throughout the volume the author has refrained from a too technical treatment of the analytical side of the subject. The book is clearly written and fully illustrated by numerous diagrams and photographic reproductions. A chapter showing how to construct a loud-speaker will appeal to many amateurs.

A Résumé of the Contents :

GENERAL ACOUSTIC PRINCIPLES: LOUDNESS OF REPRODUCTION AND ITS INFLUENCE ON QUALITY: RESONANCE CAUSING BLURRING OF COMPLEX SOUNDS: PRINCIPLES AND DESCRIPTION OF HORN-TYPE LOUD-SPEAKERS: LATERAL MOTION OF AIR: EFFECT OF HORN LENGTH: PRINCIPLES OF LARGE DIAPHRAGM SHAPE: CONE DIAPHRAGMS: REFLECTORS: ROOM RESONANCES: STANDING WAVES: ACOUSTIC SHADOWS, ETC., ETC.

From all leading booksellers or direct from the Publishers :

ILIFFE & SONS LIMITED, Dorset House, Tudor Street, London, E.C.4.

w.w.54

Disposing of Surplus Apparatus!

The letter printed below has been received from a recent advertiser in "The Wireless World." It affords convincing proof of the advertising value of the Miscellaneous Columns of the paper, and indicates a method of disposing of surplus wireless apparatus or components. Write out your advertisement to-day! Full particulars are given on the first page of Miscellaneous Advertisements.

"..... You may be interested to learn that as a result of my recent advertisement in "The Wireless World" I have already disposed of the greater part of the surplus components advertised, and have realised the sum of £6 . 11 . 6.

"The publication of this information may be of interest to others who have surplus components, and who, perhaps, do not realise that there is a market for them at reasonably low prices."

D. R. WHITE,

35, Elm Road N.,

Prenton, Birkenhead.

EVERYTHING

The
G.E.C.
your guarantee

ELECTRICAL

Build Perfection into your set
At Lower Cost /

REDUCED PRICES
of TWO HIGH CLASS COMPONENTS

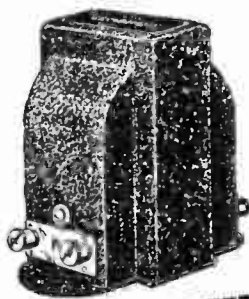
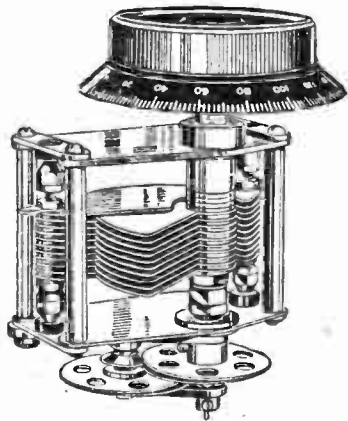

**GECOPHONE LOW LOSS
SLOW MOTION CONDENSERS**

This precision instrument combines every possible improvement in condenser design, together with slow motion movement which is far more effective than the addition of a vernier dial—more selective, easier to use, and less costly than the combination of good vernier and good condenser. With the appreciable price reduction now announced, resulting from increased production, "GECOPHONE" Low-Loss Condensers bring the best reception within reach of every constructor

REDUCED PRICES

SQUARE LAW TYPE—

| | | | | | | |
|---------|---|---|-----------|---|---|------|
| B.C.989 | - | - | '0001 MFD | - | - | 17/6 |
| B.C.991 | - | - | '0002 .. | - | - | 17/6 |
| B.C.993 | - | - | '00025 .. | - | - | 17/6 |
| B.C.995 | - | - | '0003 .. | - | - | 17/6 |
| B.C.997 | - | - | '0005 .. | - | - | 19/6 |
| B.C.999 | - | - | '001 .. | - | - | 27/6 |

STRAIGHT LINE FREQUENCY TYPE—

| | | | | | | |
|---------|---|---|-----------|---|---|------|
| B.C.670 | - | - | '0003 MFD | - | - | 19/- |
| B.C.675 | - | - | '0005 .. | - | - | 22/- |

GECOPHONE L.F. TRANSFORMER

Known everywhere as the highest standard of transformer efficiency, GECOPHONE L.F. Transformers are now absolutely guaranteed for 12 months from date of purchase. So great is the demand for the popular 4-1 ratio model, that we are able to announce a substantial price reduction. Buy GECOPHONE L.F. Transformers, knowing that they are guaranteed and are the finest transformer value obtainable anywhere.

REDUCED P I

| | | | | | | |
|---------|---|---|-----------|---|---|------|
| B.C.720 | - | - | Ratio 2-1 | - | - | 17/6 |
| B.C.725 | - | - | " 4-1 | - | - | 20/- |

GECOPHONE

(REGISTERED TRADE MARK)

THE WORLD'S STANDARD IN CONDENSER AND TRANSFORMER DESIGN.

PRICE REDUCTIONS
have also been made in
G.E.C.
D.C. Eliminators &
Cabinet Loud Speakers
ASK
YOUR LOCAL DEALER
FOR PARTICULARS.

Advt. of The General Electric Co. Ltd., Magnet House, Kingsway, London, W.C.2.



“THE fellow who told me to buy a Cossor Valve must have had a soft spot for me. Now if I want to do you people a good turn I'll just say ‘See that your valves bear the name Cossor and you can be certain of hearing radio as it should be heard’. Cossor Valves give rich colourful music with all the character and beauty of the original—with nothing added and nothing taken away—music that will satisfy the most captious critic.

Cossor

—the melody maker

Advt. A.C. Cossor, Ltd., Highbury Grove, London, N.5.

Mention of “The Wireless World,” when writing to advertisers, will ensure prompt attention.

Here is why Cossor Valves last longer

NORMALLY the Filament of a valve is a slender thread of metal subjected to intense heat. From the time the first valve was made, heat—in the form of an electric current—has been required to produce the necessary electron emission from the filament

But Heat—although a good servant—is a bad master. His thieving fingers have robbed every filament of many hours of useful life. Through excessive heat metal becomes crystallised. When in this brittle state it is susceptible to the slightest knock. Even expansion and contraction under tension is sufficient to cause a fracture. That is why the ordinary valve has only a comparatively short life.

Now at last Heat has met his match. His services have been dispensed with. The new Cossor Kalenised filament is made under entirely new principles. It is unlike any other filament. It gives off a tremendous emission practically without heat. The familiar glow is absent. Experts agree that the Kalenised filament is one of the greatest fundamental improvements in wireless.

Even after prolonged use the Cossor Kalenised filament never becomes brittle—it is still pliable. Whilst the emission is hundreds of times greater than that to be obtained from an ordinary filament.

Obviously the greater the emission, the more efficient the valve and no other valve equals in intensity the emission given off by the Cossor Kalenised Filament. That is why Cossor Valves are setting entirely new standards for volume, for purity and for uniformity.

Save money by using Cossor Valves

In 12 types for
2, 4 or 6-volts

Gilbert Ad. 9158.

B6

The Wireless World

AND
RADIO REVIEW
(15th Year of Publication)

No. 410.

WEDNESDAY, JULY 6TH, 1927.

VOL. XXI. No. 1.

Editor : HUGH S. POCOCK.

Assistant Editor : F. H. HAYNES.

Editorial Offices : 139-40, FLEET STREET, LONDON, E.C.4

Editorial Telephone : City 4011 (3 lines).

Advertising and Publishing Offices : DORSET HOUSE, TUDOR STREET, LONDON, E.C.4.

Telephone : City 2847 (13 lines).

Telegrams : "Ethaworld, Fleet, London."

COVENTRY : Hertford Street.

BIRMINGHAM : Guildhall Buildings, Navigation Street.

MANCHESTER : 199, Deansgate.

Telegrams : "Cyclist Coventry."
Telephone : 5210 Coventry.

Telegrams : "Autopress, Birmingham."
Telephone : 2970 and 2971 Midland.

Telegrams : "Hiffe, Manchester."
Telephone : 8970 and 8971 City.

Subscription Rates : Home, 17s. 4d.; Canada, 17s. 4d.; other countries abroad, 19s. 6d. per annum.

As many of the circuits and apparatus described in these pages are covered by patents, readers are advised, before making use of them, to satisfy themselves that they would not be infringing patents.

INTERFERENCE.



It is now nearly five years since broadcasting was established in this country and in various parts of Europe, and great strides have been made in the technical development of broadcasting services for the public benefit. A great deal of money has naturally had to be expended in the endeavour to make broadcasting as perfect as possible and to give the best reproduction that technical skill can achieve. On the side of reception, too, great progress has been made. Attention has been paid to improving both the selectivity and the reproduction quality of receivers, and in some directions the price has been reduced so as to bring valve sets within the reach of the majority of the population.

In spite of anything which may be said to the contrary, experience has shown that the listening public is cultivating an ever-growing interest in distant reception as well as attending to the improvement of reception of the local station, but certain obstacles have consistently interfered with ideal reception. This interference may be grouped under distinct heads:—

- (1) Atmospheric interference.
- (2) Mutual interference between broadcasting stations.
- (3) Interference from stations other than broadcasting stations.
- (4) Electrical interference from such causes as adjacent electric trams, generating stations, etc.

Dealing with these causes of interference, we may say that in the case of No. (1) no remedy has yet been found in spite of persistent endeavours on the part of engineers throughout the world to solve the problem.

No. (2) is a subject which has been and is being ably tackled by the technical representatives of broadcasting in Europe.

Passing over No. (3) for the moment, we recognise that interference coming under the heading No. (4) is

in almost all cases produced locally in the neighbourhood of the receiver.

When, however, we consider the troubles arising out of interference due to wireless transmitters other than those used for broadcasting purposes, we must feel sadly disappointed that so little has been done to remedy this evil. There are to-day in Europe a number of spark stations which could be regarded as obsolete in design even when broadcasting started some five years ago, and yet they have been retained in transmission ever since; and, as far as we are able to ascertain, and certainly as far as practical results go to show, no effort has been made to render these stations less productive of interference than they were then; rather it would seem that some of these stations have gone from bad to worse, and we would cite as a particular example the Post Office Station of North Foreland, which to-day spreads itself over a band of wavelengths almost from 400 to 800 metres, rendering reception on the broadcast band almost hopeless within its range. There are a number of other British stations in addition which cause persistent interference to an extent which we believe cannot be justified. On the French coast we have a series of transmitters which add to the difficulties of reception anywhere along our South Coast, rendering reception in a large part of Northern France impossible. We cannot, perhaps, bring any effective pressure to bear on the authorities responsible for these stations abroad, but at least we can set an example. The Post Office least of all is to be excused for operating obsolete stations, especially considering that these stations are breaking the very regulations which the Post Office insists should be observed by other transmitters. If no other means can be found to remedy the evil, what of the very large sum retained by the Post Office after the collection of the broadcast licence fees? We see no reason why some of this fund should not be expended to bring the Post Office transmitters up to date, and so bring to an end an interference with broadcast reception, the cause of which is a disgrace to this country.



How to Build to a Self-contained Four-valve Receiver.

A REASONABLE deduction to draw from the present vogue for the portable set would be that a radical change is taking place in receiver design. Where in the past it has been considered necessary to erect an elevated aerial, instal a multi-valve receiver, and wire up to a group of batteries, it is now being realised that an entirely self-contained set can be produced without depreciation of performance or increasing the difficulties of maintenance. The portable set, although primarily intended for outdoor use, is obviously the ideal home receiver, and it is safe to predict that the present form of portable set is the embryo of the wireless set of the future.

At a distance not exceeding twenty miles from a broadcasting station a small frame aerial will give sufficient input to a single-stage high-frequency amplifier, and after detection and L.F. amplification will produce good loud-speaker output. It is the self-contained properties of the portable set, rather than portability, to which its popularity is due, though it must not be inferred that it has taken designers of wireless sets three years to

appreciate this point, but that the performance of apparatus has so improved that the self-contained form of construction has only recently become possible.

Until recently one would not recommend the use of a frame when an elevated aerial would give a so much greater input, yet there is little purpose in making provision for the liberal pick up of energy by an elevated aerial if a frame working through an easily operated H.F. amplifier gives as great a signal strength to the L.F. valve as it can handle. Thus by dispensing with the unsightly outdoor aerial and the tangled leading-in and earth wires, the frame aerial set more perfectly meets public requirements.

The Self-contained Set.

Again, valves of good performance are now available with filaments requiring such a low filament wattage that a battery of quite small dimensions will run the set for a long period. The strictly portable set must contain a high-tension battery, although if in place of portable the more correct term "self-contained cabinet receiver"

is substituted, then it would be better to plug in on to the nearest power point for current to operate the H.T. battery eliminator.

The majority of portable sets in use to-day make use of a two-stage high-frequency amplifier, but as the provision of three tuning controls is out of the question, one of the stages must be untuned, and it is doubtful if the range-getting properties of the two-stage amplifier are superior, or even equal, to a single stage having good efficiency. It is, of course, desirable to dispense with the additional valve to reduce the load on the small H.T. and L.T. batteries. Probably the five-valve set is in more

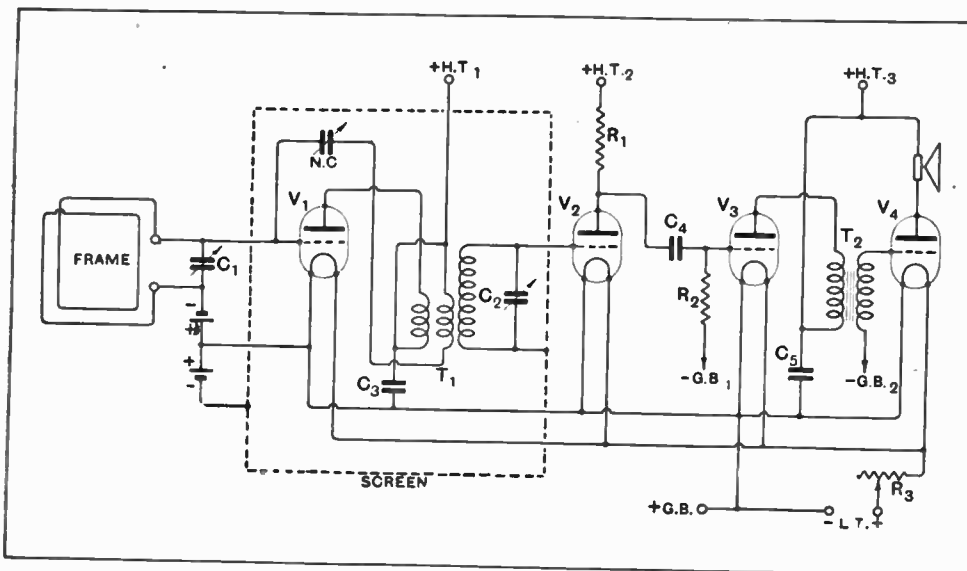

Fig. 1—The circuit is a typical arrangement embodying a screened high frequency stage. The detector valve is arranged as an anode bend rectifier with the grid negatively biased.

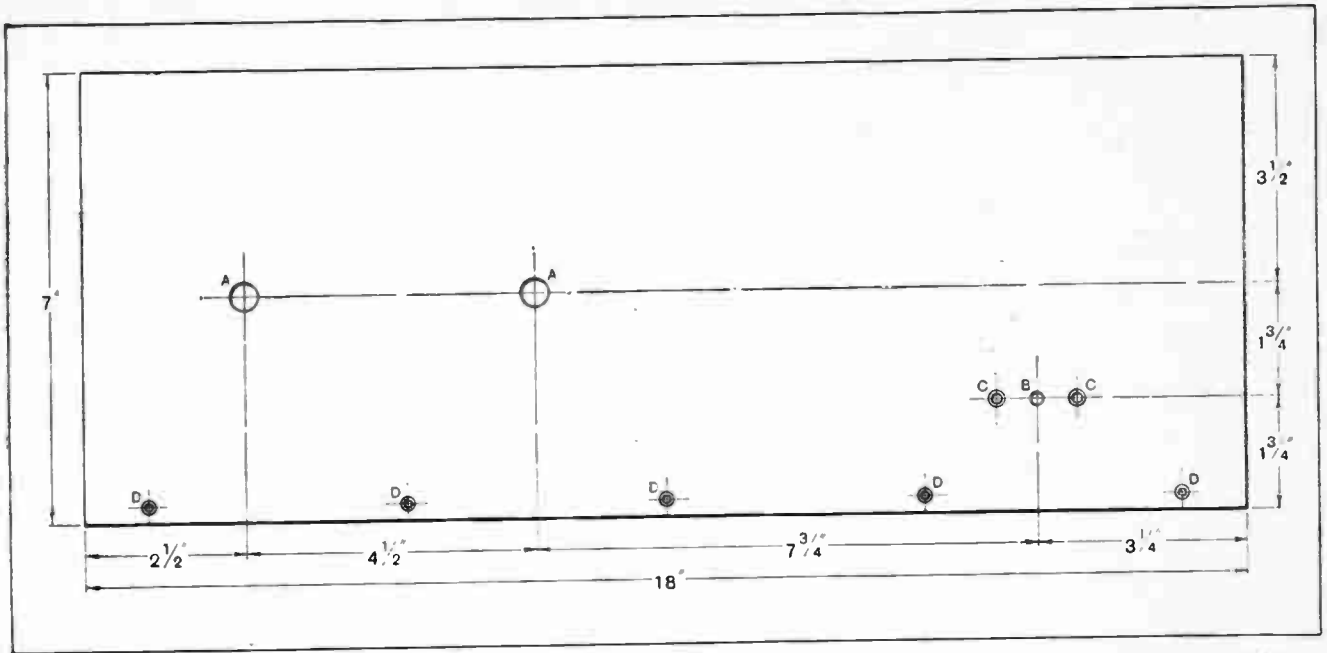

Fig. 2.—Details for drilling the front panel. Sizes of holes: A, 7/16in.; B, 3/16in.; C, 5/32in. and countersunk for 4 B.A. screws; D, 1/8in. and countersunk for No. 4 nut screws.

general demand, as many regard it as a "more powerful" set, although it is questionable whether the additional valve in any way improves the performance.

The efficiency of the H.F. stage of this four-valve receiver is made as high as possible, which necessitates the use of an anode bend detector valve as compared with detection by means of a leaky grid condenser. Thus the advantage gained by the use of the special Litzendraht wire for the construction of the transformer is not nullified by the passage of grid current through the winding. A high-frequency valve (steep-curve) is used as the anode bend detector, permitting of the use of resistance coupling to the first L.F. valve. The output of this valve is transformer-coupled to a final valve, and the self-contained loud-speaker is connected directly in its plate circuit.

Two difficulties are likely to arise in designing a self-contained set. Firstly, however the H.F. transformer is arranged with regard to the frame aerial, a sufficiently strong magnetic coupling will exist between frame and coil to stimulate self-oscillation. This is overcome by com-

pletely screening the high-frequency amplifier, including valve, tuning condenser, and the associated wiring, though, in spite of the fact that the coil is centrally placed within the screening box, a slight falling off in H.F. amplification is certain to result. It is optional,

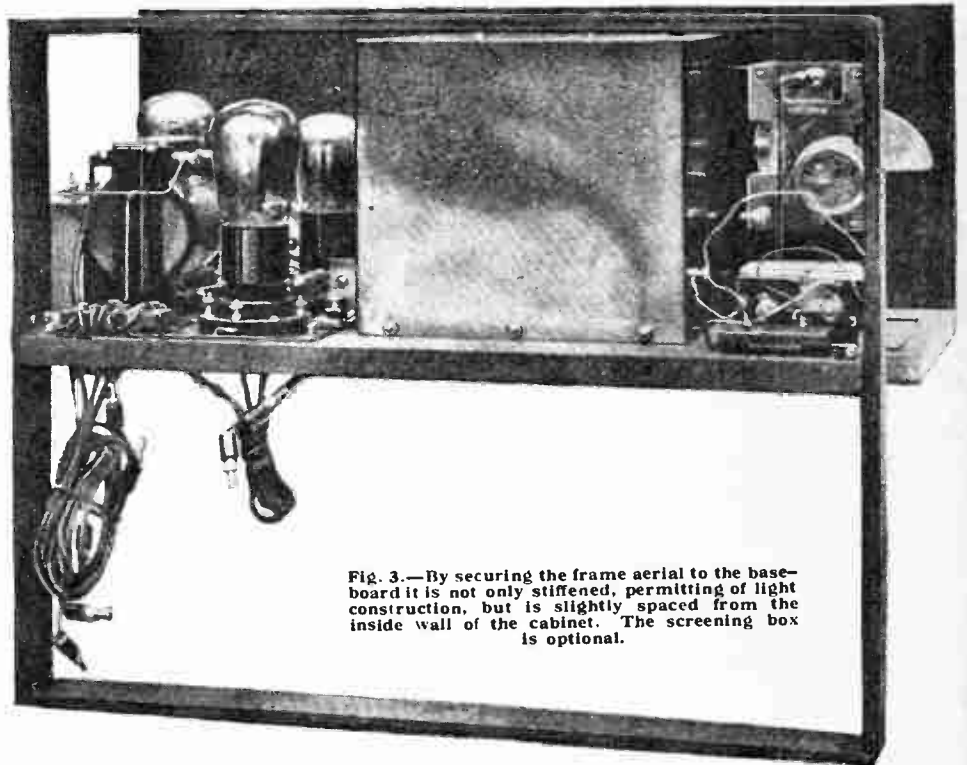

Fig. 3.—By securing the frame aerial to the baseboard it is not only stiffened, permitting of light construction, but is slightly spaced from the inside wall of the cabinet. The screening box is optional.

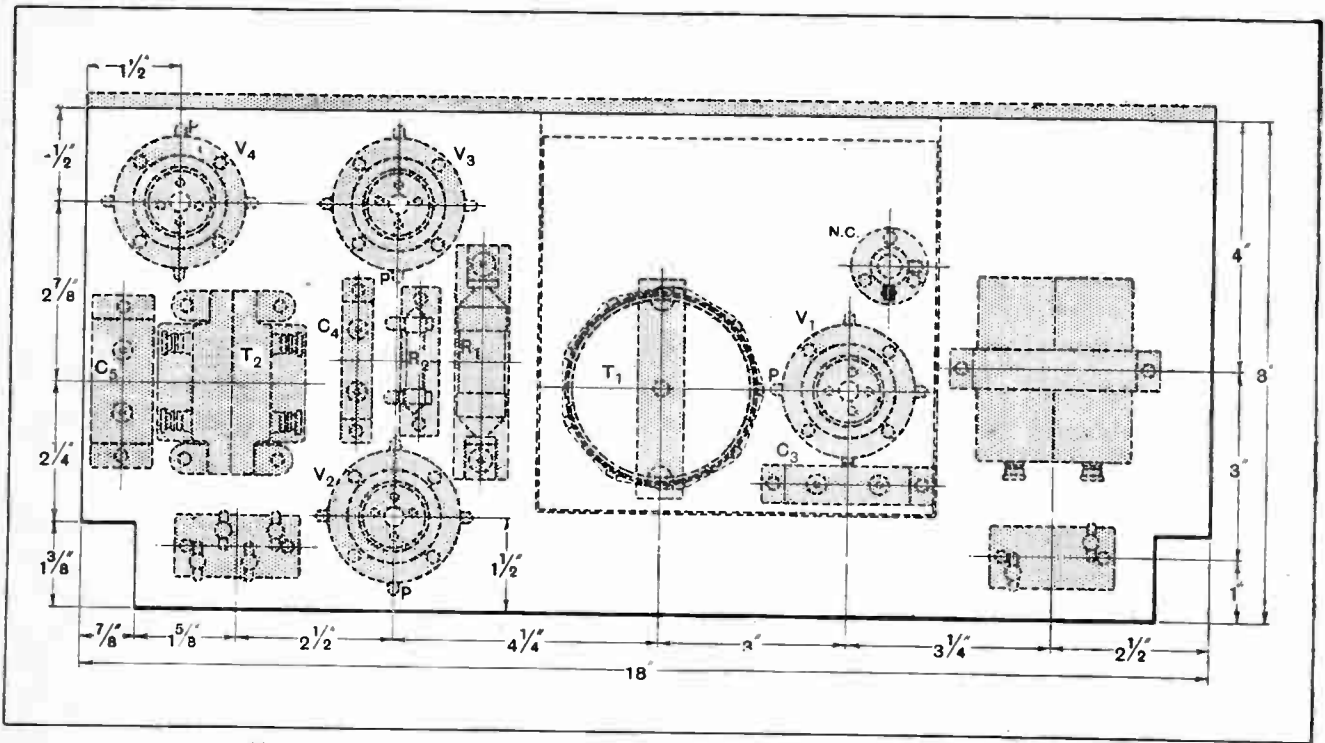

Fig. 4.—Dimensional drawing for locating the component apparatus on the baseboard.

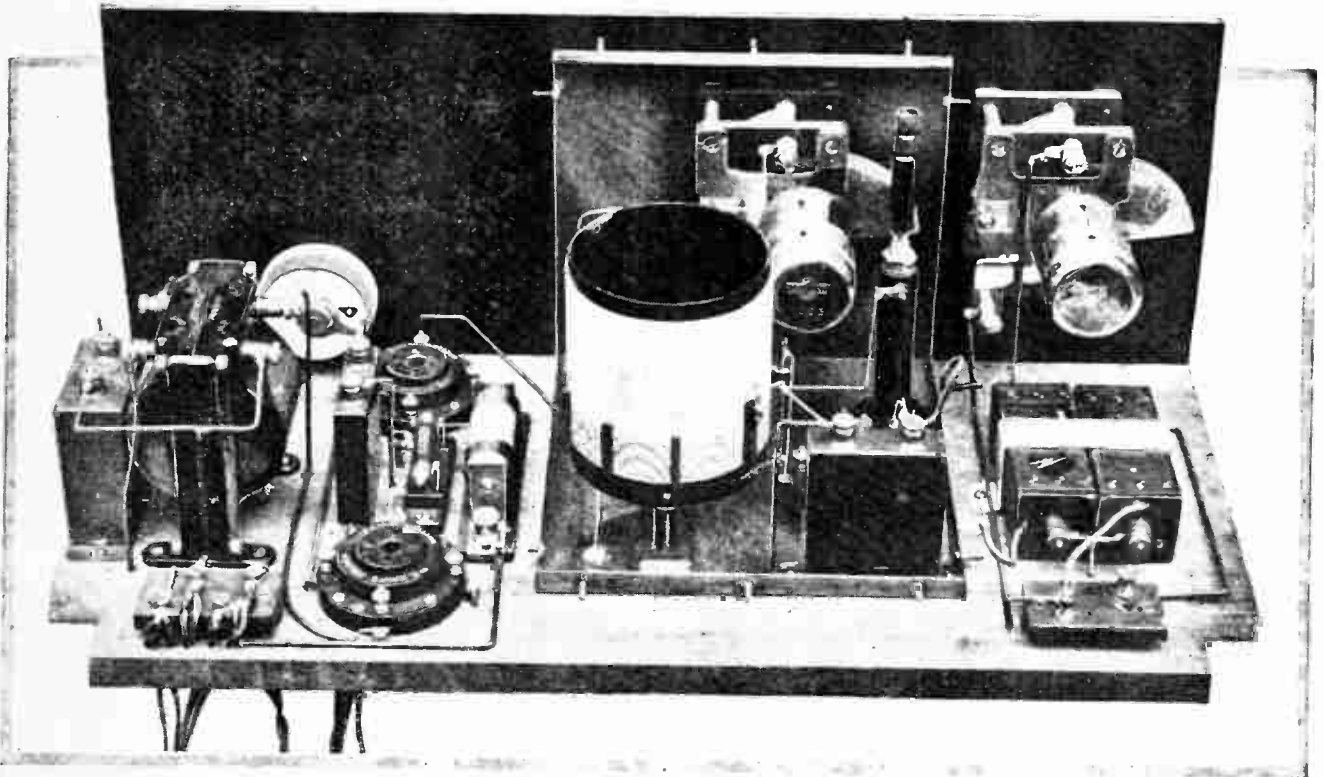

Fig. 5.—The layout adopted as well as being compact provides for short direct wiring. The leads, which are No. 18 tinned copper wire, are covered with sleeving and are kept near the surface of the baseboard.

"The Wireless World" Portable.—

therefore, whether the reader fits the box as shown in the constructional drawings, though if it is omitted—which, by the way, will greatly simplify construction—the receiver will only be stable when tuned to a particular transmitting station. Sets of this type are, of course, essentially local station receivers, and stability is probably only required on a given wavelength.

The second difficulty is that of microphonic interaction between the detector and L.F. valves and the loud-speaker. Spring-mounted valve holders, while protecting the valve filaments against damage from mechanical shock, will not prevent the setting up of distortion and loud-speaker howl should the valves, and particularly the detector valve, become microphonic. The remedy is, of course, to use suitable valves, which is

control is desirable arranged as a potential divider. With regard to the selection of components, it might be mentioned that tuning condensers of the square law type were chosen merely because the plate shape gives a very "limited" sweep, thus lessening the size of the front panel. There is an urgent need for a really compact tuning condenser specially designed for use in portable sets without the need for reverting to the square law type of plate, and, in any case, the increasing use of screening boxes would assure a big demand for an air dielectric condenser of much smaller overall dimensions than those at present available.

Separate grid cells are used for negatively biasing the H.F. and detector valves in order to prevent stray coupling, two cells being cheaper than one cell and bridging condenser and lasting much longer. These are

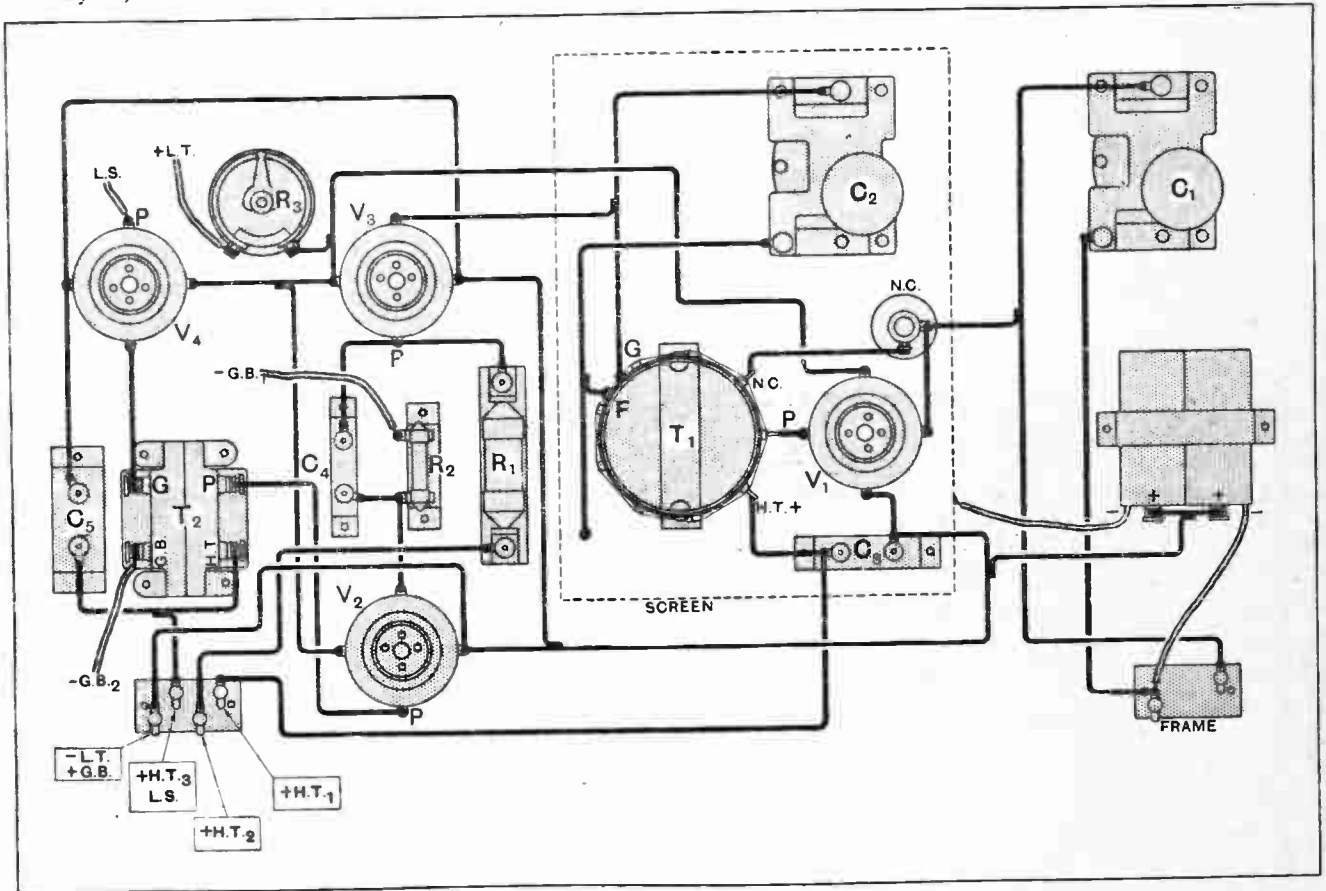

Fig. 6.—Practical wiring diagram. It should be observed that the negative bias to the detector valve is applied by making contact with the screening box. If the screen is omitted the lead from F on the transformer T₁ should be connected directly to the negative lead of the grid cell.

certainly easier than fitting non-microphonic mounts or providing a loose mounting for the loud-speaker.

Selecting Components.

Although the modern set should be fitted with a volume control, it has been omitted in this instance, as volume can be regulated by turning the set so that the pick-up of the frame is reduced. With a self-contained cabinet receiver, however, which can be built on exactly similar lines to the set described here, a volume

held to the baseboard by a strap of bent aluminium. The frame aerial connections are terminated on a small elevated ebonite panel immediately behind the cells. The arrangement of the components forming the H.F. stage remains as shown in the drawing, whether or not the screening box is used.

The coupling resistance in the anode circuit of the first valve is wire-wound, and has a value of 100,000 ohms in combination with a coupling condenser of 0.1 mfd., having mica dielectric.

LIST OF PARTS.

Ebonite panel, 18 in. \times 7 in. \times $\frac{1}{4}$ in.
 Baseboard, planed mahogany, 18 in. \times 8 in. \times $\frac{1}{4}$ in.
 Strip wood for frame aerial, 6 ft. \times $1\frac{1}{2}$ in. \times $\frac{1}{4}$ in., planed.
 2 Variable condensers, 0.0003, with Vernier No. R/120
 (Ormond Engineering Co.).
 1 Transformer, A.F.3, $3\frac{1}{2}$ to 1 (Ferranti).
 1 Fixed condenser, 1 mfd. (T.C.C.).
 1 Fixed condenser, 2 mfd. (T.C.C.).
 1 Fixed condenser, 0.1 mfd (T.C.C.).
 1 Grid leak, 0.5 meg.
 1 Dumetohm holder (Dubilier).
 4 Valve holders, "W.B." (Whiteley, Boneham & Co.).
 1 Anode resistance, 100,000 ohms, with base (R. I. & Varley).
 1 Neutrovernia (Gambrell).

In the "List of Parts" included in the descriptions of THE WIRELESS WORLD receivers are detailed the components actually used by the designer, and illustrated in the photographs of the instrument. Where the designer considers it necessary that particular components should be used in preference to others, these components are mentioned in the article itself. In all other cases the constructor can use his discretion as to the choice of components, provided they are of equal quality to those listed and that he takes into consideration in the dimensions and layout of the set any variations in the size of alternative components he may use.

1 Rheostat, 6 ohms, "Igranac-Pacnet" (Igranac Elec. Co.).
 1 "Wireless World" H.F. intervalve transformer.
 1 Copper box, "Wearite" (Wright & Weaire), optional.
 1 Coil, 100 ft. green aerial wire, "Lewcos" (London Elec. Wire Co.).
 1 loud-speaker unit, "Beco" (British Elec. Sales Organisation, 623, Australia House, Strand, W.C.2).
 2 "T" $1\frac{1}{2}$ -v. square-type cells (Siemens).
 2 G.B. batteries, 9 v.
 1 H.T. battery, "Ever-Ready," 108 v., No. W17.
 1 Unspillable accumulator, 2 v., 20 actual amp. hrs. "Exide," No. SP7.
 1 Cabinet (Aircraft Co., 156, Cherry Orchard Road, Croydon).
 Sistofox, battery leads and Wander plugs, etc.

A small terminal board for the battery connection is accommodated in a corresponding position at the other end of the baseboard to the frame aerial connector. Only four screw connectors are provided, and from the wiring diagram it will be seen that these are:—

(1) H.T. +, H.F. valve; (2) H.T. +, detector valve; (3) H.T. +, L.F. valves feeding to the transformer primary and by means of a flexible to the loud-speaker. The other loud-speaker lead is taken by a flexible to the plate of the valve; (4) H.T. - , I.T. - , and grid bias + .

The positive lead from the L.T. battery connects directly to the filament rheostat.

The layout of the components gives short wiring, which can be easily carried out, using No. 18 S.W.G. tinned wire straightened by stretching, a clean iron and a minimum of soldering flux. The $\frac{1}{4}$ in. planed mahogany baseboard which carries the components also supports the frame aerial. Planed $\frac{1}{4}$ in. wood is used for the frame, which is of simple construction, and is glued and slotted or pinned at the corners. The cut-away portions on the baseboard provide a fixing for the frame slightly spaced away from the inside of the cabinet. The frame is strengthened by bridging it with the baseboard in this way. Screws passing into the ends of the baseboard will attach the frame, though in this case it must be wound after being fixed into position. Alternatively it may be wound apart from the set and attached by small brass angle brackets.

The batteries are attached to the cabinet by means of blocks of wood and a bridging piece. They are fairly accessible for adjustment,

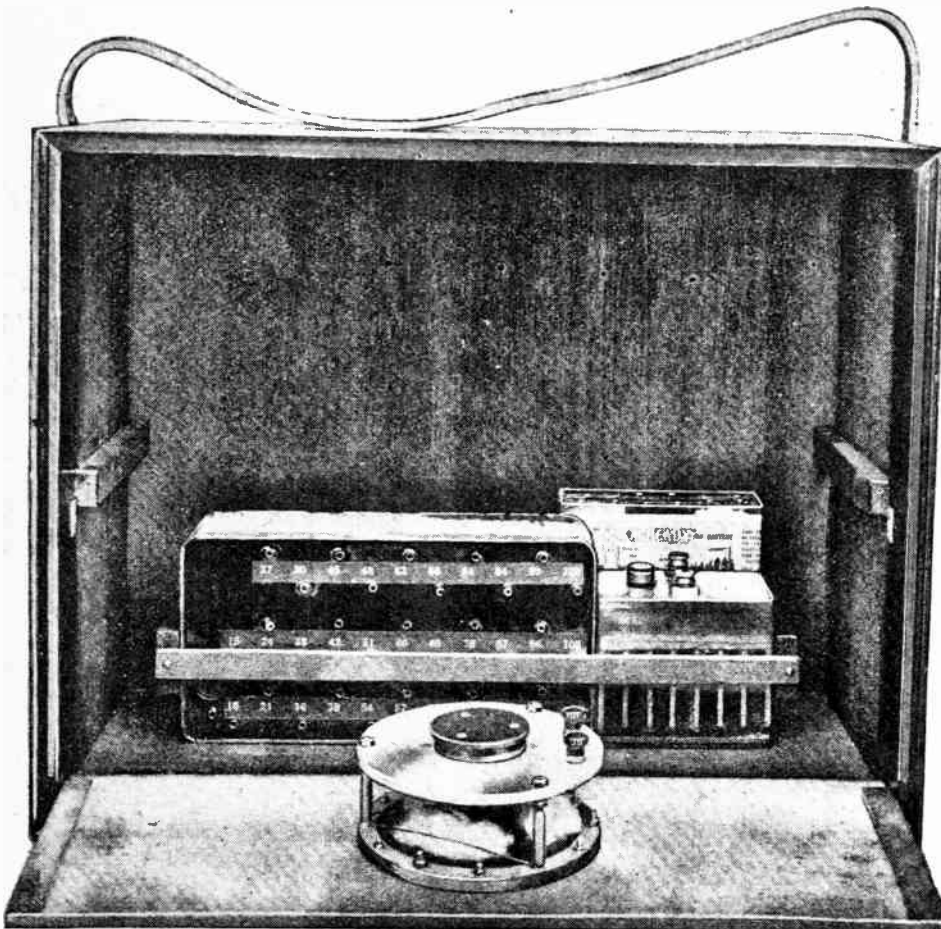

Fig. 7.—Method of securing the batteries in the lower part of the cabinet. A packing piece is inserted behind the H.T. battery and forms a shelf for the grid biasing cells. The loud-speaker is attached by six small bolts to an easily removable panel.

**"The Wireless World"
Portable.—**

and are, of course, placed in position after the set is pushed into the cabinet. Grid bias of 15 volts is obtained by two series connected batteries of 7.5 volts, and the bias applied to the first L.F. valve will probably be about 3 to 4.5, and the second L.F. valve 7.5 to 9. It might be mentioned that were two L.F. transformer coupled stages employed in the design of this set that an even larger H.T. battery would have been needed. The H.T. potentials will all be somewhere between 70 and the maximum of the H.T. battery, the two L.F. valves, of course, taking the full voltage.

With a view to limiting cost the set is shown housed in an inexpensive form of cabinet, having a sliding front. This form of cabinet does not identify it as containing a portable wireless set, but for home use manufacturers will readily supply cabinets of more attractive design. One good design makes use of a hinged door which when dropped away discloses the tuning panel, the loud-speaker grill being external and arranged without cover.

Suggested modifications which can easily be carried out are the fitting of aerial and earth terminals at the grid bias end of the frame and a tapping point four turns along it, while a break-jack might be mounted on the removable loud-speaker panel intercepting the leads to the loud-speaker to permit of the use of telephones.

The set has been tested at various distances from 2LO, and gave good loud-speaker reproduction at a distance of fifteen miles, and at a position where there was no possibility of pick up being obtained from near-by vertical conductors such as the down pipes of houses and with which a set may be coupled. For

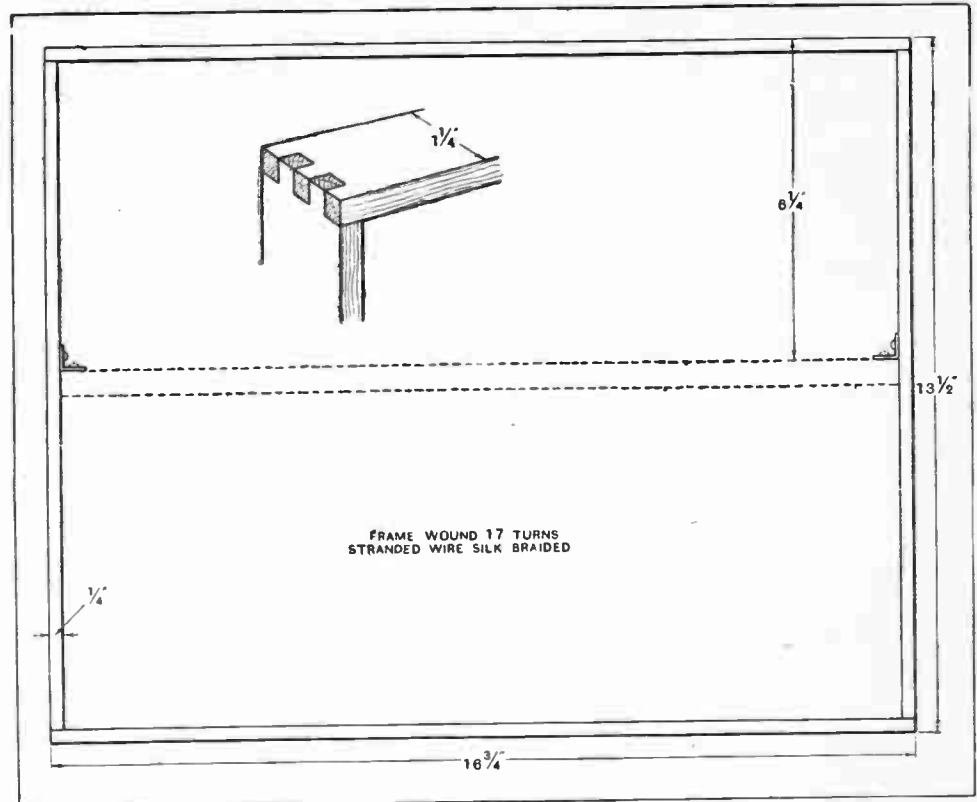

Fig. 8.—Details for constructing the frame aerial. If difficulty is experienced in making the slotted corners short pins can be used near the edges. The corner joint should be glued. It is necessary to slightly round the corners to prevent the wire becoming flattened.

testing P.M.1 H.F. valves were used as H.F. amplifier and detector with a P.M.1 L.F. in the first L.F. stage followed by a P.M.2. The total filament current required at 2 volts is 0.45 amperes, and was obtained from an "Exide" non-spillable battery type S.P.7, which on one discharge gave over forty hours continuous service. There is sufficient space to accommodate any of the usual 108-volt H.T. batteries. The grid bias battery should be adjusted to work at maximum potential without impairing reception in order to limit the current taken from the H.T. battery. A "Beco" loud-speaker was employed as it was both compact and inexpensive, and gave on small input quite good results. It is important to clamp it securely by means of six screws and nuts to the thin board which forms the cover to the battery compartment.

Danish Amateurs.

A series of tests on 45 metres has recently been carried out by three Danish amateurs, D7MT, 7BX, and 7EW, with a portable station operating in the neighbourhood of Jaegerspris, about 50 kilometres from Copenhagen. The call-sign used is D7PRS, and the tests began on Wednesday, June 29th. Reports from any listeners hearing this station will be welcomed by D7MT, Mr. E. S. Poulsen, Virginiavej 6 F, Copenhagen, or they may be sent via G6CL, Mr. J. Clarri-coats, 107, Friern Barnet Road, London, N.11.

TRANSMITTING NOTES.

Short-wave Transmission.

From a number of correspondents we have received reports and queries regarding short-wave transmissions heard from American and other stations. One correspondent reports having heard an American station which he believes to be in the neighbourhood of WLL (the R.C. of A. station at Rocky Point) calling London

by radiotelephony on about 17 metres between 22.50 and 23.50 B.S.T. Another has heard a broadcast programme on about the same wavelength.

There are undoubtedly quite a number of commercial and broadcasting stations both in the United States and in Europe at present experimenting in short-wave long-distance transmission, but it is somewhat difficult to identify them. We shall therefore welcome any information from our readers which will enable others to identify these stations as they are arousing considerable interest among listeners.

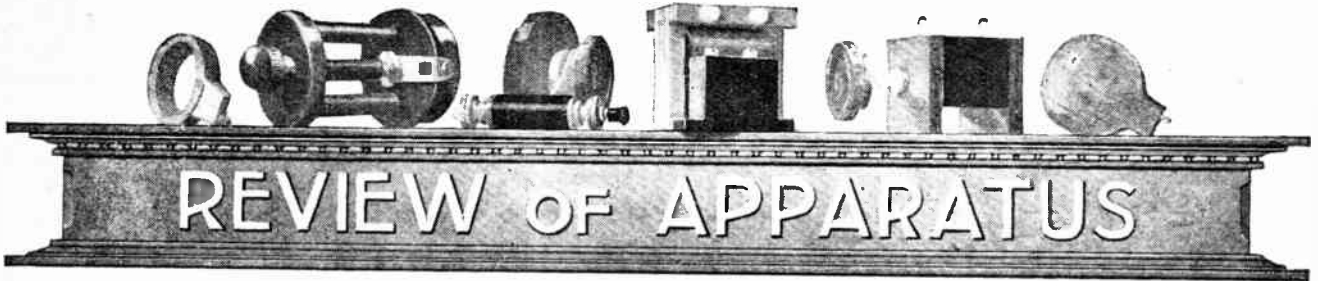

Latest Products of the Manufacturers.

ATALANTA DRILL CHUCK.

Reference was recently made in these columns to the Atalanta screw-drivers manufactured by Atalanta. Ltd., 1-3, Brixton Road, London, S.W.9.

This useful range of tools particularly suited to the construction of wireless apparatus has now been extended to include an adjustable chuck with stem mounting and milled grip similar to that

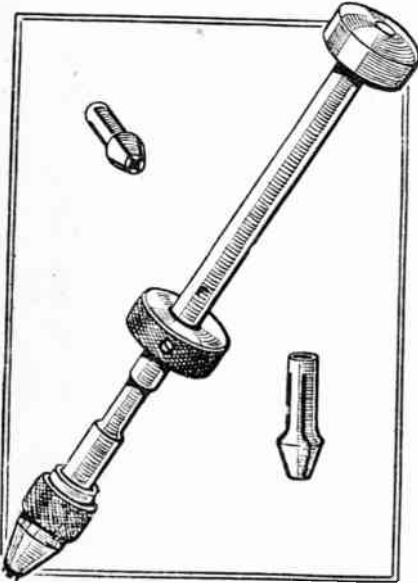

Atalanta drill chuck.

adopted in the design of the Atalanta screw-drivers. The chuck is supplied with three spring collets suitable for holding small taps, reamers, broaches, or drills up to $\frac{1}{16}$ in. diameter. As a tool holder it will be found more convenient to use than a hand brace such as is generally employed to grip the smaller tools used in wireless constructional work.

FERRANTI OUTPUT TRANSFORMERS.

Principally for the purpose of eliminating the plate current of the output valve from the loud-speaker winding, Ferranti, Ltd., Hollinwood, Lancashire, have introduced two types of output transformers having winding ratios of 1 to 1 and 25 to 1. The 1 to 1 ratio model, type OP1, is

for use with the usual form of loud-speaker having a "high-resistance" winding. By diverting the constant plate current from the loud-speaker, saturation of the pole pieces is avoided, while the loud-speaker gap can be critically adjusted and will not require resetting when changes are made in the anode or grid biasing potentials. The inductance of the primary of the Ferranti output transformer is undoubtedly higher than the normal inductance value of a loud-speaker winding although the D.C. resistance is appreciably lower. A high value of inductance so that the impedance of the winding is appreciably greater than that of the power valve is desirable if bass notes are to be correctly reproduced, while the low value of D.C. resistance avoids excessive voltage drop, thus maintaining a high anode potential to the power valve. When a battery eliminator is used as the source of H.T. an output transformer becomes essential so as to separate the loud-speaker and its leads for the main high voltage supply circuit. For use with the moving coil type loud-speaker the 25 to 1 ratio, type OP2, transformer will be found generally suitable.

The transformers are of similar external appearance to the well-known Ferranti intervalve transformers except that the terminals appear on the lower part of the metal containing case to facilitate baseboard wiring. Internally, the windings are arranged on the Ferranti sectionalised system, by which potential difference between adjacent turns is a minimum and the self-capacity kept to a low value. The core cross-section in the case of these output transformers has been increased over the size adopted in the intervalve models and a primary current of 20 mA. is permissible without saturation. These transformers meet a long felt need and will undoubtedly become as popular as the Ferranti intervalve transformers among those listeners requiring the best possible results.

STAR COILS FOR PORTABLE SETS.

When designing a portable receiver care must be taken to limit in every way possible the weight of components and the space they occupy.

A series of coils is now available manufactured by the Star Wireless Supplies, 101, Hitchin Street, Biggleswade, Beds, where the overall diameter of the winding is just over $\frac{1}{4}$ in. with a centre

hole of about $\frac{1}{16}$ in. The coils are layer wound and of good efficiency. These coils are available with a small terminal for providing a centre tapping in addition to the two-pin plug-and-socket mount.

o o o o

GAMBRELL CENTRE-TAPPED COIL HOLDER.

Particularly for long-wave reception, centre-tapped coils are commonly employed for giving stabilised H.F. intervalve coupling. On the broadcast band of wavelengths also the centre-tapped coil forms a convenient aerial coupling as well as being suitable for producing reaction. So that centre-tapped coils of the plug-in type

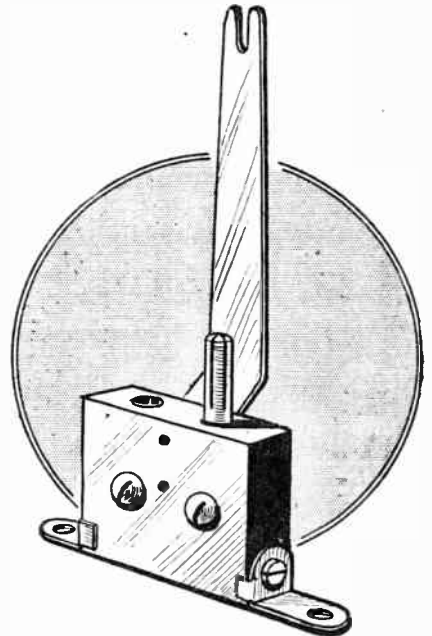

New Gambrell coil holder for use with centre-tapped coils.

may be readily interchanged without the adoption of flexible leads. Gambrell Bros., Ltd., 76, Victoria Street, London, S.W.1, have devised a new form of baseboard coil mount to which a vertical metal clip is fitted. The clip engages on the terminal of the coil and renders the use of the tapped coil as convenient as the ordinary coil carrying only two connections.

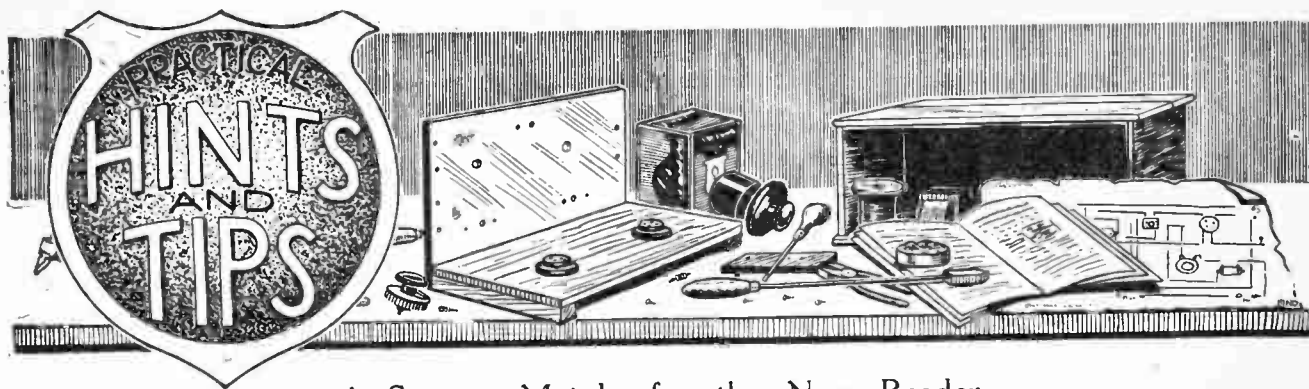

A Section Mainly for the New Reader.

A LABOUR-SAVING DEVICE.

AS the modulation of a transmission can never be perfectly constant, some form of volume control is necessary, strictly speaking, in any receiver capable of giving a reasonable output. As an example, it is often found that a set with a certain adjustment gives an insufficient intensity on speech which may be undermodulated, while on certain orchestral transmissions the output valve is being continuously overloaded on the same adjustment. Provided that this valve is of really liberal design, with a very considerable power-handling capacity, the trouble is not a serious one, as a good average setting may be found. In the great majority of cases, however, the last valve is normally worked near its limit, and some easy and simple method of control should be fitted. It is convenient if this can be operated from a distance—preferably from the listener's chair—so that any necessary adjustment may be effected with the minimum of effort.

A consideration of the problem will show that each of the many alternative methods of volume control put forward from time to time in the pages of this journal presupposes that the normal degree of sensitivity is in excess of requirements, and, in fact, it is essential that this condition should exist. Bearing this in mind, we may consider the circuit diagram of the control device shown in Fig. 1, which, though at first sight it seems open to serious criticism, on closer analysis it is found to be unobjectionable, and which in practice operates quite satisfactorily between a receiver and any point in the room in which it is operated, or even between two

adjacent rooms. It has the advantage of adaptability to almost any receiver, and can be fitted with the minimum of trouble. It consists of a simple absorption circuit, the coil of which is coupled to the aerial-grid inductance and connected to the tuning condenser at the distant point by means of a length of twin flexible wire. To reduce to a minimum the strength of signals to which the receiver is tuned, it is only necessary that the coil and its associated condenser (to the capacity of which must be added that of the extension leads) should be tuned to the same wavelength. A gradual increase in strength will be produced as the capacity is varied on either side of the minimum position.

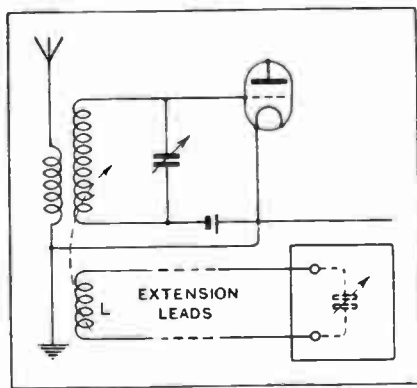

Fig. 1.—An absorption circuit arranged for remote control of volume.

The best position for the absorption coil relative to the other is best found by trial; its coupling should generally be fairly close, but in a receiver of the "Everyman Four" type it is sometimes possible to mount it co-axially with the grid coil on the outside of the cabinet. Similarly, the best size for the coil is most easily found by experiment, as

its maximum possible inductance for a given wavelength will be determined by the capacity of the leads; if this is large, the coil will be quite small.

Naturally, this method of control will be used only when receiving from a comparatively near-by station; when tuning-in distant transmissions, the absorption coil should be removed from its socket.

o o o o

FEED-BACK DUE TO LONG LOUD-SPEAKER LEADS.

AMONG the various things which may contribute to cause howling in L.F. amplifiers are long leads to loud-speakers from the output of the amplifier. A set is occasionally found which is stable as long as the loud-speaker is kept close to it, and connected with short wires, but which starts to howl when the loud-speaker is moved to a more convenient but more remote position, and connected by a length of ordinary flex. Where it is certain that the loud-speaker leads are the chief cause of instability the most certain cure is to use well-insulated lead-covered wire and to earth the lead sheathing. This is practicable enough when the loud-speaker is more or less of a fixture, but metal-sheathed wires are cumbersome where portability is required. Trouble is not nearly so likely to occur with low-resistance loud-speakers. With the latter the step-down transformer should be located at the set and not at the loud-speaker, and one side of the low-resistance secondary may be connected to earth; with this arrangement the loud-speaker leads will have very little L.F. potential on them, and the chances of reaction from this source will be very remote.

QUALITY AND THE DETECTOR.

OF the many possible sources of distortion and poor quality in a receiver, the detector stage is perhaps least often suspected. Although there is no need for the detector, whether of the leaky grid-condenser or of the anode-bend type, to introduce any distortion that the ear cannot readily tolerate, incorrect adjustments of battery voltages, or too large or too small an input of signals, will often be responsible for poor quality.

The grid detector gives of its best, so far as quality is concerned, when quite a small signal voltage is impressed upon it, the necessary final volume for the loud-speaker being produced by the use of a fairly high degree of note-magnification. So small is the suitable signal voltage for

this type of detector (it must be very much below half a volt) that anywhere within ten miles or so of a main B.B.C. station it may receive from a standard aerial far stronger signals than it can deal with faithfully. If high-frequency amplification or reaction are used, then matters are, of course, made much worse.

In any case where these remarks lead to the suspicion that the detector is overloaded with signals, it is recommended that a further stage of note-magnification be added, and the receiver detuned until signals have regained their accustomed volume. Provided that no extra distortion has been introduced by the additional note-magnification, there should be a very noticeable improvement in quality if the detector valve is now

no longer overloaded to any extent.

The anode-bend detector, on the other hand, works most satisfactorily when supplied with a fairly liberal signal input, giving then excellent quality combined with good efficiency in rectification. It is of the greatest importance, however, that an adequate high-tension voltage should be provided to enable the valve to deal with a large input, or distortion due to overloading will immediately appear. If the requisite voltage for a high-impedance detector, which may require as much as 250 volts if the receiving aerial is within a few miles of the local station, is not available, then a low-impedance valve may be substituted at the expense of some signal strength, but with a great improvement in quality.

DISSECTED DIAGRAMS.

Practical Points in Design and Construction.

No. 74 (a).—An H.T. Eliminator with Full-wave Rectifier.

(Concluded from last week's issue.)

The present series of diagrams is intended to show progressively, and in an easily understandable manner, the various points to which special attention should be paid in the design of typical wireless instruments, and at the same time to assist the beginner in mastering the art of reading circuit diagrams. The eliminator shown below uses full-wave rectification, and its basic circuit may almost be regarded as "standard" at the present time.

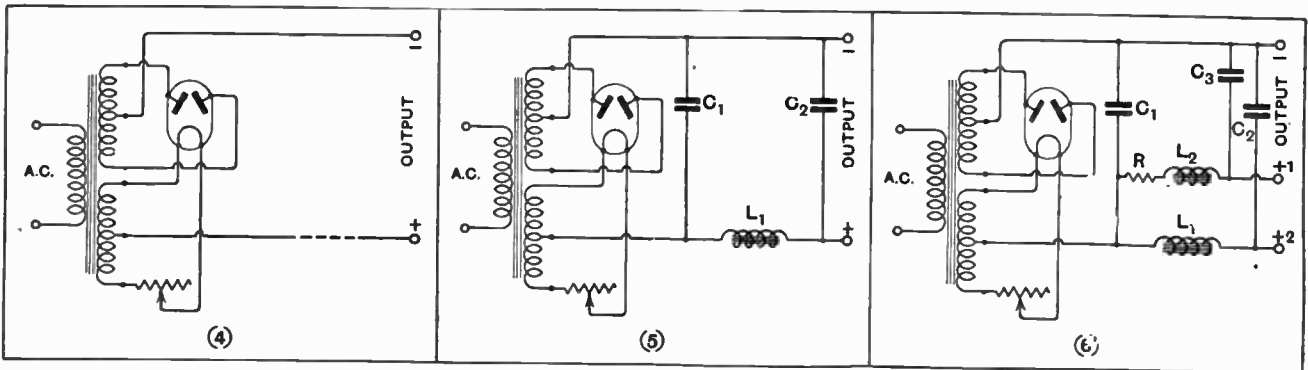

The centre taps on each of the secondary windings are joined to their respective output terminals.

A smoothing choke is inserted in the positive output lead, while reservoir condensers are added.

A low voltage output (+1) is obtained by connecting a series resistance. This output has its own choke (L_2) and condenser C_3 .

AS in the case of the half-wave rectifier discussed in this section of *The Wireless World* for June 22nd, 1927, the smoothing choke L_1 should have an inductance of at least 30 henries, and be capable of carrying the current consumed by the valves without approaching the saturation point. Both C_1 and C_2 must be of large capacity; 4 or 5 mfd. is

a suitable value, although in some cases the use of a 2-mfd. condenser at C_1 gives satisfactory results.

The amount of resistance necessary at R to reduce the output voltage to any desired value can only be stated when the current to be passed is known. This applies to almost all eliminators, and, as usual, the easiest way of finding out the best adjust-

ment is by trial. The resistance should be wire-wound, with a maximum value of about 100,000 ohms, and some five to ten tapplings. The smoothing choke L_2 will generally have to pass a smaller current than L_1 , so its inductance may with advantage be increased to as much as 100 henries. C_3 should have a capacity of 4 or 5 mfd.

THE SPIRIT OF ENTERPRISE

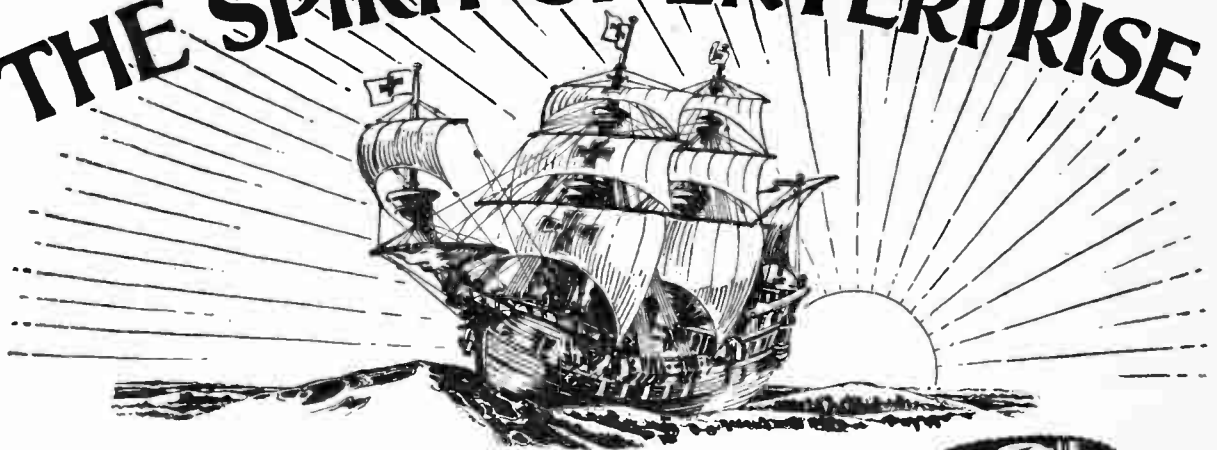

PRICES:
Complete with 4 in.
Plain Dial.

| | |
|-----------|-----|
| ·00025 .. | 5/6 |
| ·00035 .. | 5/9 |
| ·0005 .. | 6/- |

Your forefathers sailed the seas to discover new lands. You merely have to turn a dial to visit any land instantaneously. The Ormond S.L.F. Condenser assists the spirit of enterprise by making radio exploration easier and quicker. Fit them to your set and discover new and far distant stations.

The New Ormond "No. 3" S.L.F. Condenser is the precision Straight Line Frequency Condenser with a greatly reduced frame and highly finished Bakelite end-plates. Specially shaped vanes give high maximum and low minimum capacity with TRUE S.L.F. readings throughout the full 180 degrees scale. No

bunching of half the wavelengths between 0 and 27 degrees, all stations are spread evenly over the dial. Supplied either with 4-inch Bakelite Plain Dial or 4-inch Bakelite Friction Control Dial. Each is engraved in 180 single degrees showing 0 at the shortest wavelengths—stations are still referred to in metres—and towards 180 for longer wavelengths. Easy to mount. One-hole fixing. Terminals and Soldering Tags for connections.

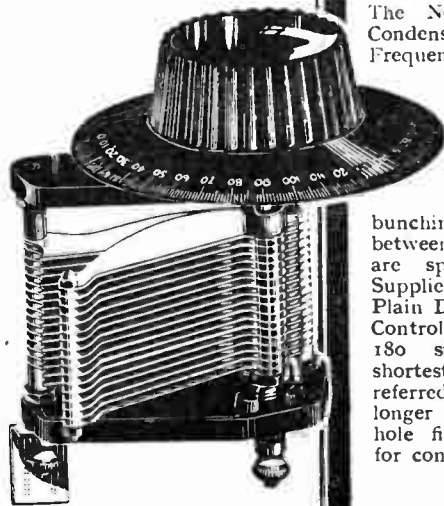

**No. 3
S.L.F.
with
PLAIN
DIAL**

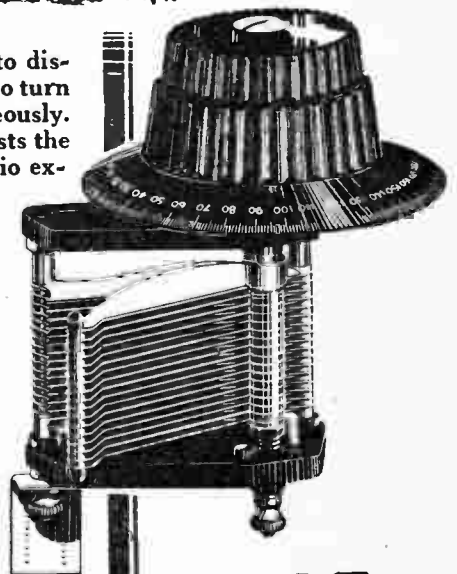

**No. 3
S.L.F.
with
FRICTION
CONTROL
DIAL**

PRICES:
Complete with Friction Control Dial.
Ratio 55-1

| | |
|-----------|------|
| ·00025 .. | 11/6 |
| ·00035 .. | 11/9 |
| ·0005 .. | 12/- |



199-205, PENTONVILLE RD., KING'S CROSS,
LONDON, N.1.

Phone: Clerkenwell 9344-5-6.
Grams: "Ormondengi, Kinross."

Factories: Whiskin Street and Hardwick Street, Clerkenwell,
London, E.C.1.

Continental Agents: Messrs. Pettigrew and Merriman, Ltd.
"Phonos House," 2 and 4, Bucknall Street, New Oxford
Street, London. W.C.1.

CAV

1927 IMPROVED MODEL H.T. ACCUMULATOR.

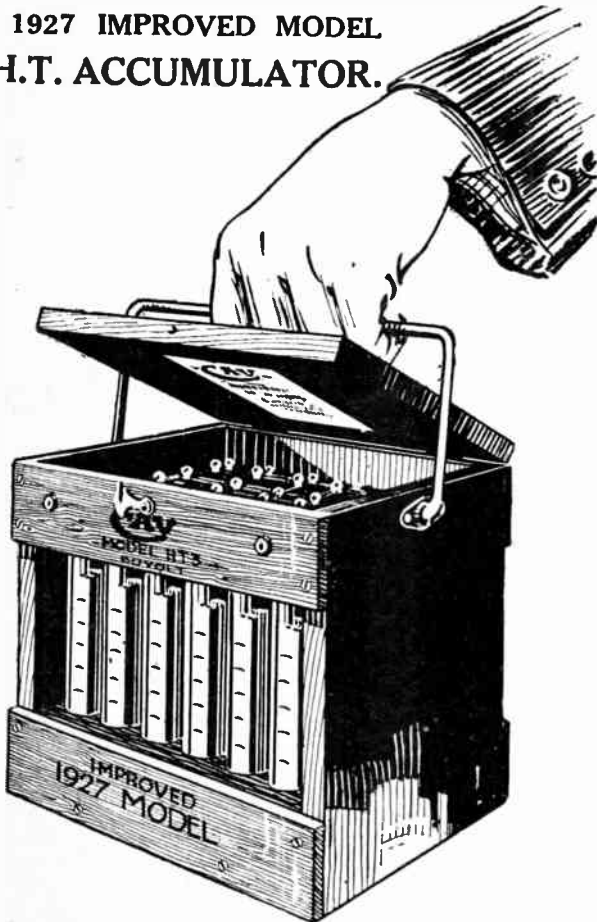

CAV. H.T. Accumulators have improved radio reception for hundreds of users who have wisely scrapped their dry batteries. They will do the same for you. Inconsistent discharges, temperature effects, crackling noises with reception, and constant regulation to correct voltage variations are all troubles peculiar to dry batteries, but these are unknown to users of the C.A.V., H.T.

The H.T.3 is fitted with a strong handle enabling it to be easily carried. Used by most leading experimenters they have also been supplied to over 100 of London's Hospitals.

MODEL
H.T. 3 **60** SUPPLIED
(60 VOLTS) READY FOR USE
NO FILLING
WITH ACID.
NO CHARGING

Dimensions $8\frac{1}{2} \times 7 \times 7\frac{3}{4}$ High
Weight Charged $16\frac{1}{2}$ lbs - Dry $13\frac{1}{2}$ lbs

ALSO SUPPLIED IN 30 & 90 VOLTS
MODEL H.T. 4 - 30 VOLTS . . . 30/-
MODEL H.T. 5 - 90 VOLTS . . . 90/-

Catalogue supplied on application.

CAVandervell & Co., Ltd.
ACTON, LONDON, W. 3.

Telephone: Chiswick 3801
(Private Branch Exchange).

Telegrams: Vanteria-Act-London.

Expenditure 1'11 Orders—nearly £4

The following letter from a recent advertiser in "The Wireless World" is of interest to all prospective advertisers:

"I should like to express my opinion of 'The Wireless World' as an advertising medium. On April 27th I had an advertisement in the paper, and in the evening a caller, who placed an order. This was followed before the end of the week by 20 enquiries, and I have since received another ten of these, 15 resulted in orders amounting to nearly £4. This, I consider, is very good, and all for the modest sum of 1/11 spent on advertising."

ALEC G. BINNIE.

1, Cromford Road,
West Hill, S.W.15.

Full particulars of advertising rates will be found on the first page of miscellaneous advertisements.

w.w.64.

Business 70 times the advertising cost!

The following letter, written by a recent advertiser in "The Wireless World," will be of interest to every wireless manufacturer and trader.

".....It may interest you to know that I have kept a very careful analysis of the results of my two advertisements in your "Classified" columns, and I find that the value of the amount of business done is approximately seventy times their cost. Personally, I consider this very satisfactory."

H. GOODWIN,
Radio Specialist,
Woodcock Hill,
ELSTREE.

w.w.67

Mention of "The Wireless World," when writing to advertisers, will ensure prompt attention.

LOUD-SPEAKER INEFFICIENCY.

Sources of Energy Loss which Reduce Efficiency to 1 per cent.

By N. W. McLACHLAN, D.Sc., M.I.E.E., F.Inst.P.

MUCH has been written on the subject of the telephone emphasising the fact that the efficiency of the instrument is so very low. At the frequency where the diaphragm resonates the efficiency is a maximum, and its value is only about 1 per cent. This compares very unfavourably with other electrical apparatus. For instance, a static transformer has an efficiency usually above 95 per cent., and for an electric motor of reasonable size the efficiency exceeds 70 per cent. The enquiring mind naturally desires to find some reason for this extremely low telephonic efficiency. Having ascertained the reason, there may be some hope of improving the situation. It seems to be generally accepted that loud-speaker efficiency borders on 1 per cent. at the best point. Now a large diaphragm loud-speaker covers a wider frequency range than one with a short horn. Although the efficiency of the diaphragm type may not exceed, or even equal, that of the short-horn type at the *resonant* frequency, it certainly sounds louder on orchestral music, when the amplifier does not cut off until 50 cycles is reached. This is due to the reproduction of the middle and part of the lower tones which are omitted by the short-horn type. In fact, we

the term efficiency. When an engineer talks about the efficiency of his machinery he means the ratio $\frac{\text{work or energy got out}}{\text{work or energy put in}}$, or, what comes to the same thing, $\frac{\text{power got out}}{\text{power put in}}$ since power merely means the amount of work done in a certain time. Now if there are no frictional losses in the diaphragm when it is in operation, it seems clear that all the *net* energy put in must be got out as sound. This is quite in accord with theory. Moreover, such a diaphragm has an efficiency of unity, or in the mechanical sense it is perfect. In practice there are losses in the diaphragm, but they are much too small to reduce the efficiency of the loud-speaker to such a low value as 1 per cent. This being so, we have to introduce the driving mechanism into the argument.

Vibrating Diaphragms.

Consider the flat, perfectly rigid disc of Fig. 1, which is freely suspended in a very large wall, so that the sound radiated from the two sides is quite separate. If it is enclosed in a vacuum actuated by an alternating force no energy is radiated, because there is no air to convey the

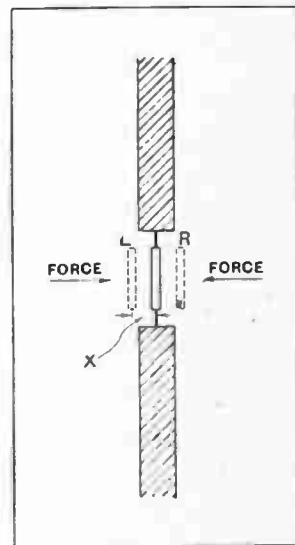

Fig. 2(a).—L, extreme left position of disc where force is a negative maximum; R, extreme right position of disc where force is a positive maximum; X, amplitude of vibration.

sound waves. The disc, however, moves to and fro under the stimulus of the force. Since the force is of an alternating character, it varies from zero to a maximum, then down to zero, through which it passes to a negative maximum (minimum) and back again to zero. This is shown in Fig. 2. When the disc is in its extreme left position the force is a maximum, as shown at L. As the disc is pushed to the centre position by the force its velocity increases, but the force decreases. At the centre position the velocity of the disc is a maximum, but the force is zero. In virtue of its velocity the disc has energy of motion (kinetic energy), and this carries it past the centre towards the right, just as a train moves onwards when steam is shut off and the brakes are not applied. If the disc were unconstrained it would fly off into space. But as soon as the disc gets beyond its mid-position it is retarded by the force which now acts in the opposite direction, *i.e.*, in the mathematical sense it is negative. As the disc gets further from mid-position, the force gradually increases (see curve

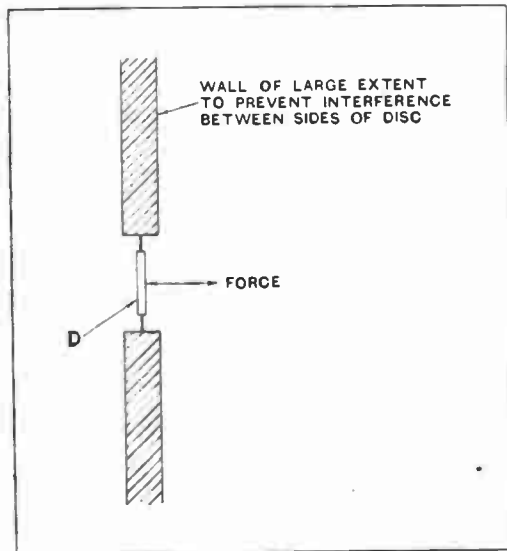

Fig. 1.—Vibrating disc D freely suspended in a wall of large extent.

saw in the article in the March 23rd issue that a horn 2ft. long cuts off everything below the middle of the piano. This presupposes the diaphragm and its associated throat and pressure chamber to be properly proportioned. Otherwise the cut-off would be higher than middle C.

We come now to one of the main purposes of this article, namely, to see whether a diaphragm in itself, apart from the mechanism which drives it to and fro, is an inefficient agent for converting electrical energy into sound energy. As a preliminary it is necessary, when dealing with the diaphragm alone, to explain precisely what is meant by

Loud-speaker Inefficiency.—

portion, O₁ R of Fig. 2 (b)) until it is a negative maximum when the disc has moved from mid-position to the right through a distance equal to that from which it started on the left. Thus the reversed force curbs the amplitude of the disc and brings it to rest. The force, however, still acts on the disc, and compels it to move towards the centre; at the same time it gradually decreases in value as before. Thus the force on the disc, whether it moves to the right or to the left, is *always acting towards mid-position*. The relation between the force and the axial velocity of the disc is illustrated in Fig. 3. The force is 90 deg. out of phase with the velocity of the disc. Since there are no transmission losses in the disc, *i.e.*, it is perfect, and since there is no air in the enclosure where the disc vibrates, no work can be done, *i.e.*, the energy output is nil. But, the reader will ask, surely the force is doing work on the disc in keeping it in vibration. The answer is No! Work done is equivalent to net energy expended, and this is defined by the product of force and distance, *i.e.*, if we push a motor car a distance of ten feet against an opposing force of 50lb. the work done is 500 foot lbs. Also, power is the rate of doing work or the work done per second. Thus if the car were moved ten feet in five

Now the driving source might be an electrical apparatus like a telephone headpiece, fitted with a reed, *e.g.*, a Brown earpiece. This would cause the disc to vibrate without supplying it with any energy. But we know very well that the resistance of the earpiece is several thousand ohms, and that a current is required in the winding to drive the reed. This flow of current in the winding is accompanied by a loss i^2r where i is the current and r the

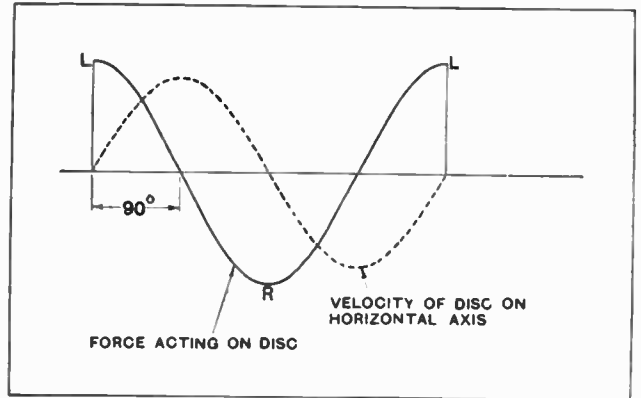

Fig. 3.—Curve showing relationship between driving force and axial velocity of disc. The force is alternating and of sine wave form.

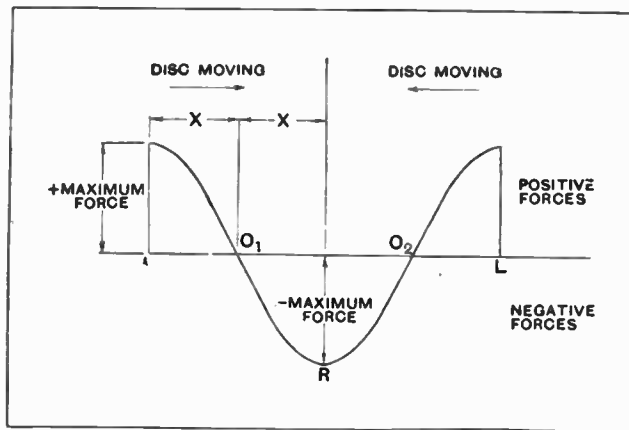

Fig. 2(b).—Sine curve of complete vibration of disc in Fig. 2(a) from L to R and back to L. O₁, O₂ represent mid-positions where the force is zero and a change from + to - or vice versa is about to take place.

effective resistance of the winding. Moreover, a large energy loss is expended in the winding to make the disc vibrate and to do no external work at all. When the disc vibrates in air at normal pressure the force upon it due to the air resistance is so small as to be negligible in comparison with that required to make the disc vibrate in vacuo. The reason for this is to be found in the low density of the air compared with that of the vibrating parts. We now begin to see more clearly why a loud-speaker is inefficient. When the disc vibrates in air an additional force is required from the driving mechanism to overcome the resistance due to the work done in generating sound waves. This force is proportional to the velocity of the disc and is in phase with it. Curve (2) of Fig. 5 shows the velocity of the disc and the corresponding acoustic force on the disc. As we have seen above, power

seconds the power would be $\frac{50 \times 10}{5} = 100$ ft. lb. per

second. But $\frac{10}{5} = \frac{\text{distance}}{\text{time}} = \text{velocity}$, so that Power

is Force \times Velocity. Now in Fig. 4 we have the force on the disc, and its velocity corresponding thereto. At X the force is BX, whilst the velocity is AX. The power at X is the product of BX and AX. If the product of all the points on the curves is taken, the result is shown by the small curve of Fig. 4. Here we have a curve in which the power consists of two equal positive parts, 1, 3, and two equal negative parts, 2, 4. Hence the total power expended throughout a complete vibration of the disc is zero, since the positive and negative portions cancel out.

Put in another way, from C to D and E to F power is supplied to the disc from the driving source, whilst from D to E and F to G the disc restores, or gives back, equal amounts of power to the driving mechanism.

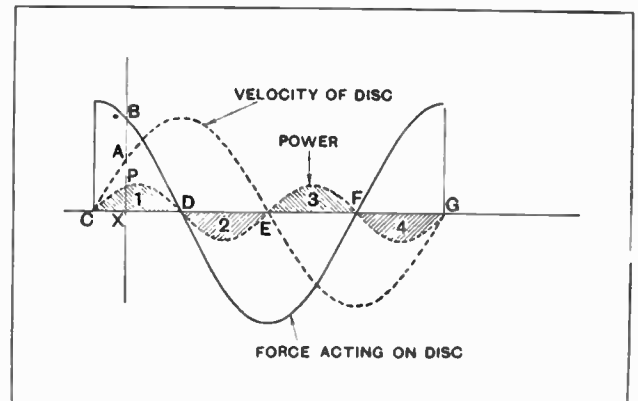

Fig. 4.—Curve showing power expended in driving disc. AX = velocity of disc at X; BX = force on disc at X; PX = power at X (drawn to reduced scale). In this case it is positive, *i.e.*, the disc is drawing power from the driving mechanism. Area 1 = 2 = 3 = 4, but 1 + 3 = 2 + 4, and since the latter is negative the total power expended in driving the disc in vacuo (apart from loss in driving mechanism) is zero.

Loud-speaker Inefficiency.—

is the product of force and velocity, and a third curve showing this has been drawn. This is the power radiated as sound waves. It should be noted that the power during both half-cycles is *positive*. Although the force and velocity are both negative in the second half-cycle the product is of course positive, *i.e.*, power is radiated during each half-cycle. The total force acting on the disc is of course the sum of curve (2). Fig. 5, and the full line curve of Fig. 4. This is shown in Fig. 6, from which it will be seen that the force curve is still a sine wave, but it is now displaced to the right by an amount depending upon the pressure or force on the disc due to sound waves. In practice the displacement is comparatively small.

Equivalent Electrical Circuit.

An electrical analogy may help to make the disc portion of the problem more clear. Suppose that in Fig. 7 *V* is a source of voltage, say an alternator, *L* is an inductance, and *R* a resistance. Voltage *V* is equivalent to the mass of the disc, and *R* to the resistance the disc experiences in generating sound waves. The voltage across *L* is ωLi

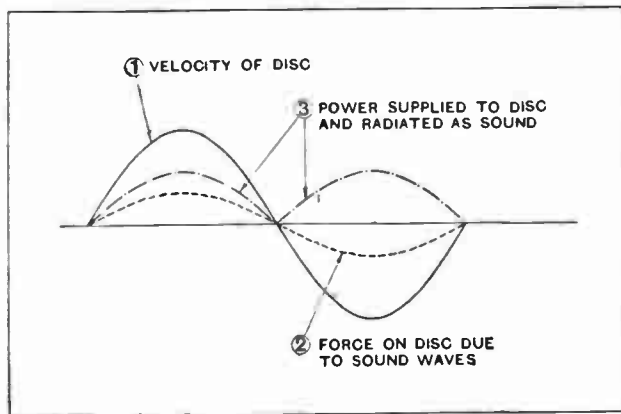

Fig. 5.—Curve of power radiated as sound.

where $\omega = 2\pi f$ and *i* = current, also the voltage across $r = ri$. They correspond respectively to the force to drive the disc in vacuo and that due to air resistance in generating sound. In practice we know that the force to move or accelerate and decelerate the disc is much greater than that due to the sound waves. Thus in our analogue we have ωLi much greater than *ri*. To all intents and purposes $V = \omega Li$ or $i = \frac{V}{\omega L}$. From this we see that the larger the value of *L* the smaller the current, because the inductance chokes it back. Thus if *r* is fixed, the smaller the volt drop *ri*. Now the *useful* work done is clearly $i^2 r$, since *L* has no resistance. The work component $i^2 r$ is kept at a low value owing to the large value of *L* causing reduced current. Put in the language of the power engineer, we are working with a very low power factor. Reverting to our equivalent items, since $i^2 r$ represents the energy radiated as sound, we see that the large mass of the diaphragm (equivalent to *L*) means that the power factor of the system is low. It is not desired to carry this analogy too far, but we may observe that the current is equivalent to the velocity with which the disc moves during its to and fro excursions. At a given rate of vibra-

tion, *i.e.*, frequency in cycles per second, the velocity of the disc depends upon its amplitude of motion, *X* (the distance it moves from the centre). Now we saw in the analogue that the current was limited by the inductance. Hence in the actual case the velocity and therefore the amplitude of the motion is limited by the mass of the

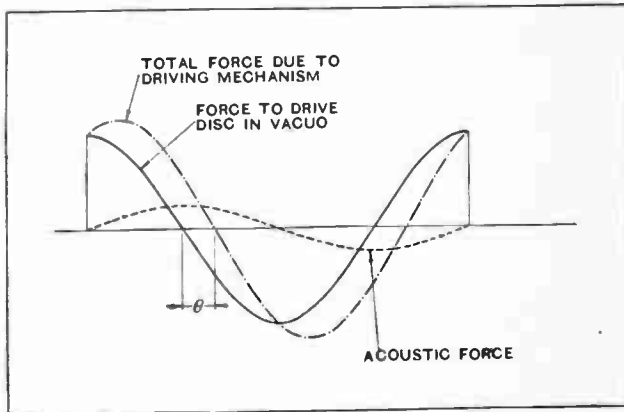

Fig. 6.—Total force acting on the disc in vibration.

diaphragm. Thus, apart from losses in the driving mechanism, if we could reduce the mass of the diaphragm appreciably, say to $\frac{1}{4}$, whilst preserving the same stiffness, the energy radiated would be increased perceptibly.

When we consider the problem more fully it is necessary to include the additional mass due to the driving mechanism. Also, as we saw in the March 23rd article, an additional mass must be added to that of the diaphragm at low frequencies due to its setting in motion an equivalent mass of air. These masses mean an additional inductance in Fig. 7, which is greatest at low frequencies. With a large diaphragm and a moderate mass due to the driving mechanism, a decrease in the mass of the diaphragm alone is of little account. Moreover, we arrive at the extremely interesting fact that there is a certain proportioning of the various components which yields maximum output over a certain band of frequencies.

Thus we see that a diaphragm is not really inefficient in itself, but owing to the relatively large mass of the moving parts the force due to the driving mechanism is expended in making the diaphragm vibrate through a comparatively small distance. This limitation of distance, or amplitude of motion, is concomitant with a reduction in the sound radiated. Nevertheless, since a definite driving force requires a definite current, and the movement or driving mechanism has resistance, there is a considerable loss in such resistance. Hence, so far as permissible, the *effective* or alternating current resistance of the movement should be as small as possible. In this direction we know that materials of con-

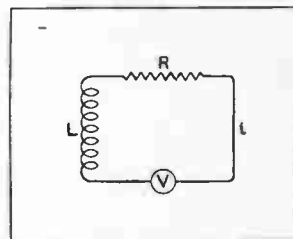

Fig. 7.—Electrical analogy of moving parts of a loud-speaker. *L* is equivalent to mass of moving parts; *R*, equivalent to air resistance due to generation of sound waves; *V*, force driving diaphragm; *i*, current equivalent to velocity of disc.

Loud-speaker Inefficiency.—

struction, e.g., iron, copper, are responsible for large losses. In loud-speaker operation it is usual to employ a power valve. The internal resistance of this valve, therefore, is also a considerable source of loss. It is, however, of little value to reduce the resistance of the power valve unless that of the driving mechanism is reduced too. Mechanical forces obtained by electromagnetic means necessitate inductance, and this curbs the current at the higher frequencies, thereby causing a reduction in the driving force and in the sound radiated.

Diaphragm Resonances.

The features already discussed are mainly responsible for the inefficiency of diaphragm type loud-speakers. We ought to indicate, however, that there are other factors which are not without importance. At the higher audio-frequencies there are comparatively large losses incurred in transmitting the energy from the driving mechanism down the diaphragm. The actual value of such losses has not been measured, but it can readily be demonstrated that certain types of paper are useless for diaphragm manufacture owing to large losses incurred. At the same time, in the practical loud-speaker we must realise that there are undoubtedly diaphragm resonances, particularly in the upper register, which complicate the issue. Under this condition a moderate amount of damping due to transmission loss in the diaphragm *may* be useful in mitigating the severity or harshness of the resonance. Also in practical design one seldom approximates to the perfect baffle as indicated by the very large wall which isolates the two sides of the diaphragm. Here, again, we have a loss in efficiency due to the interference between the front and rear of the diaphragm.

Lastly, there is the beam effect, which we discussed in detail in the March 23rd article. This we showed was due to interference between the radiation from different parts of the discs, *i.e.*, any point in space is not equidistant from all elements on the disc, so that there are intensity and phase differences in the radiation arriving

at the point from the various elements. This causes a reduced output, and therefore a loss of efficiency.

We can summarise our investigation into the inefficiency of a diaphragm loud-speaker as follows :

- (1) In producing an alternating force to actuate the diaphragm, considerable losses arise due to the alternating current resistance (a) of the driving mechanism ; (b) of the power valve which actuates the mechanism.
- (2) The inductance of the driving mechanism reduces the currents of higher frequency, thus causing a loss in output.
- (3) The mass of the diaphragm, and the moving part of its associated driving mechanism, is so heavy compared with the air it displaces that the driving force is mainly expended in accelerating and decelerating these parts. The relatively large mass means that the amplitude of vibration due to a force of given magnitude is comparatively small.

The sound energy radiated increases with the amplitude (as the square), and therefore the heavy diaphragm curbs the output. This does not mean that the diaphragm itself is inefficient, but that the mechanical conditions of operation are conducive to low efficiency.

In a lesser degree than the above we have the following sources of reduced output :

- (4) Losses due to transmission of energy down the diaphragm, *i.e.*, attenuation.
- (5) Imperfect isolation of the two sides of the diaphragm, which results in reduced output at low frequencies.
- (6) Interference of the radiation from various parts of the diaphragm at the high frequencies, resulting in a beam effect, which entails a reduction in output. This is of more importance with large than with small diaphragms.

As an offset to these six items we have diaphragm resonances which increase the efficiency, particularly in the upper register. With a reed-driven diaphragm there is also the resonance of the reed, which contributes its quota of efficiency.

Reception Tests with Portables.

The Field Day movement has another supporter in the South Woodford and District Radio Society, which has decided to hold a number of outdoor events during the present summer. It is probable that tests will be made in reception with portable receivers on the Laindon Hills, and Mr. Turbyfield, the hon. secretary, has offered the use of his bungalow.

The address of the hon. secretary is 42, Alexandra Road, South Woodford, E.18.

New Vice-President.

Mr. Maurice Child has been appointed a Vice-President of the Incorporated Radio Society of Great Britain.

A Day with a Portable Transmitter.

The first Field Day this summer was held by the Southend and District Radio Society at Eastwood House, Rochford, three miles north of Southend, on Sunday, June 26th, when experiments were conducted with 5QX, the Society's portable transmitting station. One single wire

CLUB NEWS.

aerial was used, 60 feet long and 15 to 20 feet high, while a counterpoise earth was fixed immediately under the aerial and some two feet from the ground. This proved more efficient than the alternative water-tap earth.

The transmitter, a modified Hartley, was constructed by Messrs. H. H. Burrows and H. C. Revell, and the receiver, a 3-valve Reinartz, was the work of Mr. R. C. Horsnell (2ABK).

Just before 11 o'clock the first two-way communication was established with 6WQ (Westcliff), who reported signals louder than when received from a permanent aerial and working from Southend on the town mains. Subsequently 5OK (Southend), 6QO (Kelvedon), and 5QV (Clacton) were worked, all reception being put out on the loud-speaker.

The power used on the transmitter was 240 volts from dry batteries giving

about 8 watts input, the aerial current being .4 amp.

Hon secretary : Mr. Fred Waller, Eastwood House, Rochford, Essex.

D.F. on a Field Day.

In anticipation of the direction-finding experiments to be conducted at Cuffley on Saturday next, July 9th, the North Middlesex Wireless Club devoted its last meeting to the testing and comparison of three portable receivers constructed by members.

Later in the evening Mr. A. J. Simpson, F.I.P., lectured on "Electrolytic Rectifiers," dealing briefly with the theory of the chemical rectifier and summarising its advantages and limitations. He then gave a practical description of his own installation, which employs aluminium anodes and iron cathodes, the electrolyte being ammonium phosphate solution. It was emphasised that pure aluminium was essential as well as pure phosphate.

Hon secretary : Mr. H. A. Green, 100, Pellatt Grove, Wood Green, N.22.

The LISTENER



WIRELESS LEAGUE

NOTES AND NEWS

WHY NOT RADIO DAN LENO'S?

By A. E. PARNELL

(General Secretary of the Wireless League).

IT is surprising to recall that when railways were first started they were not heralded as a great advance in transport methods. On the contrary their introduction was strenuously opposed even by apparently intelligent people on the ground that they would bring ruin to the country through sparks from engines setting fire to the crops! The development of broadcasting has been similarly obstructed in various quarters by people who labour under the misguided belief that their interests will be prejudiced by this wonderful invention.

It might have been natural had the Press feared this powerful new competitor, but they were the first to foresee a community of interests, and an agreement, since renewed in a form which gives greater freedom to the B.B.C., was entered into with the broadcasting authorities. There were, however, other parties, such as the theatres, music-halls, concert halls, copyright owners, etc., to contend with. Opposition from some of these interests has somewhat abated, but others, even in the face of information which comes from abroad confounding their fears, continue to use their influence to arrest the progress of broadcasting.

A great deal has been written recently regarding the views of well-known music-hall proprietors, and artistes have caused no little annoyance by eleventh-hour refusals to honour their contracts to broadcast. The reasons for this "pin-prick" policy are rather obscure. One *impresario* weeps crocodile tears because the "broadcasting of vaudeville has led to an increase in the number of unemployed artistes," but the fate of these performers was apparently forgotten when about a dozen Metropolitan music-halls changed hands a few weeks ago for conversion into cinemas. Neither can I find any suggestion that provision should be made for affected artistes out of the huge sum which music-hall owners now demand should be paid them to make up for an imaginary loss which they consider will be sustained through the broadcasting of variety. Like the demand for the kind of classical music rendered in concert halls, but for an entirely different reason, the attendances at music-halls has been declining for some years, but broadcasting has not been the cause. The popularity of the cinema is no doubt the reason, yet it is strange to record that music-hall artistes' contracts do not contain a clause preventing them from taking part in the production of films.

Another prominent critic agrees that "the public de-

mands broadcast variety," but thinks that it should not be undertaken by the B.B.C. He suggests that the broadcasting of this kind of entertainment should be left to the profession, although why he feels they would be better qualified to do this it is difficult to imagine. The history of the stage is full of instances of unsuccessful productions; those which have met with public approval and have run for lengthy periods have generally been "turned down" in the first instance by the very people who now pretend that they know what the listening public wants. Theatrical producers do not attempt to undertake the production of a film because the presentation of a play on the screen is an art entirely distinct from the stage, and so it is with broadcasting. Broadcasting is the acid test of humour. It is common knowledge that an artiste, who is a great success on the stage where facial expressions, make-up, costume, etc., combine to add humour to the performance, is often reduced to mediocrity by the microphone.

Discovering New Talent.

Lastly, there is the artiste who regards as inadequate the remuneration he receives from the broadcasting authority in view of the fact that he has an audience of many millions and that his jokes are useless after one performance. But surely he is a poor artiste whose repertoire is so small that it is so easily depleted! The time when an artiste could year after year "put over" the same old gags has gone, and for this reason most comedians of the old school are now to be found in revue where their lines are, of course, supplied by the author.

The B.B.C.'s course is quite clear. Their dog-like policy of licking the hand that smites them should be discontinued. The public is behind them in this matter. Nothing is to be gained by hanging round stage doors for ready-made artistes, neither can music-hall proprietors teach them anything about the presentation of invisible performers. Although up to three or four months ago broadcasting of variety items was only an occasional feature of the programmes, the names of a number of artistes whose future is already assured, and who owe their *début* to radio, come readily to mind. The Corporation should, therefore, concentrate on the discovery of suitable talent and form a corps of, say, thirty or forty performers whose styles contrast as much as possible. These artistes might be engaged on a year's contract, one of the clauses of which should ban them from appearing on the stage until the expiry of their agreement. In the course of five or six years I believe that the names of many artistes, who have come to the forefront *via* the microphone, will be household words.

A MYSTERIOUS CONCLAVE.

An experience unparalleled in the annals of journalism appears to have befallen Mr. Hereward Hearseigh, a junior reporter recently deputed to inquire into the activities of the Society for the Encouragement of the Water Analogy. Owing to a temporary lapse, or perhaps two, Mr. Hearseigh took a No. 13 'bus and arrived at the wrong destination. Being a gentleman of resource, he used his opportunities to secure the following report of the mysterious conclave which he accidentally attended.

EDITED BY E. C. T.

Not a 100 miles from Charing Cross.
Tuesday.

AS I made myself comfortable behind the screen in the spacious fireplace of the board room a loud-speaker emitted the chime of Big Ben sounding noon. A moment later the rich voice of a commissioner could be heard ringing with the reiterated salutation: "Good morning, Guv'nors all."

The individuals so addressed trooped into the apartment, and although my delicate position precluded a clear view of their features, I perceived at least one lady member of the group.

The Chief Voice spoke first. Quite simply and softly he said:

"Let us proceed to govern."

When the

murmurs of heartfelt assent

had subsided another Voice said:

"How shall we begin?"

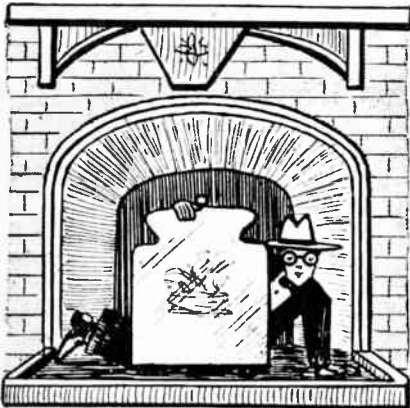

"Made myself comfortable behind the screen . . ."

This question created momentary embarrassment which was soon dissipated, however, by Voice No. 3, who said, quite simply and softly:

"Let's talk about programmes."

"Programmes?" exclaimed the others.

"Ah, yes, we remember. You mean broadcast programmes."

Quite simply and softly No. 3 bowed his head.

"In the search for originality," he continued, "have you ever considered how acceptable would be a 'My Programme'

by 'A Man in the Street'? Something fresh, y'know. I could be the 'man in the street' because I know all the latest favourites. Listen:

'When I was young they used to bowl

Their hoops upon the green,

But now they wear them round their legs

And call them crinoline.'

"Rather too daring, what?"

The Chief Voice, who had risen to his feet, raised a deprecating hand

and blushed purple.

"Let us guard the public morals," he gulped. "Let us, I say, preserve the sacred trust which—"

The door had opened suddenly to admit the commissioner.

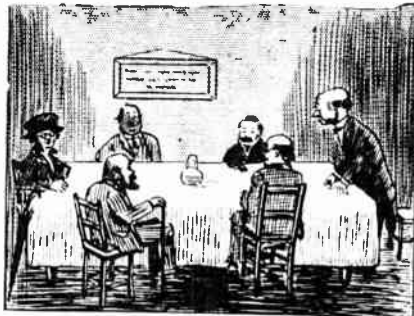

"Let us guard the public morals . . ."

"Party waiting to see you, Guv'nors," said the man.

"—which—which has been bequeathed to us by the

chaste and holy

force of public opinion," concluded the Chief Voice, who then explained that he made it an invariable rule to finish his sentences, whatever the interruption. The same rule, he added, must govern broadcast talks.

Quite simply and softly he turned to the commissioner.

"Yes?" he asked with superb crispness.

"The party's still waiting," said the commissioner.

"Are—are they 'men in the street'?" queried the lady member of the group.

"I rather think they might be," said the commissioner, changing from one leg to the other.

"I—I don't speak to men in the street," said the lady, with an appealing glance at the Chief Voice.

Here was a pretty situation! But the innate tact of the Chief Voice

saved the situation.

Quite simply and softly he said:

"Tell them to wait."

In order to preserve the privacy of the occasion the party forbore speaking until the commissioner had retired. Then No. 5 sprang to his feet and exclaimed: "What were we talking about?"

"Not so loud, not so loud," said the Chief Voice. "Let everything be done

and said quite simply and softly. Now repeat your question quietly."

No. 5 repeated his question. And here (continues Mr. Hereward Hearseigh's narrative) I clean forgot myself. I knocked over the fire screen and burst into the room. I said:

"Very simply and softly you were talking about programmes. Talk on, my friends, talk on. There are

people outside.

waiting to talk about the same topic, but don't hurry yourselves. Let them wait.

"They may have the whole British public at their back; they may know just what the people want; but are they blest with that quiet simplicity and softness that can fiddle while Rome burns? No!"

(Mr. Hearseigh remembers no more.)

PROGRAMME NOTES.

BY THE MAN IN THE STREET.

[NOTE.—The following comments and criticisms of the broadcast programmes are written by one who claims no knowledge of any items other than that of an ordinary listener. While his opinions and views are not necessarily held by the League, we hope they will be of interest to our readers.—THE EDITOR.]

THERE seems to have been an increase lately in the "variety" side of the programmes. I have not examined the issues of *The Radio Times* for the past month, and my impression may be wrong. But, at any rate, that is the impression I have. In common with a multitude of listeners, however, I wish the variety turns generally could be improved. A few are good, but very few. Weak and cheap variety turns are boring even when they can be seen as well as heard, but when one is limited to hearing only, such turns are more tiresome still, and the only remedy is to switch off and try the next one.

One outstanding feature of the month was the successful Derby broadcast. It was excellently done, and, I have no doubt, was appreciated by the bulk of those listeners who were able to listen at that time of the day.

I enjoyed, too, very much, the "Bubbly" performance. It came over well. Bright and well done, it was a very pleasing item, and many listeners, like myself, would appreciate more similar items, given with equal skill and crispness.

On the "My Programmes" I preferred that of "The Musical Man in the Street" to that of "L. du G.," but both were good and full of excellent fare.

What did listeners think of "Philemon and Baucis"? With the exception of Vulcan's Song, which was well sung, I did not find the performance very interesting, although the broadcast was well done.

I thought the B.B.C. presentation of Temple Thurston's famous play, "The

Wandering Jew," was very good. Matheson Lang, I think, has a broad casting personality. He seems to get over. I enjoyed the evening, and I am sure many thousands of listeners must have done so, too.

Flotsam and Jetsam were good, as they always are. I hope we shall hear them again, perhaps in the autumn. They are among the few broadcast artists who seem to take great pains with the preparation of their material, an example it would be to the advantage of some others to follow.

"Voices of the Past" brought back old Music Hall memories to some of us, and was interesting, showing the contrast between the popular melodies of to-day and years ago.

The B.B.C. Popular Concert from the Kingsway Hall, I should fancy, was enjoyed by all who were fortunate enough to listen. The Festal March from "Tannhauser," and Listz's First Hungarian Rhapsody, given by the Wireless Military Band were delightful. Maurice Cole's playing of Grieg's A minor Concerto pleased the audience, as did his two encores. Clapham and Dwyer convulsed the audience in the hall with laughter and I have no doubt the unseen audience gave them the same reception. Anyhow, I did. But their patter comes over clearer from the studio. We heard Sidney Coltham the previous night sing "Moon of My Delight," and it was interesting to compare within the family circle his rendering with that of Leonard Gowing's. Both delighted us. The band selections came over better than the vocal selections. The echo appeared to affect the distinctness of the vocal music.

The relay of "Carmen" from Covent Garden was all too short, but listeners, I have no doubt, are grateful that the broadcast included two such well-known and favourite airs—The Toreador Song and The Flower Song.

Very popular with all of us are the running commentaries of various sports events. Of course, a great deal depends upon the narrator, and in nearly every case the B.B.C. selection has been a happy one.

Some of us, however good the local station may be, like to "reach out" sometimes. I wonder if the B.B.C. would help us by giving early in the evening a "wireless conditions forecast" relayed, say, from Keston? O. H.

CORRESPONDENCE.

Sir,—In order that the Wireless League may more readily attain its primary object as the intermediary between the listener and the broadcasting authority it is essential that the membership should be increased. Doubtless there are many avenues leading to this goal, and I respectfully suggest that the columns of "The Listener" should be available for the exploration of such avenues.

So far, the many advantages offered to

members of the League appear to have attracted valve-users, although, strangely enough, owners of valve receivers are rarely confined to a single station and are, therefore, less clamant in the demand for better programmes and transmission. On the other hand, crystal-users are less able to afford the annual membership fee, and it should be possible to devise a method whereby they might join the League at a nominal fee.

It is not suggested that the latter class should enjoy the full membership privileges, and the nominal fee should be designed to meet the expense involved in the production of a quarterly bulletin for personal distribution by members to these "Associates." Extra labour and additional incidental expenditure at Headquarters could be avoided by the maintenance of "Associate Member" records at the Branches and Areas, whose members should be expected to enrol recruits from the ranks of their personal friends. The writer is confident that he could attract from a dozen to twenty such members, and urges Branch officials and members to a sympathetic consideration of the crystal-user, whose support we invite and whom we exist to serve.

Greenisland, JOHN G. BLAIR,
Co. Antrim. Hon. Secy., Irish Area.

Sir,—I have been very interested in the correspondence in the daily Press with regard to the B.B.C. and B.N.O.C. I should be very sorry for the latter to lose the support of the B.B.C., as they were very early broadcasters. From my point of view I should like to hear the whole opera given by the B.N.O.C., not a mutilated version in the studio: it is impossible to do justice to any opera or singer in the present way. I sincerely hope the B.B.C. will *not* undertake to produce opera in a theatre, and admit the public; such competition would be unfair to the B.N.O.C., who already possess the artists and organisation. Why should not the B.B.C. employ them?

May I suggest that the B.B.C. relay a whole opera as performed by the B.N.O.C. wherever they happen to be, putting it on the ether through those stations that are far enough away not to interfere with box office receipts, and to fill in the intervals as at present from the studio.

I trust that other members of the Wireless League think as I do and that the League will make every effort to help us to get the best opera we can.

Kensington. A. W. J. S.

Sir,—I am pleased to inform you that I have now received a cheque from the Stores in repayment of the amount paid by me for a loud-speaker, which was returned to them.

Your telephonic conversation with the firm, therefore, had the desired effect, and I hope to show my appreciation of your good services by influencing my friends, as and when opportunities arise, to become members of the League.

With many thanks. E. A. G.

AROUND THE BRANCHES.

Brighton, Hove and District Branch.

Our committee have under consideration several schemes for the activity of the branch during the autumn season.

I regret to have to inform our members that my co-secretary, Miss C. M. Foot, has been seriously ill, but is, I am glad to say, now making satisfactory progress.

Will local members please note that I have changed my address, which in future will be:—D. J. Gadsby, Esq., Joint Hon. Secretary, 30, Wilbury Villas, Hove.

o o o o

Liverpool.

Members of the League and listeners in Liverpool will be glad to learn that Mr. W. F. Jones, of 3, Perth Street, Liver-



Mr. W. F. Jones, Hon. Sec. for the Liverpool Area.

pool, has undertaken to act as our local hon. secretary. Mr. Jones will be pleased if listeners interested in the formation of an active branch will communicate with him.

o o o o

Aldershot District.

Capt. F. Harper Shove, of "Ledbury," Closeworth Road, South Farnborough, Hants, has kindly undertaken to act as the League's local representative, and members should in future communicate their views and suggestions to him. Capt. Shove is willing to help those members in need of practical technical advice upon receipt of a postcard.

o o o o

The Lancashire and Cheshire Area.

The area is again attempting to prepare for the forthcoming season, and to cope with the difficulties that are bound to arise in view of the reconstruction of the B.B.C. Much disappointment

has been felt by the apparent apathy of the League members towards the scheme to establish a sufficiently large number of members in the North of England to justify the formation of a North of England Advisory Committee. If only listeners would realise that it is useless to talk in the train, or in the train-car, or at the works, of the indifferent programmes, etc., etc. The only effective method is to join the Wireless League, get all their friends to do the same, then, at a meeting of the particular branch, discuss the programmes and find out what is required and submit this to the Advisory Committee it is proposed to form. This method would be not only of use to the members themselves, but would be welcomed by the B.B.C. Radio Societies can make effective branches of the Wireless League, and many have adopted this course.

Should this paragraph meet the eye of any real live Radio Society secretary, full particulars can be obtained from the Area Secretary for Lancashire and Cheshire:—J. E. Kemp, Esq., 50, Garswood Road, Moss Side, Manchester.

o o o o

Redruth Branch.

"The branch is going strong," reported Mr. W. S. Trevena (hon. secretary) to the annual meeting of Redruth and District branch of the Wireless League in the Market Exchange, on Tuesday, Mr. C. J. Cooke presiding.

Continuing, Mr. Trevena remarked that the membership was well over 100, which was easily the largest of any branch in the county. An efficient aerial and earth system, the gift of a donor who desired to remain anonymous, had been erected on the premises of the Market Exchange. Two visits had been received from officials of the British Broadcasting Corporation, who complimented the branch on its progress. An appeal for funds for the provision of a wireless installation for Tehidy Sanatorium was well in hand.

The Chairman paid a tribute to the

work of the hon. secretary and the vice-chairman (Mr. A. D. Trounson), who were heartily thanked.

The Chairman remarked that over £40 had been subscribed towards the £300 required for the Tehidy Sanatorium Wireless Fund.

The secretary reported that headquarters were unable to grant any further financial assistance to the branch beyond a capitation allowance of 3d. per member, which would yield £1 5s. for the year. Expenses for the winter session totalled £6 10s., and there was a debit balance of £6 7s. 6d. to be wiped off.

It was decided to continue affiliation with the National Wireless League, and to open a list of vice-presidents and subscribers to the funds of the local branch.

Officers elected were:—Chairman, Mr. C. J. Cooke; vice-chairman, Mr. A. D. Trounson; hon. secretary, Mr. W. S. Trevena; hon. treasurer, Mr. R. N. Wright; committee, Messrs. T. S. Smith, W. J. Farmer, A. G. Tonkin, E. Russell, G. F. Jones, A. J. Grenfell, F. Clemo, R. R. Stewart, W. Tredinnick, and A. O. Probert.

For the annual outing on Thursday, July 21st, the secretary was asked to make arrangements for a visit to the wireless station at Lanivet, near Bodmin.

o o o o

Queen's Park and Districts Branch.

At the last meeting of the above branch, which took place on Friday last, the 1st July, at 8.30 p.m. at No. 552, Harrow Road, W.10, one of the club members demonstrated the lay-out and construction of a four-valve neutralised receiver.

A demonstration was also given of the construction of a short-wave receiver.

Quite a number of members attended what proved to be a very interesting meeting.

A general meeting of the above branch which now comprises Queen's Park, Paddington, Maida Hill, Willesden, Harlesden, and Kensal Rise, will be held towards the end of September, and all

members are particularly requested to make a special note of this.

Particulars of future activities are obtainable from the joint hon. secretaries:—F. Batho and the Hon. C. M. de Adlersparre, 37, Enbrook Street, Queen's Park, W.10.

REGISTRATION OF QUALIFIED TRADERS AND REPAIRERS.

Further List.

The following have been added to our register of Approved Wireless Traders and Repairers:—

London.—H. E. Hull and Son, 136, Holland Park Avenue, W.11.

Reigate, Surrey.—R. G. Wilson, 70, Lesbourne Road.

Swindon, Wilts.—Wallace H. Winchcombe, 160, County Road.

Wotton-under-Edge, Glos.—A. G. Long, Electrical and Radio Engineer, Market Street.

Surbiton, Surrey.—Edes Service, 82, Victoria Road.

Yeading, Yorkshire.—Driver Brothers, 10, Ivegate.

The Joint Committee are preparing material for a campaign in the early autumn to increase the number of approved wireless traders and repairers.

We suggest that it would be of great help to the Joint Committee in this effort if members would send to the hon. secretary of the Joint Committee, Mr. D. S. Richards, at the headquarters of the League, the names and addresses of traders and repairers of good standing in their locality who do not display the joint sign of the Wireless League and the Radio Society of Great Britain, to whom the Joint Committee may communicate particulars of the Registration Scheme. The names and addresses so received will be carefully collated and in due course further steps taken in each case.

MEMBERSHIP AND RENEWAL FORM.

To be filled in by readers who wish to become members of the League, or to renew their membership for a further eighteen months.

To the Secretary, The Wireless League, Chandos House, Palmer Street, Victoria Street, S.W.1.

..... 19

Please ^{*enrol me as a member} ~~renew my membership~~ of the Wireless League. I enclose P.O. for Three Shillings,† which entitles me to membership with all the privileges and rights as enumerated in the constitution of the League, including FREE Insurance, Free Legal Advice, and Free Technical Advice, for the eighteen months ending 30th September, 1928.

* Cross out Line not required.

† Keep the Counterfoil of your Postal Order.

WRITE IN CAPITAL LETTERS. Name (in full)
(State whether Mr., Mrs., or Miss.)
Address

My Membership No. is.....
(This is only applicable in the case of renewals.)

Please enclose stamped addressed envelope.

"The Wireless World" devotes four pages in the first issue of each month to League Notes and News.



RESISTANCE - CAPACITY AMPLIFICATION

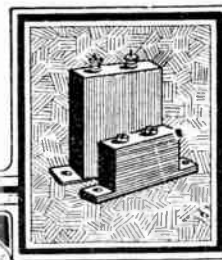

PART I.

Anode Circuit Conditions and the Calculation of Voltage Amplification.

By W. JAMES

A GOOD deal of attention is being directed at the present time to the subject of faithful loud-speaker reproduction and, as is usual when the subject is one of great interest to wireless users, all sorts of people are giving their views and describing their experiences.

The views of the purely practical man and of he who is mainly theoretical are of equal interest and importance. Our practical man, for instance, tries various types of couplings and valves; he tries components of different values and endeavours to determine the best combination of parts by listening critically to the sounds emitted by his loud-speaker. If his loud-speaker is a good one he will have the means of producing the sounds of lower and higher frequency as well as those of middle frequency, and presumably will quickly find the difference between good and bad couplings and valves, and between the right and wrong values of grid bias and anode supply voltage, when he tries to obtain all the sounds in their correct proportions. But should he be using an inferior loud-speaker he will probably give it as his opinion that one method of amplification is not vastly superior to another provided proper attention is given to the values of the couplings, the valves, and their operating conditions.

Thus our practical man is often able to give a demonstration of good quality since he is not biased in any way, but merely tries to obtain for himself music and speech of a pleasing quality to his own liking. It is certainly true that what he considers a faithful copy of the original another will record as indifferent, for musical taste and experience enter into the question. Nevertheless the man who has no musical ear, and therefore claims as pleasing what another classes as poor because of it being so utterly unlike the original, can be educated to appreciate the difference between a true and a false likeness.

Theoretical Standards of Quality.

He is usually in a much better position than our mainly theoretical man. This type of man finds by calculation the best values for the couplings and the most suitable valves, or gets them from someone else who claims to be an authority on the subject. He is the type of man who wants his amplifier to magnify evenly over the whole frequency range of 25-10,000 cycles, and feels very uncomfortable when he is made to realise that there is a reduction in amplitude at the extreme ends of the

scale. And whether or not he succeeds in building an amplifier such as he desires, and in actually getting the perfect results he believes he must get, is quite a different matter. It depends for one thing on the completeness of his knowledge of every factor affecting the question, and also, of course, on his loud-speaker. His loud-speaker may tend to emphasise the lower tones; then his amplifier with the level frequency characteristic is not the best that he can use. If, as is usually true, his loud-speaker deals improperly with the lower frequencies, then again his amplifier is not the best one to use under the circumstances.

We all know the type of man; he judges quality of reproduction mainly by the values of the couplings and the valves used, and by meters which he puts in the amplifier (he has a pain when he sees one of them give a little kick), with the result that he can often give only a tolerable demonstration of good quality.

Misleading Amplification Curves.

The manner in which really serious experimenters and the public alike allow themselves to be influenced by the various claims made for the different methods of coupling speech frequency amplifiers instead of by their own ears is amazing. A year or two ago someone took the responsibility of publishing a frequency-amplification characteristic of a single stage of low-frequency amplification comprising a valve and transformer, and it was pointed out that the notes of lower frequency were hardly amplified at all as compared with those of middle frequency. Then came along a cleverer person with the characteristic curve of a resistance-condenser stage—it was represented as a straight line from a very low frequency up to the highest audible frequencies. Many people immediately jumped to the conclusion that a transformer-coupled amplifier was of very little value, while a resistance-condenser-coupled amplifier was perfect, and that if one was used they would be bound to have perfect quality.

But such was soon found not to be the case. A comparison of amplifiers soon showed that in many instances the results were not as expected. Obviously certain unforeseen factors were affecting the results. The keener experimenters began to wonder whether such curves had much practical significance—did the characteristic curve of an isolated stage represent with any accuracy the performance of the stage when it was inserted in an amplifier?

Resistance-Capacity Amplification.

To-day we know the answer to this question: generally it is No. Reaction through stray couplings, and through the impedance in the anode power supply plays a vital part, and serves to modify profoundly the characteristics of an amplifier as compared with that of a single stage taken separately.

The nature of the source of power for the anode circuits is of prime importance. If this has an appreciable impedance, and this is more or less common to the detector and amplifier, most serious distortion is in many instances produced owing to the absence of suitable filters. It is not unusual for resistance-condenser amplifiers to be just on the verge of oscillating through stray couplings such as a common impedance in the anode circuits, with disastrous effects

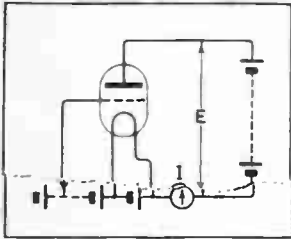

Fig. 1.—The anode current I of a valve is controlled by the anode voltage E and the potential of the grid.

on the quality. In fact, when the anode supply has only a small impedance, and the resistance-condenser amplifier is designed to pass the very low frequencies, a continuous popping sound may be heard, or the signals may increase and decrease in strength in a regular manner suggestive of bad fading.

The same remarks apply, of course, to some transformer-coupled amplifiers, particularly when the common impedance is rather high as when the anode supply is taken from certain types of battery eliminator.

The question might now well be asked as to whether it is of much value to deal in detail with a single stage of amplification when we are really interested in the performance of the amplifier as a whole. Fortunately, the

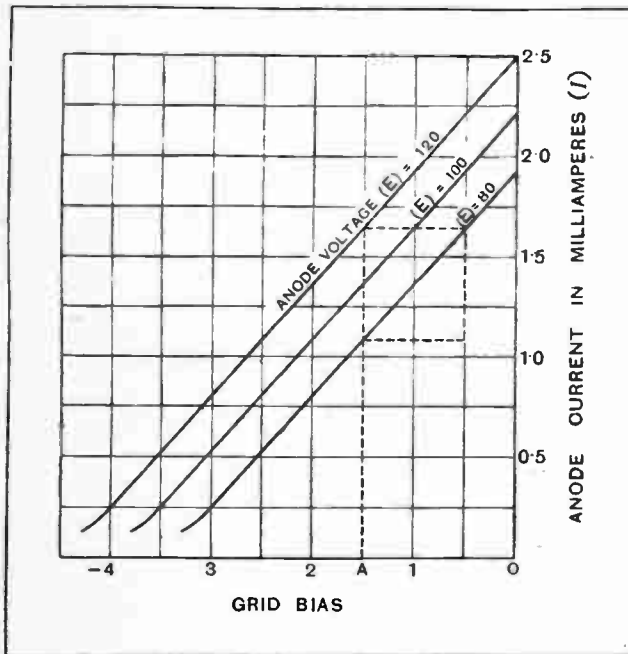

Fig. 2.—Typical characteristic curves illustrating the method of calculating amplification factor and A.C. resistance.

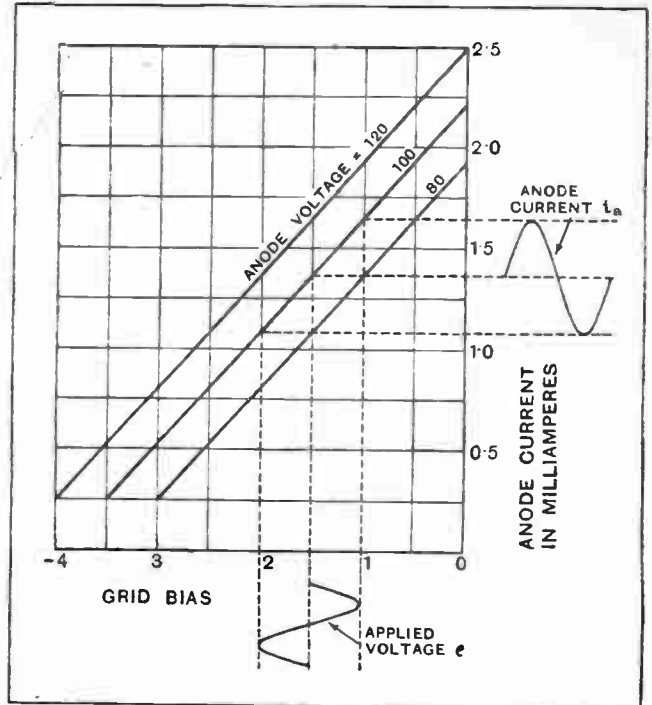

Fig. 3.—Alternating variations of grid potential are faithfully reproduced in the anode current provided that the valve is worked on the straight part of its characteristic.

answer to the question is Yes, for we can consider the stage as it is under working conditions, leaving for the present all questions relating to the reactions produced by the anode supply.

The principles of amplification are quite well known. If we have a valve, Fig. 1, with a voltage E applied to its anode, we obtain an anode current I depending on the construction of the valve, the actual value of E , and the value of the voltage applied to the grid. Further, the anode current can be varied by altering the potential of the grid because this controls the rate of flow of electrons from the filament to anode by the grid's electrostatic action.

Valve Characteristics.

A curve can therefore be drawn to represent the change of anode current with grid potential, and further, a curve can be drawn to show the change of anode current with grid bias for various anode voltages. The three curves given in Fig. 2 are for anode voltages of 80, 100, and 120, and apply to a modern valve suitable for resistance-condenser coupling.

From these it is easy to see that a change in the grid bias of 1 volt around the operating point A has as much effect in producing a variation of anode current as a change in the anode voltage of 40. For example, when the grid bias is -1.5 the anode current is 1.075 milliamperes for an anode voltage of 80; if the grid bias is reduced to -0.5 volt the anode current increases to 1.675 milliamperes. Also, if the grid bias is -1.5 volts the anode current is 1.075 milliamperes for 80 volts, as before, but increases to 1.675 milliamperes when the anode

Resistance-capacity Amplification.—

voltage is made 120. Thus the voltage factor of this valve is 40.

The important point is this, that on the straight line portion of the characteristic curves the anode current can be changed a given amount by altering the grid bias V volts or the anode voltage by μV (μ being the voltage factor of the valve).

Similarly, the A.C. resistance of the valve can be found from the curves, for when the anode voltage is increased from 100-120 (at the working point A, Fig. 2) the anode current increases from 1.375 to 1.675 milliamperes, from which the A.C. resistance is found to be $\frac{20}{0.0003}$ or 66,000 ohms.

If we now apply a small alternating voltage e to the grid of the valve (e being such that we use only the straight part of the characteristic curve) then the anode current will vary sympathetically, and the shape of the anode current variations will be precisely the same as that of the alternating voltage applied to the grid.

This is shown in Fig. 3. Here again it is not hard to see that the change in the anode current due to the grid voltage e (of 0.5 volt peak value with the anode voltage fixed at 100) could equally well have been produced by fixing the grid bias at -1.5 volts, and applying an alternating voltage of 20 volts peak value (that is 40 times as much) directly in the anode circuit.

It will now be clear that when a small alternating voltage is applied to the grid the alternating current produced in the anode circuit is given by

$$i_a = \frac{\text{change in anode voltage}}{\text{anode A.C. resistance}}$$

and, as we have previously said that a grid voltage e has the same effect in changing the anode current as a change in the anode voltage of μe we may write

$$i_a = \frac{\mu e}{R_{AC}}$$

where i_a = the alternating current produced in the anode

μ = the valve's voltage factor

e = the A.C. voltage applied to the grid

R_{AC} = the valve's anode A.C. resistance.

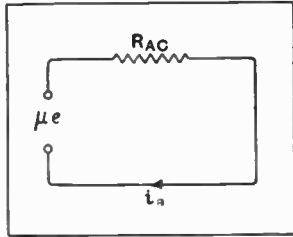

Fig. 4.—Equivalent circuit of valve as a generator of alternating current.

The valve of Fig. 1 may therefore be looked upon as a generator of alternating current having a resistance of R_{AC} ohms and generating an E.M.F. of μe volts; this is shown in Fig. 4.

Now our stage of resistance-capacity amplification comprises a valve V_1 coupled to valve V_2 by an anode coupling resistance R , a condenser C and a grid leak R_G . Fig. 5 (a). This may be simplified, for we are considering alternating currents, to give Fig. 5 (b) which shows more clearly that the grid condenser and grid leak are connected in parallel with the anode coupling resistance. We will therefore make a further simplification to arrive at Fig. 5 (c) in which the coupling condenser and grid leak are omitted. This is perfectly justifiable because we can assume that the impedance of the condenser and grid leak in series is very high compared with the anode coupling resistance; in fact, we assume that a pure resistance of R ohms is connected to the valve and that the circuit is non-inductive and non-capacitative.

Later we shall have to take into account the effect of various condensers which play an important part in the behaviour of the amplifier at the higher and lower ends of the acoustic frequency range.

Our circuit proper now comprises a valve with an anode coupling resistance and a battery having a voltage E_B . A current I will flow in the anode circuit, producing a fall in voltage over the anode resistance R , so that the actual voltage of the anode is not E_B but $E_B - RI = E$.

If a small alternating voltage e is now applied to the grid of the valve the anode current will vary sympathetically as before, but not to the same extent as in the Fig. 4 circuit; it will have a value

$$i_a = \frac{\mu e}{R_{AC} + R},$$

because now we have the coupling resistance R in series

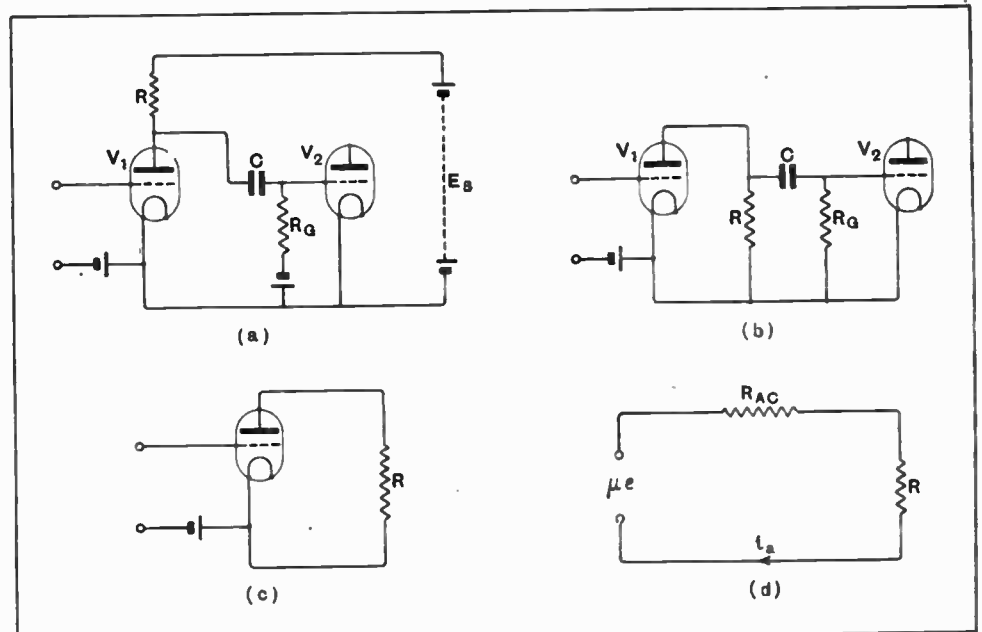

Fig. 5.—Single stage of resistance-capacity amplification with equivalent circuits.

Resistance-capacity Amplification.—

with the valve. This condition is shown in Fig. 5 (d), and it is easy to see that if R is reduced, the alternating current will increase, reaching the value $\frac{\mu c}{R_{AC}}$, when R is zero; similarly, when R is increased, the alternating current will be reduced and, in fact, will be zero when R is infinitely large.

Voltage Amplification.

Now we are interested principally in the alternating voltage actually developed across the anode coupling resistance by the grid voltage e, for the ratio of these voltages is the voltage amplification.

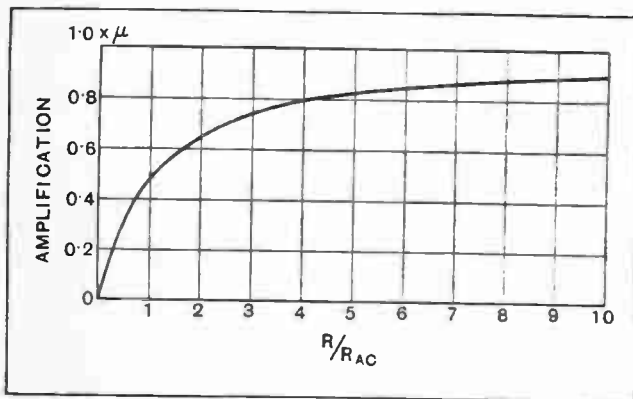

Fig. 6.—Curve showing relation between amplification and ratio between external anode resistance and valve A.C. resistance.

But we know that the alternating current flowing in the anode circuit is producing a voltage

$$Ri_a = e_a$$

and that

$$i_a = \frac{\mu e}{R_{AC} + R}$$

It therefore follows that

$$e_a = \frac{\mu e R}{R_{AC} + R}$$

and that the voltage amplification

$$A = \frac{e_a}{e} = \mu \cdot \frac{R}{R_{AC} + R}$$

Then, if R_{AC} remains constant in value, the voltage amplification obtained when R=R_{AC} is 0.5μ, and when R is twice R_{AC}, 0.66μ, and so on as shown by the figures in Table 1 and the curve of Fig. 6.

TABLE 1.

| Value of Anode Coupling Resistance. | Voltage Amplification. |
|-------------------------------------|------------------------|
| $\frac{1}{2} R_{AC}$ | $\frac{1}{3} \mu$ |
| R_{AC} | $\frac{1}{2} \mu$ |
| $2 R_{AC}$ | $\frac{2}{3} \mu$ |
| $4 R_{AC}$ | $\frac{2}{3} \mu$ |
| $6 R_{AC}$ | $\frac{3}{4} \mu$ |
| $10 R_{AC}$ | $\frac{10}{11} \mu$ |
| $20 R_{AC}$ | $\frac{20}{21} \mu$ |

Thus the amplification actually obtained depends on

the voltage factor μ of the valve and the value of the anode coupling resistance as compared with the A.C. resistance of the valve. It can never equal the voltage factor, but approaches it asymptotically.

At this stage, then, we say that the voltage amplification for a given anode A.C. resistance increases with the voltage factor of the valve; for instance, the amplification when a valve with a certain R_{AC} and a voltage factor of 20 is used will be only half the amplification given by a valve of the same R_{AC} but twice the μ. In addition, if the voltage factor of the valve is fixed but its A.C. resistance is varied, the amplification for a given coupling resistance will decrease as the R_{AC} is increased.

It is now necessary to consider the matter in a little more detail, and to find the amplification likely to be obtained in practice. The special valves for resistance-capacitor amplification have, on the whole, a voltage factor of round about 35 for an A.C. resistance of 80,000 ohms. Certain valves have a little lower A.C. resistance than this; but others again have a value of as much as 150,000 to 200,000 ohms.

A.C. Resistance Under Working Conditions.

In this connection it is important to remember that the valve makers almost invariably give the A.C. resistance for the maximum anode voltage and with zero grid bias, in order that it shall be as low as possible for a given voltage factor, of course, and it is this practice which has led to no little confusion amongst amateurs and more experienced workers alike. For if the makers value of A.C. resistance is inserted in the amplification formula one is led to expect quite a large voltage amplification per stage. For instance, with an anode coupling resistance of 500,000 ohms, and the makers figure of, say, 80,000 ohms for a valve having a voltage factor of 35 we find the theoretical amplification to be 30; in practice it is less, for the reason that the A.C. resistance of the valve under working conditions is considerably higher than the assumed value of 80,000 ohms.

Now the A.C. resistance of a given valve will depend on the anode voltage and the grid bias. We can for practical reasons fix the grid bias at -1.5 volts, which leaves us with the anode voltage as the only factor which will alter the A.C. resistance. If we made a further assumption, that the anode battery voltage is fixed at 120, we simplify the problem still further, for now the voltage of the anode is that of the anode battery less the fall in voltage over the coupling resistance.

Thus a certain valve, which is a good one of its class, with an anode battery of 120 volts, a grid bias of -1.5 volts and a coupling resistance of 600,000 ohms, has an anode current of 80 microamperes; therefore the fall in voltage over the coupling resistance is 48 volts, leaving the anode voltage as 72. Under these conditions the anode A.C. resistance is 290,000 ohms, from which it is easy to find that the theoretical voltage amplification is 0.675μ. If the anode battery had been 75 volts instead of 120, the valve's A.C. resistance under the same conditions would have been over 500,000 ohms and the amplification would be only 0.545μ.

We can now see that so far as voltage amplification is concerned there are two variables, the coupling resistance and the valve's A.C. resistance, for as we vary the

Resistance-capacity Amplification.—

former so we alter the latter. The change is not one that is directly proportional; that is, the fact that we double the coupling resistance does not mean that we have doubled the valve's A.C. resistance.

To show these things more clearly two sets of curves have been prepared. They refer to a well-known 2-volt R.C. valve. The curves of Fig. 7 are the ordinary static characteristic curves, but the anode voltages of 40, 60 and 75 were purposely made low so as to approximate to working conditions. The second set of curves, Fig. 8, refer to the same valve, but having a grid leak nominally of 0.5 megohm, but actually of 0.6 megohm connected to its anode. The battery voltages were 75, 100 and 120, the anode voltages depending of course on the grid bias which controls the anode current.

The valve has an average voltage factor of 33, and the following approximate A.C. resistances for different conditions as to grid bias and anode voltage.

| Anode Voltage. | Grid Bias (Volts). | A.C. Resistance (Ohms). | Anode Current (Microamperes). |
|----------------|--------------------|-------------------------|-------------------------------|
| 40 | 0 | 150,000 | 200 |
| 60 | 0 | 115,000 | 350 |
| 75 | 0 | 95,000 | 508 |
| 40 | -0.5 | 200,000 | 96 |
| 60 | -0.5 | 130,000 | 202 |
| 75 | -0.5 | 105,000 | 330 |
| 40 | -1.0 | 450,000 | 36 |
| 60 | -1.0 | 190,000 | 102 |
| 75 | -1.0 | 145,000 | 194 |
| 40 | -1.5 | 750,000 | 8 |
| 60 | -1.5 | 390,000 | 42 |
| 75 | -1.5 | 270,000 | 94 |

Three examples will now be worked out to show what voltage amplification one may expect to get in practice.

(1) Anode battery 120 volts; grid bias -1.5 volts; coupling resistance 600,000 ohms; anode current 80 μ A; A.C. resistance of valve 290,000 ohms; voltage factor of valve 33.

$$\text{Amplification} = \frac{600,000}{600,000 + 290,000} \times 33 = 22.$$

(2) Anode battery 120 volts; grid bias -1.5 volts; coupling resistance 1.5 megohms; anode current 40 μ A; A.C. resistance of valve 390,000 ohms; voltage factor of valve 33;

$$\text{Amplification} = \frac{1,500,000}{1,500,000 + 390,000} \times 33 = 26.$$

(3) Anode battery 120 volts; grid bias -1.5 volts; coupling resistance 3 megohms; anode current 33 μ A; A.C. resistance of valve 590,000 ohms; voltage factor of valve 33;

$$\text{Amplification} = \frac{3,000,000}{3,000,000 + 590,000} \times 33 = 27.6.$$

These examples show that even though the A.C. resistance of the valve increases when the coupling resistance is increased in value, the voltage amplification increases with the coupling resistance. For this reason one might be tempted to use a coupling resistance of more than 3 megohms; the calculation has not been made for a higher value, however, because such values would not be used in practice for various reasons.

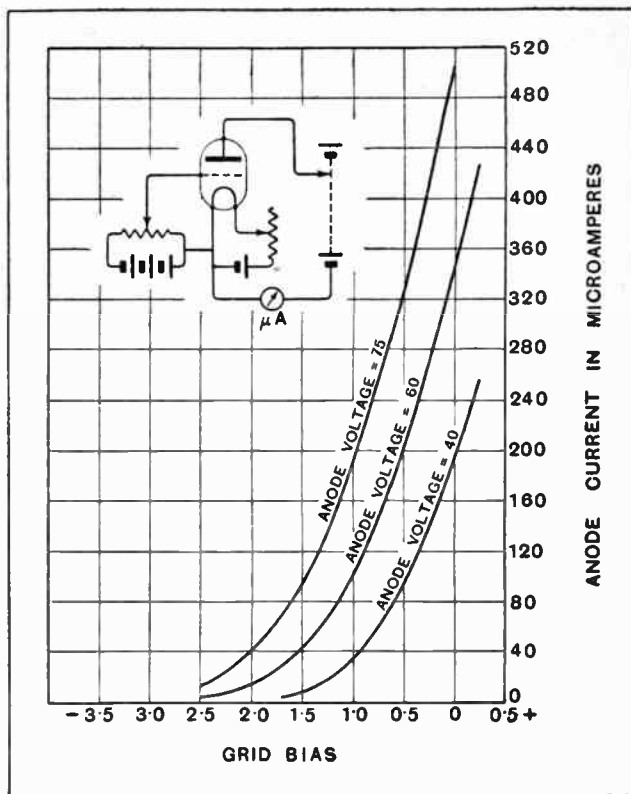

Fig. 7.—Static characteristic of a typical "R.C." valve with anode voltages approximating to working conditions.

The amplification of 22-27, according to the coupling resistance used is, of course, quite a useful one, and at this stage it might be as well to determine what A.C. input can be applied to the valve without distortion. Normally it is necessary to work out load curves for the valve in order to show as nearly as possible the actual working conditions, but as we shall usually be dealing with fairly small input voltages this is not absolutely necessary and we can form an opinion from the curves of Fig. 8, remembering of course that the curves apply only to one particular case. Thus if a different valve is used, or a different value of coupling resistance, the slope of the curves will be different, and so will their shape. We know, though, that the effect of increasing the value of coupling resistance is to lengthen further the straight portion of the curves, so that, if anything, we shall be slightly underestimating the maximum grid swing with which the valve can deal without distortion.

Permissible Grid Swing.

The curve, of Fig. 8, for 120 volts, is quite straight from zero to -2 volts grid bias. If now we fix the grid bias at -1.5 volts, we are fairly safe in allowing the applied A.C. voltage to have a peak value of 0.5 volt, which will give us an undistorted output of 11 peak volts, or should a 3 megohms coupling resistance be used, although this is not advised, an output of 14 peak volts. The grid of the succeeding valve would therefore be biased about -12 and -15 respectively.

It should be noticed that if an anode battery of less

Resistance-capacity Amplification.—

than 120 volts is used, the value of the maximum A.C. input to the grid will have to be reduced if distortionless amplification is desired; when the anode battery is more than 120 volts a little more A.C. can be applied.

So far we have considered the valve and its coupling resistance, and we have found that when an alternating voltage e is applied to the grid an undistorted voltage e_a is developed across the anode resistance (Fig. 9) provided certain conditions are fulfilled. Now a complete stage of resistance-condenser amplification comprises two valves with two resistances and a coupling condenser as shown in Fig. 5 (a). Further, acoustic frequencies range from about 25-10,000 cycles, so that it is obvious that the condenser is likely to have the effect of making the A.C. voltage actually developed across the grid leak R_G , Fig. 5 (b), less than the A.C. voltage across the anode resistance R , because the impedance of the condenser varies with the frequency. It will also be clear that the effective resistance connected to the anode of the amplifying valve will be less than the ohmic value of the coupling resistance R because the condenser C and grid leak R_G form a shunt path. Here, again, we have to remember that the impedance of the condenser C , and

grid leak of 2 megohms would normally be used, and for 3 megohms a grid leak of, say, 5-10 megohms, although it should be understood that the writer does not think it advisable to exceed 5 megohms. Let us now find the effect of the grid leak in reducing the effective resistance connected to the anode. Our values are for R , 0.5 megohm, and for R_G 2 megohms; the nett result is 400,000 ohms, or, if we take the practical example represented in Fig. 8, where the coupling resistance is 0.6 megohm, 460,000 ohms.

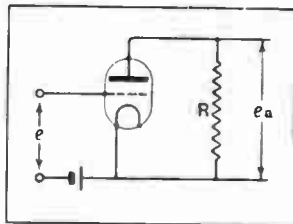

Fig. 9.—In the absence of a coupling condenser and leak a simple relation exists between e and e_a .

We can therefore modify our voltage amplification formula

$$A = \mu \cdot \frac{R}{R + R_{AC}}$$

and write for the coupling resistance R its effective value when shunted by a grid leak R_G .

Then we have

$$A = \mu \cdot \frac{RR_G}{R + R_G + R_{AC}}$$

In Example 1 on the previous page the resistance had a value of 600,000 ohms, the valve an A.C. resistance of 290,000 ohms, and a voltage factor of 3.3. If we assume that with the coupling resistance of 600,000 ohms a 2 megohm grid leak is used, the amplification will be found to be a little more than 20 as compared with 22 when the effect of the grid leak was neglected.

A further effect of the lowering of the effective resistance connected to the anode is that the working curves of the valve are changed; in fact, the length of the straight portion of the characteristic will be less. An effect of the grid leak is therefore to lower the alternating current voltage which can be applied to the valve without distortion. Thus two effects are produced; the one just mentioned, which, however, is not likely to be of much consequence, and the second, which is to reduce the voltage amplification, in the example considered from 22 to 20.

(To be continued.)

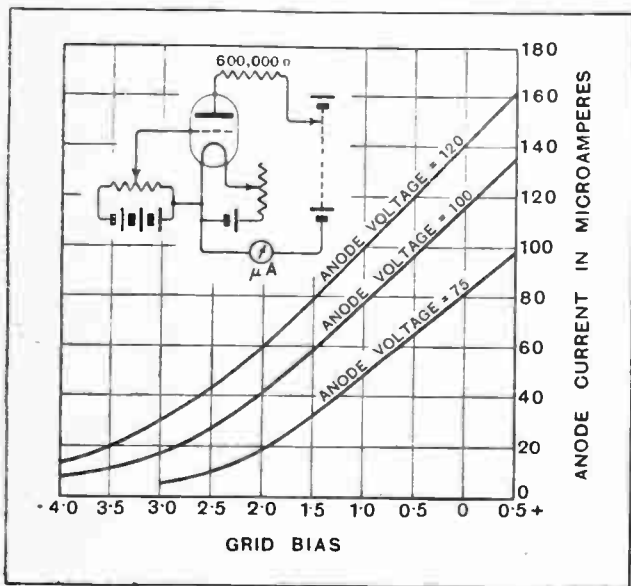

Fig. 8.—Curves of the same valve as Fig. 7 with an external anode resistance of 0.6 megohm.

therefore that of the shunt path CR_G , varies with frequency.

Fortunately, with normal values this latter effect is small, but the effect of the grid condenser in developing a voltage across its terminals which depends on the frequency is by no means unimportant—it is, in fact, one of the most important features in this method of amplification.

To deal with the effect of CR_G in parallel with the coupling resistance R ; if C is so large that for all frequencies its impedance is very small then we can ignore it, and simply consider the case of two resistances in parallel. For a coupling resistance of 0.5 megohm a

IN NEXT WEEK'S ISSUE.

AN article by Capt. P. P. Eckersley, Chief Engineer of the B.B.C., on the distribution and power of broadcast stations with special reference to the considerations leading up to the proposed Regional Scheme.

o o o o

Listeners living near the coast and subject to spark interference will also find an article of special interest dealing with the design and construction of a selective three-valve set (1-v-1) for long-wave broadcast stations.



Events of the Week

BERLIN RADIO EXHIBITION.

Berlin will hold its Radio Exhibition this year from September 2nd to 11th in the Radio Industry Hall at the Kaiserdamm Fair Ground.

○○○○

THE NINETY-FIVE THOUSAND.

Of the 125,000 wireless sets in use in Northern Ireland only 30,000 are licensed, according to counsel prosecuting on behalf of the Post Office in a wireless "pirate" case at Hillsborough Petty Sessions.

○○○○

TRUTH IN BROADCASTING.

Translation of a news item heard from a French broadcasting station:—
"A dangerous international bandit has been arrested in Paris. He was born in Roumania in 1885, and since this date the police have been searching for him."

○○○○

TOO COMFORTABLE?

When Mr. J. A. Reading, of the Meriden Guardians, stated last week that the introduction of wireless in the Meriden Union Institution would cheer up the inmates, another guardian expressed the fear that it would induce them to stop in the workhouse for ever.

○○○○

LISTENERS IN SWEDEN.

Practically every twentieth Swede now has a radio receiver, according to a report just published by the Swedish State Telegraph Department. The total number of licensed listeners in Sweden is now nearly 300,000.

○○○○

COMPETITION ON A FIELD DAY.

A direction finding competition between the Leeds and Sheffield Wireless Societies on Sunday, June 26th, ended in a draw. Each society provided two groups equipped with portable receivers, their task being to locate hidden transmitters on the moors near Penistone and Giggleswick.

○○○○

AN OYSTER'S FEELINGS.

The important question of whether Atlantic oysters resent radio is raised by Commander W. E. Parker, Chief of the U.S. Division of Hydrography and Topography, who states that operators of submarine listening equipment in the Atlantic report mysterious noises supposed to be the clicks of oysters! Apparently the bivalves of the Pacific are more partial to scientific progress, fewer clicks having been heard in those waters.

AN UNUSUAL QUERY.
"Is reception too easy?" asks a wireless expert in a Scottish newspaper.
If this is his trouble, our Information Department can introduce him to people who will speedily remove it.

○○○○

INDIAN BEAM STATIONS.

The fourth and last group of Imperial wireless beam stations will probably be completed before the end of this month, when the service with India will be tested.

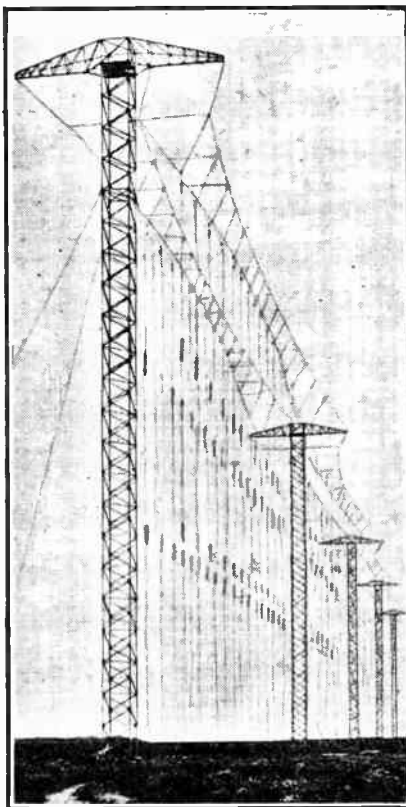

SOUTH AFRICAN BEAM TRANSMITTER. The aerial and reflector system at the Klipheuvul Marconi Beam Transmitting Station, 30 miles N.E. of Cape Town. The masts are 300 feet high and the distance between them is 650 feet.

in Brief Review.

THE RADIO LAWYER.

A reminder of the growing complexity of wireless legislation is provided by the news that Judge Stephen B. Davis, of Washington, has been awarded the Linthicum prize of a medal and a thousand dollars for his recently published book, "The Law of Radio Communication." Judge Davis' book was selected out of a hundred manuscripts.

○○○○

LAURELS FOR DUTCH WIRELESS INVENTORS.

Any Dutch member of the Netherlands Wireless Telegraphy Society who, "by invention or any new method contributes in the widest sense of the word towards the advancement of the science and technique of wireless," may be the recipient of a newly instituted annual prize which has been provided for by a donation of 100,000 Dutch florins (about £8,300) by the president of the society.

○○○○

HAPPY GREEKS.

A new market for wireless apparatus is opened up in Macedonia by the decision of the Wireless Telegraphy Board in Athens to allow the use of radio receivers in Salonica and Cavalla. For the time being the permission will be granted only to Greek subjects, but it is thought that the privilege will shortly be extended to foreigners.

○○○○

BY BEAM TO SOUTH AFRICA.

The recent successful tests with the South African beam service showed that, using two wavelengths, the two stations are capable of carrying on a high speed duplex service between London and Cape Town for the greater portion of the day and night, although the contract called for only eleven hours per day. It is estimated by the Marconi Company that the stations are able to handle 160,000 words per day in each direction.

The transmitting and receiving stations in this country are situated at Bodmin and Bridgwater respectively. The African transmitter is at Klipheuvul, thirty miles north-east of Cape Town, while the receiver is at Milnerton, five miles north of the city.

The exact wavelengths of the English station are 16.146 metres (day service) and 34.013 metres (night service). The African wavelengths are 16.077 and 33.708 metres for day and night respectively.

PROGRAMMES "ON TAP."

Subject to the approval of the Post Office a company which has just been formed at St. Annes-on-Sea under the title "Community Radio, Limited," will supply broadcast programmes "on tap" to a number of subscribers for a weekly payment of 2s. each (including licence).

The company, which possesses an eight-valve receiver, has already received applications from forty would-be subscribers spread over a wide area.

FORTHCOMING EVENTS.**WEDNESDAY, JULY 6th.**

Tottenham Wireless Society.—At 8 p.m. At 10, Bruce Grove. Business Meeting, followed by a talk on "Technical Terms," by Mr. F. E. R. Neale.

THURSDAY, JULY 7th.

Golders Green and Hendon Radio Society.—At 8 p.m. At the Club House, Willifield Way, N.W.11. Lecture: "The Ethodyne," by Mr. B. J. Aztin.

TUESDAY, JULY 12th.

Thornton Heath Radio Society.—At 8 p.m. At St. Paul's Hall, Norfolk Road. Demonstration for Beginners by Mr. Atkinson. Subject: "Grid Bias and Reduction."

SUNDAY, JULY 17th.

Golders Green and Hendon Radio Society.—Field Day.
Muswell Hill and District Radio Society.—Field Day (in conjunction with above).

WIRELESS DURING THE ECLIPSE.

Although at the time of going to press the results of wireless experiments conducted during the solar eclipse had not been fully collated, certain important conclusions had been arrived at.

The tests carried out by the Radio Research Board, with transmitting stations at Peterborough and Birmingham, served to show that the absorption of waves by the Heaviside layer during the period of the eclipse decreased to a tenth of normal, causing a tenfold increase in signal strength.

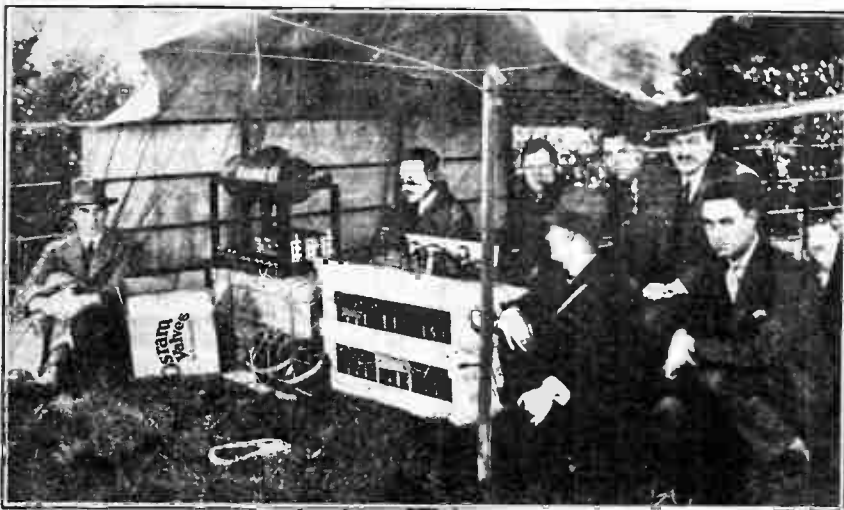

MYSTERY STATION AT WORK. 5 CT, the transmitter whose clandestine operations provided the "scent" for an exciting hunt by members of the Golders Green and Hendon Radio Society on a recent field day.

ROOM FOR RADIO DEVELOPMENT.

Out of the 22 million homes in the United States, only six million are at present equipped with wireless receivers, according to the researches of the American Federal Radio Commission. Eighteen million homes possess cars, sixteen million are wired for electricity, sixteen million are equipped with telephones, and eleven million have gramophones.

○○○○

NEWCASTLE INFIRMARY WIRELESS INSTALLATION.

In the description of this installation in the June 22nd issue it was stated that 250 pairs of phones could be used. This rather understates the capabilities of the apparatus, as we are informed that *no fewer than 2,000 pairs* can be operated, each of the eight power output valves being capable of supplying 250 phones.

○○○○

THE KING'S MICROPHONE.

When the King visits Liverpool on July 19th to open the Gladstone Dock His Majesty will again make use of the Marconiphone public address amplifying equipment.

As on previous occasions, the special Marconi Magnetophone, which is reserved exclusively for the King's use, will be employed. In this instrument the usual iron cylinder is silver plated, and the entire microphone is covered by a silver wire cage bearing the Royal Arms in gold.

His Majesty's microphone has been used on five previous occasions, which are chronicled on a gold plate affixed to the cylinder, and are as follows:—

July 19th, 1924.—Opening of Liverpool Cathedral.

May 4th, 1925.—Opening of Wembley Exhibition.

May 30th, 1925.—Opening of Great West Road.

June 27th, 1925.—Royal Air Force Pageant, Hendon.

July 13th, 1925.—Opening of British Medical Association new buildings.

It is certainly the handsomest and most valuable microphone in existence.

○○○○

PROGRESS IN AUSTRIA.

Since broadcasting started in Austria on October 1st, 1924, the number of licensed listeners has grown to 274,352. At the end of 1924 there were 94,322.



ON THE RIGHT SCENT. Mr. Maurice Child (on left) with the portable receiver which located the hidden station 5 CT.

WIRELESS AT WESTMINSTER.
By OUR PARLIAMENTARY CORRESPONDENT.**Wireless Telephony to Fishing Vessels.**

Mr. Grotian asked the Postmaster-General in the House of Commons last week whether, in view of the advantage to the fishing fleet, it was permissible for private individuals to establish a wireless telephone service with the trawlers and other vessels with which they were connected; and whether he would define the general attitude of the Post Office towards initiative of this nature which was not met by any existing State service.

Sir Wm. Mitchell-Thomson replied that in view of the risk of interference it was not practicable to permit the establishment of private wireless stations for communication with ships at sea. Vessels fitted with wireless telegraph apparatus could send and receive messages through any of the Post Office coast stations, and in order to meet the needs of a number of trawlers which had recently been fitted with wireless telephone apparatus, arrangements were being made to equip the new coast station now in course of construction at Mablethorpe with suitable apparatus for the exchange of messages with these vessels by wireless telephony.



The following abstracts are prepared, with the permission of the Controller of H.M. Stationery Office, from Specifications obtainable at the Patent Office, 25, Southampton Buildings, London, W.C.2, price 1s. each.

A Stable Superheterodyne.

(No. 244,484.)

Convention date (France): December 12th, 1924.

The above specification, granted to L. Levy, gives considerable constructional details of an eight-valve superheterodyne receiver, the arrangement of which is shown in the diagram. The most important parts of the circuit will only be referred to in detail, and those not mentioned may be considered as quite normal. The valve V_1 is employed as a local oscillator, V_2 and V_3 are first and second detectors respectively, while V_4 and V_5 are additional low-frequency amplifiers, the anode circuit of the valve V_5 containing the telephones T. The filament and anode circuits are respectively supplied by common batteries B_1 and B_2 . The local oscillator is of the shunt type consisting of a tuned circuit 9 10, a stopping condenser 11, and a high-frequency choke 12. The output of the oscillator is transferred through a special condenser comprising two fixed electrodes 15 and 16, and a movable electrode 14. The valve V_2 is arranged as a high and intermediate frequency amplifier. A frame aerial is tuned by a condenser 17 and is connected at 19 and 20. The input is connected in series with the grid circuit of the valve V_2 and a condenser 18 of small value and an air-core inductance 29. The primary of a high-frequency

iron-core transformer 25 and an intermediate frequency circuit 23 24 is included in the input circuit of the valve V_2 . The secondary of the iron core transformer 25 is connected between the grid and filament of the detector valve V_2 , while the anode circuit of this valve contains an intermediate circuit 28 26, coupled to an inductance 29. The tuned circuit 29 18 is tuned to a frequency which is considerably higher than the intermediate frequency, but is very tightly coupled to the intermediate circuit 28 26. The circuit 23 24 is coupled to the grid of an amplifier V_4 through a condenser 30, a similar arrangement being used with the other intermediate amplifiers. The circuit is stated to function in the following manner. The special coupling condenser 14 15 16 enables the effect of the local oscillator upon the grid of the valve V_2 to be made as weak as desired, since the potentials across the electrodes 15 16 are 180 degrees out of phase with respect to the common filament circuit. The valve V_2 amplifies the radio-frequency oscillations, while the valve V_3 by virtue of a rectifying effect produces beat frequency oscillations. The beat frequency is transferred by means of the coupling between 26 and 29 to the valve V_4 for amplification at intermediate frequency. The intermediate frequency voltages existing in the anode circuit of the valve V_2 are then applied to the input of the normal intermediate

amplifier, that is, the valve V_4 , where they are amplified by the valves V_4 and V_5 and are finally detected by the valve V_6 , the output of which is amplified by the low-frequency valves V_6 and V_7 . Since the circuit 29 is tuned to a frequency which is high compared with the intermediate circuits 23 24, 32 33, 35 36, the intermediate amplifier is rendered stable. A further feature of the invention consists in placing the whole system in a screened compartment to prevent the amplifier being influenced by stray fields.

o o o o

A Four-electrode Multi-vibrator.

(No. 267,279.)

Application date: February 9th, 1926.

The above British patent, granted to N. V. Phillips' Gloeilampenfabriken, describes how a four-electrode valve may be used as a multi-vibrator. The invention relates to the type of circuit in which two three-electrode valves are coupled together by a resistance, and reaction is obtained by coupling the anode of the second valve to the grid of the first. Very strong current impulses are obtained in this circuit due to the periodic charge and discharge of the coupling condenser, the frequency of this charging and discharging being determined by the time constant of the circuit comprising the coupling condenser and leak. A similar type of circuit is claimed in this speci-

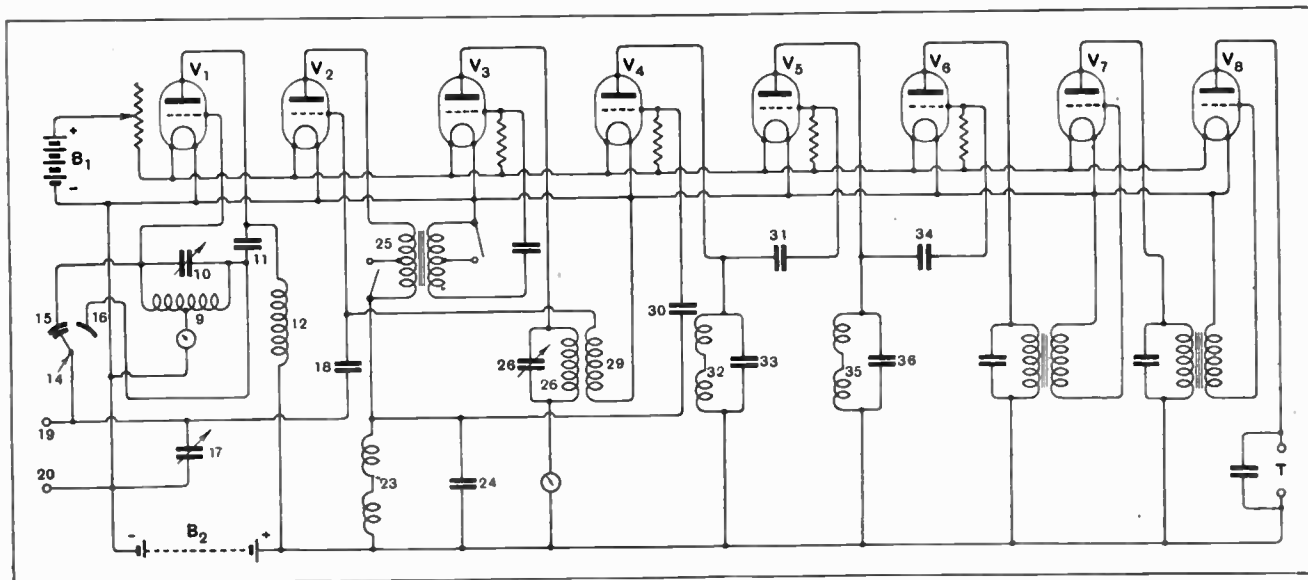

Eight-valve superheterodyne circuit. (No. 244,484.)

cation for the use of a four-electrode valve in the manner indicated in the diagram. The battery B_1 heats the filament, while the anode circuit is supplied by one battery B_2 , the anode being connected through telephones T or other indicating devices, while additional voltage is supplied by another battery B_3 . Connection is made at a point X to the inner grid G_1 through a resistance R_1 , this grid being coupled through a condenser C to the other grid G_2 , connected to the filament through a leak R_2 . The value of the coupling condenser may lie between 2,000 cms. and 1 mfd. The resistance R_2 is approximately one megohm, while the other resistance R_1 is of the order of a few thousand ohms. It is stated in the

specification that the circuit functions in the following manner. The condenser C first charges rapidly and then more slowly

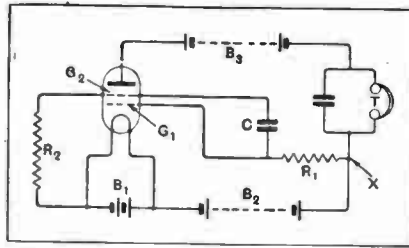

Multi-vibrator circuit using a four-electrode valve (No. 267,279.)

until a critical potential difference is reached. At this moment a rapid discharge occurs accompanied, of course, by a reversal of the current. The condenser then charges again in the same manner, but in the opposite sense. The low self-induction present in the connecting leads maintains this sequence of operations in somewhat the same manner as a fly-wheel allows the piston in a reciprocating engine to be carried over the top and bottom centres. The smaller the self-induction the greater will be the tendency for the current curves of the discharge to differ from a sine wave. This, it is stated, results in it being possible to sift out the higher harmonics very easily, and even those of radio frequency.

The Feminine Touch.

A tribute to feminine skill in an article entitled "Hats Off to the Ladies" appears in the current number of *Cossor's Radio Mail*, in which the writer describes the many difficult operations skillfully carried out by the girls in the Cossor valve factory.

Other features of special interest to retailers deal with summer sales, "truth in advertising," and hints on window dressing.

o o o o

An Annual Event.

The many wireless firms which exhibited at this year's British Industries Fair will note with interest that this function is assured of being an annual event for the next three years, the Government having leased the White City, Shepherd's Bush, for the London section of the Fair for the necessary periods in 1928, 1929, and 1930.

The next Fair, which will be held simultaneously in London and Birmingham from February 20th to March 2nd, will be by far the largest British Industries Fair on record.

NEWS FROM THE TRADE.

A Watmel Move.

Owing to the increasing demand for Watmel products, the Watmel Wireless Co., Ltd., has moved to larger and more commodious premises, its address now being Imperial Works, High-st., Edgware, Middlesex.

o o o o

Distinguishing Different Valves.

The familiar orange and blue cartons used for Cossor valves have in the past been stamped "6 volt H.F. or detector," "Stentor Six," etc., to differentiate between the various valves in each range. This method of stamping has now been abolished, and the new system is to stamp each box "610 H.F.," "610 P.," etc. This effort at standardisation should prove useful to valve users, since from the title the filament voltage and current of the valve and the use for which it is intended are at once evident.

Burndep Wireless, Limited.

In the Chancery Division last week Mr. Justice Eve made an order, on the application of Mr. Andrewes-Athwatt, on behalf of Messrs. Coultts & Co., for the appointment of a receiver of the assets of Burndep Wireless, Limited. It was submitted in the application that the matter was an important one, as the directors of Burndeps had just resolved that, owing to the company's finances, they could not continue to carry on business. The money of the applicants was not yet payable, but the assets were in jeopardy.

o o o o

"Gecophone" Price Reductions.

The General Electric Co., Ltd., of Magnet House, Kingsway, W.C.2, announce that they have made several reductions in the prices of "Gecophone" wireless apparatus. The changes affect certain accessories and loud-speakers.

o o o o

A Mullard Demonstration.

At a Midsummer Fête held at St. Luke's Church, Balham, on June 14th and 15th, the Mullard Radio Valve Co., Ltd., gave a wireless demonstration using an ordinary three-valve receiver employing Mullard valves. Four "Pure Music" speakers were distributed in the grounds and provided good musical entertainment. In addition, a microphone arrangement was installed so that announcements could be made from time to time, and a gramophone pick-up with a three-valve amplifier was used during the time when the 2LO programmes were unsuitable for the purpose.

o o o o

Changes of Address.

Owing to the increasing demand for "Ekco" H.T. units, Messrs. E. K. Cole, Ltd., the sole manufacturers, have moved to more commodious premises, their new address being "Ekco" Works, London Road, Leigh-on-Sea.

o o o o

To secure centralisation of the various departments, Messrs. Treleborg Ebonite Works, Ltd., have moved to a new address giving more facilities for efficient distribution. Their new address is Union Place, Wells Street, London, W.1.

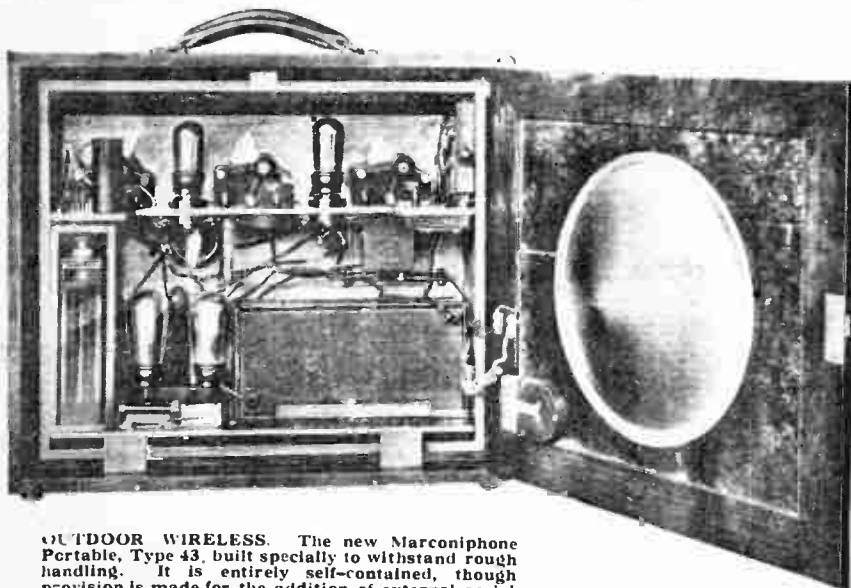

OUTDOOR WIRELESS. The new Marconiphone Portable, Type 43, built specially to withstand rough handling. It is entirely self-contained, though provision is made for the addition of external aerial and earth if distant reception is desired.



Amateur Empire Relay.—Why Do We Kilocycle?—S.O.S. Ingratitude.—Opening the Menin Gate.—Lucky Australian Amateurs.—For and Against School Wireless.

Amateur to Conduct Empire Broadcasts.

An important step in the direction of short-wave broadcasting to the Dominions is to be taken on or about August 15th, when Mr. Gerald Marcuse (G2NM), the well-known Caterham amateur, will begin experimental relays of the B.B.C. programmes on wavelengths of 23 and 33 metres.

The Postmaster-General has provisionally approved of the scheme, with a view to determining whether or not a regular broadcast service to the Dominions can be efficiently maintained.

I hear that Mr. Marcuse's transmitter has recently been rebuilt, a new power supply being installed. Marconi rectifying and transmitting valves will be used.

o o o o

'Hush-Hush' Empire Transmission?

Readers interested in short-wave broadcasting to the Dominions might do worse than listen to certain relays of the London programme emanating from the Putney district on 38 metres.

A friend who picked up this elusive relay the other evening between 9 and 10 o'clock tells me that the quality was remarkably good. Have you heard it, Dominions?

o o o o

Why We Kilocycle.

What led the B.B.C. to choose the present time for the change from wavelengths to kilocycles? The interesting fact emerges that the decision was mainly inspired by the action of the U.S. Federal Radio Commission, which issued a similar fiat shortly before the B.B.C. announcement.

It has been realised at Savoy Hill that calculation by frequency will simplify discussions at the forthcoming International Radio Conference at Washington, at which questions relating to broadcasting will fill a considerable part of the agenda.

FUTURE FEATURES.

London.

JULY 10TH.—Military Band Programme and Vocalists. Service relayed from St. Martin-in-the-Fields.

JULY 12TH.—"Histoire du Soldat" (Stravinsky), relayed from the Arts Theatre Club.

JULY 15TH.—"Les Cloches des Corneville." A Comic Opera in Three Acts.

Birmingham.

JULY 13TH.—Military Band Programme, relayed from Royal Leamington Spa.

JULY 16TH.—"A Marriage Has Been Arranged." A Play by Alfred Sutro.

Bournemouth.

JULY 14TH.—Concert by the Municipal Orchestra and Chelsea Singers.

Cardiff.

JULY 14TH.—Opening Ceremony of The Winter Gardens Pavilion.

Manchester.

JULY 12TH.—"In the Gloaming," a new play by Patience Raymond.

JULY 16TH.—"On with the Show of 1927," relayed from Blackpool.

Glasgow.

JULY 12TH.—Opening of the Kelvin Hall by His Majesty the King.

Aberdeen.

JULY 12TH.—"The White Cockade," a Romance of the "Forty-Five."

Belfast.

JULY 12TH.—Isle of Man Programme.

Internationalism in Broadcasting.

Thus the international aspect of broadcasting is more and more affecting the trend of the art in individual countries, and whereas the matters hitherto influenced by international relationships have been mainly technical, there seems little doubt that before long programmes will be similarly affected.

Perhaps the problem of original talent supply, which tends to grow greater as the years advance, will be solved by the sharing of programmes throughout the world.

A world-programme bureau, complete with "S.B." board, and situated at, say, Geneva, would be an interesting place, especially for the operators!

o o o o

A Peculiar Type.

Prompted by a vulgar curiosity, I am looking for a certain human "type." The search is rendered rather difficult by reason of the fact that his or her characteristics rather stagger the imagination. I refer to the type of person who persuades the B.B.C. to broadcast an S.O.S. and who, when the appeal has been satisfactorily answered, neglects to acknowledge his indebtedness to the Corporation.

o o o o

The Important Postcard.

There are apparently quite a lot of these amiable people about, and the B.B.C. has had to prepare a special printed postcard with which to jog their memories. This card, which is immediately forwarded to people who wish to have an S.O.S. broadcast, contains the simple question: Was the appeal successful or unsuccessful? The recipient is asked to keep the card by him for a few days in order to give the S.O.S. a chance, and then to return the card to Savoy Hill.

Saving Three-ha'pence.

In cases where a broadcast appeal has proved unsuccessful it is, perhaps, more comprehensible that the individual concerned might forget, in the stress of circumstances, to inform the B.B.C. When, however, the appeal brings the longed-for result the omission to spent three-halfpence on a letter to the B.B.C. represents something uncommonly like base ingratitude.

Since the B.B.C. have initiated their postcard scheme, the outcome of 107 out of 111 cases has been ascertained. Of the 111 cases, 57 met with success.

o o o o

Reception Forecasts.

Side by side with its regular weather report a Milwaukee newspaper publishes a regular wireless reception forecast.

Here is a typical prophecy:—"Good volume and distance to the east, on Monday night; poor distance and probably fading to the south; west and south-west distance poor. Reception on Tuesday night will be uncertain, with poor distance west and south-west."

On Tuesday Milwaukee probably went to the "pictures," and saved battery juice.

o o o o

Menin Gate Broadcast.

The ceremony of opening the Menin Gate Memorial will be broadcast from all stations on the morning of Sunday July 24. Field-Marshal Lord Plumer will open the Arch. His and other speeches, hymns, prayers, the Last Post and the Reveillé will be relayed by land line from the Menin Gate to Ypres, and thence to Brussels and Savoy Hill, London, by telephone line.

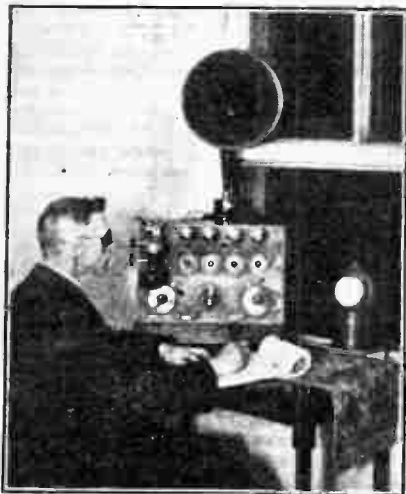

LOOKING, LISTENING, LOGGING.
How a northern reader spent the precious seconds during the total eclipse.

The ceremony will be performed in the presence of a large gathering, including relatives of those commemorated on the Memorial, and representatives of units which fought in the Salient. The voices of this vast assembly joining in the service will be heard by listeners throughout the British Isles.

The "Revue Intime."

Alice Delysia is presenting a revue entitled "Paris Calling" on July 9. This is a Continental entertainment composed by Oscar M. Sheridan and Hubert W. David, with additional sketches by Yvonne Arnaud and Lucienne Herval. It is an attempt to portray the type of "revue intime" to be found only in Paris. The cast will include Mlle. Marova, Henri Leoni, the Gresham Singers, Colleen Clifford, Rex Evans and Yvette Darnac, the revue orchestra being under the direction of Stanley Holt.

o o o o

Lucky Amateurs!

One cannot recall a case in this country where a broadcast programme has been cut short for the sake of amateur transmitters waiting to experiment. In Australia, however, the amateur is still reckoned an important personage.

On a recent Sunday evening, says a correspondent, 3LO, Melbourne, closed down abruptly at 10 o'clock in the middle of an interesting programme in deference to amateur transmitters who regard after 10 p.m. on Sundays as sacred to their own activities.

The broadcasting programme had been delayed earlier in the evening, with the result that at 10 o'clock the programme was several items "behind time." But the amateurs had to be remembered!

o o o o

Where Broadcasting Fails.

Now that the novelty associated with broadcast lessons in school has worn off, educational authorities are growing more critical regarding the scope and limitations of the broadcast teacher.

A new booklet, entitled "Educational Broadcasting," published by the B.B.C. and submitted by them at the Imperial Conference on Education, presents a very clear survey of the work already achieved in this direction and the possibilities that lie ahead. The writer, presumably a member of the B.B.C. staff, is commendably frank in his statement of the limitations of the wireless lesson.

Wireless, he affirms, cannot replace the living teacher, and the wireless lesson must always partake of the nature of a lecture. Some loss of personality is inevitable, and certain difficulties regarding curriculum are apparently insuperable; moreover, it is only within limits that wireless can provide for expression on the part of the pupil.

o o o o

A Word in Favour.

On the other hand, there are many things which wireless is eminently qualified to carry out. It can bring remote schools in touch with experts, it can strengthen the staff of a school by providing a fresh outlook and fresh voices, and is valuable in enabling school children in isolated places to participate in important events such as Armistice Day Celebrations in London, services in Westminster Abbey, etc.

There is another important recommendation I have not heard mentioned before. The loud-speaker lesson (says the writer) provides an exercise of concentrated listen-

ing to a continuous train of thought clearly spoken in good English, and is thus a valuable mental discipline.



WORLD'S LARGEST "MICROPHONE."
No, this is not a real "mike." It is the architectural symbol adorning the new building of 3LO, Melbourne.

This is true enough, provided the loud-speaker is not of the type that demands concentration to the point of madness.

o o o o

Copyright Conundrums.

In the course of the legal action between M. André Messenger and the B.B.C., an interesting point was raised with regard to the reception of broadcast music in countries where the music in question is copyright.

This is not the first time that the problem has faced the B.B.C. When contemplating the relay of an American programme the Corporation scans the advance programme very carefully to ensure that they will not be re-broadcasting tunes that are copyright in this country. On more than one occasion WGY has been asked to change a certain dance number to avoid conflict with the copyright law.

Broadcasting and Feminine Psychology.

Mr. Fred Smith, the director of the Crosley broadcasting station WLW at Cincinnati, has concluded that the psychology of women listeners is different in the morning. Exactly what he means by this audacious conclusion may be uncertain, but he is putting his views into effect by substituting practical features for the usual morning musical items.

One wonders whether the B.B.C. has ever taken into account the changes in feminine psychology at different periods of the day. The woman listener who is captivated by a Savoy band waltz at midnight may "see red" when she hears the same tune from Daventry amid the clatter of the kitchen next morning.



The Editor does not hold himself responsible for the opinions of his correspondents.

Correspondence should be addressed to the Editor, "The Wireless World," Dorset House, Tudor Street, E.C.4, and must be accompanied by the writer's name and address.

EMPIRE BROADCASTING.

Sir,—In reply to your invitation published in *The Wireless World* of May 4th, 1927, asking the Dominions to send in their views on Empire Broadcasting from England by means of short waves, I am requested by my Council to forward you the copy of a letter which was sent to the Radio Society of Great Britain in September of last year.

As the views expressed therein are still those held by us to-day, we should be glad if you would publish the letter in order, not only to assist us to attain our object, but also to let the rest of the world know that South Africa has been urging this matter on the English authorities for some time.

[copy]

"The Hon. Secretary.

Radio Society of Great Britain.

Dear Sir,

I am directed by the Council of the Radio Society of South Africa to address you with a view to inducing your society to use its influence towards the establishment of a short-wave station in the old country on such lines as would enable the Dominions to enjoy something of British broadcasting.

There are three broadcasting stations in this country—*at Capetown, Johannesburg and Durban*—all of which are under public or semi-public management—*Capetown under the auspices of the Publicity Association, Johannesburg under the Associated Scientific and Technical Societies, and Durban run by the Municipality.* I remind you of this that you may realise that these stations are under the direction of public-spirited honorary committees or boards whose one aim is the advancement of broadcasting for the benefit, enlightenment, and education of the public and whose ingrained loyalty to the old country finds it somewhat galling that the only broadcasting from overseas reaching this country with sufficient power to permit of relaying emanates from the United States (KDKA and 2XAF short-wave stations).

My Council is convinced that if only the British public, the B.B.C. (or its successors), and, indeed, all English manufacturers, could realise the effect this has on public sentiment and the wireless market generally, here, not a day would be allowed to pass before the establishment of a short-wave station were put in hand.

It is only for a few months in the year that the most sensitive of our receivers are able to record "snatches" of English broadcast programmes and copy isolated announcements, and yet on several occasions successful relays have been given of the American short-wave stations (on the last occasion when Capetown relayed KDKA *the whole* of its programme was published in the following morning's issue of our daily papers). These programmes reach us between 3 and 7 a.m. and you will, therefore, understand how they are naturally handicapped as against the English programmes which would reach us *between 10 p.m. and midnight or 1 a.m.*, a comparatively reasonable hour for listeners.

The letter by Captain Eckersley lately appearing in wireless magazines has been perused by South African wireless men with the greatest disappointment. It is felt here that what has been done by private enterprise (commercial) in America, unsubsidised by private funds or fees, should surely not prove too much for an institution financially supported so substantially as the B.B.C. (or its successors) by the British public.

If we are to wait until the development of radio science permits the establishment of a station in England that will be able to transmit programmes to South Africa with the reliability, strength and purity they are received in the Metropolis I fear none of us now living will ever enjoy them; but your society will, I am sure, realise the hunger that must necessarily exist in the Dominions for some participation, however imperfect, in the British programmes, and if only we could receive them with the strength and reliability of the American stations that would be a wonderful help towards fostering and enhancing the bond of empire all loyal Britishers desire to see strengthened.

In these circumstances my Council feels justified in urging your Society to use its very best endeavours towards ensuring the earliest possible establishment of a powerful short-wave broadcasting station in England (call it experimental if you will) to run collaterally with the existing stations and so serve as a powerful, far-reaching bond of Empire, sentimentally and commercially, between the Old Country and the Dominions.

Yours faithfully,

GEO. H. JOHN SADLER,

Hon. Secretary."

I have notified the Radio Society of Great Britain that this letter is being sent to you for publication.

GEO. H. JOHN SADLER,

Hon. Secretary.

Sir.—In connection with the Editorial survey of matters radio in your issue of May 4th last, in which you invite expressions of opinion from oversea readers, I would like to state that the great body of listeners in South Africa and Rhodesia are unanimous in their desire to listen first-hand to British broadcasting; in this connection a letter was addressed to the Broadcasting Council of Great Britain on April 26th, 1927, copy of which is enclosed for your information.

"Sir,—This Society has always been prominent in the matter of advocating ultra short-wave transmissions of ordinary broadcast programmes, and this question is the reason for inditing this letter.

As you are probably aware, the "Old Country" is held in great affection by a considerable number of English-speaking persons resident in the Colonies, who are ever on the alert to obtain first-hand news, etc., of, and from, Great Britain; the strides made in Radio seem to bridge over the gulf of space, and thousands of radio enthusiasts—almost hundreds of thousands—are particularly anxious to be in the position of being able to listen to an English Broadcasting station. Great progress has been made in England in the matter of high wavelength and ordinary broadcast-band work, but from experience it is felt that the only way in which those Colonies, lying south of the Equator, would be able to receive oversea work fairly consistently without those terrible electrical, atmospheric disturbances with which, I understand you are not greatly troubled, is by the medium of ultra short-wave transmissions; this aspect is a very interesting one in the matter of the fillip it would give to the scientific and technical side of broadcasting. . . . If a suggestion would not be received amiss, we would like to suggest for your consideration a wavelength of about 35 metres.

In this country we receive, besides American stations, the Holland ultra short-wave programmes, which are seldom

marred by atmospherics, and which, of course, substantially prove the practicability of the foregoing suggestion.

I trust you will appreciate the great boon it would be, to receive an English programme and thus enable listeners here, and probably in Australia, to hear "Big Ben" with a reasonable regularity, and so annihilate distance."

This fairly well covers the view held in this country and it is therefore unnecessary to reiterate the sentiment expressed therein.

CLAUDE LANCASHIRE.
Chairman, The Umlazi Radio Society.

Sir.—I feel I represent the opinions of a vast number of ex-wireless enthusiasts in this country. I have twice taken up wireless as an entertaining hobby, and cheerfully attempted to sift the mediocre programmes of our three local stations from the mush of the world's best atmospherics, first with a two-, then a four-valve straight circuit, but my best results would have made a pre-war gramophone manufacturer commit an act of violence on the loud-speaker.

I am not really complaining about the statics; they are just our handicap; but I do complain that after spending £20 or so and provoking much blasphemy with a soldering iron and self-pinching pliers one can get no further than hearing snatches of a market report in "Africans," or spasms of a 'cello solo representing a white ant crawling down the passage with its boots off, by a man who learnt the instrument by correspondence.

I am prepared to sit and listen to a faint transmission if only I can feel that Jack Hilton or someone is at the other end, and I know that there are hundreds of wireless sets scrapped in this country because we have no one to pick up most of the time except our well-meaning three local stations.

Wessels Nek,

Natal, June 7th, 1927.

C. R. HALLÉ.

Sir,—As a regular subscriber to your paper I am glad to see that you are taking up rather strongly the matter of Empire broadcasting.

We here in Trinidad are taxed by the local government for having wireless receivers, yet we have no local broadcasting station.

I have proved by experiment that short waves are the only practical ones for these tropical parts. Many expensive sets for long waves have been discarded in disgust.

We get good and regular reception from America, though KDKA recently seems to have got jammed by another station. Holland has proved that it is practical to receive here from Europe from two hours before sunset (Trinidad) onwards. The recent speeches by the Queen of Holland from PCJJ I heard very distinctly. There is a good market, I am sure, for short wave receivers in these parts, and they are so economical, only requiring one or two valves and as low as two volts. America has been favoured in the past for wireless goods in these parts. England should wake up to the possibilities of this trade.

(REV.) EDGAR A. JONES.

Trinidad, B.W.I.
June 13th, 1927.

Sir,—Further to other letters of mine which have appeared on the subject of Empire broadcasting, perhaps you will allow me again to occupy just a few more lines of your valuable space.

It is now obvious that the B.B.C. do not intend to hurry themselves in any way over the matter, in addition to the statement that in any event they do not consider the art of short-wave communication at present sufficiently advanced to warrant such a service being established. Capt. Eckersley has made the statement, therefore it must be so. But one wonders (very much) who the short-wave experts are at Savoy Hill (if there are any at all) who try to sling this futile rot on an unsuspecting public. The average man in the street is that type of fool who will believe practically anything one likes to tell him, but one can go too far sometimes, especially

when there is proof in large letters to the contrary to what one has said. What is the use of the B.B.C. saying they doubt the technical possibility of an Empire service when the Dutch and American short-wave stations are such a success? Simply a case, I am afraid, of high power and kilocycles touched (just slightly) with the attitude adopted by some of the other Government-controlled bodies or Government departments: "Ignore the public; we are the — Office." and so forth.

If the B.B.C. want proof of the capabilities of short waves, and if they are incapable of finding things out for themselves, as they appear to be, I suggest that here is a splendid opportunity for the T. and R. section the R.S.G.B. to provide a proof of their capabilities. This admirable organisation has never distinguished itself very greatly in any direction except allowing its members to send useless CQ's and American nonsense, and it seems that if the T. and R. section arranged for one or two of its members' stations to relay the B.B.C. programmes on short waves for a definite period, it would greatly enhance the value of the amateur transmitter in the public eye, help the B.B.C., and at the same time make the engineering staff look ridiculous, which in itself would be delightful.

One imagines that such stations as 20D, 2NM, 2LZ would be only too pleased to carry out such work providing the R.S.G.B. paid any small expenses they might incur. And if these experiments were undertaken on low power there is all the more reason why a service on high power should be highly satisfactory. No doubt, of course, many members of the T. and R. section would be far too busy sending their childish little OM's, FB's, YL's, etc., to concern themselves with mere broadcasting, but, thank goodness, there are a few seriously minded experimenters left who might carry out, at any rate, the preliminary work.

I have put my schemes (all utterly absurd, no doubt) before you, sir, in this and other letters because I know what a very great thing an Empire service would be. I have had the pleasure of advising many colonials as to what type of set they should use in various parts of the world to hear British broadcasting; it was usually a superheterodyne, and, having paid the price such a set carries, they would, in most cases, be perfectly contented with the thought of hearing Big Ben and a scrap of news through Daventry, perhaps on one or two nights a week. This may give some idea of how a short-wave station which can and would give far more satisfaction than this would be appreciated.

DALLAS BOWER.

Brighton,

June 23rd, 1927.

Sir,—It appears to me that those who advocate the erection of a short-wave broadcasting station in this country by the B.B.C. are entirely ignoring the claims of the two million licensees who provide the B.B.C.'s funds.

Money has yet to be found to provide for the proposed new high-power regional stations which it is proposed to erect shortly in this country, and more money will be required to transmit two programmes from each station. As a consequence, economy appears to be the order of the day.

How, then, can anyone expect the B.B.C. to provide gratis a broadcasting station for the Colonies in addition?

If there is the desire for a short-wave station such as some people would have us believe, why do the Colonies not take the lead by offering to bear, say, 80 per cent. of the necessary expenditure, leaving the B.B.C. to find, say, 20 per cent., particularly if it is true, as has been stated, "the cost would be negligible"?

The fact that Philips, of Holland, have erected such a station is no argument in favour of the B.B.C. doing likewise. Philips, of Holland, have no rules governing their expenditure such as those which govern the B.B.C., and in addition Philips expect to get a return for their expenditure which the B.B.C. obviously could not obtain.

In conclusion, may I, as one of the two million licensees referred to above, state emphatically that I am against the erection of a short-wave station by the B.B.C. until listeners in this country have their long overdue alternative programmes.

Manchester.

JAS. HUDSON.

June 22nd, 1927.

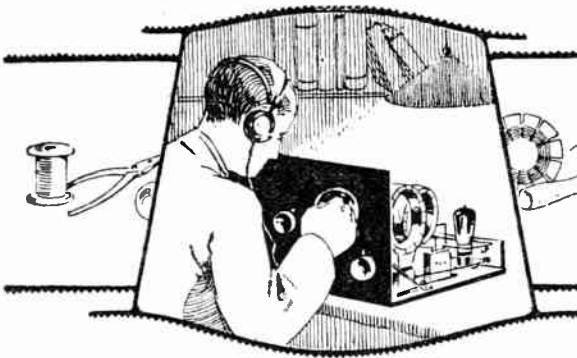

READERS' PROBLEMS

"The Wireless World" Information Department
Conducts a Free Service of Replies to Readers' Queries.

Questions should be concisely worded, and headed "Information Department." Each question must be accompanied by a stamped addressed envelope for postal reply.

Loud-speaker on 50 Volts H.T.

I desire to construct a 2-valve receiver for the reception of Daventry on a loud-speaker at a distance of 50 miles, but wish to dispense with the usual T.T. batteries and make use of the lighting supply for the necessary H.T. voltage. This is obtained from a 50-volt, 100-ampere-hour accumulator battery which is charged once a week. A careful search through the back numbers of "The Wireless World" has failed to reveal a receiver suitable for use with a limited H.T. voltage, and I should therefore be obliged if you could supply me with a circuit capable of satisfactory performance in view of the above limitations.

L. C.

We think your requirements would be adequately met by constructing a receiver to the circuit given in Fig. 1 on this page. With a maximum of 50 volts, the usual three-electrode valve will not prove very satisfactory when used as an amplifier for loud-speaker reception, and we suggest you employ a four-electrode valve for this purpose and have accordingly incorporated this in the circuit. The detector valve V_1 should have an A.C. resistance

of about 20,000 ohms, and an amplification of the order of 20, in which case the primary of the intervalve transformer must have a moderately high impedance. Either the Marconiphone 2.7 to 1 transformer or the Ferranti A.F.3 would be perfectly satisfactory when used in this receiver. It will be noticed that the loud-speaker is not connected directly in the anode circuit of the amplifier valve, but is used in conjunction with a filter output circuit. The primary reason for this is that the D.C. resistance of the speaker would account for a large voltage drop, with the result that the effective potential on the anode of the valve would be very considerably reduced.

A No. 150 coil should be used in the position L_1 and a No. 100 coil in L_2 for the reception of Daventry, but if at any time it is desired to receive stations working on the normal B.B.C. wavelength a No. 35 coil must be used in both L_1 and L_2 positions.

A suitable four-electrode valve to employ in the L.F. position would be an A.P. 412 L.F., in which case the detector valve must be one of the 4-volt range. The Cossor 410 H.F. or Mullard P.M.3 would comply with both the specified A.C. resistance and filament voltage and could

accordingly be employed in the detector position.

An Everyman Problem.

I am experiencing trouble with my receiver, which has been assembled to the instructions given in your "Everyman Four" book. Daventry is received at good strength on a loud-speaker with a loading coil in position, but on removing this coil, changing over aerial and switch, nothing can be received. If a small coil (No. 35) is now inserted in the coil plug, it is possible to receive the normal wavelength stations at excellent strength, but I cannot tune in stations below 300 metres. Can you give me some indication of the probable cause of this strange performance?

P. T.

The abnormal performance of your "Everyman Four" receiver on the normal broadcast wavelengths may be traceable to the switch not making contact when in the position for short-circuiting the loading coil. On the other hand, one of the leads connecting the switch and loading coil may have been inadvertently omitted or become unsoldered, and only appear to be making contact.

Anode Bend and Transformer Coupling.

I notice that in nearly all circuits in which an anode bend rectifier is used the valve is followed by a stage of resistance coupling. Can you tell me why this is?

T. J. R. K.

When using an anode bend rectifier, we usually choose one of the modern high-A.C. resistance, high-magnification factor valves, because it will be found that this type of valve, owing to the fact of its having a more sharply defined bottom bend, is more sensitive to weak incoming signals than other types of valve. Now, this type of valve has normally a high A.C. resistance, and this is greatly enhanced when it is used as an anode bend rectifier. If, therefore, we are not to lose on our lower musical tones, we must make the impedance of the external circuit very great, and this can only be done by using an anode resistance of not less than $\frac{1}{2}$ megohm in value.

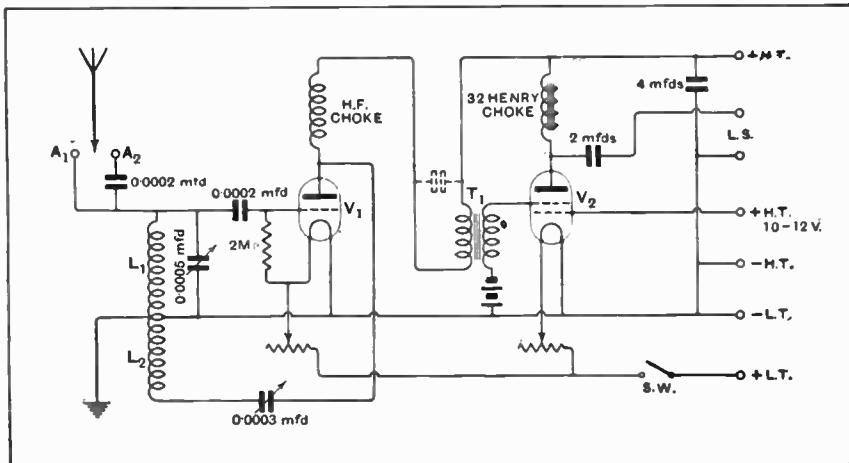

Fig. 1.—A loud-speaker set requiring a low H.T. voltage.

Reaction "Plops."

I notice that my receiver, which is a detector and two L.F. transformer-coupled instrument, goes into reaction with a loud "plop," and comes out also with a loud "plop," but does not come out of reaction at the same point as it goes into it, and does not appear to have the habit of gliding almost imperceptibly in and out of reaction as in the case of similar sets you have described from time to time in your journal. Can you tell me the cause of this, and how to cure it?

R. P. A.

The cause of this phenomenon is usually due to incorrect values of grid and anode potentials. Thus, often we find a three-volt, 0.06 amp. type of valve being used in conjunction with a 4-volt accumulator and a 30-ohm rheostat, at the same time, we find the grid return lead connected direct to L.T. +, thus applying an excessive positive potential to the grid of the valve. In this case better results would be obtained by connecting the grid return lead direct to the negative side of the valve filament (as we are, of course, assuming that the rheostat is in your positive lead) and then you would have a smaller positive voltage applied to your grid. It is often better to use a potentiometer in order to get the value of positive grid bias correct.

With regard to the H.T. supply for the detector valve, the correct value of this also requires to be found by experiment. The makers often give an approximate value to be used, but it will be found better to experiment in the neighbourhood of the voltage given by the makers by means of a wander plug until smoothest reaction is obtained. Another cause of this distressing symptom, which is usually known as electrical back-lash, is that the reaction coil you are using is too large.

○○○○

A.C. Induction Troubles.

I am troubled by an annoying hum, which presumably originates in the A.C. wiring in the house, as it may be completely stopped by taking out the mains switch. The noise is not loud enough to prevent reception. I have been told that results will be better if I fit an indoor aerial. This it would be possible to do, as the local station is only five miles away, and there is an ample margin of signal strength. Please tell me if the proposed alteration is likely to be worth while.

M. B. S.

It is most unlikely that the proposed alteration will have any good effect. On the contrary, we think it almost certain that the use of an indoor aerial will accentuate your trouble, as the wire will probably be running parallel with some of the lighting leads. You should try the addition of a loosely-coupled aerial circuit to your receiver if it does not already include one. This in itself may effect a complete cure.

Aerial Damping.

Enclosed is a circuit diagram of my receiver, and I should be glad to have your assistance in the elimination of the following trouble. Used on a normal aerial of full size, results are good, and the set is perfectly stable, but when I remove the instrument to another house where a small indoor aerial is fitted, the set becomes hopelessly unstable when a station is tuned in. How can this be prevented?

A. E. M.

We think that the effect you describe is a normal one. The circuit as shown consists of an H.F. amplifier with directly-coupled aerial and a simple tuned anode arrangement. A valve operating in this way is stabilised only by the aerial load, and when this is reduced it is natural that uncontrollable oscillation should be produced. The same effect would probably be noticed if you were to connect a small condenser in series with your large aerial. The remedy is to replace the present tuned anode with some form of neutralised coupling, but if you are unwilling to do this, the set may be stabilised by the application of a positive bias to the H.F. grid, or by the insertion of artificial resistance. Both these methods, however, are palliatives only, and we strongly recommend you to adopt a more modern neutralised circuit.

**BOOKS FOR THE
HOME CONSTRUCTOR**

Issued in conjunction with "The Wireless World."

"TUNING COILS AND METHODS OF TUNING," by W. JAMES. Price 2/6 net. By Post, 2/10.

"THE HOME CONSTRUCTOR'S WIRELESS GUIDE," by W. JAMES. Price 3/6 net. By Post, 3/9.

"MAST AND AERIAL CONSTRUCTION FOR AMATEURS," by F. J. AINSLEY, A.M.I.C.E. Price 1/6 net. By Post, 1/8.

Obtainable by post (remittance with order) from
LIFFE & SONS LIMITED,
Dorset House, Tudor St., London E.C.4.
or of Booksellers and Bookstalls

Mica or Paper?

I am about to construct the three-valve "B.B.C." receiver which you described in "The Wireless World" for April 20th. I notice that mica coupling condensers of 0.1 mfd. are specified, but as I already have two of this capacity, but with paper insulation, I should like to use them if possible, as expense is a consideration. Please let me know if this would be in order.

V. W. P.

We consider that it is most unwise to use paper-insulated condensers in this particular position, and if you are unwilling to go to the expense of obtaining capacities of 0.1 mfd. with mica insulation, we strongly advise you to substitute those of 0.01 or 0.015, which are readily obtainable at a low price. The result of this substitution will be that the lower

frequencies do not receive full amplification, but in practice the "cut off" will be very slight, and we doubt if it would be noticeable with any ordinary loud-speaker.

○○○○

How to Sharpen Tuning.

I have built the "Everyman Four" receiver for the 200 to 600 metre wavelengths only, as described in your July 28th and August 4th issues of last year. Owing to very close proximity to my local station, however, I find that selectivity is not quite sufficient for my needs. In what way could I improve on this?

R. C. D. T.

You could improve the selectivity of your receiver by using a valve of high A.C. resistance in the H.F. stage, but at the same time, if you merely choose a valve of higher resistance without it having a commensurate increase in amplification factor you will lose in sensitivity but gain in selectivity. You should, therefore, choose a valve of greater A.C. resistance, but at the same time one having a greater amplification factor. The A.C. resistance must not, however, be increased to too great a value, and we should advise that it be not more than 60,000 ohms at the very outside. The Cosmos S.P.55B valve should suit your needs.

○○○○

A Question of Fuses.

I wish to insert a flash lamp between the H.T. — and L.T. — terminals on my "Everyman Four" receiver, in order to safeguard the valve filaments in case of any accident with the H.T. battery. Will this be in order?

D. T.

In the first place you will have to make a slight alteration in the practical wiring diagram of the "Everyman Four." Referring to Fig. 7 in the "Everyman Four" book, you will notice that a wire comes down from the negative side of the valve holders and effects a junction with the wire joining H.T. — and L.T. — at a point just near the H.T. — terminal. You must move this wire so that it joins directly on to the L.T. — terminal, and then, of course, would have to insert your bulb in series between H.T. — and L.T. —, instead of having the solid junction which exists there at present. In many cases a flash lamp bulb will work admirably in this position, but in the case of many makes of these small bulbs it is found that they will carry a very considerable current for a short period before burning out, and it might so happen that the valves acted as a safeguard to the flash lamp bulb instead of vice versa as desired. It would be far better for you to insert a guaranteed fuse between H.T. — and L.T. —. One should arrange that this fuse blows at a current value less than that of any single valve in the set, but at the same time, of course, the fuse must be able to carry the total plate current of the set without blowing. A fusing value of 30 milliamperes is suitable.



No other 2-volt valves give such volume and life-like reproduction with such meagre filament consumption as the Marconi Economy series. Long life is another strong point. Long after you might reasonably expect them to deteriorate they will still be giving you the same amazing results. Learn more about this Marconi series. Full particulars and characteristic curves—including the DEP 215—sent on request.

DEH 210 14/-.

DEL 210 14/-.

Filament volts 2.0 max. Filament current 0.1 amp. Anode volts 150 max. Amplification factor 35. Impedance 75,000 ohms.

Filament volts 2.0 max. Filament current 0.1 amp. Anode volts 120 max. Amplification factor 9. Impedance 17,000 ohms.

THE MARCONIPHONE COMPANY LTD.,
AND REDUCED.

Head Office: 210-212 Tottenham Court Road. Regd. Office: Marconi House, Strand, W.C.2.

ECONOMY VALVES

D.E.L 210

D.E.H 210

M1049.

| | | |
|-------------|--|-------------|
| 60 Volts | BETTER H/T SUPPLY AT LOWER COST | 60 Volts |
| 22/6 | | 22/6 |

**AMAZING REDUCTION
FOR 28 DAYS ONLY!**

The Elite High Tension Accumulator is the true original Monoblock to be made in any country, and is entirely British. Moreover, it is the only battery with oil insulation, and many thousands of users all over the world have proved it to be the cheapest, strongest, and lowest loss battery for wireless purposes. Made entirely throughout of the best materials, it is the result of many years specialisation in the manufacture of leak-proof batteries, and in making this offer we are confident that it will introduce us to many thousands more satisfied users of this world-famous battery.

To celebrate the opening of our new and larger factory for the manufacture of the Elite Accumulator we have decided to offer, for 28 days only, our standard 60-volt semi-oil submerged type, complete in case, direct to the public at 22/6.

The steadily increasing demand for Elite Accumulators is proving that the Wireless public are ready to appreciate the enormous advance which this battery shows in comparison with the ordinary pitch covered type of which it is impossible to prevent surface leakage.

You are able by this special offer to obtain an accumulator from which the absolute maximum of current is delivered to your valves—no waste by surface leakage because of the oil insulation, the feature of the Elite Accumulator. In the long run your high tension supply will work out far cheaper if you take advantage of this reduction than by using the old method of dry batteries which are wasteful and expensive.

**ENTIRELY
BRITISH &
GUARANTEED
AGAINST ALL
SURFACE
LEAKAGE.**



**CHIEF POINTS OF ADVANTAGE
over all other Accumulators:**

Electrical surface loss entirely eliminated. No acid creeping whatever. After long use when a plate becomes done a new one can be refitted instantly without skill, consequently the battery will last a lifetime and is never done. Tappings may be taken at any intermediate two volts, and is as clean in operation as the ordinary dry battery, and is a means of obtaining a full year's H.T. at a cost of a few pence. Dead silent in operation. Sold entirely on approval system.

ACCUMULATORS ELITE
BEDFORD STREET, HALIFAX
Telephone: 4304. Telegrams: "Elite, Halifax."
TRADE SUPPLIED.
London Distributor — CECIL POHLMAN,
77, Great Portland Street, London, W.1.

FREE.—Write for our free treatise on the care of your high tension accumulator. It is very important to know how to look after these, and owing to our wide experience we are able to offer unrivalled advice on this subject.

MISCELLANEOUS ADVERTISEMENTS.

NOTICES.

THE CHARGE FOR ADVERTISEMENTS in these columns is:

12 words or less, 1/- and 1d. for every additional word, e.g., 18 words 1/6; 24 words, 2/-

Name and address must be counted.

SERIES DISCOUNTS are allowed to Trade Advertisers as follows on orders for consecutive insertions, provided a contract is placed in advance, and in the absence of fresh instructions the entire "copy" is repeated from the previous issue: 13 consecutive insertions, 5%; 28 consecutive, 10%; 52 consecutive, 15%.

ADVERTISEMENTS for these columns are accepted up to **FIRST POST** on **THURSDAY MORNING** (previous to date of issue) at the Head Offices of "The Wireless World," Dorset House, Tudor Street, London, E.C.4, or on **WEDNESDAY MORNING** at the Branch Offices, 18, Hertford Street, Coventry; Guildhall Buildings, Navigation Street, Birmingham; 199, Deansgate, Manchester.

Advertisements that arrive too late for a particular issue will automatically be inserted in the following issue unless accompanied by instructions to the contrary. All advertisements in this section must be strictly prepaid.

Postal Orders and Cheques sent in payment for advertisements should be made payable to **ILIFFE & SONS Ltd.**, and crossed **& Co. Treasury Notes**, being untraceable if lost in transit, should not be sent as remittances.

All letters relating to advertisements should quote the number which is printed at the end of each advertisement, and the date of the issue in which it appeared.

The proprietors are not responsible for clerical or printers' errors, although every care is taken to avoid mistakes.

NUMBERED ADDRESSES.

For the convenience of advertisers, letters may be addressed to numbers at "The Wireless World" Office. When this is desired, the sum of 6d. to defray the cost of registration and to cover postage on replies must be added to the advertisement charge, which must include the words Box 000, c/o "The Wireless World." Only the number will appear in the advertisement. All replies should be addressed No. 000, c/o "The Wireless World," Dorset House, Tudor Street, London; E.C.4. Readers who reply to Box No. advertisements are warned against sending remittance through the post except in registered envelopes; in all such cases the use of the Deposit System is recommended, and the envelope should be clearly marked "Deposit Department."

DEPOSIT SYSTEM.

Readers who hesitate to send money to unknown persons may deal in perfect safety by availing themselves of our Deposit System. If the money be deposited with "The Wireless World," both parties are advised of its receipt.

The time allowed for decision is three days, during which time, if the buyer decides not to retain the goods, they must be returned to the sender. If a sale is effected we remit the amount to the seller, but, if not, we return the amount to the depositor. Carriage is paid by the buyer, but in the event of no sale, and subject to there being no different arrangement between buyer and seller, each pays carriage one way. The seller takes the risk of loss or damage in transit, for which we take no responsibility. For all transactions up to £10, a deposit fee of 1/- is charged; on transactions over £10 and under £50, the fee is 2/6; over £50, 5/-. All deposit matters are dealt with at Dorset House, Tudor Street, London, E.C.4, and cheques and money orders should be made payable to Iliffe & Sons Limited.

THE SALE OF HOME-CONSTRUCTED UNLICENSED APPARATUS.

A New Service to our Readers.

We have made an arrangement with the Patentees whereby readers who wish to dispose of a home-constructed receiver not licensed under the patents made use of, can do so by means of the Deposit System referred to above.

The person desiring to sell, in sending us particulars for his advertisement, will in every case make use of a Box No., and should add to the price which he requires the amount of royalty customarily paid by manufacturers, viz. in the case of Marconi Patents the amount should be calculated at 12/6 per valve holder.

If the purchaser is satisfied with his purchase, the sum realised will be forwarded to the seller, less the amount due in respect of royalties, which amount will be paid by "The Wireless World" to the owners of the patents concerned and a certificate will be handed on to the purchaser of the set.

SPECIAL NOTE.

Readers who reply to advertisements and receive no answer to their enquiries are requested to regard the silence as an indication that the goods advertised have already been disposed of. Advertisers often receive so many enquiries that it is quite impossible to reply to each one by post.

RECEIVERS FOR SALE.

ALL-WAVE Four and the Famous Everyman Four; high-class sets only, giving maximum efficiency; full particulars and prices on application.—H. Goodwin, Woodcock Hill, Elstree. [0050]

PORTABLE Wireless Sets.—Any make supplied for deferred payments.—Write for terms, and state your requirements to Ellis Nicholls and Co., 132, Caledon Rd., East Ham, London. [4840]

GILLAN Ubique IV. Portable Receiver as new; cost £25, accept nearest £20; loud-speaker range B.B.C. stations 30 miles, Daventry 80 miles; many foreign stations on phones.—Box 2756, c/o *The Wireless World*. [4984]

MARCONI Straight Eight Complete with 11 Valves, list price £62, bargain price £40.—Saul, 8, Ansdell Rd. South, Ansdell, near Blackpool. [4986]

2 VALVE Set, Detector and L.F.; £7.—Box 2785, c/o *The Wireless World*. [4990]

EVERYMAN'S Four, polished cabinet, P.M. 6 volt 11 valves, Ormond S.L.F. con., Ferranti A.F.3 trans., etc.; £15.—Box 2780, c/o *The Wireless World*. [4992]

SHORT Wave Set.—Australia on two valves. By Harris, 12-200 metres; complete set of parts, including Bremer-Tully coils, as per designer's specification, for sale cheap, sell separate if necessary.—N. Jones, Yatesfield, Nailsworth, Glos. [4990]

NEW Portable 3, pleated speaker, in handsome case, containing set, frame aerial, and batteries, plugs for permanent aerial and earth, and phones, complete with valves and coils, bargain, £10; also Reflex 2 in light oak cabinet (glass front), loud-speaker, wet L.T. and H.T. and coils, £7/10; both sets very sensitive on one valve.—118, Braidwood Rd., Catford, after 6 p.m. [4997]

BARGAINS Taken in Exchange.—Everyman Four, £8; Solodyne, £12; 3 valver, £6.—Browne, 65, Sinclair Rd., W. [4999]

BURNEDEPT Ethophone V., guaranteed perfect in every way, all valves and batteries, seven coils, a really genuine bargain; £15.—Gaunt, Layton Avenue, Rawdon, Leeds. [5009]

UNIQUE Opportunity.—Number of marine crystal receivers, just dismantled from ocean liners, for quick disposal: Open and closed circuits, balanced crystals, 2 potentiometers, variable condenser, fixed condensers, variable coupling, several switches, etc., etc., tuning range 300 metres to 2,000 metres, accompanied by second instrument variable tuning inductance; original cost £20 to £30. A written declaration required from purchasers that these will not be used for commercial shipboard use. Price £1 per set (2 instruments), packing free, carriage forward per rail. Cash and declaration to accompany order.—J. B. Humphreys and Co., marine wireless telegraph engineers, Bombay St., Bermondsey, London, S.E.16. [5011]

SUPER HET., 7-valve, enclosed speaker, S aerial, batteries, £30; 3-valve Sterling, frame, Japanese cabinet, £25; Gecophone crystal, Western power amplifier, mains unit, Ethovox, sell as complete outfit, £20.—Anderson, Park View, Shirley Rd., Croydon. [5043]

Receivers for Sale.—Contd.

CLEARANCE Stock.—2 valve amplifier solid oak cabinet, hinged lid, enclosure valve holders; bargain, 33/-; also 1 valve 20/-.—Henry Needham, radio specialist, 112 Oldfield Rd., Stoke Newington, London, N 16. [4951]

BROWN Microphone Amplifier, also P.M.1.H.F., P.M.1.L.F., D.R.2.D.E.R. D.E.3.H.F.; offers.—Snook, Lombard St. Portsmouth. [504]

BURNEDEPT Ethodyne Mk.I. 7-valve Superhet, complete two frame aerials and seven valves; perfect condition; hardly used; cost over £80; accept £37.10 for quick sale; thoroughly genuine offer; owner wants cash deposit system your safeguard.—Box 2797, c/o *The Wireless World*. [503]

3-VALVE Receiver, straight circuit, H.F. detector and L.F., very best components throughout, mahogany cabinet with folding doors and £5.5 Amplion loud-speaker; the whole lot practically as new; can be seen and heard any time by appointment; cost £25 will accept for a genuine bargain £14.—Minchin, Norcot, Reading, Berks. [503]

EVERYMAN Four Complete, valves, batteries, etc.; no cabinet; perfect working order; £15; special reason for selling demonstration by appointment.—Wallis, 77 High St., Marylebone. [503]

9-VALVE Experimental Set in good cabinet very low price for quick sale.—Box 280, c/o *The Wireless World*. [502]

MAGNAVON 3-stage Amplifier with switching; 1, 2 and 3 valves; £4.10 cost £20; with three B4 valves, £6.—20 Clarendon Rd., Watford. [502]

NEW 2-Valve Low Loss Receiver, amplifier and all accessories, 20-50 and 300-500 metres; also large number components—sacrifice, £11 lot.—Particulars from 85, Rise Rd., Newport, Mon. [502]

F. W. SMURTHWAITE, radio engineer for high class receivers at reasonable prices; every set personally tested by me and guaranteed 12 months.

ALL-WAVE and Everyman Fours.—Beautifully made with best quality components throughout, in dark oak or mahogany cabinets, high and low power switch optional either type, £14.

HARMONY Five, the finest neutralisation straight set obtainable, irrespective of price; covers all wavelengths; perfect quality reception from local station when desired. £16.

SUPERHETS.—Burndept All-wave model £25, complete with frame; s/h receiver from £12/10; all guaranteed; details with pleasure.

B.B.C. Quality Receivers, P.M. circuits and all other published designs quoted for keenest prices consistent with real quality.

H.T. Mains Units.—A.C. or D.C., really efficient types giving up to 40 milliamps at 200 volts; complete instruments or components.

GECOPHONE 2-Valve Cabinet Set, as enclosed, with valves; indistinguishable from new; £6.

F. W. SMURTHWAITE, 15A, Onslow Gardens, Wallington, Surrey. Phone Wallington 1982. [503]

Mention of "The Wireless World," when writing to advertisers, will ensure prompt attention

BATTERIES.

WHY Buy Accumulators or Dry Batteries?
 London's Leading Hire Service improves reception. Saving time, trouble, and money. No big outlay. No deposit. Pay carman on each delivery. High tension service from 6d. per week. Low tension service from 1/3 per week. Fully charged and delivered free within 12 miles of Charing Cross. Explanatory folder post free.—Radio Service, 105, Torriono Av., N.W.5. 'Phone: North 0623/4/5.

SECRET of the Perfect Wet H.T. is the new perforated insulating liner; this insulates the inside of the zinc from the sac, price 4d. doz., supplied free with orders for complete cells; jars, 1/3 doz. plain, 1/6 doz. waxed; zinc special, 1/- doz.; sacs, high capacity, 1/6 doz.; post free on 3 doz. and over, packed in special carton with divisions for each cell; this can be used as a container for the battery when made up; send 6d. for sample complete unit, with particulars and instructions; sacs with screw tops, 9d. doz. extra; double size sacs, 3/- doz.—Spencers Stores, Ltd., 4-5, Masons Av., Coleman St., London, E.C.2 (near Bank). 'Phone: London Wall 2202.

BIRMINGHAM and District.—Send for particulars of our accumulator hire service, and we will prove to you that it is cheaper to hire an accumulator than to buy one. We supply the accumulator, collect and deliver it, and it costs no more than you are paying now for charging.—New Era Wireless & Electrical Co., Hobmoor Rd., Small Heath, Birmingham, Tel. Vic. 744.

TWO Oldham 6v. 80 amp. (actual) accumulators, new, not had acid; £2/10 each; carriage forward.—Renshaw, 17, Walter St., Blackburn.

WET H.T. Batteries.—Jars, 2 1/2 x 1 1/2 x 1 1/2, 1/3 doz.; zincs, 1/- doz.; sacs, 1/6 doz.; dozen cells complete (18 volts), 3/6; post 9d. extra. High efficiency, long life, upkeep practically nil. Orders for 3 dozen or over post free, packed in special carton with divisions for each cell, usable as container for complete battery. Send 6d. for sample complete unit with instructions. Write for free lists of wireless bargains.—W. Taylor, 57, Studley Rd., Stockwell, London.

C.A.V. 60 volt H.T. Accumulator, 30/-; will exchange for Bowyer-Lowe Model IV. oscillator coupler.—Jackson, 1, Upper Grange Rd., Bermondsey.

A.B. H.T. Batteries Cost Less Than Many other makes. The fact that they are manufactured by Messrs. Thomson Houston et Cie., of Paris, is proof of their high quality. Further, every battery carries a full and generous guarantee. Usual sizes stocked; 60 volt, 100 volt, and grid bias, etc. Ask your dealer for same. If he cannot supply you write us direct. Trade enquiries specially invited.—G. E. Ambatiello & Co., Ltd., Ambatiello House, Farringdon Road, E.C.1. Telephone: Clerkenwell 7440.

CABINETS.

ARTCRAFT Radio Cabinets and Panels for all "Wireless World" sets.

ARTCRAFT Cabinets are made in Oak and mahogany, properly french polished, and are priced from 6/- to £11/11.

ARTCRAFT Cabinets made to any specification or design. Estimates by return.

ARTCRAFT Illustrated Catalogue Free.—The Artcraft Co., 156, Cherry Orchard Rd., Croydon. 'Phone: Croydon 1981.

the big 3

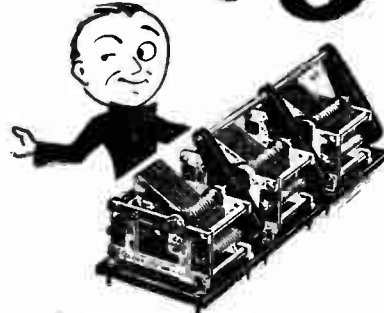

CYLDON GANG CONDENSERS

The gang condensers most constantly specified by radio journals. Logarithmic units for correct tuning.

2-Gang £2 10s. 3-Gang £3 10s. 4-Gang £4 10s.

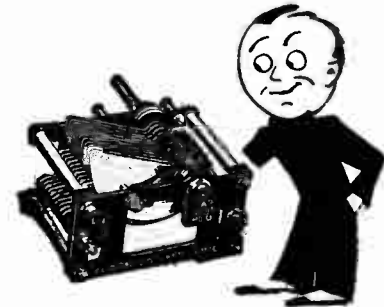

CYLDON LOG MID-LINE CONDENSERS

The first condensers to be designed on the logarithmic principle. Better than Square Law and Straight Line Frequency. Spread all stations evenly over dial. Makes possible "one-dial control" in multi-tuned circuits. The condensers of the future.

PRICES:
 .001 .. 21/- .0005 .. 17/6 .0003 .. 16/6 .00025 .. 14/-
 .0002 .. 15/6
 With 4in. Knob Dial. If dial is not required deduct 2/-.

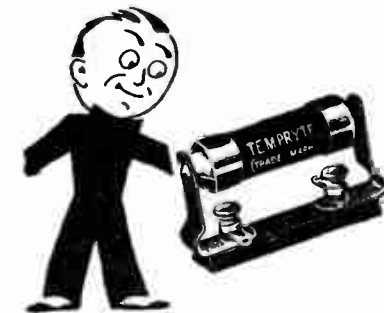

CYLDON TEMPRYTES

The proved best means of valve control. Functions perfectly with any type of valve. Cannot overheat filament. Noiseless. Tested and guaranteed to give perfect performance.
 Cyldon Temprytes 2/6 each. Holder Mountings 1/6 each.

CYLDON

CYLDON products can be obtained from stock by return, and do not believe any statements to the contrary. If any difficulty 'Phone: Enfield 0672. Wire: Enfield 0672, or use the C.O.D. system.

SYDNEY S. BIRD & SONS,
 Cyldon Works,
 ARNESFIELD RD., ENFIELD TOWN, MIDDLESEX

Cabinets.—Contd.

SUMMER Offer.—American type cabinets, figured oak, polished light or dark, fitted best polished ebonite panel, 21 x 7, each 21/-; 14 x 7, each 16/6; highest quality workmanship; write your requirements.—Order your components at the same time from Tucker and Pearce, A.M.I.R.E., Radio Engineers, 96, Victoria Rd., Swindon. [5014]

PEDESTAL Cabinets in Massive Oak Jacobean Finish (as illustrated in *The Wireless World*, May 4 issue), for Everyman Four or any set with panel up to 26in. x 8in., stands 3ft. high, 15in. deep, 10in. baseboard included; £5/5, carriage paid; may be inspected on van before acceptance; fully illustrated folder gives every detail; write to-day.—G. E. Ambatiello and Co., Ltd., Ambatiello House, Farringdon Rd., London, E.C.1. 'Phone: Clerkenwell 7440. Telegrams: Ambatiello, London. [0055]

MAKE Our All-in-One Cabinet.—Send stamp with height and size of loud-speaker flare to "The Stores," 44, Prospect Pl., Swindon, Wilts. [5025]

LOUD-SPEAKERS.

COIL Drive Loud-speakers.—We can supply the following at reasonable prices. First-class workmanship and materials only. Immediate delivery from Selhurst Radio.

IMPORTANT.—All coil driven speaker parts supplied by us are constructed by highly skilled engineers with the best possible materials. As we do not depart from the specifications given in *The Wireless World* you are assured of good results. Immediate delivery from Selhurst Radio.

UNIT No. 1.—Pot magnet with field winding for six-volt accumulator and tin moving coil. Immediate delivery from Selhurst Radio.

UNIT No. 2.—Pot magnet with field winding for six-volt accumulator or D.C. mains as required, and tin moving coil as described by N. W. McLachlan in *The Wireless World*, April 13, 1927. Immediate delivery from Selhurst Radio.

UNIT No. 3.—Permanent magnet unit as described by H. Lloyd in *The Wireless World*, June 1, 1927. Immediate delivery from Selhurst Radio.

FRAMES and Cradles specially constructed to enable unit to be assembled with ease in a few minutes. Immediate delivery from Selhurst Radio.

TRANSFORMERS.—With tapped primary in four sections, as described in *The Wireless World* by H. Lloyd. Specially designed for use with coil driven speakers. Immediate delivery from Selhurst Radio.

PEDESTAL Cabinets.—Specially suitable for coil driven speakers, beautifully finished in polished mahogany or oak. Immediate delivery from Selhurst Radio.

WE shall be glad to advise you as to the most suitable unit for your set.—Bakers, Selhurst Radio, 89, Selhurst Rd., South Norwood, S.E.25. 'Phone: Thornton Heath 1488. Works: 42, Cherry Orchard Rd., East Croydon. [4952]

BARGAINS!—Loud-speakers, 22 inches high, 14 1/2 inches diameter flare, heavy cast neck and base, black crystalline finish, adjustable diaphragm, rubber feet, cord, looks well, sounds well; 32/6; carriage free. If you have a loud-speaker bring this to the notice of a friend who hasn't.—Universal Wireless Depot, 160, County Rd., Swindon. [5013]

Loud-speakers.—Contd.

YOUR Speaker Taken in Part Exchange for New One; also several first-class speakers for sale cheap.—Browne, 65, Sinclair Rd., W. [5001]

FULL-SIZE Loud-speaker, Ericsson; £1.—Cochrane, Dryden, Oundle, Northants. [4998]

LOUND-SPEAKER (new). Brown's H.3, cost £3, or will exchange for anything useful.—Jackson, 120, Wessex Buildings, Upper Holloway, London, N.19. [4994]

HORNS for all types of loud-speakers, especially gramophone attachments and Amplion A.R.39; illustrated list free.—Maddison, Manufacturer of the Allwoodorn, 2a, Ronald's Rd., N.5. [4987]

SEVERAL Good Speakers at very Low Prices. Send for list.—Browne, 65, Sinclair Rd., W. [4980]

YOUR Speaker Taken in Part Exchange for new one.—Browne, 65, Sinclair Rd., W. [4981]

PERMANENT Magnet Coil-drive Loud-speaker parts described by H. Lloyd in June 1 issue. From Star Engineering.

WARNING.—The manufacture of parts for constructing coil-drive loud-speakers is an engineer's job. All parts made by Star Engineering are backed by 35 years' experience in the manufacture of high class machinery.

ORDER Your Parts from Star Engineering and avoid trouble; lists free.—Star Engineering, Didsbury, Manchester. [5002]

GECOPHONE Cone, cost £6/6, accept £4; also Gecophone horn type; cost £5; accept £2; both perfect.—Parkinson, Morton Hotel, Russell Sq., London. [5020]

HUTH Magnet Pots are the best obtainable.—Write for our list and printed matter, which gives you full details. You can then judge for yourself. Disinterested advice on your particular case free.

HUTH Magnet Pots can be supplied to *Wireless World* specifications if required, but we prefer to recommend our own types, which in all cases are more sensitive. All our units use much less current. This result is obtained by larger and more expensive windings. This means less profit for us but greater satisfaction to our customers.

HUTH Special Economy Pots for 1in. or 2in. coils use less than .3 amps. at 6 volts, yet are four times as sensitive as permanent magnet types. Other types with larger consumption also supplied.

HUTH Magnet Pots for all voltages from 6-250 volts. Moving coils for outputs up to 10 L.S.5.A. valves in parallel.

SEND Your Problem to Us.—We have had considerable experience with these speakers, and it is your complete satisfaction we want. Last week's best query was how to make a 4-foot baffle unobtrusive in a drawing room; that was easy; see if you have got something more difficult.

HUTH Accurate Centring Device fitted to all pots at no extra cost enables moving coil to be adjusted to a thousandth part of an inch. Without this device success with these speakers is uncertain, and continual re-adjustment necessary. In addition, coarse adjustment means a large air gap, with consequent loss of efficiency. This is one of the reasons for the supremacy of speakers constructed from Huth parts.—F. L. Huth, 17B, Vale Rd., Tunbridge Wells. [5021]

Mention of "The Wireless World," when writing to advertisers, will ensure prompt attention.

"SHORT WAVE"



This is the battery recommended as a source of H.T. supply for the short wave transmitter described in last week's "Wireless World."

Throughout the country amateurs are using this "Layerbilt" Battery for transmission with absolute success.

Ask your dealer for COLUMBIA "Layerbilt" No. 4486—45 volts.

Advt. of J. R. MORRIS, 15, Kingsway, W.C.2.

DO YOU GET TROUBLE FROM TRAMS?

The only way to eliminate tram trouble entirely from wireless reception is to support the valves in the world-famous Benjamin Valve Holders. Outside vibrations from passing traffic—although often inaudible to the human ear—are a menace to pure reproduction and should be countered by the Benjamin Valve Holder which completely disperses all microphonic noises.

Valve sockets and springs are made in one piece with no joints or rivets to work loose and cause faulty connections. Valves are free to float in every direction and can be inserted and removed easily and safely. Valve legs cannot possibly foul the baseboard. Terminals and soldering tags are provided.

BENJAMIN
Clearer-Tone
Anti-Microphonic
**VALVE
HOLDER**
2/9 each
Covered by Patent
and Registered
Designs.

THE BENJAMIN ELECTRIC LTD.
Brantwood Works, Tariff Road, Tottenham, N.17

Loud-speakers.—Contd.

WHAT Offers Lot?—Amplion A.R.38, one D.E.5 and one D.E.5B, Marconi's, used five minutes only, bought in error.—Tetley, 1, Palace Gate, London, W.8. [4913]
AMPLION, mahogany, A.R.23, cost £8/10; must sell, £3; perfect condition.—60, Rowdowns Rd., Dagenham. 'Bus 23. [4988]

VALVES.

BRITISH Valves.—2-volt .06 H.F. and L.F., 2-volt .12 H.F. and L.F., 2-volt .34 power valve, 4-volt .06 H.F. and L.F., 4-volt .12 power valve, 6-volt .25 power valve; all one price, 5/- each, post free; satisfaction guaranteed. Trade supplied. Write your name and address clearly.—H. Howarth, Ensign Depot, 288, Deansgate, Manchester. [4979]

5/-—Power valves, 2, 4, or 6 volt dull emitters, British made, guaranteed, money refunded if not satisfied, post free. Send for list of other types.—Carter & Co., 61, Lower Moseley St., Manchester. 'Phone: 3742 Central. [4911]

5 2 v. Cossor .1, 2 B.T.H. B.5, all new; 50/- or offer.—Chastney, 351, Queen's Rd., New Cross. [4993]

TRIOTRON Dark Emitters, 2 volt 0.1 amp. power valves, 9/-; Triotron general purpose valve, 2 volt 0.2 amp., 4/11; tested and guaranteed; post paid.—Storrays Wireless Mart, 143, Eastbank St., Southport. [4985]

CHARGERS & ELIMINATORS.

ACCUMULATOR Chargers (A.C.), 45/- complete. Post free. Also components for same and for A.C. battery eliminators; fully guaranteed.—Stafford O'Brien and Partners, Ltd., 66, Victoria St., S.W.1. [0052]

H.T. Mains Units.—My specially designed types are really efficient and prices reasonable. See "Receivers for Sale" columns.—F. W. Smurthwaite. [5037]

COMPONENTS, ETC., FOR SALE.

TANTALUM.—Tantalum metal sheet for A.C. rectifiers.—Blackwell's Metallurgical Works, Liverpool. [4386]

BELLING-LEE Panel Fittings are designed to give an expert finish to any home-constructed set. Catalogue post free.—Belling and Lee, Ltd., Queensway Works, Ponders End, Mx. [0018]

REED Movements.—Double Acting Reed movements specially designed to operate cone and other large diaphragms; extremely sensitive on small input, yet capable of enormous volume with sufficient input. Will work up to a 3ft. cone with ease. No rattle or distortion; 27/6 each. Fair allowance on Brown A earpieces, or Lissenolas and other units in part exchange. Send stamp for Illustrated Lists of these and seamless cones.—Goodmans, 27, Farringdon St., E.C.4. [0049]

LAKER 30ft. Handsome Steel Mast, 22/6. See descriptive advertisement, page 2. Easily erected. [0021]

AERIAL Grid Coils and H.F. Transformers for Everyman Four, with chart showing over 40 stations (on L.S.), price 17/6 each; H.F. transformers for the All-Wave Four, high and low wavelengths, set of two and base 35/-; all coils of highest quality materials and finish.—H. Goodwin, Woodcock Hill, Elstree. [0051]

Components, Etc., for Sale.—Contd.

PICK-UP, latest used by L.O for perfect gramophone reproduction; demonstrations daily by W. J. Turberville Crewe, M.Inst.R.E.; £3/15.—J. Glasscoe & Co., 49, Eastcheap, E.C.3. [4993]

REX Radio.—Shop soiled list, guaranteed R.O.K., but slightly soiled components: Igranite Indigraph vernier dials, 6/-; transformers, 3-1 14/-, 5-1 15/-; Radio switches, 2/3; Pacent switches, 1/6; Microvern dials, 7/6; S.L.F. condensers, .00035 13/-, .0005 17/-; porcelain rheostats, 6 and 30 ohms, 2/- each; plugs, P.40, 1/3; jacks, P.62 2/-, P.63 2/3, P.61 1/9; Colvern screens and base, 7/6; Formo S.L.F. condensers, 7/-; Formo vernier dials, 3/6; rheostats, Benjamin 30 and 15 ohms 2/3, Peerless 6 and 30 2/-, Ede 7 15 and dual 2/6; Ede potentiometers, 3/-; cone speaker, 20/-; S.L.F. condenser with dial, 5/-; 3 way ebonite coil holders, 2/-; single panel coil holders, 4d.; ebonite coil mounts, 4d.; WatMel variable leaks, 2/-; No. 2A and 3 Dimic coils, 8/-; above carriage free, cash or C.O.D.; money refunded if unsatisfactory; cannot repeat.—Rex Radio Co., Lowther Rd., Crumpsall, Manchester. [4947]

SCOTT SESSIONS.—Set constructor's service. Express delivery absolutely every component for all "Wireless World" sets.

SCOTT SESSIONS.—Send for wireless bargain list. Marvellous cone loud-speakers, superb tone, only 35/- each. Send us your orders. Save money, time, and trouble.

G. SCOTT SESSIONS and Co., Hill Top, Muswell Hill, N.10. [4937]

TAKEN in Exchange.—Screens, coils, transformers, condensers.—List from Browne, 65, Sinclair Rd., W. [5000]

SILENT Grid Leak and anode resistances in glass tubes, turned brass ends, 0.1 to 5 megohms, 1/6; powerful loud-speakers, 14in. horn, 3in. diaphragm, 35/-; aluminium base and diaphragm box, 17/6.—Cathedral Radio Manufacturing Co., Salisbury. [5017]

FOR Sale, Igranite Pacent triple gang condenser with balancing condensers, almost unused; cost 75/-, accept 48/-.—J. G. M. Pollock, Headington Hill, Oxford. [5016]

LAKER 30ft. Handsome Steel Mast, 22/6. See descriptive advertisement, page 2. Easily erected. [0022]

SALE, P.M.5b, 10/-; L.S.5, 17/6; 2100 Western, 17/6; 3 solid back microphones, 10/-; Ormond .0005, 3/6.—Edwards, Wellhead Lane, Perry Barr, Birmingham. [5010]

EXPERIMENTERS.—Ex R.A.F. B.T.H. 40-watt transmitting valve, 15/-, cost 35/-; Ideal transformer, C.1, perfect, 12/-; 3 Burndept coils, 17 to 80 metres, 5/-; 2-way Lotus coil holder, 2/6.—C., 10, Cornwall Rd., Littlehampton. [5007]

BRITPHONE 4A, long and short wave, 4-valve set, with D.E. valves, £10; frame aerials, 280-1,800 metres, 35/-; wave-meters, 250-2,000 metres, complete with chart, 50/-; set super-het intermediate transformers with long and short wave oscillators, £3, suitable for portable; two 60-volt C.A.V. accumulators, good condition, 30/- each; beautiful mahogany cabinets, brand new, panel size, 16x6, baseboard 16x10, 4 doors, and hinged lid, suitable any class of set, £4 each.—F. Alton, A.M.E.E., 47, Park Rd., West Hartlepool. [5006]

IT Will Pay You Before Buying to write for my list of guaranteed second-hand bargains.—Browne, 65, Sinclair Rd., W. [4982]

Eliminates Soldering



Transverse slot with clamping nut, eliminating soldering.

The Top does not rotate.
The Head does not come off.
The Smooth Stem ensures that strands of wire will not bind up with thread.
The finish is perfect throughout.

The Belling-Lee Patented Terminal, made with 30 different engravings, is used by the manufacturers of all the best battery eliminators.

Standard Model (Bakelite insulated), Type B 9d. each
Popular Model (non-insulated), Type M 6d. each

Illustrated catalogue free on request. Obtainable from all dealers, but in case of difficulty send your order to us, enclosing your dealer's name and address.

BELLING-LEE TERMINALS

Belling & Lee, Ltd., Queensway Works, Ponders End, Middlesex.

REDUCED PRICE

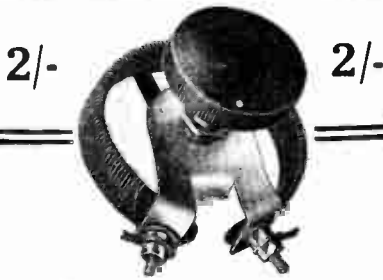

7, 15, 30, 50 ohms.
— 2/- each —
Post Free

The 'AMYCO' Light-Weight RHEOSTAT.

The RHEOSTAT that is dependable in operation.

A. M. Young & Co.,
52, Bordesley St., BIRMINGHAM

RELIABILITY COIL FORMER
46 Pin Type 1/3
Price
Without Hand 1/-
Postage 3d.
Further attractive items in Miscellaneous Columns.

J. H. TAYLOR & CO
2 RADIO HOUSE,
MACAULAY ST., HUDDERSFIELD

Send for Free Guide Now.
Trade Enquiries Solicited.

Components, Etc., for Sale.—Contd.

EXPERIMENTER'S Surplus. — Amplion, A.R.39, 15/-; Revo Senior, 25/-; hand microphone, 17/6; Marconi Ideal, 2-7-1, 17/6; Varley 100,000 and 80,000 resistances, 3/6; Cosmos H.F. choke, 3/-; 2 D.E.R., 1 D.E.3, 1 S.P.55B., 1 S.P.18B., 3 B.T.H. B.4, 1 B.5, 8/6 each; 1V.24, 7/6; 1 Weco, 7/6; 1 D.E.5, 1 S.P.55R., 10/6 each. Will consider reasonable offer for any of above; all guaranteed perfect, or money refunded.—Box 2790, c/o The Wireless World. [5005]

EVERSHED 1,000-volt 30-milliamp D.C. generator, warranted as new, £6/10; T.V.T. unit, perfect, 12/6; L.S.5 valve, new, 25/-; 1/4hp. Metro-Vick D.C. motor, 230-volt, shunt wound, as new, £4/10.—Cholerton, St. Helens. [4989]

EVERYMAN Coils, Three, Four, Five exact specification, all ebonite bases, 12/6 each; All-wave coils (May 11): short wave, 16/-, long wave 18/-, base 3/6; genuine Mikapac tubes, 3x3 1/2, one 1/4, two 2/6, three 3/6; grooved ebonite spacers, 1/- set of 8; all-wave do., 6 1 1/2in., 1/-; 12 2in., 2/6; Litzen wire (Lewcos) to wind one coil, 4/8.—Jennens, below.

WYCHE Switch, two-way, 1/3; both battery, 1/6.—Jennens, below.

RHEOSTAT, Jennens, as specified for R Nucleus receiver, 7-, 20-35 ohms, 2/- each.—Jennens, below.

LOEWE Multiple valves (3N.F.).—Detector and 2 L.F. stages, more volume and purer tone than two best L.F. transformers and power valves on local station and Daventry; H.F. stages can be added; 45/- C.O.D.—Jennens Radio, 30, Chapel St., Birmingham. [4776]

LAKER 30ft. Handsome Steel Mast, 22/6. See descriptive advertisement, page 2. Easily erected. [0023]

FERRANTI A.F.3, unused, 10/-; 4 Cossor 2-volt valves, 9/- each; Stentor Two, 11/6; 2 .0005 S.L.F. condensers, 6/- each; Trix anode inductance, 10/-; oak cabinet for panel 18in x 8in., hinged lid, 15/-; 3 6-pin S.P.H.F. transformers and 1 aerial coil, £1.—Newell, 57, Cromwell Rd., Peterborough. [4934]

RELIABILITY WIRELESS GUIDE.—New edition, No. 99A, just issued. Free upon request.

RELIABILITY FREE DELIVERY.—Orders over 5s. 5d., otherwise add 2d. per lb.

RELIABILITY WEEKLY ATTRACTION.—Atlas low loss square law .0005 condensers with dials, 3s. 11d.

RELIABILITY CLEARANCE LINES.—R Lissen T.3 Transformers, 7s. 6d.; Gents, 7s.; Atlas, 6s.; Etherplus, 5s.

RELIABILITY LISSAN COMPONENTS.—R—H.T. Batteries, 7s. 11d.; Transformer, 8s. 6d.; Mica Sparking Plug, 4s.; Rheostats, 1s. 6d. and 2s. 6d.

RELIABILITY STRAIGHT-LINE CONDENSERS.—With 4in. Trolite Dial .0005, 5s. 9d.; .0003, 5s. 6d.; Vernier Dial extra, 1s. 6d.

RELIABILITY ANTI-CAPACITY SWITCH.—Double Pole Double Throw 1-hole fixing, knob operated, screw connections, 3s.

RELIABILITY GOODS AND SERVICE.—Only obtainable from J. H. Taylor and Co., 15, Radio House, Macaulay Street, Huddersfield. Trade supplied. Send for free Guide now. [0028]

Components, Etc., for Sale.—Contd.

SIMMONDS Bros.—Coils: Everyman Four, 33/- per set; Everyman Three, 35/-; "Wireless World" Five, 50/6; All-Wave Four, 42/6; Quality Three, 16/6; all with bases, first-class material and workmanship. Screens: Everyman Four, 4/6; Everyman Three, 4/-; "Wireless World" Five, 50/-; All-Wave Four, 5/-. Cabinets: Everyman Four, from 35/-; Everyman Three, from 32/-; "Wireless World" Five, from 30/-; All-Wave Four, from 30/-; Ormiston's Litzen-draht: 20 yards, 5/6; 25 yards, 6/6; 50 yards, 12/-; 60 yards, 14/6; Paxolin formers, 1/6 each; Everyman Four booklet, 1/- The All-Wave Four coils have special five-pin non-reversible, non-shorting base, as recommended by the authors. Readers and the trade supplied with all above and other necessary components, home and abroad. Complete lists and test report of coils post free from the original specialists and leaders.—Simmonds Bros., Shireland Rd., Smethwick. [4714]

SET of Colvern Coils (with bases), long and short wave, for Columbus P.M. circuit, also R.1 H.F. choke and Franco neutralising condenser, above parts almost new; 45/- the lot.—Box 2791, c/o *The Wireless World*. [5004]

2.0005 Ormond S.L.F. variable condensers, brass vanes, plain motion, practically new, 6/- each; 2 centre-tapped coils, 250-500 metres. with bases, Becol formers, 5/- pair.—Box 2781, c/o *The Wireless World*. [4991]

AMERICAN Radiola 6-Valve Interior with Valves, needs variable condensers and cabinet; £8; Kerr, 1, Brittacy Avenue, Mill Hill, N.W.7. [5042]

LAKER 30ft. Handsome Steel Mast, 22 ft. See descriptive advertisement, page 2. Easily erected. [0035]

LEWIS H.F. Transformers: 1 Daventry S.P., 5/-; 1 Broadcast S.P., 5/-; 1 Daventry Sp. Sec., 7/-; 1 R.1. L.F. transformer, 10/-; 1 A.J.S. L.F. choke, 7/-; 1 Sing P.D.T. Burndept switch, 2/6; 1 3 Pole ditto, 2/9; 1 T.C.C. 5 mf., 1/6; 1 x 1 mf. ditto, 1/9; 1 Varley M.C. Sp. C. choke, 6/6; 2 Colvern formers and bases wound long and short Broadcast, 10/- the lot; all practically new.—19, Park Hill Rd., Harborne, Birmingham. [5041]

SPECIAL Stocktaking Offer.—All goods listed carry our full guarantee. Coils for Everyman Three and Four, complete with ebonite base, 12 6 each, complete set, 23 -; standard plug-in coils, No. 25, 35, 40, 50, 1/3 each; 60, 75, 100, 125, 1/9 each; 150, 200, 300, 2/6 each, all fitted with thumb grip coil plugs; standard coils in Bakelite case, Nos. 35, 50, and 75, 1/9 each; fixed condensers on Bakelite base, .0001 to .001, qd. each; .002 to .006, 1/3 each; low-loss coil plugs, 7d. each; filament resistances, 7, 15, 30 ohms, 1/6 each; 4in. Bakelite dials, superior finish, 1/3 each. Postage paid on orders of 5/- and over.—Finston, 45, Horse-ferry Rd., London, S.W.11. [5039]

CLEARTRON (Sterling Baby) Loudspeakers, 2,000 ohms, 30/-; Igranite square law low-loss friction drive .0005 condensers, 7 6, 2 for 14/6; both guaranteed new and perfect, carriage paid.—Selby and Co., 6, Hauberk Rd., Lavender Sweep, S.W.11. [5036]

WE Specialise in *Wireless World* Circuits.—Screen boxes, screens, coils, transformers, or any other components supplied. Expert staff ready to overhaul, rewire, or test and advise you.—Matlock Radio Manufacturers, Matlock House, Woodberry Grove, Finchley. Phone: Finchley 2837. [5022]

TUNING COILS

and
METHODS of TUNING

By W. JAMES.



A VERY useful manual giving the maximum of information on the subject. Following a simple explanation of the principles of wireless, the author discusses the many methods of tuning circuits, with explanations of spade, condenser and variometer tuning. Other chapters treat in detail of the choice, construction and design of coils, and give particulars as to size of coil required, the best shape, size of wire, type of insulation, and special uses of the various coils.

PRICE 2/6 NET
By Post 2/10

Obtainable from all booksellers
or direct from the Publishers:

ILIFFE & SONS LTD.,
Dorset House, Tudor Street,
LONDON. E.C.4.

W.W.32

Components, Etc., for Sale.—Contd.

AMPLION A.R.111, perfect, 25/-; Marconi Ideal 6-1, 15/-; Stentor Two, 12/-; Blue Band, 8/-; both new; lot 50/-.—Shepherd, 174, Grove Rd., Balham, S.W.12. [5034]

VALVES.—2 P.M.3, 1 P.M.4, 1 S.T.43 super., 1 D.E.4, 1 Stentor 2, 1.0003 double con., 1.0005 vari. con., 16 Dubilier con., 1 Ferranti A.F.3 transformer, 26 coils, complete all wavelengths, 1 Lotus 3 holder, 6 T.C.C. condensers, quantity of other material; all as new, £6/10 the lot.—21, Biddulph Rd., S. Croydon. [5029]

B. & J. Make all the Special Coils for *The Wireless World* Circuits and Guarantee Complete Satisfaction. All materials exact to specification.

B. & J. Built Sets give excellent results and carry our full guarantee.

B. & J. Wireless Co., 2, Athelstane Mews, London, N.4. [0043]

POPULAR Wall Jack.—This is another new line in keeping with all Deckorem specialities. They make for neatness and efficiency in all cases where loud-speaker and distant phone reception is to be installed in the home. In construction they are strong, in contact with all standard plugs they are sure, in appearance they are a credit to any scheme of decoration. All fittings and cover are of heavily plated nickel, the base is of high insulation material, black and nicely polished. They have a splendid and strong spring wiping contact, are supplied in either series or parallel type, and can be obtained from most dealers, or direct from A. F. Bulgin and Co., 9-10-11, Cursitor St., Chancery Lane, London, E.C.4, and what is more, they only cost 2/9 each. [0042]

LAKER 30ft. Handsome Steel Mast, 22 ft. See descriptive advertisement, page 2. Easily erected. [0036]

CONDENSERS.—Straight Line frequency, 6 brand new, 4in. Trolite dials, .0003 3 ft. .0005 3 ft. 9, less than cost price. Sold during season for double these prices.

BROWN A Type Earpieces, good order, less diaphragms, 11/6; ditto A2 type, 5/-; useful for conversion as gramophone pick-ups.—Goodmans, 27, Farringdon St., E.C.4. [5044]

MISCELLANEOUS.

LAKER 30ft. Handsome Steel Mast, 22 ft. See descriptive advertisement, page 2. Easily erected. [0037]

THE Wireless Doctor Will Call (London and Home Counties) if your set is troublesome; no cure, no charge; Wireless Association registered repairer; sets installed, maintained, and brought up to date; experiments and testing undertaken; Solodyne demonstrated.—Alexander Black, 2A, Woodville Grove, N.16. Clissold 3687. [3841]

INSCRIBE your panel with R.N.B. panel transfers. Artistic, easily applied; silver white or gold. Sixpence per set. Obtainable everywhere.—R. N. B., 50-51, High Holborn, London, W.C.1. [0037]

LAKER 30ft. Handsome Steel Mast, 22 ft. See descriptive advertisement, page 2. Easily erected. [0046]

SUPER Galena Crystals, 5/- lb., min. 50 pound lots. Special terms for quantities.—Blackwell's Metallurgical Works, Liverpool. [4387]

FOR Sale, M.L. anode converter 12-500 volts, good condition and only little used, owner selling as now using higher power for transmitting; cost £18. Any offers.—Box 2789, c/o *The Wireless World*. [5016]

Mention of "The Wireless World," when writing to advertisers, will ensure prompt attention.

Miscellaneous.—Contd.

A SUMMER Hobby—Restringing Tennis Rackets, frames, gut, tools. Lists and instructions, stamp.—Morris, 143, Lonsdale St., Bradford. [4890]

SCOTT SESSIONS, the radio doctor (London and environs).—Any set repaired, installed, modernised; distortion eliminated; specialist in "Wireless World" sets; no fee until repaired.—Scott Sessions, Hill Top, Muswell Hill, N.10. 'Phone: Mountview 4928. [4861]

LAKER 30ft. Handsome Steel Mast, 22/6. See descriptive advertisement, page 2. Easily erected. [0047]

REDUCE Accumulator Troubles.—Test your accumulator with a Utility syringe hydrometer—British made. Full instructions in booklet "Accumulators Explained" sent with each hydrometer. Post free, 4/6. Full particulars on application.—Utility Syringe Hydrometer Co., Dept. B., 16, Howard Rd., Ilford, Essex. [0060]

LAKER 30ft. Handsome Steel Mast, 22/6. See descriptive advertisement, page 2. Easily erected. [0061]

TRANSMITTERS! 1-700-1,000 volt 100 milliamper. D.C. Mackie generator complete, two pulleys, driving belt, has worked all round world, perfect condition, £5; offers.—2X.V., Jeapes, Great Shelford, Cambs. [5018]

A REAL Cinema Show in Your Own Home.—Send for bargain lists of cinematograph machines and films.—Lloyds (Desk E.), 48, Rupert St., Piccadilly Circus, W.1. [4083]

OTHER Systems are Superseded by Ealex Plug and Sockets.—Ask your dealer, or Easticks, 118, Bunhill Row, E.C.1. [0024]

WIRELESS Doctor.—If in trouble write. Expert advice by post. Evening visits arranged. Expert on Superhets, Solodyne, British Six, and later circuits. Solodyne demonstrated.—Morley, 18, Grangemill Rd., Catford, London. [5024]

LAKER 30ft. Handsome Steel Mast, 22/6. See descriptive advertisement, page 2. Easily erected. [0062]

PATENT AGENTS.

A. PETER THURSTON, D.Sc., F.R.Ae.S., M.I.A.E., A.M.I.M.E., 329, High Holborn, London, W.C.1. Patents, Trade Marks, Designs. Telephone: Holborn 2542. [2315]

PATENTS and Trade Marks—British and Foreign.—Gee and Co. (H. T. P. Gee, Member R.S.G.B. and A.M.I.R.E.), 51-52, Chancery Lane, London, W.C.2. 'Phone: Holborn 1255. [0001]

REPAIRS.

TRANSFORMERS, phones, loud-speakers rewound and repaired to maximum efficiency: all one price, 4/- post free. A 12 months' guarantee accompanies each repair. Your present transformer can also be rewound to Multi-Ratio type. Write giving particulars. Trade invited.—Transform, 115, Links Rd., Tooting, London, S.W.17. [0011]

HEADPHONES and Loud-speakers Rewound, remagnetised and overhauled, 4/-; transformers rewound from 5/-; send to our agents or direct to us. Repairs fully guaranteed by M. L. Vaughton, 88, Vyse St., Birmingham. Tel.: Mivyse, Birmingham. [4788]

VALVES Repaired and Guaranteed by Lustrolux Process.—Bright emitters, 4/6; dull emitters, 7/-; power valves, 8/6, post free: quick delivery.—British Thermit Co., The Albany, Liverpool. [4904]

WEARITE COMPONENTS

EMPIRE BROADCAST SHORT WAVE RECEIVER

(Described in June 29th issue.)

- COPPER BOX £2
- COIL WITH BASE 6/6
- H.F. CHOKES per pair 4/-

ALL WAVE FOUR H.F. TRANSFORMERS

- B.B.C. WAVELENGTH 18/9
- 5XX " 15/6
- BASE (6 PIN) " 2/9
- COPPER SCREEN 5/-

See "Wireless World" Report, June 1st issue, page 700.

EVERYMAN FOUR and EVERYMAN THREE

- COILS & BASES per pair 37/6
- QUALITY THREE COIL 18/9
- H.F. CHOKE 6/6

Send for our illustrated catalogue.

WRIGHT & WEAIRE LTD.,

740, HIGH ROAD, TOTTENHAM, N.17.
'PHONE: Tottenham 3132.



RADIAX COILS

Are made for all circuits requiring highest efficiency. A large variety of windings and couplings is available. Infringers will be proceeded against.

ALL-WAVE FOUR

- All components for this newest set. Use only the specified Coils or Formers bearing RADIAX trade mark.
- RADIAX Formers and Coils (reg'd design) are acknowledged by foremost experts to achieve an efficiency not attained by so-called "Standard Coils."
- Complete Coil, short wave 15/-
- Complete Coil, long 17/6
- Low Loss Fitted Formers 4/6
- Six Pin Base 2/6
- Set of 2 Formers and Base and 18 ebonite strips 12/6

(Catalogue 2d.)

RADIAX LTD.

30, Accessory House, Palmer Place, Holloway, N.7



The LORIOSTAT

1, 2, 3, 4, 5 or 6 valves perfectly and independently controlled by one unit.

A multiple unit superseding the fixed Resistor can be used in any circuit to control any number of valves. For downright efficiency use a LORIOSTAT in your set.

- 1 way 2/-
- 2 " 3/9
- 3 " 5/6
- 4 way 7/3
- 5 " 9/-
- 6 " 10/6

A. W. STAPLETON, 19a, Lorrimer Buildings, Lorrimer St., Walworth, S.E.17

Your First Steps in Wireless

By **HUGH S. POCOCK**
Editor of "The Wireless World"

A most helpful little book for those who are beginning to study wireless. It explains technical difficulties by simple analogies.

Price 9d By Post 11d

From **ILIFFE & SONS LIMITED**

Dorset House, Tudor Street, London, E.C.4
and leading booksellers. W.W. 14

WANTED.

WANTED, C.A.V. multiple fixed condenser.—Haines, Cinema, Stocksbridge, Sheffield. [5008]

WANTED, 3 Lewcos coil screens and bases, also Triple Gang Igranite variable condenser .0005.—Burt, 2, Lucien Rd., Tooting, S.W.17. [5023]

LARGE Brown's Speaker or Gramophone Attachment, must be cheap.—11, Nelson St., Ryde. [5037]

EXCHANGE.

WANTED, Gramophone unit (Brown preferred), in exchange for set of 3 Amplion valves, 2 volt, unused.—Moore, Hushwaite, York. [5012]

AGENCIES.

EVERYTHING Wireless.—Amateur constructors required everywhere as distributing agents; stamped envelope.—Garner, 31, Little Britain, E.C.1. [0027]

SITUATIONS VACANT.

SPLENDID opportunity for live commission men with good connections amongst wireless dealers, as representatives for well-known British loud-speaker; state ground covered.—Box 63, "Parrs," Craven House, Kingsway, London, W.C.2. [0057]

SITUATIONS WANTED.

YOUNG Man (23) with examinations in mechanical and electrical engineering and mechanical technology desires post as junior draughtsman; willing to accept small salary to start.—A. Wickham, 106A, Broughton Rd., Fulham. [4910]

YOUNG Man, 20, holds 1st class P.M.G. Workshop and test room, experience with Marconi Company, experience in designing, wiring sets, etc.—E. Munnion, 11, Springfield Rd., Chelmsford. 'Phone: 228. [4995]

BOOKS, INSTRUCTION, ETC.

"FIVE Simple Wireless Sets," by J. H. Watkins. A simple "How-to-Make" book for the beginner; 1/2 post free.—R.N.B., 50, High Holborn, W.C.1. [0020]

IT is Easy to Make a Wireless Set with R.N.B. Constructors' Envelopes 2-, 3-, 4-, 5- and 7-valve sets made simple. Obtainable everywhere. Write for list.—Radio News Bureau, Ltd., 50, High Holborn, W.C.1. [0019]

"ACCUMULATORS Explained," how they work, care hints, terms defined: booklet 6d., post free; refunded when hydrometer purchased. See under heading "Miscellaneous."—Utility Syringe Hydrometer Co., Dept. C., 16, Howard Rd., Ilford, Essex. [0058]

BRIGHTER Wireless!—Send for free specimen copy of "Brighter Wireless," the happy journal for amateur constructors. Simple, selective long range circuits. Copious wireless information. Subscription 3/6 per annum.—Brighter Wireless, 29, Paternoster Row, London, E.C.1. [4930]

3-VALVE Receiver for 30/—Write now for booklet on how to build the L.R.C.3 valve set for 30/- from guaranteed parts only—the ideal loud-speaker set.—1/- post free from H. Howarth, Lustrolux Depot, 283, Deansgate, Manchester. [5003]

INDEX TO ADVERTISEMENTS.

| | PAGE | | PAGE | | PAGE |
|-------------------------------------|------------|--------------------------------------|------------|--------------------------------|------|
| Accumulators Elite | 11 | Garnett, Whiteley & Co., Ltd. | Cover iii. | Ormiston, P. & Sons | 9 |
| A.F.A. Accumulators, Ltd. | Cover iii. | General Electric Co., Ltd. | 5 & 7 | Ormond Engineering Co., Ltd. | 2 |
| Alton, Thomas | 16 | Graham Amplion, Ltd. | Cover ii. | Peto Scott Co., Ltd. | 17 |
| Artic Fuse & Electrical Co., Ltd. | 18 | Holzman, L. | Cover iii. | Radiax, Ltd. | 18 |
| Atalanta, Ltd. | 15 | H.T.C. Electrical Co., Ltd. | 18 | Regent Radio Supply Co. | 18 |
| Belling & Lee, Ltd. | 14 | Laker, J. & J., Co. | 2 | R.I. & Varley, Ltd. | 17 |
| Benjamin Electric, Ltd., The | 13 | Langham Radio | 2 | Siemens Bros. & Co., Ltd. | 17 |
| Bird, Sydney S. & Sons | 18 | London Elec. Wire Co. & Smiths, Ltd. | 3 | Stapleton, A. W. | 4 |
| Bush House | 4 | London Radio Manf. Co., Ltd. | 18 | Stratton & Co., Ltd. | 15 |
| Charlesworth, W. J. | 8 | Lustrolux, Ltd. | 18 | Taylor, J. H., & Co. | 15 |
| Cossor, A. C., Ltd. | 4 | Marconiophone Co., Ltd., The | 11 | Telegraph Condenser Co., Ltd. | 4 |
| Digby, F. | Cover ii. | Marson, W. E., Ltd. | 18 | Tulsemere Manf. Co. | 10 |
| Dubilier Condenser Co. (1925), Ltd. | 18 | Metro-Vick Supplies, Ltd. | 1 | Vandervell, C. A., & Co., Ltd. | 17 |
| Eagle Engineering Co. | 3 | Mic Wireless Co. | 14 | Whiteley, Boneham & Co., Ltd. | 17 |
| Electradix Radios | 4 | Morris, J. R. | Cover iv. | Wilkins & Wright, Ltd. | 17 |
| Ever Ready Co. (Gt. Britain), Ltd. | 4 | Mullard Wireless Service Co., Ltd. | Cover iv. | Wright & Weaire, Ltd. | 15 |
| Gambrell Bros., Ltd. | | | | Young, A. M., & Co. | 15 |

5/- BRITISH MADE VALVES 5/-
 PRICE LOW AS ANY. QUALITY HIGH AS ANY.

Ask your Dealer for
"ENSIGN" D.E. VALVES

2v 12 H.F. & L.F. 4v '06 H.F. & L.F.
 2v 34 P.V. 5/- EACH 4v '12 P.V.

ALL ONE PRICE AND ALL ONE QUALITY — THE HIGHEST.
Every Valve Guaranteed.

Or send direct to— **LUSTROLUX LTD.,** Lower House Mills, Bollington, nr. Macclesfield.
 Cash with Order or C.O.D.

The ATALANTA SCREW-DRIVER
 Patent No. 194410 (1921).

Nothing to go wrong.

The blade does not slip out of screw slot, the handle remains stationary in the palm of the hand, pressure being applied by fingers on the knurled ring below.

Mechanic's Model
 No. 1 (5 1/2") 4/6
 No. 2 (7 1/2") 2/-
 No. 3 (8 1/2") 2/6

Electrician's Model
 with Insulated handle of Bakelite.
 No. 1 (8") 4/- No. 2 (9") 4/6

Wireless Model
 with box spanners (illustrated) in three sizes which fit on the flat of the blade and are excellent for nuts in awkward places. 3/- the Set.

Manufactured by **ATALANTA, LTD.**
 1-3, Brixton Rd., S.W.9
 Phone: Brixton 2110.

SPECIAL TERMS TO THE TRADE

The H.T.C. TWIN RECEIVER

A complete up-to-date set including loud speaker and all accessories.

Seven days trial and initial payment refunded if not entirely satisfactory.

H.T.C. ELECTRICAL CO. LTD.,
 2, Boundaries Rd., Balham, S.W.12.

Immediate delivery for 5/-
 Balance 2/6 per week or 10/- per month. Total cost £6 10 0.

Cash Price £6 4 0
 Royalty Paid.
 3 valve set, Cash Price £8 8 0
 Deferred Terms £8 15 0

WIRELESS WAREHOUSE

Buy your Wireless parts direct from the Warehouse at Warehouse prices.

Every known component in stock.
 Write NOW for List.

BUSH HOUSE, 35, Shudehill, MANCHESTER

MAHOGANY CABINETS

as illustrated

inside sizes 16" long, 11 1/2" deep, 14 1/2" high
 Panel 16" x 6" Base-board 16" x 10 1/2"
 Price £4 0 0

FRAME AERIALS
 250-1500 metres with wavechanging switch. Special double wound with L-cwcos stranded wire.
 Price £1 15 0

8-valve superonic receiver, complete with accessories All Royalties paid.
 £49 0 0

T. ALTON, A.M.E.E.
 47, Park Road, WEST BARTLEPOOL.
 Phone: 2942.

Dependable Mains Units

REGENTONE

For A.C. & D.C.

Catalogue of complete range of Mains Units, Receivers and Components on application to the manufacturers:

Regent Radio Supply Co.,
 45 Fleet St., E.C.4.
 Phone: Cent. 9661.

USE WEMCO CABINETS
 if you want QUALITY

"MOTORISTS' PORTABLE" as used in MAY 11th issue.
 Mahogany - - - - - 50/-
 Oak - - - - - 46/-

Write or phone Clissold 0997.

W. E. MARSON Ltd. Windus Works, Windus Rd., Stamford Hill, London, N.16.

ZAMPA

The **LOW LOSS** Regenerative **TUNER**
 A modern tuning device to cover all B.B.C. wavelengths (200-2000 metres). 2 hole fixing. Panel space 4 1/2" x 2" deep. From your local dealer or direct. Send for 19/6 full particulars. Price Mic Wireless Co., Market Street, Wellington.

FREE Demonstrations

Cryphar
LOUD SPEAKERS

Ask your Local Dealer for Free Demonstration (Dealers supplied on S. or R.)
LONDON RADIO MANUFACTURING Co., Ltd.
 Station Road, Merton Abbey, S.W.19.

ELECTRADIX RADIOS

Everything Electrical.

Send 4d. stamps for 68 page Illustrated Catalogue.
218, UPPER THAMES STREET, LONDON, E.C.4.
 Phone: CITY 0191.

Mention of "The Wireless World," when writing to advertisers, will ensure prompt attention.

£5

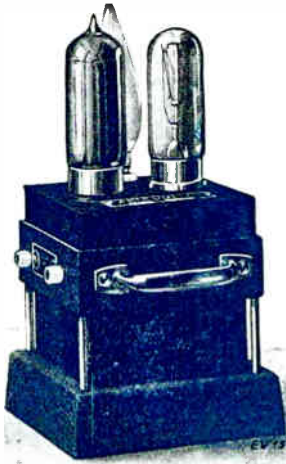

£5

THE "VARTA" DUPLEX RECTIFIER FORMS AN IDEAL MEANS OF CHARGING RADIO HIGH AND LOW TENSION BATTERIES FROM A.C. SUPPLY MAINS.

L.T. output 2-6 volts. 1.3 amperes } and
H.T. output. 60-120 volts. 50-70 milliamps. }

THESE OUTPUTS GIVEN SIMULTANEOUSLY.

THE "VARTA" DUPLEX RECTIFIER IS THE ONLY RECTIFIER THAT WILL CHARGE 6 & 120 VOLT BATTERIES SIMULTANEOUSLY.

A.F.A. Accumulators Ltd., 120, Tottenham Ct. Rd., W.1.

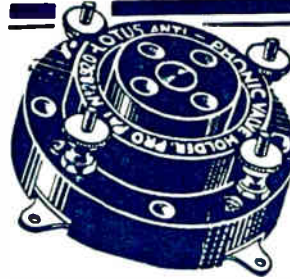

No fading away—
No microphonic noises—

Use Lotus Coil Holders and Valve Holders in YOUR set. They ensure perfect, uninterrupted reception.

Pat. No. 256833.
With terminals 2/6

Without terminals 2/3

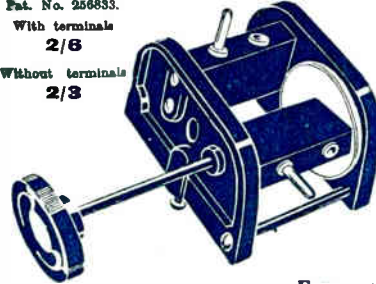

There will be no more fading away of volume, no more breaking of valves and disturbing microphonic noises once you have fitted your set with Lotus Coil Holders and Valve Holders.

From all Radio Dealers.

Two Types:

| | |
|---|------|
| For outside panel mounting. | |
| Two-way | 7/- |
| Three-way | 10/6 |
| For inside haseboard mounting with bin. handle. | |
| Two-way | 8/- |
| Three-way | 12/6 |

LOTUS
COMPONENTS.

GARNETT, WHITELEY & CO., LTD.
Lotus Works, Broadgreen Road, LIVERPOOL.

The **Wireless** AND RADIO REVIEW **World**
EVERYMAN FOUR

A 36-Page Booklet giving full Constructional Details of a remarkably efficient "Two-Control" Receiver for Long or Short Waves.

By W. JAMES.

The "EVERYMAN FOUR" attracted widespread attention when it was first described in "The Wireless World."

It is a very sensitive set and has a high degree of selectivity. The local station is perfectly received, and during a normal evening at least fifteen different stations may be received clearly at good loud-speaker strength. (Constructors claim up to twenty-eight stations.)

An additional long-wave attachment for Daventry is described in the booklet.

Price 1/- net By post 1/2

From the offices of "THE WIRELESS WORLD,"
Dorset House, Tudor Street, London, E.C.4. w.w.60

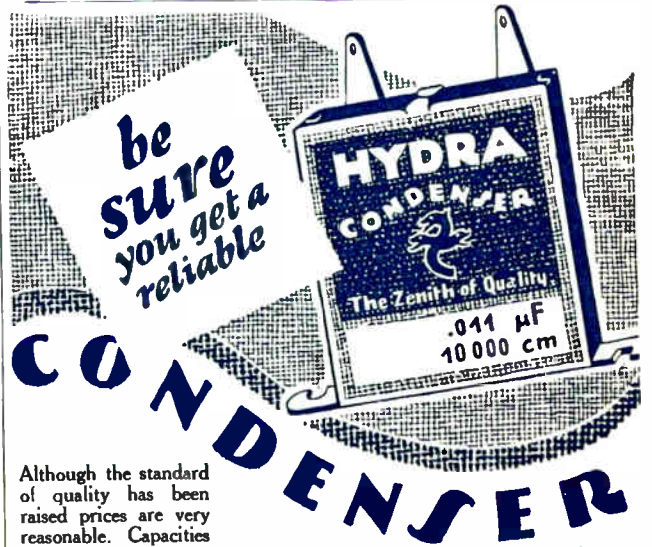

Although the standard of quality has been raised prices are very reasonable. Capacities stocked are from .00011 mfd. to 10 mfd. 1 mfd. 2/9; 2 mfd. 3/9; 4 mfd. 6/-; etc., etc.

Tested on 500 volts.

Irish Free State distributors: Briscoe Importing Co., 9, Aston's Quay, Dublin

Hydra Condensers operate perfectly at all voltages up to 700 D.C. Guaranteed precise within 5 to 10 per cent of their rated capacity and to maintain rated capacity throughout all variations in temperature. From all good dealers.

Louis Holzman
109 KINGSWAY, LONDON, W.C. 2

THE DIFFERENCE!

In this photograph the matched construction of the P.M.5 is disclosed with the anode displaced. Note the great length of the wonderful P.M. Filament.

The grids illustrated give a striking example of the matched electrode system in the case of only two of the series of Mullard P.M. Valves.

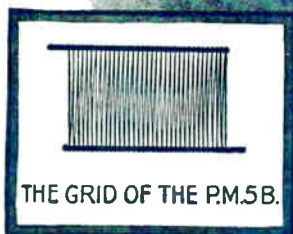

THE GRID OF THE P.M.5B.

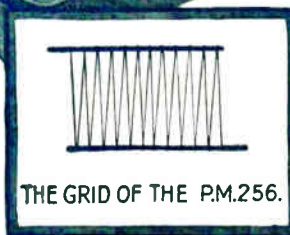

THE GRID OF THE P.M.256.

MATCHED ELECTRODES combined with the wonderful P.M. FILAMENT

MORE than a supreme filament in Mullard P.M. Valves . . . more than a master filament that has set a new standard for long life, toughness, economy and power . . . the wonderful P.M. Filament . . .

A system of matched electrodes, designed by Mullard Engineers to produce unequalled performance in every type of valve operation by completely utilising the vast energy of this master P.M. Filament to the best advantage in each case.

The result of this special P.M. construction and design is that a series of P.M. Valves has been produced from which, no matter what type of circuit you employ, positively pure and powerful amplification is assured from the first to the last stage, culminating in a final reproduction that is a delight and a revelation.

Consult your radio dealer to-day about the correct Mullard P.M. Valves for your receiver.

Mullard

THE MASTER VALVE

For 2-volt accumulator

- P.M.1 H.F. 0.1 amp. 14/-
- P.M.1 L.F. 0.1 amp. 14/-
- P.M.1A
- (Resist. Capacity) 0.1 amp. 14/-
- P.M.2 (Power) 0.15 amp. 18/6

For 4-volt accumulator or 3 dry cells

- P.M.3 (General Purpose) 0.1 amp. 14/-
- P.M.3A (Resist. Capacity) 0.1 amp. 14/-
- P.M.4 (Power) 0.1 amp. 18/6

For 6-volt accumulator or 4 dry cells

- P.M.5X (General Purpose) 0.1 amp. 14/-
- P.M.5B (Resist. Capacity) 0.1 amp. 14/-
- P.M.6 (Power) 0.1 amp. 18/6

Super power valves for last L.F. Stage

- P.M.254
- (4 volts, 0.25 amp.) 22/6
- P.M.256
- (6 volts, 0.25 amp.) 22/6

ADVT. THE MULLARD WIRELESS SERVICE CO. LTD., MULLARD HOUSE, DENMARK STREET, W. C. 2

Printed for the Publishers, ILIFFE & SONS LTD., Dorset House, Tudor Street, London, E.C.4, by The Cornwall Press Ltd., Paris Garden, Stamford Street, London, S.E.1.

Colonial and Foreign Agents:
 UNITED STATES—The International News Co., 131, Varick Street, New York. FRANCE—W. H. Smith & Son, 248, Rue Rivoli, Paris; Hachette et Cie, Rue Réaumur, Paris.
 BELGIUM—W. H. Smith & Son, 78, Marche aux Herbes, Brussels. INDIA—A. H. Wheeler & Co., Bombay, Allahabad and Calcutta. SOUTH AFRICA—Central News Agency, Ltd.
 AUSTRALIA—Gordon & Gotch, Ltd., Melbourne (Victoria), Sydney (N.S.W.), Brisbane (Queensland), Adelaide (S.A.), Perth (W.A.) and Launceston (Tasmania).
 CANADA—The American News Co., Ltd., Toronto, Winnipeg, Vancouver, Montreal, Ottawa, St. John, Halifax, Hamilton; Gordon & Gotch, Ltd., Toronto; Imperial News Co., Toronto, Montreal, Winnipeg, Vancouver, Victoria. NEW ZEALAND—Gordon & Gotch, Ltd., Wellington, Auckland, Christchurch and Dunedin.

The Wireless World

3^D

AND
RADIO REVIEW

The Paper for Every Wireless Amateur

Wednesday, July 13th, 1927.

Coastal Broadcast



Receiver

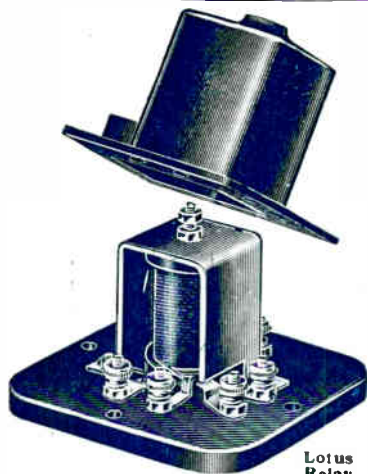

Lotus Relay

Simultaneous Reception in every room!

You can have simultaneous reception in every room in your home without interference by installing the Lotus Remote Control.

Complete outfit for wiring two rooms **30/-**
Each additional room **7/6**

THE LOTUS REMOTE CONTROL

FREE! Write for **FREE BLUE PRINTS** and instructions how to wire two rooms in half an hour to Dept. W.W.4, Garnett Whiteley & Co., Ltd., Broadgreen Road, Liverpool.

"Utility" LOW LOSS CONDENSERS

The centre spindle rotates on ball bearings, all the brass parts are heavily nickel-plated, there is a pig-tail connection from the moving plates, one end plate only is used, and all the sources of loss have been reduced to a minimum. There's no better Condenser made than this — if you take your wireless seriously you will include it in the set and so get the last bit of satisfaction.

Prices

| | Without Vernier. | With Vernier. |
|--------|------------------|---------------|
| -001 | 12/- | 17/6 |
| -0005 | 9/6 | 15/- |
| -0003 | 8/6 | 14/- |
| -00025 | 8/- | 13/6 |
| -0002 | 7/6 | 13/- |

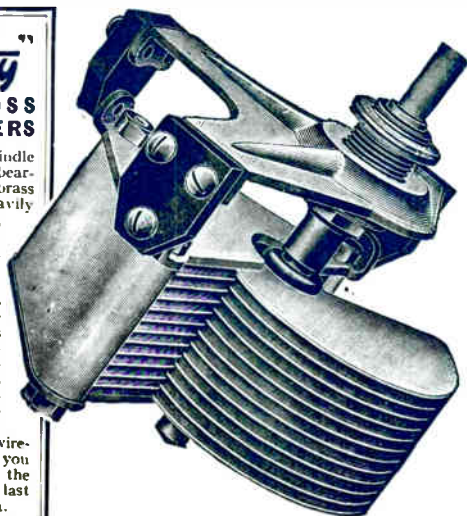

Ask your Local Dealer to show you this and other Guaranteed "Utility" Components.

All good dealers stock "Utility" Components. Ask to see the "Utility" No-capacity Change-over Switch; the Micro Dial—the last word in minute tuning; the Push-pull Switch, etc. They are all made along advanced lines of the finest materials, and beautifully finished.

N.B. If you have any difficulty in obtaining, write us direct.

WILKINS & WRIGHT LTD
KENYON ST. *Utility* BIRMINGHAM

"Wonderful Efficiency of your Advertising Columns!"

This letter from a recent advertiser is of direct interest to all readers and prospective advertisers in "The Wireless World."

"I feel that I must add my testimony to that of many others to the usefulness and wonderful efficiency of your advertisement columns.

My advertisement appeared this week and already I have had 14 callers and no less than 31 letters. Needless to say all my stuff has been sold, and could have been disposed of two or three times over.

I appreciate most of all the spirit of goodwill and natural trust which exists between readers of 'The Wireless World,' as most of my correspondents enclosed cash in their communications. In return I shall have no hesitation in sending cash with order to any of your advertisers."

A. SHAUL,
76, Felix Avenue,
Brixton Hill, S.W.2

Confidence is the soul of business and advertisers will appreciate the benefit of placing their announcements in

The **Wireless World**
and Radio Review

ILIFFE & SONS LTD. Dorset House, Tudor St., London, E.C.4

w.w.62

Mention of "The Wireless World," when writing to advertisers, will ensure prompt attention.

TRANSFORMER VERSUS RESISTANCE COUPLING

Curves showing the amplification obtained with resistance units, for domestic receiving sets, are misleading unless allowance be made for the effect at the higher frequencies (harmonics) of the necessary rectifying condenser.

Even the self capacity of the valve has a quite serious effect.

True amplification of the harmonics gives that purity of tone that makes the difference between true and false reproduction.

Incidentally resistance coupling is particularly susceptible to atmospherics.

Resistance coupling should only be employed with anode rectification and then only in the first stage.

The great majority of receiving sets employ grid leak rectification with which

FERRANTI

A.F.3. TRANSFORMERS GIVE BETTER RESULTS

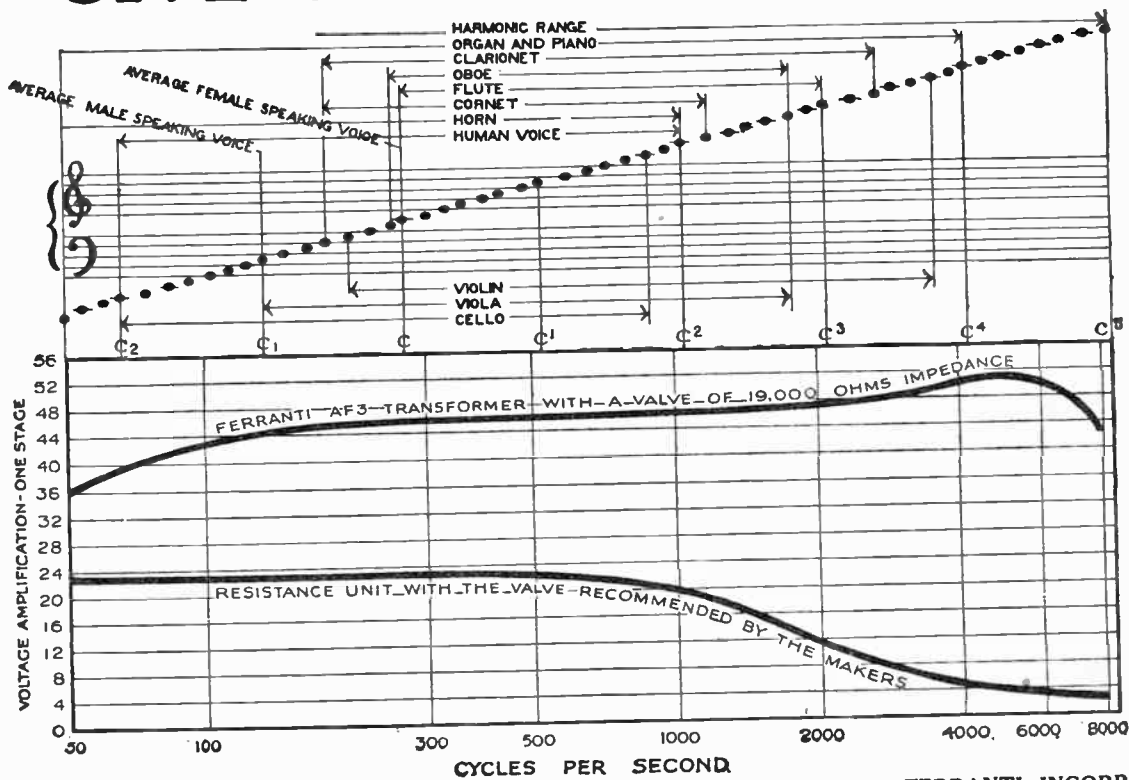

FERRANTI ELECTRIC LIMITED,
Toronto, Canada.

FERRANTI LTD.,
Hollinwood,
Lancashire.

FERRANTI, INCORPORATED,
130 West 42nd Street,
New York, U.S.A.



REDUCED to 5/-

Owing to the increased production facilities afforded by our new Works we are now able to offer the Imperial Watmel H.F. Choke at 5/- . Nothing has been sacrificed in order to bring about this reduction. The double silk covered wire wound in four accurately balanced sections ensures required constant impedance very low capacity and small external field. Transparent case and ebonite base.

WatMel

Please note new address:

WATMEL WIRELESS CO., LTD.,
Imperial Works, High St., Edgware, Middx.
Telephone: Edgware 0923.
Lancs, Yorks and Cheshire Representatives: Mr. J. B. Levee,
23, Hartley Street, Levenshulme, Manchester.
Telephones: 475, Henton Moor.

W.B.
ANTI-PHONIC LOW-LOSS VALVE HOLDER
Cut open for your inspection.

Notice that—
1.—Floating springs and valve sockets are riveted and soldered.
2.—Springs are at right angles to valve sockets avoiding side strain and snapping.
3.—The price is only 2/- each without terminals, or 2/3 each with terminals.

Supplied by all good class dealers from stock.
In case of difficulty write to the makers—
WHITELEY, BONEHAM & CO., LTD.
Duke Street, Mansfield, Notts.

T.C.C.
0003 MFD

THE fixed condenser is one of the cheapest components in your Wireless receiver. But it is also one of the most important. That is why the country's leading radio technicians consistently use

Condensers in their circuits. Because they know they are not prejudicing the success of their sets. The few pence more for T.C.C. may mean the difference between failure and success. From '004 to '0009, 2/4.

Advt. Telegraph Condenser Co., Ltd., Wales Farm Rd., N. Acton, W.3.

G.A.9221.

Chakophone
REGD

EVERYMAN FOUR COILS.

The Wireless World says: "The Chakophone Coils can be recommended for building the 'Everyman Four' receiver. As well as being electrically correct, the coils are well finished, and, with the green silk-covered Litzenbraut wire, are of particularly good appearance."

Manufacturers:

EAGLE ENGINEERING CO., LTD., WARWICK.



31/- per pair boxed with 1/- "W.W." booklet, sent post free if your Local Radio Dealer cannot supply.

WIRELESS VALVE TRANSMITTERS

The Design and Operation of Small Power Apparatus.

Obtainable from Booksellers or direct from the Publishers.

Price 9/- net. By post, 9/9.

ILIFFE & SONS LTD., Dorset House, Tudor Street, LONDON, E.C.4.

w.w.9

Mention of "The Wireless World," when writing to advertisers, will ensure prompt attention.



1927 IMPROVED MODEL
H.T. ACCUMULATOR.

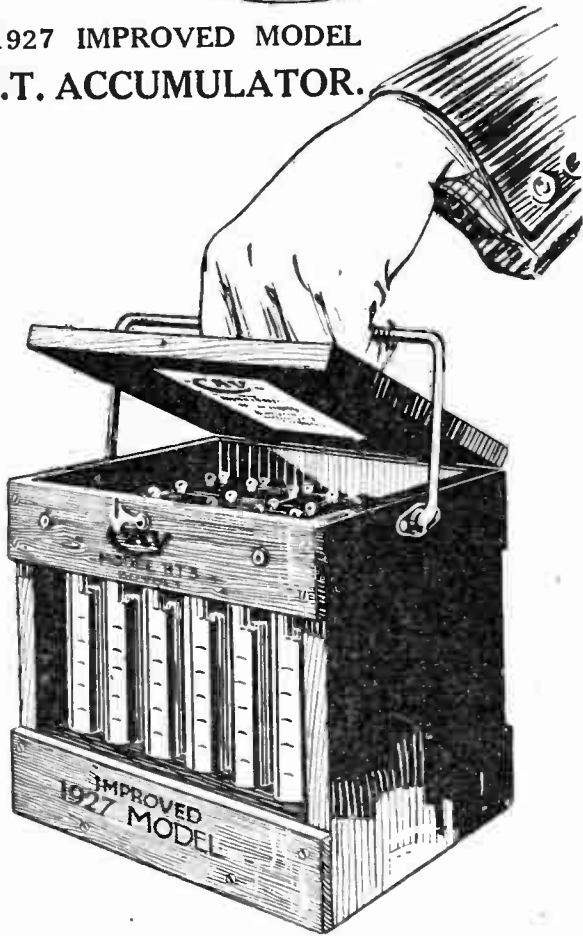

C.A.V. H.T. Accumulators have improved radio reception for hundreds of users who have wisely scrapped their dry batteries. They will do the same for you. Inconsistent discharges, temperature effects, crackling noises with reception, and constant regulation to correct voltage variations are all troubles peculiar to dry batteries but these are unknown to users of the C.A.V. H.T. The H.T.3 is fitted with a strong handle enabling it to be easily carried. Used by most leading experimenters they have also been supplied to over 100 of London's Hospitals.

MODEL H.T. 3 (60 VOLTS) **60'** SUPPLIED READY FOR USE
NO FILLING WITH ACID.
NO CHARGING

Dimensions 8½" x 7" x 7¾" High
Weight Charged 16¼ lbs - Dry 13½ lbs

ALSO SUPPLIED IN 30 & 90 VOLTS
MODEL H.T. 4 - 30 VOLTS - - 30/-
MODEL H.T. 5 - 90 VOLTS - - 90/-

Catalogue supplied on application.

C.A. Vandervell & Co. Ltd.
ACTON, LONDON, W. 3.

Telephone: Chiswick 3801
(Private Branch Exchange).

Telegrams: Vanteria-Act-1-ondon.

HERE'S THE SECRET

In the Dumetohm there is a resistance element of a metallic nature made by a process known only to ourselves. A resistance, under two inches long, which can measure as much as five million ohms and is guaranteed constant and noiseless in action !!

Use Dumetohms in your set and enjoy the same wonderful results which have made them "easily the most popular resistances."

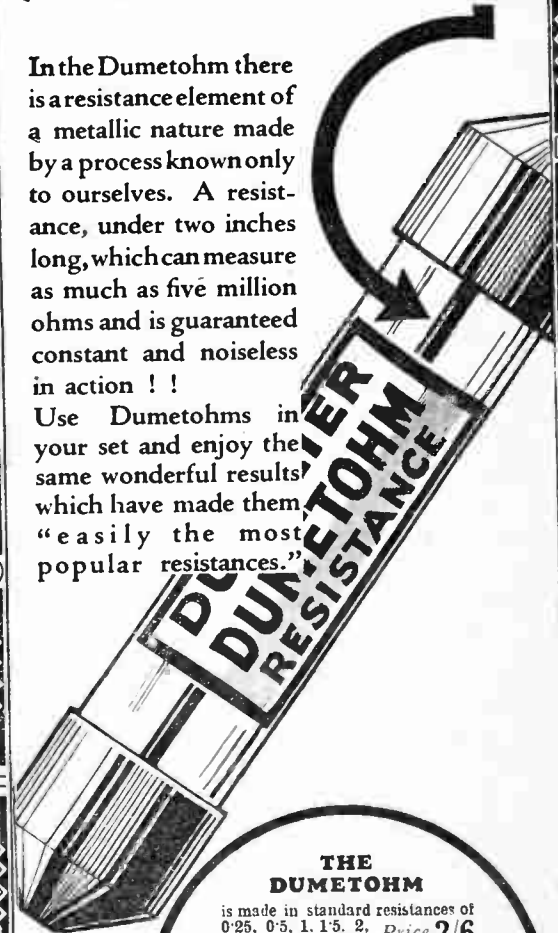

THE DUMETOHM

is made in standard resistances of 0.25, 0.5, 1, 1.5, 2, 3, 4 and 5 Megohms Price 2/6



THE DUMETOHM HOLDER

avoids the delicate operation of soldering and costs - - 1/-



Advt. of the Dubilier Condenser Co. (1925) Ltd.
Ducon Works, Victoria Road, North Acton, W.3.

A veritable Samson among Valves!



—due to the tremendous strength of its Kalenised filament

THE only vulnerable part of a valve is the filament. Be wise therefore, and choose a valve with a strong filament—a Cossor Valve with a Kalenised Filament.

The amazing strength of the Cossor Kalenised filament has been proved by actual test. Twelve Cossor Valves were hurled 600 feet from an aeroplane—and not one filament was broken. No other filament has ever withstood successfully such a drastic test.

Besides being immensely strong, the Cossor Kalenised filament gives off an enormous emission. Cossor users, therefore, in addition get superb tone, ample volume, and increased sensitivity. But remember, you can't get the advantages of the Kalenised filament in any other valve but a Cossor.

In 12 Types to suit all Receivers.

A. C. Cossor, Ltd.,
Highbury Grove, N.I.

COSSOR

Mention of "The Wireless World," when writing to advertisers, will ensure prompt attention

The Wireless World

AND
RADIO REVIEW
(15th Year of Publication)

No. 411.

WEDNESDAY, JULY 13TH, 1927.

VOL. XXI. No. 2.

Editor: HUGH S. POCOCK.

Assistant Editor: F. H. HAYNES.

Editorial Offices: 139-40, FLEET STREET, LONDON, E.C.4 - - Editorial Telephone: City 4011 (3 lines).

Advertising and Publishing Offices: DORSET HOUSE, TUDOR STREET, LONDON, E.C.4.

Telephone: City 2847 (13 lines).

Telegrams: "Ethaworld, Fleet, London."

COVENTRY: Hertford Street.

BIRMINGHAM: Guildhall Buildings, Navigation Street.

MANCHESTER: 199, Deansgate.

Telegrams: "Cyclist Coventry."
Telephone: 8210 Coventry.

Telegrams: "Autopress, Birmingham."
Telephone: 2970 and 2971 Midland.

Telegrams: "Iliffe, Manchester."
Telephone: 8970 and 8971 City.

Subscription Rates: Home, 17s. 4d.; Canada, 17s. 4d.; other countries abroad, 19s. 6d. per annum.

As many of the circuits and apparatus described in these pages are covered by patents, readers are advised, before making use of them, to satisfy themselves that they would not be infringing patents.

THE REGIONAL SCHEME.



AN article in this issue by the Chief Engineer of the British Broadcasting Corporation will appeal to all our readers who have taken an interest in the problem of the distribution of broadcasting stations in this country in order to bring about alternative programmes. In this article the problem

is discussed as a whole, and the reasons which have guided the B.B.C. to the recommendation of the Regional Scheme are set out and dealt with individually. An independent technical committee has been invited by the B.B.C. to consider these proposals and advise on them and any other alternative schemes which may be put up.

We believe that it would be in the interests of the future of broadcasting if our readers would study very carefully the proposals which Capt. Eckersley puts forward, and criticise them through the medium of the correspondence columns of the journal. We feel equally sure that such views as may be put forward with the object of making the broadcasting service in this country as nearly approaching the ideal as possible will be welcomed by the B.B.C. authorities, and that the B.B.C. would even be prepared to "scrap" their present proposals if some better alternative were put up to them before arrangements have proceeded too far for a modification to be introduced.

We have ourselves from time to time criticised the Regional Scheme as propounded by Capt. Eckersley, but we must admit that the increase in the number of stations in Europe and their power has led us to modify our original attitude, and we have come to the conclusion that the Regional Scheme forms a pretty sound basis on which to develop British broadcasting. Even if there are criticisms, we feel that unless these are serious they ought not to be allowed to interfere with the speedy realisation of the alternative programme idea. It would be much better, in our opinion, that we should have our alternative programmes within the next two or three months on the basis of the Regional Scheme rather than wait a longer period whilst some improvement on that scheme

was being got out. We think the B.B.C. themselves would agree with us that already alternative programmes have been too long delayed, and almost any system which gives us a choice of programmes is better than the present arrangement.

o o o o

THE AMATEUR'S PART IN EMPIRE BROADCASTING.

THE note which appeared on page 25 of our last issue concerning the amateur Empire relay proposals marks, in our opinion, an important step towards the achievement of this most desirable object. We are glad to see that the Postmaster-General is likely to authorise Mr. Gerald Marcuse to rebroadcast B.B.C. programmes on short waves with the object of testing out the possibilities of Empire broadcasting even with a station of amateur power. We wish all success to Mr. Marcuse in this attempt, which, we understand, has been made possible by the action of the amateur radio societies in approaching the Postmaster-General for the necessary permission.

It is interesting to see how in this case history has repeated itself, for it was the Radio Society of Great Britain which in the early days obtained the permission from the Post Office which enabled the Marconi Company to commence the regular broadcast transmissions from the experimental station at Writtle, thereby paving the way for the introduction of broadcasting on a bigger scale. But why should we have proceeded by stages to the establishment of our broadcasting service in this country? Writtle was an interesting experiment, but there was no reason why it should ever have existed. Now again there is, in our view, so serious a risk that the establishment of the experimental station of Mr. Marcuse will only be an excuse for delaying a more satisfactory project, that we might almost wish that permission for Mr. Marcuse to conduct these experiments should not be granted. The very fact that the authorities seem so ready to give permission fills us with suspicion that the object is to postpone the Empire station.



THE DISTRIBUTION OF BROADCASTING STATIONS

Considerations which Lead Up to the Proposed Regional Scheme.

By CAPTAIN P. P. ECKERSLEY (Chief Engineer, the B.B.C.).

IT is assumed that this article is written from the point of view of a national rather than a local broadcasting service, that it applies, that is to say, to organisations having a monopoly of broadcasting in a certain territory.

It is assumed, furthermore, that broadcasting is a public service, that interest must lie in what the service brings rather than how it is brought. This assumption is, to my mind, right, but I know that there are still some who believe otherwise; who say that broadcasting will die if its "romance" is done away with. My attempted refutation of this premise is by analogy. The motor car started as a romantic invention. Its radius was vastly greater than the horse-drawn vehicle, and new country was suddenly the user's for the holding of a wheel and the snapping to and fro of a lever. Kipling in many of his stories of the early days of motoring reflects this romance. To-day the Great West Road reveals if anything a lack of romance, and motors are used to get quickly (when the police let us) from here to there and back again. The motor car is a piece of our lives, we do not talk carburetters, maximum speeds, averages, magneto or coil ignition, so much as we say "I'm taking so-and-so down to Brighton for the week-end in my car."

The telephone is another example of how the public service aspect of modern invention in the end conquers the romantic aspect. See the *Punch* cartoons of the early days of the telephone—the old father and mother at home listening to their son in Australia proposing their health—and look at the cartoons now which usually signify our irritation rather than our wonder!

The Aim of Broadcasting.

If I have spent too long in explaining this point of view, I hope the reader will forgive me—it is, however, so fundamental a point that it is the basis of the technique. Broadcasting is a public service, and the technical arrangements must be such that the technique does not obtrude itself upon the user, that he must be capable

of hearing the programme and only the programme, and that in the end the broadcasting set must be merely another household electrical appliance, and as simple to use as the lamp, the vacuum cleaner, the refrigerator, the heater, the cooker, the cigar lighter, etc.

This is largely a job for the manufacturer, but he must be dependent upon the service before he can make the ideal simple set.

Service Areas.

The above argument leads me by easy stages to a more concrete definition of what may be called the "service area" of a station.

A service area is an area around a station in which the listener may be assured of a service. There are different degrees of service depending upon the distance of the listener from the station and the radiated power from the station, and the attenuation of the field strength as the point considered is further and further away from the station. I will arbitrarily define these areas as:—

- (a) Wipe out area.
- (b) An "A" service area.
- (c) A "B" service area.
- (d) A "C" service area.

In a wipe out area cutting out the local station and receiving distant stations will not be easy, although with proper apparatus it is perfectly possible.

The wipe out area is bounded by the field strength contour of 30 millivolts per meter. It could be as much as 100 millivolts per meter with really selective designs of receiving set. In an "A" service area the field strength is greater than 10 millivolts per meter, and any listener is practically certain of an uninterrupted service, however near, within limits, to a source of electrical disturbance he may live. That is to say, electric trains, trams, signs, X-ray apparatus, etc., etc., will not interfere with him. In general, perhaps 1 per cent. of people may experience this sort of interference within an "A" service area.

The Distribution of Broadcasting Stations.—

The "B" service area is an area bounded by the field strength contour line of 5 millivolts per meter, and, assuming good aerials, anyone within a "B" service area (or, of course, within an "A" or in a wipe out area) will be assured of crystal reception. As to interference (not counting oscillation), the user within a "B" service area will be more subject to this trouble, but not more than perhaps 3 per cent. of listeners in densely populated areas.

A "C" service area is an area bounded by the field strength contour line of 2.5 millivolts per meter, and within a "C" service area there can be no doubt that interference begins to present a problem. One might optimistically say that within a "C" service area the listener is at present at the mercy of all those sorts of interferences that we hope, in time, will be eliminated at the source, e.g., spark stations with flatly tuned transmitters, electric trains with unsilenced systems, electrical chemical plants with unshielded high-tension cables, etc., etc. Atmospheric and oscillation will remain as the chief sources of interference in a "C" service area. To give the reader an idea of conditions within the various areas one may say that conditions within a circle of 6 miles of the London station represent a wipe-out area, that conditions within a circle of 12-14 miles represents an "A" service area, a circle of 18-20 miles a "B" service area, and a circle of 28-32 miles a "C" service area. These figures apply almost equally, taking into account different sites, different wavelengths, etc., for all main stations, *i.e.*, Aberdeen (before it shared a wavelength with the Continent), Glasgow, Manchester, Birmingham, Cardiff, Bournemouth, and Belfast.

Daventry has not yet been measured, but, having a long wave, attenuates less rapidly than London.

Many Stations of Low Power.

On these assumptions the figures are a little alarming when it is realised that many nations have large areas to cover and have not vast funds to erect super-power stations, and that it would appear wasteful in any case to erect large stations when doubling, redoubling, and again doubling the power gives so little gain in actual service area. To give point to the above remarks the reader is asked to study the curves on this page, in which power is plotted against distance for two service areas.

This brings us to an important step in the argument, always assuming that we can get no better radiation than that on which the curves in the figure are based. (I am going to show later that I think a great deal can be done to improve radiation above that assumed, but a problem that has to be faced is that of rapid attenuation, and therefore extreme extravagance in power to obtain service areas of any great extent.) It becomes immediately obvious on the basis of the above assumptions that the right policy is to have numerous low-powered stations

rather than few large ones, and that the areas unserved should be covered by few high power stations using long waves; that, in fact, an extension of the principle adopted in the past by the B.B.C. (many small power and one high power long-wave station) is sound and economical.

Unfortunately, densely populated areas (the areas which pay, in fact) do not, except in very rare cases, lie all together. In our country they are found around Glasgow, the mouth of the Tyne, on either side of the lower Pennines, in the Midlands, and in the South-East. It is better, therefore, to cover each dense area from a local transmitter of low power and limited service area and use a lot of low-powered stations.

This policy is unfortunately right in theory but wrong in practice, because of the limitation of available wavelengths. If this policy were pursued mutual interference between broadcasting stations (in any continent) would increase to such an extent as to restrict their service areas and defeat the ends of the "many station" policy.

The "Plan de Genève."

After prolonged negotiation and after many sacrifices it has been found possible to arrange for the 200-odd stations in Europe to work (theoretically and assuming

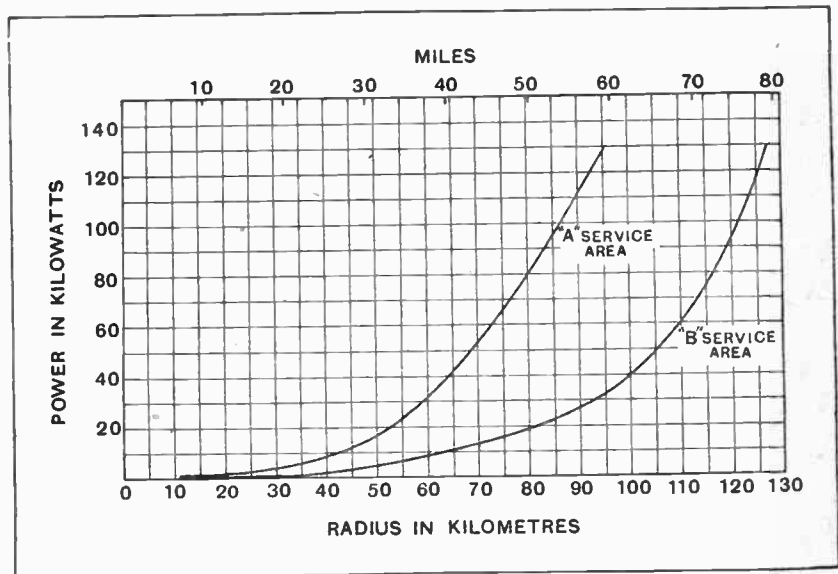

Curves showing relation between power and the radii of "A" and "B" service areas. The measurements are based on the best radiation for the various powers from the London station on 361 metres.

everyone to play the game and come into the plan) with only 100 wavelengths. To do this the surplus stations share a given wavelength all working on one channel. This means, in fact, that the service area of the surplus stations, whatever their power, if each is in relation to the other the same, is restricted. There are thus 14 common waves (or waves that may be shared by surplus European stations), leaving only 86 waves for the exclusive use of the 86 remaining stations.

The multi-station policy, therefore, while right from a theoretical point of view (or right for a small nation 3,000 miles away from any other continent), is wholly wrong in view of the crowded state of the ether. Nothing would be more lamentable than that each nation should

The Distribution of Broadcasting Stations.—

not accept this fact and adopt the slogan long promulgated by the writer, "fewer stations higher power."

I hope the reader will at this stage forgive a summary of what has gone before:—

(1) That all listeners must be brought within a service area (preferably "B") of a station in order that they may enjoy an uninterrupted service and be free from the obtrusions of the (to them) uninteresting technique upon the reality of the programme.

(2) That in order to obtain condition (1) it would appear most economical to arrange for many low-powered stations to cover the densely populated areas, while a high-power long-wave (small attenuation) station would fill up all the areas not served by the multi-station low-powered system.

(3) That, unfortunately, condition (1) cannot be fulfilled by the method proposed in (2) because such a policy would defeat its own ends by producing mutual interference between broadcasting stations over a given world territory.

(4) That therefore any system must *rely upon fewer stations and higher power.*

Having arrived logically at statement (4), it is important to study how best to increase a station's service area, how, in fact, to defeat rapid attenuation, because it won't do simply to increase power to hundreds of kilowatts before studying how to make use of tens of kilowatts.

The Aerial.

In this connection a study of the aerial system is most important.

An aerial has a total resistance R composed of two parts: dead resistance R_w , and useful or radiation resistance R_o .

The total power (P) in an aerial is $(R_o + R_w)I^2$, where I is the aerial current.

The radiated power from an aerial is $R_o I^2$, or

$$\left(\frac{R_o}{R_o + R_w} \right) P.$$

The efficiency of an aerial system (which includes the aerial inductance resistance, the losses in mast, earth, etc.,

etc.) is thus expressed in the ratio of $\frac{R_o}{R_o + R_w}$, and it is

our object to increase R_o compared with R_w .

Take what care we may with feeders and earthed masts and low-resistance coils, R_w remains a factor always, but a constant factor whatever the height of the aerial; and it must be, after reducing R_w to as small a value as may be, our object to increase R_o .

R_o is proportional to $\frac{h^2}{\lambda^2}$, where h is the *effective* height of the aerial and λ is the wavelength. By effective height we do not mean the height of the aerial itself, but the height of a point above earth which makes the aerial equivalent to a diode from which the formula R_o is proportional to $\frac{h^2}{\lambda^2}$ is calculated. The effective approaches the actual height more nearly as the extent of the horizontal part of a T or L aerial is increased.

Since, however, actual height is proportional to effective height, for a given design of aerial, it becomes obvious

that the radiation efficiency of an aerial approaches 100 per cent. as the aerial becomes infinitely high.

With low-powered systems of broadcasting it has been essential in order to cover large towns like London with a "B" service area, to have the station rather in the centre of the city than on its outskirts. Other reasons have directed this policy, such as line connection, finance, and the fact that so it was begun and so it had to continue! Thus no broadcasting station in Britain has an aerial much higher than 100ft., and the radiation efficiency of such aerials is therefore poor.

Langenberg's Lead.

On any new system undoubtedly high aerials must play a part, aerials so high as to seem at first wasteful. The Langenberg station has an aerial supported on two 300ft. masts 700ft. apart, and its gain in service area has been considerable. Its radiation resistance R_o is said to be 100 ohms, the total resistance R_o plus R_w is 140 ohms—an efficiency of 70 per cent. practically. Perhaps with 500ft. masts the efficiency might go up to 80 per cent.

There is one point that must not be overlooked, and that is that such high aerials as these will have natural wavelengths well above that to be used that a "shortening" condenser will be necessary. The radiation will be considerably tilted in an upward direction owing to the use of the shortened aerial. There may be also a marked skip distance.

I believe interference within the "C" service area of distant stations will not be serious if the wavelengths are kept dead steady, and if over-modulation with its constant introduction of harmonics is prevented. This statement is made on the basis of tests made in the "C" service area of some of our stations working with a 10 kilocycle separation from high-powered German stations.

If the principle, then, of fewer stations and higher power is adopted, there is no reason why, if the aerial design is properly studied, there should not be a "B" service area of 50-70 miles' radius using "economical" power; I mean power not in the hundreds but in the tens of kilowatts. The problem of fading is a serious one, and another limitation is to my mind imposed on power when it is appreciated that whatever the power, fading will at night time probably take place at distances beyond 80 to 100 miles. Economically, therefore, there is a limit to a broadcasting station's power imposed by fading unless equalising devices are adopted at the receiver. Even then the minimum signal is probably so small that interruption may play a part. This is said with due diffidence.

Wavelength Limitations.

The wavelength to be used is usually allocated, and the designer of the system of distribution has no choice. Suffice it to say that attenuation at short-medium waves is considerably greater than with long-medium waves, and that the difference between 300 and 500 metres is very marked. It should, however, be more economical to be able to increase the efficiency of the aerial for the shorter

than for the higher wave, as R_o is a function of $\frac{1}{\lambda^2}$. I am, therefore, assuming that systems of distribution must be based on few and high-power stations, it must

The Distribution of Broadcasting Stations.—

be obvious that, to get as far as possible an even distribution, the aerial efficiency must be increased to the utmost.

Sites for Stations.

Now as to the general principles as to the sites for such stations.

The densely populated areas require to be most favourably treated for several reasons, among these being:—

(a) In large towns the possibility of interference from electrical appliances is greatest.

(b) The densely populated areas are the most paying areas.

(c) The densely populated areas have in the past had large field strengths.

(d) There are fewer facilities for the erection of large aerials in densely populated areas.

Thus the first principle is to try and arrange for all densely populated areas to lie within an "A" service area, all areas to lie within a "B" service area, and no area to lie within a "C" service area or a wipe-out area.

All conditions above are impossible to fulfil, but in general by placing the stations perhaps 10 to 15 miles *outside* large towns the wipe-out zones cover sparsely populated districts, and part of the "A" covers the town or city, while the "B" must cover the country around.

Land Lines.

There is a further factor that determines site, and that is the existence of line facilities for linking up the transmitter with the local or any other studio or place where the microphone may be installed.

So what we may, undoubtedly the overhead line presents certain difficulties in maintenance, and yet it presents at present the only means by which good quality broadcast may be conveyed to the station. It is thus imperative to choose some position for the site that lies upon a first-class route, where all disadvantages may be reduced to a minimum. It is to be hoped in time that all stations will adopt high cut-off (*i.e.*, high-quality) cable telephone systems, when unreliability will be no longer a worry.

The sites for the stations are therefore determined by existing distribution of broadcasting to some extent, the need for good aerials and therefore open country around them, the necessity of avoiding wipe-out over large cities, the line facilities, and lastly the lie of the "A," "B," and "C" service areas in relation to the surrounding country. The "A" service area must cover densely populated, and the wipe-out area sparsely populated, districts.

Alternative Programmes.

A further problem now presents itself to the designer: that of giving alternative programmes.

Here, again, I take the stand that the ease of switching from one programme to another must be of such a degree that anyone may compass the operation without undue worry, and, secondly, that it is useless to give an alternative which is inferior (I mean technically) to another programme.

If a listener, that is, lives within the "A" service area

of his local station it is wrong to give him an alternative of "C" service area or less strength.

The public will not take advantage of schemes that do not shout their advantages obviously and directly at the public. The public are, rightly or wrongly, but quite understandably, lazy; they are also poor. Who living within the "A" service area of, say, the new station for London is going to buy a fairly selective multi-valve set to get his alternative from even 100 miles away?

He will have too many valves for the nearby and too few for the far away. Retuning will be an operation involving some skill, and the alternative when received will be liable to all those interruptions we have been, up till now in the argument, at such pains to remove. It is definitely absurd to say that night after night such an one gets Madrid or Hamburg. I, too! Plus fading, plus atmospherics, plus jamming, and *at night*—what of the day time?

Equal Strength Essential.

I also am listening with a set which gives about as good quality as any other set in the kingdom, and while interruptions to a poor quality set may not be so annoying in a good quality set, they are irritating to a degree. I am listening to a set which will be "Everyman's" in five years, and "Everyman" by that time will cease to put up with adjustment and interruptions. The ideal for *hoi polloi*, who alone must count, is the alternative at an equal strength (or as near as possible), and this can only be done by employing at one site two transmitters using different wavelengths, with as large a kilocycle separation within limits as possible.

We thus come to the last principle I propose to enumerate in this article, namely, the necessity of making all alternative programmes of as near as possible the same strength. This gives an uninterrupted service on programmes, the maximum ease of selection as between programmes, and the minimum of disturbance.

The Regional Scheme.

Britain has been allotted 10 wavelengths (including Daventry long wave), and it would appear that the best way to reframe distribution will be to use for the main service fewer transmitters than exist at present, and, in fact, to have five centres of distribution each using two wavelengths.

Many other schemes can be considered, as, for instance, one giant central station radiating out on ten different wavelengths ten different programmes, or a variant with five in the north and five in the south, but remembering the service area problem, a quantitative study will reveal the disadvantages of such proposals.

It must be finally admitted that the carping and the critical can find difficulties and disadvantages to the principles enumerated above, but can anyone propose a better scheme than the so-called Regional Scheme for the re-distribution of the service in Britain, which bases itself upon the above principles?

[Our readers are particularly invited to contribute to our Correspondence column their views on the Regional Scheme as outlined above, and any criticisms of a constructive character would, we feel sure, be welcomed generally.—ED.]

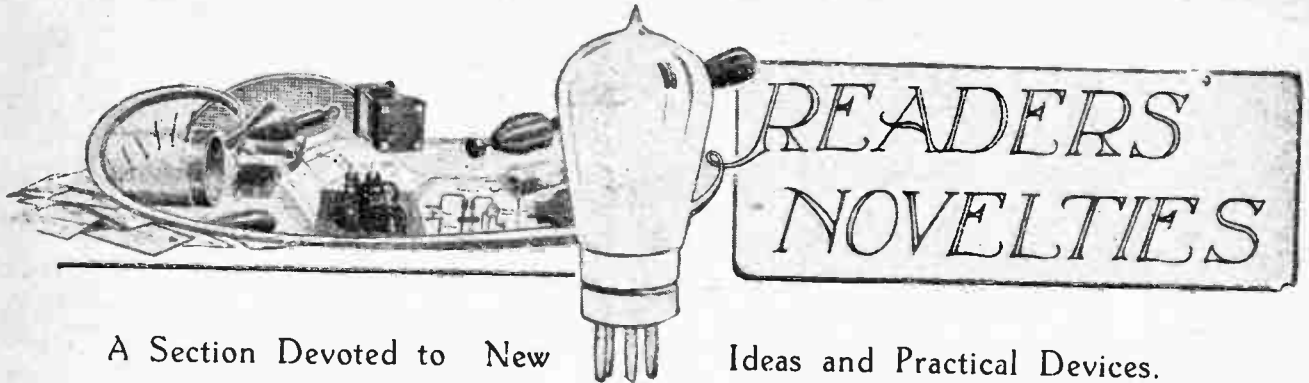

A Section Devoted to New Ideas and Practical Devices.

LOUD-SPEAKER FOR PORTABLE SETS.

An old motor horn makes an excellent flare for the self-contained loud-speaker in a portable receiver when used in conjunction with one of the many loud-speaker movements available on the market.

The horn may be mounted on a special platform or on the partition dividing off the H.T. compartment. The best way of supporting it is to use the original clip supplied with

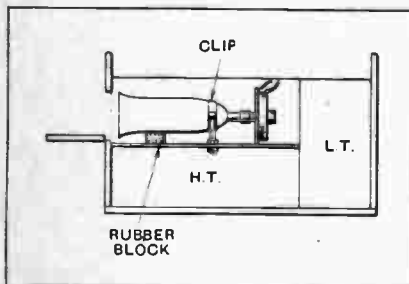

Portable loud-speaker horn.

the horn and a block of sponge rubber, as shown in the diagram. A hole should be cut in the side of the cabinet opposite the flare of the horn, the outlet being either closed with a small door or covered with a fretted grille to protect the interior of the set from dust. The interior construction of these horns gives a long path for the sound waves and the tone is pleasing and of surprising volume.—L. I. B.

o o o o

EVERYMAN SPACERS.

In the original design given for the H.F. transformers used in the "Everyman Four" set, 8BA screws were used in the spacing strips to secure the ends of the windings.

If difficulty is experienced in obtaining these screws a satisfactory substitute is to drill two holes as indicated in the diagram, and to insert

a short length of No. 26 S.W.G. tinned wire and twist it to form a terminal point to which the ends and tappings on the winding may be secured. A groove should be cut between the holes on the underside of

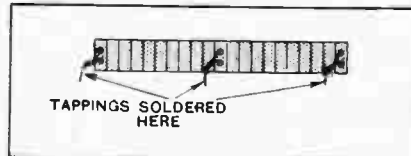

Simple method of terminating "Everyman" transformer windings.

the spacer to prevent the tinned wire from coming into contact with the secondary winding.—S. A. W.

o o o o

TAG CONNECTIONS.

Unless soldering is resorted to, the ends of flex connections are apt to pull out of their spade terminal tags. To prevent this use should be made of *two* tags of different size as indicated in the sketch. The bared end of the flex is fixed to the small tag in the usual way, while the large tag is pressed round the braiding. Both

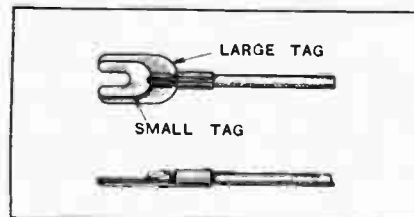

Double-tag connections to prevent wire pulling out.

Valves for Readers.

For every practical idea submitted by a reader and accepted for publication in this section the Editor will forward by post a receiving valve of British make.

tags are clamped down under the terminal, and the large tag then relieves the joint of any strain. R. H. C.

o o o o

H.F. CHOKE FORMER.

An efficient air-spaced H.F. choke for use on short wavelengths may be wound on a former of the type shown in the diagram.

An empty instrument-wire spool or large cotton reel is obtained and slotted radially by means of a hacksaw. Strips of ebonite or well-seasoned mahogany having a V-

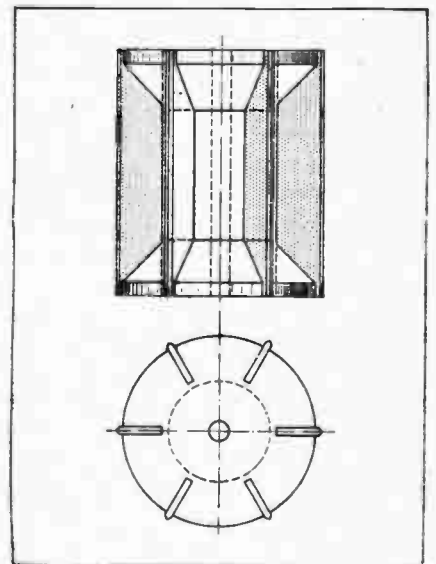

Low-capacity H.F. choke former.

shaped edge are then forced into the slots and the whole assembly well dried and then varnished.

No. 36 or 40 S.W.G. enamelled wire is suitable for the winding, and, assuming the diameter of the coil is 1½ in., 80 turns with spacing equal to the diameter of the wire will give excellent results on wavelengths down to 15 metres.—T. A. B.

BROADCAST RECEPTION

THROUGH SPARK JAMMING



Selective Long-wave Three-valve Receiver.

By A. P. CASTELLAIN, B.Sc., A.C.G.I., D.I.C.

MANY people have tried to listen in on the shorter broadcast wavelengths and have experienced the annoying interruptions of local spark stations—more especially if they happen to live on or near the coast, where the spark interference due to ships is usually very bad.

The writer took a portable car set (The Motorist's Four) to one of the south coast resorts last year and discovered for himself how bad the interference can be when the "local" station is sixty miles or so away.

On the longer wavelengths, however, there is comparatively little interference, and with a suitable set using tuned circuits the selectivity can be made quite good without the use of any elaborate apparatus. On the long waves there is the added advantage that the strength of signals received from the various stations does not vary so much during the day as the short-

wave signals; thus, if it is possible to receive a given long-wave station at all, it will probably be quite possible to receive afternoon concerts as well as the usual nightly broadcasts, while, as most readers have no doubt found to their cost, it is only after dark that the short-wave signals (other than the local station if within about 35 miles) begin to get up to decent loud-speaker strength.

Again, on the long waves, fading is not nearly so pronounced as on the shorter, due no doubt to the direct ray being received in the former case even in daylight.

It may be objected that there are many more stations transmitting on the shorter waves than on the long, and that therefore the short waves offer a better selection of programmes. So they do, in theory, but not in practice when using an aerial within a few miles of one or two (or more) stations transmitting on 300 or 600 metres (plus and minus about fifty per cent.).

Turning to the long-wave stations, there is quite a good selection of reliable transmissions—at least three and quite often five may be received whenever they happen to be on from at any rate the central and southern parts of England.

Hilversum, Königs-wusterhausen, Daventry, Radio Paris, and the Eiffel Tower offer a selection of programmes from different countries, but not such a big selection when it is remembered that any one of at least one of these may be heard for a whole afternoon or evening without interruption, and it is hard to find a d

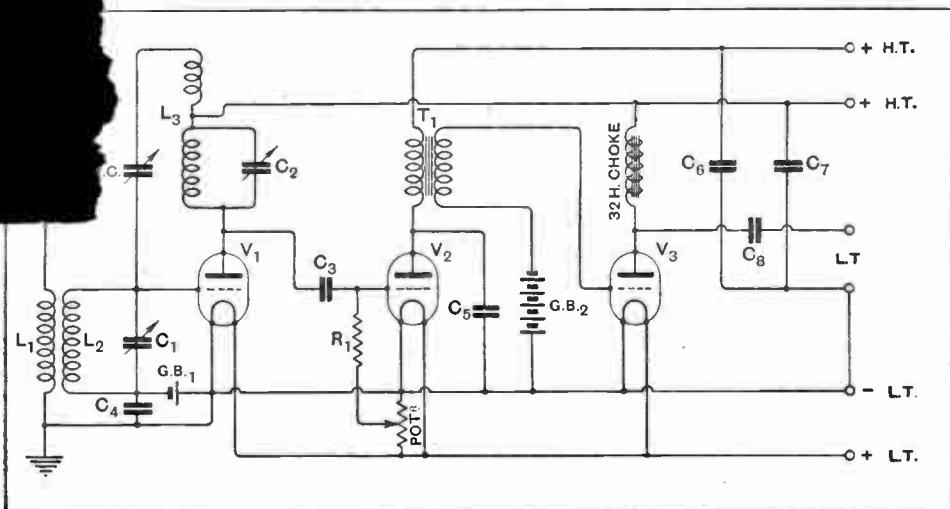

Fig. 1.—The circuit diagram of the receiver. L₁ = aerial coupling coil, No. 75 - 250 (see text); L₂ = grid coil, No. 200 or 250; L₃ = Igranic XLLOS No. 5; C₁ and C₂ = 0.0005 mfd.; C₃ = 0.0005 mfd.; C₄ = 0.005 mfd.; C₅ = 0.0003 mfd.; C₆, C₇, C₈ = 2 mfd.; R₁ = 2 megohms.

Broadcast Reception Through Spark Jamming.—

it would be possible to say the same for short-wave reception, with a three- or even four-valve receiver.

The set to be described in this article has been designed with the following points in view:—

- (1) Reception of at least three broadcast stations without serious spark interference.
- (2) Ease of assembly.
- (3) All components to be manufacturers' products.

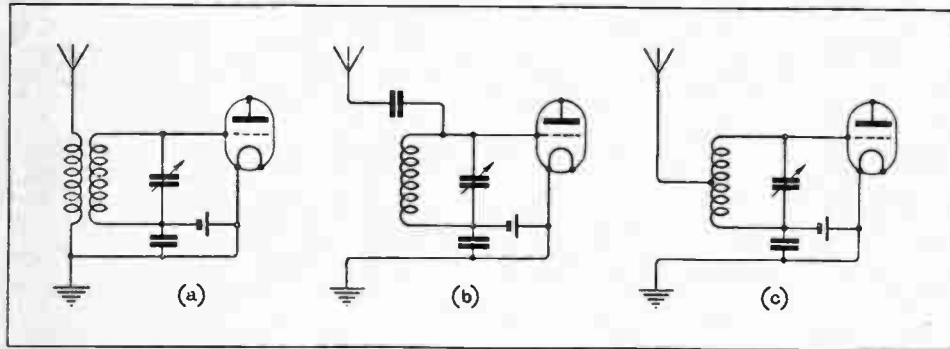

Fig. 2.—(a) (b) and (c) showing three arrangements for loose coupling the aerial.

Condition (3) ensures the minimum time of assembly, and the layout of the components is so arranged that condition (2) will be fulfilled.

The Circuit.

The complete circuit of the set is given in Fig. 1. It will be seen that the arrangement is a quite straightforward r-v-t, with the H.F. valve a stabilised tuned anode and a loose-coupled input circuit. In order to obtain reasonable selectivity it is as well to use at least two tuned circuits, and although these circuits may be on the input side of the first valve (as in the All-Wave Four recently described it is usually more convenient and efficient to use the second tuned circuit in the high-frequency stage.

There are various ways of obtaining a fair degree of selectivity on the input side with the use of only one tuning condenser, and three such arrangements are shown in diagrammatic form in Fig. 2.

The first diagram (a) shows the actual scheme used in the set to be described and consists of two coils arranged side by side as close as possible.

The other coil is connected to the aerial and the first valve. This arrangement gives a

ment, the aerial coupling may be varied within quite wide limits simply by varying the coil plugged into the aerial socket—a small aerial coil giving a small coupling and a coil of more turns giving greater coupling. An interesting point about this method of loose coupling is that if a very large coil is used in the aerial position—one large enough to self-tune to about 3,000 metres or over—the effect is practically the same as if the aerial were coupled to the grid coil through a coupling condenser, as shown in Fig. 2 (b).

Where the set is intended for use at a considerable distance from both Daventry and Radio Paris, either of the circuit arrangements shown in (b) or (c) of Fig. 2 may be used in preference to the other loose-coupling scheme of Fig. 2 (a). The double coil method of loose-coupling shown at (a) involves a little loss of signal strength as compared with more or less direct coupling, but is practically essential

when the set is to be used fairly near either Daventry or Radio Paris, which are the two stations most likely to interfere with one another on the long waveband, as their wavelengths are not so widely different.

The next point of interest in the circuit is the H.F. coupling unit, which, as has been stated before, is a stabilised tuned anode. The coil actually used is an Igranite XILLOS centre tapped No. 5 coil for this longer waveband, and covers approximately 900 to 2,600 metres with a 0.0005 mfd. tuning condenser. Stabilisation is obtained by using only one-half of the coil in the

circuit, and the other half connected between the grid of valve through a neutralising condenser N.C. (see Fig. 1).

This arrangement is perfectly straightforward and reasonably efficient, of course, not so efficient as the H.F. transformer coupling used in the All-Wave Four, which is of a different character.

The main advantage of the H.F. transformer tuned anode is that in the latter case the grid resistance is usually lower than that of the tuned circuit that it replaces, and so gives better selectivity and amplification as the result. However, it is possible to use a modern high-power type (such as M-101) with a

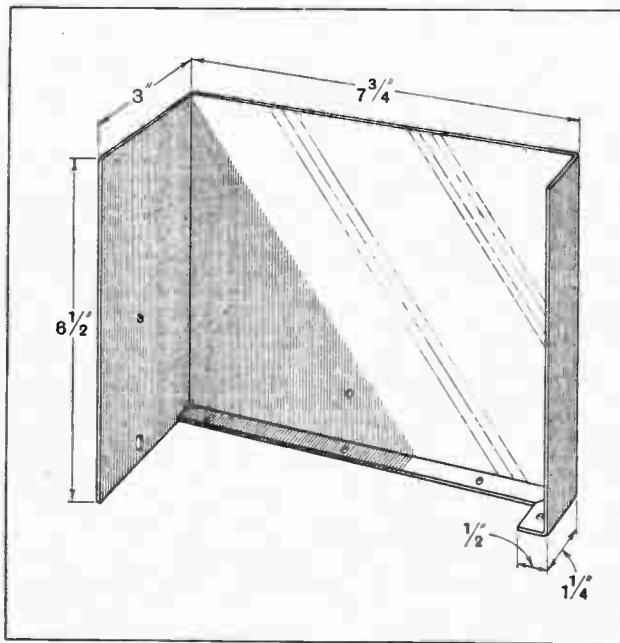
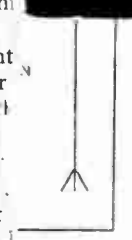

Fig. 3.—A sketch showing the construction of the aluminium screen.



earth. With
connected and
at side of
coil

Aerial

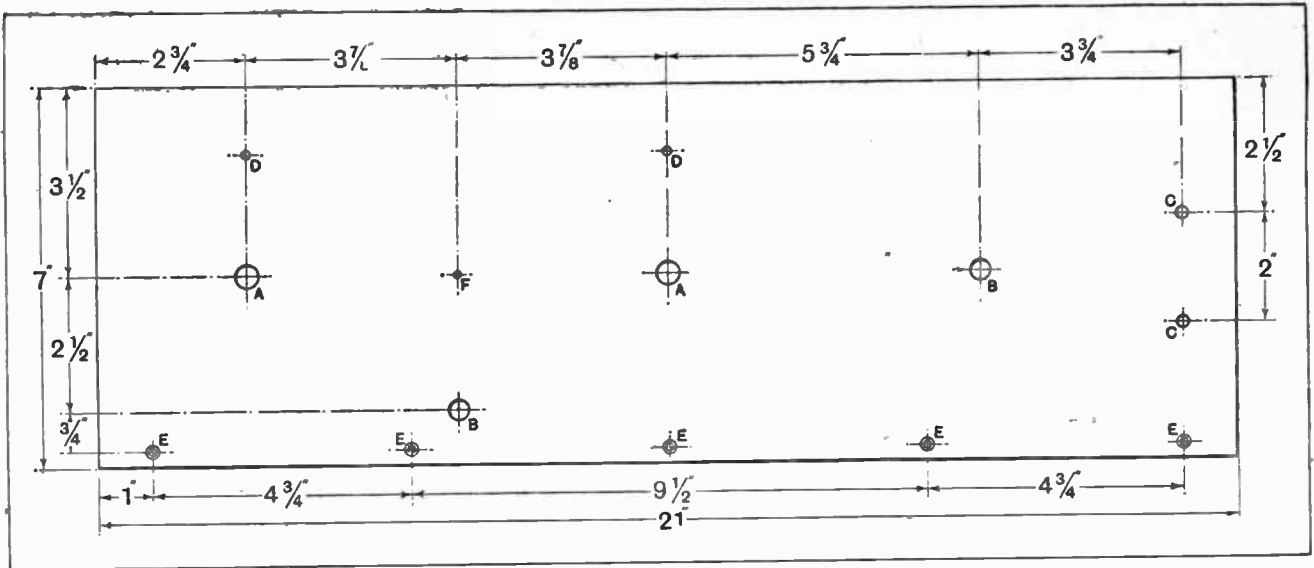
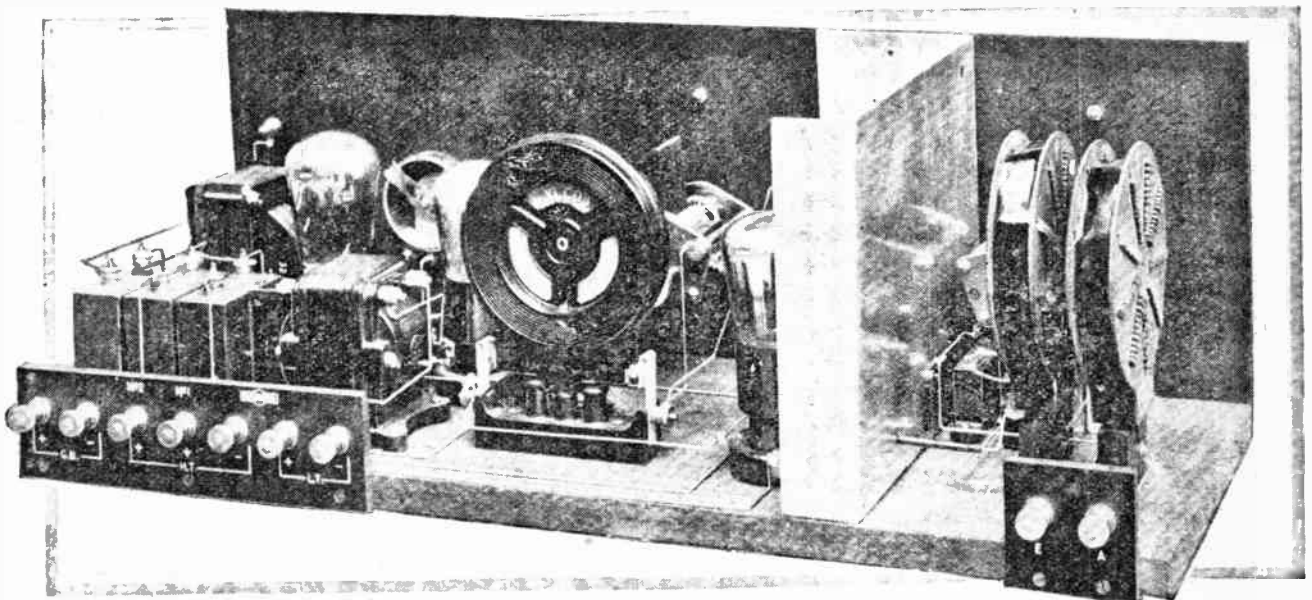

Fig. 4.—The panel dimensions. A = 7/16in. dia.; B = 3/8in. dia.; C = 7/32in. dia.; D = 5/32in. dia.; E = 1/8in. dia., countersunk for No. 4 wood screws; F = 1/8in. dia.

P.M.1A, P.M.3A, P.M.5A, or equivalents in other makes), this valve damping has nothing like the same bad effect on the selectivity, which, therefore, may be made quite reasonably good in this way. The necessary presence of the stabilising winding (exactly equivalent and closely coupled to the tuned winding) will increase the H.F. resistance of the tuned circuit quite appreciably, so that again the effect of the valve is not quite so bad as might otherwise be expected. For this reason, the writer decided to use a grid leak detector following the H.F. valve, as it is more sensitive to weak signals than an anode bend rectifier, and to adjust the normal grid potential by means of a filament potentiometer to obtain the maximum possible sensitivity. The effect of the grid leak detector will, of course, be to

load up the tuned H.F. circuit still further and so reduce selectivity, but the advantages seem in practice to outweigh the disadvantages with the particular make of coil used. If desired, of course, the detector may be converted to the anode bend type simply by disconnecting the lead from the grid leak R, to the potentiometer, and taking it either to the moving plates of C₁ (which are 1½ volts negative to the filament), or to the 1½-volt tapping on the bias battery GB₂. A more flexible scheme would be to connect another 1½-volt cell in the lead from R to the potentiometer, so that the grid is always 1½ volts more negative than the potentiometer slider. Thus, by simply rotating the latter it is possible to change from anode bend to grid leak detection.

Selectivity should be slightly increased and signal



A rear view of the set showing the arrangement of the tuning coils and the screen.

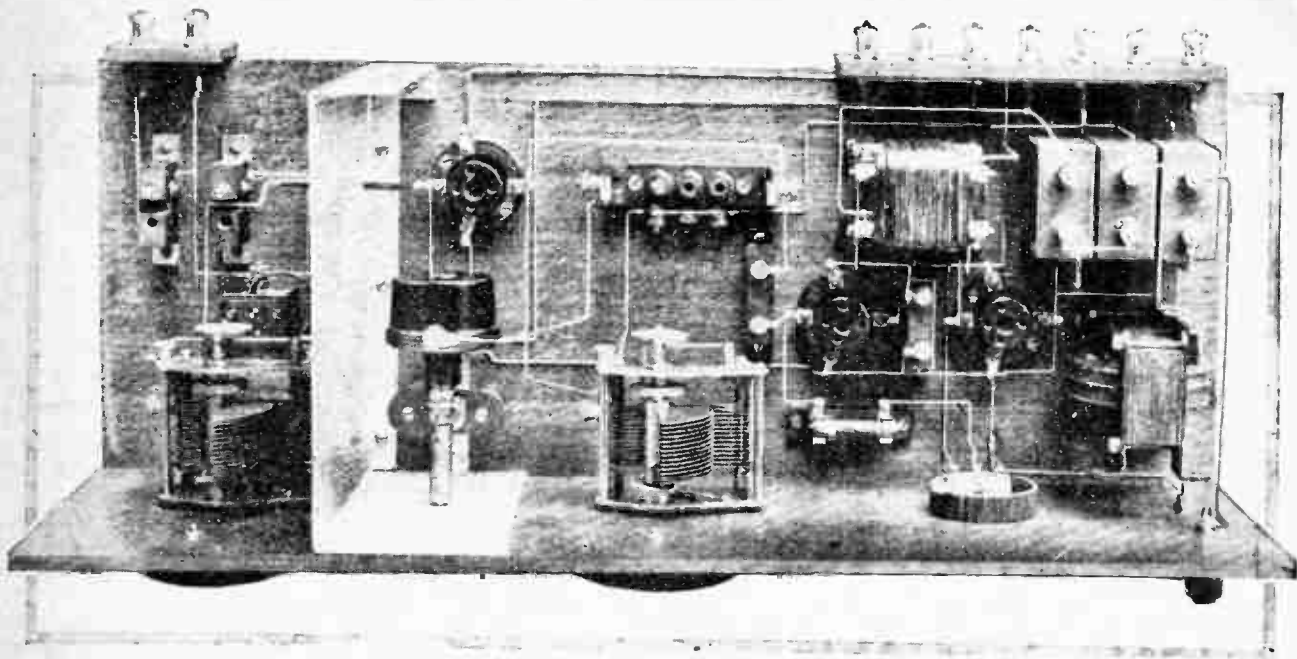

A plan view of the set showing the simple "straight line" layout of the components.

strength decreased by this alteration. The rest of the circuit is perfectly straightforward and calls for no comments.

The Layout.

The layout of the components is very simple and practically the only real constructional work involved is the screen (sketched in Fig. 3) and the bracket for supporting the Igranite neutralising condenser away from the panel. This latter arrangement is made so as to get a portion of the earthed metal screen in between the knob and the neutralising condenser in order to avoid any hand

capacity effects. A short elonite extension piece is used to insulate the set screw on the knob from any metal on the condenser, as both sets of plates on the latter are "live."

The sketches of panel dimensions, the layout and wiring diagrams should be self-explanatory, and the photographs show the appearance of the actual set.

Valves.

The first valve should preferably be of the high amplification type, such as a P.M.3A, the detector of the P.M.3 class, and the output valve of the P.M.4 or

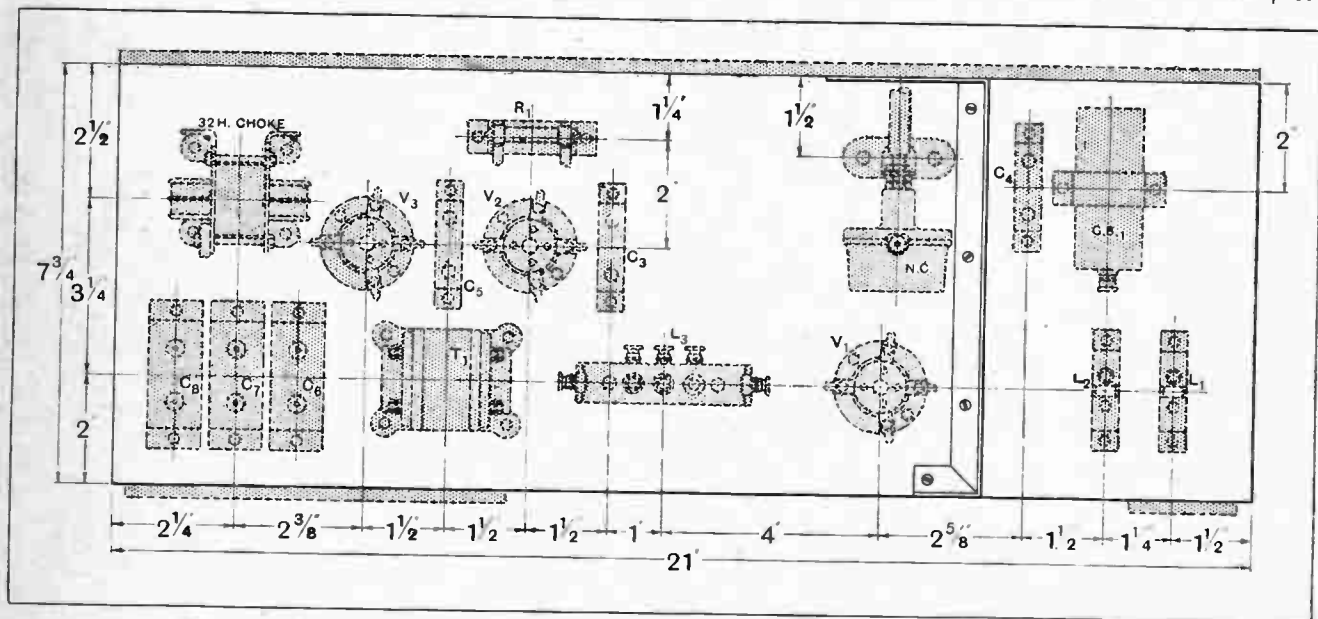

Fig. 5.—The layout of the apparatus. The components are lettered to correspond with Figs. 1 and 6.

LIST OF PARTS.

- 2 Fixed coil holders, No. LL3 "Wearite" (Wright & Weaire, Ltd.).
- 1 Centre tapped XLLOS No. 5 coil and holder (Igranic).
- 1 Micro condenser (Igranic).
- 2 Variable condensers, S.L.F. slow motion (Brandes).
- 1 Fixed condenser, 0.0005 mfd., No. 620 (Dubilier).
- 1-0.0003 mfd. condenser, No. 620 (Dubilier).
- 1-0.005 mfd. condenser, No. 620 (Dubilier).
- 3 Fixed condensers, 2 mfds. (T.C.C.).
- 1 Grid leak, 2 meg., "Dumetohm" (Dubilier).
- 1 "Dumetohm" holder (Dubilier).
- 1-400-ohm potentiometer, "Peerless" (Bedford Elec. Co.).
- 1-15 v. G.B. battery (Siemens).
- 1 Transformer, L.F., 1-1 (British Thomson-Houston).

- 1 Jack switch complete, No. P625 "Igranic-Pacent" (Igranic).
 - 1 "T" square-type cell, 1½ v. (Siemens).
 - 3 Valve holders, "H" type, "Armonic" (Jas. Christie & Sons, Ltd.).
 - 1 Terminal panel, 7-way, "Magnum" (Burne-Jones & Co.).
 - 1 Terminal panel, 2-way, "Magnum" (Burne-Jones & Co.).
 - 2 Ebonite shrouded terminals (Belling & Lee).
 - 2 Dial indicators (Belling & Lee).
 - 1-32-henry choke (Pye).
 - 1 Ebonite panel, 21in. × 7in. × ½in.
 - 1 Baseboard, 21in. × 7½in. × ¾in.
 - 1 Cabinet, 21in. × 7in. × 8in. deep, type A.G. No. 20/26 (W. & T. Lock).
- Aluminium screen, wire, flex, wander plugs, etc.

Approximate price - £9 9 0

In the "List of Parts" included in the descriptions of THE WIRELESS WORLD receivers are detailed the components actually used by the designer and illustrated in the photographs of the instrument. Where the designer considers it necessary that particular components should be used in preference to others, these components are mentioned in the article itself. In all other cases the constructor can use his discretion as to the choice of components, provided they are of equal quality to those listed and that he takes into consideration in the dimensions and layout of the set any variations in the size of alternative components he may use.

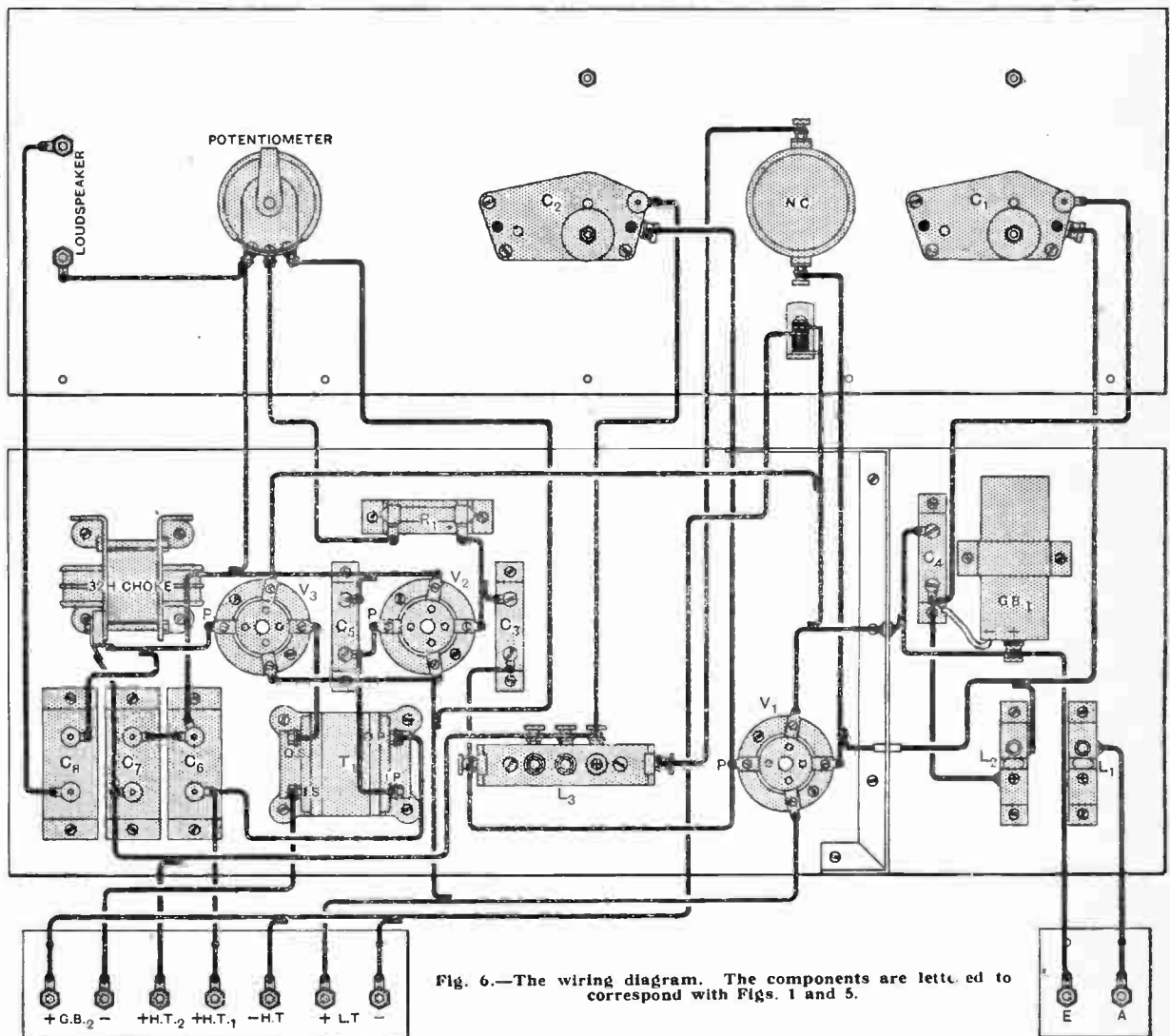

Fig. 6.—The wiring diagram. The components are lettered to correspond with Figs. 1 and 5.

Broadcast Reception Through Spark Jamming.—

P.M.254 type, or, of course, *corresponding* valves of other makes.

The wavelength range of the set as described is approximately from 900-2,600 metres, but the shorter wavelengths may be received by using smaller coils for I_1 , I_2 , and L_3 .

Coil I_3 should be Igranix XLLOS No. 2 to cover from

about 160 to 520 metres and No. 3 to cover from about 300 to 900 metres—thus with the No. 3 and No. 5 coils a waveband of 300 to 2,600 metres can be completely covered. Coil I_2 will require Nos. 50, 100, and 200 at least, ordinary plug-in type to cover the same range, and probably No. 250 as well, according to the particular make of coil used, as inductances vary considerably with different makes.

NEWS FROM THE CLUBS.

Black Future for Southend Oscillators.

Reference has already been made in *The Wireless World* to the formation of an Anti-Oscillation League in the Southend district. This League, which has its headquarters at 855, London Road, West-cliff-on-Sea, is losing no opportunity to suppress the growing nuisance of oscillation in the surrounding districts. How serious is the League in its efforts in this direction may be judged from the fact that a public meeting is to be held in the autumn with a view to the election of a president and other officers.

A number of rules have been formulated, and members are pledged not only to avoid oscillation themselves, but to give notification concerning cases which come to their notice. All complaints, together with reports of work accomplished, are sent to the British Broadcasting Corporation.

All communications to the League should be addressed to the Hon. Secretary at 12, Grange Gardens, Southend.

Debate on L.F. Coupling.

A debate on L.F. coupling held the keen attention of members of the Hounslow and District Wireless Society at their meeting on June 28th. The opening speakers were Messrs. Osborne and Panton, who championed the resistance capacity and transformer methods respectively. Mr. Osborne made light of various difficulties peculiar to resistance amplifiers, while his opponent contended that the average resistance amplifier, getting the most out of its high-magnification valves, only favoured the low notes at the expense of the high notes. A keen discussion followed, in which a strong diversity of opinion was manifest.

Hon. Secretary, Mr. W. R. Collis, 7, Algar Road, Isleworth.

○○○○

Another D.F. Field Day.

Encouraged by the success of the direction finding scheme carried out on Sunday, June 19th, the Golders Green and Hendon Radio Society has organised a similar event on a larger scale for Sunday next, July 17th.

The object of the numerous D.F. groups will be to discover the exact locality of the club's transmitting station (5CT) and to report on the effect on signal strength of surrounding objects, etc.

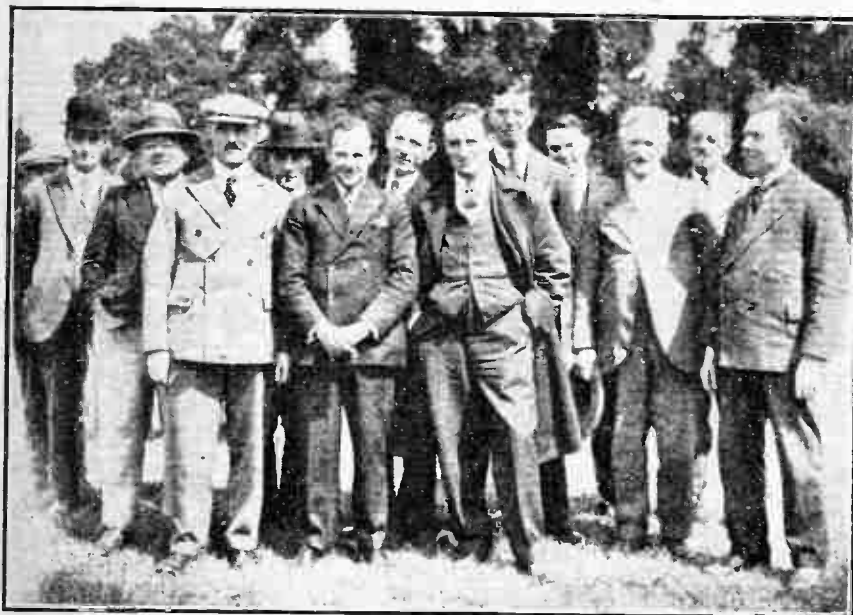

ON A FIELD DAY. Members of the Hackney and District Radio Society photographed on Sunday, June 26th, at Blackmore, Essex. Mr. Samson (second from right, front row) secured a challenge cup, presented by the chairman, Mr. Cunningham, for the quality of reception on his "Everyman Four."

FORTHCOMING EVENTS.

WEDNESDAY, JULY 13th.

Tottenham Wireless Society.—At 8 p.m. At 10, Bruce Grove, N.17. Lecture: "Valve Couplings," by Mr. F. Dyer.

SUNDAY, JULY 17th.

Golders Green and Hendon Radio Society.—Field day.

A first prize to the value of three guineas will be presented by *The Wireless World* to the winning group, while a consolation prize of one guinea will be given by the Society.

All communications regarding the scheme should be addressed to the Hon. Secretary, Lieut.-Col. H. Ashley Scarlett, 357A, Finchley Road, N.W.3.

CATALOGUES RECEIVED.

Readers wishing to obtain copies of the catalogues mentioned below should apply to the firms direct. It is advisable to forward stamps for postage.

The Mullard Wireless Service Co., Ltd., Mullard House, Denmark Street, London, W.C.2. Leaflets W.A.8 and W.A.9 dealing respectively with the Mullard Pure Music Speaker and the Mullard P.M. Mansbridge Condensers.

○○○○

Ferranti, Ltd., Hollinwood, Lancashire. Publication Wa405, illustrating and describing the Ferranti output transformers, type OP1 (ratio 1 to 1) and type OP2 (ratio 25 to 1).

○○○○

F. C. Heayberd and Co., 8-9, Talbot Court, Eastcheap, London, E.C.3. List 924, dealing with the "Overnight" battery chargers for H.T. and L.T. batteries. Also the Suprecision (model 103) testing set.

○○○○

L. McMichael, Ltd., Wexham Road, Slough, Bucks. Leaflet describing the "M.H." 5-valve portable.

○○○○

C. A. Vandervell and Co., Ltd., Acton, London, W.3. List of firms appointed as C.A.V. radio service agents.

○○○○

General Electric Co., Ltd., Magnet House, Kingsway, London, W.C.2. Leaflet BC. 4457, describing the combination of Geophone power transformer and Osram KL1 valves.

An Announcement

Concerning three new B.T.H. Valves

FOR some time past B.T.H. engineers have been engaged on the problem of increasing the efficiency of the two-volt valve. After many months of research work they have evolved a series of two-volt valves which can successfully challenge valves of any voltage so far as working efficiency is concerned, while in the matter of current consumption they are just as economical as other two-volt valves.

The Filament. The manufacture of the B.T.H. 2-Volt Valves referred to above has been made possible by the production at Rugby of a new filament which gives a useful emission at a temperature even lower than that of a dull emitter valve of the thoriated filament type. The outstanding merits of this new filament are as follows:—

1. It is longer, thicker, and consequently more efficient and durable than the ordinary 2 v. filament.
2. The filament, as mentioned above, operates at a very low temperature, and has therefore an exceptionally long life.
3. It is supported in such a manner as practically to exclude the possibility of breakage or displacement.

Life Tests. Before putting these new valves on the market they have been subjected to very careful life tests with a view to ensuring that every valve sold shall give a long useful life. These valves will give satisfactory operation right down to the point when the accumulator needs recharging. They are very definitely designed and rated at two volts, so that filament resistances are not necessary when the valves are operated from a two-volt accumulator. The continuous use of these valves at two volts will not cause any reduction in the total life of the valves.

The Power Valve. In designing the B.23 Power Valve two points were specially borne in mind:—

1. The need for a two-volt loud-speaker valve which could give results comparable to those of the world-famous B.4.
2. It was felt that the practice, introduced by some other makers, of keeping the filament current as low as 0.15 of an ampere for a loud-speaker valve involved an undue sacrifice of volume and quality for the sake of a small economy in current consumption.

It was therefore decided to use a higher filament current than was the common practice. Without going as high as 0.3 ampere, as in the case of some of the later two-volt power valves, it was found that by compromising on 0.2 ampere the desired object could be achieved. As a result we have produced a valve having a stronger filament and giving a greater emission than other makers of 2-volt power valves. In other words, we have produced a loud-speaker valve which can compare in results with the B.4. It was felt that few users would grudge the additional 0.05 ampere to secure these advantages.

TYPE B21.. 14s. 0d.
(High Frequency & Detector.)
Filament Volts 2
Filament Amps 0.1
H.T. Battery Volts .. 40 to 150
Amplification Factor 16
Impedance 32,000 ohms

TYPE B22.. 14s. 0d.
(General Purpose.)
Filament Volts 2
Filament Amps 0.1
H.T. Battery Volts .. 40 to 100
Amplification Factor 7.5
Impedance 14,000 ohms

TYPE B23.. 18s. 6d.
(Power Amplifying.)
Filament Volts 2
Filament Amps 0.2
H.T. Battery Volts .. 40 to 100
Amplification Factor 6
Impedance 8,000 ohms

The above prices are applicable in Great Britain and Northern Ireland only.

A COMPLETE RANGE OF VALVES



2 volt Valves

FOR ALL SETS AND CIRCUITS

The British Thomson-Houston Co., Ltd.

B21 { H.F. & DET. }

B22 { General Purpose }

B23 { Loud Speaker }

2788



The Tide of Progress Must be Served

As with King Canute, who, of course, failed utterly to stem the mighty tides, so will you, sooner or later, be unable to resist the tide of wireless progress represented by the substitution of "HART" 'RAY' type High Tension Accumulators for Dry Batteries.

Actually more economical to operate than dry batteries, over prolonged periods, "HART" 'RAY' type High Tension Accumulators also effect an increase in volume and improvement in tone which are a revelation to new users.

HART BATTERIES

FOR ALL WIRELESS CIRCUITS

'RAY' TYPE H.T. ACCUMULATOR
20-volt, 14/8 : 30 volt, 22/-

Any reasonable number of the above units can be utilised to build up the particular voltage desired.

*The Accumulator which makes
Dry Batteries things of the Past*

Write to Dept. "W.W." for full particulars and
FREE illustrated booklet,
of interest to all wireless users.

HART ACCUMULATOR Co., Ltd.
STRATFORD, LONDON, E.15



Goodall & Co.

Mention of "The Wireless World," when writing to advertisers, will ensure prompt attention.

Why LEWCOS Frame Aerial Wire is recommended for the "Wireless World" Portable

Enthusiastic users have proved that LEWCOS Wire guarantees an efficient Frame Aerial—the first essential in a portable receiver. Mr. G. Brammer of Copenhagen says: "It works excellently . . . I simply can't get a better frame." For every type of Frame Aerial, use this guaranteed wire. Made by the manufacturers of Glazite.

In cartons in the following colours: Bright Red, Bright Blue, Bright Green, Marone, Old Gold and Golden Brown. 3/6 per 100 ft. coil from all Radio dealers. Full particulars from:

THE
LONDON ELECTRIC WIRE
COMPANY & SMITHS, LTD.,
Playhouse Yard, Golden Lane, E.C.1.

LEWCOS

*Frame Aerial
Wire*

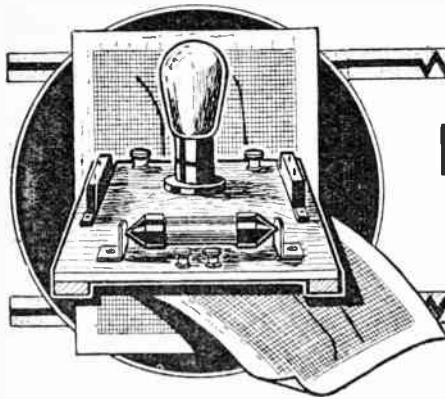

RESISTANCE - CAPACITY AMPLIFICATION

PART II.

Calculation of Coupling Condenser and Grid Leak Values.

By W. JAMES.

WE may now consider for a moment the effect of the coupling condenser in series with the grid leak, for this circuit is in parallel with the coupling resistance. The impedance of the coupling condenser is quite negligible for a large part of the acoustic frequency range, but for the very low frequencies, such as 25-50 cycles, the condenser usually has an impedance which is anything but negligible. It therefore follows that the effective resistance connected to the anode circuit will vary with frequency.

The circuit in question is given in Fig. 10, from which it is easy to see that if the grid leak has such a value that when reckoned as being in parallel with the coupling resistance R , the effective resistance of the two is much less than R , then the condenser may play an important part. For the higher frequencies the impedance of C is negligible, but the lower the frequency the greater the impedance of the condenser and of the path in parallel with the coupling resistance. Thus the effective resistance of the complete circuit connected to the anode is likely to increase in practice, which will have the effect of causing a given applied A.C. voltage to produce a slightly bigger A.C. voltage across the coupling resistance when the frequency is low than when the frequency is high.

We can now pass on to the next question and consider what amplification we are likely to get in practice. First, we will consider the lower acoustic frequencies. Now the actual amplification is given by the ratio of the voltage e_2 developed between grid and filament of the second valve to that applied to the first valve. Call-

ing the latter voltage e_1 the amplification is $\frac{e_2}{e_1}$, Fig. 11.

As is indicated by Fig. 5 (b) in Part I (July 6th issue), the voltage developed across the grid

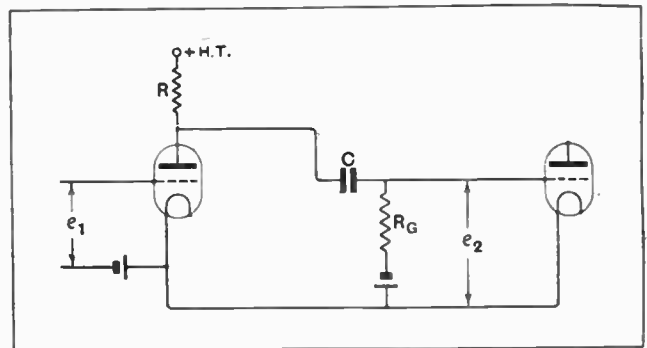

Fig. 11.—The amplification per stage is given by the ratio $\frac{e_2}{e_1}$.

leak may not be equal to the voltage developed across the coupling resistance on account of the coupling condenser C . In practice C is naturally given such a value as to make the loss negligibly small, but it has to be remembered that the importance of the condenser increases as the frequency is reduced, and it will be evident that the importance of the impedance of the condenser will depend upon its value as compared with the grid leak. For if the combination of grid condenser in series with the grid leak is such that the grid leak resistance is very high as compared with the impedance of the condenser at the lowest frequency which it is desired to amplify, then the effect of the condenser at all higher frequencies can be neglected.

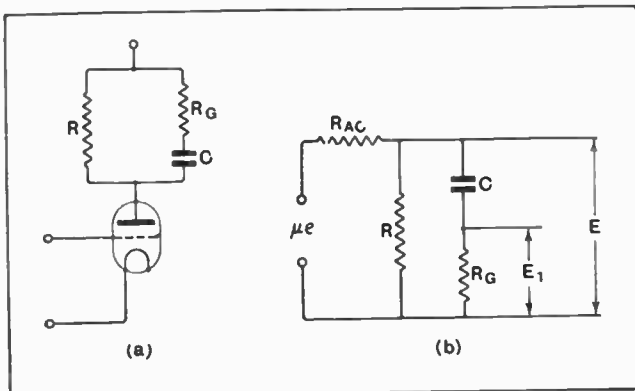

Fig. 10.—Equivalent circuits for low frequencies when the impedance of C is comparable to R_G .

Resistance-capacity Amplification.—

This, however, would involve using a large condenser and a high value of grid leak, a combination which is bad from the point of view of the time taken for a charge which may have collected on the condenser electrodes to discharge through the grid leak. In addition, we do not want to amplify the lowest frequencies to such an extent as those of middle frequency.

When a loud-speaker which hardly reproduces notes below, say, 100 cycles is used, there is not much reason in making the amplifier pass the very low tones. The question is really a practical one, best solved by the individual who will say: "I am satisfied if the reduction in amplitude of a 50-cycle note is not more than 10, 20, or perhaps 30 per cent. of the full amount available." With the majority of present-day loud-speakers it is, in the writer's opinion, absolutely futile to provide too much magnification of the lower frequencies, and for this reason we will take 80 per cent. at 50 cycles to be reasonable.

We have now to determine the value of a coupling condenser which, when used with a specified grid leak, will give the desired amplification.

Calculating Capacity of Coupling Condenser.

We can proceed in two ways: one is to assume that the A.C. voltage set up across the coupling resistance R is independent of frequency, and the second is to work out the impedance of the network comprising R, C, and R_G, and from that to find the voltage developed across the grid leak for a range of frequencies. The latter method is rather complicated, and perhaps is hardly worth while, as an accuracy of one or two per cent. is not worth bothering about.

However, those who are interested may care to work out the formula

$$C = \frac{R_{AC} + R}{2\pi f [R_G(R_{AC} + R) + R_{AC}R] \sqrt{\frac{I}{n^2} - I}}$$

where C = capacity of coupling condenser in farads.

R_{AC} = A.C. resistance of valve.

R = anode coupling resistance.

R_G = resistance of grid leak.

n = fraction of full amplification desired.

f = the lowest frequency considered.

For the case where R_{AC} is 290,000 ohms, R 500,000 ohms, R_G 2 megohms, and n is 0.8 at 50 cycles, the capacity will be found to work out at 0.00195 mfd.

The simplest method of finding the value of C, and which, moreover, shows very clearly the dependence of C on the grid leak R_G, is to assume a constant voltage to be set up across the anode coupling resistance, and therefore across C and R_G in series. This voltage will send a current i through C and R_G:

$$i = \frac{E}{\sqrt{R_G^2 + \left(\frac{I}{2\pi f C}\right)^2}}$$

while the voltage set up across the grid leak R_G will be

$$E_1 = i R_G, \text{ or } i = \frac{E_1}{R_G}$$

From these equations we find

$$\frac{E_1}{E} = \frac{R_G}{\sqrt{R_G^2 + \left(\frac{I}{2\pi f C}\right)^2}} = n$$

or

$$C = \frac{n}{2\pi f R_G \sqrt{\frac{I}{n^2} - I}}$$

This formula will give us the value of the condenser C which, when used with a given grid leak R_G, will allow a proportion, n, of the full voltage across R to be set up across the grid leak. This is not quite the same thing as the actual amplification, but, as explained above, is near enough for practical purposes.

Taking the same values as before, and inserting them in the formula, we find that C must have a value of 0.0021 mfd. This is not a very different value to that arrived at by using the longer formula.

Relation between Coupling Condenser and Leak.

If the value of R_G is varied, and the right value for condenser C is determined by working out the formula, it will be found that the values are inversely proportional; for instance, if C is 0.0021 mfd. for an R_G of 2 megohms, C will have a value of 0.0042 mfd. for an R_G of 1 megohm, the proportion of the available voltage being 80 per cent. at 50 cycles in the two examples. Other values are given in Table II, together with the values for 90 per cent. and 70 per cent. of the amplification at 50 cycles.

TABLE II.

SHOWING THE VALUES OF COUPLING CONDENSERS AND GRID LEAKS FOR DIFFERENT RATIOS OF $\frac{E_1}{E}$. (SEE FIG. 10 (b).)

| n=90% at 50 Cycles. | | n=80% at 50 Cycles. | | n=70% at 50 Cycles. | |
|--|-----------------------------------|--|-----------------------------------|--|-----------------------------------|
| Capacity of Coupling Con- denser (mfd.). | Resistance of Grid Leak (megohms) | Capacity of Coupling Con- denser (mfd.). | Resistance of Grid Leak (megohms) | Capacity of Coupling Con- denser (mfd.). | Resistance of Grid Leak (megohms) |
| 0.0132 | 0.5 | 0.0084 | 0.5 | 0.0062 | 0.5 |
| 0.0066 | 1.0 | 0.0042 | 1.0 | 0.0031 | 1.0 |
| 0.0033 | 2.0 | 0.0021 | 2.0 | 0.00156 | 2.0 |
| 0.0013 | 5.0 | 0.0008 | 5.0 | 0.0006 | 5.0 |

If further calculations are made, the ratio n can be determined for other frequencies using the values given in Table II. At the frequency of 100 cycles, for instance, the value of n is 0.97 when C is 0.0033 and R is 2 megohms, i.e., when n is 0.90 at 50 cycles. When the values which give n a value of 0.8 at 50 cycles are used, the ratio is 0.93 at 100 cycles, while for a ratio of 0.7 at 50 cycles we have 0.89 at 100 cycles. Thus, in all these instances the loss at 100 cycles is quite small, and for slightly higher frequencies the full amplification is obtained.

There are one or two practical points which have to be remembered when setting up a resistance condenser coupled stage. One of these concerns the grid circuit,

Resistance-capacity Amplification.—

for it will be obvious that should the valve or its holder throw a load across the grid leak the effective resistance of the grid circuit will be varied. This will lower the overall amplification and also slightly further reduce the amplification of the lower frequencies by altering the ratio of the value of the grid-leak resistance to that of the coupling condenser.

The valve holder itself will usually have such a high insulation resistance that it can be neglected; similarly, the insulation resistance measured across the valve pins will also be so very large as to be negligible, but when the valve is allowed to take grid current, the input impedance of the valve falls considerably and reduces the effective resistance of the grid circuit.

This will probably cause squealing or the popping sounds already referred to, thus destroying the purity of the signals. It is for this reason that a negative grid bias of much greater value than the peak voltage of the average signal is recommended, even though the use of such a negative bias reduces the normal amplification by increasing the valve's anode A.C. resistance.

Choice of Components.

Anode coupling and grid-leak resistances should, of course, have a value of resistance which is constant, regardless of the current passing through them; that is, if the unit passes a current of 10 microamperes when 10 volts is applied, 50 microamperes should flow with 50 volts, and 100 microamperes for 100 volts. Many of the grid leaks on the market are satisfactory in this respect, but lack constancy. Their resistance changes after they have been passing current for a while. Quite apart from the possible effect on amplification and quality, such resistances are apt to produce noises if the variations occur with an acoustic frequency. For this reason it is usual to regard with suspicion most coupling resistances of the grid-leak type; experience has shown, however, that grid leaks of certain makes are quite satisfactory components.

The grid condenser intended for inclusion in a resistance condenser amplifier should also be chosen with great care. Its function, of course, is merely to prevent the application of the D.C. anode voltage to the grid of the next valve, and it is in many respects a nuisance.

We should therefore at least make sure that it will prevent any D.C. voltage being communicated to the grid, and it will do this provided its insulation resistance is sufficiently high as compared with the grid leak associated with it. If this is only moderately high, there is a possibility of the negative grid bias being less than that provided by the grid battery. A condenser having an insulation resistance of 100 megohms, for instance, will pass a direct current of 1 microampere if a D.C. voltage of 100 is applied to it, and the passage of this through a two-megohm grid leak will set up 2 volts across it.

Then if the grid is biased negatively by a battery of 1.5 volts the grid will actually be positive. This will cause serious trouble. Obvious remedies are to increase the negative bias and to reduce the value of grid leak, although these, of course, are not really satisfactory ways of curing the trouble. It is much better to use a

coupling condenser of known quality. Mica condensers specially constructed for resistance-condenser amplifiers can now be obtained quite cheaply. They should be carefully handled so as not to have their insulation resistance reduced by surface leakage; this can easily happen by the careless use of soldering flux and by undue handling.

Multi-stage Amplifiers.

We have so far confined ourselves to low frequencies and to one stage; what changes are necessary to preserve the same frequency characteristic when two stages are used? Obviously, if one stage cuts down the amplification of a 50-cycle note by 20 per cent., two stages will give a further reduction. Thus, if the amplification at 50 cycles is 8, and at 200 cycles 10, with a single stage, the figures will be 64 and 100 for two similar stages of

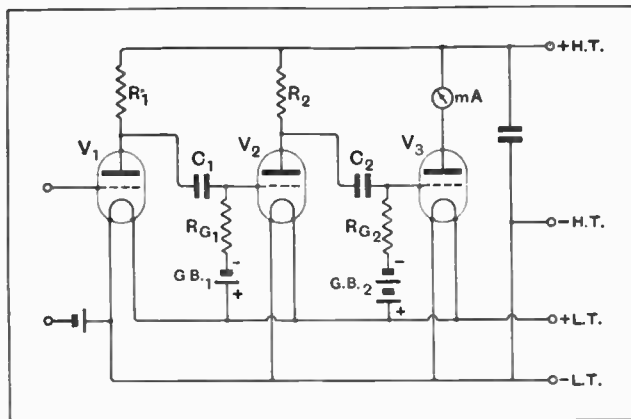

Fig. 12.—A two-stage resistance-capacity amplifier coupled to a power output valve. When setting up, a milliammeter should be connected to the loud-speaker terminals to indicate distortion.

amplification. This falling off is serious, and larger coupling condensers will have to be used when we are building a two-stage resistance-condenser amplifier than would be used for a single-stage amplifier having the same amplification-frequency characteristics. If we decide that 0.8 of the grid voltage is required at 50 cycles for a two-stage amplifier, then the value of *n* to be inserted in the approximate formula

$$C = \frac{n}{2\pi f R_G \sqrt{1 - n^2}}$$

is not 0.8, but the square root of 0.8—that is, 0.895. Similarly, if the amplifier had three stages, the value of *n* for each stage would have to be the cube root of 0.8, or 0.928. But now a practical consideration may make it advisable not to use identical stages. Let us take as an example a two-stage amplifier, Fig. 12, and work out the grid bias values likely to be used in practice. Valve V₁ we will assume has a small A.C. voltage applied to its grid, producing 0.5 volt across the grid circuit of valve V₂. This valve is negatively biased 1.5 volts, and as we are assuming that the stages are similar, valve V₃ will have an A.C. grid voltage of about 20 times this—10 volts. The grid of V₃ will therefore be biased negative 12 volts, which is a normal value for an ordinary power valve with a 120 volts anode battery.

Resistance-capacity Amplification.—

If now the A.C. voltage applied to V_2 momentarily increases to 0.7 volt, no great harm is done at this stage, the grid bias being -1.5 volts, but the A.C. voltage applied to V_3 has momentarily tended to reach 14— which is 2 volts more than the grid bias. Grid current will therefore flow in this stage, and will spoil the quality for the reasons already given.

The position is quite clear. There is a large factor of safety against momentary increases in the signal strength at valve V_2 , but practically nothing at valve V_3 , and, further, it is usually not practical to provide an adequate factor of safety in the last stage, as the majority of listeners, at all events, are not able to provide a larger anode battery to work with an increased grid bias. For this reason, the average volume of sound satisfactorily to be obtained from a loud-speaker connected to the last valve is much less than might at first be supposed—we have to allow a large margin of safety on the last valve.

Overloading the Output Valve.

This constitutes a serious drawback to the resistance-condenser amplifier, and in view of certain other characteristics of this type of amplifier it is well worth while considering whether such an amplifier is the best that the average man with the normal type of loud-speaker can use. But before passing on to this phase of the subject we will see whether it is not possible to reduce the possibility of clogging in the last stage by modifying the values of the parts used.

It does not matter, of course, how we arrange them so long as the overall characteristics are what we want them to be, giving us, say, 70 per cent. of the maximum amplification at 50 cycles. We may then try to arrange the last stage in such a way that momentary overloading will produce the least harmful effects. This can be effected by making the time constant of the last stage as low as possible, by using a coupling condenser of low capacity and a grid leak of low resistance. This will naturally tend to reduce the strength of the lower frequencies, but we can bring these up to the required proportion by redesigning the first stage. Thus we can design the first stage to give 95 per cent. at 50 cycles, and the second stage to give 75 per cent., with an overall amplification of 71 per cent. at 50 cycles. With the values which will give these characteristics our last stage will be better able to deal with overloads than when each stage is designed to give 0.71 or 87 per cent. at 50 cycles. The precise values can be found in the manner described above.

Grid Current Worse than Bottom-bend Rectification.

It might be thought that some additional protection to the last stage might be arranged by giving the grid of the power valve a rather larger negative grid bias than an examination of the valve's curves and a knowledge of the load connected to its anode would indicate. Experience indicates that the occasional distortion arising from working on a curved part of the characteristic is less distressing, being of less duration, than that due to grid current. For this reason it is usual to provide liberal negative bias, and it is advisable to connect a microammeter to the grid of the power valve and a milli-

ammeter to its anode when first setting up such an amplifier. The grid bias can then be so adjusted for a given anode battery that they give only slight kicks occasionally, the input to the last valve being adjusted to a suitable value, of course, for signals of average strength.

A movement of the grid meter indicates grid current and may be accompanied by a slight change in the anode current. When this happens, the negative grid bias should be increased. Too great a grid bias will cause the anode current meter to kick upwards, while when both meters give a varying reading for a transmission of normal strength the last stage is being overloaded. It will be found practically impossible to prevent the meters kicking occasionally, and if adjustments are made which result in the meters remaining steady, the volume will probably be most disappointing.

When making adjustments of this kind we are apt to meet a form of bass blasting. This is due to the fact that the impedance of the load connected to the power valve falls off at the lower frequencies which in turn reduces the length of the straight part of the working characteristic. Our grid bias being set for the condition where the impedance in the anode circuit is more or less high compared with the A.C. resistance of the valve, as it will be for the major portion of the frequency range, it is too big when the bass notes are present at full strength. Distortion of the bass frequencies is therefore produced by the curvature of the valve's characteristic.

Full Amplification of Low Notes Inadvisable.

The impedance of the usual (loud-speaker) load is, of course, dependent on the frequency, and may fall off to a serious extent at the higher frequencies. This is not so likely to produce noticeable distortion, since the amplitude of the notes of higher frequency is usually not so great as that of the middle and lower frequencies. But still, it is interesting to remember that the working curves of the power valve are continually changing because of the varying impedance of the load connected to it, and we must not overlook the fact that this is a likely cause of distortion—it will show up on the meters, of course. Most of the trouble is, however, due to the bass notes—here again, then, is a sound argument for not providing the very low notes at full strength. For when an amplifier giving the low notes at full strength is used the power stage must be less heavily biased and be provided with an anode battery of ample voltage so as to be sure that serious bass blasting will not occur. Pleasing quality does not necessarily demand the bass notes at great strength.

(To be concluded.)

TESTING PHONES.

WHEN it is suspected that annoying scratching noises are due to faults in the phones, it is an easy matter to make sure whether this assumption is correct by connecting across them one or two accumulator cells, the terminals of which are quite clean. If the noises still persist, it is proved definitely that the phones are at fault. The test is made more conclusive by shaking the leads while listening.



A Review of the Latest Products of the Manufacturers.

FOR THE SELF-CONTAINED SET.

The set of the immediate future is an entirely self-contained one as regards receiver, frame aerial, battery eliminator, and, perhaps, loud-speaker. Such a set will give good service as a local station receiver up to about 25 miles, requires no attention as regards battery renewals, while there are no trailing wires for aerial and earth connections, earthing switch or battery leads. For building such a set a two-section cabinet is required for separately housing a receiver and battery eliminator equipment.

A cabinet to meet this requirement has just been placed on the market by F. Dighv, 9, Banbury Road, S. Hackney, London, E.9. It is an elegant piece of furniture substantially built in stout mahogany and cannot be classed among the second-grade cabinets so frequently offered for wireless purposes. The top measures 29in. x 14in., and the height is 35in. Suitable mounting strips are provided for the instrument panel forming a polished mahogany border around a panel size of 7in. x 24in. The doors are

thick and well framed to prevent warping and fitted with brass hinges and good grade brass handle, escutcheon plate and lock, together with a cast brass bolt and guide plate. The door over the lower compartment hinges at the bottom and is supported by a chain. It is retained closed by a ball latch.

The cabinet examined was polished a dark rosewood and well finished. If required the manufacturer will supply instrument baseboard and Radion mahogany panel, fitted, and to match the polish. The set shown fitted to this cabinet is similar to the "Wireless World Demonstration Receiver" recently described in the pages of this journal, working from a frame aerial carried on wooden supports screwed to the back board. It is operated from A.C. supply, the lower compartment containing the complete battery eliminator.¹

A volume control is fitted as well as an "on and off" switch, which in one position cuts out the last L.F. stage and switches off a section of the battery eliminator. Enquiry as to price will reveal that this British-made cabinet represents exceedingly good value for money.

o o o o

ELKA COILS.

Originality in plug-in design can only lie in the direction of the method of winding. Overall dimensions are more or less fixed and the relative efficiency of coils depends upon the arrangement adopted for winding and supporting the turns. The aim is to limit self-capacity, taking care that a minimum capacity exists between turns where a difference of radio-frequency potential occurs.

This object is attained in the Elka coil, a product of L. Kremner, 49a, Shudehill, Manchester, by winding the turns in narrow sections. Only a few turns can be accommodated in the width of a section, so that only a very small difference of potential arises between the adjacent turns from layer to layer. Adequate spacing, though not too liberal, which would again increase the coil resistance

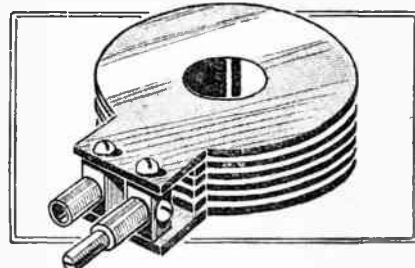

Elka section-wound coil. Note the spacing of the pin mounts.

for a given value of inductance, is provided between the sections. The former with slots and discs is composed of a form of waterproofed fibre and is extremely hard and durable. A good feature is the arrangement of the connectors on separate metal bars, giving a wide air gap between them and practically eliminating the dielectric losses usually present when the plug and socket are mounted in a piece of solid material. The metal parts are well finished and nickelled, and make a good fit into the standard socket.

The special merit of this form of coil is its robustness. It can be dropped without fear of injury or displacement of the turns. The price is moderate.

o o o o

KONTACT CONNECTING WIRE

The Standard Insulator Co., Ltd., Winsley House, Wells Street, Oxford Street, London, W.1, now supply insulated wire for use in the connecting up of receiving sets. The wire has a thin insulated covering and the carton which contains 20 feet of wire comprises four coils of various colours. Although low in price, the wire is well finished and has a good smooth surface. An important point is that the insulation is easily removed by unwinding if there is any tendency for the insulation to fray.

The best method of baring the ends of wire of this type is to cut through the insulation with an old razor blade, care being taken not to nick the wire otherwise it may fracture at this point.

¹The Wireless World, March 16th, 1927.



A form of cabinet in popular demand. It contains receiving set, battery eliminator and frame aerial and gives continuous service from a power point.

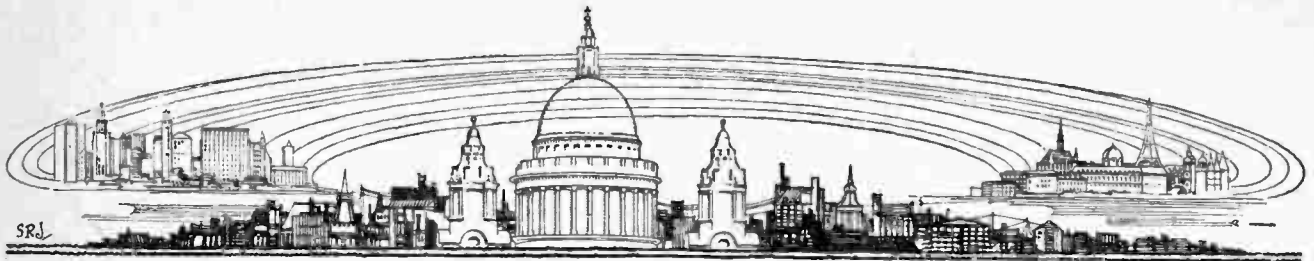

SRJ

CURRENT TOPICS

News of the Week in Brief Review.

WIRELESS FLAG DAY.

Chesterfield Guardians have decided to hold a flag day to complete the fund towards the installation of wireless in the local institution.

○○○○

THE HAPPY VILLAGE.

Each of the 300 houses in the new suburb of Malpas, near Newport (Mon.), has been provided with a mast and wireless aerial. Malpas has been dubbed "The Radio Village."

○○○○

CRYSTALS ON THE WANE ?

According to the recent referendum conducted by the B.B.C. the proportion of crystal sets to valve sets now in use is approximately 50 per cent.

Of the listeners to the London station about 30 per cent. use crystal sets.

○○○○

WOMAN'S ARCTIC WIRELESS TESTS.

The Hon. Mrs. Victor Bruce, who recently returned from a 9,000-mile motor tour in Europe and Africa, proposes to go as far into Lapland as it is possible to drive a car, taking with her a wireless set. It is hoped to collect valuable information regarding reception conditions in the Arctic.

○○○○

MEDAL FOR QUANTITATIVE MEASUREMENTS.

The medal of honour awarded annually by the American Institute of Radio Engineers has been won this year by Dr. L. W. Austin, of the U.S. Bureau of Standards.

The medal carries the inscription:—"Awarded to L. W. Austin for his pioneer work in quantitative measurement and correlation of factors involved in radio wave transmission."

○○○○

THE CEASELESS LOUD-SPEAKER.

Complaints are still being made regarding the misuse of loud-speakers by wireless dealers who seem to imagine that if a loud-speaker is kept in operation outside their premises for a long enough period it will attract the buying public.

The nuisance has somewhat abated in London, but is still prevalent in certain parts of the provinces.

OCH HONE!

The Dublin District Court is still kept busy with summonses against listeners without licences. Ten prosecutions were recorded last week.

○○○○

U.S. RADIO EXPORTS INCREASING.

During April last American radio exports reached the value of £132,919, nearly 33½ per cent. greater than in April, 1926. The principal business was in radio receivers; valves were also exported in large numbers.

○○○○

THE BINODYNE.

In order to keep pace with modern methods of screening, a contributor to an American journal has built his receiver in an open metal dustbin.

One advantage of this expedient is that, in the event of failure to secure results, it is merely necessary to replace the lid.

BROADCASTING IN DEMAND.

The Worthing Entertainments Committee is urging the B.B.C. to broadcast music from the Pier Pavilion and bandstand.

○○○○

B.B.C. AT SCOTTISH EXHIBITION.

The B.B.C. and the Baird Television Co. will be among the organisations exhibiting for the first time at the Edinburgh Empire Exhibition, to be held from July 27th to August 6th.

○○○○

SOUTH AFRICAN BEAM SERVICE OPENED.

A burnt-out transmitting valve caused a delay during the ceremonial opening of the beam service between Great Britain and South Africa on Tuesday, July 5th. The mishap occurred at the Klipphenval station, near Cape Town.

The official opening was performed by

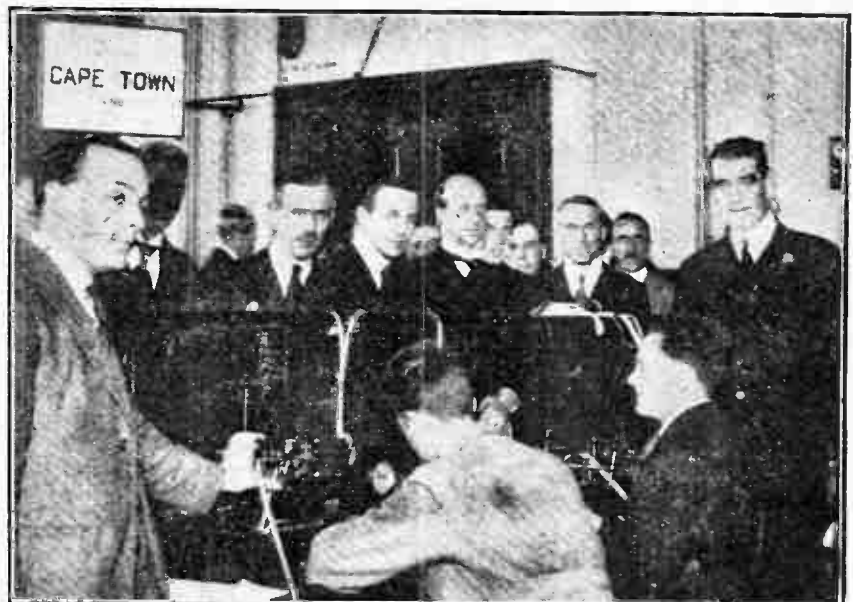

OPENING A NEW BEAM SERVICE. Sir William Mitchell-Thomson, the Postmaster-General (on right), witnessing the transmission of the first message to Cape Town by the Marconi beam system on Tuesday, July 5th.

the Postmaster-General, Sir William Mitchell-Thomson, who sent a message of greeting to Sir Drummond Chaplin, chairman of the South African Wireless Telegraph Co.

The new service places London in direct wireless communication with Cape Town, and is available for telegrams to all destinations in the Union of South Africa, Rhodesia, South-West Africa, Nyasaland, and other parts.

○○○○

A CURRENT TOPIC.

Listeners at Shipley, Yorks, who obtain the wireless current supply from the mains, are perturbed by the fact that the local council has ceased to generate its own supply, which was direct current. There is a possibility that the new supply will be A.C.

○○○○

WHY ESKIMOS LEAVE HOME.

The Eskimos of Northern Canada, hitherto a home-loving fraternity, are breaking away from the old traditions in order to listen to wireless. Instead of huddling at night in their igloos, they congregate at the Government posts to hear concerts from the North American broadcasting stations.

○○○○

FRAME AERIAL "PIRATE" TRACED.

A triumph was scored by the Post Office wireless van a few days ago at Chorlton-on-Medlock, near Manchester.

Receiving complaints of oscillation in this area, the Manchester General Post Office authorities despatched the direction finding van to the district, and after several bearings had been taken the disturbance was traced to a house in Howarth Street. The sequel was the appearance at the Manchester police court of Reginald Evans, charged with operating a wireless installation without a licence. Evans was using a frame aerial indoors.

He was fined 40s., the magistrate remarking that, but for the fact that Evans was unemployed, a fine of £10 would have been imposed.

FIRST INDIAN BROADCASTING STATION.

The Bombay station of the Indian Broadcasting Company will be opened on Saturday week, July 23rd, by the Viceroy of India.

○○○○

JOY IN NEW YORK.

The "New York Times" is overjoyed at the results obtained by the Federal Radio Commission in obtaining order out of chaos in the American ether.

"Last winter," says that journal, "the ether was not unlike the New York Stock Exchange when all the brokers are shouting at once. Now the Babel is stilled, and it is actually possible to listen to the symphony of one station without being disturbed by the jazz of another. . . . Radio has been saved from its own too zealous self."

○○○○

WIRELESS BRIGAND.

A man who steals wireless sets in the outer London suburbs is being searched for by Scotland Yard.

His method of procedure is to take a note of houses fitted with wireless. When the man of the house has left for business, he calls with the explanation that he has been ordered to see the set. If he gains admittance he takes away the set "for repairs." Needless to say, the set does not reappear.

○○○○

AMERICAN WIRELESS PEACE EFFORT.

The commercial side of American radio, which has been a fruitful field of litigation for several years past, is beginning to wear a changed aspect in consequence of the latest step of the Radio Corporation of America in concluding a number of important licensing agreements. These agreements, several of which are with companies with which the Corporation has been in litigation, cover royalties due over a period of years and amounting to over \$1,250,000.

The companies that have concluded licensing agreements with the Radio Corporation are the Radio Reception Com-

pany of receiving sets equipped with the devices licensed under the patent agreements. While Radio Corporation officials declined to estimate the income the corporation would receive under the agreements, it is known that it will run into millions.

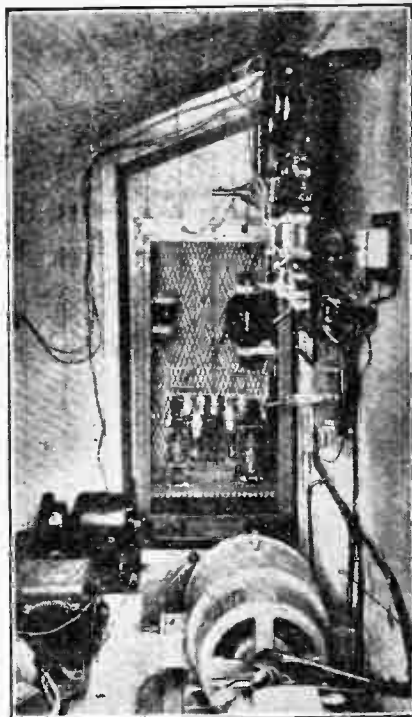

FOR EMPIRE BROADCASTING. A corner of the transmitting room at 2NM, the Caterham station of Mr. Gerald Marcuse, who will shortly relay broadcast programmes to the Dominions. Note the new Marconi M.R.1 and M.R.2 rectifying valves.

SHORT WAVES TO THE RESCUE.

The value of the short wave has just been demonstrated in a striking fashion to a sceptical critic by members of the American Radio Relay League.

The sceptic was Count Von Luckner, who recently arrived at New York from Germany in his yacht "Vaterland." Several members of the A.R.R.L. were surprised to discover that the Count relied solely on the usual 600-metre ship installation. The Count and his operator were urged to test the advantages of the short wave, but were unconvinced.

Finally an American amateur, Mr. G. Freisinger (2ABT) presented the "Vaterland" with a 50-watt short-wave transmitter and receiver. The gift soon proved its usefulness, for while the Count was conducting a cross-country lecture tour, the "Vaterland" proceeded south to the Panama, with the Countess on board, and ran into storms. For two weeks the vessel was driven off her course and beyond the range of her 600-metre transmitter. By means of the short-wave set, however, constant communication was maintained with American amateurs, who ultimately conveyed instructions which saved the ship.

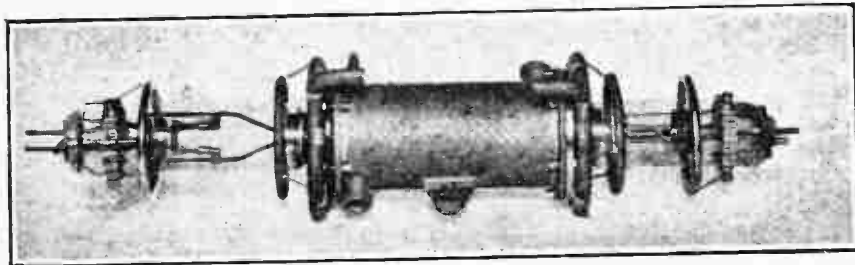

LATEST IN TRANSMITTING VALVES. A Marconi C.A.T.2 water-cooled high power valve.

TO STUDY RADIO FREQUENCIES.

Dr. J. H. Dellinger, who is shortly visiting Europe as a representative of the Washington Bureau of Standards, is to make a comparative study of the radio frequency standards of the United States, Great Britain, France, Germany, and Italy. He will bring with him a quartz oscillator.

pany, Inc., All-America Radio Corporation, American Bosch Magneto Company, Stromberg-Carlson Telephone Manufacturing Company, Crosley Radio Corporation, Zenith Radio Corporation, and Splitdorf-Bethlehem Electrical Company.

These companies will pay the Radio Corporation a uniform royalty of 7½ per cent. of their gross income from the sale



TRANSMITTERS' NOTES AND QUERIES

Canadian Expedition to Hudson Straits.

An expedition is setting out from Halifax, Nova Scotia, to conduct a survey and establish aeroplane bases and radio stations in the vicinity of Hudson Straits, the primary object being to determine the practicability of the proposed Hudson Bay Railway. Seven aeroplanes of the Royal Canadian Air Force, with sufficient staff to man them and the wireless stations, will be left there during the winter to observe ice conditions in the Straits.

o o o o

The personnel of the expedition is sailing in C.G.S. "Stanley," with Mr. C. H. Starr (whose private station, NC 1AE (ex. 3KA), at Wolfville, Nova Scotia, is well known to amateur transmitters) as a wireless operator. The call-sign of the "Stanley" is VDE, and she will transmit with a 1½-kw. set on 2,100 and 600 metres C.W. and I.C.W. She will also carry a 400-watt short-wave transmitter. Mr. Starr intends working with amateur stations whenever possible, and will welcome reports. The "Stanley" is expected to return to Halifax, N.S., early in October.

o o o o

The main base station will be equipped with both long- and short-wave apparatus, and the aerial will be 160ft. in height. The smaller base stations will work on wavelengths of about 200 metres for communicating with the aeroplanes. Official traffic on long waves will be handled *via* Belle Isle, and on short waves *via* a special station which is being erected at Ottawa. The wavelengths will probably be just outside the 20- and 40-metre wave-bands.

o o o o

Canadian Jubilee Celebration.

News of the reception of Canadian stations has naturally predominated in recent correspondence from amateurs. One correspondent reports the reception of the Jubilee Celebration relayed from Ottawa *via* the Marconi beam station on about 26 metres, beginning at 7.30 p.m. B.S.T. on Friday, July 1st. Items from 9 p.m. onwards came through very well at strength R6 to R7, the carillon being exceptionally good. Fading was slight, but atmospheric troublesome, especially during the early part of the transmission. Our correspondent does not state the type of receiver he was using.

o o o o

Another reports a similar experience using an 0-v-3 receiver of his own design, with resistance-coupled amplifying valves, intended originally for the ordinary broadcast band, but fitted, on this occasion, with short-wave coils.

o o o o

Tests, speech, and music, from the Bell Telephone Co. of Canada, have also been transmitted *via* the Beam station. Mr.

C. A. Jamblin (G 6BT) tells us that he picked up this station at 7 p.m. (B.S.T.) on Sunday, June 26th, when using only a single-valve set, and heard every item, including instructions to their various stations, and even the clicking of the keys at the exchange station in Ottawa. From 7.0 to 8.25 p.m. B.S.T. the strength was R6, with very little fading. At 8.25 p.m. a record by Galli-Curci was clearly received at R7, and at 9 p.m., when a record by John McCormack was transmitted, the 'phone strength had risen to R8, and the programme could have been put on the loud-speaker by adding another valve.

These tests were understood to be preliminary to a further series which was announced to follow at 7 p.m. E.S.T. (1 a.m. B.S.T.).

Mr. Jamblin's station is at Bury St. Edmunds, and it will be interesting to know how far on either side of the direct line to Bodmin the Beam effect is noticeable.

o o o o

Reception of Station in British Columbia.

Conditions for reception were apparently very favourable on June 26th, as a correspondent in Wimbledon reports having heard NC 5AU, in British Columbia, on a wavelength of about 20 metres and at a signal strength of R4, on an 0-v-1 standard "broadcast" receiver with short-wave plug-in coils.

o o o o

South African Transmitters.

We have received a revised list of South African amateur transmitters and give below those which have not already been published in the R.S.G.B. Log Book and Diary or the Supplementary List on page 748 of our issue of December 1st, 1926.

Except where QRAs are marked "Change of address" the new names and addresses after call-signs A3A to A7Y and 3SR to 4SR should be substituted for those appearing in the lists mentioned above.

A3A R. Drennan, Durban St., Grevtown, Natal.
A3F W. Hill, 45, Henwood Rd., Durban.
A3H King Edward VII. School Cadets (J. L. Andrew, Science Master), Johannesburg.
A3K R. S. Fisher, 71, Jorissen St., Braamfontein, Johannesburg. (Change of address.)
A3N W. S. Reid, "Dunhevel," Woodhouse Rd., Maritzburg. (Change of address.)
A3Q Albert de Beer, Box 137, Bloemfontein.
A3W C. A. W. Riedler, Burnham Rd., Sea Point, Cape Town.
A4B G. A. Mauch, 450, Spuy St., Pretoria. (Change of address.)
A4D R. K. Parker, Hull St., Kimberley.
A4J H. F. Winch, 6, Glynnville Ter., Gardens, Cape Town.
A4O C. P. Tennant, Box 610, Kimberley.
A4U J. M. Fraser, 152, Kitchener Ave., Kensington, Johannesburg. (Change of address.)

A4X H. J. Rieder, "Hilmont," St. John Rd., Sea Point, Cape Town. (Change of address.)
A4Z J. S. Streeter, "Wood Green," Liesbeek Rd., Rosebank, Cape Town. (Change of address.)
A5B J. H. Pienaar, Box 745, Johannesburg.
A5D H. Doubell, 38, Dale St., Uitenhage.
A5H K. Scott, 5, Carlton Terrace, Three Anchor Bay, C.P. (Correction.)
A5J S.A.R.R. League Divisional Headquarters Station, 91, Berea Park Rd., Durban.
A5L J. P. Malan, Box 38, Sterkstroom, C.P.
A5P E. Davis, Box 462, Port Elizabeth. (Change of address.)
A5R J. A. Fine, 33, Maynard St., Cape Town.
A5U J. P. Malan, Waterval, P.O. Huguenot, C.P.
A6E B. A. O'Brien, c/o Barclay's Bank, Humansdorp. (Change of address.)
A6G J. Gillies Jnr., 206, Church St., Kenilworth, Johannesburg.
A6J F. W. J. Andersen, 126, Longmarket St., Maritzburg, Natal.
A6K W. S. Pennel, Milian Villa, Penrith Rd., Wynberg, Cape.
A6O G. W. Smits, 13, Second Ave., Orange Grove, Johannesburg. (Change of address.)
A6P J. B. Hendry, New St., Beaufort West.
A6R H. R. Owen, 4, Osprey St., Kensington, Johannesburg.
A6S W. A. Rhodes, 40, Sidney Rd., Bertrams, Johannesburg.
A6U Arland Usher, 3, Waterfall Rd., Westcliff, Johannesburg.
A6W G. Lowe and HOS, 95, St. Amant St., Malvern, Box 7007, Johannesburg.
A6X A. M. Watt, cor. Plein St., and Victoria Rd., Woodstock, C.P.
A7D H. J. Buckley, 51, Sydney Rd., Durban. (Change of address.)
A7J C. M. Lefevre, Richmond, Natal.
A7L P. Kraus, 31, Muller St., Yeoville, Johannesburg.
A7R A. G. Curtin, 63, Dorothy Rd., Norwood, Johannesburg. (Change of address.)
A7X H. C. Hean, "Longlands," Escombe Natal.
A7Y J. C. Downey, Fordyce Rd., Walmer, Port Elizabeth. (Correction.)
A8A P. F. Symons, Box 40, Port Elizabeth.
A8B J. G. Sprigg, "Whiteheath," Martindale, C.P.
A8C B. E. Evans, "The Gums," Umlaas Rd., Natal.
A8D R. A. Hill, "Sherwood," Station Rd., Kenilworth, C.P.
A8F E. J. Thorvaldson, 235, Stamford Hill Rd., Durban.
A8G D. A. Richardson, Box 685, Cape Town.
A8H J. M. Davie, 9, Winchester Rd., Mowbray, C.P.
A8J Eric Ireland, Byrnes Ave., Wynberg, C.P.
A8K W. Torley, 17, Mutual Buildings, Port Elizabeth.
A8N A. S. Andrews, Box 1311, Durban.
A8O D. J. Mayers, 10, Duke St., Observatory, C.P.
A8P Dr. Perrott, Walmer, Port Elizabeth.
A8Q B. W. le Sueur, c/o Box 605, Cape Town.
A8R B. Davidge-Pitts, George Rd., Mossel Bay.
A8S G. A. Sloyer, Box 314, Cape Town.
A8T J. P. Friedenthal, 8, Leo St., Kenilworth, Johannesburg.
A8U F. C. Maslen, 9, Cromwell Rd., Durban.
A8V A. Louquet, 49, Evans Rd., Durban.
A8W Geo. Newinan, 3, St. George's Rd., Yeoville, Johannesburg.
A8X W. E. Levings, Main St., Kokstad, C.P.
A8Y M. C. Cockburn, "Cliffside," P.O. Richmond, Natal.
A8Z W. Gray, 5, Esselen St., Hospital Hill, Johannesburg.
A9A F. E. Frost, 2, Union Ave., Bloemfontein.
A9B J. Munro, George Rd., Mossel Bay, C.P.
A9C S. Howie, Rosemead House, Dundee Rd., Newlands, C.P.

RHODESIA.

3SR E. Jephcott, c/o G.P.O., Salisbury.
4SR Douglas Mail, Box 727, Bulawayo.
1SR A Portable Station of 1SR.
2SR A K. C. Fynn, Box 387, Salisbury.
3SR A The Rev. Tull, c/o Post Office, Mrewa.
4SR A E. C. I. Ade, Box 267, Salisbury.
5SR A Joe Mavis, Box 408, Salisbury.
6SR A F. C. Whitmore, Box 163, Bulawayo. (Divisional Headquarters Station.)
8R A4A H. R. Warren, Box 716, Bulawayo.

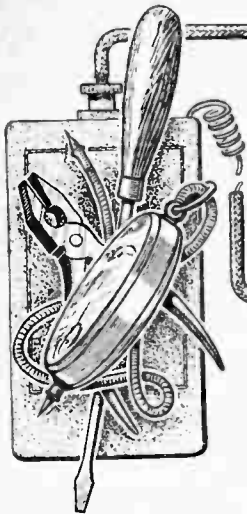

PRACTICAL HINTS AND TIPS

A Section Mainly for the New Reader.

BOTTOM BEND DETECTORS.

IT has been found that the majority of modern high-magnification valves, when used as anode rectifiers with conventional H.T. voltages and anode resistances, require approximately two volts negative on the grid for best operation. The best and most certain way of obtaining this bias is to use two dry cells in conjunction with a potentiometer connected across the L.T. supply in such a way that the negative surplus voltage of one volt may be opposed by the application of a suitable positive voltage. By this plan it is possible to make an accurate adjustment, which, it should be noted, is only necessary when dealing with weak signals, and, moreover, with such valves as have a sharply defined lower bend.

When connecting up a temporary or experimental receiver it is useful to know that a disused accumulator cell, which, though incapable of giving current, may very possibly supply the correct bias for the average detector valve.

o o o o

IMPROVING THE BUZZER WAVEMETER.

A NUMBER of amateurs who are in possession of buzzer wavemeters, many of which were designed before sharply tuned valve receivers came into general use, will often find that the emitted wave is too "broad" for accurate and close adjustment.

An examination of the average instrument will show that the shunted

buzzer, dry battery, and switch are shunted across a portion only of the coil, as shown in Fig. 1. It is useful to know that the "sharpness" of the emitted wave may be increased very considerably by reducing the number of turns included in the buzzer circuit. Referring to the diagram, this alteration may be carried out by moving the tapping Y away from the end X of the coil towards the end marked Z. This alteration

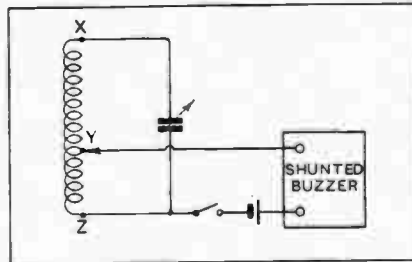

Fig. 1.—Reducing damping in a buzzer wavemeter.

will result in some diminution of signal strength, but as many wavemeters—particularly ex-Government instruments—were designed for use with crystal receivers, a considerable decrease in intensity may be tolerated when the emission is to be picked up on a modern valve set.

o o o o

TELEPHONE CONNECTIONS.

WHERE it is desired to operate several pairs of telephones from the same receiver, it is usual to connect the various pairs all in parallel with one another. This practice has probably arisen because of the fact that if the parallel connection is adopted the removal or breakdown of one pair does not affect the others, thus permitting extreme simplicity in the arrangement and wiring of the output terminals

Where a valve receiver is in use this method of connection is definitely wrong, for the impedance of any valve likely to be used to feed telephone receivers is far higher than that of one pair of telephones. If this one pair is replaced by two in parallel the total output from the valve will therefore be reduced, and as this reduced output now has to supply two pairs instead of one, the signal strength in each will be less than half the original value.

If, on the other hand, the second pair is connected in series with the first, the total output from the valve will in most cases not fall far short of double its original value, so that each pair of telephones will now give signals practically as loud as those in the original single pair. This process must not be carried too far, of course, but with the usual valves used for supplying telephones the simple series connection is best for any number of pairs, up to eight at least; with eight pairs or more the experiment may be tried of connecting in series-parallel, the telephones being arranged in two equal series chains, the two chains being connected in parallel with one another.

In the case of loud-speakers, much the same argument applies, up to any number that is likely to be required, and in addition to a little extra strength as compared with the parallel connection, the series arrangement will help to bring out those elusive low notes if the loud-speakers are capable of reproducing them.

When a crystal set is in question, it becomes difficult to lay down any hard-and-fast rule, on account of the large differences between crystals, but it is usually found that the parallel connection is best, especially when signals are loud.

SELECTIVITY AND THE RECTIFIER.

THE selectivity of a receiver is dependent, to a surprisingly large extent, upon the type of rectifier employed, an anode rectifier being very considerably better from this point of view than a grid rectifier. This superiority is due to two distinct causes.

The first reason for the poor selectivity that accompanies the use of a grid rectifier is the well-known fact that this type of rectifier, by virtue of the grid current that is essential to enable it to rectify at all, imposes a comparatively heavy load on the tuned circuit that immediately precedes it. No matter how scrupulously "low-loss" this tuned circuit may be, it must inevitably tune flatly when the damping due to grid-current is introduced, for this damping may be equivalent to introducing a resistance of any value up to fifty ohms or more into the tuned circuit.

Were this all, the cure would not be far to seek, for the introduction of reaction into this circuit can be made to wipe out all the added resistance, so that at the cost of an extra control on our receiver we could combine the sensitivity of grid rectification with the selectivity of anode rectification. If this arrangement be tried, however, it will be found that, although the point of maximum signal strength can be made as sharp as could be desired by the use of sufficient reaction, the local station cannot be completely silenced as readily as when anode rectification is in use.

This residue of local station signals over a wide range of wavelengths is due to that very property of the grid rectifier for which we employ it, namely, its sensitivity to weak signals. Suppose that the detector circuit is tuned to a distant station, not far removed from the local station in wavelength, and that the voltage fed to the detector by that station is, under these conditions, one-tenth of that supplied by the distant station. The distant station will then be heard, but there will be an annoying undercurrent of local station. If we now substitute an anode rectifier, its relative insensitiveness to weak signals will cause it to ignore altogether the small residue of signals from the local station, so that the distant transmitter only is heard.

Thus, in addition to the true selec-

tivity, due to the almost complete absence of damping of the tuned circuit by the detector, the anode rectifier provides us also with a kind of spurious selectivity by its refusal to detect weak signals. Moreover, no reaction is necessary provided a low-resistance tuned circuit is employed, so that if we are willing to put in some other control to take its place we can add another tuned circuit to our receiver, either in the form of an additional H.F. stage or as a loose-coupler.

o o o o

THE TANTALUM RECTIFIER.

ALTHOUGH electrolytic rectifiers have among amateurs generally a bad reputation as being "messy" and uncertain in operation, it may be pointed out that the combination of tantalum and lead electrodes in dilute sulphuric acid is free of many of the defects of the ordinary Nodon cells. It is probably correct to say that tantalum rectifiers may be most usefully employed for the purpose of charging H.T. accumulators, and a diagram showing the connections for this purpose is given in Fig. 2. Each cell may be mounted in a glass or earthenware vessel with a capacity of a pint or less. One electrode is made of a strip of sheet lead of sufficient length to reach to the

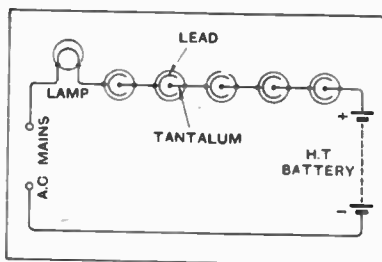

Fig. 2.—An electrolytic rectifier for charging H.T. accumulators from A.C. mains.

bottom of the jar, and with a width of $\frac{1}{2}$ inch or more. The second is a narrow strip of tantalum about $\frac{1}{8}$ inch wide and a few thousandths of an inch in thickness, which should dip about 2 inches below the surface of the electrolyte with which the cells are filled to within about an inch from the top. The electrolyte is dilute sulphuric acid, as sold for accumulators, with a specific gravity of about 1.250.

A lamp rated at 60 watts is inserted, and will generally pass a

current suitable for charging the ordinary battery; one of higher or lower resistance may, of course, be substituted if desired.

The arrangement as shown is suitable for supply voltages in the order of 200; an extra cell should be added for operation on 240-250 volt circuits.

o o o o

INCREASING THE CAPACITY OF A VARIABLE CONDENSER.

IN the course of experimenting we sometimes find that none of our spare variable condensers go up to quite a high enough capacity for the particular work in hand. A simple and effective expedient when the condenser is not built into any case or box is to immerse the vanes completely in oil. Since the dielectric in the space between the fixed and moving vanes is now oil instead of air the capacity is a little more than doubled, since the dielectric constant for most oils is between 2 and 3. High-grade transformer oil is about the best, but this is not usually likely to be at hand. Ordinary domestic paraffin oil answers well, as most samples seem to have excellent insulating properties. The condenser may be mounted with its vanes vertically downwards in a clean jar, and oil is poured into the jar until all the vanes are completely covered. The moving vanes should be briskly rotated backwards and forwards a number of times in order to expel any air bubbles between them.

o o o o

WINDING REACTION COILS.

IT is not generally realised that so-called "low-loss" construction is unnecessary in a reaction coil, and, indeed, is sometimes definitely detrimental. In the anode circuit in which this coil is included we are dealing as a rule with superabundant energy, and so high-frequency and even reasonable D.C. resistance are matters of small importance. The use of large coils of thick wire will have the effect of increasing capacity between grid and anode inductances, with the result that changes in reaction coupling will materially alter the tuning adjustment, making the operation of the receiver much more difficult. As a rule, it is as well to wind such coils with fine wire, of from No. 30 gauge downwards.

HOWLING IN L.F. TRANSFORMER-COUPLED AMPLIFIERS.

WHERE two or more transformer-coupled L.F. amplifying stages are used trouble may be experienced with the set howling at a high-pitched frequency. This is most common when the L.F. amplifier is preceded by a detector valve in which the grid condenser and leak method of rectification is employed. The grid connections of such a detector are very sensitive to stray electrostatic pick-up, and in particular are likely to be affected by the stray field set up by the large L.F. potentials generated in the last stage of the amplifier; this provides enough reaction to maintain the whole amplifier in a state of L.F. oscillation. This pick-up by the grid-leak detector is the seat of a number of troubles for which the succeeding L.F. stages are apt to be unjustly blamed. The remedy is to arrange the detector layout so that the length of connecting wire between the grid condenser and

the grid of the detector valve is an absolute minimum. Also arrange things so that nothing carrying amplified L.F. currents comes within several inches of the grid connections of the detector valve. This form of instability is entirely absent from receivers employing anode bend detection; the latter form of rectification, although not so sensitive, is strongly recommended.

Sets are sometimes described in which the detector unit is completely screened by a metal compartment of its own. This is an excellent plan as it materially assists both L.F. and H.F. stability.

Sometimes, of course, the trouble does actually arise in the amplifier itself. The simple expedient of reversing the leads to one of the intervalve transformer primaries is almost too familiar to need mention here. This is not, however, invariably effective, especially when there is electrostatic feed-back from the output to the input of the amplifier.

INCREASING VOLUME.

THE maximum grid voltage with which an output valve can deal without introducing distortion may invariably be increased by applying a greater H.T. voltage than is customary, always provided that a corresponding increase is made to the grid bias voltage. Unfortunately, however, the useful working life of the valve will be decreased by adopting this plan, but it will be realised that in any case an additional upkeep expenditure must *always* be faced when an attempt is made to obtain a greater undistorted output. The capabilities of an ordinary power valve, with extra H.T. voltage, may be regarded as intermediate between those of the same valve under normal operating conditions and of a "super-power" amplifier.

As a rough guide to the voltages to be used, it may be stated that a 7,000-ohm valve, with 150 volts on the anode, requires about 12 volts negative grid bias.

DISSECTED DIAGRAMS.

Practical Points in Design and Construction.

No. 75.—A Crystal Receiver.

(To be concluded in next week's issue.)

The present series of diagrams is intended to show progressively, and in an easily understandable manner, the various points to which special attention should be paid, and at the same time to assist the beginner in mastering the art of reading theoretical circuit diagrams. Under the projected "regional" scheme, high selectivity will, in some instances, be necessary even in a crystal set; the diagrams given below, and those to appear next week, will show how the ordinary set may be improved in this respect.

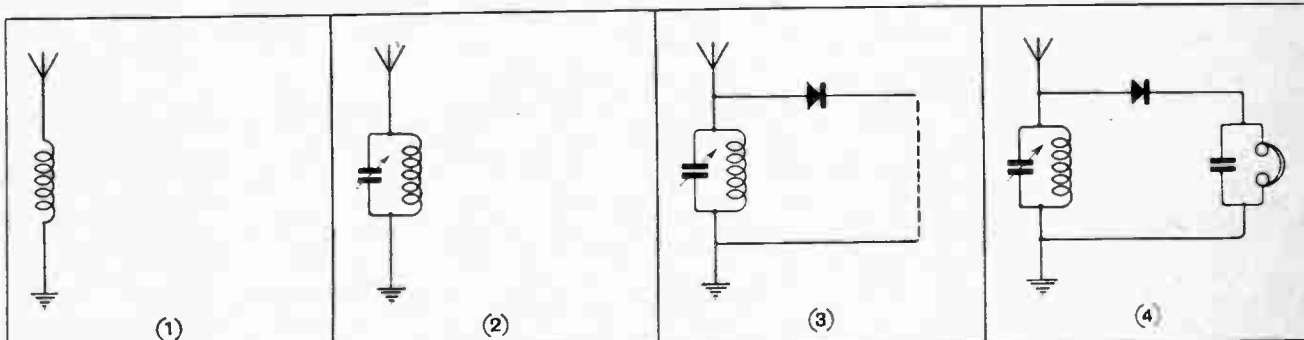

The aerial-earth circuit is completed through a tuning coil.

A variable tuning condenser is shunted across the coil.

The crystal detector is connected to the aerial end of the coil.

The addition of telephones and by-pass condenser completes the circuit.

THE inductance of the coil will, as usual, depend on the capacity of the aerial and the wavelength to be received. For the normal broadcast waveband, a conventional plug-in coil of from 35 to 50 turns will be suitable with a full-sized aerial. For Daventry, a No. 150 has about the right inductance value. There is no point whatsoever in using a coil of

extremely high efficiency, as it is affected by both aerial damping and, in the circuit shown in (4), by the full damping effect of the crystal.

A variable tuning condenser of 0.0005 mfd. is generally recommended. Its moving vanes should, strictly speaking, be connected to the "earthed" side of the circuit; capacity effects are not noticeable with

the comparatively crude circuit shown, but they come into play with the improved arrangements to be discussed later.

A by-pass condenser of from 0.0005 to 0.001 mfd. is recommended; its capacity has a certain bearing on the rectifying efficiency of the crystal and should be carefully determined by trial.



Broadcast Brevities

NEWS FROM ALL QUARTERS.

By Our Special Correspondent.

**Peace in the Ether.—Sir John Reith's American Visit.—Transatlantic Programme Exchanges ?
Tiresome Relays.—Doings at Daventry.—The Broadcast Music Lesson.**

Less Interference.

While the oscillator is still with us there seems to be a distinct falling off in other forms of interference, notably Morse from ships. Bournemouth listeners especially are rubbing their eyes (or is it their ears?) at the arrival of conditions more peaceful than they have ever before experienced.

The spirit of reform is particularly noticeable among ships of the "King's navy," and it is possible that this circumstance is not entirely fortuitous.

Sir John Reith and U.S. Programmes.

In May last *The Wireless World* gave the exclusive news that Sir John Reith had received an invitation to attend the inauguration of the new building of the

American National Broadcasting Co. in New York.

When Sir John arrives in New York in the course of the next few weeks he will concern himself with an interesting proposition which is being very warmly sponsored by the N.B.C. officials. It is nothing less, in fact, than a service of "across-the-ocean" broadcasting, by which London and New York would regularly exchange feature programmes for the edification of their respective listeners.

The Hopeful President.

This may, or may not, be an attractive prospect, but, to judge from the quality of recent relays of America in this country, the technical aspect of the

matter would demand a fair amount of consideration before anything like regularity could be approached.

Mr. Aylesworth, President of the National Broadcasting Co., would have it appear that these difficulties are vanquished, but his buoyant outlook seems a little in advance of modern thought.

A Plan.

"Tremendous technical and engineering problems, as well as difficult programme arrangements, due to the difference in time between London and New York, had to be solved before any plan could be formulated," declared Mr. Aylesworth in a recent speech at Denver. "We feel," he added, "that we have now made sufficient progress to propose a definite plan of co-operation with the British broadcasting system."

All this is good to know; the question is whether the B.B.C. is ready to fall in line with these ambitious proposals, and whether their present technical resources are adequate.

Relays Which Exasperate.

Many listeners were doubtless enjoying the excellent music by Jay Whidden's dance band on Tuesday of last week when Keston butted in with a very indifferent relay of dance music from America. I wonder how many of the aforesaid listeners experienced a thrill of pleasure at the interruption, and how many of them experienced something quite different?

Myself, I came within the latter category, and I don't suppose I was the only listener who found himself asking why Keston still performs this "turn" in the middle of other programmes.

No Novelty.

There is now no novelty in relaying programmes from America. It has become one of those things which should be done well or not at all.

A Savage Handicap.

It is sometimes forgotten, perhaps, that the engineers at Keston labour under a soul-destroying handicap. Atmospheric conditions over the Atlantic often fluctuate

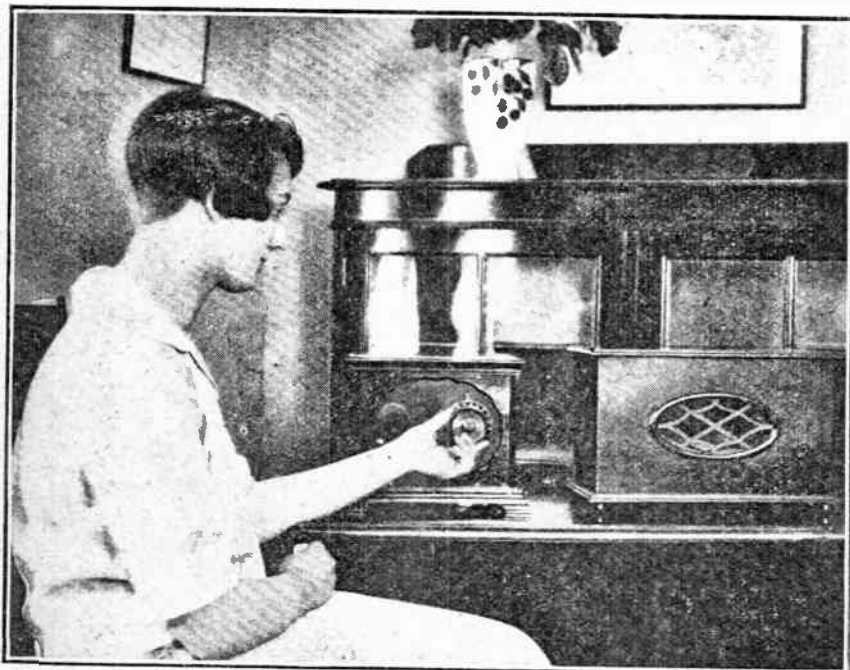

THE FINISHING TOUCH. Over 250 new houses on the Richings Park estate at Iver, Bucks, have been equipped with broadcast receivers as permanent fixtures. The photograph shows a typical instrument—a 2-valve Gecophone and loud-speaker. To avoid disfiguring the countryside with ugly aerial poles, the aerials are concealed in the attics.

tuates from minute to minute, and while an American transmission may be received well-nigh perfectly at one moment, by the time arrangements have been made to break in upon the regular programme in order to effect a relay, fading and atmospheric may have intervened with savage severity.

This explains why B.B.C. engineers whose duties take them to Keston often wear the hunted look of an electric hare.

o o o o

Hare and Hounds.

Talking of electric hares, what about a running commentary on a greyhound race? The electric hare could quite comfortably carry a microphone on the small of its back and enable us to hear the paws of the top dog.

If the hare were caught, and the microphone swallowed, the listening public would learn something of a greyhound's inner feelings.

o o o o

Doings at Daventry.

Experiments continue at Daventry with the new regional station, but I understand that we need not expect anything in the shape of a serious alternative programme until the station has been duly licensed by the Post Office, probably early in August.

That the programme will be of an alternative nature is certain, i.e., it will be distinctive, differing from the fare offered either by London or Daventry. Probably, at the beginning, 5GB's transmission will be limited to two hours daily, but, as my Pudsey correspondent puts it, an hour of blessed variety is better than a thousand of unrelieved aridity.

o o o o

Waiting for the Post Office.

I gather that the wavelength of 5GB will be nearer 300 metres than 400, but this and the question of power rests largely with the shahs of St. Martin's-le-Grand.

o o o o

Nelson Keys at 2LO.

Nelson Keys will give a quarter-hour turn from 2LO on Monday next, July 18th. The last time he was billed for the London studio the contract was cancelled at short notice, but his music-hall arrangements will not, I understand, interfere with the forthcoming broadcast.

o o o o

The King's Broadcast Speech.

The programme for the broadcast ceremony in connection with the opening of Gladstone Dock, Liverpool, by the King on July 19 will include an address to His Majesty by Mr. R. D. Holt, chairman of the Mersey Docks and Harbour Board, prayers by the Bishop of Liverpool, community singing, and a twenty-one-gun salute fired by the Royal Artillery.

o o o o

Cricket at Intervals.

A running commentary on the match between England and The Rest will be relayed from Bristol on July 23 at intervals between 3.0 and 6.30 p.m.

"Lido Lady."

The numbers to be broadcast in the excerpt from "Lido Lady," which will be relayed from the Gaiety Theatre on July 22, are as follow: "It all depends on you" (Phyllis Dare and Company), the Charleston Trio Dance (Phyllis Dare, Dave FitzGibbon, and Harry White). "Try again to-morrow" (Ciely Courtneidge and Jack Hulbert), and Finale (the Company).

Oscillator in the Dock.

A mock trial will be broadcast by the Newcastle station staff on July 18. Mr. Oscillator, alias Mr. Knob Twiddler, is caught red-handed and hailed before the Bench after having spent the night in a cell where there were no knobs except those on his uncomfortable bed.

o o o o

For Poor Artistes.

The design of American broadcasting studios trends towards the production of an artistic and romantic atmosphere. The latest suggestion is the incorporation of swimming pools.

There is much to be said for this device, provided that the pool is deep enough and is equipped with a ducking-chair.

o o o o

A Chopin Programme.

A "request" Chopin programme will be given by the well-known broadcasting pianist, Edward Isaacs, on July 20. It will consist of the three preludes, in C major, B flat major and G major, the Waltz in C sharp minor, and Polonaise in C sharp minor. On the last occasion when he appeared before the studio microphone in London Mr. Isaacs' brilliant playing gained warm applause from the orchestra, who are not always prone to a display of enthusiasm over a soloist's efforts.

o o o o

The Menin Gate Broadcast.

Two microphones will be used at Ypres on Sunday, July 24th, when the Menin Gate memorial is opened by Lord Plumer. One microphone will serve for broadcasting Lord Plumer's address and that of Sir Laming Worthington-Evans, the Minister for War, while the other microphone will pick up the band music and singing, the latter under the direction of Mr. Stanford Robinson.

Land-lines will convey the speech and music from Ypres to Ostend, whence it will travel *via* submarine and underground cable to London.

o o o o

Sir Walford Davies' Book.

Anything that Sir Walford Davies has to say on the subject of music lessons by wireless is worth listening to, for Sir Walford is rightly acknowledged to be one of the best, if not the best broadcast lecturers to-day.

In "Music Lessons: A Special Memorandum to Teachers," just issued from Savoy Hill, Sir Walford Davies gives a lucid explanation of the methods employed in the two years' course of music lessons now in progress and extending until July, 1928.

Hints are given regarding the equipment needed by scholars, the attitude of the class towards the loud-speaker, the condition of the set, and sundry matters which, unimportant at first glance, mean so much if the utmost benefit is to be obtained. A very readable book.

FUTURE FEATURES.

London.

JULY 17TH.—Orchestral and Vocal Concert Service from George Street Baptist Church, Plymouth.

JULY 18TH.—"The Vauxhall Belles." A light romantic opera in two acts, by Herbert Oliver.

JULY 19TH.—Opening of Gladstone Dock by H.M. the King, S.B. from Liverpool. Dance Music.

JULY 20TH.—Debate "That Opera is Absurd," Mr. Basil Maine and another. Sir Landon Ronald in the chair.

JULY 21ST.—The Roosters' Concert Party.

JULY 22ND.—Excerpt from "Lido Lady" relayed from the Gaiety Theatre.

JULY 23RD.—England v. The Rest—running commentary from Bristol.

Birmingham.

JULY 18TH.—"The Neer-Dowells' Concert Party," relayed from Royal Leamington Spa.

Bournemouth.

JULY 22ND.—Wagner Programme from the Winter Gardens.

Cardiff.

JULY 21ST.—"As You Like It," by William Shakespeare.

Manchester.

JULY 20TH.—"1588." A play by Walter Pearce.

JULY 21ST.—"On with the Show of 1927." An evening at Blackpool relayed from the North Pier.

Newcastle.

JULY 20TH.—Concert performance of "The Waterman." A Ballad Opera by Charles Dibdin.

JULY 23RD.—"Mr. Smith Wakes Up." A new one-act comedy by Vivian Tidmarsh.

Aberdeen.

JULY 18TH.—Lecture Recital by William Swainson.

JULY 21ST.—Scottish Programme.

Belfast.

JULY 18TH.—"A Trip to the Isle of Man." A Holiday saga.

JULY 21ST.—"Rococco." A play in one act by Granville Barker.



RECENT INVENTIONS

The following abstracts are prepared, with the permission of the Controller of H.M. Stationery Office, from Specifications obtainable at the Patent Office, 25, Southampton Buildings, London, W.C.2, price 1s. each.

Variable Neutralisation.

(No. 269,355.)

Application date: June 3rd, 1926.

An interesting form of multiple condenser for the purpose of varying the neutralisation present in a high-frequency amplifier is described in the above British patent by Standard Telephones and Cables, Ltd. It is mentioned in the specification that a neutralising condenser may be adjusted so that either exact neutralisation or, alternatively, over- or under-neutralisation may be obtained. When a neutralising condenser is employed for the purpose of introducing a certain amount of reaction its setting is not constant over the whole frequency range of the tuned circuit. According to the invention, however, the neutralising condenser is mechanically linked to the tuning condenser, and so proportioned that it is appropriately adjusted with the variation in the tuning of the circuit. A circuit embodying this arrangement is shown in the accompanying diagram. The aerial is tuned by a condenser C_1 , and an inductance L_1 which is coupled to an inductance L_2 , tuned by another condenser C_2 . The mid point of the inductance L_2 is connected to the filament and earth while one end is taken to the grid G of the valve V and the other end through a balancing condenser. This consists of the special condenser C_3 .

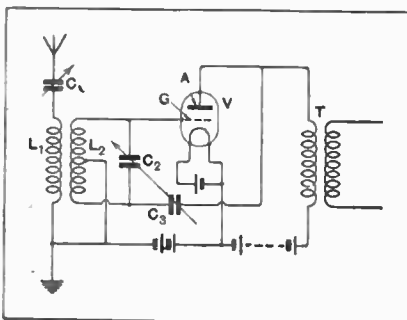

Receiving circuit in which tuning and balancing condensers are coupled together. (No. 269,355.)

The tuning condenser C_2 and balancing condenser C_3 are mechanically linked so that variation of the tuning condenser brings about a desired variation of the balancing condenser. The specification claims the construction of a condenser with a separate insulating plate working in conjunction with another plate on the rotor of the main condenser, for the purpose of producing the balancing condenser.

Rice-Kellogg Details.

(No. 245,796.)

Convention date (U.S.A.): January 9th, 1925.

Some further details of the coil-driven Rice-Kellogg type of loud-speaker are disclosed in the above specification. One of the chief features of the invention lies in the method of supporting the cone. The cone shown in the illustration is of rigid material, and is fixed to an annular support by a ring of some flexible material, such as thin rubber

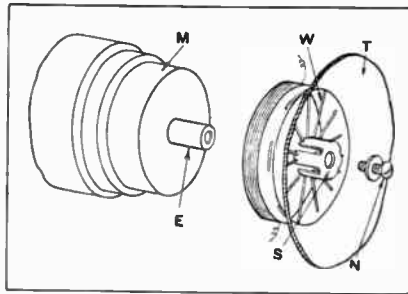

Coil suspension in the Rice-Kellogg loud-speaker. (No. 245,796.)

or silk. In order to prevent any undesired resonance, it is mentioned that the restoring force on the diaphragm should be such that the natural frequency is fairly low, preferably of the order of about 50 cycles, although fairly satisfactory results can be obtained with a natural frequency as high as 200 cycles. Owing to the very light and flexible nature of the suspension of the edge of the diaphragm, it is necessary positively to centre the truncated end of the cone which carries the coil drive, and a special form of suspension is therefore adopted. The end of the magnet pole M is provided with an extension E which carries a spider S fixed by a screw and washer N . The truncated end T of the cone is laced to the spider by means of wires or strings W . This method of construction enables the cone to move quite freely with a plunger action without any transverse motion occurring. Sizes and angles for the cone are also discussed in the specification, and should be of great assistance to those interested in this type of loud-speaker. The necessity for preventing box resonance is also dealt with, and another interesting point is the inclusion of a copper ring in the end of the pole piece to act as a short-circuited turn in the field winding to

damp out any fluctuations when the supply is affected by badly rectified current, or commutator ripple.

○○○○

Variable Coupling.

(No. 269,668.)

Application date: January 22nd, 1926.

J. K. im Thurn and G. W. Harris describe in the above specification a form of coupling in which the movable coil is caused to rotate simultaneously with a lateral movement. The arrangement should be quite clear by examination of the accompanying diagram, where the fixed coil is shown at F and the movable coil at M . This is mounted on a shaft S fixed to a carriage C , which works on guides G . A spindle A actuates a link motion located on the end of the shaft S . It will be noticed that rotation of the spindle A will cause the link motion to rotate the coil M on the carriage C , and, simultaneously, cause the carriage to move upwards or downwards according to the direction of rotation. As the furthest point of travel of the coil M is approached a pin P in the link arm X engages a guide plate Y on the link arm Z .

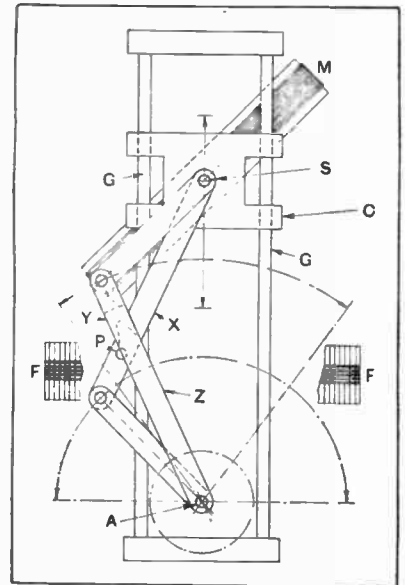

Variable coupler with link motion. (No. 269,668.)

This enables it to be carried over the top dead centre in a direction dependent upon the original rotation of the spindle A .

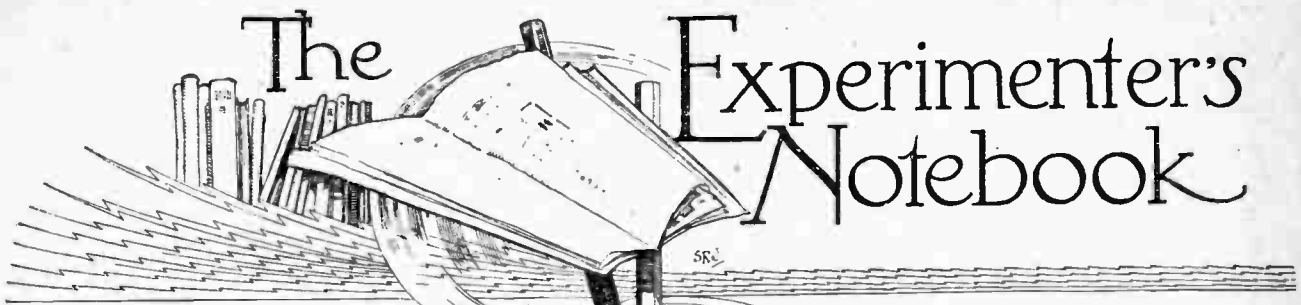

The Experimenter's Notebook

Practical Notes on Capacity Neutralisation.

By "EMPIRICIST."

HERE is no subject perhaps in the whole of wireless receiver design more deserving of careful study than the art of neutralising the effect of the inter-electrode capacities in a high-frequency amplifier. Such a subject has nearly always been approached from two extreme standpoints, either the purely theoretical, in which principles only are dealt with and practical difficulties somewhat ignored, or else the purely constructional, in which specific directions are given how to build a particular type of neutralised receiver.

The present article purports to steer a middle course between these two extremes, with the object of enabling the experimenter to tackle the practical aspects of neutralisation on his own, and in some measure to correlate these with the general theory of the subject.

A Typical Circuit.

In order to fix ideas, it would be convenient to consider a practical case of capacity neutralisation, in which a circuit is employed which is basically that of the "Everyman Four." This consists of an input tuned circuit L_1C_1 , an output tuned circuit L_2C_2 , a primary coil L_3 coupled to L_2 , and a neutralising coil L'_3 , the free terminal of the latter being coupled through a

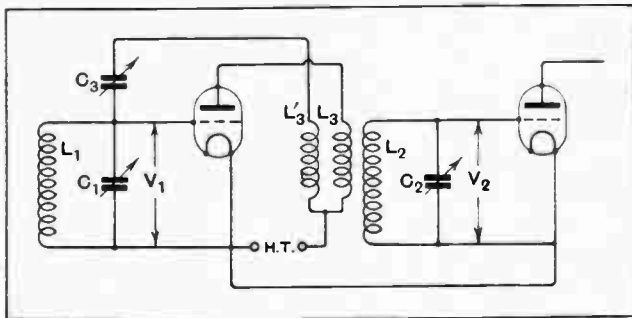

Fig. 1.—Circuit of typical neutralised H.F. coupling.

neutralising condenser C_3 to the grid terminal of L_1C_1 .

The primary object of neutralisation is to prevent any voltage developed in L_2C_2 from being transferred back to L_1C_1 , and thereby producing a regenerative effect. Such transference of voltage mainly takes place through the primary coil L_3 and the inter-electrode capacity of the first valve, and it is in order to counteract this effect that

the neutralising winding L'_3 and the condenser C_3 are introduced. On the other hand, we must regard as being strictly relevant the problem of the other possible couplings between L_1C_1 and L_2C_2 . These are of two kinds, electrostatic and electromagnetic, and, while the latter is considerably the more important the former, if present in excess, will constitute a difficulty.

In investigating a circuit of this nature it is essential first of all to have a clear idea of what to look for, and, secondly, an experimental method of looking for it.

Under the first heading let us consider what happens in a valve circuit having two tuned circuits respectively connected to the grid and plate. A simple tuned anode arrangement is shown in Fig. 2, in which the transformer coupling, characteristic of Fig. 1, is omitted for the sake of simplicity. The valve capacity has been shown in dotted lines as C_0 , and no means of neutralisation is embodied; for the purpose of the present discussion we will assume that some means exist of varying C_0 through zero to a negative value, the latter state of affairs corresponding to one where an excessive neutralising correction is employed.

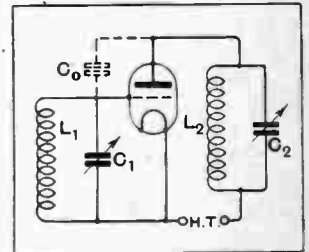

Fig. 2.—Tuned anode circuit showing valve capacity C_0 .

Regeneration and Anti-regeneration.

In considering this arrangement we will make one of two assumptions from general experience, the first being that a circuit, as shown in Fig. 3 (a), in which a pure inductance L_2 takes the place of the tuned circuit L_2C_2 , and a condenser of reasonable size C_R supplements the capacity C_0 of the valve, favours the production of oscillations in L_1C_1 . This is readily demonstrable either by mathematical analysis or by a simple experiment. On the other hand, the arrangement shown in Fig. 3 (b), in which the plate impedance takes the nature of a pure capacity, is anti-regenerative and tends to throw additional damping into the circuit L_1C_1 .

If in either of these figures we imagine the condenser C_R to be reduced in value, the regenerative or anti-regenerative effect will diminish and ultimately become zero when C_R is zero. If we then imagine C_R to be

The Experimenter's Notebook—

made negative the two cases will become reversed—that is to say, Fig. 3 (a) will represent a regenerative and Fig. 3 (b) an anti-regenerative arrangement.

Reverting now to Fig. 2 we must consider the case where the circuit L_2C_2 is tuned in any manner through resonance with the circuit L_1C_1 , or, better still, through resonance with a certain specific wavelength which it is desired to receive. At the exact resonance point it is well known that L_2C_2 partakes of the nature of a pure resist-

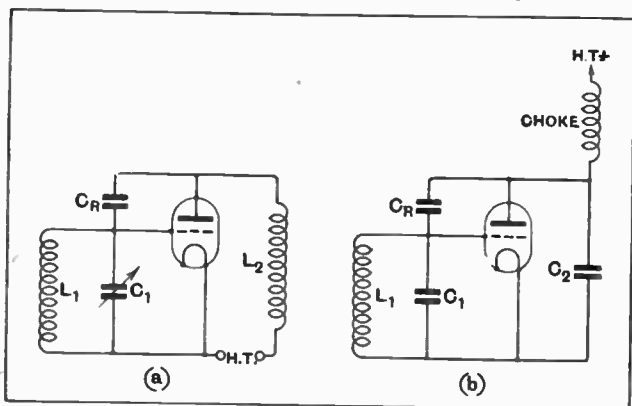

Fig. 3.—Regenerative circuit (a) with inductive load in anode circuit, and (b) anti-regenerative arrangement in which the load is capacitive.

ance of very high value. By adjusting the value of C_2 on either side of the exact position for resonance we introduce an element of reactance—that is to say, we may regard the high resistance corresponding to resonance as being shunted by either an inductance or a capacity. If the condenser C_2 is too small for resonance (*i.e.*, if the circuit L_2C_2 is "below resonance"), the reactance will be inductive, and the circuit will behave as if it were an arrangement like Fig. 4 (a). If, on the other hand, C_2 has a value greater than that corresponding to resonance (*i.e.*, L_2C_2 is above resonance), the reactance will be capacitive and the circuit equivalent to Fig. 4 (b).

Condition for Stability.

It thus appears that the tuned circuit L_2C_2 may be adjusted to produce a regenerative effect whenever there is capacitive coupling between the two circuits and independently of whether this coupling is positive or negative. In other words, nothing but a reduction of the capacitive coupling to zero or a negligible value will suffice to produce stability in the circuit, as by juggling about with the tuning condensers C_1 and C_2 we can produce a state of affairs tending to oscillation if the circuit is over-neutralised, just as readily as if it under-neutralised, or not neutralised at all.

In all our experiments, therefore, which relate to the neutralisation of the tuned circuits, we look for

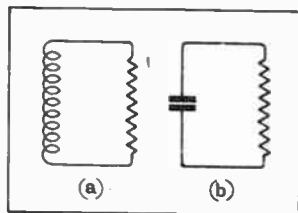
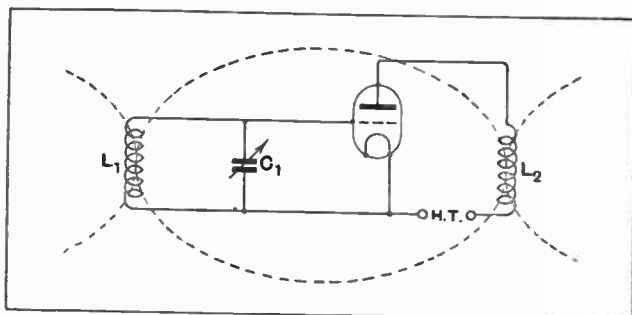

Fig. 4.—Equivalent electrical conditions in an oscillatory circuit (a) with the condenser set below resonance and (b) above resonance.

a state of affairs where the neutralising condenser has a critical position for stability, and gives rise to instability if adjusted to a value either lower or higher than this critical setting. It should be added that these remarks apply to what may be designated as reactive coupling, *i.e.*, capacitive or magnetic coupling between the elements of the tuned circuits themselves. Cases occur where a state of affairs corresponding to conductive coupling occur, and these give rise to a unidirectional effect, *i.e.*, the coupling is either regenerative or anti-regenerative for all settings of C_1 and C_2 . For instance, if in Fig. 2 we connect a resistance, suitably protected by a large condenser in series, between the grid and plate of a valve, this will always produce a damping effect on circuit L_1C_1 ; conversely a resistance in Fig. 1 placed in shunt across C_2 will always produce a regenerative effect upon L_1C_1 , however the settings of C_1 and C_2 are varied in relation to each other.

Neutralisation and Damping.

A further important principle to grasp is the necessity for neutralisation, as opposed to a mere damping of the circuit which is most prone to instability. Without going into the theoretical reason for this fact we may simply refer readers to the very simple experiment of comparing the operation, say, of an "Everyman Four" receiver, first as it stands, and secondly, deneutralised, but with the circuit L_1C_1 reduced to a state of stability by the application of positive grid bias. It is necessary therefore to counteract a reactive coupling by another re-



A circuit of this type will constitute a regenerative arrangement if coils L_1 and L_2 have their axes parallel and direction of winding in the same sense.

active coupling if satisfactory neutralisation and good signal strength is to be attained; on the other hand it would be useless to cure self-oscillation in the arrangement of Fig. 2 by the suggested anti-regenerative connection of a resistance between plate and grid.

We next come to the important question of the difference between electromagnetic and electrostatic couplings and the necessity for considering these two types separately. First with regard to the sense of electromagnetic coupling we may again argue from general experience without going into theoretical questions. In Fig. 5 the reaction coil L_2 is magnetically coupled to L_1 in the same sense as it would be if these two coils were identical, and had their axes parallel, and their windings in the same sense. Such an arrangement gives rise to the production in L_2 of a voltage opposite in sense to that in L_1 , and a regenerative effect is obtained. Since voltages

The Experimenter's Notebook—

in L_1 and L_2 are opposite in sign, it is permissible to define the mutual inductance in this case as being negative; if therefore we speak of the natural (inter-electrode) capacity couplings between the circuits as positive we arrive at the fact that a positive capacity coupling and a negative magnetic coupling have an equivalent effect.

Without going more deeply into the matter we may say that this proposition is readily extended to the case of Fig. 2, whether the effect of the coupling in any particular case is regenerative or anti-regenerative. A difficulty arises, however, in the case of Fig. 1 according as to whether the mutual inductance between L_3 and L_2 is positive or negative. If positive, then the above remarks apply as they stand, if negative then the effect of mutual inductance between I_1 and I_2 is opposite to that previously stated. On the other hand the effect of the valve capacity is entirely independent of the sense of the mutual inductance between I_3 and I_2 .

The important question with regard to magnetic coupling, however, is not its sense, but its numerical value, and it is of fundamental importance to bear in mind that a capacitive and a magnetic coupling between two tuned circuits can be numerically equal for one wavelength and one wavelength only. For values below this critical wavelength the capacitive coupling predominates, and for values above the magnetic coupling. If, therefore, the receiver is correctly balanced at one wavelength it will not be correctly balanced at any other in the event of mixed couplings being present.

We may now turn to practical considerations, and it is clear that what we require in the first place is a convenient experimental method of determining when a state of balance has been arrived at. Putting this in

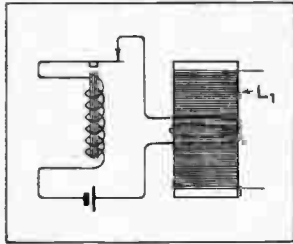

Fig. 6.—The use of a buzzer circuit for neutralising a receiver in the absence of strong signals from a nearby station.

more precise language we mean to say that the production of a voltage V_2 across L_2C_2 (see Fig. 1) will in general give rise to a voltage V_1 across L_1C_1 , and the object of our endeavours is to adjust matters so that V_1 is zero whatever the value of V_2 . As an alternative, provided the first valve is extinguished so that only its capacity effect remains, we may excite the circuit L_1C_1 so that a voltage V_1 is produced across it and make our adjustments so that V_2 is zero. This latter method has the advantage that in the case of a receiver as normally constituted we may use the detector valve and low-frequency amplifier just as it stands. On the other hand such a method of procedure fails to take into account secondary effects such as that caused by the flow of high-frequency feed current in the plate circuits of the H.F. and detector valve. Inasmuch as the second method is the simpler and will give a great deal of information regarding the behaviour of the circuits it may be conveniently considered in the first place.

Let us assume, therefore, in Fig. 1 that the first valve is extinguished; it is then necessary to find a means for strongly exciting L_1C_1 so that a signal of sufficient intensity is in general transferred to L_2C_2 to enable a balance to be obtained such that this signal is reduced to zero intensity.

Experimenters who live close to a broadcasting station may find that a connection of the aerial to the receiver in the ordinary way provides an adequate signal for the purpose. For the benefit of those who are not so situated the writer would suggest the simple arrangement of Fig. 6. Referring to this figure a single turn or two turns of wire are connected loosely round the former of L_1 , or in an equivalent position in the case of a plug-in coil. In series with this winding is connected a buzzer and a cell, for which purpose an extension of twin flexible lead is convenient. Such an arrangement produces only a negligible field of its own, the effect in the detector being entirely that of the current induced in L_1C_1 . By this means signals of ample strength are transferred to I_2C_2 in the event of any slight out-of-balance being present.

Brandes Novel Test Scheme.

A novel test scheme in connection with their 3-valve receiver has been arranged by Messrs. Brandes, Ltd. Fifty members of the public (one from each of fifty towns all over the country) have been invited to carry out private experiments in their own homes with the Brandes Three, the receivers to be installed absolutely free of charge, complete with loud-speaker and all accessories.

The object of these experiments is to determine whether the conclusions of this "jury" indicate that the receiver will meet with general requirements if put on the market. ○○○

Mullards in Leeds.

Readers in Leeds and district will be interested to note that the Mullard Wireless Service Co., Ltd., have taken new premises for their Leeds depot at 33, York Place, Leeds. The telephone and tele-

NEWS FROM THE TRADE.

graphic address will remain the same. viz., Telephone Number: Leeds 26360; Telegrams: "Mullard, Leeds."

○○○

The Osram Bulletin.

"Choosing a Low-frequency Transformer" is the title of a useful article in the current "Osram G.E.C. Bulletin." The recent "Osram" valve demonstration at Whiteley's is described and some interesting notes appear regarding the new 2-volt "Osram" valves, known as the DEH 210 and DEL 210, for which full working data and operating hints are given.

A New Brown Product.

Perhaps the most interesting article in the current "Brown Budget" relates to the "Crystaframe" receiver with frame aerial, designed for use within 6 miles from any British broadcasting station. The "Crystaframe" is fitted with a permanent detector and can be operated by the unskilled with greatest ease.

○○○

Battery Elimination.

Messrs. Rich and Bundy, the transformer manufacturers, of New Road, Ponders End, have issued a useful brochure containing valuable hints on the use of the mains supply for the operation of radio receivers. Battery eliminators already described in *The Wireless World* are dealt with, and the reader is introduced to the various types of R. & B. transformers and chokes suited to his needs.

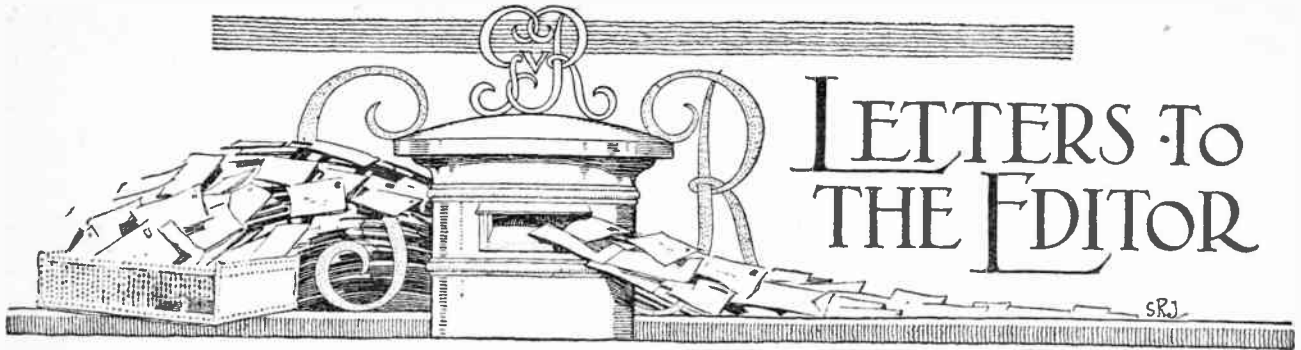

The Editor does not hold himself responsible for the opinions of his correspondents.
Correspondence should be addressed to the Editor, "The Wireless World," Dorset House, Tudor Street, E.C.4, and must be accompanied by the writer's name and address.

INTERNATIONAL ASPECTS OF BROADCASTING.

Sir,—Mr. Bertram Munn's letter, which appeared in your issue of June 29th, should be read in conjunction with your Editorial of June 22nd, and the correspondence therein referred to.

The B.B.C. holds a monopoly in so far as broadcasting from this country is concerned, and so appears to be the only present source of Empire broadcasting. Your correspondent in consequence need not be unduly alarmed, and can, for the time being at any rate, rest content in the knowledge that no part of his licence fee is likely to be squandered in keeping our emigrant population in touch with the Mother Country or assisting in the development of British enterprise, although it is unlikely that the cost of establishing a short-wave station capable of giving an intermittent Empire service would entail expenditure heavy enough to imply a reduction in the quality of the entertainment he expects and gets.

The establishment of such a station would give a further impetus to broadcasting, and encourage the erection of similar stations in other parts of the Empire to the obvious advantage of listeners in this country, whose interests are not centered round the parish pump. There is no reason why transmissions from this station should in any way interfere with the regular programmes, and its operation would give the B.B.C. valuable and first hand information on short-wave working. The writer further contends that the development of international transmissions will have the effect of materially increasing the number of listeners in this country, thus augmenting the revenues of the B.B.C., and that from this point of view alone the matter is worth perusing.

Does Mr. Munn really represent the views of the remaining two million two hundred and forty-nine thousand nine hundred and ninety-nine listeners mentioned in his letter, or is it possible that a considerable proportion of them would welcome an extension of the general interest of broadcasting on other than purely parochial lines?

G. ROLLAND WILLIAMS.

London.

June 29th, 1927.

Sir,—Mr. Munn in his letter published in your June 29th issue complains of loose thinking and talking and then proceeds to demonstrate how it is done. He presupposes that an Empire broadcasting station would be employed to disseminate propaganda of uplift to the dominions and colonies and the world at large, whereas the movement under discussion aims simply at the establishment of a short-wave station capable of radiating ordinary broadcasting programmes at a greater distance so that they may become audible in our dominions and colonies; because, some people place a different interpretation upon the functions of a short-wave station Mr. Munn condemns the whole movement. The station could, incidentally, be employed for announcements and utterances of general public interest, but that would not necessarily mean diverting the whole of the home broadcasting service from ordinary programmes.

In predicting boredom from the utterances of Prime Ministers and prominent politicians, Mr. Munn forgets that they owe their

eminence partly to their ability as public speakers, and they are usually worth listening to. Many will agree that the Prime Minister is far more interesting and at times far more amusing than many of the cross-talk comedians who favour us with their efforts. Ancient jokes are no less trying than hoary platitudes.

On the financial side Mr. Munn is rather parochial, and one cannot help feeling that his undeniable wit might have been employed to better purpose. A short-wave station if charged to B.B.C. revenue would not make any appreciable difference to the corporation's resources, and it would not, in point of fact, be without interest to B.B.C. licensees, if one may so term them, now that there is an awakening interest in short-wave work. There is nothing new in a minority paying for a movement of national interest and importance. An occurrence of this nature happened as recently as 1914; on this occasion some hundreds of thousands of colonials participated in an event of national or imperial importance without reckoning up beforehand the financial aspects of the situation as it affected their persons.

However, it would be a perfectly proper arrangement for the cost of an Empire broadcasting station to be met out of the residual of the licence money after payment of the B.B.C. allocation. This surplus would in the ordinary way, one gathers, be absorbed by the Exchequer, so in this manner the station would in effect be supported by the State and the amounts available for providing vaudeville artists and others would not be tampered with, and Mr. Munn would not feel that any portion of his annual ten shillings had been misspent.

Gaiches, France.

H. D. HARRIS.

July 2nd, 1927.

TUNING NOTES.—A SUGGESTED B.B.C. SERVICE.

Sir,—I write to point out a way in which the B.B.C. could be of very material assistance indeed to all those who are interested in determining fairly exactly the capabilities, both of their receivers and their loud-speakers, to reproduce with reasonable accuracy the music transmitted.

What is required is that each station should transmit occasionally—say once a week or once a fortnight—a set of eight or ten pure musical notes, as free as possible from harmonics, lasting perhaps a minute each, and varying in frequency from 25 to 5,000 cycles. All notes should, of course, be transmitted at the same intensity.

Those who have no measuring instruments would be able to form a fair idea of the overall reproduction of receiver and loud-speaker together by the simple process of comparing the aural intensity of the various notes: this might perhaps be facilitated by running up and down the scale a few times fairly rapidly, after the separate minute-long transmissions are over.

The receiver itself, apart from the loud-speaker, could be very simply checked by measuring, by means of a Taylor voltmeter (not necessarily calibrated), the volts across the loud-speaker terminals; this voltage should, of course, be the same for all the notes if the receiver amplifies all notes alike. and,

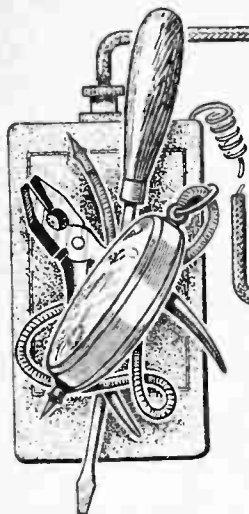

PRACTICAL HINTS AND TIPS

A Section Mainly for the New Reader.

BOTTOM BEND DETECTORS.

IT has been found that the majority of modern high-magnification valves, when used as anode rectifiers with conventional H.T. voltages and anode resistances, require approximately two volts negative on the grid for best operation. The best and most certain way of obtaining this bias is to use two dry cells in conjunction with a potentiometer connected across the L.T. supply in such a way that the negative surplus voltage of one volt may be opposed by the application of a suitable positive voltage. By this plan it is possible to make an accurate adjustment, which, it should be noted, is only necessary when dealing with weak signals, and, moreover, with such valves as have a sharply defined lower bend.

When connecting up a temporary or experimental receiver it is useful to know that a disused accumulator cell, which, though incapable of giving current, may very possibly supply the correct bias for the average detector valve.

o o o o

IMPROVING THE BUZZER WAVEMETER.

A NUMBER of amateurs who are in possession of buzzer wavemeters, many of which were designed before sharply tuned valve receivers came into general use, will often find that the emitted wave is too "broad" for accurate and close adjustment.

An examination of the average instrument will show that the shunted

buzzer, dry battery, and switch are shunted across a portion only of the coil, as shown in Fig. 1. It is useful to know that the "sharpness" of the emitted wave may be increased very considerably by reducing the number of turns included in the buzzer circuit. Referring to the diagram, this alteration may be carried out by moving the tapping Y away from the end X of the coil towards the end marked Z. This alteration

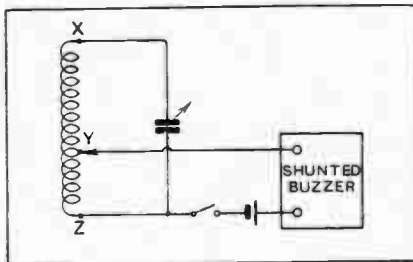

Fig. 1.—Reducing damping in a buzzer wavemeter.

will result in some diminution of signal strength, but as many wavemeters—particularly ex-Government instruments—were designed for use with crystal receivers, a considerable decrease in intensity may be tolerated when the emission is to be picked up on a modern valve set.

o o o o

TELEPHONE CONNECTIONS.

WHERE it is desired to operate several pairs of telephones from the same receiver, it is usual to connect the various pairs all in parallel with one another. This practice has probably arisen because of the fact that if the parallel connection is adopted the removal or breakdown of one pair does not affect the others, thus permitting extreme simplicity in the arrangement and wiring of the output terminals

Where a valve receiver is in use this method of connection is definitely wrong, for the impedance of any valve likely to be used to feed telephone receivers is far higher than that of one pair of telephones. If this one pair is replaced by two in parallel the *total* output from the valve will therefore be reduced, and as this reduced output now has to supply two pairs instead of one, the signal strength in each will be less than half the original value.

If, on the other hand, the second pair is connected in series with the first, the total output from the valve will in most cases not fall far short of double its original value, so that *each* pair of telephones will now give signals practically as loud as those in the original single pair. This process must not be carried too far, of course, but with the usual valves used for supplying telephones the simple series connection is best for any number of pairs, up to eight at least; with eight pairs or more the experiment may be tried of connecting in series-parallel, the telephones being arranged in two equal series chains, the two chains being connected in parallel with one another.

In the case of loud-speakers, much the same argument applies up to any number that is likely to be required, and in addition to a little extra strength as compared with the parallel connection, the series arrangement will help to bring out those elusive low notes if the loud-speakers are capable of reproducing them.

When a crystal set is in question, it becomes difficult to lay down any hard-and-fast rule, on account of the large differences between crystals, but it is usually found that the parallel connection is best, especially when signals are loud.

SELECTIVITY AND THE RECTIFIER.

THE selectivity of a receiver is dependent, to a surprisingly large extent, upon the type of rectifier employed, an anode rectifier being very considerably better from this point of view than a grid rectifier. This superiority is due to two distinct causes.

The first reason for the poor selectivity that accompanies the use of a grid rectifier is the well-known fact that this type of rectifier, by virtue of the grid current that is essential to enable it to rectify at all, imposes a comparatively heavy load on the tuned circuit that immediately precedes it. No matter how scrupulously "low-loss" this tuned circuit may be, it must inevitably tune flatly when the damping due to grid-current is introduced, for this damping may be equivalent to introducing a resistance of any value up to fifty ohms or more into the tuned circuit.

Were this all, the cure would not be far to seek, for the introduction of reaction into this circuit can be made to wipe out all the added resistance, so that at the cost of an extra control on our receiver we could combine the sensitivity of grid rectification with the selectivity of anode rectification. If this arrangement be tried, however, it will be found that, although the point of maximum signal strength can be made as sharp as could be desired by the use of sufficient reaction, the local station cannot be completely silenced as readily as when anode rectification is in use.

This residue of local station signals over a wide range of wavelengths is due to that very property of the grid rectifier for which we employ it, namely, its sensitivity to weak signals. Suppose that the detector circuit is tuned to a distant station, not far removed from the local station in wavelength, and that the voltage fed to the detector by that station is, under these conditions, one-tenth of that supplied by the distant station. The distant station will then be heard, but there will be an annoying undercurrent of local station. If we now substitute an anode rectifier, its relative insensitiveness to weak signals will cause it to ignore altogether the small residue of signals from the local station, so that the distant transmitter only is heard.

Thus, in addition to the true selec-

tivity, due to the almost complete absence of damping of the tuned circuit by the detector, the anode rectifier provides us also with a kind of spurious selectivity by its refusal to detect weak signals. Moreover, no reaction is necessary provided a low-resistance tuned circuit is employed, so that if we are willing to put in some other control to take its place we can add another tuned circuit to our receiver, either in the form of an additional H.F. stage or as a loose-coupler.

o o o o

THE TANTALUM RECTIFIER.

ALTHOUGH electrolytic rectifiers have among amateurs generally a bad reputation as being "messy" and uncertain in operation, it may be pointed out that the combination of tantalum and lead electrodes in dilute sulphuric acid is free of many of the defects of the ordinary Nodon cells. It is probably correct to say that tantalum rectifiers may be most usefully employed for the purpose of charging H.T. accumulators, and a diagram showing the connections for this purpose is given in Fig. 2. Each cell may be mounted in a glass or earthenware vessel with a capacity of a pint or less. One electrode is made of a strip of sheet lead of sufficient length to reach to the

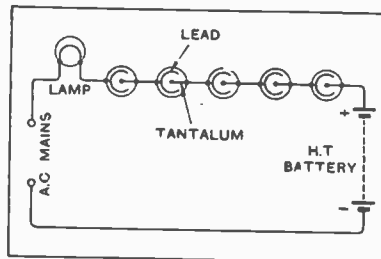

Fig. 2.—An electrolytic rectifier for charging H.T. accumulators from A.C. mains.

bottom of the jar, and with a width of $\frac{1}{2}$ inch or more. The second is a narrow strip of tantalum about $\frac{1}{8}$ th inch wide and a few thousandths of an inch in thickness, which should dip about 2 inches below the surface of the electrolyte with which the cells are filled to within about an inch from the top. The electrolyte is dilute sulphuric acid, as sold for accumulators, with a specific gravity of about 1.250.

A lamp rated at 60 watts is inserted, and will generally pass a

current suitable for charging the ordinary battery; one of higher or lower resistance may, of course, be substituted if desired.

The arrangement as shown is suitable for supply voltages in the order of 200; an extra cell should be added for operation on 240-250 volt circuits.

o o o o

INCREASING THE CAPACITY OF A VARIABLE CONDENSER.

IN the course of experimenting we sometimes find that none of our spare variable condensers go up to quite a high enough capacity for the particular work in hand. A simple and effective expedient when the condenser is not built into any case or box is to immerse the vanes completely in oil. Since the dielectric in the space between the fixed and moving vanes is now oil instead of air the capacity is a little more than doubled, since the dielectric constant for most oils is between 2 and 3. High-grade transformer oil is about the best, but this is not usually likely to be at hand. Ordinary domestic paraffin oil answers well, as most samples seem to have excellent insulating properties. The condenser may be mounted with its vanes vertically downwards in a clean jar, and oil is poured into the jar until all the vanes are completely covered. The moving vanes should be briskly rotated backwards and forwards a number of times in order to expel any air bubbles between them.

o o o o

WINDING REACTION COILS.

IT is not generally realised that so-called "low-loss" construction is unnecessary in a reaction coil, and, indeed, is sometimes definitely detrimental. In the anode circuit in which this coil is included we are dealing as a rule with superabundant energy, and so high-frequency and even reasonable D.C. resistance are matters of small importance. The use of large coils of thick wire will have the effect of increasing capacity between grid and anode inductances, with the result that changes in reaction coupling will materially alter the tuning adjustment, making the operation of the receiver much more difficult. As a rule, it is as well to wind such coils with fine wire, of from No. 30 gauge downwards.

HOWLING IN L.F. TRANSFORMER-COUPLED AMPLIFIERS.

WHERE two or more transformer-coupled L.F. amplifying stages are used trouble may be experienced with the set howling at a high-pitched frequency. This is most common when the L.F. amplifier is preceded by a detector valve in which the grid condenser and leak method of rectification is employed. The grid connections of such a detector are very sensitive to stray electrostatic pick-up, and in particular are likely to be affected by the stray field set up by the large L.F. potentials generated in the last stage of the amplifier; this provides enough reaction to maintain the whole amplifier in a state of L.F. oscillation. This pick-up by the grid-leak detector is the seat of a number of troubles for which the succeeding L.F. stages are apt to be unjustly blamed. The remedy is to arrange the detector layout so that the length of connecting wire between the grid condenser and

the grid of the detector valve is an absolute minimum. Also arrange things so that nothing carrying amplified L.F. currents comes within several inches of the grid connections of the detector valve. This form of instability is entirely absent from receivers employing anode bend detection; the latter form of rectification, although not so sensitive, is strongly recommended.

Sets are sometimes described in which the detector unit is completely screened by a metal compartment of its own. This is an excellent plan as it materially assists both L.F. and H.F. stability.

Sometimes, of course, the trouble does actually arise in the amplifier itself. The simple expedient of reversing the leads to one of the intervalve transformer primaries is almost too familiar to need mention here. This is not, however, invariably effective, especially when there is electrostatic feed-back from the output to the input of the amplifier.

INCREASING VOLUME.

THE maximum grid voltage with which an output valve can deal without introducing distortion may invariably be increased by applying a greater H.T. voltage than is customary, always provided that a corresponding increase is made to the grid bias voltage. Unfortunately, however, the useful working life of the valve will be decreased by adopting this plan, but it will be realised that in any case an additional upkeep expenditure must *always* be faced when an attempt is made to obtain a greater undistorted output. The capabilities of an ordinary power valve, with extra H.T. voltage, may be regarded as intermediate between those of the same valve under normal operating conditions and of a "super-power" amplifier.

As a rough guide to the voltages to be used, it may be stated that a 7,000-ohm valve, with 150 volts on the anode, requires about 12 volts negative grid bias.

DISSECTED DIAGRAMS.

Practical Points in Design and Construction.

No. 75.—A Crystal Receiver.

(To be concluded in next week's issue.)

The present series of diagrams is intended to show progressively, and in an easily understandable manner, the various points to which special attention should be paid, and at the same time to assist the beginner in mastering the art of reading theoretical circuit diagrams. Under the projected "regional" scheme, high selectivity will, in some instances, be necessary even in a crystal set; the diagrams given below, and those to appear next week, will show how the ordinary set may be improved in this respect.

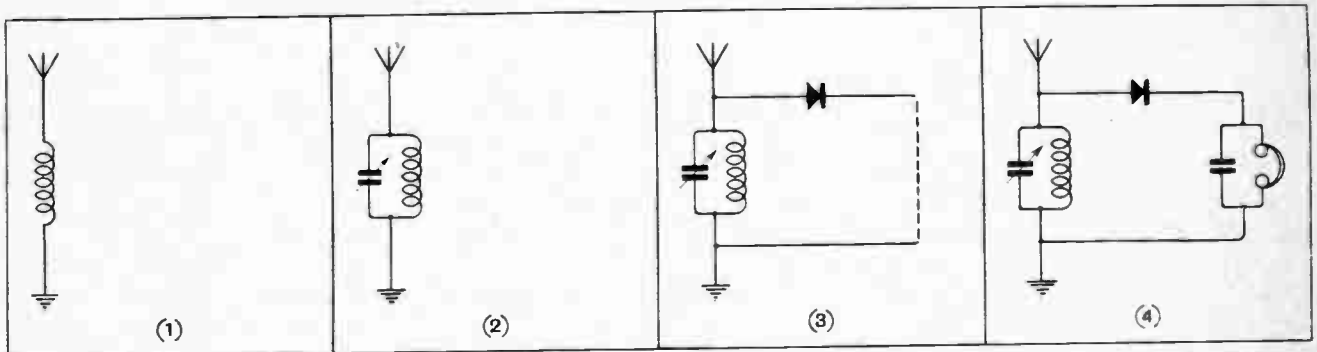

The aerial-earth circuit is completed through a tuning coil.

A variable tuning condenser is shunted across the coil.

The crystal detector is connected to the aerial end of the coil.

The addition of telephones and by-pass condenser completes the circuit.

THE inductance of the coil will, as usual, depend on the capacity of the aerial and the wavelength to be received. For the normal broadcast waveband, a conventional plug-in coil of from 35 to 50 turns will be suitable with a full-sized aerial. For Daventry, a No. 150 has about the right inductance value. There is no point whatsoever in using a coil of

extremely high efficiency, as it is affected by both aerial damping and, in the circuit shown in (4), by the full damping effect of the crystal.

A variable tuning condenser of 0.0005 mfd. is generally recommended. Its moving vanes should, strictly speaking, be connected to the "earthed" side of the circuit; capacity effects are not noticeable with

the comparatively crude circuit shown, but they come into play with the improved arrangements to be discussed later.

A by-pass condenser of from 0.0005 to 0.001 mfd. is recommended; its capacity has a certain bearing on the rectifying efficiency of the crystal and should be carefully determined by trial.



Broadcast Brevities

NEWS FROM ALL QUARTERS.

By Our Special Correspondent.

**Peace in the Ether.—Sir John Reith's American Visit.—Transatlantic Programme Exchanges ?
Tiresome Relays.—Doings at Daventry.—The Broadcast Music Lesson.**

Less Interference.

While the oscillator is still with us there seems to be a distinct falling off in other forms of interference, notably Morse from ships. Bournemouth listeners especially are rubbing their eyes (or is it their ears?) at the arrival of conditions more peaceful than they have ever before experienced.

The spirit of reform is particularly noticeable among ships of the "King's navy," and it is possible that this circumstance is not entirely fortuitous.

Sir John Reith and U.S. Programmes.

In May last *The Wireless World* gave the exclusive news that Sir John Reith had received an invitation to attend the inauguration of the new building of the

American National Broadcasting Co. in New York.

When Sir John arrives in New York in the course of the next few weeks he will concern himself with an interesting proposition which is being very warmly sponsored by the N.B.C. officials. It is nothing less, in fact, than a service of "across-the-ocean" broadcasting, by which London and New York would regularly exchange feature programmes for the edification of their respective listeners.

The Hopeful President.

This may, or may not, be an attractive prospect, but, to judge from the quality of recent relays of America in this country, the technical aspect of the

matter would demand a fair amount of consideration before anything like regularity could be approached.

Mr. Aylesworth, President of the National Broadcasting Co., would have it appear that these difficulties are vanquished, but his buoyant outlook seems a little in advance of modern thought.

A Plan.

.. Tremendous technical and engineering problems, as well as difficult programme arrangements, due to the difference in time between London and New York, had to be solved before any plan could be formulated," declared Mr. Aylesworth in a recent speech at Denver. "We feel," he added, "that we have now made sufficient progress to propose a definite plan of co-operation with the British broadcast-ing system."

All this is good to know; the question is whether the B.B.C. is ready to fall in line with these ambitious proposals, and whether their present technical resources are adequate.

Relays Which Exasperate.

Many listeners were doubtless enjoying the excellent music by Jay Whidden's dance band on Tuesday of last week when Keston butted in with a very indifferent relay of dance music from America. I wonder how many of the aforesaid listeners experienced a thrill of pleasure at the interruption, and how many of them experienced something quite different?

Myself, I came within the latter category, and I don't suppose I was the only listener who found himself asking why Keston still performs this "turn" in the middle of other programmes.

No Novelty.

There is now no novelty in relaying programmes from America. It has become one of those things which should be done well or not at all.

A Savage Handicap.

It is sometimes forgotten, perhaps, that the engineers at Keston labour under a soul-destroying handicap. Atmospheric conditions over the Atlantic often fluc-

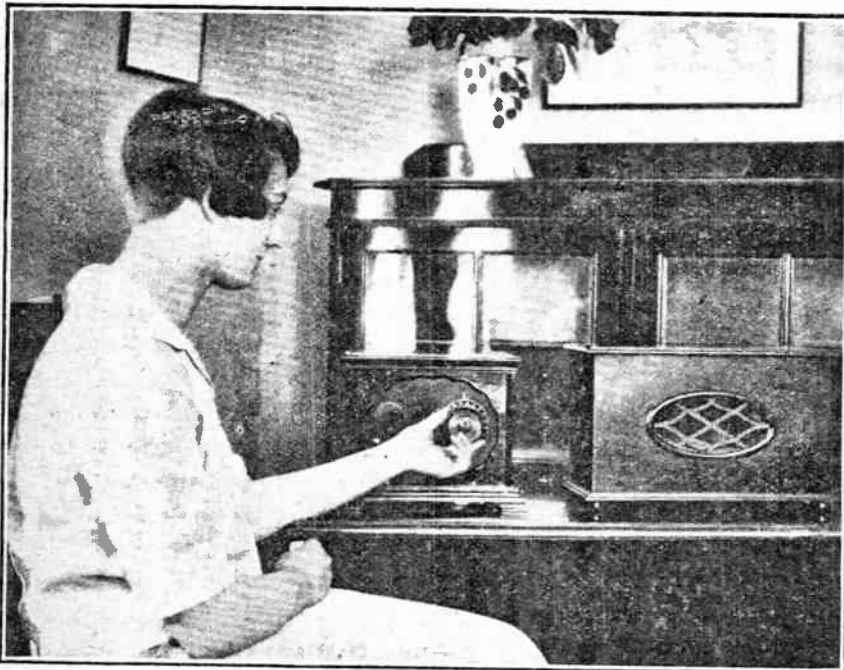

THE FINISHING TOUCH. Over 250 new houses on the Richings Park estate at Iver, Bucks, have been equipped with broadcast receivers as permanent fixtures. The photograph shows a typical instrument—a 2-valve Geophone and loud-speaker. To avoid disfiguring the countryside with ugly aerial poles, the aerials are concealed in the attics.

tuate from minute to minute, and while an American transmission may be received well-nigh perfectly at one moment, by the time arrangements have been made to break in upon the regular programme in order to effect a relay, fading and atmospheric may have intervened with savage severity.

This explains why B.B.C. engineers whose duties take them to Keston often wear the hunted look of an electric hare.

o o o o

Hare and Hounds.

Talking of electric hares, what about a running commentary on a greyhound race? The electric hare could quite comfortably carry a microphone on the small of its back and enable us to hear the paws of the top dog.

If the hare were caught, and the microphone swallowed, the listening public would learn something of a greyhound's inner feelings.

o o o o

Doings at Daventry.

Experiments continue at Daventry with the new regional station, but I understand that we need not expect anything in the shape of a serious alternative programme until the station has been duly licensed by the Post Office, probably early in August.

That the programme will be of an alternative nature is certain, i.e., it will be distinctive, differing from the fare offered either by London or Daventry. Probably, at the beginning, 5GB's transmission will be limited to two hours daily, but, as my Pudsey correspondent puts it, an hour of blessed variety is better than a thousand of unrelieved aridity.

o o o o

Waiting for the Post Office.

I gather that the wavelength of 5GB will be nearer 300 metres than 400, but this and the question of power rests largely with the shahs of St. Martin's-le-Grand.

o o o o

Nelson Keys at 2LO.

Nelson Keys will give a quarter-hour turn from 2LO on Monday next, July 18th. The last time he was billed for the London studio the contract was cancelled at short notice, but his music-hall arrangements will not, I understand, interfere with the forthcoming broadcast.

o o o o

The King's Broadcast Speech.

The programme for the broadcast ceremony in connection with the opening of Gladstone Dock, Liverpool, by the King on July 19 will include an address to His Majesty by Mr. R. D. Holt, chairman of the Mersey Docks and Harbour Board, prayers by the Bishop of Liverpool, community singing, and a twenty-one-gun salute fired by the Royal Artillery.

o o o o

Cricket at Intervals.

A running commentary on the match between England and The Rest will be relayed from Bristol on July 23 at intervals between 3.0 and 6.30 p.m.

"Lido Lady."

The numbers to be broadcast in the excerpt from "Lido Lady," which will be relayed from the Gaiety Theatre on July 22, are as follow: "It all depends on you" (Phyllis Dare and Company), the Charleston Trio Dance (Phyllis Dare, Dave FitzGibbon, and Harry White), "Try again to-morrow" (Cicely Courtneidge and Jack Hulbert), and Finale (the Company).

Oscillator in the Dock.

A mock trial will be broadcast by the Newcastle station staff on July 18. Mr. Oscillator, alias Mr. Knob Twiddler, is caught red-handed and hailed before the Bench after having spent the night in a cell where there were no knobs except those on his uncomfortable bed.

o o o o

For Poor Artistes.

The design of American broadcasting studios trends towards the production of an artistic and romantic atmosphere. The latest suggestion is the incorporation of swimming pools.

There is much to be said for this device, provided that the pool is deep enough and is equipped with a ducking-chair.

o o o o

A Chopin Programme.

A "request" Chopin programme will be given by the well-known broadcasting pianist, Edward Isaacs, on July 20. It will consist of the three preludes, in C major, B flat major and G major, the Waltz in C sharp minor, and Polonaise in C sharp minor. On the last occasion when he appeared before the studio microphone in London Mr. Isaacs' brilliant playing gained warm applause from the orchestra, who are not always prone to a display of enthusiasm over a soloist's efforts.

o o o o

The Menin Gate Broadcast.

Two microphones will be used at Ypres on Sunday, July 24th, when the Menin Gate memorial is opened by Lord Plumer. One microphone will serve for broadcasting Lord Plumer's address and that of Sir Laming Worthington-Evans, the Minister for War, while the other microphone will pick up the band music and singing, the latter under the direction of Mr. Stanford Robinson.

Land-lines will convey the speech and music from Ypres to Ostend, whence it will travel via submarine and underground cable to London.

o o o o

Sir Walford Davies' Book.

Anything that Sir Walford Davies has to say on the subject of music lessons by wireless is worth listening to, for Sir Walford is rightly acknowledged to be one of the best, if not the best broadcast lecturers to-day.

In "Music Lessons: A Special Memorandum to Teachers," just issued from Savoy Hill, Sir Walford Davies gives a lucid explanation of the methods employed in the two years' course of music lessons now in progress and extending until July, 1928.

Hints are given regarding the equipment needed by scholars, the attitude of the class towards the loud-speaker, the condition of the set, and sundry matters which, unimportant at first glance, mean so much if the utmost benefit is to be obtained. A very readable book.

FUTURE FEATURES.

London.

JULY 17TH.—Orchestral and Vocal Concert Service from George Street Baptist Church, Plymouth.

JULY 18TH.—"The Vauxhall Belles." A light romantic opera in two acts, by Herbert Oliver.

JULY 19TH.—Opening of Gladstone Dock by H.M. the King, S.B. from Liverpool. Dance Music.

JULY 20TH.—Debate "That Opera is Absurd," Mr. Basil Maine and another. Sir Landon Ronald in the chair.

JULY 21ST.—The Roosters' Concert Party.

JULY 22ND.—Excerpt from "Lido Lady" relayed from the Gaiety Theatre.

JULY 23RD.—England v. The Rest—running commentary from Bristol.

Birmingham.

JULY 18TH.—"The Neer-Dovells' Concert Party," relayed from Royal Leamington Spa.

Bournemouth.

JULY 22ND.—Wagner Programme from the Winter Gardens.

Cardiff.

JULY 21ST.—"As You Like It," by William Shakespeare.

Manchester.

JULY 20TH.—"1588." A play by Walter Pearce.

JULY 21ST.—"On with the Show of 1927." An evening at Blackpool relayed from the North Pier.

Newcastle.

JULY 20TH.—Concert performance of "The Waterman." A Ballad Opera by Charles Dibdin.

JULY 23RD.—"Mr. Smith Wakes Up." A new one-act comedy by Vivian Tidmarsh.

Aberdeen.

JULY 18TH.—Lecture Recital by William Swainson.

JULY 21ST.—Scottish Programme.

Belfast.

JULY 18TH.—"A Trip to the Isle of Man." A Holiday saga.

JULY 21ST.—"Rococco." A play in one act by Granville Barker.

RECENT INVENTIONS

The following abstracts are prepared, with the permission of the Controller of H.M. Stationery Office, from Specifications obtainable at the Patent Office, 25, Southampton Buildings, London, W.C.2, price 1s. each.

Variable Neutralisation. (No. 269,355.)

Application date: June 3rd, 1926.

An interesting form of multiple condenser for the purpose of varying the neutralisation present in a high-frequency amplifier is described in the above British patent by Standard Telephones and Cables, Ltd. It is mentioned in the specification that a neutralising condenser may be adjusted so that either exact neutralisation or, alternatively, over- or under-neutralisation may be obtained. When a neutralising condenser is employed for the purpose of introducing a certain amount of reaction its setting is not constant over the whole frequency range of the tuned circuit. According to the invention, however, the neutralising condenser is mechanically linked to the tuning condenser, and so proportioned that it is appropriately adjusted with the variation in the tuning of the circuit. A circuit embodying this arrangement is shown in the accompanying diagram. The aerial is tuned by a condenser C_1 , and an inductance L_1 , which is coupled to an inductance L_2 , tuned by another condenser C_2 . The mid point of the inductance L_2 is connected to the filament and earth while one end is taken to the grid G of the valve V and the other end through a balancing condenser. This consists of the special condenser C_3 ,

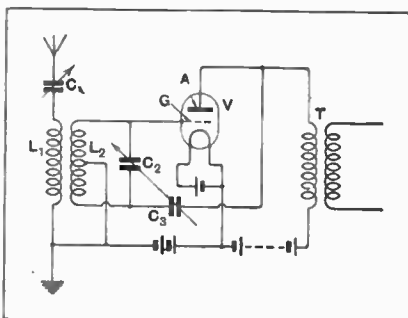

Receiving circuit in which tuning and balancing condensers are coupled together. (No. 269,355.)

The tuning condenser C_2 and balancing condenser C_3 are mechanically linked so that variation of the tuning condenser brings about a desired variation of the balancing condenser. The specification claims the construction of a condenser with a separate insulating plate working in conjunction with another plate on the rotor of the main condenser, for the purpose of producing the balancing condenser.

Rice-Kellogg Details. (No. 245,796.)

Convention date (U.S.A.): January 9th, 1925.

Some further details of the coil-driven Rice-Kellogg type of loud-speaker are disclosed in the above specification. One of the chief features of the invention lies in the method of supporting the cone. The cone shown in the illustration is of rigid material, and is fixed to an annular support by a ring of some flexible material, such as thin rubber

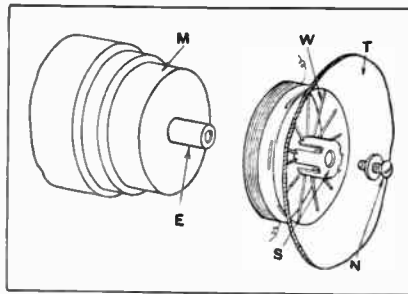

Coil suspension in the Rice-Kellogg loud-speaker. (No. 245,796.)

or silk. In order to prevent any undesired resonance, it is mentioned that the restoring force on the diaphragm should be such that the natural frequency is fairly low, preferably of the order of about 50 cycles, although fairly satisfactory results can be obtained with a natural frequency as high as 200 cycles. Owing to the very light and flexible nature of the suspension of the edge of the diaphragm, it is necessary positively to centre the truncated end of the cone which carries the coil drive, and a special form of suspension is therefore adopted. The end of the magnet pole M is provided with an extension E which carries a spider S fixed by a screw and washer N . The truncated end T of the cone is laced to the spider by means of wires or strings W . This method of construction enables the cone to move quite freely with a plunger action without any transverse motion occurring. Sizes and angles for the cone are also discussed in the specification, and should be of great assistance to those interested in this type of loud-speaker. The necessity for preventing box resonance is also dealt with, and another interesting point is the inclusion of a copper ring in the end of the pole piece to act as a short-circuited turn in the field winding to

damp out any fluctuations when the supply is affected by badly rectified current, or commutator ripple.

Variable Coupling. (No. 269,668.)

Application date: January 22nd, 1926.

J. K. im Thurn and G. W. Harris describe in the above specification a form of coupling in which the movable coil is caused to rotate simultaneously with a lateral movement. The arrangement should be quite clear by examination of the accompanying diagram, where the fixed coil is shown at F and the movable coil at M . This is mounted on a shaft S fixed to a carriage C , which works on guides G . A spindle A actuates a link motion located on the end of the shaft S . It will be noticed that rotation of the spindle A will cause the link motion to rotate the coil M on the carriage C , and, simultaneously, cause the carriage to move upwards or downwards according to the direction of rotation. As the furthest point of travel of the coil M is approached a pin P in the link arm X engages a guide plate Y on the link arm Z .

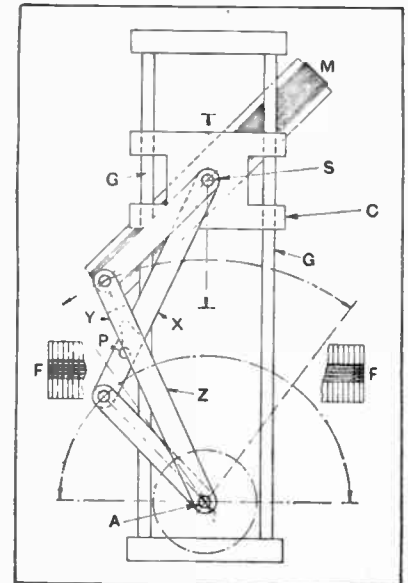

Variable coupler with link motion. (No. 269,668.)

This enables it to be carried over the top dead centre in a direction dependent upon the original rotation of the spindle A .

The Experimenter's Notebook—

in L_1 and L_2 are opposite in sign, it is permissible to define the mutual inductance in this case as being negative; if therefore we speak of the natural (inter-electrode) capacity couplings between the circuits as positive we arrive at the fact that a positive capacity coupling and a negative magnetic coupling have an equivalent effect.

Without going more deeply into the matter we may say that this proposition is readily extended to the case of Fig. 2, whether the effect of the coupling in any particular case is regenerative or anti-regenerative. A difficulty arises, however, in the case of Fig. 1 according as to whether the mutual inductance between L_3 and L_2 is positive or negative. If positive, then the above remarks apply as they stand, if negative then the effect of mutual inductance between L_1 and L_2 is opposite to that previously stated. On the other hand the effect of the valve capacity is entirely independent of the sense of the mutual inductance between L_3 and L_2 .

The important question with regard to magnetic coupling, however, is not its sense, but its numerical value, and it is of fundamental importance to bear in mind that a capacitive and a magnetic coupling between two tuned circuits can be numerically equal for one wavelength and one wavelength only. For values below this critical wavelength the capacitive coupling predominates, and for values above the magnetic coupling. If, therefore, the receiver is correctly balanced at one wavelength it will not be correctly balanced at any other in the event of mixed couplings being present.

We may now turn to practical considerations, and it is clear that what we require in the first place is a convenient experimental method of determining when a state of balance has been arrived at. Putting this in

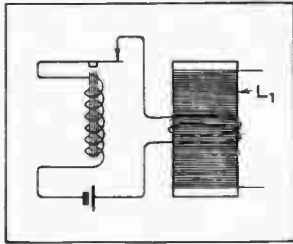

Fig. 6.—The use of a buzzer circuit for neutralising a receiver in the absence of strong signals from a nearby station.

more precise language we mean to say that the production of a voltage V_2 across L_2C_2 (see Fig. 1) will in general give rise to a voltage V_1 across L_1C_1 , and the object of our endeavours is to adjust matters so that V_1 is zero whatever the value of V_2 . As an alternative, provided the first valve is extinguished so that only its capacity effect remains, we may excite the circuit L_1C_1 so that a voltage V_1 is produced across it and make our adjustments so that V_2 is zero. This latter method has the advantage that in the case of a receiver as normally constituted we may use the detector valve and low-frequency amplifier just as it stands. On the other hand such a method of procedure fails to take into account secondary effects such as that caused by the flow of high-frequency feed current in the plate circuits of the H.F. and detector valve. Inasmuch as the second method is the simpler and will give a great deal of information regarding the behaviour of the circuits it may be conveniently considered in the first place.

Let us assume, therefore, in Fig. 1 that the first valve is extinguished; it is then necessary to find a means for strongly exciting L_1C_1 so that a signal of sufficient intensity is in general transferred to L_2C_2 to enable a balance to be obtained such that this signal is reduced to zero intensity.

Experimenters who live close to a broadcasting station may find that a connection of the aerial to the receiver in the ordinary way provides an adequate signal for the purpose. For the benefit of those who are not so situated the writer would suggest the simple arrangement of Fig. 6. Referring to this figure a single turn or two turns of wire are connected loosely round the former of L_1 , or in an equivalent position in the case of a plug-in coil. In series with this winding is connected a buzzer and a cell, for which purpose an extension of twin flexible lead is convenient. Such an arrangement produces only a negligible field of its own, the effect in the detector being entirely that of the current induced in L_1C_1 . By this means signals of ample strength are transferred to L_2C_2 in the event of any slight out-of-balance being present.

Brandes Novel Test Scheme.

A novel test scheme in connection with their 3-valve receiver has been arranged by Messrs. Brandes, Ltd. Fifty members of the public (one from each of fifty towns all over the country) have been invited to carry out private experiments in their own homes with the Brandes Three, the receivers to be installed absolutely free of charge, complete with loud-speaker and all accessories.

The object of these experiments is to determine whether the conclusions of this "jury" indicate that the receiver will meet with general requirements if put on the market. ○○○○

Mullards in Leeds.

Readers in Leeds and district will be interested to note that the Mullard Wireless Service Co., Ltd., have taken new premises for their Leeds depot at 33, York Place, Leeds. The telephone and tele-

NEWS FROM THE TRADE.

graphic address will remain the same, viz., Telephone Number: Leeds 26360; Telegrams: "Mullard, Leeds."

○○○○

The Osram Bulletin.

"Choosing a Low-frequency Transformer" is the title of a useful article in the current "Osram G.E.C. Bulletin." The recent "Osram" valve demonstration at Whiteley's is described and some interesting notes appear regarding the new 2-volt "Osram" valves, known as the DEH 210 and DEL 210, for which full working data and operating hints are given.

A New Brown Product.

Perhaps the most interesting article in the current "Brown Budget" relates to the "Crystaframe" receiver with frame aerial, designed for use within 6 miles from any British broadcasting station. The "Crystaframe" is fitted with a permanent detector and can be operated by the unskilled with greatest ease.

○○○○

Battery Elimination.

Messrs. Rich and Bundy, the transformer manufacturers, of New Road, Ponders End, have issued a useful brochure containing valuable hints on the use of the mains supply for the operation of radio receivers. Battery eliminators already described in *The Wireless World* are dealt with, and the reader is introduced to the various types of R. & B. transformers and chokes suited to his needs.

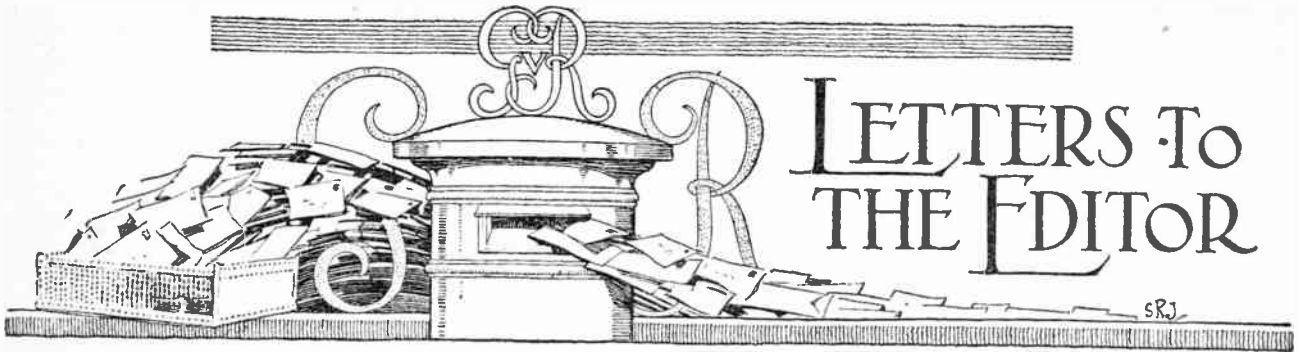

The Editor does not hold himself responsible for the opinions of his correspondents.

Correspondence should be addressed to the Editor, "The Wireless World," Dorset House, Tudor Street, E.C.4, and must be accompanied by the writer's name and address.

INTERNATIONAL ASPECTS OF BROADCASTING.

Sir,—Mr. Bertram Munn's letter, which appeared in your issue of June 29th, should be read in conjunction with your Editorial of June 22nd, and the correspondence therein referred to.

The B.B.C. holds a monopoly in so far as broadcasting from this country is concerned, and so appears to be the only present source of Empire broadcasting. Your correspondent in consequence need not be unduly alarmed, and can, for the time being at any rate, rest content in the knowledge that no part of his licence fee is likely to be squandered in keeping our emigrant population in touch with the Mother Country or assisting in the development of British enterprise, although it is unlikely that the cost of establishing a short-wave station capable of giving an intermittent Empire service would entail expenditure heavy enough to imply a reduction in the quality of the entertainment he expects and gets.

The establishment of such a station would give a further impetus to broadcasting, and encourage the erection of similar stations in other parts of the Empire to the obvious advantage of listeners in this country, whose interests are not centered round the parish pump. There is no reason why transmissions from this station should in any way interfere with the regular programmes, and its operation would give the B.B.C. valuable and first hand information on short-wave working. The writer further contends that the development of international transmissions will have the effect of materially increasing the number of listeners in this country, thus augmenting the revenues of the B.B.C., and that from this point of view alone the matter is worth perusing.

Does Mr. Munn really represent the views of the remaining two million two hundred and forty-nine thousand nine hundred and ninety-nine listeners mentioned in his letter, or is it possible that a considerable proportion of them would welcome an extension of the general interest of broadcasting on other than purely parochial lines?

G. ROLLAND WILLIAMS.

London.

June 29th, 1927.

Sir,—Mr. Munn in his letter published in your June 29th issue complains of loose thinking and talking and then proceeds to demonstrate how it is done. He presupposes that an Empire broadcasting station would be employed to disseminate propaganda of uplift to the dominions and colonies and the world at large, whereas the movement under discussion aims simply at the establishment of a short-wave station capable of radiating ordinary broadcasting programmes at a greater distance so that they may become audible in our dominions and colonies; because, some people place a different interpretation upon the functions of a short-wave station Mr. Munn condemns the whole movement. The station could, incidentally, be employed for announcements and utterances of general public interest, but that would not necessarily mean diverting the whole of the home broadcasting service from ordinary programmes.

In predicting boredom from the utterances of Prime Ministers and prominent politicians, Mr. Munn forgets that they owe their

eminence partly to their ability as public speakers, and they are usually worth listening to. Many will agree that the Prime Minister is far more interesting and at times far more amusing than many of the cross-talk comedians who favour us with their efforts. Ancient jokes are no less trying than hoary platitudes.

On the financial side Mr. Munn is rather parochial, and one cannot help feeling that his undeniable wit might have been employed to better purpose. A short-wave station if charged to B.B.C. revenue would not make any appreciable difference to the corporation's resources, and it would not, in point of fact, be without interest to B.B.C. licensees, if one may so term them, now that there is an awakening interest in short-wave work. There is nothing new in a minority paying for a movement of national interest and importance. An occurrence of this nature happened as recently as 1914; on this occasion some hundreds of thousands of colonials participated in an event of national or imperial importance without reckoning up beforehand the financial aspects of the situation as it affected their persons.

However, it would be a perfectly proper arrangement for the cost of an Empire broadcasting station to be met out of the residual of the licence money after payment of the B.B.C. allocation. This surplus would in the ordinary way, one gathers, be absorbed by the Exchequer, so in this manner the station would in effect be supported by the State and the amounts available for providing vaudeville artists and others would not be tampered with, and Mr. Munn would not feel that any portion of his annual ten shillings had been misspent.

Gaiches, France.
July 2nd, 1927.

H. D. HARRIS.

TUNING NOTES.—A SUGGESTED B.B.C. SERVICE.

Sir,—I write to point out a way in which the B.B.C. could be of very material assistance indeed to all those who are interested in determining fairly exactly the capabilities, both of their receivers and their loud-speakers, to reproduce with reasonable accuracy the music transmitted.

What is required is that each station should transmit occasionally—say once a week or once a fortnight—a set of eight or ten *pure* musical notes, as free as possible from harmonics, lasting perhaps a minute each, and varying in frequency from 25 to 5,000 cycles. All notes should, of course, be transmitted at the same intensity.

Those who have no measuring instruments would be able to form a fair idea of the overall reproduction of receiver and loud-speaker together by the simple process of comparing the aural intensity of the various notes; this might perhaps be facilitated by running up and down the scale a few times fairly rapidly, after the separate minute-long transmissions are over.

The receiver itself, apart from the loud-speaker, could be very simply checked by measuring, by means of a Taylor voltmeter (not necessarily calibrated), the volts across the loud-speaker terminals; this voltage should, of course, be the same for all the notes if the receiver amplifies all notes alike, and,

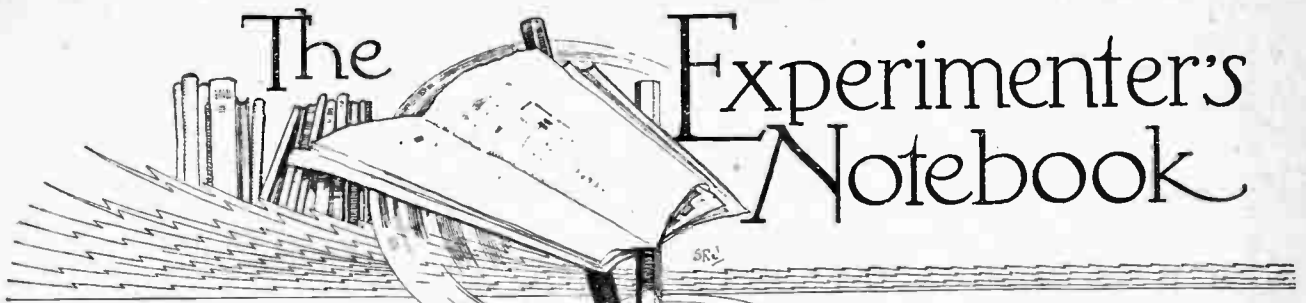

The Experimenter's Notebook

By "EMPIRICIST."

Practical Notes on Capacity Neutralisation.

THERE is no subject perhaps in the whole of wireless receiver design more deserving of careful study than the art of neutralising the effect of the inter-electrode capacities in a high-frequency amplifier. Such a subject has nearly always been approached from two extreme standpoints, either the purely theoretical, in which principles only are dealt with and practical difficulties somewhat ignored, or else the purely constructional, in which specific directions are given how to build a particular type of neutralised receiver.

The present article purports to steer a middle course between these two extremes, with the object of enabling the experimenter to tackle the practical aspects of neutralisation on his own, and in some measure to correlate these with the general theory of the subject.

A Typical Circuit.

In order to fix ideas, it would be convenient to consider a practical case of capacity neutralisation, in which a circuit is employed which is basically that of the "Everyman Four." This consists of an input tuned circuit L_1C_1 , an output tuned circuit L_2C_2 , a primary coil L_3 coupled to L_2 , and a neutralising coil L'_3 , the free terminal of the latter being coupled through a

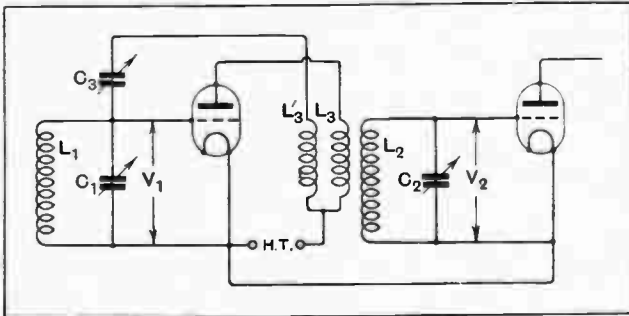

Fig. 1.—Circuit of typical neutralised H.F. coupling.

neutralising condenser C_3 to the grid terminal of L_1C_1 .

The primary object of neutralisation is to prevent any voltage developed in L_2C_2 from being transferred back to L_1C_1 , and thereby producing a regenerative effect. Such transference of voltage mainly takes place through the primary coil L_3 and the inter-electrode capacity of the first valve, and it is in order to counteract this effect that

the neutralising winding L'_3 and the condenser C_3 are introduced. On the other hand, we must regard as being strictly relevant the problem of the other possible couplings between L_1C_1 and L_2C_2 . These are of two kinds, electrostatic and electromagnetic, and, while the latter is considerably the more important the former, if present in excess, will constitute a difficulty.

In investigating a circuit of this nature it is essential first of all to have a clear idea of what to look for, and, secondly, an experimental method of looking for it.

Under the first heading let us consider what happens in a valve circuit having two tuned circuits respectively connected to the grid and plate. A simple tuned anode arrangement is shown in Fig. 2, in which the transformer coupling, characteristic of Fig. 1, is omitted for the sake of simplicity.

The valve capacity has been shown in dotted lines as C_0 , and no means of neutralisation is embodied; for the purpose of the present discussion we will assume that some means exist of varying C_0 through zero to a negative value, the latter state of affairs corresponding to one where an excessive neutralising correction is employed.

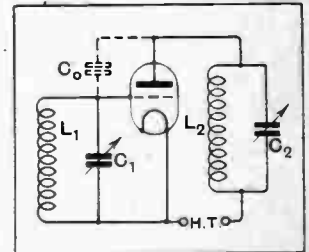

Fig. 2.—Tuned anode circuit showing valve capacity C_0 .

Regeneration and Anti-regeneration.

In considering this arrangement we will make one of two assumptions from general experience, the first being that a circuit, as shown in Fig. 3 (a), in which a pure inductance L_2 takes the place of the tuned circuit L_2C_2 , and a condenser of reasonable size C_R supplements the capacity C_0 of the valve, favours the production of oscillations in L_1C_1 . This is readily demonstrable either by mathematical analysis or by a simple experiment. On the other hand, the arrangement shown in Fig. 3 (b), in which the plate impedance takes the nature of a pure capacity, is anti-regenerative and tends to throw additional damping into the circuit L_1C_1 .

If in either of these figures we imagine the condenser C_R to be reduced in value, the regenerative or anti-regenerative effect will diminish and ultimately become zero when C_R is zero. If we then imagine C_R to be

The Experimenter's Notebook—

made negative the two cases will become reversed—that is to say, Fig. 3 (a) will represent a regenerative and Fig. 3 (b) an anti-regenerative arrangement.

Reverting now to Fig. 2 we must consider the case where the circuit L_2C_2 is tuned in any manner through resonance with the circuit L_1C_1 , or, better still, through resonance with a certain specific wavelength which it is desired to receive. At the exact resonance point it is well known that L_2C_2 partakes of the nature of a pure resist-

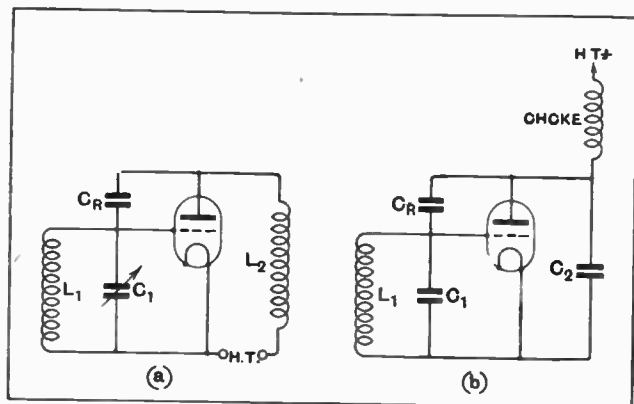

Fig. 3.—Regenerative circuit (a) with inductive load in anode circuit, and (b) anti-regenerative arrangement in which the load is capacitive.

ance of very high value. By adjusting the value of C_2 on either side of the exact position for resonance we introduce an element of reactance—that is to say, we may regard the high resistance corresponding to resonance as being shunted by either an inductance or a capacity. If the condenser C_2 is too small for resonance (*i.e.*, if the circuit L_2C_2 is "below resonance"), the reactance will be inductive, and the circuit will behave as if it were an arrangement like Fig. 4 (a). If, on the other hand, C_2 has a value greater than that corresponding to resonance (*i.e.*, L_2C_2 is above resonance), the reactance will be capacitive and the circuit equivalent to Fig. 4 (b).

Condition for Stability.

It thus appears that the tuned circuit L_2C_2 may be adjusted to produce a regenerative effect whenever there is capacitive coupling between the two circuits and independently of whether this coupling is positive or negative. In other words, nothing but a reduction of the capacitive coupling to zero or a negligible value will suffice to produce stability in the circuit, as by juggling about with the tuning condensers C_1 and C_2 we can produce a state of affairs tending to oscillation if the circuit is over-neutralised, just as readily as if it under-neutralised, or not neutralised at all.

In all our experiments, therefore, which relate to the neutralisation of the tuned circuits, we look for

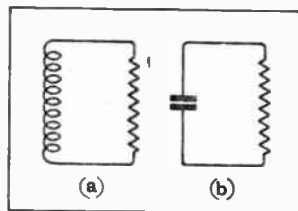
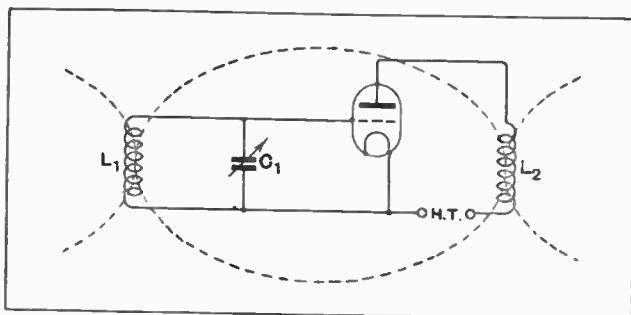

Fig. 4.—Equivalent electrical conditions in an oscillatory circuit (a) with the condenser set below resonance and (b) above resonance.

a state of affairs where the neutralising condenser has a critical position for stability, and gives rise to instability if adjusted to a value either lower or higher than this critical setting. It should be added that these remarks apply to what may be designated as reactive coupling, *i.e.*, capacitive or magnetic coupling between the elements of the tuned circuits themselves. Cases occur where a state of affairs corresponding to conductive coupling occur, and these give rise to a unidirectional effect, *i.e.*, the coupling is either regenerative or anti-regenerative for all settings of C_1 and C_2 . For instance, if in Fig. 2 we connect a resistance, suitably protected by a large condenser in series, between the grid and plate of a valve, this will always produce a damping effect on circuit L_1C_1 ; conversely a resistance in Fig. 1 placed in shunt across C_2 will always produce a regenerative effect upon L_1C_1 , however the settings of C_1 and C_2 are varied in relation to each other.

Neutralisation and Damping.

A further important principle to grasp is the necessity for neutralisation, as opposed to a mere damping of the circuit which is most prone to instability. Without going into the theoretical reason for this fact we may simply refer readers to the very simple experiment of comparing the operation, say, of an "Everyman Four" receiver, first as it stands, and secondly, deneutralised, but with the circuit L_1C_1 reduced to a state of stability by the application of positive grid bias. It is necessary therefore to counteract a reactive coupling by another re-



A circuit of this type will constitute a regenerative arrangement if coils L_1 and L_2 have their axes parallel and direction of winding in the same sense.

active coupling if satisfactory neutralisation and good signal strength is to be attained; on the other hand it would be useless to cure self-oscillation in the arrangement of Fig. 2 by the suggested anti-regenerative connection of a resistance between plate and grid.

We next come to the important question of the difference between electromagnetic and electrostatic couplings and the necessity for considering these two types separately. First with regard to the sense of electromagnetic coupling we may again argue from general experience without going into theoretical questions. In Fig. 5 the reaction coil L_2 is magnetically coupled to L_1 in the same sense as it would be if these two coils were identical, and had their axes parallel, and their windings in the same sense. Such an arrangement gives rise to the production in L_2 of a voltage opposite in sense to that in L_1 , and a regenerative effect is obtained. Since voltages

as the Taylor voltmeter has, nearly enough for this purpose, a straight-line calibration curve, the relative amplification of the different notes can be expressed simply as degrees on the scale of the meter.

If the receiver is brought up to the mark with the aid of these weekly transmissions, then any failure of the loud-speaker to reproduce the notes with equal aural intensity must be put down to the speaker itself.

Neither the expense of the necessary apparatus nor the ten minutes or so of time occupied (these transmissions could take place "after hours") would be an appreciable item in the B.B.C.'s yearly accounts; the only serious objection to the proposal that presents itself is the probable strong resentment of the trade, who might not at all like the shortcomings of the usual commercial loud-speaker and receiver brought into such vivid prominence.

A. L. M. SOWERBY.

London, W.2.
June 26th, 1927.

EMPIRE BROADCASTING.

Sir,—Having read your Editorial of June 22nd on the above subject, I have come to the conclusion that in your opinion the B.B.C. would be fully justified in spending the British listeners' money to establish and operate a short-wave station for the benefit of listeners abroad so long as performance comparable with that of short-wave stations in other countries is obtained.

In my opinion there are other things to be considered, and the first is, what service will be rendered to those whose money will have to pay for this station; and, again, how many listeners at home or abroad have receivers that will tune to the short waves such as are used by PCJJ and 2XAF, not to mention 22 metres used by 2XAD? I venture to say not one in a thousand, and how many have the skill necessary to build and operate such a receiver or even the desire to do so?

I think it would be far better if the B.B.C. spend their money on improving the existing service.

If the B.B.C. were a private concern like Philips and Western Electric it would be a different matter; there would then be no need for them to study the British listening public. Regarding supremacy, I don't think that the B.B.C. have much to worry about.

This may seem a selfish view to take, but I cannot see anything to recommend the short-wave broadcasting station from the point of view of the listener resident in Great Britain.

Colchester. T. S. W.
July 5th, 1927.

Sir,—As an old reader of *The Wireless World* I should like to add a plea for an Empire short-wave broadcasting station.

Stations 2XAF and PCJJ are received regularly here at excellent strength and their transmissions are very welcome. Owing to atmospheric disturbances being so severe, it is only occasionally that stations using the higher wavelengths can be received, and then they are not worth listening to.

As far as I can gather, there has been very little amateur work done with this Colony, and it is very difficult to secure a transmitting licence; but in the near future I hope to get busy with a 50-watt, 30-metre, crystal controlled transmitter and would welcome reports.

S. G. FISHER.

Nairobi, Kenya Colony, B.E.A.
May 25th, 1927.

Sir.—It is evident that the real obstacle in the way of the establishment of a short-wave station in Great Britain is the B.B.C. monopoly. But the B.B.C. themselves plead that the establishment of such a station lies outside their province.

The solution of the present difficulties is, therefore, to be found in the acceptance of the plea and in the restriction of the scope of the B.B.C.'s operation to what may be officially defined as "broadcasting frequencies."

The erection, operation, and maintenance of a short-wave station might then be left to the enterprise of a private company or to the co-operative enterprise of a number of companies, or, alternatively, be made the subject of an arrange-

ment between such a company (or companies) and the Government, the financial part of any such arrangement to be in the hands of the Treasury and the Colonial Office, *not* the Post Office.

The B.B.C. would, of course, continue to enjoy their monopoly of listeners' licence fees, and the expense of the short-wave station would be borne neither in whole nor in part by broadcast-listeners.

K. McCORMACK.

Newcastle-on-Tyne.
June 30th, 1927.

Sir.—I have been following with interest the correspondence and articles in the wireless and lay Press regarding the setting up of a British short-wave broadcasting station, and, after having discussed the matter in local wireless circles, I have come to the conclusion that, so far as the general listener is concerned, the letter in your June 29th issue by Mr. Bertram Munn fully covers the position.

However, as there is not much doubt that a short-wave station will eventually be foisted on to the B.B.C., there should be some *quid pro quo* and, in this instance, I think it should be in the form of the Government granting the B.B.C. free use of all telephone lines required for inter-station connection and also for outside broadcast work. If this were done, it would at least help to balance the cost of erecting and running the short-wave station.

A. J. PORTER.

Glasgow.
June 29th, 1927.



WIRELESS AND THE ECLIPSE. An amateur astronomical post on Eke Hill, Dale Head, Yorkshire. Successful photographs were taken and accurate records obtained of the times of second and third contact thanks to the special time signals from Daventry. These were received on a Liberty Superhet (seen below the cameras on the left), and it was observed that signal strength increased from three-quarter totality until well after totality.

AMATEUR SHORT-WAVE TRANSMISSIONS.

Sir.—The correspondence initiated by Mr. John Wellings has been very interesting, if only to show that, on the whole, British transmitters are a sporting crowd of men, keep silent when others ask them to, and generally behave as decent members of the community.

My own experience as an inveterate listener as well as a transmitter shows me that the interference complained of on 2XAF's wavelength is, alas, becoming worse as the days go by. I am glad to place on record, however, that British transmitters are very rarely offenders. The interfering signals are almost always French in origin, as one can determine if one listens long enough to them. Often they make no call letter, but "speak" in abbreviated French interlarded with American slang.

A definite instance of this kind of thing may be produced. Last night (June 29th), after the regular evening programme,

the B.B.C. commenced relaying 2XAF. All went merrily for some time until, at first in the background, then becoming louder, we heard the familiar Morse—"CQ—CQ—CQ" in raw A.C., *ad nauseam*. This forced the B.B.C. to conclude the relay prematurely.

I think decent research workers will agree that very little good will come of being angry in print every time another person, however unsophisticated, takes amateur transmitters to task. There is no denying that there are a few British transmitters whose lack of courtesy and mediocre knowledge of the Morse code should make it impossible for them to have obtained a transmitting licence at any time, but on the whole, whether we belong to transmitting organisations or not, I am sure we have little to be afraid of if we "play the game" according to the dictates of our own consciences.

June 30, 1927.

YORKSHIRE (2GN).

Sir,—With reference to Mr. John Wellings' letter recently published in your paper, that gentleman may be interested to learn that on a recent occasion, while listening to one of 2XAF's transmissions, I was surprised to hear another station start up on practically the same wavelength. The note of this station very closely resembled "spark," although it was possibly very badly rectified A.C. On listening further I discovered that the culprit was a certain well-known Swedish commercial station. In view of this, therefore, I should strongly advise Mr. Wellings and others like him to make full enquiries in future before aiming entirely unfounded accusations at members of the long-suffering amateur transmitting fraternity. Rather should they lay the blame at the door of the commercial stations, who seem to wander about all over the place on short waves. Under the terms of his licence the amateur transmitter is bound to keep strictly within the limits of his allotted waves, and woe betide anybody whose wavemeter errs, for the P.O. will surely track him down. In conclusion, I might mention that the very last thing in the world the amateur transmitter wishes to do is to interfere with the pleasure that anybody, no matter who they be, gets out of radio.

London, N.W.2.

M. W. PILPEL (G6PP).

June 29th, 1927.

Sir.—I seem to have stirred up a hornet's nest, but I am satisfied, for *the interference has ceased*! I have not heard a "blib" or a "blah" since my letter appeared, and all is peace again.

It is difficult to reply to the storm of vituperation which my letter evoked without indulging in personalities, so I propose to ignore it, but certain points in this week's letters call for a word of explanation from me, and my explanation will, I think, satisfy Messrs. Jay and Hudson.

Mr. Hudson wonders whether I read Morse! "A hit! A very palpable hit!" I don't. Even could I have done so I do not think it would have done me much good on this occasion. I know sufficient about amateur transmitters to tell a good station from a bad one, and from the ragged screech of this fellow's Morse and the sloppiness of the keying I should think he was transmitting from a Morse chart, with a set made from parts purchased in the Rag Market. I do not think he would have a call-sign.

A friend of mine heard the same items free from interference on the occasion to which I referred, so I rather think the ingenious suggestion of 2HJ regarding "down-under" commercials must be ruled out. It was sufficiently near me to dodge the skip effect. However, as I say, the interference has ceased, and if 2HJ, 6AS and 5GU will let me have their telephone numbers I will ring them up if it occurs again. Perhaps they will be able to identify the offender and get him well and truly scragged.

Mr. Chadfield pleads for time for the B.B.C. engineers. I would say, let them take the amateur into their confidence. It is one thing to talk about the unreliability of short waves, it is another to say that unless they can transmit free from night distortion and fading they will not transmit at all. I would not mind betting that the R.S.G.B. could erect a station in three months which would give satisfactory service to India,

South Africa and Australasia. Who expects perfection at that range? I am quite prepared to admit that 2XAF and 2XAD (particularly the latter) are rather "jazz" at times, but every item can generally be followed, and speech is nothing short of marvellous. I would recognise John Landan's "Hello, folks" among a thousand voices, and can generally distinguish between the Rochester, Syracuse and Schenectady announcers.

If the B.B.C. want money for this station let them ask for it. I, for one, would subscribe, and I am sure that thousands of Britons overseas would send their guineas along. Think of the thrill of donning the headphones in Jo'burg or Calcutta on a torrid night, and hearing the familiar voice (familiar, that is, to us) announce in dulcet tones: "There is a deep depression over Iceland, and vigorous secondaries are crossing the British Isles. Further outlook, unsettled."

If and when the regional scheme starts, the B.B.C. will do well to take a leaf from the National Broadcasting Company's book in the way of announcing and freedom from long waits. I will admit that they have little to learn in the way of programmes. Most of the American programmes are rather piffing, and, unfortunately for British listeners, the best items come on about 4 a.m.

Handsworth, Birmingham.

JOHN WELLINGS.

June 29th, 1927.

INTERFERENCE FROM LEIPZIG.

Sir,—With reference to Mr. P. J. R. King's letter in your issue of June 8th I think he is quite correct in thinking that Leipzig causes distortion of transmission from 2LO.

Recently I was listening to a talk from 2LO while Leipzig was transmitting dance music. In the intervals between the dances 2LO was fairly clear, but directly Leipzig started again distortion commenced. Later, in the same evening, the 2LO stand-by transmitter was putting out piano music after Leipzig had closed down, and this came through without any distortion at all.

With my set I can separate Dublin from Breslau and Milan, although these are separated by fewer metres than Leipzig and London.

F. PINK.

Southsea, June 9th, 1927.

MUSICAL INTERPRETATION IN THE CONTROL ROOM.

Sir.—The letter of Mr. F. Hartley in the June 29th issue expresses views which I have held for a long while. It is only occasionally, when some particularly good item is being broadcast, that the control appears to be in the hands of an intelligent engineer. General results are absurd, and we get a speaker shouting the house down, and then a singer at about a quarter of the strength, usually with a too loud piano accompaniment.

Too much attention is given to control and not enough to correct balance in the studio.

Barnt Green.

F. G. SACHETT.

June 29th, 1927.

BATTERY ELIMINATORS.

Sir.—Your recent notes and remarks on H.T. eliminators worked from D.C. mains are interesting, particularly since it has been recognised that in many houses the positive main is earthed. This is so in my own house, and I should like to mention two further points which I have not seen referred to elsewhere:

(1) In damp weather puzzling effects are produced, and unpleasant shocks may be received through leakage. It is advisable to insulate accumulators, G.B. battery, and even the set, by glass or ebonite sheets; also not to touch any metal parts of the set while wearing damp boots.

(2) There is a ripple in the "earthed" main as well as in the live main; this can be perceived on listening when the main is connected to earth *via* phones and condenser; the ripple in the earthed main is, however, much smaller. This will cause a hum when the L.S. is fed by choke and condenser and connected to earth, unless a choke is fitted in *each* main of the eliminator.

London, S.W.13.

L. WOOLLARD.

June 22nd, 1927.

READERS' PROBLEMS

"The Wireless World" Information Department Conducts a Free Service of Replies to Readers' Queries.

Questions should be concisely worded, and headed "Information Department." Each question must be accompanied by a stamped addressed envelope for postal reply.

Long Wavelengths and the "Everyman-Three."

I have constructed the "Everyman-Three," from which I am getting very good results, but I wish to include an arrangement for getting the Daventry station by the manipulation of a switch which brings in a loading coil as in the case of the "Everyman-Four." Would it not be possible also to arrange that reaction be used on the long wavelengths so that distant long-wave stations could be received as well as Daventry? If so, I should like this to be incorporated also. I am intending to add an extra L.F. stage and choke filter circuit, and presume that this will be in order.

D. L. W.

It is quite a simple matter to arrange to let in a loading coil at the low potential end of the grid circuit of the detector valve for the reception of Daventry in exactly the same manner as is done in the case of the "Everyman-Four," and also it is possible in the case of this receiver to let in a reaction coil so that long-distance long-wave stations can be received also. We reproduce in Fig. 1 the circuit diagram of the original "Everyman-

Three" receiver with these modifications added. It will be seen that the loading coil is let into the circuit in the same manner as the "Everyman-Four," and it is normally short-circuited by S_1 . At the same time, there is a reaction coil in series with the plate circuit of the detector valve, this being coupled to the loading coil and normally short-circuited by S_2 .

When desiring to receive long wavelengths, the aerial is connected to A_1 , thus apparently giving an auto-tapped aerial, although in reality the system becomes almost direct coupled, because that part of the inductance which is not included in the aerial circuit, in other words, the normal intervalve transformer secondary, has an inductance of only about 200 microhenries, or so, compared with the total inductance of the circuit which will be in the order of 5,000 microhenries. It would be an excellent plan, therefore, in our opinion, to include a 0.0003 mfd. fixed condenser in series with the lead running from terminal A_1 to the loading coil in our diagram. This would give greater selectivity, although it must be remembered that as reaction is included, a great amount of selectivity can be got in this manner. At the same time as the aerial is attached to A_1 , the knob

of the jack switch shown is pulled out, thus open-circuiting the loading and reaction coils. Needless to say, any type of double-pole switch may be used here. It might be thought by many that it is superfluous to use a double-pole switch, and that a single-pole switch for short-circuiting the loading coil would be all that is necessary, and that the series-reaction coil would do no harm on the short waves. In certain cases it might be possible to use a single-pole switch, but practical experience dictates that it is necessary also to short-circuit the reaction coil, otherwise there is a possibility of an L.F. howl being set up when listening on the normal broadcasting wavelengths. Do not forget that it is necessary to shunt the L.F. transformer primary with a fixed condenser of about 0.0003 mfd. capacity, if such an instrument is not already included in your transformer. We show this condenser in dotted lines.

It would be quite in order to add an extra L.F. stage, and to use a choke-filter output circuit. The necessary connections are quite conventional, but in case you are in any doubt, they may be obtained from the diagram given on page 737 of our June 8th issue. It will be realised that if an extra L.F. stage is added the receiver becomes a four-valve receiver, which only differs from the "Everyman-Four" in that it employs leaky-grid rectification and transformer coupling in the first L.F. stage.

There is one very important point which must be mentioned, and that is that the positions of the loading and reaction coils must be very carefully chosen in the general layout so that they do not interact with the other coils in the set. It is possible to use an ordinary two-coil holder, and plug-in coils, but owing to the large external magnetic field of the ordinary plug-in coils it may be necessary to screen these coils, and in our opinion it would be far simpler to make use of some small unit such as the "Polar" tuning unit, which, being physically small and having a small magnetic field, will not only take up comparatively little space on the baseboard, but will also enable you to avoid any extra screening or other complications. It would, indeed, be possible to mount this small unit either on the baseboard or on the front of the panel as desired. Another suggestion is that the loading and reaction coils be fixed in respect to their position to each other, and the circuit given in Fig. 1 slightly modified so that the Reinartz system of re

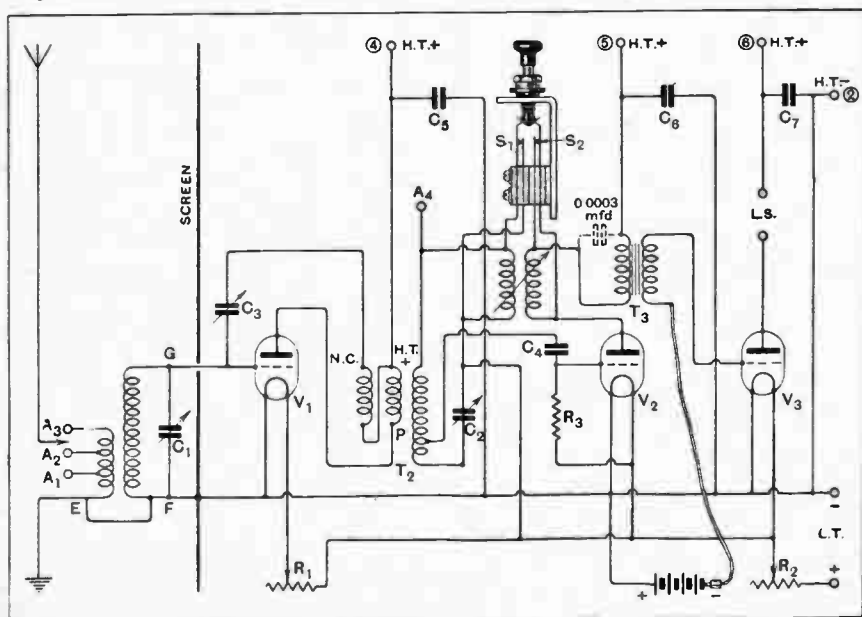

Fig. 1.—Long-wave coils in the "Everyman-Three." By pushing in the switch plunger the long wave coils are brought into action.

action control was used. This would, of course, involve the necessity of an extra 0.0003 mfd. condenser, and might thus rather complicate matters.

o o o o

Building a Super-regenerative Receiver.

I have read with very great interest your reply to M. D. D. in the matter of super-regenerative circuits in your "Readers' Problems" section of June 15th. I intend to experiment with the super-regenerative circuits which you have given in your diagrams on that page, and shall be glad if you will suggest values for the various condensers, inductances and resistances.

D. R. L. A.

The three circuits given, reading from left to right, were the "Armstrong super-regenerative circuit," the original "Flewelling circuit," and the modified "Flewelling circuit." Since all inductances, capacities and resistances in those circuits were numbered consecutively we give herewith the suggested values, using the same symbols as those in the diagrams.

Capacities—

C_{11} , C_{27} , and C_{34} =0.0005 mfd. variable.
 C_{21} , C_{23} , C_{25} , C_{29} , C_{14} , C_{15} =0.005 mfd. fixed.

C_{11} , C_{111} , C_{118} =0.0003 mfd. fixed.
 C_{33} , C_{122} , C_{17} =0.001 mfd. fixed.
 C_{8} , C_{13} , C_{18} =1 mfd. fixed.

Inductances—

L_1 —According to wavelength received. For B.B.C. wavelengths about 200 microhenries (No. 60 coil).

L_2 —According to damping present in circuit. For B.B.C. wavelengths (a No. 25 or 35 coil).

L_3 and L_4 —According to wavelength received. For B.B.C. wavelengths about 100,000 to 150,000 microhenries (No. 1250 or 1500 coil).

L_5 and L_7 —According to wavelength received and aerial capacity. For B.B.C. wavelengths about 30 to 60 microhenries (No. 25 or 35 coil).

L_8 and L_9 —According to aerial circuit damping. For B.B.C. wavelengths (No. 75 coil).

Resistances—

R_1 , R_2 , R_3 , and R_4 .—Variable, 0.5 to 5 megohms. It is sometimes desirable to include a similar variable resistance across C_{15} .

o o o o

Fading.

When listening to distant stations I notice that the signals do not remain steady but are received in waves: occasionally this variation is slow and regular, at other times very irregular. I have mentioned this effect to a number of radio friends, and they inform me that it is due to "fading," but cannot give any satisfactory explanation that will account for this. I should be obliged if you could enlighten me on the cause or causes of this strange effect.

F. B.

Variations in the strength of received signals may be attributable to more than one cause, but the most probable is that resulting from atmospheric conditions. It

is an accepted theory that all the signals received from long-distant stations do not take a direct path between the transmitter and receiver, but that the majority reach their destination after reflection. The theory is propounded by Professor Heaviside that there exists in the upper atmosphere a layer of electrified air capable of reflecting wireless waves, and this may, for easy explanatory purposes, be considered to have waves on its surface similar to those on the sea. This ever-changing surface results in the reflected wireless waves coming to earth at varying angles and hitting, or missing, the receiving station at intervals corresponding to the wave motion in the Heaviside layer. If this wave motion is regular then the "fading out" or "strengthening-up" of received signals will take place at regular intervals, and this effect is referred to as "fading."

BOOKS FOR THE WIRELESS STUDENT

Issued in conjunction with "The Wireless World."

"THE PERRY AUTO-TIME MORSE SYSTEM" by F. W. PERRY. Price 6d. net. By Post, 7d.

"WIRELESS VALVE RECEIVERS AND CIRCUITS IN PRINCIPLE AND PRACTICE" by R. D. BANGAY and N. ASHBRIDGE, B.Sc. Price 2/6 net. By Post 2/10.

"THE OSCILLATION VALVE—THE ELEMENTARY PRINCIPLES OF ITS APPLICATION TO WIRELESS TELEGRAPHY" by R. D. BANGAY. Price 6/- net. By Post, 6/3.

"ELECTRONS, ELECTRIC WAVES AND WIRELESS TELEPHONY" by Dr. J. A. FLEMING, M.A. Price 7/6 net. By Post, 8/-.

Obtainable by post (remittance with order) from
ILIFFE & SONS LIMITED
Dorset House, Tudor St., London, E.C.4
or of Booksellers and Bookstalls

H.T. and L.T. from D.C. Mains.

I have in view the construction of a receiver which, once installed, will require little or no attention, and accordingly propose to utilise the D.C. mains for L.T. and H.T. supply. Some months back you published details of a three-valve receiver embodying these refinements, but unfortunately I have been unable to locate the issue in which this appeared. Can you supply me with the required information, please?

P. T. J.

We think you refer to an article which appeared in the September 1st, 1926, issue, describing a three-valve receiver, the H.T. and L.T. being taken from the D.C. lighting mains. This receiver was designed primarily for the reception of the local station, and accordingly does not possess a high degree of sensitivity. By adopting resistance-capacity coupling between the L.F. stages, faithful reproduction is obtained, although, perhaps, slightly at the expense of amplification. An improvement which we think is to be recommended would be the incorporation of a low-frequency filter output between

the last valve and the loud-speaker. This overcomes the necessity of passing the D.C. voltage through the loud-speaker windings, at the same time localising the H.T. supply should the loud-speaker be sited at a distance from the receiver. The correct method of applying a choke-condenser feed circuit to the output valve of a receiver was described in the "Hints and Tips" columns of the issue for June 8th last, and we suggest you refer to this for full particulars.

o o o o

Aperiodic H.F. Amplification.

I should like to make up a four-valve frame aerial receiver for both long and short wavelengths with only one tuning control and reaction. The detector and L.F. part of the receiver would present no difficulties, but I have no idea as to how to proceed regarding the H.F. amplifier. Is the scheme at all practicable?

S. W. L.

Frankly, we are afraid that there is no real solution of your problem at the present time. It must, of course, be admitted that untuned coupling can be made to give a certain amount of amplification, but this is very small, and with an inefficient collector such as a frame you would find that the range of the set would be disappointingly small.

o o o o

Using Four-volt Valves.

I am building the "Everyman-Four" receiver, and intend to use a four-volt accumulator and four-volt valves throughout. I shall be glad if you will give me the values of resistors R_3 and R_4 to be used under these circumstances.

D. N.

In the case of the use of four-volt valves and a four-volt accumulator, the procedure to be adopted is exactly the same as in the case of the use of two-volt valves and a two-volt accumulator, namely, the resistors must be cut out, and the detector valve grid bias obtained from the grid battery. You are referred to the revised diagram already given in reply to A. L. C. in the "Readers' Problems" section of our April 13th issue.

o o o o

Adjusting an Anode Bend Rectifier.

When using a valve as an anode bend rectifier, I can quite understand that it is possible to bring the working point of the valve on to the bottom bend of the grid volts anode current curve by experimenting with the value of grid bias, the H.T. value being fixed. Would it not be possible to do the same by fixing the grid bias value and experimenting with the value of the H.T.?

J. T. K. R.

It would be perfectly possible within certain limits to do as you suggest, and assuming that the grid bias value was fixed at some arbitrary value, then experiment could be made with the H.T. value, thus moving the whole valve curve from left to right until the bottom bend of the curve coincided with the arbitrary fixed value of grid bias.

WIRELESS LOUD SPEAKERS

By N. W. McLACHLAN, D.Sc.

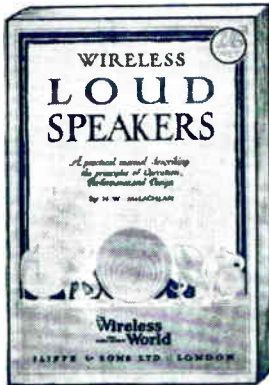

THIS book describes in a simple manner the major principles of the design of modern loud-speakers and some associated circuits.

Clearly written and fully illustrated by numerous diagrams and photographic reproductions, the volume will be of use and value to all constructors and experimenters desirous of investigating this vital aspect of wireless reception.

PRICE

2/6
net

By Post 2/8

From all booksellers or direct from the Publishers:

ILIFFE & SONS LTD., Dorset House, Tudor St., London, E.C.4.

w.w.54

DICTIONARY of WIRELESS TECHNICAL TERMS

Definitions of Terms and Expressions commonly used in wireless Telephony and Telegraphy.

Compiled by S. O. PEARSON, B.Sc., A.M.I.E.E., and issued in conjunction with "THE WIRELESS WORLD"

THIS volume is intended to serve as a guide to all those interested in wireless, who come across, from time to time, unfamiliar words in their reading. In such a case, the DICTIONARY OF WIRELESS TECHNICAL TERMS proves of very great use and value. It is well illustrated and cross-referenced to enable the required information to be rapidly obtained.

PRICE 2/- By Post 2/3

From all leading booksellers or direct from:

ILIFFE & SONS LTD., Dorset House, Tudor Street, London, E.C.4.

w.w.48

Expenditure 1'11 Orders—nearly £4

The following letter from a recent advertiser in "The Wireless World" is of interest to all prospective advertisers:

"I should like to express my opinion of 'The Wireless World' as an advertising medium. On April 27th I had an advertisement in the paper, and in the evening a caller, who placed an order. This was followed before the end of the week by 20 enquiries, and I have since received another ten of these, 15 resulted in orders amounting to nearly £4. This, I consider, is very good, and all for the modest sum of 1/11 spent on advertising."

ALEC G. BINNIE.

1, Cromford Road,
West Hill, S.W.15.

Full particulars of advertising rates will be found on the first page of miscellaneous advertisements.

w.w.64.

The Wireless AND RADIO REVIEW World EVERYMAN FOUR

A 36-Page Booklet giving full Constructional Details of a remarkably efficient "Two-Control" Receiver for Long or Short Waves.

By W. JAMES.

The "EVERYMAN FOUR" attracted widespread attention when it was first described in "The Wireless World."

It is a very sensitive set and has a high degree of selectivity. The local station is perfectly received, and during a normal evening at least fifteen different stations may be received clearly at good loud-speaker strength. (Constructors claim up to twenty-eight stations.)

An additional long-wave attachment for Daventry is described in the booklet.

Price 1/- net By post 1/2

From the offices of "THE WIRELESS WORLD," Dorset House, Tudor Street, London, E.C.4. w.w.60

In any valve it's the FILAMENT

you pay for!

Remember when you buy radio valves that the life of any valve is not one minute longer than the life of its filament and that upon the performance of the filament depends the results you obtain.

Therefore demand:

A LONG FILAMENT . . . a filament with huge proportions, to secure a gigantic emission and the best operating characteristics.

A STRONG FILAMENT . . . a filament that cannot be broken except by the very roughest handling.

A PROVED FILAMENT . . . a filament that has a published National Physical Laboratory Test Report that proves its life and power to be constant and lasting.

Be safe and satisfied. Demand

**THE WONDERFUL
MULLARD P.M. FILAMENT**

Obtainable only in Mullard P.M.
Valves from all radio dealers.

Mullard

THE · MASTER · VALVE



You may judge the toughness of the wonderful P.M. Filament from the fact that it can be tied in a knot long after 1000 hours' life.

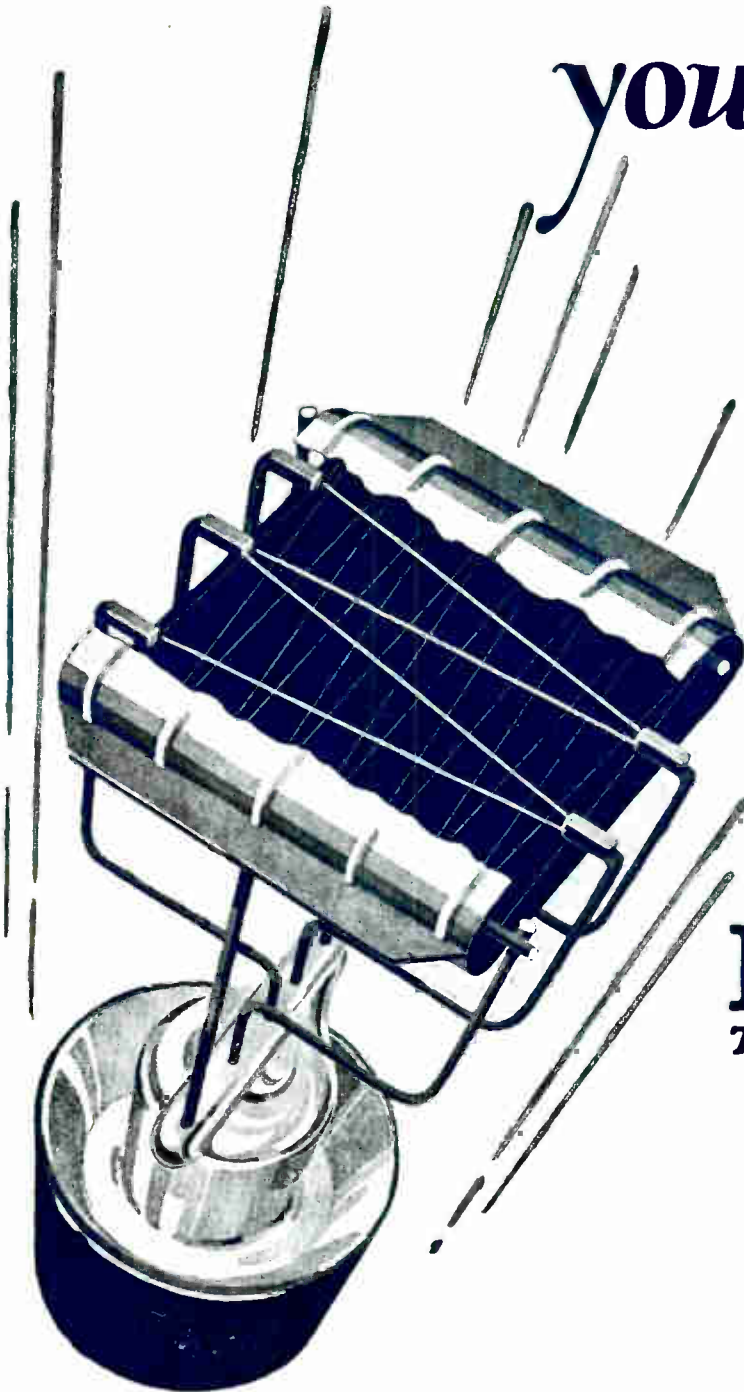

THE MULLARD WIRELESS SERVICE CO., LTD., MULLARD HOUSE, DENMARK STREET, LONDON, W.C.

Printed for the Publishers, LUFFE & SONS LTD., Dorset House, Tudor Street, London, E.C.4, by The Cornwall Press Ltd., Paris Garden, Stamford Street, London, S.E.1.

Colonial and Foreign Agents:
 UNITED STATES—The International News Co., 131, Varick Street, New York. FRANCE—W. H. Smith & Son, 248, Rue Rivoli, Paris; Hachette et Cie, Rue Réaumur, Paris.
 BELGIUM—W. H. Smith & Son, 78, Marche aux Herbes, Brussels. INDIA—A. H. Wheeler & Co., Bombay, Allahabad and Calcutta. SOUTH AFRICA—Central News Agency, Ltd.
 AUSTRALIA—Gordon & Gotch, Ltd., Melbourne (Victoria), Sydney (N.S.W.), Brisbane (Queensland), Adelaide (S.A.), Perth (W.A.) and Launceston (Tasmania).
 CANADA—The American News Co., Ltd., Toronto, Winnipeg, Vancouver, Montreal, Ottawa, St. John, Halifax, Hamilton; Gordon & Gotch, Ltd., Toronto; Imperial News Co., Toronto, Montreal, Winnipeg, Vancouver, Victoria. NEW ZEALAND—Gordon & Gotch, Ltd., Wellington, Auckland, Christchurch and Dunedin.

#1164

3^D

The Wireless World

AND RADIO REVIEW

The Paper for Every Wireless Amateur

Wednesday, July 20th, 1927.



DAVENTRY JUNIOR

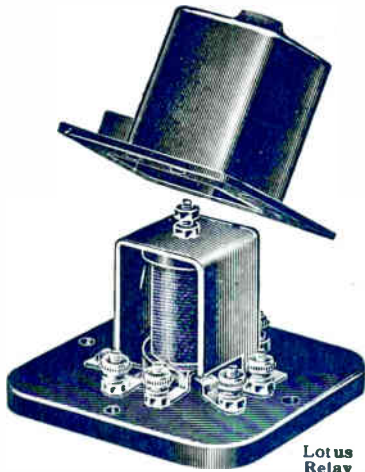

Lotus Relay

Simultaneous Reception in every room!

You can have simultaneous reception in every room in your home without interference by installing the Lotus Remote Control.

Complete outfit for wiring two rooms **30/-**
Each additional room **7/6**

THE LOTUS REMOTE CONTROL

FREE!

Write for **FREE BLUE PRINTS** and instructions how to wire two rooms in half an hour to Dept. W.W.4, Garnett Whiteley & Co., Ltd., Broadgreen Road, Liverpool.

A RELIABLE

2-6 Volt Accumulator Charger

for

£3

The **VARTA SIMPLEX**

charger will charge your 2-6 volt L.T. accumulators from A.C. mains at 1.4 amperes.

IT SAVES ITS COST IN NO TIME.

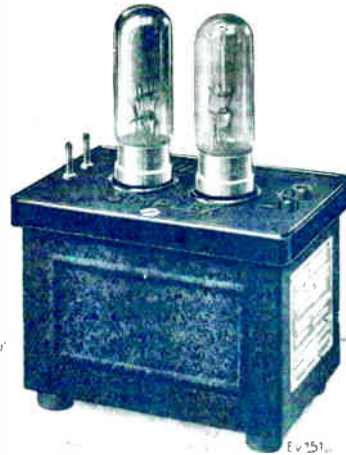

Ev 151.

The **VARTA-DUPLEX** charger capable of charging H.T. and L.T. accumulators simultaneously only costs £5.

Write for full particulars to:

A.F.A. Accumulators Ltd., 120, Tottenham Ct. Rd., W.1.



MAKES A GOOD VALVE—BETTER and A BAD VALVE—GOOD!!

Made on the principle approved by the Admiralty—

World Patents
THE MASTER NON-VIBRATORY VALVE - HOLDER

Only when you employ the "ARTIC" Anti-Microphonic Valve Holder do you give your valve a chance to give of its best. The

"Artic" principle guarantees perfect steadiness under any condition of shock or vibration. Even when the valve is moved directly, it just sags back into position. No springs or rubber are employed as ideal conditions are not possible by the use of these mediums.

PROOF.

22nd May, 1927.

Dear Sirs,
You may be interested to hear that I have now for some time been using three of your Valve Holders, and have never seen any others which, in my opinion, can be compared with them. I have also recommended them with success to numerous other wireless enthusiasts in a government scientific establishment where quality is regarded as the first essential. I enclose P.O. for 3/9d., for another of these most excellent instruments, and I remain, yours faithfully,

FROM YOUR DEALER OR DIRECT



3/9

EACH POST FREE

THE ULTRA SENSITIVE VALVE HOLDER

NO SPRINGS
—
NO RUBBER USED

"STALLOY"

(REGD. BRAND)

THE ONLY MATERIAL

for

TRANSFORMERS and DIAPHRAGMS.

INSIST ON HAVING IT

JOSEPH SANKEY & SONS, LTD.

BILSTON.

STAFFS.

LONDON:—168, REGENT STREET, W.1.

Components of Distinction & Quality

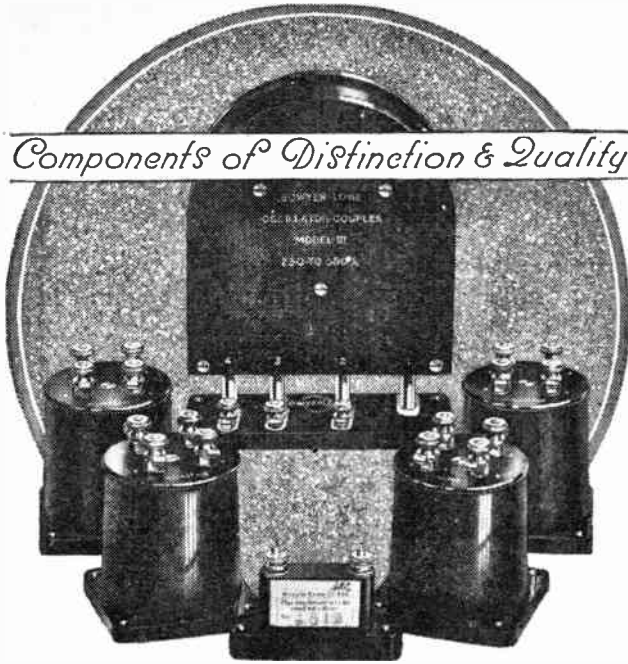

Constructor's Kit containing principal components for building a Seven Valve Set, £10. Three Transformers, one Filter, and fixed Condenser, £4. Interchangeable Oscillator Couplers: 300-600 metres, £1. 550-2000 metres, £1. Base for same, 4s.

Pioneers in Super-Het Components

The world-wide success of BOWYER-LOWE Super-Het Components and Receivers has not been due to chance. BOWYER-LOWE were Super-Het pioneers. Long before other manufacturers had begun to think of Super-het production, BOWYER-LOWE designers were at work. Laboratory research was followed by elaborate and exhaustive testing and no component was introduced until it had satisfied the high standards of BOWYER-LOWE performance.

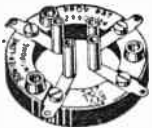

"ANTIPONG" VALVE HOLDER
3/-



"POPULAR" CONDENSER
'0003 .. 10/-
'0005 .. 10/6

WRITE TO-DAY FOR A COMPLETE LIST OF OUR PRODUCTIONS.



BOWYER-LOWE CO. LTD., LETCHWORTH



Advertisements for "The Wireless World" are only accepted from firms we believe to be thoroughly reliable.

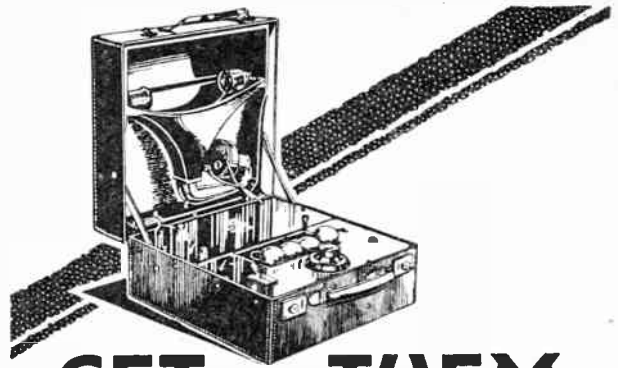

GET THEM YOURSELF!

The other evening a Langham owner picked up the following stations at ample loud-speaker strength with a Langham Portable: *Koenigswusterhausen, Daventry, Radio Paris, Bournemouth, London, Langenberg, Stuttgart, Hamburg*

and

13

other stations!

And the Langham is a self-contained ONE DIAL CONTROL instrument! **7 DAYS' TRIAL.**—Send full cash price or initial deposit, and you can try the Langham Portable for a week. If you don't like it send it back and we will refund your money in full.

GUARANTEE

We definitely guarantee every set for 12 months. If at any time it goes wrong or gives unsatisfactory results we will rectify the trouble free of charge (except in the case of misuse, neglect or accident).

30 Gns. complete and absolutely ready for use. You need buy no other accessories—they are all included with the set.

Deferred Terms.

If you wish, instead of sending us cash in full, you may send a deposit of £5, followed by 12 monthly instalments of £2 : 7 : 6.

Write for particulars.

Langham Radio

Albion House
59

NEW OXFORD STREET.
LONDON, W.C.1

Telephone: Museum 2878 & 8293.

T. McD.5.

whichever way you look at it—

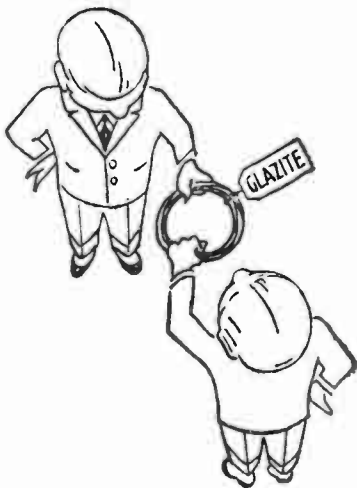

you'll find the
Glazite way better!

There isn't a single way in which GLAZITE isn't better. It's easier. It's neater. It gives perfect insulation. It's flameproof. It's damp-proof. It won't deteriorate in use. And it's cheaper!

Next time, use GLAZITE—the better way of wiring!

GLAZITE
BRITISH MADE REGD
COLOURED CONNECTING WIRE
[RED · YELLOW · BLUE · BLACK WHITE and GREEN]

Obtainable in ten-foot coils, price 1s. 2d. per coil. Or in two-foot lengths—four assorted colours—1s. per packet. From all radio dealers. Write for interesting descriptive leaflet to

The
LONDON ELECTRIC WIRE
COMPANY & SMITHS, LTD.
Playhouse Yard, Golden Lane, London, E.C.1

Makers of Electric Wire
for over  40 years

Registered

Trade Mark.

The New

RI
AND
Varley LTD.
RESISTANCE
CAPACITY
COUPLER

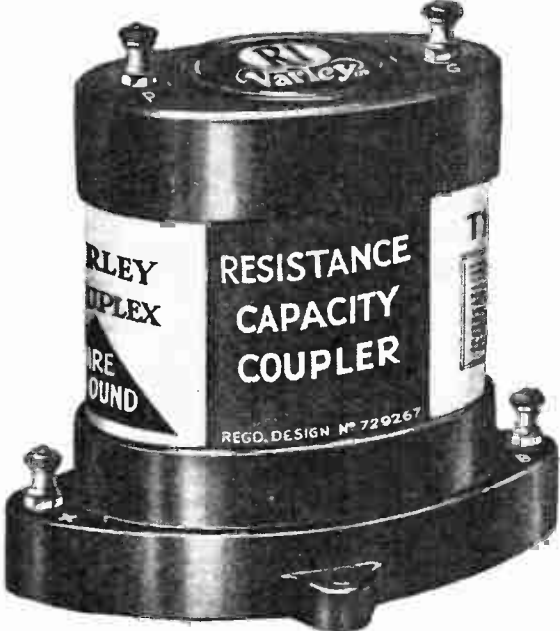

Bi-duplex Wire-wound

The only Bi-duplex wire-wound Resistance Capacity Coupler on the market. Every detail has been carefully designed to give maximum efficiency, and every part perfectly matched and balanced, thereby ensuring a combination of tonal purity and volume far and away ahead of anything hitherto attained.

Type A. Suitable for use after valves with A.C. Resistance (Impedance) of 15,000-40,000 ohms, 20/-.

Type B. Suitable for use after valves with A.C. Resistance (Impedance) of 30,000-100,000 ohms, 22 6.

Leaflet with circuits supplied with each instrument.

Visit our showrooms at: 12, Hyde Street, New Oxford Street, LONDON, W.1.

THE MARK OF

BETTER RADIO

RI
Varley LTD.

R.I. and Varley Ltd., Kingsway House, 103, Kingsway, W.C.2.
Telephone: Holborn 5303.

Mention of "The Wireless World," when writing to advertisers, will ensure prompt attention.

The most critical eye and the most sensitive ear are satisfied by this **Brown Disc Loud Speaker**

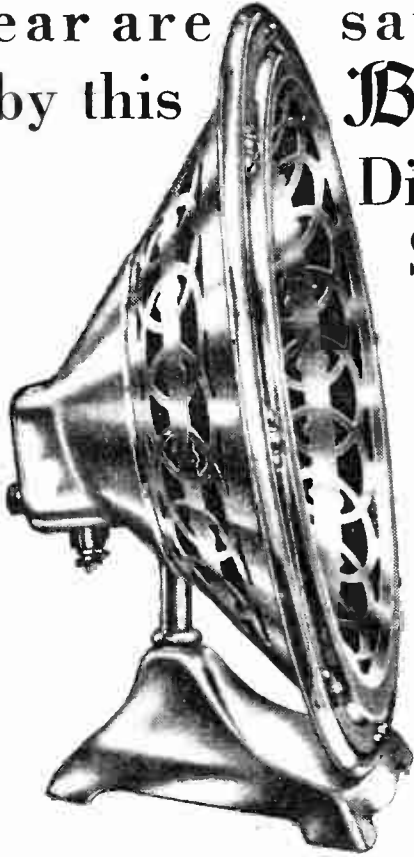

There's only one thing you want from your loud speaker—the truth. Nothing else. You want a band to sound like a band, a cornet like a cornet, a violin like a violin. No Brown Loud Speaker was ever a deceiver.

In song, in speech, and music, BROWN reproduction deviates *not one iota* from the original. It reproduces the broadcast in the home *in very truth* as it is in the studio. The Disc is made in Black, Brown or Cream and Gold, £7 7s.; in Oxydised Silver, £8 8s. At all Wireless Dealers.

THE Brown Disc Loud Speaker has set a new standard in loud speaker design. Before its advent, the loud speaker was common-place in appearance. The Disc is the first really beautiful loud speaker.

As its graceful design does justice to the most luxurious room, so the quality of its reproduction will satisfy the most critical ear.

Brown
DISC LOUD SPEAKER
tells the truth



1927 IMPROVED MODEL
H.T. ACCUMULATOR.

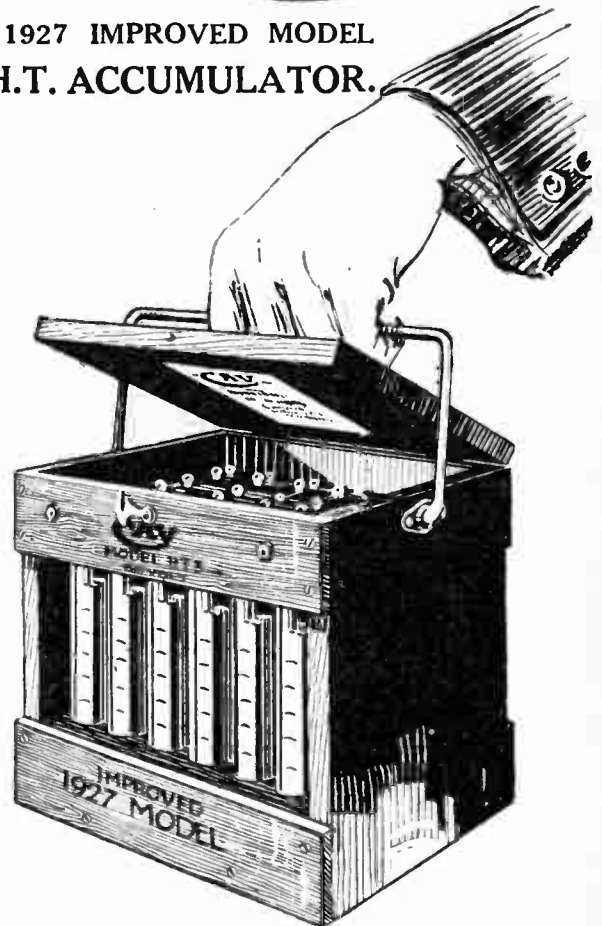

C.A.V. H.T. Accumulators have improved radio reception for hundreds of users who have wisely scrapped their dry batteries. They will do the same for you. Inconsistent discharges, temperature effects, crackling noises with reception, and constant regulation to correct voltage variations are all troubles peculiar to dry batteries, but these are unknown to users of the C.A.V., H.T.

The H.T.3 is fitted with a strong handle enabling it to be easily carried. Used by most leading experimenters they have also been supplied to over 100 of London's Hospitals.

MODEL H.T. 3 **60'** SUPPLIED READY FOR USE
(60 VOLTS) NO FILLING WITH ACID, NO CHARGING

Dimensions 8½ x 7 x 7¾ High
Weight Charged 16¼ lbs - Dry 13½ lbs

ALSO SUPPLIED IN 30 & 90 VOLTS
MODEL H.T. 4 - 30 VOLTS - - 30/-
MODEL H.T. 5 - 90 VOLTS - - 90/-

Catalogue supplied on application.

C.A.V. Vandervell & Co., Ltd.
ACTON, LONDON, W. 3.
Telephone: Chiswick 3801 (Private Branch Exchange).
Telegrams: Vanteria-Act-Lon.



RADIO CONTROL BOOKLET - Free!

Every radio amateur requires an authoritative guide to the correct electrical operation of his receiver. Here you have the opportunity of obtaining such a booklet entirely free. Just fill in and send the coupon below and a copy will be sent to you by return.

"Radio Control" has been prepared by the Weston Electrical Instrument Co., Ltd., who, for the past 30 years, have been universally acknowledged as the leading manufacturers of accurate electrical measuring instruments. Since the inception of radio the Weston Company have examined carefully every phase in its development and with each succeeding stage of progress have designed and produced appropriate instruments to assist the efforts of radio engineers.

Now the result of many years' radio experience is placed at your disposal. "Radio Control" will show you definitely how appreciable economies may be effected in the operation of radio receivers and how improved reception may be obtained at the same time.

To-day is not too soon—cut out and post the coupon now.

WESTON

STANDARD THE WORLD OVER

Pioneers since 1888

WESTON ELECTRICAL INSTRUMENT Co., Ltd.
15, GT. SAFFRON HILL, E.C.1.

Application for free copy of Booklet "Radio Control" from

Name

Address

W.W.D.

WIRELESS WORLD SAID

We take these extracts from the Wireless World's unbiased report on HYDRA Condensers.

Speaking of "Hydra" battery eliminator condensers:—

"The 500-volt A.C. condenser of 2 mfd. capacity . . . was tapped across a number of series-connected high tension batteries. The voltage was steadily increased up to 1,500, and there was no indication of breaking down, which indicates that these condensers can be relied upon as suitable for use in the smoothing circuits of battery eliminators. The stated capacities . . . were accurate to within 6 per cent . . . insulation resistance considerably exceeded the standard of 200 megohms per 1 mfd. specified by the manufacturers."

Again, of "Hydra" high voltage condensers:—

"On test the voltage across the terminals was taken up to 3,000 without breakdown. A useful feature is the provision of an earthing terminal secured to the metal case."



| | D.C. | A.C. |
|--------|------|------|
| 1 mfd. | 29 | 33 |
| 2 mfd. | 39 | 43 |
| 4 mfd. | 6- | 7- |

From all good dealers or direct:—

LOUIS HOLZMANN
109, Kingsway, London, W.C.2.

Telephone: HOLBORN 6209

HYDRA

The **Wireless**
AND RADIO REVIEW **World**

EVERYMAN FOUR

A 36-Page Booklet giving full Constructional Details of a remarkably efficient "Two-Control" Receiver for Long or Short Waves.

By W. JAMES.

The "EVERYMAN FOUR" attracted widespread attention when it was first described in "The Wireless World."

It is a very sensitive set and has a high degree of selectivity. The local station is perfectly received, and during a normal evening at least fifteen different stations may be received clearly at good loud-speaker strength. (Constructors claim up to twenty-eight stations.)

An additional long-wave attachment for Daventry is described in the booklet.

Price 1/- net By post 1/2

From the offices of "THE WIRELESS WORLD,"
Dorset House, Tudor Street, London, E.C.4. w.w.6

EVERYTHING

The
G. E. C.
your guarantee

ELECTRICAL

NEW!



Why the
'GEEKO'

H.T. ACCUMULATOR & CHARGER
FOR D.C. MAINS

is **BETTER**

Running cost varies from only 2/2 a year for a 2-valve set to 6/- a year for a 7-valve set.

One simple switch operation to connect automatically accumulator to set, or to electric light mains for charging.

Interchangeable 20-volt units tapped every two volts which means that any unit can be easily removed for inspection or replacement.

Low initial cost, Mains noises impossible, needs no attention, and is simple, efficient and mistake-proof.

PRICES :

| | |
|----------|----------------|
| | Cat. No. 0.660 |
| 100-volt | .. £6 - 6 - 0 |
| | Cat. No. 0.661 |
| 120-volt | .. £7 - 7 - 0 |

*Exclusive of OSRAM LAMP
for Resistance.*

Sold by all Wireless Dealers.

THE LATEST BOON TO DIRECT CURRENT CONSUMERS

Advt. of The General Electric Co., Ltd., Magnet House, Kingsway, London, W.C.2.

A5 *Advertisements for "The Wireless World" are only accepted from firms we believe to be thoroughly reliable.*

COSSOR

— the

Melody maker

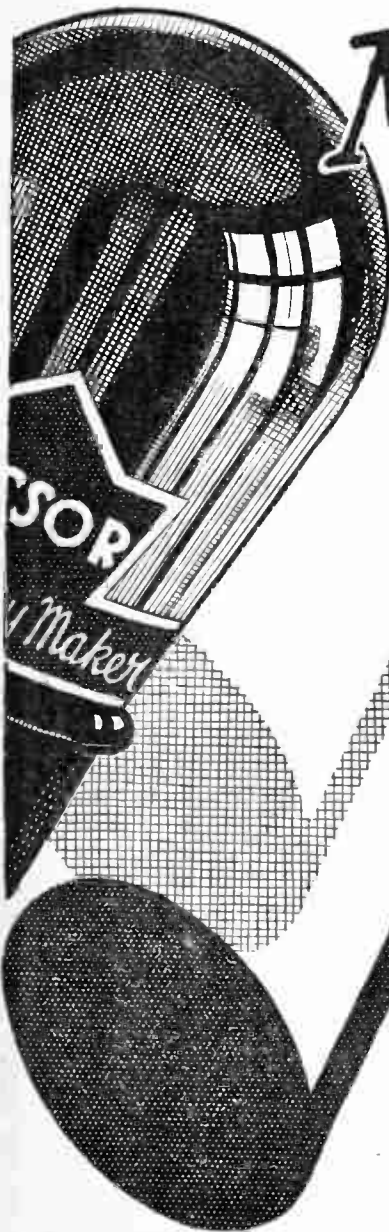

WITHOUT good valves even the best of Receiving Sets will be tongue-tied. Choose your valves with care—choose Cossor Valves, the only valves with the Kalenised filament.

Owing to the powerful emission of its Kalenised filament the Cossor Valve reproduces music that is little short of amazing. But good music is only one feature of the Cossor Valve. Its Kalenised filament is immensely strong. And being absurdly economical in current, too—accumulator charging costs are reduced to a minimum. For pure music, economy of maintenance and long service, choose Cossor Valves—and accept no substitute.

**In 12 Types
for all Sets**

Always demand
the valve with the
Kalenised filament

The Wireless World

AND
RADIO REVIEW
(15th Year of Publication)

No. 412.

WEDNESDAY, JULY 20TH, 1927.

VOL. XXI. No. 3.

Editor : HUGH S. POCKOCK.

Assistant Editor : F. H. HAYNES.

Editorial Offices : 139-40, FLEET STREET, LONDON, E.C.4

Editorial Telephone : City 4011 (3 lines).

Advertising and Publishing Offices : DORSET HOUSE, TUDOR STREET, LONDON, E.C.4.

Telephone : City 2847 (13 lines).

Telegrams : "Ethaworld, Fleet, London."

COVENTRY : Hertford Street.

BIRMINGHAM : Guildhall Buildings, Navigation Street.

MANCHESTER : 199, Deansgate.

Telegrams : "Cyclist Coventry."
Telephone : 5210 Coventry.

Telegrams : "Autopress, Birmingham."
Telephone : 2970 and 2971 Midland.

Telegrams : "1111ff, Manchester."
Telephone : 8970 and 8971 City.

Subscription Rates : Home, 17s. 4d. ; Canada, 17s. 4d. ; other countries abroad, 19s. 6d. per annum.

As many of the circuits and apparatus described in these pages are covered by patents, readers are advised, before making use of them, to satisfy themselves that they would not be infringing patents.

WIRELESS AND THE GRAMOPHONE.

THE announcement that Lord Birkenhead, Secretary of State for India, is to open the new Bombay Broadcasting Station on Saturday next, July 23rd, would come as a surprise to many people until it is realised that Lord Birkenhead will not attend at the station personally, but that his opening speech will be transmitted by means of a gramophone record which is now on its way to India, the speech having been recorded in London.

This announcement reminds us that a development to which we may look forward in the future is the combination of the wireless receiver with the gramophone. Electrical recording has raised the standard of gramophone records to a surprisingly high level, and where electrical reproduction is also employed the quality of speech and music is very close to the real thing and is generally considered equal to the best broadcast reproduction. In reproduction by electrical means we require the gramophone turntable, an electrical pick-up device to take the place of the ordinary gramophone sound-box, and beyond this the amplifier of the wireless set and the loud-speaker provide all that is required.

Already there are several manufacturers in America who market a combined instrument, and these are now becoming available also in this country, whilst the use of loud-speakers, which were primarily designed for broadcasting purposes, in connection with up-to-date gramophones is another example showing how closely the technical development of the two instruments is associated.

The more perfect the design of the loud-speaker and the amplifier, the better will be the reproduction from the records, and so when we have built or purchased the best in wireless sets we have also the best in gramophone reproduction equipment at our disposal. It would, of course, be quite absurd to suggest for one moment that

the functions of the gramophone and wireless are closely identified; they undoubtedly serve two very different objects. In the one case we are hearing the spoken word or music first-hand, whereas in the other we have available for our enjoyment what we may compare to a library of our own, choosing music which we can play over and over again, but in the case of broadcasting we are confined to what is provided for us.

In process of time we believe that the functions of broadcasting and the gramophone will tend to become even more distinct, for at present many of the programme items broadcast are little better than padding of a kind which must, of necessity, be eliminated as more useful channels for broadcasting material are opened up. There is a great deal of profitable and interesting experiment waiting to be carried out in connection with electrical reproduction from gramophone records, particularly in the design of non-resonant pick-up devices where the problems involved may be compared with those of loud-speaker design although differing in certain essentials. In this journal we have from time to time published interesting articles dealing with different aspects of this subject, and in this issue a further brief article of practical interest is included.

o o o o

SHORT-WAVE TRANSMISSION.

AS we go to press we learn that there is every probability that the Post Office will not stand in the way of granting the necessary permission to Mr. Marcuse to conduct short-wave broadcast transmissions on the lines indicated in this journal last week, but the Post Office, of course, will accept no responsibility for any difficulties which may arise as between Mr. Marcuse and the B.B.C. on questions of copyright. We understand that for the purpose of his experiments Mr. Marcuse proposes to act independently of the B.B.C., and it seems likely that quite a good programme will be forthcoming from voluntary amateur talent, sufficient, at any rate, for the purpose of these experiments.

GRAMOPHONE PICK-UP DEVICES.

The Comparison of Loud-speakers with the Aid of the Gramophone.

By G. W. SUTTON, B.Sc.

IN the present article it is proposed to describe a simple but reasonably satisfactory method of comparing the merits of different loud-speakers or of investigating the effect of alterations in the design of component parts of a loud-speaker with the aid of a good modern gramophone and "electrically-recorded" records.

Although the methods which have been developed for analysing the performance of loud-speakers, such, for instance, as the use of the Rayleigh disc, do not call for so much expensive or complicated apparatus as to put them beyond the reach of the serious amateur experimenter, they necessitate the expenditure of a great deal of time and careful work in setting-up and calibration. There is still value, in any case, in the careful comparison of one loud-speaker with another by ear. And it should be borne in mind that the ear—or, at least, the ear of a friendly musician—is the ultimate criterion. If one is not fortunate enough to possess such a friend as part of one's experimental equipment, remarkable improvement in one's own musical appreciation may be relied upon as the work progresses. Experimenters familiar with the use of headphones in A.C. bridge measurements will agree that the normal ear can be trained in a few hours of work to detect and compare sounds which originally were scarcely audible.

If one instrument is used as standard, though its own

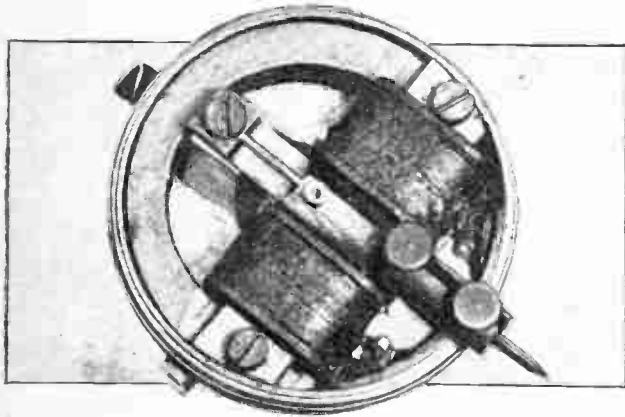

Brown earpiece modified for use as a gramophone pick-up.

performance may not be above reproach, it is possible to determine the effect of changes in design of a second one which is under construction or alteration. Certain precautions must, however, be taken. The sound outputs must be as nearly equal as possible. This calls for some considerable and rapid control in the amplifier, such as a tapped grid-leak. It must be arranged, also, to switch from one instrument to the other with greatest rapidity and ease while the observer remains in the same position relatively to the loud-speakers. Finally the instruments must be placed as close together as possible and, if of

the horn-type, must point in the same direction. By this means the effect of room echo is rendered as constant as possible.

Even under these conditions the only type of reproduction which it is possible to deal with satisfactorily is that of speech, if the local broadcast transmission is relied upon for the input. A long educational talk, read out in uniform tones, is of great value in this respect.

With broadcast music the rapid changes in volume and pitch render comparison rather tedious and irritating. The writer has, in the past, nevertheless found it possible

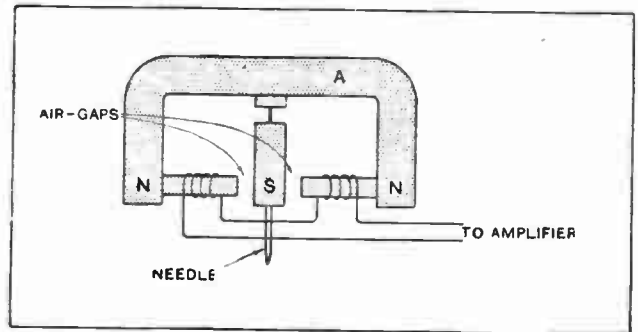

Fig. 1.—Diagrammatic representation of the pick-up used by the B.B.C.

to determine the best point of attachment of a paper-cone to a vibrating reed, the correct degree of rigidity in the diaphragm, the effect of excessive damping, and so on. But it is of great assistance to be able to employ a particular instrument, such as the bassoon or drum, playing one particular passage in an identical manner over and over again.

The use of the gramophone for this purpose was suggested to the writer by an article by Mr. Denman¹, and by the almost simultaneous appearance of some new records illustrating the instruments of the orchestra. In the latter a representative passage is played by each of the more important instruments in turn, ranging from the drums and bassoon to the flute.

The first requisite for the scheme is a satisfactory "pick-up." From its early days the B.B.C. has employed a piece of apparatus for converting the mechanical vibrations on a gramophone record directly into electrical vibrations which could be applied to the amplifier and transmitter; more recently this has received further careful attention.² The general principle of this pick-up is illustrated in Fig. 1. In this a permanent magnet A is carried by a lever replacing, and capable of movement like, the usual tone-arm of the gramophone. The needle rests in the groove of the record and, when set in vibration by it, alters the length of the air-gaps on either side

¹ *The Wireless World*, January 26th, 1927.

² *Loc. cit.*

Gramophone Pick-up Devices.—

of the armature S. The armature is attached by a fairly stiff steel strip to the centre of the permanent magnet at the point where there are consequent S poles. By this means the flux through the windings on the projecting poles is made to fluctuate and so to induce corresponding voltages in the coils.

Before either buying such an instrument or embarking on the lengthy task of designing and constructing one, the

purpose, is further decreased by the additional mass. The ill-effects are not so prominent as might be expected, however.

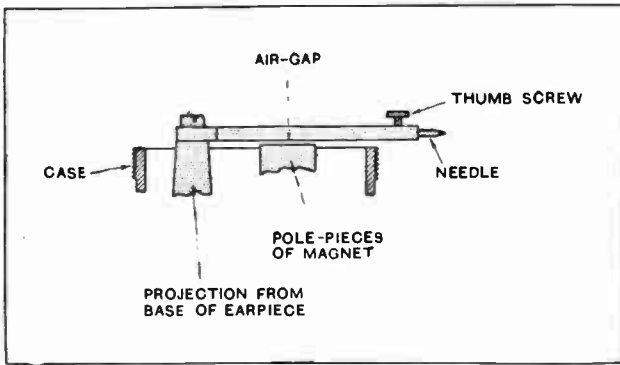

Fig. 2.—Specially constructed reed for telephone earpiece.

writer decided to attempt to adapt an ordinary type "A" Brown earpiece. It was encouraging to discover at the outset that the adjusting knob of this receiver exactly fits into the tubular projection on an ordinary gramophone tone-arm in the place of the sound-box, and in that position the reed is conveniently situated with respect to the record. The ebonite cover and aluminium cone of the earpiece is, of course, removed. For the best results the reed of the earpiece should then be replaced by a suitably shaped mild-steel bar of about twice its length drilled at its free end to carry a needle (see Fig. 2).

By fitting an ordinary wire connector of the smallest size commonly used to the reed itself, a substitute for the above may be quite quickly arranged (see Fig. 3).

The small projection *a* is gripped firmly between one thumbscrew and a grub-screw *b* inserted in line with it from below. If the connector is forced firmly against the end of the reed while these screws are being tightened with pliers and screwdriver, the resulting mechanical joint is

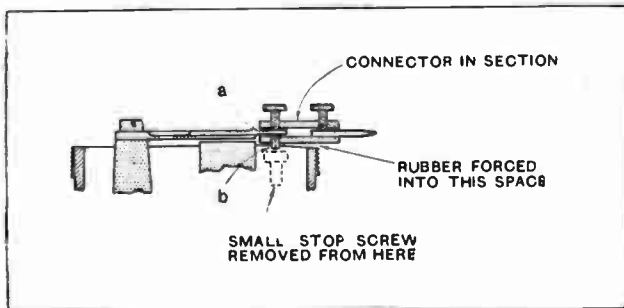

Fig. 3.—Method of adapting Brown reed to carry gramophone needle.

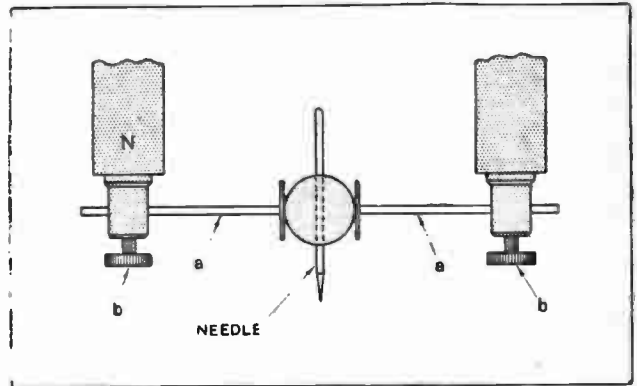

Fig. 4.—Damping device for use with the pick-up in Fig. 1.

In order to render this type of instrument satisfactory very heavy damping is required. In the particular case illustrated in Fig. 1 this is achieved by thrusting the needle through a small block of indiarubber (Fig. 4) and clamping this rubber quite tightly between the projecting rods. These are fixed in position by thumbscrews *b* when the requisite position of and pressure on the needle has been found.

In the earpiece pick-up the edge of the aluminium case is filed away a little between the projecting connector, and a block of rubber is forced quite firmly into the space.

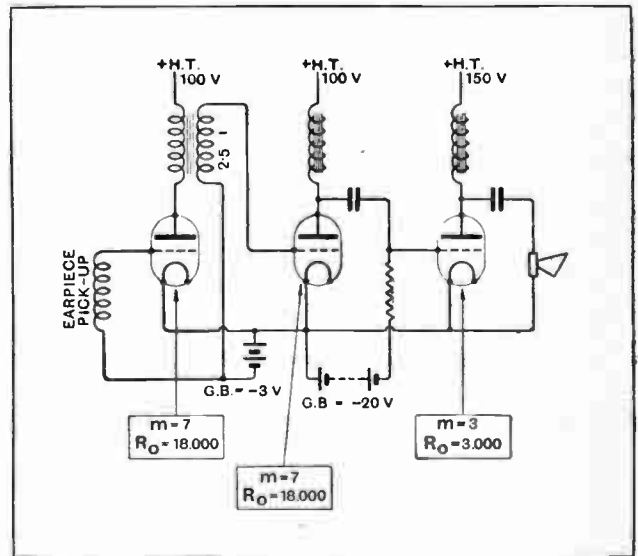

Fig. 5.—Amplifier circuit suitable for use with the earpiece pick-up device.

The degree of damping required can only be ascertained by experiment. If insufficient, a shrill vibration will be set up by sudden loud notes of almost any pitch, and, of course, by the occurrence in the music of a note of the same pitch as the vibration.

The tendency to this vibration is very much reduced

Gramophone Pick-up Devices.—

by using a "soft" gramophone needle, and with a two-stage amplifier sufficient output will then be obtained. The circuit arrangement which the writer has found to be satisfactory is shown in Fig. 5. Suggested values of H.T. and grid bias are indicated, also the approximate A.C. resistance and amplification factor of suitable valves.

Best Point of Attachment for Diaphragm.

As an example of the type of constructional problem which may be solved by use of the above method the following may prove interesting. In attaching a large conical loud-speaker paper-diaphragm to the vibrating reed which is intended to operate it, it is important to select the correct point of attachment. The problem is equivalent to that of providing an "acoustical transformer," or horn and flare, of the correct step-down ratio, to a horn-type instrument, or of connecting the crystal rectifier and telephones across a certain fraction of the aerial tuning coil. In other words, it is a matter of matching the resistance effect of the load to that of the generator.

It is well known in the case of the crystal rectifier that output and position of the tapping point are related in the manner shown in Fig. 6. Not only is the output greatest at the point *a*, where the equivalent impedance of the rectifying circuit is equal to that of the aerial circuit, but the damping is less than when the *n*th tap is used.

A similar effect may be expected when the point of attachment of the cone to the reed is moved further from the fulcrum of the latter. The best position could be determined by a series of measurements of the impedance of the telephone measured from the electrical side, but the problem may be solved with sufficient accuracy for practical purposes by drilling and tapping a row of small holes in the back of the reed and screwing the cone attachment into each in turn. The loud-speaker is com-

pared, in the manner indicated above, with some "standard" instrument with the cone screwed successively into the different holes.

It is found that the reproduction increases in "brilli-

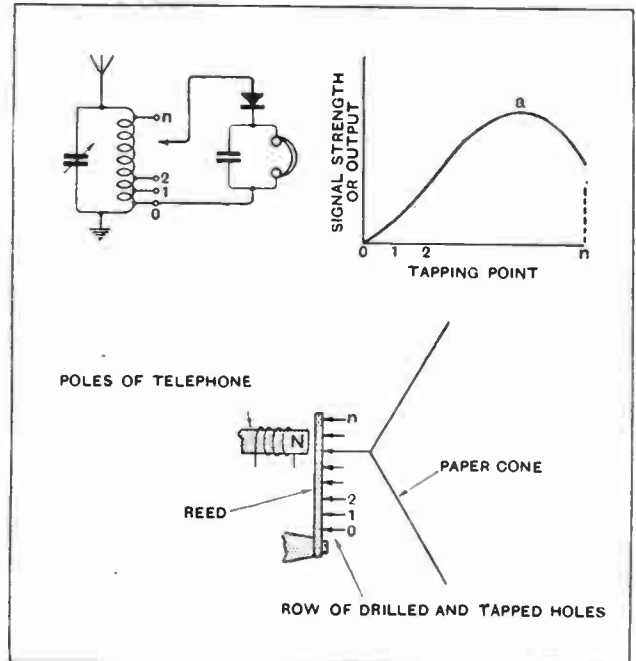

Fig. 6.—Experimental determination of the best point of attachment of a loud-speaker cone. The case is analogous to the determination of the best tapping point on the aerial circuit inductance for a crystal detector.

ancy" and loudness as the cone is moved further down the reed from the tip, but if carried too far a pronounced resonance frequency becomes apparent.

NOVELTIES FROM OUR READERS.

INSULATED SCREW-DRIVER.

Should it be necessary to make an adjustment in the interior of a set by means of a screw-driver, there is every possibility of a short circuit

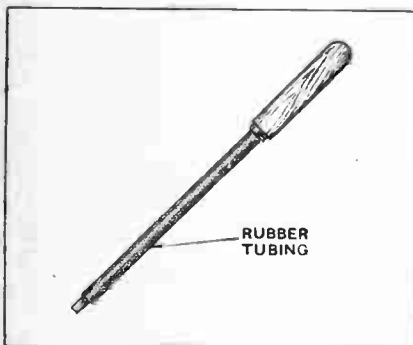

Insulated screw-driver for making adjustments in the interior of a set.

occurring through inadvertently leaving the H.T. battery connected to the set.

To avoid this possibility, the screw-driver should be covered by a length of thin walled rubber tubing, as shown in the diagram, which will effectually insulate it from contact with the wiring of the set.—W. B.

o o o o

WANDER PLUG CONNECTION.

The difficulty of making wander plug connections to H.T. batteries consisting of pocket-lamp batteries connected in series is considerably reduced if the method shown in the diagram is adopted.

The long positive contact strips are doubled back and holes drilled through both sides, the size of the

hole being an accurate fit for the wander plug. When inserting the plug the sides of the strip should be pressed together and released with the

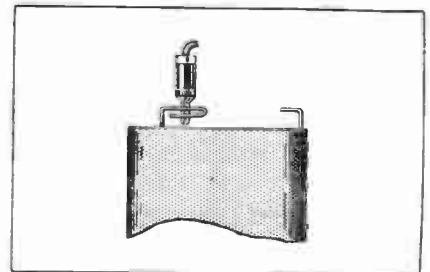

Wander plug connections to flash lamp H.T. batteries.

plug in position, when the spring action of the strip will ensure a sound electrical contact.—P. T. A. R.

5GB DAVENTRY JUNIOR

Technical Details of the New High-power Transmitter.

By H. L. KIRKE.

THE principle of operation of 5GB is modulation at low power with subsequent high-frequency amplification. Fig. 1 shows the general arrangement of the circuits. Fig. 2 shows the control room, which also contains the master oscillator and separator.

The speech amplifier is shown on the extreme right with the metal front (for screening) removed; next to it is the line corrector, in front of which is the volume control. Further left is the input switchboard and microphone amplifier for local talking. On the left-hand bench the master oscillator is on the right, the separator on the left. The circuits are very similar except that the master oscillator is made to oscillate at very constant frequency; the separator is arranged to take no load from the master oscillator, so that whatever happens after the separator valve cannot affect the master oscillator.

The Main Transmitter.

Fig. 3 shows the main transmitting room. The circuits are arranged in the same order as in Fig. 1, except for the rectifier valve panel.

On the extreme left is the modulated amplifier (the valve is shown at the bottom of the panel), with its output circuits on the left. The modulator valves and sub-modulator valve are arranged above the modulated amplifier.

The panel immediately to the right of the door is the first power amplifier, using one water-cooled valve capable of handling up to 12 kW. if necessary; the normal input power is, however, only 4 kW. The output circuits of this stage are shown on the left of the panel. The tuning control (a car steering wheel) is shown projecting to the front.

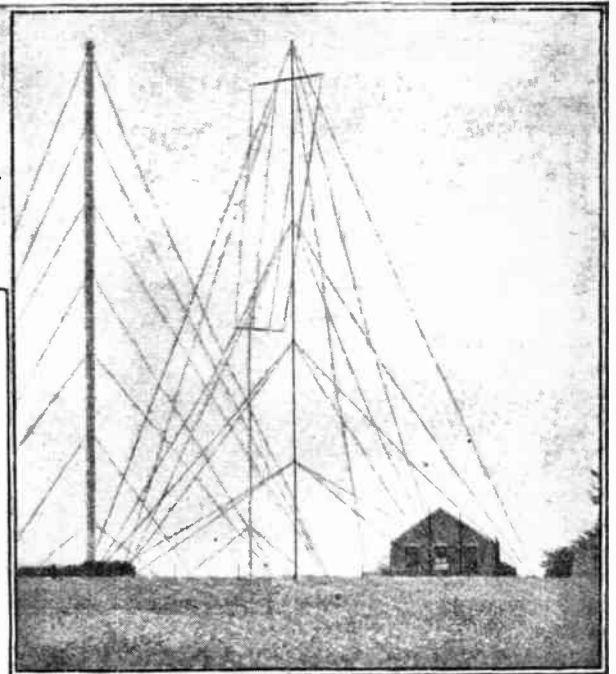

The panel on the immediate right of the first power amplifier contains six water-cooled rectifying valves of the same type as used at 5XX. Power is taken from the mains (three-phase) stepped up to 10,000 volts by the main transformer shown in the photograph on the front cover at the back of the rectifier panel and rectified by the six rectifying valves (two per phase, full-wave rectification). The smoothing chokes are at the back of the power transformer.

The main power amplifier is shown on the extreme right of Fig. 3. This consists at present of four water-cooled valves each capable of dissipating 8 kW. at the anode. The total normal maximum input is 12 kW. per valve at an efficiency of 33 per cent. The efficiency cannot be increased beyond this amount without sacrificing percentage modulation or quality. The two sector-type meters (Fig. 3) in front of the main closed circuit inductance (on the left of the main power amplifier) are for measuring the high-frequency voltages at the grids and anodes of the main power valves to ensure correct working conditions.

The closed-circuit condenser is shown at the back of the main power amplifier. It is an air condenser with plates hung from an iron framework.

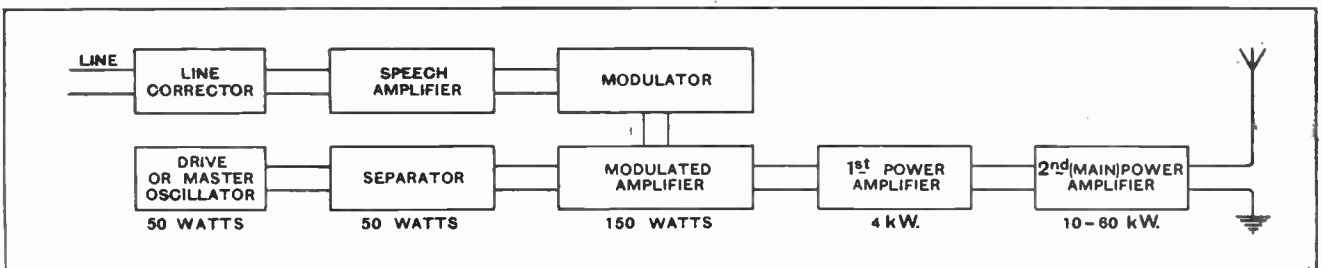

Fig. 1.—Schematic diagram showing layout of units in the transmitter.

Daventry Junior.—

The water pipes for supplying the cooling water to the anodes are shown immediately behind the main power valves. Water is supplied at four gallons per minute per valve; the total leak through the water supply is 50 milliamperes at 10,000 volts.

At the extreme end of the transmitting room, as seen in the cover picture, is the main D.C. switchboard; the high-tension cubicle is on the left, the L.T. (filament) switchboard on the right, and charging in the centre. The filament current is supplied by a 20-30 volt D.C. generator having a maximum output of 400 amperes. High-tension power can also be supplied by a 45 kW., 10,000 volt, D.C. generator (not shown), this being parallel with the rectified A.C. supply when necessary. The two different supplies were put in for experimental purposes.

On the extreme right of the photograph on the cover is the switchboard for the rectified A.C. supply.

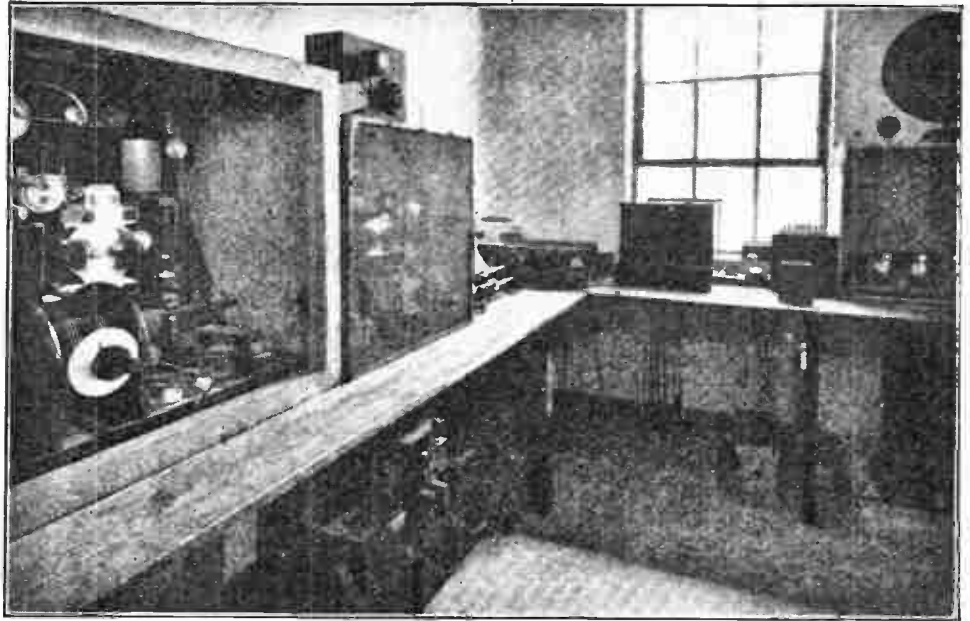

Fig. 2.—A corner of the control room. On the extreme left is the separator valve and circuits, and next to it, behind a gauze screen, is the master oscillator.

The photograph in the title of this article shows the aerial at present in use at 5GB, together with one of the 5XX masts. The aerial consists of a four-wire flat top with a 4in. cage down-lead supported on two roof masts.

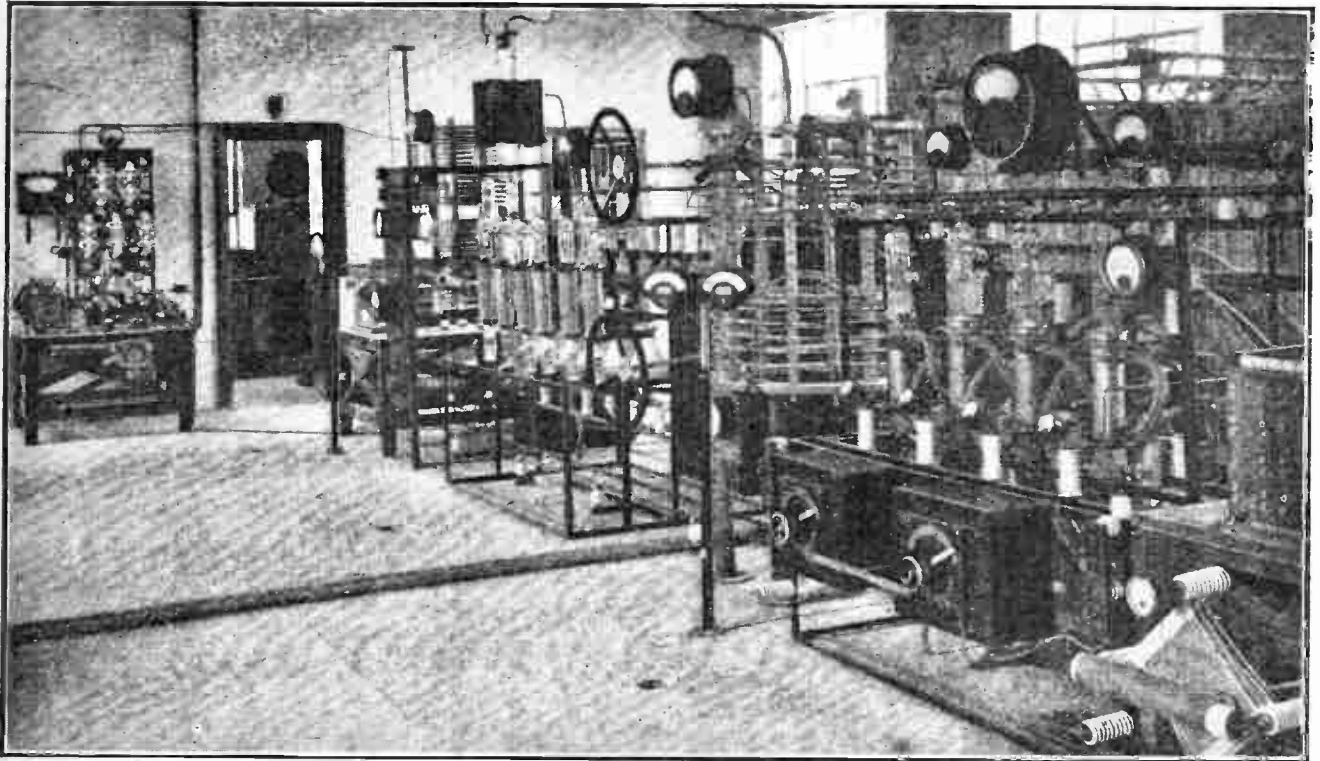
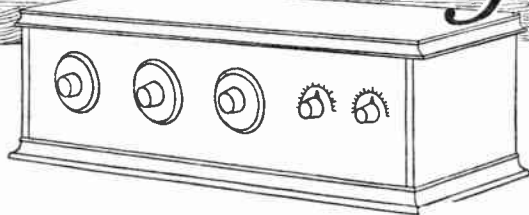

Fig. 3.—General view of the main transmitting room, showing on the right the final stage of the power amplifier, in the centre the six-phase rectifier, and on the left the modulated amplifier and sub-modulator valves.

PRACTICAL
HINTS AND TIPS



Aids to Better
Reception.

Theoretical Diagrams
Simplified.

H.F. TRANSFORMER CONSTRUCTION.

THE "Everyman Four" type of H.F. transformer is becoming increasingly popular, with the result that one sees from time to time attempts to construct such articles with materials other than those originally specified.

While it may be possible for an expert to deviate from the original specification without untoward effects, the chances are that any change will be accompanied by some diminution in efficiency.

As an instance, there is a temptation to use a larger gauge wire than the 40 S.W.G. specified for the primary and neutralising windings because of the mechanical weakness of such a small wire. There is, however, a very good reason for using the size specified, as the designer of the transformer found that electrostatic coupling, as distinct from electromagnetic coupling, between the windings, tended to reduce the step-up obtained from the transformer, and also made it more difficult to obtain a setting of the neutralising condenser which would hold throughout the tuning range of the receiver. As a very tight magnetic coupling between the windings is essential, it is impossible to space them widely, so that the only remaining way to overcome electrostatic troubles was to reduce the size of the wire used where possible to the smallest practical limit.

o o o o

THE RUNNING HALYARD.

THERE are two principal methods of attaching an aerial to its pole, these being shown in Figs. 1 (a) and 1 (b).

In Fig. 1 (a) the aerial is joined by an insulator to a piece of rope or

flexible wire which passes through a pulley, and so to the base of the pole. Raising and lowering the aerial is performed by pulling upon or slackening off the rope.

In Fig. 1 (b) a short piece of rope and an insulator join the aerial to a continuous loop (known as a running halyard) of rope (or wire) passing through a pulley at the top of the pole and reaching to the ground. Raising and lowering are now done by pulling on one or other of the two ropes forming the loop.

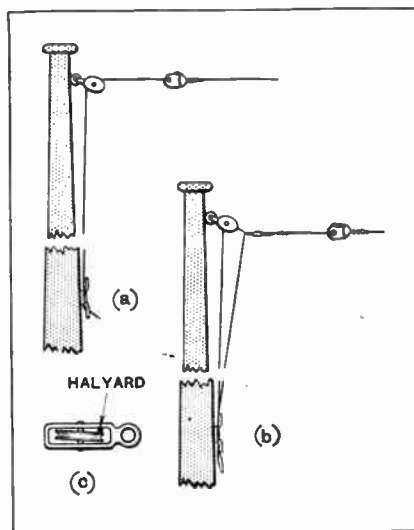

Fig. 1.—Showing alternative arrangements for aerial suspension; (a) single halyard; (b) double or running halyard.

The superiority of the second method will be apparent when the cases of a broken aerial wire or a stiff pulley are considered. In both instances it will be possible to pull the insulator down to the ground, whereas in the first arrangement it will be necessary to reach to the top of the

pole by some means to recover the insulator and so to replace the aerial.

While on the subject of aerial equipment, a word might be said about pulleys. These should, of course, be rust-proof and non-corrosive, and therefore made of brass or heavily galvanised iron. It is of the utmost importance to ensure that the rope or wire passing through the pulley block cannot become wedged between the wheel and the block as shown in Fig. 1 (c). This fault is by no means uncommon when roughly finished cast parts have been used in the construction of the block or if unduly fine rope is employed.

If the class of wire consisting for the most part of steel strands covered by a light insulation (ex-Government field telephone wire) is used instead of rope, it is important to see that the steel strands are not exposed to the atmosphere owing to damage of the insulation, as they will very rapidly rust through and let the aerial down.

o o o o

H.F. FOR SELECTIVITY.

ALTHOUGH high-frequency amplification is primarily intended for the magnification of weak incoming signals, it must not be forgotten that it has another most important function: namely, the increasing of the selectivity of a receiver. In many instances it is possible to obtain sufficient sensitivity for the desired reception by using a detector valve with reaction, and probably with an L.F. amplifier, but such a receiver will always be inferior, from the point of view of selectivity, to one which includes a stage or two of even moderately effective tuned H.F. amplification.

NEGATIVE BIAS AND VOLUME.

POPULAR opinion as to the requirements of the last valve of a receiver in the way of negative grid bias is apparently so variable that a word or two might be written on the subject with advantage.

The actual power output required from the set obviously varies with the type of loud-speaker in use and the size of the room to be filled. Many small horn types of loud-speaker, which amount to little more than a headphone fitted to a trumpet and standing, say, 12 in. high overall, undoubtedly develop nearly all their energy within a frequency band from between 1,000 to 2,000 cycles per second, which band happens to coincide with the pitch of notes to which our ears are most sensitive. As a consequence, comparatively little input to such a loud-speaker goes a very long way—in more senses than one.

Adequate input for such an instrument may be supplied by a semi-power valve biased to $-4\frac{1}{2}$ volts, and with, say, 90 volts H.T.

Next come the large domestic horn type loud-speakers which, while not giving appreciably more bass than the small instruments, sound better because their output is not confined to such a narrow frequency band. These may be worked with a power valve biased to -9 or more, with 120-150 volts on the anode. As a general rule these instruments must not be pushed much beyond the limits provided by the foregoing suggestions if the best quality of which they are capable is to be obtained.

The reed-driven cone type of loud-speaker is better able to deal with low notes than the domestic horn type instrument, and as it has a fairly even response (*i.e.*, it does not accentuate those notes which "carry" unduly), it may be allowed to handle an even greater output. Probably their effective limit is reached when driven by a super-power valve (*e.g.* D.E.5A), biased to -27 volts with 150 to 200 anode volts. Some of the smaller mechanisms to be found in this class of cone will probably have developed rattle before this limit has been reached. Individual specimens of the same pattern differ appreciably in respect to the amount of power they will handle before rattling.

Finally, we have the coil-driven, inertia-controlled, free-edged cone

with baffle, which is capable of handling almost unlimited power. Because of its very even response it has little or no more carrying power than the original sound which it is reproducing, and may therefore be worked to give approximately the original intensity of sound when required. Furthermore, unless certain compensations are made within the amplifier, such instruments should not be worked *too* quietly, as a thin, high-pitched result, similar to listening to the original at a great distance, is likely to be obtained. It will be found that the minimum satisfactory input to such loud-speakers is provided by one super-power valve (*e.g.* D.E.5A) biased to -27 volts and having 150-200 anode volts.

The above recommendations are for an average sized room in a modern house, equipped with an average amount of furniture.

o o o o

TUNED OR UNTUNED.

MANY of the advantages of both the tuned and aperiodic aerial coupling systems may be obtained by using the arrangement of Fig. 2. If the aerial lead-in is

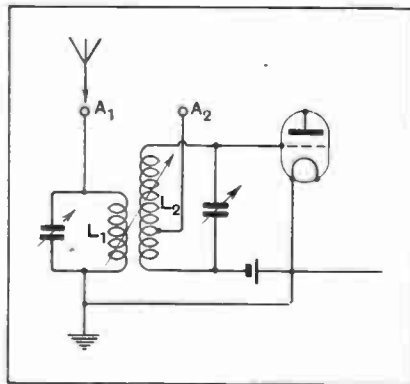

Fig. 2.—Alternative tuned or aperiodic aerial coupling. L_1 and L_2 are the aerial and secondary coils respectively.

joined to the A_1 terminal, we have the conventional loosely coupled and separately tuned circuit; by transferring this connection to A_2 and swinging clear the aerial coil, we have a simple auto-transformer, and at the same time we eliminate the third tuning control, which is, of course, the one and only disadvantage of the two-circuit tuner.

The tapping to which the A_2 terminal is joined should be made to a

point which will include very roughly one-fifth of the total number of turns in the aerial circuit. As usual, its exact position should be determined by trial, as aerial characteristics will determine the optimum inductance.

It is a matter of some little difficulty to tap an ordinary plug-in coil, but in many cases it is possible to make a connection to the junction point between two adjacent layers. The matter is, of course, simplified if a cylindrical secondary coil is used.

o o o o

INITIAL ADJUSTMENTS

IT is seldom that a newly constructed receiver does not require a number of initial adjustments before it can be considered as satisfactory, and a few hints may be of value to the less-experienced reader who finds himself at a loss to know where to start operations. This applies to even the simplest type of set, and, of course, the number of variables is increased with the number of valves and tuning adjustments. If we consider a typical four-valve receiver, comprising a neutralised H.F. amplifier, detector, and two stages of low-frequency amplification, it will be seen that the filament voltage of each valve, the H.T. voltage, grid bias for the detector and both I.F. amplifiers, the neutralising capacity, the tuning of two or even three circuits, and a few more minor adjustments must be more or less correct before signals can be heard. Admittedly, a number of these settings may be determined with some accuracy (particularly if measuring instruments are available) from the data supplied in constructional articles and by valve manufacturers, but there are others which can only be determined by trial.

The beginner is strongly advised to concentrate on one point at a time. For instance, in the type of receiver under consideration, it will be assumed that signals of a kind are heard—they certainly should be, even if a number of small faults exist. The first operation should be to neutralise the H.F. valve, and before doing so, of course, the signal is tuned in to maximum strength, when self-oscillation will normally be produced. Although the set will now be stable, provided there is no serious

fault in the H.F. transformer or its associated apparatus, quality of reproduction may possibly be poor, but this can be ignored for the present, and our attention should next be concentrated on the detector, the grid bias of which should be carefully adjusted, assuming that the popular anode bend rectifying circuit is used. It should be remembered that the best voltage is most easily ascertained when incoming signals are weak.

Provided that our receiver, up to and including the detector, is now

working fairly satisfactorily, we may proceed to the next stage, and adjust the grid bias, H.T. voltage, and filament brilliancy of the L.F. amplifying valves, at the same time paying attention to any other variables which may be included in this part of the circuit. Having proceeded so far, it is as well to return to the input (*i.e.*, the aerial end) of the receiver and to go over the same ground again, paying greater attention to details, and assuring ourselves that the set is really stable over the whole tuning

range, with the weakest aerial coupling it is possible to obtain, or even with the aerial load completely removed.

While the subject is one which can hardly be dealt with adequately, except from a specific viewpoint, the hints given above are applicable to such recent *Wireless World* receivers as the "Everyman Four," the "All-Wave Four," and the "Motorist's Portable," and they should suggest methods of procedure for dealing with almost any circuit.

DISSECTED DIAGRAMS.

Practical Points in Design and Construction.

No. 75 (a).—A Crystal Receiver.

(Concluded from last week's issue.)

The present series of diagrams is intended to show progressively, and in an easily understandable manner, the various points to which special attention should be paid, and at the same time to assist the beginner in mastering the very necessary art of reading theoretical circuit diagrams. Under the projected regional scheme, high selectivity will, in some instances, be necessary even in a crystal set. Below are shown methods whereby the simple receiver shown in (4) of last week's issue may be improved.

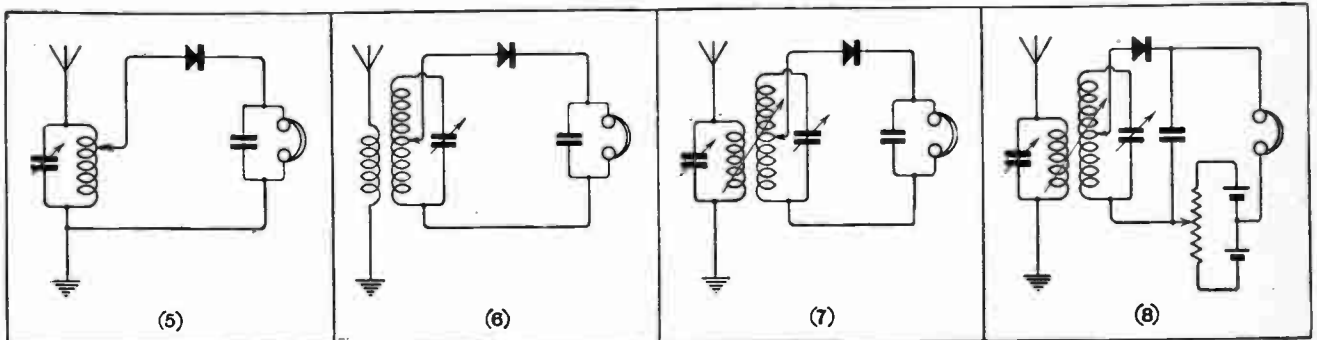

Damping is reduced by connecting the crystal and telephones across a part only of the total inductance.

Similarly, aerial damping is reduced by loose coupling. This is the so-called "aperiodic" or "untuned" method.

A variably-coupled aerial arrangement. The aerial circuit is tuned, and its coil is movable with respect to the secondary.

A similar circuit, suitable for a crystal such as carborundum, which requires a steady applied voltage.

THE circuit shown in (5) is a distinct improvement over (4), but it will not be highly selective, as there is still fairly heavy aerial damping. The best tapping point for the crystal will depend on its effective resistance, and it is only to be found by trial; with treated galena, this will generally be below the centre point. Generally speaking, a coil with some half dozen tapings should be used. This applies also to the circuits which follow.

The "untuned aerial" arrangement is a distinct improvement from the point of view of selectivity, although it is rather lacking in flexibility. For the 250-500-metre waveband, the secondary of the

coupler may have 70 turns of No. 26 D.S.C. wire on a former of 3in. diameter. The primary is wound over the low potential end of this winding (that connected to phones), and may have from 10 to 15 turns of fine wire; these should be spaced both with respect to each other and the secondary.

The circuit shown in (7) represents what is probably the best possible arrangement. The aerial coil may be of the plug-in type, with 35 to 50 turns, depending on aerial capacity and the wavelength to be received. This is variably coupled to the low-potential end of the secondary, which may comprise a coil as discussed in connection with (5)

above. For the Daventry wavelength these inductances may have respectively about 150 and 250 turns.

Carborundum crystals almost invariably require a small biasing voltage (generally from $\frac{1}{4}$ to $\frac{3}{4}$ volt) for best operation. This may most easily be applied with the help of a potentiometer of some 200 to 400 ohms and two dry cells connected as in (8). It is convenient to include a switch in series with the battery, in order that current may not be wasted when the receiver is out of use.

In all these circuits, it is suggested that a 0.0005 mfd. condenser should be used in the aerial circuit, with a 0.0003 or 0.0005 mfd. for tuning the secondary.

NEWS FROM THE CLUBS

Secretaries of Local Clubs are invited to send in for publication club news of general interest.

All photographs published will be paid for.

Tottenham Field Day Postponed.

The next Field Day of the Tottenham Wireless Society will be held on July 24th, this event having been postponed one week to enable the members to compete in the direction-finding scheme organised by the Golders Green Society.

Transmitters' Nights.

The Tottenham Wireless Society, in preparing a syllabus for the next winter session, has decided to devote one evening a month to transmission problems.

Technical Terms.

Many difficulties connected with the vast number of technical terms employed in wireless were elucidated by Mr. F. E. R. Neale in a recent lecture before the Tottenham Wireless Society. The lecturer dealt with many terms which may still be regarded as ambiguous, and many of the points raised will doubtless suggest subjects for future lectures and study.

Hon. Secretary, Mr. A. G. Tucker, 42, Drayton Road, Tottenham, N.17.

Growing Membership: New Premises.

That there are advantages in holding regular meetings during summer months has been proved by the Stretford and District Radio Society, which records a growing membership as a result of this practice. The present membership exceeds 80, and this has necessitated the removal to larger premises at 6a, Derbyshire Lane, where there is accommodation for an attendance at meetings of at least 60, together with an improved workshop.

The Society was represented in the Stretford Pageant by a decorated lorry, and, by the kindness of a member, Mr. Palin, a demonstration was given at the pageant of an improved model of the Panotrope.

Hon. Secretary, Mr. W. Hardingham, 21, Brnleigh Road, Stretford.

Sheffield Society Defies the Weather.

In spite of thunderstorms and torrential downpours the annual Field Day of the Sheffield and District Wireless Society was held on Sunday, June 26th, the full programme being successfully carried out. In view of last year's successful experiments in direction-finding using a fixed transmitter and three mobile D.F. stations, it was decided to launch out this year on a more ambitious programme and with the co-operation of the Leeds Wireless Society to establish four D.F. stations (two supplied by each society) at fixed points on the corners of a rectangle enclosing an area of approximately 190 square miles, in which a mobile transmitting station would operate from four separate points. The two D.F. stations of the Leeds Society were situated at Hollingthorpe and Womersley respectively, while Sheffield's D.F. groups were stationed at Sprotborough and Penistone.

Honours Divided.

The transmitter was conveyed in two motor cars and consisted of a loose-coupled Hartley circuit tuned to 195 metres, the H.T. being supplied from

an M-I, anode converter kindly lent by Messrs. The M-L Magneto Syndicate Co. C.W. morse transmissions of ten minutes' duration were sent from each of four previously selected points. Four bearings were taken by each D.F. station with the exception of Womersley (the third bearing was spoilt by the soaking of the frame aerial) and carefully marked on the maps supplied. When the parties, numbering 43 members, joined forces at

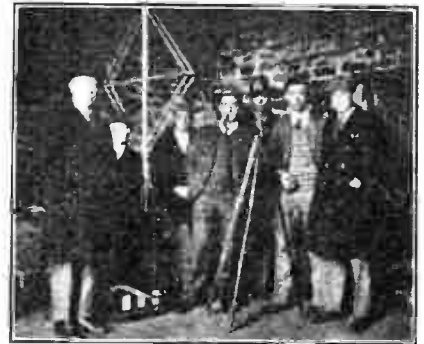

A PARTY OF SLEUTHS. A D.F. group, under Mr. Jakeman's direction, which participated in the Sheffield-Leeds field day.

Barnsley for tea, the comparison of notes showed that honours were evenly divided between the two societies. Sheffield's bearings were nearest the transmitting points 2 and 3, while Leeds were nearer the mark in regard to points 1 and 4.

Greatest enthusiasm was shown by all members despite the unpleasant weather conditions, which prevailed during the greater part of the day.

Manchester Society's Field Day.

Although special arrangements had been made in anticipation of bad weather, the Radio Experimental Society of Manchester enjoyed perfect climatic conditions for their first Field Day this year, held on July 2nd. The party set up headquarters at Nicholl's Farm, near Mottram, and two stations were speedily erected, one at the farm and another on Coomb's Edge. Excellent results were obtained. The Society's transmitter 2FZ was also working from Salford between 4 and 5 p.m. Much of the information obtained will be useful to members when the Society holds its next field day in September.

Hon. Secretary, Mr. J. Levy, 19, Lansdowne Road, West Didsbury.



A SHEFFIELD-LEEDS FIELD DAY. A direction-finding competition between the Sheffield and Leeds Wireless Societies was the feature of a recent field day described on this page. The photograph shows members of the two societies at Barnsley.

The Experimenter's Notebook

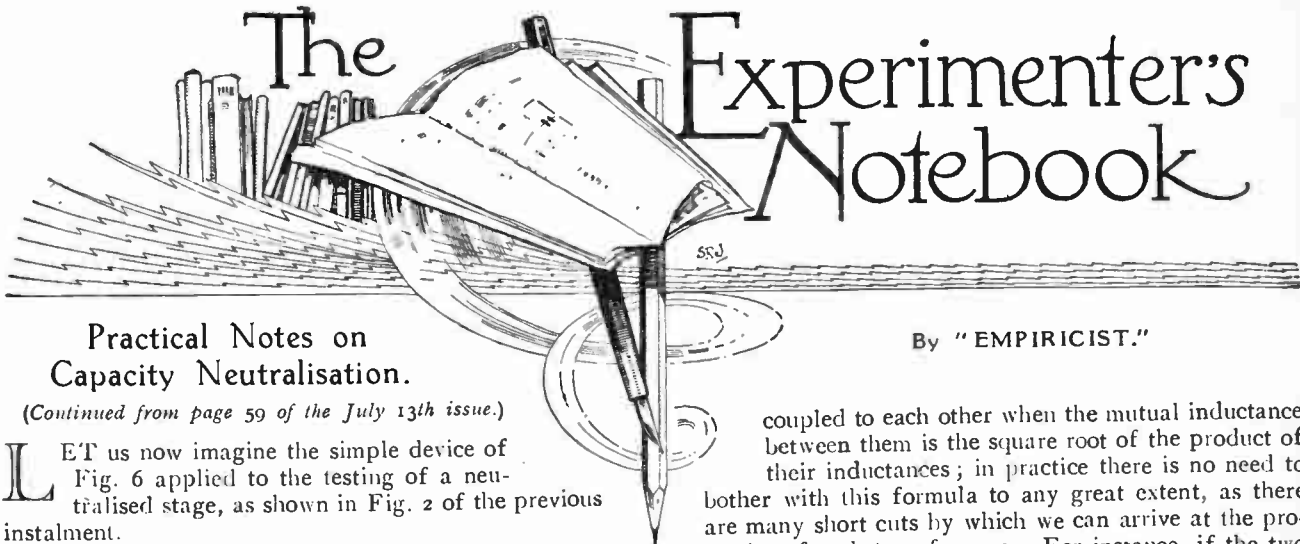

Practical Notes on Capacity Neutralisation.

By "EMPIRICIST."

(Continued from page 59 of the July 13th issue.)

LET us now imagine the simple device of Fig. 6 applied to the testing of a neutralised stage, as shown in Fig. 2 of the previous instalment.

The first point to consider is whether there is a combination of capacitive and magnetic coupling between the input and output circuits or whether only capacitive coupling exists. If there is a mixture of the two we shall expect to find a position of balance on the neutralising condenser, but one which will vary at different waves, becoming more and more widely variable at the top of the condenser scale but settling down to a more or less constant value at the bottom.

If we set up the testing device as previously described and try out the neutralisation at different settings of the two condensers, it is possible to find out what is the state of affairs in this respect and if necessary to adjust the relative positions of the coils until neutralisation is obtained up and down the scale of wavelengths for the same position of the neutralising condenser.

There is, however, another source of trouble in neutralisation which originates in the neutralising circuit itself. This also gives rise to a systematic shift in the setting of the neutralising condenser, but this time at the lower wavelengths. Fig. 7 will make this point clear. Here L_2 and L'_2 constitute as before the plate and neutralising windings of the high-frequency transformer, but there is magnetic leakage between the windings L_2 and L'_2 which may be represented by a small inductance l situated in series with L'_2 .

The term magnetic leakage may require some explanation. The windings of a transformer are said to be closely

coupled to each other when the mutual inductance between them is the square root of the product of their inductances; in practice there is no need to bother with this formula to any great extent, as there are many short cuts by which we can arrive at the properties of such transformers. For instance, if the two windings L_2 and L'_2 are closely coupled, and if we neglect the resistance in these windings, then we know that the voltage across L_2 is in a constant ratio to that across L'_2 under all conditions. In the ordinary neutralising circuit this ratio is unity and the sense is negative so that an inversion of the voltage takes place.

Effect of Magnetic Leakage.

A transformer having magnetic leakage may be described as being equivalent to a closely coupled transformer, together with an inductance in series with either or both of its windings, and in practice it is not of any importance where we imagine this "leakage inductance" to be situated provided we consider the closely coupled transformer as having an appropriate ratio. Thus if in Fig. 7 the transformer under consideration purports to be of unity ratio but actually has magnetic leakage, the windings L_2 and L'_2 need not necessarily work out as having unity ratio, but for some value of this ratio and some value for the leakage inductance the figure represents exactly what the state of affairs is in the circuit.

We thus know that the voltage across L'_2 is opposite and proportional to the voltage across L_2 and thus, but for the presence of l , normal and exact neutralisation should be obtained. We therefore have to consider what effect this element of inductance has on the circuit, and it is clearly as if, instead of having a neutralising condenser alone, we had the combination of a capacity and inductance in series, the general conditions being such that the capacity is too small to tune the inductance to any wavelength within the range of the receiver.

Under these conditions the presence of the inductance will have the effect of cancelling some of the reactance of the neutralising condenser and making it behave as if it were larger than it actually is, and progressively larger for diminishing wavelengths.

If, therefore, we set up our neutralisation tests and find that there is a systematic divergence in the position of neutralisation as the wavelength gets lower and lower, and that the setting of the neutralising condenser requires to be progressively reduced, we may conclude that the coupling between the primary and secondary of the neu-

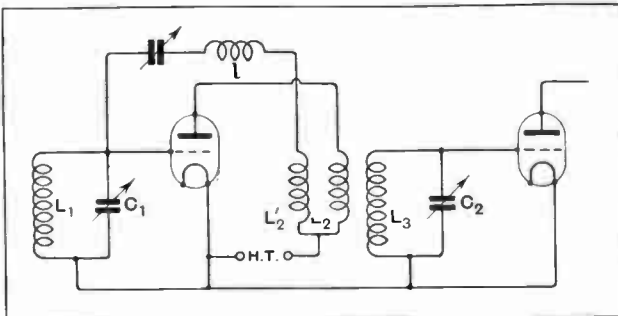

Fig. 7.—Neutralised H.F. transformer coupling with magnetic leakage between primary and neutralising windings represented by the small inductance l .

The Experimenter's Notebook.—

tralisising transformer is not tight enough, and some alteration to the design in this respect should be made. All practical designs of a neutralising transformer should take this factor into account, and there is certainly a risk in extemporising a neutralised circuit by the employment of

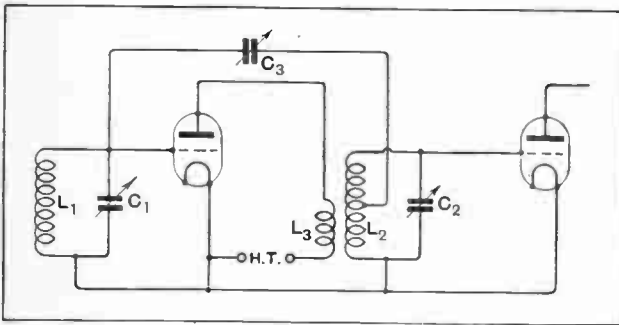

Fig. 8.—Neutralised circuit in which the intervalve transformer functions also as the neutralising transformer.

an ordinary high-frequency transformer having its two windings lumped together. In this case there will almost certainly be deneutralisation at the lower wavelength.

In some types of neutralised circuit (see Fig. 8) the high-frequency intervalve transformer is itself the neutralising transformer; in this case it is even more necessary to guard against magnetic leakage as, if there is appreciable leakage inductance, it will be impossible to neutralise at all at the shorter wavelengths in spite of the fact that when the testing method of Fig. 6 is applied a balance is obtained. This is due to the fact that the test is carried out with the first valve extinguished and thus does not take account of the effect of the currents which flow in this case through *both* of the windings of the neutralising transformer; in the circuit shown in Fig. 2 current of any appreciable magnitude flows only through the primary winding, and, as a result, neutralisation is more perfect.

A method for testing a neutralised stage which will show up lack of neutralisation is illustrated in Fig. 9.

Here a reaction valve is employed to make the circuit L_2C_2 oscillate; preferably capacity reaction is used, an inductance L_4 and a condenser C_4 being connected as shown and suitably situated so that there is no direct induction from L_4 into the circuit. The "live lead" connecting L_2C_2 to the reaction valve should be made of as

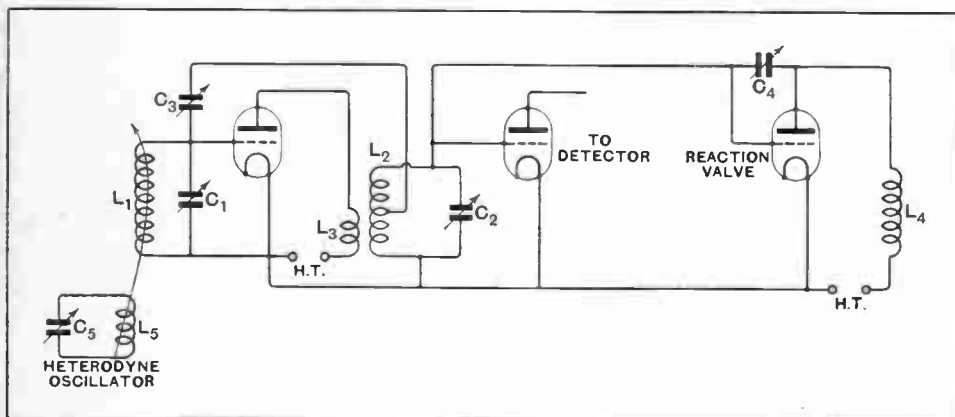

Fig. 9.—Method of testing for uniform neutralisation by observing beat frequency.

fine wire as is reasonably possible (say No. 32 S.W.G.) and connected in such a manner as not to induce directly into other parts of the receiver.

A heterodyne oscillator is very weakly coupled to the receiver so that the oscillations of L_2C_2 are perceived in the detector as a beat note. The circuit L_1C_1 is then tuned through resonance with L_2C_2 , when it will be found that a sharp change of beat frequency occurs, owing to coupling which exists between L_1C_1 and L_2C_2 . If this coupling is neutralised completely there will be no change of frequency at the resonance point, and in consequence if we can adjust C_3 to produce this effect we know that the receiver is perfectly neutralised.

A non-neutralised condition will be indicated by a fre-

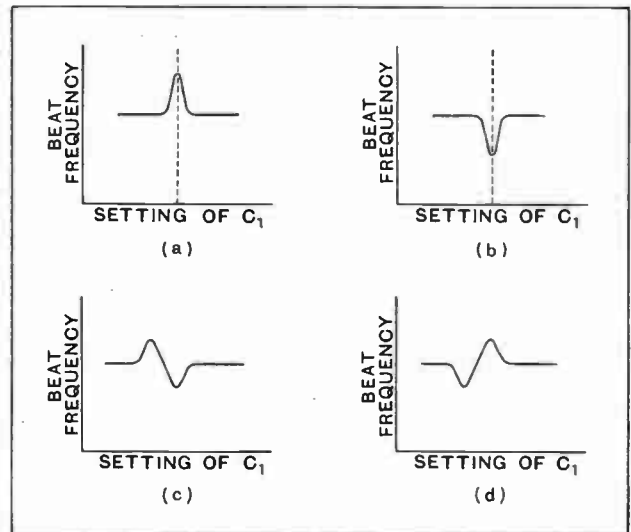

Fig. 10.—(a) and (b), normal change of beat frequency when neutralising condenser is not accurately adjusted; (c) and (d), residual change of frequency in a case where perfect neutralisation is impossible.

quency change as the resonance point is passed through, either rise or fall in the beat note being heard, as indicated in Figs. 10 (a) and (b).

As the state of neutralisation is approached by adjusting C_3 to the correct value, the "hump" in the above figures flattens out and, on passing through this setting, is changed from a form corresponding to Fig. 10 (a) to one corresponding to 10 (b), or *vice versa*. At the optimum setting the beat frequency should be uniform throughout the entire range of C_1 , but cases are often encountered when there is residual coupling between the circuits which cannot be balanced out. We then obtain curves of the form shown in Figs. 11 (a) and 11 (b).

A change of this kind is likely to occur in the circuit in Fig. 9, when there is appreciable magnetic leakage between the windings.

(To be concluded.)

THE ORMOND LOGARITHMIC CONDENSER

When two or more similar tuned circuits are used and Ormond Logarithmic Condensers are fitted to the set, the dial reading of each condenser may be adjusted to the same figure, say 90 degrees, after tuning in a certain station. On tuning in another station, all dial readings will then be found at the same figure, say 120 degrees. These readings will be in step throughout the tuning scale. For ease in searching, using multi-tuned circuits, these condensers are essential.

This type of condenser has been designed to follow the Logarithmic law, that is, the capacity change, or resulting wavelength or frequency change varies logarithmically.

The construction is similar to the Ormond S.L.F. Condenser, and efficiency at radio frequency potentials is of the same highest standard.

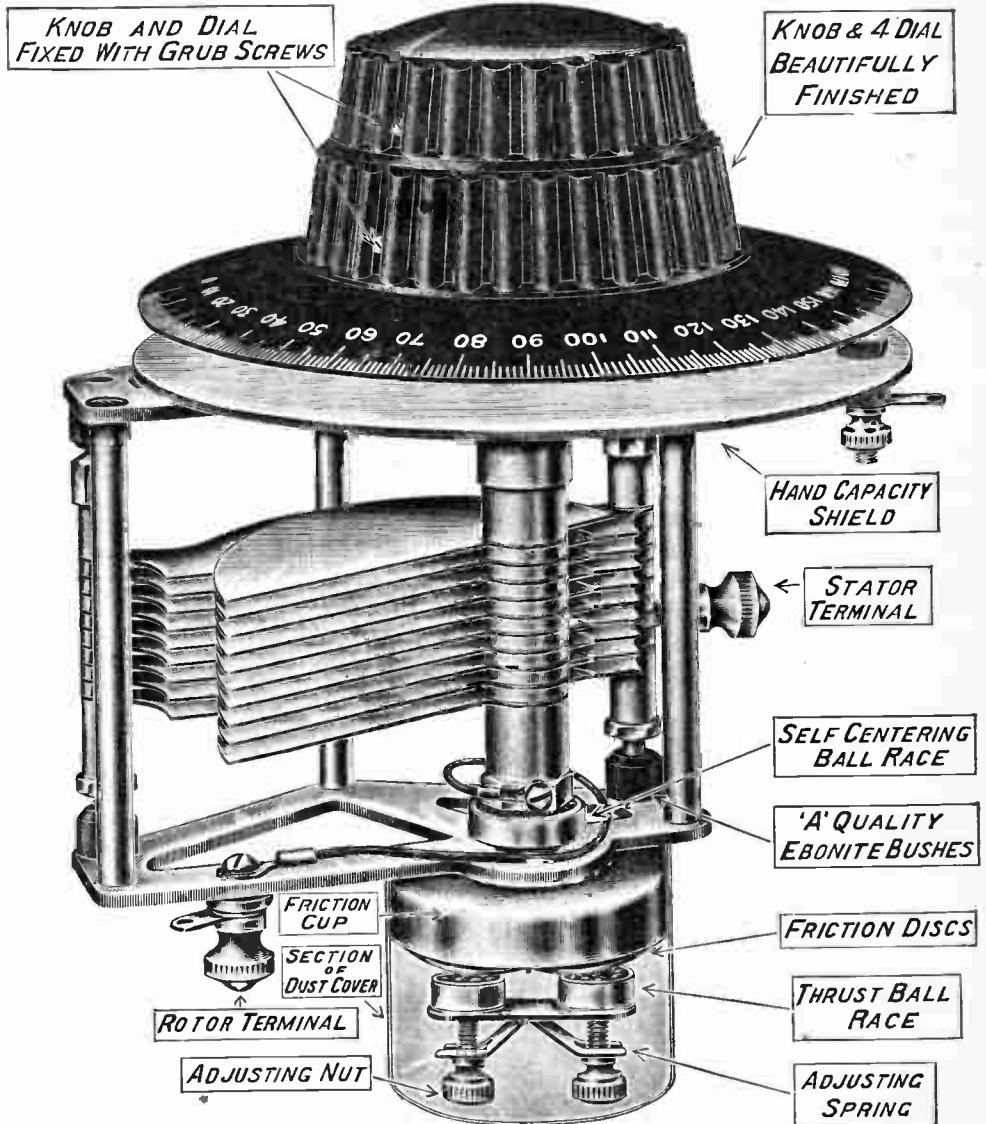

COMPLETE WITH 4" BAKELITE KNOB & DIAL & EARTHING SHIELD

PRICES:

With Friction Control

- 0005 - - 20/-
- 00035 - - 19/6
- 00025 - - 19/-



PRICES:

Without Friction Control

- 0005 - - 13/-
- 00035 - - 12/6
- 00025 - - 12/-

199-205 PENTONVILLE ROAD, KING'S CROSS, LONDON, N.1
 Telephone: Clerkenwell 9344-5-6. Telegrams: "Ormondengl, Kincross."

Factories - - - - - WHISKIN STREET AND HARDWICK STREET, CLERKENWELL, E.C.1
 Continental Agents: Messrs. Pettigrew & Merriman, Ltd., "Phonos House," 2 and 4 Bucknall Street, New Oxford Street, W.C.1

A Satisfactory Home-Built Set

The illustrations show an excellent and easily constructed set, for three valves and resistance capacity coupling built entirely of

Cosmos

Components & Valves

Prices are given for the whole range of types and sizes of each of the components used. ASK YOUR DEALER FOR A COPY OF THE CONSTRUCTION LEAFLET, No. 71171, COMPLETE WITH DRILLING TEMPLATE.

Satisfactory to build
Satisfactory to hear
Satisfactory in cost

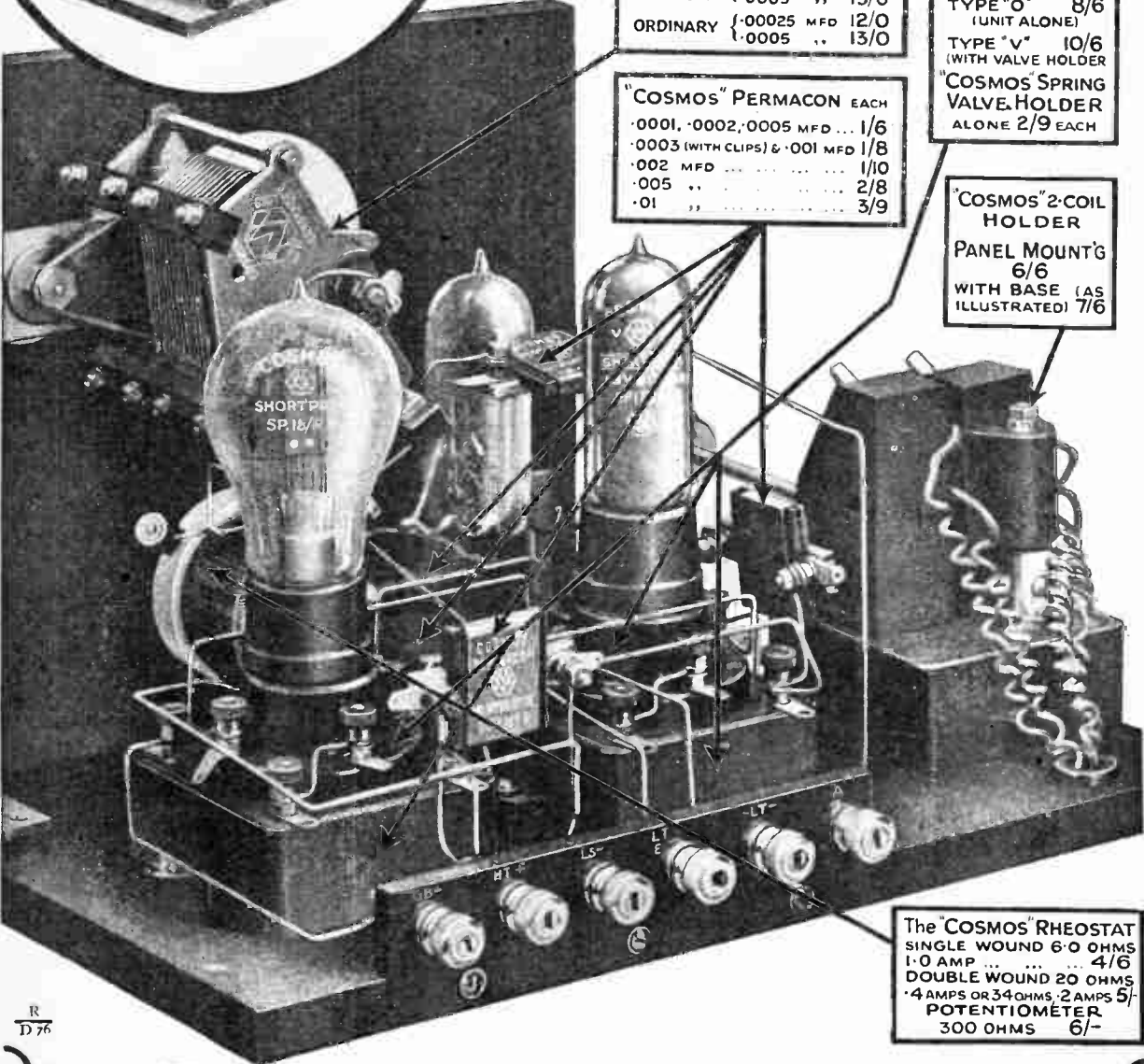

| "COSMOS" LOW LOSS SQUARE LAW CONDENSER | | |
|--|-------------|------|
| SLOW MOTION | 1-00025 MFD | 14/9 |
| | 1-0005 " | 15/6 |
| ORDINARY | 1-00025 MFD | 12/0 |
| | 1-0005 " | 13/0 |

| "COSMOS" RESISTANCE COUPLING UNIT | |
|------------------------------------|----------|
| TYPE "O" | 8/6 |
| (UNIT ALONE) | |
| TYPE "V" | 10/6 |
| (WITH VALVE HOLDER) | |
| "COSMOS" SPRING VALVE HOLDER ALONE | 2/9 EACH |

| "COSMOS" PERMACON EACH | |
|-------------------------------|------|
| .0001, .0002, .0005 MFD | 1/6 |
| .0003 (WITH CLIPS) & .001 MFD | 1/8 |
| .002 MFD | 1/10 |
| .005 " | 2/8 |
| .01 " | 3/9 |

| "COSMOS" 2-COIL HOLDER | |
|--------------------------------|-----|
| PANEL MOUNT'S | 6/6 |
| WITH BASE (AS ILLUSTRATED) 7/6 | |

| The "COSMOS" RHEOSTAT | |
|-----------------------|-------------------------------|
| SINGLE WOUND 6.0 OHMS | 1.0 AMP ... 4/6 |
| DOUBLE WOUND 20 OHMS | 4 AMPS OR 34 OHMS, 2 AMPS 5/- |
| POTENTIOMETER | 300 OHMS 6/- |

R
D76

Advt. of METRO-VICK SUPPLIES LIMITED - LONDON
Mention of "The Wireless World," when writing to advertisers, will ensure prompt attention.

GLASS PANELS.

Drilling and Mounting Sheet Glass for Use in Wireless Receivers.

By D. C. BROWN.

THERE is little doubt that glass panels are becoming increasingly popular with amateur constructors. The material has many advantages for it is cheap, has good insulating properties, and, provided the components are suitably disposed and the wiring neatly arranged, gives a most attractive appearance to the set. At the last Radio Exhibition several receiving sets mounted on glass panels were in evidence and attracted a considerable amount of attention. More recently, in North London, the Tottenham Wireless Society held an exhibition and among the sets on show was one with a glass panel. This attracted a remarkable amount of attention, as did a subsequent report of a lecture by the constructor of this receiver. There is no doubt that glass would be more extensively used were it not for the fact that glass is not drilled with tools usually found in the amateur's workshop. There is, moreover, the ever-present risk that, after devoting much time to the preparation of a panel, the last hole may be made rather hastily and the panel cracked. Contrary to the generally expressed opinion, glass is not difficult to drill. Moreover, provided reason-

As for the panel, the most suitable glass is $\frac{1}{4}$ inch English plate. Foreign glass is more difficult to work and for that reason should be avoided. You can usually tell the difference by looking at the glass edgeways. The foreign glass has a very pronounced greenish tint, while the English is almost white. Good English plate, which is very easy to drill, can be obtained from any glazier, cut to the size required, at about 1s. 6d. per foot "super."

Marking Out and Drilling.

Having obtained the panel it is now necessary to set out the holes to be drilled. By far the easiest way is, first, to paste a sheet of white paper over the glass and then mark exactly the positions of the holes with a pencil point. One of the three-square files should then be fitted with a handle, and the pencil points marked on the glass. All that is required is a sharp turn with the point of the tool. The drilling process can then be continued by hand, twisting the tool backwards and forwards, while held vertical. A better method is to transfer the file to the drill brace and proceed, turning first one way and then the other. It is very important to see that the file is held securely and *squarely* in the brace. A very slight pressure should be applied. Meanwhile turpentine should be applied fairly liberally, by means of a camel-hair brush. Particular care should be taken to lubricate sufficiently so that the fine glass powder does not come out in the form of a white paste or powder. When half-way through, remove the boring tool and turn the panel over. The centre of the hole will show through quite clearly as a white dot. The drilling operations should now be continued from this side in precisely the same manner, first marking the point and then turning the tool backwards and forwards, using plenty of lubrication and a very

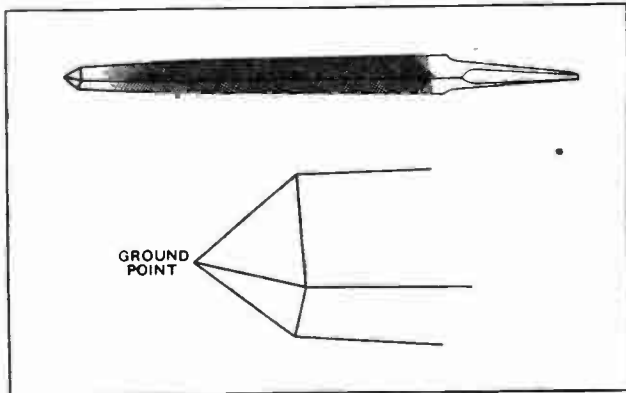

Triangular file ground for use as a glass drill.

able care is taken, panels will not crack. However, a little more care and patience are required both in drilling and in mounting the components subsequently.

The average amateur can probably make all the tools that he will require for himself. He will need some old three-square or triangular files. Most tool grinders have a large number of these files which are of no further use as such, and which, therefore, they will dispose of quite cheaply, often ground to the customers' instructions. In the writer's experience, they can be obtained already ground for a penny or twopence. Three or four files of this description should be obtained in sizes suitable for the holes which are required. If not already prepared, the ends can now be ground to the shape shown in the diagram. Any ordinary grindstone is, of course, suitable. An ordinary file handle will be required and also, if possible, a small drill brace. A little American turpentine will be required for lubrication, and this can be obtained, of course, from any oil and colour merchant.

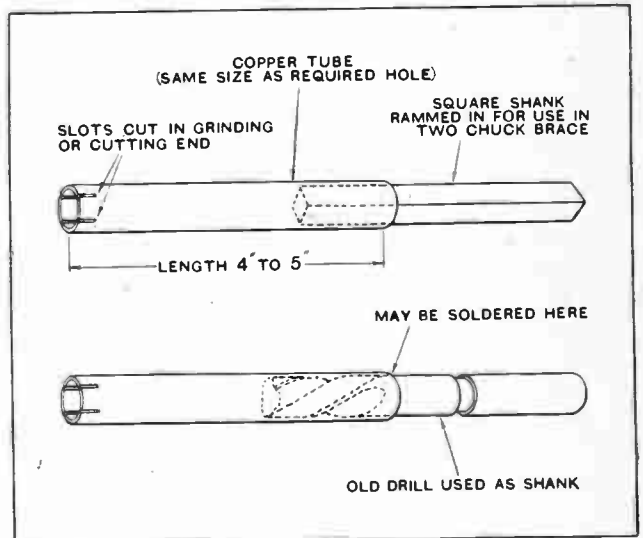

Tubular copper bits with suggested methods of mounting.

Glass Panels.—

slight pressure. Any form of what is usually described as lubricating oil should *not* be used when boring holes in glass. The edges of the tool should be sharpened on an oil-stone before starting a fresh hole. Should the hole not be large enough, it can be easily enlarged, using the tool next larger in size as a reamer. The same precautions regarding lubrication should be observed as when first drilling the hole. Should the hole be near the edge of the panel, such as for the screw which will hold the panel to fillet in the cabinet, extreme care should be taken to work very slowly and carefully. With reasonable care and patience it is possible to enlarge a hole on the edge of the panel by this means up to as large a size as $\frac{3}{8}$ in.

For large holes of this description the copper bit method is preferable and safer in inexperienced hands. First procure two battens of similar size and sufficiently long to enable one to reach the required positions on the panel. Through the centre drill a hole of the size required; if for condenser spindles, and the like, it will be $\frac{3}{8}$ in. Two wood screws should be screwed into each end of one batten and further into the second batten so that it will act as a clamp over the panel. Another batten of similar size is useful to put under the other end of the panel, when the drilling operation is proceeding, so that the panel is kept square on the table or bench. A brass or copper tube about four or five inches long is now required and should have a diameter equal to the size of the hole it is desired to make. At one end it should be slotted to a depth of about $\frac{1}{3}$ th of

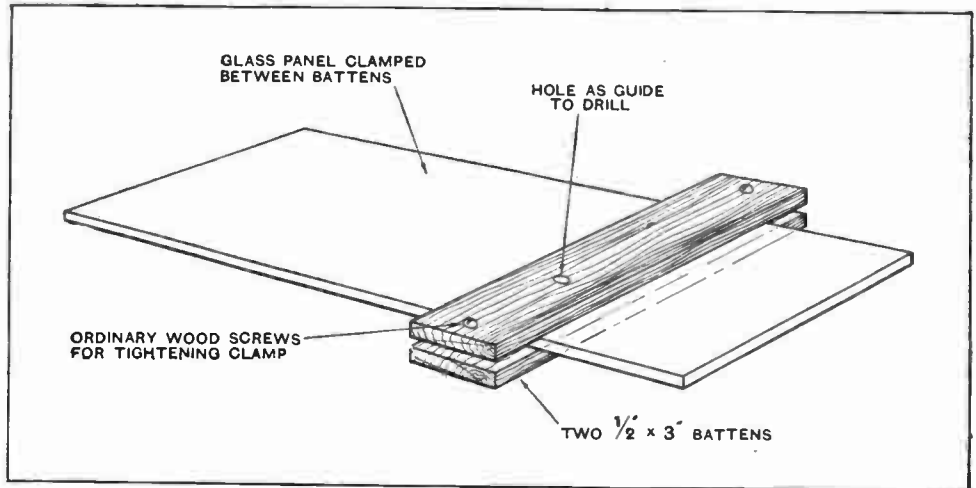

Wood battens with guiding holes for use with tubular drilling bits.

an inch. A suitable shank should be then rammed into the other end so that it can be fitted into the drill brace. With a three-chuck brace an old broken Morse drill will often prove excellent for this purpose. If the brace has only two chucks, then any square piece of hard metal will prove suitable. The battens should now be clamped over the panel taking care that the centre mark is exactly in the centre of the middle hole which has previously been drilled through the two battens. Now screw up the two wood screws until the battens are clamped firmly to the panel. The spare batten should be placed under the longest end of the panel to keep it level.

Suitable Abrasives.

Drilling must be carried out from both sides and the wooden frame acts as a guide. The cutting medium should be emery or carborundum, about 90 or 100 grade, and the lubricant turpentine as before. Such things as valve grinding paste will *not* do as they contain a greasy lubricant. Ordinary knife polish, however, can be used although the operation will take rather longer. A start should be made on one side, using the drill with a backward and forward movement at first, plenty of turpentine being meanwhile applied as lubricant. Once a start has been made the drill can be turned as rapidly as possible in the ordinary manner. When about half-way through, the panel should be turned over and, using the opposite hole in the battens as a guide, the drilling should be continued until a small circle of glass is cut clean out of the panel. Holes having perfectly clean sides are obtained, and that is one of the advantages of this

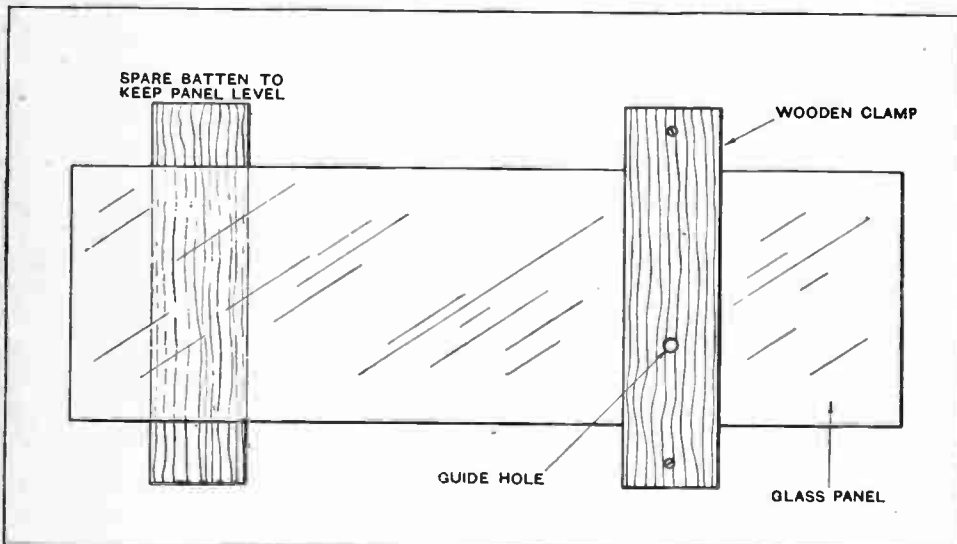

Glass panel supported ready for drilling.

Glass Panels.—

method. Professionally, diamond dust is used, and, of course, with the additional advantage of electric drilling machines, holes take little or no time to drill. For large or small holes either method may be used. The first method described needs more care, but the tools required are very simple. The copper bit method requires more time in tool construction and in the actual drilling process, but gives little trouble as regards chipping or cracking the panel.

Having provided the panel, it is now necessary to mount the components. Generally speaking, these will consist of one or two condensers and rheostats and perhaps a terminal or two. Glass will not stand so much strain as other materials generally used for panels; care should be taken, therefore, to avoid uneven pressure with the fixing screws. One screw should not be tightened down and the others screwed up afterwards. Care should be taken that the strain is applied gradually and distributed

over a wide area. With any component needing more than one screw or bolt for fixing, each screw should be tightened gradually and consecutively until it is firmly fixed. Even then one should not demonstrate the strength of one's wrists by doing up the screws exceedingly tightly, for the surface of the component to be mounted may not be quite true and a local strain may thereby be applied to the panel. Where there is a distinctly uneven or warped surface to the back of the component, a small paper or thin cardboard washer may be used between the panel and the component. Blotting-paper is a good material for this purpose.

Objection is sometimes raised to glass panels on the ground that moisture collects over the surface. Used in an ordinary house the writer has not noticed this and, in any event, the same amount of moisture must surely collect on an ebonite panel. In practice, glass seems to be an excellent insulating medium and undoubtedly possesses a distinct charm and novelty.

Tests on 8 Metres.

A series of tests with two portable stations, each equipped with a transmitter and receiver operating on 8 metres, will be carried out during July, August and September, under the auspices of the Q.R.P. Transmitters Society. The portable station will be operated by 6TA, Mr. G. D. Abbott, and 6LL, Mr. J. W. Mathews, who will use their ordinary call-signs. The first tests were conducted in Hertfordshire on July 17th, and any listener hearing these stations is asked to send a report, giving the exact time of reception, to the hon. sec., Mr. G. D. Abbott, 120, Cavendish Road, S.W.12.

o o o o

Short Wave Transmissions.

The paragraph in our issue of July 6th has elicited quite a number of interesting replies, from which we have extracted the following information:—

2XT, the R.C. of A. station at Rocky Point, New York, is transmitting on 16.02 metres nearly every evening, sometimes sending a test of 25 words which the operator asks to be written down, but its main function is Trans-Atlantic Telephony, usually starting at about 18.00 B.S.T. The aerial current is stated to be 36 amps. It is believed that this station is used for the transmission of "service" messages to G.P.O. stations in connection with the long-wave public service.

o o o o

A correspondent also reports having heard a station in one of the Dutch Colonies transmitting gramophone records at about 17.50 B.S.T. on June 25th. He gives the wavelength as 15.75 metres. Possibly the station may be ANH at Malabar, Java, whose wavelength is given in a Dutch contemporary as 17.3 metres.

o o o o

Another correspondent tells us that he heard the Rocky Point station on May 25th at 22.00 B.S.T. at about R7 and again at the same time on May 26th without aerial at strength R8. On May 30th he overheard a conversation which confirmed the transmission as working in conjunction with Rugby. He

**TRANSMITTERS' NOTES
AND QUERIES.**

also states that the station can generally be heard conducting 45-minute tests between 21.30 and 22.15 B.S.T.; these usually consist of high speed Morse, code speech, commercial telephony, and data concerning reception and transmission. It can be heard at many other times during the day, and is remarkable for its freedom from distortion.

He also heard another American station, presumably KDKA, transmitting music by the Westinghouse Band on June 4th at 23.30 B.S.T. The wavelength was 14 metres and it was announced that reports would be welcomed.

o o o o

A Rhodesian Station.

We are asked to state that FO 3SR. Mr. E. Jephcott, c/o G.P.O., Salisbury, Rhodesia, is anxious to get into touch with British stations, and would like to arrange tests at any time. He works on about 34 metres.

o o o o

Belgian Amateurs.

We understand that Mr. Louis Era, EB 4BC, 46, Avenue Van Put, Antwerp, has been appointed District Manager to the Reseau Belge for the province of Antwerp, in place of Mr. R. Verstoppe, with Mr. P. Duvisgan, EB 4AC, 16, Rue de l'Eglise, Antwerp, as City Manager. Their respective stations are now recognised as "official relay stations," which means that they will be on duty at fixed times for those having traffic or anything to transmit to the Reseau Belge or any other station in Belgium. EB 4BC will be listening between 30 and 45 metres and transmitting on 32.5 metres at the following times:—

Monday, Wednesday and Friday, 07.00

to 08.00 and 15.00 to 16.00 G.M.T.; EB 4AC will listen on 30 to 38 metres and transmit on 32.5 metres daily from 04.00 to 06.30 G.M.T., and also from 00.00 to 02.00 G.M.T. on Monday to Tuesday, Wednesday to Thursday, and Friday to Saturday.

o o o o

Belgian amateurs are now very active, 4WW, 4AX, 4CK, 4CB, 4AU, 4AC and 4BC being the stations principally engaged on distant work. They nearly all use the Levy type of aerial.

o o o o

Danish Amateurs.

ED 7AH, Mr. J. Christensen, Assistant, The GudenaaCentralens Transformatorstationen, Aarhus, Denmark, is transmitting telephony on a wavelength of 44 metres. This call-sign was formerly owned by Mr. Carl Högsholm in Copenhagen, but the latter's present call-sign is ED 7CH, and his address Dr. Abilgaard's alle 8, Copenhagen V. Mr. Högsholm will be glad if British amateurs will note this change of call-sign as he does not work on telephony and is frequently receiving communications intended for Mr. Christensen.

o o o o

New Call-signs Allotted and Stations Identified.

- 2BQV A. Handy, Prospect Place, Julian Road, Ludlow, Salop.
- 2ASL G. Hume, 124, Eversleigh Road, Battersea, S.W.11.
- 2BH (ex 2BWZ), H. Harding, Treve Radio Service, Libanus Road, Ebbw Vale, transmits on 150-200 and 440 metres and will welcome reports.
- 2WR R. D. Webster, 68, Norwood Rd., Herne Hill, transmits on 23, 45, 90 and 150-200 metres.
- 5PN V. Hamilton Penfold, 10, Highcroft Villas, Brighton. (Change of address.)
- 6SM S. G. Morgan, 3, High St., Croydon.
- 6UQ H. J. Eaves, 7, Marple St., Hulme, Manchester.
- EI 1WW M. d'Amelio, Capodimonte, Naples.
- NC 1AE (ex 3KA), C. H. Starr, Wolfville, Nova Scotia.
- VS 1AC M. J. Thorpe, 1, Park Rd., Penang, Fed. Malay States.
- VS 2AC F. J. Barnett, Central Workshops, Selangor, Malaya.

o o o o

QRA's Wanted.

G 6AS, G 6LT, OIK.



Events of the Week

NEARING 2½ MILLIONS.

A total of 2,234,988 broadcast receiving licences had been issued in this country on June 30th, excluding the 4,403 free licences granted to the blind.

○○○○

THIRD TIME: UNLUCKY.

When Leslie C. Bradley was fined £2 10s. at the Birmingham Police Court for using an unlicensed wireless set it was stated that the defendant had ignored three demands.

○○○○

B.B.C. QUICKER THAN LIGHTNING?

To avert the possibility of disaster during last week's thunderstorm, the 2LO aerial was momentarily "earthed" seventeen times. This was carried out by an engineer stationed to watch for each flash.

○○○○

U.S. BROADCASTING TIME QUEUE.

Many of the American broadcasting stations have perforce to share wavelengths under the Federal Radio Commission scheme. To avoid interference it has been necessary in many cases to arrange special transmission times which do not overlap.

○○○○

LOUD-SPEAKERS AT MENIN GATE.

The impressive ceremony of unveiling the Menin Gate Memorial on Sunday next, July 24th, will not only be broadcast *via* wireless, but will be distributed to the thousands gathered round the memorial by means of the Amplion public speech equipment. Thirty loud-speakers will be used.

○○○○

AN UNWELCOME SURPRISE.

A wireless photograph is reported to have been responsible for the identification in New York of a man wanted for bank robbery in Vera Cruz. Although travelling under an assumed name, the man admitted his identity when confronted with his radio likeness on landing in New York.

○○○○

POOR NEVADA.

New York State contains 655,850 receiving sets, and is thus ahead of all other States in this respect, according to statistics compiled by the Society for Electrical Development of New York. Pennsylvania and Illinois come next with 503,100 and 468,000 receivers respectively. Apparently the poorest State, from a wireless point of view, is Nevada, with 5,200 receiving sets.



THE CANINE ANALOGY.

A Brixton woman fined 20s. at the Lambeth Police Court for owning and operating a wireless set without a licence, explained that she thought a set was like a dog: so long as it was not more than six months old it need not be licensed.

○○○○

WIRELESS BRAIN WAVES.

The radio section of the U.S.A. Patent Office has doubled in size in the past six or seven years. Applications for radio patents number approximately 125 per month, as compared with about 60 per month in 1920.

○○○○

POLYGLOT STORM WARNINGS.

A new wireless station erected at Kowloon, a peninsula opposite Hong Kong, will broadcast storm warnings to ships in English, French, German, Japanese, and Chinese. Many of the Chinese junks in the locality carry crystal receivers, and it is hoped that they will be able to avail themselves of the new service.

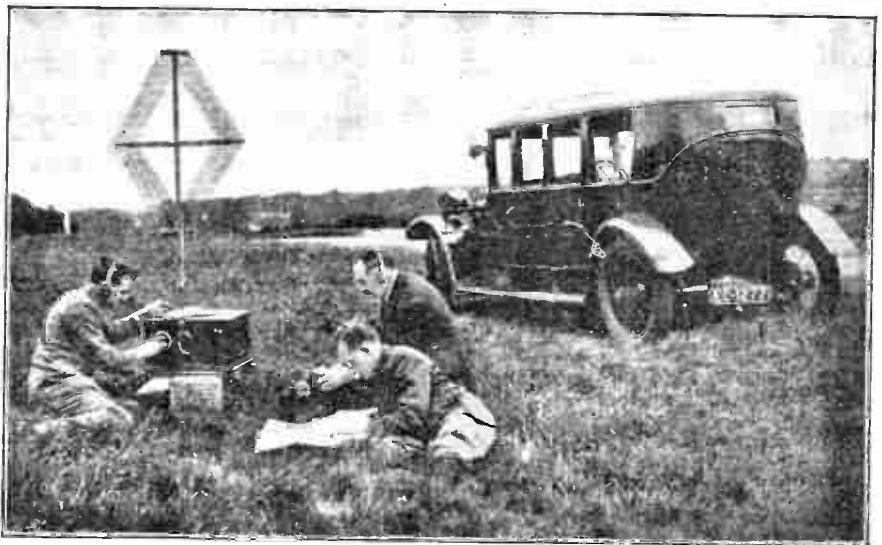

THE BEST SPORT. Radio societies throughout the country are discovering the fascinations of the D.F. hunt for a concealed transmitter. In this photograph, taken on a recent field day of the Golders Green and Hendon Radio Society, the tense faces reveal the excitement of the chase.

in Brief Review.

R.S.G.B. SUMMER MEETING.

An interesting fixture for August 1st (Bank Holiday Monday) is a "Conventionette," in the form of a lunch and tea and a visit to 5XX, to be held by the Mid-Britain section of the Radio Society of Great Britain.

The arrangements are in the hands of Mr. G. A. Jeapes (G 2XV), "Chandos," Great Shelford, Cambs.

The rendezvous for the "Conventionette" will be the Cock Hotel, Kings-thorpe, Northampton.

○○○○

BROADCAST PROGRAMME COMPETITION.

An interesting radio competition has been devised by the *Manchester Evening Chronicle*. Readers are being invited to draft two wireless programmes, one being of the "straight" musical type, and the other including variety items.

Prizes of £50, £30, £15, and £5 are offered for the best programmes submitted during the next two months, and an additional attraction is that the winning programmes will form part of the musical features at the Manchester Wireless Exhibition, the biggest of its kind outside London, and will be relayed by 2ZY.

The programmes will be judged on individual merit as decided by leading

members of the musical and entertainment world. Intending competitors should apply for an entrance form to the Radio Editor, *Evening Chronicle*, Manchester.

summoned by wireless to quell a fire on board ship.

As the s.s. *Patriotic* was approaching Liverpool recently from Belfast a fire was discovered in the hold. The vessel continued at full speed, and an urgent wireless message was despatched, this being picked up at the Seaforth station. When the *Patriotic* arrived at the quay two fire engines were ready for action, and the outbreak was speedily extinguished.

WIRELESS AT WESTMINSTER.

FROM OUR PARLIAMENTARY CORRESPONDENT.

Broadcasting to the Dominions.

In the House of Commons last week Captain Fraser asked the Colonial Secretary if any views were expressed by the representatives of the Colonies at the recent Colonial Conference as to the desirability of establishing in this country a wireless transmitter capable of conveying to the Colonies for redistribution the programmes of the British Broadcasting Corporation; if the representatives indicated that their Governments would be prepared sympathetically to consider contributing towards the expenses incidental to such a service after the initiative had been taken by Great Britain; and if any views were expressed by the representatives of the Colonies at the recent Colonial Education Conference as to the advantages which would accrue to their countries if means existed whereby they could hear British broadcasting.

Mr. Amery said that as regards the

Colonial Office Conference it was a general view of the representatives of the Dependencies that the institution of such a service, if found to be practicable, would be very widely appreciated overseas. While it was considered premature to ask them for an undertaking to contribute until the necessary experimental



COMMANDER BYRD'S WIRELESS. A view in the cockpit of the "America," showing the receiver carried by the intrepid airman in his recent Atlantic flight.

WIRELESS SUMMONS FIRE BRIGADE.

Cases must be comparatively rare in which a fire brigade on land has been

The following list corrects and supplements that previously published in the R.S.G.B. Diary and Log Book.

- 8AE Dr. Corret, 97, rue Royale, Versailles. (Change of address.)
- 8AK — Menetray, 55, rue Inkermann, Lille.
- 8AN — Meissonnier, 27, rue des trois Colombes, Avignon.
- 8AU — Jacomin, 85, Cours Lieubaud, Marseille.
- 8AV — Beguin, Ile de Beauté, Nogent-s-Marne.
- 8BX — Vatinet, 3, av. Gambetta, Vitry-sur-Seine. (Change of address.)
- 8CH — Stocklin, 20, rue Gresset, Amiens (Somme).
- 8DF — Balandreau, 68, boul. Pasteur, Paris. (Change of address.)
- 8DG — Poiret, rue Louis-Thullier, Amiens.
- 8DP Maurice Jeanne, Jardin Ouvrier No. 1, Bd. Leroy, Caen.
- 8EB — Auger, 9, rue Valhubert, Avranches (Manche).
- 8EL Arnold Pinaud, 10, rue Saint-Augustin Algiers.
- 8EO F. Bevierre, 8, rue Gambetta, Cambrai.
- 8EP Société Indépendante de T.S.F., 66, rue La Boetie, Paris.
- 8ES — Varinois, 203, rue Saint-Honoré, Paris. (Change of address.)
- 8FH — Gratade, 27, rue du Chatelet, Montlucon (Allier).
- 8FI G. Acher, 4, Avenue Trudaine, Paris (9e). Station situated at 15, Avenue Victor-Hugo, Beauvais (Oise).
- 8FK — Gagniard, 113, Avenue Du Chemin de Fer. Le Raincy (S. et O.).
- 8FQ J. de Buiffères, Nivolas Vernelle, Succieu (Isère).
- 8FS — Arossohn, 2 bis rue J. Deville, Colombes (Seine).
- 8FG Radio Club du Bas-Rhin, Operator: A. Diehl, 13, rue Oberlin, Strasbourg.
- 8GM — Chave-Dalmar, c/o M. Menars, (8FJ) Bordes (Basses-Pyrénées). (Change of address.)
- 8GP — Brissard, 32, rue de Coulmiers, Orléans, Seine.
- 8GQ R. Cizeau, 27, rue Villeneuve, Clichy (Seine). (Change of address.)

FRENCH AMATEUR TRANSMITTING STATIONS.

- 8GR Société Hydroélectrique de Lyon, 5, place Sathonay, Lyons.
- 8GX — Garres, 59, Avenue Jeanne-d'Arc, Bordeaux.
- 8HC — Serrailleur, 63, rue Saint-Ferréol, Marseille.
- 8HD — Villefourcix, 28, rue du Coninerec, Berdeaux.
- 8HI Compagnie du Gaz de Lyon, 3, Quai des Célestins, Lyons.
- 8HJ Max Tourtiquet, 44, rue des Vergeaux, Amiens.
- 8HK — Courbon, 75, rue de la Sablière, St-Etienne.
- 8HV — Rougeron, 10, route Nationale, Annapes (Nord). (Change of address.)
- 8IG — Marret, 20 bis, rue des Pres, Fontenay aux Roses. (Change of address.)
- 8IH — Desgrouas, rue de Blon, Yire (Calvados).
- 8IJ — Ritz, rue du Président-Favre, Annecy. (Change of address.)
- 8IY — Bottin, 32, rue Barbès, Ivry-sur-Seine.
- 8JC — Groislier, 12, route d'Etain, Verdun-sur-Meuse. (Change of address.)
- 8JL R. Jamas, 10 rue Bézout, Paris. (Change of address.)
- 8JU — Massoutier, 3, rue Vieille Mosquée, Oran. Société Française Radioélectrique, 79, Bld. Haussmann, Paris.
- 8JY — Bernast, 96, Avenue Sainte-Cécile, Lambersart-les-Lille (Nord).
- 8JZ — Helary, Vieux Moulin (Oise).
- 8KA — Bounefous, 3, rue du Capus, Béziers.
- 8KB — Gregoire, villa La Collinette, Pont-d'Avignon (Gard).
- 8KC — Hardy, 128, rue Mourouin, Lille (Nord).
- 8KD — Devin, 81, rue des Chesnaux, Montmorency (Seine-et-Oise).
- 8KF H. Hoffmann, 31, rue du Bois-de-Boulogne, Neuilly-sur-Seine.
- 8KK — Veillard, 1, rue Venture, Marseille.

FORTHCOMING EVENTS.

- WEDNESDAY, JULY 20th.**
Tottenham Wireless Society.—At 8 p.m. At 10. Bruce Grove, N.17. Lecture: "How Your Set Works," by Mr. A. G. Tucker.
Stretford and District Radio Society.—Lecture: "Some Humour in Radio," by Mr. Sheffield.
- THURSDAY, JULY 21st.**
Golders Green and Hendon Radio Society.—At 8 p.m. At the Club House, Wilford Way, N.W.11. Lecture by Mr. Leslie McIlhatch, M.Inst.R.E.
- MONDAY, AUGUST 1st.**
Radio Society of Great Britain (Mid. Britain Section) — "Conventionette" and visit to 5XX. (See "Current Topics.")

work in this country was further advanced, he did not for a moment anticipate that the Dependencies would show reluctance when the time came to share the expense involved in instituting and maintaining such a service

As regards the Imperial Education Conference, he understood that in view of the experimental work still to be done before such a satisfactory broadcasting system could be established, no substantial discussion developed on the subject.

- 8KG — Minguet, 101, rue Perronet, Neuilly-sur-Seine.
 - 8KH Radio Club du Nord de la France, 55, rue Neuve, Roubaix.
 - 8KI Le Roy, 23, rue des Jardins, Caulier a Lille.
 - 8KJ Ditto.
 - 8KM — Pethiot, 84, rue Jules-Ferry, Pont-Audemer.
 - 8KN Gerard Kraemer, 11, rue de la Py, Paris.
 - 8KP — Badal, 22, rue Neuve-des-Boulets, Paris.
 - 8KR P. de Sainte-Croix, 1, Bld. Mercier, Constantine (Algérie).
 - 8KS Société Hydroélectrique de Lyon, 5, place Sathonay, Lyons.
 - 8KU — Tabej, 1, place de l'Abondance, Lyons.
 - 8KV — Goud, Banque de France, Veruon (Eure).
 - 8KX — Denagt, Chief of the Station at Comines (Nord).
 - 8KY — Lefebvre, 87, rue de Cassé, Lille.
 - 8KZ — Vandybaldt, 64 bis, rue Vauban, Roubaix.
 - 8LA A. Wigniolle, 27, rue Jean de Gouy, Douai (Nord).
 - 8LB — Sauvage, 14, Bld. Raoul, Maux (S. et M.).
 - 8LC — Scalabre, 37, rue des Garliers, Tourcoing (Nord).
 - 8LD — Teller, 17, rue du Commandant-Ro'land, Le Bourget (Seine).
 - 8LE Toulemonde, route de Fontaine, Landrecies.
 - 8LF Lionne le Sambreton, Landrecies.
 - 8LG — Millon, 20, rue de la République, St. Mandé (Seine).
 - 8LH — Vitus, 90, rue Darnémont, Paris.
 - 8LI — Lafunus, 26, rue des écoles, Roanne.
 - 8LJ — Du Boisbaudry, Le Rheu (l.-et-V.).
 - 8LK — Rasp, Allée de la Robertsau, Strasbourg.
 - 8LL — Prullhomme, 17, rue des Changés, Brou (Eure-et-Loir).
 - 8LM — Delemarre, 33, place du Maréchal Pétain, Béthune.
- MOROCCO.**
— Grangier, Post Box No. 50, Casablanca.
Dr. G. Veyre, 83, Avenue du Général-Moinier, Casablanca.
- FRENCH INDO-CHINA.**
FI LB R. Jamas, 31, rue Richaud, Saigon. (Change of call-sign.)
FC 8FLO M. Fleaud, Officer, French Cruiser "Jules Michelet."

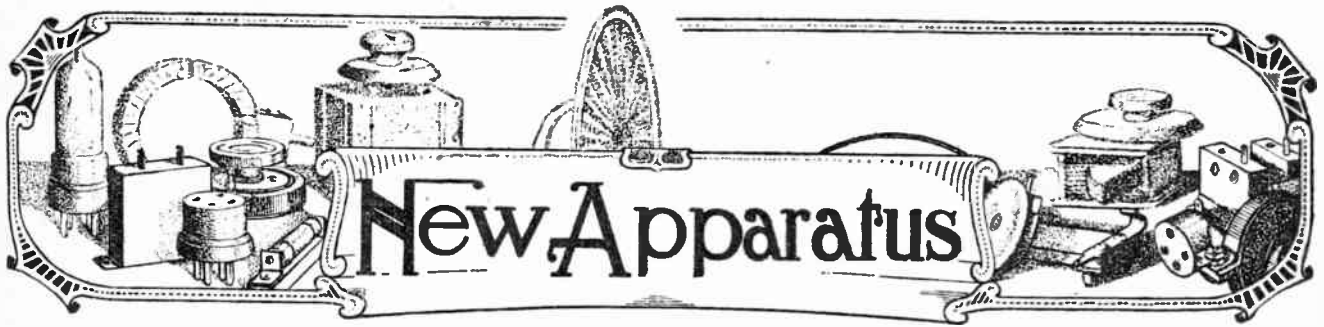

A Review of the Latest Products of the Manufacturers.

A NEW CHOKE COIL.

The use of centre-tapped tuning circuits and the growing interest in short-wave reception have increased the demand for efficient choke coils. A well-made high-frequency choke consisting of a cleanly turned ebonite former carrying a spool of wire wound in five sections has recently been placed on the market by S. M. Henry, 33, The Pleasance, Putney, London, S.W.15. The fine wire has a double cotton covering to reduce self-capacity and the wire is waxed before being run on as a protection against moisture. Attachment to baseboard or panel is provided by a 4BA screw passing into a tapped centre hole.

Possibly for convenience of wiring the winding is terminated on double-ended tags at one end of the former, though to avoid passing one of the connecting

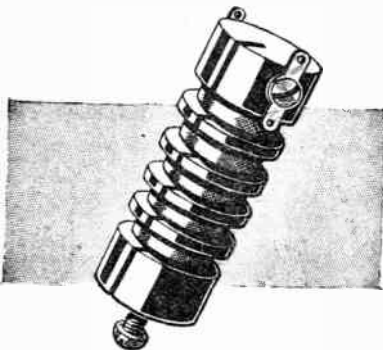

The Henry high-frequency choke.

wires from end to end of the spool it might be easier to fit the terminal tags at the top and bottom, particularly as a liberal width of ebonite is available.

o o o o

THE PERFEX AERIAL.

The elevated cage of the Perfex aerial is now a commonplace in urban districts where difficulty is experienced in erecting the usual inverted "L" aerial.

Opinion is divided regarding the relative merits of these two types of aerial so that the results of some experiments conducted under identical conditions may be of interest to readers.

A Perfex aerial was erected on the roof of a house in the garden of which

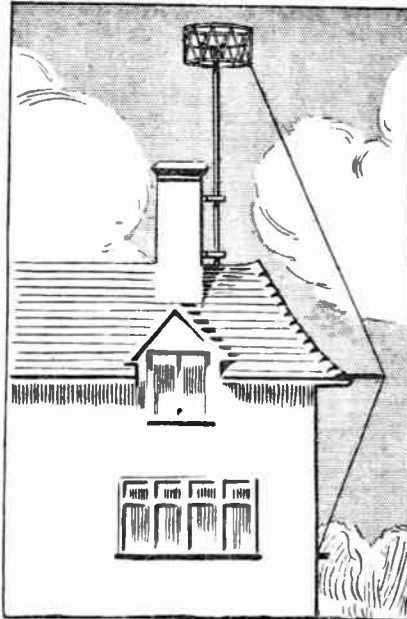

The Perfex aerial when properly erected is both neat and efficient and is conducive to selectivity.

a standard P.M.G. aerial was already in existence. The down lead from the Perfex entered the same room as the P.M.G. aerial and arrangements were made to detach the top cage of the Perfex to see if there were any difference in the results. The aeri-als were connected alternately to a tuned circuit across which was connected a valve voltmeter to measure the high-frequency voltage available for passing on to the first valve of a receiving set. The results were as follow:—

| | R.M.S. volts. |
|------------------------|---------------|
| Perfex—down lead only | 5.45 |
| Perfex—with cage top | 6.35 |
| Standard P.M.G. aerial | 8.4 |

So much for signal strength. From the point of view of selectivity it is probable that the Perfex aerial scores over the inverted "L" type. In the first place the high-frequency resistance of a vertical aerial is less than an inverted "L" not only on account of its shorter length, but because the horizontal portion of the inverted "L" is

frequently erected in close proximity to semi-conducting objects.

High-frequency resistance affects the general selectivity of the aerial circuit but there is another quality of the Perfex aerial which contributes indirectly to selectivity. The vertical type aerial is energised less by the ground component of the wave from the local station than is the horizontal aerial, but as the waves from distant stations generally descend at an angle after reflection from the Heaviside layer, the Perfex aerial is more sensitive to the distance station, and is less susceptible to the swamping effect of the local station.

o o o o

ORMOND RESISTORS.

Variable resistances are no longer used in filament circuits except perhaps to avoid suddenly applying the maximum battery potential or when filament brightness is used as a volume control in the case of H.F. valve or for reaction adjustment with a detector valve. A fixed value filament resistance has been added

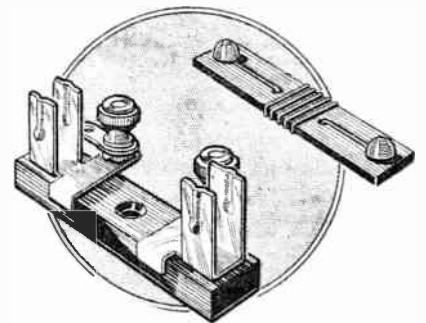

Interchangeable filament resistance, a recent Ormond product.

to the range of Ormond products (Ormond Engineering Co., Ltd., 199-205, Pentonville Road, King's Cross, London, N.1) consisting of a fibre strip carrying a resistance wire winding, terminated upon ball-shaped connectors. These connectors readily slide between spring clips carried on an ebonite mounting base. The resistance spools can be easily withdrawn yet contact is reliable. Connection is made with the mount by means of small terminals fitted with connecting tags.

THE K.L.1 VALVE.

Advantages of Indirectly Heated Cathode Valves.

By F. E. HENDERSON, A.M.I.E.E.

THE advent of valves of the indirectly heated cathode type, such as the new K.L.1 valves, which have recently appeared on the British market, has aroused a considerable amount of interest among both broadcast listeners and advanced experimenters.

The property of this type of valve of being able to function in a receiver or amplifier, and having the cathode heating power derived directly from raw A.C. without appreciably noticeable mains "hum," is usually made the outstanding merit of such valves, but from the nature of its design its advantages over the "straight" three-electrode thermionic valve do not end here, and this article is intended to show how a very considerable improvement in characteristics is obtained, affording a wide field for experimental work, in which the indirectly heated cathode valve may be utilised.

Constructional Details.

Photographs are given showing the various parts of the K.L.1 valve individually, and of the completed valve.

It will be seen that in general principle the disposition of electrodes is the same as that of the ordinary thermionic valve, in that the grid and anode are arranged in the form of concentric cylinders, with the cathode running through the axis of the grid. The anode and grid individually call for no comment in their construction.

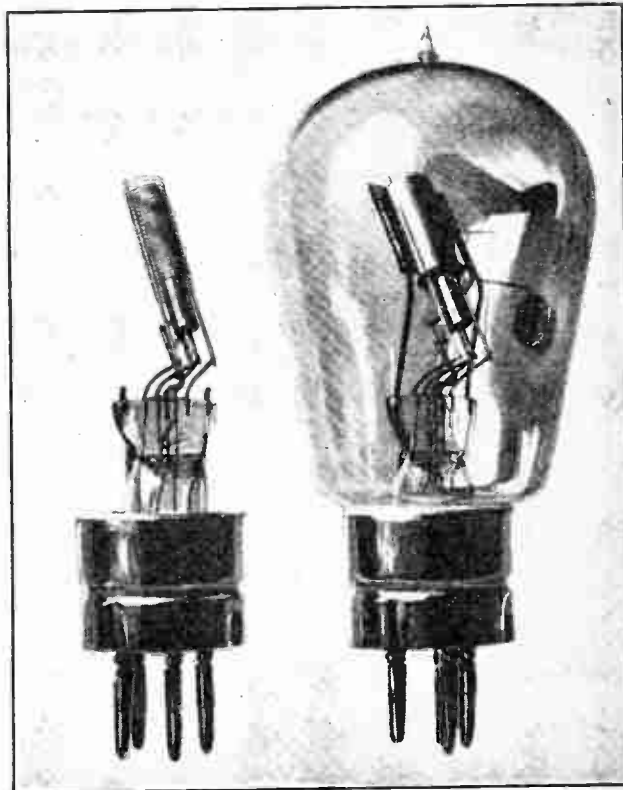

As will be seen on the left, the grid of the K.L.1 is of comparatively large diameter. The finished valve is shown on the right.

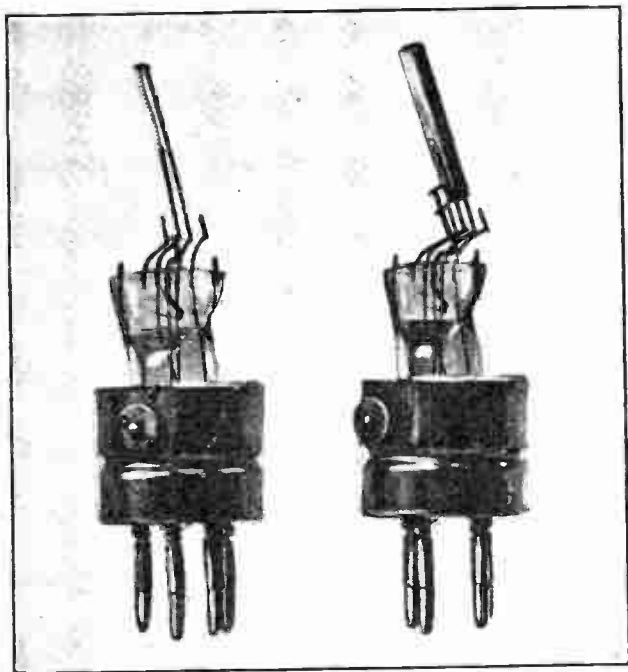

Cathode assembly of the K.L.1 valve; the spiral heater element is shown on the left and the oxide-coated nickel cathode on the right. The electrodes are inclined to prevent heating of the glass pinch.

but, as would be expected, the chief interest centres in the cathode design, or possibly more accurately in the relation between the cathode and the other electrodes.

We have grown used to a cathode consisting of a wire filament of various degrees of fineness, which is heated to the necessary temperature by means of a current passing through it—the temperature to which it has to be raised for the necessary electron emission depending on the nature of the filament surface. This cathode or filament may be a pure tungsten wire, thoriated tungsten, or consist of a metallic core coated with some highly electron emissive substance, such as platinum coated with metallic oxides.

Each variety, however, requires to be heated by the passage of current—either D.C. or A.C.—through it, and thus its diameter is necessarily restricted to small dimensions to avoid excessive expenditure of energy.

The essential difference between such valves and the indirectly heated cathode type lies in the fact that in the latter the cathode and filament are separated. The cathode consists of a nickel cylinder coated with oxides

The K.L.1 Valve.—

which have the property of giving a copious electron emission at dull-red heat. The actual filament or "heater" is a spiralsed tungsten wire rated at 2 amperes 3.5 volts, rigidly clamped to a metal support, the whole fitting inside the nickel cathode but not touching. Thus the supply current passing through the filament raises it to a white heat, and the cathode itself becomes heated by radiation to a dull cherry red.

By boxing in the cathode very little heat is lost, but the lower end, which is of necessity left open for the entry of the heater element, radiates a certain amount of heat downward. To avoid danger of liberation of gas from the glass pinch, which is in close proximity to this open end, the whole electrode system in this valve is inclined at an angle of about 40° to the vertical, and thus the liability of heating of the pinch and softening of the vacuum is minimised.

Characteristics.

From a consideration of the published characteristics for the K.L.1 valve it will be seen that the valve has a very low value of A.C. resistance when compared with its voltage amplification factor, or, in other words,

the ratio $\frac{m}{R}$ is high, where m is the amplification factor and R is the A.C. resistance.

This ratio, which is sometimes referred to as the "mutual conductance" value, is a measure of the overall amplification, or undistorted output, it is possible to obtain from a valve operating in an amplifier.

The makers' rating for the K.L.1 type is :

$$m = 7.5$$

$$R = 5,500 \text{ ohms.}$$

and thus the mutual conductance is 1,360 micromhos, or the slope of the characteristic = 1.36 mA/volt.

It is extremely interesting to compare this figure with that of a pure tungsten filament thermionic valve having approximately the same filament wattage. For example, the old Marconi-Osram L.S.2 valve had a filament rated at 6 volts 1.5 ampere, a wattage of 9—actually in excess of the K.L.1 with its 7 watts, and the characteristics of the valve were :

$$m = 6$$

$$R = 8,000 \text{ ohms}$$

and thus the mutual conductance is 750 micromhos, or the slope of the characteristic = 0.75 mA/volt.

How is it that this great improvement in characterisation is obtained? To arrive at an answer we must consider the theory of the thermionic valve.

In the design of valves it is highly desirable for the majority of purposes for which it is utilised that the internal resistance value be kept low. There are, of course, certain practical objections which might be raised if this is done, such as large currents drawn from the H.T. battery, but this cannot be taken as a serious objection, in that the old truism holds good that one cannot obtain "something for nothing," and the high-tension supply is the source of power for work done in the amplifier to produce the required loud-speaker output.

It is realised that where the anode load is an inductive one, such as a transformer primary, choke, or loud-

speaker winding, it is essential for adequate amplification or reproduction of the lowest audible frequencies that the impedance of the valve in series with the load be as low as possible. This applies equally to resistance-capacity coupling where it is desirable for the value of the anode resistance to be considerably in excess of that of the valve resistance. Unfortunately, however, from the fundamental principles of valve design, when we reduce this impedance (R) value, the voltage amplification (m) is also, though not strictly proportionally, reduced. It is obviously desirable, however, to maintain this voltage

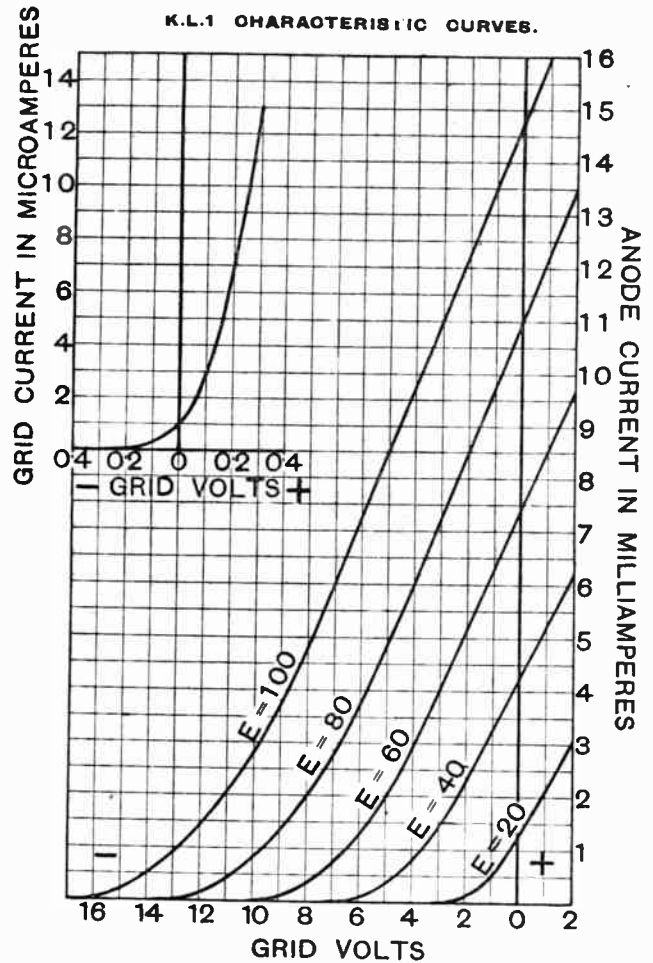

amplification, and in cases where no step-up in voltage occurs between valves connected in cascade, such as in resistance-capacity or choke-capacity coupled amplifiers, a high value of m is essential if a plurality of stages is to be avoided.

Hence it follows that the ratio $\frac{m}{R}$ is a measure of the "goodness" of a valve.

Now, this ratio $\frac{m}{R}$ is dependent to a large extent on the resistance offered to the flow of electrons from cathode to anode, and may be increased by :

- (1) Neutralisation of space charge by some positive potential applied close to the cathode.

The K.L.1 Valve.—

(2) Increase of anode voltage to the limit imposed by the saturation emission of the filament.

(3) Increase in length of filament enclosed within anode.

(4) Reduction in clearance between grid and cathode. Method (1) is achieved to a great extent by the two-grid or four-electrode valve, but this type has never grown in popularity owing to the necessarily higher cost entailed by increased difficulty in manufacture.

Method (2) is limited for the great majority of types of valves owing to the emission saturation of the cathode and possible tendencies to softening.

Method (3) explains why, with the exception of high m valves, which will be explained later, it is in general possible to obtain better characteristics with 6-volt than with 2-volt valves, providing the nature of the emissive cathodes remain equal, *i.e.*, that the cathodes operate at the same temperature. Recent improvements in filament efficiency have enabled adequate emission to be obtained at very low operating temperatures, and thus for a given voltage drop across the filament, a longer length can be employed, so increasing the area available for emission and decreasing the impedance.

We have to consider the voltage amplification factor (m) in order to obtain our good characteristics, and this value (considering the K.L.1) is related to the geometry of the electrodes in the following manner:¹

$$m = \frac{\pi N d^1 \log \frac{d}{d^1}}{\log \frac{I}{\pi N d_g}}$$

where N = number of grid wires per cm. length.
 d^1 = grid diameter.
 d = anode diameter.
 d_g = diameter of grid wires.

From this we see that a decrease in the ratio anode to grid diameters will reduce m , which explains the point raised in Method (4) for reducing impedance. Hence in order to provide a valve with good characteristics, *i.e.*, a high ratio of m to R , we are faced with the necessity that the ratio, grid to cathode diameter, shall be as near unity as possible.

With the ordinary thermionic valve in which the cathode is a fine filament of wire, it follows that the ratio of grid to cathode diameters must of necessity be fairly considerable, and if we attempt to reduce this the grid is of necessity brought very close to the filament. This convergence of the grid and filament is dependent upon mechanical limitations, there being a limit of clearance, depending upon the nature of the filament, springing, etc., beyond which there is a liability for the filament to bow out in use and touch the grid. Here is where the indirectly heated cathode valve shows a distinct advantage over the ordinary type.

The cathode, instead of consisting of a fine wire filament, now takes the form of a cylinder having an appreciable diameter, and so the ratio of grid to cathode diameter is at once very considerably reduced.

If in the K.L.1 the cathode were replaced by a tungsten filament of the same length, and more or less ordinary diameter, the mutual conductance would be much less.

Thus such a valve as the K.L.1 can be made with a high value of "mutual conductance" or $\frac{m}{R}$, and by re-

taining the relative disposition of its electrodes, may be constructed to show as low an impedance as the cathode emission will stand, whilst retaining a reasonably high voltage amplification factor, or, alternatively, with a high m for voltage amplifiers, without the attendant obligation of abnormally high internal resistance.

There being no voltage drop along the cathode as with an ordinary filament valve, high m values may be arranged for with the advantage—absent in the ordinary valve—that in this case the whole of the cathode will contribute to the anode current.

If V = the voltage difference between anode and cathode,

and v = voltage difference between grid and cathode,² then the current flowing from any small portion δl of the cathode is related to these voltages in the following manner:

$I \delta l$ is proportional to $\left(\frac{V}{m} + v \right)$ where m is the voltage amplification factor.

If the cathode is a wire filament through which a current is flowing, there is a continuous voltage drop along this filament, and the values V and v are continuously changing as we get further from the negative end. A simple substitution of actual values will show that for a high m valve there is no advantage to be gained in a long filament, the maximum useful filament voltage becoming less and less as the m of the valve is increased.

With the indirectly heated cathode type of valve this voltage drop along the cathode does not occur, and it is to be expected that, apart from its initial advantages, better characteristics could be obtained with this type at high m values than with the ordinary filament valve.

The principle of the indirectly heated cathode valve affords considerable scope for experimental work, as there are undoubted advantages by reason of the improvement in characteristics obtainable, as has been shown, and the fact that no potential drop occurs across the cathode is extremely useful.

The heater watts are of necessity somewhat high in order to provide sufficient radiation of heat, but when fed through a suitable transformer the current drawn from the supply is not by any means excessive.

² In practice v is usually negative.

THE SCREENED VALVE.

Will It Supersede Capacity Neutralisation?

In next week's issue there will appear an article on the new screened valves developed by Dr. Hull, which enable a high degree of stable H.F. amplification to be obtained without the complication of special balanced or neutralised circuits.

¹ Due to Sir J. J. Thompson.



Broadcast Brevities

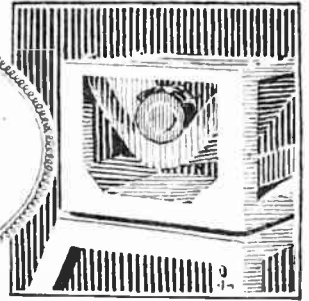

Savoy Hill Topicalities: By Our Special Correspondent.

Literature for Oscillators.—Inflating the News.—Goodbye Talks.—Indian Broadcasting Difficulties.—B.B.C. and Dominion Broadcasting.

New Oscillation Pamphlet.

That "best-seller," the B.B.C. Anti-Oscillation pamphlet, has run into so many thousands that there is a risk of its becoming hackneyed, which would never do.

I understand that a new edition, revised and enlarged, is being prepared in readiness for an Autumn offensive. It will probably appear in September.

○○○○

Dreary News.

"Never say in one word what you can say in a dozen," appears to be the motto these days of the Grand Moguls who prepare the B.B.C. news bulletins.

"In York, the famous Eboracum of the Romans, who first landed in this country in 55 B.C., there is a downward tendency in the market value of crustaceans." Thus the B.B.C. would deal with the news item "Crabs are cheaper in York."

But why worry? A diminishing number of people listen to these dreary recitals nowadays, which is the main reason why they escape criticism. The feminine element in the news is almost entirely absent.

○○○○

An Example from America.

The broadcasting of news is one of the things they do better in America. Listen any night to WGY, Schenectady, and hear the crisp little announcements, each of twenty words or so, touching lightly on more events in five minutes than the B.B.C. would cover in five hours.

○○○○

The Difference.

There are organ players and organ grinders; similarly there are people with the news sense and there are news grinders.

○○○○

John Henry Again.

The cast for the radio revue, "Calling and Recalling," by John Henry and R. Guy-Reeve, will include John Henry and Blossom, Marova, Franklyn Gilmour, Alma Vane, Philip Wade, and Henry Scatchard. The revue is to be heard by listeners on July 30.

Brussels Relays Ostend Kursaal.

During July and August "Radio Belgique," Brussels, is relaying twice weekly the Grand Concerts from the Kursaal at Ostend. These performances are of a high standard and are provided by artistes of international reputation.

Farewell Talks.

"Parting is such sweet sorrow," said Juliet; but she might have spared her tears if she had been a broadcast listener hearing a "farewell" talk. Such is the magnanimity of the British public that they could stand more farewell talks without a whimper.

Mr. Bletcher, the Spanish teacher, bade us adieu last week; *Philemon* said farewell last year. But perhaps the most poignant leave-taking was that of Mr. Eric Dunstan, the 2LO announcer, who left early this year to undertake the direction of Indian broadcasting. His final announcement was: "Good-night and—good-bye."

○○○○

Indian Programmes.

Mr. Dunstan's labours towards the establishment of Indian broadcasting on a firm basis will receive recognition on Saturday next, July 23rd, when the Indian Viceroy opens the Bombay station.

For a few months at least the transmissions will be limited to two or three hours daily, and I imagine that, in their efforts to appeal to both Indian and British interests, the directors of the Indian Broadcasting Co. will produce a rather striking medley of items.

○○○○

Posers for the I.B.C.

The problem of catering for a mixed population has always been a knotty one where broadcasting is concerned. Where it has occurred in Europe (in Belgium, for instance) language has been the doubtful factor. Music, which is generally regarded as a universal medium of expression, has hitherto overcome international barriers.

Oriental notions of what is and is not music differ from our own, however, and I should not be surprised if the I.B.C. finds itself "up against it." Who knows but what the native of an Indian "up-country village" would regard the languorous beauty of Liszt's "Liebestraum" as a tocsin call to battle?

Mr. Dunstan will have to be careful—very careful.

FUTURE FEATURES.

London.

JULY 24TH.—Menin Gate Ceremony. French National Programme.

JULY 26TH.—Emilio Colombo's Orchestra.

JULY 27TH.—Symphony Concert.

JULY 29TH.—Variety Programme.

Bournemouth.

JULY 24TH.—Service from Winchester Cathedral. Address by His Grace the Lord Archbishop of Upsala.

JULY 27TH.—A Concert of the Italian Sette Centesco.

Cardiff.

JULY 25TH.—A Welsh Programme.

Manchester.

JULY 30TH.—"On with the Show of 1927," relayed from the North Pier, Blackpool.

Newcastle.

JULY 26TH.—Concert by some of the winners at the North of England Musical Tournament.

Glasgow.

JULY 25TH.—"Bonnie Prince Charlie."

JULY 28TH.—Gems from Famous Operas.

Aberdeen.

JULY 29TH.—Scottish Programme.

Belfast.

JULY 27TH.—Visit of H.H. Princess Helena Victoria to the City of Belfast Young Men's Christian Association, relayed from the Wellington Hall.

JULY 28TH.—Military Tattoo, relayed from the Balmoral Show Ground.

Dominion Doubts.

"Nervousness" best describes the atmosphere at Savoy Hill regarding short-wave transmissions to the Dominions. The doubts and difficulties which seem to be robbing the Corporation of their schoolboy complexions can be briefly summarised as follow:—

- (1) Finance.
- (2) Who would receive the transmissions?
- (3) How could programme times be suitably adjusted to please all the Colonies and Dominions?
- (4) International copyright law.

Savoy Hill "Nerves."

Number (1) difficulty would probably vanish into thin air when the Dominions

On August Bank Holiday.

The Southern Command Tattoo will be relayed from Tidworth on August Bank Holiday from 9.35 to 11 p.m.

Novelties at the "Proms."

Music-lovers will welcome the B.B.C. announcement that the general scheme of the forthcoming season of Promenade Concerts at the Queen's Hall is to leave the best of the familiar features unchanged.

The curtailment of the season to six weeks has reduced the list of new works to the comparatively small number of ten. Of these, three come from abroad—Paul Hindemith's new Pianoforte Concerto No. 1, op. 36, will be given for the first time in this country on Saturday, Sep-

a willow grows aslant a brook," by Frank Bridge (Saturday, August 20th); Poem for Orchestra, "Elaine," by Susan Spain-Dunk (Thursday, August 25th) (these are first performances); a "Gaelic Fantasy," by B. Walton O'Donnell (Thursday, September 8th); Variations for Orchestra, by Victor Hely-Hutchinson (Saturday, September 10th) (these are novelties so far as the concert world is concerned, and the Hely-Hutchinson work was in the Carnegie Award List this year); Overture, "Portsmouth Point," by William Walton, first concert performance in London (Monday, September 12th) (the composers of the above works have all accepted invitations to conduct their respective compositions). The remaining two novelties will be conducted by Sir Henry J. Wood, namely, "A Seamen's Overture," by Dr. Thomas Wood, first concert performance in London (Tuesday, September 13th), and Five Preludes for Orchestra, by William Alwyn, first performance (Thursday, September 22nd).

Check-mating the Pirate.

There are indications that the number of "pirates" is on the increase; nor is the way of the transgressor made harder by the growing popularity of the self-contained portable.

The only practicable method of defeating the "pirate" would appear to be that adopted in South Africa, where purchasers of sets and parts are required to show their licence.

Poland's High-power Station.

Few broadcasting stations have a more imposing appearance than that of the "Polskie Radio" at Mokotow, a suburb of Warsaw, a photograph of which appears on this page. This station, which operates on a wavelength of 1,111 metres and a power of 10 kilowatts, gives excellent daily concerts at 8.30 p.m.

It is interesting to note that the station is of British construction, the transmitter having been built by the Marconi Company at Chelmsford.

An A. J. Alan Play.

"Fire," A. J. Alan's short play, which was written specially for broadcasting, will be repeated from 2LO on July 29th.

Eisteddfod Broadcasts.

Cardiff listeners will have the opportunity of hearing several of the concerts from the National Eisteddfod at Holyhead in the first week of August.

Bagpipes in the Studio.

Pipe Major George S. McLennan is to give another of his lecture recitals on "Bagpipe Music" to introduce Aberdeen's Scottish Programme on August 3rd. In the programme which follows, Joan Whitehead (mezzo-soprano) and James S. Buyers (violin) are the solo artistes. The main feature of the programme is the production of the play "Chatelard," written by Dr. C. Stewart, of Holyrood, in 1563.

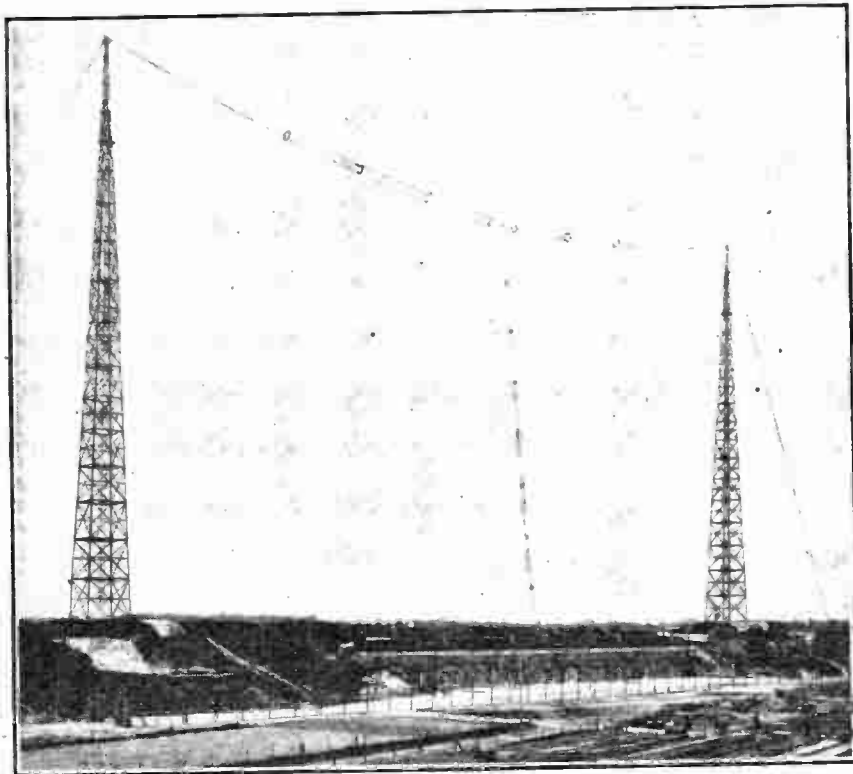

POLAND'S TEN KILOWATT STATION. A new photo of the recently erected broadcasting station at Mokotow, a suburb of Warsaw. The station, which is of British construction, is controlled by "Polskie Radio," which also directs the station at Cracow.

heard programmes from the Old Country. It is hard to imagine that they would shirk financial support of the service. No. (2) difficulty has already been solved in Australia and South Africa; there are willing amateurs everywhere who could pick up a good signal if the B.B.C. sent it; No. (3) does present problems, but a start could be made by pleasing South Africa, whose time is the same as ours. The question of copyright (No. (4)) is not insuperable; it is not necessary to send to the Dominions every item broadcast in this country.

But Savoy Hill is distinctly nervous about the whole affair.

tember 3rd, with Miss Gerda Nette (who has played the work at Leipzig, with Scherchen conducting, with great success) as soloist; a "Marche Turque," by Ippolitov-Ivanov, is down for Friday, August 26th; "Cortège et Litanie," for organ and orchestra, by M. Marcel Dupré, the well-known organist of the Cathedral of Notre-Dame, Paris, will be played by Mr. Fredk. B. Kiddle on Tuesday, September 6th.

Works by British Composers.

The English novelties are:— Impression for Orchestra, "There is

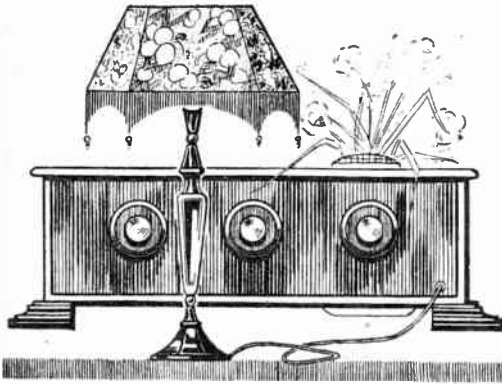

RESISTANCE-CAPACITY AMPLIFICATION.

By W. JAMES.

(Concluded from p. 46 of previous issue.)

Stray Capacities and their Effect on the Performance of Resistance Amplifiers.

SO far we have considered the valve as a resistance amplifier and described the effects produced by the coupling condenser. We have assumed that there were no stray capacities in the circuit, that neither the valve nor the coupling resistances had capacity. In practice they have capacities. This will in no way affect what has already been written, because we have confined our attention to the lower notes, but when we come to consider the notes of higher frequency, say, above 1,000 cycles per second, we shall see that the various shunting capacities play a very important part in determining the amplification. It is usual for the effect of the shunting capacities to be neglected except perhaps in the case where a bypass condenser is deliberately connected as to the anode of a rectifier. The reason for this is probably because it has not been realised that the working capacity of a valve may be very considerably greater than its static capacity, and once the existence of this working capacity is realised it is easy to see that the amplification of the higher notes may be reduced in strength by a large amount as compared with those of middle frequency. The existence of very large valve capacities immediately implies a connection between anode and grid circuits which may cause reaction effects and a diminution of the coupling impedances.

The Working Valve Capacity.

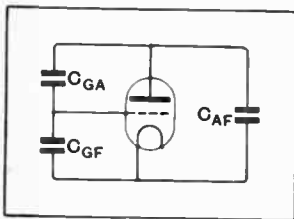

Fig. 13.—Inter-electrode capacities in a receiving valve.

are simplified we shall see that these capacities shunt the grid leak R_G which is in parallel with it, the anode coupling resistance R and the A.C. resistance of the valve, Fig. 15.

The latter resistance is in practice likely to be much less than the others, and it is therefore the important factor when we are dealing with the shunting capaci-

ties. It is not correct to consider the capacities as shunting the grid leak only, or the coupling resistance only, but it must be remembered that it is the A.C. resistance of the valve which is the controlling factor. That the working capacities across the grid and filament terminals of the valve may greatly exceed the static capacity will be evident if we consider what happens when an A.C. voltage is applied to the grid, Fig. 14. As the grid voltage rises the anode current increases, and the voltage across the coupling resistance increases; therefore, the voltage of the anode falls, and as the valve is amplifying, the anode voltage variations exceed the applied grid voltage. A current, therefore, passes from the anode to the grid circuit through the capacity of the grid and anode, and the magnitude of this current depends on the difference of the voltages and their phases. The

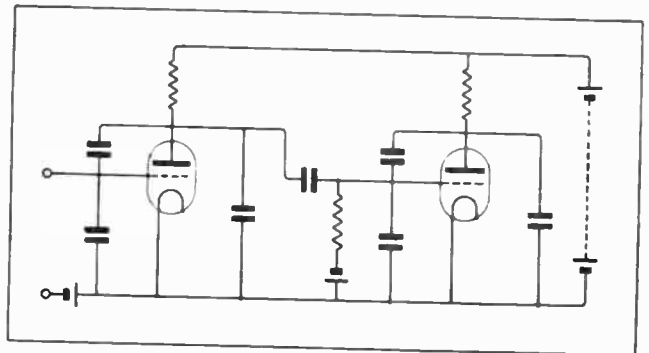

Fig. 14.—Distribution of valve capacities in a two-stage amplifier.

difference in the magnitude of the voltages will depend on the voltage factor and A.C. resistance of the valve and the value of the coupling resistance, while the working capacity will depend on the voltage amplification, the grid to anode capacity, and the grid to filament capacity. The most important capacity is that of the grid to anode; if this could be made very small the working capacity of the valve would also be small. It also follows that the working capacity is likely to be less when a valve with a lower voltage factor is used.

These effects have been described before. Von Ardenne, writing in *The Wireless World* of March 30th, 1927, distinguishes between the capacity of the valve

Resistance-capacity Amplification.—

electrodes and the working capacity, while the curves which he gives for a resistance-condenser amplifier show a marked falling-off in the amplification on the higher audio frequencies. Mr. Colebrook, writing in *Experimental Wireless* (April, 1927), seems not to have been aware of this effect when he wrote his article, "A New Development in Resistance Amplification," for he mentions the effect of $4 \mu\mu\text{F}$ across the grid leak, and recommends that this should not exceed 5 or 6 megohms. The working capacity is, of course, much greater than this, and, according to the work of Miller, may reach the value $(C_{GA}(1 + \mu) + C_{GF})$. Thus, if the grid-anode capacity is $5 \mu\mu\text{F}$ and the valve's voltage factor is 30, the effective grid capacity might well reach the value $150 \mu\mu\text{F} + C_{GF}$.

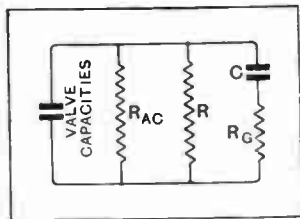

Fig. 15.—Equivalent circuit showing valve capacities in parallel with the anode resistance and valve A.C. resistance.

We do not suggest that this value is reached in practice, but we do intend to convey the idea that working capacities are of considerable magnitude and affect the amplification of the higher audio frequencies to an extent which is not always negligible.

Variation of Effective Resistance with Frequency.

Experience indicates that a working grid capacity of $60 \mu\mu\text{F}$, when using R.C. valves, is probable. Now, the effective resistance of a pure resistance R shunted by a condenser C may be found from

$$r = \frac{R}{1 + \omega^2 R^2 C^2}$$

For a resistance R of 250,000 ohms, and a capacity C of $60 \mu\mu\text{F}$, the following effective resistances are obtained:

| FREQUENCY. | EFFECTIVE RESISTANCE. |
|--------------|-----------------------|
| | ohms. |
| 2,000 | 240,000 |
| 4,000 | 220,000 |
| 6,000 | 190,000 |
| 8,000 | 160,000 |
| 10,000 | 130,000 |

For a resistance R of 500,000 ohms, and a capacity C of $60 \mu\mu\text{F}$, we obtain the following values:

| FREQUENCY. | EFFECTIVE RESISTANCE. |
|--------------|-----------------------|
| | ohms. |
| 2,000 | 440,000 |
| 4,000 | 320,000 |
| 6,000 | 220,000 |
| 8,000 | 153,000 |
| 10,000 | 110,000 |

The following values may be of interest as applying in the case when a by-pass condenser is used as in a rectifier: Resistance, 100,000 ohms; capacity, 0.0002 microfarad; $f = 4,000$ cycles; effective resistance = 95,000.

Resistance, 100,000 ohms; capacity, 0.0003 microfarad; $f = 4,000$; effective resistance, 80,000 ohms.

Resistance, 100,000 ohms; capacity, 0.0005 microfarad; $f = 4,000$; effective resistance, 39,000 ohms.

From these figures it is apparent that our resistance amplifier will not magnify the higher audio frequencies to the same extent as those of middle frequency, and it is also clear that the effect of the working capacities becomes of more importance in controlling the amplification the higher the resistances in the circuit. For instance, two R.C. valves coupled through a resistance of 1 megohm with a grid leak of 5 megohms will not give as high a percentage of the full amplification as when a 0.5 megohm coupling resistance with a grid leak of 2 megohms is used.

It is important to note that the falling off in the amplification will depend on the arrangement of the amplifier; for instance, we will take as an example the receiver of Fig. 16, which comprises a detector and two low-frequency stages. Valve V_1 will normally have a very high A.C. resistance because it is working as an anode rectifier, when the effect of valve V_2 , which is of the R.C. type having a high voltage factor and A.C. resistance, will be to put a large capacity in the circuit. The voltage applied to the grid of valve V_2 may, therefore, be considerably less for the higher frequencies than for those of middle frequency; perhaps the amplification of a 5,000-cycle note will be 60 or 70 per cent. of a 1,000-cycle note. The characteristic of the stage V_2, V_3 , will be different to this, however, because normally a power valve having a voltage factor of about 5 will be used in the last stage. The working capacity

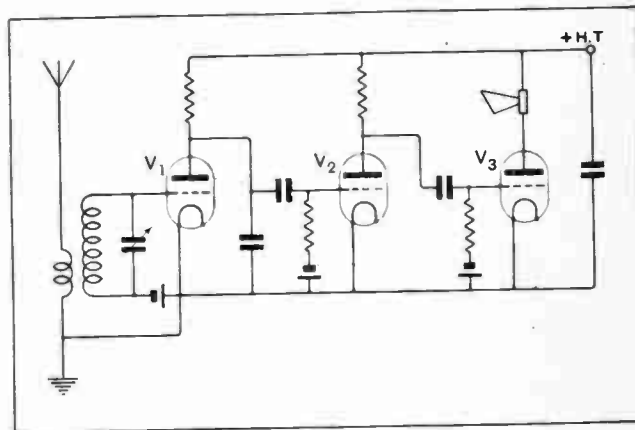

Fig. 16.—Typical receiver comprising a detector, a resistance amplifier and a power output valve.

of this valve which is shunted across the coupling connected to V_2 will, therefore, be low as compared with that across the coupling connected to V_1 . This stage may, therefore, give an amplification at 5,000 cycles of 90 per cent. of the full amount at 1,000 cycles. The proportionate amplification of the higher audio frequencies could, of course, be raised by using a valve with a lower voltage factor and, therefore, of lower A.C. resistance at V_2 , or we could lower the resistance of the detector circuit by employing a coupling resistance of low value at the detector. A falling off in the proportionate amplification at 5,000 cycles of 50 per cent. is probably not too serious. But this, taken in conjunction with the cut-off of the bass frequencies, gives the fre-

Resistance-capacity Amplification.—

frequency characteristic of a resistance-coupled amplifier using higher coupling resistance quite a humped appearance instead of the straight line which it is usually represented as having.

When the effect of a by-pass condenser connected to the anode of the detector is taken into account it is clear that great precautions have to be taken if an undue loss

using valves having a moderate A.C. resistance instead of a high one almost invariably result in a lower voltage amplification for the stage taken on the most favourable frequency. But when good quality of reproduction is the main consideration, it is necessary to sacrifice amplification in order to approach more nearly to the level frequency amplification curve.

We therefore see that it is the coupling condenser

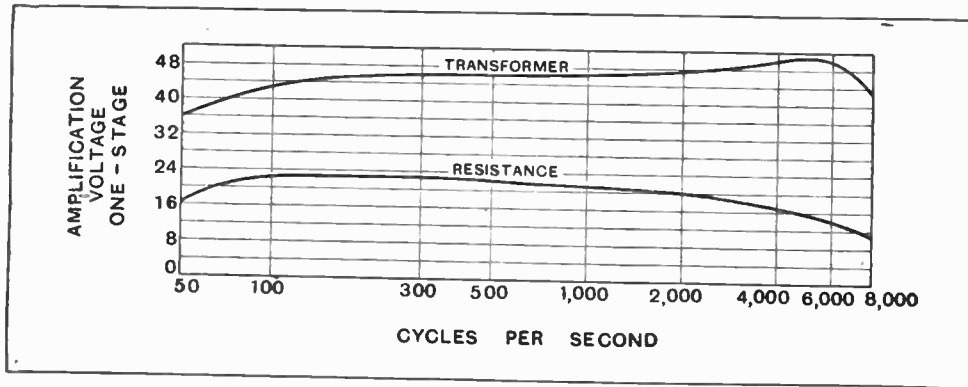

Fig. 17.—Calculated curve for a well-designed resistance amplifier compared with that of a transformer-coupled amplifier of good quality.

of high notes is not to be experienced. For this reason it is necessary to limit the ohmic resistance of the coupling resistance used and to employ valves which have a moderate working A.C. resistance. Of course, the A.C. resistance of the valves can be reduced by increasing the value of the anode battery, but usually there is a limit beyond which it is not economical to go. The valve's A.C. resistance is also cut down by using the smallest possible negative grid bias, bearing in mind that this must have a certain minimum value as explained above. Efforts to lower the working resistance in the circuit by reducing the coupling resistance and grid leak and by

but it is the type of curve likely to be obtained in practice. It can be said quite definitely that many of the resistance-condenser amplifiers put out for the benefit of home constructors by various manufacturers have a curve much worse than the one given in Fig. 17.

Resistance-condenser coupled amplifiers can be used for high-frequency amplification provided certain precautions are taken as regards the values of the components and the valves used, but this subject will be left for the moment, and will be dealt with when describing the construction of a suitable amplifier.

Burndep Wireless Ltd.

In connection with the affairs of Burndep Wireless Ltd., we learn that the recent appointment by the Court of a Receiver and Manager does not imply that the business is to close down. The manufacturing, as well as the sales side, of the business is being continued, and work will proceed in the direction of research and development.

o o o o

Is This a Valve Record?

The longevity of valves is a topic which interests most wireless amateurs. It would be interesting to know what is the record life of a valve which has been in constant use.

A customer of the General Electric Co., Ltd., who writes from Redland, Bristol, says: "Having seen a number of advertisements lately proclaiming the long life of valves, I thought that you might be interested in the 'Osram' R4B which I enclose herewith.

"I purchased this valve in June, 1921, and since that date it has been in almost constant use, either on an ordinary broad-

**NEWS FROM THE
TRADE.**

cast receiver or for experimental purposes. It has had very rough usage, and among other things, has been used as a low power transmitter with 400 volts on the plate. In spite of this, however the valve is still intact and in perfect working order."

o o o o

Stolen Correspondence.

Messrs. The B and J. Wireless Co., of 2, Athelstane Mews, Stroud Green Road, London, N.4, advise us that on Saturday, July 9th, their letter box was rifled and the thief succeeded in making his escape. "Wireless World" readers who may have responded to the Company's advertisements in this journal and who have received no reply are asked kindly to write again as their previous

communications may have disappeared through the same cause.

o o o o

Ebonart Station Log.

In future each purchaser of a Redfern "Ebonart" radio panel will receive a useful station log chart which is being presented free of charge to each purchaser.

Catalogues Received.

Fuller Accumulator Co. (1926), Ltd., Woodland Works, Chadwell Heath, Essex. New list, No. 266, describing radio accumulators in glass containers, types SDG, LDG, RHG, etc., etc.

o o o o

De Forest Radio Corporation, Ltd., 245, Carlaw Avenue, Toronto, Canada. Brochure descriptive of de Forest-Crosley radio. Also illustrated catalogue of the Royal series of de Forest-Crosley broadcast receivers.

o o o o

Philips Lamps, Ltd., Philips House, 145, Charing Cross Road, London, W.C.2. Leaflet No. 82, dealing with the Philips battery charger (No. 1001) for charging H.T. accumulators from A.C. mains.



The Editor does not hold himself responsible for the opinions of his correspondents.

Correspondence should be addressed to the Editor, "The Wireless World," Dorset House, Tadr Street, E.C.4, and must be accompanied by the writer's name and address.

EMPIRE BROADCASTING.

Sir,—As a lonely dweller on a plantation who has had to rely on a gramophone for all his music except for an occasional concert in Darjeeling, half a day's journey away, and that only once or twice in a year, I should like to add my thanks to those of others for your advocacy of Empire broadcasting. There are many in this country who would feel that they were no longer isolated from the Old Country if they could get the news of the day and the home concerts.

There are more than a few who have tried hard to get this already by installing various forms of receivers for the ordinary broadcasting wavelengths with, however, conspicuous lack of success. But now that short waves have reached India so successfully some of us would like to anticipate the Empire broadcasting and build sets to catch any further Dutch or American transmissions, or anything that will be going, and would be grateful if you could give us an article on the very best set that is possible up to date to receive these attenuated short waves.¹ Here in North East India we are 5,000 miles from England!

B. E. SHAW.

Mungpoo, Bengal.
June 18th, 1927.

Sir,—I have followed with interest the articles and correspondence on Empire broadcasting in your recent issues. Out here the Continental stations pour in, and Daventry is but a "faint voice crying in the wilderness." And with a local high-power C.W. station working on 4,800 metres that faint voice is usually "knocked out" by harmonics.

But 2XAF and KDKA (and now PCJJ) come in strongly with very little interference, even in summer weather.

A British short-wave station would be appreciated here.
Malta, July 7th, 1927.

W. W. H.

Sir,—In connection with the correspondence concerning the proposed Empire station, there are, I think, a number of salient points which appear to have been lost sight of by several of your contributors.

In the first place, what exactly do we understand by the term "Empire Station"?

As I see it, we mean a broadcast station which is capable of direct and regular transmission from England to all parts of the British Empire of all events of Imperial importance.

Although one appreciates to the full the satisfaction with which listeners in, say, India, have received the musical items of the London or Daventry programmes, I think that the Colonies themselves would be the first to realise that this, as a regular item of broadcasting, should be provided by their own stations. In other words, entertainment (save in special cases) as such—the form of which depends largely on local psychology and environment—is primarily a matter for Dominion and Colonial enterprise, leaving the function of the Empire station as broadly defined above.

In the second place many people appear to be under the impression that the responsibility for the design, erection, and maintenance of such a station lies with, or is a function of, the British Broadcasting Corporation.

Without holding any brief for that organisation, save the interest which one who was for some years a member of their engineering staff naturally feels, this is clearly not a matter for

which the corporation can be blamed. As anyone who takes the trouble carefully to examine the constitution of the B.B.C. will find the establishment, or otherwise, of an Empire station does not, *per se*, rest with them. In this connection it is perhaps pertinent to ask under what authority the B.B.C. have recently approached the Dominion Government with a view to financial aid in constructing such a station.

This brings me to my third point, namely, that the B.B.C. does not appear, in my opinion, to be the right organisation to entrust with the design or construction of an Empire short-wave broadcast station.

Rightly or wrongly, they have concentrated their finance and technical knowledge on the development of long and medium wave broadcast as it affects the British Isles only. Considering this development from purely the engineering aspect, there can be no doubt that the B.B.C. is well ahead of all other countries, but I question strongly if their policy of deprecating short-wave development fits them either by experience or ability to undertake the design of an Empire station. Lest I be misunderstood, I would wish to make it quite clear that I do not cast any criticism on the technical qualifications of their engineers, but rather on the policy of the Corporation which has prevented the expenditure of both time and money on this modern phase of broadcasting and thereby losing to their engineers the experience which is so necessary.

As a professional radio engineer who has been intimately connected with short-wave research since its inception, I would suggest that at the present time there exists no serious technical difficulty which can further delay the construction of such a station, and I would further assert that there are in this country a number of radio engineers outside the virtual monopoly held by the Post Office, Marconi's, and the B.B.C. who are quite capable of preparing detailed specifications for this station, and who, moreover, should be given the chance of competing on merit alone with that monopoly.

In conclusion it will, I think, be obvious that the Empire broadcast station must become a charge on Imperial finance. This is a matter for the authorities, but in the meantime it is quite time that tenders were called for in such a manner and under such control as will ensure a contract being placed with an all-British concern on a competitive basis.

Berkhamsted.
July 8th, 1927.

G. L. MORROW.

Sir,—May I take up a little of your valuable space to suggest to Mr. Jas. Hudson that his letter, published in the issue of *The Wireless World* for July 6th, might have been written in a slightly less selfish manner?

The erection of a suitable short-wave station for Empire broadcasting would, I think, help to show the Colonies that they are affectionately remembered by the "Old Country," and would indicate some appreciation by people here of the proverbial kindness of Colonials to visitors from these islands.

The Dutch station referred to by Mr. Hudson indicates a splendid way of keeping the Colonies in close contact with events here, and we ought to be grateful to the erectors of this station, and to many amateur transmitters, too, for showing us such a way.

With regard to the "value for money" aspect of Mr. Hudson's letter, may I suggest that Mr. Hudson obtains an extraordinarily fine broadcast service for a very small outlay per broadcast programme.

¹An article meeting our correspondent's requirements was published in the June 29th issue.—ED.

If he must have alternative programmes, let him build a set which will give him the choice of programmes which he wants. Many such sets have been described in *The Wireless World* from time to time.

As a licensee holding licences for two receiving stations, may I state emphatically that it would give me great pleasure to pay considerably more per licence, if by doing so I should assist in erecting and maintaining a station which would enable the Colonies to enjoy our programmes.

C. H. SYKES.
London, W.9.
July 6th, 1927.

Sir,—The letter published by you in the current issue of your journal over the signature of Mr. G. H. F. Sadler gives your readers the impression that my society is indifferent to this important matter, and is doing nothing to bring about the desired result. I would hasten to assure Mr. Sadler and your other correspondents that the Incorporated Radio Society of Great Britain are very much alive to the necessities for the establishment of an Empire system of broadcasting.

As one of the society's representatives upon the Radio Association's Advisory Committee, I have been insistent upon the importance of the matter, as the minutes of the meetings will show.

At first I was informed that the Corporation was itself considering the erection of a suitable short-wave station, but that it would be some eight or nine months before a service could be started. I then put in an offer from one of our members, Mr. G. Marcuse, to transmit part of the broadcast programme from London for two hours on three evenings a week. This offer was courteously received, but the fact was then made prominent that the existing licence held by Mr. Marcuse did not permit of the transmission of extended programmes in service form, the longest period of any one transmission being ten minutes with a maximum transmission of one hour per day. I then approached the Postmaster-General on behalf of the society to obtain the facilities for Mr. Marcuse, when I was informed that Mr. Marcuse had since applied direct. I understand that negotiations have now been completed for a limited experimental service to be carried out.

I would like, on behalf of my society, to thank Mr. Dallas Bower for his appreciative remarks and confidence in the abilities of the British amateur to do as good as the Dutch transmitters, but I must take emphatic exception to his remark that the T. and R. Section has never distinguished itself very greatly in any direction. This remark rather discounts the value of Mr. Bower's appreciation, for it definitely shows that he is not in possession of facts. The work of the T. and R. Section, of which I had the honour to be chairman for three years, has been highly appreciated by all who have belonged to it. The membership is close on 1,000, and though now merged into the membership of the main body is constantly being added to.

Mr. Bower and others appear to overlook two great difficulties in this matter, i.e., the fact that our experimental licences are inadequate, and, secondly, that most broadcast matter is copyright.

H. BEVAN SWIFT, Hon. Sec.,
London, S.W.1.
July 8th, 1927.

Inc. Radio Society of Great Britain.

Sir,—I would like clearly to define my position with regard to short-wave long-distance telephony and thereby correct certain statements which have appeared in the Press, technical and otherwise.

I have realised for some years, after extensive experiments on short-wave long-distance telephony, that our brother enthusiasts in distant parts of this wonderful Empire of ours think more of hearing a few words from the Old Country than all the other broadcasting in the world, and I am sure everyone who has travelled extensively off the beaten track, as I have done, realises the thrill enjoyed by those who live in isolated districts thousands of miles from England when they hear Big Ben striking the hour of midnight, or even the voice of a Britisher. I have had unlimited proof of these facts since I commenced my short-wave telephony experiments.

Out of enthusiasm and patriotism I evolved a scheme for giving

distant parts of the British Empire a skeleton programme of six to eight hours a week, and with this project in mind I approached the B.B.C. through the advisory committee with a view to relaying a part of their programmes, not including any news bulletin, all the expense to be borne by myself.

The Advisory Committee discussed my offer and approved it, and passed it on to the powers that be of the B.B.C., who have, I understand, although I have had no official intimation, rejected my offer. On the other hand, I have placed a skeleton scheme before the Postmaster-General, who, subject to possible ratifications, has provisionally and verbally approved it, and I have also had valuable private offers of a studio and first-class talent from other sources.

The foregoing shows, I think, the nature of my offer, and will, I hope, clear up any possible misunderstanding which may have arisen.

GERALD MARCUSE, Vice-President of
Caterham. The International Amateur Radio Union, etc.
July 7th, 1927.

Sir,—Although I am not one of the more famous members of the transmitting fraternity, and consequently may not command so great a hearing, nevertheless I feel I should like to state my views on the subject and to reply to one letter in particular. I refer to that from Mr. Dallas Bower in the issue of July 6th.

I cannot understand why he should think that the B.B.C. should build and maintain an expensive transmitter to provide programmes to listeners who contribute nothing to its cost.

I have always thought that B.B.C. stood for British Broadcasting Corporation, not, as Mr. Bower would have it, Broadcasting Britain Corporation.

It must be understood that I hold no brief for the B.B.C., but I think it is right that some comment should be made on schemes such as those put forward by your correspondent.

If the Dominions want the British programmes, let them finance them, and if they want the B.B.C. to provide them, then they should pay for the service. The B.B.C. is supported by public contribution, and is not in the nature of a philanthropic society. Their annual income is not magnificent when out of it over twenty stations have to be maintained.

Much has been said concerning 2XAF, KDKA, and PCJJ, but no one seems to realise that all these stations are owned by great manufacturing companies, who erected them primarily for purposes of technical research. The B.B.C. are not manufacturers, neither are they research laboratories. Their function is to provide programmes of speech and music to their subscribers, granted that this also entails a good deal of research work, but the latter is a secondary factor consequent on the former.

I most heartily agree that it would be a splendid thing to link up the Empire by means of broadcasting, but it is a job either for a company who are paid for their services, or else for the Government, and the B.B.C. is not a Government Department, neither is it Government controlled any more than a railway company is.

I have had considerable dealings with the B.B.C. from time to time and have always found them extremely polite and ready to listen to suggestions. A body which depends for its revenue on the voluntary contribution of the public cannot afford to neglect its subscribers in the manner Mr. Bower suggests.

I cannot imagine what can be the source from which he obtained his information. For example, he does not know that CQ is not used by British amateurs, also let him remember that it was these "talkers of American nonsense with their childish OM's and FB's" who demonstrated the possibilities of ultra-short-wave telephony to a sceptical world. The amateur radio movement is a great power for international peace and good fellowship, besides its research and experimental uses, a power the magnitude of which is colossal.

To return to Empire broadcasting. Mr. Bower suggests that the T. and R. should pay for it. Why on earth should everyone, except those for whom the service is intended, be expected to pay?

ARTHUR O. MILNE (G 2MI).
Broadstairs.
July 6th, 1927.

Sir,—As an interested reader of the correspondence, in your columns, on Empire broadcasting, might I be allowed to put the average amateur transmitter's side of the question before Mr. Dallas Bower and others?

He accuses us of being too interested in the telegraphy side of transmission to deign to take any interest in "mere broadcasting." I am sure that most of your readers know that this is far from being the case, and that, on the contrary, most of us would be only too willing to carry out some of the preliminary work in the foundation of an Empire broadcasting service.

As, however, the majority of us at present work under conditions laid down by the P.M.G., certain rules make the matter of any form of continuous rebroadcasting practically impossible. To quote but two examples of these conditions: (1) "The total period of transmission shall not exceed . . . ten minutes in any one hour between 8 a.m. and 11 p.m. G.M.T., or fifteen minutes in any one hour between 11 p.m. and 8 a.m. G.M.T." (2) "The transmission of general calls or the transmission of news . . . or of a non-experimental character is expressly forbidden."

However, with regard to the last condition, rebroadcasting would probably be considered as an experimental transmission, but, nevertheless, who would be willing to listen-in for an hour for the purpose of hearing fifteen minutes' transmission?

Mr. Dallas Bower will observe from this that the amateurs are not entirely to blame.

I am glad to see that it is probable that 2NM will be permitted to carry out experimental relays of broadcast programmes, and I am sure all *The Wireless World* readers will join with me in wishing him the best of luck in his enterprise. Then, once again, the amateur may show the sceptics on the B.B.C. staff and elsewhere that Empire broadcasting is not only a possibility, but an established certainty.

In this connection we must always remember that, so far back as 1925, 2NM, 2LZ, and others succeeded in relaying the London programme to all parts of the world.

New Malden. ERNEST A. DEDMAN (G 2NH).
July 6th, 1927.

Sir,—As an amateur transmitter and a member of the T. and R. section of the Radio Society of Great Britain, I feel I must take exception to certain remarks made by Mr. Dallas Bower in your issue of July 6th under the heading "Empire Broadcasting."

While in agreement with this very laudable object, I do not think it necessary to sling ink at the amateur movement.

The transmission side of radio to-day is far in advance of the receiving side, and it is the T. and R. members who have been "busy sending their childish little OM's, FB's, YL's, etc." that has brought this about. He also states that 2OD, 2NM, 2LZ, etc., would be pleased to carry out relaying B.B.C. programmes. No doubt they would, but I would remind Mr. Bower that in England the Post Office, and not the T. and R., govern all radio activities. If Mr. Bower has ever done any short-wave receiving or transmission, he would understand some of the difficulties to be overcome. I think then he would be a little more sympathetic and not so ready to throw mud at a body of men who have no voice in the country's broadcast activities.

I fancy that if the B.B.C. established a short-wave station and it was only an indifferent success, a certain section of the public would stand up on their hind legs and shout about their money being wasted.

Weybridge.
July 6th, 1927.

Sir,—As a "seriously minded" experimenter carrying out preliminary short-wave work, I beg a little space to reply to Mr. D. Bower's letter dated June 23rd.

In the first place, I have always found the engineering staff of the B.B.C. highly intelligent, business-like, and most anxious to help where genuine cases are concerned. I am sure their technical department is willing to explain the difference between kilocycles and picofarads.

I would like to know whether Mr. Bower heard the B.B.C.

relay of a Canadian transmission last week. I believe I am correct in stating that the Marconi beam station participated in this test, and I suggest that if the results then obtained are an example of what the world's greatest radio engineers can do, then it is a poor look-out for Empire broadcasting.

Has Mr. Bower ever listened with the aid of three valves and a good quality loud-speaker to station 2XAD operating on a wavelength of approximately 20 metres? Perhaps he can explain the successful regular fading.

I shall be glad to learn if it is possible to broadcast to New Zealand on 31 metres (calling Test) with an input power limited by the Post Office to 10 watts.

In response to Mr. Hudson, I quite agree that the B.B.C. are not really Communistic in their views, and I think that the Government ought to subsidise such an excellent scheme as Empire broadcasting. Finally, I wish Mr. Bower 73 es CUL.
Sutton Coldfield.

FRANK A. ROBINSON.

July 11th, 1927.

HARMONICS FROM THE LAFAYETTE STATION.

Sir,—As an exile living in south-west France, I am wondering if anything can be done to enable us to keep in touch with the home country by wireless, which at the moment is quite impossible.

I have an excellent French four-valve set which can give me Daventry with all the strength and purity one can desire except when the *parasites* are about. Now these *parasites* are of two kinds, those which are caused by the electrical disturbances in the atmosphere which we cannot help, and interfering Morse stations which we can help. I refer especially to Croix d'Hins, between Bordeaux and Arachon, which owing to alterations or repairs is now transmitting by *arc* on a wavelength which absolutely obliterates both Daventry and Radio-Paris. It goes on almost without ceasing night and day, and the nuisance is absolutely intolerable.

Thousands of local wireless enthusiasts have protested, and the director of the station has been besought not to transmit for certain periods during broadcasting hours, but the matter should be brought further, and the International Wireless Convention should try to get the wavelengths altered so that Daventry and Radio-Paris are left clear. Hoping that something may be done I sign myself

SANSFILISTE.
Libourne, France.
June 30th, 1927.

BIG BEN.

Sir,—Our attention has been drawn to a paragraph appearing in your issue of June 22nd, 1927, under the heading "When Big Ben Errs." The report from which the "errors" were drawn seems to have mystified the writer of the paragraph, and we thought it might interest your readers if we gave the actual performance of the clock. The clock automatically telegraphs its time, and the figures given were taken by our instruments which are in the Greenwich circuit.

| | |
|--|--------------------------|
| | 304 Days. |
| 38 days | Greenwich Mean Time. |
| 91 " | Did not exceed 0.2 secs. |
| 110 " | " " 0.5 secs. |
| 59 " | " " 1.0 secs. |
| 6 " .. over 1.0 but did not exceed 1.3 secs. | |

304

As custodians of the clock we are anxious to elucidate the mystery, and in our opinion there is no more satisfactory way than to give the actual figures after making allowances for the two seconds, as the clock was intentionally kept two seconds fast during the period.

This statement is in no way connected with the Astronomer-Royal's report, and is given as stated above to make quite clear that the rate of the clock, which is a turret clock, is particularly good and almost constitutes a record.

London, S.W.1. E. DENT & CO., LTD.
July 9th, 1927.

Readers Problems

"The Wireless World" Information Department Conducts a Free Service of Replies to Readers' Queries. Questions should be concisely worded, and headed "Information Department." Each question must be accompanied by a stamped addressed envelope for postal reply.

Choke Filter Circuits.

I intend to build into my receiver a choke filter output circuit, using two fixed condensers as shown in the attached sketch, in order to isolate completely the loud-speaker from the H.T. battery. Can you tell me the correct value of these condensers and whether my scheme is a sound one?

T. D. M.

We reproduce your sketch in Fig. 1 (b) on this page, together with Figs. 1 (a) and 1 (c), for explanatory purposes. Referring to Fig. 1 (a), it will be realised that although one side of the loud-speaker or telephones is connected to H.T.+, yet no D.C. current flows through the loud-speaker, owing to the presence of the fixed condenser. Furthermore, the 2-mfd. condenser offers a very low impedance to the passage of the audio frequencies even at the bottom end of the scale. There is not the slightest advantage to be gained by adopting your scheme, which is shown in (b), because there was already in (a) no D.C. current flowing through the loud-speaker. Actually, (b) confers a distinct disadvantage, because we have two 2-mfd. condensers in series, which from the point of view of the passage of alternating current have twice the impedance of one, since of course they act in the same way as if one 1-mfd. condenser had been used in (a);

in other words, the impedance of the loud-speaker circuit to the lower musical frequencies is raised disproportionately to the raising of the impedance with respect to the higher musical frequencies, and so we get a distinct sacrifice of the lower musical notes. In order to overcome this we should have to use two 4-mfd. condensers in (b).

In the case of (a), the usual condenser value of 2 mfd. is used; slightly better reproduction of the lower frequencies will be obtained by using a 4-mfd. condenser in this position (or in the case of (b) using two 8-mfd. condensers), but no appreciable advantage will be gained by using any larger capacity.

Fig. 1 (b) has, however, one advantage over Fig. 1 (a), and that is in a case where the loud-speaker was to be used at a considerable distance from the receiver, it will be appreciated that one side of the telephones or loud-speaker in (a) connects direct to H.T.+, and since H.T.— is earthed in most sets it will be obvious that should the long extension wire uniting H.T.+ and loud-speaker come into contact with any earthed object, then the H.T. battery will be short-circuited. Fig. 1 (b) obviates this disadvantage, but brings in the other disadvantage we have mentioned. The very simple expedient of adopting Fig. 1 (c) will completely rid us of the disadvantages which we have mentioned in the cases of (a) and (b). It

will be appreciated that it is not absolutely necessary in the case of (c) to extend both leads to the loud-speaker; only the lead uniting the loud-speaker to the 2-mfd. condenser need be extended, and the other terminal of the loud-speaker can be connected to a distant earth connection, thus making use of the single-wire loud-speaker extension system which has frequently been dealt with in this journal.

○○○○

H.F. Transformer Connections.

I have in my possession a "Wireless World Five" receiver constructed to the specification published in the issues of The Wireless World for January 5th and 12th last. The waveband covered by the H.F. transformers is higher than that stated in the article. This is not restricted to any one circuit, as both H.F. condensers tune at approximately the same dial readings.

R. A. S.

The reason your high-frequency transformers tune higher than normal may be due to the primary and neutralising windings being wound on the high potential end of the secondary coil, whereas in the constructional article these windings appear at the low potential end of the coil. This can be very simply corrected by reversing the connections to the secondary coil of each H.F. transformer. The proper connections to transformers of this construction are dealt with in an article entitled "Transformer Connections," which appeared under the heading "Hints and Tips" on page 619 of the May 18th issue.

○○○○

Wooden Panels.

I am about to make-up the "All-Wave Four" receiver, but should like, if possible, to use a wooden panel. I intend to bush the terminals. Will the same precaution be necessary in the case of the condenser spindles?

W. E.

Provided your panel is made of really dry wood, there is little reason why this material should not be satisfactory. We consider that it is quite unnecessary to bush the spindles of the tuning condensers, as they are all very nearly at earth potential.

Regarding the neutralising condenser, however, it would, perhaps, be as well to provide additional insulation.

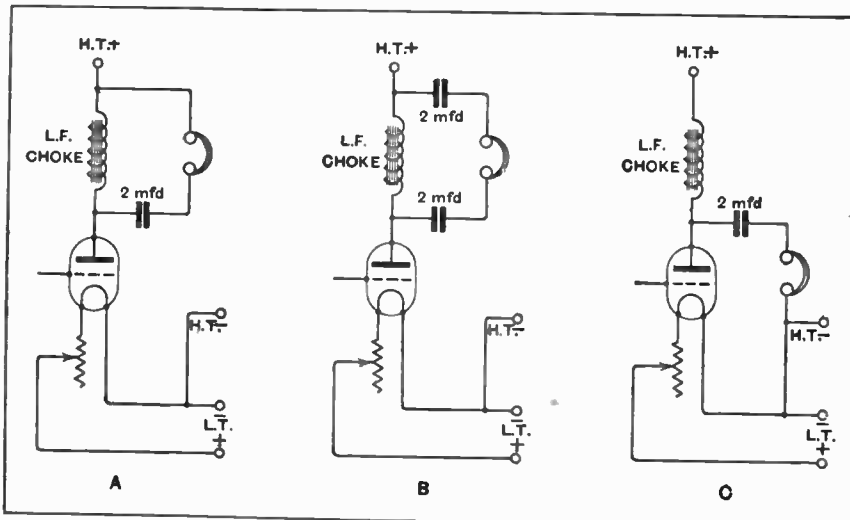

Fig. 1—Three typical choke-filter or output circuits.

L.F. Oscillation.

During the past few days my receiver has developed a high pitched whistle which persists irrespective of grid bias or H.T. adjustments. The receiver in question consists of a detector valve and two stages with transformer coupled L.F. valves, and has always given satisfactory results since its construction six months ago. I am mystified and at a loss to account for this, and would therefore appreciate any assistance you can give that would enable me to cure the above fault.

T. P.

The whistle to which you refer is without doubt due to low-frequency oscillation of the L.F. amplifier. The presence of a high resistance in the H.T. leads from the amplifier will result in an oscillation of the nature described, and in a number of cases can be cured by reversing the secondary connections to one of the L.F. transformers. In view of the fact that your receiver has only recently developed this fault we think it may be due to an increase in the internal resistance of your battery. H.T. batteries of the dry cell type develop a high internal resistance after some months of use, but if a large capacity condenser is connected between each H.T. lead and negative battery, any increase in the internal resistance of the latter will not affect the receiver. The reason for this is that a condenser of about 4 mfd. acts as a path of comparatively low resistance to frequencies within the audible scale, and an alternate path is therefore provided for the L.F. oscillations.

o o o o

Vanishing Volts.

I have built a battery eliminator for D.C. mains, and have arranged that the maximum voltage of the mains, namely, 210 volts, be applied to the output valve, which is a very large power valve. My smoothing system consists of several large fixed condensers, and also a choke consisting of a good L.F. transformer with its primary and secondary in series. I might mention that I am running the detector from a dry cell H.T. My trouble is that hum is bad, and also I do not appear to be getting anywhere near the voltage on my last valve which I should get. Can you explain a likely cause of the trouble?

—M. K.

In the first place we would say that under no circumstances should an L.F. transformer be used as a smoothing choke, since, owing to the nature of its construction, it will not carry very many milliamperes before the core saturates and renders it useless for smoothing purposes, and if you are using a large power valve you will have a very heavy plate current. You must use a properly constructed choke of about 20 henries inductance, having its core designed to deal with the heavy plate current of a power valve without saturating.

Then, again, the D.C. resistance of your "choke" will probably be very high indeed, and you will drop a large number

of volts across the choke. Your D.C. resistance must be kept as low as possible, and here the properly designed smoothing choke caters for this also by having a low D.C. resistance.

o o o o

"To What Base Uses—"

Although the following matter is probably rather beyond the normal scope of your information service, I should be very glad of an expression of opinion as to how the trick described is carried out.

I recently saw a street vendor offering for sale a "magic" crystal which was claimed to be infinitely more sensitive than any other known make. A specimen was mounted in what seemed to be an ordinary crystal set with no aerial-earth system but with a ridiculously small frame. The whole was raised above the stand on short glass pillars "to show there was no deception." A single earphone on a handle was connected, and on-lookers were invited to listen to—apparently—signals from the local station about three miles away at very good strength.

My curiosity being excited, I ventured sixpence for a specimen, but was hardly surprised on trying it to find that it was in no way superior to ordinary treated galena. My friends, to whom I have been rash enough to confide the story, "chaff" me unmercifully, but cannot put forward a plausible explanation.

E. M.

We consider it likely that the enterprising trader had concealed in his stand a single reacting valve connected to a small frame. Probably a form of "Hartley" circuit was used, as shown in Fig.

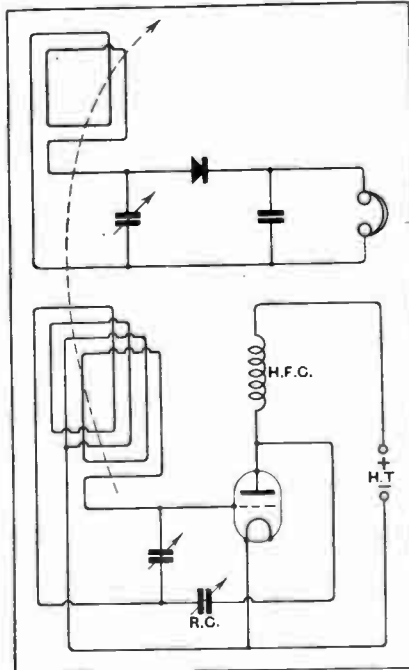

Fig. 2.—A possible method of receiving strong signals on a crystal-frame aerial set.

2. This would be permanently tuned to the local station wavelength, and a part of the amplified H.F. energy in the frame could be passed on to the crystal detector by induction between the two frames, provided that the respective positions were suitably arranged. Under these conditions good phone signals might easily be obtained at ten miles or more.

o o o o

An H.F. Amplifying Unit.

I am wondering if it would be possible to construct a 200-600-metre H.F. amplifier on the lines of the long-wave H.F. unit for the "Nucleus Receiver" described in your issue of May 18th. If possible, I should like to wind the transformer in a similar manner, and would appreciate some hints on this matter.

R. P.

The circuit of this unit is quite applicable to the broadcast waveband, although many users might consider the third tuning control to be a disadvantage. A similar form of H.F. transformer construction (in which a commercial coil with its plug removed is used as a secondary) may be adopted. We suggest that you use a No. 75 coil, and we would recommend 15 turns of No. 40 D.S.C. wire in both primary and neutralising windings. These would be arranged exactly as in the long-wave transformer.

o o o o

L.F. Instability.

My "Everyman-Four" set worked extremely well when batteries were used as the source of anode current, but since I have installed an eliminator I have been troubled with L.F. instability and howling. Could you suggest any possible modifications which would overcome this trouble? It often manifests itself as a "popping" noise at a very low frequency.

L. R. F.

Trouble of this sort is by no means uncommon, especially when the L.F. amplifier is designed to pass on the lower audible frequencies at good strength. In the first place it seems probable that the potential-dividing resistance in your eliminator (probably one is used) is acting as an interstage coupling, and you should accordingly shunt each section with larger condensers than those included in the set—say up to 5 mfd. This will probably put matters right, but if it does not, you should try a reversal of the secondary terminals of your L.F. transformer, and to be on the safe side you might insert a damping resistance of about 0.25 megohms directly in the grid circuit of the first L.F. valve.

The pass-on of the low frequencies which are causing the "popping" noise may also be prevented, or at any rate minimised, by quite a considerable reduction in the value of your L.F. coupling condenser, and you might try this, if necessary; realising, of course, that the response on the low notes will be reduced. It is doubtful, however, whether this reduction will be noticeable, unless your loud speaker happens to be an exceptionally good one.

A Super-regenerative Portable.

I am intending to build up a small portable receiver and am thinking of using the Armstrong super-regenerative circuit, and shall be pleased if you will give me the necessary circuit diagram.

J. R. R.

The Armstrong super-regenerative single valve circuit was published in a very recent issue of this journal in the "Readers' Problems" section, and we would refer you to this if you are seriously intent in incorporating this receiver into a portable set. We could not conscientiously advise you to attempt to build a portable receiver using a super-regenerative circuit of any type unless your technical knowledge is in an advanced state. Indeed, we only advocate super-regenerative circuits as a matter of interest for the experimenter, and we should never think of advising the average home constructor to use such a circuit even in an ordinary permanent set if he desired to obtain constantly good results.

o o o o

A Receiver with a 10,000 Mile Range.

I wish to construct a receiver to bring in 20,000 metres C.W. signals over a range of about 10,000 miles, and should be glad if you could advise me concerning a suitable circuit using the smallest possible number of valves and fairly simple control. D. R. T.

We would suggest to you that under the circumstances a four-valve set should suit you admirably. The receiver should consist of one H.F. stage, resistance-coupled, and employing a suitable modern valve, for, of course, resistance coupling is quite efficient on such a long wavelength as 20,000 metres. This would be followed by a detector valve, which in its turn will be followed by one stage of transformer-coupled L.F. amplification. The fourth valve will be the heterodyne valve, for on this long wavelength we are of opinion that it would be infinitely preferable to use an entirely separate valve for heterodyning, rather than to attempt to produce the beat note by the more usual "autodyne" method.

o o o o

Neutralising Difficulties.

I am experiencing some difficulty with my "Wireless World Five" receiver, and find that an adjustment of the balancing condensers holds for less than a third of the tuning range. The set has been carefully constructed with components exactly as specified, and all the valves are apparently in order, as they give good results in another set. Can you make any suggestions as to where I should look for the source of the trouble?

E. T. W.

From the information you give it is impossible to state the exact reason for your failure to neutralise, but it may be said definitely that the vast majority of failures to balance this set satisfactorily has been traced to partial short-circuits in the neutralising windings of one or more of the transformers. You should

check this point very carefully, and we would specially refer you to a paragraph on page 726 of our issue for June 8th.

If your valves happen to have a lower working impedance than those for which the transformers were designed, it would be as well to try the effect of removing two or three turns from both primary and neutralising windings. Before doing so, however, you should, if possible, rearrange the wiring inside the screening compartment in such a way as to separate as much as possible the H.F. leads in plate and grid circuits. We may add that at least one case of trouble of this sort was traced to an internal disconnection in one of the large condensers which are connected between the low potential end of the transformer secondary and L.T.

rect procedure is to add the acid to the water and not *vice versa*. When a small quantity of water is added to strong acid considerable heat is generated owing to chemical reaction, and the water is immediately converted into steam. The steam formed from a very small quantity of water occupies a very much greater space, with the result that the acid will be literally blown out of the beaker or jar, and should this alight on the hands or face serious consequences might result.

o o o o

Screening Boxes not "Tin Cans."

I am contemplating building the "Wireless World Five" receiver, and as I have a quantity of tin plate available, it is proposed to make the screening boxes from this material. Before proceeding, however, I should appreciate your advice on this matter.

V. M. C.

The use of tin plate or similar material containing iron is strongly discouraged for this purpose owing to the high resistance introduced in the fields of the coils carrying high-frequency currents. We always recommend that copper or aluminium be employed for this purpose, the latter where a partial screen is required and the former where a complete screened box having soldered joints is necessary. The reason for this being that at present no satisfactory process exists for making simple soldered joints in aluminium.

o o o o

Improving a Crystal Receiver.

I am using a crystal receiver for telephone reception of the local station, and although the results obtained are very good I should like, if possible, to make them better. The circuit at present employed comprises a plug-in coil tuned by a 0.0005 mfd. variable condenser, but I have in view the replacement of this by a variometer. Before making any alterations to the existing receiver I should appreciate your opinion on this matter.

T. R.

Replacing your coil and condenser by a variometer will certainly lead to a slight improvement in the signal strength, but we think that still better results would be forthcoming if the existing variable condenser was retained and the plug-in coil replaced by one constructed on more efficient lines and the aerial circuit either loosely coupled or auto-coupled to this coil. The tuned secondary coil should be tapped at about two-thirds the total turns and the crystal connected across this portion, the variable condenser tuning the whole coil. An efficient coil to employ in an auto-coupled circuit could be made by winding 60 turns of No. 22 D.C.C. copper wire on a paxoline tube 3 in. diameter and 3½ in. long. Tappings should be taken out at the 20th, 30th and 40th turns, the first two to be used as alternative aerial connections. The crystal should be connected across 40 turns of the coil and the tuning condenser across the whole coil.

**BOOKS FOR THE
HOME CONSTRUCTOR**

Issued in conjunction with "The Wireless World."

"TUNING COILS AND METHODS OF TUNING," by W. JAMES. Price 2/6 net. By Post, 2/10.

"THE HOME CONSTRUCTOR'S WIRELESS GUIDE," by W. JAMES. Price 3/6 net. By Post, 3/9.

"MAST AND AERIAL CONSTRUCTION FOR AMATEURS," by F. J. AINSLEY, A.M.I.C.E. Price 1/6 net. By Post, 1/8.

Obtainable by post (remittance with order) from
ILIFFE & SONS, LIMITED,
Dorset House, Tudor St., London, E.C.4,
or of Booksellers and Bookstalls.

"Topping" H.T. Accumulators.

I have had an H.T. accumulator battery in use for the past few months and notice that the level of the acid has fallen below the tops of the plates. This I understand is detrimental to the cells, and I therefore propose to fill each to its original level with weak acid. I should be obliged if you would inform me of the correct proportion of commercial acid and water to use for this purpose.

W. F. P.

The lowering of the liquid level in your battery cells is without doubt due to evaporation of the water, and should you replace this loss by dilute acid the density of the electrolyte will be increased. This would be harmful to the accumulator plates, and we therefore advise you to fill up the cells with distilled water. If by any mischance the battery has been turned on its side and the acid spilt, then it will be necessary to use dilute acid for "topping." You should examine the labels on the cells and ascertain the strength of electrolyte recommended by the makers, replacing the lost acid by some of the same density. Unless you have an hydrometer available, we think it would be advisable to purchase a quantity of sulphuric acid broken down to the requisite strength. However, should you decide to do this yourself, the cor-

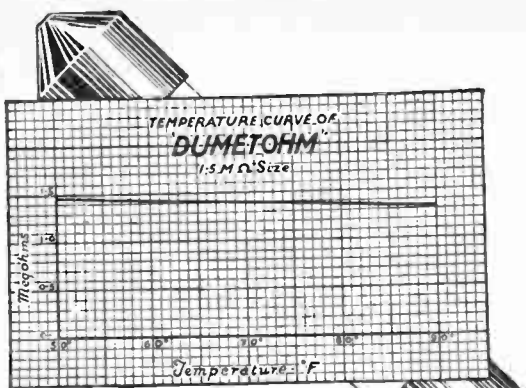

The Dumetohm defies temperature!!

LOOK through the glass case of a Dumetohm and you will see a thin golden coloured rod "of a metallic nature" stretching between the brass end-caps.

It is that rod which is the secret of the Dumetohm's extraordinary success.

Resistances employing carbon are of necessity subject to temperature variations.

The Dumetohm, however, is wonderfully constant and hardly varies at all even on the hottest day, as the curve above shows.

If you are to have consistent reception of good volume and tonal purity you must employ resistances of constant characteristics.

To ensure this ask your dealer for a Dumetohm.

Dumetohms are made in standard resistances of 0.25, 0.5, 1, 1.5, 2, 3, 4 and 5 megohms. They cost 2/6. Soldering connections to them is a delicate matter. Ask for a Dumetohm Holder, price 1/.



TC 12

Advt. of the Dubilier Condenser Co. (1925) Ltd., Ducon Works, Victoria Road, North Acton, W.3.

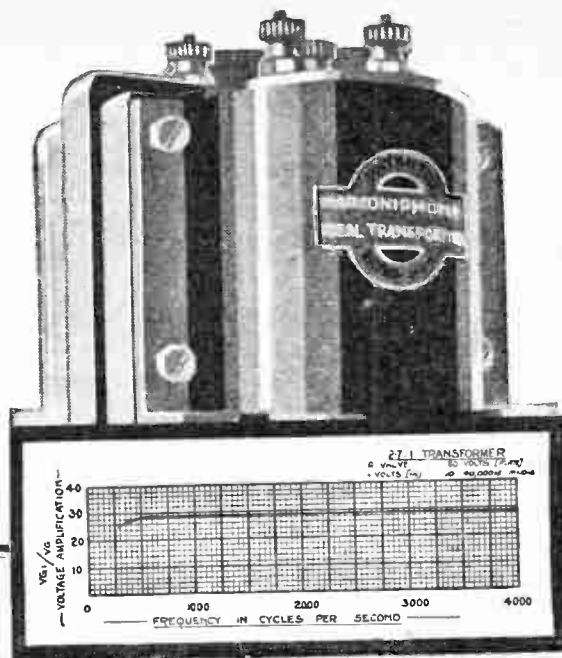

Whenever you need L.F. amplification use a Marconiphone "Ideal" Transformer. It gives wonderfully true-to-life reproduction—volume in plenty—with never a trace of harshness. The "Ideal," designed by the Marconi engineers, is a scientific instrument, perfect in every detail and so thoroughly tested at every stage of manufacture that it is fully guaranteed for 12 months. The amplification curve above shows the *naturalness* of its reproduction, and every "Ideal" Transformer possesses an amplification within 5% of this standard.

Publication No. 453 giving full particulars and guaranteed curves of Marconiphone "Ideal" Transformers, sent on request.

The Marconiphone "Ideal" Transformer is supplied in four ratios:—

2.7 to 1 6 to 1
4 to 1 8 to 1

PRICE - 25/- ALL RATIOS

MARCONIPHONE "Ideal" TRANSFORMERS

THE MARCONIPHONE COMPANY, LTD.,

Head Office: 210-212, Tottenham Court Rd., London, W.1.
Regd. Office: Marconi House, Strand, London, W.2.

MISCELLANEOUS ADVERTISEMENTS.

NOTICES.

THE CHARGE FOR ADVERTISEMENTS in these columns is:

12 words or less, 1/- and 1d. for every additional word, e.g., 18 words 1/6; 24 words, 2/- Name and address must be counted.

SERIES DISCOUNTS are allowed to Trade Advertisers as follows on orders for consecutive insertions, provided a contract is placed in advance, and in the absence of fresh instructions the entire "copy" is repeated from the previous issue: 13 consecutive insertions, 5%; 28 consecutive, 10%; 52 consecutive, 15%.

ADVERTISEMENTS for these columns are accepted up to **FIRST POST ON THURSDAY MORNING** (previous to date of issue) at the Head Offices of "The Wireless World," Dorset House, Tudor Street, London, E.C.4, or on **WEDNESDAY MORNING** at the Branch Offices, 19, Hertford Street, Coventry; Guildhall Buildings, Navigation Street, Birmingham; 199, Deansgate, Manchester.

Advertisements that arrive too late for a particular issue will automatically be inserted in the following issue unless accompanied by instructions to the contrary. All advertisements in this section must be strictly prepaid.

Postal Orders and Cheques sent in payment for advertisements should be made **& Co.** payable to **LIFFE & SONS Ltd.**, and crossed **Treasury Notes**, being untraceable if lost in transit, should not be sent as remittances.

All letters relating to advertisements should quote the number which is printed at the end of each advertisement, and the date of the issue in which it appeared.

The proprietors are not responsible for clerical or printers' errors, although every care is taken to avoid mistakes.

NUMBERED ADDRESSES.

For the convenience of advertisers, letters may be addressed to numbers at "The Wireless World" Office. When this is desired, the sum of 6d. to defray the cost of registration and to cover postage on replies must be added to the advertisement charge, which must include the words Box 000, c/o "The Wireless World." Only the number will appear in the advertisement. All replies should be addressed No. 000, c/o "The Wireless World," Dorset House, Tudor Street, London, E.C.4. Readers who reply to Box No. advertisements are warned against sending remittance through the post except in registered envelopes; in all such cases the use of the Deposit System is recommended, and the envelope should be clearly marked "Deposit Department."

DEPOSIT SYSTEM.

Readers who hesitate to send money to unknown persons may deal in perfect safety by availing themselves of our Deposit System. If the money be deposited with "The Wireless World," both parties are advised of its receipt.

The time allowed for decision is three days, during which time, if the buyer decides not to retain the goods, they must be returned to the sender. If a sale is effected we remit the amount to the seller, but, if not, we return the amount to the depositor. Carriage is paid by the buyer, but in the event of no sale, and subject to there being no different arrangement between buyer and seller, each pays carriage one way. The seller takes the risk of loss or damage in transit, for which we take no responsibility. For all transactions up to £10, a deposit fee of 1/- is charged; on transactions over £10 and under £50, the fee is 2/6; over £50, 5/-. All deposit matters are dealt with at Dorset House, Tudor Street, London, E.C.4, and cheques and money orders should be made payable to Liffe & Sons Limited.

THE SALE OF HOME-CONSTRUCTED UNLICENSED APPARATUS.

A New Service to our Readers.

We have made an arrangement with the Patentees whereby readers who wish to dispose of a home-constructed receiver not licensed under the patents made use of, can do so by means of the Deposit System referred to above.

The person desiring to sell, in sending us particulars for his advertisement, will in every case make use of a Box No., and should add to the price which he requires the amount of royalty customarily paid by manufacturers, viz. in the case of Marconi Patents the amount should be calculated at 12/6 per valve holder.

If the purchaser is satisfied with his purchase, the sum realised will be forwarded to the seller, less the amount due in respect of royalties, which amount will be paid by "The Wireless World" to the owners of the patents concerned, and a certificate will be handed on to the purchaser of the set.

SPECIAL NOTE.

Readers who reply to advertisements and receive no answer to their enquiries are requested to regard the silence as an indication that the goods advertised have already been disposed of. Advertisers often receive so many enquiries that it is quite impossible to reply to each one by post.

Mention of "The Wireless World," when writing to advertisers, will ensure prompt attention.

C.D.M.

The first Vernier Dial produced having 3 speeds. Actual Vernier has two set speeds which can be adjusted to give ratios up to 500-1. No gears or backlash. British Made, and well thought out by British Brains.

U.K. Patent No. 262229.

Canadian Patent No. 269128.

Pat. pending U.S.A.



Price

8'6

THE DIAL FOR REAL FINE TUNING! Short wave workers will find this dial a great asset. Can be fitted to any one hole fixing condenser.

Dial is 4" diameter, made of best bakelite, and finely engraved 180-0; high class finish throughout.

If your dealer does not stock, write direct to the sole manufacturer:

C. D. MELHUIH,
(Late Director and Works Manager Waimel Wireless Co. Ltd.)

8 Gt. Sutton St., Goswell Road, E.C.1.

Phone: Clerkenwell 7494.

Send for catalogue of our guaranteed products.

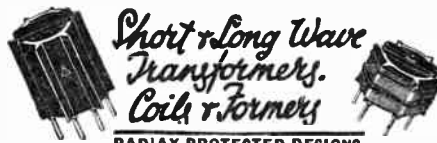

RADIAX PROTECTED DESIGNS

| | |
|------------------------------------|------|
| Tapped Aerial Coils | 6/9 |
| Split Anode Coils | 6/9 |
| Split Prim. or Sec. Transformers | 10/6 |
| Fitted Formers, 6-pln, 3 x 3 1/2 | 4/6 |
| Six-pln (low loss) Bases | 2/6 |
| All-wave Four Coils, 1000 2000 | 17/6 |
| All-wave Four Coils, 200 350 | 15/- |
| Everyman Four Coils, the pair | 28/- |
| Empire Short Wave Coil | 10/6 |
| Aluminium Sheet, All-wave Four | 1/8 |
| Aluminium Sheet, Empire Short Wave | 11/6 |

Coils wound to specification. All components for All-wave Four—Empire Short Wave—Monotone 3, etc. *Leads stamped. Full catalogue 2d.*

RADIAX LTD. 30, Accessory House, Palmer Place, Holloway Rd., N.7



Ophean LOUD SPEAKERS

Ask your Local Dealer for Free Demonstration (Dealers supplied on S. or R.)
LONDON RADIO MANUFACTURING Co., Ltd.
Station Road, Merton Abbey, S.W.18.

IMPORTANT NOTICE.

Owing to the August Bank Holiday, the issue of "THE WIRELESS WORLD" for August 3rd must be closed for press earlier than usual.

MISCELLANEOUS ADVERTISEMENTS for insertion in that issue can be accepted up to **FIRST POST WEDNESDAY, JULY 27th.**

RECEIVERS FOR SALE.

ALL-WAVE Four and the Famous Everyman Four; high-class sets only, giving maximum efficiency; full particulars and prices on application.—H. Goodwin, Woodcock Hill, Elstree. [0050]

MARCONI Straight Eight Complete with 5 Valves, list price £62, bargain price £40.—Saul, 8, Ansdell Rd. South, Ansdell, near Blackpool. [4986]

WAVENETER, G.E.C., new, cost £21, bargain for £7; B.T.H. crystal valve set, new, cost £9, bargain for £5; also T.M.C. loud-speaker, £2/10.—Write BM/BDG5, London, W.C.1. [5067]

SHORT Wave Empire Receiver, £10; short wave apparatus a speciality.—Express Radio Service, Factory Square, Streatham. 'Phone: Streatham 1373. [5047]

3-VALVE Crystal Reflex, first class components, perfect reception, complete with valves and coils, oak cabinet; accept £10.—A. V. Stokes, 95, Marylands Rd., Paddington, W.9. [5121]

5-VALVE Cosmos Radiophone, complete with new batteries, speaker, all accessories; cost £65, low price for quick sale.—Box 2938, c/o The Wireless World. [5115]

8-VALVE Marconi Receiver, type R.B.7, 5, aperiodic tuned, H.F., detector, and 2 L.F. power amplifier, in perfect condition, no accessories; for quick sale, £12.

1-VALVE Amplifiers, new and in perfect order, polished mahogany cabinets; 25/-.—Daradio, 31, Eastfield Rd., Peterborough. 'Phone: 645. [5103]

EMPIRE Short Wave Receiver, 18's gauge, aluminium box as specified; 32/- carriage paid.—J. Connor, Radio Engineer, 44, George St., Cheetham Hill, Manchester. [5089]

PORTABLE Seven-Valve Superionic McMichael unit, £10; with all accessories, £15; royalties extra.—Kerrison, 9, Saville Row, Newcastle. [5159]

CECOPHONE.—8-Valve Super-het; in perfect working condition; complete with valves and frame; heard any evening; bargain at £27/10 or nearest; also 4-valve, £12.—Bolus, 5, Friar's Rd., Coventry. [5156]

BURNDIPT All-Wave Super-het., mounted ready for wiring in mahogany cabinet, complete with 7 Burndipt valves, H.T. batteries, and frame aerial; also full range of coils for wave-length 40-3,000 metres; also

MCMICHAEL 7-Valve Super-Het. in cabinet, as new, covering wave-length from 300-2,000 metres; what offers for the lot; no reasonable offer refused.—J. W. Atkins, 6, Broadway, Worthing, Sussex. [5143]

Receivers for Sale.—Contd.

MINIATURE Wireless Set (Rosenthals' Pat. No. 233564), size of 3d. piece, hangs on watch chain; results surprised experts; 1/2 post free.—Lumb, 28, Wilson St., Monkwearmouth, Sunderland. [5152]

FOUR-VALVE All-Wave McMichael M14; all accessories; no loud-speaker; £10; offers.—Granville, Clare, Cambridge. [5138]

W. SMURTHWAITE, Radio Engineer, for high class receivers at moderate prices; every set personally tested by me and guaranteed 12 months.

EVERYMAN and All-Wave Fours.—Beautifully made with best quality components throughout, in dark oak or mahogany cabinets, hand polished and engraved panels; either type, £14.

HARMONY Five, the finest neutralised straight set available, irrespective of price; covers all wave-lengths, and gives perfect quality reception; £16.

HARMONY Three, the last word in local station receivers; with a Kone speaker the results are definitely the best obtainable; £7/10.

B.C. Quality Receivers; P.M. circuits and all other designs quoted for; lowest prices consistent with genuine workmanship.

REPAIRS, reconstructions, etc., carried out promptly; let me know your requirements; second-hand receivers at low prices; part exchanges entertained.

APPROVAL Terms. I know I can give satisfaction, and am always willing to send standard instruments on seven days' approval.

W. SMURTHWAITE, 15a, Onslow Gdns., Wallington, Surrey. 'Phone: Wallington 1982. [5148]

BATTERIES.

SECRET of the Perfect Wet H.T. is the new perforated insulating liner; this insulates the inside of the zinc from the sac, price 4d. doz., supplied free with orders for complete cells; jars, 1/3 doz. plain, 1/6 doz. waxed; zinc special, 1/- doz.; sacs, high capacity, 1/6 doz.; post free on 3 doz. and over, packed in special carton with divisions for each cell; this can be used as a container for the battery when made up; send 6d. for sample complete unit, with particulars and instructions; sacs with screw tops, 9d. doz. extra; double size sacs, 3/- doz.—Spencers Stores, Ltd., 4-5, Masons Av., Coleman St., London, E.C.2 (near Bank). 'Phone: London Wall 2292. [0045]

WET H.T. Batteries.—Jars, 2 1/2 x 1 1/2 x 1 1/2, 1/3 doz.; zincs, 1/- doz.; sacs, 1/6 doz.; dozen cells complete (18 volts), 3/6; post d. extra. High efficiency, long life, upkeep practically nil. Orders for 3 dozen or over post free, packed in special carton with divisions for each cell, usable as container for complete battery. Send 6d. for sample complete unit with instructions. Write for free lists of wireless bargains.—W. Taylor, 57, Tudley Rd., Stockwell, London. [0039]

A.B. H.T. Batteries Cost Less Than Many other makes. The fact that they are manufactured by Messrs. Thomson Houston & Co., of Paris, is proof of their high quality. Further, every battery carries a full and generous guarantee. Usual sizes stocked; 50 volt, 100 volt, and grid bias, etc. Ask our dealer for same. If he cannot supply or write us direct. Trade enquiries specially invited.—G. E. Ambatielo & Co., Ltd., Ambatielo House, Farringdon Road, E.C.1. Telephone: Clerkenwell 7440. [0063]

the big 3

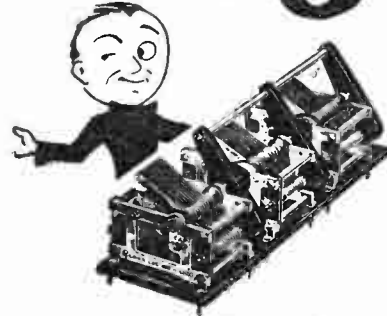

CYLDON GANG CONDENSERS
The gang condensers most constantly specified by radio journals. Logarithmic units for correct tuning.
2-Gang £2 10s. 3-Gang £3 10s. 4-Gang £4 10s.

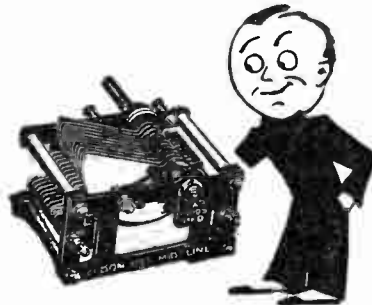

CYLDON LOG MID-LINE CONDENSERS
The first condensers to be designed on the logarithmic principle. Better than Square Law and Straight Line Frequency. Spread all stations evenly over dial. Makes possible "one-dial control" in multi-tuned circuits. The condensers of the future.
PRICES:
'001 .. 21/- '0005 .. 17/6 '0003 .. 16/6 '00025 .. 16/-
'0002 .. 15/6
With 4in. Knob Dial. If dial is not required deduct 2/-

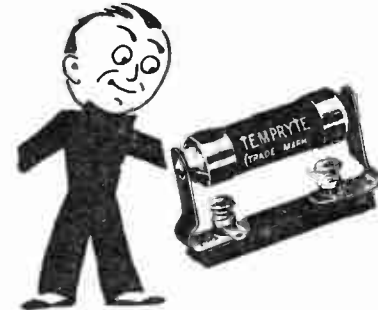

CYLDON TEMPRYTES
The proved best means of valve control. Functions perfectly with any type of valve. Cannot overheat filament. Noiseless. Tested and guaranteed to give perfect performance.
Cylidon Temprytes 2/6 each. Holder Mountings 1/6 each.

CYLDON

CYLDON products can be obtained from stock by return; and do not believe any statements to the contrary. If any difficulty 'Phone: Enfield 0672. Wire: Enfield 0672, or use the C.O.D. system.
SYDNEY S. BIRD & SONS,
Cylidon Works, Sarnesfield Road, Enfield Town, Middlesex.
Sole Australian Agents:
E. V. HUDSON, 55 7, Charlotte Street, Brisbane, Queensland.

Batteries.—Contd.

3 New 20-volt H.T. Accumulators, Three-Star 1,800 milliamps; bargain, 9/- each, carriage paid.

3 Ditto Larger Capacity, 2,500 milliamps; 10/6 each, carriage paid, all dry charged ready for use.—J. H. Hampton, 13, Montfort Street, Ipswich. [5127]

WHY Buy Accumulators or Dry Batteries? London's Leading Hire Service improves reception. Saving time, trouble, and money. No big outlay. No deposit. Pay carman on each delivery. High tension service from 6d. per week. Low tension service from 1/3 per week. Fully charged and delivered free within 12 miles of Charing Cross. Explanatory folder post free.—Radio Service, 105, Torriono Av., N.W.5. 'Phone: North 0623/4/5. [5125]

FOR Sale.—60 volt 3 amp. Seeco H.T. Accumulator, almost new; 30/-, bargain.—Write Hanwell, 42, Nurbourne St., Queen's Park, London, W.10. [5106]

OLDHAM 100 Volt High Tension Accumulator, 6 months old, perfect condition, fully charged; £3.—Box 2885, c/o The Wireless World. [5102]

H.T. Accumulator, 100 volts, Oldham's latest pattern with carrying handle, etc.; perfect condition; 40/.—Crockett, Branksome, Cassiobury Drive, Watford. [5136]

BIRMINGHAM and District.—Send for particulars of our accumulator hire service, and we will prove to you that it is cheaper to hire an accumulator than to buy one. We supply the accumulator, collect and deliver it, and it costs no more than you are paying now for charging.—New Era Wireless & Electrical Co., Hobmoor Rd., Small Heath, Birmingham. Tel.: Vic. 744. [5144]

CABINETS.

ARTCRAFT Radio Cabinets and Panels for all "Wireless World" sets.

ARTCRAFT Cabinets made in Oak and mahogany, properly french polished, and are priced at 6/- to £11/11.

ARTCRAFT Cabinets made to any specification or design. Estimates by return.

ARTCRAFT Illustrated Catalogue Free.—The Artcraft Co., 156, Cherry Orchard Rd., Croydon. 'Phone: Croydon 1981. [0040]

ALL Enclosed Solid Teak Joiner-made Cabinet, unpolished, fitted 26x8 Radial panel, separate compartments for accumulators, etc.; cost over £4, price £12 or close offer.—Turvey, Elim, Cottingham, E. Yorks. [5110]

PEDESTAL Cabinets in Massive Oak Jacobean Finish (as illustrated in The Wireless World, May 4 issue), for Everyman Four or any set with panel up to 26in. x 8in., stands 3ft. high, 15in. deep, 10in. baseboard included; £5/5, carriage paid; may be inspected on van before acceptance; fully illustrated folder gives every detail; write to-day.—G. E. Ambatielo and Co., Ltd., Ambatielo House, Farringdon Rd., London, E.C.1. 'Phone: Clerkenwell 7440. Telegrams: Ambatielo, London. [0055]

ALL in One Cabinet; original design from Sobey, 44, Prospect Place, Swindon. [5157]

LOUD-SPEAKERS.

BROWN'S Power Speaker, model P.Q., list £12/12, condition new, £8/8, offers; Amplion, A.R.19, £2/7/6; Baby Sterling, 35/-.—Drake, Priory Lane, St. Neots, Hunts. [5104]

Loud-speakers.—Contd.

BARGAINS!—Loud-speakers, 22 inches high, 14½ inches diameter flare, heavy cast neck and base, black crystalline finish, adjustable diaphragm, rubber feet, cord, looks well, sounds well; 32/6; carriage free. If you have a loud-speaker bring this to the notice of a friend who hasn't.—Universal Wireless Depot, 160, County Rd., Swindon. [5013]

PERMANENT Magnet Coil-drive Loud-speaker parts described by H. Lloyd in June 1 issue. From Star Engineering.

WARNING.—The manufacture of parts for constructing coil-drive loud-speakers is an engineer's job. All parts made by Star Engineering are backed by 35 years' experience in the manufacture of high class machinery.

SUPERIORITY of Components Made by Star Engineering is the result of long experience in the manufacture of high class machinery. Below.

WORKMANSHIP.—From Royal Naval Engineering College. The workmanship and price of all the parts are entirely to my satisfaction. Below.

FIRM of Radio Specialists write: Thanks for parts. These are, we consider, of excellent workmanship and very good finish. Below.

QUALITY.—May I congratulate you on producing a first class and very workmanlike job? Am most pleased with the components.

ORDER Your Parts from Star Engineering—Didsbury, Manchester, and avoid trouble. Lists free. [5074]

HORNS for all types of loud-speakers, especially gramophone attachments and Amplion A.R.39; illustrated list free.—Maddison, Manufacturer of the Allwoodorn, 2a, Ronald's Rd., N.5. [4987]

AMPLION, mahogany, clock type, large, A.R.51M., only been used 6 months, new; cost £8/8, accept £5.—Dixon, 43, Glen Terr. Hebburn-on-Tyne. [5128]

BROWN'S H.Q. Loud-speaker, as new; cost £6, accept £4.—A. V. Stokes, 95, Marylands Rd., Paddington, W.9. [5120]

SEVERAL Loud-speakers, guaranteed perfect condition, particulars free; very low price to clear.—Spencer, Watergate, Grantham. [5118]

EXCHANGE Specialists.—Second-hand bargains—Celestion, 75/-; A.R.23, 60/-; A.R.38, 28/-; A.R.19M., 80/-; Mullard P.M., 95/-; Geophone, 60/-; A.R.33 attachment, 38/-; Amplion concert grand, 120/-; and several Lissenolas, etc. Send goods or offers.—Aspinwall Radio Service, Ellerthwaite Rd., Windermere. [5114]

UNITS for Cone Speakers.—Highly efficient, patented, double acting reed movement, the result of years of experimenting. Very sensitive to small impulses, but capable of handling enormous power without overloading; special resonance damping device; high class workmanship and keenest value yet offered; complete with fixings for attaching cone, 30/-, carriage free. Fuller details, list of cones, complete speakers, etc., post free.—Everyman's Radio Service, Brent St., Hendon, N.W.4. [5105]

MAGNAVOX Junior, without horn, perfect; £2 or offer.—Selby & Co., 6, Hauberk Rd., Lavender Sweep, S.W.11. [5139]

FAMOUS Windsor 22 inch Free Edged Cone Speakers, adjustable magnets, £6.—The Radio House, 121, Whitegate Drive, Blackpool, Lancs. [5151]

Loud-speakers.—Contd.

AMPLION Radiolux, guaranteed perfect; £3.—Prebble, 70, Talgarth Rd., Baron's Court, London. [5141]

YOUR Old Speaker in Part Exchange for New One.—Browne, 65, Sinclair Rd., W.14. [5161]

COIL Drive Loud-speakers.—We can supply the following at reasonable prices. First-class workmanship and materials only. Immediate delivery from Baker's "Selhurst" Radio.

IMPORTANT.—All coil driven speaker parts supplied by us are constructed by highly skilled engineers with the best possible materials. As we do not depart from the specifications given in *The Wireless World* you are assured of good results. Immediate delivery from Baker's "Selhurst" Radio.

UNIT No 1.—Pot magnet with field winding for six-volt accumulator and zin. moving coil. Immediate delivery from Baker's "Selhurst" Radio.

UNIT No. 2.—Pot magnet with field winding for six-volt accumulator or D.C. mains as required, and zin. moving coil as described by N. W. McLachlan in *The Wireless World*, April 13, 1927. Immediate delivery from Baker's "Selhurst" Radio.

UNIT No. 3.—Permanent magnet unit as described by H. Lloyd in *The Wireless World*, June 1, 1927. Immediate delivery from Baker's "Selhurst" Radio.

FRAMES and Cradles specially constructed to enable unit to be assembled with ease in a few minutes. Immediate delivery from Baker's "Selhurst" Radio.

TRANSFORMERS.—With tapped primary in four sections, as described in *The Wireless World* by H. Lloyd. Specially designed for use with coil driven speakers. Immediate delivery from Baker's "Selhurst" Radio.

PEDESTAL Cabinets.—Specially suitable for coil driven speakers, beautifully finished in polished mahogany or oak. Immediate delivery from Baker's "Selhurst" Radio.

WE shall be glad to advise you as to the most suitable unit for your set.—Baker's "Selhurst" Radio, 80, Selhurst Rd., South Norwood, S.E.25. 'Phone: Thornton Heath 1488. Works: 42, Cherry Orchard Rd., East Croydon. [5150]

VALVES.

5/-—Power valves, 2, 4, or 6 volt dull-emitters, British made, guaranteed, money refunded if not satisfied, post free. Send for list of other types.—Carter & Co., 61, Lower Moseley St., Manchester. 'Phone: 3742 Central. [4911]

TRIOTRON Dark Emitters, 2 volt 0.1 amp. power valves, 9/-; Triotron general purpose valve, 2 volt 0.2 amp., 4/11; tested and guaranteed; post paid.—Storrs Wireless Mart, 143, Eastbank St., Southampton. [4985]

BRITISH Valves.—2-volt .06 H.F. and L.F., 2-volt .12 H.F. and L.F., 2-volt 34 power valve, 4-volt .06 H.F. and L.F., 4-volt .12 power valve, 6-volt .25 power valve; all one price, 5/- each, post free; satisfaction guaranteed. Trade supplied. Write your name and address clearly.—H. Howarth, Ensign Depot, 288, Deansgate, Manchester. [5060]

6 Marconi R.5 v., perfect; 15/- the lot, reg. post free.—71, Hankinson Rd., Bournemouth. [5117]

Valves.—Contd.

4/-—British Valves, .15 amps., 2, 4, 6 volts; power valves, 5/- each; a post free and guaranteed; state if H.F., detector, or L.F. required.—Lunds, "Radio House," Aigburth, Liverpool. [509]

OFFERS Invited for Following: 2 D.E.R., 1 D.E.5, 5 B.4, 1 B.5, 1 D.E.3, 1 V.24, 1 R.5, 2 Cossor P.1, 1 S.P.55R, 1 Cosmo R.C.C. unit.—Box 2959, c/o *The Wireless World*. [5163]

COSMOS S.P.18 Valves; 1 green spot, 1 Blue Spot; 10/- each.—Roach, 5, Gloucester Rd., Kingston Hill, Surrey. [514]

MARCONI D.E.R., 1 Cossor W.2 H.F. 2 valves, 25/-; as new; approval.—Whittaker, Claremont, Bury Old Rd., Heywood. [5155]

CHARGERS & ELIMINATORS.

ACCUMULATOR Chargers (A.C.), 45/ complete. Post free. Also components for same and for A.C. battery eliminators fully guaranteed.—Stafford O'Brien and Partners, Ltd., 66, Victoria St., S.W.1. [5057]

REGENTONE Mains Units; fully illustrated 12 page catalogue; the most comprehensive list of mains units ever issued in this country.

REGENTONE Mains Units for the supply of high tension current from direct-current mains.

REGENTONE Mains Units, supplying high-tension current from alternating current mains, including special models of large output.

REGENTONE Complete Power Units for the supply of both high and low tension direct and alternating current mains; any type of receiving valve; no alteration to receiver.

REGENTONE Mains Receivers entirely operated from D.C. or A.C. mains, at your service instantly on the pressure of a switch—always

REGENTONE Component Parts for home construction of mains units, including rectifying valves, power chokes, series resistances, potential dividers, transformers, high-voltage condensers, etc.

YOUR Postcard requesting Catalogue will receive immediate attention.—Sole manufacturers: Regent Radio Supply Co. Offices: 45, Fleet St., E.C.4. 'Phone: Central 9661. [5165]

COMPONENTS, ETC., FOR SALE.

BELLING-LEE Panel Fittings are designed to give an expert finish to any home-constructed set. Catalogue post free.—Belling and Lee, Ltd., Queensway Works, Ponders End, Msx. [5018]

TANTALUM.—Tantalum metal sheet for A.C. rectifiers.—Blackwell's Metallurgical Works, Liverpool. [4386]

REED Movements.—Double Acting Reed movements specially designed to operate cone and other large diaphragms; extremely sensitive on small input, yet capable of enormous volume with sufficient input. Will work up to a 3ft. cone with ease. No rattle or distortion; 27/6 each. Fair allowance on Brown A earpieces, or Lissenolas and other units in part exchange. Send stamp for Illustrated Lists of these and seamless cones.—Goodmans, 27, Farringdon St., E.C.4. [5049]

Mention of "The Wireless World," when writing to advertisers will ensure prompt attention.

Components, Etc., for Sale.—Contd.

AERIAL Grid Coils and H.F. Transformers for Everyman Four, with chart showing over 40 stations (on L.S.), price 17/6 each; H.F. transformers for the All-Wave Four, high and low wavelengths, set of two and base 35/-; all coils of highest quality materials and finish.—H. Goodwin, Woodcock Hill, Elstree. [0051]

LAKER 3oft. Handsome Steel Mast, 22/6. See descriptive advertisement, page 15. Easily erected. [0021]

EVERYMAN Coils, Three, Four, Five exact to specification, all ebonite bases, 12/6 each; All-wave coils (May 11): short wave, 16/-, long wave 18/-, base 3/6; genuine Mikapac tubes, 3x3½, one 1/4, two 2/6, three 3/6; grooved ebonite spacers, 1/- set of 8; all-wave do., 6 1½in., 1/-; 12 2in., 2/6; Litzen wire (Lewcos) to wind one coil, 4/8.—Jennens, below.

WYCHE Switch, two-way, 1/3; both battery, 1/6.—Jennens, below.

RHEOSTAT. Jennens, as specified for Nucleus receiver, 7-, 20-35 ohms, 2/- each.—Jennens, below.

LOEWE Multiple valves (3N.F.).—Detector and 2 L.F. stages, more volume and purer tone than two best L.F. transformers and power valves on local station and Davenport; H.F. stages can be added; 45/- C.O.D.—Jennens Radio, 30, Chapel St., Birmingham. [4776]

B. & J. Make all the Special Coils for *The Wireless World* Circuits and Guarantee Complete Satisfaction. All materials exact to specification.

B. & J. Built Sets give excellent results and carry our full guarantee.

B. & J. Wireless Co., 2, Athelstane Mews, London, N.4. [0043]

POPULAR Wall Jack.—This is another new line in keeping with all Deckorem specialities. They make for neatness and efficiency in all cases where loud-speaker and distant phone reception is to be installed in the home. In construction they are strong, in contact with all standard plugs they are sure, in appearance they are a credit to any scheme of decoration. All fittings and cover are of heavily plated nickel, the base is of high insulation material, black and nicely polished. They have a splendid and strong spring wiping contact, are supplied in either series or parallel type, and can be obtained from most dealers, or direct from A. F. Bulgin and Co., 9-10-11, Cursitor St., Chancery Lane, London, E.C.4, and what is more, they only cost 2/9 each. [0041]

TELETROL for Remote Control.—Simple to install, one wire only for any number of loud-speakers, indispensable for extension to sick rooms, patented; price 35/- with instructions.—Baily, Grundy and Barrett, Ltd., 2, St. Mary's Passage, Cambridge. [5061]

LAKER 3oft. Handsome Steel Mast, 22/6. See descriptive advertisement, page 15. Easily erected. [0023]

HALF Price.—3 Lewcos screens at 7/6 each; 1 Bowyer-Lowe triple .0005 condenser, 30/-; 2 Lewcos split primary coils, 5/- each; 1 Cleartron dial, 4/6.—Box 2945, c/o *The Wireless World*. [5126]

GENUINE Wireless Clearance Sale.—Valves, components, etc., all new; greatly reduced. Send ½d. stamp for Great Bargain List.—Smaller Bros., Nottingham Rd., Eastwood, Notts. [5113]



IS YOURS A NOISY NEIGHBOURHOOD?

Vibrations from passing traffic—often inaudible to the human ear—destroy tonal purity and should be counteracted by installing Benjamin Valve Holders which completely disperse all microphonic noise.

Valve sockets and springs are made in one piece with no joints or rivets to work loose and cause faulty connections. Valves are free to float in every direction and can be inserted and removed easily and safely. Valve legs cannot possibly foul the baseboard. Terminals and soldering tags are provided.

BENJAMIN



Clearer Tone
Anti-Microphonic.
**VALVE
HOLDER**
2/9 each.

*Covered by Patents
and Registered
Designs.*

THE BENJAMIN ELECTRIC LTD.
Brantwood Works, Tariff Road, Tottenham, N.17

OPPORTUNITY
—full or spare-time work . .

Increase your income by £5 to £12 per week.

Trustworthy, energetic men required where we are not adequately represented.

Write immediately for full particulars.

GENERAL RADIO CO., LTD.,
Dept. C25, Radio House,
235, REGENT STREET,
LONDON, W.1.

Components, Etc., for Sale.—Contd.

MORE Stocktaking Bargains.—7 only Marconi phone Ideal transformers, 2.7-1, each 18/6; Lewcos split secondary 6 pin coils, pairs 12/6; one only Beco rose bowl loud-speaker, listed £5/17/6, £4; one only Suprecision milliamp. panel meter, jewelled movement, 0-100, listed 24/-, 17/6; all brand new; post free; C.O.D. extra.—Arthur How, Wireless Dealer, 252, Berkhamsted Rd., Chesham. [5122]

SCOTT SESSIONS.—Set constructor's suppliers, express delivery, absolutely every component for all "Wireless World" sets.

SCOTT SESSIONS.—Fixed condensers (tubular), .0001-.002 mfd., 1/9 each.

SCOTT SESSIONS.—Mansbridge type (tested 500 volts D.C.), 1 mfd., 2/4; 2, 3/6; 4, 5/9. Send for bargain list!

SCOTT SESSIONS and Co., Hill Top, Muswell Hill, N.10. [5116]

MATEUR'S Surplus.—Coils: 250, 200, 150, 100, 90, 75, 60, 50, all good makes. Valves: 2 Ediswan A.R., 1 Mullard, 1 Cosmos Atlas vernier. T.C.C. .15 condenser, excellent condition; £2/3 the lot, or best offer; carriage paid, C.W.O.—Hubbard, Mickleton, Gloucestershire. [5123]

COPPER Screening Boxes.—Standard 6½in. x 6in. high; price 15/- post free; special requirements to order; "Wireless World" screens a speciality; we are actual manufacturers.—The "Brinford" Mfg. Co., 37-45, Middlesex Wharf, Clapton, E.5. [5130]

LAKER 3oft. Handsome Steel Mast, 22/6. See descriptive advertisement, page 15. Easily erected. [0022]

2 Pelican Slow Motion Dials, 3/-; 1 Polar neodyne condenser, 1/-; 1 screen and base, 3/-; 1 Varley wire-wound anode resistance, 250,000 w., 5/-; 3 Magnum intermediate transformers, £1; 2 lb. of 40-gauge D.S.C. wire, 7/6; 1 cone loud-speaker (£4/10 new), B.T.H., £2; 1 R.I. dual rheostat, 3/-; 1 Benjamin valve holder, 1/6; will sell whole for £3/15 in one lot.—A. Ward, 16c, Polygon Buildings, Euston. [5107]

THE World's Best Slow Motion Dial—the new Fatamic. Has quick drive as well as 260 to 1 gear; patented worm gear drive makes backlash or slipping impossible; fits either ¼in. or ⅜in. spindles, perfect appearance and precision, price only 6/6; ¼in. extension handle (detachable) 5d. extra; new season's valve holders, plated, baseboard 7d., latest covered baseboard type 7d., Perfection anti-vibratory spring type 1/3; rheostats, 40 ohms, velvet contact, only 1/7, without knob only 1/-; voltmeters, amperemeters, all sizes and prices; S.L.F. condensers (while they last), 5/6; everything stocked; prompt delivery; post free over 7/6. Send us your lists and let us quote you. Everything guaranteed—money refunded in full if goods returned in three days. Exceptional terms to the trade.—"Wireless," 39, Bishops Rd., Itchen, Southampton. [5052]

SHORT-WAVE wavemeters, 18-70 metres. Every instrument individually calibrated by hand; enables any required station to be found immediately. In upright mahogany cabinet, complete with full instructions, 30/-, cash or C.O.D.—Deepees, 22, Ganton St., Regent St., W.1. [5082]

TRIPLE Gang Condenser (Utility) with Cleartron dial; perfect condition; 25/-—Crockett, Branksome, Cassiobury Drive, Watford. [5135]

Components, Etc., for Sale.—Contd.

SIMMONDS BROS.—Coils: Everyman Four, 33/- per set; Everyman Three, 35/-; "Wireless World" Five, 50/6; All-Wave Four, 42/6; Quality Three, 16/6; all with bases, first-class material and workmanship. Screens: Everyman Four, 4/6; Everyman Three, 4/-; "Wireless World" Five, 50/-; All-Wave Four, 5/-; Cabinets: Everyman Four, from 35/-; Everyman Three, from 32/-; "Wireless World" Five, from 30/-; All-Wave Four, from 30/-; Ormiston's Litzen-draht: 20 yards, 5/6; 25 yards, 6/6; 50 yards, 12/-; 60 yards, 14/6; Paxolin formers, 1/6 each; Everyman Four booklet, 1/-; Lists free. Empire Broadcast receiver, aluminium case, 40/-; coil, 8/6 with base; H.F. choke, 5/-; phones choke with brackets, 5/6. Trade supplied home and abroad.—Simmonds Bros., Shireland Rd., Smethwick. [5078]

LAKER 30ft. Handsome Steel Mast, 22/6. See descriptive advertisement, page 15. Easily erected. [0035]

SOLODYNE dismantled, complete parts for disposal, state requirements; also 100 volts W.J. Exide accumulators, £1/15.—21, Leamington Gardens, Seven Kings, Essex. [5119]

RELIABILITY WIRELESS GUIDE.—New edition, No. 99A, just issued. Free upon request.

RELIABILITY FREE DELIVERY.—Orders over 5s. 5d., otherwise add 2d. per 1s.

RELIABILITY WEEKLY ATTRACTION.—Atlas low loss square law .0005 condensers with dials, 3s. 11d.

RELIABILITY CLEARANCE LINES.—Lissen T.3 Transformers, 7s. 6d.; Gents, 7s.; Atlas, 6s.; Etherplus, 5s.

RELIABILITY LISSAN COMPONENTS.—H.T. Batteries, 7s. 11d.; Transformer, 8s. 6d.; Mica Sparking Plug, 4s.; Rheostats, 1s. 6d. and 2s. 6d.

RELIABILITY STRAIGHT-LINE CONDENSERS.—With 4in. Trolite Dial .0005, 5s. 9d.; .0003, 5s. 6d.; Vernier Dial extra, 1s. 6d.

RELIABILITY ANTI-CAPACITY SWITCH.—Double Pole Double Throw 1-hole fixing, knob operated, screw connections, 3s.

RELIABILITY GOODS AND SERVICE.—Only obtainable from J. H. Taylor and Co., 15, Radio House, Macaulay Street, Huddersfield. Trade supplied. Send for free Guide now. [0028]

ANY Make of Component Taken in Part Exchange for New Gear.—Browne, 65, Sinclair Rd., W.14. [5160]

EXPERIMENTER'S Clearance.—McMichael 5-valve supersonic block with B.B.C., 5XX, and short wave units, Dinic S.W.3 and short wave Unimic, £3/10; D.E.7 4 electrode valve, 7/-; Watmel choke, 7/-; Lissenola and reed, 6/-; or accept £4 the lot; all perfect; nearly new.—Box 2957, c/o The Wireless World. [5147]

LAKER 30ft. Handsome Steel Mast, 22/6. See descriptive advertisement, page 15. Easily erected. [0036]

ALL-WAVE Four Six-pin Bases, 2/6; low loss formers, 4/6; Southern Cross six pin bases, 1/- and 2/-; also copper dividing screens or boxes to your requirements.—The "Brinford" Mfg. Co., 37-45, Middlesex Wharf, Clapton, E.5. [5131]

The ATALANTA SCREW-DRIVER



Nothing to go wrong.

The blade does not slip out of screw slot, the handle remains stationary in the palm of the hand, turning is effected by fingers on the knurled ring below.

WIRELESS MODEL with box spanners (illustrated) in three sizes which fit on the flat of the blade and are excellent for nuts in awkward places. **3/-** the Set.

Mechanic's Model No. 1 (5 1/2") 1/6 No. 2 (7 1/2") 2/- No. 3 (8 1/2") 2/6
Electrician's Model with Insulated handle of Bakelite. No. 1 (8") 4/- No. 2 (9") 4/6

Post free at list prices.

ATALANTA, LTD.
1-3, Brixton Rd., S.W.9.
Phone: Brixton 2110.

Manufactured by



RELIABILITY S.L.F. CONDENSER with ebonite ends and 4" Trolite Dial. .0005 5s. .0003 5s. Vernier Dial 1s extra. Post Free.

Further Attractive Items in Miscellaneous Columns.

J. H. TAYLOR & CO
2 RADIO HOUSE
MACAULAY ST HUDDERSFIELD.

Send for FREE Guide now. Trade Enquiries Solicited.

WEARITE COMPONENTS

EMPIRE BROADCAST SHORT WAVE RECEIVER
(Described in June 29th issue.)

COPPER BOX £2
COIL with BASE 6/6
H.F. CHOKES per pair 4/-

ALL WAVE FOUR H.F. TRANSFORMERS
B.B.C. WAVELENGTH 18 9
5XX 15/6
BASE (6 PIN) 2/9
COPPER SCREEN 5/-

See "Wireless World" Report, June 1st issue, page 700.

EVERYMAN FOUR and EVERYMAN THREE
COILS & BASES per pr. 37/6
QUALITY THREE COIL 18/9
H.F. CHOKE 6/6

Send for our illustrated catalogue.

WRIGHT & WEARE LTD.,
740, HIGH ROAD, TOTTENHAM, N.17.
PHONE: Tottenham 3132.

USE WEMCO CABINETS
if you want QUALITY

EVERYMAN FOUR
a distinctive cabinet for a distinctive set.

Motorists' PORTABLE as used in May 11th issue. Mahorany 60/- Oak 48/-

See Report p. 636, May 18th issue. Write for price or phone Clissold 0997.

W. E. MARSON Ltd. Windus Works, Windus Rd, Stamford Hill, London, N.16.

Components, Etc., for Sale.—Contd.

SALE or Exchange, Mullard o 30a., 2-0 20s, 2 L.S.5 valves as new, offers invited; wanted, H.T. transformer, suitable 220 volts 100 cycle 1,000 volt centre tapped, also D.E.T.1.—H. Dean Poulton, 18, Albion St., Cheltenham. [5111]

SHORT Wave Coils, low loss, for reception of Dutch, American, New Zealand, Australian, etc., signals; as used by G2RA for transatlantic work; wired to any set in a few minutes; 6/6 per set complete with base.—Warner, High Lane, Stockport. [5146]

WHAT Offers?—Amplion Radiolux, model R.S.2, new; 5 Colvern low-loss geared .0003 condensers; 1 new P.M.5.B; 2-valve R.C.C. amplifier in cabinet; all in perfect condition.—E. J. D., Spur Cottage, Malvern. [5142]

FERRANTI A.F.3, 18/-; B.T.H. B.8 valve, 10/-; Finston screen base and S.P. transformer, 11s.; service neodyne condenser (baseboard), 2/6; 40/- lot.—A. Lindley, 66, Stalker Lees Rd., Ecclesall, Sheffield. [5137]

TWO Long, one short wave, 6-pin aerial coils, 3/8 each; one long S.P. H.F. transformer 6-pin, 4/3; two 6-pin coil bases and screens (one Lewcos), 5/- each; one Formo vernier dial, 1/3; one r.c. coupling unit Polar, 3/6; one Ferranti L.F. transformer, 5/-; one 25, one 35, three 250 plug-in coils, 2/6 each; one .0003 vari. condenser, 2/6; the lot 45/-.—All in excellent condition.—Kershaw, Brampton, Stalybridge. [5155]

CECOPHONE 2-Valve Amplifier and Speaker, £3; L.S. 2-valve, 10/-; R.I.1 valve, 25/-; Fellows 3-valve set, £3; Thameside 2-valve set, 50/-.—E. Lawson, Allendale Rd., Barnsley. [5154]

LOTUS 3-Way Geared Coil Holder, new, 8/-; condensers, valves, sundries, cheap. Stamp list.—Kender, 29, John St., Lozells, Birmingham. [5153]

SURPLUS Wireless Material, transformers, condensers, and fixed resistors for sale; worth £3/13, accept £2/5.—G. Jackson, 9, Bean Rd., Dudley. [5163]

BRINFORD for Copper Screens and Six-pin bases. See advertisements under Miscellaneous. [5133]

MISCELLANEOUS.

THE Wireless Doctor Will Call (London and Home Counties) if your set is troublesome; no cure, no charge; Wireless Association registered repairer; sets installed, maintained, and brought up to date; experiments and testing undertaken; Solodyne demonstrated.—Alexander Black, 2A, Woodville Grove, N.16. Clissold 3687. [3841]

BRINFORD for all Components.—For specialities see other advertisements under Miscellaneous. [5132]

LAKER 30ft. Handsome Steel Mast, 22/6. See descriptive advertisement, page 15. Easily erected. [0037]

SUPER Galena Crystals, 5/- lb., min., 5 pound lots. Special terms for quantities.—Blackwell's Metallurgical Works, Liverpool. [4387]

A SUMMER Hobby—Restringing Tennis Rackets, frames, gut, tools. Lists and instructions, stamp.—Morris, 143, Lonsdale St., Bradford. [4890]

LAKER 30ft. Handsome Steel Mast, 22/6. See descriptive advertisement, page 15. Easily erected. [0046]

Mention of "The Wireless World," when writing to advertisers, will ensure prompt attention.

Miscellaneous.—Contd.

SCOTT SESSIONS, the radio doctor (London and environs).—Any set repaired, installed, modernised; distortion eliminated; specialist in "Wireless World" sets; no fee until repaired.—Scott Sessions, Hill Top, Muswell Hill, N.10. 'Phone: Mountview 4928. [4861]

WIRELESS Doctor, anywhere Preston, Blackpool and Fylde, 6 years' experience, repairs, installations; distortion eliminated; no fee till results.—Write Coulborn, Bryning Lane, Wrea Green. [5112]

LAKER 30ft. Handsome Steel Mast, 22/6. See descriptive advertisement, page 15. Easily erected. [0047]

BRINFORD for Lines that are Different.—The "Brinford" Mfg. Co., 37-45, Middlesex Wharf, Clapton, E.5. [5134]

WIRELESS Doctor.—If in trouble write: evening visits, moderate terms; any set modernised.—Morley, 18, Grangemill Rd., Catford. [5140]

LAKER 30ft. Handsome Steel Mast, 22/6. See descriptive advertisement, page 15. Easily erected. [0061]

OTHER Systems are Superseded by Elex Plug and Sockets.—Ask your dealer, or Easticks, 118, Bunhill Row, E.C.1. [0024]

REDUCE Accumulator Troubles.—Test your accumulator with a Utility syringe hydrometer—British made. Full instructions in booklet "Accumulators Explained" sent with each hydrometer. Post free, 4/6. Full particulars on application.—Utility Syringe Hydrometer Co., Dept. B., 16, Howard Rd., Ilford, Essex. [0060]

LAKER 30ft. Handsome Steel Mast, 22/6. See descriptive advertisement, page 15. Easily erected. [0062]

PATENT AGENTS.

A. PETER THURSTON, D.Sc., F.R.Ae.S., M.I.A.E., A.M.I.M.E., 329, High Holborn, London, W.C.1. Patents, Trade Marks. Designs. Telephone: Holborn 2542. [2315]

PATENTS and Trade Marks—British and Foreign.—Gee and Co. (H. T. P. Gee, Member R.S.G.B. and A.M.I.R.E.), 51-52, Chancery Lane, London, W.C.2. 'Phone: Holborn 1525. [0001]

REPAIRS.

TRANSFORMERS, phones, loud-speakers rewound and repaired to maximum efficiency; all one price, 4/- post free. A 12 months' guarantee accompanies each repair. Your present transformer can also be rewound to Multi-Ratio type. Write giving particulars. Trade invited.—Transform, 115, Links Rd., Tooting, London, S.W.17. [0011]

HEADPHONES and Loud-speakers, rewound, remagnetised, and overhauled, 4/- post free. Guaranteed. Only firm in the West. Established 1923.—Bradford and Co., 16, Prospect St., Plymouth. [5045]

WANTED.

WANTED.—Tungar Rectifiers, deposit system.—Particulars to Colley, Somerset Place, Teignmouth. [5101]

WILL Buyers of Scrap Ebonite please communicate prices and quantities taken to Carr, 130, Harvist Rd., London, N.W. [5124]

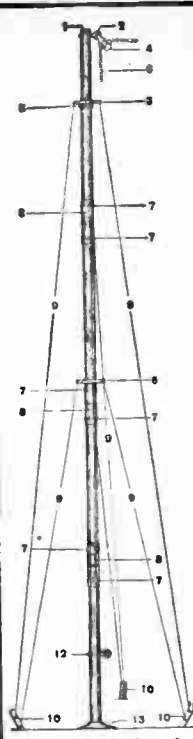

ARE YOU PROUD

OF YOUR AERIAL MAST or is it tottering beneath the burden of its responsibility?

EFFICIENT, HANDSOME, and an Ornament to any Garden is a

"LAKER" STEEL MAST 30 ft. for 22/6

COMPLETE WITH ALL ACCESSORIES AS ILLUSTRATED. Can be erected in a few minutes. Occupies only 4' 6" radius. Send 1/0 extra for part carriage. We pay the rest.

J. & J. LAKER Co. Engineers, Beckenham, Kent. Contractors to H.M. Government, The B.B.C., etc. On the Admiralty List.

Money refunded if not completely satisfied.

THE MAST for the MILLION.

RESISTANCE STRIPS

Suitable for use as Fixed Valve Resistors, or as Potential Dividers in H.T. Eliminators, etc. Can be used in series or parallel. Wound on Fibre Strips 1/2" wide by 5 1/2", with two holes for fixing. 8 ohms (1 amp.) and 35 ohms (.5 amp.).

PRICE:—6d. each post free. 5/6 doz. post free.

Delivery:—Ex Stock.

Prices for special resistances on application.

A. M. YOUNG & CO., 52, BORDESLEY STREET, BIRMINGHAM.

ELECTRADIX RADIOS

Everything Electrical.

Send 4d. stamps for 68 page Illustrated Catalogue. 218, UPPER THAMES STREET, LONDON, E.C.4. 'Phone: CITY 0191.

EXCHANGE.

EXCHANGE "Amateur Mechanic," 4 vols., as new, cost £3, for wireless components or best cash offer.—Box 2958, c/o The Wireless World. [5149]

AGENCIES.

EVERYTHING Wireless—Amateur constructors required everywhere as distributing agents; stamped envelope.—Garner, 31, Little Britain, E.C.1. [0027]

SITUATIONS VACANT.

SPLENDID opportunity for live commission men with good connections amongst wireless dealers, as representatives for well-known British loud-speaker; state ground covered.—Box 63, "Parrs," Craven House, Kingsway, London, W.C.2. [0057]

TWO Special Representatives required by leading radio manufacturers.—Apply, giving full details of previous experience (commercial and technical), age, salary expected, and whether prepared to go anywhere in Great Britain, Box 2914, c/o The Wireless World. [5109]

SITUATIONS WANTED.

YOUNG Man, 20, holds 1st class P.M.G. Workshop and test room, experience with Marconi Company, experience in designing, wiring sets, etc.—E. Munnion, 11, Springfield Rd., Chelmsford. 'Phone: 228. [4995]

BOOKS, INSTRUCTION, ETC.

"ACCUMULATORS Explained," how they work, care hints, terms defined; booklet 6d., post free; refunded when hydrometer purchased. See under heading "Miscellaneous."—Utility Syringe Hydrometer Co., Dept. C., 16, Howard Rd., Ilford, Essex. [0058]

BRIGHTER Wireless!—Send for free specimen copy of "Brighter Wireless," the happy journal for amateur constructors. Simple, selective long range circuits. Copious wireless information. Subscription 3/6 per annum.—Brighter Wireless, 29, Paternoster Row, London, E.C.1. [4930]

140 "Popular Wireless," 26 "Modern Wireless," 29 "Wireless Constructor." What offers?—A. Ward, 16c, Polygon Buildings, Euston. [5108]

3-VALVE Receiver for 30/-—Write now for booklet on how to build the L.R.C.3 valve set for 30/- from guaranteed parts only—the ideal loud-speaker set.—1/- post free from H. Howarth, Lustrolux Depot, 288, Deansgate, Manchester. [5003]

Your First Steps in Wireless

By **HUGH S. POCOCK**

Editor of "The Wireless World"

A most helpful little book for those who are beginning to study wireless. It explains technical difficulties by simple analogies.

Price 9d By Post 11d

From **ILIFFE & SONS LIMITED**

Dorset House, Tudor Street, London, E.C.4 and leading booksellers. w.w. 14

INDEX TO ADVERTISEMENTS.

| | | |
|--|--|---|
| Accumulators Elite Cover III. | Gambrell Bros., Ltd. 16 | Metro-Vick Supplies, Ltd. 8 |
| A.F.A. Accumulators, Ltd. Cover II. | Garnett, Whiteley & Co., Ltd. Cover II. | Mic Wireless Co. 16 |
| Artic Fuse & Electrical Co., Ltd. Cover II. | General Electric Co., Ltd. 5 | Mullard Wireless Service Co., Ltd. Cover IV. |
| Atalanta, Ltd. 14 | General Radio Co., Ltd. 13 | Ormond Engineering Co., Ltd. 7 |
| Benjamin Electric Co., Ltd. 13 | Hart Accumulator Co., Ltd. 1 | Radiax, Ltd. 10 |
| Bird, Sydney S., & Sons 11 | Holzmann, Louis 4 | R.I. & Varley, Ltd. 2 |
| Bowyer-Lowe Co., Ltd. 1 | H.T.C. Electrical Co. 16 | Saukey, J., & Sons, Ltd. Cover II. |
| Brown, S. G., Ltd. 3 | Jones & Stewart Cover III. | Stapleton, A. W. 16 |
| Carrington Manf. Co. 6 | Laker, J. & J., Co. 15 | Taylor, J. H., & Co. 14 |
| Cossor, A. C., Ltd. 6 | Langham Radio 1 | Telegraph Condenser Co., Ltd. 16 |
| Digby, F. 16 | London Electric Wire Co. & Smiths, Ltd. 2 | Tulsemere Manf. Co. 16 |
| Dubilier Condenser Co. (1925), Ltd. 9 | London Radio Manf. Co., Ltd. 10 | Vandervell, C. A., & Co., Ltd. 3 |
| Eagle Engineering Co. Cover III. | Lustrolux, Ltd. 16 | Weston Electrical Instrument Co., Ltd. 4 |
| Electradix Radios 15 | Marconiphone Co., Ltd., The 9 | Whiteley, Boneham & Co., Ltd. 14 |
| Ferranti, Ltd. 15 | Marson, W. E., Ltd. 14 | Wright & Weaire, Ltd. 14 |
| Forno Co. 15 | Melhuish, C. D. 10 | Young, A. M., & Co. 15 |



H.T. UNIT.
Guaranteed silent. No valves. Requires no attention or renewals. Variable tapplings for multi valve sets 0-120 volts. Please state A.C. supply voltage etc.

57/6

The TANNOLY

A.C. MAINS SUPPLY UNITS
are perfectly insulated so there is no danger of shock 7 days free trial against cash. Guaranteed for twelve months; write or phone for lists. Streatham 6731.

Sole Manufacturers and Patentees
THE TULSEMERE MANFG. CO., Tulsemere Road, West Norwood, S.E.27

L.T. UNIT.
Used in conjunction with a 2, 4 or 6 volt accumulator. Operates automatically with no fear of overcharging. Mains consumption is negligible. Charge and discharge A.M.Meter 10/- extra.



39/6



The **LOW LOSS** Regenerative **ZAMPA** TUNER

A modern tuning device to cover all B.B.C. wavelengths (200-2000 metres). 2 hole fixing. Panel space 4" x 2" deep. From your local dealer or direct. Send for full particulars. Price **19/6**

Mic Wireless Co., Market Street, Wellingborough

The H.T.C. TWIN RECEIVER
A complete up-to-date set including loud speaker and all accessories.
Seven days trial and initial payment refunded if not entirely satisfactory.

H.T.C. ELECTRICAL CO. LTD.,
2, Boundaries Rd., Balham, S.W.12.

Immediate delivery for 5/-
Balance 2/6 per week or 10/- per month. Total cost £6 10 0.

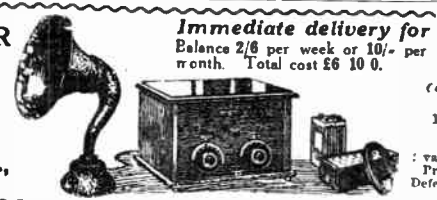

Cash Price £6 4 0
Royalty Paid.
If valve set, Cash Price £8 8 0
Deferred Terms £8 16 0



The LORIOSTAT
1, 2, 3, 4, 5 or 6 valves perfectly and independently controlled by one unit.

A multiple unit superseding the fixed Resistor can be used in any circuit to control any number of valves. For downright efficiency use a LORIOSTAT in your set.

18a, Lorrimer Buildings, Lorrimer St., Waltham, S.E.17

From a recent letter:

"... I may say that I was amazed at the response to my first advertisement in 'The Wireless World.'"

H. GOODWIN,
Woodcock Hill,
Elstree.

w.w.53

GAMBRELL
CENTRE TAPPED COILS

These are universal coils, their use not being limited to centre tapped circuits. They can be plugged into any standard coil socket. Baseboard space occupied is very small.

| SIZE. | PRICE | Approx No. o. Turns. |
|-------|-------|----------------------|
| a 2 | 4 10 | 15 |
| a | 4 10 | 23 |
| A | 5/- | 30 |
| B 1 | 5/3 | 40 |
| B | 5/3 | 50 |
| O | 5/3 | 75 |
| D | 6/3 | 100 |
| EL | 6/3 | 150 |
| K | 7/8 | 200 |
| F | 7/8 | 300 |
| G | 10/- | 500 |

Prices Quoted Standard Coils, Centre Tapped 6d. Extra

Detail of Gambrell Mains Receivers on request.

GAMBRELL BROS LTD.
76, Victoria St., London, S.W.1

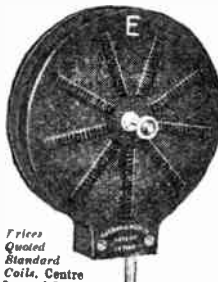

MAHOGANY
CABINET
FOR YOUR SET

A beautiful piece of furniture, French polished, Satin finish. Top compartment for set, and bottom compartment for batteries. Fitted with lock and key. Size No. 1 takes any set or panel up to 24 x 8 in. Size No. 2, set or panel up to 30 x 9 in., 10/- extra. In Oak with Twist Legs, Size No. 1, £4 7 6. Size No. 2, £4 17 6.

Special Sizes made to order. Write for Illustrated Price List. 9, Banbury Road, South Hackney, E.8. Let us quote for your own design.



£4 17 6
Delivered Free in U.K.
See report p.47 13 July issue.

WIRELESS VALVE TRANSMITTERS
By W. JAMES.

Dealing thoroughly with the Design and Operation of Small Power Apparatus

Price 2/6 Net
By Post 2/9

270 pages with 210 photographs and diagrams.

Obtainable from Booksellers or direct from the Publishers:
ILIFFE & SONS Ltd., Dorset House, Tudor Street, LONDON, E.C.4. w.w.9

The **Home** Constructor's **Wireless Guide**
by W. JAMES

THIS book forms a most convenient little encyclopaedia of wireless technology; the kind of volume to refer to when in difficulties. It solves them for you.

A few of the main features:
Outdoor, Indoor and Frame Aerials; Earths, Variometers for Broadcast Wavelengths; Basket Coils, Plug-in Coils, etc.; Coupled Circuits; Common Faults in Tuners; Reaction and Self-Oscillation; Special Chapter on Sensitive Single-Valve Receivers; Double Magnification; Points on Dry Cells and Accumulators, etc., etc.

PRICE 3/6 NETT.
By post, 3/10.

Obtainable from Booksellers, or direct from the Publishers of "The Wireless World,"
ILIFFE & SONS LTD.,
Dorset House, Tudor Street, London, E.C.4. w.w.10

THE MOTORCYCLE

The Motor Cyclist's Newspaper

EVERY THURSDAY — 3d.

Publishers: **ILIFFE & SONS LTD.,** Dorset House, Tudor Street, London, E.C.4. w.w.13

Mention of "The Wireless World," when writing to advertisers, will ensure prompt attention.

In any valve it's the FILAMENT

you pay for!

Remember when you buy radio valves that the life of any valve is not one minute longer than the life of its filament and that upon the performance of the filament depends the results you obtain.

Therefore demand:

A LONG FILAMENT . . . a filament with huge proportions, to secure a gigantic emission and the best operating characteristics.

A STRONG FILAMENT . . . a filament that cannot be broken except by the very roughest handling.

A PROVED FILAMENT . . . a filament that has a published National Physical Laboratory Test Report that proves its life and power to be constant and lasting.

Be safe and satisfied. Demand

**THE WONDERFUL
MULLARD P.M. FILAMENT**

Obtainable only in Mullard P.M.
Valves from all radio dealers.

Mullard

THE · MASTER · VALVE



You may judge the toughness of the wonderful P.M. Filament from the fact that it can be tied in a knot long after 1000 hours' life.

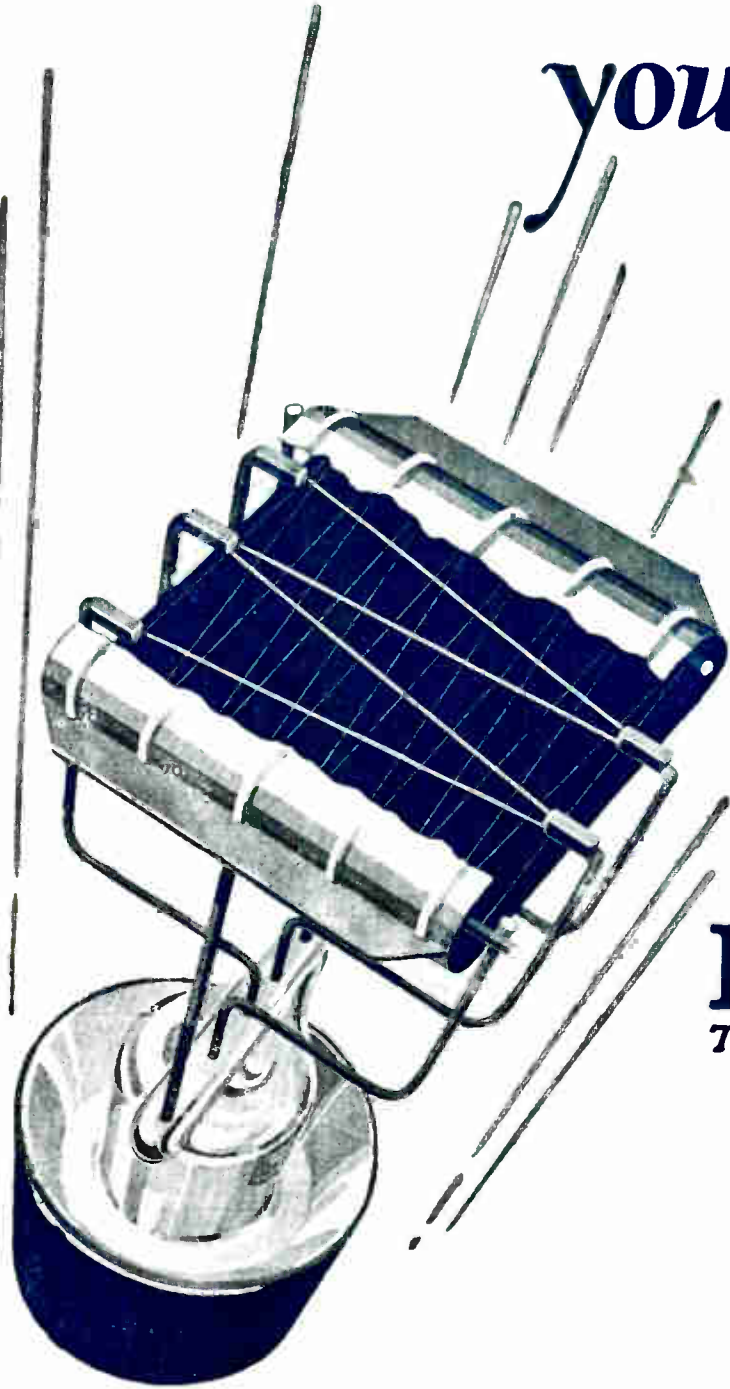

THE MULLARD WIRELESS SERVICE CO., LTD. MULLARD HOUSE, DENMARK STREET, LONDON, W.C.

Printed for the Publishers, LITTLE & SONS LTD., Dorset House, Tudor Street, London, E.C.4, by The Cornwall Press Ltd., Paris Garden, Stamford Street, London, S.E.1.

Colonial and Foreign Agents:
 UNITED STATES—The International News Co., 131, Varick Street, New York. FRANCE—W. H. Smith & Son, 248, Rue Rivoli, Paris; Hachette et Cie, Rue Réaumur, Paris.
 BELGIUM—W. H. Smith & Son, 78, Marche aux Herbes, Brussels. INDIA—A. H. Wheeler & Co., Bombay, Allahabad and Calcutta. SOUTH AFRICA—Central News Agency, Ltd.
 AUSTRALIA—Gordon & Gotch, Ltd., Melbourne (Victoria), Sydney (N.S.W.), Brisbane (Queensland), Adelaide (S.A.), Perth (W.A.) and Launceston (Tasmania).
 CANADA—The American News Co., Ltd., Toronto, Winnipeg, Vancouver, Montreal, Ottawa, St. John, Halifax, Hamilton; Gordon & Gotch, Ltd., Toronto; Imperial News Co., Toronto, Montreal, Winnipeg, Vancouver, Victoria. NEW ZEALAND—Gordon & Gotch, Ltd., Wellington, Auckland, Christchurch and Dunedin.

3^D

The Wireless World

AND RADIO REVIEW

The Paper for Every Wireless Amateur

Wednesday, July 27th, 1927.

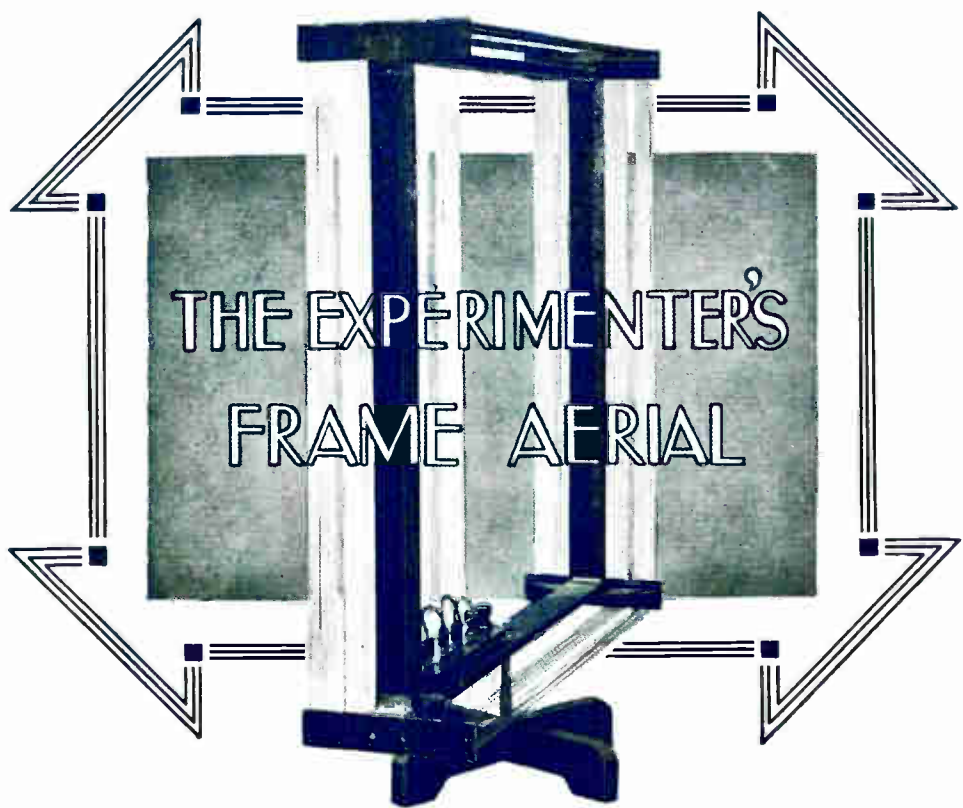

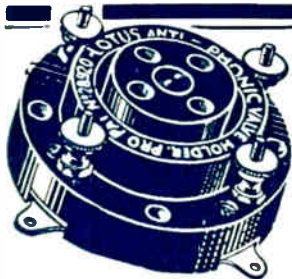

**No fading away—
No microphonic
noises—**

Use Lotus Coil Holders and Valve Holders in YOUR set. They ensure perfect, un-interrupted reception.

Pat. No. 256833.
With terminals
2/6
Without terminals
2/3

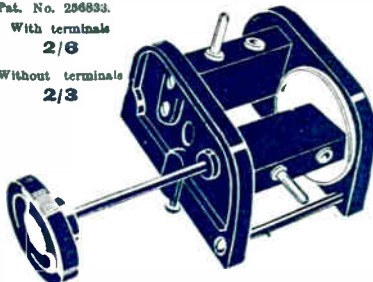

There will be no more fading away of volume, no more breaking of valves and disturbing microphonic noises once you have fitted your set with Lotus Coil Holders and Valve Holders.

From all Radio Dealers.

LOTUS

COMPONENTS.

Two Types:
For outside panel mounting.
Two-way 7/-
Three-way 10/6
For inside baseboard mounting
with bin. handle.
Two-way 8/-
Three-way 12/6

GARNETT, WHITELEY & CO., LTD.
Lotus Works, Broadgreen Road, LIVERPOOL.

**Business 70 times
the advertising cost!**

The following letter, written by a recent advertiser in "The Wireless World," will be of interest to every wireless manufacturer and trader.

".....It may interest you to know that I have kept a very careful analysis of the results of my two advertisements in your "Classified" columns, and I find that the value of the amount of business done is approximately seventy times their cost. Personally, I consider this very satisfactory."

H. GOODWIN,
Radio Specialist,
Woodcock Hill,
ELSTREE.

w.w.6r

USE **"Utility" SWITCHES**
They ARE Better



"Utility"
Push-Pull
Switch

A switch of extremely low capacity, smooth action and perfect contact—dependable for service and the very best results.

On more than one occasion "Utility" Components of one kind or another have been specified in "Set Builders" articles in this paper. Because they're of better materials and finish. Because the results are definitely better.

"UTILITY"
Components
are all
Guaranteed

Buy and use them with every confidence. The "Utility" Range, in addition to Switches includes the Micro Dial, Low Loss Condenser, Gang Condenser, etc., etc., all obtainable from good dealers or direct from the actual makers.

"Utility"

No-Capacity
Change-over
Switch

Made to change over any number of contacts—loss is practically eliminated and the contacts are permanently self-cleaning.

Knob Pattern (2 pole)
3/6

Lever Pattern (2 pole)
4/-

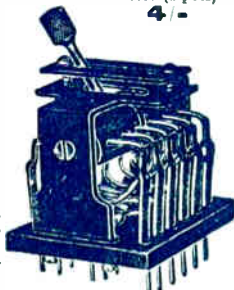

WILKINS & WRIGHT LTD
KENYON ST. **Utility** BIRMINGHAM

**Expenditure 1'11
Orders—nearly £4**

The following letter from a recent advertiser in "The Wireless World" is of interest to all prospective advertisers.

"I should like to express my opinion of 'The Wireless World' as an advertising medium. On April 27th I had an advertisement in the paper, and in the evening a caller, who placed an order. This was followed before the end of the week by 20 enquiries, and I have since received another ten of these, 15 resulted in orders amounting to nearly £4. This, I consider, is very good, and all for the modest sum of 1/11 spent on advertising."

ALEC G. BINNIE.
1, Cromford Road,
West Hill, S.W.15.

Full particulars of advertising rates will be found on the first page of miscellaneous advertisements.

w.w.6t.

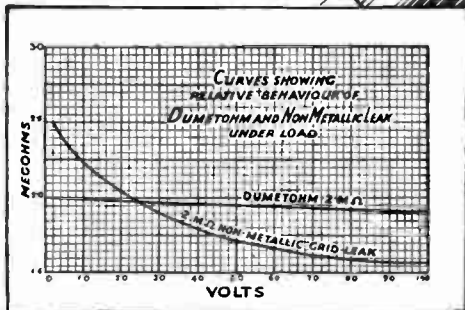

Neither temperature
nor load materially
affect the wonderful
DUMETOHM.

CERTAIN types of resistance fall off rapidly in value under a rise of temperature, whether this rise be due to the current passing through the resistance or to climatic conditions.

Such resistances also behave in a somewhat erratic manner under the application of voltage.

The resistance element of the Dumetohm "of a metallic nature" is the solution to all these difficulties. (See load curve above). Its consistent performance is maintained under any condition of climate likely to be experienced anywhere, and it will take a gross overload to upset the equanimity of "the most popular resistance in the country."

See that your set contains Dumetohm resistances and enjoy the pure noiseless reception which they afford.

Dumetohms are made in standard resistances of 0.25, 0.5, 1, 1.5, 2, 3, 4 and 5 megohms. They cost 2/6. Soldering connections to them is a delicate matter. Ask for a Dumetohm Holder, price 1/.



TC 14

Advt. of the Dubilier Condenser Co. (1925) Ltd., Ducon Works, Victoria Road, North Acton, W.3.



1927 IMPROVED MODEL
H.T. ACCUMULATOR.

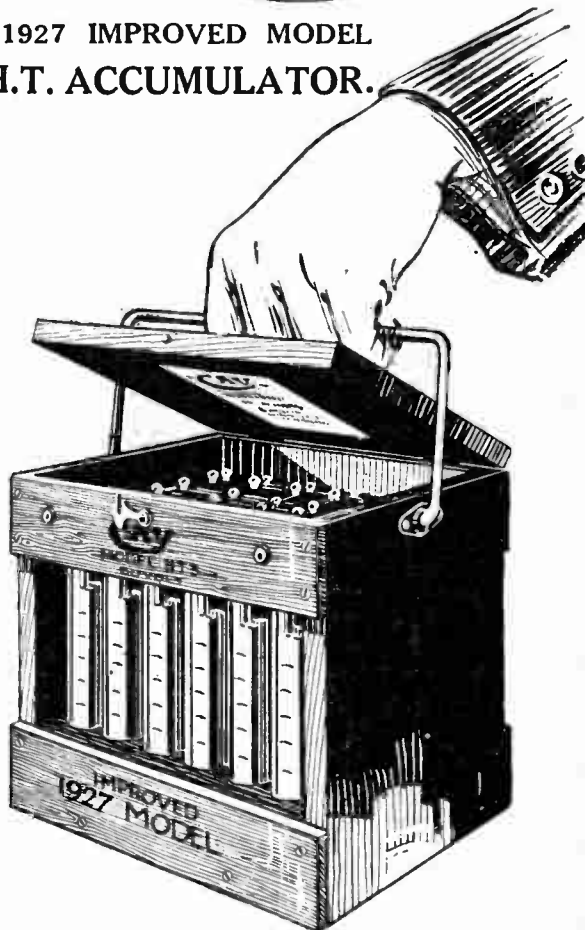

C.A.V. H.T. Accumulators have improved radio reception for hundreds of users who have wisely scrapped their dry batteries. They will do the same for you. Inconsistent discharges, temperature effects, crackling noises with reception, and constant regulation to correct voltage variations are all troubles peculiar to dry batteries, but these are unknown to users of the C.A.V. H.T.

The H.T.3 is fitted with a strong handle enabling it to be easily carried. Used by most leading experimenters they have also been supplied to over 100 of London's Hospitals.

MODEL H.T.3 **60'** SUPPLIED READY FOR USE
(60 VOLTS) NO FILLING WITH ACID, NO CHARGING
Dimensions 8½" x 7" x 7¾" High
Weight Charged 16¼ lbs - Dry 13½ lbs

ALSO SUPPLIED IN 30 & 90 VOLTS
MODEL H.T.4 - 30 VOLTS - - 30/-
MODEL H.T.5 - 90 VOLTS - - 90/-

Catalogue supplied on application.

C.A.V. Vandervell & Co., Ltd.
ACTON, LONDON, W. 3.

Telephone: Chiswick 3801
(Private Branch Exchange).

Telegrams: Vanteria-Act-London.



For Resistance Capacity Coupling—

this is the Condenser to use

WHEN buying Condensers for your resistance coupled circuit you have two alternative choices. You can buy Condensers that are nameless, that are backed by no guarantee. Or you can choose T.C.C., Condensers that are guaranteed up-to-the-hilt. If you buy unknown condensers you court failure. If you buy T.C.C. Condensers you go a long way to assure the

success of your set. For T.C.C. Condensers are thoroughly reliable. The strenuous tests each one passes before it leaves the factory safeguard you against inefficiency. Every T.C.C. Resistance Capacity Coupling Condenser is guaranteed. In its insulation qualities. impervious to climatic conditions. In its capacity . . . to be within 10% accurate up to '09 mfd. and 5% above '09 mfd. Guaranteed . . . to be utterly leakproof; never to break down.



Follow the experts lead—choose T.C.C., the Condenser in the green case. Green for safety, of course!

Here is the range :

| | s. | d. | | s. | d. |
|-----------|----|----|-----------|----|----|
| '005 to | | | '125 mfd. | 10 | 9 |
| '009 mfd. | 3 | 0 | '15 mfd. | 12 | 6 |
| '01 mfd. | 3 | 6 | '2 mfd. | 16 | 0 |
| '05 mfd. | 5 | 8 | '25 mfd. | 19 | 6 |
| '1 mfd. | 9 | 0 | '3 mfd. | 23 | 0 |

Always demand

T.C.C.

Resistance Capacity Coupling CONDENSERS

Adv. Telegraph Condenser Co., Ltd., Wales Farm Road, North Acton, W.3.

9251



Mention of "The Wireless World," when writing to advertisers, will ensure prompt attention.



SPECIAL STUDENTS' LIBRARY EDITION

FIFTY YEARS of ELECTRICITY

THE MEMORIES of an ELECTRICAL ENGINEER



By
J. A. Fleming,
M.A., D.Sc., F.R.S.

IN THIS volume the author places before the general reader a review of the chief triumphs of applied electricity during the last half-century.

PRICE
15/-
net

By post 15/9

Dr. Fleming has a word to say upon every phase of applied electricity: he indicates the trend of present research and suggests the course of future progress and development. Every student should make a point of obtaining a copy of this special edition of what may be regarded as a classic of technical literature.

From leading booksellers or direct from the Publishers:

ILIFFE & SONS LTD., Dorset House, Tudor St., London, E.C.4

W.W.11

WIRELESS VALVE RECEIVERS & CIRCUITS

IN PRINCIPLE AND PRACTICE

By R. D. BANGAY & N. ASHBRIDGE, B.Sc.

THIS BOOK will add to the pleasure of the amateur wireless experimenter by extending his theoretical knowledge of the whys and wherefores of valve receivers.

The subject is treated from a standpoint that will enable the home constructor to understand the working of any circuit which he may evolve, and he thus becomes independent of published diagrams and specifications. The volume is well illustrated.

PRICE
net **2/6**
By Post 2/10

Obtainable from all leading booksellers, or direct from the publishers.

ILIFFE & SONS LTD., Dorset House, Tudor St., London, E.C.4

W.W.40

A2

Rome — AT BOURNEMOUTH WITH THE LANGHAM PORTABLE!



BERNE HAMBURG
RADIO PARIS LANGENBERG
DAVENTRY
MADRID
LONDON
STUTTGART
BERLIN
FRANKFORT
HILVERSUM

One user of a Langham Portable has heard this every night for weeks—at full loud speaker strength, and at 900 miles range! Actually we only claim 150 miles range for short wave, and 300-400 miles for long wave stations—but you can do much better than that.

Anyhow, send us full price or initial deposit and we will send you a Langham to try for yourself. If you are not satisfied return the set and we will refund your money. The Langham Portable—a complete 4-valve set, one tuning control only, a real continental range, and 12 months guarantee.

Send to us for full particulars.
30 GNS. complete. No accessories to buy.
DEFERRED TERMS.
£5 down and 12 monthly instalments of £2-7-6.

Langham Radio
Albion House
59
NEW OXFORD STREET
LONDON, W.C.1

Telephone :
Museum
2878 & 8293.

Lewcos products specified week by week—



CENTRE TAPPED COIL.
CT60 B.B.C. range . . . 3/6 each.
CT200 Daventry range . . . 5/3 each.



FRAME AERIAL WIRE.
9/6 per 100 feet. Colours: red, blue, green, maroon, brown, old gold.

Pioneers in the introduction of Litz wound coils, LEWCOS have rapidly established an unchallenged reputation for quality. LEWCOS Radio Products are backed by over 40 years' experience in the manufacture of electric wire.

GLAZITE
BRITISH MADE REGD

Coloured Connecting Wire

**BATTERY CORDS
LEWCOFLEX
LITZ WIRE**

THE LONDON ELECTRIC WIRE COMPANY & SMITHS, LTD.,
Playhouse Yard, Golden Lane, London, E.C.

LEWCOS
Radio Products



BINOCULAR COILS.
The latest LEWCOS development.
Full particulars on application.



SIX PIN COILS.
Suitable for all circuits utilising this type. Tests prove they have lowest H.F. resistance.

Here's the cure for tongue-tied Sets!

ALMOST anyone can get a tune out of a piano. But it takes a Paderewski to persuade it to give the rich music which will live for ever. And so it is with Wireless. Almost any valve will give some sort of a result—but if you are critical and want to enjoy the thrills of perfect Radio, your set must be fitted *throughout* with Cossor Valves. Accept no substitute—let no one deceive you. There are no valves 'just as good.' The secret of their superb tone lies in the powerful Cossor Kalenised Filament and this is an exclusive Cossor development.

Cossor Valves are manufactured only by A. C. Cossor, Ltd., Highbury Grove . . . N.5

Cossor

The Melody maker

Cossor Valves are available in all voltages in a wide range of types.

 9243

The Wireless World

AND
RADIO REVIEW
(15th Year of Publication)

No. 413.

WEDNESDAY, JULY 27TH, 1927.

VOL. XXI. No. 4.

Editor: HUGH S. POCOCK.

Assistant Editor: F. H. HAYNES.

Editorial Offices: 139-40, FLEET STREET, LONDON, E.C.4

Editorial Telephone: City 4011 (3 lines).

Advertising and Publishing Offices: DORSET HOUSE, TUDOR STREET, LONDON, E.C.4.

Telephone: City 2847 (13 lines).

Telegrams: "Ethaworld, Fleet, London."

COVENTRY: Hertford Street.

BIRMINGHAM: Guildhall Buildings, Navigation Street.

MANCHESTER: 199, Deansgate.

Telegrams: "Cyclist Coventry."
Telephone: 5210 Coventry.

Telegrams: "Autopress, Birmingham."
Telephone: 2970 and 2971 Midland.

Telegrams: "Hille, Manchester."
Telephone: 8670 and 8971 City.

Subscription Rates: Home, 17s. 4d.; Canada, 17s. 4d.; other countries abroad, 19s. 6d. per annum.

As many of the circuits and apparatus described in these pages are covered by patents, readers are advised, before making use of them, to satisfy themselves that they would not be infringing patents.

HANDICAP OF THE CHEAP VALVE SET.



THE B.B.C. contend that the introduction of the Regional Scheme will give crystal set users throughout the country a choice of programmes. We hope that this may be so, although we doubt whether it will be possible in a large number of cases for the crystal sets at present in use to distinguish between the alternative wavelengths so as to get one transmission quite clear of the other. It seems probable that the introduction of the Regional Scheme, with its possibilities for alternative programmes, will result in a very large number of people at present satisfied with a crystal set changing over to a simple valve receiver which will give them the necessary range and selectivity to make sure of their alternative programmes with loud-speaker results. Wireless will, we believe, gain enormously in popularity as the valve replaces the crystal, because the results obtained will be so much more satisfactory to the listener. For this reason we attach special importance to the tendency for the price of simple valve receivers to come down to an extent which places them more easily within the range of the majority of those who are at present crystal users.

In this issue we review a two-valve set of satisfactory performance, utilising good components. The price of the set, including complete equipment of valves, batteries, loud-speaker, and materials for aerial and earth, is only £7 17s. 6d., whereas there are at present a large number of two-valve sets on the market which, with complete equipment, sell at £30 or even £40, and whose performance, *even if* superior to this cheaper set, is certainly not so much superior as to justify the enormous difference in price. We must remember that in this price of £7 17s. 6d. for the two-valve set is included the royalty payable to the Marconi Company, which amounts to 25s. Now, without questioning for one moment the right of the Marconi Co. to collect royalties in respect of patents which they control, we believe that royalties payable on

any article should be a reasonable percentage of the selling price of that article, and there must be something seriously wrong with a system which calls for the payment of 25s. royalty on an article which sells for £7 17s. 6d. when the same royalty is charged on an equipment costing £30 or £40. Since the price of £7 17s. 6d. includes loud-speaker, valves, and other equipment, the portion representing the set is probably less than £6, so that then the royal payment of 25s. net appears as an even more disproportionate charge. We can never hope to get down to cheap set production so long as the royalty payments are so high in proportion to the selling price of the article. At the time that the Marconi Co. royalty of 12s. 6d. per valve-holder was instituted the selling price of sets was very much higher than now, and at that time, no doubt, it appeared to be a reasonable proportion of the selling price. A change in the basis on which the royalties are calculated seems to us to be overdue. We doubt whether any loss in revenue would result to the Marconi Co. if the royalty charge were readjusted so as to be calculated on the basis of a proportion of the selling price of the set, since the increase in the sale of valve sets would, we feel sure, be very pronounced, especially if this change were brought about to coincide with the introduction of the Regional Scheme.

o o o o

BROADCASTING TO THE DOMINIONS.

IN our issue of last week we reported that Capt. Fraser in the House of Commons had asked the Colonial Secretary if any views were expressed by the representatives of the Colonies at the recent Colonial Conference as to the desirability of establishing a Dominions' broadcasting station. The reply was that the representatives at the Conference expressed the view that such a service, if found to be practicable, would be very widely appreciated overseas, and whilst it was considered premature

The Experimenter's Frame Aerial

Covers Wide Band of Wavelengths.

IN the course of experimental work the need for a frame aerial is often felt, and considerable time may have to be expended on improvising something suitable for the occasion. The wide range of wavelengths embraced by the present broadcasting system necessitates the employment of a frame having a large number of turns, and great care must be exercised in the design if a high standard of efficiency is to be obtained on all wavelengths covered. In the frame described, an effort has been made to achieve this by employing a sectionalised winding, and providing a terminal batten, carrying a number of selector leads and sockets, so arranged that the sections of the frame not in use can be totally isolated. The advantage of this will be appreciated, as it is well known that any tapped inductance having a "dead-end," or portion not in circuit, considerably reduces the efficiency of the "live" portion. It might well be asked: "Why go to the trouble of winding four sections when one section for the medium B.B.C. wavelengths and one for the long wavelengths would suffice?" In answer to this it can be stated that the aim is a wide-range frame giving continuous overlap in tuning from the shortest to the longest wavelength covered, and the highest possible efficiency over the whole band.

Advantages of Sectionalised Windings.

The proximity of the large inductance would considerably increase the high-frequency resistance of the short-wave section, and possibly have a rejector effect on certain wavelengths, owing to the fundamental wavelength of the large winding when open circuited, falling within the tuning band of the short-wave section. In addition, the separate frame has many advantages over the self-contained aerial, and the uses to which it can be put are too numerous for detailed consideration here. It will be seen from the illustration that the aerial consists of a wooden frame carrying four ebonite strips supporting the windings, a terminal batten and a brass pivot fitting into a socket on the base, thus enabling the frame to be rotated.

The wooden framework is built up from four lengths of oak, or other hard wood, the two horizontal pieces

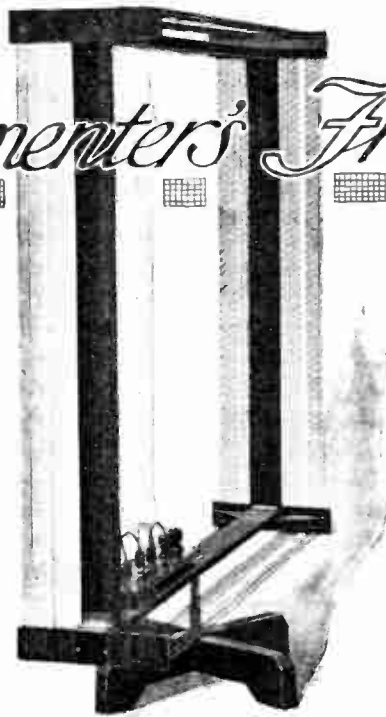

By H. B. DENT.

Collapsible Design for Portability.

measuring 23½ in. long by 1½ in. wide by ¾ in. thick, and the vertical members 21½ in. x 1½ in. x ¾ in. These are assembled as shown in Fig. 1, the vertical members being attached to the horizontal pieces by means of small brass brackets (shown at X, Fig. 1). These are screwed to the inside of the top and bottom pieces, and the vertical bars attached to the brackets by 4 B.A. screws. Two brass stops are fixed to the lower horizontal on the inside angle formed by the wooden strips, the brass brackets being on the outside

angle. The reason this method of construction is adopted will be appreciated when instructions for collapsing the frame are given. Four wooden pieces, dimensions of which can be obtained from Fig. 1, should be screwed to the ends of the horizontal members; these act as strengthening pieces for the four ebonite strips carrying the windings.

Ebonite Spacing Strips.

The dimensions of the ebonite strips are 6 in. x 1½ in. x ¼ in., these being slotted with a hacksaw to carry the wires, and the slots arranged in four separate sections, one having 10 slots and the remaining three 12 slots each. The section consisting of 10 slots should be commenced ¼ in. from the end of the ebonite strip, and each slot should be separated from its neighbour by ⅞ in. A space of ¾ in. should be left before commencing the second section, and 12 slots, also spaced ⅞ in., should then be cut. Between the end of the second section and the commencement of the third a space of 1¼ in. will be required to give a clearance for the pivot about which the frame rotates. The third section should have 12 slots also spaced ⅞ in., this being followed by a ¼ in. space before commencing the fourth section, consisting of 12 slots ⅞ in. apart. Before assembling and countersinking the screw holes, care should be taken to see that all sections of 10 slots are the same side of the vertical members. In one of the two lower ebonite strips eight ⅞ in. holes should be drilled, and through these will pass the beginning and ends of the winding on each section. Each separate section of the winding commences and finishes at the terminal batten, W., Fig. 1, which is attached to the lower horizontal member and slightly raised above the woodwork to give a clearance for the

The Experimenter's Frame Aerial.—

shanks of the terminals and sockets. This batten carries two terminals (Belling-Lee shrouded, marked FRAME), seven sockets (Messrs. Lissenin Wireless Co.), and four lengths of flex terminating in wander plugs (Messrs. Lissenin Wireless Co.).

The brass pivot is attached to the centre of the lower horizontal of the frame, and consists of a length of $\frac{1}{4}$ in. brass rod, one end of which is reduced and screwed to take a 2 B.A. wing nut. The rod must be rubbed down with emery cloth so that it easily rotates in the base attachment, this having an inside diameter of $\frac{1}{4}$ in. Before

assembling the pivot on the wooden frame a $\frac{1}{2}$ in. diameter washer is slipped over the screwed portion, and a similar washer fitted on before the wing nut is screwed down. This will prevent the brass rod from pulling through the woodwork or working loose after a short period of use.

The base socket consists of a brass tube (A), Fig. 2, having an inside diameter of $\frac{1}{4}$ in., the lower end being slightly reduced for a length of $\frac{1}{2}$ in. This is then soldered to a brass plate (B), in the centre of which a hole has been drilled to clear the reduced portion of the tube. Two holes should be drilled in the positions shown, these being required to take the wood screws fixing the socket to

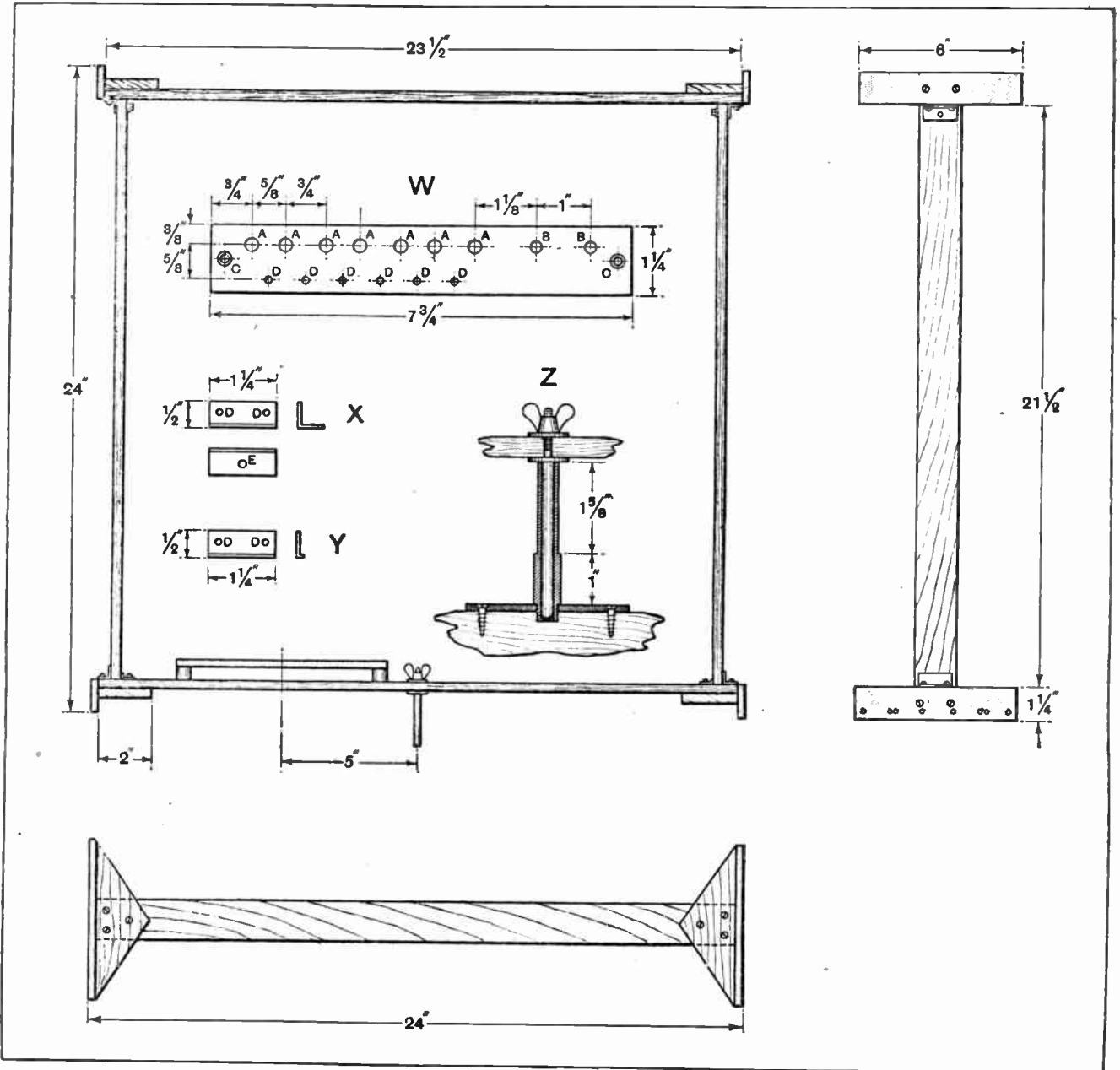

Fig. 1.—Dimensions of the wooden framework showing the method of attaching the vertical members to the two horizontals. Inset, details of the terminal batten W, the brass bracket X, the positioning stop Y, the pivot and base socket Z. A = $\frac{1}{4}$ in. diam.; B = $\frac{7}{32}$ in. diam.; C = $\frac{5}{32}$ in. diam., countersunk for No. 6 wood screw; D = $\frac{1}{8}$ in. diam.; and E, drilled and tapped No. 4 B.A.

The Experimenter's Frame Aerial.—

the wooden base. Before mounting this a hole must be drilled in the base just sufficiently large to take the end of the brass tube. The dimensions of the wooden base are given in Fig. 2, but any convenient base could be adopted, provided it was sufficiently large to support the frame without being top-heavy.

Winding the Frame.

This completes the constructional work, and the windings can now be put on. The frame has been planned with the view to collapsing should the necessity arise, and accordingly a very flexible wire will be required. The wire used on the frame described was obtained from Messrs. Ripaults, Ltd. About 380ft. will be required, and if possible should be obtained in one continuous length. The section consisting of 10 turns should be wound first, but before commencing a loop of strong twine should be taken round the frame at the opposite ends of the ebonite strips, otherwise the tension applied during winding will tend to distort the shape of the frame. The beginning of the winding should pass through the end hole in the ebonite strip and be soldered to the terminal marked T₁, Fig. 3. Ten turns should then be put on, each turn being well bedded down in its appropriate slot, and the winding finished off by soldering the end, after passing through the hole in the ebonite, to the first socket on the terminal batten (this socket is marked 1 in Fig. 3). The beginning of the second section is soldered to socket number 2, and after winding 12 turns terminates at socket number 3. The third section commences at the fourth socket and ends at the fifth, while the fourth section commences and finishes at the sixth and seventh sockets respectively. Before commencing to wind the fourth section the loop of twine should be removed, otherwise this may

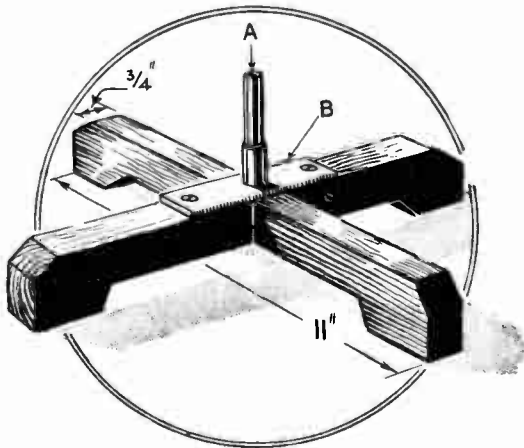

Fig. 2.—Constructional details of the base.

interfere with the winding of the last section. Three lengths of flex, about 3in. long and having wander plugs attached to one end, should be soldered to the first, third, and fifth sockets, while a 6in. length with wander plug should be soldered to the tag under terminal T₂.

The completed windings should be carefully checked with the help of Fig. 3, and if all connections are found to have been correctly made, the wires should be fixed

in position by running black sealing wax along the edges of the ebonite strips.

It would be advisable to drill three holes to the terminal batten so that the wander plugs not in use at any time could be accommodated, and thus prevented from becoming entangled in the frame windings.

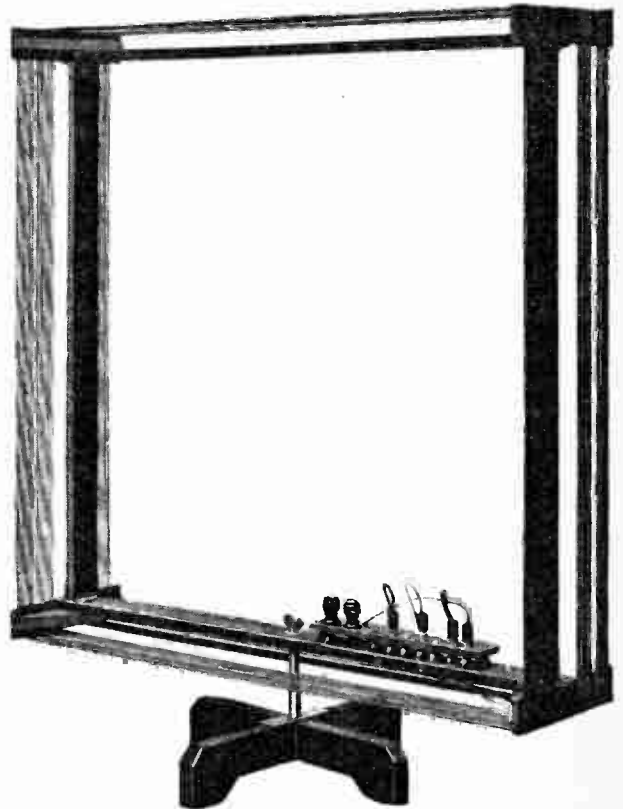

The general arrangement of the completed frame will be seen in this photograph.

The following table shows the correct positions of the various wander plugs to enable 1, 2, 3, or 4 sections to be brought into circuit. The numbers in columns 2, 3, 4, and 5 correspond with the sockets in Fig. 3, and the word "Blank" is intended to indicate that the wander plug is housed in one of the holes in the ebonite terminal batten.

| Frame Sections. | Terminal T ₂ Selector Plug. | 1st Wander Plug (Socket No. 1). | 2nd Wander Plug (Socket No. 3). | 3rd Wander Plug (Socket No. 5). |
|-----------------|--|---------------------------------|---------------------------------|---------------------------------|
| One . . . | 1 | Blank | Blank | Blank |
| Two . . . | 3 | 2 | Blank | Blank |
| Three . . . | 5 | 2 | 4 | Blank |
| Four . . . | 7 | 2 | 4 | 6 |

When one section of the frame is used and tuned by a 0.0005 mfd. variable condenser, the wave-band covered will be approximately that occupied by the medium wavelength B.B.C. stations, that is to say, about 200 to 550

The Experimenter's Frame Aerial.—

LIST OF PARTS.

8 ft. of $1\frac{1}{2}$ in. \times $\frac{3}{8}$ in. oak.
 Small quantity $\frac{1}{8}$ in. ebonite sheet.
 Short length of $\frac{1}{8}$ in. brass rod.
 Short length of brass tube, $\frac{1}{8}$ in. inside diameter.
 380 ft. of silk aerial wire, No. 1,048 (Ripaults, Ltd.,
 1, King's Road, N.W.).
 2 Ebonite shrouded terminals (Belling & Lee, Ltd., Ponders
 End, Middlesex).
 7 Sockets (Lisenin Wireless Co.).
 4 Plugs (Lisenin Wireless Co.).
 Wood for base.
 Brass, wood screws, etc.

Approximate cost - £1 0 0

In the "List of Parts" included in the descriptions of THE WIRELESS WORLD receivers are detailed the components actually used by the designer and illustrated in the photographs of the instrument. Where the designer considers it necessary that particular components should be used in preference to others, these components are mentioned in the article itself. In all other cases the constructor can use his discretion as to the choice of components, provided they are of equal quality to those listed, and that he takes into consideration in the dimensions and layout of the set any variations in the size of alternate components he may use.

metres. For the reception of stations working on the longer wavelengths, such as Daventry, etc., four sections of the frame should be brought into use, and the intermediate wavelengths can be obtained by the employment of two or three sections.

Before proceeding to collapse the frame, it would be advisable to remove it from the base and dismantle the pivot by unscrewing the wing nut. The four screws holding the vertical members in position should then be taken out and the battens gently eased out of position. When reassembling the frame, it is important to see that

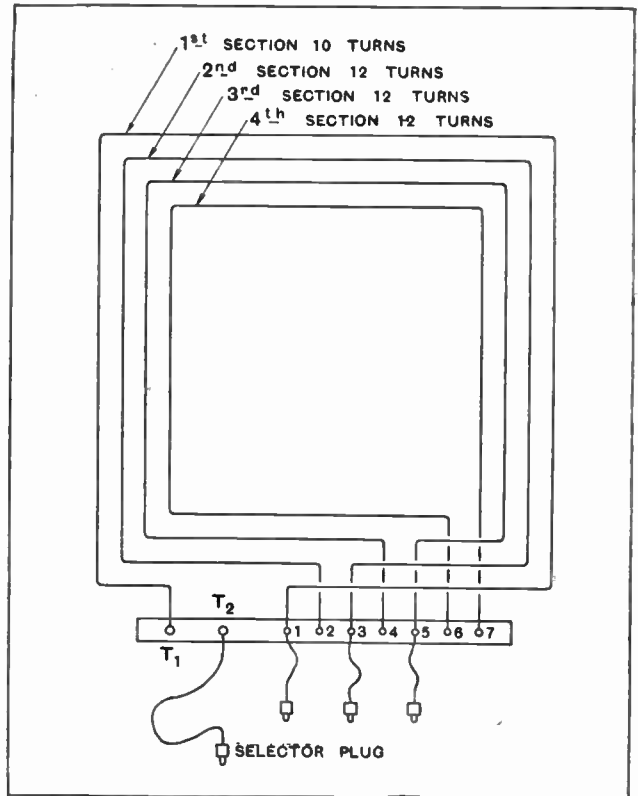

Fig. 3.—Theoretical diagram of the frame windings showing the connections of each section to the terminal batten.

all wires are free and not twisted round the corners of the framework, otherwise the windings may be damaged when the frame is stretched to the correct shape on inserting the vertical members.

Inspecting a Ship Installation.

The inspection of the wireless transmitting and receiving apparatus on board the L.M. & S. steamer "Duke of Cornwall" provided an interesting afternoon on Saturday, June 18th, for members of the Lancaster Store Institute Students Association. The party, numbering twenty-five, arrived at Heysham Harbour at 2.45 p.m. and were conducted over the vessel by the wireless operator in groups of five or six. The operator gave a careful description of the apparatus in his charge, explaining the action of the rotary converter and synchronous spark gap, as well as the various methods of tuning and the use of emergency gear.

The hon. sec. of the society is Mr. W. Salt, 5, Coverdale Road, Lancaster.

o o o o

Getting Rid of Distortion.

"Purity of Reception" was the title of a lecture given by Mr. Welstead at the last meeting of the Thornton Heath Radio Society. Speaking on the assumption that pure reproduction is a quality almost

NEWS FROM
THE CLUBS.

foreign to the performance of the average receiver, Mr. Welstead offered many suggestions. He tackled each stage in turn, viz., H.F., detector, and L.F., describing what modifications could be made in each

with the object of removing distortion. The society is considering the installation of a workshop, an additional attraction which should lead to an influx of new members in the coming winter. Enquiries regarding membership will be gladly welcomed by the hon. sec., Mr. C. H. Piper, 77, Torridge Road, Thornton Heath, Surrey.

o o o o

Transmitter Hunts.

Elsewhere in this issue will be found an illustrated record of a highly successful field day held by the Golders Green and Hendon Radio Society on Sunday, July 17th. The day's activities took the form of a D.F. hunt for a concealed transmitter, with the added excitement provided by the competitive element.

Few kinds of outdoor wireless work can rival the D.F. hunt—not only in fascination, but in the amount of solid instruction and experience that can be packed into a few hours. Many societies are taking up the sport with zest. What about it, secretaries?

FORTHCOMING EVENTS.

WEDNESDAY, JULY 27th.

Tottenham Wireless Society.—Demonstration of Society's Transmitter, by Mr. F. Dyer

THURSDAY, JULY 28th.

Stretford and District Radio Society.—Discussion and Question Night

MONDAY, AUGUST 1st.

Radio Society of Great Britain (Mid-Britain Section).—"Conventionette" and visit to 5A.A. Rendezvous: Cock Hotel, Kingsthorpe, Northampton

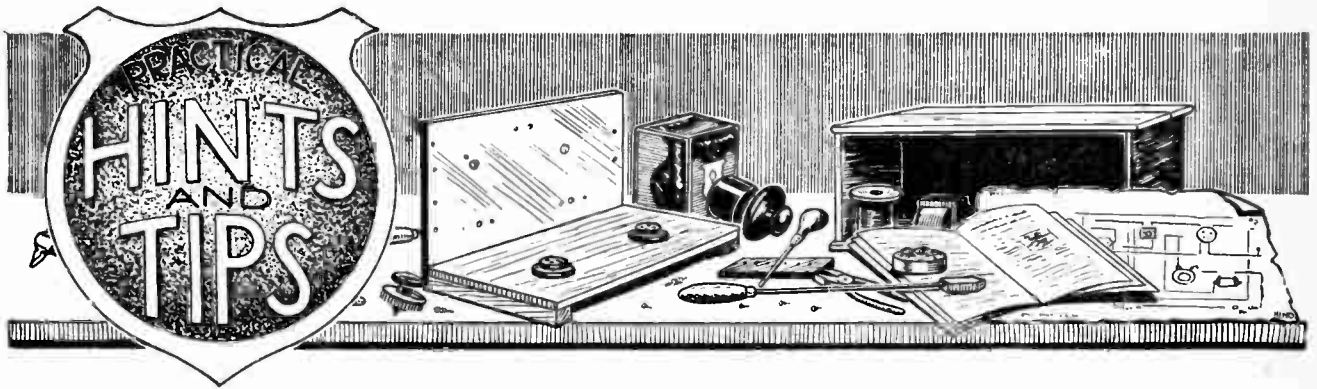

A Section Mainly for the New Reader.

HENRIES AND MAGNETISING CURRENT.

THE basis on which inductance, of which the henry is the unit, is computed, is one of the intersections between turns of wire comprising a coil and imaginary magnetic lines of force in the field of that coil due to the change of the value of the current flowing through the coil. The intersections between flux (*i.e.* lines of force) and turns produce a voltage, within the coil which tends to resist the change in current. This voltage is usually known as "back E.M.F.," since it is always opposed to the applied E.M.F., which is causing the change in current.

If iron is present in the centre of the coil a given current will produce a vastly greater number of lines of force, and therefore any change of current would be accompanied by a large "back E.M.F.," which would, in fact, prevent any rapid change in current.

The foregoing should make it clear why we use iron cored chokes when we require to smooth the output from a rectifier, or to pass direct current without passing speech current, which is, of course, a complex alternating current.

The physical size of a choke is determined by the fact that successive increases of current in a coil encircling an iron core will not go on producing increases in flux indefinitely. After a time the iron cannot be further magnetised, no matter how much current flows through the coil, and the iron is then said to be saturated.

A choke coil, then, has to be designed so that, when carrying its normal steady current, the iron is far from saturated, and it is therefore

able to offer a very large impedance to any change in the value of the current.

When purchasing an iron-cored choke coil one should demand information as to how much current it will carry without saturation, and see to it that this value of current is not exceeded, or, better still, not even approached.

In the same way care should be taken that a modern high impedance L.F. transformer is not used in conjunction with a valve taking such a heavy anode current that the transformer core is even partially saturated.

The reproduction obtained from a transformer so treated is likely to be worse than that obtained from another transformer which is actually a very much inferior article.

o o o o

THE CHOKE-CAPACITY OUTPUT CIRCUIT.

IN the "Readers' Problems" section of last week's issue there were discussed alternative methods of con-

necting a loud-speaker to the choke inserted in the anode circuit of an output valve. The conclusion was reached that the form of connection shown in Fig. 1 (a) is best, and that it has several advantages over that shown in (b). This is in agreement with the trend of modern practice; apart from the good features mentioned in the article in question, there can be no doubt that the risk of L.F. instability is reduced very considerably by diverting the greater part of the audio-frequency energy to earth through the loud-speaker instead of passing it through the H.T. battery or eliminator.

It should be realised, however, that the insulation of the feed condenser joined in series with the loud-speaker should, in the case of the (a) arrangement, be of a high order; the effects of any appreciable leakage will be much more serious than when the other form of connection is used. A consideration of the circuit diagram will show that a poorly-insulated condenser will introduce a partial short-circuit of the H.T. Battery.

o o o o

NOISY CONTACTS.

A NOT uncommon source of grating noises is the bearing in which the spindle of a rheostat is mounted. In the better-class instruments it will generally be found that special measures have been taken to ensure a good frictional contact, but some of the cheaper components are badly designed in this respect. They can often be improved by fitting a flexible wire "pigtail" between the appropriate terminal and the brush which makes contact with the resistance winding.

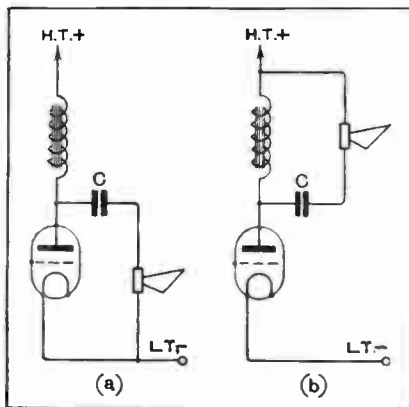

Fig. 1.—Alternative choke-condenser loud-speaker feed connections.

CASCADE H.F. AMPLIFIERS.

It has already been pointed out in these columns that the construction of a receiver having two or more H.F. stages is a matter of some difficulty as compared with a single stage set; it is not merely a question of adding another valve, and getting it and its associated apparatus into a state of satisfactory operation, but

the point of view of selectivity, results will be disappointing, being little, if any, better than those obtainable from one H.F. amplifier of modern design.

The unit system offers many advantages to those who, due to the close proximity to a powerful transmitter, or to a desire for great range, require more than the average amount

A few hints as to the practical realisation of a receiver on these lines may be useful. It will be found convenient to mount each unit in a metal screening box made of sheet copper or aluminium of a gauge sufficiently heavy to be self-supporting, and measuring approximately 5in. in height and depth (back to front), and 6in. in width. A vertical row of five

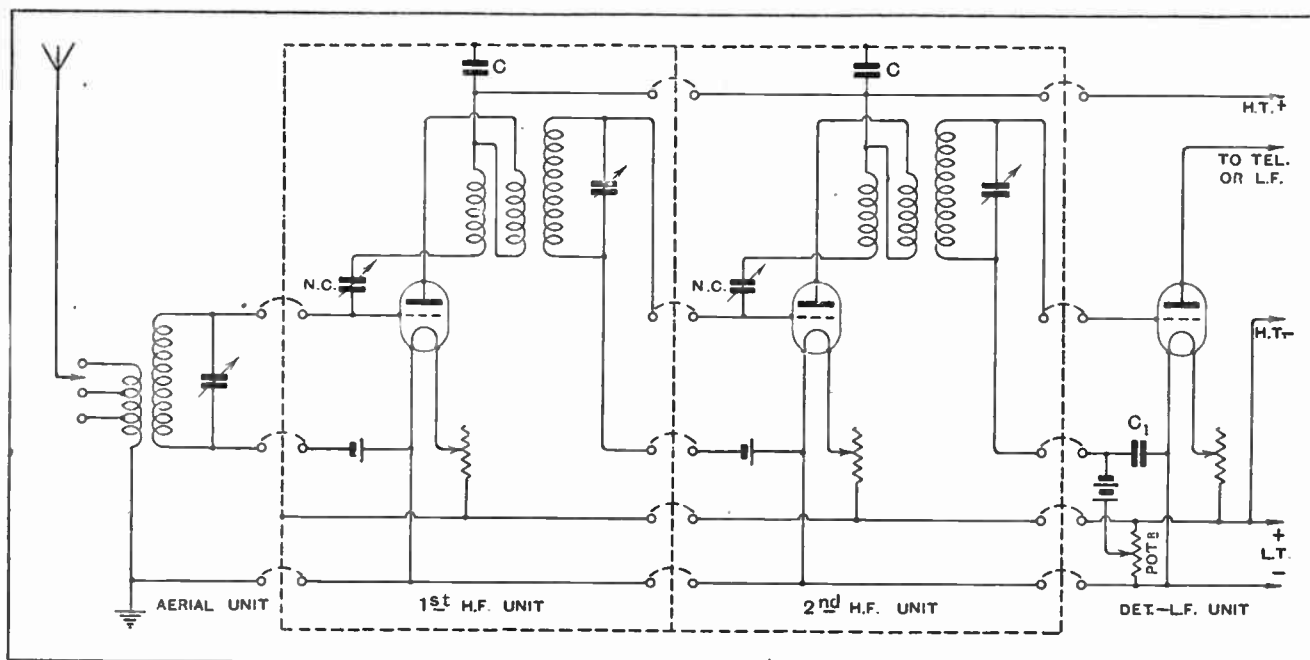

Fig. 2.—A two-stage H.F. amplifier in separate single-valve units. Position of screens is shown by dotted lines.

various kinds of interaction between the two circuits have to be taken into consideration. Due to the fact that switching is generally considered to be inadmissible in such arrangements, it is not altogether easy to test each individual stage separately, and, when trouble is encountered, the amateur is often at a loss to decide whether a comparatively simple fault exists at a single point, or whether harmful interaction is taking place in the amplifier considered as a whole. Failing a considerable experience of H.F. work, it is safe to say that two-stage instruments should be left severely alone, unless the prospective constructor is willing to follow *implicitly* a good tested design. Alternatively, an arrangement with comparatively heavily damped circuits may be adopted with a fair chance of success, but, except possibly from

of selectivity and sensitivity. Each H.F. stage may be built as a separate interchangeable unit, with its valve, transformer, and variable condenser. An aerial tuner and a detector-L.F. combination complete the receiver of which a suitable circuit arrangement is given in Fig. 2.

This method of construction has several important points of superiority over the self-containing receiver; its special merit lies in the fact that the user's knowledge of H.F. amplification may be said to grow with the set. For local-station work one or both amplifying units (depending on sensitivity necessary) may be disconnected in a few moments, while, by interchanging, it is an easy matter to find out if both are in order. There is also the financial aspect of the matter; a "unit" set may be added to as funds permit

terminals, or, better, plug sockets, are fitted on each side of the front panel of the container. Four of these must be insulated, preferably by mounting them on a strip of ebonite, clearance holes being drilled through the metal to allow the shanks to pass into the interior. The terminals which are joined to L.T. negative (and earth) should be in metallic contact with the box, while the condenser spindle must be insulated if grid bias is used.

As always, the transformer is the most important part of the amplifier, and in this matter the constructor may be guided by the details published in connection with the "Wireless World Five" in the issues of this journal dated January 5th and 12th, 1927.

Referring to the diagram, it will be seen that anode by-pass condensers (C) are connected between the low-

potential end of each transformer primary and the earthed screening box. These help to prevent inter-stage coupling due to resistances which may exist in that part of the anode circuit common to both valves (the H.T. battery, etc.), and they should be of large capacity—from a quarter of a microfarad upwards. C_1 is the usual H.F. by-pass condenser connected across the detector potentiometer and grid cells.

FAULT FINDING.

It is noticed that there is considerable reluctance on the part of many amateurs to make the necessary wiring disconnections when testing their receivers in an attempt to locate faults. Their attitude is one which can be sympathised with, as it is admittedly annoying to have to unsolder carefully placed leads, but unfortunately it is often quite impossible to test individual components

and sections of the complete circuit without removing one or more of the wires.

The more obvious faults may—and generally can—be traced by what may be called haphazard methods, but those of the more elusive kind are only revealed by careful point-to-point and stage-by-stage tests. The methods which seem at first sight to be tedious will generally be the shortest in the long run.

DISSECTED DIAGRAMS.

Practical Points in Design and Construction.

No. 76.—A Typical Short-wave Receiver.

(To be concluded in next week's issue.)

The present series of diagrams is intended to show progressively, and in an easily understandable manner, the various points to which special attention should be paid in the design of typical wireless instruments, and at the same time to assist the beginner in mastering the very necessary art of reading theoretical circuit diagrams. A simple detector L.F. combination is most generally favoured for reception of the ultra-short waves; a conventional circuit of this type, with suitable modifications for its special function, is shown below.

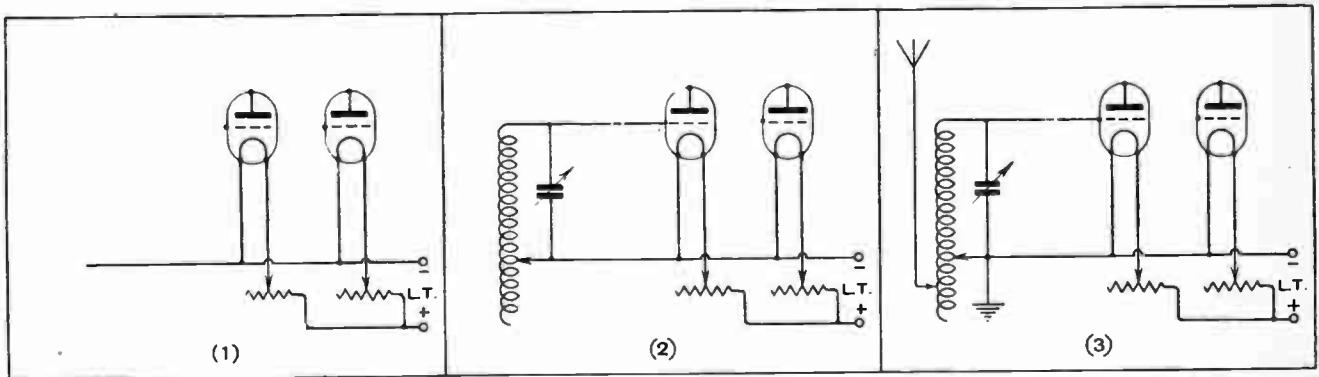

The filament circuits are completed in the usual manner, with separate controlling rheostats in the positive low-tension lead.

The grid section of the coil, with tuning condenser in parallel, is connected between grid and filament of the detector.

The aerial is connected to a suitable point on the coil, and the negative low-tension bus bar is earthed.

IN the early days of short-wave working it was considered that the use as detectors of tubular valves of low self-capacity was essential; this opinion is no longer generally held, and, in essentials, requirements are the same as on the normal waveband. An efficient so-called "H.F." valve with an impedance of, very roughly, 20,000 ohms and a voltage factor of 20 is, from an all-round point of view, the most suitable for use in this capacity.

As the L.F. amplifier will not, as a rule, be expected to handle large inputs, a valve of the "general purpose" type, with an impedance of about 15,000 ohms, is to be recommended; a small power valve will do

equally well, but may possibly be considered as being unnecessarily extravagant in anode current unless an attempt is to be made to operate a loud-speaker.

For the 20-70 metre waveband (which is the most useful and interesting at the present time) the combined aerial-grid coil may have 9 or 10 turns of No. 10 wire, 3in. in diameter, with about 1/2in. spacing between turns. We no longer wind these coils in "low-loss" fashion for the sole purpose of reducing H.F. resistance; the effect of normal coil resistance is almost negligible compared with the damping introduced by grid detection and aerial resistance. The usual "skeleton" construction is

generally retained, however, because such coils may easily be tapped at any point with the help of a spring clip.

A tuning condenser of from 0.00015 to 0.0002 mfd. is recommended; the use of a large capacity tends to make the operation of tuning unduly difficult.

For the reception of longer waves up to 150 metres it is suggested that two more interchangeable coils should be made. The first might have a total of 15 turns, and the second 30 turns.

The aerial may be connected either below the earth tapping, as shown, or between the tapping and the grid end of the coil.

NEW APPARATUS.

The Manufacturers' Latest Products.

THE TELSEN L.F. TRANSFORMER.

The Telsen Electric Co., Ltd., 207, Aston Road, Birmingham, have recently designed a new L.F. transformer. A core of liberal cross section is employed and the stampings are securely clamped together with four bolts, which also hold the metal covers.

The quality of an L.F. intervalve transformer is invariably governed by the price for which it is sold, and many endeavours have been made to produce a cheap transformer by sacrificing the amount of primary winding. Amateurs are apt,

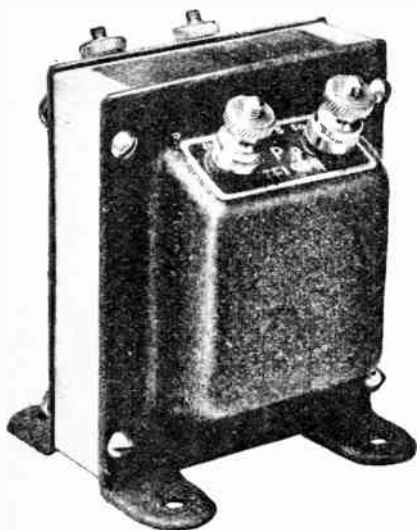

The Telsen Radio Grand L.F. transformer.

therefore, to estimate quality entirely by price, though the value given varies in every case. As well as being of good external appearance data obtained from the manufacturers reveal that the primary winding of the Telsen transformer may be considered ample, particularly in the case of the low-ratio model. While being low-priced it is interesting to note that an even cheaper type is also offered by this company.

o o o o

MAGNUM RHEOSTAT.

The practice of mounting adjustable filament resistances on the baseboard in preference to the provision of an adjusting knob on the front of the panel has led to the introduction of several new forms of filament rheostat.

Burne-Jones & Co., Ltd., Magnum House, 288, Borough High Street, London, S.E.1, now manufacture a rheostat fitted with a sliding spring contact passing over a spool of enamelled resistance wire. The winding is carried on an ebonite rod and the slider is supported

by a nickel-plated bridging piece. A feature of this rheostat is that it is cali-

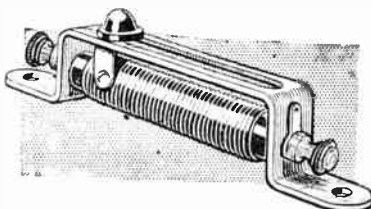

The "Magnum" rheostat for baseboard mounting. It is calibrated in ohms and has a good appearance even if mounted on the front of the panel.

brated in ohms, the indicated values being approximately correct. The movement is smooth and the contact reliable.

o o o o

NOVEL CONNECTING TAG.

It is well known how, when soldering a wire to a connecting tag the flux runs along the surface of the tag and around the screw or terminal. Flux that creeps in this way under the action of the heat cannot be removed and, while the screw is cooling off, percolates right into the spaces and eventually causes corrosion. To overcome this difficulty the Station Radio Stores, 38, Palmer Street,

Westminster, London, S.W.1, supply a bent form of connecting tag, the shape of the bend forming a complete barrier against the creeping of flux or solder.

The tags are of bright bronze and solder easily adheres to the surface. At the small end is a hole to accommodate No. 16 or smaller gauge wire, while four different sizes of tag are available for fitting over 2, 4, 6 or 8 B.A. terminals.

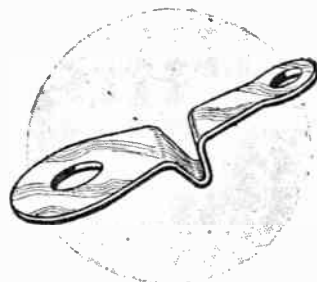

The new "S.R.S." tag. The bent back-piece forms an effective barrier to prevent soldering flux creeping by the action of heat under the terminal.

o o o o

NEW CAMCO CABINET.

To meet the growing demand for a combined receiver cabinet and battery or battery eliminator container, the Carrington Manufacturing Co., Camco Works, Sanderstead Road, S. Croydon, London, have recently designed a battery compartment which forms a base to their standard cabinets. This is of particular interest to the many readers of this journal who have constructed *The Wireless World* "Everyman Four" receiver, using a Camco cabinet of the drop-front type.

To render the set entirely self-contained, the lower compartment for the batteries can now be purchased separately, and looks well when forming a support for the standard drop-front cabinet. Rigid attachment is given to the legs by slotting, making a secure sliding fit, bolts holding them finally in position. The accompanying illustration shows the general appearance, the battery container being finished in similar colour and polish to "Camco" oak and mahogany cabinets.

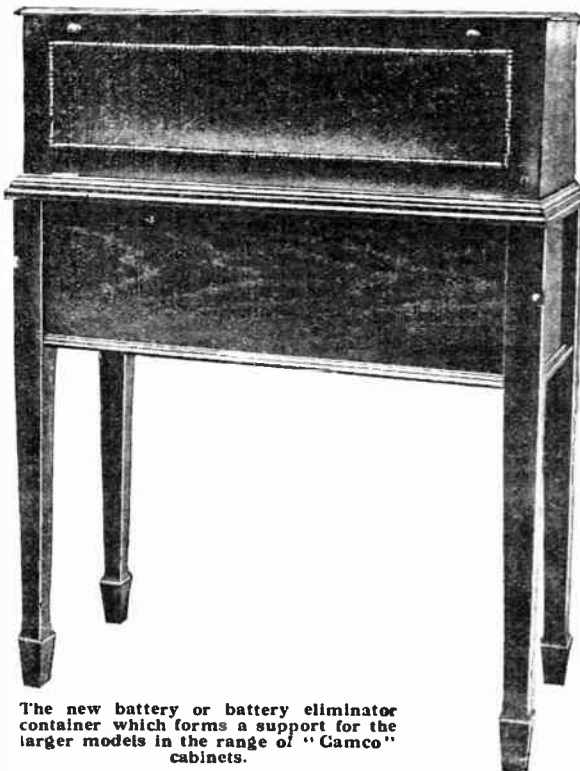

The new battery or battery eliminator container which forms a support for the larger models in the range of "Camco" cabinets.

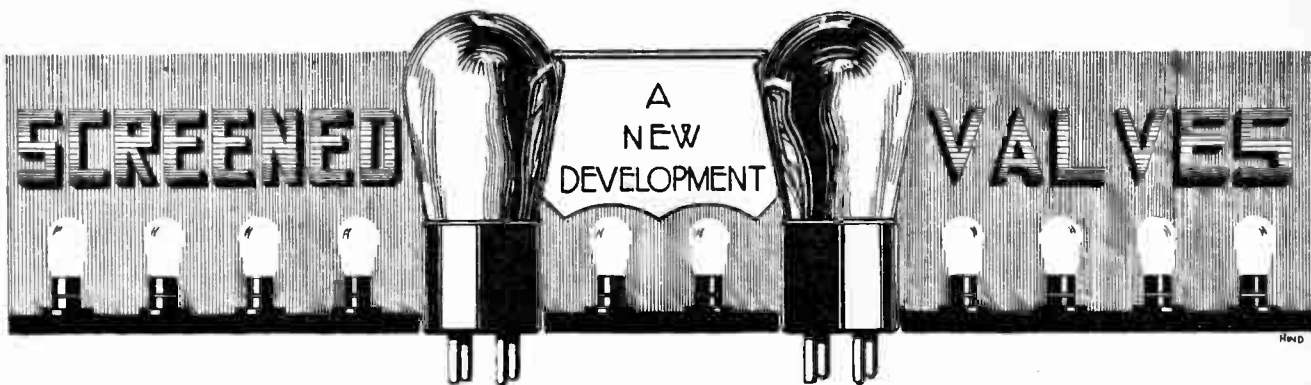

A Receiving System which Threatens to Supersede Neutralisation in H.F. Circuits.

By P. W. WILLANS.

THE problem of instability in wireless receivers is one the importance of which requires no emphasis.

From the time when it was first appreciated that the attainment of a high degree of amplification was contingent on the elimination of stray couplings between the various parts of the amplifier, there has been a constant endeavour to perfect the means for so doing, both by careful screening and by specially devised circuits for neutralising the inherent capacities of the various valves. In respect of the latter, inasmuch as the only valves available have been of the ordinary three-electrode or equivalent type, the question of counteracting the effect of capacity coupling due to such valves has been considered only from the standpoint of devising an external circuit.

A remarkable development in the design of receiving valves has now opened up the possibility of eliminating this capacity coupling, not by an external circuit, but, as it were, at the source; furthermore, a valve so designed has properties of an even more noteworthy character which render it possible to obtain very greatly increased amplification by its use.

A Four-electrode Valve.

The fundamental idea embodied in the valve is due to Schottky, who carried out a considerable amount of work with four-electrode valves. The basic idea in his valves is the employment of an auxiliary grid to which is applied a steady positive voltage; the effect of this is to neutralise the space charge due to the electrons which are actually in transit from filament to plate and, as it were, to "help them across."

Four-electrode valves operating on this principle have been popular for some time, the form generally used being that in which the steady positive voltage is applied to the inner grid. The general effect of such an arrangement is the improvement of the valve characteristic, regarding the latter from the standpoint of an ordinary three-electrode valve. In particular, a smaller value of high-tension voltage may be used, though the high-tension current consumption is increased owing to the current flowing in the auxiliary grid circuit.

Schottky's second type of valve has the auxiliary grid situated between the plate and the normal grid, and it is with this type that we are concerned in the present article.

The behaviour of such a valve is entirely different from that of a normal three-electrode valve, and, in considering the advantages to be gained by its use, we have to revise our ideas of receiver design and think along entirely new lines.

It is preferable for the present purposes to concentrate on what the valve does rather than on why it behaves in its characteristic manner. For this purpose a set of imaginary characteristics have been drawn in Fig. 1. The "screen grid" is assumed to have a steady potential applied to it of about 60 volts, and the individual curves represent the plot of plate current against plate volts. Three curves are drawn for inner grid potentials of -2, -3, and -4 volts, and the characteristics roughly conform to data given for a practical valve.

It is to be noted in the first place that each curve corresponds roughly to a normal valve characteristic, and in each case a saturation current is attained of a more or less definite value. The value of the saturation current is, however, different for each value of grid potential, and it is thus as if the variation of the latter dimmed or brightened the filament; in fact, the set of curves very closely resembles a similar set for a three-electrode valve with varying filament voltages.

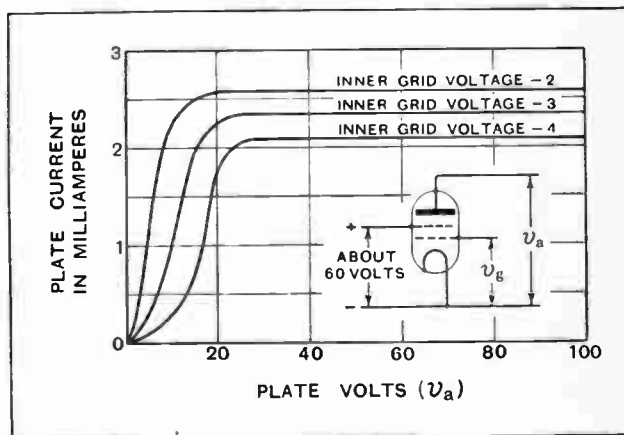

Fig. 1.—Typical characteristics of Schottky four-electrode valves ("screened grid" type). A change of plate potential from 40 to 80 volts produces no change in plate current, but the value of the latter varies about 0.3 mA per volt of grid potential.

Screened Valves.—

The significance of these characteristics from the practical standpoint is not easy to grasp at first, but when once appreciated the action of the valve is amazingly simple, far more so, in fact, than that of an ordinary valve. We see from the curves that a change of plate

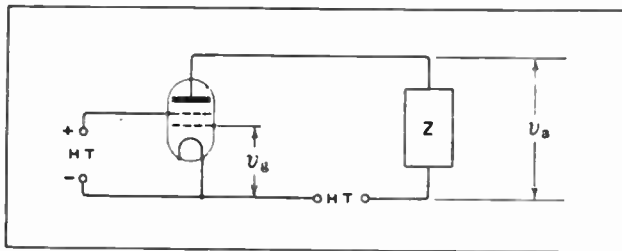

Fig. 2.—Fundamental circuit of the screened grid valve.

potential from 40 volts to 80 volts produces a negligible change in plate current, but that the latter is definitely controllable by grid voltage, varying about 0.3 milliamp per volt. Now, in the case of a normal three-electrode valve under working conditions the plate voltage exercises a very definite control of the plate current, and this fact constitutes a limitation on the amount of voltage amplification which can be got out of the valve, this, in the absence of reaction, tending to a definite limit, namely, the amplification factor of the valve. With the valve under consideration no such limitation exists except

that due to the imperfections of practical apparatus. Let us consider this question more closely. Referring to Fig. 2, an impedance Z is connected to the plate circuit, which we will imagine to be some kind of choke which offers a high impedance to some particular frequency, but the steady volt drop along which can be neglected. An alternating voltage v_g is applied to the inner grid, and an alternating voltage v_a is developed across Z .

Now, referring to the characteristics of Fig. 1, we see that, if the alternating voltage across Z never has such a value as to make the total plate voltage outrun the limits 40 volts to 80 volts, the alternating current flowing through Z is purely determined by the value of v_g . It is thus independent of the magnitude of the impedance Z , and, in fact, if we could make an impedance of infinite value, it would still hold good. Hence we can attain our limiting value of voltage across Z by applying to the grid a smaller and smaller voltage v_g in proportion as the magnitude of Z is increased, and it is only the limitation of practical design which prevents an infinite voltage amplification from being obtained.

In using a valve of this type, therefore, we have to consider simply the construction of very high impedance for the frequencies with which we are dealing, and the employment of step-up transformers at any frequency becomes entirely superfluous. The calculation of amplification becomes absurdly simple, inasmuch as we know the

fundamental constant of the valve, Plate current change
Grid voltage change
or mutual conductance, and we merely have to multiply this by the plate circuit impedance to get the voltage factor of the circuit.

So far, we have dealt only with the thermionic properties of a "screened-grid" four-electrode valve. On the basis of the foregoing it is evident that such a valve, producing as it does a voltage amplification of some hundreds per stage, might give rise to inconceivable difficulties if applied to wireless circuits in the ordinary manner, since the problems of instability would be expected to increase with the amount of amplification obtained. Modern valves having an amplification of 40 are difficult enough to deal with, we might well say, but what is to be done with a valve having a possible amplification of 200?

The answer to this question is provided by Dr. Hull, of the General Electric Co., of America, whose logical development of the Schottky valve has made the

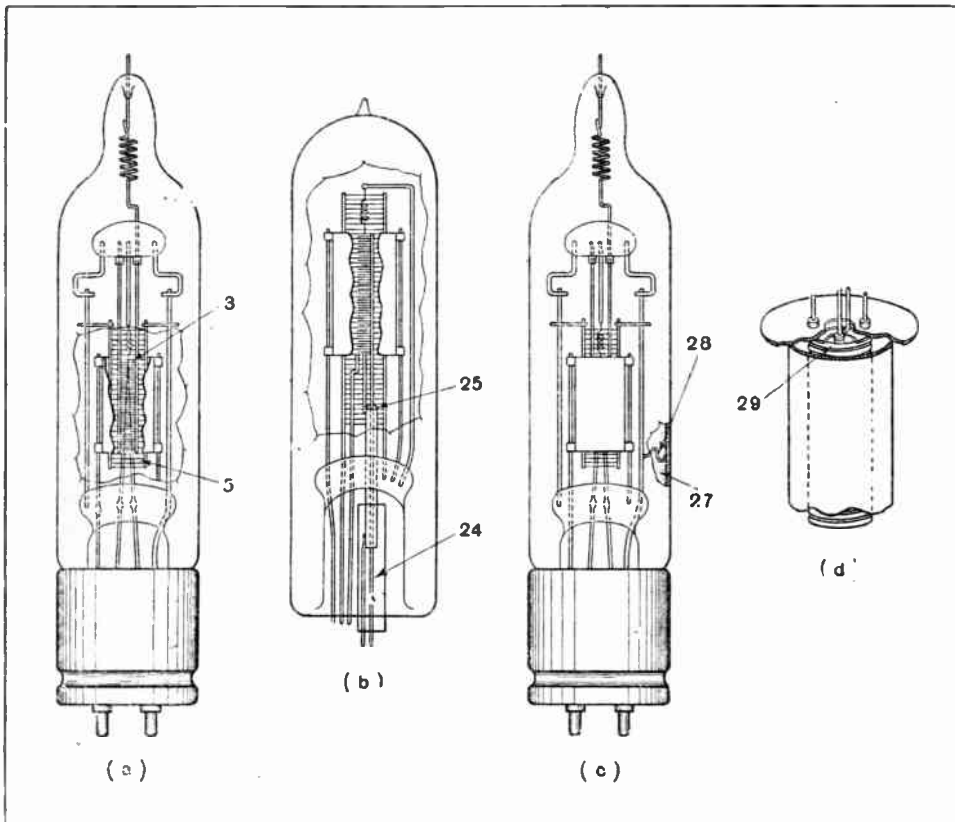

Fig. 3.—Constructional details of Hull screened valves.

Screened Valves.—

latter a device which may before long revolutionise the design of wireless receivers. The step he has made is simply the development of the "screen grid" of Schottky into a complete electrostatic shield between the normal grid and the plate, and with such success is this screening carried out that the effective capacity between the plate and grid systems is reduced to about a thousandth part of its normal value.

The construction of typical screened valves is described in the paper by Hull and Williams in the *Physical Review* for April, 1926; British Patents Nos. 230,011 and 255,441 also give details regarding these valves, the former patent corresponding to the valves described in Hull's paper. Figs 3 (a), (b), (c), and (d) are reproduced from Patent Specification No. 230,011, and the reader is referred to this specification for the fullest details regarding these valves.

In Fig. 3 (a) the simplest form of screened valve is shown; here 5 is the screening grid and 3 the control grid, the connecting lead to the latter being taken out of the top of the valve. The screening grid extends for some distance beyond the ends of the control grid and plate, so that the effect of electrostatic shielding may be fully obtained.

In Fig. 3 (b) all of the leads are brought out at the base of the valve, the control grid lead 24 being enclosed in a metal sheath 25 which acts as an electrostatic shield.

In Fig. 3 (c) the construction of the valve is similar to

that shown in Fig. 3, but there is also a metal lining 27 on the inside of the glass wall of the valve which is connected by a lead 28 to the screening grid; in this way still more perfect shielding between the grid and plate systems is obtainable.

In Fig. 3 (d) an interesting form of construction is shown for the screening grid, which consists of a number of annular discs 29 threaded on to supporting rods. It was found and remarked by Schottky that a grid so constructed was particularly effective as far as electrostatic shielding was concerned, whereas at the same time it offered very little obstruction to the path of electrons flowing to the plate.

Secondary Effects.

Some interesting points regarding these valves are brought out in Hull's paper. It appears that very considerable modifications to the characteristics shown in Fig. 1 may result from variations in the conditions of the electrode surfaces; in particular, some conditions favour the emission of secondary electrons from the plate, and the production of a characteristic of the type shown in Fig. 4, the plate current diminishing as the plate voltage increases. This is typical of a device known as the Dynatron, which is also due to Dr. Hull, and which gives rise to negative resistance effects producing oscillation. The condition of the electrodes tending to favour the emission of secondary electrons, is a semi-insulated surface such as is produced by coating the electrodes with a poor conductor. The reverse effect, *i.e.*, the minimum secondary emission, is produced by a black nickel deposit on the electrodes, the finely divided form of the metal giving a surface of the maximum possible conductivity.

A second paper by Hull, in the same number of the *Physical Review*, gives some particulars of the manner of employment of these screened valves, together with some of the results obtained. A type of amplifier for

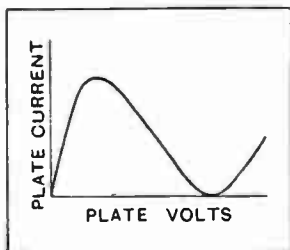

Fig. 4.—Negative resistance or falling characteristic due to the emission of secondary electrons from the surface of the valve electrodes.

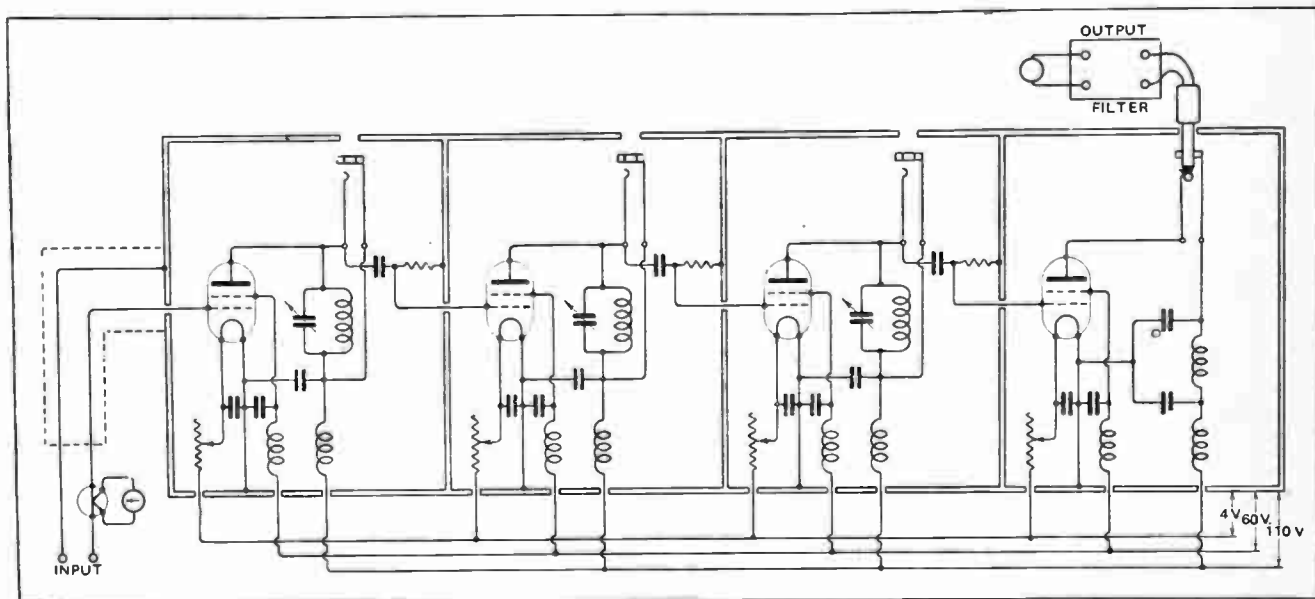

Fig. 5.—Circuit and layout of amplifier suitable for use with screened valves. Electrostatic screening of wiring and components is most important.

Screened Valves.—

use with valves of the type shown in Fig. 3 (a) is shown in Fig. 5 (extracted from this paper). In the actual instrument the various circuits are contained in a series of screening boxes vertically arranged, the tip of each valve

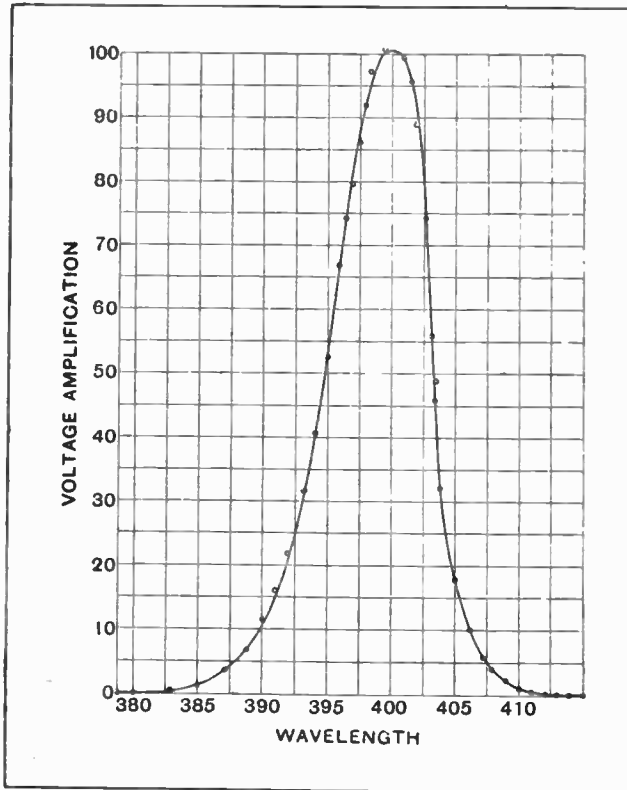

Fig. 6.—Overall amplification curve for the arrangement shown in Fig. 5.

being adjacent to a hole in the screen, so that the connecting leads are as short as possible, and the capacity couplings between adjacent plate and grid systems reduced to a minimum. Fig. 6 gives a curve, extracted from the same paper, showing the overall amplification obtained with an arrangement of this type.

The amount of amplification obtainable per stage depends, as has already been shown, upon the magnitude of the impedance which can be practically constructed for the frequency concerned. The authors give some particulars of their results in this respect as follows:—

| | Approximate Amplification. |
|---|----------------------------|
| For low radio frequencies (50 k.c.) | 200 per stage. |
| For medium radio frequencies (1,000 k.c.) | 40 " " |
| For high radio frequencies (10,000 k.c.) | 7 " " |

In the case of medium frequencies, four stages of amplification have been built to give an overall amplification of actually two millions, and it appears that the only practical limit to the amplification obtainable by the means described is the inevitable valve noises which must become comparable with the input signal when the latter is weaker than a certain limit.

It appears from the foregoing that, subject to the commercial production of screened valves, we are faced with a new era in wireless receiver design. With regard to this proviso, special reference is made in both the above papers to the fact that the work described was of a theoretical nature only, and that as far as the authors were aware, no steps were being taken to manufacture valves of this type; it is evident, however, from Patent No. 255,441 that the development of the valve into something of a practical nature is in progress in America.

It is still a matter for speculation, however, whether screened valves will displace the three-electrode valve for general purposes, though there can be little doubt that results can be achieved by their use which are barely possible in any other manner.

General Notes.

Mr. G. A. Woods, G6WD, Castle Bey, East Parade, Harrogate, will welcome co-operation with any amateur transmitters or listeners in Scotland and Ireland. He also asks us to state that he is prepared to forward any QSL cards or reports for CHAM, who is working on about 22 metres.

o o o o

NU 3VF, Mr. O. F. Grapp, 1,745, North Fanev Street, Philadelphia, Pa., will welcome reports from British amateurs.

o o o o

International List of Amateur Transmitters.

The lists of amateur transmitting stations in all parts of the world which formed a large and useful portion of the R.S.G.B. Diary and Log Book for 1927 will be revised and considerably enlarged for the 1928 edition. This work is being undertaken jointly by Mr. C. A. Jamblin (G6BT), who is in charge of the QRA section of the R.S.G.B., and ourselves. We give this early intimation of our intentions in the hope that not only British amateurs but those in all parts of the world will make a point of advising us

TRANSMITTERS' NOTES AND QUERIES.

of any new QRA's or changes of address. Lists of amateur stations from foreign countries will be warmly welcomed and any other information which will enable us to make this list as complete and reliable as possible. We would also ask those transmitters who may have given up their call-signs since the publication of the current Diary and Log Book to advise us of this fact if they have not already done so.

o o o o

Belgian Amateurs.

EB4WW, M. G. Regnier, 17, Bould, Frère Orban, Liège, has been in constant communication with the Norwegian whaler "Sir James Clark Ross" (AQE), since she left New Zealand waters home-

ward bound *via* the Panama Canal, and has also worked several Californian coast stations. His neighbour, 4ZZ, M. E. Liane, 44, Bould, Frère Orban, Liège, has been in two-way communication with AF1B, the well-known station operated by Mr. R. Jamas at Saigon, while 4AC, M. Duvignan, is reported never to sleep, and carries out regular schedules with South America at night, and with Australia and New Zealand in the small hours of the morning. He has also worked with the Nicaraguan station NN 1NIC.

o o o o

New Call-signs and Stations Identified.

5UA J. G. Ward, 7, Burn's Gardens, St. Giles, Lincoln.
6MN (ex 2BLC). E. R. Martin, Castlemount, Workson, Notts., transmits on 45 metres and will welcome reports from all distances.
2BWB A. Blake, Bramerton, Norfolk. (Change of address.)

o o o o

QRA's Wanted.

G2CT, 2PC, 5AL, 5AP, 5KV, 5LX, 5SQ (Ealing), 6QU, 6RT, 6SB, 6TR, 6TV, 6UO, 6XM, 6ZL, 6ZM, 6FY, GW 2KO, EN OAX, OEX, NR 2FG, NV 7SM, SB 11D, Z 9BH (?).

DISTANT CONTROL RELAY

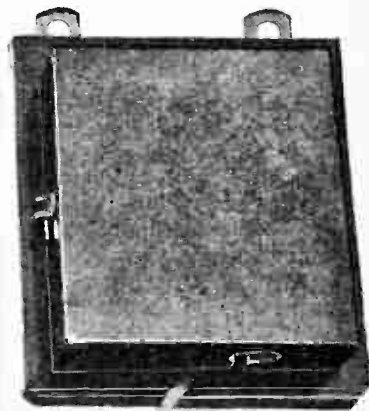
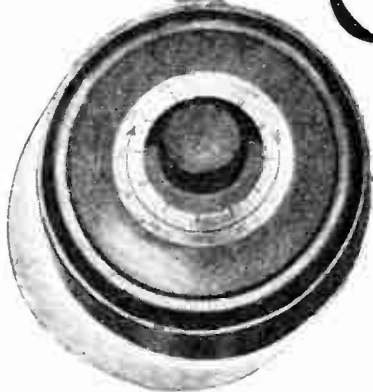

A Device for Switching Filaments and Adjusting Volume.

By H. F. SMITH.

INDICATIONS are not lacking that an increasing number of amateurs are installing their receiving apparatus in a room other than that in which the loud-speaker is operated. Those who have tried this plan will doubtless have felt the need for some form of remote control, in order to avoid the necessity of going from room to room to switch the filaments on or off. Fortunately, this problem is easy of solution, as there are on the market several excellent trip action switches which perform their function quite adequately, requiring only a momentary current from a small dry battery, which will consequently last for several months.

Satisfactory as is this form of control, it is lacking in one respect; namely, it does not permit of any volume adjustment. Now the majority of us habitually operate our output valves perilously near the point where overloading begins, for, unless we do so, it is impossible to obtain anything approaching realistic volume from the average loud-speaker of the better type, unless we use specialised valves such as those of the L.S.5a type, which require a very heavy anode current. As the depth of modulation at the transmitting end can hardly remain perfectly constant, it follows that, with a fixed sensitivity

adjustment of the receiver, deeply modulated passages will cause overloading, while others will be heard at less than comfortable strength.

There are other aspects of the question, apart from the purely technical one. Some listeners like a subdued musical background for conversation, while it is often convenient to be able to reduce the volume of an unwanted part of the programme almost to inaudibility, but yet to have some indication of the starting of the item to which it is desired to listen.

Having briefly touched on some of the advantages of remote control, we may consider the simple device illustrated at the head of this article, and shown in Fig. 1 as connected to a typical wireless receiver. It depends for its operation on the fact that the sensitivity of a receiver, and consequently the loudness of signals, may be reduced by dimming the filament of the high-frequency amplifying valve. This is the method of volume control provided in a number of popular receivers, including the "Everyman Four," and it is applied in this particular case by passing the H.F. valve filament current through both the rheostat R_1 at the distant point, and the magnet windings of a relay, which switches on the detector and L.F. filaments.

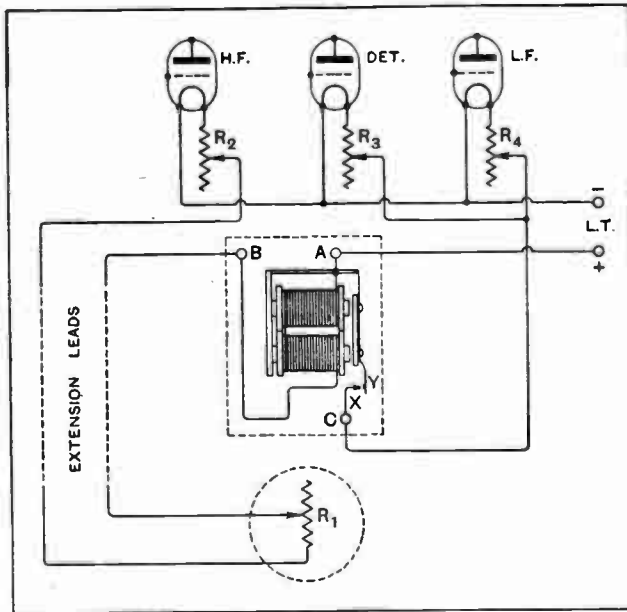

Fig. 1.—The circuit diagram, showing how the relay may be connected to any receiver having H.F. amplification. R_1 is the remote control rheostat, and R_2 , R_3 and R_4 are the filament resistances normally included in the set.

Distant Control Relay.—

When the rheostat is "off," no current can flow through either H.F. valve or relay; consequently, the armature is not attracted, and the filament circuits of the remaining valves are broken at the contact points X and Y. As soon, however, as a sufficient current is passed by turning on R_1 , the armature springs against the magnet poles, and the circuits of detector and I.F. filaments (there may, of course, be more than one of the latter) are completed through the contacts. Thus, the energy for operating the relay is supplied by the filament current of the high-frequency valve, and it might seem that we are getting something for nothing. This, of course, is impossible—at any rate, in the wireless art—and the reader will naturally ask "where is the snag?" As usual there is one, but it is not serious enough to discount the value of the device. The relay windings will have a resistance of from 3 to 5 ohms, and the extension leads may account for another 3 ohms or even more; so it will be seen that, as a rule, there is too much incidental resistance to allow of the use of an H.F. valve of the same voltage rating as that of the I.T. battery. A surplus voltage is required, so, if four- or six-volt valves are used elsewhere in the set we must choose, as an H.F. amplifier, one rated at either two or four volts, or, alternatively, connect up another accumulator or dry cell to provide the necessary surplus voltage.

As will be gathered from the illustrations, the relay is improvised from a cheap electric bell, obtainable for about half-a-crown, from which the clapper and gong



The remote control rheostat, mounted on a switch block.

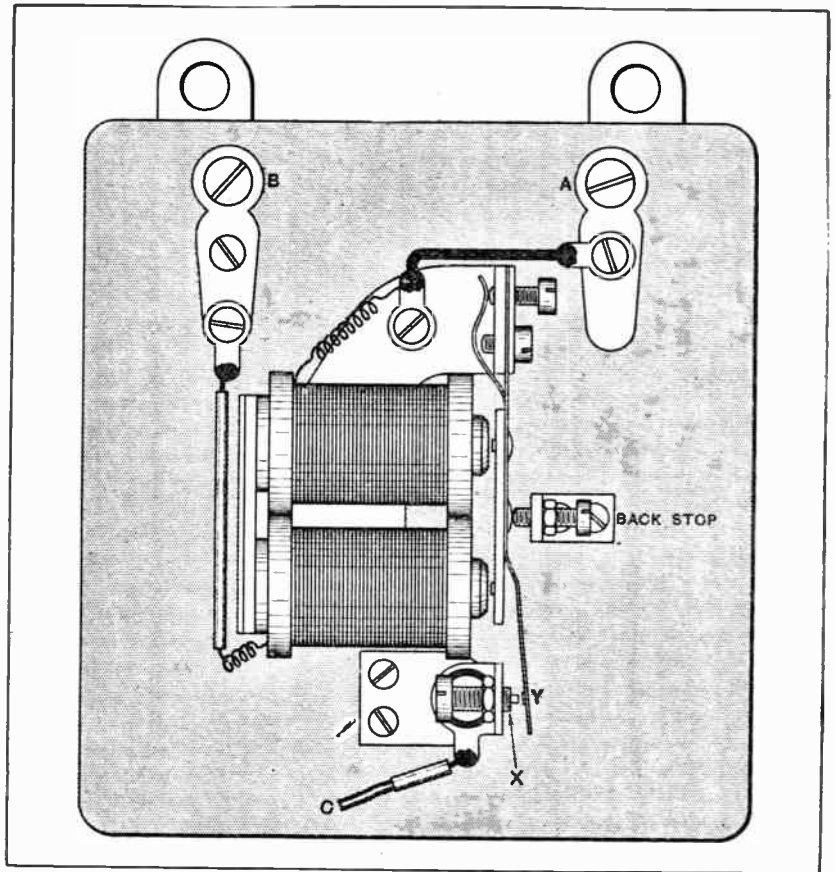

Fig. 2.—Showing method of altering the electric bell and rearranging its wiring. Lettering of terminals and contacts corresponds to that in Fig. 1. Part of the wooden base is cut away.

have been removed. Referring to Fig. 2, the fixed contact X is normally mounted on the opposite side of the tongue carrying contact Y, in such a way that the contact is broken when the armature is attracted. Its position must be changed to that shown in the diagram; the alteration may necessitate the cutting of the metal frame on which the parts are assembled. Different bells vary in construction, but an effort should be made to obtain one having a tongue projecting well beyond the magnets, as otherwise it will be necessary to fit an extension piece for carrying the contact Y. A back stop, consisting of a small piece of angle brass carrying an adjusting screw, is fitted in the position shown in order to restrict the movement of the armature, and to allow the relay to be adjusted so that it will respond to quite small currents. This refinement is only necessary when using valves normally consuming 0.1 amp., which, when dimmed, will pass about 60 milliamperes, on which current the relay will operate quite satisfactorily. The tensioning of the spring provides a second adjustment, which is obtained by turning the screw adjacent to the soldering tag on the terminal marked A (Fig. 2).

The necessary rearrangement of the bell wiring is clearly shown in Fig. 2. One end of the magnet winding is joined to the frame and to terminal A for ultimate connection to L.T. positive.

The addition of the relay to any receiver for which

Distant Control Relay.—

it is suitable is by no means a difficult matter, and the circuit diagram of Fig. 1 will serve as a guide. Briefly, the lead from the L.T. positive terminal, which normally joins direct to the filament rheostats R_3 and R_4 is, instead, interrupted by the relay, and the feed for the H.F. valve is *via* magnet windings, extension leads, control rheostat, and the rheostat R_2 , which is included in the set. This latter rheostat should have at least a sufficient resistance to reduce filament voltage to the rated value when the other (R_1) is "all out," and it may conveniently be set permanently at this adjustment when the set is in operation. If this is done, there will be no possibility of overrunning the H.F. valve by reducing the resistance of the control rheostat to too low a value.

Overcoming Residual Magnetism.

It should be remembered that a relay of this type requires less current to hold over the armature than to move it from rest; thus it will generally be necessary to turn R_1 to "full on" when putting the set into operation, after which resistance may be gradually put into circuit until volume is reduced to the desired intensity.

An examination of the average bell armature (the piece of iron which is attracted by the magnets) will show that small rivets are inserted in order to prevent the iron making actual contact with the poles; when small currents are to be dealt with, these projections should be filed down till they are *almost* flush with the surface of the iron. In cases where they are not fitted, it will sometimes be necessary to interpose a small piece of very thin paper in order that the armature may not be held over permanently by the residual magnetism of the unsuitable material used in some of the cheaper bells.

Those who do not care to go to the trouble of constructing a relay may be interested to know that suitable instruments, which require no mechanical alteration, are obtainable for a few shillings from such firms as The Economic Electric Co. and The Grafton Electric Co.

The distant control variable resistance may be mounted in any convenient manner, either as a wall fixture or on a wander lead. That illustrated was made up with a varnished tumbler switch block (obtainable from any electrical dealer) and a "Peerless" 50-ohm rheostat, which is of suitable dimensions for fitting into the limited space available, and which has a neat indicating dial. The contacts of a simple relay of this type cannot be expected to handle large currents, especially when adjusted to have a small clearance. Probably 0.5 amp. is about the safe limit, without risk of sticking. However, it is capable of controlling the average three- or four-valve receiver using modern valves. For more ambitious sets it is not a difficult matter to construct a suitable relay with a mercury dipping contact.

Suitable for the "Everyman Four."

The method of control is particularly adaptable to a number of sets recently described in this journal, as, for instance, the "Everyman Four," the "Everyman Three," the "All-Wave Four," and the "Nucleus." No internal wiring alterations are necessary when it is used in conjunction with the latter receiver.

A relay of the type described has been in continuous use for several months without requiring any attention

whatever. The contacts seem to be self-cleaning, due to small lateral movements which take place as the pull on the armature is changed.

This article should not be concluded without pointing out that the purist may object to volume control by dimming the H.F. filament on the grounds that the impedance of the valve may be unduly increased by this course, with the result that tuning may be sharp enough to introduce a cut-off of the higher audible frequencies. It

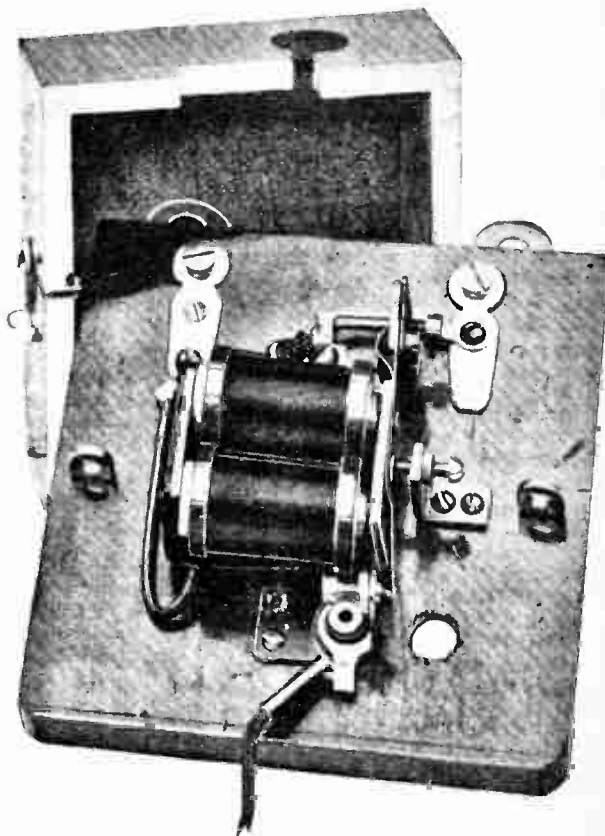

The completed relay, with cover removed.

cannot be denied that there is some justification for this attitude, particularly when the H.F. transformer secondary is of extremely low resistance. However, the use of any form of volume control implies a superabundant signal voltage, so it is an easy matter to fit a damping resistance in series with the tuned circuit to flatten the top of the resonance curve. This may conveniently consist of zin. of No. 45 S.W.G. Eureka wire, carried on a standard coil plug in order that it may be inserted in a socket connected between the low-potential end of the transformer secondary and the tuning condenser. For long-distance work, the resistor will be replaced by a short-circuited plug.

Wireless amateurs have been accused of laziness, but there is a time and place for everything, including pedestrian exercise, and the writer would submit that, except in cases where a receiver may conveniently be installed at the listener's elbow, remote control has so many advantages that those who give it a trial will not willingly abandon it.

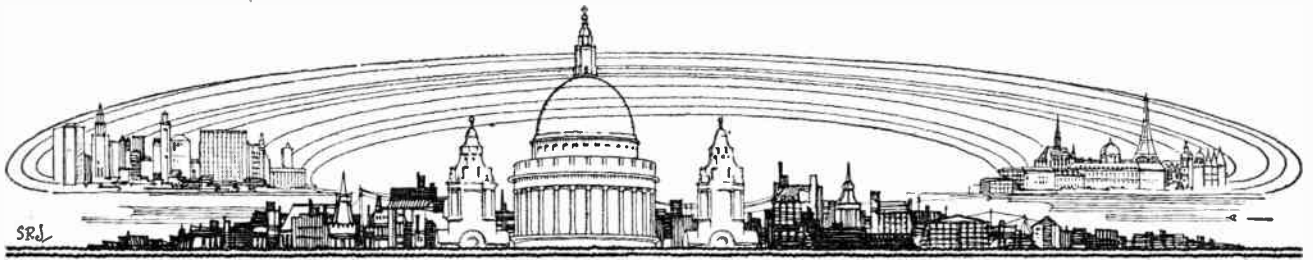

CURRENT TOPICS

News of the Week in Brief Review.

BRIGHTENING THE WORKHOUSE.

Ashby-de-la-Zouch is busy collecting funds for a wireless set for the Poor Law Institution.

○○○○

ALL'S WELL THAT

During the recent riots in Vienna all wireless and telegraphic communication with London was suspended. The Marconi service was resumed on July 19th.

○○○○

WANTED: A SEMI-LICENCE ?

A Northallerton resident, charged with operating a set without a licence, pleaded that he thought a licence was unnecessary as the instrument was only in "semi-working order." The case was dismissed on payment of costs.

○○○○

AUTOMATIC S.O.S DEVICE.

Ship's receiving equipment designed to obviate the necessity of maintaining continuous watch for distress calls has been designed by the Marconi Company and has received the official sanction of the Post Office.

The alarm device, which will only respond to a certain sequence of signals sent by ships in distress, automatically summons the operator by the ringing of a bell.

A NEW DISCOVERY.

"Why Kilowatts are Replacing Wave Lengths."—Heading in a Cheshire newspaper.

○○○○

INDIAN BROADCASTING.

The Bombay and Calcutta broadcasting stations, which were opened on Saturday last, operate on 357.1 and 370.4 metres respectively. Bombay's call-sign is 7BY; Calcutta's is 7CA.

○○○○

BUT IS IT TRUE ?

Officials of the Aberystwyth Football Club are blaming broadcasting for a decrease in gate receipts during the past season. Former patrons, it is stated, prefer to listen to wireless commentaries on First League games rather than attend local matches.

○○○○

ULTRA SHORT-WAVE VALVE.

A new short-wave transmitting valve working on a wavelength as low as 2.5 metres has been produced by the American De Forest Radio Company. The valve has an input of 300 watts and will fit a standard 50-watt valve socket.

As much as 2,500 volts has been applied to the plate with perfect safety.

AIR MINISTRY STATION NEAR LONDON.

An Air Ministry wireless station is being built on land adjoining Mitcham Common.

○○○○

WHY ?

The Middlesbrough Housing Committee has expressed considerable astonishment that, of four houses recently struck by lightning, not one was fitted with wireless.

○○○○

THE BRITISH TRANSATLANTIC FLIGHT.

Captain F. T. Courtney, who is attempting to fly across the Atlantic from east to west and to return to Europe by air, is a believer in the necessity of carrying an efficient wireless installation. The Dornier Napier seaplane on which the flight is being carried out is equipped with a Marconi telegraph transmitter and a direction-finder, both under the control of the navigator.

The seaplane is in many respects almost ideal from a wireless point of view, as it is entirely constructed of metal (duralumin), thus ensuring perfect "bonding" or electrical continuity between the various parts of the machine and a

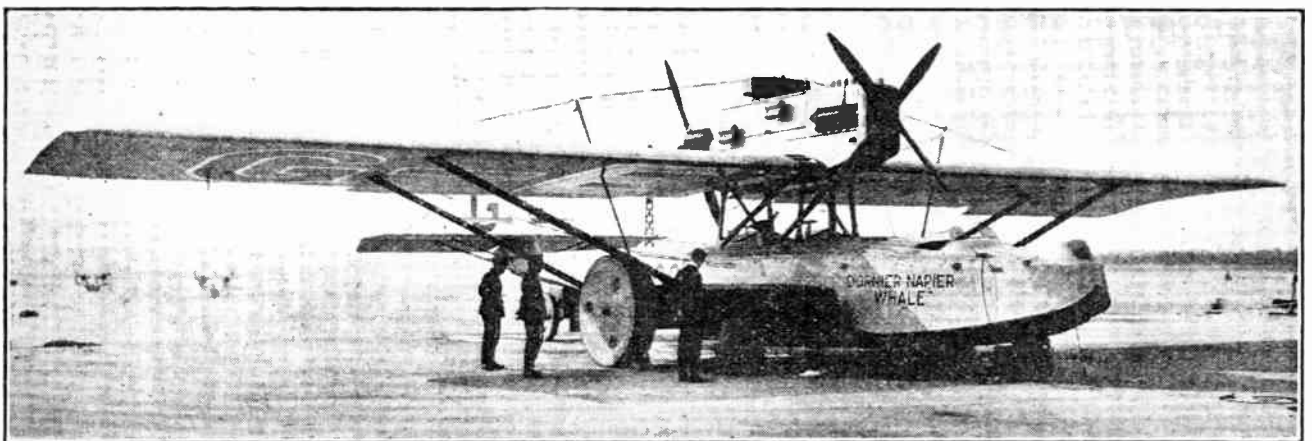

WIRELESS AND THE ATLANTIC FLIGHT. Captain F. T. Courtney's seaplane, the "Whale," in which he is attempting an Atlantic flight from east to west. The machine is fitted with a special type of loop aerial designed to overcome the effects of the all-metal body. The Marconi apparatus includes a transmitter, receiver and direction-finder.

large self capacity. The metal, however, adversely affects the receptive power of the ordinary loop aerial used for direction finding. A special type of loop aerial has, therefore, been fitted to meet these conditions and to withstand wind pressure, vibration, and shocks; and a special amplifier is provided with the direction-finder to give the necessary working range to the equipment.

The receiving apparatus fitted on the machine consists of a Marconi Bellini-Tosi direction-finding equipment, containing a specially designed combined high-frequency and supersonic amplifier using in all twelve valves. The loop aerials for reception and direction finding are rigged round the wings of the machine and between the main and tail planes.

NEW WIRELESS FACILITIES IN BRADFORD.

A Marconi wireless telegraph office has been opened at 5, Charles Street, Bradford.

R.A.F. VACANCIES.

The Air Ministry announces that vacancies exist for short service officers in the R.A.F. for flying duties. Candidates must be between the ages of 18 and 25, well educated, and in possession of good eyesight and physique. Application for forms and regulations should be made to the Secretary, Air Ministry, Kingsway, London, W.C.2

PCJJ'S 24-HOUR TEST.

At 10.40 a.m., G.M.T., this morning (Wednesday) the Philips' experimental station PCJJ, at Eindhoven, Holland, will conclude a transmission lasting 24 hours without a break. The object of the test is to determine the most suitable times for short-wave broadcasting to various parts of the world. Reports from listeners will be warmly welcomed by the engineers of the station.

WIRELESS AT THE SCIENCE MUSEUM.

Many readers are already familiar with the interesting array of wireless exhibits at the Science Museum, South Kensington. A new wireless division has recently been opened reflecting the work of the National Physical Laboratory at Teddington. The exhibits include short-wave receivers and transmitters, photographs, and other illustrations of apparatus used in the study of distortion in receivers, screening arrangements, and an interesting direction finder.

The Museum is open free from 10 a.m. to 6 p.m. on week-days, and from 2.30 to 6 p.m. on Saturdays.

THE DEMPSEY-SHARKEY BROADCAST.

The running commentary on the Dempsey-Sharkey fight, broadcast by a chain of American stations, was picked up on a *Wireless World* short-wave receiver (June 29th issue) from station 2XAF, Schenectady, transmitting on 32.79 metres. Although atmospheric conditions were not altogether favourable, the description from the ringside came through with remarkable

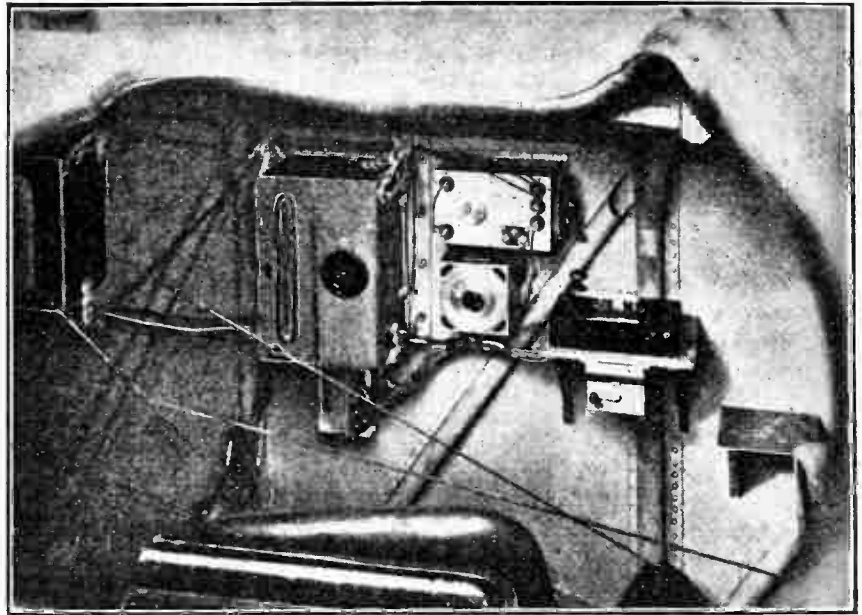

INSIDE THE "WHALE." A near view of the Marconi receiving and D.F. apparatus. An 8-valve H.F. amplifier is in the box on the extreme left; in the centre is a four-valve supersonic amplifier. The D.F. tuning unit adjoins it.

clarity, especially in the early stages. Later signal strength fell off, and with the arrival of dawn almost complete fading set in.

Alternative signals were available from 2XAD, on 22.07 metres, but 2XAF proved more reliable. During the preceding musical programme both transmissions showed a pronounced fading effect.

WIRELESS OPERATORS FOR R.A.F.

Six hundred aircraft apprentices, between the ages of 15 and 17, are required by the Royal Air Force for entry into the Schools of Technical Training at Halton, Bucks, and at Flowerdown, near Winchester. One of the principal posts open to boys is that of wireless operator-mechanic. Full particulars are obtainable from the Royal Air Force, Gwydyr House, Whitehall, London, S.W.1.

BERLIN'S RADIO SHOW.

An ambitious programme has been prepared for the Berlin Radio Exhibition, to be held from September 2nd to 11th in the Radio Industry Hall at Kaiserdamm, in the west end of the city.

"It will not be a mere show of dead apparatus and machinery," says the official announcement, "but a life picture of the radio industry."

The Radio Hall has been specially constructed for exhibitions of this kind, and includes standard indoor aerials and sound-proof cabins to enable visitors to test individual sets. A feature of the Show will be a demonstration of wireless photo transmission, while another important display will acquaint the public with activities at a typical broadcasting station.

Perhaps the most attractive "side show" will be the restaurant, situated at a height of 180 feet, on the 455ft. radio mast.

THE DISAPPEARING PIGEON.

Carrier pigeons will soon be at a discount on Ailsa Craig, a lonely island ten miles from the Ayrshire mainland, owing to the decision of the Northern Lights Commissioners to provide the island with a wireless transmitter and receiver. Hitherto the inhabitants of Ailsa Craig have relied on carrier pigeons and a beacon for communication with the outside world.

TRADE NOTES.

Runbaken Scottish Representatives.

Messrs. the Runbaken Magneto Company inform us that they have appointed Messrs. Millemon (Factors), Ltd., Glenogle Works, and 362, Broad Street (Mile End), Glasgow, as their sole Scottish representatives.

Ferranti Transformers in Canada.

The special Jubilee Dominion Day broadcast programme originating at Ottawa marked the most extensive "S.B." event yet attempted in Canada, no fewer than sixteen stations, stretching from coast to coast, being linked up. The difficulties involved in transmitting speech and music over long telephone circuits without introducing serious distortion were generally recognised, and it is interesting to note the special apparatus employed embodied Ferranti transformers. No fewer than 104 2-stage amplifiers were used, and every station in the chain gave undistorted reproduction over a frequency range extending from 100 to 5,000 cycles.

HUNTING A HIDDEN TRANSMITTER

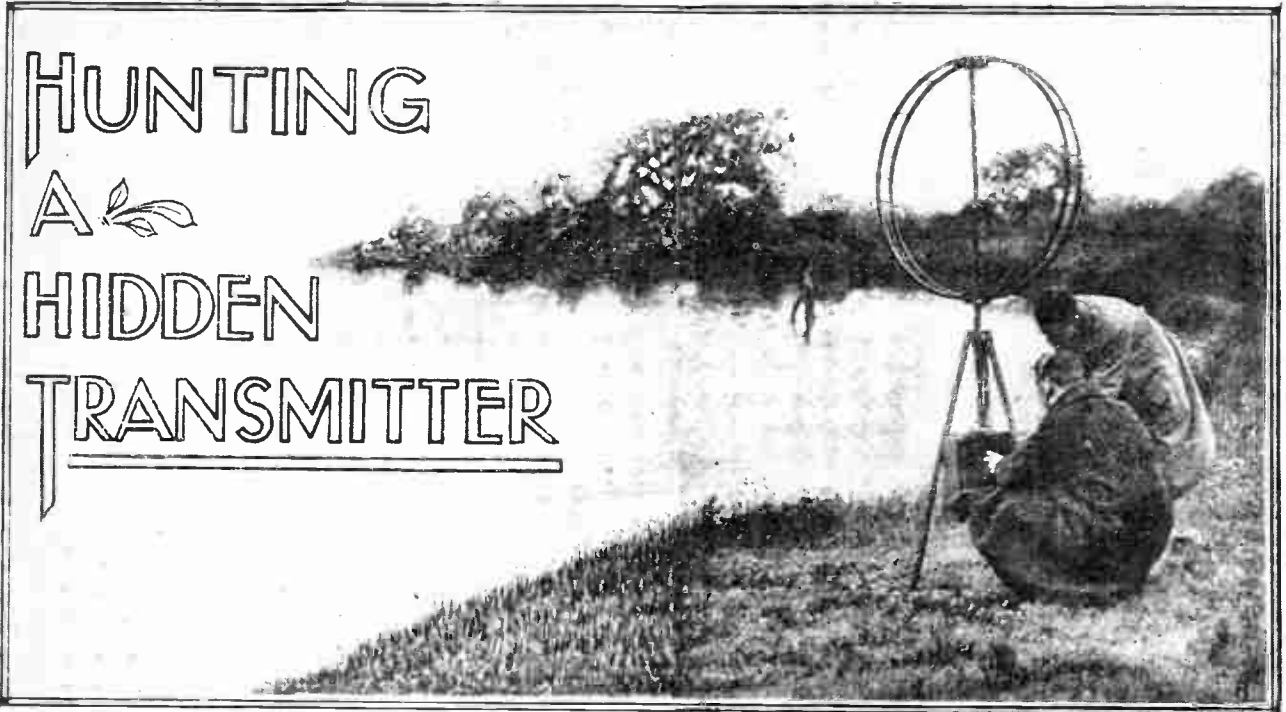

An Exciting Day with the Golders Green and Hendon Society.

ACTING on secret instructions, the writer joined a car at Chipping Barnet, some ten miles to the north of London, soon after midday and proceeded to an unknown destination. It was the occasion of the Field Day of the Golders Green and Hendon Radio Society held on Sunday, July 17th, and the day's operations entailed the running to earth of a hidden transmitting station by members of the Society banded together in sections and equipped with direction finding gear.



(Left) Taking a bearing on the hidden transmitter by the roadside.

The transmitter operating on a wavelength of 150 metres and sending out "chopped" C.W. signals at intervals, was hidden away in the outbuildings of a farm near Arkley, on the Elstree-Barnet road, with Mr. W. J. Tuberville Crewe in charge. Power was derived from a bank of accumulator high tension C.A.V. units feeding two parallel connected Osram LS5 valves.

Stretching along a ten-mile front extending from Ruislip to St. Albans, were ten sections



(Left) Remote control to prevent the wave front being influenced in the neighbourhood of the frame.

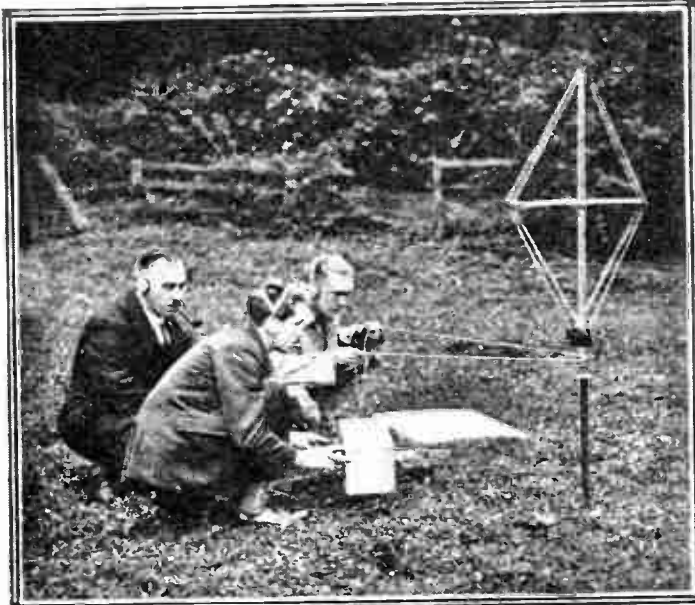

Soon after lunch, far earlier in fact than was anticipated by the judges, Mr. Maurice Child halted his car outside the farm gates, shortly afterwards handing in his report. His equipment consisted of a hoop-shaped frame 3ft. 4in. in diameter, with centre tapping and carried on a tripod to which the receiving gear was suspended. After taking the first reading Mr. Child had moved in a direction at right angles to the indicated direction of the transmitter. A reading from this second position revealed with a surprisingly small error the transmitter position. Three more readings gave the location almost within 150 yards and directed him precisely to the position. The first prize of three guineas, offered by *The Wireless World*, was awarded to Mr. Child.

Within an hour the second section under Mr. J. C. Bird, B.Sc., arrived, thus securing the second prize of one guinea given by the Society. The apparatus he employed had been carefully prepared for the work in hand, and instead of using a centre tapped frame an earthed screening winding had been added to the frame to eliminate the direct pick up effect of the elevated frame acting as a vertical aerial. The frame was mounted on a tripod fitted with an adjustable calibrated table which incorporated the compass.

Shortly afterwards, Mr. L. Michael, who was working alone, arrived. He carried a well constructed set of simple design resembling an ordinary portable. Instead of taking only a few, though accurate, readings he had moved more quickly taking numerous rough readings, relying on more careful observations when close up to the transmitter.

Four sections in all were successful in finding the transmitting set over the distance of twelve miles with their direction-finding gear.

The scheme as well as involving the technical considerations connected with the design of portable direction-finding apparatus added in many other ways to the experience of the members. Reading to a minimum signal strength, a knowledge of Morse, appreciating the allowances to be made for the differences in magnetic and true bearings, are among the difficulties which were encountered.

The spirit of competition maintained a keen interest in the day's operations and it is hoped to organise a further transmitter hunt on a larger scale. Importance attaches to the results obtained in revealing the accuracy and speed with which an unknown transmitter can be located.



(Right) Checking results and examining diaries.

all roughly equidistant from the transmitter. About twelve miles had to be covered to reach the objective, and to prevent the drawing of inferences between the relative positions of the starting points and the hidden transmitter, the locations of the sections were unknown to each other. Each section had armed itself with frame aerial and calibrated scale, receiver and batteries, compass, map and protractor, the personnel and gear being transported by car.

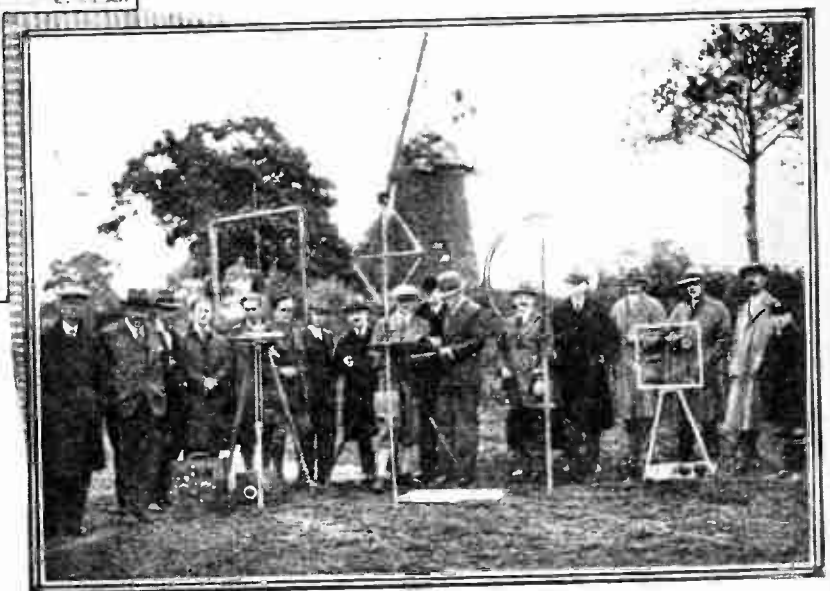

INVENTIONS OF WIRELESS INTEREST

The following abstracts are prepared, with the permission of the Controller of H.M. Stationery Office, from Specifications obtainable at the Patent Office, 25, Southampton Buildings, London, W C.2, price 1s. each.

A Smoothing Circuit. (No. 267,701.)

Application date: March 2nd, 1926.

W. Diggle describes in the above British Patent a form of smoothing circuit suitable for use with a valve rectifier, in which the chokes are coupled together. In the accompanying illustration the filament of the rectifying valve V is heated from the secondary winding of an input transformer T. The load circuit is connected to the rectifier in the usual manner, and an integrating condenser C₁ is

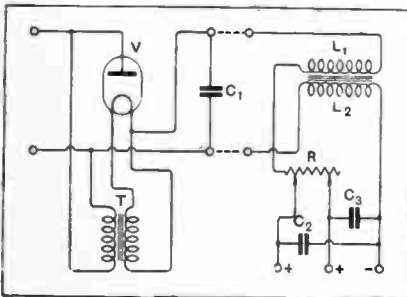

Smoothing circuit with coupled chokes.
(No. 267,701.)

connected before the two chokes L₁ and L₂, which are followed by another condenser C₂. The chokes L₁ and L₂ are coupled together and wound on a common core. An intermediate voltage is obtained as usual through a series resistance R and a shunt condenser C₃.

o o o o

Broadcast Identity Calls. (No. 269,792.)

Application date: December 16th, 1925.

In order to overcome the present difficulty of identifying distant broadcast transmissions, particularly when the announcements are made in a foreign tongue, Mr. A. A. Schaschke, of Glasgow, proposes to allot a definite numerical call sign to each operating station, and to provide a clockwork arrangement for automatically and continuously transmit-

ting this call during the interval between successive programme items.

The call number is assigned in accordance with the geographic location of the station on a squared map. If, for instance, the number is 23, the automatic transmitter would transmit two dots for the first integer followed, after a short interval, by three dots for the second, this process being continuously repeated. The call device is brought into action by the announcer pressing a button at the end of each item, and remains in automatic operation until the commencement of the next item, thus assisting a distance listener to keep constantly in touch with the transmission.

o o o o

Straight-line Condensers. (No. 270,020.)

Application date: February 10th, 1926.

The number and variety of tuning condensers is becoming legion. In the model shown in the diagram Mr. Riley mounts the interleaving plates A, B on two converging arms C, D, pivoted at E and F. The arms are brought together against a spring S by means of a pair of links mounted on a slide. The latter is moved up or down a screw-threaded spindle by the usual control knob.

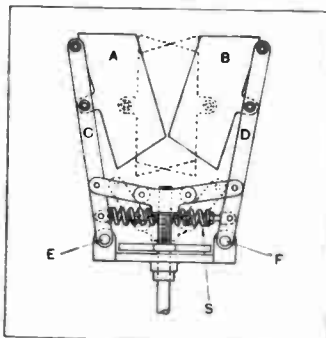

Straight line frequency condenser with link motion. (No. 270,020.)

The angular displacement of the arms C D for a given movement of the slide increases as the slide moves down-

wards, so that the rate of overlap of the plates A, B is accelerated as the plates approach the closed position. This gives a "straight-line frequency" response in tuning, according to the rule that as the capacity in circuit grows larger, the rate of increase for equal angular movements of the operating knob must also increase.

o o o o

Piezo-crystal Control. (No. 259,174.)

Convention date (U.S.A.): October 2nd, 1925.

Frequency control by means of piezo-electric oscillators is now commonplace.

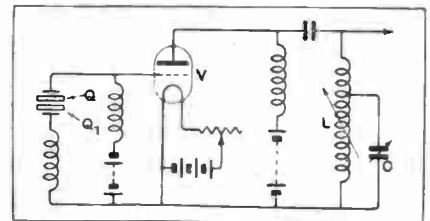

Oscillator with double crystal control.
(No. 259,174.)

Wired Radio Inc. of America have, however, discovered that it is possible to utilise a "stack" of piezo crystals simultaneously, each crystal being ground to a different fundamental frequency, and then to select one or other at will as the operative control merely by tuning the output circuit.

As shown in the circuit diagram several different crystals Q₁, Q₂ are stacked together in direct contact between upper and lower metallic electrodes in the input circuit of the valve V. The output circuit contains a tapped inductance L and variable condenser C. The tuning of this circuit determines which of the various crystals shall take control and establish the operating frequency of the system. The arrangement can be used either for heterodyne purposes, or for stabilising the carrier wave of a transmitting station at any one of a number of different frequencies.

A Superheterodyne Receiver.
(No. 267,617.)

Application date: December 18th, 1925.

An interesting form of superheterodyne receiver is described in the above British patent specification by Standard Telephones and Cables, Ltd. It is frequently

applied to the intermediate amplifier is controlled by a potentiometer in the normal manner. Valves V_3 , V_4 , and V_5 act as intermediate amplifiers, while the second detector is a valve V_6 , which is coupled to a final low-frequency amplifying valve V_7 , which contains the telephones F. It is mentioned in the speci-

secondary of which is connected to the device to be operated. The current in the secondary winding, being proportional to the rate of change of the current in the primary, rises at once to its maximum. For the same reason the cut-off is equally sharp. (A) is a graph on a time basis show-

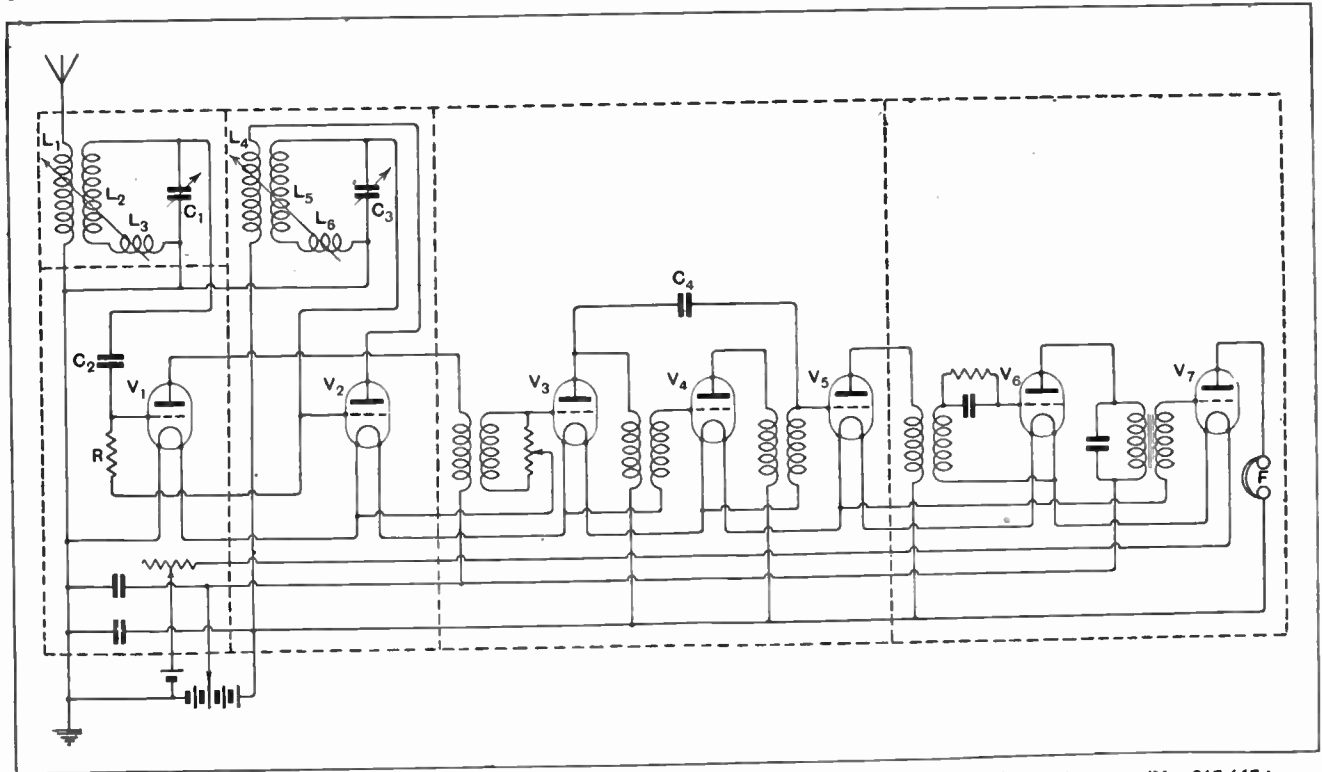

Superheterodyne circuit designed to give complete independence of tuning in local oscillator and input circuits. (No. 267,617.)

found that alteration of the local heterodyne may affect the tuning of the input circuit, and, conversely, the alteration of the input may affect that of the heterodyne. One object of the invention is to overcome this defect. In addition to screening the various portions of the circuit, which is indicated by the dotted lines, a special form of circuit is employed. The aerial circuit contains a variable inductance L_1 , coupled to a fixed inductance L_2 , and a variable inductance L_3 , all tuned by a condenser C_1 . This circuit is connected to the grid of the detector valve V_1 through a condenser C_2 in the normal manner. The oscillator circuit comprises a valve V_2 connected as usual to an inductance L_4 , coupled to the grid circuit, and consists of a fixed inductance L_5 , and a variable inductance L_6 , tuned by a condenser C_3 . The grid of the oscillator valve V_2 is connected to the grid of the detector valve through a resistance R of about two megohms, which functions partly as a grid leak and partly as a means of transferring the oscillations to the detector valve circuit. The remainder of the circuit is fairly normal, the output of the detector valve being coupled through a transformer to the grid of the first intermediate amplifier. The magnitude of the poten-

terential that the receiver thus arranged gave bad quality, probably due to the fact that certain portions of the intermediate amplifier were resonant. This effect was counteracted by the introduction of a small balancing condenser C , connected between the anode of the valve V_3 and the grid of the valve V_5 , thus introducing a reverse regenerative effect. If this condenser is made too large the amplification will fall considerably.

Television Systems.
(No. 270,222.)

Application date: October 21st, 1925.

Light-sensitive cells in general are subject to an inherent time-lag when converting light and shade effects into corresponding variations of electric current. When, for instance, the applied light signal is of very short duration, the output from the cell does not attain the same value as with a signal of longer duration from a light-ray of the same intensity.

Mr. Baird proposes to overcome this defect by utilising the "first differential" of the output current, either alone or in combination with the normal output. With this object in view the output terminals of the cell are connected to the primary winding of a transformer, the

ing the intensity of illumination falling on the light-sensitive cell; (B) the output current from the cell, which flows in the primary winding; and (C) the corresponding current induced in the secondary winding of the transformer. For impulses

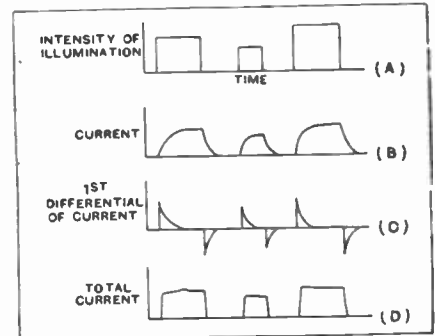

Curves of illumination and current illustrating Mr. Baird's patent. (No. 270,222.)

of very short duration the responses shown in (C) will approximate more closely to (A) than those of (B). For signals of longer duration, the responses of (B) and (C) are combined in operation so as to produce an effect substantially equal to the original impulse (A).

Dry Contact Rectifiers.
(No. 270,362.)

Application date: December 2nd, 1925.
Mr. Rubens describes a surface contact rectifier in which the electropositive element is a disc of aluminium, magnesium, or zinc, or amalgams of these metals with mercury. The electronegative element is preferably of copper combined or alloyed with silver, zinc, tin, or antimony. Good results are stated to have been secured with a mixture of 85 per cent. copper and 15 per cent. zinc.

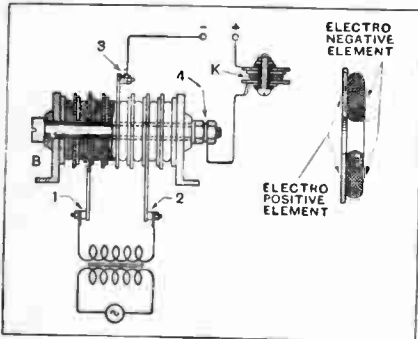

Section and circuit of Rubens dry contact rectifier. (No. 270,362.)

The elements are tightly pressed together in pairs by an insulated bolt B. For full-wave rectification the input is applied to electrodes 1, 2, situated substantially midway of the two groups formed by a common negative electrode 3, inserted between two successive electronegative units as shown. The rectified output is delivered from the terminals 3, 4. A cut-out K, formed of an asymmetric couple of the type previously described, prevents the possibility of damage due to any temporary deterioration rectifying film formed between the contact surfaces.

o o o o

Motor Car Outfit.
(No. 270,608.)

Convention date (France): October 23rd, 1926.

Filament current for the receiving set is obtained from the car accumulator 1, the connection with the dynamo 2 being first broken by means of a switch 3 (mounted on the dashboard) if the set is

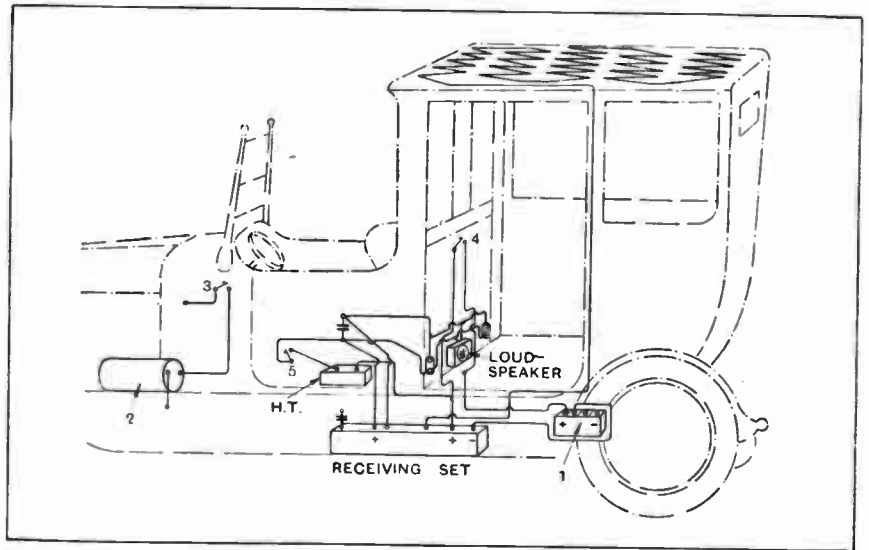

Layout of receiving installation for use in motor cars. (No. 270,608.)

to be used whilst the car is running. A second switch 4 controls the filament supply, whilst a switch 5 brings in the high-tension battery. The loud-speaker is located below the dashboard, whilst the aerial A is mounted on the roof of the vehicle.

o o o o

Level Amplification.
(No. 259,613.)

Convention date (U.S.A.): October 10th, 1925.

A multi-valve high-frequency amplifier is described by Hazeltine Corporation and W. A. MacDonald in the above British Patent. It is mentioned that any stage of amplification is a maximum at some particular frequency dependent upon the ratio of inductance and capacity, coupling between the primary and secondary, valve impedance and other factors. When a number of identical stages are used it follows that each stage will give maximum amplification at this frequency, so that the over-all amplification at this frequency will be very greatly enhanced. In order to overcome this difficulty, the amplifier is constructed so that the various stages are slightly dis-

similar, with the result that fairly level amplification will be obtained. The accompanying illustration shows a suitable circuit, which is arranged as follows. The valves V_1 to V_3 act as radio-frequency amplifiers, while the detector is V_4 . The stages are coupled respectively by transformers T_1 , T_2 and T_3 . These are of the familiar tapped secondary type, and are connected respectively through neutralising condensers C_1 , C_2 and C_3 to the grid of the preceding valve. Since the circuit is perfectly normal, it will not be described in further detail.

o o o o

Safety Devices for Valve Generators.
(No. 270,488.)

Application date: May 6th, 1926.
In order to prevent the grid or plate voltages of a power oscillator from reaching an unduly high value, or the grid current from suddenly reversing in direction, and thus causing serious damage, the Philips Gloeilamp Co. adopt the de-

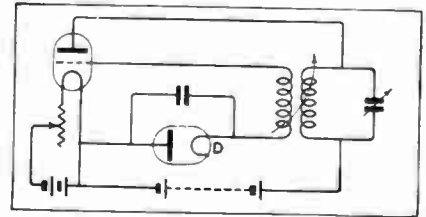

Two-electrode valve as safety device. (No. 270,488.)

vice of shunting the danger points with a two-electrode valve. For instance in the circuit shown in the diagram the direction of the grid current is liable to be reversed if the secondary emission from the grid should at any time exceed the primary emission. To prevent this contingency the diode valve D is inserted in the grid lead as shown. Any attempt at reversal is now frustrated by the one-way conductivity of the safety valve D.

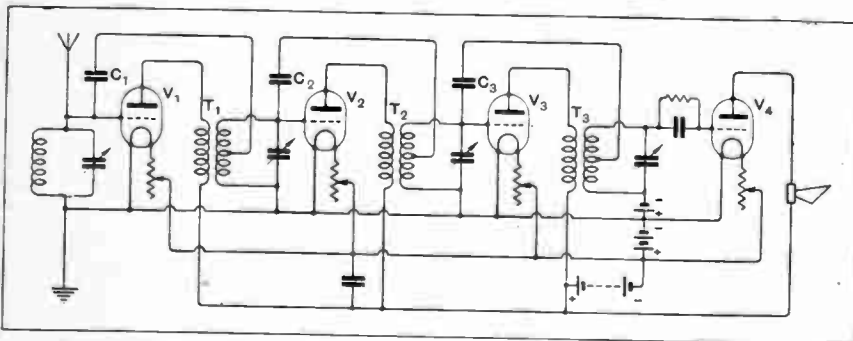

H.F. amplifier in which transformer constants are varied to give level overall amplification. (No. 259,613.)

The
GRAVES
TWO-VALVE
SET

BROADCAST RECEIVERS

Complete Loud-speaker
Equipment Representing
Excellent Value for
Money.

WE are frequently reminded by the B.B.C. engineers, who presumably have access to the facts, that the majority of licence holders are crystal set users, but there can be little doubt that only a few listen with phones from choice. The average listener is fully alive to the advantages of a loud-speaker receiver, and it is necessity rather than choice which forces him to be content with the humble crystal and phones.

Most loud-speaker equipments cost from £30 to £40, and do not in many cases represent good value for money when compared with other commodities which have been long enough established for their prices to have become stabilised by competition. The average man has a pretty shrewd sense of values, and when he is going to lay out £30 or £40 for a wireless receiver he expects in return rather exceptional service in the matter of quality of reproduction, choice of stations and selectivity. He may not be fortunate in finding the few makes at this price which will give the service required, and will probably decide to stick to the old crystal set—unless he can find a set giving loud-speaker results at a price comparable to, say, a gramophone.

A Two-station Set.

The Graves Two-valve Loud-speaker Set exactly fills this requirement, and in our opinion represents exceptional value for money. As will be seen from the photographs, the equipment is unusually complete, and all components used are of high quality, yet the price is only £7 17s. 6d. The loud-speaker gives ample volume for a moderate-sized room, and the quality is above the average for this class of set. Long or short waves may be received at will by turning a switch, so that the purchaser is assured of a service either from the nearest main station or from Daventry. This appears to be the principal object the makers had in view when producing the set, and, although they make no claim for long-distance reception, it was



found possible to tune in on the loud-speaker in London at least half a dozen Continental stations *after the local station had closed down.* From this it will be gathered that the set, though sensitive, has not a high degree of selectivity. This is unimportant under present broadcast-

ing conditions, however, if only one station or at the most two are required.

Long-wave Efficiency.

The efficiency on the Daventry wavelength is unusually good, and at sixty-five miles excellent volume is obtained. This is one of the few sets that have picked up Daventry in the basement of our Editorial Offices in Fleet Street, using only a short piece of wire for an aerial. Of course, the volume was not very great, but the set did succeed in extricating the Daventry transmission from the electrical mush present in that neighbourhood. Elsewhere in London with a standard 100ft. aerial the volume from Daventry is excellent.

The circuit made use of in this set comprises a reacting detector and a transformer-coupled I.F. amplifier. There are two tuning coils in series, one for short waves and the other a loading coil for Daventry. The range switch simply short-circuits the Daventry loading coil. A single reaction coil serves for both wave ranges. It is mounted on a rotating arm with a 180 degree movement, the operating handle on the front panel being provided with a centre zero scale. The tuning coils are mounted one on either side of the reaction coil spindle, so that when the operating handle is moved to the right the reaction coil is brought over the short-wave coil and to the left over the long wave coil: a particularly neat arrangement which is perfectly satisfactory in practice.

The Graves Two-valve Set.—

A "Utility" variable condenser with long, single bearing is used for tuning.

Following the detector valve is a Telsen low-frequency transformer. This component is both bulky and heavy, and therefore fulfils one of the first requirements of an intervalve transformer, namely, plenty of iron in the core and many turns in the windings; it is quite unlike the diminutive instruments usually associated with sets of this class. The primary winding is shunted by a Cosmos fixed condenser to by-pass the high-frequency component of the anode current from the detector valve.

A 4½-volt grid bias battery (flash lamp) for the L.F. valve is neatly mounted between the valve holders, flat spring clips being provided for making connection to the contact strips. Mullard P.M.I. valves are used, and are supported in "Aermonic" spring valve holders.

The cabinet is made of solid figured oak, and is well finished. A hinged back gives access to the interior of the set for the purpose of inserting valves or replacing the grid bias battery. Flexible leads are taken through the sides of the cabinet for connection to the H.T. and L.T. batteries, and a terminal panel is fitted on the left-hand side for aerial and earth connections. There are two aerial terminals between which a Cosmos fixed condenser is connected, and the aerial is joined to the terminal, which gives best results. In general, short aeri-als should be connected to the lower terminal, which gives direct connection to the tuning coils, and long aeri-als to the upper terminal, which introduces the fixed series condenser. The loud-speaker is connected to terminals on the front panel.

Numerous Accessories.

The accessories which complete the outfit are comprehensive and of excellent quality. Everything seems to have been thought of; there is a complete aerial-earth system, including aerial wire, porcelain insulators, rope halyard and pulley, lead-in tube, earth clip, and leads for connecting to the aerial

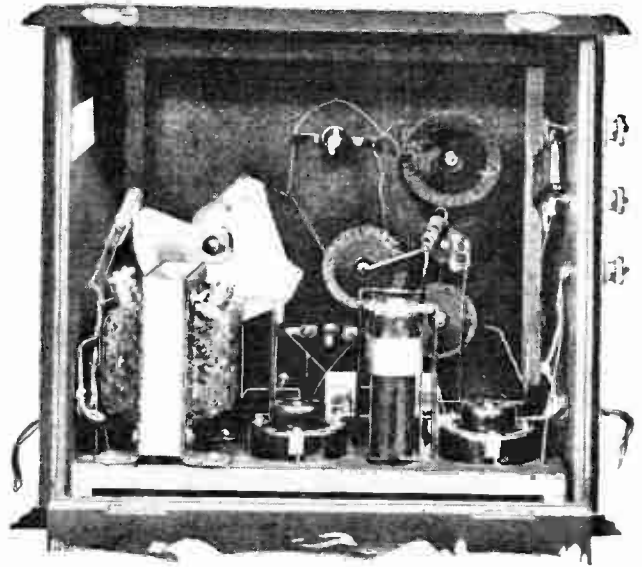

Interior of set with valves removed, showing arrangement of tuning and reaction coils.

and earth terminals of the set. The 90-volt H.T. battery is of good quality, and the accumulator is an Oldham 2-volt cell in glass container. The loud-speaker has a mica diaphragm and is adjustable, the finish being a frosted brown enamel which tones well with the cabinet.

The instructions for erecting the aerial, connecting up and tuning, are lucid, and a large wiring chart removes all possibility of wrong connections.

The price of the complete outfit, as previously noted, is £7 17s. 6d., and special terms for easy payments can be arranged with the makers, Messrs. J. G. Graves, Ltd., Sheffield.

"Back-bedroom manufacturers" and "local experts," who have done so much to discredit broadcast reception with their "junk" sets can no longer compete even in price with this high-quality outfit.

It even competes in cost with home construction, and the would-be listener who has no taste for construction and experimenting can buy this set and have the satisfaction of knowing that he could not have made it himself for a lower price.

Messrs. Graves are doing a service to the art by introducing many people of small means to the possibilities of loud-speaker reception.

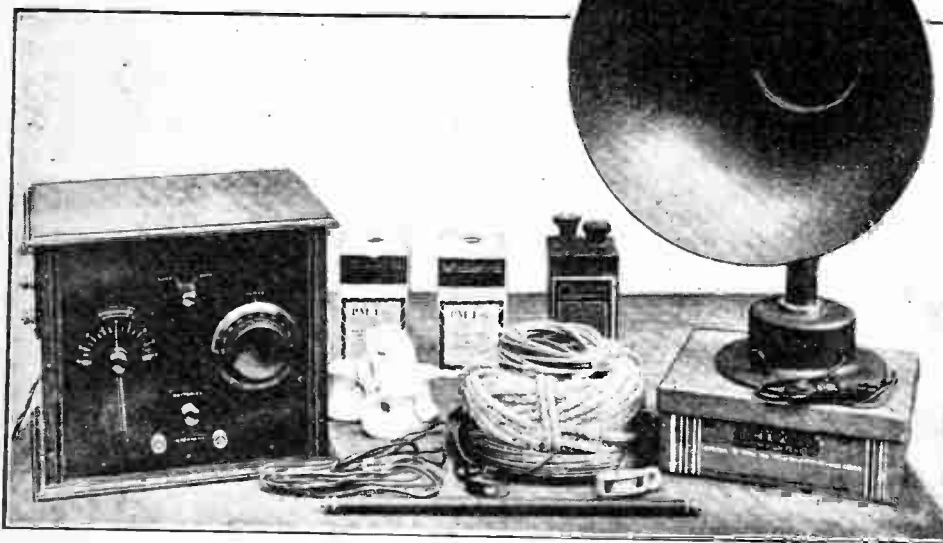

The equipment of the Graves set is unusually complete and includes valves, batteries, loud-speaker and materials for the aerial-earth system.

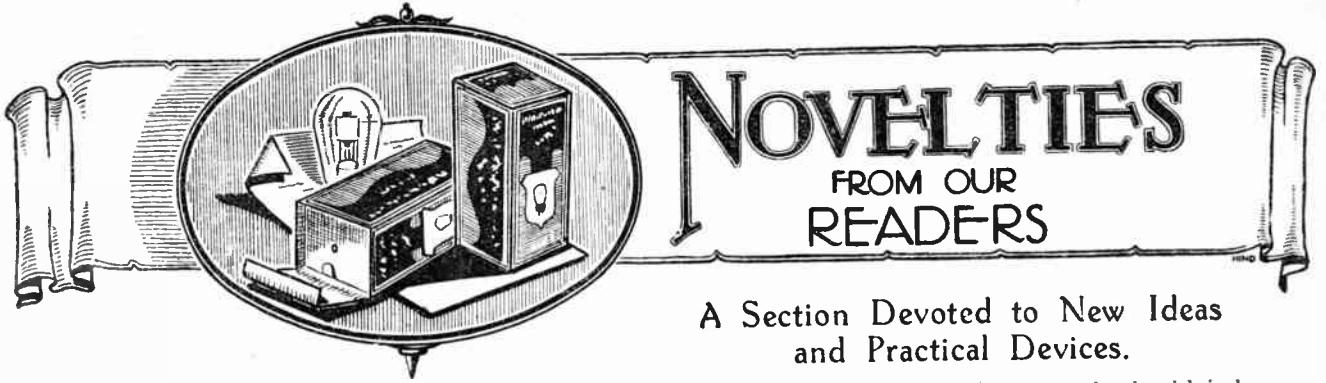

A Section Devoted to New Ideas
and Practical Devices.

L.T. WIRING.

Instead of using a solid wood baseboard, as is frequently recommended, take a piece of thick 3-ply or 5-ply of the required size and fix to it on the underside a frame of square sectioned wood halved together at the corners. Along the inner faces of the two longer sides strips of brass or copper foil, about 3/4 in. wide, are screwed. These serve as bus bar connections for L.T. + and -. Connections from various parts of the circuit are taken through holes immediately below in the 3-ply baseboard strips.

This system not only conduces to a tidy appearance in the interior of the set, but also considerably reduces the

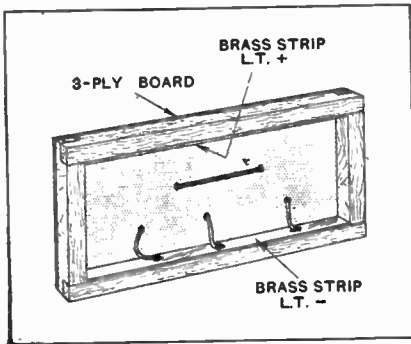

Baseboard construction with bus bar connections for L.T. + and -.

D.C. resistance of the filament circuits—an important consideration when using 2-volt valves.—A. H. B.

o o o o

TERMINAL FOR FINE WIRE.

In experimental work considerable time is saved if the ends of coils wound with fine wire can be connected directly to existing terminals. If these terminals are of the telephone type, fine wire will slip from under the clamping screw and diffi-

culty will be experienced in obtaining a satisfactory connection. To get over this, insert a split wander plug through the hole in the terminal post and insert the fine wire in the slotted

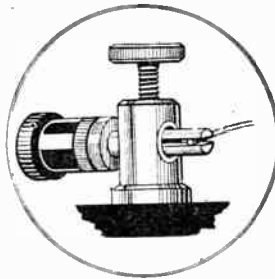

Clamping fine wire in a telephone terminal by means of a split wander plug.

end of the wander plug where it projects from the terminal. A firm connection will then be obtained by tightening up the terminal screws, which will cause the two halves of the wander plug to grip the wire.—W. A. R.

o o o o

CHECKING TURNS.

When checking the number of turns on the primary and neutralising windings of "Everyman Four" transformers, or more particularly those used in the "All Wave Four," difficulty may be experienced in seeing clearly the individual turns of the fine wire.

The mounting of the turns will be greatly facilitated if a strip of thin black paper is inserted in the space between the primary and secondary windings. This will throw up the fine wires into sharp relief, and eye strain will be considerably reduced.—H. T. W.

o o o o

REPAIRING A CRYSTAL DETECTOR.

The Harlie crystal detector is a well-known component, and the following method of renewing the

cylindrical crystal, should it become broken, is well worth trying.

After having removed the small ebonite wheel from the brass spindle upon which the crystal is mounted, the spindle is cleaned and a small cylindrical lead of the required length, but of smaller diameter, clamped round it. Temporary washers are then fitted at each end of the lead cylinder in order to keep the spindle vertical in the test tube. The edges of these washers may conveniently be nicked to allow free circulation of the liquid. The cylinder is then covered with sulphur and carefully heated over a spirit lamp or Bunsen flame until a grey mass is formed at the bottom of the tube. After allowing to cool, the cylinder is removed by breaking the glass.

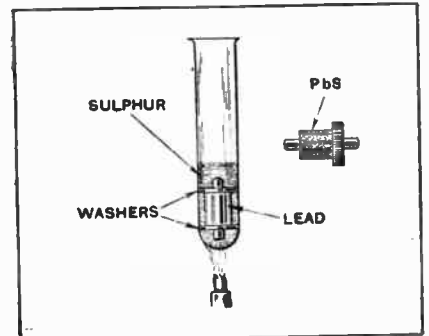

Renewing the crystal in a Harlie detector.

The washers are removed and the cylinder cleaned by immersing in carbon bisulphide, which dissolves away the superfluous sulphur. The cylinder may with advantage be left in the carbon bisulphide for a week or so to give time for the plastic sulphur to return to its original soluble form.

This process will be found to have formed a film of lead sulphide (galena) on the surface of the lead cylinder.—N. H.



**5GB's Licence.—Plans for the "Proms."—The Open Window.—A New Zealand Debut.
Listening to Yacht Races.—Why Not a Chess Commentary ?**

Burying the Hatchet ?

Sir Thomas Beecham has acquired the reputation of one who fears not to defy broadcasting and all its works. It was refreshing, therefore, to see the great conductor in one of the 2LO studios a few days ago. The occasion was a rehearsal of the Wireless Chorus in preparation for a private performance at Lady Cunard's reception to King Fuad.

o o o o

Post Office and 5GB.

Although 5GB, the Daventry regional station, is practically ready to begin transmissions, the Post Office (at the time of writing) is still preserving a Sphinx like attitude on the question of the licence.

It is for this reason, I gather, that the B.B.C. is loath to communicate details regarding the nature of the preliminary programmes from the new station. It is still possible that Post Office delays may hinder any plans which the B.B.C. may formulate.

o o o o

Have You Heard It ?

Many listeners in the London area have reported a disturbing heterodyne note on 2LO's transmissions. According to the wavemeter at Keston, the offender is operating on 824 kilocycles, which is uncomfortably near to 2LO's frequency, viz., 830 kilocycles.

It is believed that the culprit is a Spanish station.

o o o o

Promenade Concert Broadcasts.

The six weeks' season of "Proms" at the Queen's Hall, under the baton of Sir Henry Wood, will open on Saturday, August 13th, continuing nightly (except Sundays) until September 24th. Com-

FUTURE FEATURES.

London.

- JULY 31ST.—Greig Programme.
AUGUST 1ST.—"Miss Hook of Holland."
AUGUST 2ND.—"Carmen" (Bizet).
AUGUST 4TH.—National Eisteddfod Concert, relayed from Holyhead.
AUGUST 6TH.—Singing relayed from the Duke of York's Camp, New Romney.

Birmingham.

- AUGUST 3RD.—Leamington Spa Night, from the Pump Room Gardens.

Bournemouth.

- AUGUST 3RD.—"From the Romantic Period"—Vocal and Orchestral Concert.

Cardiff.

- AUGUST 5TH.—"Marged Manages It." A Comedy in One Act by Conrad Davies.

Manchester.

- AUGUST 6TH.—Another Blackpool Night.

Newcastle.

- AUGUST 3RD.—A Tyneside Programme.

Glasgow.

- JULY 31ST.—Concert and Military Band Programme, relayed from Kelvingrove Park.

Aberdeen.

- AUGUST 6TH.—"A Day in an Hour." A Novelty Entertainment, presented by the Radio Concert Party.

Belfast.

- AUGUST 5TH.—"Quinney's." A Four-act Play by Horace Annesley Vachell.

paratively few of the concerts will be broadcast—in fact, London and Daventry will be taking only about one and a half each week. Other stations will be at liberty to select a Queen's Hall programme once or twice a week, depending upon their individual arrangements.

The opening concert, which will be broadcast in its entirety by 2LO and 5XX, includes Grieg's Pianoforte Concerto in A minor, with M. Arthur de Greef as soloist.

o o o o

A Mozart Night.

The Promenade Concert on the following Tuesday, August 16th, will also be broadcast. The programme will be largely devoted to the works of Mozart, and will include the Horn Concerto No. 4 in E flat, and the Symphony No. 40 in G minor. In the former work the horn solo will be taken by Mr. Aubrey Brain.

o o o o

A Prohibited Topic.

Risks have to be taken by the B.B.C. when broadcasting "outside" events in which the speakers are not bound to submit their "copy" for censorship. Such a risk was taken the other day when Dr. Parkes Cadman, the American evangelist, broadcast from St. Martin-in-the-Fields.

As a sequel a mild flutter was created in certain circles by a chance remark of the preacher regarding the delicate question of Prohibition.

As a matter of fact, Dr. Parkes Cadman had been forewarned of the necessity of avoiding controversial subjects; nor did he transgress the rule until he was asked a question which demanded an answer—either "wet" or "dry." His answer was rather dry.

JULY 27th, 1927.

West Country Plays.

Cardiff station is enrolling fresh recruits for radio players, and in forthcoming productions the cast will be drawn from places as far apart as Bath, Gloucester, Bristol, and Cheltenham. These new players will be particularly valuable for rôles in plays about the West Country.

o o o o

A Sing-song from Camp.

The Duke of York's camp at New Romney is the event of the year for London lads. His Royal Highness usually visits the camp and mixes freely with the boys who are spending their summer holidays under canvas. This year a sing-song will be relayed from the camp to 2LO on August 6th.

o o o o

B.N.O.C. Broadcasts.

Ten operas among those to be given by the British National Opera Company during the autumn will be broadcast.

o o o o

The Open Window.

A striking revelation of the shortcomings of present studio design was afforded by a recent incident at 2LO, when the engineers praised the unusual quality of a studio performance in ignorance of the fact that the conductor had opened a window.

The "deadened" studio tradition dies slowly, but more and more it is being recognised that "outside broadcasts," often staged in odd places at short notice, are not nearly so bad acoustically as the theorists would have us believe.

Quite a number of heretics prefer "O.B.'s" to studio performances.

o o o o

Cures from the Microphone.

The enterprise of Station WGL, New York, in dispensing Christian Science treatment *via* the microphone is not likely to be emulated by the B.B.C., despite the plea of a certain listener that something of the sort would form a beneficial sequel to many of the programme items!

o o o o

High Power in New Zealand.

New Zealand's latest broadcasting station, 2YA, which was opened last week at Wellington by the Prime Minister of New Zealand, is reputed to be second only to Daventry in the Empire in the matter of actual aerial power. 2YA's aerial carries 5 kilowatts.

The new station easily dwarfs the existing stations at Auckland and Christchurch, and will be able to cover the whole of New Zealand, day and night, besides making itself heard in Australia during the hours of darkness.

o o o o

The Blind Leading the Blind.

While broadcasting has so many possibilities, it is a pity to see impossibilities attempted. The Crosley Radio Corporation station WLW, at Cincinnati, Ohio, is featuring a series of ten weekly lectures on free-hand drawing.

▲ 33

This seems about as sensible as the teaching of swimming by correspondence.

o o o o

Last Words by Wireless.

Apropos a recent note in these columns regarding the broadcasting from Newcastle of a running commentary on the departure of the pleasure cruiser *Stella Polaris* for the Norwegian fjords, an interesting item reaches me from the Norwegian broadcasting organisation Kringkastingselskapet, at Oslo.

Since February the Oslo station has made a regular practice of broadcasting the departure of liners bound from Oslo to the U.S.A. These transmissions have proved exceedingly popular, as the station broadcasts free of charge the

Hall, Westminster. There is, of course, the difficulty of finding a commentator who could stand the emotional strain.

o o o o

"Carmen."

The cast for the performance of "Carmen" on August 2nd will include Tudor Davies, Dennis Noble, Enid Cruickshank (as Carmen) and Eda Bennie.

o o o o

A Choral Concert.

The Wireless Singers, conducted by Stanford Robinson, are to broadcast a concert on August 11th. In the same programme J. Rosamund Johnson and Taylor Gordon will sing negro spirituals and Beatrice Eveline will play cello solos.

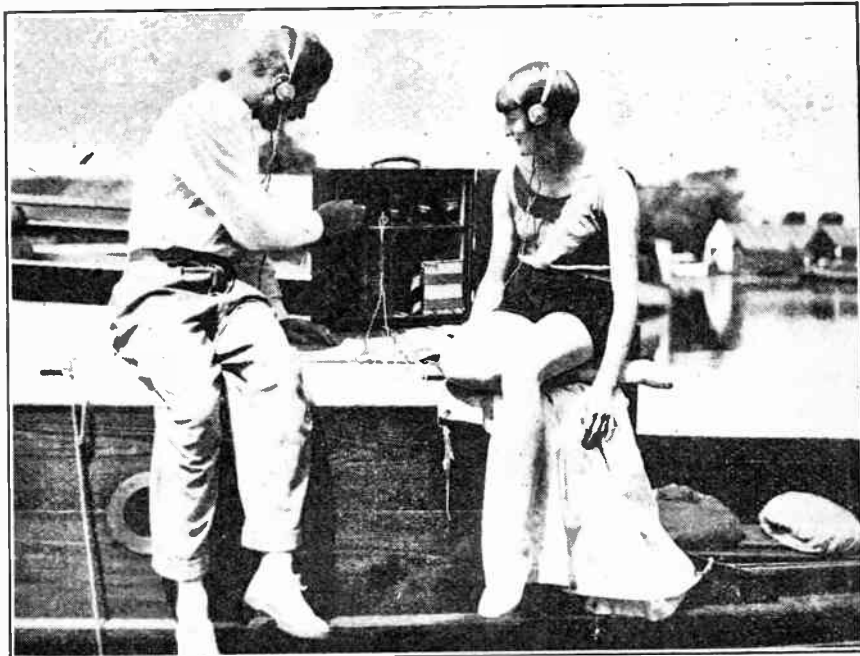

WHY WE GO TO THE BROADS. A happy snap taken last week on the Norfolk Broads, where a portable receiver sets the seal on a perfect holiday.

last farewells of the emigrants to their families and friends at home.

o o o o

Laurence Housman's Plays.

Two short plays by Laurence Housman, "A Fool and his Money" and "The House Fairy," will be broadcast from 2LO on August 10th.

o o o o

Yacht Races Described.

An eye-witness account of some of the races at Cowes Regatta will be broadcast from Bournemouth on August 2nd and relayed to London and other stations. The story will be told by Mr. John Scott Hughes, the well-known writer on yachting.

o o o o

Why Not a Chess Commentary?

The B.B.C. are missing a grand chance by omitting to give us a running commentary on the International Chess Congress, now in full blast at the Central

The Roosters Again.

More Army reminiscences are to be broadcast by the Roosters on August 4th.

o o o o

A New Compère.

Ben Blue and his band, who have just completed an engagement at the Alhambra, will broadcast on August 12th. In addition to a ten minutes' show by the band, Ben Blue will compère the programme.

o o o o

The Tidworth Tattoo.

The running commentary in connection with the Southern Command Searchlight Tattoo, which will be broadcast on August 1st from Tidworth, Hants, will be given by Captain H. B. T. Wakelam. A feature of the music will be the rendering of "Abide With Me." The first verse will be played by the band, the second by an echo band in the hills, and the third will be sung by all present to band accompaniment.



The Editor does not hold himself responsible for the opinions of his correspondents.

Correspondence should be addressed to the Editor, "The Wireless World," Dorset House, Tudor Street, E.C.4, and must be accompanied by the writer's name and address.

THE PROPOSED REGIONAL SCHEME.

Sir,—May I thank you for your enterprise in publishing an article by such an authority as Capt. P. P. Eckersley. It simply confirms what I have been feeling since February, when I first saw *The Wireless World*, that there is but one really "grown-up" wireless periodical in English.

May I submit to your notice the scheme below? There may be technical difficulties, but often the outsider sees more of the game.

Stations.—Ten; say nine of 5 kW. and one of 25-35 kW.

Wavelengths.—Each station to use two wavelengths, but share one with its neighbour, whose programme it will S.B. on this mutual wavelength.

Advantages claimed:—

(a) Each area will have two programmes, and there will be little difficulty in arranging that they are not at the same time of like nature.

(b) Larger A and B areas will result from the merging of the old ones.

(c) Twenty stations on ten wavelengths.

(d) Twenty effective stations with cost of ten programmes.

Capt. Eckersley does not mention the Z areas (70-80 miles outside A areas), where the chief difficulty is Morse from obsolete outfits owned and worked by the gentleman who issues the licences.

Your mention of the North Foreland station reached my heart. It is about nine miles away from my aerial—nine miles chiefly of open sea and marsh.

Deal. WILLIAM B. WEST.

July 14th, 1927.

Sir,—A careful examination of Captain Eckersley's article on the considerations which have led up to the proposed regional scheme of broadcast service shows one that the general idea underlying such a scheme appears to be the only one which attempts to solve the particular problems existent in this country. In considering the general scheme in detail, one regrets that Captain Eckersley has not given more particulars to indicate in what concrete manner it is proposed to put such a scheme into operation, since, in the absence of such details it is somewhat difficult to criticise and still less easy to put forward any constructive proposals which might arise therefrom. In the hope, therefore, that Captain Eckersley will be able to advance some rather fuller information, I would like to raise one or two points which, in my opinion, have a very strong bearing on the success, or otherwise, of the regional scheme.

The ideal of the B.B.C., and rightly so, appears to be towards the establishment of a reasonable factor of safety; in other words, that all listeners should be brought within a "B" service area of one station, and Captain Eckersley suggests that, with correct design of the factors governing this, such an area should have a radius of from 50 to 70 miles. He further suggests that five centres of distribution should give this service

With the help of a map of Great Britain and Northern Ireland and a pair of compasses it is frankly difficult to see how five such stations having the radius mentioned can give anything approaching the desired service if the first clause of Captain Eckersley's summary is to be complied with.

If one assumes that five stations represent the B.B.C.'s scheme in a nutshell, it becomes necessary carefully to consider the technical factors governing the general design and location of these stations. For many reasons, chief of which is the danger of interference with other radio services, it appears doubtful whether a power per station in excess of 25 kW. will be permissible. If such a power is assumed, an examination of the curves given by Captain Eckersley will show that a "B" service area of approximately 55 miles may be anticipated from a station having a similar aerial efficiency to that of 2LO, but in this connection one may be pardoned for suggesting that, in view of the power available at the London station, by far the greater part of these curves have been obtained from calculation and not from direct measurement of field strength. I stand open to correction, but if such is the case it would appear that these particular curves lose much of their value.

As Captain Eckersley rightly points out, even distribution of service depends on aerial efficiency, but in this connection one must not forget that the figures given in respect of the various zones are those obtained from existing stations under recent conditions, and therefore, whilst of considerable interest, cannot give one more than a very approximate idea of what may be anticipated from a regional station, especially as, with perhaps two exceptions, the aerial efficiency of existing stations is not high. The policy of the old company, dictated by financial reasons, was to utilise, where possible, existing smoke stacks and the like, and one would welcome the assurance of Captain Eckersley that a similar policy will not be allowed to influence the design of the new stations.

Assuming an aerial efficiency of 70% at 800 k.c. with an input of 25 kW., it is doubtful if a safe "B" area, under the worst conditions of time and season, will be obtained of more than 80 miles radius, probably less. This, again, would not give a service conforming to Captain Eckersley's ideal with only five stations.

Finally the question of location. In my opinion no service can be truly regarded as a national one which does not adequately cater for Devon and Cornwall, East Anglia and Central Wales. If the policy, based on density of population, adopted by the old B.B.C. is adhered to by the new organisation it is difficult to see how an adequate service can be given to those parts mentioned. After all, if the service is to be really national, the listener in Cornwall or Wales is as much entitled to a reasonable factor of safety as one near London or Glasgow, because he pays the same licence fee. Apart from this, the policy of placing regional stations 10 to 15 miles outside a large centre of population, whilst at the moment giving a wipe-out zone over sparsely populated districts, will in a few years' time bring the residential districts of such areas into this zone. Since it is obvious

that stations cannot be moved to cope with the shifting centres of population this policy, on the face of it, appears to be open to serious objections. If Captain Eckersley can give some definite idea as to the proposed location of the regional stations it will enable a much truer appreciation of the whole situation to be arrived at.

In conclusion, this letter is not written in any carping sense, but rather with a sincere desire to help with the speedy realisation of the regional scheme.

Berkhamsted,
July 14th, 1927.

G. LESLIE MORROW.

Sir,—In an interesting article in the July 13th number of *The Wireless World* Captain P. P. Eckersley outlines an interesting plan of alternate programmes, and he hits the nail on the head when he talks about receiving DX stations plus jamming, etc. May I put in a plea for the coastal stations?

From my own personal experiences at the mouth of the Bristol Channel I think that there ought to be two stations working on a long wavelength in Great Britain.

I have tried working with both straight sets and supers on a frame, and in both cases spark jamming prevented the normal broadcast band from giving good alternative programmes to Daventry, the salvation of broadcasting in the West.

Another point I should like to raise is that of dance music from 10.30 p.m. to 12 on the 300-600 metres band. As things now stand all stations give it on Tuesdays, Thursdays and Saturdays. Why not split up the nights? Say—

Monday.—London, Manchester, Aberdeen, Belfast.

Tuesday.—Bournemouth, Cardiff, Glasgow, Birmingham, Newcastle.

Wednesday.—Repeat Monday.

Thursday.—Repeat Tuesday.

Friday.—None.

Saturday.—All.

The relays could fit in so as to work each section of the country alternatively. This would not, I think, give any more work to the engineers, but would permit dance music to be received on most nights. Yes, Sir, I have remembered Daventry, but not all sets tune up to 1,600 metres.

In conclusion may I turn to another point, and express the pious wish that the sooner we cease lagging behind in the way of short waves the better for us and our colonies.

Doncaster,
July 15th, 1927.

H. STEVENSON BALFOUR.

Sir,—I have read with interest Captain Eckersley's article in the July 13th issue of *The Wireless World* re a regional scheme of high power transmitting stations.

This regional scheme is anything but a new idea, as we in the North (Edinburgh) interested in the wireless business have for years been begging for some such scheme, and, moreover, Captain Eckersley and the old B.B.C. have repeatedly promised us in the North improvements in broadcasting that have never materialised. Now that Captain Eckersley has raised the subject again, may I ask how many years must pass before a move is made to equalise the strength of broadcast signals throughout Great Britain?

If London and the Midlands were subjected to the same kind of treatment as we get in Scotland, and were compelled to listen to Glasgow or Aberdeen by land lines, I am afraid some serious disturbance would take place in or around the B.B.C. headquarters.

Undoubtedly the regional system of high power stations is the correct and only way of tackling the problem for Britain. Everyone with one- or two-valve sets would then get a choice of stations. Turn Daventry into a two-wave station and erect aerials for high-powered broadcast stations at Cardiff, one 20 miles out of Manchester, another 20 miles out of Newcastle, one at Perth and one in the hills south of Inverness, and wipe out all the small stations.

When this is done land lines from halls as well as a studio in, say, four or six of the principal cities or towns within a radius of 50 to 70 miles of each main station could be

laid, and programmes picked up from these various places. In this way the whole country could be tapped, and very much more interesting programmes received than we get at present, and at considerably less expense, I would imagine, than by getting highly paid unsuitable artistes into the London studios. A very much larger proportion of amateur broadcasters have superior wireless voices to the professional entertainers.

While on the subject I would like to vent one or two complaints from this part of the country, and, as they are general, I trust that some of my readers may add their testimony.

In Scotland we have only two main stations—one at Glasgow and one at Aberdeen—besides the second-rate relay stations in the capital of Scotland and in Dundee. In certain parts of the Border country Glasgow can only be heard on the loud-speaker with a four-valve set, and Edinburgh only with earphones on the same set. In the Midlands and West Coast of Scotland Aberdeen can only be heard on the loud-speaker with four valves, and Edinburgh and Dundee might not be in existence for all the use they are. Against this, however, many German and Continental stations can be heard on four-valve sets.

Captain Eckersley in his article states: "It is definitely absurd to say that night after night such an one gets Madrid or Hamburg plus fading plus atmospherics plus jamming, and at night—what of the day time?" Has Captain Eckersley toured Scotland with his extra special set, and, if so, how many British stations has he been able to get, either by night or day? It is all very well to listen-in in London or the Midlands and pick up a number of British and foreign stations on the loud-speaker, but an entirely different proposition when our listeners are 300 to 500 miles farther north amongst hills. The reason we get the foreign stations is by virtue of their extra aerial output, and for this same reason we must have more power behind our broadcasting stations.

One other serious complaint that experimenters and wireless salesmen have to make is with reference to the programme and the times of the programmes that we get from our stations. Why are we all treated like school children and compelled to listen to perpetual lectures or, what is still worse, some would-be poets and authors mutilating their own writings? Quite a number of authors I have enjoyed in their writings have completely spoiled my interest in themselves and their books by their miserable attempts to read out their own works.

Then again, wireless salesmen were always under the impression that the forenoon and afternoon programmes were principally for the purpose of demonstrating wireless sets to prospective purchasers. Everyone cannot afford a three- or four-valve set to listen to Daventry, so we can only demonstrate for one hour on two forenoons in Edinburgh. In the afternoons we are supposed to get broadcastings from 3 p.m. but for some unknown reason the time has now been changed to 3.45 or 4 p.m. This is bad enough, but what is worse is the stuff we have to listen to—gramophone records of the usual needle scratching kind, or some school lessons. Imagine trying to demonstrate or sell a wireless set to rubbish of this kind, or on Thursdays to switch on and hear someone praying at the Westminster Evensong. I am not narrow minded in religious matters, but I consider this latter broadcast during business hours very bad taste indeed, and more likely to make a farce of religion than otherwise.

I would like to have other Scottish opinions on the points I have raised.

AN EDINBURGH LISTENER-IN.

Edinburgh,
July 14th, 1927.

Sir,—After reading Capt. P. P. Eckersley's article in the July 13th number of *The Wireless World*, I feel the B.B.C. want to give us a choice of programmes—but how?

From his remarks I think two programmes from the same aerial—and suggest each station has its own short wavelength and programme as now—and use a common programme on 1,600 metres as well.

This will give a big wavelength difference, and if all stations are using the same programme on 1,600 metres no interference should take place—if wavelength is exact in each case.

This will also give the average owner who has a set for long and short waves an opportunity of using his set without any difficulty for two programmes.

This system will give the advantage that people who live between two stations will get a choice of three programmes.

Will two transmissions from the same aerial give trouble with harmonics? i.e. will either programme be quite clear on an ordinary set?

How this will work for the writer I do not know—as I live about two miles from 2LO and can pick up 2LO on a tuning coil only—over about 10 degrees with 0-v-1 valve set (ferro-concrete building).

Perhaps Capt. Eckersley will forgive me offering these suggestions, but I wish to try to show that two programmes are wanted, and that the average broadcast listener does wish to help.

I may add I am an electrical engineer, and know what difficulties the B.B.C. staff must have in giving us what we want.

W. W. MANLOVE.

London, S.W.1.

July 14th, 1927.

Sir,—Since you invite readers to express their views on the regional scheme of broadcasting, as outlined in Capt. Eckersley's article, I would like to emphasise the point that the scheme provides for a choice of programme only *partly* by increasing the range of the proposed new station or stations. Presumably, each of the programmes, whether radiated from one central station or from five in the north and five in the south, will be a *mixed* programme as at present. I do not think this plan will improve matters much. In my opinion what is required is a system of different programmes, each programme being of the same nature throughout, so that the listener who wishes to change over from dance music to a lecture can effect this by simply tuning in the particular wavelength on which the desired item is being broadcast. Thus, supposing there were one central station radiating ten different programmes on ten different wavelengths, the transmissions might be arranged as follows:—

1. Proceedings in Parliament.
2. Talks and lectures.
3. Dance band and kindred combinations.
4. Military and brass bands.
5. Symphony orchestra.
6. Chamber music.
7. Musical comedy, revue, entertainers.
8. Instrumental solos, duets, etc.
9. Vocal solos, duets, etc.
10. Opera, oratorio and similar productions.

By this system, if the central station's range covered the whole of the British Isles, the listener could choose whatever suited his mood at the time, receiving it direct; or, if several regional stations are to be employed, from the nearest in his area. Only by some such system as this do I think the B.B.C. will eventually succeed in pleasing everybody.

July 14th, 1927.

QUID RIDES.

Sir,—Capt. Eckersley's article in the current issue of *The Wireless World* is very interesting, and I notice that you invite suggestions and criticisms from your readers.

Criticisms and suggestions from persons unaware of actual facts only waste a lot of time and do not help in the very slightest, and I think that this regional scheme question involves a great deal more technical data than is in the hands of the general listening public. I am writing, therefore, as an ordinary listener with a set capable of receiving the local station and Daventry at good loud-speaker strength. These conditions, I understand, apply to the greatest majority of listeners, and their position at present is that they have no alternative programme. These conditions apply also to crystal set users, except that reception is obtained on phones.

Now, surely this state of affairs is entirely the fault of Daventry. In my opinion the whole trouble would be solved with less expense by increasing the power of Daventry to about 40 kilowatts, and by making the transmission totally different from the transmission from the lower powered stations. By different I mean both in time and in subject. When news and talks are being broadcast from local stations, Daventry should be broadcasting music, and *vice versa*.

Now, while on the subject of music, a great deal of the trouble would be overcome if the public taste were better served. It is without doubt a positive fact that light music, restaurant music, as it is aptly called, comes first in the public taste, and as things are at present we do not get enough of it. Apart from individual entertainers of special merit, practically all the S.B. programmes are composed of either heavy high-brow music or plays. On all S.B. occasions, which are many, we get, therefore, no alternative, but when ordinary middle-brow music is being broadcast we get alternatives when we don't really need them. You will see from my remarks, therefore, that I consider the constitution of the programmes to be of more importance than a regional scheme.

As far as is economical and practicable, I do not think that the stations could be better placed than they are at present. There might be a slight advantage in doing away with the relay stations and by putting the present main stations in a more sparsely populated area, but they would have to be not more than ten to fifteen miles away from their respective studios, or the quality of transmissions is bound to suffer. The power should be increased to not more than 3 kilowatts, or the scheme will defeat its own object.

Apply this idea in the case of the Manchester station. Manchester's suburbs extend on all sides for ten miles or more, and it would be difficult to find a really sparsely populated area within a radius of twenty miles. Imagine, then, that the station is put fifteen miles out on the Cheshire side; inside a six- or seven-mile radius of it there would be actually eight chief residential centres, to say nothing of countless villages; these people would undoubtedly be worse off than they were before. I think I am safe in saying that on four out of five commercially made local station receivers Manchester comes in strongly throughout half of the entire tuning range of the condenser at a distance of seven miles. What would reception be like, then, at the same distance if the power were increased to three or more kilowatts? No, I think that to serve everybody fairly the Manchester station is best situated where it is, in the centre of the town. I think these remarks will also apply to the majority of towns whose city area is not of a residential nature.

In my opinion, the ideal scheme is impracticable; if the land line snag did not enter into the argument the ideal scheme would be to have about four stations radiating about fifteen kilowatts. These stations should be in Central Wales, Wiltshire, Huntingdon, and the centre of Yorkshire. There should also be a station of about twenty kilowatts in the centre of Scotland. These stations would all transmit on the lower wavelength band, and Daventry would transmit either one or two programmes at forty kilowatts on the high band.

In conclusion, I would urge that whatever changes are made we are not denied the joy of knob twisting. Capt. Eckersley says in his article that broadcasting is a public service, but do we want it laid on like water or electric light? The moment something becomes easy all the charm and wonder of it goes. Make it better for the ordinary listener by all means, but don't forget the experimenter, the man whose hobby is his wireless; don't kill his golden goose with one fell swoop.

Timperley, Ches.

E. H. WHITTAKER.

July 15th, 1927.

Sir,—Having read Capt. P. P. Eckersley's account of the considerations which led up to the proposed regional scheme, purely from a listener's point of view I have concluded that what we listeners really want is alternative programmes—a choice of subject matter—to interest us in leisure hours.

This could very well be accomplished with the present system of broadcasting stations by giving us regular programmes from each station and abolishing the relay system, which is at the root of all the evils the B.B.C. has inflicted on the community.

We listeners are nightly compelled to turn to foreign stations for amusement, or alternatively, listen to the same old jazz band. I have gone the rounds of all B.B.C. stations and had the same horribly discordant stuff hurled at me from the loud-speaker until in disgust I pick up something really worth settling down to in an armchair after a long day's work. *But* that is in some far away land where the listeners appreciate music.

JULY 27th, 1927.

129

If all stations had a different programme, and not so much talk, there would be less grumbling.

Further, I suggest that the programme editor should see that when talk is on the air at one station music should be *de rigueur* at the next nearest station. Talks sandwiched in the centre of an evening's programme are simply unwanted items. The news bulletin is bad enough and long enough for any evening's talking. It comes to very few of us to go big game shooting at the North Pole. We would be more easily satisfied with a "wireless" talk—at least it would be more palatable—say, about once a month.

Capt. Eckersley evades the question at issue at the moment by clinging to the long-wave stations. No mention is made of giving alternate programmes on 30 or 60-60 metres. I suppose the feeble efforts of KDKA during the last couple of years are regarded as absurd. Yet this station is daily heard in every corner of the globe by someone.

Why is it impossible to rig up a small transmitter at each of the B.B.C. stations to transmit something or other on, say, 40 to 45 metres. They would not interfere with the big fellow on 300-500 metres, and certainly do not require 500ft. masts 700ft. apart for aerials. Besides, what a fillip it would be to the set manufacturers; everyone would be wanting short-wave outfits.

In conclusion, I warn Capt. Eckersley that the wireless world is incapable of digesting much more "jazz" after 10 p.m. every night. If Paris can give good concerts up to midnight why is London years behind?

T. TURNER.

Sheffield.

July 14th, 1927.

Sir,—As an ordinary listener I cannot understand the broadcast position in this country at all, and why so much space is wasted in the Press over endless discussions. With your set, the "Wireless World Five," all German stations, such as Breslau, Stuttgart, Frankfurt, Langenberg, come in regularly at full loud-speaker strength, and French and other foreign stations are good; but, with the exception of Birmingham, where are the B.B.C. stations? (London is my local.) A few faint sounds after a good deal of knob twiddling represent the B.B.C.

As a patriotic Briton I will give way to no one, but I am driven in exasperation to say, scrap the lot and get some German engineers to instal six stations with German apparatus. I don't believe the whole of the B.B.C. combined could muster up the efficiency of Frankfurt, Stuttgart, or Breslau, apart from Langenberg. Think of the alternative programmes Germans must have. Are our transmitters on a par with magnetos? If so, give me a Bosch every time.

Please note my criticism is essentially constructive. We have a very successful example in Germany, and all we have to do is to follow the same plan—if our engineers are capable of constructing the apparatus.

Why devise all sorts of wild-cat schemes when we have one to copy?

Has Dublin got British or foreign apparatus, as this is far better than any B.B.C. station except 2LO?

L. LONGDEN THURGOOD.

Much Hadham, Herts.

July 14th, 1927.

EMPIRE BROADCASTING.

Sir,—In view of the recent interest in short-wave broadcasting I thought you might like to know that at the present time PCJJ, 2XAF and KDKA are received with ease, the strongest signals being those from PCJJ, 2XAF being next; KDKA is comparatively weak. The power of PCJJ is not known to me, but loud-speaker results are obtained by using a 0-v-3 set, choke coupled.

It would appear that Empire broadcasting is a matter for the home Government, in conjunction with the Colonial Governments, to consider at once. It is not only a means of linking up the Colonies with "Home," but it is also a very powerful instrument of propaganda.

The cost of a short-wave broadcasting station, on a wavelength in the neighbourhood of 23-32 metres, should not be excessive, as there is apparently no reason, except a financial one, why Daventry should not transmit the usual programmes

on short waves at the same time as the usual long-wave transmission. The power, of course, would probably have to be much greater than that used at present.

An article in *The Times* recently stated that Daventry had been experimenting on short waves for some weeks. The power must have been very low, as no one out here has heard anything from that station.

The hours of broadcasting at home would only serve a small section of the Colonies, but a large enough portion to conduct experiments. The time in Nigeria is, luckily for residents, the same as British summer time.

This particular part of the world is one of the worst for X's, and the consequence is that, with the exception of, say, 20 days in the dry season, December to February, it is quite impossible to use a receiver on the 300-600-metre band without appalling noises. There have been good loud-speaker results, on a few occasions, from England and Spain; Barcelona being as a rule strongest, and, incidentally, Newcastle is generally stronger than London. The set used was 3-v-3 transformer H.F. and choke-coupling L.F.

Finally, it would seem that the Government would gain considerably by voting a small sum for short-wave broadcasting. It would make the whole difference to life in a country such as Nigeria, especially away from large stations.

It may be possible to obtain a certain amount of revenue from users of short-wave receivers, but this is rather a delicate matter to approach at the present time.

It will become very necessary in the near future to devise some means of preventing radiation from the receiver's aerial; this has been done on 200 metres, it will now have to be done on 30 metres!

"ENTHUSIAST."

Lagos, Nigeria.

June 19th, 1927.

Sir,—I have perused carefully the correspondence you have published on the above matter, and have noted your Editorial comments from time to time, and it appears to me that while the question of cost of erection of a short-wave station and the subsequent revenue—if any—is being discussed, the technical aspect of the matter is being overlooked. I realise that to get the money first and start experimenting afterwards is a sound idea, but to expect the B.B.C. to provide the necessary funds is hardly fair. As Mr. Jas. Hudson, in your issue of July 6th, points out, why don't the Colonies contribute, as it seems to be primarily for their benefit that the station is advocated?

To come to my main point, however, none of your correspondents, with the exception of Mr. Hankey (May 25th issue), who I am inclined to think rather wandered from the point, appears to have considered the technical difficulties involved in short-wave transmission and reception. These waves "get there," but do they get there in time? From my "Time Conversion" table I find that, to receive the 9.30 p.m. news from London, listeners in Australia will have to get up at 8.30 a.m. the next day; those in India 4.30 a.m.; while those in South Africa will have to delay going to bed until 12.30 a.m.

Americans, who have numerous short-wave stations of their own, could listen to this part of the programme in comparative ease while waiting for afternoon tea. As this proposed station of ours would most probably rely on tapping our main stations for its programme, then the Colonies would have to be content with our 5 p.m. to midnight session, whether the time was convenient or not. Incidentally, I might point out, countries west of ours appear to be most favourably situated, inasmuch as they are behind us in time.

This question of longitude is important.

A further consideration will show that on account of the "skip-distance" effect listeners in all parts of the British Empire will not be able to receive the same items of the programme unless our short-wave station transmits on two or more wavelengths at once, the length of which will have to vary with the time of day.

The technical difficulties are numerous, and I am of the opinion that the B.B.C. are wise in hesitating before spending public money on an enterprise which will require a great deal of experiment to make it a perfect Empire broadcasting service.

J. C. FINGLASS.

Wallasey.

July 12th, 1927.

READERS' PROBLEMS

"The Wireless World" Information Department Conducts a Free Service of Replies to Readers' Queries. Questions should be concisely worded, and headed "Information Department." Each question must be accompanied by a stamped addressed envelope for postal reply.

A Question of Selectivity.

I have constructed the "All Wave Four" receiver, described in your April 27th issue, but have actually made use of the modified circuit which you published in the June 8th issue. The receiver seems to bring in distant stations on both long and short wavelengths at very good volume, but the selectivity is not quite so good as I had been expecting. I am using in the H.F. stage a valve having an A.C. resistance of 16,000 ohms, and an amplification factor of 13.5.

H. M.

In all probability the lack of selectivity which you are experiencing is due to the fact that the valve you are using has an A.C. resistance less than that specified. The valve which should normally be used in this receiver should have an A.C. resistance of at least 20,000 ohms, and preferably 30,000 ohms, with, of course, as high an amplification factor as can be obtained. If still greater selectivity is desired, it will be possible to use a valve of still greater A.C. resistance up to a maximum value of about 50,000 ohms, provided that the valve has a commensurate increase in amplification factor. If this latter point is not attended to the sensitivity of the receiver may be disappointing.

○○○○

Modernising an Amplifier.

I have a four-valve receiver, employing two transformer-coupled L.F. stages, and am desirous of changing over the first stage to resistance coupling. I have got the necessary anode resistance, coupling condenser, and grid leak, but am not sure of the exact method of changing over, and should like your help in this matter. P. C.

It is quite a simple matter for you to change over from transformer to resistance coupling. All you need do is to connect the anode resistance in the position at present occupied by the transformer primary, connect the grid leak in the position at present occupied by the transformer secondary, and connect your coupling condenser from the plate of one valve to the grid of the succeeding valve. We are here assuming that your receiver employs no reaction. If it does so, the only difference will be that instead of connecting the condenser from the plate of detector valve to grid of succeeding valve, you must connect the condenser from the high A.C. potential end of the anode resistance to the grid of the succeeding

valve, at the same time connecting a 0.0001-mfd. fixed condenser in parallel with the anode resistance.

○○○○

A "Universal" Reversal.

I have built the "Universal Three-Valve Receiver" described in your issue of August 18th last, but whilst results in general are very good, I find to my astonishment that increasing the capacity of the reaction condenser decreases the reaction effect, whilst decreasing the value of the reaction condenser increases reaction until the set oscillates at minimum reaction position. I have used a 0.0003 mfd. reaction condenser as specified. Surely this is all wrong?

D. G. N. R.

You doubtless have in mind the Reinartz circuit, and the modifications of it, such as the Weagant circuit, etc., where an increase in the capacity of the reaction condenser brings about an increase in reaction effect, but in the Schnell circuit which this receiver uses things are quite different, and the action of the reaction condenser is in the reverse order to its action in the case of the Reinartz circuit, etc. If you will carefully read the article again we think that you will find that this was very clearly explained under the title of "The H.F. Traffic Problem." Your receiver, then, is behaving in a perfectly normal manner.

○○○○

From Old to New.

I possess a four-valve set employing a direct-coupled aerial and tuned anode type H.F. stage, a leaky grid rectifier, and a two-stage transformer-coupled amplifier, my reaction coil being coupled to the aerial coil. This set was constructed three years ago, and has given moderately good results, but the selectivity has always been poor. Recently I was told that I ought to modernise this receiver, and have accordingly neutralised the H.F. stage, but can detect no improvement, either in sensitivity, selectivity, or in quality. Where have I gone wrong?

J. W.

You are evidently labouring under a very common misapprehension with regard to the purposes of neutralisation. Neutralising the stray capacities of an H.F. stage will confer an increase neither in sensitivity, selectivity, nor quality, and in fact, in the case of a set like yours, will confer no benefit whatever. The sole

purpose of neutralisation is to balance out the stray capacities of an H.F. stage, and thus stabilise it in an efficient manner. Your receiver is already stabilised, in the old-fashioned and thoroughly inefficient method of putting the whole aerial load across the grid circuit of the H.F. valve, thus effectively "holding it down."

To modernise your receiver, we would suggest the following improvements. A coupled aerial circuit; an efficient method of coupling between H.F. and detector valves, using a properly designed H.F. transformer with a low resistance secondary; an anode bend detector, followed by a stage of resistance coupling, and a good transformer in the last stage of L.F. You should also, of course, use modern valves of a suitable type. You will then find that your receiver is distinctly lively, and will both need and feel the full benefit of the neutralisation of the H.F. stage. We would commend to your notice a modern circuit of the type given to "C. F. T." in the "Readers' Problems" section of this journal of June 8th, which can be thoroughly recommended. A circuit of this type is not only stable and easy to tune, but is sensitive, selective, and productive of good quality.

○○○○

A Moving Question.

I have a two-valve set which gives me reasonable results on my junior type loud-speaker, the quality being good and the volume adequate for my needs. I have been reading a great deal about the virtues of moving-coil loud-speakers. Is it worth my while building one?

L. M. T.

No, we do not think it would be worth your while going to the trouble of making a moving coil loud-speaker unless you are prepared also to remodel your receiver. In order to get satisfactory results with a loud-speaker of this type one must be sure that the output valve of the set is not only capable of dealing with plenty of power, but also that it is supplied with plenty of power. Succinctly, this means that you must first get a big power valve for use in your last stage, and you must then supply it with plenty of H.T. and corresponding G.B. in order that it will deal adequately with big power, and then you must feed it with a reasonably good input; by which we mean to indicate that the input must not only be as distortionless as possible (which postulates the use of a well-designed receiver) but the input must also be reasonably strong.

Battery Eliminators and "Howling."

I have recently replaced my high-tension battery by an eliminator working off D.C. mains, but since this change my receiver has developed a high-pitched howl. The receiver comprises a detector valve followed by two transformer-coupled L.F. valves, the first being a 2.7 to 1 ratio and the second a 4 to 1. The detector valve is a Mullard P.M.3, the first L.F. a P.M.4, and the output valve a P.M. 254. I recently tested the receiver on dry batteries, but could not reproduce the "howl" which troubles me when the eliminator is used. I cannot cure this by adjustment of the grid bias or value of H.T. on the various valves, and would be obliged if you could assist me in this matter. E. T. D.

When a battery eliminator replaces either a dry battery or an accumulator for the H.T. supply certain complications are introduced into the circuit, the most serious being a series of high resistances in the external anode circuit of each valve. These resistances will have a difference of potential across their ends which in many cases results in a feed back of low-frequency oscillation from one or more of the L.F. valves to the

anode of the last valve, and connected in the manner shown in Fig. 3 on page 795 of *The Wireless World* issue for June 22nd last. In addition we suggest you carefully read the article by "Empiricist" on the same page, explaining the probable causes of low-frequency "howls," and apply the curative measures recommended.

o o o o

A Stable Reflex Receiver.

I am very interested in reflex receivers, and during the past six months have constructed a number of sets embodying this principle. The impression I have gained is one of general instability both as regards the H.F. valve and also the L.F. valves, the latter resulting in "howls," "squeaks," and other strange sounds. I should be obliged if you could recommend a reflex circuit which does not possess these undesirable qualities. G. R. D.

The reflex principle is one of the most difficult to apply with any degree of satisfaction; this is mainly due to the "mixing up" of H.F. and L.F. in the same oscillatory circuit. However, if precautions are taken to provide separate paths for the H.F. and L.F. components, the

connected between this circuit and the anode of the H.F. valve. Grid current rectification is used as this is more sensitive than anode bend, and no advantage would accrue by the adoption of the latter in view of the damping already imposed on the detector by the circuit L_1C_1 . The usual method of reflexing is to connect the secondary of the L.F. transformer in the low-potential lead joining the circuit L_2C_1 to the valve V_1 , and the low-frequency component would be passed through the tuned circuit to the valve. By connecting a high-frequency choke to the grid of the first valve and providing a small capacity condenser between this grid and the tuned circuit, the low-frequency oscillations are conveyed direct to the grid and prevented from passing into the closed circuit. At the same time the H.F. oscillations cannot enter the low-frequency path owing to the presence of the H.F. choke. The same applies to the anode circuit of this valve, the H.F. passes to the circuit L_2C_2 and the low-frequency component passes through the H.F. choke to the L.F. transformer T_2 .

For the normal broadcast wavelengths J_2 and L_3 can be either a centre-tapped coil or two plug-in No. 50 coils. L_1 will depend upon the aerial constants, but usually a No. 35 coil will be found satis-

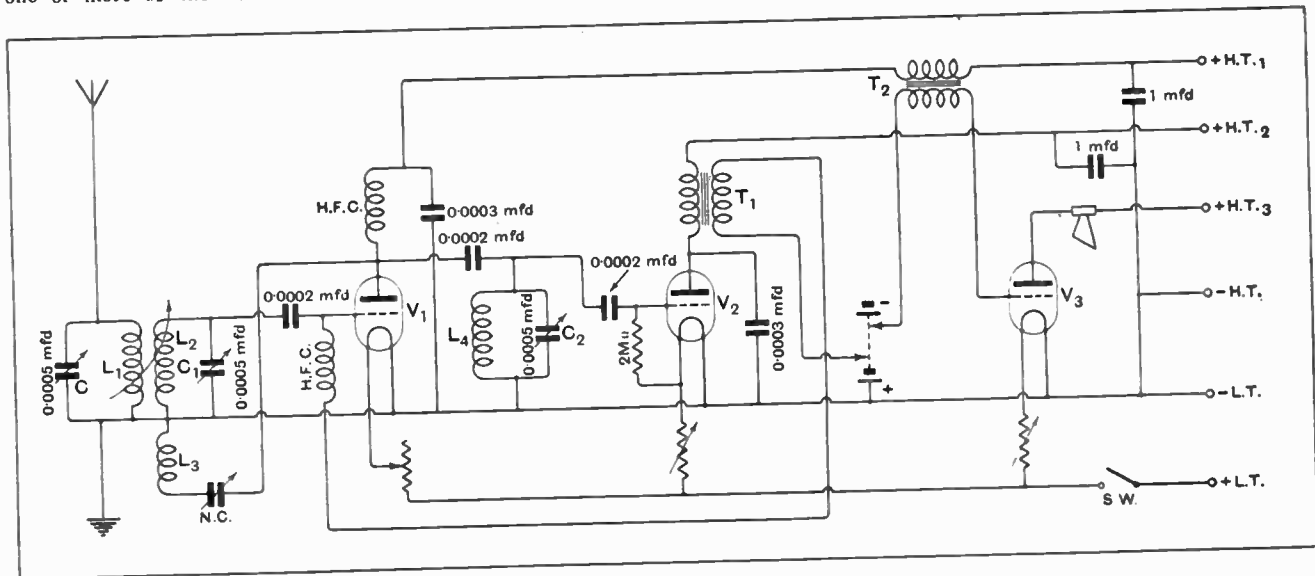

Fig. 1.—A stable three-valve reflex circuit suitable for long and short wavelengths.

detector. This "reaction" effect causes the amplifier to go into oscillation at audio frequency, the pitch of the note (generally termed a "howl") being governed by the inductance and capacity in the circuit. In the majority of similar cases experienced this instability in the amplifier has been overcome by reversing the connections to the secondary winding on one of the low-frequency transformers, and we think this may lead to a cure in your case. Further, we would recommend the inclusion of a choke-capacity output circuit in the

most serious difficulty disappears. Fig. 1 depicts a circuit embodying certain departures from the practice usually adopted in reflex receivers and by the use of H.F. chokes and small capacity condensers, the signal frequencies and the speech frequencies are guided along their respective paths. L_1C_1 is the aerial tuning circuit and L_2C_2 the closed circuit to which is coupled the H.F. neutralising coil, L_3 . The high tension is supplied to the first valve via an H.F. choke, and the radio frequency oscillations passed to the tuned circuit L_4C_2 by a 0.0002 mfd. condenser

factory for use in this position. A No. 50 coil will also be effective in position L_1 . For the longer wavelengths L_1 should be a No. 150 coil, L_2 and L_3 each No. 250 coils and the same for L_4 .

The valves V_1 and V_2 should not have a very high A.C. resistance, and one of about 20,000 ohms, such as the Mullard P.M.5X, Cossor 610 H.F., or valve of similar characteristics can be used. In the position V_3 a good power valve must be used, a typical example being the Mullard P.M. 256, Marconi D.E.5A, or one having similar constants.

Too Many Henries Spoil the Quality.

I am about to add a choke filter output circuit to my receiver, and have the opportunity of acquiring either a 100-henry or a 20-henry choke. Which would you advise? I might say that my set is of the standard four-valve type, with a 4,000 ohm valve in the output stage.

D. R.

Failing further technical data concerning the two chokes you have offered to you, we should advise you to select the 20-henry choke for your purpose. Since an output valve is always of low impedance, it is quite in order to use a choke of 20-henries inductance without fear of losing the lower musical tones. The point to bear in mind is this. Is the iron core of the choke suitably designed for carrying the magnetic field set up by the passage through the choke windings of the normal plate current of a power valve? Assuming that two chokes are made with identical cores, but with widely different inductance, brought about by different numbers of turns, the one of higher inductance will always get saturated long before the one of lower inductance. Therefore, generally speaking, choose the lower value of inductance for a choke filter output circuit, because there is less risk of saturation setting in. At the same time, this rule does not always hold good, for it would be possible to design a 20-henry choke using a large number of turns, and an iron core of inferior design, which would saturate under the influence of a current which a specially designed 100-henry choke would deal with adequately. In practice, however, one will generally not go wrong if one bears in mind the rule of choosing a high-inductance choke for use in a choke-coupled amplifier, and a low-inductance choke for use in a loud-speaker filter circuit.

○○○○

Correct Values of H.T.

I shall be glad if you can tell me the correct value of H.T. to use on my H.F. valve. The receiver which I am using is a four-valve receiver with one stage of H.F. detector and 2 L.F.

G. R. M. A.

From your question it would appear that you are under the impression that the value of H.T. to employ on an H.F. valve is critical. This is not so. The H.F. valve in any receiver is only an amplifier just the same as the L.F. valve in any receiver, and no separate tapping is needed for H.F. valves. Usually the H.T. plus leads of the H.F. valve or valves may be connected up to the H.T. plus terminal which feeds the first L.F. valve. An H.T. value of 100-120 volts may be used with the commensurate value of grid bias necessary to keep the working point on the straight part of the grid-volts anode-current characteristic curve. We mention that the H.F. valves can receive the same H.T. as the first L.F. valve, because many people are using an L.S.5A type of valve for their second L.F. (that is, output valve) with an H.T. voltage of about 200 volts, and therefore a separate H.T. tapping is required, although in cases where the D.E.5 type of valve is used as output valve

there is no reason why all H.F. and L.F. valves should not receive the same value of H.T. voltage and use a common H.T. + terminal.

○○○○

Recording Morse Signals.

I wish to operate a Morse recorder from my receiver, and shall be glad if you will inform me how to do this. Will it suffice to connect the input terminals of my instrument direct to the output terminals of my receiver?

T. P. V. R.

In the first place, it will be necessary for you to have a receiver containing at least one L.F. stage, which will be capable of giving very good signal strength. The output terminals of this set should then be connected to an output transformer of the step-down type. In other words, the primary of the transformer is connected in the plate circuit of the final valve, the secondary being connected in series with a carborundum detector and a relay. The current which actually operates the recording instrument is controlled in the usual manner by the relay.

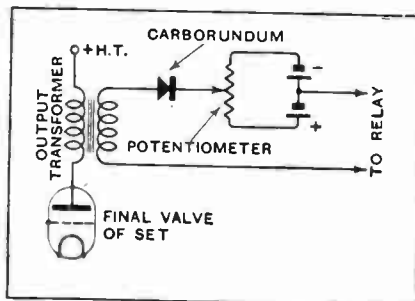

Fig. 2.—A simple circuit for Morse recording.

We illustrate this in our Fig. 2 given herewith. It will be appreciated, of course, that it is necessary to rectify the L.F. output before applying it to the relay.

○○○○

How to Choose Valves for the "Everyman Four."

I have constructed the "Everyman Four" receiver, and am wondering if you would recommend me what valves to use. I ask this because some few weeks have elapsed since the book was published, and it occurred to me that more suitable valves might have appeared on the market.

R. T. D.

In the "Everyman Four" receiver, it is advised that a valve of approximately 30,000 ohms A.C. resistance be used in the H.F. stage. Naturally, in the interests of amplification, you will choose, from among the many 30,000-ohm valves on the market, that valve which gives the highest amplification factor. This indicates that your valve will be, at any rate, a six-volt valve, and that you will only use a four- or two-volt valve, which are less efficient, if you are interested in economy. With regard to the detector valve, a valve of about 70,000 ohms A.C. resistance is re-

quired, although here it might be pointed out that usually a two-volt valve, because it has a shorter filament, and therefore lower filament resistance, has a more sharply defined bottom bend than a six-volt valve of similar type, and therefore usually makes a better anode bend rectifier. A six-volt high impedance valve, however, makes a very good anode bend rectifier.

Whatever valve you use, however, make provision for critical adjustment of bias, so that the working point can come on the bottom bend, as modern anode bend valves have much more sharply defined bottom bends than the older types, and consequently require much more careful adjustment of their mean grid potential, or results will be obtained which are inferior to those given by the older type of valve, where this point did not require such careful attention. In fact, the better the valve the more critical the adjustment might be a good slogan to observe. With regard to the first L.F. valve, you should use a valve of about 30,000 ohms impedance, again with as big a magnification factor as possible, and therefore here again a six-volt valve should be used in preference to one of lower voltage. The final valve should be one capable of handling a big grid voltage swing without the working point straying from the straight and narrow path bounded by its bottom bend on the one hand, and its intersection with the zero grid volts axis on the other hand. You should therefore choose a valve of about 4,000 ohms A.C. resistance, the amplification factor being relatively unimportant here.

You will appreciate that even a 4,000-ohm valve will only handle adequate grid voltage swing provided that it has a high H.T. voltage (120 to 150) and a commensurate value of grid bias, and so these points should be carefully attended to. A moment's thought will reveal to you that the few simple rules given above will enable you always to choose correct valves for the "Everyman Four" no matter how large the number of new valves which appear on the market, for all you have to do is to ascertain the characteristics of any new valves, and then follow the rules we have given you.

○○○○

Battery Bias.

I am building the "Everyman Four" receiver and am going to use four-volt valves throughout in conjunction with a four-volt accumulator. Please tell me the correct values of fixed resistors to use at R_3 and R_4 .

L. S. T.

In your case you must abandon the use of the resistors and take your grid bias from your grid battery instead of by means of the potential drop across the resistors. You are advised to follow the wiring diagram given to "A. L. C." in the "Readers' Problems Section" of this journal for April 13th. The question asked by "A. L. C." was similar to yours except that he was using two-volt valves, but the diagram and particulars given in full to him apply equally to the case of four-volt valves.

**THE "EVER READY" CO.
(GREAT BRITAIN) LIMITED.**

The Managing Director
states :

the fire at our Fonthill Road Works destroyed an adjoining warehouse belonging to us, but did not injure the Factory proper.

Apart from the disorganisation which will be overcome within forty-eight hours, production at this Factory will continue unimpaired.

Your orders and enquiries will receive our prompt attention.

Regd. Trade Mark

"EVER READY"
BRITAIN'S BEST BATTERIES

Head Office :

**HERCULES PLACE, HOLLOWAY,
LONDON, N.7.**

MARCONI

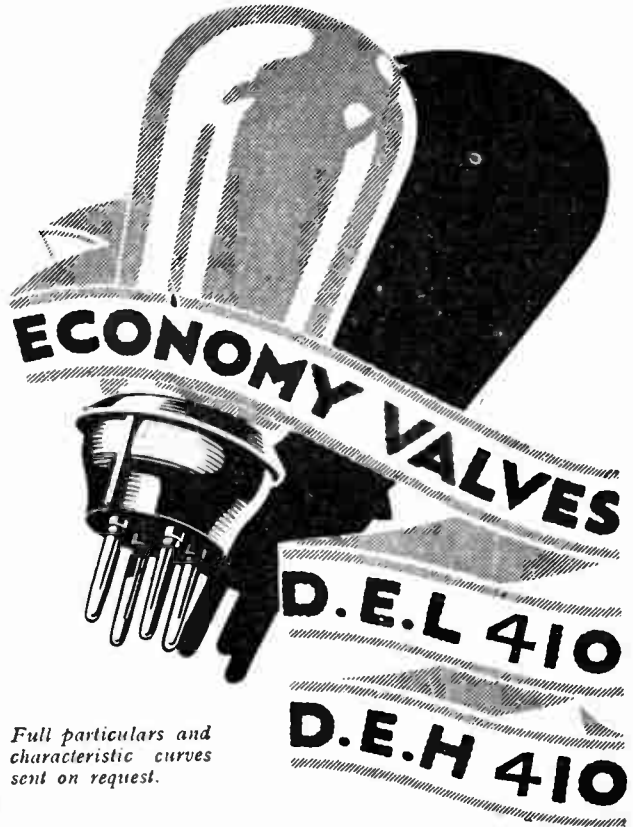

Full particulars and characteristic curves sent on request.

Running costs become much less when you use Marconi Economy valves but volume and sensitivity become much greater. And at the same time you obtain a quality of reproduction which is infinitely more life-like. Here are two of the Marconi 410 series. Whether you use 2, 4, or 6-volt valves there is a Marconi Economy valve to exactly suit your purpose. Your dealer will give you full particulars or send a postcard direct.

D.E.H. 410. 14/-

A high magnification valve for radio frequency circuits where some method of stabilising is used; for resistance capacity amplifiers; also an excellent detector.

Fil. volts 4.0 max.
Fil. current 0.1 amp.
Anode volts 150 max.
Amp. factor 40.
Impedance 70,000 ohms.

D.E.L. 410. 14/-

A general purpose valve for radio frequency circuits, for grid rectification and in the first audio-frequency stage with choke or transformer coupling.

Fil. volts 4.0 max.
Fil. current 0.1 amp.
Anode volts 120 max.
Amp. factor 13.
Impedance 14,000 ohms.

**THE MARCONIPHONE COMPANY LIMITED,
AND REDUCED.**

Head Office: 210-212, Tottenham Court Road, W.1.
Regd. Office: Marconi House, Strand, London, W.C.2.

Mo310



FORMO
TRADE MARK

A MONUMENT IN THE MARCH OF PROGRESS. The Formo Shrouded Transformer is the universal favourite.

Made in Ratios 1-1, 1-2, 1-3, 1-4, & 1-5.
10/6 1-3 & 1-5 for 1st & 2nd stages.

SEND FOR CATALOGUE AND DESCRIPTIVE LITERATURE OF COMPLETE FORMO RANGE.

THE FORMO COMPANY,
Crown Works, Cricklewood, N.W.2
Phone: Hamp. 1787.
Manchester: Mr. J. B. Levee, 23 Hartley St., Levenshulme.
Phone: Heaton Moor 473.



W.B.
ANTI-PHONIC LOW-LOSS
VALVE HOLDER
Cut open for your inspection.

Notice that—

- 1.—Floating springs and valve sockets are riveted and soldered.
- 2.—Springs are at right angles to valve sockets, avoiding side strain and snapping.
- 3.—The price is only **2/-** each without terminals, or **2/3** each with terminals.

Supplied by all good class dealers from stock.
In case of difficulty write to the makers—

WHITELEY, BONEHAM & CO., LTD.
Duke Street, Mansfield, Notts.

NEW STOCK LINES

Have you seen the new

"WALKER" PORTABLE CABINET at £5?
A positive revelation to all Portable Set Constructors.

CARBORUNDUM DETECTOR UNITS 12/6 each

THE NEW

"FERRANTI" OUTPUT TRANSFORMERS 1 to 1

"HARBRO" FLAT SILK-BRAIDED TWIN FLEX
in all colours to match any surroundings, 3d. yard.

Only a few now left.

The marvellous

"AMPLIFEX" LOOP AERIALS

with compass in base, the best frame aerial ever devised. Usual price £3.10.0 each. To clear 30/- each.

Do not hesitate to secure one of these real bargains.

DO NOT FAIL TO SECURE A COPY
OF OUR LATEST CATALOGUE JUST
PUBLISHED (free to callers) BY POST
6d. (to defray postage and packing).

WILL DAY LTD. (Dept. W.W.),

19, LISLE STREET, LEICESTER SQUARE, LONDON, W.C.2.

Telephone: Regent 4577. Telegrams: "Titles, Westrand, London."

DICTIONARY of WIRELESS TECHNICAL TERMS

Definitions of Terms and Expressions
commonly used in wireless
Telephony and Telegraphy.

Compiled by S. O. PEARSON, B.Sc., A.M.I.E.E.,
and issued in conjunction with
"THE WIRELESS WORLD"

THIS volume is intended to serve as a guide to all those interested in wireless, who come across, from time to time, unfamiliar words in their reading. In such a case, the **DICTIONARY OF WIRELESS TECHNICAL TERMS** proves of very great use and value. It is well illustrated and cross-referenced to enable the required information to be rapidly obtained.

PRICE 2/- By Post 2/3

From all leading booksellers or direct from:
ILIFFE & SONS LTD., Dorset House,
Tudor Street, London, E.C.4

w.w.48

CUT THIS OUT FOR CABINETS

and post to us for FREE list illustrating Cabinets as shown in "Wireless World," etc., etc., and for our additional Bulletin No. 2.

NAME

ADDRESS



Write in block letters, please.

CARRINGTON Mfg. Co., Ltd.,
CAMCO WORKS, Sanderstead Road,
South Croydon.

Trade enquiries especially invited.

Telephone: Croydon 3823 (2 lines).

WIRELESS VALVE TRANSMITTERS

Price

By W. James.

9/-

net

By Post 9/9.

A book that deals very thoroughly with the design and operation of small power apparatus.

ILIFFE & SONS LTD.,
Dorset House, Tudor Street, London, E.C.4

w.w.9

Mention of "The Wireless World," when writing to advertisers, will ensure prompt attention.

MISCELLANEOUS ADVERTISEMENTS.

NOTICES.

THE CHARGE FOR ADVERTISEMENTS in these columns is:

12 words or less, 1/- and 1d. for every additional word, e.g., 18 words 1/6; 24 words, 2/-

Name and address must be counted.

SERIES DISCOUNTS are allowed to Trade Advertisers as follows on orders for consecutive insertions, provided a contract is placed in advance, and in the absence of fresh instructions the entire "copy" is repeated from the previous issue: 13 consecutive insertions, 5%; 20 consecutive, 10%; 32 consecutive, 15%.

ADVERTISEMENTS for these columns are accepted up to **FIRST POST** on **THURSDAY MORNING** (previous to date of issue) at the Head Offices of "The Wireless World," Dorset House, Tudor Street, London, E.C.4, or on **WEDNESDAY MORNING** at the Branch Offices, 19, Hertford Street, Coventry; Guildhall Buildings, Navigation Street, Birmingham; 199, Deansgate, Manchester.

Advertisements that arrive too late for a particular issue will automatically be inserted in the following issue unless accompanied by instructions to the contrary. All advertisements in this section must be strictly prepaid.

Postal Orders and Cheques sent in payment for advertisements should be made payable to **LIFFE & SONS Ltd.**, and crossed **& Co. Treasury Notes**, being untraceable if lost in transit, should not be sent as remittances.

All letters relating to advertisements should quote the number which is printed at the end of each advertisement, and the date of the issue in which it appeared.

The proprietors are not responsible for clerical or printers' errors, although every care is taken to avoid mistakes.

NUMBERED ADDRESSES.

For the convenience of advertisers, letters may be addressed to numbers at "The Wireless World" Office. When this is desired, the sum of 6d. to defray the cost of registration and to cover postage on replies must be added to the advertisement charge, which must include the words Box 000, c/o "The Wireless World." Only the number will appear in the advertisement. All replies should be addressed No. 000, c/o "The Wireless World," Dorset House, Tudor Street, London, E.C.4. Readers who reply to Box No. advertisements are warned against sending remittance through the post except in registered envelopes; in all such cases the use of the Deposit System is recommended, and the envelope should be clearly marked "Deposit Department."

DEPOSIT SYSTEM.

Readers who hesitate to send money to unknown persons may deal in perfect safety by availing themselves of our Deposit System. If the money be deposited with "The Wireless World," both parties are advised of its receipt.

The time allowed for decision is three days, during which time, if the buyer decides not to retain the goods, they must be returned to the sender. If a sale is effected we remit the amount to the seller, but, if not, we return the amount to the depositor. Carriage is paid by the buyer, but in the event of no sale, and subject to there being no different arrangement between buyer and seller, each pays carriage one way. The seller takes the risk of loss or damage in transit, for which we take no responsibility. For all transactions up to £10, a deposit fee of 1/- is charged; on transactions over £10 and under £50, the fee is 2/6; over £50, 5/-. All deposit matters are dealt with at Dorset House, Tudor Street, London, E.C.4, and cheques and money orders should be made payable to Liffe & Sons Limited.

THE SALE OF HOME-CONSTRUCTED UNLICENSED APPARATUS.

A New Service to our Readers.

We have made an arrangement with the Patentees whereby readers who wish to dispose of a home-constructed receiver not licensed under the patents made use of, can do so by means of the Deposit System referred to above.

The person desiring to sell, in sending us particulars for his advertisement, will in every case make use of a Box No., and should add to the price which he requires the amount of royalty customarily paid by manufacturers, viz. in the case of Marconi Patents the amount should be calculated at 12/6 per valve holder.

If the purchaser is satisfied with his purchase, the sum realised will be forwarded to the seller, less the amount due in respect of royalties, which amount will be paid by "The Wireless World" to the owners of the patents concerned, and a certificate will be handed on to the purchaser of the set.

SPECIAL NOTE.

Readers who reply to advertisements and receive no answer to their enquiries are requested to regard the silence as an indication that the goods advertised have already been disposed of. Advertisers often receive so many enquiries that it is quite impossible to reply to each one by post.

OPPORTUNITY

—full or spare time work.

Increase your income by £5 to £12 per week.

Trustworthy, energetic men required where we are not adequately represented.

Write immediately for full particulars.

GENERAL RADIO CO. LTD.
Dept. C26 Radio House,
235 REGENT STREET,
LONDON, W.1.

Lists close and all appointments must be completed by August 25

IMPORTANT NOTICE.

Owing to the August Bank Holiday, the next issue of "THE WIRELESS WORLD" (dated August 3rd) is closing for press earlier than usual.

In accordance with the Notice that appeared last week the latest date upon which Miscellaneous Advertisements could be accepted for the above issue was **FIRST POST WEDNESDAY, July 27th.**

RECEIVERS FOR SALE.

ALL-WAVE Four and the Famous Every-man Four; high-class sets only, giving maximum efficiency; full particulars and prices on application.—H. Goodwin, Woodcock Hill, Elstree. [0050]

MARCONI Straight Eight Complete with 5 Valves, list price £62, bargain price £40.—Saul, 8, Ansdell Rd. South, Ansdell, near Blackpool. [4986]

SOLODYNE (new), Lewcos, Bowyer-Lowe, S and B.T.H. components; excellent tone, range, and selectivity, complete with Mullard valves, cabinet, batteries, and speaker; £17, royalties included.—Box 5129, c/o The Wireless World. [5129]

ELSTREE Solodyne, complete with coils but less cabinet and valves; £14/10.—Box 2983, c/o The Wireless World. [5164]

SUPERHET.—Eight valves, Geophone S components, Amplion loud-speaker, complete with valves, aerial, batteries, etc., all enclosed highly polished solid oak cabinet simple switch Daventry and low waves, £35-worth £70; Bowyer-Lowe Solodyne condenser, as new, £2; also two dual Ormone friction control S.L.F. .0005 condensers a £1 each, and three .0003 Geophone S.M condensers at 8 6 each.—Box 2968, c/o The Wireless World. [5164]

7-VALVE Superheterodyne, best components; what offers?—Missings Wireless Depot, 10, New Rd., Gravesend, Kent. [5171]

BURNDIPT Radio Apparatus!—All sets guaranteed and shop soiled only. Ethophone Grand 5-valve set, cabinet by Broadwood; Burndipt transmitter, 100 watts, Mk. II; inductor unit for above, calibrated 95 m.-130 m.; Ultra III's and Mk. III tuners; H.F. 1 2-valve receiver; Ethophone V, Mk. IV (1926); no reasonable offer refused; with or without valves or coils; 2 Magnavox loud-speakers, 18in. horns; what offers?—Stanley J. Lewis, Radio Engineer, Narberth, S. Wales. [5172]

4-VALVE Set, straight circuit, 1 H.F. Det. 2 L.F. with switches for 1, 2, 3 or 4 coils, 250, 150, 100, 75; accumulator, Gram. L.S. unit A.R.55; M.O. valves; in working order; the lot for £10. Seen by appointment.—88, Park St., W.1. [5177]

WESTERN ELECTRIC Neutralised Two-valve Receiver (H.F. and detector), new, with valves; £4/10, cost over double. Appointment only.—Clayton, 53, Calton Av., Dulwich, S.E.21. [5180]

B.T.H. Portable (self-contained frame) 3-valve and 2-valve amplifier loud-speaker unit, with valves, etc., complete; high and low waves; condition as new; just overhauled by makers; will accept £18.—R., 5, Forest Av., Starbeck, Harrogate. [5181]

REPAIRS

to **HEADPHONES, LOUDSPEAKERS, TRANSFORMERS, COILS.**

First-class workmanship only. That is just the vital difference. We are specialists with almost 30 years' experience in every form of intricate and accurate coil winding, and we guarantee that work entrusted to us will be returned to you as good as new, if not better. This is no idle claim, but the unalloyed opinion of scores of satisfied clients.

THE VARLEY MAGNET COMPANY
(Proprietors: Oliver Fell Control, Ltd.)
BLOOMFIELD ROAD, WOOLWICH, S.E.18.
Telephone: Woolwich 0888.

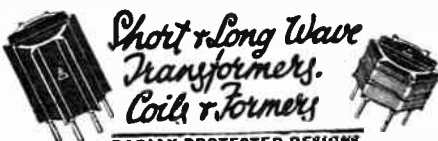

RADIAX PROTECTED DESIGNS

| | |
|--|------|
| Tapped Aerial Coils | 6/0 |
| Split Anode Coils | 6/0 |
| Split Prim. or Sec. Transformers | 10/8 |
| Fitted Formers, 6-pin, 3 x 3 1/2 | 4/6 |
| 6-pin (low loss) Bases | 5/6 |
| All-wave Four Coils, 1000/2000 | 17/6 |
| All-wave Four Coils, 200/550 | 18/- |
| Everyman Four Coils, the pair | 28/- |
| Empire Short Wave Coil | 10/6 |
| Aluminium Sheet, All-wave Four | 1/8 |
| Aluminium Sheet, Empire Short Wave | 11/8 |

Coils wound to specification. All components for All-wave Four—Empire Short Wave—3-tonetune 3, etc. Leaflet stamp. Full catalogue 2d

RADIAX LTD. 30, Accessory House, Palmer Place, Holloway Rd., N.7

Receivers for Sale.—Contd.

5-VALVE Mahogany Cabinet Receiving Set, complete with valves (P.M.), new transformers, loud-speaker; £15, no offers.—Newell, 8, Bathurst St., Sussex Sq., W.2. [5186]

1-VALVE Set, and all accessories, valve, batteries, aerial, etc.; only £3/15, including royalty.—Box 3025, c/o *The Wireless World*. [5192]

PERFECT 7-Valve Superhet in Oak Cabinet, complete with valves, accumulator, and large oak horn Amplion speaker; gift at £12/12.—Write, Baxter, 44, Creffield Rd., Ealing. [5193]

MARCONI 21 Receiver, coils, valves, new; £6; owner having Elstree Six.—A. Westlake, Hosier, 300, Barking Rd., Plaistow, E.13. [5202]

BARGAIN!—Everyman Four two-range receiver in handsome inlaid mahogany pedestal cabinet, with two valves, 6-volt 40 amp. hour accumulator, and Mullard pure music speaker; £24 or nearest offer; components to designer's specifications; a fine set.—Loughen, 20, Uxilla Terrace, Bridgend, Glam. [5204]

ALL-BRITISH Six, in handsome polished mahogany fall front cabinet, complete with valves, broadcast and Daventry coils; the best circuit for distance with quality; a set worth having; what offers?—Box 3028, c/o *The Wireless World*. [5209]

BATTERIES.

WET H.T. Batteries.—Jars, $2\frac{1}{2} \times 1\frac{1}{2} \times 1\frac{1}{2}$, 1/3 doz.; zincs, 1/- doz.; sacs, 1/6 doz.; dozen cells complete (18 volts), 3/6; post gd. extra. High efficiency, long life, upkeep practically nil. Orders for 3 dozen or over post free, packed in special carton with divisions for each cell, usable as container for complete battery. Send 6d. for sample complete unit with instructions. Write for free lists of wireless bargains.—W. Taylor, 57, Studley Rd., Stockwell, London. [5039]

A.B. H.T. Batteries Cost Less Than Many other makes. The fact that they are manufactured by Messrs. Thomson Houston et Cie., of Paris, is proof of their high quality. Further, every battery carries a full and generous guarantee. Usual sizes stocked; 60 volt, 100 volt, and grid bias, etc. Ask your dealer for same. If he cannot supply you write us direct. Trade enquiries specially invited.—G. E. Ambatiello & Co., Ltd., Ambatiello House, Farringdon Road, E.C.1. Telephone: Clerkenwell 7440. [5063]

WHY Buy Accumulators or Dry Batteries? London's Leading Hire Service improves reception. Saving time, trouble, and money. No big outlay. No deposit. Pay carman on each delivery. High tension service from 6d. per week. Low tension service from 1/3 per week. Fully charged and delivered free within 12 miles of Charing Cross. Explanatory folder post free.—Radio Service, 105, Torriano Av., N.W.5. 'Phone: North 0623/4/5. [5125]

BIRMINGHAM and District.—Send for particulars of our accumulator hire service, and we will prove to you that it is cheaper to hire an accumulator than to buy one. We supply the accumulator, collect and deliver it, and it costs no more than you are paying now for charging.—New Era Wireless & Electrical Co., Hobmoor Rd., Small Heath, Birmingham. Tel.: Vic. 744. [5144]

Batteries.—Contd.

B.B.C H.T. Batteries. See advertisement page 9.—British Battery Co., Ltd., Clarendon Rd., Watford, Herts. [5048]

4 20 volt W.J. Type Exide H.T. Accumulators; 32/—Manley, 43, Pine Rd., Cricklewood. [5203]

CABINETS.

ARTCRAFT Radio Cabinets and Panels for all "Wireless World" sets.

ARTCRAFT Cabinets made in Oak and mahogany, properly french polished, and are priced at 6/- to £11/11.

ARTCRAFT Cabinets made to any specification or design. Estimates by return.

ARTCRAFT Illustrated Catalogue Free.—The Artcraft Co., 156, Cherry Orchard Rd., Croydon. 'Phone: Croydon 1981. [5040]

MASSIVE Oak Pedestal Cabinets, Jacobean finish (as illustrated in *Wireless World* in May 4th issue), new, improved and very substantial model now ready, stands 3ft. high, 2ft. 9in. wide, 15in. deep, for panel up to 26in. x 8in. These cabinets are built to one standard size and will house almost all the best known and latest sets and circuits, including Everyman Four and Five, B.B.C. 3 and 4 valve sets. Simple adjustable fittings permit any length of panel up to 26in. to be fitted. £5, carriage paid, or free delivery by our own van London and suburbs. May be inspected on van before acceptance. Illustrated folder gives all details. Write to-day.—G. E. Ambatiello and Co., Ltd., Ambatiello House, Farringdon Rd., E.C.1. 'Phone: Clerkenwell 7440. Telegrams: Ambatiello, London. [5056]

ALL in One Cabinet; original design from Sobey, 44, Prospect Place, Swindon. [5157]

LOUD-SPEAKERS.

BARGAINS!—Loud-speakers, 22 inches high, 14½ inches diameter flare, heavy cast neck and base, black crystalline finish, adjustable diaphragm, rubber feet, cord, looks well, sounds well; 32/0; carriage free. If you have a loud-speaker bring this to the notice of a friend who hasn't.—Universal Wireless Depot, 160, County Rd., Swindon. [5013]

PERMANENT Magnet Coil-drive Loud-speaker parts described by H. Lloyd in June 1 issue. From Star Engineering.

WARNING.—The manufacture of parts for constructing coil-drive loud-speakers is an engineer's job. All parts made by Star Engineering are backed by 35 years' experience in the manufacture of high class machinery.

SUPERIORITY of Components Made by Star Engineering is the result of long experience in the manufacture of high class machinery. Below.

WORKMANSHIP.—From Royal Naval Engineering College. The workmanship and price of all the parts are entirely to my satisfaction. Below.

FIRM of Radio Specialists write: Thanks for parts. These are, we consider, of excellent workmanship and very good finish. Below.

QUALITY.—May I congratulate you on producing a first class and very workmanlike job? Am most pleased with the components.

ORDER Your Parts from Star Engineering Didsbury, Manchester, and avoid trouble. Lists free. [5074]

Loud-speakers.—Contd.

HORNS for all types of loud-speakers, especially gramophone attachments and Amplion A.R.30; illustrated list free.—Maddison, Manufacturer of the Allwoodorn, 2a, Ronald's Rd., N.5. [4987]

UNITS for Cone Speakers.—Highly efficient, patented, double acting reed movement, the result of years of experimenting. Very sensitive to small impulses, but capable of handling enormous power without overloading; special resonance damping device; high class workmanship and keenest value yet offered; complete with fixings for attaching cone, 30/-, carriage free. Fuller details, list of cones, complete speakers, etc., post free.—Everyman's Radio Service, Brent St., Hendon, N.W.4. 'Phone: Hendon 2378. [5105]

FOR Loud-speaker Bases.—Few only receivers, with 3½in. diameter diaphragms, adjustable magnets, 120 ohms, 7/6, or with one pair bobbins to fit, 1,000 ohms each, 1/6 extra; beautifully made, and an unrepeatable bargain; can be adapted for cone, gramophone, and horn type; send for our bargain sheet.—Grafton Electric Co., 54, Grafton St., W.1. [5183]

GRAMOPHONE Cone Speaker, new; cost £6/6; sell £4/15.—Box 3029, c/o *The Wireless World*. [5208]

COIL Drive Loud-speakers.—We can supply the following at reasonable prices. First-class workmanship and materials only. Immediate delivery from Baker's "Selhurst" Radio.

IMPORTANT.—All coil driven speaker parts supplied by us are constructed by highly skilled engineers with the best possible materials. As we do not depart from the specifications given in *The Wireless World* you are assured of good results. Immediate delivery from Baker's "Selhurst" Radio.

UNIT No. 1.—Pot magnet with field winding for six-volt accumulator and rim moving coil. Immediate delivery from Baker's "Selhurst" Radio.

UNIT No. 2.—Pot magnet with field winding for six-volt accumulator or D.C. mains as required, and 2in. moving coil as described by N. W. McLachlan in *The Wireless World*, April 13, 1927. Immediate delivery from Baker's "Selhurst" Radio.

UNIT No. 3.—Permanent magnet unit as described by H. Lloyd in *The Wireless World*, June 1, 1927. Immediate delivery from Baker's "Selhurst" Radio.

FRAMES and Cradles specially constructed to enable unit to be assembled with ease in a few minutes. Immediate delivery from Baker's "Selhurst" Radio.

TRANSFORMERS.—With tapped primary in four sections, as described in *The Wireless World* by H. Lloyd. Specially designed for use with coil driven speakers. Immediate delivery from Baker's "Selhurst" Radio.

PEDESTAL Cabinets.—Specially suitable for coil driven speakers, beautifully finished in polished mahogany or oak. Immediate delivery from Baker's "Selhurst" Radio.

WE shall be glad to advise you as to the most suitable unit for your set.—Baker's "Selhurst" Radio, 80, Selhurst Rd., South Norwood, S.E.25. 'Phone: Thornton Heath 1488. Works: 42, Cherry Orchard Rd., East Croydon. [5150]

Mention of "The Wireless World," when writing to advertisers, will ensure prompt attention.

Loud-speakers.—Contd.

MAGNETIC Pick-up.—2 years research results in a perfect instrument; finest cobalt steel used, resulting in 100 per cent. efficiency; whole musical range faithfully reproduced; pick-up with silk leads, 50/-; special amplifier on application.—James, 11, Mill St., Middleton, Lancs. [5184

HUTH Magnet Pots are the best obtainable.—Write for our list and printed matter, which gives you full details. You can then judge for yourself. Disinterested advice on your particular case free.

HUTH Magnet Pots can be supplied to *Wireless World* specifications if required, but we prefer to recommend our own types, which in all cases are more sensitive. All our units use much less current. This result is obtained by larger and more expensive windings. This means less profit for us but greater satisfaction to our customers.

HUTH Special Economy Pots for 1in. or 2in. coils use less than .3 amps. at 6 volts, yet are four times as sensitive as permanent magnet types. Other types with larger consumption also supplied.

HUTH Magnet Pots for all voltages from 6-250 volts. Moving coils for outputs up to 10 L.S.5.A. valves in parallel.

HUTH Service goes with all our parts.—We have had eighteen months' practical experience with these speakers, and can help you to get the perfect results you desire. Take one instance: thin rubber is the only suspension where best quality reproduction is required, but sagging necessitates constant readjustment. We have now overcome this and pass our information on to our customers free. It costs them nothing; it is part of our service.

HUTH Accurate Centring Device fitted to all pots at no extra cost enables moving coil to be adjusted to a thousandth part of an inch. Without this device success with these speakers is uncertain, and continual readjustment necessary. In addition, coarse adjustment means a large air gap, with consequent loss of efficiency. This is one of the reasons for the supremacy of speakers constructed from Huth parts.—F. L. Huth, 17B, Vale Rd., Tunbridge Wells. [5210

VALVES.

5/-.—Power valves, 2, 4, or 6 volt dull emitters, British made, guaranteed, money refunded if not satisfied, post free. Send for list of other types.—Carter & Co., 61, Lower Moseley St., Manchester. Phone: 3742 Central. [4911

TRIOTRON Dark Emitters, 2 volt 0.1 amp. I power valves, 9/-; Triotron general purpose valve, 2 volt 0.2 amp., 4/11; tested and guaranteed; post paid.—Storrys Wireless Mart, 143, Eastbank St., Southampton. [4985

BRITISH Valves.—2-volt .06 H.F. and L.F., 2-volt .12 H.F. and L.F., 2-volt 34 power valve, 4-volt .06 H.F. and L.F., 4-volt .12 power valve, 6-volt .25 power valve; all one price, 5/- each, post free; satisfaction guaranteed. Trade supplied. Write your name and address clearly.—H. Howarth, Ensign Depot, 288, Deansgate, Manchester. [5066

CHARGERS & ELIMINATORS.

CHARGING-LIGHTING Set complete, engine, dynamo, accumulators, switch-board; £15.—31, May Road, Gillingham, Kent. [5194

H.T. BATTERIES
For Perfect Reception!

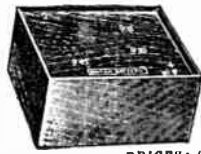

ALL BRITISH.

Here is our newest product —**B.B.C. CABINET TYPE**—Tapped every 15 volts. Has full size cells, perfect insulation, highest efficiency and made from best materials only.

PRICES: (Carriage Paid)

60 volts, **9/6** 100 volts, **16/-**

Build up the Voltage you need with these No. 1 W 4½ volt Batteries—Standard Pocket Lamp Size. Patent Spiral Wire Terminals and Wonder Plug Sockets. Permanent connections without soldering. Illustration shows how to connect in series by inserting straight terminal *Car. Pd.* in spiral of next battery. **7/-** Per doz. with plug



We supply all standard types and voltages. Write for Details Made at our Watford Works.

BRITISH BATTERY CO., LTD.,
Clarendon Road, Watford, Herts.

AGENTS WANTED.

A WELL-KNOWN firm of British Radio Manufacturers are desirous of appointing a first-class South African firm as their

SOLE AGENTS for SOUTH AFRICA.

Only those firms capable of handling the business in a satisfactory manner should apply giving full particulars and references:

Box "S.A.," Pooi's Advertising Service, Ltd.
65, London Wall, London, E.C.2.

RELIABILITY VERNIER COIL HOLDER
2-way geared Coil Holder with metal work nickel-plated. Long Control Handle. Further attractive items in Miscellaneous Columns. Trade Enquiries Solicited. Send for Free Guide now.

J. H. TAYLOR & CO
2 RADIO HOUSE - MACAULAY ST. HUDDERSFIELD

3/- Packing 6d.

WIRELESS MASTS.

GALVANIZED TUBULAR TELESCOPIC.

Complete with base plate, ground pegs, stay wires, straining screws, pulley and cleat.
34ft. High **£3 15 0** 50ft. High **£7 5 0**

HILDICK & HILDICK, Pleck Road, Walsall.



BOWYER-LOWE CO. LTD., LETCHWORTH

Chargers & Eliminators.—Contd.

ACCUMULATOR Chargers (A.C.), 45/- complete. Post free. Also components for same and for A.C. battery eliminators; fully guaranteed.—Stafford O'Brien and Partners, Ltd., 66, Victoria St., S.W.1. [0052

COMPONENTS, ETC., FOR SALE.

BELLING-LEE Panel Fittings are designed to give an expert finish to any home-constructed set. Catalogue post free.—Belling and Lee, Ltd., Queensway Works, Ponders End, Mx. [0018

TANTALUM.—Tantalum metal sheet for A.C. rectifiers.—Blackwell's Metallurgical Works, Liverpool. [4386

REED Movements.—Double Acting Reed movements specially designed to operate cone and other large diaphragms; extremely sensitive on small input, yet capable of enormous volume with sufficient input. Will work up to a 3ft. cone with ease. No rattle or distortion; 27/6 each. Fair allowance on Brown A earpieces, or Lissenolas and other units in part exchange. Send stamp for Illustrated Lists of these and seamless cones.—Goodmans, 27, Farringdon St., E.C.4. [0049

AERIAL Grid Coils and H.F. Transformers for Everyman Four, with chart showing over 40 stations (on L.S.), price 17/6 each; H.F. transformers for the All-Wave Four, high and low wavelengths, set of two and base 35/-; all coils of highest quality materials and finish.—H. Goodwin, Woodcock Hill, Elstree. [0051

COPPER Screening Boxes.—Standard 6½in. x 6in. high; price 15/- post free; special requirements to order; "Wireless World" screens a speciality; we are actual manufacturers.—The "Brinford" Mfg. Co., 37-45, Middlesex Wharf, Clapton, E.5. [5130

RELIABILITY WIRELESS GUIDE.—New edition, No. 99A, just issued. Free upon request.

RELIABILITY FREE DELIVERY.—Orders over 5s. 5d., otherwise add 2d. per 1s.

RELIABILITY WEEKLY ATTRACTION.—Atlas low loss square law .0005 condensers with dials, 3s. 11d.

RELIABILITY CLEARANCE LINES.—Lissen T.3 Transformers, 7s. 6d.; Gents, 7s.; Atlas, 6s.; Etherplus, 5s.

RELIABILITY LISSEN COMPONENTS.—H.T. Batteries, 7s. 11d.; Transformer, 8s. 6d.; Mica Sparking Plug, 4s.; Rheostats, 1s. 6d. and 2s. 6d.

RELIABILITY STRAIGHT-LINE CONDENSERS.—With 4in. Trolie Dial .0005, 5s. 9d.; .0003, 5s. 6d.; Vernier Dial extra, 1s. 6d.

RELIABILITY ANTI-CAPACITY SWITCH.—Double Pole Double Throw 1-hole fixing, knob operated, screw connections, 3s.

RELIABILITY GOODS AND SERVICE.—Only obtainable from J. H. Taylor and Co., 15, Radio House, Macaulay Street, Huddersfield. Trade supplied. Send for free Guide now. [0028

B. & J. Make all the Special Coils for *The Wireless World* Circuits and Guarantee Complete Satisfaction. All materials exact to specification.

B. & J. Built Sets give excellent results and carry our full guarantee.

B. & J. Wireless Co., 2, Athelstane Mews, London, N.4. [0043

Components, Etc., for Sale.—Contd.

EVERYMAN Coils, Three, Four, Five exact to specification, all ebonite bases, 12/6 each; All-wave coils (May 11): short wave, 16/-, long wave 18/-, base 3/6; genuine Milkapac tubes, 3x3½, one 1/4, two 2/6, three 3/6; grooved ebonite spacers, 1/- set of 8; all-wave do., 6 1½in., 1/-; 12 2in., 2/6; Litzén wire (Lewcos) to wind one coil, 4/8.—Jennens, below.

WYCHE Switch, two-way, 1/3; both battery, 1/6.—Jennens, below.

RHEOSTAT. Jennens, as specified for Nucleus receiver, 7-, 20-35 ohms, 2/- each.—Jennens, below.

LOEWE Multiple valves (3N.F.).—Detector and 2 L.F. stages, more volume and purer tone than two best L.F. transformers and power valves on local station and Daventry; H.F. stages can be added; 45/- C.O.D.—Jennens Radio, 30, Chapel St., Birmingham. [4776]

POPULAR Wall Jack.—This is another new line in keeping with all Deckorem specialities. They make for neatness and efficiency in all cases where loud-speaker and distant phone reception is to be installed in the home. In construction they are strong, in contact with all standard plugs they are sure, in appearance they are a credit to any scheme of decoration. All fittings and cover are of heavily plated nickel, the base is of high insulation material, black and nicely polished. They have a splendid and strong spring wiping contact, are supplied in either series or parallel type, and can be obtained from most dealers, or direct from A. F. Bulgín and Co., 9-10-11, Cursitor St., Chancery Lane, London, E.C.4, and what is more, they only cost 2/9 each. [0041]

TELETRON for Remote Control.—Simple to install, one wire only for any number of loud-speakers, indispensable for extension to sick rooms, patented; price 35/- with instructions.—Baily, Grundy and Barrett, Ltd., 2, St. Mary's Passage, Cambridge. [5061]

SCOTT SESSIONS.—Set constructor's suppliers, express delivery, absolutely every component for all "Wireless World" sets. [5061]

SCOTT SESSIONS.—Fixed condensers (tubular), .0001-.002 mfd., 1/9 each.

SCOTT SESSIONS.—Mansbridge type (tested 500 volts D.C.), 1 mfd., 2/4; 2, 3/6; 4, 5/9. Send for bargain list!

SCOTT SESSIONS and Co., Hill Top, Muswell Hill, N.10. [5116]

ALL-WAVE Four Six-pin Bases, 2/6; low loss formers, 4/6; Southern Cross six pin bases, 1/- and 2/-; also copper dividing screens or boxes to your requirements.—The "Brinford" Mfg. Co., 37-45, Middlesex Wharf, Clapton, E.5. [5131]

SIMMONDS BROS.—Coils: Everyman S Four, 33/- per set; Everyman Three, 35/-; "Wireless World" Five, 50/6; All-Wave Four, 42/6; Quality Three, 16/6; all with bases, first-class material and workmanship. Screens: Everyman Four, 4/6; Everyman Three, 4/-; "Wireless World" Five, 50/-; All-Wave Four, 5/-; Cabinets: Everyman Four, from 35/-; Everyman Three, from 32/-; "Wireless World" Five, from 30/-; All-Wave Four, from 30/-; Ormiston's Litzendracht: 20 yards, 5/6; 25 yards, 6/6; 50 yards, 12/-; 60 yards, 14/6; Paxolin formers, 1/6 each; Everyman Four booklet, 1/-. Lists free. Empire Broadcast receiver, aluminium case, 40/-; coil, 8/6 with base; H.F. choke, 5/-; phones choke with brackets, 5/6. Trade supplied home and abroad.—Simmonds Bros., Shireland Rd., Smethwick. [5078]



The YOUNG ENTHUSIAST. By Mrs. Steed.
(From the Beginners' Competition.)

Use your camera!

Now is the time of year when you can take pictures out-of-doors. If you would learn how to get the best results from your exposures and the greatest pleasure from your hobby — read "The Amateur Photographer" every week.

It contains a mass of helpful and interesting information, together with art reproductions of pictorial photographs and free criticism of readers' prints.

EVERY WEDNESDAY 3d.

The AMATEUR PHOTOGRAPHER

The Journal for Everybody with a Camera.

ILIFFE & SONS LIMITED,
Dorset House, Tudor Street,
LONDON, E.C.4. w.w.37

Components, Etc., for Sale.—Contd.

LEWCOS Coils, Daventry and B.B.C., 2 aerial, 2 S.P. transformers, 2 Peto-Scott bases, £1 the lot; 3 Igranic-Pacent 400 ohms potentiometers, 1/- each; 1 A.J.S. choke, 7/6; 1 Bligh choke, 5/-; 1 D.E.Q. valve, 6/-.—A. J. Williams, 73, Salisbury Rd., Dover. [5167]

BROWN Disc Speaker, £5; 2 v. power amplifier, perfect, £2 5; Marconi Ideal 6-1, 15/-.—Pearce, 56, Great Percy St., W.C.1. [5170]

NUMBER of Modern Components in Good Condition, exchange for Everyman Four components or others.—Warner, Heap Bridge, Bury. [5174]

CONSTRUCTOR'S Surplus, mostly new, low prices. Stamp for list; exchanges considered.—Johnson, Little Testwood, Totton, Southampton. [5178]

4 Marconi R.5V. Valves, 4 Cossor P.2, 3/6 each; 1 V.24 with clips, 9/-; 1 Mullard D.B.6 with clips, 6/-; Sterling Primax (bronze), £4; Polar 3-coil holder (cost 17/-), 6/-; Mk. III.* variable condensers, 1 .0005, .0025, .00035, 7/6 each; Marconi Billi condenser, 5/-.—B., 273, Pershore Rd., Birmingham. [5182]

EXPERIMENTER'S Surplus.—Transformers: Marconi Junior, 8/-; Ferranti A.F.4, 10/-; 0-500 moving coil microammeter, 10/-; fixed condensers, .001, .005, .0005, .002, 1/ each; 2µF., 2/-; D.E.5, new, 7/6.—K. Gidney, School House, East Rd., Cambridge. [5185]

TO Constructors Modernising and Rebuilding.—We will take your old gear in part exchange for new and give liberal allowances. All makes of components, speakers, etc., supplied.—State your needs to Talbot, 97, Highfield Rd., Blackpool. [5187]

AMATEUR'S Transmitting Gear, etc., for sale.—1 h.p. gas engine, Crypto H.T. generator, 600 volts, T.30 Marconi valve, 0.20 Mullard valve, Sullivan ammeter, microphone, Brown's microphone amplifier, Thompson dynamo, 30 volts 5 amps. Will sell cheap. Would consider 1 h.p. A.C. motor part exchange. Write for particulars.—Royle, 76, Liverpool Rd., Widnes. [5188]

FOR Sale.—Igranic-Pacent Triple Gang Condenser, with balancing condensers, perfect condition, half cost price, namely, 37/6.—J. G. M. Pollock, Headington Hill, Oxford. [5189]

R.I. Retroactive Tuner, cost 39/6, accept 25/-; Ferranti A.F.3 L.F. transformer, cost 25/-, accept 15/-; both new condition; approval.—Gray, 14, Long St., Dursley, Gloucestershire. [5190]

SUPERHETERODYNE Transformer, Bowyer-Lowe, 1 filter 3 interstage, perfect condition. What offers? or exchange.—3, Ryder St., Cardiff. [5191]

G.E.C. Transformer, 220-1,500 volts 80 m.a., tapped 1,200 v., £3 or nearest; Amplion Dragonfly, 10/-; Ideal Junior, 10/-; Pye L.F. choke, 7/6; T.C.C. 2µF., 2/-; Sifam 0-2 m.a., 10/-; 3-valve set Det. 2L.F. 190-600 m., £3; Lissenola, 6/-; 2 McMichael heterodyne, 4/6 each; Varley choke, 5/-; Cosmos R.C. unit with valveholder, 6/—Newell, R. Signals Mess, Catterick, Yorks. [5195]

PICK-UP, latest used by 2L.O for perfect gramophone reproduction; demonstrations daily by W. J. Turberville Crewe, M.Inst.R.E.; £3/15.—J. Glasscoe & Co., 49, Eastcheap, E.C.3. [5196]

Mention of "The Wireless World," when writing to advertisers, will ensure prompt attention.

Components, Etc., for Sale.—Contd.

BRINFORD for Copper Screens and Six-pin bases. See advertisements under Miscellaneous. [5133]

CARBORUNDUM Detector Unit, 7/6; Copex S.S.H.F. and S.P.H.F. broadcast, 6/6 each; Colvern S.S.H.F. Daventry, 6/-; 1 ohm resistor, 1/6; variable condenser, 5/-; —21, Princess St., Swansea. [5197]

SUPERHET Kit.—Bowyer-Lowe Osc. coupler and transformers, as new; also four D.E.3B. valves. Offers, or would consider exchange Marconi 2.7 to 1 or Ferranti transformers and 4-volt super power valves.—192, Whiteacre Rd., Ashton-under-Lyne. [5198]

EXPERIMENTER'S Surplus.—Condensers:—.0005 Ormond square law friction drive, 9/-; .0002 Cleartron Dikast, complete with slow-motion dial, 10/-; .0003 Polar, 5/-; Valves: P.M.4, 10/-; Cossor H.F. Point One, 8/-; set of four Igranic short wave coils, 7/-; Gamage remote control unit complete, 15/-; All bought this year, and in perfect condition.—Write E.W.B.B., 118, Palace Rd., S.W.2. [5199]

BURNDEPT Super-vernier Dials, 3/-, post free.—Selby & Co., 6, Hauberk Rd., Lavender Sweep, S.W.11. [5201]

SALE or Exchange, 3 Lissen fieldless coils with bases, 3 .0005 S.L.F. condensers with S.M. dials, as new; offers.—Bagg, Hyes Lodge, Rudgwick, Sussex. [5205]

AMATEUR'S Surplus.—2 pairs Sterling phones, good condition, 7/6 each; 1 Yesley coilholder, 4/-; 2 Jackson's .0005 S.L.F. 6/6 each; 2 M.H. H.F. transformers, 300-600, 1,100-3,000 metres, 5/- each; 1 American type cabinet, cost 30/-, take panel 7in. x 16in., 12/6; 1 K.G. transformer, 3/6; 1 Varley H.F. choke, 5/-; 1 Cosmos choke, 3/6; 1 Silvertown transformer, 7/6; 3 Igranic rheostats, 3/-; 1 ampere meter, 0-15 amps., panel mounting, 5/-; 1 Polar condenser .0002, 2/6; Climax 10,000 ohm potential divider, 2/9; 1 M.H. neodyne condenser, 2/3; Harmsworth Wireless Encyclopaedia complete, unsoiled, 7/6.—Box 3027, c/o *The Wireless World*. [5206]

EXPERIMENTER'S Surplus.—Wearite coils, Everyman Four, 20/- pair; Ferranti A.F.3, 18/6; Varley resistances, 150,000 and 250,000 ohms, 6/- each; valves, P.M.1 H.F., Cossor R.C.210, new, 10/- each; Cosmos R.C. unit, 5/-; 2 Colvern neodyne condensers, 1/6 each; rheostats, Peerless and Igranic, 1/- each; 50, 30, 7 ohms.—Rogers, 21, New Rd., Brentwood, Essex. [5211]

EXPERIMENTER'S Surplus.—Loewe triple valve and base (unused), 37/6; large assortment components and small accessories by leading makers; all nearly new, absolute bargains. Stamp for list.—Box 3035, c/o *The Wireless World*. [5212]

MISCELLANEOUS.

THE Wireless Doctor Will Call (London and Home Counties) if your set is troublesome; no cure, no charge; Wireless Association registered repairer; sets installed, maintained, and brought up to date; experiments and testing undertaken; Solodyne demonstrated.—Alexander Black, 2A, Woodville Grove, N.16. Clissold 3687. [3841]

BRINFORD for all Components.—For specialities see other advertisements under Components. [5132]

Miscellaneous.—Contd.

SUPER Galena Crystals, 5/- lb., min., pound lots. Special terms for quantities.—Blackwell's Metallurgical Works, Liverpool. [4387]

A SUMMER Hobby—Restranging Tennis Rackets, frames, gut, tools. Lists and instructions, stamp.—Morris, 143, Lonsdale St., Bradford. [4890]

SCOTT SESSIONS, the radio doctor (London and environs).—Any set repaired, installed, modernised; distortion eliminated; specialist in "Wireless World" sets; no fee until repaired.—Scott Sessions, Hill Top, Muswell Hill, N.10. 'Phone: Mountview 4928. [4861]

BRINFORD for Lines that are Different.—The "Brinford" Mfg. Co., 37-45, Middlesex Wharf, Clapton, E.5. [5134]

EELEX Standardised Plug Socket System will improve your set; lists free.—Ask any trader, or Easticks, 118, Bunhill Row, E.C.1. [0025]

HYDROMETERS, British made, suitable for all acid-lead accumulators, high quality instrument, soundly constructed; post free, 4/6, with booklet "Accumulators Explained." Full particulars on application.—Utility Syringe Hydrometer Co., Dept. A., 16, Howard Rd., Ilford, Essex. [0053]

PATENT AGENTS.

A. PETER THURSTON, D.Sc., F.R.Ae.S., A.M.I.A.E., A.M.I.M.E., 329, High Holborn, London, W.C.1. Patents, Trade Marks, Designs. Telephone: Holborn 2542. [2315]

PATENTS and Trade Marks—British and Foreign.—Gee and Co. (H. T. P. Gee, Member R.S.G.B. and A.M.I.R.E.), 51-52, Chancery Lane, London, W.C.2. 'Phone: Holborn 1525. [0001]

KING'S PATENT AGENCY, LTD. (B.T. King, Registered Patent Agent, G.B., U.S., and Can.). Free "Advice Handbook" and consultations; 40 years' references.—146A, Queen Victoria St., London, E.C.4. [0002]

REPAIRS.

TRANSFORMERS, phones, loud-speakers rewound and repaired to maximum efficiency; all one price, 4/- post free. A 12 months' guarantee accompanies each repair. Your present transformer can also be rewound to Multi-Ratio type. Write giving particulars. Trade invited.—Transform, 115, Links Rd., Tooting, London, S.W.17. [0011]

HEADPHONES and Loud-speakers, rewound, remagnetised, and overhauled, 4/- post free. Guaranteed. Only firm in the West. Established 1923.—Bradford and Co., 16, Prospect St., Plymouth. [5045]

WANTED.

WANTED.—Tungar Rectifiers, deposit system.—Particulars to Colley, Somerset Place, Teignmouth. [5101]

WANTED, Solodyne parts and cabinet; also battery eliminator or charger for A.C. 230 volts.—Butterworth, 40, Kenwood Rd., Oldham. [5168]

TUITION.

INSTRUCTION in Morse, day or evening, easy terms.—Telegraph School, 29, Telford Rd., Peckham, S.E. [5170]

EXCHANGE.

2 B.4 Valves, guaranteed perfect, list price 18/6 each, exchange for Marconi Ideal 6 to 1 transformer; also another B.4 valve for the Curtis constant tune transformer 25-800.—Cavendish, Miller's Farm, Wrotham, Kent. [5169]

ADVERTISER will Exchange Liberty A 8-valve super-het with valves, and about £45 worth wireless components, for good motor cycle combination or Morgan; or best cash offer.—Box 3016, c/o *The Wireless World*. [5175]

IGRANIC Super Audioformer, Varley multi cellular H.F. choke, Utility D.P.D.T. switch, 2 Peto-Scott neodynes for All-wave Four coils. Wearite or Simmonds preferred.—Blake, 2, Hall's Cottages, Stapleford, Notts. [5200]

AGENCIES.

EVERYTHING Wireless.—Amateur constructors required everywhere as distributing agents; stamped envelope.—Garner, 31, Little Britain, E.C.1. [0027]

SITUATIONS VACANT.

SPLENDID opportunity for live commission men with good connections amongst wireless dealers, as representatives for well-known British loud-speaker; state ground covered.—Box 63, "Parrs," Craven House, Kingsway, London, W.C.2. [0057]

WIRELESS Engineers located Lower Sydenham district require junior office assistant, shorthand and typewriting essential. Salary about 40/-. State age, speeds, and outline of experience.—Box 2997, c/o *The Wireless World*. [5172]

BOOKS, INSTRUCTION, ETC.

"ACCUMULATORS Explained," how they work, care hints, terms defined; booklet 6d., post free; refunded when hydrometer purchased. See under heading "Miscellaneous."—Utility Syringe Hydrometer Co., Dept. C., 16, Howard Rd., Ilford, Essex. [0058]

3-V. VALVE Receiver for 30/-.—Write now for booklet on how to build the L.R.C.3 valve set for 30/- from guaranteed parts only—the ideal loud-speaker set.—1/- post free from H. Howarth, Lustrolux Depot, 288, Deansgate, Manchester. [5003]

WIRELESS Encyclopaedia.—Three handsomely bound volumes, perfect condition, invaluable to constructors and students; 15/- or nearest.—Box 3015, c/o *The Wireless World*. [5176]

Your First Steps in Wireless

By **HUGH S. POCOCK**
Editor of "The Wireless World"

A most helpful little book for those who are beginning to study wireless. It explains technical difficulties by simple analogies.

Price 9d By Post 11d

From **ILIFFE & SONS LIMITED**
Dorset House, Tudor Street, London, E.C.4
and leading booksellers. w.w. 14

INDEX TO ADVERTISEMENTS.

| | PAGE | | PAGE | | PAGE |
|--------------------------------------|------|---|----------|------------------------------------|-----------|
| Accumulators Elite | 12 | Garnett, Whiteley & Co., Ltd. | Cover ii | Mullard Wireless Service Co., Ltd. | Cover iv. |
| Bedford Electrical & Radio Co., Ltd. | 9 | General Electric Co., Ltd. | 7 | Orniston, P., & Sons, Ltd. | 7 |
| Bowyer-Lowe Co., Ltd. | 9 | General Radio Co., Ltd. | 9 | Radiax, Ltd. | 7 |
| British Battery Co., Ltd. | 9 | Hart Accumulator Co., Ltd. | 12 | Sankey, J., & Sons, Ltd. | 9 |
| British Thomson-Houston Co., Ltd. | 6 | Hildick & Hildick | 12 | Siemens Bros. & Co., Ltd. | 2 |
| Brown, S. G., Ltd. | 4 | H.T.C. Electrical Co. | 12 | Taylor, J. H., & Co. | 9 |
| Carrington Manf. Co. | 4 | Jennens, J. R., Ltd. | 3 | Telegraph Condenser Co., Ltd. | 2 |
| Cossor, A. C., Ltd. | 1 | Langham Radio | 3 | Transport Supply Co., Ltd. | 12 |
| Day, Will, Ltd. | 6 | Loek, W. & T. | 3 | Tulsemere Manf. Co. | 12 |
| Dubilier Condenser Co. (1926), Ltd. | 1 | London Electric Wire Co. & Smiths, Ltd. | 3 | Valco, Ltd. | 1 |
| Eagle Engineering Co. | 12 | London Radio Supply Co. | 12 | Vandervell, C. A., & Co., Ltd. | 1 |
| Electradix Radios | 5 | Lustrolux, Ltd. | 12 | Varley Magnet Co. | 7 |
| Ever Ready Co. (Great Britain), Ltd. | 5 | Lyons, Claude, Ltd. | 12 | Watmel Wireless Co., Ltd., The | 6 |
| Ferranti, Ltd. | 6 | Marconiphone Co., Ltd., The | 5 | Wet H.T. Battery Co. | 6 |
| Forno Co. | 6 | Marson, W. E., Ltd. | 12 | Whiteley, Boneham & Co., Ltd. | 6 |
| Gambrell Bros., Ltd. | 6 | Mic Wireless Co. | 12 | Wilkins & Wright, Ltd. | Cover ii. |

60 Volts

22/6

BETTER H/T

SUPPLY AT

LOWER COST

60 Volts

22/6

AMAZING REDUCTION! FOR 28 DAYS ONLY!

The Elite High Tension Accumulator is the true original Monoblock to be made in any country, and is made in England. Moreover, it is the only battery with oil insulation, and many thousands of users all over the world have proved it to be the cheapest, strongest, and lowest loss battery for wireless purposes. Made entirely throughout of the best materials, it is the result of many years specialisation in the manufacture of leak-proof batteries, and in making this offer we are confident that it will introduce us to many thousands more satisfied users of this world-famous battery.

MADE IN ENGLAND AND GUARANTEED AGAINST SURFACE LEAKAGE.

ACCUMULATORS ELITE

BEDFORD STREET, HALIFAX

Telephone: 4304. Telegrams: "Elite, Halifax."

TRADE SUPPLIED.

London Distributor — CECIL POHLMAN,
77, Great Portland Street, London, W.1.

To celebrate the opening of our new and larger factory for the manufacture of the Elite Accumulator we have decided to offer, for 28 days only, our standard 60-volt semi-oil submerged type, complete in case direct to the public at 22/6.

The steadily increasing demand for Elite Accumulators is proving that the Wireless public are ready to appreciate the enormous advance which this battery shows in comparison with the ordinary pitch covered type with which it is impossible to prevent surface leakage.

You are able, by this special offer to obtain an accumulator from which the absolute maximum of current is delivered to your valves—no waste by surface leakage because of the oil insulation, the feature of the Elite Accumulator. In the long run your high tension supply will work out far cheaper if you take advantage of this reduction than by using the old method of dry batteries which are wasteful and expensive.

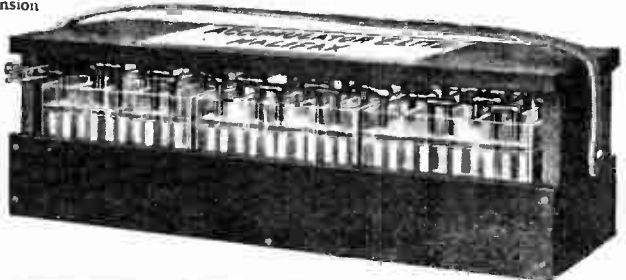

FREE.—Write for our free treatise on the care of your high tension accumulator. It is very important to know how to look after these, and owing to our wide experience we are able to offer unrivalled advice on this subject.

The H.T.C. TWIN RECEIVER

A complete up-to-date set including loud speaker and all accessories.

Seven days trial and initial payment refunded if not entirely satisfactory.

H.T.C. ELECTRICAL CO. LTD.,

2, Boundaries Rd., Baltham, S.W.12.



5/-

Immediate delivery for

Balance 2/6 per week or 10/- per month. Total cost £6 10 0.

Cash Price 16 4 0
Royalty Paid.
3 valve set, Cash Price £8 8 0
Deferred Terms £8 10 0

ELECTRADIX
RADIOS

Everything Electrical.

Send 4d. stamps for 68 page Illustrated Catalogue.

218, UPPER THAMES STREET, LONDON, E.C.4.

Phone: CITY 0191.

JENNENS

METAL FRAME RHEOSTAT.

7-20-35 OHMS

2/-

The Rheostat with the CORRECTLY CALIBRATED DIAL Baseboard Mounting Cup Included. TRADE ENQUIRIES INVITED Manufactured by J. R. JEN VENS Ltd., Jennens Row, Birmingham.

EASY PAYMENTS

We supply, by easy payments, components, accessories and sets. Any make. 10% down, balance spread over 10 months. Send list of requirements to

LONDON RADIO SUPPLY CO.,

11, OAT LANE, LONDON, E.C.2.

The LOW LOSS
ZAMPA
Regenerative
TUNER

A modern tuning device to cover all B.B.C. wavelengths (200-2000 metres). 2 hole fixing. Panel space 4 1/2" x 2" deep. From your local dealer or direct. Send for full particulars. Price 4/0. Write for price to: M.I.C. Wireless Co., Market Street, Wellington.

H.T. UNIT.

Guaranteed silent. No valves. Requires no attention or renewals. Variable tapings for multi valve sets 0-120 volts. Please state A.C. supply voltage etc.

57/6

The TANNOY

A.C. MAINS SUPPLY UNITS

are perfectly insulated so there is no danger of shock. 7 days' free trial against cash. Guaranteed for twelve months, write or phone for lists. Streatham G731.

Sole Manufacturers and Patentees:

THE TULSEMERE MANFG. CO., Tulsemere Road, West. Forwood, S.E.27.

L.T. UNIT.

Used in conjunction with a 2, 4 or 6 volt accumulator. Operates automatically with no fear of overcharging. Mains consumption is negligible. Charge and discharge A.M.M.T.E. 10/- extra.

39/6

USE WEMCO

Motorists' PORTABLE as used in May 11th issue. Mahogany 50/- Oak 48/-

CABINETS

if you want QUALITY

EVERYMAN FOUR

a distinctive cabinet

for a distinctive set. See Report p. 638, May 18th issue. Write for price or phone Clissold 0997.

W. E. MARSON LTD.

Windus Works, Windus Rd., Stamford Hill, London, N.16.

Mention of "The Wireless World," when writing to advertisers, will ensure prompt attention.

The **Wireless**
AND
RADIO REVIEW **World**

EVERYMAN FOUR

36-Page Booklet

giving
full Construc-
tional Details
of a remarkably
efficient "Two-
Control"
Receiver, for
Long or Short
Waves.

By W. JAMES.

PRICE

1/- net
By Post 1/2

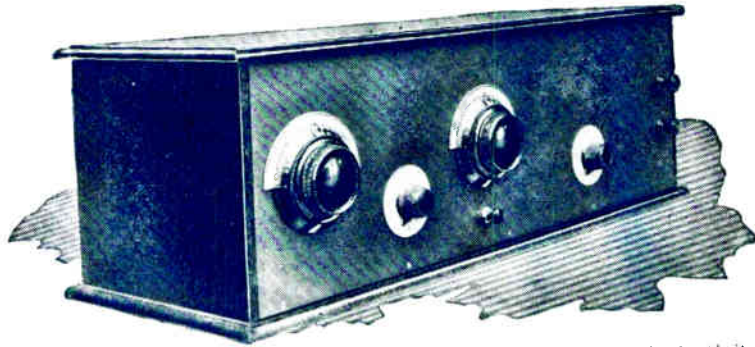

The "EVERYMAN FOUR" attracted widespread attention when it was first described in "The Wireless World."

Many constructors have built the set and have been delighted with its wonderful quality and range.

For some time past the issues describing the set have been out of print and this booklet has been prepared to meet the numerous requests for particulars and diagrams

The "Everyman Four" is very sensitive

and has a high degree of selectivity. The local station is perfectly received, and during a normal evening at least fifteen different stations may be received clearly at good loud-speaker strength. (Constructors claim up to twenty-eight stations.)

The Receiver is easily built, and very simple in operation, as it cannot oscillate if properly set up.

An additional long-wave attachment for Daventry is described in the booklet.

From the offices of "The Wireless World," Dorset House, Tudor Street, London, E.C.4

W.W. 60

WIRELESS LOUD SPEAKERS

By N. W. McLACHLAN, D.Sc.

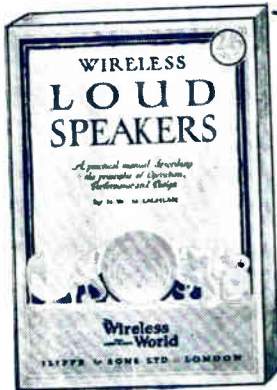

PRICE

2/6

net

By Post 2/8

From all booksellers or
direct from the Publishers:

ILIFFE & SONS LTD., Dorset House, Tudor St.,
London, E.C.4.

W.W. 54

THIS book de-
scribes in a simple
manner the major
principles of the
design of modern
loud - speakers and
some associated
circuits.

Clearly written and fully
illustrated by numerous
diagrams and photo-
graphic reproductions,
the volume will be of
use and value to all
constructors and experi-
menters desirous of
investigating this vital
aspect of wireless re-
ception.

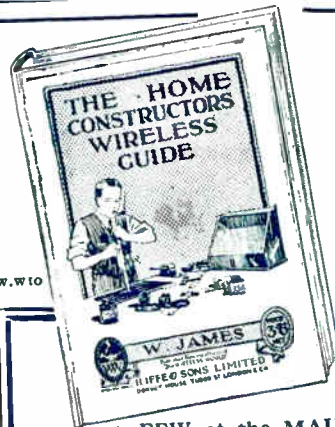

A Handy Volume

This is a perfect Encyclo-
pedia of Wireless—a book
to which you can refer
when in difficulties. It will
quickly solve your problems.

A FEW of the MAIN FEATURES :

Outdoor, Indoor and Frame Aerials, Earths, Tuners and Couplings, Variometers for Broadcast Wave-lengths, Basket Coils, Plug-in Coils, etc. Coupled Circuits. Condensers and Coils. Crystal Receivers. The Valve: the principle of its working and the correct method of operation for best results. Two and Three-Electrode Valves, Dull Emitters, etc. The effect of Variation of Filament Temperature, Plate Voltage, etc. Reaction and Self-Oscillation. The Valve Amplifier. Special Chapter on Sensitive Single-Valve Receivers. A Single-Valve Amplifier with Crystal Rectifier. Double Magnification. Points on Dry Cells and Accumulators. Current from Alternating Current Mains.

Price 3/6 net.

By post 3/10.

Obtainable from Booksellers or direct from the Publishers:

ILIFFE & SONS LTD., Dorset House, Tudor St., London, E.C.4.

Advertisements for "The Wireless World" are only accepted from firms we believe to be thoroughly reliable.

Note the generous and robust construction of the wonderful Mullard P. M. Filament shown in the sectional view of the P.M. 5X. This is the construction that brings improved results from any radio receiver.

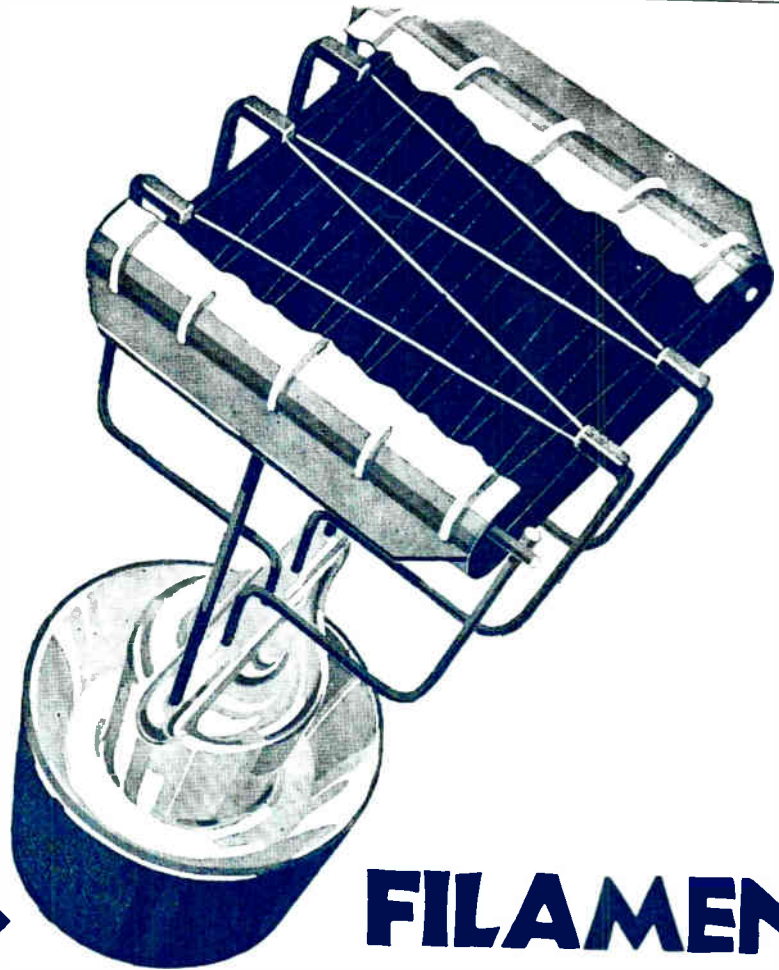

THE P.M. FILAMENT GIVES MOST VALUE

When all is said and done a valve ceases to give you a return for your money when the filament is gone. Be safe and satisfied. Secure a long, strong and lasting filament a filament that has a published National Physical Laboratory Test Report to prove its life and power to be constant and lasting. Demand a British filament

DEMAND THE WONDERFUL MULLARD P.M. FILAMENT
obtainable only in Mullard P.M. Valves.

For better radio:
The Mullard Pure Music Speaker
26 6 0
The Mullard P.M. H.T. Supply Unit for A.C. Mains
27 10 0
The Mullard P.M. L.T. Battery Charger for A.C. Mains
24 0 0
ASK YOUR DEALER.

Mullard

THE MASTER VALVE

THE MULLARD WIRELESS SERVICE CO. LTD., MULLARD HOUSE, DENMARK ST., LONDON, W.G.2. ENGLAND

Printed for the Publishers, ILIFFE & SONS LTD., Dorset House, Tudor Street, London, E.C.4, by The Cornwall Press Ltd., Paris Garden, Stamford Street, London, S.E.1.

Colonial and Foreign Agents:
 UNITED STATES—The International News Co., 131, Varick Street, New York. FRANCE—W. H. Smith & Son, 248, Rue Rivoli, Paris; Hachette et Cie, Rue Réaumur, Paris.
 BELGIUM—W. H. Smith & Son, 78, Marche aux Herbes, Brussels. INDIA—A. H. Wheeler & Co., Bombay, Allahabad and Calcutta. SOUTH AFRICA—Central News Agency, Ltd., Sydney (N.S.W.), Brisbane (Queensland), Adelaide (S.A.), Perth (W.A.) and Launceston (Tasmania).
 AUSTRALIA—Gordon & Gotch, Ltd., Melbourne (Victoria). CANADA—The American News Co., Ltd., Toronto, Winnipeg, Vancouver, Montreal, Ottawa, St. John, Halifax, Hamilton; Gordon & Gotch, Ltd., Toronto; Imperial News Co., Toronto, Montreal, Winnipeg, Vancouver, Victoria. NEW ZEALAND—Gordon & Gotch, Ltd., Wellington, Auckland, Christchurch and Dunedin.