

THE WIRELESS WORLD

AND
RADIO REVIEW



PRICE 4^D NET.

GETTING RESULTS WITH
OSCILLATING CRYSTALS

—
THE SUPER-SENSITIVE
THREE-VALVE RECEIVER

—
THE POST OFFICE AND
THE EXPERIMENTER

No. 268 [No. 1
Vol. XV]

No. 1. VOLUME XV.

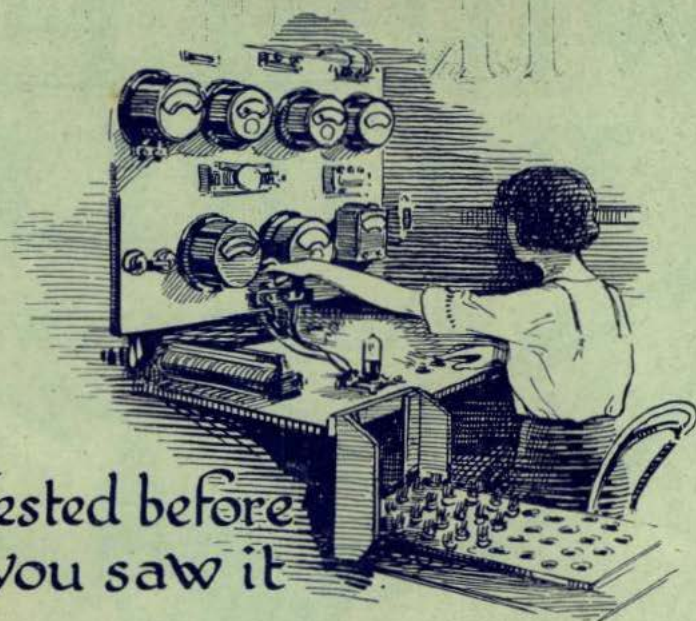

Tested before you saw it

YOUR dealer recommended an Ediswan Valve. He was on safe ground; he knew—tho' perhaps you did not—that the Ediswan he offered you had already passed its proficiency tests. He might have told you—if he did not—that every single valve that leaves our works goes out through the testing room. And unless the testing room is satisfied, it does

not get out. This happens because Ediswan have a reputation that is trusted wherever broadcasting is known. It was that reputation your dealer had in mind. It's that reputation you will think of next time you are getting a valve.

Ediswan Valves will bring the best out of your wireless set—get some on the way home and enjoy better programmes from to-night onwards. All dealers sell them.

THE EDISON SWAN ELECTRIC CO., LTD.,
QUEEN VICTORIA ST., LONDON, E.C.4

The
first Valve
ever made, was
produced in
the Ediswan
laboratory

EDISWAN VALVES

THE WIRELESS WORLD AND RADIO REVIEW

THE OFFICIAL ORGAN OF THE RADIO SOCIETY OF GREAT BRITAIN.

No. 268. (No. 1 Vol. XV.) OCTOBER 1st, 1924. WEEKLY.

EDITOR:
HUGH S. POCOCK.

RESEARCH EDITOR:
PHILIP R. COURSEY, B.Sc., F.Inst..P., A.M.I.E.E.

ASSISTANT EDITOR
F. H. HAYNES.

QUESTIONS AND ANSWERS DEPARTMENT:
Under the Supervision of W. JAMES.

CONTENTS.

	PAGE
What of the Future? By the Editor - - -	I
The Crystal as a Generator and Amplifier. By Victor Gabel - - -	2
The Position of the Scientific Amateur. By Dr. W. H. Eccles, F.R.S. - - -	6
The Super-sensitive Set. By W. James - - -	9
Readers' Practical Ideas - - -	13
The Dry Cell Receiver. By H. J. Cooke - - -	15
Constructing the Valve. A Visit to the M.O. Valve Works - - -	18
Patents and Abstracts - - -	20
Notes and Club News - - -	22
The Wireless Exhibition. A Review of Exhibits - - -	25
Readers' Problems - - -	29

THE EDITOR will be glad to consider articles and illustrations dealing with subjects within the scope of the Journal. Illustrations should preferably be confined to photographs and rough drawings. The greatest care will be taken to return all illustrations and manuscripts not required for publication if these are accompanied by stamps to pay return postage. All manuscripts and illustrations are sent at the Author's risk and the Editor cannot accept responsibility for their safe custody or return. Contributions should be addressed to the Editor, "The Wireless World and Radio Review," 12 and 13 Henrietta Street, Strand, London, W.C.2.

SUBSCRIPTION RATES :

20s. per annum, post free, Single copies 4d. each or post free 5d. Registered at the G.P.O. for transmission by Magazine Post to Canada and Newfoundland.

As many of the circuits and apparatus described in these pages are covered by patents, readers are advised, before making use of them, to satisfy themselves that they would not be infringing patents.



EDITORIAL AND PUBLISHING OFFICES :

12 and 13 Henrietta Street,
Strand, London, W.C.2.
Telephone : Gerrard 2807-8.

ADVERTISEMENT MANAGERS :

Bertram Day and Co., Ltd.,
9 & 10 Charing Cross, S.W.1
Telephone : Gerrard 8063-5.

And now —

Brandes

The Name to Know in Radio

Introduce the Table-Talker

Trade Mark

Original in the real beauty of its performance, original in its ingenious construction, original in its remarkable price. The horn is so contrived that every note registered is encompassed and emitted with absolute purity—there is no discordant echo from its walls. The full-toned accuracy of reproduction is consistent with the mellow note which is the chief characteristic of the famous Brandes Superior "Matched Tone" Radio Headphones.

The horn is matched to the unit so that the air resistance produced will exactly balance the mechanical power of the diaphragm. It has a self-adjusting diaphragm, is twenty-one inches high, with a 10-inch bell and felt-covered base. Simple lines and a neutral brown finish make it a tasteful and effective addition to your set.

42¹/₂

All Brandes products are obtainable from any reputable dealer and carry our official money-back guarantee, enabling you to return them within 10 days if dissatisfied.

*Tune with Brandes
"Matched Tone" Radio Headphones
Then listen with
Brandes "Table Talker"*

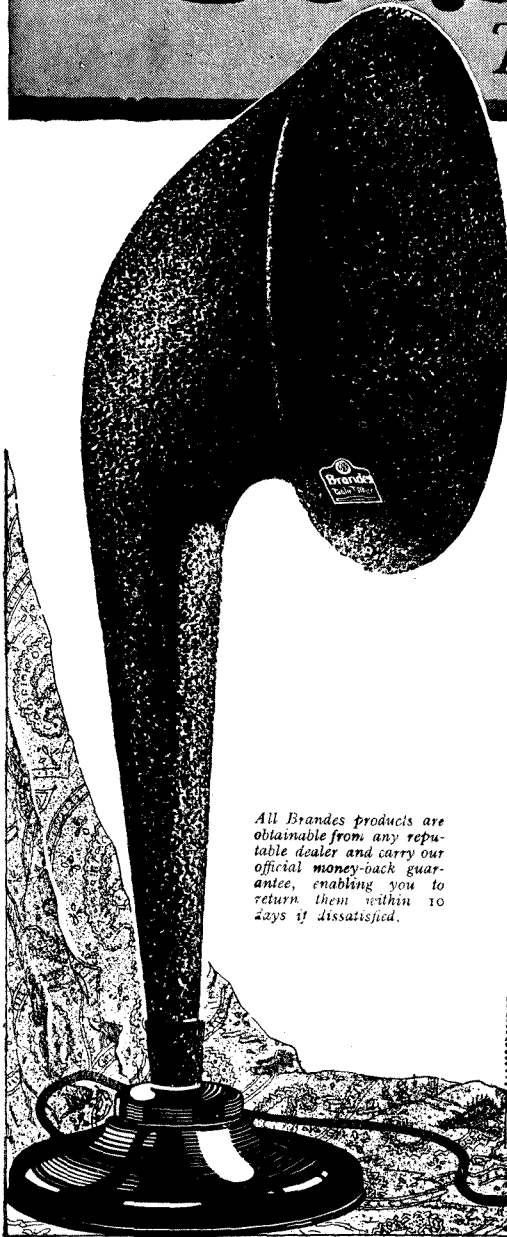

THE WIRELESS WORLD — AND RADIO REVIEW



WHAT OF THE FUTURE ?

OUR OFFER OF £500 TO DEFEND THE AMATEUR.

By THE EDITOR.

THOSE who were present to hear the address to the Radio Society of Great Britain delivered by Dr. Eccles, the President, on Wednesday last, will not easily forget that occasion.

Apart altogether from the actual words of the address, there was conveyed throughout a note of warning which amateurs will do well to heed. We have at last had brought to our notice in a forcible manner the present position of the amateur with a hint at what his future fate must be if determination and concentrated effort is lacking in the future. It is true that most of us who have made it our business to watch carefully events of the past year or two have realised that by gradual and sometimes apparently subtle means the amateur's position has been steadily undermined and weakened by those whose interests are antagonistic to the prosperity of the amateur or who, if not themselves antagonistic, have been coerced into that attitude by external pressure from powerful influences.

The time has passed when diplomatic and polite methods with the Post Office authorities can suffice to retain for the amateur the recognition and consideration which he has not only earned by his work and contributions to science but which is also his by right. The art of diplomacy is a weapon which should not be despised, but at the same time it is an indication of weakness if diplomacy is still resorted to in cases where its limitations have been made apparent.

The possibility is very naturally suggested that the necessity may arise for a test case to be fought by the Radio Society in support of the amateur's rights. *The Wireless*

World has therefore offered to support the Society to the extent of Five Hundred Pounds in the event of such a case being brought to court.

Rather more than a year ago *The Wireless World and Radio Review* issued a word of warning when it became obvious that a change in the position of the amateur was impending, and in stating what we believed to be the situation at that time, we used the following words: "The amateur's war has not yet begun, but that it may commence at any moment and that it will be a fight for his very existence should be apparent to anyone who is watching closely events which concern the official position of amateur experimenters."

Perhaps a year ago these words may have seemed a little premature, but in view of present conditions in the amateur world it cannot be said that they exaggerate the situation to-day.

"What of the future?" we may ask, and "How can we avert these disquieting possibilities?" Only one solution presents itself. This is for all amateurs, whether as individuals or as collective organisations, to show complete unity of purpose in the efforts which must be made to maintain freedom for experimental work and enterprise. The amateur is far too numerous to be over-ruled and denied what is lawfully his right, if only he determines to assert himself.

However desirable independence of action may be on any other matters of amateur concern every individual and every party must give whole-hearted support to strengthen the position of the amateur community as a whole.

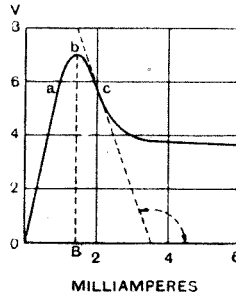
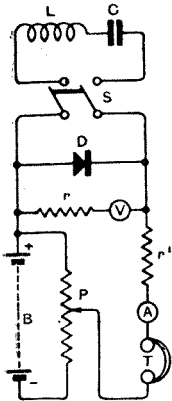

Fig. 1. Circuit for testing the aptitude of different crystals for generating or amplifying. Fig. 2. Characteristic curve of a suitable specimen of crystal.

THE CRYSTAL AS A GENERATOR AND AMPLIFIER.

By VICTOR GABEL.

THE first account published in English of the work of the Russian engineer, O. Lossev, in producing oscillation and amplification by means of crystals, appeared in *The Wireless World and Radio Review* of July 11th last, and since then references have been made to the same subject in other journals, both in this country and in America, but no additional information has been disclosed.

In this issue we have pleasure in giving publication to a further article, contributed by an engineer in Russia who is closely in touch with the work done by Mr. Lossev and others in that country. This article discloses all that has so far been recorded by way of observations on the action of the crystal and methods are given for testing crystals for oscillating properties, whilst in addition practical details are supplied on how to prepare crystals for the purpose. In addition, the author supplies a number of circuits and explains their operation so that the experimenter is provided with definite data to work upon in investigating further these extraordinarily interesting properties of the crystal.

A PART from the immense possibilities which this epoch-making discovery of a new application of the crystal foreshadows, the experiments now being conducted may lead to some light being thrown on the theory of operation of the crystal during the process of detecting, a subject which is not yet fully understood. The pioneer work in these experiments is due to a Russian engineer, O. Lossev, and the following theories, which are the result of his experiments, may serve as a guide to those experimenters who are sufficiently interested to pursue the subject.

Selecting the Crystals.

It has been found that the best and most

consistent results are obtainable when a zincite crystal is used in conjunction with a carbon contact, the oscillations once produced, remaining very stable and continuing without readjustment for indefinitely long periods, although the initial adjustment of the contact is rather more critical than is usual for ordinary detecting. The combination using a steel point also works satisfactorily. A copper contact used with zincite gives very poor results, whilst aluminium contacts are still less satisfactory.

The results obtained with other crystals, including galena, pyrites, carborundum and molybdenite, were very inconsistent, all of them oscillating badly or giving no results at all. It was found possible to obtain oscillations with the ordinary coherer,

and even with a microphone contact, but they were very unstable.

Circuit for Testing the Crystal.

The following observations relate exclusively to zincite with carbon or steel points in contact. In order to understand the physical causes and the conditions necessary for the generation of oscillations with a detector contact, it is necessary to be acquainted with the characteristic of the crystal contact. The diagram, Fig. 1, shows how this curve can be obtained. The detector which is under test, is shown at *D*, whilst a galvanometer *A* measures the strength of the current which passes through the detector. A resistance *r* of about 100,000 ohms is for voltage measurement in conjunction with a galvanometer *V*, *r*¹ being a resistance of 1,000 to 5,000 ohms, and *B* a battery across which is shunted a potentiometer *P*, which should have a resistance of approximately 800 ohms. The inductance and capacity of the oscillating circuit into which the detector may be introduced by means of the switch *S*, are represented by *L* and *C* respectively. Employing this circuit, it is possible to determine the aptitude of different crystals for generating and amplifying.

It is, of course, well known that only certain points of a crystal are suitable for detecting and these must always be found by experiment. The same may be said concerning generating, for not only are oscillations only produced when contact is made with certain suitable points, but it is impossible to obtain even a compromise elsewhere. It might be thought that generating and detecting points would coincide, but in general, such is not the case, the circumstances favouring the production of oscillation not necessarily agreeing with those needed for efficient detecting.

Assuming that it is desired to find the generating point on a really sensitive crystal utilising the circuit shown in Fig. 1, it is necessary first to close the switch *S* and to adjust the potentiometer so that from about 6 to 12 volts is placed on the detector. By searching the different points on the crystal with the contact wire, the generating point will be found when a note is heard in the telephones. If the note remains pure and steady and does not change in tone

during an interval of one minute, it is an indication that the point is a sensitive one. By cutting out the switch *S*, it will be possible to obtain the characteristic of the detector, showing graphically the relation between the applied potential and the current.

In order to obtain plotting points for the curve, the applied voltage is regulated through the agency of the potentiometer, commencing from zero and noting at each change on *A* the value of the current *i*, and on *V* the voltage. After reaching a current reading of about 5 to 6 milliamperes the measurements obtained can be marked on squared paper after the manner shown in Fig. 2. The current values are marked off along the axis of the abscissa, and the voltage along the axis of the ordinate. The resultant characteristic provides not only the direct correlation of *V* and *i* but also enables the detector to be regarded as a conductor possessing changing resistance properties.

By referring to the characteristic illustrated, it will be observed that the resistance between the points *O* and *a* remains approximately the same, after which it diminishes and becomes zero, when the current is equal to *O B*, whilst after the point *B*, for instance, at *C*, the resistance becomes negative. As a physical quantity, negative resistance has no significance, but the expression is accepted in mathematical physics where negative resistance is introduced as an algebraical quantity. It will, of course, be appreciated that the steeper the slope of the curve, the greater will be the change of resistance value. In view of this it may be assumed that the resistance of the generating point to weak currents is high and positive, after which it diminishes to zero and then becomes negative, the negative value increasing up to a certain point, after which it gradually diminishes again, as the curve shows.

If the current *i* passing through the detector is at first weak and then gradually increases, the detector will at first act as an ordinary positive resistance, that is to say, it will absorb the energy equal to $i^2 R$. This will continue until the current passes over the point *B*, after which the absorption of the energy is equal to $i^2 (-R)$ or $i^2 \bar{R}$ will become negative. When this state of affairs is reached, the energy will no longer be absorbed, but will, on the contrary, be re-

turned or added to the output, so that the detector becomes a source of energy. In the event of an alternating current being present in the oscillating circuit *LC* (Fig. 1) whilst the potential is adjusted on the detector contact so that the detector works on the steep portion of the characteristic, then the detector commences to amplify the oscillations in *LC*, maintaining and increasing the oscillating current.

This effect can, obviously, only be produced when the detector is operating upon the negative portion of the curve. Thus, by suitably adjusting the applied potential, it is possible to attain such a state of balance that on the one hand the received oscillations are amplified, and on the other the amplified oscillations take place partly in the position of the negative and partly the positive resistance, when a simultaneous operation of amplifying and detecting can be obtained with the same crystal.

Practical Details for Heating the Zincite.

In the case of a bad specimen of zincite, the crystal may be greatly improved by being fused in an arc. This is best accomplished by placing the crystal on a carbon or iron

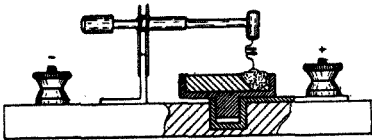

Fig. 3. A simple type of detector suitable for giving good adjustment.

plate, and sprinkling it with manganese dioxide. An arc is formed between the crystal and the carbon electrode, the process being watched through a dark glass. When the crystal is fused into an oval mass it is left to cool, after which the non-conducting crust which will be found to have formed on the surface, is cleaned off and the crystal is mounted into a cup with fusible metal in the usual way. The resistance of a crystal after being prepared in this manner is reduced about seven times.

The Crystal Holder.

For the convenience of the operator, it is advisable to pay special attention to the

construction of the detector holder. A type recommended is that shown in Fig. 3. The contact wire, which should be twisted at the top into a spiral of about two turns, with a diameter of approximately 7 mm., should be made of hard steel not larger than No. 34 S.W.G. The crystal should be mounted in a cup the inner diameter of the cup being such that when the crystal is placed near the edge, and the cup rotated, fresh points of contact will be brought opposite the steel wire. It should be noted that the crystal is connected to the positive pole of the battery and the wire to the negative. As it is essential that the detector be protected from vibration, it would be advisable to place a rubber or cloth pad under it. When searching for the generating point the contact wire should not be pressed too hard upon the crystal.

Explanation of the Action of a Crystal Detector.

It is known that conductors possessing a negative resistance are generally able to self-oscillate. Chief among such conductors the arc, possessing a characteristic greatly resembling that of the detector, calls for special attention. The similarity of the two characteristics gives rise to the thought that the action taking place in the arc, and at the contact of the detector, must be similar in physical respects. Experiments and tests carried out by the author have partly corroborated this theory. As early as 1921 Hoffman surmised that the rectifying action of the detector might be explained by electronic discharges arising in consequence of a high gradient of potential at the point of contact. The formation of the arc may be represented as in Fig. 4, where a section of a contact greatly enlarged is shown.

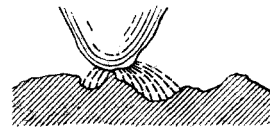

Fig. 4. An enlarged section of an arc, and it is suggested that the action of a crystal detector is due to an electron discharge, in some respects having similar properties.

As the surface of the crystal is always rough, it might happen that the end of the wire or the carbon might make contact on a

sharp projection of the crystal adjoining a depression. Due to the fact that the ohmic resistance at the point of contact is very high, whereas the difference between the contact wire and the neighbouring points of the crystal is small, there may arise, if the current be strong enough, such high gradients of potential that electron discharges become possible. This suggestion is roughly outlined in Fig. 4. These discharges, although resembling the arc, differ from the latter in that the electrodes are not incandescent. For the formation of an arc the electrodes must be made red-hot either through previous mutual contact or through a discharge at high pressure. For the arc this "puncturing pressure" is about a hundred times higher than that needed for its maintenance.

The Effect of Temperature on Crystal Adjustment.

Experiments show that this relation in a zincite detector is between two and three. The difference may be explained by two causes—(1) the contact point is heated by virtue of its resistance to a temperature sufficient for a high potential to be unnecessary for a discharge to take place, or (2) the conditions favouring the discharge of electrons are different at such small distances. In experiments undertaken with the object of investigating this matter the generating contact was heated by means of a wire spiral heated by a current, the spiral being placed at a distance of one millimetre over the surface of the crystal. The results proved that the contact is very sensitive to changes of temperature, and a generating point found at normal temperature lost its properties when the spiral reached dull red heat.

A further result of these tests, however, was of considerable importance, for it was found that sensitive points discovered on the crystal when the spiral was at dull red heat possessed, under normal temperatures, a very high maximum voltage. At the same

time the characteristic no longer indicated a negative resistance, and it became flatter and considerably lower, whilst the voltage, which corresponds to the highest point of the characteristic (point B, Fig. 2) fell much lower. Different characteristics taken at different degrees of heating showed in general that even small variations of temperature seriously affected the shape of the curves.

With one sample of zincite it was noticed that a current of 6 milliamperes was sufficient to make the characteristic lose its peak, which reappeared, however, after a time if the detector was not subjected to the influence of the current. This extreme sensitiveness to changes of temperature tends to confirm the suggestion previously made as to the difference in the conditions of the formation of the arc and the electron discharge of the crystal detector. The arc has a temperature of about 3,000 deg., whereas in the case under discussion it would seem that the action takes place at a temperature of not more than 100 deg.

There is, of course, the possibility that the electrodes of the detector may become heated by the action of the applied current. This observation suggests that care should be exercised when searching for a generating point to avoid passing an excessive current through the detector, as much time might be lost in a fruitless search under altered conditions. A current of 8 to 10 milliamperes can heat the points of contact to such an extent that the whole nature of the crystal may undergo a change.

Working the Crystal Contacts in a Vacuum.

In any event, such an overheated point would completely lose its property as a generator. It seems probable that, if the whole detector were placed in a high vacuum to prevent any of the electron energy being dissipated in air, the electron flow, and at the same time the oscillation energy, might be amplified.

[The concluding instalment of this important article, appearing in the next issue, will give numerous practical circuit arrangements.]

THE POSITION OF THE SCIENTIFIC AMATEUR.*

LATEST DEVELOPMENTS UNDER THE WIRELESS TELEGRAPHY REGULATIONS.

By Dr. W. H. ECCLES, F.R.S. (President).

THE Radio Society and its Affiliated Societies comprise every kind of amateur—the home constructor who has fallen a victim to the fascination of making or improving tuners and amplifiers, the ripe enthusiast who welcomes morse as much as music and constructs reflex circuits and other modern marvels, and the matured transmitter who fishes in the ocean of space and learns the ways of the waves in our ever-changing atmosphere. By uniting all these the Societies will surely gain in strength as time goes on. At present the Radio Society consists of about 800 ordinary members and over 200 Affiliated Societies and is governed by a Council and by a General Committee.

THE INFLUENCE OF BROADCASTING ON THE AMATEUR POSITION.

The advent of broadcasting has greatly augmented the ranks of the amateurs, especially those interested in building and experimenting with receiving apparatus. As broadcasting flourishes so will the number of amateurs increase. It is inevitable that a large proportion of these amateurs will in due time desire to supplement their knowledge of receiving apparatus by actual work with transmitting apparatus. We hope to see them join the Societies early and climb through the various stages into the Transmitter and Relay Section and thereby enter the ranks of the *élite* in the amateur movement.

We of the Society think that one of the most lasting benefits of the spread of broadcasting—a benefit much less ephemeral than the music and the speeches—lies in the stimulus it is giving to the study of electrical things; and from this point of view broadcasting is an immense force attracting the quicker minds of every country towards physical science. We think this is highly commendable because we know that the

spread of a knowledge of electricity and the cultivation of electrical skill (for which there is no better medium than wireless) is in the widest sense of the utmost national value in this glowing morning of the electrical age of mankind.

Since the time when Admiral Sir Henry Jackson, my predecessor in office, gave the first autumn Presidential Address, the custom has grown up of employing the occasion to tell members and the public of the recent joys and sorrows of the Council. I shall take advantage of this custom to-night.

THE INTERNATIONAL CONGRESS IN PARIS.

First of all, I have to inform you that the Society had the pleasure last Easter of taking part in the International Congress in Paris, held under the Chairmanship of Mr. Hiram Maxim, which led up to the formation of the International Amateur Radio Union. Mr. Marcuse, the Hon. Secretary of the Transmitter and Relay Section, represented the Society in Paris and was elected to the International Committee which is to meet next Easter to draw up schemes for international amateur work. Since the formation of the International Union, Mr. Marcuse has been travelling in America and Canada. He came back with a message from the Canadian Radio Relay League, worded as follows:—

“Please convey our greetings to the Radio Society of Great Britain with congratulations on their achievements. We also congratulate the Transmitter and Relay Section on their wonderful success in the transatlantic tests and take this opportunity of expressing our desire for a stronger affiliation between Great Britain and the Colonies for the general benefit of amateur radio.”

A CURIOUS RESTRICTION.

Very shortly after these events the Post Office began to issue their permits to transmitters with new and unexpected restrictions printed upon them. The one striking directly

* Delivered on Wednesday, September 24th, 1924, at the Institution of Electrical Engineers.

at the international co-operation of amateurs just described is numbered 7 on the printed permits. It reads:—

“Messages shall be transmitted only to stations in Great Britain or Northern Ireland which are actually co-operating in the licensee’s experiments and shall relate solely to such experiments.”

I will read to you what the *Electrician*, one of the most important electrical journals of the world, said about it:—

“A CURIOUS RESTRICTION.—The permits to transmit, which are now being issued by the Postmaster-General to wireless experimenters and amateurs, contain a condition and limitation which is likely to give a good deal of trouble and whose precise object is not altogether clear How is it to be ascertained that the energy transmitted is passing within the frontiers of Great Britain and Northern Ireland and no further? Again, what exactly is the aim of the restriction? If only experimental messages are sent there can be no objection to whoever will receive them, and in the possibility of reception in unexpected places lies a good deal of the use and interest of this class of work. But quite apart from these points, the imposition of such a restriction, except in so far as it relates to *what* is sent, seems to us unjustified, not the least because it may have a harmful effect on the development of radio communication.”

I call attention to the words in this criticism:—“in the possibility of reception in unexpected places lies a great deal of the use and interest in this class of work.” This is so obviously true that the Society got into touch with the Post Office in order to elucidate the matter. We are given to understand that the printing of the restriction on the permit was merely embodying a practice already recognised; and that each experimenter desiring facilities for foreign communications should furnish particulars of the experiments and evidence of an arrangement for co-operation by a foreign or colonial station or stations. Our comment upon this is that it is impossible to make arrangements for receiving from unexpected places and acknowledging the receipt.

HOW THE RESTRICTION HAMPERS PROGRESS.

I think the restriction may have been conceived without information of the methods necessary for carrying out this very valuable

wireless range finding. For example, during the past few weeks very strong signals have been received in London from a powerful amateur station in the Argentine. The right thing for any English amateur to do would be to reply instantly and endeavour to get into touch on the same wavelength after making sure that he would cause no local interference. If he succeeded and made records of the variations of signal strength, he would have contributed something to wireless progress. But, according to the new restriction, he would thereby be endangering his permit. As the *Electrician* says:—“What is the aim of the restriction? If only experimental messages are sent there can be no objection to whoever will receive them.” I agree. It makes no difference whatsoever whether a message is addressed by a Sheffield amateur to a man in the Shetlands or a man in Dublin, yet the latter would be a breach of the permit. It makes no difference because the same waves go forth in the same all-round way whatever morse call sign is put at the front of the message.

IS THE RESTRICTION DULY AUTHORISED?

I cannot imagine that international amenities can be assisted by any restriction that asks a British amateur to turn a deaf ear to his brother amateur in other countries who is not under such a restriction and will not understand it. The Council have received so many protests from members all over the country that they have had to enquire under what Act of Parliament and for what national or other reasons this limitation of a licence-holder’s liberty is imposed. They have found no answer and they have concluded that such a restriction would destroy one branch of research, would prevent the development of friendly relations between amateur workers in this and other countries, and would tend to isolate the British amateur from international co-operation with the rest of the active world.

THE AMATEUR AND SHORT-WAVE TRANSMISSION.

It may not be generally known that the volume of continental amateur transmission that can now be heard in this country from dusk to midnight is vastly greater than the whole volume of our own amateur transmission at all hours. At this point one cannot reiterate too forcibly that it was the

amateurs who discovered the valuable properties of short waves across long distances. Up to three years ago the commercial companies and the experts thought that short waves were no use for long ranges. Then the amateur stepped in and bit by bit extended the range across which one could communicate with another. Two years ago, as a result of the Radio Society's transatlantic experiments, the incredulous ones looked into the matter. Then the engineers of the Marconi Company, by using larger powers and reflecting screens, developed the Beam system, which, it is hoped, will afford many parts of the Empire a service of high speed telegraphy. In view of these very recent triumphs of the amateur, this seems quite the wrong moment to introduce restrictions which will push the British amateur off this field of discovery and leave it to the amateurs of other nations.

THE WIRELESS TELEGRAPHY ACT AND ITS INTERPRETATION.

The restriction and the discussion have called great attention to the Wireless Telegraphy Act. The Act seems very clear and I propose to give you my reading of it. First notice that the expression "wireless telegraphy" is defined to mean any system of communication by telegraph without the aid of any wire connecting the points from and at which the messages for other communications are sent and received. The main object of the Statute is to protect the State monopoly of the electrical transmission of messages or communications between individuals. A second object is to establish control over the sending and receiving of messages inasmuch as transmission by wireless telegraphy was thought to be a possible source of danger to the State in certain

events, especially war. Another object is to obtain such control as will minimise the interference of one user of wireless with another. All these aims are just and necessary. They are to be obtained by prohibiting persons from establishing any wireless telegraphy station or installing or working any apparatus for wireless telegraphy except under licence from the Postmaster-General.

Two very important provisos are made in the Act. The first, which governs the whole Act, is that "nothing in this Act shall prevent any person from making or using electrical apparatus for actuating machinery or for any purpose other than the transmission of messages." In other words, if the purpose of a piece of electrical apparatus is *not* the transmission of messages it need not be licensed. This provision is obviously a necessary one, for otherwise every piece of copper wire wound into a coil and every pair of metal plates fixed up as a condenser, would need to be licensed, which would reduce the Act to an absurdity.

The second proviso is that when a British subject wants a licence for the sole object of conducting experiments in wireless telegraphy, that is, in communication to a distance, a licence shall be granted to him as his right. But he must prove to the satisfaction of the Postmaster-General that his sole object is to conduct experiments; that is to say, he must not have the intention to transmit messages for money, must not intend to interfere with other users of wireless maliciously, and must not intend to do anything dangerous to the State. This is the amateurs' Magna Charta.

(To be concluded).

FORTHCOMING TRANSATLANTIC SHORT WAVE TESTS.

Reference has been made in a recent issue to the probability that long distance communication by amateurs on short wavelengths will produce some remarkable results during the coming autumn and winter. Notification has already come to hand of two or three cases where two-way transmission extending over considerable periods of time have been established between this country and the United States and Canada. That which last year was an achievement of a comparatively few individual amateurs in this country is this winter likely to be a

fairly general experience amongst a large number of transmitters.

The Transatlantic amateur tests arranged to take place in October will be certain to arouse enthusiasm amongst those who hitherto have not made any determined effort to communicate over such great distances, and the experience that will be gained during those tests will no doubt result in fairly efficient communication being established during the rest of the winter by a proportionately large body of British amateurs.

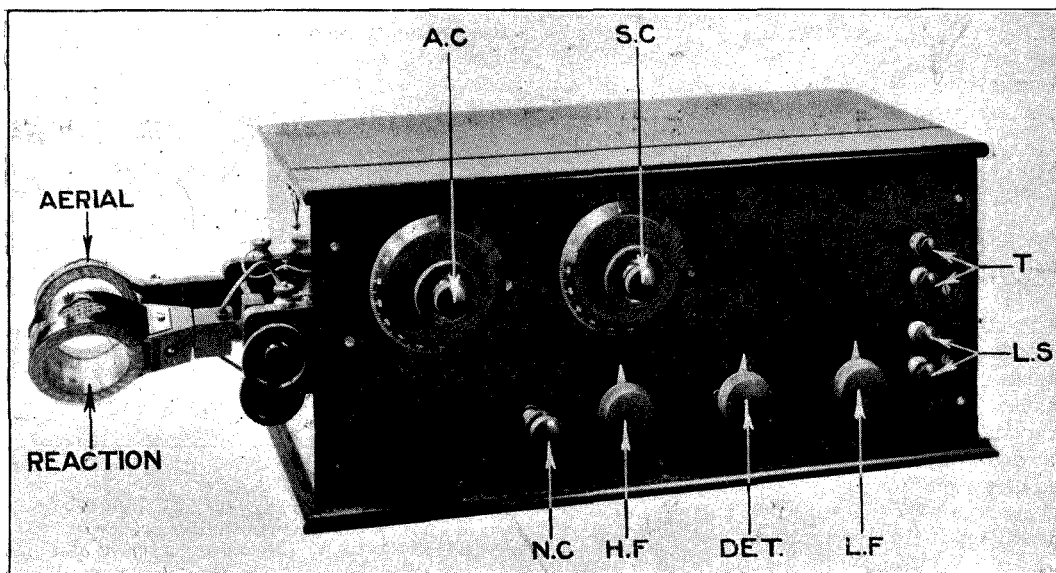

THE SUPER-SENSITIVE SET.

This three-valve receiver gives a remarkable degree of amplification with good selectivity. The receiver is simple to build and easy to operate.

By W. JAMES.

THIS receiver has three valves, giving one stage of high frequency amplification, rectification, and one stage of speech frequency amplification. Telephones may be connected to the detector or a loud speaker to the last valve.

The valve employed in the high frequency stage is a Marconi-Osram D.E.5 B, a new valve which has a voltage amplification factor of 20, and an impedance of 25,000 ohms. The valve requires a filament current of 0.22 ampere at 5 volts, and the anode current is only 1 milliampere when the anode voltage is 80 volts and the grid voltage zero. It appears to be a much better valve for high frequency amplification than a general purpose valve (such as an "R" type), even though the latter has been specially chosen for H.F. work. For instance, it

consumes about one-third of the filament power, has a much lower impedance, and has an amplification factor about $2\frac{1}{2}$ times that of an R type valve.

I have found it advisable to employ a circuit which can be adjusted to neutralise the effects of the capacity which exists between the elements of the valve and between the wiring. One effect of capacity coupling is to pass energy from the anode circuit to the grid circuit. This acts in much the same way as ordinary magnetic reaction, which might, for example, be provided by correctly coupling a coil connected in the anode circuit to one connected in the grid circuit. The energy which is passed from the anode circuit to the grid circuit increases the signal strength, which is a desirable thing so long as the amount of amplification can

be controlled. But with ordinary methods of amplification adjusted to give good efficiency, strong oscillations are usually generated when the anode and grid circuits are tuned to the same frequency. Thus the oscillations appear in the aerial, and are radiated to the annoyance of other listeners.

In addition, speech is distorted when the circuits of the receiver are oscillating, or on the point of oscillating.

METHODS OF OBTAINING GOOD HIGH FREQUENCY AMPLIFICATION.

There are two good methods of arranging the circuits in order that the effects of the unwanted capacity coupling may be minimised. These have been fully described in previous numbers of this journal.* The receiver described below is connected in such a manner that either of the two methods may be employed.

A holder consisting of a piece of ebonite with five valve sockets is wired in the circuit, and plug-in units for various wavelengths may be fitted in this socket. The plug-in unit consists of a holder having five valve pins, and carries two basket coils, which form a fairly closely coupled high frequency transformer. The two schemes of connection are shown in Figs. 1 and 2.

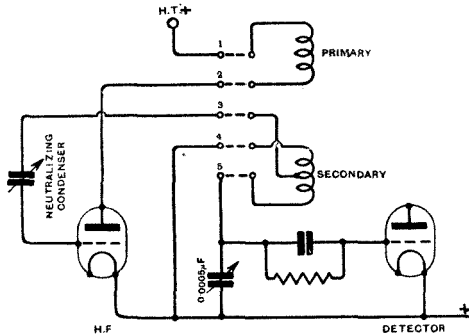

Fig. 1.

This figure shows one method of connecting the high frequency transformer to the holder. The holder has five pins which fit in five sockets, marked 1 to 5.

In Fig. 1 one basket coil (which forms the primary winding) is connected to pins 1 and 2, and the second basket coil (which forms the secondary winding) is connected to pins 4 and 5. Pin 3 is connected to a point on

the secondary winding. It will be observed that the sockets in the holder are wired in such a way that when the holder is fitted in the socket the primary winding is connected between the anode of the first valve (H.F.) and the positive terminal of the high-tension

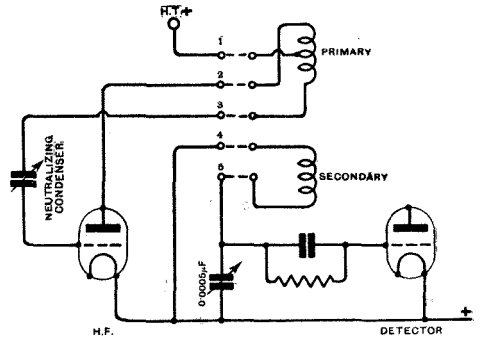

Fig. 2.

Another method of arranging the high frequency transformer. With this arrangement the primary winding has a centre tapping. In the arrangement of Fig. 1 the secondary winding is tapped. See also the photographs.

battery, and that the secondary winding is connected across a tuning condenser in the grid circuit of the detector valve. One side of the tuning condenser is, therefore, connected to the grid condenser and leak, and the other side to the positive side of the filament. To minimise hand effects, the moving plates are connected to the point of fixed potential—that is, the filament. Socket 3 is connected to one side of a small capacity variable condenser, and the other side of this condenser is joined to the grid of the high frequency amplifying valve.

When the coils of the high frequency transformer are suitably arranged as regards the ratio of turns of the primary and secondary windings, the direction of the windings, and their connection in the circuit, it is possible to make adjustments of this small condenser which balances the circuit. That is to say, when the condenser is correctly adjusted, no energy (or more correctly, a negligible amount of energy) is passed from the anode circuit to the grid circuit through capacity coupling between these circuits. Without the special connections and the small adjustable condenser the valve would probably oscillate when the grid circuit of the high frequency amplifying valve and the H.F. transformer are tuned to

* June 25th, 1924, page 358.

the same wavelength. By employing the condenser as shown in the figure, the effect of unwanted capacity coupling is neutralised, hence the balancing condenser is called a neutralising condenser. The advantages of this method of arranging the circuit are that tuning is simplified, a much higher degree of amplification is obtained, tuning is sharp, and oscillations which may be set up in the circuits of the detector valve by adjustment of its anode voltage, filament current or grid leak are not communicated to the grid

to grid condenser and leak, end of secondary to filament, and the tapping to one side of the neutralising condenser.

A SECOND METHOD OF COUPLING THE HIGH FREQUENCY AMPLIFIER.

The second method of connection, shown in Fig. 2, involves the use of a larger primary winding, in which a centre tapping is provided. This tap is connected to the positive terminal of the high tension battery, the beginning of the winding going to the

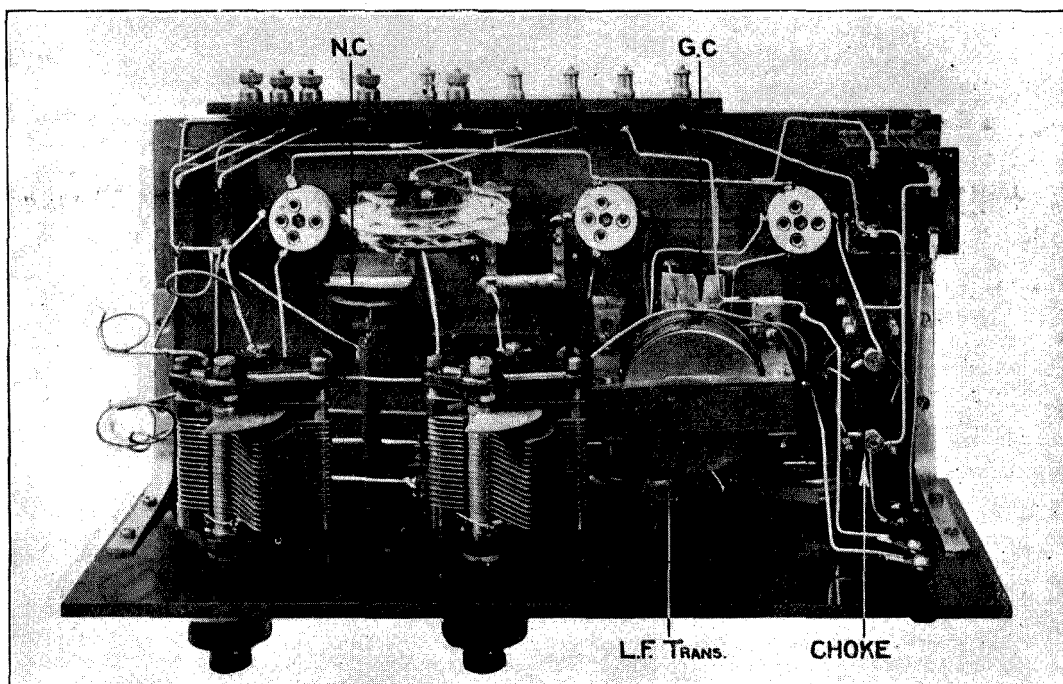

View taken from above the three-valve receiver. N.C. = neutralising condenser. G.C. = grid cells.

circuit of the high frequency amplifier (and therefore do not reach the aerial).

To tune over the broadcast band of wavelengths, the primary winding may have 24 turns of No. 24 D.C.C. wire wound as a basket coil on a former $1\frac{1}{2}$ ins. in diameter, with 13 pegs. The secondary winding may be another basket coil containing 66 turns of No. 24 D.C.C. wound on a similar former. A tapping should be made at turn 32 from the beginning of the winding. The coils are wound in the same direction, the beginning of the primary going to + H.T., end of primary to anode, beginning of secondary

neutralising condenser and the end of the winding to the anode of the valve. To tune over the B.B.C. band of wavelengths, the secondary winding may have the same number of turns as before, and is connected in circuit as described in connection with the arrangement of Fig. 1. The primary winding may have twice as many turns, that is 48 turns, with a tapping at turn 24.

THE COMPLETE CIRCUIT.

Referring now to the complete circuit of the receiver, Fig. 3, it will be noticed that a plug-in coil is employed in the aerial circuit,

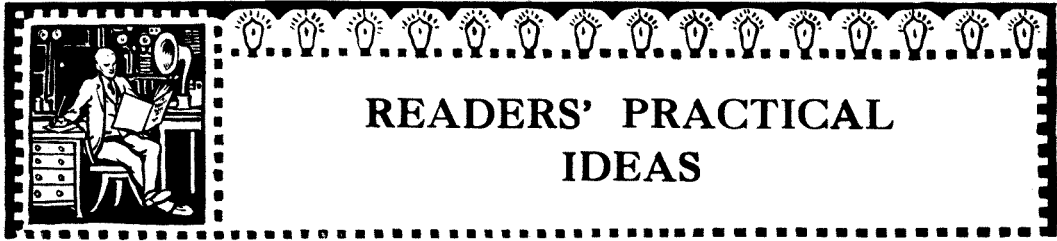

READERS' PRACTICAL IDEAS

This section is devoted to the publication of ideas submitted by readers and includes many devices which the experimenter will welcome.

Telephone Receiver Extensions on a Single Wire.

WHEN extending telephone or loud speaker leads, the simplest method consists of running only one wire and picking up an earth connection. It will be seen from the accompanying circuit diagram that the H.T. battery is earth connected when a single circuit tuner is employed, whilst even with a loose coupled set it is usual to connect the battery side of the closed circuit to the earth lead. In using the circuit shown here it is always necessary to connect in the plate lead from the H.T. battery either an iron core choke coil or a pair of high resistance telephone receivers. A very indifferent or high resistance earth connection

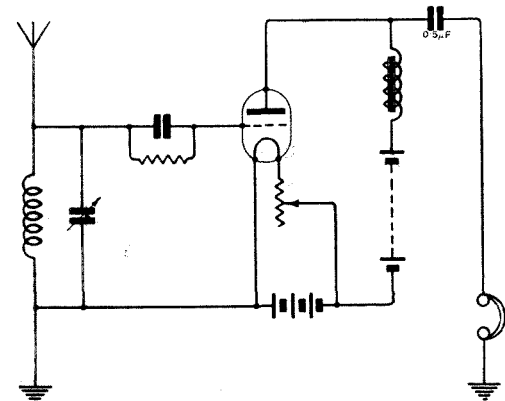

The telephone lead on the right in the diagram may be extended to pairs of telephones, picking up a local earth connection.

will suffice for the extensions, and in the event of telephone sets being used out of doors it is only necessary to drive the blade of a knife into some moist ground.

W. W.

Plug-in Crystal Detector.

THE convenience of constructing a crystal detector so that it can be plugged into circuit and interchanged with others is readily appreciated. It provides for

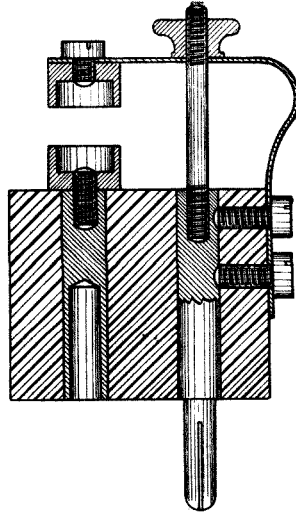

A useful plug-in detector of simple design.

reversing the connections of the crystal and moreover the detector can be entirely lifted out of circuit when the set is not in use, which prevents the crystal surfaces becoming damaged as would be the case were the detector lifted continuously on circuit.

A simple plug-in detector can easily be built up from a coil holder socket and the accompanying diagram gives the necessary constructional details which can easily be followed without further description.

W. H. G.

Fixed Condenser Connection.

SOME difficulty is usually experienced in making connection to the tags of the Dubilier type 600A condenser when used in temporarily laid out circuits. The method of twisting pieces of wire on to the tags is as a rule adopted and the connection so obtained is very doubtful and it is a very troublesome job to change one condenser for another of different value.

The simple device shown in the accompanying drawing will facilitate the making of a rapid and reliable connection. It consists of a piece of 3/16 in. or 1/4-in. ebonite, 2 3/4 in. x 1 in. and carries a pair of terminals. These terminals hold down two pieces of hard

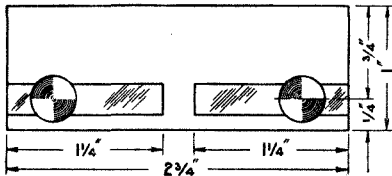

Clip for making contact with condenser tags.

brass strip of about No. 20 S.W.G. in thickness and 1 1/4 ins. in length by 1/4 in. in width. Using this device, the condenser tags simply slip beneath the brass strips, making a reliable contact.

J. N.

Sliding Contact Switch.

WHEN making up a multi-contact switch several difficulties present themselves, such as getting the spindle and bearing exactly a right angle to face of ebonite and truing up the studs and getting the arm to run smoothly. By arranging the studs in line, a rod and slider with spring contact can be utilised to traverse them. Constructional details are shown in the drawing.

J. S. B.

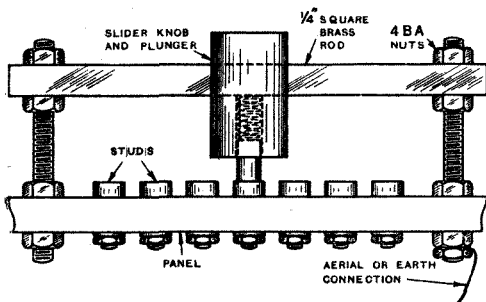

Multi-contact tapping switch.

Protecting Valve Filaments.

WHEN an additional filament resistance is connected in series with the filament battery leads of a multi-valve receiver, the following advantages will be gained:—

- (1) The filament battery can be switched on and off gradually, thus reducing the shock to the filaments and without disturbing the setting of the separate resistances.
- (2) Filament setting of a critical adjustment may be left undisturbed if required, switching off being done by the extra resistance, and thus compensating for any initial recuperation of the filament battery.
- (3) Lower resistances of larger gauge wire may be used on the filaments of the individual valves, thus providing more critical adjustment.

J. M. R.

BY fitting up as an external component a filament resistance in series with the L.T. supply a complicated set can be rendered suitable for use by unskilled operators.

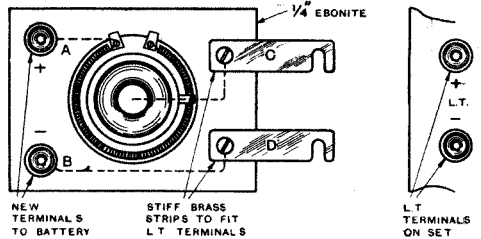

Construction of a filament resistance panel for use in addition to the filament resistances already fitted to the set.

The resistance which is mounted as shown on a separate panel has terminals and connector clips. It serves to switch on the filaments of the set without disturbing the adjustment of the individual resistance.

J. T. D.

VALVES FOR IDEAS.

Readers are invited to send in descriptions of "gadgets" for inclusion in this section. To readers whose suggestions are accepted a receiving valve of standard make will be despatched. Letters should be addressed to The Editor, *Wireless World and Radio Review*, and marked "Ideas."

The many communications which have already come to hand are being dealt with as expeditiously as possible.

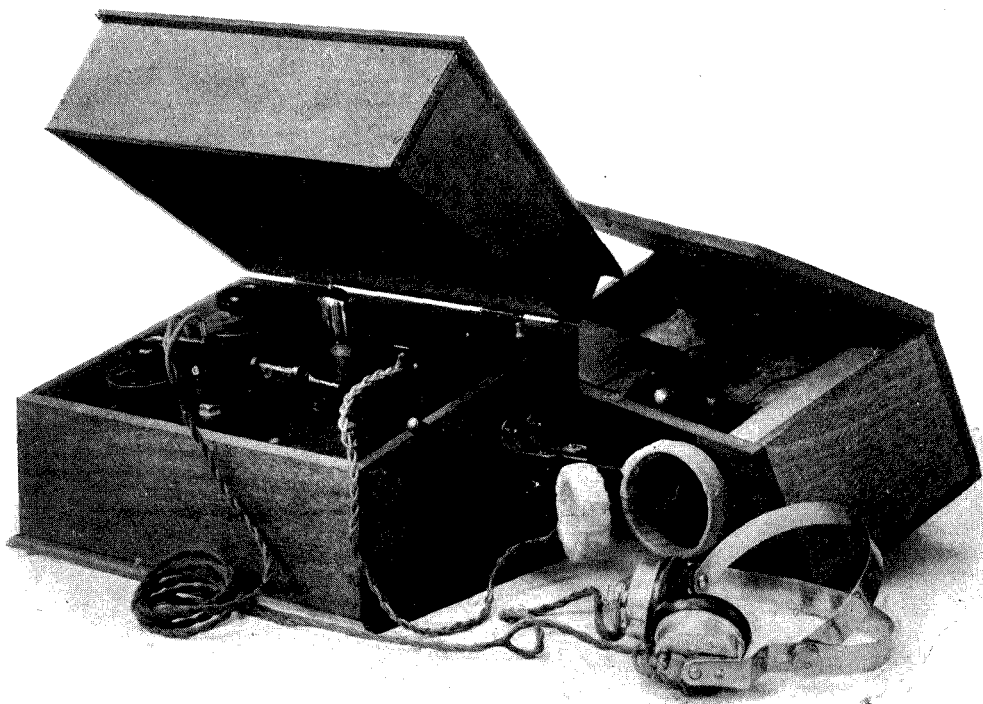

The complete set with containing box for dry batteries.

THE DRY CELL RECEIVER.

This receiver has been specially designed to obviate the difficulties of accumulator charging which beset many amateurs, particularly those resident in country districts where charging facilities are few and far between.

By H. J. COOKE.

THE purpose of this short article is to give some practical details of a set which is economical in filament current and which is simple to manipulate and easy to construct. It makes use of a circuit in which the valve is used both as a high and low frequency amplifier and detection is carried out by means of a crystal. The valve is of the 0.06 type and will, of course, work very well from a dry battery. The set is probably the most economical arrangement that can be built and is specially suitable for use where accumulator charging is a difficulty. It possesses a reasonably long range of reception accompanied by good signal strength.

Whilst appreciating that many difficulties arise in the operation of dual amplification circuits it will be found that some advantage is gained when using this circuit even on the wavelengths used for broadcasting, whilst for longer wavelengths its efficiency improves and thus very good reception can be obtained up to considerable distances from the new high power station, working as it does on 1,600 metres.

To facilitate construction of the set a complete list of components is given and is as follows:—

Ebonite panel 12 ins. by 9 ins. by $\frac{1}{4}$ in.

Ebonite panel $4\frac{1}{4}$ ins. by $3\frac{1}{2}$ ins. by $\frac{1}{4}$ in.

14 ins. 2 B.A. screwed rod.

must be precisely worked to and all sides must be kept perfectly true and square. The reader is reminded that planed mahogany boards can be obtained from dealers in fret-work supplies and when accurately planed wood is used the cabinet construction will be very much simplified. In the construction of instrument cabinets, it is a good plan to leave certain of the dimensions a little larger than is required, so that after the sides have been screwed and glued together, projecting portions can be filed down flush and square.

Following the usual procedure for the construction of simple receiving sets the positions

a number of holes close together round a circle and filing down to a slightly larger circle with a half-round file.

The valve holder is carried on a separate sub-panel which is attached to the main panel with four pieces of brass rod tapped into blind holes on the underside and held in position by means of nuts. After rubbing down the panel in the usual way with carborundum cloth, assembly can be proceeded with. The valve holder with its sub-base should be mounted first.

Stiff wiring is the only permissible method of connecting up and a practical wiring

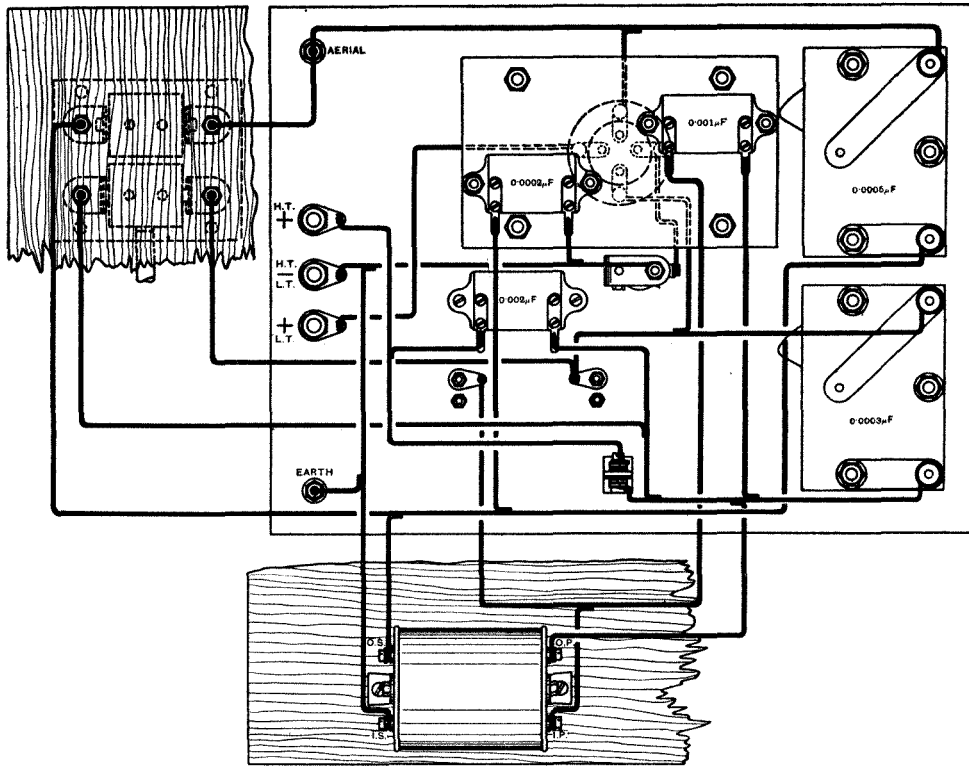

Practical wiring diagram.

for the component instruments should be carefully marked out, using either a sharp pointed pencil on the matted face of the ebonite or the sharp point of the dividers on the underside. The marks are, of course, centre-punched to hold the point of the drill before drilling is proceeded with. It will be seen from the drawings that one large hole is required where the valve projects through the panel and this can be made by drilling

diagram is given as a guide. It will be noticed that the tuning coils are attached to the side of the cabinet and there are many useful patterns of coil holder on the market already mounted on an ebonite piece for attaching to the instrument. The complete set, which is shown in the accompanying illustration, has been found to give very satisfactory results, being very cheap to run.

CONSTRUCTING THE VALVE.

A VISIT TO THE MARCONI-OSRAM VALVE CO.'S WORKS.

A VAST amount of experimental work has been necessary in order to bring the thermionic valve to its present state of perfection. The early research work in this direction was conducted in this country by Marconi's Wireless Telegraph Co., Ltd., who acquired the patent rights of the valve from Dr. Fleming, who, as is well known, invented it in 1904.

It was during the war that the application and development of the valve was most rapid, and the General Electric Co., Ltd., devoted a portion of their Osram lamp factory at Hammersmith to investigate the problems involved in valve manufacture, and huge quantities of valves were produced for the fighting forces. The results of these

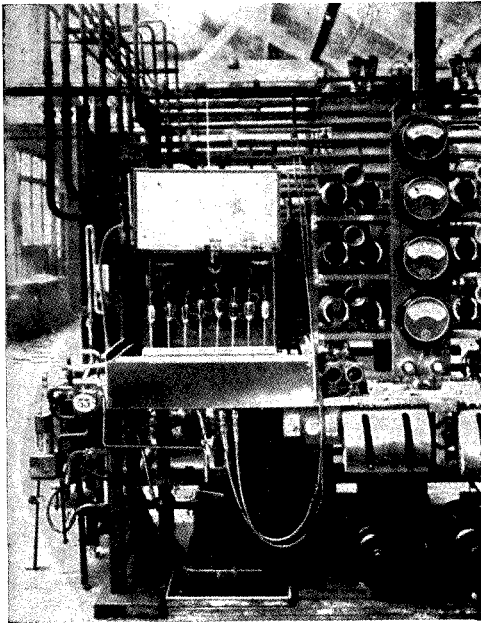

Pump tables with eddy current heating equipment for fine filament valves.

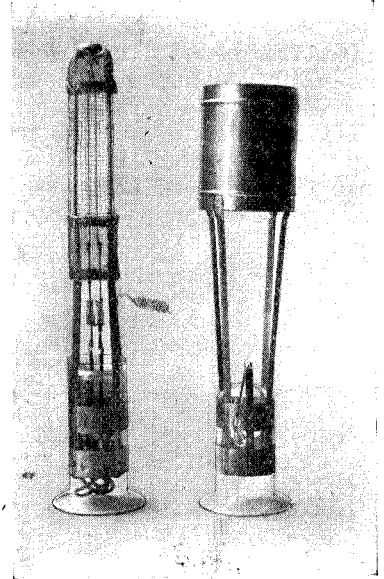

Electrodes for a typical transmitting valve.

experiences are combined in the M.O. Valve Co., Ltd., an organisation which has the joint advantage of the research laboratories of the General Electric Co., Ltd., and also the wide experience of the Marconi Company's engineering and research staff.

The resources of the M.O. Valve Co., Ltd., are to-day devoted to the production of valves marketed under the name of Marconi Osram.

It is interesting to follow through the various processes involved in the manufacture of a valve. A dull emitter valve, such as the D.E. 3 type, forms an interesting example of the skill of the operatives engaged in its construction and of the ingenuity of the various machines. The preliminary operations result in the production of what is known as a pinch or seal. Four copper wires are threaded through a short length of glass tubing, one end of which is expanded into a flange or bell mouth. The unflanged end of the tube is heated by blow lamps and squeezed flat, gripping the leading in wires and forming an air-tight seal.

The four supporting wires are bent to the correct shape according to the type of valve being constructed. In certain instances, such as in the case of a valve having a

vertical filament, grid and plate and extension of the supporting system is added at this stage, consisting of top supports. These are joined into a rigid unit and at the same

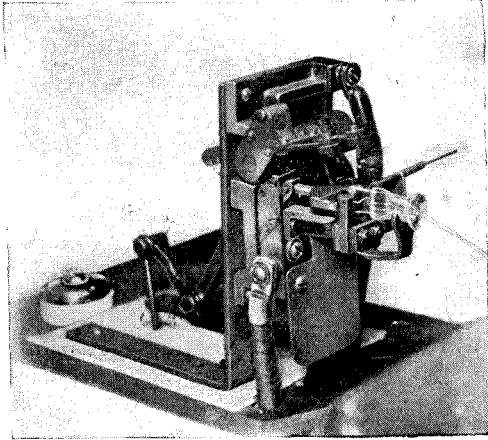

Spot-welding apparatus for assembly.

time insulated from each other by sealing them into a glass bead. This upper unit is attached to the lower portion by spot welding the upper filament support to one of the short filament stays.

In another portion of the works the grids, plates and filaments, are prepared ready for mounting upon their supports. The grids are made upon a machine on which the necessary number of turns correctly spaced are wound and spot welded at every turn to the supporting wire. The assembly of these components upon their respective supports calls for the greatest accuracy and delicacy of touch. An ingenious machine brings the parts in correct register with each other, and then swiftly and securely spot welds them into position.

The sealing-in process consists of inserting the seal with its filament plate and grid into a bulb, to the top end of which a short glass tube has been attached, through which the air will ultimately be exhausted. The seal and bulb revolve and are heated by gas flames until the two pieces of glass fuse together. The valve, when ready for exhausting, is attached to the air pump by the exhaust tube previously attached to the bulb. The high degree of vacuum necessary is obtained by raising the metal parts of the

valve and the inner surface of the bulb to an extremely high temperature, a short length of magnesium wire, which is affixed to the plate, assisting this process.

Several methods of heating the plate and flashing the magnesium are adopted. That used for D.E.3 valves is known as eddy current heating. A coil of copper wire through which a high tension current of very high frequency can be made to flow is slipped over the bulb of the valve. The closing of the pump cage doors automatically switches on the high frequency currents, and in a few seconds the eddy currents induced in the plate have raised the metal to a sufficiently high temperature to flash the magnesium.

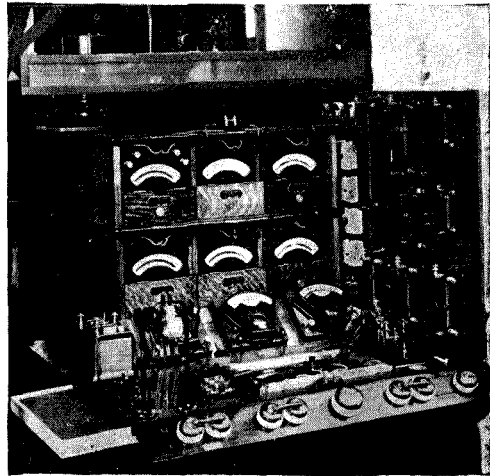

A typical test table where the valves are checked for filament consumption and emission.

The elaborate arrangements for testing every valve made at the M.O. valve works are worthy of particular note, for it is only in this way that the company are able to produce valves, in bulk, of absolutely standardised performance. A specially trained testing staff is employed to examine the valves, which are tested for filament consumption, for emission at set conditions, and for impedance. Finally a microammeter gives a reading of the maximum reverse grid current. Having successfully emerged from these tests the valves are passed to benches for capping, marking and packing.

PATENTS AND ABSTRACTS



A Pile-Wound Variometer.

The object of the designer of this variometer* is to provide a piece of apparatus in which the distributed capacity is small, and which has novel features of construction. Instead of the usual form of single-layer winding, a banked or pile winding is employed, as may be seen from Fig. 1, where A is the rotor and B the stator of the variometer.

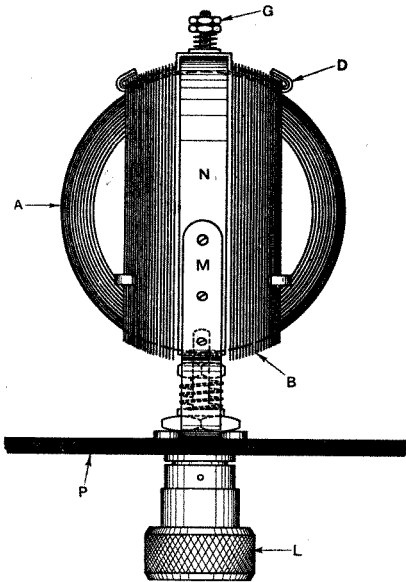

Fig. 1. A variometer having pile or banked windings.

Each coil consists of two separate parts, which are wound independently of each other, but on the same spherical-shaped former. When the winding has been completed, the turns of the coil are stuck together

by the application of a solution of amyl acetate and celluloid. The two sections of coil forming the rotor are connected together by metal straps, which are covered on the side which comes in contact with the wires with an insulating material. A similar method of securing the coils of the stator is employed, but the strips (D, Fig. 1), are turned up to prevent the end turns slipping. The other features of construction will be apparent from the figure, where G is one of the spindles, L is the knob, P the panel, and M the securing bracket fastened to the insulating support N.

Reflex Receivers.

In most reflex receivers a number of valves are arranged to give high frequency amplification, the high frequency currents are rectified, and the rectified current fed back to the grid circuits of the high frequency valves through suitable coils or condensers in such a way that the first high frequency amplifying valve also operates as the first low frequency amplifying valve, and so on. This patent* describes a reflex receiver in which it is claimed that the amplification is obtained without loading any one valve substantially more than another.

The circuit appears as Fig. 2, where V_1 , V_2 and V_3 are the amplifying valves, and V_4 the rectifying valve. Incoming signals are applied to the grid of V_1 at terminals A, B, and appear in the plate circuit, which includes the primary winding of the high frequency transformer T_1 . Condenser C_1 provides a low impedance path between the end of the primary winding of this transformer and the filament.

* British Patent No. 220,185, by C. J. Owen.

* British Patent No. 204,301, by David Grimes.

The secondary winding is connected between the grid and filament of valve V_2 , condenser C_2 providing a low impedance path between the bottom of the grid coil and the filament. Valves V_2 and V_3 are connected in the same way as valve V_1 , but valve V_4 has a grid condenser and leak connected in the grid circuit. The high frequency component of the currents which are rectified by valve V_4 has a low impedance path to the filament

The advantages of this method of connection are as follows:—The condenser C_3 , which is designed to carry the high frequency currents flowing in the plate circuit of the detector, is shunted across the primary winding of the transformer T_2 . High frequency currents may therefore pass between the primary and secondary windings of this transformer, and so reach the grid of valve V_3 . If the output from the detector were

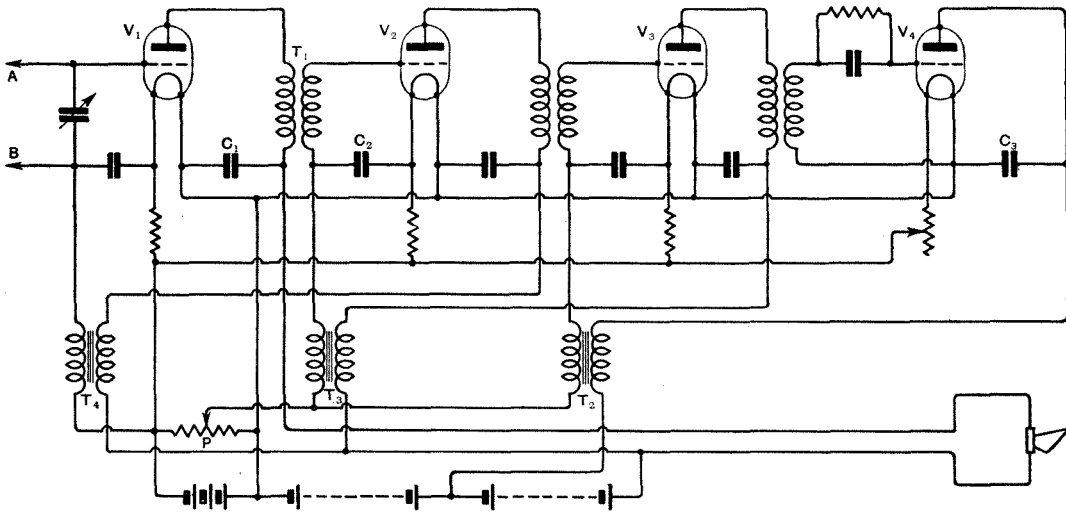

Fig. 2. Connections of a Reflex receiver.

through condenser C_3 , but the low frequency currents pass through the primary winding of transformer T_2 . The secondary winding of this transformer is connected in the grid circuit of valve V_3 , one end being joined to the filament end of the high frequency transformer, and the other to the sliding contact of the potentiometer P. Hence the low frequency currents are amplified by valve V_3 , and, appearing in the plate circuit are stepped up by a transformer, T_3 , and applied to the grid of V_2 . Valve V_2 amplifies the low frequency currents which are then applied to the grid of V_1 through the transformer T_4 .

In the plate circuit of V_1 is the loudspeaker. It will thus be seen that the high frequency currents have received three stages of high frequency amplification, and that the low frequency currents have also been magnified three times.

fed back to the first valve, the high frequency leakage current would be amplified to such an extent that probably the receiver would be unstable.

Another advantage is obtained because low frequency signals which may appear on the grid of the first valve are not amplified to the same extent as they would be if the first valve were operating as the first stage of low frequency amplification, instead of as the last stage.

The intervalve high-frequency coupling transformers indicated in the figure are untuned. Hence they should consist of a number of turns of fine wire. If ordinary pin-type transformers are to be employed, it is advantageous to tune them by shunting the secondary windings with small variable condensers.

W. J.

NOTES & CLUB NEWS



Australia's beam station is to be erected on Broadmeadows, in Victoria.

Owing to interference with local signalling, the Liverpool and Leeds relay stations will probably be moved to new sites.

Radio letters are now accepted at Marconi offices for Boston and Washington, at the rate of 3d. and 3½d. per word respectively.

According to press reports, amateur wireless communication has been secured between New Zealand and California and Buenos Aires.

Winnipeg (CKY), Moscow and Frankfurt am Main broadcasting stations now transmit regular features in Esperanto.

STRENGTHENING THE AMATEUR POSITION.

As a direct result of the outspoken statement of Dr. Eccles, in his Presidential address before the Radio Society of Great Britain on the unfair conditions imposed by the Post Office on amateur transmission, Mr. John Scott-Taggart has placed the sum of £500 at the disposal of the Radio Society to assist in fighting a test case with the authorities, should the Society so decide.

This offer, in addition to that of the same amount by *The Wireless World and Radio Review*, furnishes an imposing sum, which should prove of very material assistance to the amateur in his fight for recognition.

2 KF REACHES BRAZILIAN COAST.

Communication with the Italian naval vessel "San Marco" (1 HT) near the Brazilian coast was obtained on Wednesday, September 24th, by Mr. J. A. Partridge (2 KF), at 2.30 a.m. G.M.T.

The operator of 1 HT was the well-known Italian amateur, Signor Andriano Ducate (ACD), of Bologna. After exchanging greetings 1 HT stated that 2 KF's signals, although rather weak and badly jammed, were remarkably steady and clear and far more easily readable than many American amateurs at half the distance.

The wavelength of the two stations was practically the same, both being below 100 metres. 2 KF's power was 100 watts, with an aerial current of 1 ampere. The signals from 1 HT were very strong when a combination of detector and 1 L.F. was used.

Prior to Mr. Partridge's report we had been notified of the reception of 1 HT by Mr. W. D. Keiller (6 HR), of Southgate, and by Mr. E. J. Martin, of Cobham, Surrey.

AMATEUR TRANSATLANTIC WORKING.

Transatlantic two-way communication has already commenced for the winter and DX reports have been forwarded to us by Mr. G. Marcuse (2 NM) and Mr. J. A. Partridge (2 KF).

On Sunday, September 21st, Mr. Marcuse worked successfully with VDM, the Canadian Government Exploration Steamer "Arctic" on its way to relieve the North-West Mounted Police Posts. This communication was effected with the aid of Canadian 1 AR, Mr. Joe Fassett, of Dartmouth, N.S. The "Arctic" operated on 140 metres, using 190 cycle A.C., and about 2 kilowatts input.

At 2.50 a.m. on September 23rd, Mr. J. A. Partridge exchanged signals with American 1 AAC of Framingham, Mass. 1 AAC transmitted on 75 metres, 2 KF replying on 95 metres.

BROADCASTING FOOTBALL.

First-class side line descriptions of all important football games during the coming season are promised by WEAf, the broadcasting station of the American Telephone and Telegraph Company in New York.

The games will be graphically described by Mr. Graham McNamee, WEAf's principal announcer.

COLOGNE WIRELESS RESTRICTIONS.

A prosecution relating to the possession and operation of an unauthorised wireless receiving set took place at Cologne on Thursday, September 18th, when Herr Bodenstedt was fined 200 gold marks (£10 15s.) by a British Summary Court for contravening the wireless regulations imposed under the Peace Treaty.

From time to time the Rhineland Commission has reconsidered this restriction, which is strongly resented by the population in the occupied areas, but up till now no step has been taken to legalise broadcast reception.

WNP'S RETURN.

After 15 months in the Far North, Captain Macmillan and his party in the ship "Bowdoin" (WNP) have docked safely at Sydney, Nova Scotia. Coincident with the return of the expedition comes the news from Australia that WNP has broken all records for 200-metres long distance transmission.

Owing to limitations of space, the "Bowdoin's" transmitter, constructed by the Zenith Radio Corporation, of Chicago, was restricted to the low power of 100 watts. Notwithstanding the fact that the "Bowdoin" was frozen in during the winter within 11 degs. of the North Pole, communica-

tion was maintained all over the U.S.A. and Canada. **WNP's** operator, Mr. Donald Mix, was, however, unaware, on May 19th, that his signals were carrying to Australia. At 4.30 p.m. on that day, operator Cottrell, of Coogee, Australia, distinctly heard **WNP** working with **6 XAD**, located at Avalon on the Catalina Islands.

The distance covered by this transmission is over 9,060 miles. According to Cottrell's report, which has been closely investigated and confirmed, **WNP** was in daylight at the time of this long distance feat.

WHAT CLUB MEMBERSHIP MEANS.

At a time when no efforts are being spared to enrol new members in the radio societies throughout the country, an especially appropriate appeal was made from **2LO** on September 25th, by Mr. F. H. Haynes, who is a member of the Council the Radio Society of Great Britain.

of its own (**5 DQ**), and the course includes experimental work on the installation.

ROME BROADCASTING.

A series of concerts and talks is being transmitted regularly from the Rome Broadcasting station on a wavelength of 426 metres between about 8.30 and 9.30 (G.M.T.).

Many good reports of reception in Italy and neighbouring countries have been received by the station authorities and reports from British listeners are warmly welcomed. These may be forwarded c/o the Editor of this journal.

DX ON THE RIVER.

An original and highly successful "Field" day was spent by the members of the Société Française d'Etudes de T.S.F., on Sunday, September 14th, when a large party travelled by the launch "La Madelon" down the River Seine.

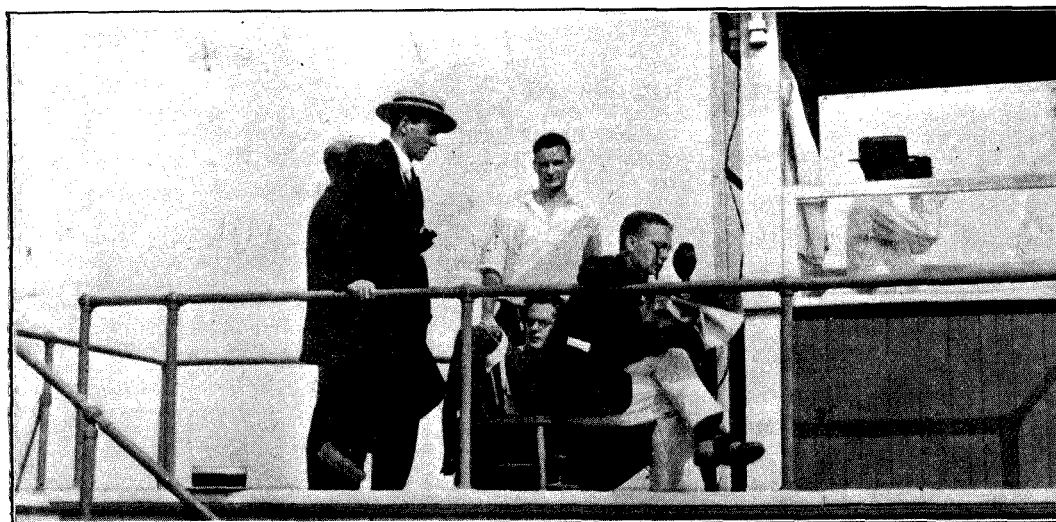

*During the International Horse Race on September 1st at the Belmont Park Race Track, New York, a description of the event was broadcast from the course through the Radio Corporation station **WJZ**. Our photo shows Capt. H. de A. Donisthorpe, and in front of him Major Andrew White at the microphone.*

Mr. Haynes pointed out the advantages of club membership to all who take even a passing interest in their wireless sets. Even those to whom popular, semi-technical and technical lectures did not appeal could reap benefit from the expert advice and help which were at all times available to club members and such service alone was well worth the nominal subscription of half-a-guinea a year.

WIRELESS AT MANCHESTER UNIVERSITY.

From a glance at the Prospectus of the Faculty of Technology of the University of Manchester for the Session 1924-25, it is evident that wireless is not neglected in the Electrical Engineering Course. The University possesses a transmitting station

A four-wire cage aerial was erected on board, and with a powerful receiving set and four loud speakers kindly lent by the Brunet Company, excellent results were obtained. A transmitter was also fitted, furnished by Messrs. L'Electro-Materiel.

During the morning and afternoon two-way communication was maintained with **8 AE**, owned by *La T.S.F. Moderne*, at Rueil, and an interesting log was compiled registering signal strength at different points on the river. Two-way working was also carried out with **M. Hueber (8 DP)** Versailles.

After luncheon, a speech of greeting by D. Franchette, the President, was broadcast from the boat on 200 metres and picked up by listeners-in in the Paris district.

Club Activities.

Correspondence for Secretaries of Societies will be forwarded if addressed to the office of this Journal, c/o the Editor.

In spite of rainy weather, the first Field Day to be organised by the North Middlesex Wireless Club, held on Saturday, September 20th, was voted a distinct success. The headquarters of the Club were located at the "Cabin," Cuffley, and here, owing to the courtesy of Mrs. Martin, two permanent aerials were available and some valuable comparative tests were carried out.

Some excellent communication with mobile car sets was obtained and among the discoveries made was that earth mats provide useful grips when starting cars which have become embedded in mud!

* * * *

Reference has already been made to the forthcoming wireless exhibition in Manchester, the largest of its kind in the City, which is to be held from October 14th to 25th, in the Exhibition Hall, Liverpool Road. Details in connection with the Exhibition were discussed by the Manchester Radio Scientific Society on September 17th and various committees have been appointed.

* * * *

Chemical rectifiers were discussed by the Streatham Radio Society on September 10th, experiences being recounted by Messrs. S. C. Anstee, A. G. Wood and A. D. Gay. The Society warmly welcomes new members and a cordial invitation to the Wednesday meetings is extended to members of provincial and affiliated societies.

* * * *

The Borough of Tynemouth Radio and Scientific Society has already held its second meeting of the new session. Amateurs in the district are perturbed to learn that the Cullercoats Station (GCC) is shortly to begin a service of weather reports in Morse, two or three times during the day.

Applications for membership of the Society are cordially invited.

* * * *

At the first meeting of the Autumn session of the Wimbledon Radio Society, held on September 19th, it was decided to hold another Field Day on October 9th. The Society has instituted a series of half-hour meetings weekly, to be devoted to Morse practice.

The Hon. Secretary welcomes enquiries from prospective members.

* * * *

An attractive programme for the winter has been prepared by the Lewisham and Catford Radio Society, including a lecture on October 2nd, by Mr. Appleton, of Messrs. Radio Instruments, Ltd., who is dealing with the subject of "Transformers and Their Circuits."

* * * *

The Brockley and District Radio Association, which recently resumed its meetings, dealt with the intriguing subject of Crystal Amplification at the



An enthusiastic group of members of the Société Française d'Etudes de T.S.F. photographed while on an experimental trip down the Seine.

last meeting, the lecturer being Mr. B. Hughes, M.I.B.

Intending members are invited to communicate with the Hon. Secretary.

* * * *

"Wireless in Schools" formed the subject of an enlightening lecture given by Mr. Usher before the Tottenham Wireless Society on September 17th. Having dealt with the subject in a general way, Mr. Usher gave an account of the formation and work of a School Radio Club with which he is connected. Mr. Loosemore then described the Morse Class and practical work, the latter being illustrated with excellently constructed crystal sets and tuners made by the scholars of the Raynham Road School, Edmonton.

* * * *

A new Society has been formed under the title of "The Dorking and District Radio Society," and will hold its first meeting on October 6th. Major G. C. Garrick has been elected President and the Hon. Secretary is Mr. A. J. Child, of High Street P.O., Dorking.

FORTHCOMING EVENTS.

WEDNESDAY, OCTOBER 1st.

Radio Research Society, Peckham. At 44 Talfourd Road. Discussion: "Electrical Units."

North Middlesex Wireless Club. Lecture: "H.F. Amplification for the Baghdad Circuit." By Mr. W. Gartland.

Clapham Park Wireless and Scientific Society. At 7.45 p.m. At 67 Balham High Road. Business Meeting.

THURSDAY, OCTOBER 2nd.

West London Wireless and Experimental Association. At Belmont Road Schools, Chiswick. Lecture: "Telephone Receivers." By Mr. E. M. Doughty.

Bournemouth and District Radio and Electrical Society. At 7 p.m. At Canford Hall, St. Peter's Road. Second Annual General Meeting.

MONDAY, OCTOBER 6th.

Dorking and District Radio Society. First Meeting.

Barnet and District Radio Society. At 8.30 p.m. At the Barnet Wesleyan Lecture Hall. "A Day at 2 LO." By Mr. A. R. Burrows, Assistant Controller and Programme Director, B.B.C.

Dulwich and District Wireless and Experimental Association. At 8.30 p.m. Opening Meeting. Sale of Wireless Apparatus.

THE WIRELESS EXHIBITION

A REVIEW OF EXHIBITS.

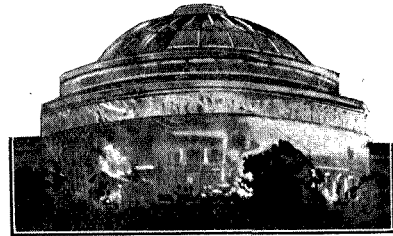

THE past twelve months have proved momentous ones for the wireless industry, and the rapid advances which have been made are strikingly portrayed at the Royal Albert Hall where the Wireless Exhibition organised by the National Association of Radio Manufacturers is now proceeding. The many improved components which the various manufacturers are exhibiting, show to a marked degree the trend of present-day design, which would appear to be towards simplification without in any way sacrificing efficiency. The Exhibition is open daily between the hours of 10.30 a.m. and 10 p.m., the price of admission being 1s. 6d. The closing date is Wednesday, October 8th. The following brief review of some of the exhibits will possibly serve as a guide to those whose time is too limited to allow of a close inspection of each stand.

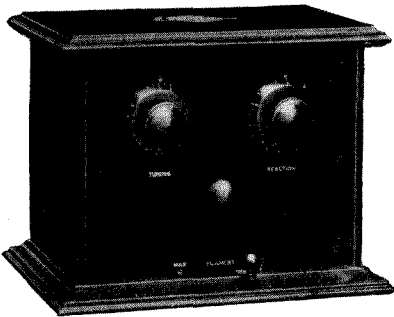

An attractive cabinet receiver by the Edison-Swan Electric Co.

At the stand of Radiophones, Ltd., a selection of high class Listoleon apparatus is displayed. The Big Ben low frequency transformer is a product of this concern. The Listoleon modulator, another component which is available for inspection, is so designed that when used as an anode resistance, it will carry a large current and therefore a circuit in which it is employed will not vary in performance due to the heating of the resistance.

Square law condensers, high and low frequency transformers, rheostats, switches and variometers figure prominently among the other wireless apparatus on the stand occupied by the Edison-Swan Electric Co. A noticeable feature is the fine Chinese lacquer finish on some of the instruments. Sets and loud speakers decorated in the same style render the wireless receiver quite a part of the decoration scheme of any room.

The centre of interest at the Radiax stand is the new reactance unit which, mounted on the panel of a set, can be used in conjunction with any plug-in H.F. transformer. It consists of an interchangeable coil mounted on an arm which is arranged to swivel on a pillar, this being clamped

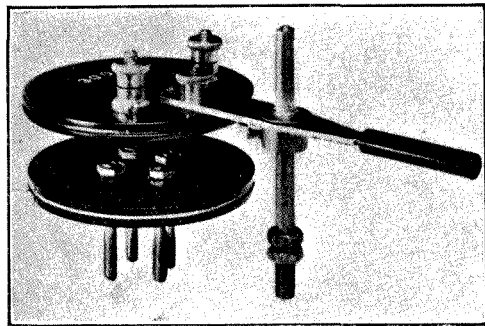

For use with plug-in H.F. transformers. The Radiax reactance unit.

to the panel. Three coils are available, providing a range of from 100 to 4,000 metres. The usual range of Radiax valve and receiving sets are shown in addition to tapped anode inductances and H.F. transformers.

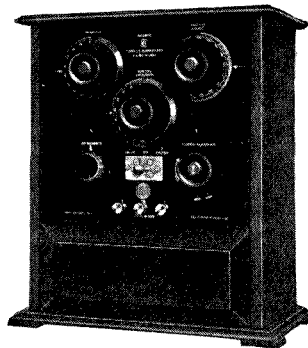

A further example of neat workmanship by The Edison-Swan Electric Co.

Those who are acquainted with the headphones manufactured by The British L.M. Ericsson Manufacturing Co., Ltd., will notice that these instruments are now fitted with considerably

lighter headbands. Their general construction, however, remains the same. Ericsson components are attractively displayed, and in addition to current designs, several unique types such as a patent dual filament resistance, a useful safety wander plug and other interesting products are shown.

Of considerable interest, the exhibit of the Western Electric Co. comprises a wide range of receiving and amplifying apparatus, the Weconomy dull emitter and the Western Electric power valves. Two types of Wecovalve are being exhibited—the spring socket type and the four-pin variety. The range of loud speakers produced by this concern are prominently displayed. Several

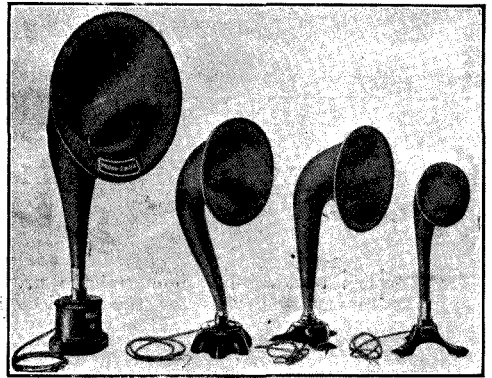

A feature on the stand of The Western Electric Co.

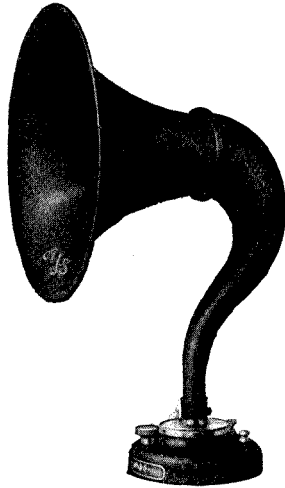

(Left) The four-pin type Wecovalve. (Right) A handsome loud speaker shown by A. J. Stevens & Co., Ltd.

tuning. The improved Microstat filament resistances, fitted with terminals instead of soldering tags, are shown and also the Supra low frequency transformer, wound in insulated layers of six sections.

Examples of their new model receiving sets are prominent on the stand of A.J. Stevens & Co. (1914) Ltd. A number of the A.J.S. variable condensers form part of the exhibit. These are fitted with

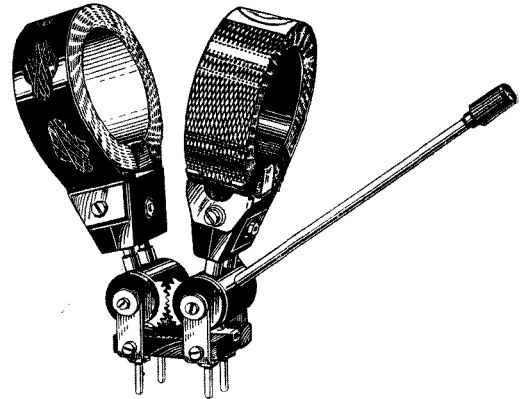

The new geared coil holder for obtaining fine adjustments. (A. J. Stevens & Co., Ltd.)

ingenious features are incorporated in these instruments, the delicately balanced armature system in one model deserving special attention.

A new Bijouphone model crystal set designed to receive on 1,600 metres is a speciality of Wates Bros. The most recent introduction of this concern is a tuned anode reactance for use in H.F. circuits. There are nine tapings, providing a range of 200 to 4,000 metres and a unique die-cast variable condenser is incorporated in the base for critical

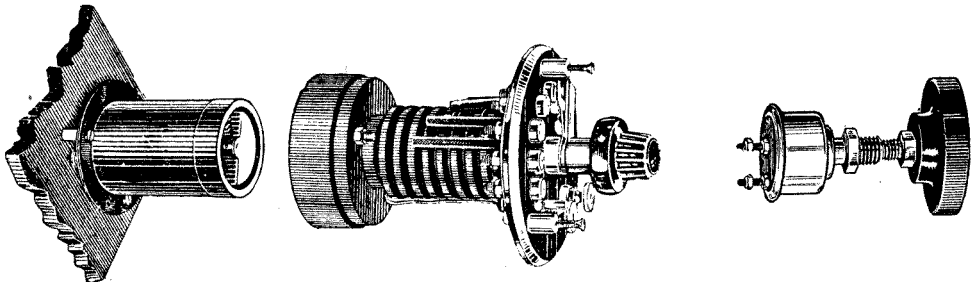

Wates Bros. tuned anode reactance unit and improved type Microstat filament resistance. Note the die cast variable condenser in the base of the reactance unit

anti-capacity shields and the vanes are so shaped as to give a negligible minimum capacity. The A.J.S. loud speaker should be worthy of detailed inspection, as should also the new types of tubular steel telescopic aerial masts.



One of the range of Hart low tension accumulators.

The various component parts of Hart batteries staged at the stand occupied by this concern should be of interest to many whose acquaintance with the construction of an accumulator is limited. It is possible to view Hart low tension batteries fitted in celluloid, glass and ebonite cases, the last named type being suitable for use in tropical countries where the high temperature conditions are unfavourable for celluloid types. The special splash-protected battery should interest owners of portable sets.

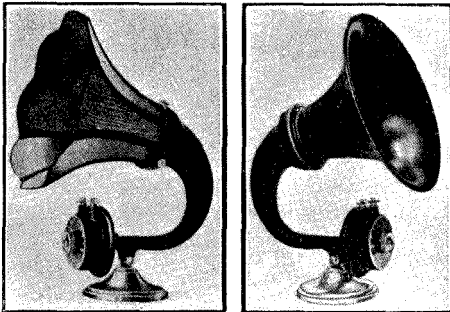

Two new Amphon models—the new Junior and the improved type of Dragon design.

It is not so very long ago that a loud speaker was considered rather a luxury, but now, due to the production of cheaper models, they are in universal use. Those in need of such an instrument will find types to suit every purse on the stand of Alfred Graham & Co. New introductions include

the Dragonfly, the "New" Junior and the "New" Junior de luxe. These have been introduced to meet the demand for a loud speaker at a figure between that of the original Junior and the standard patterns. All these new models incorporate the floating diaphragm and the sound conduit is of the most successful non-resonating type.

Much can be learnt regarding the construction of the new R.I. transformer by a careful study of the large section displayed by Radio Instruments, to operate over a wide range of wavelengths, which includes both the B.B.C. and the long Continental

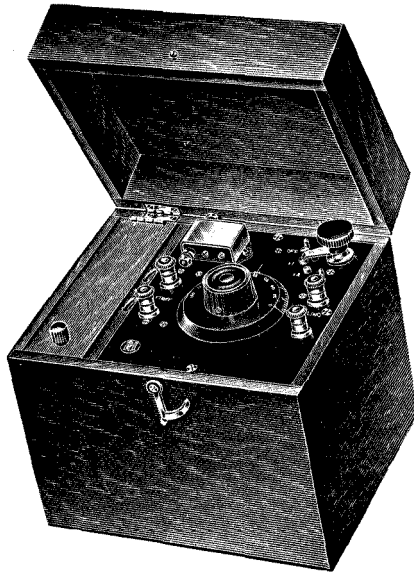

Radio Instruments' speciality. A compact wavemeter.

Ltd. A large variety of completed sets and components are to be seen at this stand, where the new type of buzzer wavemeter may be closely inspected. Special attention is drawn to the extremely wide range of high frequency components manufactured by this concern. H.F. transformers are made in two wavelength ranges up to 4,000 and 30,000 metres.

Many new and novel components are conspicuous on the stand of Beard & Fitch, Ltd. This concern is responsible for the "Success" products. The new Success tuner has been specially designed

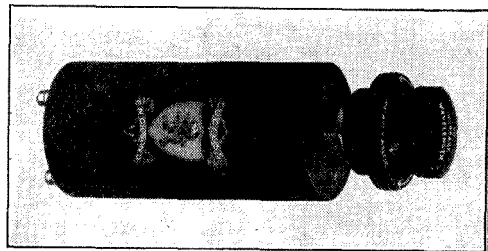

The anode capacity reactance which may be seen on the stand of Beard & Fitch, Ltd.

broadcasting waves. A companion to this unit is the anode capacity reactance by the employment of which any concert wavelength may be obtained without changing coils. Single hole fixing for both these units is a feature which should appeal to the amateur.

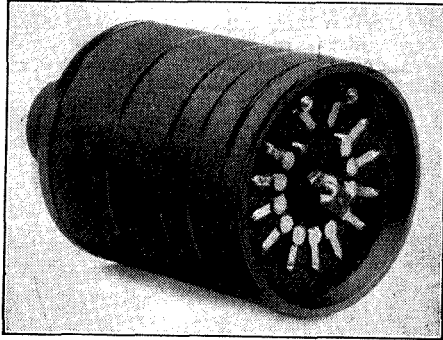

The new Success Tuner designed to operate over a wide range of wavelengths.

An easy and convenient method of assembling receivers is that adopted by the Radio Communication Co. in their Polar Blok system. It also has the advantage that further units can be added as desired. A full range of high-class components is shown by this concern amongst which may be mentioned the Polar triple condenser which consists of three similar air condensers mounted on one spindle. The micrometer condenser is one of their latest innovations and provides a means of obtaining highly delicate condenser tuning, whilst at the same time the instrument takes up the minimum of space on the panel.

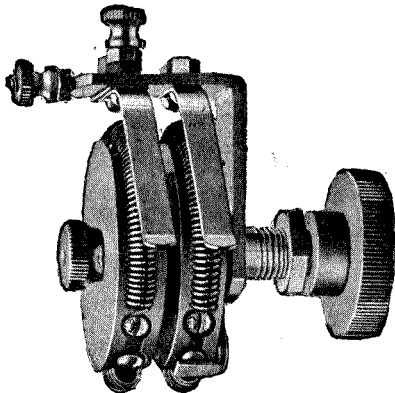

An efficient rheostat which may be inspected at the stand of The Radio Communication Co.

New features in connection with valves are always of interest and this may account for the attraction which the Cossor stand appears to hold. The new Wuncell valves which are exhibited by this concern are manufactured in three types for use as H.F. amplifiers, detector and L.F. amplifiers and small power valves. Although intended to

work from a two-volt accumulator, they may be used in conjunction with a 4 or 6-volt battery by virtue of the auxiliary resistance which is incorporated in the base. The new method of packing adopted ensures that the valve has not been used by the retailer for demonstration purposes.

A cheap wavemeter operating over a range of 300 to 1,800 metres is attracting much attention at the stand occupied by the National Wireless and Electric Co. Crystal and valve receiving sets are the other chief exhibits of this concern. A new and larger model of the Gnat crystal set is introduced, designed to receive stations operating on wavelengths up to 1,800 metres.

Several very novel features are embodied in the new Marconiphone V.1 receiver which is being shown to the public for the first time by the Marconiphone Co., Ltd. An exceptionally ingenious method of changing over for higher wavelengths is effected by changing one small block, which

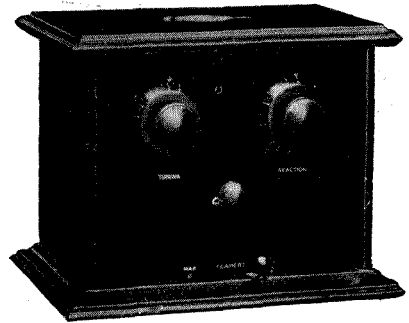

The most recent Marconiphone model, the V.1 receiver.

contains both the aerial and reaction coils. The full range of the well-known Marconiphone components are shown, which includes variable condensers, crystal detectors and "Ideal" transformers in their three ratios.

Amongst the range of valves shown by The M. O. Valve Co., Ltd., are to be noticed a number of interesting new types. Among these may be mentioned a series, denoted types D.E. 4, D.E. 5, and D.E. 6, which are specially designed low frequency amplifying valves. A further valve of interest is known as type D.E. 5B, which has been designed as a L.F. valve for use in resistance capacity coupled amplifiers. Four electrode and transmitting valves can be inspected in addition to a H.T. rectifying valve.

A novel component which combines a knife switch, lightning arrester and lead-in tube, is to be seen on the stand of J. J. Eastick & Co. Further specialities staged by this company comprise switches, coil holders and variometers, a further exhibit of interest being the H.T. battery boxes.

An extremely fine display of ebonite is arranged on the stand occupied by the British Ebonite Co., Ltd. The highly polished sheets which will be noticed are entirely free from leakage, as the polish is obtained by hand, the matted sheets being also finished by this method. The new pattern dials and knobs which are exhibited call for special attention.

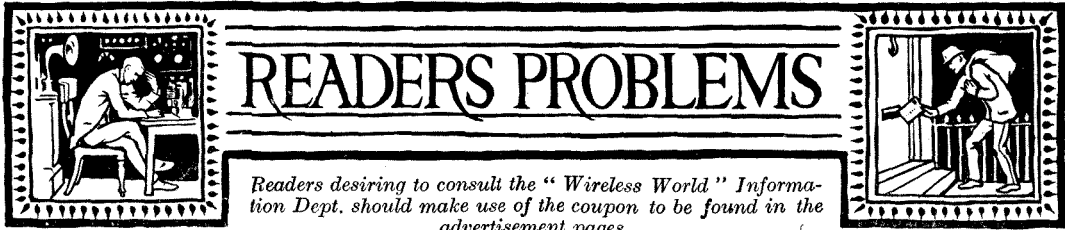

Readers desiring to consult the "Wireless World" Information Dept. should make use of the coupon to be found in the advertisement pages.

REDUCING THE ZERO CAPACITY OF VARIABLE CONDENSERS.

A GOOD variable condenser should have a high ratio of maximum to minimum capacity. When the zero capacity is high, it may not be possible to obtain a sufficiently low ratio of capacity to inductance on short wavelengths, and in all cases the lower limit of the wavelength range available with a given value of inductance will be curtailed.

In a receiver designed for general reception it is an advantage to use tuning condensers with capacities as high as 0.001 μF when receiving signals on wavelengths above 10,000 metres. On the other hand, the zero capacity of a 0.001 μF variable condenser is likely to be troublesome on wavelengths below about 300 metres, and the high rate of change of capacity with scale reading makes tuning rather critical on short wavelengths.

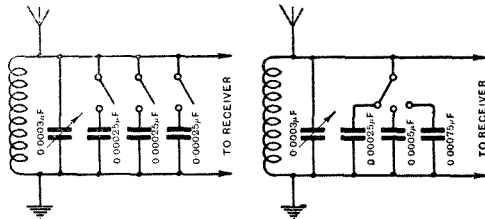

Connections of compound tuning condensers.

These difficulties may be overcome by building up the maximum capacity with a series of small fixed condensers and a single variable condenser. Thus, three fixed condensers, each of 0.00025 μF , used in conjunction with a variable condenser of 0.0003 μF maximum capacity could be used as a substitute for a 0.001 μF variable condenser. Each fixed condenser would be controlled by a separate switch suitably designed to have a low capacity when in the "off" position. Alternatively, a series of three condensers, having capacities of 0.00025, 0.0005 and 0.00075 μF respectively could be used in conjunction with a three-way radial type switch. It is imperative that the fixed condensers should be of very high quality, in order that the beneficial results of the low zero capacity may not be offset by the introduction of dielectric losses. The method of mounting the fixed condensers should be carefully studied from the point of view of reducing

their capacity to other apparatus in the receiver. In this connection it should also be noted that the sides of the condensers which are not broken by switches are connected to earth; i.e., a point of fixed potential. The variable condenser should have a maximum capacity slightly larger than the steps between the fixed condensers, and it should be borne in mind that a condenser of the square law type will be likely to have a lower zero capacity than one in which the moving vanes are semi-circular.

FREQUENCY OF TUNING FORKS

THERE seems to be some uncertainty among writers of text books on wireless telephony regarding the frequency of the note "middle C" in the musical scale. In some books the frequency is given as 256, and in others as 512, or twice the normal value. The discrepancy arises, no doubt, on account of the fact that some tuning forks are marked in "vibrations from the mean position" per second. The frequency of "middle C" is 256 complete cycles per second: thus the middle C fork would be marked 512 according to this system. A complete cycle is from the mean position to a maximum in one direction, then back to a maximum in the opposite direction, and finally back to the mean position, so that a complete cycle is equivalent to two "vibrations" of the fork. This difference in the method of expressing frequency is a frequent cause of trouble, and should not be overlooked in considering the applications of acoustics to wireless telephony.

FIXED FILAMENT RESISTANCES.

FROM the point of view of economy in apparatus and simplicity of operation, it is often an advantage to use fixed instead of variable filament resistances. The efficiency of the receiver will not be affected unless the filament current falls below the value necessary to give a sufficient emission of electrons for the particular value of H.T. voltage in use. For any given H.T. voltage there is a critical filament temperature, below which the valve will not function satisfactorily. On the other hand, an increase in the filament temperature above this value will bring about very little change in the signal strength. The fixed resistance should therefore be chosen so that the maximum filament current specified by the makers is flowing through the valve when the battery is fully charged. As the voltage of the battery decreases during discharge, the filament current will

also decrease until the critical value is reached, when the set will first give distortion, and then cease to operate. This condition may be reached before the battery is fully discharged, and a fresh charge will have to be given before the set can be put in operation again. With a variable filament resistance one can keep the filament current constant until the battery is discharged to its minimum voltage, which is, in the case of lead accumulator cells, about 1.8 volts per cell.

A GENERAL PURPOSE FOUR-VALVE RECEIVER.

THE accompanying diagram shows the connections of a four-valve receiver suitable for general reception. An inductively coupled aerial tuning circuit may be used, or the aerial may be directly coupled to the first valve by the method suggested in this section of the journal for September 3rd, 1924.

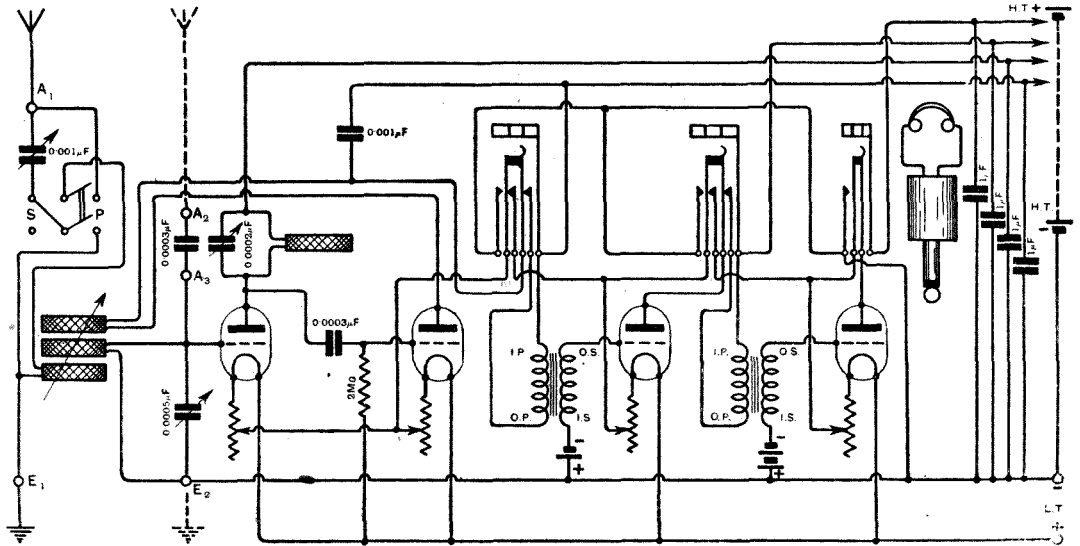

A general purpose four-valve receiver.

Tuned anode coupling will be found quite satisfactory, and is recommended because no additional components, such as H.F. transformers, are necessary if a complete set of plug-in coils is already available for the aerial tuning circuit.

The number of L.F. amplifying valves in circuit is controlled by means of a telephone plug and suitable jacks. The filament connections have been arranged so that the filament current to all the valves is switched off when the telephone plug is withdrawn from the receiver.

ADJUSTMENT OF A LOCAL OSCILLATOR.

IN adjusting a supersonic heterodyne receiver, any type of measuring instrument which will aid the operator in observing the effects of his

adjustments will prove invaluable. A correspondent has asked us to suggest a method of indicating when the separate heterodyne is in a state of oscillation.

The simplest method, of course, would be to connect a milliammeter in the plate circuit of the oscillating valve. The commencement of oscillations will be indicated by an increase in the current indicated by this meter. The current will return to the lower value when oscillations cease.

HOW TO OBTAIN SMOOTH REACTION COUPLING.

IN valve receivers employing reaction it very often happens that the adjustment of the reaction coupling is made very difficult by reason of the fact that oscillations start suddenly and do not stop again until the reaction coupling has been considerably reduced. When the receiver is properly designed and adjusted, it should be possible to

control the reaction so that oscillations start smoothly and cease with the same degree of coupling that was required to start them. To obtain this condition, the value of the grid leak should be very carefully adjusted, and the size of reaction coil should be kept as small as possible. The adjustment of the L.T. and H.T. voltages also exercises a considerable influence over the reaction conditions. The by-pass condenser across the telephones or intervalve transformer connected in series with the reaction coil should never be omitted.

Readers who are interested in the problem of obtaining smooth reaction adjustment will find much to interest them in the article entitled "The Importance of the Grid Leak," by C. Handford, in the issue of this journal for July 30th 1924.



**The Wireless Press
introduce a new
system of simplified
wireless construction**
The W.P.

EZI-WIRING
Series

- No. 1. A Three-Valve Portable Receiver
by Hugh S. Pocock.
 - No. 2. A Three-Valve Receiver by
F. H. Haynes.
 - No. 3. A Two-Valve and Crystal Reflex
Receiver by W. James.
- No technical knowledge required.

Note these distinctive features of
the W.P. EZI-WIRING SYSTEM.

- (A) Large scale wiring diagram
in 4 colours.
- (B) Progressive diagrams and
plates show the Set in vari-
ous positions and disposi-
tion of components.
- (C) Detailed measure-
ments and explan-
ations as to com-
ponents required.
- (D) Full in-
structions
on opera-
tion of Set.
No loose
sheets.

2/-
EACH

Postage 2d. extra

A HUGE DEMAND IS CERTAIN
—OBTAIN YOUR COPY AT ONCE
Visit our Stands at All-British Wireless
Exhibition. Boxes No. 104, 122 & 133



2/-
EACH
POSTAGE 2d.

**FOUR-COLOUR
WIRING DIAGRAMS**



PRICE
2/-
NET



Issued by The
WIRELESS PRESS LTD.,

**12-13 HENRIETTA STREET,
LONDON, W.C.2**

Brandes

The Name to Know in Radio.



*Result of
16 years'
experience*

Grandpa finds a new way

25/-

BRITISH
MANUFACTURE
(B.B.C. Stamped).
Manufactured at
Slough, Bucks.

of retaining his youth by coping with youth and its outburst in another irrepressible form. Every autumn, when the apples slowly ripen, offensive operations commence on the orchard front. He's C.O. of a veritable Hindenburg line of defence. Sitting at the window with the Brandes "Matched Tone" Headphones clamped to his head he is delightfully entertained while the raider's plans mature. No matter how long he has to wait for a sortie they always fit comfortably and well and their strong clear tones are thoroughly enjoyable. Aha! They come! Grandpa discards the 'phones and trots down the garden path brandishing a thick stick. He generally arrives to see the last youthful marauder disappearing through a hole in the hedge, but never mind, he's seeing life.

Ask Your Dealer for Brandes.

All Brandes products are obtainable from any reputable Dealer and carry our official money-back guarantee, enabling you to return them within 10 days if dissatisfied.

Matched Tone

TRADE MARK

Radio Headphones



Printed by Sanders Phillips & Co., Ltd., Chrysell Road, London, S.W.9, for the Proprietors and Publishers, The Wireless Press, Ltd., 12-13 Henrietta Street, London, W.C.2; Sydney, N.S.W., 97 Clarence Street; Melbourne, 422-24, Little Collins Street; New York, 326 Broadway.



THE WIRELESS WORLD

AND
RADIO REVIEW



PRICE 4^D NET.

CONSTRUCTING
SHORT WAVE RECEIVER
COMPONENTS

—
ASSEMBLING
THE SUPER-SENSITIVE
THREE-VALVE SET

No. 269 [No. 2
Vol. XV]

OSCILLATING CRYSTAL CIRCUITS

**Nothing more
Efficient**



**Strong as a
Motor Wheel**

“Tangent” Tuning Coils

Guaranteed not to buckle or crush.
Damping reduced to minimum.
Low distributed capacity.
Electrical efficiency second to none.
Mechanical strength unequalled.

Ask your dealer—or write us.

GENT & Co. Ltd. “FARADAY WORKS” LEICESTER

Manufacturing Electrical Engineers.

Est. 1872

London: 25 Victoria Street, S.W.1

Newcastle-on-Tyne: “Tangent House,” Blackett Street.

STOCKED SIZES.			
Coil No.	Min. W/L	Max. W/L	Price.
25	250	390	4/3
35	330	520	4/3
50	430	840	4/3
75	660	1070	4/6
100	840	1430	5/-
150	1100	2030	6/-
200	1610	2720	7/-
250	2009	3520	7/6
300	2400	4250	8/-
400	3300	6450	9/-
500	4500	8750	10/-

Other “Tangent” fittings include—
“Tangent” L.F. Transformers.
“Discol” H.F. Transformers.
“Tangent” Headphones.
“Tangent” Rheostats.
“Pan” Switches anti-capacity, etc etc., etc.



The
AMATEUR'S BOOK
of
WIRELESS CIRCUITS
by F. H. Haynes.

Price **3/6** nett
(Postage 6d.)

New Edition
now ready contains
117 circuits!

“I never imagined that circuits could be made so easy, interesting and practical for the beginner!”

A typical remark from the experimenter who has hitherto found circuit diagrams to be puzzling affairs. This new edition of Mr. F. H. Haynes's popular book gives the fullest possible details for wiring-up no less than 117 circuits. Nothing has been left to chance. Every value has been inserted and full explanations accompany each diagram. Moreover, every circuit has been designed by a man who knows the difficulties encountered when constructing experimental apparatus. Circuits, diagrams and accompanying text are of an essentially practical nature. Containing the following special features, it is the most complete and easily understood circuit book available to-day:—

Copious notes on Crystal Receivers, single-valve sets, high frequency, low frequency and dual amplifiers, transmitting circuits. Several pages of most useful data have been added, including the method of pile windings, tables giving tuning range of commercial types of inductances, wavelengths produced by various tuning condensers, types of receiving valves and their characteristics, etc., etc.

A Huge demand is certain—obtain your copy at once.

Issued by—

THE WIRELESS PRESS LTD.
12-13 HENRIETTA ST., LONDON, W.C.2

THE WIRELESS WORLD AND RADIO REVIEW

THE OFFICIAL ORGAN OF THE RADIO SOCIETY OF GREAT BRITAIN.

No. 269. (No. 2 Vol. XV.) OCTOBER 8th, 1924. WEEKLY.

EDITOR:
HUGH S. POCOCK.

RESEARCH EDITOR:
PHILIP R. COURSEY, B.Sc., F.Inst..P., A.M.I.E.E

ASSISTANT EDITOR
F. H. HAYNES.

QUESTIONS AND ANSWERS DEPARTMENT:
Under the Supervision of W. JAMES.

CONTENTS.

	PAGE
Radio Topics. By the Editor - - - -	31
Short Wave Components. By F. H. Haynes - - -	33
Readers' Practical Ideas - - - -	37
The Super-Sensitive Set (<i>concluded</i>). By W. James -	39
A Visit to the "Igranic" Works at Bedford - - -	44
The Crystal as a Generator and Amplifier (<i>concluded</i>). By Victor Gabel - - - -	47
Patents and Abstracts - - - -	51
The Position of the Scientific Amateur (<i>concluded</i>). By Dr. W. H. Eccles, F.R.S. - - - -	53
Notes and Club News - - - -	55
Readers' Problems - - - -	59

THE EDITOR will be glad to consider articles and illustrations dealing with subjects within the scope of the Journal. Illustrations should preferably be confined to photographs and rough drawings. The greatest care will be taken to return all illustrations and manuscripts not required for publication if these are accompanied by stamps to pay return postage. All manuscripts and illustrations are sent at the Author's risk and the Editor cannot accept responsibility for their safe custody or return. Contributions should be addressed to the Editor, "The Wireless World and Radio Review," 12 and 13 Henrietta Street, Strand, London, W.C.2.

SUBSCRIPTION RATES :

20s. per annum, post free. Single copies 4d. each or post free 5d. Registered at the G.P.O. for transmission by Magazine Post to Canada and Newfoundland.

As many of the circuits and apparatus described in these pages are covered by patents, readers are advised, before making use of them, to satisfy themselves that they would not be infringing patents.



EDITORIAL AND PUBLISHING OFFICES :

12 and 13 Henrietta Street,
Strand, London, W.C.2.
Telephone : Gerrard 2807-8.

ADVERTISEMENT MANAGERS

Bertram Day and Co., Ltd.,
9 & 10 Charing Cross, S.W.1
Telephone : Gerrard 8063-5.

Brandes

The Name to Know in Radio.

For sixteen years

the distinctive constructive and theoretical advantages of Brandes Radio Products have made their name a byword in wireless. The "Matched Tone" Superior Headphones have earpieces which are matched to an exact tone degree by unique testing apparatus, thus ensuring an equality of volume and real sensitivity which is remarkable. The Table-Talker is a quality product at a reasonable price. Its performance is equally remarkable. The horn is matched to the unit so that the air resistance produced will exactly balance the mechanical power of the diaphragm. This feature means surprising uniformity of tone and beautiful sound balance.

All Brandes products are obtainable from any reputable Dealer and carry our official money-back guarantee, enabling you to return them within ten days if dissatisfied.

Matched Tone
TRADE MARK
RADIO HEADPHONES 25/-

Table-Talker
TRADE MARK
 42/-

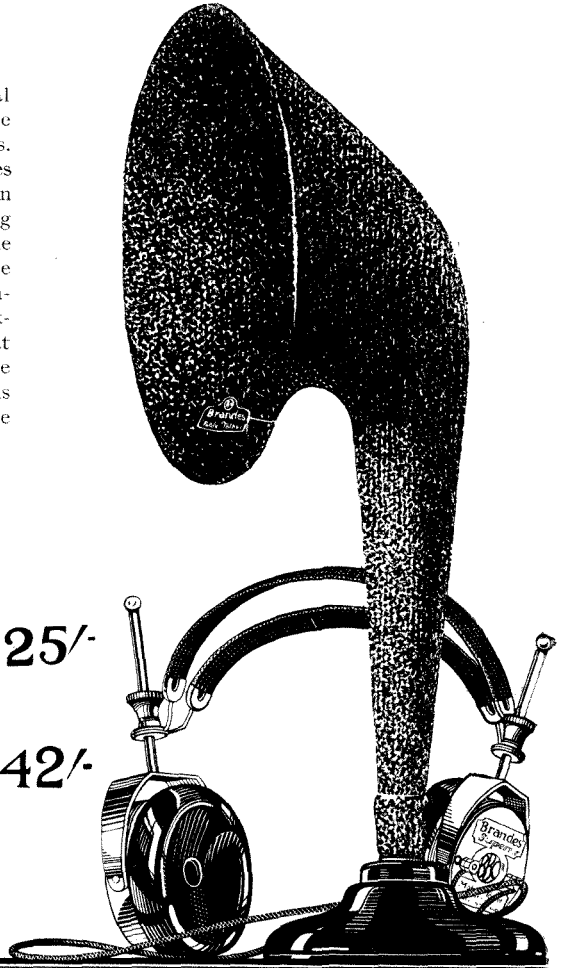

*Tune with Brandes "Matched Tone"
 Radio Headphones
 Then Listen with Brandes
 Table Talker*

The WIRELESS WORLD — AND RADIO REVIEW



RADIO TOPICS.

THE HIGH POWER STATION.

THE Post Office sanction for the erection of a permanent high power station by the British Broadcasting Company has now been given and an announcement has been made that the station will probably be in operation within the next six months. Readers will remember the concern which we expressed at a time when it was rumoured that the high power station might be located near in to London and it is therefore with considerable satisfaction that we learn that the station will be erected somewhere in a line between the Severn and the Wash. In an interview, Mr. J. C. W. Reith, Managing Director of the British Broadcasting Company, stated that the exact location would very probably be in the neighbourhood of Northampton.

The station will be licensed up to 25 kW. and will be operated on a long wavelength of the order of 1,600 metres as in the case of the present experimental station at Chelmsford. The new location will make it possible for the station to serve a very much greater area of the country than is possible from Chelmsford as the location will be more central, whereas in its present position nearly 50 per cent. of the energy must be lost in radiation oversea.

THE EMBLEM OF THE AMATEUR.

IT has often been stated that British amateurs are not knit together in a bond of union to anything like the extent of the amateurs in the United States who are members of the American Radio Relay League. A much closer co-operation might be achieved in this country and the position of the amateur strengthened to a very considerable extent if a closer understanding

existed between individual amateurs and also between different societies and organisations.

The Radio Society of Great Britain, as announced by Dr. Eccles in his autumn Presidential address, has taken a step which it is hoped will assist in bringing amateurs together in this way. The decision has been made to issue a badge to be worn by members of the Society and members of Affiliated Societies. It will take the form of a design in coloured enamels of a size approximating to a sixpence and may be worn in the button-hole. The design consists of the Union Jack surrounded by a frame aerial with the head of Mercury as a crest, whilst on either side of the head is a scroll to contain a motto. The name "Radio Society of Great Britain" appears across the Union Jack and round the lower half of the frame aerial. Those who are members of an Affiliated Society and not of the parent body will wear the badge without the head of Mercury and in place of the motto, the name of the Affiliated Society will be engraved. We believe that this badge will serve as a means of introduction amongst amateurs all over the country and that in a very short while it will become recognised wherever wireless amateurs are located in every part of the world.

IN DEFENCE OF THE AMATEUR.

THOSE who were not present to hear the Presidential address to the Radio Society of Great Britain by Dr. Eccles will by now have had the opportunity of reading it in print in *The Wireless World and Radio Review*, and they will also be aware that a sum of money amounting to £1,000 has been placed at the disposal of the Society by *The Wireless World and Radio Review* and *Wireless Weekly* in equal proportions to assist the Radio Society financially should the necessity arise for a test case to be fought

with the Post Office in support of the rights of the amateur. It is, of course, not possible to say much more on this subject until a further announcement has been made by the Radio Society as to what action they propose to take. It is, however, understood that a Committee is being appointed by the Council of the Radio Society to deal with the question and advise the Council as to the procedure which should be adopted. Our warmest support will be given to any action which the Radio Society may decide to take because we feel very strongly that in cases too numerous to mention the Post Office

be welcomed by the Post Office officials themselves who have the difficult task imposed on them at present of superintending the carrying out of regulations the legality of which they must feel, in their private opinions, is decidedly questionable.

THE WIRELESS EXHIBITION.

THE trend of development as illustrated in the Wireless Exhibition at the Albert Hall, certainly appears to us to indicate a marked tendency towards simplicity combined with compactness in broadcast receivers.

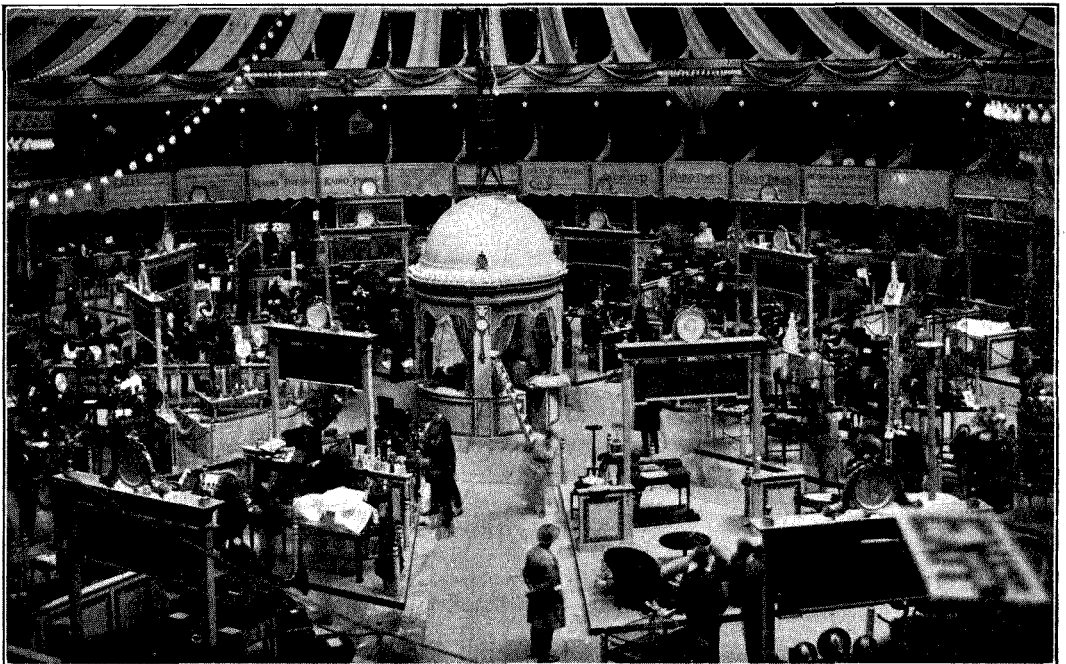

A general view of the central stands at the Exhibition at the Albert Hall.

has dealt unreasonably with applications for experimental facilities which have been made by amateurs and we consider that the sooner matters of this kind are set right the better it will be for everyone concerned. Not only the amateur, but the country as a whole, must benefit by the results which accrue from the experimental work of scientifically inclined individuals or groups of individuals carrying on one particular investigation. We believe too, that a clearing of the air on the question of licences will

Wireless, in so far as the manufacturer of broadcast receivers is concerned, has got beyond the experimental stage, if one may so describe some of the earlier efforts at the production of receivers.

The apparatus typified in the new models on view at the Albert Hall seems to indicate that manufacturers have achieved standardisation and we doubt if there will be any radical departure from the design of the present receivers by the best known manufacturers for some time to come.

THE EDITOR.

SHORT WAVE COMPONENTS

THE CONSTRUCTION OF PARTS USED FOR BUILDING A SHORT WAVE SET

THE first two-way transatlantic working with low power was carried out on a wavelength of about 100 metres. The exploitation of short wave working has revealed some remarkable results, and many experimenters have communicated over thousands of miles, using input powers which until recently would have been considered inadequate for bridging less than one-hundredth of the distance. Short wave working is rapidly opening up an entirely new field of development which is not only revealing the suitability of short wavelengths for bridging great distances, but is bringing about a concentration of effort to improve the design of receiving apparatus.

By F. H. HAYNES.

THE design of receiving circuits and tuning equipment has been developed essentially for use on wavelengths exceeding 300 metres. The attention which is now being devoted to reception on wavelengths of 200 metres and below not only calls for a review of the suitability of the usual form of instrument construction for short wave work, but is rapidly creating a need for specially designed apparatus.

The expressing of tuning adjustment by wavelength rather than by frequency obscures the vastly different conditions existing in circuits when working on 150 metres as compared with 300 metres. At 150 metres the oscillation frequency is just twice what it is at 300 metres and at 100 metres it is trebled, for the product of wavelength and frequency equals a constant. Now the losses in a circuit increase with the frequency, and thus the design of those parts in the component apparatus which give rise to loss must be carefully examined if efficiency is to be maintained.

SHORT WAVE INDUCTANCES.

The first aim in tuning coil design must be to produce minimum capacity for a given inductance. As air has a lower dielectric constant than solid insulating materials it is necessary for the turns composing the coil to be air spaced. The shape of the inductance must also be considered for a short coil consisting of several layers will require considerably fewer turns to produce a given inductance value than will be needed if the wire is formed up as a long single layer solenoid, and as a result will possess lower self-capacity.

Air is really the only permissible dielectric material, for solid dielectrics all introduce greater losses, which increase with the oscillation frequency. Thus the insulating pieces used to give rigid support to the coil should touch the turns at as few points as possible. The separating material employed for the construction of the supports must moreover possess low dielectric loss and good insulation. Comparing ebonite and oak in this respect, the dielectric losses in the

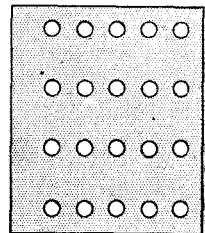
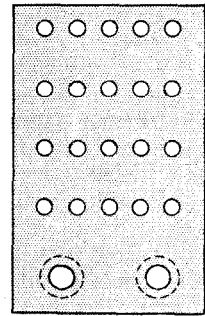
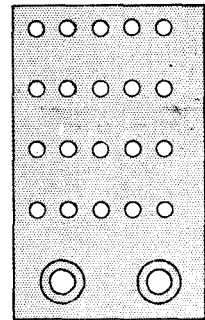
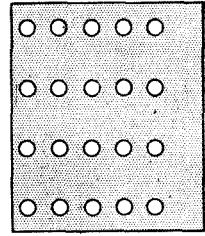

Fig. 1.
Ebonite mounting pieces for the low loss coils.

former are greater than those when the latter is used, though oak, of course, does not come up to ebonite as regards insulation. Thus when the energy is small, ebonite will be more suitable, particularly as the low insulation set up by the oak in contact with the turns will produce a noticeable degree

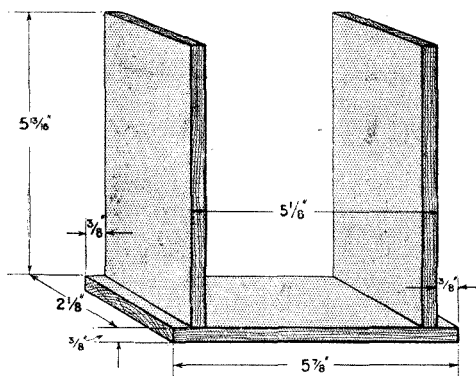

Fig. 2. Wooden frame to carry a pair of series connected coils.

of damping, evidenced by flatness of tuning. It might be mentioned, however, that when the energy is considerable, as in the case of the supports used to carry a transmitting inductance, that oak is preferable providing the insulation from turn to turn is sufficient to withstand the potential. Practical considerations must to some extent modify these ideals for a good mechanical design is a first requirement.

Low loss coils designed by the writer have been described in detail in recent issues of this journal,* and essentially consist of shaping wire of substantial gauge into spiral form, and threading drilled strips of ebonite on to the turns. Some further constructional details are given here to facilitate the building of tuning coils to a given size.

Fig. 1 represents the four ebonite supports into which the turns are threaded. It will be noticed that although all the holes are equally spaced, that they are set out at varying distances from the edges. This is necessary in order that all edges may be in line when the supports are themselves carried by the spiral turns of wire. The drawing shows these parts exact to size, the two centre

* *Wireless World*, February 13th, page 613; July 2nd, 1924, page 393.

portions being extended for attaching to a pair of wooden feet. Countersunk holes are made in these pieces to take the screws, one piece being countersunk on the top and the other on the underside. After drilling, the faces and edges should be finished with a matt surface, using medium carborundum cloth. It is advisable to mark all four pieces as finished with dot or scratch marks on a corresponding corner so that they may be readily identified in the correct order for slipping over the turns of the wire.

The wire should be shaped up by winding tightly on cylindrical formers, each about $\frac{1}{2}$ in. less than the required diameter. The actual diameter of the inside layer when set up is $2\frac{3}{8}$ ins. The holes are $\frac{5}{64}$ in. which gives easy clearance for the wire, which is No. 16 S.W.G., enamelled covered to prevent oxidation. When embodying this type of coil in a tuner designed to cover a waveband of 80 to 200 metres (to be des-

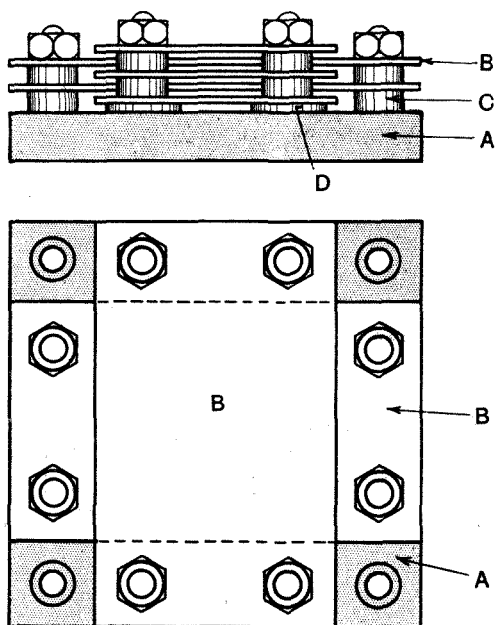
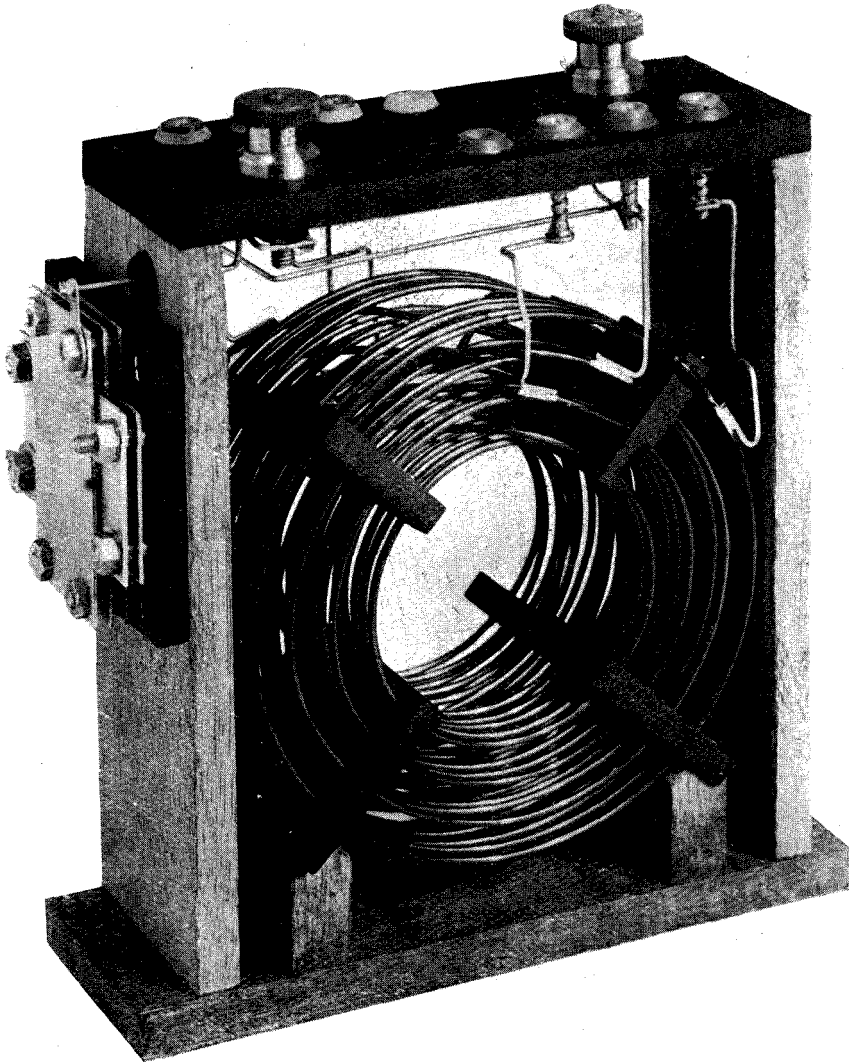

Fig. 3. Series aerial condenser, built up with zinc or aluminium plates and having air as a dielectric.

cribed later), it will be necessary to employ a pair which although connected in series and assembled side by side, cannot be built up as a single coil of twice the length a

there would be set up too great a potential drop across the ends of each successive layer. In coiling the wire, which should be previously straightened by stretching, 14 turns will be needed of each of the four

of ebonite, followed by the other pieces in their correct order and the right way round. With only five turns to a layer and liberal clearance in the holes, no difficulty will be experienced in getting on the four layers.



Complete tuning unit comprising tapped aerial and secondary inductances and air dielectric series aerial condenser.

diameters so that when divided into two portions a sufficient length of wire will be left spare on the ends for connecting up. Be careful to wind all coils in the same direction.

The inside layer is best threaded on first, taking care to start with the correct piece

The author has built many of these coils and the threading on of the turns, as a result of practice, is only a matter of a few minutes. The beginning and finishing ends of each layer will pass up through the pieces shown at the top and bottom of Fig. 1. All four ends on one side of the coil should be ter-

minated by bending back round the ebonite, well cleaned and soldered. The long projecting ends on the other side of the coil are then taken through between the layers and soldered to the terminations of the next successive layers so that all layers are in series.

Small wooden feet are made up, preferably in mahogany (obtainable from dealers in fretwork supplies), and set up so that the ebonite pieces are exactly at right angles to each other.

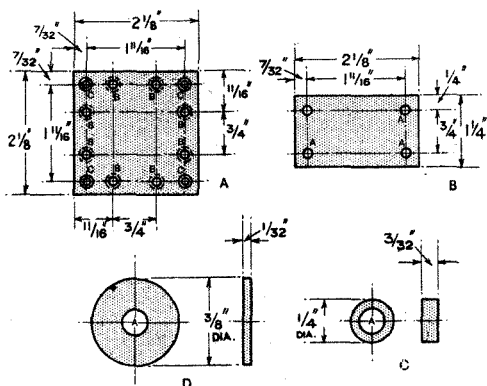

Fig. 4. Dimensional details of the air condenser. The spacing washers are also shown. A, $5\frac{3}{32}$ " B, $5\frac{3}{32}$ " and countersunk on underside, C, $\frac{1}{8}$ " and countersunk for No. 4 wood screws.

A simple mounting piece for a pair of coils is shown in Fig. 2, made from $\frac{3}{8}$ in. planed mahogany. The sides are glued (Seccotined) and screwed in position. This woodwork should be carried out with accuracy so that it may suit the complete tuner to be described.

The woodwork supports a top ebonite piece drilled to carry aerial and earth terminals, and "Clix" sockets. The holes situated on the centre line are only fitted with a "Clix" insulating bush of the same colour as those in the corresponding row. Before fitting up, all surfaces should be neatly matted by rubbing with medium carborundum cloth.

Both coils can now be mounted in the woodwork with outer faces scarcely projecting. While still accessible, connect the outside finishing end of one coil with the inside commencing end of the other, verifying that the direction of the complete winding is continuous.

Now screw the top ebonite terminal board in position and proceed to connect up.

In our next issue full details will appear for making up a short wave set (80-200 metres) suitable for the reception of American amateur and short wave broadcasting stations.

On one side will appear the three soldered connections where the layers are linked through. On the other side, one end and three bends are showing. On the former side where the end of the third layer (counting from the inside always) connects to the fourth, a wire is soldered and taken to one of the terminals which is to be "earth." Three short connections can now be made to join the beginning of the centre turn, and the other two junctions to three of the "Clix" sockets. Turning to the other side of the coil, the finishing end and the two cross-over connections next below are joined to the other three sockets. The object is to get three layers each tapped, then the earth connection and then five layers, being four on one coil and one on the other, tapped at the last three layers.

The insulating bushes without sockets are to pass out the flexible leads to the plugs.

TUNING CONDENSER.

To sharpen the tuning, shorten the wavelength, and to facilitate self-oscillating by reducing the capacity of the aerial circuit, a fixed capacity condenser is connected in series in the aerial lead. Again the aim should be to adopt air as a dielectric, and an easy form of construction is shown in Fig. 4.

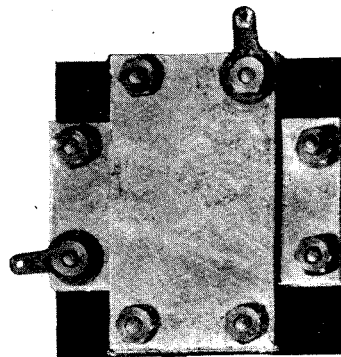

The finished air condenser. It comprises five plates and has a capacity of not less than 0.000025 mfd.

The drawing shows all necessary details. The rectangular aluminium or zinc plates are cut to shape, squared up if necessary by filing, and assembled on 4 B.A. screws with the usual spacing washers. A condenser of this pattern is quite simple to make up, and has a capacity of not less than 0.000025 mfd.

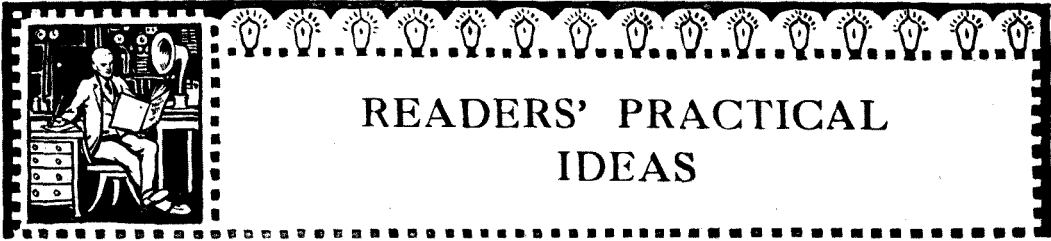

READERS' PRACTICAL IDEAS

This section is devoted to the publication of ideas submitted by readers and includes many devices which the experimenter will welcome.

Making Good Spindle Contact.

MANY are the methods put forward for making reliable connection to a revolving spindle. Good contact is essential and in the case of switch spindles it is usually the practice to make use of a piece of flexible wire soldered to the end. Another

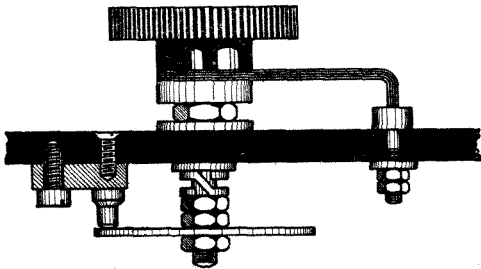

The spring peg out of a lamp socket can be used to make good contact with a revolving spindle.

method recently shown in these pages made use of a coiled bronze spring. It may be argued that this latter method possesses the disadvantage of introducing a few turns of inductance.

A good arrangement is shown in the accompanying sketch in which a brass plate is clamped on to the spindle with an additional nut. A reliable rubbing contact is made with this plate by means of one of the spring contacts removed from an electric lamp holder. This contact is fitted with two screws, one of which can be used for joining up to the circuit and the other for securing to the panel.

H. H.
F. T.

Loading up a Variometer.

WITH the introduction of broadcast transmissions on 1,600 metres many experimenters are desirous of converting

variometer tuned sets to receive on this new wavelength. Although the method of loading shown here may not produce a variometer of wide tuning range it will give sufficient tuning provided the loading inductances are carefully adjusted as to size before they are attached. Lack of space in an instrument often prevents the insertion of loading coils and this method makes use of the variometer formers themselves, to give support to the loading coils. The loading coils are wound by the usual method on a former which carries a suitable number of pegs and the layers are spaced by means of a zig-zag winding of thin string or insulated wire.

The writer has fitted coils of this type to his loose coupler which is used to introduce

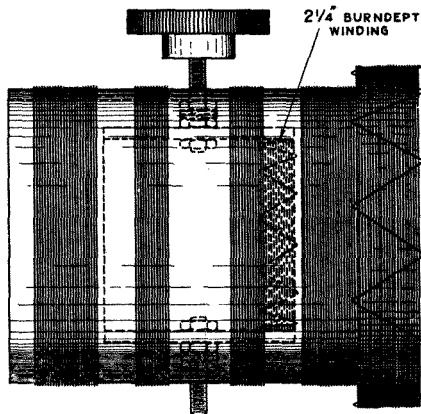

Loading a variometer.

reaction, the aerial circuit on the outside former being loaded by adding a winding of No. 26 S.W.G. wire and using about 220 ft., while the inner winding which is in the reaction circuit is made up of five

layers of No. 26 S.W.G. to a maximum diameter of $2\frac{3}{4}$ ins. and with a width across the face of about $\frac{1}{2}$ in. This smaller coil just fits inside the reaction coil former, whilst the aerial loading coil slides over the existing aerial winding.

R. G. T.

Basket Coil Tuner.

WHEN basket coils are used for tuning it is not always a simple matter to devise a system of mounting that will provide for variable coupling, particularly as tuning is so critical on short wavelengths and the basket coils are usually not sufficiently rigid to allow of accurate adjustment.

In the accompanying diagram a method is shown of mounting the coils. It will be seen that the screw on the left-hand side of the diagram not only secures the fixed coil but also carries a wooden piece to which a hinge is fixed. The hinge carries a strip of wood or ebonite to which the moving

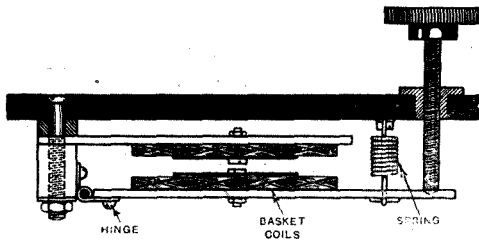

Simple coupling for basket coils.

coil is attached so that it can be propelled away from the fixed coil by means of the threaded screw shown on the right-hand side, whilst a spring keeps the hinged piece rigidly in position.

W. A. E.

Under the Panel Three-Coil Holder.

THE amateur usually considers it within the scope of his ability to build his own three-coil holder and a design is shown here which is a departure from the usual method of construction.

It possesses the advantage that the tuning coils are fitted entirely beneath the panel and for a receiver operating over a limited wavelength range this arrangement will be found particularly useful. An interchangeable mounting is provided, of course, and where it is desired to frequently

change coils, the holder must be mounted in the instrument to give the necessary access.

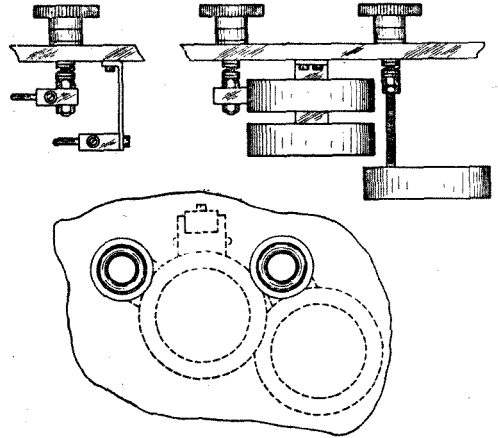

Three-coil holder constructed beneath the panel.

From the diagram it will be seen that the central coil which is stationary is carried on a brass bracket, whilst the two movable coils are secured to a threaded rod such as can usually be obtained from dealers in component materials. Other details can be seen in the drawings and it is not thought necessary to describe the construction at further length as the experimenter may make minor changes depending upon the parts he may have to hand.

A. R. T.

C.W. Buzzer.

While carrying out reception of spark, I.C.W. or telephony, it frequently happens that tuning has to be performed on a heterodyne, there being no buzzer wavemeter available.

The writer has included in the grid circuit of his wavemeter a grid leak shunted by a condenser which may be introduced at will by a small switch.

The apparatus is adjusted so that the grid leak is of rather a higher value than that generally used (about 5 to 6 megohms) and the valve is paralysed for considerable periods ($1/200$ th of a second or so). The note heard in the receiver is a buzz, and has the advantage that it maintains a constant pitch under all conditions, unlike the buzzer usually fitted.

R. W. H.

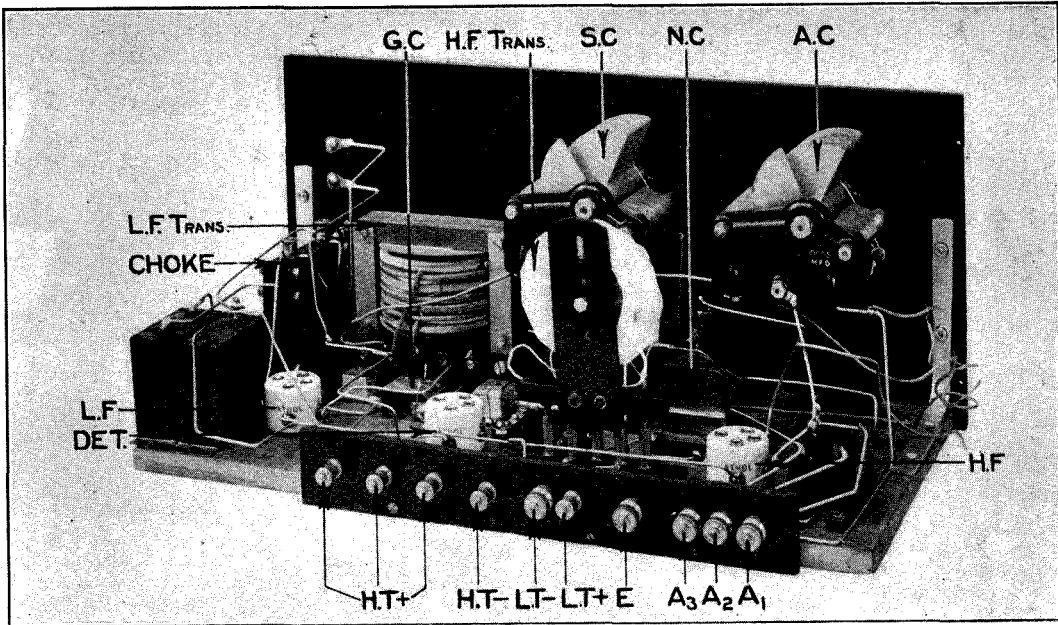

A back view of the completed receiver with cabinet removed.

THE SUPER-SENSITIVE RECEIVER.

By W. JAMES.

(Concluded from page 12 of previous issue.)

THE DETECTOR VALVE CIRCUIT.

WE have now to consider the detector valve circuit. The grid condenser and leak method of rectification is employed, the grid leak being connected across the condenser, and the return wire of the grid circuit being connected to the positive side of the filament. The grid condenser may have the usual value of 0.00025 μ F, and the grid leak a value of about 2 megohms. Several grid leaks of different resistance values should be tried, the aim being to secure good signal strength, purity, and smooth reaction control.

The size of the reaction coil and type of intervalve transformer to be connected in the anode circuit of the detector valve is decided by the type of valve. I wish to emphasise the fact that for good quality speech amplification it is not correct to take

any type of valve and use it with any type of transformer. It is sufficiently difficult to manufacture a transformer which will give good results with one type of valve. General purpose transformers (by which I mean those which are sold without any indication as to which type of valve they are designed to work with) should not be used unless it is found by experiment that they work well with the valve which is to be employed as the detector. The reason why many transformer-coupled speech amplifiers give poor results is because the valves and transformers have not been matched. This is hardly the fault of the reader—the manufacturer should design his transformers and specify the types of valve with which, under correct operating conditions, they will give good results.

In the receiver under discussion a D.E.5 valve is employed as the detector. This type of valve has a voltage amplification factor of

indicated in the figure, where the large holes marked A and B are $\frac{1}{2}$ in. and $\frac{3}{8}$ in. in diameter to clear the spindles of the condensers and filament resistances respectively. The fixing holes marked C are $\frac{5}{32}$ in. diameter and countersunk for No. 4 B.A. screws. Of the remain-

screws, which screw the panel to the case. Two 4 in. brackets are employed to hold the panel and baseboard at right angles; the holes for the fixing screws are marked C. Terminals for the telephones and loud speaker are mounted at the points marked D.

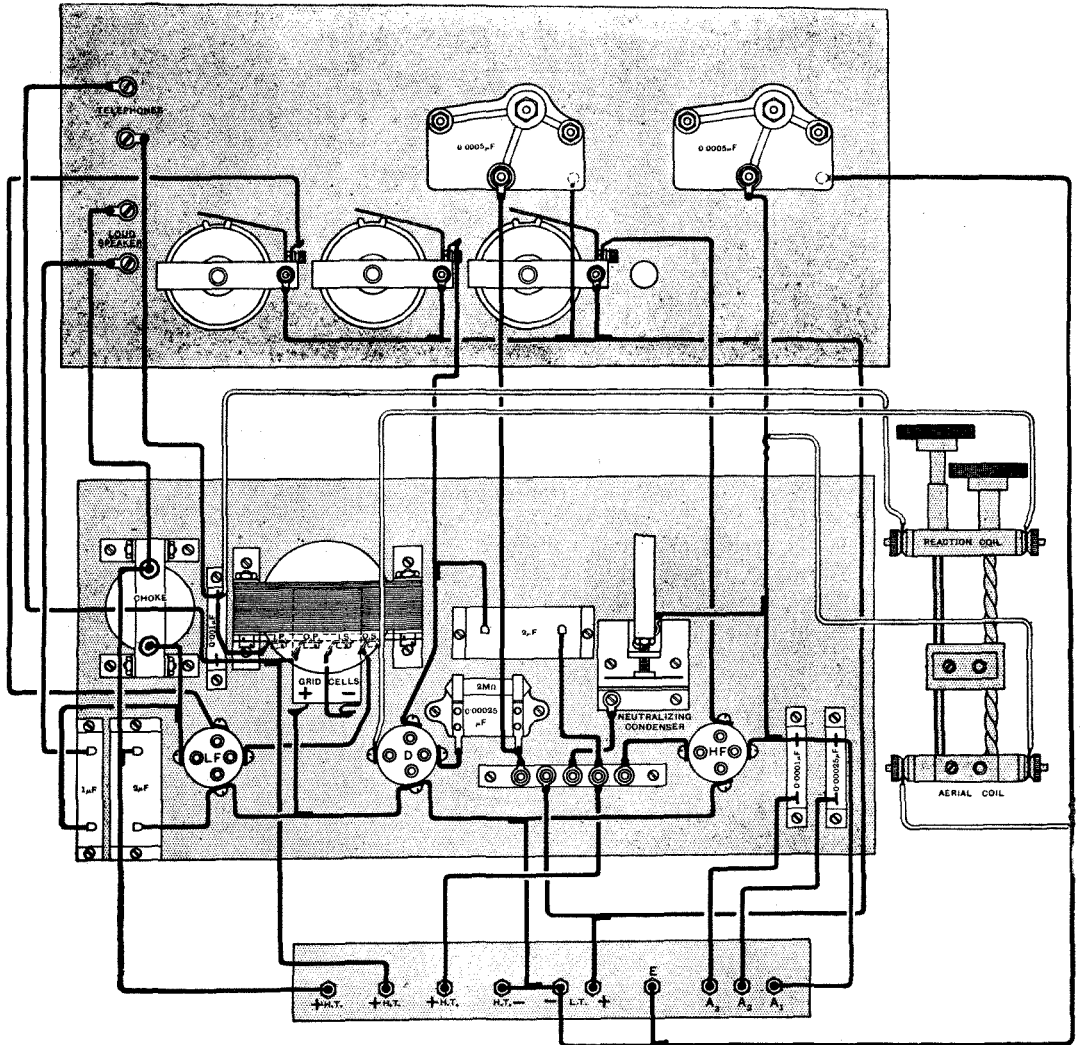

Fig. 7. Complete wiring diagram of the Super-Sensitive receiver.

ing holes, those marked E in the lower edge of the panel are $\frac{1}{8}$ in. diameter, countersunk for No. 4 wood screws; these screws fasten the bottom of the panel to the edge of the baseboard. The holes marked E on the side edges of the panel are $\frac{1}{8}$ in. diameter, countersunk for No. 4 wood

The position of the components mounted on the baseboard is given in Fig. 5, and the parts may easily be identified from the layout of Fig. 7. It will be seen that fixed condensers of 0.0001, 0.00025 (2), 0.001, 0.5 and 2.0 (2) microfarads are required, with a 2 megohm grid leak, 3 valve holders,

an intervalve transformer, and an iron-cored choke coil.

Details of the high frequency transformer, plug and socket, the terminal strip, and the neutralising condenser are given in Fig. 6.

The H.F. transformer socket consists of a piece of ebonite, $3\frac{3}{4}$ ins. by $\frac{3}{8}$ in. by $\frac{3}{8}$ in., to which are screwed five valve sockets; the plug of the transformer is a piece of ebonite 3 ins. by $\frac{3}{8}$ in. by $\frac{3}{8}$ in., carrying five valve legs, and a basket-coil holder. A number of plug-in units should be constructed to carry basket coils of different sizes if it is desired to tune over a wide range of wavelengths.

The neutralising condenser consists of a small piece of ebonite carrying a fixed plate and a movable plate. The ebonite is $1\frac{3}{4}$ ins. by $1\frac{3}{4}$ ins. by $\frac{1}{4}$ in., and the fixed plate is a piece of brass $1\frac{3}{4}$ ins. by $1\frac{7}{16}$ in., which has one side bent over in order that it may be screwed to the ebonite. As may be seen from the photographs of the receiver, the movable plate is carried by a brass bracket, and is turned by a length of $\frac{1}{2}$ in. ebonite rod which extends through the panel. The bracket is 1 in. high by $\frac{5}{8}$ in. wide, and is drilled and tapped 2 B.A. A brass disc $1\frac{1}{2}$ ins. in diameter is soldered to the head of a 2 B.A. screw 1 in. long, which is threaded in the screw hole in the bracket. The other end of the screw is screwed in the end of the ebonite rod.

Having assembled the receiver, it may be wired, but before commencing the wiring it will be found convenient to remove the variable condensers in order that the wires may easily be secured to the filament resistances. If a fairly stiff wire such as No. 16 tinned copper is employed, there will be no need to use insulating sleeving. The wiring is clearly shown in Fig. 7. It will be observed that four flexible wires are employed to connect the reaction and aerial coils to the remainder of the receiver. These flexible wires are passed through holes in the side of the box.

OPERATING THE RECEIVER.

To use the receiver, connect the aerial to one of the aerial terminals (preferably A1 to begin with), and also connect the usual batteries. For the broadcast band of wavelengths, a No. 50 aerial coil and a No. 35 reaction coil may be employed. The H.F. transformer which was described on pages 10 and 11 of the last issue should have a primary winding of 24 turns and a secondary winding of 66 turns of No. 24 D.C.C. Tune in a signal with the reaction coil at right angles to the aerial coil. When the H.F. transformer is exactly in tune with the aerial circuit, it will probably be found that oscillations generated by the receiver are passing to the aerial. The neutralising

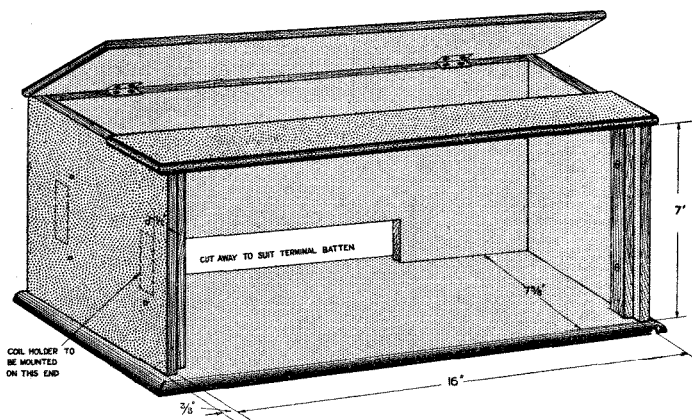

Fig. 8. Details for the construction of the cabinet.

condenser should therefore be adjusted by turning the ebonite rod attached to the moving plate until the circuit is quite stable. If the H.F. valve is inserted in the holder with a piece of paper over one of the filament pins, it will be found possible to adjust the neutralising condenser so that although the aerial and H.F. transformer circuits are in tune, nothing is heard in the head receivers. The neutralising condenser may be left in this position for reception, although sometimes a further slight adjustment is required for best results.

If the telephones are connected to the upper terminals, the filament resistance of the last valve may be turned to the "off" position as this valve is not in circuit.

A VISIT TO THE "IGRANIC" WORKS AT BEDFORD.

Discriminating amateurs, who rightly desire to obtain the utmost efficiency from their apparatus, are ever on the alert to discover the latest developments produced and would gladly welcome the opportunity of a visit to the hives of industry which are laid out specifically to cater for their requirements. We have arranged to visit the factories of the leading makers of radio components and will, from time to time, record in these pages reports of our visits and describe points of special interest for the benefit of our readers.

THE army of experimenters who build their own sets are compelled through lack of plant, to purchase at least some ready-made components such as valves, transformers, telephones and the like.

Recently we visited the works of the Igranic Electric Company at Bedford, where we were courteously received by the General Manager, Mr. A. H. Curtis, and one of his assistants, Mr. P. H. Pettyfer.

Having explained the reason of our visit, we were invited to roam through the works without let or hindrance and handle and examine the products of this well-known firm in the various stages of manufacture.

The Igranic Works was in existence long before the arrival of the wireless boom, and their chief business was the manufacture of electric control devices of all descriptions—from the small switches of the tiniest motor to the huge and complex equipments for the control of dry docks, steel mills and mines, and the movement of the bascules of some of the largest bridges in the world.

It will be appreciated therefore that when this concern decided to install a radio department as an extension to its activities, this new venture was backed by a wealth of useful knowledge and sound experience.

Possibly very few persons have the least conception that the word "Igranic," which

has established itself as a hall-mark in the world of radio, means something definite. It is a coined word introducing "Iron" to denote strength, "granite" to signify endurance, and "electricity" to explain the great force of nature which its products harness.

The works, which by the way are now being enlarged so as to almost double the floor capacity, not only consist of such departments as the machine shop, winding room, assembly room, progress and despatch stores, and the usual divisions of organisation which are necessary to well-directed output; but, in order to ensure a high standard of excellence and uniformity for its products, research work and daily tests of apparatus drawn at random from the factory are carried

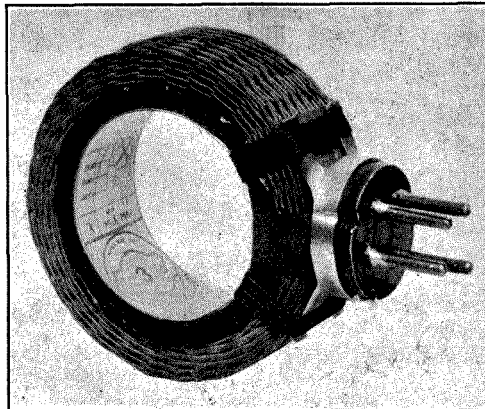

An Igranic honeycomb high frequency transformer.

out in the light, airy and well-appointed laboratory, a corner of which is here illustrated.

Having been privileged to enter this section also, we did not fail to observe that no expense has been spared in its equipment. Such standard instruments as National Physical Laboratory calibrated condensers, inductances, thermo-galvanometers, a cadmium cell giving a constant voltage stand out to the eye at the very threshold and can be picked out from the picture.

The Company use four aerials for general testing—one for transmission and three for

reception. The first of the aerials used for reception is 60 to 70 ft. high and is as efficient as it is possible to make it. The second is constructed to correspond as nearly as possible with many of the aerials in common use on many private houses where space is necessarily restricted and is low down on the roof. The third almost baffles description and has been deliberately thrown up in as shoddy a manner as could be conceived. It has high capacity, is leaky, has an uncertain earth connection and, generally, is a thorough disgrace to the neighbourhood. If

numbers of the machines used and the operators' names. The present total of employees is about 750.

The wireless devices marketed by the Company include honeycomb coils in two mountings and innumerable sizes, vario-couplers, filament rheostats for every kind of valve, potentiometers, fine tuning devices such as the "Vernob," the vernier friction pencil and anti-capacity extension handle, and electric soldering irons which, by the way, are also used by the employees in production.

Many new lines are constantly being

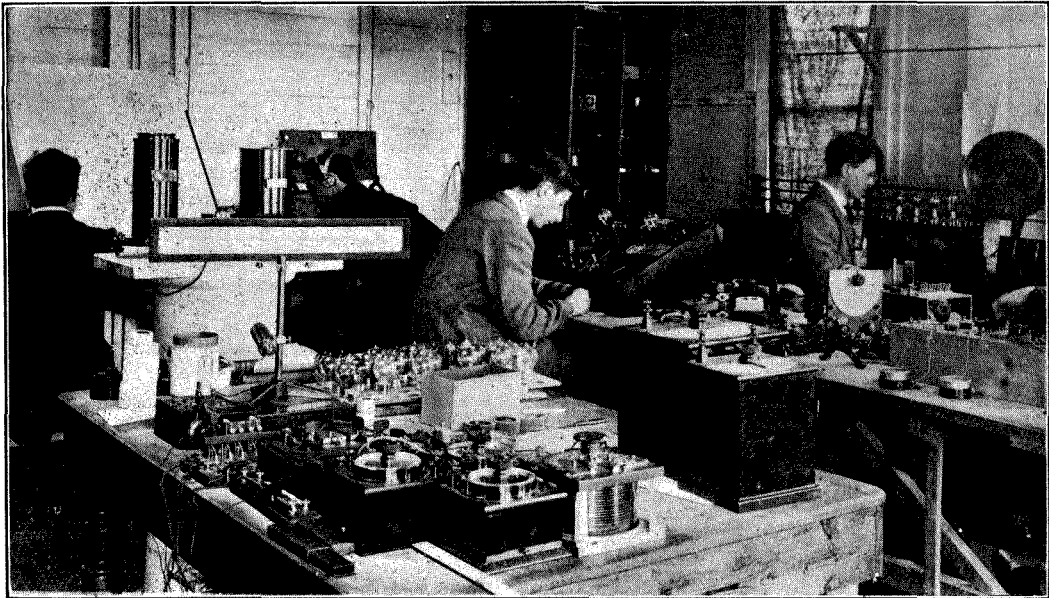

A corner of the research laboratory at the Igranic works.

apparatus will function on this creation then it should certainly work anywhere. Yet all the varied products of the radio factory are actually tried out on it!

Girls form a large proportion of the employees, but the work is so arranged that each individual becomes a specialist in the particular job allotted and there is a wonderful system of history cards by means of which any particular article can be traced through from the very start of manufacture to the moment of despatch from the works. These cards contain a mass of detail, including the

brought out and we can only touch on one or two which are of particular interest.

The "Unitune" aperiodic fixed coupler for short wavelengths consists of a plug-in coil of the usual external appearance but with primary and secondary windings of honeycomb duolateral formation. The aerial portion of the coil (primary) is aperiodic, whilst the secondary is tuned by a 0.0005 condenser in shunt. No alteration to the wiring of one's set, other than the removal of the aerial and earth leads from their customary terminals and their attachment to two special

terminals on the inside of the coil, is necessary. So great has been the initial demand for this coupler that Messrs. Igranic are unable at the moment to cope with it. In a few weeks, however, supplies should be obtainable without difficulty.

Honeycomb high frequency transformers, are deserving of particular mention. Being rather pleased with the appearance of these transformers, we selected a set at random and took them away for test. On plugging into the set one is struck with their stability

the largest transformer can be conveniently tuned with a 0.001 mfd. instrument and thus add to its effective wavelength range.

Our third photograph shows a close-up of the method of winding the potentiometer resistor elements which is of interest.

Before we left, Mr. Curtis enquired if we had any special questions to raise or any suggestions or criticisms to offer. We raised immediately the subject of a variable grid-leak which will give good performance, even regulation and consistent results.

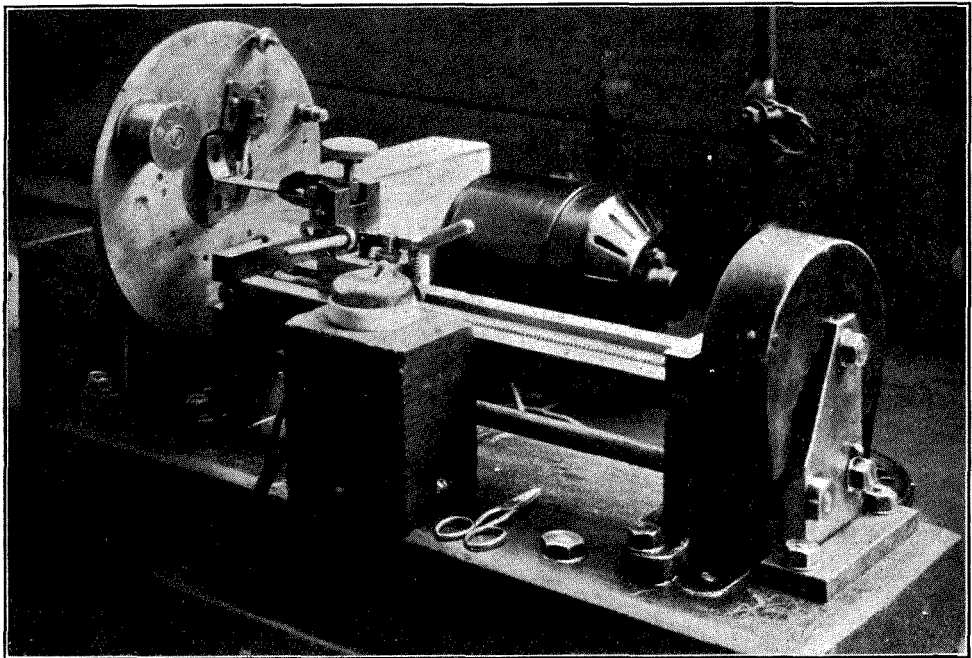

One of the potentiometer winding machines.

in operation and the four-pin plug, with diagram of connections on each coil, fits any standard valve holder. It is recommended that the tuning condenser be shunted across the secondary windings (filament terminals of valve holder). Self-capacity between the insulated windings is remarkably low.

The wavelength range covered by four of these transformers is from 250 to 3,000 metres with a 0.0005 mfd. condenser in shunt ; but

We were shown an article upon which they are now working and which has occupied some considerable time in the Research Department.

We are not permitted to divulge the details of construction at the moment, but Mr. Curtis has been good enough to promise to send one of the first batch produced for test. We shall hope, therefore, to give readers some further details and a report on its performances at a later date.

THE CRYSTAL AS A GENERATOR AND AMPLIFIER.

By VICTOR GABEL.

(Concluded from page 5 of previous issue).

Oscillating Crystal Circuits.

THE circuit of a generator was given in *The Wireless World and Radio Review* of June 11th, No. 252, page 300, but it is reproduced again in Fig. 5 for convenience of reference.

A circuit in which oscillations of audible frequency are produced is represented by C_1 and L_2 . If the switch S is set in the upper position and the telephones donned, a generating point on the crystal may be found by trial. After the oscillations have commenced the switch may be thrown into the lower position, when oscillations of high frequency will be obtained. It is of importance that the switch should contain a dead contact in the centre (as shown on the diagram), for otherwise the oscillations may cease during the process of switching over.

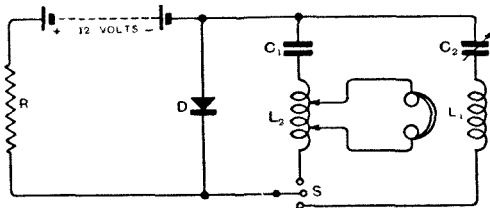

Fig. 5. Circuit for setting up oscillations.

It will be seen that the circuit also contains a resistance R in the direct current lead. The purpose of the resistance, which is indispensable in all circuits with generating crystals, is as follows. Let it be assumed that a millimeter of low resistance has been included in the circuit Fig. 1 instead of a galvanometer with a resistance r^1 as shown; in other words, that the battery is applied directly to the detector.

Under these circumstances the contact would always be at the potential applied from the potentiometer, and it would thus be impossible to obtain a negative characteristic. The presence of resistance allows a

free change of the potential applied to the detector, therefore the sum of the voltages at D and R (Fig. 5) must be constant, the potential difference at D changing in accordance with the strength of the current, it being always adjusted by corresponding changes of the voltages on the ends of the resistance.

Experiments have shown that R must always be higher than the average negative resistance of the detector, which is usually no higher than 900 ohms. The minimum value of R , therefore, is about 1,000 ohms. In order to choke back the oscillations from passing through to the battery circuit, it is desirable that the resistance should possess an inductance. For this purpose it is advisable to wind R (Fig. 5) of thin copper wire on an iron core. It is, of course, possible to include a separate choke coil of such a resistance that with the resistance R the total does not considerably exceed 1,000 to 1,500 ohms. The resistance of the inductance L_2 should also not exceed 50 ohms.

The following conditions found by means of experiments must be approximately fulfilled in order to be certain that high frequency oscillations will commence when the switch is brought over to the lower position:—

$$R_2 = R_1 \text{ and } \frac{L_1}{L_2} = \frac{C_2}{C_1} \text{ where } R_2, L_2 \text{ and } C_1$$

are the resistance, the inductance and the capacity respectively of the audio-frequency circuit and R_1, L_1 and C_2 are the resistance inductance and capacity of the high frequency circuit.

Referring to Fig. 6, a circuit useful for obtaining very short waves, it was found that the oscillating energy might be considerably increased by including a condenser C_3 in parallel with the generating detector D . For short waves of the order of 200 metres, 0.002 mfd. capacity was found a suitable

value, 0.004 mfd. suiting waves between 200 and 2,000 metres. A further advantage of including this condenser is that the purity of the oscillations obtained is considerably

the low resistance telephones. Should the telephones possess a resistance of 50 ohms or lower they may with advantage be included in the oscillating circuit instead of across the coil L_1 .

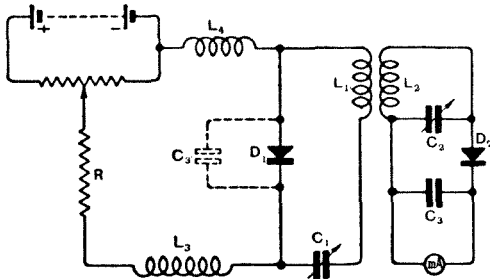

Fig. 6. Oscillating crystal circuit. C_3 is introduced and increases the amplitude on short wavelengths.

increased. Where waves of over 2,000 metres are being dealt with, the condenser becomes no longer necessary. Fig. 7 shows a complete circuit for a C.W. receiver.

The inductance L_2 is wound with copper wire not finer than 24 S.W.G. It consists of 220 turns wound on a former of 12 centimetres diameter with a length of 10 centimetres. Such a circuit is suitable for reception on wavelengths of from 2,000 to 15,000 metres. A circuit in which a zincite detector serves simultaneously as a generator of continuous waves and as a detector is shown in Fig. 8. By means of the potentiometer P it is possible to adjust the operation of the crystal in such a manner that it can work, as has been previously explained, on a point of the characteristic where it detects and where simultaneously its resistance becomes practically equal to the resistance of the antenna.

In view of the previous remarks the operation of the circuit should be easy to follow.

The note of spark and telephony stations will not be affected in any way, but only

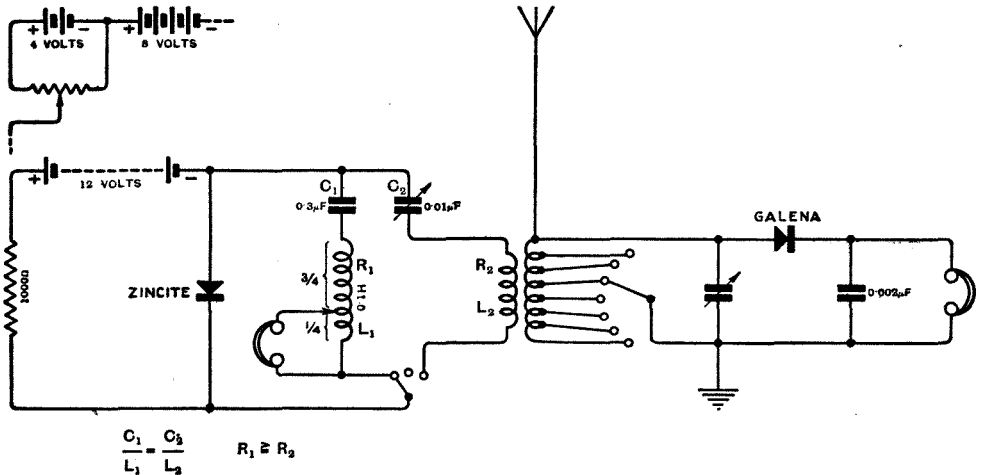

Fig. 7. Receiving circuit for C.W. reception, using a crystal oscillator for heterodyning the incoming oscillations.

The value of the heterodyne battery should be 12 volts, the current being about 3 milliamperes. For convenience the last 4 to 5 volts may be controlled through the agency of a potentiometer having a resistance of about 400 ohms. The coil L_1 having an inductance value of 0.1 henry and a resistance of 50 ohms is preferably wound with 28 S.W.G. copper wire, a section of about a quarter of the turns being shunted by

amplified, the operation being similar to that of a valve amplifier with reaction.

It may be noticed that the frequency of the oscillations generated by the crystal, changes slightly with the adjustment of the potential through the potentiometer.

Waves shorter than 1,000 metres are received, using the circuit shown in Fig. 9. In this circuit the condenser C serves for increasing the oscillation energy, its capacity

being about 0.004 mfd. In the circuit of a receiver shown by Fig. 10 the telephone receivers serve simultaneously for discovering the generating point by means of the oscillating circuit and for the reception of C.W. This dual use is accomplished by means of the double-pole switch S. Placed in the left-hand position it brings the telephones into the low frequency circuit L_2, C_2 , and when connected to the right-hand contacts the telephones serve for the reception of the oscillations of the antenna. This

detector itself amplifies the energy received in the antenna. Figs. 11, 12 and 13 are examples of such circuits.

An amplifier comprising a high frequency circuit C_1, L_1 , which serves as a tuner and

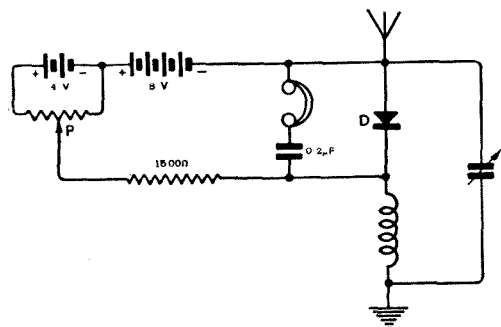

Fig. 8. Regenerative crystal receiving circuit for long wave reception.

switch must also be provided with a dead contact in the centre. The choice of the values of the inductances and capacities must depend on the same considerations as have been dealt with above.

A zincite detector can also be made to serve as an efficient amplifier. It has already been seen in the circuit of Fig. 8 that it is possible to obtain an amplifying process by means of a crystal, in a similar manner to a valve amplifier using reaction. It is, however, possible to arrange such a circuit when the

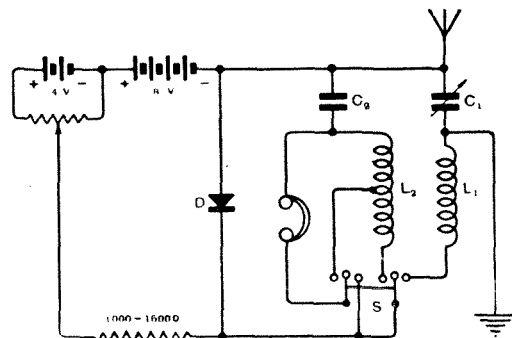

Fig. 10. A switch is here introduced so that the crystal can be adjusted to an oscillating condition.

a low frequency circuit L_2, C_2 , is shown in Fig. 11. In order to operate the amplifier successfully the potential applied to the crystal must be high enough to get the

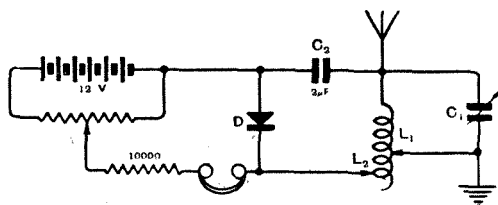

Fig. 11. Another regenerative circuit.

detector almost to a generating state, but generating must not commence, because the circuit produces oscillations of audio-frequency. A crystal can detect and at the

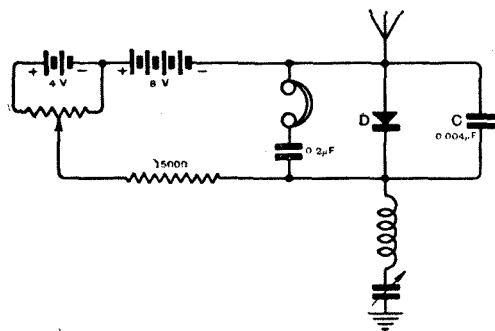

Fig. 9. Short wave regenerative crystal receiver.

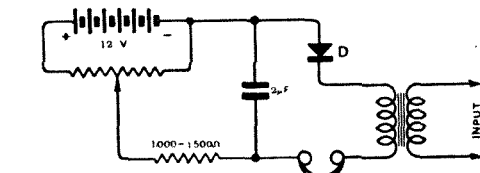

Fig. 12. An L.F. amplifying circuit.

same time produce amplification. A 15 to 1 amplification is even possible if the potentiometer is so adjusted as to keep the rise and fall of the oscillations of the circuit C_2, L_2 , in phase with the received oscillations.

A low frequency amplifier is shown in Fig. 12, which, however, gives only a low amplification factor.

The last, Fig. 13, represents the circuit of an amplifier working independently. It will be seen that the zincite detector-amplifier is connected straight on to the aerial. The receiver is used with an ordinary detector D_2 , $C L$ being the tuner.

In all instances where the detector is used as a generator or amplifier it is advisable to use telephones of low resistance of between 100 to 250 ohms.

Using some of the circuits described, it has been possible to achieve transmission over a distance of one mile. On both sides the crystal served simultaneously as a generator and detector, so that even duplex transmission was possible.

This new sphere for the use of a crystal opens up a wide field for investigations of great scientific value, and it is a matter in which both the amateur

and advanced experimenter can participate. It may be mentioned that any practical

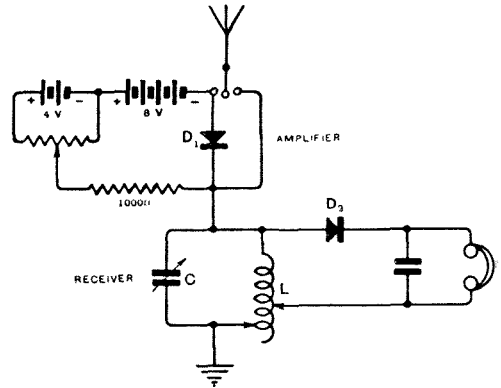
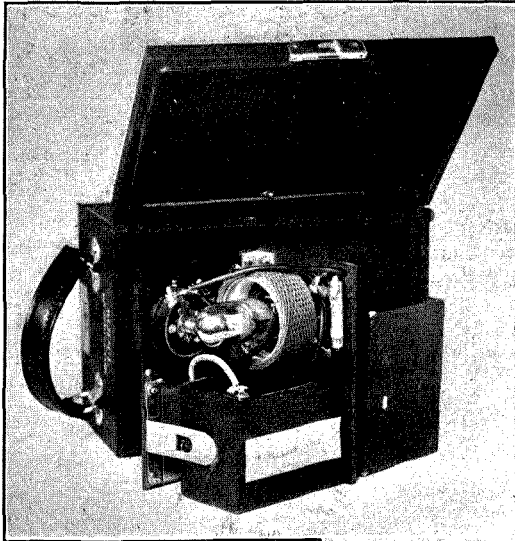

Fig. 13. Another oscillation amplifying circuit.

developments produced would be of extreme interest to those who are at present working along these lines.

THE REALLY PORTABLE SET.



This attractive set employs a single valve and is complete with plate and filament batteries. It is very simple to operate,

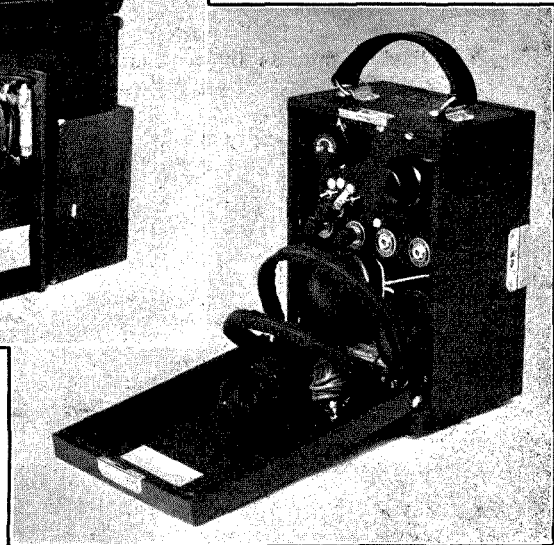

and tuning is carried out on one knob, while the circuit provides for regeneration.

Courtesy Carfax Co.

PATENTS AND ABSTRACTS

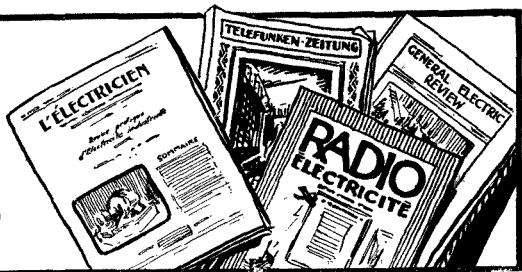

Loud Speakers.

(1) In loud speakers of the type having a sound horn, a compact design may be obtained by coiling the horn round a portion of the instrument in such a way that the centre of gravity of the horn is substantially

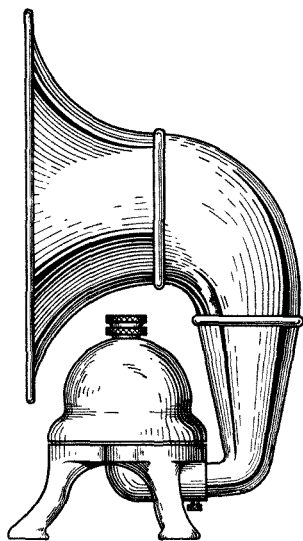

Fig. 1. A compact loud speaker suitable for mounting in a compartment of a cabinet type receiver.

vertical over the centre of gravity of the instrument. Where the horn enters the instrument at one of the sides the horn may conveniently be coiled horizontally round the instrument and then led up the side to spread out over the top.

One method of construction* may be seen from Fig. 1. A compact arrangement of this type is very suitable for mounting in a compartment of a cabinet type receiver.

(2) A good method of securing the diaphragm of a loud speaker is to clamp it

between the edge of the housing surrounding the mechanism and the element which constitutes a cover for the open end of the casing and provides a means of communication between the diaphragm and horn.

In the portion of the loud speaker sketched* (Fig. 2), 1 is the case of the instrument which contains the electromagnet 2. The diaphragm 3 is secured by screwing a massive block casting 4 to the case of the instrument, the screws passing through slots provided in the edge of the diaphragm.

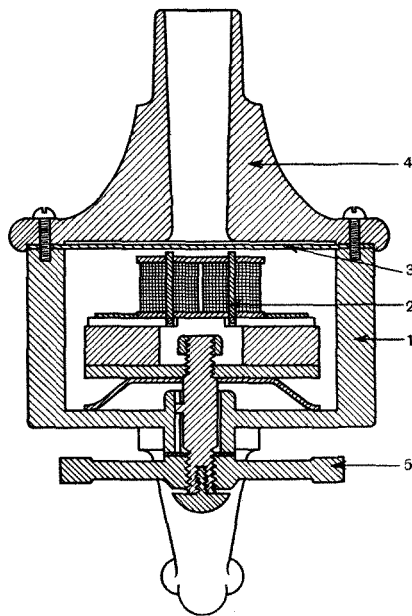

Fig. 2. A sectional view showing the construction of a loud speaker.

The position of the magnets with respect to the diaphragm may be adjusted by turning the knurled knob 5.

*British Patent No. 219,095, by The British Thomson-Houston Co., Ltd.

*British Patent No. 219,070, by Johnson and Phillips, Ltd., and W. H. Johns.

A Novel Valve.

In ordinary receivers or transmitters it is usual to connect a coil in the anode circuit and another in the grid circuit and to couple them for the purpose of obtaining reaction effects. It is proposed* to dispense with these coils and to construct the anode and grid of the valve of spirals of wire in such a manner that the magnetic coupling between them will suffice to give the desired reaction effect. Preferably the anode and the grid each are provided with two terminals to allow circuit connections being made at each end. The improved valve may be used without any external coupling or inductances for the generation of short or long waves. If necessary, the inductance of the grid and anode circuits may be increased by connecting external inductances. The use of external inductances will also permit of the coupling between anode and grid being varied.

Direction Finding System.

This invention refers to wireless direction finding systems, in which in the determination of a bearing, the occurrence of minimum current flow in a coil or circuit is noted by the effect produced in telephone receivers, or by an indicating instrument.

An improvement in this method† consists in arranging the apparatus to determine the occurrence of minimum flow in a circuit by causing the current to maintain a valve paralysed except when the current is at or near its minimum or zero value. One method may be explained with reference to Fig. 3. For determining the direction of a transmitting station, two coils or loop aerials (1, 2) are employed, these loops being fixed at right angles to one another, with their planes vertical. The direction of the transmitting station is determined by ascertaining when the current in the first loop (1) is a minimum; that is to say, when this loop is in such a position that the direction of the transmitting station is perpendicular to the plane of the loop. The plane of the second loop (2) is then directed towards the transmitting station. The terminals of the first loop, across which a tuning con-

denser 3, is connected, are joined respectively to the grid and through a potentiometer, 4, to the filament of the control valve 5. The anode of the control valve is joined to the filament through a battery 6, in series with a resistance 7, forming a potentiometer. A tuning condenser 8, is joined across the terminals of the second loop, and these are connected respectively to the grid of the main valve, 9, through a grid leak and condenser and to the movable contact of the potentiometer (7), in the anode circuit of the control valve. The terminal of the potentiometer

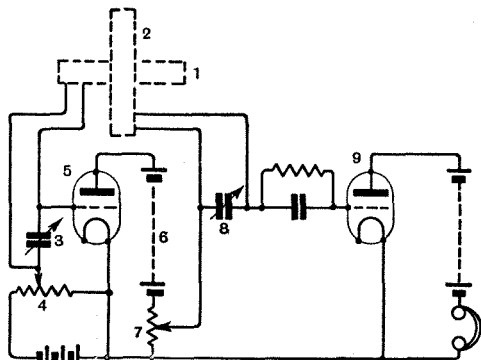

Fig. 3. Showing how a control valve is employed in the receiver of a direction finder.

which is connected to the filament of the control valve is connected to the filament of the main valve.

The movable contact of the potentiometer is so adjusted that except when the current in the first loop aerial has a minimum value, the potential of the grid of the main valve is such as to paralyse this valve. As the loop aerial is moved away from the position in which the current is a minimum, the main valve becomes paralysed, and no sound is heard in the telephone receivers. By using two loops in the manner described, a sound is produced at or near the minimum point only if radiation is being received from the transmitting station.

AUSTRALIAN AMATEUR PROGRESS.

We are glad to hear from Mr. Philip Renshaw of the rapid development of the Wireless Institute of Australia, and particularly of the New South Wales Branch, of which he is Hon. Secretary. This division has now incorporated practically the whole of the clubs in New South Wales and is the mouth-piece in all amateur wireless matters in Australia.

* British Patent No. 220,388, by J. Robinson and W. H. Derriman.

† British Patent No. 220,029 by J. Robinson and G. J. R. Joyce.

THE POSITION OF THE SCIENTIFIC AMATEUR.

AUTUMN PRESIDENTIAL ADDRESS TO THE RADIO SOCIETY OF GREAT BRITAIN.

By Dr. W. H. ECCLES, F.R.S.

(Concluded from page 8 of previous issue).

THE licence which the Postmaster-General must grant to the amateur may be "subject to such special terms, conditions and restrictions as the Postmaster-General may think proper, but shall not be subject to any rent or royalty." I think much of the trouble that has arisen comes from the last sentences. For example, they seem to have been interpreted to mean that the Post Office may restrict the licence to the use of a station for a few minutes a day between specified times and on a very low power, thus depriving the licence of nearly all utility. The phrase "terms, conditions and restrictions" has been applied to compel applicants to disclose completely the object and the method of their proposed experiments. Now there are some experiments for which the method can be foreseen and some for which it cannot. For most of them the method and the apparatus must be evolved as we go along. Hence the applicant for a permit to try experiments of this latter class is refused his licence—which is quite contrary to the spirit and the letter of the Statute. The ultimate consequence is that some surprising anomalies have arisen. For instance, at the beginning of the year the Council sent forward a select list of names of applicants of whose *bona fides* and competence the Council was confident. The list included among other experienced wireless amateurs one who has graduated in electrical engineering at a great College of the University of London. All the applications were rejected. At the same time the Council heard of licences being granted to inexperienced beginners with inferior qualifications. I am informed that the solution of this mystery is that some of the successful applicants for permits copy a few pages out of a technical

treatise or published paper and present it as a description of their proposed research.

Another instance in which the Society has tried to assist is that of a pre-war transmitter in the North of England who has retired from business and is anxious to return to the study of the variations of signal strength produced by the atmosphere. His application has been refused although, he tells us, beginners in his neighbourhood, some of them his pupils in the art, have been granted permits since.

VALUE OF EXPERIMENTS CANNOT BE KNOWN IN ADVANCE.

Even in those cases where a problem can be delimited and a method tentatively suggested, the desire of the Post Office to weigh the scientific value of the experiment and method before granting the permit is unpractical. It is an axiom of science and invention that such adjudication is worthless. It is a responsibility that no man of science, no scientific body would presume to undertake. The unexpected happens and is valuable. In short, it is much easier to spot the winner in a handicap than to forecast the result of an experiment.

THE LICENSING FEES.

While I am speaking of the Act I might refer to the enactment that the licence granted for experimental purposes shall not be subject to any rent or royalty. The experience of this Society in connection with its own experimental station is as follows. The original licence was required to cover three and a half months' operation and was granted on the 7th December last. The licensing fee of £2 and a royalty of £2 10s. for a complete half year had to be paid. The permit restricted the use of the station

to 15 minutes on any one night between the hours of 1 a.m. and 7 a.m., and the power was limited to 1 kilowatt. It is to be regretted that so severe a curb should be imposed upon altruistic scientific work. It is reminiscent of the dark ages. At the present moment the position is that the Society is prohibited from using its station, even for helping amateurs to tune their apparatus correctly, unless the Society consents to pay another £2 10s. in royalty for the remainder of the year.

HOW ANOMALIES HAVE ARISEN.

Perhaps the anomalies I cite above have grown up as the result of a system adopted long ago and have not been brought plainly before the authorities. I think it will be universally agreed that the system ought to be revised so as to remove them. An analogous case and its remedy is to hand. It will be remembered that at the beginning of the broadcasting movement in this country the Post Office applied the Wireless Telegraphy Act to compel all broadcast listeners to buy their apparatus from a specified group of firms. The upshot was that the home constructor arose in his thousands and defied the regulation. The Post Office thereupon tackled the problem afresh and rectified the mistake. This is exactly analogous to the present difficulty with the amateurs, but in this case the regulations are hindering scientific discovery, are robbing the best men of opportunities for learning advanced technique, are diminishing our wireless prestige relative to other nations, and will ultimately react adversely on the output of invention and technical improvement. The remedy is easy; it is to recast the regulations in the light of the experience of other progressive countries. British transmitters would then attain the same measure of freedom and be put under the same obligations as their fellow amateurs in America, France and elsewhere.

OTHER PROBLEMS BEFORE THE COUNCIL.

I have dwelt at some length upon the licensing anomalies because of the great importance of this matter from the national and scientific point of view; but the Council have had many other problems before them. This has been a year of re-organisation, and therefore a very arduous one for the Council, which has in fact held thirty-four meetings in the twelve months. Their work has resulted in many improvements. The first

great improvement consisted in concentrating all the work of the Society in a central office and in appointing a Secretary. Next, a number of Standing Committees were formed to deal with much of the detail work of the Society. The amount of devolution can be seen from the list of names of these Committees: The General Committee of Affiliated Societies, the Membership Committee, the Papers Committee, the Licensing Committee, the Publicity Committee and the Standards Committee. Full particulars of these Committees will be published in the Annual Report. Besides these there are permanent Committees of the two new Sections of the Society namely: the Schools Radio Society and the T. and R. Section. Since January the Committees have altogether held more than forty meetings.

The activities of the above named Committees are more or less invisible, but the scientific meetings of the general membership of the Society constitute an equally good record. During the twelve months there have been ten ordinary meetings with an average attendance of ninety, nine informal meetings with an average attendance of forty, and eleven meetings of the Transmitter and Relay Section with an average attendance of fifty-five.

Among the greater of the public efforts of the Society during the past twelve months I must mention the organisation of the Transatlantic tests last autumn. Mr. Coursey's report was published in May last and is familiar to all members. Another important piece of work was the transmission and reception tests conducted in an express train on the London and North Eastern Railway, organised by Messrs. Child, Coursey and McMichael. Full reports of these tests have now been published and the thanks of the Society duly tendered to all who had assisted.

A MEMBERSHIP BADGE.

Another matter which has engaged the attention of the Council has been the choice of a badge for the Society and its affiliated societies. In order to obtain suggestions the Council offered a prize of £5, reserving the right to use any or none of the suggestions in any manner. A large number of designs and ideas were sent in, many of them beautifully executed. They will be exhibited at the Society's Stand at the Exhibition

(Continued on page 58.)

NOTES & CLUB NEWS



☐ A wireless, electrical and cinema exhibition is to be held in the Ice Palace, Madrid, from December 6th to 26th.

* * * * *
H.M. The King of Siam has, we understand, purchased a Western Electric Supersonic Heterodyne Receiver with which he hopes to enjoy 2 LO's programmes.

* * * * *
A course of lessons in organ music is being broadcast from l'Ecole Supérieure des P.T.T., Paris.

* * * * *
The Irish Free State is shortly to have a broadcasting system with a main station in Dublin and relay stations in Cork and other centres.

* * * * *
The new relay broadcasting station at Stoke-on-Trent is to be opened on October 21st.

* * * * *
The Japanese Government have issued broadcasting regulations permitting the establishment both of high and low power stations. These will work on bands of 360 to 385 and 215 to 235 metres respectively.

MANCHESTER'S WIRELESS EXHIBITION.

Tuesday, October 14th, sees the opening of the first Wireless Exhibition to be held in Manchester. Organised under the auspices of the *Manchester Evening Chronicle*, this interesting show will be staged in the Exhibition Hall, Deansgate, and will remain open until Saturday, October 25th.

Leading wireless firms have taken stands and the result will be a very fine representative collection of modern apparatus.

The technical direction of the exhibition has been undertaken by the Manchester Radio and Scientific Society.

An interesting exhibit will be that of the Avro Company, of Manchester, who have kindly lent an aeroplane which will be fitted with wireless; a railway compartment and one of several motor-cars exhibited by the Ford Company will be similarly installed; and there is to be a duplicate of a ship's wireless cabin, fully equipped.

As a result of cordial co-operation with the B.B.C., there will be frequent transmissions for the benefit of the Exhibition during the fortnight, and amateur transmissions by leading Manchester amateurs are arranged for times when the Broadcasting station is closed down.

Not of least importance are the three constructional competitions organised by the *Evening Chronicle*, and for which prizes to the total sum of 100 guineas are being offered.

KDKA GETS BUSY.

In support of the claim of KDKA of being "the World's Premier Broadcasting Station," we have received a report of remarkable reception of the station on 60 metres by Mr. L. W. Murkham, of Stratford, London, E.

The occasion of this reception was the America-Spain tests and on Thursday, September 18th, our correspondent received the complete programme of the Pittsburg station, using a detector valve and one L.F. stage, his aerial being a 20-ft. wire hung across a room. The addition of a further stage of L.F. afforded good loud speaker strength of excellent quality.

Further tests were made on the following evening, when reception was found to be quite clear on earth alone. Indeed KDKA was still audible with both aerial and earth disconnected.

FRENCH COURSE FOR HOME CONSTRUCTORS.

It is a testimony to the success of the scheme the French School of Practical Electricity is on October 20th opening its fourth course of evening classes for those who desire instruction in the equipment of private wireless installations. The course extends over two months, and successful students are granted a diploma.

SOVIET CALL LETTERS.

The Russian Soviet wireless stations are being given call signs commencing with R. According to recent information, the following have been allocated:—Odborsk, **RAN**; Saratoff, **RAP**; Simferopol, **RAT**; and Kharkof, **RAZ**.

BELGIAN AMATEURS PLEASE NOTE.

To facilitate the interchange of reports, Belgian transmitters are asked to send particulars of their call signs, etc., to Monsieur L. Heurotay, President du Radio Club Belge de l'Est, 56 Crapaurue, Verviers, Belgium.

D.F. IN FOG.

An example of the value of direction finding at sea was furnished by the recent experience of the *Melita*, of the Canadian Pacific Service. Between Quebec and Newfoundland a dense fog was encountered and danger arose owing to the proximity of another large vessel, not fitted with D.F. apparatus, making for the same port.

In this delicate situation the *Melita* succeeded in accurately determining her own position and that of the other vessel, and in giving the latter her bearings. When the fog lifted momentarily,

visual bearings were taken which confirmed the *Melita's* readings in every respect.

GENERAL FERRIE AS AUTHOR.

General Gustav Ferrié, Chief of Radio Communications of the French Army, has recently completed a short book on the history and purpose of wireless. In the course of his remarks the General strongly advocates perseverance in short wave work, for which he sees a great future. A section of the book contains a highly eulogistic review of the work of amateurs throughout the world. Copies are obtainable, we understand, from the T.S.F. Revue, 35 Rue Tournafort, Paris.

WORLD'S FOREMOST CLUB ?

A highly satisfactory annual report for the season 1923-1924 has been issued by the Milwaukee Radio Amateur's Club. Much of the success which has made the past year a record one is attributed to the spirit of co-operation among members, and Mr. F. W. Catel, Secretary, makes the daring assertion that the club possesses the distinction of being the foremost purely amateur club in the world.

The membership committee has been very active and has secured 97 new members during the year.

THE PARIS CONCOURS LEPINE.

During the recent Paris Concours Lepine, an exhibition devoted to the productions of small inventors, demonstrations in transmission were given by MM. Jacques Chatenet and Pierre Delauney (8 BS). In spite of the heavy atmospheric disturbances at present prevalent in France, these transmissions were heard clearly by Finnish 1 NA.

SWEDISH AMATEUR TRANSMITTERS.

The following list of Swedish transmitters supplements that appearing in our issue of September 24th.

SMYY	H.S.G. Svensson, Kronudden	Waxholm
SMZA	Nässjö Radioklubb, Radhusgatan 26	Nässjö
SMZD	Jönköpings Radioklubb, Villa Annero	Jönköping
SMZF	G. H. d'Ailly, Skanegatan 31	Göteborg
SMZH	John Lundström, Kv. 15, Tomt 3	Kiruna
SMZI	Claes Fleming, Stureplan 2, Motoryachten Borgila, IV	Stockholm
SMZJ	Claes Fleming, Stureplan 2	Stockholm
SMZK	Falu Radioklubb	Falun
SMZL	Erik Holm, S. Langgatan 10	Kalmar
SMZN	Georg Holmlund, Rosenlundsgatan 3	Göteborg
SMZO	O. Mogensen, Svärdsjögatan 9	Falun

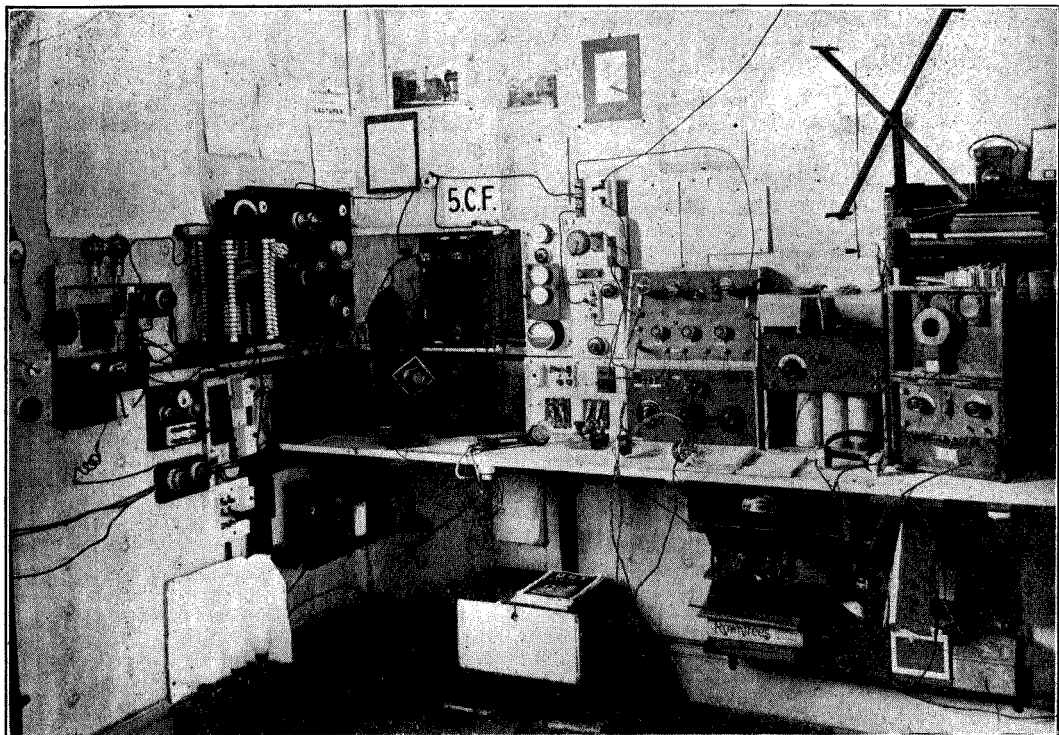

A well-arranged transmitting station owned by Mr. F. G. S. Wise, of Crouch End, London.

Radio Society of Great Britain.

FORTHCOMING MEETINGS.

An informal meeting of the Society will be held at 6 p.m. at the Institution of Electrical Engineers this evening (Wednesday), when Mr. A. Hinderlich will open a discussion on "Crystals."

The Transmitter and Relay Section will hold an informal meeting on Friday, October 10th, at 6.30 p.m., at the Institution of Electrical Engineers, when Mr. H. L. Kirk will give a talk on "Small Power Transmitters."

DISTINGUISHED LIFE MEMBER.

Members will be interested to learn that an honour has been conferred on the Society by H.R.H. The Crown Prince of Siam, who has become a life member.

AERIAL INSULATION.

Useful hints on aerial insulation were introduced by Mr. J. E. Nickless, in opening a discussion on the subject at an informal meeting of the Transmitter and Relay Section on Friday, September 26th.

The question of aerial insulation had been grossly neglected in the past, said Mr. Nickless, particularly from the amateur's point of view, and the market had been flooded with cheap insulators which in reality were not insulators at all. For instance, the cheap reel type was practically useless in a transmitting aerial and not much better for reception purposes. The shell type was a distinct improvement, but Mr. Nickless stated that he was disinclined to trust any insulator having a hole in the middle through which the wire was passed.

The ideal insulator should provide as smooth a surface as possible, and all sharp corners and curves should be avoided. In fact, every care should be taken to overcome capacity effects. The type of insulator favoured by the speaker was the "mushroom" variety, which was admirably adaptable to all kinds of weather. The mushroom insulator was also capable of surmounting great mechanical and electrical strains, and Mr. Nickless cited an instance in which an insulator of this type was submitted to a voltage of 52,000 without damage.

In the ensuing discussion the respective merits of glass and ebonite insulators were debated, but Mr. Nickless left the impression that for all-round purposes, the porcelain insulator was superior to other types.

RADIO HISTORY.

"Reminiscences of Wireless Telegraphy" formed the theme of an illustrated lecture given by Mr. Sims before the Borough of Tynemouth Radio and Scientific Society on September 25th.

The lecturer took his audience back to the time of Hertz, proceeding to the introduction of the coherer by Prof. Branly, and then to Senatore Marconi's Transatlantic experiments. After dealing with wireless in the war, Mr. Sims described modern wireless working, giving interesting details of the Imperial Wireless Chain.

CAPTAIN ECKERSLEY ON BROADCASTING DEVELOPMENTS.

SOME remarkable developments in connection with long distance broadcasting were foreshadowed by Capt. P. P. Eckersley, Chief Engineer of the British Broadcasting Company, in an address delivered to the Royal Photographic Society on Tuesday, September, 23rd.

Dealing first with the question of morse interference and jamming, Captain Eckersley expressed the contention that the broadcast waveband would, in a year or two, be entirely free from this nuisance. Until, however, this desirable state of affairs was attained, it behoved all listeners to render their sets as selective as possible. The major portion of the complaints came from listeners resident on the South Coast and the suggestion had been mooted that the power of the main stations in that vicinity should be considerably increased with the object of swamping the interference. This, Capt. Eckersley added, would have met with considerable opposition from licence holders who owned sets sufficiently sensitive to receive distant transmissions and who would, consequently, have experienced difficulty in tuning out their local station.

Referring to the question of relay stations, the speaker added that the cost of the erection of main stations in the various industrial centres would have been too high and relay stations were therefore adopted in preference to a few high power transmitters. It was estimated that with the existing main and relay stations and the proposed high power installation in operation, that practically 22 million people would be satisfactorily served, or approximately 50 per cent. of the population of the British Isles. Working on this basis less than 1 per cent. of the population were adequately served in America.

Utilising Marconi's new system of beam transmission, Capt. Eckersley anticipated the time when Great Britain and America would be linked up by wireless and constant and reliable telephonic communication, free from extraneous noises, would be possible. The speaker recalled the time, during the war, when direction finding at night in Salonica was rendered practically impossible through the shielding influence of adjacent hills, the waves appearing to originate from an entirely different source from that where they were transmitted.

At the broadcasting stations every endeavour was made to give equal electrical impulse for equal audibility, so the question of faithful reproduction mainly concerned those at the receiving end. Many telephones were designed to respond chiefly to one particular frequency, as was desirable where morse was being received. The speaker was convinced that the next outstanding development would be in connection with loud speakers and telephones.

6 MP.

Some confusion has arisen owing to the allocation of the call sign **6 MP.** to Mr. O. W. Nicholson, M.P., whose station is situated in Hampshire. This call was originally the property of the Metropolitan Police, but has since been re-allocated. Mr. Nicholson welcomes reports on his signals.

Calls Heard

Cobham, Surrey (August 26th and September 9th).
 English: 2 ASH, 2 BG, 2 CAA, 2 FN, 2 KF, 2 LF, 2 NM, 2 OD, 2 YT, 5 MA, 5 RZ, 5 ZN, 6 AL, 6 TD. French: 8 AE, 8 AQ, 8 BA, 8 BN, 8 BS, 8 CM, 8 CZ, 8 DA, 8 DI, 8 DO, 8 DX, 8 EN, 8 EX, 8 IP, 8 JM, 8 ML, 8 MN, 8 NQ, 8 NS, 8 OK, 8 RB, 8 RR, 8 RX, 8 SE, 8 TM, 8 UU, 8 VG, 8 WJ, 8 WR. Dutch: 0 BA, 0 GC, 0 GG, 0 MS, 0 RB, 0 RP, 0 ZC. Danish: 7 EC, 7 RT, 7 ZM. Belgian: 4 RS, 4 WR. Swedish: SMZS. Italian: 1 FP. German: POZ. Unknown: 3 AD, 3 CA, 3 XO, P 6 ZU, 1 CKZ, JLPL. (o—v—o.) (E. J. Martin).

Coventry (from August 26th).
 Morse: 2 ZK, 6 MP, 6 TD, 0 AB, 0 BA, 0 MS, 8 FP, 8 DO, 8 DX, 8 UU, 8 MN, 8 CG, 8 SSU, 8 BN, * ZAC, SMZP, GB, IFF, 1 OA, 1 P, 2 P, ZSW. Telephony: 2 AIT, 2 NV, 2 YX, 5 YS, 8 KK. (o—v—1 and 1—v—1.) * Also on spark R.7. (H. Maycock, 2 AVD).

Aberthaw, Glam.
 British: 2 DR, 2 DX, 2 KP, * 2 WU, * 5 AK, 5 KO, 5 LS, 5 NW, 5 RQ, 6 RS, * 6 TD, 6 TH. French: 8 BN, 8 BU, 8 DN, 8 DO, 8 EM, 8 JHL, 8 OK, 8 WL, 8 WZ, 8 SSU. Dutch: 0 BA, 0 MS, 0 XP. Others: 1 DO, 3 AD. * Telephony. (C. Prosser, 2 ACK).

Huddersfield (August 26th and September 6th, 1924).
 2 CG, 2 DX, 5 BS, 5 MA, 5 OX, 5 TZ, 5 XN, 6 GH, 6 GM, 6 LJ, 6 NF, 6 RY, 6 NN, 0 QR, 0 XP, 8 BV, 8 DO, 8 WJ, 8 WL, 7 EC, SMZP, 4 C 2, W 2, 1 NA, C 1 AR. (Reinartz, 1 D.—1 L.F.) (J. B. Kaye).

Verviers, Belgium (during August).
 English: 2 CA, 2 KZ, 2 MK, 2 OG, 2 TA, 5 LS, 5 MA, 5 OC, 5 RQ, 5 TZ, 6 GM, 6 TD. Dutch: 0 FN, 0 MR, 0 RB, 0 XG. Italian: 1 MT. Belgian: 4 WR. Danish: 7 ZM. French: 8 AE, 4, 8 BN, 8 BV, 8 CZ, 8 DO, 8 DX, 8 F 4, 8 JHL, 8 KK, 8 OK, 8 RBR, 8 RO, 8 RE, 8 SM, 8 SR. (R. Pirotte).

West Norwood, London, S.E.27.
 2 AIT, 2 AKU, 2 AMB, 2 ARY, 2 AXK, 2 DZ, 2 FV, 2 GW, 2 JB, 2 OA, 2 OF, 2 TF, 2 TK, 2 ZV, 5 CU, 5 DY, 5 NW, 5 VN, 5 XH, 6 BBC, 6 LF, 6 US, 6 ZE, 6 ZZ, 8 BS, 8 BU, 8 DI, 8 EC, 8 ED, 8 EE, 8 EU, 8 EX, 8 FJ, 8 FK, 8 FL, 8 FQ, 8 JG, 8 JHL, 8 LO, 8 MN, 8 MP, 8 NS, 8 OK, 8 PA, 8 PP, 8 RM, 8 SR, 8 TK, 8 TV, 8 VG, 8 VW, 8 XR, 8 ZC, 0 GC, 0 HD, 0 MS, 0 OX, 0 QW, 0 KQ, 0 ZO, YA 11, SMZP, SMZS, SMZY, ARRL, BX, 3 CA, 3 BS, 3 XO, 4 MG, 4 RS, 4 UN, 9 AD, in INA, in 2 NM, in 3 BA, (o—v—1.) (L. H. Thomas, 6 QB).

London, N.W.2.
 English: 2 ABZ, 2 AIT, 2 AKS, 2 ARX, 2 ASH, 2 ATI, 2 BBN, 2 CC, 2 KZ, 2 MG, 2 OA, 2 OD, 2 PY, 2 TF, 2 UV, 2 WJ, 2 XY, 2 YT, 5 BH, 5 CS, 5 EL, 5 FS, 5 GA, 5 IO, 5 JK, 5 LP, 5 MA, 5 MO, 5 MU, 5 OC, 5 QF, 5 QP, 5 RZ, 5 SZ, 5 UG, 5 US, 5 XH, 6 AH, 6 BY, 6 KL, 6 KJ, 6 LI, 6 QA, 6 QB, 6 RQ, 6 TD, 6 TM, 6 US, 6 XG. French: 8 AL, 8 BA, 8 BS, 8 BU, 8 BV, 8 DJ, 8 ED, 8 EK, 8 EM, 8 EU, 8 FK, 8 FQ, 8 FX, 8 FS, 8 JG, 8 JL, 8 KK, 8 LO, 8 MN, 8 NV, 8 OK, 8 PA, 8 PF, 8 RZ, 8 SY, 8 SR, 8 TV, 8 XY. Dutch: 0 BA, 0 BQ, 0 BS, 0 GC, 0 KX, 0 OX, 0 PA, 0 RB. Finland: 1 NA, 2 NM, 3 NB. Miscellaneous: ARRL, YA 20, L O AA, 7 EC, 3 AD, 1 GF, 4 CA, 3 CA, 4 WR, 2 XAA, GB 1, GB 2, GB 4, GB 5, GB 6, 2 XSS, 2 CAA. (o—v—o, Reinartz.) (E. A. Wilson, 6 GM).

Portsmouth, E. Lothian (during August, 1924).
 2 CC, 2 DX, 2 OD, 2 JF, 2 JU, 2 KF, 2 NM, 2 XO, 2 XY, 5 FS, 5 GB, 5 LF, 5 OC, 5 TZ, 6 GM, 6 QN, 6 TD, 6 UD, 8 AQ, 8 BN, 8 BV, 8 EX, 8 FN, 8 FZ, 8 FW, 8 KK, 8 ML, 8 RO, 8 UU, 8 XR, 3 XO, D 3 AD, FNZNM, 1 NA, 4 WR, 0 RB, 0 BQ, 4 WR. (Capt. E. A. Anson, 2 OA).

AN OMISSION.

In the article in our last issue describing the Dry Cell Receiver, a drilling diagram was shown on page 16, but the dimensions of drills required were inadvertently omitted. These should be as follows, the lettering corresponding with that on the diagram:—

- A = 1/8 in. diameter.
- B 1/8 in. diameter and countersunk.
- C = 5/32 in. "
- D = Tapped 4 B.A. and 3/16 in. deep.
- E = 1/8 in. diameter.
- F = 3/16 in. diameter.
- G = Tapped 2 B.A. and 3/16 in. deep.
- H = 5/32 in. diameter.
- J = 9/32 in. diameter.

THE POSITION OF THE SCIENTIFIC AMATEUR—concluded from page 54.

opening on Saturday. A sub-committee consisting of Admiral Sir Henry Jackson, Mr. Campbell Swinton and myself went through all the suggestions and agreed that no one of them was exactly suited to our purpose. Finally it was decided to combine some of the elements occurring in two of the best designs and to divide the prize. The winners are Mr. Frank W. Taylor of 60 Cleveland Gardens, Barnes, and Mr. H. H. Townley, 26 De Crespigny Park, S.E. Many other of the competitors deserve prizes, but I can do no more than give them honourable mention, together with the thanks of the Society for their efforts. They are Messrs. Adeane of Shepherd's Bush, Bampton of Salisbury, Bassett of Crofton Park, S.E., Bowes of Darlington, Brayshaw of Huddersfield, Church of Hendon, Clamp of Sydenham, Cooper of Acomb, Cumming of Yeovil, Farrar of Cardiff, Flinton of Scarborough, Francis of Barnet, Goundry of Barrasford, Harvey of Bristol, Helps of Bradford-on-Avon, Ibbitson of Sunderland, Larkin of Eltham, Loughlin of Salford, Marshall of Harrow, Mitchell of S. Croydon, Rowell of Gateshead, Sugarman of Abercynon, Wright of Portsmouth and Mysehall of Rotherham.

FORTHCOMING EVENTS.

WEDNESDAY, OCTOBER 8th.

- Radio Society of Great Britain.** Informal Meeting. At 6 p.m. At the Institution of Electrical Engineers, Savoy Place, W.C.2. Discussion: "Crystals." To be opened by Mr. A. Hinderlich.
- Radio Research Society, Peckham.** At 44 Talfourd Road. Discussions: "H.F. Amplification," "Telephones and Microphones."

Streatham Radio Society. At Streatham Hill College, 35 Streatham High Road, S.W. Lecture by Mr. Ward (2 QS).

THURSDAY, OCTOBER 9th.

Bournemouth and District Radio and Electrical Society. At 7 p.m. At Canford Hall, St. Peter's Road. Lecture: "Practical Uses of the Valve." By Mr. W. H. Peters, B.Sc.

West London Wireless and Experimental Association. At Belmont Road Schools, Chiswick, W.4. Lecture: "Constructional Details, Part 1." By Mr. J. F. Bruce.

- Wimbledon Radio Society.** Field Day.
- Walthamstow Amateur Radio Society.** Jumble Sale.

MONDAY, OCTOBER 13th.

Hackney and District Radio Society. At 8 p.m. At King's Hall, Lower Clapton Road, E.8. "Experiments with Frame Aerials."

TUESDAY, OCTOBER 14th.

Manchester Wireless Exhibition. Until October 25th. In City Exhibition Hall, Liverpool Road.

Merthyr Radio and Scientific Society. At Milbourne Chambers, Merthyr Tydfil. Opening Meeting of Session.

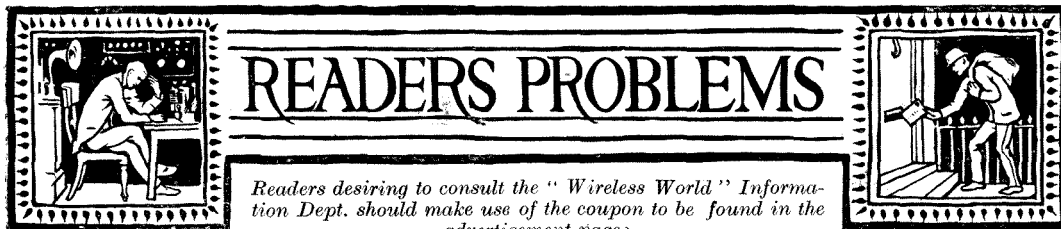

CONNECTIONS OF PLUG-IN H.F. TRANSFORMERS.

BEFORE wiring up a valve holder which is to accommodate a plug-in type H.F. transformer in a receiver, it is always wise to check the connections of the pins on the transformer in order to make quite sure that the primary and secondary windings will be connected into the circuit in the correct manner. While the method of connecting the beginnings and ends of the windings varies with different makers, it will be found that in most cases the primary winding is connected between the "grid" and "plate" pins, and the secondary winding between the "filament" pins. It is often possible to obtain a clue as to which are the begin-

With switch S1 to the left, S2 to the right, and S3 to the left, the crystal detector alone will be in operation. With S1 to the right and the other switches in the positions mentioned above, the crystal will be preceded by H.F. amplification. When S2 is in the left-hand position, one or two stages of L.F. amplification will be brought into operation, according to the positions of switches S3 and S4. The first stage of L.F. amplification is transformer coupled to the crystal detector, and choke-capacity coupling is employed between the first and second L.F. stages. Suitable values are indicated for the grid coupling condenser. To avoid complication of the wiring, the filament current of valves not in use should be switched off by means of the filament resistances.

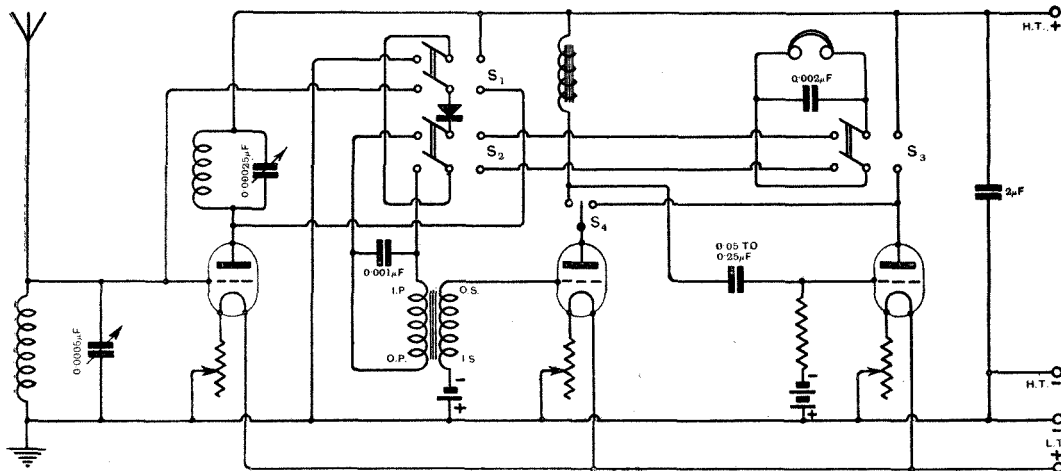

An experimental three-valve and crystal receiver.

nings and ends of the windings by an examination of the position of the holes leading to the interior of the transformer.

AN EXPERIMENTAL THREE-VALVE AND CRYSTAL RECEIVER.

THE diagram above shows the connections of a receiver employing one stage of H.F. amplification, with crystal rectification and two note magnifiers. Switches have been introduced so that any combination of valves may be used.

THE RESISTANCE OF POTENTIOMETER WINDINGS.

IN sending a diagram for criticism, a correspondent asks if the resistance of the potentiometer is too high.

The resistance of a potentiometer cannot very well be given too high a value. The higher the value of the resistance, the less will be the current drawn from the L.T. battery, and as the grid current necessary to prevent oscillation in an H.F. valve is generally only of the order of a few microamperes, a current of 1 milliampere from the

potentiometer resistance would be sufficient to ensure a grid voltage proportional to the position of the slider on the potentiometer. Generally speaking, the potentiometer should be given a resistance of not less than 300 ohms.

A FOUR-VALVE RECEIVER FOR BROADCAST RECEPTION.

THE circuit arrangement given below is suitable for the reception of broadcasting when long range and freedom from distortion are required. One stage of high frequency amplification, together with the use of reaction, ensures the reception of weak and distant stations, while the use of crystal rectification and resistance capacity coupling in the case of L.F. valves is calculated to reduce distortion. It is desirable that the crystal detector should be connected to the first L.F. amplifying valve by means of an intervalve transformer. The distortion introduced by this transformer will be negligible if this component is provided with a sufficient number of turns, and with an iron core of adequate cross section. Suitable values are given where possible, but the values of the anode resistances will depend upon the value of the H.T. battery and the type of valves used.

H.T. battery, and would prevent the flow of a destructive current. Another method of protecting the valves is to connect a small flashlight bulb in series with the H.T. battery. This bulb acts as a fuse, and will burn out in the event of a short circuit.

TAPPINGS ON H.T. BATTERIES.

WE have had many queries from readers who have purchased H.T. batteries in which a fixed positive terminal and variable negative tappings are provided, asking how such a battery could be used in a circuit requiring a variable positive tapping.

While this method of marking the tappings is misleading, there is nothing to prevent the use of a variable positive tapping. Every plug on the battery is both positive and negative, according to the end of the battery to which it is referred, so that by fixing the negative plug, the remaining plugs become positive with respect to this fixed tapping, and a variable positive tapping can therefore be obtained.

THE EXAMINATION FOR THE P.M.G.'S CERTIFICATE.

IT is not necessary to pass through a training school in order to take the examination for the Postmaster-General's certificate of proficiency in

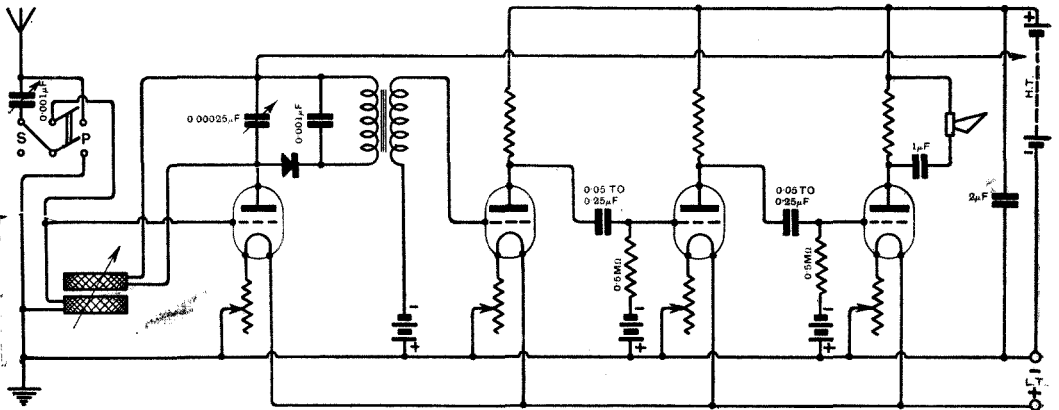

A four-valve receiver for broadcast reception.

PROTECTION OF THE H.T. BATTERY.

REFERRING to the method of protecting the H.T. battery described on page 656 of the issue of September 3rd, 1924, a reader asks if the 100 ohm resistance connected in series with the H.T. battery would appreciably affect the value of the anode current to the valve.

The effect of this resistance would be negligible, since it bears only a small ratio to the internal resistance of the valve itself, which may be of the order of 50,000 ohms in the case of a general purpose receiving valve. In the event of a short circuit taking place, however, this resistance would be large compared with the internal resistance of the

operating wireless apparatus. This examination is open to all who have filled in the necessary forms; but owing to the fact that part of the examination is of a practical nature, and requires acquaintance with the actual apparatus used on board ship, candidates generally prefer to receive their training at a recognised school, where the apparatus can be manipulated and tested.

A syllabus showing the ground covered by the examination and a copy of the application form are given in *The Handbook for Wireless Telegraph Operators Working Installations Licensed by His Majesty's Postmaster-General*, which is obtainable from H.M. Stationery Office, Imperia House, Kingsway, London, W.C.2.

Wireless Valve Transmitters

The Design and Operation of Small Power Apparatus

By W. JAMES.

CONTENTS.

- (1) *Electrical Principles.*
- (2) *Inductance Coils and Condensers.*
- (3) *Alternating Current Circuits.*
- (4) *The Supply of Power.*
- (5) *Rectifiers.*
- (6) *Valve Rectifiers.*
- (7) *Microphone and Speech Amplifiers.*
- (8) *The Three-electrode Valve as an Oscillator.*
- (9) *Modulated Waves and Wireless Telephony.*
- (10) *Miscellaneous Notes and Measurements.*

The aim of the author in writing this volume has been to deal in turn with each portion of the complete transmitting equipment so that anyone may be able to design and operate his own transmitter. Every possible difficulty which may be encountered has been thoroughly dealt with. The book is divided into 10 chapters and contains no less than 210 photographs and figures. Price 9s., post 9d. A huge demand is certain. Order your copy at once.

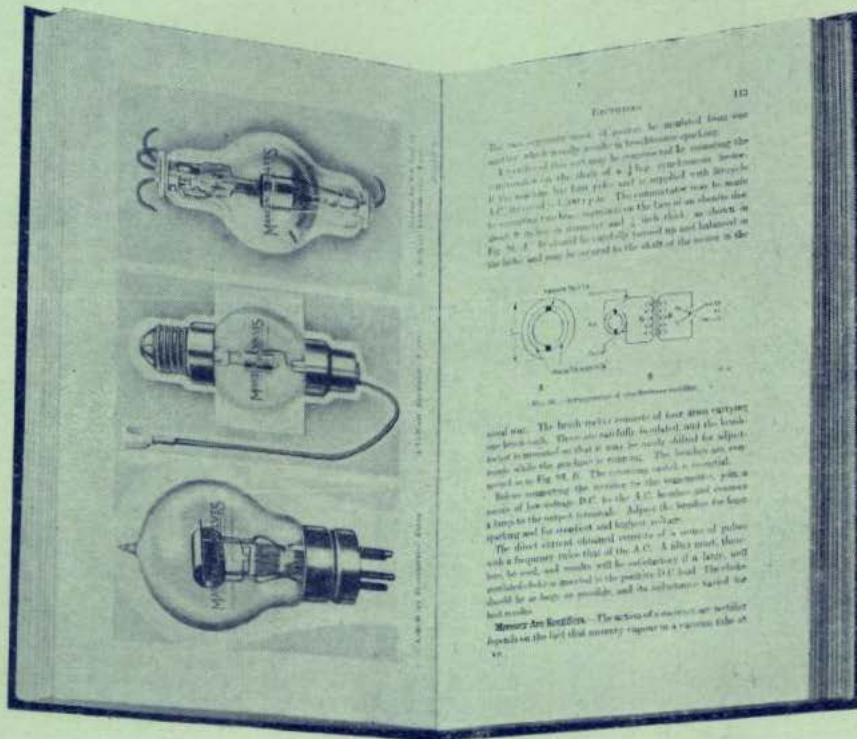

Issued by

THE WIRELESS PRESS LTD.

12-13 Henrietta Street, Strand, W.C.2





RESEARCH STANDARD

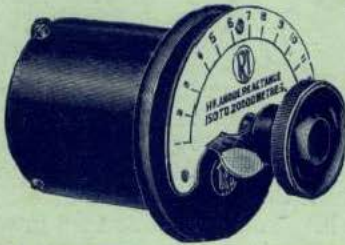

H.F. Reactance with 12 tapping points, self-contained H.F. Unit, 150-20,000 metres **35/-**



Crystal Detector. Dust-proof Micro-meter Adjustment Price **8/6**



Combined Variable Interval Reaction and Anode Reactance. Wavelength range, 200-4,000 metres **45/-**

EVERY wireless experimenter looks sooner or later for something more than ordinary results. Each component of his receiving set is reviewed with determination to keep only the best.

R.I. components are always kept. Their standard of design, workmanship and results places them above all criticism.

Have you tried R.I. high power frequency components? They are the result of 25 years of advanced wireless research.

The R.I. Anode Reactance is adopted in all the best receiving sets, because it holds the finest H.F. amplification efficiency, and does away with all plug-in coils.

R.I. high frequency Transformers are ideal for multi-valve sets.

Write for the New R.I. catalogue; you will never regret your choice of R.I. components.

RADIO INSTRUMENTS LTD

Works, Offices and Showrooms—

12 Hyde Street, New Oxford Street, W.C.1

Managing Director—J. JOSEPH, M.I.E.E.
Chief Designer—W. A. APPLETON, M.B.E., M.I.R.E. (late Admiralty Technical Research Officer).

Telephone—Regent 6214-5-6. Telegrams—"Instradio, London."



THE WIRELESS WORLD

AND
RADIO REVIEW



PRICE 4^D NET.

BUILDING AN
INEXPENSIVE
TRANSATLANTIC
RECEIVER

No. 270 [No. 3
Vol. XV]

NEW DEVELOPMENT IN COIL DESIGN

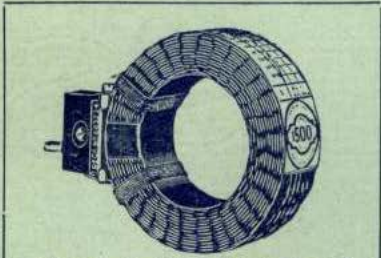

IGRANIC Honeycomb Inductance Coil
(De Forest Patent, No. 141344)
Having the qualities of an ideal inductance coil, and being obtainable in 20 sizes which allow of a selection by means of which dead-end losses are reduced to a minimum—it is the best possible inductance for short wave reception.
20 Sizes to cover wavelengths up to 25,000 metres—for short wave reception they cost 5/-.
Overcomes the difficulties of short-wave reception for it combines the advantages of both direct and loosely coupled methods. Famous Honeycomb winding is used because self-capacity—so essential for short wave reception—is reduced to a minimum. Can be used in any set which has standard coilholders, without re-wiring.

IGRANIC Unitone Aperiodic Fixed Coupler
(De Forest Pat. No. 141344)
(Other Patents pending)
Overcomes the difficulties of short-wave reception for it combines the advantages of both direct and loosely coupled methods. Famous Honeycomb winding is used because self-capacity—so essential for short wave reception—is reduced to a minimum. Can be used in any set which has standard coilholders, without re-wiring.

The Thrill of Transatlantic Reception

Like in one's childhood days when waiting for "Father Christmas" to "broadcast" his welcome load—so one waits in the early hours for the thrill of "receiving" transatlantic stations. And whether one waits with confidence or misgiving depends

to a great extent upon what components are built into the radio receiver. Though you may pay a little more for the Igranitic Components with which you build your set—you realise, when your vigil has been crowned with success, how their performance justifies your selection of Igranitic Components.

The well-known American broadcasting stations **KDKA** and **WGY** are transmitting on short wavelengths and on this page will be found details of two Igranitic devices which, being built especially for short wave reception, should form part of your receiver if you would experience to the full the thrill of transatlantic reception. They, like all other Igranitic Components are obtainable of all reputable dealers.

Write for List U90, which illustrates and describes them. Igranitic Devices carry a six months' guarantee.



149 Queen Victoria Street, London.
Works: BEDFORD.

GLASGOW
BRADFORD

BRANCHES—
MANCHESTER
NEWCASTLE

BIRMINGHAM
CARDIFF.

Variable Bridge Condenser

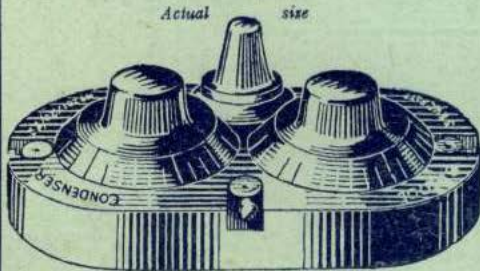

New Model A (Mica Dielectric) 14/6

The Variable Bridge Condenser is the Ultimate Radio Controller, for its fundamental principle presents finality in precision.

- Model B (3-E.V.C.) Panel Mounting (Air Dielectric) .. 37/6
- C Cabinet Mounted (Air Dielectric) 45/-
- D Bridge Tuning and Rejector Unit 60/-
- Bridge Tuning and Rejector Coils 7/6

CLIX COMBINATION PLUGSOCKET—the Electro-Link with 150 uses—inaugurates a standardised system of instantaneous wiring.

- CLIX with Locknut 3d. each
- CLIX Insulators (6 colours) 1d. each
- CLIX Bushes (6 colours) 1d. per pair

Obtainable from all Wireless Dealers or direct from the Patentees and Manufacturers:

AUTOVEYORS LTD.

Radio Engineers and Contractors

84 VICTORIA STREET, LONDON, S.W.1

A standard article—fulfils all the requirements of the ordinary user

"Tangent" L.F. Transformer

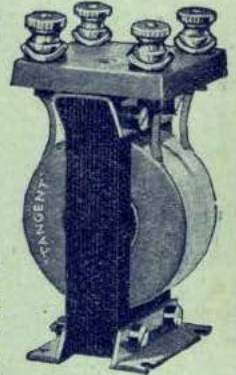

Fitted with soldering terminals—It is strongly made. Has dependable and reliable windings—is moreover scientifically designed and none is more electrically efficient. This statement is backed by the ever increasing sales which alone have allowed the low figure of

12/6

If fitted with "Tangent" patent terminals as shown, 2/- extra.

If difficulty in obtaining—write us.

GENT & Co. Ltd.

Manufacturing Electrical Engineers,
"Faraday Works,"
LEICESTER

London: 25 Victoria St., S.W.1
Newcastle-on-Tyne:
"Tangent House," Blakett St.

THE WIRELESS WORLD AND RADIO REVIEW

THE OFFICIAL ORGAN OF THE RADIO SOCIETY OF GREAT BRITAIN.

No. 270. (No. 3
Vol. XV.) OCTOBER 15th, 1924.

WEEKLY.

EDITOR:
HUGH S. POCOCK.

ASSISTANT EDITOR:
F. H. HAYNES.

RESEARCH EDITOR:
PHILIP R. COURSEY, B.Sc., F.Inst.P., A.M.I.E.E

QUESTIONS AND ANSWERS DEPARTMENT:
Under the Supervision of W. JAMES.

CONTENTS.

PAGE

Radio Topics. By the Editor	- - - - -	61
The Transatlantic Receiver. By F. H. Haynes	- - - - -	63
Distortionless Amplification	- - - - -	68
Readers' Practical Ideas	- - - - -	69
New Coils of High Efficiency By J. H. Reeves, M.A.	- - - - -	73
Valve Tests. Repaired Valves	- - - - -	78
An Easily Constructed Variometer. By H. J. Clarke	- - - - -	80
Patents and Abstracts	- - - - -	82
Correspondence	- - - - -	83
Notes and Club News	- - - - -	85
Readers' Problems	- - - - -	89

THE EDITOR will be glad to consider articles and illustrations dealing with subjects within the scope of the Journal. Illustrations should preferably be confined to photographs and rough drawings. The greatest care will be taken to return all illustrations and manuscripts not required for publication if these are accompanied by stamps to pay return postage. All manuscripts and illustrations are sent at the Author's risk and the Editor cannot accept responsibility for their safe custody or return. Contributions should be addressed to the Editor, "The Wireless World and Radio Review," 12 and 13 Henrietta Street, Strand, London, W.C.2.

SUBSCRIPTION RATES :
20s. per annum, post free. Single copies 4d. each or post free 5d. Registered at the G.P.O. for transmission by Magazine Post to Canada and Newfoundland.

As many of the circuits and apparatus described in these pages are covered by patents, readers are advised, before making use of them, to satisfy themselves that they would not be infringing patents.



EDITORIAL AND PUBLISHING OFFICES :

12 and 13 Henrietta Street,
Strand, London, W.C.2.
Telephone : Gerrard 2807-8.

ADVERTISEMENTS MANAGERS :

Bertram Day and Co., Ltd.,
9 & 10 Charing Cross, S.W.1
Telephone : Gerrard 8063-5.

Brandes

The Name to Know in Radio.

Sweet bell-like notes

which gather intensity and beautifully balanced volume. Not a suspicion of dull tonelessness in the reception given by the "Matched Tone" Headphones. They are guarded from tone-deafness and distortion by the matched receivers. Both are carefully tested with special apparatus for sensitivity and volume so that they are as nearly identical as possible and you hear the same sound in both ears—which means everything. Now take the *Table-Talker*. It has the same beautiful tone qualities. The horn is carefully matched to the unit to ensure a delightful uniformity of tone with sufficient volume to fill the largest room. Pleasantly simple lines and a neutral brown finish which blends harmoniously with any decorative scheme completes a tasteful and effective addition to your set.

All Brandes products are obtainable from any reputable Dealer and carry our official money-back guarantee, enabling you to return them within ten days if dissatisfied.

Matched Tone
TRADE MARK
RADIO HEADPHONES

25/-

Table-Talker
TRADE MARK

42/-

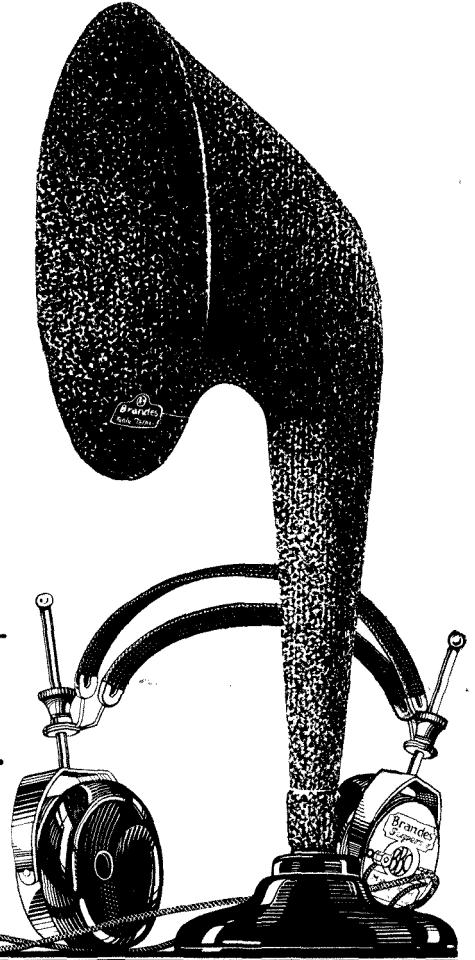

*Tune with Brandes "Matched Tone"
Radio Headphones
Then Listen with Brandes
Table Talker*

The WIRELESS WORLD — AND RADIO REVIEW



RADIO TOPICS.

THE FALLACY OF A CENTRAL AERIAL.

A REFERENCE has been made recently in the daily press to a proposal made by the Bethnal Green Borough Council for the establishment of a central aerial to supply the district and dispense with the necessity for independent aerials on every house. As we understand the proposal, the central aerial would receive broadcasting from, we presume, the local station, and would re-radiate so that small frame aerials on sets in the vicinity would be sufficient to pick up the transmissions. Such a proposal does not seem to be a practical one for an independent body to attempt. Neglecting technical difficulties altogether, it should be apparent that under the present powers of the B.B.C. that Company has a monopoly for broadcasting in this country, and such a central station and aerial as is proposed, would in our opinion differ very little from a relay station, but an inefficient one in comparison with those already established.

From an amateur point of view a scheme of this kind, if it were ever adopted, would be a matter of continual annoyance, whilst the suggestion of denying the ordinary broadcast listener an aerial would at the same time be depriving him of extending his interests beyond the programmes of his local station.

The reason which appears to have prompted the Bethnal Green Borough Council to put forward the suggestion, has been the unsightly appearance of aerials put up anyhow by tenants to suit their individual tastes. We feel some sympathy with this point of view because undoubtedly aerials of the type one sees so frequently are far from being an attractive addition to the landscape.

It is a pity that at a time when some acquaintance with wireless is so easily acquired, the public should not take the trouble to see that their aerials are put up in such a manner that they need be neither conspicuous nor unsightly. There is certainly no reason why the average broadcast listener should go to the trouble of erecting more than a single wire aerial, and yet even close up to broadcasting stations one frequently comes across multiple wire aerials which almost drag along the roof, and where not the slightest attempt has been made to make a sound and sightly job.

NEUTRODYNE TRANS- FORMERS.

EXPERIMENTERS whose wireless interest dates to before the introduction of broadcasting will remember how H.F. transformers of the plug-in type were favoured for use on the wavelengths then in use of 500 metres and above. The amateur wavelength on which there was a good deal of experimental telephony was 1,000 metres and for H.F. amplification the plug-in transformer gave very satisfactory results.

With broadcasting occupying an optimum wavelength of about 400 metres and amateur transmissions employing wavelengths considerably lower, the plug-in type of transformer has lost a good deal of its former popularity, owing to the losses which occur at the high radio frequencies of the short wavelengths.

To a Belgian correspondent we owe the suggestion of an improvement in this type of transformer which may again make it a severe competitor to the now almost universally adopted tuned anode method of high frequency amplification. This new

arrangement consists of fitting a neutrodyne condenser to the plug-in transformer itself so that the feed-back condenser may be adjusted to a capacity suitable for the wavelength range of the winding, and the other conditions existing in the set. The construction of these transformers fitted with neutrodyne condensers should not prove difficult, whilst the fact that it is necessary to make five points of connection still permits of a design somewhat similar to the old type of transformer as valve holders can now be obtained carrying five valve legs.

have set out to leave nothing undone which might be undertaken by them to provide novelty or entertainment for the public. We have recently had an instance of this activity in the broadcasting of animal noises from the Zoological Gardens, and however useless some critics may regard this effort, it has certainly made an appeal to popular taste and provided a novel interest. We do not imagine that it is the kind of thing that will enter into the regular programmes of the Broadcasting Company, because after once it has been done the novelty has passed and it could not be said that it was an enter-

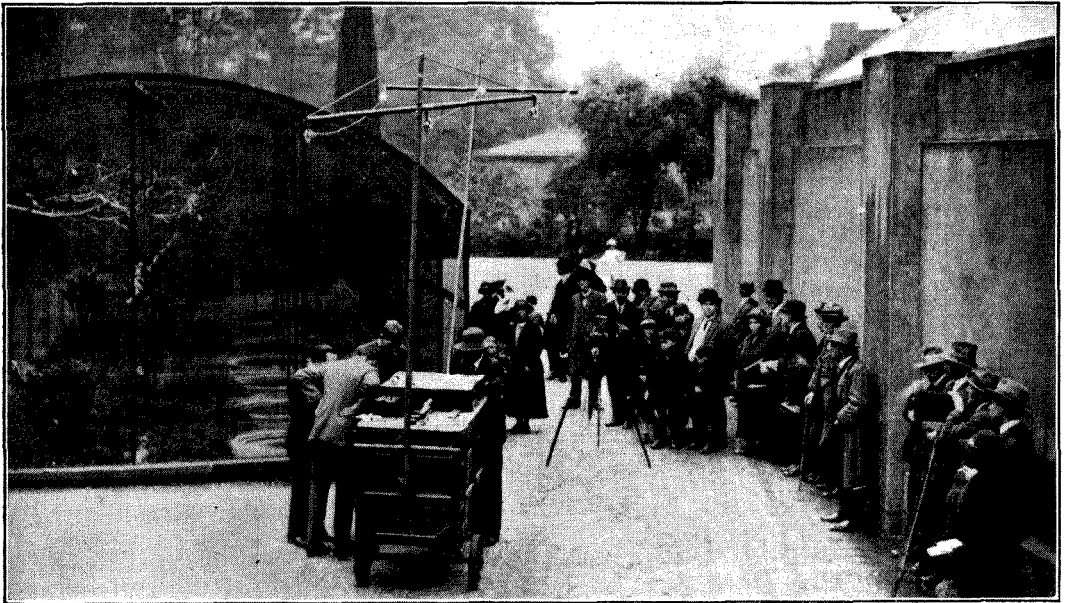

The B.B.C. portable transmitter used for relaying animal noises from the Zoological Gardens.

ENTERPRISE OF THE B.B.C.

THE enterprise of the B.B.C. is becoming almost proverbial. There seems to be nothing within their sphere of operation which they are not prepared to attempt.

Any other broadcasting organisation with such powers as have been vested in by the Post Office might have been content to settle down to transmitting programmes appealing to the public taste and to leave it at that, but not so with the B.B.C. The British Broadcasting Company appears to

tainment to listen to such noises broadcast to the home.

Captain Eckersley has just left for a visit to America and we may expect that on his return other novelties will be produced, and further progress be made in perfecting the technical and perhaps also the entertainment side of the Company's activities. The suggestion has already been made that we may look forward in the future to the possibility of broadcasting in this country the sound of the rushing waters of the Niagara Falls.

THE EDITOR.

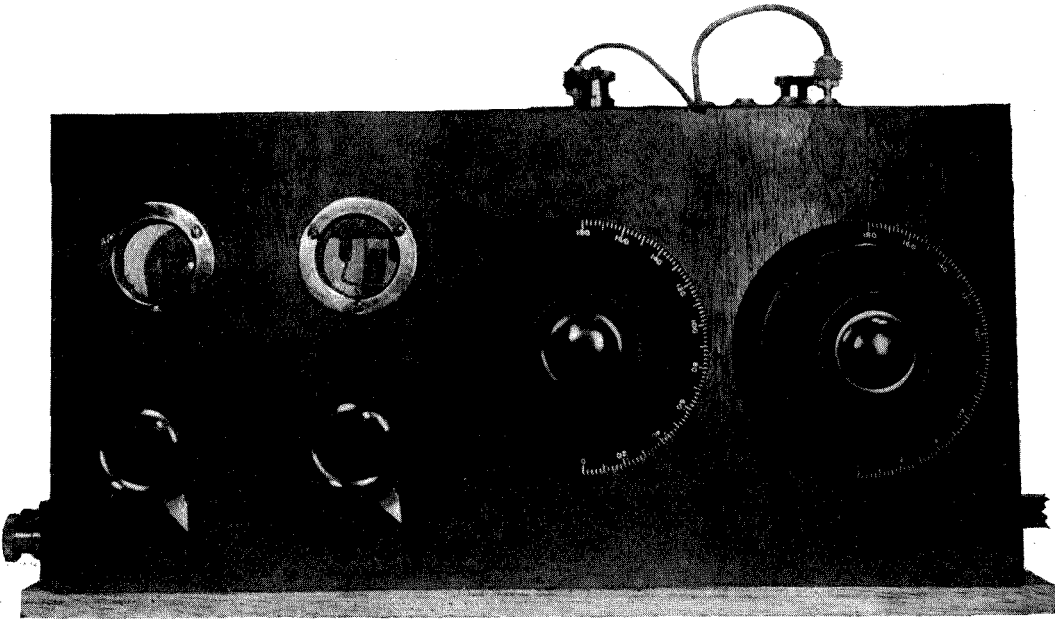

The finished short wave set. The front panel is of mahogany carrying an earthed plate on the back for eliminating hand effects. The panel measures 12¼ by 6 ins. The condenser centres are 3½ ins. apart, and the right-hand condenser, used for reaction control is 2 ins. from the edge. The resistances are 1¼ ins. and 3⅞ ins. from the other edge and 1 15/16 ins. from the base.

THE TRANSATLANTIC RECEIVER

50—200 METRES.

The transatlantic tests of the last three years have revealed that it is during the month of November that the American signals are most easily received in this country. A satisfactory explanation of why this should be is not forthcoming, but the fact is certainly well established. This year the number of American stations heard in this country is likely to far exceed that of previous years owing to the progress made in both transmission and reception on wavelengths of the order of 100 metres and the confidence with which the American transmitters have set about the improvement of their stations, spurred on by the astounding successes of last year.

By F. H. HAYNES.

Short Wave Receiving Circuits.

MANY circuits have been put forward specially designed to give good reception on the short wavelengths and mostly bearing the names of American research workers, such as the Reinartz circuit, the Weageant circuit and the Armstrong supersonic arrangement. The Reinartz and Weageant circuits are straight-forward oscillators essentially differing from the well-known single-valve reacting circuit only inasmuch as that a condenser charged by

the H.T. battery is connected in the oscillatory portion of the plate circuit with the condenser charging potential fed through a suitable choke coil. The telephone receivers instead of being connected in series with the reaction coil now by-pass the high tension supply, which is fed into the oscillating circuit.

Reference to the accompanying circuit diagram will reveal that the connections very much resemble the oscillatory systems commonly employed in transmitters.

The Reinartz circuit will be seen to consist

of a loose coupled aerial circuit—loose coupled because the earth point is taken from near the middle of the coil—with feed-back for reaction effected through both a capacity and an inductive coupling, while a portion of the aerial circuit assists in stimulating self-oscillation as its turns are virtually common to both aerial and plate circuits. It is this latter portion of the circuit which tempts one to modify it to give easier manipulation, for the coupled reaction coil in series with the feed back condenser is all that is required to throw the circuit into oscillation and it is essential in short wave work to avoid any change in the tuning of the aerial circuit when the reaction coupling is adjusted.

Making this change brings one to the Weageant circuit where the reaction coil is coupled to the aerial and closed circuit inductances, and is connected to the L.T. minus through a variable condenser. Oscillation with this circuit is brought about in two ways: firstly by tightening the coupling with the reaction coil and secondly by increasing the capacity of the variable condenser, for as its capacity is reduced its impedance to the oscillating current

feed-back. It will be observed that this portion of the circuit is really a series-tuned reaction circuit and consequently the inductive reaction coupling must consist of a suitable number of turns and remain fixed

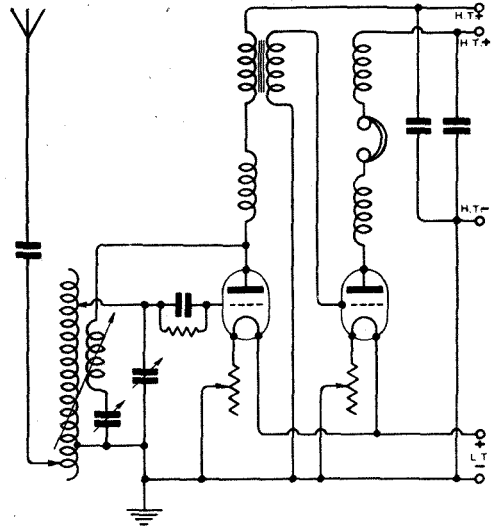

The circuit employed in the receiver here described. It resembles the Weageant arrangement and possesses the special merit that variable inductance coupling of either the closed or reaction circuits is not made use of, self-oscillation being controlled by varying the impedance of the condenser in a series tuned reaction circuit. When once set up the position of the reaction coil is not changed as such adjustment widely alters the aerial tuning.

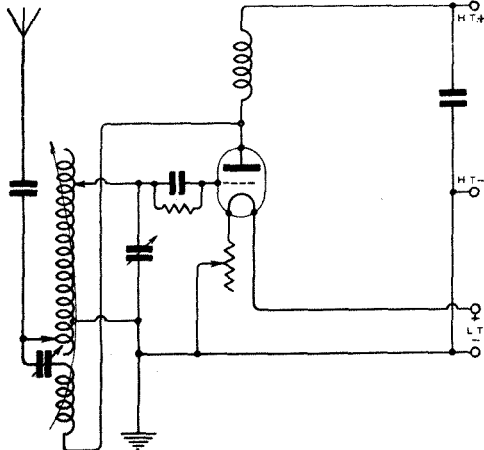

The Reimartz Circuit in which self-oscillation is set up by a combination of inductance and capacity feed-back, both of which are variable. The suitability of this circuit for short wave work is that reaction may be controlled without appreciably changing the wavelength to which the circuit is tuned.

becomes proportionately less so that the amplitude of the oscillations in the reaction coil becomes greater, producing increased

in position while the wavelength to which the reaction circuit is tuned by the variable condenser must follow the tuning of the aerial circuit.

It is this feature which makes the circuit particularly suitable for fulfilling the most important condition in short wave work, which is that *variable inductive reaction coupling must not be employed*. It must be realised that when oscillation is controlled by changing the position of the reaction inductance with regard to the aerial coil that in doing so the wavelength to which the circuit is tuned may be changed, say for example, from 70 to 110 metres. True, changes in the capacity feed-back will alter the wavelength, but not in the same drastic manner as is produced by a small movement on the short wavelength of two coupled coils.

Short Wave Tuner Construction.

The interpretation of a circuit to practical form when employed for reception on

wavelengths below 200 metres necessitates much consideration.

The inductances must be specially designed to give minimum losses. Fixed condensers in the tuning circuits should have air dielectric. Choke coils must be wound to give low self-capacity. The valve in the oscillatory circuit must have low inter-electrode capacity. Operating knobs must be as near as possible at earth potential so that body capacity will not alter the tuning as the hand advances towards the instrument.

The construction of the tuning inductances was described in the previous issue, while the reaction inductance is a basket coil wound with 25 turns of No. 22 D.S.C. wire on a boss diameter of $2\frac{1}{2}$ ins. Variable inductive reaction coupling is arranged, though final reaction adjustment is carried out entirely on the reaction condenser. The position of the reaction coil must be movable with regard to the aerial and closed circuit coils as the latter are tapped, but when the best position of reaction coupling is found, no further adjustment in the process of tuning is necessary.

The construction of the air dielectric condenser, which is connected in series with the aerial circuit has been dealt with.*

The most suitable value of capacity will depend upon the size of aerial to which the set is connected though 0.000025 mfd. will be found generally suitable.

The variable tuning condensers should possess a low zero capacity and preferably be of the square law type. Tuning condensers are

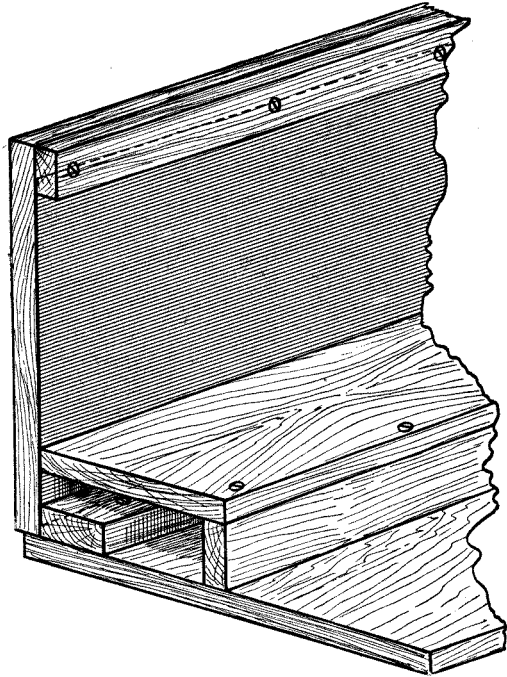

A section of the front panel and platform for mounting the two 0.000025 mfd. Sterling condensers. It is 3 ins. wide by 7 ins. long, and the face is $1\frac{3}{8}$ ins. above the base. The copper foil screen is held in position by the top and bottom battens. The base projects at the end by an amount equal to the thickness of the ends of the cover box which drops over. A slot in the top of the cover box leaves the terminal and tapping panel flush.

invariably of the air dielectric type nowadays, though unfortunately many of the patterns possessing metal end plates have thin ebonite bushes separating the fixed and moving plates and it is across this dense dielectric that most of the electrostatic strain takes place. The resulting losses on very short wavelengths may be appreciable. Vernier adjustment is desirable on both tuning condensers. Variable condensers in which the fixed plates were not connected to the securing screws could not be found on the British market and consequently it became necessary to employ the Sterling square law

* Page 36, *Wireless World*, Oct. 8th, 1924.

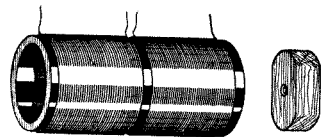
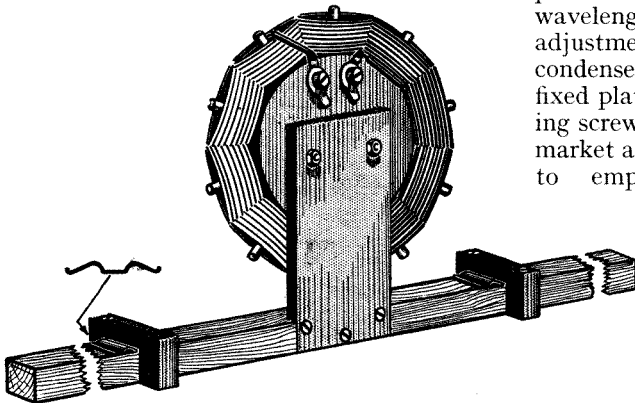

The reaction coil is operated by a mahogany rod $\frac{1}{2}$ in. by $\frac{1}{2}$ in., and carried on an ebonite support $1\frac{3}{8}$ ins. by $3\frac{1}{2}$ ins. by $3/16$ ins. The rod should be a loose fit beneath the two ebonite brackets and clamped down firmly by two pieces of bent bronze spring so that the coil will stand vertically. The former of the two choke coils in the telephone leads is 3 ins. long by $1\frac{1}{2}$ ins. in diameter, and is wound with No. 38 D.S.C.

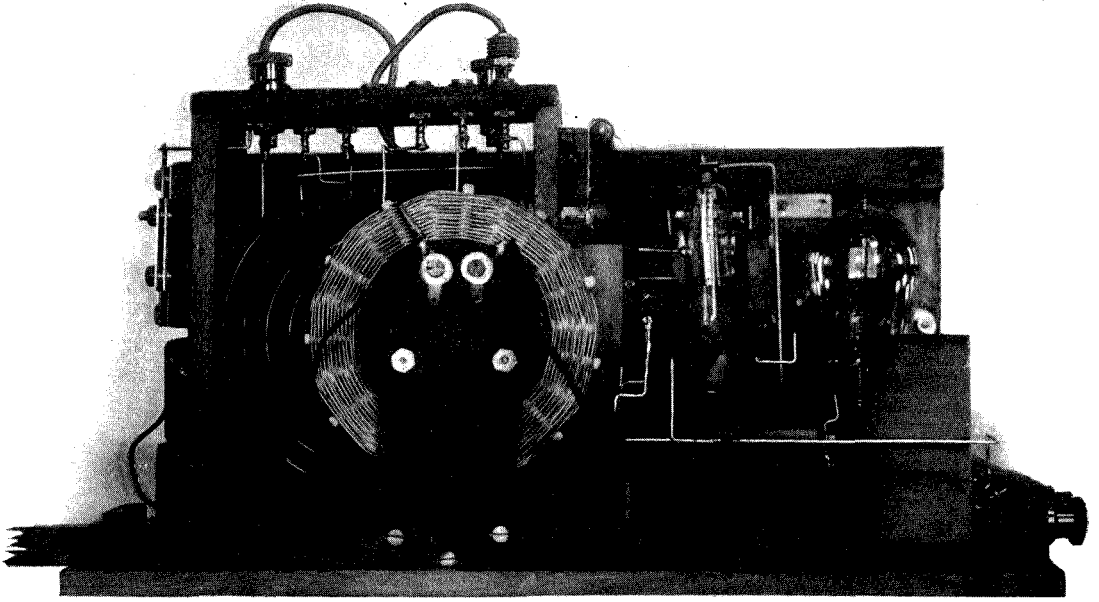

View of the back of the instrument showing the method of mounting the reaction coil: The choke coil in the detector valve plate circuit is $1\frac{1}{2}$ ins. in length by $1\frac{1}{2}$ ins. in diameter and is wound with $\frac{3}{8}$ in. of No. 38 D.S.C. so as to possess low self-capacity. It can be seen attached to the side of the inductance frame with the grid condenser and leak just above it.

type supported by a wooden bracket and set a little way back off the panel.

The construction of the choke coils is given in the accompanying illustrations and some explanation may be needed for the fitting of the two chokes in the leads to the telephones, which is a new feature. In operation both the receiver and its batteries should stand upon porcelain insulators so that only one point of earthing exists and that is at the far end of the earth lead. If a counterpoise is used instead of an earth connection it becomes far more important that the set shall not be earthed through a high resistance or capacity path, for those acquainted with transmission know how important it is to eliminate extraneous earthing and to separately tune every path which is capable of forming part of the oscillatory circuit. Thus in insulating the set and its batteries from earth, provision must be made to feed the telephones through efficient chokes to avoid oscillation leakage.

The valve adopted is a V 24 working from a six-volt accumulator with a plate potential of about 70 volts, rectification being carried

out by the usual grid condenser (0.00015 mfd.) and leak (2 megohms).

As the entire front of the instrument must be screened there is no need to construct it from high-class insulating material and in this instance the panel is made of $\frac{1}{4}$ in. mahogany (which can be purchased already planed) with vertical grain and backed with thin copper foil or tin plate.

The metal screen is connected by a short lead directly to the earth terminal of the instrument, as are also the spindle connections of the two variable condensers. Ormond filament resistances are employed and in attaching them to the panel the spindles become earthed and are made the negative side of the filament battery.

The remainder of the constructional details can be seen from the detailed diagrams and the writer has departed in this instance from giving the usual dimensional drawings as when making up a set of this sort some apparatus is certain to be ready to hand, thus necessitating modifications to any dimensions that might be given.

The set shown in the illustrations was

worked out to be compact and simple to make. Tapping of holes, which is sometimes a difficulty, is entirely avoided. The two valves, although of different types, are mounted up to come central with the windows, while the note magnifier valve presents its silvered side to the rear. The battery terminal strip is of wood, as the batteries are connected by short leads and separated by insulators from the table, while no great potentials requiring ebonite as an insulator exist between them. The aerial and earth terminals are of course on an ebonite panel above the inductance and thus connected by very short leads to the coils. The telephone terminals are set up on ebonite to prevent the head telephones, which are really at earth potential, from earthing the woodwork of the set. Wiring up is carried out with No. 18 tinned copper.

As to results, when connected up to a single wire aerial 75 feet in length including down lead, at the local wireless club (Hampstead and St. Pancras Radio Society), several American amateur stations were tuned in immediately, while **KDKA** came in on both the 100 and 65 metre waves (I am

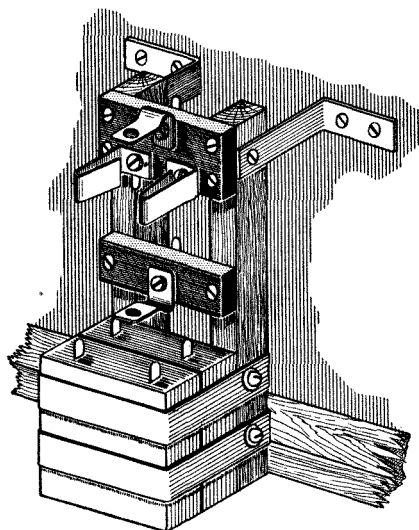

Details of simple wood bracket for mounting the V.24 valve and H.T. condensers. The vertical pieces are 5 3/8 ins. by 1/2 in. by 3/8 in., and the height of the centre of the valve windows is 4 1/8 in. from the bottom edge of the panel.

a little doubtful as to the exact value of the lower wavelength) at good strength and reasonably intelligible.

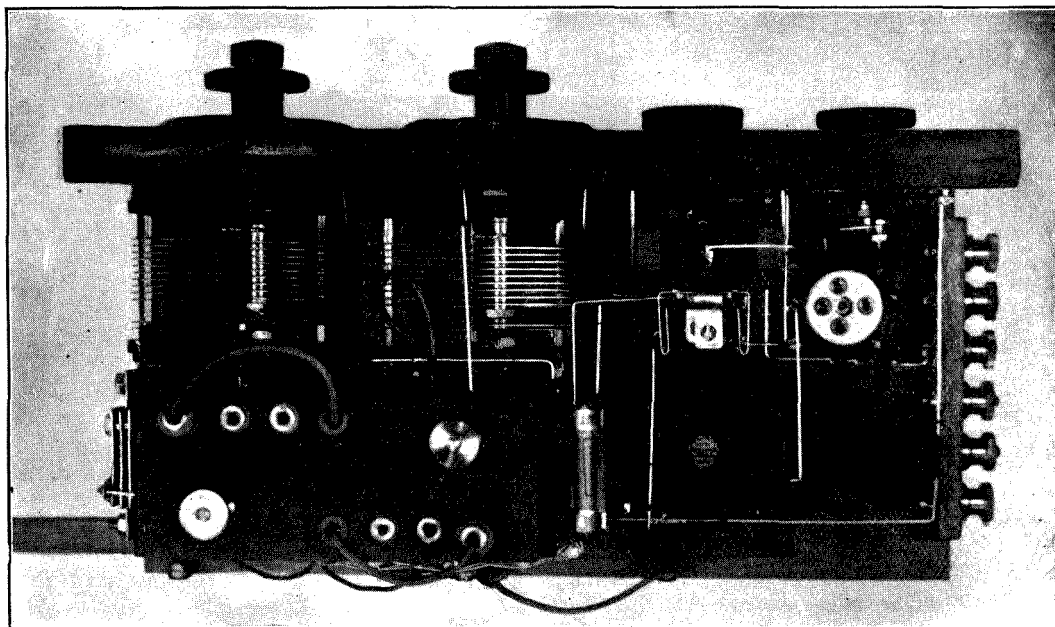

View from the top showing the relative positions of the components. The telephone terminals near the front of the instrument are inserted into ebonite bushes. The base is 6 3/8 ins. by 13 1/8 ins. by 3/8 in. The front panel projects 1/16 in. over the base and the ends extend 3/8 in. and carry the terminal strip at one end.

DISTORTIONLESS AMPLIFICATION.

THERE are three principal methods of speech frequency amplification, employing resistance capacity, choke capacity or transformer coupling.

It may quickly be shown that the first and second methods are inefficient from the point of view of the degree of amplification obtainable per stage compared with transformer coupling. On the other hand, it is much easier to obtain distortionless amplification when the resistance or choke capacity method of coupling is employed. This does not mean that it is not possible to obtain distortionless amplification with a transformer-coupled amplifier, as may be seen from the accompanying characteristic curves of the Marconiphone "Ideal" Transformer.

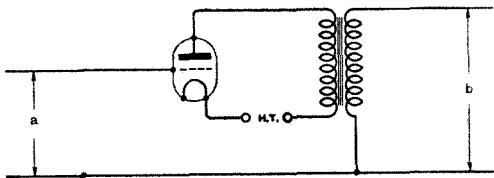
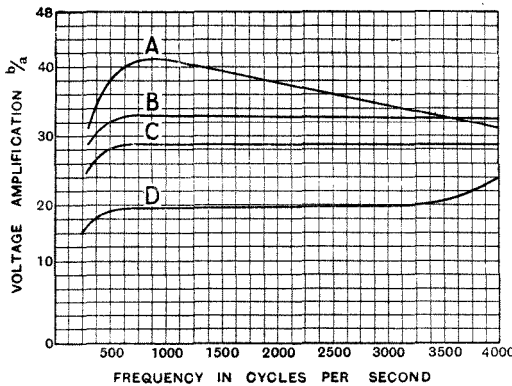

A, 4—1 transformer with *R* valve, anode volts 80, filament volts 4; $R = 40,000$ ohms, $m = 10$. *B*, 6—1 transformer with *L.S.* 5 valve; anode volts 160, filament volts 4.5; $R = 7,000$ ohms, $m = 5.5$. *C*, 2.7—1 transformer with *R* valve as above. *D*, 4—1 transformer with *D.E.* 3 valve, anode volts 80, filament volts 3; $R = 16,500$ ohms, $m = 5$.

The difficulty has been to obtain suitably matched transformers and valves. It is difficult to design a good transformer to work well with a particular type of valve, and well-nigh impossible to design one which will give faithful amplification with any type of valve. Hence the accompanying amplification-frequency curves are of special interest.

The amplification per stage is defined as the ratio of the voltage at *b* to that applied at *a*, and is measured for constant applied voltages of different known frequencies. Curve *A* shows the voltage amplification per stage for various frequencies with a transformer having a ratio of 4:1 when connected to an "R" type valve having an impedance of 40,000 ohms, and an amplification factor of 10. The tests were made with a filament voltage of 4 volts, and an anode voltage of 80. Particulars of the other curves are given below the figure. It will be seen that the degree of amplification for constant input voltages of various frequencies varies only slightly. The largest amplification is obtained when the frequency is 1,000. At 4,000 cycles the amplification is about 25 per cent. lower. The "R" type valve is a high impedance valve. Hence better results are obtained with a transformer which has a high impedance primary winding, and consequently a low turn ratio.

The curve obtained with an "R" valve and a 2.7 to 1 transformer is marked *C*. It will be seen that the degree of amplification is uniform from 600 to 4,000 cycles, and slowly falls off at the lower frequencies. This is a remarkably good characteristic curve, and indicates that under correct operating conditions the reproduction should be practically perfect.

An amplification of 30 per stage is extraordinarily good, and it is important to notice that Ideal transformers are guaranteed to have an amplification curve at all frequencies within 5 per cent. of the examples shown when used with valves having the constants quoted.

W. J.

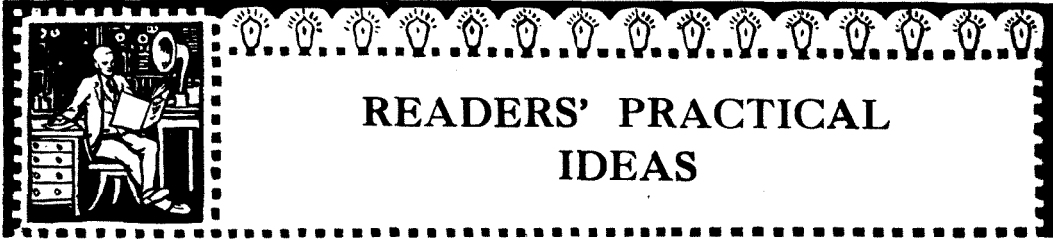

READERS' PRACTICAL IDEAS

This section is devoted to the publication of ideas submitted by readers and includes many devices which the experimenter will welcome.

Novel Remote Control Device.

THE particular feature of this design is that the valve filaments are not subjected to the strain produced by suddenly switching on full current and provision is made to rotate a filament resistance so that

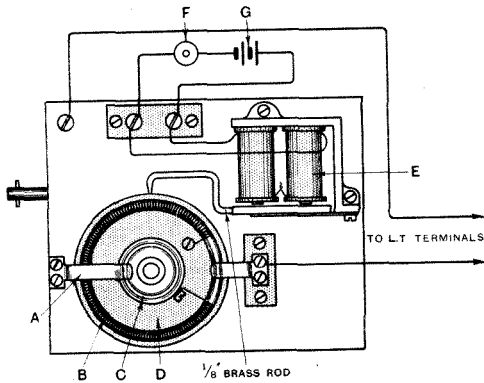

Remote filament control.

the filaments are brought slowly to full brightness. The parts used consist of an old gramophone motor to which is fitted the movement of an electric bell. The usual form of filament resistance is attached to the main spindle by means of a fibre disc. This disc is notched at the side in two places so that the brass arm which is actuated by the electric bell movement, will drop in at the correct "on" or "off" positions. When the bell push is pressed and quickly released, the armature of the bell moves upwards, allowing the motor to revolve and gradually lighting the valve filament. The edge of the brass extension of the bell armature will, of course, engage in the second notch, which will arrest the clockwork mechanism and leave the valve filament current correctly adjusted.

When it is desired to switch off the valve the push is operated for a brief interval and again the clockwork will revolve, being arrested when the brass arm engages in the second notch.

A number of switches can be connected in parallel and when the governor of the motor is correctly set, one wind will last for three or four months.

H. L. O.

Vernier Reaction Adjustment.

THE diagram shows a simple form of construction for reaction or vernier tuning to operate on the side of a plug-in type of coil. The coil former should not be constructed of cardboard as the extension used for attachment will be too weak, but thin ebonite might be employed, taking care not to cause a crack while cutting to shape. It is

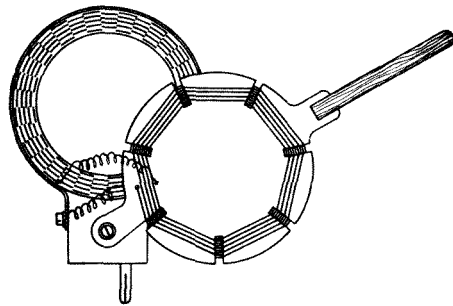

Vernier tuning for plug-in coil.

a good tip when cutting thin ebonite to either warm the scissors or warm the ebonite itself, which will render it much less brittle.

The former can, of course, be made from thin wood and the edges rounded where the wire passes through the slots.

Instead of using this additional coil as a reaction coil, the winding may be connected in series with the winding of the plug-in coil, so as to form a variometer with the coil winding. This will be found a very useful method for providing critical tuning.

E. M.

Experimental Cabinet.

TO facilitate the rapid trying-out of different circuits each component is mounted on its own separate panel. Thus variable condensers, resistances, etc., can be

wire is being soldered. In the case of Litzen-draht, however, which consists of very many strands of fine enamelled wire, it will be found very difficult to sufficiently remove the enamelled covering to permit of good soldering. When an attempt is made to scrape such wire it invariably happens that many of the strands become broken and the efficiency of stranded wire falls off very much when several of the strands are not picked up.

A good method to remove the enamelled covering consists of heating the wire in a bunsen flame until it is just red hot and then quickly immersing it in a small dish containing methylated spirits. It may be

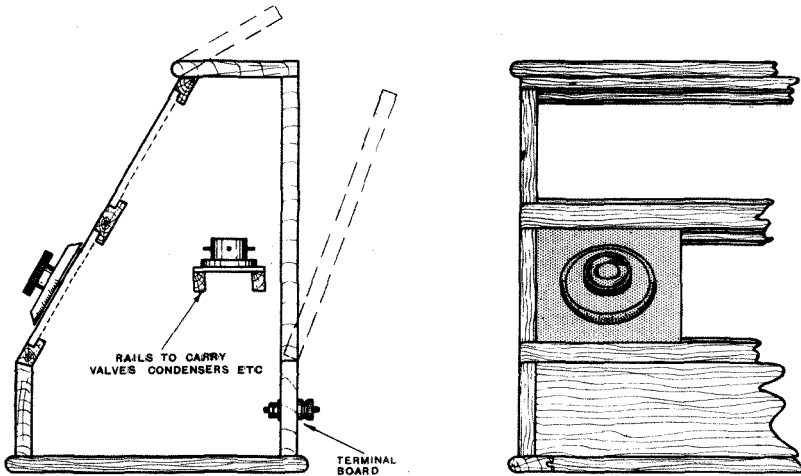

Cabinet design for experimental work.

mounted to occupy the lower section shown in the accompanying sectional view, whilst filament resistances, valve windows and switches can be mounted to occupy the upper space. The valve holders can, of course, be mounted to occupy a space inside the cabinet to conform to the usual practice. The actual constructional details of the cabinet may be followed and forms the basis of a good design for building experimental receiving sets.

R. W.

Soldering Enamelled Wire.

THE enamelled surface used as insulation on copper wire can usually be removed by a scraping when only a single

necessary to repeat the process several times. Prior to soldering it is dipped into a paste consisting of pure resin dissolved in methylated spirits and tinning is best effected by dipping the end of the wire into molten solder. When this process is being applied to Litzen-draht wire it is advisable to bind up the fine strands with a piece of clean bare wire. This process of tinning can of course be applied to ordinary bare copper wires and will be found an easy method of cleaning the surface.

E. W. C.

Frayed Telephone Cords.

WHERE the tag connects to the flexible end of the telephone cord fraying usually takes place after a while and

the frayed cord is only the forerunner of an intermittent telephone lead. To relieve the strain on the flexible wire at the point where it connects to the tag, a piece of indiarubber

in the instrument panel and then transferring it across the remaining two, can be drilled through. By this means the valve legs will come into exact register with the valve sockets, which is very necessary if a good fit is to be obtained.

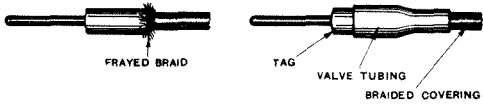

Telephone lead improvement.

tubing should be fixed over the end of the tag and passed some little way along the cord. This prevents the cord bending acutely at the junction and at the same time completely covers the frayed ends.

E. B. G.

A Useful Change-over Switch.

ALTHOUGH valve sockets were first introduced on the market for the construction of valve holders, it was soon realised that their utility went further and that they could be employed for the construction of plug-in connections. For this reason valve legs are now also obtainable and with these, built up on to a suitable small piece of ebonite, one can easily make up a good change-over switch, as shown in the accompanying drawing.

Filament Resistance for Dull Emitters.

THE lead contained in pencils varies in resistance from 30 to 300 ohms. The soft "BB" pencils may be used as a filament resistance for dull emitters, while for higher resistance values, for use in potentiometers, the lead contained in "HH" pencils may be usefully employed.

L. M.

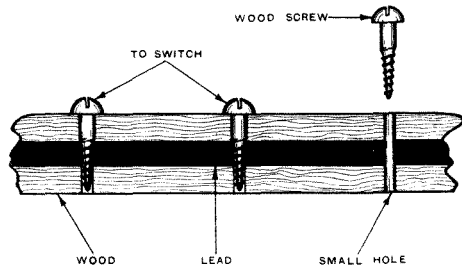

Lead pencils as filament resistances for dull emitters.

The simplest method of making the required contacts at several points along the lead, consists of carefully drilling holes into the pencil and inserting screws, taking care if possible, either not to fracture the lead or at least, not to let it slide through the wood and out at the ends. For this reason the end screws should be inserted first and wires may be conveniently soldered to the heads of the screws. The screw heads should then be connected up to a multi-stud switch which is used in place of the ordinary filament resistance.

H. W. W.

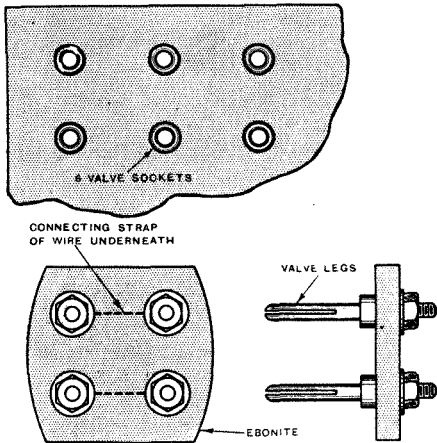

Valve legs and sockets make a useful change-over switch.

The ebonite piece which is to carry the valve legs should be made up first, and the greatest care should be taken to see that the holes are correctly located. Using this piece as a template, four holes may be put

Switching High Frequency Amplifying Circuits.

SEVERAL methods are now in common use for switching in and out of circuit, high frequency amplifiers. Avoiding switches, high frequency amplifiers can be taken out of circuit by merely transferring the aerial connection from the first valve grid to the grid of the second or detector valve. Referring to the accompanying diagram, A and B represent socket connections to which the

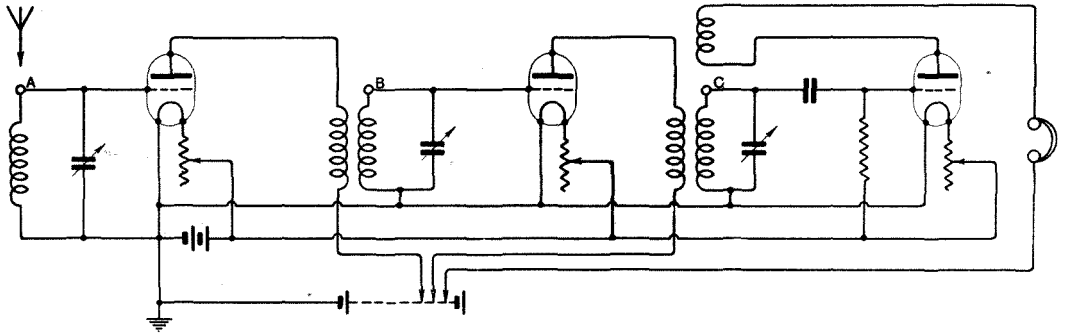

Circuit changing without switches.

aerial lead can be plugged. The H.F. transformers are constructed from plug-in coils and when the aerial plug is in the socket B, the primary of the H.F. transformer can be removed from the first valve plate circuit.

N. M.

Rack for Tuning Coils.

IF tuning coils are allowed to lie about the experimental bench they will rapidly become damaged, owing to their construction being somewhat frail, whilst one cannot quickly select a suitable coil.

A simple method of arranging them is to suitably drill a length of wood with holes having the same spacing as the pin or pin and socket. The coils can then be attached to the board by means of these holes and if they are arranged in order, any size coil can rapidly be selected.

W. E. R. S.



Rack for tuning coils.

Wooden Hoop for making Frame Aerial.

TO avoid the necessity of using wooden cross supports in constructing a frame aerial, procure two wooden hoops of a diameter of 3 ft. or upwards. Four cross pieces made from strips of ebonite are screwed to the hoops to hold them together and provide the necessary support for the winding.

These cross pieces may be slotted slightly in order to hold the wire in place and to act as a guide when putting on the turns.

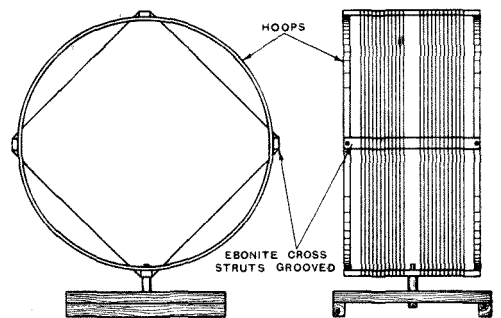

Frame aerial from wooden hoops.

The lower cross piece should perhaps be a little wider to enable some convenient form of mounting to be attached.

L. M.

An H.F. Transformer Tip.

When constructing high frequency transformers with tightly coupled windings, it is a good plan when aiming at producing two windings of equal inductance to use cotton covered twin bell wire, such as is generally used in wiring house circuits.

Honeycomb lattice coils can quickly be made up with this wire. The ends are easily identified as the two wires are given distinctive markings. Although the wire is somewhat thick, the turns will hold securely together if wax impregnated.

J. L. B.

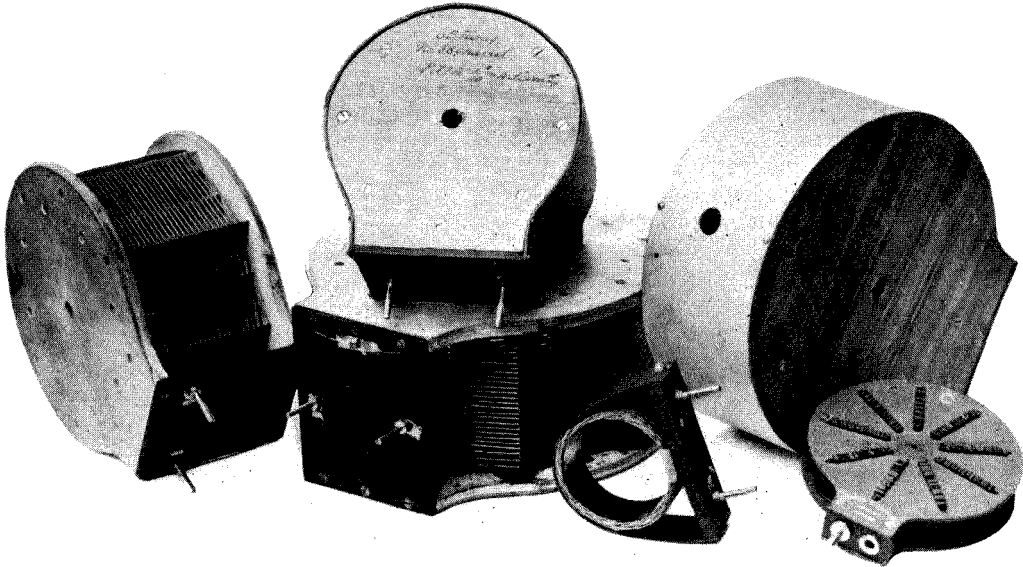

A group of plug-in coils with windings of low self-capacity.

NEW COILS OF HIGH EFFICIENCY.

A good deal of progress is being made by the amateur in the design of inductances of extreme efficiency. The problem of efficient design is not a simple one, and is governed from the theoretical standpoint by many considerations from which a compromise must be drawn, while the actual mechanical construction calls for considerable ingenuity if the desirable features which theory indicates are to be utilised to the full.

By J. H. REEVES, M.A.

CONSIDERABLE attention is being devoted to the design of tuning coils of extreme efficiency and efforts in this direction chiefly lie in the designing of inductances in which the turns are air-spaced.

The writer has constructed a number of tuning inductances having a minimum of dielectric material to support the turns and a feature of the designs employed is that the coils can be built up by one who is unskilled as an instrument maker and has only a few simple tools available.

In my article published in this journal (30th April, 1924) I pointed out that under conditions where there is ample margin of signal strength, that is within 15 miles or so of a broadcasting station, improved definition can be obtained by the use of fine wire coils in the tuning circuits.

At the time opinions differed as to whether the improved results arose from increased ohmic resistance or from decreased distributed capacity, consequently I have wound a good many coils for the purpose of testing this comparison.

For example, a set of coils is made up using No. 22 wire, first with the turns touching and then with a clearance of 1, 2 and 3 diameters. Results indicated that the coil with turns touching was inferior and that spacing 2 was better than spacing 1, while spacing 3 was a slight improvement upon spacing 2.

I had previously found much the same result with inductances constructed with a considerably finer gauge of wire, hence I was led to the conclusion that in the design of coils it was more important to devote attention to reducing distributed

capacity to a minimum than to guard against losses due to resistance. Another feature which leads to inefficiency is the electrical losses in the material used to support the wire, and comparison was made between two coils both consisting of No. 38 S.W.G., one with a quadruple cotton covering and turns touching (spacing 1/40 in.) wound on a cardboard tube and another of enamel wire practically air-supported and wound to the same pitch.

The results obtained were distinctly in favour of the latter and hence the argument in favour of self-supporting coils constructed with stiff wire is strong. Unfortunately this involves in the case of the A.T.I., a coil of large dimensions, while in the case of closed circuits the tuning inductances are clumsily big.

On reference to a standard text book it will be found that for a given length of wire, that is for a given ohmic resistance of whatever gauge is selected, the most efficient coil produced for the diameter is 2.4 times the length. Combining this with the well-known Nagaoka's formula, there is a simple rule by which the dimensions for any required wavelength can be calculated.*

Turning now to the actual construction of inductances possessing low self-capacity, the group of coils shown in an accompanying illustration have been made up to comply

with the considerations just dealt with. It is not proposed to deal in detail with the several varieties shown and reference will only be made to the coil shown on the left in the illustration on page 77 which is probably the easiest form to make up.

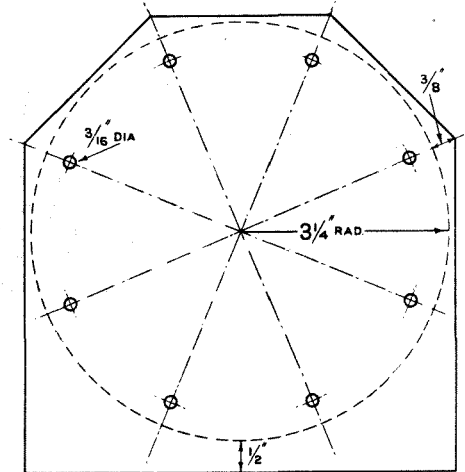

Setting out the positions for the bars.

The material required is:—

- i. Two pieces of good 1/4-in. fretwork, preferably 3-ply. I found some very good pieces on the scrap heap of a motor body builder, and in any case suitable wood can easily be obtained at a very reasonable price.

*THE DESIGN OF SINGLE LAYER CYLINDRICAL COILS.

The best proportion is when diameter = length × 2.4.

Nagaoka's formula : $L = \pi^2 D^2 n^2 lk$.

where L = the inductance.

D = the diameter.

l = the length.

n = the number of turns per 1 cm.

k is a coefficient depending on the ratio D/l

Now if D/l is to be kept constant at 2.4, k is constant, and if the coil is to be wound with wire of

diameter d and pitch m then $n = \frac{1}{md}$

therefore substituting

$$L = \text{a constant} \times \frac{D^3}{m^2 d^2}$$

The minimum wavelength of a coil in a tuned closed circuit is given by

$$\lambda = \text{a constant} \times \sqrt{L \times C_0}$$

where C_0 is the capacity introduced by the panel, valve, coil mount, etc. when the tuning condenser is set at 0°

Squaring this last equation and substituting for L

$$\lambda^2 \propto \frac{D^3}{m^2 d^2}$$

i.e., $D \propto [\lambda md]^{\frac{2}{3}}$

Example :

On a certain panel, a coil 4 ins. diameter of 60 turns No. 38, pitch 4 diameters (approx. 1/40 in.) was found to tune to 340 metres. What must be the diameter of a similarly proportioned coil wound with No. 22, pitch 3, to tune to 200 metres.

Here $\frac{D}{4} = \left[\frac{200 \times 3 \times .028}{340 \times 4 \times .006} \right]^{\frac{2}{3}}$

D = a little over 6 ins.

l = 2.6 ins.

Total turns 31 or 32 approximately.

A similar coil, No. 20, pitch 4 to tune to 340 m. works out to require

D = about 13 ins.

l = 5 1/2 ins.

turns 38.

The large two layer coil in the centre of the group on the previous page was the compromise. This is the closed circuit inductance for tuning to 2 LO and requires nearly 20° of a .00045 condenser.

What would be the size of a No. 18, pitch 4 to form even the A.T.I. for a super-crystal set to receive 5 XX is best left to the imagination.

2. Two 3-ft. lengths of $\frac{1}{2}$ -in. square strip mahogany. One 3-ft. length of $\frac{3}{16}$ in. round wood strip. These can be bought for a few pence from Messrs. Hobbies, the well-known dealers in fretwork materials. It will not be difficult, of course, to plane up suitable wood to size.
3. A strip wood cutting table to facilitate accurate cutting of the wood to the required length. Messrs. Hobbies supply a suitable table with length gauge for about 4s.

The coil to be constructed is $6\frac{1}{2}$ ins. across diagonals, the length of the bars being $5\frac{1}{2}$ ins., and is wound with 50 turns spaced 10 to 1 in., which is about the largest number of turns which can conveniently be wound with

at $\frac{3}{8}$ in. from the circumference inside the circle. Plug into this hole a piece of $\frac{3}{16}$ in. round strip. Now drill the hole the other end of this diameter, plug as before and then proceed to mark the remainder of the holes. With the two pieces

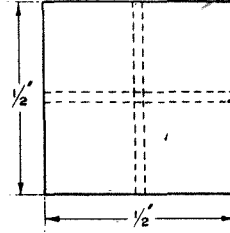

Simple method of finding the centre of ends of the bars.

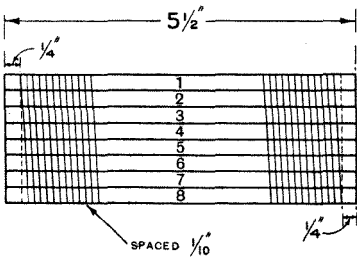

Marking out the bars for the position of the turns.

No. 20 S.W.G. The diameter of this wire is not quite $\frac{3}{16}$ in., and by winding 10 turns to the inch there is a clear spacing of approximately two diameters or, as I would prefer to call it, a coil of "Pitch 3."

To construct the end pieces, describe a circle $3\frac{1}{4}$ ins. radius, divide the circumference into eight equal parts and draw the four diameters. Next cut out points inside and outside the circumference and along each radius at distances of $\frac{3}{8}$ in. By joining up six of the points externally to the circumference, the five sides of an octagon will be produced. The ends of this line are extended so that when joined across on a line at right angles the joining line is about $\frac{1}{2}$ in. below the circumference of the circle. Drill a small centre hole large enough to pass a $\frac{1}{2}$ -in. No. 4 wood screw and secure this marked-out piece of board to a second piece. Now clamp in a vice and drill through both boards as squarely as possible one of the $\frac{3}{16}$ in. holes which is marked out

of wood secured together cut to shape, thus making two end pieces with holes exactly corresponding. The sides may be finished by filing and care must be taken to ensure that the side which is to form the base is at exact right angles to the adjoining edges before separating the two pieces marked "Front" and "Back" so that their correct relative positions will not be changed when finally assembled. Finish by rubbing down with glasspaper.

The centre holes should be enlarged so as to pass a metal rod 12 or more inches in length and about $\frac{1}{2}$ in. in diameter. This is for use when winding.

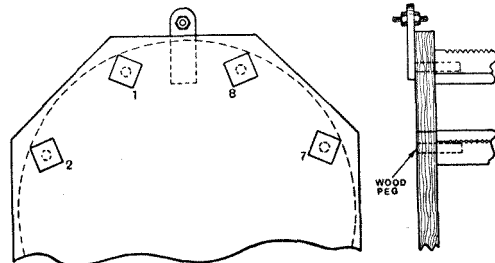

Details for setting up the end pieces.

The pieces which are to form the bars to give support to the wire must be accurately and squarely cut to length. Eight pieces $5\frac{1}{2}$ ins. in length will be needed. Now place all the eight pieces side by side and number them 1 to 8.

As the turns are to be spaced 10 to the inch, the upper edge of piece No. 1 and the upper edge of piece No. 8 should be divided

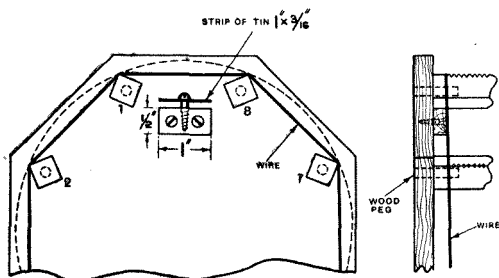

Another form of terminal piece is shown here, for securely holding the end of the wire.

into $1/10$ in. and lines should be ruled across so as to divide pieces 2, 3, 4, 5, 6 and 7. These lines are not drawn straight across, of course, but connect the dividing points of the piece No. 1 with the dividing points of piece No. 8, one further along. At each end a space should be removed of $1/4$ in. as it is not intended to wind the turns close up to the ends of the bars. The next step is to locate the centres in the ends of these pieces, which is easily done by pressing the ends against a straight piece of wood a little under $1/4$ in. in thickness and ruling lines across. The pieces should be rotated so that four lines in all are drawn on each end in each piece. In turn place each piece end up

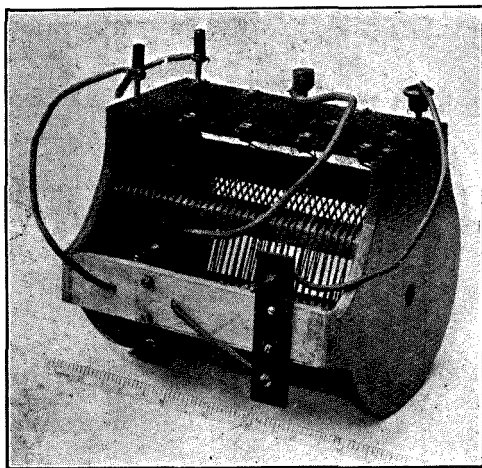

A useful tapped coil for short wave work.

in a vice, centre the punch between the four lines and drill as square as possible 16 holes about $1/2$ in. deep with a $3/16$ drill. A good plan is to drill only the alternate bars to full size right away, making slightly smaller holes in the remaining pieces and drilling them out to size when temporarily assembled in position, using those pieces with $3/16$ in. holes to facilitate a preliminary assembly. When finally assembling, the $3/16$ in. pegs may be slightly pointed and driven in with glue or seccotine. The ends can now be cleaned off and rubbed down.

Terminal pieces must be made up and fixed in position to secure the end of the wire and the precise design is left to the reader.

Before proceeding to wiring, it is advisable to make small indentations into the bars

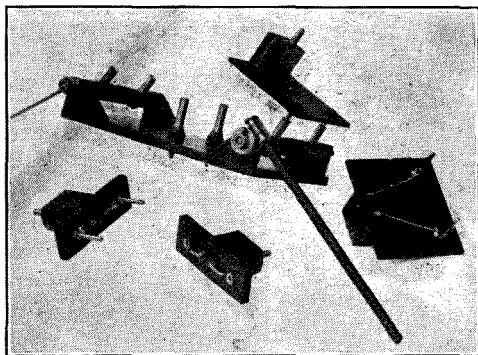

Coil holder with greater spacing between the pins than is usually provided. Several adapters are shown for using the holder with standard coils.

at the points where the wire rests, after which the whole of the wood should be treated with two or three coats of good shellac.

As the inductances of the coil will probably be varied by means of a tapping clip, tinned wire must be used, and No. 16 is a satisfactory gauge, giving good strength mechanically.

The former should be mounted on the $1/2$ -in. rod, held securely in the vice when proceeding to wiring, but the job cannot be done without assistance. One operator may rotate the former and guide the wire while another applies the necessary tension, a third strengthening the wire before it approaches the winding. Very considerable tension can thus be given.

For smaller coils, suitable for plug-in purposes for a short wave heterodyne and the

like I have tried other forms, several being based on empty reels from which fishing lines have been taken, but on the whole the method described in this article has proved more satisfactory. For an anode coil No. 20, with pitch 3 and more so with pitch 4, the size becomes enormous for the broadcast band, so I tried double-layer coils; examples can be seen on page 73. Here the inner layer was completed first, when the 8 outer bars were inserted and the coil completed. Multilayer coils are to be had commercially, small and consequently neat, with good

It is a pity that the present type of coil mount has been standardised (more or less so because mounts differ) with so small a spacing between plugs and sockets. For short wave work a wider spacing on plug-in coils seems highly desirable and I hope that

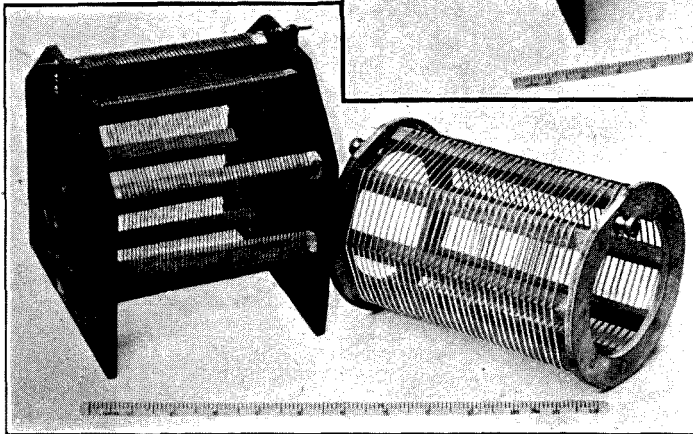
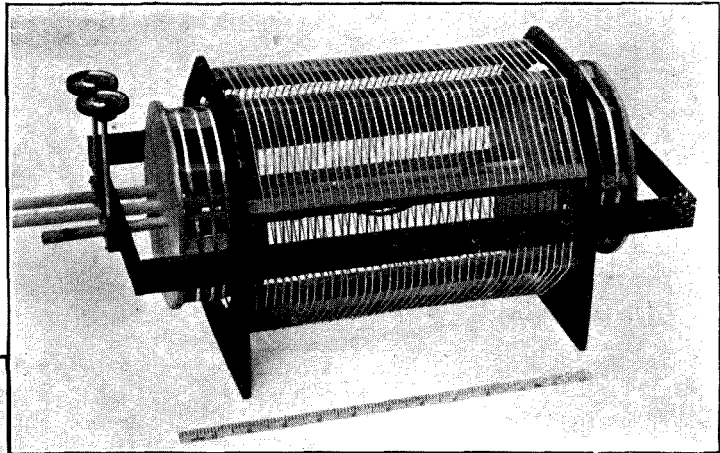

The upper coil, entirely wood supported, is suitable for use in the circuit of a low power transmitter. The lower illustration shows coils of the type referred to in the constructional details, the one on the right being slightly modified.

spacing between both turns and layers. With these the inner layers must of necessity be comparatively inefficient, while the wire cannot approach even No. 22. Yet on test, using the adaptors shown on page 76, some of these have shown up most remarkably well even against the best known makes. This only confirms the view that it is the spacing and not the low ohmic resistance which is the desirable feature.

when this comes it will be the 2-in. standard recently advocated in this journal. Those shown in the illustrations on page 73 are thus mounted and a triple mount can be made to look as neat as the present style. The one shown was made large to carry my very big coils; adaptors are shown to carry the present standard mount, also one by which the 2-in. mount can be used on present-day sets.

VALVE TESTS. REPAIRED VALVES.

Readers will look to this report with much interest, as considerable doubt exists as to the success with which a valve can be re-filamented. The repairs to the valves described below were carried out by Messrs. The Midland Valves, Ltd.

GENERALLY speaking, the life of a valve is determined by its filament, which means that a filament burn-out, either accidental or due to old age, is responsible for the greatest number of valve casualties.

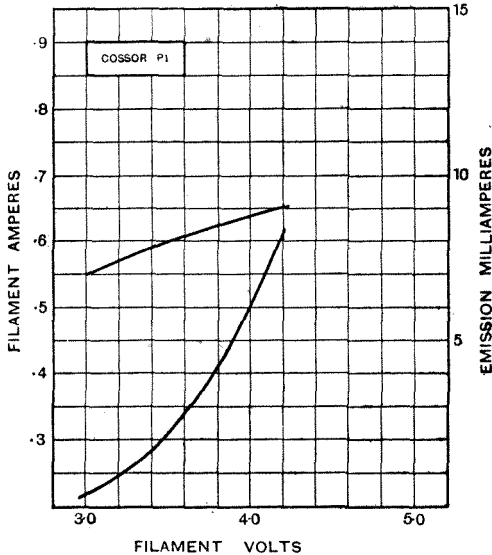

Fig. 1. Filament characteristics of a repaired Cossor valve, Type P1.

A good hard valve maintains its vacuum to the last, and if one were to go through the unserviceable valves which lumber the experimenters' shelves, "no filament" would be the result usually found.

Soon after valves became universally used among amateurs, certain firms gave their attention to repairing and re-filamenting valves, but our experience of their early efforts was not particularly satisfactory.

The vacuum was, for the most part, poor, and the filaments so different in their performance that it was almost impossible to run several repaired valves in parallel with a single filament control. Due probably to improved methods, better machinery,

and the knowledge that vacuum conditions ordinarily obtaining in lamp manufacture are not sufficient when applied to valves, satisfactory repairs are now being effected.

Messrs. The Midland Valves, Ltd., recently sent us a number of valves of different types which they had re-filamented and which they asked us to try out.

Since the grid and plate are not altered during the process of repairing, we have not deemed it necessary to apply our usual tests for magnification and impedance, etc., as this concerns the original maker rather than the repairer, but we have applied strict tests for filament current, emission and vacuum, and in addition we have plotted grid-volts plate-current curves for some of the valves.

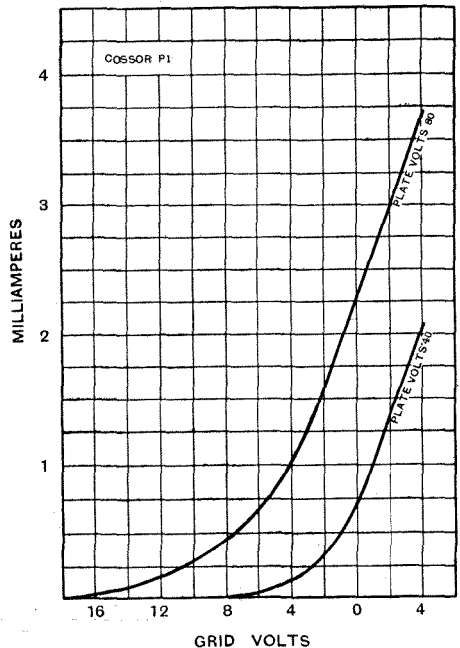

Fig. 2. Grid-volts, plate-current curves of repaired Cossor valve.

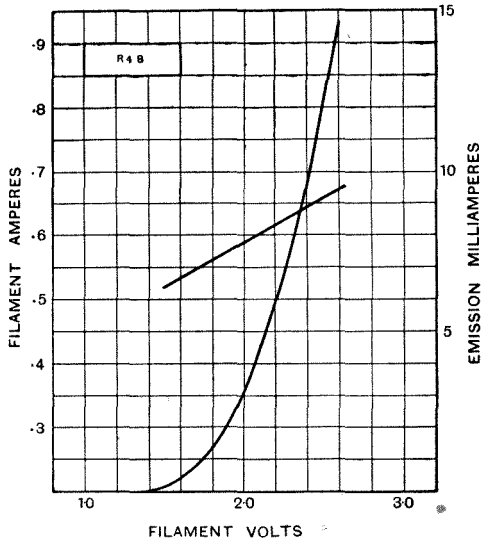

Fig. 3. Filament characteristics of the repaired R.4B. valve. Showing that a liberal emission is obtained at a filament voltage of 2.2.

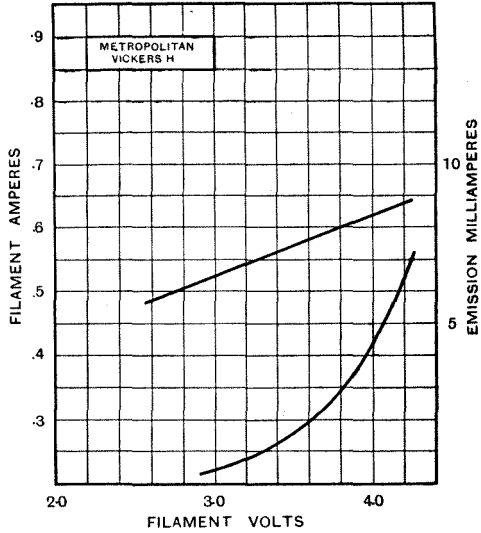

Fig. 5. Repaired Metropolitan-Vickers H type valve. The new filament here runs on 4 volts.

The types submitted were particularly varied and ranged from a small receiving valve to a 40-watt transmitter.

Figs. 1 and 2 refer to a Cossor P.1 valve, the maker's rating of which is 3.5 to 4.0 filament volts. At this latter potential

the repaired filament gives an emission of 6 milliampères with a current of 0.64 amperes. The filament is, however, apparently slightly longer than the original, which assumption is confirmed by the curves of Fig. 2, where the anode current is seen to extend

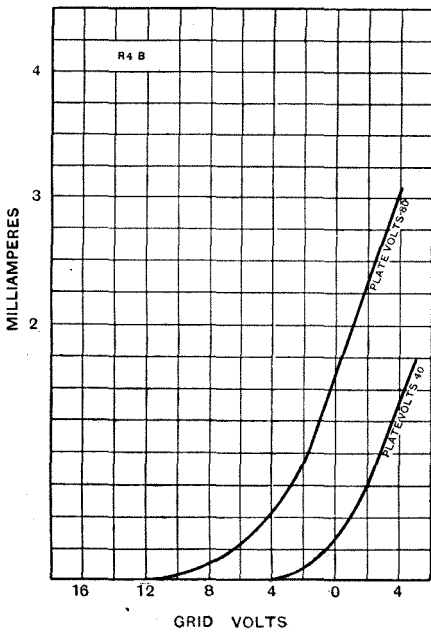

Fig. 4. Repaired R.4B., grid-volts, plate-current curves.

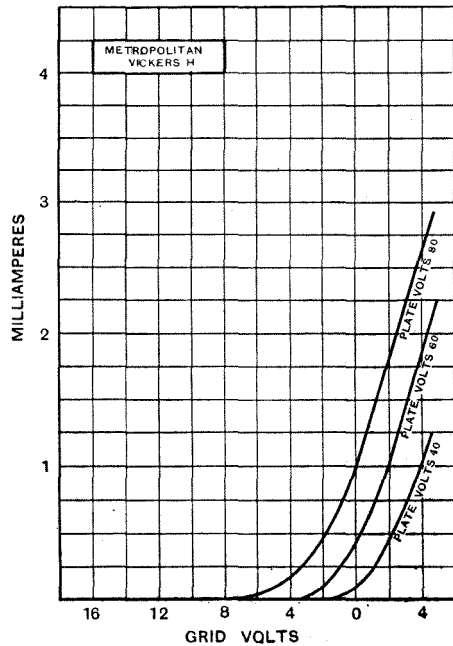

Fig. 6. Plate-current, grid-volts curves of the repaired H valve.

over a long range of negative grid voltage. The valve is well exhausted.

Figs. 3 and 4 show the results obtained on an R.4B. type valve, and an emission of 6 milliamperes is obtained at a filament voltage of 2.2, rising to 13 milliamperes at 2.5 volts. The maker's rating for this valve is 3.8 volts, so that a totally different filament has been substituted in this case. Here again the vacuum is quite good.

Figs. 5 and 6 are taken on a repaired Metropolitan Vickers type "H." In this case we have the very liberal emission of 8.2 milliamperes at a filament potential of 4, and a good steady vacuum is reflected by the curves of Fig. 6.

The filament characteristics of a B.T.H. "A.T.40" valve are given in Fig. 7. This valve normally operates with a filament voltage of 7, the current and emission of the repaired sample being 0.81 ampere and 33 milliamperes respectively.

This type of valve normally operates with from 600 to 1,000 volts plate potential, and a vacuum test at the former voltage showed the pumping to have been well carried out.

The other valve submitted to us was a French "R" type. This gave a violent

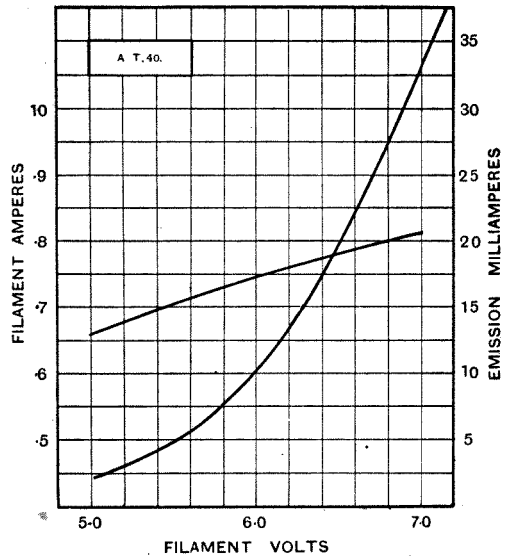

Fig. 7. The filament characteristics of a repaired transmitting valve, the A.T.40.

blue glow immediately it was put in circuit, and it was therefore useless to test further.

With the exception of the last mentioned valve, the submitted samples are capable of giving excellent service.

AN EASILY CONSTRUCTED VARIOMETER.

Many receiving sets of limited wavelength range employ variometer tuning. The instrument described here is easy to make up and efficiency is not sacrificed in simplifying the design.

By H. J. CLARKE.

THE variometer to be described is easily constructed at a comparatively low cost. It has an advantage over certain types of variometers, such as those where a ball revolves in a cylindrical tube, as the moving and stationary windings are closer together, thus giving a greater inductance change. The material required is:—

1 piece of ebonite tube 3 ins. long, outside diameter 3 ins., wall thickness $\frac{1}{8}$ in.

1 piece of ebonite tube 4 ins. long, outside diameter $3\frac{1}{2}$ ins., wall thickness $\frac{1}{8}$ in.

16 No. 6 B.A. countersunk head screws $\frac{3}{4}$ in. long.

6 ins. No. 2 B.A. threaded rod.

4 No. 2 B.A. lock nuts and a few No. 2 B.A. washers.

1 piece of ebonite $3\frac{1}{2}$ ins. by 3 ins. by $\frac{3}{8}$ in.

$\frac{1}{4}$ lb. No. 26 D.C.C. wire.

First construct the rotor by cutting the smaller diameter ebonite tube to exactly $2\frac{1}{2}$ ins. long, taking care that the ends are square and the edges smooth. The spindles are secured to this tube by means of two ebonite battens $\frac{5}{8}$ in. wide, cut in

length to fit inside each end and screwed to the tube.

After the two battens have been fixed in

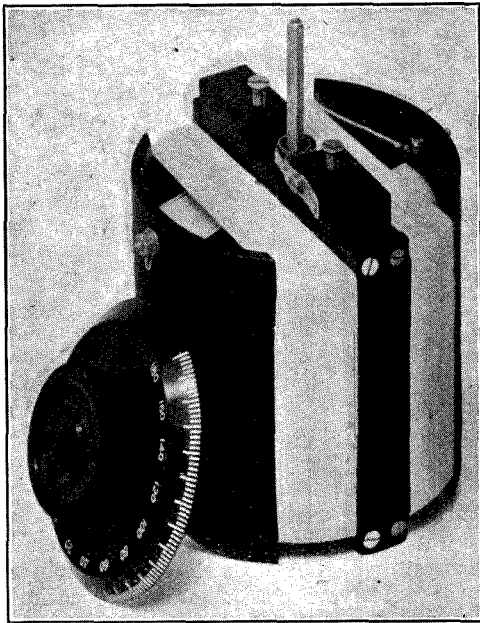

The finished variometer. Its clean design and robust construction are readily apparent.

position cut grooves on either sides of them $\frac{3}{4}$ ins. wide, and just sufficiently deep to take the wire. The outside edges of these grooves should be slightly rounded. Remove the battens and screw into a centre tapped hole the threaded rod, and lock by a nut on either side of the batten. Two small holes must be drilled into the sides of the ebonite tube in the positions shown. The end of the wire should be passed through one of these holes and soldered to the inner end of one of the spindles. Replacing the batten the winding can now be commenced, starting from the outer edge of the groove and winding towards the centre. When completed fasten the wire temporarily round the spindle and cut off with a length of wire to spare. Now wind the second groove in a similar manner. The two inside ends of the windings are soldered together and pushed home in a saw-cut in the batten. Care must be taken that the windings are in the same direction.

The stator, that is the larger outside winding, can now be constructed from the $3\frac{1}{4}$ in. diameter tube. It is similar in design

to the rotor, but differs in length, being $3\frac{1}{8}$ ins. long, and the grooves are made $\frac{3}{8}$ in. deep, while the battens, of course, are longer, being the same length as the inside diameter of this tube. The rotor, when completed, is arranged in position inside the stator and carefully adjusted between the battens. Should there be any play, pack each spindle with a washer or two.

When correctly set up, wind the stator in a similar fashion to the rotor, soldering the ends of the wire previously to the screws, which can be seen in the illustration in the sides of this tube.

The spiral connections are cut from thin strip brass, and are $\frac{1}{8}$ in. wide, and call for no special comment, only that one connection is soldered to a suitable brass standard, the one used being made from a small length of condenser spindle. The other spiral connection is screwed into one of the spacing pieces. The spacing pieces, used for attaching the instrument to the panel, are made from ebonite $1\frac{1}{2}$ in. by $\frac{5}{8}$ in. by $\frac{3}{8}$ in., with a 4 B.A. clear hole.

The writer has found this variometer to give very satisfactory results, with a liberal tuning range. The windings can be connected either in series or parallel by means

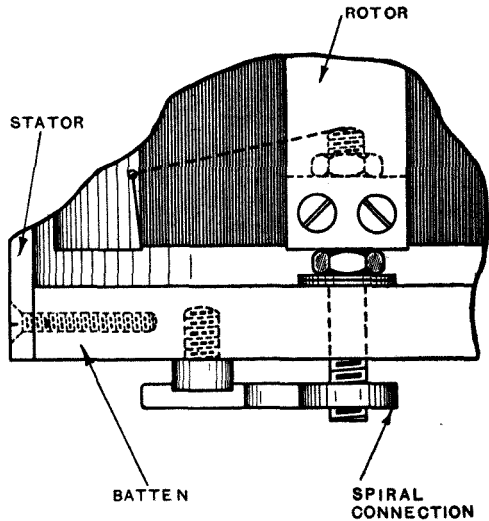

Details for setting up the spindles.

of a two-position double throw switch, or the windings bridged with a suitable fixed condenser.

PATENTS AND ABSTRACTS



A Receiver which Employs Reaction but Cannot Excite the Aerial.

In earlier numbers of this journal we have described many methods of arranging a circuit which will not radiate locally generated oscillations. Another arrangement* is shown in Fig. 1. It will be seen that the

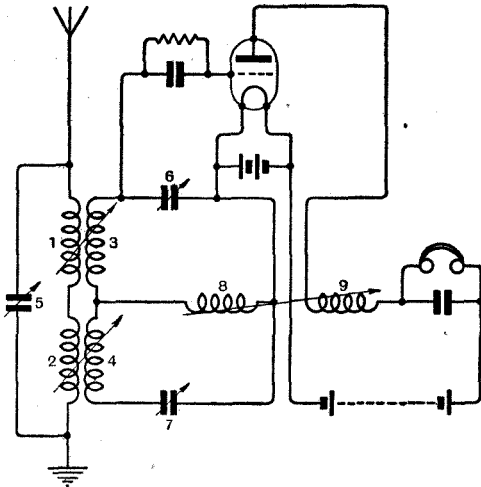

Fig. 1. An arrangement of circuits for preventing locally generated oscillations exciting the aerial.

aerial circuit contains two coils, 1, 2, which are coupled to coils 3, 4 respectively. Condenser 5 tunes the aerial circuit, and condensers 6, 7, which are mechanically connected, tune the secondary circuit. A coil 8 is included in the wire which connects the centre point of coils 3, 4, and is coupled to the reaction coil 9.

When a signal is being received from the aerial the secondary circuit will respond, the currents in the neutral wire and inductance coil 8 being equal and opposite. If the reaction coil is coupled to coil 8, the signal

currents flowing in circuit 3, 6, 8, tend to be increased in strength, but the currents flowing in the circuit 4, 7, 8 tend to be reduced in strength. Should the reaction coupling be increased so far that the valve oscillates, the oscillations will not appear in the aerial because the effect of the currents flowing in the windings 3, 4, are exactly equal and opposite.

A Method of Reducing Distortion.

In receivers employing valves it is well known that means must be provided for maintaining the grids of the amplifying valves at a suitable negative potential in order to minimise distortion. A common method is to take advantage of the fall in voltage over the filament resistance, or dry cells may be employed. In another method a resistance is connected between the filament circuit and the negative terminal of the anode battery and the fall in voltage over this resistance is utilised. It has been proposed* to add a choke coil and a con-

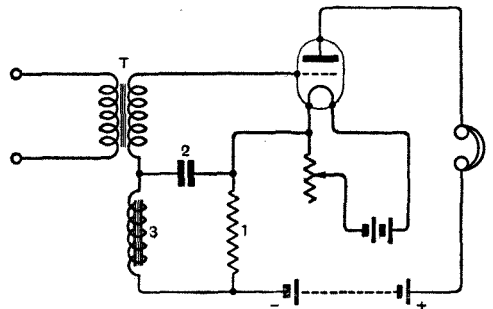

Fig. 2. A method of arranging the circuit of an amplifier to obtain a suitable operating (negative) grid potential.

denser to the circuit containing a resistance in the anode battery circuit in the manner

*British Patent No. 220,765, by N. P. Hinton and Metropolitan-Vickers Electrical Co., Ltd.

*British Patent No. 220,727, by E. A. Graham and W. J. Ricketts.

shown in Fig. 2. The resistance r is connected between the filament and the negative terminal of the anode battery. T is an intervalve transformer whose secondary winding is connected to the grid of the valve and to the filament *via* the condenser 2. A choke coil 3 is connected between the lower end of the secondary winding and negative of anode battery. If necessary the resistance r may be shunted by a condenser.

Wireless Valve Transmitters.*

THE DESIGN AND OPERATION OF SMALL POWER APPARATUS.

By W. JAMES.

This is the first and only practical book on transmitting. The subject is thoroughly dealt with from a practical standpoint in order that the reader may be able to design and operate his own transmitter. All transmitters of interest to the amateur are described in detail.

There are 270 pages which are illustrated with 210 photographs and diagrams. The brief contents of chapters below give an idea of the wide range covered by this most useful book.

1. **Electrical Principles.**
2. **Inductance Coils and Condensers.** Design and construction of fixed and variable condensers. Design of tuning coils. The construction of tuning coils and chokes for transmitters.
3. **Alternating Current Circuits.** A.C. circuits containing resistance, capacity and inductance. Series resonance effects. Parallel resonance. Variometers.
4. **The Supply of Power.** Dry cells. Accumulators. Buzzer transformer unit. Adnil vibrator. Interrupter drum and transformer unit. The

voltage raiser. Use of D.C. and A.C. mains. D.C. motors and generators. Motor generators. The dynamotor. The rotary converter. The design of transformers, choke coils and filters.

5. **Rectifiers.** Chemical rectifiers. Rectifiers for accumulator charging and for anode circuit supply. The Tantalum rectifier. Mechanical rectifiers. Mercury arc rectifiers.

6. **Valve Rectifiers.** Half and full wave, single and polyphase rectification. The supply of power for filament circuits. A commercial rectifier unit. The S tube rectifier.

7. **Microphones and Speech Amplifiers.** The valve as an amplifier. Transformer, choke and resistance coupled amplifiers. The microphone transmitter. Speech amplifiers. The double-button microphone. The Marconi-Sykes transmitter. The electro-magnetic transmitter. The condenser transmitter.

8. **The Three-electrode Valve as an Oscillator.** The three-electrode valve as a means of converting D.C. into A.C. The valve as a self-excited generator of oscillations. The Hartley circuit. The Colpitts circuit. The Meissner circuit. The modified Meissner circuit. The tuned anode circuit. The master oscillator circuit. Methods of increasing the output. Protection. The use of a valve as a grid leak. The series valve. Keying the circuit. Back loading. Particulars of transmitting valves.

9. **Modulated Waves and Wireless Telephony.** Transmitter with A.C. supply to the anode. Half-wave self rectification. Full-wave self rectification. Transmitter employing interrupted H.T. Modulated waves. Interference from modulated waves. Effect of modulation. Modulation by absorption. Modulation by shunting the aerial. Grid circuit modulation. Use of valve in grid circuit. Modulation by varying the anode voltage. A valve in series with anode supply. The choke control or constant current system of modulation. Choke control transmitters. Adjusting the transmitter. Van der Bill's system of modulation. Choke control of master oscillator transmitter. A commercial transmitter. Buzzer modulation. Choice of valves and anode voltage.

10. **Miscellaneous Notes and Measurements.** Measurement of inductance. An inductance bridge. Measurement of capacity. A capacity bridge. Moving coil voltmeters and ammeters. Hot wire ammeters. Aerials. Measurement of capacity, resistance and inductance of an aerial. Dummy aerials. Wavemeters. Oscillating crystals. Notes on inductance coils and condensers.

* Published by the Wireless Press, Ltd., 12 and 13 Henrietta St., London. Price 9s.

CORRESPONDENCE

Crystal Reception.

To the Editor of THE WIRELESS WORLD AND RADIO REVIEW.

SIR,—With reference to Mr. Steuart's criticism of the rigid "catwhisker," it should be noted that the type he recommends, viz., a spiral of very fine wire, while quite efficient for very weak signals, is by no means efficient for the strong reception enjoyed by probably 90 per cent. of B.B.C. listeners.

Under these conditions the fine springy spiral intensifies microphonic action (with absorption of energy in vibrations of the wire) and when the

signals are very strong, produces distortion. It is also more subject to mechanical shocks than a rigid type.

In making a rigid catwhisker a piece of No. 26 wire may be flattened out at the end to the requisite degree of thinness, so that the resulting "spear-point" cut from this has a point very much finer than the average spiral type of "catwhisker." With a "spear-point" catwhisker made in this way three different contacts may be employed—

- (1) The very fine point.
- (2) The knife-like edge of the spear.
- (3) The flat side of the spear-point.

In this way the area of contact with the crystal may be varied to suit the signal strength.

I use gold wire, gilt-phosphor-bronze and copper tipped with platinum.

I maintain strongly that, while it is essential to vary the area of contact and the resistance of the contact at the point, the most efficient crystal detector must be rigid, containing no members liable to vibrations of audible frequency.

I was interested to read Mr. Steuart's suggestion that maximum current strength may not coincide with maximum signal strength. From numerous experiments with a large number of crystals I have definite evidence that the volume of rectified current is by no means a measure of signal strength in many cases. For example, on the local B.B.C. station I get on the average 2 milliamps from a good synthetic galena and very loud reception. With another crystal I get the same current as measured by the galvanometer but very feeble reception, while with a third crystal I get reception only slightly inferior to the galena with only 0.15 m.a. The probable explanation of this phenomenon is that only a fraction of the rectified current consists of frequencies affecting the telephone diaphragm for the production of sound, and that this may vary with different crystals. A variation of this kind can be explained only on the basis of an electronic theory of rectification.

JAMES STRACHAN.
Aberdeen.

Wave Form in Loud Speaker Circuits.

To the Editor of THE WIRELESS WORLD
AND RADIO REVIEW.

SIR,—The accompanying oscillographs were taken in a loud speaker circuit (120 ohms) between the telephone transformer and the loud speaker itself.

The circuit was fed through a L.S. 5 power valve—250 volts anode voltage, and the curves taken on a Duddell oscillograph directly in circuit.

The top curve represents the tuning note of 2 LO, 1,000 complete cycles per second. The middle curve the note of a saxophone, approximately 900 cycles per second. The bottom curve the note of a ukalele (Hawaiian banjo), approximately 650 cycles per second.

As these represent current curves, they are rather interesting in comparison with the mechanically obtained records of sound waves now being published.

MORTIMER A. CODD.

Remarkable Transatlantic Reception.

To the Editor of THE WIRELESS WORLD AND
RADIO REVIEW.

SIR,—An instance of unusual reception may be of interest to your readers.

Whilst in Lancashire, I decided to compare the results obtained in short wave reception as compared with reception at my station in London.

I was using a hurriedly arranged Reinartz type circuit with detector and one low frequency valve, and decided to try the effect as described in August *Q.S.T.*, of placing a short wave coil in parallel with the grid circuit in order to reduce the wavelength. On the waves around 50 to 70 metres, I received signals of colossal strength from various commercial stations testing with LPZ (Buenos Aires). Suddenly I tuned in a tremendous carrier wave with music and was astonished to find that this was **KDKA**! On changing over to a small loud speaker the transmission was audible out in the street, the announcer's voice fairly booming in the room. The reception strength] was equal to 2 ZY.

A noticeable feature was that for a considerable band on either side of **KDKA**'s carrier, there was a very high-pitched heterodyne note—as in the Armstrong super. I have received many American broadcast programmes—always on detector and one L.F.—but never before of such tremendous strength!

Considering the short wavelength to which I was tuned, I can only put this reception down as a lower harmonic of **KDKA**—or a freak. The date was September 5th, 1924, at 03.00 B.S.T., and I should be pleased to know if any other of your readers recorded the same transmission. This reception was carried out at the station of Mr. Wilding (6 KB) in Wigan, Lancs., with a hurriedly thrown together "hay wire" tuner. The aerial is a 70 ft. single wire, 45 ft. high at the free end and 30 ft. at the lead in. D. B. KNOCK (6 XG)

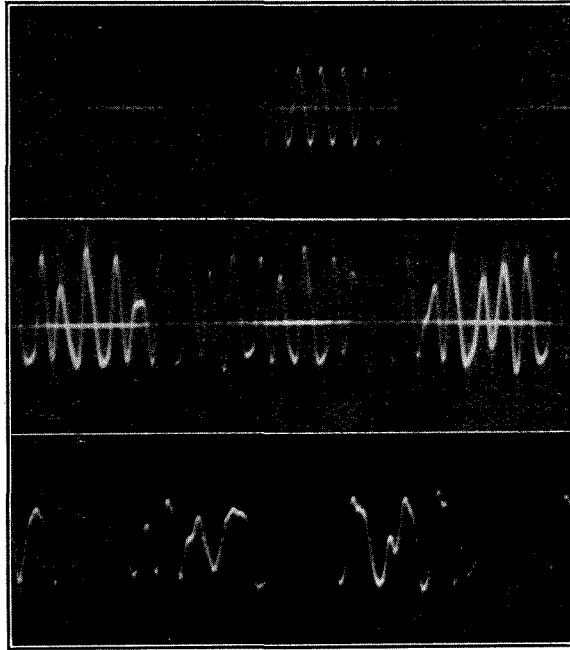

Oscillograph curves of : (Top) the tuning note from 2 LO ; (middle) the note of a saxophone ; and (bottom) the note of a ukalele.

NOTES & CLUB NEWS

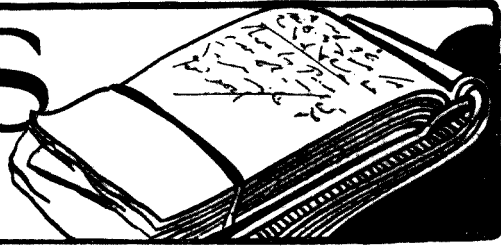

Listeners in Northern France are complaining that the rapid development of German broadcasting between 400 and 450 metres is jamming the reception of British stations.

* * * *

The Merthyr Corporation has issued a regulation that council tenants having wireless installations must include lightning arresters in their aerials.

* * * *

Two Johannesburg amateurs report the reception of broadcasting from Pittsburg, U.S.A., using a five-valve set. The distance covered is approximately 7,200 miles.

* * * *

A Californian amateur, W. B. Maguer, is reported to have worked with F. Dillon Bell, of New Zealand, thus beating the record held by Carlos Braggio, the Argentine amateur.

* * * *

SHORT WAVE U.S. BROADCASTING.

News has been received that **KDKA**, the Pittsburg broadcasting station, is now operating on a wavelength of 68 metres. Transmissions are still continuing on 100 metres and the original wavelength of 326 metres.

WGY, the General Electric Company's station at Schenectady, now operates on a wavelength of 15 metres, simultaneously with their usual transmission. Great as are the difficulties in arranging a transmitter on this low wavelength, the task of reception is infinitely greater, and the experimenter who succeeds in this can be justifiably proud.

NEW SPANISH BROADCASTING STATION.

Trials are being carried out from the new Spanish broadcasting station in Barcelona, situated at the Hotel Colon.

For testing purposes a power of 100 watts is being used, but this will be increased to 1.5 kilowatts in a few months. The call sign of the station is **EAJ 1**, and the wavelength 325 metres.

We understand that transmissions are taking place between 6 and 7 p.m. and between 9 and 11 p.m. G.M.T. Arrangements have been made to broadcast opera from the Teatro Liceo, Barcelona.

VOCABULARY TROUBLE.

The desire in many quarters to repress American slang among British amateurs has a parallel in France, where English is being discouraged in the same fashion.

Lecturing at one of the final sessions of the Paris Concours Lepine, Commandant Mesny asserted that such words as "fading," "loud speaker" and

others of the same type, should have no place in the French amateur's vocabulary.

One argument challenges Commandant Mesny. The Frenchman who adopts English terms is in most cases speaking a legitimate tongue; the Englishman's adoption of American is rather different.

DX EXTRAORDINARY.

Difficulty in answering American calls because they were so numerous is reported by Mr. E. J. Simmonds (**2 OD**), of Gerrards Cross, Bucks.

In the early hours of Sunday, October 5th, Mr. Simmonds completed a new transmitting arrangement embodying a master oscillator. At 5 a.m. he called an American amateur, and was immediately greeted with answering calls from **1 BIP**, **1 AUR**, **2 BRC**, **4 IO** and **4 OA**. It is especially noteworthy that two of these came from the Fourth District (N. Carolina, etc.).

More remarkable still was **4 OA**'s message, in which the operator stated that **2 OD**'s signals were so strong that they were more comfortably read with the aerial disconnected.

On Monday, October 6th, Mr. Simmonds worked with **U1SF**, and on the following day with **U1MY**.

OFFICIAL OPENING OF ROME STATION.

The Marconi broadcasting station in Rome, which has hitherto been engaged upon tests, began the regular transmission of programmes on October 6th. Concerts are given between 7.30 and 9.30 G.M.T.

The station operates on a wavelength of 422 metres and the apparatus consists of a Marconi 6 k.W. broadcasting transmitter of standard pattern such as is used in six of the British main stations and has been installed at Brussels, Cape Town, Durban, Lima and Rio de Janeiro.

TRANSMISSION UNDER DIFFICULTIES.

Owing to the stringent wireless regulations obtaining in Holland, amateur work has to be carried out somewhat stealthily. Some details of his experiments under restricted conditions, contributed by a Dutch amateur, may prove of interest.

The object of our correspondent, **OII**, was to discover what could be accomplished with simple apparatus, and without the aid of a special transmitting aerial or counterpoise.

Some promising results have already been obtained with a single wire aerial, 120 feet in length, slung between two houses, without masts, and insulated at each end by one small egg insulator.

The counterpoise consists of two wires in the second storey of a building. The transmitter is of the loose-coupled reversed feed-back type, and employs a Telefunken detector valve. A plate supply of 800 volts unrectified A.C. is used, with a maximum aerial current of 0.2 amperes.

With this by no means promising combination, and operating on 80 to 100 metres, OII has worked with Italian, Swiss and French stations, including 1 FP, GAD, 8 LMT and 8 UU

On September 27th, at 11 p.m. (G.M.T.), two-way working was established with Swedish SMZY, a distance of 1,200 kilometres, using an aerial current of 0.18 amperes.

MYSTERIOUS BROADCAST PREACHER.

More than one report has reached us from listeners-in who have heard an unidentified station broadcasting religious addresses between 10.30 and 11 p.m. on Sundays.

Enquiry has shown that no B.B.C. station has been conducting such transmissions at this hour, and information as to the whereabouts of the transmitter would prove of interest.

According to one report the wavelength is in the neighbourhood of 420 metres.

GIANT U.S. BROADCASTER ?

A broadcasting station with a power of 50 kilowatts, to be erected near New York, is the proposal of the Vice-President of the American Radio Corporation. The Company is ready to proceed with the work if no opposing regulations are introduced.

BROADCAST RECEPTION AT SEA.

Broadcast reception at sea usually provides valuable opportunities for signal comparison. Some notes on the reception of British and French stations have been forwarded to us by a correspondent sailing for New Zealand, who was able to make some interesting comparative tests.

A four-valve receiver was employed, as described in the *Wireless World and Radio Review* of July 9th and 16th, with the addition of grid cells in both L.F. stages.

When 375 miles out from Southampton, with an outside aerial, 2 LO was at once picked up at excellent strength, and Paris was also tuned in with ease. Later in the evening 5 XX was heard, and with careful tuning was separated from Radiola.

Good reception was also obtained at 700 miles out, but was marred by bad atmospheric. At 1,575 miles out faint orchestral music could be distinguished from Paris, but signals soon died away and our correspondent had to "pack up."

HAVE YOU HEARD CKAC ?

An important event in Canadian broadcasting occurred on October 4th, according to La Internaciona Ido-Radio-Klubo, when the Dominion's principal station, CKAC, increased its power to 28 kilowatts with new apparatus manufactured by the Canadian Marconi Company, of Montreal.

Owned and controlled by the great Canadian newspaper, *La Presse*, CKAC is the only French-English station in the world. It caters especially to some five millions of French scattered throughout the various provinces, several states of the Union, the island of St. Pierre Miquelon, and in the West Indies and Guianas. Three languages are employed in broadcasting, viz., French, English, and the international tongue, Ido.

The new apparatus employs fourteen valves of 2,000 watts each, one power amplifier, three oscillators, four modulators and six rectifiers. A feature of the set is that the energy, before going to the modulators, is treated to three-phase, double-wave rectification by means of the six valves mentioned. The ordinary commercial lighting energy being used to operate the transmitter, no motor generator is required, and rectification ensures absolute clarity and tone purity. The wavelength of CKAC is 425 metres.

FRENCH AMATEUR'S AMBITION.

Mr. L. J. Menars, the young French amateur, who claims the record for the reception of U.S. stations in France, and whose lists have appeared in the "Calls Heard" section of this Journal, is

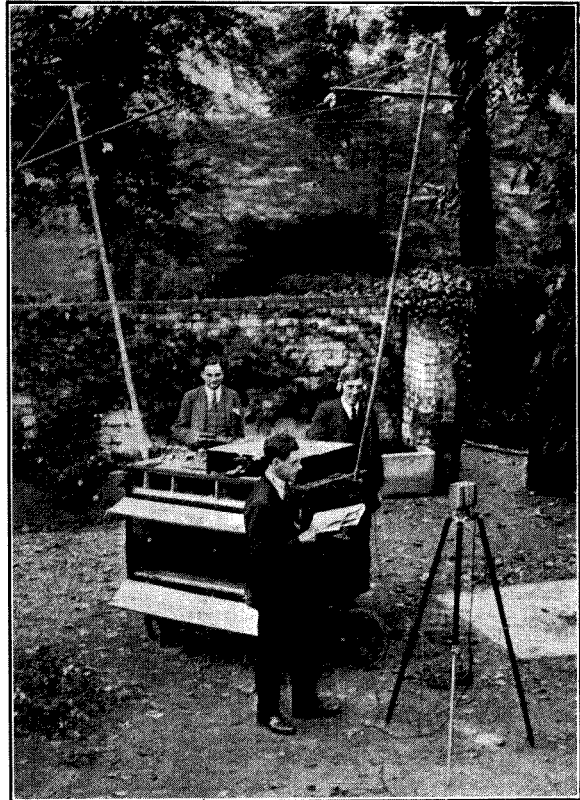

The British Broadcasting Company's portable transmitter and microphone as used for broadcasting from the Zoo. Captain West, Chief of the Company's Development Staff, is seen in the background.

about to commence transmission work, with the call sign 8 E J. He intends to confine his operations to the 40-100 metre band.

Using an input of 500 watts and an 80 ft. cage aerial, Mr. Menars hopes to work with America without difficulty, after which he will then turn his attention to the Argentine. If he is again successful, he will attempt to reach New Zealand!

THE JUNIOR INSTITUTION OF ENGINEERS.

A full programme of papers and lectures has been prepared for the coming session of the Junior Institution of Engineers, covering a variety of subjects of present-day interest. On October 17th, at a special meeting, a lecture on "High Voltage Electric Oscillations" will be delivered by R. P. Howgrave-Graham, M.I.E.E. A Lecturette on "Audio-frequency Transformers," will be given by H. J. N. Riddle (Assoc. Member), on Friday, October 31st.

Further particulars of these meetings and tickets of admission may be obtained from the Secretary at 39 Victoria Street, S.W.1.

A USEFUL BROADCAST TIME TABLE.

An excellent time table of Continental Broadcasting has been produced by Messrs. E. T. W. Dennis & Sons, Ltd., of Melrose Street, Scarborough. Transmissions are arranged in order of time, with the object of facilitating identification of unknown stations at any time of the day or night. Our only criticism is that the times should have been given as G.M.T., not B.S.T., as the book will be used principally during the coming winter. The price of the time-table is 4d.

WIRELESS AND CHANNEL FOGS.

With the approaching season of fogs, the Board of Trade and the Post Office authorities have taken a timely step in deciding to erect a wireless directional station at Niton, Isle of Wight.

The alleged inadequacy of present provision for fog on the British coasts has been the subject of some criticism and it is suggested that the Lizard station should also be improved to meet the need. This, however, is a matter for the Admiralty, which is the controlling authority.

CANADIAN WIRELESS REGULATIONS.

It is announced by the Canadian Marine Department, as a result of negotiations with the British Shipping authorities, that a wireless wavelength of 450 metres must no longer be used within 250 miles of the coasts of Canada or of Newfoundland, says a Reuter message from Ottawa. Canadian ships must refrain from using the same wavelength at the same distance from the coast of the British Isles. Great Britain, the announcement adds, undertakes to persuade Continental countries to take similar action.

INTERFERENCE PREVENTION.

Some instances of interference were discussed by Mr. Maurice Child, speaking recently from 2 LO on behalf of the Radio Society of Great Britain.

Mr. Child referred to an extract from the American Radio Service Bulletin, in which two sources

of radio interference and the manner in which they were effectively overcome are reported.

"The first trouble," said Mr. Child, "was produced over a large area by the operation of a precipitator. For the benefit of those who may not be acquainted with the function of this device I would mention that it is for precipitating particles of coal or other matter which have not been consumed in the furnaces, thereby preventing a considerable pollution of the surrounding atmosphere. The precipitation is accomplished by maintaining a series of conductors inserted in the chimney stack or up-take, at a very high difference of continuous electrical pressure—something to the order of 60,000 volts.

"The apparatus which produced this electrical energy incidentally also functioned as a free emitter—although quite unintentionally, but was subsequently prevented from so doing by the insertion of suitable resistances in the high voltage wires, and shunting a closed oscillatory circuit across a spark gap which formed part of the plant.

"The other cause of interference was due to a defective overhead power line working at a pressure of 13,000 volts situated in the town of Augusta, U.S.A., and supplying nine arc lighting circuits, although actually tungsten lamps were in use in place of the original arcs. It was found that one of these circuits was exceptionally bad, and the maximum disturbance was traced with a three-valve receiver connected to a frame aerial, to a certain street standard supporting one of the lamps. The lamp was dead short-circuited without effect, but careful investigation involving considerable patience and time eventually led to the discovery that one of the standard guy wires was periodically lying across a 2,300 volt circuit, and all the trouble ceased on the defect being rectified.

"About a year ago the Radio Society of Great Britain invited an inspection by the Southern Railway Company of their overhead lines for the electrified system between Victoria and the Crystal Palace, with excellent results to the listening public in the neighbourhood of Balham."

Mr. Child stated that his object in mentioning these instances was to indicate that it is possible to trace and cure various troublesome kinds of interferences. He invited members to assist in locating them, for by so doing they would not only learn interesting facts themselves, but might obtain some measure of gratitude from the non-technical public.

AN ERROR.

We regret that by an unfortunate error, a photograph appeared in the left-hand column on page 25 of our issue of October 1st, purporting to depict a cabinet receiver of Messrs. Edison-Swan Electric Co. The receiver illustrated is actually the Marconiophone V.1.

CHANGE OF ADDRESS.

Owing to the growth of their business, Messrs. G. W. L., Ltd., component distributors and valve repairers, have removed their offices to Imperial House, 43 Grafton Street, Tottenham Court Road, London, W.1.

Calls Heard

Hammersmith, London, W.6.

American and Canadian: 1 AQ, 1 AR, 1 AJA, 1 ALJ, 1 AER, 1 ASU, 1 BDL, 1 CK, 1 CMP, 1 CRU, 1 DD, 1 MO, 1 IV, 1 WET, 1 XA, 1 XW, 1 XAK, 1 XAR, 2 ABB, 2 AWY, 2 BG, 2 BY, 2 CY, 2 LZ, 2 WR, 2 XAA, 2 BP, 3 BG, 3 IL, 3 IM, 3 OE, 3 OT, 3 TE, 3 TK, 3 VW, 4 AA, 4 BZ, 4 LV, 4 TN, 5 EV, 5 XA, 6 BCL, 6 BY, 7 DF, 8 ARM, 8 FM, 9 EFH, 9 XG. Dutch: 0 AA, 0 AG, 0 BA, 0 BQ, 0 FN, 0 KP, 0 KK, 0 KZ, 0 MR, 0 MS, 0 NN, 0 PB, 0 PC, 0 PZ, 0 RV, 0 SA, 0 XW, 0 YS, 0 ZB, PA 5, PA 9, PCIL, PCGG, PCTT. Danish, Belgian, Italian: 7 EF, 7 QF, 7 GG, P 2, P 5, W 2, 4 C 2, 1 CF, 1 ST, ACD, MU. French: 8 AA, 8 AB, 8 AE, 8 AE 2, 8 AE 3, 8 AE 4, 8 AG, 8 AL, 8 AZ, 8 BF, 8 BM, 8 BT, 8 CC, 8 CG, 8 CH, 8 CM, 8 CS, 8 CT, 8 CZ, 8 DO, 8 DU, 8 EL, 8 EN, 8 EO, 8 JC, 8 JL, 8 OH, 8 OL, 8 QA, 8 RL, 8 ZM. (0-V-2.) (S. Riesen).

Hove, Sussex (August 22nd-September 12th).

Below 100 metres:—British: 2 GW, 2 KF, 2 KZ, 2 LS, 2 NM, 2 YW, 2 XY, 2 YB, 5 DH, 5 LF, 5 LS. French: 6 EK, 6 TD, 6 TM, 6 XX, 6 YB, 8 AQ, 8 BN, 8 BV, 8 CO, 8 DA, 8 DD, 8 DI, 8 DO, 8 DV, 8 DX, 8 FK, 8 FL, 8 FG, 8 FSE, 8 SHL, 8 ML, 7 MN, 8 OK, 8 QL, 8 SR, 8 VU, 8 VG, 8 VR, 8 WS, 8 XR. Belgian: 4 AA, 4 AD, 4 RS, 4 WR, W 2, P 2. Dutch: 0 BA, 0 MS. Danish: 7 VG. Swedish: SMZS. Unknown: 9 AD, 8 AD, 3 CA. Amateurs on 200 metres:—British: 2 KA, 2 OM, 5 MS, 5 YN, 5 TZ, 8 QB. (0-V-1.) (C. L. Fry).

Islington, London, N. (September 1st-11th).

1 AR, 2 AJR, 2 CG, 2 FV, 2 IH, 2 NL, 2 VW, 5 MA, 5 NW, 5 OC, 5 OT, 5 SL, 5 SZ, 5 TJ, 6 AL, 6 BY, 6 FV, 6 MP, 6 US, 7 AB, 8 FE, 8 SM, 8 WJ, 8 ZZ, 0 BA, 0 GC, 0 HD, 0 QW. (0-V-1.) (J. G. Sandford).

Wembley (July 13th-September 7th).

2 FA, 2 FN, 2 FP, 2 FV, 2 JA, 2 JB, 2 JP, 2 OA, 2 TA, 2 WY, 2 YO, 2 ZA, 2 AJA, 2 AQV, 2 ART, 2 AUJ, 2 CAA, 5 AR, 5 BE, 5 CQ, 5 GA, 5 KM, 5 OC, 5 RE, 5 SU, 5 SZ, 5 VM, 6 EY, 6 GH, 6 KG, 6 QA, 6 TA, 6 UD, 6 VP. French: 8 AE 4, 8 AP, 8 BA, 8 BN, 8 BS, 8 BU, 8 BV, 8 CZ, 8 DL, 8 DU, 8 EE, 8 EX, 8 FI, 8 FNN, 8 FQ, 8 FEF, 8 G 4, 8 JBV, 8 JL, 8 ML, 8 NS, 8 PA, 8 RX, 8 SR, 8 UI, 8 VG, 8 WZ. Dutch: 0 BQ, 0 HD, 0 MS. Luxembourg: 0 AA, Belgian: 4 MG, 4 RS, 4 WR, 4 YZ. Italian: 1 FP, 1 MT. Swedish: SMZS. SMZV. American: 1 AHM, 1 CGG, 2 CK, 2 CRP, 2 CVJ, 2 WZ, 3 LB, 4 SA, 8 ADG. Canadian: 1 BQ, 1 EF. Unknown: 8 AD, 9 AD, CP, 8 XO, YA 13. (0-V-0.) (A. L. Carrad).

Holyhead (Saturday, September 6th, 1924. 12.0 midnight to 3.30 a.m., B.S.T.).

American: 1 BLX, 1 XAK, 1 XDB, 1 AMW, 1 AAL, 1 MY, SF, 1 FD, 1 ALI, 1 BTA, 2 RRB, 2 GK, 2 CU, 3 MB, 4 FS, 5 LL, 6 CRW, 8 ADD, 8 ZG, 9 DPX, 9 ZB, 9 ZC, 9 ABF, 9 AYX. Argentine: CB 8(?). (R. E. Williams).

CLUB ACTIVITIES.

Correspondence for Secretaries of Societies will be forwarded if addressed to the office of this Journal, c/o the Editor.

Mr. L. F. Fogarty, A.M.I.E.E., provided an interesting lecture on "Inductance and Capacity" at the last meeting of the Croydon Wireless and Physical Society. By means of mechanical analogies and blackboard illustrations Mr. Fogarty rendered his remarks sufficiently clear to be understood by the beginner.

"Measuring Instruments used in Amateur Radio" were dealt with by Mr. G. A. V. Sowter, B.Sc., lecturing before the Walthamstow Amateur Radio Society on October 2nd. The lucid manner in which he demonstrated by means of a compass, accumulator, some iron core and a few yards of wire, added considerably to the value of the lecture.

"Wireless: Past, Present and Future," formed the title of an instructive and entertaining lecture

delivered by Mr. H. R. Rivers-Moore, B.Sc., at the opening meeting of the South Croydon and District Radio Society. From 10 till 12 o'clock, an enjoyable dance was held to the strains of the Savoy bands on the loudspeaker.

Permission to attend a series of wireless lectures to be given by Professor W. A. Andrews, B.Sc., at the Merchant Venturers' Technical College, has been obtained for members of the Bristol and District Radio Society. These lectures are educational and are divided into two courses, elementary and advanced. The last two or three lectures in the latter course will be on the subject of transmission.

At a time when there is much dissatisfaction being expressed as to the behaviour of the Post Office in the issue of transmitting permits, the Hampstead and St. Pancras Radio Society ask us to state that they made application for a licence on September 16th last and received a reply on October 9th (awarding them most liberal transmitting facilities).

The Society makes the suggestion that the Post Office will act in a perfectly sane manner if approached with reasonable courtesy, and if no technical details are withheld such as would assist in deciding to grant the privilege of conducting experiments with transmitting apparatus. After all, the Post Office must have something to go upon.

The Bognor and District Wireless Society opens its session on Monday, October 20th, with a meeting at 8 p.m. at the Observer offices, Lennox Street. All enthusiasts are invited to attend.

Regular Morse practice at each meeting features on the programme of the Middlesex Wireless Club. On October 1st Mr. Gartland lectured on "H.F. Amplification for Reflex Circuits," giving many useful hints, and describing common pitfalls.

FORTHCOMING EVENTS.

WEDNESDAY, OCTOBER 15th.
North Middlesex Wireless Club. Half-yearly Sale of Instruments.
Radio Research Society, Peckham. At 44 Talfourd Road. Discussions: "Sources of Electric Current," "Some Experiments with Room Aerials."
Bristol and District Radio Society. Demonstration by Messrs. Siemens and English Electric Lamp Co.
Clapham Wireless and Scientific Society. At 7.45 p.m. At 67 Balham High Road. Annual General Meeting.

THURSDAY, OCTOBER 16th.
Bournemouth and District Radio and Experimental Society. At 7 p.m. At Canford Hall, St. Peter's Road. Short Talks, Evening Lecture: "Standard Circuits and their Characteristics." By Mr. W. H. Peters, B.Sc.
Derby Wireless Club. Lecture by Mr. E. F. Clark, B.A., B.Sc.
Walthamstow Amateur Radio Society. Lecture: "An International Language for Radio." By Mr. Montague C. Butler, L.R.A.M.

FRIDAY, OCTOBER 17th.
Bristol and District Radio Society. Demonstration by General Electric Company. "Manufacture of Wireless Valves."

MONDAY, OCTOBER 20th.
Hackney and District Radio Society. At 8 p.m. At King's Hall, Lower Clapton Road, E.8. Query Night.

WEDNESDAY, OCTOBER 22nd.
Radio Society of Great Britain. Ordinary Meeting. At 6 p.m. (tea at 5.30). At the Institution of Electrical Engineers, Savoy Place, W.C.2. Lecture: "Unsolved Problems of Wireless." By Mr. R. H. Barnard, M.Sc.



READERS PROBLEMS



Readers desiring to consult the "Wireless World" Information Dept. should make use of the coupon to be found in the advertisement pages.

PLOTTING CRYSTAL CHARACTERISTICS.

FROM the static or D.C. characteristics of a crystal detector it is possible to predict with a reasonable degree of accuracy whether the crystal will be suitable for use in a wireless circuit, and also to determine the conditions under which it will give best results.

The apparatus necessary to obtain the curve is very simple, and consists of a sensitive high resistance galvanometer, a potentiometer wire such as a metre bridge, a 2-volt accumulator, and, as a refinement, a reversing switch for the battery.

The method of connecting up the apparatus is illustrated in Fig. 1 (a). If the metre bridge wire is of uniform cross section and conductivity, there will be a uniform fall of voltage along the whole length of the wire, so that a series of known voltages may be applied to the crystal detector by varying the position of the tapping point on the wire. The current flowing through the crystal contact for each value of the applied voltage will be indicated by the galvanometer G, which should be of the suspended moving coil type, used in conjunction with a lamp and scale. Having obtained a series of galvanometer deflections for various positions of the potentiometer slider, the battery should be reversed, and a further series taken, with the E.M.F. applied in the opposite direction. Before plotting the curve it will be necessary to reduce the galvanometer and potentiometer scale readings to absolute values of current and E.M.F. respectively. Where great accuracy is not required, the E.M.F. may be obtained by measuring the voltage of the accumulator with a voltmeter, and assuming that this is the potential difference between the ends of the meter bridge wire. A more accurate method of calibration is indicated in Fig. 1 (b). A standard cell, S, of the Weston or Clark type, is connected in series with the galvanometer, care being taken that the polarity of the cell is arranged to oppose the E.M.F. due to the accumulator cell. The slider contact is then adjusted until no current flows through the galvanometer. The length of bridge wire XY will then be equivalent to the E.M.F. of the standard cell. A key is placed in the galvanometer circuit, so that this circuit may be broken instantly if the galvanometer indicates that an excessive current is flowing through the standard cell. The current delivered from a standard cell should never be allowed to exceed 1 microampere, and a current of this value should not be allowed to flow for more than a few seconds. The galvanometer scale readings may be reduced to microamperes by connecting the standard cell in series with the

galvanometer, and a standard resistance, R , of 1 megohm.

The circuit for the calibration of the current is given in Fig. 1 (c).

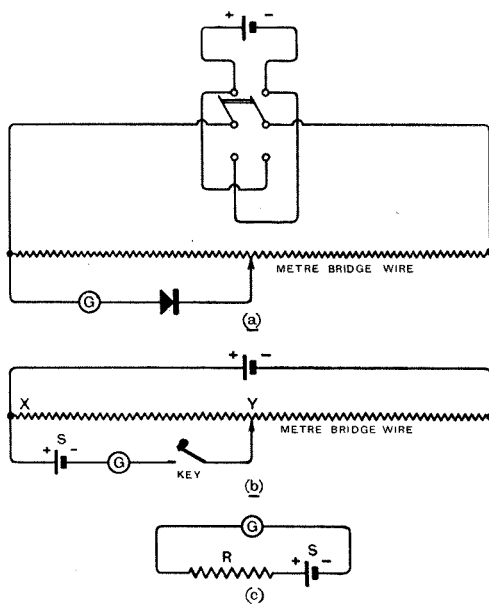

Fig. 1. Circuits for plotting crystal characteristics.

CALCULATION OF ANODE RESISTANCES.

THE external resistance connected in the anode circuit of a valve for H.F. or L.F. amplification should have a value several times as great as the anode-filament resistance of the valve. The higher the ratio of the external resistance to the resistance of the valve, the higher will be the amplification obtainable from each stage. The upper limit to this ratio is determined in practice by the size of the H.T. battery which can be used. As the value of the anode resistance is increased, the H.T. voltage must be increased also to compensate for the fall of voltage through the resistance and to ensure that the potential difference between the anode and filament of the valve is sufficiently high. The total H.T. voltage will be divided in the ratio of the external and internal resistances.

The *internal resistance* of the valve for a given H.T. voltage and filament current is dependent on the grid voltage and may therefore have a value different from the *impedance* of the valve which is calculated from the valve characteristics.

In calculating the value of an anode resistance it is usual to start by fixing the value of the H.T. battery. To take a concrete example, let us assume that 200 volts is the maximum H.T. voltage that it is practicable to employ. If the valve takes a steady anode current of 1.5 milliamperes at 80 volts when a suitable negative grid bias is applied it is a simple matter to calculate the value of the anode resistance from Ohm's law, for this resistance must dispose of the remaining 120 volts when a current of 1.5 milliamperes is passing. The resistance required is therefore 120 divided by 0.0015, or 80,000 ohms.

Starting with a fixed value for the anode resistance, and knowing the conditions under which the valve is to be operated, the H.T. voltage required can be calculated by a similar process.

A FOUR-VALVE AND CRYSTAL RECEIVER FOR BROADCAST RECEPTION.

THE diagram given below shows the method of connecting a useful four-valve and crystal

cause of distortion. The set should therefore be capable of giving a high quality of reproduction if the transformers and valves in the two L.F. stages are chosen with care.

COUPLINGS BETWEEN H.F. VALVES.

A READER asks if a H.F. coupling consisting of two plug-in coils coupled together to form a transformer would give better results than the tuned anode method of coupling.

The results obtained with a coupling of this kind would not be very much better than those obtained with tuned anode coupling, as far as signal strength is concerned, but if both coils are tuned and a variable coupling is provided, it would be possible to obtain a much higher degree of selectivity than is possible in the case of tuned anode coupling. The method can therefore be regarded as superior to tuned anode coupling.

H.T. SUPPLY FROM D.C. MAINS.

REFERRING to the diagram on page 725 of the issue of September 17th, 1924, a reader asks if it would be possible to obtain more than one positive tapping from the H.T. supply.

This could be done quite easily by arranging three instead of two lamps in series. The two H.T.

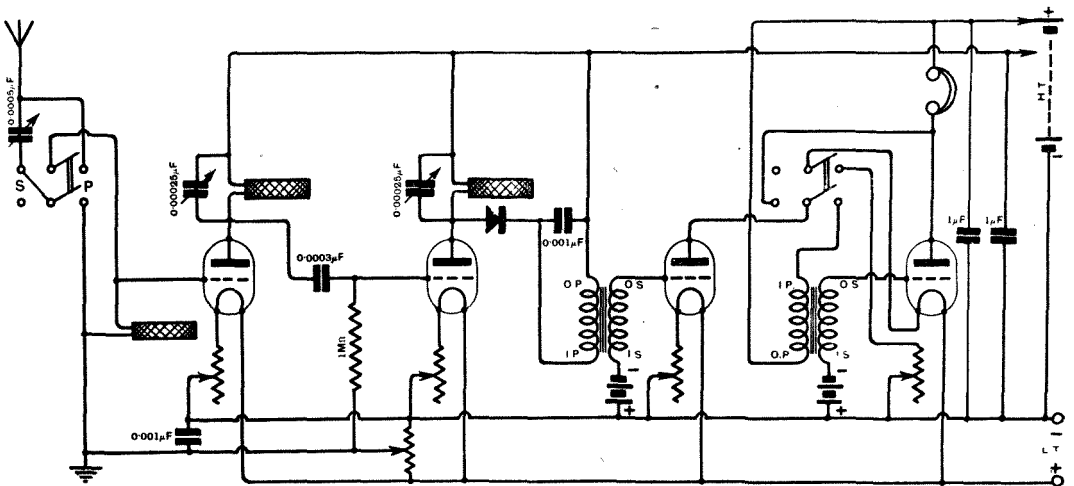

Fig. 2. A four-valve and crystal receiver for broadcast reception.

circuit, with two stages of H.F. amplification, crystal rectification, and two stages of transformer-coupled L.F. amplification.

Tuned anode coupling is employed for the H.F. stages, and a potentiometer is included to control the grid potential in the case of these valves. Separate H.T. tappings are provided for the H.F. and L.F. valves, and a switch is included to cut out the last note magnifier when sufficient signal strength is obtained with three valves.

The use of two stages of H.F. amplification enables the range of the receiver to be increased without the use of reaction, which is a frequent

tappings would be taken from either side of the centre lamp, and an additional smoothing choke would have to be connected in the new H.T. lead. Condensers should then be connected between each side of the choke to the negative lead in the usual way. One condenser is connected on the side of the chokes nearest the lamps, and the other across the H.T. output terminals.

Under certain circumstances the choke in the negative lead may be omitted without affecting the results. If it is found in actual practice that this can be done, the choke might be used for the new positive tapping.

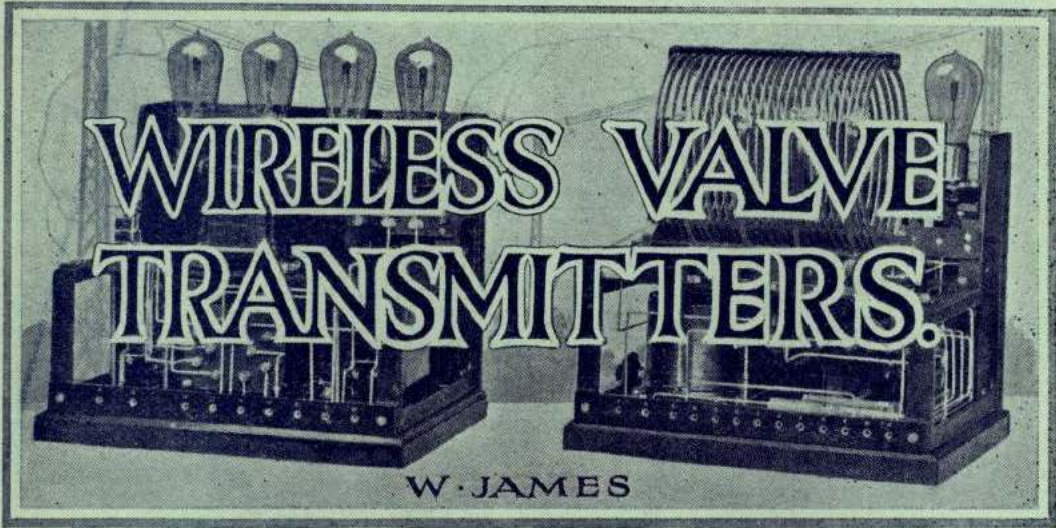

CONTENTS.

- (1) *Electrical Principles.*
- (2) *Inductance Coils and Condensers.*
- (3) *Alternating Current Circuits.*
- (4) *The Supply of Power.*
- (5) *Rectifiers.*
- (6) *Valve Rectifiers.*
- (7) *Microphone and Speech Amplifiers.*
- (8) *The Three-Electrode Valve as an Oscillator.*
- (9) *Modulated Waves and Wireless Telephony.*
- (10) *Miscellaneous Notes and Measurements.*

The Design and Operation of Small Power Apparatus

The aim of the author in writing this volume has been to deal in turn with each portion of the complete transmitting equipment so that anyone may be able to design and operate his own transmitter. Every possible difficulty which may be encountered has been thoroughly dealt with. The book is divided into 10 chapters and contains no less than 210 photographs and figures.

9/-

Postage 9d.

A huge demand is certain. Order your copy at once.

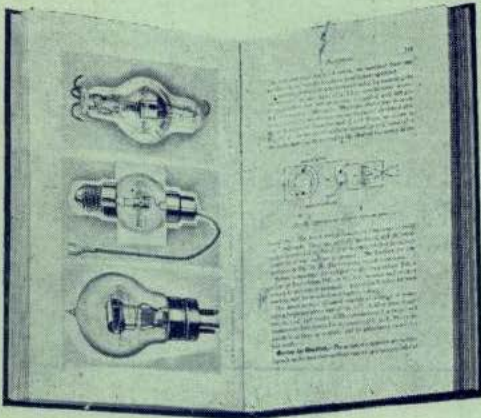

THE WIRELESS PRESS LTD.

12-13 Henrietta Street, Strand, W.C.2



SULLIVAN

Broadcast Receiver List 512

PRICE £8-15-0

(Includes Royalty to Marconi's Wireless Telegraph Co., Ltd., etc., but without Valves.)

Dimensions 12 $\frac{3}{8}$ " x 6 $\frac{1}{2}$ " x 9 $\frac{1}{4}$ " high
Weight 8 $\frac{1}{2}$ lbs.

EFFICIENCY

Full particulars of complete Sets both for Reception and Low Power Transmission as well as Standard Wavemeters and Heterodynes on application.

RELIABILITY

If a Loud Speaker is to be used with this receiver, the sound volume can be greatly augmented by the addition of Single or Two Valve Low Frequency Amplifiers, List Nos. 521, 522 or 522A, which are of similar appearance and very easily attached.



Write for Catalogue of Wireless Components, List W.5(c).

LIST 512

DESIGN

An extremely efficient self-contained Two-Valve Receiving Set covering the whole of the Broadcast Wavelengths with any type or size of aerial. High Frequency Amplification only is employed, thus permitting the addition of several stages of note magnification if desired. Although not actually shown in the above illustration this Set has an important addition of POSITIVE and NEGATIVE REACTION on to the Aerial circuit; the differential action of this "INTENSIFIER" ENABLES THE RECEIVER TO BE BROUGHT UP TO THE PROXIMITY OF EXTREME REACTION UNDER COMPLETE CONTROL WITHOUT FEAR OF BURSTING INTO SELF OSCILLATION. Thus it will readily be seen that this set has the great advantage of REACTION WITHOUT the many DISADVANTAGES generally associated with it.

WORKMANSHIP

H. W. SULLIVAN, LTD.

ESTABLISHED IN 1900

Works and Showrooms: LIVERPOOL HOUSE, MIDDLESEX ST., LONDON, E.1. Phone: Avenue 4871
Offices: WINCHESTER HOUSE, LONDON, E.C.2. London Wall 3518

Telegrams: "Sullivans", London.



Printed by Sanders Phillips & Co., Ltd., Chrysell Road, London, S.W.9, for the Proprietors and Publishers, The Wireless Press, Ltd., 112-13 Henrietta Street, London, W.C.2; Sydney, N.S.W., 97 Clarence Street; Melbourne, 422-24 Little Collins Street; New York, 326 Broadway.



THE WIRELESS WORLD

AND
RADIO REVIEW



PRICE 4^D NET.

THE
ALL PURPOSE
RECEIVER

NEW METHOD FOR
H.T. FROM A.C. MAINS

No. 271 [No. 4
Vol. XV]

OSCILLATING CRYSTALS BY THEIR DISCOVERER

WESTON

ELECTRICAL
MEASURING
INSTRUMENTS

THE WESTON Filament Voltmeter for Receiving Sets

MODEL 301.

Simplified tuning by eliminating guesswork as to valve adjustments.
Filament voltage control increases the life of the valve from two to three times.
The Weston Filament Voltmeter is accurate and can be relied upon for duplication of results.

ALL THIS MEANS
BETTER RECEPTION!

List Price £2 : 9 : 0

WESTON ELECTRICAL INSTRUMENT CO., LTD.

15 Great Saffron Hill, London, E.C.1

Telephone:

Telegrams: "Pivoted, Smith, London."



MODEL 301.
FILAMENT VOLTMETER.

Rigid as a Motor Wheel!

Unshrouded Efficiency!

"Tangent" Tuning Coils

Mechanical strength unequalled.
Guaranteed not to buckle or crush.
Electrical efficiency second to none.
Low distributed capacity.
Damping reduced to minimum.



Ask your Dealer &
Take no substitute

GENT & Co.
Ltd.

Manufacturing Electrical Engineers

"Faraday Works"

LEICESTER

London—25 Victoria Street, S.W.1.
Newcastle-on-Tyne—"Tangent House," Blakett Street. Est. 1872

STOCKED SIZES.			
Coil No.	Min. W/L	Max. W/L	Price.
25	250	390	4/3
35	330	520	4/3
50	430	840	4/3
75	660	1070	4/8
100	840	1430	5/-
150	1100	2030	6/-
200	1610	2720	7/-
250	2009	3520	7/6
300	2400	4250	8/-
400	3300	6450	9/-
600	4500	8750	10/-

Other "Tangent" fittings include:—
"Tangent" L.F. Transformers.
"Discol" H.F. Transformers.
"Tangent" Head Phones.
"Tangent" Rheostats.
"Pan" Switches—anti-capacity, et., etc., etc.

Complete set of Concert Coils (Nos. 25 to 175)
16/-

Complete set of Concert Coils (Nos. 25 to 500)
£3 : 7 : 0

THE WIRELESS WORLD AND RADIO REVIEW

THE OFFICIAL ORGAN OF THE RADIO SOCIETY OF GREAT BRITAIN.

No. 271. (No. 4 Vol. XV.) OCTOBER 22nd, 1924. WEEKLY.

EDITOR:
HUGH S. POOCK.

RESEARCH EDITOR:
PHILIP R. COURSEY, *B.Sc., F.Inst..P., A.M.I.E.E.*

ASSISTANT EDITOR:
F. H. HAYNES.

QUESTIONS AND ANSWERS DEPARTMENT:
Under the Supervision of W. JAMES.

CONTENTS.

	PAGE
Radio Topics. By the Editor - - - - -	91
Oscillating Crystals. By O. Lossev - - - - -	93
The All Purpose Receiver. By W. R. Clark - - - - -	97
Simple Rectifier for H.T. Supply. By S. O. Pearson - - - - -	102
Valve Tests. The Cossor P.1 and P.2 Valves - - - - -	107
Notes and News - - - - -	109
Readers' Practical Ideas - - - - -	111
Patents and Abstracts - - - - -	113
Broadcasting Table - - - - -	115
Calls Heard - - - - -	116
Among the Societies - - - - -	117
Correspondence - - - - -	118
Readers' Problems - - - - -	119

THE EDITOR will be glad to consider articles and illustrations dealing with subjects within the scope of the Journal. Illustrations should preferably be confined to photographs and rough drawings. The greatest care will be taken to return all illustrations and manuscripts not required for publication if these are accompanied by stamps to pay return postage. All manuscripts and illustrations are sent at the Author's risk and the Editor cannot accept responsibility for their safe custody or return. Contributions should be addressed to the Editor, "The Wireless World and Radio Review," 12 and 13 Henrietta Street, Strand, London, W.C.2.

SUBSCRIPTION RATES:

20s. per annum, post free. Single copies 4d. each or post free 5d. Registered at the G.P.O. for transmission by Magazine Post to Canada and Newfoundland.

As many of the circuits and apparatus described in these pages are covered by patents, readers are advised, before making use of them, to satisfy themselves that they would not be infringing patents.



EDITORIAL AND PUBLISHING OFFICES:

12 and 13 Henrietta Street,
Strand, London, W.C.2.
Telephone: Gerrard 2807-8.

ADVERTISEMENT MANAGERS:

Bertram Day and Co., Ltd.,
9 & 10 Charing Cross, S.W.1
Telephone: Gerrard 8063-5.

Brandes

The Name to Know in Radio.

To some people

a receiver is merely a piece of mechanism. It has never occurred to them to give it a real chance—to help it become vitally alive. Brandes "Matched Tone" Headphones will exploit the full merit of your set, bringing it to eager life. The *Table Talker* will make it talk clearly and melodiously. All the liquid tones, the pulsating warmth of a soprano, will come to you unspoiled, without any unnatural harshness. It does not matter—the rioting madness of the violin, the immense grandeur of the organ, or the intoxicating rhythm of a dance band, they all speak to you—ALIVE with their OWN throbbing cadences. Let Brandes products dispense with dull tonelessness, and bring your receiver to vigorous life.

All Brandes products are obtainable from any reputable Dealer and carry our official money-back guarantee, enabling you to return them within ten days if dissatisfied.

Matched Tone
TRADE MARK
RADIO HEADPHONES 25/-

Table-Talker
TRADE MARK
42/-

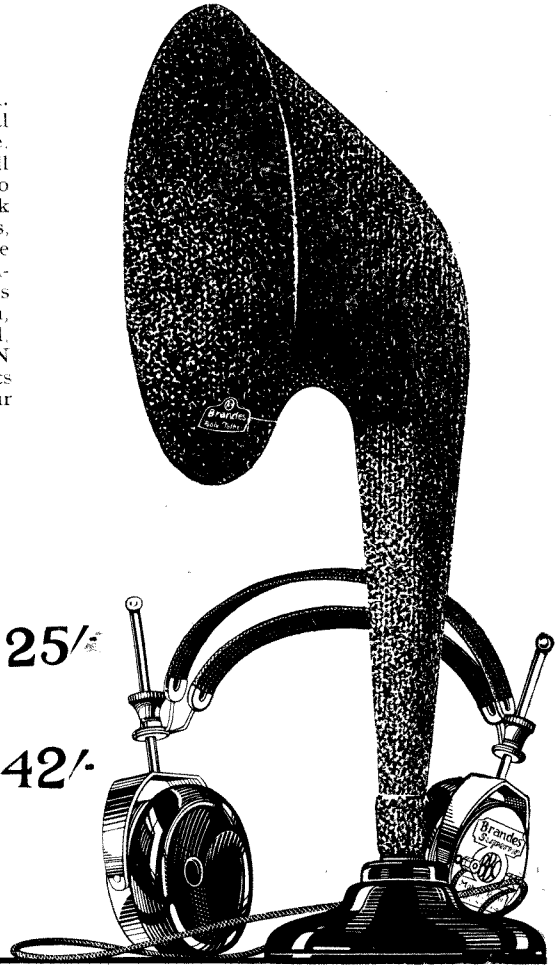
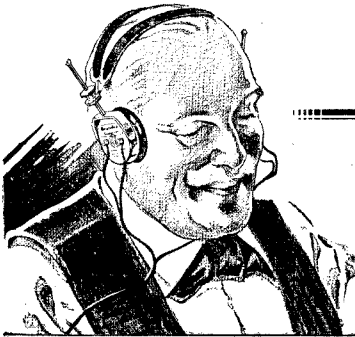

*Tune with Brandes "Matched Tone"
Radio Headphones
Then Listen with Brandes
Table Talker*

THE WIRELESS WORLD — AND RADIO REVIEW



RADIO TOPICS.

THE POSTMASTER-GENERAL'S STATEMENT.

IN view of the dissatisfaction which exists at present, and has been voiced by the Radio Society of Great Britain; on account of certain Post Office restrictions to free experiment, we feel that special attention should be drawn to the recent statement made by the Postmaster-General.

A question was put by Mr. T. Thomson (Member for Middlesbrough West) asking if the Postmaster-General was aware of the dissatisfaction existing amongst wireless amateurs at the present restrictions which prohibited messages being transmitted abroad; and whether he would revise the existing rules with a view to removing all restrictions which are an obstruction to free experiment and research. In reply the Postmaster-General made the following statement:—

“It is the present practice to grant permission for *bona fide* experiments with places abroad when special application is made. Many such permits have already been issued, and arrangements are being made with the Radio Societies for the grant of increased facilities for experiments, which will be carried out by their members in co-operation with amateurs in the United States and many other countries. The general conditions governing the grant of licences for wireless transmission were adopted after consultation with the other interests concerned, including the radio societies. Some restrictions are necessary in order to prevent interference with other services, but I am at all times prepared to consider any definite suggestions which the radio societies may put forward for altering the rules.”

Such a statement coming from the Postmaster-General at the present juncture constitutes, in our opinion, an invitation to

the amateur which should under no circumstances be ignored. If the attitude of the Post Office is that they are prepared to reconsider the whole question of the regulations governing amateur use of wireless, then it is up to the amateur, as represented by the societies, to assist in every possible way in the framing of such regulations as will give him all reasonable freedom, whilst at the same time reserving to the Post Office sufficient control to prevent the abuse of privileges granted, and to ensure that interference with Government and commercial traffic shall not occur.

We believe that the right course to adopt at the present time is to accept this invitation in the friendliest spirit, and to put in the background all thought of antagonistic action until every channel for harmonious agreement on both sides has been fully explored.

THE TRANSOCEAN AMATEUR TESTS.

AT the time of writing, the Transatlantic (or rather this year we should say the Transocean) Amateur Tests have started, and it is to be expected that far-reaching achievements will result. At the moment of writing news comes to hand that New Zealand 4 AG has actually been heard in this country by Mr. E. J. Simmonds, 2 OD. Provided that this remarkable feat is confirmed, relay working with Australia and New Zealand becomes almost a certainty before the conclusion of the winter season, unless the summer weather now starting in the Antipodes presents an insuperable obstacle.

We reproduce here in miniature, a map which is of special interest in connection with the Transocean Tests. It has been drawn on a special projection so as to show correct

distance and directions of any place from England, London being taken as a centre.

The map was compiled specially for The Wireless Press, Ltd., by the late Mr. J. St. Vincent Pletts, and although it has already been found extremely useful in connection

The great feature of the tests to be conducted this year is relay work from point to point which has not been attempted during previous tests. It will be remembered that in the communications with the United States, prior to the success of last year, the

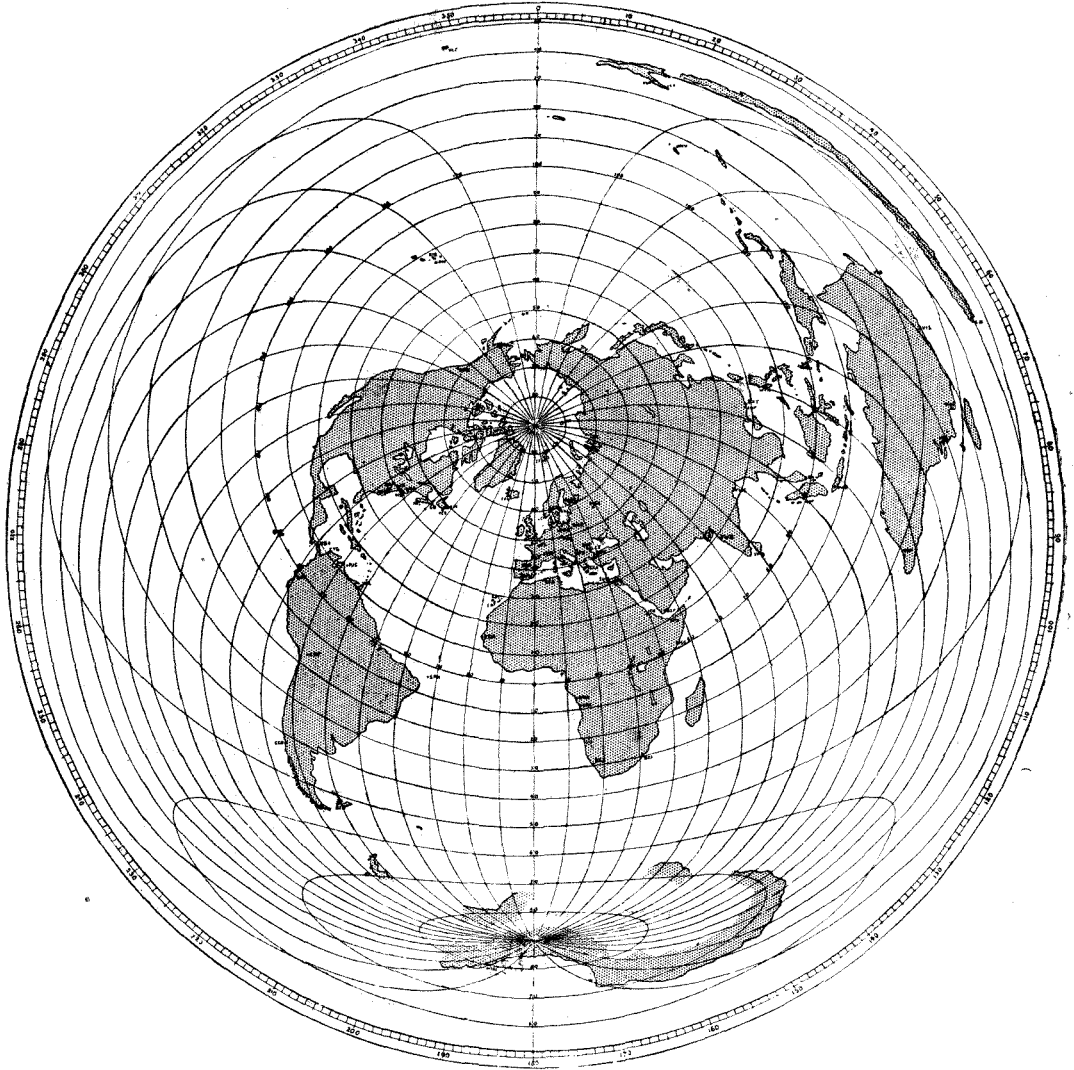

This chart, which has been considerably reduced from the original, gives the direction and distance from London to all parts of the globe, and is invaluable in amateur intercontinental work. The scale of the original is 1 in. to 1,000 miles, or 1.5 cm. to 1,000 kilometres and the scale of the above is approximately 1 in. to 4,370 miles.

with long distance transmission records during previous tests, its value is greatly enhanced this year, when the transmissions are no longer confined between this country and the United States of America, but are extended in addition to more distant parts of the globe.

main object was to get across, but now that inter-communication has been so firmly established and maintained by quite a large number of amateurs, it is possible to extend the activities and introduce these schemes for relaying.

THE EDITOR.

OSCILLATING CRYSTALS.

The author of this article, Mr. O. Lossev of Russia, has in a comparatively short space of time achieved world-wide fame in connection with his discoveries of the oscillating properties of certain crystals. At our request Mr. Lossev has contributed for publication in *The Wireless World and Radio Review* this important article dealing with observations on the behaviour of crystals whilst in an oscillating condition. Of special interest are the illustrations in Figs. 3, 4 and 5, showing actual photographs taken of the point of contact of the crystal in operation. The author questions whether this luminosity is due to actual arcing at the point of contact or to electronic bombardment. Fig. 6 illustrates the first oscillograph records ever obtained of the wave form of oscillations produced by crystals.

By O. LOSSEV.

SINCE the attention which has been drawn to the use of crystals as oscillators and amplifiers, I have been carrying out further research work, devoted essentially to an investigation of the process by which oscillation is set up.

It has probably been apparent from articles already published that I hold the idea that generation is caused by a microscopical arc which occurs at the point marked i_0 in the graph shown in Fig. 1. However, the electrodes of this arc are not incandescent, and the temperature rise at the point of contact does not exceed 100°C . Referring again to the upper curve in Fig. 1, only small discharges take place across the gap around the contacts, which has the effect of deflecting the initial part of the characteristic curve from a straight line.

With a view to gaining a better understanding of the operation of contact detectors I will deal with the problem under the following headings:—

1. The influence of temperature on the generating contact.
2. The effect of the temperature gradient produced by external heating.
3. The coefficients of crystal resistance change depending upon the temperature.
4. The luminescence produced at the contacts of the carborundum detector.
5. The luminescence of the contact of the generating zincite detector.
6. The wave form of the generated oscillations.
7. The generating characteristic of tin-stone.

(1) *The Influence of Temperature on the Generating Contact.*

A series of characteristic curves have been plotted with the generating point at various temperatures, heat being applied externally, which indicated that the contacts of a generating detector, when working, are, in fact, very

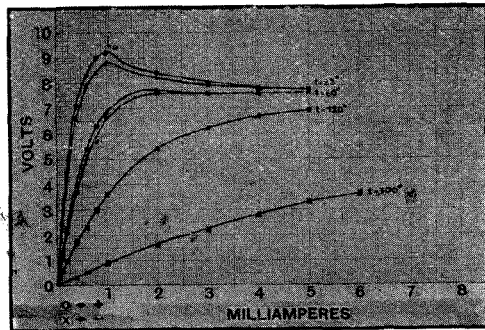

Fig. 1. Curves showing the conductivity of a zincite-steel wire detector with various applied potentials and under varying conditions of temperature. The curve at the top and that third from top are plotted with the positive of the applied current to the steel wire, while the second and fourth were given with the positive to the zincite. The fifth and sixth curves indicate no change in conductivity with current reversal.

feebly heated. It was apparent from these curves that the generating properties of the contact changed considerably as the temperature rose to 60°C ., and it was also observed that the negative resistance diminished. Another property which was noticed was that different results were obtained while the crystal was in the process of cooling.

The series of curves given in Fig. 1 were obtained with crystal contacts operating at various temperatures. The crystal used for plotting these curves consisted of a contact between a steel wire and a specimen of zincite and the direction of the applied current across the contact was reversed. This is indicated in the curves by marking the plotting points, either by O or X.

(2) *The effect of the temperature gradient produced by external heating.*

The curves showing the effect of the temperature gradient when heat is produced by external means are shown in Fig. 2. In this instance the heater was placed at

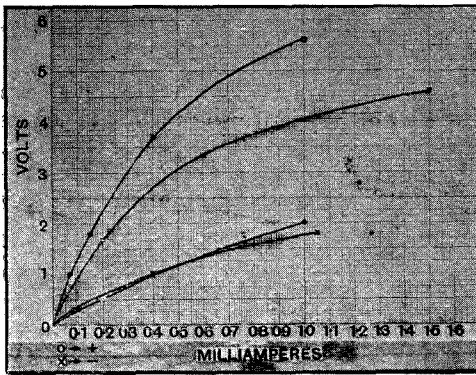

Fig. 2. *The effect of applying heat by conduction from the steel wire is shown in the lower two curves. The curves with plotting points marked O were given with the applied positive potential to the steel wire, and the points marked X with current in the reverse direction. The scale of plotting is enlarged as compared with Fig. 1 and the curves are only taken to a point equivalent to i_0 (Fig. 1).*

some distance from the zincite crystal, the heat being conducted to the contact points through the steel spring, which also served as a contact. As the heat in this case is reaching the contacts mainly through conduction by the steel wire, a temperature gradient is produced from the wire to the crystal. The characteristic working under normal conditions, is given by the upper two curves and the lower curves show the results obtained with external heat applied, and conducted to the contact by the steel wire.

The portions of the characteristics to the point i_0 only are shown, as this simplifies the graphs and enables a clearer conception to be gained of the asymmetry. This

asymmetry of the positive curve, in comparison with the negative one, changes in the opposite direction if a temperature gradient is externally produced. If the contact is uniformly heated this asymmetry change does not take place. The asymmetry may also be explained as follows. If the point of the metal contact wire is not heated from outside it attains a rise of temperature due to the Joule effect, during the operation of the detector. Therefore the thermionic emission from this point when serving as a cathode is not so great as that of a crystal serving as a cathode and becoming heated to a greater extent owing to the poor heat conducting properties of the crystal.

If we now produce, by means of external heating, a temperature gradient across the detector from the contact point to the crystal, it will be evident that the characteristic must change in the opposite direction, for the point being heated to a greater extent its thermionic emission will be greater than when it is operating as a cathode. With stronger currents (on Fig. 2 more than 0.4 milliampere) the character of asymmetry does not change, as the Joule effect is already so great that the effect it produces prevails.

The necessity for making the wire point the cathode is due to a greater negative resistance being obtained. This is explained by the different heating properties of the point and the crystal, which produce a smaller thermionic emission.

The ordinary detection effect may also be partly explained by the different cathode and anode heating of the contact detector.

(3) *Co-efficients of crystal resistance change depending upon the temperature.*

Calculations made by Mr. G. Ostroumoff prove that the coefficient for magnetite is 1, for carborundum 2, and 3 for the best zincite. These are negative, and correspond to (1) 0.0065, (2) 0.0027 and (3) 0.007.

(4) *Carborundum Contact Luminescence.*

Many attempts have been made to discover the hypothetical voltaic arc at the detector contacts with the aid of a microscope. Two years ago a rather strong luminescence was observed with the naked eye at the contact of a carborundum (—) and a steel wire detector, with a direct current flowing

through it from the crystal to the wire. After a detailed investigation under the microscope it was found that the luminescence disappeared if the pole signs were changed, although this makes the direct current value greater. Ordinary detection depends upon this luminescence, and it may be observed beginning from currents of a value higher than 0.1 milliampere.

Microscopic photographs, magnified 120 times, are shown in Figs. 3, 4 and 5. They appear to show a microscopic electron discharge which it would seem emanates from the crystal, due to the bombardment of the electrons, in a similar manner to the luminescence of different minerals in the Crooke's tube. It has already been mentioned that the luminescence takes place only when the cathode is a metallic electrode.

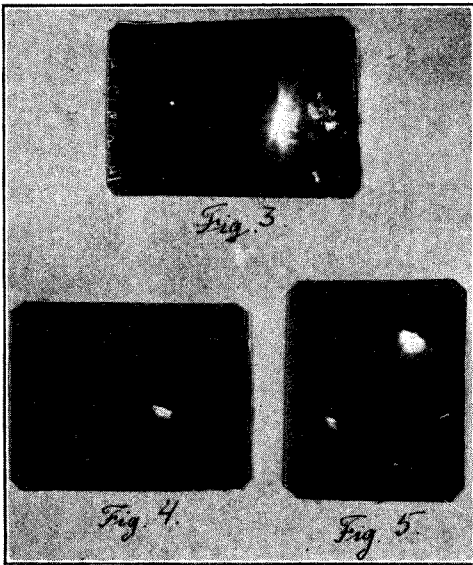

Figs. 3, 4 and 5. Some interesting microphotographs of the luminescence occurring at the contacts of a detector. Magnified 120 times.

Taken with a very short exposure, Fig. 4 shows the stratification of light near the contact electrodes, whilst Fig. 5, on which the same point of the crystal was taken with a longer exposure, shows the whole spot of light. From Fig. 4 it is a simple matter to calculate the cross area of luminescence, which is 700 microns wide. Investigations will also be made regarding the spectrum of the carborundum luminescence.

(5) *Generating Zincite Contact Luminescence.*

It has been found that the carborundum contact rarely generates, in spite of the



Fig. 6. Oscillograph records showing the waveform of the oscillations set up by a zincite detector.

profuse electronic discharge. This can be explained by the low conductivity of the crystal in comparison with zincite, and also by the nature of the crystal surface and its heating, which gives no negative resistance effect. Attempts have been made to observe a similar luminescence with a zincite contact during generation, but as in this case the crystal is opaque the surface roughness prevents the possibility of observing any possible luminescence.

When currents of more than 5 milliamperes are flowing through the detector, however, the luminescence can be clearly seen, but oscillations are generated only at its commencement. With small currents of the order of 0.3 to 0.5 milliampere, even if the contact does generate, luminescence can rarely be observed.

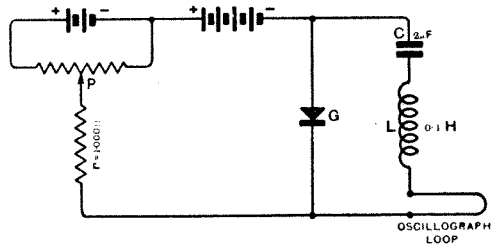

Fig. 7. The oscillating crystal circuit used for taking oscillograph records.

(6) *The Wave-form of the Generated Oscillations.*

Oscillographs of the generated oscillations taken by Mr. A. M. Coogusheff, are shown in Fig. 6; (a) with a comparatively large

negative detector resistance, and (b) with a smaller resistance. In these experiments the oscillograph loop was directly connected to the oscillating detector circuit, as is shown by Fig. 7.

(7) *The generating characteristic of tinstone.*

During the period of these experiments more than fifty different natural minerals have been investigated with regard to the generation of oscillations, and it has been found that, next to zincite, tinstone generates rather well. Although pyrotite, bornite, magnetite, carborundum and corellite were fairly satisfactory, their generating properties did not equal zincite or tinstone.

With tinstone, as can be seen from its characteristic curves (Fig. 8), oscillations commence at 3 to 8 milliamperes and 2.5 to 3 volts.

Referring to Mr. Leslie Miller's letter in *The Wireless World and Radio Review* of June 25th, 1924, it may be stated that the practical use of generating detectors wholly depends upon the quality of the crystal. In my laboratory good zincite

crystals producing stable and regular oscillations were obtained by fusing zincite in an arc. These oscillations were maintained with the same frequency and amplitude

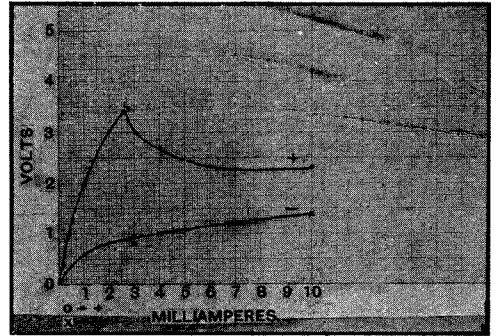
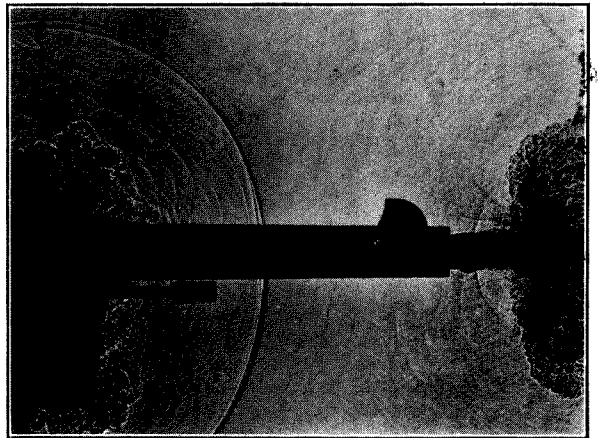
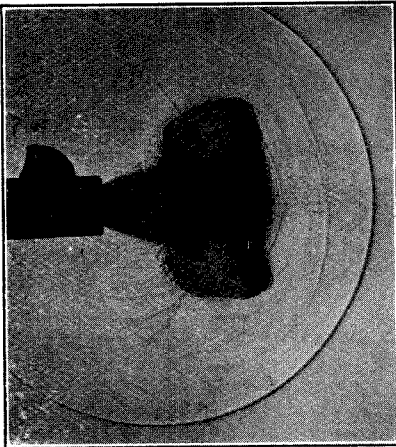

Fig. 8. Characteristic curves of tinstone. The two curves are obtained by applying the current in either direction of the contact.

for more than three days, despite the mechanical shaking to which the detector was submitted.

PHOTOGRAPHING SOUND WAVES.



[By Courtesy of the Royal Photographic Society.]

The articles by Professor Mallett in this Journal draw the attention of the wireless experimenter to the properties of sound waves as propagated through the air. These remarkable photographs show the setting up of sound waves both around the barrel and chambers of a discharging revolver. The spontaneous expansion necessary to expel the bullet creates considerable compression of the air in the form of a sphere which travels outwards owing to the air's elasticity. The wave of compression can be photographed owing to the change in the refractive index of the air when subjected to such great pressure.

THE ALL PURPOSE RECEIVER.

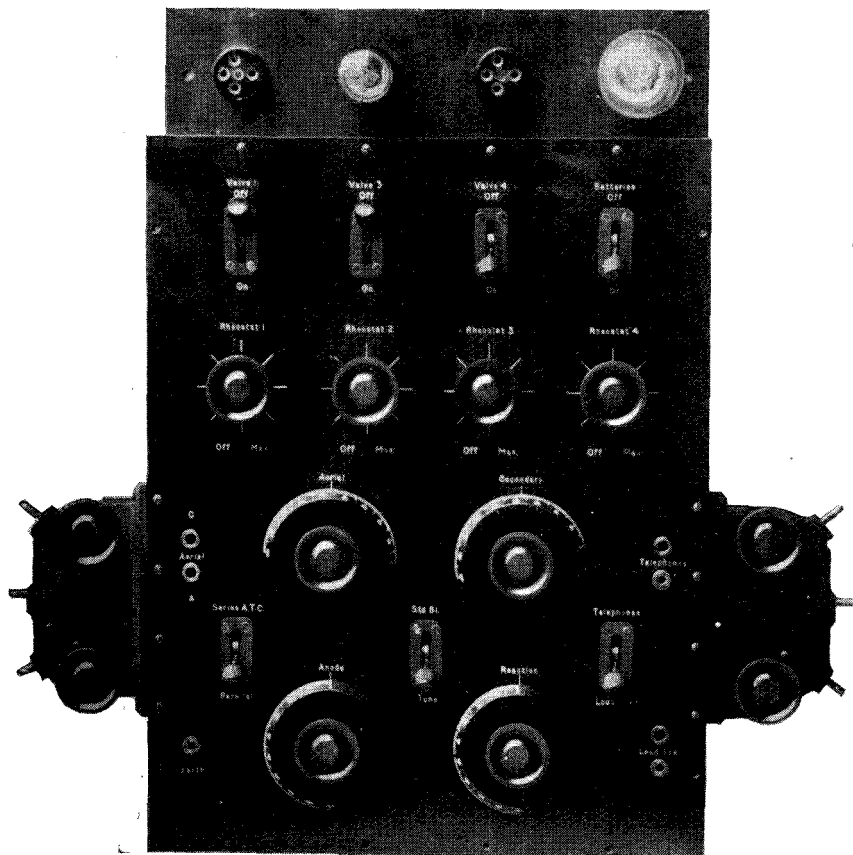

The finished receiver.

Although requiring time and patience to construct, this receiver can be said to represent the ultimate design arrived at by the man who builds his own apparatus. While fairly simple to operate, it provides a large variety of circuit arrangements and will tune from 150 metres up to the highest wavelengths.

By W. R. CLARK.

THE need for a receiver capable of working at extreme range when required, and on all wavelengths was the reason why the construction of a four-valve set with switching to give changes in the circuit arrangements was undertaken. Although it may be said that a complicated set of this sort involves

an enormous amount of work, one is correct in saying that a design such as described in this article is the ultimate one which is generally arrived at by the man who constructs his own apparatus. Nowadays a receiver is not really the property of the experimenter, but usually belongs to the household as a whole and consequently

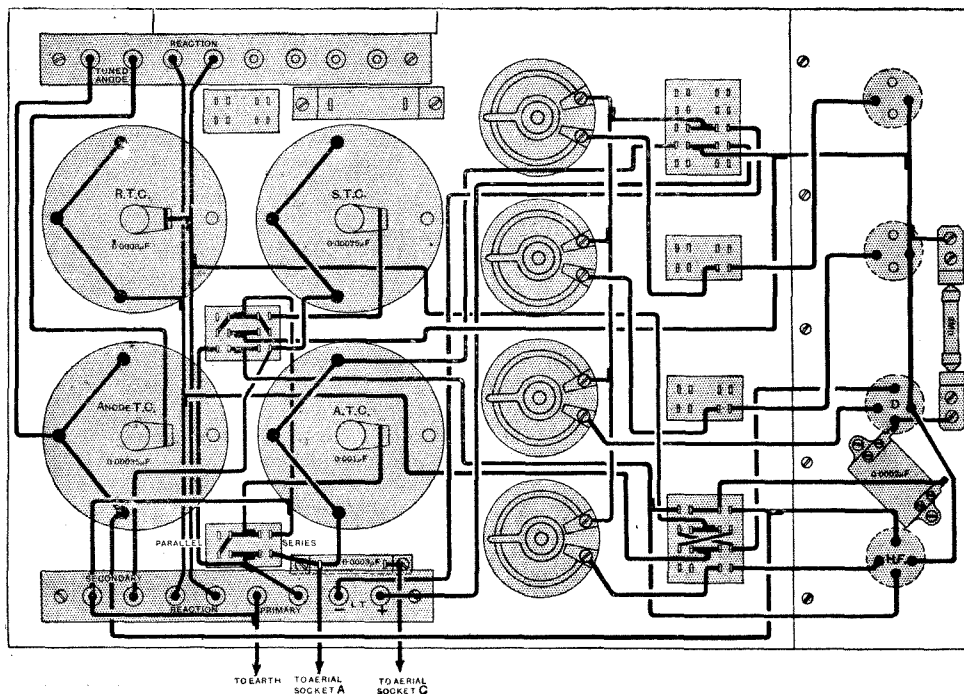

Fig. 2. Wiring of the aerial circuit, H.F. and detector valves and all filament leads.

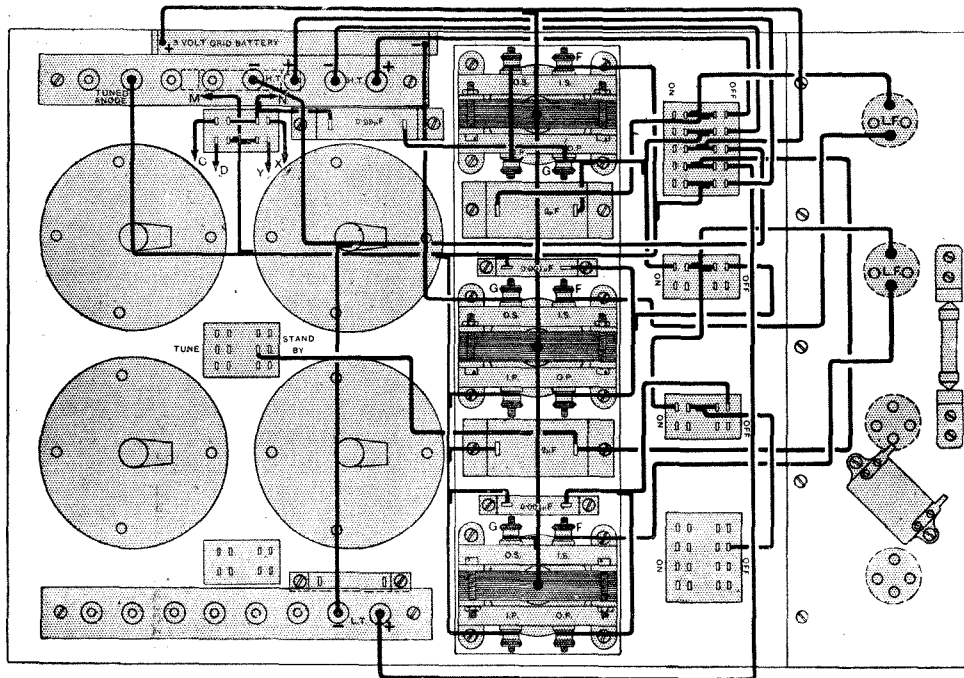

Fig. 3. The leads for wiring up the L.F. amplifying circuits.

be mentioned that all blind holes are $7/64$ in. in diameter and take $\frac{1}{8}$ in. Whitworth brass screws without the necessity of actually tapping out the holes after drilling.

The ebonite platform which carries the three transformers is also used to give support to the 2 mfd. H.T. battery bridging condensers and two 0.002 mfd. condensers. The platform is supported by six pieces of ebonite rod $1\frac{1}{2}$ ins. in length and $\frac{1}{2}$ in. in diameter. These rods are attached to the panel by means of short pieces of 4 B.A. threaded brass and attention might be drawn to the necessity of carefully squaring up the ends of these pieces and at the same time adjusting them all to be exactly equal in length.

Referring again to the front view of the set, it will be seen that aerial, earth, telephone and loud speaker connections are made by means of plug and socket connectors. These are of the "Gecophone" type and must be inserted in position before any of the other components are assembled. The sockets are driven home by means of a hammer and a block of wood into a $5/16$ in. hole. Since it is not desirable for battery terminals to appear on the face of the panel, terminal strips are fitted up at the back and are clearly shown in the view of the back of the instrument. These strips are supported in precisely the same manner as the transformer platform.

The two coil holders on either side of the panel are carried on suitable blocks of wood, measuring $5\frac{5}{8}$ ins. by $3\frac{1}{4}$ ins. by $\frac{1}{2}$ in. in thickness. These wooden blocks are secured to the front panel by means of raised headed screws. The actual fixing of the coil holders to the main panel was not carried out until the wiring had been completed.

The three-cell grid battery used for biasing the grid of the power valve is a pocket torch refill measuring approximately 4 ins. in length and $\frac{5}{8}$ in. in diameter. It is held in place on one of the terminal strips by mounting between two brass clips.

It is the wiring up of a complicated receiver that often proves so difficult to the inexperienced instrument maker, and the theory circuit is interpreted in practical form in Figs. 2 and 3. Fig. 2 shows the wiring of the aerial circuit, the high frequency and detector valves and all of the filament leads, while Fig. 3 shows the wiring up of the two low frequency amplifiers. The points marked

X and Y are connected to the loud speaker sockets on the front of the panel and C and D are connected to the telephone sockets. N and M are joined to the small fixed condenser mounted on the underside of the H.T. battery terminal strip. The terminals F and G are fitted with clips so that leak resistances having a value of 0.5 megohm may be fitted across the secondary windings of the transformers. The wiring up is carried out entirely with No. 16 tinned copper wire, perfectly straightened by stretching, and all joints are soldered. The filament resistances should be wired up first or otherwise it may be found a matter of difficulty when other sections of the wiring have been fitted. The aerial, earth, telephone and loud speaker sockets are wired next and also the 0.0003 mfd. condenser which is connected to the aerial circuit between the sockets C and A. The telephone condenser of capacity 0.002 mfd. is attached to the underside of the main ebonite panel directly below the left-hand terminal strip (rear view) and is connected across the two centre contacts of the telephone and loud speaker switch. The leads from the L.T. battery terminals on the right-hand terminal strip are run side by side in sleeving to the master switch and are raised away from the rest of the wiring. Included in the wiring is the lead bridging the cores of the transformers.

The primaries of the first and second transformers are usually bridged with the 0.5 megohm leak resistances. The primary and secondary windings of the third transformer are connected in series for use as a choke in the loud speaker feed circuit. It will be evident from the diagrams that reaction can be applied to either the aerial or anode inductances, the reaction sockets of the two coil holders being wired across in parallel. The bottom coil holder on the tuned anode side is again wired in parallel with the reaction leads, but the flexible wires are crossed over so as to reverse the direction of reaction coupling on to the tuned anode coil if required.

In operation the instrument fills the want for which it was designed. It will tune down to 150 metres, whilst on the other hand it will bring in transmissions on the longest wavelengths, such as the Bordeaux station. The broadcasting station **2BD** is exactly one mile from the receiving aerial and by switching into service the tuned closed circuit, it is

signals can be completely eliminated; then by carefully tuning, Newcastle can be received on the loud speaker without a trace of the former station. No wave trap is employed, as loose coupling is, of course, far more effective, and the writer recommends the use of a loose-coupled receiver for the elimination of interference, though, of course, some practice is required in order to be able to tune two circuits simultaneously. 5XX

Aberdeen it is found more difficult to receive Manchester, Birmingham and Glasgow; it is probable, in fact, that Glasgow is the most difficult station from which to obtain even satisfactory headphone reception. Most of the Continental stations come in well and give good loud speaker signals, even during daylight when using the four valves.

It might be mentioned that the set is housed in a mahogany cabinet which stands

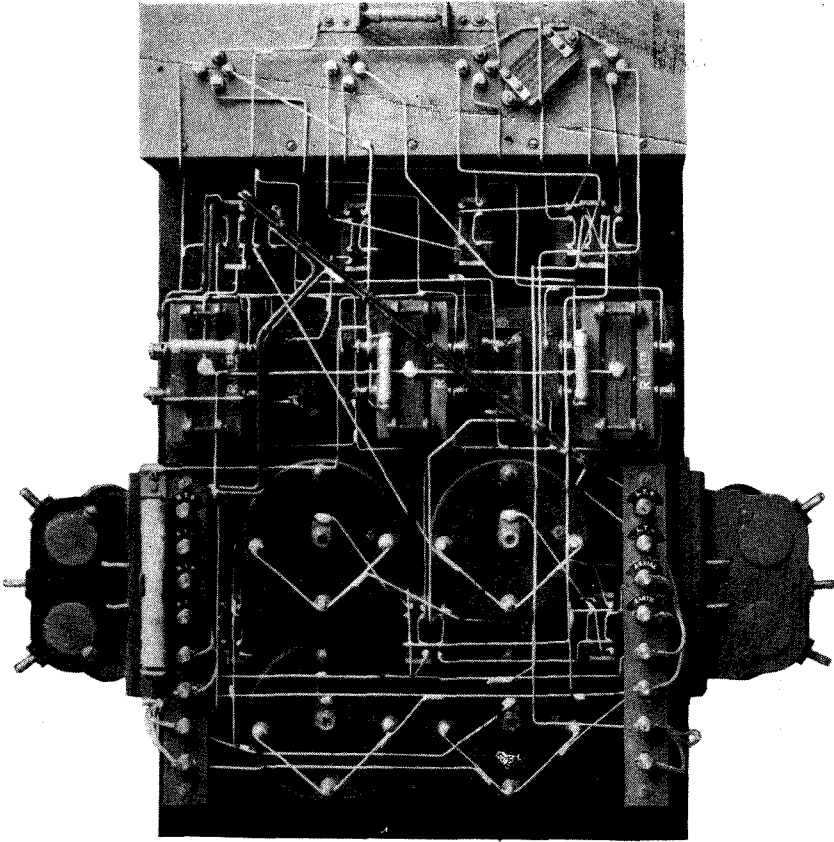

A rear view of the panel.

comes in well on the loud speaker with the last low frequency valve out of operation. Fairly good reception can be obtained after dark from Bournemouth, Cardiff and London and it is rather strange that in

4½ ft. high and has an overall length of 3½ ft., measuring 15 ins. from front to rear. Two side compartments are fitted with false backs behind which the low and high tension batteries are fitted.

RECTIFIER FOR H.T. SUPPLY.

The instrument here described represents something new in rectifier design. A polarised relay is employed to suitably interrupt the supply, while neon lamps are introduced to regulate the output. For moderate voltages this instrument possesses great advantages over the usual thermionic or rotary type rectifiers. The connections are so arranged that D.C. voltages up to 500 can be obtained from the 200 volt A.C. mains without the use of a transformer.

By S. O. PEARSON, B.Sc., A.M.I.E.E.

SOME time ago the writer had occasion to construct an instrument for supplying direct current at a pressure of approximately 350 volts for the purpose of a demonstration in a hall where no direct current was available, the electric supply being A.C. at a pressure of 200 volts. The arrangement appeared to work so well that it was decided to try it out as a means of supplying the H.T. current for a 10-watt valve transmitter. The results obtained

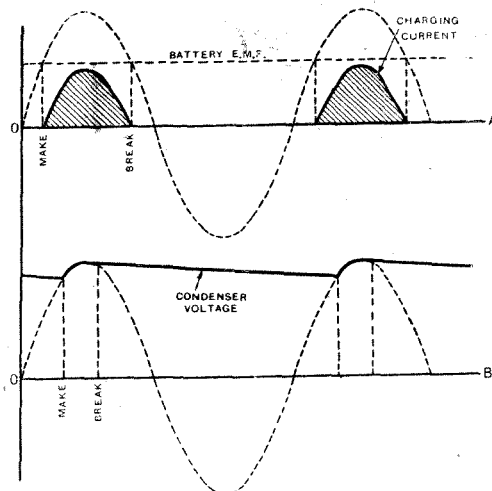
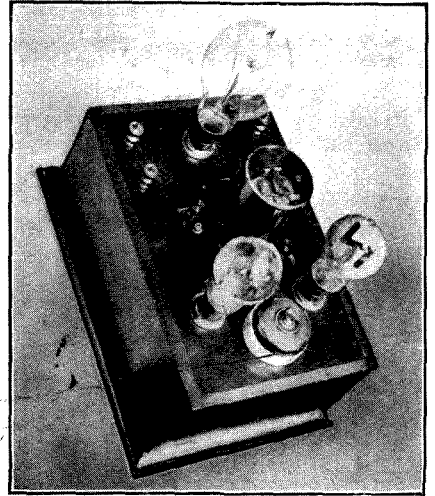

Fig. 1. The upper curve shows the duration of contact required with a vibrating contact rectifier when used for battery charging. In the lower curve the duration of contact is shown for a rectifier used for charging a condenser for plate current supply.



The complete rectifier.

were very satisfactory considering the simplicity of the apparatus.

The rectifier operates on the principle of the synchronous vibrating contact-maker as often used for charging accumulators, various forms of which have been described in this journal. The conditions to be fulfilled for supplying H.T. are somewhat different from those obtaining in an ordinary rectifier for charging batteries, namely, that contact must be made for a very short period only, during the time that the supply E.M.F. is passing through its highest values. For accumulator charging at low voltages the contact must be closed during the major portion of each half wave. The difference can be easily seen by reference to the diagrams of Fig. 1, where half-wave rectification only is shown for clearness.

In the case of the battery charger we require a relatively large average current at low voltage and since the contact must be opened and closed at the times when the instantaneous values of the alternating E.M.F. are just equal to the back E.M.F. of the battery (in order to prevent sparking) it follows that the R.M.S. or effective value of the alternating voltage must be at least twice as great as the battery voltage if the period of closed contact is to last during the greater part of the half wave. In the case of the rectifier for supplying H.T., however, we require a small current only and as high an average value of E.M.F. as possible, and thus

contact must be made only during the time when the alternating E.M.F. is passing through its highest values. This means that the ratio of "make" to "break" will be quite a small fraction, of the order of one-third of the half wave, or one-sixth when taken over the whole cycle, where half-wave rectification only is obtained. Hence to get an average steady current of 30 milliamps on the D.C. side, the average current drawn from the supply during one period of contact would have to be $30 \times 6 = 180$ milliamps. From this it follows that some means must be provided for storing the energy of each impulse of current, and capable of giving it out again at a steady rate. This can be effected by means of a condenser of large capacity, which is charged up by the current pulsations from the rectifier and kept charged. A simple arrangement of this nature is shown in Fig. 2, and needs no further explanation.

If no current were drawn from the condenser the voltage across it would build up until it became approximately equal to the peak value of the E.M.F. wave and practically no current would flow through the contact of the vibrator. If now a small steady current is drawn from the condenser, some of the charge will be gradually lost during the period of open contact and the voltage would fall at a rate depending on the capacity of the condenser, the rate of fall for a given current being inversely proportional to the capacity of the condenser. When

of a combination of chokes and condensers is connected between the rectifier and the valves. Smoothing is also very much facilitated by using full-wave rectification, *i.e.*, by utilising both halves of the A.C. wave and thus doubling the frequency of the pulsations.

In the instrument described below, full-wave rectification is employed and the connections are so arranged that D.C. voltages up to 500 can be obtained from the 200-volt A.C. mains *without the use of a transformer.*

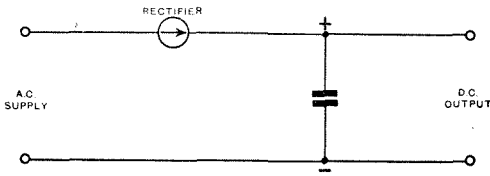

Fig. 2. The rectifier closes the circuit at peak voltage and maintains an almost constant potential across the large capacity condenser.

contact is made again the voltage of the condenser is raised to its full value once more and so the process repeats itself. The full line of Fig. 1 (b) shows how the voltage across the condenser would vary under these conditions. The larger the capacity of the condenser the less would be the cyclic variation of voltage, but in practice a condenser sufficiently large to suppress all A.C. hum would be too bulky and expensive, so that a special smoothing circuit consisting

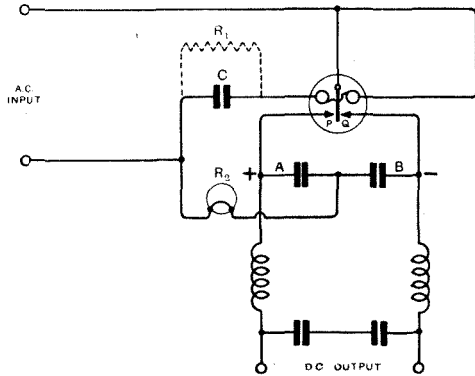

Fig. 3. Connections of full wave vibrator rectifier, employing a polarised relay.

The diagram of connections is shown in Fig. 3. The chief part of the rectifier, namely, the polarised vibrator and energising coils, consists of an ordinary Post Office recording relay, the one actually used being of the rocking armature type, as shown in Fig. 4, but no doubt any type of high speed recording relay would work equally well provided the insulation is sufficiently good to stand the high voltages. The coils, which each had a resistance of 500 ohms, were connected in series and supplied with A.C., which caused the armature to vibrate against the contacts at the same frequency as that of the supply.

In any synchronous rectifier where a vibrating contact-maker is employed it is essential that the vibrating member shall have the correct phase relation to the voltage of supply. In this case contact must be made just before the peak value of the voltage is reached and broken just after. Thus, assuming for the present that the armature responds perfectly to the magnetic pull of the coils, *i.e.*, that there is no mechanical lag due to inertia, it follows that the magnetic field, and thus the current through the coils, must be exactly in phase with the

supply voltage. But actually the inertia of the moving part causes a mechanical lag (unless the armature constitutes a tuned reed, which is not the case here), and therefore to compensate for this the current through the energising coils should reach its maximum value some time before the voltage reaches its peak value, *i.e.*, the current should be made to lead the voltage by a certain phase angle.

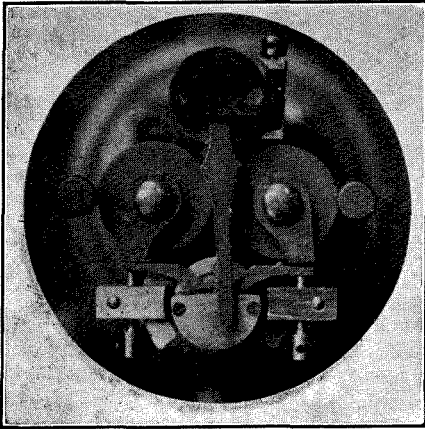

Fig. 4. The movement of a Post Office pattern relay used in the construction of the rectifier.

If one complete cycle or wave represents 360 electrical degrees, then, in any coil possessing resistance R and inductance L , the current wave will lag behind the impressed E.M.F. wave by an angle ϕ electrical degrees, where $\tan \phi = 2\pi f L/R$, f being the frequency. Thus if the relay coils were connected directly to the supply the contacts would be made, not near the peaks of the E.M.F. waves as required, but a considerable fraction of a period later, this fraction being $\phi/360$, on the assumption of no mechanical lag. Taking into account the mechanical lag, the instant of make would be still later. Thus a compensating device to correct the phase of the current must be employed and this usually consists of a condenser C (Fig. 3) shunted by a resistance R_1 and connected in series with the relay coils. When allowance is made for the mechanical lag, of the armature the current must be made to lead the supply voltage by a considerable angle, and since this varies for different relays, the correct values for C and R_1 must be found by trial. It must be borne in mind that this is a circuit partly

tuned to the supply frequency and will probably pass too heavy a current if the full mains voltage is applied to its ends. Adding resistance in series to limit the current will necessitate a re-adjustment of the capacity, so that on the whole this system is rather complicated. The writer found that the mechanical lag was so large that the current had to lead the voltage by nearly a quarter of a cycle and this was effected quite easily by connecting a small condenser of about 0.25 mfd. capacity in series with the relay coils instead of the shunted condenser shown in Fig. 3. This small capacity had the additional effect of limiting the current through the relay coils so that the full 200 volts could be applied without overheating or over-magnetising the relay. Fig. 5 shows the vector diagram for this arrangement, where V = the voltage of supply (200), V_1 = voltage across the condenser, V_2 = voltage across relay and I = current through relay.

We come now to consider the operation of the device. It will be noticed from Fig. 3 that the vibrating armature is connected directly to one of the supply mains and that the two contact stops, P and Q, are connected across two 3 microfarad condensers A and B in series. The other main is joined through a lamp R_2 to the mid-point between the two condensers. When the relay is excited the armature vibrates against the contacts P and Q at the same frequency as that of the supply. Suppose that each time

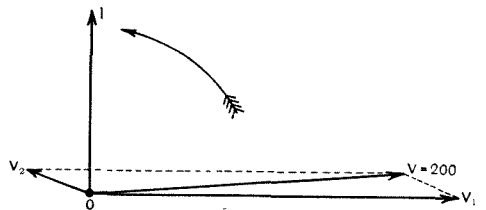

Fig. 5. Vector diagram showing the voltage displacement.

the alternating voltage is passing through its positive half wave, the left-hand contact closes just before the peak value, and that the right-hand contact does exactly the same for each negative half wave; then each of the condensers A and B will be charged up through the lamp R_2 to a voltage approximating to the maximum or peak value of the alternating E.M.F. wave and the polarity

of each will be as shown by the signs + and - in the figure. Thus the voltage obtained across the two condensers in series will be nearly *twice* the maximum value of the alternating voltage. For a 200-volt circuit the peak value is $200 \times \sqrt{2} = 281$ volts, and therefore the theoretical maximum value of the D.C. voltage which could be obtained would be 281 across each condenser, or 562 volts across the two condensers in series. Actually on open circuit, *i.e.*, without drawing any D.C., the voltage was found to be about 520. A load of 20 milliamperes drawn directly from the condensers A and B caused the voltage to drop to about 450 (average value). Obviously by using larger reservoir condensers this drop could be considerably reduced.

The voltage across A and B was not sufficiently smooth for use on a telephony transmitter so that the smoothing chokes and condensers shown in the figure had to be employed. The only chokes available at the time of the experiments had a fairly high ohmic resistance, with the result that, with a current of 20 m.a., there was a drop in voltage of about 100, bringing the useful output pressure down to 350 volts practically free from A.C. hum. By using low resistance chokes and large reservoir condensers a useful working voltage well over 450 volts could easily be maintained.

The lamp R_2 is included to prevent sudden rushes of charging current into the condensers A and B, as this would cause welding of the contacts and sticking. The lamp should not have too high a resistance; one rated at 200v. 100 watts was found suitable. A lamp is used rather than an ordinary resistance because with its use there is no possibility of burning it out or doing other damage should the contacts become short-circuited, as might easily occur whilst making adjustments with a metal screwdriver.

It should be noted that the two condensers A and B have their charges replenished alternately from the respective half waves of the supply so that we have full-wave rectification, and the frequency of the A.C. hum, if any, in the transmitter, will be twice that of the supply, *e.g.*, 100 cycles per second from a 50 cycle supply. Since the supply system is earthed, the necessary precautions must be taken to prevent a short circuit to earth on the D.C. side; either a counterpoise should be used instead of the usual "earth,"

or, if the latter is used, a condenser of good insulation should be connected in the earth lead. The *earthed main* should be connected to the mid-point between the reservoir condensers A and B, so that the output terminals of the rectifier have equal potentials above and below that of the earth, thus greatly reducing the possibility of severe shock by accidental contact between any part of the system and earth.

A relay of the type employed here is usually very carefully constructed and the various parts are well insulated with good ebonite bushes, etc. The author has experienced no trouble of the nature of a breakdown of insulation as might at first be expected, since such an instrument is really designed only for use on about 10 or 20 volts.

The complete instrument is shown on page 102. On the top of the panel are mounted the relay, the input and output terminals, the metal filament lamp (represented by R_2 in Fig. 3), and two neon lamps, the use of which is explained below. Inside the box are the reservoir condensers and the smoothing chokes and condensers.

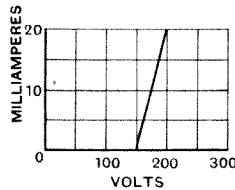

Fig. 7. The current-voltage characteristic of a neon lamp.

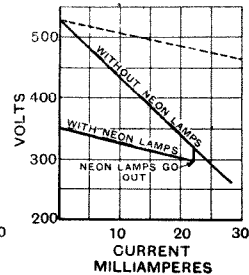

Fig. 8. The effect of employing neon lamps as regulators.

Thus the instrument comprises a complete unit for supplying high tension D.C. from the A.C. mains. It requires no accessories whatever, and for moderate voltages it possesses great advantages over the usual thermionic type of rectifier which requires a special transformer, filament heating batteries, etc., and over the rotary type of rectifier which requires a special synchronous motor. The energy losses are quite small, resulting in a very high efficiency.

The two neon lamps shown in the photograph are connected in series across the output terminals and have the effect of keeping the output voltage fairly constant

over a wide range of loads in spite of the fact that very high resistance chokes were used for smoothing purposes. A consideration of the current-voltage characteristic of a neon tube (Fig. 7) should make the reason for this quite clear. A small change in voltage across the neon lamp produces a relatively large change of current through the lamp and so the actual current flowing through the chokes is kept fairly constant for all outputs, resulting in a more or less steady terminal P.D. Since one neon lamp requires about 170 volts it was necessary to use two in series in order to get over 300 volts output. In order to get over 450 volts it is necessary

to use large reservoir condensers, low resistance chokes, and three neon lamps in series across the output terminals.

The curves of Fig. 8 show the "regulation" of the instrument with and without the use of neon lamps respectively. When neon lamps are used in this way the contacts of the relay will work absolutely sparklessly, whether the instrument is on load or not, which is not the case if the neon lamps are omitted; there is a tendency to spark slightly when the load is completely removed. However, this may not occur if larger reservoir condensers are used and is a matter for further experiment.

AN EASILY MADE VARIABLE CONDENSER.

Variable condensers can now be purchased so cheaply that the experimenter rarely undertakes the making of this component himself, particularly as the usual design involves the accurate setting up of a spindle for the moving plates. On the score of cheapness alone, however, the condenser shown here warrants the attention of the amateur.

The constructional details are readily apparent from the accompanying drawing,

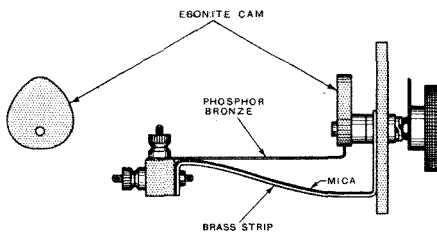

and the condenser will be seen to consist of very few parts, all of easy construction. The ebonite terminal piece is about $\frac{1}{2}$ in. square by $1\frac{1}{8}$ in. in length. The stiff brass piece is $1\frac{1}{8}$ in. wide, and gives a spacing of about $3\frac{1}{2}$ in. from the face of the panel. It is faced with a strip of mica, which for durability is about 0.006 in.

in thickness, though it is not necessary, of course, for this dimension to be precisely as stated. The bearing and bush are parts easily procurable from dealers in wireless components, and the knob can be obtained fitted with a 2 B.A. nut. The ebonite cam which operates on the springy brass piece is heart-shaped, and can be designed to produce a true square law effect.

C. R.

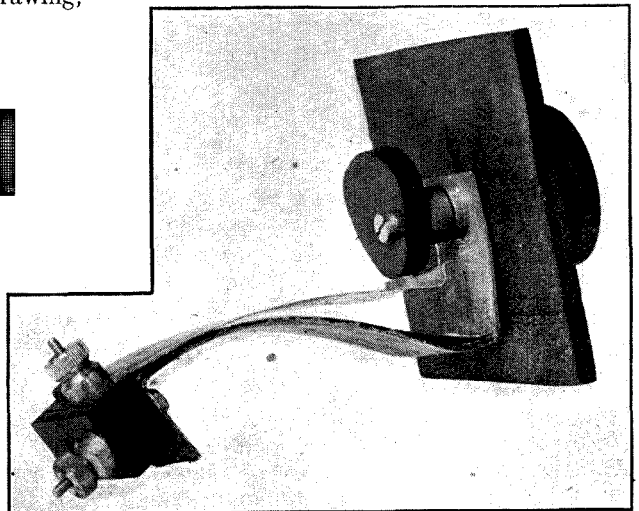

The spring piece is depressed into contact with the mica-faced support by the heart-shaped cam.

VALVE TESTS.

THE COSSOR P.1 AND P.2 VALVES.

THIS week we deal with two Cossor products, the P.1 and P.2. The appearance and method of assembly of these valves, with their hood-shaped anodes, is so well-known as to need no further description here.

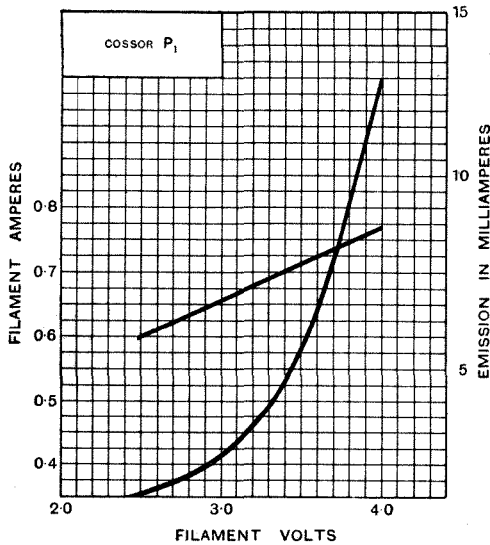

Fig. 1.

The P.2 is designed and recommended for high frequency work only, whereas the P.1 is intended for use as a detector and low frequency amplifier. Both types are fitted with similar filaments, rated at 3.5 to 4.0 volts, and for this reason the filament characteristics of Fig. 1 refer to both valves, for while tests were carried out on the two, the results were almost identical.

At 3.5 volts the filament emission is slightly below 5 milliamperes, rising to 13 milliamperes at the maximum rated voltage, so that at the latter value we have ample emission when using the valve as a low frequency amplifier.

The heating current varies roughly between 0.7 and 0.77 ampere.

Confining our attention firstly to the P.1, plate-current grid-volts curves are shown in Fig. 2, which suggest good low frequency amplification when using a plate potential of 80 volts, and a negative grid bias of 1.5 to 2.0 volts. The magnification and impedance curves are given in Fig. 3, from which we find their values to be around 8.5 and 25,000 ohms respectively at a plate potential of 80. The curves, however, suggest that

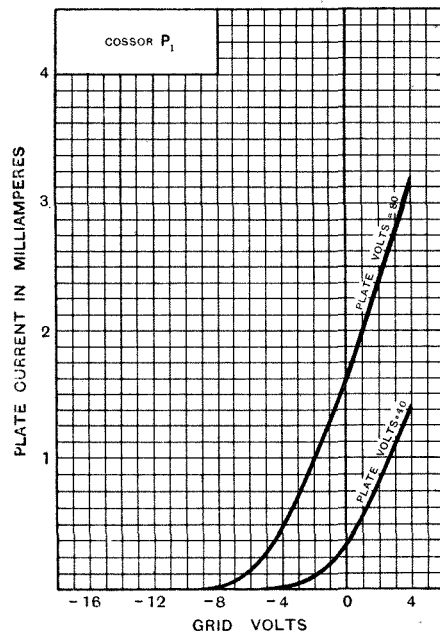

Fig. 2.

improvement might be effected by raising the plate potential to something over 100 volts, which would, of course, in addition, lengthen the operating region to the left of the zero grid volts line.

Turning next to the P.2, to which, as we have already stated, Fig. 1 also refers, we come to the plate-current grid-volts curves of Fig. 4, which at once suggest a higher plate impedance than obtains with the P.1. This is confirmed by the impedance curve of Fig. 5, which shows an impedance of 35,000 ohms at a plate potential of 80, the magnification factor at the same point being 10.

Tested on our standard arrangement, the P.2, operating with a plate potential of 50, gave excellent results as a high frequency amplifier, and it was, moreover, found possible considerably to reduce the filament brilliancy without losing signal strength.

In short, these bright emitting valves are good specimens of their class, and can

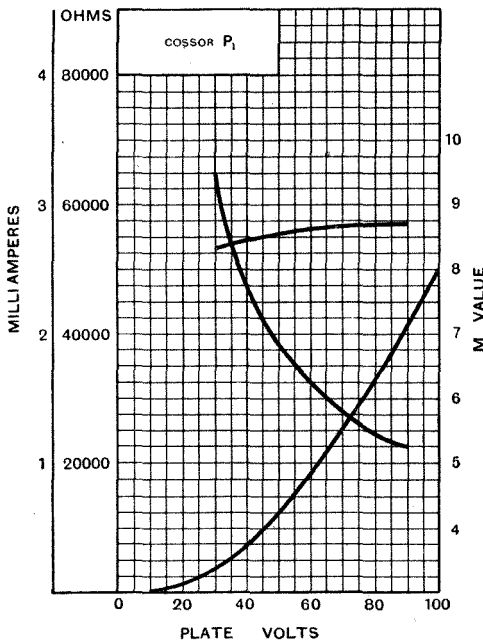

Fig. 3.

The P.1. was next tried, first as a detector, when about 40 volts plate potential appeared to be the most suitable. As a low frequency amplifier anything above 50 volts, according, of course, to the input, gave good results. With 100 volts plate potential, backed off with a grid bias of -3, plenty of signal strength was obtained and this was of excellent quality, but it is, of course, desirable to keep the filament volts up when using the higher plate potentials.

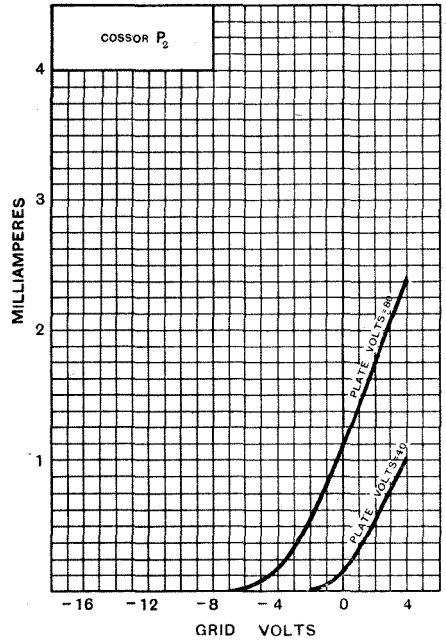

Fig. 4.

be recommended for the particular work for which they have been designed.

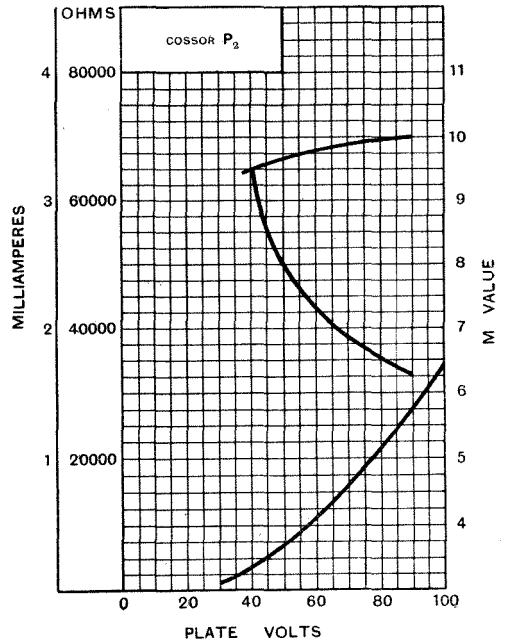

Fig. 5.

NOTES & NEWS



Milan is to be provided with a broadcasting station which, we understand, is now in process of erection. The wavelength is provisionally fixed at 650 metres.

* * * *

According to the latest statistics, there are now a quarter of a million receiving sets in use in Germany, 120,000 being licensed in Berlin alone.

* * * *

M. Belin, inventor of the telautograph, has accepted the honorary presidency of the Internacia Radio Asocio, which is the international radio Esperanto organisation.

Open air radio concerts are finding favour in Moscow, where large crowds assemble nightly in the grounds of the "People's House," in which are placed seven large loud speakers.

A company, backed by French interest, is to erect a broadcasting station in Poland.

The "Petit Parisien" broadcasting station has reduced its wavelength to 340 metres.

NEW ZEALAND AMATEUR HEARD IN BRITAIN.

Subject to confirmation, which is almost certain, the world record for amateur wireless communication was created on Thursday, October 16th, when New Zealand 4 AG was heard in England by Mr. E. J. Simmonds (2 OD) of Gerrard's Cross, Bucks.

Listening-in on a wavelength of about 80 metres at 6.30 a.m. Mr. Simmonds picked up clear signals from the New Zealander, who worked first with American 5 MI and later with American 6 ARB.

Prior to this 5 MI had sent out a CQ, prefixing his call with the code word ALABAMA, to which 4 AG replied.

Corroborative evidence is [also afforded] by the

current issue of *Q.S.T.*, in which 6 ARB is described as one of the American amateurs in regular touch with New Zealand.

The distance covered by this remarkable transmission is approximately 11,500 miles. Mr. Simmonds, who was using a super-heterodyne receiver, reports that 4 AG transmitted with a low A.C. note.

44-METRE WORKING WITH U.S.

M. Pierre Louis (8 BF), is now operating on 44 metres and has already worked successfully with U.S. amateurs, at Philadelphia and Fall River. He has been reported in America at "phones-on-the-table" strength, with a two-valve set.

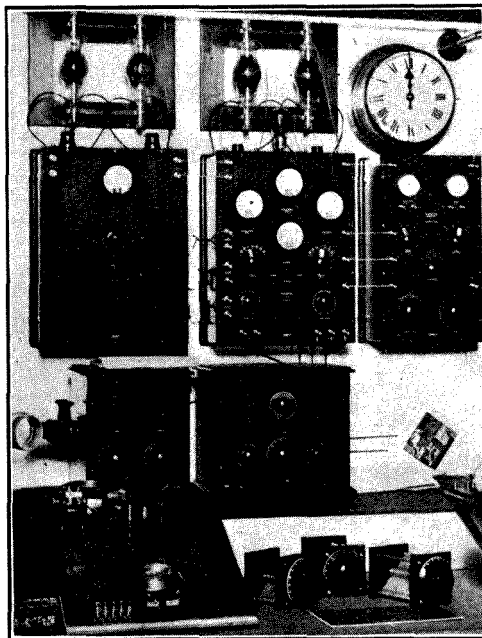

A complete transmitting and receiving plant for telegraphy and telephony which formed an attractive item on the stand of Messrs. Burndept, Ltd., at the All-British Wireless Exhibition.

ROME BROADCASTING.

A definite programme of transmissions has now been adopted by the Rome broadcasting station, which has been allotted the call sign of 1 RO. Transmissions now take place nightly from 7.30 to 9.30 G.M.T., on a wavelength of 422 metres.

The station announcement is: "Stazione di Roma — Unione Radiofonica Italiana."

FREE STATE'S BROADCASTING SCHEMES.

The statement that 150,000 licensed listeners-in can be found in the Free State to defray the expense of a broadcasting station was characterised by the Secretary of the

Irish G.P.O. as "sheer nonsense."

It will be remembered that the Dail decided against private ownership of broadcasting stations. Unless, therefore, the Ministry of Finance decides to expend public money, such stations cannot be established. Should plans materialise, the proposed site of the first station is Phoenix Park, Dublin,

FRENCH DEMAND FOR REGIONAL BROADCASTING.

An appeal for a system of broadcasting to provide an adequate service for all parts of France, is made in the October issue of *La T.S.F. Moderne*. At present the principal broadcasting stations are situated in Paris, which is not in the centre of the country. The erection of one powerful main station has been proposed, but our contemporary points out that France is too large to permit of such a scheme. Under the present conditions, amateurs in three quarters of the country are disinherited. To obtain broadcast reception they must spend a small fortune, and are happy if they get any results at all.

In conclusion, the authorities are urged to emulate the example of Great Britain. French amateurs are now waiting, but at the moment they see nothing. And thus, sighs our contemporary, the 1924-1925 season will pass like its predecessors.

CIRCUIT INVENTOR'S LOVING CUP.

Some interesting awards have been made in the competitions held in connection with the Radio World's Fair, which closed on September 28th after a successful week at the Madison Square Garden, New York.

For the "Originality and Perfection" of his new circuit, Mr. E. T. Flewelling received a silver loving cup. Similar presentations were made to Mr. Herbert Frost for the successful adaption of Bakelite to loud speaker manufacture, to Mrs. Frank L. Savage for her "Portable Antenna," and other competitors.

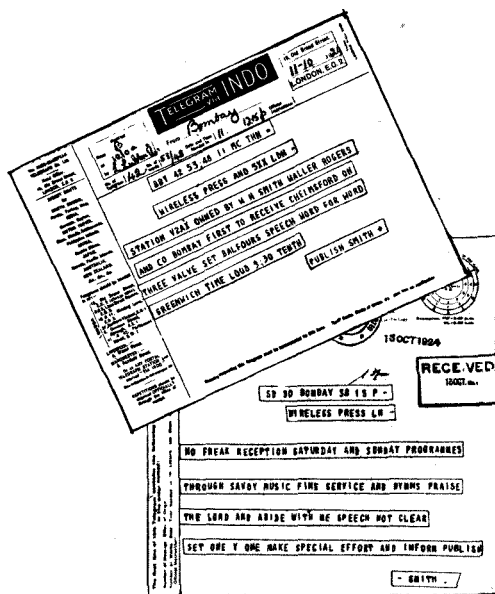

Proof of the world-wide efficiency of 5XX is furnished by the above telegrams which have been sent to us by a Bombay reader.

FRENCH 8 AB ACTIVE.

Many readers are no doubt aware that M. Leon Déloy (8 AB), the well-known pioneer of short wave transatlantic working, has returned to Nice and is again using his characteristic 25-cycle transmission on 95 metres. Mr. W. K. Alford, of Camberley, Surrey, reports signals of "terrific strength" from the French veteran while using a superheterodyne. The station was still audible without heterodyning.

THAT EARTH CONNECTION.

"I believe the earth connection is more important than anything else, but few people are able to get a good one," said Mr. H. R. Rivers-Moore, B.Sc., giving the R.S.G.B. talk from 2 LO on October 16th. "At sea, where the earth is made by the huge hull of a vessel immersed in salt water, I have easily heard B.B.C. stations with a crystal set and small aerial at ranges of several hundred miles. If," he continued, "it were possible to bury the 'Mauretania' in the backyard, the results would, I believe, astonish you."

Mr. Rivers-Moore then hinted at the fascinating experiments which could be conducted with crystals used to amplify and oscillate. The purchase of a small battery would enable the experimenter to start at once and the speaker referred to the circuits given in *The Wireless World and Radio Review* of October 1st and 8th. In view of these developments the crystal user could feel not only that his field of experiment was greatly widened, but that he was in the forefront of research once more, and in a position to contribute really valuable information.

HONOLULU CALLING.

M. J. L. Menars, 8 FS, who is rapidly becoming one of the foremost of French amateurs, informs us that on October 8th, at 5.30 a.m., he heard Hawaiian 6 CEU transmitting a CQ call on about 80 metres. The strength of the signals was R4 with a three-valve receiver.

The distance between Honolulu and M. Menars' station at Le Blancat, near the Pyrenees, is approximately 9,500 miles.

THE AMPLION "DRAGONFLY."

Messrs. Alfred Graham & Co. ask us to draw attention to mistakes which occurred in the advertisement of the 'Amplion "Dragonfly"' appearing on page xxvi of our issue of October 15th. The dimensions of the instrument should have been given as follows: Diameter of trumpet, 5½ ins.; overall height, 9 ins.

The address of the Company is St. Andrew's Works, Crofton Park, London, S.E.4.

FREEDOM FOR JAPANESE AMATEURS.

For some months Japanese amateurs have been waging war with certain authorities who have endeavoured to curtail freedom of reception under the pretext of securing secrecy for official messages.

An official regulation has been issued, however, allowing greater freedom for amateurs, and wireless traders are now preparing a vigorous campaign.



READERS' PRACTICAL IDEAS.



This section is devoted to the publication of ideas submitted by readers and includes many devices which the experimenter will welcome.

One-hole Fixing for Variometers.

THE ordinary motor car tyre valve body and cap makes a very useful fitting for securing a variometer to the instrument panel, and at the same time serving as a bearing to the spindle. It is only necessary to drill a $\frac{3}{16}$ in. hole down the centre of the plug and cut off the small end. The valve cap should be cut into two pieces after filing off the blind end, so as to form two nuts. The actual method of fitting up is shown in the drawing, from which it will be seen that a 2 B.A. rod serves as a centre spindle, making a good fit in the $\frac{3}{16}$ in. hole.

J. L.

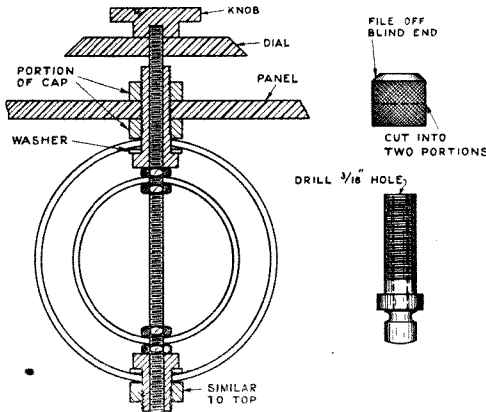

Using motor tyre valve parts in variometer construction.

Regulating the Grid Potential.

THERE are many types of valves available for use in the various circuits of a multi-valve receiver. It is essential to carefully adjust the grid potential so that

the valves are correctly operated. This can be effected both easily and inexpensively by making use of the lead removed from an

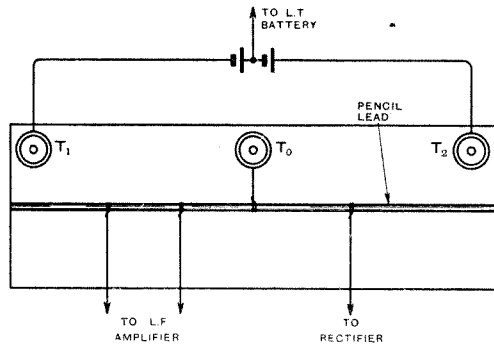

The lead removed from a pencil makes a good variometer.

“H” pencil and connected up as a potentiometer. The lead can be mounted up on a piece of ebonite to facilitate connection across it of two small cells by means of terminals T_1 and T_2 . Terminal T_0 gives zero potential, whilst positive and negative biasing potentials may be picked up on either side of the zero.

A. L. B.

Compact High Efficiency Switch.

IN constructing switches for panel mounting, one must aim at producing a component that will occupy very little space and if to be connected in high frequency circuits, the switch parts must be small and present low capacity one to another. A switch of simple construction fulfilling these requirements is shown in the accompanying illustration, from which sufficient detail can almost be gathered for making it up.

The base piece from which the contacts are assembled is $1\frac{1}{2}$ ins. by $1\frac{1}{2}$ ins. by $\frac{1}{4}$ in. and twelve small holes are drilled on a $\frac{3}{4}$ in. circle into which pieces of No. 20 copper wire are fitted. These pieces of wire are turned over on the other side of the panel, one being left projecting about $\frac{3}{4}$ in. so that it can be bent back for the purpose of making connection. The spindle is attached to the ebonite between two nuts and the nut on the underside locks up against the ebonite arm into which the spindle is

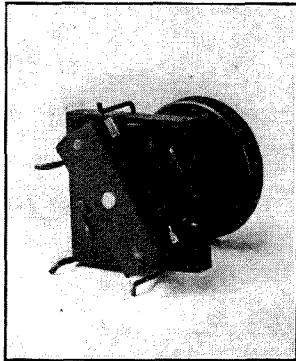

Compact double pole two-position switch suitable for use in high and low frequency circuits.

threaded. The arm is fitted with a pair of spring contacts which each bridge two of the wire contacts. These spring pieces are made from brass and attached to the arm by means of two 4 B.A. cheese headed screws. To restrict the movement of the switch a pair of ebonite pegs are driven into holes into which they fit tightly. The switch shown is a double pole change-over and can be made up at very little cost.

W. S. R.

Variable Grid Leaks as a Potentiometer.

It is usually an advantage to fit a potentiometer between the earth end of the inductance and the filament circuit in the case of a high frequency amplifying valve. Quite a good potentiometer can be made up from two grid leaks. The two leak resistances are connected in series through a battery of one or two cells, the positive or negative of which is connected to the filament circuit, depending upon whether a positive or negative bias is needed. The other ends

of the resistances are linked across and taken to the end of the coil which leads to the grid.

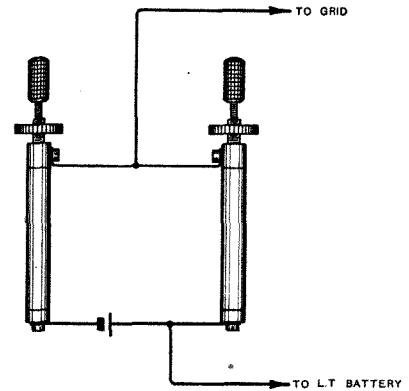

Two variable grid leaks connected up to form a grid potentiometer.

The potential is varied by increasing the value of one resistance and reducing the value of the other.

W. H. B.

A Sub-Panel to Avoid Screw Heads.

Those who construct their own sets and have particular regard for appearance, usually experience difficulty in devising a method for attaching the very many components to the panel and avoiding the appearance on the face of a large number of screw heads. One of the simplest methods of effecting this is to employ a sub-panel which gives the advantage of providing accommodation for many more components than can be carried by the front panel.

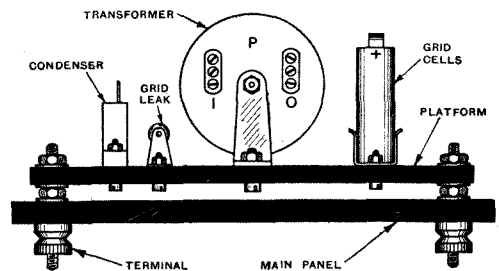

Method of avoiding the appearance of screw heads on the face of the instrument panel.

This additional panel may be secured by the stems of the terminals in the manner shown.

O. M. D.

PATENTS AND ABSTRACTS



An Improved Generator of Oscillations.

It is well known that for the most efficient production of oscillations by a valve, it is essential that the anode currents through the valve vary from a minimum value in a sudden or impulsive manner. In this invention* oscillations are generated impulsively by the amplifier or power valve.

A highly negative polarising potential on the grid of the valve normally opposes the transmission of any substantial amount of anode current through the valve. The reaction coil coupled between the output and input circuits of the power valve includes a relay valve, the grid of which is

current will therefore consist of sharp non-sinusoidal impulses of anode current, which are transmitted through the input coupling of the power valve, and cause the grid of the power valve periodically to become highly positive for extremely small intervals of time, thereby causing very sharp impulses of anode current to flow in the output circuit of the power valve. Hence oscillations are produced in the tuned circuit connected to the power valve.

By using a relatively high anode voltage, and a high grid polarising potential, a very high efficiency may be obtained in generating oscillations of the desired frequency. The

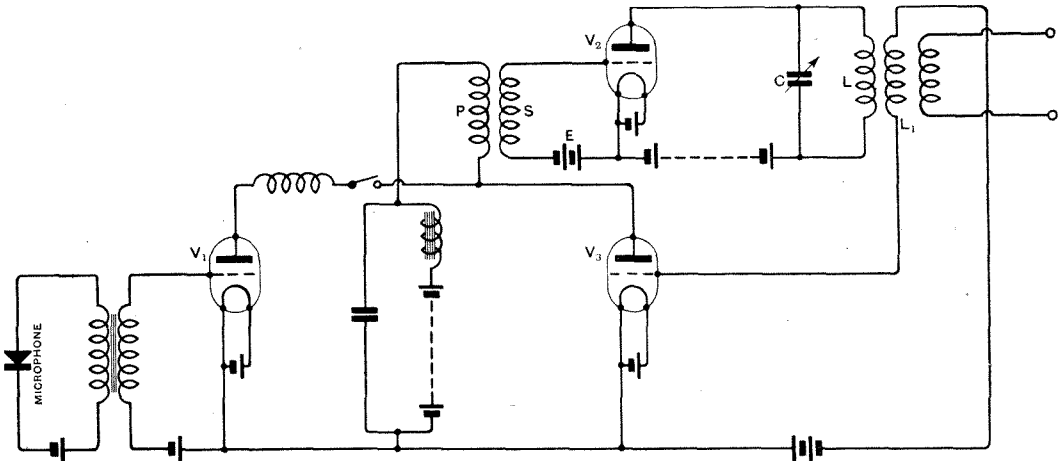

Fig. 1. The connections of an improved oscillator which is shown connected to a modulator.

provided with a highly negative polarising potential. Hence only the positive peaks of oscillations impressed thereon are effective in producing anode current in the output circuit of the auxiliary valve. The output

excitation by a non-sinusoidal impulse permits the power valve to operate with a minimum or very small loss of electrical energy within the valve as compared to the energy delivered to the output circuit in the form of oscillations of the desired frequency.

Fig. 1 is a circuit diagram showing one arrangement with means for modulating the

* British Patent No. 213,562, by The Western Electric Company and H. W. Nicholls.

oscillations. V_1 is the modulating valve, V_2 the power valve, and V_3 the auxiliary valve connected to the grid circuit of the power valve.

The operation of the circuit may be understood more clearly by referring to Figs. 2 and 3. In Fig. 2, the curve refers to the auxiliary valve, and shows the value of anode current, I_{b_1} , for the different values of grid potential, E_{c_1} .

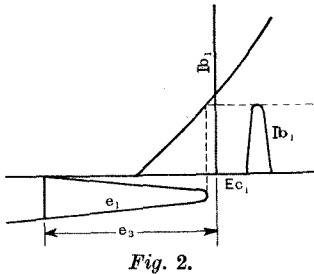

Fig. 2.

Assuming that circuit CL, Fig. 1, is tuned to the correct frequency, and oscillations are flowing in it, voltages will be induced in L_1 , producing an alternating voltage which may be represented as e_1 (Fig. 2). The voltage e_1 produces a rapid increase in anode current, thus producing an impulse of current through the primary winding P of the input transformer. Since the grid of the auxiliary valve becomes positive only once during each cycle, there will be one impulse, I_{b_1} , for each cycle of the oscillations being generated.

The curve of Fig. 3 applies to the power valve, and shows the values of grid potential, E_{c_2} . The negative polarising potential of the grid battery E is represented as e_4 . The

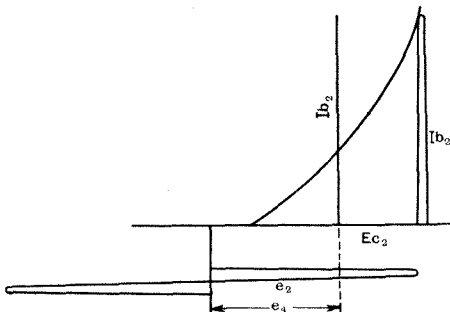

Fig. 3.

voltage e_2 is that induced in the secondary winding S of the transformer, by the impulse passing through the primary winding. It will be noticed that the voltage e_2 applies a much sharper positive peak of potential to the grid of the power valve than the voltage e_1 applied to the grid of the auxiliary valve. As a result of this abrupt change in the voltage of the grid of V_2 , a current impulse I_{b_2} is transmitted through the output circuit of the power valve. The effect of these sharp impulses upon the tuned circuit CL is to set up and maintain in this circuit free oscillations of the natural frequency of the circuit.

A Device for Giving Fine and Coarse Adjustments.

It is very helpful to employ variable condensers and variometers which may be adjusted exactly to the value required for best results.

Some tuning condensers have a single plate which may be turned without disturbing the main adjustment. Others are provided with a device which provides a quick and slow movement.

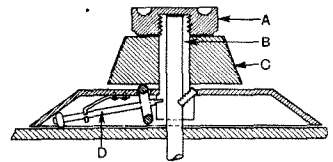

Fig. 4. A special device for giving fine adjustments.

The knob and dial* sketched in Fig. 4 may be secured to the shaft of a variable condenser or variometer to give it the desired close adjustment.

A is a knob which is screwed to a bush B, and the shaft of the instrument for coarse adjustment.

The knob C fits comparatively loosely over the bush B, and, when it is turned, moves the shaft D. The shaft D forms part of a reducing gear, as may be seen from the sketch. Hence, when knob B is turned, the shaft of the instrument is only slowly turned through the reduction gear, and provides the desired "vernier" adjustment.

W.J.

*British Patent No. 221,053, by C. H. Clarabut.



BROADCASTING.

REGULAR PROGRAMMES ARE BROADCAST
FROM THE FOLLOWING EUROPEAN STATIONS :



GREAT BRITAIN.

CHELMSFORD 5 XX, 1,600 metres, Tests.
ABERDEEN 2 BD, 495 metres; **BIRMINGHAM 5 IT**, 475 metres; **BELFAST 2 BE**, 435 metres;
GLASGOW 5 SC, 420 metres; **NEWCASTLE 5 NO**, 400 metres; **BOURNEMOUTH 6 BM**, 385 metres;
MANCHESTER 2 ZY, 375 metres; **LONDON 2 LO**, 365 metres; **CARDIFF 5 WA**, 351 metres;
RELAY STATIONS: LEEDS-BRADFORD 2 LS, 346 and 310 metres; **PLYMOUTH 5 PY**, 335 metres; **EDINBURGH 2 EH**, 225 metres; **NOTTINGHAM 5 NG**, 322 metres; **HULL 6 KH**, 320 metres; **LIVERPOOL 6 LV**, 315 metres; **SHEFFIELD 6 FL**, 301 metres. Tuesdays, Thursdays and Fridays, 1.0 p.m. to 2.0 p.m. (**2 LO** only). Regular daily programmes, 3.0 to 7.30 p.m., 8.0 to 11.30 p.m. Sundays, 3.0 to 5.0 p.m., 8.30 to 10.30 p.m.

FRANCE.

PARIS ("Radio Paris"), **SFR**, 1,780 metres. 12.30 p.m., Cotton Prices, News; 12.45 p.m., Concert; 1.30 p.m., Exchange Prices; 4.30 p.m., Financial Report; 5.0 p.m., Concert; 8.30 p.m., News and Concert.

PARIS (Ecole Supérieure des Postes et Télégraphes), 450 metres. 3.45 p.m. (Wednesday), Talk on History; 8.0 p.m. (Tuesday) English Lesson; 8.30 p.m., Concert; 9.0 p.m., Relayed Concert or Play.

PARIS (Station du Petit Parisien), 340 metres; 8.30 p.m., Tests.

BELGIUM.

BRUSSELS, BAV, 1,100 metres. At 2.0 p.m. and 6.50 p.m., Meteorological Forecast.

BRUSSELS ("Radio-Belgique"), 265 metres. Weekdays, 5.0 p.m. to 6.0 p.m., and 8.0 p.m. to 10.0 p.m.; Sunday, 5.0 p.m. to 6.0 p.m., and 8.30 p.m. to 10.0 p.m.

HOLLAND.

THE HAGUE, PCGG, 1,070 metres. 4.0 to 6.0 p.m. (Sunday), 9.40 to 11.40 p.m. (Monday and Thursday), Concerts.

THE HAGUE (Heussen Laboratory), **PCUU**, 1,050 metres. 10.40 to 11.40 a.m. (Sunday), Concert; 9.40 to 10.40 p.m., Concert; 8.45 to 9.0 p.m. (Thursday), Concert.

HILVERSUM, 1,050 metres. 9.10 to 11.10 (Sunday), Concert and News.

IJMUIDEN (Middelraad), **PCMM**, 1,050 metres. Saturday, 9.10 to 10.40 p.m., Concert.

AMSTERDAM, PA 5, 1,050 metres (Irregular). 8.40 to 10.10 p.m., Concert.

AMSTERDAM (Vas Diaz), **PCFF**, 2,000 metres, 9.0 a.m. and 5.0 p.m., Share Market Report, Exchange Rates and News.

DENMARK.

LYNGBY, OXE, 2,400 metres. 8.30 to 9.45 p.m. (Weekdays), 8.0 to 9.0 (Sunday), Concert.

SWEDEN.

STOCKHOLM (Telegrafverket), 440 metres. Daily, 12.45 to 1.0 p.m., Weather Report and Nauen Time Signal; Monday, Wednesday and Saturday, 8.0 to 9.0 p.m., Concert and News; Sunday, 11.0 a.m. to 12.30 p.m., Divine Service from St. James' Church.

STOCKHOLM (Radiolaget), 470 metres. Tuesday and Thursday, 8.0 to 9.30 p.m., Concert and News.

GOTHENBURG (Nya Varvet), 700 metres. Wednesday, 7.0 to 8.0 p.m.

BODEN, 2,800 metres. Tuesday and Friday, 6.30 to 7.30 p.m., Sunday, 5.30 to 6.30 p.m., Concert and News.

GERMANY.

BERLIN (Koenigswusterhausen), **LP**, 680 metres. Sunday, 10.50 to 11.50 a.m., Concert; 2,800 metres, Sunday, 11.50 a.m. to 12.50 p.m., Concert.

EBERSWALDE, 2,930 metres. Daily, 1.0 to 2.0 p.m., Address and Concert; 6.0 to 7.30 p.m., Address and Concert; Thursday and Saturday, 7.20 p.m., Concert.

BERLIN (Vox Haus), 430 metres. 11.0 a.m., Stock Exchange; 1.55 p.m., Time Signals; 5.40 to 7.0 p.m., Concert; 7.0 to 8.0 p.m. (Sunday), Concert.

BRESLAU, 415 metres.

HAMBURG, 387 metres.

STUTTGART, 437 metres.

KONIGSBERG, 460 metres.

FRANKFURT-AM-MAIN, 467 metres. 7.30 to 10.0 p.m., Tests, Gramophone Records.

LEIPZIG (Mitteldeutsche Rundfunk A.G.), 452 metres.

MUNCHEN (Die Deutsche Stunde in Bayern), 485 metres.

AUSTRIA.

VIENNA (Radio-Hekaphon), 770 metres. Monday and Friday, 8.0 to 8.30 p.m.

CZECHO SLOVAKIA.

PRAGUE, PRG, 1,800 metres. 8.0 a.m., 12.0 a.m., and 4.0 p.m., Meteorological Bulletin and News; 4,500 metres, 10.0 a.m., 3.0 p.m., and 10.0 p.m., Concert.

KBELY (near Prague), 1,150 metres. Weekdays, 7.15 p.m. and 10.0 p.m., Sundays, 11.0 a.m. to 12.0 noon, Concert and News.

BRUNN, 1,800 metres. 10.0 to 11.0 a.m., Concert; 2.30 p.m., News.

SPAIN.

MADRID, PTT, 400 to 700 metres. 6.0 to 8.0 p.m., Tests.

MADRID (Radio Iberica), 392 metres. Daily (except Thursdays and Sundays), 7.0 to 9.0 p.m. Thursdays and Sundays, 10.0 to 12.0 p.m., Concerts.

MADRID, 1,800 metres. Irregular.

CARTAGENA, EBX, 1,200 metres, 12.0 to 12.30 p.m., 5.0 to 5.30 p.m., Lectures and Concerts.

PORTUGAL.

LISBON (Aero Lisboa), 370 to 400 metres. Wednesdays and Fridays, 9.30 to 12.0 p.m., Irregular Tests.

SWITZERLAND.

GENEVA, HB 1, 1,100 metres. Weekdays, 3.15 and 8.0 p.m., Concert or Lecture.

LAUSANNE, HB 2, 850 metres. Daily, 9.15 p.m., Concert and Address.

ZURICH, HBZ, 650 to 800 metres. 1.0 p.m., News and Weather Forecast; 8.15 p.m. to 10.15 p.m., Concert.

ITALY.

ROME, ICD, 3,200 metres. Weekdays, 12.0 a.m. 1,800 metres, 4.0 p.m. and 8.30 p.m., Tests, Gramophone Records.



Wimbledon, London, S.W.19 (all American on 70 metres, September 22nd).

1 AAC, 1 AMW, 1 BGT, 1 BGG, 1 BKR, 1 PA, 1 BQK, 1 XAM, 1 AVJ, 1 PTC, 1 AR (Canada), 1 ARE, 1 CKP, 1 ZT, 1 AID, 1 SF, 1 DD, 1 ZZ, 1 MY, 1 AJP, 1 ALL, 1 MW, 1 AZL, 1 RY, 1 YB, 1 ABT, 2 DX, 2 GK, 2 BRB, 2 TGB, 2 AGB, 3 CMG, BBTA, 3 CHG, 3 ADY, 3 MB, 3 BQ, 3 BG, 3 BVA, 3 VW, 4 SA, 4 XE, 4 EQ, 4 TJ, 4 IO, 8 CYL, 8 DME, 8 GZ, 8 NB, 8 BXH, 8 PL, 8 CCG, 8 DNF, 8 ADD. September 28th: 1 SF, 1 ZE, 1 ER, 1 FD, 1 OW, 1 DD, 1 MW, 1 BIA, 1 PA, 1 BGG, 1 AWW, 1 CKP, 1 XAX, 1 AUR, 1 XAV, 1 AJP, 1 BKR, 2 GK, 3 GE, 3 CBL, 2 CRU, 2 WC, 2 PD, 2 BRB, 2 CQZ, 2 BY, 2 AGB, 2 CMK, 2 APY, 2 ABD, 2 KU, 4 KU, 3 COL, 3 GE, 3 CBL, 3 BTU, 3 LV, 3 BG, 3 AJD, 4 WB, 3 BSB, 3 QVA, 3 BWJ, 3 QV, 4 SA, 4 KUA, 4 KUD, 4 KU, 5 ZAS, 5 CN, 8 XS, 8 VQ, 8 CYL, 8 CEL, 8 ADD, 9 DQ, 9 BP. (o—v—i.)

(A. L. Austen.)

Newcastle-on-Tyne.

2 AM, 2 BG, 2 CC, 2 CF, 2 DR, 2 DQ, 2 DX, 2 GG, 2 JP, 2 JU, 2 KF, 2 MC, 2 NM, 2 NN, 2 PY, 2 QZ, 2 SH, 2 XX, 2 XF, 2 YT, 2 ZF, 5 AV, 5 BH, 5 GA, 5 MA, 5 MO, 5 NT, 5 NW, 5 OC, 5 OX, 5 GH, 5 RG, 5 RZ, 5 SI, 5 SZ, 5 SN, 5 TJ, 5 WI, 5 XN, 6 FG, 6 FQ, 6 GG, 6 UG, 6 UZ, 6 5R, 6 RY. French: 8 BQ, 8 BS, 8 CN, 8 DO, 8 RG, 8 SM, 8 VG, 8 ZF. Dutch: 0 AAB, 0 BA, 0 GC, 0 NN, 0 QR, 0 QW, 0 RE. Belgian: 4 BA, 4 IX, 4 US, W 2, W 2 L, 4 C 2. German: 1 CF, 1 SF, 1 VA. American: 4 TET, 5 ATI 1 FGL. Unknown: G 84, G 8 V, NY, EAB. (o—v—i.)

(F. Thompson, 2 AWK.)

Northampton (August 21st—September 21st).

Telephony: British: 2 AH, 2 ATT, 2 BZ, 2 DU, 2 FV, 2 GG, 2 IL, 2 JR, 2 KO, 2 KP, 2 KV, 2 NM, 2 NP, 2 NV, 2 MP, 2 QR, 2 TU, 2 VG, 2 YV, 2 YX, 5 AK, 5 CP, 5 DY, 5 IY, 5 FI, 5 QV, 5 YS, 5 YI, 5 YW, 6 BBC, 6 IM, 6 MJ, 6 NL, 6 XQ. American: 2 XI. Morse, British: 2 AM, 2 ASH, 2 CA, 2 CC, 2 DQ, 2 DX, 2 GW, 2 HF, 2 IM, 2 JF, 2 JP, 2 MC, 2 NO, 2 OA, 2 OD, 2 PP, 2 FQ, 2 QQ, 2 SH, 2 TO, 2 VW, 2 WA, 2 XG, 2 YI, 5 BH, 5 BV, 5 CQ, 5 FS, 5 GA, 5 KM, 5 LF, 5 LS, 5 MA, 5 MO, 5 DN, 5 FW, 5 NW, 5 OC, 5 RQ, 5 RZ, 5 SL, 5 SU, 5 SZ, 5 UL, 6 GW, 6 GM, 6 LJ, 6 MP, 6 NF, 6 RK, 6 RY, 6 TD, 6 TM, 6 UC, 6 XX. French: 3 AD, 3 CA, 3 XO, 3 AG, 3 AQ, 3 BA, 3 BC, 3 BN, 3 BP, 3 BS, 3 BV, 3 CA, 3 CF, 3 CN, 3 CO, 3 CT, 3 CZ, 3 DA, 3 DI, 3 DO, 3 DP, 3 DS, 3 EK, 3 EM, 3 EU, 3 FC, 3 FK, 3 GP, 3 HP, 3 IQ, 3 JEL, 3 JL, 3 MN, 3 MU, 3 NO, 3 NS, 3 OK, 3 PA, 3 PP, 3 PQ, 3 RCR, 3 RL, 3 RO, 3 RR, 3 MP, 3 SM, 3 SR, 3 SSU, 3 SU, 3 VG, 3 WJ, 3 WY, 3 WL, 3 WZ, 3 ZM, 3 ZG, 3 GB. Dutch: 0 BA, 0 BQ, 0 BU, 0 GA, 0 GC, 0 MR, 0 MS, 0 NN, 0 QW, 0 RE, 0 TP, 0 XP, 0 XQ. Luxembourg: 0 PG. Belgian: 4 C 2, 4 LA, 4 RS, 4 RT, 4 WR, 4 YZ, W 2. Danish: 7 EC. Italian: 1 MT, 1 FF, 1 GN, MM, ICS, IDO. Swedish: SMZS, SMZV, SMZY. Norwegian: EGA. German: AGW. Algiers: HBS. Unknown: 10 2, CA, YA 1, YA 20, YA 24. (P. H. Brigstocke Trasler.)

Northampton (August 31st to September 21st).

British: 2 AFL, 2 ASH, 2 C 2, 2 DU, 2 DX, 2 FN, 2 GG, 2 GW, 2 IH, 2 JR, 2 JU, 2 KO, 2 KV, 2 NM, 2 NV, 2 OA, 2 OD, 2 PP, 2 QR, 2 RL, 2 SH, 2 TD, 2 TE, 2 VG, 2 VJ, 2 VW, 2 WD, 2 XD, 2 XG, 2 XY, 2 YK, 2 YX, 2 ZU, 5 AK, 5 BH, 5 BV, 5 DT, 5 FL, 5 ID, 5 IK, 5 IY, 5 KM, 5 LF, 5 LS, 5 MA, 5 MO, 5 ON, 5 RZ, 5 SI, 5 SU, 5 UL, 5 UQ, 5 YW, 6 BBC, 6 GM, 6 HY, 6 MJ, 6 MP, 6 NF, 6 PE, 6 TD, 6 TM, 6 Q. French: 8 BC, 8 BG, 8 BN, 8 BP,

8 CA, 8 CF, 8 CH, 8 CN, 8 CO, 8 CT, 8 CZ, 8 DD, 8 DI, 8 DO, 8 DP, 8 EK, 8 EO, 8 EP, 8 EU, 8 FC, 8 FH, 8 FK, 8 FV, 8 FW, 8 GG, 8 GV, 8 HP, 8 JEL, 8 KBR, 8 ML, 8 MN, 8 MP, 8 NS, 8 OK, 8 OS, 8 PD, 8 PF, 8 PP, 8 PQ, 8 RG, 8 RM, 8 RO, 8 RR, 8 SR, 8 SSU, 8 UU, 8 VG, 8 WL, 8 WZ, 8 XH, 8 XR, 8 ZM, 8 ZZ, 3 AD, 3 CA, 3 XO. Dutch: 0 BA, 0 BQ, 0 GA, 0 JR, 0 KV, 0 MS, 0 NN, 0 PA, 0 QW, 0 XP, 0 FQ, 0 ZO. Swedish: SMZM, SMZP, SMZV, SMZY, SMZZ. Italian: 1 EP, 1 GN, 1 MT, 1 CS, 1 DO, 1 MM. Belgian: 4 AU, 4 RS, 4 YZ, W 2. Luxembourg: 0 AA. Finnish: 2 NM. Swiss: 9 AD. Danish: 7 EC. Algiers: HBS. American: 2 GK. Unknown: YA 24, IO 2, GB, 9 XX. (r—v—o.)

(W. F. B. Shaw.)

Watford (during September). All below 200 metres.

British: 2 BR, 2 CC, 2 DR, 2 GW, 2 KZ, 2 MC, 2 NM, 2 OD, 2 PY, 2 TD, 2 VE, 2 VW, 2 WC, 5 BV, 5 DN, 5 ID, 5 KM, 5 LF, 5 MA, 5 MO, 5 OX, 5 PE, 5 QG, 5 SL, 5 UL, 6 AL, 6 AN, 6 BY, 6 DW, 6 GH, 6 GM, 6 KJ, 6 NF, 6 ON, 6 OU, 6 TM, 6 UD. French: 8 AC, 8 AU, 8 BC, 8 CA, 8 CZ, 8 DA, 8 DI, 8 DP, 8 EU, 8 GI, 8 JEL, 8 FQ, 8 PP, 8 RM, 8 RR, 8 SR, 8 SSU, 8 UU, 8 VG. Dutch: 0 ZO, 0 BA. Danish: 7 EC. Swedish: 4 SMZY. Finnish: FN 2 NM. Italian: 1 FP. American: 1 SF, 3 BVA, 3 MB, 4 SA, 8 KL, 8 NB, 8 PL. Canadian: 1 AR. Miscellaneous: 1 GN, 3 CA, 3 XO, 4 YZ, 10 KZ, UX 8. (H. E. Nicholson, 6 VP.)

Islington, London, N.1 (during September).

British: 2 ABJ, 2 ARB, 2 AU, 2 CA, 2 DX, 2 IS, 2 KT, 2 KX, 2 KZ, 2 NM, 2 OD, 2 ON, 2 QQ, 2 TF, 2 UV, 2 VW, 2 YT, 2 ZA, 5 AL, 5 DN, 5 JX, 5 KM, 5 LF, 5 MA, 5 NW, 5 OX, 5 PU, 5 FZ, 5 RZ, 5 SI, 5 TR, 5 UL, 6 AL, 6 DM, 6 GM, 6 HP, 6 HY, 6 MP, 6 NF, 6 NG, 6 QZ, 6 SB, 6 TM, 6 UD. French: 8 FC, 8 KK, 8 RG, 8 SM, 8 VG, 8 WL. Dutch: 0 BA, 0 GA. Danish: 7 EC, 7 ZM. Swedish: SMZV. Unknown: 4 YZ, QRA, PSE, 9 AN. (C. E. Bradley.)

West Norwood, S.E.27 (during September).

2 CV, 2 EX, 2 IH, 2 NK, 2 QI, 2 ZK, 2 XAU, 5 CF, 5 KM, 6 JO, 6 PE, 6 US, 8 BC, 8 CA, 8 CO, 8 FC, 8 FK, 8 FVQ, 8 GI, 8 JEL, 8 GL, 8 OK, 8 PP, 8 PQ, 8 RR, 8 UU, 0 GA, 0 KM, 0 LO, 0 TP, 0 QW. Various: GB, 4 YZ, IO 2, F 8, SMZV, WGH. American: 1 XAV, 2 BRB, 3 AD, 3 AJD, 3 BTU, 4 SA, 5 ZA, 3 BDO, NFV. (o—v—o and o—v—i.) (L. F. Aldous, 2 ACK.)

East Aberthaw, near Cardiff (September 1st to 30th). All C.W. or I.C.W., except telephony.

British: 2 BN, 2 CC, 2 DX, 2 IH, 2 JF, 2 KO, 2 NM, 2 OA, 2 DD, 2 TF, 2 TO, 2 WG, 2 KD, 2 YT, 5 BH, 5 BS, 5 BV, 5 CQ, 5 FS, 5 GL, 5 HT, 5 LS, 5 MO, 5 RQ, 5 SU, 6 BN, 6 GB, 6 NF, 6 SH, 6 TD, 6 TH, 6 UD. French: 8 AR, 8 AL, 8 AW, 8 BU, 8 BN, 8 BP, 8 CA, 8 CO, 8 CF, 8 DL, 8 DO, 8 DP, 8 EK, 8 EM, 8 FN, 8 GB, 8 GL, 8 HS, 8 HL, 8 JEL, 8 LO, 8 LW, 8 MUF, 8 NU, 8 NS, 8 OK, 8 PG, 8 RL, 8 RQ, 8 RM, 8 RR, 8 SL, 8 SU, 8 SSU, 8 UU, 8 WK, 8 WL, 8 WZ, 8 WO, 8 XH, 8 XR, 8 YR, 8 ZM, FL. Dutch: 0 IL, 0 KD, 0 GDJ, 0 LO, 0 TP, 0 XP, P 1. Belgian: W 2, 4 WR. Swedish: SMZY. Italian: 1 DO, 1 HT. Danish: 7 EC. Various: 3 CA, 4 SS, HBS, LOAA, 1 FL, 1 ER, WGH. * Telephony. (All between 90-150 metres.) (o—v—o.) (C. Prosser, 2 ACK.)

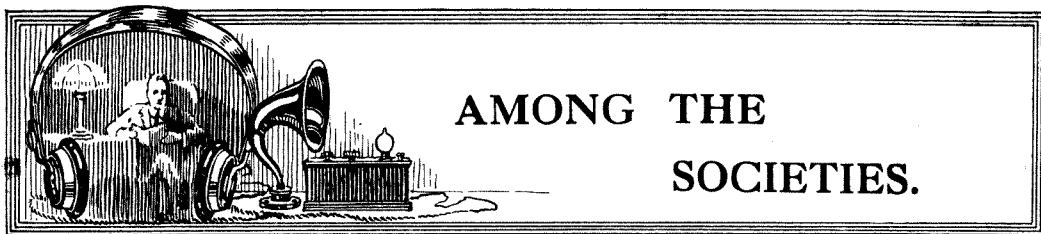

AMONG THE SOCIETIES.

RADIO SOCIETY OF GREAT BRITAIN.

An Ordinary Meeting of the Society will be held at the Institution of Electrical Engineers, Savoy Place, W.C. 2, at 6 p.m. this evening (Wednesday), when Mr. R. H. Barfield, M.Sc., will deliver a lecture entitled "Unsolved Problems of Wireless." A meeting of the Transmitter and Relay Section will be held in the same building at 6.30 p.m. on Friday, October 24th, when Mr. P. R. Coursey, B.Sc., will give a talk on High Tension Condensers.

Modern amateur transmitting apparatus formed the subject of Col. F. E. Wenger's Presidential address before the Stoke-on-Trent Wireless Society on October 9th. Before proceeding to a consideration of present-day practice, Col. Wenger had some interesting things to say on the hardships of the early amateur transmitter, who was up against the troubles of spark transmission. Rapid progress had been made in recent years since the introduction of the thermionic valve.

After the many circuits in use had been clearly explained, transmission experiments were carried out in the Lecture Room and received on one of the Society's sets.

* * * *

Over a hundred persons were present at the Hackney and District Radio Society's Public Meeting and Exhibition held on October 6th.

A large number of sets were on show and transmissions from 2 LO were reproduced on two five-valve receivers constructed by Messrs. G. E. Sandy and J. R. Jones.

Among the speakers during the evening was the Mayor of Hackney.

It is hoped that this demonstration will bring in new members.

* * * *

A Presidential Address on "Electrons" was given before the Smethwick Wireless Society by Dr. Murray, M.Sc., on October 3rd. Over 100 members and visitors were present.

Dr. Murray, who illustrated his extremely lucid remarks with numerous lantern slides, dealt with both the chemical and physical sides of his subject and enumerated the theories of Sir Oliver Lodge, Dr. Wall and others.

* * * *

A party of members of the Wimbledon Radio Society visited the All-British Wireless Exhibition on October 4th, proceeding afterwards to the London Coliseum, where Harry Tate's sketch, "Broadcasting," was included in the programme.

On the Sunday following experiments were conducted with portable apparatus on Great Bookham Common, Surrey.

At the Glasgow and District Radio Society's inaugural meeting for the winter session, held on October 8th, Mr. Eric Snodgrass, a former President, lectured on "A Neutrodine Receiver." In addition to the set under discussion, which comprised four valves, some interesting high and low frequency units were shown in which many novel features had been introduced.

FORTHCOMING EVENTS.

WEDNESDAY, OCTOBER 22nd.

Radio Society of Great Britain. Ordinary Meeting. At 6 p.m. (tea at 5.30). At the Institution of Electrical Engineers, Savoy Place, W.C.2. Lecture: "Unsolved Problems of Wireless." By Mr. R. H. Barfield, M.Sc.

Streatham Radio Society. At 35 Streatham High Road. Surprise Night.

Radio Research Society, Peckham. At 44 Talfourd Road. Lecture with apparatus "The Winhurst Machine and Static Electricity."

Halifax Wireless Club. At the White Swan Hotel. Lecture: "The Design of Broadcast Receivers." By Mr. F. H. Haynes.

Clapham Park Wireless and Scientific Society. At 7.45 p.m. At 67 Balham High Road. Lecture: "The Scientific Work of James Clerk-Maxwell." By Prof. W. Wilson.

Edinburgh and District Radio Society. Lecture: "The Flewelling Receiver." By Mr. S. Cursitor.

Tottenham Wireless Society. Discussion: "How it Works—The Valve."

THURSDAY, OCTOBER 23rd.

Institution of Electrical Engineers. At 6 p.m. (light refreshments at 5.30). At the Institution, Savoy Place, W.C.2. Inaugural Address by Mr. W. B. Woodhouse, President. Presentation of Premiums.

Bournemouth and District Radio and Electrical Society. At 7 p.m. At Canford Hall, St. Peter's Road. Lecture by Capt. E. J. Hobbs, M.C.

Derby Wireless Club. Demonstration of H.T.-less Circuits, by Mr. Groy.

Walthamstow Amateur Radio Society. Lecture: "Elementary Radio Theory." By Mr. R. H. Cook.

Luton Wireless Society. At 8 p.m. At Hitchin Road Boys' School. Experiments with New Circuits and Demonstrations for Beginners.

Hounslow and District Wireless Society. Surprise Night.

FRIDAY, OCTOBER 24th.

Bristol and District Radio Society. Social Evening at Comer's Restaurant. 7 p.m. onwards.

MONDAY, OCTOBER 27th.

Hackney and District Radio Society. At 8 p.m. At King's Hall. Demonstration of Reflex Set. By Mr. Neilson.

TUESDAY, OCTOBER 28th.

Leicestershire Radio and Scientific Society. At the Y.M.C.A. Discussion on Radio Problems.

HOW TO OBTAIN THE PLETTS MAP.

Full-size copies of the ingeniously designed map of the world on page 92 of this issue, giving the true distance and direction from London of any point of the globe, can be obtained post free for 1s. 1d. from the Wireless Press, Ltd., 12-13 Henrietta Street, London, W.C.2.

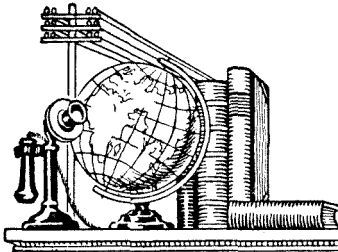

CORRESPONDENCE.

Capacity Effects on Mutual Inductance.

To the Editor of THE WIRELESS WORLD AND RADIO REVIEW.

SIR,—Referring to the enquiry on coupling in three-coil tuners on page 726 of *The Wireless World and Radio Review* of September 17th, the enquirer has stumbled across what I found out some two years ago and which appeared in a paper before the Wireless Society of London (*The Wireless World and Radio Review*, June 17th, 24th, and July 22nd, 1922) entitled "The Effects of Capacity on Mutual Inductance." I then showed that in the case of two right-handed helical coils joined as shown the electrostatic and the electromagnctic couplings are in phase; if one pair, say Ae and E,

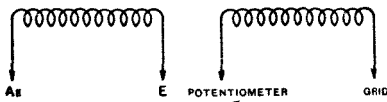

Fig. 1.

are interchanged the reverse is the case and under a certain degree of coupling may balance one another. I developed this theory into what I called the "silent point" method of elimination and I wonder that none on our southern coasts have tried this to receive 2LO through the 600 metres disturbance. I think your correspondent will find that the longer the wavelength the closer must be the coupling.

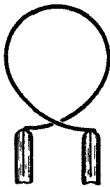

Fig. 2.

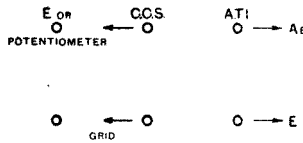

Fig. 3.

Now to make single-layer cylindrical right-handed coils correspond with honeycomb and the like as regards sign in coupling, I have found the connections to the holder should be as in Fig. 2.

Hence to avoid the silent point the connections in a three-coil mount should be, looking from the front, as given in Fig. 3.

London, S.W.5.

J. H. REEVES.

Ido and the A.R.R.L.

To the Editor of THE WIRELESS WORLD AND RADIO REVIEW.

SIR,—I am sorry to note from page 626 of your issue for August 27th, that we have embarrassed your correspondent, Mr. E. H. Turle, by our apparent inconsistency with respect to an international auxiliary language. It is quite true that when we originally undertook the solicitation of sentiments of the various national amateur radio societies of the world on this question we recommended the consideration of Ido, and I trust I am myself not unaware of the good points of that language. There is a difference, however, between recommending consideration of a thing and endorsing it.

Perhaps it is fairer to say that we did had actual Idist leanings at one time, but as our study of this problem continued we became convinced that our decision should be in favour of Esperanto. With certain minor reservations the A.R.R.L. has endorsed Esperanto, and is recommending that language to its membership.

K. B. WARNER,

Hartford, Connecticut.

Secretary-Editor.

Swedish Transmitters.

To the Editor of THE WIRELESS WORLD AND RADIO REVIEW.

SIR,—I notice with pleasure that you publish particulars of the Swedish stations at present in operation and have pleasure in adding the wavelength of SMZP, which is about 120 metres.

Signals from the short wave Swedish stations come in here very strongly and can be easily read on a single valve without aerial or earth connected, i.e., with send-receive switch open. This arrangement reduces signals to about half strength and atmospherics to about 10 per cent. of their strength on the aerial.

Reports have been received from SMZP and Finnish 2 NM of signals from my station with an aerial current of 0.22 amps on 117 metres (aerial height, 40 ft.), in each case at great strength. This radiation gives me an effective night range of about 1,000 miles, which seems to be quite satisfactory for an input of just under 10 watts.

I would be very glad to have reports from anyone using a separate heterodyne or loose coupled set stating their opinion of my note, which I am given to believe is fairly steady. My transmission times are Wednesday and Saturday, 2200-2400, G.M.T.

Edinburgh.

W. WINKLER, 2 TF.

With this method it does not necessarily follow that the vernier condenser can be dispensed with. The test gives coils of the same natural wavelength, but not necessarily of the same inductance value. If the two coils, after being balanced in this manner, have different self-capacities, the rate of change of capacity required to give a uniform rate of change of wavelength will be different in each case, and a vernier condenser will still be necessary if best results are to be obtained.

A FOUR-VALVE RECEIVER WITH SEPARATE H.T. SUPPLIES FOR H.F., DETECTOR AND L.F. VALVES.

IN the diagram given below, three separate H.T. tapings are provided for the H.F., detector, and L.F. valves, and the switching of the valves has been so arranged that each valve receives the correct anode voltage, with every possible combination of the valves.

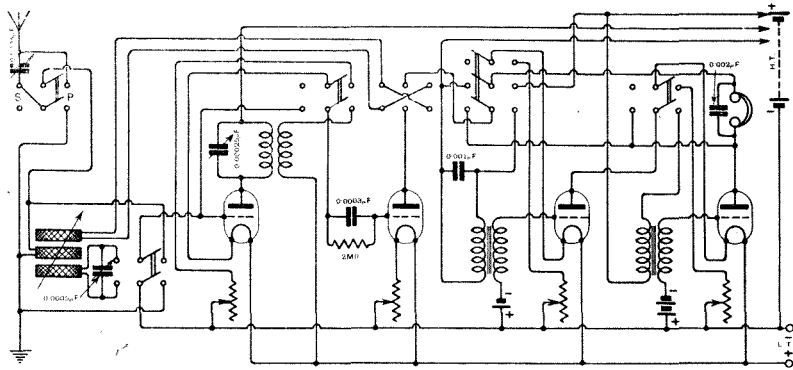

A four-valve receiver with separate H.T. supplies for the H.F., detector and L.F. valves.

In addition to the two-pole change-over switches for the H.F. valve and the last L.F. valve, a three-pole change-over switch will be required for the first L.F. valve, in order to connect the telephones to the detector H.T. tapping, when both L.F. valves are switched out of circuit. A coupled tuning circuit is employed, and the H.F. valve is transformer coupled to the detector.

It will be noticed that separate by-pass condensers are connected across the primary winding of the first intervalve transformer and the telephones. By this means the telephone condenser will always be in circuit, and may be adjusted to suit the characteristics of the telephones or loud-speaker. If the telephones or loud-speaker are not sensitive to changes of the shunting condenser, a single condenser may be connected between one side of the reaction coil and the detector + H.T. tapping, and will then be automatically connected across either the transformer primary winding or the telephones, whichever happen to be in series with the reaction coil.

THE CURVATURE OF SQUARE LAW CONDENSER PLATES.

WE have been asked recently to give an account of the methods used to calculate the curvature of condensers in which the capacity varies as the square of the angle of rotation. The method is somewhat involved, and it would not be possible to describe it in full in the small space at our disposal. Readers who are interested in this subject are referred to Chapter II of *The Calculation of Inductance and Capacity*, by W. H. Nottage, and to Chapter X of *The Principles of Radio Communication*, by Professor J. H. Morecroft. The method of calculation was due originally to Duddell.

SEPARATE H.T. VOLTAGES FOR L.F. VALVES.

WHEN switches are used to control the number of valves in use in an L.F. amplifier, there is often a difficulty in ensuring that the H.T. voltage received by a given valve is not affected when the

circuit is changed. One method which has been suggested consists in using a single main H.T. battery for all the valves, and in supplementing this voltage with auxiliary batteries connected between the plates of the valves and the change-over switches. We have been asked whether this method possesses any serious disadvantages.

The only objection that can be raised to the use of extra H.T. batteries is that these batteries must be very carefully insulated and placed in such a way that their capacity to earth is as small as possible. Any capacity to earth possessed by these batteries will be shunted between the plate of the valve and earth, and may act in such a way as to reduce the amplitude of the voltage fluctuations at the plate of the valve. It is better to employ three-pole switches to obtain variable tapings from the main H.T. battery. A circuit showing the use of switches of this type was given on page 639 of the issue of August 26th, 1924.

Another very satisfactory method of switching consists in the use of telephone plugs and jacks.

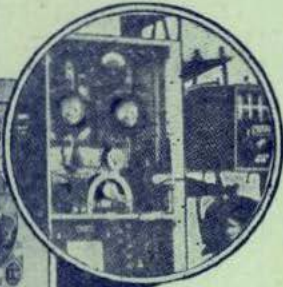
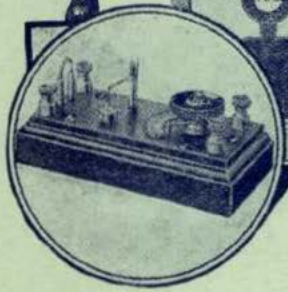

The ideal way to progressive wireless construction.

RADIO is essentially a progressive hobby. Half the attraction lies in the advancement from the chrysalis stage of the Crystal Receiver to a "Five-Valver" or even a full-blown transmitter. Yet your ultimate success depends upon the books which guide your steps along the path of wireless progress. You cannot do better than put your trust in *Wireless Press* publications. With their aid it is a simple matter for you to obtain a complete knowledge of the subject from A to Z.



The Wireless Press are the pioneers of authoritative wireless literature, catering for every possible need.

- "Crystal Receivers for Broadcast Reception." By PERCY W. HARRIS. Price 1/6. Postage 2d.
- "Construction of Amateur Valve Stations." By A. L. M. DOUGLAS. 1/6. Postage 2d.
- "Practical Wireless Sets for All-Home Construction Made Easy." By PERCY W. HARRIS. 1/6. Postage 2d.
- "The Wireless Press Ezi-Wiring Series":
 1. A Three-Valve Portable Receiver. By H. S. POCOCK.
 2. A Three-Valve Receiver (Cabinet). By F. H. HAYNES.
 3. A Two-Valve and Crystal Reflex Receiver. By W. JAMES. 2/- each. Postage 2d.
- "The Amateur's Book of Wireless Circuits." By F. H. HAYNES. 3/6. Postage 6d.
- "The Home Constructor's Wireless Guide." By W. JAMES. 3/6. Postage 3d.
- "Radio Experimenter's Handbook." Two Parts, 3/6 each. Postage 4d. each.
- "The Wireless Telephone: What It Is and How It Works." By P. R. COURSEY. 2/6. Postage 3d.
- "Wireless Telephony: A Simplified Explanation." By R. D. BANGAY. 2/6. Postage 3d.
- "The Elementary Principles of Wireless Telephony." By R. D. BANGAY. 7/6. Postage 6d.
- "Electrons, Electric Waves and Wireless Telephony." By J. A. FLEMING. 7/6. Postage 6d.
- "Wireless Valve Transmitters: The Construction of Small Power Apparatus." By W. JAMES. 9/- . Postage 9d.

THE WIRELESS PRESS, LIMITED,
12-13 Henrietta Street, Strand, London, W.C.2

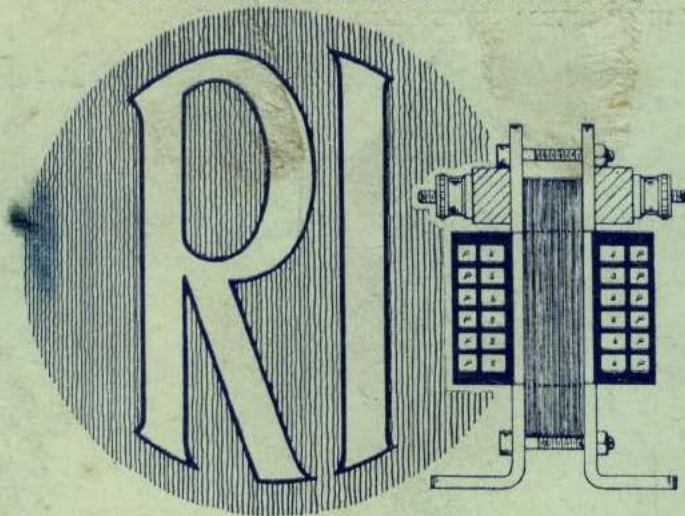

The construction that counts

True judgement and appreciation require to be based on more than outward appearance. Time after time the public are persuaded to buy the "just as good" article on the strength of similar outward appearances. The result is disappointment and distrust. Too late we rediscover the knowledge that it's the heart of things that counts.

Just look at the internal construction of the New R.I. Transformer. Note the careful symmetry of design and heavy insulation between coils. The primary and secondary are wound in twelve sections, the six sections of the primary being placed on the outside of the secondary sections, giving the lowest self-capacity (18 micro-microfarads) of any transformer in general use.

The further security of one year's guarantee is given with every new R.I. Transformer. Apart from these strong features of real worth the monogram R.I. carries more confidence for you of perfect workmanship in wireless components and sets than any other trade mark.

Price 25/-

*Ask your friends, and then write
for the New R.I. Catalogue.*

Telephone—Regent 6214-5-6.

Telegrams—"Instradio, London."

Radio Instruments Ltd.
12 Hyde Street, Oxford Street, W.1



Printed by Sanders Phillips & Co., Ltd., Chrysell Road, London, S.W.9, for the Proprietors and Publishers, The Wireless Press, Ltd., 12-13 Henrietta Street, London, W.C.2; Sydney, N.S.W., 97 Clarence Street; Melbourne, 422-24 Little Collins Street; New York, 326 Broadway.



THE WIRELESS WORLD

AND
RADIO REVIEW



PRICE 4^D NET.

LOW CAPACITY COIL

—
PICTURE TRANSMISSION
BY WIRE AND WIRELESS

—
COHERERS AND
CONTACT DETECTORS

No. 272 [No. 5]
[Vol. XV]

UNIT RECEIVER FOR EXPERIMENTAL WORK

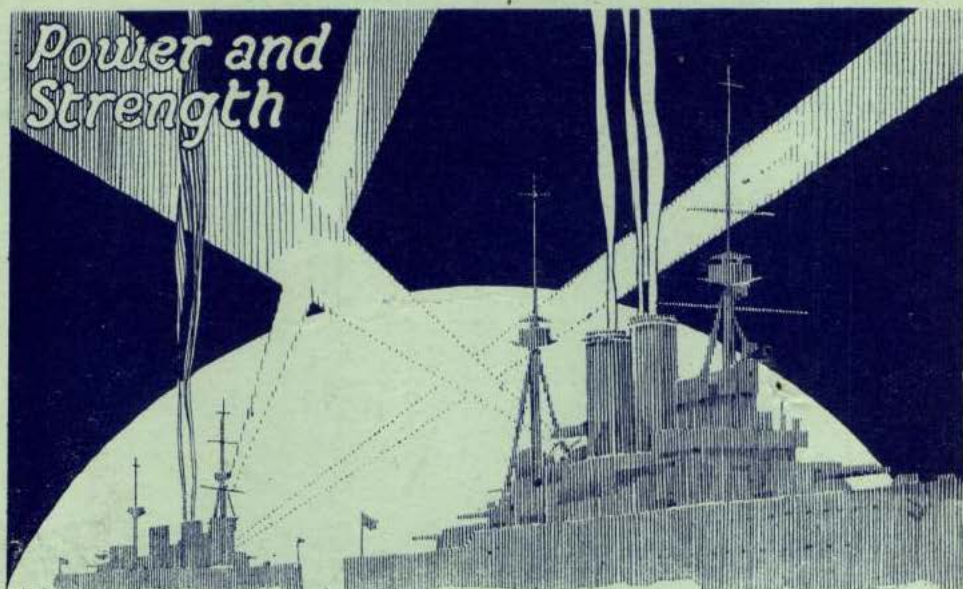

STRENGTH IN CONSTRUCTION and POWER IN OPERATION

belong to Mullard Master Valves.

Thousands of radio engineers and experimenters all over the world have secured for themselves the very best results by demanding Mullard Master Valves.

You can obtain that perfect reproduction of the broadcasting programmes that you have been seeking so long by choosing the same Master Valves.

Ask for MULLARD H.F. AND L.F. MASTER VALVES.

These wonderful valves have been designed for the wireless amateur who requires something better than general purpose valves.

The H.F. type are for **STRONG HIGH-FREQUENCY AMPLIFICATION OR DETECTION** and the L.F. type are for **PURE LOW-FREQUENCY AMPLIFICATION FREE FROM DISTORTION.**

Note the colour distinguishing rings :

Mullard H.F. Red Ring Valves, 12/6 each.

Mullard L.F. Green Ring Valves, 12/6 each.

Write for Leaflet M.8. and take greater care of your valves by asking your dealer for the Mullard safety disc, free on request. If he cannot give you this disc send us his name and address and we will send him a supply.

Mullard

THE · MASTER · VALVE

Advt. - The Mullard Radio Valve Co., Ltd. (W.W.), Nightingale Works, Nightingale Lane, Balham, S.W.12

THE WIRELESS WORLD AND RADIO REVIEW

THE OFFICIAL ORGAN OF THE RADIO SOCIETY OF GREAT BRITAIN.

No. 272. (No. 5 Vol. XV.) OCTOBER 29th, 1924. WEEKLY.

EDITOR:
HUGH S. POCKOCK.

RESEARCH EDITOR:
PHILIP R. COURSEY, *B.Sc., F.Inst., P., A.M.I.E.E.*

ASSISTANT EDITOR:
F. H. HAYNES.

QUESTIONS AND ANSWERS DEPARTMENT.
Under the Supervision of W. JAMES.

CONTENTS.

	PAGE
Radio Topics. By the Editor - - - -	121
A Three-Valve Unit Receiver. By R. H. Cook - -	123
Coherers and Contact Detectors. By James Strachan -	127
Broadcasting in Paris - - - - -	131
Inductance Calculation of Lattice Coils. By J. G. Hart	133
Readers' Practical Ideas - - - - -	135
Low Capacity Coil Design. By P. J. Parmitter - -	137
New Appliances - - - - -	138
Experimental Equipment at 2 DX. By W. K. Alford -	139
Efficient Reaction. By H. Stopher - - - - -	141
Notes and News - - - - -	143
The Transmission of Pictures by Wire and Wireless -	145
Correspondence - - - - -	146
Among the Societies - - - - -	147
Readers' Problems - - - - -	149

THE EDITOR will be glad to consider articles and illustrations dealing with subjects within the scope of the Journal. Illustrations should preferably be confined to photographs and rough drawings. The greatest care will be taken to return all illustrations and manuscripts not required for publication if these are accompanied by stamps to pay return postage. All manuscripts and illustrations are sent at the Author's risk and the Editor cannot accept responsibility for their safe custody or return. Contributions should be addressed to the Editor, "The Wireless World and Radio Review," 12 and 13 Henrietta Street, Strand, London, W.C.2.

SUBSCRIPTION RATES:
20s. per annum, post free. Single copies 4d. each or post free 5d. Registered at the G.P.O. for transmission by Magazine Post to Canada and Newfoundland.

As many of the circuits and apparatus described in these pages are covered by patents, readers are advised, before making use of them, to satisfy themselves that they would not be infringing patents.



EDITORIAL AND PUBLISHING OFFICES:

12 and 13 Henrietta Street,
Strand, London, W.C.2.
Telephone: Gerrard 2807-8.

ADVERTISEMENT MANAGERS:

Bertram Day and Co., Ltd.,
9 & 10 Charing Cross, S.W.1
Telephone: Gerrard 8063-5.

LISSENIUM

CONTROL—

and what it means.

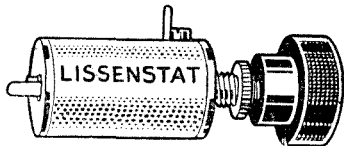

LISSESTAT (patents pending)—gives the most acute tuning possible **7/6**

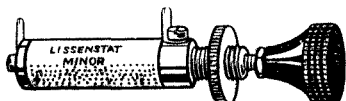

LISSESTAT MINOR (patents pending)—is replacing thousands of discarded and inefficient rheostats. Provides LISSESTAT control at a popular price. **3/6**



LISSESTAT UNIVERSAL (patents pending)—with its protective device for dull emitters **10/6**

All types have LISSEN ONE-HOLE FIXING, OF COURSE.

The express train—

the huge liner—

the record breaking car—

the super aeroplane—

efficient—powerful—capable of covering great distances at tremendous speed. Each and every one dependent upon efficient control. So, too, with the radio receiver used for distant reception—

EFFICIENT VALVE CONTROL IS ESSENTIAL.

For the purpose of covering distance—for bringing in that elusive station—efficient control is of vital importance, and efficient control means LISSESTAT CONTROL.

RECEIVERS FITTED WITH LISSESTAT CONTROL ARE EQUIPPED FOR THE FINEST DETECTION POSSIBLE.

SENSITIVITY

and its allied control, the LISSEN GRID LEAK



SMOOTH OUT YOUR LOUD SPEAKER DISTORTION BY PUTTING A LISSEN VARIABLE GRID LEAK ACROSS THE SECONDARY OF THE LAST TRANSFORMER OR ACROSS THE LOUD SPEAKER ITSELF. First position is best. The difference will be very noticeable.

Every valve you use has different characteristics—every circuit, too. Whether you are out for distant stations, or undistorted reception of nearby stations, you will find the LISSEN VARIABLE GRID LEAK very important in its effect. Only by using it can you be sure that you are using the correct grid potential for every condition of reception.

It covers a wide range of resistance values, with continuous variation throughout.

LISSEN ONE-HOLE FIXING, OF COURSE —POSITIVE STOPS BOTH WAYS. **2/6**

LISSEN VARIABLE ANODE RESISTANCE, 20,000 to 250,000 ohms, same outward appearance as the LISSEN Variable Grid Leak **2/6**

LISSEN LIMITED

Woodger Road, Goldhawk Road, Shepherd's Bush, London, W.12
Phones—3380, 3381, 3382, 1072 Riverside. Grams—"LISSENIUM, London."

DON'T MIX YOUR PARTS

The WIRELESS WORLD AND RADIO REVIEW



RADIO TOPICS

AMATEURS GIRDLE THE WORLD

[AMERICAN PAPERS PLEASE COPY]

AMATEUR achievement has made such enormous strides during the last twelve months that almost anything in the way of long distance communication seemed possible of fulfilment. We say "almost" anything because we doubt whether the dreams of the most optimistic British amateurs could ever have imagined that direct communication on such low power as they are entitled to use could have succeeded in establishing intercourse between this country and New Zealand, which is practically the farthest point from England on the globe which could be reached. For months past American amateurs have endeavoured to establish two-way communication with New Zealand, but so far without success, and therefore it is all the more to the credit of British amateurs that they should have achieved these successes in spite of the greater distance which they have had to cover.

The first intimation which we received of the possibility of Australasian signals from amateur stations reaching this country was a report from Mr. R. W. Galpin, **5 NF**, on October 6th, that on the morning of the previous Sunday, at 5.45, he heard a station calling CQ DE A2ADJ. Mr. Galpin points out that it was not for some while that he realised what he had done on account of failing to recognise the significance of the initial letter "A," which is, of course, the prefix for Australian amateur transmissions. Up till now, however, we have had no confirmation of this reception, and we believe there are no three-letter calls yet issued to Australian amateurs.

The next achievement reported to us was on Saturday morning, October 18th, when Mr. C. W. Goyder, working with the Mill Hill transmitting set, **G 2 SZ**, actually established two-way communication with New Zealand, carrying on an exchange of signals with **Z 4 AA** for over half-an-hour from 6.15 a.m. He received a congratulatory message to the Radio Society of Great Britain and was asked to inform Mr. E. J. Simmonds, **G 2 OD**, that he also had been heard strongly in New Zealand on the previous night, so that this appears to establish that the first British amateur signals to be received in New Zealand emanated from the station of Mr. Simmonds, whilst the distinction of achieving the first two-way working falls to Mr. Goyder. Mr Galpin's reception, if confirmed, would be the first reception of an Australian amateur by a British amateur.

On the morning of Thursday, October 16th, Mr. Simmonds heard the New Zealand station, **Z 4 AG**, working, and this reception was confirmed by an exchange of cables between *The Wireless World* and Mr. Slade, the owner of the New Zealand Station. Since these first achievements two-way working has also been carried out by Mr. J. A. Partridge on the morning of October 19th, and by Mr. Gerald Marcuse, Secretary of the Transmitter and Relay Section of the Radio Society. Mr. Goyder, Mr. Partridge, and Mr. Simmonds have, in addition, repeated their earlier successes, Mr. Partridge conveying congratulatory messages between the Premier of New Zealand and the High Commissioner in London.

Reports of reception of New Zealand amateur stations have also been received from several additional sources. Mr. W. A. S. Batement, of London, N.W., **G 6 TM**, heard **Z 4 AA**, **Z 4 AG** and **Z 4 AK** on the morning of October 20th; Mr. R. L. Royle, of Palmers Green, **G 2 WJ**, received these same stations also on the morning of the 19th inst. Mr. C. L. Ward, of South Farnborough, Hants, heard **Z 4 AK** calling a French and a British station, also on the morning of the 19th inst., whilst Mr. J. H. D. Ridley, of Blackheath, on an Ultra III receiver, listened to **Z 4 AA** on the mornings of the 19th and 20th inst., and Mr. F. R. Neill, of Whitehead, Co. Antrim, received **Z 4 AA** and **Z 4 AG** on 2 valves on the 19th, 20th and 21st, between 6 and 7.30 a.m., signals from the former being still readable at 7.45 in broad daylight. A further report from Mr. Hugh N. Ryan, of Wimbledon, states that he has so far heard the three stations **Z 4 AA**, **Z 4 AG** and **Z 4 AK** and that **Z 4 AA** could be heard quite well using a single-valve receiver.

It is interesting to mention that Mr. R. J. Orbell, New Zealand, **3 AA**, who has recently conducted experimental transmissions whilst on the s.s. "Timaru," from New Zealand to London, arrived in London two or three days ago and was able to work to his New Zealand friends from Mr. Goyder's station.

Such an extraordinary achievement must do much to add to the status which the amateur has already earned for himself, and there is no doubt that these results provide data of the utmost scientific value.

A "TELLING" NATIONAL SERVICE.

IT is refreshing to be able to express views having a direct relation to the General Election which is now taking place, but without encroachment on the non-political character of a wireless journal. Amid all the many activities of the interested parties plunging into the fray, there is *one* factor which is the servant of all parties, and, above all, the servant of the electorate.

To those who have watched the gradual extension of applications of wireless it is highly gratifying to note the great use which is being made of wireless throughout the length and breadth of the land for

carrying the political message to those, under ordinary conditions, beyond the reach of the speakers. We perhaps hardly realise the real value from a national standpoint of this tremendous neutral force in these days when it is a much too common habit to take things for granted. But, however nonchalant the general public may be as to the facilities provided for their general edification during the election by the medium of wireless, it must provide a source of the greatest satisfaction to those who have contributed so much in the past and those who still continue to contribute to the development and perfection of transmission and of reception.

To what higher use can the wireless be put than national service? The B.B.C. in the present crisis are deserving of the unstinted thanks of the nation at large for their patriotic action in obtaining authority to offer equal facilities to all parties for the broadcasting of political speeches. By its action in thus grasping the opportunity to serve the nation in this manner, the B.B.C. have set an example which it would be for the general well-being of the nation for all to emulate. The political educational value of the broadcasting of representative political utterances is of the highest importance.

There is no doubt that it is advisable that a limit should be put upon the extent to which wireless should be used in politics. As a means whereby leaders of political parties may acquaint the country of their policy it is invaluable, but we still hold to views expressed in an editorial paragraph recently, when we indicated that it is not always the best orator who, with his eloquence, can influence the masses, who is necessarily the best statesman or the advocate of the wisest policy.

Most of us can recall how, during the early days of wireless in this country, there was much pessimism expressed as to the ultimate value of broadcasting, but, viewing the wonderful stream of successes which have been achieved, the further hopes yet to be consummated, we take the opportunity of congratulating on this occasion all the participants in the "wireless way of progress" which, under highly efficient organisers, is rendering definite national service in many spheres, not the least of which is Education.

THE EDITOR.

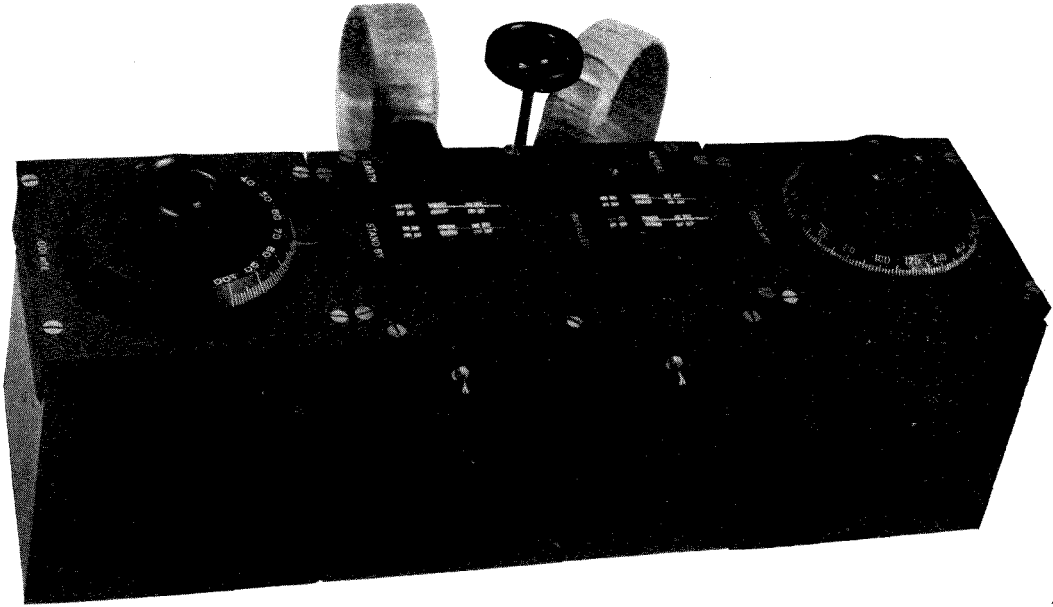

A THREE-VALVE UNIT RECEIVER.

The units of this receiver have been specially designed to permit of a number of different circuits being tried, not by altering the connections, but by plugging-in appropriate units.

By R. H. COOK.

ONE of the most popular types of receiver has always been the unit system, due, no doubt, to the fact that for a small outlay one can start with a complete set, and yet can always add to it and increase its efficiency and possibilities. Most of these sets are designed so that there is a separate type of unit for each part of the circuit. For instance, the tuner unit, the H.F. unit, the detector unit, and the L.F. unit. If only a one-valve set, consisting of the detector and tuner units, is bought or made at the outset, then, when one wishes for an extra valve, either a note magnifier or a H.F. unit is added. In this way, without incurring any heavy initial expense, one can, in time, build up quite a powerful receiver.

This is all very nice, but there is still one great limitation which stops this type of receiver from being the perfect one. To

have a two-valve unit receiver one must first of all decide which type of circuit to have, and in the general run of straight circuits one can use two valves in any of the following combinations:

- 2 H.F. valves and crystal.
- 1 H.F., crystal and note magnifier.
- Crystal, and two note magnifiers.
- 1 H.F. and valve detector.
- Detector and 1 note magnifier.

There are at least five circuits from which one can choose, and if the number of H.F. and L.F. couplings is taken into consideration, then one can more than double this number.

With the usual type of unit receiver, separate and distinct units are required when it is desired to introduce a variety of couplings.

The purpose of the present article is to describe the design of a system in which an

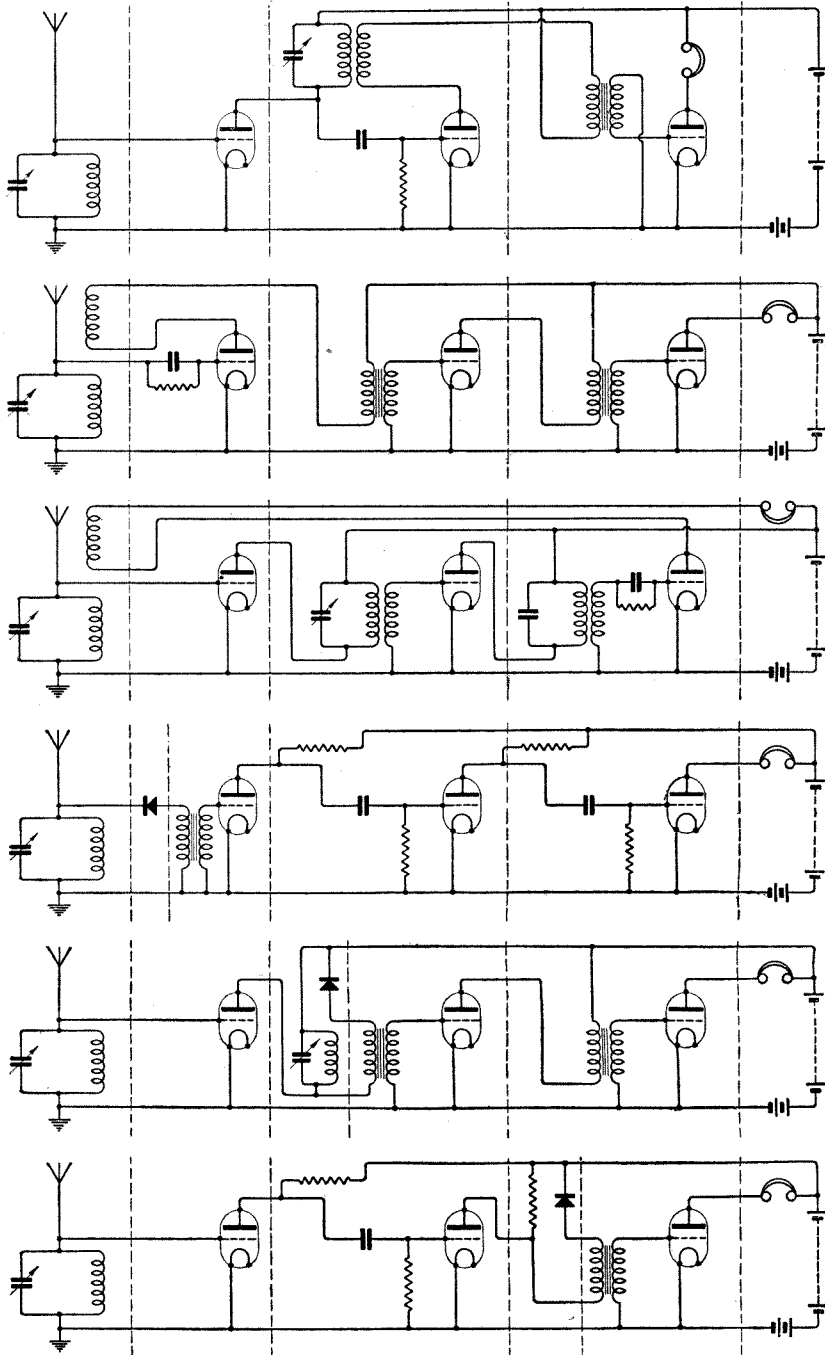

Circuits which may be tried with the unit receiver :—

Upper circuit, H.F. (tuned anode), detector, and transformer-coupled L.F.

Second circuit, detector and two stages of transformer-coupled L.F.

Third circuit, two stages of transformer-coupled H.F. and detector.

Fourth circuit, crystal detector and three stages of resistance-coupled L.F.

Fifth circuit, H.F. (tuned anode), crystal detector, and two stages of transformer-coupled L.F.

Sixth circuit, two stages of resistance-coupled H.F., crystal detector, and one stage of L.F.

attempt has been made to do away with these great limitations.

First of all it occurred to the writer that the most popular number of valves would be three. With this number of valves one can get quite a large number of circuits, some of which are shown in Fig. 1. They are divided up into units as indicated by means of dotted lines.

These circuits can be altered further by having different methods of coupling, as will be shown when describing the amplifier and detector units.

A glance at Fig. 1 will show the reader, unless he is already familiar with the fact, that all valve circuits are the same except for the method of coupling, and that even the connections for these methods of coupling are very similar.

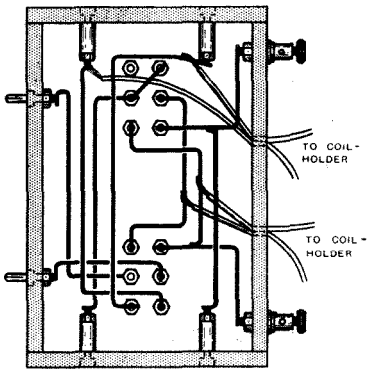

Fig. 2. Wiring of the tuning unit.

It is this fact that is made use of in the present design, and was also responsible for the H.F. amplifier published in the issue of August 13th last. Whereas in most unit systems different types of valve panels are employed, in the writer's design all valve panels are the same, whether used for detector, H.F. or L.F., and the coupling unit is plugged in.

In the article mentioned above, this method was used with high frequency couplings, but in this unit receiver the method is employed with all methods of coupling. By plugging in an L.F. transformer we have a note magnifier. By removing the transformer and plugging in an H.F. coupling the unit can be used as a second stage of high frequency amplification, or as a detector following an H.F. amplifier.

THE TUNING UNIT.

This unit consists of a panel carrying two double-pole switches, and is mounted on ebonite strips on all four sides (Figs. 2 and 3.) One of the double-pole switches is connected to the aerial circuit for the purpose of switching the aerial condenser in series or parallel with the aerial tuning coil. The second switch is connected to the aerial and closed circuits, and is employed to switch the aerial or the closed circuit to the output terminals of the unit.

The panel measures 4 ins. by 6 ins. by 1/4 in., and the ebonite strips to which the panel is secured are 3/4 in. wide. The panel and side strips are in turn mounted on a box, making the complete unit 6 ins. by 4 ins. by 4 ins.

On the left-hand side of the box is mounted the two-coil holder, as may be seen from the photograph. This can be used to accommodate the aerial and secondary coils, or the aerial and reaction coils. The two terminals fixed on the left-hand strip are for the aerial and earth connections. On the right-hand strip two valve pins are mounted. These are connected across the centre contacts of the stand-by tune switch, and fit sockets on the next unit, which are joined to the grid and filament of the valve respectively.

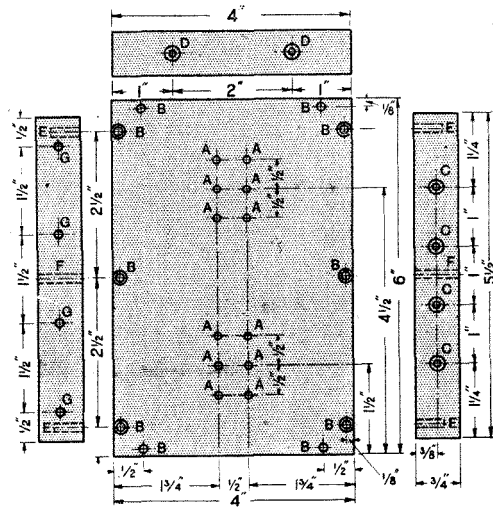
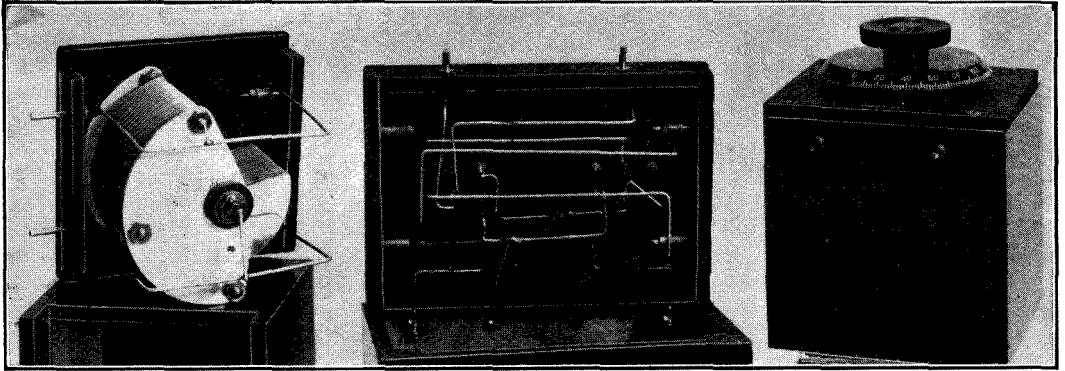

Fig. 3. Details of the panel and side strips of the tuning unit. Drilling particulars are as follows: A, 1/8" for 6 B.A. clearance; B, 5/32" and countersunk for 4 B.A. screws; C, 1/8" for 6 B.A. screws and counter bored 1/4" dia. and 1/8" deep; D, 5/32" for 4 B.A. screws and counter bored 1/4" dia. and 1/8" deep; E, tapped for 4 B.A. screws and 1/8" deep; G, 5/32" for 4 B.A. screws; H, 7/16" dia.



View of the condenser unit, the tuner unit, and of the condenser in its box.

Valve sockets are provided on the top and bottom strips of this unit. The aerial tuning condenser may be plugged in the lower sockets and the secondary tuning condenser in the upper sockets. When it is desired to couple the reaction coil with the aerial coil the plugs provided on the flexible leads from

The condenser units are simply variable condensers mounted in boxes having ebonite

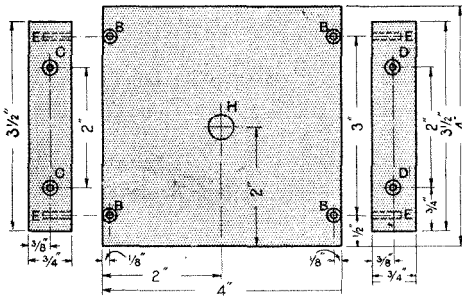

Fig. 4. Details of panel and side strips of condenser units. For drilling details see particulars given below Fig. 3.

the reaction coil unit (to be described later) are plugged in the sockets provided for the secondary circuit tuning condenser.

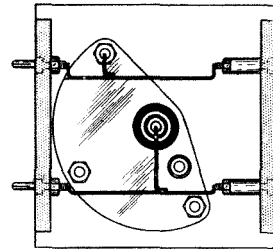

Fig. 5. Wiring of condenser unit.

strips, carrying two valve sockets on one side and two valve pins on the other side. One condenser has a maximum capacity of 0.001 microfarads, and may be employed to tune the aerial circuit; the second condenser has a capacity of 0.0005 microfarads, and is used for tuning the secondary circuit. Details of the boxes and strips and the wiring of the parts are given in Figs. 4 and 5.

RADIO POSSIBILITIES IN FINLAND.

Wireless development in Finland is not solely represented by the indefatigable efforts of **1 NA** and his confrères. Two active radio societies exist, the Finnish Radioforening and the Nuoren Voiman Liitto, the latter having a section, 100 strong, composed entirely of amateurs. The former body has over 600 members, and has as its objects

the fostering of the amateur cause, providing assistance for professional experimenters and in all radio matters acting as an intermediary between the Government and the ordinary citizen. Broadcasting is likely to begin in the very near future and already several British firms have secured orders for the manufacture of receiving sets.

COHERERS AND CONTACT DETECTORS.

Some references were made to coherers in the author's articles on "The Crystal Detector in Theory and Practice," published in this Journal recently. In the present article the subject of coherers and their relationship to modern crystal detectors is dealt with more fully.

By JAMES STRACHAN, F.Inst.P.

THERE are three distinct electrical instruments in which the peculiar properties of "loose contacts" are made use of, and which, although nearly related, differ essentially in their mode of operation.

These are,

- (1) The Carbon Microphone,
- (2) The Branly Coherer, and
- (3) The Crystal Detector.

In dealing with the theory of crystal detectors, I have so far ignored true coherer action and also microphonic action, because it was quite clear to me that they had nothing to do with rectification. Some modern writers on the subject of crystal rectification do not appear to be quite clear on this subject, with the result that their theories of rectification have been confused by the introduction of explanations of phenomena not directly connected with rectification. This confusion may be accounted for by the facts (1) that the modern crystal detector has been evolved from microphone and coherer types of apparatus and (2) that with the exceptions of Pierce and Tutton, whose suggestions I have developed into a rational theory of electronic action in crystal rectification, all other investigators have based their theories on molecular actions, such as are produced by heating effects, electrostatic and electrolytic reactions.

Further, Ettenreich* has confirmed the validity of the electronic theory of crystal rectification by his investigations of the time of reaction of the crystal detector, thus giving final and positive proof that the grosser movements of molecules or ions are not concerned in rectification. Apart from such modern evidence, however, it should

have been quite clear from simpler observations that microphonic and pure coherer action are distinct from rectification because the latter is not essential to the functioning of either microphones or true coherers.

HISTORICAL.

The first practical application of a loose contact was in the microphone invented by Hughes about 1878. The first microphone had slightly oxidised metallic contacts, but Hughes soon found carbon contacts to be the best for the purpose. It should be noted here, however, that a few years later, when attempts were being made to produce a speaking microphone or microphone-telephone, one patent covered the use of galena and pyrites as the contact materials.

The failure of clean metallic surfaces to produce microphonic contacts was explained by the observations made by Stroh, that the passage of a current through a loose metallic contact caused cohesion of adjacent molecules, resulting in a permanent reduction of resistance so long as the contact was not disturbed mechanically.

The nature of microphonic contacts was thoroughly investigated by Shelford Bidwell (1883), who showed that in the case of carbon the variation of resistance at the loose contact was not accompanied by permanent molecular cohesion, as in the case of metals, thus confirming Stroh's observations. We thus see that long before the first contact detector was invented (1890), loose contacts involving the use of carbon, metals and metallic sulphides, had been employed and their nature investigated.

The first detector used for exploring an oscillating field was the Hertz spark-gap. In 1890, Fitzgerald discovered accidentally that by reducing the spark-gap to microscopic dimensions and placing a galvanometer in the circuit, a deflection of the needle was

* *Wireless World Correspondence*, July 9th, 1924, page 431.

obtained. In this experiment the "spark-gap" was really a loose contact and rectification was obtained at the slightly oxidised metallic surfaces. This phenomenon was investigated by Lodge, who developed the idea of the loose-contact detector as distinct from the spark-gap.

In the same year (1890) Branly invented the first practical coherer operated by an applied potential. This consisted of a layer of finely divided metallic copper on a ground-glass surface in circuit with a Daniell cell and a H.R. galvanometer. In 1891 he followed this with his famous Branly tube or filings coherer, in which the copper film was replaced by a glass tube containing metallic filaments or powder.

During the subsequent five years the experiments of Branly were repeated and investigated by physicists all over Europe, and many modifications of the Branly tube were devised, but in its simplest form it remained for a long time the most sensitive and practical detector available.

From this point the development of contact detectors proceeded along two distinct lines. The idea of the single-point loose contact was followed by Lodge and Castelli and later by Eccles, giving rise eventually in other hands to the modern single-point crystal detector. The idea of the multiple-point contact of the Branly tube was developed practically by Marconi, in whose hands the filings coherer reached perfection.

The comparative inefficiency of the best coherer, however, soon gave place to the single-point contact of the galena crystal detector.

The term "coherer" (which we owe to Lodge) was applied without discrimination to all the early forms of loose-contact

detectors, which, it should be noted, were all operated by an applied potential from a local battery. The word "coherer" suggested a loose description of the mode of operation of these detectors which, by "coherence" of the loose contacts, effected a reduction of their resistance, thus allowing the current to pass from the local battery.

THEORIES OF COHERER ACTION.

The early workers on contact detectors invented various theories to account for the cohering of the loose contacts. Branly was of the opinion that in addition to electrostatic attraction of the adjacent particles, the thin intervening layer of dielectric became a conductor under the influence of oscillations. Turner, Minchin and Appleyard showed that coherer action still took place when the air dielectric in a Branly tube was replaced by such substances as resin, gelatine and gutta percha, the metallic

filings being immersed in these media. Haga (1896) was the first to observe through the microscope the actual bridging of the air dielectric film between two metal conductors in close proximity under the influence of a potential difference,

Diagram showing the Evolution of the Crystal Detector in 25 years.

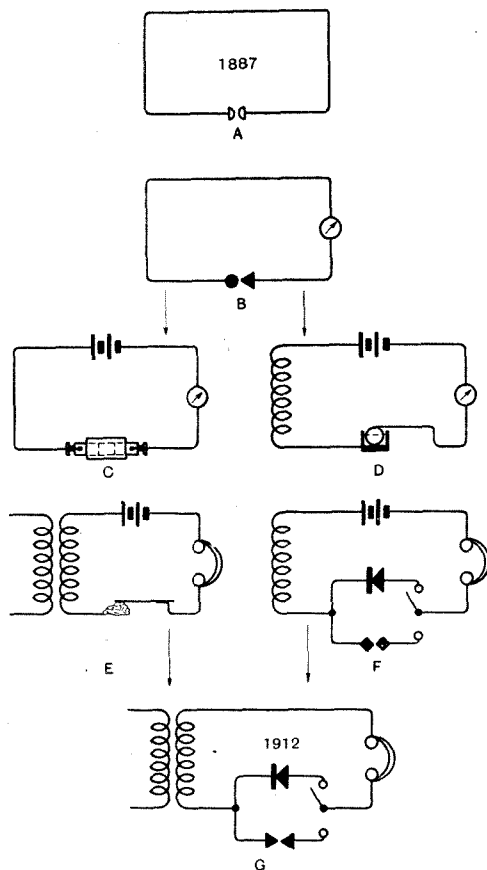

A, spark gap (Hertz); B, microscopic spark gap = loose contact (Fitzgerald & Lodge); C, multiple-contact coherer (Branly); D, single-contact coherer (Lodge-Muirhead); E, multiple-contact carborundum detector; F, single-point film coherer and galena coherer; G, modern galena and perikon crystal detectors.

a practical confirmation of the observations made by Stroh and Shelford Bidwell many years previously. Turner and others observed that the most sensitive coherers were obtained with certain easily oxidisable metals such as copper and aluminium, whence arose the theory that the variations in resistance of a coherer were due to the formation and disruption of oxide films. It was also observed that with such oxide-film coherers, actual repulsions of the loose contacts occurred so that the idea of "cohering" action was not quite adequate. More recently, as fully described and referred to in my recent contributions in this Journal on "The Crystal Detector in Theory and Practice," Eccles developed the thermal theory in explanation of the action of the oxide film coherer. Finally, in the same articles, I have shown that film coherers (both oxide and sulphide) are essentially identical in operation with crystal rectifiers and that rectification is associated with electronic movements. In this respect film coherers, whether oxide or sulphide, are distinct, in their mode of operation, from true metallic coherers.

CLASSIFICATION OF COHERERS.

All the early forms of coherer detectors were of the "non-self-restoring" type, the cohering of the loose contacts being permanent until the sensitive condition was restored by some automatic mechanical arrangement. The Branly tube type of coherer was "decohered" by a tap from an electro-magnet worked through a relay. In the so-called "self-restoring" type of single contact coherers with carbon-mercury and steel-mercury contacts (Castelli and Lodge-Muirhead types), similar results were obtained in decoherence by taking advantage of the electro-capillary properties of mercury and rotation of the contact point. This division of coherers into "self-restoring" and "non-self-restoring" types was arbitrary. The first true self-restoring detector was arrived at when carborundum powder was used instead of metal filings in the Branly tube. This was an advance but it was really a rather inefficient crystal detector and led back to the single contact type of detector.

When it became recognised that oxide and sulphide films on metal were not only better as detectors than clean metallic contacts,

but that with a proper thickness of the oxide or sulphide film and a single point of contact rectification was effected, the rapid evolution of the modern crystal detector became possible.

DISTINCTION BETWEEN METAL COHERERS AND FILM COHERERS.

Experiment with the powerful oscillations of B.B.C. telephony brings out clearly the distinction between true coherer action with clean metallic filings, and that of film coherers in which the metals used are oxidised or sulphidised. In the former, when care is taken to exclude atmospheric influences by immersion of the contacts in oil or in an inert gas, the Branly tube will not respond to telephony. Film coherers, however, rectify and bring in telephony. In the latter the degree of rectification depends on the thickness of the film and the resistance of the contacts. With a low resistance multiple-point contact (such as a Branly tube with very slightly oxidised filings), the degree of rectification is very small. With a suitable thickness of film and a single-point contact the degree of rectification is, in some cases, quite as good as with a crystal detector. From numerous experiments it appears quite certain that the increased sensitivity of very slightly oxidised surfaces in the early coherers was due partly to the slight degree of rectification obtained and partly to the fact that such contacts responded more rapidly to mechanical decoherence in the reception of oscillation trains.

NATURE OF THE REACTIONS AT LOOSE CONTACTS.

During the writer's exhaustive experiments with contact detectors of all kinds, he was able to distinguish between three types of reaction, as indicated above, at loose contacts, *viz.* :—

- (1) Microphone action.
- (2) True coherer action.
- (3) Rectification.

From these experiments it appears that :
(1) Microphonic action occurs at any loose contact having a variable resistance but without cohesion of the contact molecules. Substances giving microphonic contacts are carbon, certain metallic oxides and sulphides and intimate mixtures of finely divided metals with inert substances. The action is molecular.

(2) True coherer action takes place perfectly only between clean metallic contacts and is accompanied by cohesion of the contact molecules. The cohesion produced by a feeble current is destroyed by a mechanical shock. With very slightly oxidised metallic contacts the degree of cohesion is much less and de-cohesion more easily effected. The action is molecular, and most probably electrostatic in nature.

(3) Rectification occurs at loose contacts between metals and certain badly conducting substances, chiefly oxides and sulphides, or between the latter themselves. The action is electronic but is accompanied by attraction and repulsion of the contact molecules, giving rise to molecular vibrations and microphonic action. The best degree of rectification with the least microphonic action is obtained between a rigid metallic point and a rigid rectifying substance. When the contact is made between rectifying substances (without a metal point) held in position by springy metallic fittings, microphonic action is most pronounced and the degree of rectification is not so perfect.

RECTIFICATION A SURFACE PHENOMENON.

In the electronic theory of rectification advanced recently by the present writer, stress was laid upon the fact that this reaction is a surface phenomenon. This is most clearly brought out in experiments with single-point film coherers, which latter should really be described as film rectifiers as they are *not coherers*. Round was the first to point out that crystalline structure is not essential in rectifying substances. Many amorphous powders under proper conditions will rectify. It cannot be denied, however, the orientation of the molecules in crystalline rectifiers determines the most efficient degree of rectification at the surface, and that the conditions under which amorphous substances act as efficient rectifiers are such that they become or behave as crystalline bodies.

For example, galena or lead sulphide may be used as a detector in three different forms, using a metal point at the loose contact.

- (1) Crystalline, as in the modern crystal detector.
- (2) As a thin film deposited in "metallic" form on a metal surface.
- (3) As an amorphous powder lying loosely on a metal plate.

(1) and (2) rectify without an applied potential while (3) requires an applied potential from a local battery.

In (2) the galena film is crystalline and probably pseudomorphous after the crystalline structure of the metal.

In (3) the application of the applied potential induces crystalline conditions at the loose contact and rectification persists after the applied potential is removed, so long as the loose contact is not disturbed mechanically. In each of the three cases the direction of the rectified current is the same as that of the natural galena in a pure state, *viz.*, galena — *ve*, "catwhisker" + *ve*.

While the conditions under which (2) and (3) are exactly those of the so-called film coherers, it should be apparent that the nature of the reaction is the same in each case and is produced at the surface of the contact molecules. In this connection it should be remembered that there is really no difference in the ultimate structure of most amorphous substances as compared with their crystalline forms. The difference lies in the orderly orientation of the crystalline form. This order may be natural, it may be pseudomorphous, or it may be acquired under the conditions described above.

A film coherer, whether oxide or sulphide, is really a good conductor coated with a film of rectifying substance, and as rectification is a surface phenomenon, a film of the requisite thickness is all that is required.

In my theory of rectification I postulated that the outside film of a crystal alone was concerned in the rectification and that this film possessed different physical properties from the interior molecules. This statement of a fact hitherto unrecognised has received unexpected support from an entirely different quarter, in Professor Desch's work on the surface-tension of crystals recently read at the British Association meeting in Canada.*

PRACTICAL POINTS.

So far this description of coherers and their relationship to the modern crystal detector is largely historical and theoretical, nevertheless useful, I hope, in clearing up some of the confusion that has surrounded the subject.

The question remains as to whether anything of practical importance may yet arise

* "The Crystal Surface," by Prof. C. H. Desch, Mathematics and Physics Section of the B.A.

out of the coherer. The modern crystal detector has been evolved from the coherer—is there any other line of research in this subject offering prospects of interesting work?

With regard to pure coherer action with pure metals, the most promising line of research lies in experiments with colloidal suspensions in non-conducting liquids.

With reference to microscopic effects, while we should endeavour to reduce these as much as possible in the crystal detector by proper design of apparatus, there is an interesting field in the opposite direction, *viz.*, by developing the microphonic reaction

to the utmost so that the rectifier becomes also the reproducer of telephony. Leslie Miller's "Thermophone," described several years ago, is a step in this direction. The combination of crystal rectification with speech reproduction and without a magnetic circuit is enticing.

In a subsequent contribution I shall deal with some practical forms of "film coherers," all of which are much better than the best of the early forms of this type of apparatus, and of considerable theoretical interest, while some of them are not inferior to the best crystal detector, although more difficult to manipulate.

BROADCASTING IN PARIS.

THE PETIT PARISIEN STATION.



The erection of the aerial masts is shown in the above pictures.

Few broadcast listeners in this country possessing valve receivers are unfamiliar with the transmissions from at least one of the Paris broadcasting stations. In this article first-hand information is given concerning the equipment of the most recently erected station in the French capital.

UNLIKE London, Paris has several broadcasting stations in operation, and although Eiffel Tower, PTT and Radio-Paris have been well-known for a considerable time, public interest

is now being directed in a large measure to the more recently opened station, which is owned by the *Petit Parisien*, the largest French daily newspaper, which claims a total circulation of about 1,600,000.

The station is located in the building occupied by the offices of the journal itself on the Rue d'Enghien, in the centre of the busiest thoroughfares of Paris. The aerial masts were erected on the roof of the building, a task which proved very difficult, since the roof, or rather roofs (for it is actually supported on two), were not designed to carry this additional weight. The two masts are uniform in pattern, and since they are erected on the roofs of two separate buildings which differ in height, the aerial is not quite horizontal. The height of one roof is 77 ft., whilst the other is 74 ft. Each mast weighs $2\frac{1}{2}$ tons, and is 70 ft. high.

same type as that at present used at the station PTT. A Western Electric carbon diaphragm microphone is used, and an amplifier for amplification between the microphone and the modulator valve. The power for the transmitter is furnished by the city power mains, two generators supplying plate and filament currents for the valves.

The illustrations which we reproduce here are of interest. Those showing the erection of the masts indicate clearly the difficulties which had to be contended with in putting up these on the roofs of the buildings. The centre photograph shows the completed mast

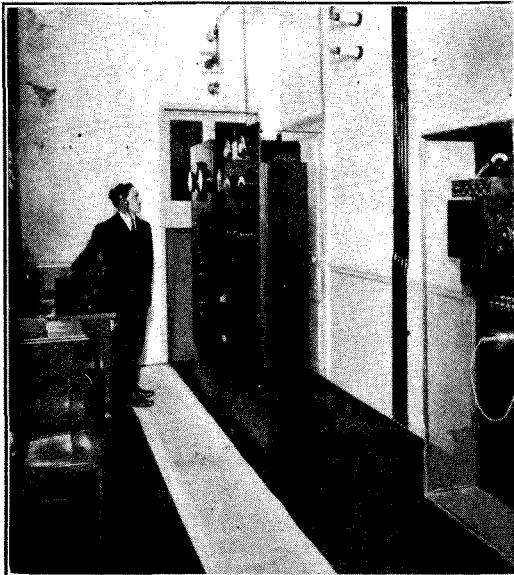

The control room is shown in the picture on the left and below, a view of the studio with the microphone on the extreme right.



The aerial is about 90 ft. in length, and consists of three horizontal parallel wires. The radiation from the aerial is stated to be 500 watts, and the input is $1\frac{1}{2}$ kilowatts. The station, as is generally known, works on a wavelength of 340 metres.

A counterpoise is used instead of a direct earth connection, and this is formed of ten wires about 120 ft. long, comprising a sort of "mat" 30 ft. wide under the aerial. The employment of the counterpoise was found to obviate interference from the large number of motors and other electrical machinery employed in connection with the newspaper printing presses.

The actual apparatus is designed by the Western Electric Company, and is of the

towers and aerial. Other photographs on this page show the control room and the studio. It will be observed that the studio is draped in the usual manner now adopted in broadcasting in order to eliminate echo effect and otherwise improve the acoustic properties of the room.

In France public interest in this station is growing very rapidly, but is not confined to that country, since the station can be heard over a wide area.

Numerous reports from amateurs and others are received from Scandinavia, Algeria, Spain (including the South of Spain), and from Germany, whilst reception in England is commonly reported from many parts.

THE INDUCTANCE OF LATTICE COILS.

A rapid method is outlined for the calculation of the inductance of lattice-wound coils which extends the graphical method of Mr. W. H. Nottage, in his "Calculation and Measurement of Inductance and Capacity," the second enlarged edition of which has recently been published.

By J. G. HART, B.Sc.

RECENT articles show that a need is being felt by experimenters for more exact methods in the measurement of the electrical constants. Unfortunately this frequently involves more than the average mathematical knowledge and more time than can be spared. Nevertheless it is inevitable that as a science progresses more exact processes of calculation are needed and in this connection the following words of Lord Kelvin should be taken to heart by experimenters: "When you can measure what you are speaking about and express it in numbers, you know something about it, but when you cannot measure it, when you cannot express it in numbers, your knowledge is of a meagre and unsatisfactory kind."

It is to be hoped that in time all manufacturers will quote the inductance values of their coils.

Lattice coils are easily made and are efficient, as the spacing between layers renders them of reasonably low self-capacity.

The formula $L = 0.001 \pi^2 (N^2 d^2/l) K^1$ microhenries (on page 19 of Mr. Nottage's book*) gives results rather too high, especially for the first few layers, but is sufficiently accurate for a first approximation. When a closer result is required it is better to find the self-inductance of each layer and the mutual inductance between layers. The method outlined below shows how to arrive at these values by a graphical method with the minimum of labour; it is in fact only necessary to calculate

- (a) Self-inductance of first and last layers as solenoids,

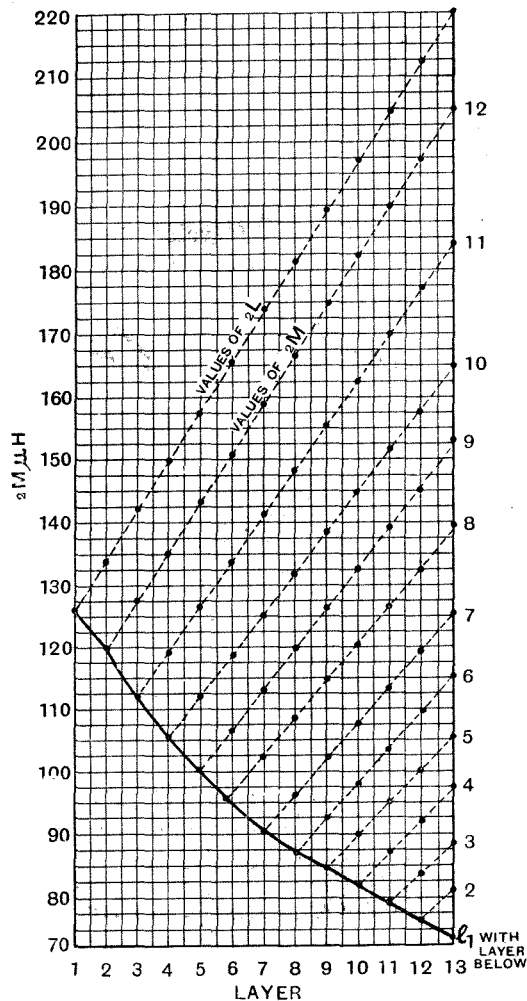

Fig. 1. Mutual inductance between layers of lattice coils wound with No. 32 D.C.C. wire; 30 turns per layer.

* Published by The Wireless Press, Ltd., price 7/6 net.

(b) Mutual inductance between first and second, first and third, and so on.

With a coil having 16 layers, therefore, it is only necessary to make $2 + 15 = 17$ calculations instead of $17 + 17 (16) = 289$, the reason being that the graphs show that it is sufficiently accurate to assume a straight-line law for the remaining values.

The calculation of the mutual self-inductances are best carried out by Mr. Nottage's graphical method (page 37 of his book) and it is found that it is sufficiently accurate to arrange the numbers of turns N_1 in each layer in such a way that there are $\sqrt{N_1}$ groups or the nearest integer to that value, e.g., if there are 30 turns it suffices to take 5 groups of 6. This can be readily seen by taking different groupings and plotting a graph for the values of M_x ; it will be seen that the curve becomes asymptotic where the number of groups is approximately $\sqrt{N_1}$.

The majority of the work involved is that in the calculation of M_x values and the graphical extension saves the majority of these being separately determined. Similarly the calculation of

$2M_{AB} = 0.002 N_1 N_2 \sqrt{R_1 R_2} M_x$ microhenries is also saved as the values of $2M_{AB}$ are necessary only for the end values indicated above.

Figure 1 shows the relation between the various values of $2M$ and $2L$; the thick lines join the minimum number of points which have to be determined in the usual manner and the dotted lines show those which can be predicted from those already known. If great accuracy is desired it is better to calculate also $2M$ between the last layer and each of the others to give the exact slopes of the dotted lines which diminish slightly as we reach the bottom of the graph. All that remains then to find the total inductance of the coil is to sum up the values of L and of $2M$ between each pair of layers. This diagram incidentally shows the relation between L and M .

Figure 2 shows the final result compared with that obtained by using the Coursey formula.

The example taken was that of a lattice wound 32 d.c.c. coil on a cardboard former of approximately 5 cm. diameter—the axial length was 1.67 cm. for 30 turns, and the radial increase per layer was 0.11 cm.

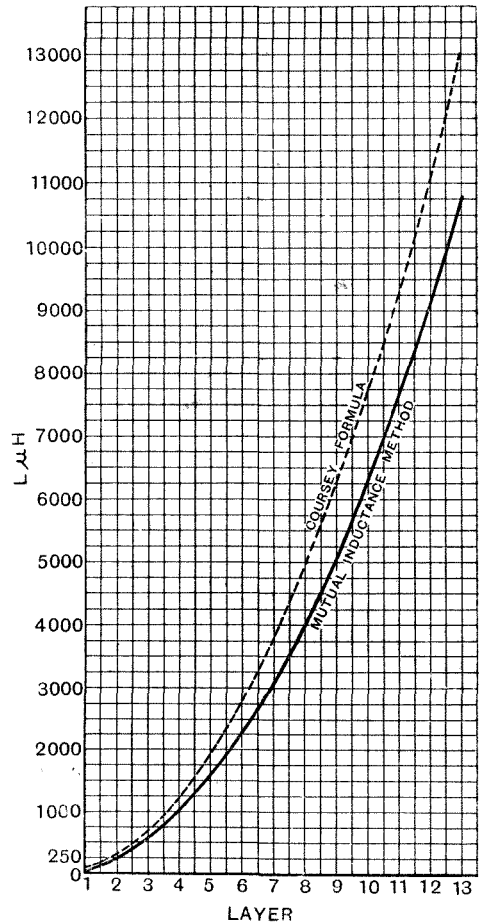
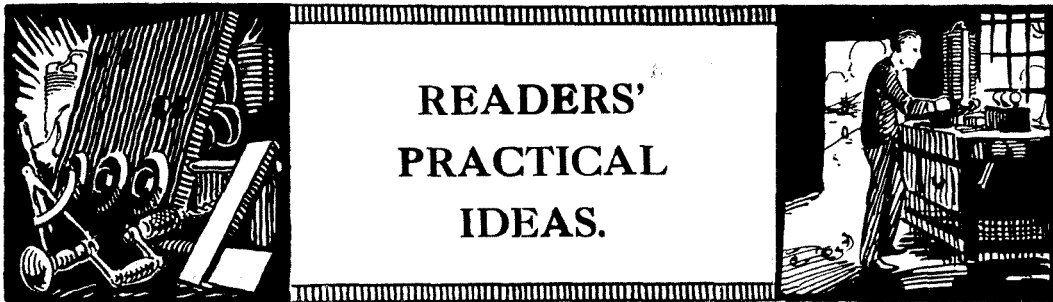

Fig. 2. Inductance of lattice coils, No. 32 D.C.C.; 30 turns per layer.

Similar results have been worked out for 26 d.c.c. wire and the curves follow the same law.

The corrections for spacing have been found to be sufficiently small to neglect, being only 22 microhenries for a coil of 15 layers.



This section is devoted to the publication of ideas submitted by readers and includes many devices which the experimenter will welcome.

Simple Extension Handle.

WHEN tuning to distant stations it is a well-known fact that an extension handle attached to the knob of the variable condenser is a great help in avoiding hand capacity effects, while the long handle greatly facilitates critical adjustment. One of the easiest methods of fitting an extension handle consists of tapping a hole into the side of the knob and inserting a piece of

holder of rigid construction which can be relied upon to make good contact.

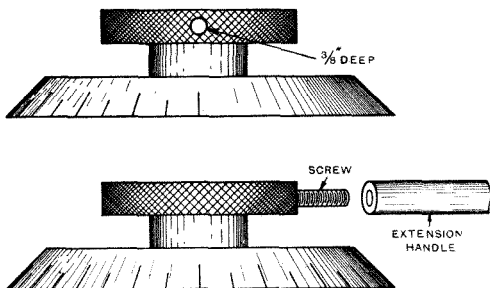

A simple method of connecting an extension handle.

6 B.A. threaded rod. The projecting piece of rod is made to engage on the tapped ebonite handle, which may be about 6 ins. in length. C. S. B.

Interchangeable Coil Mounting.

IT is doubtful if adjustable coil mounting can be constructed to a more economical design than that shown in the accompanying illustration. The sockets are made by twisting No. 16 wire tightly round a piece of 1/8 in. brass rod, whilst the stem consists of a hook-shaped bent wire. Attachment is made to the ebonite merely by putting the wire through a hole and the result is a coil

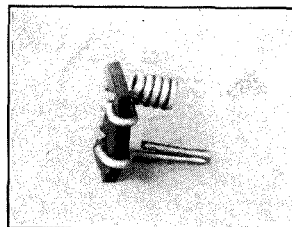

Showing how bent wire can form a good coil mount.

Two coils can be coupled together by means of a swivelling joint built up from

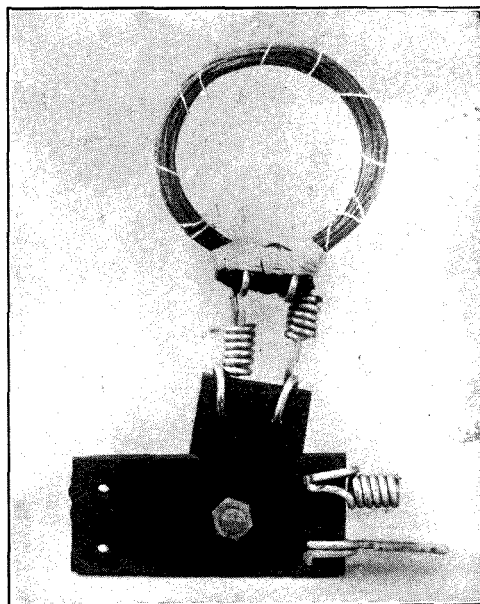

A two-coil holder with provision for variable coupling.

a piece of threaded rod, two nuts, a few washers and a split spring washer. The mount for attaching to the coil is shown in the smaller illustration.

G. W. A.

Tapped Plug-in Coils for Long Wavelengths.

THE inefficiency which may result by using tapped coils is not so serious on an inductance entirely devoted to long wave tuning as in the case where a short wave coil is loaded up to receive on the longest wavelengths. As the large plug-in coils are expensive and a considerable number of them may be required to cover the wave-band of 2,000 to 20,000 metres, it will be found useful to tap out a large inductance.

The method of making the tapplings is shown and the first and last of the plugs connects to the beginning and end of the winding so that any portion can be put in circuit by means of the two sockets attached

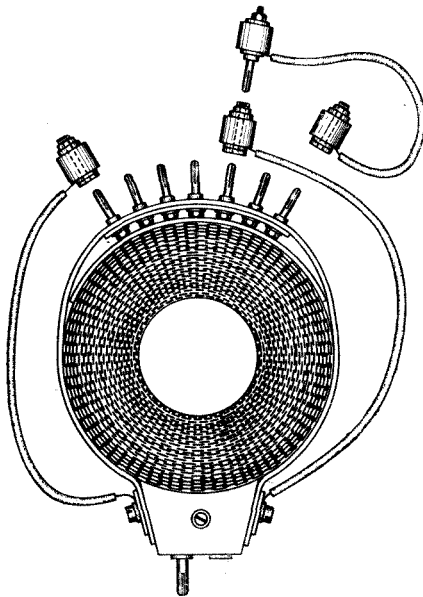

The coil can be tapped as desired, and dead-end turns can be short-circuited.

to flexible leads joined to the base of the coil holder. The pegs are the usual valve legs inserted in a piece of ebonite

1/32 in. in thickness, whilst another piece of ebonite is placed over the winding to prevent the nuts damaging the insulation on the wire. A short circuiting plug is shown and this will be found useful for extending the wavelength range, by connecting portions of the coil in parallel.

H. M.

Double Pole Panel Switch for H.F.

THE accompanying drawing shows all the necessary constructional details for making up a switch of high efficiency for use in high frequency circuits.

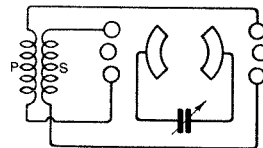
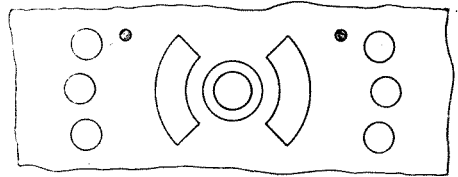
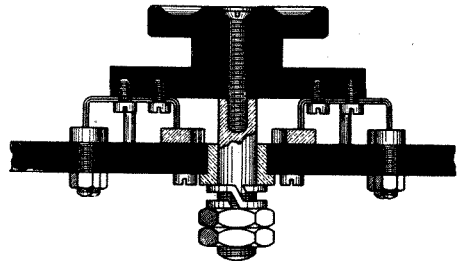

Design for an efficient panel switch and a suggested application.

A switch of this sort has many applications and one way in which it can be usefully employed is shown in the circuit diagram. Here the tuning condenser is transferred from the primary to the secondary winding, and if the coupling between the primary and secondary is not excessively tight the tuning range may be extended in this manner when the two windings consist of a different number of turns.

A. L.

LOW CAPACITY COILS

A NOVEL METHOD OF SUPPORT

By P. J. PARMITER.

IN the design of low capacity inductance coils for short wave reception such as those described in *The Wireless World and Radio Review*, Vol. XIII, p. 613, drilled ebonite strips are used to support the turns. This method of construction involves a considerable amount of accurate drilling, and the subsequent assembling is a rather difficult matter as the ebonite strips are liable to split when manipulating the relatively stiff wire through the holes.

Now a No. 16 gauge wire is practically self-supporting, and therefore, as the principal use of the strips is to keep the coils in shape, there is no considerable strain imposed upon the supports when the final assembling is completed.

Another way to achieve the same result with the advantages of greater strength and unbreakable construction is as follows.

First wind the coil of the desired dimensions and number of turns, using say a No. 16 gauge wire (which may be insulated if so desired) upon a firm yet somewhat resilient mandril. The writer uses a length of strawboard tubing, $3\frac{1}{2}$ ins. diam. and $\frac{3}{8}$ in. thick.

After winding, the wire is sufficiently springy to render its removal from the former an easy matter.

The loose coils are now secured by means of cotton or thin string, and electrical insulating beads in the following manner.

A doubled length of the string or silk is passed over the top turn, a bead is then slipped over the free ends of the string and

pushed up close to the wire. The ends of the string are separated so as to embrace the next turn, after which they are brought together and another bead slipped on, this process being continued until all the turns have been secured. The free ends of the string are then tied and cut off.

This is repeated four times at intervals of 90 degs. around the circumference of the coil, or with small coils three rows at intervals of 120 degs. will suffice to render the coil both rigid and unbreakable.

If the turns are required to be closer together than the thinnest available beads will permit, they may be replaced by knots in the string, or even by crossing thicker string, lattice pattern, between the turns.

The ends of the coils may be joined to the standard plug

contacts. Similar coils may be wound for transmitting inductances, in which case one long coil may be subdivided into a number of sections. The ends can be connected in series by single plugs and sockets, which are staggered around the built up inductance. In this way the inductance of the coil may be adjusted as desired by adding or by removing the "units" or small coils of which it is composed, the plug and socket connections rendering this an easy matter.

If the final inductance is too long to be self-supporting it can be strengthened by a skeleton former of insulating material.

Tappings can be taken from the plug and socket connections by means of clips or by soldering on short leads.

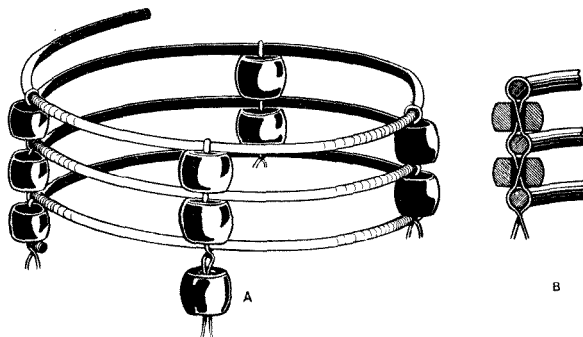

Bead spacers for low capacity coils.

NEW APPLIANCES.

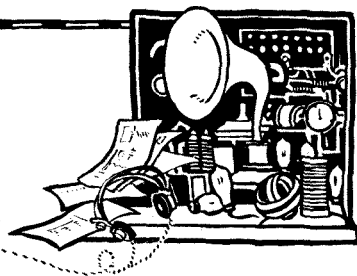

The Anti-phonic Valve Holder.*

The valve holder is sketched in Fig. 1, where A is a base provided with fixing holes B, and C is the holder which contains the valve sockets. The holder C is fastened to the base by four springs D, which are secured at one end to the valve sockets, and at the

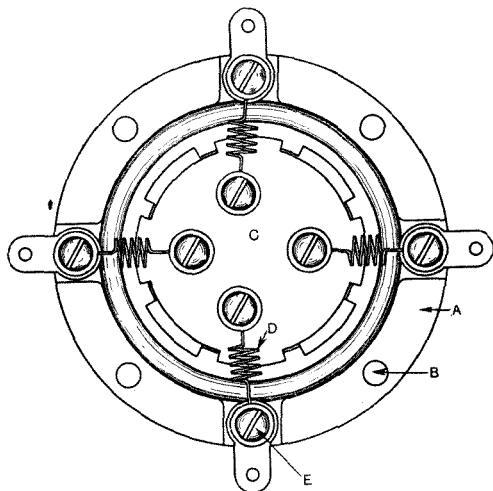

Fig. 1. A sketch of the underside of the holder showing more clearly the principle adopted.

other to the base by screws E. The valve is thus supported on springs, which absorb mechanical shocks and protect the filament. The springs are of sufficient strength to withstand straining when a valve is inserted or withdrawn.

The risk of burning out the filament by inserting the valve in the wrong position is eliminated, the sockets being sunk below the surface of the holder.

* Messrs. Burndept, Ltd.

The valve holder is $2\frac{1}{8}$ ins. in diameter, and is suitable for mounting on a baseboard, or may be mounted on the rear side of the panel, and will be found very useful in portable receivers as well as in receivers employing dull-emitter valves, particularly those of the class which take a filament current of 0.06 ampere.

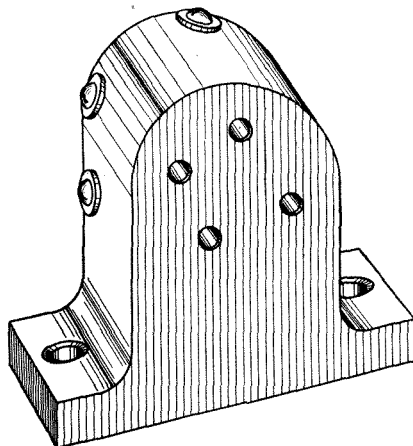

Fig. 2

The Aermonic Valve Holder.

The valve holder sketched in Fig. 2 has been designed for screwing to the back of the panel. The base of the holder is 2 ins. long by 1 in. wide, and the centre of the valve, when mounted in the holder, is about $1\frac{1}{4}$ ins. from the edge of the base.

The material of the holder appears to have satisfactory insulating properties.

To remove the possibility of the valve being inserted in an incorrect position, the brass sockets terminate about $\frac{1}{8}$ in. from the surface. Special attention has been given to the arrangement of the sockets from the point of view of easy wiring.

EXPERIMENTAL EQUIPMENT AT 2DX.

By W. K. ALFORD.

A RATHER interesting indication of the remarkable advances of amateur wireless during the last ten years may be gained by turning up the October 1914 number of *The Wireless World*. The equipment of **TXK**, now **2DX**, is therein described, with a photograph of the apparatus.

Gone is the 400 cycle spark set whose range seemed to vary inversely as the power input; likewise the receiver with its loose couplers, crystal detectors and enormous

THE PRESENT TRANSMITTER.

The general arrangement of the transmitting gear is shown in the photograph, which at first sight gives an impression of inadaptability.

However, the whole system is capable of the most flexible re-arrangement for experimental purposes, bus-bars and terminal boards being provided at the back of the panel, which is quite open.

This method, incorporating tidiness with efficiency, appeals to the writer, and pickle

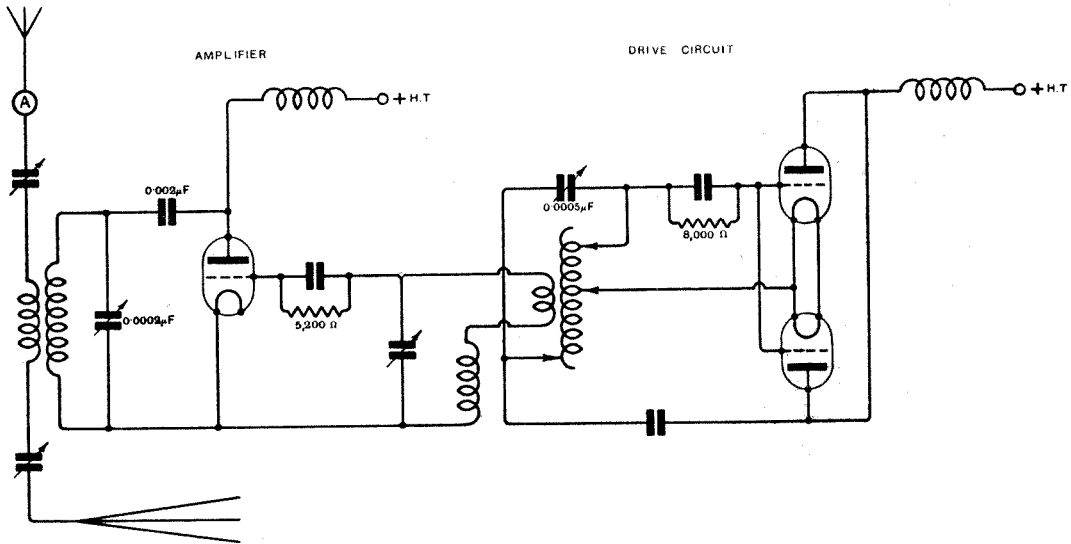

Fig. 1. Diagram of the transmitter circuit now in use.

variable condensers, though this receiver achieved the somewhat noteworthy reception of the old Marconi spark station at Glace Bay, Nova Scotia, on 9,000 metres, hence the enormous "cheese box" inductance in the left centre of the photograph.

A point of interest lies in the fact that a De Forest Audion valve was obtained at the end of 1913 and used quite successfully, but since the principle of regeneration was unknown at that time little advantage was gained over the crystal receiver.

jar and jampot apparatus does not find its place in the equipment.

Lastly, and not least, safety in operation has been considered, as fairly high voltages, between 4,000 and 5,000, are available. Nobody who is continually receiving shocks from the apparatus can maintain a mental equilibrium consistent with fruitful research.

The investigations proceeding at the time of taking the photograph concerned the application of the master oscillator system to short wave transmissions.

The aerial, closed circuit, and grid circuit inductances are seen at the top right, and are wound with 6 S.W.G. H.C. copper wire.

The master oscillator or drive circuit inductances are seen at the left, and although rather more than necessarily large, happened to be available and function perfectly.

The high potential is rectified by two Mullard U 50 rectifying valves, which handle up to 3,000 volts at a maximum of 0.12 amperes.

Four Amrad "S" tubes W4,000 are being tried in the rectifying circuit. These tubes have a remarkable rectification characteristic,

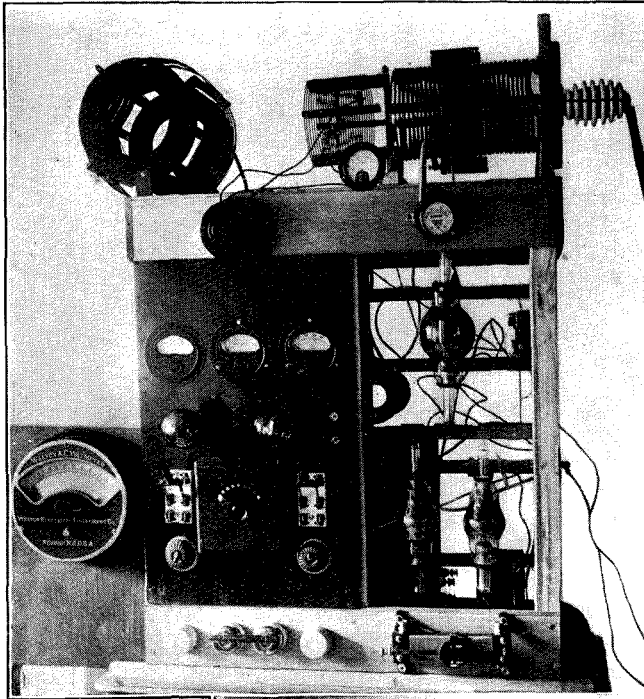
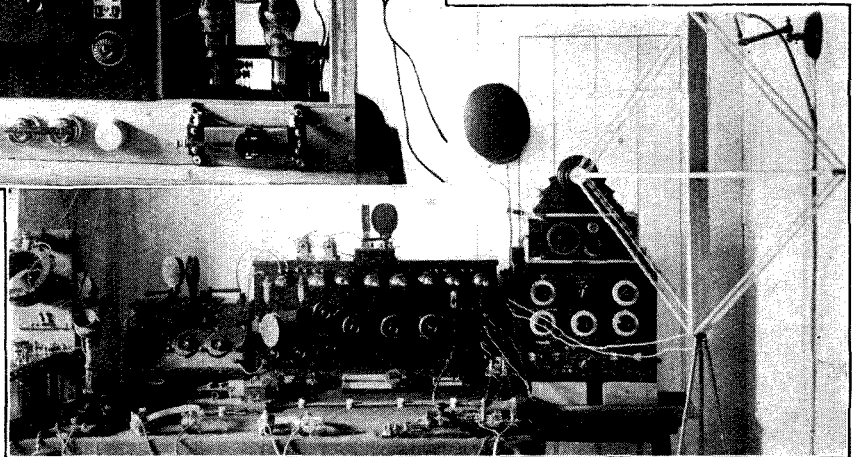

Fig. 2. An illustration of the Transmitter panel. Everything is arranged for easy access for experimental connections.

Fig. 3. The Supersonic Receiver and auxiliary apparatus.



This drive circuit employs two A.T. 40 valves in parallel, the amplifier being a Mullard 0-150, rated at 2,000 volts anode potential, and requiring 10.4 volts at 4 amperes for the filament.

The anode potential and filament lighting current is provided from a Zenith transformer rated at 160 K.V.A.

have an extraordinarily small "back flow," and pass large currents without any detriment to their life or efficiency.

The complete circuit, operating at the moment from 70-120 metres, is shown in the accompanying diagram (Fig. 1).

The overall efficiency is not as high as might be desired owing to unavoidably long

aerial and counterpoise leads, one ampere of high frequency energy being transferred to the aerial with an input of about 40 watts to the main amplifier valve.

wave transmissions are looked forward to with great interest during the coming winter.

The Westinghouse Broadcasting Station, **KDKA**, operating on 53 metres, is received at tremendous strength, as were also the calibration waves sent out from the Eiffel Tower, Paris, on 25 metres.

After using the superheterodyne one must pause to admire the wonderful patience and skill displayed by the exponents of the "detector and one step" (obnoxious phrase) on short wavelengths. The mental and physical strain must be awful.

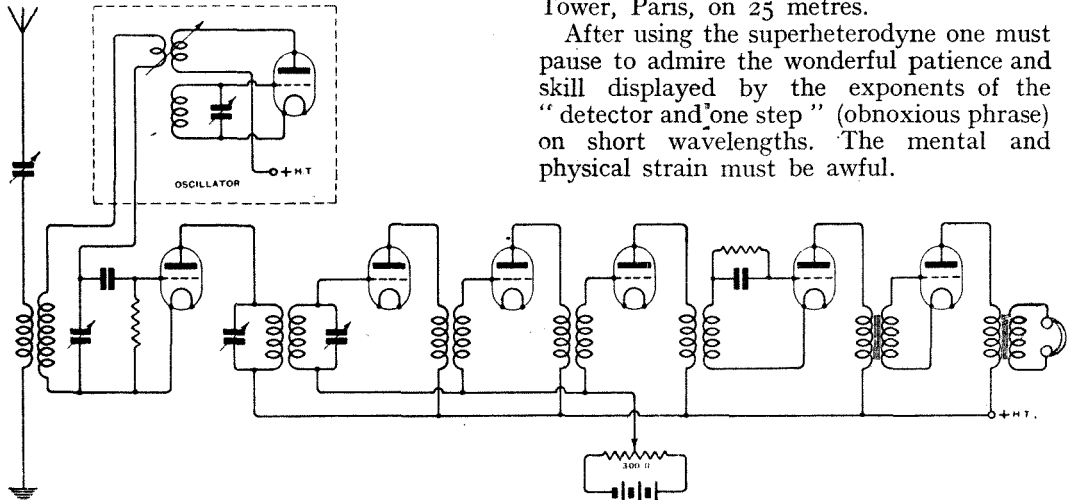

Fig. 4. Skeleton diagram of the circuit of the receiver.

THE RECEIVER.

For short wave reception an Armstrong supersonic heterodyne (Fig. 4) is employed, using up to ten valves, and has proved highly satisfactory in operation. Uniform amplification, with the characteristic ease of operation, being obtained as low as 20 metres, and by its use the investigation of short

THE AERIAL.

The aerial is an eight-wire cone, tapering from 4 ft. 6 ins. to 6 ins., 47 ft. long, and 55 ft. in average height.

The counterpoise is an eight-wire fan-shape, and is untuned, its dimensions having been altered to obtain the best results on 100 metres and less.

EFFICIENT REACTION.

By H. STOPHER (5 GF).

ONE frequently encounters the case in home constructed sets in which great attention has been paid to the tuning arrangements and general wiring, but little or no thought given to the design of the reaction system, there appearing to exist a prevalent idea among many constructors that any coil which can conveniently be coupled to the A.T.I. will serve as a reaction coil, the only stipulation being that it must make the set oscillate. As in the majority of receivers the reception

of weak signals depends largely upon the feed-back effect which is obtained by the use of reaction, the correct functioning of this portion of the circuit is of as much importance as the design of the tuning system.

The chief trouble experienced is overlap in reaction. Despite all that has been written regarding this phenomenon, in the technical press, the author has seen few home-constructed sets in which absolutely no overlap is present. Overlap is always indicated by the circuit commencing to oscillate with

a pop when the coupling is tightened and the degree of coupling at which oscillation starts does not coincide with that at which it stops. The space intervening between these two points may only be very slight or it may be very pronounced but its presence even in a very small degree renders it almost impossible to obtain just that degree of regeneration necessary to read some extremely faint signal.

Overlap can be entirely eliminated by varying the filament current, the high tension voltage and the grid leak preceding the detector valve. In the case of a two or three-valve receiver with only one pair of H.T. terminals, it is often inconvenient to vary the plate potential and providing this is not excessive for the valves in use, the overlap can generally be eliminated by the use of a variable grid leak. As, however, the detecting properties of a valve vary enormously with different values of grid leak, it is best if possible to adjust the H.T. voltage of the detector valve and to obtain fine adjustment through the agency of the filament rheostat. When correctly adjusted it should be difficult to tell at what point of the reaction coupling oscillation starts and stops, assuming that the circuit is quite quiet and no signals are being received.

A trouble which is closely allied with overlap but which has very many other disadvantages, is the use of too large a reaction coil. It should never be necessary to use more turns of wire on the reaction coil than are included in the grid circuit. A large reaction coil will usually work as far as generating oscillations is concerned, but the tuning of the set suffers and it will generally be found that the set refuses to oscillate below the natural wavelength of the reaction coil. In the majority of cases, inability to oscillate on short wavelengths may be traced to this cause. A coil of 12 to 14 turns with reasonably tight coupling is ample for wavelengths up to 200 metres, but sets employing as many as 50 turns are frequently encountered.

In addition to the general inability of a set to oscillate below the natural wavelength of the reaction coil, two other important disadvantages accrue from making this coil too large. Firstly, the tuning of the set will vary enormously with any slight adjustment of the coupling. The disadvantages of this are obvious. Secondly, it will be necessary

continually to adjust the reaction when varying the A.T.C. On most receivers best C.W. signals are generally obtained when the set is oscillating weakly, and when varying the A.T.C. from minimum to maximum the reaction coupling may have to be increased by as much as 45 degrees to keep the circuit just oscillating, if an unsuitable size of reaction coil is used. Coils either too large or too small both give this effect, so that if it is desired to tune over a fairly wide range a tapped reaction coil is essential. With the correct number of turns in the reaction it should only be necessary to vary the coupling a few degrees over the whole range of the aerial tuning condenser, which enables rapid searching to be carried out.

A three or five-plate condenser across the reaction coil is of great assistance in obtaining very fine adjustment and frequently enables weak stations to be received which it would be almost impossible to get without it. Its use, however, may cause complications if the reaction coil becomes tuned to the same wavelength as the aerial circuit, as oscillation may then become somewhat difficult to control. The reaction coil should in all cases be connected directly next to the plate of the valve, any other apparatus such as telephones, L.F. transformers, etc., coming afterwards. The author once experienced a case in which persistent refusal of a receiver to oscillate below 250 metres was traced to the first intervalve transformer having been placed between the plate of the detector valve and the reaction coil. The capacity between the primary and secondary windings was thus in shunt across the plate and filament of the valve and was sufficient on the higher frequencies to stop the valve oscillating.

Difficulty in getting a set to oscillate may also be caused through the 'phones transformer or other apparatus in the plate circuit of the valve not being shunted by a sufficiently large condenser to by-pass the H.F. circuits. Intermittent and unsteady oscillation may be due to variations in the internal resistance of a bad or aged H.T. battery. A 2 or 4 mfd. condenser across the battery will generally cure this trouble, besides generally quietening the circuit. A bad grid leak can also be responsible for unsteady oscillation. On the very short waves, around 100 metres, the set will probably refuse to oscillate if the tuning circuits are wound with too fine a gauge wire.



Crystal reception of 5 XX without an external aerial is reported by a French amateur at Charenton, near Paris.

* * * *

Whaling vessels in the North Sea are adopting the Marconi Direction Finder as a means of locating each other in fog and darkness.

* * * *

It is understood that from 10 p.m. onwards this evening (Wednesday) the Election results will be broadcast. Details as to the state of the Parties will be given every hour.

* * * *

A course of University lectures is being broadcast from WJZ, the Westinghouse station in New York. Fifty-four lectures, each of twenty minutes duration, covering eight subjects, will constitute the "Fall" term.

* * * *

"... the nation which makes the freest and most systematic use of broadcasting will be the one to take the foremost place intellectually and industrially."—Mr. A. R. Burrows, in his new book, "The Story of Broadcasting."

* * * *

CAPTAIN ECKERSLEY'S TRANSATLANTIC SPEECH.

Numerous readers report reception of the speech of Captain Eckersley, which was broadcast from WGY, the General Electric Company's station at Schenectady, New York, in the early hours of Sunday, October 12th.

Excellent reception was reported by Mr. Crewe of Golders Green, whilst Messrs. Bathurst and Martin, of West Croydon and Workop respectively, report clear reception of the speech on one valve.

SWISS BROADCASTING TRIALS.

Preliminary trials from the new Swiss Broadcasting station at Hoengg, near Zurich, have proved very satisfactory and signals have been reported in both England and Sweden. A Western Electric transmitter is employed, operating on a wavelength of 650 metres. It is probable that the wavelength will, however, be altered owing to the interference caused by marine and coastal signals.

GERMANY'S BROADCASTING ANNIVERSARY

To-day (Wednesday) Germany celebrates her first anniversary of broadcasting and the newspapers are hailing the event with great enthusiasm. Public opinion is that wireless telephony has come to stay and in years to come will play a role too large to be gauged in the light of past achievements.

RECORD LOG FOR ONE EVENING ?

Four American amateurs of the Sixth (Pacific Coast) district were "logged" by Mr. W. A. S.

Batement, of N.W. London, on October 12th, with one, and occasionally two valves. These stations were 6 BKA, 6 BQR, 6 BJJ and 6 ARB. Seventy-nine other American amateurs were heard on the same evening.

GREEKS USE PRIVATE WIRELESS.

Wireless telephony has been seized upon as a valuable aid by a number of business houses in Greece, where the wireless regulations permit of the private use of this means of communication. Four important firms are already equipping their premises with the Marconi "Popular" wireless telephone set (type XP), to link up their head offices in Athens with their branch offices in the Piræus, and further enquiries for similar sets have been received from other commercial firms. This type of wireless telephone set has been designed for use by people possessing no technical knowledge, and is as easy to operate as the ordinary Post Office telephone.

GENEVA AS EXHIBITION CENTRE.

It is proposed that an International Wireless Exposition should be held in Geneva during September, 1925. The Exposition, which will occupy the Electoral Palace, will be designed to attract exhibitors and visitors from every corner of the globe.

COPYRIGHT TROUBLES IN FRANCE.

French broadcasting is threatened with trouble in the near future, in connection with the Copyright Law as it affects the playwrights, authors and music composers, who are claiming that the broadcasting stations are infringing copyrights wholesale.

It appears that when the matter comes before the Courts the broadcasting interests will have to contend with the three associations representing their opponents.

RADIO CONTROL IDEALS.

The successful voyage of the Zeppelin Z R 3 to America has prompted some remarkable assertions by the Italian inventor, Signor Fiamma, whose radio control device has recently roused great interest.

In an interview with a *Daily Telegraph* correspondent, Signor Fiamma said that he could have guided the ZR 3 to America from any part of the world at any distance, and could, with equal ease, have brought the airship back without a human being on board. The inventor added that with his apparatus it will soon be possible also to establish cross-channel air transportation at all times and in any kind of weather without any person on

board. The aeroplanes would be directed simply by someone in a London office.

Similarly, affirms Signor Fiamma, covered-in, stormproof ships could be conducted across the seas, carrying goods to Calais, Boulogne, Ostend or any Continental port.

"MYSTERIOUS" BROADCAST PREACHER.

Reference was made in a recent issue to an unknown station broadcasting religious addresses at a late hour on Sunday evenings. A reader in the Bristol district replies to our query with the information that a religious service is broadcast between 10 and 11 p.m. on Sundays by Mr. Appleton, manager of the Cardiff station.

A CLUB MAGAZINE.

Other radio societies anxious to preserve enthusiasm among their members would do well to follow the example of the Woolwich Radio Society, who now produce a monthly magazine, "The Oscillograph."

From a perusal of the October number, a copy of which has reached our hands, it is evident that the personal note is well to the fore in the affairs of the Society. Among other features, "The Oscillograph" contains useful hints on transatlantic reception, notes of activities during the coming month and some delightfully informal reports of recent events. That inevitable

section, "Things we should like to know," also finds a place. The cost of producing the magazine should not be high, as it is "Roneod."

FRENCH SCIENTIST ON SHORT WAVES,

M. Marius Latour, the famous French wireless engineer, expressed some interesting opinions on the subject of short waves in the course of a recent interview with our Paris correspondent.

M. Latour holds that, in spite of the experiments now being conducted on the lower wavelengths, the higher wavelengths of 1600 metres and above will always be extensively used. These waves at present possess a great advantage in that they are more stable in reception than those below 900 metres; moreover it is difficult to predict that successful and reliable daylight transmissions on short wavelengths will be ultimately achieved.

Asked whether he regarded satisfactory two-way Transatlantic broadcasting as possible, M. Latour stated that such a project was not only possible but probable. He doubted, however, whether American programmes would suit European tastes and *vice versa*.

PUBLIC ADDRESS SYSTEM.

Messrs. Autoveyors, Ltd., of 84 Victoria Street, London, S.W.1, inform us that they have been appointed Distributing Agents for the well-known Western Electric Public Address System.



The use of loud speaking apparatus for political speeches has gained increased favour during the present Election. The candidate in the above photo is seen using a microphone part of the Marcomphone equipment, suspended round his neck.

THE TRANSMISSION OF PICTURES BY WIRE AND WIRELESS.

AN interesting paper on this subject was read by Mr. Thorne Baker, F.R.P.S., on October 17th, at the Royal Photographic Society's Headquarters, 35 Russell Square.

The lecturer is, of course, a well-known worker in this field of research and his remarks were illustrated by a series of lantern slides. He explained the several systems of photo-telegraphy which have been tried, and described the pioneer work of Korn and Bellini and his own researches.

It often happens in research work that methods which had been dropped are again revived in the light of some new discovery having an important bearing on it, and so it is with "photo-telegraphy."

The most successful system to-day is a development of that previously used by Korn, the principle of which may be understood by reference to Fig. 1. The picture which is to be transmitted is in the form of a transparency printed on celluloid and fixed around the glass cylinder G. This is rotated and a spot of light is caused to pass through the film and act on a selenium cell A. The intensity of the light acting on this cell, and consequently the resistance of the cell will, of course, depend upon the thickness of the deposit on the film and consequently the current in the output circuit will vary in sympathy. At the receiver the current passes through a special galvanometer and according to its strength will open a shutter to a varying

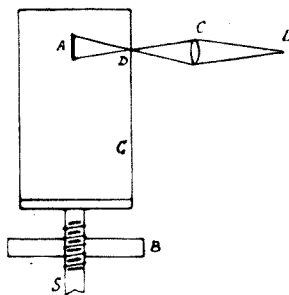

Fig. 1. The arrangement employed by Korn in early experiments.

extent, thus allowing a spot of light to fall on a sheet of photographic paper attached to a cylinder which is rotating at the same speed as the one at the transmitter.

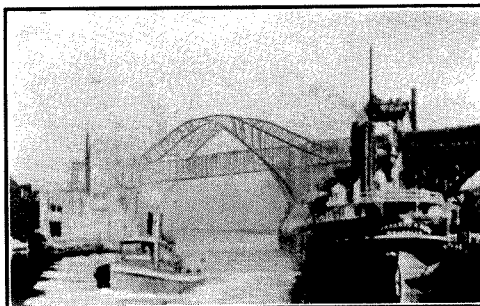

Fig. 2. A picture transmitted over a considerable distance

Elaborate arrangements are, of course, necessary to keep the speeds of these two cylinders exactly the same. The apparatus of to-day employs a photoelectric cell in place of the selenium, the latter having certain disadvantages, in particular that of lag.

The lecturer emphasised the difficulties experienced in actual working over long lines as against laboratory tests. In the latter case good results were certain, whereas the capacity of a long line often made faithful transmission almost impossible. From this point of view, therefore, the lecturer looks to radio as being capable of giving much more stable results, and a simple diagram of an early transmitter and receiver used by him was shown in a lantern slide.

Work is still progressing and the sensitive apparatus and stable form of transmitters now available leads Mr. Thorne Baker to predict that in perhaps a comparatively short time pictures transmitted by telegraph will be a regular feature in the pictorial newspaper world.

That this work has already reached a high standard is shown by the picture Fig. 2 reproduced here, which was transmitted over a considerable distance in America.

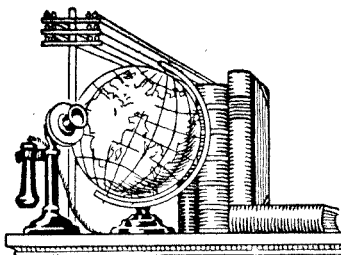

CORRESPONDENCE.

Transmitting Licences.

To the Editor of THE WIRELESS WORLD AND RADIO REVIEW.

SIR,—Referring to the correspondence on the above in your issue of September 3rd, I am of the opinion that "Newcastle" is somewhat hurt, but I should like him to think seriously, and try to place himself in the position of the P.M.G. and his staff, and to consider the difficulties they have to meet when application is made for a transmitting licence. Twelve months ago I applied for a licence, and in the end one was issued for the use of artificial aerial; to this I appealed but with no avail.

Now I really felt as much hurt as "Newcastle" does, but after twelve months with artificial aerial work I am now certain that the P.M.G. did me a good turn, for under such a condition one does much finer work than when permission for open aerial work is given in the first place. If I had to illustrate the work undertaken with artificial aerial, it would take up a great deal of space. And I think this is the best way one can really obtain perfection in transmitting apparatus when fitting up from components. Twelve months later I again appealed to the P.M.G. and after I had pointed out my experiments and progress, the necessary permission was granted to me.

In my opinion there is nothing unreasonable about this procedure, and before "Newcastle" can condemn anything that he hears on the receiver he should pay a visit to the transmitting end and see what is going on there.

And when he refers to qualifications, he may be interested in my record.

I have been lecturing and demonstrating X-rays, high frequency, including wireless, for a number of years, and have over half a ton of electrical and wireless apparatus to experiment with, three parts of which is of my own manufacture; half of this again is not even built from the bought components, but is constructed from the rough material

JOSEPH NODEN (6 TW).

Nr. Nantwich.

A Word for Transmitters.

To the Editor of THE WIRELESS WORLD AND RADIO REVIEW.

SIR,—You publish a letter from John P. Wilson, of this town, in your issue of September 17th.

Mr. Wilson seems to have a grievance against local transmitters.

If your correspondent will cast his mind back to two years ago when there was no official broadcasting he will remember that amateur transmissions were a source of great benefit and inci-

dentally brought into being the nucleus of the present listening-in public.

It is agreed that (based on present-day broadcasting) the amateur transmissions of these days were poor stuff, but half a loaf is better than no bread. It may interest Mr. Wilson to know that the present excellence of apparatus for short wave reception was mainly developed by experience gained from listening to these amateur(ish) transmissions, and local transmissions were thankfully received.

I think that your correspondent will find, if he listens in between the time stated, that the old hands, who at one time bore the brunt of the transmissions, are not now heard between the wavelengths of 300 and 500, but he will probably find them between 50 and 150, where they do no harm to anyone but themselves.

How does your correspondent know that the transmitters of whom he complains do not possess accurate measuring instruments? All the licensed transmitters whom I know have very good instruments and do carry out genuine experiments. I am afraid your correspondent is confusing the pirate who, under a wrongly granted or poached call sign, makes the ether hideous, Sunday after Sunday. Why should a man with a non-radiating licence have a call sign?

LOUIS J. WOOD,
(Hon. Sec., Halifax Wireless Club).

U.S. on 10-ft. Aerial.

To the Editor of THE WIRELESS WORLD AND RADIO REVIEW.

SIR,—In the early hours of Sunday, October 12th, with a three-valve receiver (2-v-0), and using a 10-ft. piece of wire hung across the room on a second-floor London flat, the writers heard the speeches made at a banquet given by the H. J. Heinz Co., of U.S.A., and broadcast by KDKA, Pittsburg.

The speeches lasted for over an hour and at 2.26 a.m. the chairman was heard, with a rap on the table, asking for order. He announced that President Coolidge would speak to the guests over the telephone from the White House, 400 miles away. Every word of the President's speech, which lasted for 20 minutes, was distinctly heard.

Later the chairman announced that he had just received a telegram from a "listener-in" that the speeches were being heard as if they were taking place in the room.

The conversation of the guests between the speeches was plainly heard.

THEODORE BRUMBY,
WILLIAM NICHOLSON,
(Members of the Hampstead and St. Pancras
Radio Society).

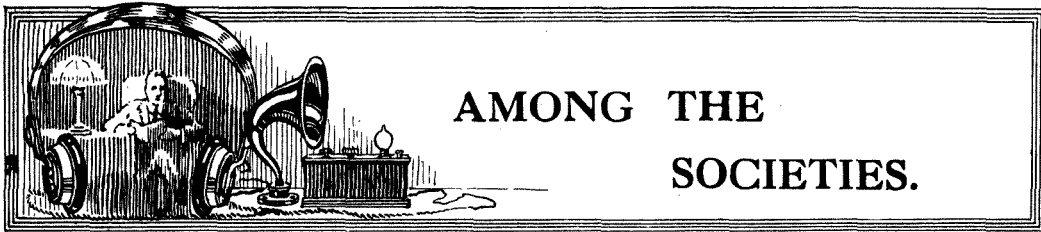

AMONG THE SOCIETIES.

Radio Society of Great Britain.

At the meeting of the Society held on Wednesday, October 22nd, the President, Dr. W. H. Eccles, F.R.S., moved, and Admiral Sir Henry Jackson, G.C.B., seconded, the following motion :

The Radio Society of Great Britain tender their congratulations to those members of the Society, namely, Mr. C. W. Goyder, Mr. Gerald Marcuse, Mr. E. J. Simmonds and Mr. J. A. Partridge, who have successfully established two-way radio communication with New Zealand, and they desire also to convey their felicitations to the Radio Society of New Zealand and to those New Zealand amateurs who co-operated in the experiments.

In moving the resolution it was pointed out that the fact that these experiments had been carried out in the early morning, about 6 a.m., raised the question as to which direction had been taken by the radio signals. The shortest route is an easterly one, by which the waves would travel over parts of Europe, Asia and India, but in the early hours of the morning in this country that route would be in full daylight and therefore probably a difficult one for the waves. The alternative route, which would be mostly in darkness, is via Greenland, the United States and right across the Pacific Ocean. This is a much longer route and it is also one which is mainly over water.

In either case the success of these experiments should point out the way for further research on this interesting scientific phenomenon.

The unstinted admiration of all amateurs for the performance of the first four to communicate with New Zealand was well expressed in the following telegram addressed to Mr. J. A. Partridge :—

“Congratulations of Manchester transmitters on London gang’s wonderful achievement.”

A VISIT TO THE N.P.L.

A party of about 80 members of affiliated societies in the Eastern Metropolitan group paid a highly interesting visit to the National Physical Laboratory, Teddington, on Saturday afternoon, October 18th. The party, which arrived in two detachments, was conducted over the wireless section by Dr. Smith-Rose and Mr. Colebrook, who explained everything with great care and lucidity.

After the aerial and counterpoise system had been inspected, the apparatus in the transmitting shed was examined, and special interest was shown

in the means of maintaining the wavelength absolutely constant by means of a master oscillator. The apparatus in the receiving hut was next visited, and the refinements employed to ensure absolute accuracy of measurement of signal strength and distortion proved a revelation to the amateur who is content to get his results accurate to 1 or 2 per cent. Several members wished they had brought their wavemeters along to be calibrated ! The thanks of the group are due to Dr. Smith-Rose and Mr. Colebrook, and to all the officials who made the visit such a success.

* * * *

One of the chief difficulties of the Birmingham Wireless Club during the past year has been the lack of library accommodation. This has now been found, together with facilities for storing the club apparatus.

Many interesting fixtures have been arranged for the coming session, with as many demonstrations as possible.

* * * *

Considering that the modern valve is the outcome of the electric lamp, Mr. F. Bodenham’s recent talk on “Electric Lamps,” before the Radio Experimental Association of Nottingham, proved of extreme interest. The speaker described the early experiments of manufacturers with filaments of platinum, carbon and tungsten. Modern methods were also dealt with.

* * * *

Members of the Borough of Tynemouth Radio and Scientific Society turned out in full force to hear a recent debate on Broadcasting v. Experimenting.

Mr. Cowell spoke in praise of broadcasting as an aid to amateur experimenting, as it provided unique opportunities for testing. Mr. Byers contested that much of the best amateur work had been carried on independently of broadcasting. The meeting was unanimous in the opinion that broadcast listeners should join a wireless society and thus learn more about the fundamental principles of the science.

* * * *

The question of resistance capacity coupling formed the theme of discussion among members of the Battersea and District Radio Society on Thursday, October 9th, when an interesting lecture on the subject was given by Mr. A. E. Duffield, Chairman.

The Society is now starting actively on the winter session and applications for membership are invited.

Many types of apparatus were on view at the October meeting of the Kensington Radio Society, including multivalve resistance capacity coupled receivers, coils for transmission and reception, buzzer and valve wavemeters. These had all been constructed by members and were intended for exhibition at the Paddington Technical Institute in connection with the Western Metropolitan Association of Affiliated Societies.

"An International Language for Radio" formed the subject of a lecture delivered by Mr. George T. Smith before the Walthamstow Amateur Radio Society on October 16th.

The lecturer recounted how Esperanto had helped him in communicating with continental amateurs, by whom it was extensively used. After the lecture many members undertook to study Esperanto, and a resolution was passed expressing the Society's faith in this language as the best medium for international radio intercourse.

A highly satisfactory year was reported at the annual general meeting of the Sale and District Radio Society, held on October 17th.

During the winter session, the Society's rooms will be open every evening. Arrangements are well in hand for the preparation of an attractive programme, and new members will be warmly welcomed.

HIGH EFFICIENCY COILS.

In the article entitled "New Coils of High Efficiency," by Mr. J. H. Reeves, M.B.E., appearing in our issue of October 15th, the following additions or corrections should be made:—

Page 75, column 1, 2nd line under figure: for 3 16 read .036.

Page 75, column 1, 9th line under figure: for "cut-out" read "mark."

Page 75, column 2, 5th line from top: for "mark" read "drill."

Page 75, column 2, bottom: add "clamp tightly together."

Page 76, column 1, 3rd line from top: for "upper" read "lower."

Page 76, column 2: add "unskilled workers should drill first all bars with a 6 B.A., and assemble with use of wood screws. The edge carrying the wire is the upper edge of each bar, as seen in Fig. page 75, column 1."

Page 76, column 2, 5th line from bottom: for "strengthening" read "straightening."

Page 77, column 1, 4th line from bottom: for "the best known makes" read "the best of mine."

FORTHCOMING EVENTS.

WEDNESDAY, OCTOBER 29th.

Tottenham Wireless Society. "Elementary Talks on Magnetism and Electricity, I."

Bristol and District Radio Society. "Wireless Lecture No. 1," by Mr. W. A. Andrews, B.Sc.

Clapham Park Wireless and Scientific Society. At 7.45 p.m. At 67 Balham High Road. Lecture: "Ebonite." By a representative of the British Ebonite Co.

Radio Research Society, Peckham. At 44 Talfourd Road. Lectures: "X Rays" and "Principle of the Multiple Tuner."

THURSDAY, OCTOBER 30th.

Bournemouth and District Radio and Electrical Society. At 7 p.m. At the Y.M.C.A., St. Peter's Road. Lecture: "The Microphone and Its Uses" (with demonstration). By Mr. J. Skinderviken.

Derby Wireless Club. Lecture by Mr. E. V. R. Martin.

Walthamstow Amateur Radio Society. General Discussion.

Hounslow and District Wireless Society. Lecture: "The Scientific Future." By Prof. A. M. Low.

Luton Wireless Society. At 8 p.m. At Hitchin Road Boy's School. Discussion of Difficulties.

West London Wireless and Experimental Association. At Belmont Road Schools. Question Night.

FRIDAY, OCTOBER 31st.

Bristol and District Radio Society. Demonstration and Address by Radio Instruments, Ltd.

MONDAY, NOVEMBER 3rd.

Hackney and District Radio Society. Vest Pocket Lectures.

TUESDAY, NOVEMBER 4th.

Manchester and District Radio Transmitters' Society. At 7.30 p.m. At the Grand Hotel, Aytoun Street, Manchester. Second Presidential Address, by Dr. L. S. Palmer.



A view of the Manchester Radio Scientific Society's stand at the recent wireless exhibition in that city.



READERS PROBLEMS



Readers desiring to consult the "Wireless World" Information Dept. should make use of the coupon to be found in the advertisement pages.

VALVES FOR REFLEX RECEIVERS.

WITH the production of new types of valves, some with low impedance and others with high amplification factors, it is natural to ask whether any of these new types may be used with advantage in dual amplification receivers.

In our opinion it would be best to employ valves designed for general reception. Valves of this type generally have an average value of amplification factor and a moderately high impedance, and are therefore likely to give better results when called upon to amplify signals at both high and low frequency.

RECORDING OF MORSE SIGNALS.

WE have recently received many enquiries from readers who wish to record Morse transmissions, either by means of a G.P.O. tape machine or the syphon recorder, and who would like to know the best method of connecting the recorder to their existing receivers.

The connections of one of the most reliable and simple methods are given below. The method consists in rectifying the alternating current output from the secondary winding of a telephone transformer connected in the plate circuit of the last valve, by means of a carborundum steel detector. A suitable relay is connected in series with the transformer secondary winding and the crystal detector,

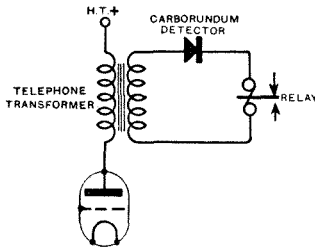

and the current operating the recording instrument is controlled by the moving tongue and contacts of the relay in the usual way. To prevent sparking at the contacts, a non-inductive resistance of suitable value should be connected between the tongue and the "marking" contact. A relay of the G.P.O. or Siemen's type is very suitable for this purpose, and for comparatively slow speeds a Weston moving coil relay may be employed.

The object of using a telephone transformer with a high step-down ratio is to obtain as large a current as possible in the relay circuit. With the same object in view, a very small fragment of carborundum crystal should be used for the detector, in order that the resistance of the relay circuit may be kept as low as possible. By choosing the crystals with care, it will be possible to obtain a rectified current of at least 1 milliampere under favourable conditions. This current is more than sufficient for the operation of the relays mentioned above.

THE EFFECT OF FILAMENT TEMPERATURE ON SIGNAL STRENGTH.

A READER sends an account of some experiments which he has been carrying out with a receiver, the results of which seem to form an exception to the laws of the emission of electrons from valve filaments.

To explain the nature of the experiments, we cannot do better than quote from his original letter: "When the secondary cell supplying the filament current becomes discharged, the cutting out of the filament resistance temporarily restores signal strength, but there comes a point at which, although the filament is at normal brightness, and therefore normal temperature, the signal strength falls away. On connecting a newly charged accumulator, normal signal strength is obtained when the valve filaments are duller, and therefore much lower in temperature than was obtained using the nearly discharged cell."

The point which our correspondent wishes to make is that for a given filament temperature the results obtained from the set depend upon whether the battery is in a fully charged or partially discharged condition. Before questioning the validity of Richardson's formula for the emission of electrons from incandescent bodies, he should have made quite sure that all other conditions in the circuit were the same for both tests. As a matter of fact, the amount of external resistance connected in series with the filament was greater in the case of the fully charged battery, and the value of the grid bias applied to the valve is therefore much higher. When the battery was discharged, and the whole of the filament resistance cut out of circuit, the grid bias would be the same as the side of the filament to which the grid return lead was connected. The difference in the grid bias could easily account for the difference in the signal strength obtained.

A RELIABLE THREE-VALVE RECEIVER.

A DIAGRAM is given below of a three-valve receiver suitable for reception of British and Continental broadcasting. With a good outdoor aerial it should be possible to receive all the B.B.C. stations and most of the Continental stations at telephone strength, while it should be capable of operating a small loud speaker at distances up to 50 miles from a main B.B.C. station.

In order that the selectivity may be kept as high as possible, the aerial tuning condenser is connected permanently in series with the aerial circuit. With this arrangement there will be no difficulty in tuning on the band of wavelengths between 300 and 500 metres; but on the longer wavelengths the operation of the set may be simplified if the condenser is connected in parallel with the A.T.I.

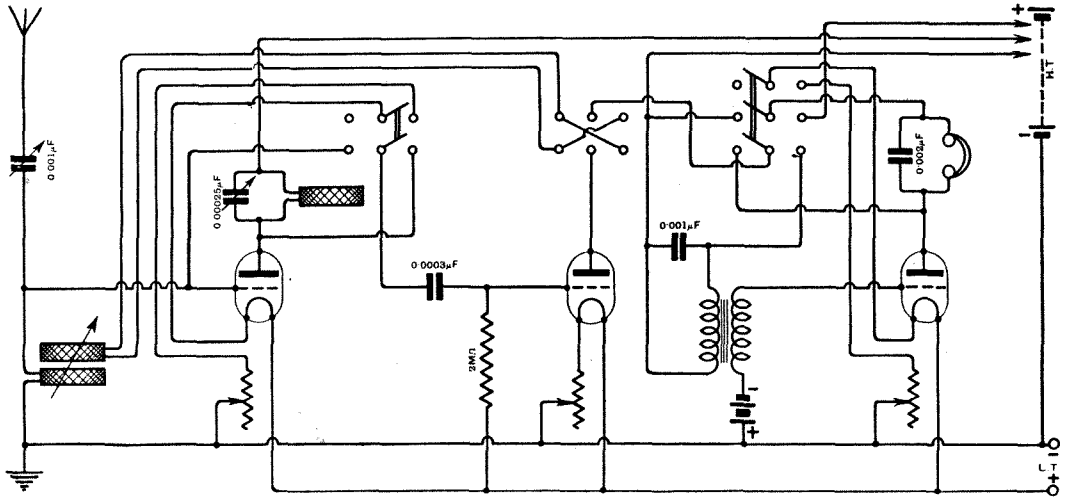

A reliable three-valve receiver.

From the point of view of signal strength and selectivity, it would be advisable to leave the A.T.C. in series for longer wavelengths. When using the series condenser on long wavelengths, the aerial coil will have to be chosen with greater care, as the variation of wavelength given by the condenser is not so great.

Separate H.T. tapplings have been provided for the valves, each of which functions under different conditions. The modern tendency is to employ valves specially designed for the uses to which they will be put, and separate H.T. tapplings are being used to a greater extent. With this arrangement a three-pole change-over switch is necessary for the L.F. valve, in order that the detector valve may receive the correct H.T. voltage under all conditions.

TRANSFORMER CORE STAMPINGS.

MANY experimenters who are building their own small power transformers have enquired where special silicon iron stampings to build the core may be obtained.

Sheet stallo iron and stampings of special shapes can be obtained from Messrs. Joseph Sankey & Sons, Ltd., Bilston, Staffs. Messrs. Sankey have two London offices: one at 168 Regent Street, W.1, and the other at 118 Cannon Street, E.C.4.

AN EASILY BUILT TWO-VALVE RECEIVER.

REFERRING to the article under the above title, in the issue of September 3rd, 1924, a reader asks where the 0.0005 μF condenser shown at the left-hand side of Fig. 4 is mounted in the actual instrument.

This condenser is fixed to the under side of the valve panel, immediately below the 0.0003 μF. grid condenser. The same screws are used to secure both condensers.

VALVES FOR A POWER AMPLIFIER.

A READER asks if D.E.4 type valves could be substituted for D.E.5 valves in the power amplifier described on page 210 of the issue of May 21st, 1924, and if any alteration in the values of components will be necessary.

As the resistance of the D.E.4 valve filament is approximately half that of the D.E.5, filament rheostats also of lower resistance may be used. An alteration in the value of the grid bias will also be necessary. With an anode potential of 120 volts and a grid bias of 5 volts, the anode current is 4.5 milliamps in the case of the D.E.4 valve. The total anode current will therefore be 9 milliamps, and a grid resistance of 550 ohms will be required to give a negative bias of 5 volts. If the same H.T. voltage is used for both valves, both grid return leads may be connected to - H.T.

The power that the D.E.4 valve is capable of handling is slightly less than that of the D.E.5, but will be quite sufficient to operate a large loud speaker of standard type without producing distortion.



The ideal way to progressive wireless construction.

RADIO is essentially a progressive hobby. Half the attraction lies in the advancement from the chrysalis stage of the Crystal Receiver to a "Five-Valver" or even a full-blown transmitter. Yet your ultimate success depends upon the books which guide your steps along the path of wireless progress. You cannot do better than put your trust in *Wireless Press* publications. With their aid it is a simple matter for you to obtain a complete knowledge of the subject from A to Z.



The Wireless Press are the pioneers of authoritative wireless literature, catering for every possible need.

- "Crystal Receivers for Broadcast Reception." By PERCY W. HARRIS. Price 1/6. Postage 2d.
- "Construction of Amateur Valve Stations." By A. L. M. DOUGLAS. 1/6. Postage 2d.
- "Practical Wireless Sets for All-Home Construction Made Easy." By PERCY W. HARRIS. 1/6. Postage 2d.
- "The Wireless Press Ezi-Wiring Series":
 1. A Three-Valve Portable Receiver. By H. S. POCOCK.
 2. A Three-Valve Receiver (Cabinet). By F. H. HAYNES.
 3. A Two-Valve and Crystal Reflex Receiver. By W. JAMES. 2/- each. Postage 2d.
- "The Amateur's Book of Wireless Circuits." By F. H. HAYNES. 3/6. Postage 6d.
- "The Home Constructor's Wireless Guide." By W. JAMES. 3/6. Postage 3d.
- "Radio Experimenter's Handbook." Two Parts, 3/6 each. Postage 4d. each.
- "The Wireless Telephone: What It Is and How It Works." By P. R. COURSEY. 2/6. Postage 3d.
- "Wireless Telephony: A Simplified Explanation." By R. D. BANGAY. 2/6. Postage 3d.
- "The Elementary Principles of Wireless Telephony." By R. D. BANGAY. 7/6. Postage 6d.
- "Electrons, Electric Waves and Wireless Telephony." By J. A. FLEMING. 7/6. Postage 6d.
- "Wireless Valve Transmitters: The Construction of Small Power Apparatus." By W. JAMES. 9/- . Postage 9d.

THE WIRELESS PRESS, LIMITED,
12-13 Henrietta Street, Strand, London, W.C.2

Brandes

The Name to Know in Radio.

"Is it natural?"

Does your receiver reveal the real qualities of the human voice? Does it give you the changing inflection registered by varying emotion and expression, or bring the technique of the trained singer? Or yet the strains of a delicate instrument throbbing with nervous life beneath the hands of a master? The beautiful texture of the notes of a skilfully woven melody—are they detected with ease—is their fineness unblemished? Let Brandes receiving instruments achieve this end for YOU—the "MATCHED TONE" Headphone and *Table-Talker* bring your receiver to life with no hint of the distance between. Let them give the thought to your imagination that you stand watching the actual performance—that you are but a step away from the golden voice. Ask your dealer for Brandes.

All Brandes products are obtainable from any reputable Dealer and carry our official money-back guarantee, enabling you to return them within ten days if dissatisfied.

Matched Tone
TRADE MARK
RADIO HEADPHONES 25/-

Table-Talker
TRADE MARK
42/-



Tune with Brandes "Matched Tone"
Radio Headphones
Then Listen with Brandes
Table Talker

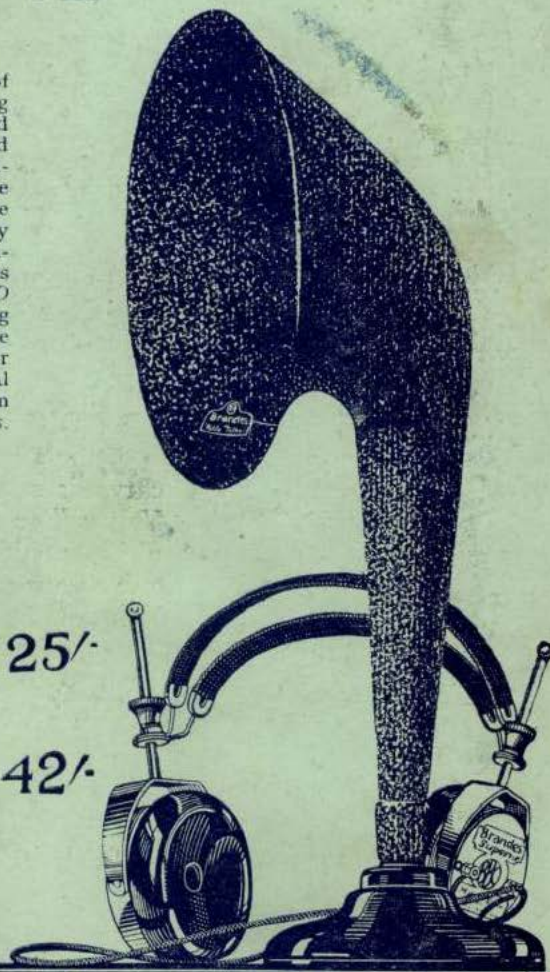

Brandes Limited, 296 Regent St., W.1

WORKS—Slough, Bucks.



Printed by Sanders Phillips & Co., Ltd., Chryssell Road, London, S.W.9, for the Proprietors and Publishers, The Wireless Press, Ltd., 12-13 Henrietta Street, London, W.C.2.; Sydney, N.S.W., 97, Clarence Street; Melbourne, 422-24 Little Collins Street; New York, 326 Broadway.

