

THE WIRELESS WORLD AND RADIO REVIEW

THE OFFICIAL ORGAN OF THE RADIO SOCIETY OF GREAT BRITAIN.

No. 229. (No. 14.
Vol. XIII.)

JANUARY 2nd, 1924.

WEEKLY

EDITOR:
HUGH S. POCOCK.

RESEARCH EDITOR:
PHILIP R. COURSEY, B.Sc., F.Inst.P., A.M.I.E.E.

ASSISTANT EDITOR:
F. H. HAYNES.

QUESTIONS AND ANSWERS DEPARTMENT:
Under the Supervision of W. JAMES.

CONTENTS

	PAGE
Denmark's Broadcasting Station - - - - -	428
A French Circuit with Some Interesting Features -	431
Short Wavelength Transmission (<i>continued</i>). By W. James - - - - -	432
Galena—Natural and Artificial. By James Strachan	435
Novel Ideas and Inventions - - - - -	437
New Ideas in Receiver Design (<i>continued</i>). By F. H. Haynes - - - - -	439
The Leafield Imperial Wireless Service. By E. H. Shaughnessy, O.B.E., M.I.E.E. - - - - -	443
Our Transatlantic Broadcasting Tests—Further Reports of Reception - - - - -	448
Around the Wireless World - - - - -	449
With the Societies - - - - -	453
Questions and Answers - - - - -	455

THE EDITOR will be glad to consider articles and illustrations dealing with subjects within the scope of the Journal. Illustrations should preferably be confined to photographs and rough drawings. The greatest care will be taken to return all illustrations and manuscripts not required for publication if these are accompanied by stamps to pay return postage. All manuscripts and illustrations are sent at the Author's risk and the Editor cannot accept responsibility for their safe custody or return. Contributions should be addressed to the Editor, "The Wireless World and Radio Review," 12 and 13, Henrietta Street, Strand, London, W.C.2.

SUBSCRIPTION RATES:

20s. per annum, post free. Single copies 4d. each or post free 5d. Registered at the G.P.O. for transmission by Magazine Post to Canada and Newfoundland.

EDITORIAL AND PUBLISHING OFFICES:

12 and 13 Henrietta Street,
Strand, London, W.C.2.

Telephone: Gerrard 2807-9.



ADVERTISEMENT MANAGERS:

Bertram Day and Co., Ltd.,
9 & 10 Charing Cross, S.W.1.

Telephone: Gerrard 8063-8.

DENMARK'S BROADCASTING STATION.

DESCRIPTION OF THE EQUIPMENT AT LYNGBY.

SITUATED two miles to the north of Copenhagen is the Lyngby station, which is equipped for telegraphic and telephonic transmissions. The installation essentially comprises two independent equipments, one a telegraphic set which handles the European correspondence of

counterpoise consists of a network of wires close to the ground, all leads being carefully laid out to produce equal tuning effects. In addition, a number of copper plates have been sunk into the water-carrying strata, and the counterpoise and actual earth connection are balanced through suitable inductances.

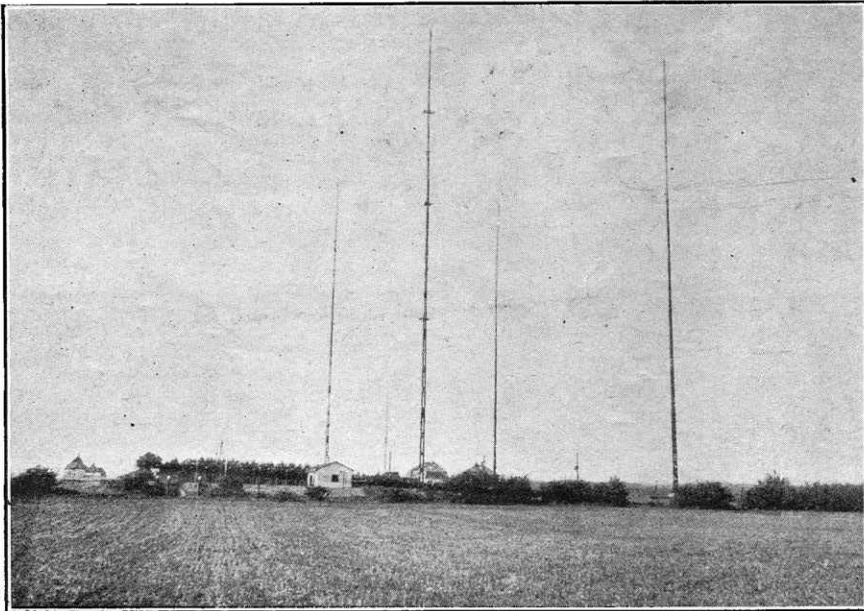

The aerial system at Lyngby. The masts are of wood, those in the foreground being used for supporting the aerial of the telegraph set, whilst the smaller ones in the distance are used for telephony transmissions.

Denmark, and a telephony set for communication with the Island of Bornholm and, in addition, apparatus for the broadcasting of concerts.

The aerial system consists of four masts, each 230 ft. in height, between which are suspended 18 wires each about 250 ft. long. The masts are built of teak.

Owing to the fact that the station is situated on the slope of a hill, difficulties were experienced in providing a reliable connection to earth and, as a result of experimental tests, it has been found that the use of a counterpoise gave improved results. The

The transmitting apparatus consists of two Poulsen arc generators, one of which dates back to the days of Mr. Poulsen himself. The other is of more recent construction and has an output of from 25 to 40 kW.

The telephony installation operates on an independent aerial of very similar construction to that used on the telegraph set. The Poulsen system is employed here again, the apparatus being supplied by the German Lorenz Company, the same concern that operates the Eberswald Radiotelephony Station near Berlin. The power handled on

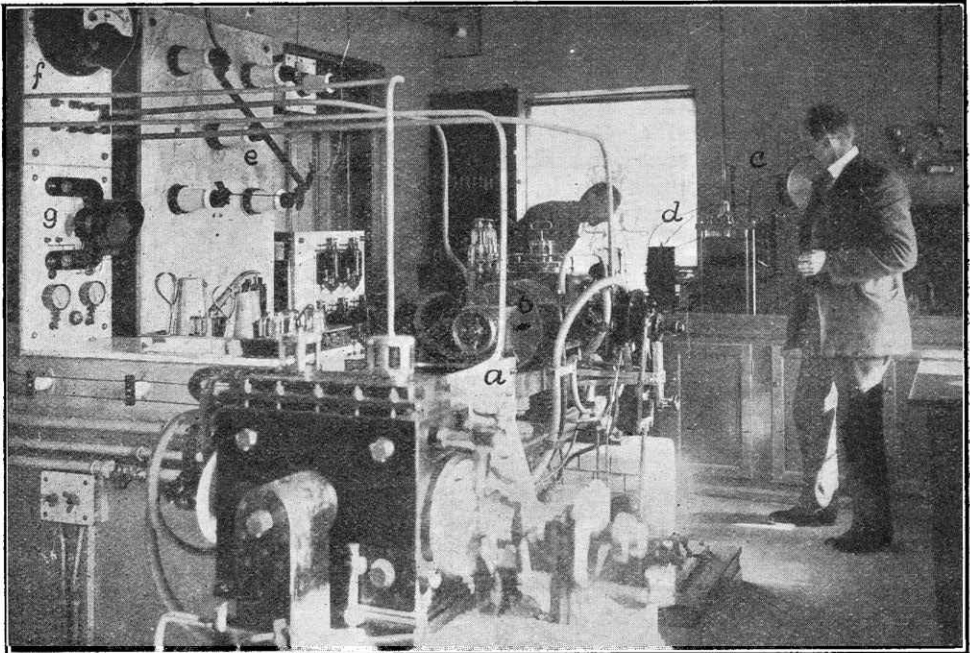

The arcs of the telegraph set. (a) and (b) enclose Poulsen arcs; (c) tuning apparatus; (d) the transmitting relay; (e) aerial switch gear; (f) aerial ammeter; (g) a control device for observing that the arcs are correctly functioning at the right frequency.

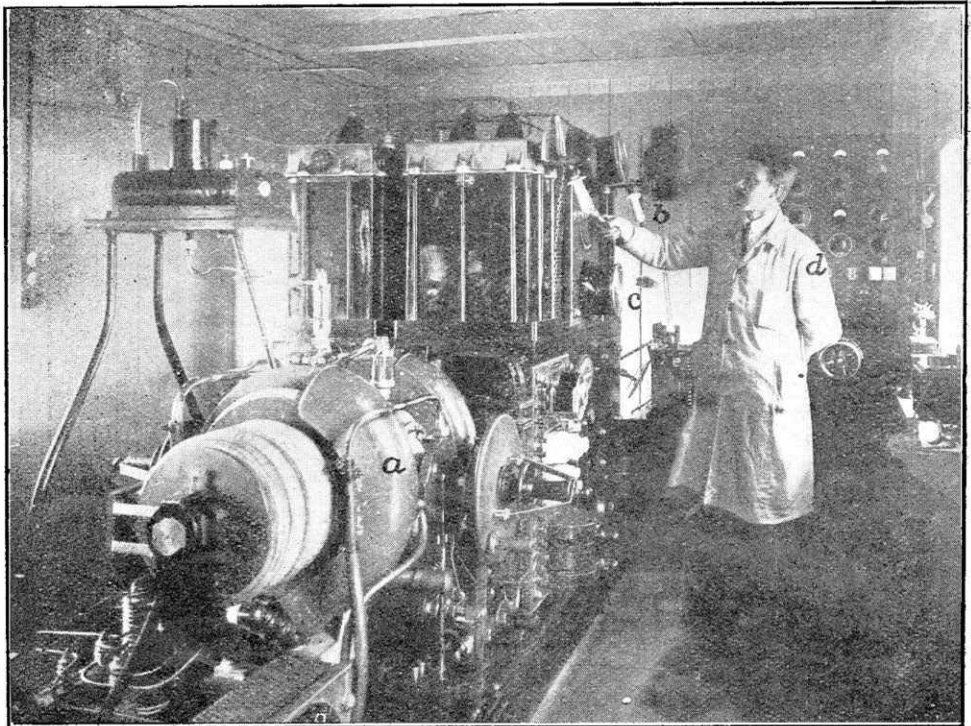

The transmitting room of the telephony set. (a) Poulsen generator; (b) tuning apparatus; (c) aerial ammeter; (d) speech control and modulating equipment.

the arc telephony set is approximately 10 kW.

The telephony transmitter is arranged for connecting up to the ordinary land-line telephone service for conversations between Copenhagen and the Island of Bornholm, and for this service it is necessary to arrange for duplex working. Reception is effected by means of directional frame aerials, in order to eliminate interference. These frame aerials are housed in large wooden towers, so that they may be rotatable and at the same time protected from the weather. By the use of a pair of frames, simultaneous working is affected with two stations, which are connected up to four-stage high-frequency amplifiers.

A broadcasting service is now in operation from this station between the hours of 7.30 and 8.45 p.m., excepting Sundays. The wavelength employed is 2,400 metres and the call sign **OXE**.

Listeners-in will appreciate the difference in quality between the arc operated telephony set, such as is installed in this instance, and the valve operated transmitters of the type with which we are familiar in England.

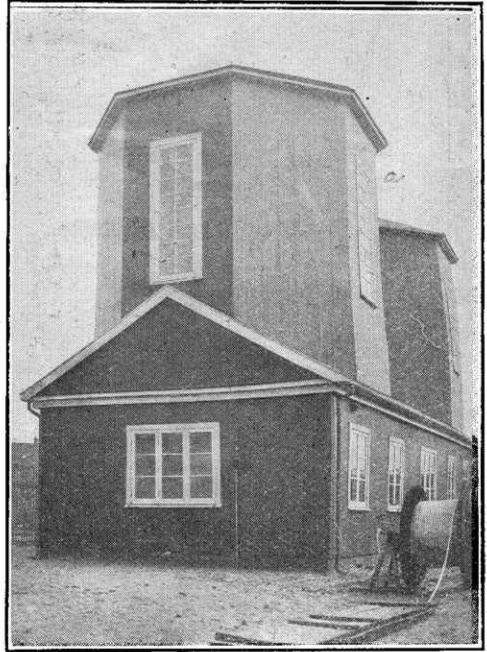

Wooden towers in which the frame aerials are housed.

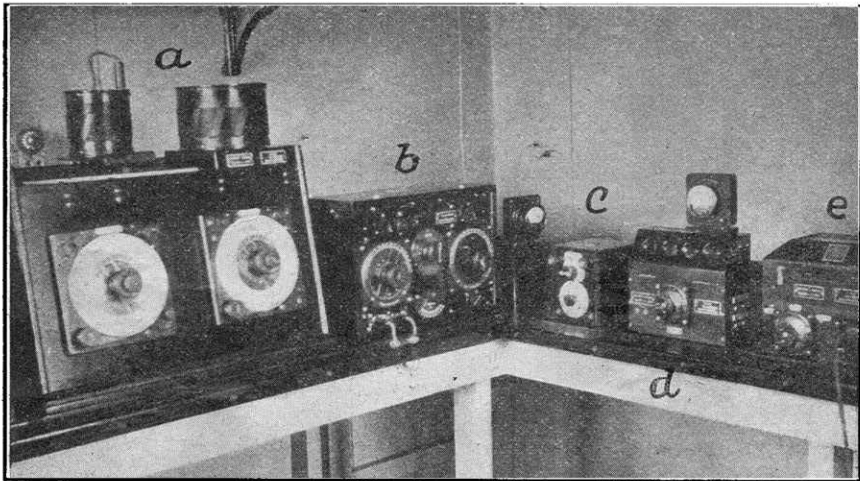

Some of the receiving apparatus used for duplex-telephony working. (a) loose-coupled tuner; (b) rejector apparatus; (c) H.F. transformer; (d) high-frequency amplifier; (e) low-frequency amplifier.

The operation of telephony apparatus with arc generators presents many problems,

as it is no easy matter to modulate oscillations as set up by the arc.

A FRENCH CIRCUIT WITH SOME INTERESTING FEATURES.

THE connections of a receiver which it is stated is considerably used by French amateurs is given in the figure. The receiver is known as the "Abelé Receptor," and was designed by an officer of the French Signal Corps, Monsieur J. Abelé, during the war. The receiver was designed principally for the reception of long wavelength signals, that is, from 1,500 metres upwards. The receiver has however been thoroughly tried out on short wavelengths, and the results are said to be very satisfactory.

Referring to the diagram, C_1 is the aerial tuning condenser and L_1 the inductance, which is connected across the grid and filament of the first valve V_1 . In the plate circuit is connected the portion B-C of coil L_2 , point C being connected with the positive terminal of the high tension battery. The second valve is connected to operate as a detector, and the grid is connected to point A of coil L_2 . The portion A-D is tuned with the variable condenser, C_2 . The connections are such that we have in effect a tuned anode circuit, but instead of the grid connection being taken from the plate terminal of the valve V_1 , it is taken from another portion of the coil, so that the coil operates as an auto-transformer, depending upon the position of the contacts A and B. The plate circuit of the detector valve is also joined to coil L_2 , and the inductance in circuit may be changed by altering the position of the contact C. The coil L_2 therefore acts as a tuned anode coil, an auto-transformer, and provides regeneration as well. It is said the best ratio of turns A-D to B-C is about 2 : 3, and the adjustment is not critical. The ratio A-D to C-D is much higher, and may be in the neighbourhood of 10. This adjustment is fairly critical if good amplification is to be obtained.

For short wavelength work, coil L_1 may consist of 60 turns of No. 20 D.C.C. wire on a former $3\frac{1}{2}$ ins. in diameter. The variable condenser C may have a maximum value

of 0.001 mfd. or smaller. The coils L_1 and L_2 should be placed so that there is no coupling between them. Coil L_2 may consist of 60 turns of No. 24 D.C.C. wound on a former $3\frac{1}{2}$ ins. in diameter, with tapplings taken from every two turns. The coil may be tuned with a 0.0003 μF variable condenser.

The operation of the receiver is fairly simple. First of all the primary circuit is tuned to the wavelength by means of the condenser C_1 and the tapped inductance L_1 . Taps B and C are located about in the centre portion of the coil, and A nearer the end of the coil. The condenser C_2 is then adjusted so that the secondary circuit is in resonance with the primary.

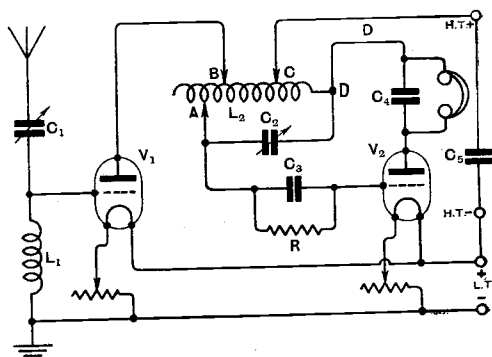

The circuit of the receiver.

When signals have been received, the tapplings B and C should be properly found by experiment. It is also important that tapping A should be carefully adjusted. Once the correct positions for these tapplings have been found, they need not be altered again, so that once the adjustments are made, it is only necessary to tune the aerial circuit and the anode circuit.

Particulars of the receiver were described in the magazine *Radio*, for November, by Lloyd Jacquet, 2 OZ.

SHORT WAVELENGTH TRANSMISSION.

THE MASTER OSCILLATOR SYSTEM.—II.

The oscillator and power amplifier were described in the issue of December 27th, pages 404 to 407.

By W. JAMES.

13.—THE COUPLED AERIAL CIRCUIT.

IN the transmitters of Figs. 2 and 4, the power valve is shown directly connected to the aerial tuning inductance L_1 . The coupling between the valve and the aerial is varied by changing the position of the tap T_1 , and the wavelength of the aerial circuit is adjusted by changing the position of the tap T_2 . There are advantages to be gained by using a coupled circuit between the output circuit of the valve, and the aerial.

Referring to Fig. 5, the aerial circuit contains the tuning coil L_1 with the tapping T_2 , and the fixed condenser in the earth wire. The valve output circuit contains the coil L_4 , tapped at T_1 , and the condenser C_6 . The coupling between the coils is variable.

The wavelength of the aerial circuit is settled by the position of the tap T_2 . The amount of power transferred from the plate circuit to the aerial circuit is controlled by the coupling between the coils L_1 and L_4 .

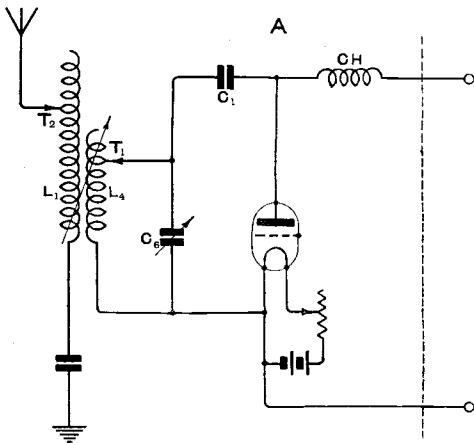

Fig. 5. Showing the connections when a coupled circuit is used.

To obtain the maximum efficiency from the power valve, the plate circuit $C_6 L_4$ should be carefully adjusted. The condenser

C_6 is not always required. If it is used, there need not be so many turns between the tap T_1 and the filament end of the coil L_4 . The adjustment of the circuit $C_6 L_4$ is, however, much easier when the condenser is used, and provided the condenser has low losses, it is preferable to use it.

Naturally, the losses in the plate circuit ought to be as small as possible, and unfortunately it is difficult to find a really good variable condenser which will stand the voltage. In commercial work it is customary to use specially constructed air dielectric condensers at this place in the circuit.

The use of a coupled circuit generally involves a loss in aerial current, but this is perhaps compensated by the greater flexibility of the arrangement, the ease with which the adjustments are made, and because the adjustments are independent.

A suitable condenser would have a capacity of about 0.0005 microfarads, designed with special regard to low losses, and able to stand a voltage about twice that applied to the plate of the valve.

The aerial coil may remain as before, and the plate coil consist of about 20 turns of No. 18 bare wire, 5 ins. in diameter.

14.—THE KEY.

The position of the key is not of great importance in small power sets. Some prefer to join the key in the power circuit, and to shunt the contacts with a condenser such as 0.01 microfarads, joined in series with a resistance of about 100 ohms. Another method is to connect the key in the grid leak circuit so that when the key is raised, the grid leak is disconnected from the grid condenser. Alternatively, the key may be joined across a fixed condenser, such as 0.01 microfarads, in the grid circuit, so that when it is pressed, this condenser is short-circuited. Another way is to insert the key between the tap T_3 and earth. The oscillator or the amplifier may be keyed, preferably

the oscillator. Whichever method of keying is employed, it is advisable, to prevent shocks, to join the bar of the key to a point of low or zero voltage. Two connections are shown in Fig. 6.

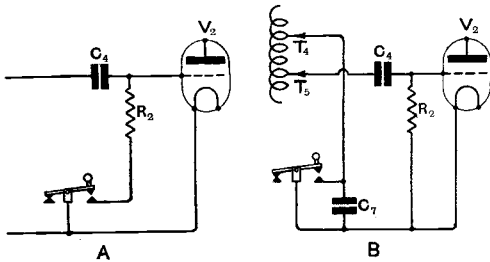

Fig. 6. Two ways of connecting a key. $C_7 = 0.01$ microfarad.

15.—THE MODULATOR.*

It is possible to modulate the high frequency oscillations in several ways. Perhaps the simplest, and the best, is that known as the constant-current system of modulation.

The connections of a modulator unit are given in Fig. 7. This unit is connected in parallel to the power valve, or preferably to the power and the oscillator valves. A choke coil, CH_3 , is joined in the positive supply wire to the valves. The microphone is connected to the primary winding of a microphone transformer P, and the secondary winding S is joined to the grid circuit of the valve V_3 .

When the microphone is disturbed by speech, its resistance varies, and the current in the primary circuit varies accordingly. Corresponding voltages are set up across the secondary winding; therefore the grid circuit of the valve V_3 has voltage variations applied to it corresponding to the speech which operated the microphone.

When the microphone is normal, i.e., there is no speech, there is a steady current flowing between the plate and filament of the valve. The effect of the voltages applied to the grid by speech, is to vary

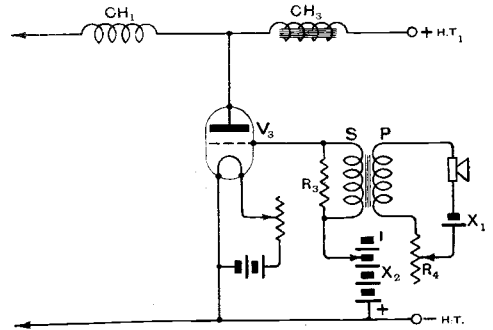

Fig. 7. Connections of a modulator unit. X_1 = microphone battery, about 6 volts. X_2 = grid battery of dry cells. P and S = primary and secondary of microphone transformer. $R_3 = 0.2$ to 0.5 megohms.

this plate current. Now the choke coil CH_3 is designed so that in effect the voltage amplification shall be as large as possible. If the choke had a very large inductance,

* See page 582, issue of August 1st, 1923.

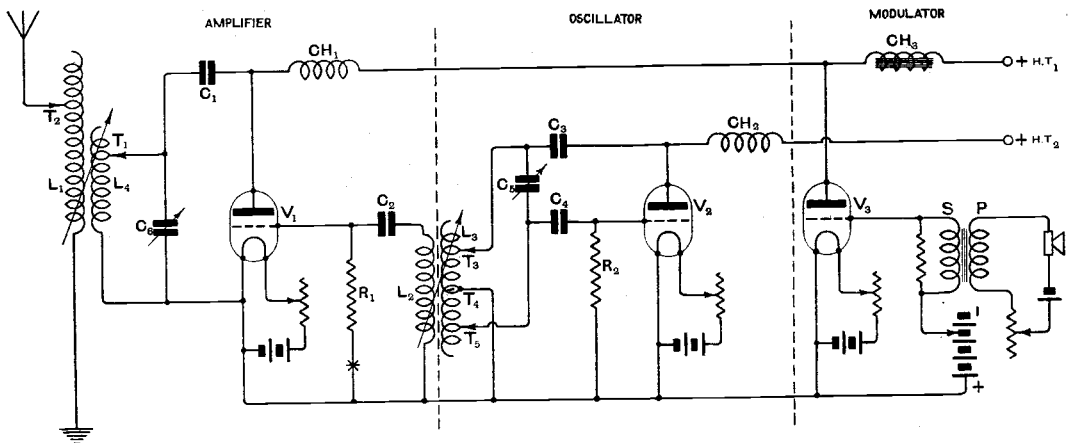

Fig. 8. The complete telephone transmitter.

the plate current would not vary at all, and the voltage amplification is then a maximum. If there were no choke coil at all, the supply current would simply vary according to the demands of the modulator valve, and the voltage across the valve would remain unchanged.

In Fig. 8, the modulator is shown connected to the power valve. The current for the power and modulator valves passes through the choke coil L_3 . Consequently, the voltage variations due to speech set up across the modulator are applied to the power valve. When there is no speech, the normal plate voltage is operating the power valve, but when the microphone is disturbed, the corresponding voltages set up across the modulator valve are of course applied to the power valve, as these are in parallel.

The continuous oscillations are modulated in accordance with the speech because the output from the power valve is proportional to the plate voltage. If an element of speech causes a reduction in the modulator valve current, the voltage across the valve increases, and the power valve takes more current. When the modulator has a voltage applied to its grid circuit, so that the plate current increases, the voltage falls, and the plate current of the power valve falls with it.

The high frequency circuits must therefore be so adjusted, that the output is directly proportional to the applied voltage. This relationship should hold good over a wide range of voltages, from a low value to about twice the normal plate voltage, if good modulation is to be obtained. For this reason it is better to connect the terminal HT_2 to the modulator side of the choke coil CH_3 , through a resistance if it is necessary to operate valve V_2 with lower plate voltage.

A power valve such as V_1 , excited by the oscillator V_2 , connected to a separate plate voltage, has not got a straight line characteristic between plate voltage and aerial current. When the oscillator is modulated as well as the power valve, the characteristic is a straight line, because then the grid excitation of the power valve is also modulated.

16.—THE MODULATOR CONSTRUCTION.

The resistance of the microphone ordinarily used is quite low, perhaps in the neighbourhood of 70 ohms, under non-

working conditions. The grid filament resistance of the valve is very high, therefore a transformer must be used for good results. The primary winding will consist of a relatively few turns, because of the low resistance of the microphone, while the secondary should have many turns, because it is connected to a very high resistance circuit.

For ordinary microphones, a satisfactory transformer consists of 250 turns of No. 22 D.S.C. for the primary, and 20,000 turns of No. 42 S.S.C. for the secondary, wound on a former 1 in. in diameter and 3 ins. long, with an open iron core built up of a bundle of No. 24 soft iron wires to a diameter of $\frac{3}{4}$ in.

The resistance, R_4 , of a few ohms, is included in the primary circuit to provide a means of controlling the amount of power given to the primary winding.

The grid circuit requires careful attention. If grid current is allowed to flow during part of a speech signal, the voltage across the secondary falls, and the secondary voltage is not a true copy of the primary voltage. To prevent grid current, a hard modulator valve should be used, with cells X_2 joined in the grid circuit so that during no part of the signal will grid current flow. The grid voltage should always be carefully adjusted.

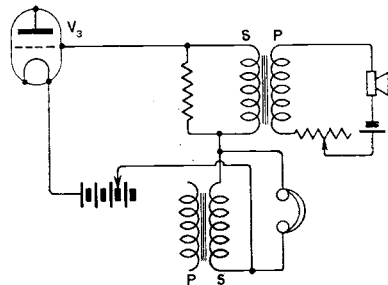

Fig. 9. A side-tone arrangement.

It will be clear that if a soft valve is used, a reverse grid current may flow, so that even though the grid has a proper negative voltage, grid current may still load the secondary of the transformer.

A transformer works best when a definite load is connected across it. For this reason a high resistance of about 0.2 to 0.5 megohms is joined across the secondary winding.

A useful connection, permitting one to hear one's own speech as it appears in the grid circuit of the modulator, is given in Fig. 9. The transformer shown, represents the telephone transformer of the receiver used with the transmitter when communicating. The low resistance telephones are connected across the secondary winding of the telephone transformer.

Of course, the speech heard is no guide whatever to the quality of speech radiated. The only reliable test, perhaps, is that afforded by a receiver located a mile or so away from the transmitter.

17.—THE VALVES.

Suitable valves for use in a transmitter of this description would be those rated at 10 watts, for the modulator and power valves, and an ordinary "R" type receiving valve for the oscillator. If 50-watt valves were used as the power and modulator valves, a 10-watt will be satisfactory in the oscillator. The plate and filament voltages are of course determined by the rating of the valves.

It is a good plan to *never* overload the valves.

GALENA—NATURAL AND ARTIFICIAL.

By JAMES STRACHAN, F.Inst.P.

GALENA, the chief lead ore, is a natural crystalline sulphide of lead. It crystallises in the cubic system and in many mineral veins it occurs in groups of perfect cubes. It occurs more frequently, however, in massive form with cubic cleavage and many of the crystals sold as "natural galena" are simply cleavage forms prepared by breaking up massive galena. The majority of the crystals sold for wireless purposes under a variety of trade names consist of galena, natural or artificial. Artificial galena, contrary to all that has been published about it in wireless journalism, is very easily prepared, and is much more sensitive as a rectifier than most specimens of natural galena.

The reason for the greater sensitivity of artificial galena is probably a physical one to a great extent because insensitive natural galena may be sensitised by artificial re-crystallisation. In this connection it should be noted that, according to mineralogical and geological evidences, most natural galenas have been formed in the wet way, viz., by deposition from thermal waters, while artificial galena is prepared in the dry way, viz., by fusion in a furnace and by the application of heat only. Natural galena almost invariably contains a small percentage of impurities in the form of other metals or metallic sulphides, such as silver, zinc, iron, antimony and copper. A few specimens contain selenium, as selenide of lead, and more rarely, traces of platinum are found in this mineral. The commonest impurity

is a trace of silver sulphide, and it seems probable, from certain experiments carried out by the writer, that silver, even in minute quantities, has some effect in increasing the sensitivity of galena as a rectifier.

Natural galena may be sensitised in several ways. Numerous methods have been employed, such as etching the natural crystals with acids, roasting the crystals in an atmosphere of sulphur vapour, roasting with traces of selenium, or prolonged heating in a neutral atmosphere at a temperature approaching the melting point of galena. The simplest and best method, however, consists in fusion and recrystallisation.

Galena fuses at a temperature of about 1120° centigrade (not nearly 2000° C. as recently stated by a correspondent in *The Wireless World and Radio Review**), and the presence of small quantities of silver brings the melting point below 1,000° C. As low a melting point as 935° C. has been observed with a fairly pure galena. This temperature is quite within the range of amateurs who desire to experiment in the production of their own crystals, and an expensive electric furnace is not necessary.

This temperature is well within the range of a large Bunsen burner (provided the crucible is surrounded by a fire-clay muffle) and can easily be obtained in the smith's forge or an ordinary kitchen stove using a fair draught and good coal. In the latter case the fire-clay crucible (smallest size of Battersea round) should be supported

* Page 838, Vol. 12.

on a half fire-brick towards the back of the fire. The temperature reached may be judged from the following colours, and the crucible should have the same colour as the surrounding fire :—

Dull red heat .. about	700°C.
Cherry red heat about	900°C.
Deep orange heat about	1,100°C.
White heat .. about	1,300°C.
Bright white heat about	1,500°C.

The natural galena, costing only a few shillings per pound for selected specimens, should be broken up small in an iron mortar or on an iron plate with a flat hammer. This is placed in the crucible, with a few fragments of sulphur to prevent oxidation, and the lid luted on with a little moist clay. The temperature of fusion should be maintained, with a small crucible, for 20 minutes to half an hour. More important even than the fusion is the rate of cooling. If the crucible is lifted out of the fire and allowed to cool rather quickly by exposure to the atmosphere, on breaking the smelt it will be found to consist of a very finely or minutely crystallised mass with sensitive spots here and there, but not all over. The crucible should be allowed to cool very slowly and this is accomplished best by allowing the fire to go out before removing the crucible. If a Bunsen furnace is used, after fusion the flame should be gradually reduced and the crucible kept at a dull red heat for about an hour before gradually reducing the flame further. By this simple method of re-crystallisation satisfactory crystals may be prepared from insensitive natural galena.

Black amorphous sulphide of lead may be purchased from any dealer in chemicals, and this powder may be treated in the same way with good results.

The same process may be used for the preparation of synthetic galena from lead and sulphur, but this is a little more troublesome because of the low melting points of these elements. Lead melts at 327°C. and sulphur boils at 445°C. At the latter temperature molten lead rapidly combines with sulphur to form solid sulphide, and the formation of the latter renders complete union imperfect in one operation. A good quality of lead (particularly free from any appreciable percentage of tin) should be used. The lead is first melted in a fairly large fire-clay crucible, and stirred with a carbon rod (an arc lamp carbon) while sulphur

is added gradually until the lead is transformed into a black mass, solid at this low temperature. This is cooled, powdered up finely and mixed with about ten per cent. of its own weight of powdered sulphur and then fused exactly as in the case of galena, and crystallised in the same way.

In the treatment of natural galena or the preparation of synthetic galena too great an excess of sulphur should be avoided, otherwise higher sulphides of lead may be formed to a small extent, with the result that crystals prepared thus lose some of their sensitivity by oxidation or exposure to air.

In the preparation of synthetic galena from one to two per cent. of metallic silver may be added to the lead with advantage because, after numerous experiments, I have discovered that a mixture of lead and silver sulphides dissolves a certain proportion of sulphur in much the same fashion as molten silver dissolves oxygen. This dissolved sulphur is expelled from the smelt during cooling, and, if only a small percentage of silver be used, yields a sufficient excess of sulphur to give great sensitivity to the resulting galena. This property of dissolving sulphur is not possessed by pure lead sulphide or pure silver sulphide, but only by a combination of both. In the same way most natural galenas may be improved by the addition of a small amount of silver during fusion. The silver sulphide is isomorphous with the galena and crystallises in cubes. Experiments have shown that the addition of larger quantities of silver is not advantageous. We hope at a later date to describe further experiments in the crystallisation of galena with the addition of other elements, some of which have yielded interesting results.

AN IRISH WIRELESS JOURNAL.

We have received a copy of No. 1 of "The Irish Radio Journal," the official organ of the Radio Association of Ireland. The new paper claims as its objects the promotion of wireless interests in Ireland, and the establishment of means whereby readers may make their opinions known to the public. Besides a foreword on Broadcasting contributed by the Postmaster-General of the Free State, the first issue contains a valuable article upon "The Electric Valve: Its Action and Applications," penned by Professor John J. Dowling, M.A., F.Inst.P., etc. The address of the publishers is 2-5, Wellington Street, Dublin, and the price per copy is 3d. (Annual subscription, 4/6.)

NOVEL IDEAS AND INVENTIONS

Abstracted by PHILIP R. COURSEY, B.Sc., F.Inst.P., A.M.I.E.E.

Methods of Keying an Arc Transmitter.

It is sometimes desirable to arrange a radio transmitter so that no energy is radiated from the aerial when the signalling key is in the "up" or "spacing" position. With oscillation generators where it is not easy to interrupt the oscillations—as in the case of Poulsen arcs—special means must be adopted to absorb the oscillatory energy and to withdraw it from the aerial when the radiation of a "spacing wave" is not desired. One way of controlling this absorbing or "back-shunt" circuit is sketched in Fig. 1,* where G is the arc generator,

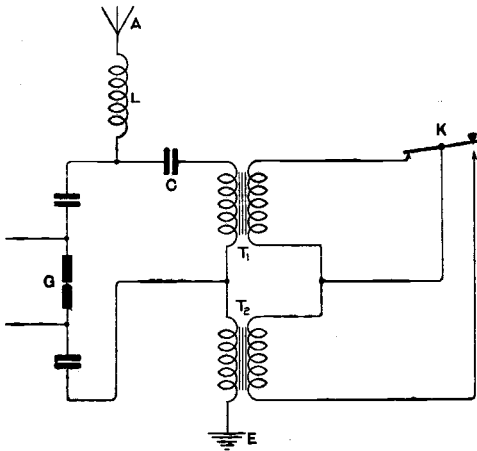

Fig. 1.

A the aerial and K the signalling key. This last is arranged so that it short-circuits the secondary winding of one or other of the transformers $T_1 T_2$ which have iron cores with and primary windings in the aerial circuit. In the key position shown in the diagram the secondary of T_1 is short-circuited so that T_1 primary offers only a small impedance to the oscillatory current, and the bulk of the arc energy is expended in the shunt circuit CT_1 . At the same time the

primary of T_2 offers a high impedance in the aerial circuit and prevents the flow of current in that circuit. When the key is depressed, the short circuit is removed from T_1 which consequently chokes back the flow of current in the shunt circuit, and the impedance of T_2 is reduced so that current can flow in the aerial circuit.

An improved control can be obtained with arrangements of this type by using a modulating or "keying" valve between the key and the chokes or transformers.

Neon Lamps as Amplifiers.

Some ways in which standard forms of neon filled lamps may be used as amplifiers have recently been described in these columns.† Improved results may, however, be obtained if the lamps are built with special electrodes. A species of three-electrode neon lamp has recently been developed in Holland,‡ in which the cathode consists of a thin rod or plate of magnesium or similar "alkaline" metal, the glow being confined to the surface of this electrode. Surrounding the cathode are two spirals of iron wire, one serving as the anode, and maintained at a positive potential of about 120 volts with respect to the cathode, while the other serves as an auxiliary control electrode and is maintained at a steady positive potential with respect to the cathode, of about 20 volts less than the main anode. There is thus little or no current flow to this electrode, but by its position it is well adapted to control the flow of current through the gas from the main anode. The lamp is thus enabled to act as an efficient amplifier.

* British Patent No. 195718, by C. Lorenz Company (Berlin).

† *The Wireless World and Radio Review*, 12, pp. 700-704, August 22nd, 1923.

‡ British Patent No. 175258, by N. V. Philips, Gloeilampenfabrieken.

High-Speed Radio Signalling.

The speed of a radio transmission may be increased by shortening the time required for the "dash" signal. Normally the "dash" is made three times the length of the "dot," so that by reducing the "dash" to the "dot" length, a considerable percentage of the signalling time is saved.* This can be done by transmitting the dots and the dashes at different wavelengths, using two oscillation generators of different frequencies to feed one aerial. At the receiver two separate detectors operated from the one aerial can be used to sort out the "dots" and "dashes" so as to record them both on a single paper strip.

Wired Wireless Transmission on Power Lines.

When it is desired to transmit intelligence by wired-wireless methods over high tension power lines difficulties sometimes arise in coupling the radio or high-frequency apparatus to the wires without at the same time rendering the former liable to damage by the high voltages. In the main two methods have been employed, one being to stretch a small aerial wire up in the proximity of the power wires so that the high-frequency energy is transferred to the power lines by induction, and the other to use coupling condensers designed to operate upon the line voltage.

Another method which at the same time involves small cost, is to make use of the capacity effect between the parts of the suspension or other insulators which are supporting the power lines.† By joining the radio circuit to one of the metallic couplings between the suspension insulator units a convenient coupling capacity is very simply obtained. The capacity effects of the insulators may also be utilised to tune or help tune the line to the frequency of the oscillations impressed upon it.

The use of the insulator units to form the coupling capacities necessarily involves the fitting of extra insulators in most cases as otherwise the electrical safety of the line might be impaired.

By the use of this method of coupling to the power wires it is possible to arrange

* *British Patent No. 196062*, by British Thomson-Houston Company (communicated by the General Electric Company, U.S.A.).

† *British Patent No. 169724*, by E. F. Huth, Gesellschaft (Berlin) and Dr. J. Oppenheimer.

the receiver so that the H.T. for the valves is derived through rectifiers from the potential drop across one of the units of the insulator.

The "Dancing-Contact" Relay.

The construction of a simple relay for operating a recorder or similar mechanism from radio signals is sketched in Fig. 2.* In this diagram, T is a telephone receiver

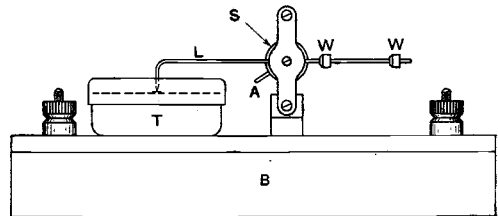

Fig. 2.

mounted upon any convenient base B carrying terminals for the relay. A platinum contact is mounted in the centre of the diaphragm of the telephone, and the bent tip of the lever L rests lightly upon this contact under normal conditions. On the receipt of a radio signal the vibrations of the diaphragm throw the tip of the lever away from the contact and break the local circuit (which may advantageously include a reversing relay). The pressure of the lever on the diaphragm is controlled by the spring S and adjusting lever A, and by the counter weights WW.

A Simple Automatic Transmitter.

Most forms of automatic transmitter, whether used for radio or landline telegraphy, are complex in construction and costly to instal. In many cases, however, the provision of some form of automatic or semi-automatic transmitter is advantageous. A simple transmitter can easily be built up in which the various letters of the alphabet, numerals, etc., are each given a separate key, resembling a typewriter key, which is geared to suitable contacts so that the pressing of a key causes the appropriate Morse or other code signals to be transmitted.† Thus any desired signal or message can be transmitted merely by pressing the correct keys in the proper order.

* *British Patent No. 195657*, by C. P. Ryan.

† *British Patent No. 195796*, by E. J. Quinn.

NEW IDEAS IN RECEIVER DESIGN.

CONSTRUCTIONAL DETAILS OF A THREE-VALVE SET—*Continued.*

By F. H. HAYNES.

IN building any instrument one usually finds that by far the most difficult task is making the cabinet. Good workshop facilities for woodworking should be available, and the constructor must be in a position to obtain suitable supplies of well-seasoned wood. The cabinet should be made first, and for the reader who is skilled in woodwork a drawing is given which includes all necessary measurements for its construction. If woodworking facilities are not available, the drawing should be passed to a reliable cabinet maker, found on the Small Advertisement pages, who

be accurately fitted to the front of the instrument and hinged to the woodwork. No. 4 B.A. screws are used, and in consequence the thickness of the panel must be $\frac{5}{16}$ in., as these screws and three others used for holding the panel to the woodwork are driven into the edges. The ebonite panel can be detached from the hinge after a good fit has been obtained, and the mounting of the components proceeded with. Little need be said concerning the fitting up of these parts except that accurate setting out such as can only be obtained by the use of steel rule and square and spring dividers.

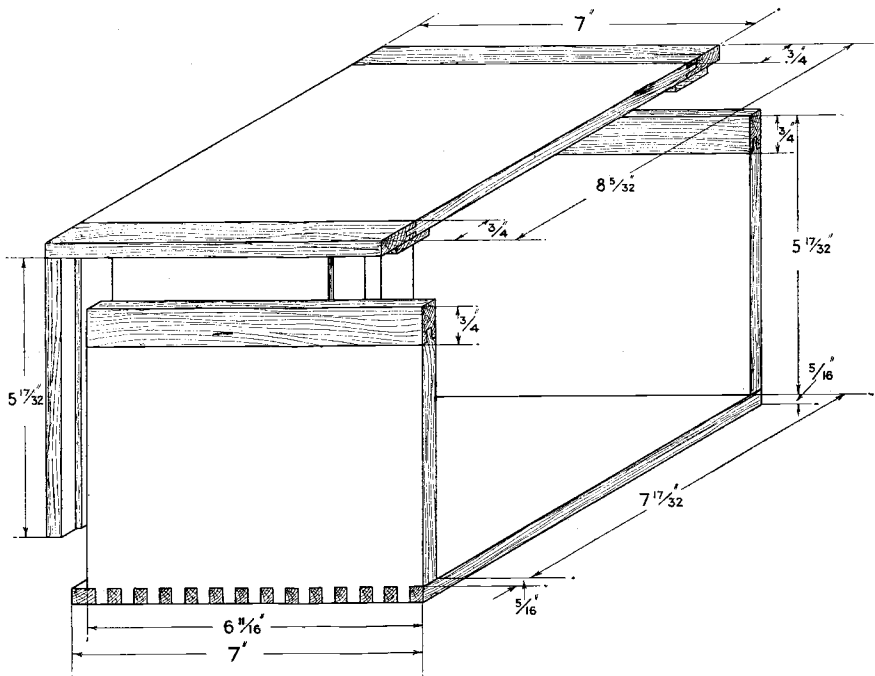

Details of the containing cabinet. A camera screw back is inserted in the bottom board so that the receiver can be easily attached in the bench by a wing screw or supported by the stand.

will undertake to work at least to the nearest thirty-second of an inch. He might also be instructed to fit the hinges, which are pieces of best quality piano hinge carefully fitted. The ebonite front panel must now

All necessary dimensions were given in the previous instalment. Some little difficulty may be met with in fitting the resistances as they are designed for fitting to panels only $\frac{1}{4}$ in. in thickness. However, the knobs

and lock-nuts can be made to hold securely if the lock-nuts are slightly thinned down by filing. The holes for the resistance spindles should give plenty of clearance. The telephone jacks are fitted without their nickelled rings, as the thickness of the panel does not permit of sufficient threads engaging were the rings used. No. 7 B.A. by $\frac{1}{4}$ in. countersunk headed screws are used for securing the small connectors, and one is recommended to try out the mounting of one of these on a piece of scrap ebonite before drilling the panel. It will be found that by using a drill a little larger than the usual 7 B.A. tapping size that the screws can be driven down into the holes without tapping, which is probably preferable to attempting to drive such a small tap down into blind holes. If a hole is made through a piece of ebonite rod so that it fits securely on to the drill being used for making these blind holes it is possible to drill them all to maximum depth without the slightest danger of the point coming through, for only sufficient of the drill should be left projecting from the ebonite rod as is necessary to make a hole of the required depth. When all holes are made and the various components tested to ensure correct fitting, the panel may be rubbed down with coarse carborundum cloth. The instrument shown is rubbed down on the outer face in straight lines parallel to the longer sides, which produces quite a pleasing effect, while the inside face is rubbed in small circles and thus given a uniform matt finish.

The three other connector strips might be made up on the completion of the front panel to complete the ebonite work, and thus have all the necessary components ready for fitting up on to the top and back wooden panels. The two terminal strips also must be fitted up, and if the reader finds difficulty in procuring suitable valve holders he will need also to make up an ebonite strip carrying three sets of valve legs. The exact location for all the components which are attached to the top wooden panel has already been given, and these dimensions should be carefully followed or wiring may become a little awkward. The transformers are secured by 4 B.A. screws and nuts, while the coil holder is similarly held through two of its holes, though ordinary wood screws must be used for the two front ones owing to the position of the hinge. The grid condenser

is placed in such a position that the grid leads can be kept extremely short, and one is reminded that the saving of perhaps only a few inches of wire in the grid circuit of a high frequency amplifier leads to better results. The grid battery of two cells is attached by means of a piece of suitably bent brass, and empire cloth should be placed between the brass strap and the cells. One might be reminded that grid cells are fitted not because an additional H.T. potential is to be applied to the note magnifying valve, but because the filament resistance is connected in the positive lead, an arrangement which does not give quite so much bias as when it is arranged in the negative lead, and the cells are used to make up for this difference. By using this arrangement the grid potential is not affected as adjustments are made with the filament resistance which would be the case if the resistance was in the negative lead and the I.S. terminal of the intervalve transformer connected to minus of the L.T. battery. Little need be said of the fitting up of the condensers and connector strip on to the back panel except that by staggering the condensers as shown the leads from their terminals will not coincide.

The small flexible connectors must now be made up, and ordinary pieces of flexible electric light wire may be used. The ends should be looped and bound up with thread in order to take in frayed ends. As an alternative, bundles of fine flexible wire may be used such as can be obtained by removing the insulation from electric light flex, and threading this bare wire with beads. The connectors should be completely made up apart from the instrument, exact to length, and with the end loops carefully wrapped. An equal number of beads is threaded on to each lead, and for easy identification various colours should be used. By using beads, better spacing is obtained between the wires when the instrument is closed, and the air-spaced beads give lower capacity effects between the leads than would be set up with rubber-covered flexibles lying in contact. Flexible leads must also be run between the coil holder and certain of the connector taps, whilst the remainder should be put through in readiness for connecting to positions on the wiring.

Proceeding with the wiring up it may be pointed out that owing to the nearness of

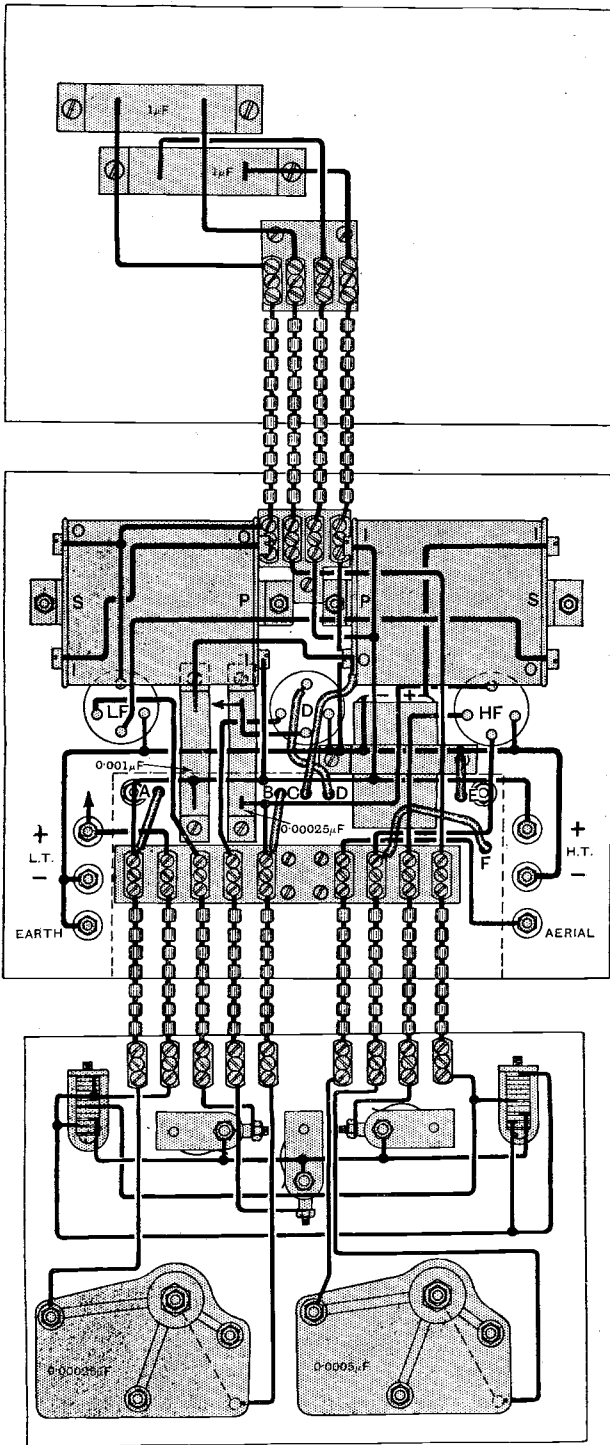

The practical wiring of the three pane's, which are hinged together and connected by flexibles.

the components and the short leads necessary that there is no need to use such heavy wire as No. 16 as is usually recommended in larger instruments. No. 20 tinned copper wire is employed in this instance, and does not occupy so much space as the thicker wire. It is somewhat difficult, however, to connect up with this thin wire, and requires a little patience. The wire is first stretched in order to render it stiff, and the paths to be taken by the various wires must be carefully considered. The accompanying practical wiring diagram was prepared from the instrument, and shows the actual points between which connection must be made. The flexible leads from the coil holder must be critically connected up, in order that suitable reaction effects may be obtained. Viewing the instrument from the front, the aerial coil is on the left, the reaction coil in the centre, and the tuned anode inductance on the right, and it will be observed that the plugs of the coil holder are standing up at the back, with the sockets to the front. The actual connections are aerial plug to grid; aerial socket to L.T. -; reaction plug to plate; reaction socket to transformer primary; tuned anode plug to H.T. +; tuned anode socket to plate.

The grid leak is supported by soldered connections to the wires, and care must be taken not to over-heat its ends when making a connection. No difficulty will be experienced, provided soft tinman's solder is used for the purpose.

With regard to operation, it will be found that the aerial circuit will be tuned to broadcasting wavelengths by inserting a 50, 75 or 100 coil, depending upon the dimensions of the aerial. The reaction coil may be a 75 or 100, while the tuned anode will probably be a 75. The tuning condensers have to be operated more or less

simultaneously, and the extent of reaction coupling must be critically adjusted. It will be found that as the aerial coil approaches the reaction coil, that self-oscillation will occur, whilst oscillation may be again reduced by bringing the tuned anode coil nearer to the reaction coil. Critical combinations of reaction on to aerial

and tuned anode inductances will render the receiver very sensitive, and smooth self-oscillation can be obtained for all adjustments of the tuning condensers.

"R" valves on 4 to 6 volts may be used with this receiver, whilst "D.E.R." or "A.R.D.E." dull emitters will give equally good results on 1.8 to 2 volts.

THE TRANSATLANTIC AMATEUR STATIONS.



Mr. F. L. Hogg at his Station (2 SH).

[Photo: Barratt's]

Quickly following the news of Mr. J. A. Partridge's (2 KF) successful two-way working with America came the report that Mr. F. L. Hogg (2 SH), of Highgate, had also succeeded in effecting communication with the other side. He first established communication with America (1 MO) between 4.45 and 8.10 p.m. on December 12th, and he has quickly followed this achievement by working with other American and Canadian stations, including 3 BP in Toronto, while signals from his station are reported to have been heard by several American listeners further west than the stations with which he has communicated.

A description of Mr. Hogg's transmitting equipment was given in this Journal some little while ago, though we understand that he has carried out some modifications since that time. The results that he has obtained indicate what the experimenter can do working, as he does, under rather difficult conditions. It is understood that 2 SH is operating from an A.C. supply and is using chemical rectifiers. It was due to a breakdown of this part of his apparatus, combined with a few other unfortunate troubles, which rather delayed the opening up of communication with the American transmitters.

From the illustration it does not appear that Mr. Hogg has a well-finished or elaborate layout of his apparatus, though this does not detract from its electrical efficiency. On close examination one can identify the tuning inductance, a Moscicki condenser, a Mullard transmitting valve, and his variable grid leak, consisting of wires immersed in water. From recent reports it would appear that signals from 2 SH are getting across when a power of only 30 watts anode energy is employed.

THE LEAFIELD IMPERIAL WIRELESS SERVICE*

By E. H. SHAUGHNESSY, O.B.E., M.I.E.E.

THE Leaffield station was originally planned in 1913, and it was to be a station of the spark type using 300 Kw. Owing to the outbreak of war, fortunately that form of construction did not develop. During the war there were marked developments in radio transmitting apparatus, but the most marked development of all was the development of the arc for high power. Before 1914 the biggest arc that had been made use of, I think I am safe in saying, was one of 100 Kw., and there were many 25 and 30 Kw. arcs developed during the war. Then, towards the end of the war, there were developments in the high frequency alternator. Apart from one alternator running in America, when we were designing the Leaffield station there was no high frequency generator that had proved itself capable of dealing with 250 Kw. satisfactorily, except the improved design of Poulsen arc, which had proved itself quite satisfactory and had carried out satisfactory programmes. I personally visited the biggest arc stations on the Continent and saw the first Latour high-frequency alternator running in France, but quite apart from seeing these things and spending some time observing their working, there is a much better way of determining the commercial efficiency of any generator, and that is by establishing a watching station and putting expert telegraphists there to take down the whole of the traffic and analyse the whole of the traffic at that station. We did this, and our opinions that the arc is the best and most suitable generator for high power work were confirmed.

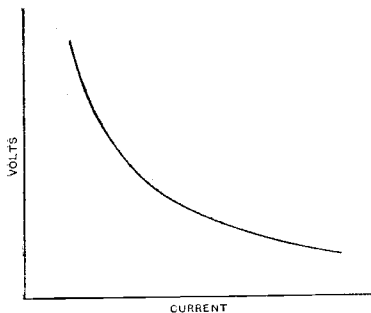

Fig. 1. Characteristic curve of the arc.

Perhaps this evening I can assume that most of you, at any rate, are mainly conversant with the receiving side, and that therefore I shall be justified

* Paper read before the Radio Society of Great Britain on Wednesday, November 28th, 1923.

in giving you some idea of the principle on which the arc works.

In the first place the ordinary arc was studied and it was found that it behaved in a very peculiar manner—that the arc did not obey Ohm's law.

If you look at the curve of Fig. 1 you will observe that the lower line indicates current and the vertical part indicates volts applied at the terminals. The interesting part of this curve is that when you have low volts at the terminals you have a big current; when the current passing through the arc diminishes you have an increase of potential across the arc. In other words, we say the arc has a negative characteristic. The smaller the current flowing through the arc, the larger is the potential difference across the arc. Duddell considered this negative characteristic, and concluded that it could be used

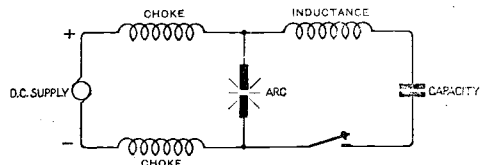

Fig. 2. An oscillatory circuit.

to produce oscillations. He took an ordinary arc and joined across the terminals an inductance and capacity (Fig. 2), and fed the arc with a direct current supply. Let us assume that we put a direct current supply through the arc, and then we join up the wire connecting the arc to the condenser and inductance. The first effect of joining up this circuit will be to cause the condenser to suck current from the path through the arc into the condenser path, thus making the current going through the arc smaller. The result of making that current smaller is to make the potential difference across the arc, and thus the potential difference across the condenser larger than it was, with the result that the condenser can be charged a little more, and this process goes on until we charge the condenser up fully and until the current through the arc is reduced to a very small amount. When you attain that stage no more current will flow into the arc, and as you have a conducting path through the arc, the condenser will now discharge back through the arc. By properly balancing the inductances, or by properly valuing the capacity and inductance you can produce oscillations. But such oscillations as Duddell produced are oscillations of audible frequency, and are therefore unsuitable for high frequency oscillations for wireless work.

Poulsen studied this subject, but he did not get to his final type of Poulsen arc immediately. He

tried various arrangements with different electrodes, and burning the arc inside a chamber containing hydrocarbon gas and put a strong magnetic field across the arc. The effect of enclosing this arc in a chamber and using a gas, and also putting a strong magnetic field through, was to enable him to do two things—to get much higher frequencies from the arc, and also to get an arc which would deal with much higher powers.

Fig. 3 is the same as Fig. 2 except that we have now changed the oscillating circuit of inductance and condenser for an aerial. The capacity due to the aerial and the inductance in series with that capacity gives an oscillating

There is another important point to realise with regard to the oscillating arc, and that is that it is possible to arrange the circuits—a bad arrangement of circuits—so that you can overcharge the aerial or condenser circuit, and actually reverse the direction of current in the arc, but the normal method of working the arc is to adjust the magnetic field, the arc length, and the hydrocarbon gas in such a manner that when the current, which is normally feeding in the arc, begins to flow into the aerial, it is entirely sucked out of the arc path, and the current through the arc just falls to zero immediately after the aerial begins to discharge through the arc. What you want to realise is that

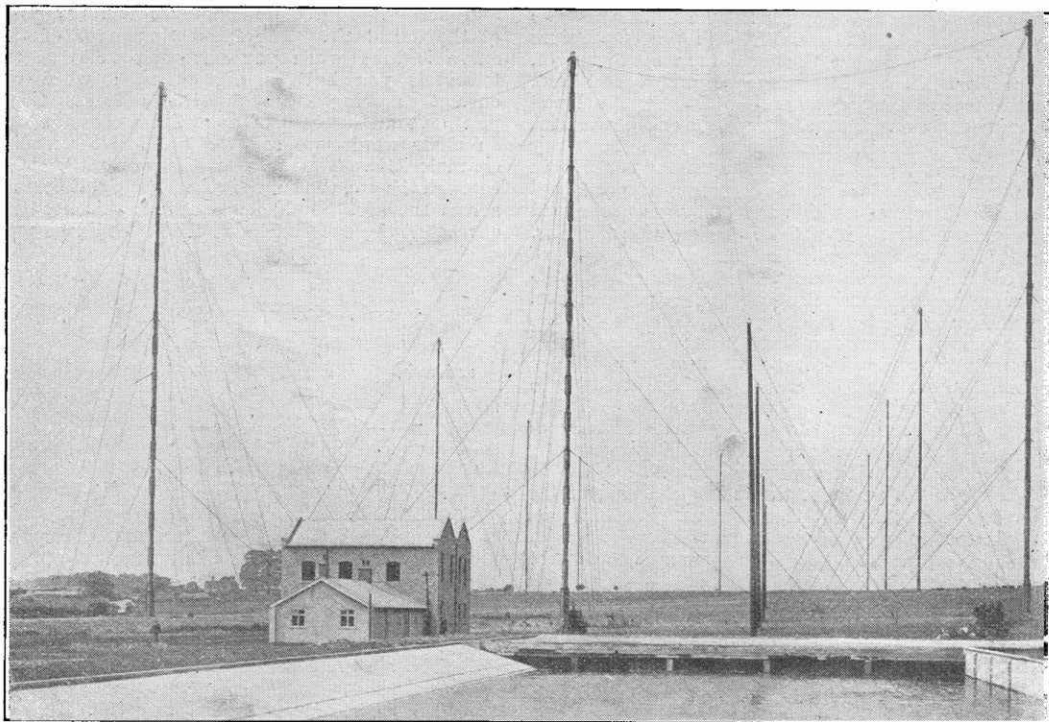

Wireless buildings, masts and cooling ponds.

circuit. The function of the two chokes is to keep the current supply to the arc constant. That is the simplest way of looking at it.

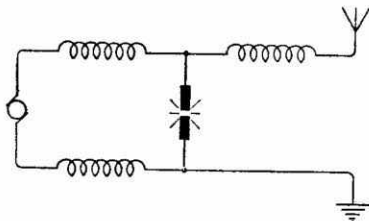

Fig. 3. Connections of arc to aerial.

although you are getting oscillations in your aerial you are not getting alternations of current through the arc.

Now we want to see how these things are brought into actual practice.

The main buildings of the station consist of the power house and the wireless building.

The boiler room has two boilers capable of evaporating 10,000 lbs. of water per hour, and in the next room we have our machinery; two turbo-generators of 250 Kw. capacity each, for the main supply to the arcs. These generators are rather special machines. We have the machines entirely insulated from the bedplates. Each unit consists of a turbine driving two machines off the same shaft, each machine being capable of giving 500 volts, the two being joined in series. The machines

have been tested to about 20,000 volts insulation. They are capable of adjustment between 500 volts and 1,000 volts for the two machines in series. In addition, we have two 60 Kw. turbo-generators which are used for lighting purposes, providing power for circulating water for the condensers; also for working the pumps for circulating water for the arcs; the pumps for the air compressors for working the pneumatic high speed keys and blowing out the sparks at the keys.

In Fig. 3 are shown choke coils leading from the generator to the arc. In practice these choke

arc chamber itself is water-cooled on all its faces. You can see the rubber tube which directs the water into the jacket of the arc chamber. The anode is water-cooled right up to the tip, and the anode insulator keeps the copper electrode insulated from the body of the arc. All the other metal parts of the arc are connected together.

It is rather interesting to observe that the arc is worked between 600 volts and 900 volts. A lot of care is taken to put in a good anode insulator, and then they are connected together with a water column. The water column is, however,

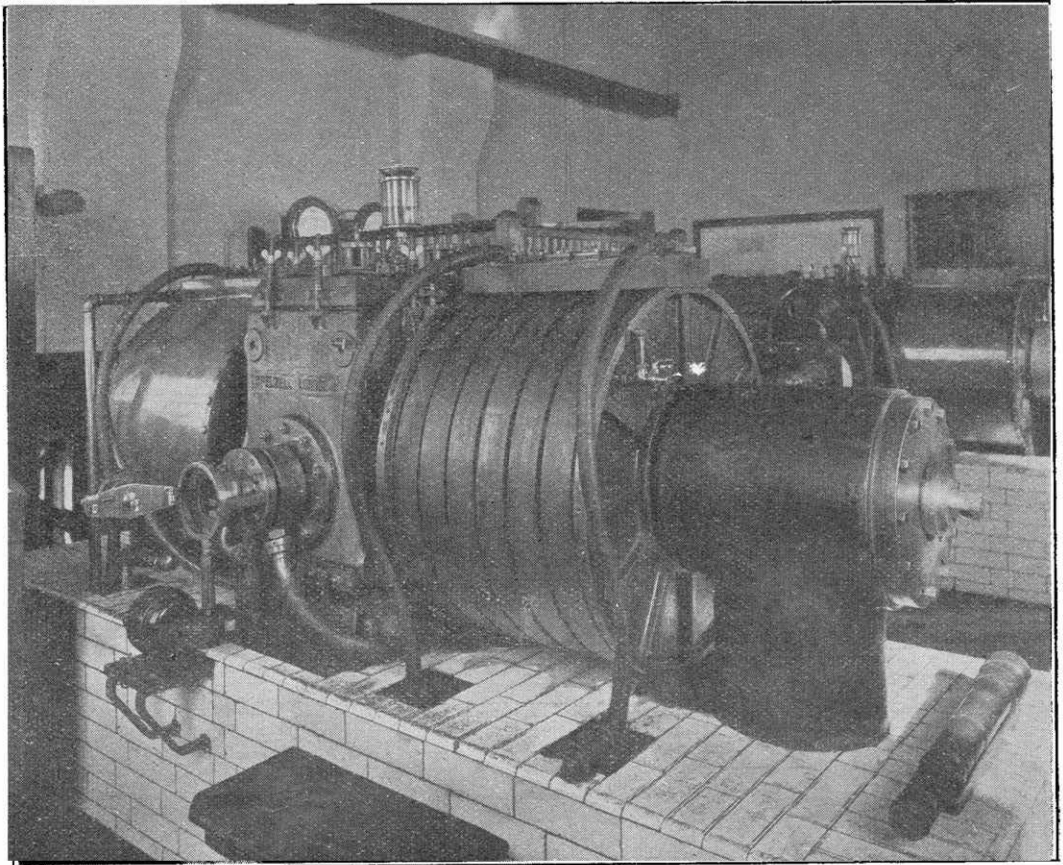

Fig. 4. Leaffield Wireless Station 250 Kw. arc.

coils are about 6 ft. high and made to carry 500 amperes.

The Elwell Poulsen arcs at Leaffield (Fig. 4) weigh about 7 tons. Each of the field magnet coils weigh 30 cwt., and they are supported on a concrete tile-lined base by means of the supports at the ends. The field magnet coils are on one of the parts of the field magnet which continues below the base, the pole pieces project into the arc chamber. The latter is fed by means of these lubricating vessels with methylated spirit. The

of very high resistance so that even if we get a small current flowing through the water it does not affect the working. But it is important that we should have a good anode insulator.

One of our troubles was this anode insulator. We used a quartz insulator to begin with, but it was not unusual for some of these insulators to go in seven or eight hours, and they were very expensive things. We have got over the trouble now, and we use an outer insulator such as you see, and another insulator is put inside it which

covers the copper electrode that goes right inside the arc chamber; the space between the two is filled with asbestos rope. By that means we are now using insulators which cost very little, and last a very long time. The cost of these has come down to a negligible quantity.

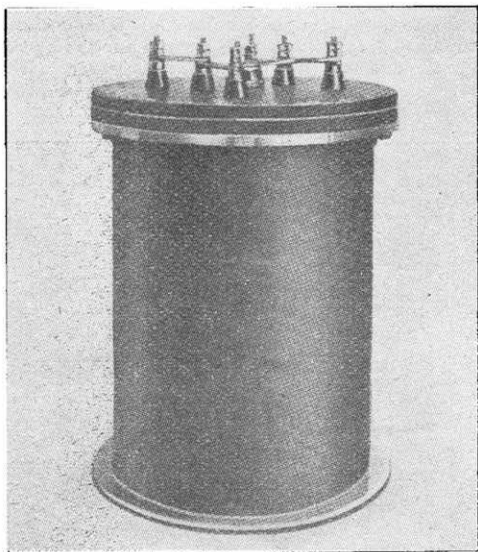

Fig. 5. Oil immersed condenser.

If you start up an arc after it has been cooled down for a little while you find that the old gases, or some of them, are still there, and the air gets in through the lid and the crevices, with the result that when you start an arc by pushing the carbon up against the copper, you also start a very loud explosion. We have had the lid of the air chamber blown off.

We have extended the bolts that hold the lid on and fitted longer springs to take any upward pressure when the lid is lifted by an explosion. A better method of getting over the trouble, we have found, is to let the arc cool down and before starting it up again to blow through the arc with dry air. In that way you can clear the old gases right away, and it is possible to start up with the methylated spirit without trouble from explosion.

Fig. 5. shows one of the oil immersed condensers.

Fig. 6 is a choke coil. The loading inductance at Leaffield has 22 turns, and is 12 feet in diameter. The coil is designed to carry a heavy current, and when we started working at Leaffield we had trouble with the supports of this coil. We got 190 amperes in it, and after working for a little while we found that smoke was issuing from the side columns. The column was punctured, and it was found that the paxolin rods inside the porcelain reels of the columns could not stand up to the high frequency effect. We got over the trouble by building a wooden spider over the top of the inductance coil.

I am sure you would not like me to finish Leaffield without saying something about the harmonics.

As a matter of interest we have taken very careful measurements of the strength of the harmonics at Leaffield, and of the fundamental value, and we find that when we are radiating with 190 amperes in the aerial we actually radiate on the fundamental 4 Kw. approximately, and the value of the second harmonic is 0.0002 Kw. That is a very insignificant fraction of the total radiated energy. It should be realised that a very small fraction of 200 Kw. input when using 300 ft. masts will give you signals over a fairly large area. When Leaffield was first started there was a lot of work to be done in order to get it into proper trim. We had to find out exactly the best field strength, the best adjustment of the arc length and the best mixture in the arc chamber to suit the particular arcs and the particular loads. The same field strength does not do for all wavelengths. These things can only be determined by experience, and I think that our Leaffield arcs are now tuned to such a condition that they are at least equal to any other.

With regard to harmonics, I read in the paper the other day that G.B.L. meant "God Bless Leaffield." I am sure we feel that we have been blessed on very many occasions. (Laughter.) There has been a lot of bad shouting about Leaffield, and whenever anybody gets any harmonics it is always Leaffield. (Renewed laughter.) That is, of course, due to one or two things, and mainly to ignorance. I am out to be shot at after the paper, and to answer questions—(Laughter)—but the first thing to remember is that unless one is a very good operator and can read Morse it is impossible to say what station is causing

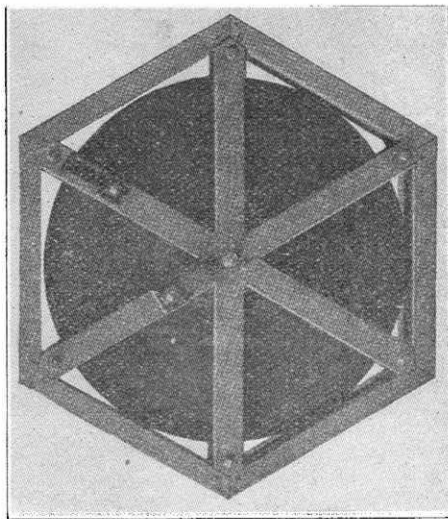

Fig. 6. Choke coil.

the harmonics. I daresay we get credit for all harmonics, including the valve continuous wave stations. I live at Tulse Hill, about six miles from Kidbrook, and I can get Kidbrook about eight times between 300 metres and 800 metres without heterodyning. That is a valve continuous wave

station which is not supposed to be on any of these wavelengths; but the harmonics have a characteristic tonic train note.

Then I was very much interested in a statement I saw in one of the popular journals that come out weekly—not the journal of this Society. It said that Northolt is not very much bother now because the Post Office had put valves in, and he supposed that some day or other we should have valves at Leaffield. That seems to indicate that valves do not produce harmonics. Do not be misled. There

emissions. If you live next to the aerial of any high power station you will have some trouble, but we worked on these coupled circuits for some time, giving reasonable satisfaction to the stations with which the arcs originally interfered. Then one day we got our valves going with a little more current into the aerial, but we were promptly told that we had gone back to the plain aerial arc again and were causing more disturbance than ever.

To get back to Leaffield, we have tried various means of reducing the mush and the harmonics

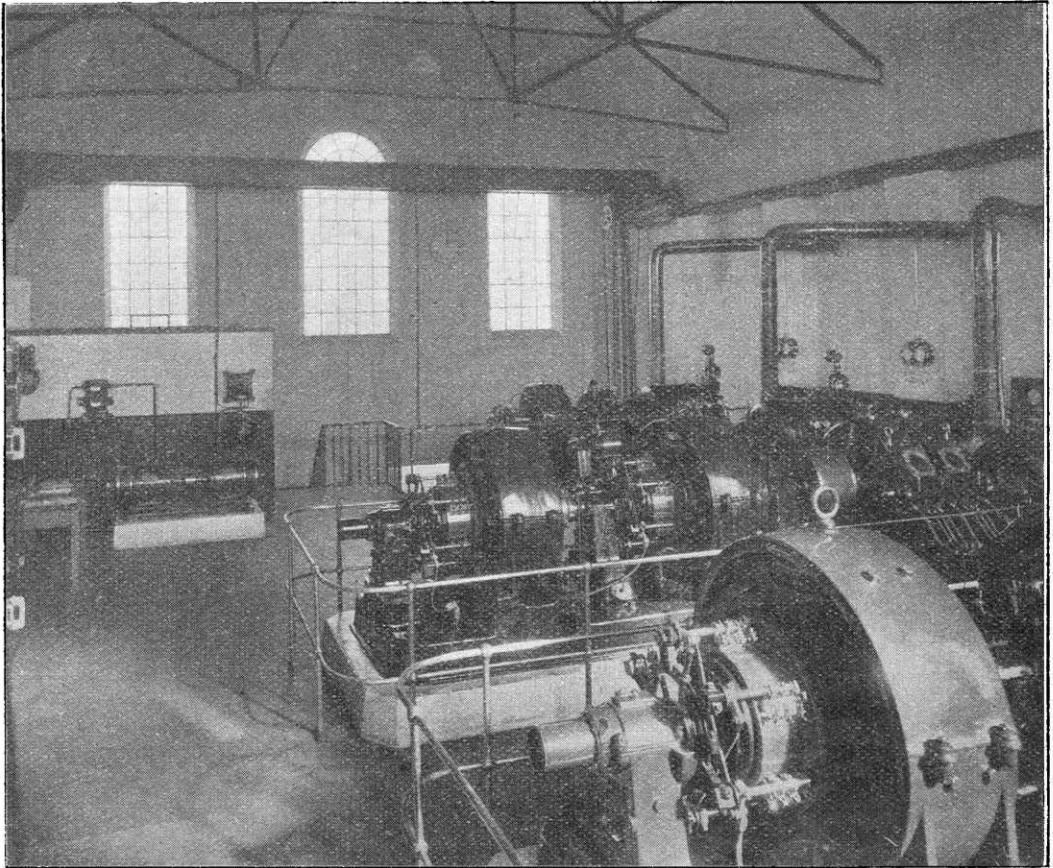

The engine room at Leaffield.

is no greater fallacy. We did put in valves at Northolt, and we have valves at Northolt. It is very interesting to know that when we put in arcs at Northolt we were told by some very wise people that we were very archaic to put them in, and that if we had put in valves there would have been no harmonics. We developed the arcs at Northolt, and put in a coupled circuit, and there is no doubt about it that the coupled circuit at Northolt is very satisfactory both from the working point of view and from the marked reduction in undesirable

there. We have coated one of the carbons used there with a silica paint, but it has not produced very much effect. Then we have tried water cooling of the carbon in the same way as we water cool the copper electrode, the idea being that as the arc rises up between the electrodes it will strike the cool surface at the same instant every time, and we shall get regular kicks or regular impulses into our aerial, and thus get a reduction in the harmonics.

I have got a sample mast stay insulator on the table. That is a stay insulator after it has been in

use on the stays at Leafield for six months. The dielectric stresses in the body of the material have been so great that a very intense heat is developed and the porcelain disintegrates.

These are some of the troubles you get. It is not always the highest insulating material that is the most suitable for use in a high power wireless station.

I do not think there is anything else I want to say about the subject. I have tried to explain something about Leafield, and I shall feel very pleased if we have a discussion. I should like to acknowledge with thanks the loan of slides from Messrs. C. F. Elwell, Ltd.

(The Discussion following the reading of this paper will be published in a subsequent issue.)

OUR TRANSATLANTIC BROADCASTING TESTS.

Further Reports of Reception.

Name and District.	Stations Heard.	Type of Receiver.	Name and District.	Stations Heard.	Type of Receiver.
R. Darbyshire, Altrincham	WGY	3 valves.	Hy. Rogers, Ilfracombe	WGY	2-valve Gecophone.
P. R. Purves, Bickley, Kent	WGY	1-v-1	W. W. Allan, Jr., Glasgow	WGY	1-v-1
	WJZ		J. R. Christie, Aberdeen	WGY	1-v-1
	WHAZ		Redway, Exmouth	WGY	—
G. S. Dobson, Rothwell, nr. Leeds ..	WGY	1-v-0	Wilfred H. Powell, S. Norwood ..	WGY(?)	1-c-1
	WOR(?)		C. V. Hillier, Croydon	WGY(?)	1-v-1
Joseph Noden, Nantwich	WGY	1-v-2	F. Lang, Bideford, N. Devon ..	WGY	4 valves.
Leonard Hirschfeld, London, N. ..	WGY	1-c-0 (dual)	T. A. Alcock, nr. Stoke-on-Trent ..	WGY	0-v-0
Ernest Humpherson, London, S.W. ..	WGY	1-v-0	J. Bishop, Gt. Yarmouth	WGY	—
	WJZ		L. E. Smith, Eccles	WGY	3 valves.
T. F. Lox, N. Devon	WGY	1-v-1		KDKA	
Alfred H. Workman, London, N.22 ..	WGY	1-v-1	A. E. Underdown, Eltham, S.E.9 ..	WGY	1-v-2
H. R. Goodall (2IL), Southampton ..	WGY	4 valves.	J. de Burgh Daly M.D., Cardiff ..	WGY	2-v-1
	WBAN		E. R. Martin Workshp.	WGY	0-v-0
D. Ness, Drem, N.B.	WGY	1-v-2	H. Andrews, Highgate	KDKA	1-v-0
Tom Lee, Jersey	WGY	2-v-1	G. Laity, Launceston	WGY	1-v-1
A. Richardson, London, S.W.2. ..	WGY	0-v-1	E. G. Griffiths, Ipswich	WGY	—
	WHAZ		Mortimer W. Larkin, Essex	WGY	2-v-1
	KSD		J. A. Somerville, Monkscaton ..	WGY	4 valves.
Walter Thos. Taylor, nr. Barnsley ..	WGY	0-v-1	T. Mooney, Newcastle-on-Tyne ..	WGY	1-v-0
R. W. Taylor, Warrington	WGY	1-v-1	A. C. Smith, Sidcup	WGY	1-v-1
	WEAM		V. A. Pask, Gosforth	WJZ	2-v-0
C. Prosser, nr. Cardiff	WGY	0-v-0	J. K. Bridle, Durham	WGY	Gecophone 2 valves.
	KDKA		Eddy Pearce, Newcastle	WGY	1-v-1
Frederick Cooper, Northwood, Middlesex	WGY	—	R. T. Haywood, London, S.E.14 ..	WGY	0-v-1
A. H. Robinson, Tyldesley, nr. Man- chester	WGY	0-v-1	E. H. Blackwood-Price, co. Down ..	WGY	Marconiphone V2
	KDKA		H. W. Williams, Wakefield	WGY(?)	—
D. Lomas, Wilmslow, nr. Manchester ..	WGY	0-v-1	A. H. Hawkesford, Altrincham, Cheshire	WGY	1-v-1
W. O. Bentley, S. Kensington, London, W.	WGY	2 valves.		WHAZ	
H. Platt, Windsor	WGY	—		WJZ	
D. J. Martyr, London, S.E.25	WGY	—	B. Draper, Mill Hill, London, N.W.7.	WGY	0-v-1
H. Cameron Beaumont, Huddersfield ..	WGY	1-v-1	W. H. Tunstall, Earlestown, Lancs. ..	WGY	1-v-1
W. N. Harrison, Longbridge, Birmingham	WGY	0-v-0	A. Simons, Mablethorpe, Lincs. ..	KDKA	0-v-1
C. Warriner, Birkenhead	WGY	Marconiphone V2.		WGY	
	WHAZ(?)			WHAZ	
Walter McC. Armstrong	WGY	—	V. O. Jones, Glamorgan	WGY	1-v-1
	WHAZ		A. N. C. Horne, Queenstown	WGY	0-v-2
W. A. Haworth, High Lane, Cheshire ..	WGY	Marconiphone V2.		KDKA	
	WHAZ			WGY	
E. Seymour Clarke, Godalming	WGY	1-v-0	P. Nicoll, Burnley	WGY	Burndept Ultra IV.
A. C. B. Smith, Colwyn Bay	WGY	1-v-0		WGY	0-v-0
C. W. Smith, Harlesden, N.W.10 ..	WGY	1-v-2	Garrett J. Spiers, London, S.E.4 ..	WGY	—
A. E. P. Witham, Frome	WGY(?)	3 valves.	T. A. St. Johnston, Aringford, Essex	KDKA	—
W. Brian Parker, Monkscaton, North- umberland	WGY	1-v-1	Harold E. Bourne, London, S.W. ..	WGY	1-v-1
W. H. Harding, Cardiff	WGY	—	El Conde de Alba, Salamanca, Spain	WJZ(?)	1-v-2
C. Hartland Shropshire	WGY(?)	1 v-0	Vernon Foster, Barrow-in-Furness ..	WGY	1-v-0
Walter Horsley, B.Sc. Bangor	WGY	Marconiphone V2		WHAZ	
	WHAZ			KDKA	
J. B. Cole, Jersey	WGY	3 valves.	G. A. V. Sowter, B.Sc., London, N.1	KDKA	—
W. G. Pattman, Birmingham	WGY	—	Beaumont, Bath.	WGY	—
J. R. Randall, Sutton Coldfield	WGY	1 v-1		WGY	
J. Howells, Newport, Salop	WGY	4 valves.	G. W. Melland, Colwyn, N. Wales ..	WGY	5 valves.
H. Hall, Birmingham	WGY	Burndept Ultra IV.		KDKA	
	WGY	1-v-1	E. P. Sentance, Grantham	WGY	0-v-2
H. Jones, Cannock, Staffs.	WGY(?)	1-v-1		KDKA(?)	
D. E. Price, B.Sc., Hinckley, Leeds ..	WGY(?)	3 valves plus crystal.	A. S. Cutcliffe, Ilfracombe	WGY	0-v-0
	WGY	1-v-1		KDKA	
F. J. B. Whitfield, Newport, Salop ..	WGY	—	M. H. Atkinson, Hawkhurst, Kent ..	WGY	1-v-1
A. J. Bromley, Leicester	WGY	—		KDKA	
J. E. Roberts, Widnes	WGY	1-v-1	A. E. Crisp, Woolwich	WGY	0-v-2
	WHAZ			KDKA	
W. Matthews, Aston, Birmingham ..	WGY(?)	2-c-0	J. R. Forshaw, Ormskirk	KDKA	1-v-0
R. Stephen, Pontypool	WGY(?)	2-v-0	A. J. Rowe, Golder's Green, London, N.W.11.	WGY	0-v-1
F. G. Lang, Grays, Essex	WGY	0-v-1	Wilson Reid, Hawick, N.B.	WGY(?)	0-v-1
H. Maitland Cole, London, N.14 ..	WGY	2 valves.	A. S. Jensen, Laurberg, Denmark ..	WGY(?)	0-v-3

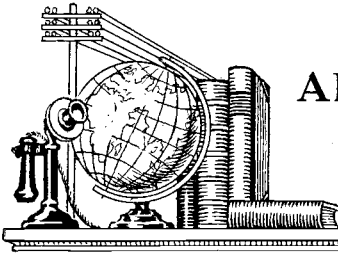

AROUND THE WIRELESS WORLD

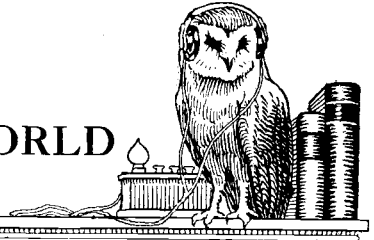

Italian Amateur Heard in England.

M. Giulio Salom (**1 MT**) of Venice, reports that on the night of December 9th he exchanged wireless messages with British **2 HF** (Mr. W. G. Gold, of Four Oaks, Nr. Birmingham), who told him that his signals were being well received on a two-valve set. The distance from Venice to Birmingham is over 800 miles.

The "Model Engineer" Exhibition.

The seventh exhibition, organised by the proprietors of the "Model Engineer," will be opened on January 4th, at the Royal Horticultural Hall, Vincent Square, London, S.W.1.

Besides the usual excellent display of models of all kinds, this year ranging from the tiniest internal combustion engine in the world to a model steam engine capable of hauling visitors round the Hall, a special radio section will be provided. A strong representation of the wireless trade has been arranged, and wireless amateurs of all classes may expect to find much to interest them. The closing date of the exhibition is January 11th.

Another Transatlantic Relay Test.

Reference has already been made in the daily Press to the British Broadcasting Company's attempt on December 22nd to relay a broadcast transmission from America to listeners in this country. Before these lines are in print a further experiment on the same lines will have been commenced, organised by the Metropolitan Vickers Electrical Company, who have made arrangements with the Westinghouse Electric and Manufacturing Company of Pittsburgh to conduct a series of tests during the first week of the New Year.

With a view to testing the character of the re-radiation of these received messages, the Metropolitan-Vickers Company is using a transmitting power of $1\frac{1}{2}$ kilowatts on 400 metres, with the call sign "**2 AC**" The transmissions are being carried out from the special experimental plant of the Company's Research Laboratories at Trafford Park, and the signals are picked up from **KDKA**, the Westinghouse Company's broadcasting station at Pittsburgh.

The actual transmissions from **KDKA** are carried out on a new system which this series of experiments is intended to test.

Relaying is taking place on favourable nights from 11.30 to midnight and it is particularly requested that during these periods, amateurs in this country will refrain from oscillating.

Anyone who is able to pick up the ordinary transmissions from the Manchester Broadcasting Station (**2 ZY**) should be able to receive this re-transmission. Reports of reception will be welcomed and should be addressed to Mr. A. P. M.

Fleming, Manager of Research and Educational Departments, Metropolitan-Vickers Electrical Co., Ltd., Trafford Park, Manchester.

The Annual Exhibition of the Physical Society.

The Annual Exhibition of the Physical Society of London and the Optical Society is being held on Wednesday and Thursday, January 2nd and 3rd, 1924, at the Imperial College of Science and Technology, South Kensington. The Exhibition will be open each day from 3 to 6 p.m., and from 7 to 10 p.m.

A lecture on "The Heape and Grylls Rapid Cinema Machine" will be given by Mr. H. B. Grylls at 4 p.m. on January 2nd, and at 8 p.m. on January 3rd. Sir Richard Paget, Bart., will give a lecture on "The Nature and Artificial Production of Human Speech (Vowel Sounds)" at 8 p.m. on January 2nd, and at 4 p.m. on January 3rd.

We understand that invitations have been given to the Radio Society of Great Britain, the Institution of Electrical Engineers, the Institution of Mechanical Engineers, the Chemical Society, the Röntgen Society and the Faraday Society. Admission in all cases will be by ticket only, and Members of the Societies just mentioned should apply to the respective Secretaries. Others interested should apply direct to Prof. A. O. Rankine, Hon. Secretary of the Physical Society, Imperial College of Science and Technology, South Kensington, S.W.7.

New Belgian Wireless Station.

King Albert presided on December 19th at the laying of the foundation stone of the wireless station at Ruysselede, a village some ten miles south of Bruges. This it is understood will be one of the most powerful stations in the world, and will enable Belgium to communicate with the Congo. The installation is being carried out by the Société Belge de Télégraphie sans Fil, with State assistance.

The Valve on the Film.

A cinematograph film giving a diagrammatic explanation of the thermionic valve and its application has been produced by the International Western Electric Company, and has been shown at the Savoy Picture House, Edinburgh. The film also includes a series of wireless telephony experiments conducted during aerial manoeuvres by a flying squadron.

Wanted: A Clerical Assistant.

The Radio Society of Great Britain requires a clerical assistant, preferably with a knowledge of amateur wireless. The salary offered is from £120 up to £150 per annum according to qualifications. Applications should be made to the Hon. Secretary, 32, Quex Road, West Hampstead, N.W.6.

The Radio Society of Great Britain.

TRANSMITTER AND RELAY SECTION.

The Franco-British Tests on 200 Metres.

In our issue of November 28th (p. 290), we gave particulars of the transmission tests between British and French transmitters which had been arranged to take place from November 26th to December 9th. French amateurs began transmitting on November 26th and continued on alternate nights, and British amateurs transmitted on the intervening dates.

The results of the French transmissions given below are extremely interesting, particularly when read in conjunction with the list of localities of the transmitters, included at the end.

The undermentioned French Stations were heard by British amateurs receiving in the places given:—

November 26th, 1923.

- 8 DY** Sheffield, Cambridge, Palmer's Green, Shipley.
8 AE Sheffield, Bristol, Shipley, Palmer's Green, Edinburgh, and also Switzerland.
8 CF Sheffield, Shipley, Palmer's Green, Bristol, and also Switzerland.
8 BE Sheffield, Edinburgh, Palmer's Green, and also Switzerland.
8 CS Bristol, Shipley, Palmer's Green, and also Switzerland.
8 BA Sheffield, Palmer's Green, Berwick.
8 AF York, Shipley.
8 AE2 Bristol, Palmer's Green.
8 DA Switzerland.
8 BU Switzerland.
8 AA Switzerland.
8 EN Palmer's Green.
8 EC Cambridge.

November 25th, 1923.

- 8 DY** Hampstead, Sheffield, Edinburgh, Cambridge, Calne, London, York, Bradford, Cricklewood, Folkestone, Birmingham, Bristol, Nottingham, Baildon, Stalybridge, Sheerness.
8 AE Sheffield, Edinburgh, Calne, Bayswater, Cricklewood, Stalybridge, London, Bradford, Folkestone, Gowerton, Glasgow, Nottingham, York, Baildon.
8 BL Calne.
8 DG Gowerton.
8 CF Hampstead, Sheffield, Calne, Edinburgh, Bayswater, Macclesfield, Cricklewood, Bradford, Folkestone, Gowerton, Glasgow, Bristol, Nottingham, London, Stalybridge, Gt. Malvern, York, Baildon.
8 BE Hampstead, Sheffield, Edinburgh, Calne, Bayswater, Stalybridge, Bradford, Folkestone, Gowerton, Glasgow, Nottingham, Baildon, York.
8 CS Sheffield.
8 AL Folkestone.
8 BA Sheffield, Calne, Bayswater, Cricklewood, Stalybridge, London, Edinburgh, Bradford, Gowerton, Baildon, Glasgow, Nottingham.
8 DA London, Folkestone, Bristol, Nottingham.
5 PU Sheerness, Nottingham.
8 BU Sheerness, Nottingham, Baildon.
8 DX Cricklewood.
8 AA Folkestone.
8 BM Cricklewood, Tottenham.
8 BF Baildon.
8 DP Gowerton, Bristol, Nottingham, Baildon.
PCL Sheffield, Edinburgh, Stalybridge, Gt. Malvern, London, Shipley, Sheerness, Cricklewood, Nottingham, York, Baildon.

- 8 AU** Edinburgh, Cambridge, Sheerness, Nottingham, York.
8 FF Calne.
8 BS Gt. Malvern, York.
8 CY Cambridge, Bayswater, Cricklewood, Macclesfield, Sheerness, Nottingham, York.
8 AP Cambridge, Bradford.

November 30th, 1923.

- 8 CJ** Hampstead, Folkestone, Clacton, Stalybridge, Calne, Cricklewood, Nottingham, Bristol, Monkseaton, Essex, Gowerton, Edinburgh, London.
8 DY Cricklewood, Nottingham, Bristol, Monkseaton, Gowerton, Calne, Suffolk.
8 AE Hampstead, Suffolk, Clacton, Cricklewood, Earl's Court, Dulwich, Nottingham, Bristol, Monkseaton, Essex, Edinburgh, Gowerton, Calne, London.

- 8 CF** Folkestone, Calne, Nottingham, Bristol, Monkseaton, Essex, Gowerton.
8 BE Folkestone.
8 AF Folkestone.
8 BU London.
8 CS Hampstead, Folkestone, Clacton, Cricklewood, Dulwich, Nottingham, Bristol, Monkseaton, Essex, Gowerton.
8 BA Clacton, Nottingham, Bristol, Monkseaton, Essex, Calne, Gowerton, London.
8 AE2 Clacton, Cricklewood, Nottingham, Bristol, Monkseaton, Gowerton, Edinburgh, London.
8 DY Hove, Hampstead, Folkestone, Bradford, Sheffield, Nottingham, Gowerton, Bristol, Monkseaton, Bradford, Calne, East Grinstead, London, Dollar.
8 DA Calne, Nottingham, Bristol, Gowerton.
8 AU Cambridge.
8 LG Suffolk.
8 CY Nottingham, Bristol, Gowerton.
8 CM Essex.
8 AH Cambridge.
8 DM Monkseaton.
8 EN Cricklewood, Nottingham, Bristol, Monkseaton, Gowerton, London.

December 4th, 1923.

- 8 CJ** Hove, Folkestone, Bradford, Sheffield, Nottingham, Edinburgh, Monkseaton, London.
8 AG Hampstead, Bradford, Sheffield, Calne, Nottingham, Gowerton, Bristol, Edinburgh, London, Monkseaton, Dollar.
8 CG Folkestone, Bradford, Sheffield, Calne, Nottingham, Gowerton, Edinburgh, London, Monkseaton.
8 AE Edinburgh, Earl's Court, Bradford, Sheffield, Essex, East Grinstead, Nottingham, Gowerton, London, Bristol, Bradford, Nottingham, Edinburgh, Monkseaton, Calne, Dollar.
8 BL Nottingham.
8 AQ Nottingham.
8 CF Folkestone, Bradford, Sheffield, Nottingham, Gowerton, Bradford, Edinburgh.
8 CS Hampstead, Bradford, Sheffield, Calne, Nottingham, Gowerton, Edinburgh, London.
8 BA Folkestone, Bradford, Sheffield, Nottingham, Gowerton, London, Dollar.
8 AC2 Hampstead, Bradford, Nottingham.
PC II Essex.
8 AE2 Folkestone, Bradford, Sheffield, Calne, Nottingham, Gowerton, Bristol, Edinburgh, Monkseaton, London.
8 DA Folkestone, Bradford, Sheffield, London.
8 EU Folkestone.
8 AA Nottingham.
8 CF Nottingham.
8 CH Nottingham.
8 DU Nottingham.

December 6th, 1923.

- 8 CJ** Hove, Nottingham, Dollar.
8 AG Bradford, Earl's Court, Palmer's Green, Nottingham, London, Monkseaton.
8 DY Hove, Bradford, Earl's Court, Nottingham, Monkseaton, London.
8 CG Hove, Bradford, Earl's Court, Palmer's Green, Nottingham, London, Monkseaton.
8 AE Bradford, Nottingham, London.
8 CT Hove, Bradford.
8 BL Bradford, Earl's Court, Palmer's Green, Nottingham, Monkseaton, London.
8 DU Bradford, London, Dollar.
8 AQ London, Monkseaton.
8 CS London.
8 EQ Dollar.

December 8th, 1923.

- 8 CJ** Hove.
8 DY New Southgate, Edinburgh, York, Calne, Hove, Earl's Court, London.
8 CG Calne, Hove, Edinburgh, London.
8 AE Nottingham, Edinburgh.
8 CT York.
8 BL Edinburgh, Hove.
8 AQ Hampstead, Folkestone, York, Calne, Watford, Hove, Edinburgh, Earl's Court, New Southgate, London.
8 CF New Southgate, Calne, Hove, London.
8 AA York, Calne, Edinburgh.
8 BF Folkestone, Calne, York, Edinburgh.
8 FF Hove.
8 DH London.
8 GS Hove.

FRANCO-BRITISH TESTS—continued.

- 8 CC Hove.
- 8 BP York.
- 8 AG Edinburgh.
- 8 DX Bristol.

December 10th, 1923.

- 8 AQ Edinburgh.
- 8 CF Nottingham.
- 8 BE Nottingham.
- 8 CS Nottingham.
- 8 BU Nottingham.

Undated Receptions During Test Period.

- 8 CJ Nottingham.
- 8 DY Nottingham.
- 8 OG Nottingham.
- 8 AE Aberdeen, Nottingham.
- 8 BL Aberdeen.
- 8 AQ Aberdeen, Nottingham.
- 8 CF Nottingham.
- 8 BE Nottingham.
- 8 CS Nottingham.
- 8 BA Nottingham.
- 8 FF Nottingham.
- 8 CH Aberdeen.

- 8 CR Marseille.
- 8 GS Reims.
- 8 CT Arcachon.
- 8 CU Orleans.
- 8 CV Chmoges.
- 8 CX Vert-en-Drouais.
- 8 CY Reims.
- 8 CZ Vaucresson.
- 8 DA Marseille.
- 8 DE Alger.
- 8 DC Rouen.
- 8 DD Grenoble.
- 8 DE Marseille.
- 8 DF Paris.
- 8 DG Caen.
- 8 DH Marseille.
- 8 DI Nimes.
- 8 DJ Paris.

- 8 DL Fecamp.
- 8 DM Charleville.
- 8 DN Lyon.
- 8 DO Epemay.
- 8 DP Versailles.
- 8 DQ Guebwiller.
- 8 DE Paris.
- 8 DS Marseille.
- 8 DT Toulouse.
- 8 DU Metz.
- 8 DV Port-St. Louis du Rhone.
- 8 DX Paris.
- 8 DY Boisguillaume.
- 8 DZ Paris.
- 8 EA Paris.
- 8 EB Moulins.
- 8 EC Caval.
- 8 EF Pantin.

Location of French Stations Participating.

- 8 AA Boulogne-sur-Mer.
- 8 AB Nice.
- 8 AC Albi.
- 8 AD Juvisy-sur-Orge.
- 8 AE Versailles.
- 8 AE1 Versailles.
- 8 AE2 Versailles.
- 8 AF Paris.
- 8 AG Chateney.
- 8 AH Paris.
- 8 AI Paris.
- 8 AJ Paris.
- 8 AK Paris.
- 8 AL Amboise.
- 8 AM Marseille.
- 8 AN Paris.
- 8 AO Le Mans
- 8 AP Audincourt.
- 8 AQ Arpajon.
- 8 AR Bihorel.
- 8 AS Rueil.
- 8 AT Lyon.
- 8 AU Le Mans.
- 8 AV Reims.
- 8 AX Alger.
- 8 AY Alger.
- 8 AZ Savigny-sur-Orge.
- 8 BA Paris.
- 8 BB Paris.
- 8 BC Compeigne.
- 8 BD Paris.
- 8 BE Orleans.
- 8 BF Orleans.
- 8 BG Nuisement.
- 8 BH Tourcoing.
- 8 BI Paris.
- 8 BK Colombes.
- 8 BL Paris.
- 8 BM La Briquette.
- 8 BN Paris.
- 8 BO Nice.
- 8 BQ Marseille.
- 8 BR Marseille.
- 8 BS Rugles.
- 8 BT Paris.
- 8 BU Marseille.
- 8 BV Paris.
- 8 BX Vitry-sur-Seine.
- 8 BY Marseille.
- 8 BZ Montelimar.
- 8 CA Paris.
- 8 CB Paris.
- 8 CC Paris.
- 8 CD Toulouse.
- 8 CE Amiens.
- 8 CF Sainte-Foy-les-Lyon.
- 8 CG Paris.
- 8 CH Vaucresson.
- 8 CI Charleville.
- 8 CJ Paris.
- 8 CK Montelimar.
- 8 CL Moisson.
- 8 CM Paris.
- 8 CN Rouen.
- 8 CO Issy-les-Moulineaux.
- 8 CP La Queuc-en-Brie.
- 8 CQ Sotteville-les-Rouen.

FORTHCOMING EVENTS.

WEDNESDAY, JANUARY 2nd.

Tottenham Wireless Society. At 8 p.m. At the Institute, 10, Bruce Grove, N.17. Monthly Business Meeting and Reports of Experiments.

FRIDAY, JANUARY 4th.

Seventh "Model Engineer" Exhibition (January 4th to 11th inclusive). At the Royal Horticultural Hall, Vincent Square, S.W.1.

Wireless Society of Hull and District. At 7.30 p.m. Debate: "Has the Advent of Broadcasting proved beneficial to the Wireless Amateur?"

MONDAY, JANUARY 7th.

Kingston and District Radio Society. Lecture: "An Electric Wave from Transmitting to Receiving Station" (illustrated with lantern slides). By Mr. F. Peake Sexton, A.R.C.S., A.M.I.E.E.

Dulwich and District Wireless and Experimental Association. Lecture and Demonstration on "Practical Wave-Trap Construction." By Mr. Harrie King.

At the Scientific Novelties Exhibition, King's College, Strand. At 2.30 and 6.30 p.m. Lecture: "Wireless at Sea." By Commander J. A. Slee.

Radio Association of Ireland (Dublin). Annual General Meeting.

Re-election of Officers of R.S.G.B.

In our issue of December 19th, it was stated that Mr. Frank Hope-Jones (Chairman of the Radio Society of Great Britain), Mr. L. McMichael (Hon. Secretary) and Mr. L. F. Fogarty (Hon. Treasurer), had been asked to accept office as Vice-Chairmen. Actually the gentlemen referred to were asked to accept office as Vice-Presidents, and we regret the error in our previous paragraph.

DESCRIPTIONS OF APPARATUS USED FOR RECEPTION OF AMERICAN BROADCASTING.

Announcements have already appeared in these pages inviting readers to furnish descriptions of their apparatus with which they have been successful in listening to the American broadcasting. To this invitation large numbers of readers have responded, but it should be pointed out that it is not possible to judge the merits of apparatus without at least a rough sketch of its general layout and, possibly, a photograph. Many experimenters have submitted detailed descriptions of their sets, but have only accompanied them with a circuit diagram. As the efficiency of a receiver not only depends upon the circuit used, but the manner in which the circuit arrangement is incorporated into the receiver, it is necessary for more complete details to be furnished, particularly as it is hoped to publish certain of these descriptions for the benefit of other readers, for it must be admitted that the reception of the American broadcasting on a home-built set, is more or less an endorsement of its efficiency. As stated in previous issues, prizes of £10 and £5 will be awarded for the two best descriptions received.

NEW DEVICES OF EXPERIMENTAL INTEREST.

Holder for Coupled Inductances.

CONSIDERABLE attention has been devoted to the design of coil-holders which permit of critical adjustments of coupling, and one which has recently made its appearance is worthy of special interest. It combines a number of movements, and in consequence, permits of the most critical adjustment being obtained, which is, of course, an essential

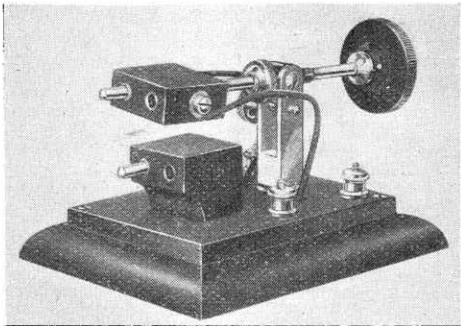

The new "Polar" Coil-holder.

(Courtesy Radio Communication Co., Ltd.)

feature, particularly when the inductances form part of a circuit which may be thrown into self-oscillation.

The coil holders shown in the accompanying photographs, in one instance assembled on a baseboard, and in the other as a number of component parts, are so designed that when critical adjustment is obtained, the locking screws can be brought into action and the position of the coils rigidly fixed. This coil-holder provides for a movement by which one coil slides over the other, another action by which one coil can be tilted out of the plane of the other, and a third adjustment which allows for rotating the axis of the movable coil. All of these adjustments are

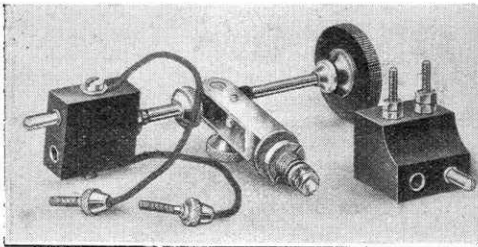

Components of the "Polar" Coil-holder for panel mounting.

easily made by manipulating the one knob, and the manufacturers are to be complimented for putting out such a useful component instrument.

The stem and movable coil holder alone has many applications, such as introducing reaction in either direction on to a tuned anode inductance or H.F. transformer, or for converting a two-coil receiver to a three-coil set, by securing the rotatable pillar to the panel. The instrument is well finished.

Plugs and Sockets for Inductance Mounting.

One is quite familiar with the ebonite socket so generally used for terminating the ends of the windings of a plug-in inductance coil, which is customarily made of ebonite. A new plug and socket connector has recently made its appearance, in which the brass connectors are secured in porcelain instead of being pressed into machined ebonite or moulded material. The purpose of introducing this new porcelain mountant is with the object of reducing capacity effects between the brass connectors, and improving insulation generally.

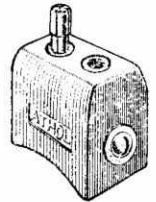

Porcelain Coil Socket by the Athol Engineering Co.

The connector shown is well finished and has a divided plug, which is well machined and makes reliable contact with the socket in which it is inserted. This new white porcelain mounted coil-holder connector is of good appearance, with high insulating properties, and possesses a minimum of distributed capacity between plug and socket.

A Reliable Sliding Contact.

To vary the number of turns of wire in circuit by means of a sliding contact is often a very desirable arrangement, although presenting many difficulties, inasmuch as the connection between the turns of the coil and the face of the slider is usually intermittent. It is probable that one of the foremost reasons for the sliding contact coil not being very popular is the unreliability of connection with the face of the slider. A new type of slider of simple construction has recently appeared on the market.

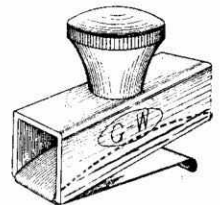

The G-W Slider.

It is a good job mechanically and the spring face on its interior maintains the slider in a rigid position on its rod, which helps very much towards obtaining good contact between its spring blade and the turns of the coil.



Particulars of Membership of any Society can be obtained on application to the Secretary. Societies marked with an asterisk are affiliated to the Radio Society of Great Britain.

Leyton Radio Association.*

"Wood Polishing" was the title of a lecture delivered on Tuesday, December 11th, by Mr. Festerazzi, whose remarks were closely followed by a large gathering.

Both the practical and theoretical side of wireless is well catered for in the series of winter session lectures arranged and a most successful season is foreshadowed. Electricity, mathematics and craftsmanship are all to be dealt with in turn.

Hon. Sec., Capt. Thorley, Church Army Social Centre, Goldsmith Road, E.10.

The Radio Society of Willesden.*

An interesting meeting of the above Society took place at 34, The Croft, Harlesden, on December 4th, when Mr. L. A. Bray demonstrated the efficiency of his four-valve receiver. Mr. Bray, whose apparatus is installed for portability in two carrying cases, was complimented on its neatness and on the admirable arrangement of the selector switching.

On Tuesday, December 11th, Mr. E. Earnshaw Wall demonstrated to an interested audience his S.T.100 receiver. Very good results were obtained, and Mr. Wall was complimented upon its compactness.

At the suggestion of Mr. A. H. Amall, the Society's technical adviser, a pennant to fly from the Society's mast has been made, and looks very imposing. It is anticipated that the Society will be able to take part in the forthcoming Transatlantic Transmitting Tests. Will members please note the change of address from the Harlesden Public Library to 34, The Croft, Harlesden, N.W.10. Intending members are requested to communicate with the Hon. Sec., F. H. H. Cootte, 183, Carlton Vale, Maida Vale, N.W.6.

The Leeds Radio Society.*

At an instructional meeting held on Nov. 30th, Mr. F. Bowman lectured upon "Electric Oscillations and Electric Waves," his remarks being received with great interest.

On December 7th the Past President of the Society, Professor R. Whiddington, M.A., D.Sc., lectured upon "Atomic Physics." The Professor dealt very closely with the electronic theory of matter, and showed by experiments many practical applications of the theory to the study of physics. Amongst the apparatus demonstrated was a Langmuir vacuum pump and the passage of electrons from filament to anode was rendered visible.

Applications for membership are invited by the Hon. Sec., D. E. Pettigrew, 37, Mexborough Avenue, Leeds.

The Manchester Radio Scientific Society.*

A paper on "Electrical Measuring Instruments" was read by Mr. Owen on December 12th. A very clear and concise description was given of volt-

meters and ammeters and their construction, proving of great interest to all members.

Hon. Sec., G. A. F. Mercer, 116, Burton Road, Withington, Manchester.

Wimbledon Radio Society.*

The construction of the Society's receiving set was materially advanced on December 14th, the whole of the tuner panel being drilled and tapped ready for assembly.

The new model of the "Magnora" loud speaker was also on view, but as no receiving set was available, a demonstration was not possible.

Mr. W. J. Rawlings brought along a very useful power buzzer and Morse practice was indulged in.

A buzzer wavemeter, manufactured by the Marconi Scientific Instrument Company, was exhibited by Mr. W. J. Rawlings on Friday, December 27th, and much comment was aroused on the compactness and finish of the instrument.

A discussion was held on the relative merits of ordinary and low temperature valves, the general belief being that the former are slightly superior in operation than the latter. It was held, however, that the advantage afforded by low temperature valves in that accumulators could be dispensed with, was sufficient to compensate for the slight inferiority.

Morse practice concluded the proceedings of the evening.

Several new members were present, but there is plenty of room for other enthusiasts, and full particulars of the Society will be forwarded on application to the Hon. Secretary, C. G. Stokes, 6, Worple Avenue, Wimbledon, S.W.19.

Tottenham Wireless Society.*

The monthly business meeting took place on Wednesday, December 5th, important items being dealt with. A proposed accommodation scheme submitted by the Committee was accepted, and members were asked to help in every way possible to make it a success. In consequence various gifts of cash were offered. The President's (Prof. A. M. Low) Competition Cup was exhibited on this evening. At the conclusion of business, Mr. Usher gave a very interesting lecture on the various forms in which electricity can be utilised.

A sale and exchange was held on Wednesday, December 12th, when many members obtained excellent bargains.

Hon. Sec., S. J. Glyde, 137, Winchelsea Road, Bruce Grove, Tottenham, N.17.

The North London Wireless Association.*

At a meeting held on Monday, December 10th, Mr. Hinkley demonstrated an electrostatic loud speaker of his own construction. Although the instrument was only in an experimental stage, very clear speech and music was recorded

by it, when working on 2LO, behind a crystal and 2 L.F. valves.

Mr. F. S. Angel then gave a short discourse on "Electrical Power Distribution."

Hon. Sec., F. Irvine, Northern Polytechnic Institute, Holloway, N.7.

Radio Society of Highgate.*

On December 14th, Mr. G. A. V. Sowler delivered a lecture on "Reception of Telephony on 100 metres," in which he described in detail the apparatus he employs for the reception of KDKA, an American broadcasting station working on 326 metres. The peculiarity of this station, explained the lecturer, is that its third harmonic (109 metres) is remarkably strong and steady, there being a very marked absence of fading. In giving advice on the reception of very low wavelengths, Mr. Sowler emphasised the importance of using a very small variable condenser in series with the aerial.

During the discussion which followed, Mr. Andrewes (2TA) recounted his experiences in the reception of KDKA and Mr. Hogg (2SH) reported that he had succeeded in establishing two-way communication with the American amateur 1MO.

Hon. Sec., J. F. Stanley, B.Sc., A.C.G.I., 49, Cholmeley Park, Highgate, N.6.

Southampton and District Radio Society.*

The Society is now installed at more commodious headquarters over the showrooms of the Southampton Gas Light and Coke Company (entrance in Manchester Street). At the meeting held on December 13th, Dr. McDougall presented the prizes to the winners in the recent crystal competition, in which the reception of Bournemouth broadcasting was exceptionally good. The successful competitors and the awards are as follows:—

Open Section: 1. Mr. Doran (Prize: Polar condenser, presented by the Radio Communication Co., Ltd.). 2. Mr. Udall (Prize: Cam-vernier coil holder presented by Radio Communication Co., Ltd.).

Members' Section: 1. Mr. Rowlands (Prize: loud speaker presented by Messrs. Young & Co.). 2. Mr. Spear (Prize: Silvertown transformer, presented by Messrs. Munn & Underwood). 3. Sergt. Lucioni (Prize: variable condenser, presented by General Electric Co., Ltd.).

The set entered by Mr. Parker was highly commended for general finish and workmanship.

The sets were afterwards described by the prize winners, and passed round for the inspection of the members.

Dr. McDougall expressed the thanks of the Society to the donors of the prizes, and this was responded to by Capt. Young, who assured the members he would always be glad to help in any way possible.

As the number of competitors in the open competition was not so great as anticipated, the prizes presented by Messrs. Siemens Bros. & Co., Ltd., J. & M. Millett and W. Holgate are being reserved for a further competition, details of which will be announced shortly.

Hon. Sec., P. Sawyer, 55, Waterloo Road, Southampton.

The Wireless Society of Hul and District.

That this Society can provide a variety of subjects for its lectures and papers is evident from the fact that recent successful lectures include such topics as "Simple Cells" (Mr. G. E. Steel), "Some Circuits I have Tried" (Mr. A. W. Spreckley), "Loud Speakers" (Mr. W. Blanshard), "The History and Development of the Telephone" (Mr. W. Ward, Grad. I.E.E.).

Mr Steel treated his subject from the historical, theoretical and practical points of view, and illustrated his instructive remarks with excellent blackboard diagrams.

Mr. Spreckley told his hearers what they may expect to receive from such circuits as a three-valve tuned anode circuit, the May circuit, the Flewelling and a valve and crystal circuit, using a variometer. The latter circuit he strongly advised every member to experiment with.

Mr. Blanshard very ably explained the construction and functions of a loud speaker. He then dealt briefly with the principal ideas embodied in a number of these instruments of various makes which are at present on the market. He dwelt at some length on the "growing" of certain crystals for use in connection with loud speakers, and passed round for inspection several specimens he had "grown" himself, adding that he was at the present experimenting in this direction.

Mr. Ward, who is incidentally an operator at the local automatic telephone exchange, was instrumental in providing a very profitable evening in describing the working of an ordinary common battery exchange as compared with the automatic exchange.

The lecturer also gave a brief outline of the history of the telephone.

The Hon. Sec. would be grateful for any offers to read papers, give lectures, or initiate discussions during the present winter session.

Hon. Sec., H. Nightscales, "Green Avon," Cottingham Road, Hull.

The Radio Society of Tollington School.

This Society, which has recently been restarted, is a revival of a wireless section which existed at the Tollington School previous to the war. Its object is to instruct the boys of the school in the elementary principles of wireless, enabling them to take a greater interest in this subject. The society at present possesses a three-valve low frequency amplifier, and a three-valve panel, comprising two H.F. and detector, is under construction. It is hoped in the near future to give a series of lectures on the elements of electricity. Membership is open to present boys and Old Boys.

Hon. Sec., L. Hirschfeld, B.Sc., 136, Duke's Avenue, Muswell Hill N.10.

The Dublin Wireless Club.

Under the Presidency of Professor J. J. Nolan, M.A., D.Sc., this old-established Club held a very successful meeting in the Physics Lecture Theatre of University College, Dublin, on November 29th. A demonstration in broadcasting reception was carried out by Professor J. Bayley-Butler, M.A., M.B., and Commandant J. Smyth, Signal Corps, National Army.

In opening a discussion on Broadcasting from the amateur's point of view, Professor Bayley-Butler explained the working and wiring of a single valve set, enlarged models of the various components being shown. Commandant Smyth showed by diagrams how a wireless set is built up, then building up a set on the blackboard by replacing the chalk lines with instruments and wires; the set when completed received items of the broadcast programme of **2LO, 6EM, 5SC**, etc.

The following have agreed to act as President and Vice-Presidents of the Club: President, The Hon. Judge W. H. Brown, M.A., B.Sc., L.L.B., K.C.; Vice-Presidents, Sir Robt. Woods, M.B., F.R.C.S.I., Professor J. Bayley-Butler, M.A., M.B., B.Ch., B.A.O.; Col. M. J. C. Dennis, C.B., Commandant J. Smyth, National Army, J. P. Campbell, Esq., and Professor J. J. Nolan, M.A. D.Sc.

The membership of the Club is increasing very satisfactorily. The new club-room is being put in order, and it is hoped to have it open by the time wireless licences are again issued in the Irish Free State. The executive are prepared to receive applications from Secretaries of other radio clubs throughout Ireland for affiliation. The Secretary's address is 29, South Anne Street, Dublin.

Civil Service Clerical Association Radio Society.

On November 27th Mr. H. R. Harbottle gave a very interesting lecture on "Valves." The history of the thermionic valve and its various functions were fully explained and specimens of both the "R" and dull emitter types were exhibited. Mr. Harbottle demonstrated by means of a galvanometer the method of drawing a characteristic curve, and emphasised the importance of the curve in the efficient use of a valve. The lecture was keenly appreciated, and many questions relative to members' experiences with valves were answered by Mr. Harbottle.

Mr. C. E. Carter on November 21st gave a short talk on "Reaction," followed by a demonstration of his home-made one-valve set, with reaction. Mr. Carter has successfully used this apparatus in various parts of the country, and had received American telephony on it on several occasions. A short length of wire was hung across the room, and **2LO** was heard distinctly throughout the room by means of a loud speaker.

Hon. Sec., J. A. Nash, 125, Neasden Lane, London, N.W.10.

The Middlebrough and District Wireless Society.

At the annual general meeting held on December 3rd, Mr. A. H. Marshall was re-elected President. Mr. C. Thewlis was elected Chairman, and Messrs. King and Appleton were appointed Hon. Secretary and Treasurer respectively. In reviewing the past year's work the Chairman commented on the very satisfactory progress made and the sound financial position of the Society. The Society's new receiving set was demonstrated, and great credit is due to its constructor, Mr. W. Smith.

A technical committee has been formed to deal with the inconvenience caused in the neighbourhood by the misuse of reaction.

It has been decided that in future the meetings of the Society shall be held on Tuesdays.

Hon. Sec., Frank King, 45, Queen's Road, Linthorpe, Middlebrough.

The Honor Oak Park Radio Society.

The members listened to an extremely interesting lecture by Mr. R. J. Stanley at their last weekly meeting on "How to

Obtain the Maximum Results from H.F. Amplification."

The lecturer, aided by formal circuits, compared and contrasted the three methods of H.F. amplification, viz., transformer-coupled, resistance-coupled, and tuned-anode coupled, pointing out the advantages and defects of each method.

After giving some very novel views on distortion, capacity effects and reaction, Mr. Stanley closed his lecture with an account of his experiments with H.F. amplification.

Hon. Sec., G. J. Price, 22, Honor Oak Park, S.E.23.

Isle of Man Radio Society.

On Monday, December 17th, an exhibition was held at the Headquarters, Derby Road, Douglas, and numerous members exhibited apparatus, both home constructed and otherwise. The meeting was purely informal, and after examining the apparatus displayed, the members sat round the fire, while Mr. Holmes kindly demonstrated the reception of broadcasting on his five-valve receiver and loud speaker.

Joint. Hon. Secs., R. C. Cannell, 14, Thorny Road, Douglas, E. R. Greenwood, 4, Thorny Road, Douglas.

Golder's Green Radio Society.

An interesting inaugural meeting was held on Wednesday, December 5th, 1923, at 17, The Grove, Golder's Green by the courtesy of Mr. Mullings, who placed a room at the disposal of the promoters. Mr. J. H. Reeves, M.B.E., took the chair and an attendance of 35 ladies and gentlemen was recorded.

The question of permanent headquarters is now under consideration, together with the programme for 1924.

The Secretary will be glad to hear from prospective members as quickly as possible, and also from anyone who would volunteer to lecture, demonstrate or otherwise assist in the compilation of a tip-top programme.

Hon. Sec., W. J. T., Crewe, "The Dawn," 111, Prince's Park Avenue Golder's Green, N.W.11.

Barnet and District Radio Society.

An entertaining and instructive evening was provided on Wednesday, December 12th, when Mr. R. M. H. Lucy, a representative of the firm of Messrs. S. G. Brown, Ltd., gave an interesting lecture on "Phones and Loud Speakers." The lecturer dealt chiefly with his firm's own products, notably the "Crystavox," the loud speaker for crystal sets, the microphone amplifier, and the "Frenophone." He also gave a brief description of some of the stages in the manufacture of phones and loud speakers, and showed the members two excellent specimens of the earliest of Brown's phones. He afterwards answered several questions of interest asked by members.

Hon. Sec., J. Nokes, "Sunnyside," Staplyton Road, Barnet.

Hendon Radio Society.

The first meeting of the Hendon Radio Society at their new headquarters (Brent Works, Brent Street), was held on December 13th, when the directional properties of a frame aerial were tested. It is interesting to note that **2LO** was received at fair strength in spite of the fact that the aerial was screened by the double iron walls and the roof of the hut in which the experiment was made.

Hon. Sec., A. E. Lynn, B.Sc., 79, Sunny Gardens, Hendon, N.W.4.

Questions & Answers

Solutions of Readers' Difficulties

This section of the magazine is placed at the disposal of all readers who wish to receive advice and information on matters pertaining to both the technical and non-technical sides of wireless work. Readers should comply with the following rules:—(1) Each question should be numbered and written on a separate sheet on one side of the paper, and addressed "Questions and Answers," Editor, *The Wireless World and Radio Review*, 12/13, Henrietta Street, London, W.C.2. Queries should be clear and concise. (2) Before sending in their questions readers are advised to search recent numbers to see whether the same queries have not been dealt with before. (3) All questions will be answered through the post. Those of general interest will also be published. (4) Every question, except those under (5) below, should be accompanied by a postal order for 1s., or 3s. 6d. for a maximum of four questions, and also the coupon taken from the advertisement pages of the current issue. (5) For the benefit of those readers who would rather not pay the charges, a free Questions and Answers Coupon will be placed in the advertisement pages of the first issue of every month. This coupon should accompany the question submitted, together with a stamped addressed envelope. The free coupon is valid for the current week only. (6) In view of the fact that a large proportion of the circuits and apparatus described in these answers are covered by patents, readers are advised, before making use of them, to satisfy themselves that they would not be infringing patents. (7) Four questions is the maximum which may be sent in at one time.

"H.A.P." (London, W.9.) asks for a diagram of a three-valve set (I-V-1) using variometers to tune the aerial and anode circuits, with switches to connect the variometer windings either in series or in parallel.

The diagram is given in Fig. 1. A switch is provided to cut out the L.F. valve when not in use. It will be found an advantage to connect a fixed condenser of 0.0001 μ F permanently across the anode variometer. The fixed series aerial condenser may be short circuited when receiving on long wavelengths.

"W.H." (Blackpool) asks what is the object of connecting a large condenser across the high tension battery.

A condenser with a large capacity, such as 1 or 2 mfd., is connected across the high tension battery to reduce noises due, perhaps, to faulty cells in the battery, and to prevent coupling between valves through the internal resistance of the battery. The high tension battery resistance is included in the plate circuit of each valve, because the plate current returns to the filament of the

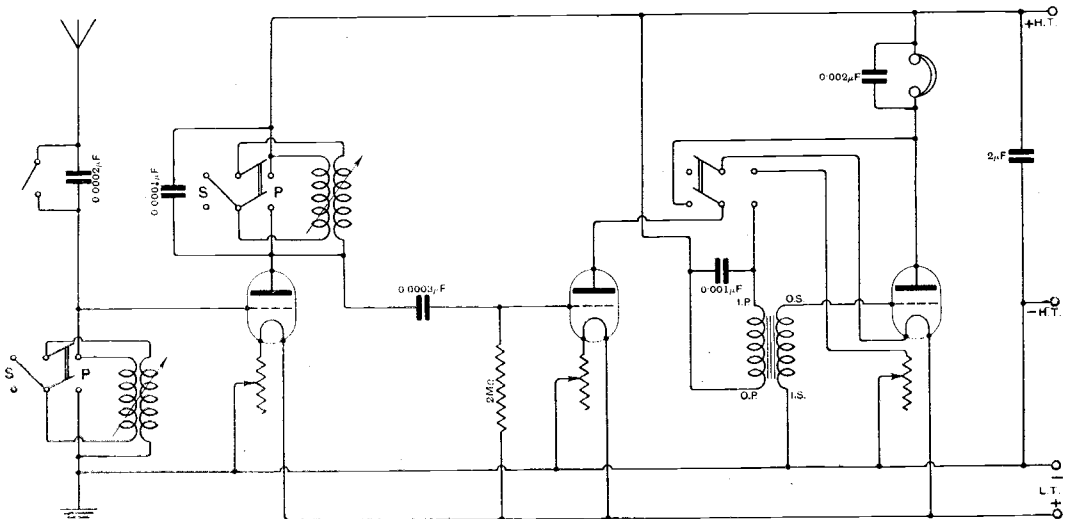

Fig. 1. "H.A.P." (London, W.9). A three-valve receiver with variometer tuning. Switches are provided to connect the windings in series or parallel.

valves, and when the signal causes a variation in the plate circuit current, a corresponding voltage would be set up across the high resistance battery, which would be communicated to all the valves; consequently the receiver may generate oscillations.

"W.A.D." (Stockport) refers to a Flewelling receiver, and asks (1) What coils should be used in the three-coil holder. (2) Is the coil-holder which is described satisfactory. (3) How may one stop howling. (4) Which would be the best construction of indoor aerial.

(1) When receiving the short wavelength transmissions we suggest you employ a No. 75 coil in the aerial circuit with the tuning condenser in series, a No. 50 coil in the closed circuit, and No. 75 in

"O.B." (Swindon) asks for a diagram of a five-valve receiver (2-V-2) with switches to control the number of valves in use, and a switch to use either transformer or tuned anode coupling between the second H.F. and detector valves.

The diagram is given in Fig. 2. By means of a change-over switch the reaction coil may be coupled either with the tuned anode coil or with the A.T.I.

"G.W." (Halifax) refers to the reply to "C.P.E." (Birmingham) in the issue of October 17th.

The anode circuit coils may be either plug-in coils or ordinary cylindrical coils with tappings. Preferably use the plug-in coils, when for the reception of British broadcast transmissions No. 75 Igranic coils will be satisfactory. The correct tuning coils

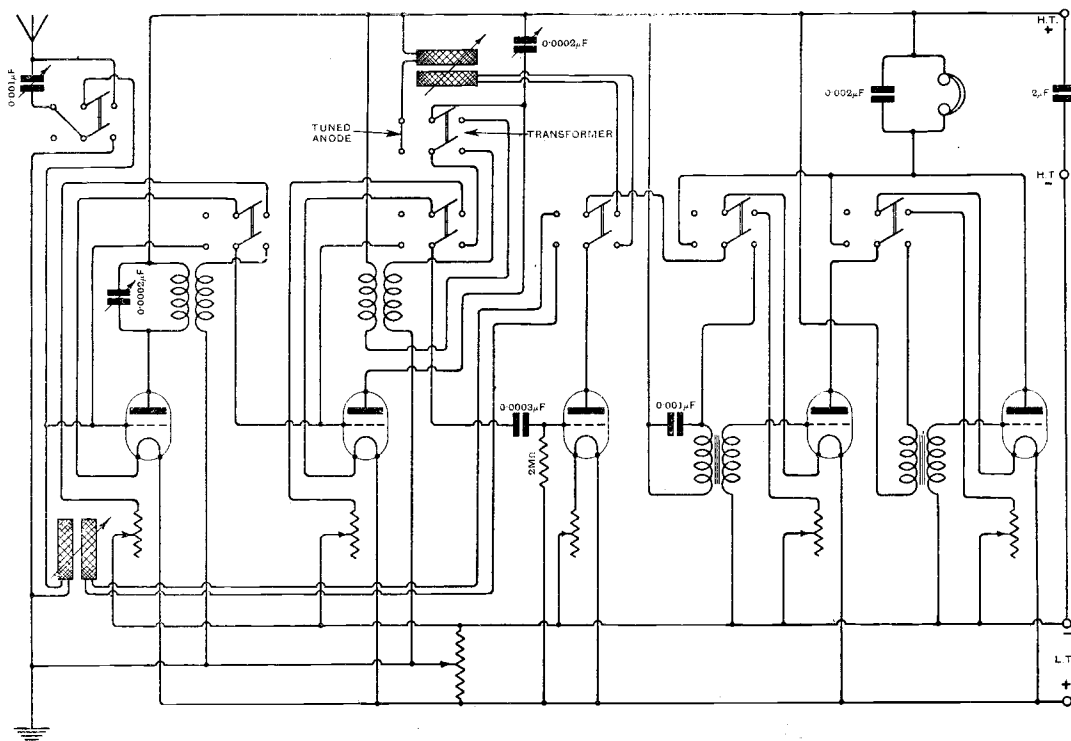

Fig. 2. "O.B." (Swindon). A five-valve receiver using two stages of transformer coupled H.F. amplification, with switch on the second valve to employ tuned anode if desired, and switching for reaction to either the tuned anode or aerial inductance. Switches have also been inserted to enable any number of valves to be used.

the reaction circuit. (2) Because it is necessary to make delicate adjustments with a receiver of this sort, it would be better to employ a good quality coil holder so that the coupling may be critically varied. (3) The howling may only be stopped by careful adjustment of the grid leak. If the variable grid leaks which you have by you have not sufficient range, you could try such expedients as a lead pencil line or a piece of damped cotton. (4) The best indoor aerial in your case would probably consist of a number of parallel wires, one end of the wires being connected together and taken to the instrument, and the other end being insulated exactly in the same way as an outdoor inverted L-type aerial is constructed.

to be used are No. 50 or No. 75 for the aerial circuit when the condenser is in series and a No. 50 in the closed circuit. The rejector circuit coil in the aerial circuit may be a No. 25 plug-in coil and the closed circuit coupled with it may be a No. 50 coil. For the reaction circuit try a No. 100. The coils used in the receiver given in reply to "H.N." (Northwick) in the issue of October 17th have the same size as those given above. The different connections do not make it necessary to use different size coils. The difference between the diagram given to "H.N." and that given to "C.P.E." is that in the latter a rejector circuit is used, which may be tuned to the wavelength of an interfering signal so that it may be cut out if desired.

THE WIRELESS WORLD AND RADIO REVIEW

THE OFFICIAL ORGAN OF THE RADIO SOCIETY OF GREAT BRITAIN.

No. 230. (No. 15.
Vol. XIII.)

JANUARY 9th, 1924.

WEEKLY

EDITOR :
HUGH S. POCOCK.

RESEARCH EDITOR :
PHILIP R. COURSEY, B.Sc., F.Inst.P., A.M.I.E.E.

ASSISTANT EDITOR :
F. H. HAYNES.

QUESTIONS AND ANSWERS DEPARTMENT :
Under the Supervision of W. JAMES.

CONTENTS

	PAGE
The Holweck Valve - - - - -	458
The Paris Wireless and Physical Exhibition - - - - -	461
An Inductance Calculator. By E. J. Hobbs - - - - -	464
A New Clock for Wireless Purposes - - - - -	466
5 HW. By R. L. Smith-Rose, Ph.D. - - - - -	467
Discussion on Loud Speakers for Wireless and Other Purposes - - - - -	472
A Microphone for Divers - - - - -	474
The Radio Society of Great Britain - - - - -	475
Patent Abstracts - - - - -	476
Around the Wireless World - - - - -	477
With the Societies - - - - -	481
The Leafield Imperial Wireless Service (<i>concluded</i>) - - - - -	482
Questions and Answers - - - - -	485

THE EDITOR will be glad to consider articles and illustrations dealing with subjects within the scope of the Journal. Illustrations should preferably be confined to photographs and rough drawings. The greatest care will be taken to return all illustrations and manuscripts not required for publication if these are accompanied by stamps to pay return postage. All manuscripts and illustrations are sent at the Author's risk and the Editor cannot accept responsibility for their safe custody or return. Contributions should be addressed to the Editor, "The Wireless World and Radio Review," 12 and 13, Henrietta Street, Strand, London, W.C.2.

SUBSCRIPTION RATES :

20s. per annum, post free. Single copies 4d. each or post free 5d. Registered at the G.P.O. for transmission by Magazine Post to Canada and Newfoundland.

EDITORIAL AND PUBLISHING
OFFICES :

12 and 13 Henrietta Street,
Strand, London, W.C.2.

Telephone: Gerrard 2807-9.



ADVERTISEMENT MANAGERS :

Pertram Day and Co., Ltd.,
1 Charing Cross, S.W.1.

Telephone: Gerrard 8063-8.

THE HOLWECK VALVE.

A NEW DEPARTURE IN HIGH POWER TRANSMITTING TRIODES.

FROM a technical point of view probably the most interesting of the many recent developments in valve manufacture is the Holweck valve, which is an entirely new departure in high power transmission valves.

It is well known that in the construction of ordinary valves for transmission purposes the valve is completely exhausted of air and sealed before use, and it is usual to employ in the construction of the bulb and other parts, substances which can withstand considerable heat without decomposition, such as glass, quartz, and metal. In the construction of the usual types of valves, the various components are either welded together or sealed, as in the case of metal to glass. In the design of the Holweck valve, however, the problem of construction is solved in a different manner, all the parts comprising the valve being capable of being assembled and dissembled at will—the components being jointed together. Instead of being exhausted once and for all, as in the case of the ordinary types of valves, the Holweck valve is exhausted when it is required to put it into operation and the vacuum is maintained by means of special apparatus whilst the valve is functioning. The anode is water-cooled, the water being circulated. In order to put the valve into operation an oil pump is first employed to provide a partial vacuum. If necessary this partial vacuum can be made at any time after the valve has been assembled and prior to operating it. A molecular pump is next used to maintain the vacuum and this remains in operation throughout the period that the valve is used for transmission purposes. It is obvious that whenever a valve is taken down for renewal of a filament or for any other purpose it is necessary to free the electrodes from accumulated gases, and this operation takes approximately one hour. In actual operation the valve functions in an exactly similar manner to ordinary types of valves. The special point of interest is that difficulties in construction are overcome by

finding an alternative means for maintaining a satisfactory vacuum throughout the life of the valve.

The Holweck valve has now been in use on trial at the Eiffel Tower for some six

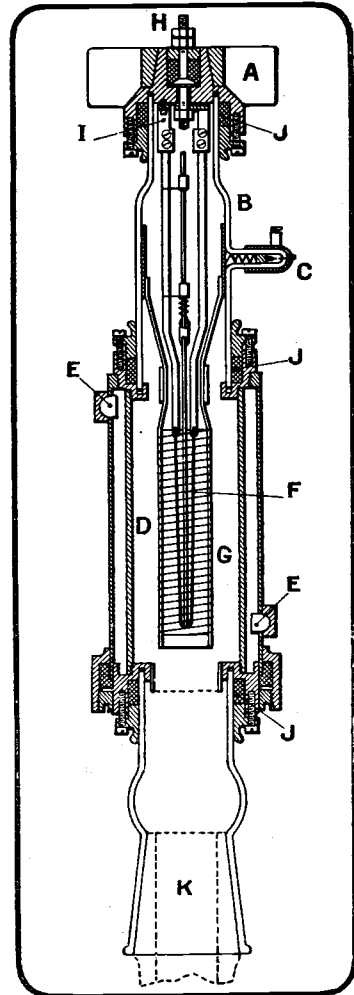

[Radio Électricité.

Fig. 1. Section of the Holweck 10 Kw. valve showing details.

or seven months. The valve employed there has its filament changed approximately once a month, and since two

valves are available the change can be effected without any interruption to the service, even though this might be continuous. As used at present, the Holweck valve is connected directly to the aerial at the Eiffel Tower without interposing an intermediate circuit. Unfortunately many harmonics are therefore emitted and complaints naturally arise owing to the fact that in the neighbourhood of Paris the transmissions can be heard almost as loudly on the short wavelengths as on the fundamental.

A brief description will be given here of the operation of the special apparatus used in conjunction with the Holweck valve, and with the aid of the accompanying illustrations the principle should be clear. Fig. 1 shows a section of the 10 kilowatt valve which is identical in type with that at present under test at the Eiffel Tower. The connections "J" are made by means of rubber rings in the construction of which excess of sulphur and of volatile substances has been avoided. These rings are placed round the glass parts "B" and "K" and are screwed up and packed. The joint so constructed is sound, whilst at the same time it can easily be undone. The joint has very little surface contact with the gas at low pressure.

The filament is supported by two nickel arms mounted on a metal base. An insulated terminal "H" serves to carry the current to one of the wires, the other end "I" being joined to the frame. A molybdenum wire consisting of two insulated portions compressed by means of a spring, maintains the tension on the filament. A radiator with vanes "A" serves to increase the surface of the head for cooling purposes. The grid "G," of molybdenum, is supported by a split ring having a friction fit on the tube "B." A soldered terminal "C" makes electrical contact with the grid. The anode consists of a copper cylinder "D," water cooled by circulation of the water over its entire surface. A thermometer which is not shown in the illustration indicates the temperature of the water as it leaves the anode, and thus serves as an indication of the efficiency. The filament consists of 36 centimetres of cylindrical tungsten 0.5 millimetres in diameter. The filament consists of two wires mounted in parallel. The heating current is 36 amperes. The

filament temperature is 2,700 degrees absolute, and the saturation current about 6 amperes.

The grid is a helix 1.8 centimetres in diameter wound with molybdenum wire, 0.04 centimetres in diameter, the turns being spaced 0.3 centimetres. The anode is 4.5 centimetres in diameter, and 11 centimetres long.

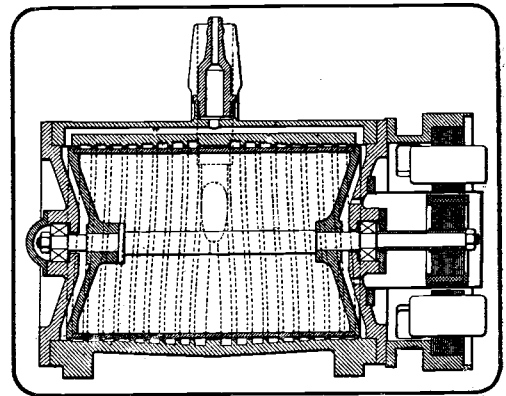

[Radio Électricité.

Fig. 2. Sketch of the special Gaede pump.

With an anode potential of 5,000 volts the energy transferred to the aerial is 8 kilowatts, corresponding to a current of 35 amperes. With 4,000 volts the energy is still 5.8 kilowatts (30 amperes).

The time required before the valve can be put into operation is dependent upon the speed of operation of the pump, but is somewhere in the neighbourhood of thirty seconds after the preliminary vacuum has been obtained. Since May 23rd last a valve of this type has been used exclusively for telephony transmissions from the Eiffel Tower, and the power delivered to the aerial with good modulation is between 5 and 6 kilowatts.

The very complete vacuum obtained with this valve is made possible by employing a helicoidal molecular pump, working on the principle of the Gaede pump, after a partial vacuum has been obtained with the oil pump. In fact, the arrangements for maintaining the vacuum whilst the valve is in operation are almost identical with the methods adopted for obtaining a vacuum in valves of the ordinary types prior to sealing. Fig. 2 shows some details of this special Gaede pump, and the details of this

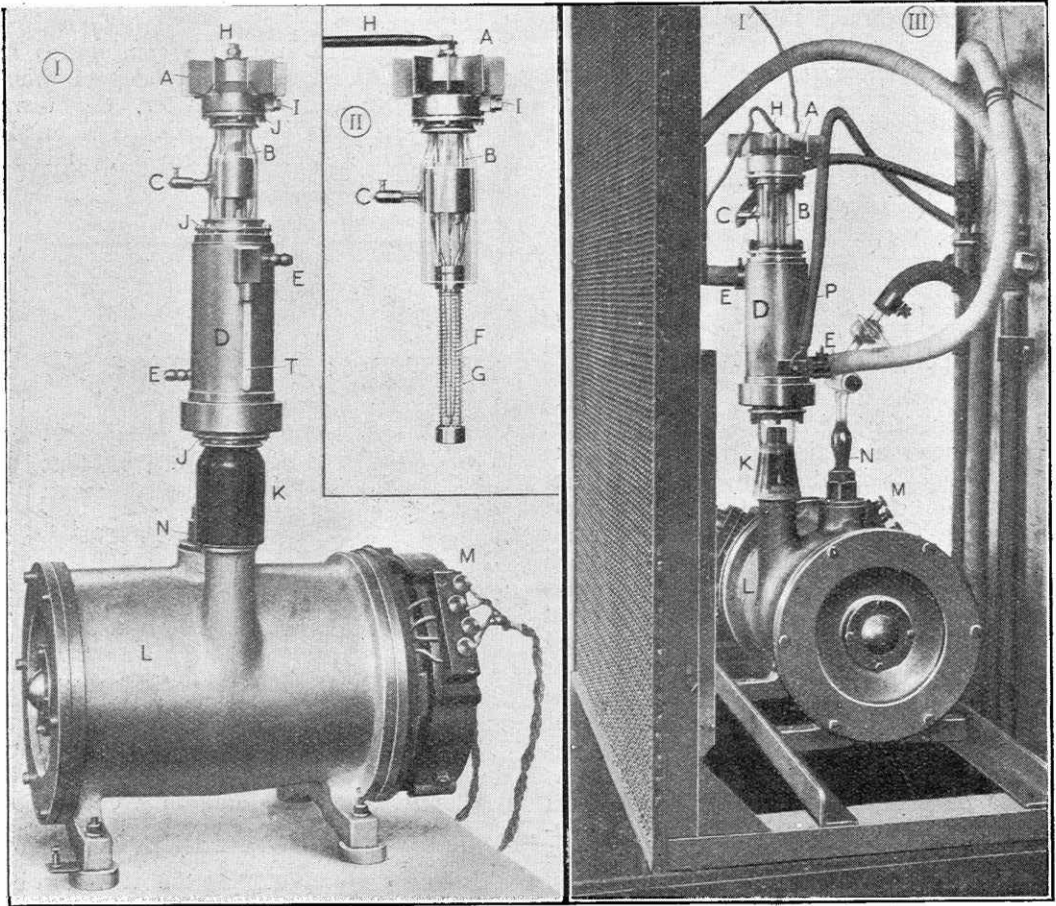

Complete valve and pump.

The cooling jacket is here fitted up for water circulating and the valve connected for operation.

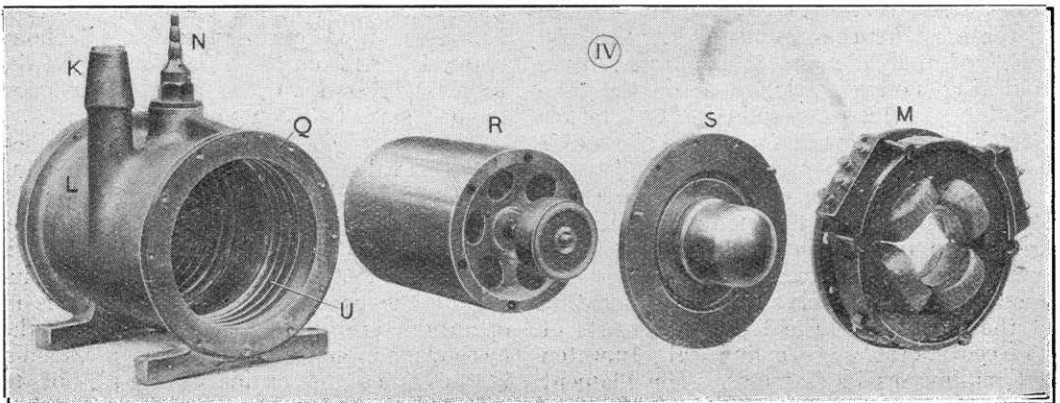

Fig. 3. Photographs showing details of the Holweck valve and pump.

should be followed in conjunction with the photographs. Several types of pump have been constructed; the normal speed of rotation is about 4,500 revolutions per minute.

It is difficult to predict the future of a valve of this type, and to estimate the extent to which it may be expected to

replace valves where the vacuum is made permanently. No doubt the problem is one of cost, since the initial cost of the Holweck valve is naturally higher, but in use it is probable that an economy can be effected. Much would depend, no doubt, on the skill of the personnel of the station in operating the auxiliary apparatus. H. S. P.

THE PARIS WIRELESS AND PHYSICAL EXHIBITION.

THE Exhibition which has recently been held in Paris, was originally announced as open from November 30th to December 17th, but as a result of the large amount of interest which the Exhibition attracted, the date was extended until December 24th.

The Exhibition embraced Physics as well as Wireless, and was organised by the Société Française de Physique. It was certainly a happy idea to associate the Wireless Exhibition with the Physical Exhibition, particularly as it served to show the relationship between the two branches of

science. Unfortunately, the wireless exhibitions held in this country have been of comparatively little scientific interest, the exhibitions having provided a means of displaying an enormous variety of wireless apparatus, but without stimulating sufficiently the scientific interest of the public. In the case of the Paris Exhibition, demonstrations of all kinds were taking place in different parts of the hall, and in this way a scientific atmosphere was created which, unfortunately, has been somewhat lacking from our own exhibitions. Approximately half the space of the hall was devoted to



A general view of one side of the hall.



Professor E. Branly visiting the stand of the Radio Club de France.

wireless exhibits, whilst the remainder related to other branches of physics.

Apart from apparatus exhibited by commercial wireless firms, there was in the centre

of the hall a section set apart for Naval and Military exhibits of wireless interest, and some of the apparatus shown here was of considerable historic interest. There was on



A wireless equipped tank which attracted much interest.

view, for example, the first French Army valve transmitter, together with a large number of similar military sets.

One part of the hall was devoted to an exhibition of historical wireless and electrical apparatus, which made an extraordinary comparison with some of the most modern developments which were shown alongside.

A very noticeable point about this Exhibition was the excellent quality of the loud-speaker reproductions of broadcast concerts in the hall. A number of loud-speakers were arranged in a gallery alongside the orchestra, and so good was the loud-speaker reproduction, that it was necessary to look up to know whether it was the orchestra or the loud-speakers providing the music. The loud-speakers most in evidence at the Exhibition were certainly those of the Gaumont and Pathé Companies, these appearing to find favour with by far the majority of the manufacturers.

Amongst the apparatus on view there was very little of outstanding novelty. Of course the designs of most of the apparatus differed very considerably from the British designs, but these differences were mostly to be found in detail. The degree of finish in the apparatus does not come up to the

standard of the British manufacturers, except in the case of some of the older established wireless firms.

The majority of the larger firms displayed a card indicating that they were members of the Syndicat National des Industries Radio-Electriques, which is the equivalent to our National Association of Radio Manufacturers.

On the stand of the S.I.F. Company, where a large number of different types of valves were shown, an item of special interest was noticed in a telegram addressed to the Company from Mr. Deloy of Nice (French **8 AB**), acknowledging receipt of valves despatched to him, and reporting his first historic achievement of establishing amateur two-way communication between France and America. Naturally, this telegram attracted a considerable amount of attention.

Messrs. G. Péricaud were showing for the first time a complete receiver designed to operate for both filament and plate current from alternating current mains, and very satisfactory results were claimed for the set. The new Holweck valve is naturally a centre of attraction in French wireless circles at the present time, and this is described elsewhere in this issue.

THE RETRANSMISSION OF AMERICAN BROADCASTING

Considerable interest has been taken in the attempt made by the British Broadcasting Company to receive signals from **KDKA**, situated at Pittsburg, in the United States, and to re-broadcast the transmissions from the various stations of the British Broadcasting Company. Many listeners in have followed these experiments very closely, and it is interesting to know the style of apparatus employed, and the conditions under which the tests were carried out.

A cage aerial was employed for reception, 30 ft. in length and 45 ft. high. The wires were spaced by means of hoops 6 ins. in diameter, and the lead-in taken from the exact middle. The receiving apparatus consisted of a semi-aperiodic aerial circuit, and a loosely-coupled tuned enclosed circuit, followed by an amplifier, comprising six high frequency valves transformer coupled. The transformers were specially designed to operate on a wavelength of 100 metres. A valve detector and two low-frequency amplifiers completed the receiving equipment. Capacity reaction was arranged between the first and third valves.

As was observed by the many listeners, it was found necessary to continually re-tune the apparatus during reception, partly owing to varying signal

strength, and also to slight changes in wavelength, which is very marked, of course, on such a short wavelength as 100 metres.

On the first attempt, it was certainly possible to hear something of the transmission, but on that night atmospheric conditions were so bad that one could hardly expect to get successful results.

On the second test, conditions were a little better, and the retransmission was very creditable. For quite long periods it was possible to listen to the transmission taking place at Pittsburg without any interruption.

It might be mentioned that **KDKA** works on two wavelengths simultaneously. It is believed that two independent transmitting sets are operated from a common microphone, and it is the transmission of 100 metres that is received so regularly over here.

This latest achievement of the British Broadcasting Company quickly follows the test organised by this journal, in conjunction with *Radio Broadcast* of America, which took place recently. The logical outcome of such tests was the operation of a British Broadcasting Station by signals received from America, and this was referred to in our issue of December 5th, page 304.

AN INDUCTANCE CALCULATOR.

By E. J. HOBBS, M.C., A.M.I.R.E.

THE ordinary slide rule can be employed as an inductance slide rule without alteration. Calculations can best be based on 10 turns per centimetre and corrected for any other number of turns arithmetically or by slide, using the formula:—

$$L_{\mu H} = D^2 l K, \text{ where:}$$

D = diameter of solenoid in centimetres.

l = length of winding in cms.

K is Nagaoka's correction factor depending on the ratio $\frac{D}{l}$

An error of + 1 per cent. occurs in this case, and is remedied by subtracting from the answer one microhenry for every hundred or part of a hundred in the answer.

A similar correction is also necessary when the slide rule is employed. In the diagram given (Fig. 1), however, the necessary correction has been made so that a cheap slide rule can be obtained by carefully cutting out the drawing and pasting it on a piece of stout card or thin boxwood. After pasting on card or thin wood and allowing to dry, the surface should be varnished; a very sharp knife should then be used to cut along the line $\times \times$.

A cursor may be made as indicated in Fig. 2 to speed up the use of the rule. The cursor is merely a small piece of celluloid, in a suitable frame to slide over the face of the rule, with a thin hair-line scratched on it.

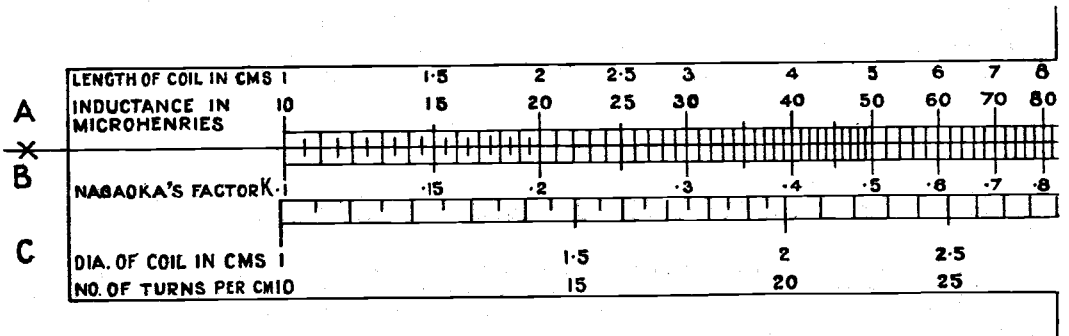

Left-hand portion of slide rule.

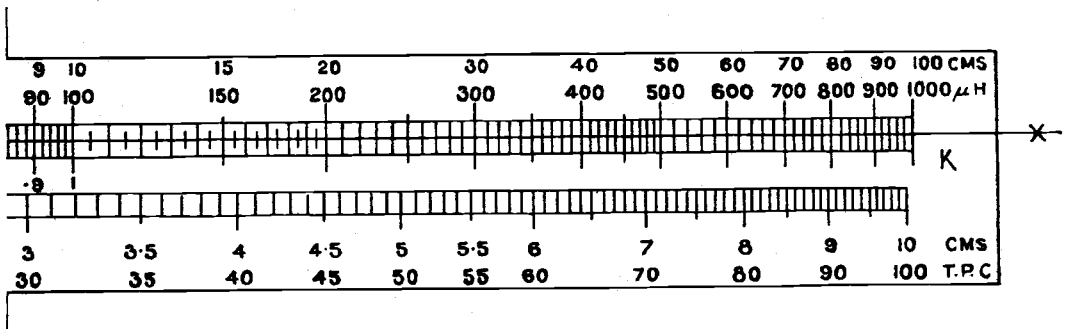

Right-hand portion of slide rule.

Fig. 1.

An ordinary slide rule has four scales, usually called A, B, C and D, but for our purpose we need only employ A, B and C. B and C are fixed in relation to one another and A will be movable. Their scales are allocated as follows:—

A represents the length of coil in centimetres, when the figures will be read as 1 to 100; also for inductance in microhenries reading the figures as 10 to 1,000.

B provides the index for scale C when the latter is used for diameters in centimetres. B also carries out the necessary correction for Nagaoka's factor *K*.

C is used alternately as the diameter in centimetres (the index on slide B to be employed), and to correct for any number of turns per centimetre other than 10; its own index must obviously be used in the latter case.

The correction necessary to counteract the error of + 1 per cent. is due to the difference between π^2 (9.8696), and 10 has been allowed for in the diagram (Fig. 1), but with a slide rule not so adjusted the correction must be made in the answer.

To use the slide rule as applied to inductances we will take a definite case as an example: a coil 5 cms. diameter and 5 cms. long. Place the index in the centre of scale B opposite the length of the coil in cms. on scale A; next place the hair-line on the cursor over the diameter in centimetres on scale C. The cursor and A must not now be moved, but the index of B moved until it is immediately beneath the line on the cursor; now keep the two scales stationary and move the cursor to the left until the line is over the correction factor *K*. When the ratio of $\frac{D}{l}$ is 1, $K = 0.6884$, as in this case.

The line will now cut the scales A and B at 85.7 and 0.6884 respectively; the former is the inductance in μH when the coil is wound 10 turns per centimetre.

Suppose we now wish to wind the coil with 20 turns per centimetre. Place the index of C under the line on the cursor—it will then be exactly opposite the inductance in μH for 10 turns per centimetre—and then move the cursor until the line is over the number of turns to be used (20) when it will also indicate the inductance on A, viz., $344\mu H$. Deduct 4 and the answer

is $340\mu H$ —the direct reading will be 340, of course, if Fig. 1 is cut out and used. Without moving the scales further any other number of turns per cm. could have been calculated by merely moving the cursor to the number of turns applicable to the gauge of wire to be used.

It is also obvious that we need only set the slide rule to the diameter and length of former we have to wind, correct it for *K*, set the index of scale C under the cursor, and then by moving the cursor to the inductance we require to find the size of wire we must use to give us that inductance.

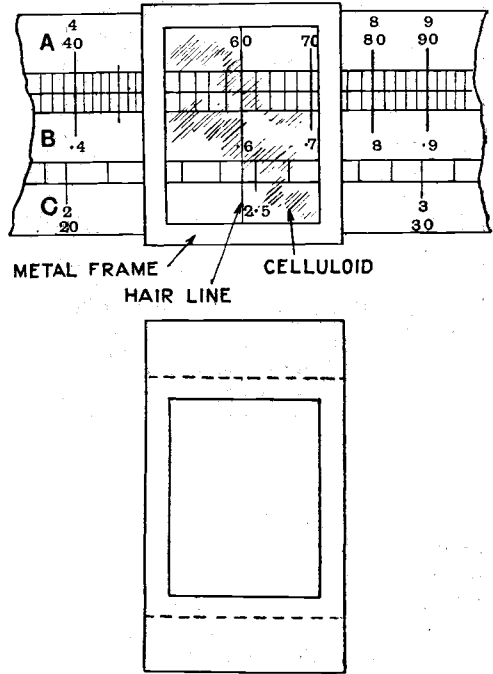

Fig. 2. Showing the cursor.

One or two trial calculations will rapidly familiarise the reader with this easy method; the results of the calculations can then be checked and compared with the tables which have already appeared in this journal.*

* Page 431, *The Wireless World*, Vol. VIII, also Table I, "Calculation and Measurement of Inductance and Capacity." by W. H. Nottage.

A NEW CLOCK FOR WIRELESS PURPOSES.

A NEW sort of clock, called the polytopic clock, has been constructed especially for use in wireless stations. It is used at the new Berlin "Betriebszetrals."

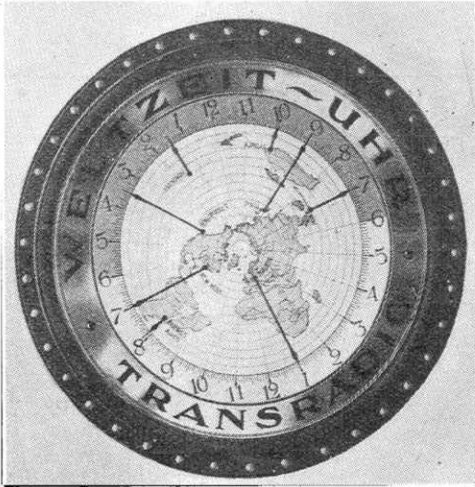

It is well known that the range of a wireless station is much greater during darkness than in the daytime. Therefore for long distance communication it is better to transmit the wireless messages during the night, and the telegraphists of large stations who desire to communicate with all parts of the world must know in which parts of the earth it is dark and where there is daylight. Further, they must know the time as shown by the clocks in all the receiving stations located throughout the world.

It is not easy to construct a clock which tells at the same time all these things, and it is usual to work out the time shown by the clocks in other parts, or else to use a number of clocks, each one set at the time corresponding with the various foreign stations. This arrangement is not satisfactory in large wireless stations because,

apart from checking the large number of clocks, they would not indicate whether there is darkness or light between the transmitting and the distant stations.

Therefore a new clock was constructed. Referring to the illustration, the hours of day and night are marked on a fixed plate, and the continents and oceans are painted on a glass plate which is mounted so that it revolves. Arrows are going from each station to the hour plate. The glass plate is lighted from behind, and as it turns, a shadow indicates where at a given time it is night.

It was not easy to construct such a clock, because in the projection of the whole earth on a plate, the meridians are lines and not circles, and because there are further differences in the measures of the degrees of latitude. The rotating dial-plate is therefore

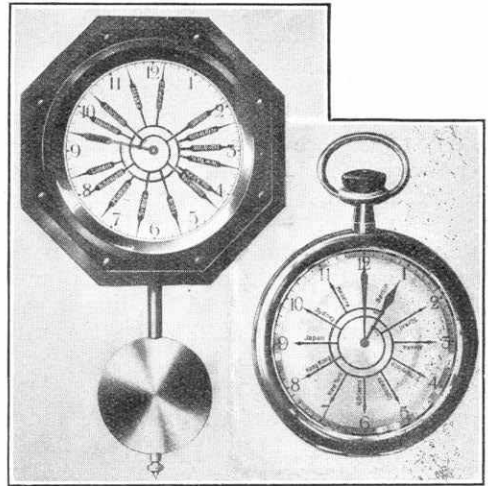

mounted on a special spiral fixed in the interior of the clock.

The lower illustrations show simpler clocks. The arrows are each marked with the name of a distant wireless station.

A map of the world, showing the position of various wireless stations, called "The Plett's Zenithal Map," may be obtained from The Wireless Press, Ltd. (7d. post free.)

5 HW.

THE EXPERIMENTAL TRANSMITTING STATION OF THE NATIONAL PHYSICAL LABORATORY.

By R. L. SMITH-ROSE, Ph.D., M.Sc., D.I.C., A.M.I.E.E.

THE majority of the readers of this journal are probably familiar with the above call sign, allotted to the experimental transmitting station of the National Physical Laboratory.

As the transmissions from this station poured into an already well-filled ether have given rise to a number of complaints of interference received at the Laboratory, and more particularly at the offices of the British Broadcasting Company, it is thought that a few words on the function and operation of the station will help to clear away some misconceptions which have apparently arisen.

First and foremost, all interfering signals received on the broadcast band of wavelengths and during broadcasting hours do *not* emanate from **5 HW**; there are other sinners. In our case, to those who have a working knowledge of the Morse

code, there can never be any doubt as to the identity of the station as the regulations are strictly complied with and the call sign (**5 HW**, not **L1** or **O2**, etc.) is sent twice or three times at the beginning and end of each transmission. Secondly, the personnel connected with the station bear no malice against either the B.B.C. or the wireless experimenter, and the transmissions are not sent out with the idea of spoiling anyone's enjoyment of broadcast programmes or of retarding the progress of any serious experimenter. The normal laboratory hours terminate at 5.30 p.m. daily, and keen as the staff of the wireless division may be, they do not usually delay until after the above time experiments or tests which may be quite well carried out in the daytime.

The laboratory transmitting station was set up in 1921-22, for the purpose of assisting in and expediting certain classes of national

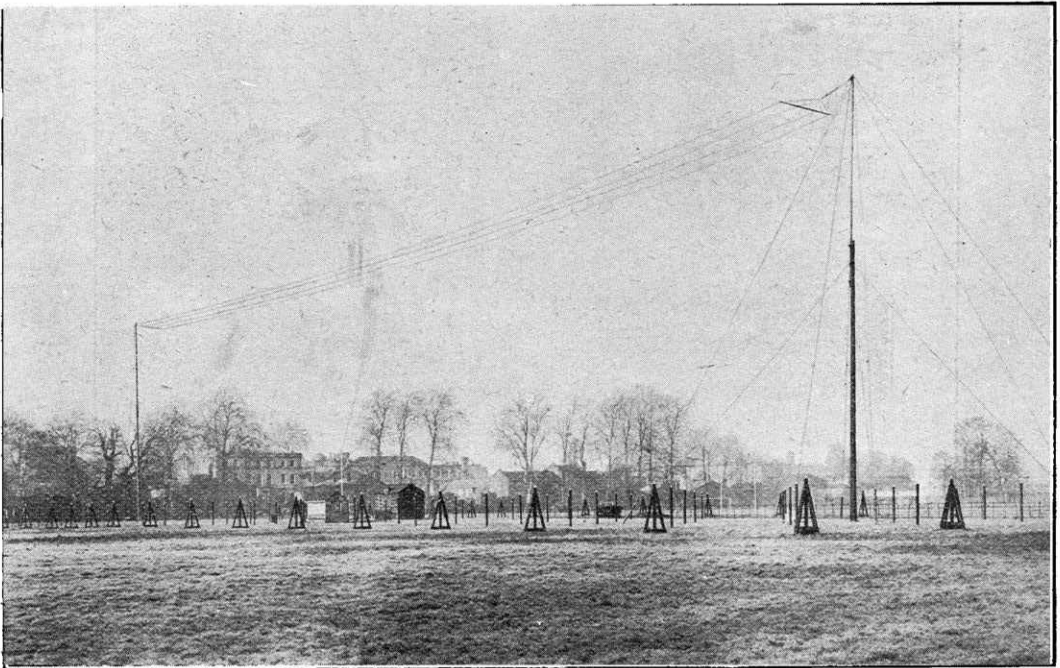

The T-type aerial and counterpoise of experimental station 5 HW.

research work being undertaken for the Radio Research Board; this work necessitating the employment of a transmitter under our complete control. Up to the present time the station has been very largely used in connection with directional wireless research.

therefore, in many of the experiments in connection with this part of the work, to imitate as closely as possible the wireless conditions prevailing in ship and shore communication. For certain reasons, the majority of this communication is, and for

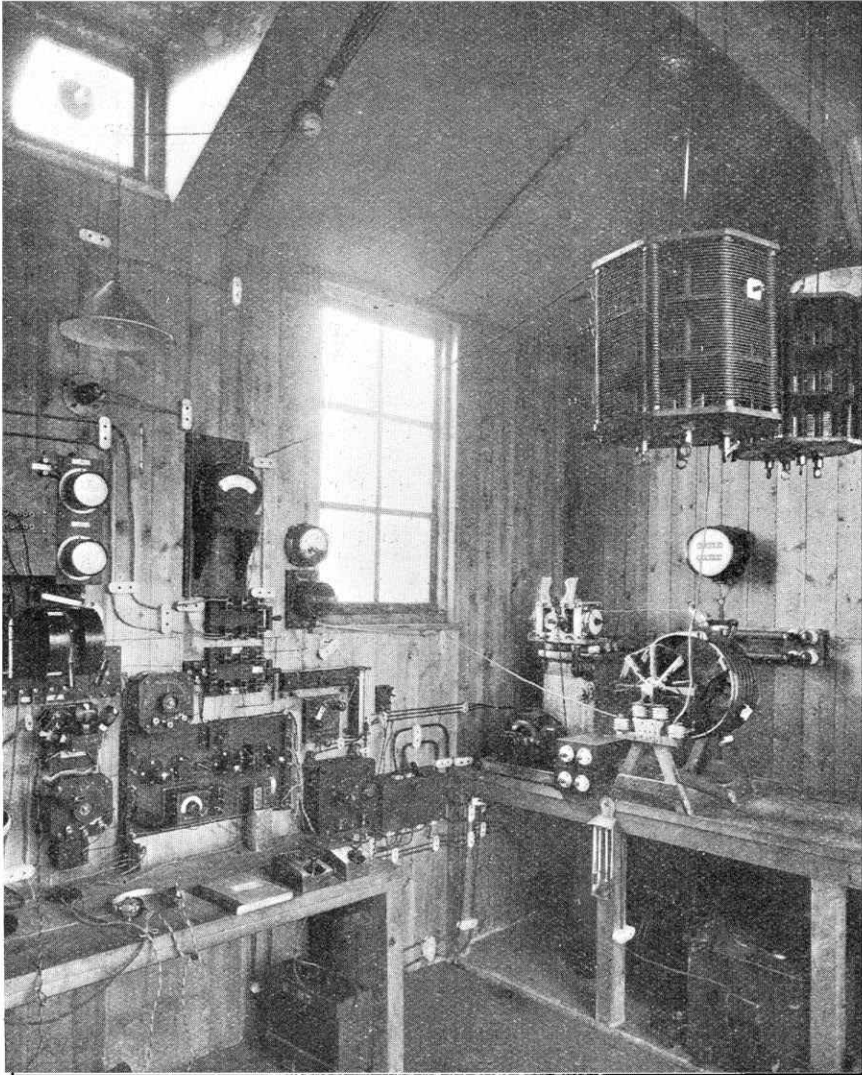

A view of the transmitting room. On the right is the quenched gap transmitter of Navy design.

Now one of the most important applications of wireless direction finding is directed towards the safety of life at sea by its provision of an additional aid to marine navigation. It was considered essential,

some considerable time will continue to be, carried out on the ordinary spark-transmitter system. Also the wavelengths employed in commercial direction finding around this country are 600 and 450 metres,

and the first of these is obviously a "tabooed" wave, for experimental purposes. The necessity for installing a ship's type spark transmitting set, and operating it on a wavelength of 450 metres thus becomes clear. Again, it is a peculiarity of direction-finding work that the phenomena observed and the results obtained are very often quite different during the day and night respectively. In a complete study of the effects which are obtainable in practice, it therefore becomes necessary to make observations during each of the twenty-four hours of the day.

In the formal licensing of the N.P.L. station by the responsible authorities the use of several different wavelengths was granted with various restrictions placed upon each. Among these terms the use of the wavelength of 450 metres was granted for all times with the exception of the evening broadcasting hours. This condition has always been strictly adhered to, and during the past year no transmissions whatever have been made on the 450 metre wave during the evening broadcasting hours, and on only one or two occasions has the experimental work necessitated about half an hour's overlapping of the morning broadcasting period, on which occasions the power of the laboratory station was considerably reduced to cause as little inconvenience as possible. Even when such transmission is in progress its interference with the reception of London broadcasting on a wavelength of 363 metres* should not be serious on any but the simplest type of receiving set, for it is the experience of several members of the laboratory staff that, at distances greater than about one mile, the use of a moderately, but not elaborately, selective receiver enables almost complete elimination of 5 HW's spark note.

With the object of satisfying the condition for a complete investigation over the twenty-four hours of the day, the wavelength of 750 metres was selected as being suitable for this work and causing the minimum of interference to general wireless traffic. Accordingly, therefore, two tests have been made recently in which transmissions have been made at regular ten-minute intervals for 24 consecutive hours. Although the usual length of a transmission for commercial

direction finding is two minutes, in the present experiments the time of transmission has been reduced to about one minute to decrease any interference caused thereby. In view, however, of the large difference between the wavelength of 750 metres and those of the broadcast band (350-500 metres), the interference caused should only be perceptible on the simplest type of unselective receiver used at a very short distance, probably within half a mile, of the laboratory aerial. Since the laboratory is surrounded by open park over a sector of 220° out of the 360°, the number of broadcast listeners within a radius of half a mile is fortunately comparatively small. On a better class receiver used at considerably less than one mile distance, the signals from the 750 metre wave are inaudible when it is tuned in to the London broadcasting wavelength.

With the adoption of the 750 metre wavelength, a valve transmitting set has been brought into service, and using an interrupted continuous wave this was employed in the last twenty-four hour test. As, however, the radiation was found to contain a harmonic within the broadcast waveband the operation of this set was suspended during the broadcasting hours. With the work of correlation of the effects observed with damped and undamped waves now in progress, it is anticipated that the spark transmitter will be used to a steadily diminishing extent, and later work carried out entirely on the continuous wave transmitter which naturally gives a much higher degree of selectivity.

It is hoped that these brief notes will be of interest in explaining the serious scientific nature of the experimental work being performed by the N.P.L. transmitting station, and that while being in sympathy with those whose only interest in wireless is for the entertainment which broadcasting gives, those responsible for the experiments consider it imperative at times to work right through the broadcasting periods.

To the more serious experimenter in wireless the 750 metre transmissions will probably have given no difficulties, and it is the 450 metre wavelength which gives most cause for complaint in view of its close proximity to the 440 metre wavelength allotted to him. It must certainly have been rather annoying to an enthusiast who had arranged a test on his 10-watt transmitter to commence

* Now 365 metres.

at, say, 11 p.m. to be safely after **2LO** had closed down, only to find that **5HW** was endeavouring to monopolise the ether with apparently nonsensical transmissions on a much higher power. The writer has listened to a good many of the invectives levelled against this station, both *via* radio and

was about one to one and a half minutes' duration. The obvious thing for the experimenter to do then is to close down during that one and a half minutes, and then immediately commence activities with renewed vigour in an attempt to get some sort of test through in the remaining eight and a

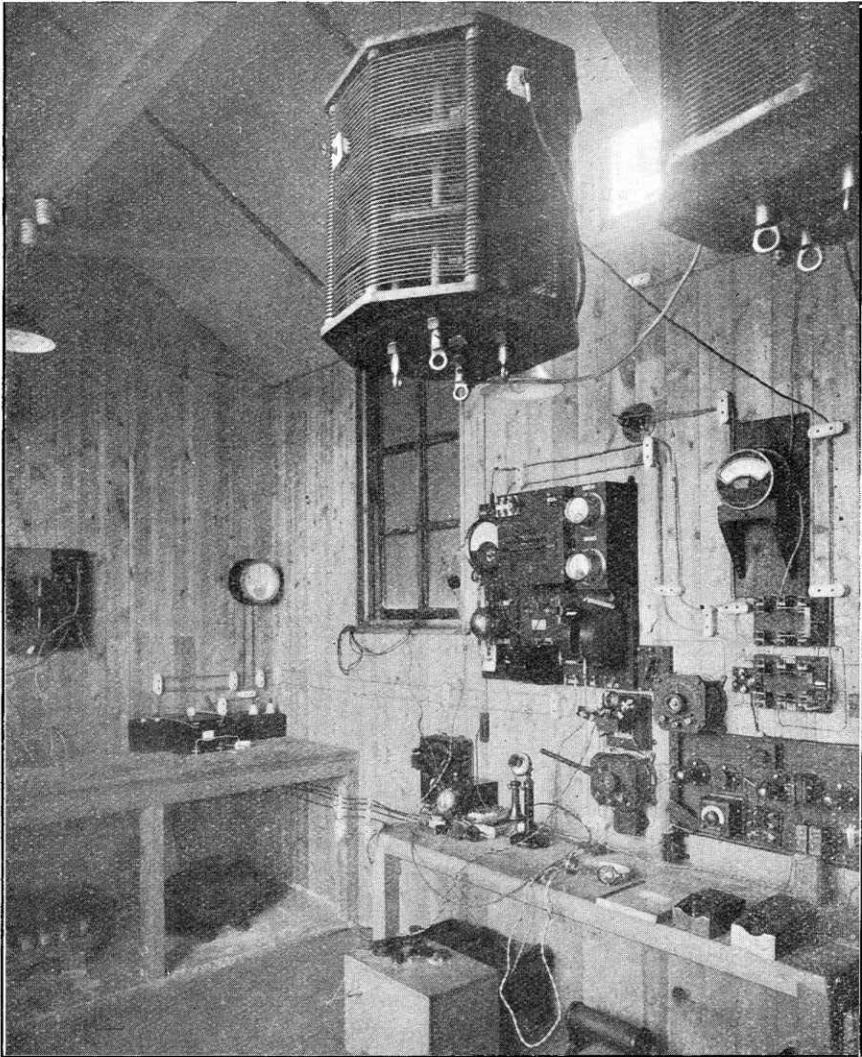

Another view of the transmitter. The panel in the centre is a telephony set.

otherwise, and feels bound to take this opportunity of suggesting that there is another side to the question. It was naturally soon discovered that **5HW**'s transmissions occurred at regular intervals, viz., ten minutes, and that each signal

half minutes. But in this last period a direction-finding observer situated a few miles from Teddington is endeavouring to get accurate bearing observations upon certain ship and shore stations located at distances varying from one hundred to

three hundred miles, and in a large number of cases these observations have been impossible owing to the interference caused by telephony transmitters whose wavelength was much nearer 450 than 440 metres.

would be well advised to carry out some of their initial experiments on modulation, etc., with an artificial aerial circuit, and thus avoid much unnecessary repetition and fruitless waste of effort. It is indeed galling to a serious scientific experimenter who has waited until after 11 p.m. to commence taking observations in a frail wooden hut which is occasionally neither wind nor waterproof, only to find his attempts foiled by voices continually repeating such expressions as "Your remarks received O.K., old man—er—O.K.—er—how are you getting me—er—changing over," interspersed with sounds reminiscent of a dog howling in the neighbouring village. At other times one has perforce to listen for several minutes to a lecture on the elementary principles of something or other, which lecture would be much more easily and conveniently communicated by post or by direct word of mouth. One consolation to set off against the frosty approach of the small hours is the joy of hearing these enthusiasts closing down and retiring for the evening.

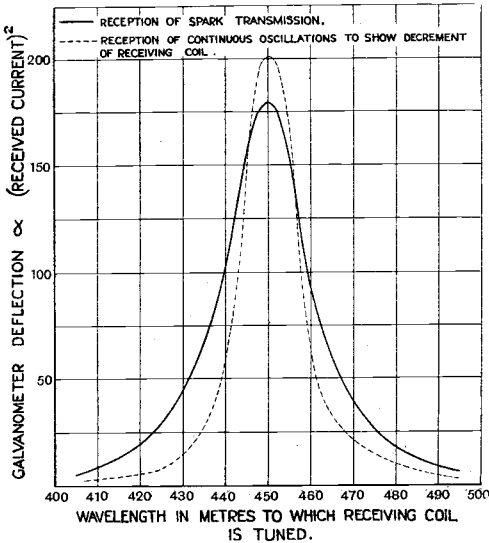

Resonance curves.

Several tests showed that the reduction of the telephony wavelength to its correct value eliminated all interference caused by the transmitter at the direction finding installation. Further, while the transmissions by a number of well-known experimenters can only be described as excellent, a large number of the less experienced licensees

Finally, since 5 HW's wave is reputed to be very flatly tuned, it may be of interest to reproduce here a resonance curve plotted from readings taken on a frame coil at about 250 yards from the transmitting aerial. The dotted line is a corresponding curve for an undamped wave from a valve oscillator and shows the proportion of width of the resonance curve which is due to the receiving coil.

A NEW PLUG CONNECTOR.

There is probably nothing better for connecting the telephones in the receiver circuit than the plug and jack arrangement, for by putting in the plug it is possible to provide for filament current to be switched on, or for the circuit to be changed, such as the bringing in or cutting out of low-frequency amplifiers.

One drawback, however, to the use of the plug is that it is not possible to connect additional telephone receivers without unscrewing the cap of the plug and rearranging the connections.

The plug shown in the accompanying illustration makes provision for connecting in circuit any number of pairs of telephone receivers. Holes are provided round the circumference of the three metal rings, and the tags of the telephones are inserted. Three rings are fitted, so that it is possible to connect two pairs of telephones in a series or parallel. The centre ring is merely an insulated piece, and thus if one tag is inserted in the end nearest to the plug, and the other into the centre, whilst the second pair of telephones has one tag inserted in the centre and other end, the telephones are connected in series.

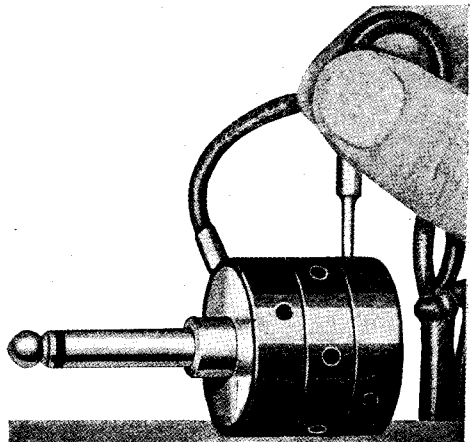

The Multi-Terminal Plug.

DISCUSSION ON LOUD SPEAKERS FOR WIRELESS AND OTHER PURPOSES.*

PROFESSOR A. O. RANKIN, D.Sc., opened the discussion and dealt with many theoretical considerations which have an important bearing on the subject.

Some of them are rather obvious, and have probably already been taken into account by manufacturers; but few who have worked in acoustics have not, at some time or other, been faced with apparent contradictions between theory and practice. It is wise, therefore, to pause and consider what is fundamental and true. We wish to procure at one place the emission of sounds which are a sufficiently faithful copy of those originating at another place. Whatever the original sounds are, we want the reproduction to be like them, and, further, and this is apparently the chief difficulty, we require considerable intensity. The ideal loud speaker would be a secondary source, in every acoustical respect equivalent to the primary source, whether speaker, singer or musical instrument. Put into the language of mechanics, this means that the vibratory movements of the air at any specified distance from the loud speaker shall be identical with those which would occur if the original source were substituted for the loud speaker.

There is, in my view, little cause for complaint in the behaviour of good quality telephone receivers applied close to the ear, and emitting sounds then just comfortably audible. Again, it will be generally admitted as true, that the quality of the sounds given out, even from a loud speaker, may be improved by reducing the output attempted. It is when large emission intensity is required that the distortion becomes too marked even for non-critical ears. The various stages in the process will give rise to the possibility of distortion and the effect is presumably cumulative; thus each stage requires careful consideration.

Broadly speaking, there are three operations; first the amplification of the electrical fluctuations; secondly the process whereby the current excites corresponding variation of air pressure; and thirdly, we have the treatment of the aerial vibrations after they have been created. The first part is dealt with later by the speaker. Dealing with the second part, it is stated in Lamb's "Dynamical Theory of Sound" that the simple harmonic type is the only one which is unaltered in character when it is transmitted. . . . the character of the composite vibration being different from that of the generating force. In particular, if one of the imposed speeds p_1, p_2 be nearly coincident with the natural speed n , the corresponding element in the forced vibration may predominate over the rest.

Thus we cannot reproduce sounds in general, with complete precision; all we can do is to take steps to avoid too great changes of character

in the often very complicated vibrations which we sometimes dissect for convenience into harmonic components. And the quotation just given directs attention to one of the chief dangers, namely, resonance.

In aiming at loudness there is, no doubt, a temptation to resort to resonance as a means to that end. In the majority of telephone diaphragms, for example, there are natural frequencies where they ought not to be, *i.e.*, within the range of frequencies of the sounds used, and the corresponding components of the sounds inevitably get preferential treatment. This, of course, can be rectified to some extent by damping the diaphragm, a process which diminishes the selectivity of the resonance by broadening the range of frequencies over which it occurs. But inevitably the general sensitivity is thereby reduced, and it seems to be at least worthy of greater consideration whether, especially in view of the fact that in operating loud speakers it is usually possible to detect one or more diaphragm notes, advantages might not accrue from plans alternative to permitting resonance and only partially suppressing it.

There are two obvious ways of proceeding. One is to increase the natural frequencies of the mechanism to values above the upper limit of audibility, or at least as far in that direction as may be practicable. The other is to choose mechanisms of very low natural frequencies, so that none but the relatively high overtones—which are not very liable to be excited—reach the lower limit of audibility. On theoretical grounds the former method is to be preferred, since it would give displacement components more closely corresponding to the exciting force. Where loudness is not important this procedure has, I believe, proved very satisfactory; it remains to be seen whether the sensitivity necessary for loud-speakers is attainable under like conditions. Perhaps others with more knowledge of the mechanical properties of, for example, a diaphragm, will be able to say what are the prospects in this direction.

The other alternative, that of using mechanisms of very low, *i.e.*, nearly zero, natural frequencies, is also worthy of continued consideration as possessing, at any rate, advantages over more resonant arrangements. One device of this type, of which I heard not long ago, presents certain features novel enough to be worth mentioning.

It is attributed to Siemens Halske, and is said to consist of a strip of thin metal foil suspended between the poles of an electro-magnet, as in the Einthoven galvanometer. The plane of the foil is parallel to the magnetic field, and the incoming telephone current, doubtless properly transformed to suit the arrangement, flows through the foil. This responds by mechanical movements perpendicular to its plane, and is the equivalent of the ordinary telephone diaphragm. Its fundamental natural period is two seconds, or thereabouts,

*An abstract of the papers read at the Institution of Electrical Engineers, November 29th, 1923. (Joint Meeting with the Physical Society.)

and it is reported to operate efficiently without a horn. I mention this instrument for the purpose also of directing attention to the fact that the diaphragm (*i.e.*, the foil) suffers no transverse forces except those due to the telephonic currents. In this respect it differs rather fundamentally from the ordinary telephone receiver in which the diaphragm, or reed, is actuated by comparatively small increments and decrements of an attractive force of large magnitude, which is present in order that the sensitive part of the magnetisation curve may be utilised. Under these conditions a really sensitive diaphragm, *i.e.*, one which at its centre responds with large displacement to the operation of a small force, seems to be ruled out, for it would be pulled over permanently into contact with the magnet poles. The modification of the system so that the diaphragm experiences no average force, as, for example, in the gramophone diaphragm, might lead to valuable results.

The speaker said it is difficult to choose points for consideration from the many that present themselves. It is said that in ordinary telephony only a very small fraction of the electrical energy received is converted into sound energy and it might appear advantageous if we could increase this proportion. It is also suggested that it may not be wise to follow this line too far, otherwise complications arising from reaction may appear. Our forced vibration should presumably not be sufficiently energetic to be capable of altering appreciably the character of the forcing vibration.

With regard to the third sub-division, that is, the treatment of aerial vibrations after they have been developed, horns, if at all possible, ought to be dispensed with because of their resonant character. The ideal sound radiator would be a spherical one which in some way could be excited by the electrical vibrations, so as to impart to the neighbouring air symmetrical fluctuations of large enough amplitude.

A problem of importance is that of the conditions of listening to a loud speaker, as, indeed, it is also in listening to a live speaker. It seems reasonable to suppose that in either case ideal listening would consist of hearing speech, at any rate, by the direct effect alone, without any reverberation or echo. For this we should have to damp out all room reflections both at the sending and the receiving stations. This is, in effect, frequently done in broadcasting, if we limit the case to that of listening on receivers applied close to the ear. But a considerable proportion of listeners appear to be asking for echo effects. Although I do not agree with them, I can admit the argument, more particularly in relation to music as opposed to speech, that the custom of listening in a hall has led some to prefer the admixture of a certain amount of reverberation. All I would point out now is that in practical circumstances, if we admit the desirability of appropriate "room effect," as it is sometimes called, we must recognise that the problem is different according to the mode of listening, whether with head receivers or with a loud-speaker. With the former, the echo effect, if wanted, must be imparted at the transmitting station; with the latter it is liable to develop in the listening room also. Doubting as I do the value of even one system of echoes,

I cannot be expected to tolerate two different ones superimposed, such as would arise, in the absence of suitable precautions, in a room or hall in which was operating a loud-speaker emitting sounds already bearing an echo impress. My submission is that for loud speakers, as a general rule, echoes and reverberation should be eliminated at one end at least. For broadcast opera, for example, where transmission already unavoidably has the effect, the listening room should be draped much in the same way as transmitting rooms usually are.

With regard to methods of testing results. Audition as a test of the degree of perfection of reproduction is liable to be a matter of opinion as between one person and another. From a scientific standpoint it would be much better to adopt a plan of taking simultaneous records of a visible type both of the original sounds and their reproduced copies, and comparing them. Even if feasible, however, I am not convinced of the value of this method except as a matter of scientific interest. Unless we could attain the ideal of identical records, a degree of attainment probably quite unnecessary for present purposes, and, indeed, theoretically impossible, we could be sure of nothing. After all, the problem is to deceive our auditory mechanisms by offering imitations; a listening comparison therefore constitutes the most direct test. It ought, of course, to be as nearly as possible a direct comparison; the original and the reproduced sounds ought to be capable of being heard, not, perhaps, simultaneously, but at least alternately at frequent intervals. Our problem will be solved when the inventor is able to deceive the most critical ear, so that its owner does not know whether he is listening to the original or to the copy. It remains to be settled who is the severest critic. Those of us who have heard his recent lectures, and know of his almost uncanny faculty of mentally performing Fourier analyses, would probably nominate Sir Richard Paget.

A New Intervalve Transformer.

We have recently examined a low frequency intervalve transformer manufactured by Messrs. J. Jarvis, 29, New Kent Road, S.E. The primary winding has 3,500 turns of No. 42 enamelled wire, and the secondary 17,500 turns of No. 45 enamelled wire. The turn ratio is therefore 5 to 1. Each layer of the windings is spaced with a piece of empire cloth. The iron core is built up of good quality transformer iron stampings, and appears to be well designed. The connecting terminals are clearly marked, and brass feet are provided for fixing.

When connected up in a receiver with one note magnifier, the results were about the same as when another transformer of well-known make was used. Considering the price, the results were quite satisfactory. A transformer of this sort should be useful for coupling a crystal and valve, or for use in a receiver having but one note magnifier.

A Microphone for Divers.

COMMUNICATION between a diver under water and those above water has always been a very difficult problem and one which has to a great extent hampered diving operations, and particularly salvage work,

One of the methods in use for communication is the employment of code signals communicated to those above, but this had many disadvantages when compared with actual speech conversation. The employment of an ordinary microphone for the diver to speak into has been found quite impracticable, chiefly on account of the extraneous noises produced by the air supply being pumped into the diver's helmet. A method of overcoming these difficulties has been found in the employment, in place of an ordinary microphone transmitter, of a "Laryngaphone," an instrument developed particularly by Mr. Murray of the Telephone Manufacturing Co. Ltd. This instrument is held in contact with the throat, as shown in the photograph, and reproduces the voice with perfect clearness whilst being at the same time unaffected by extraneous noises.



The "Laryngaphone" in position, being worn by Captain Lawson Smith.

The "Laryngaphone" has been in constant use for diving operations at Folkestone for the past two years and has given every satisfaction.

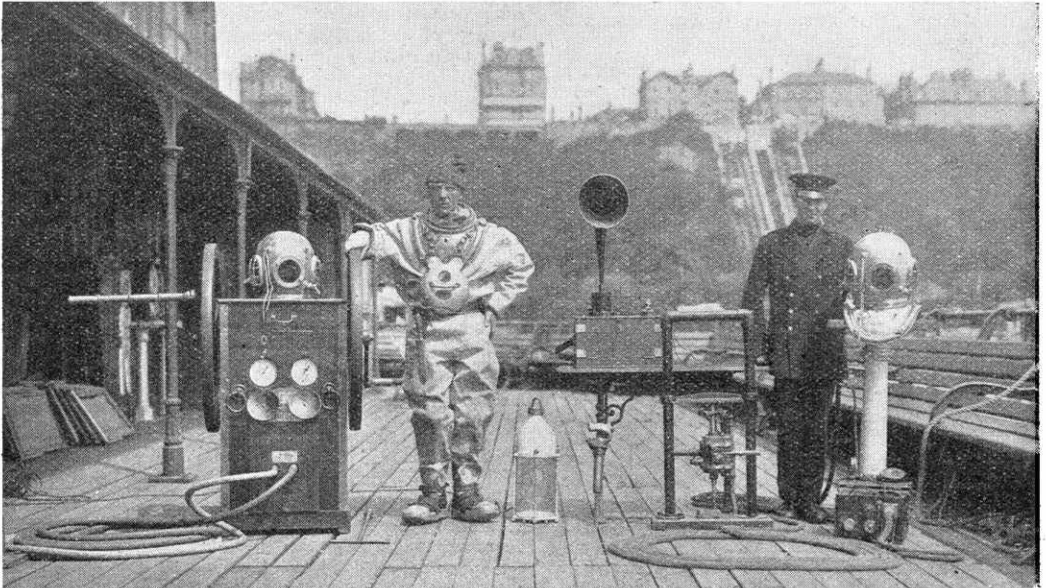

The apparatus employed above water is shown in this photograph. An amplifier and loud speaker are used to convey instructions from the diver, while on the right below the diver's helmet is seen the ordinary telephone apparatus for conversation with the diver.

The Radio Society of Great Britain.

THE TRANSATLANTIC AMATEUR TESTS.

During the past fortnight further progress has been made in the field of amateur radio transmission. As has already been announced, this season the amateur Transatlantic tests commenced on December 22nd, and from that date onwards the ether has been disturbed in the small hours of the morning by numerous calls addressed to America, originating from radio experimental stations in several countries of Europe. In the main these calls have been sent on a wavelength in the neighbourhood of 180-200 metres.

To eliminate all possibility of error in reporting reception of these calls in the United States a series of special 5-letter code words has been allocated to each station taking part in the test, these codes being changed every morning to ensure secrecy. The American Radio Relay League, who have organised in the United States the collection of the reports of reception and their checking with the official schedules, have been furnished with a secret copy of the code words and transmission schedules for each European station. Up to the present 13 British, 6 French and 3 Dutch stations have been reported as heard in the United States, and their code words verified. Some other calls have also been reported, but these receptions have not as yet been verified by the code words.

The thirteen British stations referred to above as having been heard in the United States and their code words verified are as follows:—**2 FQ, 2 KF, 2 SZ, 5 AT, 5 LC, 5 PU, 6 NI, 6 XX, 6 YA, 5 BV, 2 KW, 2 NM, 2 OD.**

It will be noted from this list that the majority of these stations are situated in the neighbourhood of London, a few only being in the provinces. This fact seems to negative the suggestion that has sometimes been made that good transmission on short wavelengths is not possible from the neighbourhood of a large city like London.

These results show up better than last year's tests for two reasons: firstly, there are a greater number of British amateurs transmitting and a greater number having a licensed power for the purpose of these tests in excess of the normal 10 watts granted to most experimental stations, several permits having been granted by the Post Office for use during these tests of a power of 250, 500 and 1,000 watts; secondly, the Americans have had more opportunity for and experience in listening for long distance C.W. transmission. This additional experience has also been accompanied by a corresponding development of the receiving apparatus, and in particular a development in the use of radio frequency amplification. An additional encouragement has been provided this year by a series of prizes which have been offered for the best records of reception of the European signals, and this has doubtless restrained many U.S. amateurs from transmitting during the hours when we are sending from this side of the Atlantic. This has undoubtedly lessened the jamming on their side as compared with that experienced last year.

Perhaps the most interesting development in radio work that has accompanied the tests has been the success that has been achieved in the use of two shorter wavelengths than those above mentioned. By using these shorter wavelengths two-way communication across the Atlantic has been effected on many occasions by several British experimenters, as well as two French and one Dutch amateur. Further experiments are in progress in this direction.

Soon after the tests started, the American Radio Relay League sent a special message to this country asking particularly that all the transmissions forming part of the Transatlantic tests and made during the schedule period should be carried out on a wavelength in the neighbourhood of 200 metres, and that a shorter wavelength should not be used for the purpose of the schedule period. The reason for this is doubtless that the special object of these tests was to further investigate the two hundred metre transmission as well as to establish two-way communication on that wavelength if possible.

As soon as the schedule periods are finished further work will doubtless be done in this direction on 200 metres, and on the shorter wavelengths.

PHILIP R. COURSEY.

Presidential Address.

The Presidential Address of the Society will be delivered by Dr. W. H. Eccles, F.R.S., at the Institution of Electrical Engineers, on Wednesday, January 23rd, at 6 p.m.

Conference of Affiliated Societies.

The Conference of Affiliated Wireless Societies will be held at 2 p.m. on Wednesday, January 23rd, at the Institution of Electrical Engineers. It is hoped that secretaries of affiliated societies will notify the Hon. Secretary of the R.S.G.B. of the names of the delegates who will be able to attend. Particulars of the matters to be discussed, which are of an important nature, are being sent to Hon. Secretaries.

The R.S.G.B.'s. Dinner.—The Dinner of the Radio Society of Great Britain will be held on the evening of January 23rd after the Presidential Address. Ladies are specially invited. Single tickets 12/6 each, and double tickets £1 1/- each, may be obtained on application to the Hon. Secretary of the Society.

Forthcoming Events.

WEDNESDAY, JANUARY 9th.

East Ham and District Radio Society. At the C.A. Social Centre, Barking Road, E.6. Informal Meeting.

FRIDAY, JANUARY 11th.

Wireless Society of Hull and District. At 7.30 p.m. Visit to Offices of the "Hull Evening News" (by kind permission), to view Creed Machines in Operation.

MONDAY, JANUARY 14th.

Ipswich and District Radio Society. At 55, Fonnereau Road, Open Night.

WEDNESDAY, JANUARY 16th.

East Ham and District Radio Society. Lecture: "Insulators." By Mr. J. E. Nickless.

PATENT ABSTRACTS.

Mounting for Crystal Rectifiers.*

A simple mounting for the crystal and the stem which carries the contact wire is given in Fig. 1. The crystal is held between the sides of a metal clip, and connection is made with it through the back holding-down screw. The stem, which ought to be so mounted that easy movement in any direction is possible, is held in place by the wire strands. The figure is self-explanatory.

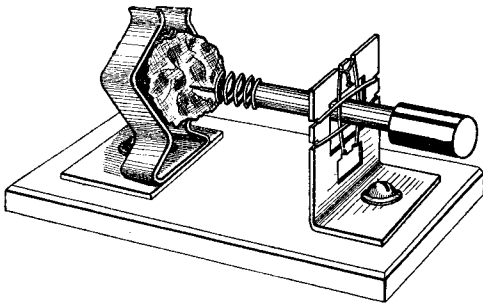

Fig. 1.

Switches for Wireless Receivers.

Readers are probably familiar with plug and jack controls. In the case of a multi-valve receiver, it is often desirable to have easy control over the number of stages of amplification in circuit. To secure this advantage without introducing serious losses, requires that the switching device shall be carefully designed, and the circuit cut out should, when necessary, be completely removed from electrical contact with the remainder.

Patent No. 201,014 describes the use of jacks for switching circuits.† The method of connecting the jacks and plug in a receiver is shown in Fig. 2. When the plug is not in any jack, the filament battery is disconnected from the filaments. If the plug is inserted in the first jack, only the first valve filament is lighted, and the telephones are joined in the first valve

anode circuit. Both valves are brought into use when the plug is inserted in the second jack.

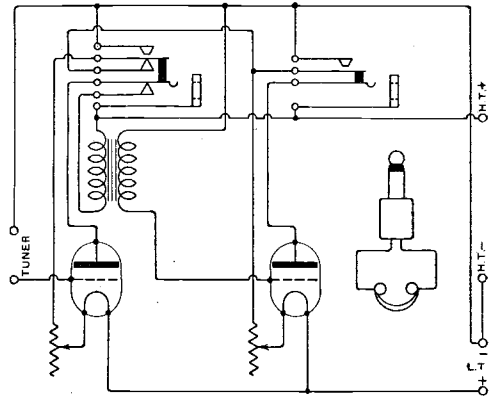

Fig. 2.

Improvements in the Construction of the Valve.*

Readers are probably aware of the type of valve with elements of the shape shown in Fig. 3. The anode and grid may be shaped as shown in the figure, or be box shaped with only the lower ends open. The filament is of the inverted U shape. It is claimed the construction is such that the valve is robust,

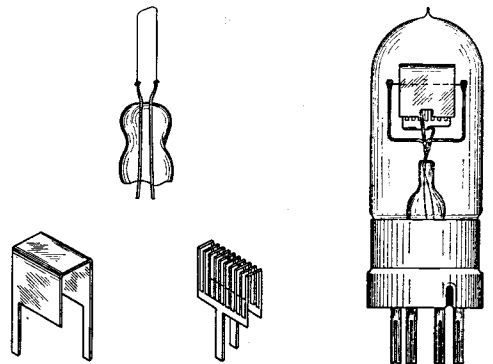

Fig. 3.

although it is difficult to see what advantages are gained over the more usual constructions.

W. J.

* U.S. Patent No. 1,463,554, by A. N. Piesman.

† British Patent, No. 201,014, by C. F. Elwell and R. E. G. Mitchell.

* British, Patent No. 201,250 by C. Holt.

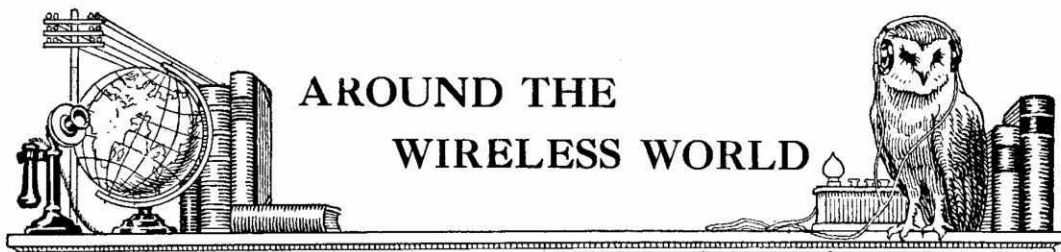

South Africa Hears 2 LO.

We have received the following cable from Middelburg, near Capetown: "Excellent reception 2 LO twenty-ninth five valves unquestionable evidence writing. Swart Bolus."

Another Two-Way Amateur Success.

Yet another success has to be recorded in Transatlantic two-way working. On December 28th, Mr. Hugh N. Ryan (5 BV), of Wimbledon, was able to exchange signals with Canadian 1 BQ, and on the following night with American 1 XW. Mr. Ryan employed an aerial current of 1.35 amperes.

Wireless in Persia.

It is reported that the Electric Trust Company has signed an agreement with the Persian Government for the installation of a powerful wireless station in Teheran and eleven auxiliary stations in other centres. The total cost of the order is estimated at £50,000.

Arctic Explorer's Tribute to Wireless.

An effusive wireless message has been received by the Zenith Radio Corporation, Chicago, Ill., from Captain McDonald, the Polar explorer on board the *Bowdoin*, which is fitted with Zenith apparatus. The little vessel is at present icebound in the Arctic night 11½ degrees from the North Pole. Nevertheless, the members of the expedition are able to listen to vocal and instrumental music, speeches, prayers and sermons, all emanating from the heart of civilisation, and Captain McMillan expresses incredulity almost equalling, he says, that of the Eskimos, at the marvellous achievements of radio.

The "Vertex" Aerial.

In the description of the "Vertex" aerial, which appeared in our issue of December 12th, it should have been stated that the manufacturers of this novel device are Messrs. Wireless Apparatus, Ltd., of 62, Haymarket, London, S.W.1.

"International Language."

The growth of wireless communications throughout the world has renewed interest in many quarters in the development and adoption of Esperanto as a means of strengthening international ties. A wide circulation should therefore await "International Language," a new monthly magazine, to appear on January 15th, dealing with Esperanto, national languages, travel, literature, commerce, radio and other subjects of international interest. The address of the publishers is 17, Hart Street, W.C.1., and single copies will be available at 2d. (postage ½d.).

Californian Broadcasting.

One of our readers has received an enquiry in Esperanto from Oakland, California, asking whether the radio concerts broadcast from the "Tribune Tower" station (KLX) have been heard in this country.

Any readers who have heard these transmissions are requested to communicate with Mr. H. A. Epton, Chairman of the Hackney and District Radio Society, 17, Chatsworth Road, London, E.5. Mr. Epton has arranged to send any reports received to the proper authorities in Oakland, California.

BIG BEN BROADCAST.



[Photopress.

How it was done. The microphone was connected by land line to 2 LO.

An Amateur's Experiments in Spain.

Some remarkable experiences in Spain with a Burndept IV Receiver, and Mark I H.F. amplifier, are related in a letter, received by Messrs. Burndept, Ltd., from Senor R. de San Juan, a customer residing at Gijon.

The first experiment, states the writer, was the reception of Cardiff, Manchester, London, Glasgow, Newcastle, Birmingham and Aberdeen, without aerial, earth or frame. Feeble carrier waves were first received, but by dint of perseverance in manipulating the controls, he succeeded in receiving perfectly clear music and speech. This experiment has been frequently repeated with success, the only requirement being that the coils must be directional to England.

Another remarkable achievement claimed by the writer is the reception of all the British broadcasting stations on a detector valve alone. In this case an aerial of 100 ft. long was employed and perfect reception was obtained in the telephones. It is mentioned as a point of interest, that under the same conditions, only weak carrier waves are obtainable from the French broadcasting stations.

The final experiment related by Senor R. de San Juan is the reception of the British broadcasting stations with a highly insulated indoor aerial 12 ft. long, in the form of an inverted "L." With this arrangement the concerts are received in great volume, the Bournemouth station particularly being heard with extraordinary strength.

Business Expansion.

It is gratifying to observe that, in spite of the present stress of unemployment, certain firms continue to expand their business. A case in point is that of Messrs. Bertram Day & Co., the well-known wireless advertising agents, who have been obliged for the second time within the last three years to remove their service department to larger premises. Their new address is 1, Charing Cross, London, S.W.1.

An Ebonite Trade Mark.

Realising the dissatisfaction which may arise from the sale of unmarked and, possibly, inferior ebonite, the British Ebonite Company are taking steps to protect the interests of dealers who stock their products. In future, therefore, all panels, sheets and other products of the firm which can be conveniently marked, will bear the Company's stamped trade mark "Becol" and the words "British Made."

The Fallon Condenser Co., Ltd.

To cope with increased business, the Fallon Condenser Co., Ltd., has acquired extensive new works. Whilst it is not expected that there will be any delay in the delivery of Fallon condensers, the Company wishes to state that should any such delay occur it will be only temporary, and due to the slight disorganisation caused by the removal. The Company's new address is White Ribbon Works, Broad Lane, London, N.15.

5 DT.

Readers are asked to note that in the "Wireless Experimenter's Diary" and the "Wireless Annual" for 1924, both containing amateur call signs, 5 DT is wrongly inserted. We apologise for the mistake, this station being in no way connected,

as indicated, with the firm of Hutchinson & Co. (F. Pinkerton) of 101, Dartmouth Road, Forest Hill, S.E.23. For the benefit of both transmitting and receiving amateurs, however, it may be stated that 5 DT is situated in Forest Hill, London, S.E.23.

Broadcasting.

REGULAR PROGRAMMES ARE BROADCAST FROM THE FOLLOWING EUROPEAN STATIONS:

GREAT BRITAIN.

ABERDEEN 2 BD, 495 metres; **BIRMINGHAM 5 IT**, 475 metres; **CARDIFF 5 WA**, 435 metres; **GLASGOW 5 SC**, 420 metres; **MANCHESTER 2ZY**, 400 metres; **BOURNEMOUTH 6 BM**, 385 metres; **LONDON 2LO**, 365 metres; **NEWCASTLE 2NO**, 350 metres; **SHEFFIELD** (Relay from 2LO), 303 metres. Regular daily programmes. Weekdays, 11.30 to 12.30 p.m. (2LO only), 3.30 to 4.30 p.m., 4.30 p.m., 5 to 10.30 p.m. Sundays, (2LO only), 3.30 to 4.30 p.m., 5 to 10.30 p.m. Sundays, 3 to 5 p.m., 8.30 to 10.30 p.m.

FRANCE.

PARIS (Eiffel Tower), FL, 2,600 metres. Daily, 6.40 to 7 a.m. Weather Forecasts; 10.5 a.m. (Thursday and Friday), 11.15 to 11.30 a.m., Time Signal and Weather Forecast; 12.0 noon, Live-stock prices; 3.40 p.m. (Saturday excepted); Financial report, 5.30 p.m. (Saturday excepted) Bourse Closing Prices; 6.10 p.m., Concert or Address; 7 p.m., Weather Forecast; 7.20 p.m. (Sunday), Concert and Address; 10.10 p.m., General Weather Forecast.

PARIS (Compagnie Francaise de Radiophonie Emissions "Radiola"), **SFR**, 1,780 metres. Daily, 12.30 p.m., Cotton Oil and Cafe Prices, News, Concert; 1.45 p.m., First Bourse Report; 4.30 p.m., Bourse Closing Prices; 4.45 p.m., Concert; 5.45 p.m., News and Racing Results; 8.30 to 9.30 p.m., News; 9.10 p.m., Concert; 10 p.m. to 10.45 p.m., Radio Dance Music.

ECOLE SUPERIEURE des Postes et Télégraphes, 450 metres 3.30 to 4 p.m. (Wednesday and Friday), 7.45 p.m. to 10 p.m. (Tuesday and Thursday), Tests (Music, etc.); 2.30 p.m. to 7.30 p.m. (Saturday), Tests (Music, etc.).

LYONS, YN, 3,100 metres. Daily, 9.45 a.m. to 10.15 a.m., Gramophone Records.

BELGIUM.

BRUSSELS, BAV, 1,100 metres. 1 p.m. to 5.30 p.m., Meteorological Forecast; 9 p.m. (Tuesday), Concert.

BRUSSELS ("Radio Electrique"), 410 metres. Daily, 5 to 6 p.m., 8.30 p.m. to 9.30 p.m., Concert.

HOLLAND.

THE HAGUE, PCGG. Temporarily suspended.

THE HAGUE (Heussen Laboratory), **PGUU**, 1,070 metres. 9.40 to 10.40 a.m. (Sunday), Concert; 9.40 to 10.40 p.m., Concert; 7.45 to 10 p.m. (Thursday), Concert.

THE HAGUE (Velthuisen), **PCKK**, 1,070 metres. 8.40 to 9.40 p.m. (Friday), Concert.

IJMUIDEN (Middelraad), **PCMM**, 1,050 metres. Saturday, 8.40 to 9.40 p.m., Concert.

AMSTERDAM, PA 5, 1,100 metres (Irregular). 10 to 11 a.m., Concert; 5 to 6.30 p.m., Concert; 8.10 to 9.10 p.m., Concert.

DENMARK.

LYNGBY, OXE, 2,400 metres. 7.30 p.m. to 8.45 p.m., Concert (Sunday excepted).

GERMANY.

BERLIN (Koenigsrueterhausen), **L.P.**, 4,000 metres. (Sunday), 10 to 11 a.m., Music and Lecture; 2.700 metres 11 a.m. to 12 noon Music and Lecture. Daily, 4,000 metres, 6 to 7 a.m., Music and News.

EBERSWALDE, 2,930 metres. Daily, 12 to 1 p.m., Address and Concert; 7 to 8 p.m., Address and Concert; (Thursday and Saturday), 5.30 to 6.30 p.m., Concert.

CZECHO-SLOVAKIA.

PRAGUE, PRG, 1,800 metres. 7 a.m., 11 a.m. and 3 p.m., Meteorological Bulletin and News; 4,500 metres, 9 a.m., 2 p.m., and 9 p.m., Concert.

KBEL (near Prague), 1,000 metres. Daily, 6.20 p.m., Concert, Meteorological Report and News.

SWITZERLAND.

GENEVA, HB 1 (Radio Club de Genève). Temporarily suspended. **LAUSANNE, HB 2**, 1,100 metres. Tuesday, Thursday, Saturday, 4 p.m., Concert; Monday, Wednesday, Friday and Saturday, 7 p.m., Concert.

SPAIN.

MADRID, 1,650, 2,200 metres (Irregular). 12 to 1 p.m., Tests. **MADRID, PTT**, 400 to 700 metres. 4 to 5 p.m., Tests.

Calls Heard.

London, E.C.1.

2 BZ, 2 DY, 2 DZ, 2 FG, 2 FP, 2 FQ, 2 ID, 2 JX, 2 KT, 2 KF, 2 LL, 2 MF, 2 NH, 2 OM, 2 ON, 2 PA, 2 PW, 2 PX, 2 PY, 2 QQ, 2 QL, 2 SF, 2 SZ, 2 VV, 2 XB, 2 XL, 2 XR, 2 XZ, 2 ZO, 2 BW, 5 CB, 5 CP, 5 DK, 5 DT, 5 HL, 5 HW, 5 HY, 5 IO, 5 JW, 5 LP, 5 OB, 5 PD, 5 PU, 5 SM, 5 SU, 5 U, 5 VD, 5 VL, 5 VR, 5 VT, 5 XD, 5 XN, 5 YX, 6 BX, 6 IM, 6 OY, 6 QV, 6 QZ, 6 BL. (1-c-1.) (V.L. Thompson.)

Peterborough.

2 AU, 2 BP, 2 BU, 2 DD, 2 DU, 2 FQ, 2 GJ, 2 HB, 2 HF, 2 HS, 2 KO, 2 KF, 2 KS, 2 LL, 2 MC, 2 MO, 2 NP, 2 OM, 2 ON, 2 OX, 2 SD, 2 SQ, 2 ST, 2 SZ, 2 TV, 2 TO, 2 VQ, 2 VR, 2 WJ, 2 WX, 2 YX, 5 CD, 5 CK, 5 HY, 5 KY, 5 MU, 5 RO, 5 SU, 5 TW, 5 VR, 5 WM, 5 WO, 5 YS, 6 HM, 6 OM, 6 SY. (1, 2, 3 and 4 valves.) (William Carter.)

West Norwood, S.E.27.

2 AD, 2 AH, 2 AJ, 2 AN, 2 AO, 2 AQ, 2 AU, 2 AX, 2 BO, 2 BS, 2 BZ, 2 CT, 2 CW, 2 DC, 2 DF, 2 DR, 2 DX, 2 DY, 2 EK(?), 2 FG, 2 FJ, 2 FK, 2 FP, 2 FQ, 2 G, 2 GO, 2 GN, 2 GO, 2 GW, 2 HF, 2 HP, 2 HS, 2 ID, 2 LJ, 2 KN, 2 LZ, 2 JA, 2 JF, 2 JL, 2 JP, 2 JU, 2 JX, 2 JZ, 2 KF, 2 KG(?), 2 KK, 2 KA, 2 KS, 2 KL, 2 KV, 2 KW, 2 KX, 2 KZ, 2 LD, 2 LP, 2 LT, 2 LW, 2 LZ, 2 NA, 2 NH, 2 NK, 2 NM, 2 NS, 2 OD, 2 OG, 2 OM, 2 ON, 2 OS, 2 PA, 2 PB, 2 PW, 2 PX, 2 PY, 2 PZ, 2 QD, 2 QI, 2 QQ, 2 QS, 2 QX(?), 2 RB, 2 RG, 2 RS, 2 SE, 2 SF, 2 SH, 2 SI, 2 ST, 2 SX, 2 SZ, 2 TA, 2 TB, 2 TC, 2 TD, 2 TO, 2 TP, 2 TQ, 2 TS, 2 UC, 2 UL, 2 UV, 2 VB, 2 VF, 2 VJ, 2 VK, 2 VN, 2 VO, 2 VS, 2 VT, 2 VW, 2 WA, 2 WD, 2 WG, 2 WJ, 2 WK, 2 WP, 2 WQ, 2 WY, 2 XB, 2 XD, 2 XI, 2 XL, 2 XO, 2 XP, 2 XR, 2 XS, 2 XX, 2 XZ, 2 YD, 2 YH, 2 YJ, 2 YL, 2 YQ, 2 YR, 2 YT, 2 ZC, 2 ZG, 2 ZK, 2 ZL, 2 ZS, 2 ZT, 2 ZU, 2 ZZ, 5 AC, 5 AG, 5 AQ, 5 AR, 5 BA, 5 BM, 5 BT, 5 BV, 5 BU, 5 CB, 5 CE, 5 CN, 5 CO, 5 CP, 5 CS, 5 CV, 5 CX, 5 DB, 5 DL, 5 DJ, 5 DK, 5 DN, 5 DS, 5 DT, 5 FL, 5 FM, 5 FR, 5 FS, 5 GF, 5 GS, 5 GX, 5 HA, 5 HL, 5 HK, 5 HV, 5 HW, 5 HY, 5 IC, 5 IK, 5 IM, 5 IO, 5 IS, 5 JS, 5 JT, 5 JW, 5 KM, 5 KS, 5 KX, 5 LC, 5 LF, 5 LP, 5 LZ, 5 MA, 5 MJ, 5 MO, 5 MQ, 5 MU, 5 MY, 5 MZ, 5 NN, 5 OB, 5 OS, 5 OX, 5 OY, 5 PD, 5 PS, 5 PU, 5 PZ, 5 QJ, 5 QK, 5 QM, 5 QV, 5 RB, 5 RF, 5 RQ, 5 RZ, 5 SU, 5 SZ, 5 TB, 5 TG, 5 TM, 5 TR, 5 UC, 5 UL, 5 UO, 5 US, 5 VD, 5 VJ, 5 VM, 5 VP, 5 VR, 5 WF, 5 WO, 5 WN, 5 WR, 5 XA, 5 XC, 5 XG, 5 XR, 5 XS, 5 XZ, 5 ZB, 6 AH, 6 AL, 6 AY, 6 BA, 6 CW, 6 CK, 6 DD, 6 DW, 6 EA(?), 6 FB(?), 6 HD, 6 HM, 6 IY, 6 JO, 6 JX, 6 KL, 6 LJ, 6 MZ, 6 NB, 6 NF, 6 NH, 6 NI, 6 OM, 6 OY, 6 QM, 6 QZ, 6 RJ, 6 RM, 6 RY, 6 SO, 6 TL, 6 TM, 6 TS, 6 UH, 6 VT, 6 WX, 6 XX, 2 AAH, 8 AA, 8 AB, 8 AE, 8 AEI, 8 AG, 8 AS, 8 AW, 8 BA, 8 BF, 8 BM, 8 BN, 8 BT, 8 BV, 8 BW, 8 BX, 8 CF, 8 CD, 8 CS, 8 CM, 8 C, 8 DD, 8 DK, 8 DO, 8 DX, 8 AA, 8 BQ, 8 BS, 8 DV, 8 FR(?), 8 LA, 8 MK, 8 NX, 8 NY, 8 XO, 8 XP, 8 XR, 8 YS, 8 ZZ, PCIL, PCTT, 7 FS, 7 TT, 9 AN, 9 AS, 9 AT, 9 TU, 1 RW. (L. H. Thomas, 6 QB.)

West Norwood, London, S.E.27.

2 CW, 2 DJ, 2 DR, 2 DZ, 2 FN, 2 ZP, 2 JZ, 2 IJ, 2 IN, 2 OG, 2 SE, 2 VF, 2 VO, 2 WK, 2 XD, 2 ZG, 2 ZS, 5 BA, 5 DN, 5 EL, 5 FD, 5 GJ, 5 GS, 5 JX, 5 MO, 5 MU, 5 SZ, 5 US, 5 YI, 6 DE, 6 EA, 6 EY, 6 KO, 6 RY, 6 SO, 6 UC, 6 WL, 6 XN, 8 AE, 8 AEZ, 8 AG, 8 AS, 8 AQ, 8 AW, 8 BA, 8 BE, 8 BF, 8 BM, 8 BN, 8 BV, 8 CB, 8 CD, 8 CF, 8 CJ, 8 CM, 8 CS, 8 DK, 8 DX, 8 DY, 8 AB, 8 DV, 8 OY, 8 MX, 8 YS. (One Valve only.) (L. F. Aldous.)

Ilford, Essex.

2 CW, 2 FG, 2 FK, 2 FP, 2 FQ, 2 JX, 2 KF, 2 KT, 2 LT, 2 MF, 2 OM, 2 ON, 2 PT, 2 PW, 2 PX, 2 QQ, 2 SK, 2 MD, 2 XP, 2 XR, 2 XX, 2 KG, 2 RE, 2 KZ, 2 BZ, 2 LZ, 2 VS, 2 XK, 2 TQ, 2 NM, 2 SH, 2 VH, 2 KV, 2 WD, 5 AC, 5 AG, 5 BB, 5 CB, 5 DK, 5 DT, 5 GC, 5 GW, 5 HI, 5 HR, 5 IC, 5 JJ, 5 JT, 5 JW, 5 LP, 5 LZ, 5 OB, 5 OC, 5 PU, 5 PZ, 5 QJ, 5 SU, 5 TR, 5 UC, 5 UL, 5 UO, 5 VR, 5 WR, 5 XD, 5 IO, 5 YX, 5 HY, 5 AL, 5 PD, 5 JS, 5 WN, 5 CP, 5 SL, 6 CD, 6 IM, 6 QV, 6 ZO, 6 NH, 6 XV, 6 DW, 6 PS, 6 UV, 5 WA, 6 BM, 5 NO, 5 SC, 2 ZY, 2 BD, FL (R.E.). (1-c-0.) (C. E. Lergen.)

Dublin.

2 II, 2 ZK, 2 ZU, 5 CC, 6 LI. (1-v-1.) (S. M. Ashe.)

Utrecht, Holland.

1 MT (probably at Venice), 2 DF, 2 FN, 2 GM, 2 HF, 2 LZ, 2 NM, 2 OJ, 2 QH, 2 TE, 2 VS, 5 DN, 5 HL, 5 KO, 5 KZ, 5 MO, 5 TG, 6 AL, 6 EA, 6 RY, 8 CJ, 8 DX, 8 DY, 8 DV, 8 NN, 8 NY, 8 RD. (0-v-0.) (H. H. Everwyn.)

Oundle, Northants.

2 AJ, 2 DG, 2 DU, 2 GJ, 2 GZ, 2 IN, 2 IQ, 2 LX, 2 ND, 2 NK, 2 PP, 2 QK, 2 QZ, 2 UM, 2 VC, 2 WA, 2 WU, 2 ZK, 2 ZU, 5 BG, 5 BH, 5 CI, 5 CX, 5 DN, 5 FU, 5 IK, 5 KI, 5 KZ, 5 PR, 5 VP, 6 AV, 6 NI, 6 NK. (2 valves.) (Douglas C. Birkenshaw.)

New Southgate, London, N.11.

2 AO, 2 CW, 2 DR, 2 HR, 2 IN, 2 JF, 2 MC, 2 QN, 2 TF, 2 WK, 2 ZG, 5 BA, 5 CK, 5 DN, 5 GJ, 5 KO, 5 MO, 5 SZ, 7 BA(?), 8 DV, 8 NY, 8 XO. (W. D. Keiller, 6 HR.)

Dartford, Kent.

2 BZ, 2 KT, 2 LZ, 2 ME, 2 MO, 2 NK, 2 ON, 2 OZ, 2 PX, 2 XR, 5 DT, 5 IO, 5 MO, 5 PU, 5 XN, 6 OW. (1 valve.) (Harry Sutherland, age 12.)

Sunderland.

2 AW, 2 CW, 2 DF, 2 DX, 2 FN, 2 GR, 2 GV, 2 HF, 2 IJ, 2 IN, 2 KF, 2 KW, 2 LZ, 2 MG, 2 NA, 2 NM, 2 OD, 2 OM, 2 PW, 2 RG, 2 RP, 2 SQ, 2 SZ, 2 TB, 2 TR, 2 UV, 2 VN, 2 VR, 2 VS, 2 WK, 2 XR, 2 YQ, 2 ZG, 5 AT, 5 BA, 5 BT, 5 BV, 5 CX, 5 HI, 5 HY, 5 JX, 5 KO, 5 LT, 5 MO, 5 SU, 5 NN, 5 OT, 5 OX, 5 PU, 5 QL, 5 RL, 5 RQ, 5 RZ, 5 SZ, 5 UP, 5 US, 5 WR, 6 AA, 6 AL, 6 AL, 6 EA, 6 GO, 6 IR, 6 NI, 6 NY, 6 RY, 7 GB, 7 ZM, 8 AE, 8 AG, 8 AQ, 8 AW, 8 BA, 8 BE, 8 BM, 8 BW, 8 CS, 8 DX, 8 RI, 8 ZZ, 8 XD. (0-v-1.) (F. F. Rendall, 2 ACY.)

Bedford.

2 AB, 2 AH, 2 AJ, 2 AN, 2 AO, 2 AW, 2 BM, 2 BZ, 2 DF, 2 DJ, 2 DU, 2 DX, 2 EF, 2 FL, 2 FM, 2 FN, 2 FP, 2 FQ, 2 FU, 2 GG, 2 HF, 2 HT, 2 JF, 2 JP, 2 JX, 2 JZ, 2 KF, 2 KL, 2 KQ, 2 KT, 2 KU, 2 KW, 2 KX, 2 KZ, 2 LG, 2 LN, 2 LW, 2 LZ, 2 MR, 2 MM, 2 MJ, 2 NA, 2 NM, 2 NP, 2 OD, 2 OM, 2 ON, 2 OP, 2 PZ, 2 QN, 2 QQ, 2 QS, 2 RB, 2 SF, 2 SH, 2 SI, 2 SX, 2 SZ, 2 TA, 2 TB, 2 TN, 2 TO, 2 TQ, 2 TV, 2 UU, 2 UV, 2 VC, 2 VK, 2 VJ, 2 VV, 2 WA, 2 WD, 2 WG, 2 WR, 2 XD, 2 XI, 2 XR, 2 XZ, 2 YL, 2 YM, 2 YR, 2 ZM, 2 ZK, 2 ZO, 2 ZS, 2 ZZ, 5 BO, 5 BV, 5 CP, 5 CV, 5 CX, 5 DX, 5 FU, 5 HY, 5 KO, 5 LP, 5 LO, 5 MS, 5 NN, 5 NX, 5 OS, 5 OT, 5 PD, 5 PU, 5 QV, 5 RI, 5 SU, 5 VM, 5 VR, 5 WR, 5 XE, 6 EA, 6 IM, 6 LJ, 6 OY, 6 TM, 6 VT, 8 AB, 8 AG, 8 BF, 8 BM, 8 BA, 8 BQ, 8 BV, 8 CH, 8 CS, 8 DD, 8 DO, 8 DL, 8 XX, 8 BQ, 8 BS, 8 DV, 8 MX, 8 NY, 8 XO, 8 XP. (1-v-0.) (L. J. Heaton-Armstrong.)

Settle, Yorkshire.

2 II, 2 KS, 2 ZK, 2 ZU, 5 CR, 5 DC, 5 DF, 5 KS, 5 LA, 5 LB, 5 NX, 5 OT, 5 VK, 6 HS, 6 JT, 6 KA, 6 LD, 6 RC. (1-c-1.) (T. Gyte.)

Catalogues, Price Lists, etc., Received.

Hestavox, Ltd. (32, Palmerston Road, Acton, London, W.3). An illustrated 20-page catalogue of the firm's range of "Hestavox" wireless instruments and accessories.

Ormond Engineering Co. (199, Pentonville Road, King's Cross, London, N.1). An artistically produced and well illustrated catalogue, descriptive of the Company's tools, wireless parts, etc. Leslie Dixon & Co. (9, Colonial Avenue, Minories, London, E.1). Leaflets describing the numerous radio and electrical products of the firm.

Economic Electric, Ltd. (10, Fitzroy Square, London, W.1). Illustrated catalogue of a wide range of wireless sets and accessories.

A. W. Gamage, Ltd. (Holborn, London, E.C.1.). List of wireless apparatus, fully illustrated and consisting of 32 pages.

General Electric Co., Ltd. (Magnet House, Kingsway, London W.C.2.). Leaflet describing the Geophone Constructor's Set. Also booklet No. B.C. 2855, dealing with Geophone Loud speakers.

Marconi's Wireless Telegraph Co., Ltd. (Marconi House, Strand, London, W.C.2.). Pamphlet No. 223, describing multi-valve amplifying detectors and low frequency signal magnifiers, with practical notes and illustrations on art paper.

Western Electric Co., Ltd. (Connaught House, Aldwych, W.C.2.). A booklet describing Western Electric Loud Speakers, Weconomy amplifiers and Weconvolvers.

Dent & Co., & Johnson, Ltd. (Linwood, nr. Paisley). Two pamphlets dealing respectively with "Linwood" Radio Receiving apparatus and "Linwood" loud speakers.

Sterling Telephone & Electric Co., Ltd. (Telephone House, 210-212, Tottenham Court Road, London, W.1). Publication No. 353: "Sterling" Radio Receiving Sets, Loud Speakers, Amplifiers, and Accessories; and Publication No. 375: An attractive brochure, dealing with "Sterling" Radio Receiving Sets.

Books Received.

Wireless Broadcasting Licence (copy of Supplementary Agreement between the P.M.G. and the B.C. for the modification of the former licence). (Obtainable from H.M. Stationery Office, Imperial House, Kingsway, London, W.C.2. Price 6d. net.)

Wireless of To-day. Describing the growth of Wireless Telegraphy and Telephony from their inception to the present day, the principles on which they work, the methods by which they are operated, and their most up-to-date improvements, all told in non-technical language. By Charles R. Gibson, F.R.S.E., and Wm. B. Cole, A.M.I.E.E. With 54 illustrations and diagrams. (London: Seeley, Service & Co., Ltd., 196, Shaftesbury Avenue. Price 7s. 6d. net.)

An Introduction to Wireless Telegraphy and Telephony. By J. A. Fleming, M.A., D.Sc., F.R.S. (London: Sir Isaac Pitman & Sons, Ltd., Parker Street, Kingsway, W.C.2. 109 pages. 65 figures. Price 3s. 6d. net.)

CORRESPONDENCE

Long-Range Crystal Reception.*

To the Editor of THE WIRELESS WORLD AND
RADIO REVIEW.

SIR,—It is often stated that reception of telephony from broadcasting stations by means of crystal detectors, without high-frequency amplification, is impossible at distances exceeding 30 to 40 miles at the utmost, except as the result of a temporary combination of unusually favourable circumstances.

It is also said that low frequency amplification is useless to increase the effective range of radio receiving apparatus, or, as it is alternatively expressed—unless signals are already audible without it.

Having recently assembled from components two crystal receivers of the variometer type, intended for use in the near neighbourhood of a broadcasting station, the writer, in order to ascertain that they were in good working order, coupled them up to his aerial, situated near Llandudno in North Wales, expecting merely to receive spark signals from ships, coastal stations, etc. While searching with the first set, faint speech and music was heard. Any fading rendered it inaudible, but eventually the call sign of Glasgow **5 SC** was clearly and unmistakably heard. After some further searching, London (**2 LO**) was picked up in just the same way. Both these stations were tuned in repeatedly during the evening, and it was thought that whispers of telephony from other stations could be detected at times.

The second crystal receiver was finished and tested in the same way. Again **5 SC** was heard, and faint sounds, suggestive of music or speech, on other settings of the variometer.

As an experiment, the crystal set was then connected up to a two-valve, transformer-coupled low-frequency amplifier, forming part of the writer's regular set.

Telephony at fair headphone strength was at once received from London (**2 LO**), Glasgow (**5 SC**) and Aberdeen (**2 BD**), all of whose call signs were heard without any possibility of mistake. Speech could often be followed quite easily with the 'phones held a foot to eighteen inches away from the ears. Several other B.B.C. stations were heard fairly loudly on many occasions during the evening, and either Bar or Formby Lightship telling Liverpool Dock Office that the *Marjorie* had not yet been sighted, came in strongly. Cardiff (**5 WA**) has not been heard, but this is hardly surprising in view of the tremendous screening effect of the Welsh mountains. This station is by no means easy to get as a rule with a valve receiver having a stage of H.F. amplification and reaction.

The stations have been heard many times. Fading is no worse than when using three valves (one H.F.), and the only serious difficulty in reception was caused by lack of selectivity, due to the use of a direct-coupled tuning circuit, without reaction. It is quite clear that even a variometer, under these conditions, is nothing like selective enough. Spark jamming was extremely troublesome everywhere, and nearly all the time, being often almost deafening, and blotting out telephony completely.

It was also impossible to separate many of the B.B.C. stations, especially London, Bournemouth and Manchester. This made the definite logging of particular stations difficult, and largely a matter of luck.

Details of the receivers may be of interest. One crystal was Hertzite fixed with Wood's metal. The other was apparently galena, of no definite brand, fixed with screws. A rather stubby cat-whisker of unknown metal, looking like brass wire, was used with the first crystal, and a No. 34 gauge copper whisker with the second. No difficulty was experienced in setting, and any number of sufficiently sensitive points were available, some better than others, of course. A light contact was essential, but no trouble due to instability of the crystal setting was experienced. The panel could be lightly rapped with the knuckle, or the set picked up and put down again on the table, reasonably gently, without any effect on signals.

The telephones used were 4,000 ohms, of unknown make.

The aerial is a single wire about 75 ft. long, including down-lead, about 30 ft. high at the lead-in end, and 28 ft. at the free end. The station stands on a ridge about 100 ft. above sea-level, is unscreened by any near objects, but screened by hills and mountains in every direction except to the North and West. The connections are quite standard.

It would be foolish to make sweeping deductions from the foregoing, to the effect that crystals may be used for regular radio reception at much greater distances than is commonly believed, or that the most efficient way to use valves, in conjunction with a crystal, is as L.F. amplifiers. These results do, however, seem to indicate that crystals are capable of rectifying very weak signals, and that there are distinct possibilities of obtaining what amounts, practically at any rate, to a moderate extension of the actual receiving range of crystal sets, by means of L.F. amplification, and at the same time securing the large increase in volume, in the case of transmissions from comparatively near-by stations, together with the extreme simplicity of operation, which are the very useful characteristics of "note-magnifiers."

J. H. S. FIELDS.
A.M.I.Mech.E.

* In his covering letter, Mr. Fildes says, "the results have surprised me more than a little, and if, before I had myself obtained them I had heard someone else claiming something similar, it would have put a rather severe strain upon my credulity."

Our attitude in the matter is that, while we do not wish anyone to obtain the impression that the *reliable* range for the reception of broadcast of a crystal receiver, even with note magnifiers, exceeds 20 to 30 miles, yet we are so often informed of the regular reception over much greater distances that, for this reason, it is felt desirable to publish the above letter, which is typical of so many received. The long range in this case is not, we believe, due to radiation from the aerials of other listeners.—EDITOR.



WITH THE SOCIETIES

Particulars of Membership of any Society can be obtained on application to the Secretary. Societies marked with an asterisk are affiliated to the Radio Society of Great Britain.

Fulham and Putney Radio Society.*

On Friday, December 14th, Captain Dobson gave an excellent lecture on the construction of the thermionic valve from the earliest stages to the finished article. During the lecture parts of the valve in different phases of manufacture were passed round for inspection. In this way the explanations of the lecturer were rendered particularly clear.

The Chairman, Mr. Wooding, then gave a short demonstration on a large frame aerial of a new type capable of folding into a very small compass.

Asst. Hon. Sec., B. Houston, 125, Hurlingham Road, Parsons Green.

Tottenham Wireless Society.*

Prof. A. M. Low, D.Sc., the President of the Society, gave a talk on "Television" on December 19th.

The wireless transmission of photographs, said Prof. Low, is comparatively easy by either of two methods. The selenium cell method of modulating the transmitter is familiar. Another successful method of modulation uses the resistance of a gelatinised film on a drum. The thickness of the film corresponds to the degree of blackness of the photograph and the varying resistance between the moving drum and a pointer on the surface controls the transmitter. In considering wireless television, retentivity of vision is an important factor. A 5-in. square picture takes about 20 minutes to send. If this time could be reduced to four-fifths of a second and a fresh picture of a series commenced immediately, the effect of a flickering cinematograph would be obtained. To get a quick picture very coarse screening might be resorted to, but this would render the picture unintelligible.

The Chairman of the Society, Mr. J. Kaine-Fish, then explained with diagrams the novel apparatus he is constructing to experiment in television.

Hon. Sec., S. J. Glyde, 137, Winchelsea Road, Bruce Grove, Tottenham, N.17.

The Southampton and District Radio Society.*

On Thursday evening, December 20th, at the kind invitation of Mr. J. S. Brown, sectional engineer of the Post Office Engineering Dept., a party of members of the Society paid a visit to the Automatic Telephone Exchange. The visitors were conducted around the Exchange by Mr. Brown, and two members of his staff, and the mysteries of the installation were thoroughly explained.

Hon. Sec., P. Sawyer, 55, Waterloo Road, Southampton.

Wembley Wireless Society.*

An almost entire absence of bought sets characterised the second exhibition of members' apparatus at Park Lane

Schools on Saturday, December 15th. There were some 80 exhibits, sets ranging from a single crystal set to 5 valves being shown. Reflex circuits were in evidence, also the P.W. combination set, and it was noticeable that the majority of the members employed switches to control the number of valves in use. Coils wound on the Society's coil winder were frequently to be seen and, in all, eight types of coils were shown.

Mr. Gregory exhibited a working model thermionic valve, which showed the varying electron emission from the filament due to the change in grid volts during one complete wave.

Hon. Sec., W. P. Mickelwright, 10, Westbury Avenue, Wembley, Middlesex.

Kensington Radio Society.*

The lecturer on December 6th was Mr. L. Bland Flagg, who dealt with the use of various types of jacks and plugs on multi-valve sets, illustrating his remarks with diagrams. Special attention was given to the best types for use on low wavelengths, with a view to reducing capacity effects, and these methods were illustrated on a 5-valve set built by the lecturer.

Hon. Sec., John Murchie, 33, Elm Bank Gardens, Barnes.

North Middlesex Wireless Club.*

On December 12th a lecture on "Selective Reception" was given by Mr. W. H. Norvill, of Autoveyors, Ltd. The object of the paper, which was freely illustrated by means of lantern slides, was to demonstrate the selectivity and freedom from atmospheric disturbance of the "bridge" method of reception. Mr. Norvill had brought with him some very fine apparatus and a number of excellent slides, which helped in a large measure to illustrate the points of the lecture.

The efficiency of the three-electrode variable condenser as an interference eliminator was well established under practical conditions, 2 LQ being entirely cut out while other broadcasting stations were being received.

Hon. Sec., H. A. Green, 100, Pellatt Grove, Wood Green, N.22.

Kingston and District Radio Society.

Mr. W. Hamilton Wilson, M.I.E.E., the vice-president and well-known inventor of the Wilson coil, which figured so prominently during the war, delivered a very interesting and instructive lecture before the Society on December 10th, taking for his subject "Methods of Producing High Tension Currents for Spark and Continuous Wave Transmission, X-Rays, etc."

The lecturer commenced by generally reviewing the rapid progress which has been made during recent years in improv-

ing the efficiency of spark transmission. He contrasted the old, but not yet obsolete, system consisting of a bulky induction coil so constructed that it generates many thousands of volts for the purpose of obtaining the requisite spark to excite the transmitting aerial, with the present highly efficient, portable and comparatively low voltage arrangements which were embodied in the sets brought along for demonstration purposes. Circuit diagrams of the 100, 250 and 500 watt sets respectively, were drawn on the board and very fully explained. The ingenious "buffer" circuit which eliminated the necessity for large transformers was also clearly described.

Mr. Hamilton Wilson then explained how the resultant pulsating high tension current could be made suitable for supplying the anodes of transmitting valves for radio telephony and pure C.W., and finally its use for the generation of X-rays which are now so indispensable to the medical world.

The lecture concluded with a popular demonstration, in which Mr. Hamilton Wilson allowed those present to examine their own bones under X-rays.

Hon. Sec., R. J. W. Lankester, Wanderings Farm, Kingston-on-Thames.

The Hornsey and District Wireless Society.

On December 17th Mr. F. H. Haynes, Assistant Editor, *The Wireless World and Radio Review*, delivered a lecture on "Points in Design when Setting up Valve and Crystal Receivers." The lecturer commenced with some useful hints on the subject of aerials and earths, and proceeded to describe an ordinary crystal receiver, and gave his views upon the merits of various types of crystals. The lecturer then gave an interesting description of the construction and design of valve sets, and exhibited a very compact three-valve receiver of his own construction, in order to illustrate his remarks. A variety of other topics were discussed, including the elimination of distortion and the rejection of unwanted signals. Mr. Haynes was subjected to a bombardment of questions, all of which he replied to in a most satisfactory manner.

A very hearty vote of thanks was accorded to Mr. Haynes at the conclusion of his lecture.

Hon. Sec., H. Hyams, 188, Nelson Road, Hornsey, N.5.

Hampton and District Radio Society.

This Society has now been formed and the first lecture and demonstration will be given on January 9th at 8 p.m., by Captain Coxon. The headquarters are the Parish Hut, Oldfield Lane, Hampton. Application has been made for affiliation to the Radio Society of Great Britain.

Secretary, G. W. Thompson, 8, Percy Road.

THE LEAFIELD IMPERIAL WIRELESS SERVICE.

By E. H. SHAUGHNESSY, O.B.E., M.I.E.E.

(Continued from pp. 448).

DISCUSSION.

Mr. Coursey.

I am sure we all wish to thank Mr. Shaughnessy for taking the trouble to come down here to-night to tell us some of the difficulties that have been experienced in getting a high power station into a going concern.

I can appreciate the difficulties he has mentioned about dielectric losses since, as a user of arc generators (although only of a comparatively small power of 10 to 15 kW.) for testing purposes, I have had some experience of the difficulties obtained in getting an insulator which will stand up to C.W. work. After trying most things that one can lay hands on, one frequently comes back to wood for many purposes as being the best in the long run. An improperly designed insulator, or one in which the dielectric stress is too high, very soon burns out and breaks down.

I do not think there is much I wish to discuss in the paper that we have just heard, but there is, however, one thing I should like to emphasise with regard to the harmonics which have been mentioned by Mr. Shaughnessy. I think most of us can agree with Mr. Shaughnessy that valves do produce harmonics as well as do arcs. The chief difference one finds, from the listener's point of view, is the "mush" which accompanies the harmonics from the arc. This is not found to the same extent with the harmonics from the valve. A pure C.W., generated by a valve, when it gives harmonics, gives, usually, fairly sharply defined harmonics, whereas with the arc, of course, the harmonics are usually accompanied by a mush which pretty well fills up the space from one harmonic to the next. This effect means that the interference in this case will be greater than with the valves, although the harmonics may be no more numerous.

Mr. Child.

One or two points have occurred to me which I should like to ask Mr. Shaughnessy about. The first is with regard to the consumption of methylated spirit. This, perhaps, is not a very important point, but it would be interesting to know how much spirit is used in the course of a day's work at Leaffield, and I take it that Mr. Shaughnessy will be rather concerned as to the substitute for the spirit in the near future. There is another question. I understood Mr. Shaughnessy to say that they are using some type of circuit at Northolt which gets over the difficulty of harmonics with the arc. I imagine it is some form of intermediate circuit, and it would be interesting to know how it is worked. If such a circuit is employed I should like to know how they get over the question of keying, because if an intermediate circuit is used I take it that it has to be tuned accurately to one particular wavelength, and if they signal by altering the wavelength of the station, the energy drawn from the arc on the intermediate circuit will be

materially affected, and there may be a difficulty in obtaining a stable arc. If we could have some information on that point it would be very interesting. I did not hear Mr. Shaughnessy mention anything with regard to the earth system at Leaffield. I should like to know if the earth system is of a special character, and how it is arranged.

Major Hamilton.

Mr. Shaughnessy mentioned a coupled circuit at Northolt, but he did not tell us if any attempt has been made to put in a coupled circuit at Leaffield. Has any experimental work been done on these lines?

Mr. G. G. Blake.

There are two questions I should like to ask Mr. Shaughnessy. With regard to the use of methylated spirit, he mentioned the explosions which have occurred. I have heard of a method— I do not know whether it has been found practicable—of putting methylated spirit into the arc, setting fire to it, and then closing the arc down and waiting until the spirit has burned up so that there should be no further oxygen in the arc after it had been cleared. Has that been tried, and, if so, has it been found satisfactory at Leaffield? Then, with regard to insulators, I thought that possibly Mr. Child or Mr. Coursey might have mentioned our experience (on a small scale) at 5 WS last year. We put a piece of ebonite between the aerial circuit and the primary circuit, and it very quickly showed signs of catching fire, even with the small power we were using. There is another question. What about the spider arrangement which Mr. Shaughnessy mentioned at the top of the inductance. He just mentioned the use of a spider which overcame the trouble, but he did not give us any idea of the arrangement.

Captain Hobbs.

The harmonics at Leaffield are not nearly so troublesome in the South of England as, perhaps, the station at Horsey. That is our worst trouble in the South of England. Devizes, too, is far more troublesome than Northolt or Leaffield.

Mr. Fogarty.

I should be glad to know if Mr. Shaughnessy can give us some idea of the overall efficiency of the Leaffield station, *i.e.*, the overall efficiency of current input to radiated energy at both Leaffield and Northolt. I should also like to know the gain or loss of efficiency resulting from the installation of valves as against arcs.

Mr. Lambert.

I want to ask Mr. Shaughnessy two questions. It has been said that a coupled circuit would cure most of the harmonic and mush trouble at Leaffield, and I simply ask whether it is proposed in the near future to put in such a circuit. If it is not proposed

to do this I should like to ask whether the cost of the condenser with the closed circuit is the rock on which the Post Office is, so to speak, splitting. If that is the question—a matter of cost, in other words—it occurs to me that there are so many amateurs who curse Leafield every day in one way or another, say 100,000, that if they only put up 9d. each there would be a sum of £3,750 for the Post Office to get a new condenser. I believe you can get a wonderful condenser for £3,000 which will stand anything—even Leafield!—and that leaves £750 for putting it in. I am sure you need only put a little notice in the paper or circularise the members and you would simply have money flowing in. I have mentioned it to two or three of my friends and have had offers of £1 each already, and they live near London. What the people near Oxford would give I do not know—probably all they have got—and I think it would make the air a bit purer. We are only too anxious to help in this matter. (Loud laughter*)

A Speaker.

May I ask Mr. Shaughnessy what is the difference in wavelength between the spacing and marking waves at Leafield and Northolt?

The President.

At the beginning of the lecture Mr. Shaughnessy alluded to Mr. Duddell, and it reminded me of an interesting fact about the early experiments in 1900 when Duddell discovered the oscillating arc. He tried the arc in various gases—first in air, naturally, and then in carbon dioxide, and in one or two other gases. He told me some few years afterwards—after Poulsen had published his results—that it was by an accident that he was prevented from trying it in hydrogen. He had had a bottle of hydrogen prepared, but the glass vessel was finally broken and the gas escaped before the experiment could be tried. This shows how a small accident may make a very great difference in a discovery or invention of that type. Mr. Shaughnessy alluded to coupled circuits, and it occurs to me that there is an inherent disadvantage of inductively coupled circuits when they are applied as intermediate circuits for the removal of harmonics. If we use, as has always been done hitherto, the mutual inductance between two coils, then the fundamental is transferred across the coupling proportionately to mutual inductance multiplied by the frequency. The double harmonic is transferred in the proportion mutual inductance multiplied by *its* frequency, and a harmonic, say of the tenth order, is transferred with a strength proportional to the mutual inductance multiplied by *its* frequency, which is ten times stronger than the then fundamental. So that by using electromagnetic couplings, *i.e.*, inductive couplings, we are favouring the transfer of harmonics. It would be better, therefore, to use some other kind of coupling. If we could use, for instance, condenser couplings, then everything would work in the opposite direction. The transference in a condenser coupling is proportional to the reciprocal of the capacity multiplied by the frequency. The greater the frequency the less the E.M.F. that is transferred. Therefore, the higher harmonics would be cut down relatively to the fundamental if only we can use an intermediate circuit coupled, not by coils, but by condensers.

The mush is another question that is of considerable interest. I do not think anyone has ever threshed out the real cause of mush, but perhaps that is because it is one of those things that one thinks is obvious. I am very wary of taking things as obvious. Therefore, I should have liked to have heard if anyone has experimented on the cause of mush. The suggestion that appears obvious is this. In the formation of the oscillating arc, the chances are that there will be a short train of waves (say ten) perfectly regular. They may have a fundamental and various harmonics, but they will be regular waves, equal in period. Then comes a break—a very minute break in point of time—but the next train of waves may start out of phase relative to where they ought to be if the first train had gone on unbroken. That train may persist for seven or eight or ten oscillations, and then it breaks, and another train of waves starts, having no phase relation at all to the preceding trains. Now, you can imagine that if that goes on all the time with an arc, every start of a new train of waves is equivalent to a blow, and impulses the sending aerial, and perhaps also the receiving apparatus.

Mr. Shaughnessy (replying to the discussion) said:—

Mr. Coursey pointed out that harmonics from arc stations are usually accompanied by mush. Our experience shows that to be the case, but one of the troubles from mush is that you do not get the mush at one definite harmonic. When working at 9,000 metres at Leafield we found the bulk of the mush was at about 2,000 metres, which consisted of a rushing noise which upset reception. Mr. Child asked how much methylated spirit was used. It is 1½ pints per hour, and we get it very cheap, but we cannot supply it for refining. (Laughter.) He also wanted to know the method of keying with the coupled circuit. Well, we alter the tuning of the primary circuit very slightly—enough to give us a spacing wave that produces forced oscillations in the aerial at the new wavelength with less aerial current. As to the coupled circuit at Leafield, which has been mentioned by two speakers, I think all our troubles are at an end by Mr. Lambert's generous offer. (Laughter.) I am quite prepared to accept £3,700, if that will satisfy you. (Laughter.) I will not, however, guarantee any results, but you might be interested to know that the condensers at Leafield are almost finished. We have doubled the size of our aerial tuning inductance room, and the aerial tuning inductance is almost finished. We are going ahead, but it is not a simple job.

With regard to the remarks as to the people near Oxford, I was very interested at one of the informal meetings two or three weeks ago when Mr. Coursey raised the question of short wave reception, when a gentleman from Oxford told us what marvellous things he did on short wave reception. I suggest that Mr. Lambert should get into touch with that gentleman and find out how to receive, despite Leafield. At Banbury, which is 20 miles from Leafield (I do not know how far Mr. Lambert is), with an ordinary two-valve receiver we have been able to get Marconi House morning programme without using reaction when Leafield is running full power. We have also gone 10 miles from Leafield, pointed a frame at Leafield and America while Leafield is

working at 12,300 metres full power, and have got signals on 11,600 metres without any difficulty, giving ourselves the very worst conditions of reception from the interference point of view. Mr. Blake raised the question of burning methylated spirit in an arc. That is sometimes done at Northolt, as is also the burning of a piece of paper, but it would be too big a job to do at Leaffield to take the arc lid off when there are far too many screws, and the lid is so heavy that it is a matter of using a small crane to lift it. The spider at the top of the aerial tuning coil consisted of a wooden frame ringed round all the tops of the columns, and then just ordinary spoke wheels made of wood. That supports the top, and the bottom is held by a ring of concrete. I am interested to find that Devizes is one of the troublesome stations. Devizes is our station, and was built by the Marconi Company; it is a valve station also. Horsea is also a valve station built by the Admiralty, and Kidbrooke is also a valve station rich in harmonics. Mr. Fogarty asked about the over-all efficiency. The over-all efficiency of Leaffield is about 50 per cent. We have put in coupled arcs at Stonehaven. That was the first station where we carried out experimental work on a 25 kW. arc. Next a coupled circuit was put in with the 50 kW. at Northolt. In both cases we have had to increase our input about 20 per cent. to get the same aerial current. The recent experiments which have been carried out at Northolt have probably caused you some disturbance, but they showed that we can actually get more current in the aerial with a smaller input under certain conditions with the coupled circuit, but the conditions are not suitable. We are investigating it to see whether they can be made stable. Somebody else wanted to know the

difference in wavelength of marking and spacing. At Leaffield the difference is 80 metres—less than 0.8 per cent.

Admiral Sir Henry Jackson.

I have very great pleasure in proposing a vote of thanks to Mr. Shaughnessy for his very interesting paper. I was one of the privileged few who attended the official opening of the Leaffield station, and I thought I went away knowing a good deal about it, but I must have forgotten it all, because I feel I know a great deal more now than I did then. What struck me most was the extremely simple layout of the whole show. It all struck me as a very economical way of running a station of that size, especially as regards the circulating water, which makes a very nice bathing pond to bathe in in the winter. (Laughter.) I think that Mr. Shaughnessy has not only given us a very instructive lecture but a very pleasant one, and the discussion has also gone off without any nasty remarks. (Renewed laughter.)

Mr. Carpenter.

It gives me very great pleasure to second the vote of thanks. One knows that any lecture by Mr. Shaughnessy has always got a good deal of punch in it, and that if anybody has a shot at Mr. Shaughnessy he always gets it back cent. per cent.

The vote of thanks was carried unanimously.

The President then announced that the next meeting would be held on December 19th. This is the annual business meeting.

The President also announced that 22 new members had been elected that evening, and 8 new societies affiliated.

TRANSATLANTIC RECEPTION UNDER DIFFICULTIES.

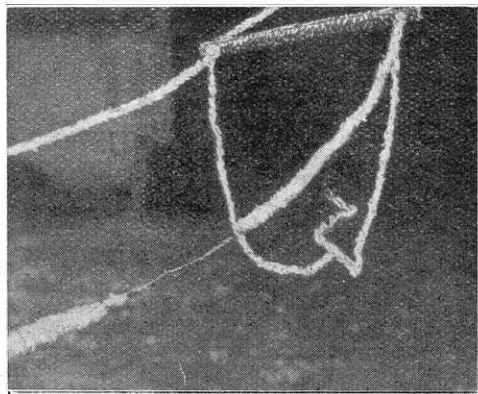
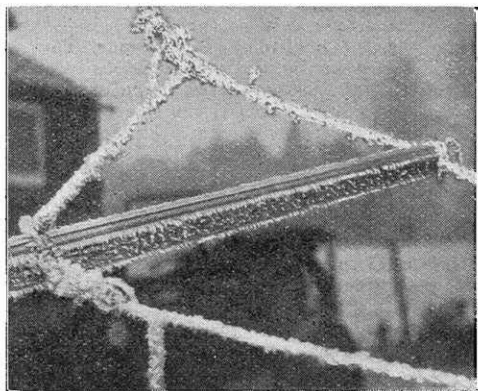

Photo: Edward G. Tong,

Thick hoar-frost on his aerial did not prevent a West London reader from receiving American broadcasting. The left-hand photograph shows a completely enveloped insulator, while that on the right gives an idea of the thickness of the frost deposit. Probably many amateurs encountered a similar experience during the recent cold spell.

Questions & Answers

Solutions of Readers' Difficulties

This section of the magazine is placed at the disposal of all readers who wish to receive advice and information on matters pertaining to both the technical and non-technical sides of wireless work. Readers should comply with the following rules:—(1) Each question should be numbered and written on a separate sheet on one side of the paper, and addressed "Questions and Answers," Editor, **The Wireless World and Radio Review**, 12/13, Henrietta Street, London, W.C.2. Queries should be clear and concise. (2) Before sending in their questions readers are advised to search recent numbers to see whether the same queries have not been dealt with before. (3) All questions will be answered through the post. Those of general interest will also be published. (4) Every question, except those under (5) below, should be accompanied by a postal order for **1s., or 3s. 6d.** for a maximum of four questions, and also the coupon taken from the advertisement pages of the current issue. (5) For the benefit of those readers who would rather not pay the charges, a free Questions and Answers Coupon will be placed in the advertisement pages of the first issue of every month. This coupon should accompany the question submitted, together with a stamped addressed envelope. The free coupon is valid for the current week only. (6) In view of the fact that a large proportion of the circuits and apparatus described in these answers are covered by patents, readers are advised, before making use of them, to satisfy themselves that they would not be infringing patents. (7) Four questions is the maximum which may be sent in at one time.

"R.C.D." (Wolverhampton) asks (1) Whether a switch to disconnect the potentiometer is useful. (2) If he should expect to obtain good results with the resistance capacity method of coupling on wavelengths below 1,000 metres. (3) The signals received from the local station are too loud. In what way is it best to reduce the strength.

(1) A potentiometer switch would be an advantage because, with the present arrangement, the potentiometer current still flows when all the valves are switched off. (2) We do not recommend resistance capacity high frequency coupling for wavelengths below about 2,000 metres. It is better to employ the tuned anode method of coupling. If a switch is included so that for the shorter wavelengths the latter method of coupling is employed, while for the higher wavelengths resistance coupling is used; it should be remembered that a higher plate voltage should be switched into circuit along with the resistance coupling. (3) Signals will be badly distorted if it is attempted to reduce the strength by reducing the filament current. It would be better to connect a switch for the purpose of cutting off the note magnifier. A number of circuits are given in these columns from time to time.

"T.W." (Dundee) asks questions concerning aerials.

Unfortunately, when two aerials are supported side by side, the tuning of one set very often affects the other circuit. If a valve receiver is connected to each aerial and one of the receivers oscillates, the oscillations may be very strongly received on the second receiver, should that receiver happen to be tuned near the wavelength. There is a tendency for both aerials to tune to the same wavelength, so that it is difficult for one receiver to successfully tune in distant transmissions while the other receiver is tuned to the local broadcast transmissions.

It would be better to construct the aerials as far apart as convenient.

"E.J." (Belgium) asks (1) Whether capacity coupling between the aerial and closed circuits is satisfactory. (2) Whether the ordinary wavelength formula applies in the case of an aerial circuit. (3) Whether two anode coils may be coupled together to produce reaction effects.

(1) Capacity coupling has been considerably used in America, but is not considered so satisfactory as magnetic coupling. If you would like to try the arrangement, the two coupling condensers should have the maximum values of 0.0005 mfd., and may be conveniently mounted on the same spindle so that they are operated with one knob. The condensers are connected exactly as in your diagram. (2) The ordinary formula for wavelength is

$$\lambda = 1884 \sqrt{LC} \text{ metres.}$$

where L is the inductance in microhenries and C the capacity in microfarads. The formula is only strictly accurate when the inductance and capacity are lumped. In the case of an aerial circuit the capacity is distributed, and this formula will only give approximate results. If you wish to calculate the wavelength of the aerial circuit exactly, we would refer you to Nottage's book called "The Calculation and Measurement of Inductance and Capacity." In this book are given a number of tables, with the aid of which one is able to find the wavelength quite closely. (3) It is certainly possible to couple the two anode coils to give reaction effects. When making this coupling be sure the anode coils are connected in the right direction. If the signal strength is weakened through the coils being brought closely together, the connections to one of them must be reversed.

"J.S.R." (Keighley) asks for a diagram of a sensitive three-valve receiver, simple in operation,

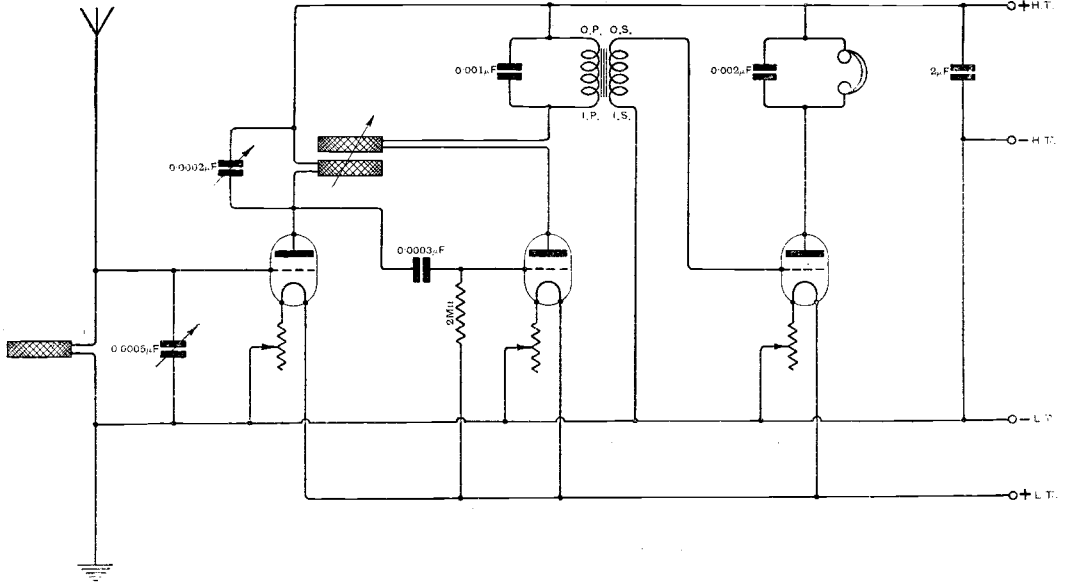

Fig. 1. "J.S.R." (Keighley). A simple three-valve receiver with reaction coupled to the anode coil.

which must be capable of receiving on all wavelengths up to 4,000 metres.

The receiver given in Fig. 1 can be thoroughly recommended from the point of view of sensitivity and ease of operation. Only three adjustments are necessary when tuning, namely, the A.T.C., anode condenser and reaction coupling. Tables of plug-in coils suitable for different wavelengths are issued by the manufacturers of these coils.

"E.S.W." (London, S.E.20) asks for a diagram of a five-valve receiver (2-v-2), with tuned transformer coupling for the first H.F. valve, and tuned anode coupling for the second. Switches to be provided to control the number of valves in use.

The diagram is given in Fig. 2. A change over switch is provided so that reaction may be coupled either with the anode circuit or the A.T.I.

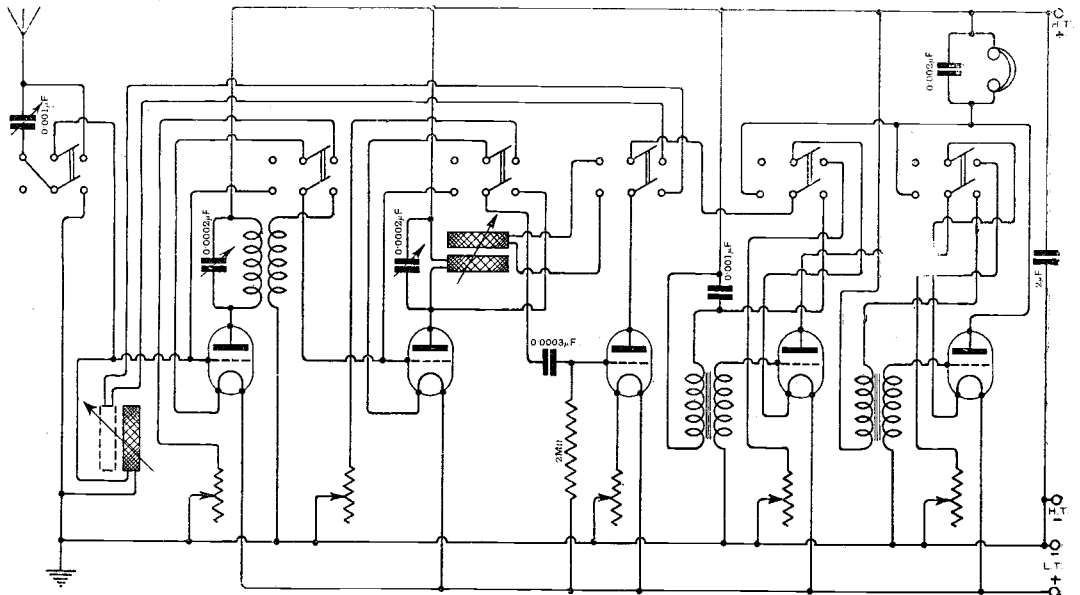

Fig. 2. "E.S.W." (London S.E.20). A five-valve receiver (2-v-2) with switches connected, so that the number of valves in circuit may be controlled.

THE WIRELESS WORLD AND RADIO REVIEW

THE OFFICIAL ORGAN OF THE RADIO SOCIETY OF GREAT BRITAIN.

No. 231. (No. 16.
Vol. XIII.)

JANUARY 16th, 1924.

WEEKLY

EDITOR:

HUGH S. POCOCK.

RESEARCH EDITOR:

PHILIP R. COURSEY, *B.Sc., F.Inst.P., A.M.I.E.E.*

ASSISTANT EDITOR:

F. H. HAYNES.

QUESTIONS AND ANSWERS DEPARTMENT:

Under the Supervision of W. JAMES.

CONTENTS

	PAGE
Notable Developments in Many Directions - -	488
The Principles Underlying the Operation of the Thermionic Valve. By W. S. Barrell - -	491
Calibrating Small Condensers By F. H. Haynes. - -	494
Loud Speakers for Wireless Purposes - -	497
A High Power Wireless Station Without Masts - -	502
Aerials and Earths. By Hugh S. Pocock - -	504
Patent Abstracts - - - - -	506
The Radio Society of Great Britain - - - - -	507
Around the Wireless World - - - - -	511
With the Societies - - - - -	515
Questions and Answers - - - - -	517

THE EDITOR will be glad to consider articles and illustrations dealing with subjects within the scope of the Journal. Illustrations should preferably be confined to photographs and rough drawings. The greatest care will be taken to return all illustrations and manuscripts not required for publication if these are accompanied by stamps to pay return postage. All manuscripts and illustrations are sent at the Author's risk and the Editor cannot accept responsibility for their safe custody or return. Contributions should be addressed to the Editor, "The Wireless World and Radio Review," 12 and 13, Henrietta Street, Strand, London, W.C.2.

SUBSCRIPTION RATES:

20s. per annum, post free. Single copies 4d. each or post free 5d. Registered at the G.P.O. for transmission by Magazine Post to Canada and Newfoundland.

EDITORIAL AND PUBLISHING
OFFICES:

12 and 13 Henrietta Street,
Strand, London, W.C.2.

Telephone: Gerrard 2807-9.



ADVERTISEMENT MANAGERS:

Bertram Day and Co., Ltd.,
1 Charing Cross, S.W.1.

Telephone: Gerrard 8063-8.

NOTABLE DEVELOPMENTS IN MANY DIRECTIONS.

The Neutrodyne Receiver.

AMONG the various "super" circuits that have made their appearance during the last twelve months the Hazeltine "Neutrodyne" merits special attention. The problem it attempts to solve is that of eliminating or neutralising fortuitous capacity coupling, particularly as exemplified in the undesired transfer of energy that occurs between the input and output circuits of a valve, across the internal electrodes. This effect is particularly troublesome in the high frequency stages of amplification, and in practice places a narrow limit upon the number of amplifiers that can be successfully used in cascade.

According to the principle employed in the Neutrodyne receiver, undesired capacity coupling between any two circuits are eliminated by means of a third auxiliary circuit, which is electromagnetically coupled to one of the original circuits and capacitively coupled to the second. If a disturbing voltage should exist in the second circuit, it will cause currents to flow both in the first circuit and in the auxiliary circuit, due to the capacity coupling. The electromagnetic coupling between the auxiliary and first circuits is then adjusted so that the magnetic transfer neutralises the capacity current in the first circuit. Reciprocally, if a disturbing voltage exists in the first circuit it will be similarly neutralised in the second circuit by virtue of the mutual coupling.

As constructed, the receiver is divided by a grounded metal partition which separates the aerial circuit from the detector circuit. The moving elements of the primary and secondary tuning condensers are earthed so that no external capacity coupling effects are present. The secondary inductance coil is earthed at an intermediate point, the remainder of the coil being wound over the upper part and left free-ended or carried to a point where slight capacity coupling is effected with the grid circuit. The electrostatic coupling between the primary and secondary coils is thus neutralised, partly by the opposed magnetic coupling of the free

end of the secondary coil, and partly by the inherent capacity effects introduced by the secondary windings.

When applied to a single valve amplifier (the simplest case), the capacity effect between the grid and plate electrodes is neutralised by connecting the free end of the reversely-wound part of the secondary coil to one side of a stabilising condenser, the other side of which is connected to the grid of the valve. The ratio of the stabilising capacity to the inter-electrode capacity is the same as the ratio of the number of direct turns to the number of opposed turns in the secondary coil; or more generally the capacity ratio is the inverse ratio of the coils forming the electromagnetic coupling.

Valves.

Turning to the thermionic valve, the present year has seen further developments of the original dull-emitter type, some of which operate with the extraordinary low filament current of 0.06 amps. at a voltage of approximately 2.5. The advance here represented is due to new and improved methods of preparing filaments of high emissivity.

These fall into two classes, oxide coated and thoriated. In the former it is now possible to lay upwards of a dozen separate coatings of the sensitive oxide upon a platinum-iridium wire core and successfully to amalgamate them. In the latter variety, the thorium content of a tungsten core has been brought into more effective operation by a process of carbonisation during manufacture.

In spite of their remarkable thinness—less than that of a human hair—the new filaments are remarkably robust and will stand ordinary usage without risk of breaking.

An interesting development in valve construction is designed to allow the adoption of mass methods of manufacture by comparatively unskilled operators, and may possibly be reflected in the near future by some reduction in the present high prices. Instead of sealing the electrodes directly into the glass stub or "pinch," they are

first mounted in short metal tubes, which are then spaced and fitted into a jig. The leading-in wires are then secured to the lower ends, the glass foot-tube is slipped over, and the end softened to form the "pinch," in which the tubes are firmly embedded. The electrode supports are finally inserted in the upper ends of the tubes and secured by indenting or "spot welding."

Considerable attention has also been devoted to the Magnetron type of valve, which promises in fact to be the high-powered thermionic generator of the future. In the Magnetron, as is well-known, the

cooled by direct immersion in water and so limits the power that can be handled.

In order to avoid this limitation, a linear cathode of refractory material and of comparatively large diameter is now designed to carry a current of such strength that the magnetic field so produced is itself sufficient to prevent or control the passage of the electrons between the cathode and anode. The tungsten cathode of another variety of magnetron is made in the form of a solenoid, wound non-inductively, and carries a current which alternates at the same frequency as the output current from the

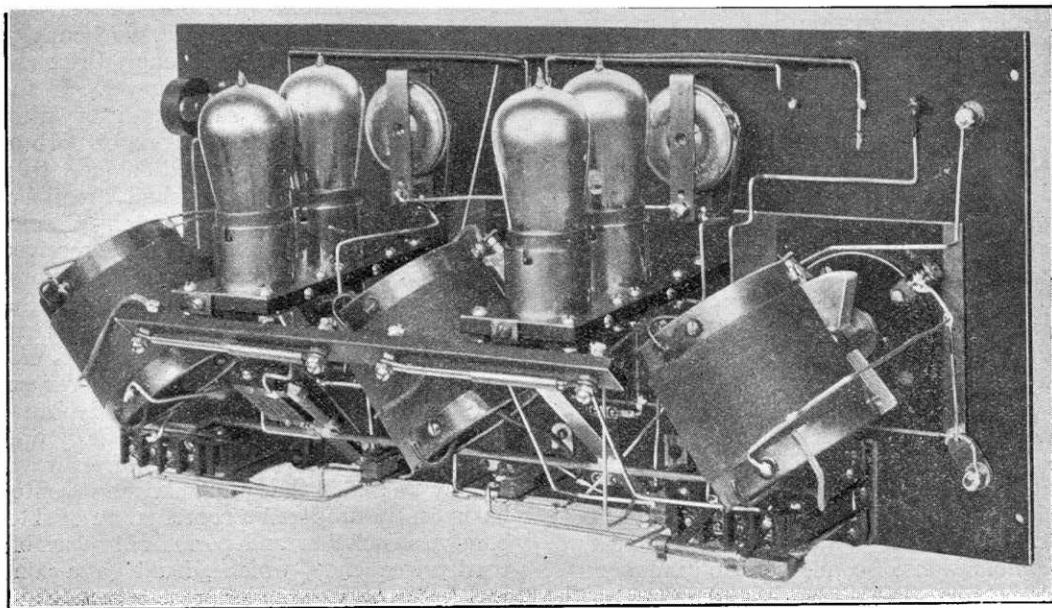

(By courtesy Hazeltine Neutrodyne Radio Sets, Ltd.)

A British-built Neutrodyne Receiver. Many of the components special to this type of receiver can be easily identified.

space current between cathode and anode is controlled wholly or in part by a magnetic field. It has been usual to generate the control field by means of an electric current flowing in a coil winding located outside the tube surrounding the anode.

Owing, however, to the shielding effect of the ordinary type of cylindrical anode it is necessary to split or laminate the anode in order to allow the magnetic field to penetrate the inter-electrode space. This renders it impossible to make the anode as an external envelope which could be

tube. The plate is an external copper cylinder sealed into two extensions of glass or silica, and is cooled by means of a water jacket. The internal magnetic field from the cathode is confined to the inter-electrode space by the reflection effects of eddy currents set up in the anode cylinders and in special end plates or shields. In both types the cathode therefore functions in a dual capacity (a) as an electron-emitter and (b) as the seat of a magnetic controlling field which replaces the electrostatic or grid action in the ordinary triode valve.

Interference.

The problem of preventing interference, either from undesired signals or from atmospheric strays, continues to attract more attention from investigators than probably any other aspect of wireless science. Among the many solutions that have been advanced during the last year the Marrec "interference preventor" may be mentioned. This receiver comprises two separate groups of valves. The circuits of the first are aperiodic, whilst those of the second group are tuned to the desired signal wavelength and are coupled by special tuned transformers. The aperiodic valves are set to act as current limiters, whilst the tuned circuits in the second group function both to filter out the undesired signals and at the same time to restore the signal strength deliberately sacrificed in the aperiodic circuits.

"Secret" Telephony.

Strenuous efforts are also being made to develop and perfect "secret" systems of wireless telephony. A simple and practical solution to this problem if applied to Broadcasting, would not be to the advantage of the listener-in who depends upon the humble crystal for his nightly feast of entertainment. Possibly with an eye to the "pirate" who would not indulge in a licence, a system has been invented of mixing discordant notes or noises with the transmitted speech or music, an "adulteration" which cannot be removed at the receiving end except by means of "eliminators" supplied only to subscribers. The eliminator comprises filter circuits, or combinations of condensers and inductances, designed to reject the discordant notes, the inductances being set in concrete or like

solid material so as to render the production of duplicates difficult.

A number of similar proposals are based on the idea of periodically varying the wavelength of the emitted waves and in providing subscribers with means for synchronously varying the tuning of the receiving circuits. Such methods as these are of doubtful merit owing to the complicated character of the special receiving apparatus and its consequent liability to get out of order.

Perhaps the most promising method of attaining secrecy lies in the use of what has become known as side band transmission. A speech-modulated wave may be analysed into a pure carrier wave and two bands of waves, one higher in frequency than the pure carrier, and the other lower. If the pure carrier wave is suppressed by filter circuits or other means, and one or both of the side bands transmitted alone, then reception by crystal or other similar rectifiers will not give an intelligible signal. Correct reception can only be obtained if the received energy is first combined with locally-produced waves of the suppressed carrier frequency. Apart altogether from considerations of secrecy, this method, which was first suggested some years ago by the Western Electric Co., has the undoubted advantage of eliminating the great waste of power involved in radiating the whole carrier wave. It may be added that an American inventor has recently proposed a combination of side-band transmission and periodically-variable carrier frequency, which should go a long way towards rendering unauthorised "eavesdropping" impossible.

THE ANNUAL EXHIBITION OF THE PHYSICAL SOCIETY OF LONDON.

Among the instruments of special interest to wireless experimenters may be mentioned the selenium magnifier, designed by Mr. K. C. Cox, essentially for use in submarine telegraphy, and shown by Messrs. W. H. Sullivan, Ltd.

The image of a grating is projected on to the mirror of a galvanometer and thence to a selenium cell of new design. This cell is sub-divided into independent sections to correspond with the image of the grating. The resistance of the illuminated and screened sections are balanced in the limbs of the usual Wheatstone bridge arrangement, fine adjustment being obtained by means of an apex resistance. Deflections of the galvanometer cause corresponding movements in the image of the grating on the sectioned cell, producing an unbalance of the bridge, and a resultant current in the local receiving apparatus. Selenium "inertia" is elimi-

nated by shunting the local apparatus with a suitable inductance. When this operates, a direct magnification of 200/1,000 times is normally obtained and in special cases it may be as high as 20,000. Selenium cells of various types and sizes were also on view.

Valve exhibits by the M.O. Valve Co. and the Mullard Radio Valve Co., Ltd., included many of new design. Some of the dull emitter type and designed for various purposes, were shown, and also the latest types of transmitting valves.

The new Holweck molecular pump, which is coupled up to a specially built valve and arranged in a manner such that pumping can be carried out whilst the valve is in use, and a vacuum of constant pressure maintained.*

* A description of the Holweck Transmitting Valve may be found on page 458, Jan. 9th, 1924.

THE PRINCIPLES UNDERLYING THE OPERATION OF THE THERMIONIC VALVE.

Whatever the apparatus, the results obtained depend to a great extent on adjustment, and in this and the following articles the operating features and phenomena associated with the thermionic valve are discussed with a view to indicating some of its constants and how they are controlled.

By W. SYDNEY BARRELL.

ELECTRIC currents are streams of electrons which move under the influence of an electro-motive force so that if a difference of potential exists between two points and these are joined by a conductor, electrons will move along its length, producing what is generally called a current of electricity.

These electrons are not mere figures of the imagination, but are established entities, being particles of electricity, and the charge carried by each is equal to 1.57×10^{-19}

dislodged from the parent substance and, while several ways of performing this are available, only one, namely heat, need concern us here.

When a metal is heated to a high temperature in a vacuum, electrons (charges of negative electricity) are continually shot off from its surface into the surrounding space, the number depending upon—

- (1) The size of the heated metal.
- (2) The temperature to which it is raised.



Photograph of the apparatus connected to obtain voltage saturation curves. The connections are given in Fig. 3.

of a coulomb; or, put in another way, a current of one ampere flowing for one second is carried by some 6,000,000,000,000,000 electrons! In size the electron is so extremely minute that it is impossible for the mind to conceive its dimensions.

For the purpose of producing a discharge through a vacuum tube it is, however, necessary for the electrons to be completely

(3) The material of which it is composed.
The mechanism underlying the emission of electrons from hot bodies was first explained by Dr. O. W. Richardson in 1901, who showed that it takes place simply by reason of their kinetic energy, and that, contrary to ideas then prevalent, needs no chemical reaction at the surface of the emitting body.

It is of course well known that the molecules of matter are continuously on the move, and their motion is a function of temperature; so should the temperature of a substance be raised, an increased movement or agitation of its constituent molecules results. In the case of a substance such as a metal, which contains free electrons, these will also take part in this agitation until, when a certain temperature is reached, a number will be forced out into the surrounding space. Although any body will give off electrons when raised to a sufficiently high temperature, the source of electrons in a valve is a filament which is usually in the form of a tungsten wire, which is heated electrically by passing a current through it.

This electronic emission has the effect of converting the surrounding space into a conductor, and, if a positively charged body is placed near to the emitting surface, the electrons will traverse the intervening space and constitute an electric current. It must, however, be remembered that this current can only take place from the hot to the cold positively charged body, and not in the reverse direction. So then we see that by sufficiently heating a body we may cause it to emit electrons which as already noted carry a charge of electricity, and since moving electrons constitute an electric current, we may, by controlling their motion and path, obtain an electric current which can be put to our particular use. The emission of electrons and its control is indeed the basis of valve action.

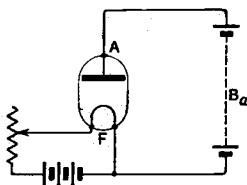

Fig. 1.

The phenomena outlined above can be very conveniently studied by a consideration of a filament F and a metal anode A sealed into a bulb evacuated to the highest possible degree and arranged as in Fig. 1. When the filament F is heated it will emit electrons into the surrounding space, and if the anode A is maintained at a positive potential with respect to the filament, a flow of electrons

will be established across the space separating F and A, and we shall have a current flowing in the circuit F A Ba F.

If the filament temperature is maintained constant the number of electrons emitted by it per unit time will also remain constant, but

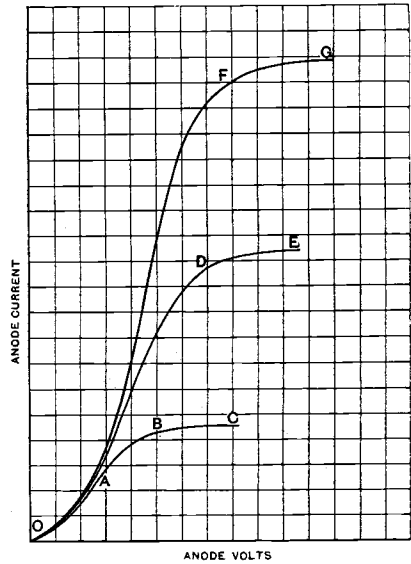

Fig. 2.

the number attracted to the anode will depend upon its potential relative to the filament. Starting therefore with the anode at zero potential, and then gradually increasing its voltage, the number of electrons reaching the anode, and consequently the current, will increase, as represented by the curve O A Fig. 2. Sooner or later, depending on the design of the tube, a certain anode potential will be reached beyond which any increase in anode voltage fails to produce an increase in anode current. At this point all the electrons are being received by the anode at the same rate as they are emitted from the filament, and we therefore obtain the horizontal part BC of the curve OABC, Fig. 2, which indicates the saturation current for the particular filament temperature. In practical operation we have no direct means of measuring the filament temperature, and have to rely on voltmeters and ammeters in the circuit. We do, however, know that an increase in the current through or the voltage across the filament results in an increased temperature.

Now it must, of course, be obvious that the number of electrons arriving at the anode cannot exceed the number leaving the filament,* and therefore if a larger current is desired in the anode circuit the electron emission must be increased, which can only be done by raising the filament temperature, that is, by augmenting the filament current. The curve for this increased emission is given by OADE, Fig. 2, where the maximum anode current has been increased by an amount equal to the difference between the horizontal parts BC, and DE. Still further increasing the filament current gives the curve OAFG. It will thus be seen that for each value of filament temperature (filament current) there is a corresponding value of saturation current which obtains when the anode attracts all the electrons as fast as they are emitted. It will be noted, however, that the lower portions of these curves remain substantially unchanged.

The curves of Figs. 2, as well as others which will appear in these notes, can easily be verified by the reader making a few simple experiments, and indeed all theoretical studies should, where possible, be supplemented by practical work if full benefit is to be derived.

Experiment No. 1.—Voltage Saturation Curves.

Apparatus required :—

- Filament battery.
- High tension battery for anode circuit.
- Ammeter for filament circuit.
- Milliammeter for anode circuit.
- Voltmeter for anode battery.
- Valve with suitable holder.
- Filament resistance.

It is not necessary to obtain a two-electrode valve specially for this experiment, for the grid and anode of a three-electrode valve can be connected together to act as one electrode.

The apparatus should be arranged as shown in Fig. 2A, and particular note should be taken as to how the anode voltmeter is connected. It is required to show how the anode current varies with the anode volts. The first set of readings should be taken with the filament current somewhat lower than normal so that supposing the

normal working current to be, say, 0.6 ampere, let us start with 0.4. Starting with zero volts, that is with the plug at X, the anode voltage should be increased step by step

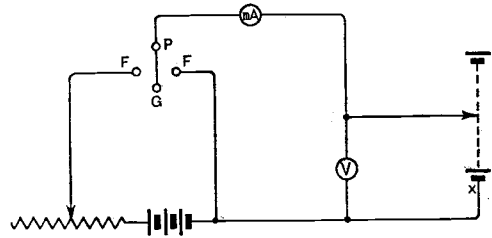

Fig. 3.

(this is easily done by means of a wander plug) and a reading of anode current as shown by the milliammeter mA taken for each setting of the anode voltage. Continue until it is found that increasing the anode voltage gives no further increase in current. The foregoing experiment will provide two sets of figures (1) anode volts, and (2) corresponding anode current, which when plotted on squared paper will give a curve of the nature of that shown by OABC, Fig. 2.

The filament current should next be increased to, say, 0.5 ampere, and the process repeated starting again with zero anode volts.

This will give the curve OADE, Fig. 2. We thus establish the fact that the emission of electrons from a heated filament varies with the temperature much the same as the rate at which a liquid evaporates varies with its temperature. The higher the temperature the faster will it evaporate, and in the same way by increasing the filament temperature we increase the rate at which the electrons are emitted and hence the available current.

Although the exact significance of the curves of Fig. 2 will be considered later, the following outstanding features may be mentioned now. In the first place it will be seen that the current through the valve does not follow Ohms Law, that is to say, the current is not directly proportional to the voltage across the tube, and secondly, the current through the valve is limited, but this limit is increased with increase of filament current.

(To be continued.)

*This pre-supposes the space within the bulb to be free from gas, i.e., the valve is what is generally termed "hard."

CALIBRATING SMALL CONDENSERS.

A simple practical method is here described for rapidly and accurately measuring the values of small condensers. The apparatus necessary can be easily set up and the capacities of a number of condensers measured quite quickly.

By F. H. HAYNES.

The Principle.

WHEN oscillations are set up in a simple valve oscillator circuit the value of the steady current passing from the high tension battery is considerably greater than that which flows when the grid is given the usual negative potential by being joined to the negative end of the filament battery, and when oscillations are not taking place. For instance, employing an "R" valve working on a filament voltage of about 4.5 for the generation of oscillations and a plate battery of 25 volts, it will be found that a current of probably less than 1 milli-ampere passes from the battery when the circuit is not oscillating, but as soon as oscillations occur this may increase to as much as 5 milliamperes. The oscillator circuit is shown in the accompanying diagram, and the beginner is reminded that it may be necessary to reverse the leads to either the plate or grid coils before oscillations are produced. Now, if the coupling between the grid and plate inductances is loosened to a point approaching that where oscillation ceases and a third coil, tuned with a variable condenser, is brought near to the grid coil, it will be observed that oscillation is stopped, and the reading of the milliammeter will fall off as the wavelengths to which the two circuits are tuned become equal. If this additional coil is critically tuned with its condenser so as to damp down oscillation in the valve circuit and a small condenser of unknown value is then connected across this tuning condenser, oscillation will be restored because this additional capacity has thrown the circuits out of tune. The value of the tuning condenser will now have to be reduced before the point is again reached where the circuits are in tune as indicated by a drop in the plate current of the valve and the

amount by which the capacity of the variable condenser is reduced is, of course, equal to that of the condenser connected across it.

Apparatus Required.

The valve oscillator can usually be set up from apparatus to hand. The inductances may be wound in the usual basket formation, or may be duolateral coils of the plug-in type. The valve should be of the "R" type, and dull emitters are, in general, unsuitable, as a more sensitive milliammeter would be required.

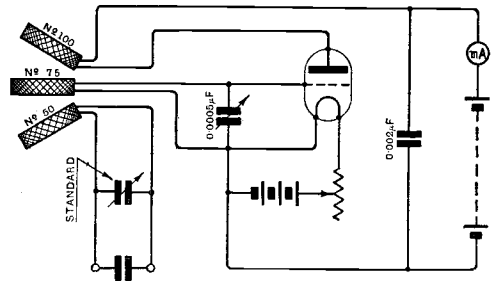

Circuit of apparatus for quickly measuring the capacity of small condensers.

The milliammeter should, preferably, have a good open scale with a maximum reading of not more than 10 milliamperes. There are many reliable ex-Government instruments to be obtained from dealers, and the writer has one with a parralax scale about 6 ins. in length, which was originally a voltmeter, but with the series resistance removed makes an excellent milliammeter, giving a full scale reading of 7 milliamps.

Other apparatus required in the oscillator circuit includes a variable tuning condenser of between 0.0005 and 0.001 mfd., the usual filament resistance, 6 volt accumulator, H.T. battery of 25 to 30 volts, small condenser between 0.0001 to 0.005 mfd.

The separate tuned circuit includes an inductance a little smaller than that used in the grid circuit of the oscillator, and a well-built variable condenser having a capacity of 0.0015 mfd. or greater. This condenser must be accurately and rigidly built up and so designed that it can be relied upon to not change in value when once calibrated.

The one shown in the photograph has air dielectric and double sets of plates giving a maximum capacity of 0.0027 mfd., and this high maximum has a great advantage in that it can be used for measuring capacities up to 0.0025 mfd., for it will be seen that the maximum capacity that can be measured by this method cannot exceed the capacity of this condenser. A pair of terminals mounted on ebonite are needed for connecting in parallel with the calibrated condenser, other condensers whose values are to be determined.

Calibrating the Standard.

By far the best course to adopt is to put a good variable condenser in reliable hands for calibration.* In this instance where the condenser is calibrated throughout the entire scale, a point is taken some few degrees from the 180 position, and is marked "0" on a new scale about to be set out. By reference to the calibration curve or chart, marks can be made on this new scale commencing

at "0" at every point where the movement of the condenser has diminished by 0.0001 mfd., continuing to a position about 10 degrees from the zero value of the condenser. The ends of the condenser scale are not made use of as the capacity variations are not uniform for a given movement of the plates at these positions. A "square

law" condenser cannot, of course, be made use of. Subdivisions of the steps of 0.0001 mfd. can be marked.

If a calibrated variable condenser is not available a standard can be set up without much difficulty. Three small fixed value condensers of reliable make should be procured, say 0.001, 0.0005, and 0.0002 mfd. The oscillator is set in operation with just sufficient coupling between its grid and plate coils to produce oscillation and give a full reading on the milliammeter. The inductance of the calibrated

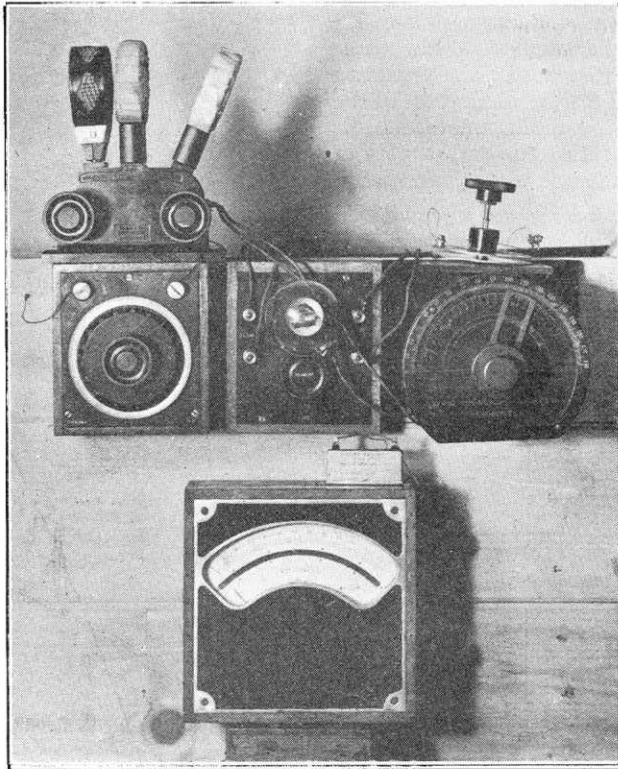

Simple condenser capacity measuring equipment. The condenser on the left tunes the grid circuit, while that on the right is calibrated and has a scale for reading capacities direct. The left-hand coil is in the plate circuit, the centre one is the grid coil, and that on the right is the tuned circuit coil. The capacity of a small circular type condenser is being measured.

condenser circuit is now moved nearer to the grid coil, while the condenser to be calibrated has its pointer at about 170, which is the point to be called "0" on the new scale. The grid circuit condenser is now rotated to a position where the reading on the milli-

*The technical staff of this Journal will undertake the calibration of condensers for regular readers without charge if sent (at owner's risk) carefully packed and accompanied by remittance for return carriage or postage and four consecutive Questions and Answers coupons which are to be found in the Advertisement pages.

ammeter falls off to a minimum. If two minimums are obtained, that is, the needle drops back as the condenser is rotated and then advances a little way, drops back again, and then advances to a full reading, it is because the grid circuit coil and the condenser coil are too tightly coupled, whilst the plate circuit coupling may be slightly reduced also, though not so far as to break oscillation.

Having reached the correct positions, the inductances and grid condenser must not be touched, and the smallest of the three condensers is connected across the standard condenser. This will restore oscillation in the valve circuit, and the milliammeter needle will advance. By rotating the dial or pointer of the standard condenser under calibration in the direction of its zero, the position will soon be reached where the milliammeter needle will drop back. When the milliammeter is at its lowest reading the setting of the condenser is marked with the value of the small fixed condenser which is connected across it. The process is repeated, using the other two condensers, taking care not to make use of the first 10 degrees of the condenser scale.

If the condenser is fitted with a rotating dial instead of a pointer, these reversed calibrations may conveniently be marked upon the plain portion of the bevel and operated with a scratch line arranged diametrically opposite to that used with the degrees scale. It might be mentioned here that a boxed up condenser calibrating instrument can be built up from this description and fitted on its panel with milliammeter, filament resistance, grid and calibrated variable condensers and a knob to give variable coupling between the grid circuit and the calibrated condenser inductance. In this instance suitable fixed coupling may be provided between the grid and plate circuits of the oscillator.

Operation.

The standard condenser is first set at zero on its calibrated scale, and the grid condenser adjusted to a position where the milliammeter reading is a minimum, though if it rotated the smallest amount in either direction the needle will immediately advance. Now, when a small condenser is connected across the standard a full reading

will be obtained on the milliammeter and the dial of the standard must be revolved to again produce the low reading on the meter. The setting of the standard now indicates the value of the condenser which is connected across it and the capacities of any number of condensers can be similarly measured with considerable rapidity. The coupling between the coils must be sufficiently loose to prevent the setting up of

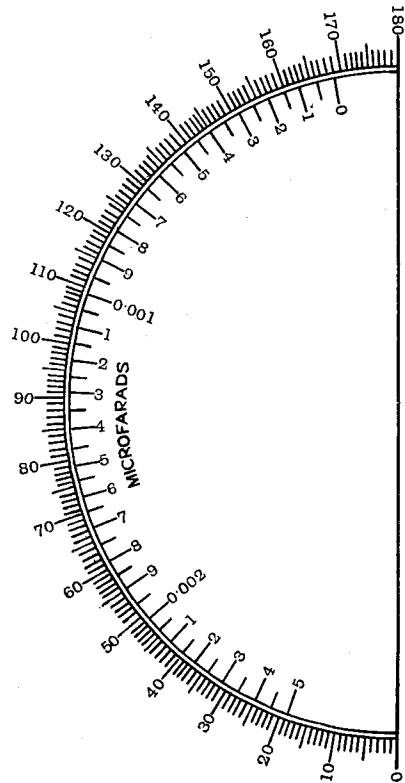

The scale of the calibrated condenser. Capacities are marked off from near the maximum end of scale, showing the reduction in value as the pointer is rotated.

two minimums as mentioned, though alternatively, of course, one might work to the small maximum which is to be found between the two minimums.

LOUD SPEAKERS FOR WIRELESS PURPOSES.*

Theory of Loud-Speaker Design : Some Factors Affecting Faithful and Efficient Reproduction.

By L. C. POCOCK, B.Sc., A.M.I.E.E.

IF it is assumed that properly amplified and undistorted speech voltage is available in the output circuit of a final amplifier, the problem is to procure the reproduction of speech efficiently and faithfully. The exact criteria for the reproduction of speech are better known than for music, but it is probably safe to say that a system capable of reproducing speech perfectly will give a highly satisfactory performance with music.

If V is an impressed voltage of any frequency or amplitude within the region to be amplified without distortion, and P the resulting alternating air pressure outside the system, the conditions are :—

$$P = AV$$

where A is an efficiency constant independent of the frequency and amplitude. It is also necessary that there shall be no asymmetric distortion, that is, any single frequency V must produce only the corresponding single frequency P . This condition is also expressed by the equation above.

Present-day electromagnetic loud speakers are, without exception, a compromise between relatively good efficiency and good quality, such efficiency as can be secured being obtained only with the aid of mechanical resonance, which is contrary to the criterion for faithful reproduction given above. Further, although telephonic speech has generally been handled in the past as a steady-state problem, recent improvements in transmission have rendered the transient phenomena associated with consonant sounds and every change of amplitude of some importance. The reproduction of severe transients cannot be perfect in any resonant system or in any system containing mass and stiffness, even though the damping be such as to prevent any natural oscillation; the severity of transients actually encountered in speech is dependent on the damping of the vocal resonances, and information on this subject, together with like information on the auditory mechanism, might indicate the desirable degree of damping from the point of view of transient phenomena. It is clear that the use of resonance to increase the efficiency cannot be pushed too far.

Practical loud speakers consist of a rather sharply resonant system working into an acoustical load, namely, a horn. It is not quite accurate to describe the horn as a load, because the useful work is the energy transmitted through the horn. The horn is operating in a capacity analagous

both to an electrical transformer and to an electrical transmission line. The likeness to a transformer is seen in the passage of energy from the high mechanical impedance of the diaphragm to the low impedance of the open end through a coupling device, which reduces energy reflection to a minimum and aims at obtaining the greatest possible transfer of energy. The likeness to a transmission line lies in the propagation of waves across the non-uniform section of the horn; the

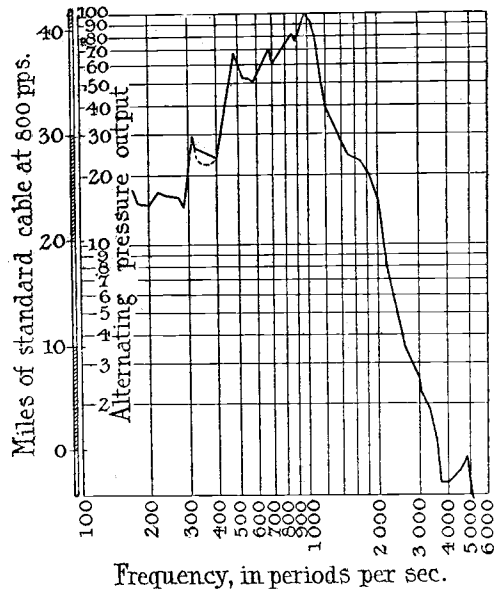

Fig. 1. Alternating pressure output of loud-speaking receiver corrected for impedance of circuit and receiver. Average of five receivers.

analogy is to a non-dissipative line containing distributed inductance and capacitance, the line constants changing steadily from end to end of the line in such a way that the impedance measured at one end of the line is high, and that measured at the other end is low. Such a system would form a maximum energy coupling between two different impedances.

The acoustical impedance of a horn at its small end depends a good deal on the cross section and also varies with the solid angle and the form of the horn, but, as in the electrical analogies, the

* An abstract of the Discussion on Loud Speakers for Wireless and Other Purposes, at the Institution of Electrical Engineers, November 29th, 1923, (Joint meeting with the Physical Society).

impedance is also a function of the impedance into which energy is delivered, *i.e.*, at the open end. Another view of the acoustical impedance at the small end is to regard it as the impedance of the large end modified by the horn through which it is measured. In general, the horn impedance also varies with frequency, and, though horns of approximately uniform impedance can be made, it is clear, from a consideration of the varying mechanical impedance of the diaphragm, that such a horn is not necessarily the best.

These are some of the factors which enter into the performance of a horn. The practical considerations are usually those of size; for indoor use the horn must not be too long, so that the problem is equivalent to attempting to obtain an electrical line of length equal to a wavelength or less and having a very much higher line impedance measured from one end than when measured from the other end. The acoustical impedance is virtually coupled to the diaphragm, so that some idea of its variations with frequency can be obtained by observing the motional impedance of the receiver. A large number of horns, of a size suitable for use in private houses, have been examined in this way, and resonances of varying degree have been found in all; larger horns might, however, be expected to show lesser effects.

The resonance of a receiver without horn may be such that the diaphragm vibrates with more than 50 per cent. of the amplitude at resonance over a frequency region about 100 periods wide. When the horn is put in place, the diaphragm is made to do more work and the resonance is made much less sharp. The new damping co-efficient cannot be simply expressed, because the resonance is no longer simple but is complicated by the coupled horn resonances.

The actual pressure variation in the air when the receiver is excited at different frequencies can be measured. Figs. 1 and 2 show the characteristics of two types of receiver. The curve in Fig. 1 is for a flexible diaphragm driven by a small armature supported on a spring. The effective moving mass is not appreciably greater than that of the ordinary telephone receiver. The curve is an average of the results of five receivers and shows definite peaks in the lower frequency region, due to the horn. It is seen that the distortion due to these resonances is small compared with the general effect, due to the mechanical resonance of the system. This is an important point: horn distortion can be brought within reasonable limits; the receiver mechanism is often responsible for defects of tone for which the horn is blamed.

In connection with Fig. 1 it may also be stated that the perfection of reproduction is a great deal better than the appearance of the characteristic would suggest; the contracted logarithmic scale disguises the really rather gradual fall of the curve at the higher frequencies; even at the extreme end of the curve the highest frequency shown is reproduced with sufficient intensity to add greatly to the quality of reproduction.

Fig. 2 is the characteristic of a loud speaker of the iron-diaphragm kind, similar in principle to the ordinary telephone receiver; in this case the curve is an average of several tests taken on the same receiver. The frequency of maximum response is seen to be a little lower than in Fig. 1

and the curve drops somewhat steeply between 1,000 and 2,000 periods per sec. (p.p.s.).

In both the above cases the receiver output is corrected for the impedance of the associated amplifier, that is, a fixed voltage is operating on the loud speaker through a fixed resistance representative of the amplifier output impedance that would be suitable for use with the receiver considered. Since the impedance of most receivers at about 4,000 p.p.s. is two, three or more times as great as the impedance at 1,000 p.p.s., the reproduction of the higher frequencies is somewhat impaired due to this cause.

Receivers have been constructed in which large vibrating surfaces are used without a horn. It appears that the vibrating surface must be of such dimensions that there is difficulty in securing the necessary lightness of the moving parts, especially when the added mass, due to the reaction of the air, is taken into consideration. In any case, the very important distortion due to the use of mechanical resonance to obtain good efficiency remains in evidence.

With regard to the mechanical construction of an electromagnetic receiver, the ordinary construction of a telephone receiver requires considerable modification if it is to handle more than

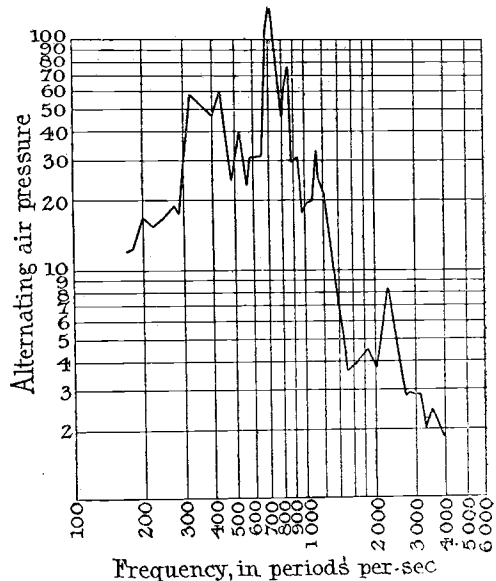

Fig. 2. Alternating air-pressure variation with frequency for large receiver when used with constant e.m.f. in a circuit of which the output impedance is 1,000 ohms.

a very small amount of power and, even when so modified, there is danger of distortion due to the asymmetrical forces called into play by the passage of symmetrical currents. A receiver of the type giving the characteristic shown in Fig. 1 is capable of handling about 10 watts without asymmetrical distortion, because the armature is driven by symmetrical forces. The amplitude of vibration may be of the order of 0.01 in.

To sum up, with the present-day constructions of receivers, faithfulness in reproduction cannot be obtained beyond a certain degree without making receivers very inefficient. Reproduction can, by careful design, be made very satisfactory, but to obtain the very last degrees of perfection, *e.g.*, by filters, enormous increases in the power amplification would be necessary to operate the receiver, in fact, valves of far higher power capacity than are used in any radio receiving sets. As it is an easy matter to obtain the present amount of amplification it is seen that the chief interest in raising the efficiency of loud speakers is to permit the application of quality-correcting devices, provided of course that increased efficiency is obtained without sacrifice of quality.

With regard to the overall efficiency obtained in loud speaking receivers, it is probable that 1 per cent is a high estimate and that a few tenths of 1 per cent. would generally be nearer the mark. The principal loss is iron loss, and (though lamination will reduce this) hysteresis still accounts for a very considerable loss on account of the high frequencies concerned. It does not seem likely that any great improvement in real efficiency can be obtained unless a magnetic material with exceptionally low hysteresis loss and good permeability is discovered. Small improvements are possible by building receivers on a larger scale and using more powerful magnets, but the necessity of making some part of the moving system of iron and of low mass makes the employment of high alternating flux density in this vital part unavoidable.

The Sources of Distortion in the Amplifier.

By Professor C. L. FORTESCUE, M.A., M.I.E.E.

1.—SCOPE.

In this note the output P.D. from the rectifying valve or crystal is taken as the starting point. With an ideal amplifier this P.D. is magnified and a current of precisely the same waveform as the output P.D. from the rectifier is supplied to the loud speaker. In many actual amplifiers, however, the waveform is not faithfully reproduced and distortion is introduced.

2.—THE CAUSES OF INACCURATE REPRODUCTION.

These may be put under the following headings:—

- (a) Curvature of the valve characteristics.
- (b) The use of intermediate circuits having more or less clearly defined natural frequencies.
- (c) The unavoidable reaction effects present in most designs of note magnifiers.
- (d) Unsatisfactory reproduction in the last (or output) transformer.

3.—THE EFFECTS OF CURVATURE OF THE ANODE CURRENT CHARACTERISTICS.

(a) *Resistance Amplifier.*—The ideal resistance amplifier is as shown in Fig. 1, and consists of a valve with a non-inductive and capacityless resistance, R_a , in series with the anode and a condenser of very large capacity across the battery terminals. The valve characteristics may be conveniently plotted as a characteristic surface in terms of V_b and V_g , allowance being made for the resistance R_a .

The surface shown in Fig. 3 is the ordinary characteristic surface, the lines corresponding to constant anode current, but allowance is made for a series resistance of 10,000 ohms. The fluctuations of the grid P.D. above and below the main value may be plotted below the diagram of Fig. 3 as at G. Then, by projecting up to the line PQ, corresponding to the given value of the battery

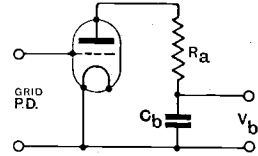

Fig. 1. Resistance amplifier.

voltage, the values of the anode current can be plotted above and below the mean value at C. A reference to Fig. 3 shows that the anode current waveform can only be an exact replica of that of the grid P.D. when the constant current lines are equally spaced along the line PQ. Thus, if the surfaces are plotted out for any given value, the possible range of anode current and grid voltage over which faithful reproduction can be obtained will be easily seen and the appropriate values of V_{g0} and V_b can be chosen. The values taken in plotting Fig. 3 are $V_b = 200$, $V_{g0} = -4$. The amplitude of the fluctuations of V_g is 3.5 volts and of i_a , 1.75 mA.

(b) *Transformer Amplifier.*—Except in the last stage, a transformer in the anode circuit should closely approximate to a resistance. When very heavily damped, due to its own losses and the load of the valve, and when near the resonant point, this is actually the case. The effective resistance to the alternating P.D.'s (which are the ones under consideration) is, however, very much greater than the resistance of the anode winding as measured by direct current. The resistance must be ascertained by A.C. bridge methods at the resonant

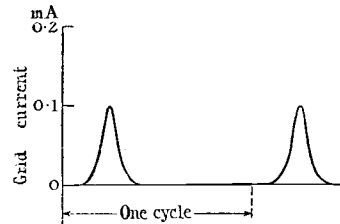

Fig. 2. Wave form of grid current with conditions of Fig. 3.

frequency. Some transformers having a direct-current resistance of the order of 2,000 ohms are found at the resonance point to have effective resistances of 200,000 to 300,000 ohms when loaded on the secondary side with resistances corresponding to the resistance of the next valve. The representative characteristic surfaces must therefore be plotted for this high value of R_a and not for the D.C. resistance; the latter is only used to obtain the effective starting-point for any actual battery voltage.

For frequencies other than the resonant frequency of the transformer the conditions are more complicated, and merely plotting the characteristic surface with a correction for a series resistance is insufficient. The surface must be plotted without correction and both the grid and the anode fluctuations must be allowed for. The line PQ of Fig. 3 becomes a curve—an ellipse in the case of two pure sine waves—and so long as this curve remains within the zone where the constant-current contours are equally spaced the reproduction will be satisfactory.

4.—EFFECT OF CURVATURE OF THE GRID CHARACTERISTICS.

If the grid voltage fluctuations have any considerable positive values the grid currents will be quite appreciable, and the waveform of the grid current will differ very widely from that of the grid P.D. Fig. 2 shows approximately the curve of grid current corresponding to the conditions assumed for Fig. 3. The grid currents will generally react on the source of P.D. and lead to a change of waveform somewhat in the same way that the waveform of the E.M.F. of an alternator is dependent upon the waveform of the current which it is supplying.

The only way of avoiding this difficulty is to render the effect of the grid current negligible. Valves have not yet been produced in which the grid current is negligible when the grid is positive and the anode voltage low, and consequently positive values of the grid voltage must be avoided. This gives another limitation to the range of the anode current characteristic curves that can be used, and indicates that the anode battery voltages should be high, and that the mean grid voltages should be considerably negative.

5.—EFFECT OF THE NATURAL PERIOD OF THE INTERMEDIATE CIRCUITS.

This trouble arises in the case of a transformer amplifier. In the first place any marked resonance means that the effective impedance in the anode circuit is dependent upon the frequency. The impedance—and therefore the amplification—will be greatest at the resonant frequency. Thus any sustained harmonic having this frequency will be unduly pronounced and the speech will appear "tinny" or "drummy," depending upon the pitch of the accentuated harmonic. The larger the number of stages of amplification that are used, the more marked is the effect.

In the case of those high frequency components which are not sustained, the effects are less pronounced. This effect is thus most noticeable with musical sounds and with the vowel sounds. Secondly, for frequencies other than the resonant frequency, the transformer is no longer equivalent to a resistance, and complications arise from the relative phase of the grid and anode potential fluctuations on account of which it becomes very difficult to determine the waveform of the anode current when the amplitudes are fairly large.

6.—REACTION EFFECTS.

These effects are well known, particularly in high frequency amplifiers used as self heterodynes. They are equally important, however, in note magnifiers, as is shown by the tendency of a high-power magnifier to "howl" when adjusted for maximum amplification. This reaction effect is greatest in transformer amplifiers and is attributable to the capacity between the electrodes of the valves. The coupling between consecutive grid and anode circuits tends to produce stability and decreases the effective amplification. But where more

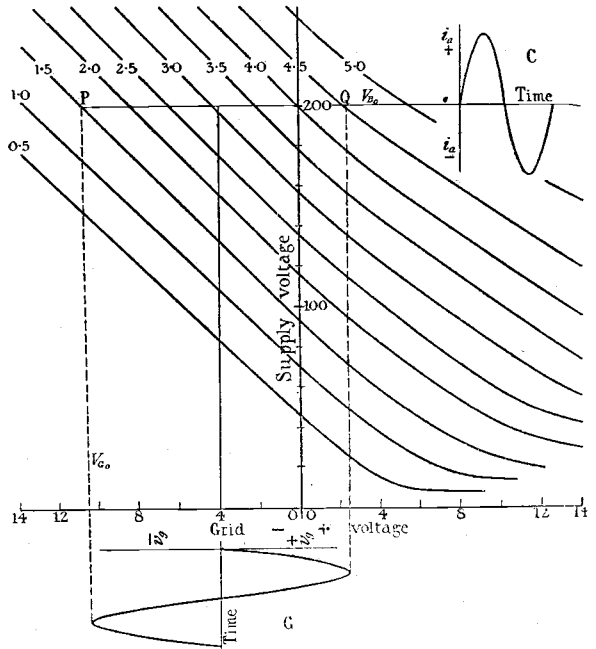

Fig. 3. Characteristic surface.

than one stage is employed there is also a coupling between a grid circuit of one valve and the anode circuit of the valve next but one to it. This coupling acts through the two valve capacities in series, but if the voltage step-up per valve is more than two the coupling effect tending towards instability is greater than that from the immediately adjacent anode circuit opposing instability. With three valves the effect of the last anode circuit on the first grid should be in the direction of stabilising but on the second grid circuit it may well produce instability.

The effect of this reaction is that with sustained waves the frequency which renders the system most nearly unstable attains to a higher amplitude, relatively, than other waves of other frequency.

It seems probable that there are in general several frequencies which are thus accentuated, but owing to the similarity of the consecutive stages in most amplifiers these frequencies are close together and are usually near the natural

resonance point. The resulting effect is thus an accentuation of the defects arising from marked resonance.

The pure resistance amplifier is not entirely immune from the effects of reaction unless the condenser across the anode battery is of very large capacity indeed. Under certain circumstances, also, if the capacity across the anode resistance is appreciable, a resistance amplifier will "howl" owing to an oscillation being set up in the same way as in the "Kallirotron."

7.—DISTORTION IN THE LAST STAGE.

The last stage is not infrequently a source of serious trouble for two reasons:—

- (i) The amplitudes are large.
- (ii) The "load" on the output transformer, viz., the winding of the loud speaker, is inductive and this inductance is not constant.

With regard to (i), the output required for a sustained musical note is of the order of 10 mA (R.M.S.) at 5 volts (R.M.S.). To give an equivalent volume of sound with ordinary speech a peak of perhaps double these figures will be necessary, and after allowing for the losses in the transformer it seems that the output from the anode circuit of the last valve will be equivalent to an alternating current of peak value 30 mA at an alternating P.D. of peak value 15 volts. A transformer is almost invariably used and the actual values would more

probably be 10 mA at 45 volts. This involves a valve giving an emission current of perhaps 50 mA with a fluctuation of anode current over the range 15 to 35 mA; and a voltage at the anode of perhaps 120, fluctuating between the limits of 75 and 165. General numerical considerations such as these show the necessity for valves of considerable output in the last stage.

High battery voltages are also necessary—in the above case the steady fall of P.D. in the anode circuit would be of the order of 50 to 100 volts, and a battery giving something in the neighbourhood of 200 volts would be unavoidable.

With regard to (ii), owing to the inductive nature of the load the last stage cannot be regarded as being even approximately a resistance, and the same effects are noticed as with a transformer operating out of resonance.

8.—CONCLUSION.

With properly designed valves and circuits it does not appear that any serious distortion can be charged against the amplifier. Valves giving considerable power output must, however, be used in the last stage.

Some resonance effect seems unavoidable in the transformers and may be accentuated by reaction. The presence of this effect may, however, be an advantage owing to the fact that it can be used to some extent to compensate for defects in other parts of the equipment.

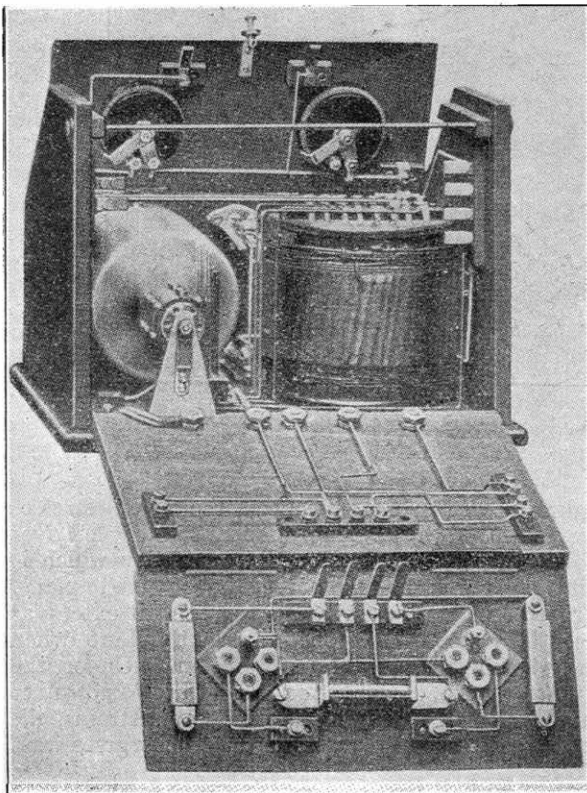

A Useful Feature in Receiver Design.

When building a compact receiving set it is often difficult to arrange for all component parts to be easily accessible. The method by which components are secured to several of the internal faces of the box permits of easy inspection though suitable connections must be fitted. A receiver employing flexible connections was described recently, whilst the set shown in the accompanying illustration makes use of spring contacts. This is a very good scheme and should appeal at once to those designing their own sets. This receiver is built by the German Kramolin Company.

A HIGH POWER WIRELESS STATION WITHOUT MASTS.

A NEW high power wireless station is under construction between Kochel and Walchen in the south of Munich.

Taking into account the fact that the costs for the construction of the antennæ masts represent by far the largest expenditure for the equipment of a high power station, the engineers have tried to make use of the natural altitudes in the mountains for this

conditions for the earthing equipment. Referring to the illustration, a rope has been placed between the Herzogstand and the "Stone," at the very middle of which, namely, at an equal distance of 1,300 metres, the supply main to the station is fastened. In order to guard against the rope breaking when subjected to hoar-frost or to the pressure of the wind, provision has been made at the Stone for a special

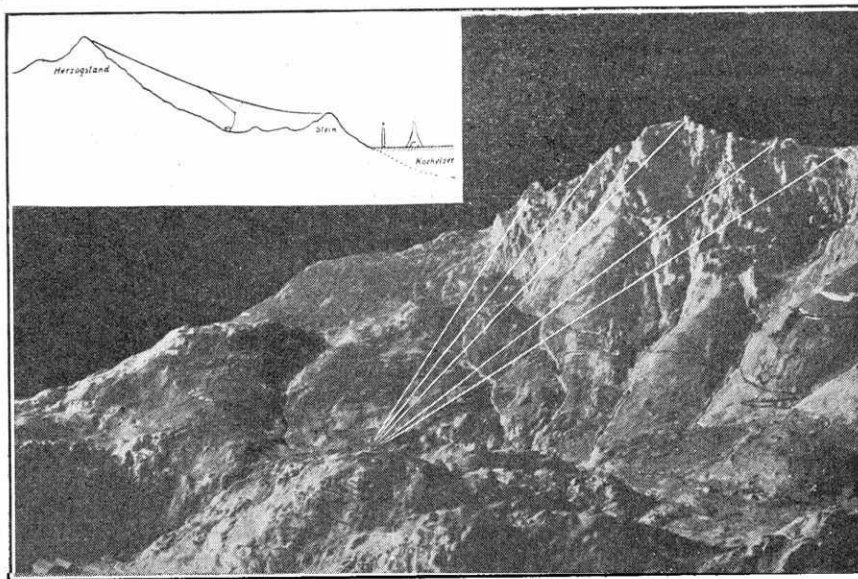

Illustrating the antennæ system of a new high power wireless station under construction between Kochel and Walchen, in the south of Munich.

purpose. The Herzogstand, with a height of 1,732 metres, situated in the north-west of the Walchen Lake, is very precipitous towards the north. In an easterly distance of 2.6 kilometres the ground rises to a height of 940 metres at the Kochel Lake. Between these two points there is rather swampy ground—the Jochbach Dale—in which the station has been erected, for here in this valley are the most favourable primary

device which balances the large stresses in the rope. The rope is insulated, led over a roller, and fastened to a trolley which is running on rails over an inclined plane. This trolley is loaded to such an extent as to keep the rope sufficiently taut when subjected to normal tension. Under the effects of wind or hoar-frost, known to sometimes produce considerable strains, the rope slackens down as the trolley gives way.

The illustration indicates at the right-hand over the level of water the heights of the Eiffel Tower and the Nauen Station, so that it is quite evident what great economy is made with regard to the height of antennæ by the construction and utilisation of mountain antennæ.

Extensive measurements made have proved that especially with one type of antenna (the so-called "L" antenna), very good results have been obtained. It has also been proved that large stations can be constructed without the use of masts, but making use of the different altitudes of the mountains. With the use of a high voltage for the antennæ, even larger ranges may be obtained than those produced by the usual type of station. One rope alone is, however, not sufficient for a large station of this sort, but several ropes, about four or five, are needed. Their arrangement can be seen in the photograph. The whole aerial equipment has a span of more than $2\frac{1}{2}$ kilometres, and a free height of about 300 metres. The easy accessibility of the top of the Herzogstand represented a great advantage. A highway makes good communication with the staff quarters erected at an altitude of 1,575 metres. Another decisive factor in the choice of the site for the radio station was the vicinity of the huge power station of Walchen Lake, which is said to have an average output of 168,000 h.p., and which can easily supply a main wireless station with sufficient power without impairing its general current output. The power station obtains its power from a 200-metres fall of water. Such a power station is well able to supply energy much more cheaply than works making use of coal for the generation of electricity.

It is intended to equip the station with a Lorenz-Poulsen generator of about 2,000 Kw., as well as with a Lorenz high frequency machine of the same output. The production of high frequency currents by machines will be effected directly or by means of a frequency transformer. Thus either system may be used, according to the needs of the moment. With this arrangement there is the possibility of making use of long wavelengths for very long distance transmissions, and on the other hand, of using shorter wavelengths for short distance transmissions.

The American Amateur Station 1 MO.

IN recent issues we have described the amateur transmitting stations of Mr. J. A. Partridge (**2 KF**) and Mr. F. L. Hogg (**2 SH**), who have conducted two-way working with the American amateur station **1 MO**. The following particulars of **1 MO** are of special interest.

The aerial of **1 MO** is of the inverted L type. The flat top section is 81 feet long, and consists of a cage of six wires of No. 14 enamelled wire 15 ins. in diameter. The far end is supported by a 72-ft. mast. The near end is supported by a mast on top of the house, making it about 45 feet above the ground. The lead-in is a six-wire cage about 6 ins. in diameter, and 46 feet long. The total length of the antenna from the near to the far end is about 127 feet.

A counterpoise is used, and consists of six wires, caged to a diameter of 15 ins. for 50 feet, the remaining section being fanned slightly to increase the capacity. The total length of the counterpoise is 85 feet and it is supported about 8 feet above the ground.

A Hartley circuit, slightly modified, is used. Two series condensers, each of $0.00043\mu\text{F}$ are connected, one in the antennæ and the other in the counterpoise. Both condensers are adjusted at the same time, by one control.

The wavelength of **1 MO** is about 192 metres. The range of wavelengths permitted under the present licence is 176/200 metres. The wavelength can be changed instantaneously, and while the set is in operation. When there is a lot of interference on 192 metres, **1 MO** shifts his wavelength down to 176 metres. On 192 metres the aerial current is 5.6 amperes; on 200 metres, 6.4 amperes. The normal plate current is about 300 milliamps, with about 1,250 volts. Four 50-watt valves are used, two on each half of the cycle, self-rectified and unfiltered at present.

For receiving, a separate single-wire aerial 150 ft. long and 20 ft. high is used.

The receiver is in operation while the transmitter is being used, similar to a break-in system. The receiver is calibrated quite accurately, and it is an easy matter to take a reading of the wavelength of any transmitter.

AERIALS AND EARTHS.

A POPULAR TALK BROADCAST RECENTLY FROM 2LO.

By HUGH S. POCOCK, Editor.

IF only one could have wireless without the bother of putting up an aerial," is a remark which must have been made by thousands of people when they first began to realise the possibilities which a wireless set could provide. The erection of the aerial may present some difficulties, but the object of this short talk this evening is to point out how very important an item, in the efficiency of the receiver as a whole, is the aerial and the earth system. It is often stated that, with modern valve apparatus, an inefficient aerial and earth system does not matter, for the reason that the addition of an extra valve or two, or a little more reaction, will easily compensate for any loss in signal strength. It may be so, it is true, but there is something of far greater importance in wireless reception, particularly of telephony, than strong signals. In telephony reception the first aim should be to obtain purity and good quality. The next most important point, both in the reception of telephony and morse transmissions, is selectivity.

It is a simple matter for anyone who cares to spend money enough on valves and additional apparatus, to get strong signals, but of what use is this if the speech is unrecognisable, and if, through absence of selectivity in tuning, you find that your

reception is interrupted at frequent intervals by other transmissions which, *because* of your flat tuning, appear to you to be on exactly the same wavelength.

I feel sure that a good many people do not realise that the aerials and earths have any connection with quality of reception and freedom from interference, and consequently they may be blaming the set for inefficiency when all the while it is the aerial and earth which are responsible.

Let us consider first of all the question of selectivity. For those who do not read any wireless paper, and have not studied how their wireless set works, it should be explained what is meant by "selectivity." (Your *Radio Times* does not tell you these things because that publication is not intended to be a technical one.)

A selective receiver is one which, for any given adjustment of the inductance and capacity values (obtained through regulating the controls) only responds to transmissions over a very narrow band of wavelengths. The wider the band of wavelengths, the flatter is the tuning, and the greater is the probability that there will be stations working within this band which will cause interference.

Now, apart from the receiver itself, one of the most serious causes of flat tuning

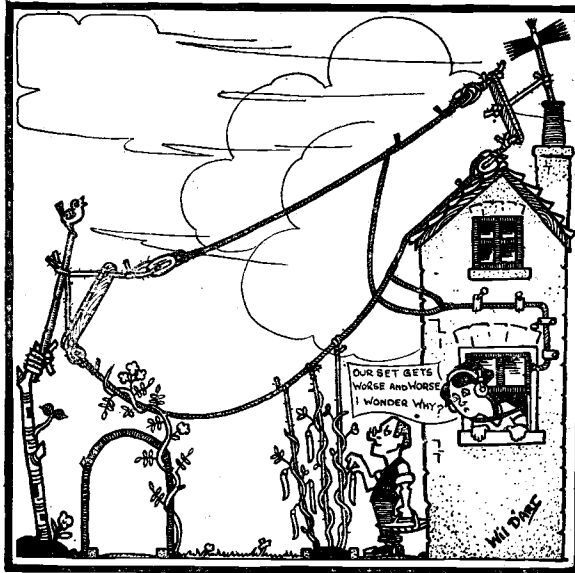

Some aerials are far from ideal.

will be found to be due to the presence of stray capacities which are produced in the aerial and earth leads through proximity to buildings, house walls and so on. The ideal aerial would be one where the aerial wires and the lead-in did not come within several feet of any building or trees until the point where the aerial terminal of the receiver is reached. If you think about this you will realise how far from ideal is that aerial your neighbour has put up which is just about a foot above the roof, with a lead-in fastened down the side of the house and, after entering the window, is brought round the side of the room before it reaches the set. Yet there must be hundreds of aerials in existence where just as little attention is paid to theoretical considerations.

In putting up an aerial one must of course remember to keep it within the limits as regards length which the Postmaster-General authorises. This limit is 100 feet for a single or double wire aerial, the dimensions being intended to include the down lead from the aerial to the receiver.

The next point is that the aerial should be as high as possible and kept well out of the way of buildings and other masses, such as trees. If a long aerial would have to run close to such obstacles, it is far better to employ a rather smaller aerial instead.

Next, see that your lead-in goes straight to the set instead of wandering about and getting lost on the way. Remember that there are only two possible points to which the lead down to the aerial should be connected to the aerial wires. Either the lead down should be taken from the exact centre, or from one or other of the extreme ends. That is, connect the extreme end up

against the insulator or else the true centre.

Now, very much the same remarks may be made about the earth. The earth lead should be as direct as possible from the earth terminal of the set to the earthing point. If the earth lead touches anything on its way to the earthing point, it should be insulated just as carefully as you insulate your aerial from points of contact. As to the earth itself; for reception, the water main is usually quite satisfactory, but care should be taken that a good connection is made to the water pipe, and that it is at a point as near as is convenient to

where the water main enters the house. Where connection to a water pipe is not possible, the alternative is to bury a metal plate in moist ground at a depth of a couple of feet with the earth wire soldered to the plate to ensure good contact.

I have not explained so far how attention to the efficiency of the aerial and earth can help in giving good quality in reception, and I think I still have just time enough to get this in.

Valves and the apparatus which goes to comprise their circuits are intended to amplify the energy which the aerial picks up. The only exception is the valve used as a detector, and this too amplifies at the same time. Perhaps, however, you may be using a crystal for detection, which of course does not amplify. Now practically every stage of valve amplification produces a certain amount of loss of quality, especially in the low frequency stages, after detection. Since this is so, it is obvious that the less amplification we employ, the better will be our results as far as quality goes, and this undoubtedly is the case. To avoid unnecessary amplifica-

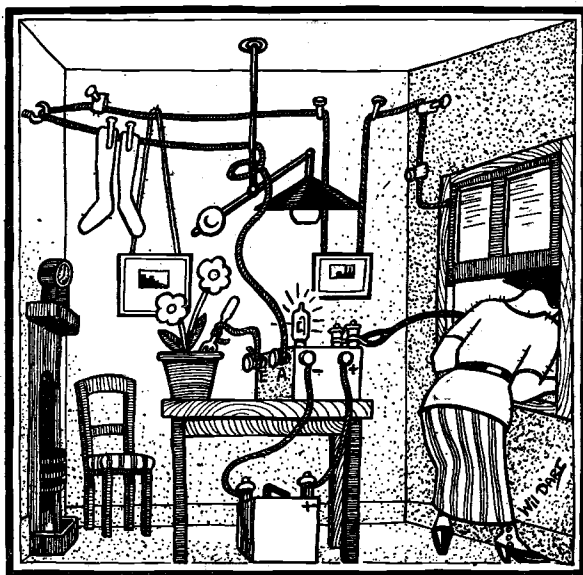

Where the lead-in trails round the room in search of the aerial terminal of the receiver.

tion then, we must make our aerial as good a collector of energy as possible, and assure ourselves that no losses take place owing to such causes as bad insulation. This shows the fallacy of the suggestion that it is quite satisfactory to make up for a bad aerial by adding an extra valve or two, or worse still by using a large reaction coil, for apart from the fact that extra attention

to the aerial costs you only a little more time and care at the outset, the extra valve or valves means a greater expense, and more trouble to maintain.

In conclusion, my advice is to pay particular attention to your aerial and earth if you are not fully satisfied with your present results, and do not blame your receiver until you have done so.

PATENT ABSTRACTS.

The Filament Resistances.

In Patent Specification No. 201,088 (C. V. Norris) is described an arrangement consisting of a valve socket around which is secured the filament resistance. The arrangement is shown in Fig. 1, and is self-explana-

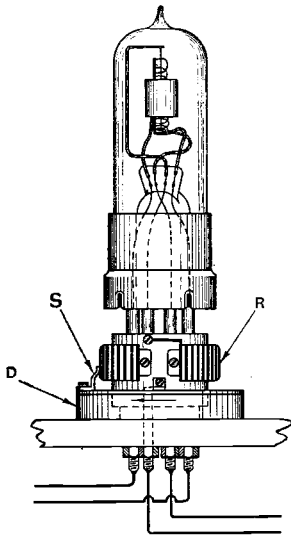

Fig. 1.

tory. The filament resistance is marked R, and the sliding contact, S. As piece D is revolved, the length of resistance wire in circuit is varied.

Crystal or Valve Rectifiers.

It is useful to be able to employ a crystal rectifier in place of the valve rectifier, in the event of the latter failing to function without disturbing circuit connections. An arrangement is shown in Fig. 2.* Here the circuit is as usual, but a switch is connected between the anode circuit and positive H.T. The valve rectifier is connected in the usual manner, but if it fails, a crystal rectifier connected with a valve socket may be plugged in the holder in the place of the

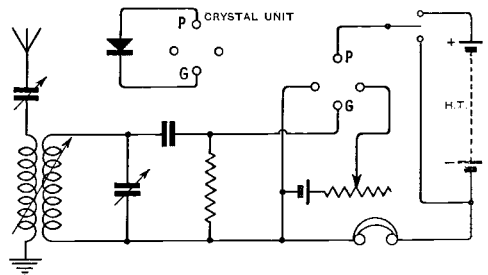

Fig. 2.

valve. With the switch moved down (to negative H.T.), the receiver functions as an ordinary crystal receiver.

Instead of using the switch as a separate unit, a method is described of fixing a switch to the valve holder, so that by the insertion of the socket connected with the crystal the switch is operated.

W.J.

* British Patent No. 185,102.

The Radio Society of Great Britain.

REPORT OF THE ANNUAL GENERAL MEETING.

THE Annual General Meeting of the Radio Society of Great Britain was held at the Institution of Electrical Engineers, Victoria Embankment, London, on Wednesday, December 19th, the President, Dr. W. H. Eccles, F.R.S., in the Chair.

The minutes of the last annual general meeting were read and confirmed.

The President, addressing the meeting, said:—

The next business is the award of the prizes which were offered by the President and Committee of the Society for the best apparatus constructed by amateurs who were members of affiliated societies, and shown at the recent all-British Wireless Exhibition. The first prize has been awarded for a set shown by the Woolwich Radio Society, the constructors being Messrs. Beeson and Everett. These gentlemen have selected sets of Brown head telephones. The second prize is awarded to Mr. Cox, of Sydenham Radio Society, who exhibited a condenser and coils, and he has selected a G.E. converter. The third prize has been awarded to Mr. Horstbury, of the Maidenhead Wireless Society, who exhibited another receiving set, and he has chosen a box of crystal detectors and valves. I should mention that the set which the judges thought the best was that sent by the Kensington Radio Society, and constructed by Mr. J. H. Reeves. Mr. Reeves, however, being a member of the Committee at the time, having been co-opted by us, preferred to forego the prize under the circumstances. It was a very generous offer on his part. The schools exhibits were of extreme interest, and the one that was thought to be of outstanding merit was a siphon recorder sent in by the Mill Hill School by Mr. John Catesby. (*The prizes were awarded amid applause.*)

The Hon. Secretary then read the annual report for the year ending October, 1923.

The Annual Report last year foreshadowed the change of name from the Wireless Society of London to the more comprehensive title of the Radio Society of Great Britain, which is more in keeping with the enlarged scope and increasing country and foreign membership of the Society during recent years.

The Society has been fortunate in having Dr. W. H. Eccles, F.R.S., in the Presidential Chair this year. The ever-increasing work of the Society has been under his close supervision, and the Committee have found his advice and guidance of the greatest value during this critical year—the tenth of the Society's existence.

The advent of broadcasting in this country which took place in November, 1922, had, as may be expected, an immediate effect upon the activities of this Society.

Those holding transmitting licences immediately found their times of working curtailed, and two or three special meetings of transmitting amateurs

were convened by this Society and self-imposed rules and restrictions agreed to.

Negotiations have taken place with the Post Office with regard to the wavelength band available for amateur transmitters, and Dr. Eccles, our President, was invited by the Postmaster-General to sit on the Committee appointed to consider the broadcasting situation. His efforts on behalf of the experimenter were evidenced in the subsequent report. Mr. A. A. Campbell Swinton, Past President of this Society, was elected to appear as a witness for the Society.

Broadcasting brought in an entirely new body of wireless enthusiasts eager to begin the study of the science. To provide for these the grade of Associate was formed at the beginning of 1923. Six lectures of an elementary nature were delivered in the first session.

Arrangements were also made during the year for members of the Committee and other members of the Society to lecture before Affiliated Societies. Unfortunately the demand for lecturers has greatly exceeded the supply, and it is hoped that in future years more members will offer their services.

The Transatlantic Tests this year were carried out with great enthusiasm by a few members of the Committee, headed by Mr. P. R. Coursey, and it is satisfactory to record that the station of the Radio Society of Great Britain specially erected at Wandsworth for this purpose was reported as being received clearly in America on at least four nights of the test.

A competition was arranged for the best set using the Armstrong super-regenerative circuit. The first prize of £15 was won by Mr. Cowper, and the second prize of £10 went to Mr. G. P. Mair.

The Fourth Annual Conference of Affiliated Societies took place on January 24th, 1923, under the Presidency of Admiral Sir Henry B. Jackson, the retiring President. The Affiliated Societies represented directly or indirectly were 120, and at the close of the year under review no less than 180 Societies were affiliated.

This year has seen a rules sub-committee almost in constant session, busy reframing the constitution of the Society and its relation to the Affiliated Societies. It is intended to have the new constitution ready to put forward at the next Annual General Meeting in December. The services of Mr. H. Levy, Honorary Solicitor to the Society, have been frequently made use of, and we are indebted to him for his assistance.

In order to get the view of the Affiliated Societies voiced at our committee meetings, representatives were invited to attend. Three country and three metropolitan representatives have attended and been of great assistance in drafting the new constitution as it affects Affiliated Societies.

The social events this year included the Annual Dinner held at the Waldorf Hotel when about 60 were present. This being held on the same day

as the Annual Conference and Presidential Address, makes it possible for our country members and delegates from Affiliated Societies to attend.

A most enjoyable excursion took place in July, when a visit was paid to The General Electric Company's Laboratories at Wembley and the Northolt Wireless Station, thanks to the courtesy of the General Electric Company and the General Post Office respectively.

An innovation during the autumn session has been the holding of informal meetings, at which discussions have taken place on matters of general interest to experimenters. These have been exceptionally well attended, and it is hoped that they will be continued now regularly each month, in addition to the ordinary more formal lectures of the Society.

During this session the Committee elected Sir Wm. Noble to be a Vice-President of the Society, and he has accepted.

The Schools Radio Society, which owes its inception to Mr. J. Hibberd, and was formed to bring together elementary, secondary and public schools interested in radio work, was accepted as a section of the Radio Society of Great Britain.

The British Wireless Relay League, comprising some 30 or 40 transmitting experimenters, merged its identity in that of this Society, and the newly-formed transmitters and relay section have taken over its membership.

The membership of this Society at the beginning of the period covered by this Report was 511, and is now 723.

LESLIE MCMICHAEL,
Hon. Sec.

On the motion of the President, seconded by Mr. Child, the report was adopted without discussion.

The Hon. Treasurer's Statement was next made, as follows:—

The present account is for the tenth year of the Society's existence, and is in the usual form of a cash statement, showing the actual items of income and expenditure.

All creditors have been paid up to September 30th last, on which date the books were closed. There are no liabilities outstanding, and with the exception of a small amount of furniture, instruments and stationery, the assets of the Society are entirely in cash at the bank.

For the information of members, I desire to explain that the item for printing, distribution of Journal and Notices, includes the cost of duplicating, addressing, and posting of publications issued by the Secretary, and that the actual cost of the Journals issued this year is under £50.

Efforts were made to issue the Journal for the period December-July, in time for the cost to be included in this year's account, but unfortunately the printers have not yet completed this work. I understand, however, that publication will be effected within the next few days, and that the cost will be approximately £70.

The increased expense for printing list of members, rules, and hire of hall, printed stationery, postage and clerical assistance, is all due to the greater activities and larger membership of the Society, needing more of the commodities mentioned.

Although the total expenditure of £585 includes such extra items as £44 for transatlantic test,

RADIO SOCIETY OF GREAT BRITAIN.

CASH STATEMENT FOR YEAR ENDING 1923.

Dr.	£	s.	d.	Cr.	£	s.	d.
To Balance brought forward, October 1922	180	7	9	By Printing and Distribution of Journal and Notices	205	5	2
„ Subscriptions	862	11	4	„ Hire of Lecture Hall and Refreshments at Meetings	79	19	6
„ Subscription Prize Fund	25	0	0	„ Printing and Stationery	67	0	1
„ Sale of Journal	1	9		„ Printing List of Members and Book of Rules	18	4	7
„ Suspense Account	1	6	6	„ Prize Fund Expended	25	0	0
				„ Postage and Clerical Assistance ..	93	7	8
				„ Annual Dinner and Visits to Works .. £34 7 0			
				„ Less Sale of Tickets 32 6 3			
				2 0 9	2	0	9
				By Transatlantic Transmission, Installation Attendance, etc. ..	44	14	9
				„ Stand at Ideal Home Exhibition ..	32	4	0
				„ Purchase of Filing Cabinets ..	11	13	9
				„ Sundries, Cheque Book, Rubber Stamps, etc	5	18	10
				585 9 1			
				Balance in Bank ..	483	18	3
				£1,069 7 4			

(Signed) L. F. FOGARTY,
Hon. Treasurer.
November, 1923. 

(Signed) J. OCKLESHAW, F.C.A.,
Hon. Auditor.

and £32 for exhibition, it only exceeds the expenses of last year by about 40 per cent, whilst the income shows an increase of 125 per cent, with the result that the Society carries over a larger cash balance than in any previous year.

As the roll now includes 10 life members, I suggest that a sum equal to the total composition fees be set aside, and if necessary, invested.

The Subscription Income of the Society includes an amount of £8 12s. transferred by the British Wireless Relay League, at the time when their activities were taken over. Forty-nine members had agreed to transfer at the time when the account was made.

The total membership of the Society is 723, including 606 members, of which two are honorary members, 10 foreign members, 40 Associate members, and 67 Associates.

180 Societies have completed their Affiliation, and are enrolled on the list.

In conclusion I desire to propose that a formal vote of thanks be passed and conveyed to Mr. J. Ockleshaw, F.C.A., for his honorary services in auditing the present account.

On the motion of Mr. Burbury, seconded by Mr. Hesketh, the Treasurer's report was unanimously adopted, also without discussion.

The President.

The next business is to deal with the changes in the constitution which the Committee has made recently. I have not much that is new to tell you, because the matter has been discussed or announced *ad nauseum* in the wireless press and broadcast, and has been the subject of circular letters to the affiliated societies, private letters, and letters to the Press. The changes are few in number, but they are necessary in order to provide for things that were not taken into consideration in the old rules. The first of these is the management of the affairs of the affiliated societies by the societies themselves. That was not provided for in the old rules. We have now introduced rules that give to the affiliated societies a measure of collective self-government. That is one change. Another change is that we have adopted a method of admitting groups of people to sections where special work is being carried on. One such section is practically a separate society, but it is regarded by our rules as a section more closely related to the parent society than an affiliated society. I refer to the Schools Section, which is largely due to the energy and enterprise of Mr. Hibberd, and is now a very flourishing concern. Another section is the Transmitters and Relay Section, which arose in this manner. Last June the British Wireless Relay League invited the Radio Society to take over its business and run it, if possible, as part of the Society. That was originally going to be formed into a Relay Section, but in September or October we changed the name to the Transmitters and Relay Section. I think everybody has had ample warning of that change. In the wireless press the Transmitters and Relay Section has been referred to nearly every week; it has also been mentioned on broadcast, and I do not think it will surprise anybody to see that our new rules provide for admitting such a section. A third change is that we propose to make a new management for

this Society more in keeping with the custom of other prominent societies. In the first place we want to make the Society a registered company under the Board of Trade in the same way that most other large societies are. Secondly, we want to mould our officers and council on lines similar to those adopted by these older societies; and thirdly we want that Council to admit representatives of all the affiliated societies, and also of the Transmitters and Relay Section, the Schools Section, or any other section that may be formed in the future. The changes that we want to make and propose to make are implied in this Memorandum and Articles of Association, but we are not going to pass this Memorandum or these Rules to-night. We are not even going to discuss them to-night, because that is not the purpose of this meeting. What I am going to ask this meeting to do is to approve broadly the principles embodied in this Memorandum and these Rules, and specially to approve—in order to admit of their operation at once—of Rules Nos. 49 to 52, which relate to the appointment of officers, so that the resolution which will be put to you this evening has nothing to do with any rules except Nos. 49 to 52. I should say that the resolution will not deal explicitly with any rules except those particular ones. As regards the other rules, we merely adopt them, or, rather, approve them, or, if you wish, disapprove them, in principle. Then the whole thing comes to the new Council if the Council is elected. They will then work on these new rules further, because they are still incomplete. We shall then call a special meeting some time in February to discuss the rules one by one if you like. The necessity of holding that meeting after the end of January is that we shall have to put the rules which relate to the affiliated societies before the Conference of Affiliated Societies which meets in January. These proposals may be knocked about at that Conference of Affiliated Societies, and therefore we could not possibly pass them to-night because we cannot tie the hands of the affiliated societies at their conference. A special general meeting to adopt these rules word for word will therefore be held after the Annual Conference of the Affiliated Societies. The resolution to be put will simply propose that the spirit of this change be approved; that the three or four articles I have mentioned be adopted so that we can elect the new Council, and then it follows as a consequence that the Articles will be fully discussed at the Annual Conference of Affiliated Societies in January, and then subsequently at a Special General Meeting of the Radio Society in February or afterwards.

Mr. Rivers Moore.

I do not think I need apologise for taking on myself to move this resolution in view of the fact that I think I was one of the very first members to join the Wireless Society of London, as it was when it was first formed, with premises behind Gamage's, just before the war, and secondly, because I have had considerable experience of drafting constitutions, and I know something of the tremendous amount of work involved, especially in the case of a Society like this, which has its centre in London and branches and affiliated societies all over the country. That always leads to a difficulty which is quite keenly felt by those at

headquarters, and yet it is one which it is difficult to remedy. The provinces, I think, rather feel they are out of touch with things because it is difficult to get to the meetings in London. Nevertheless, nobody would hesitate to say that a Society like this, especially in its present form, must have its headquarters in London, and its general council and main body of officers must be in London. These things have to be reconciled, and I think the Committee have done their very best to draw up the constitution in a manner that fulfils these conditions. Under the new constitution it is hoped that the affiliated societies will form their own committees and sectional committees, and send up their members to the General Committee. I think this scheme should work very smoothly indeed, and should preserve the unity and secure the flexibility which is also required. I have seen to-day a Press attack on what is being proposed, which seems to me to be based on a very considerable ignorance of the whole situation. The suggestion is made that this scheme has been rushed forward and that nobody knows anything about it. I also gather that the old committee is no good, according to the Press attack, yet it should not have resigned. I have only read it very hastily, but that is the impression I have got. I do not think we need fear that that criticism will carry any weight to-night, or that anyone will object to the new constitution on these grounds. As the President has pointed out, this matter has been before the members for a very long time. Another suggestion has been made, and that is that the Constitution should be discussed in detail by all the members. Such a thing is quite unworkable, and the only thing to do is what has been done—to appoint a Committee to work the matter up by taking the constitutions of societies which have stood the test of time, model the rules on these by adapting them to meet the special requirements of your own Society, and modifying them where necessary. I am quite sure that has been done with a great deal of care and thought. A great deal of time has been given to this matter quite gratuitously, and therefore we need not doubt that this Constitution, subject to criticism of details, is in the best form in which we can have it for the particular purpose. I therefore have great pleasure in moving the following resolution:—

“That the changes in the rules shown by the draft Memorandum and Articles of Association be approved in principle, and that Articles 49 to 52 be adopted with the following words added to Rule 52: “together with one or two persons co-opted to represent the Transmitter and Relay Section.”

I would just like to call attention to Rule 86, in which the singular has been used for the plural—“matters *is* to be discussed.”

Mr. Reeves.

I have very much pleasure in seconding this resolution, and in doing so I should like to say that I feel I am in a particularly strong position to bear testimony to the thorough-going manner in which the Committee has tackled this job. Some little while ago they did me the honour of co-opting me on to their Rules Sub-Committee which had to draft these rules; therefore I have seen their growth during the last few months, and have noted the exceedingly great care with which this subject

has been tackled. The proposer of the motion said that it is necessary, when preparing a Constitution of this kind, to take into account what previous societies and institutions have done. I think I may say this, that we have had—and I say “we” because I was one of the Rules Committee—under consideration two centuries of past experience. The constitutions of four or five societies have been carefully sifted, every good point has been considered as to how it could be applied to ourselves, and a few points have been added naturally, because of the peculiar nature of our own hobby. Therefore I think that the rules which have been put before us are the outcome of very great care, and I have much pleasure in seconding the resolution.

The President.

I call for any discussion. If any of the members would like a little more explanation or a little more detail from myself regarding the Memorandum and Articles of Association, I shall be pleased to give it.

Mr. H. A. Epton (Hackney Radio Society) asked whether it would be necessary, as the Society is to be incorporated, to place the word “Incorporated” on all the stationery and letterheading.

The President said that was not necessary. The Institution of Electrical Engineers, up to the time when it recently obtained a charter, worked for 50 years under the Board of Trade in the manner now proposed, and they did not call themselves “incorporated” or “limited,” or anything else.

Mr. H. A. Epton.

I asked that question because I belong to a society which is also incorporated by guarantee, in the same way as is now proposed under a Memorandum and Articles of Association, and they have put the word “Incorporated” after their name. Another question is that I understand at the present time the affiliated societies are entitled to elect a delegate who has full rights of membership as representing the particular society on the parent body. I have only just seen the Memorandum and Articles of Association, and I can see no reference to that. May I take it that the existing practice in that respect will be continued under the new Constitution.

The President.

That will come in the by-laws. It need not come in the Memorandum and Articles of Association, which are merely legal. Under the Articles the Council may make by-laws, and the point you mention would come under these. The Council, no doubt, will try to incorporate all the practice and custom that has been in vogue with the old Society, so that although you will not find that point mentioned in the Articles any more than it is mentioned now in the rules of the old Society, that practice, in all probability, will be carried on.

Mr. H. A. Epton.

May I ask whether the final form of the Memorandum and Articles of Association will be submitted to the affiliated societies for their consideration. May I ask that it be sent to the societies in any case so that they may consider it in detail. As a matter of fact I have only seen the document this evening for the first time, and our Society has had no time to consider it. I understand that we are not going to discuss the matter to-night, and therefore I would like to ask that these be sent out a week

before the affiliated societies come up to their conference so that they may consider them.

The President.

The copies have gone out now, so that the officials of the affiliated societies will have a month to study them before the Conference of Affiliated Societies on January 23rd.

Mr. P. W. Harris.

At the risk of being in a minority, I should like to make one or two remarks which I think are in the general interests of the Society, although they may not please all the members. First of all, however, I would like to join with Mr. Rivers Moore in expressing appreciation of the work done in preparing this Memorandum and Articles of Association. I also fully appreciate Mr. Reeves' remarks regarding the care which has been taken, but the fact still remains that, in common with a large number of members, I have only this evening received a copy of the new Memorandum and Articles of Association, and I think it is wrong in principle, in a Society of the importance of this one, that even in principle one should be asked to approve such a Memorandum as this within a few minutes of receiving it, when it has been a physical impossibility to read 50 per cent. of it, without missing the discussion which has been taking place. I should like, therefore, to move the adjournment of the meeting until such time as the members have had an opportunity of considering these, even in general principle.

The President.

A motion of that kind would not be acceptable. The Chairman of any meeting cannot accept a motion which prevents business. You can vote against the resolution or you can move an amendment to it, but you cannot do anything that stops business. The proper meaning of "motion" is to get a move on. Anybody who produces a stoppage is doing the opposite, and the Chairman cannot possibly accept such a motion.

Mr. Harris.

I thank you for the explanation. Is it possible to word it in the form of an amendment, then?

The President.

You can ask for a fuller explanation before voting, but you cannot stop a vote being taken.

Mr. Harris.

The matter seems of such seriousness that unless we have some means of expressing ourselves, either in words or some other form, there is the danger, as Mr. Rivers Moore has said has been mentioned in a certain part of the Press, of the matter being rushed through, which, personally, I think is dangerous.

The President.

What item do you think is being rushed through?

Mr. Harris.

We are asked to approve these in general principle, and, in particular, certain items. I object in principle to having to vote on such a matter at such short notice.

The President.

The notice is not short. What we ask you to vote upon to-night has been in the Press and in most of the wireless papers repeatedly during the past four months. There is nothing more than that that you are asked to vote for. You will have to

take my word for it that this Memorandum and Articles of Association does not contain anything that has not been well aired, and I hope you will. There is nothing in them which has not been thoroughly discussed in the public press and announced on the broadcast repeatedly. If there are no further comments I will put the motion to the meeting.

(There were four votes against the resolution moved by Mr. Rivers Moore, and the President declared the motion carried.)

Correspondence.

The Dull Emitter Valve.

To the Editor of THE WIRELESS WORLD AND RADIO REVIEW.

SIR,—Many people now using the "dull emitter" type of valve are using a 2-volt accumulator. As this type of valve functions on slightly over 1 volt and consumes very little current, the battery gets completely exhausted, and is consequently liable to sulphate, necessitating a very long charge to put matters right again (which cannot always be done). The instructions invariably given on the accumulator make it clear that to discharge below 1.8 volts is harmful to the cell, and until people realise what is really happening when they exhaust a battery completely they will find that dull emitter valves will cost much more in the long run than the ordinary type.

In my charging station most of the trouble I get is with the 2-volt cells, and it costs me more for the current to charge them than I get from my clients. I have nothing to say against the low consumption valve; the expense will be the replacement of accumulators.

W. C. SPIKINS, Jun.

Kingston-on-Thames.

Reception of British Amateurs in Italy.

To the Editor of THE WIRELESS WORLD AND RADIO REVIEW.

SIR,—Supposing that it may be of some interest to English and French amateurs to know that their transmissions are clearly received in Italy, I have pleasure in communicating the following calls heard:—

December 4th .. 8 AG, 8 DA
 ,, 5th .. 8 DA, 2 HF, 2 OD, 2 FQ
 (excellent), 5 QV, 2 NM, 2 VS
 5 SZ.
 ,, 10th .. 1 MT (very strong), 8 BF,
 8 BM.

The above-mentioned amateurs have been received on my set situated at Osimo (near Ancona), using a single valve. The distance between Osimo and the centre of England is about 1,000 miles.

ANTONIO FIORENZI.

Osimo, Italy.

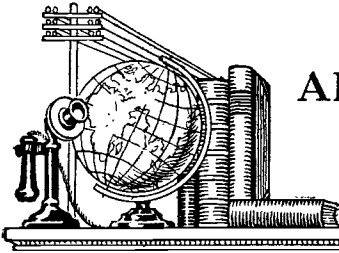

AROUND THE WIRELESS WORLD

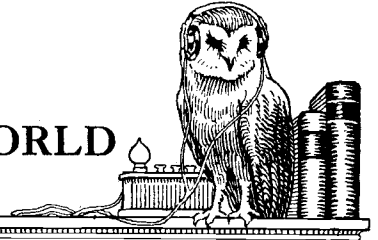

Broadcasting Reception in Sweden.

From Trällebog, Sweden, a correspondent sends us the following account of his experiences in the reception of British and European broadcasting stations.

"Some of the B.B.C. stations," he writes, "are plainly heard with detector alone, and by using three valves (H.F., D., L.F.) they are heard in the phones all over the room. 2LO and 5WA are best, though in every case fading is very perceptible. Of the European stations, Eberswalde, Konigswusterhausen, Brussels and Lyngby are strong, besides FL spark transmissions. In addition, an unknown American broadcasting station has been heard.

That Ugly Aerial.

With a sudden and unaccountable zeal for the beautiful, the Southbourne National Citizens Union has lodged a strong protest with the Town Council against the disfigurement of the residential district of Bournemouth by wireless aerials. It appears that the hitherto chaste houses now bristle with aerial poles, in many cases of the roughest description, while some citizens even desecrate chimneys and trees with suspended wires.

If the use of wireless aerials in the neighbourhood is indeed so widespread it seems pertinent to ask precisely what body of citizens the Southbourne Branch of the National Citizens Union actually represents.

1 MT.

In view of the interest that has been taken in the success of the Italian 1MT in effecting successful two-way communication with British 2HF, Dutch OAR, and French 8BM and 8BF, we repeat particulars of this station. The owner is Signor Giulio Salom, and his address is:—Palazzo Spinelli, Venice, Italy. Signor Salom welcomes reports of his transmissions, which are being carried out daily on 200 metres, between 8 p.m. and 9.30 p.m. G.M.T.

An Ambitious Broadcasting Scheme.

The establishment of a powerful broadcasting station in Honolulu to serve Japan, China, Siam, Australia, Canada and the United States is an undertaking now being discussed by the Trans-Pacific Union, the presidency of which is held by President Coolidge.

A committee is at present investigating the cost and possibilities of the scheme.

It is understood that the project is being sympathetically regarded in Japan, and it is

probable that in the near future receiving licences will be available for the general public in that country. Both China and Siam are interesting themselves in the venture, but it remains to be seen how the question of language will be solved.

Canadian Broadcasting Difficulties.

At the beginning of 1923, the number of broadcast receiving licences held in Canada was 26. To-day that number has swollen to 100,000.

The problem now confronting the Department of Marine, which supervises the broadcasting services, is how to assist the broadcasting stations to maintain their service. In Manitoba this assistance is rendered by the Provincial Government through the telephone system, the Dominion Government refunding to the province half of the licence money collected.

American Amateurs to Assist Snow-bound Trains.

In anticipation of snow-storms in the States of Colorado, Kansas and Idaho, the management of the Santa Fe Railroad have concluded arrangements with the Rocky Mountains Division of the American Radio Relay League for the operation of special emergency plans.

To maintain communications along the railway a number of amateurs have been drilled in relay work between six stations on the system and every confidence is felt in the ability of the wireless men to carry out this very commendable piece of public service.

Griffin Wireless Supplies Co.

We have been asked to direct the attention of our readers to the fact that the above firm has now opened a new branch at 18, Kingsland Road, E.2. The new establishment is well stocked, and should prove very useful to wireless enthusiasts in the neighbourhood.

Wireless on Foreign Warships.

An Admiralty Order issued on January 1st, directs that foreign warships in British harbours must obtain permission from the Senior British Naval Officer to use wireless telegraphy or telephony, full particulars being given of the apparatus to be employed.

Further regulations enjoin that transmission on 600 metres must not be carried on except for making or answering signals of distress.



The above photo was taken at the laboratory of "Radio Broadcast," New York, on the first night of the recent Transatlantic Broadcast Tests, organised by that Journal in conjunction with the "Wireless World." Two super heterodynes were used with six high frequency valves. From left to right are seen Messrs. George J. Eltz, Jnr., George Toohill, A. J. Haynes, Paul F. Godley, C. L. Farrard, and Arthur Lynch, Editor of "Radio Broadcast."

Interference with naval, military or Air Force signalling must be avoided, and transmission must be discontinued at the request of any Naval authority, the Port Authorities or any fixed shore station.

A New Radio Dictionary.

Of exceptional interest to the wireless experimenter is the latest publication of The British Engineering Standards Association, issued under the title of The British Standard List of Terms and Definitions used in Radio Communications. This list forms one section of a Vocabulary of Terms and Definitions used in Electrical Engineering which is in active preparation by The British Engineering Standards Association, and which will be issued shortly.

The present list contains definitions of about 170 terms in general use, but owing to the rapid growth of the subject, it has not been found possible to include every term used in connection with radio science, and such new terms as survive are to be incorporated in future revisions of the list. Where the same definition applies to more than one term, the term recommended for general use is printed in bold type, the other terms being given in lighter type as synonyms of the preferred term. In this way the Committee responsible for drawing up the list hope to encourage uniformity in the matter of nomenclature, a step which is specially desirable in the

case of such a rapidly developing science as radio communication.

Copies of the list are obtainable from the B.E.S.A. Publications Department, 28, Victoria Street, London, S.W.1. Price 1s. 2d. post free.

Forthcoming Events.

WEDNESDAY, JANUARY 16th.

Ipswich and District Radio Society. At 7.30 p.m. At the Waterside Works Recreation Hall, Harland Street, Stoke. Lecture: "The Manufacture of Wireless Valves." By Mr. A. H. Howe (Marconi-Osram Valve Co., Ltd.).

British Thomson-Houston Radio Society. Cinema Lecture on Valves, etc. By the President, Mr. R. C. Clinker.

East Ham and District Radio Society. At the C.A. Social Centre, Barking Road, E.6. Lecture: "Insulators." By Mr. J. E. Nickless.

THURSDAY, JANUARY 17th.

Hendon Radio Society. At 8 p.m. At the Town Hall, The Burroughs, Hendon. Lecture: "Reflex Circuits." By Mr. W. Milton Ayres, A.M.I.E.E.

FRIDAY, JANUARY 18th.

Radio Society of Highgate. At 8 p.m. At Edco Hall, Archway Road, Highgate. Demonstration by Messrs. Peto Scott & Co.

Brockley and District Radio Association. At the Gladstone Hall, New Cross Road. Extraordinary General Meeting, followed by Short Paper by Mr. Harrie King.

Wireless Society of Hull and District. At 7.30 p.m. Lecture: "A C.W. Transmitter." Lecture by Mr. J. Brazendale.

MONDAY, JANUARY 21st.

Kingston and District Radio Society. Lecture: "Interference Elimination." By Mr. R. C. Older.

Calls Heard.

Grimsbay.

2 AO, 2 AR, 2 AW, 2 CH, 2 DU, 2 DX, 2 FL, 2 FN, 2 FQ, 2 FR, 2 FF, 2 GK, 2 HC, 2 HF, 2 IF, 2 LJ, 2 IN, 2 IP, 2 IQ, 2 JN, 2 JO, 2 JP, 2 KD, 2 KF, 2 KM, 2 KQ, 2 KS, 2 KW, 2 KY, 2 LG, 2 LQ, 2 LX, 2 LZ, 2 MG, 2 MZ, 2 NJ, 2 NM, 2 OD, 2 OG, 2 OJ, 2 OM, 2 PL, 2 QK, 2 SH, 2 SQ, 2 SX, 2 SZ, 2 TB, 2 TC, 2 TO, 2 TV, 2 UL, 2 VC, 2 VQ, 2 WO, 2 ZK, 2 YZ, 5 BH, 5 CU, 5 CX, 5 DL, 5 DN, 5 GL, 5 GS, 5 FU, 5 IK, 5 LT, 5 OD, 5 QV, 5 RI, 5 US, 5 ZV, 5 SX, 6 JQ, 6 RY, 6 ST, 4 AA, 7 ZM, 8 AQ, 8 BN, 8 BM, 8 BV, 8 CF, 8 CM, 8 CS, 8 DA, 8 DK, 0 SA, 0 AA, 0 MX, 0 FN, 0 GA, 0 BQ, 0 NY, 0 XP, 0 YS, 0 PE, 0 SH. (i-v-i). (C. Hewins, 2 HQ).

Cricklewood, London, N.W.2.

2 AH, 2 DC, 2 DF, 2 DY, 2 DX, 2 GO, 2 KF, 2 KT, 2 MK, 2 NA, 2 NM, 2 NV, 2 OD, 2 OM, 2 ON, 2 PL, 2 PO, 2 PX, 2 PY, 2 PZ, 2 QS, 2 SE, 2 SF, 2 SH, 2 SM, 2 SX, 2 SZ, 2 TB, 2 UV, 2 VJ, 2 VS, 2 VW, 2 WJ, 2 XI, 2 YR, 2 YQ, 5 BA, 5 BV, 5 CB, 5 CP, 5 CV, 5 DK, 5 DY, 5 GD, 5 GP, 5 IO, 5 JS, 5 JW, 5 KS, 5 LC, 5 LP, 5 MA, 5 OB, 5 PS, 5 PU, 5 SO, 5 TT, 5 VM, 6 EA, 6 HD, 6 IH, 6 IM, 6 KO, 6 KR, 6 NH, 6 NI, 6 LQ, 6 OY, 6 TR, 6 WS, 8 AW, 8 BF, 8 BM, 8 BN, 8 BW, 8 CD, 8 DX, 0 NY, 0 MX. (Various circuits.)

(H. Stopher 5 GF).

Margate.

2 FZ, 2 KF, 2 KT, 2 LZ, 2 ON, 2 PX, 2 SF, 2 TQ, 2 VH, 5 CB, 5 HW, 5 TB, 5 TG, 5 VU, 5 WF, 5 ZR, 6 IM, 6 PS, 8 CF. ("Listener.")

Blackheath, London, S.E.3.

2 BF(?), 2 FP, 2 FQ, 2 FV, 2 HR, 2 KK, 2 KV, 2 LK, 2 LT, 2 LW, 2 MH, 2 MT, 2 OF, 2 OM, 2 ON, 2 PX, 2 PZ, 2 QQ, 2 SK, 2 SL, 2 UV, 2 VR, 2 VZ, 2 XR, 2 YZ, 2 YH, 5 AC, 5 BD, 5 CP, 5 DH, 5 DT, 5 HZ, 5 IO, 5 JW, 5 KD(?), 5 MA(?), 5 MH, 5 PU, 5 TR, 5 VR, 5 WN, 5 XR, 6 IM, 6 NH. (o-v-i or 2). (C. Eric Stuart.)

Atlantic, 900 miles W. of Havre.

6 NI, 8 BM.

600 miles W. of Havre.

2 JF, 6 NI, 8 BE, 8 BM.

300 miles W. of Havre.

0 DV, 2 DF, 2 JF, 2 KW, 2 NA, 2 OD, 2 VW, 5 GX, 5 TT, 6 TM, 8 BF. (Reception during October, 1923.) (Léon Deloy.)

Barnstaple, N. Devon.

2 FN, 2 LZ, 2 NM, 2 OM, 2 QH, 2 SM, 2 ZG, 2 ZW, 5 MO, 5 OU, 5 SZ, 6 KY, 8 BF, 8 BV, 8 CC, 8 CS, 8 CZ, 0 AD, 0 NY, 0 YS, 0 XP. (Reinartz). (J. B. Joyce.)

London, N.7.

2 BM, 2 DF, 2 DZ, 2 FQ, 2 HT, 2 MK, 2 NQ, 2 MK, 2 OM, 2 OS, 2 VW, 2 WJ, 2 XO, 2 XR, 2 XZ, 5 AO, 5 CP, 5 DT, 5 HY, 5 IO, 5 JW, 5 LP, 5 MA, 5 OP, 5 PD, 5 PU, 5 SU, 5 WF, 5 ZH, 6 GM, 6 IM, 7 KI, 6 MK, 6 WK, 6 ZO, 6 OW. (o-c-i). (W. H. R. Clegg.)

London, N.W.8.

2 BM, 2 BZ, 2 DC, 2 DO, 2 FQ, 2 FU, 2 HT, 2 KF, 2 KT, 2 LW, 2 MF, 2 MI, 2 MK, 2 MO, 2 MT, 2 NM, 2 OD, 2 OM, 2 ON, 2 PA, 2 PZ, 2 QQ, 2 SX, 2 SZ, 2 TA, 2 TI, 2 TU, 2 UV, 2 VS, 2 VW, 2 WJ, 2 XB, 2 XI, 2 XL, 2 XR, 2 YH, 2 YR, 2 ZO, 5 AC, 5 BF, 5 BV, 5 BW, 5 CB, 5 CP, 5 DK, 5 DT, 5 HY, 5 IS, 5 LF, 5 LP, 5 MA, 5 OX, 5 PD, 5 PU, 5 SU, 5 VD, 5 VM, 5 VR, 5 XR, 6 HD, 6 IM, 6 LI, 6 LJ, 6 KO, 6 MT, 6 OY, 6 SO, 6 SY, 6 TB, 2 ABR. (i-v-o). (M. F. J. Samuel.)

Who is 2UU?

Enquiries having been received concerning reception from the above station, we should be pleased to receive details of its identity.

Book Review.

"Wireless of To-day." By Chas. R. Gibson, F.R.S.E., and W. B. Cole, A.M.I.E.E. Extra Cr. 8vo, pp. 318, 7s. 6d. Seeley Service & Co.

"Wireless of To-day" is a substantial volume of 24 chapters. It is thoroughly up-to-date, and deals in a popular and clear manner with all the various applications of present-day wireless—Time Signals, Direction Finding, Directive Transmission, Calling-up Devices, Ship, Shore and Aircraft Installations, the Valve and its application to Wireless Telephony and Broadcasting.

It is not a textbook in the ordinary sense of the word, but one for the general reader who desires to obtain a comprehensive idea of the various activities in the wireless world, with a fundamental knowledge of their first principles, without delving into any mathematical or detailed considerations.

To carry out this object and to make the book a harmonious whole, a few chapters on the fundamental principles introduce the reader gradually to the subject. An excellent feature is the glossary of terms inserted at the beginning of the book, and at the end some 40 pages of interesting dates in the development of wireless telegraphy will prove valuable for reference purposes.

The whole is handsomely produced and well illustrated by 57 diagrams and photographic reproductions, the latter being exceptionally clear.

Broadcasting.

REGULAR PROGRAMMES ARE BROADCAST FROM THE FOLLOWING EUROPEAN STATIONS:

GREAT BRITAIN.

ABERDEEN 2 BD, 495 metres; **BIRMINGHAM** 5 IT, 475 metres; **GLASGOW** 5 SC, 420 metres; **NEWCASTLE** 5 NO, 400 metres; **BOURNEMOUTH** 6 BM, 385 metres; **MANCHESTER** 2 ZY, 375 metres; **LONDON** 2 LO, 365 metres; **CARDIFF** 5 WA, 350 metres; **SHEFFIELD** (Relay from 2 LO), 303 metres. Regular daily programmes. Weekdays, 11.30 to 12.30 p.m. (2 LO only), 3.30 to 4.30 p.m., 4.30 p.m., 5 to 10.30 p.m. Sundays, (2 LO only), 3.30 to 4.30 p.m., 5 to 10.30 p.m. Sundays, 3 to 5 p.m., 8.30 to 10.30 p.m.

FRANCE.

PARIS (Eiffel Tower), FL, 2,600 metres. Daily, 6.40 to 7 a.m. Weather Forecasts; 10.5 a.m. (Thursday and Friday), 11.15 to 11.30 a.m., Time Signal and Weather Forecast; 12.0 noon, Live-stock prices; 3.40 p.m. (Saturday excepted); Financial report, 5.30 p.m. (Saturday excepted) Bourse Closing Prices; 6.10 p.m., Concert or Address; 7 p.m., Weather Forecast; 7.30 p.m. (Sunday), Concert and Address; 10.10 p.m., General Weather Forecast.

PARIS (Compagnie Française de Radiophonie Emissions "Radiola"), SFR, 1,780 metres. Daily, 12.30 p.m., Cotton Oil and Café Prices, News, Concert; 1.45 p.m., First Bourse Report; 4.30 p.m., Bourse Closing Prices; 4.45 p.m., Concert; 5.45 p.m., News and Racing Results; 8.30 to 9.30 p.m., News; 9.10 p.m., Concert; 10 p.m. to 10.45 p.m., Radio Dance Music.

ECOLE SUPERIEURE des Postes et Télégraphes, 450 metres 3.30 to 4 p.m. (Wednesday and Friday), 7.45 p.m. to 10 p.m. (Tuesday and Thursday), Tests (Music, etc.); 2.30 p.m. to 7.30 p.m. (Saturday), Tests (Music, etc.).

LYONS, YN, 3,100 metres. Daily, 9.45 a.m. to 10.15 a.m., Gramophone Records.

BELGIUM.

BRUSSELS, BAV, 1,100 metres. 1 p.m. to 5.30 p.m., Meteorological Forecast; 9 p.m. (Tuesday), Concert.

BRUSSELS ("Radio Electrique"), 470 metres. Daily, 5 to 6 p.m., 8.30 p.m. to 9.30 p.m., Concert.

HOLLAND.

THE HAGUE, PCGG. Temporarily suspended.

THE HAGUE (Henssen Laboratory), PCUU, 1,070 metres, 9.40 to 10.40 a.m. (Sunday), Concert; 9.40 to 10.40 p.m., Concert; 7.45 to 10 p.m. (Thursday), Concert.

THE HAGUE (Velthuisen), PCKK, 1,070 metres. 8.40 to 9.40 p.m. (Friday), Concert.

IJMUIDEN (Middelraad), PCMM, 1,050 metres. Saturday, 8.40 to 9.40 p.m., Concert.

AMSTERDAM, PA 5, 1,100 metres (Irregular). 10 to 11 a.m., Concert; 5 to 6.30 p.m., Concert; 8.10 to 9.10 p.m., Concert.

DENMARK.

LYNGBY, OXE, 2,400 metres. 7 p.m. to 8 p.m., Concert (Sunday excepted).

GERMANY.

BERLIN (Koenigswusterhausen), L.P., 4,000 metres. (Sunday), 10 to 11 a.m., Music and Lecture; 2,700 metres 11 a.m. to 12 noon, Music and Lecture. Daily, 4,000 metres, 6 to 7 a.m., Music and News.

EBERSWALDE, 2,930 metres. Daily, 12 to 1 p.m., Address and Concert; 7 to 8 p.m., Address and Concert; (Thursday and Saturday), 5.30 to 6.30 p.m., Concert.

CZECHO-SLOVAKIA.

PRAGUE, PRG, 1,800 metres. 7 a.m., 11 a.m. and 3 p.m., Meteorological Bulletin and News; 4,500 metres, 9 a.m., 2 p.m., and 9 p.m., Concert.

KBEL (near Prague), 1,000 metres. Daily, 6.20 p.m., Concert, Meteorological Report and News.

SWITZERLAND.

GENEVA, HB 1 (Radio Club de Genève). Temporarily suspended.

LAUSANNE, HB 2, 1,100 metres. Tuesday, Thursday, Saturday, 4 p.m., Concert; Monday, Wednesday, Friday and Saturday, 7 p.m., Concert.

SPAIN.

MADRID, 1,650, 2,200 metres (Irregular). 12 to 1 p.m., Tests

MADRID, PTT, 400 to 700 metres. 4 to 5 p.m., Tests.



WITH THE SOCIETIES

Particulars of Membership of any Society can be obtained on application to the Secretary. Societies marked with an asterisk are affiliated to the Radio Society of Great Britain.

Radio Society of Willesden.*

The Society desires to place on record the highly successful efforts of Mr. C. Giles, a member, in receiving an experimental transmission from WGR. For over an hour Mr. Giles, assisted by his daughter, made a shorthand record of a speech which was transmitted for test purposes. This record was submitted to the station authorities, from whom a gratifying acknowledgment was received. A four-valve set was used, employing three stages of H.F.

On December 20th the Society held an enjoyable dance at the Leafield Road Schools, and an excellent programme was supplied by the Springers Dance Band. Mr. E. Earnshaw Ball briefly addressed the gathering, and it is hoped that his speech has attracted many recruits to the membership. Applications regarding membership should be addressed to the Hon. Sec., Mr. F. H. H. Coote, 183, Carlton Vale, Maida Vale, N.W.6.

Wireless and Experimental Association.*

At the Association's meeting on January 2nd, it was announced that the members would be honoured with a visit from Capt. Eckersley of the B.B.C. on January 9th.

It was hoped that the highbrows would then have something to occupy their minds and the present meeting was devoted to the interests of the juniors and those members whose knowledge of radio matters did not quite reach the top notch of attainment. The Secretary described the means he had adopted for adding several cubits to the stature of the wireless pole in his back garden.

Hon. Sec., Geo. Sutton, 18, Melford Road, S.E.22.

Hackney and District Radio Society.*

On Thursday, January 4th, Mr. J. F. Stanley, B.Sc., A.C.G.I., gave a talk on "Distortion in Valve Receivers." Mr. Stanley proved the fallacy of the popular idea that high-frequency amplification does not cause distortion, also that the use of reaction increased distortion. He next considered the valve as a rectifier and discussed the merits of anode and grid rectification. Undoubtedly, the valve functions best, both as regards detection and clarity, when working on the straight line of the graph with which we are all familiar. Transformers are the chief causes of low frequency distortion as amplification is greater on the higher frequencies than the lower. Mr. Stanley indicated various remedies for the faults he had explained and afterwards kindly answered many questions.

Hon. Sec., C. C. Phillips, 57, Highfield Avenue, Golders Green, N.W.11.

The Radio Society of Highgate.*

An exceedingly interesting and amusing evening was spent on January 4th, when

the meeting was devoted to three-minute speeches, each member present being called upon to speak for three minutes upon a subject drawn from a hat. The following were the principal subjects dealt with:—

The Rectifying Action of a Gridleak and Condenser. Should Parliament be Broadcast? Are Dull-Emitter Valves Worth Their Cost? The Type of Lecture That Appeals to Me Most. Single v. Twin Aerials. The Best Solution of the Licence Problem. The Best Wireless Paper and My Opinion of the Others. The Greatest Development Achieved during 1923. Distortion in High-Frequency Circuits. Suggestions for Running the Radio Society on Better Lines. What I Think of the B.B.C. The Advantages of Joining a Radio Society. Should the Tuning Condenser be in Series or in Parallel with the Tuning Inductance?

As might be expected, some speakers treated their subject seriously, while others spoke in a more humorous vein. All the speeches were impromptu.

An unusually attractive programme has been arranged for the next few months, full particulars of which can be obtained from the Hon. Sec., J. F. Stanley, B.Sc., 49, Cholmeley Park, Highgate, N.6.

High Wycombe and District Radio Society.*

Recent meetings of this Society have included a discourse by the Chairman (Mr. Russell Jackson) on "Receiving Circuits" when his experiences with various types of circuit were related, and also a lecture by the President (Mr. T. J. Northy) on "short-cut calculations." The real saving of time in solving some of the most-used radio equations shown by Mr. Northy's methods, prompted a unanimous request for a continuation lecture.

The Society has also been favoured by a lecture from Mr. R. C. Clinker, M.I.E.E., of Rugby, on "Radio Principles," illustrated by lantern slides, and an unique mechanical model of a valve detector circuit.

Another welcome visitor was Mr. J. F. Stanley, B.Sc., who occupied an evening on the subject of "Distortion in Valve Receivers."

The Society's membership is now 71 and prospective members will be gladly supplied with information by the Hon. Sec., A. C. Yates, 30, High Street, High Wycombe.

Wimbledon Radio Society.*

At a well-attended meeting on Friday, December 28th, the Assistant Hon. Sec. demonstrated his cabinet receiving set, which embodies many novel features, and the 2ZY Christmas Party entertained the members. Mr. Rawlings also demonstrated the M.S.I. three-valve

set, and "Radiola" was well received.

The Society now possesses a full range of tools and several members are constructing their receiving sets at headquarters. A constructional evening was spent on January 4th. The Society's set is rapidly approaching completion and on January 4th the amplifier panel was assembled for wiring up.

All enthusiasts in the Wimbledon district are invited to become members of this flourishing Society and enquiries should be addressed to the Hon. Sec., C. G. Stokes, 6, Worples Avenue, Wimbledon, S.W.19.

Dulwich and District Wireless and Experimental Association.

At the final meeting of the 1923 Season, it was the privilege of the members to listen to yet another lecture by Mr. Frank R. Bartlett, who spoke on "Commercial Spark Stations." Mr. Bartlett went fully into both the theory and practice of all the methods of spark transmission, and added greatly to the value of his explanations by drawing numerous diagrams.

The Association is still desirous of increasing its membership, and a letter to the Assistant Hon. Sec., at 2, Henslowe Road, East Dulwich, S.E.22, will receive an instant response.

The Peck, Freaton Social and Sports Club (Radio Section).

At a meeting held on Tuesday, January 1st, Mr. H. Bevan Swift (2TT), of the Streatham Radio Society, lectured on "Elementary Valve Principles," before a small but interested audience.

Hon. Sec., G. C. Betts, c/o The Peck, Freaton Social and Sports Club (Radio Section), Keetons Road, Bermondsey, S.E.16.

Brockley and District Radio Association.

At a recent meeting an excellent lecture was delivered by the Hon. Secretary, Mr. R. O. Watters. The trend of his discourse chiefly related to wireless reception and transmission in the good old days, and spoke at length on the coherer, spark transmitter, and kindred instruments beloved by the old hands but to a very large extent unknown to the modern wireless enthusiast.

In view of the fact that a number of the new members are novices in the science of wireless, it has been decided to graduate the lectures to suit all classes. Accordingly, at the first meeting of the 1924 season, held on January 4th, Mr. Harrie gave a talk on "Crystal Circuits," which he illustrated with blackboard diagrams.

New members are welcomed to the Association and particulars can be obtained from the Hon. Sec., R. O. Watters, "Grove House," Brockley Grove, S.E.4.

Radio Association of Ireland.

On December 10th, in the Physics Laboratory, University College, Dublin, the Association gave a demonstration of wireless reception under the control of Mr. Henry J. Farrell.

A special meeting was held at the Municipal Technical Institute, Dublin, on December 19th, when the Executive Committee invited the opinion of members on certain wireless matters of current interest.

After a favourable report of the Hon. Secretary of the new branch at Waterford, Mr. Arthur L. Callan, Hon. Treasurer, gave an interesting lecture on "The Reception of Wireless Signals." After dealing with the early forms of detector the lecturer mentioned the Transatlantic tests of 1907, carried out from Poldhu, Cornwall, to Glace Bay, Nova Scotia, and expressed wonder that the signals got through at all, in the light of present-day practice.

Hon. Sec., H. Hodgens, 92, Lower Baggot Street, Dublin.

Sydenham and Forest Hill Radio Society.

A competition of members' apparatus was recently held at the Greyhound Hotel, and three prizes were given by Mr. Leonard Downing, Mr. Cox, senr., and Captain Huss respectively.

An excellently designed tuner by Mr. Ivor Cox was adjudged the first in order of merit, and it was decided that his exhibit would be awarded the honour of being forwarded to the White City as an entry in the competition organised by the Radio Society of Great Britain. The next in order of merit was a set constructed by Mr. S. C. Smith and was awarded the first prize; the second went to Mr. H. S. Pace, and the third to Mr. S. J. Anderson.

The tuner constructed by Mr. Ivor Cox was awarded the second prize in the competition organised by the Radio Society of Great Britain.

It is perhaps with pardonable pride that we place on record the fact that a member of our Society—perhaps one of the youngest of wireless societies—succeeded in carrying off one of the chief prizes for amateur-made apparatus exhibited at the White City.

Hon. Sec., M. E. Hampshire, 139 Sydenham Road, S.E.26.

The British Thomson-Houston Radio Society.

A very interesting and instructive lecture was given by Mr. E. C. Stubbens,

on January 2nd, entitled "The Practical Side of Radio Construction." The lecture was illustrated with various radio parts. Although the attendance was not large, a very enjoyable evening was spent.

Hon. Sec., P. T. Harris, Recreation Club, British Thomson-Houston Co., Ltd., Rugby.

Hon. Sec., A. Crawford Todd, 12, Albert Road North, Pollokshields, Glasgow.

Honor Oak Park Radio Society.

An excellent lecture entitled "Radio Principles and Tuning" was given by Mr. H. Bevan-Swift on December 28th.

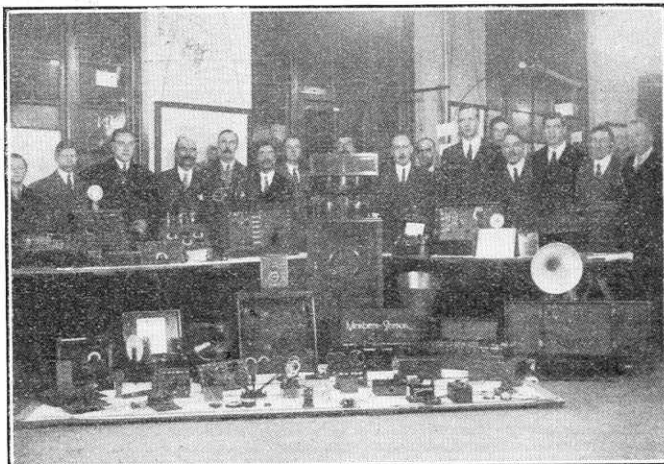

An excellent display of members' apparatus on view at the recent exhibition of the Wembley Wireless Society.

Glasgow and District Radio Society.

The sixth ordinary meeting of the above Society was held at the Royal Philosophical Society's rooms on December 19th, when a lecture was given by Mr. Wm. K. Fulton, C.E., on "Physics." After dealing with the phenomena common to all forms of wave motion, such as dispersion and interference, the lecturer showed the relationship between light, "visible and invisible," and the more familiar radio wave. He mentioned that in the ultra violet part of the spectrum frequencies of about 3,000 billions per second were known to exist, "and were known as Schumann's limit."

Under the subtitle "Aether" the lecturer dealt shortly with the Fleming theory, jamming and the underlying principles of transmitting. The theory of tuning was clearly demonstrated by the pendulum analogy, while capacity, inductance, radio and audio frequency, the principle of the condenser, and the aerial were explained in an interesting and clear manner, many illustrations and valuable hints being given. After an amusing description of the effects of a near-by electric railway upon his own experiments, the lecturer gave much valuable information concerning rejector circuits and coils.

Hon. Sec., G. J. Price, 22, Honor Oak Park, S.E.

HOW REPORTS OF RECEPTION OF BRITISH BROADCASTING STATIONS WERE ACKNOWLEDGED IN AMERICA.

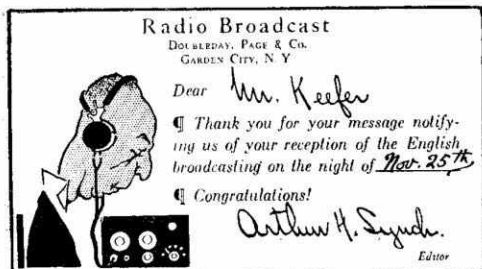

Reproduction of the post-card sent out to receivers of the British Stations.

The accompanying picture illustrates the post-card which was sent out by *Radio Broadcast* to all those who heard British Stations in the Transatlantic Broadcasting Tests recently arranged between *The Wireless World* and *Radio Broadcast* of America.

We have not yet had any information as to the total number of these cards despatched as acknowledgments, but judging from the interest which was taken in America, the number must have been very great.

The post-card makes an interesting souvenir for those American amateurs who heard British Broadcasting for the first time on the occasion of these tests.

Questions & Answers

Solutions of Readers' Difficulties

This section of the magazine is placed at the disposal of all readers who wish to receive advice and information on matters pertaining to both the technical and non-technical sides of wireless work. Readers should comply with the following rules:—(1) Each question should be numbered and written on a separate sheet on one side of the paper, and addressed "Questions and Answers," Editor, The Wireless World and Radio Review, 12/13, Henrietta Street, London, W.C.2. Queries should be clear and concise. (2) Before sending in their questions readers are advised to search recent numbers to see whether the same queries have not been dealt with before. (3) All questions will be answered through the post. Those of general interest will also be published. (4) Every question, except those under (5) below, should be accompanied by a postal order for 1s., or 3s. 6d. for a maximum of four questions, and also the coupon taken from the advertisement pages of the current issue. (5) For the benefit of those readers who would rather not pay the charges, a free Questions and Answers Coupon will be placed in the advertisement pages of the first issue of every month. This coupon should accompany the question submitted, together with a stamped addressed envelope. The free coupon is valid for the current week only. (6) In view of the fact that a large proportion of the circuits and apparatus described in these answers are covered by patents, readers are advised, before making use of them, to satisfy themselves that they would not be infringing patents. (7) Four questions is the maximum which may be sent in at one time.

"W.J.R." (London, S.W.2) has a variometer consisting of an outer fixed coil of 120 turns, tapped at every 10 turns, and an inner rotating coil of 25 turns. He asks how to connect the variometer to form a tuner for a crystal receiver.

The diagram in Fig. 1 shows a convenient method of connecting the particular variometer in question. The rotor is connected in series with that portion of the fixed coil which is included in the circuit by the distributing switch.

"G.S." (S. Africa) asks for a diagram of a three-valve receiver (O-V-2) for the reception of the high-power European stations; a loose coupler to be used for tuning, and telephone jacks to be arranged so that either the detector valve or the detector and two note magnifiers may be used.

The diagram is given in Fig. 2. When the telephone plug is connected in the first jack, the filament current to the two L.F. valves is automatically switched off, and the telephones are connected in the plate circuit of the detector valve in place of the primary winding of the first L.F. transformer.

"C.G.B." (Ipswich) has a three-valve receiver with one stage of high frequency amplification (tuned anode), rectifier, and one note magnifier. He wishes to know how to stop the receiver oscillating.

We suggest you connect the aerial condenser in parallel with the aerial tuning coil; also connect

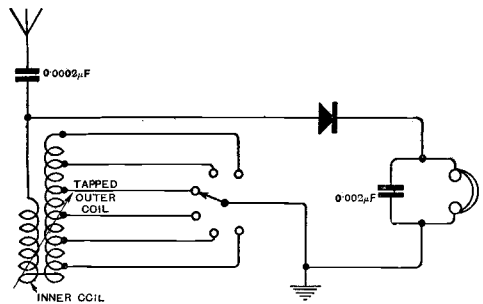

Fig. 1. "W.J.R." (London, S.W.2). A simple crystal receiver with a tapped variometer tuner.

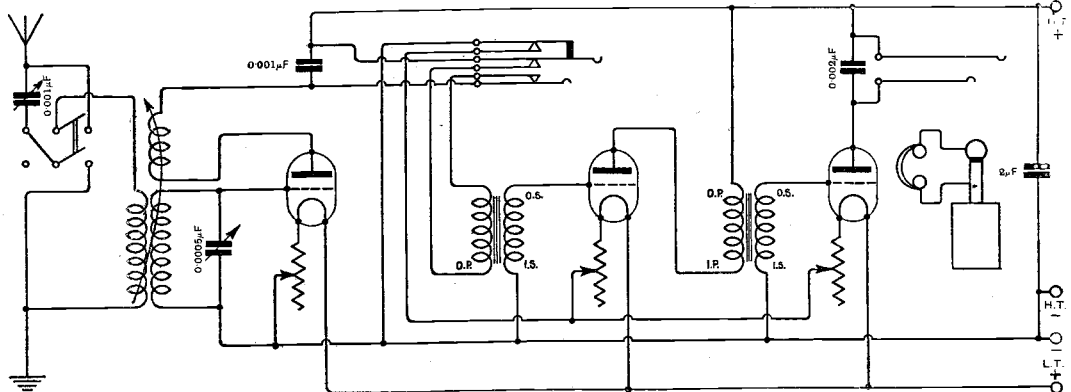

Fig. 2. "G.S." (S. Africa). A receiver with a detector and two note magnifiers. The telephones may be connected in the plate circuit of the detector or the second note magnifier.

the lower end of the inductance with the top end of the filament resistance or with +L.T. Try changing the size of the reaction coil. Probably your reaction coil has too many turns, making adjustments difficult, and if a few are removed, results will probably be better. Try joining a fixed condenser of 0.001 mfd. across the intervalve transformer primary winding. With any valve receiver oscillating may often be stopped by paying attention to the wiring. Try the effect of shifting the position of different wires with the idea of removing capacity back coupling.,

“SPECIAL” (Belfast) refers to the double amplification receiver described in “The Wireless World and Radio Review,” of July 21st, 1923, and asks for a theoretical diagram of the circuit, using double pole, change-over switches instead of telephone jacks.

See Fig. 3.

“H.A.” (N.8) refers to the sensitive single-valve receiver described on page 167 of the issue of

should be screwed to the reed near its mid-point, the best position being found by experiment. The magnet coils in these instruments are usually

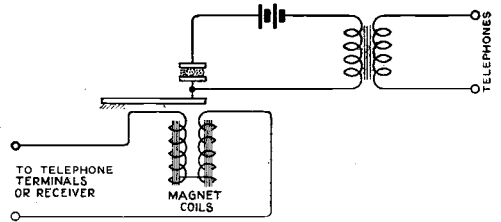

Fig. 4. “J.H.W.” (Stoke-on-Trent). Method of connecting a microphone amplifier to a receiver.

of low resistance, so that if high resistance telephones are normally used in the receiving circuit, the coils should be rewound with No. 42 or No. 44 S.S.C. (2) See Fig. 4. The dimensions of the microphone

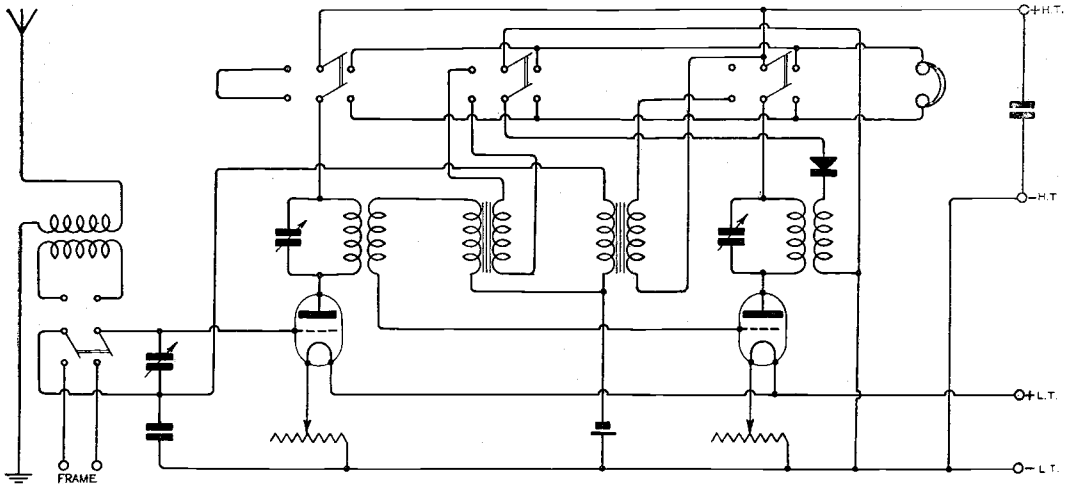

Fig. 3. “SPECIAL” (Belfast). Circuit diagram for two-valve and crystal double magnification receiver, using double pole change-over switches.

November 7th, and asks whether we would recommend the addition of a high frequency amplifier.

We do not recommend the addition of a high frequency connected valve to a sensitive valve receiver of the sort described on page 167 of the issue of November 7th. It is found that in general the sensitivity of the specially arranged circuit disappears when a high-frequency valve is added.

“J.H.W.” (Stoke-on-Trent) sends diagram of a type of telephone relay and asks for (1) The best use to which it could be put. (2) Instructions for connecting in the receiving circuit.

(1) The apparatus sketched could be converted to a microphone amplifier. We would advise you to experiment with reeds other than the one at present used. These could conveniently be screwed to the brass bridge piece. A microphone button

transformer will depend on the resistance of the telephones available.

“C.D.” (London, N.W.2) refers to the wiring diagram on page 441, January 2nd issue, in the article “New Ideas in Receiver Design, a Three-valve Receiver,” and asks for explanation of several connections.

Referring to the diagram—

- Connect A to back of tuned anode coil.
- B to front of tuned anode coil.
- C to front of reaction coil.
- D to back of reaction coil.
- E to front of aerial coil.
- F to back of aerial coil.

The grid leak is connected between the points marked with arrows.

THE WIRELESS WORLD AND RADIO REVIEW

THE OFFICIAL ORGAN OF THE RADIO SOCIETY OF GREAT BRITAIN.

No. 232. (No. 17.)
(Vol. XIII.)

JANUARY 23rd, 1924.

WEEKLY

EDITOR :
HUGH S. POCOCK.

RESEARCH EDITOR :
PHILIP R. COURSEY, B.Sc., F.Inst.P., A.M.I.E.E.

ASSISTANT EDITOR :
F. H. HAYNES.

QUESTIONS AND ANSWERS DEPARTMENT :
Under the Supervision of W. JAMES.

CONTENTS

	PAGE
Editorial - - - - -	520
Loud Speakers. By E. K. Sandeman - - - - -	521
A Stable Dual Amplification Circuit - - - - -	525
The Principles Underlying the Operation of the Thermionic Valve (<i>continued</i>). By W. Sydney Barrell - - - - -	528
A Useful Variometer - - - - -	531
Electrolytic Detectors and Liquid Valves. By James Strachan - - - - -	533
200-Metre Transmission during Broadcasting - - - - -	535
The Radio Society of Great Britain - - - - -	539
Correspondence - - - - -	540
Around the Wireless World - - - - -	542
Calls Heard - - - - -	546
Wireless Time Signals - - - - -	547
With the Societies - - - - -	548
Questions and Answers - - - - -	549

THE EDITOR will be glad to consider articles and illustrations dealing with subjects within the scope of the Journal. Illustrations should preferably be confined to photographs and rough drawings. The greatest care will be taken to return all illustrations and manuscripts not required for publication if these are accompanied by stamps to pay return postage. All manuscripts and illustrations are sent at the Author's risk and the Editor cannot accept responsibility for their safe custody or return. Contributions should be addressed to the Editor, "The Wireless World and Radio Review," 12 and 13, Henrietta Street, Strand, London, W.C.2.

SUBSCRIPTION RATES :
20s. per annum, post free. Single copies 4d. each or post free 5d. Registered at the G.P.O. for transmission by Magazine Post to Canada and Newfoundland.

As many of the circuits and apparatus described in these pages are covered by patents, readers are advised, before making use of them, to satisfy themselves that they would not be infringing patents.



EDITORIAL AND PUBLISHING
OFFICES :

12 and 13 Henrietta Street,
Strand, London, W.C.2.
Telephone : Gerrard 2807-9.

ADVERTISEMENT MANAGERS :

Bertram Day and Co., Ltd.,
1 Charing Cross, S.W.1.
Telephone : Gerrard 8063-8.

THE PROBLEM OF OSCILLATION.

By THE EDITOR.

IT is quite obvious to anyone that the satisfactory development of broadcasting depends very largely on the extent to which interference with the receiving stations can be avoided, and interference from oscillation is now considered to be one of the principal causes of interruption in the broadcast programmes.

Shortly after the war, the Post Office only authorised the use of valve apparatus by experimenters, after a considerable amount of discussion, on account of the fear which was entertained that valve receiving sets would cause interference. Everyone knows too the extent to which the problem was taken into consideration in the initial regulations for broadcasting in this country. The Post Office then undertook to test all sets which were to bear the official stamp of the British Broadcasting Company, so as to ensure that they did not radiate sufficiently to cause interference, and it was made illegal to sell for broadcast reception any complete set which did not bear the official stamp.

The Post Office, in consultation with the Broadcasting Company and the manufacturers, considered that this was the best way of ensuring that interference would not be caused by those who had no technical knowledge of wireless. Later on, however, a new difficulty arose. There were many people who wished to construct their own apparatus, who had not, perhaps, sufficient technical knowledge to take the necessary precautions to prevent interference of this nature.

We have ourselves always expressed the opinion that as far as users' experimental or home-made receivers were concerned, the only solution to the problem was to be sought in the direction of education, so that the user of the apparatus should have sufficient knowledge to exercise due care in operating his receiver and so avoid interference.

Efforts in all directions have been made to spread knowledge of the operation of receivers with this end in view, but still the Broadcasting Company is not satisfied that things are going as they should. In fact, there appears to be almost a panic among the Company's officials on account of the increase in the amount of interference from this source which has taken place recently, and unfortunately the Broadcasting Company and others appear to put most of the blame on the experimenter and those who hold constructor's licences.

There is, however, another side of the question to which we would like to refer before the amateur is blamed for all the trouble. It will be remembered how extensively the Broadcasting Company, the manufacturers and the Post Office, advertised the fact that broadcast receivers bearing the official broadcast stamp were incapable of radiating so as to cause interference, and would therefore be totally harmless in the hands of the novice.

We believe therefore, that it will come as a great surprise to the majority of readers and users of wireless apparatus in this country, to learn that the Post Office no longer undertakes to test broadcast receivers for oscillation, and that the only test carried out is in relation to wavelength range. Exactly what circumstances have brought about such a complete reversion of policy on the part of the Post Office is difficult to follow. Probably it is out of consideration for the manufacturers who were naturally very seriously handicapped in the design of receivers when they had to make them pass the test of non-radiation. In fact it is exceedingly difficult to design a truly efficient receiver which will pass such a test.

Is it surprising that interference from oscillation should be so much on the increase, remembering that these sets go usually to complete novices who hold broadcasting licences?

If it has been found that official broadcast receivers cannot be satisfactorily designed for non-radiation, then surely publicity should be given to the fact, in order that those using them shall be aware of the interference they may cause and learn how to operate their sets in order to avoid interference.

As the position stands at present, many thousands of sets are going out to new users of wireless who have every confidence in the apparatus and are entirely unaware that official broadcast receivers are no longer harmless in the matter of oscillation and interference.

LOUD SPEAKERS.

So much interest is centering at the present time around the problem of loud-speaker design, that the following article, contributed by one who is an acknowledged expert on the subject, should make a strong appeal to engineers and experimenters.

By E. K. SANDEMAN, B.Sc.

INTRODUCTION.

THE purpose of a loud speaker, or more correctly, a loud speaking telephone, is to reproduce at the ear of the listener the same impression that would be received by an ear situated at the best position for hearing at the place where speech or music is being produced. This, perhaps, sounds to be a statement of rather an obvious fact, but, as we shall see later, it is necessary to keep this fact rigidly in the mind if it is to be realised in practice.

The immediate function of a loud speaker is the efficient and faithful conversion of electrical into acoustical energy. The efficiency of a loud speaker is the ratio of the output sound energy to the input electrical energy. The energy of normal speech is of the order of 125 ergs per second (equivalent to 1.25×10^{-2} milliwatts), and the electrical input to a loud speaker to give this loudness is about 2 milliwatts. Hence we see that the efficiency of a loud speaker considered as a converter of power is extraordinarily low, being under 1 per cent.

The faithfulness of a loud speaker depends on two things. Firstly it is necessary, all other things being equal, that for equal input electrical energy all frequencies shall be reproduced as an equal volume of sound, and secondly, the volume of output sound energy must be directly proportional to the input current.

In general it is also true that the ideal loud speaker should have an impedance constant throughout the frequency range, and constant for all volumes of input current. The reason will appear under.

IMPEDANCE MEASUREMENTS ON LOUD SPEAKERS.

We see therefore that an impedance measurement at all frequencies within the

speech range will indicate the probability of distortion occurring from impedance variations. Actually, in the present state of the technique, an impedance measurement is not by any means a conclusive test, as is readily appreciated by considering the effect of diaphragm resonances, and horn resonances, but it is a *sine qua non* in that

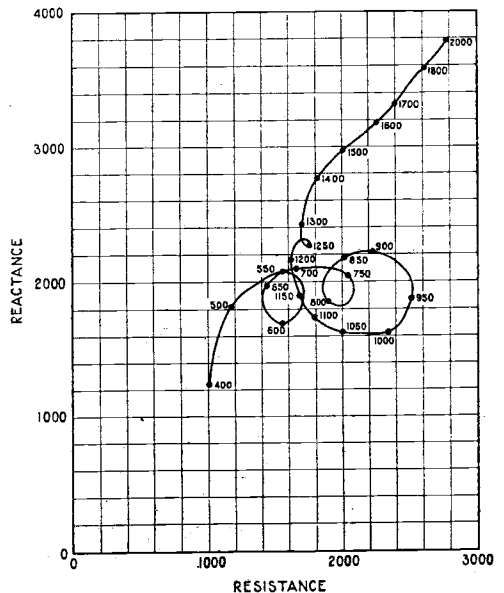

Fig. 1. Relation between resistance and reactance of a typical loud speaker. (Courtesy Western Electric Co.).

unless a loud speaker has a flat impedance characteristic it is practically impossible for faithful reproduction to be obtained.

Mr. A. E. Kennelly has developed a theory relating the acoustic impedance of a telephone receiver to the measured electrical impedance. He shows from theoretical considerations that in a loud speaker having many resonant points, if the resistance

component of the impedance is plotted against the reactance component, a curve of the form shown in Fig. 1 is obtained, where each loop corresponds to a resonant point. Fig. 1A shows a characteristic almost free from resonance points. Both Figs. 1 and 1A

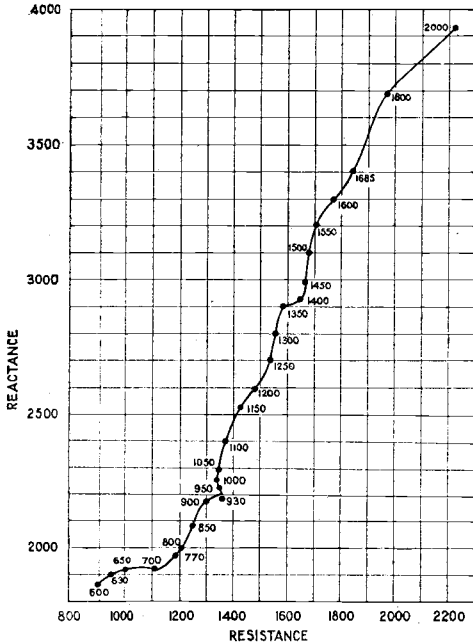

Fig. 1A. Impedance of loud speaker shown in Fig. 5. (Courtesy Western Electric Co.)

are taken from actual experimental curves, the figures on the curves indicating frequencies in cycles per second. These curves are only shown up to 2,000 cycles in order to obtain a convenient scale; above this frequency they are substantially straight lines. It is possible to define the shape of the resonant peaks from a consideration of these loops, but the method is laborious, and although it may be useful for analysing causes of distortion, does not give such informative results as the more simple direct method which we will now consider.

RESPONSE MEASUREMENTS.

We have mentioned above, the fact that the output energy must be a linear function of the input energy. This is because non-linearity gives rise to harmonics of each fundamental tone, and also to combination tones when more than one frequency is

simultaneously transmitted. Actually, in practice it is found that there is no difficulty in obtaining such a straight line law, but if it is desired to make a test for this type of distortion it is only necessary to plot the output sound energy against the input electrical energy and to see if a straight line is obtained. The apparatus would be similar to that described below. The type of distortion due to this deficiency is called asymmetric distortion, since pulses in one sense are not transmitted with equal amplitude to pulses with opposite sense.

The other type of distortion, which we will call frequency response distortion, is, as described above, due to the fact that all frequencies are not transmitted with equal intensity (for equal input energy at all frequencies, see under). The most obvious way of finding out what degree of response distortion exists in a loud speaker is to plot the relative amplitudes of the output sound energy against frequency (equal values of input understood) for all frequencies within the speech range. This means that we must have, firstly, a means of measuring the input energy, which may be very conveniently accomplished with a thermo-couple and a milliammeter, and secondly, a means of measuring the sound energy. This last is not so easy, but may be done in several ways, according to whether absolute values or merely relative values of sound energy are required.

A very convenient method of doing this is by means of a calibrated condenser transmitter. The method of calibrating such a transmitter is given in the *American Physical*

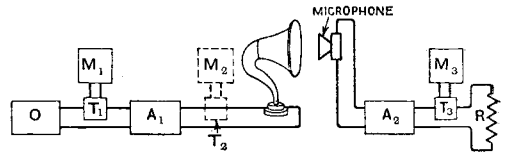

Fig. 2. O = oscillator, 16-10,000, o.p.s. M₁ = micro-ammeter, T₁ = thermocouple. M₂T₂ = position for constant current method (M₂ = milli-ammeter). A₁ = calibrated amplifier. A₂ = calibrated amplifier. R = resistance load, giving correct output impedance to amplifier A₂. M₃ = milli-ammeter. T₃ = thermocouple.

Review, Vol. XIX, p. 333 (The Thermophone, by E. C. Wentz). This apparatus admits of either absolute or relative tests being

made, the general circuit arrangement being shown in Fig. 2.

In Fig. 3 is shown a typical frequency response characteristic obtained by this method. The abscissæ represent frequency, and the ordinates represent the ratio of output sound pressure to input voltage,

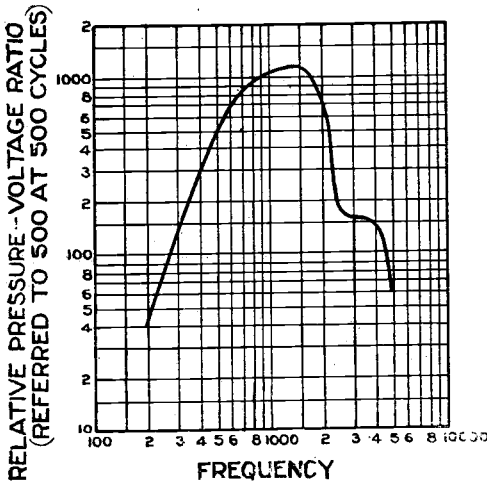

Fig. 3. Example of response characteristic of a loud-speaker. (Courtesy Western Electric Co., and Institution of Electrical Engineers).

multiplied by a constant to make the scale convenient for plotting. Double logarithmic paper is used for two reasons; firstly the ear hears logarithmically, that is to say the intensity of sensation or loudness is proportional to the logarithm of the sound energy, while on the frequency range the ear hears in octaves, that is to say each doubling of frequency produces an equal change in sensation. This again indicates a logarithmic law although the evidence cannot be regarded as being so complete in this case. With this arrangement for plotting, equal vertical distances represent equal changes in loudness. The ordinates on the left represent relative sound pressures or amplitudes for equal input voltages. Care must be taken in defining the arrangements for this equal input voltage, and the considerations bearing on it are as follows. In all practical cases a loud speaker is operated from the output of a valve amplifier, in which case for equal input energies to the amplifier (assumed distortionless) equal speech frequency alternating voltages are

generated in the plate circuit of the last valve, and these are the voltages to be regarded as constant. It is therefore evident that in the practical case for equal energy input to the amplifier there would not be equal energy input to the loud speaker, owing to its variation in impedance. Hence, if the tests are made directly on the loud speaker either by inputting constant current or constant voltage to its windings at each frequency, a suitable correction must be made for the circuit in which it will ultimately be operated.

For instance, in the constant current case, if Z_i is the input impedance of the loud speaker at any frequency f and V_i is the output impedance at any frequency f of the circuit in which it will ultimately be used, then the current through the loud speaker under operating conditions instead of being constant will be inversely proportional to $(Z_i + V_i)$. We must therefore make allowance for this by dividing each ordinate of the frequency characteristic by $(Z_i + V_i)$, and since we are only really concerned with relative values, we can make up for their division by multiplying all ordinates by the same constant to obtain a scale convenient for plotting. This constant may very conveniently be the value of $(Z_i + V_i)$ at some arbitrarily chosen frequency.

INTERPRETATION OF FREQUENCY CHARACTERISTICS.

Looking for the moment at Fig. 3 we see that the maximum response is at 1,000

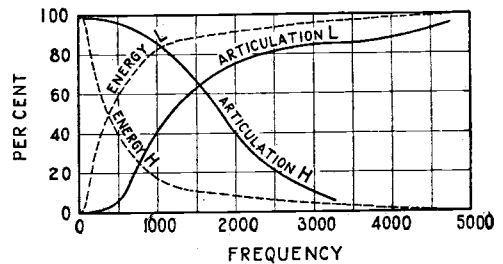

Fig. 4. Effect upon the articulation and the energy of speech of eliminating certain frequency regions. (Courtesy Western Electric Co.).

cycles, the characteristic forming a large bump with its highest point at this frequency, probably due in a large measure to diaphragm resonance. Above 4,500 cycles there

is practically no reproduction, while the same is true below 200 cycles. In general, it is true that naturalness depends on the lower frequencies, while articulation and intelligibility depend on the higher frequencies. By articulation we mean in general the percentage number of elemental sounds which can be understood when separately voiced. This is more correctly termed syllable articulation, and is definitely allied to word articulation, the meaning of which is obvious. It may surprise people to learn how much the mind supplies in interpreting speech on the telephone. For instance a circuit having a syllable articulation of only 50 per cent. may have a word articulation of 70 per cent., and an idea intelligibility of 80 per cent. or more.

The lower frequencies carry most of the energy of speech, and the curves in Fig. 4 are intended to show firstly, the distribution of speech energy, and secondly, the importance of each frequency range in carrying articulation.

The abscissæ represent frequency and the ordinates percentage energy (per cent. of total speech energy) or percentage articulation.

The full line curve sloping up from left to right represents the percentage articulation obtained when all frequencies below any specific frequency are transmitted, the remainder being attenuated below audibility.

The full line curve sloping down from left to right represents the percentage articulation when all frequencies above any specific frequency are transmitted.

The dotted curves show the energy function of normal speech in the same way.

It is evident that since these curves are the summation or integral of the properties of the frequencies from zero to a certain frequency, in the one case, and from a certain frequency to infinity in the other, the first differential or slope of the curves must show the amount contributed by each speech frequency region to the total properties of undistorted speech. For instance the slope of the energy curve is a measure of the energy distribution in the speech spectrum.

We are now in a position to criticise the frequency characteristic shown in Fig. 3.

From what has been said it is hardly necessary to point out that the ideal frequency characteristic would be a straight line parallel to the axis of frequency.

Looking at the characteristic of the loud speaker we see that virtually all frequencies between 300 and 4,000 cycles are fairly well transmitted, and from Fig. 4 we see that the syllable articulation to be expected is about 85 per cent.

From Fig. 4 we also see that the non-reproduction of the frequencies below 300 cycles is not important from an articulation point of view, although it is of consequence from a point of view of naturalness, as yet we know no function portraying naturalness.

In this connection it may be pointed out that experiment has shown that, provided no frequency is reproduced with less than one-tenth of the efficiency of the best reproduced frequency, the distortion resulting will not be objectionable, and in many cases will not be detectable by ear.

So much for speech on the loud speaker. How about music?

The highest note employed in ordinary music is C_5 (equivalent to a frequency of 4,096 cycles per second), although musical notation goes up to C_7 , with a frequency of 16,840 cycles per second; and, of course, the harmonics are still higher, but since the limit of audibility for the normal ear is round 20,000 cycles it is evident that harmonics as high as this cannot play a very important part in reproduction. Authorities differ as to the range of frequencies required for the exact reproduction of music, but it probably extends from about 16 cycles to about 10,000 cycles per second.

Actually a loud speaker having a characteristic as shown in Fig. 3 is capable of producing very pleasing results indeed; in fact, it would probably satisfy any but the most critical audience, and compete very seriously in quality of reproduction with the best gramophones at present on the market. It is, however, possible to detect the loss of both the high and the low frequencies, the former deficiency making a violin tend to sound flute-like, and the latter making a voice sound rather high pitched.

(To be concluded.)

A STABLE DUAL AMPLIFICATION CIRCUIT.

This interesting circuit is put forward by an experimenter for overcoming many of the difficulties usually encountered in dual amplification.

It is normally found, when working with dual amplification circuits employing valve rectification, that there is a considerable tendency to low frequency oscillation which can only be controlled by means which reduce seriously the amplification which could otherwise be obtained. The circuit arrangement to be described is an attempt which has, so far, proved highly satisfactory in minimising this trouble. No claims are made as to novelty.*

The set illustrated was hurriedly built up by a little circle of enthusiasts to test the

The circuit diagram is shown in Fig. 1, from which the chief features may readily be seen. The first point is the system of separating the L.F. and H.F. components in the anode circuit of the amplifier valve. The main anode circuit consists of a radio-frequency choke and the headphones or loud speaker, while the tuned anode circuit is also coupled to the anode through a small coupling condenser. This enables the detector valve grid to be coupled to the tuned anode circuit by the usual leaky grid condenser arrangement with no danger of

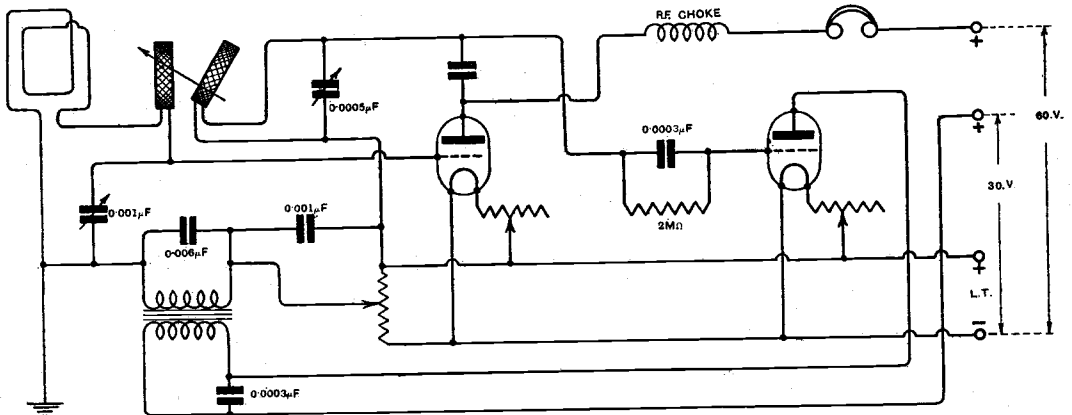

Fig. 1. The dual circuit with modified H.F. amplifying arrangement. The oscillatory currents in the tuned anode circuit are fed through a small condenser to the plate, whilst current is supplied through a carefully designed choke coil.

writer's circuit diagram, and it is not put forward in any way as a model set, for the layout obviously leaves much to be desired. On the other hand, it certainly works uncommonly well, and is also reasonably compact, while the apparent crowding and lack of system in the wiring has, nevertheless, led to highly satisfactory results.

any stray low frequency currents normally passing to the detector valve, and setting up L.F. oscillations. In this way the H.F. amplification can be made highly efficient without detriment to the L.F. amplification, which cannot be said of the usual tuned anode dual coupling. The second point is that means have been taken to suppress any reaction effects which might arise from the anode circuit of the detector valve. These include first, separate high tension supply at a lower voltage to the detector valve, and secondly, a fairly large by-pass condenser across the primary of the inter-valve transformer, whereby the latter is prevented from transferring any H.F. energy back into the

*The tuning arrangement here described is very similar to the series tuned anode arrangement, the principles of which were described in the *Wireless World* of September 19th, 1923, p. 819, and November 21st, 1923, p. 249. It might be mentioned that the series tuned anode principle has been employed in certain broadcast receivers for over a year.

aerial circuit. The fitting of this condenser in the set caused a considerable increase of signal strength, despite the fact that it must to some extent reduce the L.F. amplification.

It will be noticed that in Fig. 1 a frame aerial is indicated, though, of course, an outside aerial will function equally well with this circuit. The set has actually, however, been used mostly with a collapsible frame about six feet square, wound with five turns of 20 S.W.G. bare wire, spaced about $1\frac{1}{2}$ ins. apart. The aerial tuning inductance in Fig. 1 is a 15-turn honeycomb coil whose function is to provide a reaction coupling into the aerial circuit. Using an A.T.C. of 0.001 μF , the wavelength range is approximately 330 to 700 metres, and the results obtained are about equal to those from a good outside aerial containing 50 feet of wire.

A set built to work on this circuit is shown in Fig. 2. The components are standard bought ones, with the exception of the R.F. choke, and one of the variable condensers.

The high frequency choke may be seen at the back of the set, and consists of a cardboard tube 2 ins. diameter and 11 ins. long, wound for 10 ins. with 36 S.W.G. wire (about 1,200 turns). This coil is of course, quite unnecessarily large for broadcast wavelengths, but it is intended to enable the set to work on any wavelength up to 2,600, by using suitable plug-in coils.

It will be noticed that reaction is provided between the tuned anode circuit and the aerial circuit. This is now permitted by the P.M.G. for broadcast work if due care and skill are exercised in its use; but owing to a peculiarity of this dual circuit there is little likelihood of interference with one's radio neighbours by excessive reaction. This is

because, using normal H.T. values, H.F. oscillations occur with simultaneous L.F. oscillations, the latter making such a horrid noise in the telephones or loud speaker that one hastily reduces the reaction coupling out of sheer self defence.

It may be asked how this agrees with my earlier statement that H.F. amplification could be made highly efficient without detriment to the L.F. amplification. I think the explanation is that the howls which are heard are not due to L.F. reaction effects, but rather to the rectification of the H.F. local oscillations producing an intermittent saturation effect on the detector valve.

It might seem that tuning and "searching" would be difficult on this set, since it is not

normally possible to obtain a heterodyne howl, but it is easy after having picked up two or three stations of known wavelength and determined their positions on the tuned anode condenser to guess the approximate positions required for other stations. When first using the set, the following method of handling will be the best if a wavemeter is not available. After

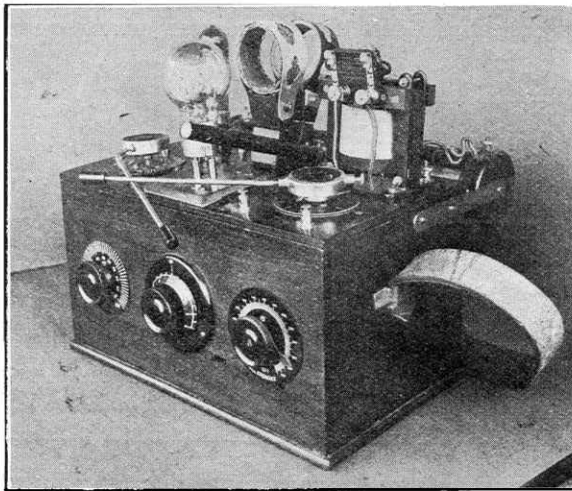

Fig. 2. An instrument embodying the circuit described.

lighting up the valves, set the potentiometer at the extreme negative end of its range, and the aerial condenser at the middle of the range; then bring the coils gradually up together with each movement of the coils, turning the tuned anode condenser through its whole range, until the coupling is just sufficient to cause howling at one particular point of the tuned anode range. Leaving the tuned anode condenser at this place, stop the howl by a slight movement of the potentiometer. The positions of the aerial and tuned anode condenser are now corresponding settings, the circuits being correctly tuned to receive any signals which might be on that wavelength. Now alter the aerial condenser setting by, say two degrees, and

search out on the tuned anode condenser by moving it in the same direction, repeating this performance until a signal is picked up. This procedure avoids any serious risk of inadvertently producing interference, while tuning in before the wavelength values of the set are known. The potentiometer will be found very valuable as a fine control of the reaction, but only the negative end of the range should be utilised. The set seems to work quite well with most types of valves.

Working about 35 miles from **2 ZY**, there is no difficulty in working a loud speaker from **2 ZY** or **5 IT** to fill an ordinary sized room, using the frame aerial, while the high selectivity and directional properties of the latter allows of complete elimination of **GLV**, the Seaforth Coast Station (about five miles distant), whose working causes intense jamming in the neighbourhood on wavelengths between 300 and 2,000, when an ordinary outside aerial is employed with a single circuit tuner. H. W. R.

CONSTRUCTING VERNIER CONDENSERS.

The accompanying drawings show two simple methods for building up variable condensers of small capacity, suitable for use as verniers.

can be obtained. This arrangement is quite useful for providing the necessary capacity back coupling in neutrodyne circuits

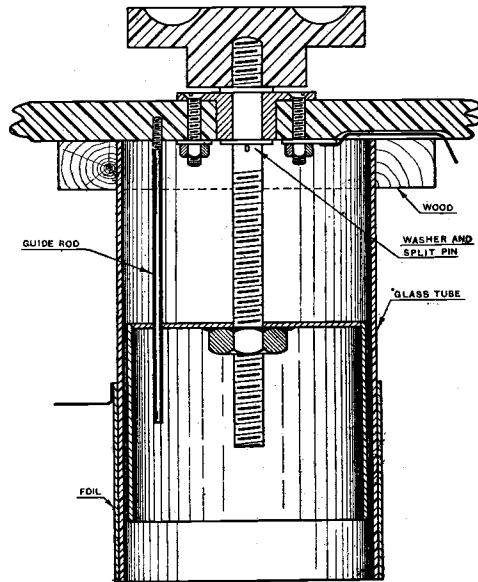
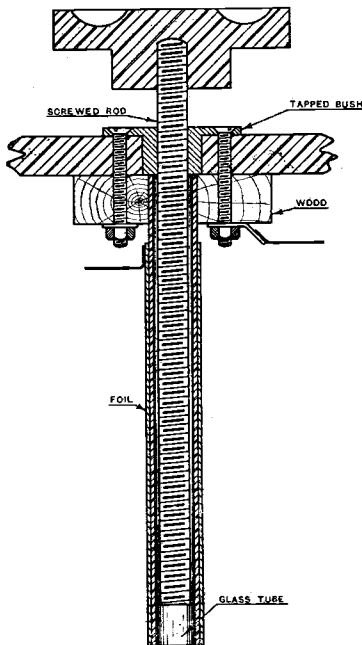

That on the left consists essentially of a bushed and threaded spindle which advances through a glass tube, having a wrapping of copper foil. As the screw advances, critical adjustments of capacity

The other design is a little more elaborate and employs a glass tube of larger diameter and provides a bigger capacity variation, though in this instance the copper foil only extends half-way along the glass tube.

THE PRINCIPLES UNDERLYING THE OPERATION OF THE THERMIONIC VALVE.

In the previous instalment we briefly discussed the emission of electrons from a heated filament, and the method of obtaining the voltage saturation curves of a simple two electrode thermionic device.

By W. SYDNEY BARRELL.

(Continued from page 493 of previous issue).

Let us now consider the case of the tube in Fig. 1* but with the plate potential constant and varying filament temperature. Commencing with the filament cold there will be no electron emission, and consequently no current in the circuit FAB_2F . If the filament is now heated to a low temperature, comparatively few electrons are emitted per second, their velocity steadily increasing as they move toward the positively charged anode. For any given anode potential they acquire a definite velocity, so that some certain time will be taken for their passage from filament to anode, and at any instant there will be a certain number of electrons in the interelectrode space. These electrons all move towards the anode and are in turn absorbed by it.

As the filament temperature is increased, so will also the emission and the number of electrons in the space filament to anode be similarly increased, and the effect of this space charge on the electrons leaving the filament is exactly opposite to that of the anode potential. It would thus be expected that if the filament temperature be sufficiently increased a point would be reached when the two effects, anode potential and space charge, balance each other and no further increase in anode current would result. This is actually the case, and is represented graphically by the curves in Fig. 4. Taking for example the lowest curve in the figure, it will be seen that after a certain point the anode current no longer increases with increased filament current, and that indicated by the horizontal line is called the "temperature saturation current." The reason why the plate current does not go on increasing is because the

anode potential is not sufficiently high to attract all the emitted electrons. If a larger anode current is required, the anode potential must be increased as has been done in the case of the curves E_2 and E_3 (Fig. 4). It is, however, to be noted that the higher the anode voltage the higher must be the filament temperature before saturation sets in. We thus see that for each value of plate voltage there is a corresponding value of filament temperature beyond which there is no increase in anode current.

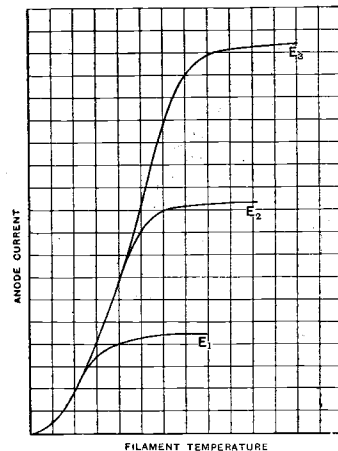

Fig 4.

Experiment No. 2.—Temperature Saturation Curves.

The apparatus required and the circuit arrangement is the same as in Experiment No. 1, but in the present case the anode voltage is kept constant, and the filament current varied.

Commencing with an anode potential of, say, 20 volts, all the series resistance is included in the filament circuit, thus reducing

the brilliancy to a minimum. The filament brilliancy is then gradually increased, a note being taken of the anode current for each setting of filament current. Continue until increase in filament brilliancy ceases to increase the anode current. Two sets of figures will thus be obtained — (1) Filament current, and (2) Corresponding anode current. Plotting on squared paper as before produces a curve similar to the lower one in Fig. 4. The anode

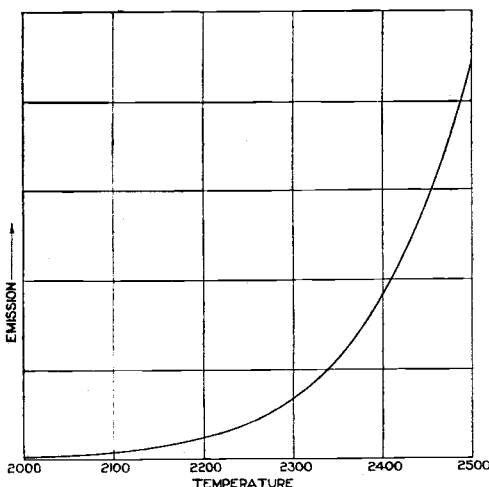

Fig. 5.

voltage is then increased to, say, 30 volts, and the operation repeated, giving the middle curve in Fig. 4, and so on.

The variation of emission with temperature is shown in Fig. 5. It will be observed that at low temperatures the emission is small, and further, the rate at which it increases with temperature is also low. Around 2400° the emission is extremely sensitive to small temperature changes.

Taking any one of the curves of Fig. 2,* say OABC, it can be shown to be made up essentially of two parts:—

(1) That in which the current is determined by the space charge, and

(2) A saturation region in which the current is independent of the voltage, but is determined by the filament emission.

There is actually a third region, involving negative anode potentials, where the current is determined by the initial velocities of the electrons, but this need not concern us here.

For the range in which the plate current is limited by the space charge Langmuir† has shown that the current increases in proportion to the $3/2$ power of the anode voltage, and is practically independent of the filament temperature.

In deriving this formula two assumptions were made—(1) That the electrons leave the filament with zero velocity, and (2) That the filament is an equipotential surface. In practice neither of these assumptions are fulfilled, but as the two effects produce opposite results they tend to neutralise each other to a great extent, although in general the effect of (2) is rather the greater.

In practice, of course, the emitting surface is not an equipotential surface, but takes the form of a filament which is heated by the passage of a current through it. Consequently there will always be a voltage drop down the length of the filament, the general effect of which is to reduce the current through the valve, because the *average* plate potential is somewhat lower than that between the anode and the negative end of the filament, which is the voltage usually indicated by the voltmeter. This is further explained diagrammatically in Fig. 6. Actually the effect of the voltage drop down the filament is to cause a shift of the whole curve to the right of the $3/2$ power curve. On the other hand the effect of the initial velocities is to cause the curve to deviate to the left, more particularly for low anode voltages.

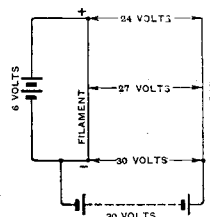

Fig. 6.

Proceeding along the characteristic from the lower voltage values, we see that the curve slowly bends over towards saturation. It is to be noted that the curve does not suddenly attain the saturation

† Langmuir, *Phys. Rev.*, 1913.

value, but passes through a transition region the extent of which depends upon several factors. Chief among these may be mentioned the voltage drop in the filament and the shape of the anode. For example, as the anode voltage is increased, the current from some parts of the filament becomes saturated before that from other parts, thus extending the transition region. With coated filaments the transition region is usually

much more extended than with tungsten filaments. It is thus seen that a variety of factors contribute to produce the curved characteristic practically obtained, and the foregoing remarks will show the inability of deriving a simple equation for the whole of the characteristic, but for small parts a simple law can usually be applied. This, however, will be dealt with more fully when considering three-electrode valves.

PATENT ABSTRACTS.

Variometers.

The usual variometer has two windings, the stator and the rotor, which in general are joined in series. When, however, it is

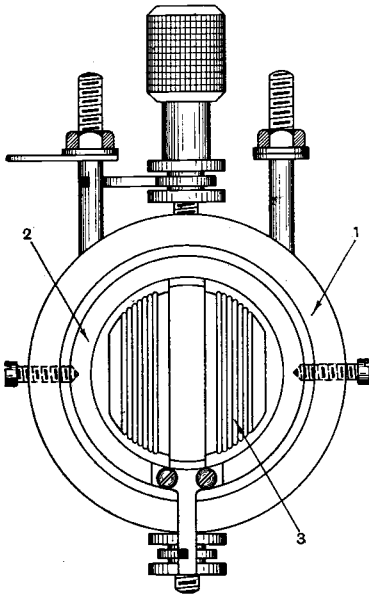

Fig. 1.

simply desired to couple two circuits, the rotor may be joined with one circuit and the stator with the other; for example, the rotor may be used as a reaction coil, which is coupled with the anode or aerial circuits.

Another form of variometer has three distinct windings. There are two stators,

and a single rotor. The arrangement is shown in Fig. 1.*

An application is shown in Fig. 2. Here coil 1 is one stator, coil 2 the other, and coil 3 the rotor. Coil 1 is connected as the reaction coil, and coils 2 and 3 in series as a variometer to tune the aerial circuit. By suitable design the reaction effects through the coupling of coils 1 with 2 and 3 may be made satisfactory over the wavelengths covered when tuning the aerial circuit.

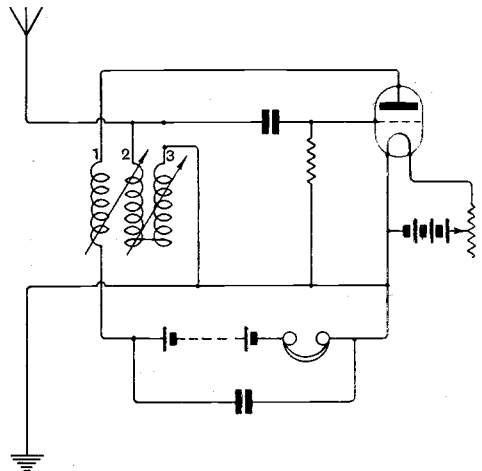

Fig. 2.

Readers will quickly notice other uses for this type of variometer. W.J.

* British Patent No. 200,645, by R. T. Smith and R. C. Bookless.

A USEFUL VARIOMETER. 180-650 METRES.

THE variometer which forms the subject of this article possesses several advantages. Firstly, the distance between fixed and moving coils has been reduced to approximately three thousandths of an inch, and secondly, it possesses the desirable feature of fully variable and reversible magnetic coupling.

Regarding the coils themselves, these are of the single layer type, all turns being in the same plane, and the method of winding is as under. A centre former is cut from $\frac{1}{8}$ in. ebonite or other suitable material to the dimensions given in Fig. 2, and a hole $\frac{1}{8}$ in. in diameter drilled centrally.

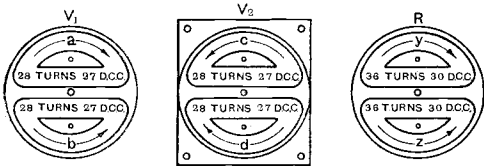

Fig. 1.

There are many obvious uses to which this instrument may be put, and the addition of a variable condenser, connected across the coils (primarily intended for reaction) will complete a tuner with variometer primary and condenser tuned secondary.

With regard to size, it will be seen that this is by no means excessive. The height from the upper control knob to the base is $3\frac{1}{8}$ ins.,

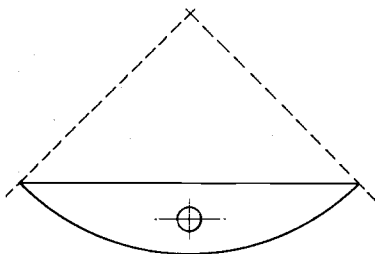

Fig. 2.

while the length and width are $5\frac{1}{2}$ ins. and 5 ins. respectively. The external measurements of the wood case are $5\frac{1}{2}$ ins. by 5 ins. by $1\frac{3}{4}$ ins. The sides are $\frac{3}{8}$ in. thick and the base $\frac{1}{4}$ in. The two discs, shown diagrammatically in Fig. 4 as V1 and R, are cut from $\frac{1}{8}$ in. ebonite with a fretsaw, $4\frac{1}{8}$ ins. in diameter. V2 is a piece of ebonite, measuring $4\frac{1}{2}$ ins. by $4\frac{1}{8}$ ins. by $1/16$ in., and has two coils similar to V1.

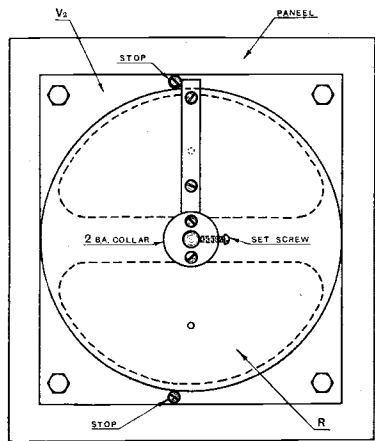
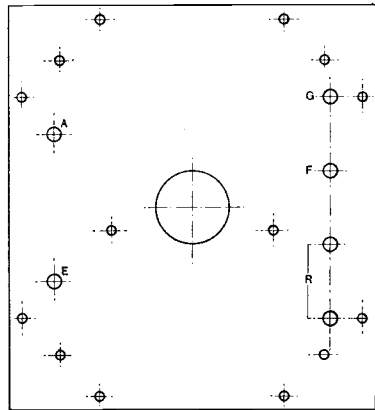

Fig. 3.

This is then fixed in position by means of a 6 B.A. screw and nut. A small hole is now drilled in the ebonite close to the edge of the former, and after pouring a small quantity of molten beeswax on the surface the end of the wire is passed through to the extent of a few inches for connecting purposes, and as the winding of the coil is proceeded with, the turns of wire are waxed

to the ebonite by the application of a gentle heat through the agency of a small screw-driver.

Great care must be taken not to injure the insulation, the turns must lie closely together, and on completion of the coil, another hole is drilled, and the end of wire passed through as before.

In order that no misunderstanding may arise regarding Fig. 4, it may be mentioned that the space between the lower paper disc and V2 is to allow of connection between and from the coils on V2.

The arrangement of stops to prevent a movement of more than 180° of the lower disc is shown in Fig. 3.

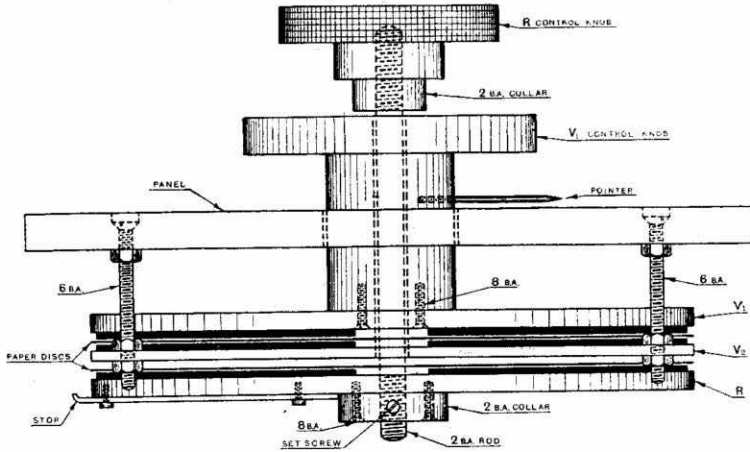

Fig. 4.

The former is removed on completion of each coil, and may be scrapped on completion of the instrument.

The arrows on the diagram (Fig. 1) indicate the direction taken by the wire as the winding proceeds.

All superfluous wax should be carefully removed and the coils given two coats of shellac varnish.

Referring again to Fig. 1 (taking *s* as the starting, and *f* as the finishing ends of coils) the connections are as follows:—

1. Aerial terminal to grid terminal, and by flexible lead to *s* of coil *a*.
2. *f* coil *a*, to *s* coil *b*.
3. *f* coil *b*, by flexible lead to *s* coil *c*.
4. *f* coil *c*, to *s* coil *d*.
5. *f* coil *d*, to earth terminal and to filament terminal.
6. *f* coil *y*, to *s* coil *z*.
- 7 and 8. Insulated flexible leads connect *s* coil *y*, and *f* coil *z* to the reaction terminals *R*.

The positions of the various terminals are marked on the top panel diagram Fig. 3.

0.003 in. leatheroid will be found suitable material for the discs which separate V1 and R from actual contact with V2.

All terminals and heads of screws are lacquered, as is also the brass pointer, which in conjunction with the two cheese-head 6 B.A. screws used to fix the ivory scale in position, limits the movement of V1.

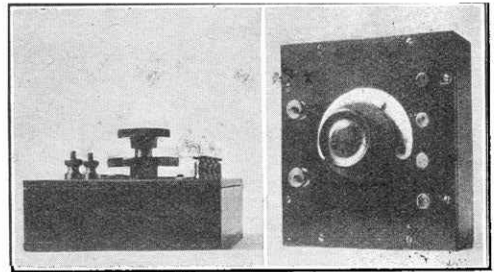

Fig. 5.

In order that the diagrams might not be unduly complicated, all terminals and the ivory scale have been omitted, but are shown in the two photographs of the finished instrument (Fig 5).

The wavelength range may be considerably augmented by the addition of a 0.0005 mfd. fixed condenser and a series-parallel switch.

W. F. D.

ELECTROLYTIC DETECTORS AND LIQUID VALVES.

Before the days of valves, there were many experimenters who adopted the electrolytic type of detector as being a particularly sensitive device. This type of detector has been neglected in recent years, though it is simple to set up and warrants the attention of the experimenter. A description is given of its development and details concerning its operation, while more recent developments are mentioned.

By JAMES STRACHAN, F.Inst.P.

THE electrolytic detector occupies, in both history and sensitivity, an intermediate position between the coherer and the crystal detector. For some time it displaced the former in wireless telegraphy but was rapidly discarded in favour of the more sensitive crystal. In its simplest form it consists of two platinum wire electrodes dipping into dilute sulphuric acid (10 per cent.), the cathode or negative electrode having a comparatively large surface in contact with the acid, while the anode or positive electrode has an extremely small surface *e.g.*, the end of a very fine platinum wire 0.03 mm. in diameter, exposed to the liquid. The size of the active anode may be regulated by a micrometric adjustment whereby the fine wire is made to dip more or less through the surface film of the electrolyte, but it is usually fused into the end of a thin glass tube so that only the tip of the wire makes contact with the acid, when the tube is immersed in same, while the upper portion of the tube receives a stouter wire, making the necessary electrical connection with the dry end of the anode by means of a mercury joint. Lead or carbon may be used for the cathode in place of platinum. A wide-mouthed glass bottle (2 to 4 ozs. capacity) makes a convenient holder for the acid and the electrodes may be suspended through perforations in the cork. The latter should be prepared by boiling in paraffin wax and its under surface should be smeared with vaseline. The electrolytic detector is inserted in the circuit in exactly the same way as a carborundum detector, using an applied potential from a small dry battery (3 volts), so controlled by a potentiometer that a current of approximately 1 milliamp. passes through the electrolyte. Numerous modifications of this detector have been described and one form used in France dispenses with

the applied potential from an outside battery by transforming the detector into a voltaic cell, in which one of the electrodes is the usual platinum point, while the other is composed of an amalgam of zinc and pure tin in mercury, into which an insulated wire is plunged. The amalgam may be prepared by mixing 4 grams of zinc filings and 1 gram of tin-foil in 4 cubic centimetres of mercury.

The theory of the electrolytic detector has been a source of much dispute. De Forest and others have maintained a purely electrolytic theory in which the polarisation film of gas formed on the anode varies in dimension and resistance with the high frequency oscillations, thus allowing of the passage of a varying current from the battery through the phones. The modern trend of physical opinion is in favour of the theory that the electrolytic detector is a heat-operated device and that the variation in resistance of the polarisation film is due entirely to the heating effect of the high frequency oscillations, thus acting as a variable negative resistance in the battery circuit. In the present writer's opinion the latter theory does not explain all the phenomena observed with electrolytic detectors.

Although the electrolytic detector assumed numerous and diverse forms, it was displaced all too rapidly by the more sensitive crystal detector in much the same fashion as the valve has taken the place of the crystal.

There is a wide field of research open in this direction and there are at present signs of renewed interest, not only in perfecting the crystal detector, but also in improving the electrolytic detector.

An interesting development of the electrolytic detector lies in the attempts by experimenters in France and Germany, and more lately in America, to devise liquid valves in which the high tension battery current

passes to the "plate" by means of streams of ions or groups of ions suspended in a suitable liquid. By this means the ideal liquid valve would go further than an electrolytic rectifier and by the application of a high tension battery yield low frequency amplification. These experimental liquid valves consist of two electrodes and a "grid" immersed in a cell containing a suspension of a colloidal metal in a liquid. The difficulty is to find a suitable liquid which will give a stable suspension of the colloid metal without exhibiting the phenomena of ionisation and electrolysis under H.T. Given the ideal liquid containing a very fine suspension of colloid metal, the application of the H.T. current to the electrodes is supposed to produce a cataphoretic stream of ions between the latter which would be varied by the potential of the interposed "grid."

In 1922, Suprin in France experimented with some signs of success on these lines, using colloidal silver suspended in a mixture of acetone and chloroform. He suggested that benzine would prove a suitable liquid if a stable metallic colloid could be obtained in that liquid. More recently, Nienhold in Germany claims to have solved the problem, but withholds the composition of the liquid. There have also been similar claims from America.

In the present writer's opinion such devices cannot be compared in their action with the thermionic valve. In the latter we have a flow of electrons from the incandescent filament to the plate, while in the "liquid valve" it appears to him that the action is more akin to that of the coherer and that the colloidal particles of metal arrange themselves between the electrodes along lines of force in the liquid dielectric.

At any rate up to the present we have a reliable rectifier in a good crystal, and no better amplifier than a good valve, so that with regard to certain electrolytic devices for which rather extravagant claims are made, my advice to the amateur is to try them out thoroughly before purchasing.

As I have already remarked, however, there is a wide field open in this direction for experiment, a field that has been neglected on account of the rapid perfection of the thermionic valve, and one that will repay the experimenter with at least many interesting results, while he *may* stumble across something really important.

A Novel Variable Condenser.

There is considerable scope in the design of variable condensers, as is evident by the variety of patterns to be found upon the market.

A condenser designed on a new principle has recently made its appearance in France,

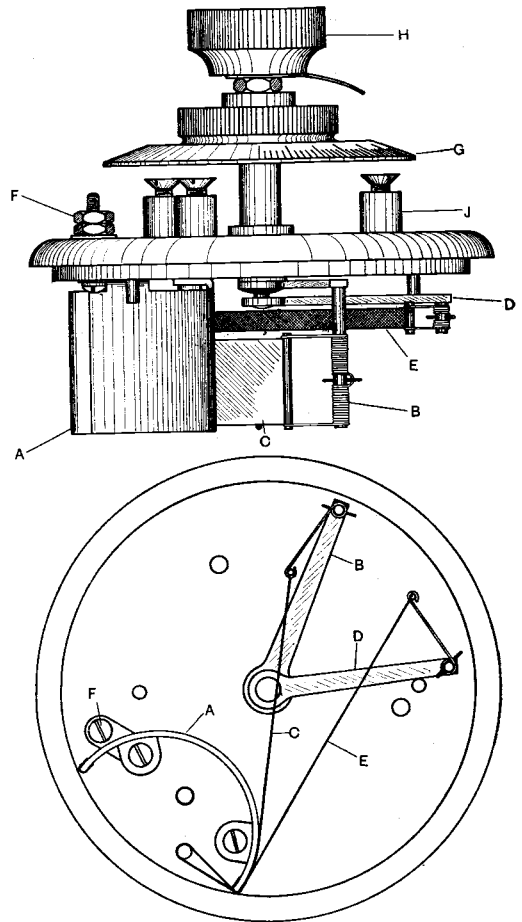

and is shown in the accompanying drawing.

The knob operates a lever which drags the metallic band, so as to wind it on a mica-faced semi-circle plate. Provision is made for fine adjustment by a concentric spindle operating a second lever, attached to which is a metallic strip narrower than that which is operated by the main knob.

This condenser is ingenious and is quite simple in construction.

200-METRE TRANSMISSION DURING BROADCASTING.

A DESCRIPTION OF SOME EXPERIMENTS OF CONSIDERABLE INTEREST TO TRANSMITTERS.

A good deal of careless comment has been made on the subject of interference with broadcast programmes by amateurs utilising the 200-metre wavelength, and it is therefore of interest that as much accurate data as possible upon the matter should be collected and considered. Primarily with the object of determining to what extent interference is caused, some interesting experiments were recently arranged by Captain Ian Fraser, who is so closely associated with matters of interest to transmitting licence holders, a description of which is given below.

AS the hours occupied by broadcasting increase, and the time left to the amateur transmitter becomes restricted, it is of interest to consider any arrangement which would give greater freedom to amateur work. At one time shortly after the war the experimental wavelength was 1,000 metres, and although there was reluctance on the part of many experimenters to adopt the 440 metre wavelength subsequently allotted to them, it has generally been agreed that the shorter wavelength has proved to possess many merits for experimental transmission. When the 440 metre wave was reallocated by the Post Office to the Broadcasting Company, the experimenter was obliged to search out and recommend a new wavelength, on which his transmission would not interfere with the broadcast listeners, and on which the broadcast transmissions would not interfere with the reception of his signals.

A new wavelength of 200 metres was proposed and many stations are at present licensed only to work on this wave, and although the use of the 440 metre wavelength has only been forbidden during broadcasting hours, comparatively little use is made of it. Some experimenters are somewhat opposed to the adoption of the wavelength of 200 metres, but from an entirely technical standpoint it has no disadvantages as compared with the 440 metre wavelength, and perhaps in some respects possesses advantages. To say difficulty is experienced in receiving and transmitting on the short wavelength of 200 metres belittles the ability of the experimenter, and those who are reasonably skilled in their work find no difficulty in setting up suitable apparatus.

From his station in Regent's Park, a test was recently carried out by Capt. Ian Fraser (**5 SU**) on 200 metres, and suitable receiving apparatus was installed at the headquarters of the St. Pancras Radio Society so that members could witness the results obtained. The distance between these points is approximately $1\frac{1}{2}$ miles, and each is about 2 miles from **2 LO**.

Before a well-attended meeting it was shown that there was not the slightest difficulty in receiving signals from **5 SU** during the Broadcast transmission from **2 LO**, when a loose coupled receiver was employed, and it was also observed that interference was almost negligible when using a direct coupled receiving set.

High frequency amplification on the tuned anode principle was made use of, followed by a detector valve with plate circuit reaction and two low frequency amplifiers, and the speech from **5 SU** was applied to a loud speaker. Reception was so good that it was found possible for Captain Fraser to proceed with an address to the Society, which was clearly heard and understood by members.

In order that useful data might come to hand, announcements were made periodically, requesting that broadcast listeners whose reception was interfered with by the 200 metre transmission from **5 SU**, would communicate with Captain Fraser, advising him as to their location, type of receiving apparatus employed, and the extent to which interference was experienced. No reports of interference during these tests have however come to hand, although transmission was maintained for a long period and a very conclusive experiment was carried

out. This consisted in receiving the **2 LO** transmission on an aerial, greater in height, and near to the transmitting aerial, and applying it, after suitable amplification, to the modulating apparatus of **5 SU's** transmitter. A description of the apparatus employed, and some technical details in

wave transmitter introduced little or no distortion.

From these tests it can be concluded that amateur 200 metre transmissions need not interfere with broadcast reception, as emphasised by the fact that it was possible to receive the **2 LO** transmission close up

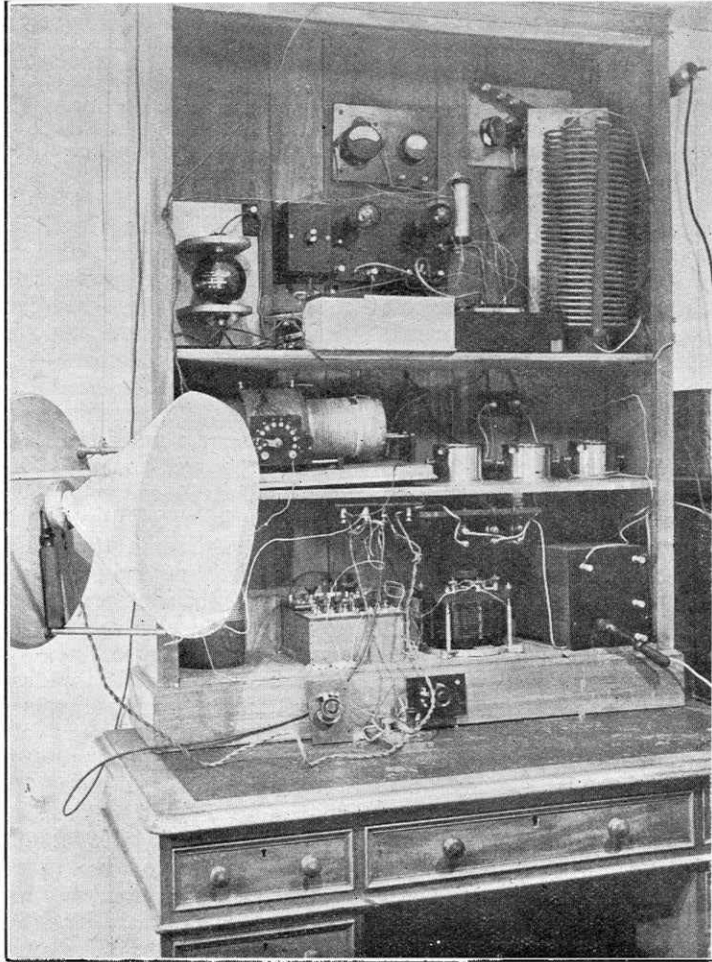

The transmitter at 5 SU.

regard to the experiment will be found on another page.

It was interesting to observe that the retransmitted speech from **2 LO** was clear and undistorted, whereas speech with a carbon microphone and the same transmitter was much less perfect. This clearly demonstrated the imperfections of even the best carbon microphone, and that the control and radio frequency circuits of the short-

against the 200 metre transmitting apparatus, and moreover that it is possible for the experimenter to receive transmissions on the short wavelength without interference from broadcast stations.

These observations are controlled, however, by certain limits. Tests made with the same receiving apparatus at a distance of only half a mile from **2 LO** indicated that it is quite impossible to tune out the B.B.C.'s

transmission even when employing the most elaborate apparatus, and at the same time maintain a sensitive adjustment for short wave receptions.

The power used by 5 SU during these tests was approximately 12 watts, being 25 milliamperes to the plate of the oscillator from the supply mains at a potential of 480 volts. An aerial current of 0.58 amp. was obtained.

NOTES ON THE APPARATUS EMPLOYED AT 5 SU.

The transmitter employs the "choke-control" system of modulation and utilises three valves. The first functions as a sub-control stage (V1) and is arranged to amplify

The sub-control valve is rated at 15 watts, the control valve at 40 watts, and the oscillator valve at 100 watts. The average input to the oscillator on 200 metres wavelength is 12 watts. This valve is of low impedance and is consequently very flexible—a desirable feature which ensures sustained oscillation during periods of full control when the voltage changes at its anode are great.

The resistance to earth at 5 SU is relatively high, and since practical considerations render undesirable the installation of an earth screen, inductively coupled oscillating circuits are employed, the retroactive winding being arranged to link with both the anode

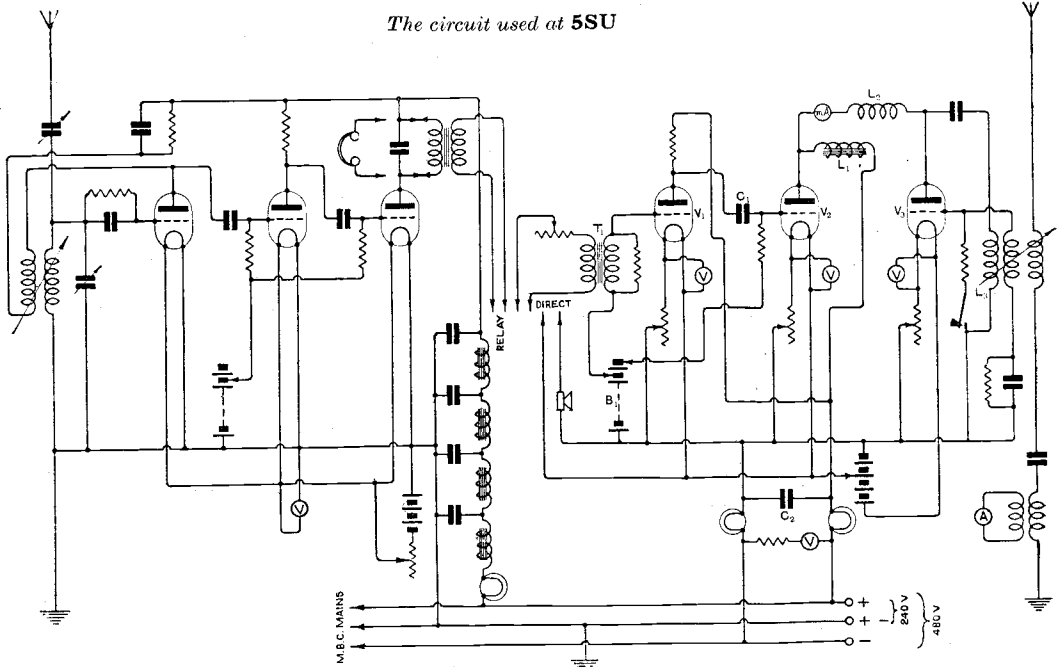

the currents traversing the secondary winding of transformer (T1). The potential variations thus secured are communicated to the grid of the control valve (V2) through condenser (C1). This valve effects further amplification and voltage variations are thereby set up across inductance (L1) which lead to corresponding fluctuations of potential at the anode of the oscillator valve (V3). Since the output from this valve is proportional to the value of its anode supply, it follows that the oscillatory energy animating (L3) will undergo variations in amplitude in time with the characteristics of the currents actuating the sub-control circuits.

and aerial coils. In addition to removing a considerable load from the oscillator valve, the coupled-circuit arrangement renders the wavelength of the emission mainly dependent upon the constants of the anode circuit. This is peculiarly advantageous in short wave work since slight variations of aerial capacity due to swaying wires or to the movements of people near the feeders cannot lead to interrupted communication.

The resistance of the aerial hot-wire ammeter being appreciable, it is inductively coupled to the earth lead.

Up to 20 watts, the anode supply to the valves is derived from the Marylebone mains,

but upon the rare occasions when it is desired to increase power, a rotary transformer is employed. Since the power expended in the control circuit is proportional to the power radiated, an additional 40-watt valve is then paralleled with the control valve.

The aerial used for transmission on wavelengths between 130 and 200 metres is composed of one length of 7/20 enamelled copper wire, 110 feet long, with an average height of 35 feet, and exhibits directional properties eastwards. For transmission on 440 metres and for long wave reception, the aerial used comprises two wires spaced 15 feet, each 110 feet long, average height 60 feet. It is non-directional.

The modulation choking coil (L_1) is sectionally wound upon an "open" iron-wire core. The radio frequency choking coil (L_2) is wound to possess negligible self-capacity—an important consideration. The secondary winding of transformer (T_1) is shunted to maintain a constant load, and a suitable negative bias is imparted to the grids of the sub-control and control valves by means of battery (B_1).

The indicating needles of the various metres pass over dials inscribed in Braille. When taking a reading, the needle is firmly held in a rubber-lined clamp actuated by an external plunger. The finger is then moved over the surface of the dial until the needle is located, the corresponding reading being noted.

When the apparatus is used for continuous wave telegraphy, a non-inductive resistance is placed across the grid circuit of the oscillator valve to enforce quiescent periods. A well-sustained tone characteristic is secured, the "chirping" occasioned by the usual grid-keying arrangement being avoided. Tonic train telegraphy, although rarely used at 5 SU, is effected by exciting the grid of the sub-control valve by a buzzer or, alternatively, by removing the cushioning condenser (C_2) and allowing the periodic variation of mains voltage to influence the anode of the oscillator valve.

One of the main reasons in "relaying" 2 LO was to observe the measure of distortion introduced by the transmitting circuits, as distinct from the microphone. It was, of course, found necessary to amplify 2 LO's transmission before feeding it into the transmitter. This was carried out with the help of valves having openly spaced grids, a low

M. value, and very good characteristics for speech amplification. Two non-inductively wire-wound resistance coupled stages of note amplification were employed and no distortion was noticeable at the input to the transmitter. Comparisons made at a distance between the quality of 2 LO and the quality of 2 LO via 5 SU indicated no discernible difference. This proved that the transmitter circuits at 5 SU were, to all intents and purposes, distortionless. The carbon microphone was switched into circuit immediately following speech from 2 LO, and, as was expected, the difference in quality was great. This microphone is one of the best of its type so that the experiment conclusively demonstrates the baneful influence of the ordinary carbon microphone in introducing great distortion into what may be otherwise a practically distortionless transmitter.

With reference to the above article, the following communication has been received from Capt. Fraser:
To the Editor of THE WIRELESS WORLD AND
RADIO REVIEW.

DEAR SIR,—As you have been good enough to let me read the proof of your Editorial article on some tests which I recently carried out with the kind assistance of Mr. Oswald Carpenter, Mr. F. H. Haynes, and the St. Pancras Radio Society, and have asked for my comments on it, I append them herewith.

I agree with your observation that telephony transmissions on 200 metres need not interfere with the reception by neighbouring listeners of the B.B.C. programmes. I think the experiment we undertook showed that even when the receiving aerial is within 20 or 30 feet of a transmitting aerial, as is the case at my station, it is possible without undue complication to receive 2 LO on the one without any interference from the other. It is, of course, understood that when a crystal detector is employed near to an amateur's transmitter, much greater difficulties in avoiding interference are experienced. Without taking space to marshal the many arguments that could be brought forward in favour of the following contention, I venture to submit that it is in the best interests of the wireless art that amateurs should not be restricted in the use of low power wireless telephony on wavelengths of from 150 to 200 metres during broadcasting hours. Legislation which might have the effect of overcoming the difficulties of the relatively small number of crystal users would restrict the serious and useful work of a number of transmitters. In this matter, as in many others, goodwill and not legislation is the best medium for securing general satisfaction. If transmitters would be careful to use only the minimum amount of power required for their experiments, and further, if they would, as I have done, ask neighbouring listeners to report interference, and give them assistance in the matter of rendering their simple crystal receivers more selective, each could pursue his research or hobby without troubling the other.

Yours sincerely, IAN FRASER.

The Radio Society of Great Britain.

REPORT OF THE ANNUAL GENERAL MEETING.

(Continued from page 511 of previous issue.)

Mr. A. A. Campbell Swinton.

I have pleasure in moving that the following be elected officers and Committee of the Society for 1924:—President, Dr. W. H. Eccles, F.R.S., D.Sc., A.R.C.S., M.I.E.E.; Acting Vice-President, Brig.-General Sir Capel Holden, K.C.B., F.R.S.; Hon. Secretary, P. R. Coursey, B.Sc., A.M.I.E.E.; Hon. Treasurer, Prof. Ernest Wilson, M.Inst.C.E.; Committee, R. Carpenter, H. S. Pocock, J. H. Reeves, M.A., J. H. Hibberd, R. L. Smith-Rose, Ph.D., Captain M. Ainslie, R.N., Thomas Hesketh, M.I.E.E., and Stanley Ward.

Col. Macdonald.

I have much pleasure in seconding that proposition. On looking through the names one notices that the majority, if not all, are well known for their activities in the radio world. I am quite sure that we could not have a better list of names.

The motion was carried unanimously.

The President.

I have to propose a cordial vote of thanks to the retiring officers. There is, first of all, Mr. Hope-Jones, whom everybody who belongs to the Society knows very well indeed. Mr. Hope-Jones has been responsible for a very great many of the triumphs of the Society in past years. He has worked in this one office for ten years—that is the whole life of the Society—and is probably better known personally to the membership than any other officer. I know that the Treasurer and the Secretary do a great deal more worrying of the members by correspondence, but Mr. Hope-Jones, I think, has scored in the number of personal relationships he has established up and down the country during his term of office. I cannot speak too highly of the amount of interest he has taken in his work during that period. I think I have known him the whole of the ten years, or at least nine of them, and he has always been intensely eager to help the Society in every way. Mr. Fogarty, the Treasurer, has been in his office the same number of years, but he cannot be said to have endeared himself to the members, because his duty entails calling in the subscriptions. He can, however, claim to have become known to hundreds of members scattered throughout the country by the lectures he has given in many places on behalf of the Society. His work in that way has helped the Society to greater strength in the provinces in a manner which cannot be over-estimated. We owe our cordial thanks to him. Mr. McMichael, too, has been in his office as Secretary for five years. Before that he was in office as Vice-Chairman. He is beloved by all the members who have come in contact with him. We could not desire and we never shall have anybody more capable or more amiable in their respective offices than these three gentlemen, and I want to put them prominently forward above the heads of the other officers who are retiring on account of the fact of their long service

and popularity with the Society. In order to save time, I will put in one vote not only their names, but also the names of the other officers who are retiring. There are two acting vice-presidents (Major Binyon and Mr. Klein) and the vice-chairmen (Mr. Child and Mr. Mair). We wish to join their names in this vote of thanks. Mr. Child and Mr. Mair have been specially active workers on behalf of the Society. I mention them specially, but without wishing to put them upon any higher plane than the others so far as your thanks are concerned. I propose, therefore, that a very hearty vote of thanks be accorded to all these gentlemen. It needs no seconder, and I ask you to pass the motion with acclamation.

(The vote of thanks was accorded with enthusiasm.)

Mr. Hope-Jones.

I feel very grateful to you for your kind words. Perhaps I may speak on behalf of my colleagues as well in replying, because I know they will appreciate just as deeply as I do what has been said on the occasion of their resigning office. I feel as if I had reached the end of a very interesting chapter of my life. That is a small and personal matter, but what I do feel to be of real importance is this—that every society of this kind must pass through a certain stage—a crisis in its career. It is just as if we had outgrown a small temporary building. You are now setting up a fine new structure—the permanent home, may we call it—and in approving in principle the new Constitution you are laying a very fine foundation stone for this extension, which, though it already represents a great deal of hard work done, will involve still further work for the new Committee. I believe the new Committee will take on that work and finish it, and lay that foundation stone well and truly under the guidance of your President. It has been really a proud privilege both to my colleagues and myself to have been associated with unselfish people for so many years in fostering the amateur movement, and to have seen its outcome this evening in your expanding into a national society with a very carefully-prepared constitution which will form your foundation stone, and, I hope, will bring a great and prosperous career to the Society.

Col. Macdonald.

It is a great pleasure to me to propose a hearty vote of thanks to the members of the retiring Committee. In a rapidly growing Society like this the duties of a committeeman are very arduous, and I think I can say that the retiring committeemen have carried out their duties in such a way as to found a tradition which their followers will find a pleasure to endeavour to live up to. The work, as I have said, is very hard, and we can only reward them by passing a very hearty vote of thanks for the splendid way in which they have served the Society.

Mr. Dougall.

I have very much pleasure in seconding that.
(*The vote of thanks was carried with acclamation.*)

Votes of thanks were also passed to the Institution of Electrical Engineers for the loan of their lecture hall and other rooms during the year, and also to Mr. J. Ockleshaw, F.C.A., the honorary auditor.

Mr. Ockleshaw was re-elected honorary auditor.

The President.

At the last meeting of the Committee, Mr. Hope-Jones, Mr. McMichael and Mr. Fogarty were

elected Vice-Presidents of the Society. We are putting them in the House of Lords, so to speak, so as to be able to pull them out any time we want somebody to work for us.

This concluding the business of the meeting, the President then called upon Captain E. J. Hobbs to read a paper entitled "Simplified Wireless Calculations." (*See subsequent issue of this Journal.*)

After discussion on the paper the meeting concluded with a vote of thanks to the lecturer.

CORRESPONDENCE

Another Link in International Amateur Communication.

To the Editor of THE WIRELESS WORLD AND RADIO REVIEW.

SIR,—Last Sunday, January 13th, between 7 and 7.45 p.m. I was successful in carrying out two-way communication between my station **5 DN** at the above address and Italian **1 MT** in Venice. My station is only licensed for 10 watts and this was the power used on a wavelength of 200 metres, my aerial radiation being only 0.5 amperes. I am not sure if this is the first time that amateur communication has been carried out between England and Italy, but I have not heard of such before, especially on this low power.

The previous Sunday, January 6th, I was successful in carrying out two-way communication with **XY** situated in Geneva, Switzerland, under the same conditions as above.
Sheffield.

L. A. K. HALCOMB, Capt.
Operating **5 DN**.

Radio and Orchestral Works.

To the Editor of THE WIRELESS WORLD AND RADIO REVIEW.

SIR,—When it comes to hearing orchestral music in a loud speaker or on a gramophone, I think what one misses is the effect of space. The sounds coming directly towards one from a point source do not quite *re-present* the wide sweep of the orchestra. What we really require is some form of "stereoscopic" sound. It is well known that we are able to judge direction of sound by its relative intensity on the two ears, and by turning to face the noise we unconsciously equalise it in them. This can be done consciously to locate an aeroplane in the sky. The head is swung until the sound appears directly in front, then the eyes are slowly swept vertically upwards and the aeroplane is discovered. For stereoscopic vision we require two eyes, which, having slightly separated viewpoints, perceive slightly differing views. Stereoscopic photographs are made on this principle.

Let us then try to produce "stereoscopic" sound (the Greek is getting a bit distorted!) by having two spaced loud speakers. But if these are identical, only a pseudo-effect will be obtained. My suggestion is to place on the left a loud speaker

resonant to low tones, corresponding to the left-hand instruments in an orchestra which are, on the whole, deeper toned, and on the right a speaker resonant to high tones. I haven't any loud speakers myself with which to experiment, but perhaps some manufacturer's laboratory staff would give it a trial and report on the result. It might be possible by having "unmatched" ear-phones to attain a similar result.

H. E. ADSHEAD.

"Blind Spots."

To the Editor of THE WIRELESS WORLD AND RADIO REVIEW.

SIR,—Previous to reading the interesting article by Mr. Chapman on "Blind Spots and Fading of Signals" in your issue of November 7th, I had, in some unexplained way, missed the fact that with amateur co-operation the Radio Research Board was investigating the subject.

I have been studying signal strengths for some time and in order to measure the comparative strengths I have used the shunted phone method. I attempted to "recalibrate" my results to suit the R.R.B. standard, viz., R1—R9 and in doing so I find that owing to their adopting a standard in which R8 is "strong," it is necessary for R9 to be extended to cover a very wide range. When the process was applied to my results I found that their true characteristics were entirely destroyed in some cases and much altered in others. The R.R.B. inform me that they "cannot advise their observers generally to employ shunted phones" and my results are evidently of no interest to them. It is not feasible to scale my results down.

It is not my intention to criticise this decision. My object in asking you to afford me space for this letter is the hope that anyone who would be willing to carry out synchronous experiments with me by means of shunted phones would be good enough to write to me and I will give them full particulars of my suggestions. The necessary additional apparatus need not cost more than a few shillings. The subject is full of interest.

For reasons I need not go into here, I find 6 p.m. to 7 p.m. the most suitable hour for experiments.

(MAJOR) H. A. LITTLEDALE,
The Rise, Streatley-on-Thames.

The Master Oscillator.

To the Editor of THE WIRELESS WORLD AND RADIO REVIEW.

SIR,—I was very interested in the article by Mr. W. James on the Master Oscillator. I have done a fair amount of work with this circuit recently, and I should like to make one or two comments.

Too much cannot be said about the superiority of this circuit over any other (although the same overall efficiency cannot be obtained, due to the necessity of providing an extra valve), because of its great steadiness of note, and this is a point of very great importance in any but local work. It means getting a greater distance on a lower power, and this makes up for the complications and extra valve. As regards the oscillator valve, I would warn anyone trying this not to use too small a valve. A receiving valve must be hard pressed to supply a 10-watt set with any ease, and nothing less than a 50-watt valve should be used for a 250 watter. I know it is quite possible to use a valve of very low capacity when everything is got just so, but it is far more satisfactory to use a larger valve and then to cut down the filament current to a minimum when all is adjusted correctly. This is very economical in valve expense in the long run, and saves an enormous time in adjustments. I was recently trying to oscillate an 0-250 with an A.T.25, but it seemed impossible to get the larger valve to its full output without an absurd amount of fiddling about. (If plenty of meters are available this trouble does not arise, but few of us have any to spare.) I found it possible to get excellent results ultimately, but rapid wave changing was impossible. While a friend was not looking, I borrowed his 200 watter, and in five minutes I had the set so that I could get any wave over a band of 150 metres in a few moments with an enormous range of power inputs as desired. I found that once I had it adjusted I could cut the filament voltage from 11 to 7 with the same results, and on 7 volts the valve is almost everlasting. It can easily be seen from an investigation of the curves, etc., that the A.T.25 would have to be worked at its full capacity—or near it—to oscillate the other on full power, and this means a high anode voltage—so high that the valve was in danger from sparking over between the pins. I speak from bitter experience, as I have had two casualties! In the other case the same anode voltage could be safely used. If it is necessary to use a lower anode voltage, the simplest way is to use a series resistance in the circuit of a suitable value which can easily be determined. The r.f. choke could be made of resistance wire.

The other point I should like to mention is the oscillator circuit. I would like to suggest it would be more suitable to use, say, a tuned-grid circuit reaction coil or "reversed feed back." It will be found that on observing meters in the Hartley circuit when altering the tuning condenser one gets points of good output and powerful oscillations, and other points of none. If a circuit is used in which variation of wavelength does not radically alter the output, the operation of the set is very greatly simplified. I found much of my trouble vanished on using the circuit shown below.

The plate grid coupling is not in any way critical, in fact it is not necessary in many cases. This was of the greatest assistance to me immediately in tuning to any particular wave in a few moments.

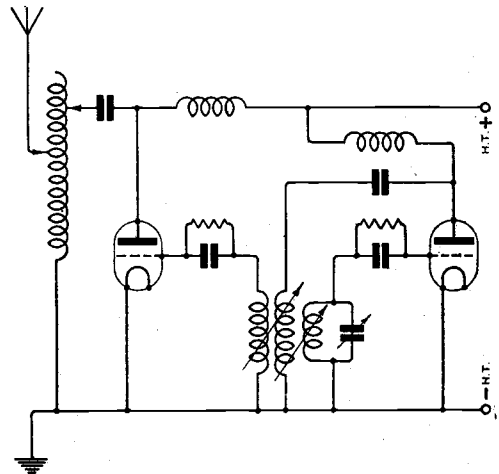

Circuit employed by Mr. Hogg for short-wave transmission.

I hope this letter will interest your readers, and that you will pardon its length.

FREDERIC L. HOGG,
2 SH.

Highgate, N.6.
December 29th, 1923.

AN HISTORIC BELL.

On Tuesday mornings during January, under the auspices of the New York State Museum, the broadcasting station **WHAZ** at Troy, N.Y., transmitted the tones of the identical bell used by Professor Joseph Henry in his original experiments with electro-magnets in 1831. This bell, which was kept by Dr. Phillip Ten Eyck, an assistant of the Professor, is now the property of the New York State Museum.

It was while a Professor in the Albany Academy in 1831, that Professor Joseph Henry invented an electro-magnet by which he was able to transmit signals to a distance, and it is interesting to reflect that on this experiment are largely based the inventions which have rendered it possible to broadcast the ringing of the Professor's bell round the world.

During the present month the bell has been rung at **WHAZ** on Tuesday mornings at about 3 a.m. (G.M.T.), and broadcast on 380 metres. Reports from readers who happen to have heard this remarkable transmission will be welcomed.

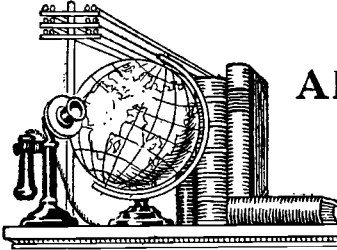

AROUND THE WIRELESS WORLD

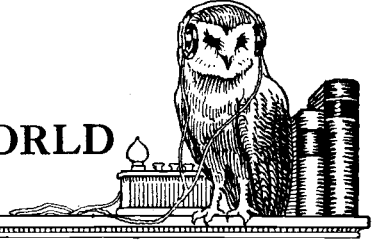

Calcutta Hears 2LO.

News of the reception of London broadcasting in Calcutta was contained in a recent message from the *Daily Telegraph* correspondent in that city.

This remarkable feat, it appears, was accomplished accidentally on January 5th by the secretary of the Radio Club of Bengal, who, with a number of enthusiastic colleagues, was experimenting with a two-valve set. On the first occasion of tuning-in, a man's voice was heard saying, "Hello, everybody. Mr. Frazer (or Fisher), will now—." Here the message ended abruptly. For several hours no further success was obtained, but on the following day, with a five-valve receiver, the experimenters once more succeeded in tuning-in the carrier wave. Male voices, with organ accompaniment, were then heard—a particularly interesting result in view of the fact that on the day in question London was broadcasting a service from St. Martin's-in-the-Fields.

On the following days further items were received, the best of which was a violin solo. A lady contralto was also heard, though most of her words were rendered indistinguishable by atmospherics. While there is no claim that these experiments yielded anything like perfection, it is confidently believed that future attempts will produce really satisfactory results.

London-Vienna Wireless Service Opened.

A wireless telegraph service between England and Austria was officially inaugurated on Saturday, January 12th, when several telegrams of congratulation passed between the two countries. The service is operated by Marconi's Wireless Telegraph Company, in conjunction with the Austrian Marconi Company.

This is a direct and continuous duplex service, transmission passing from Radio House, London, through the Marconi station at Ongar, Essex, to

Laaerberg, where the messages are automatically relayed to the Central Office at Renngass 14, Vienna. Transmission from Vienna is carried on through the Deutsch-Altenburg station, and messages for Great Britain are received at the Brentwood Station, and automatically relayed to Radio House.

A wireless service between Vienna and Berlin has also been opened, and the operations of the Austrian station will in time be extended to place Vienna in wireless communication with all the principal European cities.

A New French Radio Development.

Thursday, January 17th, saw the establishment of direct wireless communication between France and Indo-China.

This step marks the materialisation of a scheme which was interrupted by the war. Until recently, the international cables serving Indo-China have been in foreign hands, and for the purpose of communicating with her colony in the Far East, France has been dependent on other nations. To overcome the inconvenience and possible danger of this arrangement, the present scheme was initiated by France several years ago, and the construction of a high power wireless station at Saigon was decided upon.

The station at Saigon, now completed, communicates with Bordeaux,

6,250 miles away. Besides being employed on national propaganda work, the new station is to form one of a network of stations on French and foreign territory for the purpose of carrying on a commercial service.

Wireless Weather Reports in the Atlantic.

The establishment of two floating broadcasting stations to cover the North Atlantic sea routes is a proposal put forward by the United States Weather Bureau. The main objects of these broadcasting stations would be to assist navigation and to increase the comfort of passengers. Weather

OUR PRECOCIOUS AMATEURS.

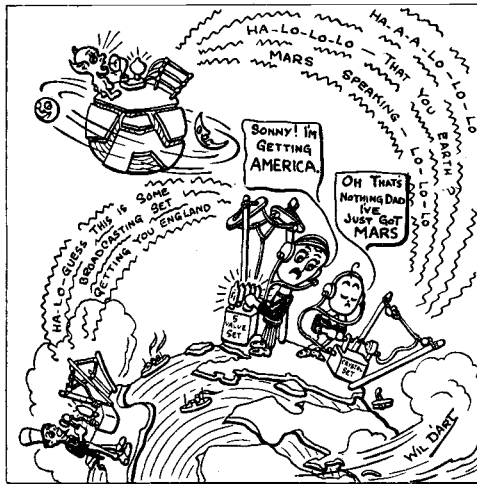

Moved by recent amateur successes with home-made gear, our cartoonist indulges his prophetic instincts.

observations received from various vessels on the routes would be transmitted for the benefit of mariners, and efficient forecasters aboard the broadcasting ships would also prepare their own observations for transmission in the same manner.

Amateur Transatlantic Telephony.

To Mr. Lewis T. Dixon (**2 XZ**), of Heythorp Street, Southfields, belongs the distinction of being the first amateur to bridge the Atlantic by radio-telephony.

According to a report received, Mr. Dixon's station, transmitting pianoforte music on December 28th, was heard by Mr. M. Allen White, of Kansas City, Missouri, about 4,500 miles distant. The receiver was a home-made 9-valve set. On identifying **2 XZ**, Mr. White immediately wrote asking for a confirmation of the transmission, Mr. Dixon replying by cable.

2 XZ employs ten watts, and on December 28th was transmitting to (**5 OX**) at Putney, on a wavelength of 195 metres. Interviewed by a Press representative, Mr. Dixon said that the night was an excellent one for long distance work, and a friend in London had commented on the exceptional strength of his transmission on the night in question.

Religion by Wireless.

Mr. J. C. W. Reith, Managing Director of the British Broadcasting Company, contributes a thought-provoking article on the subject of broadcasting and the Church in the January 11th issue of *The Guardian*.

In replying to certain criticisms which have been levelled at the B.B.C. for "thrusting religion upon listeners-in," Mr. Reith states that the Company has received hundreds of communications in the most appreciative and almost pathetic vein from invalids and the aged, to whom the broadcasting of

hymns and religious addresses has brought consolation long denied them.

More Amateur Transatlantic Working.

A further success in two-way working across the Atlantic is recorded by Mr. J. A. Partridge (**2 KF**), whose previous exploits in this direction were described in *The Wireless World and Radio Review* of December 27th.

At 5.30 a.m. on January 14th, Mr. Partridge established communication with **3 XAO**, situated at Washington D.C. Two messages were handled each way, the signals being strong on both sides.

The usual call sign of the American station is **3 ALN**, but the first-mentioned has been allotted for 100-metre working. We understand that all American amateurs licensed for 100 to 150-metre working have been given new call signs, all commencing with "X."

2 KF also reports two-way working with Italian **ACD** at Bologna, on the evening of January 14th.

On the mornings of January 13th and 14th, Mr. Gerald Marcuse (**2 NM**) of Caterham, Surrey, established communication with **2 BSC**, New York, and **1 BQ**, Halifax.

The Holweck Transmitting Valve.

Readers of our article on the Holweck valve (*Wireless World*, January 9th), will be interested to learn that the Holweck pump, used in conjunction with the new valve, is manufactured in this country by the Mullard Radio Valve Co., Ltd. Photographs and a diagram of the Holweck valve and pump accompanied the article above referred to.

Relay Broadcasting Station to Edinburgh.
According to *The Scotsman* the town clerk of Edinburgh has received a letter from the B.B.C. stating that the Company will establish a relay broadcasting station in Edinburgh at the earliest possible date.

A WELL-EQUIPPED TRANSMITTER AND RECEIVER.

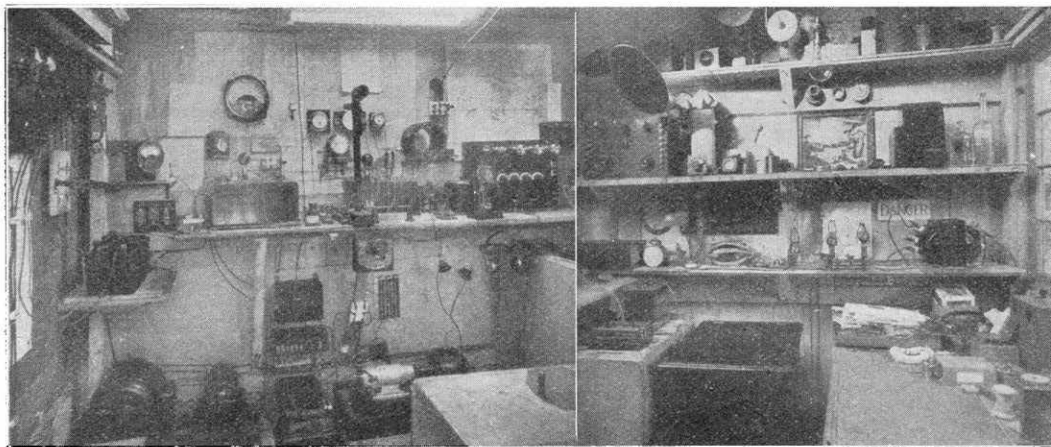

These photographs depict the experimental station **2 IL**, owned by Mr. H. R. Goodall of Bassett, Southampton. A single phase motor, dynamo and switchboard for charging accumulators are seen on the left, while in the centre of the left-hand illustration are the grid control and choke control transmitters. The right-hand picture shows the receiving gear, with transformer and rectifying valves on the extreme right.

Pittsburg-Manchester Relay Broadcasting.

Wishing to correct a possible impression that may have been gathered from certain statements made to the Press that **KDKA** has not been making special efforts to be heard in Great Britain, the Westinghouse Company of Pittsburg has sent a cablegram to the Metropolitan-Vickers Company, assuring them of the American station's co-operation.

On Saturday, January 5th, the entire evening performance from Pittsburg was re-radiated from **2 AC**. As a result a large number of letters has been received by the Metropolitan-Vickers Company from listeners in all parts of the British Isles, France, Belgium, Switzerland and Scandinavia, commenting on the surprisingly good quality of the re-radiation. One correspondent in London even went so far as to declare that the quality was as good as, if not better, than he had experienced a fortnight previously when listening in Pittsburg itself to **KDKA**.

The Multiphone Connector.

A useful device is shown in the accompanying illustration, its purpose being to permit the combination of several sets of telephones with a

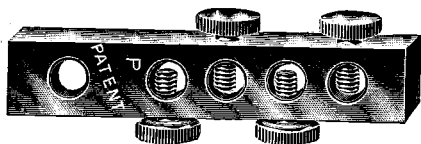

single pair of terminals. A multiphone connector is screwed on each terminal, the telephone leads being secured in the holes shown. The manufacturers are Messrs. The Multiphone Terminal Co., of 21, Great Russell Street, London, W.C.1.

"The Fortieth Milestone."

The above forms the title of a singularly attractive brochure produced by the Western Electric Company, Limited. "The Fortieth Milestone" presents a record of forty years' achievement in the advancement of International Communication, a record of which any organisation might well be proud. Excellently printed on art paper and lavishly illustrated, the book covers the period from the pioneer work of Alexander Graham Bell in 1876 to the termination of the Great War, which saw the development of the Western Electric Company's wonderfully efficient submarine detector. It is impossible in a paragraph to give more than the barest summary of the contents of this fascinating history book, but some idea of the scope of the Company's activities is afforded by a glance at the section headings. After a description of the growth of manual telephone working, the various types of automatic telephone are touched upon. The Company's Multiplex printing telegraph system is next described, and the reader is then given an extremely interesting account of telegraph

and power cable operation. Then follows the largest and most absorbing section in the brochure, covering the development of the thermionic valve and its vital influence on radio. The history concludes with a record of the Western Electric Company's contributions to the naval conduct of the war.

A New Directory.

All connected with the wireless industry will learn with interest that Kelly's Directories, Limited, are publishing an entirely new directory devoted exclusively to the Electrical Industry, Wireless and Allied Trades. The first edition of this book, which will be published shortly, price 30s., post free, will contain an extensive list of proprietary articles and trade names throughout England, Scotland and Wales.

Secret Wireless Communication ?

A new system of wireless communication, claiming to secure complete secrecy in transmission and reception, is being championed in Chicago.

Known as the "Dunmore" relay, the new machine is said to transmute wireless impulses into a specially devised telegraphic code which can be decoded only by means of certain apparatus at the receiving end, where messages are transcribed on an ordinary printing ticker.

S.O.S. Messages.

It is intimated by the Board of Trade that if a vessel in distress sends a call for assistance as a private message, and no general distress message is sent out, the authorities concerned will be unable to render assistance or take steps to make the need generally known.

It is therefore essential that a shipmaster should in such circumstances send out a general distress message, even although he is sending a private message shortly before or after.

Wireless Rent in Liverpool.

Broadcast listeners residing in the Liverpool Corporation dwellings will in future be required to pay an annual rent of 1s. in respect of wireless apparatus on the premises. The apparatus, it is stated, must satisfy the demands of the Director of Housing. It seems unlikely, however, that tenants will be satisfied by this questionable imposition on the part of their landlords.

American Broadcast Reception in South Africa.

We have received an interesting communication from Mr. S. W. Watson, Physics Lecturer at Grahamstown, South Africa, recounting his experiences in the reception of American broadcast transmissions. As early as May of last year Mr. Watson heard music and speech from the U.S., and he claims to be the first amateur in South Africa to have performed the feat.

A four-valve home-made set is employed with 2 H.F., and our correspondent states that except when atmospherics are troublesome, he can invariably tune-in from two to eight American stations in the early hours of the morning.

Broadcasting.



[Courtesy Western Electric Co.]

Valve amplifying equipment such as is now generally used on trunk telephone circuits.

Forthcoming Events.

WEDNESDAY, JANUARY 23rd.

- Radio Society of Great Britain.** At 6 p.m. (Tea at 5.30). At the Institution of Electrical Engineers, Savoy Place, W.C.2. Presidential Address. By Dr. W. H. Eccles, F.R.S.
- Conference of Affiliated Societies.** At 2 p.m. At the Institution of Electrical Engineers, Savoy Place, W.C.2.
- East Ham and District Radio Society.** At C.A. Social Centre, Barking Road, E. Informal Meeting.
- North Middlesex Wireless Club.** At Shaftesbury Hall, Bowes Park, N.W.1. Lecture: "Valves and their Characteristics." By Mr. W. J. Jones, B.Sc., A.M.I.E.E.
- Clapham Park Wireless and Scientific Society.** At 8 p.m. 67, Balham High Road. Testing Night.
- Edinburgh and District Radio Society.** At 8 p.m. At 117, George Street. Lecture: "Electrical Measuring Instruments." By Mr. W. Winkler.

THURSDAY, JANUARY 24th.

- Liverpool Wireless Society.** At 7.30 p.m. At Liverpool Royal Institution, Colquhitt Street. Annual General Meeting.

FRIDAY, JANUARY 25th.

- Brockley and District Radio Association.** At Gladstone Hall, New Cross Road. Lecturer from the South London League of Radio Societies.

MONDAY, JANUARY 28th.

- Ipswich and District Radio Society.** At 55, Fonnereau Road. Lecture: "Detectors." By Mr. F. J. Dyers.

ABERDEEN 2 BD, 495 metres; **BIRMINGHAM 5 IT,** 475 metres; **GLASGOW 5 SC,** 420 metres; **NEWCASTLE 2 NO,** 400 metres; **BOURNEMOUTH 6 BM,** 385 metres; **MANCHESTER 2 ZY,** 375 metres; **LONDON 2 LO,** 365 metres; **GARDIFF 5 WA,** 350 metres; **SHEFFIELD** (Relay from 2 LO), 303 metres. Regular daily programmes. Weekdays, 11.30 to 12.30 p.m. (2 LO only), 3.30 to 4.30 p.m., 4.30 p.m., 5 to 10.30 p.m. Sundays, (2 LO only), 3.30 to 4.30 p.m., 5 to 10.30 p.m. Sundays, 3 to 5 p.m., 8.30 to 10.30 p.m.

FRANCE.

PARIS (Eiffel Tower), FL, 2,600 metres. Daily, 6.40 to 7 a.m. Weather Forecasts; 10.5 a.m. (Thursday and Friday), 11.15 to 11.30 a.m., Time Signal and Weather Forecast; 12.0 noon, Livestock prices; 3.40 p.m. (Saturday excepted); Financial report, 5.30 p.m. (Saturday excepted) Bourse Closing Prices; 6.10 p.m., Concert or Address; 7 p.m., Weather Forecast; 7.30 p.m. (Sunday), Concert and Address; 10.10 p.m., General Weather Forecast.

PARIS (Compagnie Francaise de Radiophonie Emissions "Radiola"), SFR, 1,780 metres. Daily, 12.30 p.m., Cotton Oil and Café Prices, News, Concert; 1.45 p.m., First Bourse Report; 4.30 p.m., Bourse Closing Prices; 4.45 p.m., Concert; 5.45 p.m., News and Racing Results; 8.30 to 9.30 p.m., News; 9.10 p.m., Concert; 10 p.m. to 10.45 p.m., Radio Dance Music.

ECOLE SUPERIEURE des Postes et Télégraphes, 450 metres 3.30 to 4 p.m. (Wednesday and Friday), 7.45 p.m. to 10 p.m. (Tuesday and Thursday), Tests (Music, etc.); 2.30 p.m. to 7.30 p.m. (Saturday), Tests (Music, etc.).

LYONS, YN, 3,100 metres. Daily, 9.45 a.m. to 10.15 a.m., Gramophone Records.

BELGIUM.

BRUSSELS, BAV, 1,100 metres. 1 p.m. to 5.30 p.m., Meteorological Forecast; 9 p.m. (Tuesday), Concert.

BRUSSELS ("Radio Electrique"), 410 metres. Daily, 5 to 6 p.m., 8.30 p.m. to 9.30 p.m., Concert.

HOLLAND.

THE HAGUE, PCGG. Temporarily suspended.

THE HAGUE (Heussen Laboratory), PCUU, 1,070 metres. 9.40 to 10.40 a.m. (Sunday), Concert; 9.40 to 10.40 p.m., Concert; 7.45 to 10 p.m. (Thursday), Concert.

THE HAGUE (Velthuisen), PCKK, 1,070 metres. 8.40 to 9.40 p.m. (Friday), Concert.

LJMUUDEN (Middelraad), PCMM, 1,050 metres. Saturday, 8.40 to 9.40 p.m., Concert.

AMSTERDAM, PA 5, 1,100 metres (Irregular). 10 to 11 a.m., Concert; 5 to 6.30 p.m., Concert; 8.10 to 9.10 p.m., Concert.

DENMARK.

LYNGBY, OXE, 2,400 metres. 7 p.m. to 8 p.m., Concert (Sunday excepted).

GERMANY.

BERLIN (Koenigswusterhausen), L.P., 4,000 metres. (Sunday), 10 to 11 a.m., Music and Lecture; 2,700 metres 11 a.m. to 12 noon, Music and Lecture. Daily, 4,000 metres, 6 to 7 a.m., Music and Speech; 11.30 a.m. to 12.30 p.m., Music and Speech; 4 to 4.30 p.m., News.

EBERSWALDE, 2,930 metres. Daily, 12 to 1 p.m., Address and Concert; 7 to 8 p.m., Address and Concert; (Thursday and Saturday), 5.30 to 6.30 p.m., Concert.

CZECHO-SLOVAKIA.

PRAGUE, PRG, 1,800 metres. 7 a.m., 11 a.m. and 3 p.m., Meteorological Bulletin and News; 4,500 metres, 9 a.m., 2 p.m., and 9 p.m., Concert.

KBEL (near Prague), 1,000 metres. Daily, 6.20 p.m., Concert, Meteorological Report and News.

SWITZERLAND.

GENEVA, HB 1 (Radio Club de Genève), Temporarily suspended.

LAUSANNE, HB 2, 1,100 metres. Tuesday, Thursday, Saturday, 4 p.m., Concert; Monday, Wednesday, Friday and Saturday, 7 p.m., Concert.

SPAIN.

MADRID, 1,650, 2,200 metres (Irregular). 12 to 1 p.m., Tests.

MADRID, PTT, 400 to 700 metres. 4 to 5 p.m., Tests.

Calls Heard.

Marseilles.

(On 110 metres) : 8 AB, 8 BF, 8 EK, 2 OD, 2 SZ, 5 KO, 5 PU,
6 NI, NPA 9, 0 NY. (On 200 metres) 8 AE, 8 AE, 8 AO, 8 AP,
8 AQ, 8 AU, 8 AW, 8 AZ, 8 BE, 8 BF, 8 BM, 8 BN, 8 CD, 8 CF,
8 CJ, 8 CK, 8 CM, 8 CS, 8 CZ, 8 DD, 8 DT, 8 DU, 8 EB, 8 EK,
8 JL, 8 LS, 8 LY, 8 RD, 8 RS, 8 WV, 2 CN, 2 CW, 2 FL, 2 FN, 2 FQ,
2 GG, 2 JF, 2 KF, 2 KR, 2 KW, 2 NM, 2 OD, 2 OJ, 2 OM, 2 ON,
2 SZ, 2 TA, 2 UF, 2 VN, 2 VS, 2 WC, 2 XP, 5 AT, 5 BV, 5 CX, 5 FS,
5 KO, 5 NN, 5 PU, 5 QV, 5 RZ, 6 NH, 6 NI, 6 XX, NPA 9, 0 AB,
0 DV, 0 NY, 0 YS, 0 YT, CDA. (M. Saumont, 8 DA).

Kensington, W.14.

2 AJ, 2 BZ, 2 KB, 2 MK, 2 OM, 2 ON, 2 PB, 2 PY, 2 QQ, 2 SZ,
2 UV, 2 VW, 2 WX, 2 XZ, 2 YR, 2 ZO, 5 BB, 4 BD, 5 BT(?), 5 CB,
5 CP, 5 DB, 5 DK, 5 HW, 5 IO, 5 IS, 5 LP, 5 OB, 5 OF, 5 PB, 5 PD,
5 PY(?), 5 VR, 6 HD, 6 IM, 6 KI. (Variometer-tuned crystal.)
(R. C. Croxton).

Cowes, I. of W.

2 AO, 2 FB, 2 GG, 2 GH, 2 IL, 2 KF, 2 OD, 2 OM, 2 SZ, 2 TF,
2 WZ, 5 BA, 5 CO, 5 DN, 5 DO, 5 IG, 5 MO, 5 MU, 5 PS, 5 VN,
6 DY, 6 GY, 8 AA, 8 AB, 8 AS, 8 CJ, 8 DP, 8 DX, 8 WV, 0 DV,
0 NY, 0 XP. (o-v-o.) (W. G. Sherratt, 5 TZ).

Hornsey, London, N.8.

2 AH, 2 AJ, 2 AQ, 2 AU, 2 BH, 2 BT, 2 BZ, 2 FQ, 2 ID, 2 JX,
2 KF, 2 LI, 2 LP, 2 MF, 2 MK, 2 MS, 2 OM, 2 ON, 2 PA, 2 PU,
2 FX, 2 QL, 2 QQ, 2 SF, 2 SH, 2 SZ, 2 TI, 2 TQ, 2 UI, 2 UJ, 2 UR,
2 VH, 2 VI, 2 VT, 2 WJ, 2 XB, 2 XZ, 2 YL, 2 YR, 2 ZO,
5 AB, 5 BW, 5 BT, 5 CB, 5 CD, 5 HY, 5 IO, 5 IS, 5 JW, 5 LF, 5 LP,
5 OB, 5 OX, 5 PD, 5 PU, 5 PV, 5 QB, 5 QV, 5 SU, 5 TR, 5 VA,
5 VD, 5 VM, 5 VR, 5 XD, 5 YM, 5 ZJ, 6 AI, 6 BS, 6 BX, 6 IM,
6 QV, 6 VO. (o-v-r.) (F. E. Rayner).

Snaith, Yorks.

2 CW, 2 DF, 2 KF, 2 NA, 2 OG, 2 RK, 2 TA, 2 VO, 2 WJ, 5 CX,
5 KO, 5 MO, 5 RZ, 5 US, 8 BA, 8 BN, 8 CJ, 8 RZ. (o-v-r.)
(J. L. Greatorex.)

Fulham, S.W.6.

2 AQ, 2 BZ, 2 DO, 2 FJ, 2 FQ, 2 HS, 2 ID, 2 KN, 2 KZ, 2 MF,
2 MK, 2 OM, 2 PY, 2 PZ, 2 QQ, 2 SF, 2 SX, 2 TI, 2 TQ, 2 XB,
2 XL, 2 XO, 2 XR, 2 XZ, 2 ZO, 2 ZZ, 5 AQ, 5 AW, 5 BB, 5 CB,
5 CP, 5 DK, 5 FG, 5 GA, 5 HW, 5 HY, 5 IM, 5 IO, 5 KS, 5 LP,
5 OB, 5 OX, 5 PD, 5 PU, 5 UO, 5 VR, 6 AI, 6 BF, 6 IM, 6 KI,
6 MH, 6 NH(?), 6 TM, 6 XX, 6 ZL, 6 ZO. (o-v-o.)
(Chas. E. Horner.)

Southport.

1 BF, 2 AD, 2 AG, 2 AM, 2 AW, 2 AX, 2 BF, 2 EI, 2 LJ, 2 IN,
2 KF, 2 KH, 2 KM, 2 KO, 2 KX, 2 KY, 2 NY, 2 OM, 2 UY, 2 VF,
2 ZK, 2 ZU, 2 ZY, 5 AJ, 5 AO, 5 AW, 5 AY, 5 BF, 5 CR, 5 DC,
5 DF, 5 FW, 5 FR, 5 IG, 5 IK, 5 KX, 5 LB, 5 LH, 5 LT, 5 NL,
5 NX, 5 OQ, 5 OT, 5 QA, 5 RK, 5 RI, 5 RL, 5 RT, 5 SD, 5 SW,
5 TQ, 5 TR, 5 UQ, 5 VK, 5 ZX, 5 LX, 5 FY, 5 OK, 6 LF, 6 LG,
6 NI, 6 OL, 6 RR, 6 RS, 6 UW, 2 ZT, 2 KS, 6 IC. (r-v-z.)
(O. B. Kellett.)

Woking.

2 AM, 2 DD, 2 DF, 2 FA, 2 ID, 2 IK, 2 IL, 2 IT, 2 IU, 2 KP,
2 KT, 2 MA, 2 MF, 2 MK, 2 MO, 2 MM, 2 MS, 2 NM, 2 OF, 2 OK,
2 OM, 2 PI, 2 SQ, 2 SS, 2 SZ, 2 TF, 2 TO, 2 UM, 2 VT, 2 WA,
2 WD, 2 WM, 2 XZ, 2 ZP, 2 ZO, 2 ZV, 5 AQ, 5 CS, 5 CU, 5 DD,
5 DG, 5 DP, 5 FR, 5 HZ, 5 ID, 5 IO, 5 LA, 5 LO, 5 LP, 5 MK,
5 OC, 5 OT, 5 OX, 5 PO, 5 PX, 5 TF, 5 TH, 5 TQ, 5 TX,
5 VT, 5 WM, 6 BM, 6 CF, 6 CG, 6 CW, 6 IM, 6 WM, 8 AB, 8 BC.
(r-v-o.) (T. A. Lloyd Davies.)

Edinburgh.

2 CW, 2 DF, 2 DR, 2 FL, 2 FN, 2 FQ, 2 FU, 2 HF, 2 IN, 2 JF,
2 JO, 2 KF, 2 LZ, 2 NA, 2 NM, 2 OD, 2 OG, 2 ON, 2 PF, 2 PX,
2 QH, 2 QR, 2 SH, 2 TB, 2 TF, 2 UV, 2 VO, 2 VS, 2 WJ, 2 WK, 2 YQ,
2 ZG, 5 AA, 5 BA, 5 BV, 5 CX, 5 DN, 5 FD, 5 FS, 5 GL, 5 HI,
5 HN, 5 IP, 5 JX, 5 KO, 5 MO, 5 NN, 5 PU, 5 PS, 5 SI, 5 SZ, 5 TU,
5 US, 5 WR, 5 YI, 6 NI, 6 RY, 6 UC, 6 XX(?), 7 ZM, 7 QF, 8 AE,
8 AG, 8 BF, 8 BM, 8 CJ, 8 CT, 8 DY, 8 DZ(?), 8 QA, 0 DV, 0 GS,
0 NY, 0 MX, 0 PZ, 0 XP, 0 YS. (Single valve Armstrong Super
and 2 ft. frame.) (J. G. W. Thompson.)

Finchley, N.3.

2 AA, 2 AB, 2 AH, 2 AQ, 2 AO, 2 AU, 2 AZ, 2 AJ, 2 BZ, 2 CB,
2 CF, 2 DC, 2 DK, 2 DZ, 2 FN, 2 FQ, 2 FG, 2 GZ, 2 GO, 2 HP,
2 HR, 2 HF, 2 IF, 2 JL, 2 JV, 2 JX, 2 KF, 2 KR, 2 KZ, 2 KT, 2 KV,
2 LP, 2 LR, 2 LI, 2 LW, 2 MF, 2 MI, 2 MK, 2 MO, 2 MT, 2 NI,
2 OD, 2 OF, 2 OM, 2 ON, 2 OA, 2 PA, 2 PX, 2 PZ, 2 QQ, 2 QU,
2 QL, 2 QS, 2 SF, 2 SH, 2 SI, 2 SX, 2 SZ, 2 TA, 2 TP, 2 TQ, 2 TX,
2 UJ, 2 UV, 2 US, 2 VR, 2 VM, 2 VN, 2 VW, 2 VS, 2 VJ, 2 WB,
2 WJ, 2 WJ, 2 WI, 2 XB, 2 XR, 2 XX, 2 XG, 2 XZ, 2 XL, 2 YH,
2 YZ, 2 YR, 2 KA, 2 XP, 2 YZ, 2 ZK, 2 ZZ, 5 AO, 5 AT, 5 BV,
5 BB, 5 BA, 5 BZ, 5 CF, 5 CY, 5 CB, 5 CS, 5 DT, 5 DB, 5 FN, 5 FS,
5 GF, 5 GF, 5 GH, 5 HY, 5 HA, 5 IS, 5 KS, 5 LP, 5 MJ, 5 NN, 5 NY,
5 PU, 5 PD, 5 PX, 5 AP, 5 UA, 5 US, 5 UL, 5 VD, 5 VR, 5 VL,
5 VP, 5 XD, 5 XY, 6 DW, 6 IM, 6 JX, 6 LJ, 6 MK, 6 OY, 6 RS.

6 QM, 6 RR, 6 TM, 6 VT, 2 ABR, 2 ABZ, 2 ACU, 8 AB, 8 AE,
8 AF, 8 AQ, 8 AU, 8 AX, 8 BF, 8 BM, 8 BU, 8 BV, 8 CJ, 8 CS,
8 CT, 8 CY, 8 DA, 8 EB, 8 FZ, 8 LY, 8 NM, 8 NT, 8 QV, 8 SB,
8 WK, 8 WV, 0 AW, 0 DD, 0 FL, 0 MX, 0 NY, 0 OD, 0 PX, 0 XP,
Italian: 1 MT. American: 1 OA, 2 CCX, 2 CG, 3 TE, 3 AEC,
4 AE, 9 XW. (E. L. Gardiner.)

American Calls.

Kingston, Surrey.

2 EL, 3 BN, 8 AA, 8 AW, 2 CFB, 2 GFN, 8 BCP, 8 AMM, 2 CCK,
4 CCKM, 8 KS, 2 GXL, 9 AYX. (W. J. Thompson.)

London, S.W.19.

(Nov. 17th) : 1 LM, 2 CXL, 4 FT, 1 YB, 3 BGT.
(Nov. 18th) : 1 CMP, 8 TT, 2 YA, 6 FE.
(Nov. 25th) : 1 CMP, 1 ALU, 8 XAN, 1 DF, 1 AR (Can.).
(Dec. 2nd) : 2 CXL, 2 AIM, 3 AWP, 1 XM, 4 FT, 1 AR, 2 BY,
1 AUR, 1 YK, 8 CEI, 9 BRK, 8 UK, 1 ALL, 3 CTP, 5 YW, 8 BD,
9 VM, 8 XAN, 8 BFM, 8 BCP, 8 CWU, 3 TE, 4 FG, 1 ZL, 9 VCU,
8 UF. (S. L. Austen, 2 AAH.)

AN INCONSPICUOUS FRAME AERIAL.

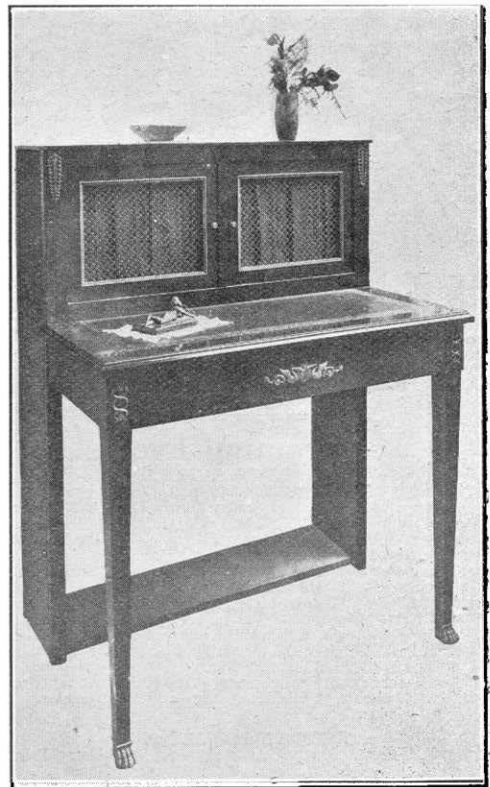

To facilitate the mounting and use of a frame aerial, particularly for broadcast reception, the frame may with advantage be built as an integral part of the table which is used to accommodate the receiving equipment. (Patent No. 195310 by P. Hemardinquer, Paris.)

WIRELESS TIME SIGNALS.

ALTERATIONS RECENTLY INTRODUCED.

IN *The Wireless World and Radio Review* of August 8th last it was stated that preparations were being made to alter the method of transmitting vernier time signals in France with a view to eliminating the risk of these signals being impaired by atmospheric disturbance.

The new method has now been introduced. The signals are transmitted from Paris (Eiffel Tower), Lafayette (Bordeaux) and Lyons, and the times and procedure are as follows:—
PARIS (EIFFEL TOWER).

Times of transmission, 1000 and 2200 G.M.T. Wavelength 2,600 metres, spark.

The signals consist of the transmission of 300 dots (representing the beats of a clock), except that Nos. 60 and 61, 120 and 121, 180 and 181, and 240 and 241 are omitted and replaced by a dash of nearly one second's duration, or the equivalent of two beats (or dots). The interval between successive dots represents one beat of a clock adjusted to beat 50 times in 49 seconds (Sidereal time).

The procedure is as follows:—

0958	} A series of trial for	2158	} nearly one minute.
0959		2159	
1000	} to {	1005	} Beats Nos. 1, 2, 3, etc.,
2200		2205	

Each dot = $\frac{49}{50}$ sec. Sidereal time (= $\frac{44}{45}$ sec. mean time nearly). The comparative numbers giving the exact times of the first and last dots are transmitted the same day immediately before the commencement of the ordinary time signals at 1045 and 2245:—
“Temps Sidéral” followed by two groups of six figures sent three times. The first two figures in each group represent the

minutes, the second two the seconds, and the third two decimals of a second. Hours are omitted.

LAFAYETTE (BORDEAUX).

Time of transmission 2000 G.M.T. Wavelength, 18,940 metres C.W.

1955 URSI de LY followed by the exact wavelength and character of the emissions to be used.

1957 A series of trial for nearly one minute.

1958 — — — — etc., followed by call sign LY — — (silent interval) Temps Sidéral.

2000 A series of 300 beats in exactly the same manner as those given by Eiffel Tower (see above).

The comparative numbers giving the exact times of the first and last dots are transmitted at 2115 G.M.T. in the same manner as for Eiffel Tower.

LYONS.

Time of transmission 0800 G.M.T. Wavelength 15,500 metres C.W.

0757 A series of trial for nearly one minute.

0758 — — — — etc., followed by call sign YN — — (silent interval) Temps Sidéral.

0800 A series of 300 beats in exactly the same manner as those given by Eiffel Tower (see above).

The comparative numbers are as for the Eiffel Tower signals and are transmitted at 0900 G.M.T.

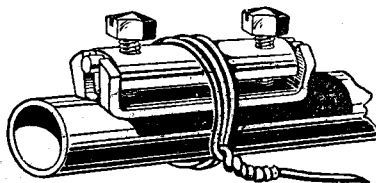

(Courtesy General Electric Co., Ltd.)

A reliable type of earthing clip. The screws force the metal plates apart, causing the wire to bind tightly on the pipe, whilst the under face of the clip makes good contact.



WITH THE SOCIETIES

Particulars of Membership of any Society can be obtained on application to the Secretary. Societies marked with an asterisk are affiliated to the Radio Society of Great Britain.

Chesterfield and District Radio Society.*

On January 9th a wireless demonstration was given with a three-valve set provided by one of the members. Clear reception was obtained using a magnetic relay and Brown and Amplion loud speakers. A series of constructional evenings has been arranged during which various circuits will be compared.

Hon. Sec., A. F. N. Wood, 15, Spital Lane, Chesterfield.

North Middlesex Wireless Club.*

The President of the Club, Mr. A. G. Arthur, addressed the members on January 9th. The President, who has the gift of holding an audience, recalled the fact that the North Middlesex Wireless Club was one of the first wireless clubs to be formed, and that he had written a history of the Club, which he had been asked to read. This history, which was couched in humorous vein reminiscent of the Books of Artemas, dealt with some of the vicissitudes through which the Club has passed since its foundation before the war.

The President's paper was followed by a discussion opened by Mr. L. C. Holton on the most efficient way of loading a receiver designed only to receive "Broadcast" wavelengths, so that Paris and other long-wave stations could be received.

Mr. W. Gartland described some modifications of the popular double magnification circuit which he had devised and found to be improvements on the original circuit. Three new members were elected.

Hon. Sec., H. A. Green, 100, Pellatt Grove, Wood Green, N.22.

Huddersfield Radio Society.*

Great interest was aroused in a lecture and demonstration given on January 8th by Messrs. J. L. Goss and J. T. Thornton, who dealt with the subjects of inductance and capacity.

After speaking of the inductive influence of two parallel wires, Mr. Goss proceeded to describe the induction effects of coils, concluding with remarks on capacity in relation to aerials. Experiments dealing with each subject were carried out by Mr. Thornton, with the aid of a few simple pieces of apparatus.

A lecture on "Interference and How to Avoid It," is being arranged and it is hoped that there will be a large audience on this occasion.

Hon. Sec., C. Dyson, 14, John William Street, Huddersfield.

West London Wireless and Experimental Association.*

A programme has been arranged for the new session and many members are busy in the construction of the Association's new set. At the first meeting of the new year, held on January 8th, the youngest member, Mr. Sydney

Jones, read a paper on "Loud Speakers and their Construction," and great credit is due to him for the manner in which he delivered it.

Particulars of membership will be gladly furnished by the Hon. Sec., Horace W. Cotton, 19, Bushey Road, Hayes, Middlesex.

Northampton and District Amateur Radio Society.*

The Society met in the new club-room over the County Café, The Drapery, on January 7th, much satisfaction being expressed regarding the new premises.

Mr. J. E. Webster, of the Premier Accumulator Co., gave an instructive lecture on the subject of accumulators, dealing with both their manufacture and their maintenance, and exhibiting numerous specimens.

At the Annual General Meeting of the Society, held in December, it was agreed that the fees of membership should be as follows: Entrance fee, 2s. 6d.; annual subscription, 5s.; Juniors, 2s. 6d.

Asst. Hon. Sec., M. Hipwell, Governor's House, Campbell Square, Northampton.

Wireless and Experimental Association.*

Members of the Association had the pleasure on January 9th of listening to an illuminating and racy lecture by Capt. P. P. Eckersley, the Engineer-in-Chief of the British Broadcasting Company.

The members were enlightened on many of the difficulties of broadcasting, and as an outcome it was resolved to assist the B.B.C. by educating the public in the use and abuse of reactive receiving circuits.

Capt. Eckersley promised to be the Association's Guest of Honour at their dinner on January 26th.

Hon. Sec., Geo. Sutton, 18, Melford Road, S.E.22.

Kensington Radio Society.*

The Annual General Meeting was held at 2, Penywern Road, Earl's Court, on Thursday, January 3rd, at 8.30 p.m.

The Hon. Treasurer's report and balance sheets were submitted and approved, and also the Hon. Secretary's report. In order to retain the services of Dr. Gordon Wilson as Chairman for the ensuing year, the President, Mr. J. H. Reeves, proposed that the rules be waived in his favour. This was unanimously agreed to.

The following were elected:—President, Mr. J. H. Reeves; Chairman, Dr. Gordon Wilson; Hon. Auditor, Mr. E. Griffiths; Hon. Treasurer, Mr. M. Child; Hon. Secretary, Mr. J. Murchie.

Mr. Macmillan demonstrated on the Club aerial and explained the construction of a 6-valve receiver (dull emitter), in which were incorporated 2 H.F. valves, one rectifier and three low frequency resistance coupled valves. A general discussion followed on the best

values to use for the resistances and the value of grid bias and high tension supply.

The Hon. Secretary would again remind members (and those wishing to become members) that informal meetings are held on the third Thursday of each month at 8 p.m.

Hon. Sec., John Murchie, 33, Elm Bank Gardens, Barnes, S.W.

Hackney and District Radio Society.*

On January 10th Mr. G. A. V. Sowter, B.Sc., demonstrated his one-valve portable receiver, which is contained in a small attaché case, and weighs 4 lbs., including batteries. Seven circuits are available from crystal to dual amplification, the latter giving sufficient volume to work a small loud speaker. Much interest was evinced by members, many of whom took copies of the circuit and lay out. The set is ideal for picnics and parties.

Hon. Sec., Chas. C. Phillips, 57, Highfield Avenue, Golders Green, N.W.11.

Golders Green Radio Society.

An interesting lecture was delivered by Mr. P. Harris, a Vice-President of the Society, on Wednesday, January 2nd, when, with a makeshift indoor aerial and no actual earth, the lecturer obtained music and speech from **2LO** on a loud speaker.

The evening marked an interesting event in the history of the Society, it being the occasion of meeting for the first time in the new headquarters, The Club House, Willifield Green, N.W.11.

Visitors (ladies and gentlemen) are cordially invited to attend the ordinary meetings, held at 8 p.m. on the first and third Wednesday in the month. Great enthusiasm is shown in the Morse class, which meets every Wednesday.

Particulars of membership, etc., are obtainable from the Hon. Sec., W. J. T. Crewe, "The Dawn," 111, Prince's Park Avenue, Golders Green, N.W.11.

Bournville Radio Society.

On Tuesday, December 4th, 1923, the meeting took the form of a "working night" when the Society's set was demonstrated with satisfactory results. It is proposed to purchase a loud speaker without delay, and with the set recently acquired, added interest will be introduced at future meetings.

There are, doubtless, employees of the firm who are not Radio Society members, but who desire information regarding the construction or purchasing of receiving apparatus. The Radio Society extends to such a cordial invitation to attend the meetings, which are held on alternate Tuesday evenings in the Clerks' Dining-room at 7.15 p.m.

Asst. Hon. Sec., H. Wightman, c/o, Cadbury Bros., Ltd., Bournville, Birmingham.

Questions & Answers

Solutions of Readers' Difficulties

1. All questions are answered through the post. A selection of those of general interest is published.
2. Not more than four questions may be sent in at any one time.
3. Every question should be accompanied by a postal order for 1/-, or 3/6 for four questions, and by a coupon taken from the current issue.
4. Alternatively, advantage may be taken of our free service by using the free coupon. This appears in the first issue of each month, and is valid during the current week only.

“H.M.S.R.” (Waterfoot) gives a sketch of a seven-valve panel carrying numerous parts, and asks for a circuit diagram.

The arrangement shown in Fig. 1 is probably the best for your purpose. An additional filament rheostat on the first L.F. valve would, however, be an advantage, as it is not good practice to light more than two valves through any one resistance.

“A.E.H.” (Willesden) gives a diagram of a crystal set and asks (1) For dimensions of the A.T.I. (2) For the capacity of the tuning condenser required and whether the diagram is correct. (3) Wavelength range of set using an aerial 20 ft. high and 30 ft. long. (4) Whether basket coils could be used.

(1) The size of former for the A.T.I. depends upon the wavelength range required. A coil 4' in diameter and 6" long, wound with Nos. 20 or 22 S.W.G. D.C.C. wire and with tapings at every fifteen turns would be useful. As a tuning condenser is used, the fine tapings and switch may be dispensed with. (2) A corrected diagram giving the

values of condensers required is given in Fig. 2. (3) The set should give a wavelength range of approximately 300 to 1,000 metres. (4) Basket coils could be used in this circuit; they would replace the tapped cylindrical coil mentioned above.

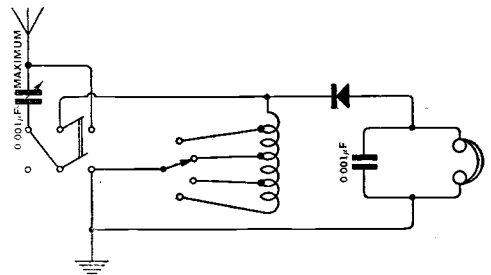

Fig. 2. “A.E.H.” (Willesden). Connections for a simple crystal receiver.

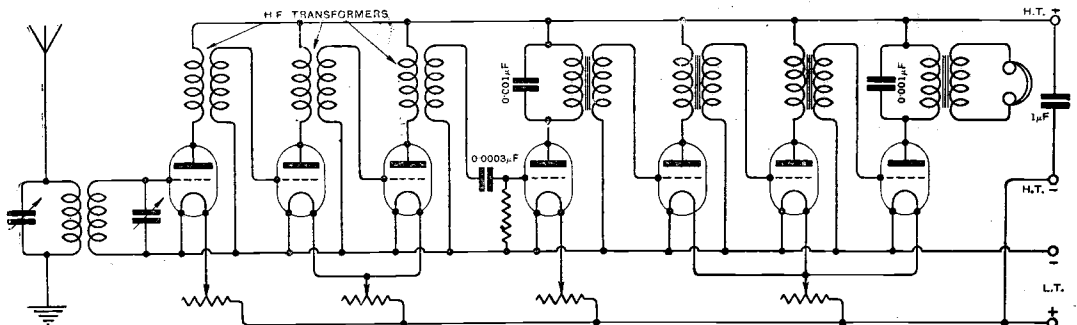

Fig. 1. “H.M.S.R.” (Waterfoot). A receiver with three stages of untuned H.F. amplification, detector, and three note magnifiers.

"S.I." (N.W.10) has constructed a receiver according to circuit No. 47 of "The Amateur's Book of Wireless Circuits," and asks (1) For an explanation of the fact that in his receiver loudest signals are obtained in the "stand-by" position. (2) For a diagram of a four-valve set (1-v-2), the

former to resistance-capacity coupling you might use a plug-in unit similar to that described in the article on "A Five-Valve Receiver" in the issue of August 29th. The transformer tuning condenser should be set at zero when using resistance capacity coupling.

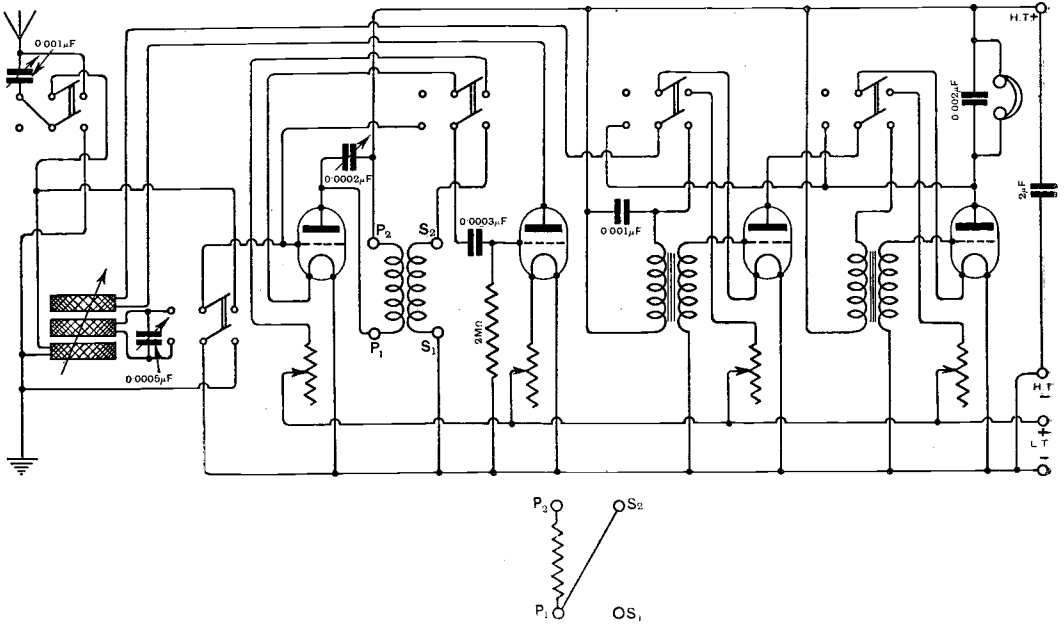

Fig. 3. "S.I." (N.W.10). A receiver with one stage of H.F. amplification, detector, and two note magnifiers. Alternative H.F. coupling is provided.

H.F. valve to be either transformer or resistance-capacity coupled, and with switches provided to cut out valves, reverse reaction coil, etc.

(1) In all probability the secondary coil is too large or too small, and cannot therefore be tuned to resonance with the aerial circuit. (2) The diagram is shown in Fig. 3. To change from trans-

"R.W." (Bristol) asks for a circuit diagram of the three-valve unit receiver described in "How to Build Amateur Valve Stations."

A circuit diagram corresponding with the wiring diagrams given in the above-mentioned handbook is given in Fig. 4.

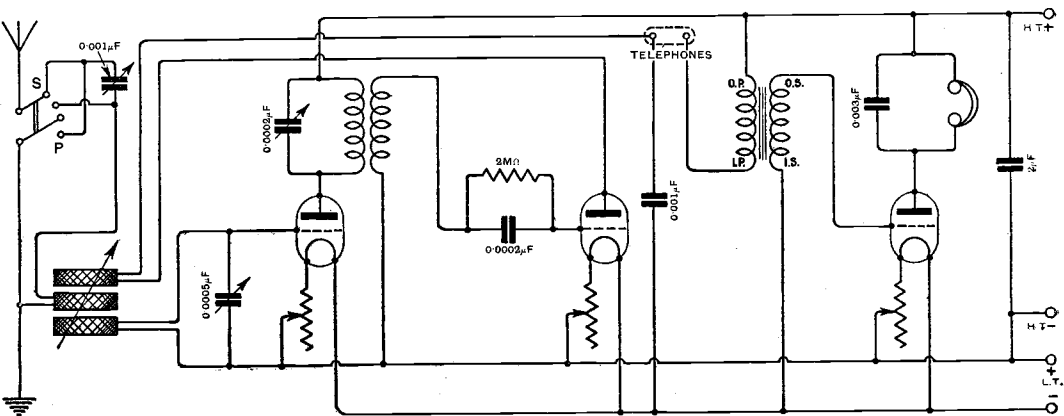

Fig. 4. "R.W." (Bristol). A receiver with one stage of H.F. (tuned transformer), detector and note magnifier.

THE WIRELESS WORLD AND RADIO REVIEW

THE OFFICIAL ORGAN OF THE RADIO SOCIETY OF GREAT BRITAIN.

No. 233. (No. 18.
Vol. XIII.)

JANUARY 30th, 1924.

WEEKLY

EDITOR:
HUGH S. POCOCK.

RESEARCH EDITOR
PHILIP R. COURSEY, B.Sc., F.Inst.P., A.M.I.E.E.

ASSISTANT EDITOR
F. H. HAYNES.

QUESTIONS AND ANSWERS DEPARTMENT:
Under the Supervision of W. JAMES.

CONTENTS

	PAGE
Editorial - - - - -	552
Carnarvon's New Aerial - - - - -	553
A Four-Valve Dual Neutrodyne Receiver. By W. James - - - - -	555
Loud Speakers (concluded). By E. K. Sandeman - - - - -	560
Patent Abstracts - - - - -	563
The Principles Underlying the Operation of the Thermionic Valve. By W. Sydney Barrell - - - - -	565
Record of Long Distance Amateur Transmissions - - - - -	568
Around the Wireless World - - - - -	569
Some Notes on Calculating the Inductance of Coils. By E. J. Hobbs - - - - -	572
With the Societies - - - - -	576
Questions and Answers - - - - -	577

THE EDITOR will be glad to consider articles and illustrations dealing with subjects within the scope of the Journal. Illustrations should preferably be confined to photographs and rough drawings. The greatest care will be taken to return all illustrations and manuscripts not required for publication if these are accompanied by stamps to pay return postage. All manuscripts and illustrations are sent at the Author's risk and the Editor cannot accept responsibility for their safe custody or return. Contributions should be addressed to the Editor, "The Wireless World and Radio Review," 12 and 13, Henrietta Street Strand, London, W.C.2.

SUBSCRIPTION RATES:

20s. per annum, post free. Single copies 4d. each or post free 5d. Registered at the G.P.O. for transmission by Magazine Post to Canada and Newfoundland.

As many of the circuits and apparatus described in these pages are covered by patents, readers are advised, before making use of them, to satisfy themselves that they would not be infringing patents.



EDITORIAL AND PUBLISHING OFFICES:

12 and 13 Henrietta Street,
Strand, London, W.C.2.
Telephone: Gerrard 2807-9.

ADVERTISEMENT MANAGERS:

Bertam Day and Co., Ltd.,
9 & 10 Charing Cross, S.W.1
Telephone: Gerrard 8063-8.

SHORT WAVE RADIO TRANSMISSION.

By PHILIP R. COURSEY, B.Sc., F.Inst.P., A.M.I.E.E.

BEFORE the transmission of short wave signals across the Atlantic was an accomplished fact, much doubt was cast upon the possibility of receiving such signals over so great a range, and the idea of carrying out tests of such transmission was considered by many to be absurd. The events of the past two years, and of the past few weeks in particular, have demonstrated that not only is the idea of such signalling far from being ridiculous, but that communication over such ranges and with such waves possesses a fair measure of reliability.

Even when allowance is made for the removal of the atmospheric absorption effects at night it seems that the transmission is better than would at first sight be expected, and as was pointed out at a meeting of the Radio Society of Great Britain, at which last year's Transatlantic Tests were being discussed, we have as yet no proof of the validity of the Austin transmission formula at these wavelengths and ranges. It may therefore be quite possible that this formula is not a complete statement of all the factors affecting such transmissions.

We have also to consider in connection with such transmissions, the efficiency of the aerial as a radiator of energy. At wavelengths of 180-200 metres, the radiation resistance of an average amateur's aerial amounts usually to several ohms and in consequence the actual energy radiation may be considerable. The more the wavelength is reduced with a given aerial (provided that the aerial can be caused to oscillate at the shorter wavelengths) the greater becomes the radiation of energy, since the radiation resistance rises at the shorter wavelengths.

The amount of energy radiated from an aerial is I^2R_r , where I is the current at the foot of the aerial and R_r is the radiation resistance. The former quantity can of course be read with a suitable hot-wire or thermo-ammeter connected in the aerial circuit (provided that the ammeter is a suitable one for use with the frequencies in question), while the latter is dependent upon the effective height of the aerial, and the wavelength in use. If h is the effective height of the aerial and λ is the wavelength in use, the radiation resistance will be

$$R_r = k \left(\frac{h}{\lambda} \right)^2$$

where k is a constant depending to some extent upon the form of the aerial. Hence we see that for a given aerial where h will remain sensibly constant, the radiation resistance will increase inversely with the square of the wavelength. Thus reducing the wavelength of an aerial from about 212 to 150 metres will approximately double the radiation resistance—*i.e.*, it will also double the radiation of energy for the same current in the aerial.

This being the case it follows that the actual energy radiation from one of these short wave transmitters may be quite comparable with the energy radiation from a long-wave radio station using a very much greater number of kilowatts.

Hence under night conditions, when the absorption seems to be small, the signal strength should be quite good, and comparable in fact with that from a long-wave higher powered station working over an equivalent range.

The proper design of the aerial system and of the apparatus to radiate and to receive signals of these short wavelengths with the highest possible efficiency should still provide further material for extensive experiment and research—experiments which may conceivably lead to very useful and important results. Closely allied to such experiments is the investigation of the variations of such transmission over long distances under varying meteorological conditions and at different times of the day, and at different periods of the year. An investigation of this type naturally requires a considerable expenditure of time and effort to carry out effectively, but is necessary if a better understanding of the phenomena associated with such transmissions is to be obtained.

CARNARVON'S NEW AERIAL.

The wireless station at Carnarvon is one of the most important links in Transatlantic commercial working. With a view to augmenting still further the efficiency of this powerful installation a new set of towers of unique design has recently been erected.

DURING the past few years we have heard a great deal about new high power stations which have been erected for long distance work, and these have embodied all the latest developments of the science. It must not, however, be thought that on this account the older stations have been neglected or allowed to become obsolete.

In spite of the fact that it is one of the earliest high power stations ever erected, the Marconi Wireless Station at Carnarvon still remains one of the most powerful in the world, and nothing is spared to ensure that

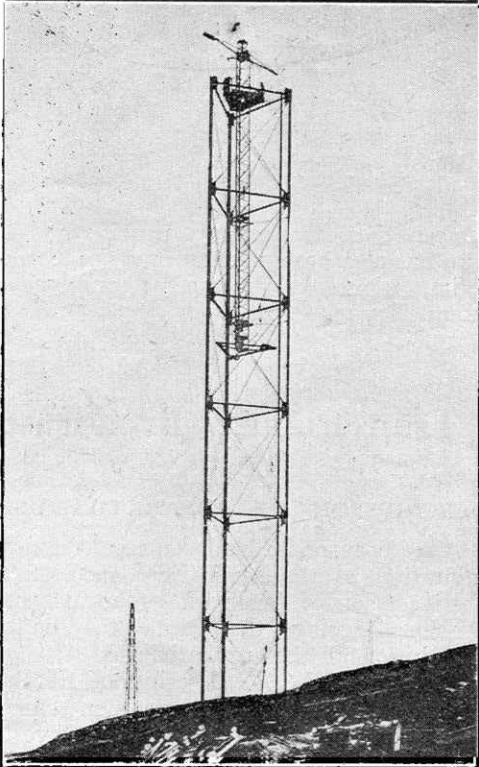

Showing one of the new masts in process of erection.

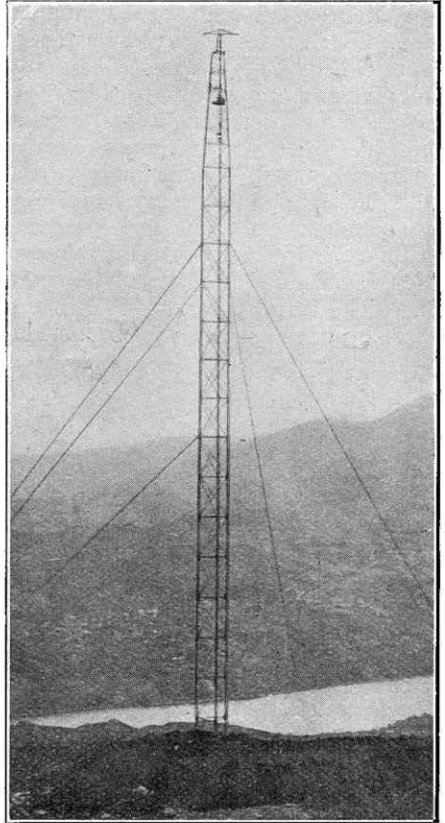

Nearing completion. When finished the 400-ft. mast is self-supporting, except for three substantial stays at a height of 320 ft.

it is kept up-to-date in all the latest improvements which may add usefully to its efficiency.

During recent months an interesting addition has been made to this station, consisting of a very considerable elaboration and extension of the aerial system. The object being to enable a higher transmission speed to be maintained throughout the 24 hours. To accommodate this extension of the aerial, six additional masts have been

erected, each mast being 400 feet in height. The masts were designed by the Marconi Company and manufactured and erected by Messrs. Francis Morton of Birkenhead.

The accompanying illustrations show these masts in course of erection and as they now appear when complete.

The new extension is inductively coupled to the former aerial system on the principle of the multiple tuned aerial. The masts are arranged in pairs and are triangular in section. Each mast is stayed by three stay wires at a height of 320 feet.

To give an approximate idea of the structure it is interesting to note that the anchor blocks to which these stayed wires are brought weigh approximately 30 tons each. The masts themselves are of steel lattice construction. The aerial system consists of 12 wires supported by means of triatics, suspended between the pairs of masts. The aerial wire used is No. 1 gauge silicon bronze solid wire (considerably

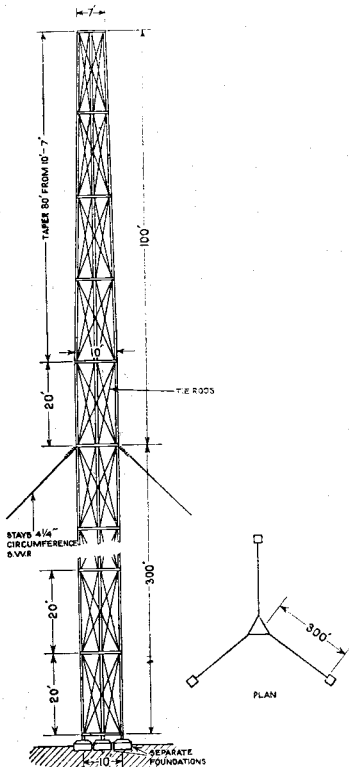

A sketch which shows the general design of the mast and some details of construction.

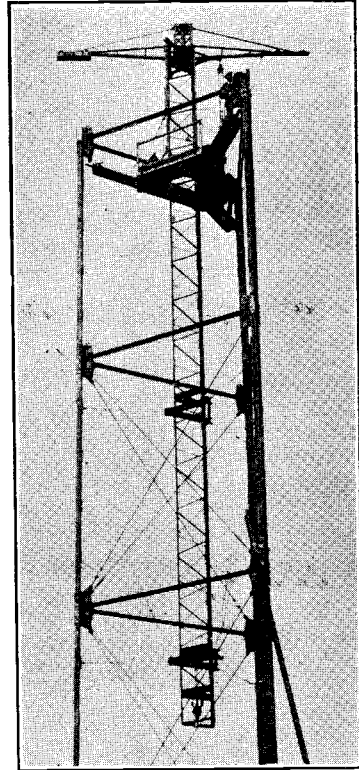

A near view showing the method of raising the mast, section by section.

thicker than the average pencil), and this wire has also been used to replace the old aerial, which was formerly composed of stranded wire.

Transatlantic Broadcast Tests.

DESCRIPTION OF APPARATUS USED.

A ready response has been received to the invitation to those who were successful in the reception of American Broadcast transmissions during the Tests to send in descriptions of the apparatus used.

A large number of descriptions have yet to be judged before a decision can be arrived at as to which should receive the awards of £10 and £5.

The results will be published in our next issue.

A FOUR-VALVE DUAL NEUTRODYNE RECEIVER.

By W. JAMES.

IN *The Wireless World and Radio Review* of December 19th we described a five-valve Neutrodyne receiver, consisting of two stages of high frequency amplification, detector, and two note magnifiers. No switching arrangements were provided. The receiver described below has two stages of high-frequency amplification, with the first stage dualled, detector, and one stage of ordinary note magnification. Reaction effects are obtained by tuning the plate

When the plug is inserted in the note magnifier jack, the filament is lighted, and the telephones joined in the plate circuit.

The receiver follows the same general lay-out as the one described in the earlier article. A photograph of the complete instrument is given in Fig. 1. The three tuning condensers, 0.0005 microfarads, are marked 1, 2 and 3. The first filament resistance, 10, is connected in the filament circuit of the note magnifier; the other

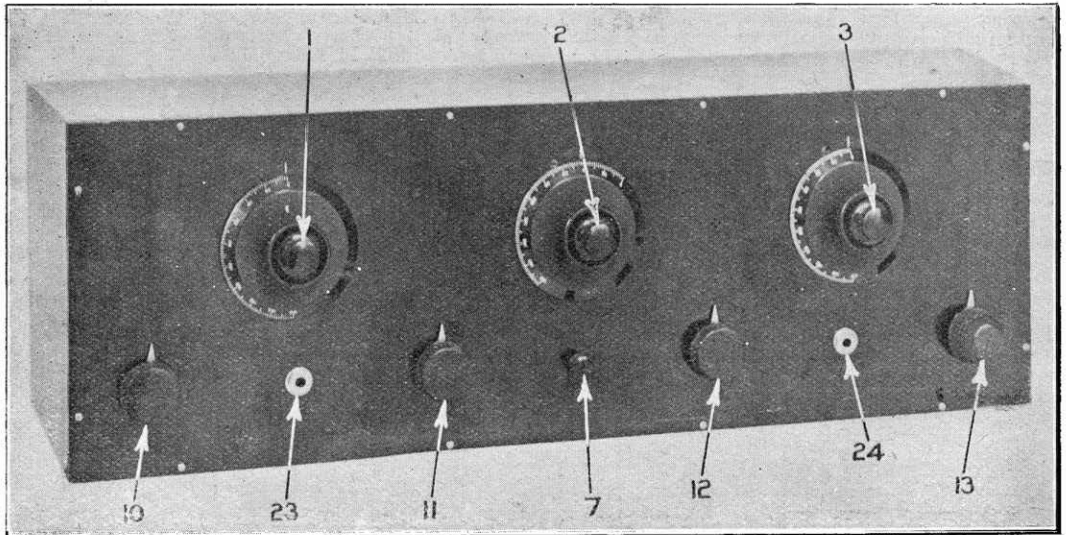

Fig. 1. Front view of the receiver in its box. The three tuning condensers are marked 1, 2 and 3. The filament resistances control the valves as follows: 1st, 2nd and 3rd valves, Nos. 11, 12 and 13; 4th valve, No. 10. Jack 24 is associated with the detector valve, and jack 23 with the note magnifier. No. 7 is the reaction variometer knob.

circuit of the detector valve with a variometer. A jack is connected in the detector valve plate circuit, and another is joined in the plate and filament circuits of the note magnifier. When the telephone plug is pushed in the detector jack the telephones are connected to the detector, and there is only the two stages of high frequency amplification and the detector in circuit. The filament circuit of the note magnifier is broken by the note magnifier jack springs.

resistances (11, 12 and 13) are connected to the first valve (combined H.F. and L.F.), the second valve (ordinary H.F.) and the third valve (detector). The left-hand jack (23), is an Elwell jack, type D.F. It has six contacts altogether, but one of them is not used. The right-hand jack (24) is an Elwell type S.C., and has three contacts, all of which are used. The small knob (7) in the middle, is fastened to the moving element of the reaction variometer.

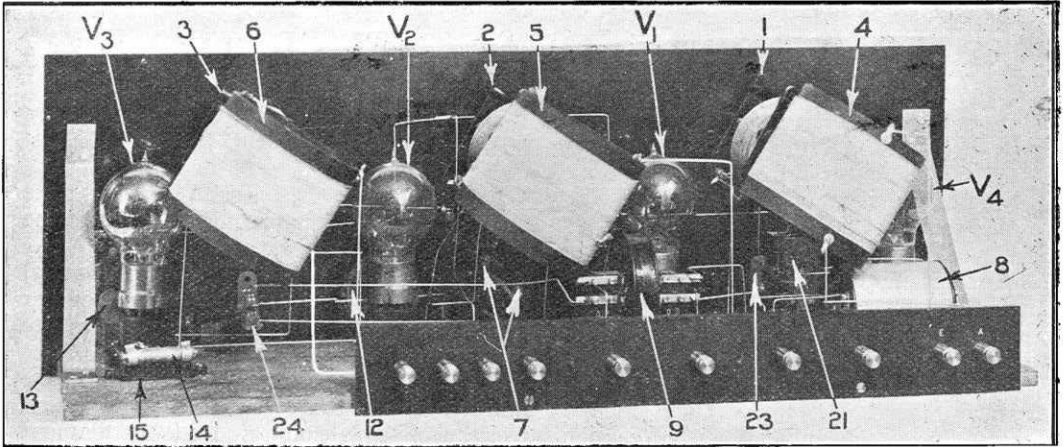

Fig. 2. Rear view of the receiver with the case removed. The parts are labelled as follows : tuning condensers 1, 2 and 3; high frequency transformers 4, 5 and 6; valve V_1 operates as a dual amplifier, V_2 as a high frequency amplifier, V_3 as detector and V_4 as a note magnifier; note magnifier transformer, 8; transformer in the dual circuit, 9; reaction variometer 7; detector valve jack 24; note magnifier jack 23; grid bias battery 21; grid condenser and leak 15 and 14.

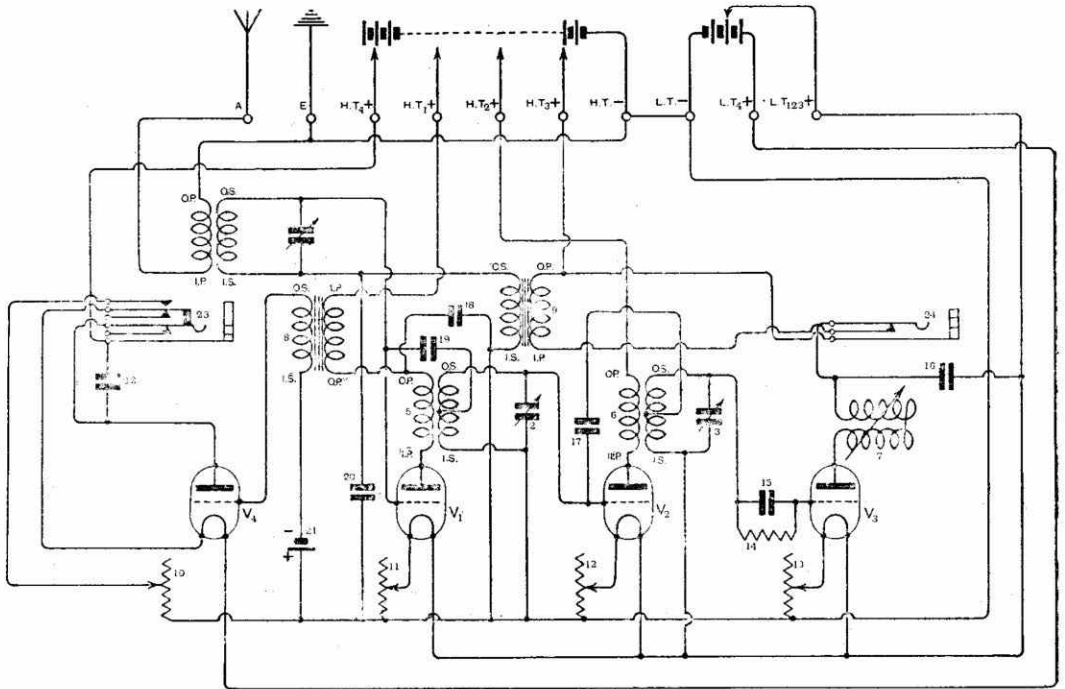

Fig. 3. Theoretical diagram of the receiver. The values of the components which are lettered the same in all diagrams are as follows : 1, 2 and 3, 0.0005 with vernier (Sterling Telephone & Electric Co.); 4, 5 and 6 transformers, see Fig. 7; 7, reaction variometer, 50 turns of No. 30 D.S.C. each winding; 8, interval transformer (Marconi Scientific Instrument Co.); 9, Pye, type No. 1 interval transformer (W. G. Pye & Co.); fixed condensers, 16 = 0.002 μF , 15 = 0.00025 μF , 17 and 19 = neutralising condensers, 18 = 0.005 μF , 20 = 0.0002 μF , 22 = 0.002 μF ; 21 = two dry cells; jack 24, Elwell, type S.C.; jack 23, Elwell, type D.F.

A back view of the receiver is given in Fig. 2. The three tuning condensers, 1, 2 and 3, will be noticed. On the ends of these condensers is mounted the high-frequency transformers, 4, 5 and 6. The first valve is marked V_1 , and close to it is the intervalve transformer 9, which is joined between the detector and this valve. The second valve

The aerial and earth terminals, which are those seen on the right-hand side of the connection strip (Fig. 2) are joined to the primary winding of the first high-frequency transformer. The next four terminals are connected to the four plate circuits, so that any voltage may be applied to these plate circuits. The seventh terminal is the

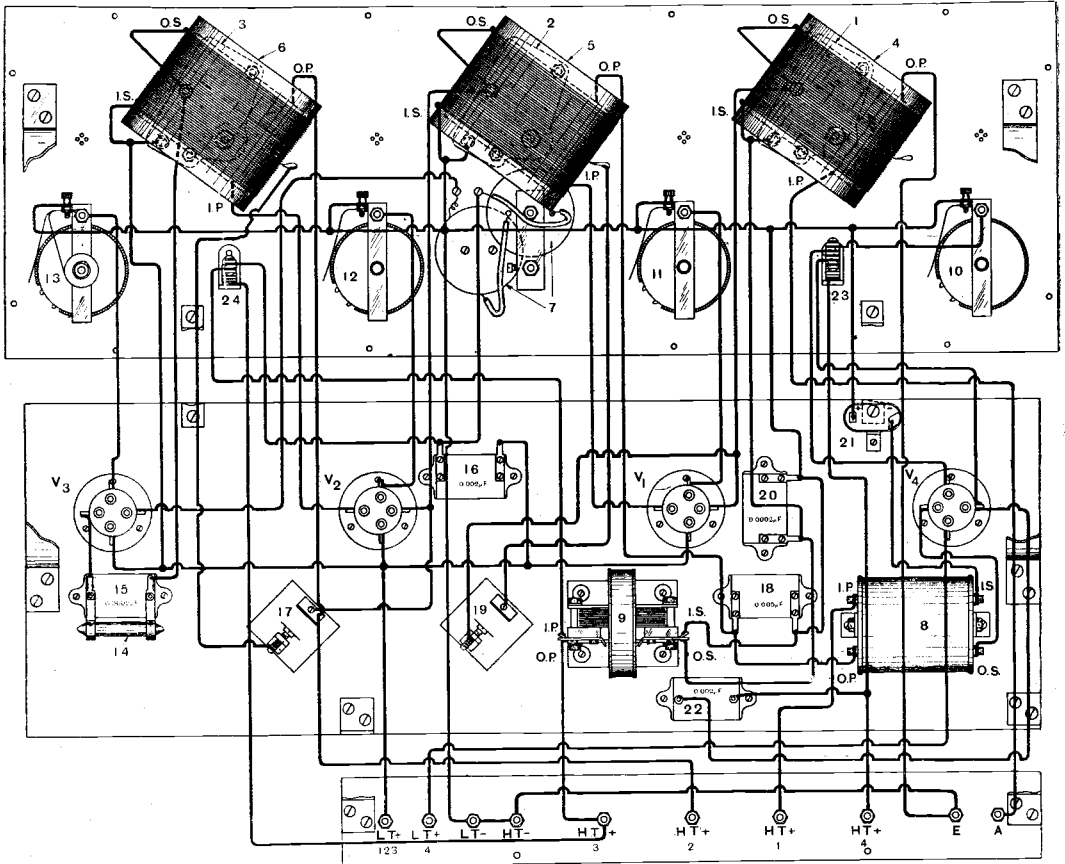

Fig. 4. The wiring diagram. The upper panel is the ebonite front panel which carries the tuning condensers, filament resistances, jacks and reaction variometer. The lower panel is a wooden baseboard. The components and wiring are arranged as though the panel and board were laid out flat. The ebonite connection strip is shown at the bottom.

is V_2 , and the detector valve V_3 . Valve V_4 is the note magnifier. It will be noticed the external connections are all made to the terminals carried by the connection strip. The face of the strip is level with the surface of the back of the box, so that the terminals stand out.

The theoretical diagram (Fig. 3) will enable one to easily follow the connections.

common negative connected to the high tension battery, and the eighth is connected to the negative of the filament heating battery. The last two terminals are joined to the filament circuits. The end terminal of all is connected to the filaments of valves V_1 , V_2 and V_3 ; the other terminal connects with the note magnifier. The reason for this is that it may be desired to use valves of the

dull emitter type, such as the D.E.R. (2-volt filament) or the R-06 for the two H.F. stages, and detector, and an ordinary R type or power valve as the note magnifier.

The arrangement of the parts and the wiring are shown in Fig. 4. The upper panel is the front ebonite panel of the instrument,

THE FRONT PANEL.

The front panel is of 5/16 in. ebonite, 24 ins. long by 8 ins. wide, and is secured to the baseboard with brass brackets of the dimensions shown in Figs. 5 and 6. It carries the tuning condensers, filament resistances, jacks and reaction variometer.

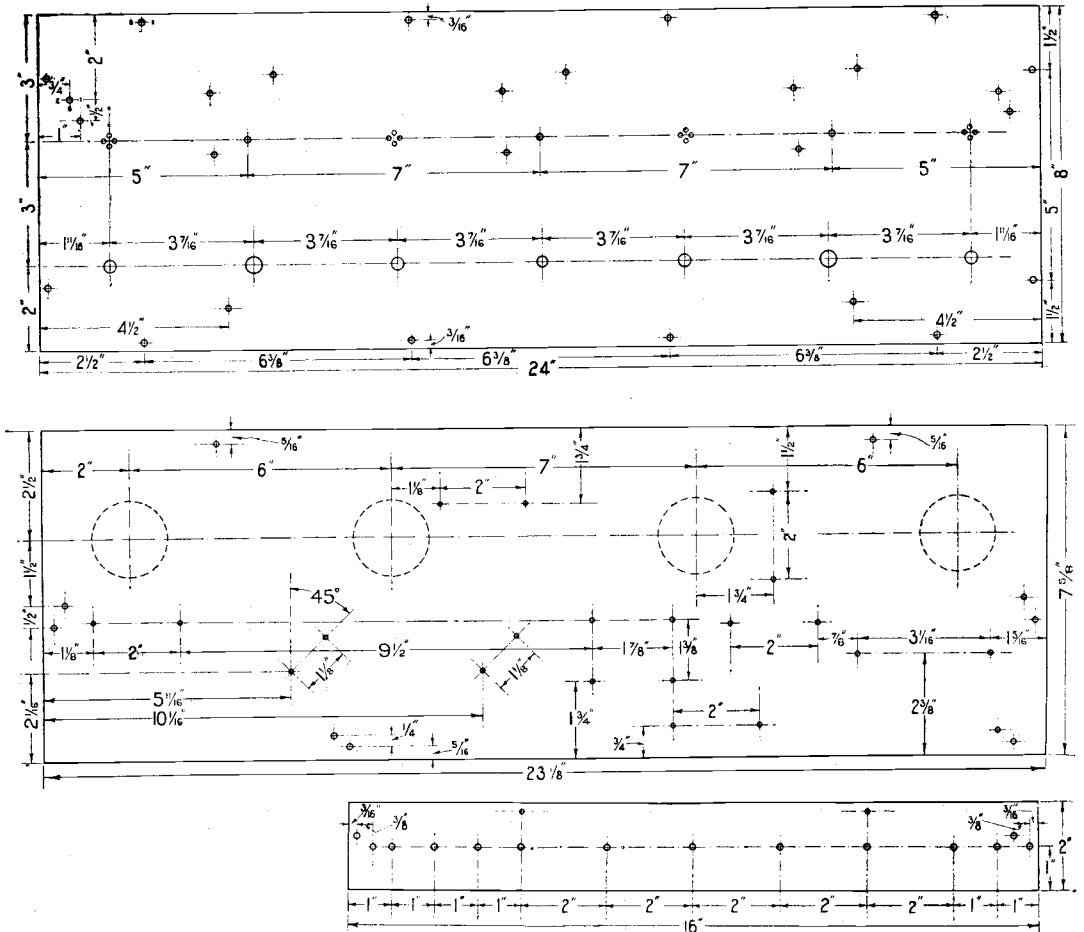

Fig. 5. Leading dimensions : The upper drawing is of the ebonite panel, the one beneath is of the baseboard. The terminal strip is at the bottom.

and the lower panel is the wooden baseboard. The drawing is arranged as though the ebonite panel and wooden baseboard were laid flat in one plane. Fig. 5 gives the leading dimensions, and Fig. 6 an end view of the base with the panel and baseboard in position but with the end of the box removed.

The variable condensers have a maximum capacity of 0.005 microfarads, and those used are manufactured by the Sterling Telephone and Electric Co. They are fitted with a single plate adjustment for fine tuning. The plates are specially shaped to give a wavelength which varies

directly with the setting of the dial. On the ends of these condensers are mounted the H.F. transformers. The transformers are constructed alike, and each consists of

The secondary windings consist of 70 turns of No. 22 D.C.C. with a tapping at the 25th turn from the lower end. The primary windings are of 25 turns of No. 22 D.C.C., wound at the bottom end of the smaller tubes, so that when the primary is placed inside the secondary, the primary winding is covered by the portion of the secondary winding included between the end and the tapping. Both coils are wound in the same direction, and the connections in the diagrams are given for transformers wound in this way. The two lower ends of the transformer windings which are adjacent are labelled I.P. and I.S. It will be found convenient to solder the ends of the windings to tags held by No. 6 or 8 B.A. screws passed through the uncovered ends of the ebonite tubes. The windings should of course be dried, and given a thin coat of shellac varnish. The top ends of the secondaries are connected

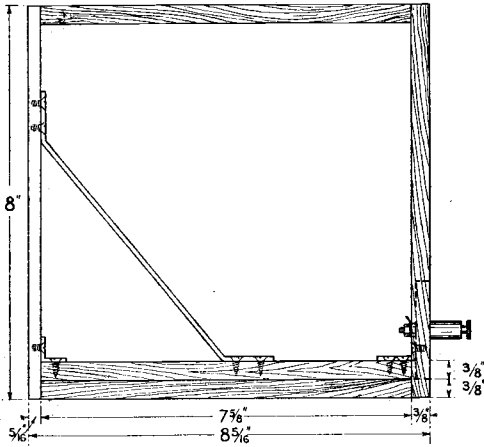

Fig. 6. End view of the instrument with the end of the box removed. The baseboard is held to the panel with brass brackets. The terminal strip is fastened to the baseboard with the smaller brackets.

two tubes ; the outer ones carry the secondary windings and the inner ones carry the primary windings. The outer tubes are of ebonite, $3\frac{1}{2}$ ins. in diameter and 3 ins. long. The wall is about $\frac{1}{8}$ in. thick. The inner tubes are of cardboard, $3\frac{1}{8}$ ins. in diameter. If it is found difficult to obtain tubes with these diameters, others of approximately this size may, of course, be used without affecting the results in any way, provided the difference in diameter of the two sets of tubes is not more than $\frac{3}{8}$ in., and an appropriate adjustment is made to the number of turns. To fasten the transformers to the ends of the variable condensers remove the nuts from the ends of the side spindles of the condensers and screw on valve sockets. The valve sockets were reduced in length, as shown in Fig. 7, and threaded 4 B.A. The holes in the sockets are just the right size for threading. The distance between the sockets when screwed up tight is $2\frac{1}{2}$ in., and a hole was drilled in each end of the ebonite tubes, $2\frac{1}{2}$ ins. apart, to take the screwed ends of the sockets. The drawing of the transformers (Fig. 7) will make the construction clear.

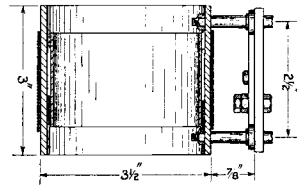

Fig. 7. Dimensions of the high-frequency transformers and the method of mounting on the ends of the tuning condensers.

to the contact of the fixed plates, and the bottom end to the moving plates.

The condenser transformer units are mounted at an angle of about 55° with the vertical to prevent magnetic coupling.

(To be concluded.)



LOUD SPEAKERS.

By E. K. SANDEMAN, B.Sc.

(Concluded from page 524 of previous issue).

OTHER FACTORS BEARING ON FAITHFUL REPRODUCTION.

Everyone is probably aware how the acoustics of a building can affect adversely the production of music or speech, though probably few are aware of the reasons underlying this. They are various, but are almost entirely bound up in reflection from the walls and roof of the building. When the reflecting properties of the walls are sufficiently good, a sound wave may be reflected several times before it reaches the ear of the listener, and arriving just after the direct sound wave may so confuse matters as to make speech unintelligible or as to rob music of its character. Such a condition tends to prolong any note in the building, and is spoken of as reverberation. A certain amount is beneficial, and actually essential, but the exact balance is not always easy to obtain. It is this "balance" which gives music its required degree of "brilliance."

In the case of speech reproduction with a loud speaker we have two chances of reverberation, one in the place where speech or music is being produced and the other in the place where it is being reproduced. This is a point which does not occur to everyone, and it immediately becomes evident that music which already contains sufficient brilliance and is suitable for reproduction in headphones, cannot be reproduced equally well on a loud speaker, which introduces the sound into a second reverberating space. It seems probable that in the future a balance will have to be struck between these two considerations.

The exact position of the loud speaker and the listener in the room are also matters that have not received their due share of attention. This is a matter for experiment, and although general consideration of the laws of reflection may be a guide, no definite rule can be laid down for any specific case.

VARIOUS TYPES OF LOUD SPEAKERS.

There are now on the market for the reproduction of wireless broadcasting a large

number of types of loud speakers operating on different principles.

The conversion of electrical into acoustic energy may be regarded as occurring in two parts. There is, firstly, a conversion of electrical into mechanical energy, which is accomplished by means of the "motor" part of the loud speaker, and, secondly, the conversion of mechanical energy into acoustic energy, which is, in general, accomplished by means of a diaphragm. A horn is sometimes employed to effect a tapering of acoustic impedance from the diaphragm to the open air.

(The acoustic impedance of air is measured in abohms, which have the dimensions of dyne-seconds per centimetre, and actually is the ratio between the maximum excess pressure and maximum velocity of displacement of the air particles at a point).

There are various types of "motor" on the market, varying from the common telephone receiver to a device consisting of a coil energised by speech currents and situated in a strong magnetic field, this last demonstrating most clearly a justification of the term "motor," adopted above.

In constructing these motors there are two chief objects to be attained. Firstly the loud speaker must be reasonably efficient, and, secondly, the moving parts must be as light as possible to avoid the effect of resonance. Actually, of course, lightness of moving parts makes for efficiency, since the mechanical impedance to movement for light objects is obviously less than that for heavy objects. Efficiency can be further obtained by designing all magnetic circuits to have a minimum reluctance, reducing all air gaps in magnetic paths to a minimum, and by a careful designing of all coils with a view to keeping resistance and self-capacity as small as possible.

The loud-speaking receiver in which these details of motor construction have been most fully realised is that shown in Fig. 5, and whose impedance curve is shown in Fig. 1A. The freedom from resonance is

most marked. The actual details of construction are worthy of note, since considerable ingenuity has been adopted in reducing the mass of moving parts to a minimum. A small armature pivotted at its centre is situated between two pole pieces so that both its ends are capable of being attracted by the poles. An energising coil which surrounds the armature, *but does not move with it*, causes the polarity and strength of magnetism in the armature to vary proportionally to the speech currents flowing through the coil, and so causes mechanical forces to be developed by the armature, which are transferred to a diaphragm by means of a short connecting rod.

This diaphragm is corrugated concentrically to give it additional strength and to prevent the possibility of nodal points occurring, the effect of the corrugations being to make the diaphragm effectively a cone.

The horn of this loud speaker is of logarithmic contour, that is to say the area of cross section increases by equal percentages for equal increases in distance measured along the axis of the horn.

This particular graduation is adopted since, by this means, reflection losses due to change of impedance are reduced to a minimum, resulting in a greater efficiency, while the tendency of the horn to resonate is reduced to negligible proportions.

The performance of this loud speaker does much to refute the general opinion that loud speakers are still only in the development stage. It can be stated most definitely that the modern loud speaker not merely equals the performance of the best modern gramophones, but actually surpasses them, both in clearness of speech and in faithful reproduction of music. This is not true for all loud speakers, of course, but it is true if we compare the best loud speakers with the best gramophone. Further, loud speaking telephones, as described under, can deliver clear speech and music to distances which no gramophone has ever attempted. This comparison is hardly fair, since gramophones were never designed for this purpose, but it is a fact.

The horn, as we have seen above, is a method of "coupling" between the diaphragm and the air. This type of coupling may be avoided by employing a large light diaphragm, whose impedance approximates

more nearly to the characteristic impedance of air.

In France, the tendency has been to develop loud speakers along these lines, and some very pleasing results have been obtained, although it is not yet possible to say whether the loud speaker of the future is most likely to follow this method of design or the rather more conservative one using a small diaphragm and a horn.

The firm who, in the author's opinion, have achieved the greatest success with the large diaphragm, have also developed a novel type of loud speaker "motor" for use with a small diaphragm and a horn.

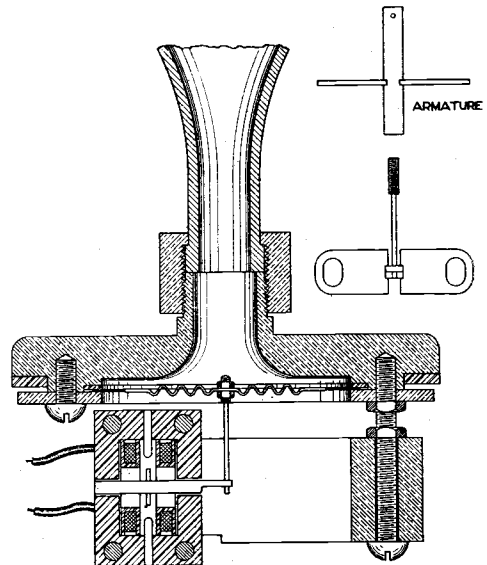

(Courtesy Western Electric Co.)

Fig. 5. Cross section through loud speaker.

In this motor the diaphragm itself consists of a conical spiral of wire, the cone having an angle of about 90 degrees. This cone is situated in a strong magnetic field, and the speech currents are arranged to traverse the spiral of wire. By this means each integral part of the diaphragm is made to supply the force actuating it, a theoretically ideal arrangement, and one from which great results might be expected, especially as the cone form of construction gives great rigidity and prevents the formation of nodes. Actually, however, the performance of this instrument on the occasions when the author has heard it, did not compare

with the corrugated diaphragm type of loud speaker described in detail above.

Probably the most close competitors of the loud speaker shown in Fig. 5 are firstly, the large diaphragm type described above, and secondly, one in which the designer has gone back to first principles and employed what is essentially nothing more than a large telephone receiver of ordinary pattern. No loud speaker at present on the market can, however, be considered to have reached its final form, and, if not in the immediate future, at any rate at a not very distant date, we can expect a very definite improvement both in the efficiency and the quality of reproduction.

thousand people at a time, but in America at the inaugural address by President Harding, over 125,000 people were able to hear his voice, while on September 18th, 1922, approximately 200,000 people were addressed at Detroit, Michigan, on the occasion of the laying of the foundation stone of the new Masonic Temple.

At Southampton, experiments were made with a view to testing the range of one of the giant loud speakers employed with the system above, and which is shown in the accompanying photograph slung from a derrick. On this occasion clear speech was heard out to sea at a distance of one and a half miles away from the sound pro-

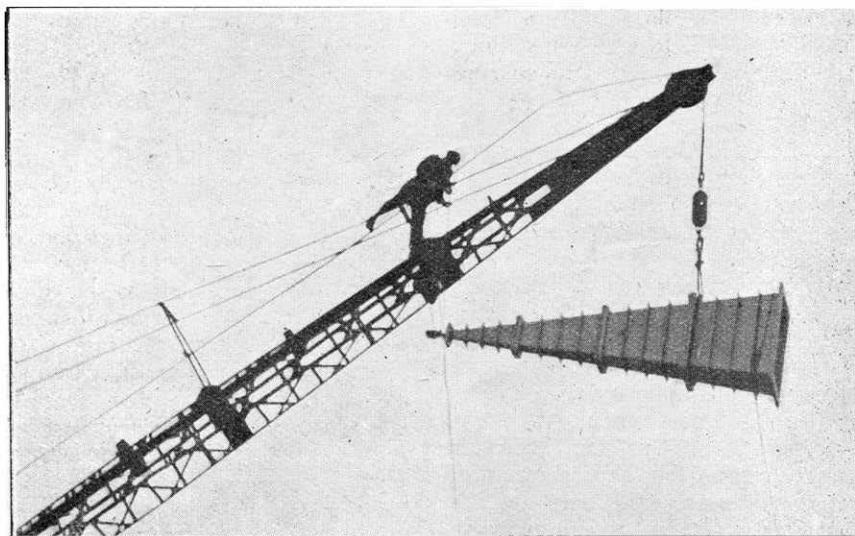

(James' Press Agency.)

A large loud speaker. Clear speech has been heard four miles away from the sound projector.

APPLICATIONS OF LOUD SPEAKING TELEPHONES.

Probably everyone to whom a loud speaker is brought to mind thinks of it in connection with wireless broadcasting, for which the types above are chiefly designed, although probably during the last year a good many have come to realise its possibilities in connection with the addressing of large meetings by public speakers.

A loud speaking system has been developed which is capable of addressing over a million people, and which is now in continual use both in England and America.

In this country it has never been called on to address more than about thirty-five

jector, which employed a horn over 12 feet long. On other occasions speech has been projected to a distance of about four miles.

It is conceivable that in the future loud speakers will be constructed to be heard as far away as a fog horn, and we can imagine the lighthouse of the future being equipped with a gramophone and a loud speaker, shouting out its name and any particulars of recent wrecks for the guidance of all ships passing. A loud speaker rated at two kilowatts has already been constructed.

I wish to express my indebtedness to Mr. L. C. Pocock, B.Sc., for his suggestions and advice in the preparation of this paper.

PATENT ABSTRACTS.

Condensers.

In the ordinary type of fixed condenser, copper plates are suitably separated with a dielectric, generally mica.

Another construction of fixed condenser consists of a small mica plate which is chemically silver-plated on both sides and then electrolytically copper plated.

Owing to the absence of any layer of air, the capacity is substantially increased in such a condenser, the large dielectric constant of the mica of about 6 being fully utilised. In the case of a small plate 90 mms. long, 35 mms. wide and 0.06 to 0.07 mms. thick, the capacity is 1,800 cms., the metal coatings being about 5 mms. apart at the edge.

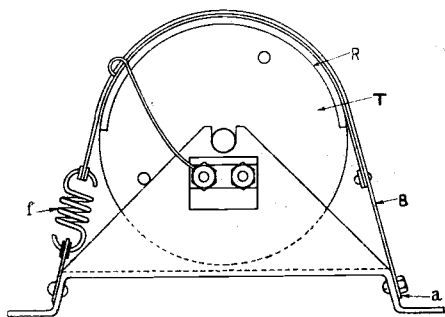

Fig. 1.

Experiments carried out with the object of producing a rotary condenser, in which use is made of such a coated mica plate, led to a rotary condenser of the form shown in Fig. 1.*

Drum T of ebonite is lined over half of its periphery with metal, for instance by screwing on to it a portion of a brass tube R which has been cut in the longitudinal direction. A small and very thin sheet of mica is silver-plated and copper-plated only on one side, and then is placed with its non-coated side on to the drum, being lightly pressed against the drum by means of a spring B. The other side of the band

is connected to spring F, which is anchored to the base A.

It will be seen that one plate of the condenser consists of the coating on the surface of the mica sheet. When the drum is rotated, the size of the metal surfaces facing each other will be varied and consequently also the capacity of the condenser.

The diameter of the drum should not be made smaller than 50 mms., when the thickness of the mica is between 0.06 and 0.07 mms., otherwise the mica will break.

As regards damping, mica condensers constructed according to the above arrangement are almost equal to air condensers, even in the case of high frequency oscillations.

A Variable Grid Leak.

A good variable resistance should be constructed so that the ohmic value of the resistance at various settings does not change appreciably after a little use. It is said that a resistance made as shown in Fig. 2* can be varied over a wide range, is simple to adjust, and is fairly accurate.

The resistance is of the carbon pile type, comprising a number of discs or pellets, which may be composed of fibrous material, impregnated with carbon, arranged in a pile within a tubular container of insulating material. The container is closed at the ends by caps, covers or plugs, a screw for

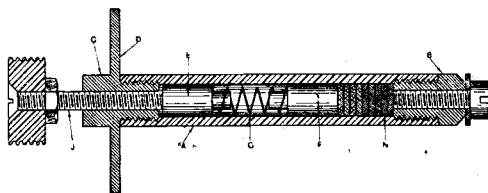

Fig. 2.

applying variable pressure to the pile being screwed through one of the end closures.

The number of pellets used is of course chosen according to the resistance required.

Referring to the drawing, A is a tube of insulating material closed at one end by a

* British Patent 198,662, by Dr. Georg Seibt.

* British Patent 206,098, by A. E. Watkins.

brass terminal plug B and at the front end by a brass terminal plug C, which is made in one with a disc D. Within the tube there are two plungers E and F with a compression spring G between them. Through the plug C is screwed a screw J. Pellets N are placed between the plunger F and the plug D.

It will be clear that by screwing in the screw the plunger will be forced inwards, and compress the spring; the latter will press the plunger F tightly against the pellets and these being more tightly pressed together, the effective resistance will be reduced.

Improvements in Loud Speaking Telephones.

An interesting loud-speaking arrangement is described by Gesellschaft Für Drahtlose Telegraphie.*

The arrangement is shown in Fig. 3. A loud-speaking telephone is formed on an ordinary gramophone sound-box, the needle of which is vibrated at right angles to its length by the armature of an electromagnet, in the coils of which flow the currents representing the sound to be reproduced.

Referring to the Fig. 3, A is an electromagnet, the coils of which are connected in a circuit B, in which flow currents due to the speech. The armature C of the magnet carries a projection D, in which is seated the needle E connected by a lever F to the diaphragm of the ordinary gramophone sound-box G. The sound-box G is connected through a tone arm H to a horn J.

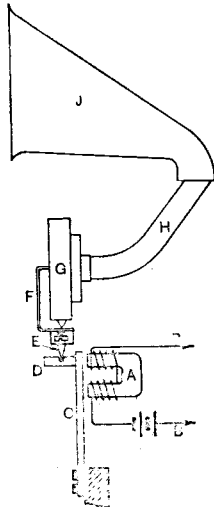

Fig. 3.

Improvements Relating to Contacts for Relays.

It has generally been found that when a small speck of dust is on the contacts of a

relay, this may seriously interfere with the proper working of the relay.

In order to overcome this difficulty an oscillating potential may be applied between the contacts of the relay as long as no

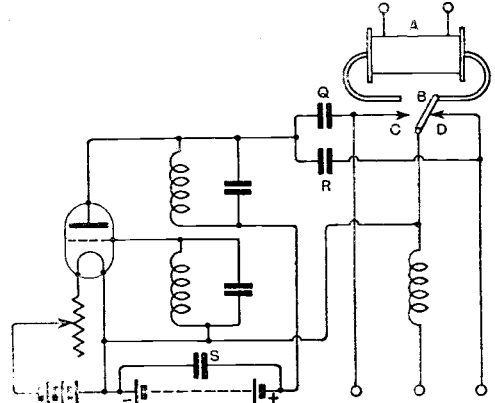

Fig. 4.

contact is made, this oscillating potential however, being removed as soon as contact is made, the source of potential being disconnected until contact is broken again.*

One arrangement is shown in Fig. 4. The relay is marked A, with contacts B, C and D.

The oscillator generates oscillations in the circuits provided. The tuning of the valve circuits is accomplished through the inductance and condenser shown.

When the valve is oscillating, an oscillating potential is applied between the tongue B and the contacts C and D. After tongue B makes contact with D, as shown in the figure, the condenser R and another condenser S connected across the high tension battery will be joined in series across the condenser joined in the anode circuit of the valve, and will therefore put the plate circuit of the valve out of tune with the grid circuit, so that the valve no longer generates oscillations.

Similarly, if the tongue B makes contact with the contact C, the valve will start generating oscillations as soon as the tongue leaves either the contact C or contact D; the oscillating potential will rapidly build up, and is then ready to provide the extra electromotive force necessary to break down any insulation on the faces of the contacts B C D.

* Patent Specification 202,953.

* British Patent 201,299 by J. B. Bolitho.

THE PRINCIPLES UNDERLYING THE OPERATION OF THE THERMIONIC VALVE.

In earlier articles we briefly discussed the emission of electrons from a heated filament, and the method of obtaining the voltage and temperature saturation curves of a simple two-electrode valve.

By W. SYDNEY BARRELL.

(Continued from page 530 of previous issue.)

FILAMENT EFFICIENCY.

The efficiency of any device may be defined as the ratio of the work it does to the amount which is put into it. The filament of a valve has a definite function to perform, namely, to emit electrons, and for any given purpose it must emit a certain number. The less the energy that must be supplied to the filament for any given emission the greater the efficiency.

Now there are two main factors to be considered with regard to a valve filament, and these are its life and the maximum emission that can be obtained from it for any given amount of power expended in heating.

The saturation current, as has already been explained, depends upon the area of the filament and its temperature, while the power required to maintain the filament at any desired temperature depends upon its size and the temperature.

Now, as the temperature approaches white heat the emission increases much more rapidly than does the filament power required for heating, or in other words, the saturation current increases more rapidly with the temperature than does the power, and in this connection the following data is of interest.

To raise the temperature from 2,100 degs. to 2,400 degs., requires an increase in power of 75 per cent., whereas the emission is increased no less than 25 times. It is thus seen that around the operating temperature the emission is particularly sensitive to change in filament current, and this is further illustrated by the following table extracted from a paper by S. Dushman which appeared in the *G.E. Review*, of 1915.

The first column gives the temperature of the filament, the second the power necessary to maintain the filament at the

temperature given in column one, while the third column shows the saturation emission

Temperature Degrees Absolute.	Watts per sq. cm.	Emission Milliamperes per sq. cm.
1,800	16.4	.3
2,000	26.9	4.2
2,100	34	15.1
2,200	43	48.3
2,300	53	137.7
2,400	65	364.8
2,500	77.5	891.6

in milliamperes per sq. cm. of filament surface.

To ensure the maximum possible life when working valves fitted with tungsten filaments, always remember on no account to exceed the rated filament voltage and always operate the tube with as low a filament current as possible consistent with satisfactory signals.

According to the area of the filament and the temperature at which it shall be run, the designer has determined the maximum plate current, and it is poor policy to over-run the filament for the sake of a little extra power. A factor which has an important bearing on the life of a filament is the actual evaporation of the tungsten.

The high temperature at which a filament is operated in order to produce the necessary emission causes it gradually to evaporate, with a consequent decrease in diameter. This naturally increases the filament resistance. Evaporation is slow at temperatures below about 2,400 degs., but at higher values increases very rapidly. The life of the

filament will therefore depend upon the rate at which it evaporates. In this respect the dull emitting valves are vastly superior, as having a higher filament efficiency require a much lower temperature than the ordinary filament for a given emission, and this means a longer life.

Since a filament is continuously evaporating, its temperature conditions are variable, as

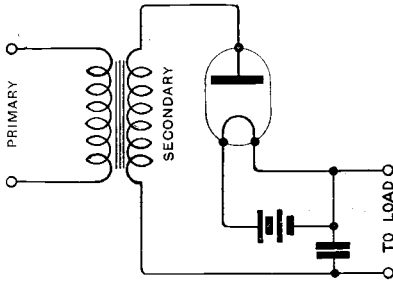

Fig. 7.

will be seen from the following. In practice there are two ways of operating the filament.

- (1) Keeping the filament current constant.
- (2) Maintaining a constant voltage across it.

These methods produce widely different results.

It has already been pointed out that as the filament is used its diameter decreases, and consequently its resistance must increase. If, then, the filament current is kept constant the watts expended in it will also be increased. (This, of course, follows from the fact that as the resistance has increased, the voltage must be raised to maintain the same current). This results in a higher filament temperature and consequent higher rate of evaporation. This cycle keeps up, the effects are cumulative, and the life decreases very rapidly.

When the valve is operated with constant filament volts the watts expended will gradually decrease (owing to the higher resistance), and consequently the temperature would tend to decrease during the operating life.

Comparing the above two methods of operation it is undoubtedly better, as far as valve life goes, to work with constant filament voltage rather than constant filament current. The consequent slight reduction in

filament current when using the former method will result in a somewhat smaller emission, but this is generally unimportant and is preferable to short life.

RECTIFICATION.

It is not proposed to discuss the two-electrode valve as a detector of radio frequency oscillations because it is nowadays seldom used as such, its sensitivity being considerably less than the three-electrode valve which has now completely superseded it.

The two-electrode valve in a somewhat larger form has, however, a distinct field of utility as a rectifier of alternating current for transmitting purposes, for the reason that if an alternating E.M.F. is applied between anode and filament no current will flow when the plate is made negative with respect to the filament, but during the half-cycle that the plate is positive, current will, of course, pass through the valve. This rectifying property would, however, to a great extent be destroyed if the anode became incandescent, as would occur if the potential across the valve were too high. If, then, a rectifier is connected in series with the lead from a transformer secondary as shown in Fig. 7, pulses of unidirectional current will flow to the load.

Let us now consider a little more closely the anode volts—anode current characteristic of Fig. 8. It will be seen that there is a certain voltage E_0 , beyond which the anode current increases very slowly. Let this

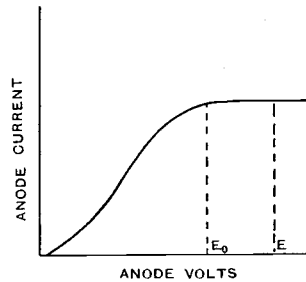
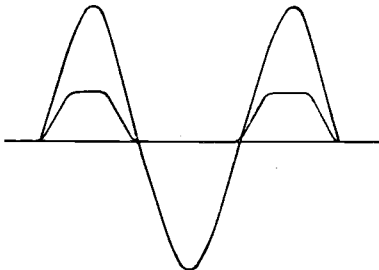
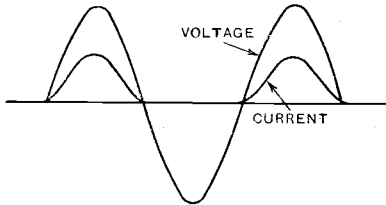

Fig. 8.

voltage be called the peak voltage. Therefore, if an alternating voltage is applied across the valve and its maximum value does not exceed E_0 , then, during the half cycles when the plate is positive, the current flowing will follow the shape of the voltage

curve as shown in Fig. 9, but on the other hand, if the voltage applied exceeds that represented by E_0 , say, E , Fig. 8, then the current will take the form somewhat as shown in Fig. 9A, in which the peaks have been flattened. This is due to the fact that while the impressed voltage has exceeded E_0 , the current through the valve cannot increase beyond the saturation value. Now the voltage necessary to produce saturation depends upon the design of the valve, as will be shown in a diagrammatic way.

To fix our ideas, suppose we start with a valve having the following electrode dimensions. Filament 3 centimetres long, anode 1 centimetre diameter, and 2.5 centimetres long, and let us suppose that the anode volts anode current curve from this valve is given by the curve OXY, Fig. 10, the voltage required to produce saturation being indicated by E_0 . Now suppose the anode diameter to be increased, keeping its length and also the filament size and temperature constant. The resulting curve will be OZY.



Figs. 9 and 9A.

Now it will be at once seen that the saturation current is unchanged, as was to be expected, for we have already seen* that this is only dependent upon the filament size and

temperature. The size and diameter of the anode does not enter into the saturation current equation, but the increase in diameter has had the effect of flattening out the curve and a peak voltage greater than E_0 is now required to produce saturation.

If now the anode diameter is reduced to less than 1 cm. diameter, other factors

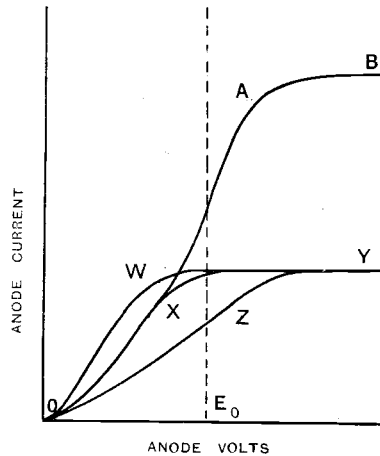

Fig. 10.

constant, we should, in view of the above, expect an opposite effect to the one previously described, and actually we get the curve OWY. Again the saturation current has remained unchanged, but the voltage E_0 is less.

Returning now to the original dimensions given, let us increase the filament current. We now obtain the curve OXAB, from which we see that the saturation current has been increased; but so has, also, the voltage E_0 to produce it.

This result is in accordance with our previous knowledge, and was to be expected.

The results of the foregoing experiment may therefore be summarised as follows:

The value of the saturation current depends solely upon filament conditions, and is independent of the distance filament to anode. This distance will, however, determine the anode voltage necessary to give saturation, the less the distance the smaller the voltage, and *vice versa*.

* *Wireless World*, Jan. 23rd, p. 528.

LONG DISTANCE TRANSMISSIONS

RECORD OF AMATEUR WORK DURING DECEMBER.

DURING the last few weeks all previous records in amateur long distance transmission have gone to the wall and new achievements beyond the keenest anticipations of the DX enthusiast have been accomplished.

On November 25th, 1923, as recently recorded in these pages, French **8 AB** opened up European communication with America for the first time, although as early as September, from reports lately received, many of our own stations had been logged just off the American coasts, by ships' operators.

Since this French success many English stations have been successful in establishing two-way working with Canadian and American amateurs, and messages of congratulation and greeting have been handled with complete success.

The English stations at present in communication with the other side are:—**2 FU**, **2 KF**, **2 NM**, **2 OD**, **2 SH**, **2 SZ**, **5 BV**, and **5 NN**, and it is interesting to note that most of these stations are within the London area, which seems to ridicule the idea that considerable losses due to absorption and screening effects are noticeable in large towns where high buildings and numerous telephone wires abound. It is worthy of note, too, that in the case of **2 FU**, **2 KF**, and **5 BV**, the number of neighbouring broadcast receiving aerials is considerable.

These British stations have collectively worked with American stations, **1 XW**, **1 XAQ**, **1 XAM**, **2 AGB**, **2 AWS**, **2 BSC**, **2 CFB**, **3 XAO**, and Canadian stations **1 BQ** and **3 BP**.

The most constant of the American stations is **2 AGB**, who is situated at Summit, N.J., and whose aerial current varies between 2 and 4 amperes. Of the Canadians **1 BQ** is the better, and he uses a D.C. machine, but fading is very noticeable with this station at nearly all times.

The French amateur stations are also carrying out some very useful work, and

although only two of their number have succeeded in working both ways with U.S.A. (**8 AB**, **8 BF**), yet signals from many of their stations are received in London with considerable strength, the loudest of all being **8 AZ**, who is overpowering on two valves. He employs I.C.W., and the note is very piercing.

The Dutch stations **PCII** and **PA 9** (special station for the tests) may be heard almost any morning working with **1 XW** or **2 AGB**, and Dutch **ODV** is also attempting two-way working.

With regard to American working in general it has been noticed that the most favourable periods occur when there is a sudden change in the weather conditions on the English side, although very few days during the last month have been bad enough to prevent some two-way working from taking place. A damp and rainy morning always permits more reliable reception on both sides than one that is clear and starry.

The records for low-power transmission to the U.S.A. are at present held by **G 2OD** who worked **U 2AGB** with an input of only 30 watts. This is almost equalled by **F 8BF** who succeeded in establishing contact with the other side when his aerial current was only 0.7 of an ampere and his input very low indeed. On the other side the best performance is that of **2 AWS**, N.Y., who worked with **G 2KF** with an aerial current of 0.8 of an ampere and an input of what he calls 10 watts of rectified A.C.C.W. on December 15th.

The long distance record is at present held by **F 8AB**, who has been reported received on the Pacific Coast. This is followed by **G 2SH** who was logged in Kansas, and **G 2KF** at Chicago. No doubt these results will soon be eclipsed.

British transmitting work proceeds apace, and owing to the advent of broadcasting, most of the experimental work with distant stations is conducted on Sundays during the brief intervals between the B.B.C. programmes. Amateur stations in the North,

such as **2 HF**, **5 DN**, **5 JX**, **2 JF** and many others may be heard carrying out some very interesting work with London stations **2 DF**, **5 BV**, **5 NN**, and others, and also with **5 KO** of Bristol.

2 HF (Birmingham) recently opened up communication with Italy, when he exchanged signals with **1 MT** at Venice, and this has been followed by two-way tests between **G 2KF** and **ACD** at Bologna. A station signing "**XY**" has been logged in London, and is believed to be somewhere in Switzerland, the signals from this station being quite strong as a rule. **2 NM** (Caterham) has recently received a report from Algiers,

where a French experimenter logged his **C.W.** signals.

Last, but not least, we have the exceptional reception of telephony. It is reported that **2 XZ** (Southfields, S.W.) has been heard by an American amateur at Kansas City, Missouri, during an ordinary local test transmission. The receiver employed was a nine-valve "super."

2 XZ is arranging further tests with this station in hopes of a more definite report and he may be heard some mornings at 6 a.m. testing out with music and speech.

J. A. P.

AROUND THE WIRELESS WORLD

Newcastle Corporation Town Improvement Committee has forbidden aerials in any public street in the City.

* * * * *

At the end of December last, 58,000 experimental licences had been issued and 527,000 for broadcast reception.

* * * * *

Aberdeen Police are investigating many cases of malicious damage to wireless aerials in the district.

* * * * *

The suggestion is made that bull-fights might be broadcast from Spain during the coming summer. But it is doubtful whether even this will allay the disappointment of those who wish to hear Parliamentary proceedings broadcast.

* * * * *

While patrons of a Berlin café were enjoying a wireless talk on the methods of thieves, a young man present seized the opportunity to decamp with another customer's fur-lined overcoat.

* * * * *

Oratory by the Wayside.

Whatever may be the arguments against the broadcasting of Parliamentary debates, these have been speedily overruled in Argentina. According to our contemporary, *Electricité pour Tous*, speeches by deputies in the Argentine Parliament are broadcast by the big station at Palermo, on 2,000 metres. To avoid any wastage of oratory, it is proposed to mount loud speakers on motor cars to enable wayfarers to enjoy the Ministerial rhetoric.

Calcutta Hears **2 LO**.

We now learn that the remarkable feat of tuning-in **2 LO** at Calcutta, reported in our last issue, was performed by Mr. Briggs, of the Bengal Radio Club, the instrument being a five-valve receiver of the Marconi Scientific Instrument Company.

Two-Way Working Successes.

The first report of amateur radio communication between Great Britain and Denmark has reached us from Mr. R. L. Royle (**2 WJ**) of Palmer's Green, London, N. On Saturday, January 12th, **2 WJ** established touch with Danish **7 EC**, whose reception was carried out with a single valve. Strong signals were reported by **7 EC**, though there was a certain amount of jamming by icebound ships in the neighbourhood.

On Sunday, January 13th, Mr. J. H. Ridley (British **5 NN**) maintained communication with American **2 BSC**, and on the following day with American **3 XAO** in Washington. Transmissions were carried out on 105 metres, on a strict schedule, and the radiation from **5 NN** was 1.4 amperes.

Mr. E. J. Simmonds (**2 OD**) of Gerrard's Cross, succeeded on January 17th in getting through a complete message to Mr. Hiram P. Maxim, of the A.R.R.L., Connecticut, via Canadian **1 BQ**, and the reply was received on January 21st by Mr. J. A. Partridge (**2 KF**) of Wimbledon, who was working with two valves.

1 MT, the well-known Italian station of Signor Giulio Salom, reports another success in working with **5 DN** of Sheffield on January 13th. **5 DN's** power was 10 watts, with 0.5 amperes radiation. The signals from **1 MT** are reported to have been heard with the telephones on the table.

Free State Listeners-in Perturbed.

Some alarm is being felt by wireless enthusiasts in the Irish Free State at a report that the Government is about to confiscate all broadcast receivers within its jurisdiction.

For some time past a Committee of the Free State Parliament has been laboriously dissecting the whole question of broadcasting, but in the meantime licences have been withheld. Even the worm will turn, however, and a number of zealous souls have taken the law into their own hands. It is estimated that there are several hundreds of

broadcast receivers in Dublin alone. The owners of these sets are anxious and willing to obtain licences and are only awaiting for the Government's belated decision.

We cannot but feel that, instead of organising confiscation plans, the Irish Free State Government would be better advised in devoting the same amount of energy to a quick solution of the licence problem. Much unpleasantness would be avoided and the inauguration of a definite broadcasting scheme, which must ultimately come into operation, would be expedited very considerably.

The Ether Poacher.

The misuse of his call sign by another transmitter in the London area is reported by Mr. F. A. Durrant (5 PD) of Walthamstow. If this call sign has been erroneously allotted to two stations, Mr. Durrant will be glad to receive information to this effect.

Mr. Thomas Geeson (2 SO) of Macclesfield reports the similar illicit use of his call sign.

It is surely in the interest of all experimenters that this futile practice of appropriating "the other man's" identity should cease, and *The Wireless World and Radio Review* welcomes any information that may lead to the discovery of these poachers of the ether.

The Broadcasting Board.

The Postmaster-General announces that in accordance with a recommendation in the Broadcasting Committee's report of last year, he has appointed the following gentlemen to constitute a Board to advise him in broadcasting matters:

Major-General Sir Frederick Sykes, K.C.B., C.M.G., M.P. (Chairman); Lord Riddell; Sir Francis Ogilvie, C.B.; Mr. F. J. Brown, C.B., C.B.E.; Mr. Guy Burney; Mr. Walter Payne, O.B.E.; Mr. J. C. W. Reith; Mr. A. A. Campbell Swinton, F.R.S. and a representative of Labour (to be nominated later).

Of particular interest to the wireless amateur is the appointment to the Board of Mr. A. A. Campbell Swinton, whose Presidency of the Radio Society of Great Britain from 1913 to 1921 has rendered him singularly fit to voice the opinion

of amateurs as a whole in all matters affecting their progress and welfare.

New Broadcasting Stations.

Hot on the news that Edinburgh is to be favoured with a relay broadcasting station comes the report that a similar plant may shortly be installed in Dundee. At present the locality boasts very few crystal sets capable of picking up Aberdeen or Glasgow, but the proposed relay station would probably enable a quarter of a million more people to enjoy broadcasting without valves.

Plans are rapidly proceeding in connection with the new relay station at Edinburgh, mentioned in our last issue. Discussions have taken place as

to whether programmes should be relayed from Glasgow or London and opinion is emphatically in favour of the latter. The new station, it is stated, will transmit with a power of 100 watts, and the wavelength has been fixed provisionally at 305 metres.

The establishment of broadcasting stations in other parts of the country is also under consideration, and it is stated that the Léeds, Bradford, Liverpool, Hull and Plymouth areas will shortly be served by relay stations. Northern Ireland is not to be overlooked, and Belfast may be expected to have its own broadcasting station in three months' time.

"Exide" Service.

Messrs. The Chloride Electrical Storage Company, Ltd., are to be congratulated on their latest step in the develop-

ment of "Exide" Service. A number of Technical Letters is being prepared (the first is already circulated) in which many useful hints are given concerning the charging and maintenance of storage batteries. The letters will be distributed periodically to all Exide agents.

French Colonial Call Signs.

Those who are in the habit of intercepting French Colonial stations may be interested to learn that, as from February 1st, practically all the three-letter call signs of these stations, now commencing with "F" will be altered, "H" being the initial letter in future.



Mr. Hugh N. Ryan of 5 BV. He is one of the eight English amateurs heard in the United States.

2 LO heard in South Africa.

An excellent report of the concert broadcast from 2 LO on December 29th has reached us from Messrs. Swart & Bolus, of Middelburg, near Capetown, confirming their telegram published in our issue of January 9th.

The instrument used was a five-valve receiver (2-v-2), built from data contained in *The Wireless World and Radio Review* of September 23rd, 1922.

Musical items were received with exceptional clarity, and could be followed with the headphones off or clipped into an improvised loud speaker. An additional interest is given to this report by reason of the fact that on the night in question the B.B.C. relayed American broadcasting. This was distinctly heard, although the musical items could not be identified.

A similar success was achieved on the same night by Mr. H. Mercer, of Camps Bay, Capetown.

Forthcoming Events.

WEDNESDAY, JANUARY 30th.

- Edinburgh and District Radio Society.** At 8 p.m. At 117, George Street. Lecture: "The Armstrong Super Receiver." By Mr. J. W. G. Thompson.
- British Thomson-Houston Radio Society.** Elementary Class and Discussion.
- East Ham and District Radio Society.** At the C.A. Social Centre, Barking Road. Lecture: "Wireless Woodwork." By Mr. H. Orbell.

Clapham Park Wireless and Scientific Society. At 8 p.m. At 67, Balham High Road. Lecture: "Television." By a representative of General Radio Company.

THURSDAY, JANUARY 31st.

- Hendon Radio Society.** At 8 p.m. At the Society Hut, Brent Works. Demonstration of Reflex Circuits.
- Radio Association of Ireland (Dublin).** Lecture: "The Oscillating Valve, viewed as a Converter." By Mr. T. J. Monaghan, B.Sc., A.M.I.E.E.
- Hackney and District Radio Society.** Lecture: "The Manufacture and Marketing of Wireless Material." By Mr. Dougan (British L. M. Ericsson Mfg. Co., Ltd.).

FRIDAY, FEBRUARY 1st.

- Radio Transmitters' Society.** At 6.30 p.m. At the Institute of Electrical Engineers, Savoy Place, W.C.2. Extraordinary General Meeting.
- Radio Society of Highgate.** At 8 p.m. At Edco Hall, Archway Road. Debate: "Should Parliament be Broadcast?"
- Brookley and District Radio Association.** At Gladstone Hall, New Cross Road. Lecture: "Efficiency of Fixed Condensers." By Mr. E. W. Campbell.
- Sheffield and District Wireless Society.** At 7.30 p.m. At Dept. of Applied Science, St. George's Square. Lecture by Mr. W. Burnet.

MONDAY, FEBRUARY 4th.

- Ipswich and District Radio Society.** At 55, Fonnereau Road. Lecture: "Induction and its Application to Wireless." By Mr. E. A. Griffley.
- Kingston and District Radio Society.** Lecture: "Telephones." By Messrs. Brown.
- Dulwich and District Wireless and Experimental Association.** Lecture and Demonstration: "Transmitting Circuits." By Messrs. J. Barrett and Harrie King.

TUESDAY, FEBRUARY 5th.

- West London Wireless and Experimental Association.** Lecture: "1½ kW. Transmitter." By Mr. Hyme Jones.

The Radio Society of Great Britain.

An Ordinary General Meeting of the Society was held at the Institution of Electrical Engineers, Savoy Place, W.C.2, on Wednesday, January 23rd, at 6 p.m., when a Presidential address was delivered by Dr. W. H. Eccles, F.R.S.

Dr. Eccles' remarks were devoted to the question of the amateur's position to-day and his place in the development of radio science.

At the conclusion of the Presidential address the following were elected to membership of the Society:—Sir James B. Wilkie Dalryell, Bart., L. Scott Langley, A. E. Pitcher, L. E. Renaud, and Eric Steadman.

The following societies were accepted for affiliation:—Golders Green Radio Society, Hampton and District Radio Society, Holy Trinity Meccano and Radio Club.

* * *

The annual dinner of the Society was held on the same evening at eight o'clock, at the Waldorf Hotel. Sixty-four guests were present, including a large proportion of ladies. The toasts of the evening were as follows:—To the Ladies and the Guests, proposed by Mr. A. A. Campbell Swinton, responded to by Captain Loring; to the Radio Society of Great Britain, proposed by Mr. Gerald Marcuse, who referred to the fact that the position of the Society never inspired more confidence than at present; and to the Retiring Officers, proposed by the President and responded to by Mr. F. Hope-Jones.

* * *

The Conference of Affiliated Societies, which had been arranged for Wednesday, January 23rd,

has been postponed in view of the railway strike and the consequent inability of many provincial representatives to attend. This announcement was duly communicated to society secretaries by telegram. The following agenda has been drawn up for the Conference, the revised date of which will be announced shortly.

1. To discuss the principles of the alterations proposed by the Radio Society in its constitution, as follows:—
 - (a) A General Committee should be formed for the discussion of national wireless affairs affecting amateurs.
 - (b) This General Committee should be elected mainly by the Affiliated Societies.
 - (c) Communications with public bodies on national affairs should be made by the Council on the advice of the General Committee, provided that—
 - (i) The Affiliated Societies have representation on the Council.
 - (ii) All administrative expenses of the General Committee be defrayed by the Radio Society.
 - (d) For the purpose of electing the General Committee the Affiliated Societies should be divided into groups which shall each elect one member.
 - (e) The division of the Affiliated Societies into groups should be left to the General Committee and revised frequently.
 - (f) The General Committee should from time to time fix the fees of affiliation, but not lower than those existing at present.
2. To discuss Clauses 87 to 100 of the Memorandum and Articles of Association in the light of the foregoing principles.
3. To elect the first General Committee and the Officers.
4. To discuss facilities for obtaining amateur transmitting licences.
5. To discuss the proposal of the Derby Wireless Club to establish an Amateur Research Fund.
6. To discuss other items submitted by Societies or Delegates.
7. Other business, if any.

NOTE.—The progress of item 3 will be assisted if each Delegate comes prepared with suggestions for the grouping of the Societies in his immediate neighbourhood.

(The new address of the R.S.G.B. is 53, Victoria Street, S.W.1.)

SOME NOTES ON CALCULATING THE INDUCTANCE OF COILS.*

By E. J. HOBBS, M.C., Ass.Mem.I.R.E.

THE object of this paper is to bring to your notice a simple method of reducing calculations to a minimum. It is based on the use of the powers of ten and is intended to assist in the elimination of calculations and trial and error in so far as wavelength, inductance and capacity are concerned.

This paper is divided into three parts.

Part I enables one to find at a glance the correct inductance and capacity required to tune to a given wavelength; but as the graphs and full data have already been published † only a brief reference will be made here as the time at my disposal is limited.

Part II deals with the inductance of single layer coils of all sizes. The particular novelty in this case is the simple method employed to correct for Nagaoka's factor *K* and any number of turns per centimetre length of winding.

Part III shows a further application of logarithmic graphs to condensers of all sizes, both fixed and variable.

The formula for the inductance of a coil is—

$$L = \pi^2 d^2 n^2 l K \quad (1)$$

where *L* = inductance in centimetres.

d = diameter of the coil in centimetres.

l = length of coil in centimetres.

n = number of turns per centimetre.

K = is a value dependent upon the ratio of $\frac{d}{l}$

$$\text{or, } L (\mu H) = D^2 n^2 K \quad (2)$$

But the value of *K* in formula (2) depends upon the

ratio of $\frac{l}{d}$ and necessitates the use of a second table. As 1,000 cms. = 1μH we may divide formula (1) by 1,000 to obtain the inductance in microhenries. The formula then becomes:—

$$L \mu H = \frac{\pi^2 d^2 n^2 l K}{10^3} \text{ or } L \mu H = \pi^2 d^2 n^2 l K 10^{-3} \quad (3)$$

and only one table of the values of *K* is necessary, i.e., for the ratio $\frac{d}{l}$.

Formula (3) may now be simplified.

$$\pi = 3.1416 \text{ and } \pi^2 = 9.8696.$$

$$\therefore L (\mu H) = \frac{9.8696 d^2 n^2 l K_1}{10^3} \text{ or } 9.8696 d^2 n^2 l K 10^{-3}.$$

If *n* = 10 turns per centimetre $L (\mu H) = 9.8696 \times d^2 \times 10^2 \times l K \times 10^{-3} = 0.98696 d^2 l K$.

The quantity 0.98696 for rough practical work may be regarded as unity and, as it will be multiplied by $d^2 l K$, may be neglected.

The correction for any number of turns is made by multiplying the answer by $\frac{n^2}{100}$, where *n* = the actual number of turns to be employed.

* First portion of a paper read before the Radio Society of Great Britain at a meeting held on December 19th at the Institution of Electrical Engineers.

† *Wireless World*, July 14th, 1923.

Compare the effect of removing $\pi^2 n^2 \times 10^{-3}$ in the following examples, both coils being wound 10 turns per centimetre.

Coil (1) is 4 cms. diameter and 4 cms. long.

Coil (2) is 10 cms. diameter and 10 cms. long.

$$(1) L (\mu H) = \pi^2 n^2 d^2 l K \times 10^{-3} = 9.8696 \times 100 \times 16 \times 4 \times 0.6884 \times 0.001 = 43.48 \mu H.$$

$$\text{or if } L \mu H = d^2 l K = 4^2 \times 4 \times 0.6884 = 44.0576 \mu H.$$

$$(2) L (\mu H) = \pi^2 n^2 d^2 l K 10^{-3} = 9.8696 \times 100 \times 100 \times 10 \times 0.6884 \times 0.001 = 679.32 \mu H.$$

$$\text{or, if } L \mu H = d^2 l K = 100 \times 10 \times 0.6884 = 688.4 \mu H.$$

It will be observed that the error is a negligible increase of just over 1 per cent. and may be counteracted by deducting 1μH for every 100 μH in the answer; a saving of time is thus effected. If we

omit *K* the formula becomes $L = \frac{\pi^2 n^2 d^2 l}{10^3}$, and we

find that by plotting *L* against *l* for various values of *d* on logarithmic sectional paper a series of straight lines inclined at an angle of 45 degs. are obtained. From these lines any value of *L* may be read off direct given *l* and *d*. *L* must now be multiplied by *K* which is found from a table or graph. *K*, which depends upon the ratio $\frac{d}{l}$, always reduces the inductance given by the formula from which graphs C and D were plotted.

Values of *K* for ratios of $\frac{d}{l}$ from 0.01 to 10 are given in Table I, pp. 121 and 122 of "The Calculation of Measurement of Inductance and Capacity," by W. H. Nottage (Wireless Press, Ltd.). ‡

Graphs C and D are based on formula (3) above, *n* being 10 and *K* omitted. ∴ $L = 0.98696 d^2 l$.

As *K* cannot be found without knowing the $\frac{d}{l}$ ratio one must decide on the size of the former to be used, and from graph C or D (whichever is the most convenient) find *L* and correct for the value *K* direct, by means of the slide. We may select, for example, a former 10 cms. diameter, 8 cms. long which, on graph C or D gives a reading of 790.

$\frac{d}{l} = \frac{10}{8} = 1.25$ and from a table of *K* values for $\frac{d}{l}$, *K* = 0.638. We may now either multiply 790 by 0.638 in the ordinary manner, or use the slide* provided with the graphs and take a direct reading in the true microhenries. $790 \times 0.638 = 504.02$. For the benefit of readers

‡ Also see the curves showing the value of *K* for the ratio $\frac{d}{l}$, *Wireless World*, page 833, September 19th, 1923.

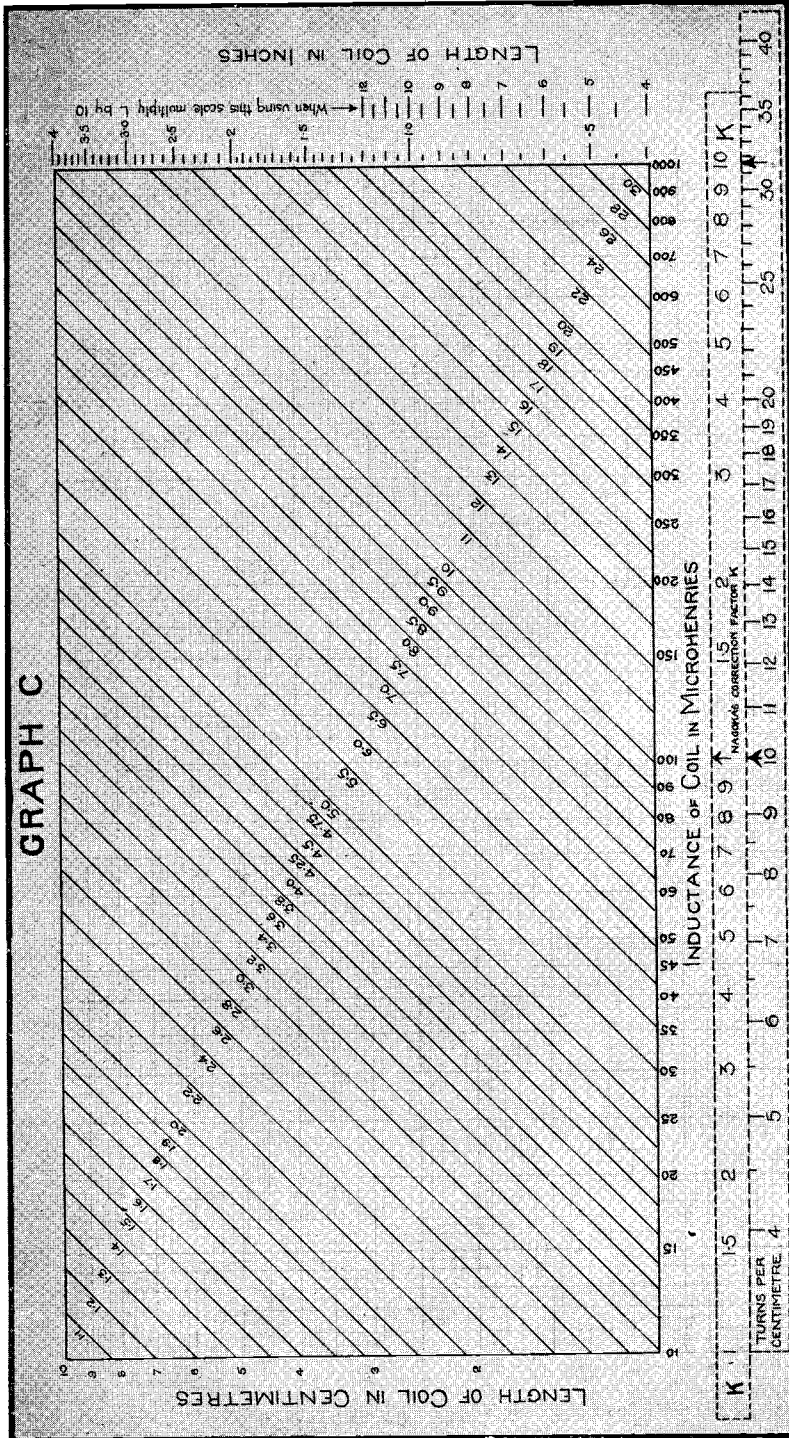

This graph, and also graph D are based on the fact that the inductance L is proportional to 0.98696d²l when there are 10 turns per cm.

who have no knowledge of slide rule principles the following will be a guide to the use of slide *K*. Always place the index arrow on the inductance (in the example taken = 790 μH), and to the left of the index opposite the value of *K* on the slide (*K* in this case = 0.638) will be found the true inductance of 504 μH . If in any calculation it is found that the required value of *K* extends beyond the limits of the graph, use the scale on the right hand side of the index and divide the reading obtained by 10. These facts will be apparent after trying one or two readings.

A coil more than 10 centimetres long may be required, in which case the lengths shown on the left-hand side of graph C should be multiplied by 10, so that 2 = 20, 3 = 30, etc., and intermediate readings proportional. Proceed as before, but multiply the answer by 10.

When $d = 9$, $l = 18$ and *L* reading 143.

$$\frac{d}{l} = \frac{9}{18} = 0.5 \therefore K = 0.8181 \text{ and by}$$

means of the *K* slide $L (\mu H) = 117.5 \times 10 = 1,175 \mu H$.

The number of turns per cm. has been fixed at 10 for convenience, but owing to the variety of wire gauges and coverings it is frequently necessary to use wire which will wind more or less than 10 turns to the cm. For this contingency a second slide calibrated direct in turns per cm. is supplied. It covers any number of turns from 4 to 40 per centimetre and the method of using it is simple. Take the case of the coil 10 cms. diameter, 8 cms. long, and wound 10 turns per cm. as a further example. The inductance in microhenries = 504. If we now place the index of the slide dealing with turns per cm. opposite 504 μH . the inductance for any other winding may be read direct from the graph opposite the number of turns to be used. In the example quoted ($d = 10$, $l = 8$, $n = 10$ and $L \mu H = 504$), the scale enables us to vary the turns only between 4 and 14 per cm. owing to the limits of the graph. We therefore use the alternative index situated between 31 and 32 turns and read the inductance against 20 turns. This is 201.6, and if multiplied by 10 it gives the correct inductance, viz.: 2,061 μH , which would have been the direct reading were the graph extended beyond 1,000 μH .

These graphs cover an almost unlimited range and their scope may be considerably extended by intelligent application of the powers of 10. Graph

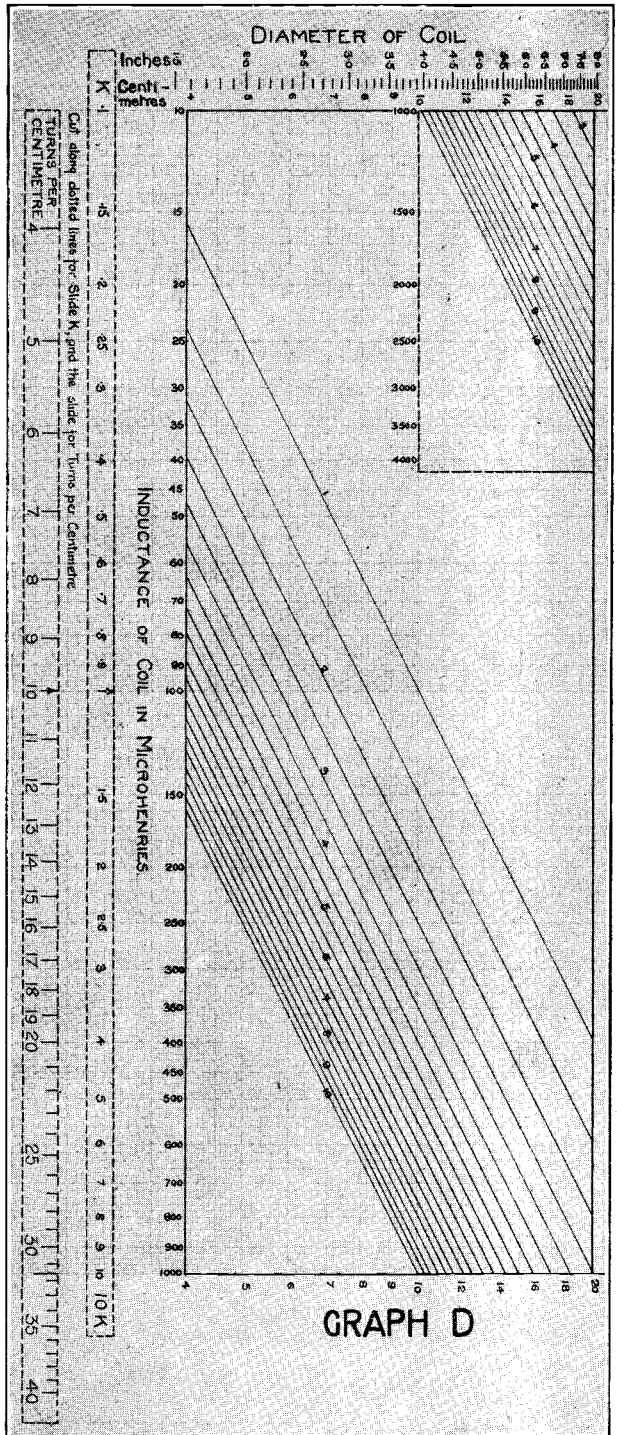

C allows the use of any intermediate value of l and graph D provides for all diameters between 4 and 20 centimetres. An extra scale is added on each graph for the benefit of readers who wish to use inches.

Graph E will enable K to be found for all ratios of $\frac{d}{l}$ between 0.01 and 10. The curve A is complete in itself, but owing to the steepness of the left-hand portion an additional curve B is provided to facilitate reading when the $\frac{d}{l}$ ratio is between 0.01 and 1. All readings of K above the dotted line are to be used when the $\frac{d}{l}$ ratio is lower than unity.

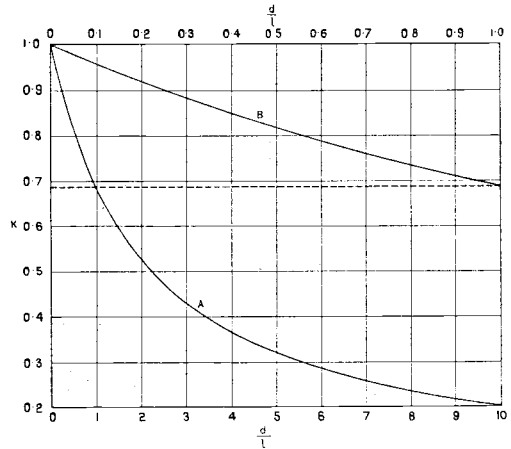

(To be concluded.)

Graph E.

RADIO TRANSMITTERS' SOCIETY.

Through the courtesy of Captain Ian Fraser, Chairman of the Radio Transmitters' Society, we are able to publish below details of the Agenda of an important meeting of the Society called for February 1st, and to be held at 6.30 p.m. at the Institution of Electrical Engineers.

The purpose of this meeting is to bring about an amalgamation between the Radio Transmitters' Society and the Transmitter and Relay Section of the Radio Society of Great Britain.

We have on several occasions pointed out the strength which unity can give to the amateur and experimenter, and that, unless strongly united, his position, especially at the present time, might become very difficult indeed. This latest evidence of the desire for unity on the part of two bodies, representing probably the most important section of experimenters, will be welcomed as a further indication of unanimity and strength.

An EXTRAORDINARY GENERAL MEETING of the RADIO TRANSMITTERS' SOCIETY is to be held at the Institute of Electrical Engineers on Friday, February 1st, at 6.30 p.m., to consider the important matter about which details are given on the following AGENDA.

After business has been transacted, Captain P. P. ECKERSLEY, President of the Society, has kindly undertaken to deliver a lecture upon

SOME RECENT EXPERIMENTS IN RELAYING WIRELESS TELEPHONY.

It is understood that Captain Eckersley will deal particularly with the Short-Wave Portable Transmitter and Receiver employed by the B.B.C. for the transmission of performances from the OLD VIC THEATRE. As a relatively low wavelength was utilised, and successful transmission and relay of the Old Vic was the first automatic wireless link carried out in this country, the lecture will be of special interest to Members of the Society.

AGENDA.

1. To consider and if thought fit approve the following Resolution:—

THAT this meeting of the Members of the Radio Transmitters' Society approves the negotiations that have been undertaken between the Committee of the Society and the Radio Society of Great Britain, with a view

to securing the fusion of the two Societies, and instructs the Committee to make the necessary arrangements for giving effect thereto, upon the following basis:—

(a) The Radio Transmitters' Society agrees to join the Radio Society of Great Britain by amalgamating with the Transmitting and Relay Section of the Radio Society.

(b) The Radio Society of Great Britain agrees to the formation of a Joint Managing Committee for Section, consisting of seven members of the existing R.T.S. Committee, three members of the existing T. and R. Section Committee, the President and Hon. Sec. of the R.S.G.B. being also ex-officio members.

(c) The R.S.G.B. undertakes to co-opt. on to their Council two Members of the Joint Managing Committee, when formed. The Joint Managing Committee to nominate three persons from whom the R.S.G.B. Council will choose two.

(d) Dr. Eccles personally undertakes to propose the election of Captain Eckersley as a Vice-President of the R.S.G.B.

(e) The R.T.S. and R.S.G.B. both agree that mutually satisfactory arrangements will be made whereby Members only pay one subscription, and that existing subscriptions to either or both Societies will be credited to Members.



Particulars of Membership of any Society can be obtained on application to the Secretary. Societies marked with an asterisk are affiliated to the Radio Society of Great Britain.

Kingston and District Radio Society.*

On Monday, January 7th, Mr. F. Peake Sexton, A.R.C.S., A.M.I.E.E. (a Past President), delivered a highly interesting and instructive lecture on "The Propagation of Electric Waves," which was illustrated with lantern slides.

The lecturer commenced by explaining the dissemination and reflection of sound waves through many different media. Particulars were then given of the various aether waves in the order in which they are revealed by the spectrum. Mr. Sexton then dealt with the early experiments which have been made to utilise these rays, including the work of Hertz, Lodge and Preece. Slides were shown of an object actually photographed by invisible rays beyond the violet, and by rays beyond the red, proving that the eye does not see everything.

Fading and "Blind Spots," which have been so conspicuous of late as the result of broadcasting, were touched upon, and suggestions were made for experiments in this direction in the district.

Hon. Sec., R. J. W. Lankester, Wanderings Farm, Kingston-on-Thames.

Fulham and Putney Radio Society.*

The second annual meeting of the Society took place on January 4th.

After the election of the Committee, on which most of the past members were retained, the treasurer submitted a highly satisfactory balance sheet.

The Society's five-valve set has recently been overhauled and, together with a loud speaker, is now available for loan to members. The Technical Committee is now engaged on the construction of a short wave meter for Club use.

Particulars of membership will be gladly furnished by the Hon. Sec., B. Houston, 125, Hurlingham Road, Putney.

South Woodford Radio Society.*

On January 7th an interesting meeting was held at headquarters, when Mr. C. F. S. Hearn gave a lecture and demonstration on "Valve Curves." Several curves were taken of hard and soft valves, the results being plotted and shown on the blackboard.

Fortcoming fixtures include lectures and demonstrations on broadcast reception, Neon tubes, electrical measurements, reflex circuits, etc.

Hon. Sec., Cyril F. S. Hearn, 25, Walpole Road, South Woodford.

West London Wireless and Experimental Association.*

The experimental night arranged for January 15th was postponed in view of the non-arrival of certain units under construction, and the evening was accordingly devoted to informal discussion, and the reception of broadcasting.

It has been decided to hold a monthly meeting for actual experimental work.

The new apparatus now being mounted as separate units will permit of tests with a great number of circuits, and demonstrations for members who happen to be in difficulties.

Headquarters: Acton and Chiswick Polytechnic.

Particulars regarding membership will be gladly forwarded on application to the Hon. Sec., Horace W. Cotton, 19, Bushey Road, Hayes, Middlesex.

The Woolwich Radio Society.*

During the last month the Society has held several very interesting meetings. On January 2nd, 1924, Mr. Elliott, of the D.P. Battery Company, delivered a very interesting and practical lecture on "Storage Batteries, their Management, Care, and Construction," illustrated by lantern slides.

On January 9th, 1924, the President, Captain C. T. Hughes, gave an instructive demonstration on "Choice-coil Amplifiers." He had constructed a 2-stage L.F. amplifier, which was shown to be practically devoid of any sign of distortion, and was proved to be very much better than a 2-stage L.F. amplifier, using intervalve transformers.

On January 16th the annual general meeting was held. After the various reports by the Secretary and Treasurer had been read and adopted, the existing officers resigned, and new officers were elected as follows—President, Captain C. T. Hughes, R.E.; Vice-Presidents, Captain C. C. J. Frost (of the B.B.C.), Mr. A. F. Bartle, L.D.S., of Blackheath, Dr. A. S. Webley, Mr. H. Houghton; Secretary, Mr. H. J. South; Treasurer, Mr. G. Dowling; Chairman, Mr. H. W. Everitt; and Vice-Chairman, Mr. H. V. Potter.

A competition has been arranged for members—prizes to be awarded to the value of £1, 15s. and 10s. At the close of the meeting two members, Messrs. Beeson and Everitt, described how they had been very successful in receiving **KDKA** on his 100 metre wave on the loud speaker. New members are welcomed on any Wednesday evening at the Y.M.C.A., Thomas Street, Woolwich, at any time from 7.30 p.m.

Hon. Sec., H. J. South, 42, Greenvale Road, Eltham, S.E.

Sheffield and District Wireless Society.*

On January 18th, Mr. H. Lloyd, M.Eng., delivered an illuminating lecture on the "Armstrong Super-heterodyne Receiver." Mr. Lloyd pointed out that the employment of the super-heterodyne principle enabled one to solve the otherwise difficult problem of applying high frequency amplification to the Reinartz receiver. A very successful experimental demonstration of the arrangement was given.

Hon. Sec., R. Jakeman, "Woodville," Hope, Sheffield.

B.T.H. Radio Society.

Mr. R. C. Clinker (President of the Society), recently gave an extremely interesting lecture on "Radio Valves" illustrated by a cinema film entitled "The Audion," kindly loaned by the Western Electric Company.

During the course of the lecture important points were illustrated with lantern slides, and Mr. Clinker demonstrated the action of the three-electrode valve in an oscillatory circuit by means of his most ingenious working model. The latter, which he recently demonstrated before the Institution of Electrical Engineers, clearly shows the underlying principles by a direct mechanical analogy.

This was followed by the cinematograph film, which shows in great detail the functioning of the valve in wireless circuits by means of animated diagrams. One of the most attractive features of this film was the section dealing with the "space-charge" effect in a wireless valve under various conditions. A second film dealing with the manufacture of commercial telephone instruments, was then projected, which illustrated the manufacturing processes in a most striking manner.

The acknowledgements of the Society are due to the B.T.H. Co. for the facilities given, and for the use of the cinema projector.

Hon. Sec., Mr. Bradley, B.T.H. Radio Society, British Thomson-Houston Co., Ltd., Rugby.

Holy Trinity Meccano and Radio Club.

The first session of the Club's Radio Section has been fairly successful. The construction of a club radio set on the unit system has been commenced, and the valve-detector unit has already been finished. Although the Radio Section's balance sheet shows a small balance on the right side, it was quite evident that lack of funds was the chief handicap, and consequently at a recent committee meeting revised subscriptions and rules to take effect next session were considered and finally agreed to.

Affiliation with the Radio Society of Great Britain has also been applied for.

The membership and attendance has been very good, but more adult members would be welcomed. (The minimum age is 16, but boys who are also members of the Meccano Guild, over 14 years of age, may also join.) The new session began on Saturday, January 26th, 1924, in the Holy Trinity Parish Hall, Richmond Road, N.1. (Room 2), at 6.30 p.m. Copies of the revised rules and subscriptions may be obtained on application to the Hon. Sec. (Radio Section) Mr. W. Stretton, 15, Thornhill Houses, Thornhill Road, N.1.

Questions & Answers

Solutions of Readers' Difficulties

1. All questions are answered through the post. A selection of those of general interest is published.
2. Not more than four questions may be sent in at any one time.
3. Every question should be accompanied by a postal order for 1/-, or 3/6 for four questions, and by a coupon taken from the current issue.
4. Alternatively, advantage may be taken of our free service by using the free coupon. This appears in the first issue of each month, and is valid during the current week only.

“F.F.” (Purley) asks for a circuit for a three-valve receiver using two stages of H.F. amplification followed by a valve detector with reaction on to the aerial circuit.

The circuit required is given in Fig. 1. Switches are provided to switch off one or both H.F. valves when not required.

“W.G.B.C.” (Shrewsbury) asks if we could give the name of any publication dealing with the history and development of wireless telegraphy.

An excellent paper on this subject was read before the Radio Society of Great Britain by Mr. G. G. Blake. The paper was reprinted in the issues of *The Wireless World* and *Radio Review*

of May 26th and June 2nd, 1923, and also in the *Journal of the Radio Society of Great Britain*, Volume IV, Part I.

“R.J.” (London, N.W.) asks for a comparison of the resistance capacity and transformer methods of low frequency coupling.

The resistance coupled L.F. amplifier does not give so great an amplification per valve as the transformer coupled type, but with proper adjustment, in general, the distortion produced is less in the case of the former. It must be remembered that a plate voltage of at least twice that normally used is required with resistance couplings. For general reception the transformer method of coupling is perhaps best, since two valves instead of

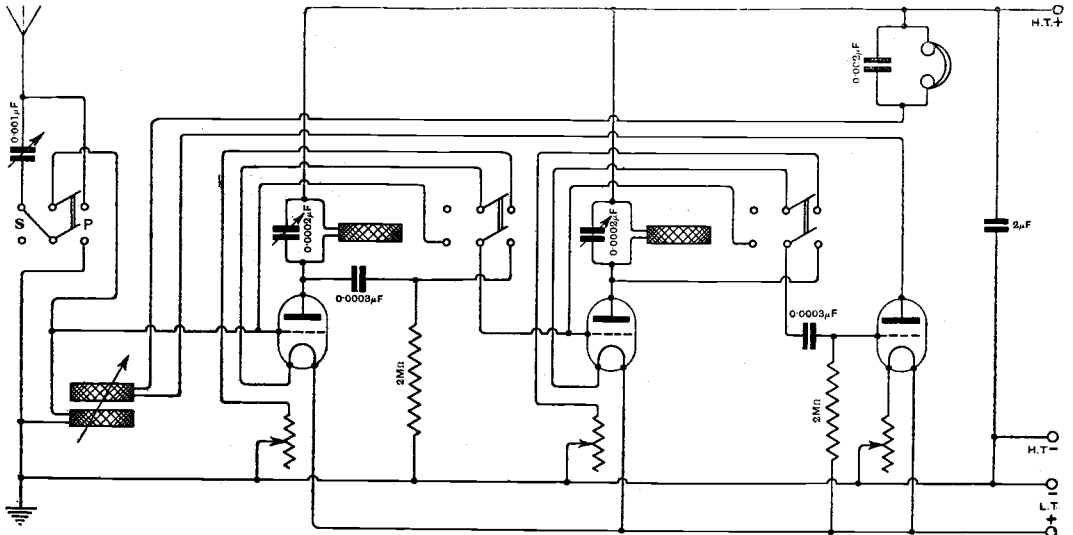

Fig. 1. “F.F.” (Purley). A receiver with two stages of H.F. (tuned anode) and detector, with the reaction coil coupled to the aerial coil.

three may be used to operate a loud speaker, and distortion may be considerably reduced by careful choice of the transformers and the adjustment of the L.F. circuits. In this connection we would refer you to a note on page 99 of the issue of October 24th, 1923.

“C.E.P.” (London, S.E.22) asks for a diagram

“J.C.H.” (Burnley) asks for a diagram of a five valve receiver with one stage of H.F. amplification, one rectifier and three note magnifiers.

A diagram of the receiver required is given in Fig. 3. In general it will be found that two stages of L.F. amplification will give best results when

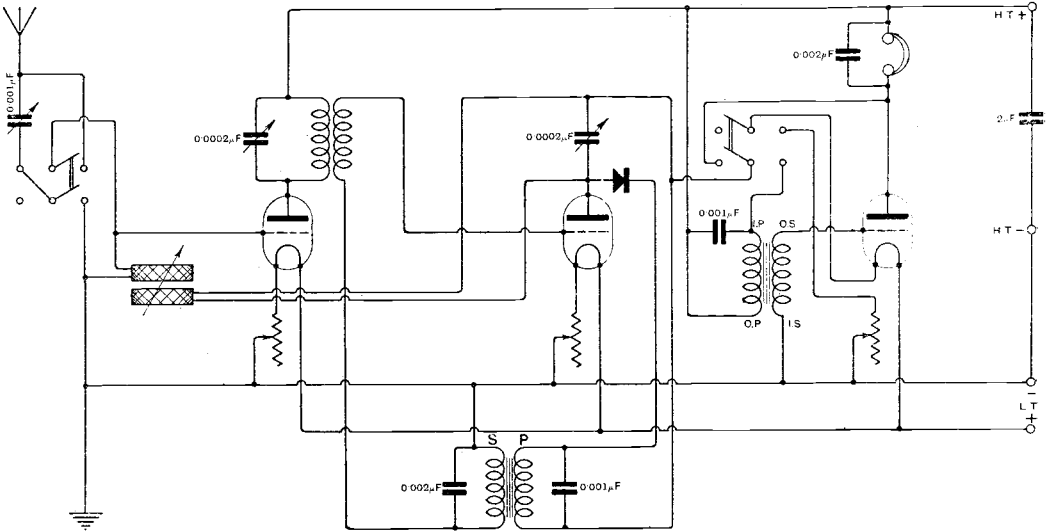

Fig. 2. “C.E.P.” (London, S.E.22). A receiver with one stage of H.F., one stage of dual amplification, crystal detector and optional note magnifier.

of a three-valve receiver in which the first valve functions purely as a high frequency amplifier, the second as a dual amplifier, and the last as a note magnifier.

The diagram is given in Fig. 2. A crystal rectifier is used, and a switch is provided to cut the note magnifier out of circuit when not required.

transformer coupling is employed. The distortion introduced by the last L.F. valve may be considerably reduced by connecting cells in the grid circuit as shown in the diagram. The correct value for this grid bias must be found by experiment. A reaction switch is provided so that reaction may be used either to the aerial or tuned anode circuits.

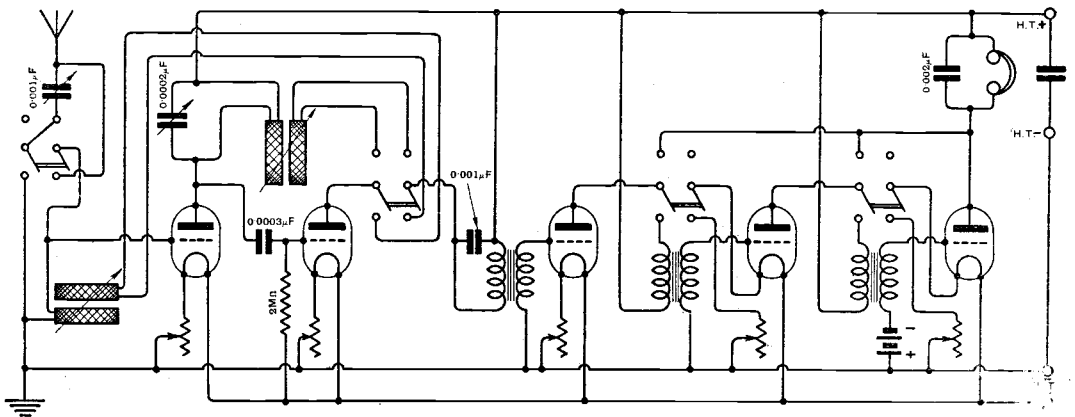

Fig. 3. “J.C.H.” (Burnley). A five-valve receiver with one H.F., detector, and one, two or three note magnifiers.