

THE WIRELESS WORLD AND RADIO REVIEW

THE OFFICIAL ORGAN OF THE RADIO SOCIETY OF GREAT BRITAIN.

No. 225. (No. 10.
Vol. XIII.)

DECEMBER 5th, 1923.

WEEKLY

EDITOR :

HUGH S. POCOCK.

RESEARCH EDITOR :

PHILIP R. COURSEY, B.Sc., F.Inst.P., A.M.I.E.E.

ASSISTANT EDITOR :

F. H. HAYNES.

QUESTIONS AND ANSWERS DEPARTMENT :

Under the Supervision of W. JAMES.

CONTENTS

	PAGE
Editorial - - - - -	304
The Construction of Variable Condensers. By W. James	305
Investigations with the Cathode Ray Oscillograph. By N. V. Kipping - - - - -	309
Detector and Amplifier for Telephony Reception - - -	313
A Three-Valve Receiver (<i>concluded</i>). By Philip R. Coursey, B.Sc. - - - - -	315
Novel Ideas and Inventions - - - - -	318
Correspondence - - - - -	320
Our Transatlantic Broadcasting Tests - - - - -	321
Around the Wireless World - - - - -	325
Distortion in Radio Telephony (<i>Discussion continued</i>), By H. A. Thomas, M.Sc. - - - - -	328
With the Societies - - - - -	330
Questions and Answers - - - - -	333

THE EDITOR will be glad to consider articles and illustrations dealing with subjects within the scope of the Journal. Illustrations should preferably be confined to photographs and rough drawings. The greatest care will be taken to return all illustrations and manuscripts not required for publication if these are accompanied by stamps to pay return postage. All manuscripts and illustrations are sent at the Author's risk and the Editor cannot accept responsibility for their safe custody or return. Contributions should be addressed to the Editor, "The Wireless World and Radio Review," 12 and 13, Henrietta Street, Strand, London, W.C.2.

SUBSCRIPTION RATES :

20s. per annum, post free. Single copies 4d. each or post free 5d. Registered at the G.P.O. for transmission by Magazine Post to Canada and Newfoundland.

EDITORIAL AND PUBLISHING
OFFICES :

12 and 13 Henrietta Street,
Strand, London, W.C.2.
Telephone : Gerrard 2807-8.



ADVERTISEMENT MANAGERS :

Bertram Day and Co., Ltd.,
9 & 10 Charing Cross, S.W.1.
Telephone : Gerrard 8063-4.

THE TRANSATLANTIC BROADCASTING SUCCESS.

ELSEWHERE in this issue, pages are devoted to recording reports of reception in this country of the American broadcasting stations which took part in the first day's tests. It was, however, practically a foregone conclusion that most of these stations would be heard by British amateurs, as their reception had been recorded in this country on many previous occasions. The special point of novelty in these transmission tests has been the fact that for the first time in the history of wireless, America has been able to listen to wireless telephony transmissions emanating from broadcast stations in England.

The Wireless World and Radio Review, jointly with *Radio Broadcast of America*, cannot but feel a sense of pride at having been responsible for promoting a series of tests of so much international importance, and we feel sure that this satisfaction will be shared by our readers, particularly by those who have contributed so largely to the success achieved by listening in for the transmissions from the other side; indeed, without this co-operation on the part of amateurs here and in the United States, the tests could not have been carried out.

It will, of course, have been realised why it was necessary for the transmissions by the British broadcasting stations to take place at the extremely inconvenient hour of 3 a.m.

It was thought essential for such a time as this to be chosen in order that the broadcasting should take place during a period of darkness all across the Atlantic, since, as is well known, transmission over long distances is much more effective during darkness.

A good deal of organisation had to be done in the way of preparation in America, as amongst other things it was realised that it would be necessary for the hundreds of broadcasting stations throughout America to close down for the period of the test transmission from England in order that reception might be possible. Unfortunately this closing down appears to have been only partially effective on the occasion of the transmission made on the morning of Wednesday the 28th when Senatore Marconi and Monsieur Georges Carpentier spoke to America from **2 LO**. A cable stated that complete reception in many districts was interrupted owing to interference from certain broadcasting stations.

It is not easy at the present moment to

prophecy what may be the outcome of these successful transmissions. An interesting experiment to be looked forward to would be the simultaneous operation of the British broadcasting stations by received signals of an American transmission. In this way the B.B.C. would be able to entertain us to the American programmes, by way of variety.

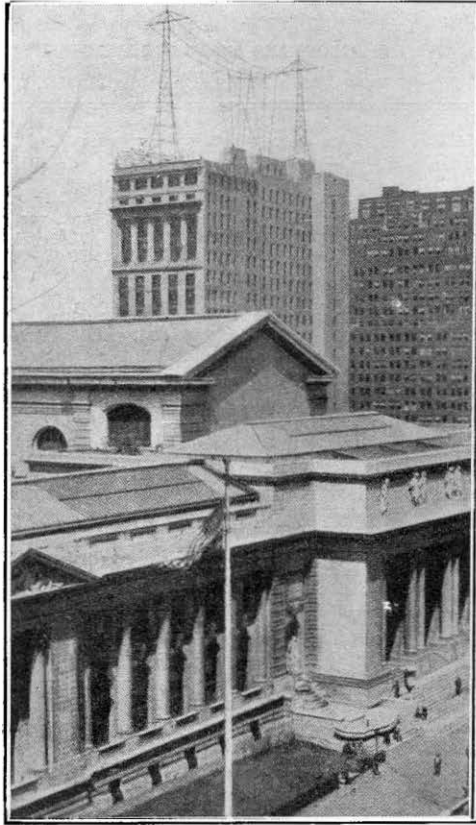

WJZ, one of the American Broadcast stations taking part in the tests and heard here all over the country.

THE CONSTRUCTION OF VARIABLE CONDENSERS

By W. JAMES.

I. GENERAL PRINCIPLES.

VARIABLE condensers are generally used for fine tuning purposes because it is easier to build variable condensers than variable inductances, and further, condensers are reliable, compact, and may be constructed with small losses. The best variable inductances (variometers), in general, do not have an inductance ratio greater than 8 or 9 to 1, while variable condensers may easily have

fixed plates. The fixed and moving plates may have any convenient shape. They are generally semi-circular, the moving plates having an extension through which passes the spindle; the fixed plates have a corresponding recess to permit free movement of the spindle.

The plates need not, of course, be semi-circular, but may have any other shape, according to whether it is desired to have a variable condenser, the capacity of which

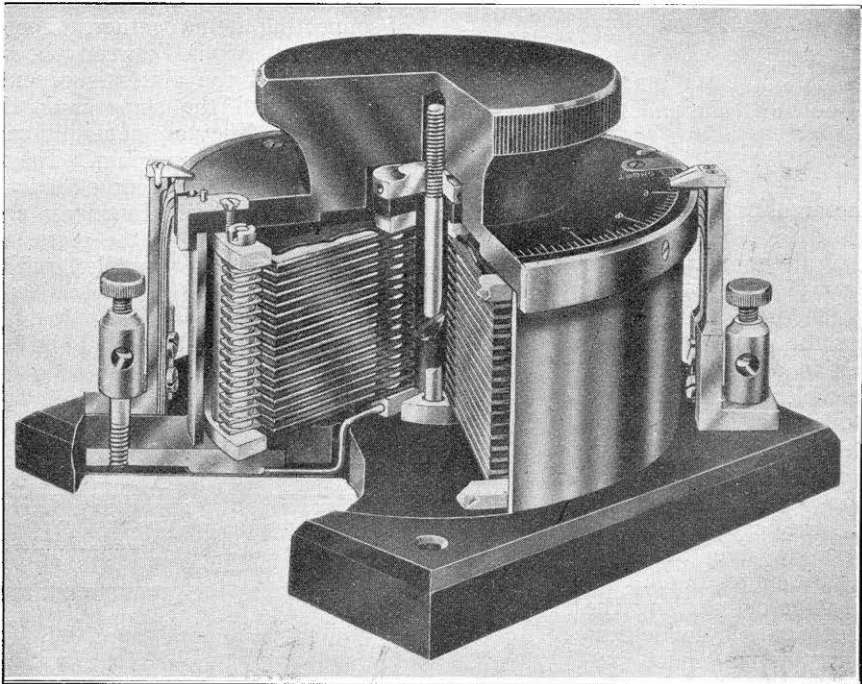

Fig. 1. A "double plate-variable condenser" illustrated in section. This type of condenser provides a large variation in capacity, although the bulk is small. (Marconi's Wireless Telegraph Co.)

a useful capacity ratio of 30 to 1 (for example, 0.00004 μ F. to 0.0012 μ F).

The most common sort of variable condenser consists of a set of fixed plates and another set of moving plates. The moving plates are supported so that they interleave with the fixed plates, and the capacity variation is obtained by changing the area of the moving plates, which lies between the

varies directly with the angle of movement of the moving plates, or with the square of the angle of movement. Other condensers have the plates so shaped that the percentage change of capacity for a given angular movement is constant.

In general, the dielectric (that is, the material between the plates) is air, but when large capacities are required, mica or ebonite

sheets or similar material may be used, giving a mixed dielectric which is partly air and partly solid material. The capacity depends upon the distance between the

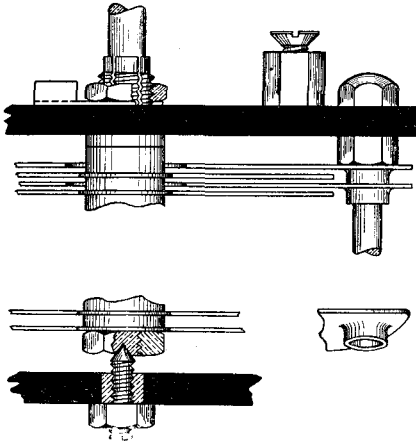

Fig. 2. A usual method of supporting the plates of a variable condenser, but instead of spacing washers between the fixed plates, the plates are pressed out to accommodate the spindles.

plates, the area, and the specific inductive capacity of the dielectric. The dielectric constant of air is unity, and for most other substances which might be used lies between two and seven. Sometimes the condenser plates are placed in a case containing oil. The dielectric constant of suitable oils lies between two and five, so that if the maximum capacity of the condenser, when air is in the dielectric, is $0.001 \mu F.$, the capacity is increased two to five times by immersing the plates in oil.

Formulae for determining the capacity of variable condensers have been given quite recently.*

The aim in condenser construction is to provide capacity only. Unfortunately, condensers, like all other electrical apparatus, cannot be constructed with zero losses. Ideally, when a condenser is connected in a circuit, the only change in the characteristics of the circuit is due to

the added capacity. Actually, when a condenser is joined in a circuit the losses are increased. Power is lost because the condenser possesses a number of imperfections.

As explained in "Wireless Theory"—VII, when a condenser has no losses, and an alternating voltage is connected across its terminals, the resulting current leads the pressure by 90° ; that is, the pressure and current are 90° out of phase. Consequently the power factor is zero. Due to various losses, however, the phase angle of condensers ordinarily used by amateurs may be considerably less than 90° .

RESISTANCE.

The losses may be due to a number of things. Thus, there is ohmic resistance, due to the material of the plates and the method of connecting them together. The resistance of the connections between the condenser terminals and the plates is generally quite negligible, and the same with the plates themselves. They are generally constructed of brass or hard aluminium. The resistance is often due to the poor electrical contact between the plates. In many condensers, holes are punched in the plates which are then threaded on spindles with spacing

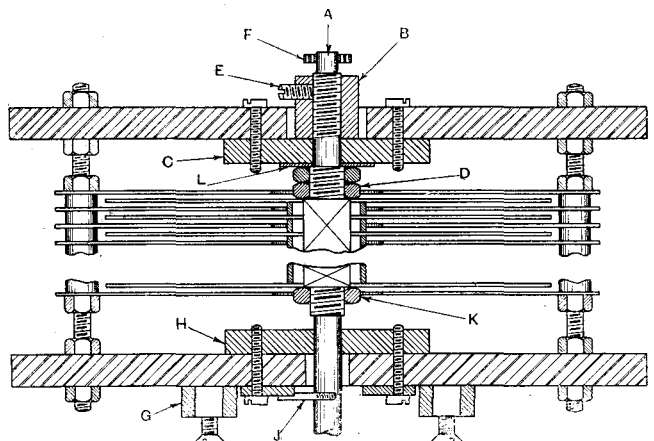

Fig. 3. Top and bottom section of a variable condenser with end plates of bakelite. Losses at the bearing are made small by cutting away the insulating plates between the shaft, the insulation and the fixed plates. (Burndept, Ltd.)

washers to provide clearance between the fixed and moving plates. If the holes are punched close to the edge and the metal is thin, it often happens that the plates

* "How to Find the Capacity of Condensers," *Wireless World and Radio Review*, Vol. XII, No. 199.

are distorted, and the spacing washers do not lie flat and make contact over their whole surface. In addition, during assembly, the washers are handled, and may be made dirty and greasy. Consequently only poor electrical contact is made between the plates.

The resistance may be reduced by careful design. In the better grade condensers brass plates are used, which are soldered together. In other types the plates are fixed into slots in the supports, giving good electrical connection.

The effect of resistance is more pronounced at the higher frequencies.

DIELECTRIC LOSSES.

By dielectric losses is meant losses due to dielectric hysteresis and absorption. In the case of air dielectric condensers, the only dielectric losses are those due to the insulating material used to insulate the two sets of plates. In some condensers, the top and bottom plates consist of an insulating material to which is secured the fixed plates. The moving plates are then arranged to rotate in metal bearings provided in the insulating material. In other types, metal end plates are used, and the bearings are fitted to bushes of insulating material set in the end plates.

Probably the best condensers are constructed with the moving plates mounted in bearings provided in metal plates, while the fixed plates are carried on insulators.

Whichever method of supporting the plates is used, however, there is some capacity through the insulating material, and if the electric field is dense and the material of poor quality the losses may be quite high and certainly not negligible.

LEAKAGE.

If the resistance of the insulating material between the two sets of plates is not infinity, the condenser may be considered as equivalent to a capacity in parallel with a resistance. Then the current which flows in the condenser circuit is made up of two portions, the capacity current and the leakage current. The leakage current is, of course, undesirable, because it represents so much waste.

EFFECTIVE RESISTANCE.

All the losses occurring in the condenser may be considered as equivalent to a single series or parallel resistance. For example,

if the total losses represent a waste of 0.05 watts, and the current flowing in the condenser circuit is 0.1 ampere, the effective series resistance (approximately) from the relation, $\text{Watts} = I^2R$ is equal to $\frac{0.05}{0.1^2} = 5$ ohms.

Many of the ordinary types of variable condenser have an effective resistance of 50 ohms, or more, measured at 10^6 frequency, (300 metres).

If the voltage applied to the condenser terminals is known, the equivalent parallel resistance may be approximately determined from the formula, $\text{Watts} = \frac{E^2}{R}$.

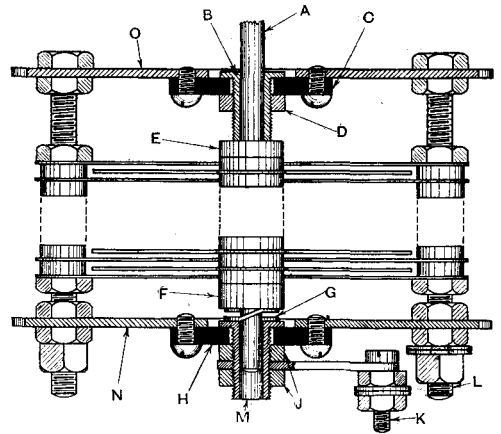

Fig. 4. In this type of condenser the end plates are of metal carrying insulated bushes to which the bearings are fixed.

In those cases where mica or other insulating material is employed between the plates as a dielectric for the purpose of increasing the capacity, the losses may be very much greater than when the dielectric is air.

METHODS OF SUPPORTING THE PLATES.

A usual method of supporting the plates is shown in Fig. 2. In this condenser no separate spacing washers are used with the fixed plates. Instead of the usual holes being punched out to accommodate the spindles, the plates are pressed so that no washers are required. The surface of the portions pressed out are ground and planished. The upper portion of the figure shows the method of making contact with the rotating

element. A screwed split bush fits closely round the shaft, and the nut serves to hold the metal connecting piece in place, and to hold the bush tightly against the shaft. The rubbing contact between the bush and shaft is sufficient to provide good electrical contact, and also to prevent too easy movement of the rotating plates.

The lower bearing consists of a steel pin screwed in a metal bush provided in the bottom insulating plate, which fits in and bears against the bottom of the shaft. In some condensers, instead of a pointed steel screw of this sort, a screw with a flat end is used, and a steel ball is placed in a hole drilled in the end of the shaft. The rubbing contact is then made between opposite faces of the ball, the end of the screw, and the shaft. The position of the moving plates is easily corrected by adjusting the screw.

When solid insulating end plates are used in this way, care should be taken that they have the required thickness and composition, otherwise they may warp or crack with use.

Another type of condenser which has end plates of insulating material (bakelite) is shown in Fig. 3.

The top and bottom of the condenser only is shown. The parts are marked as follows: A, spindle; B, collar; C, bearing (bottom); D, lock-nuts (moving plates); E, locking screw for spindle; F, flexible connection for moving plate; G, bosses for securing; H, bearing (top); J, stop-pin; K, lock-nut for moving plates; L, spring washer for bearing.

Notice in particular the design of the bearings. The losses at these points are made small by cutting away the insulating plates to reduce the capacity between the shaft, the insulation and the fixed plates.

Another condenser which has metal end plates, carrying insulating bushes in which the bearings are fixed is shown in Fig. 4. Here the parts are as follows: A, spindle; B, bush (top bearing); C, insulating bush; D, lock-nut (top bearing); E, lock-nut (top bearing); F, lock-nut (moving plates); G, spring washer; H, insulating bush; J, lock-nuts (bottom bearing); K, terminal (moving plates); L, terminal (fixed plates); M, bush (bottom bearing); N, bottom metal end plate; O, top metal end plate.

Notice in particular the insulating pieces between the fixed and moving plates. The diameter of the insulation should be as large as mechanical considerations permit. Large losses occur in this insulation, unless the material is very carefully chosen and the shape carefully designed.

TYPES OF CONDENSERS.

A good example of sound condenser construction is given in Fig. 5. The top plate consists of a heavy aluminium casting, shaped so that it may be easily secured to a panel, and hold a covering case. The plates and washers are of heavy gauge material, giving low resistance and strength. The

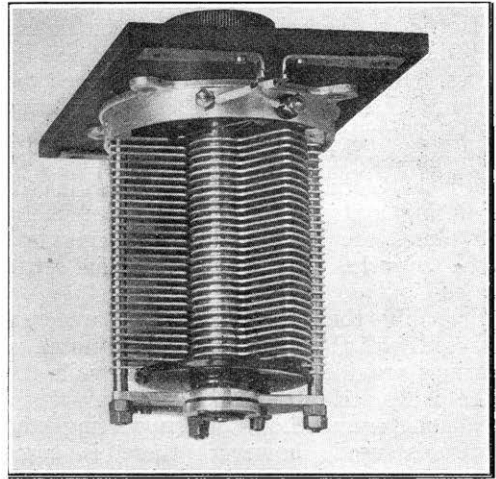

Fig. 5. A good example of sound condenser construction. The top plate is of heavy aluminium casting, which can easily be secured to a panel. (Marconi's Wireless Telegraph Co.)

losses are further reduced by the careful design of the bearings and insulating bushes between the sets of plates.

A variable condenser which provides a large variation in capacity, although the bulk is quite small, is illustrated in section in Fig. 1. The condenser is called a "double plate condenser" because it has a double set of fixed and moving plates. To increase the capacity, ebonite is used between the plates. The features of the design may be seen in the figure.

(To be continued.)

INVESTIGATIONS WITH THE CATHODE RAY OSCILLOGRAPH.

By N. V. KIPPING.

THE field of investigation which may be covered by the cathode ray oscillograph is by no means limited to the examination of the conditions in circuits, the subject treated in the last of these articles. The parts which go to make up the circuit are naturally as important themselves—"the chain is only as strong as its weakest link."

It is the author's intention, therefore, to demonstrate a few typical instances of the oscillograph's use in this respect.

In general, the most vital part of a radio circuit, excepting in simple crystal sets, is the thermionic valve itself.

of valves is a little tedious for one or two valves, practically impossible for each valve leaving a factory. By means of the cathode ray oscillograph, however, and a standard circuit arranged for the purpose, the characteristics of valves may be charted almost instantaneously.

Let us take, for example, the plotting of the grid voltage-plate current curves. A suitable circuit is shown in Fig. 1.

An alternating potential of suitable value—sufficient for saturation to be reached when the grid is most positive—is applied to the grid. The value of the bias on the grid would be different for different values, but would be so chosen that the maximum negative and maximum positive values of the grid potential would go beyond the points where the curve becomes flat, either due to too great a negative grid bias, and consequently no plate current flowing, or to saturation being reached.

A variable resistance is inserted in the plate filament circuit, and the oscillograph plates governing vertical deflection are connected across this resistance, whose value is so adjusted by trial as to give a convenient amount of deflection on the oscillograph screen.

The horizontal deflection is obtained by connecting the horizontally deflecting plates across from grid to filament.

The curve charted by the oscillograph spot is then the curve of anode current variations

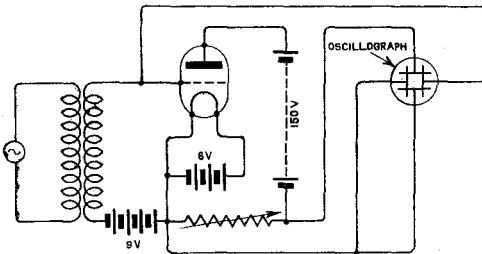

Fig. 1.

It is doubtful whether the vast majority of amateurs worry much about the characteristics of the valves they use. Possibly if they did, a good deal of trouble would be accounted for.

The ordinary plotting of the characteristics

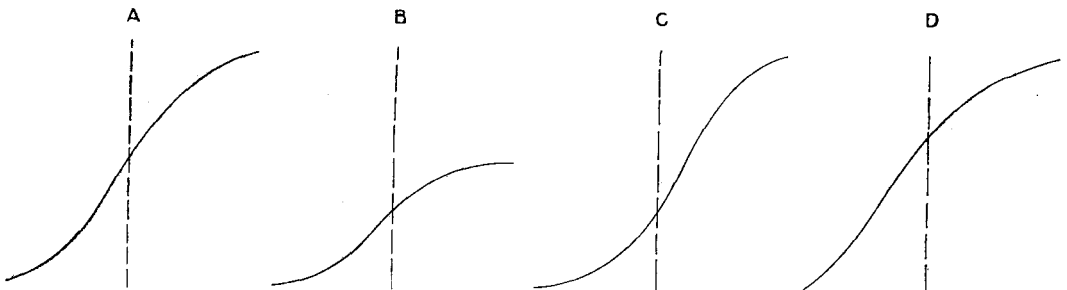

Fig. 2.

with changing grid potential. Fig. 2A shows the curve obtained with a Western Electric 208A valve. The filament current was 1.25 amps, and the plate potential 150 volts. It was interesting to notice, when plotting this curve, the time taken for the plate current to build up to the saturation value, after the grid voltage had been switched on. This was usually of the order of a second.

The effects of alterations in the operating conditions of the tube are easily observed. Fig. 2B shows the effect of reducing the filament current to 0.95 amperes. The maximum plate current is reduced to about half its former value with the filament taking 1.35 amperes.

In Fig. 2C the plate potential has been reduced from 150 volts (as in 2A and 2B) to 100 volts, while in Fig. 2D the plate potential is increased to 200 volts. As will be seen from the figures, most interesting information is instantaneously produced of the effects of such alterations in the operation of a valve. It would appear that a valuable factory test might be arranged by drawing on the oscillograph screen the outline of the permissible limits of the grid voltage—plate current characteristic curve of each type of valve, when a glance would tell whether each individual sample was satisfactory.

In Fig. 3 the four curves 2A, B, C and D, have been superposed, so that a comparison may easily be made of the results of the experiments.

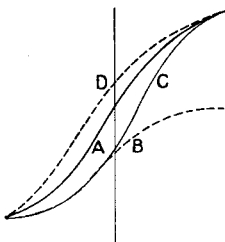

Fig. 3.

An entirely different type of experiment is that in which it is desired to examine the wave form of an A.C. supply, or of a rectifier, etc., etc.

For this it is necessary to obtain a deflection proportional with time from, say, the horizontal pair of deflecting plates, while the alternating current to be examined is applied to the vertical pair of plates. Other methods have been suggested hitherto, but nearly all

have had low frequency limits of operation, or have given a curve on the straight line basis, where a sinusoidal basis is far simpler for examination purposes. Others have given a complicated figure which afterwards required to be "translated" into the sinusoidal form. The external revolving mirror is not easily applicable to the cathode ray oscillograph, and in any case is not suitable for high frequency working.

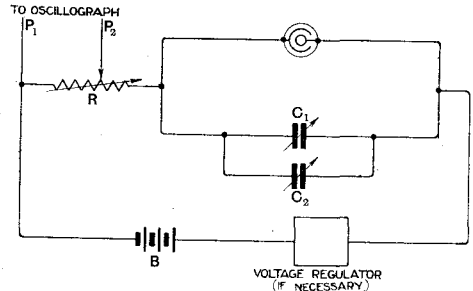

Fig. 4.

A method adapted by the author has the advantage of simplicity, and the direct production of an image on the sinusoidal basis on the screen. The means used is the circuit shown in Fig. 4, a circuit whose essential functions were first described in the "Faraday House Journal," Vol. X, No. 3. A neon filled glow discharge lamp of the "Osglim" type is arranged to "blink," the circuit being such that the potential difference across the lamp would alternately build up to the necessary value for the discharge in the lamp to "strike," and fall again below this value, until the discharge "failed" again.

In the circuit of Fig. 4, when the voltage is switched on, the lamp may be said to be on open circuit, and the potential difference across the condenser, and therefore across the lamp at any time t will be given by :

$$e = B - B\epsilon^{-\frac{t}{rc}}$$

As the potential reaches the value at which the discharge "strikes," the condenser discharges until the P.D. has dropped sufficiently for the discharge to fail again. Adjustment of the values of r and c varies the frequency at which this blinking effect takes place.

If now the pair of plates on the cathode ray oscillograph which govern horizontal deflec-

tion are connected across a suitable portion of the resistance R in Fig. 4, the spot is deflected proportionally with the potential variations occurring in this resistance. These variations have a wave form approximating to the saw-tooth shape, so that the spot is deflected horizontally across the screen in a manner depending upon the A.C. wave form (connected to the vertically deflecting pair of plates), after which the spot flashes back to the starting point and again traces out the A.C. wave. If the two deflections are synchronous, or if any integral multiple of the "time" deflections is equal to the A.C. frequency, the A.C. wave is traced out into a stationary pattern, the length of one wave and the number of complete waves shown depending on the value of the above integral multiple. When this is one, one complete wave is traced.

A curious and at the same time useful effect is obtained when the neon lamp time deflection makes two complete vibrations, while the generator supply makes one, three, five or any odd number of cycles. This means that the "time" deflection must go through two complete cycles before the same track is retraced by the oscillograph spot, so that two reproductions of the generator wave are superposed, 180 degrees apart in phase. A useful means is thus obtained of comparing the top half of the wave with the lower half, making irregularities between the two halves more easily seen.

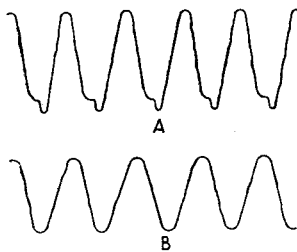

Fig. 5.

This time deflection device has been most successfully used in the examination of the wave forms of oscillations at frequencies of 100,000 cycles per second, the highest attempted.

The operation of the device is simple and quick, and so should prove a useful adjunct to the oscillograph itself.

Figs. 5a and 5b were produced with the help of this circuit, and show the wave of a three-valve oscillator, *a* normally, and *b* with a filter in circuit. The frequency of the oscillations was 17,000 cycles per second.

Fig. 6 shows the wave form examined with the "time" deflection device of the output from a single valve rectifier. Figs. 6a and 6b

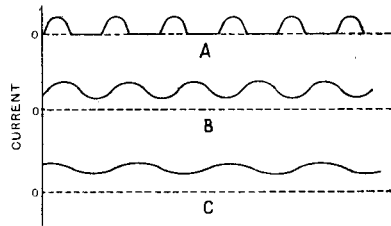

Fig. 6.

were produced with different chokes in the rectifier output. A reliable means of examining the efficiency of a rectifying system is thus obtained, and an immediate idea can be gained of the effectiveness of alterations in the choke system of a rectifier.

Another use of the time deflection arrangement is in the comparison of the wave form of a valve oscillator at various frequencies, before and after passing through a transformer. The distortion introduced by the transformer may be gauged in this way, and the effectiveness of its working at high and low frequencies.

The phase relationships between the potentials in the two sides of a transformer may be examined by yet another application of the oscillograph. The two windings should be correctly terminated for impedance by pure resistance, together with, on one side, an oscillator. The pairs of deflecting plates would be connected across the two windings of the transformers, and oscillations supplied at various frequencies.

If the potentials across each winding of the transformer are in phase, or 180° apart in phase, a sloping straight line is shown on the oscillograph screen, while for 90° difference in phase, a circle is produced. Slight deviations from the straight line are easily observed, a thin ellipse being the result.

The most frequent cause of trouble in a transformer, however, is probably the iron core. More iron of low permeability is required for the same flux than with a high-

grade iron, and a cheap transformer sometimes has an insufficiently large core, in order to save the cost of extra copper in the turns. A good iron, therefore, saves money in the long run.

It is therefore an advantage, at any rate from the manufacturer's point of view, to have a quick method of producing the hysteresis curve of a sample of iron or of a magnetic alloy. The hysteresis curve, of course, shows the relationship between the induction and the magnetic field for the sample under test.

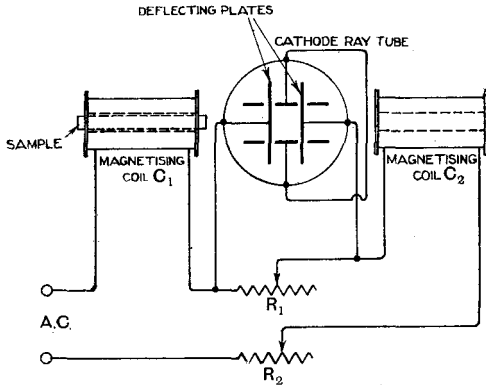

Fig. 7.

The curve is most conveniently produced by causing the cathode ray to be deflected simultaneously, proportional to the magnetising force horizontally, and to the magnetic flux in the sample, vertically. The method employed is to magnetise and demagnetise the sample continuously by means of a coil through which an alternating current is passed. The circuit which may be used is shown in Fig. 7.

A pair of similar coaxial coils C_1 and C_2 are set horizontally one on each side of the tube, their axes at right angles to the tube, and opposite the deflecting plates. The coils are connected in series with two adjustable resistances R_1 and R_2 , and the alternating current supply. They are so connected that their magnetic effects on the cathode ray are in opposition, so that when current is passing through them, no deflection of the ray is produced after slightly adjusting the distances from the oscillograph tube.

The terminals of R_1 are now connected across the horizontally deflecting plates of

the oscillograph, the vertically deflecting pair being short circuited as they are not required for the experiment. Deflections horizontally are thus proportional to the current flowing through R_1 and through the magnetising coils, and therefore to the magnetising field.

The sample of steel, which should be roughly pencil-shaped, is now inserted in the coil C_1 . The magnetic flux in the sample produces a vertical deflection of the ray, which is proportional to it.

It follows, then, that when the alternating current is switched on at any instant, the deflection of the ray will have two components at right angles:—

(a) Horizontally proportional to the magnetising field.

(b) Vertically proportional to the magnetic flux in the sample produced at that instant.

Thus as the field is caused to alternate successively through zero from positive to negative values and *vice versa*, the ray will trace out a hysteresis curve such as could be obtained by any of the usual methods in the laboratory. The result, however, is produced more quickly.

The resistance R_2 is used to regulate the magnetising field, and R_1 for obtaining a suitable deflection on the oscillograph screen.

In Fig. 8 curves are shown which were traced from the screen, produced with samples of steel, soft iron, and stalloy.

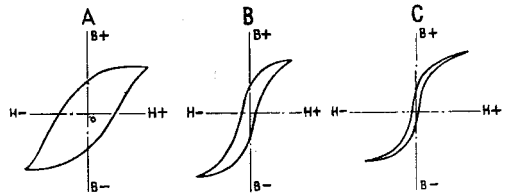

Fig. 8.

Much could be written concerning the study of transmitters and receivers, with the cathode ray oscillograph, but the author's intention has been to confine his remarks to subjects of interest to every amateur, and not to touch "specialist" problems. However, an idea will have been gained of the way in which radio investigations may be carried out with the help of this most useful apparatus.

DETECTOR AND AMPLIFIER FOR TELEPHONY RECEPTION.

IT is the intention of the writer to give the benefit of his experience with an audio frequency magnifier of uncommon design and built essentially for the reception of broadcast music with practically little or no distortion. Nowadays one hears so many loud speakers which represent anything but the quality of the good class band playing at the broadcasting

transformers do produce a certain amount of distortion, but it is not the writer's intention to go into the "whys" and "wherefores" in this brief article as this topic has been dealt with recently in so much detail. Yet there is the method of magnifying speech and music without the aid of transformers, and this is accomplished by resistance capacity intervalve coupling, which

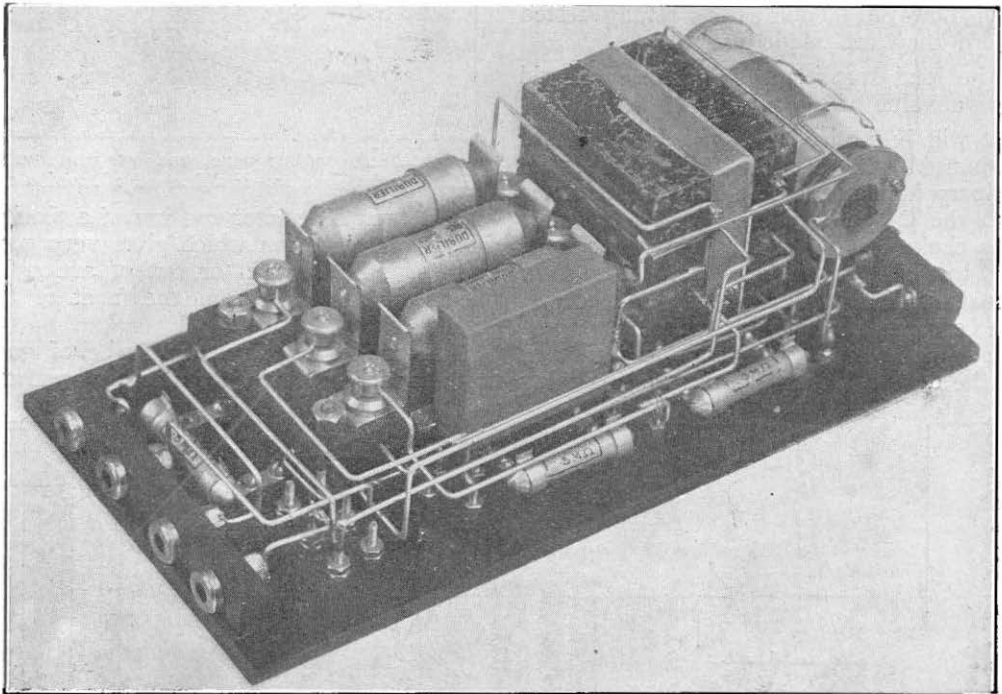

Fig. 1. The underside of the resistance coupled low frequency amplifier.

station. A good many enthusiasts attach the blame to the loud speaker, but, provided this instrument is of reputable make, one must look elsewhere for the root of the trouble.

Our attention then wanders to the magnifier. It may be that our transformers are of poor design, and perhaps we cannot afford those of good make and which naturally are very much more expensive than the general run. In any case closed core iron

is by far the most successful way of getting loud and undistorted telephony. Indeed, this is the writer's opinion.

We now turn to the set which is shown in Figs. 1 and 2, while the circuit diagram is given in Fig. 3.

The components appear to be rather cramped, the reason being that the writer had at hand a rather small but well polished case which he wished to utilise. For those

making up the set, a different method of setting out could be arranged to suit individual taste. The anode leaks can be seen mounted on an ebonite panel which covers the three filament rheostats. This panel also carries the three grid condensers and H.T. bridging condenser, as well as the loud speaker feed condenser which can be seen next to one of the anode leaks.

The grid and H.T. bridging condensers can be of any value from say $1/100$ to $1/10$ microfarad. The writer was able to pick up condensers with a capacity of $1/36$ mfd. for twopence each off a stall in a London market. Condensers bought in such a way, however, should be carefully tested before they are made use of.

The loud speaker feed condenser should have a value of 0.5 mfd.

It will be noticed that the loud speaker is shunted with a choke coil. This is an ordinary home-made step-down transformer with the OP and IS ends joined together. This choke can be seen in the photograph next to the bank of condensers. If the loud speaker is of high resistance the connections can be made as shown, but if of low resistance, the connection is made as indicated by the dotted line in the diagram, meaning

which incidentally adds to the general appearance of the underside.

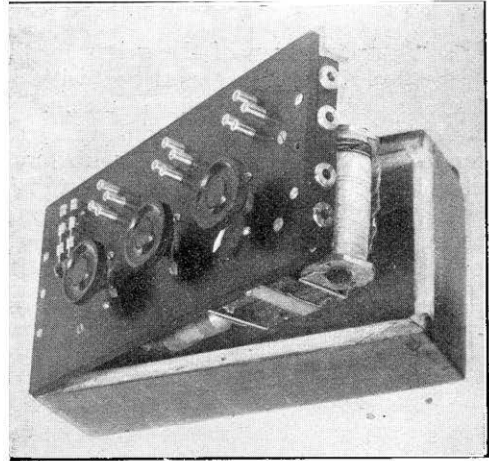

Fig. 2. Top of the panel and box container. Plugs and sockets are used instead of terminals.

The crystal detector consists of a zincite-bornite combination which gives very good results and is put in or out of action by means of the switch on the front of the panel.

The anode resistances must be of good make and be capable of remaining constant.

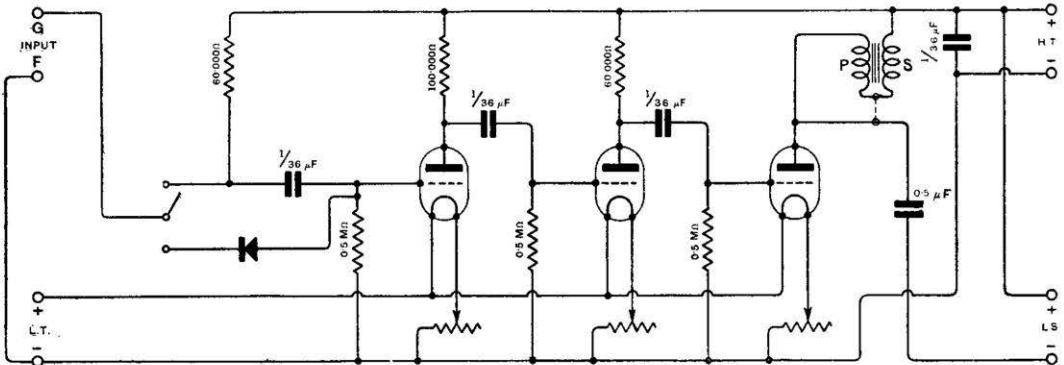

Fig. 3. Diagram of connections. When the crystal detector is in circuit, a potential is set up across the resistance which is normally used as a leak.

that the tap is taken from the point where the OP and IS windings were joined. No terminals are used in this set. In place, sockets are arranged, four at each end, which are mounted on strips of ebonite attached to the underside of the panel. The wiring is carried out with No. 16 tinned copper, which by reason of its stiffness makes insulating sleeving unnecessary, and

The anode voltage should be about 150, but the set will work well on 120.

In conclusion the writer confidently recommends this set to give good results with very little management, and considering the outlay need not be more than two pounds, this item sinks into insignificance when one is entertaining people with something really worth listening to.

S. J. H.

A THREE-VALVE RECEIVER

In the previous issue the principles were described. A novel feature is that tuning is simplified by the simultaneous adjustment of the aerial and tuned anode circuits. Practical details for constructing the inductances, and setting up the condensers were also given, and this instalment gives the general layout and method of wiring, together with operating instructions.

By PHILIP R. COURSEY, B.Sc., F.Inst.P., A.M.I.E.E.

(Concluded from p. 276 of previous issue.)

The layout of the front panel of the instrument is sketched in Fig. 9, together with a plan view of the set showing the arrangement of the parts behind the panel, and a side elevation of the set. These three views of the set show the relative positions

whole, extremely important, a sufficiently good idea of their positions can be obtained from the scale of the drawings.

The detailed wiring of the set is given in Fig. 10, which gives all the connections of the parts, including the three fixed

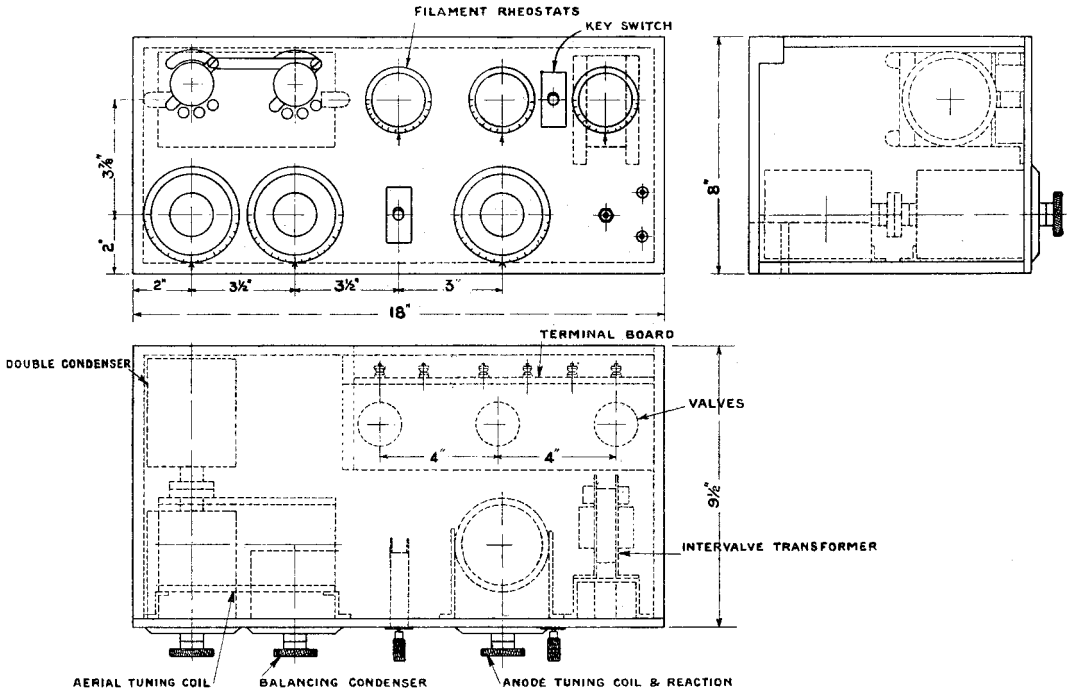

Fig. 9. Arrangement of parts of receiver on panel and inside the instrument.

of the two tuning coils and the other parts, and should aid the assembly of the set. The panel required is 18 ins. long by 8 ins. wide, and it should be attached to the framework of a box 9 1/2 ins. deep. All the dimensions of the parts in Fig. 9 have not been marked on, but as their exact relative positions except those specially dimensioned are not, on the

condensers forming the H.F. coupling to the detector valve, and the L.F. transformer and telephone bypass condensers. This wiring should be carried out in No. 16 S.W.G. bare tinned copper wire. It will be noted that two double-pole throw-over "key" switches are shown on this wiring diagram. The left-hand one of these is an "on and off"

switch. In one position it puts the set into normal operation, in the other it disconnects the H.T. and L.T. batteries and joins the aerial through to earth. The right-hand switch serves to switch the third (L.F.) valve into or out of circuit, the filament circuit of this valve being automatically opened by this switch when the valve is cut out of circuit.

The four-way double-pole switch mounted near the upper left-hand corner of the panel provides simultaneous switching of the two tuning coils. The first left-hand contact of each switch should be joined to the 20th turn tapplings on the tuning coils; the second

jack can easily be fitted at the right-hand end of the panel, as sketched in Fig. 9, if it is desired to use a plug for the telephones. This jack should be wired in parallel with the two telephone terminals marked in Fig. 10.

The approximate wavelength ranges to be expected on each of the four stud positions of the range switch are as follows:—

- (1) 300 to 520 metres.
- (2) 450 to 900 metres.
- (3) 800 to 1,650 metres.
- (4) 1,550 to 3,100 metres.

Slight variations in these ranges may be found in different receiving sets, but if the windings are carefully carried out there

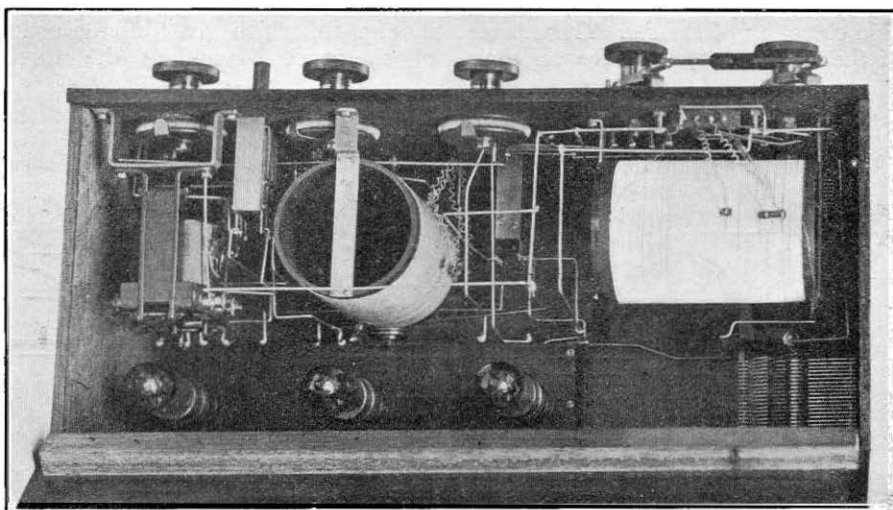

The interior of the receiver as seen looking down through the open lid.

to the 40-turn tapplings; the third to the 85-turn tapplings; and the fourth to the ends of the coil (206th turn). The two switch arms should be linked together by a strip of ebonite so that turning one or other of the switch knobs moves both switches together. The exact design of these switches is unimportant, and any convenient standard parts can be used for their assembly.

Each filament rheostat, as it controls a single valve only, should have a resistance of 4 to 5 ohms in order to provide adequate control of the filament brightness of each valve when using a 6-volt accumulator to provide the L.T. current supply.

In Fig. 10, two terminals only for the telephones are shown, but a telephone

should be ample overlap between the ranges for satisfactory tuning.

In using the set it will generally be found that on the shorter wavelengths the setting of the balancing condenser must be increased in order to balance out the increase in the effective capacity of the aerial at the shorter wavelengths. Usually this change is not a very large one, and the amount of the change for each tuning range will easily be found when operating the set.

Any ordinary hard receiving valves may be used in this receiving set, an L.T. voltage of 6 and an H.T. of about 60 will usually be found satisfactory. If desired, a bypass condenser of about $1\mu\text{F}$ may be connected across the H.T. battery inside the set in

the position marked in Fig. 10. The use of this condenser will frequently be found to improve the working of the set. A paper dielectric condenser will serve for this use.

The H.T. and L.T. batteries may be left permanently wired up to this set, as when it is not in use the moving of the switch to the "OFF" position disconnects both batteries from the internal wiring of the set.

So far no mention has been made of the mounting of the set. The panel sketched

separately from the main containing box.

A very convenient arrangement is to secure the ebonite panel to the front edge of the base board and to hold the two firmly together by the two wooden ends of the set, 9½ ins. wide by 8 ins. high. A bar across the top back edge should be fitted in to unite the two wooden ends so that the lid can be hinged to this. The back of the box should be cut away to permit of ready access to the recessed terminal strip, this

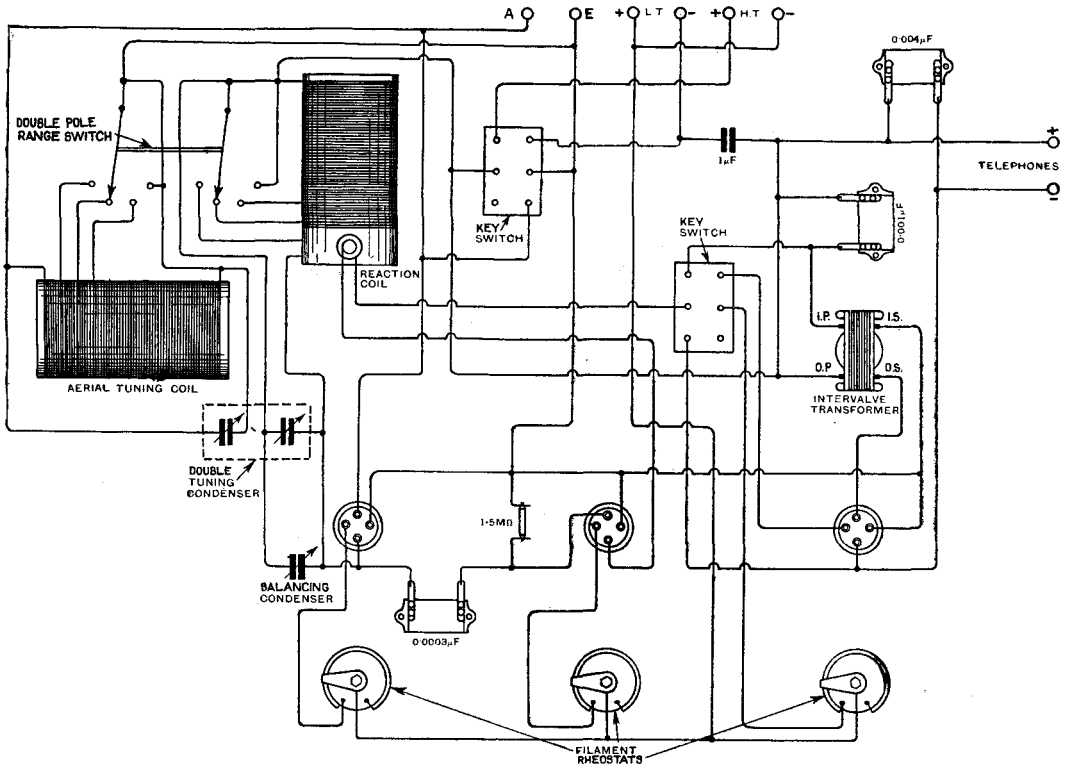

Fig. 10. Wiring diagram of three-valve receiver.

in Fig. 9, on which most of the parts of the set are mounted, may be fixed merely to the front edge of a base board which carries the ebonite terminal board and valve holders near its back edge, but preferably wooden ends should be fitted to the set, and a hinged back and lid. Normally it is only necessary to be able to open the lid, which should therefore be hinged in order to provide access to the valves in the interior of the set, but for convenience in wiring up the set the back also should be fixed

ebonite terminal strip being mounted about 1 in. in from the back of the panel so that the terminals do not project from the back when the box is closed. The six terminals mounted on this strip should be lettered in the order marked on the wiring diagram in Fig. 10, this marking being given as if viewed from the front panel of the set, so that the terminals as drawn in Fig. 10 are in the same relative positions to the remainder of the parts as they actually occupy in the instrument itself.

NOVEL IDEAS AND INVENTIONS.

Abstracted by PHILIP R. COURSEY, B.Sc., F.Inst.P., A.M.I.E.E.

Reducing Atmospheric Interference.

When receiving radio signals, particularly over great distances, it is frequently difficult to read the message accurately owing to atmospheric interference. If the same message can be received in two or more different localities, and with different types of receiving apparatus, the chances of obtaining a correct reception of the message are increased.* Preferably each receiver is arranged to produce a record (photographically or in some similar way) of the signal, the two or more records being arranged side by side on the same strip so that they can readily be compared together. By this means it is frequently possible to see whether any given part of the signal record is truly signal or whether it is caused by interference. This result is aided if the separate receivers are separated by considerable distances.

A Multiple Directive Receiver.

The ordinary D.F. receiver, whether of the radiogoniometer or of the rotating loop type, can customarily only be arranged to D.F. a single station at a time. By arranging double radiogoniometers, however, it is possible to so arrange matters that the station can be simultaneously doubly selective and doubly directive.† Such an arrangement has two possible fields of utility—firstly, to D.F. two stations simultaneously, and secondly, to receive two long-distance transmissions from different directions on the same aerials, whether the signals are of the same or different wavelengths. The general principles underlying the method may be seen from Fig. 1. In this diagram A_1 and A_2 are the two triangular D.F. aerials of the Bellini-Tosi type placed at right angles with each other. G_1 and G_2 are the two radiogoniometers which are connected in parallel, and in parallel with the two loop aerials as sketched. The two search coils S_1 and S_2 are tuned by

the condensers C_1 and C_2 to the two desired wavelengths and are coupled to the two receivers, R_1 and R_2 . Search coil S_1 collects one signal and S_2 the other.

In the practical arrangement of the receiver to operate in this manner, additional refinements are introduced to avoid undesirable reaction effects between the two

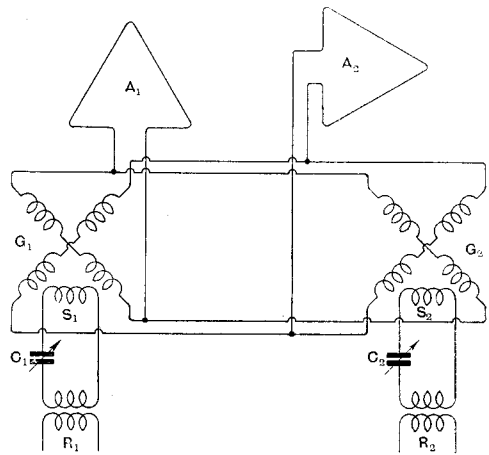

Fig. 1.

receivers, so that each can be tuned and operated independently of the other, but the arrangement sketched serves to indicate the general idea of the method.

Diaphragms for Telephones.

The disadvantage of mica diaphragms which are sometimes used for telephone receivers, and frequently for gramophones, is the liability of the mica to become cracked or scratched, which damage spoils the tone and quality of the reproduction. Such diaphragms may be protected mechanically by coating them with a film of celluloid, collodion or some similar material, either on the exposed side only, or if preferred, on both sides.*

*British Patent No. 188670, by R. H. Ranger and Marconi's Wireless Telegraph Company, Ltd.

† British Patent No. 199471, by C. S. Franklin, B. J. Witt, G. M. Wright and S. B. Smith.

* British Patent No. 196392, by E. A. Graham.

A D.F. Receiver and Recorder.

When using a D.F. receiver, either of the rotating loop or of the radio-goniometer type, it is frequently difficult to determine the directions of the maxima and minima of signal strength with any great accuracy. If, however, the received signal is caused to operate an oscillograph or galvanometer so that a record is made photographically or by other equivalent means, on a chart controlled by the radiogoniometer, the determination of the bearing becomes a matter of geometry.* The chart may be either linear or polar and may be moved along or rotated by the movement of the radiogoniometer or by the turning of the loop aerial if one is used.

Radio Frequency Amplifiers.

The radio-frequency amplifying arrangement sketched in Fig. 2 is of the reactance capacity coupled type. Usually, in order to obtain adequate and useful amplification, it is desirable to proportion the size of the

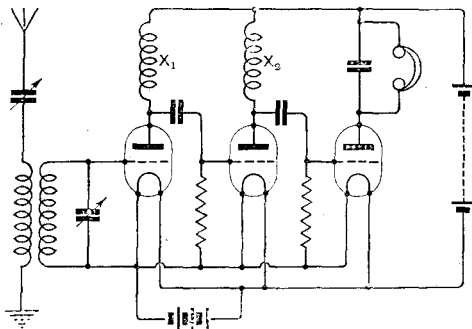

Fig. 2.

reactances X_1 X_2 , so that either they are tuned or approximately tuned to the wavelength to be amplified by virtue of their own self-capacity acting in conjunction with the internal capacities of the valves, or so that they can be so tuned by the aid of small external variable capacities. If, however, the reactances X_1 X_2 are wound with many turns of very fine wire in the form of a narrow "pancake" coil, they can be built to have a very high inductance while retaining a self-capacity of only a few

micro-microfarads. Under these circumstances approximately the same amplification is obtained whatever the wavelength of the signals being received.* It is claimed that if these coils are wound with several thousand turns of a fine enamelled wire of the order of No. 44 gauge, so as to have an inductance of about half a henry with a self-capacity of only about $2\frac{1}{2}$ micro-microfarads, that effective amplification is obtainable over the wavelength range of 200 to 20,000 metres, the amplification per stage being sensibly equal to the voltage amplification of each valve.

An Oscillator Valve without a Grid.

The conventional forms of three-electrode valve having an anode, a filament and a grid have now become so familiar that the ability to control the electron emission by other than electrostatic means is apt to be overlooked. Since the function of the grid is mainly to control the flow of electrons between the filament and the anode, and since a moving electron can be deflected as readily by a magnetic field as by an electric one, it follows that the grid in a valve can be replaced by a solenoid placed so as to produce a magnetic field of the required strength and direction in the space between the anode and the filament. This idea, of course, is by no means new and has been utilised from time to time in experimental work in radio laboratories since the discovery of the valve and its properties by Dr. J. A. Fleming. The main difficulty experienced in carrying out the method of control arises from the fact that the anode is usually constructed in the form of a closed or nearly closed metal cylinder, and that therefore the space inside the anode is to a certain extent shielded from the effects of a varying magnetic field by reason of the eddy currents induced in the anode. It has recently been shown† however, that by properly constructing the valve, the solenoid or winding producing the field can be inside the valve itself—even inside the anode—so that this shielding effect is thereby eliminated, and it becomes possible to construct the valves operated in this way in quite large sizes to handle considerable power.

* British Patent No. 173510, by A. Blondel (France). [Patent void].

* British Patent No. 177161, by J. M. Miller (Bureau of Standards, U.S.A.).

† British Patent No. 196678, by E. V. Robinson.

CORRESPONDENCE

Legal Points for Amateurs.

To the Editor of THE WIRELESS WORLD AND RADIO REVIEW.

SIR,—Our only comment on the questions raised by "Enquirer" in your issue of November 7th, is that they all appear to be reasonable causes of accident, which might occur under the best regulated conditions. If the landlord is entitled to recover at law, he may be able to do so, but whether he is successful in doing so depends very largely upon the financial position of the tenant. Innumerable cases have come before our notice where the tenant has actually signed a form of indemnity to protect the landlord against this damage, and such indemnity is absolutely binding upon him. The landlord relies upon this agreement but when he finds that his tenant is a man of straw, he may have eventually to pay for the damage out of his own pocket. Even if he has recourse to the Court, he will still find that if successful, he may have to be satisfied with a small weekly or monthly payment.

Enough consideration is not given, in our opinion, to the landlord's position in the matter. More serious damage may be done to the premises by a tenant walking on the roof, as is suggested in the letter, and damage of this kind raises innumerable legal difficulties.

So far as the question of lightning is concerned, there is undoubtedly a risk of it as your correspondent shows.

The last paragraph of his letter, however, interests us the most, and it may be news to your correspondent that this Company, who were the pioneers of this class of business, have always been willing to deal with any points of interest, either to the owner of the wireless set in respect of his set, or to help him with any difficulties he may have with his landlord.

Yours, etc.,

DOUGLAS LAWSON,

Accident Manager.

Liverpool Marine and General Insurance Co., Ltd.

In answer to the points raised by "Enquirer" in connection with the recent article on "Legal Points for the Wireless Amateur," our legal correspondent writes as follows:—

The purpose of the article, so far as it dealt with landlord and tenant, was mainly directed to emphasising the fact that a landlord has *prima facie* no more right to object to the erection of a wireless aerial than he has to prevent his tenant from putting up a flag-mast, or celebrating Guy Fawkes day in the time-honoured manner, or making any other reasonable use of his premises.

This does not, of course, relieve the tenant from any consequences of his own default or negligence. Accordingly if he commits damage to the house in the process either of erecting or dismantling his aerial he must foot the bill. If he employs a careless contractor to do the work, and damage results, the tenant is again responsible, but he can sue the contractor in turn. The point here is that the tenant must exercise his own judg-

ment in so locating and fixing his mast that damage will not arise in the ordinary way, provided reasonable care is taken.

These remarks cover the points raised in questions 1 and 3, and it may be added that they would apply with equal force in the case of a flag-post erected under similar circumstances. But one does not hear of any widespread objection on the part of landlords to the harmless flag-post.

In the particular case mentioned in question 4, the responsibility is upon the person who erected the mast, but if this was well and truly set up in the first place, the chances of its falling and doing damage are too remote to give rise to any reasonable apprehension. Of course if it is interfered with by one or other of the common tenants, the question of contributory negligence may arise.

"Enquirer" would undoubtedly consider that he has the right to set off fireworks in his garden on the 5th November without obtaining the written permission of his landlord, but he will realise that he must pay for his neighbour's window should that be shattered by an errant rocket fired by his hand.

As regards question 2, the damage in this case is again upon the tenant. But as a practical wireless man, "Enquirer" will admit that a *properly erected aerial* should be capable of standing the test of an ordinary gale. The resistance offered by masts and a single wire to wind pressure is very slight, and the strain is of corresponding dimensions. Of course a phenomenal wind may arise, and the whole house may collapse, but in that case the tenant doesn't pay, and it would be exceedingly difficult to convince any Court that the presence of an aerial added any appreciable risk to that already existing. For those who desire to meet every possible contingency, however remote, the written consent of the landlord would of course relieve them of any responsibility for damage arising in this particular way.

In connection with lightning risks, the article clearly stated that there was no definite proof that an aerial added anything to the infinitesimal risk, which is always present, of the house being struck. In the case quoted by "Inquirer," there is nothing to show that the damage was due to the aerial. The house would probably have been struck in any case.

Finally, as previously stated, certain insurance companies will cover contingent risks to the building under an existing policy provided that the aerial is kept earthed when out of use. This does not, of course, cover damage to the wireless set itself which can, however, be met if desired by the payment of a trifling premium. The point as to insuring against claims made by the landlord upon his tenant arising from *quite exceptional* circumstances is one that must ultimately be left to the discretion and temperament of particular individuals. In times when it is possible to ensure against practically every contingency, including bad weather at the seaside, it is only natural that insurance companies should regard the nervous tenant and his wireless set as good "business."

OUR TRANSATLANTIC BROADCASTING TESTS.

AS we go to press we have before us an abundance of letters, telegrams and telephone messages, all yielding testimony to the success of the test transmissions between this country and America on November 26th and 27th respectively.

The first message from America notifying results of the transmissions from this country was received on November 26th by *The Wireless World and Radio Review*, which has organized the tests in conjunction with *Radio Broadcast*, of New York. The telegram ran as follows: "Reports successful reception various parts of country. London, Bournemouth, Glasgow, Cardiff and Newcastle were heard. Notify us immediately American programme heard in England to-morrow. Congratulations—*Radio Broadcast*." Subsequent messages from the Central News and Reuter reported that the British programmes had been received in Garden City (Long Island), and in Chatham, Massachusetts.

Far more information is available concerning the experiences of listeners in this country in the early hours of November 27th. The weather conditions were by no means ideal and a number of correspondents state that their aerials and insulators were enveloped in hoar-frost! According to many reports atmospheric conditions were prevalent, and in not a few cases fading was very pronounced. The chief ground for complaint, however, appears to be the interference caused by the use of extreme reaction by many listeners, who thus drowned the American signals.

In the following list two notable facts are apparent. First, the reports contained therein emanate from all parts of the country and even from Ireland. Secondly, the American station most generally received was **WGY**, that of the General Electric Company at Schenectady. Nearly all the successful listeners appear to have heard the two verses of "God Save the King" played at that station, and also portions, at least, of the speech of Mr. Owen Young, President of the Board of Directors of the General Electric Company. **WHAZ**, the station of

the Rensselaer Polytechnic Institute, Troy, N.Y. comes next in respect of its reception, and the remaining honours are shared more or less equally by some six other stations.

Of the British transmission test on November 28th, the reports are less gratifying. On this occasion Senatore Marconi broadcast a personal message, but it appears that this was imperfectly heard on the other

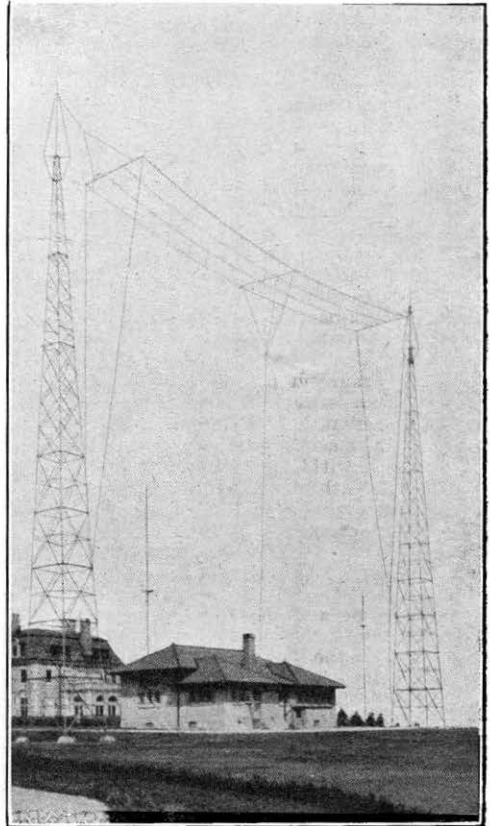

The aerial system of **WMAF** at South Dartmouth, Mass.

side in some districts owing to interruption by American broadcasting stations. Senatore Marconi spoke of his recent experiments with short wavelengths and prophesied secret transmission by their use in the future. A short speech by Monsieur Georges Carpentier was also broadcast.

FIRST LIST OF TRANSATLANTIC BROADCAST RECEPTIONS.

News of the reception of American broadcasting has reached us from all parts of the country, and the first influx of reports is represented by the following list. The widespread reception of **WGY**, the G.E.C. station at Schenectady, N.Y., is especially noticeable.

Name and District.	Station.	Receiver used.	Remarks.	Name and District.	Station Heard.	Receiver Used.	Remarks.
Tye, Sevenoaks	WGY	Burndep Ultra IV with 3 valves. 1-V-2	Quite clearly.	Norman Rofs, Woking, Surrey..	WGY	2-V-0	Complete program received, no fading.
McAndrew, Kilmarnock ..	WGY . Another audible ..	1-V-2	Excellent.	Hardman (2 DO), Whitefield ..	WGY, WJZ	Dull emitter only ..	No fading. Weaker.
A. S. Walker, Brentford, Middlesex	WGY, KDKA, WMAA, WBAZ, KSD.	1-V-2	Amplifiers and interference bad.	West Ealing	WGY	2-V-2	Jammed after 4 min.
Lt. A. R. Williams, R.N., 8, Palace Gardens, Kensington.	WGY	1-V-2	American National Anthem, Speeches, etc.	Ernest Watts & Son, Ltd., Hove ..	WGY	(no ..	Local interferences
Walker Copfield, E. ston, Exeter	WDY, Pittsburg, 300m.	1-V-2	Very clear. Interference.	Major D. M. Lovatt, Hollybank, Willowbridge, Market Drayton, call sign).	WGY, 4 others ..	2-V-2	Speech and music. R-7.
A. R. V. Garnett, Cambertley (5 RB).	WGY	2-V-0	Voice clear.	A. G. S. Richards, Chorley Wood ..	WGY	1-V-1	Jamming, sigs. weak.
Alford (2 DX)	WGL, WGY, WBAH.	10-Valve Super Heterodyne ..	Very clear, fading very soon.	Edghill, Hampstead	WGY	3-V-1	Interference very bad.
Cartwright, Bristol	WGY	Mark IV Tuner ..	R.6, R.9, R.2, R.4. Whole programme.	Rogers, Glentor, Torrington, Devon.	WGY , also 3 others un-identified.	?	Perfect
Jas. Morris, Knott End, Fleetwood.	WGY	1-V-2	Speech and National Anthem. Very clear but with interference.	Arnott Monmouth	WGY	?	Local oscillation, audibility good.
Harvey, 91, Brunedje Rd., Woolwich.	WDBAR	1-V-2	Perfect reception, full programme.	E. J. Clark, Holloway	WGY	1-V-1	Speech and music very clear.
Maurice Edoloff, 91, Lordship Pk., Stoke Newington.	WGY (?)	1-V-1	Hy. Ford speech (?) Spark jamming and oscillation.	P. H. Audsley, Loftus, Yorks ..	WGY	4 Valves	Fairly loud.
Inman, Hampstead	—	1-V-1	Speech for about 4 mins. Very good.	H. J. Price, Cardiff	KPKA, WGY ..	1-V-0	Speech and music.
Holmes, 235, Portobello Rd., Rollings, 20, Bapaume Rd., Hilsea.	WJZ, WGY	2-V-1	Speech, 3.10.	A. H. Thornhill, Cambridge ..	WGY	1-V-1	R-5.
Leach, Petersfield	WJZ	1-V-1	Nat. Anthem, 3.15.	W. Martin, Burton-on-Trent ..	WGY	1-V-1	Very plain and loud.
Mead, Longeaton, nr. Notting-ham.	WGY	1-V-1	3.0. Lecture on Wireless, 3.5. Speech.	D. K. Cameron, Ryde, I.O.W. ..	WIO, WGY	1-V-2	R-9.
Capt. Young, Southampton ..	WGY	1-V-1	Speech and National Anthem.	K. Mackenzie, Lt.-Comm. R.N., Lillitngow.	WJZ, WGY	2-V-1	with inter-ference.
Bates, Buckinghamshire	WGY	Burndep V. Power valve cut out.	Speech. National Anthem. Close down.	J. Grant Bruce, Dundee	WGY, WHAZ, WOR, WMAF.	1-V-1	WGY readable with detector alone.
Hall, Doncaster	WGY, WBY	2-V-2	Speech only.	Stanley W. Troupe, Brighton..	WGY	1-V-1	Music clear.
Peasons, Dorchester	WGY, WBY	1-V-1	Address. Chairman Rad. Corp. "God Save the King."	J. W. F. Cornwell (6 HK), New-quay, Cornwall	KDKA, WGY, WHAD	1-V-1	Reception good.
Linney	WGY	2-V-2	Speech. Orchestra. Complete program.	H. B. Scargill, Harrogate	WGY, 2 stations un-known.	1-V-1	Morse jamming.
? West End Lane, N.W.6 ..	WGY, WOR	One-Valve	Speech. Orchestra. Fading pronounced.	A. H. Yeates, Lincoln	WGY	1-V-1	Clear and strong.
S. Hunter, Market St., Limavady	WGY	1-V-0	—	A. H. Orcutt, Lapworth, nr. Birmingham.	WGY	2-V-0	Very clear.
Dadd, Clapham Junction	—	1-V-1	—	L. Leslie Miell, Bath	WGY, WHAZ ..	1-V-2	Audible 10 ft. from loud speaker.
Holmberg, Cheskaunt, Herts ..	WGY	1-V-1	—	H. J. Galliers, Brighton.. ..	WGY, WHAZ ..	1-V-2	Clear. with inter-ference.
				Oscar W. Walker, Tapsbam, Devon.	Unknown station on 300 metres, WGY, WBAE.	1-V-2	Very clear.
				S. Hex, London, W.C.1.	WGY, WJZ	1-V-1	Faint, becoming stronger.
				Harold F. Bateman, Nelson, Lancs.	WGY, WAAD ..	1-V-1	Good quality.
				L. Lott, Burnham-on-Sea.	WGY, WHAZ, WOR	0-V-0	Bad jamming but clear periods
				T. F. Salsbury, Oundle, Northants	WGY	1-C-1	Speech plainly.

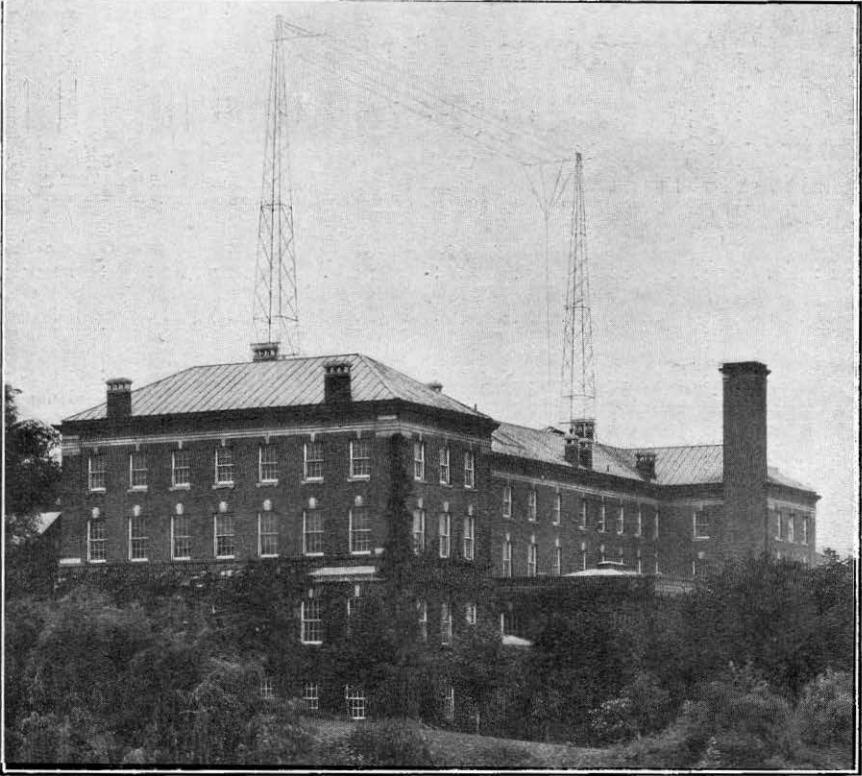

*The aerial arrangement of **WHAZ**, the broadcasting station of the Rensselaer Polytechnic Institute at Troy, New York.*

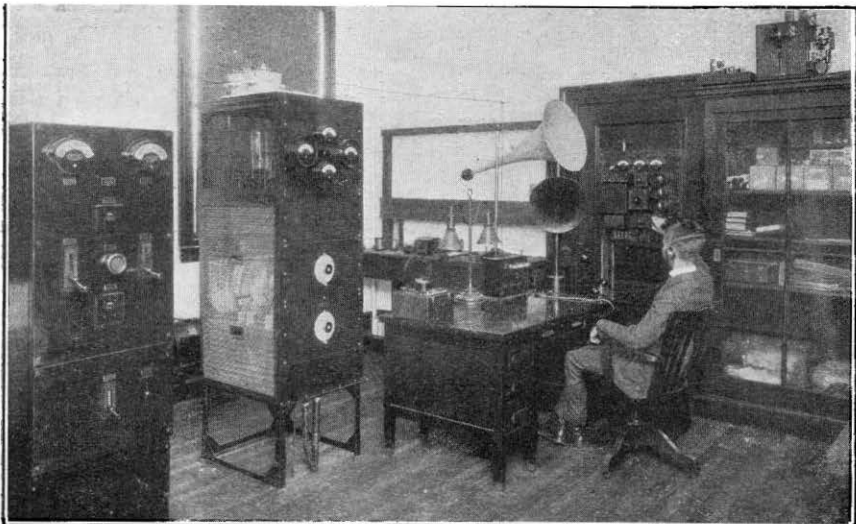

*The apparatus room at **WHAZ**. The power unit is on the left, and the oscillator equipment in the centre.*

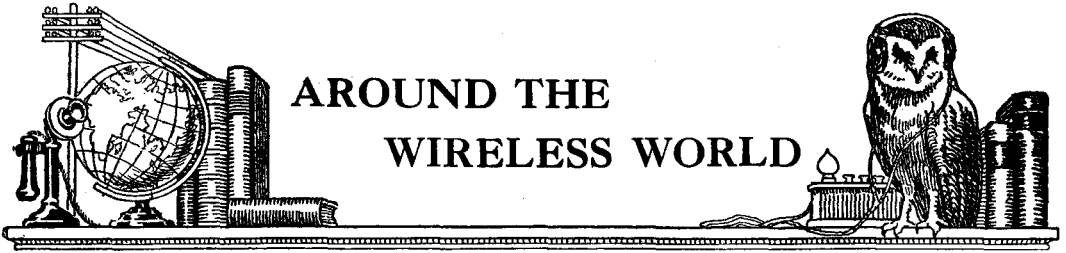

AROUND THE WIRELESS WORLD

School Wireless Banned in Worcestershire.

Instructions have been issued to the head masters of Worcestershire elementary schools to remove existing radio apparatus on their school premises.

This step has been taken, it is stated, in consequence of damage done to property and danger arising to school children through climbing on roofs of schools to inspect aerials. We think it would have sufficed in the circumstances if school-masters exerted their authority to keep their pupils out of danger. The new measure appears rather drastic and will deprive scholars of a form of practical study which could only be to their advantage.

Relay Broadcasting Station for Edinburgh?

Much interest has been aroused among wireless workers in Edinburgh by a local request for a relay broadcasting station in the district. Bailie J. D. Philips Smith, in the Edinburgh Town Council, has given notice of motion that the Lord Provost's Committee should be asked to consider and report as to the advisability of urging the Postmaster-General or the B.B.C. to instal such a station, thus extending the use of crystal sets in the city.

The Sheffield Relay Station.

Mr. S. Charnas, of Ascot, reports that on Monday, November 26th, he picked up the Sheffield Relay Broadcasting station on 300 metres, the strength being R 3. He was using a three-valve set.

A New York Wireless Wedding.

An enquirer on the telephone recently asked the authorities of one of the New York Broadcasting stations if the Wedding March could be played by the station orchestra on the following day, when he was to be married. "Sorry," was the reply, "but we haven't an orchestra to-morrow. Why not postpone the marriage a day, and we'll see what can be done for you?" This suggestion was agreed to, and the Wedding March was duly broadcast as desired, two days later.

A New Irish Radio Society.

It is proposed to form a Radio Society for Tipperary provided that sufficient support is forthcoming. All interested in the advancement of the amateur cause in the district are asked to communicate with the Rev. E. Mackay, C.C., Gurtinahoe, or Mr. Joseph P. Coffey, Abbeyville, Fethard, or with Mr. Harold Goldsbrough, Shaftesbury House, Fethard, Co. Tipperary.

The "Crystavox" Loud Speaker.

With reference to the "Crystavox" loud speaker exhibited by Messrs. S. G. Brown, Ltd., at the

recent All-British Wireless Exhibition, we have been asked to correct a current impression that this instrument is actually on sale at the moment. Owing to the large amount of experimental work which has been necessary to bring the loud speaker to perfection, the makers (Messrs. S. G. Brown, Ltd.), regret to state that they will be unable to make deliveries for at least another two or three weeks.

An Interesting Model.

One of the outstanding publicity features at the All-British Wireless Exhibition at the White City was the large illuminated model of the R.I. Transformer. The interest taken in this model from a publicity point of view has induced the manufacturers, Messrs. Radio Instruments, Ltd., to have a number of similar models built, and these will be available to prominent dealers in various parts of the country for window display during the Christmas season.

From the same firm we have received an attractive catalogue of their wireless apparatus for every purpose, ranging from simple crystal receivers to elaborate valve sets and every type of component and accessory.

FORTHCOMING EVENTS.

WEDNESDAY, DECEMBER 5th.

- East Ham and District Radio Society.** At 7.30 p.m. At the Church Army Social Centre, Barking Road, E.C. Lecture: "Multi-Valve Sets."
- Barnet and District Radio Club.** At 8 p.m. At the Radio Club Room, Bells Hill, Barnet, Lantern Lecture: "The Manufacture and Operation of the Cossor Valve." By Mr. W. J. Jones.
- B.T.H. Recreation Club, Rugby.** At 7.30 p.m. At the Caldecott Girls' School, Church Street. Lecture: "Design of Broadcast Receivers." By Mr. W. Forbes-Boyd.
- Stockport Wireless Society.** At 7.30 p.m. Lecture: "Circuit Wiring Diagrams." By Sergeant Bunter.
- Edinburgh and District Radio Society.** At 117, George Street. Business and Informal Meeting.
- Manchester Radio and Scientific Society.** At 7 p.m. At 16, Todd Street. Lecture by Mr. Hand.

THURSDAY, DECEMBER 6th.

- Derby Wireless Club.** At 7.30 p.m. Lecture: "Some Gadgets I have Tried." By Mr. F. Harrison.
- Ilford and District Radio Society.** Informal Meeting.
- Luton Wireless Society.** At 8 p.m. At Hitchin Road Boys' School. Lecture: "The Care and Maintenance of Accumulators." By Mr. H. S. Barber.
- Hackney and District Radio Society.** Lecture: "The 'Popular Wireless' Combination Set." By Mr. G. V. Dowding, A.C.G.I.
- Kensington Radio Society.** Lecture: "The Plug and Jack Method of Switching Multi-Valve Sets." By Mr. Bland-Flagg.

FRIDAY, DECEMBER 7th.

- Wembley Wireless Society.** At 8 p.m. At Park Lane School. Lecture: "The Valve." By Mr. W. E. Wallis.
- Sheffield and District Wireless Society.** At 7.30 p.m. At the Dept. of Applied Science, St. George's Square. Practical Work.

FORTHCOMING EVENTS (continued).

FRIDAY, DECEMBER 7th.

Leeds Radio Society. At 7.30 p.m. At Woodhouse Lane U.M. Church Schools. Lecture: "Atomic Physics." By Prof. R. Whiddington, M.A., D.Sc.
Norwich and District Radio Society. At 8 p.m. Annual General Meeting and Election of Officers.

SATURDAY, DECEMBER 8th.

Borough of Tynemouth Y.M.C.A. Radio and Scientific Society. Visit to Ashington Colliery for Wireless Experiments.

MONDAY, DECEMBER 10th.

Kingston and District Radio Society. Lecture: "Methods of Production of High Tension Currents for Spark and C.W. Transmission, X-Rays, etc." By Mr. W. Hamilton Wilson, M.I.E.E.

TUESDAY, DECEMBER 11th.

Plymouth Wireless and Scientific Society. At 8 p.m. At the Y.M.C.A. Building, Old Town Street. Lecture: "Coil Winding." Mr. P. M. Fowler.

Calls Heard.

Stratford, E.15.

2 AQ, 2 AU, 2 DY, 2 FK, 2 FP, 2 FQ, 2 JX, 2 KT, 2 KZ, 2 LT, 2 OM, 2 ON, 2 OS, 2 PW, 2 PX, 2 QQ, 2 SZ, 2 VH, 2 WJ, 2 XP, 2 XR, 2 XX, 5 AC, 5 BW, 5 CF, 5 DT, 5 EL, 5 IC, 5 IO, 5 JT, 5 JW, 5 KT, 5 LP, 5 LZ, 5 OF, 5 OZ, 5 PU, 5 PZ, 5 SU, 5 TR, 5 UL, 5 VR, 5 WF, 5 WN, 5 XM, 5 XN, 5 XR, 6 CD, 6 LJ, 6 IP, 6 PD, 6 VV. (V. det.). (A. Hudson.)

Falmouth, Cornwall.

2 AW, 2 AZ, 2 DF, 2 DX, 2 FP, 2 FT, 2 FN, 2 FU, 2 GG, 2 GM, 2 GW, 2 GZ, 2 HT, 2 IN, 2 JI, 2 JF, 2 JO, 2 JX, 2 JZ, 2 KF, 2 KW, 2 KX, 2 LG, 2 LZ, 2 MS, 2 NM, 2 NR, 2 NA, 2 NK, 2 OD, 2 OM, 2 ON, 2 OB, 2 RB, 2 SZ, 2 TA, 2 VT, 2 VW, 2 WJ, 2 XR, 2 XP, 2 YQ, 2 ZS, 2 ZK, 5 BV, 5 CX, 5 DN, 5 GS, 5 HL, 5 HA, 5 IC, 5 JX, 5 KO, 5 KM, 5 LG, 5 MX, 5 MS, 5 MI, 5 NN, 5 OS, 5 OX, 5 LR, 5 RZ, 5 TU, 5 WR, 5 XC, 5 ZV, 6 BV, 6 NL, 8 AA, 8 AB, 8 AR, 8 ARA, 8 AG, 8 AP, 8 AQ, 8 AS, 8 AW, 8 BA, 8 BM, 8 BF, 8 BN, 8 BV, 8 CD, 8 CF, 8 CS, 8 CZ, 8 CM, 8 DF, 8 XY, 8 ZZ, 8 BQ, 8 DV, 8 FN, 8 LA, 8 MX, 8 NY, 8 XL, 8 KP, 8 YB, 8 YS, PCL, PCT, 7 ZM. J. Rodgers (6JO).

Enfield.

2 AH, 2 AJ, 2 AU, 2 BZ, 2 DC, 2 DF, 2 FK, 2 FL, 2 FP, 2 FQ, 2 FU, 2 ID, 2 IE, 2 IJ, 2 IV, 2 JF, 2 JX, 2 KF, 2 KT, 2 KW, 2 KZ, 2 LP, 2 LT, 2 LZ, 2 NA, 2 NB, 2 NG, 2 OD, 2 OM, 2 ON, 2 OS, 2 PA, 2 PW, 2 FX, 2 QN, 2 SF, 2 SO, 2 TL, 2 TR, 2 TV, 2 UV, 2 VJ, 2 VW, 2 WA, 2 WD, 2 WJ, 2 WE, 2 XB, 2 XD, 2 XP, 2 XR, 2 XZ, 2 YR, 2 ZO, 5 AC, 5 AL, 5 BE, 5 BG, 5 BV, 5 CF, 5 CT, 5 CX, 5 CZ, 5 DB, 5 DD, 5 DE, 5 DH, 5 DN, 5 DV, 5 FE, 5 GS, 5 GP, 5 HL, 5 IO, 5 JJ, 5 JW, 5 KO, 5 LP, 5 LY, 5 LZ, 5 MF, 5 MJ, 5 MO, 5 MY, 5 NN, 5 OB, 5 OX, 5 PS, 5 PU, 5 PZ, 5 QP, 5 RB, 5 RZ, 5 SL, 5 SP, 5 SU, 5 TR, 5 UL, 5 VU, 5 VP, 5 VR, 5 VK, 5 WN, 5 WR, 5 XC, 5 XN, 5 XR, 5 XV, 5 XZ, 5 ZV, 5 ZZ, 6 AH, 6 HD, 6 HL, 6 IM, 6 KL, 6 LJ, 6 MF, 6 NL, 6 NH, 6 OL, 6 OY, 6 QV, 6 TH, 6 VO, 6 ZS, 8 AQ, 8 AW, 8 BA, 8 BE, 8 BM, 8 BQ, 8 BV, 8 BF, 8 CM, 8 CZ, 7 GB, PCL, 0 FN, 0 MX, 0 NY, 0 CP. (H.F.-D.) (S. E. Payne).

Jersey, C.1.

2 AZ, 2 CW, 2 DF, 2 DN, 2 FL, 2 GG, 2 GM, 2 GN, 2 GZ, 2 HF, 2 JF, 2 KF, 2 KW, 2 OD, 2 NM, 2 OM, 2 OY, 2 PK, 2 SZ, 2 WA, 2 ZG, 5 CX, 5 MQ, 5 MU, 5 NN, 5 WZ, 6 NL, 6 OX, 8 AP, 8 AQ, 8 AW, 8 BA, 8 BE, 8 BM, 8 BN, 8 BV, 8 CD, 8 CM, 8 CS, 8 DD, 8 DE, 8 DK, 8 DO, 8 DV, 0 DU, 0 YS. (T-v-o) (D. Grove-White).

Coventry.

2 AR, 2 AQ, 2 DU, 2 FH, 2 FD, 2 FL, 2 FY, 2 HF, 2 HS, 2 HV, 2 KB, 2 KO, 2 KQ, 2 KR, 2 LG, 2 LV, 2 LX, 2 ML, 2 NA, 2 NO, 2 NV, 2 OJ, 2 ON, 2 OG, 2 OX, 2 PV, 2 SY, 2 TB, 2 TH, 2 TN, 2 TV, 2 UX, 2 UT, 2 VC, 2 WZ, 2 XQ, 2 TY, 2 YX, 5 FL, 5 HS, 5 KB, 5 KD, 5 KO, 5 KW, 5 KY, 5 LB, 5 RL, 5 TL, 5 TV, 5 TX, 5 YS, 5 YZ. (O-v-r). (P. N. Goulston, 6JL).

Brixton Hill, S.W.2.

2 AQ, 2 BB, 2 BW, 2 BT, 2 CW, 2 DM, 2 FG, 2 FN, 2 FU, 2 ID, 2 JF, 2 KV, 2 KQ, 2 KR, 2 KZ, 2 LD, 2 LW, 2 LR, 2 MK, 2 MJ, 2 OS, 2 PX, 2 PY, 2 ST, 2 TA, 2 TP, 2 TV, 2 VJ, 2 VS, 2 VN, 2 WO, 2 XL, 2 YQ, 2 ZL, 5 BA, 5 BW, 5 DE, 5 DJ, 5 FR, 5 HW, 5 HL, 5 IE, 5 IO, 5 IS, 5 JW, 5 KS, 5 LN, 5 LK, 5 LZ, 5 OY, 5 PD, 5 PS, 5 SU, 5 TQ, 5 UC, 5 UD, 5 VL, 5 XD, 5 XP, 6 AH, 6 BL, 6 CB, 6 DB, 6 DW, 6 IO, 6 KI, 6 LJ, 6 MZ, 6 NL, 6 NH, 6 NX, 6 OS, 6 QB, 6 RJ, 6 RM, 6 WX, 8 AP, 8 AS, 0 MX, PCL, 7 ZT, HAAZ. (O-v-r). (A. Richardson).

Bradford.

2 AO, 2 CU, 2 CW, 2 DF, 2 DR, 2 DX, 2 FL, 2 FN, 2 FU, 2 GG, 2 GZ, 2 JP, 2 KS, 2 KX, 2 LZ, 2 MM, 2 NY, 2 OX, 2 QN, 2 RP,

2 SH, 2 SZ, 2 VW, 2 WA, 2 XP, 2 ZG, 2 ZU, 5 FD, 5 GL, 5 GS, 5 HT, 5 IK, 5 NP, 5 OT, 5 QV, 5 RB, 5 RD, 5 RI, 5 RY, 5 TG, 5 US, 5 XX, 6 GV, 6 KK, 6 MD, 6 MK, 6 MS, 6 OY, 6 SS, 6 TM, 8 AG, 8 BA, 8 BV, 8 BQ, 8 CD, 8 CM, 8 DN, 8 DX, 8 XX, 0 AA, 0 DV, 0 MN, 0 MU, 0 MX, 0 NY, 0 WQ, 0 XO, 0 XP, PCT, 7 GB, 7 ZM, 1 AL, 1 BQ. (T-v-r). (Francis W. Garrett, 6XL).

Margate.

2 FQ, 2 IF, 2 IL, 2 MR, 2 MS, 2 OD, 2 OM, 2 ON, 2 QQ, 2 RH, 5 LP, 5 PU, 5 VR, 5 ZR, 6 IM, 6 OZ. (J. Byers, 6TU).

Belfast.

2 AD, 2 AH, 2 CW, 2 FU, 2 HF, 2 LG, 2 MG, 2 XP, 5 BG, 5 FS, 5 RT, 5 WR, 8 ZZ, 8 BG, ONY. (F. R. Neill).

Broadcasting.

REGULAR PROGRAMMES ARE BROADCAST FROM THE FOLLOWING EUROPEAN STATIONS:

GREAT BRITAIN.

LONDON 2 LO, 363 metres; **MANCHESTER** 2 ZY, 370 metres; **BIRMINGHAM** 5 IT, 423 metres; **CARDIFF** 5 WA, 353 metres; **NEWCASTLE** 2 NO, 400 metres; **GLASGOW** 5 SC, 415 metres; **ABERDEEN** 2 ED, 497 metres; **BOURNEMOUTH** 6 BM, 485 metres. Regular daily programmes. Weekdays, 11.30 to 12.30 p.m. (2 LO only), 3.30 to 4.30 p.m., 5 to 10.30 p.m. Sundays, 3 to 5 p.m., 8.30 to 10.30 p.m.

FRANCE.

PARIS (Eiffel Tower), FL, 2,600 metres. Daily, 6.40 to 7 a.m. Weather Forecasts; 10.5 a.m. (Thursday and Friday), 11.15 to 11.30 a.m., Time Signal and Weather Forecast; 12.0 noon, Live-stock prices; 3.40 p.m. (Saturday excepted); Financial report, 3.30 p.m. (Saturday excepted) Bourse Closing Prices; 6.10 p.m., Concert or Address; 7 p.m., Weather Forecast; 7.20 p.m. (Sunday), Concert and Address; 10.10 p.m., General Weather Forecast.

PARIS (Compagnie Francaise de Radiophonie Emissions "Radiola"), SFR, 1,780 metres. Daily, 12.30 p.m., Cotton, Oil and Cafe Prices, News, Concert; 1.45 p.m., First Bourse Report; 4.30 p.m., Bourse Closing Prices; 4.45 p.m., Concert; 5.45 p.m., News and Racing Results; 8.30 to 9.30 p.m., News; 9.10 p.m., Concert; 10 p.m. to 10.45 p.m., Radio Dance Music.

ECOLE SUPERIEURE des Postes et Telegraphes, 450 metres. 3.30 to 4 p.m. (Wednesday and Friday), 7.45 p.m. to 10 p.m. (Tuesday and Thursday), Tests (Music, etc.); 2.30 p.m. to 7.30 p.m. (Saturday), Tests (Music, etc.).

LYONS, YN, 3,100 metres. Daily, 9.45 a.m. to 10.15 a.m., Gramophone Records.

BELGIUM.

BRUSSELS, BAV, 1,100 metres. 1 p.m. to 5.30 p.m., Meteorological Forecast; 9 p.m. (Tuesday), Concert.

BRUSSELS ("Rad o Electricque") 410 metres. Daily, 8.30 p.m. to 9.30 p.m., Concert.

HOLLAND.

THE HAGUE, PGGG. Temporarily suspended.

THE HAGUE (Heussen Laboratory), PCUU, 1,070 metres. 9.40 to 10.40 a.m. (Sunday), Concert; 9.40 to 10.40 p.m., Concert; 7.45 to 10 p.m. (Thursday), Concert.

THE HAGUE (Velthuisen), POKK, 1,070 metres. 8.40 to 9.40 p.m. (Friday), Concert.

UTMUIDEN (Middelraad), PCMM, 1,050 metres. Saturday, 8.40 to 9.40 p.m., Concert.

AMSTERDAM, PA 5, 1,100 metres (Irregular). 10 to 11 a.m., Concert; 5 to 6.30 p.m., Concert; 8.10 to 9.10 p.m., Concert.

DENMARK.

LYNGBY, OKE, 2,400 metres. 7.30 p.m. to 8.45 p.m., Concert (Sunday excepted).

GERMANY.

BERLIN (Koenigswusterhausen), L.P., 4,000 metres. (Sunday), 10 to 11 a.m., Music and Lecture; 2.700 metres 11 a.m. to 12 noon, Music and Lecture. Daily, 4,000 metres, 6 to 7 a.m., Music and Speech; 11.30 a.m. to 12.30 p.m., Music and Speech; 4 to 4.30 p.m., News.

EBERSWALDE, 2,930 metres. Daily, 12 to 1 p.m., Address and Concert; 7 to 8 p.m., Address and Concert; (Thursday and Saturday), 5.30 to 6.30 p.m., Concert.

CZECHO-SLOVAKIA.

PRAGUE, PRG, 1,800 metres. 7 a.m., 11 a.m. and 3 p.m., Meteorological Bulletin and News; 4,500 metres, 9 a.m., 2 p.m. and 9 p.m., Concert.

KBEL (near Prague), 1,000 metres. Daily, 6.20 p.m., Concert, Meteorological Report and News.

SWITZERLAND.

GENEVA, HB 1 (Radio Club de Genève). Temporarily suspended.

LAUSANNE, HB 2, 1,100 metres. Tuesday, Thursday, Saturday, 4 p.m., Concert; Monday, Wednesday, Friday and Saturday, 7 p.m., Concert.

SPAIN.

MADRID, 1,650, 2,200 metres (Irregular). 12 to 1 p.m., Tests. **MADRID, PTT**, 400 to 700 metres. 4 to 5 p.m., Tests.

Radio Society of Great Britain.

Important : The Annual General Meeting.

The Annual General Meeting of the Radio Society of Great Britain will be held on Wednesday, December 19th, at 6 p.m. (Tea at 5.30), at the Institution of Electrical Engineers. This will be a business meeting, and it is hoped that as large a number of members as possible will arrange to attend.

Transmitter and Relay Section.

During the week ending the 25th November, many members of the Transmitter and Relay Section were endeavouring to work relays. This was the first attempt at forming organised chains of communication. Acting on experience gained in the preceding tests, the chains were formed when possible of members resident within 50 miles of each other. The results show that it is not easy to establish perfect relay communication. It is a striking fact that several of the stations which are received well at considerable distances—*e.g.*, in France, Holland and even Switzerland—cannot always be heard for certain at distances of only 50 or 100 miles.

Concurrently with the Franco-British tests, arrangements have been made with the Cercle Vervietois d'Etudes Radioelectrique to listen-in for signals on about 440 metres which will be sent out by members of the Transmitter and Relay Section early in December.

Reports regarding the reception of the French amateur signals are being received and the substance of these will be published after the conclusion of the tests.

The views of the members of the Section are invited on the transmissions of calibration waves recently arranged. It is desired to ascertain the extent to which these are made use of, and their value to members.

Electrical Steering of Aeroplanes.

We are asked to announce that members of the Radio Society of Great Britain who desire to attend the lecture which will be given by Mr. John Gray, B.Sc., of the Institution of Aeronautical Engineers, on "Leader Cable Systems for Electrical Steering of Aeroplanes," at the Royal Society of Arts at 7.30 p.m. on December 14th, should send a post-card to the Hon. Secretary of the Radio Society, Mr. L. McMichael, 32, Quex Road, West Hampstead.

The Wireless Exhibition.

At a recent Committee meeting of the Radio Society of Great Britain, votes of thanks were passed to the organisers of the All-British Wireless Exhibition, Messrs. Bertram Day & Co., and the National Association of Radio Manufacturers, Ltd., for having given facilities for the R.S.G.B. stand. The interest taken in the apparatus sent in for competition by the Affiliated Societies was gratifying to those who made the arrangements. The first prize was actually won by Mr. J. H. Reeves, of Kensington Wireless Society, but as this gentleman is on the Committee of the R.S.G.B., repre-

senting one of the groups, he wishes the prize to be taken by the next best selected exhibit sent in by a member of the Woolwich Radio Society.

The second and third prizes go respectively to members of the Sydenham and Forest Hill Radio Society, and the Maidenhead and District Radio Society.

The judging was done by Dr. W. H. Eccles, assisted by a small committee, and the awards will be made by the President at the Annual General Meeting on December 19th.

It was estimated that no less than 20,000 people actually passed through the stand of the R.S.G.B. and examined the exhibits.

Votes of thanks were accorded to the Schools Radio Society for exhibits, and a special prize was awarded to Catesby, of Mill Hill School for a cleverly constructed recording set.

The Radio Research Board sent in at the request of Dr. Eccles an interesting selection of charts relating to atmospheric observations, which were much appreciated.

Messrs. G. G. Blake, J. H. Reeves, M. Child, F. Stanley, and Major W. H. Hamilton deserve the best thanks of members for their energy in contributing to the success of the Radio Society stand.

Proposed Society for Golder's Green.

Sufficient support now being forthcoming, a meeting has been called to form a Golder's Green Radio Society, to be held on Wednesday, December 5th, at 8.30 p.m., at 17, The Grove, Golder's Green (off Golder's Green Road). The chair will be taken by Mr. J. H. Reeves, M.B.E., on behalf of the Radio Society of Great Britain.

It is hoped that all interested will make a special effort to attend, and it is requested that those who propose to do so will telephone Hampstead 3792.

Correspondence.

To the Editor of THE WIRELESS WORLD AND RADIO REVIEW.

"L'Ecole Superieure" on a Crystal.

SIR,—Whilst listening in last night on a zincite-bornite crystal, at about 9.37 p.m., during the time all B.B.C. stations were transmitting the "late news" from London, I was surprised to hear some music on about 450 metres wavelength. As it quickly faded away, I turned on my valve set and tuned it in to the same station, which subsequently proved to be "Ecole Supérieure des Postes et Télégraphes." I should very much like to know through your valuable journal if this station has ever been heard before so far north as Halifax on a crystal.

Later in the evening, from 10.45 to 11 p.m., I heard it again quite well.

I also heard 6 BM, 5 SC and 5 NO at various times, but due to fading, speech was only readable occasionally. 2 LO came in at readable strength all the evening.

Halifax.

H. WHITAKER.

DISTORTION IN RADIO TELEPHONY

By H. A. THOMAS, M.Sc.

DISCUSSION (continued from p. 293 of previous issue).

Captain Ainslie.

The last speaker mentioned some practical points, and that has overcome my natural shyness, and has emboldened me to address you for the first time at one of these meetings. He spoke of the application of a high resistance across the transformer—I forget whether he put it across the secondary or primary—as having a beneficial effect. I have, for the last week or two, been getting considerable benefit from a tuned secondary to the low frequency transformer. I put in a condenser which runs up to somewhere in the neighbourhood of about two to three microfarads, and it has a really striking effect. You can, for example, tune in to the very bass quality of a bass voice, and you can tune out some of the screeching quality of a soprano voice; you can differentiate between the oboe and the clarinet, and it does a great deal to enable you to hear the instruments as the composer of the music originally intended they should be heard. Another point has always struck me—I have never really understood it, and perhaps I may be allowed to ask for an explanation—and that is why distortion should be so much less objectionable, or much less in evidence, from distant stations. I am about seven miles from 2LO, but when we have a simultaneous broadcasting I get a distinctly better quality from Glasgow. I want more amplification, of course. Why is it, when one is using a high frequency amplifier and two low frequency valves, there is less distortion than when using only just the amplifier or one stage of low frequency? Is it that the overtones, which are so troublesome often, are dimmed by transmission through the ether, or has it something to do with the initial amplitude of the waves as they strike the aerial? I ask because I get a neighbouring broadcasting station more pleasantly with no aerial than with the ordinary outdoor aerial.

Mr. Blake.

It has given me very much pleasure to hear the paper to-night, and I think we have to thank the lecturer for the enormous amount of work he has put into it. It has been a most useful paper. There are one or two questions which I should like to ask. Has the lecturer tried out any experiments or plotted any curves with the Thomas glow discharge microphone; and if so what results has he obtained. This microphone was described some time ago in an American journal, and had been used for broadcasting in America. Also, has he carried out experiments with the Symons arc transmitter? It would be interesting to know if either of these instruments has lessened the defects he mentions, also with regard to the vibration of the horns. Of course, I expect we are all familiar with these effects; no wonder the speech quality is far from perfect. It has come home to me particularly this evening when thinking of the very small movement of the diaphragm of

the loud speaking telephone, what a very small movement produces the large volume of sound, and that when we think of the whole horn vibrating in response in the case of a badly designed horn, it might be capable of giving out very nearly as great a volume of sound as the original movement in the diaphragm, and it is wonderful that the whole of the speech does not get absolutely spoiled. I was also interested with regard to the electrostatic condenser. One similar to that described by the lecturer was used some years ago by Dolbear, and it is interesting to see that the condenser is now brought forward again. There is another question I should like to ask, and that is with regard to the audio frequency amplification. The resistance coupled amplifier the lecturer spoke about, I take it, was for audio frequency amplification and not radio frequency amplification, because I think it has not been proved possible to go much below 3,000 metres with a resistance capacity coupled amplifier, and I would ask him what wavelengths he listened to when he got the results mentioned. I have very much pleasure in thanking the author for his paper.

The President.

The paper that we have heard read to-night was a very deep one, and the discussion has been a very good one. I have been very delighted at the amount of insight and information conveyed by all the speakers. They have covered most of the points, and I will, therefore, make only very general remarks on the paper. In the first place, is it not marvellous that because somebody is moving with the voice a small diaphragm, a lot of other diaphragms distributed all over the country are moving at the same speed and at approximately proportional frequencies at various distances? A few years ago, if asked is it possible to make a piece of metal move at speeds of 1,000 or 2,000 cycles per second at reasonably proportional amplitudes to the amplitudes at the place of origin, we should have said it was impossible, and I join with the audience in feeling disappointed that the author has attacked this wonderful performance we all admire. But he has done it of set purpose in order to emphasise his points. Exaggeration is usually the best method of emphasis, and I know he has been taking that standpoint. As a fact, right up to the stage where he reaches the high frequency circuits, he deals with what is a commonplace in ordinary line telephony, which is, after all, pretty good. In the ordinary line telephony we have usually a carbon microphone, we have one of these bad diaphragms he describes, with all these natural frequencies and other defects, we have transformers with iron in them at both ends, and yet we get through the diaphragm at the receiving end speech so good that most of us can recognise the voices of our friends when they speak over the telephone. After all, that is a very creditable performance, and when the

author points out all these troubles that have worried him, we discount them by thinking of the wonderful performance that the line telephone gives up to that stage. The high frequency circuits provide other troubles. The antenna itself provides troubles. If it is sharply tuned, an antenna will resonate better to the frequency of the carrier wave than to that of the side band waves which we know are necessary in telephony, and therefore you get distortion in the act of radiation. Then the author alluded to distortion by the medium. There is very likely to be distortion in the medium. The medium is one that appears to transmit different wavelengths at different speeds; the mathematical physicists would call it a dispersive medium. Therefore one expects high frequencies to travel at different speeds than low frequencies. I was speaking to Captain Round the other evening, and he was describing the enormous distortion they used to get, and still get, in speaking from England to Holland at night on the short wavelength, and he said that distortion was so dreadful at times that the understanding of speech was utterly impossible,

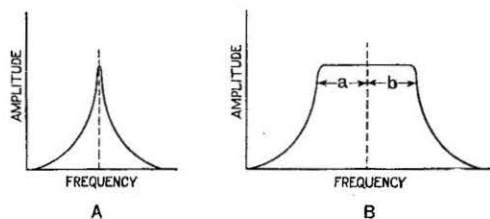

and he suggested—and I think it is a very ingenious suggestion—that because the medium through which the waves travel is a dispersive medium, in which the high frequencies travel at a different speed from the low frequencies, therefore the upper tones of the speech arrive before or later than—I forget which—the lower tones; it is just as if the piccolo of a band were heard a bar ahead of the bassoon. He suggests that this is the cause of the distortion produced by the medium, and it is very possible, it seems to me. There is another point where the distortion comes in prominently; it was noticed long before the war, when telephony was in its infancy—it was noticed first in Germany. It was found that if the circuit were highly selective, then there was distortion because the receiving antenna favoured one wave more than another. If you have a carrier wave of a million, and transmit a note of 1,000 frequency, then there is a high frequency component present carrying that note, and its value is one million and one thousand. If the receiving antenna is sharply tuned, it receives one million better than it receives a million and a thousand, and better than it receives one million and five hundred, and, in fact, all these frequencies are received with different strengths. A resonance curve of an ideally sharp receiving system is shown in Fig. A.

It is an exceedingly steep curve, and I have exaggerated it to make my point clear. If the receiving system is tuned to a million, then a million and a thousand might be reproduced only by a very small amount; a million and five hundred would be reproduced stronger, and a million stronger still. The reproduction of distortion by that means was well known before the war. But since

the boom in broadcasting in America, filter circuits are being designed, as Mr. Coursey mentioned, with which you get the shape of resonance curve given in Fig. B, so that one million comes in the centre, and one million and three thousand also comes on the flat portion of the curve (on A and B) and therefore everything is produced with about equal intensity. I wish that some of our experimenters in this country would turn their attention to this matter because it may be the next movement in the direction of improving the receiving of speech and of music. One of the speakers remarked on the width of the wave band required for broadcasting. It is interesting to notice that in New York one of the newest of the broadcasting stations set up by the Radio Corporation has got a single antenna on the top of a high building, excited by two circuits. One circuit is, I think, on a 400 metres wavelength. That sends out classical music—what they call in America the highbrow stuff (laughter)—and the other circuit, working on the same aerial, is 450 metres in wavelength, and is sending out jazz and other popular items. In New York, and in the district all round, anybody who likes appears to be able to tune to one or the other of these, and pick out either concert, according to taste. That shows that 50 metres of wavelength is ample difference for separating stations in the same neighbourhood, and that answers one of the questions which was raised. I will not take up any more of your time, but will ask the author to reply to the discussion.

(To be concluded.)

A VARIO-TRANSFORMER.

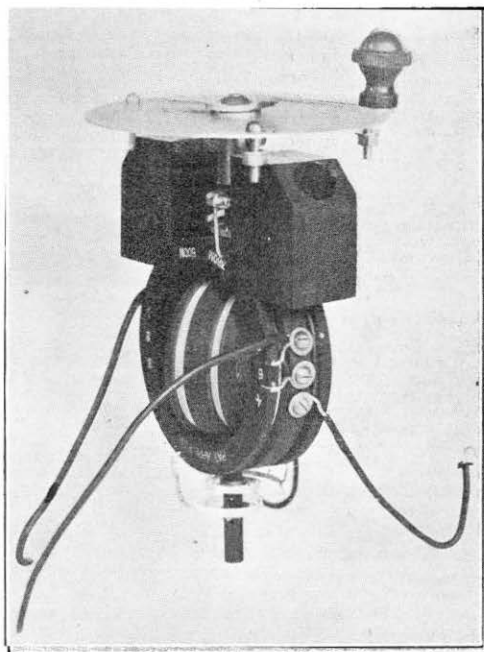

A variometer with a double set of windings, as explained on page 247, November 21st issue. (Metropolitan Vickers, Ltd.)

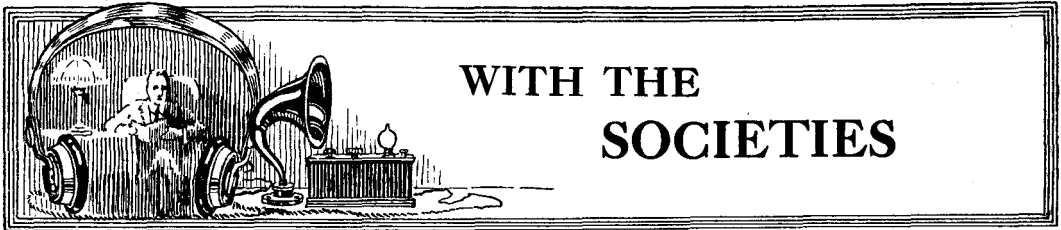

Particulars of Membership of any Society can be obtained on application to the Secretary. Societies marked with an asterisk are affiliated to the Radio Society of Great Britain.

SHEFFIELD AND DISTRICT WIRELESS SOCIETY.*

On November 2nd, Mr. C. F. Newton Wade, the Postmaster-General of North Borneo, and one of the Society's Vice-Presidents, delivered an address on "Wireless in the Far East." The excellent lantern-slides which the lecturer exhibited showed the difficulty of laying ordinary land-lines through the dense tropical jungle, and made manifest the extreme utility of wireless telegraphy in such circumstances.

As might be expected, continuous wave working was very much superior to spark transmission systems, said the lecturer, and was being increasingly adopted in the Far East.

Hon. Sec., R. Jakeman, "Woodville," Hope, near Sheffield.

THE WOOLWICH RADIO SOCIETY.*

Mr. Bartle, of Blackheath, spoke, on October 31st, on the possibility of running a wireless station entirely from the electric mains (A.C.), first giving details how to make a transformer to transform the A.C. current either up for H.T. supply or down for L.T. Dealing with rectifiers for H.T., the lecturer gave details of an electrolytic type, which he had found most efficient. Methods of smoothing the rectified current were then touched upon, and the lecturer claimed that with sufficient capacity all trace of ripple could be wiped out, both in receiving and transmitting sets.

The Society holds meetings every Wednesday evening, 7.30 to 10 p.m. at the Y.M.C.A., Thomas Street, Woolwich. Wireless enthusiasts in the neighbourhood are cordially invited to attend.

Hon. Sec., H. J. South, 42, Greenvale Road, Eltham, S.E.

AFFILIATED SOCIETIES OF YORKSHIRE.

A well-attended meeting of delegates from affiliated societies in Yorkshire met at the Guildford Hotel, Leeds, on Saturday, October 20th. The question of the re-constitution of the Radio Society of Great Britain was discussed, and a small committee was appointed to draw up a scheme for submission to a further meeting.

Communications should be addressed to the Hon. Sec., The Huddersfield Radio Society, 14, John William Street, Huddersfield, or The Halifax Wireless Club, 26, Glen View, Halifax.

THE NORTH MIDDLESEX WIRELESS CLUB.*

The question of the desirability of closer co-operation between the Radio Society of Great Britain and its affiliated societies was discussed at the meeting of the North Middlesex Wireless Club at Shaftesbury Hall, Bowes Park, N.,

on October 31st. Mr. J. H. Reeves, the representative of the extra Metropolitan Wireless Societies, explained to the members the advantages of unity from the wireless experimenter's point of view.

Mr. N. F. Scaife then gave a lecture on "The Manufacture of Wireless Valves." The lecturer, who is engaged professionally in the manufacture of a well-known valve, presented a very lucid and interesting account of the various processes employed during the making of the "New Aladdin's Lamp" as it has been called.

The Hon. Sec. will be pleased to hear from those desirous of becoming members of the Club.

Hon. Sec., H. A. Green, 100, Pellatt Grove, Wood Green, N.22.

THE FULHAM AND PUTNEY RADIO SOCIETY.*

On November 16th, an interesting informal discussion took place on the design of some modern component parts which had been tested.

It was agreed that the Club's five-valve set and other apparatus, such as batteries, loud speaker, etc., should be lent to members for the nominal fee of 1s. to go towards the Club's funds.

Hon. Sec., H. Finlay, 169, New King's Road, S.W.6.

THE RADIO SOCIETY OF HIGHGATE.*

A lecture was given on November 2nd, by Mr. G. A. V. Sowler, B.Sc., on the subject of "Rectifiers." Mr. Sowler outlined the relative merits of an alternating and a direct current supply from the lighting mains from a wireless point of view. An explanation was also given of the smoothing action of inductances and condensers when used as filters to convert a pulsating unidirectional current or voltage into a smooth direct current or voltage. Mr. Sowler then dealt with rotary converters, and details were given of how to use a "Vollite" cycle generator for this purpose.

On November 9th, Mr. F. G. S. Wise lectured on "The Growth of a Transmitter." In the course of his remarks Mr. Wise urged experimenters to regard the possession of a transmitting licence as a privilege, and to value that privilege very highly.

On November 16th a sale of apparatus was held. A large number of members brought along apparatus which, although in good condition, they did not wish to be encumbered with. The result was a very fine display, putting the White City Exhibition quite in the shade! A brisk sale was maintained throughout the evening, and the Club funds benefited quite handsomely. (Ten per cent of the takings were handed over to the Treasurer).

Members are reminded that on and after November 30th the Society's headquarters

will be moved to Edco Hall, 270, Archway Road, where meetings will be held every Friday at 7.45 p.m. Full particulars of the Society may be obtained from the Hon. Sec., J. F. Stanley, B.Sc., A.C.G.I., 49, Cholmeley Park, Highgate, N.6.

WEMBLEY WIRELESS SOCIETY.*

On Friday, November 16th, Mr. L. V. Gordon, B.Sc., gave an instructive paper on "Distortion."

The lecturer opened with the rudiments of sound, and explained the principles of ether wave transmission. Comparison was made between crystal and valve detectors and the causes of distortion due to amplifying valves were described. A constructive discussion ensued.

Hon. Sec., W. R. Mickelwright, 10, Westbury Avenue, Wembley, Middlesex.

HONOR OAK PARK RADIO SOCIETY;

A lecture on "Dual Amplification" was given by Mr. J. C. Macvey on November 16th.

The lecturer drew out various reflex circuits, and explained the principles of the system, following with a description of the design and making of his own two-valve set, which he proceeded to operate, using the outdoor aerial, an indoor aerial, and finally with both aerials and earth entirely disconnected, using a tin plate in the lid of the cabinet. The tone of the music on the Society's Amplion loud speaker was particularly good, owing to the crystal detection incorporated in the circuit.

Hon. Sec., G. J. Price, 22, Honor Oak Park.

BELVEDERE, ERITH AND DISTRICT RADIO AND SCIENTIFIC SOCIETY.

On Monday, November 12th, the secretary continued his elementary lectures on radio work, the subject for the evening being "Capacity and Inductance." These two important quantities formed the basis of wireless as generally understood, and the lecturer observed that it was impossible for anyone to make progress in wireless or allied phenomena unless he made himself thoroughly acquainted with these fundamental principles.

On Wednesday, November 14th, the members at Morse instruction were given a novel method of determining the correct timing and spacing, which is of the utmost importance in good Morse signalling.

On Friday, November 16th, Mr. A. H. Norman gave a lecture on "Faults in Receiving Circuits." After detailing the most common faults likely to be met with in simple crystal circuits, the lecturer proceeded with faults in valve circuits, and their remedies. A discussion followed, during which several members' difficulties were satisfactorily solved.

Hon. Sec., S. G. Meadows, 110, Bexley Road, Erith, Kent.

SOUTH SHIELDS AND DISTRICT RADIO CLUB.*

A visit was recently paid by the members to the Marconiphone showrooms, Newcastle-on-Tyne, where an enjoyable evening was spent. Several of the Marconi Company's broadcast receivers were demonstrated, reception from the local broadcasting station (5NO) being excellent, both as to quality and strength. Although the attendance was poor, those members who were present keenly appreciated Mr. R. B. Armstrong's talk.

Meetings of this Club will be held every Thursday evening in future, commencing at 7.30.

Those interested in wireless in the district are urged to become members, and are cordially invited to the Club room, at 34, King Street, any Thursday evening.

Hon. Sec., W. Smith, High Dock House, South Shields.

which he is an acknowledged authority. He explained very fully the causes of distortion and of the production of oscillations in amplifiers, and showed how amplifiers may be stabilised.

Hon. Sec., R. Jakeman, "Woodville," Hope, Sheffield.

THE LEEDS RADIO SOCIETY.*

On November 9th Mr. J. Croysdale lectured on "Experimental Station 5US," describing various aerial and earth systems that had been used. The antenna design was primarily governed in this case by transmission, reception being invariably effected by means of frame or other indoor aerials. 5US works at a maximum power of 10 watts on I.C.W., on wavelengths 150 to 200 metres. Dutch amateurs are easily worked. For reception the single valve Armstrong super is usually practised with a four-foot frame. U.S. amateurs and broadcast traffic had been logged.

On November 16th Mr. W. J. Featherstone gave an interesting lecture on "Relays in Line Telegraph Working."

New members will be welcomed, and full particulars will be supplied by the Hon. Sec., H. Nightscales, "Glen-Avon," Cottingham Road, Hull.

WESTERN METROPOLITAN ASSOCIATION OF AFFILIATED SOCIETIES.

A meeting of the delegates from Western Metropolitan Affiliated Societies was held at 2, Penywern Road, Earl's Court, on Thursday, November 15th.

The Association is receiving the support of the majority of societies in this area, and it is expected that the three outstanding societies will have assented before the next meeting. Arrangements are being made for the interchange of lectures throughout the societies of the Association, and by common consent the

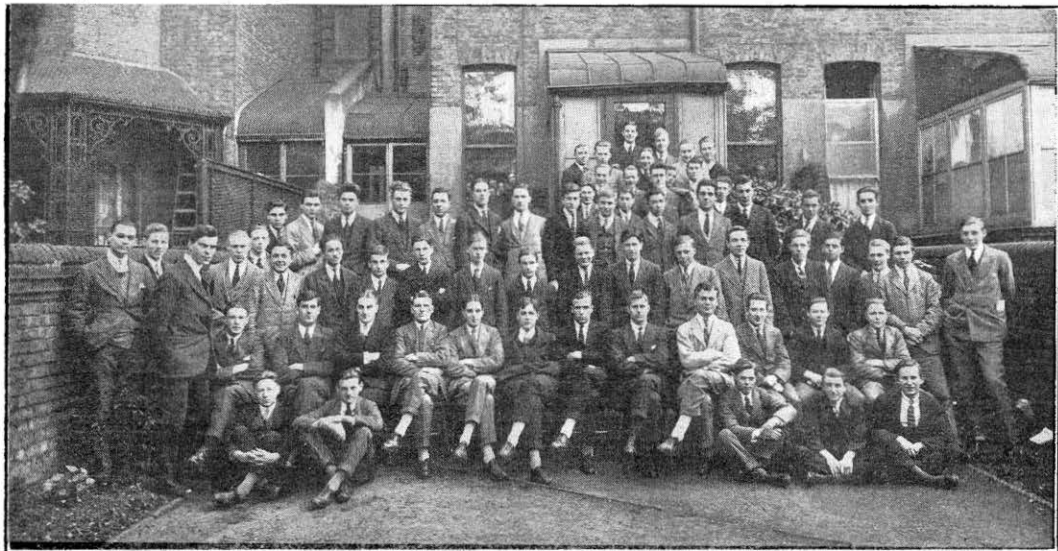

A recent photograph of some of the students at the London Telegraph Training College, Earl's Court, S.W. 5.

THE MANCHESTER RADIO SCIENTIFIC SOCIETY.*

Mr. L. J. Woods, the Hon. Secretary of the Halifax Wireless Club, on Wednesday, November 21st, gave his talk on "Wireless Circuits." This was illustrated by lantern slides, and proved of great interest to all present. The lecturer dealt with all types of circuits in a very lucid manner, and explained the advantages and disadvantages of each particular "hook-up" in turn. The lecturer recommended the neutrodyne for efficient and selective working. A cordial invitation to all amateurs is extended by the above Society. Meetings are held every Wednesday, at 7 p.m., at headquarters.

Hon. Sec., G. A. F. Mercer, 116, Burton Road, Withington, Manchester.

SHEFFIELD AND DISTRICT WIRELESS SOCIETY.*

On Friday, November 16th, the Society again welcomed Mr. J. Hollingworth, M.A., of the staff of the National Physical Laboratory. Mr. Hollingworth delivered an exceedingly fascinating and instructive lecture on "Amplifiers," a subject upon

An instructional meeting was held on November 16th. Mr. R. E. Timms (Hon. Treasurer) described his three-valve receiver, which gives excellent results.

On November 23rd the discussion was continued upon Mr. W. G. Marshall's paper, read at a recent meeting, on the subject of "The Propagation of Electromagnetic Waves." Heartly support was given to the discussion, which Mr. Marshall very ably led.

Hon. Sec., D. E. Pettigrew, 37, Mexborough Avenue, Leeds.

THE WIRELESS SOCIETY OF HULL AND DISTRICT.*

The Society continues to make progress, although the advent of new members would be acceptable. Two lectures have been recently delivered by Mr. Atkinson (of the Igranic Electric Co., Bedford) and the President, Mr. C. B. Snowden, the subjects being respectively "The Screening of Aerials and the Construction of a Five-Valve Set" and "The Care of Accumulators." Mr. G. E. Steel recently described a new wavemeter acquired by the Society for the benefit of members.

question of interference caused by transmitters in the London area will be gone into with a view to stopping this nuisance or at least cutting it down to a great extent. The Secretary will be pleased to supply particulars to societies of this area not yet affiliated to the R.S.G.B., and to assist in the formation of similar bodies throughout the U.K.

Hon. Sec., L. Bland Flagg, 6r, Burlington Road, Bayswater, London, W.2.

NORTH MIDDLESEX WIRELESS CLUB.*

The above Club held its 127th meeting at Shaftesbury Hall, Bowes Park, N., on November 14th, Mr. A. G. Arthur being in the chair.

An interesting lecture on "Wiring Receiving Panel" was given by Mr. W. A. Saville. After referring to the very complicated and usually inefficient methods adopted by some amateurs in wiring up radio apparatus, Mr. Saville explained that his object was to demonstrate that by the use of a little forethought in the lay-out of the components, and by "picking up" as many points as possible

with one wire, a much simpler and therefore more effective system of wiring could be obtained.

The set chosen for demonstration was a standard three-valve set with one stage each of high frequency and low frequency amplification. Mr. Saville took each circuit separately, first completing the filament circuits, then the plate circuits, and so on. The result was certainly much less complicated than the average three-valve receiver, and the shortness of all high frequency leads was very apparent.

Hon. Sec., H. A. Green, 100, Pellatt Grove, Wood Green, N.22.

WIMBLEDON RADIO SOCIETY.*

The winter session of the above Society is now in full swing, and meetings are held weekly at headquarters, 59, Church Road, Wimbledon, S.W.19. At a special general meeting held on Thursday, November 15th, Mr. W. J. Rawlings was elected to fill the vacancy on the committee occasioned by the departure of Mr. E. W. Webb for Gibraltar. A special "Works" committee of five members was also elected to carry out the construction of the Society's receiving and transmitting sets. This committee will have the advice and assistance of Mr. T. Allison (5 PU) and Mr. J. Wood, and it is hoped that before long the Society's call sign (6 JB) will be heard in the ether.

Some members find that Thursday is an inconvenient day for their attendance at meetings, and a ballot is to be taken on this point. It is probable that Friday will be chosen as an alternative. Morse practice, under the supervision of Mr. J. Wood, has commenced. It may be mentioned that the subscription for the winter session has been fixed at exactly half that for the full year, and intending new members should lose no time in communicating with the Hon. Sec., Mr. C. G. Stokes, of 6, Worple Avenue, Wimbledon, S.W.19.

ILFORD AND DISTRICT RADIO SOCIETY.*

On November 15th Miss Denton lectured upon, and demonstrated, the "Reception of Long Distance Telephony." Miss Denton showed us what could be done in the reception of some of the little-known continental stations, and received, among other stations, Prague, whose music was made audible to the audience on a loud speaker.

Miss Denton explained the circuit used (one H.F., detector and 2 L.F. valves), and gave us a checked schedule of the times and wavelengths of the European transmissions.

The lecturer was accorded a very hearty vote of thanks, and it is to be hoped that more ladies will join our ranks, as apparently they make good "radio fans."

Hon. Sec., L. Vizard, 12, Seymour Gardens, Ilford.

THE NORTH LONDON WIRELESS ASSOCIATION.*

A meeting of the above was held at the headquarters in the physics lecture theatre at the Northern Polytechnic Institute, on Monday, November 19th, at 8 p.m.

The lecturer for the evening having been prevented from attending, the Club's newly constructed 2 L.F. valve panel was put into operation behind a crystal detector and various plate voltages up to 240 volts, and grid cells were tried out, the results being recorded on the loud speaker.

Amplifying from a microphone circuit operated by a gramophone was also tried with fair results. Owing to a marked difference of opinion on the quality of the reproduction, it was proposed to have at the next meeting a comparison test of loud speakers. Six members offered each

to bring a different make of loud speaker, it being regarded as a good opportunity for tracing the fault to the weak link in the chain of amplification and reproduction.

The Hon. Secretary would be pleased to receive enquiries regarding the Association from prospective members at the Northern Polytechnic Institute, Holloway, London, N.7.

BOROUGH OF TYNEMOUTH Y.M.C.A. RADIO AND SCIENTIFIC SOCIETY.*

At a meeting of the above Society, held on Thursday, November 15th, Mr. Duncan G. Scott gave a lecture upon "Aerials and Earths." The speaker dealt with this subject in a very lucid manner, his remarks being much appreciated by all present.

On Saturday, November 17th, a party of members paid a visit to 6 NO. After being shown around the studio and the engineers' control room, the party proceeded, under the able guidance of the station engineer, to inspect the transmitting apparatus. The best thanks of the Society are due to Mr. E. L. Odhams, station director, and to the efficient guide.

Hon. Sec., L. L. Sims, Radio Society, Y.M.C.A. Buildings, Bedford Street, North Shields.

WEMBLEY WIRELESS SOCIETY.*

On Friday, November 23rd, Mr. B. P. Rossi, President of the junior section, gave a résumé of the Society's activities from the time of its inception over twelve months ago. The Junior Hon. Treasurer and Secretary gave demonstrations with their valve sets.

Hon. Sec., W. R. Mickelwright, 10, Westbury Avenue, Wembley, Middlesex.

TOTTENHAM WIRELESS SOCIETY.

On Wednesday, November 14th, Mr. J. V. Mulholland, of Eustace Watkins, Ltd., demonstrated with the "Gambrell Inductance," and fully explained its good points compared with other types of coils. Many questions were asked, each of which received a satisfactory reply.

On Wednesday, November 21st, Mr. Neale read a paper on "Receptor Circuits." Besides showing diagrams of his circuits, Mr. Neale gave notes as to their relative efficiencies. Unfortunately the most efficient circuits, both as regards losing unwanted signals and receiving those desired, were rather complicated.

Mr. Snow followed Mr. Neale with a brief talk on crystal circuits, after which the meeting was opened for general discussion and experiment. The Secretary has pleasure in announcing that the President (Prof. A. M. Low) has kindly presented the Society with a Cup to be competed for, particulars of which will be announced at the next business meeting.

Hon. Sec., S. J. Glyde, 137, Winchelsea Road, Bruce Grove, Tottenham, N.7.

SALISBURY AND DISTRICT RADIO SOCIETY.

A meeting of the above Society was held on Thursday, November 22nd, when Major Hallett gave a demonstration of his set.

A most instructive and enjoyable evening was spent, from which the members derived great benefit. Many thanks are due to Major Hallett for all the trouble he took in preparing his demonstration.

Joint Hon. Secs., H. F. Futcher, S. W. Johnson, 29, Fisherton Street, Salisbury.

THE BIRMINGHAM WIRELESS CLUB.

At the fourth annual general meeting the word "Experimental" was ruled out of the Club's name. On Friday, November 16th, Mr. F. W. G. Towers gave a

very interesting lecture on "Valves," describing their working and uses. The President, Dr. J. R. Ratcliffe, was in the chair.

Hon. Sec., H. G. Jennings, 133, Ladywood Road, Birmingham.

RADIO ASSOCIATION OF SOUTH NORWOOD AND DISTRICT.

On Thursday, November 15th, at headquarters, Mr. J. L. Jeffree (6 FR), gave a detailed account of a recent visit he had made to 2 LO, describing the control room, studio and generating plant in a thorough manner.

Mr. E. A. Saunders (6 SF) then opened a discussion on "Reaction." This gentleman is not only a real experimenter, but a decidedly good humorist, and his outlines of the principles of regeneration delighted his audience.

Hon. Sec., C. H. P. Nutter (5 DB), Radio Corner, 243a, Selhurst Road, Norwood Junction, S.E.25.

THE WEST LONDON WIRELESS AND EXPERIMENTAL ASSOCIATION.

At a meeting held on November 13th, Mr. W. T. Fair read a paper entitled "Construction of a Buzzing Wavemeter."

At a meeting held on November 20th, Mr. P. Lowry-Mullings read a paper entitled "Crystals for Wireless Reception." This was a paper by Mr. Balhacht, read before the Junior Institution of Engineers on October 26th last. Mr. W. Casson then gave a report of the meeting which he attended at the Royal Society of Arts on November 14th, when a lecture and demonstration were given dealing with the process of transmitting and reproducing writing, drawing and photographs without wires, by M. Edouard Belin.

Hon. Sec., Horace W. Cotton, 19, Bushey Road, Hayes, Middlesex.

THE WARRINGTON RADIO ASSOCIATION.

The third meeting of the winter session 1923-24 took place at Atkinson's Café, Bridge Street, on November 23rd. Mr. W. F. Welsby took the chair.

Mr. W. H. Taylor gave a lecture on "Inductance and Tuning Methods," and hearty appreciation was shown in the usual manner.

Hon. Sec., S. K. Hughes, Stockton Mount, Stockton Heath.

KINGSTON AND DISTRICT RADIO SOCIETY.

At the recent annual general meeting of the Society much business relative to the amendment of the existing and the formulation of new rules found necessary from the experience gained during the year's working was dealt with, and owing to a reduction in rent it was also found possible to decrease subscriptions. It was also decided that a rule should be made permitting a member to bring a visitor to any of the ordinary meetings, and there is every indication that the privilege will be well exercised.

The following officers were elected for the ensuing year:—President, Capt. S. R. Mullard, M.B.E., A.M.I.E.E.; Vice-President, Mr. W. Hamilton Wilson, M.I.E.E.; Chairman, Mr. T. W. Bloxam, M.I.E.E.; Vice-Chairman, Mr. R. C. Older; Hon. Treasurer, Mr. A. A. Woods. The Hon. Secretary's report was highly satisfactory, and the Hon. Treasurer's report and statement of accounts revealed a gratifying state of affairs, and there will be a balance in hand of about £5 when the outstanding arrears are received.

Hon. Sec., R. J. W. Lankster, Wanderings Farm, Kingston-on-Thames.

Questions & Answers

Solutions of Readers' Difficulties

This section of the magazine is placed at the disposal of all readers who wish to receive advice and information on matters pertaining to both the technical and non-technical sides of wireless work. Readers should comply with the following rules:—(1) Each question should be numbered and written on a separate sheet on one side of the paper, and addressed "Questions and Answers," Editor, *The Wireless World and Radio Review*, 12/13, Henrietta Street, London, W.C.2. Queries should be clear and concise. (2) Before sending in their questions readers are advised to search recent numbers to see whether the same queries have not been dealt with before. (3) All questions will be answered through the post. Those of general interest will also be published. (4) Every question, except those under (5) below, should be accompanied by a postal order for 1s., or 3s. 6d. for a maximum of four questions, and also the coupon taken from the advertisement pages of the current issue. (5) For the benefit of those readers who would rather not pay the charges, a free Questions and Answers Coupon will be placed in the advertisement pages of the first issue of every month. This coupon should accompany the question submitted, together with a stamped addressed envelope. The free coupon is valid for the current week only. (6) In view of the fact that a large proportion of the circuits and apparatus described in these answers are covered by patents, readers are advised, before making use of them, to satisfy themselves that they would not be infringing patents. (7) Four questions is the maximum which may be sent in at one time.

"A.G.S." (Hailsham) has a receiver in which the degree of amplification given by the L.F. valve is not satisfactory. He describes certain effects and asks for the probable cause of the trouble.

It seems probable that the loss of efficiency in the L.F. stage is due to self-oscillation at a frequency above the audible limit. To prevent this, try connecting a $2\ \mu\text{F}$ condenser across the H.T. battery, and if necessary a $0.5\ \text{M}\Omega$ resistance in parallel with the secondary winding of the L.F. transformer. The effect should be tried of reversing the connections to the primary transformer winding, keeping O.S. connected to the grid and I.S. to the filament.

"J.R." (Southend) asks if it is possible to construct anode resistances, as he has a supply of ebonite tube of a convenient size.

Anode resistances have been made by packing an ebonite tube with a mixture of finely-powdered charcoal or coke and chalk. The results, however, are not satisfactory, and we recommend that you purchase the resistances from a reliable maker.

"C.K." (Streatham, S.W.16) is able to receive all the British broadcasting and most of the Continental stations, but is unable to receive the American broadcasting stations, and wishes to know the sizes of coils required for the latter stations.

The reception of American broadcasting is by no means easy, and success will depend upon the meteorological conditions and amount of jamming present at the time of listening. American broadcasting stations transmit on wavelengths between 300 and 550 metres, so that the coils with which you receive British broadcasting will be suitable.

"J.C.E." (Worthing) asks the meaning of the term "Kilocycle."

The frequency of a wireless signal is sometimes given instead of the wavelength and is then ex-

pressed in "kilocycles" or "thousand cycles per second."

"NEON" (Adel) asks (1) For a diagram showing the method of using neon lamps to rectify the output from an ex-Army "T.V.T." generator. (2) Why the H.T. terminals of the "T.V.T." unit are marked + and - when rectification is necessary. (3) What is the natural wavelength of a coil 6" in diameter, wound with 21 turns of No. 18 S.W.G., spaced $\frac{1}{2}$ " apart. (4) If a single-valve transmitter circuit submitted is correct.

(1) We would refer you to the article on page 106 of the issue of October 24th. (2) The output

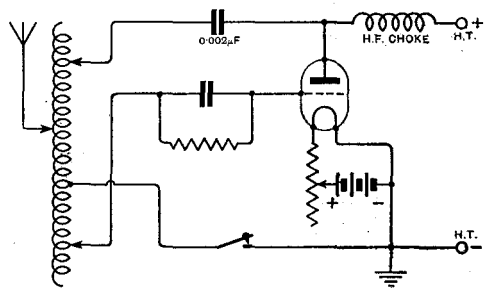

Fig. 1. "NEON" (Adel). Small power transmitter connections.

obtained from the "T.V.T." unit is equivalent to an interrupted direct current, since the impulses in one direction are much greater than those in the other. The use of neon lamps for suppressing the small negative half-cycles in this current can only be regarded as experimental and large smoothing chokes and condensers would have to be used

before the unit could be used in a telephony transmitter. (3) The wavelength of this coil would be approximately 50 metres. (4) The circuit suggested is not very satisfactory. We recommend that you use that given in Fig. 1.

“D.L.” (Aberdeen) asks questions concerning the Neutrodyne receiver described in the issue of April 21st, 1923.

The secondary of the high frequency transformer may be connected to either the positive or negative low tension terminal, the object being to ensure that the third valve is acting as an efficient detector. The use of switching arrangements in this receiver is not to be recommended on account of the stray capacities which are introduced. These stray capacities and possibly coupling between the high frequency transformer are undoubtedly the cause of much of your trouble. The tendency to self-oscillation should be reduced to a minimum by changing the relative positions of transformers and connections and the neutralising

“H.C.E.” (Clapham Common) asks for data for constructing a step-up transformer to the following specification:—Input, 205 volts at 50 cycles; Output, 15 watts, 1,000 volts, 15 milliamps.

If the core has a cross section or area of 4 sq. ins., the number of primary turns should be 615, and the number of secondary turns 3,100. For the primary we suggest you use No. 20 D.C.C., and for the secondary No. 34 or No. 36 D.S.C. You could wind the coils upon a bobbin which is 4" long. If you wish to reduce the size of the core, then the number of turns should be increased accordingly. For example, if you wish to use a core with a cross section of only 2 sq. ins., then you must use double the number of turns in the primary and secondary windings, and in this case it would be better to use No. 36 D.S.C. for the secondary. The core must be carefully constructed so that it is complete; there must be no air gaps in the magnetic circuit. We cannot say exactly the size of the bobbin, because a good deal depends upon the method of winding. Skilled winders

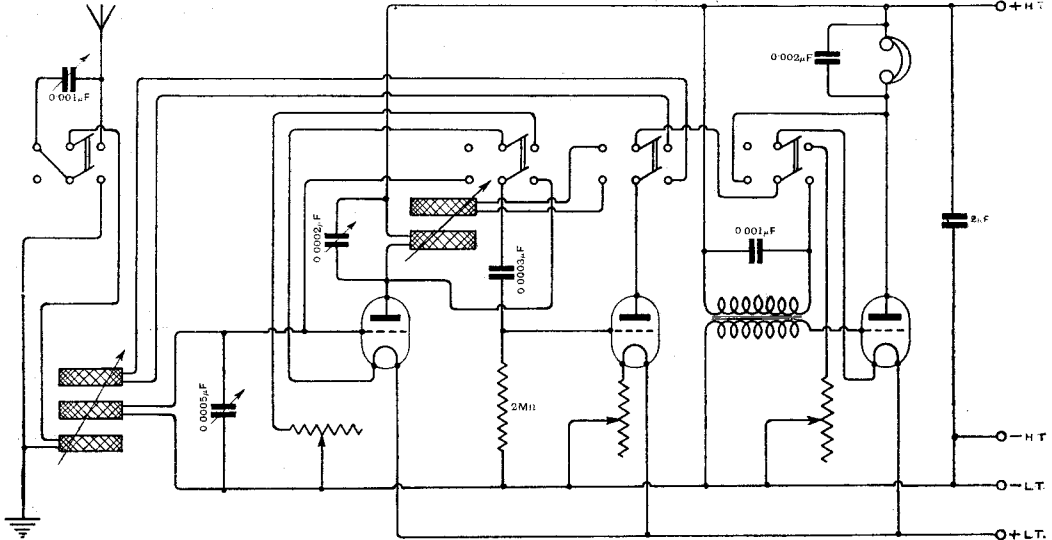

Fig. 2. “C.H.” (Kingston-on-Thames). Connections of receiver with H.F. (tuned anode) detector and note magnifier with switch to connect reaction coil to anode or aerial circuits.

condensers could be used to eliminate any slight self-oscillation which cannot be eliminated by the above methods. The addition of low frequency amplifying valves does not in any way affect the working of the high frequency portion of the receiver.

are often able to get the wire into about half the space taken by one who has not much practice. We suggest that you put a thin layer of paper between every two or three layers of the secondary winding.

“C.H.” (Kingston-on-Thames) asks (1) For a diagram of a three-valve receiver (1-V-1) with reaction to either the aerial or tuned anode circuits, and with switches to cut out the H.F. and L.F. valves. (2) The number of plates required for the variable condensers used in the above receiver.

“L.E.” (Leicester) asks for the conditions under which transmitting licences may be obtained.

(1) The diagram is given in Fig. 2. (2) The number of plates required will depend upon their area and upon the thickness of the spacing washers which it is proposed to use. We would refer you to the article on “Condensers” in the issue of June 9th.

Application for a transmitting licence should be made to the Secretary of the Post Office, London. It is necessary to state what experimental work you intend conducting. Whether or not the Postmaster General will grant you permission to use an outdoor aerial depends essentially upon the nature of these experiments. If the work could obviously be done using a dummy aerial only, then he will not grant you permission to connect up to an outdoor aerial.

THE WIRELESS WORLD AND RADIO REVIEW

THE OFFICIAL ORGAN OF THE RADIO SOCIETY OF GREAT BRITAIN.

No. 226. (No. 11.) DECEMBER 12th, 1923. WEEKLY
(Vol. XIII.)

EDITOR:
HUGH S. POCOCK.

RESEARCH EDITOR:
PHILIP R. COURSEY, *B.Sc., F.Inst.P., A.M.I.E.E.*

ASSISTANT EDITOR:
F. H. HAYNES.

QUESTIONS AND ANSWERS DEPARTMENT:
Under the Supervision of W. JAMES.

CONTENTS

	PAGE
Switch Design for Multi-Valve Circuits - - - - -	336
Economical Valve Circuits - - - - -	338
The Fundamentals of Loud Speaker Construction. By A. Nyman - - - - -	340
The Construction of Variable Condensers (<i>continued</i>). By W. James - - - - -	346
Adapting the R.A.F. Receiver Type 10. By A. J. Bull	349
Two New Broadcasting Stations - - - - -	352
Around the Wireless World - - - - -	355
Distortion in Radio Telephony (<i>Discussion concluded</i>). -	357
With the Societies - - - - -	358
The Operation of the Armstrong Super - - - - -	360
Our Transatlantic Broadcasting Tests - - - - -	361
Questions and Answers - - - - -	365

THE EDITOR will be glad to consider articles and illustrations dealing with subjects within the scope of the Journal. Illustrations should preferably be confined to photographs and rough drawings. The greatest care will be taken to return all illustrations and manuscripts not required for publication if these are accompanied by stamps to pay return postage. All manuscripts and illustrations are sent at the Author's risk and the Editor cannot accept responsibility for their safe custody or return. Contributions should be addressed to the Editor, "The Wireless World and Radio Review," 12 and 13, Henrietta Street, Strand, London, W.C.2.

SUBSCRIPTION RATES:

20s. per annum, post free. Single copies 4d. each or post free 5d. Registered at the G.P.O. for transmission by Magazine Post to Canada and Newfoundland.

EDITORIAL AND PUBLISHING
OFFICES:

12 and 13 Henrietta Street,
Strand, London, W.C.2.
Telephone: Gerrard 2807-8.



ADVERTISEMENT MANAGERS:

Bertram Day and Co., Ltd.,
9 & 10 Charing Cross, S.W.1.
Telephone: Gerrard 8063-4.

SWITCH DESIGN

FOR USE IN MULTI-VALVE CIRCUITS.

BOTH the barrel and disc type switches shown in the accompanying photographs were designed for the purpose of changing the value of inductance in three or more circuits simultaneously with one control, which with the addition of variable condensers would permit of the reception of wavelengths from 300 to approximately 4,000 metres.

The design of the barrel switch, as will be seen, necessitated the employment of comparatively large metal surfaces, which detail was viewed with disfavour from the point of view of capacity losses, so much so that the design of a further model was proceeded with and which has for convenience been referred to as the "disc type." It will be noticed that the surface of the metal segments and brushes are much smaller than those on the barrel

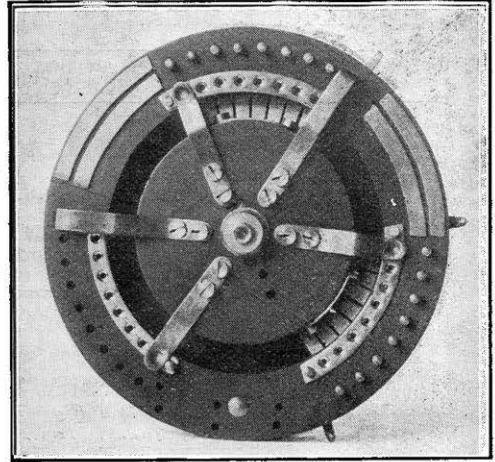

A disc type switch (back view).

as seen from the dial and index on the front of the instrument which position the switch is in and whether it is in true position.

Where switches are thought to be necessary for a certain class of

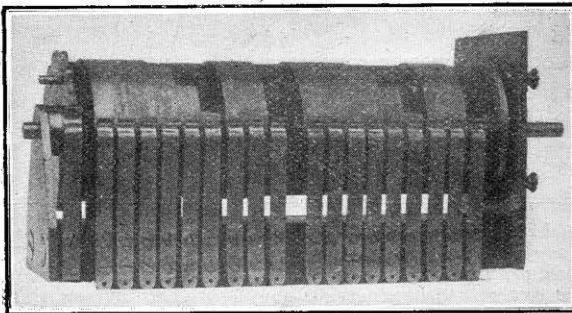

The barrel type of switch.

type, and beneficially arranged. In this respect the switch justified the effort, but unfortunately in its present form it was found to be not quite so reliable as the barrel pattern for hard and continuous use.

Both types have been designed for fixing behind panels and have for this reason been provided with pawl and register devices, which detail is dissimilar in the two models. The register of the pawl in notch (on the barrel type), and hollow (on the disc type), is such that one can distinctly feel as well

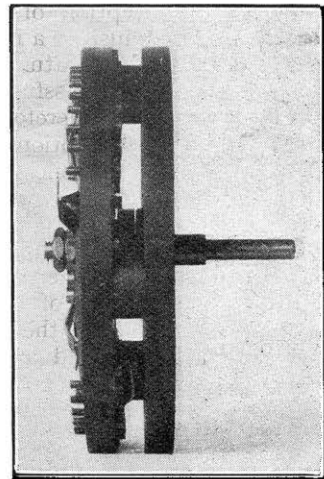

Disc type switch (side view).

apparatus, there is no reason why they should be supposed to be so very inefficient, providing reasonable pains are taken in their

a receiver inefficient. My own set is fitted with five valves, and provision is made by means of a complicated switch to alter the

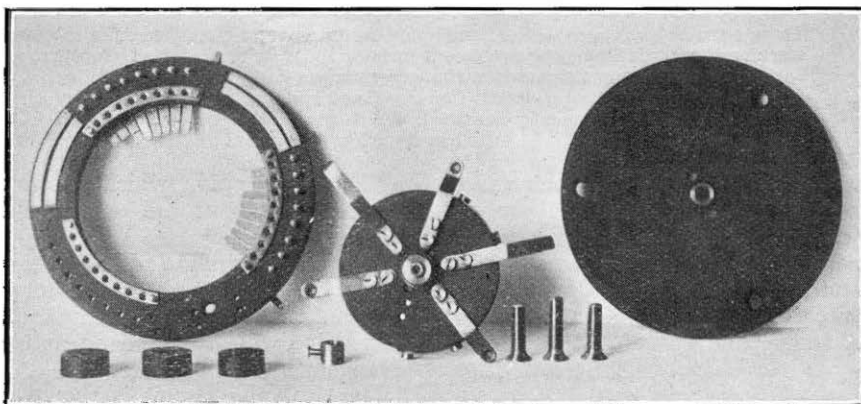

Component parts of the disc type switch.

construction and the choice of all items connected to them and used elsewhere in the instrument. Switches of the barrel or disc types shown will in no way render

circuit arrangement employed, yet I get good reception from all the British and Continental broadcasting stations.

L. E. T.

What Receiver did you use?

The principal interest aroused by the Broadcast Tests recently organised, appears to centre around the other man's receiver.

Judging by the enormous number of reports received of the reception of the American stations, it is believed that there must be a mine of interesting information in the nature of the apparatus used, and other circumstances contributing to the successful reception.

We are therefore anxious to collect from those who took part, descriptions of the apparatus used by them, with particular reference to unusual or special features which may have been the reason for particular efficiency.

All descriptions should be sent in on or before 1st January, 1924, addressed: "**Wireless World Broadcast Tests**," 12/13, Henrietta Street, London, W.C.2.

An award of TEN POUNDS will be made for what, in the opinion of the Editor, constitutes the best description received, and a second award of FIVE POUNDS will be made for the second best description. In these awards consideration will be given principally to originality, either in the circuit employed or the design of the receiver.

ECONOMICAL VALVE CIRCUITS.

These circuits have been devised solely for the purpose of giving economical working as regards filament current consumption. Being typical dual circuits with some interesting refinements, the experimenter can derive a knowledge of the operation of dual amplification receivers and judge their merits by testing out the arrangements described, which probably represent the best dual systems.

FOR those who like to use their valves to the best advantage, dual amplification is thoroughly to be recommended. A noteworthy single valve and crystal circuit is illustrated in Fig. 1. This circuit will be found to be very sensitive, stable, and easy to control. The

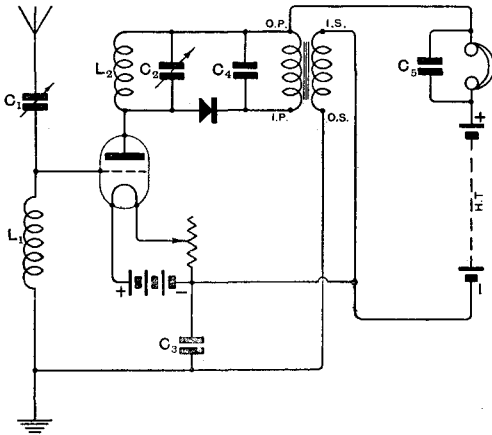

Fig. 1. A simple dual circuit. With this arrangement the tuning of the plate circuit is broadened as a result of connecting the crystal detector and transformer across its ends.

aerial tuning inductance L_1 and the tuned-anode coil L_2 are the normal size. The aerial tuning condenser C_1 may be of 0.00075 mfd. capacity, and the tuned anode condenser C_2 of 0.00025 mfd. capacity. The fixed condenser C_3 connecting the earth to the filament should be of 0.0002 mfd. capacity. The other two fixed condensers C_4 and C_5 should both be about 0.001 mfd. capacity. On wavelengths other than those set apart for broadcasting the set may be made to oscillate gently and completely under control by coupling L_1 and L_2 together.

The crystal detector used in all these circuits is the zincite-bornite or perikon detector, which is more stable and robust than the usual cat-whisker types. The leads to the detector should be reversed to find out which way works better. Using

a "Metal" R valve, which was found to be satisfactory, about 46 volts H.T. gave the best results.

When it is desired to add another valve this should preferably be a straightforward high frequency valve. The addition of another dual valve will give louder results, but the arrangement is not advised.

The two-valve circuit is shown in Fig. 2. The coupling condenser C_7 should be about 0.0002 mfd. capacity, and the radio-frequency choke L_4 about coil No. 200. If a bigger choke is used the circuit tends to oscillate, while if a smaller choke is used the signals are weakened. The values for the other components are the same as in Fig. 1.

This circuit will be found to be just as stable as the first one. When broadcasting is not in progress it may be made to oscillate gently either by coupling L_2 and L_3 together, or by means of electrostatic reaction, by connecting a very small capacity variable condenser in the position C_8 . This con-

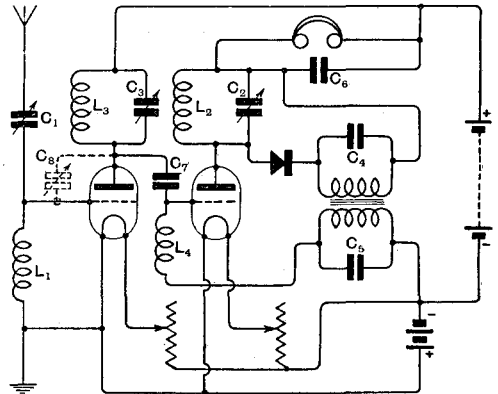

Fig. 2. The efficiency of a high frequency amplifier is impaired when converted into a dual circuit. In this diagram the first valve operates only as a H.F. amplifier.

denser should be constructed to have a negligible minimum capacity, and may consist of two insulated metal plates, which may be moved well away from each other.

H.F. transformer coupling may be used in either circuit, the one-valve circuit being shown in Fig. 3. This gives about the same signal strength as Fig. 1, and is, if anything, a little more stable, but it is not quite so convenient in use.

Now, as to results. Using Fig. 1 on a sheltered aerial 23 miles south of **2 LO**, a small Brown's loud-speaker may be worked well in daylight. A large number of amateurs have been heard, including **2 ZK** (near Birkenhead) and **2 JP** (Yorkshire), **2 ZK** using telephony. Fourteen different French amateurs on 180 metres have also been logged.

Using the two-valve circuit shown in Fig. 2, all the B.B.C. stations may be listened to after dark, some needing a trace of reaction. Glasgow and Birmingham will often work the loud speaker towards the end of their evening programme.

Finally, those people who have hitherto used a valve as a detector will be interested

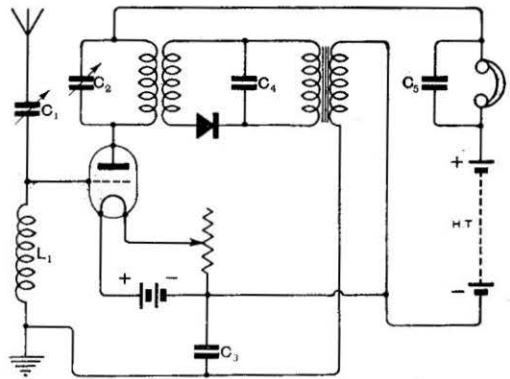
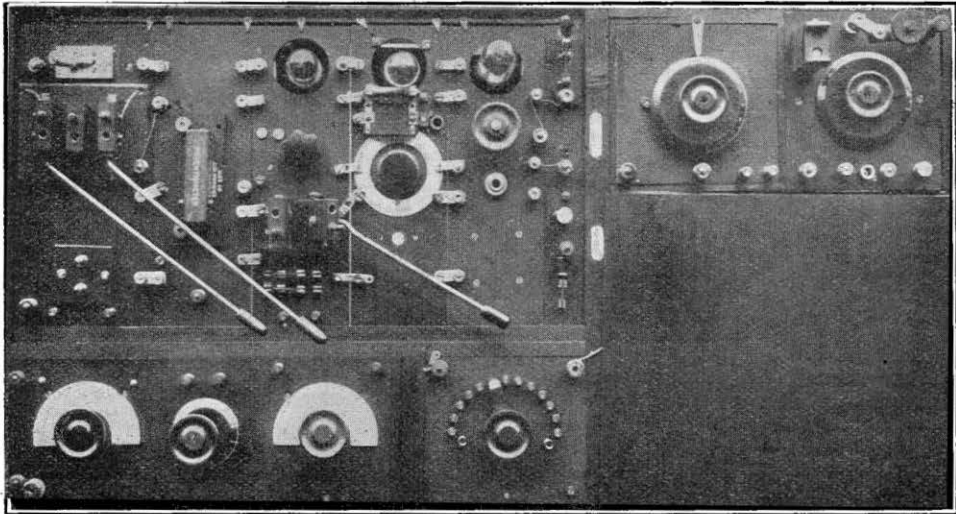

Fig. 3. In this circuit the detector is operated through a transformer, so that the crystal is not liable to be rendered insensitive by the potential of the H.T. battery, while less damping is produced in the tuned plate circuit.

by the purity and absence of distortion of the signals obtained by using these circuits.

E. J. M.

An Interesting Experimental Receiver Design.



Easy accessibility combined with efficiency was the aim of the constructor, Mr. Douglas V. Brewer, in setting up this unit receiver. Various circuit combinations can be obtained and the panels are easily removable. The telephones are connected with plugs and jacks. The batteries are contained in the cupboard on the right.

THE FUNDAMENTALS OF LOUD SPEAKER CONSTRUCTION.

Recent years have seen a very rapid development in loud speakers for use with wireless receiving sets. In this paper, which was read by Mr. A. Nyman at a meeting of the Radio Club of America* on September 28th, 1923, the author outlines the essential features of a successful loud speaker and also some of the experimental results obtained.

By A. NYMAN.

IT has been found that music reproduction requires the presence of notes ranging in frequency from 25 cycles per second to 5,000 cycles per second. The quality of reproduction is affected to a large extent by the loudness of individual frequencies; hence the necessity of bringing in each frequency at a value proportional to the original volume. It can readily be seen that the quality of the pick-up instrument or microphone, as well as the design of the transmitting and receiving systems, is of the utmost importance.

Apart from the pick-up and transmission, the following qualities are required in the loud speaker itself:—

- (1) Uniform intensity of sound at all frequencies from 25 cycles to 5,000 cycles.
 - (2) Absence of resonance points capable of responding at a frequency different from that applied or giving an excessive volume of sound when their own fundamental frequency is applied.
 - (3) The ability to reproduce a combination of frequencies with a volume of each frequency proportional to the input.
 - (4) Absence of distorting harmonics at any individual frequency applied.
- (1) Uniform intensity of sound at all frequencies is particularly important in reproducing every kind of sound. For example, a weak or missing range of frequency is noticeable even to an untrained ear. However, if it is near either end of the total range, *i.e.*, below 400 or above 3,000 cycles, an untrained ear may sometimes fail to detect this defect. Similarly, an individual missing frequency can be occasionally overlooked. A loud range distorts the quality to a considerable extent, and a loud individual note has a very unpleasant blasting effect.
- (2) If overlooked, is particularly liable to give blasting or an unnatural ring to certain notes. The fundamental may be suppressed and a harmonic of an altogether different pitch come through, possibly considerably louder than the applied note.
- (3) Dealing with combinations of frequencies, is particularly noticeable in speech reproduction. Normal vowel sounds consist of a fundamental of rather small volume and harmonics often much larger than the fundamental. Unless the proportionality is maintained, the sound of the voice will change, giving the impression of a changed pitch; a tenor voice may sound like a bass;

a soprano like a contralto, or *vice versa*. The higher harmonics again determine the individual characteristics of the voice. Thus, in order to recognise a person's voice, the higher harmonics up to the 20th or 30th must be included and kept at their proportional value. What is true of the voice is true of most musical instruments.

(4) The absence of distorting harmonics at any individual frequency—certain materials have qualities which give them peculiar forms of vibration. Thus, the vibrations of brass are usually different from those of aluminium, wood, etc. This is generally due to a number of harmonics, each modifying the original note. In a loud speaker the pleasing quality and the naturalness of reproduction are dependent to a very great extent on the choice of materials, particularly of the material carrying a large amount of energy of sound.

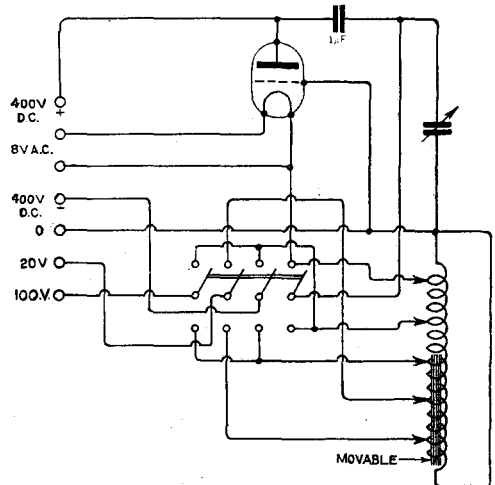

Fig. 1. Audio frequency oscillator designed to produce note frequencies of 150 to 10,000.

METHODS OF TESTING LOUD SPEAKERS.

The four essential features of the loud speaker have been investigated by different test methods, partly dynamical and partly physiological; *i.e.*, depending on aural observation.

Fig. 1 shows a diagram of an oscillator designed to cover a range from 150 to 10,000 cycles. A number of steps of condenser capacity raise the

*From Radio Broadcast (America).

frequency about 50 to 100 per cent., while for each step the movement of an inductive coil on and off an iron core gives gradual variations of frequency. Each step of condenser is calibrated for frequency at different coil settings which are indicated on a graduated scale. The coil acts as an inductance and also as a transformer. Operating the set at 20 watts, the amount of power drawn to the loud speaker is small, giving good voltage and frequency regulation on load. In order to make the loud speaker circuit equivalent to a tube circuit, a resistance equal to the tube impedance is included in series with the loud speaker. Although the voltage on the oscillator remains fairly constant throughout the whole range, for quantitative measurements the voltage can be checked at each reading.

measured at each frequency. This arrangement gives a complete cycle from current to current and is evidently equivalent to the cycle from sound to sound. In addition, a point is obtained at 60 cycles to determine the loudness of very low notes.

The above test gives valuable data for investigation of the uniformity of sound and of the absence of resonance points. Listening to the sound, while performing this test, makes it possible to detect any foreign noise, rattle, or sound at a different frequency from that applied.

The ability to reproduce accurately any kind of musical sound or speech can be tested best by actual music and speech reproduction. Again, a condenser transmitter has been used for the pick-up of sound. A number of stages of amplification (resistance coupled) bring the current to the loud

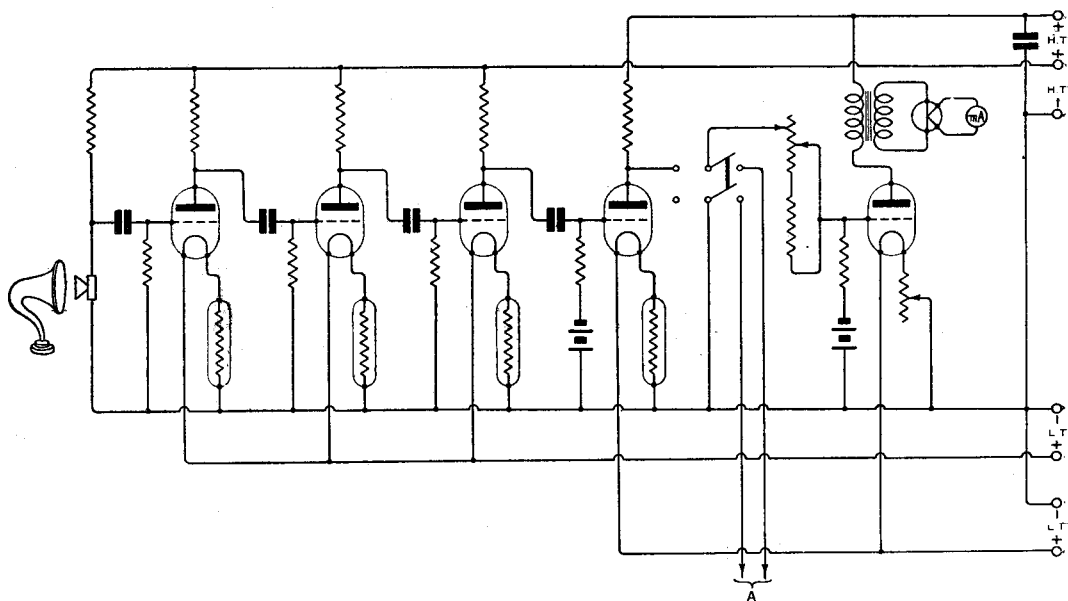

Fig. 2. Circuit arrangement employed for judging the intensity of the sound emitted from the loud speaker.

Fig. 2 shows the pick-up arrangement for measuring the sound from a loud speaker. A condenser transmitter is considered very close to the ideal sound-receiving instrument and has been used by many investigators as a sound standard. Amplification is arranged through a resistance amplifier, excluding distortion, and the resultant current measured on a milliammeter. The last stage, containing a step-down transformer, is also used for checking the voltage at each frequency. Hence any possibility of reduction of received current at low frequencies is balanced by a corresponding reduction of the measured value of voltage.

Sound volume tests are conducted as follows :— The oscillator was operated through the complete range at fairly constant voltage, while measurements of sound by condenser transmitter were recorded and corrected by the value of voltage

speaker, while an audibility meter is so arranged that the volume can be cut down to any suitable loudness. Repeating each note on the piano several times is one of the best means of detecting any disturbing harmonics. Each note should come through clearly and should correspond exactly to the original piano note. Low notes in particular should be checked for the presence of the fundamental tone. Some designs of loud speakers, while giving a loud note at these pitches, are found to be completely devoid of the fundamental—the note is just the sum of all overtones.

Speech transmission over the same circuit gives a splendid test for quality and recognisability of reproduction. For proper speech reproduction the volume should be adjusted to equal, approximately, the loudness of the original speech. Of course, in a loud speaker designed for a large audience, with a special view to great volume,

the speech must sound normal at the volume desired. The same loud speaker would not necessarily give natural reproduction at a lower volume.

An additional test for actual music reproduction is essential. Thus, a piano selection, a baritone solo, and a soprano solo are particularly good for detecting any faults in quality. In addition, a violin or a flute solo can be used to advantage to determine the ability of the loud speaker to reproduce the high notes naturally. The table below shows the list of tests and results that can be learned from each :-

TESTS OF LOUD SPEAKERS.

1. Measurement of volume (60 to 5,000 cycles) - - -	Uniformity of volume, absence of resonance points and foreign sounds.
2. Musical scales on piano - - -	Accurate reproduction of quality on each note, particularly the low notes.
3. Speech - - -	Clearness of articulation. Individuality of voice.
4. Piano selection -	Clearness and naturalness on abrupt tones.
5. Baritone and soprano singing -	Clearness and naturalness of sustained notes.
6. Flute or violin -	Reproduction of high notes.
7. Speech and music	Naturalness of superimposed sounds.

Fig. 3 shows a loud speaker operating on the same principle as an ordinary telephone receiver. It has a thin iron diaphragm held at a small distance from two magnetic pole pieces which are energised by a permanent magnet and also by

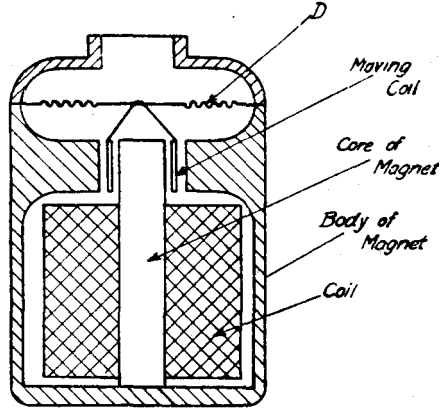

Fig. 4. Another form of electromagnetic circuit.

two coils, one on each pole piece. The volume that can be obtained from this type of loud speaker is somewhat limited on account of the close spacing between the diaphragm and the pole pieces. Moreover, certain notes are accentuated, due to the resonance of the diaphragm. This, however, is not necessarily a defect. It is possible to overcome the resonance feature by means of a proper sound-amplifying device. The magnet in this type is often made adjustable. This permits a very close magnetic balancing of the diaphragm and a consequent improvement in quality.

Fig. 4 shows a moving coil type of loud speaker. A circular coil is located in a round air-gap, with an iron core in the centre. This air-gap is traversed by a strong magnetic field, excited by an inner coil which carries direct current, while the circular coil mentioned above carries sound-producing alternating current and is attached to

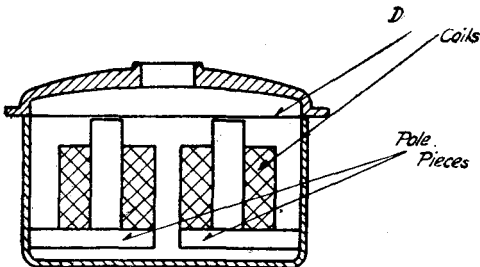

Fig. 3. A simple action, showing the electromagnetic structure.

The last test, the combination of music and speech, is very desirable. Each possesses individual characteristics, and the ideal loud speaker would maintain them. Very often, however, the presence of music will distort the speech, and vice versa. Of course, in this latter case we could not expect the loud speaker to reproduce correctly a number of musical instruments simultaneously, although the distorting effect might not be as noticeable as in the case of speech and music.

THE STRUCTURE OF LOUD SPEAKERS.

In a complete loud speaker the following mechanical parts can be segregated and investigated separately :-

- (1) The electromagnetic structure.
- (2) The sound-producing element.
- (3) The sound amplifying and distributing element.

Figs. 3, 4, 5 and 7 show four distinct types of electromagnetic structures.

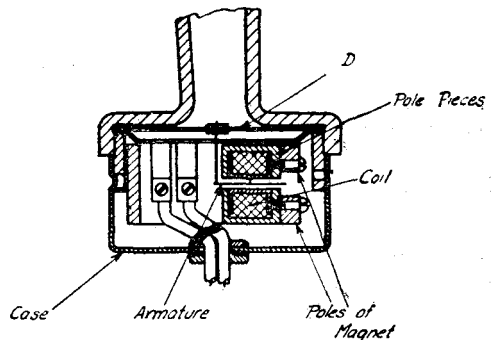

Fig. 5. A loud speaker action in which a suspended armature is arranged between the poles of a horizontal magnetic system.

the centre of a diaphragm. Very satisfactory results can be obtained with this type of loud speaker.

Fig. 5 shows what may be termed the enclosed-armature type. A small iron armature is located in the centre of a coil and suspended by two thin piano wires. The coil is surrounded by two U-shaped pole pieces, forming two air-gaps. A permanent magnet produces magnetic flux in these air-gaps. The current in the coil causes diametrically opposite pole pieces to be energised simultaneously, which causes the armature to rock. This rocking is communicated through a thin connecting rod to the centre of the diaphragm.

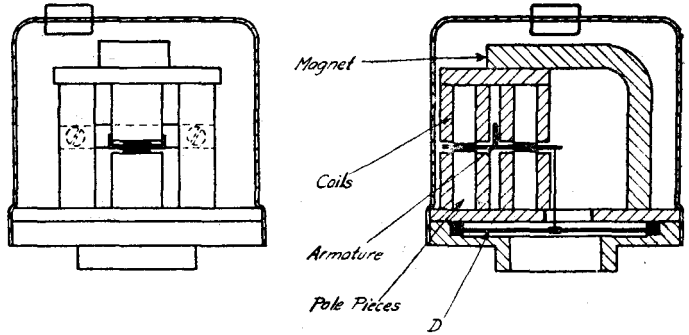

Fig. 7. The "Relay type" loud speaker.

are connected in such a manner that diametrically opposite pole pieces exert simultaneous attraction. The armature operates through a rod on a diaphragm.

Fig. 8 gives a representative curve of this loud speaker. The range is fairly wide, while no part of it is exaggerated in volume.

In all the above structures the sound-producing element is a diaphragm. Considerable variation is possible in the design of this diaphragm. Of course, the first type requires an iron or steel diaphragm, or at least an iron centre. The other types have a free choice of material. Aluminium and micarta have both been used successfully. It has been found that the quality of the loud-speaker is considerably improved by proper corrugation of the diaphragm.

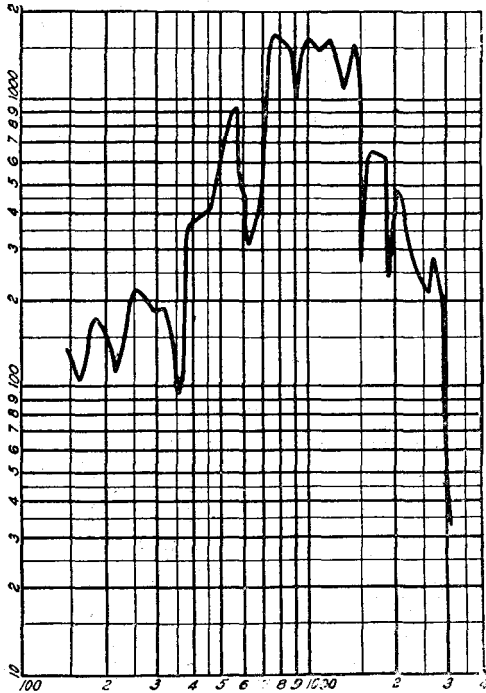

Fig. 6. Sound distribution at various note frequencies. Loudness is plotted against frequency.

Fig. 6 shows the sound distribution for a loud speaker constructed on this principle. The loudness is fairly uniform over the range. The graph shows the frequency from 100 cycles to 10,000 cycles on the horizontal axis, and loudness along the vertical axis.

Fig. 7 shows the "relay type" loud speaker recently developed. Its construction is similar to that of a polarised telegraph relay. A thin iron armature is located between four pole pieces, each carrying a coil. These pole pieces are magnetised by an L-shaped magnet and the coils

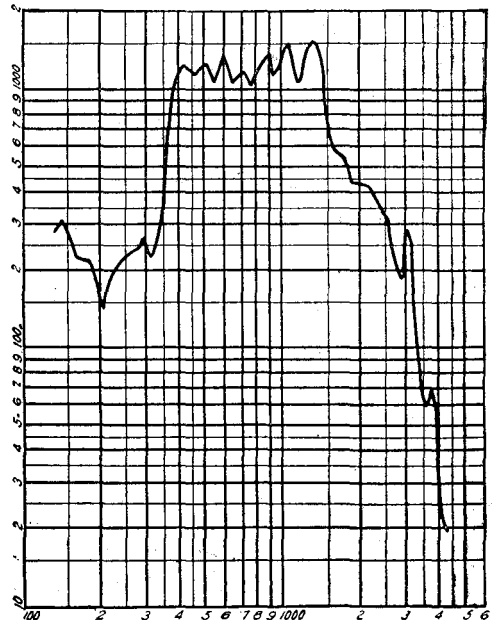

Fig. 8. Sound distribution curve given by the loud speaker action shown in Fig. 7.

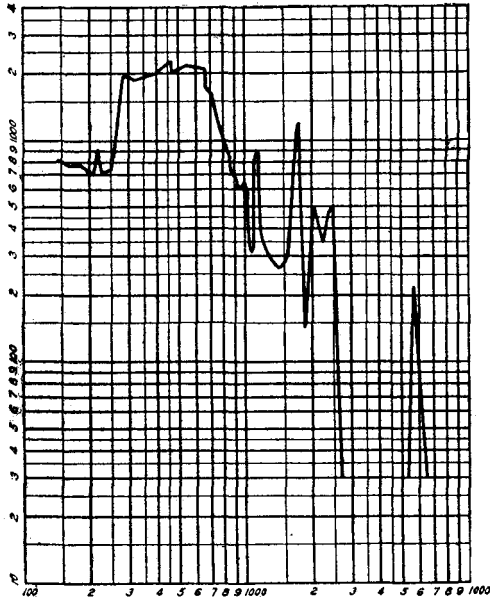

Fig. 9. Curve obtained when using a small stiff diaphragm.

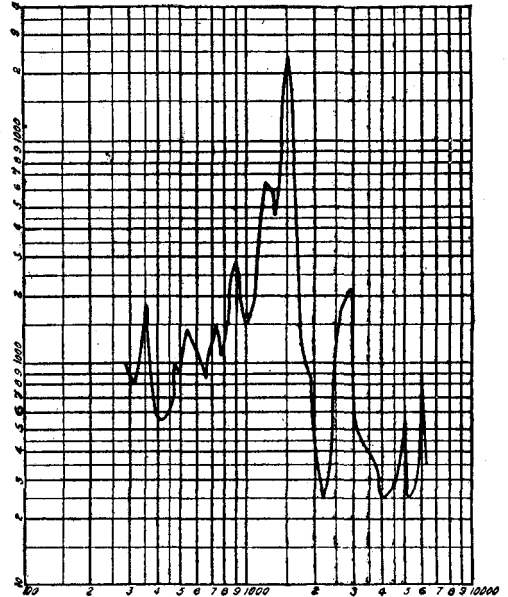

Fig. 10. The resonance points given with a fairly thin aluminium diaphragm.

Figs. 9, 10 and 11 show, respectively, the variation of sound intensity with frequency for three different types of diaphragm.

Fig. 9 shows the resonance points with a very stiff small diaphragm. The lowest resonant point is at 1,500 cycles. The harmonics are at 2,900, 5,000 and 6,000 cycles, *i.e.*, approximately in the proportion 1:2:3:4. These resonance points may have been modified by the presence of the horn. The resonance points below 1,500 cycles are due to the horn.

Fig. 10 is the same relation for a fairly thin flat aluminium diaphragm. The resonance points are still very pronounced.

Fig. 11 shows the relation for a corrugated aluminium diaphragm of the same dimensions as the one used in the case of Fig. 6. Up to 3,000 cycles, the resonance points are not prominent.

Fig. 12 shows some of the types of diaphragm that have been tried. (b) and (c) have been found to give the most satisfactory results. The one marked (c) is the diaphragm whose performance is represented by the curve in Fig. 11. It has the corrugations spaced at radii bearing a ratio to each other corresponding to prime numbers. This diaphragm is based on mathematical considerations worked out by Dr. Philip Thomas.

Diaphragms (g) and (h) have the property of having the same depression from either side. Diaphragm (i) has, in addition, an identical pattern from either side, and, consequently is less liable to buckle either one way or the other. This quality is important, as demonstrated in a succeeding paragraph.

So far only two types of sound amplifier and distributor have come into practice, namely, a horn and a large conical diaphragm. Considerable controversy ranges about the type of horn which

would give the most satisfactory results. It is difficult to record the effect of horns with the method outlined above.

Speech and music are both modified considerably depending upon the length and shape of the horn

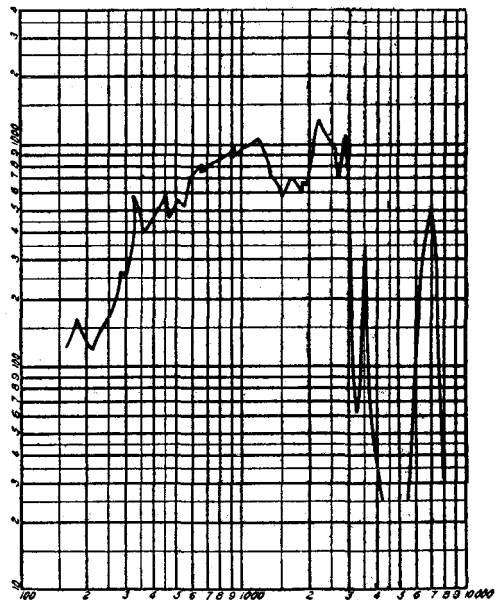

Fig. 11. Curve given by a corrugated aluminium diaphragm. The resonance points are less marked.

and on the volume of the sound. A horn longer than one quarter of the wavelength of the lowest pitch available gives the best reproduction. However, in practice, the length of the horn seldom exceeds three feet, approximately one fourth of the wavelength of 90 cycles, the fundamental of the horn. If the horn is shorter than one foot (270 cycles fundamental), the bass and baritone voices are likely to be distorted, since their funda-

is least likely to introduce a strange quality. Horns of large volume carry considerable energy at resonance, which is dissipated only gradually unless the design is correct. Slow dissipation of energy would mean that some notes would be dragged out after this note had been silenced at the sending end. Aural observations give the most accurate information on horns. Experience points to the use of horns as large as possible, but designed

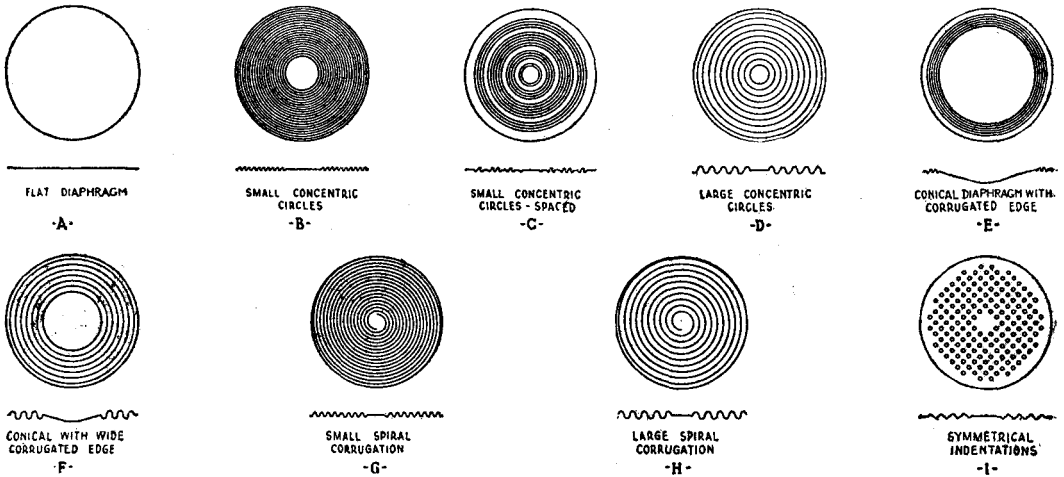

Fig. 12. The various types of diaphragms used in making the tests.

mental, which is below 270 cycles, would be reduced. It has been found that a loud speaker with a magnetic balance and a horn about two feet long is capable of very good reproduction of even very low frequencies.

Careful study has been made of materials to be used in the horn, in so far as they affect the quality of reproduction. A wood horn, or horn made of some "dead" material like hard rubber,

with sufficient divergence and wide enough mouth to dissipate the energy.

Large conical diaphragms made of parchment or stiff paper have been used successfully. As a rule, it is difficult to reproduce the low range and the high range on this type of diaphragm. However, this type of sound amplifier is inherently free from resonance characteristics and therefore carries the greatest promise of future utility.

(To be concluded.)

A SHORT WAVELENGTH RECEIVER with TWO STAGES of H.F. AMPLIFICATION

Following Part I of the article with the above title which appeared in the issue of November 21st, a receiver employing two stages of tuned high-frequency amplification, with detector and optional one or two stages of note magnification, will be described in the next issue.

There are only three tuning adjustments, and stray capacity due to the circuit and valves is neutralised so that the tuned circuits cannot generate oscillations. Tuning is remarkably simple and the receiver is designed to tune from 150 to 520 metres, which includes the amateur and broadcast band of wavelengths

THE CONSTRUCTION OF VARIABLE CONDENSERS.

By W. JAMES.

(Continued from page 308 of previous issue.)

SOME unusual designs are illustrated in Figs. 6, 7 and 8. It was mentioned earlier, that in order to reduce resistance losses, great care should be given to the method of holding the sets of plates together; and further, the construction should be robust, in order that the

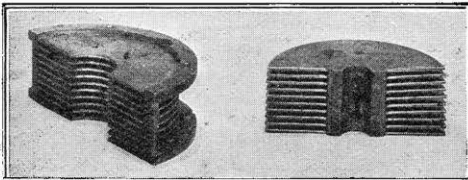

Fig. 6. Showing the construction of the plates of a small variable condenser. The elements are die-cast.

plates will not warp or change their position as the result of rough handling. The reduction in resistance may be obtained by the elimination of spacing washers.

Referring to Fig. 6, the left-hand portion shows the set of fixed plates, and the right-

hand portion the set of moving plates of a small capacity variable condenser. Each unit is die-cast complete, that is, the plates and supports are cast together. An interesting feature is the way one edge of the moving plates is bevelled off to give the condenser a very small minimum capacity. The lower plate is a full semi-circle, the next plate has a little of one edge removed, and the following plates all have a little more of one edge removed. Consequently, when the condenser is set at its minimum value, the capacity is very small, because there is a good average distance between the edges of the sets of plates. If the moving plates are turned a little, a small portion of the bottom plates is interleaved with the fixed plates, and it is only after the moving plates have been turned by several degrees (about 15 degrees) that the top plates commence to interleave with the fixed plates. This gradual increase in capacity helps to make the tuning of signals, using only a small value of the total condenser capacity, much easier.

It is perhaps not always realised to what extent the use of a variable condenser with

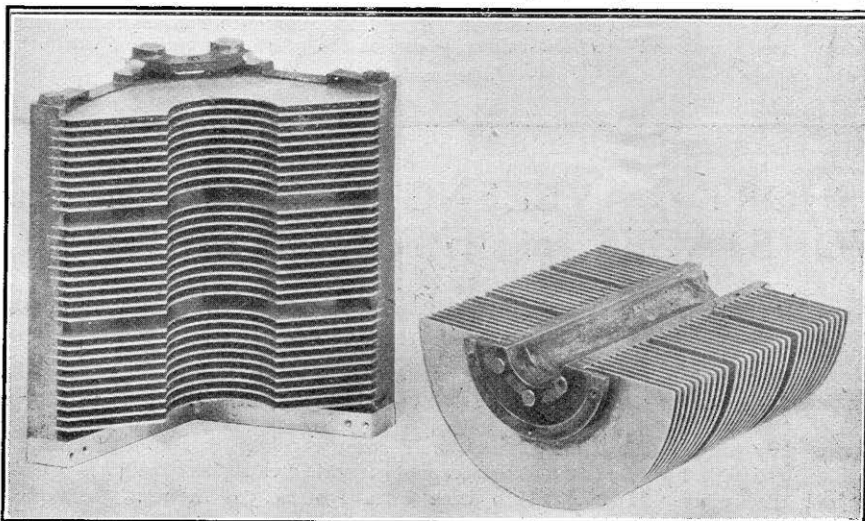

Fig. 7. The supports of the plates of this condenser are cast on.

a small minimum capacity is advantageous. Thus, suppose the maximum value is 0.0005

considerable percentage the value of minimum capacity with only a small increase in the maximum capacity. The wavelength range is therefore reduced.

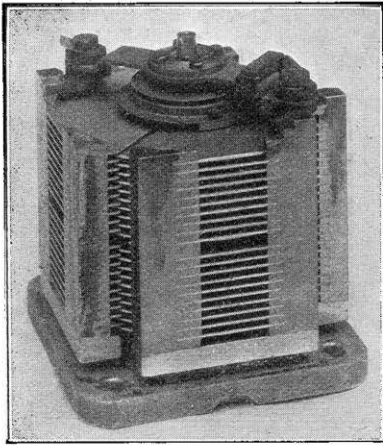

Fig. 8. A double plate condenser.

A larger variable condenser is illustrated in Fig. 7. The peculiar construction should be noted. The fixed plates are triangular in shape, and are held by heavy supports which are cast on the plates. The moving plates have the usual semi-circular shape. Condensers of this sort are very sturdy and generally have small losses. The electrical connection between the plates is of course very good.

A double-plate condenser which consists practically of two condensers like that of Fig. 7 appropriately mounted is shown in Fig. 8; one end bearing may be clearly seen. It is carefully designed with the object of keeping the dielectric losses due

microfarads, and the minimum value is 0.0001 microfarads. When connected across a coil with an inductance of 50 microhenries the wavelength range is 296 to 132 metres. If the minimum value of capacity is reduced to 0.00005 microfarads, the minimum wavelength is 93 metres—quite a considerable increase in the wavelength range. It should be noted that the self capacity of the coil, and that of the connecting wires is very important, in so far that they increase by a

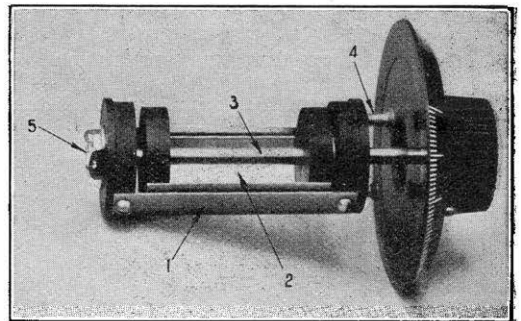

Fig. 10. A small variable condenser.

to the insulating bushes as small as possible. It will be noticed the bearing is held by a metal plate which is insulated at the ends where it is screwed to the supports of the fixed plates. Condensers of this sort are constructed with a maximum capacity of 0.004 microfarads, and the minimum value is quite small.

A variable "double plate" condenser of rather unusual construction is illustrated in Fig. 9. The plates are pressed from flat sheet brass and are mounted so that they interleave. Referring to the figure, 1 and 2 are spring connections taken from the moving plates; 3 the moving plates, and 4 the fixed plates. The whole of the plates are assembled on the end plate, 5. This instrument is of French manufacture. It gives a large maximum capacity in a small space.

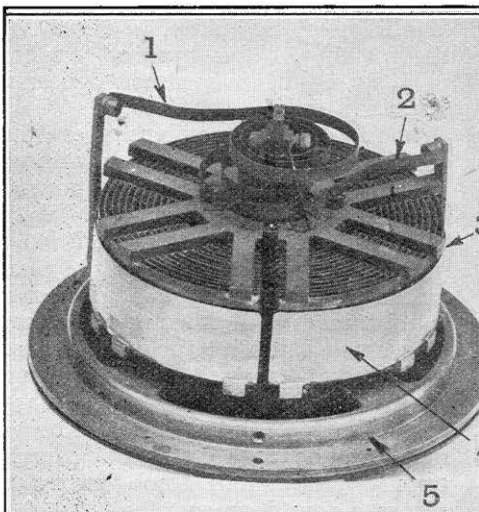

Fig. 9. A variable condenser of French manufacture.

VERNIER CONDENSERS.

It is not always possible to obtain that small change in capacity which is so often required when tuning a circuit, and for this reason it is the practice (1) to connect a variable condenser whose maximum capacity is equal to one-tenth or one-fifteenth that of the main condenser in parallel with it, or (2) to build the small condenser into the main condenser, or (3) to provide some sort of slow motion device.

- (1) Small auxiliary condensers, termed "vernier" condensers, are not considered to be a satisfactory means of obtaining fine adjustments, because of the extra space occupied. A condenser of this sort is illustrated in Fig. 10. The fixed plate is marked 1, and the moving plate 2; 3 is the spindle, 4 the fixing screws, and 5 the contact with the moving plate.
- (2) It is much more convenient to build the small condenser into the main condenser as illustrated in Fig. 11. Here, 1 is the knob which controls

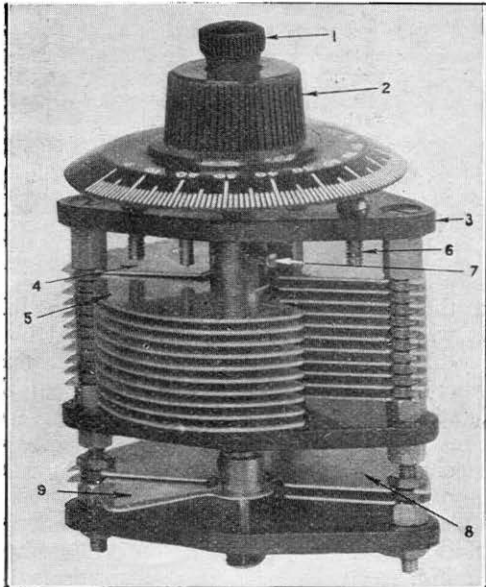

Fig. 11. A variable condenser with vernier.
(G. E. Marbaix.)

the moving plate 9 of the small condenser, and 8 is the fixed plate. The knob and dial 2 are joined with the moving plates 5; 4 is the fixed plates, 3 the top plate of insulating

material, 6 the fixing screws and 7 the stop pin. The disadvantage of this sort of condenser lies in the difficulty of calibration. Of course the main condenser could be calibrated with the

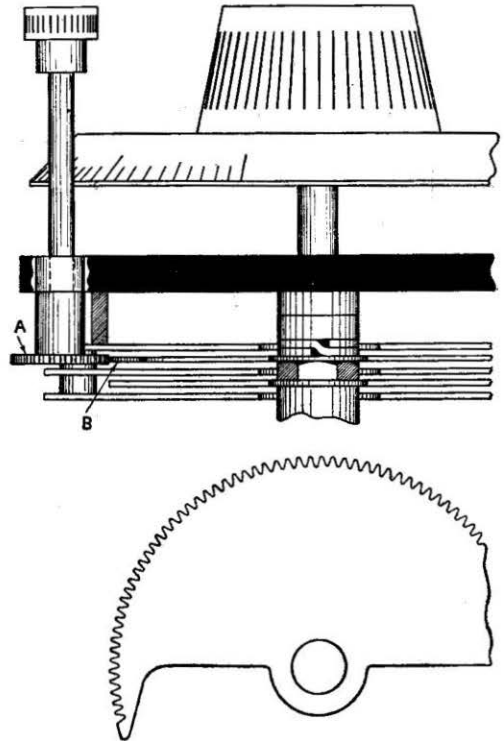

Fig. 12. One sort of slow motion device.

small condenser held fixed, but in actual use, the plate 9 turns with the plates 5. This type of condenser is very useful in ordinary receiving circuits.

- (3) Probably the best condensers are those which are fitted with a slow motion device. Two types are shown in Figs. 12 and 13. Referring to Fig. 12, the large knob is fixed directly to the shaft carrying the moving plates, and a rough adjustment of capacity is obtained by turning the knob. The small knob at the side carries a gear wheel, A, which engages with the toothed plate, B, shown enlarged at the bottom of the figure. The gear ratio is made large so that one complete turn of the small knob moves the plates a few degrees.

(To be continued.)

ADAPTING THE R.A.F. RECEIVER TYPE 10.

A number of instruments of this type are offered for sale by dealers, and in view of the wavelength range through which they are tunable, make good broadcast receivers. This article describes an extremely simple method for changing the number of valves in circuit and extending the tuning range. The principle described can be applied to most multivalve receiving sets with advantage.

By A. J. BULL.

THE R.A.F. receiver Type 10, as shown in the photograph, was designed primarily for the reception of wireless telephony signals by aircraft in flight. It is a five-valve receiver-amplifier and comprises two H.F. valves (transformer coupled), one detecting and two L.F. amplifying valves. The instrument is extremely compact, measuring only $12" \times 6\frac{1}{2}" \times 3\frac{1}{2}"$. The external appear-

rheostat for adjusting the filament current of the fourth and fifth valves only, and an aerial tuning inductance inductively coupled to the grid of the first H.F. valve.

Remote from this box is another small box containing two small condensers connected in parallel for aerial tuning purposes, and a filament rheostat controlling the five valves and joined in series with the smaller one already referred to.

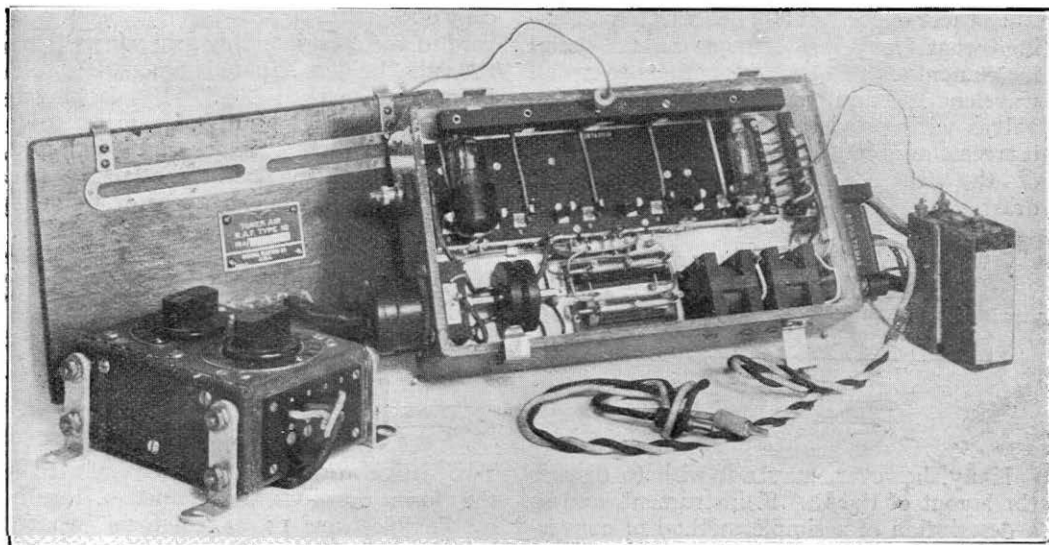

The R.A.F. Type 10 receiver with tuning unit. The sockets and a pair of plugs provide an easy method for changing the number of valves in circuit. The grid cells and clip can be seen.

ance of the instrument is that of a weather-proof rectangular box, and it is intended to be slung in aircraft by means of springs or elastic.

Into this box are fitted five valve holders and valves, two H.F. transformers, a potentiometer connected to the grids of the two H.F. valves, two L.F. transformers, a filament

The two boxes are connected together by means of a four-pin plug and leads. The H.F. transformers contained in the set and tested by the writer were wound for an optimum wavelength of 400 metres, and gave good amplification between 200 and 600 metres; they are therefore quite useful over the broadcast band of wavelengths.

The valves intended for use with the amplifier are of the naval pattern, such as the "Ora B," one of which, together with a "V.24" valve, can be seen in the photograph. If valves of the "V.24" type are employed, it is necessary to make use of a small adaptor, owing to the difference in length of the two types of valves.

Although the instrument was undoubtedly very useful for the purpose for which it was designed, viz., to deliver a signal which could be heard above engine and other noises, yet in its present form it can scarcely be considered a perfect instrument to the present-day experimenter who, among other demands, requires that his apparatus shall be flexible, especially with regard to range of wavelengths and number of valves. As a number of the instruments have been offered for sale from time to time by dealers in second-hand apparatus, a suggestion for its conversion to an instrument of greater use to the experimenter is given.

To those experimenters desirous of possessing what may be termed an all-round instrument which will function over all wavelengths, and employing one to five valves with provision for extra H.T., etc., it is recommended that the form of conversion of the R.A.F. instrument be somewhat drastic.

A piece of ebonite measuring $10" \times \frac{1}{2}" \times \frac{1}{2}"$ should first be prepared for fixing to a position on the underside of the top of the amplifier box by means of three wood screws. Before fixing in position obtain five single valve sockets and reduce them in size, cut a thread on the outside of each and screw them on the position on the ebonite strip spaced approximately 2 ins. apart as indicated in the drawing.

Screw the ebonite strip in position and connect each socket by means of covered

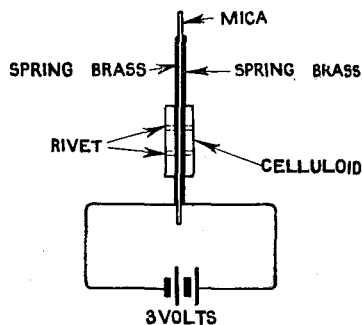

The clip for giving grid a negative bias.

wire to the corresponding grid connection of the valve holders situated immediately below them and marked "G." By slacking the screw which secures the grid spring to the rectangular ebonite panel and passing the wire connection under the head of the screw the necessary connections are easily made.

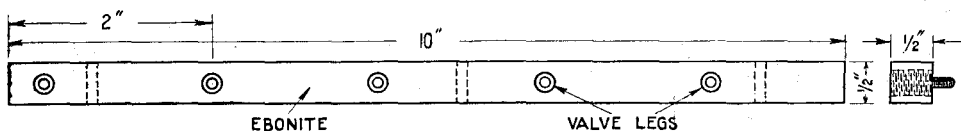

Strip carrying the valve sockets.

Many, however, may not wish to disturb the layout of the R.A.F. instrument, and so a description of a simple method of conversion which does not necessitate any structural alterations whatever is given below. If the instrument is altered in the manner to be described it will be possible, by means of the modified apparatus, to receive telephony and Morse over a range of wavelength from 200 to 600 metres, utilising for the purpose one to five valves. For the reception of other wavelengths the two H.F. valves are not made use of, consequently the detecting valve alone (No. 3) or followed by the L.F. valve No. 5 or Nos. 4 and 5 only are available.

Two valve pins should be mounted in the form of plugs and connected together by flexible wire so as to form what is often referred to as a wandering lead.

From a little consideration the reader will realise that by connecting selected sockets (which are of course connected to the grid of each valve) together by means of the wandering lead any number of valves can be cut in or out of use within the compass of the instrument. For example, if only one valve is required, sockets 1 and 5 are connected together by means of the wandering lead, and valves 1 to 4 inclusive removed from the instrument. Supposing that one H.F. and one detecting valve are required,

then sockets Nos. 2 and 5 are connected, and valves 2, 3 and 4 removed, and so on. Should it be desired to operate a loud speaker and to make use of increased plate potential for the fifth valve, the loud speaker and battery should be connected as indicated

of mica, the whole being held together by two small rivets. To each piece of springy brass a piece of flexible wire is soldered, the other end of the wire is connected to two or more dry cells joined in series, due care being observed that the wire connected

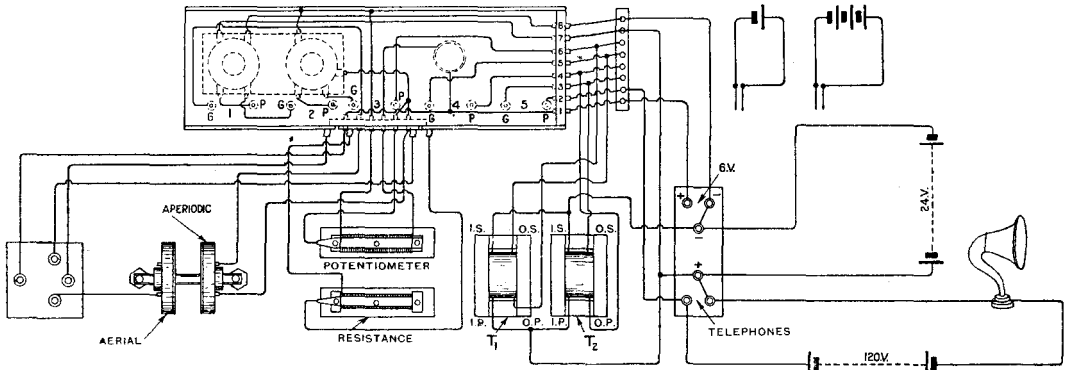

The connections of the instrument. The method of introducing additional plate potential is shown.

If a "V.24" valve is employed for the purpose it will be found that 150 volts is a suitable voltage, providing that the grid is made 3 volts negative. An easy means of making the grid negative is by means of a clip consisting of two flat

to the negative terminal of dry cell battery has its other end connected to the springy brass which is in contact with the grid terminal on the valve.

In conclusion it is reiterated that the method of conversion described is recom-

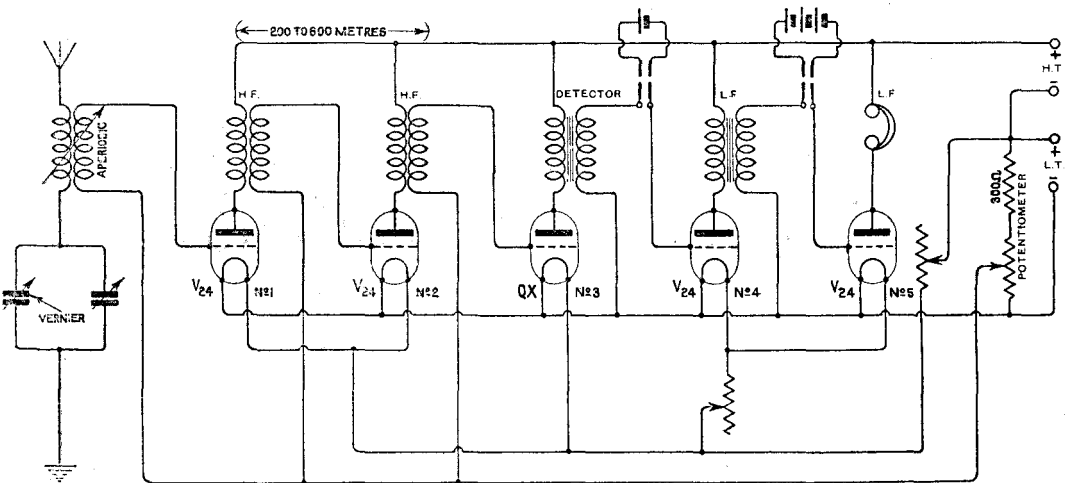

The circuit from which the effect of the plug and socket connections can be understood.

springs inserted between the grid terminal of the valve and the spring connection of the valve holder. It is built up from two pieces of thin springy brass separated and insulated from each other by a thin piece

mended only to those amateurs who from a lack of sufficient tools or absence of desire to disturb the wiring of the amplifier, etc., thus preserving the intrinsic value of the instrument as a piece of ex-Government apparatus.

TWO NEW BROADCASTING STATIONS BRUSSELS AND ROME.

TWO new broadcasting stations have recently been opened, and since both of these should be heard in this country, a brief description of them will no doubt be of interest.

The broadcasting station recently erected at Brussels conducted its first transmission on November 24th, and now works regularly every evening. The station belongs to the Société Belge Radio-Électrique, and is situated at 34 Rue de Stassart, Brussels.

Two steel lattice towers are used to support the aerial, and each of these is about 50 ft. high. One is erected on the roof of No. 34, Rue de Stassart, and the other on the roof of the Hotel des Ventes. The two towers are about 150 ft. apart. The two buildings being about 50 ft. high gives a total height of about 100 ft. to the points where the aerial is suspended. The earth is obtained by connecting together all metallic masses throughout the building in which the trans-

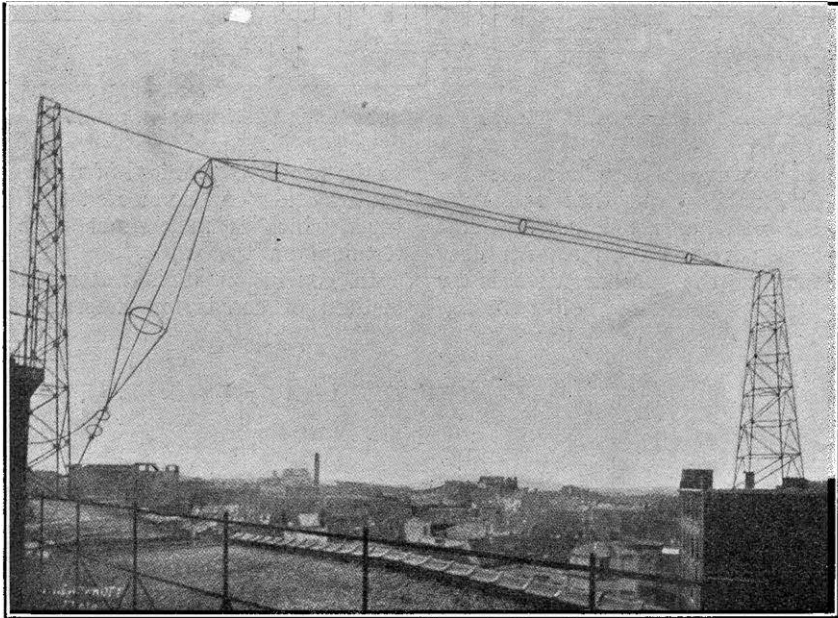

Masts and aerial of the Brussels station.

The studio is located on the fourth floor and special precautions have had to be taken here to keep out from the studio external sounds, as this building is also used for concerts and lectures.

The apparatus installed at the Brussels station is similar to that at **2 LO**, and has been supplied by the Marconi Company, although installed by Belgian engineers. Since the apparatus is practically standard, it is not necessary here to go into details, but some notes regarding the aerial arrangements may be of interest.

mitter is installed, and copper connectors have been run between all metallic masses such as central heating, water pipes, etc., whilst in addition, a buried earth is provided. The wavelength used is 410 metres, and reports received from many directions indicate the efficiency of the transmissions, and there should be no difficulty whatever in receiving them in this country.

The second broadcasting station is one which has been recently erected in Rome by the Western Electric Italiana for Ing. Ranieri, who for many years has provided

music from theatres and the latest news in the homes of thousands of dwellers in Rome and other big cities of Italy by means of his "Araldo Telephonico" system. This system comprises a series of transmitters in the important theatres which are connected by wires with the offices of Ing. Ranieri which form an exchange from which wires radiate to his many subscribers. He has installed this "wired" broadcasting system in Rome, Milan and Bologna, and has met with great success. Ing. Ranieri has now

with felt about $\frac{1}{8}$ in. thick, the felt being covered with some lighter material more in keeping with the surroundings.

The motor generator which supplies the filament and plate current to the transmitting valves is situated on a balcony at a distance of about 15 ft. from the transmitting room. ANTENNA.

An inverted "L" type aerial is used, the total length between the insulators being 150 ft.

The conductor used in the construction

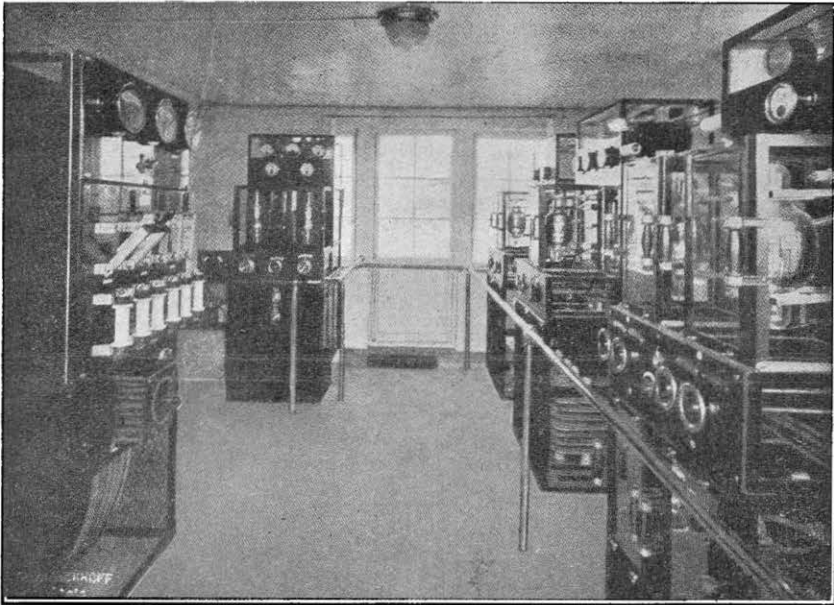

The apparatus room of the Brussels Broadcasting station.

turned his attention to wireless broadcasting with the title "Radio-Araldo."

We are indebted to Mr. F. H. Amis, one of the engineers responsible for the installation, for a description of the station.

The station is erected in the centre of Rome at Piazza Poli 37, the offices of Ing. Ranieri being situated on the sixth floor. The transmitting room, which is about 18 ft. by 12 ft., contains the speech input amplifier, the radio transmitter, the power panel and receiving sets for checking the quality of the transmission. The studio, which is a small room about 10 ft. square, is separated from the transmission room by an office. To keep out the "echo" effect the walls and ceiling of the studio are draped

of the antenna is of 7/1.0 mm. stranded copper. Four conductors are used running parallel and spaced about 6 ft. apart.

The height of the aerial above ground is of the order of 80 ft., but the effective height is probably less, due to the presence of neighbouring structures, telephone lines, etc.

WAVELENGTH.

The regulations covering the wavelength and radio broadcasting generally have not yet been issued by the Italian Government, but it was thought that the wavelengths allocated for broadcasting purposes would have a maximum value set at somewhere about 575 metres.

To keep within the limits therefore, the circuit was adjusted to transmit at a wavelength of 540 metres. Later, however, it was learnt that the maximum would be 475 metres, so the set was readjusted to transmit at 450 metres, at which wavelength experimental transmissions were carried out. VALVES.

The transmitting valves make use of an oxide coated filament and operate at a temperature corresponding to the filament burning at a dull red heat. These are the Western Electric valves, and need no further

of 450 metres. In addition to these transmissions, broadcasting is occasionally carried out for exhibition purposes, the transmission being received at various exhibitions where receiving sets were being shown. Wireless reception has been a great attraction at these exhibitions when music has been transmitted from the broadcasting station for the purpose.

Previous to the erection of this station in Rome, some radio telephony had been carried out irregularly by the aircraft radio station, and the public were very pleased

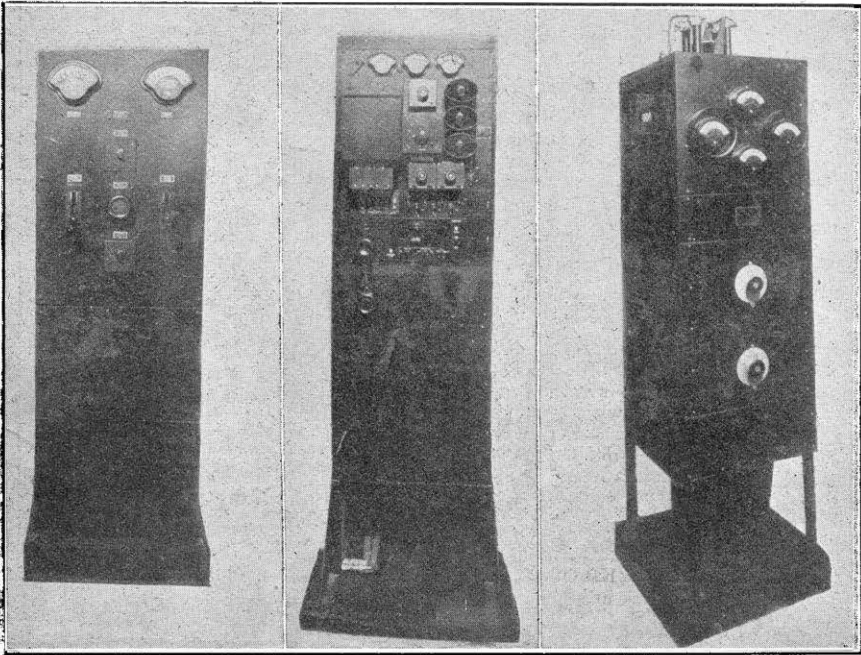

Apparatus panels of the Rome Broadcasting station recently opened.

description here, as these tubes have been described in *The Wireless World and Radio Review*, November 4th 1922, in an article by E. M. Deloraine on "An Experimental Transmitting Set," and also in a description of the Birmingham Broadcasting Station by the same author, appearing in *The Wireless World and Radio Review* of December 16th, 1922.

TRANSMISSION.

Until the regulations covering broadcasting are issued by the Italian Government, transmission can only be carried out experimentally. The experimental transmissions are carried out daily from 4.30 p.m. to 5.30 p.m. (Italian time) at a wavelength

at the quality of transmission from the broadcasting station.

RANGE.

Reception was reported, shortly after transmission commenced, at a distance of 27 km. on a crystal with frame antenna and up to 500 km. using two valve receiving sets. Possibly most of the people in Rome will use crystal sets, utilising the electric light wires for the aerial.

REPORTS.

Reports received from the Aircraft Wireless Station, the military and chief civil radio authorities were very favourable, and showed that development in broadcasting is being watched with keen interest.

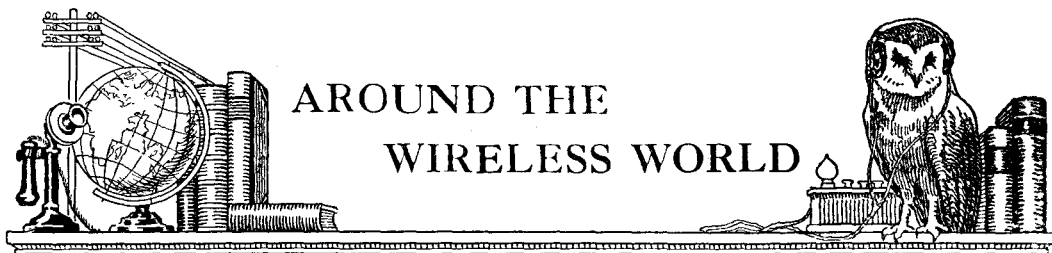

Short Wave Transmission.

Valuable experiments in the production of short waves have recently been conducted in the Paris district. General Ferrié, of the Eiffel Tower wireless station, in describing the results before the Academy of Science, said that it had been found possible to communicate at a distance of $1\frac{1}{4}$ miles with a two-metre wavelength, and the intensity of the oscillations did not exceed 80 milliamperes. By increasing this intensity and by other devices, said the General, it would be possible considerably to increase the distance at which messages could be heard.

Empire Wireless.

An interesting disclosure of trans-Pacific wireless tests during last summer appeared in the *Times* of November 29th.

It is understood, says the Vancouver correspondent of that newspaper, that exhaustive tests have been carried out by Commander E. C. Watson, representing the Pacific Cable Board, and the British Post Office, from the coast of British Columbia to Australia, via Fanning Island, with such success that an extension of the scheme is likely to include China and South Africa. Commander Watson's plans have been kept secret, and the tests have been conducted at isolated points along the coast.

A New South African Station.

Work is proceeding rapidly on the construction of a large wireless station at Klipheuvcl, some 27 miles from Cape Town. There are to be 16 masts of an average height of 830 ft.

Radio Association of Ireland.

The executive committee of the newly-formed Radio Society of Ireland is endeavouring to increase the number of its branches in various centres. The Secretary would therefore welcome information regarding the possibility of setting up branches at Kilkenny, Cavan, Dundalk, Wexford, Sligo, and Longford, and any other district where a branch of the Association would be necessary. All interested in this movement and those desiring to become members, are requested to communicate with H. Hodgins, Esq., Hon. Secretary, Radio Association of Ireland, 92, Lower Bagott Street, Dublin.

Broadcast Reception in Cornwall.

With reference to the letter of Mr. Geo. Laity, on the above subject published in our issue of November 7th, we have received some interesting details of broadcast reception in West Cornwall from Mr. W. M. Martyn, who employs a three-valve set (H.F., detector, L.F.). Using a single wire aerial 30 ft. long and 12 ft. high and an ordinary "poker" earth, our correspondent

has received good signals from 5 NO, 2 LO, 5 IT and 2 ZY, reception being audible from the phones all over the room. 5 WA and 5 SC and several continental stations are also received. Mr. Martyn endorses the opinion of Mr. George Laity that a relay broadcasting station could, with advantage, be erected at Plymouth or further west.

A League of French Wireless Societies.

An effort has been made in France to consolidate the position of the wireless amateur, and, with this object in view there has been formed a Comité Intersocietaire de T.S.F. The new league is at present composed of the three principal societies in the country, viz., Société des Amis de la T.S.F., Société Française d'Etudes de T.S.F., and the Radio Club de France.

The objects of the League are to foster popular interest in radio telephony, to promote national and international conferences on the subject of reception and elimination of atmospherics, and to the study of other phases of the science. All correspondence should be addressed to M. David, 56, Rue de Vaugirard, Paris 6e.

Help Wanted in Sidmouth.

A reader in Sidmouth, Devon, is anxious to get into touch with a local amateur who would be ready to give him the benefit of his experience in the installation of a broadcast receiver using a frame aerial. In this connection we shall be pleased to forward any communication to the proper quarter, and letters should be addressed to C. W. Cosgrove, c/o Editor, *The Wireless World and Radio Review*.

"Freak" Reception.

The request in our issue of November 28th for records of "freak" reception" has brought forth a response from Mr. John Bonnett, of Cheshunt, Herts.

On November 22nd our correspondent succeeded in hearing the broadcast transmission from Aberdeen while employing a single circuit crystal receiver.

FORTHCOMING EVENTS.

WEDNESDAY, DECEMBER 12th.

Stockport Wireless Society. At 7.30 p.m. Lecture: "Transmitting." By Mr. H. A. Woodyer.
Edinburgh and District Radio Society. At 117, George Street. Lecture: "Power Transformers." By Mr. H. V. Shore.
Manchester Radio Scientific Society. At 7 p.m. At 16, Todd Street. Lecture: "Electrical Measuring Instruments." By Mr. Owen.
Streatham Radio Society. Lecture by Mr. Gibbon (of the G.P.O.).
Clapham Park Wireless and Scientific Society. At 8 p.m. At 67, Balham High Road. Lecture by representative of Igranic Electric Co.

FORTHCOMING EVENTS (continued).

THURSDAY, DECEMBER 13th.

South Norwood and District Radio Association. At the Stanley Halls, South Norwood Hill. Soirée and Exhibition of Members' apparatus.

Luton Wireless Society. At 8 p.m. At Hitchin Road Boys' School. Experimental Demonstration. By Mr. G. W. Chandler.

Stoke-on-Trent Wireless and Experimental Association. Lecture by Mr. L. F. Fogarty, A.M.I.E.E., F.R.S.A.

Hackney and District Radio Society. Demonstration of Vecovalve and other wireless apparatus. By Mr. Miller (of the Western Electric Co., Ltd.).

FRIDAY, DECEMBER 14th.

Wembley Wireless Society. At 8 p.m. At Park Lane School. "The Exhibition." By Mr. W. E. Meldrum.

Manchester Wireless Society. At 7.30 p.m. In the Council Chamber, Houldsworth Hall. Lecture: "My Wireless Life." By Dr. Stanley Hodgson, M.R.C.S., L.R.C.P.

Sheffield and District Wireless Society. Concert and Whist Drive.

Leeds Radio Society. Open Meeting and Demonstration.

Norwich and District Radio Society. Lecture: "Morse Code and Procedure." By Mr. Harcourt.

Honor Oak Park Radio Society. Lecture by Mr. Stevens.

MONDAY, DECEMBER 17th.

North London Wireless Association. At 8 p.m. At the Northern Polytechnic Institute, Holloway Road, N. Ordinary Meeting.

TUESDAY, DECEMBER 18th.

Plymouth Wireless and Scientific Society. At 8 p.m. At the Y.M.C.A. Building, Old Town Street. Lecture: "The Working of the Three-Electrode Valve, introducing the Electron Theory." By Mr. Lock.

Radio Society of Willesden. At 8 p.m. At 34, The Croft, Harlesden, N.W.10. General Discussion and Completion of New Year's Syllabus.

Broadcasting.

REGULAR PROGRAMMES ARE BROADCAST FROM THE FOLLOWING EUROPEAN STATIONS:

GREAT BRITAIN.

LONDON 2 LO, 363 metres; **MANCHESTER 2 ZY,** 370 metres; **BIRMINGHAM 5 IT,** 423 metres; **CARDIFF 5 WA,** 353 metres; **NEWCASTLE 2 NO,** 400 metres; **GLASGOW 5 SC,** 415 metres; **ABERDEEN 2 BD,** 497 metres; **BOURNEMOUTH 6 BM,** 485 metres. Regular daily programmes. Weekdays, 11.30 to 12.30 p.m. (2 LO only), 3.30 to 4.30 p.m., 5 to 10.30 p.m. Sundays, 3 to 5 p.m., 8.30 to 10.30 p.m.

FRANCE.

PARIS (Eiffel Tower), FL, 2,600 metres. Daily, 6.40 to 7 a.m. Weather Forecasts; 10.5 a.m. (Thursday and Friday), 11.15 to 11.30 a.m., Time Signal and Weather Forecast; 12.0 noon, Live-stock prices; 3.40 p.m. (Saturday excepted); Financial report. 5.30 p.m. (Saturday excepted) Bourse Closing Prices; 6.10 p.m., Concert or Address; 7 p.m., Weather Forecast; 7.20 p.m. (Sunday), Concert and Address; 10.10 p.m., General Weather Forecast.

PARIS (Compagnie Française de Radiophonie Emissions "Radiola"), SFR, 178 metres. Daily, 12.30 p.m., Cotton, Oil and Café Prices, News, Concert; 1.45 p.m., First Bourse Report; 4.30 p.m., Bourse Closing Prices; 4.45 p.m., Concert; 5.45 p.m., News and Racing Results; 8.30 to 9.30 p.m., News; 9.10 p.m., Concert; 10 p.m. to 10.45 p.m., Radio Dance Music.

ECOLE SUPERIEURE des Postes et Télégraphes, 450 metres 3.30 to 4 p.m. (Wednesday and Friday), 7.45 p.m. to 10 p.m. (Tuesday and Thursday), Tests (Music, etc.); 2.30 p.m. to 7.30 p.m. (Saturday), Tests (Music, etc.).

LYONS, YN, 3,100 metres. Daily, 9.45 a.m. to 10.15 a.m., Gramophone Records.

BELGIUM.

BRUSSELS, BAV, 1,100 metres. 1 p.m. to 5.30 p.m., Meteorological Forecast; 9 p.m. (Tuesday), Conce t.

BRUSSELS ("Radio Ele. trique"), 470 metres. Daily, 8.30 p.m. to 9.30 p.m., Conce t.

HOLLAND.

THE HAGUE, PCGG, Temporarily suspended.

THE HAGUE (Heussen Laboratory), PCUF, 1,070 metres. 9.40 to 10.40 a.m. (Sunday), Concert; 9.40 to 10.40 p.m., Concert; 7.45 to 10 p.m. (Thursday), Concert.

THE HAGUE (Velthuisen), PCKK, 1,070 metres. 8.40 to 9.40 p.m. (Friday), Concert.

IJMUIDEN (Middelraad), PCMM, 1,050 metres. Saturday, 8.40 to 9.40 p.m., Concert.

AMSTERDAM, PA 5, 1,100 metres (Irregular). 10 to 11 a.m., Concert; 5 to 6.30 p.m., Concert; 8 to 9.10 p.m., Concert.

DENMARK.

LYNGBY, OXE, 2,400 metres. 7.30 p.m. to 8.45 p.m., Concert (Sunday excepted).

GERMANY.

BERLIN (Koenigswusterhausen), L.P., 4,000 metres. (Sunday), 10 to 11 a.m., Music and Lecture; 2,700 metres 11 a.m. to 12 noon, Music and Lecture. Daily, 4,000 metres, 6 to 7 a.m., Music and Speech; 11.30 a.m. to 12.30 p.m., Music and Speech; 4 to 4.30 p.m., News.

EBERSWALDE, 2,930 metres. Daily, 12 to 1 p.m., Address and Concert; 7 to 8 p.m., Address and Concert; (Thursday and Saturday), 5.30 to 6.30 p.m., Concert.

CZECHO-SLOVAKIA.

PRAGUE, PRG, 1,800 metres. 7 a.m., 11 a.m. and 3 p.m., Meteorological Bulletin and News; 4,500 metres, 9 a.m., 2 p.m., and 9 p.m., Concert.

KBEL (near Prague), 1,000 metres. Daily, 6.20 p.m., Concert, Meteorological Report and News.

SWITZERLAND.

GENEVA, HB 1 (Radio Club de Genève). Temporarily suspended.

LAUSANNE, HB 2, 1,100 metres. Tuesday, Thursday, Saturday, 4 p.m., Concert; Monday, Wednesday, Friday and Saturday, 7 p.m., Concert.

SPAIN.

MADRID, 1,650, 2,200 metres (Irregular). 12 to 1 p.m., Tests.

MADRID, PTT, 400 to 700 metres. 4 to 5 p.m., Tests.

Distortion in Radio Telephony.

By H. A. THOMAS, M.Sc.

(Concluded from p. 339 of previous issue).

Mr. Thomas, replying to the discussion, said:

With reference to the remarks made by Mr. Child, I can quite naturally understand his surprise at the value of the condenser which I find requisite to couple two audio valves. I commenced my test with a 0.01 mfd. condenser, and this was reduced to 0.001 mfd. without any diminution of amplitude. After that the curve given was obtained and shows that quite a small condenser is sufficient to pass the audio frequency energy.

Certainly the use of short waves facilitates closer packing of the wavelengths, but it appears to be difficult to produce large power transmitters at very short wavelengths.

Mr. Phillips spoke of the difficulty of obtaining high resistances, of the order of 100,000 ohms to carry a current of 25 milliamperes. The wire resistance is, of course, the only method, and I have seen quite neat wire resistances of this value non-inductively wound and taking up little more room than an ordinary anode resistance.

With regard to the remarks of Mr. Coursey, I wish to point out that the paper was meant to be an analytical survey from a theoretical standpoint. The difficulties of obtaining actual figures are almost insuperable. By a large number of voltage readings obtained by electrostatic voltmeters, one could obtain some information, but it would be impossible by any method to observe the flattening of the positive half of a wave. Any instrument for high frequency work can only integrate a series of instantaneous values. I admit that selectivity must of necessity be considered, but the time has come when selectivity and distortion must be considered as mutually opposed, and a compromise must always be made. I wished merely to point out the tendencies, because the exaggerated conception which I put forward now, may at some future date become quite a real one, and I wish that to be understood with regard to the whole paper. In practice the

various defects may be quite small, but nevertheless, the summation of them produces the observed result.

It is quite possible that the distortion effect of one component may be partially or wholly compensated for by the characteristics of another component, but it appears unlikely that such a happy state of affairs would be the rule. I admit that a loud speaking horn may be able to straighten out an effect produced in a transformer, and I think in some cases it takes place, but generally it is not likely to materially modify a bad characteristic, for after all the resonance points of the speaking device would need to be very beautifully synchronised with the transformer resonance.

I agree with Mr. Smith-Rose on the physiological importance of the question of the theoretical value of the current in the receiver as contrasted with the effect produced upon our sense organs. This effect is dependent largely upon the musical training and natural aptitude for appreciation of the listener. A man might say that a certain jazz-band was good, and another having had a refined musical training would say it was dreadful. I admit that in the B-H curve that I gave, I meant to give merely the idea, and have introduced no detail. In the receiving circuit I admit that the 3,000 audio change on the carrier 840,000 is small, and in practice probably produces a very small change, but again I am looking at the problem from a theoretical point of view, and am thinking of the time when we shall get to such selective conditions that these small points will be of importance.

With regard to the transformer, Mr. Smith-Rose spoke of being able to arrange the connections in such a way that self-capacity reactance and inductive reactance could compensate themselves, so giving a constant voltage step up at all frequencies. I quite realise the possibility, but feel that it is improbable in most cases that self capacity and inductance are so nicely arranged that this is possible. If the transformer were so designed that the self-capacity reactance were able to balance out the inductive reactance, it would be very advantageous, but self-capacity is so difficult to calculate that I fear that only by a series of long and tedious experiments could one hit upon that case.

Mr. Holbeach was particularly surprised at the result I obtained from the resistance amplifier, and here again I must say that the result was obtained on a three-stage amplifier, and quite a number of people to whom I have communicated the information have tried it, with about the same amount of success as I obtained. I am only speaking of two or three stages, and I do not know how far this could be carried. I do not suggest that it would be effective for a really large loud-speaker demonstration. Undoubtedly the voltages and size of valve which he suggests at the output end is in direct contradiction to the results given by Mr. Smith-Rose, but whereas the latter probably is speaking of reasonable intensity in a small room, the former member refers to bawling 2LO about two miles. In that case the requisite power is not alarming.

The next speaker asked about various circuit arrangements for eliminating the steady anode

current in the loud speaker, and I would like to add that there is a method which I have tried, as well as his, which is quite successful, namely, to put two large condensers in series with the loud speaker. Practically the whole of the audio energy is passed to the speaker, while it is relieved of the steady anode current. It also appears to smooth out amplifier noises. I most heartily agree that the bad reception at a good many of the trade demonstrations I have heard will do more to ruin broadcasting than anything else. I have heard a demonstration three miles from 2LO, with twelve valves in cascade (laughter), and I can assure you that a demonstration such as this would do a great deal of harm.

Captain Ainslie spoke of the adoption of tuned secondaries on audio transformers, and I cannot pass his remarks without a smile. The possibilities of such a device are almost endless. In a duet the most successful attempt could be made to predominate while the other member could be successfully subordinated. In fact, we should be able to apply our own musical ideas to the interpretation of the music; that is, we have at last obtained the pianola radio receiver. From a distortion aspect of course, the method is barbaric. Nothing could give such big distortion effects. I cannot understand his statement about maximum distortion over the short distances. Certainly everyone has obtained a reciprocal result. I am sure, both from a theoretical and practical point of view, the phenomena is impossible, because at greater distances we have distortion due to the medium, and also due to the greater amplification which is necessary.

Mr. Blake asked me whether I had ever performed any experiments with the glow discharge type of microphone. I have not, but as to the arc transmitter, I have tried one type, but the difficulties of maintaining a steady arc were such as to merit a refusal of the method.

The results given are of course independent of the radio-frequency side of the apparatus, but they were carried out on 369 metres.

With regard to the remarks of Dr. Eccles, I must say that I intended to attack, and also hoped that the attack would prove instructive as well as of a constructive nature. I have exaggerated every detailed point in order to make each possible source of distortion quite clear. I am sorry that I could not give a quantitative figure of the different defects, because it is very difficult to obtain a measure of any of these. I hope that in the future I shall be able to give more accurate details, but my whole object was to arouse attention to the very vital factors producing distortion, and I shall be satisfied if I feel that I have performed that duty.

I have to thank Dr. Eccles for his remarks, and especially for the information—which I did not appreciate before—that, since the transmitting medium is dispersive, the velocity of propagation of ether waves is dependent upon the frequency.

[With reference to the Discussion on the above paper, Nov. 28th issue, page 293, Mr. Holbeach points out that he is quoted as having said: "I have tried it myself, and have had a number of milliamperes on the last stage quite satisfactorily," whereas what he actually said was: "I have tried it myself, and have had 100 milliamperes &c.".]

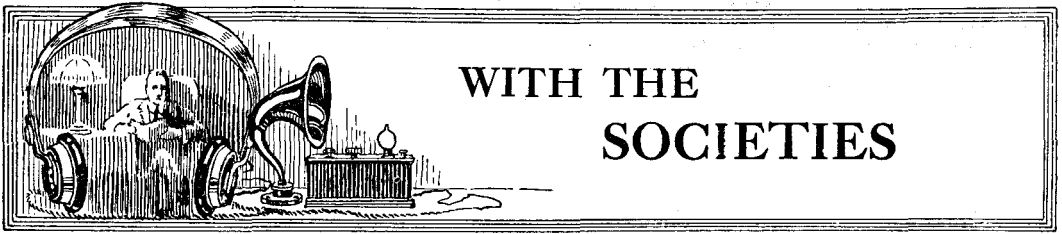

WITH THE SOCIETIES

Particulars of Membership of any Society can be obtained on application to the Secretary. Societies marked with an asterisk are affiliated to the Radio Society of Great Britain.

HACKNEY AND DISTRICT RADIO SOCIETY.*

Over 1,000 persons attended a wireless demonstration and exhibition organised by this Society, and held at the Clapton Palais de Danse on Wednesday, November 21st, when speeches were made by Mr. A. R. Burrows ("Uncle Arthur"), and Captain P. P. Eckersley, of the British Broadcasting Company. The exhibits, which had been constructed by members of the Society, were valued at £1,000 and ranged from a humble crystal set costing a few shillings to elaborate valve sets worth about £70.

Mr. Harry A. Epton, F.B.F.A., Chairman of the Society, who presided at the opening ceremony, read a letter from Col. Sir Arthur Lever, M.P., expressing regret at his inability to occupy the chair as arranged.

In an entertaining speech, Mr. Burrows referred to the difficulties of arranging broadcast programmes so as to please everybody, and Captain Eckersley followed with an amusing discourse on the technical difficulties of broadcasting, including fading and jamming.

Hon. Sec., Chas. C. Phillips, 57, Highfield Avenue, Golder's Green, N.W.11.

NORWICH AND DISTRICT RADIO SOCIETY.

"X-Rays" formed the subject of an interesting lecture and demonstration given by Mr. I. S. Spain, on November 16th, when, by means of lantern slides, he thoroughly explained the principles of the waves discovered by Dr. Röntgen. Having read Dr. Rontgen's first lecture on the new discovery, Mr. Spain dealt with the numerous uses of X-Rays, particularly in connection with medical practice, concluding with a demonstration which at once interested and startled the members.

Hon. Sec., J. G. Hayward, 42, Surrey Street, Norwich.

GLASGOW AND DISTRICT RADIO SOCIETY.

The fourth meeting of the Session was recently held at the Glasgow University, where a lecture was delivered by Dr. G. E. Allan on "Sound as the Handmaid of Radiotelegraphy." He dealt mainly with the wave phenomena of sound, demonstrating by experiments the propagation of air waves of frequencies ranging from 30 per sec. up to 32,000 per sec. and explained the limits of audibility. Resonance, harmonics, sensitive flames, and the production of best notes were also demonstrated.

Assist. Hon. Sec., Wm. K. Fulton, 148, Kenmore Street, Glasgow.

RADIO SOCIETY OF WILLESDEN.*

The headquarters of the Society have been moved to 34, The Croft, Harlesden,

N.W.10. Adequate apparatus has been installed for reception, and in view of the Transatlantic Transmitting Tests, a six-wire cage aerial has been erected.

Meetings are now held on Monday, Tuesday, Thursday and Friday of each week.

Applications for membership should be addressed to the Hon. Sec., F. H. H. Coote, 183, Carlton Vale, Maida Vale, N.W.6.

BARKING AND DISTRICT RADIO SOCIETY.

On Monday, November 26th, Mr. R. C. Jones gave a lecture on the "Thermionic Valve." The lecturer described the workings of the earlier type of two-electrode and later the three-electrode valve, together with their underlying principles. Mr. Jones then went on to describe the operation of the valve in receiving and transmitting, and after dealing with the subject very fully, answered questions raised by the members.

Hon. Sec., C. R. Willett, Congregational School Room, The Broadway, Barking.

NEWCASTLE RADIO SOCIETY.*

Members who wish to be included in parties which are to visit **5 NO**, the Newcastle Broadcasting Station, are asked to send in their names to the Secretary without delay. Members may choose either a Wednesday or a Saturday for their visit, and will be informed later of the week allocated to them.

Hon. Sec., Colin Bain, 51, Grainger Street, Newcastle-on-Tyne.

RADIO ASSOCIATION OF IRELAND.

At a special meeting of the Association, held on November 27th, the Secretary announced that a programme had been arranged up to April next. Amongst those who have promised to read papers are:—Mr. T. J. Monaghan, B.Sc., A.M.I.E.E.; and Rev. H. V. Gill, S.J., M.A., M.Sc., and Professor F. E. Hackett. Demonstrations of wireless receiving apparatus will be held next month under the auspices of the Radio Association.

Branches covering the following counties of Cork, Limerick, Waterford and Tipperary have been organised and the Secretary is in communication with Galway and other centres regarding the formation of branches.

The Secretary then read a letter from the Secretary of the Radio Society of Great Britain extending an invitation to its meetings to the officers and members of the Radio Association of Ireland who are visiting London.

Mr. P. E. Belas, B.A., A.R.C.Sc., University College, Cork, has accepted a vice-Presidency of the Association.

An interesting lecture entitled: "Facts about Frequency," was delivered by Prof. J. J. Dowling, M.A., F.Inst.P., who dealt with the phenomenon of frequency

which occurs in so many branches of scientific inquiry.

The harmonic vibrations of musical instruments were touched upon and the lecturer spoke of their equivalents in electricity. These harmonic phenomena were illustrated by experiments and their application to radio science explained. Prof. Dowling concluded with an exposition of the principles employed for the measurement of frequency.

Hon. Sec., H. Hodgins, 92, Lower Faggo St., Dub.in.

THE SOUTHAMPTON AND DISTRICT RADIO SOCIETY.*

On Thursday, November 22nd, Captain E. H. Robinson lectured to a large number of the members on "Professor L. A. Hazeltine's Neutrodyne Radio-Frequency Amplifier," which has achieved great popularity in the United States. Captain Robinson described at great length the manner in which the inter-electrode capacities of the valve, and self-oscillation, were overcome. The lecturer also gave constructional details of a set embodying this circuit, and demonstrated with a Neutrodyne 4-valve set, **2LO** being heard on a loud-speaker with remarkable clarity and freedom from distortion.

Hon. Sec., P. Sawyer, 55, Waterloo Road, Southampton.

WIMBLEDON RADIO SOCIETY.

At a general meeting, held on Thursday, the 22nd inst., the Hon. Sec. reported that, in reply to letters sent to members, he had received an overwhelming majority of replies in favour of holding the weekly meeting on Friday, and it was unanimously resolved that meetings would be held on this day in future. Mr. W. J. Rawlings gave a demonstration of the new "Sterling" four-valve cabinet receiver, which, coupled to one of the latest pattern "Amplion" loud-speakers with floating diaphragm, gave an immense volume of undistorted music and speech from the **2LO** transmission. Other broadcasting stations were also successfully tuned-in on the loud-speaker, without interference from **2LO**.

All the components for the Society's four-valve receiver have now been purchased, and its construction commenced. The Society is indebted to Messrs. Gambrell Bros., Messrs. the Igran Electric Co., Messrs. Burndept, Ltd., and others, for gifts of coils, coil-holders, filament rheostats, and other useful accessories. The Hon. Treasurer has also very kindly presented the Society with a "Music Master" pattern Amplion loud-speaker. All members are requested to make a note of the new meeting-night, i.e., Friday, and intending new members should communicate with the Hon. Sec., C. G. Stokes, of 6, Worpole Avenue, Wimbledon, S.W.19.

BELVEDERE, ERITH AND DISTRICT RADIO AND SCIENTIFIC SOCIETY.

On Monday, November 26th, Mr. C. E. Morriss gave an elementary lecture on "Crystals and Crystal Circuits," explaining in very simple language the theory of crystal rectification, and showing how the crystal possessed the property of converting the inaudible high frequency signal oscillations into pulses of audible frequencies.

He next showed how to apply the crystal to simple circuits and then to more elaborate ones. The quality of music and speech, when received on a crystal was very much superior to that received on a valve as there was practically no distortion with crystal-rectification. A simple crystal circuit of special design was then explained with which, said the lecturer, he had successfully received all the British Broadcasting Stations except Manchester.

Hon. Sec., S. G. Meadows, 110, Bexley Road, Erith, Kent.

THE NORTH LONDON WIRELESS ASSOCIATION.*

On Monday, November 26th, the "Loud Speaker Competition" was held before a good attendance and twelve different loud speakers were brought along by various members. The Chair was taken by the President, R. S. Clay, Esq., B.A., D.Sc.

The instruments were placed on the lecture table and their leads brought together so that each could be put in circuit without revealing which instrument was being connected.

Speech was received from **2LO** on a crystal, two L.F. valves following this, the final output terminals being brought to a pair of mercury cups into which could be dipped the leads from the loud speakers. The instruments were given numbers, and marks for quality and loudness were given by each member privately. The average marks were then taken and the places awarded. The results, it is thought, mainly proved the real difficulty of comparing the various modern makes of loud speaking telephones, as those which in the opinion of the club came out lowest in the test, were evidently not intended to deal with the same signal strength.

The actual test occupied about an hour and a half and proved of great interest to those present, who were well satisfied with the return for the trouble taken in bringing their instruments to the club.

Hon. Sec., J. C. Lane, The Northern Polytechnic Institute, Holloway, N.7.

HONOR OAK PARK RADIO SOCIETY.

At a recent meeting, the Vice-President, Dr. J. Russell Higson, M.B., gave a lecture on "Sound Distortion." He explained the principles of energy and motion in relation to sound, proceeding with a very full account of the production of the human voice and the action of the ear in reproducing these sounds, and transmitting them to the brain. Various simple experiments were suggested and the hope was expressed that members would take up the study of sound, it being so closely allied to wireless telephony.

The evening closed with a discussion on the possible causes of distortion in a certain dual amplification receiver.

Hon. Sec., G. J. Price, 22, Honor Oak Park, S.E.

LEYTON RADIO ASSOCIATION.*

On November 27th, the Association demonstrated its claim to have the most efficient antenna of any East London Radio Society.

Mr. Williamson, a member, reported reception of **WGY** on one valve on Sunday last, at 2.50 a.m.; the reception with the addition of an L.F. valve being almost of loud-speaker strength.

The rival merits of L.F. transformer and H.F. amplification were then discussed at some length, and a decision was arrived at to construct a resistance-coupled amplifier for comparison.

Hon. Sec., Capt. Thorley, C.A. Social Centre, Leyton, E.10.

MIDHURST AND DISTRICT RADIO SOCIETY.*

The November meeting was held (by courtesy of Major F. R. Harding Newman) at Rotherfield House, on Tuesday, Nov. 20th. The chief interest of the meeting centred in a five-valve set assembled by Mr. S. F. Broadway. Only four valves were used on this occasion (one H.F.,

detector, two L.F., reaction on tuned anode). The appearance of the set was most pleasing and its performance excellent. A loud speaker (Amplion) made itself heard all over the large billiard room in which the meeting was held, distortion being noticeably absent.

Future meetings will be held on the second Thursday in each month.

Hon. Sec., H. J. Dyer Cossins, Hunsdon, Midhurst.

LIVERPOOL WIRELESS SOCIETY.

At the Royal Institution, Colquitt Street, on Thursday, November 22nd, November, Mr. H. H. Harrison, of The Automatic Telephone Manufacturing Co., Ltd., gave an address on "Automatic Recording of High Speed Transmissions of Radio Telegraphy."

Mr. Harrison gave an historic survey of various methods of recording and transmitting Morse messages, and lime-light projections, illustrated throughout the variety of mechanisms ensuring absolute accuracy, coupled with the highest rapidity. High speed messages received by the Society's set were duly recorded at the meeting, and the members were permitted to inspect the apparatus.

Hon. Sec., G. H. Miller, 138, Belmont Road, Liverpool.

CITY OF LONDON PHONOGRAPH AND RADIO SOCIETY.

At the November meeting the Society was particularly fortunate in having a demonstration by Mr. T. Allison (**5FU**), who has accepted office as Vice-President. Using a straightforward circuit, 1 D and 1 L.F. (power valve), with 120 H.T. and a frame aerial, the demonstrator proved to those who had hitherto looked upon the loud speaker as a necessary evil, that purity of tone and faithfulness to the original can be obtained such as to gramophone can give.

Mr. Allison recounted some of his wireless experiences and mentioned that he had that morning received no less than 14 American amateurs. He has promised to give the Society a transmitting demonstration at an early date.

Particulars of the Society can be obtained from the Hon. Sec., J. W. Crawley, 27, Horsham Avenue, N.12.

Radio Society of Great Britain.

At the unanimous request of the officers and committee, Dr. W. H. Eccles, F.R.S., has consented to continue in the office of President for the forthcoming year.

The following nominations for other offices have been made: *Acting Vice-President*, Brig.-Gen. Sir Capel Holden, K.C.B., F.R.S., M.I.E.E.; *Hon. Secretary*, P. R. Coursey, B.Sc., A.M.I.E.E., F.Inst.P.; *Hon. Treasurer*, Prof. Ernest Wilson, M.Inst.C.E., M.I.E.E.

From amongst a large number of names considered, the Committee have selected the following as nominations to serve on the Committee for the forthcoming year, and these will be submitted for confirmation at the Annual General Meeting to be held on December 19th, at 6 p.m., at the Institute of Electrical Engineers: R. L. Smith-Rose, Ph.D., R. Carpenter, H. S. Pocock, Captain M. Ainslie, R.N., J. H. Reeves, M.A., M.B.E., Thomas Hesketh,

M.I.E.E., Stanley Ward, J. H. Hibberd.

The Chairman (F. Hope Jones, M.I.E.E.), Hon. Secretary (L. McMichael) and Hon. Treasurer (L. F. Fogarty, A.M.I.E.E.), although eligible for re-election, have intimated to the President and Committee that, in view of the fact that they have served some ten years in office, they do not desire their names to go forward for re-election.

It will be found that in the new constitution of the Society which is being submitted to members, it is not proposed to continue the offices of chairman or vice-chairman, and consequently no nominations for these offices are put forward.

The Committee recommend that the early appointment shall be made of a salaried assistant, and that an office shall be provided, on account of the very large increase in the clerical work connected with the conduct of the affairs of the Society and affiliated societies.

THE OPERATION OF THE ARMSTRONG SUPER.

Since writing the article called "The Operation of the Armstrong Super" (*Wireless World and Radio Review*, November 21st, page 239), an article has been published by H. Andrews, B.Sc. ("Some Laboratory Experiments with the Armstrong Circuit," page 805, *The Wireless World and Radio Review*, September 12th), on the results of his measurements on this circuit. Although these results are very excellent, might I criticise his method of plotting them.

Ratio b/a	Transmitter current. A.	Signal Strength Armstrong Detector b.	Ratio b/c D.
10.3	43.7	450	10.5
10.6	40.5	430	8.0
11.6	37.0	430	7.2
13.0	33.0	430	6.2
14.8	28.4	422	3.9
17.8	23.0	410	2.6
20.0	20.5	410	1.2
22.7	17.6	400	1.1
24.4	16.2	394	1.0
26.2	14.7	385	0.4
28.5	13.0	370	0.2
32.9	10.8	355	0.1

As plotted in Fig. 4 of the above article, the amplification factor is taken as the ratio of Armstrong signal to simple reaction signal. Now the latter is complicated by the fact that for excessively weak signals (*e.g.*, an entirely inaudible carrier wave) rectification becomes almost nil. This is very well shown by a comparison of his figures on transmitter current and signal strength without the Armstrong Oscillation.

The actual wave at the receiving station is naturally proportional to the current in the transmitter, but the simple reaction signal drops to

zero at 10 milliamperes transmitter current, *i.e.*, amplification by the Armstrong circuit then becomes infinite.

If his figures for signal strength in the Armstrong circuit are plotted against transmitter current, it becomes much more evident what is happening. This is done in Fig. 1.

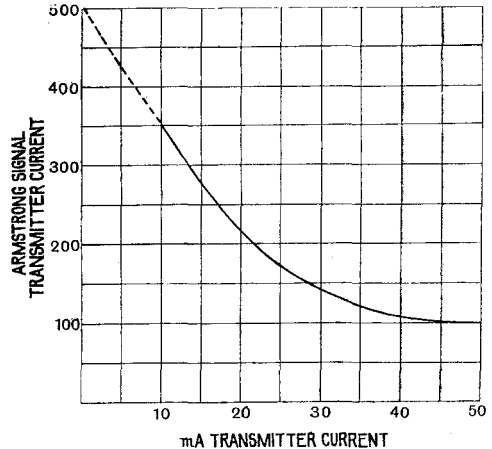

Fig. 2.

It is well known that the circuit possesses a "limiting factor" and from Fig. 1 it is evident that, although the transmitter was some distance away, "strong signals" are still being considered. The really interesting part of the plot is between 10 mA and 0, or the same effect produced by removing the transmitter to a greater distance.

In Fig. 2 is given a plot of the ratio of his Armstrong signal to transmitter current for varying transmitter currents, *i.e.*, relative "amplification factor" of received waves. Although this increases as the signal becomes weaker, it is almost entirely due to the limiting factor.

Fig. 1 can evidently be divided into two distinct portions, weak and strong signals. In the former, signal strength is roughly proportional to the received wave, and in the latter, signal strength is practically constant.

D. F. STEDMAN.

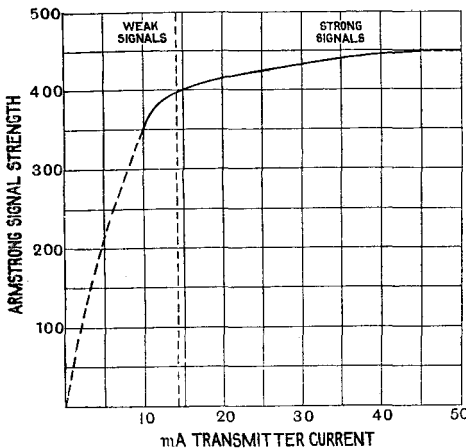

Fig. 1.



OUR TRANSATLANTIC BROADCASTING TESTS.

ONE outstanding feature of the week of Transatlantic Broadcasting which concluded in the early hours of Sunday, December 2nd, was the success of the British transmissions. The first reports which have reached this country from America give every indication that the entire British programme was received, despite the adverse weather conditions prevailing towards the end of the week.

The Westinghouse Electric Company at Pittsburgh, Pa., records the complete reception of the British transmissions, and this experience was repeated at Northport, Long Island. It appears, however, that the U.S. amateurs were not nearly so successful during the last two-way test, a fact for which atmospheric conditions must be held responsible. From the reports received it is evident that on December 2nd the most clearly heard of the British stations were London and Newcastle. In this connection we have received some useful information from British listeners regarding the quality of the transmissions on this side, and in almost every case the unusual signal strength

from all British stations is commented upon.

Concerning the amateur reception in this country of the U.S. transmissions, the following list furnishes the best criterion. *The Wireless World and Radio Review* has been inundated with letters of congratulation from all parts of the United Kingdom and Ireland, and even from France and Holland, and we take this opportunity of thanking our numerous correspondents for the valuable information with which they have supplied us. Every effort is being made to send individual acknowledgments as early as possible, and should delay occur, we feel sure that our readers will exercise forbearance, remembering the extreme pressure on our post bag. **WGY**, the G.E.C. station at Schenectady, remains easily first in regard to its reception in this country, and in not a few cases, was received on a single valve. **WHAZ**, the station at the Rensselaer Polytechnic Institute, Troy, N.Y., comes second, but of the remaining army of American broadcasting stations, amateur reports are, in the majority of cases, eloquently silent.

TRANSATLANTIC BROADCAST RECEPTIONS.

Below we publish a further list of successful participants in the Transatlantic Broadcasting Tests. A continuation of the list will appear in our next issue.

Name and District.	Stations Heard.	Type of Set.	Name and District.	Stations Heard.	Type of Set.
"R.W.R.," Exmouth.	WGY ..	—	E. Harrison, Sandiacre	WJAZ(?)	1—v—0
R. Stephen, Pontypool	WGY ..	2—v—0	W. R. Stainton, Leigh, Lincs. . .	WGY ..	0—v—1
A. E. Crisp, Woolwich	WGY ..	0—v—2		WHAZ	
J. W. G. Thompson, Edinburgh ..	WGY ..	Armstrong		WMAK(?)	
	KDKA	Super.	W. A. Evenden, Arras, France ..	WGY ..	—
A. H. Broomfield and S. R. Smith, Clapham Common.	WGY ..	1—v—2	J. Connelly, Liverpool	WGY ..	1—v—1
N. T. Smith, Broadstairs	WGY ..	1—v—1	J. Gibb, Stoke-on-Trent	WJAZ(?)	—
C. Keith Murray, Romsey, Hants ..	WGY ..	4 valves.	L. S. Constable, Blackpool	WGY ..	1—v—0
B. Wedmore, Winccombe, Somerset. .	WGY ..	2—v—1	E. A. Woolcock, Southport, Lincs. .	WGY ..	—
J. W. F. Cardell, Newquay	WGY ..	1—v—1	F. A. Cornford, Maidenhead .. .	WGY ..	—
	KDKA		H. R. Phillip, Arundel	WGY ..	3 valves.
N. C. Powell, Hitchin, Herts. . . .	WAOB ?	1—v—1	H. Evans, Birmingham	WGY ..	3 valves.
R. Leonard Thompson, Saffron Walden	WGY ..	0—v—0	E. Winterbottom, Southport .. .	WGY ..	2 valves.
Denis C. Weston, Halesowen, B'ham. .	WGY ..	1—v—0	S. Dann, nr. Rochester	WGY ..	1—v—2
J. H. Clarke, Staffs.	WGY ..	1—v—2	J. H. Gregory, Matlock	WGY ..	1—v—1
R. C. Rowley, Bradford	WGY ..	—	B. Jones, Bedford	WGY ..	0—v—1
J. F. Bruce, Bedford Park, W.4 .. .	WGY ..	0—v—0	E. Gwynne Lloyd, Neath, S. Wales	WJZ ..	1—v—1
	WJZ		F. W. Burford, Weston-super-Mare	WGY ..	—
W. G. Fudger (6 IX), Godalming ..	WGY ..	3—v—0	A. J. West, Chandlers Ford, Hants ..	WGY ..	3 valves.
J. P. Beeson, Southwell, Notts. . .	WGY ..	1—v—0	W. E. Price, B.Sc., Hincley, Leicester	WJAZ(?)	3 valves and crystal.
C. Bernard Childs, Edinburgh .. .	WNAV ?	1—v—1	R. Crees, Deal	WGY ..	1—v—2
G. W. Melland, N. Wales	WGY(?)	5 valves.	C. A. Copinjer, Bentham, Yorks ..	WGY ..	1—v—2
	WGY		Miss Morrise, Penmaenmawr, N. Wales	WGY ..	4 valves.
T. Grierson, Brondesbury, N.W. . .	Chicago(?)	3—v—2	J. H. Shores, Frodsham, Cheshire ..	WGY ..	1—v—0

Name and District.	Stations Heard.	Type of Set.
H. Grimshaw, Warrington ..	WGY ..	0-V-2
R. Greig, Wells, Somerset ..	WGY ..	3 valves.
F. A. Beckett, Edinburgh ..	?	4 & 5 valves
B. Griffin, Bristol ..	WGY ..	1-V-2
R. S. Turner, Maldon, Essex ..	WEAR ..	—
S. H. Page, M.P.S., Oundle, Northants	?	4 valves.
R. Cartwright, Chelmsford ..	WSY ..	2-V-1
	WGY ..	—
	WIZ ..	—
E. Edwards, Bramley, Surrey ..	WGY ..	1-V-0
H. C. Rowe, Blackpool ..	WGY ..	0-V-1
Stafford, Honey, Exeter ..	WGY ..	1-V-0
A. P. Hudson, S. Lines ..	WGY ..	1-V-2
J. Cuttriss, nr. Doncaster ..	WGY ..	0-V-2
R. Keith Common, Stirling ..	WGY ..	4 valves.
	WHAY ..	—
R. D. Duncan, Edinburgh ..	WGY ..	2-V-1
	KGKA(?) ..	—
	WCAE(?) ..	—
L. W. Bide, Clevedon, Som. ..	WGY ..	4 valves.
R. Macrory, Londonderry ..	WGY ..	5 valves.
H. C. Forder, Caterham ..	WGY ..	2-C-2
R. W. Simpson, Darlington ..	WGY ..	1-V-2
L. Austin, Hook, Surrey ..	WGY ..	0-V-1
J. Hincley, Stoke-on-Trent ..	WGY ..	—
W. L. M. Blount, Edinburgh ..	WGY ..	2-V-2
	WOR ..	—
D. R. Greenway, Bristol ..	WGY ..	2 valves.
J. H. Porter, Sheringham ..	WGY ..	1-V-1
W. C. Hinley, Brynmawr ..	WGY ..	1-V-1
P. N. Langham, Leicester ..	WGY ..	1-V-1
W. J. White, Jersey, C.I. ..	WGY ..	3 valves.
	WHAZ ..	—
A. E. Barnes, Jersey, C.I. ..	WGY ..	—
R. Lec. Wetherby, Yorks ..	WGY ..	1-V-2
G. H. Hodgson, Sheffield ..	WGY ..	2-V-1
W. S. Williamson, Alderley Edge, Cheshire.	WGY ..	0-V-0
	WHAZ ..	—
N. S. Capper, Belfast ..	WGY ..	1-V-1
S. J. Hume, Hull ..	WGY ..	3 valves.
G. W. Carr, Newport, Mon. ..	WGY ..	0-V-1
W. K. Freeman, Rugby ..	WGY ..	3 valves.
R. D. Newill, Newport, Salop ..	WGY ..	2 valves.
F. Parry, Liverpool ..	WGY ..	0-V-2
A. Gibson, Rochdale ..	WGY ..	1-V-1
A. S. Cutcliffe, Ilfracombe ..	WHAV ..	1-V-1
	WGY ..	—
	WOR ..	—
	KDKA ..	—
W. Hartree, Cambridge ..	WGY ..	1-V-1
D. Pitcavin Shearer, B.Eng., Leicester	WGY ..	1-V-1
	WJZ ..	—
	WNAC ..	—
	WDAR ..	—
H. V. Prescott, Wetheral, Cumberland	WGY ..	—
	JDKA ..	—
	WHAV ..	—
	WOR ..	—
Thos. Russell, nr. York ..	WGY(?) ..	—
W. Edward Jones, Leamington, Spa.	WGY ..	4 valves.
J. Hourston, Prestwick, Ayrshire ..	WGY ..	2 valves.
Harold Hall, Edgbaston, Birmingham	WGY ..	2-V-1
C. B. Nicoll, and P. Nicoll, Burnley..	WGY ..	Burndept
	WHAD ..	Ultra IV.
J. G. Bomford, Cardiff ..	WGY ..	R.I. 4 valve.
Ivor Ll. Williams, Newport, Pem. ..	WHAZ ..	4 valves
	WGY ..	—
	WBAA ..	—
Dudley F. Owen (2BC), Sale, nr. Manchester.	WGY ..	1-V-0 (Indoor aerial).
W. J. Hall, Sherborne, Dorset ..	WGY ..	1-V-1
Peter Eadie, Paisley ..	WGY ..	1-V-2
R. H. Coleman, nr. Leicester ..	WGY ..	3 valves.
J. Denton Robinson, Darlington ..	WGY ..	—
J. W. Claridge, Rushden, Northants..	WGY ..	1-V-2
F. E. Weekes, Chorley, Lancs ..	WGY ..	Marconi-phone V2.
	WHAZ ..	—
E. N. Haynes, Anglesey ..	WGY ..	1-C-1
R. Harris, Wimborne, Dorset ..	WGY ..	1-V-1
D. E. H. Fabry, Margate ..	WGY ..	1-V-0
Sidney H. Wellington, Gloucester ..	WGY ..	1-V-2
	WHAV ..	—
H. Nelson Smith, nr. Coventry ..	WGY ..	2-V-1
K. Youngusband, nr. Chester ..	WGY ..	2-V-1
Rev. W. Waite, Faversham ..	WGY ..	3 valves
Hylton L. Heelis, Appleby ..	WGY ..	1-V-1
	WHAZ ..	—
	WOR ..	—

Name and District.	Stations Heard.	Type of Set.
A. J. West, Chandlers Ford, Hants. . .	WGY ..	—
Chas. Parker, Warwick ..	KDKA ..	1-V-1
D. R. O. Prytherch, Penygroes, N. Wales.	WGY ..	1-V-0
S. C. Searles, Chelmsford ..	WGY ..	3 valves.
Marcus G. Scroggie, Edinburgh ..	WGY ..	1-V-1
H. Mead, Long Eaton, nr. Nottingham	WGY ..	1-V-1
"H.D.," Hoylake, Cheshire ..	WHAZ ..	1-V-0
	WGY ..	—
Major R. J. Campbell, nr. Dawlish ..	WGY(?) ..	4 valves.
A. Bonney, Bradford ..	WGY ..	1-V-1
John Corse, Edinburgh ..	WGY ..	1-V-1
J. McNeil, Macduff, Banff. ..	WGY ..	—
J. Shepherd Nicholson, Edinburgh ..	WGY ..	1-V-0
	WOO ..	—
	WOR ..	—
	WMAK ..	—
	WJAZ ..	—
	WGAE ..	—
	WSY ..	—
	WJZ ..	—
	WMAF ..	—
	WBAA ..	—
H. G. Ede, Islington, N.1 ..	WGY ..	2-V-0
Cyril V. Alcock, Letchworth ..	WGY ..	1-V-2
J. Jennings, Ambleside ..	WGY ..	4 valves.
R. W. Elder, Stockton-on-Tees ..	WGY ..	2-C-0
A. S. Fleming, Escrick, York. . .	WGY ..	1-V-1
	WHAZ ..	—
Wm. Dobson, Blackburn ..	WGY ..	—
J. C. Webb, Markethill, co. Armagh ..	WGY ..	3 valves.
W. A. Hayes, Portadown ..	WGY ..	0-C-1*
	WHAZ ..	—
	WJZ ..	—
D. B. Alcock, Tayport, Fife ..	WJZ ..	—
	WHAZ ..	—
J. S. Lindley, Stoke-on-Trent ..	WGY ..	2-valve "Gecophone."
Wm. Ellis, Appledore, N. Devon ..	WGY ..	—
	WHAZ ..	—
	WOR ..	—
	WJAZ ..	—
E. Turner, Bradford, Yorks. . .	WGY ..	3 valves.
Wm. Stewart, Renfrew ..	WGY ..	1-V-0
E. Détroyat, Anglet, Biarritz ..	WGY ..	—
D. Lithgow, Glasgow ..	WGY ..	1-V-0
	WHAZ ..	—
Capt. C. W. Hinds, Belfast ..	WGY ..	1-V-2
	KDKA ..	—
E. Dagger, Otley ..	WGY ..	—
	WOR ..	—
	WGI ..	—
W. Hird Jones, Hoole, Chester ..	WGY ..	2-V-2
	WHAZ ..	—
F. Coulthurst, Colwyn Bay ..	WGY ..	0-V-0
Eric Eadie, Lisbelleur, co. Fermanagh	WGY ..	2-V-2
Leonard Slater, Junr., Sheffield ..	WGY ..	7 valves.
Towler, Wivelscombe ..	WGY ..	2 valves.
John Angus, Edinburgh ..	WGY ..	2 valves.
Crawshay, Bridesstow, Cornwall ..	WGY ..	—
Messrs. Braidwood, Donaldfield, and Johnstone, Renfrewshire.	WGY ..	2 valve, Gecophone.
Rev. E. Blackwood-Price, Saintfield, County Down.	WGY ..	Marconi-phone V2.
C. Lewis Levy, Rochester ..	WJZ ..	3 valves.
W. McC. Armstrong, Girvan ..	WGY ..	3 valves.
	WHAZ ..	—
A. E. Gardner, Belfast ..	WGY ..	—
Jas. H. Cunningham, Ayr ..	WGY ..	2 valves.
	WHAZ ..	—
E. Watts & Son, Ltd., Hove ..	WGY ..	—
A. D. Swanston, Bo'ness, N.B. ..	WGY ..	3 valves.
Arthur M. Kemp, nr. Spalding ..	WGY ..	0-V-2
Ernest H. Lewis, Cardiff ..	WGY ..	1-V-2
Eric A. Haliburton, Stoke-on-Trent ..	WGY ..	1-V-0
	KDKA ..	—
James Crosbie, Girvan ..	WGY ..	Marconi-phone V2.
	WHAZ ..	—
D. C. Horngate, Hull ..	WGY ..	3 valves.
Geoffrey W. Salt, Bath ..	WOR ..	0-V-0
Laurence Bell, M.I.A.E., Edinburgh	WGY ..	—
L. Fildeu, Exeter ..	WGY ..	1-V-1
Wm. F. Young, Holytown, Lanarkshire	WGY ..	Burndept
	WHAF ..	Ultra IV.
W. J. Williams, Prestatyn, N.W. ..	WGY ..	—

* It would be interesting to investigate the conditions under which this remarkable reception was carried out.

A NOVEL AERIAL.

A new form of aerial, known as the "Vertex," has recently been evolved. It consists essentially of two metal rings, spaced 15 ins. apart by means of vertical rods, and held to the mast by cross-wooden framework. About one hundred feet of wire is wound zigzag between two rings, which gives, perhaps, a little more capacity than would be possessed by a short single wire. The whole arrangement is easily supported

Name and District.	Stations Heard.	Type of Set.
John Munro, Oban, N.B.	WGYP WBAE WHAZ WHAB WHAS	4 valve Ethophone
F. E. Greig, Birmingham	WGYP	3 valves.
Wm. A. Sutton, Finchley, N.12	WGYP	1-V-0
R. A. Bill, Birmingham	WGYP	1-V-2
A. C. Gill, Thrapston, Northants	WGYP	4 valves.
B. E. Peal, Woking	WHAD WGYP	3-V-1 —
F. Dallin Paul, Brighton	WGYP	1-V-2
N. C. Haigh, Henley-on-Thames	WGYP KDKA	1-V-0 —
G. W. Krapton, Rotherham	WGYP	4 valves.
Inman, Hampstead	WGYP	1-V-1
C. Warriner, Birkenhead	WGYP WHAZ	Marconi- phone V2.
C. Chevallier, Ipswich	WGYP	3 valves.
Geo. H. Brown, Liverpool	WGYP	—
J. Cedric King, Rochdale	WGYP	1-V-2
T. M. Linkie, W. Linton, N.B.	WGYP	Gecophone 2 valves.
C. W. Ashton, Stoke-on-Trent	WGYP	1-V-1
Wm. Scott, Alexandria, Dumbarton-shire.	WGYP	1-V-0
E. H. Secker, Morar, Inverness	WHAZ	—
F. T. S. Marsh, Camberley	WGYP	1-V-1
Geo. Inch, Bootle	WGYP	Marconi- phone V2.
C. Richardson, Liverpool	WGYP	2 valves.
J. Williams, New Ferry, Cheshire	WGYP	2 valves.
B. G. Reid, Longton, Staffs.	WGYP	3 valves.
J. Greaves, nr. Blackburn	WGYP	1-V-1
A. Franklyn, nr. Macclesfield	WGYP	1-V-1
Miss Lena Walker, Radcliffe	WGYP	2 valve Gecophone.
J. Wardle, Barrow-in-Furness	WGYP	1-V-0
R. Walter Anderson, Scarborough	WGYP	—
W. J. Masser-Horniman, Alresford	WCAE	5 valves.
D. P. Garner, Birkenhead	WGYP	1-V-0
Geo. H. Mouson, Hull	WGYP	—
A. W. Landamore, Norwich	WGYP	1-V-2
H. L. Pugh, Bishop's Castle, Shropshire.	WGYP	1-V-1
H. Claude Owen, Faversham	WGYP	Marconi- phone V2.
Humphrey Cheatham, Stockport	WGYP	0-V-0
F. W. Treadwell, Shrewsbury	WGYP	2 valves.
E. N. Bickley, Birmingham	WGYP WJZ	Burndep 3 valves.
Edward Opie, Scorrier, Cornwall	WGYP WHAB	4 valves. —
L. B. Lawson, Milngaire, N.B.	WGYP	—
E. F. Eggington, Narborough	WGYP	1-V-2
Geo D. Perkins, nr. Bristol	WGYP	Gecophone 2 valves.
H. W. W. Hoskyns, Buxton, Norfolk	WGYP	4 valves.
Wilfred J. Baker, nr. Rochester	WHAZ(?)	Marconi- phone V2.
C. G. G. Braidwood, Renfrewshire	WGYP	Gecophone 2 valves.
R. Knox, Berwick-on-Tweed	WGYP	1-V-0
F. H. Jackson, Redcar, Yorks	WGYP	1-V-1
W. S. Wilkinson, Alderley Edge	WGYP WHAZ	0-V-1 —
H. T. Robins, Sunderland	WGYP	1-V-1
A. E. Clay, Leeds	WGYP WHAZ WOR	1-V-1 — —
John Carlson, South Shields	WGYP	1-C-0
F. J. Frost, Canterbury	WGYP	1-V-1
G. W. Taylor, Blaby	WGYP	1-V-2
Geo. E. Old, Nottingham	WGYP	1-V-0
H. Vernon George, Weston-super-Mare	WGYP	—
W. Christie, Paisley	WGYP	0-V-1
E. Topham, Bradford	WGYP	4 valves.
W. Ian O. Williamson, Kinghorn, Fife	WGYP WHAZ	3 valves. —
Major M. S. Aldham, Bodmin, Cornwall.	WGYP WHAZ	1-V-2 —

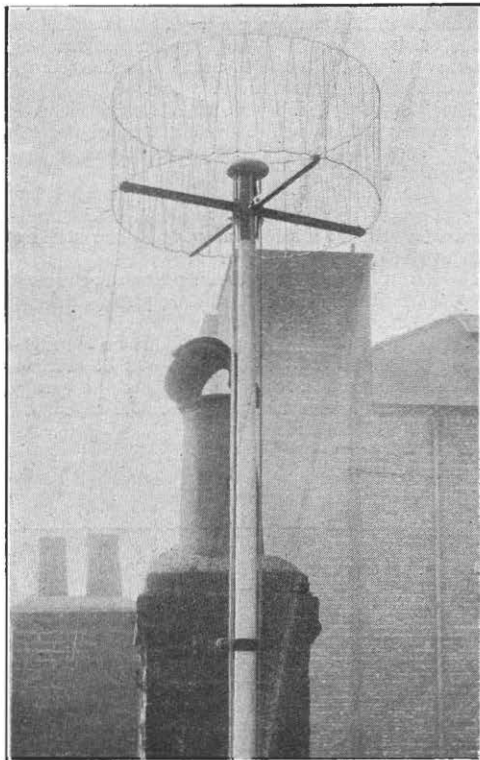

The "Vertex" aerial.

by means of a single mast, and is raised and lowered by means of a pulley and two halliards.

The advantages of this aerial arrangement are probably compactness and ease of setting up, for when attached to the mast there is no sideways pull and the symmetrical arrangement does not render necessary the use of guy wires. This class of aerial would be conveniently erected when it is quite impossible to sling up a short length of wire of equivalent height.

CORRESPONDENCE.

A New Short Wave Receiver.

To the Editor of THE WIRELESS WORLD AND RADIO REVIEW.

SIR,—It has long been realised that for short wave work, and particularly for the reception of the many 150 metre transmissions now being carried out, that the standard methods of amplification on the H.F. side are very inefficient. Several methods have been adopted for reducing the stray capacities that make themselves felt below 300 metres, but most of the new circuits are too complicated or tricky in operation to become generally popular.

This circuit, however, employs an ultra-efficient detector circuit, and low frequency amplifiers only, thus avoiding the troubles usually connected with H.F. amplifiers on low wavelengths.

The "hook-up" is by no means original, as it is in common use in the United States of America, but, efficient as it is, I have never seen it in an English station.

Its secret of success lies in the fact that by a careful use of regeneration even the feeble impulses from very distant stations are enabled to affect the grid of the detector.

Once amplified signal currents flow in the anode circuit, amplification by audio-frequency means is a simple matter.

The outline of the circuit without note magnification is shown in Fig. 1, and it will be seen that it is quite a simple matter to wire such an arrangement up; simpler, in fact, than the usual single valve and regeneration circuit.

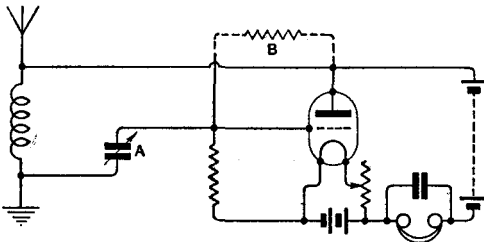

Fig. 1. General principles.

The condenser in the grid lead, A, is the most important gadget, as it is this capacity that controls the regeneration of the system. A capacity of about 0.0001 mfd. is usually sufficient to send the tube into oscillation, and so the capacity of the variable condenser should not exceed 0.0003 mfd.

The grid leak should have the normal value of about $2M\Omega$, but in some cases it may be dispensed with and no difference in results noticed. A further experiment that sometimes makes an improvement in the strength of signals obtained with even an ordinary receiver is to connect a high resistance of a few megohms between grid and plate. This sometimes improves rectification, but the normal position of the leak should be tried first.

Having examined the simple form of circuit, we may pass to the complete diagram shown in Fig. 2. This circuit diagram was copied directly from the set in use, without any alterations whatsoever.

It will be seen that in the detector circuit several departures have been made from the circuit in Fig. 1. The small variable in the grid lead has been replaced by a fixed condenser of a capacity of about 0.0003 mfd. Regeneration is still controlled, however, by the variable condenser, but connected in this case across the coil.

Loose-coupled tuning is employed because, apart from selectivity, the size of the secondary coil is not greatly dependent on the wavelength, and consequently a step-up effect may be obtained which adds to signal strength.

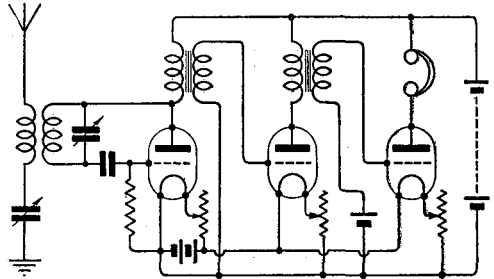

Fig. 2. The complete receiver. A cell with negative terminal joined to the transformer, is connected in the grid circuit of the last valve.

If it is found possible to oscillate on low wavelengths without the series condenser, it is better to omit it, as the primary coil will then be reduced in size and the step-up effect will consequently be greater.

On the audio-frequency side of the set nothing unusual is incorporated, but it may be mentioned that, providing signals are sufficiently loud, a high resistance leak may be connected across the primary of the last L.F. transformer in order to improve the quality of speech.

Much experimenting may be done in this direction, and the pure and natural tone obtainable will amply repay any loss of signal strength that occurs.

It will be noted that a grid cell is incorporated in the last valve circuit, but unless the strength of signals is sufficiently great or a high plate voltage is used, it may be found advisable to omit it.

The circuit is extremely easy to manipulate, and with a little practice excellent results can be obtained.

The secondary condenser should be set at minimum and the rheostats adjusted until the set just breaks into oscillation. Tuning is then done with the series condenser and the detector is then reduced to the state of being just off the oscillation point by means of the other variable condenser.

A fact that will appeal to users of sets employing ticklers, is that regeneration is constant over a wide range of wavelengths; thus the set can be fixed so that it is just off the oscillation point and tuning will not seriously alter this adjustment.

Signal strength is not greatly diminished even if the tuning condenser is placed in parallel, and the earth connected to one terminal of the primary coil in place of any aerial. Here again, the regeneration adjustment is constant.

Questions & Answers

Solutions of Readers' Difficulties

This section of the magazine is placed at the disposal of all readers who wish to receive advice and information on matters pertaining to both the technical and non-technical sides of wireless work. Readers should comply with the following rules:—(1) Each question should be numbered and written on a separate sheet on one side of the paper, and addressed "Questions and Answers," Editor, **The Wireless World and Radio Review**, 12/13, Henrietta Street, London, W.C.2. Queries should be clear and concise. (2) Before sending in their questions readers are advised to search recent numbers to see whether the same queries have not been dealt with before. (3) All questions will be answered through the post. Those of general interest will also be published. (4) Every question, except those under (5) below, should be accompanied by a postal order for 1s., or 3s. 6d. for a maximum of four questions, and also the coupon taken from the advertisement pages of the current issue. (5) For the benefit of those readers who would rather not pay the charges, a free Questions and Answers Coupon will be placed in the advertisement pages of the first issue of every month. This coupon should accompany the question submitted, together with a stamped addressed envelope. The free coupon is valid for the current week only. (6) In view of the fact that a large proportion of the circuits and apparatus described in these answers are covered by patents, readers are advised, before making use of them, to satisfy themselves that they would not be infringing patents. (7) Four questions is the maximum which may be sent in at one time.

"B.P." (Manchester) is able to receive 5 IT, 5 SC and 5 NO when situated only two miles from 2 ZY. He cannot receive 2 LO without interference from the local station. This he is particularly desirous of doing, and asks for advice.

We think you will have some difficulty in eliminating Manchester's transmission while listening to London, as the difference in wavelength between these two stations is not very great. Much depends upon the skill with which the receiver is adjusted, and we would not say that it would be impossible to cut out Manchester if you use one or more of the following remedies:—(1) The tuning circuit should be inductively coupled and the A.T.I. and the secondary circuit should be wound with thick wire. The tuning condensers used with these two circuits should be kept as small as possible and the coupling between them should be as loose as possible. (2) An absorption circuit tuned to Manchester's wavelength may be coupled to the aerial circuit. (3) The first high frequency valve may be transformer coupled, both windings of the transformer being tuned and the coupling between the windings being variable instead of fixed, as in the usual type of transformer.

"S.W.W." (Barnes) is troubled with interference from local spark stations and asks how this may be eliminated.

Interference from adjacent spark transmitters may be minimised if not entirely eliminated by the following methods:—(1) The use of a loosely coupled tuning circuit. (2) The use of some form of filter or absorption circuit tuned to the wavelength of the interfering station. We would refer you to the article on the "Prevention of Interference" in the issue of June 23rd, 1923, and to the discussion on "Methods of Reducing Interferences in Wireless Receiving Sets" in the issues of June 30th, July 7th and July 14th, 1923.

"G.B." (Stoke-on-Trent) asks how the H.T. supply for a receiver may be obtained from the 240 volt D.C. mains.

Perhaps the simplest method is to connect three small lamps of equal candle power in series across the mains, and to tap off the H.T. supply from across one of them. The diagram in Fig. 1 will make this point clear. The method is only practicable where the negative side of the mains is earthed, and this point should receive attention before connecting up the apparatus.

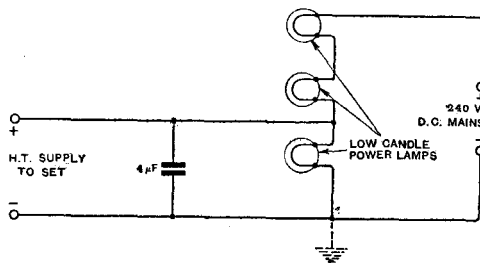

Fig. 1. "G.B." (Stoke-on-Trent).

"V.G.W." (High Wycombe) asks questions concerning dual amplification circuits, and also with regard to self-oscillation in tuned anode H.F. receivers.

Dual amplification circuits have been fully tested, and a number of arrangements were described in the issues of May 12th and 19th. It is agreed by competent observers that a good dual amplification receiver, consisting of one valve with crystal rectifier, is about equal to a two-valve receiver of ordinary design (1-V-O). It is well known that if a circuit is used in which the anode

of the first valve is tuned to the same wavelength as the closed circuit attached to its grid and filament, and there is coupling of any description between them, oscillations will be generated. The coupling may be magnetic or electrostatic. When magnetic coupling is absent, there is still valve and other stray capacity to contend with, and unless these are reduced, oscillations will be generated.

"R.T.D." (Kirky Lonsdale) asks (1) *If in a certain receiver the aerial circuit may be connected directly to the first valve instead of through a coupled circuit.* (2) *If the grid condenser and leak connecting H.F. valves do not actually cause rectification to take place.* (3) *If in a certain receiver the two tuned anode circuits can be tuned by means of a double tuning condenser.* (4) *To which terminal of the L.T. battery the -H.T. lead should be connected.*

(1) The aerial circuit may be coupled directly to the receiver if required, though the result will be a decrease in the selectivity. (2) The values given for the H.F. coupling condenser and leak are only intended as a guide. The values should be adjusted for the particular valves in use so that the minimum amount of rectification takes place at the second H.F. stage. (3) In the case of this particular receiver it is not practicable to tune the anode circuits by means of a double tuning condenser, as the reaction coil coupling affects the wavelength of the first tuned anode circuit. The double tuning condenser may be used, however, if a small variable condenser is connected across one side to restore the balance between the two circuits. (4) The negative H.T. terminal may be connected to either positive or negative L.T. It is generally found that slightly better results are obtained, especially on short wavelengths, when connection is made to the negative L.T. lead.

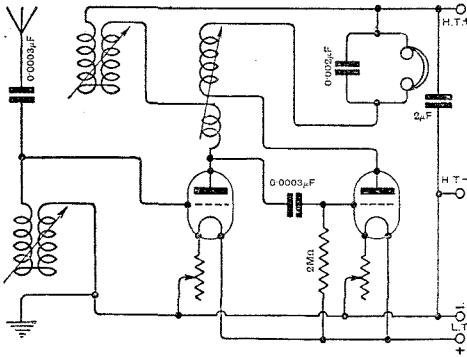

Fig. 2. "A.W.G." (Dundee). Variometer tuned H.F., with the reaction coil coupled to an extra coil in the plate circuit.

"A.W.G." (Dundee) asks how reaction may be obtained in a two-valve receiver employing variometer tuning in the aerial and tuned anode circuits.

Reaction effects may be obtained either by inserting an additional variometer in the plate

circuit of the detector valve or by coupling a reaction coil to a small auxiliary coil connected in series with the anode variometer. The diagram in Fig. 2 will make this latter point clear.

"H.T.G." (Shrewsbury) submits a diagram of a two-valve set in which one-valve, acting as a detector, is followed by one stage of L.F. amplification and asks if he would be able to receive certain of the B.B.C. stations.

The range of the set described would not be much more than 40 to 50 miles. We recommend that you use one stage of H.F. amplification, tuned anode coupled to the detector valve. If a reaction coil is coupled to the tuned anode coil, it should be possible to receive all the B.B.C. stations on a good aerial.

"G.E.W." (W.14) asks (1) *Whether he should be able to tune out the London station in order to receive other B.B.C. transmissions.* (2) *What are suitable coils for reception of Paris broadcasting stations.* (3) *What is the purpose of a tune stand-by switch.*

(1) You will be able to receive distant stations, provided that care is taken with the tuning adjustments. (2) The correct Burndep coils are as follows:

	A.T.I.	Secondary.	Reaction.
Paris (Radiola) . . .	1,780 m.	150	300
Paris (Eiffel Twr) . . .	2,600 m.	200	400
		400	300

(3) The object in using a secondary tuning circuit is mainly to enable one to sharply tune in a signal. The switch should be first of all placed in the "stand-by" position, and the aerial circuit tuned. Then put the switch in the "tune" position, couple the two circuits closely and tune the secondary. Alter the coupling, and at the same time the tuning adjustments until the signal is heard with greatest strength. If interference is experienced, make the coupling looser. The signal required will not be heard so loudly, but the interfering signal will be tuned out.

"W.E.S." (Hants) refers to a diagram given in the issue of July 21st and asks (1) *What sort of cell is used in the grid circuit of note magnifiers.* (2) *What is the usual capacity of the condenser joined across the H.T. battery.* (3) *What is a suitable transformer ratio.* (4) *Is any special type of valve recommended.*

(1) Small dry cells are used. Each has a voltage of about 1.4 volts. Join three or four in series, and try the effect of varying the number in circuit. (2) The condenser which is used across the H.T. battery may be a Mansbridge type condenser with a capacity of 1 or 2 microfarads. It is useless to employ a condenser of 0.001 μF. (3) The best transformers have a low ratio, 1 to 2½ or 3. Ratio, however, is not all that matters. The primary winding should have a large number of turns, 10,000 or more. The thickness of the wire used largely determines the size of the transformer. Good transformers are expensive, but in the end it pays to take the trouble of getting a good one. Two stages of note magnification is all that one normally requires. (4) We do not think you will do better than use "R" type valves for general use throughout the receiver.

THE WIRELESS WORLD AND RADIO REVIEW

THE OFFICIAL ORGAN OF THE RADIO SOCIETY OF GREAT BRITAIN.

No. 227. (No. 12.
Vol. XIII.) DECEMBER 19th, 1923.

WEEKLY

EDITOR:
HUGH S. POOOCK.

RESEARCH EDITOR:
PHILIP R. COURSEY, *B.Sc., F.Inst.P., A.M.I.E.E.*

ASSISTANT EDITOR:
F. H. HAYNES.

QUESTIONS AND ANSWERS DEPARTMENT:
Under the Supervision of W. JAMES.

CONTENTS

	PAGE
Another Wireless Milestone - - - - -	368
A Short Wavelength Receiver with Two Stages of H.F. Amplification. By W. James - - - - -	369
The Thermionic Rectifier for Battery Charging. By R. L. Smith-Rose, Ph.D. - - - - -	376
Novel Ideas and Inventions - - - - -	379
A Compact Two-Valve Receiver. By J. Baty, B.Sc. The Construction of Variable Condensers (<i>continued</i>). By W. James - - - - -	381
The Fundamentals of Loud Speaker Construction (<i>con- cluded</i>). By A. Nyman - - - - -	382
Correspondence - - - - -	385
Around the Wireless World - - - - -	387
With the Societies - - - - -	388
The Transatlantic Broadcasting Tests - - - - -	392
Questions and Answers - - - - -	393
	395

THE EDITOR will be glad to consider articles and illustrations dealing with subjects within the scope of the Journal. Illustrations should preferably be confined to photographs and rough drawings. The greatest care will be taken to return all illustrations and manuscripts not required for publication if these are accompanied by stamps to pay return postage. All manuscripts and illustrations are sent at the Author's risk and the Editor cannot accept responsibility for their safe custody or return. Contributions should be addressed to the Editor, "The Wireless World and Radio Review," 12 and 13, Henrietta Street, Strand, London, W.C.2.

SUBSCRIPTION RATES:
20s. per annum, post free. Single copies 4d. each or post free 5d. Registered at the G.P.O. for transmission by Magazine Post to Canada and Newfoundland.

EDITORIAL AND PUBLISHING
OFFICES:

12 and 13 Henrietta Street,
Strand, London, W.C.2.
Telephone: Gerrard 2807-8.



ADVERTISEMENT MANAGERS:

Bertram Day and Co., Ltd.,
1 & 10 Charing Cross, S.W.1.
Telephone: Gerrard 806; 4.

ANOTHER WIRELESS MILESTONE.

By THE EDITOR.

WHATEVER strides are being made in the commercial development of wireless, it is quite evident that the amateur has no intention of being left behind. Events which have transpired during the past week are of such outstanding importance that they must be described as a milestone in the history of wireless, and they serve once more to emphasise the importance of the work of the experimenter.

At the time of going to press with the last issue, a report reached us that Mr. Leon Deloy (French **8 AB**) whose station is located at Nice, had been in regular telegraphic communication on successive nights with two American amateur stations, **1 MO**, operated by Mr. F. H. Snell, Traffic Manager of the American Radio Relay League, and **1 XAM**, operated by John Reinartz.

One naturally hesitates to give publication to reports of such a startling nature without confirmation, and accordingly, rather than announce this information in the last issue, it was decided to communicate with Mr. Deloy for confirmation. Mr. Deloy's reply indicates that there is no doubt about the truth of the report. His signals have been heard by **1 MO** readable twenty feet from the 'phones, and have operated a loud speaker at **1 XAM**.

Next after Mr. Deloy's achievement comes a report from Mr. J. A. Partridge, of Merton, London, in reference to two-way morse working with **1 MO**, this time with Mr. K. B. Warner, Secretary of the A.R.R.L., on the key. Mr. Partridge's station (**2 KF**) first got into touch with **1 MO** with the assistance of **8 AB** on the morning of December 8th. Touch was maintained by the two stations until long after daylight on this side of the Atlantic, and personal messages were exchanged. By wireless communication, a further test working was arranged for the following Sunday night. On that occasion, again working well into the morning, Mr. Partridge maintained communication and received special messages, one addressed to *The Wireless World and Radio Review*, another to the Radio Society of Great Britain, another to Mr. Burnham, and another to Senatore Marconi, some messages being from Mr. Warner and others from different officials of the American Radio Relay League. Communication has since been maintained on other nights.

There is probably a great deal yet to be investigated before a proper understanding is arrived at regarding the theory of transmissions on short wavelengths, and what is of special interest is the effect of atmospheric conditions, and also, perhaps, the season, upon the distance which can be covered. It is interesting to note that the first successful attempt at amateur transatlantic communication was made on December 8th, 1921, when it will be remembered a number of American amateur stations were heard in this country for the first time. Again, a date corresponding very closely, viz., November 27th, 1922, was the first occasion on which reception by amateurs in this country of American broadcast transmissions was recorded. Certainly these facts, coupled with the general reports of excellent reception about this time of the year, seem to emphasise that seasonal influences play a considerable part in long distance reception. And so another landmark has been added to the record of amateur achievement.

A SHORT WAVELENGTH RECEIVER WITH TWO STAGES OF H.F. AMPLIFICATION.

By W. JAMES.

IN a previous issue* we discussed the difficulties of obtaining proper high-frequency amplification, and it was pointed out that the trouble experienced is largely due to the coupling between the output and input circuits of the amplifier. The coupling is in the form of a capacity, and is due to the capacity between the elements of the valve and holder, the capacity

would like electrical details of a receiver, in which the coupling capacities may be exactly neutralised. With the experience gained with a receiver of this sort, the experimenter will find himself better equipped so far as high-frequency amplification is concerned.

The receiver has two stages of high-frequency amplification, detector, and

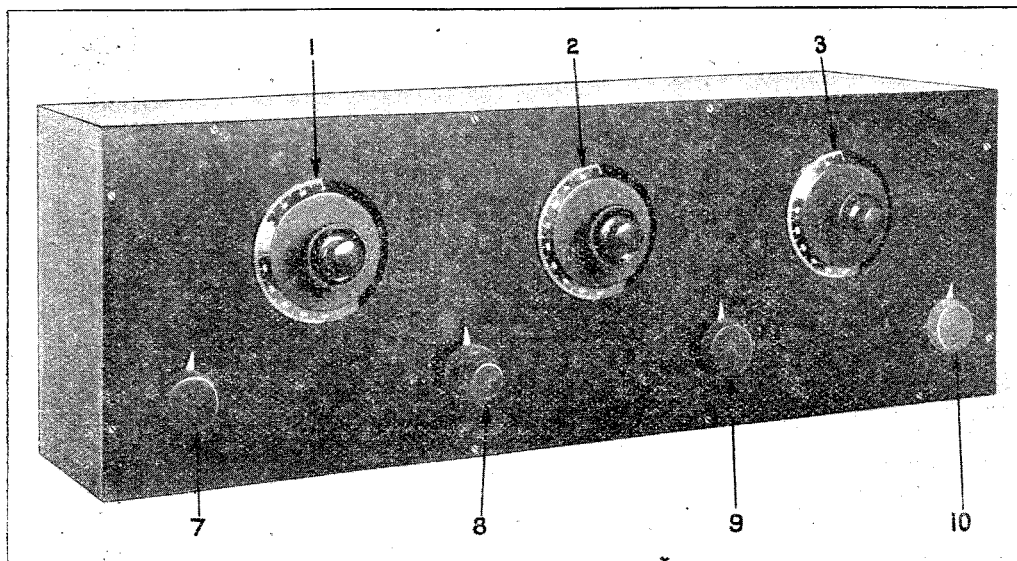

Fig. 1. Front view of receiver. The three tuning condensers are marked 1, 2, and 3, and the filament resistances 7, 8, 9, and 10.

between the connecting wires, and also between the apparatus.

To prevent the instability due to this unavoidable back coupling, it is necessary to pay attention to the wiring, the arrangement of the parts, and to balance out the remaining capacity. One method has been brought prominently to the public notice, recently, through the work of Prof. Hazeltine, in America. It is thought experimenters

* November 21st, pp. 250—252.

optional note magnifiers. With it, we may receive the same signals that would be received with any other receiver of first-class design, using the same number of valves, but with very much less trouble. Because there is no back coupling, the high-frequency circuits do not generate oscillations; consequently there is an entire absence of squealing, and the distortion caused by the use of reaction in ordinary receivers is, of course, not experienced.

The photographs of Figs. 1 and 2 show front and back views of the instrument. Fig. 3 is the diagram of connections of the receiver and the batteries, telephones, etc., Fig. 4 the layout, Fig. 5 the leading dimensions, Fig. 6 an end view of the receiver, and Fig. 7 a section through a high-frequency transformer.

THE HIGH FREQUENCY CIRCUIT.

It will be seen from the figures that there are three tuning units, which are identical in construction, and therefore electrical characteristics. These units each consist of a variable condenser, maximum capacity 0.0005 μ F., with vernier, and a high-frequency transformer. There is no great

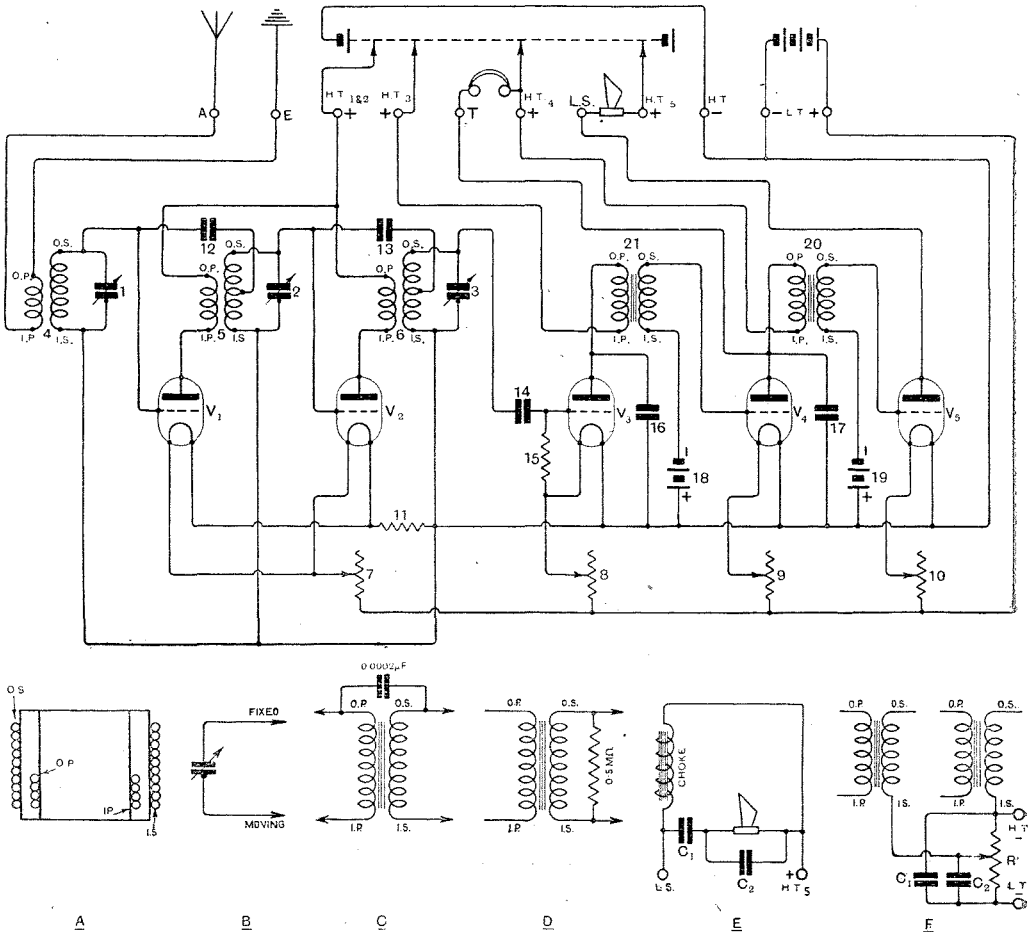

Fig. 3. The circuit diagram of the receiver. The components are as follows: Valves, 1st H.F. V_1 ; 2nd H.F. V_2 ; detector, V_3 ; 1st note magnifier V_4 ; 2nd note magnifier, V_5 . H.F. coupling transformers 4, 5 and 6, tuned with 0.0005 Sterling condensers 1, 2 and 3. Neutralising condensers, 12 and 13. Grid condenser 0.00025 μ F, 14; grid leak 2M ω , 15. Filament resistances 7, 8, 9 and 10; grid bias resistance, 11. Lissen low ratio transformer 21; Marconi Scientific Instrument Co. intervalve transformer 20. By-pass condensers, 0.005 μ F, 16 and 17. Grid circuit bias batteries, two cells, and three cells, 18 and 19.

Fig. 3A shows the method of connecting the H.F. transformers; 3B the connections of the tuning condensers; Figs. 3C and D methods of improving quality caused by poor transformers. Fig. 3E shows how to connect a filter circuit to the loud speaker; $C_1=2\mu$ F to 0.1 μ F, $C_2=$ about 0.02 μ F. Fig. 3F gives the connections of a method of obtaining negative bias for the grids of V_4 and V_5 as explained in Vol. X, No. 212, page 772. The resistance may be 1,500 ohms, tapped at 1,000 ohms, and the condensers C_1 and C_2 , 1 or 2 μ F.

need for the use of vernier condensers, but they are certainly helpful. I use those manufactured by the Sterling Telephone & Electric Company (called square law variable condensers), because the plates are specially shaped, so that the wavelength scale is uniformly divided all round the dial. With ordinary condensers, the wavelengths are crowded together at the lower scale readings and wide apart at the higher, which is a serious disadvantage when one wishes to

condenser at its minimum value it tunes to this wavelength. The coil chosen has a winding of 48 turns of No. 24 D.C.C. wound on a damp-proofed cardboard former 3 ins. in diameter. The former is $2\frac{1}{4}$ ins. long, and the winding length $1\frac{3}{8}$ ins. Its inductance is about 185 microhenries.

A coil of this size, tuned with a $0.0005 \mu\text{F}$. variable condenser, is joined in the grid circuit of both H.F. valves and the detector. The primary windings are connected in the

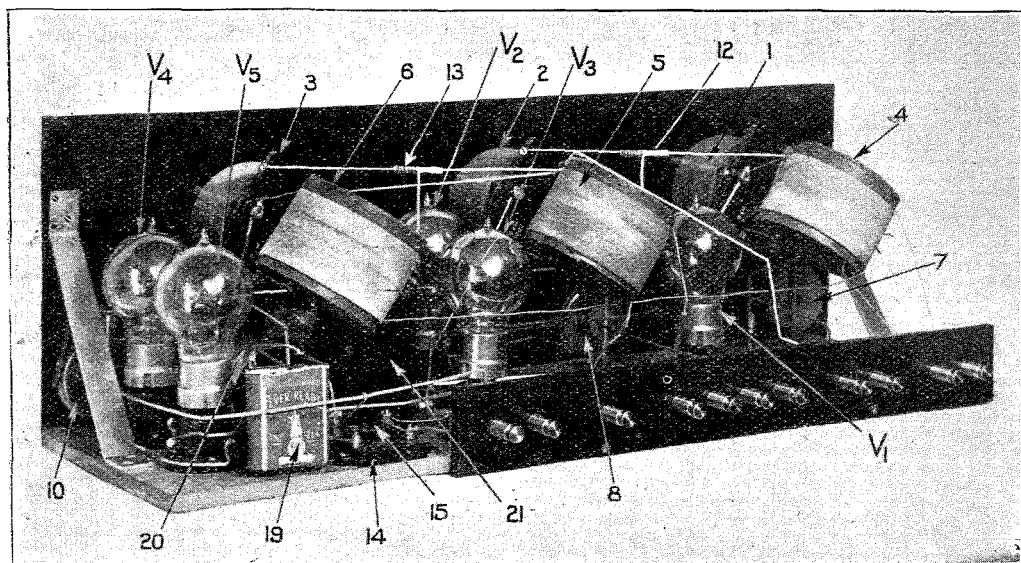

Fig. 2. Rear view of the receiver with the case removed. The parts are as follows:—Tuning condensers 1, 2, and 3; high-frequency transformers 4, 5, and 6; valves V_1 and V_2 are for high-frequency amplification, V_3 detector, V_4 and V_5 note magnifiers. The neutralising condensers are marked 12 and 13; the low frequency transformers 20 (M.S.I. Co.), and 21 (Lissen low ratio), the grid condenser and leak, 14 and 15. All external communications are made to the terminals on the terminal strip.

tune in amateur signals on wavelengths in the neighbourhood of 150 metres.

The transformers are constructed with a view to maximum signal strength with the requisite selectivity. There is no necessity to employ fine wire coils, stabilisers, or any other sort of damping device, as in most types of high-frequency amplifiers. Consequently, the coils are wound with No. 24 D.C.C. upon cylindrical tubes with reasonable regard to the best shape of coil so far as the ratio, diameter to length, is concerned. The shortest wavelength required is 150 metres, therefore the coil is chosen so that with the

aerial circuit and the plate circuits of the two H.F. valves.

In designing the primary windings, we have to consider selectivity and signal strength. From the point of view of strength alone, it is better to give the primary windings about half as many turns as the secondary. Selectivity is governed, among other things, such as the losses in the circuits, by the ratio of the windings and the distance between them. In this instrument, the primary windings have 18 turns of No. 24 D.C.C. each, wound upon a tube $2\frac{3}{4}$ ins. diameter. The distance between the wind-

ings is, therefore, about $\frac{1}{8}$ in. Those who experiment with the transformers, will find that the tuning is sharper the bigger the separation of the windings and the smaller the number of primary turns. Very good results will be obtained if the number of primary turns are 12. The selectivity is such that signals a few metres apart may be

battery. If one tries the effect of winding the coils in opposite directions, the connections of the primary should be the reverse to that given above. Results are generally not so good with this connection.

To avoid hand effects, the spindles of the variable condensers are connected with that side of the secondary which is connected to

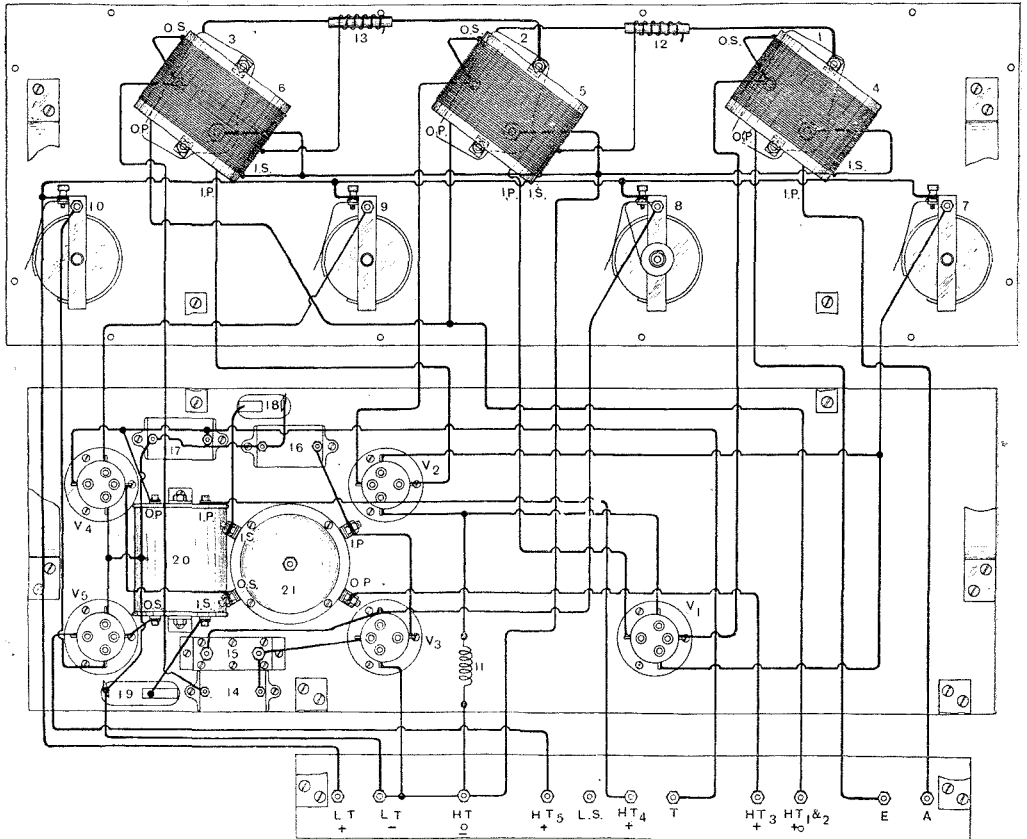

Fig. 4. Wiring diagram of the receiver. The upper panel is the ebonite front panel which carries the three H.F. tuning units and the filament resistances. The lower panel is a wooden base board. The wiring and components are arranged as though the panel and base board were laid out flat. Notice the ebonite terminal strip at the bottom, which is screwed to the back edge of the base board, so that the terminals project through the back of the box. The components are numbered to correspond with the other figures.

separated with ease, but there is, of course, a slight falling off in the signal strength.

For best results, the primary winding is wound at one end of the tube, and both coils are wound in the same direction. The beginning of the primary winding should be joined to plate, and the beginning of the secondary to the filament. The other ends are joined to grid, and positive of plate

filament. This is shown in Fig. 3B.

The construction of the transformers is shown in Fig. 7. For the purpose of easily balancing the circuits a tapping is made at the twentieth turn on the secondary windings, counting from the bottom.

By referring to the circuit, Fig. 3, it will be noticed that the aerial circuit does not contain a tuning condenser. It contains the

primary winding of the first transformer. Signal strength is not much reduced by this method, and selectivity is greatly improved, sometimes results are improved if the earth terminal is connected to -L.T.

For convenience, the transformers are mounted on the end plates of the variable condensers, Fig. 7. They are held with small brass brackets, which are secured by the nuts attached to the ends of the condenser spindles. To avoid coupling between them they are mounted sideways. The correct angle is 55° .

The writer is aware that the use of $0.0005 \mu\text{F.}$ variable condensers, especially when set near the maximum value, is not good from the point of view of signal strength or selectivity. For maximum signal strength and selectivity, best results are obtained with a small value of capacity. The receiver, however, is designed for short wavelengths, and when these are being tuned the condenser settings are quite small. The tuning of broadcast signals is not a difficult matter with a receiver of this sort, and since we wish to tune them in as well, the condenser must have a wide capacity range. The shortest wavelength one can tune with the coupling transformer units described is 150 metres, and the highest just above 550 metres.

Those who wish to tune in amateur transmissions only, with a wavelength between 100 and 250 metres, are recommended to use a primary winding of 12 turns and a secondary winding of 40 turns. The tuning condenser may have a maximum capacity of 0.0002 F.

Those who wish to tune in the broadcast transmissions only, 320 metres upwards, are recommended to use 18 turns for the primary, and 70 for the secondary, with a $0.0003 \mu\text{F.}$ variable condenser.

The tuning condensers are numbered 1, 2 and 3 in the figures, and the coils 4, 5 and 6.

Referring to the diagram of connections, Figs. 3 and 4, it will be noticed that one filament resistance (7) controls both H.F. valves; resistance (11) of 0.8 ohms is joined in the negative connection to the heating battery. When "R" valves are used the heating current is about 0.65 amperes to each valve, and the fall in voltage is, therefore, $2 \times 0.65 \times 0.8 = 1$ volt. The filament connections of the three transformers are made to negative L.T., and, with respect to

the negative side of the filament, are 1 volt negative. The resistance consists of 22 ins. of No. 22 Eureka wire. The negative bias of 1 volt is suitable when "R" valves are used with about 75 volts in the plate circuit.

The neutralising condensers, 12 and 13, are joined between the grids and the taps taken off the secondary windings of the transformers. The capacity is small (of the order of a few micro-microfards), and may be constructed in a number of ways. Referring to the photograph (Fig. 2) and to Fig. 4, it will be seen a stiff wire is run from the top support of the coils, which is connected to the side of the condenser, joined to the grid, to a screw screwed into a tapped hole originally provided in the condensers for fixing purposes. The wire is soldered to the head of the screw and the support, and forms one plate of the condenser. A piece of insulated tubing is threaded over the wire. The other plate of the condenser consists of a few turns of No. 24 D.C.C. wire, one end of which is joined to the tap on the coil. The end is cut off short, after the capacity has been experimentally adjusted. The screw which is screwed into the condenser end plate should not be too long, because it has capacity with the condenser spindle, which acts in the same way as the neutralising condenser proper.

Another sort of neutralising condenser consists of a piece of ebonite upon which is mounted two pieces of $\frac{1}{8}$ in. brass rod with their ends $\frac{1}{4}$ in. apart. A glass tube fits over the brass rods. On the outside of the glass tube is a brass tube. The capacity between the two $\frac{1}{8}$ in. rods is adjusted by shifting the position of the metal tube. When correct, the tube is soldered to a support.

It will be noticed that there are two of these neutralising condensers. Particular care should be taken with the wiring of these circuits. Make the grid wires as short as possible and keep other wires away from them.

THE DETECTOR CIRCUIT.

The grid condenser (14) has a value of $0.00025 \mu\text{F.}$, and the grid leak (15) 2 MΩ. The leak is connected between the grid and the positive side of the filament. The plate circuit contains the primary winding of a Lissen low ratio intervalve transformer, 21, connected as in the figures. A large fixed condenser (16), capacity $0.005 \mu\text{F.}$, is connected between the plate and -L.T. The

used. With some loud speakers, the quality is much improved if a large condenser, about $0.02 \mu\text{F}$., is joined across its connecting wires.

Fig. 3F shows an alternative method of obtaining a negative potential for the grids of V_4 and V_5 . The resistance should have a total value of 1,500 ohms, and the tapping is at 1,000 ohms. The coil is wound with No. 40 S.S.C. Eureka wire.

OPERATION.

When the receiver is wired, connect the aerial and earth, batteries and telephones as in Fig. 3. The last valve, not being required, will not have its filament heated. Set the second and third condensers at, say, 90, and very slowly turn the first condenser knob. When a signal is heard, carefully adjust the second and third condensers together.

Now place a piece of paper over the filament leg of the first valve, and place it back in its holder. The filament will not light, of course, but the signal will, in all probability, still be heard. The signal is transmitted

the neutralising condenser, 12. Start with no capacity at all and gradually increase it. If the signals are strengthened and the coils have been properly connected, the wiring should be rearranged a little. As the capacity is increased, the signal should sound

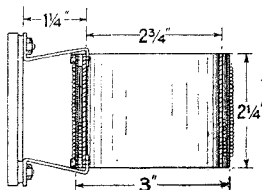

Fig. 7. Showing the method of mounting the H.F. transformers on the end of the tuning condensers.

weaker, until a point is reached when no signal is heard at all. To be sure the stray capacity is balanced, take the valve out of its socket, when it will be found the signal is heard once more. Fix the neutralising condenser with wax, or by soldering.

Light the filament of the first valve, and adjust the second neutralising condenser as described above, but with the piece of paper on a filament leg of the second valve.

It would be better, for testing purposes, to set up an oscillatory valve circuit, and to modulate the output from it with an interrupter, such as a buzzer.

A method which is not quite so good is to induce signals into the aerial circuit from a buzzer wavemeter. One may be made up for the purpose by connecting a $0.0003 \mu\text{F}$. variable condenser with a coil of 50 turns of No. 24 D.C.C. wound on a 3 in. tube. A buzzer with a few dry cells is connected across the tuned circuit.

Always set the neutralising condensers with the receiver tuned to a short wavelength. When they are properly set it will be noticed that with no adjustment will a whistle or carrier wave be heard in the receivers.

Tuning is very simple on account of the second and third condenser readings always being the same. The reading of the first may be a few degrees different on account of the capacity of the aerial.

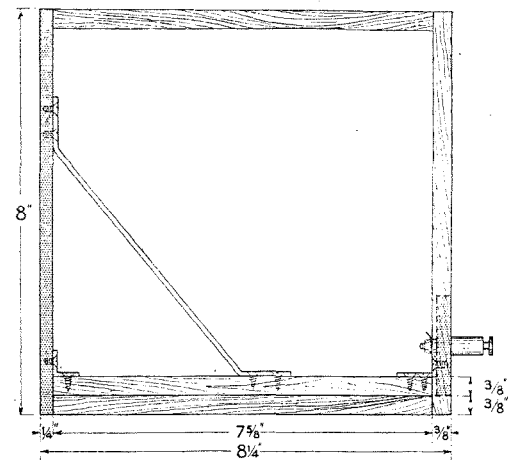

Fig. 6. Side view of the instrument. The base board is held to the ebonite panel with brass brackets, and is raised a little from the bottom to allow the box to fit. Notice the brackets which hold the connection strip.

through the capacity between the input and output circuits of the first valve. Tune the circuit once more, and then carefully adjust

THE THERMIONIC RECTIFIER FOR BATTERY CHARGING.

By R. L. SMITH-ROSE, PH.D., M.Sc., D.I.C., A.R.C.S., A.M.I.E.E.

I.—The Development and Application of the Gas-Filled Thermionic Valve.

WITH the modern widespread use of radio receiving apparatus in the home and the accompaniment of valves to meet the insatiable demand for louder signals, the problem of charging small accumulators has to be faced. In the majority of cases this is solved either by becoming a regular customer of the local garage or of arranging a suitable means of utilising the ordinary electric lighting supply for the purpose. Many users prefer the latter, giving personal attention to their cells, as the treatment inflicted by the garage "electricians" is frequently more profitable to the makers of batteries than to the users thereof. When the domestic supply is in the form of direct current, a very simple charging board can be erected from which to charge accumulators as required. With alternating current supply, however, the problem is somewhat more difficult, involving as it does some means of rectifying the current passed through the accumulators. Various forms of rotary, vibrating reed, chemical and "arc" rectifiers exist for this purpose, but the development of the thermionic valve has provided an alternative method which may prove a serious rival to these.

All students and experimenters in wireless telegraphy are familiar with the rectification properties of the ordinary two-electrode valve, as largely used nowadays for the production of high-tension direct current supply for valve oscillators in radio transmitting sets. In connection with this application the common conception is that it is absolutely necessary to employ anode potentials of hundreds or thousands of volts if a rectified current of more than a few milli-amperes is required. This being true of the high vacuum two-electrode, it is obviously impracticable to make use of this type for the charging of accumulators of any appreciable capacity.

The necessity for this high voltage is to overcome the effect of the "space charge" of the electrons in limiting the current passing through the valve between the filament and anode. By introducing a minute trace of gas into such a valve under certain conditions a number of positive ions may be formed by collision with the electrons and these will partially neutralise the space charge and so reduce the voltage required to produce a given current. This is the reason that in the early types of "soft" valves the saturation current could be attained for a comparatively low applied voltage, the gas present being the residual air left in the tube after exhaustion to the highest vacuum then obtainable. As in the case of the Fleming oscillation valve, these tubes were characterised by some irregularity in their action. Since that time many investigations upon the thermionic emission of various substances in the presence of different gases have been carried out by several observers. In particular, Dr. Irving Langmuir has studied the effect of gases on the emission from tungsten.¹

Tungsten is now very largely employed for a cathode in thermionic tubes, on account of its high rate of emission and also because its high melting point permits of its being raised to a higher temperature than other substances. The gases experimented with by Langmuir include hydrogen, water vapour, oxygen, nitrogen and argon, and the result of his experiments may be put briefly by saying that, in every case except that of argon, the presence of the gas reduced the thermionic emission of the tungsten from its value in vacuo. In the presence of the gas argon, however, the rate of emission of electrons by incandescent tungsten remains unaltered. The only

¹ O. W. Richardson: "Emission of Electricity from Hot Bodies," pp. 117-126; also I. Langmuir: "The Effect of Space Charge and Residual Gases on Thermionic Currents in High Vacua." *Phys. Review*, Vol. II, p. 450, December, 1913.

effect of the presence of argon in a small quantity is to reduce the space charge effect by supplying positive ions, and so reduce the voltage necessary to attain the saturation value of the thermionic current. Argon is one of the monatomic gases of the "inert" group, and it is probable that the other gases of this group would behave in a similar manner.

This mode of "softening" a valve by the introduction of an inert gas has been applied

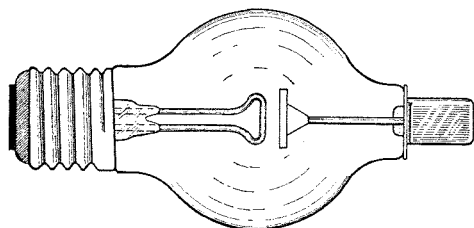

Fig. 1. Diagram showing construction of a typical Tungar bulb.

in the construction of a low voltage rectifying valve, and the types and construction of such valves were described in a paper by G. S. Meikle in 1916.² With the introduction of gas into the tube, the positive ions thereby formed serve in part to convey the current, moving in the opposite direction to the negatively charged electrons, viz., from anode to cathode. Now, under certain conditions, the velocities of these positive ions may attain very high values, and on striking the cathode may cause its rapid disintegration, since they are of relatively

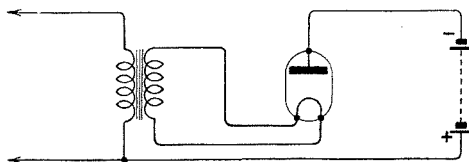

Fig. 2. Circuit connections for half-wave rectifier.

large mass. With increased gas pressure within the bulb, the velocity of these ions is diminished, but the number of ions is considerably increased, so that the nett

result on the bombardment of the cathode may be augmented. Long and accurate investigations, however, have shown that by proper adjustment of the pressure of the gas within the tube, disintegration can be eliminated, and when rectifying heavy currents, the emission of electrons from the cathode may actually be sufficient to cool the latter.

These gas-filled thermionic tubes have found application as low-voltage rectifiers, and commercial forms of these are manufactured by the General Electric Company of America and the British Thomson Houston Company in this country under the name of the "Tungar" rectifier, for the charging of small batteries of accumulators from the usual alternating current supply.³

The principle of the construction of the bulb is shown by the diagram in Fig. 1. It comprises a tungsten filament cathode, of either straight or spiral form, and an anode:

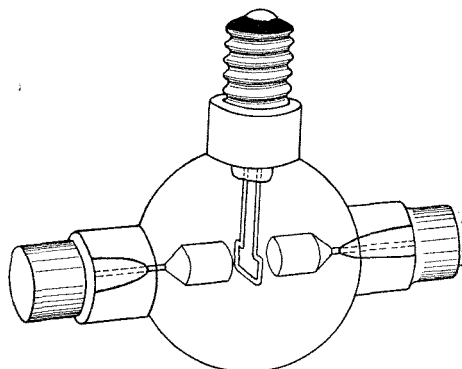

Fig. 3. Rectifier bulb with two anodes.

of tungsten, copper or graphite, mounted inside a bulb of special heat-resisting glass, two or three inches in diameter. The anode is preferably in the form of a flat disc to provide a large surface. The leads from the cathode are brought out to a standard Edison screw cap, while the anode is connected through the top of the bulb by a flexible lead.

The tubes are very carefully exhausted and then filled with argon in a high state of purity to a pressure of from 3-8 cms. of mercury, measured cold. A chemically

² G. S. Meikle: "The Hot Cathode Argon Gas-Filled Rectifier." *G. E. Review*, Vol. XIX, p. 297, April, 1916; also *Electrical Review*, Vol. LXXVIII, p. 472, April, 1916.

³ R. E. Russell: "The Tungar Rectifier," *Gen. Elec. Review*, Vol. XX, March, 1917; also *Electrical Review*, Vol. LXXX, p. 584, May, 1917.

active purifying agent is introduced in the tube, usually in the form of a coil round one of the cathode leads. During operation of the tube, this material evaporates and absorbs any foreign gases which may be liberated from anode or cathode, or from over-heated glass parts. It is this purifying material which often gives rise to the discolouration of the bulbs of the "Tungar" rectifier.

To rectify both halves of the alternating wave, two such rectifiers may be used; but the two rectifiers may be combined in a single bulb containing two anodes and a common cathode, as shown in Fig. 3, the scheme of connections for this bulb being shown in Fig. 4. The resulting pulsating direct current may be smoothed out by a series reactance, or by a parallel condenser, as in the case of high-voltage rectifiers.

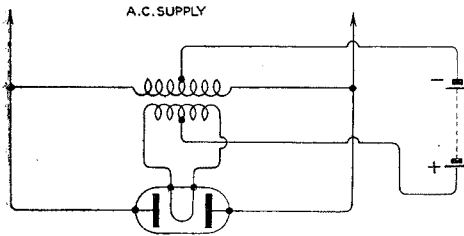

Fig. 4. Circuit connections for full-wave rectifier.

The circuit for a half-wave rectifier is shown in Fig. 2, where the cathode is heated by current from the main supply through a step-down transformer.

Such rectifying tubes operate satisfactorily on currents ranging from a fraction to many amperes, and on alternating supplies at 20 volts and upwards. No auxiliary starting load is required when commencing to charge a battery. The supply switch is closed, and the charging current picks up immediately, giving a slightly tapering charge as the battery voltage increases. The fact that this rectifier is self-starting and that there is no lower limit of the current are two distinct advantages which it has over the mercury arc rectifier.

Several types of the Tungar rectifier have been standardised for operation on supply at various voltages and frequencies to charge batteries of three to thirty-six cells at from about 1 ampere up to 6 amperes.

(To be concluded).

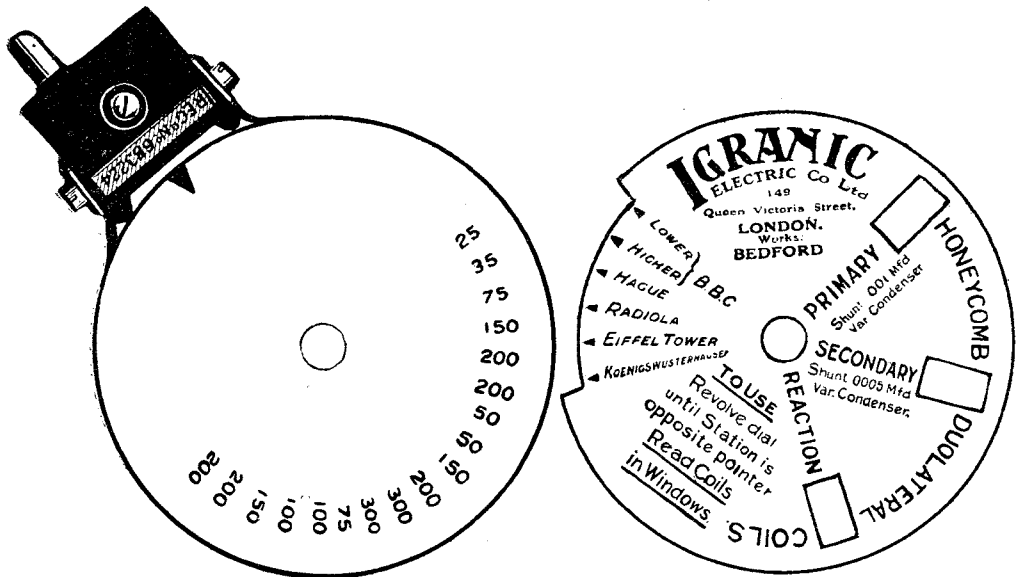

A useful cardboard novelty supplied by the Igranig Electric Co., Ltd. The card on the right covers, and is rotated over that on the left. The "windows" opposite the words "Primary," "Secondary" and "Reaction" then reveal the correct size of coil for use in receiving the station indicated by the arrow.

NOVEL IDEAS AND INVENTIONS.

Abstracted by PHILIP R. COURSEY, B.Sc., F.Inst.P., A.M.I.E.E.

Multiple High Frequency Telephony (Wired Wireless).

In a simple wired wireless circuit a separate thermionic valve or similar oscillation generator must necessarily be employed, but when it is desired to transmit a number of independent messages along the same wire circuit, the apparatus is apt to become cumbersome if a separate oscillator is used for each communication channel. To overcome this difficulty a common high frequency generator can be employed for a number of circuits in conjunction with static-frequency raisers, multiple tuned circuits, or similar apparatus, so as to produce a number of separate sources of different frequencies from the common high frequency oscillator*. When such an arrangement is used, it is necessary to employ a distinct modulating apparatus for each communication channel, such apparatus modulating the oscillations in its own circuit only without interference with the steady production of oscillations by the master oscillator.

Radiophare Transmitters.

The approximate determination of bearings from a radiophare transmitter may be made easier by arranging that the transmitter sends a distinctive signal on two or more of the cardinal points of the compass. Hence the receiver can determine its bearing by a rough time measurement of the interval between maximum signal strength and the nearest distinctive signal.†

Safeguarding Valve Transmitters.

With most arrangements of valve transmitters considerably more energy is passing through the circuits than can be dissipated by the valve anodes. Hence it follows that if for any reason the valves cease oscillating they would be overloaded and probably damaged. This overloading shows up by the heating of the anodes.

One method of safeguarding the valves is to mount inside the valve a small auxiliary anode on the outside of the main anode, so that normally it is shielded from the electron stream from the filament and no current flows to it.* If the main anode becomes overheated it will emit electrons itself, and these being caught by the auxiliary anode can produce a current through a relay winding in the circuit of the auxiliary anode, thus enabling the H.T. feed current to the main anode to be cut off and the valve saved from damage.

Limiting the Wave Band of a Radiotelephone Transmitter.

If all the upper harmonics of speech or music are efficiently transmitted by a radiotelephone sending station, the band of wavelengths that is occupied by the transmission becomes very broad, especially if the mean wavelength is long. It has been found that most of the higher harmonics can be suppressed without causing too great a distortion of speech to introduce loss of

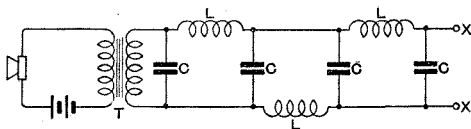

Fig. 1.

intelligibility.† These harmonics can be suppressed by inserting a filter circuit between the microphone and the transmitting valves, the constants of the filter being such that it blocks all frequencies above about 1,000 cycles. The general arrangement of a suitable filter is sketched in Fig. 1, in which diagram T represents the microphone transformer, while the modulating valve is joined on to the leads xx. By altering

* British Patent No. 199412, by C. Lorenz Company (Berlin).

† British Patent No. 196085, by G. P. Grenfel and J. Robinson.

* British Patent No. 189095, by Gesellschaft für drahtlose Telegraphie.

† British Patent No. 174076, by Gesellschaft für drahtlose Telegraphie.

the values of the condensers and inductances, the cut-off point of the filter can be adjusted to various frequencies.

Errors in Radio Direction Finding.

Errors sometimes arise in a D.F. receiver due to the loop aerial being unsymmetrical with respect to capacity to earth. The difference in the capacity to earth of the two halves of the frame may arise in the aerial itself or in apparatus associated with it. It may be balanced out by making an earth connection to the frame at some point near to its centre and moving this point until balance is obtained, or by the use of two tuning condensers instead of one, the mid point of the condensers being earthed.

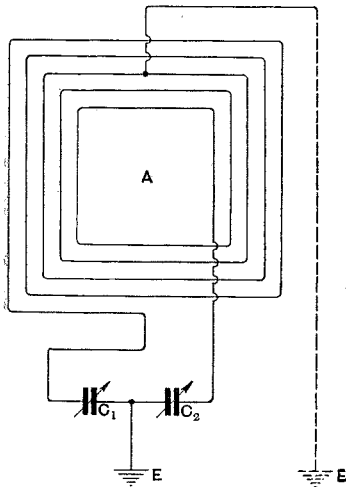

Fig. 2.

The relative values of the capacities of C_1 and C_2 in Fig. 2 may be varied while retaining the aerial A, tuned to a given wavelength.* If desired, a combination of these and similar methods may be employed until the desired result is obtained.

Condensers for High - Power Radio Circuits.

Insulation difficulties become very apparent when high voltages exist in radio frequency transmitting circuits. This fact

is emphasised in the construction of condensers for operation in such circuits, as the several units of which the complete condenser must necessarily be built up

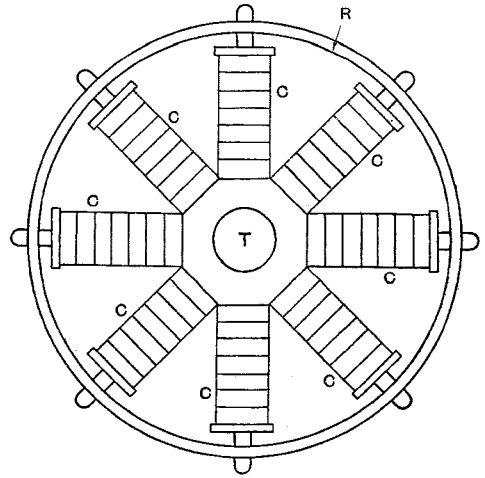

Fig. 3.

require not only mechanical support, but electrical insulation. These difficulties are overcome in the form of construction sketched in Fig. 3 in plan.* It consists of a metallic ring R, which acts both as a clamping member and as one terminal of the condenser. Between it and the central part T, a number of condensers CCC are clamped, such condensers forming the "arms" or spokes of a wheel-like structure, of which the ring R forms the rim. Each condenser "arm" is built up of numerous condenser sections connected in series or parallel as required to give the necessary capacity and to support the necessary voltage. Thus the central terminal rod or tube T which is common to all the condenser arms not only makes the connection to the condensers, but is supported mechanically by them and also insulated by them without the use of any other insulating supports. Thus the condensers which are by virtue of their design well adapted to withstand high C.W. voltages provide their own insulation for the high tension terminal. A number of such rings of condensers may be connected in series or parallel as required for any particular use.

* British Patent No. 172942, by Gesellschaft für drahtlose Telegraphie.

* British Patent No. 195266, by W. H. Goodman and Dubilier Condenser Company, Ltd.

A COMPACT TWO-VALVE RECEIVER.

By E. J. BATY, B.Sc.

THE little set illustrated resembles that described in the *Wireless World and Radio Review* for October 3rd, the only differences being in the details of manufacture of the various components, which are now mounted on standard hubs, making it possible to use a wooden panel instead of ebonite, the terminals and valve sockets only being mounted on an ebonite strip 9 ins. by 1 in. by $\frac{3}{16}$ in.

The wood panel measures 12 ins. by 6 ins. by $\frac{3}{8}$ in., and may either be mounted as the lid of a box or may be stood vertically. The

mica in between. This gives the optimum value when the insulation area is about $\frac{1}{3}$ of a square inch, using mica 2 mils. thick. The circuit is as illustrated in the *Wireless World and Radio Review*, October 3rd, 1923. When using the 3-in. condensers illustrated and the 100-turn coils with the condenser screwed hard up, the anode circuit tunes to about 1,100 metres.

One-third of a turn of the condenser reduces the wavelength to about 600 metres, two-thirds of a turn gives 400 metres, and one turn gives about 360 metres. A wavelength of 300 metres may be sharply tuned

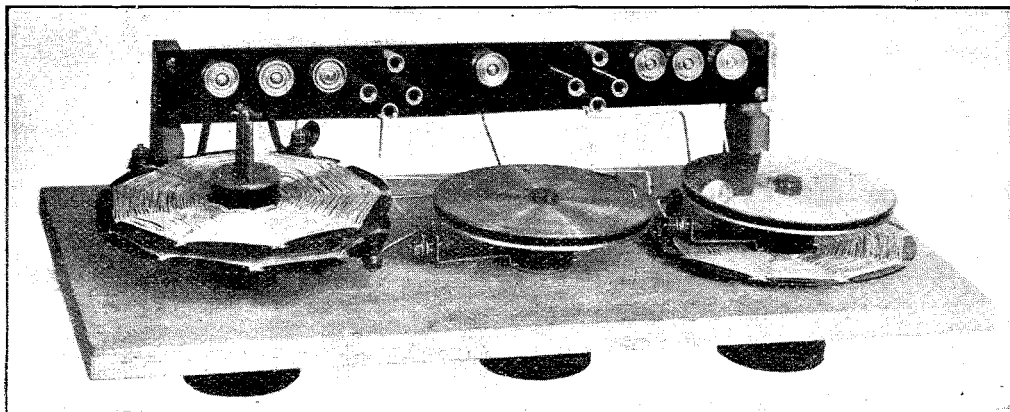

The fixing of condensers and coils is quite easy, and ebonite is only used where it is necessary.

total weight of the set as illustrated is $1\frac{1}{2}$ lbs.

The aerial circuit is aperiodic, the aerial coil being the movable coil of the variocoupler. This coil has 100 turns of 30 D.C.C. wire on an ebonite former with nine $\frac{1}{4}$ -in. slots, the inner and outer diameters being 1 in. and $3\frac{1}{4}$ ins. respectively. The secondary coil is an exactly similar coil and is tuned by the condenser in the middle of the set. The range covered by the combination is from 300-800 metres for oscillation of the secondary, and up to 1,100 metres not oscillating. The tuned anode coil is identical with the other coils and is fixed behind the anode tuning condenser.

The grid condenser consists of a piece of copper strip wound round the terminal arm of the variable condenser with a layer of

in, but tuning gets rather flat below 280 metres. Coupling has to be slackened as the wavelength is increased, the secondary condenser being at the same position for practically all wavelengths.

There is no reaction in the set, but the secondary circuit oscillates whenever coupling is sufficiently loose.

All stations come in well on two or three pairs of telephones. London at 32 miles works a small Brown loud speaker very clearly on speech. Birmingham at 80 miles can just be heard in a loud speaker. With the coils mentioned **2LO** and Bournemouth come in at about equal strength 2 miles from **2LO** when tuned to Bournemouth's wavelength.

The set is very cheap to make up.

THE CONSTRUCTION OF VARIABLE CONDENSERS.

By W. JAMES.

(Continued from page 348 of previous issue.)

ANOTHER type of variable condenser, which has a slow motion attachment, is illustrated in Fig. 13. Coarse adjustments of capacity are made by turning the large knob, and fine

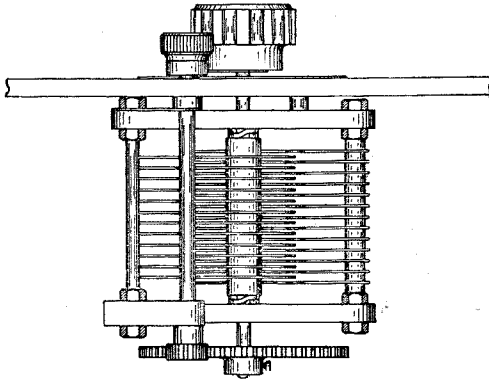

Fig. 13. Another type of condenser fitted with a slow motion device.

adjustments are obtained by turning the small knob, which turns the moving plates through gears.

An excellent design, due to H. W. Sullivan, Ltd., is illustrated in Figs. 14 and 15.

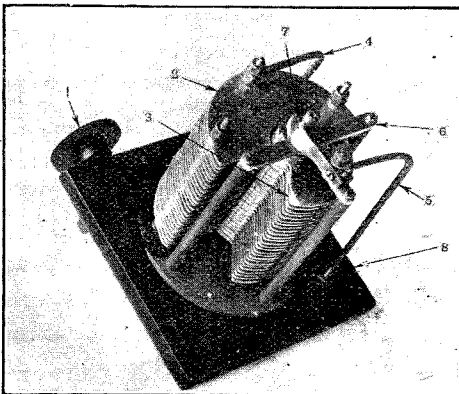

Fig. 14. One view of a variable condenser fitted with a vernier adjustment. (H. W. Sullivan, Ltd.)

Referring to the figures, the fixed plates are marked 2 and the moving plates 3. The bottom bearing is carried in the arm 6, and contact with the moving plates is made with the spring 7, which presses against the spindle. The connecting wires are marked 4 and 5; 8 is the ebonite plate to which the condenser is fixed by means of screws passing through the top plate. One of the connecting terminals is marked 9. The slow motion attachment is best seen in Fig. 15. The spindle is marked 6, and carries the ordinary knob and dial 3. An ebonite piece 5 is shaped to accommodate

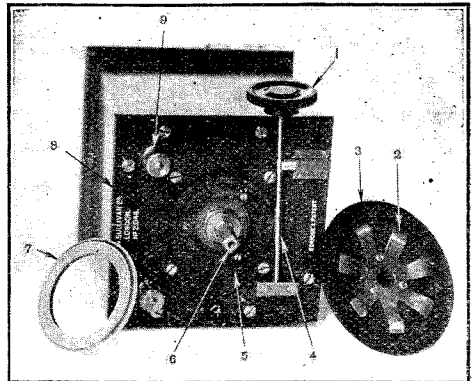

Fig. 15. Another view of the condenser of Fig. 14. (H. W. Sullivan, Ltd.)

the toothed ring 7 which meshes with the gear provided on the spindle to which the knob 1 is attached. The ring 7 is held in place with the springs 2 fastened to the dial. Coarse adjustment is obtained by turning the main knob. The fine adjustment is made by turning the knob 1.

This condenser has a maximum capacity of 0.0011 microfarads, and is particularly suitable for tuning circuits or wavemeters where the highest degree of permanence and accuracy, combined with a very low high-frequency resistance, is required.

CONDENSERS WITH SPECIALLY SHAPED PLATES.

The variable condensers described above, except Fig. 9, have semi-circular plates. The capacity is directly proportional to the

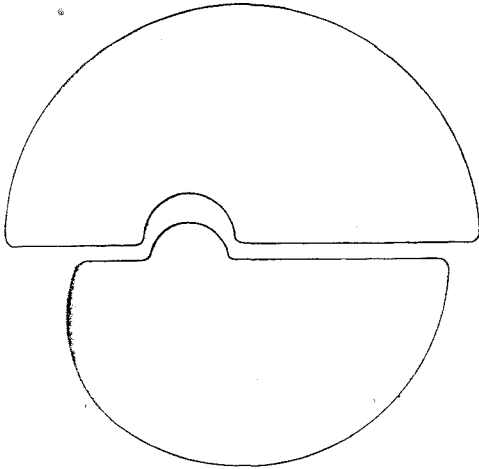

Fig. 16. The shape of the plates used in a "square law variable condenser."

area of the moving plates which lie between the fixed plates. Consequently, the capacity increases directly with the angle of movement of the knob, and is, therefore, directly proportional to the setting of the dial.

The wavelength of a circuit, $\lambda = 1884 \sqrt{LC}$; consequently the wavelength varies as the square root of the setting of the dial. The wavelength scale is therefore irregular, being closer at the smaller settings than at the higher settings. It is, therefore, more difficult to accurately tune a circuit to a wavelength when the condenser has a small value, than to a higher wavelength when a larger portion of the total capacity is used. This

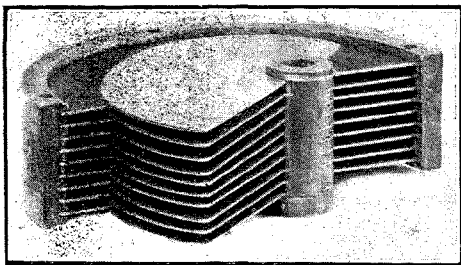

Fig. 17. The arrangement of the plates of a "square law variable condenser."

is a serious disadvantage, and attempts have been made to so design the condenser that the wavelength scale is uniform, instead of the capacity scale being uniform. The capacity of the condenser will then vary as the square of the setting. Condensers of this sort are called *square law variable condensers*.

The fixed plates are generally made semi-circular, but with the recess, which is provided to make room for the spindle, placed to one side, Fig. 16. The moving plates are given the peculiar shape seen in

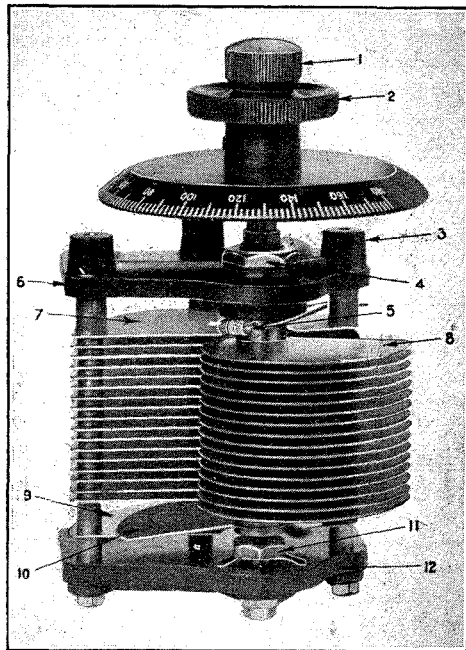

Fig. 18. A good example of condenser construction. The plates are shaped to give a capacity proportional to the square of the movement of the knob. (Sterling Telephone and Electric Co.)

the figure. The plates are not mounted in the relative position shown in Fig. 16; their position is clearly shown in Fig. 17. The sets of plates of this condenser are held together by metal which is cast on.

An excellent design, due to the Sterling Telephone and Electric Co., Ltd., is illustrated in Fig. 18. The knob and dial 2 are fastened to the main moving plates 8; the corresponding fixed plates are marked 7. Knob 1 is fastened to the single plate 10, with which is associated the fixed plate 9.

The top and bottom plates, of a moulded insulating material, are marked 6 and 12; 3 is threaded for fixing, 4 is a lock nut on the spindle, and 11 a spring washer. Contact with the moving plates is obtained through the wire contacts 5, which are held tightly against the spindle by the spring.

SOLID DIELECTRIC VARIABLE CONDENSERS.

When space and cheapness are the main considerations, a solid dielectric is often

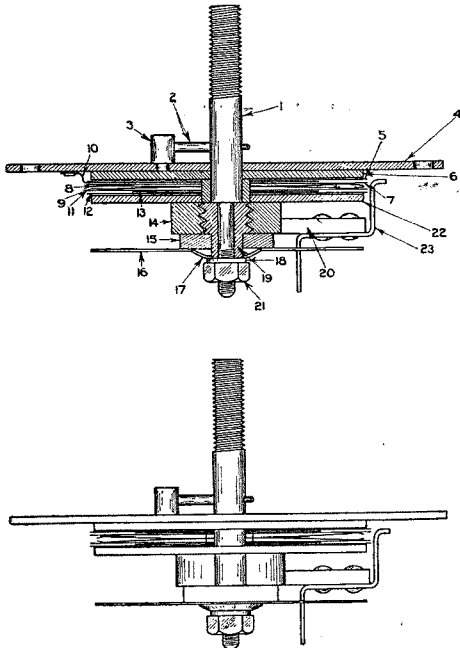

Fig. 19. A mica dielectric variable condenser. (Radio Communication Co.)

employed between the plates. A satisfactory condenser which has a mica dielectric is

shown in Fig. 19. The upper view is a section and the lower, a side view. The spindle

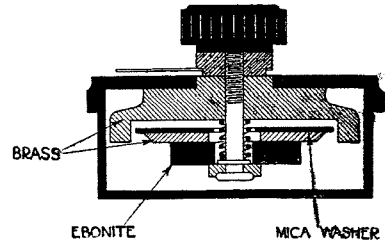

Fig. 20. Another mica dielectric condenser.

is marked 1, stop pins 2 and 3, top plate the case 4. The condenser plates are 6 and 22. Between them are the mica sheets 5 and 12; 8 and 9 are metal springs, and 11 and 13 mica sheets. One connection 10, is made to the containing case, and the other is taken from the strip 23, which is held by the insulating block 20. The remaining parts are easily identified. The capacity is varied by turning the knob which varies the distance between the plates.

The change of capacity with the movement of the knob is not the same as with a condenser employing semi-circular plates. The wavelength readings when connected with a coil are a little more uniform, though not exactly uniform as in the case of the square law variable condensers.

Perhaps the section of Fig. 20 will give a better idea of the construction of a variable condenser with a mica dielectric. The portions marked "brass" are the fixed and moving plates, and the capacity is varied by turning the knob, which brings the bottom plate closer, or moves it further away from the upper fixed plate.

In Next Issue:

NEW IDEAS IN RECEIVER DESIGN.

Building a Three-Valve Set - - - by F. H. Haynes
 200 METRE TRANSMISSION FOR AMATEURS.

The Master Oscillator System - - - by W. James
LIST OF REGULAR TRANSMISSIONS.

The publication date of this issue will be advanced to Thursday, December 27th, owing to Bank Holiday falling on Wednesday. Subsequent issues will appear on Wednesday as usual.

THE FUNDAMENTALS OF LOUD SPEAKER CONSTRUCTION.

Recent years have seen a very rapid development in loud speakers for use with wireless receiving sets. In this paper, which was read by Mr. A. Nyman at a meeting of the Radio Club of America* on September 28th, 1923, the author outlines the essential features of a successful loud speaker and also some of the experimental results obtained.

By A. NYMAN.

(Continued from page 345 of previous issue.)

RESONATING SYSTEMS.

Considered from a mechanical standpoint, a loud speaker is invariably a complicated resonance system. Certain subdivisions of resonance, however, are possible.

1.—The Mechanism as a Whole.

The force of a magnetic field is, in all types except the moving coil type, counteracted by a strain in the diaphragm. In a loud speaker of

For a movement of the diaphragm, the magnetic field begins to exert a force helping this movement. If the magnetism is increased by using a stronger magnet, the force of the magnet may be made so large that it pulls the diaphragm over. Normally, a balanced condition may be obtained where very little force is required to produce a certain movement. Fig. 13 illustrates this fact. The two curves show the variation of force on the diaphragm with movement of the diaphragm, and show that, with the magnet, the diaphragm requires distinctly smaller force for the same movement.

In this way the strength of the magnet and the tension of the diaphragm determine the force for certain movements, and, consequently, the resonant frequency of the whole mechanism. By adjusting the magnetism in a way to get a very close balance, this resonant frequency may be placed very low. As a rule, the damping at these low frequencies is high enough to conceal the resonance; however, the whole of the low range will be found raised. This is demonstrated in Fig. 14, showing two curves for one loud speaker, one with a 0.015-in. gap, and the other with a

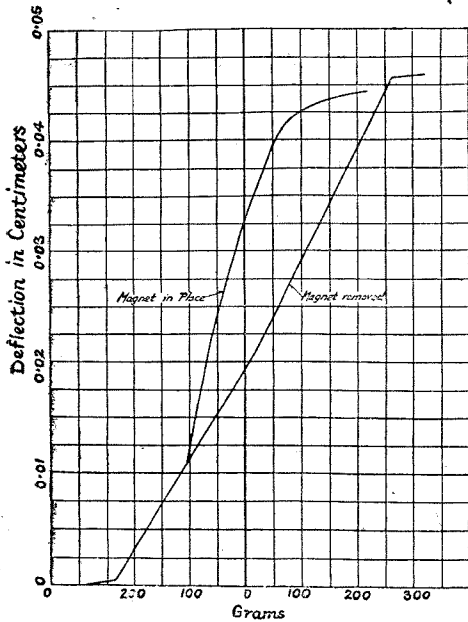

Fig. 13. Curve showing the deflection of the diaphragm due to the pull of the magnet.

the type shown in Fig. 3, that is, the telephone receiver type, this action is automatic. The diaphragm pulls down until its tension is equal to the pull of magnetic field. In the type shown in Figs. 4, 5, and 7, the normal position of the armature is such that the magnetic pole is zero. Actually, however, it is very difficult to keep the armature in this position. Generally there is a little pull one way or another, balanced by the strain in the diaphragm.

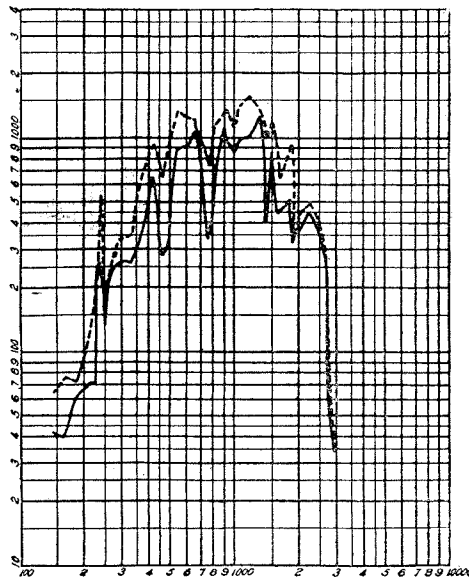

Fig. 14. Two curves taken with the same relay type loud speaker; in one case the gap was 0.015 in. (solid line) and in the other, the gap was 0.010 in. (dotted line).

*From Radio Broadcast (America).

0.010-in. gap. The latter had a close magnetic balance; hence all notes, and the low notes in particular, are increased. These curves were taken on the relay type loud speaker. It is evident that similar adjustment is possible on all types except the moving-coil type, in which the resonance point is determined entirely by mechanical strain and the mass of moving parts.

Fig. 13 shows a bend in the curve when the magnet is in place, *i.e.*, there is an equality in pull for the two directions of movement. This is caused by a lack of symmetry in the diaphragm equivalent to a slight dish in one direction. A diaphragm free from this dish would give a straight line characteristic. Hence the importance of the development of a diaphragm of some such type as (g), (h), or (i) of Fig. 12.

2.—The Diaphragm and Horn.

In a foregoing paragraph the resonance points of diaphragm and horn were discussed. It must be remembered that the horn constitutes a load on the loud speaker. If it is possible to construct a load that remains constant at all frequencies, and large for a small movement of diaphragm, then the resonance of the diaphragm will be unimportant. This is one of the chief reasons of the success of the large horns.

If the load due to the horn is small between its resonance points, and a resonance point of the diaphragm should occur at one of these points, the vibration may be excessive, with a resulting rattle and noise. The longer horn favours a more uniform load at different frequencies.

3.—The Armature.

The armature of a loud speaker of enclosed-armature or relay type is a strip of steel very

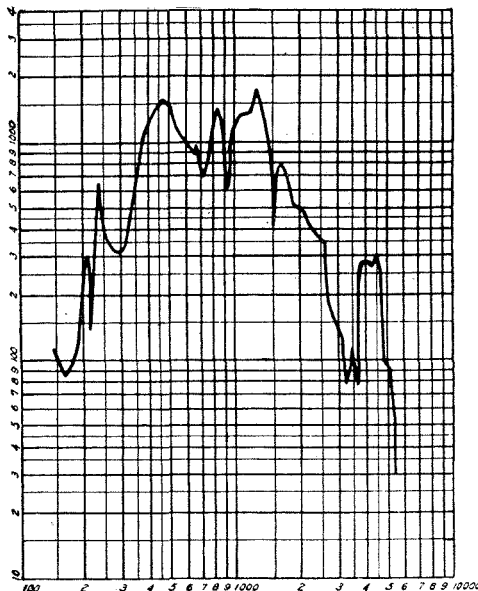

Fig. 15. Curve obtained when using a very small stiff armature.

short and stiff, but nevertheless possessing a resonance point within the audible range. It has been found that frequencies above this resonance point are difficult to reproduce. Thus, Fig. 15, made using a loud speaker with a very small

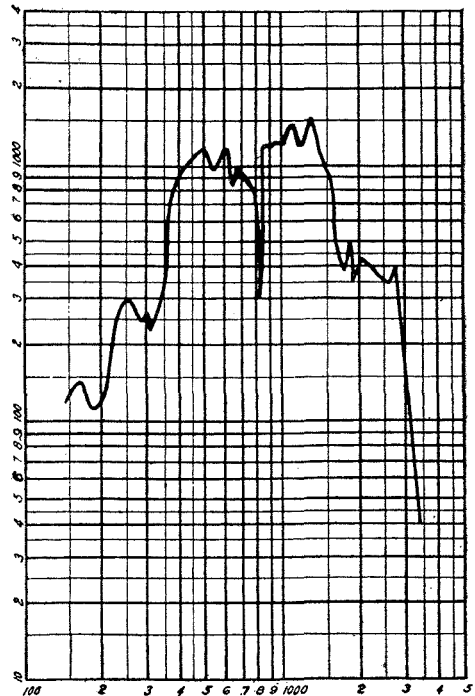

Fig. 16. The armature in this case is too weak. Foreign notes are introduced, and a reduction of amplification is produced at 800 cycles.

stiff armature, shows a range on higher notes extending to 5,000 cycles.

Another effect of resonance of armature is the introduction of foreign notes. An example is seen in Fig. 16, showing a reduction in volume at 800 cycles. At this frequency it was observed that the note had a strange high-pitched harmonic; however, damping the armature by a piece of rubber cleared this note and brought up the volume of its fundamental. The trouble was eventually overcome by using a much stiffer armature.

4.—The Strip.

The strip supporting the armature has a resonance note, but the forces acting in it are generally very small compared with the forces in the rest of the system. Hence the effect of the strip is negligible. The only exception is in attaching the strip to supports. It seems that any looseness at this point will result in a rattle.

5.—The Connecting Rod.

The connecting rod is subject to a complicated torsional and longitudinal strain. Unless this rod is sufficiently stiff, vibrations may be set up which introduce a foreign note at the lower fre-

quencies and limit the sound at the higher frequencies.

CONCLUSION.

In conclusion, a brief summary will be given covering the outstanding points. The function of loud speakers is considered as that of a device for converting electric current, of frequencies ranging from 25 cycles to 5,000 cycles, into sound waves.

The art of designing a loud speaker is extremely new. The empirical work for ascertaining the

effect of various factors is only in its embryo stage. Eventually we may expect to design a horn or a vibrating structure with the same facility as an electric motor, because a loud speaker is really an electric motor though its load is less tangible than the load of most motors.

The design of a loud speaker must be based on a scientific analysis of this load. This involves considerable acoustic research work, mechanical research on vibrating structures, and electrical work on the effects of vibrating parts in an electromagnetic structure.

CORRESPONDENCE

Harmonics from High-Power Stations.

To the Editor of THE WIRELESS WORLD AND RADIO REVIEW.

SIR,—We have read a great deal of late regarding the growing difficulty of assigning new wavelengths to various wireless enterprises, at the same time preventing interference to existing services.

The Government have very properly placed a ban on reaction and kindred noises. The regulations stipulate that wireless transmitters shall be sharply tuned to the wave assigned to them, amateurs are forbidden to use their transmitters during broadcasting hours, etc., all in order to prevent interference to others using the ether.

What can be said then in justification for the horrible harmonics and "hash" that emanate from Leafield and Northolt when those stations go into action, making life miserable for those working on the lower wavelengths. It is realised, of course, that public business should take precedence over amateur and entertainment work, but since the Post Office has granted licences for them to use the air, it would seem that they might find it necessary to follow rules that they have laid down for others and eliminate or reduce to a minimum what has become a public nuisance.

I understand that the United States authorities have practically eliminated the "hash" and other parasitic noises from their high power arc stations, and I have no doubt the Post Office would take similar steps should the matter be brought to their attention in a proper way.

I should be glad to hear from others what they have accomplished to eliminate the nuisance.

London, W.C.

A. B. SMITH.

Automatic Reception of Wireless Signals.

To the Editor of THE WIRELESS WORLD AND RADIO REVIEW.

SIR,—I am not quite sure of the intention of the latter paragraph of Mr. E. R. Batten's letter published in your issue of November 21st; but in case it is intended to suggest that I obtained the material for my paper from Messrs. Creed's publication entitled "The Application to Radio Telegraphy of the Creed Printing Telegraph," I would point out that I wrote the whole of the booklet in question.

Furthermore your contributor's reproduction of some phrases used is so exact that it is possible to state that the transcription was made from the Radio Society Paper and not from the booklet.
London, W.C.2 R. E. H. CARPENTER.

Misuse of Call Signs.

To the Editor of THE WIRELESS WORLD AND RADIO REVIEW.

SIR,—I wish to draw the attention of experimenters, through your columns, to the fact that apparently the call sign 2AW is being made use of by some unauthorised person. From reports received it would appear to be in the London area. Reports have been received of 2AW working, and stations with whom we were supposed to be working have been communicated with, with the result that the check thus taken proves neither station to have been working at the time.

It is hoped that this may check unauthorised use of call signs, and possibly assist in the detection of the offenders. So far as phonety is concerned, the possible phonetic errors have been carefully eliminated.

A copy of this letter has been communicated to the Radio Society of Great Britain.

H. E. H. BURBURY,
Lieutenant R.N. Retired,
Operating 2AW.

Wakefield.

NEW METEOROLOGICAL JOURNAL.

We have received from H.M. Stationery Office a copy of the first number of "The Marine Observer." The functions of the new publication are to provide information useful to navigation, concerning winds, weather, climate, currents, derelicts and ice; to stimulate interest in observation and the practice of Meteorology at sea; to promote the use of wireless weather reporting for shipping, to provide a means whereby mariners may give their experiences to others and to foster the traditions of Marine Meteorology upon international lines. All these aims are enumerated in the Editorial note and we are convinced that such a publication will serve a valuable purpose. The price per copy is 2s. net (annual subscription 25s. net post free) and copies can be obtained from H.M. Stationery Office, Kingsway, W.C.2.

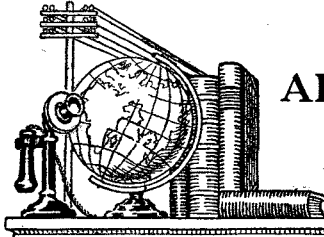

AROUND THE WIRELESS WORLD

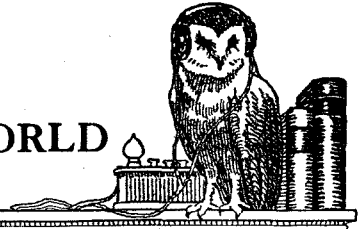

Radio Society of Great Britain and A.R.R.L. Exchange Greetings.

Elsewhere in this issue reference has been made to the two-way working between **2 KF** (Mr. J. A. Partridge) and **1 MO** (U.S.A.). Mr. Warner transmitted several messages from America, one of which was addressed by Mr. Hiram Percy Maxim, President of the American Radio Relay League,

greetings and join with you in tendering felicitations to the amateurs of America and of Britain now united by this triumph."

Mr. F. L. Hogg (**2 SH**) has been successful in exchanging signals with **1 MO** between 4.45 and 8.10 am., on December 12th. This rapidly follows the achievement of Mr. J. A. Partridge (**2 KF**) reported elsewhere in this issue.

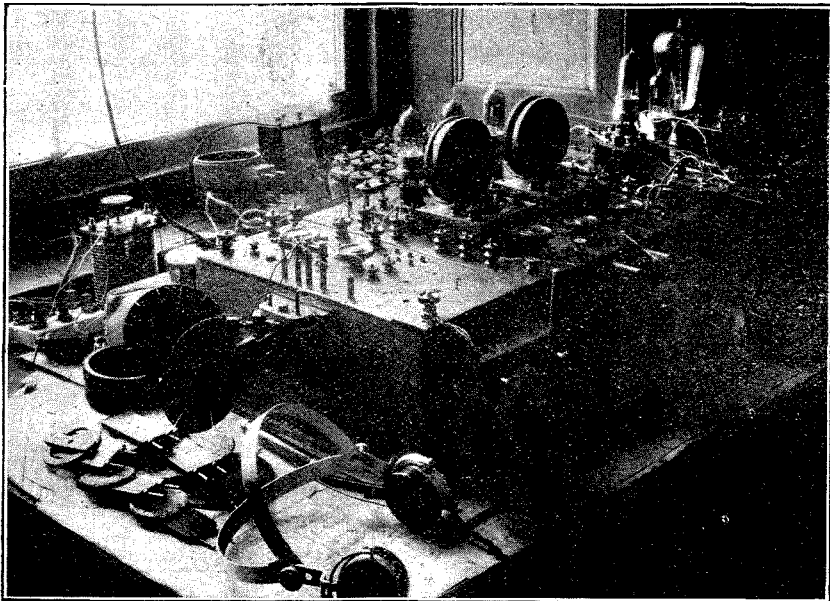

A South African experimental station. The owner is Mr. R. Rascher, of Caledon, Cape Province, whose call sign is 1 AS.

to Admiral of the Fleet Sir Henry Jackson, who last year was President of the Radio Society of Great Britain. The message reads as follows:

"Sir Henry Jackson, London. A.R.R.L. have great pleasure in transmitting to R.S.G.B. greetings by direct amateur contact across Atlantic (stop). Expect visit you in London February. Hiram Percy Maxim.

"From **1 MO** to **2 KF**."

The President of the Radio Society of Great Britain has asked Mr. Partridge to transmit the following message to Mr. Maxim at the first opportunity:

"The President and Past-President of the Radio Society of Great Britain have received your

Re-Election of Officers of R.S.G.B.

As announced recently, Mr. Frank Hope-Jones (Chairman of the Radio Society of Great Britain), Mr. N. McMichael (Hon. Secretary), and Mr. L. F. Fogarty (Hon. Treasurer), have requested that their names should not go forward for re-election to those offices for the forthcoming year. The committee of the Radio Society of Great Britain have asked these gentlemen to accept office as vice-chairmen of the Society as a mark of appreciation of their long service in the interests of the Society.

The Marconi Direction Finder.

Six vessels of the Peninsular and Oriental Steam Navigation Co., belonging to the "K" class, are to

WHAT RECEIVER DID YOU USE?

With reference to the invitation to those who took part in the recent Transatlantic Broadcast Tests to send in descriptions of the apparatus they used, it has been found advisable to extend the date up to which descriptions can be sent in to January 16th, so as to give facilities to those who may require more time.

Further particulars of this announcement appeared, it will be remembered, on page 337 of the issue of this journal for December 12th, when it was stated that an award of Ten Pounds would be given for the best description sent in and Five Pounds for the second best.

All descriptions should be addressed "*Wireless World Broadcast Tests*," 12/13, Henrietta Street, London, W.C.2.

be fitted with the Marconi direction finder, their names being *Khiva, Khyber, Kalyan, Karmala, Kashgar* and *Kashmir*.

Wireless Progress in Czecho-Slovakia.

It is reported from Prague that the wireless service in Czecho-Slovakia is being further developed, and the construction of new wireless stations in various parts of the Republic is proceeding satisfactorily. It is expected that the central wireless station at Pobebrady will be in working order by the new year, while at the present time the

To assist in the operation of the first Czecho-Slovak air-line Prague-Bratislava, a small wireless station is being erected at Bratislava. All preparations for the wireless station at Nemecky-Brod are now complete, and the construction should be undertaken in a few days.

Interesting experiments were made recently on the Paris-Prague and Prague-London air-lines with small transmitters and receivers which were installed in aeroplanes, a distance of 100-150 kilometres being covered.

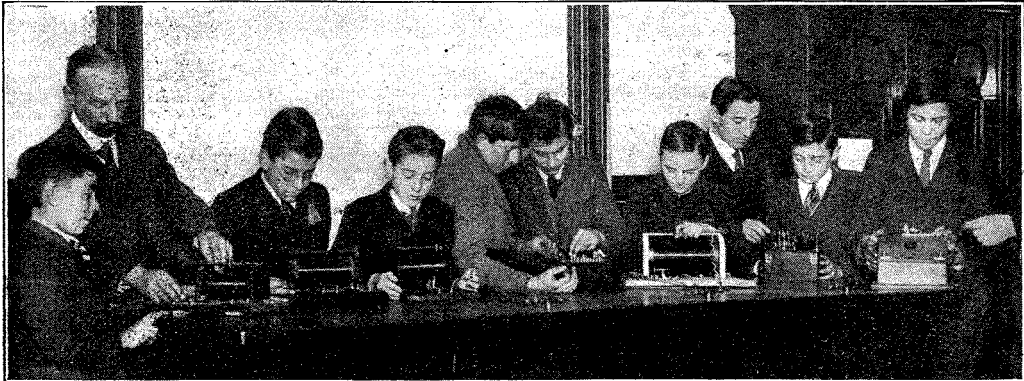

[Photopress

An "official" wireless lesson in progress at the Broadwater Road School, Tooting. Wireless has now been included in the curriculum of twenty-five London County Council Schools.

provisional 5 kilowatt station is successfully operating with Paris, London and Bukarest. Other wireless stations at Kosice and Bratislava are now under construction.

Further wireless developments in Czecho-Slovakia may be expected after the ratification by the Senate of the Wireless law adopted by the Chamber of Deputies, and the issue of necessary regulations.

EASTERN METROPOLITAN GROUP OF AFFILIATED SOCIETIES.

A meeting of Representatives of the Affiliated Societies in the Eastern Metropolitan Group was held on Wednesday, November 28th, 1923, at the Literary and Scientific Institute, South Grove, Highgate. Mr. H. Andrewes, the Chairman of the Radio Society of Highgate, in welcoming the representatives, explained that the object of the meeting was primarily to enable Mr. J. F. Stanley to meet delegates from the societies in the Eastern Metropolitan Group, and to obtain the views of those societies on certain matters in which they were mutually interested. It was hoped that such meetings would be held at frequent intervals, thus enabling a closer degree of co-operation to be established between neighbouring societies.

Mr. Stanley gave a brief report of the progress which had been made in the formulation of a scheme which would give a greater degree of representation

to the affiliated societies. The outline of this scheme was published in *The Wireless World and Radio Review* of November 14th, and Mr. Stanley expressed the opinion that this scheme was the most satisfactory compromise that could be made at the present time.

A lively discussion ensued, at the conclusion of which the following resolution was carried:—

"That this meeting is in favour of the system of grouping outlined on page 874 of *The Wireless World and Radio Review* of September 26th, 1923."

Mr. Stanley thereupon explained that if it proved to be the wish of the affiliated societies to adopt the scheme referred to in the resolution, or any similar system of grouping, the general committee as proposed by the Radio Society of Great Britain would provide the best, if not the only, machinery for bringing that scheme into force.

THE ANNUAL TRANSATLANTIC AMATEUR TESTS.

AT this time of the year the thoughts of most radio experimenters are turning generally in the direction of long-distance signalling records, and towards Transatlantic Tests in particular. The great success that has been achieved during the past two years, and especially since last December, in the reception of short-wave signals from American amateur transmitters has cleared the way for more specialised tests this winter.

It will be recalled that during ten nights of last December over 2,000 receptions of American amateur signals were made by experimenters in this country, and that since that time such receptions as well as the reception of American broadcasting as well as a fairly frequent occurrence. Before enlarging on the scope of this year's experiments, I should like to emphasise the distinction between these Transatlantic Tests which are now being arranged by the Radio Society of Great Britain, and the tests which were made recently by the British Broadcasting Company. The latter were made on the usual broadcasting wavelengths, whereas the Radio Society tests will all be conducted on a wavelength of 200 metres or less. In general, too, the amateur tests will be conducted with much less power than that used by the broadcasting stations, and most of the transmissions will be in the Morse code and not speech.

The Amateur Transatlantic Tests being organised by the Radio Society will consist for the first part of transmission tests from experimental stations in this country, alternating with similar transmissions from radio experimenters in France. These transmissions will commence on December 22nd, and will continue for a period of approximately three weeks. Transmissions will be made between the hours of 1 a.m. and 6 a.m. G.M.T. The first two-and-a-half hours of this period each night coincides with the times of broadcasting in the Eastern States, and as there are fewer amateur transmissions in progress during this time, the conditions are more favourable for the reception of European signals.

During last year's Transatlantic Tests the only British Station that was heard with certainty in America was a special experimental station erected at Wandsworth, London, by a few of the Radio Society members, and operated on behalf of the Society. It is hoped, however, that this year more of our stations will be successful, in view of the improved receiving conditions in the United States during their "quiet hours." In order to increase the probability of successful transmissions from this country a number of experimenters taking part in the tests will be using rather more power than the customary 10 watts—permits for increased power for use during the tests having been granted by the Post Office.

In connection with these permits some difficulty has been experienced in obtaining permission to use the increased power for an adequate transmission time each week, but I am glad to be able

to announce that the Post Office authorities have now largely met our wishes in this matter, and that considerably increased facilities will be granted to those taking part in the tests, as compared with what was allowed at first. Unity of aim and purpose on the part of all transmitting and other radio experimenters in the country is the only means that will enable them to obtain adequate facilities for special tests such as these. Any division of opinion and action may, and probably will, only lead to lessened facilities.

Before the conclusion of the transmission tests just referred to, we shall have received by means of radio reports from the United States, information as to which of our stations have been heard there, and it is then intended to carry out further tests aimed at two-way communication and exchange of messages, utilising especially for these second tests those stations which have made the best transmission record during the first tests.

Apart from those experimenters who have already entered for the transmissions, several have intimated their desire to participate in reception tests, and these will be asked to co-operate by reporting on receptions during the whole of the period of the Tests, and specially during the second part. Full details will be circulated by post in due course to those who send in their names.

One may perhaps ask as to the reasons for making these long-distance signalling tests. It will suffice, I think, to say briefly that as a result of past tests a closer union and friendship is growing up between radio workers in different countries, while at the same time experimental results of not inconsiderable scientific importance are being obtained.

PHILIP R. COURSEY.

FORTHCOMING EVENTS.

WEDNESDAY, DECEMBER 19th

Radio Society of Great Britain. At 6 p.m. (Tea at 5.30). At the Institution of Electrical Engineers. Annual General Meeting.
B.T.H. Recreation Club, Rugby. At 7.30 p.m. At the Caldecott Girls' School, Church Street. Open Meeting.
Stockport Wireless Society. At 7.30 p.m. Lecture: "Explanation of Wireless Circuits." By Sergt. Bunter.
Edinburgh and District Radio Society. At 117, George Street. Lecture: "The Flewelling Receiver." By Mr. R. O. Crombie.
Manchester Radio Society. At 7 p.m. At 16, Todd Street. Lecture: "Transmission." By Mr. Megson.

THURSDAY, DECEMBER 20th.

Derby Wireless Club. At 7.30 p.m. Lecture: "Broadcasting and How to Listen to It." By Mr. J. Lowe.
Ilford and District Radio Society. Informal Meeting.
Luton Wireless Society. At 8 p.m. At the Hitchin Road Boys' School. Exchange of Apparatus.
Hackney and District Radio Society. Lecture: "Distortion in Valve Receivers." By Mr. J. F. Stanley, B.Sc., A.C.G.I.
Radio Society of Willesden. At Leopold Road Schools. Dance (Tickets from C. Swindin, 8, Bruce Road, N.W.14; or from the Hon. Sec., F. H. Coote, 183, Carlton Vale, N.W.6.).
Hendon Radio Society. Lecture: "Aerials, their Construction and Proportions." By Mr. A. C. Warren, B.Sc., A.M.I.E.E.

FRIDAY, DECEMBER 21st.

The Wembley Wireless Society. At 8 p.m. At Park Lane School. Lecture: "What Happens between Transmission and Reception." By Mr. F. R. Rice.
Leeds Radio Society. Annual Social Meeting.
Norwich and District Radio Society. At 8 p.m. Lecture: "Simple Circuits." By Mr. Hayward.

Calls Heard.

Lincoln.
 2 DF, 2 DU, 2 DV, 2 FL, 2 FN, 2 FH, 2 JF, 2 JI, 2 KM, 2 LN,
 2 LS, 2 LT, 2 LX, 2 LZ, 2 MP, 2 NA, 2 NN, 2 OD, 2 OM, 2 PU,
 2 QH, 2 SQ, 2 SZ, 2 UG, 2 VC, 2 VQ, 2 XP, 2 WA, 2 WZ, 2 ZK,
 2 ZU, 2 ZV, 5 BG, 5 CK, 5 DM, 5 DT, 5 FG, 5 FU, 5 GL, 5 GS,
 5 HL, 5 IC, 5 KO, 5 NN, 5 OK, 5 OM, 5 RI, 5 TKM, 5 YL, 6 NI,
 6 RY, 7 ZM, 8 AQ, 8 BF, 8 BM, 8 BN, 8 BW, 8 CS, 8 CZ, 8 PK,
 8 XX, 0 AA, 0 DV, 0 FN, 0 YS. (o-v-i.) (W. Herring, 5-ZV).

King's Heath, Birmingham.
 2 FH, 2 HA, 2 HO, 2 HV, 2 IG, 2 JU, 2 KC, 2 KN, 2 KO, 2 KT,
 2 KY, 2 LG, 2 LK, 2 NA, 2 NP, 2 NW, 2 OD, 2 OG, 2 OH, 2 OM,
 2 OQ, 2 OX, 2 PU, 2 QS, 2 RA, 2 RG, 2 SI, 2 SV, 2 SY, 2 TN,
 2 TQ, 2 UC, 2 UJ, 2 UY, 2 WQ, 2 WR, 2 WV, 2 XQ, 2 XS, 2 YV,
 2 YX, 2 YZ, 2 ZD, 2 ZK, 2 ZQ, 2 ZU, 5 CI, 5 FH, 5 FL, 5 KG,
 5 KO, 5 KT, 5 KY, 5 LO, 5 LT, 5 PX, 5 QW, 5 RH, 5 TW, 5 YS.
 6 AG, 6 UR. (2 or 3 valves.) (K. Bagley.)

Withington, Manchester.
 American Amateurs.
 1 AW, 1 ABS, 1 ACU, 1 AWP, 1 BDT, 1 BGC, 1 BWF, 1 BWJ,
 1 CDU, 1 CMK, 1 CPN, 1 PL, 2 ARP, 2 AGE, 2 AH, 2 BR, 2 BQH,
 2 BSC, 2 CKL, 2 FP, 2 IL, 2 WA, 2 WR, 3 AAO, 3 BG, 3 BGT,
 3 BOF, 3 CO, 3 TO, 3 TJ, 3 XN, 4 FT, 8 AIB, 8 BCI, 8 CNW, 8 CTP,
 8 GZ, 8 HV, 8 TT, 8 XAN, 9 BR, 9 MC, 1 ACA, 5 ZVA, 1 CDA,
 1 CKQ, 2 BY, 2 TSY. (i-v-o and o-v-i.)
 B. L. Stephenson (5 IK).

Heaton Moor, Stockport.
 1 PA, 1 AW, 1 BWJ, 2 OY, 2 AGE, 2 BQC, 3 CO, 3 AAO, 3 BEQ
 4 EA, 5 BV, 8 CS, 8 CSJ, 8 DK. Canadian—3 BP. (One valve,
 only.) (H. A. Woodyer, 2 XW).

Jersey, Channel Islands.
 1 AR, 1 ARW, 1 BM, 1 BWJ, 9 VCD. (i-v-i.)
 (D. Grove-White).

Harrow.
 2 BZ, 2 ID*, 2 KV, 2 OD, 2 OM*, 2 SH, 2 SQ, 2 SU, 2 SZ*,
 2 VJ, 2 VK, 2 WD, 2 WJ, 2 XZ, 2 ZO*, 5 DT, 5 IL, 5 LD*, 5 LV,
 5 PU*, 5 SC, 5 SD, 5 SU, 5 VL*, 5 VR, 6 BM, 6 IM*, 6 VL, SFR
 (Paris). (i H.F., D.) (D. C. Slipper.)
 * One on valve only.

Snaith, Yorks.
 2 AW, 2 FN, 2 HF, 2 IG, 2 MG, 2 MM, 2 LZ, 2 OD, 2 TF, 2 XR,
 2 YQ, 2 SH, 5 SZ, 5 TG, 5 DN, 5 FS, 6 NF, 6 LA(?), 7 ZM,
 8 DX, 8 AS, 8 QA, 0 DV, 0 MX, 0 XP. Receiver, D-1 L.F.
 *Quite readable, and heard repeatedly calling 4 AA. (J. L. Greatorex)

Watford, Herts.
 2 AB, 2 AN, 2 AU, 2 AY, 2 BM, 2 BZ, 2 CW, 2 DF, 2 DR, 2 DX,
 2 FC, 2 FT, 2 FK, 2 FQ, 2 FU, 2 HF, 2 IN, 2 JX, 2 KF, 2 KO, 2 KI,
 2 KV, 2 KZ, 2 LW, 2 MR, 2 MN, 2 MK, 2 MO, 2 MX, 2 NM, 2 ON,
 2 OM, 2 ON, 2 OP, 2 PA, 2 PF, 2 PU, 2 VS, 2 QG, 2 QS, 2 SH,
 2 ST, 2 SU, 2 SX, 2 SZ, 2 TA, 2 VI, 2 VS, 2 VW, 2 WD, 2 WJ,
 2 WN, 2 WP, 2 XB, 2 XI, 2 XL, 2 XR, 2 XZ, 2 YG, 2 YH, 2 YL,
 2 YK, 2 YR, 2 ZD, 2 ZT, 5 AB, 5 BA, 5 AC, 5 AD, 5 BC, 5 BT,
 5 BV, 5 BZ, 5 CB, 5 CP, 5 CX, 5 DX, 5 HI, 5 HJ, 5 HY, 5 IO, 5 JS,
 5 KB, 5 KO, 5 LP, 5 MO, 5 NN, 5 PU, 5 QV, 5 SU, 5 SZ, 5 UW,
 5 VD, 5 VR, 5 VX, 6 EA, 6 IM, 6 IY, 6 JX, 6 KU, 6 NL, 6 OY, 6 SO,
 7 ZM, 8 AW, 8 BE, 8 BF, 8 BM, 8 CD, 8 CM, 8 CZ, 8 DX, 8 DY,
 0 AB, 0 DV, 0 MX, 0 OP. (H. E. Nicholson.)

Kirkcaldy, N.B.
 2 BW, 2 CW, 2 FL, 2 FN, 2 FQ, 2 HF, 2 JF, 2 KF, 2 LZ, 2 NN,
 2 OD, 2 OG, 2 OM, 2 ON, 2 PF, 2 VS, 2 YQ, 2 ZK, 5 BA, 5 BA, 5 DN,
 5 DO, 5 FD, 5 FS, 5 GL, 5 JX, 5 KO, 5 MO, 5 NX, 5 PU, 5 SI, 5 SZ,
 5 TN, 5 US, 6 EA, 6 NI, 6 RY, 6 UC, 7 ZM, 8 AE, 8 AU, 8 BA,
 8 BF, 8 BL, 8 BM, 8 BN, 8 CH, 8 CS, 8 BQ, 2 DF, 8 DA, 8 DO,
 8 DY, 0 DV, 0 NY, 0 XP, 0 XQ. (i-v-i.) (A Shields.)

Nr. Congleton, Staffs.
 2 CC, 2 CW, 2 FC, 2 FN, 2 FQ, 2 HF, 2 JF, 2 KF, 2 KW, 2 LW,
 2 LF, 2 LZ, 2 MG, 2 MV, 2 NW, 2 NK, 2 NN, 2 NY, 2 NV,
 2 OD, 2 PF, 2 PP, 2 PS, 2 RM, 2 RP, 2 SO, 2 VS, 2 WV, 2 XE,
 2 XW, 2 YQ, 2 ZD, 2 ZK, 2 ZL, 2 ZM, 5 BC, 5 BK, 5 BG, 5 BV, 5 CE,
 5 DC, 5 DN, 5 FD, 5 FW, 5 HG, 5 IK, 5 KC, 5 KV, 5 LE,
 5 MO, 5 NB, 5 NC, 5 OT, 5 PU, 5 QA, 5 RD, 5 RI, 5 RP, 5 RT,
 5 SW, 5 SZ, 5 TX, 5 UW, 5 VK, 5 WR, 5 XI, 5 YF, 6 AZ, 6 DZ,
 6 GX, 6 HF, 6 HS, 6 HZ, 6 LF, 6 LJ, 6 NL, 6 OM, 6 PL, 6 RW,
 6 RY, 6 UC, 0 AB, 0 DV, 0 MX, 0 NY, 0 XP, 0 YS, 8 AB, 8 AE,
 8 AEZ, 8 AW, 8 BA, 8 BF, 8 BM, 8 CF, 8 CI, 8 CK, 8 CS, 8 DA,
 8 DY. (1 to 4 valves.) (A. W. Bannister.)

Chelsea, S.W.3. Calls heard since September.
 English—2 AAH, 2 CH, 2 CW, 2 DR, 2 FL, 2 FJ, 2 IL, 2 ID,
 2 JJ, 2 JW, 2 JI, 2 KW, 2 KN, 2 LD, 2 OT, 2 PY, 2 PZ, 2 PG,
 2 PO, 2 QH, 2 RX, 2 SA, 2 TQ, 2 TF, 2 VS, 2 WK, 2 ZG, 5 BG,
 5 BA, 5 CX, 5 DB, 5 FS, 5 FR, 5 GA, 5 HA, 5 IK, 5 JY, 5 KZ,
 5 LL, 5 LZ, 5 LF, 5 OB, 5 MO, 5 PS, 5 SZ, 5 SD(?), 6 AH, 6 BI,
 6 EA, 6 HN, 6 JX, 6 LJ, 6 MZ, 6 NE, 6 OM, 6 QZ, 6 RM, 6 RY,
 6 LF.

French: 8 AG, 8 BE, 8 BO, 8 BQ, 8 BW, 8 CH, 8 CI, 8 DA,
 8 DT, 8 DX, 8 DW, 8 EJ, 8 RJ, 8 WV, 8 XE, 8 ZZ.

Dutch: 0 BQ, 0 DK, 0 KG, 0 NW, 0 XG.

Danish: 7 ZM.
 American: 1 AR, 1 AW, 1 ABS, 1 AJP, 2 AGE, 2 BY,
 1 CQZ, 1 CP, 1 CES, 2 CPD, 8 CPI, 1 FD, 2 RS, 2 RJS, 2 TN,
 1 WRU. (F. Walker.)

Broadcasting.

REGULAR PROGRAMMES ARE BROADCAST FROM THE FOLLOWING EUROPEAN STATIONS:

GREAT BRITAIN.
ABERDEEN 2 BD, 495 metres; **BIRMINGHAM** 5 IT, 475 metres; **CARDIFF** 5 WA, 435 metres; **GLASGOW** 5 SC, 420 metres; **MANCHESTER** 2 ZY, 400 metres; **BOURNEMOUTH** 6 BM, 385 metres; **NEWCASTLE** 2 NO, 370 metres; **LONDON** 2 LO, 350 metres; **SHEFFIELD** (Relay from 2 LC), 303 metres. Regular daily programmes. Weekdays, 11.30 to 12.30 p.m. (2 LO only), 3.30 to 4.30 p.m., 4.30 p.m., 5 to 10.30 p.m. Sundays, (2 LO only), 3.30 to 4.30 p.m., 5 to 10.30 p.m. Sundays, 3 to 5 p.m., 8.30 to 10.30 p.m.

FRANCE.
PARIS (Eiffel Tower), FL, 2,600 metres. Daily, 6.40 to 7 a.m. Weather Forecasts; 10.5 a.m. (Thursday and Friday), 11.15 to 11.30 a.m., Time Signal and Weather Forecast; 12.0 noon, L. v. stock prices; 3.40 p.m. (Saturday excepted); financial report, 5.30 p.m. (Saturday excepted) Bourse Closing Prices; 6.10 p.m., Concert or Address; 7 p.m., Weather Forecast; 7.20 p.m. (Sunday), Concert and Address; 10.10 p.m., General Weather Forecast.
PARIS (Compagnie Francaise de Radiophonie Emissions "Radiola"), SFR, 1,780 metres. Daily, 12.30 p.m., Cotton, Oil and Café Prices, News, Concert; 1.45 p.m., First Bourse Report; 4.30 p.m., Bourse Closing Prices; 4.45 p.m., Concert; 5.45 p.m., News and Racing Results; 8.30 to 9.30 p.m., News; 9.10 p.m., Concert; 10 p.m. to 10.45 p.m., Radio Dance Music.

ECOLE SUPERIEURE des Postes et Télégraphes, 450 metres 3.30 to 4 p.m. (Wednesday and Friday), 7.45 p.m. to 10 p.m. (Tuesday and Thursday), Tests (Music, etc.); 2.30 p.m. to 7.30 p.m. (Saturday), Tests (Music, etc.).
LYONS, YN, 3,100 metres. Daily, 9.45 a.m. to 10.15 a.m., Gramophone Records.

Belgium.
BRUSSELS, BAV, 1,100 metres. 1 p.m. to 5.30 p.m., Meteorological Forecast; 9 p.m. (Tuesday), Concert.
BRUSSELS ("Radio Electrique"), 410 metres. Daily, 8.30 p.m. to 9.30 p.m., Concert.

HOLLAND.
THE HAGUE, PCGG. Temporarily suspended.
THE HAGUE (Heussen Laboratory), PCUU, 1,070 metres. 9.40 to 10.40 a.m. (Sunday), Concert; 9.40 to 10.40 p.m., Concert; 7.45 to 10 p.m. (Thursday), Concert.
THE HAGUE (Velthuisen), PCKK, 1,070 metres. 8.40 to 9.40 p.m. (Friday), Concert.
LJMUDEN (Middelraad), PCMM, 1,050 metres. Saturday, 8.40 to 9.40 p.m., Concert.
AMSTERDAM, PA 5, 1,100 metres (Irregular). 10 to 11 a.m., Concert; 5 to 6.30 p.m., Concert; 8.10 to 9.10 p.m., Concert.

DENMARK.
LYNGBY, OXE, 2,400 metres. 7.30 p.m. to 8.45 p.m., Concert (Sunday excepted).

GERMANY.
BERLIN (Koenigswusterhausen), L.F., 4,000 metres. (Sunday) 10 to 11 a.m., Music and Lecture; 2.700 metres 11 a.m. to 12 noon, Music and Lecture. Daily, 4.000 metres, 6 to 7 a.m., Music and Speech; 11.30 a.m. to 12.30 p.m., Music and Speech; 4 to 4.30 p.m., News.
EBERSWALDE, 2,930 metres. Daily, 12 to 1 p.m., Address and Concert; 7 to 8 p.m., Address and Concert; (Thursday and Saturday), 5.30 to 6.30 p.m., Concert.

CZECHO-SLOVAKIA.
PRAGUE, PRG, 1,800 metres. 7 a.m., 11 a.m. and 3 p.m. Meteorological Bulletin and News; 4,500 metres, 9 a.m., 2 p.m. and 9 p.m., Concert.
KBEL (near Prague), 1,000 metres. Daily, 6.20 p.m., Concert, Meteorological Report and News.

SWITZERLAND.
GENEVA, HB 1 (Radio Club de Genève). Temporarily suspended
LAUSANNE, HB 2, 1,100 metres. Tuesday, Thursday, Saturday, 4 p.m., Concert; Monday, Wednesday, Friday and Saturday 7 p.m., Concert.

SPAIN.
MADRID, 1,650, 2,200 metres (Irregular). 12 to 1 p.m., Tests.
MADRID, PTT, 400 to 700 metres. 4 to 5 p.m., Tests.

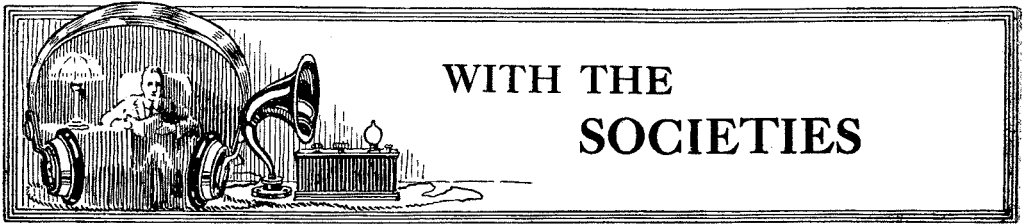

WITH THE SOCIETIES

Particulars of Membership of any Society can be obtained on application to the Secretary. Societies marked with an asterisk are affiliated to the Radio Society of Great Britain.

Wembley Wireless Society.*

On November 29th, Mr. W. A. Robinson addressed the members on "The Composition of Matter." He opened by describing the construction of compounds and how the different elementary atoms unite in a variety of ways to form molecules of compound substances.

The lecturer explained the original conception of positive and negative electricity and its relation to chemical affinity. A piece of iron was taken, mentally, to illustrate the porosity of solids, and at some length it was described how, by the application of heat, it could be turned first into a liquid and then into a gaseous state. "Radiant matter," the fourth state of matter, the discovery of Sir William Crookes, was also dealt with.

Hon. Sec., W. R. Mickelwright, 10, Westbury Avenue, Wembley.

Manchester Wireless Society.*

On Thursday, November 15th, Capt. Hollingsworth, M.A., B.Sc., lectured on the subject of "Amplifiers." He commenced with the suggestion that he would endeavour to prove why amplifiers did not amplify, and by a series of lucid explanations succeeded in pointing out in a very non-technical manner the several drawbacks which prevent users from obtaining the full percentage of amplification which is in most cases expected. In the lecturer's opinion the greatest enemy of amplifiers and incidentally, the experimenter, is "stray capacity" in the circuit, and it was very clearly illustrated how this could be overcome to a great extent, but even then only a small percentage of amplification could be expected. Correct grid potential on the rectifier was essential, and the grid leak was also a most important factor. The most important circuit of all amplifiers is the resonance or aerial circuit, and this should be of the very lowest resistance, and preferably nothing finer than 20 S.W.G. should be used. In conclusion the lecturer stated that it was essential that all experimenters should have a sound knowledge of alternating currents, and that they should experiment with all kinds of circuits. If amplifiers did really amplify as they ought to be according to theory, there would be very little to worry about and, therefore, half the interest of wireless work would be lost.

The Transatlantic Station at Sorrel Bank, Pendleton, is now fully equipped with a ten-watt transmitter and a 1,000 watt set, both capable of working on wavelengths from 150 metres upwards. A four-valve set is provided for the general use of the members and also a six-valve heterodyne set for the purpose of long distance work. Electric lighting and heating have been installed and an aerial

erected on 60-ft. masts for the purpose of winter experiments. Several types of aerials have been constructed, and these can be raised and lowered at will, depending upon the particular experiments in view. The room is suitably equipped for all-night sittings, every convenience is provided against cold, and tired members can even turn in on the army camp beds provided for this purpose. Reports on the winter experiments will be published from time to time in all the leading wireless and electrical journals in this country and America.

Hon. Sec., Y. W. P. Evans, A.M.Inst. R.E., 2, Parkside Road, Princess Road, Manchester.

The Radio Society of Highgate.*

The Society's headquarters have now been moved to Edco Hall, 270, Archway Road, Highgate, N.6, where all meetings will in future be held. The first meeting in these new premises took place on Friday, November 30th, when a lecture was given by Mr. J. F. Stanley, B.Sc., A.C.G.I., entitled "Distortion in Valve Receivers." It was shown how distortion can and does occur in high-frequency circuits, and how the use of reaction increases this distortion by reducing the time constant of the circuit. The behaviour of a valve was then considered when acting as a rectifier, and the relative merits of anode rectification and grid rectification were discussed from the point of view of distortion. It was shown that the valve gives least distortion when working in such a condition as to give the most efficient rectification—a most fortunate circumstance. Low frequency amplifiers were next considered, it being explained how transformer amplifiers tend to give higher amplification on the higher notes than on the bass notes. The remedies for the various causes of distortion were indicated and a few hints given on how to obtain the maximum volume with the least distortion.

Hon. Sec., H. Stanley, B.Sc., 49, Cholmeley Park, Highgate, N.6, will be pleased to forward full particulars of the Society on application.

The Hounslow and District Wireless Society.*

The Society has been very active during the past month. On November 1st, Mr. G. G. Blake, M.I.E.E., A.Inst.P., gave a very interesting and instructive lecture on the "Development of Radio Telegraphy and Telephony," with lantern slides, and a demonstration of an R.A.F. model, showing the action of a valve. On November 8th, Mr. Scot-Simmonds demonstrated his model, showing the action of a valve, which proved very instructive.

On November 15th, Mr. A. Hinde, which

delivered a lecture on "A New Unit System," later giving a demonstration showing the ease with which a receiver of any kind could be connected up. On November 22nd an excellent lecture was delivered by Mr. Stanley Ward, his subject being "The Application of A.C. to the Transmitter." On November 29th, Lt. H. S. Walker, A.M.I.R.E. (a Vice-President of the Society) delivered an instructive lecture on "Distortion in Radio Telephony." Any ladies or gentlemen in the district who are interested in wireless, will have particulars of membership sent them on application to the Hon. Sec., Arthur J. Myland, 219 Hanworth Road, Hounslow.

Mount Pleasant Radio Research Society.

On Saturday, November 24th, Capt. A. Hinderlich, M.A., addressed the above Society on "Crystals." He spoke of their purity and the peculiarities of each, dealing briefly with the contacts most suitable, advocating where possible the use of gold or silver owing to non-oxidation. He spoke of the numerous sensitive "ites" now procurable, and gave some useful advice on crystals generally.

The lecturer concluded with some remarks on carborundum, emphasising its great stability.

Hon. Sec., Geo. H. Vine, 23, Melville Road, Walthamstow, E.17.

Radio Association of Ireland.

A largely attended special meeting of the Association was held in the Physics Laboratory, Trinity College, Dublin, on November 20th. An interesting and important lecture was delivered by the President of the Association, Professor W. J. Lyons, who dealt with "Some Technical Aspects of Broadcasting."

Ireland, he said, might be late in the matter of Broadcasting, but, in the case of Broadcasting it was better to be late. Broadcasting from a technical point of view was not perfect. The lecturer hoped that Ireland would take its place in dealing with these technical difficulties. The lecture was illustrated by an interesting collection of slides, the whole subject being treated in a technical but popular manner.

In concluding, Professor Lyons referred to the association of Ireland with the early phases of wireless by the work of Professor G. F. Fitzgerald of Trinity College, Dublin; of Professor T. Preston, of the old "Royal," and the early experiments of Senator Marconi off Kings-town; also the important work of Turner on the rate of decay of intensity with distance carried out from Howth.

Hon. Sec., H. Hodgins, Radio Dept., Municipal Technical Institute, Kevin Street, Dublin.

OUR TRANSATLANTIC BROADCASTING TESTS.

Below we print a continuation of our list of successful participants in the Transatlantic Broadcasting Tests organised by the *Wireless World and Radio Review* in conjunction with *Radio Broadcast* of New York. As announced, this test concluded on the morning of December 2nd, when an attempt was made at two-way communication. Although the last experiment cannot, by any stretch of the imagination, be considered a success (atmospheric conditions were most unfavourable), the universal opinion of British listeners points to the immense interest which the experiment aroused, and no words have been spared by our correspondents in praise of the heroic efforts of the B.B.C. engineers to "get through," and also to hear the American signals. In the early hours of Tuesday, December 11th, an individual transatlantic broadcasting test was carried out by **WOO**, the station of J. Wanamaker at Philadelphia, Pa., a speech by President Coolidge being transmitted on a wavelength of 509 metres. At the time of going to press, reports of the reception of **WOO** have reached us from several quarters. Mr. R. J. Hibberd, M.I.R.E., Hon. Sec. of the Schools' Radio Society (Haslemere, Surrey), records the reception of President Coolidge's speech, which dealt with the potentialities of wireless for binding together the English and American peoples, and similar reports have reached us from Mr. Kenyon Secretan, of Barnes, London, and Mr. H. Constable, of Shepherd's Bush, London.

Name and District.	Stations Heard.	Type of Receiver.	Name and District.	Stations Heard.	Type of Receiver.
W. H. Redwood, Fife, N.B.	WGY . . . ? WHAZ WOR WJZ WHAZ		Ralph Fallows, co. Londonderry	WGY . . . 2 valve Marconiphone.	
H. T. Wright, London, N.W.4	WGY . . . 1-V-1		R. W. Arnott, Monmouth	WGY . . . —	
J. E. Brazendale (6CU) and Geo. Steel, Hull	WGY . . . 1-V-2		Wm. Diggle, Blackpool	WGY . . . 1-V-1	
E. J. Flint, Stafford	3 stns. (?)	0-V-0	S. W. Baker, Bournemouth	WGY . . . 2-V-1	
H. W. Baldwin, Tunbridge Wells	WGY . . . —		Herbert E. W. Nicholls, Bristol	WGY . . . 2-V-1	
W. Hartley, Harrogate	WAAD (?)	1-V-1	A. F. Paterson, Montrose, N.B.	WGY . . . 2-V-1	
Miss Norrish, Penmaenmawr	WGY (?)	McMichael	H. Constable, Shepherd's Bush, London, W.12.	KDKA . . . 1-V-2 WGY WDAP	
J. H. Rudd, Hull	WGY . . . 4 valve.		R. Jackson, Manchester	WGY . . . —	
H. Marsden, Manchester	KDKA . . . 1-V-1		J. Hunt, Ramsgate, Kent	WGY . . . —	
A. E. Clay, Leeds	WGY . . . 1-V-1 WHAZ WOR		D. L. Paterson, Blackburn	WGY . . . 1-C-1	
H. J. Walden, Peterboro'	WGY . . . 1-V-1		D. A. Broun, Birmingham	WGY . . . 0-V-1	
Robt. Stevenson, Glasgow	WGY . . . 0-V-1		J. W. G. Thompson, Edinburgh	WGY . . . — KDKA	
A. Towell, nr. Rotherham	WGY . . . 1-V-0		T. Bennett, Crewe	WGY . . . 0-V-0	
J. L. Mitchell, Mauchline, Ayrshire . . .	WGY . . . —		C. E. Markham, Leicester	WGY . . . —	
Ralph Bates, Lincoln	WGY . . . 0-V-1		Frank Leigh, Glamorgan	WGY . . . 1-V-1	
James C. Hall, Manchester	WGY . . . 1-V-1		S. T. Henshaw, Doncaster	WGY . . . 1-V-0	
C. W. Hillier, Croydon	WGY . . . —		James R. Clark, Castle Douglas	WGY (?) . . . 1-V-0	
J. F. Bruce, Bedford Park, London, W.4	WGY . . . 0-V-0 (relief)		J. White, Hucknall, Notts.	WGY . . . 1-V-1	
V. I. N. Williams, Cheshire	WGY . . . —		James Robbins, Grangemouth, N.B. . . .	WGY . . . 1-V-0	
Jas. McIntosh, Inverness, N.B.	WGY . . . 2 valve WHAZ (?) dual.		Chas. F. Peach, Gt. Bridgford, nr. Stafford	WGY . . . 1-C-1	
"G. L.," East Coast, Ireland	WGY . . . 2-V-2		A. A. Barnes, nr. Abergavenny	WGY . . . 1-V-0	
J. B. Stradling, nr. Newbury, Berks . . .	WGY . . . 0-V-3		G. A. Knight, Leyton, London, E. 10 . . .	WGY . . . 1-V-0	
B. J. Williams, Inverness, N.B.	WGY . . . 2 valve Gecophone.		Lt.-Col. H. B. Prothero Smith, Newquay, Cornwall	WGY . . . 5 valves. WHAZ	
Mareus G. Scroggie, Edinburgh	WGY . . . 1-V-1		W. Brian Parker, Monkseaton, Northumberland.	WGY . . . 1-V-1	
Alexander Kirk, Walsall	WGY . . . 1-V-1		J. F. Johnston, Altrincham	WGY . . . —	
B. A. Woolcock, Southport	WGY . . . 1-V-2		Fred Mugerdge, nr. Rochester	WGY . . . 3 valves.	
Gordon Castagnoli, Braintree, Essex . . .	WGY . . . 1-V-0		G. A. Gordon, nr. Leeds	WGY . . . 1-V-1 WOR WJA (?)	
W. C. Hinley, Brynmawr	WHAZ		F. Turner, Exeter	WGY . . . 1-V-2	
A. P. Hudson, S. Lincolnshire	WGY . . . 1-V-1 WGY . . . 1-V-2		H. Jackson, Preston, Lancs	WGY . . . 3 valves.	
			H. B. Courtice, Leeds	WGY . . . 3 valves.	
			J. A. Peoples, Gainsboro', Lines.	WGY . . . 3 valves.	
			Robt. McGill, Kilmarnock, N.B.	WGY . . . 2-V-1	
			W. W. Knight, Stafford	WGY . . . Gecophone, 2 valves.	
			W. B. Broad, Kingston-on-Thames	WGY . . . 4 valves.	

Name and District.	Stations Heard.	Type of Receiver.	Name and District.	Stations Heard.	Type of Receiver.
W. H. L. Hurman, Banwell, Somerset.	WGY	3 valves.	Hugh Kirton, Seaham Harbour	WGY	3 valves.
Charles Wilson, Cleckheaton, Yorks	WGY	4 valves.	H. C. Hatton, Hoylake, Cheshire	WGY	—
J. B. Stewart, Ayr, N.B.	WGY	1—C—1		KDKA	—
M. Young, Auchterpool, Fife	WGY	Metropolitan-Vickers 2-valve with 2 v. amplifier.	J. W. Allen, N. Finchley, London.	WGY	—
Eng. Comdr. W. J. Ford, Portsmouth.	WGY(?)	—	W. A. Merrick, London, N.W.1	WGY	4 valves.
L. H. Lomas (2HB), nr. Manchester	WGY	—	Stephenson, Bros., Shirebrook.	WGY(?)	—
Sir Robert C. Lockhart, Allanbank, Kirkcaldy.	WGY	Geophone, 2 valves with power amp.	A. C. Harrington, Montgomeryshire, Wales.	WGY	—
J. L. Moorhouse, Ashton-under-Lyne.	WGY	1—V—1	G. Jenkins, Cambridge	WGY	1—V—0
Louis, J. Wood, Halifax.	WGY	1—V—1	P. L. Chant, Highbridge, Som.	WGY	4—V—1
	WOR	—	R. V. Sinclair, Yatton, Som.	WGY	Burndept. Ethophone V
	WJZ(?)	—	J. D. Acland, Allerford, Som.	WGY	3 valves.
W. R. Erdington, Cheshire	WHAZ	1—V—2	Wm. Hall, Boro' Green, Kent	WGY	—
	WGY	—	P. Bowerstock, Portsmouth	WGY	4 valves.
Wm. H. Palmer, Gorleston-on-Sea	WGY	Burndept		WOO	—
	WGY	4 valves.		WGAB	—
F. Burton, Grantham	WGY	0—V—0	Robt. Hughes, Sanquhar, N.B.	WGY	Marconiphone Va.
P. Richards, Haworth, Yorks	WGY	1—V—1		WGY	4 valves.
	WHAZ	—	Edmund M. McLachlan, Margate	WGY	—
T. Lee, Bristol	WGY	1—V—2	Brig.-Gen. Noel C. Lory, Crickhowell, Wales.	WGY	7 valves.
B. Boswell	WGY	—	R. M. Bell, Hastings	WGY	4—V—1
S. W. Troupe, Brighton	WGY	—	F. Phil. Phillips, St. Anstell, Cornwall.	WGY	1—V—0
Major C. T. Williams, Grove Park, London, S.E.12	WGY(?)	1—V—1		WJZ	—
Eric D. Dickson, Woking	WGY	2—V—1	B. Gipson (5NC), Herne Bay	WGY	1—V—1
J. H. L. Musker, Norfolk	WGY	3 stns. 6 valves, and loud speaker.	Edgar Smith, Coventry	WGY	1—V—2
	WOB	(Flewellling)	Geo. G. Vivian, Southampton	WGY	—
	WGY	0—V—1	"Listener," Croydon	WGY	—
C. G. Mayer, Herne Bay	WGY	2—V—2	Granville Bedford, Oldham	WGY(?)	—
C. R. Bates, Stokenchurch, Bucks	WGY	2—V—2	M. V. Reifel, Kew, Surrey	WGY	1—V—1
H. J. Coxon, Warrington	WGY	3 valves.	J. Leach, Portobello, N.B.	WHAZ(?)	5 valves.
G. Baldwin Banks, Manchester	WGY	—	Rex F. Stedman, Leeds	WGY	1—V—1
W. H. Harding, Cardiff	WGY	1—C—1	W. T. Davies, Cowes	WGY(?)	1—V—1
E. C. Stanford, Upminster	WGY	—	A. D. Glyn Jones, Co. Derry	WGY	4 valves.
A. Lander, Canterbury	WGY	—	T. W. P. Gomley, Arbroath, N.B.	WGY(?)	Geophone 2-valve.
P. H. Battersley, Gillingham, Kent	WGY	—	Jas. G. Wright, Kirkpatrick-Fleming, N.B.	WGY	Marconiphone Va.
Jack Dohoo, Hornchurch	WGY(?)	1—V—1	C. Phillipson, Cheshire	WGY	—
F. Duerth, Whitstable	WGY(?)	3 valves.	A. Machardy, Silloth, Cumberland	WGY(?)	1—V—0
Edward Tarplee, Gloucester	WGY	1—V—2	J. S. Hastie, Glasgow	WGY	1—V—1
H. Goddard, Walthamstow	WGY	—		WEAF	—
Graham Hunt, Torquay	WGY	—		WFAM	—
Denis C. Welch, Bath	WGY	1—V—2	K. C. Zarketsky, Hellingly, Sussex	WGY	5 valves.
Wm. S. Skinner, Dartmouth, Devon	WGY(?)	1—V—1	E. Wellstein, Zurich	WGY	—
T. F. Cox, N. Devon	WGY(?)	1—V—1	J. C. H. Martin, Lewes, Sussex	WGY	Marconiphone V2 and 2 L.F.
G. E. Prance, Plymouth	WGY	2—V—2		KSD	1—V—1
F. J. Hall, London, N.W.10	WGY	1—C—0	A. T. Lyon, Forfarshire, N.B.	WGY	1—V—2
F. G. Briant, nr. Warrington	WGY	2—V—2	A. W. Fawcett (Surg. Lt.), Bristol	WGY	1—V—1
W. D. Watts & Son, Burnham-on-Sea	WGY	1—V—1	A. H. Walpole, London, W.12	WGY	1—C—1
Alan D. Carnes, Taunton	WGY	1—C—0	A. Pepper, Rothley, nr. Leicester	WGY	—
A. Towel, Rotherham	WHAZ	1—C—0	G. W. Gosling, nr. Boston, Lincs.	WGY	Marconiphone V2 with L.F.
Ian Stuart, Craigieachie, N.B.	WGY	—		WGY	2 valves.
Walter T. Taylor, nr. Barnsley	WGY(?)	1—V—1	W. T. Gearing, Margate	WGY	Geophone 2-valve.
J. D. Craven, Selby	WGY	1—C—1	T. Hudson, Sunderland	WGY	2 valves.
Robert Spencer, Richmond, Yorks	WGY	4 valves.	H. R. Briscoe, Grimsby	WGY	1—V—1
H. Edmonds Hull, London, W.11	WGY	—	H. W. Harris, Blackburn, Lancs.	WGY	1—V—1
W. K. Goodall, Hereford	WHAZ(?)	3 valves.	J. Barnes, Liverpool	WGY	4—V—0
J. C. Webber, Honiton, Devon	WGY	1—V—1	Charles J. Crimmen, nr. Cardiff, Glam.	WGY	5 valves.
	WOC	—	J. R. Topham-Haynes, Peterborough	WGY	—
	WOR	—	Hy. Cottam, Stocks-in-Bowland, Yorks	WGY	4 valves.
J. A. M. Scobie, Oxford	WGY(?)	Geophone 2 valves.	J. Bishop, Gt. Yarmouth	WGY	2—V—1
	WGY	1—V—1	W. A. Gill, Nottingham	WGY	1—V—2
John E. Beasley, Weymouth	WGY	—		WHAZ	—
Mrs. Edith Steer, Surbiton Hill, Surrey	WGY(?)	—	C. Buckley, Northwich	WHAZ	1—V—1
Bernard W. Harrison, Barnstaple	WGY	1—V—1	W. J. Colwell, Co. Durham	WGY	1—V—1
A. H. Bruce, Stoke Newington, London, N.16.	WGY	1—V—0	A. Sutcliffe, Leyland	WGY	—
J. B. Miller, Wells, Somerset	WGY	1—V—1	G. E. Penrose, Southport	WGY	1—V—1
	KDKA	—	D. S. W. Pullin, London, S.E.23	WHE	0—V—1
W. Whorton, Cannock, Staffs.	WMAF	2 valves.	Miss E. West, Canterbury	WGY	1—V—0
	WHAZ	—	Edwin Blake, Cirencester	WGY	1—V—2
Henry Field (8ZX), Leicestershire	WGY	—	F. J. Southwell, Hull	WGY	1—V—1
V. Craven, Bradford	KDKA	—	A. Towel, Rotherham	WJZ(?)	—
	WGY	—		WHAZ	—
Arthur O. Milne, Margate	WGY	—	L. C. Dove, Erith, Kent	WGY(?)	1—V—2
G. H. Frampton, Botley, Hants	WGY(?)	1—V—2	H. J. Harvey, Plumstead	WHAZ	1—V—2
C. H. Summersby, Muswell Hill, London, N.10.	WGY(?)	—	H. Crowther, Bruton, Som.	WGY	1—V—1
	WGY	1—V—1	R. W. Taylor and W. Hughes, Warrington	WGY	1—V—1
J. Heath, Farnham, Surrey	WGY	1—V—1	Hy. Rogers, Ilfracombe	WGY	Geophone 4-valve.
"Amateur Constructor," Stroud, Glos.	WGY(?)	1—V—2		WJAZ	—
P. Brassey, Chichester	WGY	1—V—1	H. Walker, Kendal	WGY	1—V—0
Chas. C. Ellis, London, N.W.11	KSD(?)	1—V—2	A. P. MacGrory, Kintyre	WGY	1—V—0
T. Carter, Heavitree, Exeter	WGY	3 valves.		KDKA	—
	WMAF	—	Frank E. Whiting, Bideford, Devon	WGY	2—V—2
			W. Dey, Leicester	WGY	—
			D. Ballantyne, Glasgow	WGY	1—V—1

THE WIRELESS WORLD AND RADIO REVIEW

THE OFFICIAL ORGAN OF THE RADIO SOCIETY OF GREAT BRITAIN.

No. 228. (No. 13.) DECEMBER 27th, 1923. WEEKLY
Vol. XIII.)

EDITOR:
HUGH S. POCOCK.

RESEARCH EDITOR:
PHILIP R. COURSEY, B.Sc., F.Inst.P., A.M.I.E.E.

ASSISTANT EDITOR:
F. H. HAYNES.

QUESTIONS AND ANSWERS DEPARTMENT:
Under the Supervision of W. JAMES.

CONTENTS

	PAGE
Editorial - - - - -	398
Some New Ideas in Receiver Design. By F. H. Haynes - - - - -	399
Short Wavelength Transmission. By W. James - - - - -	404
The Thermionic Rectifier for Battery Charging (concluded). By R. L. Smith-Rose, Ph.D. - - - - -	408
Novel Ideas and Inventions - - - - -	411
First Successful Amateur Two-way Communication with U.S.A. By 2 KF - - - - -	412
Meteorological and other European Wireless Stations (Additional Transmissions) - - - - -	417
Around the Wireless World - - - - -	419
With the Societies - - - - -	423
Questions and Answers - - - - -	425

THE EDITOR will be glad to consider articles and illustrations dealing with subjects within the scope of the Journal. Illustrations should preferably be confined to photographs and rough drawings. The greatest care will be taken to return all illustrations and manuscripts not required for publication if these are accompanied by stamps to pay return postage. All manuscripts and illustrations are sent at the Author's risk and the Editor cannot accept responsibility for their safe custody or return. Contributions should be addressed to the Editor, "The Wireless World and Radio Review," 12 and 13, Henrietta Street, Strand, London, W.C.2.

SUBSCRIPTION RATES:

20s. per annum, post free. Single copies 4d. each or post free 5d. Registered at the G.P.O. for transmission by Magazine Post to Canada and Newfoundland.

EDITORIAL AND PUBLISHING OFFICES:

12 and 13 Henrietta Street,
Strand, London, W.C.2.

Telephone: Gerrard 2807-9.



ADVERTISEMENT MANAGERS:

Bertram Day and Co., Ltd.,
9 & 10 Charing Cross, S.W.1.

Telephone: Gerrard 8063-8.

THE YEAR'S PROGRESS.

THE Amateur can do well to reflect on the progress made throughout the year now closing. He may say at the outset that nothing new has been invented, and true nothing fundamentally new has appeared, yet developments by way of improvements in the practical application of ideas has given a greater advancement than the sighting of new themes or the observation of new phenomena.

Many new circuit principles evolved during the year might be mentioned—the simplified Armstrong arrangement, the Flewelling circuit, and the application of the Neurodyne principle to high frequency amplification. The importance of the last-mentioned cannot be over estimated. In the straightforward neurodyne arrangement we have a scheme for stabilising high frequency amplifying circuits and controlling the extent of self-oscillation. Although the system first described may not in itself become an entirely standard practice, it opens up a new road to successful receiving circuit manipulation, and draws attention to the importance of carefully considering the effects of self-oscillation in high frequency amplifiers and the necessity for introducing into the design of receiving apparatus a scheme for suppressing as well as stimulating self-oscillation, and in a form in which it can be critically controlled.

With regard to what might be called the practical developments of the year should be included improvements in the design of low frequency transformers, and a better understanding by manufacturers of the underlying principles. The appearance of well-designed variable condensers, in particular those having specially shaped plates, although by no means new, must be regarded as a development, and provides the experimenter with a component instrument almost indispensable for the critical tuning of circuits.

Dull emitter valves mark a big leap forward in manufacturing processes, for although the principles of these valves have been known for some time, the putting of them on the market in large numbers, all exactly similar as regards characteristic, can only be the outcome of considerable research work in manufacturing processes.

One observes also with satisfaction the steady fall in price of wireless apparatus, due essentially to improved methods of production.

The amateur has, without doubt, taken his share in the year's development, and in particular must be mentioned the astounding success achieved by way of transatlantic transmission and reception. These results are truly gratifying, for one has not yet forgotten the great surprise with which we learnt that, firstly, American amateur stations operating telegraphy could be heard in this country, and, next, when the American Broadcasting Stations were first picked up over here. Both of these occurrences are now quite commonplace.

Within the past few weeks another advancement has been recorded, and already the claim is not restricted to one experimenter, for now several European amateur stations are working reliably both ways with their confrères on the other side of the Atlantic, handling messages relating to their experiments with speed and absolute reliability.

With such developments as these the amateur has so endorsed his ability as to deserve the almost unrestricted granting of facilities for him to proceed with the great work of national importance which he is undertaking, and not prompted by pecuniary gain but because of his love for this attractive and progressive science.

SOME NEW IDEAS IN RECEIVER DESIGN

BUILDING A THREE-VALVE SET.

Sooner or later every amateur builds a three-valve set, and in this article careful attention is given to considerations of design. The points discussed relating to circuit principle are all important, whilst the actual construction is distinctly unique. The article is full of information and offers many useful suggestions.

By F. H. HAYNES.

THE CIRCUIT.

HERE is little doubt that the most popular of receivers is the three-valve set, comprising a high-frequency amplifier, valve detector and note magnifier. It has long receiving range, and on the average aerial should bring in the more important American broadcasting and amateur stations, which at the

detector also, when connected across an inductance, produces so much damping that steady self-oscillation is out of the question. Again, to get the utmost out of the number of valves employed dualling is often attempted, but, in fact, careful observation shows that little or no advantage is gained. To cause the first valve to function as an amplifier at both high and low frequencies

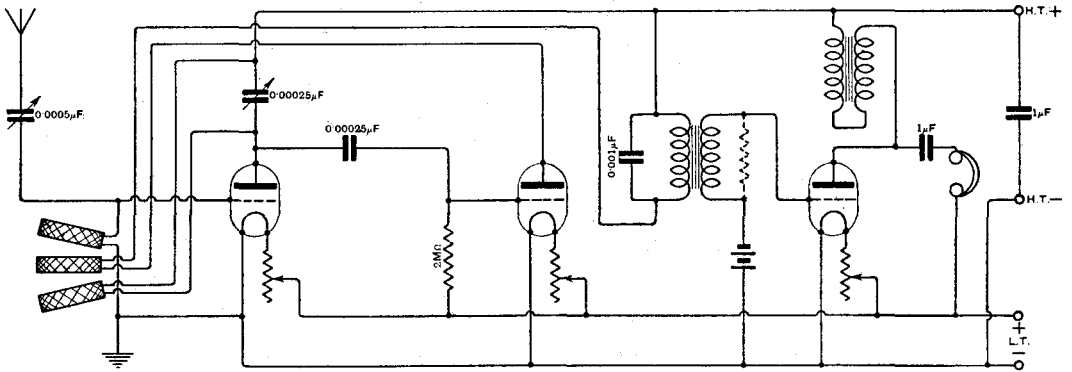

The circuit. Reaction operates on to both aerial and anode inductances, stimulating oscillation in one coil and suppressing it in the other.

present time is probably the hall mark of receiver efficiency.

Economy by way of substituting a crystal for the valve detector is not warranted, for with its position in the circuit directly in contact with the H.T. lead it stands a chance of being rendered completely insensitive by a potential from the H.T. battery, whilst to operate it through a H.F. transformer complicates not only the circuit arrangement, but the actual construction and manipulation with regard to the interchanging of inductances. A crystal

it may be said that it does both partly but neither efficiently. To convert a straight-forward set to a dual set has the effect of reducing the range of reception, whilst very much increasing the volume of normally strong signals, or, in other words, such a set should be called not a "one-valve H.F. dual with note magnifier," but a "half-valve H.F. with one and a half valves L.F." Actually dual sets give good signal strength when oscillating and receiving a normally strong signal, and the action of the first valve should be regarded more in the light of an

oscillator, modulated by the detected signal rather than a system of simultaneous high and low frequency amplification.

Boiling down the results of one's experience with many types of receivers, the circuit shown is arrived at. The aerial is a single tuned circuit. A secondary circuit has its advantages particularly with regard to the elimina-

the aerial and closed circuits in conjunction with the tuned anode circuit. These advantages must, as far as possible, be gained by some other means. A series aerial tuning condenser renders the circuit much more selective than the parallel arrangement, and this is adopted in the set under description, while for those who need it, an additional

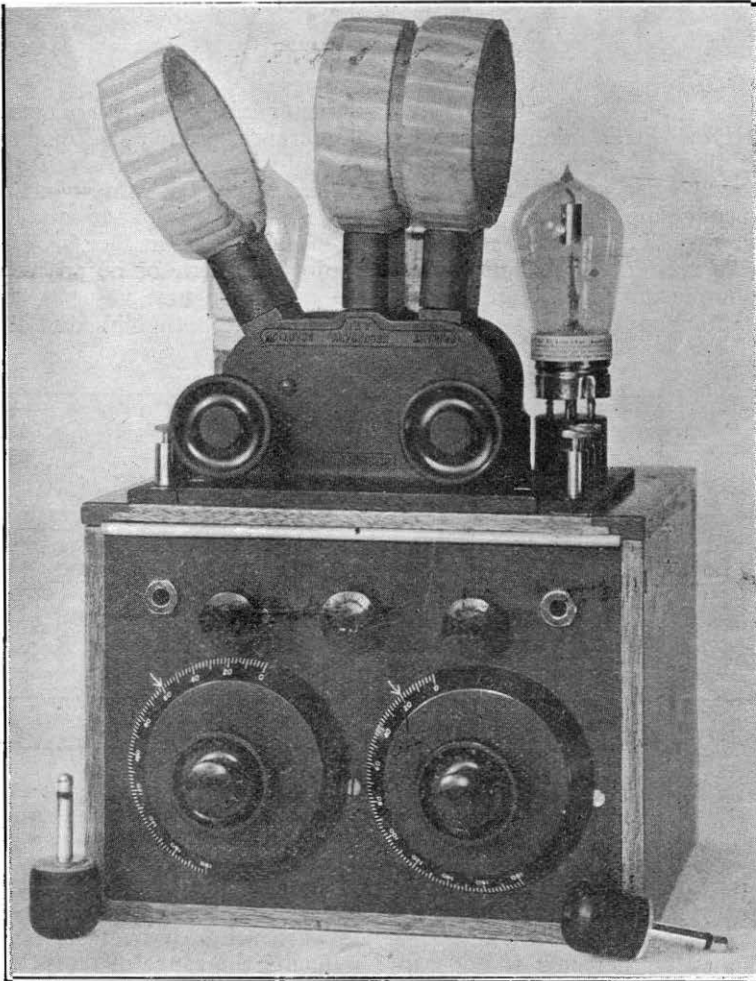

The finished instrument. It is compact and simple to manipulate.

tion of interference and giving an additional and critical control of self-oscillation and frequently a step-up of potential for operating the high-frequency valve, but offset against these advantages is the difficulty of tuning

terminal will give the parallel arrangement when required, a system which the pre-war crystal user is quite familiar with, and such as was adopted in many war-time instruments. The series tuning arrangement gives

a maximum of potential across the inductance and a further degree of selectivity is obtained by the tuned anode circuit.

Now, as to self-oscillation, considerable advantage is gained by feeding back on to the aerial circuit to nullify the damping produced by resistance and other losses. The question of local interference may be set aside at once, for whenever a high-frequency amplifier is efficiently used, with or without reaction, the aerial circuit is certain to be energised, and the greatest degree of interference is caused not when the set is "howling," or emitting a shrill note, but when it has that sensitive sound so sought after by the listener.

Whilst aerial circuit losses are reduced by reaction, a degree of coupling back between the tuned anode inductance and the reaction coil gives an extremely critical control of self-oscillation, and can balance out the tendency to oscillate created by the grid-plate capacity of the high-frequency valve. This is the aim in the neutrodyne receiver, but with the arrangement here described it is achieved incidentally, and inductive as well as capacity feed-back is obtained by adjusting the relative positions of a pair of plug-in

coils, though a point of vital importance is the direction and disposition of the windings and the manner in which they are connected in the circuit. These details will be given later. Thus, the reaction coil is placed between the

aerial and tuned anode coils in a three-coil holder. Tightening the coupling of the aerial coil stimulates self-oscillation, whilst increased coupling with the tuned anode inductance nullifies it, and a suitable balance accompanied by careful tuning can easily be struck which will give a steady and critical degree of oscillation over the entire range of the condensers.

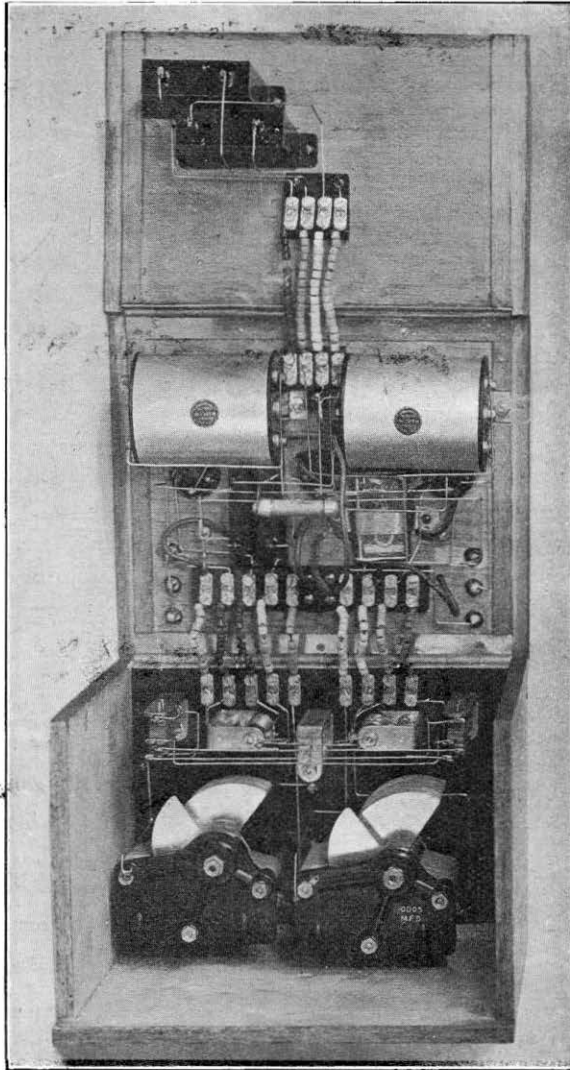

The interior. Components are attached to three of the sides, which are hinged together. Everything is immediately accessible, and when closed occupies a minimum of space.

CONSTRUCTIONAL CONSIDERATIONS.

Coming to the actual design, such points are considered, as type of components to be used, cost, weight, compactness and portability, ease of construction, convenience of manipulation and quickness of tuning, and such unique features as may have appealed to the designer. On the question of components there is

considerable scope, as the market carries ample efficient and well-designed apparatus. Those used by the author are mentioned inasmuch as their dimensions and positions for drilling of holes, etc.,

are given in the working drawings and are as follows:—

Tuning condensers, with air dielectric, made by the Sterling Telegraph and Telephone Company, having specially shaped plates to give uniform tuning, and fitted with verniers. Aerial circuit 0.0005 mfd., anode circuit 0.00025 mfd.

Three filament resistances by T. C. Ball, which are very compact, and type A

Three batten-type valve holders.

Two Dubilier condensers, type 600A, 0.00025 mfd. and 0.001 mfd.

Two intervalve transformers by the Marconi Scientific Instrument Company, mounted in cases.

One "Ever-Ready" battery for grid cells, type No. 1450.

Two T.C.C. condensers, each 1 mfd., and fitted with strips for mounting.

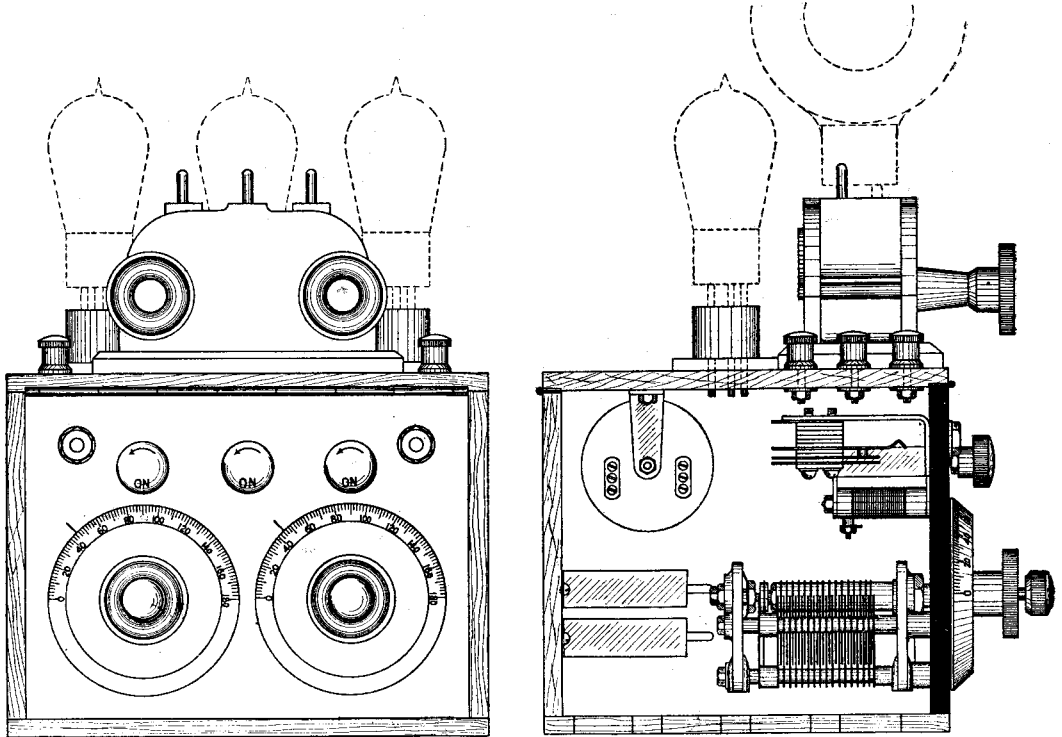

Scale drawing (approximate size) showing the disposition of the components.

is suitable for use with "R" valves on 4 or 6 volts, or "D.E.R." on 2 volts, whilst another pattern suits the 0.06 dull emitters.

Two telephone jacks, with a pair of break contacts for switching off the filaments when the jack is removed, Edison Bell.

A Burndept three-coil holder which is geared, gives critical adjustment, and does not allow the heavy coils to fall when the holder is mounted on the top of the set.

Three dozen small connectors, M.S.I. Co.

One Dubilier 2-megohm leak.

Six terminals.

In order to make the set compact it is necessary to limit the area of the front panel to only just those components which need to be ebonite mounted for insulation and those which are operated when tuning. To obtain the maximum interior space, the height, width and depth should approximate a cube. To effect this the component parts are mounted on three faces of the box, which are

SHORT WAVELENGTH TRANSMISSION.

THE MASTER OSCILLATOR SYSTEM.

By W. JAMES.

IN most valve transmitters, the valve is excited by transferring a little of the plate circuit energy to the grid circuit by capacity or magnetic coupling. In the master oscillator system, the power valve is excited from an oscillator which is capable of generating enough power to meet the losses in the grid circuit of the power valve. The oscillator must also, of course,

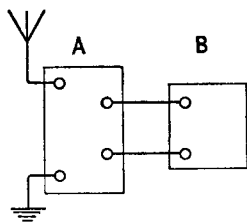

Fig. 1. Explaining the master oscillator transmitter.

A = Amplifier.
B = Oscillator.

supply the power necessary to excite its own grid circuit and make good the losses in its own circuits.

Referring to Fig. 1, A represents a power valve with the associated tuning circuits. B represents an oscillator, which is connected to the grid or exciting circuit of the power valve. The power valve circuit is shown in more detail in Fig. 2. The power valve is represented by V_1 . The plate circuit is connected to a source of high voltage, HT, through the air core choke coil, Ch_1 . The portion of the plate circuit carrying oscillating currents consists of the blocking condenser C_1 , which is connected to the inductance coil L_1 at tapping T_1 . The earth end of L_1 is joined to the filament heating battery. The aerial circuit consists of the aerial, that part of coil L_1 between the tap T_2 and earth, and the earth or counterpoise.

The exciting circuit is represented by the coupled coils L_2 and L_3 , and the generator of radio-frequency energy H.F.

I.—THE CHOKE COIL.

The function of the choke coil, Ch_1 is to prevent the radio frequency energy from passing out to the plate voltage supply,

to negative H.T., and the filament battery. Any radio frequency energy which might flow in this circuit contributes nothing to the aerial current, and is therefore waste. It merely causes a larger drain on the plate voltage source and a heating of the valve plate, and consequently a reduction in the efficiency of the valve as a converter of high voltage direct current (or alternating current) into radio frequency currents. If there were no choke coil, probably there would be no oscillations generated, because the supply would in effect short-circuit the valve.

For 200 metre transmission, using a small power valve such as a 10 or 20 watt, this coil may be about 350 turns of No. 30 D.S.C. wound on a tube 3 ins. in diameter. It is sometimes found that results are better, if this coil is tuned to the frequency of the radio frequency circuits. However, it is not recommended that a tuning condenser should be used, because it adds another adjustment and its use may be troublesome.

The insulation of this coil should be carefully attended to. Apart from its being

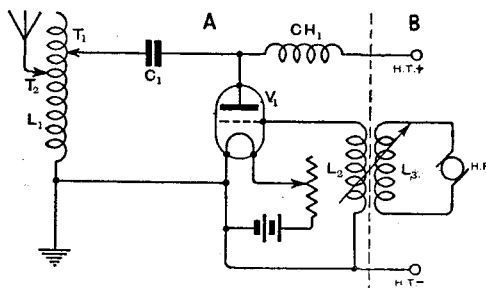

Fig. 2. The amplifier, or power circuit.

$Ch_1 = 350$ turns of No. 30 D.S.C., 3 inches diameter.

$C_1 = 0.0005 \mu F$ to $0.002 \mu F$.

$L_1 = 10$ or 12 turns of No. 12 bare copper wire or strip, 6 inches diameter, and 30 turns of No. 20 D.C.C., 5 inches in diameter; or, 35 turns of No. 12 copper wire or strip.

$L_2 = 20$ turns of No. 20 D.C.C. 5 inches in diameter.

at high potential to earth, which is obvious from the figure, a considerable radio-frequency voltage may be generated across it.

It will be clear that a coil with a small inductance (nearly 4,000 μH), such as this, will offer negligible impedance to currents of speech frequency which may pass through it when a modulator is connected.

2.—THE CONDENSER C_1 .

The stopping condenser C_1 is for the purpose of breaking the circuit: plate, T_1 , L_1 , and filament, so far as the direct current plate voltage is concerned. If it were not used, the plate voltage supply would be short-circuited. On the other hand, its use does not hinder the flow of radio-frequency currents in the above circuit.

The capacity value is not critical, and may be between 0.0005 and 0.002 μF .

The full plate voltage is across this condenser, so that it should be well made, and constructed to withstand three or four thousand volts. Ordinary receiving condensers will not do. The fact that this condenser is connected in a circuit which carries high-frequency currents, means that the condenser must be well made, and capable of withstanding a direct current pressure several times greater than that of the plate circuit power supply.

3.—THE TAP, T_1 .

The tap, T_1 , is called the anode tap, and it is made variable so that the coupling between the plate circuit and the aerial circuit may be adjusted. Varying the position of the tap changes the coupling.

If the tapping is made low down on the coil L_1 , near the earth end, an excessive current may flow in the plate circuit, and heat up the valve.

If the tapping point is raised, so that a larger portion of the coil L_1 is included between the point T_1 and earth, the plate current falls off.

There is one adjustment which gives maximum efficiency, that is, best ratio of aerial current to plate feed current. It is not worth while lowering the anode tap, to gain a small increase in aerial current, at the expense of a proportionately larger plate feed current. Apart from the reduced efficiency, there is the possibility of damage to the valve through the plate becoming hot.

The anode tap adjustment should always be very carefully made.

4.—COIL L_1 .

This coil may be divided into two portions; that required by the plate circuit, included between T_1 and earth, and that portion in the aerial circuit, T_2 and earth.

The inductance between T_2 and earth should be designed so that its losses are as small as possible. Any losses in the coil here cause a reduction in the efficiency of the aerial circuit.

The value of the inductance between T_2 and earth is decided by the wavelength. When a condenser is connected in the aerial circuit for the purpose of reducing its wavelength, the tuning inductance may be about 10 or 12 turns, 6 ins. in diameter. The coil should be very carefully wound with heavy gauge copper, preferably strip. For small power sets, bare No. 12 gauge wire, with the turns spaced about $\frac{1}{4}$ in. apart is satisfactory, but it is better to use copper strip.

The insulation should be carefully attended to, and no more material than is essential for mechanical strength employed in the former. A former of skeleton construction, with grooves to retain the wire or strip, is preferable.

Many will prefer that L_1 shall be in the form of a single coil. In this case, the coil should be wound with 30 to 35 turns of the heavy gauge wire.

The portion of the coil between T_1 and T_2 only carries the relatively small plate current, and if desired, may be wound with a small diameter wire, such as No. 20 or 22 D.C.C. Therefore, if it is preferred to use two coils, one providing the aerial tuning inductance, and the other the plate circuit inductance between T_1 and T_2 , concentrate on securing the lowest loss coil for the aerial circuit, and then use a coil of finer wire connected in series, and coupled with the aerial coil, for the plate circuit. When the aerial coil is 6 ins. in diameter, the plate coil may be about 5 ins. in diameter, with about 30 turns of No. 20 or 22 D.C.C. placed inside, at one end of the aerial coil.

It is convenient to make the contacts T_1 and T_2 with clips, and if the coil is constructed so that it stands upright, it is an easy matter to obtain fine adjustments by placing the clips on any part of the windings. In general, there is no necessity to make adjustments of the anode tap T_1 to closer than one turn, but when a fixed aerial condenser, or none at all is used,

there is a decided advantage in being able to critically vary the amount of inductance in the aerial circuit.

Sometimes it is found convenient to connect a well-insulated variable condenser between T_1 and earth. This reduces the inductance required in the coil. The connection is not greatly to be recommended.

5.—THE GRID CIRCUIT.

The grid circuit contains a coupling coil L_2 . It is shown coupled to the source of radio-frequency oscillations, H.F. through the coil L_3 . When oscillations with a given frequency, are generated by the H.F. generator connected to coil L_3 , oscillations are induced in the coil L_2 . The magnitude of the oscillating voltages induced in the grid circuit of V_1 may be varied by changing the coupling. The generator must supply sufficient power to supply the losses in its own circuits, and the grid circuit of V_1 . In any case, when a valve is used as the source of H.F. oscillations, it will in general

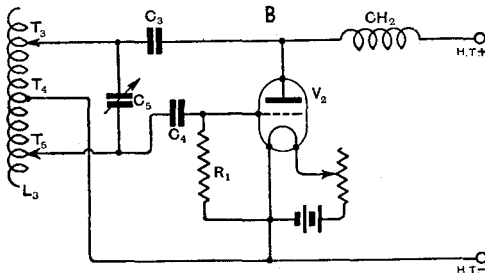

Fig. 3. The oscillator connections.

$CH_2 = 350$ turns of No. 40 D.S.C., 3 inches in diameter.

$C_3 = 0.0005 \mu F$ to $0.002 \mu F$.

$L_2 = 35$ turns of No. 18 bare copper wire, 6 inches in diameter.

$C_5 = 0.0005 \mu F$, well insulated.

$C_4 = 0.002 \mu F$.

$R_1 = 10,000$ to $15,000$ ohms.

be satisfactory if it is rated at about 5 to 10 per cent. that of V_1 .

The coil may consist of a winding of No. 20 D.C.C. Generally about 20 turns are required. The coil should fit inside coil L_3 , which is 6 ins. in diameter (section 9).

6.—OPERATION.

When the aerial circuit is tuned to the frequency of the oscillator B, the circuit A operates as an amplifier of the oscillations applied to its grid circuit. The frequency of the oscillations is determined principally by the constants of the master oscillator.

Changes in the constants of the amplifier tuning circuits do not change the frequency of the oscillating energy to any great extent. The operation will be more fully dealt with in a later section.

7.—THE OSCILLATOR, B.

A convenient method of generating oscillations is shown in Fig. 3. The coil L_2 has tappings taken, as shown, at T_3 for the plate circuit, T_4 for the filament, and T_5 for the grid circuit. The condenser C_5 is connected across the inductance to tune it to the frequency required. The frequency is determined by the position of T_3 and T_5 as well as the condenser C_5 . Condenser C_3 is the stopping condenser, and CH_2 the radio-frequency choke coil.

An oscillator of this sort is called the Hartley oscillator, because the connections were suggested by R. Hartley, of the Western Electric Company.

8.—THE CHOKE COIL AND STOPPING CONDENSER.

The function of the choke coil, CH_2 , and stopping condenser, C_3 , was described in sections 1 and 2. Because the oscillator valve may be a much smaller valve than the amplifier valve, working off a lower plate voltage, we may use a choke coil wound with fine wire, and the condenser need not be built to withstand such a high voltage. A suitable choke coil would have 350 turns of No. 38 or 40 D.S.C. wound on a tube 3 ins. in diameter.

The stopping condenser should have a capacity of between 0.0005 and $0.002 \mu F$, and be able to withstand about 1,000 volts.

9.—INDUCTANCE. L_3 .

This inductance may consist of 30 to 35 turns of wire wound on a former 6 ins. in diameter. When a receiving valve is used in this circuit, results will be satisfactory if the coil is wound with No. 18 bare wire, with the turns spaced about $\frac{1}{4}$ in. apart. If a skeleton construction former is used the losses will be lower, and it is easier to properly adjust the circuit by placing the clip contacts at any part of a turn.

10.—CONDENSER C_5 .

The purpose of the variable condenser C_5 is to tune the coil L_2 . Some may prefer to use a fixed condenser here, and to rely upon the adjustments available with the tappings T_3 , T_4 and T_5 . It is, however, an advantage to employ a variable condenser.

If a condenser were not used at all, it would be necessary to employ a larger coil L_1 , and the valve would not operate so easily as a generator.

The condenser may have a maximum capacity of $0.0005\mu\text{F}$. It must be built to withstand a voltage several times greater than the valve plate voltage. For this reason, it is convenient to employ a fixed condenser, shunted with a variable condenser having a few plates well spaced.

II.—THE GRID CONDENSER AND LEAK.

The function of the grid condenser C_4 , and leak R_2 , is to provide the grid with a suitable mean negative potential with respect to the filament. The values, in general, are not critical. Good average values are

that taps may be easily made. It is always an advantage to provide several taps.

The adjustment of the grid leak is important, because it decides to some extent the efficiency of the valve. If the grid leak is given a high resistance, the output is, in general, lowered, although the efficiency is increased. The output may be brought up to the desired value again by raising the plate voltage. Increasing the resistance also reduces the filament current required for oscillations.

12.—THE COMPLETE CIRCUIT.

The complete circuit of the master oscillator transmitter is given in Fig. 4. It consists of the amplifier of Fig. 2, and the oscillator of Fig. 3.

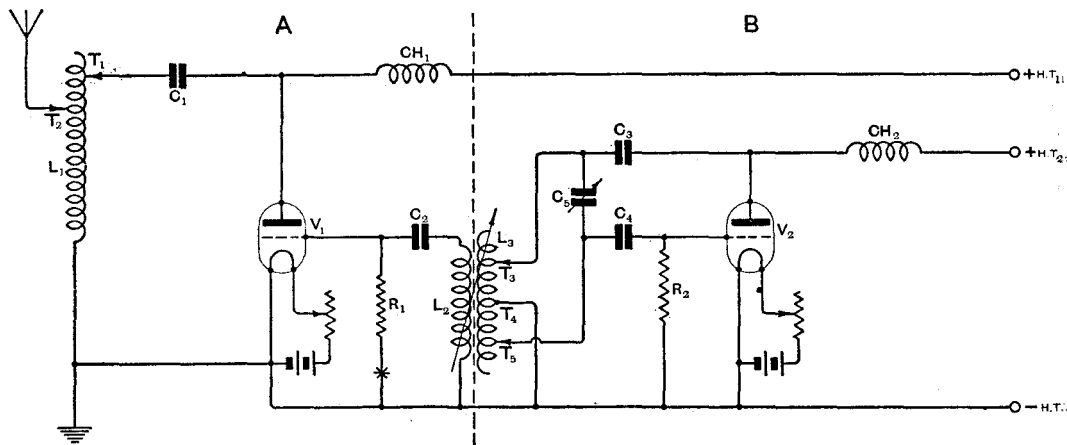

Fig. 4. The combined oscillator and amplifier. Values as above. $C_3 = 0.002\mu\text{F}$. $R_1 = 10,000$ to $15,000$ ohms. * = Choke coil, 200 to 300 turns of No. 40 D.S.C., 2 inches in diameter.

$0.002\mu\text{F}$, and $15,000$ to $10,000$ ohms. Sometimes a resistance so low as $5,000$ ohms is satisfactory.

The grid condenser should have a mica dielectric, and when a small power valve, or a receiving valve, is used in the circuit, a good receiving fixed condenser is satisfactory.

The grid leak may be constructed by winding a bobbin with No. 44 D.S.C. resistance wire, such as German silver or Eureka; No. 44 German silver wire has a resistance of $40,000$ ohms per $1,000$ yards, and Eureka, $83,600$ ohms per $1,000$ yards. When using larger valves, sometimes a grid leak in the form of a bobbin will burn out. For this reason, many prefer to wind the wire upon a strip of mica, and this construction has the additional advantage

To the amplifier grid circuit we have added the grid condenser and leak $C_2 R_1$. These are, of course, essential components.

The grid condenser may have a value of $0.002\mu\text{F}$, and the leak a resistance of $15,000$ to $10,000$ ohms, or even lower, depending on the valve V_1 and the value of its plate voltage. The leak should be constructed as in section II above, but with No. 40 D.S.C. resistance wire.

It may be necessary to connect a high frequency choke coil in the grid leak wire at the point marked by a star, to prevent too much current flowing in this circuit. Two or three hundred turns of No. 40 D.S.C. wire may be wound on a 2-in. diameter tube and connected here.

(The addition and construction of a modulator for telephony will be described in the next issue.)

THE THERMIONIC RECTIFIER FOR BATTERY CHARGING.

By R. L. SMITH-ROSE, PH.D., M.Sc., D.I.C., A.R.C., A.M.I.E.E.

(Concluded from page 378 of previous issue.)

II.—Some Experiments on a Tungar Rectifier.*

It will be interesting to give here some results which have been obtained upon one of the smallest size, a half-wave rectifier capable of charging three cells at 2 amperes, or eight cells at 0.75 ampere, and intermediately. The rectifier set is compactly made up in a sheet metal case, about 8 ins. high by 6½ ins. square, weighing about 10 pounds; this box contains the Tungar bulb with screw socket receptacle, a 3-ampere fuse also in a screw socket receptacle, and a reactance or auto-transformer wound on a single rectangular closed iron core. The diagram of connections of the set is given in Fig. 5, illustrating the mode of tapping off from the reactance to the cathode and battery leads respectively.

(a) OPERATION TEST.

A performance test was carried out by connecting the rectifier set to its normal supply of 115 volts 50 cycles alternating current. With the reactance only connected in circuit, the consumption was 1 watt, and with the bulb inserted but no output current taken, the consumption rose to 20 watts, and the effective D.C. voltage across the charging leads was 11.0 volts. Commencing with 1 cell, a gradually increasing load of accumulators was connected direct across the charging leads and the input and output measured in each case.

The output current was observed simultaneously on a soft iron A.C. ammeter and also on a moving coil D.C. instrument, these giving the R.M.S. and mean values respectively of the charging current supplied

to the battery. The D.C. meter readings were found to give good agreement with a moving coil wattmeter inserted in the output circuit and the readings of these instruments have accordingly been utilised in the determination of output energy and efficiencies. The average value of the output current ranged from a maximum of 2.02 amperes to zero, as the voltage of the battery on charge was increased from 0 to 31.0 volts. The actual variations in current for increasing battery voltage are shown in Fig. 6, and this illustrates the somewhat irregular characteristics which the set possesses at times. This variation only occurs, however, when the load is changing,

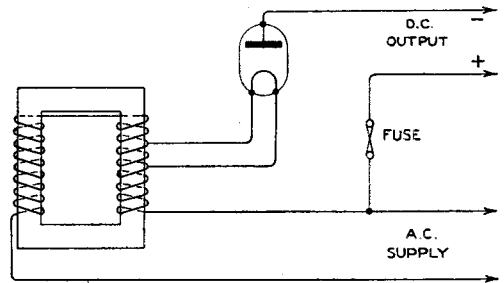

Fig. 5. Diagram of connections for a complete Tungar rectifier.

as will be shown later from the continuous running test.

The same diagram also gives the output watts and efficiency curves for the set. The output has a maximum value of 12.5 watts when charging a battery of eight to nine cells at 18 volts, the efficiency then having a maximum value of about 34 per cent. In considering this figure, it should be remembered that with this set only one half of the alternating current wave is being rectified, and that a full-wave rectifier set using either a double-anode bulb or two single-anode bulbs, would probably have a much higher efficiency.

* In view of the article on the Tungar Rectifier, published during the preparation of the present paper (see A. Rushton: *The Wireless World and Radio Review* Vol. XI, p. 540, 1923), it is hoped that these experiments provide sufficient new data to warrant their publication here.

(b) STATE OF VALVE DURING OPERATION.

With the set connected up to the correct supply voltage, there is a very noticeable increase in the brightness of the filament when the charging circuit is completed, due to the increased current through the reactance, and hence through the filament.

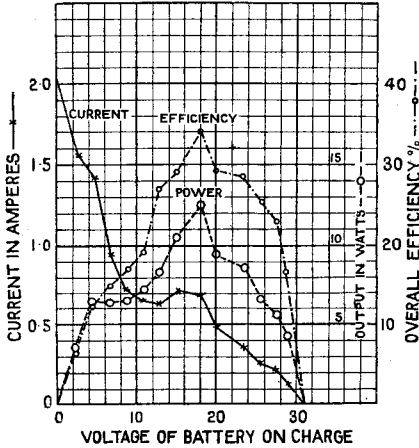

Fig. 6. Operating characteristics of Tungar rectifier.

When the charging current from the rectifier exceeds one ampere, a vivid purple glow, due to gas ionisation, is seen inside the bulb surrounding the anode. The persistence of this ionisation is very marked and a simple experiment showed that once it has commenced, the heating current through the filament may be cut off, and the set will still remain in operation, the filament being maintained at a bright white heat under the bombardment of the positive gas ions driven towards it.

(c) CONTINUOUS TEST.

In a running test, the rectifier was set to charge a 16-volt battery continuously for a period of seven hours. Only slight variations in output current were observed during the test, the general result being that the charging current fell from 0.96 ampere to 0.72 ampere, the battery voltage meanwhile rising from 15.3 to 16.4 volts. In this test, the output of the set was 12-15 watts, and the overall efficiency 30 per cent.

After the set has been in operation a few minutes, the bulb becomes very hot and during the seven hours' run a maximum temperature of 65°C was recorded at a distance of one quarter of an inch from the

bulb; the temperature of the outside of the case meanwhile rising to 34°C.

(d) OSCILLOGRAPH RECORDS ON RECTIFIER.

In Fig. 7 oscillograms are shown of the primary current to the rectifier, (A) with the valve filament incandescent, but no output current taken; and (B) with the set charging a 24-volt battery at 0.26 ampere.

In the latter case an oscillogram was also taken recording simultaneously the P.D. between anode filament of the valve and the current passing through the valve into the battery. This record is reproduced in Fig. 8, and it shows firstly that the rectification is practically complete, and secondly that no current passes through the bulb until the P.D. between the electrodes is 9.1 volts, and that this suddenly drops to zero with the commencement of the current. The subsequent effective charging voltage is, at the maximum, about 5 volts above that of the battery (24 volts). This agrees fairly well with the result obtained above, that the voltage drop along the portion of the reactance connected to the charging leads is about 31 volts, when no charging current is passing.

(e) CHARACTERISTICS OF THE TUNGAR VALVE.

The resistance-current curve of the Tungar valve cathode as determined from direct-current measurements is shown in Fig. 9, this representing a normal characteristic of a tungsten filament in a gaseous atmosphere.

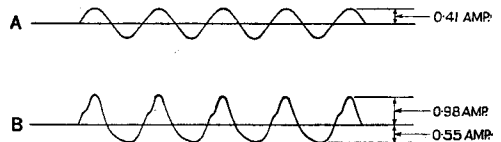

Fig. 7. Oscillograms of input current to rectifier: A. Battery disconnected; supply=115v. 50 cycles. B. Battery on charge receiving 0.26 ampere at 24 volts.

With the filament heated by a steady current, no current passes between the anode and the cathode (filament) until the potential difference between these reaches about 11.3 volts, the actual value depending upon the temperature of the cathode. With the commencement of current flow through the valve, the P.D. between anode and cathode falls rapidly, finally attaining a steady value at about 9 volts (Fig. 10).

When the filament is initially heated and the anode voltage is sufficiently raised to pass a current of 1.3 amperes through the valve, the filament current may be cut

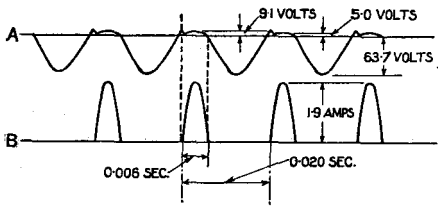

Fig. 8. Tungar Rectifier charging 24-volt battery at 0.26 ampere from supply at 115 volts 50 cycles.
A. P.D. anode to filament.
B. Output current to battery.

off, and the valve continues to pass the anode current, which may be varied from 0.65 up to 9.0 amperes, the anode potential meanwhile falling from 15.2 to 11.0 volts. The filament in this case is maintained at a bright red and sometimes at a white heat, and for the larger currents the bulb is filled with a vivid purple glow. The characteristics of the valve under the above conditions are shown in Fig. 10. It will probably come as a surprise to many valve users to observe that a small valve only two inches in diameter can pass an anode current of 9 amperes in a normal condition.

The above diagram well illustrates the steep negative characteristic possessed by the anode circuit of this gas-filled valve.

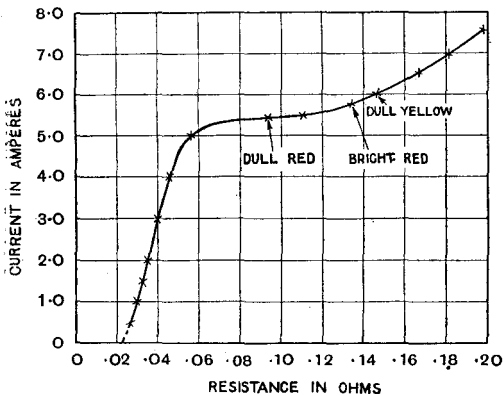

Fig. 9. Resistance-current characteristic for filament of Tungar valve.

This property has been applied to give a new form of oscillation generator, connecting a resonant circuit in shunt to the bulb in

a manner analogous to that of the Duddell-Poulsen arc.⁴

In a later experiment it was found that the passage of anode current through the valve could be maintained without filament current, when an alternating voltage was applied between anode and filament. The filament was first heated up with about 7 amperes direct current to start the anode current through the valve. When this current, reached a value above 0.5 ampere it continued to pass when the filament current was cut off. The appearance of the valve was similar to that when using direct current, although the filament appeared to

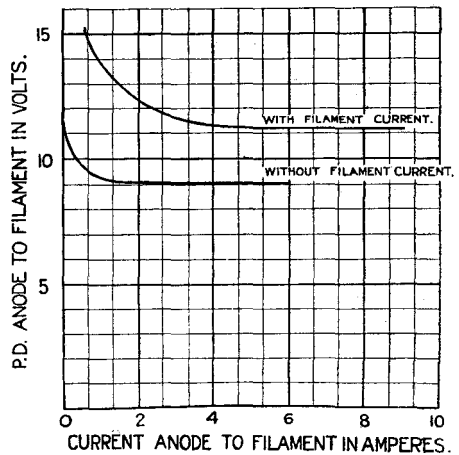

Fig. 10. Anode current characteristics of Tungar valve with and without filament current.

be much whiter. This phenomenon illustrates the persistence of ionisation in the valve as mentioned under (b) above.

Fig. 11 is a copy of an oscillogram taken of the anode voltage and current of the valve when operating under these conditions. This is essentially similar to that reproduced in Fig. 8 and shows that the anode current is perfectly rectified with a peak value of 5.1 amperes.

(f) CONCLUSIONS.

It is hoped that these results will serve to demonstrate the utility of this type of rectifying set for the charging of both high and low tension batteries of accumulators, and particularly for those in isolated positions

⁴ British Thomson, Houston Company. British Patent, 103,047/1917.

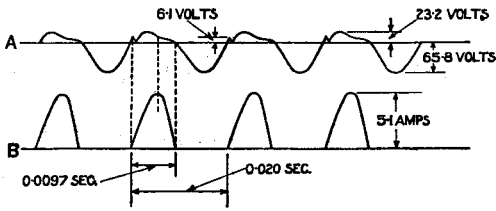

Fig. 11. Oscillograms of rectifier operating on 50 cycles A.C. supply with no filament current.
 A. P.D. anode to filament.
 B. Current, anode to filament.

where compactness and fool-proofness are more important considerations than a very high efficiency. If the fluctuating current is undesirable this can be reduced to a steady current with a very slight superimposed ripple by using a full-wave rectifier with suitable smoothing condensers and choke-coils. No information was obtained as to the life of the Tungar valve, but 3,440 hours working has been recorded for a 6-ampere 75-volt bulb, although this is probably in excess of the average life under normal conditions.

NOVEL IDEAS AND INVENTIONS.

Abstracted by PHILIP R. COURSEY, B.Sc., F.Inst.P., A.M.I.E.E.

Soft Valves Having "Hard" Characteristics.

When gas is present in a valve the valve characteristics are altered by reason of the ionisation set up in the gas by the electrons moving through it. The longer the paths through which the electrons move, other conditions remaining the same, the greater will be the ionisation set up. Hence

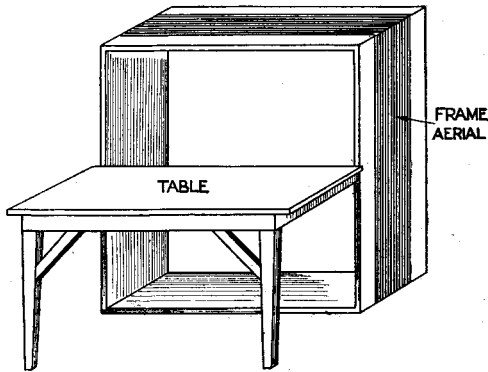

Fig. 1.

by making the electron paths extremely short the effects of gas in the tubes becomes much less important, and it is possible to retain the desired characteristics of hard valves—i.e., lack of ionisation—even though a considerable amount of gas is present.*

* British Patent No. 195691, by E. Y. Robinson.

It may be recalled that a somewhat similar principle has been made use of to produce rectification of an alternating current by making the gap very short between the electrodes in a partially exhausted tube, thus avoiding ionisation of the gas.

Combined Frame Aerial and Radio Set.

To facilitate the mounting and use of a frame aerial, particularly for broadcast reception, the frame may be made an integral part of the table on which the radio receiver is mounted.* The arrangement is sketched in outline in Fig. 1.

Mounting Flat Coils.

A method of mounting flat coils is sketched in Fig. 2. It consists of an insulating rod D, to which is secured by a bolt B, the holder A, so that the coil C is clamped between the two.† This holder may be fitted with terminals to which the ends of the winding may be joined and with plugs for fitting into a standard coil holder socket.

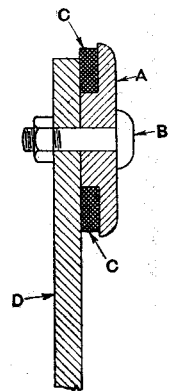

Fig. 2.

* British Patent No. 195310, by P. Hemardier (Paris).

† British Patent No. 195134, by G. H. Moody and H. D. Butler.

FIRST SUCCESSFUL AMATEUR TWO-WAY COMMUNICATION WITH U.S.A.

By **2KF**.

AT last, after many nights of listening and many unsuccessful attempts between amateur stations in the two continents, two-way working between London and Hartford, Conn., the headquarters of the amateur organisation, "the A.R.R.L.," has been accomplished.

The luck of being the "first" English station to effect two-way communication has fallen to the "South," and British **2KF**, Merton, S.W., has the honour of being the first station to effect and maintain communication for 2½ hours, the test ending in full daylight, at 8.30 a.m., G.M.T., on December 8th.

The honour of being the first amateur to establish direct two-way working falls to French **8AB**, M. Leon Deloy, of Nice, to whom I am indebted for having arranged matters, and who put the American

station into touch with me. **8AB** has been working American **1MO** now for some days, and the stations appear to have no great difficulty in effecting communication after the first call or so.

During the past year or more amateur stations in England, France and Holland have had little difficulty in receiving American stations under favourable weather conditions, but although many English transmitting stations have attempted to raise the Americans, no reply has been received and no reports of reception have reached us here.

The best performances last year during the tests, excluding the special station of the Radio Society of Great Britain (**5WS**), which got across on two nights, were those of **2OM** and **2SH**, who were both heard just a few hundred miles off the American coast.

Experimental station **2KF** has recently followed the tests between **F8AB** and American **1MO** on several nights, or rather mornings, and finally called **F8AB** and asked to be put into touch with the U.S.A. station if possible. To this request **F8AB** kindly com-

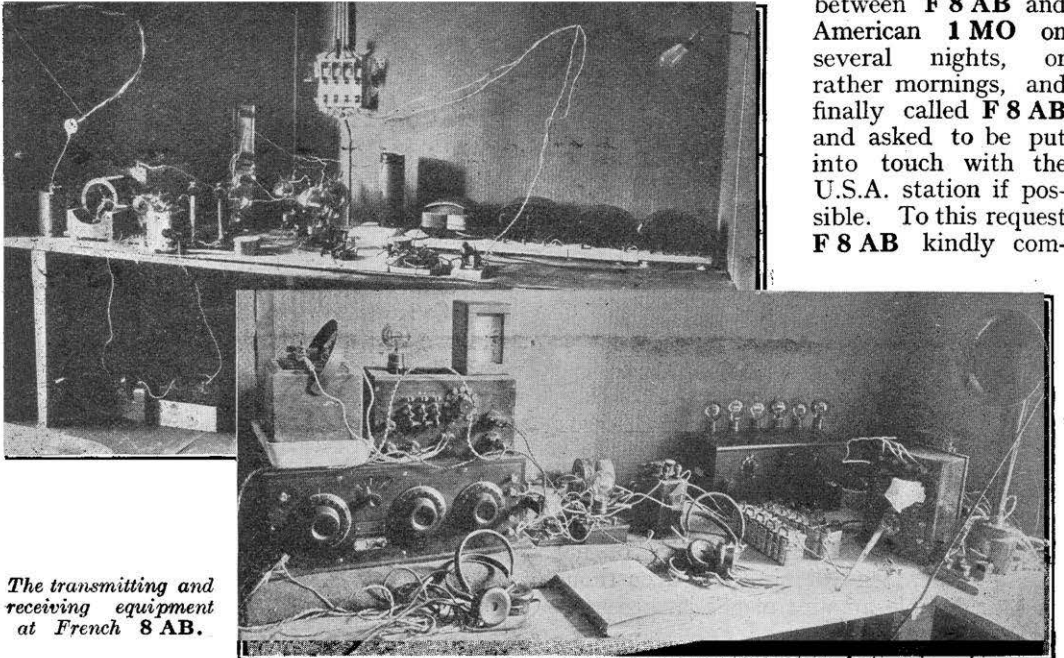

*The transmitting and receiving equipment at French **8AB**.*

plied, and informed the Hartford station of **G 2 KF's** wavelength and note.

A1 MO then called **G 2 KF** and gave the "K" signal, but did not receive the British station until he had called twice.

At approximately 5.45 a.m., G.M.T., **A 1 MO** first received **G 2 KF**, and gave him the O.K. signal, wishing him good morning, and opening up with, "Some more amateur history in the making. This is first two-way working with Great Britain. Here Warner of Q.S.T. Q.R.A.?"

After this there was slight QRM on the American side, but within the next few

he was quite used to it, and wanted to know if the operator at **2 KF** was also. He was told the inevitable.

The American station then reported the signals from this side as gradually increasing in intensity, and, although they were not loud, were comfortably readable to him, and steady, with no fading at all. This point seems very remarkable indeed, and he said so. As day broke on this side the signals of **G 2 KF** became stronger to the U.S. station, and this increase continued until it was full daylight, when the climax was reached, and slowly—very slowly—both stations began to

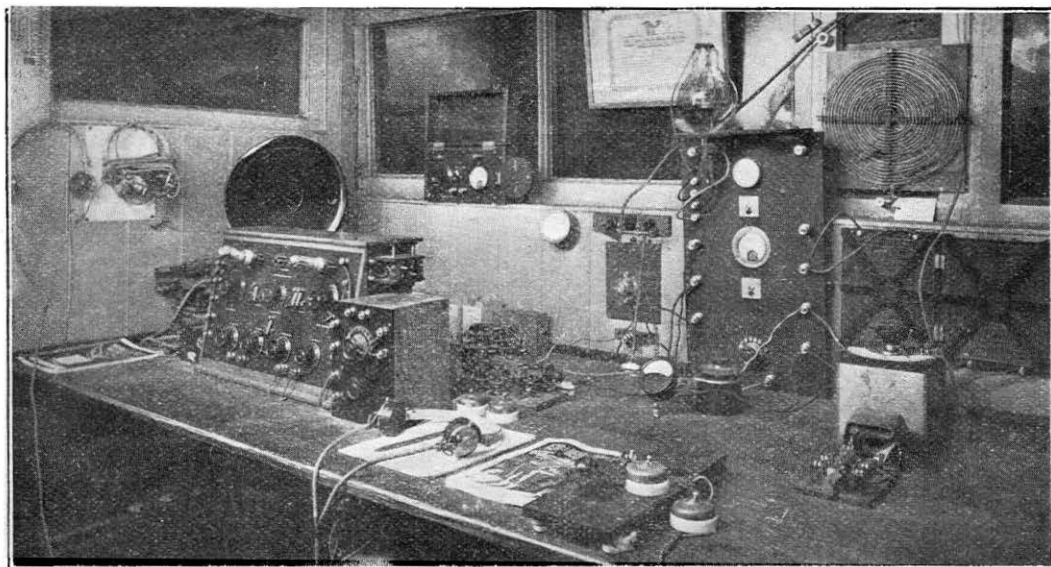

The first British Station to effect successful two-way working with America. Mr. Partridge's station worked American 1 MO on the morning of December 8th.

minutes **2 KF** was being received well with no call for repetition of transmissions.

Messages of an experimental nature regarding power and aerial current were then exchanged, and then **A 1 MO** gave the British station messages of congratulation for Mr. H. S. Pocock, of the *Wireless World and Radio Review*, Mr. W. Burnham and Mr. P. R. Coursey, who is arranging the tests this year, from Messrs. Schnell and Warner, of the A.R.R.L.

The operator of **1 MO** was Mr. Warner himself, and he jokingly mentioned that he would have to go to business without having had any sleep, but remarked that

fade out. However, the two stations did not lose touch until about 8.30 a.m., when the American could not read **G 2 KF**, although reception went on here until the last message came over at 8.27, when **A 1 MO** said, "Going now O.M. very QRZ; this is the end of a wonderful night. Good-bye," and after this, until 8.38, only a few letters here and there were received, and finally the signals became inaudible, and these two stations 3,500 miles apart, using amateur-made gear and very small powers, lost touch with each other.

The receivers used at both stations were, strange to relate, almost the same, each

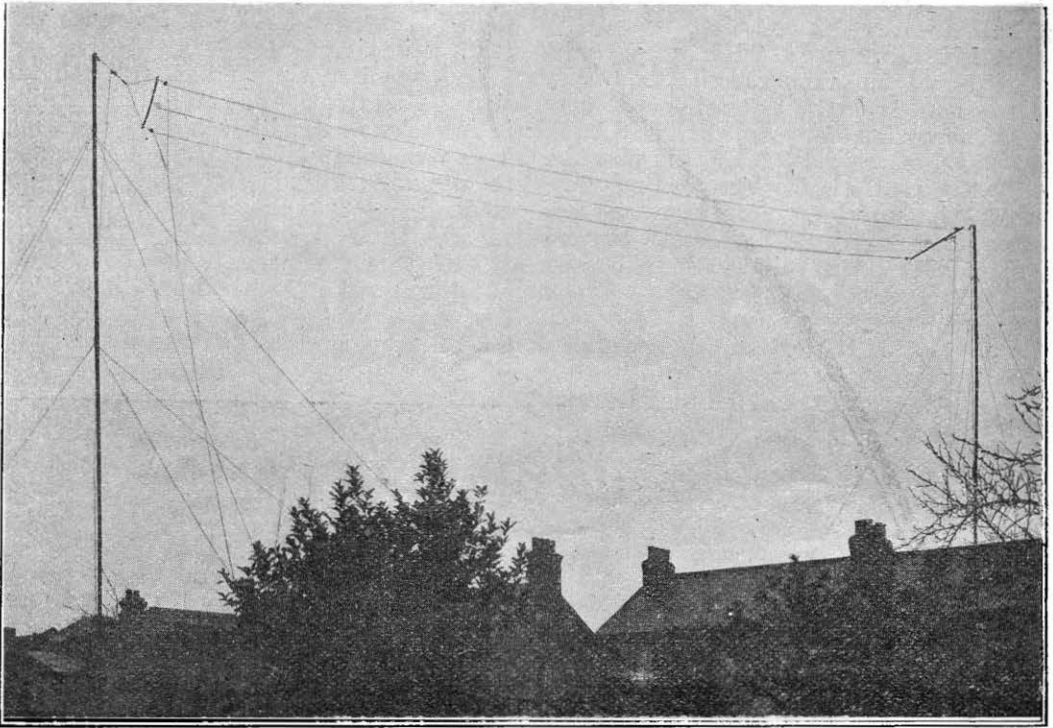

Aerial of 2 KF

using two valves—one detector and one L.F.—and to the English station's query about multi-valve super sets, **1 MO** replied, "Keep the supers." The American was most anxious to maintain communication to the very end, and asked **2 KF** to "stay till fading out," which he did at 8.25 a.m. British **2 SH** was working at the time, and several times **2 KF** asked **A 1 MO** to listen for his signals, but, owing to some trouble, Mr. Hogg was unfortunately not successful in reaching Hartford. During one period of the transmission a fowl from a neighbouring run flew over on to the wires of the counterpoise, which came into contact with some damp woodwork, causing the aerial ammeter to jazz somewhat, and **1 MO** was asked to wait a minute, the operator this end rushing out and persuading the offender to move with the aid of a few half bricks and things!

It was very remarkable that communication should have been possible for such a long period, and more remarkable still that **A 1 MO** should have reported signals from **2 KF** as being stronger than those of the American Pacific Coast stations.

No special arrangements had been made by the British station, and the aerial current was only 1.8 amperes. The American was radiating 2.5 amperes, with an input, according to his own statements, of 400 watts. The equipment at **2 KF** is entirely of amateur construction, and the circuits on both transmitter and receiver are being constantly changed from time to time.

No specially arranged test was being carried out at the time, and the whole affair was entirely impromptu.

The receiving apparatus used was an ordinary detector and 1 L.F. set, using a vario-coupler type of tuner, which is always in use at the station, and covers all wavelengths from 100 to 1,100 metres, having, of course, "dead end" switching arrangements.

The valves employed were two D.E.3's, with about 60 volts on the plates, which is ample for all purposes.

The transmitter was the usual 1 D.H. circuit loosely coupled to the aerial, and the valve employed was a Mullard 0-150, which has been re-filamented by the makers, and

one of the British stations effects communication, leave it to him to ask the other man to listen for the calling station on a certain wavelength. In this way, and this way only, was **F 8 AB** able to put **G 2 KF** into touch, and the British station stood by for nearly two hours before the "line" was clear.

In conclusion, don't use unnecessary high voltages on the detector valves when trying for the U.S.A. stations. It is entirely wrong to think that with a high plate voltage you are bound to succeed. Most English valves

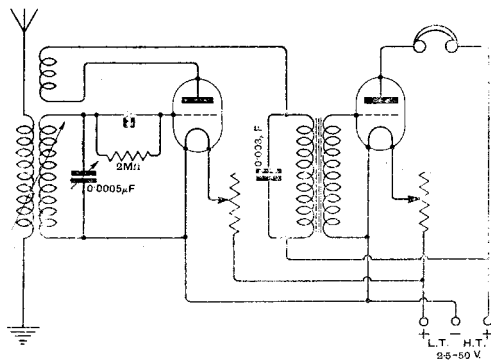

Receiver circuit of **2 KF**.

will work very well on about 50-70 volts H.T. at the most, and the use of anything more only prevents a dozen other stations from getting the weak signal that is coming through.

* * * *

[Since preparing this account of the first success **2 KF** has been again in communication on two or three nights by arrangement with **1 MO**, and has been equally successful, receiving messages of congratulation addressed again to *The Wireless World and Radio Review*, the Radio Society of Great Britain, and to Senatore Marconi.—EDITOR.]

* * * *

The following note has been received from Mr. R. H. J. McCue, and is of special interest in connection with these tests:—

The first occasion on which I heard transatlantic two-way working (which was also, I believe, the first time it had occurred) was on November 28th about half-an-hour after **2 LO** had ceased transmitting to America. I was searching round for **KDKA** when I heard a station about R.5 sending

morse, perfectly steady, and with no fading. This turned out to be **1 MO**, of Hartford, Connecticut, calling **F 8 AB**. They very soon got into touch, apparently without much difficulty, and congratulatory messages were exchanged, including, "Greetings for the first time by amateur radio," sent to General Ferrié and Dr. Pierre Corret. Also **8 AB** sent a message to be relayed to **WNP**, ss. *Bowdoin*. Station **1 MO** was being operated by Messrs. K. B. Warner and F. S. Schnell of the American Radio Relay League. Very soon another American station (**1 XAM**) was heard trying to attract the Frenchman's attention, which he soon managed to do. This station was not quite so strong as **1 MO**. The transmission back and forth across the "herring pond" continued for about an hour and a-half.

The next occasion on which American signals were heard was at 5.40 a.m. on December 3rd. This time it was **1 XAQ** who was heard working **F 8 AB**. His signals were quite as good as the other two stations.

The next, and to my mind the most interesting reception of American signals, was at 11.25 p.m. on Monday, 10th inst. I may say that although I have heard some dozens of American amateur transmissions, this was the first time I had done so before midnight. I had been talking to a friend about the absence of fading on the short waves, when I switched on my receiver and very soon heard the inevitable **F 8 AB**. I must confess, however, that I was very much surprised to hear **1 MO** and **1 XAM** replying to the French station. The strength of **1 MO** was about R.5 on one valve. Mr. F. S. Schnell was telling **F 8 AB** that he had not been in bed since Saturday morning, and that he was going to stay up that night to make a new tuner!

After listening to these stations for about five minutes I gave the condenser a final "swish" round, and succeeded in hearing "Test test de **9 XW 9 XW**."

* * * *

Following fast on the news of Mr. Partridge's successful two-way working came the report that Mr. F. L. Hogg (**2 SH**) of Highgate, had also succeeded in effecting communication with the other side. Signals were exchanged between **2 SH** and **1 MO** during the period from 4.45 to 8.10 on the morning of December 12th.

Meteorological and Other European Wireless Telegraphy and Telephony Stations.

LIST OF ADDITIONAL TRANSMISSIONS.

Time G.M.T.	Station.	Call Sign.	Wave-length.		Remarks.
0105	Cranwell	GFC	1,300	C.W.	Synoptic report.
0105	Guernsey	GEY	1,300	C.W.	Synoptic report; transmitted immediately after Cranwell report.
0502	Abbeville	FNI	1,680	C.W.	Aviation weather report.
0515	Dijon	FND	1,350	C.W.	Aviation weather report.
0516	Nancy	FNC	1,720	C.W.	Aviation weather report.
0530	Annapolis	NSS	17,145	C.W.	"Angot" weather bulletin.
0550	Le Bourget	FNB	1,680	C.W.	Repetition of "Météo Europe." 0100 observations.
0602	Abbeville	FNI	1,680	C.W.	Aviation weather report.
0605	Strasbourg	FNS	1,720	C.W.	Aviation weather report.
0615	Dijon	FND	1,350	C.W.	Aviation weather report.
0616	Nancy	FNC	1,720	C.W.	Aviation weather report.
0702	Abbeville	FNI	1,680	C.W.	Aviation weather report.
0705	Strasbourg	FNS	1,720	C.W.	Aviation weather report.
0705	Andover	GFI	1,300	C.W.	Synoptic reports transmitted in succession by stations named.
0705	South Farnborough	GFQ	1,300	C.W.	
0705	Guernsey	GEY	1,300	C.W.	
0715	Dijon	FND	1,350	C.W.	Aviation weather report.
0715	Fauske	LDW	1,800	Spark	Norwegian weather bulletin.
0716	Nancy	FNC	1,720	C.W.	Aviation weather report.
0716	Cologne	GEK	1,680	C.W.	Aerial route report.
0725	Reval	AZA	1,900	Spark	Esthonian synoptic report.
0802	Abbeville	FNI	1,680	C.W.	Aviation weather report.
0816	Nancy	FNC	1,720	C.W.	Aviation weather report.
0816	Cologne	GEK	1,680	C.W.	Aerial route report.
0844	Le Bourget	FNB	900	C.W.	Calibration wave.
0847	Le Bourget	FNB	1,400	C.W.	Calibration wave.
0850	Le Bourget	FNB	1,680	C.W.	Calibration wave.
0900	Air Ministry	GFA	4,100	C.W.	British Isles weather forecast and outlook (commencing January 1st, 1924).
0900	Air Ministry	GFA	1,300	C.W.	Weather forecast in code. (Time of sending may vary slightly.)
0902	Abbeville	FNI	1,680	C.W.	Aviation weather report.
0905	Strasbourg	FNS	1,720	C.W.	Aviation weather report.
0915	Dijon	FND	1,350	C.W.	Aviation weather report.
0916	Nancy	FNC	1,720	C.W.	Aviation weather report.
0955	Abu Zabal	SUC	11,000	C.W.	Egyptian weather bulletin.
1002	Abbeville	FNI	1,680	C.W.	Aviation weather report.
1005	Strasbourg	FNS	1,720	C.W.	Aviation weather report.
1016	Nancy	FNC	1,720	C.W.	Aviation weather report.
1025	Dijon	FND	1,350	C.W.	Aviation weather report.
1030	Königsberg	KO	2,200	C.W.	Weather forecast for Eastern Baltic in German.
1102	Abbeville	FNI	1,680	C.W.	Aviation weather report.
1105	Strasbourg	FNS	1,720	C.W.	Aviation weather report.
1116	Nancy	FNC	1,720	C.W.	Aviation weather report.
1202	Abbeville	FNI	1,680	C.W.	Aviation weather report.
1216	Nancy	FNC	1,720	C.W.	Aviation weather report.
1250	Reval	AZA	1,900	Spark	Esthonian synoptic report.
1300	Sevastopol	RCT	2,500	Spark	Black Sea weather bulletin.
1302	Abbeville	FNI	1,680	C.W.	Aviation weather report.
1305	Strasbourg	FNS	1,720	C.W.	Aviation weather report.
1305	Andover	GFI	1,300	C.W.	Synoptic reports transmitted in succession by stations named.
1305	South Farnborough	GFQ	1,300	C.W.	
1305	Guernsey	GEY	1,300	C.W.	

Time G.M.T.	Station.	Call Sign.	Wave- length.	System.	Remarks.
1310	Freidrichsort	KBK	720	Spark	Synoptic report.
1315	Dijon	FND	1,350	C.W.	Aviation weather report.
1315	Fauske	LDW	1,800	Spark	Norwegian weather bulletin.
1316	Nancy	FNC	1,720	C.W.	Aviation weather report.
1340	Malta	GHA	4,800	C.W.	Weather bulletin.
1350	Libau	KCB	1,200	Spark	Latvian weather bulletin.
1350	Le Bourget	FNB	1,680	C.W.	Aviation weather report.
1402	Abbeville	FNI	1,680	C.W.	Aviation weather report.
1416	Nancy	FNC	1,720	C.W.	Aviation weather report.
1430	Bucharest-Herestrau	BUC	8,150	C.W.	Roumanian synoptic report.
1500	Air Ministry	GFA	1,300	C.W.	Weather forecast in code (time of sending may vary slightly).
1502	Abbeville	FNI	1,680	C.W.	Aviation weather report.
1516	Nancy	FNC	1,720	C.W.	Aviation weather report.
1530	Brussels	OPO	1,100	Tele- phony	Weather bulletin.
1602	Abbeville	FNI	1,680	C.W.	Aviation weather report.
1616	Nancy	FNC	1,720	C.W.	Aviation weather report.
1700	Grudziadz	AXK	10,300	C.W.	Press message in French.
1802	Abbeville	FNI	1,680	C.W.	Aviation weather report.
1805	Andover	GFL	1,300	C.W.	Synoptic reports transmitted in succession by stations named.
1805	South Farnborough	GFI	1,300	C.W.	
1805	Calshot	GEY	1,300	C.W.	
1805	Strasbourg	FNS	1,720	C.W.	
1815	Fauske	LDW	1,800	Spark	
1815	Dijon	FND	1,350	C.W.	Aviation weather report.
1930	Bucharest-Herestrau	BUC	8,150	C.W.	Roumanian synoptic report.
2000	Air Ministry	GFA	4,100	C.W.	British Isles weather forecast and outlook (commencing January 1st, 1924).
2000	Air Ministry	GFA	1,300	C.W.	Weather forecast in code (time of sending may vary slightly).
2055	Reval	AZA	1,900	Spark	Esthonian synoptic report.
2210	Moscow	RAI	5,000	Spark	Russian synoptic report.
2215	Sevastopol	RCT	1,500	Spark	Navigational warnings (in Russian).

"THE WIRELESS ANNUAL FOR AMATEURS AND EXPERIMENTERS."

The object of this publication is to provide amateurs and experimenters with information of interest to them without overloading the book with data chiefly applicable to commercial radiotelegraphy. A short summary of the notable events of the past year has been written by Mr. W. H. Nottage, and Mr. H. S. Pocock, the editor of *The Wireless World and Radio Review*, deals with the progress during 1923 from the amateur's point of view. Numerous short articles of a general nature have been contributed by well-known writers, including "The Amateur in Wireless Development," by Dr. W. H. Eccles, the President of the Radio Society of Great Britain, "The Progress and Objects of the B.B.C.," by Sir William Noble, "Technical Problems of Broadcasting," by Capt. P. P. Eckersley, and a humorous description of the experiences of a beginner, by Mr. E. Blake. The technical articles include a most interesting description by Senatore Marconi of the apparatus used in the directional transmission and reception of wireless beams, "Loud Speaking Telephones," by Mr. P. R. Coursey, "Rectification and Amplification," by W. S. Barrell, "Transmission," by Major H. C. Parker, "Mast Construction," by F. J. Ainsley, "Aerials and Earths," by F. H.

Haynes, in which the writer points out some of the commoner faults of aerial design, and "The Design of a Receiver," by W. S. James, in which is demonstrated the practical application of the tables and data found in another part of the book.

Mr. W. G. W. Mitchell, whose writings are familiar to readers of *The Wireless World and Radio Review*, contributes an interesting article on time and weather signals. Among the information compiled for useful reference is found a very complete set of tables and wireless data, a glossary of technical terms and their equivalents in French, Italian, Spanish and German, the Laws and Regulations applicable to amateur and experimental wireless in Great Britain, an alphabetical list of the call signs of all land stations in the world, a list of the experimental transmitting stations in Great Britain, the Wireless Societies and Clubs, the regular transmissions from European stations and those likely to be of interest to the amateur experimenter, and a very complete atlas of 32 pages giving the position of all land stations of the world.

The price of the book is 2s. 6d., and it should undoubtedly prove a valuable addition to the reference library of every listener and experimenter.

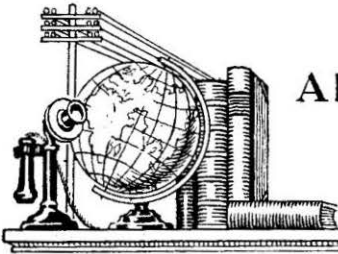

AROUND THE WIRELESS WORLD

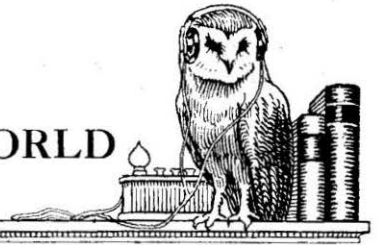

Amateur Transmissions in Three Languages.

It will be of interest to readers to know that the well-known French amateur of Transatlantic Tests fame, Dr. Pierre Corret, of Paris, has lately been sending out Morse transmissions under the call sign of "8 AE 2." He works at 11 p.m. on Monday, Tuesday, Thursday and Friday of each week, and sends out the following message in French, English, and Esperanto:—"Wireless amateurs who hear these signals are requested to be good enough to report to Dr. Corret, 97 Rue Royale, à Versailles, Paris, how these signals have been received." Dr. Corret first gives the general call "CQ de 8 AE 2," then the call in French, English, and Esperanto, on a wavelength 200 metres. We trust that this little experiment will meet with the success it deserves.

Plans for Irish Broadcasting.

An outline of a scheme for an Irish Broadcasting Company forms the subject of a White Paper which the Postmaster-General proposes to submit to Parliament at an early date.

The proposed company will have no official connection with the Government, and will have a guaranteed capital of £30,000, the bulk of which will be provided by firms interested in the wireless industry.

Private receiving sets will be licensed, and all apparatus will be imported through a clearing-

house under the control of the broadcasting company, which will collect the amount due to it on every set as a contribution towards the expenses of broadcasting.

A Cipher Wireless Transmitter.

A new German machine for the transmission of wireless messages in cipher was tested on December 11th, states the Berlin correspondent of the *Times*. Telegrams exchanged between Dr. Höfle, the German Minister of Posts and the Swiss Postal Administration at Berne were correctly decoded.

It is claimed as a result of this experiment that no unauthorised receiver can decipher messages despatched on the new machine. There is no loss of time in transmission.

Glasgow Broadcasting Heard in the Arctic.

Our readers will be interested to learn that WNP, the MacMillan expedition ship *Bowdoin*, has reported reception of Glasgow's transmission during the recent Transatlantic Broadcasting Test.

The news is contained in a radiogram sent from the *Bowdoin* to the

American Radio Relay League, Hartford, Conn. The message runs: "Heard broadcasting station at Glasgow, Scotland. Music and calling America very QSA here to-night."

For the benefit of those who may wish to attempt reception of the *Bowdoin's* signals, it may be stated

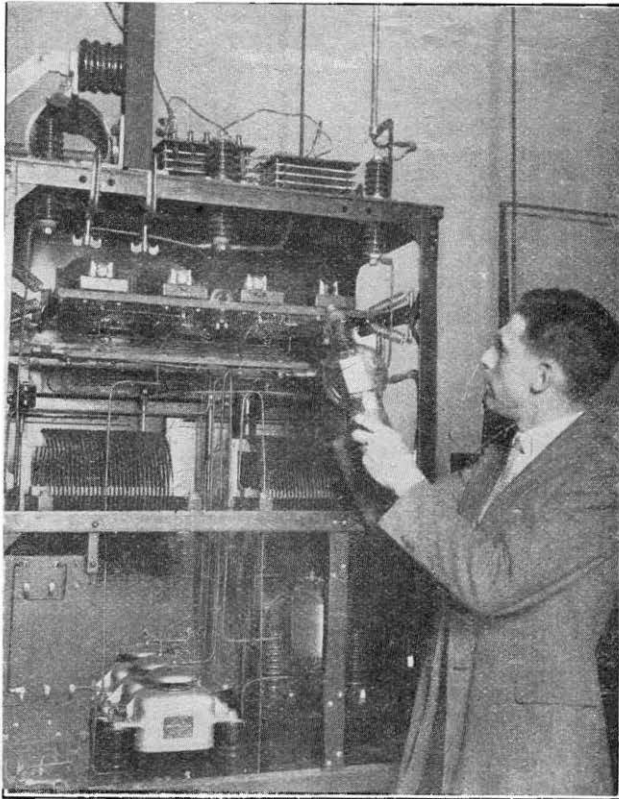

Mr. Gerald Gray, of American 3 CG is here seen beside WJZ's telephony transmitter. Mr. Gray's transmissions from 3 CG have more than once been heard in England.

that WNP transmits a 500-word story of the expedition every Monday morning at 6 a.m. (G.M.T.), generally on a wavelength of 220 metres, although, we believe, 185 and 300 metres are occasionally employed.

West Indies Wireless.

The Post Office has placed contracts in this country for the equipment of several wireless stations to operate between various islands in the West Indies and for new cables to connect the main islands.

There will be seven wireless stations, one each at the following places: Barbados, St. Kitts, Antigua, Dominica, St. Lucia, St. Vincent, and Grenada.

OUR TRANSATLANTIC BROADCASTING TESTS.

We print below a continuation of our list of successful listeners in this country:—

W. H. Jennings, Trefrew, N. Wales ..	WGY	..	3 valves.
H. B. Gardner, Barnet ..	WGY	..	—
Norman H. A. McKee, Portland ..	WGY	..	0—v—0
			(Flewelling)
Wm. Redpath, Co. Antrim ..	WGY	..	Marconi- phone V2.
Capt. Edgar Elwell Winkleigh, N. Devon	WGY	..	5 valves.
H. Monkhouse, Manchester ..	WGY	..	0—v—2
Rev. D. Richards, Pembroke ..	WGY	..	—
John H. Childs, Barrow-in-Furness ..	WGY	..	3 valves.
Leslie Ward, near Liverpool ..	WGY	..	0—v—0
Vernon West, Levershulme ..	WGY	..	1—v—1
E. J. White (6 MU), Blackley, Manchester	WGY	..	—
J. A. Walshaw (5 GU), Otley, Yorks	WGY	..	2—v—2
"S.M.S.," Leeds ..	WGY	..	—
C. Giles, Sherwood, Notts ..	WGY	..	4 valves

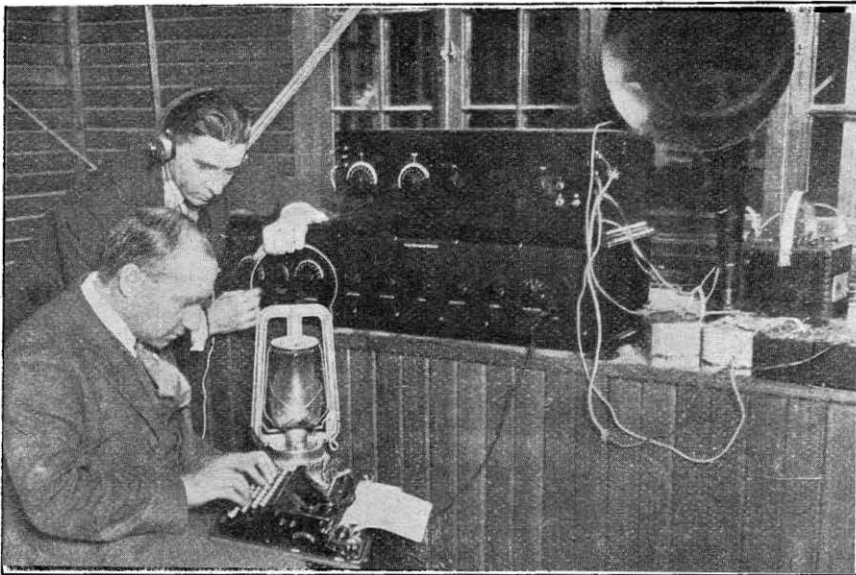

Burning the midnight oil in New York. Our photo shows Mr. Arthur Lynch (Editor of "Radio Broadcast") listening for the British Broadcasting Stations during the recent tests. The newspaper reporter is busy taking down particulars of the stations and items received.

Proposed Edinburgh Broadcasting Station.

The establishment of a wireless relay station in Edinburgh, referred to in our issue of December 5th, has been discussed at a meeting of the Edinburgh and District Radio Society.

With regard to a suggestion that selfishness on the part of owners of valve receivers induces them to oppose the installation of a local station, the comment was made that neither valve nor crystal receiver within 10 miles of a broadcast station is able to hear other stations without complicated appliances. This would indubitably limit the crystal set to hearing one station, and one only, whereas the use of valve receivers can eliminate more easily any undesired signals, and the longer pocket can afford more elaborations.

Evaus, Nr. Walsall ..	WGY	..	1—v—1
	WOR(?)	..	—
H. D. Kirk, Birmingham ..	WGY	..	4 valves.
	WJZ	..	—
Hudson, Birchfield ..	WGY	..	5 valves.
Bickley, Birchfield ..	WJZ	..	—
James, Four Oaks ..	WGY	..	2 valves.
	WOR	..	—
Dewsbury, Walsall ..	WGY	..	4 valves.
B. Hall, Handsworth ..	WGY	..	3 valves.
Bromley, Stafford ..	WHAZ	..	4 valves.
Pedling, Stechford ..	WGY(?)	..	0—v—2
C. Giles, Sherwood, Notts ..	WGY	..	4 valves.
H. Jones, Cannock, Staffs ..	WGY(?)	..	3 valves.
W. E. Pattman, King's Heath, Birmingham	WGY	..	—
L. T. Park r, near Derby ..	WHAZ(?)	..	1—v—2
J. R. Randall, Sutton Coldfield ..	WGY	..	3 valves.
J. Howells, Newport, Salop ..	WGY	..	—
C. G. Gardener, Leicester ..	WCA(?)	..	2 valves.
F. J. B. Whitfield, Newport, Salop	WGY	..	3 valves.
A. J. Bromley, Leicester ..	WGY	..	—
Arthur Brown, Staffs ..	WHAZ	..	4 valves

Another Two-way Transatlantic Success

At 0315 on Monday, December 17th, Mr. E. J. Simmonds (2 OD) of Gerrard's Cross, Bucks, worked with 2 AGB, who gave his name as Dodman, of Oakridge Avenue, Summit, New Jersey, and three messages were successfully passed. It is interesting to note that Mr. Simmonds was using an A.T. 40x valve, operating from a plate supply voltage of 900, and passing a current of 32-35 milliamperes, i.e., an approximate input of 30 watts.

This is the fourth successful amateur attempt at Europe-America two-way working, and in this instance a record is probably created in view of the small power used

Calls were also heard from 1 XO and 2 BQ (Canadian), but were too weak for satisfactory working.

The Schools Radio Society.

A large number of exhibits contributed by members of the Schools Radio Society was on view on the stand of the Radio Society of Great Britain at the recent All-British Wireless Exhibition at Shepherd's Bush. The standard of workmanship was exceptionally high and many original features were apparent in the designs.

At next year's exhibition it is hoped that the Schools Radio Society will have its own stand. In addition consideration is being given to the possibility of awarding a shield to the school carrying out the best all-round wireless work for the year.

"Distortion in Radio Telephony."

A small but important error crept into the report of Captain Maurice Ainsley's remarks during the discussion on the above paper, on page 328 of our issue of December 5th. The capacity which was mentioned as having been put across the secondary of the L.F. transformer should be .002 or .003 microfarads, not "two or three microfarads," as printed.

New Microphone Amplifier Design.

This instrument has been evolved for loud speaker working without the use of valves. The construction combines a relay of special design with the loud speaker and a small local current is made use of, such as can be obtained from a single dry cell. Good results are given with the instrument from a crystal set providing the original signal is reasonably strong. Of course, even when operated behind a single valve set there is still a considerable saving of battery current.



The "Crystavox" Amplifier and Loud Speaker, by Messrs. S. G. Brown, Ltd.

Correspondence.

To the Editor of THE WIRELESS WORLD AND RADIO REVIEW.

SIR,—With reference to the article entitled "An Easy Method of Winding Honeycomb Coils," September 26th issue, I have experimentally determined the wavelengths to which coils wound with various turns will tune. Particulars are given in the table below.

NUMBER OF TURNS.	MAX. WAVELENGTH (Metres). On average aerial with .00075 μF condenser.
25	400
35	520
50	740
80	1,010
110	1,450
150	2,000
210	2,700
280	3,470
380	4,750
500	6,500

EDWARD L. G. ROBBINS

South Kensington, W.

FORTHCOMING EVENTS.

THURSDAY, DECEMBER 27th.
Plymouth Wireless and Scientific Society. At 8 p.m. At the Y.M.C.A. Building, Old Town Street. General Discussion and Questions.

FRIDAY, DECEMBER 28th.
Leeds Radio Society. At 7.30 p.m. At Woodhouse Lane United Methodist Church Schools. Lecture: "The Possibilities of Crystal Reception in Leeds." By Mr. D. E. Pettigrew (Hon. Sec.).

WEDNESDAY, JANUARY 2nd, 1924.
The Institution of Electrical Engineers (Wireless Section). At 6 p.m. (tea at 5.30). "Some Experiments on the Screening of Radio Receiving Apparatus." By Mr. R. H. Barfield, M.Sc. (Student).

Radio Society of Great Britain.

TRANSMITTER AND RELAY SECTION.

The election of the Committee of the Transmitter and Relay Section took place in the last week in November. Nearly every member of the Section sent in his postcard. Mr. Coursey headed the poll, Mr. Child was second, Mr. Winkler, of Edinburgh, was third, and Mr. Corsham, of Harlesden, fourth. As Mr. Coursey is an *ex officio* member of the Committee, the other three were asked, to serve and have kindly consented to do so.

With regard to the Franco-British tests just completed, a great many reports of the receptions of the French signals have been received. These are now being analysed, and it is hoped to publish the substance of them very shortly. Anyone who has logged any of the French signals and who has not yet reported their reception is asked to send them in immediately to the Secretary, Transmitter and Relay Section, Finsbury Technical College, Leonard Street, London, E.C.2.

Requests have been received from several members of the Transmitter and Relay Section that calibration signals be sent out regularly from the Society's station. Arrangements are being made to meet this need, and it is hoped to send a definite announcement to the members of the Transmitter and Relay Section very shortly. It should be mentioned that any possessor of an experimental licence may become a member of the Transmitter and Relay Section whether he belongs to any Society or not.

Book Review.

"Particulars of Meteorological Reports issued by Wireless Telegraphy in Great Britain and the Countries of Europe and North Africa." M.O. 252. (Second edition). H.M. Stationery Office, 1923. 2s. 6d. net.

The second edition of this reference book contains particulars of all weather reports issued daily by wireless telegraphy in Great Britain. Both forecasts and data messages are included, these latter being actual weather observations made at the various observing stations. It also gives the more important issues made by foreign countries. Most messages are in figure codes, which are fully described. From the details given herein it is possible for the amateur to prepare large scale synoptic reports such as appear in most of the daily newspapers. The decoding and charting of these data messages soon becomes a matter of routine and takes very little time once the code is familiar.

The wavelengths employed range from 600 metres to 11,000 metres, and the issues included in the book amount to about 200 daily. In order that those who are interested in this subject may be kept up-to-date with changes that take place, amendments are issued from time to time and subscribers may, if they wish, be placed on a mailing list and be notified of these amendments.

W.G.W.M.

Calls Heard.

[The Editor regrets that considerations of space have compelled the holding over of this section until the next issue.]

Broadcasting.

REGULAR PROGRAMMES ARE BROADCAST FROM THE FOLLOWING EUROPEAN STATIONS:

GREAT BRITAIN.

ABERDEEN 2 BD, 495 metres; **BIRMINGHAM 5 IT**, 475 metres; **CARDIFF 5 WA**, 435 metres; **GLASGOW 5 SG**, 420 metres; **MANCHESTER 2 ZY**, 400 metres; **BOURNEMOUTH 6 BM**, 385 metres; **NEWCASTLE 2 NO**, 350 metres; **LONDON 2 LO**, 365 metres; **SHEFFIELD** (Relay from 2 LO), 305 metres. Regular daily programmes. Weekdays, 11.30 to 12.30 p.m. (2 LO only), 3.30 to 4.30 p.m., 4.30 p.m., 5 to 10.30 p.m. Sundays, (2 LO only), 3.30 to 4.30 p.m., 5 to 10.30 p.m. Sundays, 3 to 5 p.m., 8.30 to 10.30 p.m.

FRANCE.

PARIS (Eiffel Tower) FL, 2,600 metres. Daily, 6.40 to 7 a.m. Weather Forecasts; 10.5 a.m. (Thursday and Friday), 11.15 to 11.30 a.m., Time Signal and Weather Forecast; 12.0 noon, L veatock prices; 3.40 p.m. (Saturday excepted); Financial report, 5.30 p.m. (Saturday excepted) Bourse Closing Prices; 6.10 p.m., Concert or Address; 7 p.m., Weather Forecast; 7.20 p.m. (Sunday), Concert and Address; 10.10 p.m., General Weather Forecast.

PARIS (Compagnie Francaise de Radiophonie Emission "Radiola") SFR, 1,780 metres. Daily, 12.30 p.m., Cotton, Oil and Café Prices, News, Concert; 1.45 p.m., First Bourse Report; 4.30 p.m., Bourse Closing Prices; 4.45 p.m., Concert; 5.45 p.m., News and Racing Results; 8.30 to 9.30 p.m., News; 9.10 p.m., Concert; 10 p.m. to 10.45 p.m., Radio Dance Music.

ECOLE SUPERIEURE des Postes et Télégraphes, 450 metres 3.30 to 4 p.m. (Wednesday and Friday), 7.45 p.m. to 10 p.m. (Tuesday and Thursday), Tests (Music, etc.); 2.30 p.m. to 7.30 p.m. (Saturday), Tests (Music, etc.).

LYONS, YN, 3,100 metres. Daily, 9.45 a.m. to 10.15 a.m., Gramophone Records.

BELGIUM.

BRUSSELS, BAV, 1,100 metres. 1 p.m. to 5.30 p.m., Meteorological Forecast; 9 p.m. (Tuesday), Concert.

BRUSSELS ("Radio Electrique") 410 metres. Daily, 8.30 p.m. to 9.30 p.m., Concert.

HOLLAND.

THE HAGUE, PCGG. Temporarily suspended.

THE HAGUE (Heussen Laboratory), PCUU, 1,070 metres. 9.40 to 10.40 a.m. (Sunday), Concert; 9.40 to 10.40 p.m., Concert; 7.45 to 10 p.m. (Thursday), Concert.

THE HAGUE (Velthuisen), PCKK, 1,070 metres. 8.40 to 9.40 p.m. (Friday), Concert.

LIJMUDEN (Middelraad), PCMM, 1,050 metres. Saturday, 8.40 to 9.40 p.m., Concert.

AMSTERDAM, PA 5, 1,100 metres (Irregular). 10 to 11 a.m., Concert; 5 to 6.30 p.m., Concert; 8.10 to 9.10 p.m., Concert.

DENMARK.

LYNGBY, OXE, 2,400 metres. 7.30 p.m. to 8.45 p.m., Concert (Sunday excepted).

GERMANY.

BERLIN (Koenigswusterhausen), L.P., 4,000 metres. (Sunday) 10 to 11 a.m., Music and Lecture; 2.700 metres 11 a.m. to 12 noon, Music and Lecture. Daily, 4,000 metres, 6 to 7 a.m., Music and Speech; 11.30 a.m. to 12.30 p.m., Music and Speech; 4 to 4.30 p.m., News.

EBERSWALDE, 2,930 metres. Daily, 12 to 1 p.m., Address and Concert; 7 to 8 p.m., Address and Concert; (Thursday and Saturday), 5.30 to 6.30 p.m., Concert.

CZECHO-SLOVAKIA.

PRAGUE, PRG, 1,800 metres. 7 a.m., 11 a.m. and 3 p.m. Meteorological Bulletin and News; 4,500 metres, 9 a.m., 2 p.m. and 9 p.m., Concert.

KBEL (near Prague), 1,000 metres. Daily, 6.20 p.m., Concert Meteorological Report and News.

SWITZERLAND.

GENEVA, HB 1 (Radio Club de Genève). Temporarily suspended
LAUSANNE, HB 2, 1,100 metres. Tuesday, Thursday, Saturday, 4 p.m., Concert; Monday, Wednesday, Friday and Saturday 7 p.m., Concert.

SPAIN.

MADRID, 1,650, 2,200 metres (Irregular). 12 to 1 p.m., Tests
MADRID, PTT, 400 to 700 metres. 4 to 5 p.m., Tests.

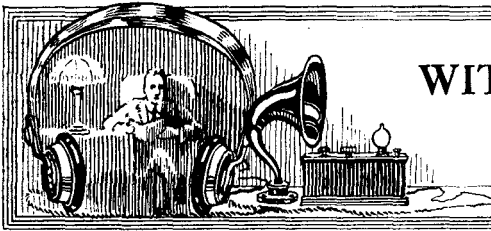

WITH THE SOCIETIES

Particulars of Membership of any Society can be obtained on application to the Secretary. Societies marked with an asterisk are affiliated to the Radio Society of Great Britain.

Tottenham Wireless Society.*

On Wednesday, November 28th, Mr. J. Kaine-Fish gave the second of his series of lectures on "The Fundamentals of Wireless," his special subject being Condensers. The lecturer dealt with the theory and practice of the use of condensers, and explained methods of determining capacity.

Hon. Sec., S. J. Glyde, 137, Winchelsea Road, Bruce Grove, Tottenham, N.17.

North Middlesex Wireless Club.

"Short Wave Practice," was the subject of a lecture delivered by Mr. L. C. Holton on November 28th.

The lecturer defined "short waves" as being those of about 275 metres and less, and his opening remarks were intended to show the necessity of resorting to the lower band of wavelengths to relieve the present congestion in the ether. Coming to the essential features in the design of short wave receivers, the lecturer emphasised the importance of high insulation and of reducing stray capacities to a minimum. Various data for inductances and condensers and useful practical hints for "leading in" were given.

On Saturday, December 1st, by the courtesy of the authorities, a party of members spent a very instructive and enjoyable afternoon at the National Physical Laboratory. It is impossible to see more than a small section of the laboratory in a single visit, but those who were fortunate enough to be able to join the party were taken over the departments dealing with the testing of hulls of ships and aeroplanes, fine measurements and wireless research. The guide was very helpful in elucidating some of the extremely complicated apparatus used in the various tests, and the visit was voted a great success.

Hon. Sec., H. A. Green, 100, Pellatt Grove, Wood Green, N.22.

Manchester Radio Scientific Society.*

On Wednesday, November 30th, Mr. Southern gave a very interesting and instructive paper on "Batteries," dealing in a very lucid manner with the construction and care of secondary cells. After the lecture the forthcoming social was discussed.

At the weekly meeting on December 5th, Mr. J. W. Hand, Jnr., gave a talk to a large gathering of members and visitors on "The Application of Valves to Crystal Receivers." This was illustrated by lantern slides showing different circuits which the lecturer had tested, and recommended to others for experiment.

Hon. Sec., G. A. F. Mercer, 116, Buxton Road, Withington, Manchester.

Wembley Wireless Society.*

On Friday, December 7th, Mr. W. E. Wallis lectured on "The Valve," dealing

first with the fundamental theory of the valve, and showing by numerous curves on the board how the electron emission from the heated filament affected the plate circuit of the receiver.

The three methods of operating a valve to rectify were shown, viz., by using the bend of the characteristic curve, by using the straight portion at a point where grid current is set up, and by means of the popular grid condenser and leak.

A few remarks on the distortion due to valves concluded a very instructive lecture. Mr. H. E. Comben ably assisted by demonstrating at intervals with valve apparatus.

Hon. Sec., W. R. Mickelwright, 10, Westbury Avenue, Wembley, Middlesex.

Wireless and Scientific Society.*

A general meeting of the Society was held on Thursday, December 13th, when in the absence of the advertised lecturer, the Hon. Secretary read a paper entitled "Plug and Jack Control." A number of blackboard illustrations and the demonstration of a five-valve receiver embodying a number of the principles, proved the simplicity and efficiency of the system. At an informal meeting held on Friday, November 23rd, the Hon. Secretary addressed the members on the question of "Wave Traps and Rejectors," and a number of experiments were carried out to prove what could be done to eliminate interference from neighbouring transmitters.

The Hon. Secretary would be pleased to hear from persons in the neighbourhood who are interested in wireless and its associated matters.

Hon. Sec., L. Bland Flagg, 6r, Burlington Road, Bayswater, London, W.2.

Ipswich and District Radio Society.*

The Ipswich and District Radio Society held its annual meeting at St. Nicholas Church Hall on Monday, December 10th, the chair being taken by Mr. R. Stanley Lewis.

In presenting the annual report the Hon. Secretary referred to the enlarged scope of the Club now that better accommodation had been obtained, and the satisfactory growth of the apparatus installed. The membership now stood at 119 in spite of several resignations due to removal from the town.

The Society has recently instituted an associate class of membership for people who own approved "broadcasting" receivers, but who wish to become acquainted with scientific wireless work. Special lectures to suit this class are periodically delivered.

The meeting unanimously passed a vote of confidence to the retiring officers and committee by re-electing them with the addition of three new members.

Hon. Sec., H. E. Barbrook, 46, Foundation Street, Ipswich.

The Fulham and Putney Radio Society.*

The winter session is now in full swing, and meetings are held fortnightly at Fulham House.

On Friday, November 30th, Mr. Wooding gave a practical demonstration in designing, marking off and drilling panels, also exhibiting a noiseless power transformer, a revolving crystal cap holder, and a very neat dual condenser. Mr. Houston gave a demonstration with a single valve set, also undertaking, with the assistance of the technical committee, to reconstruct the Club's six-valve set. Excellent results were obtained from the Club's new loud speaker.

Free entrance forms can be obtained from Assist. Hon. Sec., B. Houston, 125, Hurlingham Road, S.W.6.

The Woolwich Radio Society.*

At the usual monthly meeting, on Wednesday, December 5th, the Hon. Secretary made the pleasing announcement that the Club set, which had been submitted to the Wireless Exhibition at the White City, had been awarded the first prize by the Radio Society of Great Britain.

Mr. J. H. L. Ridley, of Norwood, then gave an interesting talk on how he received the American amateur and broadcasting stations. Beginning with last year's experiences, when he was able to receive many American amateurs on a three-valve set, he related how this year he was able to get even better results using a single valve, finding it better to do without either H.F. or L.F. On five successive nights he had logged 120 different amateur stations of America, beside many broadcasting stations, employing a one-valve Reinartz set. The lecturer gave a humorous account of his attempts to record some of these on a Dictograph, and then described his receiving sets, his valve (a Q.X.), and his aerial and earth. Two points were emphasised, viz., (a) The necessity of cutting down to the absolute minimum all capacities in his set (especially in the valves), and (b) The necessity of vernier condensers in his tuning arrangements.

The discussion that followed showed how keenly members had followed his talk, and how desirous they were of emulating his wonderful achievements.

Hon. Sec., H. J. South, 42, Greenvale Road, Etham, S.E.

Sheffield and District Wireless Society.*

On Friday, November 30th, the Society welcomed one of its Vice-Presidents, Mr. W. Forbes Boyd. Mr. Boyd, who is on the staff of the British Thomson-Houston Co., of Rugby, dealt with "The Design of Broadcast Receivers," and explained several useful circuits which were eminently suitable for broadcasting work.

Hon. Sec., R. Jakeman, "Woodville," Hope, Sheffield.

The North London Wireless Association.*

At a meeting on Monday, December 3rd, 1923, Mr. J. Nicol, B.A., B.Sc., gave a lecture on the Moullin voltmeter.

The lecturer described the difficulties in the way of constructing instruments on ordinary A.C. principles to measure H.F. voltages. He also explained the construction of moving coil D.C. instruments, and showed the ease with which a deflection could be obtained on such an instrument with a current of one microampere.

Both types of Moullin voltmeter were then described, and the type which makes use of the bend of the characteristic curve of a valve, for rectification, was used to measure the H.F. voltage across a coil tuned to receive 2 LO. The arrangement was first of all calibrated, by means of a slide wire connected to the 50 cycle A.C. mains.

Hon. Sec., J. C. Lane, Physics Department, Northern Polytechnic Institute, N.7.

Battersea and District Radio Society.*

On Thursday, November 8th, an interesting lecture on the 1½ kw. Ship Set was given by Mr. A. E. Duffield. The lecturer dealt with his subject very fully, and with the aid of slides described the construction and use of the various components used in the set.

On Saturday, November 24th, a concert was held with the object of increasing the membership of the Society. This was an immense success, and another is contemplated in the near future.

Hon. Sec., A. E. P. Walters, 31, Holden Street, Grayshott Road, Lavender Hill, S.W.11.

The Clapham Park Wireless and Scientific Society.

On October 1st, Mr. H. T. Cooper gave a demonstration of his S.T.100 receiver, which was examined with interest by members.

Lt. H. S. Walker (2 OM) delivered an excellent lecture on November 7th, on "Short Wave Reception," dealing with general efficiency on the lower band of amateur wavelengths and describing a circuit of his own design. At the following meeting, Mr. P. W. Harris explained types of "Rejectors." His remarks were much appreciated, and members had the opportunity of examining a "Wave Trap" which the lecturer had brought.

On November 21st, Mr. H. C. Excell lectured on "Electrons," explaining their sources and properties, and the measurement of their mass and charge.

The following Wednesday was devoted to members' apparatus. Mr. Richardson demonstrated an efficient one-valve receiver, and the Secretary brought a transformer and rectifier for charging accumulators off A.C. mains. Mr. Richardson was heartily congratulated on being elected Chairman of the South London League of Radio Societies, and the Society wish him and the League every success.

Hon. Sec., H. C. Excell, B.Sc., 41, Cautley Avenue, S.W.4.

Wimbledon Radio Society.

An interesting discussion on the reception of American broadcast telephony and amateur transmissions took place on November 30th, and was led by Mr. J. A. Partridge (2 KF), who related how he frequently arises at 2 a.m., and, on these occasions is nearly always successful in picking up a transmission emanating from across "The Herring Pond." Mr. T. Allison (5 FU) also reported that he had had similar success, and both gentlemen left before the close of the meeting in order to continue their preparations for the Transatlantic Tests, in which they are taking an active part.

Later, the construction of the Society's receiving set was further proceeded with.

The Society meets once weekly, on Friday evening, and the Hon. Sec., C. G. Stokes, 6, Worple Avenue, Wimbledon, S.W.19, will be pleased to furnish information with regard to membership.

The Birmingham Wireless Club.

Owing to the postponement of the President's lecture announced for November 30th, the Hon. Secretary delivered a short lecture on "Tuning," which was much appreciated.

Hon. Sec., H. G. Jennings, 133, Ladywood Road, Birmingham.

Honor Oak Park Radio Society.

An interesting lecture and demonstration on "Dual Amplification" was given at a meeting of the Society at headquarters on November 30th, by Mr. Voigt, the well-known authority in this branch of wireless research.

During a brief history of his experiments the lecturer, commencing with a simple crystal circuit diagram as a base, illustrated each stage of his advance towards the present efficiency of "Dual" by placing in position on the basic diagram, superimposed illustrations corresponding with each successful step in his experiments.

A demonstration was given with a "single valve dual" set of the lecturer's own design and construction.

Hon. Sec., G. J. Price, 22, Honor Oak Park, S.E.23.

Brockley and District Radio Association.

The Association gave its first annual demonstration on Friday, November 30th, at the Deptford Town Hall (by kind permission) under the Chairmanship of His Worship the Mayor of Deptford.

After the Mayor had opened the proceedings with a short address, Prof. P. M. Baker, B.Sc., A.M.I.E.E., A.M.I.E.E., etc., lectured on "How Wireless Works," his remarks proving of great interest to the large audience.

The next item on the programme was an extremely novel demonstration by Major Raymond Phillips showing the possibilities of wireless control. Guns were fired, a model train was controlled along a large track, bells were made to ring, a fountain played, and numerous other wonders were worked by Major Phillips with the aid of a small wireless transmitter.

Prof. A. M. Low, D.Sc., A.C.G.I., F.S.C., F.I.P.I., then demonstrated his invention, the "Audiometer," which enables sound waves to be projected on to a revolving screen. The lecture was profoundly interesting, and the speaker concluded by generously inviting all and sundry to come up on the platform to inspect the instrument for themselves.

On December 7th, a highly interesting and instructive lecture was delivered by the Chairman, Mr. B. Hughes, M.I.B.Lon., his subject being "Mathematical Data for Use in Finding Inductance Values of Various Wavelengths."

Potential members are cordially invited to communicate with either the Hon. Sec., R. O. Watters, at "Grove House," Brockley Grove, S.E.4., or the Asst. Hon. Sec., Harrie King, at 2, Henslowe Road, S.E.22, who will be pleased to forward a syllabus for the forthcoming season.

Wireless enthusiasts in the Brockley district are strongly advised to write for particulars of membership to the Hon. Sec., R. O. Watters, "Grove House," Brockley Grove, S.E.4.

Isle of Man Radio Society.

A highly interesting lecture on the "Thermionic Valve as a Detector" was given by Mr. N. Kermode on Monday,

December 3rd. The lecturer briefly dealt with the theory of the valve and explained, with the aid of diagrams, its function in rectifying the oscillating currents induced in the aerial. A very lucid explanation was given of the superiority of the soft valve over the hard type as a rectifier.

On Monday, December 10th, Mr. Kermode gave the second lecture of his series on "High Frequency Amplification," in which he explained with the aid of diagrams, the four methods of valve coupling, viz., resistance-capacity, reactance-capacity, transformer and tuned anode. He also dealt with the principles of regeneration and super-regeneration.

Joint Hon. Secs., R. C. Cannell, 14, Thorny Road, Douglas; E. R. Greenwood, 4, Thorny Road, Douglas.

Ormskirk and District Radio Society.

The total membership of this Society now reaches thirty, this total includes twelve members who hold experimental licences and two holding transmitting licences.

A number of interesting and well-attended meetings have recently been spent, from which the members have undoubtedly derived great benefit.

By kind permission of the President, regular attenders have the opportunity of carrying out experiments in transmitting from 2 ZU. Arrangements have also been made for the Society to hold a bi-monthly meeting at the President's address, and it is hoped that all members will take advantage of the splendid facilities offered to carry out experiments on short wavelengths and to try out "gadgets" of their own.

A transmitting set is now in course of construction for the benefit of the Society.

Hon. Sec., J. Fitzsimmons, 11, Sunny fields, Ormskirk.

Dulwich and District Wireless and Experimental Association.

On Monday, November 12th, after the ordinary business of the evening had been dealt with, a discussion arose as to the desirability of this Association becoming affiliated to the Radio Society of Great Britain. Opinions being varied, it was proposed by Mr. Barrett, and unanimously carried, that the matter should be put in abeyance for one month, and then brought up for reconsideration.

A lecture and demonstration then followed on "Dual Working," by Messrs. Moss and Skinner. A number of circuits were wired up and explained, among them being the Voigt dual, P.W. super, and S.T.100, and the lecturers are to be congratulated on the inexpensive, and sometimes unique means by which they obtained some really excellent results.

On November 26th the first item on the programme, after the ordinary business, was the report by the two delegates (Messrs. Bartlett and King) of the meeting of the South London League of Radio Societies. Taken as a whole the report was fairly satisfactory, and with the exception of one or two items, was passed without comment.

Mr. Barrett then delivered a lecture and demonstration on "Cabinet-making," which afforded quite a change from the usual wireless topics, and proved of great interest. The expert wireless amateur is not always an expert woodworker, and many practical tips were given which should prove extremely valuable to those who intend one day to put that mass of "junk" at present reclining on the bench into a box, or possibly a highly ornamental cabinet.

The Hon. Sec., L. Pilbeam, at 499, Lordship Lane, East Dulwich, S.E.22, welcomes any enquiries regarding membership.

Questions & Answers

Solutions of Readers' Difficulties

This section of the magazine is placed at the disposal of all readers who wish to receive advice and information on matters pertaining to both the technical and non-technical sides of wireless work. Readers should comply with the following rules:—(1) Each question should be numbered and written on a separate sheet on one side of the paper, and addressed "Questions and Answers," Editor, **The Wireless World and Radio Review**, 12/13, Henrietta Street, London, W.C.2. Queries should be clear and concise. (2) Before sending in their questions readers are advised to search recent numbers to see whether the same queries have not been dealt with before. (3) All questions will be answered through the post. Those of general interest will also be published. (4) Every question, except those under (5) below, should be accompanied by a postal order for **1s.**, or **3s. 6d.** for a maximum of four questions, and also the coupon taken from the advertisement pages of the current issue. (5) For the benefit of those readers who would rather not pay the charges, a free Questions and Answers Coupon will be placed in the advertisement pages of the first issue of every month. This coupon should accompany the question submitted, together with a stamped addressed envelope. The free coupon is valid for the current week only. (6) In view of the fact that a large proportion of the circuits and apparatus described in these answers are covered by patents, readers are advised, before making use of them, to satisfy themselves that they would not be infringing patents. (7) Four questions is the maximum which may be sent in at one time.

"E.G.D." (S.W.19) asks for a diagram of a receiver with which he will be sure to receive the American transmissions.

It is not possible to give a circuit of a receiver with which you will be sure to receive the American broadcast transmissions. As you know, many readers of this journal have received the transmissions using only one or two valves, while many try and are not successful, even though four or five valves are used. We suggest, however, that you employ a receiver using one stage of high frequency amplification (tuned anode) with a

rectifier and one note magnifier, this arrangement probably being the most suitable for all-round use.

"R.J.E." (New Barnet) asks for a diagram of a three-valve and crystal receiver, in which the first valve operates both as an H.F. and L.F. amplifier.

A suitable arrangement is given in Fig. 1. The incoming signal is amplified at radio-frequency by the first two valves, and is then rectified by the crystal detector. The low frequency output from the detector is transferred back to the first valve for L.F. amplification and then to the last valve, which operates purely as an L.F. amplifier.

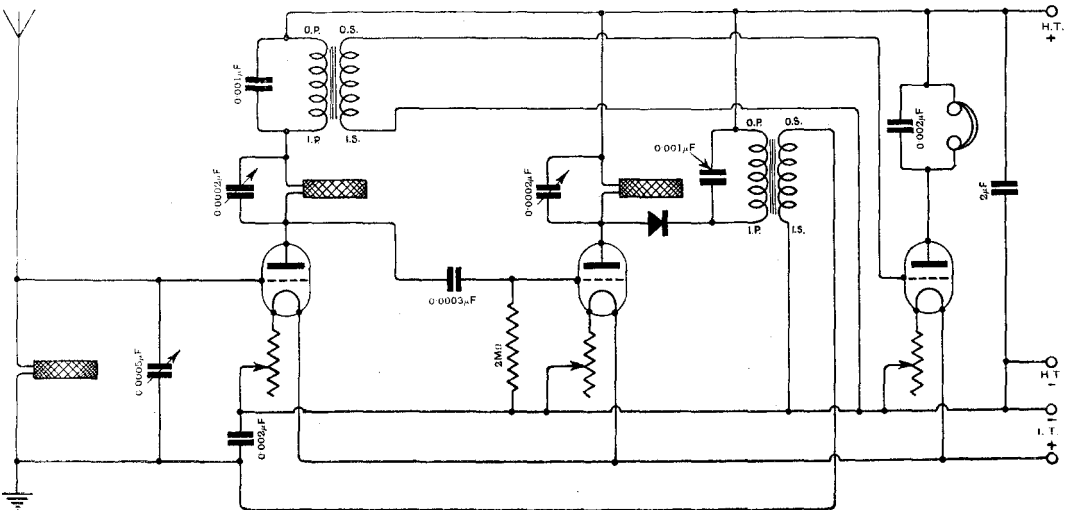

Fig. 1. R.J.E (New Barnet) — A receiver with two H.F., tuned anode, crystal detector and one note magnifier, with first H.F. valve operating as a dual amplifier.

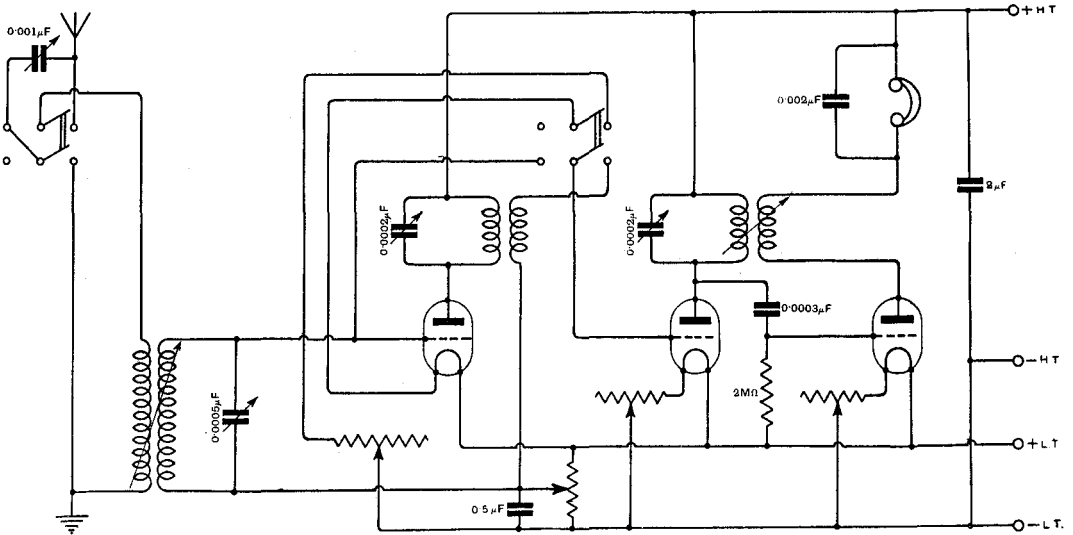

Fig. 2. "S.W." (London, S.W.2.). Receiver with two stages of H.F. and detector, with switch to cut out one stage if required.

"S.W." (London, S.W.2) asks for a diagram of a three-valve receiver (2-V-O) with tuned transformer coupling between the first and second valves, and a tuned anode between the second H.F. and detector valves. He asks if potentiometer control of the grids of the H.F. valves is necessary, and if so how the potentiometer should be connected.

Fig. 2 shows the method of connecting the receiver. Potentiometer grid control is provided and will be found an advantage in controlling

the tendency to self-oscillation in the receiver.

"R.B." (Hampstead) asks for a diagram of a five-valve receiver, using two stages of H.F. amplification, tuned anode coupled crystal or valve rectification, and two stages of L.F. amplification. Switches to be provided to control the number of valves in use and to enable reaction to be used to either the secondary or first tuned anode coil.

The diagram required is given in Fig. 3.

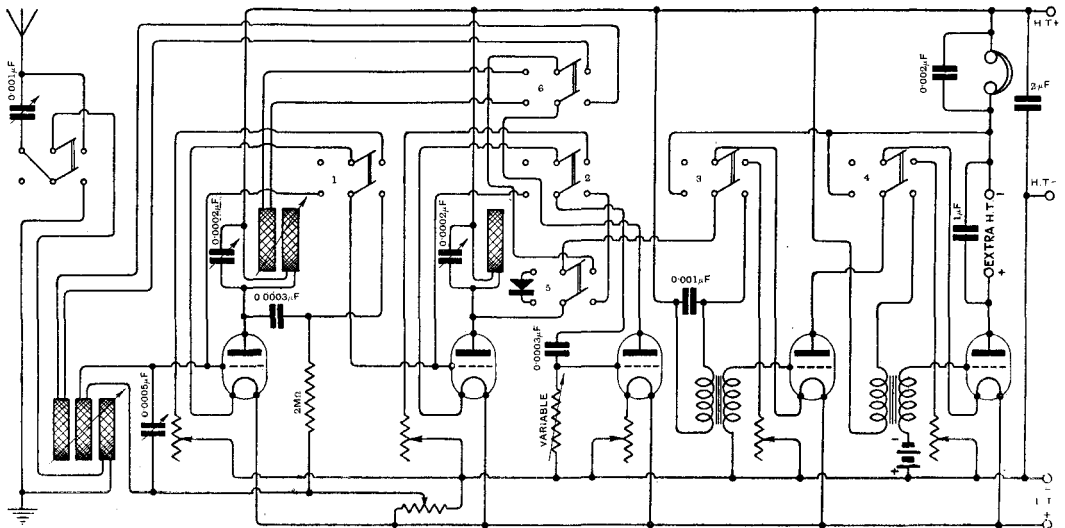

Fig. 3. "R.B." (Hampstead). A five-valve receiver with switches to control the number of valves in circuit, or to use a crystal detector in place of the valve. Switches 1, 2, 3 and 4 put 1st, 2nd, 4th and 5th valves in or out. To use valve as detector, switch 5 to right. To use crystal as detector, switch 5 to left.