

WIRELESS WORLD

AND

RADIO REVIEW

VOL. X. No. 19.

5th AUGUST, 1922.

Registered at the G.P.O. as a Weekly Newspaper.

The Name "BURNDEPT" GUARANTEES Cent. Per Cent. QUALITY & EFFICIENCY.

BIRMINGHAM:
138 NEW STREET.

LIVERPOOL:
10, SOUTH JOHN STREET.

BURNDEPT

MANCHESTER:
81, BRIDGE STREET,
DEANSBATE.

LEEDS:
48, ST. GEORGE STREET.

WIRELESS APPARATUS

LONDON OFFICE & SHOWROOMS
15 Bedford Street, Strand, W.C.2

The BURNDEPT ULTRA IV RECEIVER

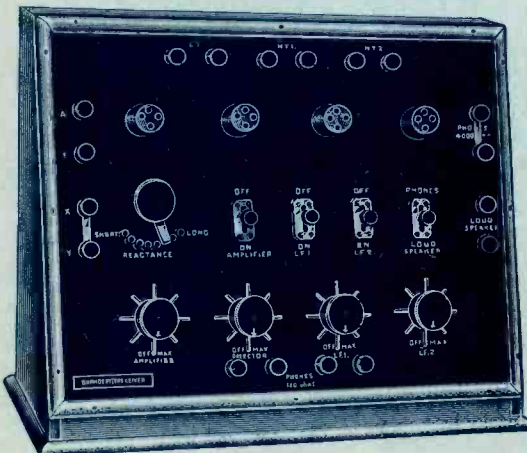

Wireless Music, Song and Speech in the Home.

In addition to receiving ALL BRITISH CONCERTS will also receive loudly and clearly the Hague, Paris and Berlin Concerts as well as morse code messages from all European, North African, and some American commercial stations.

SHORT WAVE (CONCERT) COILS.
These coils have been specially designed for BROADCASTING and NEW AMATEUR WAVELENGTHS. They are 3" in diameter and mounted on standard BURNDEPT coil plug so that they are interchangeable with BURNDEPT PATENT COILS

The new coils (4 in number) replace Burndept Coils No. 25 and 50 which are now discontinued.

Price 25/- Set of Four Coils.

ILLUSTRATED CATALOGUE
containing much useful information including details of all our apparatus and complete receiving equipments for one up to four valve sets is sent Post Free for 6d.

LONDON SHOWROOMS:
15, Bedford Street, Strand, W.C.2.

BURNDEPT LTD.,

Manufacturers of WIRELESS APPARATUS,
AERIAL WORKS, BLACKHEATH, LONDON, S.E.3

WESTON ELECTRICAL MEASURING INSTRUMENTS

THE WESTON MODEL 280 VOLT-AMMETER

Triple Range. 150/15/3 Volts. 15/1.5/0.15 amps.

This Precision Instrument is especially suitable for Wireless Research Work, i.e.

3 Volt Range.—Testing accumulator cells, dry batteries, measuring fall of potential across potentiometers.

15 Volt Range.—Testing 6 or 12 volt accumulator supplying voltage to valves, etc.

150 Volt Range.—Testing H.T. Batteries, etc.

0.15 Amp Range (150M.A.)—Measuring H.T. current to transmitting valves, determining resistance of Transformers, chokes, telephones, rheostats, etc.

1.5 Amp Range.—Adjusting filament currents, etc.

15 Amp Range.—Measuring output or charging current of accumulators, etc.

NOTE.—The 3 volt range may be used as a sensitive low range Milli-Ammeter. SEVEN INSTRUMENTS IN ONE CASE.

PRICE £15, less 20 per cent. Leather Case 15/-

Write for further particulars.

WESTON ELECTRICAL INSTRUMENT CO., LTD.

Audrey House, Ely Place, Holborn, E.C.1

Telephone: Holborn 2029.

Telegrams: "Pivoted, Smith, London.

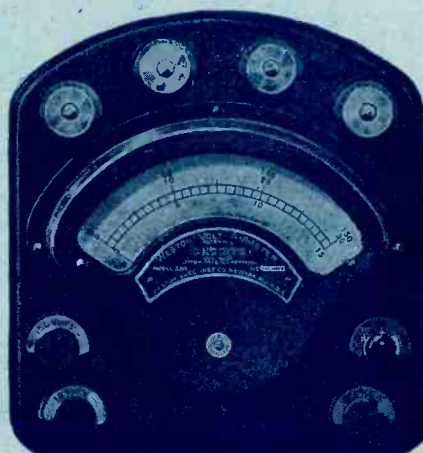

MODEL 280

MAGNAVOX

THE WORLD'S FINEST

LOUD SPEAKER

RADIO
brings it
MAGNAVOX
tells it.

Broadcasting faithfully reproduced with marvellous clarity and volume

Sterling Telephone & Electric Co., Ltd.

TELEPHONE HOUSE,

210/212, Tottenham Court Road, London, W.1

Telephone No.: 4144 Museum (7 lines). Telegrams: "Cucumis, Wesdo, London."

Works: DAGENHAM, ESSEX.

BRANCHES: NEWCASTLE-ON-TYNE: 9, Clavering Place.

CARDIFF: 8, Park Place.



No. R1293
(14" Horn).

YOUR
ENQUIRIES
INVITED.

GAMAGES

LEAD IN AMATEUR WIRELESS

FIRST IN 1908—FOREMOST TO-DAY

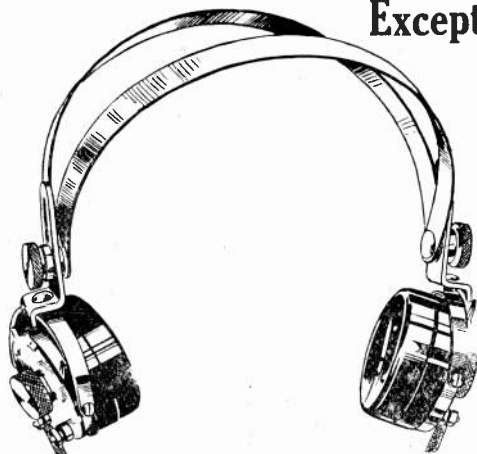

Exceptional Offer of 'PHONES

BROWN'S Double Head-piece Receivers, 8,000 ohms.

49/6

Ditto, 120 ohms.

42/6

SULLIVAN'S Double Head-piece Receivers, 8,000 ohms.

36/6

Without leads. In perfect condition and absolutely new.

All sent post free.



IMPROVED TYPE OF FILAMENT RESISTANCE

The above has been produced by us to meet the present demand for a cheap yet efficient Filament Resistance suitable for mounting to the purchaser's own instruments. It is easily attached, and when fixed is very neat and attractive looking. The Resistance is wound on an air core in a grooved Ebonite former. When mounting all that is necessary is to drill a hole in the panel for the spindle and three holes for the fixing screws. Remove the ebonite knob and screws from the resistance, insert the spindle and collar through the centre hole in the panel and attach firmly by means of the screws. Replace knob to complete. To indicate the "Off" position a mark should be made on the panel to correspond with the arrow on the knob. These resistances are suitable for one, two, or three valves. Size 2½" wide by 2" high.

PRICE 8/6

LOW FREQUENCY AMPLIFIER

The single stage low frequency Amplifier here illustrated can be easily connected to any valve or crystal receiving set, thereby increasing the efficiency of the receiver by 50%. With the use of this instrument, signals are rendered very distinct, and many otherwise inaudible messages are sufficiently strengthened as to become readable. This Amplifier is particularly suited for the reception of telephony and music owing to the absence of noise usual with multi-valve amplifiers. The transformer used is the finest on the market, and the design and finish of the whole instrument are up to our usual high standard of excellence. Length 8", width 6", height 3½". We are offering this fine piece of apparatus at the extraordinary **low price of 42/-** Post Free.

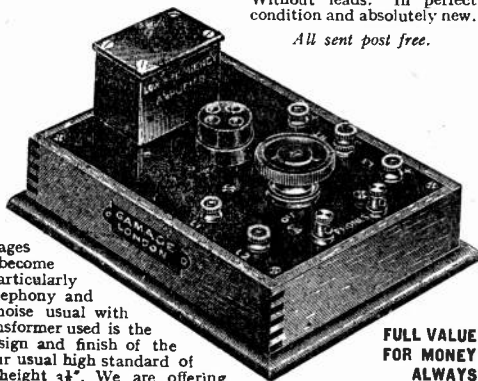

FULL VALUE FOR MONEY ALWAYS

WRITE NOW FOR OUR WIRELESS CATALOGUE

Fully illustrated, giving all details and prices, indispensable to the man who wants the best apparatus at the lowest prices. A copy will be gladly sent **POST FREE ON REQUEST.**

"WESTON" MOVING COIL RELAYS

This well-known instrument is one of the most sensitive relays obtainable. It consists of a very delicate permanent magnet ("Weston"), moving coil instrument movement and is provided with a platinum circuit closer in place of a pointer. The contact screws are adjustable and are so arranged that the contact closer can be set to move through an arc ranging from ¼" to less than 1-root. It is highly recommended for all classes of work where an extremely sensitive relay is required; the attention of wireless enthusiasts being especially drawn to same for the purpose of experimenting in wireless recording. We are now offering this beautiful instrument at the **low price of 55/-** Post Free.

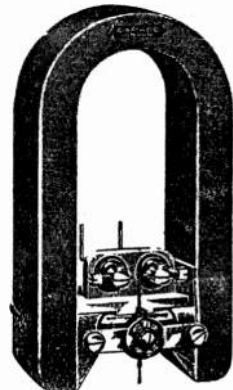

GAMAGES, HOLBORN, LONDON, E.C. 1.

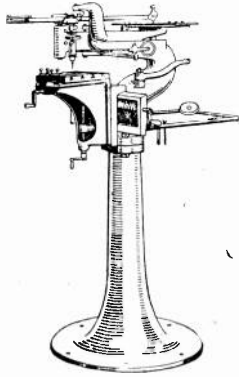

All-round Engraving

Nothing comes amiss to the Taylor-Hobson Engraving Machine.

Moulds for tyres or tiny seals come within its scope.

Bold lettering for Name-plates, Indicators, Scale or Clock Dials—all are cut quickly and accurately.

The output of the Taylor-Hobson Engraving Machine is uniform and of high quality. Its speed alone earns it a place in every efficient factory.

It costs little to run. It pays for itself quickly.

It is used all over the world for work on Metals, Hard Rubber, Wood and Celluloid.

Write for fullest particulars immediately.

TAYLOR, TAYLOR & HOBSON, LTD.

74a, Newman Street, London, W.1

Works : LEICESTER.

IMPORTANT NOTICE

A. C. Cossor, Limited, hereby give notice that the order of Mr. Justice Russell of the 1st March, 1922, continually advertised by the Marconi Co., was an order **ARRIVED AT BY CONSENT.**

Being engaged at the time in the production of an improved and different type of valve, A. C. Cossor, Limited, did not consider the patents in question of sufficient importance to warrant the expense of litigation.

A. C. Cossor, Limited, respectfully leave the public and the Trade to judge whether the constant repetition of the notification of the judgment referred to is necessary or expedient in the circumstances.

A. C. Cossor, Limited,
Aberdeen Works,
Aberdeen Lane,
Highbury Grove, N.5.

REVOLUTION IN PRICES.

For the convenience of those Amateurs who prefer to make up their own Variable Condensers we are offering complete sets of parts, ready to assemble, no drilling or fitting required, at hitherto unheard of prices, in the following Capacities:

·0015	·001	·00075	·0005	·0003	·0002
21/-	17/6	15/-	10/-	8/-	7/-

For Assembled add 2/6 to price of each model except ·0015 and ·001 which are 4/6 extra.

The above are for Panel mounting and, at the price, are absolutely the best Condenser value on the market. With Engraved Ivory Scale, 1/3 extra. Mounted in Mahogany polished Cases, 4 1/4 x 4 1/4 x 3 1/4", with ebony top and knob, scale and pointer, ·0005, 12/6; ·0003, 16/-; Vernier Condensers, unmounted, 3 plates, 4/-; 5 plates, 4/9.

How can we Sell so Cheaply?

Buy from the makers and save middlemen's profits. Post Paid on £1 Orders

W. J. FALLON & Co., The Condenser People,
230a, HERMITAGE ROAD, LONDON, N.4.

Here is EVIDENCE
of the SUPERIORITY, EFFICIENCY and the
EXTRAORDINARY RANGE of

THE
Crystophone
REGISTERED

Headingley,
Arnold Road,
Clacton-on-Sea.

Wireless Supplies,
64, Mortimer Street, W.

26th July, 1922.

Dear Sirs,

As promised, I let you know that I succeeded in catching up the WRITTLE Concert last eve—over 40 MILES AWAY—but I had to put on a much larger condenser. Will call when near your address.

A. J. PAINE.

The following comment has been received from the Chief Designer of the Manufacturers :—

“ Thanks for copy of the very interesting letter from your Clacton-on-Sea customer, which confirms experiments we have been conducting. I repeat that in our opinion the developments in Crystal Receivers will, if anything, be even more amazing than the developmen's in Wireless Telephony itself.”

J. W. FOTHERGILL.

For Local Broadcasting for use with headphones the Crystophone is *all* you require, but there are good, solid reasons why it must be



Specially designed Variable Condensers for the Crystophone will be available in 10-14 days. PRICE - 40/-
Book your Order now.

WIRELESS SUPPLIES CO.,
64, Mortimer Street, London, W.1

Telephone : Museum 2672.

Telegrams : “ Adragonax, Wesdo, London.”



CQ Std bi for ERICSSON PHONES

WHEN you instal your wireless set—crystal or valve —you'll get maximum results if you fit Ericsson Phones—clarity, sensitivity, strength of signals and absence of "click." Specially suited to telephony. Ericsson Phones embody the accumulated experience of telephone manufacture for a generation. Easy to the head, light and comfortable. The magnets never lose their strength and "shorts" are non-existent.

Write for Particulars
The BRITISH L. M. ERICSSON
MANUFACTURING Co., Ltd.

Head Office:
60, Lincoln's Inn Fields, E.C.2



HIGH FREQUENCY TRANSFORMERS

To Fit Ordinary R Valve Socket

No. 0	Range	150 Metres	-	5/6
No. 1	"	300	-	6/-
No. 2	"	600	"	6/3
No. 3	"	1200	"	6/9
No. 4	"	1800	"	7/6
No. 5	"	2500	"	8/3
No. 6	"	6000	"	9/9
No. 7	"	8000	"	12/-
No. 8	"	24000	"	14/3

UNWOUND FORMERS 4/6 EACH.

There is a good latitude on these Coils for higher and lower ranges.

Fully Illustrated List Post Free - - 4d.

H. D. BUTLER & CO., LTD.

Bank Buildings, 222 Great Dover Street, Borough, S.E.1. Tel.: Hop 3029.

MITCHELL-PHONE HEADGEAR.



35/- Pair.

Over 27,000 pair distributed to the trade in three months, is sufficient guarantee to quality. Although not quite as illustration (a new mechanical improvement being fitted) they are comfortable, highly efficient, and sold on a money back basis.

IMMEDIATE DELIVERY FROM STOCK, and the trade should grasp the opportunity without delay. GOOD DISCOUNTS, and the quality is such that you will obtain many REPEAT ORDERS. SHIPPING ORDERS A SPECIALITY.

MITCHELL'S ELECTRICAL & WIRELESS Ltd.

McDermott Road, Peckham, S.E.15.
Retail Store, 188, Rye Lane, Peckham, S.E.15.

Phones: NEW CROSS 1540/1.

DUBILIER

A New Condenser for Wireless Receivers

THE DUBILIER TYPE 600 MICA CONDENSER

The illustrations show two types of this new condenser for wireless receiving circuits. The condensers have the same perfect mica insulation, the same high efficiency and the same permanence of capacity as the larger Dubilier Mica Condensers used in wireless transmitters. Distortion when receiving telephony is often due to bad design of the components of the receiver—therefore use efficient Dubilier Condensers in your receiver to obtain the best out of your set.

PRICES:

- Capacity between 0.0001 and 0.001 mfd - 2/6 each
- " " 0.001 " 0.005 " - 3/- "
- (inclusive)
- Condensers complete with Grid Leaks - 7/6 "

TRADE TERMS ON APPLICATION.

Both types of condenser (with or without clips for a grid leak) are fitted with screw terminals as well as tags for making soldered connections.

With Clips for Grid Leak.

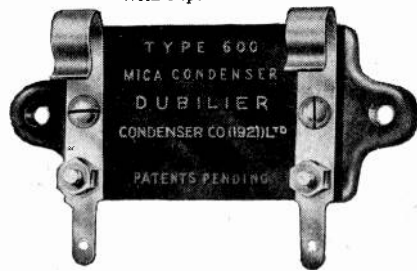

Without Clips for Grid Leak.

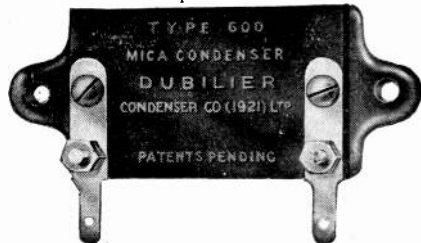

THE WAY TO DUBILIERS.

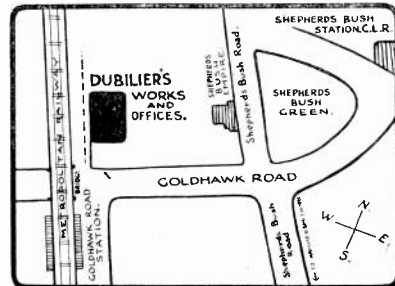

THE DUBILIER CONDENSER CO. (1921), LTD.,
DUCON WORKS, Goldhawk Road, Shepherd's Bush, London, W.12

Telephone—Hammersmith 1084.

Telegrams—Hivolcon, Phone, London.

Code—Marconi International.

BATTERIES FOR WIRELESS

High Tension Block Accumulators

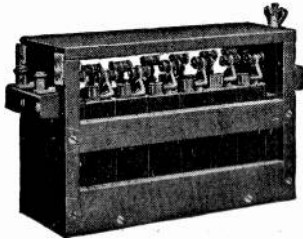

Block Accumulators, unlike the ordinary Plate Type, retain their energy for **12-18 months on one charge**. Unequaled for use with Wireless Thermionic Valves. Standardised sizes— $1\frac{1}{2}$ and 3 A.H. capacity.

Fuller Plate and Patent Block Cells (4 and 6-volt sets) are eminently suitable for Wireless Work.

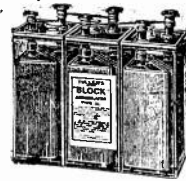

Fuller "Chad" Batteries



Designed for use in supplying the anode (sheath) circuit of thermionic valves for reception purposes. Expert tests in every case confirm its superiority over the Standard Battery usually employed.

Last much longer than ordinary Dry Cells, free from risks of leakage and short circuits.

Type	No. of cells	Voltage	Capacity	Price
A 12/Z	12	24	$1\frac{1}{2}$ A.H.	£4 15 0
A 30/Z	30	60	$1\frac{1}{2}$ A.H.	£10 0 0
A 12/K	12	24	3 A.H.	£5 15 0
A 30/K	30	60	3 A.H.	£12 10 0

Type	No. of cells	Voltage	Capacity A.H.	Price
A	8	12	1 approx.	5/-
	10	15	1 approx.	7/-
B	8	12	$4\frac{1}{2}$ approx.	11/9
	10	15	$4\frac{1}{2}$ approx.	16/-

EBONITE—Rod, Sheet and Tube

FULLER'S UNITED ELECTRIC WORKS, LTD.

WOODLAND WORKS, CHADWELL HEATH, ESSEX.

Telegrams: "Fuller, Chadwell Heath."

Telephone: Ilford 171 (4 lines), London Telephone Area.



"SEMAPHORE"

High Tension Dry Batteries for Wireless Receiving Sets



TERMINALS.—The 15 volt Batteries are supplied (unless otherwise ordered) with 2 Brass Connecting Strips as illustrated. All the other sizes have 2 Insulated Plugs. Brass Sockets are fixed to every other Cell so that Tappings can be taken at each 3 volts.

Other sizes can be supplied and quotations given on receipt of enquiries.

The "SEMAPHORE" is THE Battery for Wireless Work.

Its Specialities:—No "Crackle." Low resistance throughout long life. London Made.

Volts	Number of Cells	Price Each Carriage paid
15	11	3/9
30	22	8/6
36	24	9/3
50	36	13/6
60	44	16/6
90	66	24/6
100	72	26/6

Trade supplied promptly. Terms on application.

SEMAPHORE, Ltd., DRY BATTERY SPECIALISTS

28, John Street, Bedford Row, London, W.C.1.

Telephones : : MUSEUM, 5422 and 5423.
Telegrams : : ARWELIDITE, HOLB. LONDON.

The most reliable and efficient Batteries for Wireless Work are

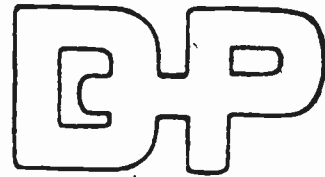

STORAGE BATTERIES

D.P. Batteries are made to fit almost any size of box. The output of our Works runs to hundreds of thousands of plates yearly.

Write us for particulars

The D. P. BATTERY CO., td.
BAKEWELL — DERBYSHIRE
& 11 Victoria St., London, S.W.

<p>THE R. & S.</p>	<p>CRYSTAL RECEIVING SET</p>	<p>PRICE</p>
<p>Complete with H.R. Telephones, 100 ft. Aerial Wire, &c.</p>		<p>126/-</p>
<p>British Valves:— “R” 27/-. “R.M.R.” 17/6. “Ora” 15/-.</p>		
<p>RUSSELL & SHAW, 38, Great James Street, Bedford Row, W.C. 1</p>		

THE WIRELESS WORLD AND RADIO REVIEW

THE OFFICIAL ORGAN OF THE WIRELESS SOCIETY OF LONDON
A MAGAZINE DEVOTED TO WIRELESS TELEGRAPHY AND TELEPHONY

CONTENTS

Radio House: The Central Wireless Telegraph Station	577
Experimental Station Design	581
An Amateur Station at Harringay. By A. S. Mills	585
Remote Control by Radio. A New Relay Recorder. By F. W. Dunmore	586

Contents continued on next page.

SELF CONTAINED OR UNIT SYSTEMS

Marconiphones, Marconi Scientific Units, Waveora System, Etc.

*Crystal Set complete
with Phone, Aerial
and Insulators*
£3 2 6.

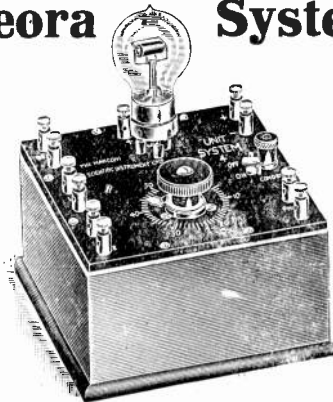

*At our Showrooms
168 Regent Street,
W.1
we give demonstrations
to purchasers.*

Tuners, Coils, Rectifiers, Amplifiers, Valves, Loud Speakers, Microphone Amplifiers, H.T. and L.T. Batteries, and all Wireless Accessories.

Special quotations for Technical Colleges, Schools and Educational Institutions.

Telephones:
Gerrard 3039.
Western 847.

The Radio Waveora Co.
168 Regent Street, London, W.1

Telegrams:
Wychwood,
Phone, London.

MEN IN THE WIRELESS SERVICES DESIRING RAPID ADVANCEMENT
 should train in spare time with the College which ensures this
 "U.E.C." (Regent's Park, London, N.W.1) has in Twelve Years secured hundreds of successes by
 Individual Postal Training for Engineering Examinations and Professional Work.
 State YOUR ambition in confidence, to—SECRETARY'S DEPT. (Desk W.),
UNIVERSITY ENGINEERING COLLEGE, WESTGATE-ON-SEA, KENT.
 and expert advice with the New prospectus, No. 8, will be sent you without obligation.

CONTENTS *(Continued)*

Manchester 1 K.W. Amateur Station	592
How to Get the Best from your Set <i>(continued)</i> . By Percy W. Harris.	593
Notes	594
Correspondence	595
Wireless Club Reports	597
The Wireless Telegraphy and Signalling Bill	601
Questions and Answers	603

THE WIRELESS WORLD AND RADIO REVIEW is published weekly on Saturdays.

All correspondence relating to contributions should be addressed to THE EDITOR, THE WIRELESS WORLD AND RADIO REVIEW, 12-13, Henrietta Street, London, W.C.2.

No responsibility can be taken for MSS. or photographs sent without stamps to defray cost of return postage.

Editorial and Publishing Offices, 12-13, Henrietta Street, Strand, London, W.C.2.

Telegraphic Address: "Radionic, Rand, London." Telephone No.: Gerrard 2807.

Advertisement Managers, Bertram Day & Co., Ltd., 9 & 10, Charing Cross, S.W.1.

Telephone No.: Gerrard 8063 and 8064.

SUBSCRIPTION RATES.—

28s. per annum, post free. Single Copies 6d. or post free 7d.

Registered at the G.P.O. for transmission by Magazine Post to Canada & Newfoundland.

HOLLOW STEEL MASTS FOR AERIALS

These masts are light, strong, easily erected, and will last a lifetime. All lengths over 15ft. are made in sections and each mast is supplied complete with baseplate, finial, rope cleat, pulley sheave, guy clips, three steel guy ropes and strainers, painted one coat ready for immediate erection. Being made of steel, no lightning conductors are required

PROMPT DELIVERY.

PRICES F.O.R. FOR CASH WITH ORDER, EACH

10ft. ...	32/6	15ft. ...	42/6	20ft. ...	45/-
25ft. ...	57/6	30ft. ...	84/-	40ft. ...	126/-

Other Lengths supplied at equally Low Prices.

Trade Inquiries Invited

THE WIRELESS STEEL MAST & ACCESSORY COMPANY
 Lombard Street West, West Bromwich

Telephone No. 447

THE IDEAL WIRELESS SET CAN BE BUILT UP ON THE MARCONI SCIENTIFIC UNIT SYSTEM

IF you invest in this series of units you need not scrap any of your gear when you wish to improve your set.

Units 1, 2 and 4 form a nucleus which will give you all the broadcast programmes and all telephony and telegraphy between 300 metres and 26,000 metres.

NUCLEUS

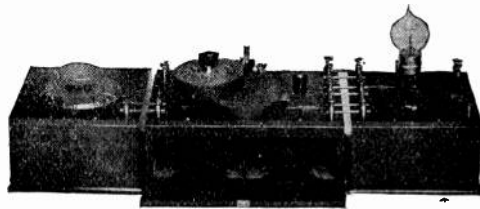

SET

This nucleus consists of a Variable Condenser ; a Retroactive Tuner ; and an Amplifying Detector.

If you want greater range add Unit 3, a High Frequency Amplifier.

If you want greater audibility add Unit 5, a Note Magnifier.

If you wish to use low resistance telephones add Unit 6, a Telephone Transformer.

THE FULL SYSTEM.

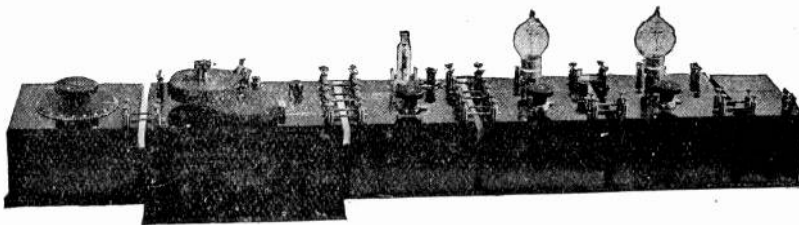

FULL DETAILS AND FREE ADVICE
upon the combination most suitable for your special
needs will be sent on receipt of your enquiry by

THE
MARCONI SCIENTIFIC INSTRUMENT CO., LTD.

40 DEAN STREET, SOHO, W.1

TELEGRAMS: THEMASINCO. WESTCENT
TELEPHONE: : GERRARD 7745

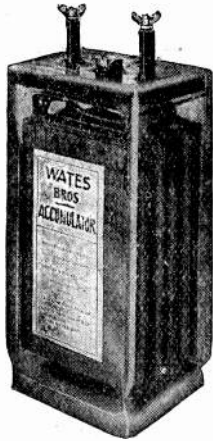

Ideal Valve Accumulator:
50 Amps.

By far the best value in Accumulators on the market. Ask those who already have them.

2 volts ..	10/-
4 " ..	20/-
6 " ..	30/-

* Carriage.

2 volts ..	1/-
4 " ..	2/-
6 " ..	3/-

Dimensions of each cell 8 x 4 x 3.
Weight without Acid 5½ lbs.



Brown-Sterling Phones.

Multi-Magnet Type
The world renowned headphones giving unsurpassed efficiency.

120 ohms ..	48/-
2,000 " ..	51/-
4,000 " ..	52/-

Complete with best quality cords.

WATES for VALUE, QUALITY and EFFICIENT SERVICE

Illustrated Catalogue of complete sets and component parts sent free on request.

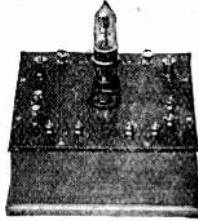

A one valve panel suitable for receiving broadcasts up to 50 miles. Soundly constructed, carefully tested, and supplied complete with full instructions for working.

Price £4 each (without valves)

A De Luxe Crystal Set

of remarkable efficiency.

Capable of receiving broadcasts up to 35 miles from high power sending stations, also special coil for receiving Paris time signals. Supplied in handsome polished teak cabinet with hinged lid and best quality high resistance phones

Price £7 12 6

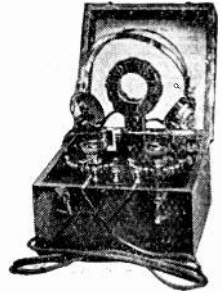

High Tension Battery.

Wates Speciality.
15 volt, 11 cell standard size 9½" x 7" x 2½".
Price 3/6 each.

VALVES

We Stock.
Mullard's "Ora" 15/- each.
Marconi - Osram R Type 26/6 each.



WATES BROS. WIRELESS ENGINEERS
13-14, C/ QUEEN ST. KINGSWAY LONDON W.C.2
Phone GERRARD 576 Telegrams ZWATESENG WESTCENT



Don't Buy Shoddy CONDENSERS

when we can offer strong, well-made Fine Tuning and Variable Condensers that are both better and cost less.

We must apologise for the delay in executing orders until now, owing to the huge demand and the difficulty of obtaining raw material, but having made arrangements to overcome this, we are now in a position to greatly augment our production, which is now running into four figures weekly.

Prices:—Fine Tuning Condensers, 6/9. Variable Condensers, 7 fixed vanes (nominally .0003), 13/-; 15 fixed vanes (nominally .0005), 16/-; 26 fixed vanes (nominally .001), 22/6.

We can also supply Ebonite Knobs, Mica, and other Insulating Materials, Terminals, Switch Studs, and other Brass Parts.

Agents:—LONDON—Selfridge & Co., Ltd.; Gamages, Ltd.; Radio Supplies, High Holborn; R. Winter, Radioelectric, Little Titchfield Street, Oxford Circus; Hamblin Clapp & Co., 110, Strand; Scientific Appliances, Ltd., Sicilian Avenue, Southampton Row; Russell & Shaw, Ltd., Gt. James Street, Bedford Row. PROVINCES—Beresford Bros., Bull Street, Birmingham; Mechanical & Electrical Engineering Co. Bradford Street, Walsall; G. S. Baynton, New Street, Birmingham; E. Dyson, Baker Street, Oakes, Huddersfield; Radio Experimental Co., Ltd., Gell Street, Sheffield; Bates & Co., Electrical Engineer, Bury St. Edmunds; Electrical Supply Stores, Albert Terrace, King's Cross, Halifax; Reynolds, Ltd., Greyfriar Gate, Nottingham; Brantingham Bros., Holmeside, Sunderland; E. T. Chapman, Serpentine Road, Poole, Dorset; Tunbridge Wells Wireless Co., The Pantyles, Tunbridge Wells; Santon, Ltd., Bridge Street, Newport, Mon.; Barnsley Co-operative Society, Radio Section, New Street, Barnsley; F. Hough, Sussex Road, Southport; Cross Bros., Ltd., Cardiff; Bacon & Coates, Royal Arcade, Keighley. Others wanted in districts not represented, also Colonial and foreign. Genuine Traders please write for discounts.

Post free if no agent in your district. Send P.O. to—

H. E. Ashdown (Birmingham) Ltd.
Aldridge Road, Perry Barr, Birmingham.

W. A. C. SMITH
236, Argyle Street,
GLASGOW,
are Sole Scottish Agents for the
Famous Burndept Receivers

F. WIGGINS & SONS

MICA Telephone :
Avenue 2248
Largest Stock
in the World.

FOR CONDENSERS
AND ALL PURPOSES.

102, 103 & 104, Minories, London, E.1

THE WIRELESS WORLD AND RADIO REVIEW

THE OFFICIAL ORGAN OF THE WIRELESS SOCIETY OF LONDON

VOL. X. No. 19.

AUGUST 5TH, 1922

WEEKLY

Radio House

LONDON'S MAIN WIRELESS TELEGRAPH OFFICE.

IN the following article it is proposed to give some account of what may be termed the nerve centre of the commercial high speed wireless telegraph services of the Marconi Company.

Radio House, situated at the corner of Wilson Street and Eldon Street, in the city, is the building from which all these services are now controlled, and traffic with the United States, Canada, France, Spain and Switzerland, and the extension of the American service to South America, the West Indies, and Australasia, all passes through the instruments located here. At Radio House every effort has been made to meet the special requirements of speed and accuracy, and the whole organisation for dealing with the traffic is as up-to-date as possible.

From the counter in the public office runs a conveyer to a circulation table equipped with numerous time-saving devices, and the different transmitting and receiving circuits are located round this table in the main operating room. Each circuit has its own special table, and Fig. 1 shows the table allotted to the service with Paris, the call-sign of the wireless station at Paris being UFP. This table is typical of the others. At these tables, which are standard in design, messages are first reproduced in Morse characters on a perforated paper tape, by means of keyboard perforators seen on the extreme right of the table. These keyboard perforators are operated in the same way as a typewriter. The paper tape is then fed into automatic high speed transmitters, which in the case of the French and Swiss circuits, actually operate the wireless transmitting stations located at Ongar, in Essex.

Alongside the transmitting instruments are the receiving circuits from the respective countries, so that it is possible for the operator who is transmitting to be checked or interrupted at any moment by the receiving station at the other end. It is of interest to consider in detail the handling of traffic on these tables, and as an example we will take the case of the Paris circuit shown in Fig. 1, and trace the operation of the instruments shown.

The messages to be transmitted are taken in turn from the rack shown on the right of the table, and are punched up on the paper tape by means of the keyboard perforator. Fig. 2, which illustrates the table of the Berne circuit, shows an operator engaged on this work. As messages are punched in Morse symbols on this paper tape, the tape is fed through a Wheatstone transmitter, this instrument serving to reproduce the dots and dashes in the punched tape as electrical impulses of correct duration, on the line which goes to the wireless transmitting station and controls its operation.

For those who are not familiar with the Wheatstone transmitter, it may be mentioned that it is practically a special form of Morse key, which is mechanically driven, and capable of high speed operation, and is controlled by means of the punched paper tape instead of by hand. At Radio House the Wheatstone transmitters are driven by special electric motors having a wide range of speed, and can be set to run exceedingly steadily at any particular speed required.

Alongside the Wheatstone transmitter is placed an ordinary hand-operated key, which can be used when the volume of traffic does not justify the use of high-speed working.

The galvanometer shown near the key is for

the purpose of balancing the line against the artificial line in duplex working.

As is well known, a simplex telegraph circuit is an arrangement of a key, battery and sounder at each station, so that either one or the other station can transmit.

In duplex working, both stations can transmit and receive at once, and repetitions, etc., can be asked whenever required.

There are two main systems of duplex working, known as the "bridge" and the

So far, reference has only been made to the apparatus connected with the transmitting side. On the left of the artificial line are the instruments which record the received wireless signals from the distant station, which, in the case of Fig. 1, is Paris. The wireless receiving station for Paris is located at Brentwood, and from thence to Radio House the received wireless signals are conveyed by land line. The receiving apparatus at Brentwood is very much of the usual type used at a C.W.

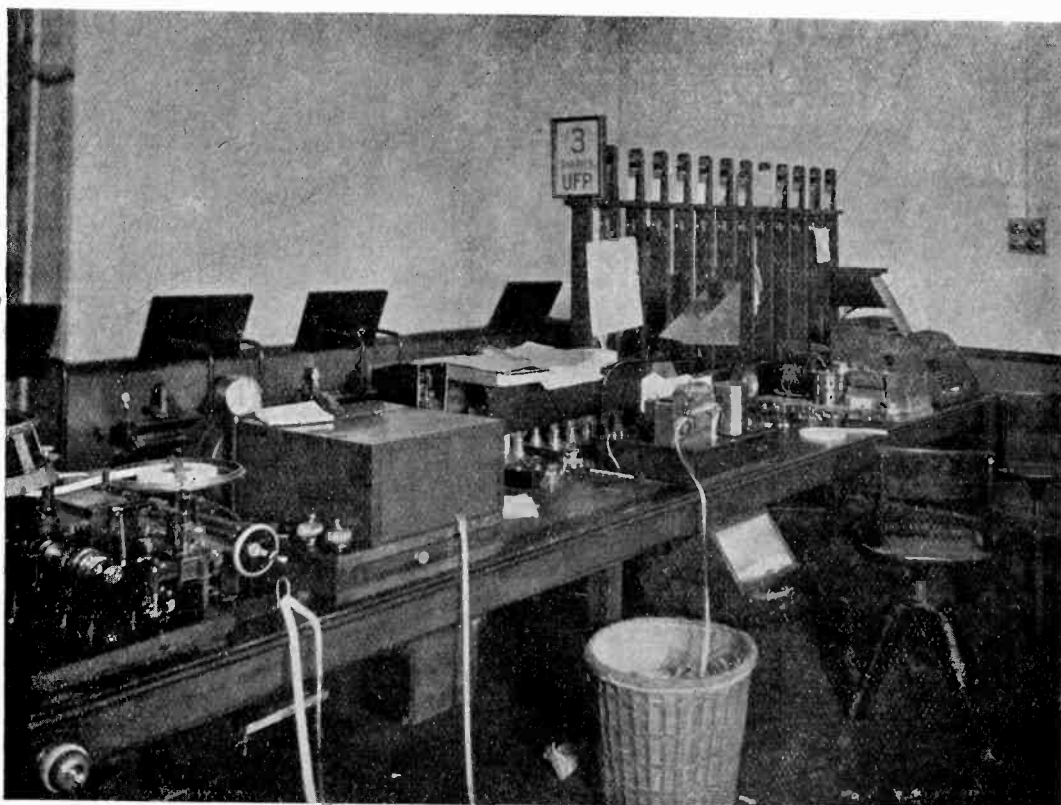

Fig. 1. The Paris Table.

"differential" methods. The differential system is employed at Radio House. On the left of the key, and sunk in a glass-covered well in the table, are located the instruments, comprising the artificial line, together with two relays—one a differential relay (which is the distinctive feature of the differential duplex system), and the other a transmitting relay, which is controlled either by Wheatstone or hand-operated key, and passes out the signalling current to the line.

receiving station, but instead of receiving the signals in telephone headgear in the ordinary way, these signals have to be sent over the land line to Radio House and there operate inductive, pulsating currents which are relays. Since the average relay is highly suited to telephonic reception are not suitable for actuating relays. It is therefore necessary to smooth out these pulsating currents in order that they may be able to control a relay, and this relay in turn conveys the Morse signals

into the land line connecting Brentwood with Radio House. In the case of reception by head telephones, it is of course necessary that the currents should be pulsating, in order that they may actuate the telephone diaphragms.

Returning again to the standard table of the Paris circuit at Radio House, shown in Fig. 1, the signals from Brentwood are fed to the coils of the differential relay referred to above, and this in turn controls a local circuit consisting of either a sounder or an undulator or Creed

the usual manner by means of a sensitive electro-magnet. Whilst spacing current flows through the coils of the electro-magnet, a continuous straight line is drawn by the syphon on the tape, but when marking current is flowing, the syphon is deflected across the tape, and remains there until the spacing current returns. The result is that a reproduction is made of the dots and dashes sent into the line by the relay, the relay being controlled direct by the wireless signals received at



Fig. 2. Traffic handling at the Berne Table.

apparatus. The Morse sounder is not capable of working at speeds of the order of 80 to 110 words a minute, and the undulator is therefore used for high speed reception, the sounder only being used in conjunction with the hand-operated key when there is a small volume of traffic, or for the purpose of breaking in during transmission. The apparatus is actually a type of syphon recorder. It is driven by a small motor, and feeds paper tape past a silver or glass syphon. The syphon is controlled in

Brentwood.

With the undulator it is possible to receive at very high speeds, and it may be mentioned that messages are frequently transmitted and received duplex at speeds of about 110 words a minute for hours on end. Messages received in this way are recorded in Morse symbols on the paper tape, which next passes to operators who are working typewriters, each fitted with a special rest to hold the message form in a convenient position for typing. The operator

translates the Morse slip and types out the message in Roman capitals on another form, which is the actual message handed to the addressee.

So far we have referred only to the undulator and sounder methods of reception, but these are not the most important, since the principal method for dealing with traffic is now by means of the Creed receiver and Creed printer. A description of this apparatus has already appeared in this journal, on pages 475 to 480 of the issue of October 29th, 1921.

offers a variety of methods for sending and receiving. The particular method to be used is decided by the operator, who is guided in his decision by the volume of traffic to be handled at the time, and also by the wireless conditions. In cases of rush of traffic, and under good wireless conditions, the Wheatstone transmitter would be used at high speed for transmitting, and the Creed receiver for receiving, duplex working being conducted.

In the event of any interruption owing to a

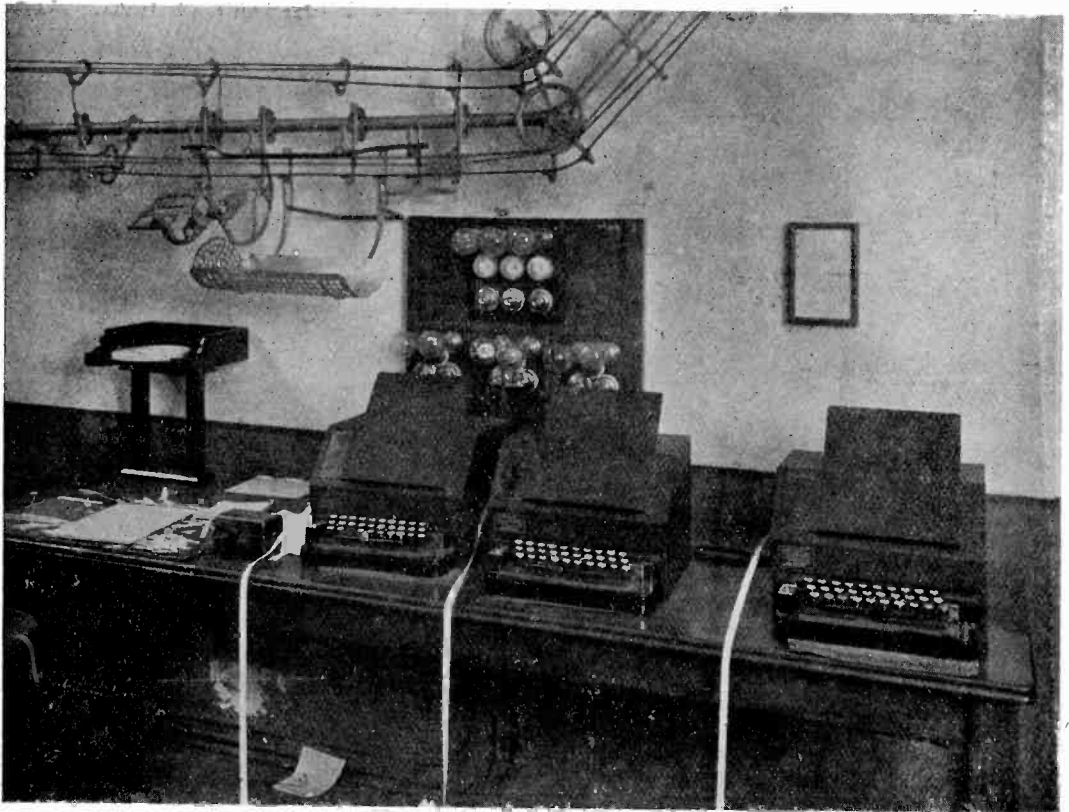

Fig. 3. Teletype Machines and Lamson Carriers.

By means of this apparatus, the received signals are made to punch paper tape in exactly the same way as the keyboard perforator already referred to. This tape is then fed through the Creed printer, which automatically translates the punched Morse signals on the tape into Roman capitals, and types out the message on a paper strip in Roman capitals. This paper strip is gummed on the message form for delivery to the public.

It will be seen, therefore, that the table

fault in any of the instruments, one of the other methods can be used till the fault is rectified.

In addition to these methods, it is also possible to receive by means of telephone headgear in the ordinary way, provision being made on the table for plugging in telephone leads when required. and the receiving station at Brentwood would then be requested to send through the signals in the form of pulsating currents, instead of smoothed-out currents,

to which reference has been made in the case of operating a relay.

It may be of interest to trace the course of a message from the time it is handed in over the counter until its arrival in the rack on the right-hand side of the table shown in Fig. 1. Messages handed over the counter at one of the Marconi branch telegraph offices are sent to Radio House by teletype, which, being a special form of printing telegraph at the receiving end of the telegraph line, prints the message which has been typed out on a typewriter keyboard at the transmitting end. Fig. 3 shows some of these instruments.

All messages arriving at Radio House go direct to a distribution table, whence they are distributed to their correct pigeon-holes on the respective tables. Lamson conveyers (shown in Fig. 3) are used extensively in Radio House for conveying messages from one place to another.

In addition to the principal tables, which deal with foreign circuits, there are a number of lines for conducting the traffic of many business houses.

Beneath the instrument room there is a special repair shop for the purpose of effecting repairs to any of the apparatus in use.

Experimental Station Design

Continued from p. 511, July 22nd, 1922.

These articles, which will appear in alternate issues, are intended not only to be a complete guide to those new to wireless, but to give explicit details on the construction of all the components of the experimental station. Actual designs will of necessity in some instances be somewhat crude, in order that they may be made up without elaborate workshop equipment. Practical working instructions will be given where necessary for the help of those unacquainted with the more simple processes of instrument making. Of course, where good workshop facilities exist, the designs may be readily modified.

Economy is made an essential feature, bearing in mind always that where low-priced component parts can be obtained their use has been embodied in the designs. For those who do not desire to make their own apparatus, the descriptions will assist them in selecting the equipment for their stations.

The information contained in the first few articles under this heading is to help those new to wireless and whose first aim is to build a simple set capable of receiving broadcasted telephony and consequently may cover ground already familiar to many readers. The succeeding instalments, however, will advance by easy stages, and in the course of the series the construction of an elaborate station will be evolved.

IX. AN AIR DIELECTRIC VARIABLE CONDENSER.

IT is intended that this condenser shall be constructed without the use of a lathe, and to permit of this certain departures from the usual practice have been made, such as the omission of metal bushes for bearings for the main spindle and collars on the spindle which can only be obtained by turning. The end plates (Fig. 1) are made first from $\frac{3}{8}$ in. polished ebonite sheet. These are made to size by careful filing and the edges are finished as described in previous articles under this heading, and must be at right angles to each other and at right angles to the faces. The dimensions given are based upon the use of condenser plates of the sizes shown in Fig. 2. There are many varieties of condenser plates on the market, which, though very similar in outline, vary slightly as to radius and location of holes. If the reader is unable to obtain plates similar to these

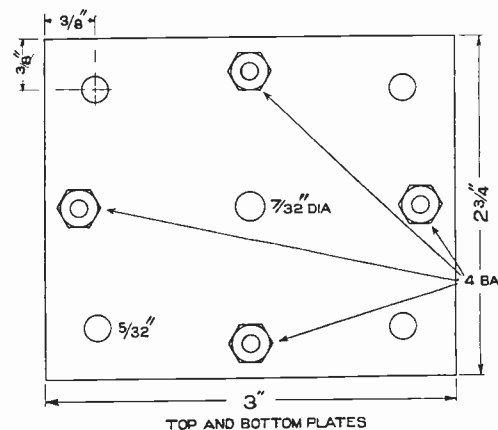

Fig. 1. Ebonite end plates, Thickness $\frac{3}{8}$ ". Three of the nuts are on the rods carrying the plates and the other holds the steadying rod.

shown he will need to make slight modifications in the dimensions of the end plates, which will present no great difficulty. One of the fixed plates may be used as a template for making the holes in the correct positions. A plate can be clamped to the face of one of the end pieces in the vice and two of the holes drilled through, taking care not to force the holes in the soft plate aside as the drill passes through into the ebonite. Placing the shanks of similar size drills or well fitting brass rods through these two holes, the plate will be held in position for drilling the third. A hole is also made to carry a steadying rod,

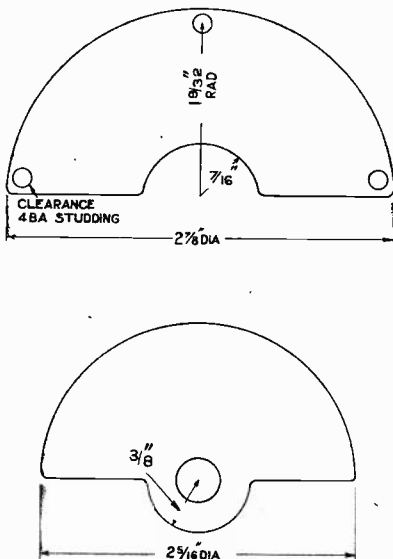

Fig. 2. Condenser Plates of the pattern usually obtainable. Thickness is No. 20 S.W.G.

and the position for this is found by placing a plate with its two corner holes over the two side holes just made, but with the third hole in the plate on the opposite side. The third hole now indicates the position for making the hole for the steadying rod. Holes are also made through the four corners at $\frac{3}{8}$ in. from each edge to provide for fixing the condenser to the panel or other apparatus in which it is mounted. The two end pieces may be drilled through together, one over the other, but if this is done great care must be taken that the drill passes in exactly at right angles to the face. Especially does this apply to the centre hole, which forms the bearing for the spindle.

The dimensional drawing of the spindle (Fig. 3) can only be worked to provided the spacing washers are $\frac{3}{32}$ in. thick and the plates of 20 S.W.G. If washers and plates of these dimensions are not available a simple calculation must be made to determine the length of spindle that is required between the two screw-threads. There is no reason of course, why the number of plates shown in the drawing should be adhered to, as no exact capacity is aimed at. For simplicity one might easily adopt the dimensions given, putting on as many plates as space permits. The spindle is made from hard brass rod of a size exactly fitting the hole in the movable plates, which is usually $\frac{5}{16}$ in. After being cut to length, the ends are filed clean and by means of a centre-punch, holes are punched in the ends to indicate the exact centres. The spindle can be then spun between pin-points to observe whether there is any wobble indicating whether or not it is perfectly true. Alternatively, it can be tested by rolling on a flat surface. Truing up can be done by hammering with a wooden mallet should it be necessary. Absolute trueness is essential, and will save a great deal of trouble when assembling. The filing of the ends to a smaller diameter must be very carefully carried out in order that they may be concentric with the main portion. Opposite sides are filed down to nearly the required diameter, and the new edges which are now presented should appear exactly parallel to each other. Two other flat faces are next made at right angles to those just made. This will leave four corners, or four rounded corners, according to the amount of reduction in the diameter required. These corners are filed away until the width between opposite corners is the same as between the two opposite faces first made. The rod is by this process reduced to octagonal section and all edges must run precisely parallel. Measuring for distance between opposite faces can be accomplished by means of callipers or if not available, a slot can be made in a piece of brass sheet of the exact width and used as a gauge. The eight corners which the rod now presents must be removed by filing until the width of the face thus made is equal to the width of the remaining portion of face. The rod now presents 16 edges, and these are removed by revolving the rod on the side of the bench whilst the file moves across it. It will soon become quite round, and must be tested for fit from time to time

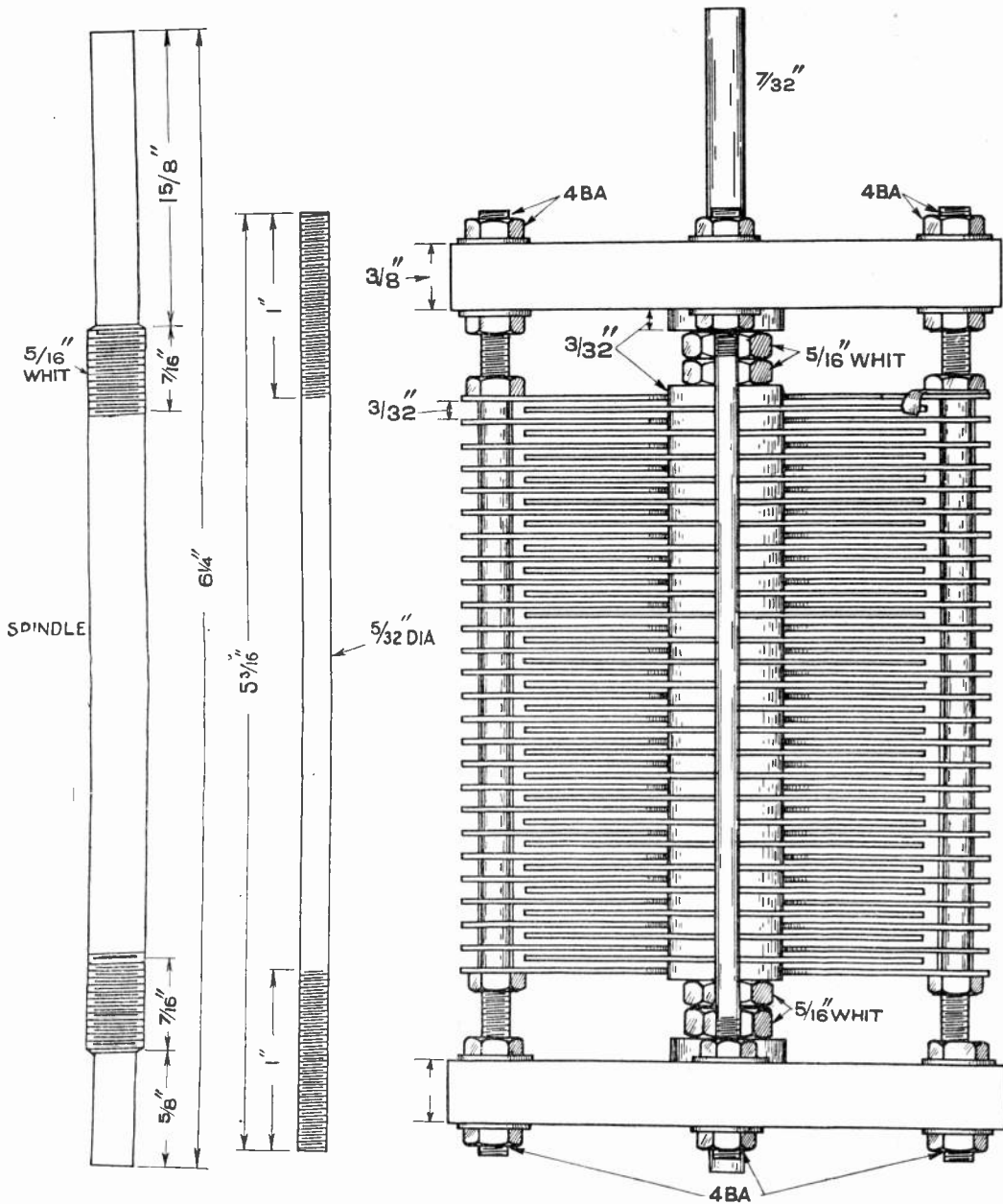

Fig. 3. Method of assembling the Condenser. The arrangement of the end pieces permits of critical adjustment and correct setting for movable plates and a condenser made to these dimensions and with the plates very carefully and evenly spaced has a capacity of about .0012 mfd.

in the holes made in the ebonite. It should be filed down until it is a very tight fit, and then by the use of emery cloth the scratches can be removed and the fit of the spindle in its ebonite bearings made a little easier. The two ends are treated in this manner to the distances shown in the drawing. The cutting of the threads is effected by the use of a die of the required size. The spindle is held vertically in the vice, the jaws of which should

be faced with zinc or lead to prevent damage to the spindle. It should not project out of the vice more than is necessary, to eliminate the danger of bending. The die securely fixed in its holder is forced down on the shoulder produced by the reduction in diameter of the end of the spindle, and rotated in a clockwise direction. It is as well to turn the die back through a distance of half a revolution after every one or two complete revolutions in order to break off the chips that may get wedged in the die. If the reader has never attempted the cutting of small screw threads previously he should experiment on a piece of scrap rod. It is not necessary to make a shoulder for practical purposes, but the removal of the abrupt edge at the end of the rod will assist the starting of the die. The job could easily be carried out by the iron-monger if necessary, and a light file mark might be made on the spindle to indicate to him the distance to which the thread must be carried.

On completing the spindle, the next step is to assemble the moving plates upon it. Two hexagon brass nuts are locked together at one end, followed by a spacing washer of about $\frac{3}{8}$ in. in diameter, or as may be supplied with the particular style of plates purchased. A plate is then placed on the spacing washer and followed by other plates and washers alternately until the plain portion of the spindle is completely covered, when the plates are pressed together tightly. A spacing washer, followed by two lock-nuts screwed home tightly, will hold the plates securely in position after they have been arranged in alignment. Two other washers are then placed over the ends beyond the nuts, and the distance at which the ebonite end pieces are to be mounted will be indicated.

When this is done the supporting rods for the ebonite pieces and fixed plates can be cut to length from brass rod of such a size as will just pass through the holes in the fixed plates. These holes are usually of a size that will just pass rod which is suitable for taking a 4BA thread, but unfortunately, as the size of the hole is not standardised, the reader may require to use larger rods, such as may need a 3BA thread. The construction of the rods is quite apparent from the drawings, and little explanation is required, four rods being necessary, one of which is merely for the purpose of steadying. Before proceeding to assemble the fixed plates the

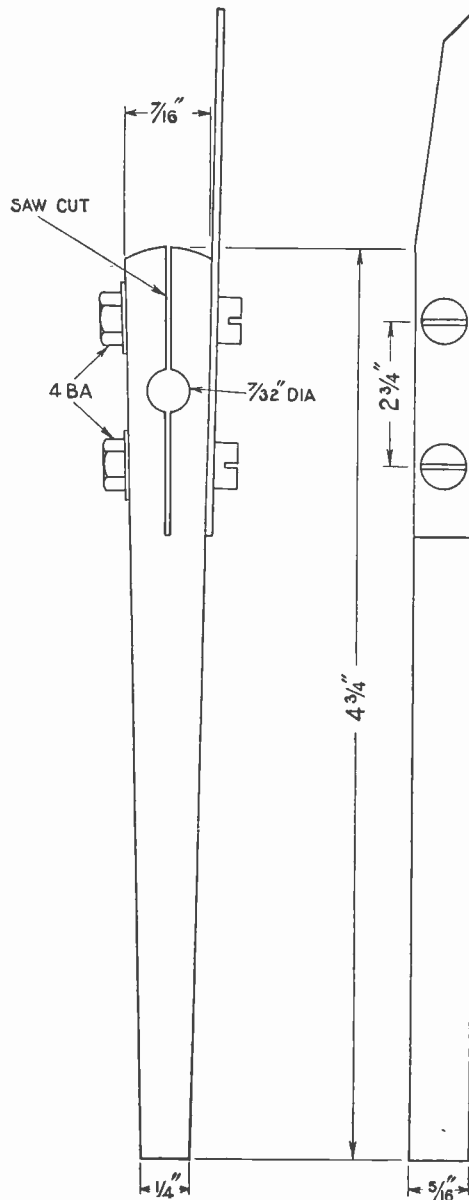

Fig. 4. Handle and Pointer.

ebonite end pieces should be rubbed down with fine emery paper, as described in an earlier article, and given a good matt finish. The fixed plates can now be assembled on the rods and tightly locked home by means of end nuts. The moving plates are then dropped into position, and the ebonite pieces pushed on. The other nuts carried by the rods supporting the fixed plates serve for critically adjusting the ebonite pieces, so that there is no play on the spindle, and also facilitate the correct setting of the fixed plates relative to the moving ones. Should the reader require to provide a stop to prevent the moving plates from rotating through more than 180 degrees, this can be done by inserting under one of the nuts which clamp down the fixed plates, a small piece of brass sheet bent round to engage on the end moving plate. This serves also as a short circuiting contact to connect across the fixed and moving plates, and so throw the condenser out of action after it has reached the position of maximum value. For the purpose of making contact with the spindle, a small curl of wire is soldered to its projecting bottom end and carried across to the supporting rod which does not pass through the fixed plates.

The condenser is now complete except for a manipulating handle, which may be constructed from a strip of 5/16 in. ebonite sheet to the design shown in Fig. 4, which is a sufficient guide to its construction without further explanation, excepting perhaps that it might be mentioned that the hole which is to carry the spindle should be made prior to the saw-cut. This type of handle is to be recommended on account of the fact that the hand of the operator is kept well away from the spindle while adjusting the condenser.

In fitting the condenser to an instrument panel a clearance hole must be made for the spindle, say of $\frac{3}{8}$ in. diameter for a $\frac{7}{32}$ in. spindle, as it is not intended that the panel to which the condenser is mounted should serve as a further bearing. Attachment is arranged by passing four brass screws through holes in the panel which coincide with the corner holes in the ebonite end pieces. Nuts are run up on these screws tight against the back face of the panel, and with the aid of four other pairs of nuts the condenser is spaced a little way from the panel to allow for the nuts projecting from the ebonite end plate of the condenser.

F. H. H.

An Amateur Station at Harringay

By A. S. MILLS.

THE accompanying photograph is of my five-valve set. This set tunes from 200 to 25,000 metres—from 200 to 2,000 by means of a loose coupler (I find this still best for the shorter wavelengths) and from 2,000 upwards I use honeycomb coils. The loose coupler can be seen in the centre of the photograph with the coils on the left. The switches in the front of the coil holder are for changing over from the loose coupler to the coils.

On the extreme left is a three-valve L.F. amplifier, and behind this a loud speaker mounted on a single-valve amplifier. Actually this is in a room below the set so that the family may get the benefit of the concerts. It is, however, soon to be replaced by a Brown H.I.

The switch-board on the right contains the H.T. and L.T. batteries and voltmeters,

series parallel switch for A.T.C., switch for cutting out the amplifier and aerial earthing switch. All connections are made beneath the table, and altogether the set has a very neat appearance.

Results are very good on spark, C.W. and telephony. Many amateurs can be heard at quite a distance from the phones, whilst Marconi House can be heard using no aerial whatever.

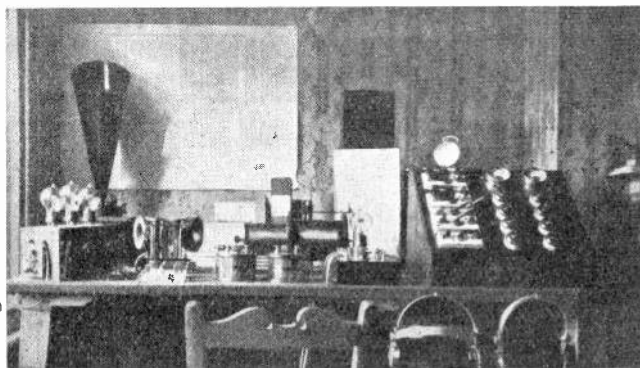

Mr. A. S. Mills' Amateur Station at Harringay.

Remote Control by Radio.

A NEW RELAY RECORDER.

By F. W. DUNMORE.

The following abstract of a paper read before the American Institute of Electrical Engineers on April 19th, 1922, describes the development and method of operation of a new type of relay recorder which operates directly from the output terminals of a wireless receiver. Two types of relay are described, which are classified as Type A and Type B. Type A is designed to be operated by batteries, whilst Type B is operated from 60 cycle 110 volt lighting circuits.

A valuable and distinctive feature of the relay is that it is tunable to different frequencies and can be made to respond only to signals of one particular frequency.

TYPE A.—FOR USE WITH BATTERIES.

1. *Object of Development.* The object of this investigation was to develop a relay which should operate by received radio signals.

2. *Requirements.* To be satisfactory as a relay recorder the device should have the following characteristics: (1) it must be of simple construction with few adjustments;

and capable of maintaining its adjustments; (7) it must be portable.

3. *Circuit Used.* In order to avoid the use of a very sensitive relay designed to operate on currents of a milliampere or less, with delicate adjustments and light contacts and spring tension, advantage was taken of the radio-audio amplifier (which has now become

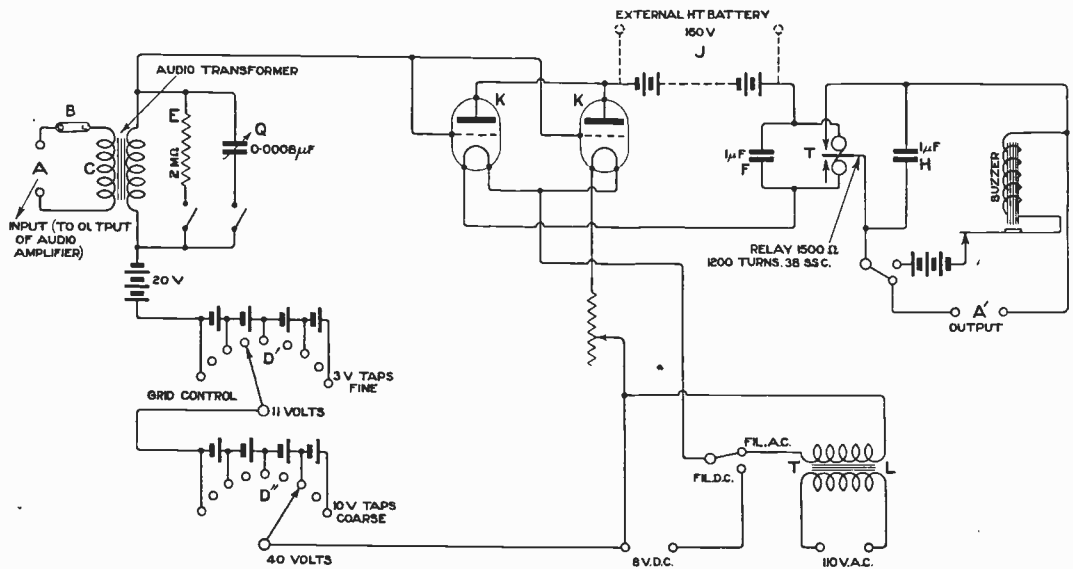

Fig. 4. Circuit diagram of Relay Recorder for use with Batteries.

(2) it must be easy to adjust and capable of being put into operation quickly; (3) it must be selective and as free from static and such disturbances as possible; (4) it must be capable of operating at a speed of at least 12 times per second; (5) it must respond to weak signals; (6) it must be of strong design, durable,

a reliable radio instrument) to increase the input voltage to the relay circuit, thus making possible the use of a simple ordinary high-resistance telegraph relay. The relay device has therefore been developed to operate from the output circuit of any suitable amplifier in place of the ordinary telephone receivers.

The only adjustment necessary is that of an ordinary telegraph relay.

Fig. 1 shows the wiring diagram. *A** is a telephone plug for connecting the relay device to the amplifier output. *B* are phone terminals so that if desired the operator may listen to the received signal in the ordinary way. *C* is an audio transformer of the type used in audio amplifiers. *E* is a two-megohm, grid leak. *Q* is a 0.0006-microfarad variable condenser

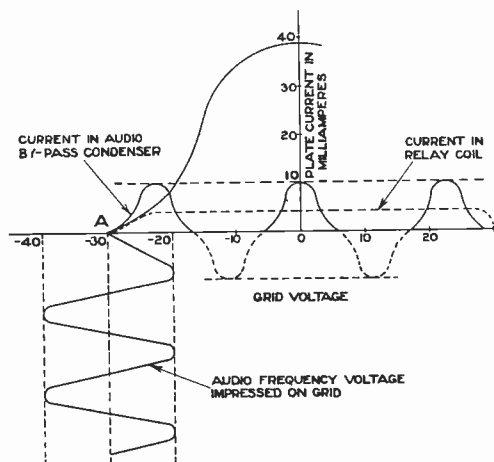

Fig. 2. Tube Characteristic showing principle of operation of Relay Recorder.

or 0.0003-microfarad fixed condenser. *D* is a 60-volt variable grid battery, variable in steps of approximately three volts. *J* is a 160-volt dry H.T. battery, self-contained within the set. *K* is a type UV-201 Radiotron. *F* and *H* are each a one-microfarad paper condenser. *T* is an ordinary telegraph relay rewound with 1,200 turns of number 38 S.S.C. enamel wire. *A'* is the output to be connected to the apparatus to be controlled. *L* is a step-down transformer for operating the tube filaments from the 110-volt A.C. supply when such a supply is available.

4. *Principle of Operation.* The principle of operation is illustrated in Fig. 2. By means of the variable filament battery *D*, the grid voltage is adjusted to approximately 30 volts, at which value the plate current is zero, as shown at *A*. The incoming audio-frequency voltage impressed on the grid varies the grid potential, for example, from - 30 to - 20 volts. The 10 volts decrease from - 30 to - 20 causes an increase, for example, from 0 to 10 milliamperes, while the increase from - 30 to - 40 volts, is not

effective in causing a plate current to flow, due to the fact that - 30 volts is already sufficient to reduce the plate current to zero. The result will be a pulsating direct current of 10 milliamperes, maximum amplitude, in the plate circuit. This current, flowing through the plate circuit and condenser *F*, (Fig. 1), causes an increase in the plate current at the keying frequency, which change, passing through the relay coil, will pull the relay armature over, making contact at *T*, which contact may control any mechanism desired. With the grid battery voltage adjusted for maximum sensitivity it was found that static induction, etc., operated the relay. When these disturbances are not as strong as the signal, their effect on the relay may be overcome as shown in Fig. 3. For example, the grid battery is shown increased to - 35 volts, the critical value for maximum sensitivity being - 30 volts. The disturbances due to stray currents, etc., merely reduce the grid battery voltage to - 30, which is not sufficient to cause plate current to flow. However, the signal, being of greater intensity than the stray currents, reduces the voltage to - 25, which causes a plate current of five milliamperes.

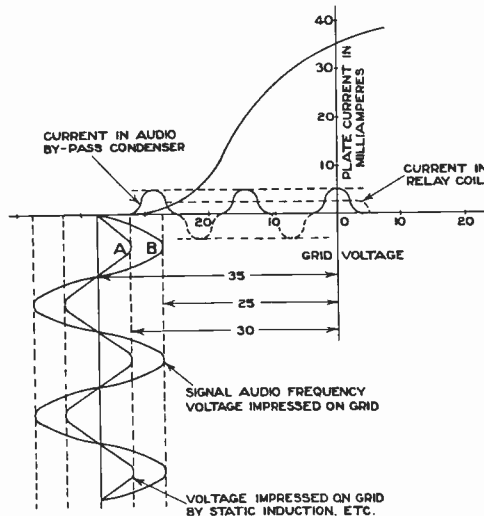

Fig. 3. Method of eliminating static and induction noises which are not stronger than the signals.

It will be seen, therefore, that all disturbing effects, if of less intensity than the signal, do not affect the relay.

5. *Method of Increasing Sensitivity and Selectivity.* During the development of this

relay it was found that the rectified audio-frequency current in the plate circuit caused the relay armature to chatter rapidly and make a poor contact with the fixed contact point through which the circuit is closed. This was overcome completely, however, by the addition of a one-microfarad condenser across the relay coils. This served the purpose of an audio-frequency by-path for the highly inductive winding of the relay, thus greatly decreasing the resistance of the circuit. The change of plate current due to this audio-frequency caused a second change, which occurred at the keying frequency. This latter change passes readily through the relay coils and exerts a strong steady pull on the relay armature without the least chattering.

It was also found that the 0.0006-microfarad variable condenser (Fig. 1) across the secondary of the input audio transformer made possible

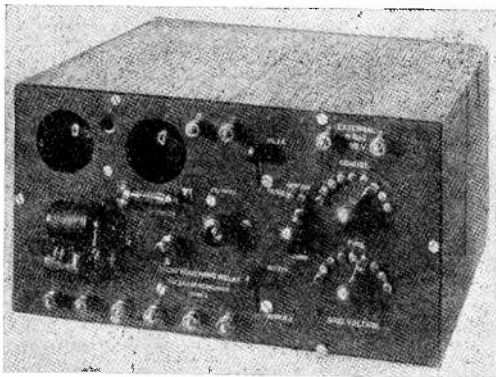

Fig. 4. Type A Relay Recorder for use with Batteries.

audio tuning, which increased the selectivity considerably. This tuning was very sharp, and it was found that the European stations could be made to operate the relay while a high-power station here in the United States would fail to operate it, although the high-power station was coming in on the same wavelength and slightly stronger. This was made possible by adjusting the heterodyne note of the European station to a frequency different from that of the local station and then tuning the secondary of the audio transformer to that frequency. The 0.0006-microfarad variable condenser may be replaced by a 0.0003-microfarad fixed condenser and the audio tuning accomplished by adjusting the heterodyne note to the resonant frequency. By means of this audio tuning one of three stations transmitting simul-

taneously has been selected and caused to operate the relay although all were of equal intensity.

By the use of two relay recorders connected in series across the output terminals of a single radio receiving set, two messages, sent on practically the same wavelength, but of different audio frequencies, have been accurately received simultaneously.

6. *Speed of Operation.* Tests showed that with a signal strength sufficient to produce a plate current of 10 milliamperes the relay could be operated at a speed of 48 contacts per second, the contact being sufficient to operate a buzzer. With three milliamperes in the plate circuit a speed of 27 contacts per second was obtained. With one milliampere a speed of 19 per second. In each case the relay armature spring tension was adjusted for the best operation.

7. *Sensitivity.* As stated above, this relay was designed primarily with the intention of obtaining a device which should be durable, simple in operation, and strong in construction. Sensitivity is obtained by means of radio-audio amplification, thereby increasing the voltage input to the relay circuit and eliminating the necessity of extreme sensitivity in the relay. Tests at 600 cycles showed that the relay circuit was fairly sensitive, as approximately 1.3 volts at the input terminals of the audio transformer in the relay circuit caused a current of five milliamperes to flow through the relay coil in the plate circuit.

8. *Durability.* As the relay instrument used in this recorder is of the ordinary telegraph type its durability is well established. The only elements requiring occasional renewal are the two electron tubes, the 60-volt grid battery, and the 160-volt H.T. battery.

9. *Portability.* The complete recorder, with the exception of the filament lighting battery, is contained in a cabinet 7 ins. by 13 ins. by 11 ins., as shown in Fig. 4.

10. *Uses.*—(1) As an ordinary receiver it has advantages over reception with telephone receivers, for one may receive by buzzer or sounder with all induction and interfering noises eliminated (if not louder than the signal).

(2) A tape or drum-type recorder may be used and a copy made without a trained radio operator.

(3) Time signals may be recorded.

(4) A call system may be worked by a time switch connected to close the filament circuit for a given time at set calling intervals.

(5) Any form of mechanism may be operated by an incoming signal.

(6) A receiving station may be located remotely from the transmitting station and the radio signals relayed by wire to the operating room some miles distant.

In conclusion it may be stated that a relay of this type should operate satisfactorily, *without attention*, on an airplane where mechanical

except that the plate and grid voltages are supplied from the 60-cycle, 110-volt A.C. supply. The current for operating the tube filaments is also obtained from this source, so that the recorder is operated entirely independently of any form of batteries. It is only necessary, therefore, to connect to the 110-volt A.C. line and the recorder is ready to operate.

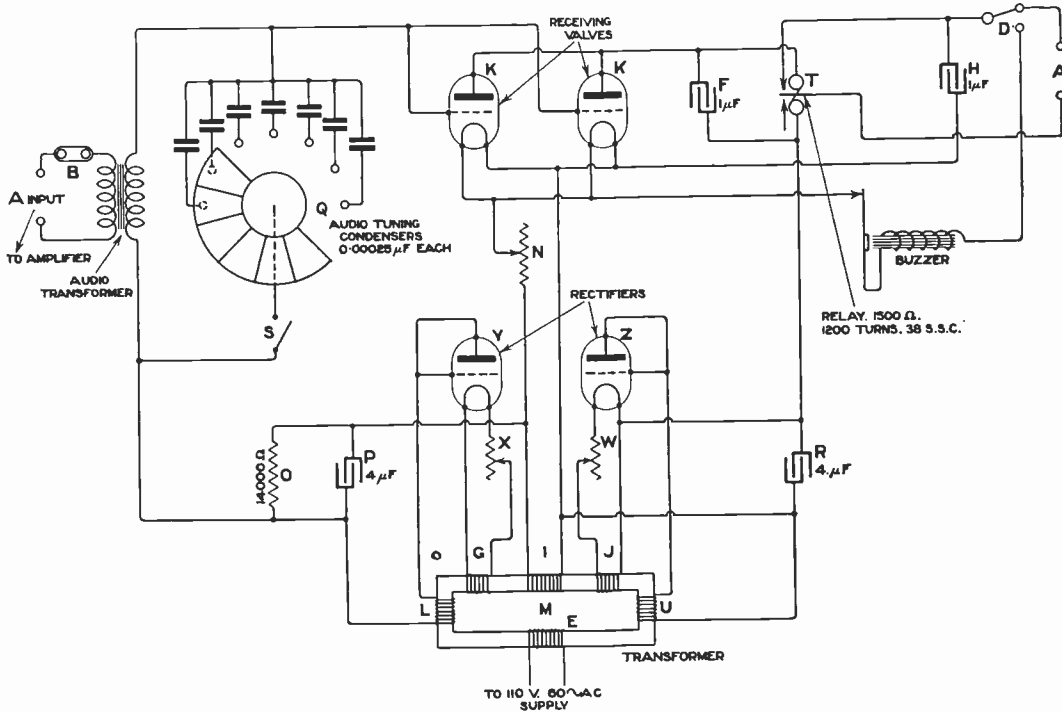

Fig. 5. Circuit diagram of Relay Recorder for use on the 110-Volt A.C. Supply.

vibration may be excessive, as the pull on the armature with three milliamperes, or over, in the relay coil makes possible the use of a spring tension on the relay armature sufficient to keep it from moving due to mechanical vibration of the relay.

It would seem that the above-mentioned feature makes this remote control relay more serviceable than those now on the market, which require delicate adjustment of spring tension, contact points, and suspended vibrating elements.

TYPE B.—FOR USE ON THE 60-CYCLE, 110-VOLT A.C. SUPPLY.

This recorder is similar in construction and operation to the Type A recorder,

The method of operating the recorder from the A.C. supply consists in the use of the two receiving tubes as rectifiers, as shown in Fig. 5. The tubes Y and Z are used as half-wave rectifiers, one supplying the plate voltage, and the other the grid voltage. When used as rectifiers, receiving tubes should have the grids and plates electrically connected together. A special transformer M with six windings is used. Two of the windings, G and I, supply the filaments of the two rectifier tubes. A third, L, the filaments of the recorder tubes. A fourth, U, the high voltage for the plates. The fifth, L, supplies the grid voltage, and the sixth, E, is the 110-volt primary winding. The rectified alternating current is smoothed out by means of four-microfarad condensers, P

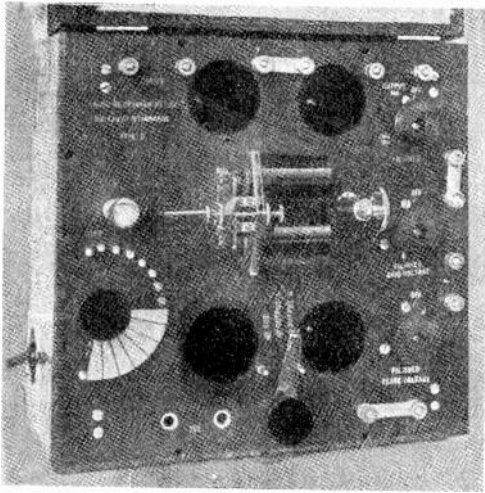

Fig. 6. Type B Relay Recorder for use on the 110-volt A.C. supply.

and *R*, connected across the output terminals. As the currents in the grid and plate circuits are small, smoothing out inductance was found unnecessary. It was found necessary to put 40,000 ohms as shown at *O*, across the output circuit of the rectifier tube supplying the voltage to the grid, as the grid is otherwise insulated from the filament of tubes *K* by the rectifier tube. By means of the filament rheostats, *X* and *W*, the grid and plate voltages may be varied over any ranges desirable for the most efficient operation of the recorder. By the use of binding posts with straps, as shown in Fig. 6, the type *B* recorder may be operated from filament, H.T. and grid batteries for supplying the filament, plate and grid voltages respectively in cases where the A.C. supply is not available.

In cases where very high-speed operation is desired, the ordinary relay may be replaced by one designed for high-speed operation.

Manchester's 1 kW. Amateur Station

By A MEMBER.

A PROPOS of the success attained by Mr. W. R. Burne, of the Manchester Wireless Society, in gaining the first prize in the recent transatlantic receiving test, Mr. Y. W. P. Evans, Hon. Secretary of

the Society, suggested that an effort be made to get into touch with the American amateurs by means of a special transmitting plant to be erected by the members.

A formal application was made to H.M.

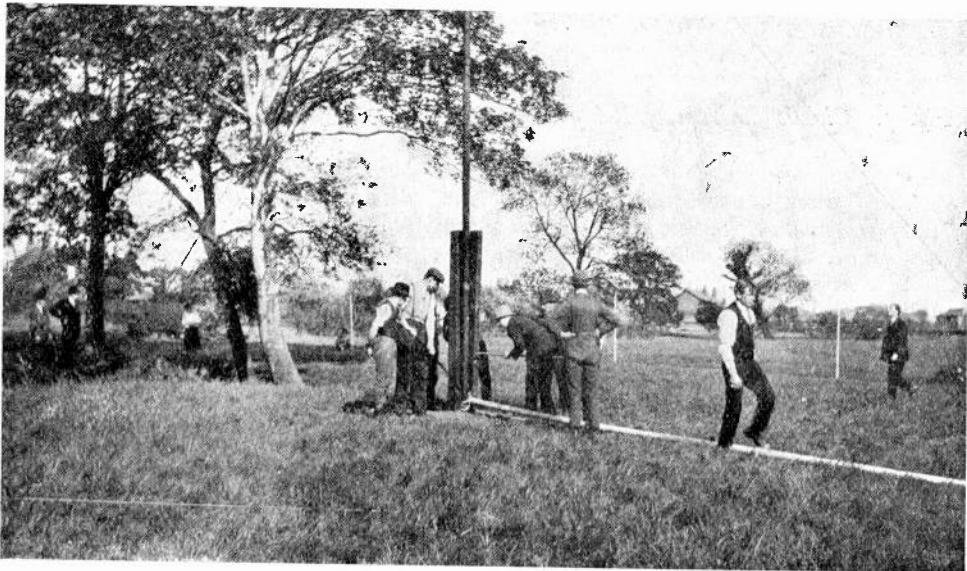

Laying out the mast preparatory to erecting.

Postmaster-General for permission to use an input of 1 kW. and special aerials.

The preliminary details were forwarded to London, with the application, in March, and

tion by asking for a special licence to cover a period of twelve calendar months from June 1st, 1922, and up to the time of writing this had not been confirmed.

Whilst these various negotiations were in progress the members of the Society were busy erecting the station. Difficulty was at first experienced in the choosing of a suitable site. Altogether eight different sites were offered, all having certain advantages and a supply of A.C. or D.C., on the spot. Eventually, Mr. J. H. Brown (Vice-President), of Redbrook, Baguley, very generously offered to purchase a plot of land about one and a half acres in extent, and loan this to the Society for an indefinite period, and this site was finally chosen. A committee of four members was elected for the purpose of working out the approximate cost of the station and after allowing a suitable margin for sundry expenses, this was estimated at £120. A working committee of twelve members was then formed and invested with the authority to design a 1 kW. station at a minimum cost.

The masts were the first consideration and these, it was decided, should be 80 ft. high, consisting of two 40-ft. poles, 6 to 3 in. taper, surmounted by five 8-ft. socketed steel sections. The first method of raising this mast was of simple design consisting of two 12-ft. ground timbers, 6 ins. by 3 ins., sunk to a depth of 6 ft., 6 ins. apart. Two holes were bored at a height of 4 ft. from the ground, and a similar hole through the wooden pole at the same height from the base. A bolt was then passed through these holes, the foot of the mast being raised accordingly, so that it was pivoted at a point 4 ft. from its lower extremity and 4 ft. from the ground. Stays were fixed at equal intervals along the mast and brought to a common point, being secured together by means of a rope strop which was hooked in the one-ton hauling blocks, the other end of the blocks being secured to a double line between two trees at a height of 20 ft. from the ground. The mast was then raised to an angle of 20 degrees by means of ladders and very gradually worked up until the strain of the whole mast could be taken by the blocks, this position being with the mast at an angle of 40 degrees. Three ladders were used, 20 ft., 30 ft., and 45 ft., the latter two were now removed and each side stay manned by two members, slowly the weight was taken and a good 45 degree angle obtained. This was the most critical point, and consequently

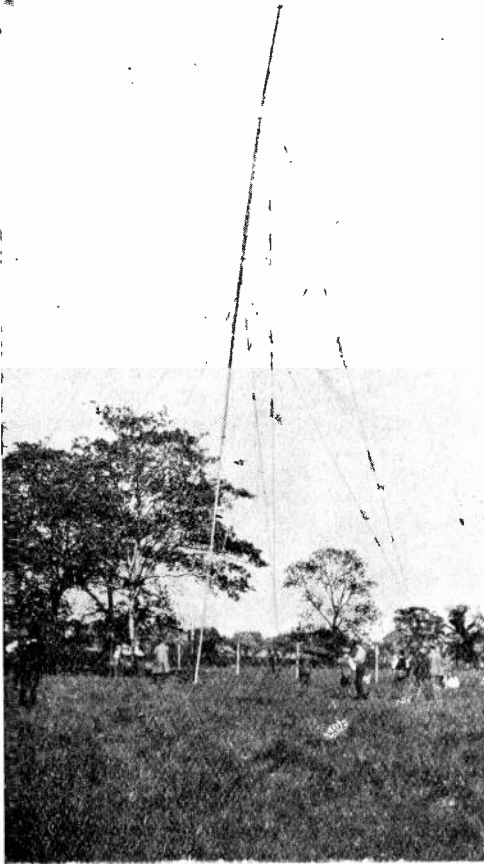

The mast nearing the vertical position.

after consulting the various government departments concerned, facilities were granted by the Post Office authorities whereby the Society would be allowed to make a special test extending over a period of two to three days, using the 1 kW. transmission power.

It was obvious that to make the attempt in midsummer would be asking for failure or practically so, observing that most American amateur stations reported excessive atmospheric and consequently were closing down, as far as long distance work was concerned.

Not wishing to abandon the idea of a test, it was decided to modify the original applica-

the greatest strain was exercised at this moment. The wooden mast proved unequal to the task and after buckling slightly at about 30 ft. from its base the whole mast collapsed, fortunately without any casualties.

From this moment the system employed for raising the mast was abandoned, and after the working committee had reviewed the situation it was decided to adopt the falling derrick principle. Mr. Hallam constructed a model mast and derrick to scale, equal to an 80-ft. mast with a 30-ft. derrick, and

steel sections, 3 ins. in diameter and raised in precisely the same manner as the three-section mast. On this mast, four sets of stays were necessary owing to the number of sections used and adjustment was much more difficult than with one of fewer sections. A six-wire aerial was next constructed, pending the authority of the P.M.G., and this was erected on 6-ft. star spreaders. The two end spreaders were made up of six $\frac{1}{2}$ -in. canes, 6 ft. long, three couples being lashed together and these double lengths secured at

the centre, forming a six-point star, 6 ft. in diameter. The four intermediate spreaders were made of three single $\frac{1}{2}$ -in. canes similarly arranged. The lead-in was made on the same lines, with 6 in. three-ply discs, $\frac{3}{8}$ -in. thick as spreaders. The peripheries of these were divided into six, at each point of which a slot was cut, $\frac{1}{8}$ in. wide and $\frac{3}{8}$ in. deep, the centre section of three-ply



A group of Members of the Manchester Society and Friends.

working from this he demonstrated that with a 2 lb. weight at the top of the model mast, a pull of 6 lbs. was registered on the spring balance for the first pull, gradually diminishing until the falling derrick balanced the mast proper, after which the mast assumed an upright position quite easily. Material being obtained, the second mast was constructed and consisted of three 27 ft. sections of 3-in., 2-in., and $1\frac{1}{2}$ -in. steam piping, with a falling derrick 30 ft. long of 3-in. piping.

The stays were measured off to the exact length on two sides and made secure to stakes driven obliquely into the ground, the back set of stays being made fast to the head of the derrick. The blocks were then fixed to the derrick and a pull taken from a section of the broken wooden mast, which had been previously laid to rest in a 3 ft. trench, around which was a steel rope strop.

Everything being in readiness, the mast was raised comfortably by six of the members, and lent itself readily to adjustment by means of the bottle screws in each stay. The second mast was constructed of eleven 8-ft. socketed

was turned out to a depth of $\frac{1}{4}$ in., thus forming a channel around which binding wire could be secured after fixing the six lead-in wires in the slots. The total length of wire in the aerial is 660 ft. and in the feeder 618 ft. of 7/22 enamelled with 1/18 core. The total cost of the work above described was approximately £40.

The next item was the earth, and it was decided to dig a trench 5 ft. deep by 3 ft. wide between the masts, and as there is water at this depth it was considered to be a better system than counterpoise wires which had at first been proposed. Four $\frac{1}{4}$ -in. copper conductors were laid in the trench and a connection taken from the centre of each to the transmitting room. The area covered by the water at a depth of 5 ft. is roughly three to four acres, so that this may be said to constitute the earth. It is damp all the year round, thus ensuring a constant earth resistance. The above work was carried out by about 30 to 40 members at week-ends, and is really very creditable to so small a society (145 members).

How to Get the Best from Your Set

HINTS ON THE MAINTENANCE OF RECEIVING APPARATUS

By PERCY W. HARRIS.

(Author of "The Maintenance of Wireless Telegraph Apparatus.")

V. THE HIGH TENSION BATTERY AND ITS MAINTENANCE.

WHILE many amateurs and beginners exercise considerable care in regard to their accumulators, the high-tension battery is often carelessly chosen. In this, as in practically everything else in wireless, you get just what you pay for. And seeing that faults in the high tension supply are not readily recognised, trouble arising from this source is often neglected.

The first consideration in choosing a high tension battery is, what voltage is needed for the particular valve or valves in use? Whilst most valves are sold for given voltages, much depends upon the use to which the valve is put, and the circuit in which it is used. The popular hard "R" valve will work quite well as a detector with forty to fifty volts on the plate, but sixty to eighty may often give better results. When used as a high frequency amplifier with transformer or reactance capacity coupling, the same voltage can be used, but with resistance-capacity coupling a hundred volts will not be found too high. When valves are advertised for certain voltages, no account is taken of the drop in voltage in resistance-capacity couplings, and if such couplings are used the voltage must be increased thirty to fifty per cent. to obtain the best results. The QX valve, which works well as a detector with 25 to 30 volts on the plate, needs 60 to 80 if used in reactance-capacity or transformer coupled amplifying circuits, and 100 with resistance coupling.

High tension batteries are sold in several forms. Very popular and useful are the 15-volt units now made by several firms. It is very convenient to make a wooden box to hold four units side by side, and to place the batteries with their unlike poles together, so that short wires can be soldered on to the lugs to make the necessary series connections. Connection should be permanently made to one end of the series, the other connection from the set being a flexible lead, terminating in a spring clip which can be clipped on the end of the first, second, third or fourth unit.

Some makers sell high tension units with tappings for every three volts, and plug con-

nections for the desired points. These are also useful but are naturally more expensive. Very close adjustment of the plate voltage is not often required, variation of the filament brilliancy being all that is sufficient for fine adjustment in most cases. Personally, I have given up the "wander plug" type in favour of the 15-volt units, as the former do not seem to me to be worth the additional cost.

The individual cells in a high tension battery should not be too small, as although very little current is taken from them the utmost steadiness is required and this cannot be obtained with very small cells. Further, the larger cells last much longer and the cost of high tension batteries *per annum* (the only true way of comparing values), is always lower if good cells of fair size are purchased in the first place.

If a high tension battery is bad, failing or worn out, it gives evidence of its state by noises which are frequently taken to be atmospheric. To test whether the noises are due to atmospheric or to faults in the receiver itself, disconnect the aerial and see if they still continue. If they cease, they are invariably due to causes outside the receiver. If they continue, they may be due to bad connections, bad valves, faulty grid leak or coupling resistances, faulty low tension battery, faulty low or high frequency transformers, or more likely than any of these, to one or more faulty cells in the H.T. battery.

To remedy the trouble, if 15-volt units are used, cut out each unit individually. More often than not the fault will be in one unit only, and this should be discarded and a new unit put in place. With "wander-plug" batteries take a short length of wire and quickly tap each successive pair of contacts, being careful not to short them for more than a moment at a time. Usually the noises will cease when one pair of plug sockets is shorted. The bad cells thus found can be permanently shorted in any convenient way, such as by two spare plugs connected by a length of wire.

High tension accumulators made up of tiny secondary cells are obtainable. They are much more expensive than the dry cell type, and, of course, must be periodically charged. High tension wet batteries of the "leclanche"

type are also on the market. The results obtainable with both are good, and the reader can judge for himself whether in his particular case the advantages outweigh the disadvantages. The first cost is high, but in the long run they are both probably cheaper than the dry cell type, although rather messy.

A fixed condenser connected across the high tension terminals of a receiver is always an improvement. The value should never be less than 0.01 mfd. and is better much larger. This condenser serves the double purpose of preventing high frequency current passing through the battery (this always does harm) and smoothing out slight irregularities in voltage.

It is usually better to use separate H.T. batteries for note magnifiers. A common H.T. battery for several valves is a fruitful source of interaction and howling.

Finally, buy your H.T. batteries from a maker of repute and from a dealer whom you know to keep his stocks fresh.

Notes

Clifden Receiving Station Destroyed.

Marconi's Station at Clifden, West Galway, which had been held by Irish rebels for a few days, was put out of action on July 25th. The Receiving house was soaked in petrol and burned. We understand its work has now been transferred to Ongar, Essex.

New Berne List.

Le Bureau International de L'Union Telegraphique, Berne, is publishing a new list of stations arranged alphabetically. Persons desiring to obtain the list, including supplements covering 1922 and 1923, should send to the Bureau International six Swiss francs.

Memorial Service to Cardiff Student.

A memorial service was held at St. John's Church, Canton, on July 16th, for the late Mr. Eric Preen, a student of the Cardiff Wireless College. Mr. Preen was drowned on his first sea voyage.

New Companies.

We note that the Ashley Wireless Telephone Company of Liverpool, and the Wrent Mores Amalgamated Engineering and Construction Company have just been formed. The Ashley Company has a capital of £50,000 in £1 shares, and the Wrent Mores Company's capital is £12,500. The objects of these two new concerns are both on wireless lines, the former dealing in telephone apparatus, the latter carrying on business as electrical and wireless engineers.

Broadcasting Licences.

The Postmaster-General said in the House of Commons on July 27th:—

"No licences have yet been issued to establish broadcasting stations, but I understand that the principal manufacturers of wireless apparatus in Great Britain will combine to form a company or companies to provide broadcasting services. Any *bona-fide* manufacturer in this country will be admitted to membership of any company so formed, and the companies will make themselves responsible for raising the necessary capital and maintaining efficient services. It is proposed that the receiving apparatus which may be used under the licence shall be limited to types submitted by members of the broadcasting companies, and that it should conform to certain technical standards.

"I have been informed that the broadcasting companies, when formed, will probably desire to impose on their members the condition that British-made apparatus only shall be sold by them, and I have intimated that I will assent to this condition for a period of two years. It will rest with membership of the companies to determine to what extent this condition shall apply to the component parts of the apparatus.

"The functions of the Post Office will be limited to approving types of apparatus submitted by members of the company, and inspection of individual sets will not be necessary. Provision will be made under which amateurs who construct their own receiving sets, and licensees who have already purchased imported receiving sets, will be allowed to use them.

"The revenue required for providing the services will be derived partly from a contribution by the manufacturers to the company on each set sold by them, and partly by a proportion of the annual licence fee, which I shall propose to the House shall be paid to the companies financing the services. The cost of erecting the stations and providing these services is likely to be considerable, and I have received no intimation from any firm that they are willing to undertake it without guarantee or payment."

Mersey Dock Music Discontinued.

The Postmaster-General has forbidden the sending of musical items from the Mersey Docks and Harbour Board's telephone station at the Dock Office. The musical items which have hitherto been given at about 9 o'clock each evening have therefore been discontinued.

Reservation of Wavelengths.

Mr. Pike Pease said in the House of Commons that steps had been taken to reserve for the Empire the right to use certain wavelengths necessary for long distance transmission.

First Sermon by Wireless.

Dr. J. Boon, President of the Peckham Christian Union preached a sermon to his congregation on Sunday, July 30th, by means of wireless telephony from the station of Mr. W. W. Burnham at Blackheath.

French Agricultural Service.

For the benefit of agriculturists the Ministerial Council has decided that the Eiffel Tower shall transmit weather reports three times a day. Receiving sets are to be erected by the Mayors of every locality in order to pass on to farmers the information which may be of use to them.

Correspondence

To the Editor of THE WIRELESS WORLD AND RADIO REVIEW.

SIR,—I read with interest this morning the article on Major Armstrong's new super-regenerative receiver. I have not had the opportunity of testing the circuit myself yet, owing to lack of the necessary components, but I have a friend in Newark, N.J., to whom I am indebted for the following information re this receiver and thought that it might be of sufficient interest for you to publish for your readers.

The valves used should be capable of taking a plate potential of at least 90 volts and the higher this can be raised, the greater the volume of sound produced in the telephones. The American UV-202 is suitable, but doubtless the M.O. Valve Co. produce similar valves.

If an entirely new receiver is desired to be built up then the arrangement shown in the figure is perhaps the most convenient

C_1 and $C_2 = 0.001$ mfd. (or more).

The coils L_1 and L_2 may be plug-in type of the Burndeft short wave series and are varied according to the wavelength to be tuned to.

L_4 and L_5 may be Burndeft coils Nos. 1000 (L_4) and 750 (L_5), and of course, do not vary with wavelength changes occasioned by L_1 , L_2 and L_3 (a variometer).

An outdoor aerial may, of course, be used instead of the loop, but if both are used together then interference from other stations on a slightly different wavelength may be entirely eliminated.

The outside aerial is loosely coupled to L_1 by a coil about the same size as L_1 , and has a variable condenser of 0.001 mfd. in series for tuning. The coupling may vary with somewhat different sized aerials.

The desired signal is then tuned in on the loop and the outside aerial is tuned to resonance with the interfering signal and then the coupling between the aerial coil and L_1 is gradually increased until the jamming signal is balanced out.

The sensitivity of this receiver being so great, loop antenna reception is possible and atmospherics can almost wholly be eliminated.

JOHN C. STOTT.

To the Editor of THE WIRELESS WORLD AND RADIO REVIEW.

SIR,—On June 20th. at 8 p.m., while I was listening-in on 750 metres, I heard telephony in English by 5 BO working to 5 CH. Can you or any of your readers tell me who these are? Speech was excellent even under very trying conditions, viz., jamming by spark stations, condenser-turning fiends (I heartily endorse the recent letters by M. J. G., Mr. Banks and Mr. Whiteside and others on this subject), and the hash from Leafields arc. The latter is especially bad here, as, of course, I am situated less than 20 miles from Leafield, but it is particularly annoying in all parts of the country and it is quite unnecessary for me to describe what unfortunately is heard from this station which is "the latest production of an up-to-date country." Might I suggest that a petition be sent to the P.M.G. (say through the Wireless Society of London), asking that transmitting be done by valves instead of the present arc. It is, of course, appreciated that harmonics would still exist but it is what is rightly described as the "hash" of the arc that is so particularly troublesome.

I have just been listening to 2 LO sending out a most excellent programme by members of Dalys and the Lyric theatres, to St. Dunstan's, which was punctuated by the hash, and if this is allowed to continue when broadcasting becomes general, I would advise amateurs around this part of the country to keep their money in their pockets.

G. COURTENAY PRICE (2 OP).

To the Editor of THE WIRELESS WORLD AND RADIO REVIEW.

SIR,—A conference of Midland Wireless Clubs is being promoted by this Club, with a view to discussing the interchange of lectures, and other matters of mutual interest.

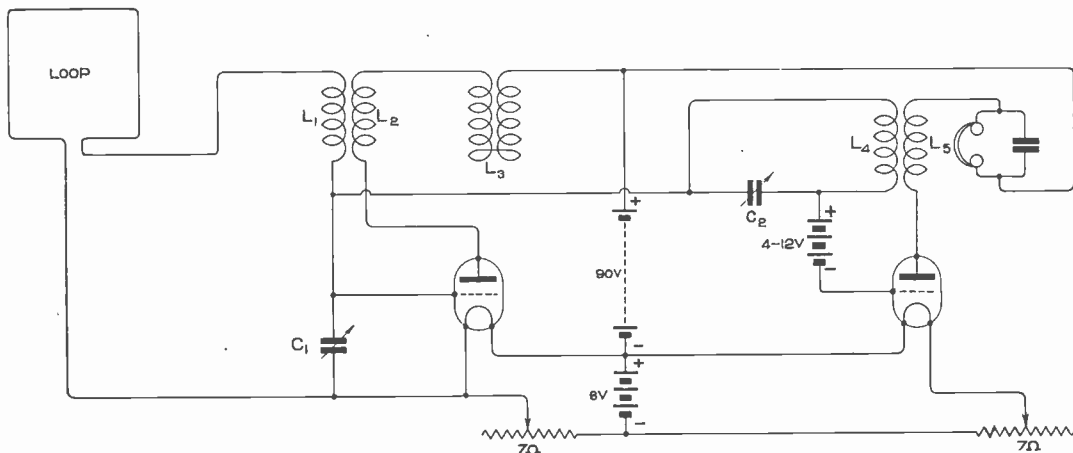

Diagram of the Armstrong Super-regenerative Circuit referred to above.

It is proposed that the conference shall be held in Birmingham, as early as possible in September, and all Midland clubs are invited to send delegates. I shall therefore be very glad if secretaries of such organisations will communicate with me at the earliest possible date.

FRANK S. ADAMS,
Hon. Secretary.
Birmingham Experimental Wireless Club.

To the Editor of THE WIRELESS WORLD
AND RADIO REVIEW.

SIR,—With the advent of wireless broadcasting there is, without doubt, a very great number of the public, both young and old, who desire to become more conversant with this branch of science. Also there will be a vast number of "home" installations set up; some will be of a very simple character, whilst others will be of more or less elaborate construction, according to the abilities of the person launching out to fathom the æther. There will, of course be many difficulties to be overcome before any kind of apparatus of home construction is completed. For the person who does not desire to know anything more of wireless than the manipulation of a "fool-proof" receiving instrument, much cannot be said, but for the genuine experimentists, who wish to discover or know the "why and the wherefore," there is something to be said, i.e., there is help awaiting them, if they will only avail themselves of the opportunities which are open for them.

This help may be found in any of the Amateur Wireless Societies or Associations of which many now exist, and those which have been in existence for any length of time have been affiliated to the Wireless Society of London. Of course, no one is under any obligation, at present, to join such an Association, if they are going in for the reception of "Broadcasting" Just one further point, and one that cannot be too strongly emphasised: It is certainly most advisable for any person who anticipates using valve circuits or apparatus to become acquainted both theoretically and practically with them before endeavouring to search the æther, for if one has not attained even the most elementary knowledge of the functions of the oscillation valve, then there is a likelihood of causing disturbances in the æther that neither themselves or others will get much enjoyment for their labours. The writer will be very pleased indeed to answer any enquiries respecting the Association to which he is the Hon. Secretary.

HORACE W. COTTON,
Hon. Secretary.
The West London Wireless and
Experimental Association.

19, Bushey Road,
Harlington, Middlesex.
21st July, 1922.

To the Editor of THE WIRELESS WORLD
AND RADIO REVIEW.

SIR,—There must be a number of amateurs having receiving apparatus of their own construction who, not being able to get an opportunity of comparing their results with those of others more experienced by actual listening-in on other

sets, would welcome some reports through your columns on results obtained by other people.

Low power telephony is a subject in which we are all interested and it would be a great help to many to know at what distance it should be possible to receive the telephonic transmissions of amateurs using 10 watts or less, on a single valve.

Perhaps some of these gentlemen who hold transmission licences and who give us much pleasure by their excellent music, would kindly publish the distances they regularly work when using one, two, three or more valves.

ROBERT G. ELLIS.

Calendar of Current Events

Sunday, August 6th.

Transmission of Telephony from 8 to 9 p.m. on 1,070 metres by PCGG, The Hague, Holland.

Monday, August 7th.

SOUTHEND AND DISTRICT WIRELESS CLUB.
Garden Fête and Public Demonstration in the Rectory at Leigh-on-Sea.

Wednesday, August 9th.

Transmission of Telephony at 8 p.m. on 400 metres by 2 MT, Writtle, near Chelmsford.

Thursday, August 10th.

Transmission of Telephony from 8 to 9 p.m. on 1,085 metres by PCGG, The Hague, Holland.

ILKLEY AND DISTRICT WIRELESS SOCIETY.

7 p.m. Regent Café. Meeting.

STOCKTON AND DISTRICT AMATEUR WIRELESS SOCIETY.

Monthly Meeting.

WEST LONDON WIRELESS AND EXPERIMENTAL ASSOCIATION.

No meeting. (Closed until August 31st.)

ILFORD AND DISTRICT RADIO SOCIETY.

At St. Mary's Hill, High Road, Ilford. Lecture on "Reaction," by Mr. J. F. Payne.

Friday, August 11th.

SOUTH SHIELDS Y.M.C.A. AMATEUR WIRELESS SOCIETY.

8 p.m., at Y.M.C.A. Buildings, Fowler Street, South Shields. Meeting.

Sunday, August 13th.

Transmission of Telephony in afternoon and from 8 to 9 p.m. on 1,085 metres by PCGG, The Hague, Holland.

Tuesday, August 15th.

Transmission of Telephony at 8 p.m. on 400 metres by 2 MT, Writtle, near Chelmsford.

WIRELESS SOCIETY OF EAST DORSETSHIRE.

At Branksome Liberal Club, Salisbury Road, Upper Parkstone. General Meeting and Enrollment of Members.

Wednesday, August 16th.

YORK WIRELESS SOCIETY.

8 p.m., at Grand Picture House Café, Clarence Street, York. Preliminary Meeting.

Thursday, August 17th.

Transmission of Telephony from 7 to 8 p.m. on 1,070 metres by PCGG, The Hague, Holland.

Transmissions from 2 LO.

We understand that 2 LO may transmit on August 7th from 5 to 5.30, 6 to 6.30, on August 9th and 10th 5 to 5.30, 6 to 6.30, 7 to 7.30.

Wireless Club Reports

NOTE.—Under this heading the Editor will be pleased to give publication to reports of the meetings of Wireless Clubs and Societies. Such reports should be submitted without covering letter in the exact form in which they are to appear and as concise as possible, the Editor reserving the right to edit and curtail the reports if necessary. The Editor will be pleased to consider for publication papers read before Societies. An Asterisk denotes affiliation with the Wireless Society of London.

Newcastle and District Amateur Wireless Association.*

Hon. Secretary, Mr. Colin Bain, 51, Grainger Street, Newcastle-on-Tyne.

On Monday, July 10th, an Ordinary Meeting was held. After the committee had finished business in private an address was given by Mr. Mason on his experiences and difficulties during the development of his present receiver (a four-valve circuit, using two high frequency, tuned transformer method of coupling). Several of his remarks were severely criticised by members present. The criticism, however, as usual, proved of benefit and interest. Mr. Dixon rose and dealt at length with the various methods of connecting the individual windings of the transformers, and with the inter-relationship of the windings of the transformers following in the circuit. The remarks passed by critics were very instructive as to the effect of the reduction in transmitting wavelengths down to 180 to 450 metres. It appeared that the tuned transformer method had been giving much disappointment (so far) on the shorter waves. Transmissions from Marconi House (2 LO), Writtle (2 MT), and various amateurs had all been received so weak as to be useless (that is, when anything had been received at all).

The majority of members seemed to be turning to the variometer type of regenerative circuits. Experiences with the Reinhardt tuner showed many desirable features, including very sharp tuning with complete absence of undesirable capacity effects from the body and hands.

After the minutes of the last general meeting had been read and passed, the Chairman called on Mr. Colin Bain to deliver his lecture upon the relationship between wavelength and frequency. Mr. Bain dealt with the subject in a most interesting and lucid manner, chiefly in order to assist those members who have but recently joined the ranks of wireless experimenters.

Mr. Dixon, the Chairman, then lectured on the various oscillations produced in "Spark" transmission, giving a very detailed account of the production of wave trains, dealing first with the induction coil, the the spark gap, and finally with the oscillations between the aerial and earth. He then explained the systems used by some of the large commercial spark transmitting stations, and the wave effects produced from each, illustrating each section of his lecture with very clear diagrams.

A discussion followed upon the peculiar action of a tapped high frequency transformer, which gave three high efficiency "peaks" at different wavelengths for the first tapping. Further experiments are being carried out with this transformer, the results of which, when completed, will be explained to the members.

A meeting was held on Monday, July 17th, at Headquarters, Wireless School, Eldon Square.

Birmingham Experimental Wireless Club.*

Hon. Secretary, Mr. Frank S. Adams, 110, Ivor Road, Sparkhill, Birmingham.

At a meeting held at Digbeth Institute on Friday, July 14th, Mr. L. J. Dore lectured on "Condensers in Radio-Circuits." The President (Mr. A. L. Lancaster) took the chair.

Mr. Dore commenced with the electroscopes as a means of detecting static charges, and gave a description of the action of a condenser. He then described a large number of different methods of constructing condensers, which could easily be used by amateurs. Many of the ideas described were extremely ingenious, particular reference being made to methods of obtaining fine adjustment.

Some particulars were then given of the uses to which condensers could be put in valve circuits, and the functions which they performed when inserted in various positions. A discussion followed, in the course of which regenerative and retroactive circuits were drawn on the blackboard, and their relative advantages discussed.

Mr. Dore, who is a vice-president of the Club, was unanimously accorded a vote of thanks.

A new financial year commenced on August 1st. Intending members are advised to communicate with the Hon. Secretary.

The West London Wireless and Experimental Association.*

Hon. Secretary, Horace W. Cotton, 19, Bushey Road, Harlington, Middlesex.

A meeting was held on Thursday, July 20th. Morse practice was given by Mr. R. T. Wright and several members availed themselves of the opportunity to brighten up their reading.

Owing to the large number of new members now joining the Association, Mr. J. F. Bruce commenced a series of elementary instructional chats, which dealt with inductances in various forms and methods of construction. In turn he minutely explained the making of formers, the winding, various methods of tapping, finishing and mounting of coils, and gave some data for a very efficient loose coupler, which from personal use and experience he has found most effective and efficient. Mr. Bruce was shown how his chatty lecture was appreciated by the round of applause which burst forth when the President asked the assembly to express their hearty thanks. The next "chat" of this series will be "Single Valve Panels" and "Reactance Inductance." Owing to so many members taking their annual vacation just now the committee desire all members and prospective members to note that the next meeting will not be held until Thursday, August 31st next, at the Club Rooms, Belmont Road Schools, Chiswick,

W.4. The Secretary will be pleased to reply to all enquiries from intending members, respecting objects and subscriptions to the Association.

North Middlesex Wireless Club.*

Hon. Secretary, Mr. E. M. Savage, "Nithsdale," Eversley Park Road, N.21.

The 93rd meeting of the Club was held at Shaftesbury Hall, Bowes Park, on July 12th. As previously announced, a special instruction class for beginners was held from 7.30 p.m. to 8.30 p.m., when the chair was taken by Mr. A. G. Arthur, the President of the Club.

Owing to pressure of business, the Hon. Secretary was unable to be present, and in consequence many duties, such as interviewing prospective members, which usually fall to the Secretary, devolved on Mr. Holton. Having received from a correspondent, Mr. Vincent, in India, a very interesting booklet, containing the results of his researches on atmospheric, Mr. Holton read these out to the audience. A very interesting discussion then resulted on the origin of these atmospheric disturbances. Mr. Holton explained the nature of lightning, as far as is understood, and showed how a lightning arrester works. Mr. Wordham also contributed to the discussion, and explained how he had endeavoured, with considerable success, to screen his aerial from interference from high tension overhead wires.

During the evening four new members were declared elected.

Particulars of the club may be had on application to the Hon. Secretary.

Wakefield and District Wireless Society.*

Hon. Secretary, Mr. Ed. Swale, 11, Thornes Road, Wakefield.

A meeting of the above was held at 8 p.m. on July 21st, at the Y.M.C.A., Grove Road. Mr. H. A. T. Burbury (President) was in the chair. About 40 members were present.

The minutes were read, after which Mr. Burbury, jun., ably dealt with "The Formation of a Valve Receiver," in a clear and concise manner, with blackboard illustrations.

Questions were then put and answered, on different difficulties that had attended members' sets, the answers to queries being both interesting and edifying.

A hearty vote of thanks was expressed to Messrs. Burbury for their joint kindness in making the meeting such a success.

The Hon. Secretary will be happy to receive names of prospective members.

South Shields Y.M.C.A. Amateur Wireless Society.

Hon. Secretary, Mr. J. Teasdale, 38, Readhead Avenue, Westoe, South Shields.

The above Club has now been formed, and a single-valve receiver has been installed.

Intending members should communicate with the Secretary or attend any of the meetings, which are held every Friday, at 8 p.m. in the Y.M.C.A. Buildings, Fowler Street, South Shields.

Port Talbot Wireless Club.

Mr. T. E. Nicholas, 22, Beverley Street, Port Talbot, Glamorganshire, would be glad to receive communications from those in his district who are desirous that a society or club shall be formed. Amateurs particularly are requested to write direct to Mr. Nicholas.

The Dewsbury and District Wireless Society.

Hon. Secretary, Mr. A. Horsfall, Willow Grove, Lee Street, Ravensthorpe, Dewsbury.

On July 13th a General Meeting was held in the society's rooms in South Street, Dewsbury, at 7.30 p.m., the President, Mr. S. S. Davies, presiding over a good attendance of members.

The chief items under discussion were the new rules and suggestions for Morse classes; the first item was speedily dealt with, and the arrangements for Morse classes are that a class be formed and meet on Thursdays at 7.30 p.m. to receive instruction and buzzer practice. Mr. C. J. Johnson (a member of the committee) will instruct, and it is hoped that a good number will take advantage of these classes.

At the close of the business a lecture was given by the President, his subject being "How to Make a Single Valve Receiver."

The lecturer first enumerated and explained all the necessary gear, and by diagrams and practical demonstration made it quite clear how a single valve receiver could be made and work efficiently at a moderate cost.

The lecture was most interesting and profitable to those members who are constructing their own sets. At the termination of the lecture an interesting discussion followed, after which the usual vote of thanks was accorded the lecturer, which was suitably acknowledged.

The Malta Radio Society.

Hon. Secretary, Mr. Paolo Bonnici, Workers' Union Headquarters, S. Santa Lucia, Valetta, Malta.

A wireless society has been formed under the above name. The committee consists of:—President, Senator Zammit-Hammet; Vice-President, Mr. E. Tonna-Barthet, F.R.Met.Soc., M.B.S.E.; Hon. Secretary, Mr. P. Bonnici; Hon. Treasurer, Mr. E. Xerri; General Member, Mr. R. Galea, M.B.S.E., Stud.I.E.E.

The present number of members is 22, but this figure is steadily increasing.

Paddington Wireless and Scientific Society.

Hon. Secretary, Mr. L. Bland Flagg, 61, Burlington Road, Bayswater.

The above Society held their first field day on Sunday, July 16th, at Stanmore, Herts, and, taking into account the inclement weather, a very enjoyable day was spent.

During the day the members were able to hear through the medium of a nine-valve H.F. amplifier, to which was connected another amplifier (three-valve L.F.) and a loud speaker, some excellent signals and music, which were thoroughly enjoyed by a large and appreciative audience.

The Committee tender their thanks to the following gentlemen for the loan of apparatus: Dr. Eccles, F.R.S., of Finsbury College, who kindly lent the nine-valve amplifier, and Mr. L. McMichael, M.Inst.R.E., of Kilburn, for the loan of the L.F. amplifier.

To Capt. Palmer, of the Stanmore Brewery, Stanmore, the members are very grateful for the use of the park known as "The Grove," Stanmore, where the apparatus was installed, and which was protected from the elements by a spacious pavilion.

A further field day is being arranged for August 20th, of which an announcement will appear in Calendar of Current Events.

The Leicestershire Radio and Scientific Society.

Hon. Secretary, Mr. J. R. Crawley, 269, Mere Road, Leicester.

The monthly meeting of the above Society was held on Monday, July 17th, at Headquarters, Vaughan College. The President, Mr. C. T. Atkinson, was in the chair. The usual business was transacted, together with certain special matters of great interest to all. Two new members were elected. The President then called upon Mr. J. W. Pallett to read his paper on "Continuous Wave Transmitters." With the aid of diagrams, Mr. Pallett showed a number of circuits as used in practical C.W. work and concluded with a selection of slides kindly lent by the Marconi Co., depicting various types of actual gear, including the well-known 2LO.

The paper was given in the characteristic style of its author and at the conclusion a hearty vote of thanks was given to Mr. Pallett, proposed by the President, and seconded by Mr. H. E. Dyson.

All communications should be addressed to the Hon. Secretary.

The Hornsey and District Wireless and Model Engineering Society.

Hon. Secretary, Mr. H. Davey, 134, Inderwick Road, Hornsey, N.8.

A meeting of the above Society was held on July 18th, 1922, at 29, Felix Avenue, Weston Park, Crouch End.

The first demonstration of the club set was given. A good selection of Morse messages were heard and taken down by advanced members, also all members enjoyed the music, etc., from 2MT and 2FQ. The set is of the progressive type, mounted so as to be convenient for fixing to wall or to stand on a table. The set at present consists of a rectifying panel and single note magnifier, with positions for adding high and low frequency amplifiers. All connections are made in such a fashion and with different coloured insulated wire, that the circuits can be easily traced.

Meetings of this Society are held on Tuesdays and Fridays, at 7.30 p.m. New members are cordially invited. A series of lectures for beginners has just been started.

Hackney and District Radio Society.

Hon. Secretary, Mr. E. R. Walker, 48, Dagmar Road, South Hackney, E.9.

A meeting of the above Society took place at 111, Chatsworth Road, Clapton, at 8 p.m. on July 20th. A large number of members were present. Nine new members were enrolled during the evening. Mr. D. R. Ison opened the meeting with Morse instruction. He then proceeded to lecture on the "Three Electrode Valve" and showed how the filament, on becoming incandescent, discharged electrons, and how these were controlled by the grid. The subject was capably handled and made clear even to the beginner.

Numerous questions were asked and an animated discussion followed, showing how keenly enthusiastic were the members. Later on a lengthy discussion on accumulators took place.

On July 27th, Mr. Valins gave a demonstration

and lecture on H.F. currents, Tesla coils, and Wimshurst machines.

Those desirous of joining should write to the Hon. Secretary or apply personally at 111, Chatsworth Road, Clapton, Thursdays only.

York Wireless Club.

In connection with the formation of a Society in the York district a meeting has been arranged for August 16th, at 8 p.m., at the Grand Picture House Café, Clarence Street, York, to discuss the organisation.

Mr. White, Grand Buildings, Clarence Street, York, will be glad to give any information to interested persons, and to receive any suggestions which may be offered.

The Lowestoft and District Wireless Society.

Hon. Secretary, Mr. L. W. Burcham, "Gouzeacourt," Chestnut Avenue, Oulton Broad.

The above Society has not been by any means inactive. The lectures that have been given include "Earth Currents and their Detection," the lecturer dealing with his work in France in a very interesting and at times amusing way. Another lecture dealing with the work in France was "Sound Ranging." This lecture, although not dealing with wireless, nevertheless proved very interesting and showed how British science played a great part in winning the war. Another interesting evening was also spent on a discussion on short wave reception and the efficiency of the Reinartz tuner.

It is with much regret that the Committee have to announce that the proposed exhibition for August 3rd and 4th has had to be postponed indefinitely owing to the unsettled conditions prevailing in the manufacturing wireless line.

The membership of the Society has increased considerably in the last month or so but there is still room for more.

Fulham and Putney Radio Society.

Hon. Secretary, Mr. J. W. Dewhurst, 52, North End Road, West Kensington, W.14.

The above Society has been recently formed and held a meeting at their temporary headquarters on Wednesday, July 19th. Considerable business was done regarding starting the Society on a proper basis, the officers were elected, the subscription fixed, and the meetings arranged for every Thursday evening at 7.30 p.m. Also it has been proposed to start a technical library and workshop for the use of the members. There is an aerial fitted to the Society's headquarters and the founder, Mr. Houston, has promised a valve panel and other apparatus. The standard will not be too high for the beginner and yet a good selection of experienced amateurs have joined as members and the Committee will cater for both. An elaborate programme is being prepared for the coming season and prospective members of both sexes are invited to write to the Hon. Secretary for particulars.

The Wireless Society of East Dorsetshire.

Hon. Secretary, Mr. E. T. Chapman, I.R.E., "Abbotsford," Serpentine Road, Poole.

On Tuesday, August 15th, at Branksome Liberal Club, Salisbury Road, Upper Parkstone, a General Meeting is to be held, and new members will be enrolled.

Sheffield and District Wireless Society.*

Hon. Secretary, Mr. L. H. Crowther, A.M.I.E.E.,
156, Meadow Head, Norton Woodseats, Shef-
field.

In accordance with a pre-arranged programme, on Sunday, July 16th, 20 members, including two ladies, of the society journeyed to Castleton for the purpose of carrying out experiments with a portable apparatus in the famous Blue John

candles. Then a weird descent was made to the "Lords dining room," a cavern 300 ft. below the surface. A short single wire aerial was erected across the cavern 10 ft. from the floor and connected to a low power transmitting and three-valve low frequency receiving set.

The technical committee were quickly engrossed in the operation of getting into communication with Mr. Jakeman at his house in Hope, three

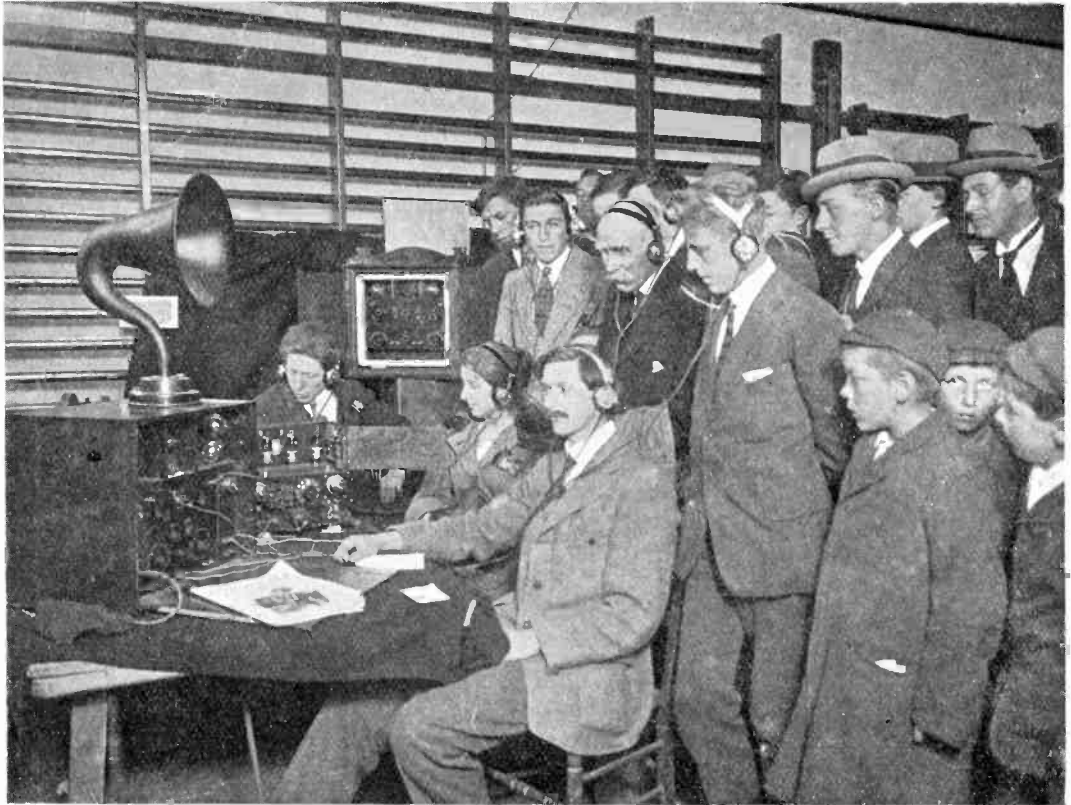

A Birmingham Wireless Concert.

A novel feature of the Midland Musical Festival held recently at Bournville, Birmingham, was a wireless exhibition and telephonic concert arranged for the entertainment of visitors. The instruments were operated by students of the Stirchley Continuation School, under the able supervision of Mr. A. E. Vick, the wireless instructor of the School.

Special music was transmitted to the Festival by prominent Birmingham amateurs, Messrs. Baynton, Whitfield, Rogers, Beresford and Scammell.

The Stirchley School is one of the few of its kind to hold a transmitting licence. The wireless class is held on Friday evenings. The students hope to arrange shortly a similar public exhibition and concert at the School.

mines of Derbyshire. Although the ascent of Mam Tor Road and crossing to the entrance to the mine was made in heavy rain and high wind, everyone cheerfully accepted the adverse conditions, no doubt thrilled by anticipation of the most interesting experiments about to be carried out. Each member willingly carried his share of the gear and other necessary stores, and on arrival at the entrance to the mine was provided with one or more lighted

miles away. Success was soon attained, and telegraphic messages freely exchanged.

Those who had the unique experience of listening to messages to the accompaniment of the ceaseless noise of unseen underground rivers will not soon forget it.

The results obtained fully justify further and early experiments in working mines which it is hoped will be attempted at an early date.

Burnley Y.M.C.A. Wireless Society.

We are informed by Mr. Arthur L. Critchard, General Secretary of the Y.M.C.A., 11, St. James' Row, Burnley, that a society has been formed with the above title.

Wireless Society of Hoylake, West Kirby and District.

Mr. T. C. Welding, 6, Marine Parade, Hoylake, Cheshire, has intimated his willingness to convene a meeting with a view to the formation of a society in his district. He will be glad to hear from anyone who is likely to become a member. Communications should be sent direct to the address given above.

Coventry Wireless Society.

Mr. H. H. Thompson (2 LY and 2 VX), 44, Northumberland Road, Coventry, is forming a society, and would be glad to correspond with amateurs in his district who would like to become members. Those interested should write direct to Mr. Thompson.

Hereford and District Radio and Scientific Society.

Hon. Secretary, Mr. G. C. Davies, Y.M.C.A., Hereford.

An inaugural meeting was held at the Y.M.C.A., Hereford, on July 31st, when the President, Mr. J. C. Mackay, gave his opening address.

It is hoped that considerable interest will be shown by the amateurs and other wireless people in the district, who will be warmly welcomed at any of the meetings. Particulars of the Society may be obtained from the Hon. Secretary.

The Anerley Wireless Society.

The fourth general meeting was held at the Society's headquarters, 179, Maple Road, Penge, on Wednesday, July 5th.

The business of the meeting included the election of officers, and Mr. Bailey and Mr. Ford were re-elected Secretary and Treasurer respectively.

The Society will be glad to welcome new members, who can obtain any information, etc., from Mr. G. D. Ford, 63, King's Hall Road, Beckenham.

Stockton and District Amateur Wireless Society.

Hon. Secretary, Mr. W. F. Wood, 4, Birkley Square, Norton-on-Tees.

This Society held its usual monthly meeting in the concert hall of the Malleable Workmen's Institute, Stockton, on Thursday, July 13th.

The Secretary read the minutes of the previous meeting and discussion arose as to the best methods of using the time at disposal each evening, so as to enable each section to receive the maximum benefit. It was announced that the membership had gone up by leaps and bounds, and a definite time-table was decided upon, which would in a short time cover all grades. Morse instruction will be given each evening and at times that will suit any member.

The business meeting closed at nine o'clock, after which the Secretary gave a short paper entitled "The Transmission of Electrical Energy."

The next monthly meeting will be held on Thursday, August 10th, and the name of the lecturer and his subject will be duly announced.

The Wireless Telegraphy and Signalling Bill.

The following is the text of the Bill which amends the Wireless Telegraphy Act, 1904, and makes further provision with respect to the regulation of Wireless Telegraphy and Visual and Sound Signalling.

BE it enacted by the King's most Excellent Majesty, by and with the advice and consent of the Lords Spiritual and Temporal, and Commons, in this present Parliament assembled, and by the authority of the same, as follows:—

1.—The Wireless Telegraphy Act, 1904 (hereinafter referred to as the principal Act), shall become a permanent Act, and any provision in any Act in force at the time of the passing of this Act which limits the period for which the principal Act is to remain in force shall cease to have effect.

2.—(1) The Postmaster-General may, notwithstanding anything in the principal Act, make regulations—

- (a) as to the terms, conditions, and restrictions on or subject to which licences or any class of licence under the principal Act are to be granted, renewed, suspended, or withdrawn; and
- (b) requiring any operators or other persons engaged in the working of wireless telegraphy to be provided with certificates, and making provision as to the manner and conditions of the issue and renewal of any such certificate, including the examinations and tests to be undergone, and the form, custody, production, cancellation, suspension, endorsement and surrender of any such certificate, whether issued before or after the passing of this Act; and
- (c) for preventing interference with the working of wireless telegraphy by the generation or use of etheric waves for any purpose other than the transmission or reception of wireless messages; and
- (d) for giving effect to, and securing compliance with, the provisions of any international convention signed on behalf of His Majesty, and any regulations made thereunder, so far as the same relate to wireless telegraphy; and
- (e) prescribing, subject to the consent of the Treasury, the fees to be paid in respect of the grant or renewal of any licence or certificate.

(2) Regulations under this section may provide that any person acting in contravention of or failing to comply with the regulations or any of them, or the terms, conditions and restrictions or any of them, on or subject to which any such licence or certificate as aforesaid has been granted, shall be liable, on summary conviction, to imprisonment for a term not exceeding three months, or to a fine not exceeding fifty pounds, and, in the case of a continuing offence, a further fine not exceeding five pounds for each day during which the offence continues.

(3) Subsection (6) of section one of the principal Act is hereby repealed.

3.—Subsection (1) of section two of the principal Act, which makes special provisions as to licences for experimental purposes, shall cease to have effect, and licences for those purposes shall be subject to the general provisions as to licences for wireless telegraphy contained in section one of the principal Act.

4.—(1) A person shall not—

- (a) send or attempt to send by wireless telegraphy a message or communication of an indecent, obscene, or offensive character; or
- (b) send or attempt to send by wireless telegraphy a signal of distress of a false or misleading character, or a false or misleading message as to a vessel in distress; or
- (c) improperly divulge the purport of any message sent or proposed to be sent by wireless telegraphy.

(2) If any person acts in contravention of this section he shall be liable on summary conviction to a fine not exceeding ten pounds, or on conviction on indictment to imprisonment for a term not exceeding twelve months.

5.—The penalty to which a person is liable on summary conviction for an offence under subsection (3) of section one of the principal Act shall be imprisonment for a term not exceeding three months, or a fine not exceeding fifty pounds, and, in the case of a continuing offence, a further fine not exceeding five pounds for each day during which the offence continues.

6.—Any provisions of the principal Act or this Act which are applicable to ships, shall apply also to aircraft, with the necessary modifications, and in particular with the following modifications:—

- (1) For the reference to British ships in the territorial waters abutting on the coast of the British Islands there shall be substituted a reference to British aircraft in or over the British Islands and in or over the territorial waters abutting on the coast thereof; and
- (2) For the reference to British ships whilst on the high seas there shall be substituted a reference to British aircraft outside the British Islands and the territorial waters abutting on the coast thereof; and
- (3) For the reference to a foreign ship in territorial waters there shall be substituted a reference to a foreign aircraft whilst in or over the British Islands or the territorial waters abutting on the coast thereof; and
- (4) Subsection (5) of section one of the principal Act as amended by this Act shall not apply.

7.—(1) The provisions of the principal Act as amended by this Act shall apply to any visual or sound signalling station used or intended to be used for the purpose of communication from the British Islands with ships at sea as they apply to wireless telegraphy stations.

(2) For the purposes of this section "visual or sound signalling station" includes any permanent or fixed apparatus for the purpose of visual or sound signalling, and the provisions of the principal Act and this Act shall apply to the maintenance of any visual or sound signalling station in existence at the time of the passing of this Act as they apply to the establishment of a visual or sound signalling station.

Provided that nothing in the principal Act or this Act shall apply to visual or sound signalling stations or apparatus on ships or aircraft, or to any signal station established by Lloyd's under the powers conferred by the Lloyd's Signalling Stations Act, 1888, or to signalling stations and lighthouses under the control of the Board of Trade or of any General or Local Lighthouse Authority.

8.—If at any time in the opinion of a Secretary of State an emergency has arisen in which it is expedient for the public service that His Majesty's Government should have control over the transmission and reception of messages by wireless telegraphy or visual or sound signalling, and notice to that effect is published in the Gazette, it shall be lawful for the Postmaster-General during the continuance of the emergency to make such rules as appear necessary with respect to the possession, sale, purchase, construction, and use of apparatus for wireless telegraphy or visual or sound signalling, or component parts of such apparatus, and to impose penalties and forfeitures in respect of any breach of the rules, and make such further provision as appears necessary for the enforcement of the rules:

Provided that—

- (a) rules under this section shall not provide for the imposition of a term of imprisonment exceeding six months, or a fine exceeding one hundred pounds, or, in the case of a continuing offence, ten pounds for each day during which the offence continues; and
- (b) any rules made under this section shall be laid as soon as may be before both Houses of Parliament.

9.—The principal Act as amended by this Act shall not extend to British ships or British aircraft registered outside the British Islands, except that any such ships or aircraft shall, whilst in or over the British Islands or the territorial waters abutting on the coast thereof, be subject to the provisions of the principal Act as so amended with respect to foreign ships and aircraft in like circumstances.

Provided that if after the establishment of the Irish Free State the legislature thereof makes other provision with respect to ships and aircraft registered in the Irish Free State and with respect to ships and aircraft when in or over the Irish Free State, or the territorial waters abutting on the coast thereof, the foregoing provisions of this section shall have effect as if the expression "British Islands" did not include the Irish Free State, and the principal Act as amended by this Act shall cease to apply to foreign ships and aircraft when in or over the Irish Free State or the territorial waters abutting on the coast thereof.

10.—(1) This Act may be cited as the Wireless Telegraphy and Signalling Act, 1922, and shall be construed as one with the principal Act, and the principal Act and this Act may be cited together as the Wireless Telegraphy and Signalling Acts, 1904 and 1922.

(2) Any reference in this Act to the principal Act or any provision thereof shall, unless the contrary intention appears, be construed as a reference to that Act or provision as amended by this Act.

Questions and Answers

NOTE.—This section of the magazine is placed at the disposal of all readers who wish to receive advice and information on matters pertaining to both the technical and non-technical sides of wireless work. Readers should comply with the following rules:—(1) Each question should be numbered and written on a separate sheet on one side of the paper, and addressed "Questions and Answers," Editor, The Wireless World and Radio Review, 12/13, Henrietta Street, London, W.C.2. Queries should be clear and concise. (2) Before sending in their questions readers are advised to search recent numbers to see whether the same queries have not been dealt with before. (3) Each communication sent in to be accompanied by the "Questions and Answers" coupon to be found in the advertisement columns of the issue current at the time of forwarding the questions. (4) The name and address of the querist, which is for reference and not for publication, to appear at the top of every sheet or sheets, and unless typewritten, this should be in block capitals. Queries will be answered under the initials and town of the correspondent, or, if so desired, under a "nom de plume." (5) In view of the fact that a large proportion of the circuits and apparatus described in these answers are covered by patents, readers are advised, before making use of them, to satisfy themselves that they would not be infringing patents. (6) Where a reply through the post is required every question sent in must be accompanied by a postal order for the amount of 1s., or 3s. 6d. for a maximum of four questions. (7) Four questions is the maximum which may be sent in at one time.

"EARTH" (London) asks (1) For the capacities of condensers C.1, C.2 and C.3, and the maximum capacity of the A.T.C. in a certain set described in the June issue. (2) Maximum and minimum wavelength of the same set.

(1) Insufficient data is given for calculation, but suitable values would be—A.T.C., 0.0005 mfd.; C.1, 0.0002 mfd.; C.2, 0.002 mfd.; and C.3, 0.0003 mfd. (2) Suitable for all wavelengths up to say, 10,000 metres with appropriate coils, but insensitive below 1,000 unless the A.T.C. is used in series.

"E.H.C." (Ardingly College) encloses a diagram of set and asks (1) For windings of basket coils if suitable. (2) Capacities of C.1 and C.3.—(3) Will a home-made telephone transformer be efficient. (4) Would flash-lamp batteries do for B.1 and B.2.

The set shown is of very poor type. The crystal is useless in an L.F. circuit as shown. The grid circuit of the valve is untuned, and the reaction coil couples into the aerial circuit (see Fig. 5, page 124, April 22nd issue), but with an aerial circuit loose coupling into the lower end of the closed circuit inductance. (1) Basket coils may be used, their size depending on the wavelength required, which you do not state. (2) A closed circuit condenser 0.0005 mfd., grid condenser, 0.0002 mfd., anode circuit condenser, 0.0005 mfd. Series A.T.C. if used, 0.001 mfd. (3) Yes, if of sound design and carefully made. (4) Yes, but they must be switched off when not in use.

"J.A.B." (Bayswater) encloses diagram of set and asks (1) If the circuit sketched is suitable for telephony. (2) If it would work with a frame aerial. (3) Particulars of a suitable aerial.

(1) O.K. if a leak is supplied for the second valve. (2) Yes, but it would not be very sensitive. (3) Frame 4 ft. square, wound with 40 turns of No. 18, spaced ¼" and tapped at 3, 6 and 15 turns.

"RADIO 3 UC" (Nottingham) asks (1) If values given for four condensers are suitable, and what should be the number of foils, with size, in each case, using 0.002 mica. (2) The maximum capacity of a certain variable condenser, and dimensions and number of foils for a fixed condenser of the same capacity.

(1) and (2) We think it would be far more profitable to you to work these out for yourself, and will therefore quote the formula.

$$C \text{ mfd.} = \frac{1}{900,000} \times \frac{Kau}{4\pi d}$$

K = specific inductive capacity of di-electric, say 8 for mica and 1 for air.

a = area in sq. cms. of overlap of foils.

n = number of sheets of dielectric.

π = 3.14.

d = thickness of dielectric in cms.

We add calculations for your 0.001 mfd. condenser as an example:—

0.001 = 1/1,000. Mica = 0.002" = 1/200 cms. Assume an overlap of 3 sq. cms., which is a convenient figure, then formula gives:—

$$\frac{1}{1,000} = \frac{1}{900,000} \times \frac{8 \times 3 \times n}{12.4 \times \frac{1}{200}}$$

$$1 = \frac{48n}{9 \times 12.4} n = \frac{1,116}{48} = 23.$$

"———" (Southend-on-Sea) asks (1) For a circuit for use with certain apparatus. (2) Details of plates for condenser.

(1) See diagram page 465, Fig. 1, issue for July 8th. Filament resistance 5 ohms., other dimensions as usually given. (2) Assuming 1/8" is the distance between the neighbouring fixed plates, 16 fixed and 15 moving will be sufficient.

"B.C." (Seven Kings) sends a sketch of a circuit and asks if it will receive the London broadcasting.

Except for the leads shown short circuiting the telephones, which is probably a clerical error, the circuit is correct and should give the desired results, but a series A.T.C. of about 0.0002 mfd. would be an improvement.

"E.W." (Hornsea) asks (1) If it is necessary to have a reaction coil with a certain tuner. (2) Particulars of how to connect the reaction coil. (3) Diagram of a one-valve set for use with a tuner.

(1) A reaction coil is not necessary, but skilfully used would considerably increase the range of the set. Unskilfully used it might lead to serious re-radiation. (2) The coils might be 3" x 5" of No. 32, connected in the anode circuit and coupling into the end of the secondary of the loose coupler remote from the primary. (3) See Fig. 1, p. 465, issue for July 8th, for a simplified theoretical diagram of the circuit.

"L.R.C." (Cheshire) encloses a diagram of his set and asks (1) If a variable H.F. transformer is more efficient than a plug-in. (2) Could he get 2MT telephony. (3) Is it safe to use a six-volt accumulator on "Ora" valves. (4) Any suggested improvements to his circuit to receive telephony.

(1) No, we prefer the plug-in type as a rule. (2) For some reason, at present unknown, Cheshire appears a bad district for 2MT. Except for this, you should get results. (3) Only with the use of some series resistance. (4) Set is O.K. as it stands except that a condenser is required across the primary of the L.F. inter-valve transformer.

"G.W.C." (New Southgate) asks two questions about engraving ebonite, and (3) For an inexpensive book on the construction of sets. (4) Times and wavelength of FL Sunday telephony.

(1) and (2) This is generally done on engraving machines, which are very expensive machine tools. You might be able to devise a substitute by means of a flexibly driven drill chuck guided by a suitable pantograph. Filling is effected with a special white wax, resembling in composition sealing wax. (3) "Radio Experimenters' Handbook," by P. R. Coursey (3s. 6d.); "How to Make Commercial Type Radio Apparatus," by M. B. Sleeper, obtainable from Wireless Press.

"S.F.H." (Barnes) asks (1) What is the highest wavelength that can be received by a crystal set. (2) How many loose coupled tuners will be required from zero to this wavelength. (3) What gauge of enamelled wire is needed from the primary and secondary of the coils. (4) Could more than one slider be used on the primary.

(1) Any wavelength could be received if suitable transmitting sets were in use, but at present there is no spark transmission over about 3,500 metres. (2) It is impossible to make a tuner to tune down to zero wavelength. 100 metres is a common minimum. We suggest the use of the coils you mention wound with No. 22 and No. 26, and another pair 6" x 4" wound with No. 22, and 5" x 3" wound with No. 26 for short wave work. (3) Primaries with sliders, secondaries with 12 taps each, the distance between the taps being approximately proportional to the number of turns of wire in the circuit at each tap. (4) More than one is unnecessary.

"F.H." (Romford) asks (1) If H.F. plug-in transformers must be mounted on ebonite. (2) Whether 0.001 mfd. A.T.C. is better than 0.0015 for general work.

(1) Ebonite is about the best material, but presspahn, paxoline, micanite, bakelite and various similar insulating materials may be used if desired. (2) Somewhat preferable, but very little in it.

"C.W." (Wimbledon Park) asks for advice in purchasing a receiving set on which he can hear the English broadcasting stations, Eiffel Tower and the Hague Concerts, also (1) Minimum length for aerial. (2) Approximate cost of set. (3) If he would save money by assembling the set himself. (4) What apparatus to obtain.

(1) Aerial suggested would do quite well if of sufficient height above the ground or buildings—say not less than 20'. (2) If you wish to hear all the English broadcasting stations satisfactorily the price would probably come out at nearly £100,

but very useful results, including PCGG and FL, could be obtained with a set costing about £25. (3) Yes, provided you have some aptitude for work of this nature. (4) Many circuits are possible, but we recommend that you look through the diagrams given in these columns and pick out a three-valve or two-valve and crystal set with dimensions for the parts quoted.

"J.G.N." (Tonbridge) asks (1) Why no signals are received above 600 metres when the set receives 2MT and 600 metre spark signals quite well. (2) Approximate maximum and minimum wavelengths using two methods. (3) If the method shown is a satisfactory way of adding a L.F. valve to existing set. (4) If an "Ora" valve will work in conjunction with "R" valves, having 45 volts on the plate and using the "Ora" as L.F.

(1) Set should be O.K. but there is little to be heard above 600 metres until you get up to about 2,600 metres, except air stations, which you should be able to get. (2) (a) About 1,500 metres. (b) Approximately the same. PCGG should probably be received with series condenser and about half the coil, but difficult to predict exactly. (3) Yes, quite O.K. (4) Yes.

"J.McV" (Belfast) has a two-valve resistance capacity coupled set with reaction and asks (1) If a four-valve L.F. amplifier is added could he receive Dutch Concerts. (2) How to make the set more suitable for receiving short wavelengths. (3) If a range of 300/30,000 metres is possible in view of the coupling employed.

(1) Doubtful. We should prefer more H.F., but in any case do not think your prospects of good results very great. (2) Suitable transformer coupling for resistance capacity. (3) Yes.

"A.S." (Stockport) encloses diagram of his single valve set and asks (1) If a two-valve L.F. amplifier added to a panel would be the best three-valve combination. (2) If so, how to add amplifier with least disturbance of panel connections. (3) How to make a L.F. transformer for same. (4) If No. 32 S.S.C. wire would do for making the above.

(1) Possible, but it would be better to add one valve as H.F. amplifier and one as L.F., diagram becoming similar to Fig. 3, page 340, issue for June 10th. (2) For your suggestion connect filaments in parallel on the same supply, put transformer in place of telephones, and bring anode circuit of each valve back to the positive of the H.T. battery. (3) Core $\frac{1}{2}$ " x 4" of iron wires, winding 1 oz. and 3 oz. of No. 44. (4) No.

"P.P." (Liverpool) asks (1) If the ends of an inductance coil should be connected directly to the first valve of a circuit. (2) What relation should the inductance of the secondary bear to the inductance of aerial circuit. (3) How is the value of the reaction related to the number of turns in the primary or secondary coils.

(1) Coupling through a secondary inductance is better as it gives better selectivity. (2) The inductance of a secondary should be such as to tune to any required wavelength with a parallel condenser of capacity not greater than 0.0005 mfd. (3) There is no fixed relation, the value depending on constants of the valve, etc. For most circuits a value somewhat smaller than that of the coil with which it couples is desirable except on very small wavelengths, when rather more is required.

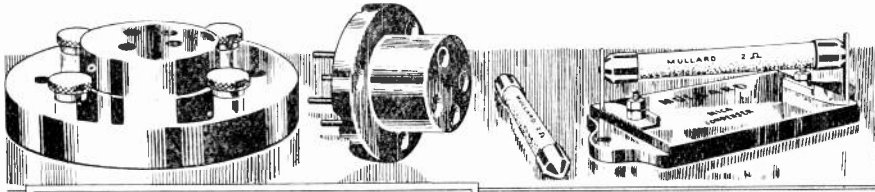

GREAT REDUCTIONS
in PRICES of
MULLARD ACCESSORIES

VALVE BASES. Specially designed with four convenient terminals. Moulded from the best materials. Internal connections completely enclosed.
Greatly Reduced Price .. 5/- each

VALVE SOCKETS. Eminently suitable for constructing complete valve receivers, amplifiers, etc. Moulded from the best materials. Impossible to insert the valve the wrong way.
Greatly Reduced Price .. 1/3 each

MULLARD PATENT RESISTANCES. Absolutely 'silent' and constant in use. Grid A. Grid B. Anode A. or Anode B.
Greatly Reduced Price .. 5/- each

B.A. CONDENSER. .0003 mfd., mica insulated .. 2/6 each

NEW DESIGN COMBINED CONDENSER AND GRID LEAK. Grid B Resistance with .0003 mfd. B.A. Condenser .. 7/6 each

RESISTANCE CLIPS .. 9d. per pair

MULLARD TELEPHONE HEADSETS
4000 ohm., immediate delivery
30/- each

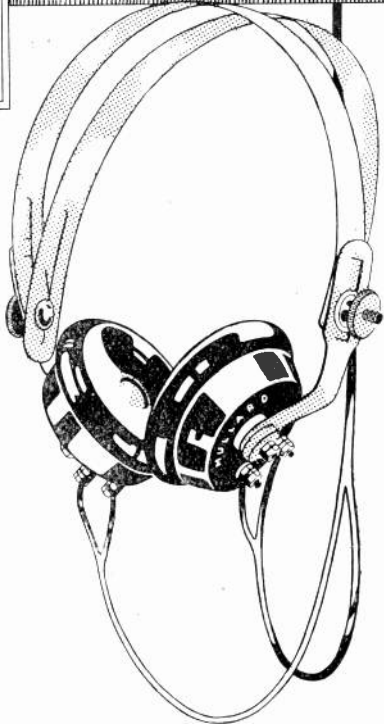

All Mullard accessories are British Manufacture throughout. These big reductions in price will cause a greatly increased demand for Mullard accessories.

To ensure early delivery, send coupon to-day.

Mullard Radio Valve Co. Ltd.

Claybrook Road, Hammersmith, W.6.

Contractors to H.M. Admiralty.
War Office, Royal Air Force & Post Office.
Telephone: Codes: Telegrams:
Hammersmith 312 ABC (Ed) Radio Valve Hammer Lond



Name and Address		Please send me per free		I enclose (cheque)	
To the MULLARD RADIO VALVE CO., LTD., 35, Claybrook Road, Hammersmith, London, W.6		Quantity	Description and Price	Money Order, P.O. value	
Telephone Head Sets	80/- per set	Grid A Valves	15/- each	Valve Bases with Terminals	7/8 each
Grid A or B Resistances	5/- each	BA Condensers, .0003 mfd.	2/6 each	Valve Sockets	5/- each
Combined Resistances	9d. per pair	Resistance Clips	9d. per pair	Terminals	1/6 each
				to cover the cost.	
Name of usual Wireless Dealer				SEND THIS TO-DAY	

THE "BROWN" LOUD SPEAKERS WITH NEW IMPROVED CURVED HORNS.



H. 2 (Small) Height 12"

The requisites of a Loud Speaker are pure tone, clear articulation, and good volume of sound. The "BROWN" Loud Speaker possesses these qualities, and they are enhanced by the new improved curved horn.

THE AMATEUR does not always need the full sized Loud Speaker (H.1) as used in Lecture Halls, and a small type (H.2) has been designed to meet his more modest home requirements.

THE NEW HORN used with both H.1 and H.2, is constructed on the logarithmic law of increasing openings and is acoustically perfect.



H.1 (Large) Height 21"

PRICES:

H.1 (Large) Low Resistance, 120 ohms	£6 5 0
H.2 (Small) " " " " " "	£3 0 0
The "BROWN" Standard Pattern (with upright funnel)	£5 10 0

Low Resistance, 120 ohms £5 10 0

(High Resistances for all patterns 2/6 to 5/- extra)

Catalogues post free on application.

SOLE

MANUFACTURERS: **S. G. BROWN, LTD.,**

SHOWROOMS: 19 MORTIMER STREET, LONDON, W.1 Telephone: Museum 4950

Works: Victoria Road, North Acton, London, W.3

Sole Agent for the Argentine:

Telegrams: "Sadbrownix, London." Telephone: Chiswick 1469. Horacio D. Guerrero, Las Heras 2480, Buenos Aires

Brown's Wireless Apparatus can be purchased from all Wireless Suppliers.

EARLY DELIVERY of Telephones and Loud Speakers can now be given.

SPECIAL ANNOUNCEMENT!

Our name is so well known as MANUFACTURERS of

BRASS TERMINALS, STUDS, SCREWS, NUTS, WASHERS

and in fact every description of **TURNED AND PRESSED PARTS**, that we are constantly receiving enquiries for small quantities from enthusiasts building up their own sets, and we therefore take this opportunity of stating that we do **NOT** supply **RETAIL**. Our trade is with **MANUFACTURERS, SUPPLIERS AND USERS OF FAIR QUANTITIES ONLY**. We do **NOT** supply small lots to amateurs.

TRADE NOTE!

Wherever possible in sending us your enquiries, kindly submit samples to quote to, stating quantities required and thus ensure rock bottom prices. The larger the quantity the keener the price!

SPEARS and COMPANY

CAPSTAN REPETITION WORKS,

PARK ROAD, HOCKLEY, BIRMINGHAM

Telephone: 3265 Central.

Telegrams: "Firettes, Birmingham."

"S.C." (Beckenham) is constructing a three-valve receiver, and asks (1) *Dimensions of coils and number of tappings for an aerial inductance tuning from 200 to 3,000 metres* (2) *Dimensions of reaction coil to rotate in the aerial primary.* (3) *Dimensions of aerial inductance for tuning from 3,000 to 30,000 metres, and* (4) *A reaction coil, 3,000 to 30,000 metres.*

Size of the inductance depends upon the dimensions and design of your aerial. If of the two-wire type, and of the maximum dimensions laid down by the P.M.G., you should use a coil 6" in diameter, with 5" of winding of No. 28 D.C.C. wire. The winding should be tapped out on to a switch having 15 to 20 studs, the long wave tappings stepping off further distances along the coil than those for short wave. Such a coil will not efficiently tune to such low wavelengths as 200 metres, and you would be well advised to construct a special inductance for short wave reception. This may consist of 1" of winding of No. 24 D.C.C. on a 4" former. (2) Former 3½" in diameter, having 1½" of winding of No. 34 S.S.C. with about 10 tappings at increasing distances along the turns. For short wave work a sliding coil should be used, closely fitting inside the aerial coil, and being of approximately equivalent inductance. (3) These windings must be found by experiment, and you would do well to build up inductances of the type shown on page 328 of June 10th issue, assembling a large number in series with insulated paper between, and making sure that they are connected up so that there is no reversal in the direction of winding. They should be held securely in position, as any fluctuation in the distance between the coils materially alters the inductance value. (4) The reaction inductance may be similarly constructed, and for the purpose of providing coupling between the two inductances, one coil of each should be brought out and so arranged that their relative positions may be varied.

"S.F.H." (Barnes) asks (1) *What is the highest wavelength.* (2) *How many loose coupled tuners with primary 6" x 12" will be required to tune to the highest wavelength.* (3) *What gauge of wire is required for the primary, and whether more than one is required.* (4) *Gauge of wire for secondary and number of tappings.*

(1) Wavelengths of 23,000 metres are at present used, and the tendency may be to increase this. (2), (3) and (4) We presume you mean to connect your tuners in series with one another, which is not a very satisfactory arrangement. The amount of wire depends upon the size of the aerial, and for one wave you are advised to make use of specially wound coils of the basket, slab, honeycomb, or other well-known type. When using a receiving circuit embodying reaction, resistance in the aerial circuit is, within certain limits, of little consequence, as any jamming that may be produced is compensated for by tightening the reaction coupling. No. 28 D.C.C. is suitable for aerial circuit, and No. 32 D.C.C. for reaction coil.

"G.D.G.T." (Oundle) asks two questions about a four-valve circuit.

We prefer two H.F., one detector and one L.F. valve, which should give quite good results on a 6-ft. frame aerial.

"W.C.P." (Watford) asks for help with his set which gives very distorted speech.

The arrangement of the set is quite correct and we are not clear why you are getting distortion. It may be due to one or two causes, namely poor design of the L.F. intervalve transformer or your allowing the set to oscillate. You might try a grid potentiometer to the first valve, and weaker reactance coupling.

"C.C.B." (Sheffield) asks (1) *For windings of a reaction coil suitable for use with a loose coupler.* (2) *For capacities of condensers.* (3) *Wavelength range of his set.* (4) *Ratio between A.T.I. and reaction when honeycomb coils are used.*

(1) Coil might be 5½" x 4" of No. 26. (2) 0.001 for the aerial circuit, 0.0005 for the closed circuit. (3) About 3,500 metres. (4) There is no definite best ratio but, except for very short wavelengths, the reaction coil can generally be somewhat smaller than the A.T.I.

"DYNAMO" (Clapham Junction) asks for advice on the erection of an aerial.

Your situation appears somewhat unfavourable and you do not give us much idea as to the possibilities. Fairly useful results might be obtained by fixing a mast in the top of the tree and running a lead from the receiving room up towards the eaves above it, but not too close to the wall, and from thence to the mast in the tree. A better alternative, if possible, would be to run an aerial up to the same point near the eaves and thence to the house 60' away. We are afraid your range with a single valve set would be somewhat limited.

"H.C.S." (Kirkby Stephen) asks (1) *If a transformer sketched will do for amplification of telephony on 300 to 600 metres.* (2) *If a H.F. transformer sketched would be more efficient if two sections were used as primary with switch for the other six.* (3) *Where to obtain particulars for the construction of H.F. and L.F. intervalve transformers in order to make them in quantities.*

(1) If properly made this should give useful results. (2) The suggested scheme would probably be satisfactory, but experimental test would be necessary to determine the best wavelength for each one of the sections. (3) These columns are intended for the assistance of amateurs in difficulties and not for the guidance of persons desiring to undertake quantity production—presumably for commercial purposes.

"A.R.B." (New Barking) asks (1) *For a diagram of three and seven-valve circuits with details of construction.* (2) *If a circuit with one valve as H.F. amplifier, one as rectifier and one as L.F. amplifier needs transformer coupler.*

(1) For a three-valve circuit see Fig. 2, page 304, issue for June 3rd. For six-valve circuit see Fig. 1, page 368, issue for June 17th, to which an additional H.F. or L.F. valve can be added if desired. We have not space to give full design details for these sets, but typical values for each component have been frequently quoted. Details of a valve set, were given in issues 16 to 22 of Vol. 8. (2) Transformer coupling is probably the best for all-round purposes, but needs a series of transformers to cover a big range. A resistance capacity coupling is good for all wavelengths above 1,000 metres, but very poor below this figure.

"E.A.A." (West Ham) gives particulars of his set, from which he gets no results, and asks why.

The set appears fairly correct and should give results. It would be better, however, to connect one end of the coil to earth and one side of the condenser, and one slider to the aerial and the other slider to the other side of the condenser. Try reversing the polarity of the potentiometer battery. No. 30 is rather thin for the A.T.I. Possibly the crystal is defective. (The resistance of carborundum is far too high for you to light the lamp through it.)

"T.B.R." (Newcastle) asks questions about Marconi high speed services.

A certain amount of fairly high speed work is done by the transatlantic stations, with speeds up to 50 to 60 words per minute; times irregular, depending on traffic requirements and reception conditions. The London-Paris medium power service is nearly all high speed, varying from 70 to 130 words per minute, according to traffic requirements. The service is at all hours of the day and night, but generally slack during the night. No call letters are used, but stations are in constant communication. The wavelengths used are 3,800 metres for the English station, and 2,300 for the French.

"J.B.B." (Cambridge) asks (1) Particulars of a certain loose coupler. (2) Gauge of wire to be used. (3) Under what wavelength are resistance capacity coupled H.F. amplifiers inefficient.

(1) and (2) Primary 6" x 4" of No. 22, tapped at 1½", 2½" and 4". Reaction 4" x 6" of No. 26, with tappings at 2" and 3". (3) About 1,000 metres.

"K.W." (Sidcup) asks (1) The best type of coil to use to receive wavelengths from 100 to 25,000 metres. (2) Sizes of the coils and gauges of wires.

(1) and (2) To cover such a range of wavelengths it would be best to use a series of honeycomb coils, with the number of turns ranging from about 40 to 1,500. These coils are generally wound with about No. 26 or 28, and can be bought from various dealers.

"EXPERIMENTER" (Folkestone) asks with regard to a diagram for a three-valve amplifier on page 340 of June 10th issue (1) Would not a potentiometer control for the third and fourth grids be an advantage. (2) Would the use of a 0.002 mfd. condenser across the primary of a H.F. transformer improve the set. (3) For short wavelengths, would results be improved by using a loose coupled tuner with reaction.

(1) For first and second grids it would be an improvement; not necessary for the third. (2) Yes, but the value is rather high. (3) This would give greater selectivity on all wavelengths.

"K.H." (Delhi) encloses a diagram of his set and asks (1) If the circuit is correct. (2) If further similar H.F. and L.F. amplifier units can be attached. (3) If the grid potentiometer X on the H.F. amplifier is desirable. (4) Should the blocking condenser Y on the rectifier be variable or fixed.

(1) Quite good. (2) Yes. (3) Yes, unless condenser rectification is employed. (4) Fixed will do. About 0.001 mfd.

"C.H.W." (Capetown) asks (1) If a circuit sketched is correct. (2) If he could use certain transformer cores for intervalve transformers, with details of winding.

(1) Diagram is correct except that the reaction coil should be on the valve side of the iron-cored winding, but should have a 0.001 mfd. condenser across it. (2) Yes. Wind full with two coils of No. 44, the secondary having approximately twice as many turns as the primary.

"H.W.K." (Peckham) asks (1) Gauge and insulation of three samples of wire enclosed. (2) If 130 ohm telephones could be used. (3) If he would get results from a 30' aerial running parallel with a tram and electric railway system.

(1) No. 1 = No. 37. No. 2 = No. 37. No. 3 = No. 32. (2) It should be O.K. (3) You may have rather troublesome induction effects.

"A.F.R." (Boscombe) has made up a Reinhardt tuner, described in May 13th last, and wishes to know if he can add a five-valve magnifier, a circuit diagram of which he submits, and comprising two H.F. valves, one detector, and two L.F.

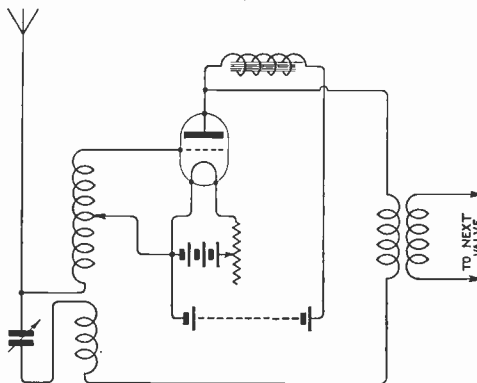

Fig. 1.

You cannot conveniently add your amplifier to this receiver and work with common H.T. and L.T. batteries, unless you care to make use of a choke coil at the point of distribution of the H.T. For circuit diagram see Fig. 1.

"HOPEFUL" (Brixton) asks (1) If a diagram is correct. (2) If any additional condensers are necessary and their capacity. (3) If the set would receive the Dutch concerts.

(1) and (2) Correct, except that the grid potentiometer shown to the first valve must be omitted from this set, and a condenser of say 0.001 mfd. should be in circuit across the primary of the first intervalve transformer. (3) Yes.

"CONSTANT READER" (West Kensington) asks certain questions about H.F. transformers.

The method of winding you suggest is not very good as it involves considerable risk of breakdown between the coils. There is no formula for calculating the wave range of such transformers, as this depends on the self and mutual capacity of the coils which it is impossible to predict. The wavelengths of the transformers you mention might come out about 500 metres, 800 and 1,200 metres, but it is quite possible that the values may vary very considerably from this.

"ZETHERDOWN" (Mill Hill) asks (1) What stations he could receive with a crystal receiver using an aerial 40/45' high and 60' long, twin wire. (2) The name of the Wireless Society covering the Mill Hill district. (3) A list of the instruments

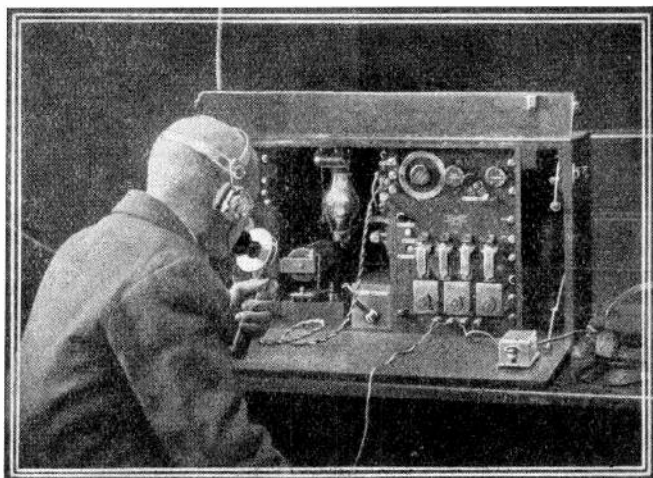

The First Commercial Wireless Telephone Service in Great Britain

is used for

Communications between the offices of the Mersey Docks & Harbour Board in Liverpool and the Bar Lightship beyond the mouth of the Mersey. The Marconi apparatus in each case is operated by the ordinary Harbour Board staff and has been in continual use since its installation over a year ago. — "Calling up" is performed by means of the
 ♦ ♦ *Marconi wireless bell* ♦ ♦

MARCONI'S WIRELESS TELEGRAPH CO., LTD.
 MARCONI HOUSE, STRAND, LONDON, W.C.2
 Telephone: CITY 8710.

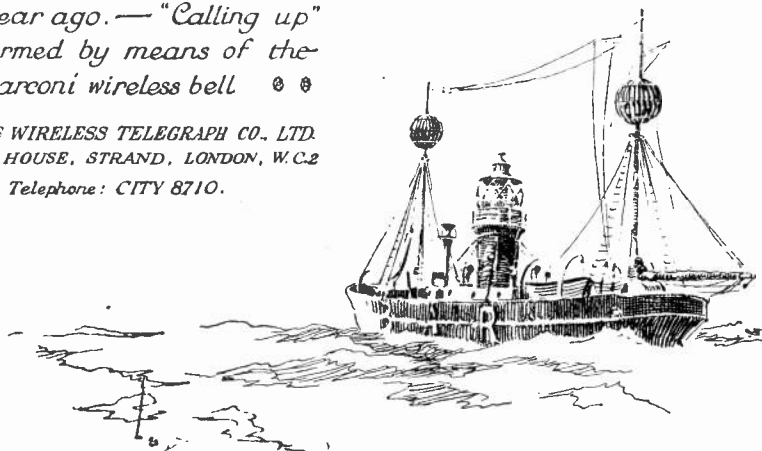

DELIVERY FROM STOCK

can be given by very few firms nowadays, but we can supply most of your requirements immediately.

WE stock complete sets and all accessories required by the amateur at reasonable prices consistent with quality.

We can supply in quantity the following goods of our own manufacture, immediate delivery.

Tuning coils, filament resistances, low frequency transformers, telephones, valve legs, valve holders, condenser vanes, slab inductances, switch arms, ivorine scales, grid condensers and leaks, etc.

Our works are fitted with latest type engraving machines, and we can engrave ebonite panels to your requirements.

Send for Illustrated List, post free 3d.

POST AND TRADE ORDERS TO

BRITISH WIRELESS SUPPLY COMPANY

6, BLENHEIM TERRACE, LEEDS.

Telephone : 26926.

And at :

11 Church St., West Hartlepool. Tel. : 373.

18 Eldon Square, Newcastle-on-Tyne. Tel. 360 City

33 High Street, Southampton. Telephone 403

“Exide” BATTERIES FOR WIRELESS

WE specialize in the manufacture of batteries for filament current supply to Valves and high-tension batteries for application of Anode Potential. We can supply these batteries in glass, ebonite or celluloid containers to any desired voltage.

Exide batteries can be relied upon for wireless work and retain their charge over very long periods.

Prices and Particulars on Application.

THE Chloride ELECTRICAL STORAGE COMPANY LIMITED

Head Office : Clifton Junction, Nr. Manchester.
London Showrooms : 219/220 Shaftesbury Av. W.C.2

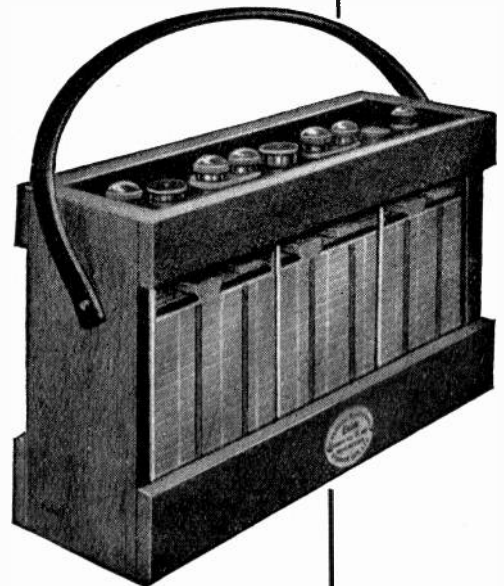

6 Volt 80 Amp. Hour Exide Battery.

necessary to construct a simple and efficient crystal set. (4) Details of the station near Hendon Aerodrome.

(1) Ships, broadcasting and other shore telephony in London, air stations and stations such as Eiffel. (2) Wireless Society of Highgate, Highgate Literary and Scientific Institute, South Grove, Highgate. (3) Aerial, earth connection, loose coupler with slider tuning of primary, variable condenser, perikon or similar crystal, pair of H.R. telephones. (4) If you mean the Marconi Company's research station, we regret that the only information we have is that published on page 219, May 20th issue.

"AMATEUR" (Shepherd's Bush) asks four questions about a set of which he gives a diagram.

(1) We do not understand your circuit, as you speak of a loose coupler and show a single coil. Also, your data for coupler are very vague. The

"C.W.A." (Wandsworth Common) wishes to make use of alternating current supply at 50 periods 205 volts for the purpose of supplying the high tension current at 400 volts required by his small power telephony transmitter, and asks (1) For diagram of connections. (2) Size and type of transformer to be used. (3) Details of chokes and condensers. (4) Details as to power consumption for the purpose of working his transmitting valve on 10 watts.

(1) See diagram Fig. 3. (2) The transformer should be of the closed core type, the core of which may be made either of soft iron strip or wire. That part of the core which passes through the windings should have a cross sectional area of not less than three square cms. and 2 3/4" long. The primary should be wound with No. 22 double cotton covered wire and consist of five layers. The secondary should be wound with No. 28 D.C.C wire up

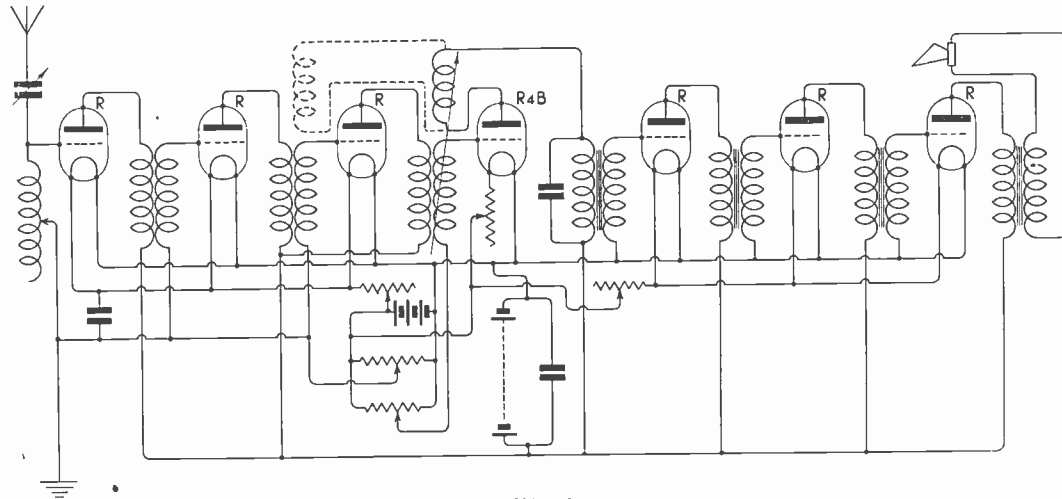

Fig. 2

circuit might possibly tune up to 1,500 metres. (2) The circuit is fairly good as shown except that a parallel A.T. condenser should not be used on short waves. (3) London broadcasting and many amateurs in London district, and air stations near London. (4) Very few additional stations would come into your range unless you also introduced reaction, although all stations would be increased in strength.

"E.R.W." (E.9) asks for circuit diagram of receiver suitable for the reception of short wave telephony, and capable of operating a loud speaker.

We would advise you to use three H.F. amplifiers and efficient rectifier, and three note magnifiers. The only difficulty in making up such a set is the design of the H.F. transformers. These must all be identical in value, for should one have a slightly different optimum wavelength, it will filter out signals on which the other two would be capable of giving good amplification. These transformers should be wound on 1" ebonite rod, the primaries and secondaries being wound in the same direction, insulated from one another by a single layer of empire cloth, and consisting of 300 turns of No. 38 S.S.C. The finishing ends should be taken to the grids and plates. For circuit, see Fig. 2.

to a diameter of 2". The secondary would best be wound in 11 flat sections. A separate choke coil should be made up and connected in series with the primary winding for the purpose of still further reducing the current taken from the mains, and also for adjusting the power factor. (3) The two choke coils shown should be wound on iron wire cores, 6" long by 1/2" in diameter, with No. 32 S.S.C. wire, up to a diameter of 1 1/2". A piece of thin insulating paper should be placed between each layer. The condensers should have the values shown and be capable of withstanding 1,000 volts, i.e., mica insulation of not less than 0.002" should be used for building them up. (4) You would find it very convenient to connect a milliammeter with a maximum reading of 25 in the negative lead. If your oscillation circuit is so connected that the H.T. plus is above earth potential, the accumulator which heats the filaments must be well insulated. You will be well advised to use special rectifying valves instead of the ordinary "R" type. Alternatively connect two valves in parallel on either side of the transformer.

"A.E.F." (Fleetwood) asks (1) What languages the press and weather transmissions from Bucarest, Budapest, Prague, Sarajevo and Nikolaiev are in.

(2) Where it is possible to obtain the Berne international list of wireless stations and regulations. (3) Where to obtain a diagram of the Marconi multiple tuner. (4) If it could be used with a valve for ship stations.

(1) French is usually employed. (2) Bureau International de T.S.F., Berne. (3) See diagram

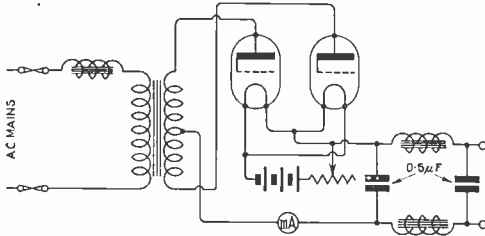

Fig. 3.

Fig. 4, which is simplified by the omission of the switching arrangements. (4) Not suitable for use in this way, as it was designed for use with a magnetic detector, which has a low resistance. We should recommend dismantling, and re-arranging the parts to form a modern tuner.

"E.A.D." (Wooler) has a three-valve which does not give very satisfactory results. He describes the components, and wishes to know the probable cause of his trouble.

In the circuit you submit you have connected small condensers in series with the grids of all valves. This should not be done. The grid condenser and leak should only be connected to the last H.F. valve, that is the one which is to rectify. It is very important that a condenser having a value of about 0.001 mfd. should be connected across the telephone receivers as a by-pass for H.F. current that is to pass to the reaction coil. The reaction coil is incorrectly connected, and should be arranged as shown in the diagram given to "J.W.B." (Northfield). We would recommend you to procure a low frequency intervalve transformer, in order that the last valve may be connected as a note

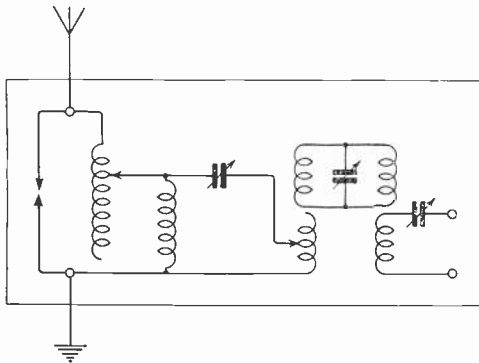

Fig. 4.

magnifier, as it is very difficult to make two intervalve oscillation transformers of identical value, and moreover, a low frequency amplifier will give greater amplification. For the reception of short wave telephony, you should, of course, connect your

aerial tuning condenser in series with the inductance, and you may find it convenient also to bridge the reaction coil with a small variable condenser, having a maximum value of about 0.0004 mfd. The diagram referred to gives the amended circuit diagram, and in addition, shows how you may make up additional amplification circuits. From your sketch it is difficult to say the best method for connecting in the H.F. transformer, as we are unacquainted with the direction of winding. If the windings are in the same direction, the inner ends of primary and secondary should be taken to grid and plate, and if in opposite directions, the two ends that come out between primary and secondary winding, should be the grid and plate.

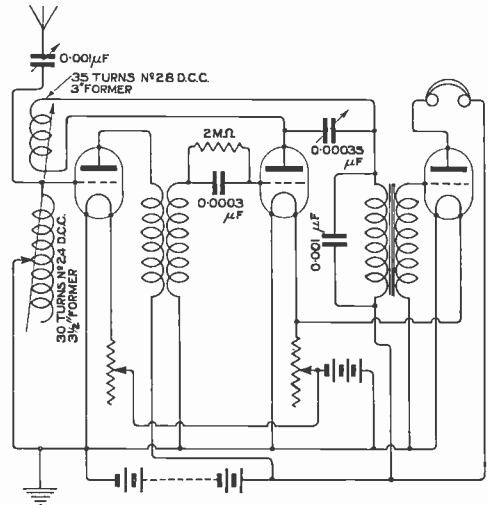

Fig. 5.

"J.W.B." (Northfield) gives particulars of his tuning coils and asks (1) What wavelengths they will tune. (2) For a circuit diagram of three-valve receiver suitable for the reception of telephony.

(1) It is impossible to advise you as to the wavelength range of your coils as it materially depends upon the dimensions of your aerial. The approximate range on a two-wire aerial of maximum dimensions would be 200/1,700 metres. (2) For circuit, making use of the apparatus you have, see Fig. 5.

SHARE MARKET REPORT

Prices as we go to press on July 31st, are :-

Marconi Ordinary	£2 5 0
.. Preference	2 1 3
.. Inter. Marine..	1 6 1½
.. Canadian	10 6

Radio Corporation of America :-

Ordinary	1 0 7½
Preference	13 6

JUST OUT!

WIRELESS VALVES

SIMPLY EXPLAINED

By JOHN SCOTT-TAGGART, F.Inst.P.

Author of "Elementary Text-book on Wireless Vacuum Tubes," and "Thermionic Tubes in Radio Telegraphy and Telephony," etc., etc.

This brand new book is the ideal one for all amateurs who do not desire to spend very much on books. It is sold at 2s. 6d. in an attractive paper cover, and also at 3s. in a well-bound cloth cover. It is only by very large quantities being sold that the remarkably low price is being justified. No book of as wide a scope has before been produced at a similar price, and prospective purchasers should remember that this new volume from Mr. Scott-Taggart's pen is not one written years ago, but represents the very latest practice and ideas.

CONTENTS.

Preliminary Remarks — Introduction — Fleming Valves — The Three-Electrode Valve and its Applications — Cascade Valve Amplifiers — Reaction Amplification and Self-Oscillation — Reaction Reception of Wireless Signals — Continuous Wave Receiving Circuits — Valve Transmitters — Wireless Telephone Transmitter Using Valves — Notes on Wireless Broadcast Receivers — Conclusion.

130 pages of sound practical instruction written in a simple lucid style by an expert for the beginner.

Buy your copy from your wireless dealer or order direct, post free, from us.

PRICE **2/6** NET. CLOTH **3/-** NET.
POST FREE.

THE CONSTRUCTION OF WIRELESS RECEIVING APPARATUS

By PAUL D. TYERS.

AN IMMEDIATE SUCCESS — THOUSANDS SOLD.

The huge sales of this book in a few days are due to the fact that it contains the information the amateur wants. It explains how to make the various parts of a crystal or valve set without the use of a lathe or expensive tools. It is the result of years of experimental work based on sound principles, by a practical man. Buy your copy now.

1/6 NET, POST FREE

Our books are sold by all wireless dealers of standing or may be obtained post free by return from

RADIO PRESS LTD.

Publishers of Authoritative Wireless Books

34/35, NORFOLK STREET, LONDON, W.C.2

THE WIRELESS WORLD EXCHANGE AND MART

TARIFF. Advertisements are accepted for this Section at the rate of twopence per word with a minimum charge of two shillings. The advertiser's name and address will be charged for, and single letters and single figures will be counted as words. Compound words will be counted as two words.

DEPOSITS. All advertisements must be prepaid in the form of Postal Orders, the remittance being forwarded to Messrs. Bertram Day & Co., Ltd., 9 & 10, Charing Cross, S.W.1.

I Buy Wireless Gear of every description.
Send your particulars to:
WILKINSON,
Lonsdale Rd., Kilburn, N.W.6
SAME ADDRESS SINCE 1900.

Potteries Wireless Men
Get all your wireless requirements from
BEW & COMPANY,
Liverpool Rd., BURSLEM.
Postal orders dispatched same day. Telephone Enquiries invited. Expert advice.
SEE OUR WINDOWS.
Telephone—Central 1225.

Enamelled Wires for Wireless.

40 42 44 46 47 S.W.G.
6/6 8/- 12/6 19/6 30/- lb.

AERIALS H.D. Copper.

7/22 7/20
PLAIN 4/- 5/- 100 ft. Coils.
ENAMD. 5/- 6/6 " " "

Silk and Cotton Covered
Prices on Application.

Terms:—CASH WITH ORDER POSTAGE EXTRA.

HORROCKS & ASPIN,
12, SCHWABE STREET.
RHODES, MANCHESTER.

TELEPHONE TRANSFORMERS
for 120 w. phones.
High-class job, complete with terminals, and guaranteed by the actual manufacturers.
Price 13/6 post free.
Delivery per return.
H. H. SPICER Rockland Works,
Eagle St., Coventry

SITUATIONS VACANT.

Advertisers require an experienced man, capable of making spare parts, or complete wireless instruments.—Apply, stating salary required, **TEXALO MANUFACTURING CO.,** South Shore, Blackpool.

Wireless Engineer who is conversant with Wireless Circuits and capable of designing Wireless Apparatus wanted immediately. Very good prospects.—**PEEL-CONNER TELEPHONE WORKS,** Coventry.

FOR SALE.

Aerial Wire, 7/22 Stranded Copper, 100 ft., 45. rod.; Engraved Ebonite Condenser Dials, with bevelled edge, 2s. 8d.; Condenser Vanes, 1s. 8d. per doz. pairs. All carriage paid.—**BIRCH, 22, Portland Street, Hereford.**

Wireless Masts.—Selected pine, painted. Sixteen feet, 2 1/2" base, 2s. 3d.; 13' by 1 1/2", 1s. 8d.; 8' by 1 1/2", 1s. 2d.; 17' by 1 1/2", 2s. 3d. (two parts) each. Easily joined. Fittings, or complete aerials or masts. Stamp for reply.—**DOWNES, 61, Arthur Street, Derby.**

Three-Valve Set Complete, Tuner, Condensers, Valves, Batteries, Telephones, Loud Speaker, etc., £15.—**SIMPSON, 233, Gipsy Road, West Norwood, London.**

Variable Condensers, New.—Ebonite top and knob, scale 21 plates in polished mahogany cabinet, 14s. 6d. each.—**D. LEES, 209, Selhurst Road, South Norwood.**

Wireless Headphones, 4,000 ohms, latest model for valve or crystal set, 35s. post free. Money returned if not satisfied. P.O. to **DEPT. W, 18, De Crespigny Park, S.E.5.**

Single Valve H.F. Panel, fitted Sullivan's Transformer, Mullard's Grid Leak and Condenser, etc., £2 15s. 0005 Mark III Variable Condenser, £1.—**DAWE, 14, Oakfield Road, Southgate, N.14.**

Spark Transmitters, Model 54 A complete. Fitted with high-class spark gap, auto transformer and coupled aerial inductance, Dubilier condenser, Helix enclosed, all ebonite panels, splendid instruments, approximate size, 12" by 12" by 6", fitted with sliding back panel. Price 32s. each. Carriage and packing 3s.—**CADNEY BROS., Alpha Mews, Alpha Road, New Cross, London, S.E.14.**

Two-Valve Receiver Cabinet, etc., perfect condition, used two weeks, cost £11, sacrifice £8. Inspection invited.—**Cox, 42, Clayton Road, Peckham.**

Wanted.—Mark III Tuner, state condition and price.—**BARKER, Oxford Road, Worthing.**

Condensers at Condensed Prices.—Scientifically made variable condensers, capacities .003, 42s. 6d.; .0015, 34s.; .001, 27s.; .0005, 18s.; .0002, 17s.; .0003, 16s.; .0002, 13s. 6d. Fitted in ebonised or mahogany finished cabinets, complete with scale and pointer. We also make cabinets to amateurs own specifications. Trade supplied.—**CLARMAC Co., 13, Stonest Street, London, N.4.**

C.M.K. III three-valve amplifier and single-valve receiving set, spark C.W. Telephony, 180-4,000 metres, forming complete station. Good reason for selling, £10.—"B," Hill House, Alton, Hants.

Telephones, 4,000 ohms, Headband and Cords, new, 31s. 6d. Telephone Transformers, 12s. 6d. Earth to Valve, 15s. V24 Valve holders, upright, 4s. Army type buzzers, 3s. Vernier Condensers, 5 Plate, 5s., etc.—**LASSMAN, 429, Barking Road, East Ham.**

Condenser Vanes.—Fixed and movable, in best quality aluminium, 7s. 9d. per gross, 10d. per dozen post free.—**A. CLARKE, 24, Albert Place, Rusholme, Manchester.**

ELECTRADIX RADIOS



Hundreds of Head Sets in Stock. All with cords. Sterling Brown Phones, Marconi Standard 2,000 ohms, 51/- pair; 4,000 ohms, 52/- pair; Brown's A 120 ohm L.R. head 'phones, 40/- pair; Sullivan's L.R. ditto, with 6 ft. cord plug and jack, 22/- High Res. Head Sets, 1,500 ohms, 26/-; 4,000 ohms, 30/- complete. Second-hand 80-ohm head-sets

guaranteed, 15/- Single L.R. Receivers, 4/6. Cords for double 'phone, new, 2/6 and 3/9. Used, 1/6. 4 Way Plugs, 2/- Microphone Transmitters, breast plate, 12/6; Hand, 2/6. Insets, 9d. Aerials.—Wire and every accessory in stock. Condensers.—Fixed and variable in all sizes. Relays, G.P.O., 21/-; Weston M.C. £2 10s. Morse Inkers, 45/- Sounder sets for making rectifiers, 12/6 each. Panel Switch Flush Fitting, D.P., 3/6. Plugs and Jacks, 1/6 pair. 60 volt Battery. 4 1/2 units, in polished mahogany case, six sockets, two plugs, 17/6. Finest set ever offered. Receivers, all new. Marconi Trench, 50 D.C. Cost £40. Complete, £5 10s. Amplifier Receiver, Mark II, 2 valve, with variable condenser, £7 10s. Single valve panel, 35/6. 3-valve Amplifier, Mark IV. £8. H.T. Motor Generators to 1,000 volts, £15. 1 kW 220 to 25 volts, £30. **EVERYTHING FOR WIRELESS.** Call at our Electrical Showrooms and inspect. **LESLIE DIXON & CO.,** Near Aldgate Station, Met. Ry. First Turning on left in Minories.

FOR SECURING YOUR AERIALS
and a Thousand Purposes where Great Strength and Strain is needed :

FLEXIBLE STEEL WIRE ROPE.
Aeroplane Cable made to Govt. specification to specified breaking strains.



PRICES BELOW COST.

No.	Dia.	Breaking Strain.	Price per roo ft.
1	3/32"	10 cwt.	6/-
3	1/2"	20 cwt.	8/-
51	5/32"	25 cwt.	10/-
53	3/16"	45 cwt.	12/-
5	7/32"	70 cwt.	16/-
6	1/2"	80 cwt.	18/-
7	5/16"	100 cwt.	20/-
8	3/8"	120 cwt.	22/-
9	7/16"	140 cwt.	24/-
10	1/2"	160 cwt.	26/-

STRAINERS for use with above, right and left hand threads, 9d. each, or 8/6 per doz. Orders of 10/- and over carriage paid, otherwise please add 1/- for postage.

SMITH & ELLIS
(Dept. 65), 11, LITTLE BRITAIN, E.C.1
Tel. No. City 8994.

THE WIRELESS WORLD EXCHANGE AND MART

THIS COMBINED OFFER SAVES YOU OVER 50%

and enables you to get signals perfectly.

SULLIVAN HEADPHONES, 120 Ohms.

Double 'phones, complete with cords and adjustable double headbands. Perfectly new. Equal to expensive high resistance 'phones when used with Transformer below. Price (while stock lasts) ...

18/6

WIRELESS 'PHONE TRANSFORMERS.

For panel mounting; very compact. Specially designed for use with Low Resistance 'phones. Strengthen and clarify signals to exceptionally high degree. Every one tested before despatch. Only ...

13/6

SEND ONLY 30/- FOR THE TWO.

Terms: Cash with order and Post free. Order NOW to avoid disappointment.

F. HARRISON,

48, Brooke Road, Walthamstow, E.17.

MULTICRYST

Fit a "Multicryst" to your Wireless Set and increase its Utility, Efficiency and Delicacy by 300%. No single crystal can possibly give best results under all conditions.

With a "Multicryst" you have a choice of three crystals, thus ensuring the most efficient signals under EVERY condition. To fit the "Multicryst" simply unscrew existing crystal holder and replace with the "Multicryst."

6/-

Post Free.

AGENTS WANTED EVERYWHERE CASH WITH TRADE DELIVERIES GUARANTEED ORDER

WIRELESS SUPPLIES Co.

Phone: 64 Mortimer St., London, W.1 'Grams.' Museum 2672. "Adragonax, Wesdo, London."

PURCHASE YOUR WIRELESS REQUIREMENTS THROUGH

The Viper Re-Covering Co., Ltd.

7/8, POULTRY, E.C.2.

(1 minute from Bank) Tele.: City 1897

Marcomiphones, Sterling and R.F.H. Sets, etc., can be supplied. Place your orders NOW.

RADIOPHONE TUNERS,

200-1,400ms. 38/-

Valve Panels for above 21/-

0005 Variable Condensers 18/6

Above 3 make an Ideal Receiver.

Broadcast Concert Coils pair 2/-

Grid Leaks and Condensers 3/6

Fixed Condensers 2/6

5-Plate Condensers 6/6

2-Valve H.F. Amplifier Panels 32/-

Get our New Bargain List.

AMATEUR SUPPLIES,

134, COTEFORD STREET, TOOTING, LONDON, S.W.

W. J. HENDERSON,

2, Hollywood Road, South Kensington. (Nearest Station, Earl's Court. 'Bus Routes, Nos. 31, 14, 96).

Delivery by Return. Satisfaction Guaranteed. Amplifiers, C.Mk. IV, 3-Valve, L.F., every one guaranteed perfect, complete with telephone transformer, each 28 6s.

Plug and Jack, suitable for plugging-in tele-phones, transformers, etc., etc. 1/6.

Low Resistance Telephones, 150 ohms, double, complete with headbands, very sensitive, per pair, 15/-.

Condensers, Mk. III Type, complete with bevelled scale and knob, .0015, 40/-.

Accumulators, unspillable type, in wooden case, actual capacity, 16 amps., in new condition, every one guaranteed, less than half list price.

6 volts 30/-
10 volts 50/-

Valve Boxes, wooden with padded interior, to take three valves, each 2/-.

Rubber-Covered Cable, 40/36 stranded tinned copper, per yard, 4/6d.

Valveholders, ebonite type with flange, each 1/6. Aerial Stay Wire, steel flexible cable, 15 cwt. breaking strain, sample on request, per 100 ft., 5/-.

Trade Enquiries Invited. Terms, Cash with order. Goods above 22 in value, carriage paid.

FOR SALE—continued.

Hague Receiver, Complete, including selected valve, two Vcs., £5 5s. Headgear and transformer, 31s. Marconi Scientific Detector panel, including Mo. valve. £3 10s. French intervalve, 19s. .006 Vc. cost £20. Brown loud speaker and amplifier, B. Valves, sensitive galvanometers, other items, all new. Stamp, requirements. Demonstrated week-ends.—W., 113, St. James Road, Tooting.

Two-Valve Panel, two valves, two condensers, transformers, inductances and all accessories, complete set. Never used, £8 10s. Reason for selling, landlord forbids erection of aerial.—Letters to F. WILSON, 36, Boundaries Road, Balham.

Radio Fans use "Orosite" Crystal, for best results, mounted 25 cents.—H. J. DAVIS, 200, Ridgewood Avenue, Brooklyn, N.Y.

Special Line, Wireless Girder Masts, Light and Strong, 30' £1, 35' 22s. 6d., 40' 25s., 45' 30s., 50' 35s. Cash with order, carriage forward.—F. ARMSTRONG, Weybridge.

Wireless Instrument Cases, Walnut or Mahogany, finest finish, 12" by 7 1/2" by 4" (outside), 8s. 6d. Second quality, 7s. 6d. Any size proportionately. prompt delivery. Trade inquiries invited.—HITCHCOCK, Colchester.

Aerial Insulators.—British Made Egg Type insulators 6s. per doz. post free.—CUBITT, 20 Star Street, Edgware Road, W.

Tungsten Rivets, diameter of Head 1/8" shanks screwed 9 B A 3/16" long. Price carriage 16s. a gross.—BELOW.

Wireless Transmitters, Complete. These instruments are very popular with wireless enthusiasts, internal fittings include high class spark gap, 1" Sterling spark coil and condenser, external Helix and tuning aerial clips on ebonite panel, spark gap adjuster, all terminals, etc., and diagram of internal connections. Price 17s. 6d. each, post and packing 2s. extra.—CADNEY BROS., Alpha Mews, Alpha Road, New Cross, London, S.E. 14.

MISCELLANEOUS.

Printing.—Memos, Billheads, Cards, Price Lists, etc., very low prices, samples free.—VICTORIA PRESS, 368, Knutsford Road, Warrington
Designs of Receiving Sets, Motors, Generators, etc., supplied.—PUCKLE, 33, Sandringham Gardens, Baling, London, W.5.

HEATH & Co., Ltd.

Instrument Works, New Eltham, S.E.9 are prepared to undertake in their fully equipped works—Wireless Apparatus and Parts for the trade. Quotations given to Blue Prints. Immediate attention. Phone—Lee Green 301. Wire—Polaris, London.

Tubular Steel Masts with baseplate finial, rope cleat, gup clips, painted, light and durable, 12 ft., 25/-; 25 ft. (2 sections), 40/-; 40 ft. (3 sections), 80/-. Training Wire, 4 insulators, halyard, pulley, lead in tube, 100 ft. 7/22 copper wire, 17/6 extra. Carriage forward.

Works: 5, Kramer Mews, Earl's Court.

[L. S. COMPTON,]

17, FERNSHAW ROAD, CHELSEA, S.W.10

TRADE ENQUIRIES.

Wireless Repetition Work for trade.—LIBERTY ENGINEERING Co., LTD., Acton Town Station, W.3.

Keen Quotations Wanted for all Wireless Parts and materials, manufacturers only. Also stampings and diecastings.—IRVINE BROOK, LTD., Brooksmouth Mills, Brighouse, Yorks.

To Manufacturers.—Wanted quotations for all Radio Accessories and components from actual makers only. Please quote lowest trade prices and state when delivery can be given.—Box E2, BERTRAM DAY'S ADVERTISING OFFICES, 9 and 10, Charing Cross, S.W.1.

Advertisers Request Quotations from manufacturers for all parts used in construction of wireless instruments, also condenser scales, knobs rheostats, switches, etc.—TEXALO MANUFACTURING Co., South Shore, Blackpool.

Advertiser (Business Man, who is also Wireless Amateur) about purchase shop Birmingham District, to set up Show Room Wireless Goods, requires Partner with Wireless or Electrical Knowledge and able invest portion capital necessary. Box B.3, BERTRAM DAY'S ADVERTISING OFFICES, 9 and 10 Charing Cross, S.W.1.

BUSINESS FOR SALE.

Wireless Business for Sale, London Suburb.—Good will and fittings, £1,500 per annum. Lock-up shop. Best offer accepted.—Box D2, BERTRAM DAY'S ADVERTISING OFFICES, 9 and 10, Charing Cross, S.W.1.

WANTED.

Wanted.—Intervalve Transformer. Loud Speaker. Good condition, cheap. Also any broken wireless components.—ROBERTS, 55, Fairfield Road, Bow, E.

SITUATIONS WANTED.

Wireless and Electrical Engineer.—Ex Officer R.N.A.S., 3 1/2 years technical training. Diploma Nine years wireless research. Any progressive capacity.—Box C4, BERTRAM DAY'S ADVERTISING OFFICES, 9 and 10, Charing Cross, S.W.1.

Drawings and Tracings from Sketches.—C. STANTON, 6, St. Leonard's Avenue, Stafford.

Young Man Skilled in Wireless, do all except lathe work, wants situation, wireless firm, or firm taking up W/T., or will instal aeriads and instruct in using any type receivers for anyone. Terms, fares, and time.—WALKER, 43, Liverpool Street, King's Cross, W.C.1.

Young Amateur, four years experimenting, wants situation connected with wireless, can read Morse, also drive a car. Willing to go anywhere.—KITCHEN, 10, Beech Road, Epsom.

LESLIE McMICHAEL LTD.

PROVIDENCE PLACE, WEST END LANE, KILBURN, N.W.6

Bus Services 1, 8, 16, 28, 31 all pass West End Lane

Telephone: HAMPSTEAD 1261 Nearest Tube Station: KILBURN PARK (BAKERLOO)

Complete Concert Receiver

This Set has been specially designed to give maximum amplification for use with three Valves. The first valve acts as a high frequency amplifier, with valve holder provided for plug in high frequency transformers. The second valve is the rectifying valve, and in connection with this will be found a grid leak and grid leak condenser of special design. The third valve, which is a low frequency amplifier, is provided with a low frequency transformer, giving maximum results, and has been chosen from a number of other types of transformers after careful test. Filament resistances are provided controlling the filament voltage, and the accurate working of these and gradual increase and reduction of filament voltage is one of the features of the Set. Two variable condensers with ebonite calibrated scales are provided, the right hand being across the primary of the high frequency plug in transformer, giving great selectivity in reception. The left-hand condenser is the aerial tuning condenser. The whole Set is mounted in a polished mahogany box, the finish of the panel work being superfine. All terminals are lacquered, and the general appearance of the Set is one that pronounces it to be of the finest workmanship.

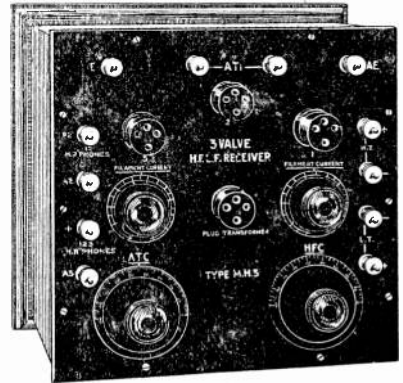

The Price of this 3-Valve Instrument (without valves) ... **£10 10 0**

COMPLETE installation including aerial insulators, high tension battery, accumulator, set of 3 high-frequency transformers, set of 6 tuning coils, mahogany and ebonite coil holder, leading-in tube and full instructions for anyone without previous experience to enjoy wireless music and speech **£21 16 0**

For your WIRELESS APPARATUS come to a firm of WIRELESS ENGINEERS. The Directors of this firm have had Twelve Years' Wireless Experience.

CONDENSERS (In Stock)

VARIABLE in Oak Cabinet.

·001 mfd. .. 30/-	·0005 mfd. .. 22/6
-------------------	--------------------

PANEL TYPE for mounting in sets. Well made and guaranteed.

·001 mfd. .. 22/6	·0003 mfd. .. 12/6
·0005 ,, .. 17/6	·00005 ,, .. 6/9

“LESMAC” TYPE (as illustrated).

This condenser which although entirely suitable for panel mounting is provided with ebonite feet and terminals and can be used therefore without further mounting.

Capacity ·001 mfd. .. 24/-	·0003 mfd. .. 16/-
„ ·0005 ,, .. 18/6	·00005 ,, .. 8/-

“LESMAC.” CONDENSER

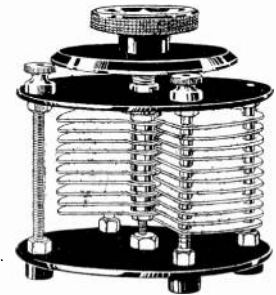

Fully Illustrated Catalogue, 16 pages, post free 6d.

This is Not **PETO'S** First Appearance

See Our Advertisements long before the Boom
EVERY ARTICLE ILLUSTRATED DELIVERED FROM STOCK

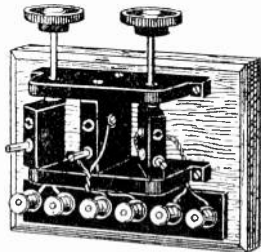

TUNING STANDS on Polished Mahogany base, 22/6. Supplied less Terminal Board & base, 19/- Long Tuning Handles supplied if desired, same price.

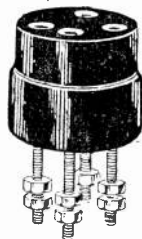

VALVE HOLDERS.
 Turned from solid Ebonite, 1/8



Series Parallel or Double Pole Change-Over SWITCH for Panel Mounting.
 Illustration one-third actual size.
 Price 2/-



COIL MOUNTS supplied to fit any size coil, 2/9. Fits standard coil holders.

SEND FOR OUR NEW ILLUSTRATED CATALOGUE WITH LIST OF TRANSMITTING STATIONS. POST FREE 6d.

NOTE PETO'S NEW HOME

PETO SCOTT (The Condenser King)

Featherstone House, 64, High Holborn, W.C.1
 (Also at— 17, FROME ROAD, WOOD GREEN)

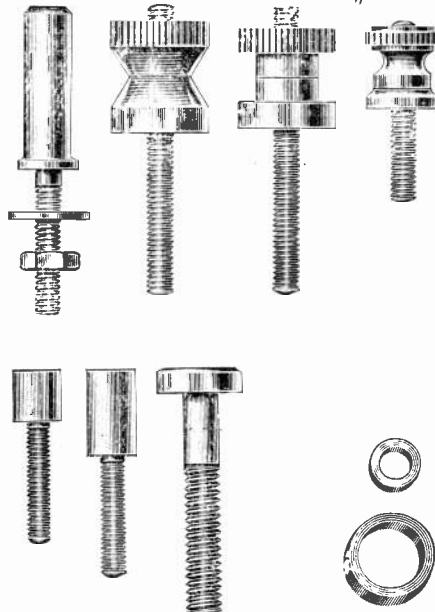
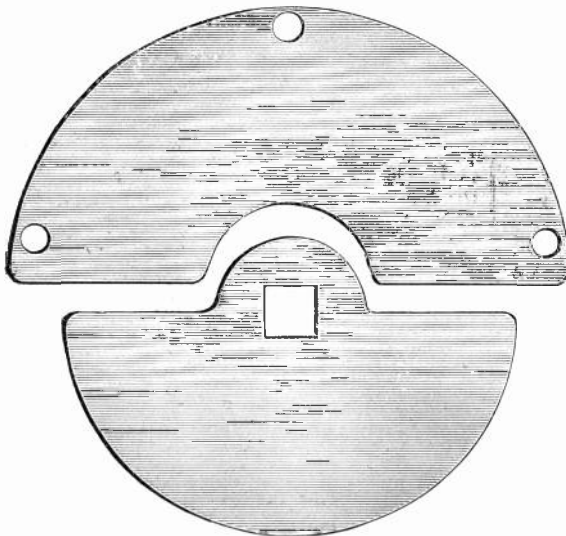

MANUFACTURERS & RETAILERS
 apply for Illustrated List
 and **TRADE TERMS.**

KEEN PRICES. PROMPT DELIVERY.

Phone—1 Holborn 1812 **ORMOND ENGINEERING CO., 199, Pentonville Rd., King's Cross, N.1.**

WIRELESS

Large or Small Contact Studs doz. 1 0
 Valve Legs, complete with nut and washer . . . each 3
 Hart Accumulators, 4-volt, 24 amp. hour . . . each 14 9
 Postage and Packing extra each 1 3

STILL THE CHEAPEST FIRM FOR WIRES.

S.W.G.	S.C.C.	D.C.C.	Single Silk	Dbl. Silk	Emd.
12	1/10	1/11	4/-	5/4	1/8
14	1/11	2/-	4/-	5/4	1/9
16	2/-	2/1	4/2	5/6	1/10
18	2/1	2/2	4/4	5/6	1/11
20	2/2	2/3	4/8	6/2	2/6
22	2/6	2/11	5/-	6/8	2/8
24	3/-	3/6	5/6	7/4	2/8
26	3/7	4/1	6/8	8/2	3/2
28	4/4	4/7	7/2	9/-	3/6
30	5/-	5/6	8/-	10/-	3/10
32	6/-	7/3	9/2	13/-	4/2
34	7/-	8/3	11/6	14/-	4/4
36	8/8	10/2	14/-	15/6	4/8
38	11/3	13/2	16/-	19/-	5/3
40	15/-	18/-	18/6	22/6	6/6
42	17/3	21/-	31/6	34/-	9/-

At per lb.
 All orders of 1 lb. or over wound on reels free. For less than 1 lb. reel 3d. extra.
 Further Lists on application. Trade Supplied. Postages extra

J. B. Bower & Co., Ltd.

Wireless Manufacturers.
 15, Kingston Road, WIMBLEDON, S.W.19
 'Phone : Wimbleton 1030. Works : Merton.

A £20,000 DEAL IN WHICH EVERY WIRELESS AMATEUR MAY PARTICIPATE

"BROWN" "A" TYPE RADIO HEADPHONES

Guaranteed new and unused. NOT re-conditioned.

120 ohms.
42/6

Maker's Price 58/-



8,000 ohms
49/6

Maker's Price 66/-

SULLIVAN 8,000 ohms, ... **36/6**

Why pay the full price and wait weeks for delivery when we can supply from stock at less than trade price?
 Terms cash with order. Postage 1/- extra. Approval for 7 days.

Trade enquiries for quantities solicited.

FULLER "BLOCK" TYPE ACCUMULATORS 4 volts, 4 amp., **32/6**

the only practical battery for wireless.

THE CITY ACCUMULATOR CO.

79, MARK LANE, E.C.3.

Phone : Avenue gr. Telegrams : 'Tyche, Fen, London.'

YOU WANT

ACCUMULATORS

GET THEM AT

F. YATES & Son, Ltd

HAVE THE BEST.

BRAND NEW, GUARANTEED BRITISH.

6 volt 40 amp. Actual in 3·2 volt separate Glass Cells, contained in Teak Crate - **49/6**

4 volt 24 amp., Celluloid Case, **11/-** Postage 1/-
 2 " 16 " Ebonite " **3/9** Post Free.

ALL IN CELLULOID CASES.

4 volt 40 amp. **18/6** 6 volt 40 amp. **26/3**

4 " 60 " **21/6** 6 " 60 " **31/9**

4 " 80 " **28/2** 6 " 80 " **37/3**

4 " 100 " **30/-** 6 " 100 " **41/6**

PACKING FREE.

Wireless Set in Upright Oak Cabinet, Sloping Panel, One Valve, **£5.** Two Valve, **£7.** Three Valve, **£10.**
 Crystal Set, very superior quality, - - - **30/-**
 Head Phones, 4,000 ohms, - - - **33/-**
 7/22 Aerial Wire - - - per 100 ft. **5/-**

Trade Supplied. All Goods Carriage Forward.

144, Church Street, Kensington, W.8.

'Phone—Park 4276. One Minute from Notting Hill Gate.

ACCUMULATORS ETC.

ALL NEW STOCK & GUARANTEED.

4 Volt 25 Amp. Celluloid - - - - - 11/3 each.

4 Volt 40 Amp. - 17/6 | Postage 1/-

4 " 60 " - 21/3 | 6 Volt. 40 Amp. - 25/6

4 " 80 " - 27/- | 6 " 60 " - 31/-

4 " " " - 27/- | 6 " 80 " - 36/-

Packing 1/6 extra. Packing 2/- extra.

7/22 Aerial Wire - - - - - 6/- per 100 ft.

Mullard Ora Valves - - - - - 15/- each.

15 Volt Siemens H.T. Batteries - - - - - 4/-

Accumulator Charging Board - - - - - 37/6

Voltmeters, Watch Pattern, 0/12 Volts - - - - - 6/-

CASH WITH ORDER. Goods despatched per return.

W. H. PORTER & CO.

44, CHURCH STREET, BIRMINGHAM

Special Quotations to the Trade for Quantities.

Wireless Parts & Apparatus

A general list is supplied but for special quantities always state particular lines and quantities.

Variable Condensers, Grid Leaks and Condensers.

Filament Resistances. The finest makes on the market.

Marconi Type 16 Receivers to the trade in quantities

@ **£8** each.

Marconi Short Wave Tuners less Condensers in splendid condition and most suitable for converting into valve sets **£1 10 0** each.

North Wales Wireless College & Amateur Supplies

COLWYN BAY. Phone 407.

Most Complete Stock of all Wireless Instruments and Accessories.
PROMPT DELIVERIES.

Students prepared under ideal conditions as Wireless and Cable Operators
POSTAL AND RESIDENTIAL TUITION.
SPECIAL POSTAL COURSE FOR AMATEURS.
PROSPECTUS POST FREE.

LIST BY RETURN. 1/4d. STAMP.

BE UP-TO-DATE

MAKE A JONSEN-RABECK LOUD SPEAKER AS ILLUSTRATED IN THE "W.W." AND
Let Your Friends Hear.

AGATE CYLINDER FOR ABOVE	£1 2 6
TWO-VALVE DETECTOR-AMPLIFIER	2 17 6
CRYSTAL RECEIVER	2 0 0
CRYSTAL DETECTOR	5 0
FIXED CAPACITY CONDENSER	1 6
FILAMENT RESISTANCE	4 6

EVLINS Mail Order Office—
126, FOREST ROAD,
DALSTON, LONDON, E.8
Price List Post Free on application. TRADE SUPPLIED.

CONDENSERS.

.0003 Variable Air Condensers	12/6
.0005 " " "	15/-
.001 " " "	24/-
.00005 Vernier	4/6
.00001 " " "	4/6
High Resistance Phones	£2 10 0
Filament Resistances	3/6 & 5/-
Contact Studs	doz. 1/6
Switch Arms	2/6

Mullard Ora Valves. Parts to build your own sets.

B. L. HOUSTON,

Regent 4911. 65, ENDELL STREET, W.C.2.

THE TINGEY UNIT SYSTEM

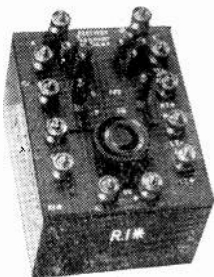

has proved its efficiency

Write for

ILLUSTRATED CATALOGUE

which contains an article on Wireless Made Easy and a

Complete List of all Wireless Goods in Stock

Write for Illustrated Catalogue 3d. post free

W. R. H. TINGEY, 92, Queen Street, Hammersmith, London, W.6.

THE "ESI-FIX" AERIAL

Patent applied for

"FIX IT LIKE A CLOTHES LINE."

A new "one-piece" aerial with patented continuous insulation, complete with straining eye, adjustable suspension and terminal. No lead-in tube, or other insulators required. No joints, no soldering, no leakage, no bother. Can be thrown up anywhere, and is absolutely weatherproof. Maximum efficiency guaranteed. Send cash with order and secure delivery at once. Length 50 ft., 10/-; 75 ft., 12/6; 100 ft., 15/-.

Carriage paid in U.K.

Agents wanted.

CHAMBERS & ELLIS

6 & 7 Craven House, Kingsway, London, W.C.2

SPECIAL THIS WEEK!

VAR. CONDENSERS .003

Skeleton type 9/6

HEADPHONES British 27/6

HENRY J. BREWSTER & CO.
11 QUEEN VICTORIA STREET, E.C.4

Phone: City 768.



SKINDERVIKEN BUTTON.

A Supersensitive Microphone.

Known all over the world and patented in every civilized country. Over 60,000 sold. ENGLISH Manufacture.

Make up your own Loud Speaker.

Transmit your GRAMOPHONE music to any room in your house.

The only practical Microphone for use in Detectophone Sets.

Price 5/- each

Special Low Resistance Receivers (for use with Skinderviken Buttons) 10/- each

Special Gramophone Attachments 1/-

Write for 16 page BOOKLET fully illustrated and containing much useful information for all interested in Electrical Sound Transmission. 6d. Post free.

Sole Proprietors:

MIKRO LTD., 274/6, Pentonville Rd., London, N.1
(Opp. King's Cross (Met.) Rly Station).

PHONES (Pair complete. Guaranteed) 30/- CRYSTAL SET 40/-

Special Wireless Telephones, 4,000 ohms, 30/- post free. Receiving Set on Mahogany base, double slide Tuning Inductance, Fixed Condenser, Crystal Detector, Terminals, 40/- post free. Valveholders in Ebonite, first quality only, 1/-.

I. K. STEVENS & Co. Wireless Section, 32a, Chester St., Grosvenor Place, S.W.1

EXPE **RI** *ENCE*

WIRELESS TELEPHONE HEAD SETS

IMMEDIATE
DELIVERY
FROM STOCK

DESIGN. These telephones are of the highest grade diaphragm type and have been specially designed for the reception of wireless broadcasting.

CONSTRUCTION. Every part is of standardised construction and thoroughly well finished. The cases are of polished aluminium. The terminals are fitted with insulating caps. The set is light and comfortable to the head.

SENSITIVITY. These telephones are highly sensitive, being of 4000 ohms resistance. The diaphragms in every set have been accurately adjusted for maximum sensitivity. Other diaphragm type telephones may cost more, but none are more sensitive.

PRICE. Each set complete with two earpieces and flexible connections.

35/6

Carriage paid in the U.K.

Do not confuse these high grade telephones with the cheap inferior imitations you may be offered. **CALL AND SEE THEM.** Let us show you their perfect internal construction.

Order at once to secure delivery.

OTHER PRODUCTS. We also invite enquiries for:—Short Wave Anode Reactances; Efficient Tuning Inductances; Precision Air Condensers; H.F. Transformers, and any other components used in wireless practice. Every article is manufactured at our own works under the direct supervision of the directors.

RADIO INSTRUMENTS Ltd.

Managing Director: J. Joseph, M.I.E.E.

Late Manager to Mr. H. Sullivan.

Chief Designer: W. A. Appleton, M.E.E., M.I.R.E.

Late Admiralty Technical Research Officer.

ONLY ADDRESS—

Works, Offices, Showrooms:

**12a, Hyde Street,
NEW OXFORD ST., W.C.1**

'Phone: Regent 1908. 'Grams: Instradio, London.

L. 6. E.P.S.

A BARGAIN **£85**

Cannot replace under £285

Electric Lighting & Power Plants

for **Country Houses
Workshops, Cinemas**

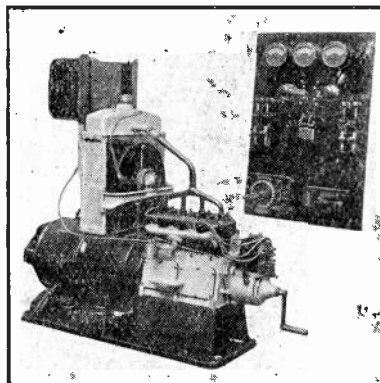

AUSTIN and STANDARD $3\frac{1}{2}$ K.W. and $4\frac{3}{4}$ K.W., 110 volt, direct coupled LIGHTING AND POWER PLANTS, complete as above, £85 F.O.R. Suitable for either 110 volt or 50 volt, country house lighting, garage, workshop and cinema plants.

AUSTIN 220 volt 20 amp. plants also supplied. Will run on petrol, paraffin, or gas. Special Switchboard £10 extra. Spares of every description always in stock.

COMPLETE ARMY WORKSHOPS
AND LATHES ALWAYS IN STOCK.

C. H. & L. O. SMITH **75, Canal Street, NOTTINGHAM**

At What Station does the train of Oscillations stop ? A Prize for the Best Answer.
 Watch these Advertisements for Winners.

Write on a separate piece of paper (one side only).

Endorse "Competition" top of left hand corner of paper.

Aerial Wire, 7/22's Enamelled Hard Drawn Copper, 6/- per 100 ft.
Aerial Pullers, 2/6 each.
Aerial Insulators, Shell type, 2½ x 2½", green, 1/6 each.
 " Reel type, 2" diam., white, 5½d. each.
Batteries, For H.T. Make your own. Flash Lamp Batteries, 5/- doz.
Buzzers for Morse practice, 3/- each.
Condensers, Fixed. Exceptional quality. Terminal connections; from .0001 to .001, 2/9 each.
Condenser Vanes. Not rubbish. Best Aluminium, 1/- doz.
Condenser Spacing Washers. Accurate. Small, 4d. doz.; large, 8d. doz.
Condenser Screwed Rod. Brass, 12" lengths, 2 B.A., 9d. each. 4 B.A., 6d. each.
Contact Studs. Studs, not rubbish, 2/- doz.
Copper Foil Sheets. 9" x 3", 6d. each.
Dials, Ebonite, graduated 0-180, 2/6 each.
Ebonite. Best quality. Any size, rod or sheet, 5/- per lb.
Filament Resistances. For panel mounting. A speciality. 4/- each.
Inductance Tubes, 12" long. Specially impregnated. 2½", 6d. ... 3½", 7d.; 3½", 8d.; 4", 10d.; 4½", 1/-; 5", 1/2; 6", 1/6 each. Postage, 9d. each.
Inductance Slider Rod, ½" square in 12" lengths, 7d. each.
Insulating Tubing, 6d. per yard.
Ivory Scales. 0 to 180°. Engraved (not printed), 1/2 each.
Ivory Tablets. Set of 6, 9d.
Knobs. Ebonite. 1½" diam. Superior finish. Knurled, 8d. each.
Mica. Pure Ruby. Pieces, 3" x 3" x .002" thick. 6d. each.
Paraffin Wax, 1/- per lb.
Resistance Wires. "Elsi" brand. 22's (1 ohm per yard), 24's (1.7 ohms per yard), and 28's, enamelled (4 ohms per yard), 2d. per yard.
Switch Arms. Exceptionally strong and well made, 3-leaf. 2/6 each.
Terminals. A very neat wireless terminal. Polished, complete with nut and washer, 2/6 doz.

Tin Foil. Free from lead. Sheets, 26" by 13", 4d. each.
Valve Sockets. With nut and washer. Fine finish, set of four, 10d.
Valve Holders. Best quality ebonite, 1/6 each.
Valves. 4-pin vertical filament, 10/6 each.
VALVE PANELS. Single Valve. Mahogany case. Baize-covered base, ebonite top. Containing grid, leak and condenser, telephone condenser. Filament resistance, and with terminals to allow the addition of extra panels. A beautiful piece of workmanship. Price, 29/6 each.

SUPERIOR QUALITY WIRE.				BRITISH MADE		
All wire wound free.				Post extra.		
S.W.G.	S.C.C.	D.C.C.	Single Silk	D. Silk	Emd.	
12	1/10	1/11	4/-	5/4	1/8	
14	1/11	2/-	4/-	5/4	1/9	
16	2/-	2/1	4/2	5/6	1/10	
18	2/1	2/2	4/4	5/6	1/11	
20	2/2	2/3	4/8	6/2	2/6	
22	2/6	2/11	5/-	6/8	2/8	
24	3/-	3/6	5/6	7/4	2/8	
26	3/7	4/1	6/8	8/2	3/2	
28	4/4	4/7	7/2	9/-	3/6	
30	5/-	5/6	8/-	10/-	3/10	
32	6/-	7/3	9/2	13/-	4/2	
34	7/-	8/3	11/6	14/-	4/4	
36	8/8	10/2	14/-	15/6	4/8	
38	11/3	13/2	16/-	19/-	5/8	
40	15/-	18/-	18/6	22/6	6/6	
42	17/3	21/-	31/6	34/-	9/-	

At per lb.

Carriage extra. Please remit ample postage, balance returned. Orders over £2 carriage paid. Money back if not satisfied.

J. L. CARTWRIGHT & CO., Manufacturing Electrical and Radio Engineers
 "Dept. W."
 'Phone—Cent. 4209. Dept. W. 130/132, LONDON ROAD, MANCHESTER. 'Grams—Pladuram, Manchester.
 Special Terms to the Trade.

SALES AGENTS WANTED

for an unlimited supply of

"BROADCASTO"

Crystal Receiving Sets, price 70/- complete, i.e. Receiver, 'Phone, Aerial and Insulators.

The Maximum Efficiency at a Minimum Price

ENTIRELY BRITISH MADE

Send for illustrated pamphlet and trade terms to:

THE BROADCAST WIRELESS CO.
 2, Tower Royal, Cannon Street, E.C.4

'Phone—CITY 8482. Telegrams—ADORNERS PHONE LONDON.

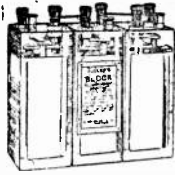

**INSIST ON HAVING A
FULLER 'BLOCK' TYPE
ACCUMULATOR**

FOR YOUR WIRELESS SET!

The only Accumulator on the market that will hold its charge from 12 to 18 months when not in use.

4-volt 40 amp. hours, £1 12 6, plus 1/3 carriage
6-volt 40 £2 8 9, .. 1/6

Note:—These prices are 33½% below those of the actual makers.

8,000 Sold. 20,000 still in stock.

Descriptive and Instructive Pamphlet on request from—

The CITY ACCUMULATOR Co. (Dept. 88)

79, MARK LANE, E.C.3 (Tel. No. Avenue 91)

ALSO SUPPLIED BY—

Selfridge & Co., Ltd., Wireless Section; A. W. Gamage, Ltd., Wireless Dept.; Barnsley British Co-operative Society, Radio Section; Richford & Co., 153, Fleet Street, E.C.3. The South Wales Wireless Installation Co., Ltd., 18, West Butte Street, Cardiff.

AGENTS WANTED IN ALL PARTS.



**TUBE, SHEET,
WIRE, STRIP,
ROD & CASTINGS**
IN
**PHOSPHOR BRONZE,
COPPER, BRASS, &c., &c.**

**CHARLES CLIFFORD & SON, LTD.,
BIRMINGHAM.**

**I HAVE IN STOCK
5000 BROWN'S
PAIRS (120 ohms) "A" PHONES
NEW AND UNISSUED**

POST FREE **45/-** PER PAIR
CASH WITH ORDER

**WILKINSON, Lonsdale Rd., Kilburn,
TRADE SUPPLIED (Same address since 1900) N.W.6**

**30th EDITION
NOW READY!**

The Most Interesting, Instructive and Complete CATALOGUE of "Everything Electrical and Wireless" ever published.
POST FREE 6d.

A wide range of Crystal and Valve Receiving Sets is shown and in addition we list the most wonderful range of Units and components for making own sets.

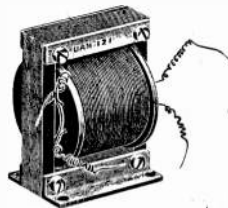

Low-Frequency Inter-Valve Transformer.
Best quality, £1 7s. 6d.
Competition Type, reliable quality, £1 1s.
Telephone Transformers.
Best quality, £1 2s. 6d.
Competition type, £1 1s.
Inductance Tubes.
Length 12".
Diam. Diam.
2½" .. 6d. 4" .. 1/-
3" .. 8d. 5" .. 1/6
3½" .. 10d. 6" .. 2/-

**The
Universal Electric Supply
MANCHESTER**

G.P.O. Box No. 512

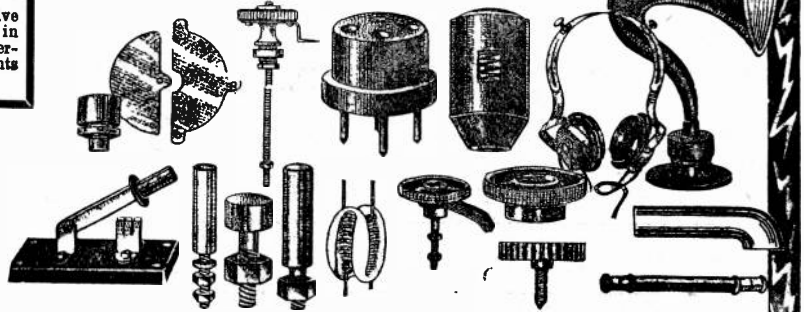

Small Condensers.
·0004 and ·0005 .. 3/-
Anode Resistances.
50,000 & 80,000 ohms 3/6
Variable Anode Resistance.
20,000 to 100,000 ohms, 7/6
Filament Rheostat, 7/6.
Condenser Parts, Fixed & Moving Vanes, 2/6 doz.
Centre Rod, 4½", 4/6
Laminated Switch Arms, 2/6.
Valve Socket, 1/9.

Contact Studs.
Small Size .. 2/- per doz.
Large .. 3/- ..
Aerial Insulator.
1½" .. 1/3 2½" .. 2/6
2" Reel, 4d.
Aerial Wire.
per 100 feet.
3/20 .. 4/- 7/22 .. 5/
3/19 .. 4/6 3/18 .. 6/6
7/20 .. 7/6
Regulating Screw, 1/-
Ebonite Knobs, 3d., 1/-, and 1/6
Insulite Sliders, 1/-

Knife Switches.
S.P. 1 way, 1/8; 2 way, 2/4
D.P. 1 way, 3/8; 2 way, 5/-
Grid Condenser and Leak, 7/6
Blocking Condenser, 5/-
Grid Leak, 3/-
Skeleton Buzzer.
Extremely sensitive, for Crystal Testing, 2/6.
Single Receiver, With Head-Band & Cord, 120 ohm, 24/-; 500 ohm, 27/6; 1,000 ohm, 30/-; 2,000 ohm, 32/6

Valve Socket Terminals, 1/3 per set of 4.
Plug Connector, 2-pin, 1/8
Double Receiver, With Head-Band & Cord, 2,000 ohm; 35/-; 4,000 ohm, 37/6; 8,000 ohm, 45/-
Brown's Loud Speaker, Type H.2, 23 0 0
High Tension Batteries, 15 v., 3/6. Variable Type, 36 v., Tappings every 3 v., 7/6.
Postage Extra.

HENDON PATENT POTENTIAL BATTERY ACCUMULATOR

25 VOLT UNITS,
FOR USE AS
GRID BATTERY.
NO CONNECTIONS
BETWEEN CELLS.

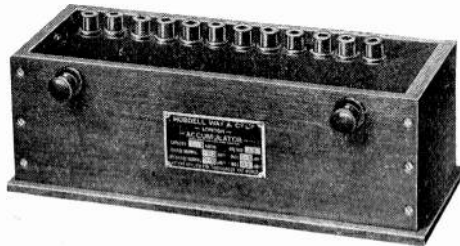

LEAKAGE
REDUCED TO
AN ABSOLUTE
MINIMUM

Designed and Manufactured with particular regard to the
Requirements of Wireless Telegraphy and Telephony

by

HOBDELL, WAY & CO., LTD., 124 MINORIES, LONDON, E.1

DESCRIPTIVE MATTER ON APPLICATION

Telegraphic Address : Hobnails, Ald, London.

Telephone : Avenue 3810.



**HELLESEN DRY
BATTERIES** ALL
TYPES
KNOWN THE WORLD OVER AS
THE BEST

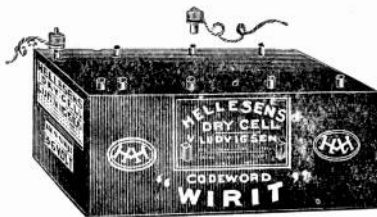

CODEWORD : " WIRIT " Size 6 7/8 x 2 1/2 x 3. CODEWORD : " WIRIT " 36 volts.

SPECIAL TRADE & WHOLESALE TERMS.

CODEWORD	VOLTS	DETAILS	PRICE
" WIRON "	15	Screw terminals	4/-
" WIRTO "	15	Strip	4/-
" WIRIT "	36	2 wander plugs	8/6
" WIRIN "	60	" " "	14/-

ALL LISTS FREE ON APPLICATION.

A. H. HUNT, LTD.
H.A.H. Works, Tunstall Rd., Croydon, Surrey

DON'T READ THIS

If you are a millionaire



- Price, 2/6 per dozen, plated : 3/- brass ; small type, 9d. per doz.
 - One valve detector panel complete with filament resistance valve holder, and grid leak and condenser, fitted with insulated terminals, mounted on solid ebonite base in mahogany instrument case . . . PRICE 25/-
 - Leading-in Tube, ebonite, R.A.F. pattern with brass rod and fittings. PRICE 3/6
 - Aerial Real Insulators, tested to 25000 volts PRICE 4
 - Accumulator Charging Resistances PRICE 25/-
 - Universal Tuners. These tuners have been designed to tune in Marconi concerts, broadcasting, and Dutch Concerts, so that a baby can use them. Wavelength range, 300-1,500 metres, with .0005 m.f. condenser, PRICE 7/-
 - 4,000 ohm phones, new patent 3-magnet type, fitted cords and tags, complete with nickel plated head bands PRICE 35/-
 - Transmitting Keys, G.P.O. pattern, fitted platinum contacts PRICE 5/-
 - Valve Holders, fitted in solid ebonite, fixing case drilled fitted with valve earthing clip PRICE 2/6
 - Grid Leaks and Condensers, mounted on solid ebonite PRICE 5/-
 - Instrument Cases, solid mahogany, 9" x 6" x 2 1/4", highly finished, fitted ebonite panel, undrilled PRICE 8/-
- Postage extra on all the above prices.
The trade supplied. Enquiries solicited.

J. LIPOWSKY, 614, OLD FORD RD.
Bow,
LONDON, E.3 'Phone : East 3345

LESLIE McMICHAEL LTD.

PROVIDENCE PLACE, WEST END LANE, KILBURN, N.W.6

Bus Services 1, 8, 16, 28, 31 all pass West End Lane

Telephone: HAMPSTEAD 1261 Nearest Tube Station: KILBURN PARK (BAKERLOO)

BROWN'S HIGH RESISTANCE TELEPHONES

(With Cords)
8,000 ohms.

Price **55/-** Per Pair

We have completed an exclusive purchase with Messrs. S. G. Brown, Ltd., for some thousands of their re-conditioned Ex-Government Telephones.

The telephones we offer bear the hall mark of Messrs. S. G. Brown Ltd.—purchasers should not be misled into buying ex-Government Brown Phones which are of the older type with paper diaphragms—these we are offering have ALUMINUM diaphragms, and are direct from Brown's factory



There is no telephone headgear in the world so sensitive and so comfortable to wear as a "BROWN."

BROWN'S LOW RESISTANCE TELEPHONES

(With Cords)
120 ohms.

Price **50/-** Per Pair

We shall supply to amateurs and our friends in the trade as freely as deliveries permit.

A considerable stock is at present available.

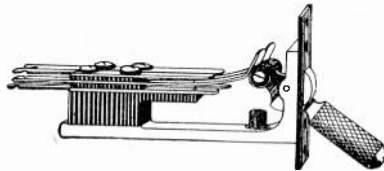

This switch is a double pole change over—a most useful piece of apparatus for panel mounting One 3/6
Mounted in teak box with terminals Two 7/-



LEADING-IN TUBES.

6" long, 2/3 12" long, 3/- 18" long 3/9



EBONITE VALVE
PANEL & RESISTANCE.
In Polished Box.
Price 14/-



SWITCH ARMS.
Price 2/9

EGG INSULATORS.

9d. each.

AERIAL WIRE.

Enamelled Copper,	7/22
100 ft.	7/6
150 coil	10/-

SPECIAL TERMS TO THE TRADE

We hold enormous stocks of all these and hundreds of other lines of wireless apparatus. You are specially invited to send your enquiries—get the benefit of our experience and if possible inspect our stock.

POSTAGE MUST BE INCLUDED (Except where orders are for £2 or over).



HIGH TENSION DRY BATTERIES for WIRELESS SETS

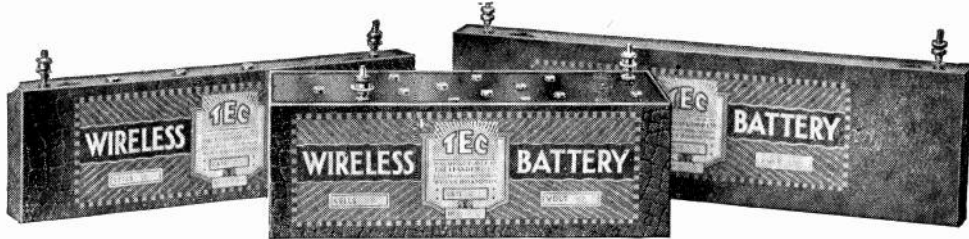

NORMAL SIZE, No. W 70 V, 15 Volts
Price 5/-

W 71 V, 50 Volts
Price 15/-

GIANT SIZE, No. W 73, 15 Volts
Price 6/6

SUPPLIED IN TWO SIZES FOR 15, 50 or 60 VOLTS.

and with Tappings in 3 Volt Steps.

ALL BATTERIES FITTED WITH PLUG SOCKETS AND MOVABLE TERMINALS.

Complete Illustrated Price List on Application.

**THE EFANDEM CO., LTD., FALLINGS PARK WORKS,
DRY BATTERY MANUFACTURERS WOLVERHAMPTON**

SENSATIONAL REDUCTIONS.

- Slab Inductances, 300-30,000 m. Set of 8, 9/- . Ditto "Oojah" make, 10/- per set. Postage, 9d. extra.
 - Basket Inductances, 300-3,000 m. Set of 7, 6/- . Ditto "Oojah" make, 7/- per set. Postage 6d.
 - Basket Inductances, 150-1,300 m. Set of 5, 4/9. Post 3d.
 - SCIENTIFIC TUNING INDUCTANCES, 150-1,300 m. Set of 5, 6/- Post, 6d. The Ideal Inductance for Telephony. Designed for simple and efficient tuning for the Dutch and all Broadcasting and amateur telephony.
 - Condenser Plates, Fixed or Moving, 1/- per doz. Post 3d.
 - Washers for Fixed Plates, 3d. per doz. Moving, 5d. per doz. Post, 2d.
 - Threaded Rod for Spindles, etc., 5d. per foot. Post 3d.
 - Nuts for same, 3d. per doz.
 - 3" Semi-Circular Scales, 0-180 degrees, 8d. each. Post 2d.
 - 1 1/2" Ebonite Knobs, with threaded centre, 6d. Post 2d.
 - Pointers, 2d. each. Stop-pins, 1/- per doz. Bush and Locknut, 5d.
 - Extension Handles, 4d. Post extra.
 - Valve Legs or Sockets, 1/10 per doz. Post 3d. (complete with screws or nuts).
 - Mark III Terminals, with nut and washer, 2/3 doz. Post 4d.
 - Vernier Condensers, 3-plate, 6/-; 5-plate, 7/- . Post 9d.
 - 7-Strand Silicon Bronze Aerial Wire, per 100 ft., 4/-; per 150 ft., 5/9. Post 9d.
 - Best Shellac Varnish, 9d. and 1/3 per bottle. Post 6d. and 9d.
 - Copper Foil, per square foot, 6d. Post 2d.
 - Wood's Metal, 6d. per 1/2 oz. stick.
 - Knife Switches on Ebonite, S.P.D.T., 1/6; D.P.D.T., 2/3. Post 4d.
 - Contact Studs, 3" diam., 10d. per doz; 5/16 diam., 1/- per doz.
 - Nuts for same, 3d. per doz. Washers, 2d. per doz. Post extra.
 - Filament Resistances for panel mounting, 3/9.
- These are only a few of the numerous items contained in our catalogue, which will be sent free with order.

RADIO, ELECTRICAL & MECHANICAL SUPPLIES.

SCIENTIFIC SUPPLY STORES

PHONE 8, NEWINGTON CAUSEWAY,
LONDON, SE1.

KEYSTONE AERIAL INSULATORS

Keystone Specially Treated
RADIO CORD
and Fixing Connectors
for Effective Aerials

STOCKED BY ALL DEALERS IN
RADIO MATERIAL.

The
EQUIPMENT & ENGINEERING Co.
2-3, NORFOLK STREET, STRAND,
LONDON, W.C.2
Wholesale only.

Telephone : City 1088 Telegrams : Kharparts Estrand, LONDON.

ALL BRITISH WIRELESS EXHIBITION & CONVENTION

will be held at the
HORTICULTURAL HALL
WESTMINSTER : LONDON : S.W.1
SEPT. 30TH TO OCT. 7TH
(SATURDAY) (SATURDAY)

This will be the most representative
Wireless Exhibition ever held in
Great Britain

THIS EXHIBITION has the full support
of the trade

THE CONVENTION will be held under
the auspices of the WIRELESS SOCIETY
OF LONDON and all affiliated societies.

APPLICATIONS for stands will only be
accepted from BRITISH Allied and
Kindred Trades.

Applications should be addressed to

THE ORGANISERS

BERTRAM DAY & CO., LTD.

WIRELESS PUBLICITY SPECIALISTS

9 and 10, Charing Cross, S.W.1

Gerrard 8063/4

NOW READY

**The YEAR BOOK of WIRELESS
Telegraphy and Telephony 1922**

1476 Pages.

Price 15/- Nett.

Demy 8vo.

Postage 1/-.

Abroad 1/4.

CONTENTS

Record of the Development of Wireless Telegraphy—National and International Wireless Laws and Regulations—Directory of the World's Land and Ship Wireless Stations—International Allocation of Call Letters—Alphabetical List of Call Letters—Meteorological Section—International Time and Weather Signals—National Résumés of Progress in Wireless Telegraphy—Particulars of Wireless Telegraph Patents, 1921—Aviation Section—Tabular List of Aviation Stations—Useful Data Section—Wireless Terminology—Conventional Signs used in Wireless Diagrams—Companies Engaged in the Commercial Development of Wireless Telegraphy—Biographical Section—Literature on Wireless Telegraphy and Telephony—Directory of the World's Wireless Societies—Directory of Wireless Colleges and Schools—List of Licensed Amateur Transmitting Stations—Code Section—Special Articles on "The Earthing Resistance of Antennæ," by Dr. Miessner—"The Recording of Wireless Signals," by Dr. Abraham—"The Birth and History of Long Distance Wireless Telegraphy"—"The Rectification Effect in its Reaction to the Composition and Structure of Crystals."

A valuable feature of the present issue is the specially drawn map, which gives, for the first time, a simple means of finding the distance and true direction of Wireless Stations in all parts of the World, from London as the centre.

THE WIRELESS PRESS, LIMITED,

DEPT. W.W., 12-13 HENRIETTA ST., STRAND, LONDON, W.C.2

WARNING.

MARCONI'S WIRELESS TELEGRAPH CO., LTD.,

v.

A. C. COSSOR, LTD.

Marconi's Wireless Telegraph Company, Limited, **GIVE NOTICE** that an **ORDER** was made in the High Court of Justice, Chancery Division, by Mr. Justice Russell on the 1st March, 1922, restraining Messrs. A. C. Cossor, Ltd., from infringing the Marconi Company's Letters Patent Nos. 28413 of 1913 and 126658, except so far as Messrs. A. C. Cossor, Ltd. manufacture for H.M. Government.

Messrs. A. C. Cossor, Ltd., were further **ORDERED** upon oath to **DESTROY** all articles and apparatus (other than those constructed to the order of H.M. Government) made or used by them in **INFRINGEMENT** of these patents, and **TO PAY THE MARCONI COMPANY DAMAGES AND COSTS.**

The M-O Valve Company, Limited, of Osram Works, Brook Green, Hammersmith, London, W.6, is the only firm in this country licensed to manufacture thermionic valves under the patents belonging to the Marconi Company.

Any valve similar to those generally known as the "French type" constitutes an infringement of the above patents whether manufactured in this country or imported from abroad. Marconi House, Strand, London, W.C. 2.

**WITH GOOD APPARATUS YOU
CAN GET GOOD RESULTS**

THE "W.P."

Morse Practice Key

Well Made. First-class Finish. Thoroughly Reliable

Price 7/6 Post Free

THE WIRELESS PRESS, LTD.
12-13 HENRIETTA STREET, LONDON, W.C. 2

**Questions and Answers
COUPON**

**To accompany Questions
sent in during the week
commencing Aug. 5th, 1922.**

VOL. X, NO. 19.

See Conditions on Page 603.

THE ONLY WAY
to prevent
SURFACE LEAKAGE
is to fit

Crystor
COWL INSULATORS

Patent applied for.

which alone guarantee
100% EFFICIENCY
from Aerial to Instrument

Rain, fog, soot and dirt are all electrical conductors producing surface leakage which causes endless trouble, indistinct messages and often complete disorganisation.

The "Crystor Cowl" Insulators are unique—made of the best quality Ebonite, they are absolutely essential to every aerial. Fit them NOW, and immediately you will increase the efficiency of your receiver.

AGENTS:—The "Crystor Cowl" Insulators will be used universally, and you will find them the best selling proposition in the industry. Order your stocks without delay.

WIRELESS SUPPLIES CO.
64, MORTIMER ST., LONDON, W.1

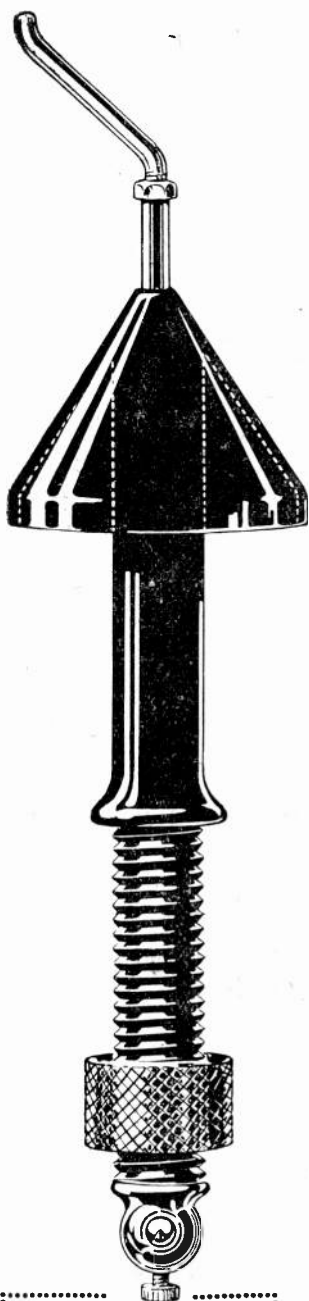

Vertical Roof
LEAD IN

Dia. of Cowl $2\frac{1}{2}$ "
Dia. of Shank $\frac{3}{4}$ "
Length Overall 11"
Price 10/- post free.



Aerial Insulator

Length of Body 3"
Dia. $1\frac{1}{2}$ " Length
Overall 4". 2/6 each.
Set of four 10/-
post free.

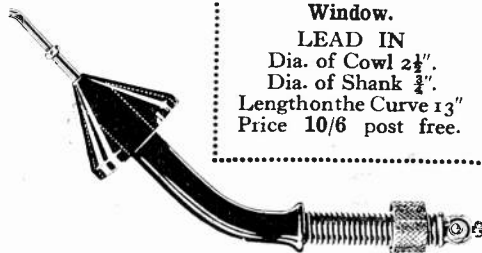

Horizontal Wall or
Window.

LEAD IN
Dia. of Cowl $2\frac{1}{2}$ "
Dia. of Shank $\frac{3}{4}$ "
Length on the Curve 13"
Price 10/6 post free.

SIMPLICITY

"K.B." UNITS

ECONOMY

IMMEDIATE DELIVERY

EFFICIENCY

IMMEDIATE SATISFACTION

By means of these units you can build up a complete one to seven valve receiving set in easy stages to suit your pocket; while in the meantime, the units already bought are in themselves a complete receiving set, whatever their number may be. All you have to do is to place the units side by side straight across with the brass links provided.

HERE THEY ARE:—

UNIT No. 1.
CONDENSER PANEL.
No. Reqd. : Optional.

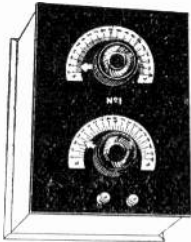

Price.

Complete (as above) 34/- each.
Set of Parts (panel only). 22/6 per set.

UNIT No. 2.
DETECTOR PANEL.
No. Reqd. One.

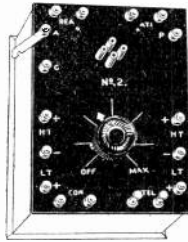

Price.

Complete (as above) 34/6 each.
Set of Parts (panel only). 20/- per set.

UNIT No. 3.
L.F. AMPLIFYING PANEL.
No. Reqd. : 1, 2 or 3.

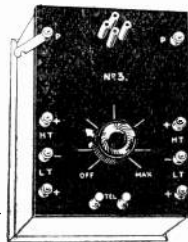

Price.

Complete (as above) 43/6 each.
Set of Parts (panel only) 33/- per set.

UNIT No. 4.
H.F. AMPLIFYING PANEL.
No. Reqd. : 1, 2 or 3.

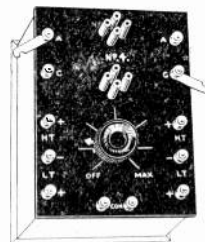

Price.

Complete (as above) 33/6 each.
Set of Parts (Panel only). 18/6 per set.

Mahogany Cabinet 6/- each. Mahogany Cabinet 6/- each. Mahogany Cabinet 6/- each. Mahogany Cabinet 6/- each

We also hold large stocks of complete Receiving Sets, Coilholders, Coils, Variable Condensers (Assembled and in Parts), Valve Holders, Filament Resistances, H.T. Batteries, Accumulators, Aerial Insulators; in fact ALL AMATEUR REQUIREMENTS.

TRADE ENQUIRIES INVITED.

CATALOGUE POST FREE 4d.

COME AND "LISTEN IN" AT OUR SHOWROOMS. OPEN DAILY from 9 a.m. till 7 p.m.

THE "K.B." RADIO EQUIPMENT COMPANY,

Head Offices & Showrooms : 109, High Road, Kilburn, N.W.6.

Bus Services—8, 16, 28 & 51, pass door.

3 mins. Kilburn Park Stn. (Bakerloo Rly.)

WIRELESS

RECEIVERS REWOUND
4000 Ohms AND UPWARDS
PER **12/-** SET

G TURNOCK 41 HIGH ST ASTON BHAM

WIRELESS

Telephone Headgear Receivers
ALL Resistances

Special Trade Quotations

Send Enquiries—
PREMIER TELEPHONE CO.,
62, OXFORD STREET, W.1.



*Specially
designed
for
Broadcasting*

HEADGEAR RECEIVERS

Designed and manufactured by
leading Telephone Manufacturers.
Backed by many years' experience.

Highest efficiency, concentrated
magnetic field, instantaneously
adjusted to the ears, comfortable
in wear, either receiver detachable
from headband, protected termi-
nals, light weight, twin series cord.

**A.T.M. LOUD
SPEAKING
RECEIVERS**
Three types of
amplifying horn.

**A.T.M. Crystal
Detector Sets**
Highest Grade.
Maximum Efficiency.
Moderate Cost.

*Ask your dealer for
A.T.M.
Broadcasting Apparatus*

Automatic Telephone Manufacturing
Co., Ltd.

Head Office & Works: London Office:
Milton Rd., Edge Lane, 60 Lincoln's Inn Fields
Liverpool. W.C.2.

EVERYTHING FOR WIRELESS

Aluminium Condenser Vanes, $3\frac{1}{4}$ ", $2\frac{1}{2}$ d pair.
Spacing Washers for fixed and moving plate,
3d. and 5d. doz.
Brass Rod, threaded $3/16$ th, 6d ft.
Brass Rod, $\frac{1}{4}$ " square, 4d. ft.; $3/16$ th round,
 $3\frac{1}{2}$ d. ft.
Brass Hex Nuts, $\frac{1}{8}$, $4\frac{1}{2}$ d doz.; $3/16$ th, 1d each,
9d. doz.; $\frac{1}{4}$ ", $1/3$ doz. 6 BA, 4d.; 5 BA,
5d.; 3 BA, 6d.; 2 BA, 7d. doz.
Brass Strip, $\frac{1}{2}$ " \times 22 gauge, 2d. ft.; $\frac{1}{4}$ " \times 21
gauge, $1\frac{1}{2}$ d. ft.
Brass Tube, $5/16$ th bore, 8d. ft.; $3/16$ th \times $\frac{1}{4}$ ",
4d. ft. All sizes tube from $\frac{1}{8}$ outside.
Brass Screws, $\frac{1}{2}$ " and $\frac{3}{4}$ ", 4 BA or Whitworth,
9d. doz.
Washers, all sizes, $3/16$ th and 2 BA, 2d. doz.
Condenser Spindles, $\frac{1}{4}$ " square threaded top and
bottom, for 25 plate condenser, 8d. each.
Ebonite Knobs, 7d.; tapped $\frac{1}{4}$ " whit., 8d. each.
Extension Handles, 1/- Engraved Scales,
180 degs., 1/6.
Stops, $\frac{1}{8}$ threaded, 3d. pair. Knob with pointer,
1/-.
Filament Resistance with Knob and Pointer, 3/9.
Grid Condenser and Leak, 2/6. Telephone Con-
denser, 2/6 each.
Contact Studs, 1d. and 2d. each. Copper
Foil, .005, 6d piece.
Crystal Cups, 6d. Tested Crystals, 6d. Wood's
Metal, 4d.
Tuning Coils, with polished mahogany ends,
1,000 metres, 12/6; 1,500 metres, 16/6;
2,000 metres, 20/-.
Ebonite Sliders, 1/3. Brass Detector with vernier
adjustment, 5/- each.
Ebonite Valve Panels, $9'' \times 6'' \times \frac{1}{4}''$, 3/-;
 $4'' \times 4''$, 1/3; larger, 4/- lb.
Ebonite Rod, $\frac{1}{2}''$, 6d. ft.; $7/18''$, $1/6$ ft.; $1\frac{1}{4}''$,
 $3/6$ ft. Sheet Ebonite, $\frac{1}{4}''$, 4/- lb.; $3/16$
and $\frac{1}{8}''$, 5/- lb.
Ebonite Discs to $3\frac{1}{2}''$ diameter, $1/4$ each.
Mica, best ruby, $2'' \times 1\frac{1}{2}''$, for condensers,
2d. each, $1/6$ doz.
Polished Mahogany Baseboards, $9'' \times 7'' \times \frac{3}{8}''$,
4/- each.
Polished Mahogany Boxes for Valve Panel,
 $9'' \times 6'' \times \frac{1}{4}''$, 7/6 each.
Lead-in Tubes, Ebonite and Brass, 1/-, tube 8d.
ft.
Crystal Receivers on baseboard with 4,000 ohm
telephones, £3.
Crystal Receivers in Cabinet, with variable
condenser and telephones, £4.
Single-valve Panel, with .00075 variable,
£4 10s.
Two-valve Amplifier, £6 10s.
Accumulators, 4v. 20a., 15/6; 4v. 40a., 21/-;
6v. 40 a., 32/6.

Post Free on Orders Value £2.

J. BRIDGE & SONS,
NELSON ST. WORKS, SOUTHEM-ON-SEA
and 300, LONDON RD., WESTCLIFF-ON-SEA.

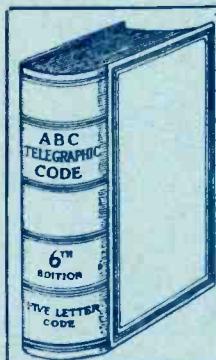

AN ENTIRELY NEW WORK.
The ABC Telegraphic CODE 6th Edition

FIVE-LETTER CODE.

An up-to-date Work, containing Five letter Artificial Code Words with at least a TWO-letter difference and a **TERMINAL-INDEX** of the words at the end of the Book.

Cost of Cabling brought to a Minimum :: Simple to Use.

PRICE **£3 3s. 0d.** net (U.K. and Colonies.)

Publishers :- *Inland Parcel Post 1/6 per copy. Continental Book Post 2/- per copy.*

EDEN FISHER & CO., LTD., 6, 7 & 8, Clements Lane, E.C.4
And 95, 96 and 97 Fenchurch Street, London, E.C. 3.

RADIO INSULATION

AS SPECIFIED AND USED BY THE BRITISH ADMIRALTY

BRITISH MADE

PAXOLIN

BRITISH MADE

TUBES DISCS PLATES, &c.

MANUFACTURED IN ALL FORMS, SIZES AND THICKNESSES

BY

THE MICANITE & INSULATORS CO. LTD.

EMPIRE WORKS

WALTHAMSTOW

LONDON, E.17

TELEGRAMS :- "MYTILITE, PHONE, LONDON."

TELEPHONES :- WALTHAMSTOW 738, 739

Registered "NIPHAN" Trade Mark.

WATER-TIGHT PLUGS
and CABLE COUPLINGS
TO MEET HOME OFFICE REQUIREMENTS



COUPLING CONNECTING CABLES

Phones :
 2600 Gerrard. 12061 Central.

Telegrams :
 "Niphon. London."
 Patented in England and Abroad.

As used by H.M. War Office, Electric Supply Companies, Railway Companies, Marconi's Wireless Telegraph Company

SIMMONDS BROS., LTD.
 4, 6 & 8, NEWTON STREET, HOLBORN, W.C.

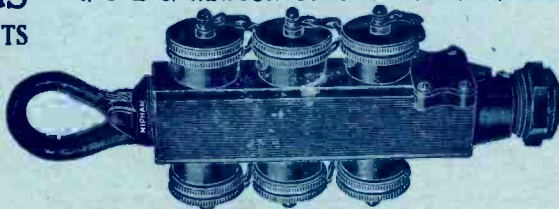

SIX WAY TEE CONNECTORS

AUCKLAND'S

SPECIAL OFFER! CRYSTAL DETECTORS

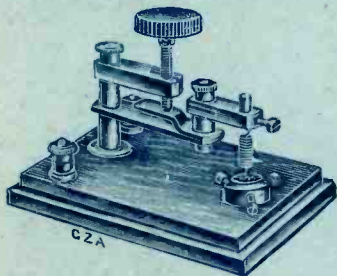

EXACT AS ILLUSTRATED.
BRASSWORK LACQUERED POLISHED
BASE, WITH CRYSTAL... .. 6/6

PRICES UNMOUNTED

Coil No.	Wave Range ..001 Mid Condenser in parl.	Price
1	130-250	2/-
2	180-450	2/3
3	250-700	3/-
4	400-1,200	4/-
5	500-1,600	4/6
6	600-2,500	4/6
7	1,000-3,000	4/8
8	1,200-4,500	5/-
9	1,500-5,500	6/8
10	2,000-7,500	7/6
11	3,000-7,500	8/-
12	4,000-12,000	9/-
13	5,000-14,000	9/8
14	6,000-18,000	10 -
15	10,000-22,000	12/6
16	15,000-30,000	15/-

Mounted 3/6 each extra.

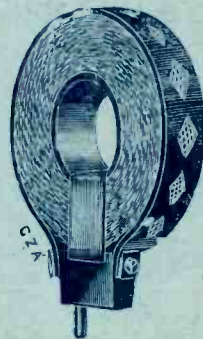

Mounted Coil

TABLE STAND FOR COILS

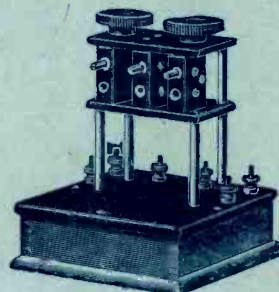

Regd. Design 688454.
EXACT AS ILLUSTRATED.
PRICE EACH 21/-



IVORINE SCALES
0-180° Each 10d.



CONDENSER SCALES
Engraved 0-180° with Knob and Bush 3/8

TELEPHONE TRANSFORMERS

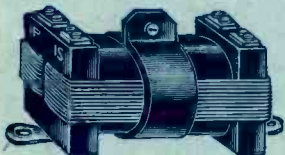

Unmounted (as illustration),
Suitable for 120 w Phones.
Unmounted 15/-
In Box with Terminals 18/6



VALVE LEGS, with Nut and Washer, 3d. each
VALVE PINS, with Nut and Washer, 2 1/2d. each

FIXED CAPACITY CONDENSERS

From '0002 to '005.



Price each ... 3/-
Mica Dielectric



SWITCH ARMS
4-Leaf Contact.
Brass Bush and
Nuts. Each
2/9
Over 4,000 sold.



FILAMENT RESISTANCES
Resistance wound on Erinoid
Former, knob fitted with
brass bush and pointer. Price
5/8 each. Thousands of these
resistances are now in use.

G. Z. AUCKLAND & SON

395, ST. JOHN STREET, LONDON, E.C.1

Manufacturers of Radio Apparatus

Factories: ISLINGTON, N.

Phone—CLERKENWELL 3173. Telegrams—"ZAUCKADIO, LONDON."



Printed by Sanders Phillips & Co., Ltd., Chrysell Road, London, S.W.9, for the Proprietors and Publishers, The Wireless Press, Ltd., 12-13, Henrietta Street, London, W.C.2; Sydney, N.S.W., 97, Clarence Street; Melbourne, 422-24, Little Collins Street; New York, 326, Broadway.



WIRELESS WORLD

AND

RADIO REVIEW

VOL. X. No. 20.

12th AUGUST, 1922.

Registered at the G.P.O.
as a Weekly Newspaper.

A New Condenser for Wireless Receivers THE DUBILIER TYPE 600 MICA CONDENSER

The illustrations show two types of this new condenser for wireless receiving circuits. These condensers have the same perfect mica insulation, the same high efficiency and the same permanence of capacity as the larger Dubilier Mica Condensers used in wireless transmitters. Distortion when receiving telephony is often due to bad design of the components of the receiver—therefore use efficient Dubilier Condensers in your receiver to obtain the best out of your set.

With Clips for Grid Leak.

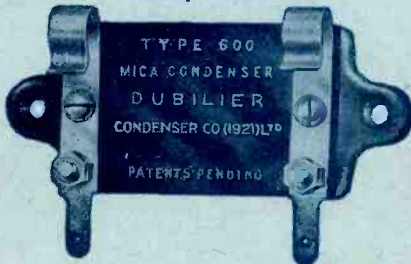

Without Clips for Grid Leak.

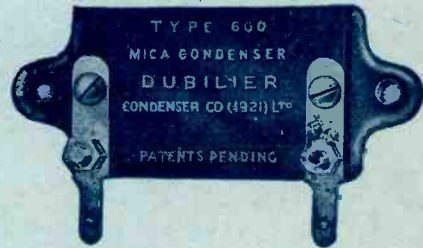

PRICES.

Capacities from 0'0001 to 0'0009 mfd.	2/6 each
Capacities " 0'001 " 0'005 " inclusive	3/- "
Condensers complete with Grid Leaks "	7/6 "

TRADE TERMS ON APPLICATION.

Both types of condenser (with or without clips for a grid leak) are fitted with screw terminals as well as tags for making soldered connections.

THE DUBILIER CONDENSER CO. (1921), LTD.,

DUCON WORKS, Goldhawk Road, Shepherd's Bush, London, W.12

Telephone—Hammersmith 1084

Telegrams—Hivoltcon, Phone, London.

Code—Marconi International

All American Enquiries to be addressed—

DUBILIER CONDENSER CO., Inc., 217, Centre Street, New York.

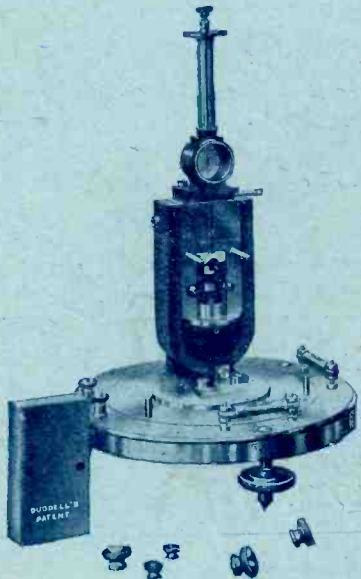

CAMBRIDGE THERMO-GALVANOMETER

(Duddell's Patent)

For measuring extremely small
alternating currents of high frequency

Will measure 20 micro-amperes, or
detect 2 micro-amperes, and can be
used for currents of any frequency

Further particulars on request.

**The Cambridge and Paul
INSTRUMENT CO LTD**

WORKS: LONDON & CAMBRIDGE *Head Office & Showrooms* 45, GROSVENOR PLACE, LONDON S.W.1

“Wireless for all”

Before you decide on the
construction of your set.
It will pay you to have
particulars of—

Condensite Celoron

For PANELS and OTHER PARTS.

This material is waterproof, immune to atmospheric and climatic conditions, will not warp, has high surface and volume resistivity, high di-electric strength, low specific gravity.

LET US QUOTE YOU

SEND PARTICULARS OF YOUR EXACT REQUIREMENTS TO
THE MANUFACTURERS

DIAMOND FIBRE CO. LTD.

DIAMOND-FIBRE WORKS HIGH ROAD SOUTH TOTTENHAM, N.15.

*Fine Instruments
for Library and
Drawing-Room*

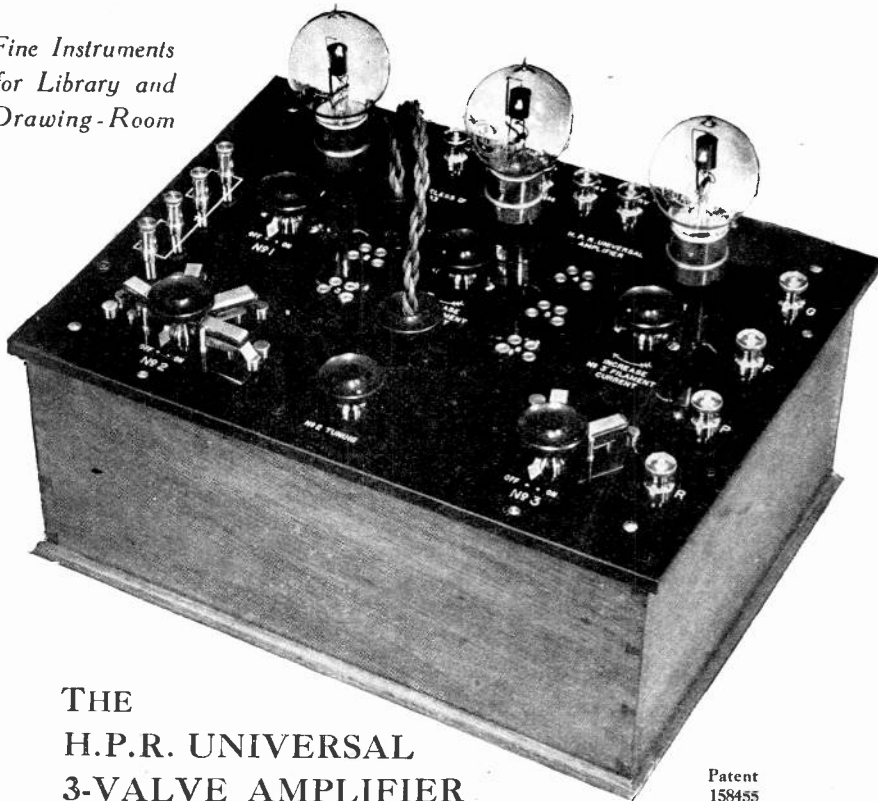

**THE
H.P.R. UNIVERSAL
3-VALVE AMPLIFIER**

Patent
158455

One rectifying, one H.F., one L.F. valve, as supplied to the Air Ministry. The H.F. circuit, which is tuned over the entire range from 150 metres to 30,000 metres, is of the highest possible efficiency, six patent H.P.R. tuneable H.F. transformers being employed. These are instantly changed and tuned in a few seconds without any difficulty. No loose parts. Easily operated by anyone—absolutely no technical knowledge of any kind required. Perfectly finished within and without. Each instrument certified and guaranteed. Demonstrated with pleasure. **Price £40 : 0 : 0**

This instrument, combined with the H.P.R. Universal Tuner, constitutes the handsomest, most easily operated, complete, compact and efficient 3-valve receiving station obtainable at any price. May be dismantled and re-erected in five minutes. Provision is made for the addition of further amplifying units (high and low frequency) as required.

Full particulars of these and many other instruments of convenience for expert and novice alike may be had upon application Trade Supplied

H.P.R. WIRELESS, LTD.

*Pioneer Designers and Makers of Fine Value Receiving Instruments
for Amateurs*

Head Office and Demonstration Room :

**CARLTON HOUSE, GT. QUEEN STREET,
KINGSWAY, LONDON, W.C.2**

Tel. : REGENT 1719



---CQ Std bi for ERICSSON PHONES

WHEN you instal your wireless set—crystal or valve —you'll get maximum results if you fit Ericsson Phones—clarity, sensitivity, strength of signals and absence of "click." Specially suited to telephony. Ericsson Phones embody the accumulated experience of telephone manufacture for a generation. Easy to the head, light and comfortable. The magnets never lose their strength and "shorts" are non-existent.

Write for Particulars

The BRITISH L. M. ERICSSON
MANUFACTURING Co., Ltd.

Head Office:
60, Lincoln's Inn Fields, E.C.2

Ericsson

Telephones

RADIO INSULATION

AS SPECIFIED AND USED BY THE BRITISH ADMIRALTY

BRITISH MADE

PAXOLIN

BRITISH MADE

TUBES DISCS PLATES, &c.

MANUFACTURED IN ALL FORMS, SIZES AND THICKNESSES

BY

THE MICANITE & INSULATORS CO. LTD.

EMPIRE WORKS

WALTHAMSTOW

LONDON, E.17

TELEGRAMS:—"MYTILITE, PHONE, LONDON."

TELEPHONES:—WALTHAMSTOW 738, 739

Everything in the Ether is yours with certainty if you use

BIRMINGHAM:
133 NEW STREET.

LIVERPOOL:
1C, SOUTH JOHN STREET.

BURNDEPT

MANCHESTER:
61, BRIDGE STREET,
DEANSGATE.

LEEDS:
48, ST. GEORGE STREET.

WIRELESS APPARATUS

LONDON OFFICE & SHOWROOMS
15 Bedford Street, Strand, W.C.2

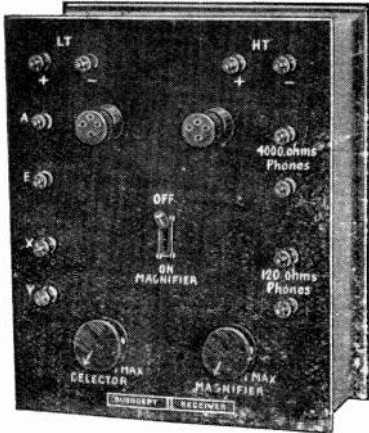

For Broadcast and Concert Reception the Burndept Ultra II

This Set will receive the broadcast concerts loudly within 150 miles radius on headphones—within 50 miles radius of London or other high power broadcasting stations it will receive on loud speaker. Extra note magnification can always be added if desired for large halls, demonstrations, etc.

Complete **ULTRA II** Set consisting of Burndept Tuner, Ultra II—Set short wave coils, pair Brown's 120 ohm Phones, 2 Marconi Valves, 6 volt 60 amp. Accumulator, 60 volt H.T. Battery in case, Aerial wire and Insulators.

£30 - 0 - 0 Packed free. Prompt delivery

THE ETHOPHONE No. 1

(Trade Mark)

Price: **£12 10 0**
(without Valves)

This Instrument has been specially designed for the reception of Broadcast Music, Speech, etc.

It can be used with satisfaction by two listeners at the same time. Receiving radius 25 to 40 miles of transmitting stations.

A special arrangement is included which permits reception of time signals from Paris. **THIS SET COMPLETE AND READY FOR USE** includes one good set of High Resistance Phones, Coil of Aerial Wire, Insulators and complete instructions. No knowledge of Wireless required to operate. **Price £8 - 0 - 0. Packing and Postage free.**

SHORT WAVE (CONCERT) COILS. These coils have been specially designed for BROADCASTING and NEW AMATEUR WAVELENGTHS. They are 3" in diameter and mounted on standard BURNDEPT coil plug so that they are interchangeable with BURNDEPT PATENT COILS. The new coils (4 in number) replace Burndept Coils No. 25 and 50 which are now discontinued. **Price (set of 4 coils) 25/-.** Wavelength range approx. 150-750 metres in conjunction with .00075 mfd. variable condenser (BURNDEPT VERNIER).

ILLUSTRATED CATALOGUE post free 6d.; returnable with first order. This gives full details of our **ABSOLUTELY COMPLETE** receiving equipment for ONE up to FOUR VALVE Sets.

PRICES RANGE FROM £21.

BURNDEPT, LTD., MANUFACTURERS OF WIRELESS APPARATUS
AERIAL WORKS, BLACKHEATH, LONDON, S.E.3

The Western Counties Electrical & Engineering

COMPANY

Telegrams—"Electron, Yeovil."

Telephone—223 Yeovil

Electric Lighting & Power Engineers
MIDLAND BANK CHAMBERS, YEovil.

SOLE AGENTS for

MESSRS. BURNDEPT LTD.

for South-Midland and South-Western Counties (excepting the City of Bristol) to whom applications for sub-agencies for that area should be addressed.

THE ONLY WAY TO PREVENT SURFACE LEAKAGE

is to fit

Crystor COWL INSULATORS

(Patent applied for)

100% EFFICIENCY GUARANTEED

Rain, fog, soot and dirt are all electrical conductors producing surface leakage which causes endless trouble, indistinct messages and often complete disorganisation. The "Crystor Cowl" Insulators are unique—made of the best quality Ebonite, they are absolutely essential to every aerial. Fit them NOW, and immediately you will increase the efficiency of your receiver.

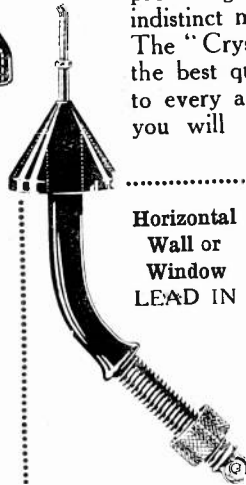

Horizontal
Wall or
Window
LEAD IN

Dia. of Cowl $2\frac{1}{2}$ "
Dia. of Shank $\frac{1}{2}$ "
Length on the Curve $1\frac{1}{2}$ "
Price 10/6 post free.

HERE IS REAL PROOF
OF THE EFFICIENCY OF

THE
Crystophone

Wireless Supplies,
64, Mortimer Street, W.

Headingley, Arnold Road,
Clacton-on-Sea.

26th July, 1922

Dear Sirs,
As promised, I let you know that I succeeded in catching up the WRITTLE Concert last eve—over 40 MILES AWAY. Will call when near your address.
A. J. PAINE.

NEED MORE BE SAID?
Complete Sets from £2 10 0

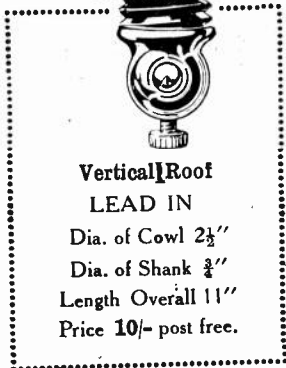

Vertical/Roof
LEAD IN
Dia. of Cowl $2\frac{1}{2}$ "
Dia. of Shank $\frac{1}{2}$ "
Length Overall $1\frac{1}{2}$ "
Price 10/- post free.

AERIAL INSULATOR

Length of Body 3". Dia. $1\frac{1}{2}$ ".
Length Overall 4". 2/6 each.
Set of four 10/- post free.



**WIRELESS
SUPPLIES CO.**

64, Mortimer Street,
LONDON, W.1

Telephone : Museum 2672

LESLIE McMICHAEL LTD.

PROVIDENCE PLACE, WEST END LANE, KILBURN, N.W.6

Bus Services 1, 8, 16, 28, 31 all pass West End Lane

Telephone: HAMPSTEAD 1261 Nearest Tube Station: KILBURN PARK (BAKERLOO)

BROWN'S TELEPHONES GUARANTEED IN PERFECT CONDITION. These Type A (Reed type) of telephones are produced in every way. They are recognised as the finest produced, are unused and guaranteed in perfect condition.

BROWN'S
HIGH RESISTANCE
TELEPHONES
8,000 ohms.

Price **55/-** Per Pair

ILLUSTRATED CATALOGUE
16 Pages. 100 Illustrations.

Write for Catalogue (W)
6d. post free.

Catalogue (W) includes list of
Complete Crystal and Valve Sets
from 95/- post paid.



To get the best
from your set use
the best phones:
BROWN'S

BROWN'S
LOW RESISTANCE
TELEPHONES
120 ohms.

Price **50/-** Per Pair

ILLUSTRATED CATALOGUE
16 Pages. 100 Illustrations.

Write for Catalogue (W)
6d. post free.

Catalogue (W) includes list of
Complete Crystals and Valve Sets
from 95/- post paid.

There is no Telephone Headgear in the World so Sensitive and so Comfortable to Wear.
We hold the largest Stock in the country of Disposal Board Apparatus, tuners, receivers, amplifiers, etc.

TEC

HIGH TENSION DRY BATTERIES for WIRELESS SETS

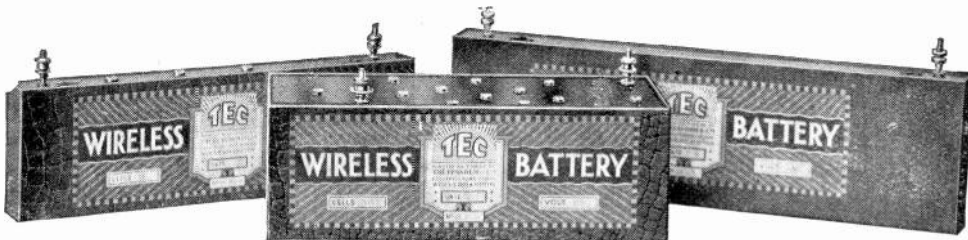

[NORMAL SIZE, No. W 70 V, 15 Volts

Price 5/-

W 71 V, 50 Volts

Price 15/-

GIANT SIZE, No. W 73, 15 Volts

Price 6/6

SUPPLIED IN TWO SIZES FOR 15, 50 or 60 VOLTS.

and with Tappings in 3 Volt Steps.

ALL BATTERIES FITTED WITH PLUG SOCKETS AND MOVABLE TERMINALS.

Complete Illustrated Price List on Application.

**THE EFANDEM CO., LTD., FALLINGS PARK WORKS,
DRY BATTERY MANUFACTURERS— WOLVERHAMPTON**

BATTERIES FOR WIRELESS

High Tension Block Accumulators

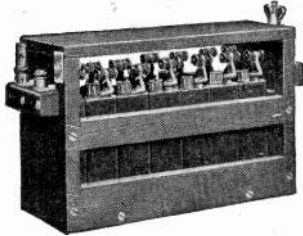

Block Accumulators, unlike the ordinary Plate Type, retain their energy for **12-18 months on one charge**. Unequaled for use with Wireless Thermionic Valves. Standardised sizes— $1\frac{1}{2}$ and 3 A.H. capacity.

Type	No. of cells	Voltage.	Capacity	Price
A 12/Z	12	24	$1\frac{1}{2}$ A.H.	\$4 15 0
A 30/Z	30	60	$1\frac{1}{2}$ A.H.	£10 0 0
A 12/K	12	24	3 A.H.	£5 15 0
A 30/K	30	60	3 A.H.	£12 10 0

Fuller Plate and Patent Block Cells (4 and 6-volt sets) are eminently suitable for Wireless Work.



Fuller "Chad" Batteries



Designed for use in supplying the anode (sheath) circuit of thermionic valves for reception purposes. Expert tests in every case confirm its superiority over the Standard Battery usually employed.

Last much longer than ordinary Dry Cells, free from risks of leakage and short circuits.

Type	No. of cells	Voltage	Capacity A.H.	Price
A	8	12	1 approx.	5/-
	10	15	1 approx.	7/-
B	8	12	$4\frac{1}{2}$ approx.	11/9
	10	15	$4\frac{1}{2}$ approx.	16/-

EBONITE—Rod, Sheet and Tube

FULLER'S UNITED ELECTRIC WORKS, LTD.

WOODLAND WORKS, CHADWELL HEATH, ESSEX.

Telegrams: "Fuller, Chadwell Heath."

Telephone: Ilford 171 (4 lines), London Telephone Area.



TRADE MARK

**The WHITECROSS
COMPANY, LIMITED
:: WARRINGTON ::**

Manufacturers of All Descriptions of

**WIRE ROPES
AND WIRES**

FOR YOUR AERIAL



100 ft. 7/22 COPPER WIRE, 4 REEL INSULATORS, 20 yd. SKEIN ROPE CORD, 1 MAST PULLEY, LEAD-IN-TUBE.

10/6

COMPLETE
Post free British Isles.

Henry J. Brewster & Co.
11, Queen-Victoria St., London, E.C.4

THE TINGEY UNIT SYSTEM

has proved its efficiency

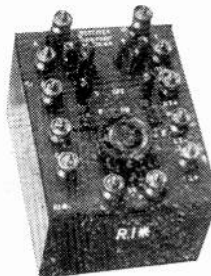

Write for

ILLUSTRATED CATALOGUE

which contains an article on Wireless Made Easy and a

Complete List of all Wireless Goods in Stock

Write for Illustrated Catalogue 3d. post free

W. R. H. TINGEY, 92, Queen Street, Hammersmith, London, W.6.

WIRELESS EQUIPMENT LTD.

Tel: GERRARD 6785.

RADIO ENGINEERS AND MANUFACTURERS
:: APPARATUS AND SPARES ::

Telegrams: WIREQUIP WESTCENT LONDON

WRITE FOR OUR ILLUSTRATED LISTS OF SETS AND COMPONENT PARTS, 3d. POST FREE
Head Office: 90, CHARING CROSS ROAD LONDON, W.C.2

THE WIRELESS WORLD AND RADIO REVIEW

THE OFFICIAL ORGAN OF THE WIRELESS SOCIETY OF LONDON
A MAGAZINE DEVOTED TO WIRELESS TELEGRAPHY AND TELEPHONY

CONTENTS

Wireless and Meteorology. By W. G. W. Mitchell, B.Sc., F.R.A.S., F.R.Met.S.	609
Some Experiments with a Kite Aerial. By E. S. and J. C.	614
An Anti-Radiation Circuit. By G. P. K.	615
A Four-Valve Station suitable for Short Wavelengths (<i>continued</i>). By Percy W. Harris	616

Contents continued on next page.

RADIO TELEGRAPHY & TELEPHONY

ALL YOUR REQUIREMENTS SUPPLIED FROM STOCK.



PULLEY BLOCKS, best galvanized, as illustrated, 2/0 post free.
SPREADERS, finest stout ash, free from cracks, 6' x 1/2" diam., 3/- each. Carriage 6d. extra.

AERIAL WIRES, best quality only supplied. Phosphor Bronze—7/20, 18/-; 7/22, 13/6; 7/25, 7/-; Copper—7/20, 15/-; 7/22, 11/6; 7/25, 6/-. All per 150' coil. Longer or shorter lengths supplied at proportionate prices.

SHELL INSULATORS.

Green porcelain, size "A," 2 1/2" square, weight 4 ozs. Price 1/8 each. Size "B," 3" square, weight 6 ozs. Price 2/2 each.



EGG INSULATORS.

As illustrated, size 1 1/2" x 1". Green porcelain. Price 9d. each. Postage extra.



REEL INSULATORS.

As illustrated, 1/2" diam., white porcelain, per dozen, 2/3, post free.

LEAD-IN INSULATORS, as illustrated, 9" long, 3/-; 12" long, 3/3. Postage 4d. extra.



32 PAGE ILLUSTRATED CATALOGUE 7d. POST FREE.

RADIO SUPPLIES (DEPT. 1), 236, HIGH HOLBORN, LONDON, W.C. 1

Phone—Museum 6894.

NOW IS THE TIME to acquire a sound theoretical and practical knowledge of **THREE ELECTRODE VALVES**, (as applied to C.W. Radio-telegraphy and Radio-telephony), by means of my **POSTAL INSTRUCTION COURSE.**

Perfectly Simple

May I Send you Particulars?

2/Lt. E. REDPATH,

19, Niger St., BARROW-IN-FURNESS

CONTENTS *(Continued)*

The Principles of Tuning in Wireless Telegraphy. By C. E. Field, B.Sc.	620
A Liverpool Amateur Receiving Station. By Samuel Lowey	624
International Amateur Wireless	627
Notes	628
Calendar of Current Events	629
Wireless Club Reports	630
Questions and Answers	633
Share Market Report	640

THE WIRELESS WORLD AND RADIO REVIEW is published weekly on Saturdays.

All correspondence relating to contributions should be addressed to THE EDITOR, THE WIRELESS WORLD AND RADIO REVIEW, 12-13, Henrietta Street, London, W.C.2.

No responsibility can be taken for MSS. or photographs sent without stamps to defray cost of return postage.

Editorial and Publishing Offices, 12-13, Henrietta Street, Strand, London, W.C.2.

Telegraphic Address: "Radionic, Rand, London." Telephone No.: Gerrard 2807.

Advertisement Managers, Bertram Day & Co., Ltd., 9 & 10, Charing Cross, S.W.1.

Telephone No.: Gerrard 8063 and 8064.

SUBSCRIPTION RATES.—

28s. per annum, post free. Single Copies 6d. or post free 7d.

Registered at the G.P.O. for transmission by Magazine Post to Canada & Newfoundland.

HOLLOW STEEL MASTS FOR AERIALS

These masts are light, strong, easily erected, and will last a lifetime. All lengths over 15ft. are made in sections and each mast is supplied complete with baseplate, finial, rope cleat, pulley sheave, guy clips, three steel guy ropes and strainers, painted one coat ready for immediate erection. Being made of steel, no lightning conductors are required

PROMPT DELIVERY.

PRICES F.O.R. FOR CASH WITH ORDER, EACH

10ft. ...	32/6	15ft. ...	42/6	20ft. ...	45/-
25ft. ...	57/6	30ft. ...	84/-	40ft. ...	126/-

Other Lengths supplied at equally Low Prices.

Trade Inquiries Invited

THE WIRELESS STEEL MAST & ACCESSORY COMPANY
Lombard Street West, West Bromwich

Telephone No. 447

2MT-WRITTLE

The Pioneer British Radio Concert

The Marconi Scientific Instrument Company, Ltd.,
are offering two

CASH PRIZES

in connection with their $\frac{1}{4}$ K.W. Radiophone
Transmission on 400 metres from

2MT ON AUGUST THE 15TH
at 8 p.m. (B.S.T.)

A number of experimental circuit arrangements will be
used on this occasion and the **FIRST PRIZE**
of **£5** will be awarded to the amateur who, in the
opinion of Capt. P. P. Eckersley, of 2MT, has
submitted the most comprehensive
REPORT UPON RECEPTION RESULTS.

SECOND and THIRD PRIZES of **£2** and **£1**
respectively will also be given.

Results will be published in an article upon 2MT
appearing in "The Wireless World" of Sept. the 9th.

LISTEN—IN!

Reports should reach the undermentioned address
not later than August the 21st.

THE MARCONI SCIENTIFIC INSTRUMENT Co. Ltd.
RESEARCH DEPT.,
21-25, St. Anne's Court, Dean Street, Soho, London, W. 1

Telephone : Gerrard 7745.
(Private Branch Exchange).

Telegrams : Themasinco,
Westcent

Codes : Marconi International,
A.B.C. 4th & 5th Ed.

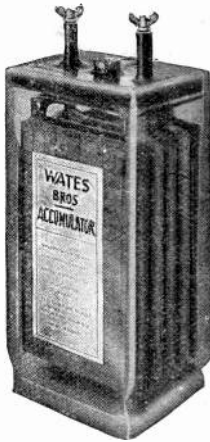

Ideal Valve Accumulator.
50 Amps.

By far the best value in Accumulators on the market. Ask those who already have them.

2 volts ..	10/-
4 " ..	20/-
6 " ..	30/-

Carriage.

2 volts ..	1/-
4 " ..	2/-
6 " ..	3/-

Dimensions of each cell 8 x 4 x 3.
Weight without Acid 5½.



Brown Sterling Phones.

Multi-Magnet Type
The world renowned headphones giving unsurpassed efficiency.

120 ohms ..	48/-
2,000 " ..	51/-
4,000 " ..	52/-

Complete with best quality cords.

WATES for
VALUE, QUALITY and EFFICIENT SERVICE

Illustrated Catalogue of complete sets and component parts sent free on request.



High Tension Battery.

Wates Specialty.
15 volt, 11 cell standard size 9½" x 7" x 2½".
Price 3/6 each.

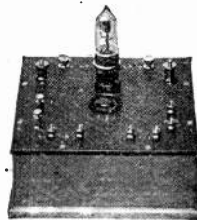

A De Luxe Crystal Set

of remarkable efficiency. Capable of receiving broadcasts up to 35 miles from high power sending stations, also special coil for receiving Paris time signals. Supplied in handsome polished teak cabinet with hinged lid and best quality high resistance phones

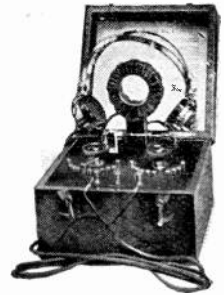

Price £7 12 6

A one valve panel suitable for receiving broadcasts up to 50 miles. Specially constructed, carefully tested, and supplied complete with full instructions for working.
Price £4 each (without valves)

VALVES

We Stock.
Mullard's "Ora" 15/- each.
Marconi - Osram R Type 28/6 each.



WATES BROS.
WIRELESS ENGINEERS
13-14, G. QUEEN ST., KINGSWAY, LONDON, W.C.2
Phone GERRARD 576 Telegrams ZWATESENG WESTCENT

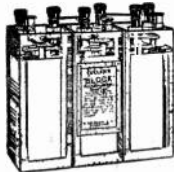

Important Announcement to the Trade

LIVE AGENTS WANTED IMMEDIATELY IN ALL PARTS OF THE COUNTRY TO STOCK
FULLER BLOCK ACCUMULATORS
FOR WIRELESS PURPOSES.

There is an unprecedented opportunity for the retailer to build up a wide connection amongst wireless enthusiasts by supplying a really efficient Accumulator, one that is fool-proof, an important factor when the same is to be used by the Amateur.

Don't run the risk of making a dissatisfied customer by supplying a plate-type battery, which will not hold its charge when not in use. The E.M.F. of the "Block" cell will not fall below 2 volts even if left unattended for a period of 12 to 18 months.

We are about to establish reliable

ACCUMULATOR CHARGING STATIONS throughout the country in readiness for the rush of business which is sure to follow as the broadcasting scheme is launched.

If interested, please write to "AGENCY"

THE CITY ACCUMULATOR CO. (Dept. 88)
79, MARK LANE, E.C.3

Phone : Avenue 91 (3 Lines) Telegrams : Tyche, Fen. London

EBONITE AND VULCANITE

TUBES-RODS-SHEETS

LARGE STOCKS

BRITANNIA RUBBER AND KAMPTULICON CO., LTD.
7, NEWGATE ST., LONDON, E.C.1
Telephone : 2168 Central Telegrams : Britannia, London

THE WIRELESS WORLD AND RADIO REVIEW

THE OFFICIAL ORGAN OF THE WIRELESS SOCIETY OF LONDON

VOL. X. No. 20.

AUGUST 12TH, 1922.

WEEKLY

Wireless and Meteorology

By W. G. W. MITCHELL, B.Sc., F.R.A.S., F.R.Met.S.

THERE are many classes of the community to whom the weather conditions are of the utmost importance. The aviator, the sailor, the farmer, the holiday-maker and motorist are all interested in the weather, though in very different ways. For whereas some of these are chiefly interested in present weather conditions over a large *area*, others are more naturally concerned with future weather conditions spread over a considerable period of *time* (*i.e.*, in weather forecasts). Yet again, for each of the classes mentioned there are problems of very special concern. The aviator is more naturally interested in the strength and direction of the wind and the visibility and amount of cloud in the atmosphere above the ground. This is specially so in the cross-channel flights (see Fig. 1). The farmer, on the other hand, naturally seeks information of future weather, likely rainfall and sunshine. It will thus be apparent that any organisation which attempts the dissemination of meteorological data must be far-reaching both in regard to the area covered and the diversity of the elements recorded and transmitted. But in any case there must be included a great deal of information which does not interest individual members of the community. This difficulty has to some extent been overcome in France by the issue of a special "Agricultural meteor" at 0710 G.M.T. daily, intended for farmers. For this purpose France is divided into several regions and a forecast for the next 24 hours for each district is sent in plain language by telephony.

During the war, the demand for early meteorological information became very acute, and although codes for use in weather telegraphy had been devised as far back as 1875,

they were not sufficiently comprehensive for the more immediate needs of war. The impetus given by the war has no doubt brought about a more general interest in meteorology, and the immense amount of data now dealt with requires the use of a code for the sake of brevity.

In the organisation of a meteorological service three problems are involved, namely, the collection, exchange and distribution of reports. The following brief outline deals with the services undertaken in this country:—

(i) The collection of observations of present weather from a number of stations embracing the British Isles and the surrounding regions. Nearly 60 stations are now included in this network and report daily to the Meteorological Office at the Air Ministry. In this country reports are collected by W/T from about ten stations, and the remaining reports are collected by telegram and in certain cases by telephone. The reporting stations are of different kinds:—

(a) A first-order land station or normal Meteorological Observatory is one at which *continuous* records or hourly readings of the following elements are taken: air pressure, temperature, wind, sunshine and rain, with eye observations at fixed hours of the amount, form and motion of clouds, together with notes on the weather.

(b) Second-order stations: observations are recorded daily at two fixed hours at least of pressure, temperature (wet and dry bulb), wind, cloud and weather, with daily maxima and minima of temperature, daily rainfall and general remarks on the weather. In some cases the duration of bright sunshine is added.

(c) Third-order or auxiliary stations are

of the same kind as (b), but report either (i) less full or (ii) observations taken once a day only, or (iii) observations taken at other than the recognised reporting hours. Besides reports from these 60 stations, the Meteorological Office exchanges reports with nearly all the principal meteorological

observatories in Europe. Reports from ships on the Atlantic are also received by W/T and are often of great value to the professional meteorologist at headquarters when making a forecast. They are often indicative of impending changes on the western seaboard, and their value will be referred to later.

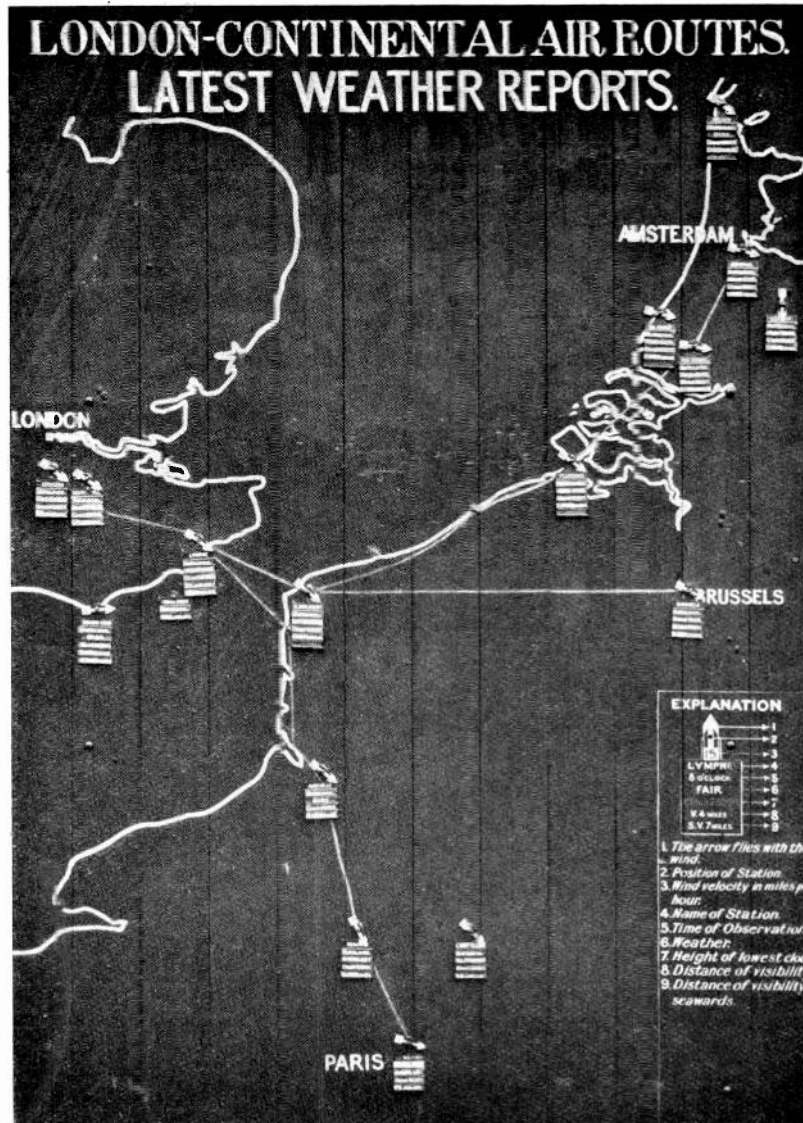

Fig. 1. Weather chart for the guidance of pilots at the London Terminal Aerodrome. The chart gives in a graphical form, information of great value to the airman. Wind, weather, cloud and visibility observations along the route are shown by means of the arrows and indicators which are frequently "set" by the meteorological staff at the Aerodrome from reports received by W/T.

The central Meteorological Office translates the individual reports into a graphical form by entering the chief elements on a map. These maps, or *synoptic charts*, give a general impression of the present weather at a certain instant of time over a very large area (compared with the area covered by individual reports).

They are the basis of modern forecasting. The trained meteorologist thinks in maps.

The most general thing which could be said about the weather is that it is constantly changing, or perhaps more precisely, it is constantly subject to change. It is consequently necessary to devise means for rapidly



Fig. 2. Croydon Aerodrome Meteorological Station. "Atmospheric" D.F. Apparatus, or "Thunderstorm Finder"—an auxiliary investigation carried out in the field of meteorology by means of wireless.

making known in a comprehensive form the various changes which are going on in the atmosphere. As we have indicated, before the war there was no national distribution, although some headway had been made by the publication of charts and forecasts in the daily newspapers. Information through these channels was of necessity several hours old. W/T furnishes a means of rapidly broadcasting this information.

The distribution now carried out by W/T from the Meteorological Office comprises three distinct forms of report.

(a) The "general inference" which is issued in plain language (Morse code) at 0915 and 2000 G.M.T., and of which the following is a specimen: Saturday, July 29, 1922. "General inference from observations at 7 p.m. (18 h.):—A secondary depression has developed off South-west Ireland and will probably move north-eastward, causing rain in the west and north. Over the midland, southern and eastern districts the weather is likely to continue mainly fair with moderately high temperature." This general inference embraces the whole of the British Isles, and its very general character is evident at once.

In drawing any conclusions from a *single* inference, great care must be exercised. However, if this inference is used in conjunction with a synoptic chart drawn up a few hours previously (as for example those published in several of the daily newspapers), a good general idea of the changes likely to come about in any particular area can generally be estimated. A similar forecast is issued for the "western seaboard" from Clifden, and particulars of these transmissions is given in the table below:—

(β) Coded forecasts for various districts in the British Isles are also issued. They are sent in code for the sake of brevity, but they would be of greater value if they could be sent in plain language in a similar form to the French agricultural meteor.

The districts covered are roughly as follows:—

Group III.—Southern England (central part): Dorset, Wiltshire, Berkshire, Hampshire.

Group 222.—South-east England: London, Middlesex, Essex, Surrey, Sussex and Kent.

Group 333.—Yorkshire, Lincolnshire, Nottinghamshire.

STATIONS TRANSMITTING METEOROLOGICAL INFORMATION IN GREAT BRITAIN.

Station.	Call Sign.	Latitude.	Longitude.	Wave-length.	Nature and Time of Transmission (G.M.T.)
Air Ministry	GFA	51° 31' N.	0° 07' W.	1,400 C.W.	Synoptic data for 0100 sent at 0200.
Air Ministry	GFA	51° 31' N.	0° 07' W.	4,100 C.W.*	Synoptic data for 0100 sent at 0600.
Air Ministry	GFA	51° 31' N.	0° 07' W.	4,100 C.W.	Synoptic data for 0700 sent at 0800.
Air Ministry	GFA	51° 31' N.	0° 07' W.	4,100 C.W.	Synoptic data for 1300 sent at 1400.
Air Ministry	GFA	51° 31' N.	0° 07' W.	4,100 C.W.	Synoptic data for 1800 sent at 1900.
Air Ministry	GFA	51° 31' N.	0° 07' W.	1,680 C.W.	Aviation reports at 0335, 0435, 0535, 0635, 0735, 0835, 0935, 1035, 1135, 1235, 1335, 1435, 1535, 1635.
Air Ministry	GFA	51° 31' N.	0° 07' W.	1,300 C.W.	Coded district forecasts sent at 0900 (approx.), 1500 (approx.) and 2000 (approx.)
Air Ministry	GFA	51° 31' N.	0° 07' W.	4,100 C.W.	General inferences sent at 0915 and 2000.
Clifden (Ireland)	MFT	53° 27' N.	10° 1' W.	5,750 spk.	Western seaboard forecast and data issued at 0950 and 2150.
Croydon ..	GED	51° 21' N.	0° 08' W.	900 C.W.	Radio-telephonic communication with aircraft in flight.
Lympne ..	GEG	51° 05' N.	1° 01' E.	900 C.W.	Radio-telephonic communication with aircraft in flight.
Renfrew ..	GER	55° 52' N.	4° 24' W.	900 C.W.	Radio-telephonic communication with aircraft in flight.
Renfrew ..	GER	55° 52' N.	4° 24' W.	1,300 C.W.	Meteor reports to Air Ministry at 0705, 1005, 1305, 1605, 1805.
Lerwick ..	GEL	60° 09' N.	1° 10' W.	900 spk.	Meteor report (Reykjavik) to Air Ministry at 1005.

* Note.—In cases of breakdown of the main set or other delay in commencing transmission on 4,100 m. the message will be issued on 1,400 m., commencing 10 minutes after the routine time.

Group 444.—South-east Scotland (places within a 50 mile radius of North Berwick).

Group 555.—South-west England: Devonshire and Cornwall.

Group 666.—North-west district: Lancashire, Cheshire, Shropshire and North Wales.

Group 999.—England and Southern Scotland taken collectively. The forecast for this group is appended to the "general inference" issued at 2000 G.M.T.

(γ) Synoptic reports are issued in code. The information contained in these messages, when plotted on a chart, graphically describe the distribution of barometric pressure (reduced to sea level and to a temperature of 32° F. in latitude 45°), the direction and velocity of the wind, the state of the sky and/or sea and the character of the weather from simultaneous observations taken at certain fixed meteorological stations on land supplemented by information transmitted by ships. To make full use of these transmissions, the amateur requires some knowledge of the principles of meteorology. A brief explanation of the

method adopted will be given in a future article.

The table on page 612 gives a complete list of regular transmissions of meteorological data in Great Britain.

The main problems involved in the application of W/T to the science of meteorology have been indicated above. There are, of course, other matters such as the electrical, optical and acoustical phenomena occurring in the atmosphere which are closely allied to the science of meteorology. Among these auxiliary problems, W/T has been used in the location of thunderstorms. Fig. 2 shows the form of direction finding apparatus employed at the meteorological station at Croydon. A frame aerial is installed in the room above the instruments. A wavelength of 30,000 metres is used, and the number of "atmospherics" heard in different directions in 15 seconds is counted. During the war this method was extensively used by the D.F. stations of the Admiralty in locating the position of thunderstorms by determining the direction from which the radio disturbances created by a storm were received.

Litzendraht

Its value in the Construction of Tuning Coils.

IT is not generally realised, I think, what a great aid to efficiency is to be found in the use of Litzendraht for tuning coils. It is perhaps as well to explain here that this is a form of wire made up of a large number of fine separately insulated strands, which has the valuable property of very low high-frequency resistance (that is, when compared with a solid conductor of equivalent direct current resistance). Such wire is extremely desirable in all circuits whose damping cannot be annulled with reaction, such as the aerial circuit of a loose-coupled tuner where the reaction coil is coupled to the secondary circuit, its use giving stronger signals and sharper tuning. The objection to Litz, of course, is its cost, but this is not very heavy for short-wave coils, and it is greatly to be desired for all waves below 600 metres. It is even arguable that it should be used for circuits which are boosted

with reaction, for some authorities, while agreeing that it can compensate for the flatness of tuning which results from high resistance coils, hold that reaction cannot altogether make good the loss of signal strength.

The only difficulty likely to be met with in using Litz is the matter of making connection to the ends of the coil. Soldered connections are absolutely essential, and care must be taken to see that every strand is well tinned and soldered into the joint. If the strands are enamelled and silk-covered it may be found a little difficult to bare them for tinning without damaging them. The safest way to do it is to carefully scrape off the silk and then burn off the enamel by placing the wire momentarily in a relatively cool flame, such as a match or candle. More careful scraping will then produce a clean surface to tin.

G. P. K.

Some Experiments with a Kite Aerial

By E. S. AND J. C.

THERE will be some amateurs who are thinking about field days with a portable set now that the fine weather is here. Their thoughts may naturally turn to the possibilities of a kite aerial.

The writers give below some details of the results of several outings spent on the Yorkshire moors with a valve set and a kite aerial.

The receiver was a Mark III converted to a single valve set with a wavelength range of 160 to 20,000 metres. The accumulator and H.T. were carried in a separate box. The aerial, a kite, was constructed on the following lines, after the well-known "fin" type. The length was 6 ft. and the greatest breadth 4 ft. Two strong bamboo canes formed the sticks; light calico was used for the covering. The complete kite weighed 14 ounces. A "tail" consisting of six dusters and handkerchiefs was used. We first tried an aerial of 20 S.W.G. steel piano wire, to be on the safe side for strength and as a guide to the lifting power of the kite. In a light wind, about 10-20 m.p.h., the kite easily lifted 600 feet of this wire and remained flying very steadily. We

might mention that a winch constructed out of a large sea-fishing reel was used to wind in the wire. The antenna system was completed with an earth pin, simply a 2-ft. brass



Kite-lifted aerial comprising 600 ft. 20 S.W.G. steel piano wire.

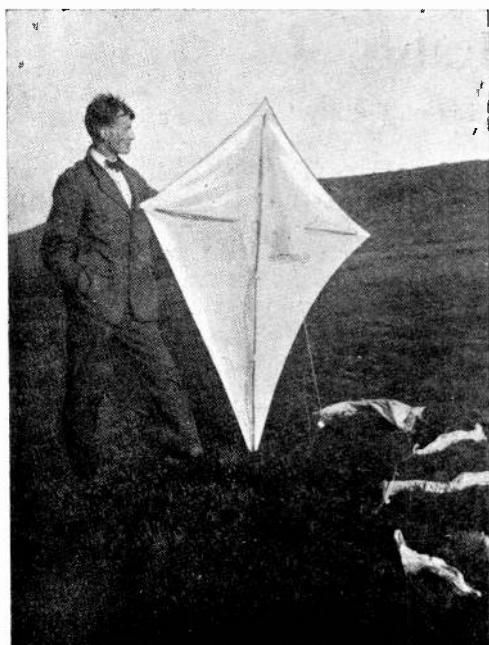

Kite used in successful experiments with portable aerial.

rod driven into the heather and a lead soldered on.

We tried reception on the above aerial, inefficient as it must have been, with 600 ft. of wire out. The long wave stations, Carnarvon, Rome, Lyons, etc., came in louder than on two valves with a good P.M.G. aerial. The aerial was reeled in for 300 feet for shorter waves, a small series condenser being used. Ship stations could be read with telephones on the ground. The strength of signals on the lower waves, 300 to 450, was extremely good. 2 FQ, both speech and music, was heard nicely until BVN chipped in and about burnt the telephones out! Local amateurs, 2 QK especially, were very strong. On these short waves we found no fluctuation of wavelength from any swinging of the aerial.

Encouraged somewhat by the results obtained from the steel wire we tried one of copper,

bare 20 S.W.G., using the same tackle as before. Results with this were considerably better of course and, since it was Sunday afternoon, we tested signals on the Dutch concert. This came in comfortably strong and with a stage or so of low-frequency amplification would have been readable out of a loud speaker.

tried a counterpoise earth, simply a 300 ft. length of bare copper wire, 18 S.W.G., laid along the top of the dry heather directly under the aerial and connected to the earth terminal. Signals were not much stronger by this method, but it was found that the set would oscillate much more readily and enabled us to get down to a lower wavelength, using more aerial wire than before.

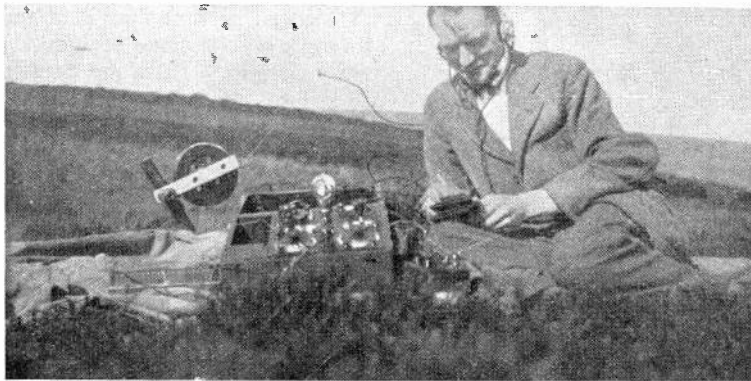

Mark III Receiver converted to single valve set with 160 to 20,000 metres range.

Of course we had the usual interested passers-by who wanted to listen to "wireless music," and there was some competition for the spare headphones.

the plates and a continuous ticking is heard in the telephones.

As a comparison with the earth pin we

Our height above sea level was about 950 feet, that is to say, for the bottom of the aerial; the direction of wind was W.N.W.

An Anti-Radiation Circuit

THOSE amateurs who use the well-known "tuned plate circuit" method of H.F. amplification have it in their power to adopt an extremely simple device to prevent radiation from their sets when oscillating. The device, though not new, is by no means so widely known as it deserves to be. It consists in reacting into the tuned plate circuit instead of the aerial circuit, and it results (in the case of a well-arranged set, *i.e.*, one in which the various circuits are well separated) in complete freedom from radiation when the set is oscillating for the reception of C.W. or searching for carrier-waves. (It is surely unnecessary to explain that no set should ever be allowed to oscillate when receiving telephony?)

The arrangement of a typical circuit employing this device is shown in the figure. Two points which should be noted are, firstly, that the reaction coil only needs about half the number of turns which would be required to

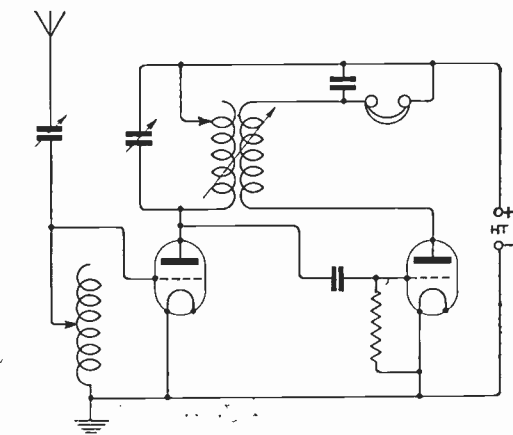

react into the aerial circuit, and secondly, that since the damping of the aerial circuit can no longer be reduced with reaction it must be kept as low as possible by using low-resistance wire and the very best of insulation throughout.

G. P. K.

A Four-Valve Station Suitable for Short Wavelengths *(continued)*.

By PERCY W. HARRIS.

3.—THE TWO-VALVE L.F. AMPLIFIER *(continued from page 509)*.

THE third unit of the four-valve set is a two-valve low frequency amplifier, fitted with a switch so that one or two stages of note magnification can be used at

In the first place, this note-magnifier unit is designed to work off the same accumulator as the previously described H.F. and detector unit, and a separate H.T. battery need not be used. It will be noticed that there are H.T. terminals on each of the two units.

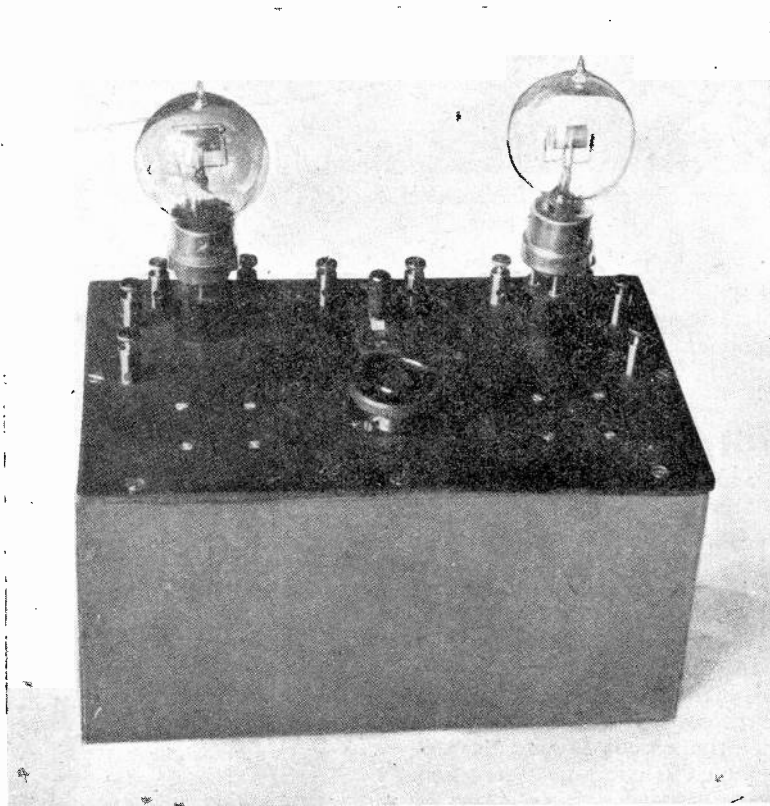

Fig. 1. Photograph of the two-valve amplifier.

will. The general appearance of the unit can be gathered from the photograph, Fig. 1. The construction in detail is shown in the drawings. The circuit is of conventional design, but there are one or two details which require special mention.

When both units are used together the H.T. battery should be connected to the terminals on the note-magnifying unit, those on the H.F. and detector unit being left disconnected.

The second point is the provision of

terminals for grid cells or potentiometer. A study of the valve as an amplifier shows that, with most valves, much better results are obtained if the grid is maintained at a constant negative potential. This negative potential can be obtained either with a potentiometer connected to two or three dry cells or by placing one or two cells in the circuit of the grid. The first arrangement yields a finer adjustment, but has the disadvantage that the cells are continually running down through the winding of the potentiometer. Grid cells in circuit can be varied only in steps of $1\frac{1}{2}$ volts, but will last for a long period as the current taken

described by which the telephones could be connected to the plate of any particular valve of a multi-valve set, the valves not in use being switched off. In the case of the writer's instrument the method was not entirely applicable as it stood, as it was desired to use but one filament rheostat, for the reason that both valves perform the same function and can be controlled together. When only one filament rheostat is used for two or more valves, switching off one of them will mean a sudden increase in brilliancy of the remaining valve or valves, which is undesirable. The switching method was therefore modified so that besides changing

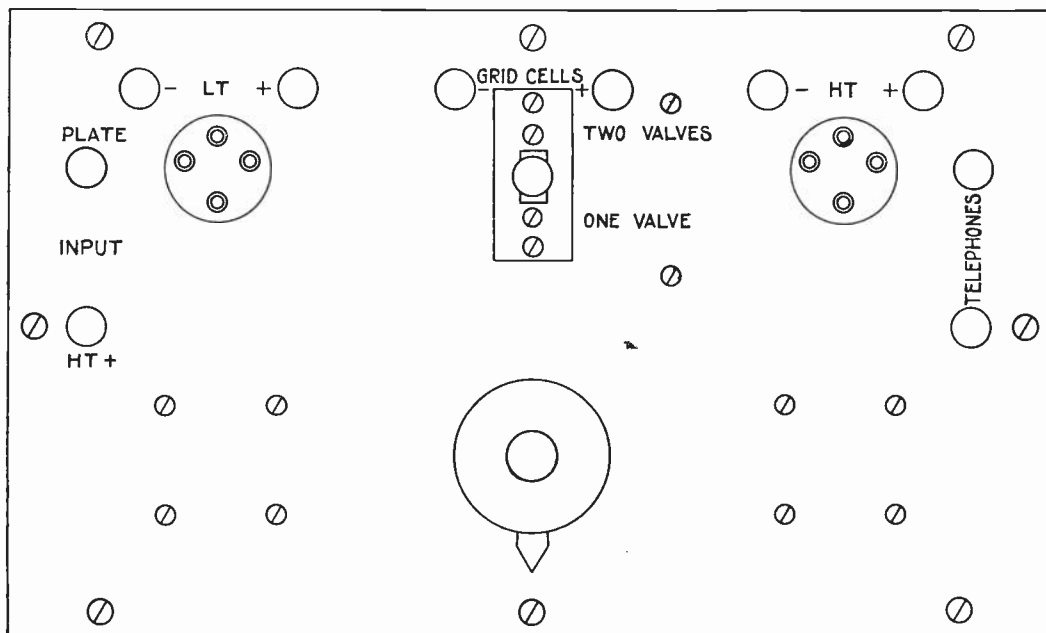

Fig. 2. The lay-out of the panel.

from them is extremely small. In the instrument described, terminals are provided for grid cells, and the writer usually connects two or three cells in series between the terminals marked. If desired, the terminals can be shorted, whereupon the grid is maintained at approximately zero potential, but distinctly better results are obtained with cells in circuit.

The switch to change from one valve to two is of the telephone switchboard type. The method of switching was suggested to the author by the article in the May 14th, 1921 issue of *The Wireless World*, p. 118. In the article referred to, a method was

the telephones from one plate to another, when the first valve only is used, the plate circuit of the last valve is broken. So long as both valves are in their sockets both filaments will be alight, even if one is not in use. When one valve alone is used for a considerable period the second can be removed from its socket and the filament resistance readjusted. Of course, if two separate filament resistances are used, the switch can be made to break the filament circuit of the second valve instead of the plate circuit. The writer did not consider the advantage so gained to be worth the cost of a further filament rheostat, but others may think differently. The modification necessary

to arrange this will be understood on studying the circuit diagram, Fig. 4.

Two fixed condensers are used, one across the high tension terminals (0.01 mfd.) and one across the telephone terminals (0.002 mfd.). This last is not very important in practice. All connections are soldered and the condensers are secured by the method described in the last article.

As first made up, the set was found to be oscillating at a frequency above audibility, this was amplified suffering considerably. This was at once remedied by connecting together the primaries of the transformers in the way

take a file and carefully file away the ebonite until the limits of the marking are reached. It is not easy to do this, but on the other hand it is not so difficult as it sounds.

The intervalve transformers should be chosen carefully, and the dealer from whom they are purchased should be asked what type of valve they best suit. Certain transformers work best with certain valves. The army intervalve transformers, for example, work very well with V24's. Beware of cheap intervalve transformers of unknown make. They may burn out with strong signals and prove very expensive in the long run.

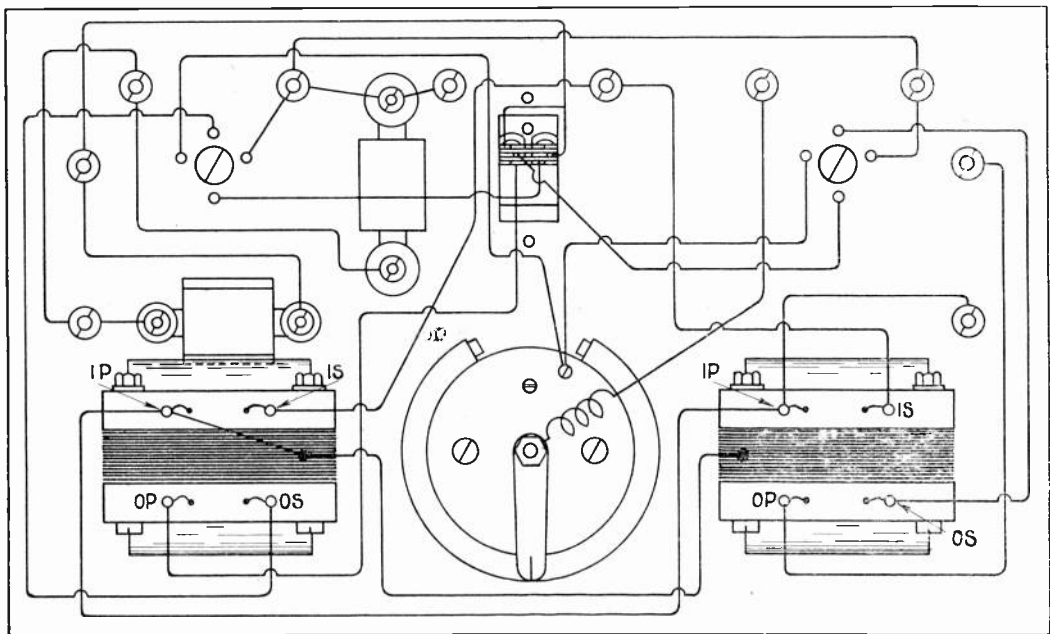

Fig. 3. Wiring of the instrument.

shown. At the same time the two cores were connected together, and to the positive pole of the H.T. battery. By making these two modifications all trouble from self oscillation ceased and the magnification was all that could be expected.

In view of the fact that full constructional details were given in the previous article, little need be said here regarding the actual fitting of parts and the connecting up. The most difficult matter is cutting an oblong hole to take the telephone switch. To do this, mark out on the panel the shape and size of the hole and then drill a number of round holes until the middle of the square falls out. Then

The transformers are best secured to the panel by drilling holes right through the ebonite of a size sufficient to allow clearance for a 6 BA screw with cheese head. The upper part of the hole should then be recessed with a drill of the size of the cheese head for just sufficient depth to allow the cheese head to fit flush when in place. To mark the position of the holes place the transformer in position and pencil through the openings in the frame. When the holes have been drilled and the screws pushed through, the transformer can be fitted over them and secured with nuts as shown.

Whatever transformers are used, see that

the I.P., O.P., I.S. and O.S. terminals are connected as shown.

Other constructional details will be evident from the Figures 1, 2, and 3. If desired, clips for V.24 valves can be fitted instead of four-pin sockets, as the V.24 is a very good L.F. amplifying valve with most transformers.

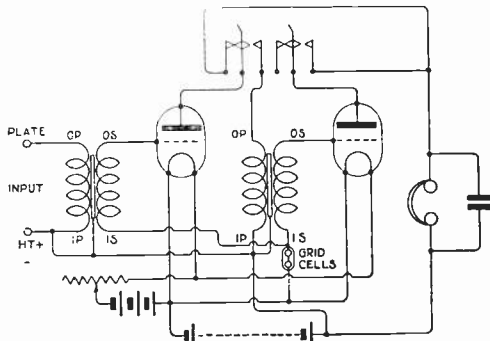

Fig. 4. The Circuit diagram.

NOTES ON THE COMPLETE STATION.

The writer ventures to think that any reader who follows the instructions given in these articles will be well satisfied with the station so built. At first there will be a little difficulty in tuning to signals, but after a little practice the difficulty will disappear. In most cases excellent results will be obtained on "stand-by," with the condenser in parallel, and probably the majority of work will be done in this fashion. For the highest selectivity the "tune" adjustment is advisable, although it is rather more difficult to operate.

Readers who have a complete set of plug-in coils will be able to use the reactance-capacity method up to about 7,000 or 8,000 metres, with a 0.0001 mfd. condenser. Very little loss of efficiency will be found on long wavelengths with a larger condenser, so that much higher figures can easily be reached. With the resistance unit the longest waves can be received quite efficiently, and with much greater ease of tuning. For long waves, however, the writer prefers his three-valve set described in the issues of April 1st and 8th, using the new tuner in place of the converted "Mark III.," and with one of the note magnifiers added if four valves are required. There is little to choose between the two in regard to signal strength, the preference being largely due to the convenience of handling.

If it is found inconvenient to handle the reactance-tuning condenser behind the second unit, it can be stood in front and flexible leads

taken across the instrument. All tuning condensers will then be in front of the set.

It is always advisable to use a telephone transformer, and this is best fitted in a separate box which can be connected either to the output terminals of the two-valve H.F. and detector unit, or to the output terminals of the note-magnifier unit. In this way, with only one telephone transformer, the set can be used with two, three or four valves and with a minimum of switching.

When listening to telephony it will rarely be necessary to use all four valves, except when a loud speaker is used.

It will be found very convenient to make a special box for the H.T. battery. The writer encloses five 15-volt units in a box just big enough to take them, the lugs being soldered together so as to give a total voltage of 75. The lid of the box is fitted with an ebonite strip with five large terminals, for negative 30 v., 45 v., 60 v. and 75 v. (positive).

Connections from the aerial and earth to the set are made with silk-covered electric lighting flex, the bared ends of the two wires being joined and soldered to tags. Leads to the L.T. and H.T. batteries are made of the same flex, the positive wire being knotted at each end so as to avoid confusion. The fact that the wires are twisted together is no disadvantage whatever in the case of the L.T. battery, and in the H.T. leads it is a distinct advantage, as the capacity effect adds to the value of the condenser shunted across the H.T. battery! Twisted electric lighting flex is also used for the connection between the two units, and from the telephone terminals to the telephone transformer.

Finally the whole set is placed within an oak bureau from which the pigeon-holes and other impedimenta have been removed. Interchangeable coils, H.T. battery, separate heterodynes, spare telephones and the like are placed in the drawers below, so that the whole station is self-contained.

Note.—In the last article the H.T. negative of the H.F. and detector unit was shown connected to the L.T. positive. It should be connected to the L.T. negative if it is desired to use one accumulator for both units. The change is very simply made without disturbing other connections. There will be no difference in signal strength or efficiency.

So far thirty-four of the telephony transmitters listed in *The Wireless World and Radio Review* for July 1st have been heard on this set.

The Principles of Tuning in Wireless Telegraphy

By C. E. FIELD, B.Sc.

WHEN an amateur first takes up wireless telegraphy, he finds that the successful working of an installation depends upon certain electrical circuits being "in tune" with one another, and one of his most important pieces of apparatus is a "tuning coil." He is, however, frequently at a loss to know exactly what is meant by two circuits being "in tune," and if he endeavours to find out from a text-book he will probably be confronted with pages of mathematics which are of very little assistance.

Electrical tuning, however, which is the basis of satisfactory wireless transmission or reception, can be simply explained with the aid of analogies drawn from mechanical experiments, once the working of an electric circuit is thoroughly understood.

Consider first an ordinary steam engine. Steam from the boiler exerts pressure on a piston and produces mechanical movement. The greater the steam pressure, the faster will the piston travel, or in other words, the greater will be the amount of movement in a given time. Also, for a given speed, the pressure required depends upon the resistance that is offered to the motion of the piston.

In an electrical circuit, electrical pressure, or voltage, is supplied from some source, and produces a *movement of electricity*, i.e., an electrical current. The greater the electrical pressure, the greater is the current it produces, and for a given current to flow, the pressure required depends upon the resistance of the circuit. This result is known as Ohm's Law, and is concisely expressed by the equation $V = IR$, an expression probably familiar to all readers.

Referring again to the steam engine, we know that if pressure is applied alternately to each side of the piston it will cause the latter to travel backwards and forwards, the speed of the piston being greatest in the centre of its stroke. In other words, an alternating steam pressure produces an alternating movement.

Similarly, in an electric circuit, an alternating or rapidly reversing voltage produces an

alternating current, and Ohm's Law holds good for an alternating current circuit just as for a direct current circuit.

There are two other properties besides resistance which every electric circuit possesses in a greater or less degree. These are *inductance* and *capacity*, and it is these properties which are of the greatest importance in circuits connected with wireless telegraphy, and will now be discussed.

INDUCTANCE.

Any conductor carrying an electric current is surrounded by "lines of magnetic force," the number of which depends upon the value of the current flowing. If the value of the current changes, therefore, the number of lines of magnetic force changes, the lines either growing outwards in concentric circles from the centre of the conductor or shrinking into the conductor, which is cut by the lines of force as they do so. Now, whenever lines of magnetic force and a conductor cut one another, a voltage is set up in the conductor proportional to the number of lines of force cut per second.

Hence the changing magnetic field caused by a changing current produces a voltage in the conductor carrying the current, and this voltage acts in such a direction as to tend to maintain the current at its former value. i.e., a back voltage is set up by an increasing current, and a forward voltage by a decreasing current.

The inductance of a circuit is a measure of the voltage set up by a given rate of change of current. If a rate of change of current of 1 ampere per second causes 1 volt to act in the circuit, the inductance of the circuit is 1 henry. If 2 volts are set up, the inductance is 2 henries, whereas if a rate of change of 2 amperes per second were required to produce 1 volt, the inductance would be $\frac{1}{2}$ henry, and so on.

Inductance is thus a property of a circuit which *opposes any change in the value of the current flowing*. An alternating current, therefore, which is continually changing, encounters considerable opposition in an inductive circuit.

To obtain a mechanical property comparable with inductance, we must find that which tends to prevent any alteration in the rate at which a body moves. Inertia, or momentum, does this, and so a moving body with a large moment of inertia, such as a heavy pendulum, or flywheel, may be compared with an inductive circuit carrying current. A flywheel can only be brought up to speed, or brought to a standstill gradually, and a very great alternating force would be required to cause it to oscillate rapidly backwards and forwards through a small arc.

CAPACITY.

A condenser, which is the apparatus employed to give a circuit a large amount of capacity, consists essentially of a layer of insulating material such as mica or air, sandwiched between two metal plates.

When a voltage is applied to one of the plates, a current flows into the condenser, and fills, or "charges," it with a certain quantity of electricity. As the charge increases, the electrical pressure on the plate rises, in opposition to the impressed voltage, until the two pressures are equal, when no more current will flow into the condenser. The capacity of a condenser is a measure of the current required to produce a difference of pressure between the plates of 1 volt in 1 second. If this is brought about by a current of 1 ampere the capacity of the condenser is 1 farad. If 2 amperes are required, the capacity is 2 farads, and so on.

When a condenser is put in a closed alternating current circuit, the pressure on one plate relative to that on the other is alternatively raised or lowered, so that when one plate is gaining a charge of electricity, the other is losing a similar charge. A current therefore flows first into one plate and out of the other, and then in the reverse direction, so that an alternating current appears to go *through* the condenser.

The greater the capacity of a condenser, the greater is the current that flows into it when a definite voltage is applied, so that in an alternating current circuit the amount of current going "through" a condenser depends upon its capacity, *i.e.*, the greater the capacity of a condenser, the less the opposition it offers to an alternating current.

When a condenser is being charged, the back voltage across the plates increases, and so the current flowing becomes less and less, and finally stops. Thus, unlike an inductance,

a condenser is always *trying to charge the value of the current.*

A comparison may be made between a condenser and a steel spring. If, say, a steel rule is gripped at one end in a vice, and the free end is bent backwards and forwards, the greater the deflection of the rule the greater is the pressure required to bend it any further, and if the pressure is kept constant, the slower does the movement become. The more flexible the rule, the greater is the movement that can be produced in a given time by a given pressure.

Thus the flexibility of the rule may be compared with the capacity of the condenser. THE EFFECT OF DIFFERENT FREQUENCIES.

We must now see what is the effect produced by altering the rapidity, or frequency, with which an alternating pressure is applied to a circuit containing inductance or capacity.

If the pressure (or torque) applied to a heavy flywheel is very rapidly alternated, the flywheel will never have time to "get going" in either direction, and so very little movement will take place. Similarly, if a very rapidly alternating (or high frequency) voltage be applied to an inductive circuit, very little current will flow.

Thus the resistance effect due to an inductive circuit depends upon the frequency of the current, or voltage, as well as upon the value of the inductance. It can be shown that if a voltage of frequency f cycles per second is applied to a circuit of inductance L henries, the resistance offered to the current is given by $2\pi fL$ "apparent ohms," so that for an inductive circuit, neglecting any resistance, we can write Ohm's Law thus:—

$$V = C \times 2\pi fL.$$

If a rapidly alternating pressure is applied to the rule held in the vice, there will be no time for the rule ever to be deflected far in either direction, and so it will never offer much resistance to movement, which will consequently be very rapid.

Similarly, a high frequency voltage will send a large current "through" a condenser, or in other words, a condenser offers little opposition to high frequency currents.

Hence the resistance effect of a condenser varies *inversely* as the frequency, and also as the capacity, and it can be shown that Ohm's Law for a condenser is

$$V = I \times \frac{1}{2\pi fC}$$

where C is the capacity in farads.

Now we have seen that whereas an inductance always tries to *prevent* a current from changing, a condenser always tries to *make* a current change. The resistance effects of the two at any instant, therefore, work in opposite directions, so that in a circuit containing both inductance and capacity, the resistance effect of the two combined is the *difference* between their individual effects.

In such a circuit, therefore,

$$V = I \times \left(2\pi fL - \frac{1}{2\pi fC} \right),$$

the term in brackets being known as the *reactance* of the circuit, to distinguish it from the ordinary resistance, which is being neglected in the cases under consideration.

Let us now consider the circuits used in connection with wireless telegraphy.

The simplest, but fundamental wireless transmitting circuit consists of a condenser and an inductance coil joined in series, the two being shunted by a spark gap, the ends of which are connected to a high tension supply, such as an induction coil. (See Fig. 1.) When the electrical pressure is applied to the circuit, a current flows and charges the condenser. The pressure across the spark gap will always be the same as that across the condenser, and so, as the latter becomes charged, it is increased until it becomes too great for the electric strength of the air in the gap. When this occurs, the condenser discharges across the gap by means of a spark.

This action could be imitated by bending the rule in the vice, and letting it fly back. As there was some inductance in the electric

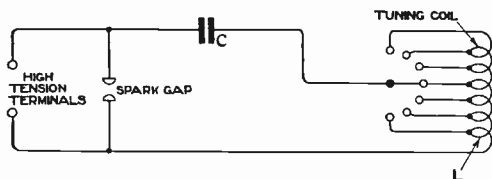

Fig. 1. Simple Transmitting Circuit with Fixed Capacity and Variable Inductance.

circuit, however, to make the comparison complete we must add some inertia to the mechanical "circuit," which could be done by fixing a lump of lead on to the free end of the rule. When this was allowed to spring back, it would continue vibrating for some time at a definite frequency, known as the *natural frequency* of the system.

If the lump of lead were very heavy, and

the spring were very flexible, it would vibrate much less rapidly than if the reverse were the case.

The action of the condenser discharge in the electric circuit is exactly similar. When the spark passes across the air gap, a very rapidly alternating current passes round the circuit, oscillating backwards and forwards, and gradually dying away. The greater the inductance or capacity in the circuit, the lower is the frequency of this current.

The rapidly alternating discharge across the spark gap sends out "wireless waves," the length of which depends upon the frequency of the discharge (not to be confused with the frequency with which the sparks pass across the gap, this being determined by the rapidity

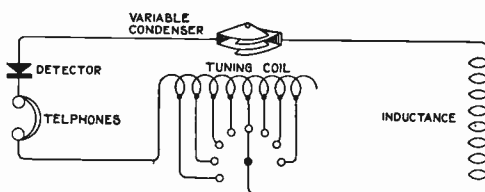

Fig. 2. Receiving Circuit with Variable Condenser and Auxiliary Tuning Coil.

with which the primary current of the induction coil is interrupted, if the high voltage is supplied by that means). The length of the wave in centimetres is given by dividing the frequency into the velocity of light, the latter being 30,000 million centimetres per second.

For example, a wavelength of 300 metres is produced by a circuit having a natural frequency of 1,000,000 cycles per second.

The wavelength can therefore be adjusted by altering either the capacity or the inductance of the transmitting circuit.

As it is much more convenient, the inductance is usually altered (by increasing or decreasing the size of that portion of the inductance coil included in the circuit), and it is this variable inductance that is known as a "tuning coil."

This "tuning coil" may constitute the whole of the inductance in the circuit as in Fig. 1, or it may be an additional coil, as shown in Fig. 2, which represents a simple receiving circuit.

A receiving circuit is exactly similar to the transmitting circuit described, except that the place of the spark gap is taken by a detecting apparatus, shown in Fig. 2, by a pair of telephones and a crystal detector, and the only

electrical supply to the circuit is the high frequency disturbance coming from the transmitting station.

Suppose that waves coming at a frequency of 1,000,000 per second strike the receiving circuit, a voltage and consequent current of the same frequency will be set up in the circuit.

Now we have seen that the reactance of this circuit is given by the expression

$$2\pi fL - \frac{1}{2\pi fC}$$

If we want the current flowing in the circuit to be a maximum (which we do, for the amount of energy caught by the circuit is exceedingly small) the reactance must be as small as possible, and obviously this occurs when

$$2\pi fL - \frac{1}{2\pi fC} = 0.$$

$$\therefore 2\pi fL = \frac{1}{2\pi fC}.$$

$$\therefore f^2 = \frac{1}{2\pi \times 2\pi \times CL}.$$

$$\therefore f = \frac{1}{2\pi \sqrt{CL}}.$$

Hence, if the inductance or capacity in the circuit is adjusted to such a value that

$$f = \frac{1}{2\pi \sqrt{CL}}$$

there will be no reactance in the circuit, and the high-frequency voltage will only have the negligible resistance of the wires to overcome.

In the receiving circuit, therefore, just as in the transmitting circuit, a "tuning coil" is employed, and is adjusted until the reactance in the circuit is a minimum, which is indicated by a maximum noise in the telephones. A "tuning condenser" is frequently used as well as a "tuning coil," although it is not generally given that name.

It may at first sight appear as if there were no need to have any inductance or capacity in a receiving circuit, since some trouble is expended in making them neutralise one another.

A circuit containing only resistance, however, would be like a piece of thick copper wire held in a vice, there being nothing tending to make an oscillatory movement take place.

It can be shown mathematically that the natural frequency of the transmitting circuit (or of any circuit) is also given by the expression

$$f = \frac{1}{2\pi \sqrt{CL}},$$

which really means that a circuit naturally discharges in such a way that a minimum amount of work is done in overcoming reactance. Thus in each circuit, the

value $\frac{1}{2\pi \sqrt{CL}}$ is the same, and so the value

of $L \times C$ must be the same in both. When this state of affairs has been brought about, the two circuits are said to be "in tune," or "tuned to the same frequency."

Next time, then, that you "tune up" your wireless set, remember that you are simply altering the value $L \times C$ in your circuit until it is the same as the corresponding value in another circuit, possibly hundreds of miles away, and you are using exactly the same principles as when you regulate a clock by altering the length of its pendulum.

In this article, no mention has been made of aerials, only the most fundamental circuits being considered. An aerial circuit is exactly similar to those described, except that the aerial wire acts as one plate in the condenser, and the earth acts as the other, the air between being the insulating material.

It is, of course, quite impossible to deal at all fully either with wireless circuits or with electrical vibrations in an article of this length, but it is hoped that some may be encouraged to look a little deeper, and gain a clearer conception of the true nature of any electrical phenomena they may encounter in working wireless or other apparatus.

Wireless Exhibition & Convention

WIRELESS Societies are coming into being all over the country. Those which have firmly established themselves have in most cases affiliated with the Wireless Society of London. At the Convention which is to be held from September 30th to October 7th of this year members of affiliated societies will have an excellent opportunity of meeting with the members of other societies.

Great benefit may be derived from the Exhibition by those amateurs and experimenters who are not yet associated with any society. The social element of the clubs assembled, coupled with an atmosphere of scientific gregariousness, should be an impetus to all who are interested in wireless matters to encourage unity.

A Liverpool Amateur Receiving Station

By SAMUEL LOWEY.

THE writer received his post-war permit about the middle of October, 1919, and at once commenced experiments.

The aerial installed was an indoor one consisting of four 28-ft. lengths at greatest height of 27 ft. above ground, and, with the exception of a period when, owing to earthing in damp weather, four 12 ft. lengths were temporarily installed, has been in use since that time. Its capacity is over half a milli-microfarad, the single down lead being 3/20 cab tyre sheathed cable.

After trying numerous types of inductance coils, including an elaborate one wound on 21 pegs in a board, missing three pegs each time as shown in Fig. 1, giving a coil of extremely low self capacity, the opinion was formed that the merits of single layer coils, especially for the longer waves, had been overrated.

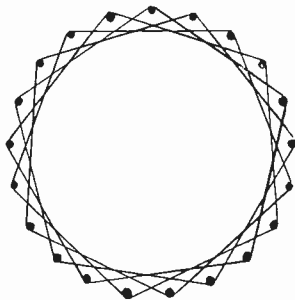

Fig. 1. Showing method of winding a coil.

Finally, dry wood formers were turned and grooved, as shown in Fig. 2, the largest pair being rather over 3 ins. diameter and wound with 100 turns of 36 S.W.G. in each slot to give an inductance value of a tenth of a henry.

Tappings were left out at grooves 5, 7 and 10, and on trial these were found to give excellent results, the best adjustment of coupling being obtained by sliding the end of one coil on to the end of another, when a definite zero of coupling could be reached, or coupling in the reverse sense obtained if required.

The next pair of coils was wound using identical formers, about 48 turns per slot being used, the arrangement being such that

consecutive tappings gave about the same percentage change in inductance value.

In the box, shown in Fig. 3 with one end and front removed, may be seen one pair of coils mounted in position, the lower or A.T.I. coil being attached to a loose board which slides in the bottom of the box, while the secondary coil is attached to the underside of the box top.

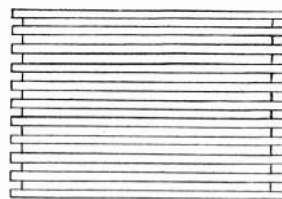

Fig. 2. The former with slots cut.

The bottom of the box has transverse grooves cut to accommodate any wood borings, etc., that might prevent the free movement of the sliding board.

A thin board is screwed at right angles to the moving board, and carries the switches for the A.T.I. (Fig. 4), the connections to arms of switches being by two flexible cords to a reversing switch mounted on top of box.

Only four wires enter the box; two for A.T.I. and two for secondary, all other connections being external.

The secondary switches are on top of the box, being identical with the A.T.I. switches just described.

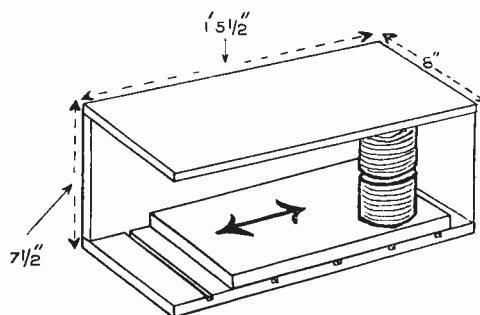

Fig. 3. The box in which coils are mounted.

Coil 5 (Fig. 4) is on a smaller grooved former (13 slots), with tappings at grooves 10 and 13.

Coil 4: Single layer, range to about 1,800 metres, with 0.0005 microfarad capacity, and has four tappings.

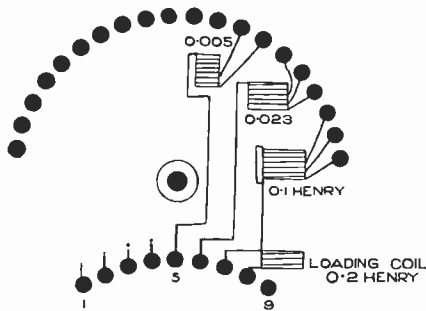

Fig. 4. Showing tappings.

Coil 3: Loose coupler pattern, four tappings, 200 to 800 metres, while coil 2 is a basket coil with three tappings from 600 to 1,100 metres.

When all switch arms are on the first contact, connection is made to four terminals enabling any special coils to be used. The secondary coils are exactly similar to the A.T.I. coils.

In the photograph (Fig. 5) the aerial tuning condenser is on the left of the primary switches, and the secondary condenser is on the right, the latter being fitted with a brass flat spring connected to moving vanes of condenser, the distance from the fixed vanes being variable by a screwed brass plug with long ebonite handle.

This makes an excellent vernier, having a maximum capacity of about 0.000015 mfd.

The valve panel is mounted on the top of the box, and the method of construction is indicated in Fig. 6.

The resistance wire for filament rheostats is wound in a shallow screw thread cut in a 5/16 in. diameter fibre rod.

The connecting wires are through holes bored in solid ebonite, all connections being soldered.

The valve sockets are 1/4 in. Whitworth brass screws drilled 1/8 in. to take valve pins.

The interval L.F. transformers are mounted in a box fixed at back of tuner.

The number of turns on such transformers may apparently be varied between wide limits without much difference in results.

The first transformer made had a primary of 6,000 turns, secondary 30,000 turns of No. 42 enamelled.

Later transformers had 8,000 and 24,000 turns of No. 40 silk covered, 10,000 No. 36 silk covered to 30,000 turns of No. 42 enamelled.

The number of secondary turns, above 20,000, did not seem to matter much, but a good primary (about 10,000 turns) having an inductance of about 8 henries seemed an advantage.

The transformer windings were on old wire bobbins, and in constructing these, the writer soon gave up the common method

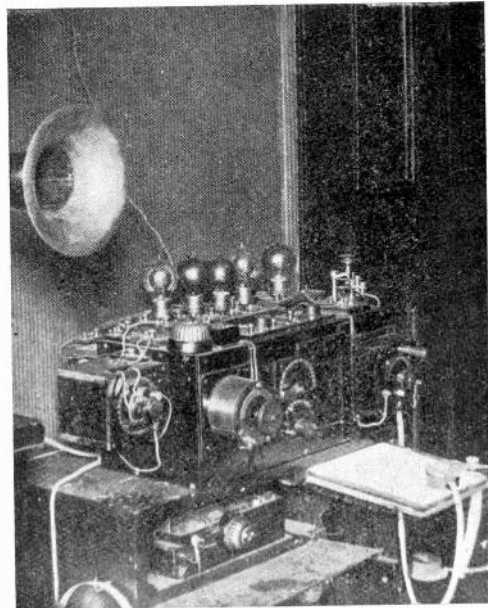

Fig. 5. View of the complete set.

of joining a heavier wire to start and finish of winding wire and found it more reliable to bring out the fine wires themselves, soldering them carefully to unscrewed part of brass wood screws in flanges of the bobbins, the windings always being connected as shown in Fig. 7, it being quite easy to solder connecting wires after the transformers were completed.

After boring and turning the bobbins to size, they were boiled for some hours in paraffin wax; this process always elongates

the bobbin, and if wound first and boiled after a space is usually left.

It was found advantageous when using three L.F. transformers to reverse the direction when starting to wind the secondary of one

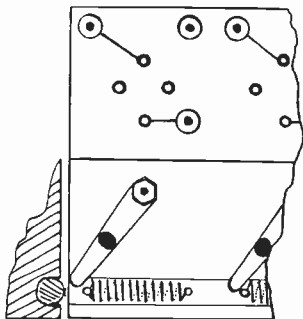

Fig. 6. Valve panel mounting.

(the middle) transformer; it seemed to stop low frequency coupling between transformers.

The telephone transformer has 10,000 turns of No. 36 (silk) for primary and 1,000 turns of No. 28 (silk) for the secondary. It is used with single 60 ohm "Brown A" telephones connected in parallel.

The loud speaker is a "Brown A" telephone fitted with phonograph trumpet. Instead of the standard 60 ohm winding 2×700 turns, it is wound with 2×400 turns of No. 36 silk covered.

The apparatus as described up to now was

completed at Easter, 1920; in June, 1921, a variable H.F. transformer was added (extreme left of photo).

The coils were wound in shallow grooves in cylindrical formers similar to that shown in Fig. 2. The advantage of this type of transformer is that while it gives a reasonably tight coupling (about 75 per cent.), the capacity between windings is low.

The transformer for wavelengths 4,000 to 23,000 metres is about 3 ins. diameter, while for the smaller wavelengths it is $1\frac{1}{2}$ ins.

Both were wound with No. 42 silk-covered copper, the direction of winding being such that at one end the plate and grid wires came

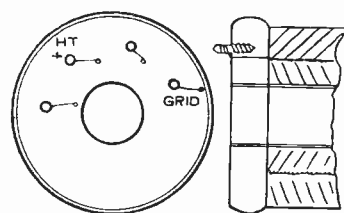

Fig. 7.

out clockwise and counter-clockwise respectively.

The control of both is made by an 8-way 4-pole switch. The circuit diagram is given in Fig. 8. In these days Morse is getting neglected generally, and the range has to be expressed in terms of music.

2 MT came in very well on three valves

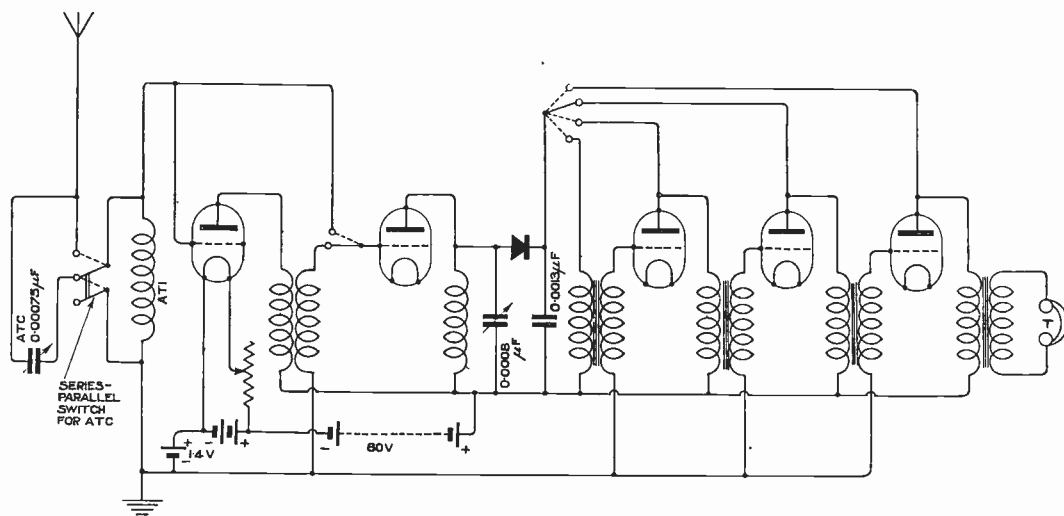

Fig. 8. Circuit diagram.

on 700 metres, but since the change to 400 metres it is not received so well.

2 LO is quite good on three valves, and FL music is quite clear all over the house on five valves, while the Marconi installation for the Mersey Docks and Harbour Board beats the lot.

PCGG is audible four feet away, using three valves. A Johnsen-Rahbek loud speaker is sometimes used instead of a "Brown," being nearly as good.

It has a slate drum—not agate. The set

has now given quite a number of demonstrations with great success.

On the last occasion it was in competition with a steam organ on a roundabout at a recent garden fête, and won easily, the telephony (including an amateur transmission) being quite loud, and every word audible in the next room with door shut.

No apology is offered for the presence of crystal detector on the set; the writer considers it to be far more efficient and reliable than any method of valve rectification.

International Amateur Wireless

THE hat which is seen here being worn by Mr. K. B. Warner, of the American Radio Relay League, has a history. It will be remembered that a photograph of the hat appeared in our issue of April 29th, when it was announced that the hat had just been despatched to Mr. Warner by Mr. W. W. Burnham, who had taken on a bet of a "new spring hat" in connection with the Transatlantic Amateur Tests.

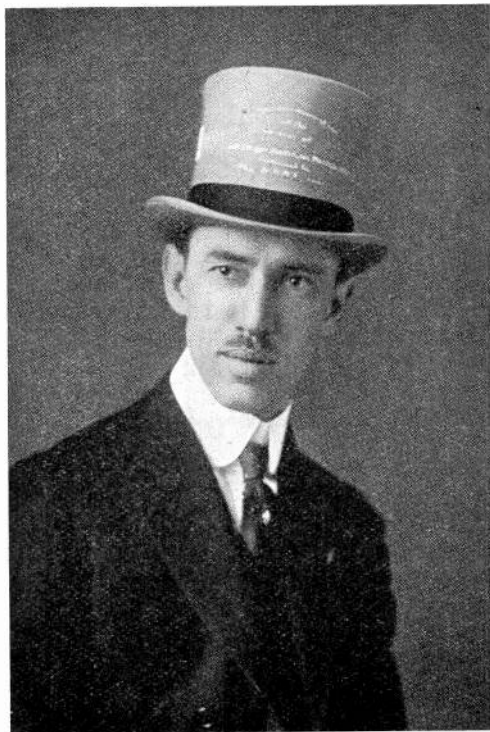

In the July issue of *Q.S.T.* Mr. Warner acknowledges receipt of the hat, and has posed for the photographer. In referring to the tests, Mr. Warner acknowledges the success of the British amateurs, and says: "Radio history was written, of course, with those tests, and although the British amateurs were equally as successful as Mr. Godley, the bet of the new spring hat still stood. Mr. Burnham promptly cabled "congratulations. Cable size of hat," and the result is the special "lid" of our photograph.

After describing the decoration and inscription on the hat, Mr. Warner says:—

"We must express our great admiration for the beautiful way in which Mr. Burnham 'came through.' We thank you, sir, and send cordial greetings to the British amateurs you typify. While the hat is hardly one which we would feel safe in wearing to church on Sunday morning, it is nevertheless our intent to wear it on official A.R.R.L. occasions. It fits perfectly; thank you—our normal head size having been given you in spite of the temporary swelling that existed immediately after the success of the test," and he closes with the hint, "Now who wants to bet us something about a cut-away coat?"

The hat is of light grey felt and bears on one side the Stars and Stripes, and on the other the Union Jack united by wireless flashes encircling the crown. In front can be seen the inscription of dedication. Unfortunately, the photograph does not give a true estimate of the artistic appearance of the hat as the effect of colour is lacking.

Notes

Extension in India.

Madras Wireless Station is to be converted into a high-speed automatic plant for working inland and to Rangoon. It is reported that the Rangoon section will replace the present land lines and cables from Calcutta to Rangoon for traffic between India and Burma. According to Lloyd's List the present apparatus for communicating with ships is to be replaced by a small station to be erected near St. Thomas's Mount. This will render the working with ships easier than hitherto, and at the same time free the big station in Madras for inland work.

The Department of Public Works now have the work in hand of extending the present station and also the erection of the new station at St. Thomas's Mount. The bulk of the new apparatus and plant has already arrived, and it is hoped that the stations will be completed and ready for work before the beginning of next year.

P.M.G. on Reception in Cinemas.

A firm of picture theatre proprietors who had installed apparatus for providing audiences with broadcasted music have received the following letter from the Postmaster-General:—

"With reference to your letter of 11th inst. and telegram of the 24th inst., I am directed to inform you that, pending the receipt of the proposals of the representatives of the wireless manufacturing companies concerning wireless broadcasting stations, the Postmaster-General is unable to issue permits for the use of wireless receiving apparatus for public entertainments in cinemas, etc., or to say under what precise conditions such permits will be issued. As at present proposed, however, permits of this kind will cover reception only from broadcasting stations in this country. The Postmaster-General hopes to be in a position to make further announcement later."

Motorists' Concert.

On July 29th a concert was transmitted by the Jowett Light Car Social Club, Bradford, for the benefit of its members and all other motorists who cared to accept an open invitation. Demonstrations were given at 3.30 p.m. and 6.30 p.m., each lasting about an hour and a-half. In the evening a speech was transmitted by the Lord Mayor of Bradford for the special benefit of the assemblage. Mr. Bever, a member of the Club, has recently experimented with an adaptation of a relay and stentophone set. His efforts were so successful that it was decided to make use of high power telephony amplification as a means of entertainment with a view to fostering camaraderie among motorists by inviting them to a demonstration.

Regulations in France.

According to the *Times* the departmental committee appointed by the French Under-Secretary of the Post Office to inquire into the regulation of wireless installations have drawn their report. It is expected that rules based on their recommendations will shortly be issued.

The broad principle followed is that receiving apparatus may be freely used after formal registration, while sending apparatus can only be installed by private individuals on the authorisation of the Under-Secretary of State acting on the advice of a mixed committee of officials and experts. Sending installations will be divided into five classes—private stations, stations for financial news, scientific stations, mobile stations (*e.g.*, of ships), and amateurs' installations. There will be a limit of wavelength.

Honour for Senatore Marconi.

Senatore Marconi, G.C.V.O., LL.D., D.Sc., was elected a Vice-President of the Royal Society of Arts on July 28th.

Successful Demonstration.

An open-air demonstration at the small hamlet of Bolton Villas proved highly successful on July 17th. The whole of the inhabitants listened to a programme of music and conversation carried out by a concert party assembled at Heaton. Reception was particularly loud.

Report of Research Board Sub-Committee.

A report has just been issued of the Radio Research Board Sub-Committee which was appointed on October 4th, 1921, to investigate the subject of telephony development. Witnesses were heard from the Navy, Army and R.A.F., the Marconi Company and the Radio Communication Company. The report (Cmd 1,707) is signed by Admiral Sir Henry B. Jackson, Professors C. L. Fortescue and G. W. O. Howe, and Major A. G. Lee.

Call Sign 2FU Misused.

2FU complains that his call sign is being used by another transmitter. The use of another man's officially recognised sign is likely to lead to serious trouble.

Air Route Call Sign Amendments.

Notification is made by the Air Ministry as follows:—

1. With effect from August 1st, 1922, the W/T call signs of Haren, Air Port of Brussels (BAV); Brussels, Royal Meteorological Institute (HS); and Ostend (OPV) have been altered as follows:—

Haren (Air Port of Brussels)	OPVH
Brussels (Royal Meteorological Institute)	OPO
Ostend	OPVO

2. The following changes in transmissions from Brussels (OPO) have been effected:—

(a) The meteorological reports transmitted on 1,400 metres at 0715 and 1325 G.M.T. have been discontinued.

(b) The report hitherto transmitted on 1,400 metres at 1815 is now transmitted on 1,680 metres at 1824 G.M.T.

Other routine transmissions remain unaltered.

3. The tables in Section II (Belgium), paragraphs 4 and 5, of Notice to Airmen No. 43 of 1922 are amended accordingly.

Death of Dr. Graham Bell.

Dr. Alexander Graham Bell passed away on the night of August 1st-2nd.

We deeply regret to learn of the passing of a pioneer among scientists whose lifework has made vast revolutions in the daily conduct of industry and every form of business. His research work in connection with the telephone has had results which are beyond estimation. He was born at Edinburgh on March 3rd, 1847, educated at the High School and the Edinburgh University, went to America and became professor of vocal physiology at Boston University, where he made his first telephone apparatus in



1875. He transmitted speech over a long distance for the first time in August, 1876.

The experiments were conducted in Canada and the Dominion Telegraph Co.'s wires were used, a transmitting apparatus being installed at Paris, Ontario, and a receiver placed at Brantford, eight miles away. A few months later conversation was possible both ways, and the present-day telephone was born.

Dr. Graham Bell held the Albert Medal of the Royal Society of Arts since 1902, the Hughes Medal of the Royal Society since 1918, and several honorary degrees. He was a freeman of Edinburgh, the freedom being conferred in 1920.

Calendar of Current Events

Sunday, August 13th.

Transmission of Telephony from 2.30 to 5 p.m. and from 8 to 9 p.m. on 1,085 metres by PCGG The Hague, Holland.

Monday, August 14th.

WIRELESS SOCIETY OF HULL AND DISTRICT.

7.30 p.m.—At Signal Corps Headquarters, Park Street, Hull. Lecture on "Accumulators, their Use and Abuse," by Mr. J. Nicholson.

Tuesday, August 15th.

Transmission of Telephony at 8 p.m. on 400 metres by 2MT, Writtle near Chelmsford.

WIRELESS SOCIETY OF EAST DORSETSHIRE.

At Branksome Liberal Club, Salisbury Road, Upper Parkstone. General meeting and enrolment of members.

Wednesday, August 16th.

YORKSHIRE WIRELESS SOCIETY.

8 p.m.—Grand Picture House Café, Clarence Street, York. Preliminary meeting.

Thursday, August 17th.

Transmission of Telephony at 8 to 9 p.m. on 1085 metres by PCGG, The Hague, Holland.

Sunday, August 20th.

Transmission of Telephony from 2.30 to 5 p.m. and from 8 to 9 p.m. on 1085 metres by PCGG The Hague, Holland.

PADDINGTON WIRELESS AND SCIENTIFIC SOCIETY.

Field Day.

Tuesday, August 22nd.

Transmission of Telephony at 8 p.m. on 400 metres by 2MT, Writtle, near Chelmsford.

Thursday, August 24th.

Transmission of Telephony at 8 to 9 p.m. on 1085 metres by PCGG, The Hague, Holland.

ILFORD AND DISTRICT RADIO SOCIETY.

At St. Mary's Hall, High Road, Ilford. Lecture on "Short Wave Reception—with special reference to Damped Waves," by Mr. E. E. Hale.

Books Received

ELEMENTS OF RADIO TELEPHONY. By William C. Ballard, Jr., M.E. (London: McGraw-Hill Publishing Co., Ltd. 1922. 7½" x 5¼").

RADIO FOR AMATEURS. By A. Hyatt Verrill. (London: William Heinemann. 1922. 7½" x 5½").

Sir William Noble's Future Work.

It is understood that Sir William Noble, who has been elected to the Board of the General Electric Company, will in future devote his attention chiefly to the wireless and telephone side of that company's development.

Hotel Wireless.

The "New Metropole," Northumberland Avenue, London, claims to be the first London hotel to be equipped with a wireless telephone receiver. The apparatus was installed by the engineer of the Gordon Hotels, Ltd., Mr. W. J. Crampton, M.I.E.E.

Wireless Club Reports

NOTE.—Under this heading the Editor will be pleased to give publication to reports of the meetings of Wireless Clubs and Societies. Such reports should be submitted without covering letter in the exact form in which they are to appear and as concise as possible, the Editor reserving the right to edit and curtail the reports if necessary. The Editor will be pleased to consider for publication papers read before Societies. An Asterisk denotes affiliation with the Wireless Society of London.

Stoke-on-Trent Wireless and Experimental Society.*

Hon. Secretary, Mr. F. T. Jones, 360, Cobridge Road, Hanley, Stoke-on-Trent.

At a meeting of the Stoke-on-Trent Wireless and Experimental Society on Thursday, July 27th, it was unanimously decided to change their headquarters to the new Y.M.C.A. building in Marsh Street, Hanley. Since the Wireless Exhibition, held under the auspices of the Society a few months ago, the membership has nearly trebled, and it has been felt for a long time that their present headquarters were far from satisfactory. The Y.M.C.A. have kindly offered the Society the use of their lecture room for meetings and experiments, and the offer has been accepted. A meeting will hold in the new headquarters at 7.30 p.m., August 3rd.

It was also decided to send a delegate to the conference of the Midland Wireless Societies, to be held about the end of August, in order to arrange the interchange of lecturers.

Mr. W. J. Forster (Member) read a paper on "Electrical Measuring Instruments."

After first elucidating some of the more common electrical terms, the lecturer explained the working principles and construction of various types of ammeters, voltmeters, wattmeters and energy meters, as used in modern power-station practice and by consumers. He clearly pointed out the difference between pressure measuring instruments, and some actual instruments were available, the insides of which the members were able to inspect for themselves, and note the difference.

In the subsequent discussion, the importance of electrical measuring instruments in wireless work was emphasised, and how that without them we should not know what the exact conditions were in our circuits, especially for transmitting stations, and progress would hardly have made such rapid strides without their use. It was also remarked that Mr. Forster had not touched upon galvanometers, and the hope was expressed that he would give a lecture on what was perhaps the most widely used measuring instrument among wireless amateurs.

A vote of thanks, carried unanimously, brought the meeting to a close.

Sunderland and District Amateur Radio Society.*

Hon. Secretary, Mr. H. Burnley, 8, Briery Vale, Ashbrook, Sunderland.

The above Society is being reformed, and has changed its headquarters and name. The new name is "Sunderland Y.M.C.A. Radio Society." All communications should be addressed to the Hon. Secretary at the above address.

Folkestone and District Wireless Society.*

Hon. Secretary, Mr. H. Alec S. Gothard, A.M.I.R.E., 8, Longford Terrace, Folkestone.

A General Meeting of the above Society was held at Cave's Café on Wednesday, July 5th, at 7.30 p.m., Mr. A. H. Ulyett in the chair.

The meeting proved very successful, and the following were elected to serve until July, 1923:— President: His Worship the Mayor, Mr. R. C. Wood. Past President: Mr. T. Hesketh, M.I.E.E., A.M.I.Mech.E., M.A.I.E.E. Vice-President: Capt. St. John Butler, R.C.S.† Vice-Chairman: Mr. A. G. Mills.† Committee: Messrs. L. Curtis,† A. G. Cox, A. Cumberbirch and T. C. Gilbert. Hon. Treasurer: Mr. R. W. Piper.† Hon. Secretary: Mr. H. Alec S. Gothard, A.F.Aer.Inst., A.M.I.R.E.†

After the programme for the forthcoming year had been discussed, the meeting adjourned at 9.45 p.m.

On Wednesday, July 26th, a very successful demonstration in radio-telephony was given by Mr. C. G. F. Pritchett, who had made special arrangements with Mr. Bligh, of Canterbury, to transmit on that evening for the benefit of the Society. Mr. Pritchett took great pains in explaining the methods of working the circuits employed. A hearty vote of thanks was given to both Messrs. Pritchett and Bligh, the first for his successful efforts in obtaining the transmission, the latter for his kindness in transmitting.

The activities of the Society are at present carried on in a private room at Cave's Café, Sandgate Road, Folkestone, where meetings are held at 7.30 p.m. every Wednesday.

Mr. Cox has very kindly consented to give quarter hour buzzer practice every week before the meeting. Members who desire to take advantage of this opportunity of practising their Morse are requested to be at the club-room at 7.15 p.m.

Full particulars as to membership, etc., can be obtained on application to the Hon. Secretary.

† Denotes re-election.

North Middlesex Wireless Club.*

Hon. Secretary, Mr. E. M. Savage, "Nithsdale," Eversley Park Road, Winchmore Hill, N.21.

The 96th meeting of the Club was held on Wednesday, July, 26th in Shaftesbury Hall, Bowes Park. The chair was taken at 8.30 p.m. by Mr. G. Evans, who introduced Mr. F. H. Haynes, who had kindly consented to lecture on the "Johnson-Rahbek Loud Speaker."

Mr. Haynes had brought to the hall the instrument which formed the subject of his lecture, and this was on view during the evening. He described the action of the instrument, and illustrated his remarks by diagrams drawn on the blackboard. He also explained the construction,

more particularly with regard to the agate cylinder which forms an essential part of the instrument, and drew the attention of the audience to the importance of obtaining even electrical contact between the agate cylinder and the steel spindle on which it is fixed.

The instrument was then set in operation, and a demonstration given of its capabilities. The principle on which it works, which has already been described in *The Wireless World and Radio Review*, is most interesting, quite apart from its possible commercial application, and it was evident from the questions put to Mr. Haynes at the close of his lecture that several members had already decided to experiment in the same direction.

When the Chairman called for a vote of thanks to Mr. Haynes, which was heartily responded to, he mentioned that Mr. Haynes had applied for membership to the Club, an announcement which gave great satisfaction to all present, and another talk from him at an early date will be welcomed by members.

Particulars of the Club may be had on application to the Hon. Secretary.

Newcastle and District Amateur Wireless Association.*

Hon. Secretary, Mr. Colin Bain, 51, Grainger Street, Newcastle-on-Tyne.

A General Meeting of the above Association was held at headquarters on Monday, July 24th.

Dr. Smallwood was present for the first time since the last general meeting, and gave thanks to the assembly for his election as President of the Association. The President then called on Mr. Dixon, the Chairman, to read out certain alterations to the existing rules. The amendments then proposed, seconded and carried, were:—(1) That all candidates must be over 21 years of age and to fulfil the conditions as stated in the P.M.G. licence. (2) All applicants to send in cards with applications and proposal forms to the committee, stating name and address, at least one week before the next committee meeting. (3) No visitor to be admitted more than three times per year either by one member or more than one member.

Copies of the amended rules will be supplied to all members. It was then proposed and seconded that Mr. M. C. Jones should be appointed Assistant Secretary.

Mr. Dixon then gave his lecture upon wavelengths and wavemeters in general. After dealing with the advantages obtained by using a wavemeter, Mr. Dixon went on to describe the Park wavemeter. He explained in detail the method of using this instrument to tune the receiving set preparatory to receiving another transmitting station. He then went on to describe the honeycomb inductances contained in the meter which he stated were effective to 8,000 metres, dealing at the same time with the combinations possible with parallel fixed condensers.

With the aid of diagrams, Mr. Dixon explained in a most interesting manner the method of calibrating external inductances by cutting out the internal inductances, and of calibrating condensers by comparison with the standard condenser contained in the wavemeter.

He then went on to deal with the static potentiometer method, describing with diagrams the method

of tapping the inductances by connecting between two condensers in series across the inductance. He demonstrated how different capacity condensers affected the position of the tapping and observed that he had obtained very satisfactory results on wavelengths as high as 25,000 metres.

After further explanation of the large capacity grid condenser and the low resistance grid leak to prevent howling, the method of using the meter as a separate heterodyne was put forward.

The members were then informed of the case of a local amateur who was using a valve receiving set without the P.M.G. licence. Owing to his instrument howling incessantly he was located from the Berwick and Stockton-on-Tees direction finding stations, illustrating the remarkable amount of damage which a badly handled valve set could do. **Newport and District Radio Association.**

Hon. Secretary, Mr. Edward R. Brown, M.S.A., A.T.P.I., 92, Corporation Road, Newport.

On Thursday evening, July 13th, the above Association held their second enrolment meeting at the Boys' Municipal Secondary School, Newport.

Before a large and enthusiastic audience Capt. C. H. Bailey (Vice-President) gave an address, in which he expressed the opinion that America was at the present ten years in advance of England as far as wireless was concerned, but that if British amateurs were given better facilities for experimenting they would beat the Americans in three months. The lecturer also gave some very interesting reminiscences of a visit to New York.

An excellent demonstration was given on a splendidly equipped set, and a detailed explanation of same was given to the members.

A large number of new members were enrolled and a pleasing announcement made that a large hall in the centre of the town had been obtained for headquarters.

A buzzer class is to be held throughout the winter months, and an immediate start is to be made towards a library collection.

A well-attended meeting of the above Association was held on Thursday, July 27th, at Headquarters, Memorial Institute, Queens Hill, Newport.

Mr. E. Ogden, of Cardiff, gave a lecture on "Points to Beginners," and Mr. J. H. M. Wakefield presided. The lecturer advised all amateurs to get into the theory of wireless, which was an elementary essential. He indicated the various books and journals the amateur should read.

Commencing with the aerial, the lecturer proceeded to take each part of a simple set, illustrating with diagrams their functions, faults and remedies, and in a simple order of sequence eventually worked up to a complicated valve set.

The lecture was closely followed by the members, who at the end bombarded Mr. Ogden with questions. Enthusiasm ran very high, and the speaker was invited to give a further address in the near future, he being promised a warmer time at questions.

On the motion of Mr. W. B. Edwards, seconded by Mr. H. W. Winslow, Mr. Ogden was heartily thanked. Replying to the vote the lecturer congratulated the Association upon the rapid strides made.

The membership now stands at 135.

Intending members in Monmouthshire should communicate with the Secretary.

The Ealing Wireless and Scientific Association.

Hon. Secretary, Mr. Wm. Frank Clark, 52, Uxbridge Road, Ealing, W.5.

The third meeting of the above Society having been held at the Vestry Hall, Ranelagh Road, Ealing, W.5., the Association may now be considered safely launched upon a career of great usefulness in the immediate locality.

It has been decided, in view of the fact that so many of the members are beginners in the new science, to commence with a series of elementary lectures, in which branch of the club's work Mr. A. Snell is contributing a very valuable part after some twenty years of wireless telegraphy in all its branches.

At the meeting held on July 22nd, 1922, Mr. Snell gave, in an informative and eloquent manner, an outline of the electron theory of matter, and explained how very important this subject is in the theory of wireless.

A cordial welcome is extended to all who care to accept membership with the Society, and those who contemplate joining are urged to take advantage of these first series of lectures.

As soon as circumstances permit, an aerial will be erected and practical work and demonstrations undertaken.

The Wireless Society of Hull and District.

Hon. Secretary, Mr. H. Nightscales, 16, Portobello Street, Hull.

There was a large attendance of members on the occasion of the second annual meeting of this Society, which was held at the Signal Corps Headquarters, Park Street, on July 10th.

Mr. G. H. Strong (President) occupied the chair, and was supported by Capt. W. E. Dennis, R.C.S., and Mr. Hy. Strong (Acting Vice-Presidents). The Secretary's report showed that much progress had been made, many interesting and instructive lectures and demonstrations having been held during the year. The membership had been increased to over 50. The report concluded with a vote of thanks to Capt. Dennis for his kindness in placing the room at the disposal of the Society for its meetings. The Hon. Treasurer's statement showed a balance in hand of £17 15s. 10d. This, together with the Secretary's report, was considered very satisfactory, and both reports were adopted. Mr. G. H. Strong was re-elected President, together with Capt. W. E. Dennis, R.C.S., and Mr. Hy. Strong as Acting Vice-Presidents. Mr. W. Nightscales was re-elected Hon. Secretary and Treasurer with Mr. C. B. Snowden as Assistant Hon. Secretary. A ballot for the four positions on the Committee resulted in the following being elected:—Messrs. W. J. Featherstone, Major F. Holman, C. B. Snowden and J. Nicholson. Messrs. T. Forster and T. H. Straker were appointed Hon. Auditors. Other business included the adoption of the by-laws of the newly formed library which had been framed by the Committee. Mr. Hy. Strong was appointed Hon. Librarian, and for the present the library will be held at the office of Messrs. G. H. Strong & Son, Prudential Buildings, King Edward Street, by kind permission. The offices are open from 9.30 to 5 p.m.; Saturdays, 9.30 to 1 p.m. It is hoped to add further volumes shortly to the library, which is free to all members.

During the evening, Capt. Dennis mentioned that the wireless section of the Northumbrian

Signals in Hull would be pleased to send out on their own set one evening per week calibration signals on fixed wavelengths for the benefit of the members of the Society if so desired. This was accepted with thanks, and the Hon. Secretary was instructed to go into the matter with the wireless officer and report at the next committee meeting, when arrangements could be completed and an announcement made to all members.

The concluding part of the evening was devoted to questions and answers, which proved very useful, a large number of members availing themselves of the opportunity of becoming enlightened upon some difficulty or another that was causing them trouble. Fourteen new members were elected, bringing the present membership to over 70.

Mr. J. Nicholson will lecture on Monday, August 14th, on "Accumulators: Their Use and Abuse," when it is hoped there will be a large attendance to hear this important subject.

Meetings of the Society are now held on the second Monday and the fourth Friday in each month at 7.30 p.m., at the Signal Corps Headquarters in Park Street.

Willesden Wireless Society.

Hon. Secretary, Mr. G. D. Wyatt, 70, Craven Park, Willesden, N.W.10.

This Society has now recommenced operations, and a meeting was held on July 4th to decide upon the future programme. Mr. F. A. Tuck announced his resignation from the position of Hon. Secretary on account of pressure of business, and Mr. G. D. Wyatt was elected in his place. The Society has now decided as to its future policy. The social side is to be developed. A larger room is to be obtained, and a good receiving set installed. Wireless dances, socials, and demonstrations are to be organised during the winter, and a successful season is expected. Now that the society is in full swing it is hoped that hearty co-operation by all members will assist to make the season a complete success. New members are being especially catered for. The society invites lady members who are interested in radio to join the membership. New headquarters, which it is hoped will be occupied in a few weeks, will have every facility for carrying out the programme, the accommodation being sufficient for about 200 persons. It is announced that T. Illingworth, Esq., J.P., has consented to become President.

Otley and District Wireless Society.

Hon. Secretary, Mr. N. Weston, 24, Guycroft, Otley, Yorks.

There was a gathering at Queen's Hall, Otley, on July 27th.

It was proposed and carried that the Club be called "Otley and District Wireless Society."

The following honorary officers were elected:—Mr. A. Woodhead, Chairman; Mr. N. Weston, Secretary; Mr. Preston, Treasurer.

Mr. N. Weston gave a lecture on "Spark Telegraphy" that was well received. Mr. Jones, A.M.I.E.E., kindly lent a four-valve set, and considering that the aerial was only 20 ft. high, and one end on a lamp-post and the other on a ladder, results were satisfactory. Upwards of 30 members were enrolled. Ladies are especially asked to come forward. There are still a number of vacancies open to complete membership to full strength.

Questions and Answers

NOTE.—This section of the magazine is placed at the disposal of all readers who wish to receive advice and information on matters pertaining to both the technical and non-technical sides of wireless work. Readers should comply with the following rules:—(1) Each question should be numbered and written on a separate sheet on one side of the paper, and addressed "Questions and Answers," Editor, THE WIRELESS WORLD AND RADIO REVIEW, 12/13, Henrietta Street, London, W.C.2. Queries should be clear and concise. (2) Before sending in their questions readers are advised to search recent numbers to see whether the same queries have not been dealt with before. (3) Each communication sent in to be accompanied by the "Questions and Answers" coupon to be found in the advertisement columns of the issue current at the time of forwarding the questions. (4) The name and address of the querist, which is for reference and not for publication, to appear at the top of every sheet or sheets, and unless typewritten, this should be in block capitals. Queries will be answered under the initials and town of the correspondent, or, if so desired, under a "nom de plume." (5) In view of the fact that a large proportion of the circuits and apparatus described in these answers are covered by patents, readers are advised before making use of them, to satisfy themselves that they would not be infringing patents. (6) Where a reply through the post is required every question sent in must be accompanied by a postal order for the amount of 1s., or 3s. 6d. for a maximum of four questions. (7) Four questions is the maximum which may be sent in at one time.

"SPARKS" (Birmingham) asks (1) For a diagram of a two-valve circuit. (2) Could he get PCGG with a two-wire aerial 30 ft. high. (3) Could he make a reaction coil. (4) What would the inductance of a basket coil be wound with 44 turns of No. 30 S.C.C. wire.

(1) See diagram Fig. 1. (2) Doubtful, but possible. (3) Yes; a reaction coil is made in exactly the same way as any other coil. (4) The dimensions given for the coil do not appear to be self-consistent. Assuming the number of turns is correct as stated, the inductance would be approximately 300 mhys.

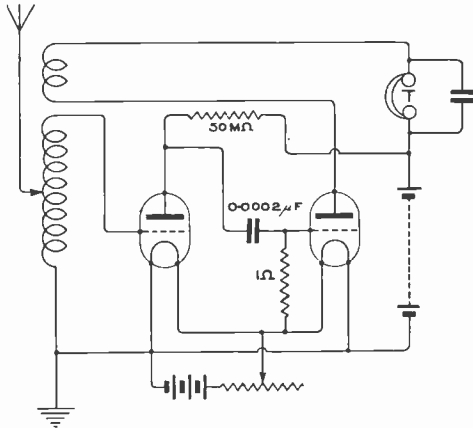

Fig. 1.

"LEARNER" (Walsall) asks (1) The size and number of plates and the size of spacing washers for a 0.0015 condenser and for a 0.0004 mfd. (2) Is a Mullard "Ora" valve suitable for a single valve set. (3) Is enamelled aerial wire more efficient than bare copper. (4) If 1,000 ohms high or low resistances.

(1) Plates should be 4" diameter, with 1 m/m between the fixed and moving plate. For 0.0015 mfd. condenser there should be 26 fixed and 25 moving plates. For 0.0004 mfd. condenser seven fixed and six moving plates. (2) Quite good, but not better than various others. (3) Very little better. (4) Too high for efficient low resistance and too low for efficient high resistance.

"A.L." (Torquay) asks if it is possible to receive the Hague concerts and telephony at Torquay with a certain three-valve set.

Some results might be obtained, but we should not expect them to be very good at such a distance. You might find one or two additional stages of H.F. useful, but reception at this distance will in no case be easy.

"J.B.B.M." (Bothwell) sends diagram of his circuit and asks (1) For criticism. (2) For dimensions of A.T.I. and reactance coils for use with 0.0004 variable condenser; what broadcasting stations he could receive with an aerial 36' high and 60' long. (4) How much wire netting is it necessary to bury at a depth of 3' to form a suitable earth.

(1) Circuit is quite O.K. (2) A.T.I. about 80 turns with a mean diameter of 2". Reaction coil 50 turns, also with a mean diameter of 2". N.B.—On short waves, such as the Broadcasting Band, only approximate windings can be given, as variations in aerial capacity, etc., lead to considerable variations in tuning. (3) The range on broadcasting stations would be approximately 75 miles. (4) Two or three square yards would probably be sufficient.

"F.P.J.B." (Ealing) asks (1) To what wavelength will a certain set tune. (2) If the set would receive 2 MT, FL on 180 and 2 LO. Should PCGG be heard at all, and what broadcasting stations.

(1) About 3,500 metres. (2) 2 MT, FL and 2 LO, yes. 180 metres and 2 LO doubtful, and probably only the London broadcasting station.

"J.D." (S.E.18) asks (1) Which of four methods of connecting up a valve panel is best. (2) Details of certain condenser plates. (3) Details of stopping condenser. (4) Exact size of foils and number required for a certain condenser.

(1) We prefer 3 and 4 to 1 and 2. 3 and 4 about equally good. (2) For 0.0003 mfd. one pair of foils overlapping $\frac{1}{2}'' \times \frac{3}{4}''$. For 0.001 mfd. four foils overlapping $\frac{1}{2}'' \times \frac{3}{4}''$. (3) Five foils. (4) Overlap should be $\frac{3}{4}'' \times \frac{1}{2}''$, using ten foils. (It is impossible to give more than quite a rough estimate, as the specific inductive capacity of the mica may vary between wide limits, and the thickness of the sheets will vary from the dimensions given.)

"CONTACT STUD" (Rotherham) asks with regard to the Reinartz Tuner (1) For a diagram of circuit adapted for three valves. (2) Could the broadcast signals be heard with this circuit and the loud speaker at a distance of about 80 miles. (3) Is the length of a receiving aerial still restricted to 100 ft. (4) Will the Reinartz Tuner tune to any wavelength by means of external coils.

(1) We have no information on a modification of this set in this way, but think the scheme outlined in the diagram (Fig. 2) should be satisfactory. (2) We doubt if sufficient strength for a loud speaker would be obtained at this distance. (3) We believe that the restrictions are still enforced, but the requirements of the P.M.G. are not finally decided as yet. (4) Yes, up to reasonably high values of wavelengths. We should not recommend this circuit for very long wavelengths above, say, 5,000 metres.

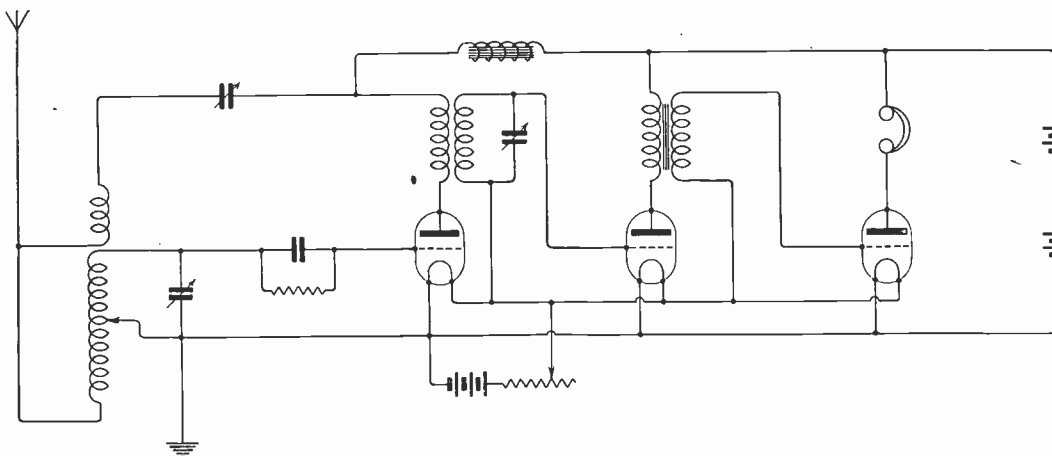

Fig. 2.

"R.C." (Brussels) asks (1) For winding data for constructing a coil on a phonograph disc. (2) Would such a coil do for the reactance. (3) If 400 ohm telephones be used with an L.F. transformer. (4) A formula for calculating the resistance of copper wire.

(1) A single coil of this nature would not be very efficient. If you use a 12" record and wind it with No. 32, you would get to about 4,000 metres. Put taps in at every half-inch. (2) A similar coil, of about 8" in diameter, wound with the same wire, would be suitable for reaction. (3) No transformer is necessary. (4)

$$R = \frac{4L \times S}{\pi d^2} \quad \left. \begin{array}{l} L = \text{Length.} \\ d = \text{Diam.} \\ S = \text{Specific resist-} \\ \quad \text{ance of copper.} \end{array} \right\} \text{-in cms.} \\ = 2.4 \times 10^{-6}$$

"L.C.E." (Sleaford) asks if No. 38 wire is thick enough for basket coils. (2) Wiring data for a set of basket coils. (3) What weight of wire is required. (4) If the reaction coil should be larger or smaller than the A.T.I.

(1) Yes, as a rule. (2) For 250 metres the coil

might be 1" internal diameter with 60 turns of wire. For longer wavelengths increase up to 8" outside diameter by 1" internal, two of which, in series, will tune to 3,000 metres. (4) Generally somewhat smaller considering that the A.T.I. is itself very small.

"E.B." (Charlwood) has a two-valve receiving set with capacity reaction, but is unable to receive on a wavelength below 1,000 metres and asks how set may be altered so that he can receive 300/400 metre wavelengths.

As you give us practically no information about your set we are unable to say what improvements might be effected, except that increased efficiency at 400 metres could be obtained by using a H.F. transformer in place of resistance capacity coupling. A similar effect can be obtained by retaining grid condenser and leak, but using a tuned H.F. circuit in place of the anode resistance.

"E.J.K." (Portsmouth) sends a sketch of his set with which he is having trouble, and asks (1) If the aerial is too small. (2) If the inductance value is right. (3) Should he be able to receive 2MT and PCGG. (4) For list of stations transmitting telephony, with times, etc.

(1) No. (2) Rather big, but probably O.K. (3) Difficult with only one valve. (4) 2MT 8 to 8.30 B.S.M. on Tuesdays (400 m.); PCGG 7 to 8 p.m. Thursdays and Sundays (1,070 m.). Other telephony is of an experimental nature at irregular times.

"H.W.C." (Luton) describes his crystal set and asks (1) What condensers he will require with their capacities. (2) What resistance telephones would be most suitable. (3) What is the most suitable wire for connecting. (4) The maximum and minimum ranges of set.

(1) Condensers for each circuit might be 0.0005 mfd. variable. (2) About 4,000 ohms. (3) About No. 20, or flexible cable with about the same capacity. (4) Maximum about 9,000 metres. There are, however, no spark stations working above 3,500 metres. Minimum wavelength uncertain—probably about 600 metres. (The coils are much bigger than necessary.)

MAGNAVOX

THE WORLD'S FINEST

LOUD SPEAKER

RADIO
brings it
MAGNAVOX
tells it.

*Broadcasting faithfully reproduced
with marvellous clarity and volume*

Sterling Telephone & Electric Co., Ltd.

TELEPHONE HOUSE,
210/212, Tottenham Court Road, London, W.1
Telephone No.: 4144 Museum (7 lines). Telegrams: "Cucumis, Wesdo, London."

Works: DAGENHAM, ESSEX.

BRANCHES: NEWCASTLE-ON-TYNE: 9, Clavering Place.
CARDIFF: 8, Park Place.

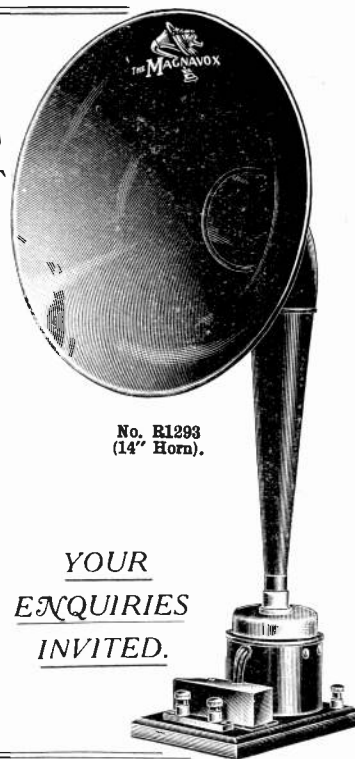

No. R1293
(14" Horn).

YOUR
ENQUIRIES
INVITED.

SIEMENS PRIMARY CELLS & BATTERIES

DRY AND FLUID

for the

High-Tension Circuit of Wireless Apparatus
using Thermionic Valves.

*Descriptive Pamphlet (Supplement 1 to Catalogue No. 600) will be
sent on application to the Manufacturers:*

SIEMENS BROTHERS & CO. LTD.

WOOLWICH, LONDON, S.E.18

Telegrams: "SIEMENS WOOLWICH."

Telephone: CITY 6400

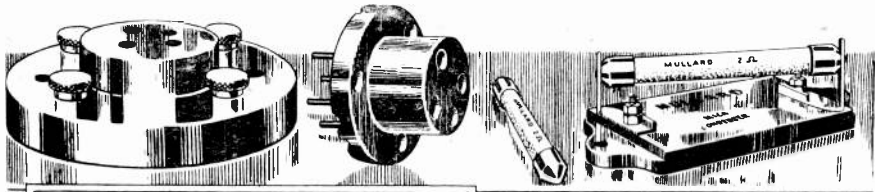

GREAT REDUCTIONS
in PRICES of
MULLARD ACCESSORIES

- VALVE BASES.** Specially designed with four convenient terminals. Moulded from the best materials. Internal connections completely enclosed.
Greatly Reduced Price .. 5/- each
- VALVE SOCKETS.** Eminently suitable for constructing complete valve receivers, amplifiers, etc. Moulded from the best materials. Impossible to insert the valve the wrong way.
Greatly Reduced Price .. 1/3 each
- MULLARD PATENT RESISTANCES.** Absolutely 'silent' and constant in use. Grid A. Grid B. Anode A. or Anode B.
Greatly Reduced Price .. 5/- each
- B.A. CONDENSER.** '0003 mfd., mica insulated 2/6 each
- NEW DESIGN COMBINED CONDENSER AND GRID LEAK.** Grid B Resistance with '0003 mfd. B.A. Condenser 7/6 each
- RESISTANCE CLIPS ..** 9d. per pair
- MULLARD TELEPHONE HEADSETS.** 4000 ohm., immediate delivery
30/- each



All Mullard accessories are British Manufacture throughout. These big reductions in price will cause a greatly increased demand for Mullard accessories.

To ensure early delivery, send coupon to-day.

Mullard Radio Valve Co. Ltd.

Claybrook Road, Hammersmith, W.6.

Contractors to H.M. Admiralty,
War Office, Royal Air Force & Post Office.

Telephone: Codes: Telegrams:
Hammersmith 312 ABC(5Ed) Radiovalve Hammer Lond



Name and Address

To the MULLARD RADIO VALVE CO., LTD., 35, Claybrook Road, Hammersmith, London, W.6

Please send me my free Description and Price.

Telephone Head Sets	30/-	Per set
Grid A Resistances	15/-	each
Anode A. or B Resistances	5/-	each
B.A. Condensers, 000 mfd.	2/6	each
Combined Condensers and Resistances	7/6	each
Valve Bases	5/-	each
Valve Sockets	1/3	each
Terminal Clips	9d.	per pair

Name of usual Wireless Dealer

Money Order, P.O. value

to cover the post.

SEND THIS TO-DAY

"A.S.H." (Stoneyhurst) asks (1) *Dimensions for certain windings.* (2) *Where a certain condenser should be used.* (3) *If a telephone transformer is necessary with 4,000 ohm telephones.*

(1) Coil A, 12" x 6" of No. 26; reaction coil, 6" x 4", of No. 26. Coil B, 12" x 6" of No. 30. (2) This condenser could be used for the anode circuit. 0.001 mfd. would do for the aerial circuit. (3) No.

"W.M.R." (Croydon) asks (1) *If a circuit will give satisfactory results on telephony.* (2) *Maximum capacities of various condensers.* (3) *Information regarding his batteries.* (4) *Which of two telephones would give best results.*

(1) No. The circuit is very poor. See the various valve and crystal circuits given in these columns recently. (2) A might be 0.001 mfd., B 0.005 mfd., and D 0.002 mfd. (3) L.T. batteries 6 volts, not less than 20 ampere hours. H.T. 50 volts, flashlamp size, or preferably somewhat larger cells. (4) The higher resistance telephones should be the better. No transformer is necessary.

"W.J.W." (Gosport) asks (1) *If pancake coils are suitable for telephony.* (2) *What wavelengths could be obtained with certain arrangements of such coils.*

(1) Certainly. (2) You do not give us enough information to enable us to say, as you do not state the diameter of your coils. If the mean diameter of each coil was about 2", the maximum wavelength would probably be 5,000 metres, but 0.005 mfd. is too great a capacity to use for tuning.

"K.L.E.D." (East Sheen).—(1) A up to 3,000 metres. B up to 5,000 metres. (2) 0.005 mfd. would be fairly suitable. (3) Reactance should be coupled inside secondary, say 12" x 3½" of No. 36. (4) Impossible to say at all accurately. Probably round about 600 metres.

"S.J.W." (Keynsham).—(1) You are correct in assuming that the resistance of the winding of a telephone, or similar instrument, is of no actual use, but serves as an indication of the number of turns which the winding contains. The windings of H.R. telephones are of copper, generally of about No. 47 or 48. Resistance wire is quite useless for the purpose. Inter-valve transformers are generally wound with somewhat coarser wire, say about No. 44, which accounts for the considerably greater size. (2) Finer wires are presumably in closed circuits and in aerial circuits owing to the fact that these closed circuits have in general much less additional resistance than the aerial circuit. Resistance of the wire itself in the closed circuit may therefore be greater without making the diameter excessive. The main object of resistance in a circuit is not so much the direct loss of conductivity for H.F. currents as the damping, and consequent flat tuning which it causes.

"AUTO" (Enfield) asks (1) *In what cases can receivers of 120 ohms, 2,000, 4,000 and 8,000 ohms be used in wireless telegraphy and telephony.* (2) *What is the advantage of using slab inductances.*

(1) 120 ohms with a transformer can be used for any purpose, and are specially useful in the valve circuits with high voltage valves. H.R. telephones are good for all purposes. The higher the resistance the more sensitive, but the less robust. (2) Slab coils are less efficient, but more compact than solenoid or basket.

"H.McG." (Lincoln) sends a sketch of his crystal set which gives no signals and asks (1) *Why.* (2) *The wavelength range of coil.* (3) *The wavelength range of set.* (4) *How could he best add a valve to the set.*

(1) We cannot say without test. Everything appears O.K. (2) You do not give us enough information to enable us to say. (3) It should receive ship sets up to 100 miles. (4) Rearrange as in Fig. 2, page 369, issue for June 17th.

"O.J.L." (Euston Road) asks how to add a valve to his set of which he encloses a diagram.

It is difficult to advise you with any certainty without a knowledge of the internal connections of your set, but the addition of an L.F. valve, as in the diagram (Fig. 3), would probably be satisfactory.

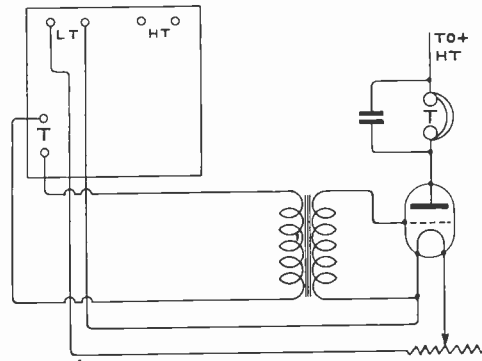

Fig. 3.

"V.B." (London) asks (1) *If a two-valve circuit sketched is correct.* (2) *For criticism of tuning inductance as sketched and maximum wavelength of same.* (3) *If he should get signals with a certain aerial of which he gives particulars.* (4) *The cause of buzzing which he gets, and how to tell when the set is oscillating.*

(1) Correct, but a parallel A.T.C. is not wanted at short waves; also second arrangement sketched is of little utility. (2) Arrangement poor, as it allows too much coupling between the A.T.I. and reaction. Maximum wavelength about 1,500 metres. (3) Aerial very poor, but should give some results. Why not run it out from the bathroom window up to the top of the tree? (4) This sounds like a bad connection in the grid circuit, but we cannot say without test. Oscillation may be detected by howls or muffled and broken up speech and spark reception, or by clicks when the aerial circuit is touched.

"F.K." (Wimbledon) asks (1) *If a crystal circuit sketched is correct for telegraphy.* (2) *If a valve circuit sketched is correct for the capacity for the variable condenser.* (3) *If copper aerial wire is better than phosphor bronze or silicon bronze.* (4) *If a 30' pump well would make a good earth.*

(1) No. See Fig. 2, page 405, issue for June 24th. (2) This circuit might be used, but is very poor. See many diagrams in these columns for a better one. (3) No, it is not so strong mechanically. (4) Yes, if it has water in it.

"BRIAR" (London) asks (1) *If a three-valve circuit is capable of receiving the Dutch concerts.* (2) *For a list of the necessary apparatus to make it.*

(1) See Fig. 1, page 435, July 1st issue. (2) The necessary material consists of:—One coil holder, to carry three valves; set of slab, or honey-comb coils; H.F. transformer; two valve sockets; three variable condensers, 0.0005 mfd.; one condenser, 0.002 mfd.; one grid leak; one L.F. inter-valve transformer; one filament resistance; one L.T. battery; one H.T. battery; one pair telephones.

"R.W.H." (W.C.2) asks (1) *For a circuit embodying H.F. amplifier and crystal as detector.* (2) *A circuit embodying crystal detector and valve as L.F. amplifier.* (3) *A circuit giving H.F. amplification with crystal detector and note magnifier.*

(1) The use of a valve as H.F. amplifier followed by crystal rectifier can be thoroughly recommended for short wave reception. Suitable circuit is given in Fig. 4. (2) See Fig. 5. (3) See Fig. 6. All of these circuits are admirably suited for your purposes.

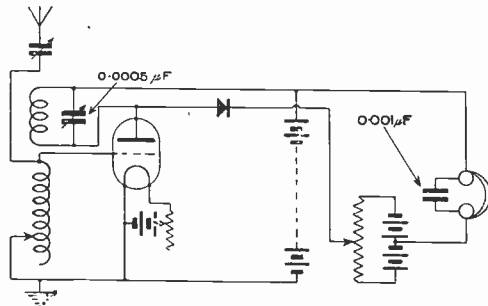

Fig. 4.

"GUNGA" (Edinburgh) encloses a diagram of his set and asks (1) *What should be the capacity of the variable condenser.* (2) *The capacity of the two fixed condensers.* (3) *Resistance of the grid leak.* (4) *Wavelength range of the set.*

(1) 0.0005 mfd., but a series A.T.C. is much better for short wave work. (2) Grid condenser, 0.0002 mfd., and blocking condenser, 0.001 mfd. (3) About 2 megohms. (4) Telephony up to 50 miles, telegraphy from ships up to 100 miles, high power stations further.

"W.B." (Sunderland).—(1) Coils should have 80 turns of No. 28. (2) Wind coils 1" wide of No. 28, sixteen layers with taps at every alternate layer. (3) Difficult to give an average range for a single valve set. Probably 200 miles on ships, Continental high-power stations and telephony within 50 miles.

"RADIO MANIAC" (Wimbledon).—(1) 5,000 metres with condenser, 4,500 without it. (2) Yes, provided that the wavelength of the closed circuit is also brought up. (3) Yes, if the dielectric between the plates is not more than $1/4,000$ " thick, preferably mica. (4) See Fig. 1, page 90, April 15th issue, and others.

"W.E.C." (Putney) asks if a circuit given to "D.F.T." (Lincoln), in the issue of June 10th, can be used with a set of "Oojah" coils.

Yes, quite satisfactorily.

"E.C.L." (Newark-on-Trent) asks (1) *Why is FL telephony received best with no reaction.* (2) *Which is the better reaction, capacity or magnetic.* (3) *Would an amplifier, designed as per sketch enclosed, work.* (4) *If ebonite for the formers of basket coils is of any special advantage.*

(1) This is a peculiarity of your set. Possibly the sense of your reaction coupling is reversed, or you have some accidental reaction in the circuit besides that due to the reaction coil. (2) There is little to choose, but magnetic reaction is somewhat more stable and controllable. (3) We think the principle involved is quite sound, in fact it approximates fairly closely to that of some commercial semi-a-periodic amplifiers. (4) No.

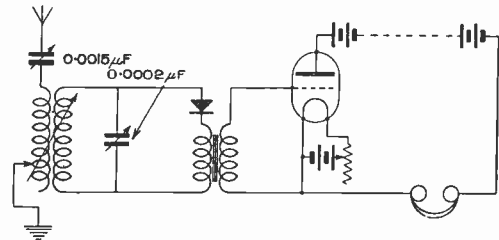

Fig. 5.

"L.C.V." (Southsea) sends a diagram of his set and asks (1) *How to add a reaction coil.* (2) *Size of coils and gauge of wire to tune to 4,000 metres with a 0.0005 mfd. condenser.*

(1) Connect the reaction coil in the plate circuit of the third valve, but it is not at all necessary if you use capacity reactance, as your diagram shows. (2) The coil may be $8'' \times 6''$ of No. 24.

"STUCKPHAST" (Rochdale) asks the reason for certain noises in his telephones when he touches the aerial terminal.

We cannot suggest the reason for this behaviour, although possibly your A.T.I. may have a bad connection in it. Try rearranging the leads to the valve as these may be run too closely together. Try also reversing the connections to the reaction coil.

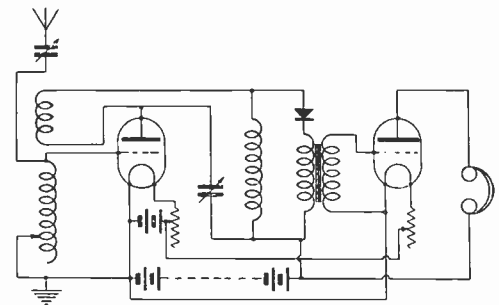

Fig. 6.

"W.H.L." (London).—The circuit submitted should give quite good results, but we should have preferred one stage of high frequency amplification, and 0.002 mfd. is too high for grid condenser for short waves.



HIGH FREQUENCY AMPLIFICATION

100 to 20,000 METRES

IMPROVED ADJUSTABLE
REACTANCE COIL.
SELF-TUNED.

SPECIALLY DESIGNED FOR
SHORT WAVELENGTHS
HIGHEST EFFICIENCY.

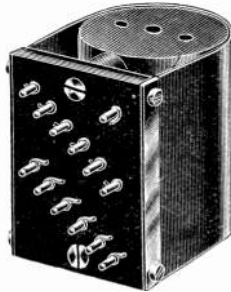

This is the high frequency unit that every wireless experimenter has been waiting for. The fact that it bears our name is a guarantee that it will do all that is asked of it.

ADVANTAGE OF HIGH FREQUENCY AMPLIFICATION.

All serious wireless experimenters will appreciate the great advantages of high frequency amplification before rectifying. It makes signals far below audible strength easily readable and permits additional audio frequency amplification (after rectifying) without rendering the receiving set unstable.

THE TAPPED ANODE REACTANCE COIL.

This coil, originally developed by Mr. W. A. Appleton, our research director, and specially designed for short wavelengths, has now been still further improved by a finer sub-division of the tapings to obtain the best efficiency for broadcasting.

NEW AND IMPROVED DESIGN.

The coil is sectionally wound and cylindrical in form as this design allows greater mechanical strength in the winding at the tapping points than does the earlier disc type.

100 TO 20,000 METRE RANGE.

Twelve tapping points are provided covering a range of wavelengths from 100 to 20,000 metres.

CONSTANT REACTANCE VALUE.

The tapings have been selected to keep the reactance value approximately constant for all wavelengths.

NO TUNING CONDENSER NEEDED.

No tuning condenser is necessary as the capacity of the winding renders the coil self-tuned.

HIGHEST EFFICIENCY.

This type of coil gives a higher efficiency on short wavelengths than any other method of intervalve coupling.

DELIVERY—Immediately from stock.

PRICE—Tapped Reactance Coil as specified - - £1 5 0

„ Twelve point switch for use with same - - 16 0

RADIO INSTRUMENTS LIMITED

Managing Director : J. Joseph, M.I.E.E., late Manager to Mr. H. Sullivan.
Chief Designer : W. A. Appleton, M.E.E., M.I.R.E., late Admiralty Technical Research Officer.

ONLY ADDRESS— *Works, Offices, Showrooms :*

12a, Hyde Street, NEW OXFORD STREET, W.C.1

We have the largest wireless works in Central London.
We are wireless engineers of established reputation.
Our name on wireless apparatus is a guarantee of satisfaction.

THE "BROWN" MICROPHONE AMPLIFIER

This Amplifier magnifies signals, or music, without distortion, and is of considerable interest to amateurs and scientific investigators. The Magnification is much greater than that obtained from two valves, and the current consumption is about 50 milliamps. In construction, this instrument is simple, and it is much more robust than other sensitive relays of this class. This instrument satisfies the urgent demand for a reliable, inexpensive amplifier, which the most inexperienced amateur can use, and which the most experienced requires. It is much cheaper, ultimately, than a multi-valve amplifier, and the operator is relieved from many of the varied causes of break-down. It includes a transformer suitable for low resistance telephones or loud speakers. The price of the "Brown" Microphone Amplifier is £8 for low resistance (120 ohms) input and £8 2s. 6d. for high resistance (2,000 ohms) input.

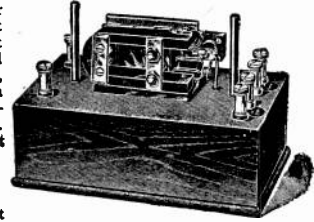

THE "BROWN" LOUD SPEAKER

With an Amplifier signals or telephony may be so magnified as to cause discomfort to wearers of headphones, yet not be loud enough to be audible at any appreciable distance from the head. Every wireless experimenter sometimes wishes to let his friends hear, which would involve the use of several pairs of telephones simultaneously with consequent loss of signal strength, as well as considerable expense. The "Brown" Loud Speaker was designed to meet this need efficiently and economically, and is used in all up-to-date receiving stations. The sound is intensified by means of a horn.

The "Brown" Loud Speaker (120 ohms), Standard Pattern with Upright Funnel
 Would to special high resistance up to £5 10 0 £5 15 0

THE "BROWN" SUPER-SENSITIVE TELEPHONES FOR WIRELESS, ETC.

These Telephones are unquestionably the clearest and most sensitive made, and, consequently, increase the distance over which the wireless can be heard.

BY UNIVERSAL USE. As supplied to British, Allied and Foreign Governments.

The "Brown" "A" Type Radio Headphones— £ 2 s. d.
 Low resistance per pair 2 18 0
 High resistance per pair £3 2s. and 3 6 0
 The "Brown" "D" Type Headphones (Improved flat diaphragm type)—
 Low resistance per pair 2 8 0
 High resistance per pair 2 12 0
 The above telephone prices include Cords.

CATALOGUE POST FREE ON APPLICATION.

Sole Manufacturers: **S. G. BROWN, LTD.**

SHOWROOMS where the above Instruments may be inspected **19, MORTIMER STREET, W.1**

Works: Victoria Road, North Acton, London, W.3. Telephone: Chiswick 1469.
 Sole Agent for the Argentine: Horacio D. Guerrero, Las eras 2480, Buenos Aires.

Brown's Wireless Apparatus can be purchased from all Wireless Suppliers.
EARLY DELIVERY of Telephones and Loud Speakers can now be given.

YOUR WIRELESS SET IS ONLY AS EFFICIENT
 AS YOUR BATTERY IS RELIABLE,
 THEREFORE ALWAYS USE

HART BATTERIES

SUITABLE FOR
 HIGH AND LOW TENSION CIRCUITS.

IMMEDIATE DESPATCH FROM STOCK OF FOLLOWING TYPES.—

TYPE	Voltage	AMPERE HOUR CAPACITY		APPROXIMATE OVERALL DIMENSIONS			TYPE OF BOX	NET PRICE EACH	
		Contin-uous	Inter-mittent	WIDTH	LENGTH	HEIGHT		Cash with Order.	Carriage Paid
P.L. 3	2	I	2	27/32"	2 1/4"	3"	CELLULOID	3s. 0d.	2s. 6d.
"	2	I	2	1 5/32"	2 11/16"	3 1/4"		EBONITE	6s. 0d.
"	2	I	2	1 1/4"	1 1/2"	4 1/2"	GLASS	5s. 5d.	5s. 0d.
E 5	2	5	10	1 1/2"	1 1/2"	6"	GLASS	6s. 9d.	6s. 3d.
A.P. 7	2	11	22	1 1/2"	1 1/2"	6 1/2"	EBONITE	6s. 0d.	5s. 9d.

THESE CELLS CAN BE SUPPLIED MADE UP IN BATTERIES OF ANY REQUIRED VOLTAGE. SPECIAL PRICES FOR SUCH BATTERIES WILL BE QUOTED ON APPLICATION.

HART ACCUMULATOR CO., LTD.
STRATFORD, LONDON, E.15

BRANCHES:
BELFAST 41, CHICHESTER STREET
BIRMINGHAM 174, CORPORATION STREET
BRISTOL 37, VICTORIA STREET
GLASGOW ... 107, WELLINGTON STREET
LONDON ... 36, VICTORIA STREET, S.W.1
MANCHESTER 4, VICTORIA BRIDGE
 YORK—6, BRIDGE STREET

"ROGNON" (Rochester) asks (1) *If it is necessary for a fixed condenser to be connected across the telephone terminals of a Reinartz tuner.* (2) *The quantity of wire and length of former for Reinartz tuner.* (3) *Is an "Ora" valve suitable.* (4) *How to increase the wavelength of his set.*

(1) No, in this circuit it is essential that no telephone condenser should be used. Compare the article in the issue of May 13th issue. This information is given on pages 382 and 383. The length of former may be about 5". (3) Yes. (4) This set is not suitable for very long waves, but the wavelength can be increased somewhat by increasing the number of turns on the coils.

"S.A.B." (Gloucester) encloses a diagram of his set and asks (1) *For criticism.* (2) *Should we advise alterations to the circuit given in page 438, July 1st issue.* (3) *Which is better for low wavelengths for telephony.*

(1) The circuit is of quite standard type and O.K., except for the fact that it is capable of giving considerable reradiation. (2) The alterations suggested are quite optional. (3) There is very little to choose between them.

"C.R.W." (Malabar Coast) asks (1) *For a comparison of two transformers.* (2) *If one would be more selective than the other.* (3) *What is the most efficient inter-valve transformer covering a range of 600 to 20,000 metres.* (4) *If potentiometer control of H.T. potential is as efficient as cutting out or putting cells in the circuit.*

(1) The first instrument should give somewhat finer adjustment to correct value, but there will probably not be much difference between them. (2) To cover such a big range several entirely distinct transformers are desirable. (3) No single transformer is efficient over such a large range. Over shorter ranges we are unable to discriminate between the products of our various advertisers. (4) Very wasteful owing to the rapid running down of the battery through the potentiometer resistance, unless this is exceedingly high, which is undesirable from several points of view. Adjustment of H.T. voltage is very seldom required.

"J.H.E." (County Durham) asks (1) *If it is possible to add one stage of H.F. to a circuit of which he encloses diagram.* (2) *Why does the set howl when the primary switch is off the studs.* (3) *If it is possible to receive FL on a three-valve set without an aerial.* (4) *Why he gets signals on a one-valve set and the H.T. switched off.*

(1) See Fig. 4, page 467, issue for July 8th. (2) Owing to the breaking down of the grid circuit the result may be a true oscillation or a sequence of rapid discharges from the A.T.C. (3) It should be possible on an indoor aerial or a good frame. (4) This is not uncommon. Some valves will function without H.T., but in a much less sensitive way.

"IN DOUBT" (Staines) has constructed the American short-wave receiver described in the June 3rd issue, and is unable to obtain satisfactory results, and he asks if the component parts of his outfit are correctly constructed.

From the information you furnish, and your drawings, everything would appear to be in order, and without describing to some extent what

happens when you connect up and attempt to obtain signals, it is difficult to suggest the cause of your trouble. The condenser of the "billi" type is suitable for use with the set, and should be kept for a small value. The direction of winding of the variometer is important, and should be such that when the inner winding coincides with the outer, the two windings are in opposite directions. Reaction effects are obtained in this set by the closeness in the two variometer coils marked in your diagram, B and C. These must be in the right direction one with regard to the other, and you might try reversing the leads which pass from one of the variometers; that is, in the diagram given on page 284, change over the leads that pass to terminal P and one of the telephone terminals; otherwise everything would appear to be in order, and should function correctly. If you care to send us the instrument we shall be pleased to criticise it for you.

"G.G.S.C." (Pengam) asks (1) *Whether it is better to connect low resistance telephones in series or parallel when operated from a step-down transformer.* (2) *How should a separate heterodyne be connected, and how can he tell if his apparatus is radiating when using autodyne reception.* (3) *Windings for frame aerial 5' square, to be equivalent in wavelength effect to one consisting of two 70" wires; and (4) Which is the better of two circuits, one giving potentiometer control to the H.F. valves and the other to the rectifier valve only, and whether Zenith valves can be used with his set.*

When using a step-down transformer, better results are usually obtained with the telephones in parallel. When high resistance telephones are connected directly in the H.T. lead, they should be in series. (2) To operate a separate heterodyne such as described by Mr. Coursey, it is only necessary to slightly couple the wavemeter coils with the tuning inductance of the receiver. Even the use of a separate heterodyne, if coupled to the aerial circuit, may give rise to slight reradiation. All autodyne or heterodyne receivers when adjusted to the oscillating point, that is when they are capable of the reception of C.W., cause reradiation. The extent of reradiation depends on the potential of the H.T. battery, and consequently the value of the plate current, the type of valve, and the extent of coupling between grid and plate circuits. (3) Use 11 turns of bell wire or single flexible wire. It is not possible to construct a frame aerial that will give a wavelength variation equal to that of a two-wire aerial for a given change of inductance or capacity. For reception over a wide range of wavelength, you might wind on your frame in addition, many turns of single No. 22 D.C.C., and arrange for connecting in or out of circuit by means of switches which obviate dead end effects. (4) Where a number of H.F. valves are used, it is always advisable to arrange potentiometer control for the grids of the H.F. valves, mainly in order to prevent self-oscillation. Separate potentiometer control is desirable for the rectifier valve, which should be of a type specially designed for use as a detector. Your circuit consisting of three H.F. valves, one detector and L.F. valve should be admirably suitable for the reception of telephony and telegraphy. We have no information concerning the type of valves to which you refer.

"L.H." (Mansfield) is using a three-valve receiver, comprising one H.F., one rectifier, and one L.F. He is not obtaining satisfactory results, and asks us to suggest the probable cause of his trouble.

There is little doubt that the trouble lies in the design or construction of the intervalve high frequency transformer. The spacing of the primary and secondary windings, and the direction of winding, is important. If you bridge the primary with a small condenser for tuning, it is advisable not to run on the primary and secondary windings simultaneously. If your transformer is wound in a groove, it is as well to wind primary and secondary in opposite directions, taking the finishing end of the inner winding to the plate, and the beginning end of the secondary winding to the grid. We would suggest that you construct a number of interchangeable transformers, experimenting with short-wave high frequency amplification first. Build up a transformer on a piece of 1" ebonite rod, putting on 600 turns for primary, and 600 for secondary, each being single layer and separated from each other by a single layer of empire cloth. If you make these two windings in the same direction, the terminating ends of each winding will be taken to grid and plate. The wire used should be about No. 40 S.S.C. and will be suitable for use on wavelengths between 500 and 700 metres.

"D. McN." (Dublin) has constructed a single valve receiving set with reaction, and is unable to obtain satisfactory results, while his tuning inductance alone works quite well with crystal.

From your description everything would appear to be in order. The only thing we can suggest is that you might try reversing the connections to the reaction coil. You do not say what circuit you are using, but we think if you were to connect a variable condenser in series with the aerial inductance, and another across the reaction coil, you would probably get oscillations produced, and then the tuning-in of signals will be quite easy. It may be that the wavelength range of the aerial tuning inductance, when joined to your aerial, is not sufficiently close to that given by the reaction inductance.

"C.J.M.D." (Mill Hill) asks (1) How much No. 30 wire to put on a 4" coil to suit an A.T.I., 5" x 11", of No. 24. (2) Which is the better arrangement, valve as H.F. amplifier with a crystal detector or a single valve used as a detector. (3) How many ohms will it take to reduce a current from 4 volts to 2 volts.

(1) Wind about 5" length of the tube. (2) The former arrangement. (3) Volts are the measure of electromotive force. A current is measured in amperes. If you will tell us the amount of current flowing we could tell you how many ohms would be required to reduce the pressure from 4 volts to 2 volts, but not otherwise. You should buy an elementary text-book on electricity and study it carefully.

"N.G." (Barry).—(1) Use about $\frac{1}{2}$ lb. of No. 26, make coils up to 4" diameter, and connect as many as necessary in series for both A.T.I. and reaction coils. (2) Sliding the coils over each other will be satisfactory. (3) One tap per coil would be sufficient, but probably this will not be essential. (4) 0.001 mfd.

"ROBRIDE" (Tottenham).—(1) Circuit shown is correct, except that a blocking condenser should be inserted across the telephones; also, a parallel A.T.C. is undesirable at short wavelengths. (2) Yes, it is quite suitable. (3) You should receive London broadcasting easily. Dutch concerts only weakly. (4) Any resistance not less than 2,000 ohms.

"W.H.S." (Sutton-on-Sea) gives a list of apparatus and asks if this is complete, and how to connect up the various pieces. (2) Is it necessary to have a licence before purchasing apparatus.

(1) The apparatus suggested would be sufficient, but a grid condenser and leak would be an advantage. Connect up as in diagram Fig. 7. (2) No, but a licence must be obtained before the apparatus is used.

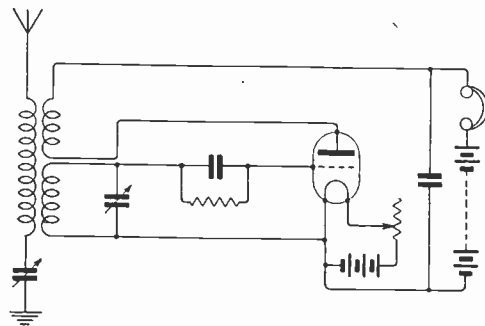

Fig. 7.

"W.H.D." (Hull) asks re the American short-wave tuner described in the issue of June 3rd (1) What resistance telephones should be used. (2) Value for the fixed condenser. (3) Distance it will receive telephony. (4) What transmitting stations work in its limited wavelength.

(1) Not less than 2,000 ohms. (2) About 0.001 mfd. (3) Perhaps up to 50 miles. (4) Amateur stations about 300 metres and broadcast stations between 350 and 400, but it is not proposed to erect a broadcasting station within 50 miles of Hull.

"H.K.M." (Newbury) asks for certain information in regard to a modified Reinartz tuner.

Some of the information you require is given in the article on page 445 of July 8th issue. Your former being 9" in diameter, we should suggest the following values: Grid coil 35 turns, tapped at 10, 16 and 25. Aerial coupling 15 turns, tapped at every three. Reaction 30 turns, tapped at every five. This should cover the broadcast band easily.

"TELEPHONIST" (Llanwrda Caom) encloses a diagram of set and asks for suggestions for improvements to enable him to receive broadcasting telephony from all stations in the British Isles, The Hague and Eiffel Tower.

The circuit shown is quite O.K. except for the anode circuit of the first valve. The grid condenser should be connected on the valve side of the tuned circuit, but some reaction would be advisable and a parallel A.Y.C. is bad on short waves. 300 ohms. appears to us excessive for a filament resistance.



MARCONI
GIVES
UNRIVALLED
WIRELESS
SERVICE

7/6⁸ MARCONI INTERNATIONAL
MARINE COMMUNICATION CO. LTD.
MARCONI HOUSE, STRAND, LONDON

'BRITWIRE' WIRELESS ACCESSORIES

Interval Transformers, ratio 1-5	22/6 and 25/-	Ebonite, any size cut square, edges finished, .. lb.	5/6
Telephone Transformers	15/-	Large Porcelain Insulators, high insulation	1/-
Switch arms, phosphor bronze, laminated	2/9	Rotary Switches 5 point.. .. .	5/-
Valve holders, with legs screwed and nutted	1/9	10 point.. .. .	7/-
Studs, per dozen	1/6	19 point.. .. .	8/8
Duros Cells, 2 volt 45 amp, ready charged	12/6	Britwire Tuning Coils, duolaterally wound	from 2/-
Condenser Vanes, per pair	2½d.	Siemens 15 volt units	each 4/-
Condenser Washers, rotary 1/- dozen Fixed 3¼d. doz.		Crystal Detectors, very sensitive, universal movement .. 5/-	
Valve Pins, with nuts, per dozen	2/6	Etc. Etc. Etc.	
Reactance Formers, specially suitable for short waves	7/6	Send for illustrated List post free 3d.	
Hellesen H.T. Batteries, tappea 36 volts, and plugs ..	8/6		
P.O. Solid Back Microphones	15/-	All orders over 40/- carriage paid.	
Filament Resistances, smooth contact	5/6		
Ivoryine Scales, each	1/3	We have large stocks of all the above, and are continually	
Set indicating tabs, per seven	2/3	adding new lines. Ebonite panels engraved for the trade.	
Valve Legs, with washer and two nuts, each	3d.	NOTE TO BUYERS. A large amount of rubbish is being	
Pocket Voltmeters, 9 to 6 volts	5/-	placed on the market at present by irresponsible firms, so	
		deal with an old-established firm, who have been selling	
		wireless apparatus since 1913, and who for the past nine	
		years, have dealt and specialised in nothing but 'wireless.'	

POST ORDERS TO

BRITISH WIRELESS SUPPLY COMPANY

6, BLENHEIM TERRACE, LEEDS. Telephone : 26926.

And at :

11 Church St., West Hartlepool. Tel. : 373. 18 Eldon Square, Newcastle-on-Tyne. Tel. 360 City

33 High Street, Southampton. Telephone 403

"Exide" BATTERIES FOR WIRELESS

WE specialize in the manufacture of batteries for filament current supply to Valves and high-tension batteries for application of Anode Potential. We can supply these batteries in glass, ebonite or celluloid containers to any desired voltage.

Exide batteries can be relied upon for wireless work and retain their charge over very long periods.

Prices and Particulars on Application.

THE Chloride ELECTRICAL STORAGE COMPANY LIMITED.

Head Office : London Showrooms :
Clifton Junction, 219/229 Shaftesbury Av.
Nr. Manchester. W.C.2



6 Volt 80 Amp. Hour Exide Battery.

"J.A.H." (Farnborough) asks (1) *The weight and gauge of wire required to wind the honeycomb coils described on page 539, October, 1920, issue.*

Use No. 28 wire. 1lb. should be sufficient for all the coils required, which may have turns ranging from 150 to 500. N.B.—We regret that, as we have replied to a considerable number of letters from you lately, pressure on our space will prevent us doing so again at present.

"R.D.M." (Belfast) asks (1) *With reference to page 35 of the "Construction of Amateur Valve Stations," how can the secondary 9" diameter fit inside the primary 8" diameter as given.* (2) *If dead-end switches in the secondary coil as well as in the primary will improve the set.* (3) *If a transformer and 120 ohm telephones are better than 4,000 ohm telephones.*

(1) 9" should read 7" and is a printing error. (2) Yes. (3) There is little to choose. H.R. telephones are slightly cheaper and more sensitive, but L.R. are more robust.

"INTERFERED WITH" (Leicester) asks *how to overcome interference due to the adjacent tramway system.*

We are afraid we can give you little help as you have tried all the usual remedies. The Leicester tram system is notoriously bad in this way. You might try a directional aerial system as, for instance, one giving a heart-shaped diagram with the blind side to the trams, though we doubt if this would give good results, or H.F. chokes across the aerial circuit; also iron screening of your L.F. circuits.

"S.S.R.C." (Stoke-on-Trent) asks (1) *The wavelength used for Croydon telephony.* (2) *If he can receive Paris telephony.* (3) *If he can add more valves by means of a "Ford" spark coil used as a transformer.* (4) *The cause of a loud hissing note in the telephones.*

(1) About 900 metres. (2) Possible, but somewhat doubtful. (3) No, the windings are quite unsuitable. (4) We cannot say for certain, but it is probably due to a defective cell in the H.T. battery.

"J.H.S." (Finchley) sends a diagram of his five-valve set, and asks (1) *For switching arrangement for switching in one to five valves.* (2) *If the diagram is correct.* (3) *If the set can be improved.*

(1) The switching arrangement shown in Fig. 5, page 62, April 8th issue, can easily be extended to suit a five-valve circuit such as yours. (2) Circuit is correct except that blocking condenser in the anode of the third valve should be across the iron-cored coil only, and not reaction coil as well. (3) The set would be somewhat improved by a potential adjustment of the first three valves.

"H.P.A." (Jersey) asks (1) *For a four-valve circuit to fulfil certain requirements.* (2) *How to alter a certain set for short waves.* (3) *If transformer coupling is better than condenser coupling on short waves.*

(1) and (2) For short wave work we should recommend circuit as shown in Fig. 5, page 62, April 8th issue, with the addition of a further H.F. valve, the switching being extended on the same lines as shown. (3) Yes. (4) A wide range of wavelengths, including short waves. A plug-in arrangement to enable either condenser coupling or transformer coupling to be used is very convenient.

"G.H.G." (Bedford) (1) *Refers to the instructions given in the issue of June 24th for constructing a buzzer wavemeter to set up oscillations of precisely 400 metres, and asks for the dimensions of the condensers and inductances to give 1,500 metres and 2,600 metres.* (2) *Asks how to add two additional valves to his two-valve set without materially disturbing the present connections.*

(1) The details given in the article referred to were determined by careful experiment, and it is impossible to obtain, by relative calculation, the exact data for constructing these wavemeters. It can only be found by direct experiment and tests against a standard wavemeter. The data was given for 400 metres, for use by experimenters not in possession of a wavemeter. We would suggest that you insert six additional plates in the condenser, which will increase its capacity by four times, and add one extra slab coil to the inductance, wound in the same direction as the one already fitted and spaced $\frac{1}{2}$ " away from it for producing a wavelength of 1,050 metres. For 2,600 metres you might make the condenser with strips twice as wide and twice as long, and by using nine plates you will increase the capacity to sixteen times that given in the article, and this large condenser should be used in conjunction with four slab coils. The utility of this apparatus depends entirely upon precise calibration.

"C.H.S." (Wolverhampton) submits a circuit of a two-valve receiver with high frequency inter-valve coupling and a coil coupled to the H.F. transformer for producing reaction effects and wishes to know windings for primary, secondary and reaction coils for this arrangement to tune to 350/500 metres.

When working to this arrangement you are recommended to provide for a moderately loose coupling between the windings of the transformer. The primary which is connected with the plate circuit and bridged by a small value variable condenser (0.0003 mfd.), should consist of 170 turns of No. 28 D.C.C. on a 2" former, and this should be wrapped at the ends beyond the winding to support the windings on another former at a distance of about $\frac{1}{4}$ " away. The secondary wound on this outside former should also consist of 190 turns of No. 32 D.C.C. coinciding with the primary winding. The reaction coil can be made to slide outside the secondary and should consist of 200 turns of No. 32 S.C.C.

"H.C.P." (Birmingham) asks (1) *To what wavelength will a certain coil tune.* (2) *The capacity of variable condensers suitable for the above.* (3) *If he could receive 2 MT and PCGG with the above coil in a three-valve set.* (4) *If shellacing the wire will affect the coil.*

(1) The primary circuit will receive up to about 5,000 metres without a condenser. Up to 10,000 metres with a condenser as below. (2) Primary 0.001 mfd., secondary 0.0005 mfd. (3) Probably not; the coils are much too big and wound with too thin a wire. (4) It makes it less susceptible to atmospheric changes, and usually slightly affects the tuning range.

"LEARNER" (Walsall) asks for winding details for a set of honeycomb coils.

Try values as follows, adjusting finally by experiment, but the values you suggest appear very inconvenient. 30, 40, 70, 85, 150, 250, 550, 650.

"KO SINE" (Whitehaven) asks how H.F. currents are changed into L.F. currents.

An adequate discussion is out of the range of these columns and we should advise you to buy a book such as Bangay's "Elementary Principles," which will give you some idea as to the wireless theory. As you suggest, the valves used for H.F. and L.F. amplification are the same, and generally the same valves are used for rectification. The difference in action is in each case due to the circuits employed. Very roughly speaking, the large number of H.F. pulses of current corresponding to each spark are passed through a rectifier, which may be a valve or crystal, by which all the negative half-cycles are wiped out. The series of positive half-cycles, if passed through a high impedance, such as an iron-cored transformer, behave as one L.F. pulse through the transformer.

"ANDREA COLLEGIUM" (Bradford) asks (1) How to add another valve through a resistance capacity to a circuit sketched, so that he can switch over quickly from one valve to two. (2) Whether English broadcasting stations could be heard on one valve at Rouen.

(1) Use a spherical reaction coil. Preferably couple the switch shown with a switch to break the filament of the second valve (Fig. 8) when not required, and use separate filament resistances for each valve. (2) Very doubtful.

"A.W." (Plumstead) encloses a diagram of circuit and asks (1) For criticism. (2) Capacities of condensers suitable for the set. (3) Wavelength of set.

(1) Not very efficient. We prefer the circuit of Fig. 3, page 501, issue July 15th. (2) Closed circuit condenser 0.0005 mfd., grid condenser 0.0002 mfd. (3) Wavelengths up to 4,500 metres with an additional aerial loading inductance. Without this only up to about 2,700 metres.

"READER" (Royston) refers to Fig. 7, page 276, May 27th issue, and asks (1) The capacity of the reaction condenser. (2) If honeycomb coils are suitable for coupling the valves. (3) If he is infringing any patent by selling a receiver using this circuit.

(1) Up to about 0.0001 mfd. (2) Not very suitable, but something might be done with them in special circumstances. (3) We believe that capacity reaction as well as magnetic is covered by existing patents.

"J.S." (Byfleet) wishes to know (1) and (2) How to arrange a "B Mark I" set for short wave reception. (3) The wavelength range of his tuner, wound with 92 turns of No. 24 D.C.C. on 4" former for primary and 175 turns of No. 36 D.C.C. on 3" former for secondary.

(1) and (2) See December 10th, December 24th and January 7th last issues. (3) When connected to a single wire aerial 100' in length, the maximum wavelength to which the set will tune will be approximately 900 metres. For telephony reception we recommend you to construct two special coils, the exact dimension of which can easily be found by experiment specially suitable for use on your aerial.

"FINE ADJUSTMENT" (Douai School)

asks with regard to a Reinartz tuner he is constructing (1) If the wavelength depends on the aerial or grid circuit, and how to calculate the dimensions of the coil. (2) How can another valve be added to the tuner for H.F. amplification. (3) Would such a set with a 100' x 60' high aerial receive 2 NT and PCGG at Addlestone, Surrey. (4) If a crystal detector can be used with a Reinartz tuner.

(1) Chiefly on the grid circuit. About 5" x 4" of No. 20, with 0.0005 mfd. condenser will be O.K. (2) See the article in the issue of July 8th. (3) Probably. (4) Not efficiently.

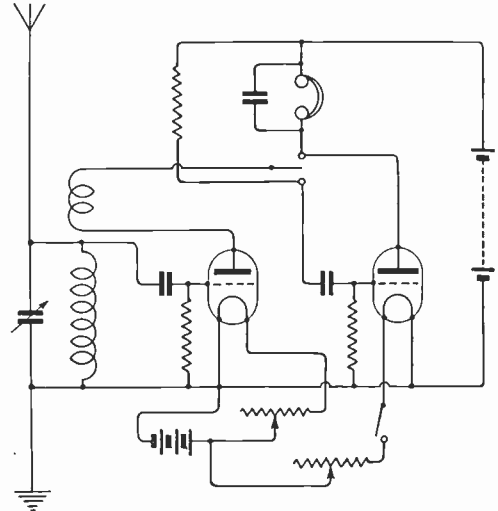

Fig. 8.

"A.M.H.C." (Shoreham) asks re reaction coil on page 33 in Alan Douglas's book, how many windings are necessary, as the diagram shows five and the letterpress stipulates 34. (2) If an illustration can be given showing the attachment of the reaction coil. (3) For a sketch of the circuit.

(1) Apparently 34 were intended, as page 33 distinctly says that it is the secondary taps which are visible in the illustration. 34 is, however, rather a large number. (2) We think the letterpress gives a very fair description. One or two rods are passed right through the cheeks of the inner coil, and are arranged so that this coil can slide on them. The rods are fixed in any convenient way parallel with the base carrying the primary coil. The coupler may be used in the circuit of Fig. 4, page 11, or in many of the circuits given in these columns.

SHARE MARKET REPORT.

Prices as we go to press on August 4th are:—

Marconi Ordinary	£2	3	0
.. Preference	2	0	7½
.. Inter. Marine..	1	8	0
.. Canadian	10	0	0

Radio Corporation of America:—

Ordinary	19	3
Preference	13	

WHY DID THE GRID LEAK ?

A Prize for the best Answer.

Write on a separate piece of paper (one side only).

Watch these Advertisements for Winners.

Endorse "Competition" top of left-hand corner of paper.

Aerial Wire, 7/22's Enamelled Hard Drawn Copper, 6/- per 100 ft.
Aerial Pulleys, 3 1/2" 1 -, 5" with tackle hook and bucket, 2/6.
Aerial Insulators, Shell type, 2 1/2" x 2 1/2", green, 1/6 each.
Aerial Insulators, Reel type, 2" diam., white, 4 1/2d. each.
Batteries, for H.T. Make your own. Flash Lamp Batteries, 5/- doz.
Buzzers for Morse practice, new improved line, best quality, 4/6.
Condenser Scales, 1/- each.
Condenser Dials, Engraved fine finish 1/9 ea.
Condensers, Fixed. Exceptional quality. Terminal connections; from '000r to '001, 2/9 each.
Condenser Vanes. Not rubbish. Best Aluminium, 1/- doz.
Condenser Spacing Washers. Accurate. Small, 4d. doz.; large, 8d. doz.
Condenser Screwed Rod. Brass, 12" lengths, 2 B.A. 9d. each. 4 B.A., 6d. each.
Contact Studs. Studs, not rubbish, 2/- doz.
Copper Foil Sheets, 9" x 3", 6d. each.
Core Wire, soft iron, 2/4 per lb.
Ebonite. Best quality. Any size, rod or sheet, 5/- per lb.
Filament Resistances. For panel mounting. A speciality, 4/- each.

Inductance Tubes, 12" long. Specially impregnated, 2 1/2", 6d.; 3", 7d.; 3 1/2", 8d.; 4", 10d.; 4 1/2", 1/-; 5", 1/2; 6", 1/6 each. Postage, 9d. each.
Inductance Slider Rod, 1/4" square in 12" lengths, 7d. each.
Inductance Sliders, ebonite only, 6d. each.
Insulating Tubing, 6d. per yard.
Ivory Scales, 0 to 180 degs. Engraved (not printed), 1/2 each.
Ivory Tablets. Set of 6, 9d.
Knobs. Ebonite, 1 1/2" diameter. Superior finish. Knurled, 7d. each.
Mica. Pure Ruby. Pieces, 3" x 3" x .002" thick, 6d. each.
Paraffin Wax, 1/- per lb.
Resistance Wires. "Elsi" brand, 22's (1 ohm per yard), 24's (1.7 ohms per yard), and 28's, enamelled (4 ohms per yard), 2d. per yard.
Switch Arms. Exceptionally strong and well made, 2/6 each.
Terminals. A very neat wireless terminal. Polished, complete with nut and washer, 2/6 dozen.
Tin Foil. Free from Lead. Sheets, 26" by 13", 4d. each.
Valve Sockets. With nut and washer. Fine finish, set of four, 9d.
Valve Holders. Best quality ebonite, with nuts, 1/4 each.

Valves. 4-pin vertical filament, 10/6 each. Wood's Metal, 8d. per packet.
Crystals. Carborundum, galena, bornite, copper pyrites, silicon, iron pyrites, manganese, 8d. per packet.

SUPERIOR QUALITY WIRE. British made. All wire wound free. Post extra.

S.W.G.	S.C.C.	D.C.C.	Single			En.
			Silk	Silk	Dble.	
12	1/10	1/11	4/-	5/4	1/8	
14	1/11	2/-	4/-	5/4	1/9	
16	2/-	2/1	4/2	5/6	1/10	
18	2/1	2/2	4/4	5/6	1/11	
20	2/2	2/3	4/8	6/2	2/6	
22	2 6	2,11	5/-	6/8	2/8	
24	3.-	3 6	5 6	7/4	2/8	
26	3/7	4/1	6/8	8/2	3/2	
28	4/4	4/7	7/2	9.-	3/6	
30	5/-	5/6	8/-	10/-	3/10	
32	6/-	7/3	9/2	13/-	4/2	
34	7/-	8/3	11/6	14/-	4/4	
36	8/8	10/2	14/-	15/6	4/8	
38	11/3	13/2	16/-	19/-	5/3	
40	15/-	18.-	18 6	22/6	6/6	
42	17/3	21/-	31/6	34/-	9/-	

At per lb.

Carriage extra. Please remit ample postage, balance returned. Orders over £2 carriage paid. Money back if not satisfied.

J. L. CARTWRIGHT & CO., Manufacturing Electrical and Radio Engineers, DEPT. W.

*Phone—Cent. 4209. 130/132, LONDON ROAD, MANCHESTER. Grams—Pladuram, Manchester.
 Special Terms to the Trade. No Catalogues yet.

SPLENDID SETS
 FOR CONVERSION.

TUNERS, 60W. C.W. - - £3 10
 TRANSMITTERS ,, - - £3 10
 WILSON 130W. TRANS-
 MITTERS - - - - £7 0
 WAVEMETERS - - - - £2 10

E. W. LEE & CO.
 68, WOOD STREET, LIVERPOOL.

BEWARE !!
 OF GOODS SOLD WITHOUT A GUARANTEE.
 ALL OUR INSTRUMENTS ARE GUARANTEED.

TELEPHONY TUNERS, Range 300-1,100 metres. Perfect for DUTCH CONCERTS and all telephony. A complete tuning and reaction unit (angular motion). Price 18/-. Postage 1/-.

SINGLE VALVE RECEIVER. First quality components only used. Ideal for use with above or any other tuner. (Less valve) Price 38/6. Postage 1/-.

TWO-VALVE L.F. AMPLIFIER. A perfect amplifier. Speech distortion entirely absent. Price 14. Postage 1/6 (less valve).

THREE-VALVE AMPLIFIER. 1 H.F., Rect. 1 L.F. The finest receiver constructed. RANGE UNLIMITED. Details per request. (Less valves) Price £8 8s. 0d., post free.

PANELS (EBONITE) CUT AND DRILLED TO YOUR PLANS. ADVICE GRATIS TO PURCHASERS.

EAST LONDON INSTRUMENT COMPANY, (Postal Dept.)
 28, NORTHBANK ROAD, WALTHAMSTOW, LONDON, E.17.

WIRELESS VALVES
 SIMPLY EXPLAINED
 By John Scott-Taggart, F.Inst.P.

This brand new book is the first new book on valves which is more than a sketchy description. It is complete.

WHY YOU SHOULD BUY THIS BOOK

- It explains fully how valves work.
- It is crammed with practical circuits.
- It is written by an expert, solely for the amateur.
- It is written so that the beginner can understand it all.
- It is the latest and most up-to-date book on valves.
- It contains 140 pages and 56 illustrations.

SOME OF THE CONTENTS.
 Three-electrode Valves, Amplifiers, Self-oscillations, Reaction Reception, C.W. Receiving Circuits, Valve Transmitters, Telephone Transmitters, Telephony Receivers, Broadcast Receivers, etc., etc.

Price 2/6 Net. Cloth 3/- Net.

Our books are sold by Wireless dealers of standing, or may be obtained POST FREE by return from

RADIO PRESS, LTD.
 Publishers of Authoritative Wireless Books -
 34/35, Norfolk Street, London, W.C.2

THE WIRELESS WORLD EXCHANGE AND MART

TARIFF. Advertisements are accepted for this Section at the rate of twopence per word, with a minimum charge of two shillings. The advertiser's name and address will be charged for, and single letters and single figures will be counted as words. Compound words will be counted as two words.

DEPOSITS. All advertisements must be prepaid in the form of Postal Orders, the remittance being forwarded to Messrs. Bertram Day & Co., Ltd., 9 & 10, Charing Cross, S.W.1.

Wireless Expert, ready for the wireless boom, First-class Postmaster-General's Certificate, experience in various parts of the world with latest instruments, commercial education, correspondence typewriting, desires position where above would be of value.—F. F. WARNER, High Lane, nr. Stockport.

Huge Purchase.—Wireless Transmitter, Type No. 1, fitted with high class variable spark gap, condenser and tuning, 1 Sterling spark coil, Helix mounted on ebonite panel, terminals and external fittings mounted on ebonite panel. Internal fittings in mahogany case. Range, 100-500 metres, work on 4 to 6 volts. Tested before dispatch and sent complete at 17s. 6d. each, plus 2d. for packing and postage.—CADNEY BROS., Alpha Mews, Alpha Road, New Cross, S.E.24.

VELO

HIGH QUALITY GUARANTEED RECEIVING SETS.

Valve Sets complete with every accessory, including Phones, Valves, Accumulator, Battery, Aerial, Insulators ready for immediate use and guaranteed to give best results.

- Single Valve Set £11 11s.
- Two-Valve Set £14 14s.
- Three-Valve Set £17 17s.

It will be found highly advantageous to purchase these complete sets, but all accessories can be supplied singly if required.

- Interval Transformers, uncased. 21/-
- Interval Transformers, in Mahogany Case and Terminals. 26/-
- Telephone Transformers, uncased. 17/-
- Telephone Transformers, in Mahogany Case and Terminals. 21/-

Prompt delivery given of all parts and enquiries and price lists sent by return.

H. C. DALY,
22 Walbrook, London, E.C.4
To the Trade.—Selling Agencies available.

HEATH & Co., Ltd.

Instrument Works, New Eltham, S.E.9 are prepared to undertake in their fully equipped works—**Wireless Apparatus and Parts for the trade.** Quotations given to Blue Prints. Immediate attention.
Phone—Lee Green 301. Wire—Polaris, London.

FOR SALE.

Fibre Sheet.—Best hard vulcanised, at greatly reduced prices per square foot—2", 2s. 6d.; 3", 4s.; 4", 5s.; 9/16", 6s. 6d. Strips for panels, 11" x 3" x 3/8", 1s. 6d. each, other sizes pro rata. Postage extra.—Trade enquiries invited.—F. W. HOLY, 120, Arbor Vale, Slough.

Complete Tingey Receiving Set, consisting of Cl, Rx, A3, telephone transformer, two A coils, 60 volt H.T. Perfect condition, brand new, owner building larger set. What offers?—ALLARDICE, "Ravensbury," Caterham Valley, Surrey.

Variable Mica Condensers.—New, accurate adjustments. 0.0005, 9s.; 0.001, 12s. 6d. Money returned if dissatisfied.—THOMAS, Redbourne, St. Albans.

Rigging.—Flexible steel cable, blocks, fittings in stock. Stays with insulators, strainers, etc., made up to instructions. Prompt delivery. Galvanised steel cable, 6-strand, 3/8" 10-wire, 7s. 3d.; 3/4" 7-wire 7s. 6d.; 1/2" 7-wire, 9s. 3d. per 100 ft. Delivery F.O.R. London. Also few good second-hand one and two-valve Receiving Sets and accessory parts.—"S.A. CUTTERS," 61, Lee Park, Blackheath S.E.3.

Great Success.—Morse Code easily mastered with the "Little Brick" (Prov.: Pat. 13846). Sends any message any speed, and will last a lifetime. Price, complete, 6s. post free. Further particulars stamped envelope.—GRIMSHAW (Dept. W), Leigh Street, Golborne, Lanes.

Aerial Wire.—Our Speciality 7/22 Hard Drawn Stranded Copper, guaranteed, 100', 5s. 3d.; 140', 7s.; 100 yards, 13s. Carriage paid.—FAIRBROTHER & Co., Vulcan Street, Leeds.

Complete Wireless Receiving Station, including tuner, crystal detector, aerial, telephones (4,000 ohms), insulators, ready to fit up. Guaranteed to receive speech, music and Morse. 75s., no offers, first P.O. secure.—H., 16, Lordship Park, London, N.16.

Brand New Mk. III* Tuner, £10 10s. 10d. B Mk. I* 2-Valve Receiver, £4 10s.—W. SEED, Crigglestone, Wakefield.

Instrument Boxes of every description. Splendid finish. Enquiries invited.—SMITH, Terling, Essex. **Designs of Receiving Sets,** Motors, Generators, etc., supplied. Sound advice given. Calls arranged if desired. Note new address—PUCKLE, Buckhurst Hill, Essex.

"Multiwave" Tuning Coils.—Set of nine 200-25,000 metres. Shellac impregnated, silk-taped mounted complete with table tuning stand, chart, 35s. Specification stamp.—RADIO COIL Co., 20, Maybank Avenue, Harrow.

Operators Uniform and Bridge Coat, "condition New." Suit five feet eight or nine.—Write, JAMES MURDOCH, 17, St. John Street, Prestwick, Ayrshire.

Small Parts Supplied from Stock.—Condenser plates, crystal detectors, terminals, spacers, washers, nuts, contact studs and stops, valve legs. List free.—FRASER, Sentinel House, Southampton Row, London.

Special Line, Wireless Girder Masts Light and Strong, 30' £1, 35' 22s. 6d., 40' 25s., 45' 30s., 50' 35s. Cash with order, carriage forward.—F. ARMSTRONG, Weybridge.

B.A. Screws, Nuts and Washers, assorted gross, 2s., lists 2d.—J. H. BENNETT, Station Road, Willesden Junction.

For Sale.—Ebonite—1/4", 3/16", 1/8" and 3/32", any size cut. 3/8" 3s. 6d. per square foot, other sizes in proportion. Carriage paid on ros. lots. Scrap Ebonite Sheet suitable for condensers, insulators, etc., 3s. per lb., postage 8d. New Hart Accumulators in 2-volt units—2v. 40 amp. (1) 14s. 6d., (2) 28s.; 2v. 60amp. (1) 17s., (2) 33s.; 2v. 80amp. (1) 20s., (2) 38s. Carriage forward. Aerials—Rubber covered on wind-up reels, with 2 R.A.F. ebonite insulators, 2s. 6d. each, postage 9d. Valveholders—Best quality, 1s. 9d.; cheaper quality, 1s. 6d., screwed legs. "Ora" Valves—15s. each, Postage 3d.—RENSHAW & MARSDEN, Penny Street, Blackburn.

ELECTRADIX WIRES

Gauge.	Highest Conductivity at Lowest Prices.		
	D.C.C.	S.S.C.	D.S.C.
16	1 7	—	3 6
18	1 9 1/2	—	3 9
20	1 11	4 0	4 6
22	2 5	4 6	5 0
24	3 0	5 0	5 9
26	3 6	5 6	6 6
28	4 2	5 9	6 10
30	5 2	6 6	8 1 1/2
32	6 0 1/2	8 2	9 0
34	7 9	9 6	10 7
36	9 2	11 3	12 3 1/2
38	11 10	13 6	17 3
40	16 2 1/2	17 0	23 5

Prices at per lb. Postage Extra. Earth Clips, 6d. each. 7/22 Aerial Wire, 7/- per 100 ft.

EVERYTHING FOR WIRELESS IN STOCK.
LESLIE DIXON & CO.,
9, Colonial Avenue, Minories, E.1
(near Aldgate Station. Telephone Avenue 4166)

EBONITE "A" TYPE 4 PRONG VALVE HOLDERS

1/9 each, post free.

WILKINSON,
LONSDALE RD., KILBURN, N.W.6
TRADE SUPPLIED. Established 1900

KEYSTONE WIRELESS SUPPLIES

WHOLESALE ONLY.

Ebonite, cabinet work, engraving, expert designers in amplifiers. Slab inductances, basket coils, etc. Switch arms, contacts. Terminals, Scales.

Low Prices Offices: High Finish.
33, Trinity Road, TOOTING, S.W.

Send us your enquiries for
BOXES, CABINETS, SPREADERS, CONDENSERS and parts, LEAD-IN-TUBES, and all accessories, to the Trade.

COMPETITIVE PRICES
PROMPT DELIVERIES

The Central Aircraft Co.
179 High Rd., Kilburn, N.W.6
Phone—Hampstead 4403-4 8018.

THE WIRELESS WORLD EXCHANGE AND MART

Instrument Wires

FROM STOCK

S.W.G.	S.C.C.	D.C.C.	S.S.C.	D.S.C.	En.
47	—	—	110/-	120/-	41/-
48	—	—	97/-	107/-	26/-
45	—	—	64/-	80/-	20/-
44	—	—	50/-	68/-	16/-
43	—	—	40/-	52/-	13/-
42	—	—	31/-	38/-	9/-
41	—	—	30/-	32/-	8/-
40	14/-	17/-	18/-	22/-	6/8
39	12/6	15/-	17/-	21/8	6/-
38	11/-	13/-	16/-	19/-	5/8
37	10/-	12/-	14/6	17/3	4/11
36	8/8	10/-	13/9	15/-	4/8
35	7/9	9/3	12/9	14/-	4/6
34	6/10	8/-	11/3	13/9	4/4
33	6/2	7/6	10/6	13/-	4/3
32	5/10	7/2	9/1	12/10	4/2
31	5/6	6/10	8/9	11/6	4/-
30	5/-	5/4	7/9	9/10	3/10
29	4/9	5/-	7/6	9/6	3/8
28	4/3	4/6	7/2	9/-	3/6
27	4/2	4/5	7/-	8/6	3/5

Prices per lb. Bobbins free.

Orders of £2 or over, Carriage Paid, G.B.

Terms—Cash with Order.

FINE WIRE SUPPLIES,

(A. E. DAVIS)

41, Arlingford Road,
Brixton, S.W.2

PURCHASE YOUR WIRELESS REQUIREMENTS THROUGH

The Viper Re-Covering Co., Ltd.

7/8, POULTRY, E.C.2.

(1 minute from Bank) Tel.: City 1897

Marconiphones, Sterling and R.F.H. Sets, etc., can be supplied. Place your orders NOW.

THE UNIQUE N.M.C. (Wireless Patents)
Two-valve Receiving Unit, combining Filament Resistance, Aerial, Tuning Inductance, Aerial Tuning Condenser, Grid Tuning Inductance and Oscillating Condenser, complete in polished case, 12" x 8" x 6", 26 6s. less Valves.

The Set to obtain maximum efficiency.
N.M.C. 4,000 W., Double Head Gear, 35/- Inductance Tubes.

All Experimenters' Supplies in Stock.
N. M. CO., 145, Northcote Road,
Trade Supplied. London, S.W.11.

CONNOLLY, BROTHERS

WIRELESS APPARATUS MANUFACTURERS,
LOSTOCK RD., URMSTON, MANCHESTER.

Spares & Complete Components at Trade Prices.

Examples: 50' x 6' Double Wire Aerial, 40' Lead in, ready for fixing, 17/6. 7/22 Stranded Wire, 1d. per foot. 2" Reel Insulators, 41d. each. 4" x 12" Wound Inductance Coil, 4/9. 28's Enamelled Wire, 1lb., 2/-, 1lb., 3/6.

CARRIAGE PAID ON ORDERS OVER £2.

SITUATIONS WANTED.

Ex-Chief Telegraphist, R.N.—Young man desires post, Fitting, Instruction. Thorough knowledge wireless, all branches, practical, theoretical. Last post staff instructor. Expert operator.—King, 16, Bell Green, Lower Sydenham, S.E.

Ex C.P.O. W/T (29), 12 years experience all grades, thorough knowledge theory and practical working, including high power shore stations, desires employment any capacity, selling, Demonstrating, etc., where above experience necessary.—E.J.M., 8, Speranza Street, Plumstead, S.E.18.

Amateur, with four years' experience, requires employment.—Box A.3, BERTRAM DAY'S ADVERTISING OFFICES, 9 and 10, Charing Cross, S.W.1.

Ex-Lieut. R.E. (29), Single, over ten years' experience Wireless, Navy, Army, Marconi. Thorough up-to-date knowledge of Wireless, both theoretical and practical. Expert lecturer and demonstrator. Seeks employment with Wireless firm.—"W", 1, Oatlands Drive, Weybridge.

SITUATIONS VACANT.

Wireless—Patent Agent requires technical Assistant with thorough knowledge of wireless. Experience in Patent Work desirable.—Write giving full particulars and salary required to Box 515, SELLS ADVERTISING OFFICES, Fleet Street, E.C.4.

BOOKS.

Radio Magazines, all the latest. "Radio World," 10½d.; "Popular Radio," 10½d.; "Radio Broadcast," 1s. 6d.; "Radio News," 1s. 6d.; "Science and Invention," 1s. 9d.; "Scientific American," 2s. 6d. Post Free.—INTERNATIONAL NEWS COMPANY, LTD., 15, Bream's Buildings, London, E.C.4.

TRADE ENQUIRIES.

Manufacturers and Factors—Catalogues and Terms, for all wireless goods desired by wireless specialists in excellent Northern District. Agencies considered.—Box L1, BERTRAM DAY'S ADVERTISING OFFICES, 9 and 10, Charing Cross, S.W.1.

Wireless Repetition Work for trade.—LIBERTY ENGINEERING CO., LTD., Acton Town Station. W.3

WANTED TO PURCHASE.

Wanted to Purchase—Mark 3* Short Wave Tuner. State condition and price.—Box H.1, BERTRAM DAY'S ADVERTISING OFFICES, 9 and 10, Charing Cross, S.W.1.

MISCELLANEOUS.

Expert Advice for the Amateur—Designs and diagrams, information on all wireless matters: Advice on faults and difficulties. Prospectus post free.—G. P. KENDALL, B.Sc., Wireless Consultant, Moortown, Leeds.

Printing—Memos, Billheads, Cards, Price Lists, etc., very low prices, samples free. VICTORIA PRESS, 368, Knutsford Road, Warrington.

TRADE:

Wireless Exhibition—Will be held on the 24th, 25th, 26th Aug., by the South London Wireless & Scientific Club at St. John's Institute Larcom Street, S.E.17 (2 mins. Southwark Town Hall). Special Attractions. Admission One Shilling, inc. tax. Trade and Amateur Exhibits especially invited. Sec. W. ANSELL, 67, Larcom Street, S.E.17.

Wireless Manufacturer of British Patented portable crystal set desires retailers or dealers to negotiate for output. Sample sent by apt.—Write W.M., 54, New Oxford Street.

Mullard Valves, Brown's Phones, Speakers, Batteries, Aerial Wires 7/22, 13 ft. Poles, and Sundries.—G. R. ALEXANDER, The Motor House, Hale, Altrincham.

ELECTRADIX RADIOS



Hundreds of Head Sets in Stock. All with cords. Sterling Brown Phones, Marconi Standard 2,000 ohms, 51/- pair; 4,000 ohms, 52/- pair; Brown's A 120 ohm L.R. head 'phones, 40/- pair, Sullivan's L.R. ditto, with 6 ft. cord plug and jack, 22/-.

High Res. Head Sets, 1,500 ohms, 26/-; 4,000 ohms, 30/- complete. Second-hand 60-ohm head sets

guaranteed, 15/-.

Single L.R. Receivers, 4/6. Cords for double 'phone, new, 2/6 and 3/9. Used, 1/6. 4 Way Plugs, 2/-.

Microphone Transmitters, breast plate, 12/6; Hand, 2/6. Insets, 9d.

Aerials—Wire and every accessory in stock. **Condensers**—Fixed and variable in all sizes. Relys, G.P.O. 21/-; Weston M.C., 22 10s. Morse Inkers, 45/-.

Sounder sets for making rectifiers, 12/6 each. Panel Switch Flush Fitting, D.P., 3/6. Plugs and Jacks, 1/8 pair. 60 volt Battery, 4½v. units, in polished mahogany case, six sockets, two plugs, 17/6. Finest set ever offered.

Receivers, all new. Marconi Trench, 50 D.C. Cost £40. Complete, 25 10s.

Amplifier Receiver, Mark II, 2 valve, with variable condenser, 27 10s. Single valve panel, 35/6. 3-valve Amplifier, Mark IV, 28. H.T. Motor Generators to 1,000 volts, £15. 1 kW 220 to 25 volts, 280.

EVERYTHING FOR WIRELESS.

Call at our Electrical Showrooms and inspect.

LESLIE DIXON & CO.,

Near Aldgate Station, Met Ry. First Turning on left in Minories.

RADIOPHONE TUNERS,

- 200-1,400ms. 38/-
- Valve Panels for above 21/-
- 0005 Variable Condensers 18/6
- Above 3 make an Ideal Receiver.
- Broadcast Concert Coils pair 2/-
- Grid Leaks and Condensers 3/6
- Fixed Condensers 2/6
- 5-Plate Condensers 6/6
- 2-Valve H.F. Amplifier Panels 32/-

Get our New Bargain List.

AMATEUR SUPPLIES,

134, COTEFORD STREET,
TOOTING, LONDON, S.W.

OUR SPECIALITIES.

PHONE TRANSFORMERS in polished Mahogany Case, engraved sbonite top, Condenser incorporated, 21/-. Unmounted, 14/-. L.F. Intervalve Transformers, 18/-. •0005 V. Condensers in Polished Mahogany Case, scale and Brass Pointer, 17/6. All own manufactures. Mahogany Cases made to order. Lowest Prices.

WOODMASON,

Electrical and Wireless Engineer,
COLCHESTER, and at IPSWICH.

THE WIRELESS WORLD EXCHANGE AND MART

"S.A. CUTTERS"

Manufacturers of
HIGH CLASS CUTTING TOOLS
and
ELECTRICAL GEAR

BURNDEPT

Apparatus Always in Stock.

Also

**HEADPHONES, LOUD SPEAKERS,
RELAYS, CABLE WIRES,
MASTS, FLEXIBLE STEEL CABLE
FITTINGS**

Write for Quotations

**COMPLETE INSTALLATIONS,
ACCESSORIES, PARTS, ETC.**

Demonstrations of All
Apparatus by Appointment.

London Office Open Shortly.

**61, LEE PARK,
BLACKHEATH S.E.3**

SPECIAL OFFER

Complete set of parts for Single Valve Receiver ready to assemble with Cabinet and Tuner, 17/6, with all orders received in 7 days we will include set of tuning coils, 300 to 2,600 metres.

**MIDLAND RADIO MANF. CO.,
43, Dame Agnes Street, Nottingham.**

F. ARMSTRONG, Weybridge.

Phone: Wey, 620. **Wireless Girder Mast Works**

London Agent: Wilkinson, Lonsdale Road, Kilburn. Agent for Lancashire, Yorkshire, Cheshire, Shropshire, Staffordshire and North Wales: Fred Moore & Co., 46, Park Lane, Liverpool.

Agents Wanted where not represented.

BUILD YOUR OWN SET

Half the pleasure in Wireless lies in building your own Instruments. Send stamp to-day for our complete lists, and get to work yourself.

**ELECTRICAL SUPPLY STORES,
5, Albert Terrace, King Cross, HALIFAX.**

WE SUPPLY THE PARTS

The Year Book of Wireless Telegraphy and Telephony

1922

1,476 Pages. Demy 8vo.

PRICE **15/-** NET.

(Postage Inland 1/-. Abroad 1/4)

CONTENTS—

Record of the Development of Wireless Telegraphy—National and International Wireless Laws and Regulations—Directory of the World's Land and Ship Wireless Stations—International Allocation of Call Letters—Alphabetical List of Call Letters—Meteorological Section—International Time and Weather Signals—National Résumés of Progress in Wireless Telegraphy—Particulars of Wireless Telegraph Patents, 1921—Aviation Section—Tabular List of Aviation Stations—Useful Data Section—Wireless Terminology—Conventional Signs used in Wireless Diagrams—Companies Engaged in the Commercial Development of Wireless Telegraphy—Biographical Section—Literature on Wireless Telegraphy and Telephony—Directory of the World's Wireless Societies—Directory of Wireless Colleges and Schools—List of Licensed Amateur Transmitting Stations—Code Section—Special Articles on "The Earthing Resistance of Antennae," by Dr. Miessner—"The Recording of Wireless Signals," by Dr. Abraham—"The Birth and History of Long Distance Wireless Telegraphy"—"The Rectification Effect in its Reaction to the Composition and Structure of Crystals."

A valuable feature of the present issue is the specially drawn map, which gives, for the first time, a simple means of finding the distance and true direction of Wireless Stations in all parts of the World, from London as the centre.

The Wireless Press, Ltd.

(Dept. W.W.),

12-13, Henrietta St., London, W.C.2



**WHOLESALE
WIRELESS
SUPPLIES**

Send on your
Requirements

We Sell at Low-
est Rates con-
sistent with
Good Quality

4 Little Titchfield Street,
Oxford Circus,
LONDON, W.1.

Phone: GERRARD 6123 **LET US
QUOTE YOU**

RESULTS

Whether as a source of practical information for the Amateur or as a valuable medium for every Advertiser, the **best results** are invariably obtained through the **"Wireless World"**

For full particulars and advertising rates apply to **BERTRAM DAY & CO., LTD.** Complete Advertising Service, 9 and 10 CHARING CROSS, S.W.1

L.F. TRANSFORMERS - 15/-
H.F. do. with 4 tappings - 25/-
Vario meter - 12/6
2-Valve Note Magnifier - 40/-

Send Stamp for List.

**CLARKE,
41, Hatchlands Road, Redhill.**

EBONITE

**VALVE HOLDERS. KNOBS.
Panels and Pieces cut to size.**

Prompt Delivery. Amateurs and
Trade Supplied. Send your enquiries.

**C. OLIVER, 207 ALTMORE AVE.,
EAST HAM, E.6**

FOR SALE.**HONEYCOMB COILS.**

In sets of Eight Coils, Wave Range with .001 Condenser, 300 to 7,000 Metres. Price, £1 7s. Unmounted, £2 10s. Mounted.

Send for Lists.

These coils are HAND WOUND, and combine maximum efficiency with lowest possible self-capacity. There is a big demand for these coils, but at present they can be supplied from stock by:—

**CHAMP, KAY & CO.,
95, Saltisford, WARWICK.**



THE
**FELLOWS
 HEADPHONE**

PRICE **30|**-

Complete with cord
Stock resistance 4000 ohms
Other resistances to order

These Headphones are highly efficient, well finished and British throughout.

We also Manufacture—

Complete Valve Receiving Set ; Crystal Sets ;
 Valve Holders ; Ebonite Knobs ; Grid Leaks ;
 Grid Condensers (mounted and unmounted) ;
 Valve Legs ; Condenser Vanes ; Variable Con-
 densers ; Filament Resistances ; Valves ; High
 Tension Batteries ; Accumulators ; &c., &c.

Write for List. Deliveries from Stock.

FELLOWS MAGNETO Co. LTD.

CUMBERLAND AVENUE, PARK ROYAL, N.W.10.

Telephone : WILLESDEN 1560.

Telegrams : QUIXMAG.

UNITS, COMPONENTS AND SUNDRIES

TUNER PANEL.

Containing '001 mf. Variable Condenser, Fine Tuning Condenser and Coil Stand for Honeycomb Coils. Fitted with Series-Parallel Switch ... **£5 0 0**

HIGH FREQUENCY AMPLIFYING PANELS

For Two Valves and Transformers. Fitted with Double Tuning Condenser. **£3 10 0**

NOTE MAGNIFIER.

With Transformer ... **£3 10 0**

All above supplied with walnut or mahogany cases, matt finish ebonite panels, gold lacquered brass work. Condensers with bevelled dials.

Send stamp for List of Condensers and Parts, and all sundries for Wireless.

Manufacturers:

KERR & THOMAS,
BARR HILL WORKS,
DALBEATTIE, SCOTLAND.

REVOLUTION IN PRICES.

For the convenience of those Amateurs who prefer to make up their own Variable Condensers we are offering complete sets of parts, ready to assemble, no drilling or fitting required, at hitherto unheard of prices, in the following Capacities:

'0015	'001	'00075	'0005	'0003	'0002
21/-	17/6	15/-	10/-	8/-	7/-

For Assembled add 2/6 to price of each model except '0015 and '001 which are 4/6 extra.

The above are for Panel mounting and, at the price, are absolutely the best Condenser value on the market. With Engraved Ivorine Scale, 1/3 extra. Mounted in Mahogany polished Cases, 4 1/4 x 4 1/4 x 3 1/4, with ebonite top and knob, scale and pointer. '0003, 12/6; '0005, 16/-; Vernier Condensers, unmounted, 3 plates, 4/-; 5 plates, 4/9.

How can we Sell so Cheaply?

Buy from the makers and save middlemen's profits. Post Paid on £1 Orders

W. J. FALLON & Co., The Condenser People,
230a, HERMITAGE ROAD, LONDON, N.4.

WIRELESS

CRYSTAL RECEIVING SET.

Specification.—Solenoid type inductance with tappings. '0005 variable condenser, perikon detector or galena, the whole being assembled on 1" ebonite, and mounted in a highly polished cabinet. This receiver is ideal for the reception of telephony. Wavelength, 180/1,800 metres approx. Price, complete with phones (4,000) ... **£5 12 6**

CRYSTAL RECEIVING SET.

Specification.—Double slide tuning inductance, galena detector with dustproof case, blocking condenser, the whole being assembled on a highly polished mahogany base, being an ideal receiver for the reception of telephony. Price, complete with phones (4,000) ... **£4 10 0**

Filament Switches, under panel type, ebonite	3/9
Aerial Insulators	3d.
Valve Legs with two nuts	per set of 4 10 3d.
Ex-Govt. 2-valve Receiver (less valves etc.)	£7 5 0
Variable Condensers (21 plate)	17/-
H.T. Units, 15v.	3/3 & 3/9
H.T. Battery Boxes, complete with switch and fuses, etc.	6/6
Condenser Spindles with knob	1/-
Grid Condensers	2/6
Valve Holders	each 1/-
Fuller Inert Cells, 1 1/2 v.	9d.
Ali Condenser Plates	per doz. 1/6
Crystals	per piece 6d.
Zincite	per piece 9d.
Valve Pins with nut	per doz. 1/9
Single-valve and 2-valve panels	
Accumulators for Valves	from 16 6
Dutch Concert Coils	per pair 4/6
Inductances wound on formers	4/9
Aerial Wire, 7/22	per 100 ft. 5/9
Microphones with replaceable insets	2/6
H.T. Leads (red and black)	each 4d.
Phones, new (4,000 m.), double	30/-
Ebonite Knobs	each 6d.
Switch Arms, laminated with bush	2/-

Carriage Free on £1 and over.

C. S. SWAN, 191 Bishopsgate,
(NEXT TO BRANDON'S),
and 65 Windsor Road, Leyton, E.10 E.C.2

SHEET, ROD AND TUBE stocked in qualities suitable for all Wireless work.
KNOB (Moulded), various patterns stocked
CONDENSER DIAL AND KNOB.

3" and 4" dia.—0"—100°

Watch this Advert.

for new mouldings.

EBONITE
(HARD RUBBER)

Enquiries Solicited.

WHOLESALE ONLY.

AMERICAN HARD RUBBER CO.

(BRITAIN) LIMITED

13a, FORE STREET, LONDON, E.C.2

Teleg. "Eboniseth, Ave., London." Phone: Central 12754

“Ever-Ready”

British Made

DRY CELLS BATTERIES

were the first in the field, and their fine qualities make them peculiarly suited for wireless installations.

THE ‘UNIT’ DRY CELL

“Build up your batteries as you build up your Marconi sets.”

Unlimited flexibility in size, voltage and intermediate tappings. Each cell is fitted with brass screw terminal and looped wire, and they are efficiently insulated to prevent current leak.



No. UW1 7/6 dozen
EMF. 1½ volts Weight 3½ ozs.
Dimensions 2½ ins. × 1 5/16 ins. Diam.

Art catalogue of standard sizes and list of accumulators for valve filament supply sent on request.

The EVER-READY Works, Hercules Pl., Holloway, LONDON, N.7

HIGH TENSION BATTERIES

Any size or voltage with any tappings or sockets at 3 or 6 volt intervals for use with wander plugs can be supplied to order.

With 13 Sockets

No. W. 19, 36 volts, 24 cells, 3/6 each.
Size 6½ × 2½ × 3½. Weight 2 lbs. 8 ozs.
Wander plugs for use with above, 1/- per pair.

With 2 Spring Contacts. As illustrated.

No. W. 11, 15 volts, 11 cells, 3/6 each.
Size 9½ × 7 × 2½
Weight 1 lb. 2 ozs.

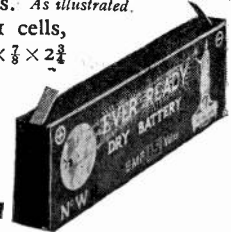

Dept. D.L.

“SEMAPHORE”

High Tension Dry Batteries for Wireless Receiving Sets



TERMINALS. — The 15 volt Batteries are supplied (unless otherwise ordered) with 2 Brass Connecting Strips as illustrated. All the other sizes have 2 Insulated Plugs. Brass Sockets are fixed to every other Cell so that Tappings can be taken at each 3 volts.

Other sizes can be supplied and quotations given on receipt of enquiries.

In order to prove that “SEMAPHORES” are THE BEST and induce a trial, we have reduced our price for 15-volt to 3/3 each.

Volts	Number of Cells	Price Each Carriage paid
15	11	3/3
30	22	8/6
36	24	9/3
50	36	13/6
60	44	16/6
90	66	24/6
100	72	26/6

Trade supplied promptly. Terms on application.

SEMAPHORE, Ltd., DRY BATTERY SPECIALISTS

28, John Street, Bedford Row, London, W.C.1.

Telephones : : MUSEUM, 5422 and 5423.
Telegrams : : ARWELIDITE, HOLB. LONDON.

HIGH QUALITY :: CONDENSERS ::



'001 mf. 24 -

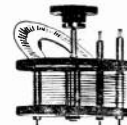

'0005 mf. 18 - Complete with scales, post free.

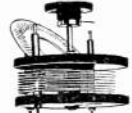

'0003 mf. 14 -



UNIT COIL HOLDERS



Made of Ebonite and brass throughout with excellent gun metal finish.

Fixed Unit 4/2
Moving Unit 5/8

Shows method of fixing.

Prices post free.

ASHLEY RADIO

69, Renshaw Street, LIVERPOOL

Telephone : 4628 Bank.

Telegrams : "Rotary, Liverpool."

WE OFFER PROMPT DELIVERY
of complete Receiving Sets and all apparatus required
by the Amateur Experimenter.

ONE TO THREE VALVE SETS COMPLETE. "K.B." UNIT SYSTEMS.
COMPLETE SETS OF PARTS to build Valve Panels, Condenser Panels,
Variable Condensers, etc.

AERIAL WIRE
INSULATORS
FILAMENT RESISTANCES
ACCUMULATORS

H.T. BATTERIES
VALVE HOLDERS
SWITCHES
KNOBS

TERMINALS,
&c., &c.
EBONITE SHEET,
ROD AND TUBE
Catalogue post free, 4d.

Trade Enquiries Invited.

VISIT OUR SHOWROOMS (open 9 a.m. to 7 p.m.), WHERE YOU CAN "LISTEN IN" ON OUR RECEIVING SETS AND INSPECT OUR LATEST PRODUCTIONS.

THE
"K.B." RADIO EQUIPMENT COMPANY
HEAD OFFICES & SHOWROOMS : 109, HIGH ROAD, KILBURN, LONDON, N.W.6.
WORKS : QUEEN'S PARK, N.W.

Bus Services 8, 16, 28 and 51 pass the door.

3 minutes Kilburn Park Station (Bakerloo Railway).

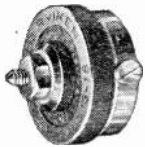

SKINDERVIKEN BUTTON.
A Supersensitive Microphone.
Known all over the world and patented
in every civilized country. Over 60,000
sold. ENGLISH Manufacture.
Make up your own Loud Speaker.
Transmit your GRAMOPHONE music
to any room in your house.

The only practical Microphone for use in Detectophone Sets.

Price 5/- each

Special Low Resistance Receivers (for use with Skinderviken Buttons) 10/- each
 Special Gramophone Attachments 1/- "

Write for 16 page **BOOKLET** fully illustrated and containing much useful information for all interested in Electrical Sound Transmission. 6d. Post free.

Sole Proprietors :

MIKRO LTD., 274/6, Pentonville Rd., London, N.1
 (Opp. King's Cross (Met.) Rly Station).

SENSATIONAL REDUCTIONS.

SLAB INDUCTANCES, set of 8, 9/-
OOJAH make 10/-, post 9d.
3-plate VERNIER CONDENSERS, 6/-, post 9d
L.F. TRANSFORMERS, 19/6, post 6d. PHONE,
TRANSFORMERS 13/6, post 6d.
FILAMENT RESISTANCES for panel mounting,
3/9, post 3d.
The POPULAR H.T. BATTERY 36v. 4/9 post 1/-
CATALOGUE FREE WITH ORDER.

RADIO, ELECTRICAL & MECHANICAL SUPPLIES.

SCIENTIFIC SUPPLY STORES

8, NEWINGTON CAUSEWAY,
 LONDON, SE.1.

PHONE
 NEP-4177.

ACCUMULATORS

Absolutely Guaranteed Best Quality

CELLULOID CASES

4 volt 40 amp.	18/6	4 volt 80 amp.	28/2
4 " 60 "	21/6	4 " 100 "	30/-
6 " 40 "	26/3	6 " 80 "	37/3
6 " 60 "	31/9	6 " 100 "	41/6

PACKING FREE.

SPECIAL PRICES TO TRADE
 for quantities on application.

SPECIAL OFFER

6 volt 40 ACTUAL AMP. SET three glass cells sealed tops in well-made **TEAK** crate, a handsome set @ 49/6.

4 volt 24 amp., celluloid cases, 11/9, postage 1/-
2 " 16 " ebonite cases, 3/9 each, post free

AERIAL WIRE, 5/- per 100 ft. Coil.

ALL SIZES of ACCUMULATORS QUOTED FOR
Dynamos, Motors, Electrical Accessories.

Write for Lists.

F. Yates & Son, Ltd. Wholesale Electricians

144, Church Street, Kensington, London, W.8
 (One minute from Notting Hill Gate Station.) Phone-Park 4276

The London Telegraph Training College, Ltd.

Telephone
WESTERN 2696.

Morse House, Earl's Court, S.W.

ESTABLISHED
25 YEARS.

OFFICIALLY RECOGNISED BY THE WAR OFFICE AND POST OFFICE AUTHORITIES

CABLE AND WIRELESS TELEGRAPHY.

PARENTS desirous of placing their sons in either of the above Services and of affording them the best training facilities should apply for particulars of Courses and the methods of instruction which place this Institution in the first rank. **Cable Telegraphy** offers at the present time excellent prospects to youths from 15 years of age and upwards, and the **College has exclusive facilities** for obtaining posts for qualified students in the leading Cable Companies at **commencing salaries** of £150 to £300 per annum, with yearly increments of £12 to £25, and ultimate possibilities of obtaining positions as Supervisors, Assistant Superintendents, Managers, etc.

In the Wireless Telegraph Service the commencing remuneration at the present time is approximately £150 per annum, and Operators, when qualified by obtaining the Postmaster-General's Certificate of Proficiency, are nominated by the College for appointments.

No Correspondence Classes or Branches.

DAY AND EVENING CLASSES.

Prospectus containing all information will be forwarded on application to

THE SECRETARY (Dept. H.), 262, Earl's Court Road, Earl's Court, London, S.W.5

Sole Proprietors of the "Scott" Training Disc, which contains useful formulæ and other information for Wireless Telegraph Operators and is invaluable to Army Signalling Officers for range finding, etc.

Price, complete with instructions for use, 1/-. Postage 2d.

Present Purchasing Power of a Pound

is equal to *Pre-War Value* when you purchase

PETO P-UNITS

SIMPLICITY WITH MAXIMUM RESULTS

Unit No. 3



No. 3 — H.F. Unit Amplifying Unit (Transformer extra).

Price 37/6

Unit No. 4

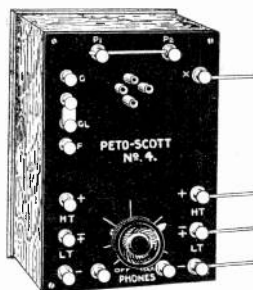

No. 4—Detecting Unit.

Price 37/6

Unit No. 5



No. 5—Low Frequency Unit (can be used on any other set as note magnifier, with transformer).

Price 45/-

No connections to puzzle over, just push as many units as you can afford against each other, slip the little rods through and turn a screw and there you are.
SETS OF PARTS can be supplied to build any of the above. For prices see our **ILLUSTRATED CATALOGUE** with lists of transmitting times and wavelengths. 6d. post free.

PETO SCOTT,
THE CONDENSER KING

DON'T FORGET THE NEW ADDRESS:—

Featherstone House, 64, High Holborn, London,
Still at 17, Frome Road, Wood Green. W.C. 1.



*Specially
designed
for
Broadcasting*

HEADGEAR RECEIVERS

Designed and manufactured by leading Telephone Manufacturers. Backed by many years' experience.

Highest efficiency, concentrated magnetic field, instantaneously adjusted to the ears, comfortable in wear, either receiver detachable from headband, protected terminals, light weight, twin series cord.

**A.T.M. LOUD
SPEAKING
RECEIVERS**

Three types of amplifying horn.

**A.T.M. Crystal
Detector Sets**

Highest Grade.
Maximum Efficiency.
Moderate Cost.

*Ask your dealer for
A.T.M.
Broadcasting Apparatus*

Automatic Telephone Manufacturing
Co., Ltd.

Head Office & Works : London Office :
Milton Rd., Edge Lane, 60 Lincoln's Inn Fields
Liverpool. W.C.2.

IMPORTANT NOTICE

A. C. COSSOR, Limited, hereby give notice that the order of Mr. Justice Russell of the 1st March, 1922, continually advertised by the Marconi Co., was an order ARRIVED AT BY CONSENT.

Being engaged at the time in the production of an improved and different type of valve, A. C. COSSOR, Limited, did not consider the patents in question of sufficient importance to warrant the expense of litigation.

A. C. COSSOR, Limited, respectfully leave the public and the Trade to judge whether the constant repetition of the notification of the judgement referred to is necessary or expedient in the circumstances.

A. C. COSSOR, LIMITED
Aberdeen Works, Aberdeen Lane,
Highbury Grove, N.5

WARNING.

MARCONI'S WIRELESS TELEGRAPH CO., LTD.,
v.
A. C. COSSOR, LTD.

Marconi's Wireless Telegraph Company, Limited, **GIVE NOTICE** that an **ORDER** was made in the High Court of Justice, Chancery Division, by Mr. Justice Russell on the 1st March, 1922, restraining Messrs. A. C. Cossor, Ltd., from infringing the Marconi Company's Letters Patent Nos. 28413 of 1913 and 126658, except so far as Messrs. A. C. Cossor, Ltd. manufacture for H.M. Government.

Messrs. A. C. Cossor, Ltd., were further **ORDERED** upon oath to **DESTROY** all articles and apparatus (other than those constructed to the order of H.M. Government) made or used by them in **INFRINGEMENT** of these patents, and **TO PAY THE MARCONI COMPANY DAMAGES AND COSTS.**

The M-O Valve Company, Limited, of Osram Works, Brook Green, Hammersmith, London, W.6, is the only firm in this country licensed to manufacture thermionic valves under the patents belonging to the Marconi Company.

Any valve similar to those generally known as the "French type" constitutes an infringement of the above patents whether manufactured in this country or imported from abroad. Marconi House, Strand, London, W.C. 2.

North Wales Wireless College & Amateur Supplies

COLWYN BAY. Phone 407.

Most Complete Stock of all Wireless Instruments and Accessories.
PROMPT DELIVERIES.

LIST BY RETURN. $\frac{1}{4}$ d. STAMP.

Students prepared under ideal conditions as Wireless and Cable Operators
POSTAL AND RESIDENTIAL TUITION.
SPECIAL POSTAL COURSE FOR AMATEURS.
PROSPECTUS POST FREE.

"DIOPLION" INTERVALVE TRANSFORMS

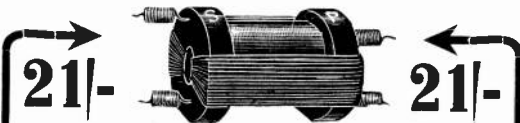

Are the result of 18 months careful research, and will be found equal to any. They are sold on the "money back" principle, and we are confident that once you have made a test, your future supplies will all be "DIOPLION" types.

IMMEDIATE DELIVERY can be given to EARLY APPLICANTS and the trade should take advantage without delay.

MITCHELL'S ELECTRICAL & WIRELESS Ltd.

McDermott Road, Peckham, S.E.15
(Retail Store, 188, Rye Lane, S.E.15)

DON'T READ THIS

If you are a millionaire



Price, 2/6 per dozen, plated; 3/- brass; small type, 9d. per doz.
One valve detector panel complete with filament resistance valve holder, and grid leak and condenser, fitted with insulated terminals, mounted on solid ebonite base in mahogany instrument case . . . PRICE 25/-
Leading-in Tube, ebonite, R.A.F. pattern with brass rod and fittings. PRICE 3/8
Aerial Real Insulators, tested to 25000 volts PRICE 4
Accumulator Charging Resistances PRICE 25/-
Universal Tuners. These tuners have been designed to tune in Marconi concerts, broadcasting, and Dutch Concerts, so that a baby can use them. Wavelength range, 300-1,500 metres, with .0005 m.f. condenser, PRICE 7/-
4,000 ohm phones, new patent 3-magnet type, fitted cords and tags, complete with nickel plated head bands PRICE 35/-
*Transmitting Keys, G.P.O. pattern, fitted platinum contacts PRICE 5/-
Valve Holders, fitted in solid ebonite, fixing case drilled fitted with valve earthing clip PRICE 2/6
Grid Leaks and Condensers, mounted on solid ebonite PRICE 5/-
Instrument Cases, solid mahogany, 9" x 6" x 2 1/2", highly finished, fitted ebonite panel, undrilled PRICE 8/-
Postage extra on all the above prices.
The trade supplied. Enquiries solicited.

J. LIPOWSKY, 614, Old Ford Rd. Bow,
LONDON, E.3 Phone: East 3345

ACCUMULATORS ETC.

ALL NEW STOCK & GUARANTEED.

4 Volt 25 Amp. Celluloid	-	-	-	11/3 each.
		Postage 1/-		
4 Volt 40 Amp.	-	17/6	6 Volt. 40 Amp.	- 25/6
4 " 60 "	-	21/3	6 " 60 "	- 31/-
4 " 80 "	-	27/-	6 " 80 "	- 36/-
		Packing 1/6 extra.		Packing 2/- extra.
7/22 Aerial Wire	-	-	-	6/- per 100 ft.
Mullard Ora Valves	-	-	-	15/- each.
15 Volt Siemens H.T. Batteries	-	-	-	4/-
Accumulator Charging Board	-	-	-	37/6
Voltmeters, Watch Pattern, 0/12 Volts	-	-	-	6/-

CASH WITH ORDER. Goods despatched per return.

LOWKE & SONS, Ltd., Northampton.

I HAVE IN STOCK
5000 BROWN'S
PAIRS (120 ohms) "A" PHONES
NEW AND UNISSUED

POST FREE **45/-** PER PAIR
CASH WITH ORDER

WILKINSON, Lonsdale Rd., Kilburn,
TRADE SUPPLIED (Same address since 1900) N.W.6

PHONES (Pair complete. Guaranteed) 30/- CRYSTAL SET 40/-

Special Wireless Telephones, 4,000 ohms, 30/- post free. Receiving Set on Mahogany base, double slide Tuning Inductance, Fixed Condenser, Crystal Detector, Terminals, 40/- post free. Terminals complete, 2/6 doz. Valve Legs complete, 2/6 doz. Contact Studs complete, 2/- doz. Postage extras.

I. K. STEVENS & Co. Wireless Section, 32a, Chester St., Grosvenor Place, S.W.1

GENUINE & ORIGINAL

HELLESEN DRY BATTERIES

ALL TYPES
 KNOWN THE WORLD OVER AS
THE BEST



CODEWORD: "WIRIT" Size 6½ x 2½ x 4"
CODEWORD: "WIRIT" 36 volts.

SPECIAL TRADE & WHOLESALE TERMS.

CODEWORD	VOLTS	DETAILS	PRICE
"WIRON"	15	Screw terminals	4/-
"WIRTO"	15	Strip	4/-
"WIRIT"	36	2 wander plugs	8/6
"WIRIN"	60		14/-

ALL LISTS FREE ON APPLICATION.

A. H. HUNT, LTD.

H.A.H. Works, Tunstall Rd., Croydon, Surrey.

NEW VALVE

UNIVERSAL

While retaining the superior detecting qualities of the "Soft" R.M.R. Valve is an efficient Amplifier.

L.T. 4 Volts. H.T. 30 to 45 Volts.

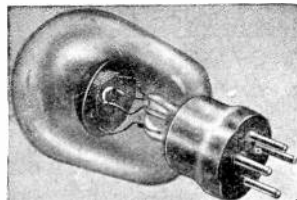

Rectifies
Amplifies
Oscillates
17/6
 POST FREE.

R. M. RADIO, LTD.

5, Regent Square, Gray's Inn Road, W.C. 1

The Construction of Amateur Valve Stations

By ALAN L. M. DOUGLAS

78 pages. 55 Diagrams and Illustrations.

PRICE **1/6** NETT.
 (Postage 2d.)

The aim of the author in compiling this volume has been to place within the reach of the amateur who is interested in Wireless Telegraphy and Telephony a Handbook which will enable him to obtain data that he has otherwise difficulty in acquiring, in order that he may construct for himself apparatus which he desires to make, but does not quite know how to design correctly.

The Wireless Press, Limited

12-13, Henrietta Street, Strand, London, W.C.2

"The Model Engineer"

A special paper for young Engineers, Apprentices, Students and Amateurs interested in Mechanics, Electricity and Model Making. It contains practical articles by experienced writers on Electrical and Mechanical subjects, Locomotives, Motor Cycling, Model Aeroplanes and Wireless Telegraphy.
Published every Thursday. 5d. post free.

"Junior Mechanics & Electricity"

The paper for beginners of all ages in Mechanics, Electricity and Model Making. All the articles are written in simple language so that everybody can read and understand them. It is well illustrated. There is also a Queries and Replies section, from which much valuable information can be obtained.
Published on 1st of each month. 4d. post free.

SOME USEFUL BOOKS.

Practical Lessons in Metal Turning .. 29	Small Accumulators .. 10½d
Engineering Mathematics Simply Explained .. 25	Electric Bells & Alarms .. 10½d
Practical Dynamo and Motor Construction .. 19	Electric Batteries .. 10½d
Practical Induction Coil Construction .. 19	Small Dynamos and Motors .. 10½d
Petrol Motors Simply Explained .. 19	Induction Coils for Amateurs .. 10½d
Workshop Wrinkles and Recipes .. 19	Small Electric Motors .. 10½d
	Alternating Currents .. 10½d
	Windmills and Wind Motors .. 10½d
	Wireless Telegraphy Simply Explained .. 10½d

Every Boy's Book of Electricity, 3d.
Every Boy's Book of Engines, 3d.

Book List sent post free on receipt of card.
PERCIVAL MARSHALL & CO.,
 66m, FARRINGDON ST., LONDON, E.C.

HIGH GRADE EBONITE

SHEETS RODS TUBES MOULDINGS

"Bakelite," "Wittonite" & Fireproof Mouldings

Suitable for Electrical, Wireless and Mechanical Requirements.



ENQUIRIES INVITED
THE GENERAL ELECTRIC CO., LTD.,

Insulation Dept., MAGNET HOUSE, KINGSWAY, LONDON, W.C.2

Insulation Works : WITTON and COVENTRY.



CONDENSERS.

·0003 Variable Air Condensers	12/6
·0005 "	15/-
·001 "	24/-
·00005 Vernier "	4/6
·00001 "	4/6
High Resistance Phones	£2 10 0
Filament Resistances	3/6 & 5/-
Contact Studs	doz. 1/6
Switch Arms	2/6

Mullard Ora Valves. Parts to build your own sets.

B. L. HOUSTON,

Regent 4911. 65, ENDELL STREET, W.C.2.

WIRELESS



PER 12/- SET
G TURNOCK 41 HIGH ST ASTON BHAM

Castagnoli Instruments
cannot be bettered for
Efficiency and Workmanship.

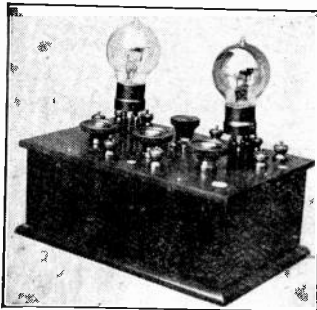

For the "Broadcasts."———You Require this Receiver.
A high-class 2-Valve Amplifier Receiver, fitted with
Variable Air Condenser, two Filament Rheostats, and
an internal new type variable High Frequency Air Core
Transformer, extremely efficient on all wavelengths
200-4,000 metres and over.

PRICE **£6 10** less valves.

Write for Illustrated List 3d. Post Free.

GORDON CASTAGNOLI
MANUFACTURER OF WIRELESS APPARATUS
15, Rayne Road, Braintree, Essex

WIRELESS

Take advantage of our 14 years' experience of Wire-
less. Build your own receivers. We can supply all
parts, and show you how to do it.

JAMES FRASER & CO.
(In collaboration with E.T.C. Address as below)

SCHOOL INSTRUCTION

Day, Evening and Postal courses in Wireless, Valves,
etc. P.M.G. (Exam.), and amateur classes. Also
Cable and Telegraphy. Prospectus from

'Phone : North 1036. Principal :
ELECTRICAL TRAINING COLLEGE,
Radio House, Manor G'dns, Holloway, N.7

WITH GOOD APPARATUS YOU
CAN GET GOOD RESULTS

THE "W.P."

Morse Practice Key

Well Made. First-class Finish. Thoroughly Reliable

Price **7/6** Post Free

THE WIRELESS PRESS, LTD.
12-13 HENRIETTA STREET, LONDON, W.C.2

AUCKLAND'S

Undoubtedly the finest results are obtainable by using Tuned High Frequency Transformers. We can now supply from stock Interchangeable (Standard 4-pin type) Transformers wound as under :

No. 1	150-600	5/-
2	380-800	6/-
3	570-1,300	6/6
4	1,000-2,175	7/-
5	1,600-3,200	7/6
6	2,200-5,600	8/6



Demonstrations
at
Showrooms

It is essential that these Transformers be tuned by a '0002 Condenser.

G. Z. AUCKLAND & SON

395, ST. JOHN STREET, LONDON, E.C.1

Manufacturers of Radio Apparatus

Factories: ISLINGTON, N.

Phone—CLERKENWELL 3173. Telegrams—"ZAUCKADIO, LONDON."

If You Want to Buy
CHEAP
Buy
EX-GOVT. SURPLUS
STOCK. 250 TONS
TO SELECT FROM

WIRELESS MANUFACTURERS
please inspect our SMALL PARTS
WIRELESS AMATEURS
before making your sets come and
view our stock.

THE Electrical Disposals Synd.

Office :
6, MARKET PLACE, OXFORD CIRCUS
Warehouse : 84a, Glengall Road, Peckham
Phone—Museum 643

TECHNICAL ADVICE FREE
call in and see us about it.
We have 10 Years' experience

BE UP-TO-DATE

READ THE
WIRELESS TRANSMISSION
OF PHOTOGRAPHS,

By MARCUS J. MARTIN.

143 pages. 139 Diagrams and Illustrations.
Price 5/- net. Post free 5/6

THE WIRELESS PRESS. LIMITED,
DEPT. W.W.
12/13, HENRIETTA ST. STRAND, LONDON W.C.2

Questions and Answers COUPON

To accompany Questions
sent in during the week
commencing Aug. 12th, 1922.

VOL. X, NO. 20.

See Conditions on Page 633.

ALL - BRITISH WIRELESS EXHIBITION & CONVENTION

will be held at the
HORTICULTURAL HALL
WESTMINSTER : LONDON : S.W.1
SEPT. 30TH TO OCT. 7TH
(SATURDAY) (SATURDAY)

This will be the most representative
Wireless Exhibition ever held in
Great Britain.

THE CONVENTION will be held under
the auspices of the WIRELESS SOCIETY
OF LONDON and all affiliated societies.

APPLICATIONS for stands will only be
accepted from BRITISH Allied and
Kindred Trades.



IMPORTANT PUBLIC WARNING.

In view of certain misleading statements at present circulating, it is desired to emphasize that this will be the first and only Wireless Exhibition held this year carrying the full support of the entire Trade, the latter by common consent being pledged to participate in no other similar gathering.

Applications should be addressed to
THE ORGANISERS

BERTRAM DAY & CO., LTD.

WIRELESS PUBLICITY SPECIALISTS

9 and 10, Charing Cross, S.W.1 Gerrard 8063/4

1. Perfect insulation of grid connection ensures silent operation.

2. All connections shown in diagram ready made for you and brought out to terminals.

3. To add an amplifying stage, connect to terminals and insert valve.

4. Tapped holes in two sides and base make fitting easy.

The most important detail improvement yet made in Wireless Receiving Sets.

THE ELWELL AMPLIFYING UNIT

Comprising valve socket and ironclad intervalve transformer, mechanically and electrically combined in one unit.

*Exclusive design covered by patents.
British made and guaranteed throughout.*

To secure early delivery order at once.

Price **39/6** only, for complete amplifying unit, less valve.

This patented amplifying unit, when provided with a valve and connected as marked on the terminals, is all that is necessary to give one stage of amplification to your existing set. No soldering is necessary. The unit is easily attached to panel or shelf, or will stand alone.

The self-contained permanent connections are a big practical advantage, while the perfect insulation of the grid connection will appeal to all amateurs troubled with "noise."

Enquiries for all wireless components invited.

C. F. ELWELL, LTD., CRAVEN HOUSE, KINGSWAY, LONDON, W.C.2.

BROADCASTING

SULLIVAN PATENT TELEPHONE RECEIVERS for RADIO TELEPHONY AND TELEGRAPHY

Of High and Uniform sensitivity and DISTORTION-LESS being thus specially adapted for receiving speeches, news and concerts from BROADCASTING and other stations



Windings highly insulated, durable and reliable in all climates and under all conditions of service. This was strikingly evidenced during the Great War when a vessel carrying "SULLIVAN" phones shipped to the order of an Allied Government was sunk through misadventure, but at a later date was successfully raised and her cargo salvaged. The Telephones themselves were found to have sustained much damage through the action of sea water, but the coils proved to be perfect electrically and mechanically notwithstanding their long immersion, and all were again brought into requisition.

IMPORTANT NOTICE

These Telephone Receivers must not be confused with the old and comparatively insensitive "SULLIVAN" phones, sold by the Disposals Board and still being retailed by certain dealers, nor with those new but equally insensitive Radio Telephone Receivers of Continental and other origin bearing a misleading resemblance to my present pattern.

WHITE METAL HEADBANDS SUPPLIED IF DESIRED

Without public advertisement of any kind, over one quarter of a million sets of "SULLIVAN" phones have been made and sold for "Wireless" alone.

Trade Terms on Application.

DEMONSTRATION AND SHOWROOMS AT
LIVERPOOL HOUSE, MIDDLESEX STREET, LONDON, E.1.
(Two minutes' walk from Liverpool Street and Broad Street Stations)

Works. "LIVERPOOL HOUSE" MIDDLESEX ST., LONDON, E.1. Phone: Avenue 4871	HW SULLIVAN	Offices. WINCHESTER HOUSE LONDON, E.C.2., ENGLAND Phone: London Wall 3518
TELEGRAMS: "DEADBEAT, STOCK, LONDON."		

WIRELESS WORLD

AND

RADIO REVIEW

VOL. X. No. 21.

19th AUGUST, 1922.

Registered at the G.P.O. as a Weekly Newspaper.

THE TINGEY UNIT SYSTEM

HAS PROVED ITS EFFICIENCY



Write for

ILLUSTRATED CATALOGUE

which contains an article on Wireless Made Easy and a

Complete List of all Wireless Goods in Stock

WRITE FOR ILLUSTRATED CATALOGUE 3d. POST FREE

	£ s. d.		£ s. d.
C 1. CONDENSERS. One pair mounted in case	5 0 0	I 1. INDUCTANCES. B. Coil—1,000-8,500 metres with approximate calibration	1 17 6
R*. RECEIVER (for R. Valves)	4 17 6	I 1. INDUCTANCES. C. Coil—5,000-24,000 metres with approximate calibration	3 2 6
R 1*. RECEIVERS (for Mullard Valves)	4 7 6	J 1. JUNCTION BRACKETS (8 styles) from 3/- to 6/6 each	2 8 6
R.S. SINGLE VALVE RECEIVER	3 10 0	P 2. BROWN'S PHONES (D Type), 120 w. Per pair	2 8 6
R.V. UNIT H.F. to follow R.S. Unit	2 0 0	BROWN'S RELAY UNIT (mounted in case), for rapid attachment to Tingeys Units. No loose connections (2,000 ohms input)	6 15 0
A 2. MULTI H.F. AMPLIFIER UNIT, Choke and resistance type	3 15 0	BROWN'S RELAY (without Tingeys adaptation)	6 2 6
A 3. MULTI L.F. AMPLIFIER UNIT	3 15 0	"ORA" MULLARD'S VALVES each	0 15 0
A 4. MULTI H.F. AMPLIFIER UNIT, without inductances or variable condenser	2 10 0	P 1. INDUCTANCE PLUGS	0 4 0
A 24. COMBINED UNIT, tuned or stand-by position	3 15 0	T 2. INTERCHANGEABLE TRANSFORMERS (300 to 24,000 metres) each 6/- to 12/-	
T 1. MULTI TELEPHONE TRANSFORMER UNIT	2 0 0	TINGEY (3-Valve) RECEIVER, 1 valve H.F., 1 Rect. 1 L.F. (without valves)	8 10 0
I 1. INDUCTANCES. A. Coil—200-1,600 metres with approximate calibration. Price	1 5 0		

COMPLETE RECEIVING SETS (VALVE) From £14.

Showrooms Open 8 a.m. to 8 p.m.

Saturdays 8 a.m. to 1 p.m.

Offices & Works

Phone
HAMMERSMITH 1916
Telegs.
TINGOIDAR LONDON

W.R.H. TINGEY.

SPECIALIST IN WIRELESS

Offices & Showrooms

92 Queen St.
Hammersmith.
London, W. 6.

MAGNAVOX

THE WORLD'S FINEST

LOUD SPEAKER

RADIO
brings it
MAGNAVOX
tells it.



No. R1293
(14" Horn).

*Broadcasting faithfully reproduced
with marvellous clarity and volume*

Sterling Telephone & Electric Co., Ltd.

TELEPHONE HOUSE,

210/212, Tottenham Court Road, London, W.1

Telephone No.: 4144 Museum (7 lines). Telegrams: "Cucumis, Wesds, London."

Works: DAGENHAM, ESSEX.

BRANCHES: NEWCASTLE-ON-TYNE: 9, Clavering Place.

CARDIFF: 8, Park Place.

*YOUR
ENQUIRIES
INVITED.*

This Book Will Help YOU.

The more generally useful
formulæ and methods of
measurement for inductance
and capacity are brought to-
gether in a convenient form in

The Calculation and Measurement of Inductance and Capacity

By

W. H. NOTTAGE, B.Sc.

Price **3/6** Nett.

(Postage 5d.)

The Wireless Press, Ltd.,

Dept. W.W., 8/4,

12-13, Henrietta Street, London, W.C.2

IF YOU WANT A

GOOD

BOOK ON RADIOTELEPHONY

GET

**TELEPHONY
WITHOUT WIRES**

BY

PHILIP R. COURSEY, B.Sc. (ENG.), A.M.I.E.E.

Price **15/-** Nett

(Postage 9d.)

It contains a complete collection of information on the
various schemes, proposed and tried, relative to the
electrical transmission of the sound of voices through
space without wires.

An excellent list of references to
papers and articles, forms a complete
bibliography of the whole subject.

THE WIRELESS PRESS, LTD.

Dept. W.W. 8/4

12-13, Henrietta St., London, W.C.2

GAMAGES

LEAD IN AMATEUR WIRELESS FIRST IN 1908—FOREMOST TO-DAY



Exceptional Offer of 'PHONES

BROWN'S Double Head-piece Receivers, 8,000 ohms.

49/6

Ditto, 120 ohms.

42/6

SULLIVAN'S Double Head-piece Receivers, 8,000 ohms.

36/6

Without leads. In perfect condition and absolutely new.

All sent post free.

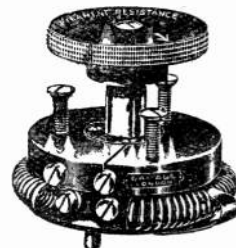

IMPROVED TYPE OF FILAMENT RESISTANCE

The above has been produced by us to meet the present demand for a cheap yet efficient Filament Resistance suitable for mounting to the purchaser's own instruments. It is easily attached, and when fixed is very neat and attractive looking. The Resistance is wound on an air core in a grooved Ebonite former. When mounting all that is necessary is to drill a hole in the panel for the spindle and three holes for the fixing screws. Remove the ebonite knob and screws from the resistance, insert the spindle and collar through the centre hole in the panel and attach firmly by means of the screws. Replace knob to complete. To indicate the "Off" position a mark should be made on the panel to correspond with the arrow on the knob. These resistances are suitable for one, two, or three valves. Size 2½" wide by 2" high.

PRICE 8/6

LOW FREQUENCY AMPLIFIER

The single stage low frequency Amplifier here illustrated can be easily connected to any valve or crystal receiving set, thereby increasing the efficiency of the receiver by 50%. With the use of this instrument, signals are rendered very distinct, and many otherwise inaudible messages are sufficiently strengthened as to become readable. This Amplifier is particularly suited for the reception of telephony and music owing to the absence of noise usual with multi-valve amplifiers. The transformer used is the finest on the market, and the design and finish of the whole instrument are up to our usual high standard of excellence. Length 8", width 6", height 3½". We are offering this fine piece of apparatus at the extraordinary

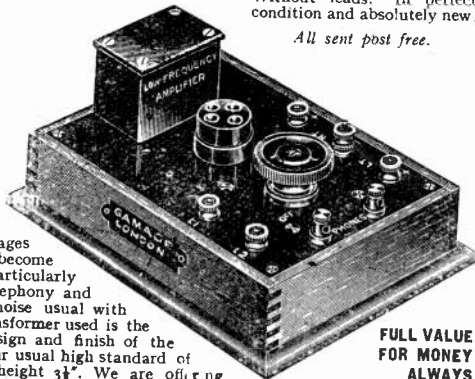

FULL VALUE FOR MONEY ALWAYS

low price of 42/- Post Free.

WRITE NOW FOR OUR WIRELESS CATALOGUE

Fully illustrated, giving all details and prices, indispensable to the man who wants the best apparatus at the lowest prices. A copy will be gladly sent **POST FREE ON REQUEST.**

"WESTON" MOVING COIL RELAYS

This well-known instrument is one of the most sensitive relays obtainable. It consists of a very delicate permanent magnet ("Weston"), moving coil instrument movement and is provided with a platinum circuit closer in place of a pointer. The contact screws are adjustable and are so arranged that the contact closer can be set to move through an arc ranging from ¼" to less than 1/100th. It is highly recommended for all classes of work where an extremely sensitive relay is required; the attention of wireless enthusiasts being especially drawn to same for the purpose of experimenting in wireless recording. We are now offering this beautiful instrument at the

low price of 55/- Post Free.

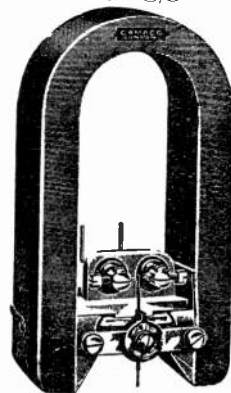

GAMAGES, HOLBORN, LONDON, E.C. 1.

W. H. PORTER & CO.

44, Church Street,
BIRMINGHAM.

WHOLESALE ONLY.

ALWAYS STATE QUANTITY AND FULLEST PARTICULARS
RE THE ARTICLE YOU WISH TO BE QUOTED FOR,
AND IF POSSIBLE SEND A SPECIMEN.

Condensers—best and cheapest on the market. Ebonite parts
and fittings.

Specially made moulded parts and fitting to special designs.

Filament Resistances.

Grid Leaks and Condensers.

Head 'Phones.

Loud Speakers.

Interval Transformers.

Telephone Transformers.

Valve Holders.

Turned and Moulded Knobs and Fittings.

Coil Holders and Sockets.

All Brass—turned and Pressed Parts a very special department.

Ebonite Dials.

Condenser Parts.

Aerial Wire.

Condenser Scales.

Switch Arms.

Complete Telephony Receiving Sets.

GENTS' MAKE FITMENTS

SEND FOR OUR
SUNDRIES
PAMPHLET

MAKE USE
OF OUR
STOCKS

ASK US
TO QUOTE
FOR YOUR
WHOLESALE REQUIREMENTS

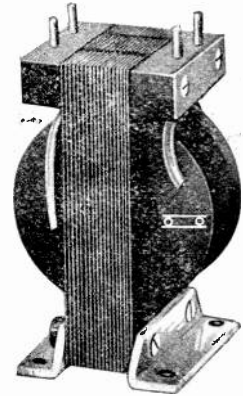

GENT & CO. LTD. FARADAY WORKS LEICESTER
LONDON: 25, Victoria Street, S.W.1
NEWCASTLE-ON-TYNE: Tangent House, 52, Blackett Street

H.F. TRANSFORMERS.

TO FIT VALVE SOCKETS.

No. 0	Range	150 Metres	-	5/6
No. 1	"	300	"	6/-
No. 2	"	600	"	6/3
No. 3	"	1200	"	6/9
No. 4	"	1800	"	7/6
No. 5	"	2500	"	8/3
No. 6	"	6000	"	9/9
No. 7	"	8000	"	12/-
No. 8	"	24000	"	14/3

There is good latitude on these Coils for higher and lower ranges.

H.T. BATTERIES (Fully Guaranteed)

15	Volt strip connection	3/6	post 6d.
15	" 3-terminal type	3/6	" 6d.
15	" Wander plug 3-		
	volt Variation	4/-	" 6d.
36	" " "	7/6	" 1/-
60	" " "	14/6	" 1-
108	" " "	22/6	" 1/3

Fully Illustrated List containing over 100 illustrations, post free 4d.

H. D. BUTLER & CO., LTD.

Office: Bank Buildings, 222, Great Dover Street,
BOROUGH, S.E.1 (Opposite Boro Tube Station)

Works: Canonbury, London, N.7

Telephone: Hop 3029. Telegrams: Ingenuity, Phone, London.

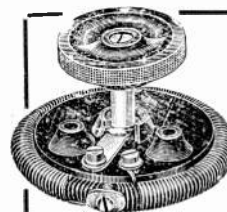

The THOR Goes one Better

Strength, efficiency, sound workmanship, and value
are four outstanding features of the

THOR Filament Resistance

Although on the market for such a short time, some
makers are already offering inferior imitations.

Protect yourself by insisting on the genuine Thor. Ask
your dealer about it—ask him to show you the THOR.

Price only 6/-

Stocks held by London Representative: Mr. J. O. Maddock,
11, Bayham Road, Bedford Park, W.4.

Purchasing agents wanted where not
represented. If unobtainable locally,
send P.O. to—

*Showing the
Phosphor-
bronze Blade*

H. E. Ashdown

(Birmingham) Ltd.

Perry Barr, Birmingham

'Phone: Northern 859.

Tel.: Segment, Birmingham.

Code: A.B.C., 5th Edition, Western.

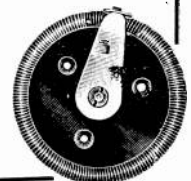

The Name "BURNDEPT" GUARANTEES Cent. Per Cent. QUALITY & EFFICIENCY.

BIRMINGHAM:
193 NEW STREET.

LIVERPOOL:
10, SOUTH JOHN STREET.

BURNDEPT

MANCHESTER:
61, BRIDGE STREET,
DEANSGATE.

LEEDS:
48, GT. GEORGE STREET.

WIRELESS APPARATUS

LONDON OFFICE & SHOWROOMS
15 Bedford Street, Strand, W.C.2.

THE BURNDEPT ULTRA III RECEIVER

(New Series Mk. 4)

The most Perfect all purpose Receiver

ALL the well-known features of the previous series are retained, viz., separate valve control— independent use of valves, etc. A telephone transformer is incorporated so that either high or low resistance phones can be used at option.



THIS high-class receiving set has had more refinements added, further improving H.F. Amplification for very short waves—we now claim to obtain the maximum H.F. amplification it is possible to obtain from one valve from 140 to 20,000 metres.

ILLUSTRATED CATALOGUE
Post free, 6d.
Returnable with first Order.

Burndept III Ultra Receiver
Price - - £25
(less valves)

ILLUSTRATED CATALOGUE
Post free, 6d.
Returnable with first Order.

This Catalogue gives full details of our one, two, three and four Valve Receiving Sets

Absolutely complete and ready for Signals, Telephony and Music
(Prices range from £21)

LONDON SHOWROOMS:
15, BEDFORD ST.,
STRAND, W.C.2

BURNDEPT LTD.

LONDON SHOWROOMS:
15, BEDFORD ST.,
STRAND, W.C.2

Manufacturers of Wireless Apparatus

Aerial Works & Eastnor Works, BLACKHEATH, LONDON, S.E.3

CRAY INSTALLATIONS, L.D.

Electrical & Mechanical Engineers.

'Phone 288
Southampton

72b, High Street,
SOUTHAMPTON.

'Phone 288
Southampton

HAMPSHIRE AGENTS for "BURNDEPT"
Wireless Apparatus.

Transmitting and Receiving Sets in Stock.
All Accessories for Amateur use.
Call and inspect our Stock, when full Particulars and Demonstrations will be given.

W. A. C. SMITH

236, Argyle Street,
GLASGOW,

are Sole Scottish Agents for the
Famous Burndept Receivers

"Transform" Engraving Costs to Profits.

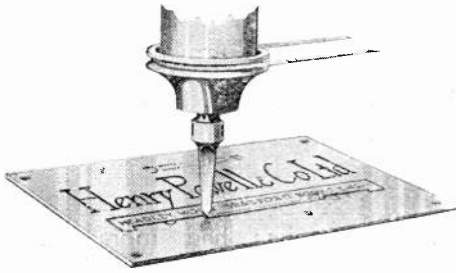

Cutter at Work.

THE present high costs of engraving are reduced to a minimum with Taylor-Hobson Engraving Machines.

The speed and efficiency of these machines make them a profitable section of every plant.

They turn out high quality work on hard or soft surfaces at a fraction of the old cost.

They are invaluable for rapid mass production.

General Engravers everywhere have adopted these machines for all styles of engraving.

Send a Post Card for full particulars.

TAYLOR, TAYLOR & HOBSON, LTD.

74a, Newman Street, London, W.1

Works: LEICESTER.

RADIO INSULATION

AS SPECIFIED AND USED BY THE BRITISH ADMIRALTY

BRITISH MADE

PAXOLIN

BRITISH MADE

TUBES DISCS PLATES, &c.

MANUFACTURED IN ALL FORMS, SIZES AND THICKNESSES

BY

THE MICANITE & INSULATORS CO. LTD.

EMPIRE WORKS

WALTHAMSTOW

LONDON, E.17

TELEGRAMS:—"MYTILITE, PHONE, LONDON."

TELEPHONES:—WALTHAMSTOW 738, 739

DUBILIER

A New Condenser for Wireless Receivers

THE DUBILIER TYPE 600 MICA CONDENSER

The illustrations show two types of this new condenser for wireless receiving circuits. The condensers have the same perfect mica insulation, the same high efficiency and the same permanence of capacity as the larger Dubilier Mica Condensers used in wireless transmitters. Distortion when receiving telephony is often due to bad design of the components of the receiver—therefore use efficient Dubilier Condensers in your receiver to obtain the best out of your set.

PRICES:

Capacity between 0'0001 and 0'001 mfd - 2/6 each

” ” 0'001 ” 0'005 ” - 3/- ”
(inclusive)

Condensers complete with Grid Leaks - 7/6 ”

TRADE TERMS ON APPLICATION.

Both types of condenser (with or without clips for a grid leak) are fitted with screw terminals as well as tags for making soldered connections.

With Clips for Grid Leak.

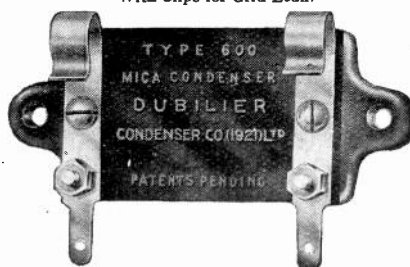

Without Clips for Grid Leak.

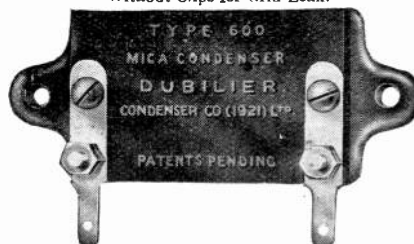

THE WAY TO DUBILIERS.

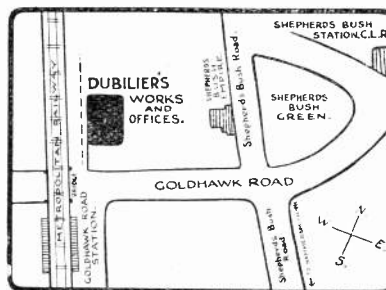

THE DUBILIER CONDENSER CO. (1921), LTD.,
DUCON WORKS, Goldhawk Road, Shepherd's Bush, London, W.12

Telephone—Hammersmith 1084.

Telegrams—Hivolcon, Phone, London.

Code—Marconi International.

EXPERIENCE

HIGH-FREQUENCY AMPLIFICATION

100 to 20,000 METRES

IMPROVED ADJUSTABLE REACTANCE COIL,
SELF-TUNED. SPECIALLY DESIGNED FOR
SHORT WAVELENGTHS HIGHEST EFFICIENCY.

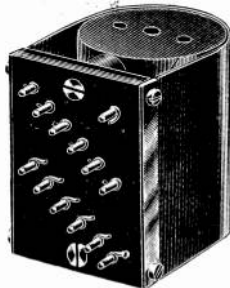

This is the high frequency unit that every wireless experimenter has been waiting for. The fact that it bears our name is a guarantee that it will do all that is asked of it.

ADVANTAGE OF HIGH FREQUENCY AMPLIFICATION
All serious wireless experimenters will appreciate the great advantages of high frequency amplification before rectifying. It makes signals far below audible strength easily readable and permits additional audio frequency amplification (after rectifying) without rendering the receiving set unstable.

THE TAPPED ANODE REACTANCE COIL.

This coil, originally developed by Mr. W. A. Appleton, our research director and specially designed for short wavelengths has now been still further improved by a finer sub-division of the tappings to obtain the best efficiency for broadcasting.

NEW AND IMPROVED DESIGN.

The coil is sectionally wound and cylindrical in form as this design allows greater mechanical strength in the winding at the tapping points than does the earlier disc type.

100 TO 20,000 METRE RANGE.

Twelve tapping points are provided covering a range of wavelengths from 100 to 20,000 metres.

CONSTANT REACTANCE VALUE.

The tappings have been selected to keep the reactance value approximately constant for all wavelengths.

NO TUNING CONDENSER NEEDED.

No tuning condenser is necessary as the capacity of the winding renders the coil self tuned.

HIGHEST EFFICIENCY.

This type of coil gives a higher efficiency on short wavelengths than any other method of intervalve coupling.

DELIVERY—Immediately from stock.

PRICE—Tapped Reactance Coil as specified .. £1 5 0
Twelve point switch for use with same .. 16 0

Radio Instruments Limited

Managing Director: J. Joseph, M.I.E.E., late Manager to Mr. H. Sullivan. Chief Designer: W. A. Appleton, M.E.E., M.I.R.E., late Admiralty Technical Research Officer.

ONLY ADDRESS. Works, Offices & Showrooms

12a, Hyde Street,

NEW OXFORD ST., W.C.1

We have the largest wireless works in Central London.
We are wireless engineers of established reputation.
Our name on wireless apparatus is a guarantee of satisfaction.



*Specially
designed
for
Broadcasting*

HEADGEAR RECEIVERS

Designed and manufactured by
leading Telephone Manufacturers.
Backed by many years' experience.

Highest efficiency, concentrated
magnetic field, instantaneously
adjusted to the ears, comfortable
in wear, either receiver detachable
from headband, protected term-
inals, light weight, twin series cord.

**A.T.M. LOUD
SPEAKING
RECEIVERS**
Three types of
amplifying horn.

**A.T.M. Crystal
Detector Sets**
Highest Grade.
Maximum Efficiency.
Moderate Cost.

*Ask your dealer for
A.T.M.*

Broadcasting Apparatus

Automatic Telephone Manufacturing
Co., Ltd.

Head Office & Works: London Office:
Milton Rd., Edge Lane, 60 Lincoln's Inn Fields
Liverpool. W.C.2.

AFA "DUROS" CELLS

The only accumulator supplied in a charged state. They retain their charge for very long periods.
Stocked by all leading dealers in "Wireless Supplies."

E. G. LIND & CO., 58a, BUCKINGHAM PALACE ROAD, WESTMINSTER, S.W.1

THE WIRELESS WORLD AND RADIO REVIEW

THE OFFICIAL ORGAN OF THE WIRELESS SOCIETY OF LONDON
A MAGAZINE DEVOTED TO WIRELESS TELEGRAPHY AND TELEPHONY

CONTENTS

Valve Manufacture	- - - - -	641
More About the Armstrong Super-Regenerative Receiver	- - - - -	648
An Amateur-made Two-valve Set in Buckinghamshire. By A. F. H. Baldry	- - - - -	652
An Experimental Station at Yeovil. By L. W. C. Martin	- - - - -	654

Contents continued on next page.

BATTERIES FOR WIRELESS

High Tension Block Accumulators

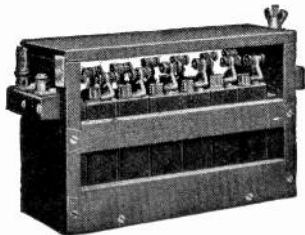

Block Accumulators, unlike the ordinary Plate Type, retain their energy for **12-18 months on one charge**. Unequaled for use with Wireless Thermionic Valves. Standardised sizes— $1\frac{1}{2}$ and 3 A.H. capacity.

Fuller Plate and Patent Block Cells (4 and 6-volt sets) are eminently suitable for Wireless Work.

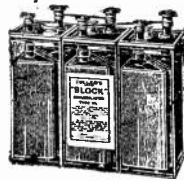

Fuller "Chad" Batteries



Designed for use in supplying the anode (sheath) circuit of thermionic valves for reception purposes. Expert tests in every case confirm its superiority over the Standard Battery usually employed.

Last much longer than ordinary Dry

Cells, free from risks of leakage and short circuits.

Type	No. of cells	Voltage.	Capacity	Price
A 12/Z	12	24	$1\frac{1}{2}$ A.H.	£4 15 0
A 30/Z	30	60	$1\frac{1}{2}$ A.H.	£10 0 0
A 12/K	12	24	3 A.H.	£5 15 0
A 30/K	30	60	3 A.H.	£12 10 0

Type	No. of cells	Voltage	Capacity A.H.	Price
A	8	12	1 approx.	6/-
	10	15	1 approx.	7/-
B	8	12	$4\frac{1}{2}$ approx.	11/9
	10	15	$4\frac{1}{2}$ approx.	18/-

EBONITE—Rod, Sheet and Tube

FULLER'S UNITED ELECTRIC WORKS, LTD.

WOODLAND WORKS, CHADWELL HEATH, ESSEX.

Telegrams: "Fuller, Chadwell Heath."

Telephone: Ilford 171 (4 lines), London Telephone Area.



MEN IN THE WIRELESS SERVICES DESIRING RAPID ADVANCEMENT
 should train in spare time with the College which ensures this
 "U.E.C." (Regent's Park, London, N.W.1) has in Twelve Years secured hundreds of successes by
Individual Postal Training for Engineering Examinations and Professional Work.
 State YOUR ambition in confidence, to—SECRETARY'S DEPT. (Desk W.).
UNIVERSITY ENGINEERING COLLEGE, WESTGATE-ON-SEA, KENT,
 and expert advice with the New prospectus, No. 8, will be sent you without obligation.

CONTENTS *(Continued)*

Croydon Aerodrome Wireless Station	- - - - -	655
Experimental Station Design. By F. H. H. <i>(Continued)</i>	- - - - -	659
Notes	- - - - -	663
Correspondence	- - - - -	665
Calendar of Current Events	- - - - -	665
Wireless Club Reports	- - - - -	666
Questions and Answers	- - - - -	670
Share Market Report	- - - - -	676

THE WIRELESS WORLD AND RADIO REVIEW is published weekly on Saturdays.

All correspondence relating to contributions should be addressed to THE EDITOR, THE WIRELESS WORLD AND RADIO REVIEW, 12-13, Henrietta Street, London, W.C.2.

No responsibility can be taken for MSS. or photographs sent without stamps to defray cost of return postage.

Editorial and Publishing Offices 12-13, Henrietta Street, Strand, London, W.C.2.

Telegraphic Address: "Radionic, Rand, London." Telephone No.: Gerrard 2807.

Advertisement Managers, Bertram Day & Co., Ltd., 9 and 10, Charing Cross, S.W.1.

Telephone No.: Gerrard 8063 and 8064.

SUBSCRIPTION RATES.—

28s. per annum, post free. Single Copies 6d., or post free 7d.

Registered at the G.P.O. for transmission by Magazine Post to Canada and Newfoundland.

HOLLOW STEEL MASTS FOR AERIALS

These masts are light, strong, easily erected, and will last a lifetime. All lengths over 15ft. are made in sections and each mast is supplied complete with baseplate, finial, rope cleat, pulley sheave, guy clips, three steel guy ropes and strainers, painted one coat ready for immediate erection. Being made of steel, no lightning conductors are required

PROMPT DELIVERY.

PRICES F.O.R. FOR CASH WITH ORDER, EACH

10ft. ... 32/6	15ft. ... 42/6	20ft. ... 45/-
25ft. ... 57/6	30ft. ... 84/-	40ft. ... 126/-

Other Lengths supplied at equally Low Prices.

Trade Inquiries Invited

THE WIRELESS STEEL MAST & ACCESSORY COMPANY
 Lombard Street West, West Bromwich

Telephone No. 447

THE IDEAL WIRELESS SET CAN BE BUILT UP ON THE MARCONI SCIENTIFIC UNIT SYSTEM

IF you invest in this series of units you need not scrap any of your gear when you wish to improve your set.

Units 1, 2 and 4 form a nucleus which will give you all the broadcast programmes and all telephony and telegraphy between 300 metres and 26,000 metres.

NUCLEUS

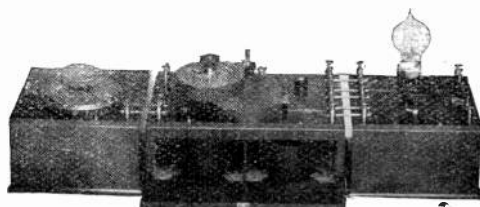

SET

This nucleus consists of a Variable Condenser ; a Retroactive Tuner ; and an Amplifying Detector.

If you want greater range add Unit 3, a High Frequency Amplifier.

If you want greater audibility add Unit 5, a Note Magnifier.

If you wish to use low resistance telephones add Unit 6, a Telephone Transformer.

THE FULL SYSTEM,

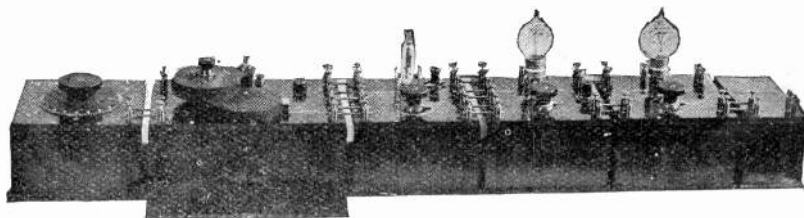

FULL DETAILS AND FREE ADVICE
upon the combination most suitable for your special
needs will be sent on receipt of your enquiry by

THE
MARCONI SCIENTIFIC INSTRUMENT CO., LTD.

40 DEAN STREET, SOHO, W.1

TELEGRAMS: THEMASINCO, WESTOENT
TELEPHONE: : GERRARD 7745

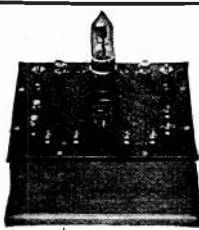

ONE VALVE PANEL

"Delighted with results obtained from the ONE VALVE RECEIVER purchased yesterday. With telephones on table we heard "broadcast" telephony in adjoining room although door was closed."

The above is an extract from unsolicited letter received last week.

These panels are all carefully tested on short wavelength telephony. They are suitable for receiving telephony or telegraphy. Price (without valve) £4

MAGNAVOX LOUD SPEAKERS.

Immediate delivery if ordered now.

Junior Magnavox Price £10 10 0 Senior Magnavox Price £20 0 0

BROWN-STERLING 'PHONES.

Multi-magnet Head Telephones (with cords).

120 ohms .. 48/- 2,000 ohms .. 51/- 4,000 ohms .. 52/-

Wates' Speciality: SPHINX H. T. Batteries

These batteries compare most favourably under test with other well known makes. Standard 15 volt 11 cell battery. Price: 3/6 each.

Send for Illustrated Catalogue (W), post free, 6d.

AN IDEAL VALVE ACCUMULATOR

50 Amps

2 volts	10/-
4 "	20/-
6 "	30/-

Carriage—

2 volts	1/-
4 "	2/-
6 "	3/-

Dimensions of each cell, 8 x 4 x 3
Weight without Acid, 5½ lbs.

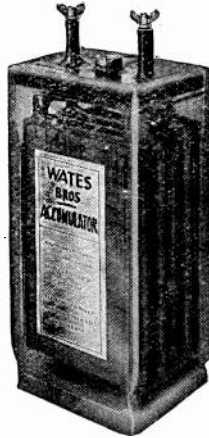

6 Volt 50 Amp Accumulator

Consisting of three as illustrated, in strong wooden container, with leather strap handle,

35/-

(Postage 3/- extra.)



WATES BROS.
WIRELESS ENGINEERS
13-14, Gt QUEEN ST. KINGSWAY, LONDON, W.C.2.
Phone: GERRARD 576. Telegrams: ZYWATESENG, WESTCENT

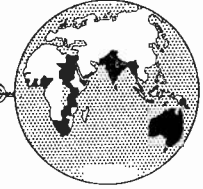

ECONOMIC ELECTRIC LIMITED

ESTAB. 1896

Telephone: MUSEUM 1056.

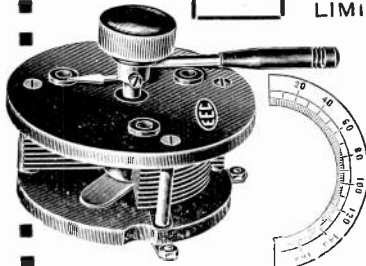

Large Selection of Variable Air Condensers

GET OUR 32 PAGE RADIO REQUISITES CATALOGUE, OVER 200 ILLUSTRATIONS INCLUDING CRYSTAL AND

VALVE CIRCUITS, MAILED BY RETURN FOR 4d.

R E S I S T A N C E S

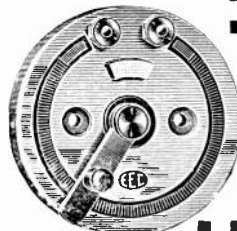

CONFIDENCE

WIRELESS VALVES SIMPLY EXPLAINED

By JOHN SCOTT TAGGART, F. Inst. P.

is the very latest book on valves. If you are not confident that your knowledge of the valve is complete and accurate, you should buy this book immediately. There are 134 pages and 56 illustrations. Last week's "Wireless World" tells you more about it. It is selling at the low price of

2/6 NET and 3/- NET cloth bound.

This, and our other publications are sold by Wireless Dealers of standing or they may be obtained, by return, POST FREE,

From **RADIO PRESS LIMITED,**

Publishers of Authoritative Wireless Books,

34/35, Norfolk Street, London, W.C.2

WIRELESS VALVES SIMPLY EXPLAINED

AS AN ADVERTISEMENT WE ARE OFFERING **500 (ONLY)**

HEAD-PHONES

BEST ENGLISH MAKE 8000 OHMS

CASH WITH ORDER

AT **35/-** PER PAIR

POSTAGE 1/- EXTRA

Angell's Wireless Supply Stores
95 Highbury New Park, London, N.5

THE WIRELESS WORLD AND RADIO REVIEW

THE OFFICIAL ORGAN OF THE WIRELESS SOCIETY OF LONDON

VOL. X. No. 21.

AUGUST 19TH, 1922

WEEKLY

Valve Manufacture

A BRIEF DESCRIPTION OF THE SIMPLER PROCESSES ADOPTED IN THE
MANUFACTURE OF M.O. VALVES

NOW that valves are so extensively used for transmission and reception, and by their use the production and detection of continuous waves and the trans-

mission of telephony are rendered possible, it is perhaps surprising that so little information is available dealing with the manufacturing processes adopted in this new industry. Before describing the methods of manufacture, an explanation of the term "M.O." may be

given. The inception of the present company for manufacturing valves, which carries on business at the Osram-G.E.C. Lamp Works, Hammersmith, is due to a combination of

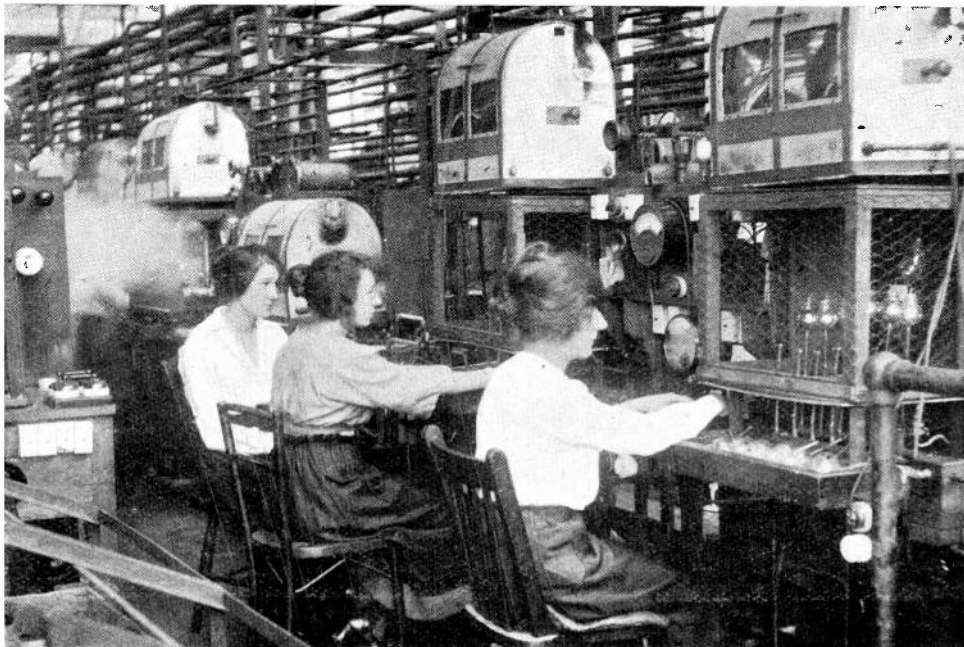

Valves of the "R" type connected to the pump whilst the operator controls the potentials applied to the electrodes.

mission of telephony are rendered possible, it is perhaps surprising that so little information is available dealing with the manufacturing processes adopted in this new industry.

Before describing the methods of manufacture, an explanation of the term "M.O." may be

the experiences of Marconi's Wireless Telegraph Company, Ltd. and the General Electric Company, Ltd., who have combined together the valve business and manufacture under the title of the M.O. Valve Company, Ltd.

The first consideration in valve production

is the selection of materials having suitable properties. The glass is supplied by the glassworks in the form of bulbs, tube and rod, of such dimensions and shapes as are required. Its composition must be such as will render it suitable for the particular service in which

softening temperature, and high non-conductive properties at moderately high temperature. If these conditions are not met, serious trouble will arise, due to electrolysis and the liberation of gas, which will either prevent a good vacuum from being obtained or else result in the

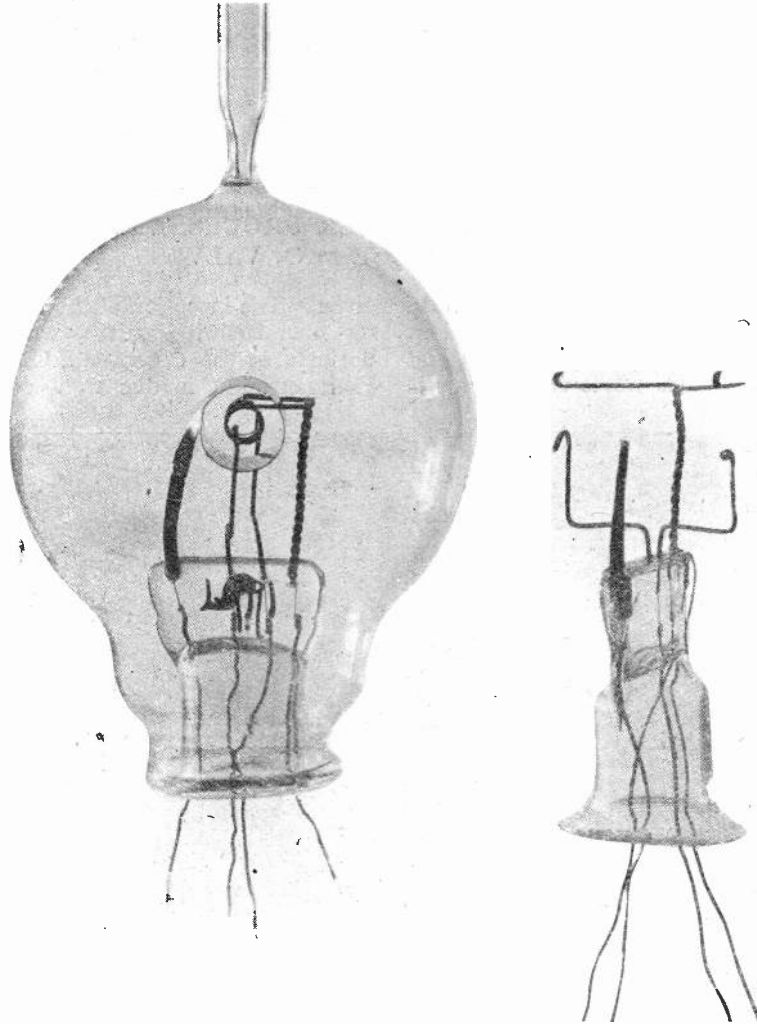

*The "R" Valve. Left. Ready for preliminary pumping.
Right. Foot tube with electrode supports.*

it is to be employed. The nature and composition of the glass is of the greatest importance, and successful valve manufacture is largely dependent upon this. The essential features, particularly with respect to transmitting valves, are that bulbs and tube shall have a uniform thickness of wall, a high

rapid deterioration of valves through poor vacuum after they have been put into service.

The various metals employed in valve construction must also be of the highest degree of purity, and capable of being effectively gas-freed. Nickel is at present almost exclusively employed in anode construction,

and is supplied in rolled sheets of the thickness of 0.2 mm., in the form of wire and flat strip. Nickel is also used for making the supports for the electrodes, though under special circumstances molybdenum, or "nichrome," is to be preferred. Molybdenum is not so

leads pass through the pinch, which is that part of the valve at which the electrode connections enter, and in the case of small receiving valves forms the point of attachment for the electrode supports.

In all valves, one or more of the electrodes

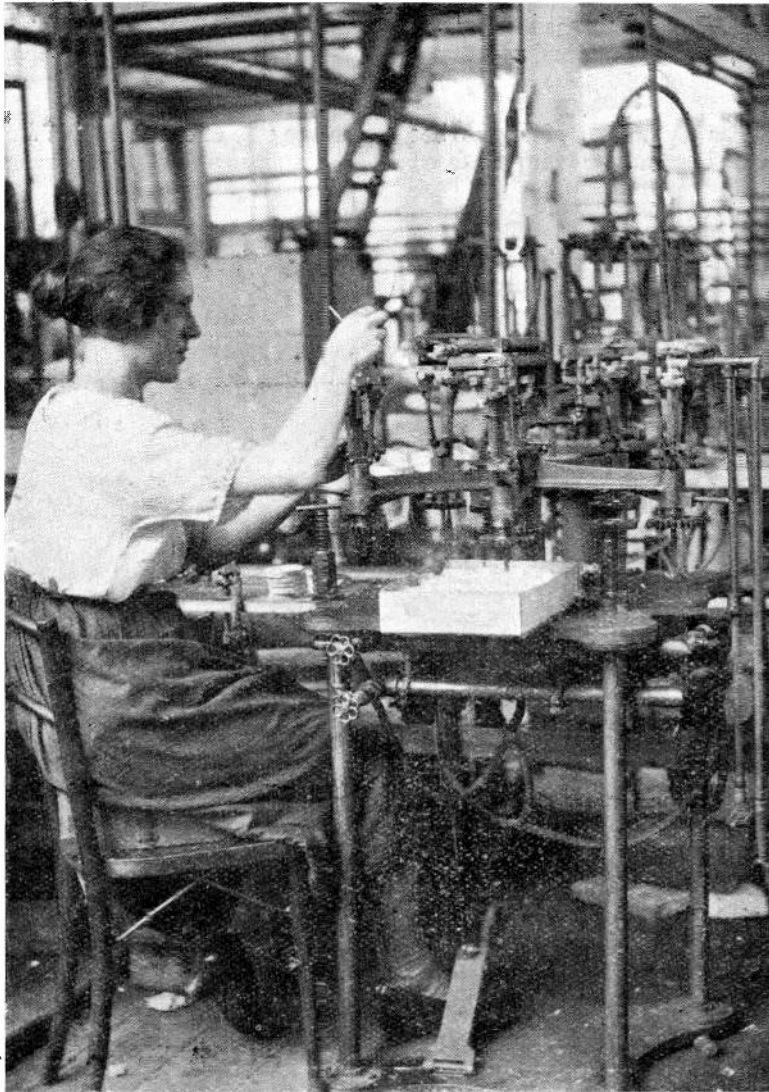

Machine for clamping electrode supports and leads in the foot tube.

soft as nickel under heating, and consequently makes a stiffer support. Nichrome is almost as good in this respect, and has a further advantage in the fact that it can be more easily gas freed. Platinum is used solely for making a vacuum-tight seal where the electrode

is supported from a flanged glass foot tube, which is subsequently welded to the neck of the bulb. Foot tubes vary considerably in size and type, dependent upon the form of valve in which they will be used.

In the case of receiving valves of the ordinary

type, such as the "R" valve, the foot tube is prepared from a short length of suitable glass tube, cut to a predetermined length. One end is heated and spread out in the form of a flange. The wires that are to pass through the foot tube are first cut to the required length, each complete "wire" consisting of three parts welded together, the external leads being of copper. The part that is to form the seal is of platinum, and the internal support of nickel, molybdenum or nichrome as the case may be.

Welding is done by means of a fine hot blowpipe flame. The copper wire is fused

These operations are carried out in a vacuum furnace, the wires referred to, together with the other parts, being packed in a nickel tray. The furnace has a fused silica heating chamber in the form of a tube. After the internal metallic parts have been thus treated, they are placed in the foot tube on a machine which rotates in front of a series of blowpipe flames, and when sufficiently hot, two flat jaws are brought up and completely embed the wires in the glass in their correct position relative to each other.

In the case of special valves and many types of transmitting valves, the arrangement of the

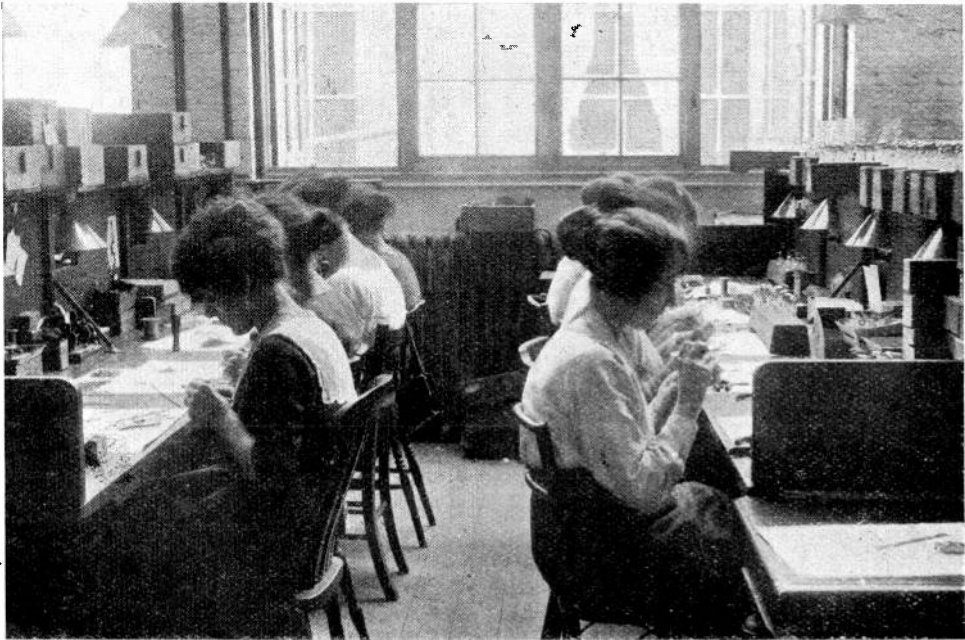

An assembling bay, where filaments, grids and plates are fitted.

directly to the platinum strip; the other end of the platinum strip, after having a small amount of copper fused to it, is welded to the nickel.

It is, of course, necessary, before sealing in, to thoroughly clean the whole of the interior metallic parts of the valve, to remove from their surface all impurities which may have accumulated through constant handling in the course of manufacture, and further they must be gas-freed as far as is possible before the actual bombardment to which they will subsequently be subjected during exhaustion.

"pinch" cannot be conveniently accomplished by machine methods, and has to be largely effected by hand. In such valves the two filament leads usually share the same pinch, whilst the anode and grid leads may each have a separate one. The effect of electrolysis in this connection is that owing to the high temperature the glass becomes conductive, and current passes between the electrode leads in the pinch, with the consequent liberation of gas from the glass. In the case of valves of very high power, such as will be operated by voltages of 10,000 or more, the method of

bringing the grid and filament leads together through the same foot tube cannot well be employed, and so in valves of this type the three sets of leads are kept as far apart as possible. The anode lead is taken from one foot tube, the filament leads through the opposite one, and the grid lead through an additional sealing tube in the bottom of the bulb, but as this part of the bulb is more liable to metallic deposit than the necks are, it is essential that precautions be taken to ensure perfect insulation between this deposit and the grid lead.

In the case of small valves, the grid is kept straight and the spacing correct by lacing it to a stiff support called a "damping wire," having two loops or eyes made in it, and spaced the correct distance apart, corresponding to the total length of the finished grid. The ends of the damping wire are afterwards attached to the vertical grid support wire, which is mounted on the pinch. To prevent vibration in use, the individual turns of the grid helix are each bound to the damping wire.

Grids for larger valves require more than a

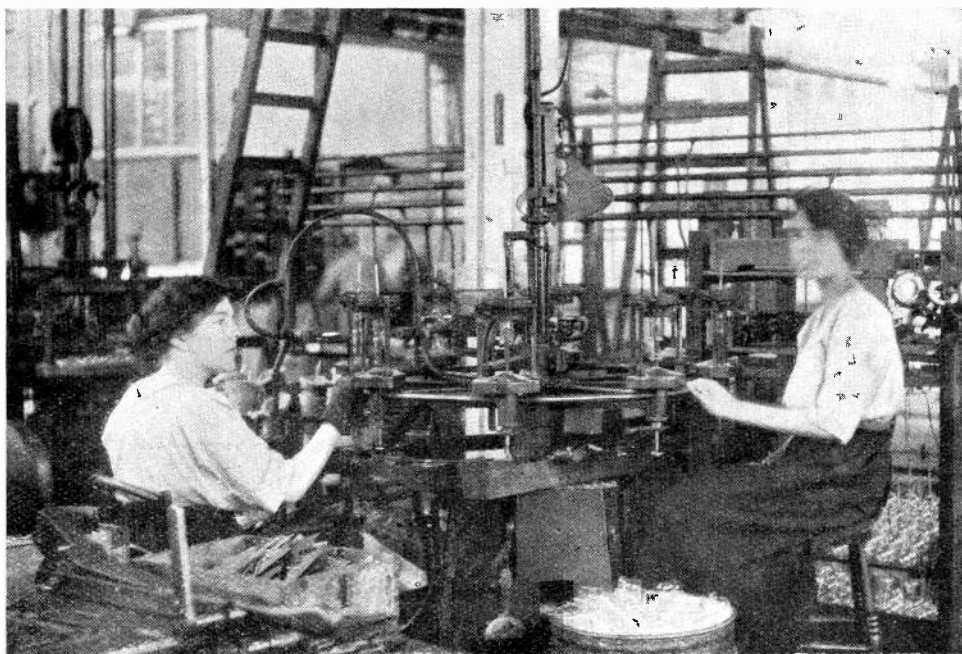

Machine for sealing in the mounted electrodes.

There are two types of grid, one composed of a wire wound into a helix, the other being of wire mesh formed into a hollow cylinder. The helical grid is used when liberal spacing is required, while mesh is more suitable, and also more convenient from a manufacturing point of view, for valves in which close grid spacing is required. A mandrill is made having a diameter equal to that required for the grid, and on this the wire is wound in a long helix. The overall length of each grid is predetermined, and the number of turns which it shall have per centimetre, and also the number of turns in that length.

single support. In such cases three support wires are laid along a mandrill in which a light screw thread has been cut. The grid is wound over the supports, and the operator sews each turn to each of the three supports, using for the purpose a needle threaded with fine molybdenum wire, and making the helix follow the screw thread on the mandrill. After lacing, the end turns may be arc-welded to prevent slipping. Close-meshed grids are cut to size, and after being bent to the required shape, the ends are stitched together with molybdenum wire. Some forms of grid are open-ended, while others have the top end

entirely closed. The former are used in low power valves which are not intended to operate on very high tension circuits, and they have

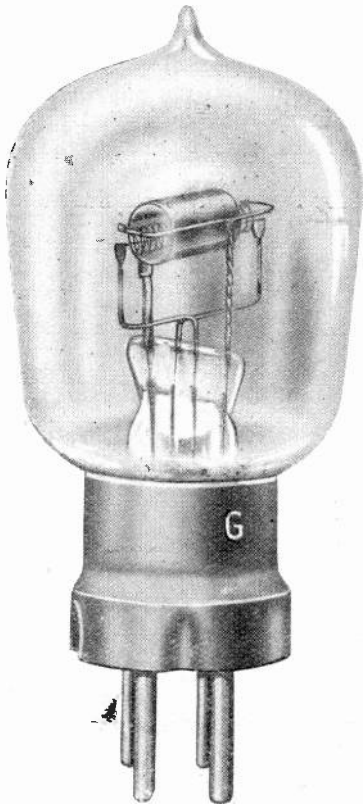

Detector Valve, Type R.A.B. Filament volts 3.8, filament amps. 0.65. Normal anode volts, 50/70. Designed for use as a detector or low frequency amplifier.

the loop end of the filament supported by a wire which may be fixed to the grid foot tube, or it may terminate in a closed stud, forming part of the anode foot tube at the other end of the bulb, and designed to ensure good insulation between the anode and filament.

Grids with domed ends have a small diameter opening left in the centre, into which is fitted a flanged button of highly insulating, heat-resisting material. This has a small diameter hole through its centre, through which the filament tension wire passes to a spring. As previously stated, nickel is generally used for making valve anodes.

Blanks are stamped out in the various sizes required, and formed up into cylinders by rolling them round mandrills. Anodes of small receiving valves are plain cylinders having a projecting tongue which is afterwards arc-welded to the anode support wire, which is satisfactory, owing to their small size and weight. With larger valves a tripod arrangement is adopted, the anode being blanked out and holes punched for rivetting to three support legs. Large anodes are stiffened by rolling ribs round them, and in some cases by also turning the edges over.

The valve filaments are all of drawn Tungsten wire, but there are some slight differences between the wire used for receiving valves and that for transmitters. The filaments are accurately cut to size on gauges and jigs, and the correct mounting position located by means of a sharp bend, so as to ensure correct length between support points. Filament wires are thoroughly cleaned before they are sealed in, so as to remove from their surface all impurities, by being heated

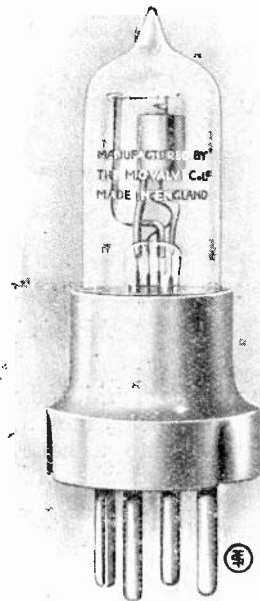

Low Temperature Emitter, Type L.T.3. Requires a filament potential of only 1.8 volts and passes a current of 0.11 amperes. An efficient detector, oscillator, high and low frequency amplifier.

in dry hydrogen to a bright red heat. This treatment not only cleans the surfaces, but removes springiness and kinks from the wire.

tungsten, and good electrical contact ensured. The projecting ends of the filament may in special circumstances be bent back and arc-

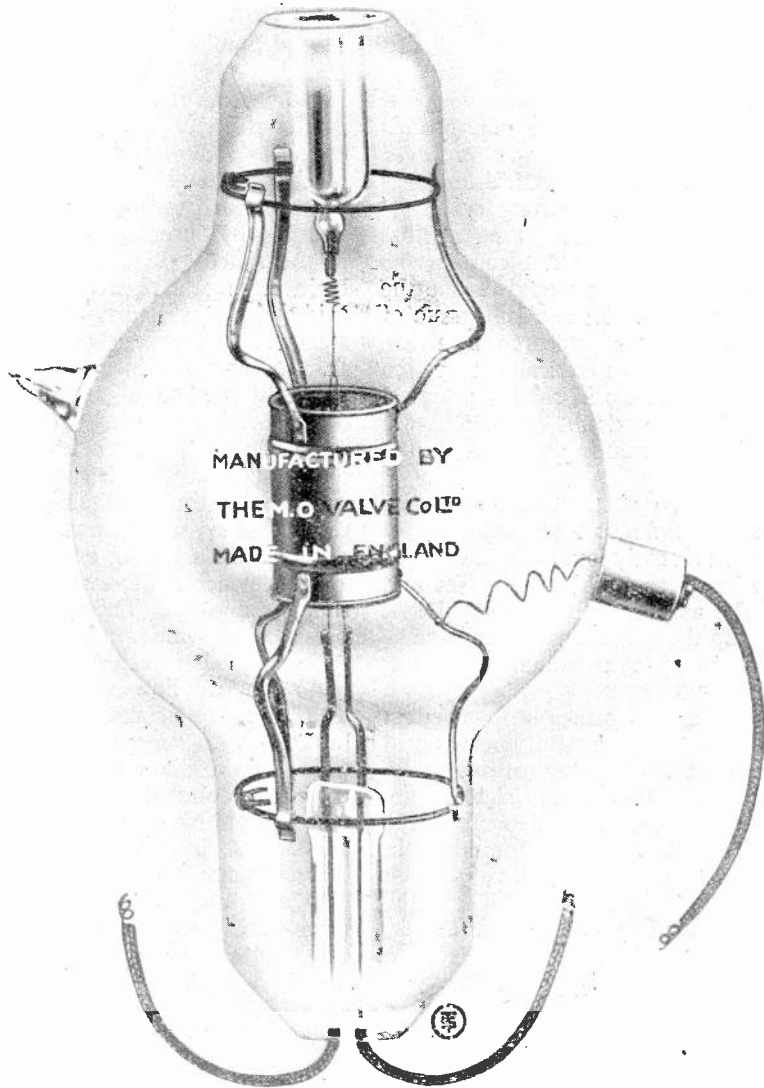

A Power Rectifier, Type U.100.

The mounting of the filament is effected by first flattening out the ends of the supporting wires by pliers having specially shaped jaws. The hooks are then tightly pinched over the

welded to the supports, an operation which requires considerable skill.

(To be concluded in issue of 26th August, 1922.)

More about the Armstrong Super-Regenerative Receiver

THE article which appeared in our issue of July 29th regarding E. H. Armstrong's new circuit has created widespread interest. That article was the first information on the subject to be published in this country, and as that was prepared in haste from the very little practical information divulged by Mr. Armstrong when he described the apparatus before the Institute of Radio Engineers, it does not contain the practical information which would enable the circuit to be tried out. In the July issue of *The Wireless Age* there appears an article which gives some more practical data which may at least serve to help in solving practical difficulties which no doubt amateurs are experiencing in endeavouring to operate the circuit.

We give below an abstract of the article appearing in *The Wireless Age*, and this we hope to follow in an early issue with a detailed description of how to build up the set and operate it. The author of the article, Mr. A. Ringel, opens up the subject with a consideration of the theory of regeneration.

THEORY OF REGENERATION.

Before describing the principle involved in this new extension of regeneration, we will consider the behaviour of an ordinary regenerative receiver. Incoming signals are applied between the grid and filament of the valve. These oscillations are amplified in the valve, and as a result, we get very much greater variations in the plate circuit. If the plate circuit is coupled back to the grid circuit, the reinforced oscillations are fed back to the grid and are once more re-amplified by the valve. In this way we can build up a very weak signal until it is of sufficient amplitude to give a loud sound on detection.

This process is called regeneration. The amount of amplification is controlled by the coupling between the grid and plate circuits. In the case where a reaction coil is used in the plate circuit, the extent of regeneration depends on the magnetic coupling between the reaction coil and the grid coil. Where a variometer is employed in the plate circuit, the coupling

is capacitive, due to the capacity between the grid and plate of the tube itself, and the magnitude of this coupling is determined by the value of the variometer inductance.

The effect of regeneration is to reduce the effective radio-frequency resistance of the receiving circuit to a very low value. This the operator can prove to his own satisfaction by actually inserting several hundred ohms in the tuned grid circuit. He will find that by increasing the regenerative coupling between grid and plate circuits, he will obtain the same signal as if the resistance were not present. In other words, in regeneration we have a powerful method of annulling the resistance of a receiving circuit. In this way it can be reduced to as low as a few hundredths of an ohm. This low resistance accounts for the sharpness of tuning obtained on a regenerative receiver—very often a variation of only half a degree on a tuning knob is enough to lose a signal which is otherwise of several hundred times audibility. This helps to explain the presence of vernier adjustments on all good types of such receivers.

As the coupling is increased still further, the resistance of the circuit is lowered and lowered, with consequently greater amplification. When the resistance approaches zero, the valve commences oscillating at a frequency determined by the tuned circuits. These oscillations are identical to those obtained in continuous wave transmitters, except that they are much feebler. Although the signal received is very much louder, its quality is entirely lost. If it is a spark note, it becomes hoarse and mushy, losing its characteristic note—and speech and music, although their presence is apparent, become absolutely unintelligible gibberish. If no signals are coming in, the presence of oscillations can be detected as follows:—

1. As the regenerative coupling is increased to the oscillating point, a sudden rushing or hissing, is heard in the phones.
2. Touching the grid terminal of the valve with the finger will produce a dull thump in the phones—and removal of

the finger will cause a similar thumping noise.

THEORY UNDERLYING SUPER-REGENERATION.

As explained before, much greater signal strength is obtained when regeneration is increased—but this is all upset when the valve breaks into oscillation. In his super-regenerative circuit, Armstrong increases the coupling so that the valve is far beyond the oscillation point, and the effective resistance of the circuit is made even less than zero—the circuit is made to have a negative resistance. And he stops the oscillations so that he can take advantage of this negative resistance and thus obtain powerful signals.

Before going any further, let us diverge a bit and delve into the theory of various tuned circuits containing (1) positive resistance, (2) zero resistance, and (3) negative resistance. In the first case, when continuous oscillations are impressed, after a short building up time, the oscillations attain and preserve

the amplitude will be proportional to the actual amplitude of the speech waves at the moment of application. No matter how small this initial voltage is, it will at once commence to build up to an infinitely large value. So much for pure theory. In actual practice, if we go to the negative resistance circuits, we cannot secure the above results, because the circuit breaks into oscillation at the slightest shock, thus paralysing the tube.

THEORY OF THE SUPER-REGENERATIVE CIRCUIT.

Armstrong takes advantage of regeneration to the limit of a valve, and still prevents it from oscillating. He has discovered that he can stop oscillations in a negative resistance circuit either by introducing resistance in the circuit at definite intervals or by reducing the amount of regeneration so that the circuit resistance becomes positive and negative alternately. In both cases the effect is to give the circuit first a positive and then a negative resistance. This alternation is sufficient to prevent oscillations. During the negative resistance period

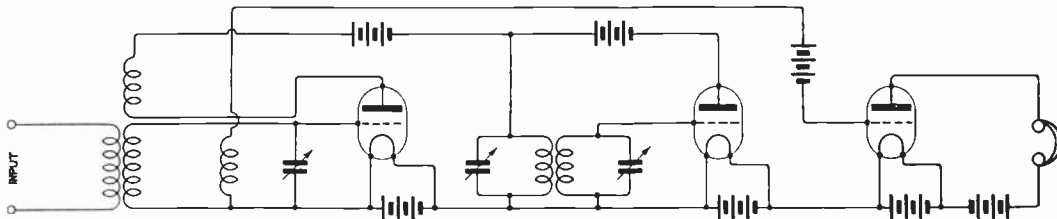

Fig. 1. Control of regeneration by varying the H.T. supply.

a definite constant amplitude. When the impressed oscillations are removed they die away to zero. The greater this resistance, the longer it takes to build up the oscillations and the faster they die off—and *vice versa*. In the second case, when continuous oscillations are impressed, they keep on steadily increasing in value, depending on how long they are applied. If the source of oscillations is removed, the circuit keeps on oscillating at the same amplitude it had when the voltage was removed.

In a negative resistance circuit, if oscillations are applied, they continue building up to an extremely great value, regardless as to whether the voltage is removed or not. However, at any given time after the e.m.f. is impressed, this amplitude, although very large, is always proportional to the initial applied amplitude. Thus, if we have continuous waves modulated by speech or music applied,

we can make full use of the very great amplification produced—but just as the circuit is about to start oscillating of its own accord, we introduce a positive resistance. During the positive resistance period, the circuit, of course, cannot oscillate and the resulting amplification of the incoming signals is much less than before.

This variation between positive and negative resistance may be made at any frequency desired, provided that it is less than that of the incoming oscillations. No doubt it could be done mechanically by connecting a resistance in the tuned grid circuit, regenerating beyond the oscillation point, with the resistance short circuited, and then alternately short and open circuiting the resistance at any desired frequency. Variation in regeneration may be accomplished in a similar manner by mechanically varying the plate voltage of the regenerating valve so that the grid circuit

resistance is alternately positive and negative. Then again, we may use a combination of both methods.

But moving mechanical parts may be dispensed with and vacuum tube oscillators employed to produce this variation in circuit resistance or amount of regeneration. These methods are illustrated in the diagrams.

SUPER-REGENERATION BY PLATE VOLTAGE VARIATION.

Fig. 1 shows how the amount of regeneration is varied by varying the plate voltage. The first valve is the regenerator, which introduces negative resistance in the grid circuit. Incoming signals are coupled to the grid circuit, amplified in the first valve and fed back to the grid by means of the reaction coil. The reaction coupling is made large enough to carry the circuit beyond the oscillating point. The second valve acts as oscillator of any frequency desired. Generally, one of about 10,000 cycles is suitable. The amateur and experimenter will recognise the usual oscillating circuits. The coils and condensers should be so selected as to give this frequency (which corresponds to a wavelength of about 30,000 metres).

Note that the plate oscillatory circuit is also in the plate circuit of the first valve. The plate voltage of this regenerating valve is thus varied at a frequency of 10,000 cycles. When the oscillations are such as to make the plate more positive, regeneration is increased beyond the oscillating point, and the signal amplitude increases to a very great value. Just as the valve is ready to burst into oscillations of the circuit frequency, the applied frequency reduces the plate voltage to a low value, and thus reduces regeneration and introduces a positive resistance in the grid circuit—effectually cutting off any sign of free oscillation. A very high degree of amplification is thus obtained during those half cycles of the 10,000 cycle oscillations when the plate is made more positive.

The grid circuit of the first valve is coupled to an aperiodic coil in the grid circuit of the last valve, which acts as a detector. Rectification is accomplished by applying a negative potential to the grid, instead of the usual condenser and leak. But it is really immaterial which method is used. The first valve may be an amplifying valve. But it is desirable, though not essential, to have power valves for the oscillator and detector, because of the

energy they are required to handle. For the receiving circuits, the coils and condensers should be of values suitable for tuning to the wavelength range desired. In the oscillatory circuit, the coils should be quite large—with an inductance of the order of 100 or 200 millihenries. (Honeycomb or duo-lateral coils No. 1250 or 1500, approximately.) Pie-shaped coils used in spark transformers, having 1,500 to 2,000 turns, are suitable here. The condensers are ordinary 43 plate variable air condensers.

The system shown in Fig. 1 should present no great difficulty in operating or adjusting. The condensers and coupling in the oscillator are adjusted until a very high pitched whistle is obtained. Then the receiving and regenerative circuits are tuned to the station to be received in the usual manner. In fact, the operation should be much easier than that of the average receiver.

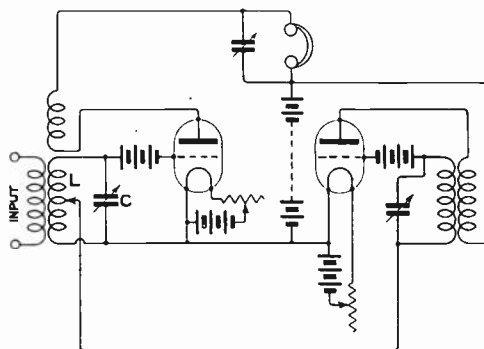

Fig. 2. Control by positive resistance in the grid circuit.

SUPER-REGENERATION BY RESISTANCE VARIATION.

Fig. 2 shows a method whereby a positive resistance is introduced into the tuned grid circuit of the regenerating valve. Incoming signals are applied to the grid of the first valve and amplified by regeneration due to the reaction coupling. The second valve acts as a 10,000 cycle oscillator—and these oscillations are also impressed on the grid of the first valve. The regeneration is carried beyond the normal oscillation point of this valve. During that half cycle, when the local oscillations make the first grid negative, no grid current is drawn and the effective radio frequency resistance of the circuit is negative

because of the super-regeneration. The incoming signal is built up to very great amplitude during this interval. Just as the first valve is ready to go into oscillation, the local oscillations are reversed and tend to give the first grid a positive potential. In this case, a stream of electrons commences to flow from the filament to the grid and this is equivalent to connecting a resistance of several thousand ohms across the tuned circuit. The effective resistance of this circuit is thus increased until it is no longer negative, but positive, and thus chokes out free or self oscillation in the receiving circuits. Of course, we obtain very high amplification in the negative resistance periods. In the circuit shown, the first valve acts as the detector. Evidently Armstrong prefers to use a grid cell instead of condenser and grid leak to obtain rectification.

circuits are used to produce the necessary 10,000 cycle oscillations. The condensers C_1 and C_2 should be of fairly large capacity, say 0.001 microfarad, in order to provide a by-pass for the incoming high frequency signals—since the latter would be blocked by the high inductance coils L_1 and L_2 (of about 200 millihenries each).

The received signals are super-regenerated as usual during that interval when the 10,000 cycle oscillation applies a negative potential to the grid, and at the same time tends to increase the effective plate voltage. The oscillations in the grid and plate circuits must be of the proper phase, so as to produce both the above effects at the same time. During this half cycle, the effective resistance of circuit $L C$ is made negative, resulting in considerable regenerative amplification. Just

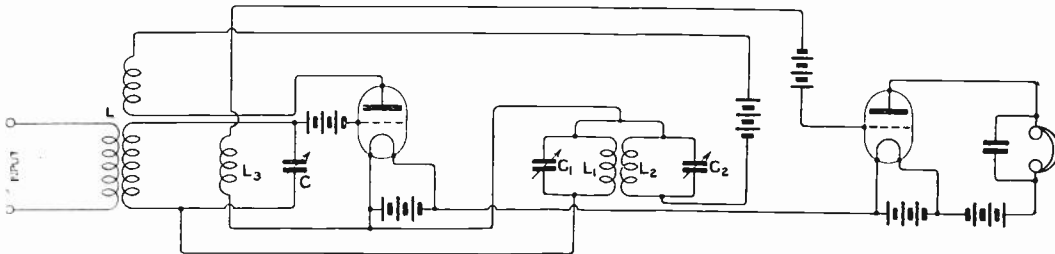

Fig. 3. A combination of the methods shown Figs. 1 and 2.

Only two valves are used in this arrangement, the first performing two functions, regenerator and detector, the other acting only as an oscillator. Since the only thing that controls the amount of amplification is the limit of the valve, better results could be obtained by using power valves instead of ordinary receiving valves in cases where extraordinarily great intensity is required.

SUPER-REGENERATION BY COMBINED RESISTANCE AND PLATE VOLTAGE VARIATION.

Fig. 3 shows a method of varying the resistance in the tuned grid circuit and plate voltage simultaneously.

The circuit $L C$ is tuned to the incoming signals and these are impressed on the grid of the first valve—the signal being amplified by regeneration in the manner described above. In series with L and C , we have another tuned circuit $L_1 C_1$ coupled to $L_2 C_2$, which is in series with the reaction coil. These

as $L C$ is on the verge of self oscillation, the polarity of the applied 10,000 cycles reverses, so that the grid is made positive and the plate voltage is lowered: The former causes grid current to flow, thus introducing positive resistance. The reduction in plate voltage decreases the amount of regeneration and thus aids in increasing the positive resistance. Under such circumstances, of course, free oscillations are completely choked off.

In this arrangement, both regeneration and 10,000 cycle oscillation are performed within a single valve. A second valve, the grid of which is coupled to L , acts as the detector. The adjustments both for tuning and local oscillation are very critical. Hence this circuit is not suitable for use by the average experimenter because of the great pains necessary in order to secure super-regeneration.

PRACTICAL SUPER-REGENERATIVE CIRCUIT.

Fig. 4 shows a practical two-valve circuit.

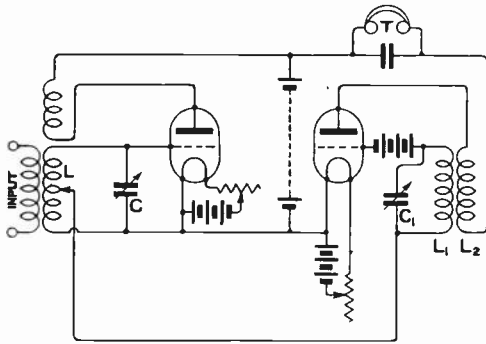

Fig. 4. A practical two-valve circuit.

It is essentially the same as that of Fig. 2. The first valve is the regenerator and the second the local oscillator. Free oscillations in the receiver circuit are stopped by those half cycles of the local oscillations which make the first grid positive.

The unusual feature in this arrangement lies in the use of the oscillator valve as the detector of the signals which are amplified by super-regeneration by the first valve. The amplified signals are impressed upon the grid of the oscillator valve, which rectifies them, in the plate circuit, thus making them audible.

An Amateur-Made Two-Valve Set in Buckinghamshire

By A. F. H. BALDRY.

WHILE nothing out of the ordinary is claimed for this set, either in design or results accomplished, it is thought that this description may be of interest to fellow amateurs in the fascinating hobby of wireless.

The apparatus consists of one rectifying and one note-magnifying valve with L.F. transformer mounted on an ebonite panel measuring 11 ins. by 9 ins. and enclosed in a polished wooden cabinet 11 ins. by 9 ins. by 4½ ins. With the exception of the usual items, L.F. transformer valves, phones, etc., the set is entirely amateur-made. There are two sets of inductances incorporated, together with reactances, which are so connected with a four-pole switch that either may be used at will. The inductance formers both measure 3 ins. diameter, and were made of ebonite with reactances measuring 2½ ins. diameter, arranged to turn within. The set being divided into two sections, it was found that by making six tappings in the short wave inductance, an effective range of 200 metres to 1,000 metres was available. Each tapping was brought out to a brass contact stud turned up out of the solid. A similar process was adopted with the long wave inductance, twelve tappings being made in this instance. This gives an approximate range of 1,000 metres to 12,000 metres. Each valve is controlled by a separate filament resistance which are both mounted on a

small ebonite panel measuring approximately 4 ins. by 2½ ins. let into the centre of the front side of the cabinet.

The long wave reactance has two tappings brought out and controlled by a small switch

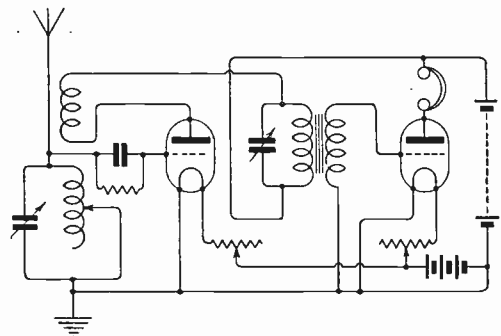

Circuit Diagram of Mr. Baldry's Set.

which enables varying amounts of reactance to be used. This feature has been of considerable use at times.

The variable condenser (A.T.C.) is of the air dielectric type and consists of 21 plates, 11 fixed and 10 moving, cut from aluminium sheet approximately 1/64 in. thick. Great care was exercised in ensuring that the vanes should be absolutely flat and true, this being effected by careful pressing while under gentle heat.

All internal connections are made with No. 20 S.W.G. rubber-covered, which was found to be sufficiently stiff for the purpose.

The switchboard was gradually assembled as the occasion arose, and the various switches and instruments were mounted on a polished teak board measuring 2 ft. 6 ins. by 2 ft. 6 ins. by $\frac{1}{8}$ in. All terminals were fitted in $\frac{3}{4}$ in.

fitted to enable an instant change over from phones to loud-speaker. The panel on the right carries a three-valve L.F. amplifier which is still incomplete.

The aerial used is a standard P.M.G. aerial of 140 ft. twin wire carried on two masts 50 ft. high, the whole being very carefully insulated.

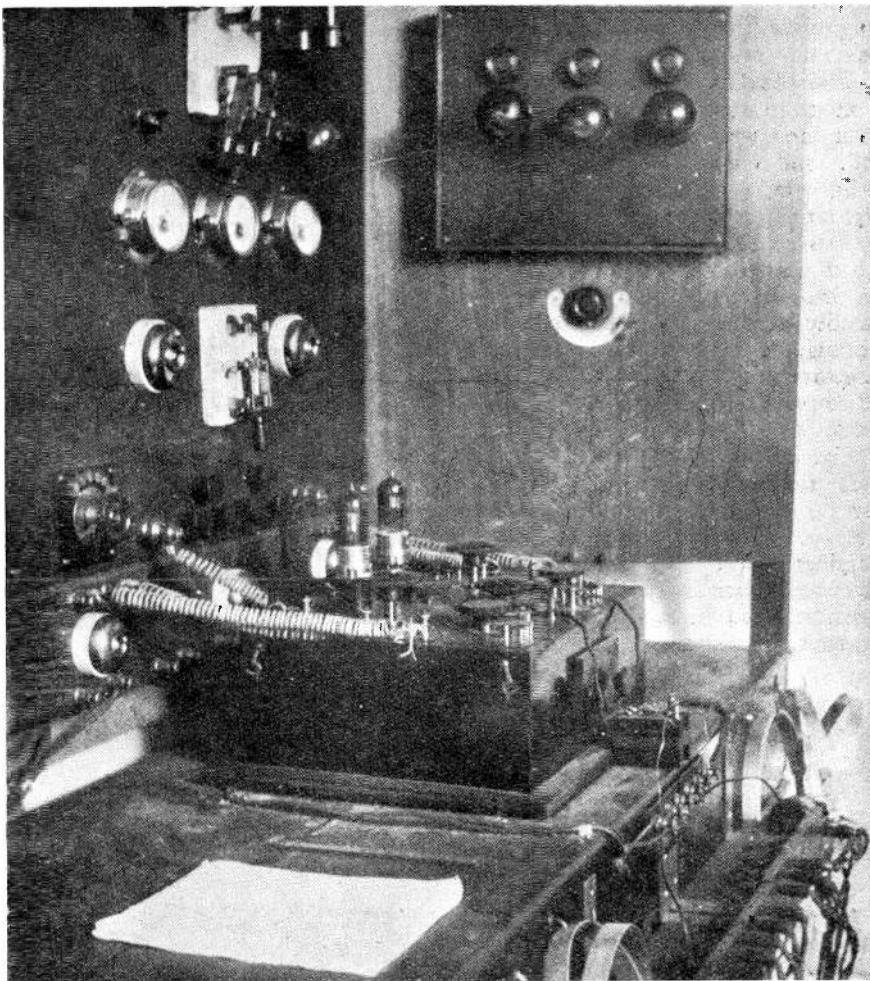

The complete Receiver, showing Plugs and Jacks.

ebonite plugs, thereby reducing capacity effects to a minimum. At the top of the board will be seen a single pole change over switch which enables the aerial to be connected to earth when not in use. The instruments consist of two voltmeters for measuring H.T. and L.T. voltage and one amperemeter. The double pole change over switch in the centre is

Results are very good, all Continental stations coming in clear and strong, whilst Croydon and 2 MT telephony can be heard comfortably on the loud speaker. PCGG is clear, but not so strong. The set being situated near Marlow-on-Thames, considerable interference is caused at times by Leafield, which is but 23 miles distant.

An Experimenter's Station at Yeovil

By L. W. C. MARTIN.

ON the left of the photograph (Fig. 1), mounted in the box, is a short and long wave tuner. The short waves are received on a variometer type of inductance enclosed inside the box, with five tappings, and tuning from 200 to 1,600 metres; also mounted in the box are two variable condensers of 0.002 mfd. and 0.0005 mfd. respectively.

The long wave coils are of the plug-in type, with tappings mounted on the side of the box, basket coils being used for waves up to 5,000 metres and lattice wound coils for above that wavelength and up to 24,450. For portability all tuning coils will pack away in the box through the small door seen in the front.

A change over from short to long wave coils, also series to parallel of condensers, is effected by one plug (2 pin) as shown in the circuit diagram, Fig. 2, thus doing away with two double-pole double-throw switches, which would take up rather too much room. There is another 2-pin plug for reaction coils.

The amplifier is 1, 2, 3 or 4 valves, all cutting out of valves being done by plugs; also various circuits can be tried in a few moments by changing about the plugs.

The first valve can be either H.F. transformer, tuned anode, or resistance-coupled.

Two transformers (H.F.) can be seen in the photograph, one of which is in position. These I have made from 300 to 2,800 metres. Above this wavelength I use resistances of 50,000 ohms.

The second valve rectifies; both these valves are "V.24" and have been in constant use for eighteen months. The two "R" valves are note magnifiers, and are controlled by one rheostat.

In the diagram of connections I have purposely omitted plugs and switches to avoid complication, except in the diagram of the tuner.

The amplifier has a hinge at each end of the base, and a box-like cover fits over the whole and is secured by two screws.

The H.T. battery is shown on the extreme right. With the four valves in use, and a very good indoor aerial, WII (New Brunswick), 13,400 metres, is easily readable with the telephones on the table when there is no jamming by Carnarvon.

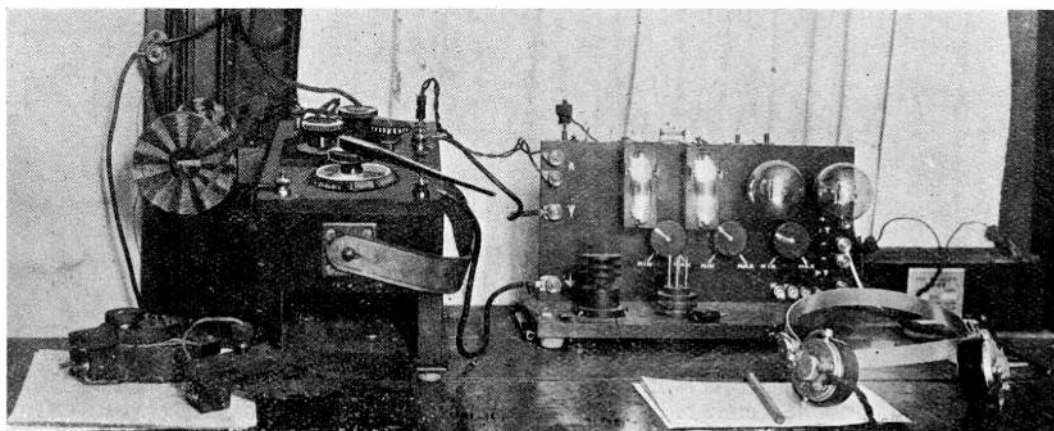

Fig 1. The Tuner is on the left, and the Detector-Amplifier, using "V. 24" and "R" valves, on the right.

PCGG can be heard anywhere in the room with a gramophone horn attached on one earpiece of the telephones. Croydon need not be mentioned.

If I use my outside aerial and one more valve variometer coupled to the first valve of amplifier, PCGG can be heard anywhere in the house.

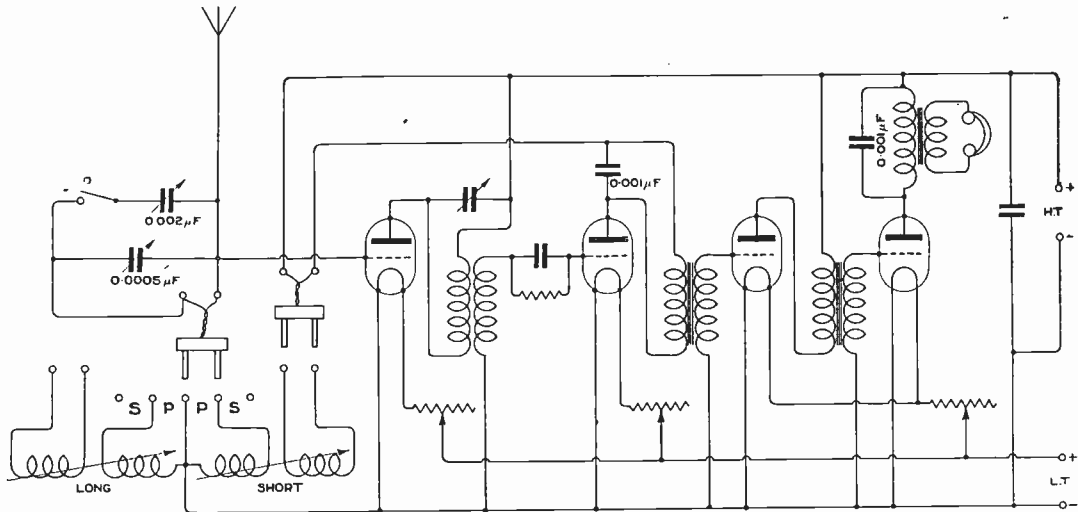

Fig. 2. Circuit diagram showing Switching Arrangements for Short and Long Wave Tuning.

Croydon Aerodrome Wireless Station

THE EQUIPMENT OF THE LONDON TERMINUS OF CIVIL AIR ROUTES.

THE wireless telephony station of the Croydon Aerodrome is perhaps the most familiar of all stations which the amateur in this country hears.

Visits have been made to the station by a good number of wireless societies in the London area, thanks to the courtesy of the Air Ministry, but the accompanying photographs of the station are published as being thought to be of general interest, especially to those who are familiar with the station on the wireless telephone but have not had the opportunity of visiting it.

At the Aerodrome there are two stations, one the direction-finding station and the other the radio-telephone station which is used for communication with aircraft.

The purpose of the direction-finding station

is, of course, to take bearings on aircraft whilst in flight, and these are transmitted to the aircraft through the medium of the wireless telephone.

Fig. 1 shows the mast which carries the D.F. receiving station and the hut in which the instruments are located. The apparatus seen in Fig. 2 is the standard Marconi direction finder and receiver. On the right of the picture may be seen a wavemeter, and just in front of this the telegraph key.

Immediately in front of the main instrument can be seen a row of eight switches, which serve to control various circuits.

One serves to start up the main generators for the transmitter. Another serves to put into connection with the land-line telephone the table microphone seen in the picture,

which is the microphone used for the transmissions by wireless telephone. In this way it is possible to relay ordinary land-line telephony through the local telephone exchange direct to aircraft in flight, and in this way

The main aerial, that of the transmitting station, is supported between two lattice masts as shown in the illustration (Fig. 4).

The main generating unit consists of an A.C. motor which is run by the supply mains,

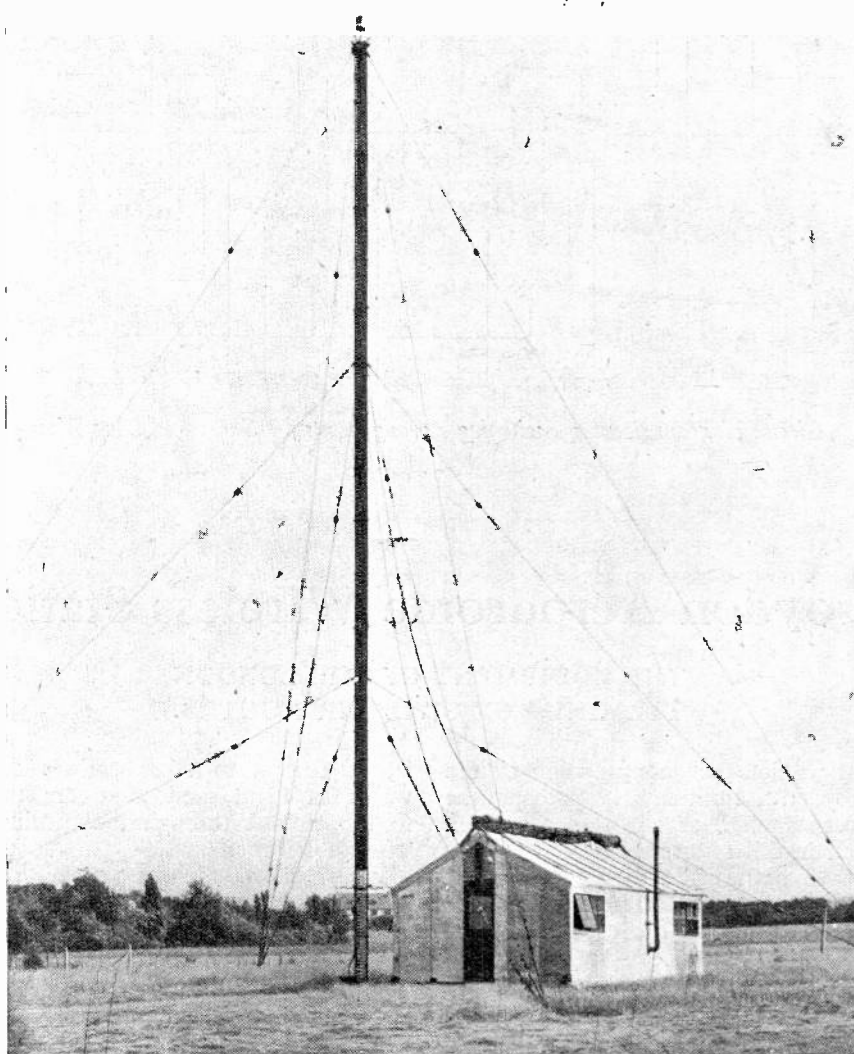

Fig. 1. The Mast carrying the D.F. Aerials.

passengers may be kept in communication with the ground whilst travelling.

Fig. 3 illustrates the transmitting apparatus, which consists of a Marconi $1\frac{1}{2}$ kW. telephony transmitter.

and drives an A.C. generator. The generating plant is duplicated so as to avoid any risk of a breakdown in the service. D.C. generators for battery charging are also in duplicate for this reason.

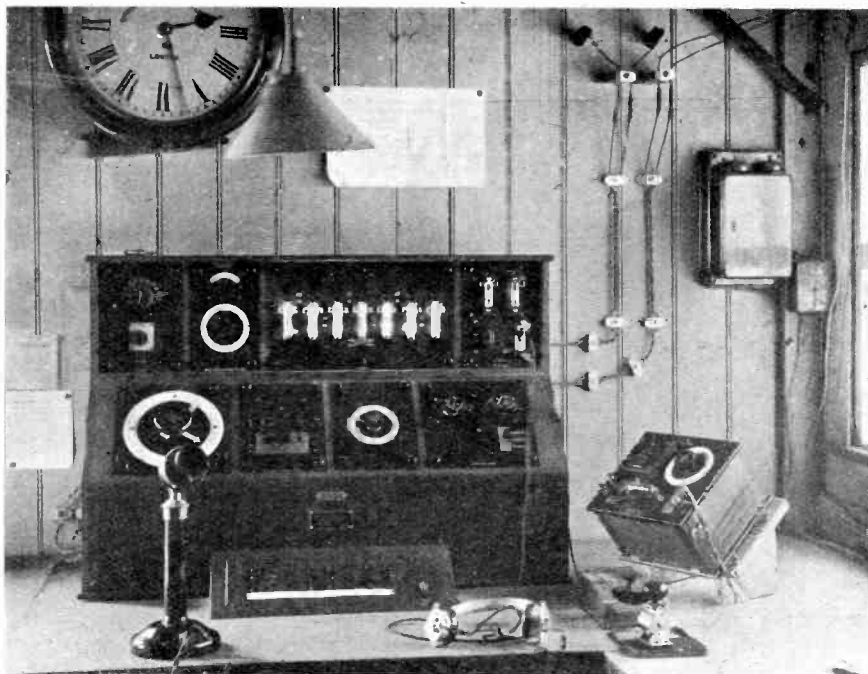

Fig. 2. The Direction Finder and Receiver.

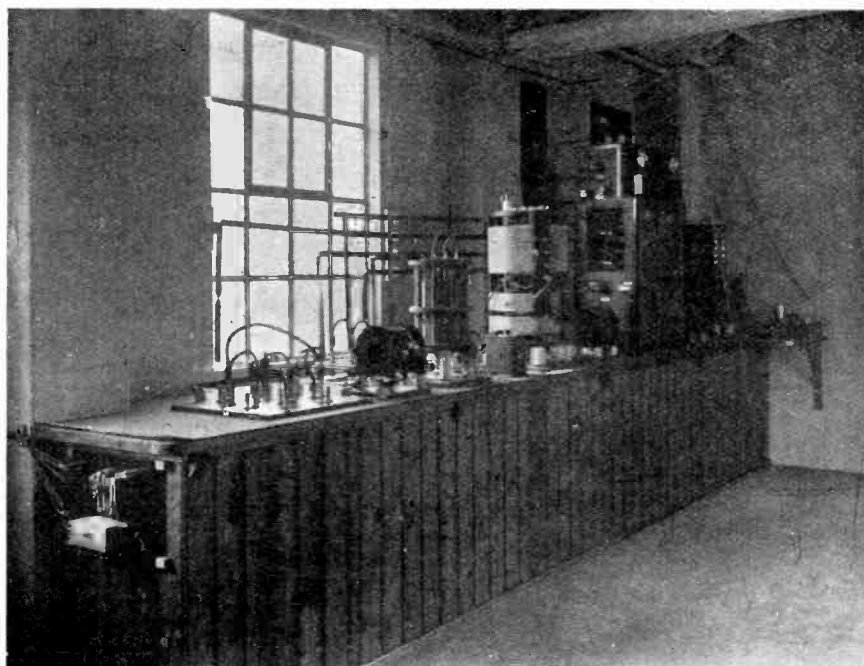

Fig. 3. The Main Transmitting Apparatus.

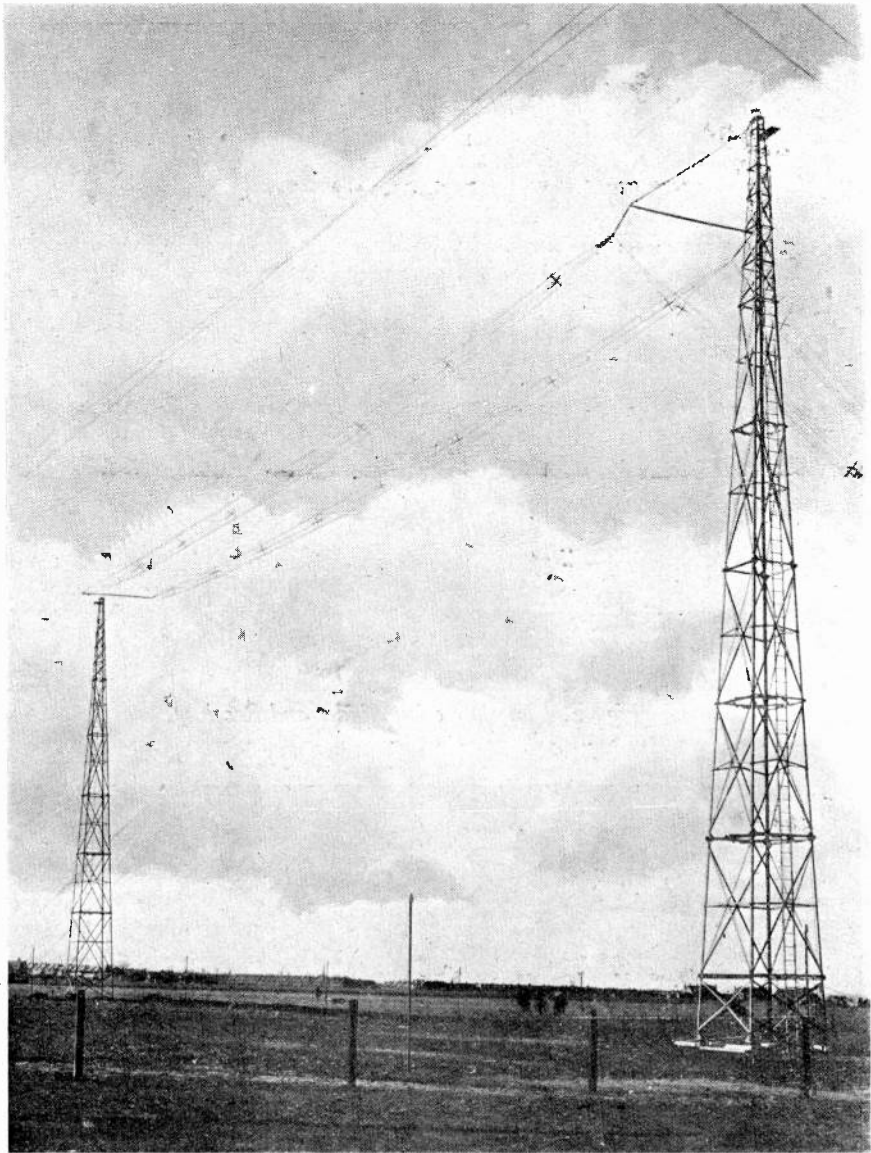

Fig. 4. The Aerial and Mast of the Transmitter.

Progress of the Broadcasting Scheme.

At last a definite scheme for broadcasting has been agreed upon for the London area, and it is hoped that this will be put into operation on Monday, August 21st. It is hoped to commence in the provincial areas in six or seven weeks' time.

There will be a broadcasting centre for London. The apparatus is in readiness. All that remains to be done is to secure the Postmaster-General's approval of the company's memoranda and articles of association. The board of directors of the new company will proceed to deal with the provision of the provincial stations.

The Postmaster-General has laid down several conditions under which the broadcasting company will work. Profits are limited to $7\frac{1}{2}$ per cent. per

annum. For two years the apparatus will be limited to types submitted for the approval of the Post Office by members of the company, but to avoid anything in the shape of a monopoly the Postmaster-General has laid it down that any *bona fide* British manufacturer of wireless apparatus must be allowed to become a member of the broadcasting company, simply by taking a £1 qualifying share. The licence of the company will be subject to the maintenance of an efficient service. Towards the expenses of the broadcasting company, the Post Office will contribute a portion of the licensing fees paid for receiving sets, and a further contribution will be paid out of the purchase money on each set sold by the manufacturers.

Experimental Station Design

Continued from p. 585, August 5th, 1922.

These articles, which will appear in alternate issues, are intended not only to be a complete guide to those new to wireless, but to give explicit details on the construction of all the components of the experimental station. Actual designs will of necessity in some instances be somewhat crude, in order that they may be made up without elaborate workshop equipment. Practical working instructions will be given where necessary for the help of those unacquainted with the more simple processes of instrument making. Of course, where good workshop facilities exist, the designs may be readily modified.

Economy is made an essential feature, bearing in mind always that where low-priced component parts can be obtained their use has been embodied in the designs. For those who do not desire to make their own apparatus, the descriptions will assist them in selecting the equipment for their stations.

The information contained in the first few articles under this heading is to help those new to wireless and whose first aim is to build a simple set capable of receiving broadcasted telephony and consequently may cover ground already familiar to many readers. The succeeding instalments, however, will advance by easy stages, and in the course of the series the construction of an elaborate station will be evolved.

X. LOW FREQUENCY INTERVALVE TRANSFORMER.

As a step in the construction of a note magnifying unit a design is required for the intervalve transformer, and the following materials will be required.

Polished ebonite sheet $2\frac{1}{8}$ ins. by $4\frac{1}{4}$ ins. by $7/16$ in., 1 lb. No. 22 S.W.G. soft iron core

end pieces. Two circles, each 1 in. radius, are marked on the ebonite with dividers, and the ebonite sawn in two. The four corners of each piece are then cut away, going to within $1/16$ in. of the line. If a lathe is available the next step will be to drill the holes

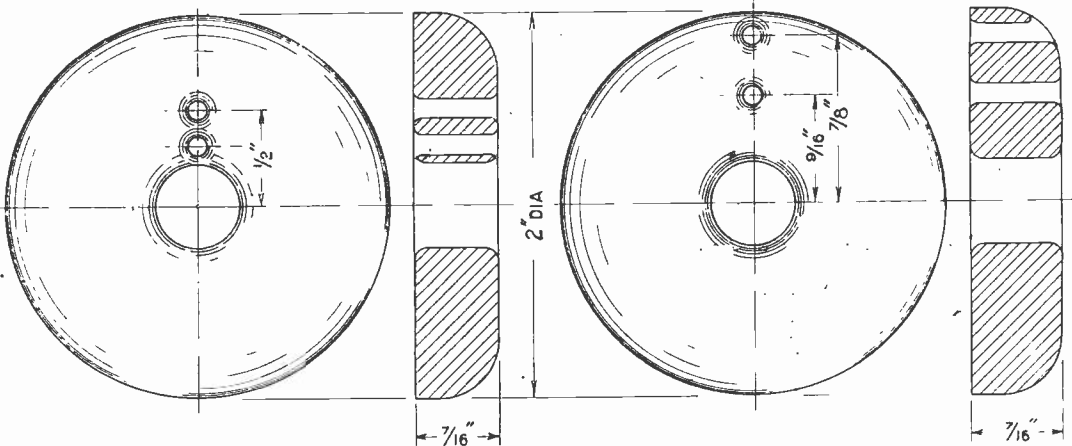

Fig. 1. Ebonite end plates with rounded corners.

wires in $9\frac{1}{2}$ -in. to 10-in. lengths, a piece of black fibre 6 ins. by 12 ins. by $1/32$ in. in thickness, two 6 B.A. by $\frac{1}{4}$ in. round-headed brass screws with nuts, 5 ounces No. 46 S.S.C., a small piece of scrap hard brass sheet about 18 S.W.G., odd pieces of silk ribbon and a few feet of insulated wire, 28 to 34 S.W.G., 12 ins of empire cloth 6 ins. wide.

The first step is the construction of the

in the centres and mount the two pieces on a spindle for turning down to size, and at the same time rounding the edges as shown in Fig. 1. Without a lathe, however, it is quite easy to file accurately down to the scratched circle. Having done this, set the dividers to $\frac{7}{8}$ in. and make another circle on one side of each piece. Again resetting the dividers to $\frac{1}{8}$ in., rest one leg just on to the

face on which this circle has been made and run a scratch line round the edge. This gives two scratch lines, one round the outside edge and another as a circle on the face. Carefully file away down to these lines, thus making a bevel. Having gone accurately to the line and so constructed a new face of equal width all the way round, remove the sharp edges as shown in the sectional drawing in Fig. 1. The hole can now be made through the centre, and if a hand brace is to be used, it is advisable to put a small hole through first, followed by the $\frac{7}{16}$ -in. drill. Two other holes are made in each piece for the leads at the positions shown. All of these holes are rounded, the small ones with the

slightly moistened with oil to prevent rusting. With a little care it is easily possible to securely fix the end discs in position on the core.

This being done the core is wrapped twice round with empire cloth. It should be cut to about $2\frac{3}{16}$ ins. in width, and tiny cuts nearly $\frac{1}{8}$ in. deep made at intervals of $\frac{1}{16}$ in. long. This will facilitate the edges spreading and building up against the ebonite, and so obviating the possibility of the primary winding pulling down in contact with the core. For the purpose of providing a short flexible lead three strands of instrument wire of about 30 S.W.G. are twisted together. One wire is left about 6 ins. longer than the other two, and at the point where the two terminate, the

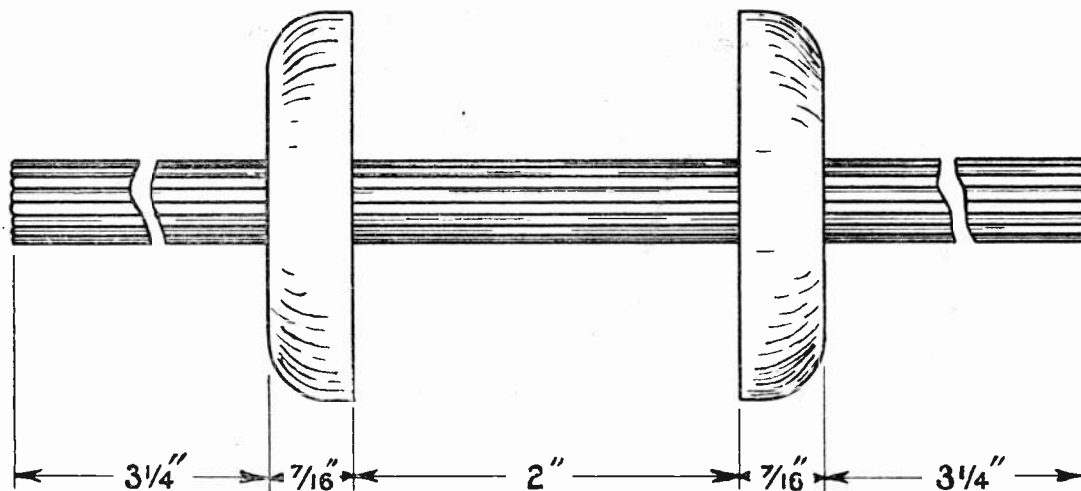

Fig. 2. The core, consisting of soft iron wires, with ebonite end plates securely wedged in position.

point of a large drill and the large ones either with the point of a drill or a rose bit. The small holes are slightly drilled out at both ends to prevent damage to the wires. It is advisable also to run a fine file lightly and evenly round the sharp edges of the discs to prevent the very fine wire with which the transformer is wound from becoming damaged should it come in contact with the end pieces during winding.

The end pieces are now mounted on a bundle of core wires (Fig. 2), and it is most important that all wires shall be perfectly straight and parallel. Should there be any crossing over of wires in the core the ends may become slack when the wires are bent round. It is advisable that the wires be

longer wire is scraped bare of insulation and twisted with the bared ends of the two shorter pieces. The joint should be soldered by using a little resin as flux, and with the tip of a well tinned iron. The end of the long wire is joined to the end of the wire with which the transformer is to be wound, taking very great care not to burn or overheat this fine wire.

Winding is somewhat difficult for the man not in possession of a lathe, but with a little patience the winding can be successfully accomplished with some improvised arrangement. As a suggestion the core wires may be mounted as a spindle in upright wooden bearings. To prevent friction on the wood causing the wires to grip and so displacing

them, they should be wrapped very tightly with a piece of 22 gauge brass sheet at the bearing points. A driving handle can be made from a strip of ebonite with hole and slot for gripping the core wires to the design shown on p. 584, August 5th issue. A $3/16$ in. brass rod fixed through this with nuts will serve to revolve the arm and spindle. The reel from which the wire is being unwound must be carefully mounted so as to turn quite easily, or otherwise the wire will not be sufficiently strong to revolve it. If the winding is being done in the lathe the reel must be particularly free and should be plugged with a rod with pointed ends which run in

Fine wires such as are used for winding low frequency transformers should not be purchased in reels carrying more than 4 to 5 ounces, or great difficulty will be experienced in unwinding owing to the momentum which a heavy reel will gather as it spins.

The primary is wound on up to a diameter of $13/16$ in. This can be measured by means of callipers, but care must be taken not to damage the wire by sharp edges. Kinks must be avoided, and should breaks or kinks occur a joint must be made by cautiously twisting the ends together and lightly soldering, wrapping the joint with a piece of thin silk before continuing. The wire must be wound

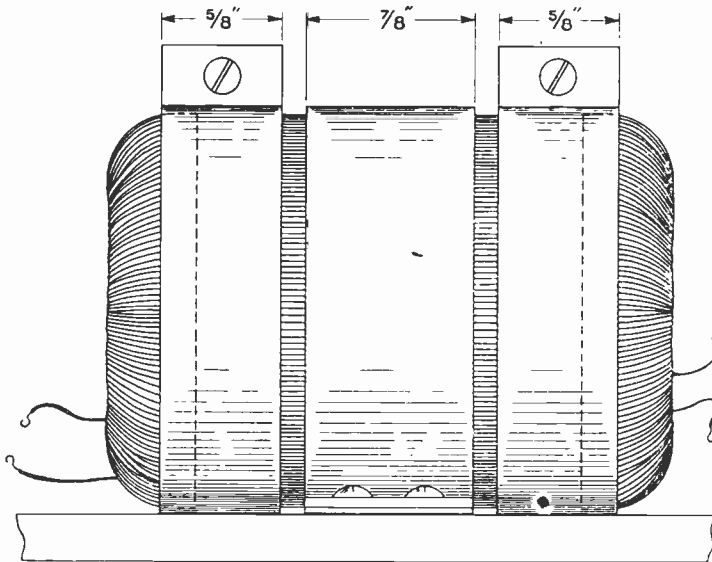

Fig. 3. Side view of finished transformer. The dotted lines indicate the position of the ebonite ends.

holes in the ends of screws. When a stop is made during winding the reel should not be allowed to revolve on with impetus it may have gathered. Care is also necessary when starting, by not attempting to make the reel suddenly revolve rapidly. Start slowly, and gently speed up and steadily slow down before stopping. These difficulties do not apply when hand winding, but one must be careful not to turn with a jerky motion. When winding by hand a smooth brass rod through the centre of the reel will usually provide a bearing without too much friction.

on evenly by slowly running from end to end in order to avoid any comparatively big difference of potential between consecutive turns. On completing the primary it should be tested for continuity with a milliammeter or delicate galvanometer and a four-volt battery.

Three layers of empire cloth with frilled edges are wrapped over the primary winding to thoroughly insulate the two windings from one another and form a good bed for the secondary. One end of the empire cloth is held in place with the leading out wire of

the secondary, whilst the other end must be tightly tied off with another piece of wire to prevent the empire cloth springing open before sufficient turns are put on to hold it down. This latter piece of wire must of course be removed, and on no account buried in with the winding. The secondary is wound on up to a diameter of $1\frac{3}{4}$ ins., and more care is needed than when winding the primary owing to the increased diameter and consequently higher speed at which the wire runs from the reel to bobbin. On completing to the required diameter the winding is wrapped with empire cloth of exact width to fit between the cheeks without turning up at the edges. A single layer of thread put on over the empire cloth will hold it down and entirely protect the wire.

Next a strip of fibre is cut to the exact width between the ebonite end pieces and yet not so tightly fitting as to force them apart, for it must not be overlooked that there is a great danger of breaking the winding if the cheeks bend outwards at all or move on the cores. The fibre is wrapped round and tied off at

each end with thread. This piece of fibre is for keeping the end pieces perfectly spaced and for preventing them crushing in as the core wires are bent round.

The core wires must now be spread out from a point at the exact centre at either end and bent down evenly all round and interlaced. Figs. 3 and 4 are sufficiently indicative of what has to be done and it is quite worth while making an effort to get all wires evenly distributed and free from bends other than at the centre and edges of the end pieces. Bends once made in the soft iron wires are hard to remove.

The wires should reach just beyond the

ebonite pieces, on which their ends should rest, and are held in position by means of two fibre bands which should be placed over the wires so that they clamp them down on to the ebonite discs and completely hide the free ends. To give strength to the joint in the fibre bands small brass plates are made which are clamped together with the 6 B.A. screws and nuts.

The transformer is held to its base with another band of fibre, and it is advisable to mount the transformer permanently on a wooden base, holes in the corners of which serve for fixing to bench or panel.

This transformer has a turns ratio of approximately 1:2, and a resistance ratio of 1:4. Although in transformer design higher ratios

are sometimes used, frequently no better results are obtained owing to insufficient primary turns. A 1:1 transformer with an efficient primary winding will give far superior results to a 1:4 transformer which has not sufficient primary turns.

The direction in which the windings are connected up in the amplifying circuit is important, first in order to get the right direction of potential fluctuation to the grid of the valve connected to the secondary, and secondly to obtain the correct capacity coupling between the two valves and making use of the capacity between primary and secondary windings. Both windings are put on in the same direction. The beginning end of the primary is marked "I.P.," and the finishing end "O.P.," the beginning end of the secondary "I.S." and its finishing end "O.S." "I.P." is taken to H.T. +, "O.P." to plate, "I.S." to grid and "O.S." to L.T.—.

F. H. H.

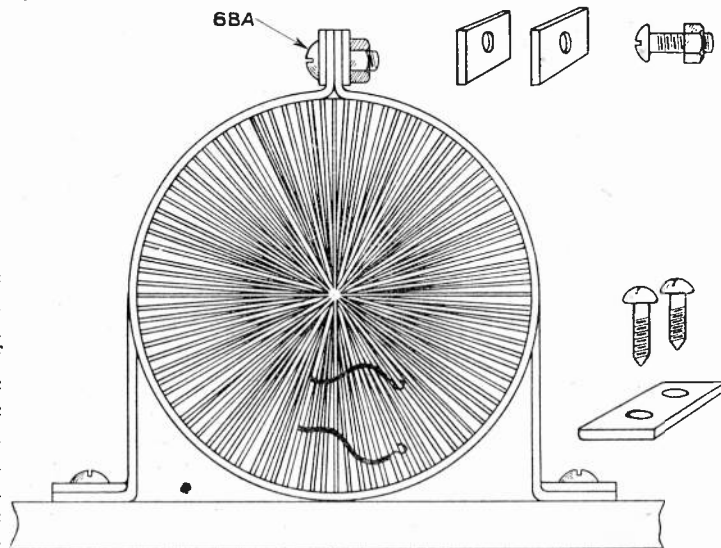

Fig. 4. End view of Transformer when mounted.

Notes

Imperial Chain Station at Bourne.

Proposals have been made to erect near Spalding, Lincolnshire, a transmitting station to operate as a link in the Imperial Chain. Its receiving station will be at Banbury.

Eight steel masts, each 800 feet high, will support the antennæ at Bourne. The masts are designed to take a horizontal pull of ten tons at the top and a wind load of 60 lbs. per square foot. They will form a square with the station in the centre.

Thermionic valve sets are to be installed, capable of transmitting continuously 90 words a minute in direct communication with Poona, Johannesburg and Perth (Australia).

At Banbury the new station is to be built on similar lines to the one now in existence which receives for Leafield.

If the above proposals are carried through, Bourne will be the largest station in this country.

Special Arrangements for Aviators.

An Air Ministry notification to airmen states that when meteorological and wireless facilities, in addition to or different from those normally available, are likely to be required, either: (a) for a special individual flight; or (b) for regular services on new routes; or (c) through changes in the routine services of aviation companies operating on recognised air routes, particulars should be forwarded (marked URGENT) to the Director of Civil Aviation (Room 550), Air Ministry, Admiralty House, Kingsway, W.C.2.

In case (a) one week's notice should be given, with full particulars of the route, the proposed date and time of flight, and of the W/T or R/T equipment of the aeroplane.

In case (b) the period required for making any necessary arrangements before the commencement of the contemplated service will vary according to circumstances, but the necessary details should be supplied as early as possible.

In case (c) at least 48 hours' notice (Sundays excluded) of proposed changes should be given.

Dutch Concert.

Authority has been given by the Dutch P.M.G. for Concerts to be broadcast from PCGG, The Hague, on 1,300 metres when the new aerial is erected toward the end of this month.

Until August 20th, by reason of the *Daily Mail* assistance, transmission will take place from 8.40 to 9.40 B.S.T. nightly, in addition to the present programme, and the power has been increased to 1 k.W.

Suggested Association for Ireland.

We have received a letter from Mr. H. L. Fletcher, Mona, Shankill, Co. Dublin, who states that having obtained permission from the authorities he is desirous of forming a Wireless Association for Ireland. He would be glad to receive communications from likely members, and secretaries of existing clubs.

Sainte Assise Opened.

Near the Forest of Fontainebleau, less than 30

miles from Paris, the largest station was opened at St. Assise, Melun, on August 7th. Although only one transmitting plant out of four is at present in operation, the other three are expected to commence work in a few weeks.

There are 17 masts, each 800 feet high, and when the station is in full working condition it is hoped to transmit 500 to 600 words a minute by sending five or six messages simultaneously.



Miss E. Scarborough, of Messrs. Scarborough, Mitchell & Co., who won a prize for the very latest in carnival costumes. She went to a ball as "The Wireless World."

An Amateur Station at Guildford.

The telephony from 2 HX is familiar to amateurs in the Guildford district. The power used for transmission is only 4 watts and so the range is not very wide. Power for the valve is taken from a 600-volt generator, hand-driven, located under the bench, and the system of modulation is by grid control. Receiving side consists of detector valve, followed by two L.F. amplifiers. Tuning is accomplished by means of a set of lattice coils described by Mr. Philip Coursey, in the *Wireless World*, in December, 1920.

By kind permission of the Postmaster-General, much experimental work has been carried out on the low power, also a good deal of local demon-

APOLOGY

"IMPORTANT PUBLIC WARNING"

We regret that in the advertisement columns of our issue of the 12th August we inadvertently published a statement under the above heading which we now realise was a very injurious one to the forthcoming Exhibition of the Radio and Wireless Exhibition and Convention which is to be opened at the Central Hall, Westminster, on September 2nd.

We desire to express our regret at the inaccuracy of such advertisement and for any injury or damage occasioned.

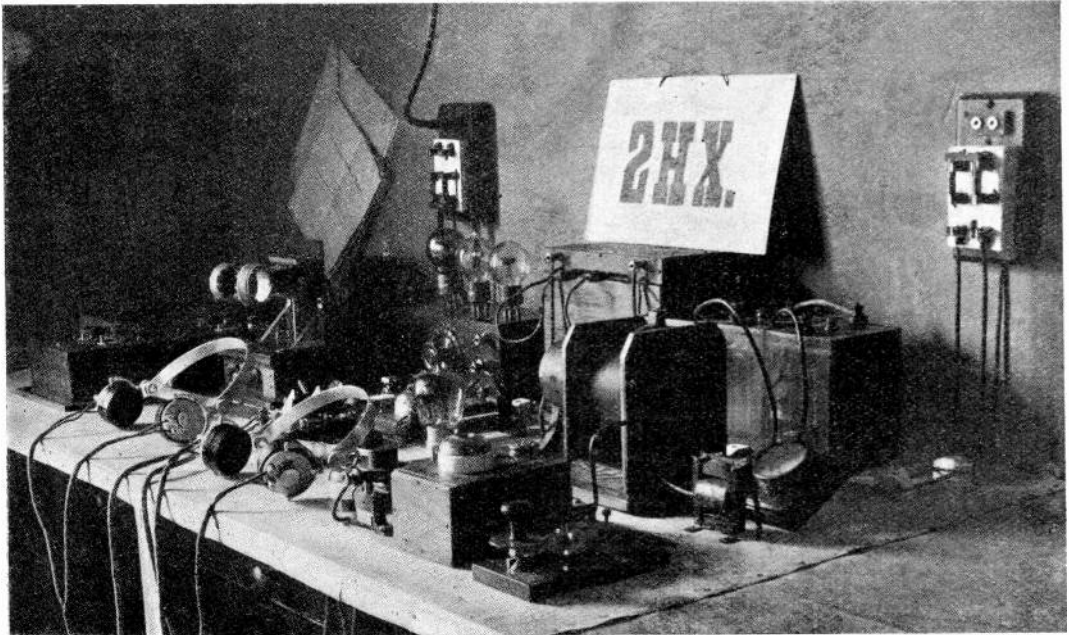

2 HX, an Amateur Station at Guildford.

stration work. Signals have been reported as good from stations as far as 35 miles away.

Most of the apparatus is home-made by Mr. F. A. Love, and seems to be fairly efficient, besides having provided many happy hours in the construction.

Ramsgate's First Concert.

The first wireless concert at Ramsgate was held a few days ago at a fête in Ellington Park.

Mr. F. Harrison, of Rochester Cottage, High Street, St. Lawrence, who is an enthusiastic amateur, is making an effort to form a local society.

A Tuner for All Wavelengths.

In our issue dated July 29th, on page 543, a paragraph commencing "The A.T.I. Section," at the bottom of the right-hand column should precede the paragraph above it commencing "For the purpose of tuning."

Australian Wireless Service.

It is stated in the *Commonwealth of Australia Gazette* that the control of wireless service in the Commonwealth has been transferred from the Postmaster-General to the Prime Minister "with such of the existing staff as the Prime Minister may require for the economic and efficient working of the service." The Wireless Telegraph Act, 1905-1919, is now administered by the Prime Minister as from June 1st, 1922.

Sale of Apparatus.

A Committee of the Council of the Electrical Contractors' Association is investigating the subject, from the contractor's point of view, of whose business it is to sell and equip receiving stations. So far the Association thinks that if complaints and disappointments are to be avoided the business should remain in technical hands.

Correspondence

Freak Reception.

To the Editor of THE WIRELESS WORLD
AND RADIO REVIEW.

SIR,—I note in the July 29th issue of your paper a letter from Mr. Stevenson with reference to harmonics from EAB. I have had the same effect from EAA (Aranjuez) calling POZ. The wavelength would be somewhere about 350-400 m. I could not be certain, as I took no notice of it at the time. In this case I did not tune to the fundamental wavelength at all, but the signals were quite clear and readable, using 1 rectifier and a L.F. note magnifier.

Curiously enough, these effects were received at about the same time as with Mr. Stephenson—about 2200 B.S.T. I do not know if the effect is due to this particular period at night. I too have noticed that the French coastal stations come in very strongly about this time—recognisable by the call beginning with "F," and have often had GRL jammed out by them.

Is there any explanation for this "freak" reception?

COURTNEY DRUMMOND.

2 PF Heard on Indoor Aerial.

To the Editor of THE WIRELESS WORLD
AND RADIO REVIEW.

SIR,—It may interest 2 PF to know that I received his music and read his speech here in Leicester, using three valves, and an indoor aerial; horizontal part nine feet long and lead to instruments five feet long.

He was working to 2 FN on Sunday, July 30th, at 1845 hrs. G.M.T. 2 FN comes through much louder, of course, by reason of his position.

The aerial is about eighteen feet from ground level, in the centre of the town, and close to the electric traction routes.

T. S. SKEET.

Leicester.

The Reinartz Transmitter.

To the Editor of THE WIRELESS WORLD
AND RADIO REVIEW.

SIR,—I am pleased to note the interest of *The Wireless World and Radio Review* in the circuit arrangements of Mr. John L. Reinartz which has been presented through *QST*. As the author of this article in June *QST*, which is reproduced on pages 447 and 448 of your issue of July 8th, however, may I point out an error in your Fig. 1? The choke coils as shown in *QST* were radio chokes, but in your diagram you have shown them with iron cores, which is incorrect. The one in the anode supply is to prevent the radio frequency oscillations from by-passing through the source of power and as nearly as possible should be resonant to the oscillating frequency. The choke in the grid lead is the customary very small inductance which American amateurs use in power tubes for the purpose of choking out parasitic oscillations at an

ultra-radio frequency. Such a choke may well consist of about 20 turns of wire on a $\frac{1}{2}$ -inch form. Their use is desirable only when a multiplicity of tubes is used in parallel.

K. B. WARNER.

The American Radio Relay League.

Calendar of Current Events

Sunday, August 20th

Transmission of *Daily Mail* Concert from 2.30 to 5 p.m. and from 8 to 9 p.m. on 1,085 metres by PGGG The Hague, Holland.

PADDINGTON WIRELESS AND SCIENTIFIC SOCIETY. Field Day.

Tuesday, August 22nd

Transmission of Telephony at 8 p.m. on 400 metres, by 2MT Writtle, near Chelmsford.

Thursday, August 24th

Transmission of *Daily Mail* Concert at 8 to 9 p.m., on 1,085 metres, by PGGG The Hague, Holland. ILFORD AND DISTRICT RADIO SOCIETY.

At St. Mary's Hall, High Road, Ilford. Lecture on "Short Wave Reception, with Special reference to Damped Waves," by Mr. E. E. Hale.

Tuesday, August 29th

Transmission of Telephony at 8 p.m. on 400 metres by 2MT Writtle, near Chelmsford.

Wednesday, August 30th

SOUTH SHIELDS Y.M.C.A. WIRELESS SOCIETY. 7.30 p.m.—Fowler Street. General Meeting.

Thursday, August 31st

RADIO EXPERIMENTAL ASSOCIATION, NOTTINGHAM AND DISTRICT.

Meeting.

WEST LONDON WIRELESS AND EXPERIMENTAL ASSOCIATION.

At Belmont Road Schools, Chiswick, W. First meeting after vacation.

CROYDON WIRELESS AND PHYSICAL SOCIETY. Meeting.

Eastbourne College Wireless Club.

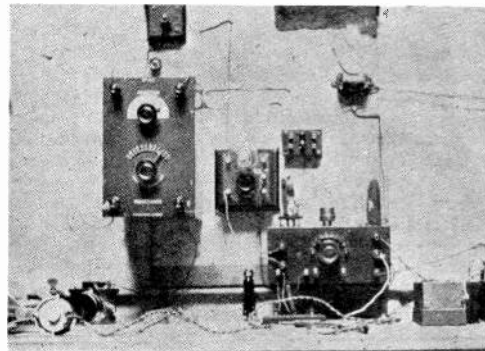

Eastbourne College Receiving Set.

The Club whose apparatus is shown above, holds its meetings on Tuesday evenings. It has fifteen members. Next term the Club hopes to obtain a transmitting licence.

Wireless Club Reports

NOTE.—Under this heading the Editor will be pleased to give publication to reports of the meetings of Wireless Clubs and Societies. Such reports should be submitted without covering letter in the exact form in which they are to appear and as concise as possible, the Editor reserving the right to edit and curtail the reports if necessary. The Editor will be pleased to consider for publication papers read before Societies. An Asterisk denotes affiliation with the Wireless Society of London.

Derby Wireless Club.*

Hon. Secretary's address, "The Limes," Chellaston, Derby.

In a series of eight lectures, extending over the last twelve months, Mr. E. Fowler Clark, B.Sc., B.A., A.M.I.E.E., has described the results as progressively obtained, of a very thorough mathematical and experimental investigation of the behaviour of an ordinary hard three-electrode thermionic valve as applied to radio reception.

As a preliminary, the first lecture consisted of a description of up-to-date ideas of charges, direct and alternating currents, unilateral conductivity, potential, electric and magnetic strains, energy transformations, ether waves, and electronic emissions from hot bodies, in terms of the electronic nature of electricity and of the atomic constitution of matter.

The second lecture dealt with inductance and capacity, the various arrangements of tuned aerial receiving circuits, types of transmitted waves and received oscillations and impulses and the utilisation of the maximum induced alternating potential to actuate detecting devices, also with the advantages of the closed secondary oscillatory circuit.

Mr. Clark then proceeded to describe, with the aid of a series of very carefully taken experimental curves, the various characteristics of the two and three-electrode hard valves and the methods by which, utilising suitable features of these characteristics, the rectification effect necessary to convert intermittent radio oscillation trains into audio-frequency telephonic impulses could be obtained, coupled in the second instance with amplification. Bend and grid leak condenser rectification were considered in detail and particularly the effects of experimentally varying the applied anode and grid potentials.

Following this, and as a preliminary to the consideration of the valve receiving circuit with loaded anode circuit to which it is analogous, an alternating current circuit consisting of inductance and capacity in parallel, supplied from an alternator through a resistance, was considered. The changes occurring in the magnitudes and phases of the total and branch currents as first the inductance and then the capacity in the circuit is increased, under the action of the alternator P.D. or that impressed on the grid, as the case may be, were illustrated by means of a vector circle diagram, attention being drawn to the cases of tuning and over-tuning of the varied (anode) circuit.

Reception of spark transmissions on a tuned anode circuit with crystal rectification and no reaction, on the above principle, was then referred to, after which Mr. Clark diverted to describe, with the aid of distributed diagrams, his circuit arrangements, by which nearly the whole of the

experimental portion of his investigations could be carried out by switching only.

The principles of electro-magnetic and electro-static reaction, by which the anode circuit current and voltage respectively are utilised via suitable inductive or capacity coupling to inject into the grid oscillatory circuit assisting components of voltage and current, were then indicated, and, on a straight line valve characteristic and zero grid current basis, the phenomena associated with changes of the variable quantities, including those relating to the limits of oscillation, which had been arrived at mathematically and confirmed experimentally, were pointed out.

Finally, Mr. Clark described, with the necessary explanations, the results of experimental work on the production of the oscillation with various values of grid and anode potential, also of grid leak potential in the case of the grid leak, indicating the conditions in which the phenomenon known as "overlap" would occur.

Mr. Clark consented to give further lectures, describing from time to time his further experiments as they progress.

Hounslow and District Wireless Society.*

Hon. Secretary, Mr. A. J. Rolfe, 20, Standard Road, Hounslow.

On Saturday, July 22nd, a demonstration was given at the Isleworth Hospital Fête, all members assisting in erecting the apparatus and aerial. Special permission was obtained from the P.M.G. enabling Lieut. Walker (2 OM) of Brentford, to transmit music. This he did in his usual style. Everything went off well and a good sum was handed to the Hospital Fund.

On Thursday, July 27th, a public demonstration was arranged at the Council House. This being the first night of the *Daily Mail* broadcasting from Holland, nearly 700 people were present and reception was very good indeed, except for the usual interference. Afterwards, Lieut. Walker gave a very stirring address to the audience, pointing out the Society's work in the district, and stating further that after the success that evening in receiving the Hague concert, support was desired more than ever. He also promised to transmit when he got home. This he did at 9 p.m. His music was extremely loud and was heard in the street on the Society's Brown H.I loud speaker. Councillor W. J. Heath, J.P., chairman for the evening, received a message transmitted for his special benefit by Lieut. Walker, and enjoyed the experience as much as the audience. At 9.30 p.m. the Society's first public demonstration closed down.

On Saturday, July 29th, another demonstration was given at the Hounslow Hospital Fête. Lieut. Walker again obliged, and at 9.10 p.m. Marconi House (2 LO) was picked up, where a local singer

was performing. This demonstration went off without any trouble and a further good sum was handed to the Hospital.

The members are well pleased with a brisk week's work. If any gentleman would care to join the Society, he should write to the Secretary.

Stoke-on Trent Wireless and Experimental Society.*

Hon. Secretary, Mr. F. T. Jones, 360, Cobridge Road, Hanley.

At a meeting of the Stoke-on-Trent Wireless and Experimental Society, held on Thursday, August 3rd, it was decided to admit the members of the Y.M.C.A., in whose building the Society have made their headquarters, at a reduced annual subscription.

A Committee meeting has been called, to hurry forward as rapidly as possible the erection of the aerial and the fitting up of the new club-room to suit the Society's needs. It is hoped to have everything ready by the end of the month, and to have a formal and probably public opening.

The Gloucester Wireless and Scientific Society*

Hon. Secretary, Mr. G. T. Peck, 45, Denmark Road, Gloucester.

At a meeting held at headquarters on July 3rd, Mr. B. T. Gowing demonstrated with a two-valve set of original design. The resistance-capacity circuit used—the outcome of much experimental work—worked well over all wavelengths, even as low as 300 metres, and Mr. Gowing seems to have overcome the usual drawback of the resistance-capacity circuit, i.e., inability to work below 1,000 metres. During the course of the evening some very good signals were obtained on the club's aerial.

At a meeting of the Society on July 31st, Mr. C. Minchin gave a second lecture on "Dynamos." This proved to be very interesting, the lecturer producing several formers and coil-winding machines used in the manufacture of dynamos.

Although during the summer months the Society's activities have been somewhat curtailed, it is hoped that anyone interested in amateur wireless will communicate with the Hon. Secretary, who will be pleased to answer all enquiries at the above address.

Ilford and District Radio Society.*

Hon. Secretary, Mr. A. E. Gregory, 77, Khedive Road, E.7.

At the request of several of the members, Mr. E. E. Hale had prepared a lecture on "Don'ts." This he delivered on Thursday, July 13th, with his customary vigour and in a systematic manner, commencing with the aerial and working through the set to the telephones, emphasising the things that an amateur should not do under any circumstances, and criticising the experiments that, while permissible, are from a beginner's point of view best left alone. The discourse proved most informative without being redundant in any way, and was greatly appreciated.

Mr. A. J. Thompson lectured on Thursday, July 27th, and demonstrated "Aerials, Earths and Wiring." The lecturer condensed his information exceedingly well, and his explanations of the different types of aerials in use with their respective merits and demerits were of high value.

By the courtesy of the Electrical Engineer to the L.C.C. Tramways, who had kindly provided

the Society with the necessary permit, a party of members were enabled to pay a visit to the Council's generating station at Greenwich on Saturday, July 29th. A guide took the party round, and the visit proved an afternoon's thorough enjoyment. The active membership of the Society is steadily increasing, and now stands at 52, nearly all of whom have receiving permits, while there are eleven transmitting licences including the two possessed by the Society itself.

The Society's latest step on the road of progress is the completion of affiliation to the Wireless Society of London.

Wireless and Experimental Association.*

Secretary, Mr. Geo. Sutton, A.M.I.E.E., 18, Melford Road, S.E.22.

The meeting on Wednesday, July 26th, was very well attended, and general queries were very fully dealt with for the edification of the newer members. The Chairman started a very interesting discussion on multiple aerials, and aerials used multiply. That involved finding out what would happen were several aerials in close proximity used at the same time on the same wavelength, and how interference could be prevented by having their ends connected together, thus forming parallel oscillatory circuits which, if oscillating, would do so at a common frequency. Mr. Voigt followed up by describing what would happen in almost every possible arrangement of three stations working near each other on the same, separate and connected aerials. Most of the points, although not practicable for the amateur, were of exceptional interest.

On Wednesday, August 2nd, the application and advantages of two-slide inductances over single slide inductances was explained. The Chairman then described practically every practicable form of detector, giving useful information for the handling and use of the multitudinous combinations of crystals and pointing out as far as possible how each may be identified. A competition was announced for the best wireless gadget. No limits were placed, except that it had better be some little valuable article.

Communications and enquiries to the Assistant Secretary (Mr. W. J. Joughin), 21, Troughton Road, Charlton, S.E.7.

Lion Radio Club, Shoreditch.

Hon. Secretary (pro tem.), Mr. A. V. Turner, 35, Aske Street, Pitfield Street, N.1.

The above club is in the course of formation and the Secretary would be glad to hear from amateurs in the district who are likely to become members. He would also welcome catalogues and literature which might be of interest to the members. Intending members should write or call at the above address.

Otley and District Wireless Society.

Hon. Secretary, Mr. Y. C. Weston, 24, Guycroft, Otley, Yorks.

On August 3rd, at 7.30 p.m., the second meeting was held at the Café, Queen's Hall, Otley.

After the minutes of the last meeting had been read and passed, two lectures were given. Mr. N. Weston lectured on "Electrostatics," and Mr. Deay lectured on the subject of "Signalling."

Several new members were enrolled. A further meeting was held on August 17th.

The North Essex Wireless Society.

Hon. Secretary, Mr. F. T. Smith, Headquarters, 15, Rayne Road, Braintree.

A field day was arranged for August Bank Holiday for members, at Mr. Lagden's station, (St. Leighs). The object of the experiments was to prove to those possessing reaction circuits exactly what an amount of local interference their misuse caused.

Using the above gentleman's station as a base, a temporary station was erected about 300 yards away. The result was that those present were able to learn how to reduce their re-radiation to a minimum. As a forcible proof to those who might have been careless about tight-coupling, a microphone was placed in the anode circuit of one receiver and both music and speech were received clearly and loud in the other receiver. Single valve sets were used in both cases, and it is thought that by mutual agreement, arrived at through these experiments, there will be much less local interference in the district. At the conclusion Mr. Lagden kindly entertained the members of the Society to tea and was accorded a hearty vote of thanks for his kindness. Before leaving, music was transmitted by 2 ZV, and this concluded a highly successful and satisfactory day.

Southampton and District Wireless Society.

Hon. Secretary, Mr. T. Cutler, 24, Floating Bridge Road, Southampton.

A meeting of the above Society was held on July 26th at the Assembly Rooms and a pleasant evening was spent.

The members of the Society did exceedingly well with their amateur constructed sets in receiving the broadcasted concerts from the Hague on July 27th. The best attempt to hand is that of Mr. Lush, of Fitzhugh, Southampton. Using a four-valve L.F. constructed set he was able to hear the whole of the concert all over the large room without the aid of a loud speaker. Mr. Lush states the music was louder than FL, which goes to show the excellent results obtained. Congratulations from all the members of the Society are offered to Mr. Lush.

A further meeting, held on Wednesday, August 2nd inst., resulted in one of the largest attended meetings of its members yet recorded. As members are steadily increasing, great things are being looked forward to during the winter. It has not yet been definitely decided to engage the present club-room for a further period of six months as it is hoped to obtain another room. Therefore, the improvement of the club aerial is at present at a standstill.

The following were elected as members on July 27th and August 2nd:—Col. Neade, Messrs. Bovey, Southard, Smith, Hirst, Dickenson.

All amateurs in Southampton and district can be supplied with particulars of the Society on application to the Secretary.

The Hornsey and District Wireless and Model Engineering Society.

Hon. Secretary, Mr. H. Davy, 134, Inderwick Road, Hornsey, N.8.

On Tuesday, August 1st, 1922, a successful meeting was held at 29, Felix Avenue, Weston Park, Crouch End.

A two-valve resistance-capacity set was tried out

and the reception of C.W. and spark signals was loud and clear.

Also a one-valve set was demonstrated and music and telephony from several amateur stations were listened to with interest, including 2 MT, who are to be congratulated on their splendid transmission.

Several new members were enrolled and others are heartily welcome. All particulars from the Hon. Secretary.

Clapham Park Wireless Society (Embracing Streatham Hill, Balham, and Tooting Districts).

Hon. Secretary, Mr. J. C. Elvy, 3, Fontenoy Road, Bedford Hill, S.W.12.

A very successful inaugural meeting was held under the chairmanship of Mr. J. C. Elvy, A.M.I.E.E., etc., Consulting Electrical Engineer, at the Studios, 67, Balham High Road, which were graciously lent for that purpose by Mr. M. P. Prout, Cantab., at 8 p.m. on August 1st, 1922.

After a brief conversazione, the fifteen present, namely, Messrs. J. Gray, C. A. Griffiths, W. W. Millar, M. P. Prout, J. C. Elvy, A. E. Redburn, W. Brierley, R. H. J. McCue, H. R. Knott, H. E. Austin, A. L. Beedle, R. McCue, F. H. Austin, V. L. Natusch, R. O. Rippon, sat down to business. Mr. J. C. Elvy was elected Hon. Secretary. Mr. M. P. Prout was elected Hon. Treasurer. Elected to serve on Committee:—Messrs. J. Gray, W. Brierley, A. L. Beedle, R. H. J. McCue.

In furtherance of an endeavour to secure a representative of each sub-district to facilitate future organisation, further nominees may be selected for Streatham Hill and Battersea portions of area concerned.

The next item dealt with was a suitable title for the club. The proposed word "Scientific" was omitted as it was agreed that the abbreviated title would not preclude dealings with other subjects should members so desire on occasion. The decision therefore is as above.

It was decided to hold meetings every Wednesday at 7.30 p.m. in winter, and alternate Wednesdays in summer at 7.30 p.m., i.e., fortnightly up to September 30th next, the next meeting being fixed for August 9th.

The question of subscriptions arose, Mr. M. P. Prout generously offering to extend the loan of the premises till further notice, and after discussing varying rates for juniors and seniors, it was provisionally decided that the subscription be 7s. 6d. annually, payable in advance, as from August 1st of each year, and within one month. Entrants in last six months of the year to pay 4s. subscription, to carry them up to following July 31st. All entrants after the first fifty enrolled to pay 2s. 6d. entrance fee in addition.

After a hearty vote of thanks had been accorded to Mr. M. P. Prout for material assistance rendered by allowing use of his studios as provisional headquarters; also to Mr. J. Gray for offering to institute buzzer practice as an appetiser at 7.30 p.m. each meeting; and to the Chairman for so ably conducting the Society through its initial stages, to which suitable references were made, the meeting was brought to a close at 9.30 p.m.

The question of aerial and other equipment for the Studios, has already been touched upon.

Aberdare and District Wireless Society.

Hon. Secretary (*pro tem.*), Mr. J. Owen Lewis, Altyblacca, Danyderi Street, Godreanan, Aberdare.

A meeting of wireless enthusiasts of the Aberdare Valley was held at the Cwmaman Public Hall on Thursday, July 27th, when it was unanimously decided to form a Society under the above name.

Mr. A. E. Hay ((2 KG), of "Glendale," College Street, Aberdare, was elected to the chair, and under his able guidance, a very profitable evening was spent. A membership of nineteen was registered, but in view of the fact that about 18 to 20 prospective members were unable to attend, it was decided to hold an official inaugural meeting at a later date.

In the meantime Mr. Hay, Mr. J. Owen Lewis, Mr. Parry and Mr. Duffy were appointed to act as Chairman, Hon. Secretary, and a committee of two, *pro tem.*, until the first official meeting, which is to be held in Aberdare on Thursday evening, August 10th, at 7 o'clock.

The Society is extremely fortunate in having secured the active interest of Mr. Hay, who, as the founder of the South Wales Wireless Society, is well known as the pioneer of amateur wireless work in Wales, and who has achieved some records in amateur transmission.

The Society has been offered the use of an excellent lecture hall in the main thoroughfare of Aberdare, and it is anticipated that the meeting which will be held there on August 10th will be very successful, as at the beginning of August upwards of fifty applications for membership are to hand, and all local electrical workers are keenly interested in the new society.

A vote of thanks was tendered to Mr. Ray of the Cwmaman Public Hall for his kindness in having placed a room free of charge at the disposal of the meeting.

Candidates for membership can obtain all particulars from the Hon. Secretary.

Walthamstow Amateur Radio Club.

Hon. Secretary, Mr. R. Cook, 49, Ulverstone Road, Walthamstow, E.17.

A most successful wireless demonstration was given on July 25th at the Club headquarters, Y.M.C.A., Church Hill, Walthamstow.

Over 400 were present and greatly enjoyed the short lectures given by Mr. Oswald Carpenter (Research Dept.), of the Marconi's Scientific Instrument Company, Ltd., and also the music which was received from various sources. Mr. Carpenter informed the audience that this was the first demonstration of the "Magnavox" loud speaker and the "Magnavox" power amplifier before an English wireless society.

Several times during the various items of music Mr. Carpenter had to shut down owing to the jamming from various inexperienced amateurs in the neighbourhood.

2 MT, who gave us a special call, came through very loudly and distinctly, and could be heard with ease all over the large hall.

Mr. Carpenter also brought with him some very interesting lantern slides, showing some of the earlier stations and also the modern ones, including one of Senatore Marconi endeavouring to fly a kite in Newfoundland when the first transatlantic wireless message was sent.

A hearty vote of thanks was passed by the meeting to Mr. Carpenter for his kindness in giving such an interesting demonstration.

Over thirty new members were enrolled, bringing the total up to 70, and the Club is now looking for a larger room.

Meeting every Wednesday night 7.30 to 10 p.m. at above address.

Guildford and District Wireless Society.

Hon. Secretary, Mr. Rowland T. Bailey, 46, High Street, Guildford.

On Saturday, July 29th the members of the above Society gave some demonstrations in aid of Chiddingfold Hospital Saturday Fund. On the whole the day proved successful. Mr. F. A. Love, of Guildford (2 HX) very kindly gave three transmissions of music in the afternoon, and at 7 p.m. gave out cricket results, etc., from the evening newspaper. A call from Marconi House (2 LO), and the reception of their three concerts at 5, 6 and 9 p.m. also added to the success and popularity of the demonstrations. A four-valve set, the property of Mr. R. C. Patrick, a member of the Society, was used, and in spite of being transported ten miles, performed the duties expected of it most admirably. It is hoped the efforts proved beneficial to the Hospital Fund.

The Society is still anxious to swell its membership, and therefore the number of sets; a good piece of advice would be for everyone starting on the fields of wireless to become a member of the nearest Society, where they will find first-class advice given willingly. Any amateur in the neighbourhood is heartily invited to come to the Society's room at 46, High Street, Guildford, on any Monday evening at 7 p.m.

The Fulham and Putney Radio Society.

Hon. Secretary, Mr. J. Wright Dewhurst, 52, North End Road, West Kensington, London, W.14.

The monthly meeting of the above Society was held at their temporary headquarters, 232, Putney Bridge Road, on Thursday, August 3rd. There was a fair attendance and several new members were enrolled. Amongst other business it was proposed that as soon as the question of suitable accommodation was settled, that the Society become affiliated to the Wireless Society of London. A very interesting discussion on wireless topics took place amongst the members and several gave their experiences with wireless during the late war.

At the next meeting it was arranged to have a three-valve set (lent by Mr. Houstoun) working to receive some amateur transmissions.

Sutton and District Wireless Society, Surrey.

Hon. Secretary, Mr. E. A. Pywell, "Stanley Lodge," Rosebery Road, Cheam, Surrey.

The Secretary begs to announce that, owing to a considerable increase in the number of members, a larger room has been engaged for the meetings.

This necessitates a change of meeting night from Thursday to Wednesday, commencing on 9th August (8-10 p.m.).

This new room is in the same building, namely, the Adult School, Benhill Avenue, and, with the increased facilities, a special effort will be made to help the beginners.

Will all in the district interested in wireless, both beginners and experts, attach themselves to the Society and thus ensure its continued success.

Questions and Answers

NOTE.—This section of the magazine is placed at the disposal of all readers who wish to receive advice and information on matters pertaining to both the technical and non-technical sides of wireless work. Readers should comply with the following rules:—(1) Each question should be numbered and written on a separate sheet on one side of the paper, and addressed "Questions and Answers," Editor, THE WIRELESS WORLD AND RADIO REVIEW, 12/13, Henrietta Street, London, W.C.2. Queries should be clear and concise. (2) Before sending in their questions readers are advised to search recent numbers to see whether the same queries have not been dealt with before. (3) Each communication sent in to be accompanied by the "Questions and Answers" coupon to be found in the advertisement columns of the issue current at the time of forwarding the questions. (4) The name and address of the querist, which is for reference and not for publication, to appear at the top of every sheet or sheets, and unless typewritten, this should be in block capitals. Queries will be answered under the initials and town of the correspondent, or, if so desired, under a "nom de plume." (5) In view of the fact that a large proportion of the circuits and apparatus described in these answers are covered by patents, readers are advised before making use of them, to satisfy themselves that they would not be infringing patents. (6) Where a reply through the post is required every question sent in must be accompanied by a postal order for the amount of 1s., or 3s. 6d. for a maximum of four questions. (7) Four questions is the maximum which may be sent in at one time.

"H.E.P." (North Greenwich).—We gather from your remarks that you have added a L.F. to your crystal set. The further improvement you request could be obtained by adding a H.F. valve, one of various suitable circuits being as shown in Fig. 1. The circuit should then give the results required.

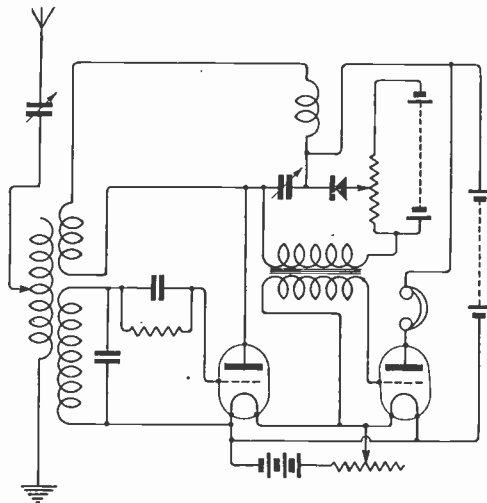

Fig. 1.

"F.W.S." (Nottingham) wishes to know (1) How to convert a Mk. III long wave tuner to give reaction effects. (2) Whether in attaching his Mk. III tuner for use as a component of the Armstrong super-regenerative circuit, he should make connection between the oscillator valve, grid coil, and the A.T.I. by means of a variable coupled inductance, or by connection to the top of the coil. (3) Should the oscillator valve grid coil tune to the same wavelength as the A.T.I. of the tuner.

(1) Isolate the closed circuit, which can be done by placing the change-over switch in the stand-by position. The telephone terminals should be short circuited, and leads taken from the opposite sides of the crystal detector, which should be put out

of action to the grid and L.T. minus of the valve. The closed circuit should then be connected to the plate, and one of the telephone leads. A condenser having a value of about 0.002 mfd. should be connected across the telephones. A suitable condenser will be found inside the set already connected to the short circuited telephone terminals. The other telephone lead is then taken to H.T. plus, H.T. minus being taken to the filament battery. This tuner is usually provided with two contacts, which are closed when the change-over switch is placed in the tuned position. As you will be making use of the closed circuit whilst the switch is over on the other side, you will need to short circuit these two contacts. This tuner is quite good for giving reaction effects when so corrected. (2) The position of the tap should be variable, and it is better to use an additional coil wound in the same direction as the secondary inductance, one end of which is connected to the L.T. battery and the other taken across to the grid of the oscillator valve. The oscillator must be arranged to give wavelengths of the order of 30,000 metres—that is, just above audible frequency. (3) It is regretted that we are unable to advise you further in the manipulation of this circuit, as very little data concerning the dimensions of the coils is at present available.

"P.H." (Coventry) is constructing a three valve receiver built up on the unit system, and wishes to know whether his panel wiring, as shown in his diagram, is correct. (2) The values for the grid leak, grid condenser, and telephone condenser. (3) Whether the set could be used in conjunction with the tuner described in the issue of July 15th, and (4) Whether we consider it advisable for him to abandon the unit system he has devised and adopt that described in recent issues.

(1) Your circuit diagram is quite in order, but it is difficult to trace out precisely your practical wiring diagram. However, it appears to possess no special merits over the designs put forward in the articles to which you refer, and we strongly recommend you to follow these articles as a guide for the construction of a long range multivalve receiving station. The advice given is in every way reliable and complete, and should you experience any difficulty in making up the apparatus, we shall be pleased to assist you.



STERLING No. 1 CRYSTAL W/T RECEIVING SET

Specially designed for use in connection with the Wireless Telephony Broadcasting Scheme, and is suitable for a range of about 25 miles.

PRICE £7-12-6

**STERLING TELEPHONE
& ELECTRIC CO., LTD.**

210-212, Tottenham Court Road,
LONDON : : : W.1

Telephone No. : 4144 Museum (7 lines)
Telegrams : "Cucumis, Weedo, London."

Works : DAGENHAM, ESSEX.

BRANCHES :

NEWCASTLE-ON-TYNE : 9, Clavering Place.
CARDIFF : 8, Park Place.

IMMEDIATE DELIVERY

SELF CONTAINED OR UNIT SYSTEMS

Marconiphones, Marconi Scientific Units, Waveora System, Etc.

*Crystal Set complete
with Phone, Aerial
and Insulators*
£3 2 6.

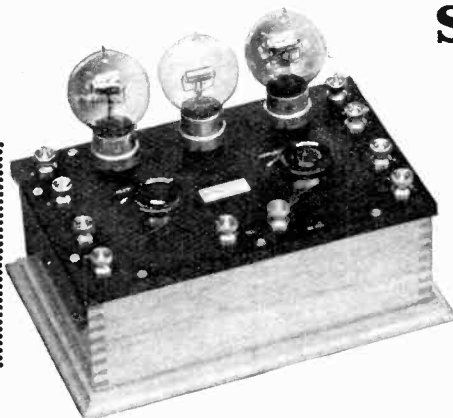

*At our Showrooms
168 Regent Street,
W.1
we give demonstrations
to purchasers.*

Tuners, Coils, Rectifiers, Amplifiers, Valves, Loud Speakers, Microphone Amplifiers, H.T. and L.T. Batteries, and all Wireless Accessories.

Special quotations for Technical Colleges, Schools and Educational Institutions.

Telephones:
Gerrard 3039.
Western 847.

The Radio Waveora Co.
168 Regent Street, London, W.1

Telegrams:
Wychwood,
Phone, London,

NOTICE

MESSRS. S. G. BROWN, LTD., HEREBY GIVE NOTICE that the only Telephones of their make acquired from the Disposal Board which have been RECONDITIONED by them and are GUARANTEED are those advertised by Messrs. L. McMichael, Ltd.

The "Brown" Telephones advertised as "New and Unused" at prices below their list quotations are of an obsolete Type which is not fitted with the all-aluminium diaphragm. They were supplied to the British Government during the war. They have not been re-conditioned by S. G. Brown, Ltd.

Please note that all "BROWN" Telephones are numbered and bear an index letter to indicate the year of manufacture. The numbers of the "A" Type Telephones began a year ago at E.27,000, so that all "A" Type Telephones bearing higher numbers than this have been manufactured during the last year. Hence, buyers of "BROWN" "A" Type Telephones are afforded hereby an indication of the date of an instrument's manufacture.

S. G. BROWN, LTD.

Works: VICTORIA ROAD, NORTH ACTON, LONDON, W.3.
London Showrooms: 19, MORTIMER STREET, LONDON, W.1. Telephone: Museum 4950.

SEA, LAND and AIR

THE AUSTRALIAN
MONTHLY JOURNAL
of Aviation, Radio-Tele-
graphy & Radio-Telephony

Price
1/9
Post Free

Annual
Subscription
21/-

THE WIRELESS PRESS LIMITED
12/13, Henrietta St., London, W.C.2

INFORMATION THAT IS VALUABLE TO YOU

is to be found in every issue
of

"CONQUEST"

(The Monthly Magazine of Popular Science)

The wonderful contents of the

AUGUST ISSUE

include articles on

HOW TO ERECT YOUR WIRELESS AERIAL
Wireless Notes—The Way of an Eagle—
How Bells are Made—Some Difficulties in
the Theory of Relativity—The Cannibal
Ladybird—A Scientist's Diary—Strange
Locomotives—Useful Hints for the Home
—Home Experiments in Science—Is
There Vegetation on the Moon—Wanted:
A Popular Science Theatre—Questions
and Answers—Ancient Hawaiian Rock
Pictures, etc.

ABUNDANTLY ILLUSTRATED.

PRICE: **1/-**

Obtainable at all Bookstalls and Newsagents, or Post Free 1/8
from The Publishers, CONQUEST, 12-13, Henrietta St., W.C.2

A big Shillingsworth! Get your copy to-day.

"SPARKS" (Bingley) describes his three-valve set and asks for a wiring diagram for same, so that one or both of the H.F. valves may be cut out.

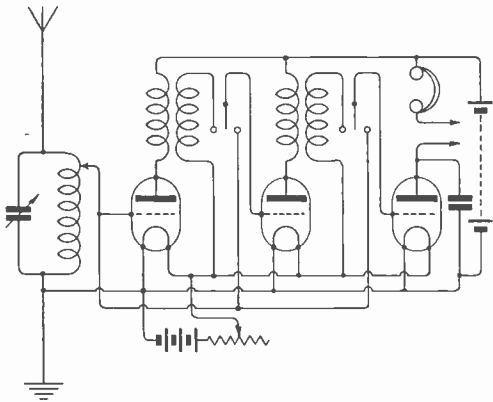

Fig. 2.

Without knowing the nature of your switches we cannot give the exact information required, but your circuits might be arranged approximately as in the diagram (Fig. 2).

"N.L." (Co. Down) submits two circuit diagrams, one comprising six valves with resistance capacity coupling, followed by two note magnifiers, and the other a four-valve set with H.F. transformer coupling, all inductances being tuned by means of condensers, and asks which circuit is the better for the purpose of receiving telephony. (2) What type of H.F. transformer we should recommend. (3) Whether the values of condensers and resistances are suitable for use with "V24" or "R" valves, and what values should be used with "Ora" valves.

(1) Both circuits will give you very satisfactory results, and the relative merits can only be considered with regard to ease of manipulation. In your No. 1 circuit it is not an advantage to tune both primary and secondary of H.F. transformers, as it makes manipulation very complicated, and the connecting condenser across the secondary of a H.F. transformer drops the potential which is applied to the grid of the next valve. In constructing an outfit to your No. 2 circuit, you should take great care to ensure that the values of condensers and resistances are precisely correct. (2) H.F. transformers of the Sullivan type can be relied upon as quite suitable for use in your No. 1 circuit. (3) The values of condensers and inductances are all quite correct for use with "V24" and "R" valves, these valves having been specially designed for use in the circuits in which you propose to connect them. It is very important that all valves shall be of identical properties.

"M.H.C." (Wendover) submits a plan showing the layout of his apparatus, comprising three inductances and single valve panel, and asks (1) Why he is unable to receive signals though the panel itself is O.K., having been tested on another set. (2) If the wire as shown by him is correct. (3) Whether another variable condenser would be helpful, and if so, where it should be connected. (4) What should be the capacity of such a condenser.

(1) (2), (3) and (4) It is difficult to suggest the cause of the apparatus not functioning correctly, as the diagram you give is quite correct. The addition of a variable condenser having a maximum value from 0.0005 to 0.0015 mfd. and connected in series or parallel with the aerial circuit would be found helpful, as it is quite probable that the range of the tuning coil and the aerial circuit as it stands does not come within that of the closed circuit coil. A condenser having a maximum value of 0.0005 mfd., may with advantage be connected across the reaction coil. As you do not define the actual results given by the set as it stands, we can hardly locate the fault. The variety of valve you use may be the cause of the trouble, as it may be of the slightly soft variety, and require a potentiometer to control the potential of the grid. We think if you make the addition of the condenser suggested, you should have no difficulty in bringing in signals, presuming no internal fault exists on the valve panel, which being of reliable make, we do not look to as a source of trouble.

"G.A.H." (Farnborough) has a number of accumulators which he wishes to lay aside, and enquires what condition they should be in in order that no deterioration may result.

The cells, whether charged or uncharged, should be completely emptied of acid and filled with distilled water, and allowed to stand for several days. This should then be tipped away and the accumulator left standing wrong way up, in order that all moisture may drain from the plates. When the interior has become dry, the stoppers should be replaced to prevent dust entering the interior.

"C.H.B." (Fleetwood) asks (1) For alternative diagram to Fig. 5, page 15, April 1st issue, substituting connections for single slide A.T.I. with reaction. (2) If A.T.I., wound on a tube $8\frac{1}{2}'' \times 4''$ with No. 30 S.S.C., is suitable. (3) Approximate wavelength of same.

(1) See diagram (Fig. 3), but an alteration of this nature will quite spoil the set. The remainder of the set as in the diagram referred to. (2) We

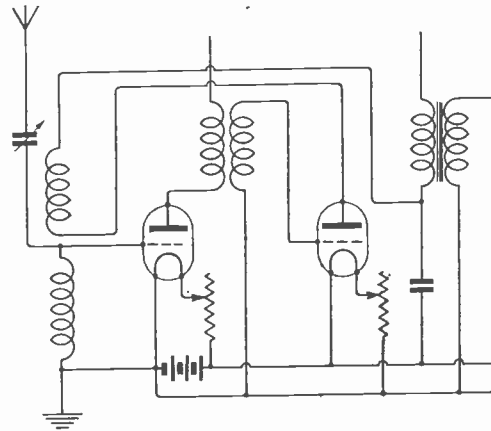

Fig. 3.

should prefer a coil of larger diameter wound with thicker wire. (3) Up to 4,000 metres with a normal P.M.G. aerial.

"UNCLE TOM" (Bournemouth) asks (1) For a diagram of a two-valve transmitter for C.W. and telephony. (2) Data for wiring transmitter. (3) If more valves can be added without dismantling set. (4) Values of condensers and resistances.

(1) See diagram (Fig. 4). (2) It depends largely on the aerial. Try about 40 turns on a former 3" diameter for the A.T.I., and 80 turns on a 2" diameter former for the reaction. (3) Not

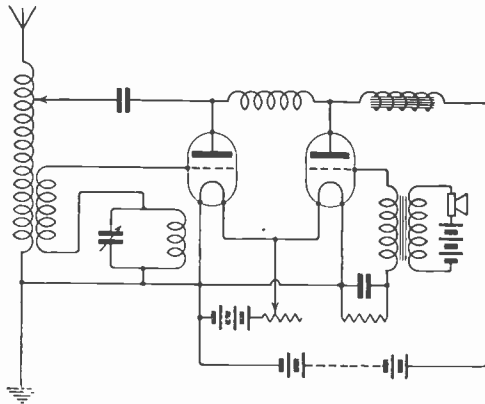

Fig. 4.

usefully, except in parallel with the oscillating valve. (4) For grid condenser 0.001 mfd., with 250,000 ohms. Feed condenser try 0.0005 mfd.

"P.H." (Coventry) asks (1) Wiring data for a detecting, H.F. and L.F. set of panels, using the same H.F. and L.F. batteries. (2) Would single layer coils for short wavelengths and duolateral coils for long wavelengths give a range of from 250/30,000 metres. (3) Should reactance be used, and if so how wired. (4) What valves should be used for the different stages of the multi-valve circuit.

(1) Many different methods are possible, one of which we give in diagram Fig. 5. (2) Yes. (3) Reactance can be used and will give greater selectivity. For method of wiring, see the diagram. (4) "R" valves may be used throughout, or "V 24" valves for amplifiers and "QX" for rectifier.

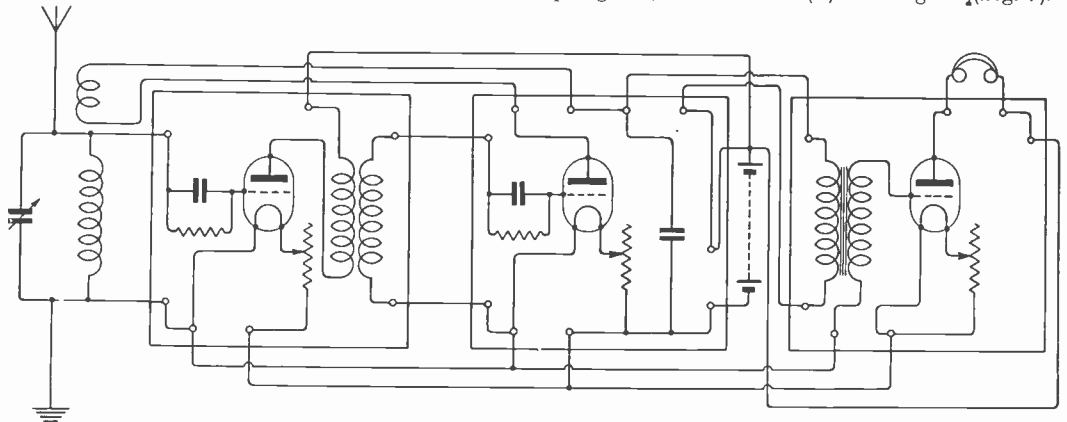

Fig. 5.

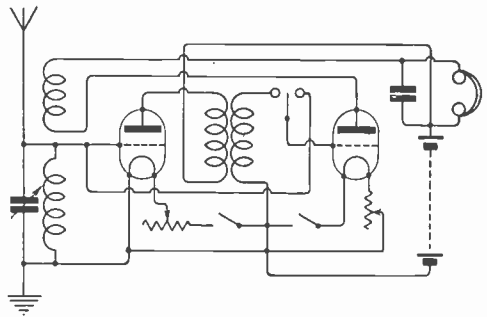

Fig. 6.

"R.J." (Christiana) sends a diagram of a circuit for transmitter, and asks (1) If circuit is correct. (2) How can he add another valve to his single valve receiver.

(1) The circuit will do, except that for transmission by arc, D.C. must be used with electrodes of copper and carbon. Consult a good text-book, as there are many technical points to be considered before successful radiation can be obtained. (2) See diagram (Fig. 6).

"J.H.W." (Newbury) asks (1) For connections for a resistance coupled to L.F. amplifier. (2) How to add a panel as H.F. resistance amplifier to a single panel shown.

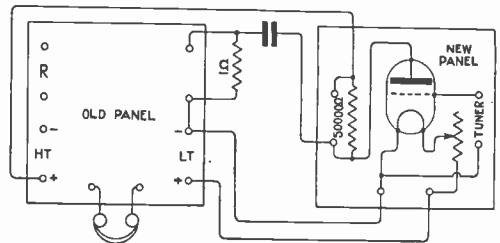

Fig. 7.

(1) The connections for a L.F. amplifier are exactly the same as for a H.F. amplifier of this type, but larger values of coupling condenser, say 0.0005 mfd., and smaller values of grid leak, say 1/2 megohm, are suitable. (2) See diagram (Fig. 7).

30/-

with immediate delivery from stock
**MULLARD TELEPHONE
 HEAD SETS**

specially made for the reception of wireless broadcasting, are thoroughly well-made and fit securely and comfortably to the head.

British Manufacture.

The two high resistance ear pieces (4,000 ohms total) are flexibly attached to the fully adjustable, double head bands. The set is nicely finished in nickel plate and supplied complete with standard flexible cords.

A large stock is available at once but is being rapidly booked up. Send the coupon to secure immediate delivery to-day.

These telephones are made by the makers of the famous ORA valve and Mullard valve accessories.

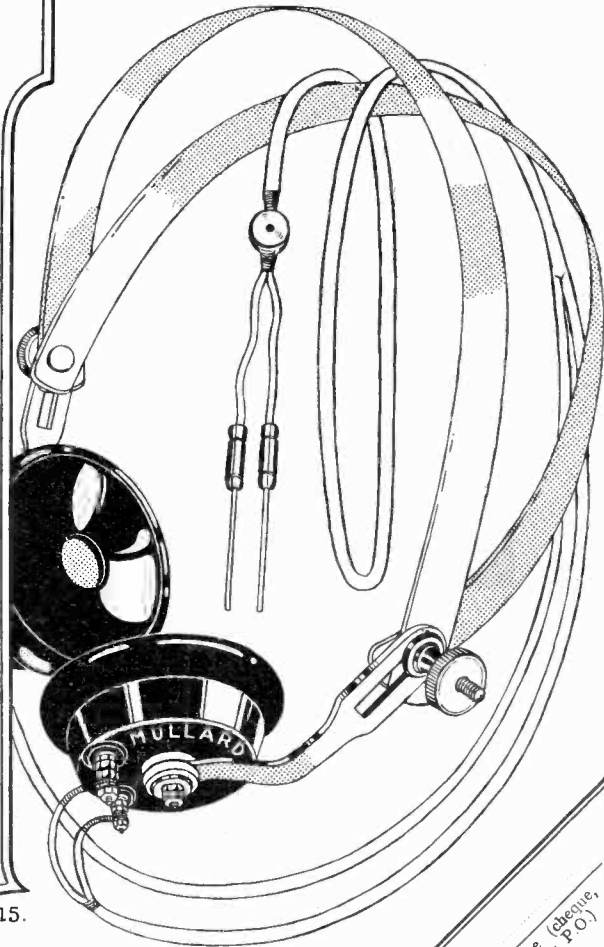

E.P.S.

15.

Mullard Radio Valve Co. Ltd.

Claybrook Road, Hammersmith, W.6.

Contractors to H.M. Admiralty,
 War Office Royal Air Force & Post Office.

Telephone: Codes: Telegrams:
 Hammersmith 312 ABC (5 Ed) Radiovalve Hammer Lond.



Name and Address
 To the
**MULLARD RADIO
 VALVE Co. Ltd.**
 35, Claybrook Rd.
 LONDON,
 W. 6

Please send me post free:
 Quantity:
 Telephone Head Sets 30/- per set
 ORA Valves 15/- each
 Grid A Resistances 2/6
 Anode A or B Resistances 2/6
 1/2 A Condensers 0.005 mfd 1/3
 Combined res and condenser 1/3
 Valve bases with terminals 9d. per pair
 Terminal clips
 Name of usual wireless dealer:

I enclose (cheque,
 Money Order, P.O.)
 to cover the
 cost.

**SEND
 THIS
 TO-DAY.**

THE "BROWN" LOUD SPEAKERS WITH NEW IMPROVED CURVED HORNS.



H. 2 (Small) Height 12"

The requisites of a Loud Speaker are pure tone, clear articulation, and good volume of sound. The "BROWN" Loud Speaker possesses these qualities, and they are enhanced by the new improved curved horn.

THE AMATEUR does not always need the full sized Loud Speaker (H.1) as used in Lecture Halls, and a small type (H.2) has been designed to meet his more modest home requirements.

THE NEW HORN used with both H.1 and H.2, is constructed on the logarithmic law of increasing openings and is acoustically perfect.



H.1 (Large) Height 21"

PRICES:

H.1 (Large) Low Resistance, 120 ohms	£6 5 0
H.2 (Small) " " " " " "	£3 0 0
The "BROWN" Standard Pattern (with upright funnel)				
Low Resistance, 120 ohms	£5 10 0

(High Resistances for all patterns 2/6 to 5/- extra)

Catalogues post free on application.

SOLE MANUFACTURERS: **S. G. BROWN, LTD.,**
SHOWROOMS: 19 MORTIMER STREET, LONDON, W.1 Telephone: Museum 4950
Works: Victoria Road, North Acton, London, W.3 Sole Agent for the Argentine:
Telegrams: "Sidprownix, London." Telephone: Chiswick 1469. Horacio D. Guerrero, Las Heras 2480, Buenos Aires
Brown's Wireless Apparatus can be purchased from all Wireless Suppliers.
EARLY DELIVERY of Telephones and Loud Speakers can now be given.

WIRELESS CONSTRUCTION PARTS TO BUILD YOUR OWN SETS

<p>Our Famous "Atlantic" 3 Valve Receiver and Amplifier, Panel Type, range 200 to 3,000 metres, 1 H.F., 1 Rect., 1 L.F., 2 Variable Condensers, 3 Fil. Res., Coil Holders and Plug in Coils. 175/-</p> <p>Full Set of Parts for the above 125/-</p> <p>Our "Super Atlantic" 4 Valve Receiver and Amplifier, designed especially for telephony, Panel type as above, 1 H.F., 1 Rect., 2 L.F., 2 Variable Condensers, Coils and Coil Holder, Price, tested on aerial 215/-</p> <p>Full Set of Parts 175/-</p> <p>3 Valve Amplifier, 1 H.F., 1 Rect., 1 L.F., same as our "Atlantic," less Inductances and Variable Condensers 110/-</p> <p>3 Plate Vernier Condenser 4/6</p> <p>5 " " " " " " 6/-</p>	<p>Grid Leak and Condenser for remounting 3/6</p> <p>Fil. Res. and Valve Holder on Ebonite. . . 6/6</p> <p>3 Valve Holders, 2 Fil. Res. on Ebonite. . 12/6</p> <p>Concert Coils, for Marconi Concerts, etc. Pair 2/-</p> <p>Set of Basket and Slab Inductances, includes our Concert Coils—</p> <p>500 to 8,000 metres, Set of 6 6/6</p> <p>500 to 20,000 metres, set of 7 8/9</p> <p>Ebonite Plugs for Mounting Slabs, etc. . . 2/-</p> <p>1001 Semi-Variable Condensers 17/6</p> <p>Cabinet Concert Tuners 38/-</p> <p>Double Slide Crystal Receiver 42/-</p> <p>Skeleton Variable Condensers for remounting, 25 plate 12/6, 31 plate 14/6, 43 plate 18/6. The finest Condensers made.</p> <p style="text-align: center;">Get our NEW LIST FULL OF GOOD THINGS.</p>
---	---

AMATEUR SUPPLIES ASSOCIATION, 134, Coteford Street, Tooting,
Works: 196, High Street, Merton. LONDON, S.W.17.

“P.W.” (Maidstone) asks (1) Number of moving plates $2\frac{1}{2}$ " in diameter required for construction of condenser having a capacity of 0.0005 mfd. (2) For a diagram embodying one H.F. amplifier, rectifying valve and one note magnifier, and also dimensions of condenser.

Where D is diameter of coil in cms., $n =$ No. of turns in cms.

$L =$ length in cms. and k is a constant depending on $\frac{d}{l}$, a few values of which are given:—

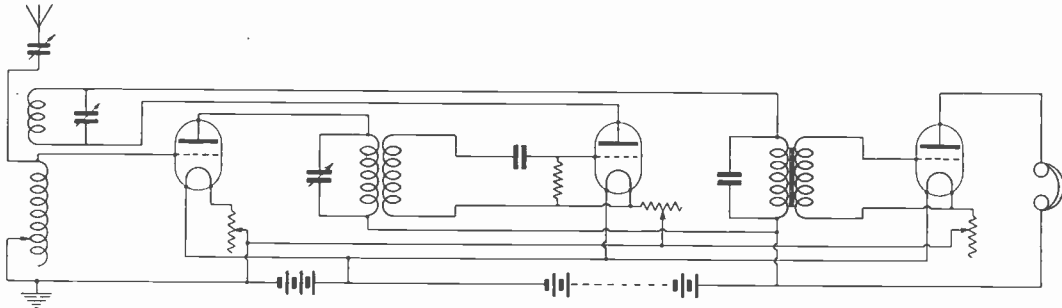

Fig. 8.

(1) If the spacing between the successive moving plates is $5/64$ " and the gauge is No. 20 S.W.G., then ten will be required. From this information you can easily calculate the number required and your spacing washers will be of different dimensions. The thickness of air space in the particulars given above to the thickness that you propose to adopt is inversely proportional to the number of plates required. See Fig. 8. A.T.C., 0.001/0.0015 mfd.; reaction tuning condensers, 0.0004 mfd.; grid condenser, 0.0003 mfd.; the condenser that bridges the primary of the transformer, 0.001; H.T. condenser, 0.01/0.25 mfd. H.F. primary tuning condenser, 0.0003 mfd. maximum.

$\frac{d}{l}$	K	$\frac{d}{l}$	K
0.1	0.96	10.0	0.20
0.25	0.90	0.50	0.82
0.75	0.75	1.0	0.69
1.5	0.59	2.0	0.52
3.0	0.43	5.0	0.32

“P.L.” (Teignmouth) asks (1) What wavelength and system is the GFA meteorological report and the R.A.F. news sent at 08.35 G.M.T. (2) Why do some C.W. stations “splutter.” (3) What is the system which makes its dots and dashes on different notes. (4) If GBL (Leafield) is an arc station, and if so, is the note which fills the spaces between the dots and dashes the carrier wave.

(1) Formerly 1,400 m., but from 1st July 4,100 m., and in cases of breakdown reverts to 1,400 m. (2) “Spluttering” in a C.W. station is generally due to a badly adjusted arc as generator of the C.W. (3) This is the general method of keying an arc, by changing the wavelength. By suitable tuning one of the notes may be made inaudible, the other is then easily read. (4) Yes, the second note is the spacing wave—quite a different thing from the carrier wave of a telephone set.

“CURIOSITY” (Cambridge) asks (1) For a diagram of a four-valve set, using a Reinartz Tuner. (2) Maximum wavelength a Reinartz Tuner can be made to work upon. (3) Formula for calculating the inductance of single layer coils.

(1) See diagram (Fig. 9) (2) No exact figures are available. We doubt, however, if the tuner would be very much use about 1,500 metres.

(3) L mhy. = $\frac{\pi^2 d^2 n^2 L k}{1,000}$

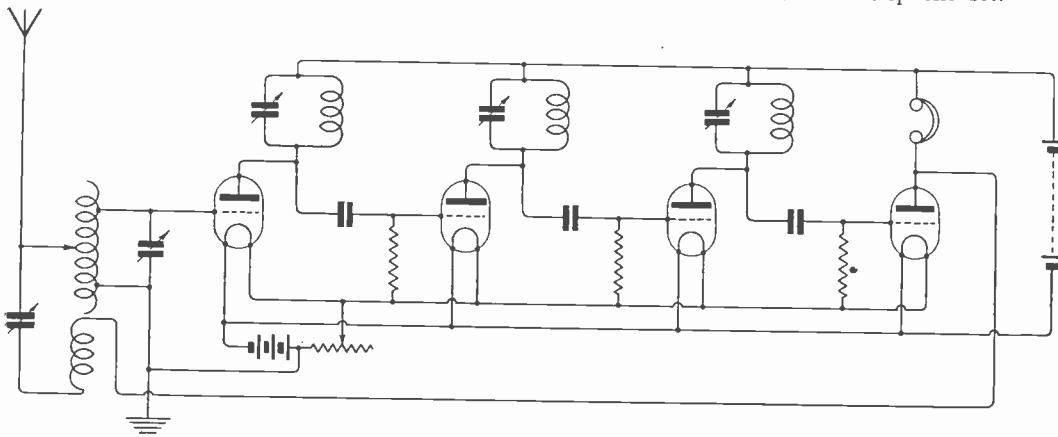

Fig. 9.

"A.H." (Bradford) wishes to purchase wireless receiving outfit, and asks us to advise him with regard to the relative merits of apparatus supplied by various manufacturers.

It is regretted that we cannot advise you with regard to the relative efficiency of the various outfits you mention. You should, if possible, inspect the apparatus, and if purchasing from a firm of not long standing, a demonstration of the set in use on an aerial similar to your own would help to satisfy you as to its merits.

"C.W.N." (Wandsworth Common) asks for a diagram of a certain two-valve set.

See diagram (Fig. 10). A set of this type would not be very efficient, and would hardly be worth the complication and expense involved.

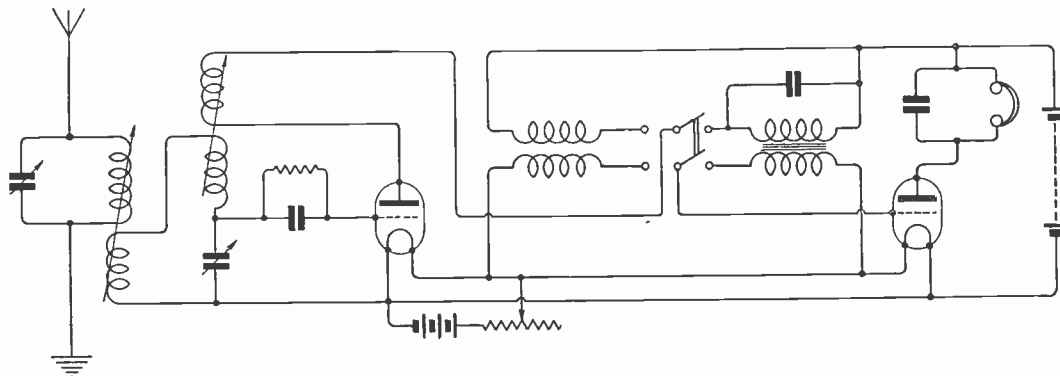

Fig. 10.

"A.T.G." (Whetstone) has a loose coupled tuner with primary 6" in diameter by 9" long and secondary 5" in diameter by 7" long, and asks for windings for tuning up to 3,000 metres.

Wind primary with No. 24 D.C.C. and secondary with No. 26 D.C.C., making tapings at $\frac{1}{2}$ ", 1", 1 $\frac{1}{2}$ ", 2", 2 $\frac{1}{2}$ ", 3 $\frac{1}{2}$ ", 4 $\frac{1}{2}$ ", 5 $\frac{1}{2}$ ", 6 $\frac{1}{2}$ ", 7 $\frac{1}{2}$ ", and 9" on the primary; and at $\frac{1}{2}$ ", 1", 1 $\frac{1}{2}$ ", 2 $\frac{1}{2}$ ", 3", 3 $\frac{1}{2}$ ", 4 $\frac{1}{2}$ ", 5 $\frac{1}{2}$ ", and 7" on the secondary. This tuner may not work efficiently on wavelengths below 400 metres, for which two special coils should be constructed.

"H.H.J." (Sydenham) has a tuning coil 6" in diameter by 4 $\frac{1}{2}$ " long, wound with 220 turns and tapped for 10 turns, and asks (1) Whether it would be suitable for the reception of Paris spark signals when coupled to a crystal detector. (2) The best type of crystal for use without potentiometer, and (3) Should resistance of telephones be 4,000 ohms, or whether ones of lower resistance might be used.

(1) We do not think that your coil will tune to 2,600 metres. It is impossible to advise you as to the wavelength to which a coil will tune without knowing the dimensions of the aerial to which it is connected. In making tapings on a coil, equal distances should not be spaced off. They should be made at increasing intervals along the coil. (2) Silicon and artificial galena used in conjunction with a light iron wire can be recommended, also many of the special crystals at present on the market, particulars of which can be seen in the advertisement columns. (3) A minimum resistance of 4,000 ohms is advisable.

"K.B." (W.1) asks (1) How to convert a B Mark II receiver for the reception of short wave telephony. (2) Which is the more suitable for the construction of a frame aerial, wire having 105 strands of No. 42, or single No. 18. (3) The capacities of the aerial tuning and grid condensers in the B Mark II set.

(1) Remove the small tuning coil from the instrument and bring out four leads for the purpose of connecting to two coils which you must arrange external to the set. The 4 megohm leak must also be removed, and the four wires which terminate on one of the leak terminals should be carefully tied together and wrapped with insulating tape. The other lead may be removed from the set. A small circular condenser may also be removed, or at any

rate taken out of circuit, but the lead which formerly goes to the coil and from thence up to the valve holders must still be left connected through. Construct two coils as described on page 328 of June 10th issue, and these are connected to the four leads which were formerly joined to the inductance coil of the set. One coil is connected to the lead which passes from the valve holder, and also the right-hand tag of the three when the instrument is viewed from the inside with the filament resistance on the left. The other two tags—that is, the left-hand pair—are connected to the other coil, and when in use these two coils are placed over one another. For short wave telephony reception a condenser having a maximum value of 0.0005 mfd. should be connected in series between the aerial lead and the aerial terminal of the instrument, whilst another of similar value should be connected across the coil which is joined to the plate circuit. (2) The flexible wire would probably be found more suitable, as it will lie closer to the sides of the frame, and it is more easy to arrange strands of flexible wire parallel to one another. If you take the trouble of fixing small pieces of ebonite with spaced holes drilled in them at intervals along the outside of the frame, you may be able to use the No. 18 by passing it through the holes. (3) The aerial tuning condenser would have a value of something less than 0.0001 mfd. This value is not specified, as it is adjusted according to the value of the inductance to which it is connected. This set is not usually fitted with a grid condenser, and the leak which is

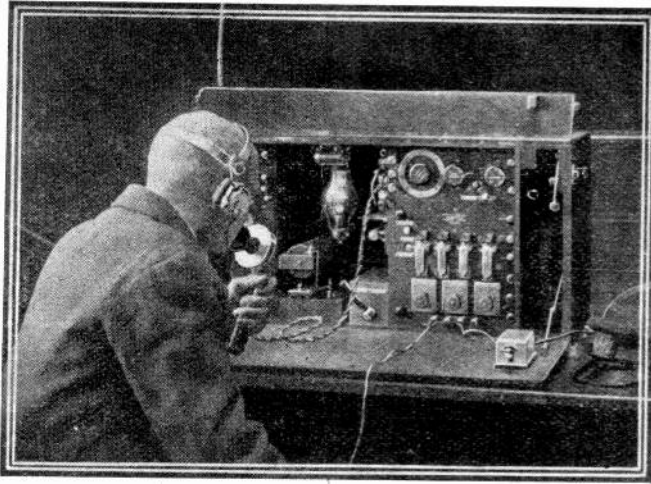

The First Commercial Wireless Telephone Service in Great Britain

is used for

Communications between the offices of the Mersey Docks & Harbour Board in Liverpool and the Bar Lightship beyond the mouth of the Mersey. The Marconi apparatus in each case is operated by the ordinary Harbour Board staff and has been in continual use since its installation over a year ago. — "Calling up" is performed by means of the
 ❖ ❖ *Marconi wireless bell* ❖ ❖

MARCONI'S WIRELESS TELEGRAPH CO., LTD.
 MARCONI HOUSE, STRAND, LONDON, W.C.2
 Telephone: CITY 8710.

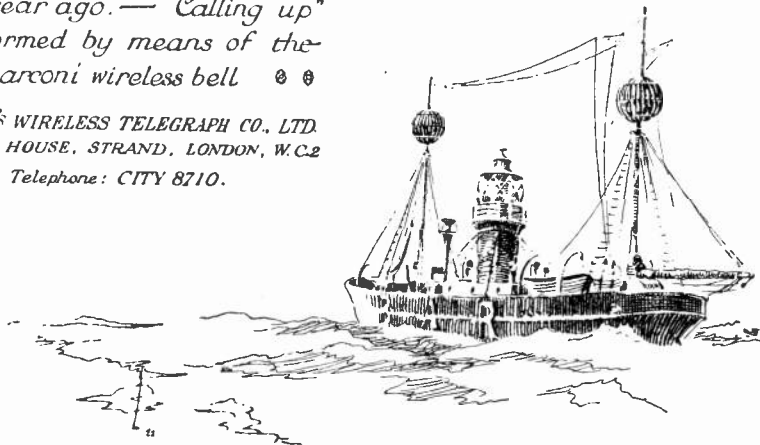

“BRITWIRE” CONDENSERS.

OWING to the demand for a good condenser, which at the same time is cheap, we are now manufacturing a Balanced Condenser for panel mounting, replacing the imported condensers hitherto sold. The plates are die-cast into the supporting columns, and are counterbalanced so that they will remain in any position when mounted on an upright panel. At present only two capacities are being manufactured, viz.: '0005 and '001, but other capacity condensers will be made in due course. Orders booked and executed in strict rotation.

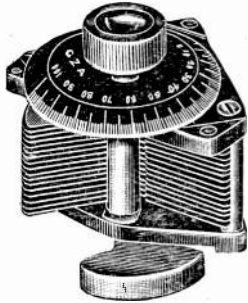

PRICE

WITH EBONITE REVOLVING SCALE :

'0005	17/6
'001	25/-

*Liberal Discounts to the Trade.
Send for Illustrated List, post free 3d.*

POST ORDERS TO—

BRITISH WIRELESS SUPPLY COMPANY
 6 BLENHEIM TERRACE, LEEDS. Telephone : 26926 **LTD.**

And at
 11 Church St., West Hartlepool. Tel. 373. 18 Eldon Sq., Newcastle-on-Tyne. Tel. City 360
 33 High Street, Southampton. Telephone 403.

“Exide” BATTERIES FOR WIRELESS

WE specialize in the manufacture of batteries for filament current supply to Valves and high-tension batteries for application of Anode Potential. We can supply these batteries in glass, ebonite or celluloid containers to any desired voltage.

Exide batteries can be relied upon for wireless work and retain their charge over very long periods.

Prices and Particulars on Application.

THE **Chloride** ELECTRICAL STORAGE COMPANY LIMITED.

Head Office : London Showrooms :
 Clifton Junction, 219/220 Shaftesbury Av.
 Nr. Manchester. W.C.2



6 Volt 80 Amp. Hour Exide Battery.

shown across the aerial and earth terminals is for the purpose of flattening the tuning.

"W.E.P." (Sussex) asks (1) For instructions as to the best method of constructing a balanced capacity for use in conjunction with his telephony transmitter, and (2) Whether there would be any appreciable loss in running the aerial of the earth connections of transmitter and receiver to a double pole change-over switch, together with the aerial and earth leads.

(1) As you are no doubt restricted as to space, it may be very difficult for you to arrange an efficient capacity. It should consist of a number of insulated wires placed near the ground and running beneath the aerial. For good work you may find that you need at least six or eight such wires, at least as long as the aerial wires, and spaced as wide apart as possible, say a minimum of 8 feet. As your set is installed on the second floor, you might possibly arrange a row of insulators along a distant wall, and run out a number of wires, fanlike. With this lower capacity and big dimensions you will find that by its use you will need to add a few more turns of inductance in the aerial circuit of the transmitter, in order to work on your present wavelength. (2) With a valve transmitter there is no objection to you arranging a china-based switch for the purpose of switching over from transmitter to receiver. There is one variety in which the arms of the switch are well spaced, which is quite suitable. Alternatively you might remove the arms and contacts from the usual pattern switch and remount them on an ebonite base, fitting a new ebonite bridging piece between the two levers, as in many switches at present on the market, this is made of black fibre of uncertain insulating properties.

"F.J.L." (Plumstead) is constructing a two-wire aerial with mid point lead-in, and is unable to bring down the leading-in wires directly from the middle of the aerial, owing to the projecting edge of the roof, which is likely to foul one of the leads, and asks whether equally good results will be obtained if one wire is brought across almost directly to the other, and thence down to the instruments.

A point to be considered is that an equal length of wire must be in each limb of the aerial up to the point of joining, and as you are unable to arrange this, we would suggest that you join the two aerial wires straight across in the middle, and run your leading wire from the mid point of this connecting wire. If there is still any tendency to foul the edge of the roof, the lead-in wire may be tied back a little out of the perpendicular. What you must avoid is joining together two leading wires of unequal length, or the aerial will prove inefficient, particularly for short wave reception.

"V.E.C." (Walsall) asks (1) For dimensions of coils for wavelengths between 500 and 14,000 metres for use in conjunction with an aerial tuning condenser of 0.0016 mfd. (2) How many condenser plates are required to give 0.0015 mfd. and also 0.004 mfd. (3) Whether bare copper wire is more efficient than enamelled for aerial construction, and (4) Where he can obtain a map of the world showing the location of the wireless stations, also stating the times of transmission and wavelengths.

(1) It is not possible to advise you exactly as to the number of turns required to tune your aerial to given wavelengths without knowing its dimen-

sions and arrangement. It is quite easy to wind a number of coils of increasing dimensions, and by a very simple experiment you will soon discover the wavelengths to which they will tune the aerial. Then working on, you might make many coils, equal in size to the largest, and by connecting them up in series you can keep on building up until the maximum wavelength range is attained. (2) 30 moving and 31 fixed plates, spacing washer 5/64", plates 20 S.W.G., radius of moving plates 1 1/8". It would have been better had you stated the dimensions of the plates and washers you can obtain, and then we could have told you the number you would need. (See article on Condenser Construction in issue of August 5th.) (3) Enamelled wire is better, because the enamelling protects the surface and prevents it being broken up by corrosion. Bare wire can, however, be used, and will give quite good results. (4) A map of the wireless stations of the world was formerly published in the "Year-Book of Wireless Telegraphy and Telephony," but owing to the difficulty of including all the stations on one map, it has been subdivided into a number of smaller maps, drawn on various scales. The list of regular transmissions published from time to time by this journal is supplied with the issue of August 5th.

"G.L.H." (N.W.2) asks for windings for an aperiodic resistance, H.F. transformer with optimum wavelength of 900 metres. He intends to incorporate the transformer with a seven-valve H.F. amplifier.

As you will need to make several transformers, it is essential that a design must be adopted which will ensure that all are of precisely the same dimensions, for should one be wound slightly differently, it will filter out signals on wavelengths on which the others function most efficiently, consequently primaries and secondaries should consist only of a single layer, and be wound with No. 44 S.S.C. "Eureka" wire. Both primary and secondary should consist of 650 turns on a 2" former, separated from each other by a single layer of empire cloth. The direction of wire is important, and if both values are made in the same direction, the finishing ends should be taken to grid and plate.

"H.C." (Manchester) asks (1) Why he is unable to receive telephony on his single valve receiver, whilst he is able to receive Morse quite strongly from FL. (2) Number of plates required for constructing an aerial tuning condenser, the moving plates being 2 1/2" in diameter. (3) The cause of the loud shriek obtained in the telephones while tuning. (4) Details for the construction of a H.F. transformer for use on 200-2,500 metres, making use of the No. 29 and 36 wire he has in his possession.

(1) We notice that you connect your aerial tuning condenser in parallel across the aerial tuning inductance. With the type of condenser you are using, this takes the minimum range of your set well above that on which telephony is usually transmitted. Particulars as to dimensions of aerial would have been helpful in giving you exact instructions, but in any case, your present aerial tuning inductance is too large for short wave reception. You should construct two special coils for short wave work, of about 3 1/2" and 4" in diameter, one turning or sliding inside the other, and having 1/2" of the winding of No. 24 D.C.C.; or alternatively you might construct coils to the instructions given on page 328 of June 10th issue. It is very helpful

with short wave work to tune the reaction coil by bridging it with a variable condenser, and the one that is at present connected in your long wave set should be suitable for the purpose. (2) You neither state the thickness of your new condenser plates nor of the spacing washers, consequently we cannot advise you as to the number of plates required, but if the plates happen to be of 20 S.W.G. and the spacing washers $\frac{3}{32}$ of an inch, you will require about 24 movable and 25 fixed to give a capacity of 0.001 mfd. You may find it an advantage to build such a deep condenser, and one having similar capacity may be found quite suitable if your aerial dimensions are fairly great, and a smaller condenser, moreover, will permit of finer tuning. (See article on Condenser Construction in issue of August 5th.) (3) This is due to the use of too tight a coupling between aerial and reaction circuits, and the tuning condenser across the reaction coil should permit of critical adjustment to the point where the noise just ceases. A modification of grid condenser and leak may make the reaction adjustment less critical. (4) 200 to 2,500 metres cannot be obtained by the use of one transformer. Using your No. 36 wire, you might construct a transformer having 280 turns each for primary and secondary, of mean diameter of $1\frac{1}{4}$ ", the two windings being separated by a wrapping of insulating material. The one that is connected in the plate circuit should be bridged with a small variable condenser. The direction of winding is important, and if your transformer is wound in a groove, the two windings should be in opposite directions, and the end of the primary and the beginning of the secondary—that is, the two leads that pass out between the windings—should be taken to grid and plate.

"J.E.L." (Letchworth) asks for a diagram of a three-valve circuit comprising one H.F., one detector, and one L.F., suitable for the reception of telephony, and in particular PGGG, 2 MT, 2 LO, and Croydon, and sufficiently strong for operating a small pattern Brown loud speaker. A circuit diagram is submitted, and it is stated that it is very difficult to obtain strong signals with a loud speaker.

Your circuit would appear to be in every way satisfactory, except that perhaps you might get better results by connecting the aerial tuning condenser in series with the inductance, which will permit of the use of more turns in the A.T.I., and consequently a bigger potential will be bridged off. You did not describe the construction of the H.F. transformer, and it may be in this instrument that inefficiency arises. The two windings should not be put on simultaneously, but should be separate and insulated from one another, and with this form of construction it is an advantage to bridge the primary winding with a small value variable condenser. The direction of winding is important, and if both primary and secondary are wound in the same direction, the finishing ends should be taken to grid and plate, and the beginning ends to H.T. plus and L.T. minus of the potentiometer. The detector valve should be of such a type as will give efficient rectification, and one of the slightly soft variety, or a "Q" controlled with a potentiometer may considerably improve your results. It is an advantage to loosely couple the aerial inductance with a secondary inductance, which is taken to the first valve grid and L.T.

minus, and if this is done, the variable condenser should be connected in series with aerial circuit, and another connected across the secondary winding. Although you complain that the results you obtain are not entirely satisfactory, we do not think it easy with your equipment to obtain signals from PGGG sufficiently strong for the operation of a loud speaker.

SHARE MARKET REPORT.

Prices as we go to press on August 11th are:—

Marconi Ordinary	£2	6	7½
„ Preference	2	3	6
„ Inter. Marine.. ..	1	8	9
„ Canadian	10	10½	

Radio Corporation of America:—

Ordinary	19	3
Preference	13	9

Marconi Annual Report.

At the Annual General Meeting of Marconi's Wireless Telegraph Company, Ltd., held on August 15th, the report of the directors and statement of accounts were rendered for the year ended December 31st, 1921.

It was pointed out that owing to the many matters which still remain unsettled, the accounts once more do not reflect the true strength of the Company's position.

The Credit Balance of Profit and Loss Account for the year amounted to £275,361 7s. 8d., which, added to the balance brought forward from the last account, leaves to the credit of Profit and Loss Account a sum of £1,093,928 9s. 11d., subject to Corporation Profits Tax and Income Tax. From this have to be deducted the following dividends:—On Preference Shares, 7 per cent. paid on January 31st, 1922, £17,500; on the Ordinary Shares an interim dividend of 5 per cent. paid on January 31st, 1922, £131,555 3s. 7d., together making £149,055 3s. 7d., leaving available for distribution a balance of £944,873 6s. 4d.

The directors recommended payment of further dividends for the year ended December 31st, 1921:—On the Ordinary Shares, 10 per cent. (making 15 per cent. for the year), £265,543 0s. 10d.; on the Preference Shares, 5 per cent. (making 12 per cent. for the year), £12,500, together making £278,043 0s. 10d., leaving a balance to carry forward to next account of £666,830 5s. 6d. ½

W. T. Henley's Dividend.

The directors of Messrs. W. T. Henley's Telegraph Works Company, Ltd., Blomfield Street, London Wall, E.C.2, have declared a dividend on the Preference Shares at the rate of $4\frac{1}{2}$ per cent. per annum, less Income Tax, for the half-year ended June 30th last. Also an interim dividend on the Ordinary Shares of 1s. per share, less Income Tax, both to be paid on September 1st next.

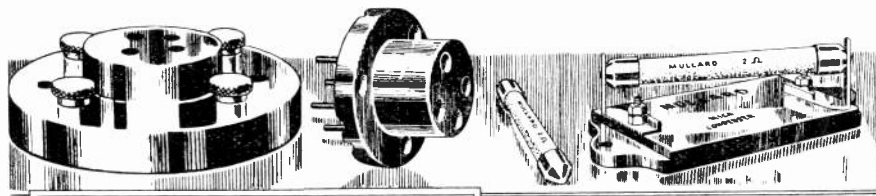

GREAT REDUCTIONS
in PRICES of
MULLARD ACCESSORIES

VALVE BASES. Specially designed with four convenient terminals. Moulded from the best materials. Internal connections completely enclosed.
Greatly Reduced Price .. 5/- each

VALVE SOCKETS. Eminently suitable for constructing complete valve receivers, amplifiers, etc. Moulded from the best materials. Impossible to insert the valve the wrong way.
Greatly Reduced Price .. 1/3 each

MULLARD PATENT RESISTANCES. Absolutely 'silent' and constant in use. Grid A. Grid B. Anode A. or Anode B.
Greatly Reduced Price .. 5/- each

B.A. CONDENSER. .0003 mfd., mica insulated 2/6 each

NEW DESIGN COMBINED CONDENSER AND GRID LEAK. Grid B Resistance with .0003 mfd. B.A. Condenser 7/6 each

RESISTANCE CLIPS .. 9d. per pair

MULLARD TELEPHONE HEADSETS
4000 ohm., immediate delivery
30/- each

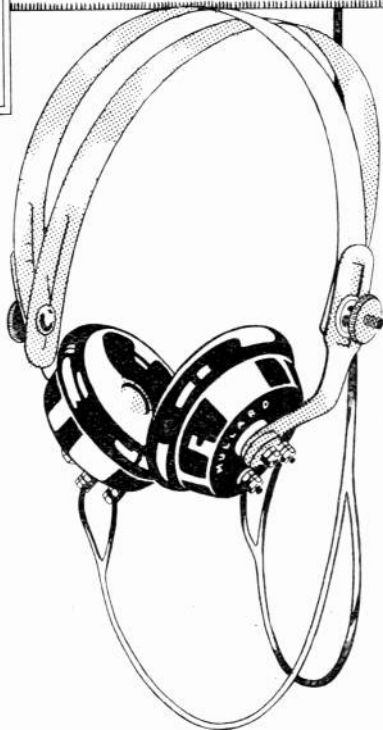

All Mullard accessories are British Manufacture throughout. These big reductions in price will cause a greatly increased demand for Mullard accessories.

To ensure early delivery, send coupon to-day.

Mullard Radio Valve Co. Ltd.

Claybrook Road, Hammersmith, W.6.

Contractors to H.M. Admiralty,
War Office, Royal Air Force & Post Office.

Telephone: Codes: Telegrams:
Hammersmith 312 ABC15Ed) Radiovalve Hammer Londt



Glasgow Depot : 15, Woodside Terrace. Newcastle Depot : 17, Sandhill.

Please send me per post

Name and Address.....	Description and Price.....	Enclose (cheques)
To the MULLARD RADIO VALVE CO., LTD., 35, Claybrook Road, Hammersmith, W.6	Telephone Head Sets .. 89/-	Money Order, P.O. value
Quantity.....	ORA Valves .. 15/- each	to cover
Grid A Resistances .. 5/- each	Grid A or B Resistances .. 5/- each	the
B.A. Condensers, .0003 mfd. 2/6 each	Combined Resistances with Bases Terminals .. 7/6 each	cost.
Valve Sockets .. 5/- each	Terminal Clips .. 9d. per pair	
Name of usual Wireless Dealer.....		

SEND THIS TO-DAY

THE ONLY WAY TO PREVENT SURFACE LEAKAGE IS TO FIT

Crystor REGISTERED COWL INSULATORS

100% EFFICIENCY GUARANTEED

The "Crystor Cowl" Insulators are unique—made of the best quality Ebonite, they are absolutely essential to every aerial. Fit them NOW, and immediately you will increase the efficiency of your receiver.

CRYSTOR COMPLETE AERIAL OUTFITS

Single Wire Aerial

Containing 2 Crystor Cowl Aerial Insulators, 1 Crystor Cowl Lead-in (vertical or horizontal), 100 ft. Best Quality stranded copper Aerial Wire, 100 ft best Hemp Rope and 1 pulley block, packed in block.

Price Complete 21/-
Postage 1/6 extra.

Two - Wire Aerial

Containing 4 Crystor Cowl Aerial Insulators, 1 Crystor Cowl Lead-in (vertical or horizontal type), 100 ft. Best Quality stranded copper Aerial Wire, 100 ft best Hemp Rope and 1 pulley block, packed in box.

Price Complete 25/-
Postage 1/6 extra.



**Vertical Roof
LEAD IN**
Dia. of Cowl 2½"
Dia. of Shank ¾"
Length Overall 11"
Price 10/- post free.

THE Crystophone REGISTERED

is all you require to receive broadcasting and there is no better value on the market.

Crystophone Type	PRICE
20 T.T. wavelength 180 to 3,500 metres	£5 10 0
Crystor Single Valve Note Amplifier	£2 10 0
Crystor Double Valve Note Amplifier	£3 10 0
Crystor Variable Condenser	£2 0 0

For attachment to any Crystophone outfit.

Write for particulars of the New Model.

Horizontal Wall (or Window) LEAD IN

Dia. of Cowl 2½". Dia. of Shank ¾"
Length on the Curve 13".
Price 10/6 post free.

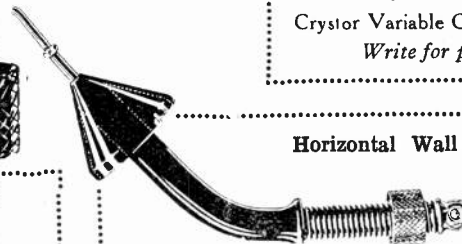

AERIAL INSULATOR

Length of Body 3". Dia. 1½". Length Overall 4"
2/6 each. Set of four 10/- post free.

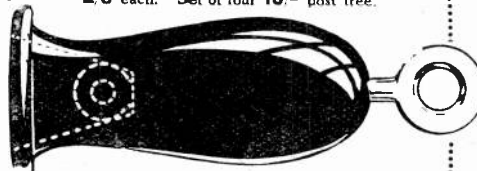

WIRELESS SUPPLIES CO.

64 Mortimer Street,
LONDON, W.1

Phone : Museum 2672

B'HAM WIRELESS COMPONENTS CO.

2 Booth St., BIRMINGHAM.

Condensers, .001, 14/-; 0.0005, 10/6; 0.0003, 8/-. Vernier Condensers, 3/6. Perfectly made and for Panel Mounting.
 Ebonite Dials with Scale, 2/- each.
 Filament Resistances, 2/6—the best made and finest article on the market for Panel Mounting.
 Grid Leak and Condenser, 2/-. A special design and superior to any other make.
WESTERN ELECTRIC HEAD 'PHONES.—4,000 ohms, 26/- per pair. The finest 'phone on the market. Orders now taken in advance. Delivery in four to six weeks.
WESTERN ELECTRIC LOUD SPEAKERS.—4,000 ohms, £2 5s. Switch Arms, 2/- each.
 Aerial Wire, 7/22, 4/- per 100'.
 Engraved Condenser Scales, 9d. each.
 Condenser scales, 9d. per doz.
 Sleeving all colours, 4d. per yard.
 Insulators, 1½d. each.
 Valve Legs, 1½d. each.
 Terminals, 4 B.A., 2½d. each.
 Square rods, screwed both ends for condensers, 5" 2½d. each 3½" 2d. each, 2½" 1½d. each.
 Round Rods screwed both ends, 3½" 2d., 2½" 1½d. each.
 Washers, 3d. per doz. small 4d. per doz. large.
 Complete Single Valve Receiving Set with coils, less valve, 'Phones, Batter, and Aerial, £8 5s.
 Two-Valve Set, £7 10s.
 Carriage extra. Cash with order.

THE LARGEST STOCK OF 4 B.A. TERMINALS IN ENGLAND.



Actual size

Price, 2 6 per dozen, plated, 3/- brass; 2 B.A. Single, 9d. per dozen.

One valve detector panel complete with filament resistance valve holder, and grid leak and condenser, fitted with insulated terminals, mounted on solid ebonite base in mahogany instrument case . . . PRICE 25/-
 Leading-in Tube, ebonite, R.A.F. pattern with brass rod and fittings. . . PRICE 3/6
 Aerial Real Insulators, tested to 25000 volts . . . PRICE 4
 Accumulator Charging Resistances . . . PRICE 25/
 Universal Tuners. These tuners have been designed to tune in Marconi concerts, broadcasting, and Dutch Concerts, so that a baby can use them. Wavelength range, 300-1,500 metres, with .0005 m.f. condenser, . . . PRICE 7/-
 4,000 ohm phones, new patent 3-magnet type, fitted cords and tags, complete with nickel plated head bands . . . PRICE 35/-
 Transmitting Keys, G.P.O. pattern, fitted platinum contacts . . . PRICE 5/-
 Valve Holders, fitted in solid ebonite, fixing case drilled fitted with valve earthing clip . . . PRICE 2/6
 Grid Leaks and Condensers, mounted on solid ebonite . . . PRICE 5/-
 Instrument Cases, solid mahogany, 9" x 6" x 2½", highly finished, fitted ebonite panel, undrilled . . . PRICE 8/
 Pos. age extra on all the above prices.
 The trade supplied. Enquiries so cit. J.

J. LIPOWSKY, 614, Old Ford Rd. Bow, LONDON, E.3 'Phone: East 3345



MITCHELL-PHONE HEADGEAR.

Over 27,000 pair distributed to the trade in three months, is sufficient guarantee to quality. Although not quite as illustration (a new mechanical improvement being fitted) they are comfortable, highly efficient, and sold on a money back basis.

35/- Pair.

IMMEDIATE DELIVERY FROM STOCK, and the trade should grasp the opportunity without delay. **GOOD DISCOUNTS**, and the quality is such that you will obtain many **REPEAT ORDERS**. **SHIPPING ORDERS A SPECIALITY.**

MITCHELL'S ELECTRICAL & WIRELESS Ltd.
 McDermott Road, Peckham, S.E.15.
 Retail Store, 188, Rye Lane, Peckham, S.E.15.
 'Phones: NEW CROSS 1540/1.

SENSATIONAL REDUCTIONS.

SLAB INDUCTANCES, set of 8, 9/-
 OOJAH make 10/-, post 9d.
 3-plate VERNIER CONDENSERS, 6/-, post 9d
 L.F. TRANSFORMERS, 19/6, post 6d. PHONE TRANSFORMERS 13/6, post 6d
 FILAMENT RESISTANCES for panel mounting, 3/9, post 3d.
 The POPULAR H.T. BATTERY 36v 4/9, post 1/-
 CATALOGUE FREE WITH ORDER.

RADIO, ELECTRICAL & MECHANICAL SUPPLIES.
SCIENTIFIC SUPPLY STORES
 8, NEWINGTON CAUSEWAY,
 LONDON, S.E.1.
 PHONE 4177.

WE ARE THE ONLY FIRM
 WHO SUPPLY INSULATING TUBING COMPLETE WITH TINNED COPPER WIRE AT 6d. PER YARD.

SET OF 7 BASKET COILS (UP TO 4,000 METRES), 6/-
 INDUCTANCE SWITCHES—5 STUD 7/6, 19 STUD 12/6.
 H.F. TRANSFORMER BOBBINS—UNWOUND—2/6.
 VALVE LEGS—TURNED AND LACQUERED, 10d. PER SET.
 L.F. INTERVALVE TRANSFORMER, 19/6.
 5-OHM FILAMENT RESISTANCE, 4/6.
 SPECIAL—AGATE CYLINDERS FOR JONSEN RABECK LOUD SPEAKER, 22/6.

EVLINS Mail Order Office—
 126, FOREST ROAD,
 DALSTON, LONDON, E.8.
 Price List Post Free. TRADE SUPPLIED.

THE WIRELESS WORLD EXCHANGE AND MART

TARIFF. Advertisements are accepted for this Section at the rate of twopence per word, with a minimum charge of two shillings. The advertiser's name and address will be charged for, and single letters and single figures will be counted as words. Compound words will be counted as two words.

WIRELESS AT HOME

Make your own wireless set. We supply all parts. Send two stamps for complete lists of instruments, parts, sundries, etc.

Electrical Supply Stores
5, Albert Terrace, King Cross, HALIFAX.

VELO

EVERY SET TESTED

The name carries a guarantee of the highest quality material and workmanship. If you purchase a set thus guaranteed you obtain the best value for your money and you are assured of obtaining endless pleasure for yourself and friends.

- VELO.—Single Valve Set including Panel, Tuner (200-1,200 metres), Valve, Phones, Accumulator 4-volt, 40 amp., 88 volt. Battery, 100' 7/22 Aerial Wire, Insulators and Pulleys, Receiving Range-Telephony up to 100 miles . . . \$11 11s.
 - VELO.—Double Valve Set (1 detector and 1 L.F.) including all accessories. Receiving range—Telephony up to 200 miles. \$14 14s.
 - VELO.—Triple Valve Set (1 detector and 2 L.F.) including all accessories. Receiving range—Telephony up to 300 miles. \$17 17s.
 - VELO.—Crystal Sets. Wavelengths 200-3,000 metres, including 'phones, potentiometer and aerial . . . \$5 15s.
- Immediate deliveries of all the above and of any parts required for experimental sets. Interval transformers (L.F.) of high finish. Cased, 28/-, Uncased 21/-.
- Spare Telephones—fine British make, 2,000 ohms, 30/-.
- Sent per return on receipt of your order and remittance.

From **H. C. DALY,**
22 Walbrook, London, E.C.4
or Authorised Agents. Enquiries welcomed from the trade.

SITUATIONS VACANT.

Wireless.—Agents wanted all over the country to sell London manufacturers British made apparatus to private persons during the coming boom. Broadcasting is developing daily and big sales can be made. Gentlemen of education of strictest integrity with some electrical knowledge who can give sound references and either deposit Fidelity Guarantee Bond or £25 purely as security (returnable). No cheap or foreign apparatus. No salary or expenses. Ten per cent. commission. Commercial travellers calling on dealers not wanted.—Box E.3, BERTRAM DAY'S ADVERTISING OFFICES, 9 and 10, Charing Cross, S.W.1.

SITUATIONS WANTED.

Experienced Wireless Man, with capital, desires engagement with progressive firm. Full particulars on application to—**RADIO, 6, The Drive, Roundhay, Leeds.**

FOR SALE.

All Wireless and Electrical Goods stocked at 9, Colonial Avenue, Minorics, near Aldgate Station. Handiest place for City buyers—**LESLIE DIXON & Co.** Telephone No. Avenue 4166.

Two 24 H.P. Motor Generators, one 40' Mast Direction Finders, Drafting Instruments, etc. ex Admiralty surplus. Half prices.—**THE LONDON ELECTRIC FIRM, Croydon.**

B.A. Screws, Nuts and Washers, assorted gross 2s., lists 2d.—**J. H. BENNETT, Station Road, Willesden Junction.**

For Sale.—Ebonite— $\frac{1}{4}$ ", $\frac{3}{16}$ ", $\frac{1}{2}$ " and $\frac{3}{4}$ ", any size cut, $\frac{1}{2}$ " 3s. 6. per square foot, other sizes in proportion. Carriage paid on ros. lots. Scrap Ebonite Sheet suitable for condensers, insulators etc., 3s. per lb., postage 8d. New Hart Accumulators in 2-volt units—2v. 40 amp. (1) 14s. 6d.; (2) 28s.; 2v. 60 amp. (1) 17s., (2) 33s.; 2v. 80 amp. (1) 20s., (2) 38s. Carriage forward. Aerials—Rubber covered on wind-up reels, with 2 R.A.F. ebonite insulators, 2s. 6d. each, postage 9d. Valveholders—Best quality, 1s. 9d.; cheaper quality, 1s. 6d., screwed legs. "Ora" Valves—15s. each. Postage 3d.—**RENSHAW & MARSDEN, Penny Street, Blackburn.**

Aerial Wire.—Our Speciality 7/22 Hard Drawn Stranded Copper, guaranteed, 100' 5s. 3d.; 140', 7s.; 100 yards, 13s. Carriage paid.—**FAIRBROTHER & Co., Vulcan Street, Leeds.**

New Wireless List Ready, post free. Write now.—**THOMPSON, 5, Westborough, Scarborough.**

Wireless Masts.—Improved Girder Type. Light and strong. 30 to 50 ft. at 1s. ft. 50 to 100 ft. at 1s. 6d. ft. Cash with order, carriage forward.—**F. ARMSTRONG, Weybridge.**

Wireless Instrument Cases, Walnut or Mahogany, finest finish, 12" by 7 $\frac{1}{2}$ " by 4" (outside), 8s. 6d. Second quality, 7s. 6d. Any size proportionately, prompt delivery. Trade inquiries invited.—**HITCHCOCK, Colchester.**

Two-Valve Amplifier.—One High Frequency, one Rect. comprising ebonite panel mounted mahogany, 45s. 1,000 metre transformer, 6s. Slab coils, 9s. set.—**E. G., 81, Church Street, Stoke Newington, London.**

Mark III Star Receiving Instrument.—Quite new. Never been used. Best offer.—**CARTER, Gleneagle Mansions, Streatham, London.**

For Sale.—Marconi wavemeter, complete, £5. Also Weston relay, £2 or nearest offer.—**Box D.3, BERTRAM DAY'S ADVERTISING OFFICES, 9 and 10, Charing Cross, S.W.1.**

Variable Condenser, 0-001 mfd., 23s. 6d.; copper aerials, 4s. 6d. 100'; reel insulators, 3d.; terminals 1s. 9d. dozen; 4,000 ohm headphones, 30s.; 24 S.W.G. enamelled copper, 2s. 6d. lb. Price list.—**CONWY KIRKHAM, 2, Whitworth Terrace, Rusholme, Manchester.**

Cabinet Valve Receiver. All accessories, new, £9.—**RAHA, 21, Cromwell Road, London.**

"Eyrelectron" Wireless Battery, 15 Volt, 3s. 3d. carriage forward. 60-Volt, 11s. carriage forward. Wide range of voltageappings on each size.—**EYRE Co., South Yardley, Birmingham.**

Accumulator C.A.V.—4 Volts 100 Amp. Charged, metal case, nearly new, £2.—**MILLARD, 7, Barton Street, W.14.**

Fifteen Glass Jars, 5 $\frac{1}{2}$ " by 4 $\frac{1}{2}$ ", inside and 10 $\frac{1}{2}$ " deep. Complete with wooden trays, 20s. Three Marconi Leyden Jars, believed to be one quart. All in good condition, 5s. One 4-in. spark coil with platinum contacts polished mahogany base, as new, £3 10s. One transmitting aluminium Helix polished mahogany woodwork, as new, 7s. 6d.—**HEPWORTH, Moorings, Dovercourt.**

4-Valve Receiving Set, complete except batteries, 300-3,000 metres, £15.—**W. A. SMITH, 15, St. Julians Road, Kilburn.**

Wireless Double Headphones.—2,000 ohm, 27s. 6d. complete. Money returned if not satisfied.—**DIRECT WIRELESS SUPPLY, 49, Heaton Road, Peckham, London, S.E.**

Variable Licon Condensers, New, accurate adjustments, 0-0005, 9s.; 0-001, 12s. 6d. Money returned if dissatisfied.—**THOMAS, Redbourn, St. Albans.**

STAR DELTA WIRELESS SUPPLY COMPANY

INSTRUMENTS TESTED FREE.

The House For All Wireless Accessories
Have You Called? If Not, Why Not?

383a, Oxford Road, MANCHESTER.

I Buy Wireless Gear of every description.

Send your particulars to:

WILKINSON,
Lonsdale Rd., Kilburn, N.W.6
SAME ADDRESS SINCE 1900.

PURCHASE YOUR WIRELESS REQUIREMENTS THROUGH

The Viper Re-Covering Co., Ltd.
7/8, POULTRY, E.C.2.
(1 minute from Bank) Tele.: City 1897

Marconiphones, Sterling and R.F.H. Sets, etc., can be supplied. Place your orders NOW.

HEATH & Co., Ltd.

Instrument Works, New Eltham, S.E.9 are prepared to undertake in their fully equipped works—**Wireless Apparatus and Parts for the trade.** Quotations given to Blue Prints. Immediate attention.
Phone—Lee Green 301. Wire—Polaris, London.

CONNOLLY, BROTHERS

WIRELESS APPARATUS MANUFACTURERS,
LOSTOCK RD., URMSTON, MANCHESTER.
Spares & Complete Components at Trade Prices.
Examples: 50' x 6' Double Wire Aerial, 40' Lead in, ready for fixing, 17/8. 7/22 Stranded Wire, 4d. per foot. 2" Reel Insulators, 4 $\frac{1}{2}$ d. each. 4" x 12" Wound Inductance Coil, 4/9. 28's Enamelled Wire, 1 $\frac{1}{2}$ lb., 2/-, 1lb., 3/8.
CARRIAGE PAID, ON ORDERS OVER £2.

THE UNIQUE N.M.C. (Wireless Patents)

Two-valve Receiving Unit, combining Filament Resistance, Aerial, Tuning Inductance, Aerial Tuning Condenser, Grid Tuning Inductance and Oscillating Condenser, complete in polished case, 12" x 8" x 6", 28 6s. less Valves.
The Set to obtain maximum efficiency. N.M.C. 4,000 W., Double Head Gear, 35/- Inductance Tubes.
All Experimenters' Supplies in Stock.
N. M. CO., 145, Northcote Road, London, S.W.11.

Make your own Cigarette & see what you save.

ALWAYS USE **A.G.** CIGARETTE PAPER

BEST & PUREST

THE WIRELESS WORLD EXCHANGE AND MART

Strawboard Inductance Tubes

2" to 6" dia., for Crystal Sets, etc.
Attractive Prices—Quick Delivery

Enquiries attended to promptly.

A. EATON LEE & CO.,
4, Little College Street, LONDON, E.C. 4
Central 4711. (Nr. Cannon St. Station.)

FOR SALE—continued

Complete Tingey Receiving Set, consisting of C.1, Rx, A3, telephone transformer, two A Coils, 60 volt H.T., perfect condition, brand new, owner building larger set. What offers?—ALLENDEICE, "Ravensbury," Caterham Valley, Surrey.

Tuner Mark III, New. What offers?—Box G.2, BERTRAM DAY'S ADVERTISING OFFICES, 9 and 10, Charing Cross, S.W.1.

Amateur Selling quantity Wireless Receiving apparatus, send for list. Bargains.—Box B.P., BERTRAM DAY'S ADVERTISING OFFICES, 9 and 10, Charing Cross, S.W.1.

Cylindrical Coil Winding Machine, winds up to 6" diameter by 18" long, 7s. carriage paid. Large stocks drills and taps.—R.E.P. ENGINEERING, Robert Street, Sheffield.

Small Parts Supplied from Stock.—Condenser plates, crystal detectors, terminals, spacers, washers, nuts, contact studs and stops, valve legs. List free.—FRASER, Sentinel House, Southampton Row, London.

Wireless Items to Note.—Aerial Wire, 7/22 enamelled, 100' 5s. 6d. 0.001 variable condensers Ivorine scale, pointed. Panel or cabinet, each 16s. 6d. 0.0005 Fittings, as above, 12s. 6d. each. Crystal cups, lacquered, washer and nut 5d. each, 4s. dozen. Ebonite, all sizes, to 4s. 9d. Insulite slides, contact and spring, each 7½d. Inductance tuning switch, best finish, 5 studs each, 4s. 3d. 7 studs 4s. 9d. Terminals, large, best, nut and washer, 2s. 3d. doz. Valve sockets, set of 4 rod. Contact studs, best, nut and washer, 1s. 9d. doz. No 24's enamelled wire, 2s. d., to vulcanite any size, 3s. 9d. lb. Stamp for list Carriage paid over 12.—WRIGHT BROS., Electrical Engineers, 38A, Cross Street, Sale, Manchester.

WANTED TO PURCHASE.

Wanted to Purchase.—Mark 3* Short Wave Tuner. State condition and price.—Box H.1, BERTRAM DAY'S ADVERTISING OFFICES, 9 and 10, Charing Cross, S.W.1.

MISCELLANEOUS.

Expert Advice for the Amateur.—Designs and diagrams, information on all wireless matters. Advice on faults and difficulties. Prospectus post free.—G. P. KENDALL, B.Sc., Wireless Consultant, Moortown, Leeds.

East Ham, Wanstead, Ilford, Manor Park and Forest Gate. Amateurs should not fail to come to the RADIORENDEZVOUS. 709, Manor Park Broadway (over Liptons). Club open till 10 p.m. nightly.

TRADE ENQUIRIES.

Aerials Fixed under supervision of a certified electrical engineer. Masts, spreaders, wire, etc., supplied if necessary.—SMITH & GALEY, Builders and Decorators, Lismore Road, N.W.5. 'Phone, Hampstead, 5858.

Quotations, with particulars required for all parts of apparatus appertaining to Wireless.—BREWER & BRUNT, Radio Dept., Albert Road, Hoylake.

Wireless for All.—Weekly payments or cash. Best make. Cheapest terms.—Stamp, Bush, 119, Sutherland Avenue, London, W.9.

Master Cabinet Maker and Electrical and Surgical Instrument Specialist. Finest workmanship guaranteed. Strictly lowest terms. Let me quote you.—S. L. GEDGE, 6, Torriano Mews, Torriano Avenue, Kentish Town, N.W.5.

EBONITE!!!

SHEET

¾" 4/-; 1" 6/6; 1½" 10/- Sq. foot

BEST PHOSPHOR BRONZE AERIAL WIRE

7 Strand Enamelled 100' 7/6, 150' 10/-

Porcelain Reel Insulators

2" Diam. 4d. Each.

All Postage Extra.

ALL DELIVERY PER RETURN.

Everything for the Experimenter.

HOUGHTON'S WIRELESS AND ELECTRICAL SUPPLIES
HIGH STREET. BLACKWOOD. MON.

RESULTS

Whether as a source of practical information for the Amateur or as a valuable medium for every Advertiser, the **best results** are invariably obtained through the "Wireless World"

For full particulars and advertising rates apply to **BERTRAM DAY & CO., LTD.** Complete Advertising Service, 9 and 10 CHARING CROSS, S.W.1

WE CAN SUPPLY FROM STOCK

- CONDENSER VANES.
- TERMINALS.
- CONTACT STUDS.
- SPACERS SPINDLES.
- VARIABLE CONDENSERS.
- DETECTORS.
- POINTERS.
- LAMINATIONS, ETC.
- WRITE FOR LIST.

Also Spinnings, Stampings and Press Tools made to specifications.

THE GLENFIELD ENGINEERING CO., LTD.

225, Pentonville Rd., London, N.1

Telephone: Holborn 4714.

Climax Bargains.

4,000 ohm coupled head phones, tested perfect, 22s. 6d., half price. Three-valve panel, £3. Valves, 10s. 6d. 0/00r Condensers 21s. Set valve diagrams, 1s. 6d. 4v. 24 ab. Acc/re 12s. 6d., and others, twinbell wire 6s. 100 yards. 8v. 2 amps. dynamos, 17s. 6d. Cash with order. Postage extra.

CLIMAX ENGINEERING CO.
182 Church Street, Kensington. 2023 Park

Your Case Work

Let us quote you for your wireless casework. We are specialists in this class of work and feel sure our workmanship and prices will interest you.

Phone: L.W. 2720.

CARRINGTON & NEWBERY LTD.,
18/20, Norman Buildings, Old Street, E.C.

Enamelled Wires for Wireless.

40 42 44 46 47 S.W.G.
6/6 8/- 12/6 19/6 30/- lb.

AERIALS H.D. Copper.

7/22 7/20
PLAIN 4/- 5/- 100 ft. Coils.
ENAMD. 5/- 6/6 " " "
Silk and Cotton Covered
Prices on Application.

Terms:—CASH WITH ORDER
POSTAGE EXTRA.

HORROCKS & ASPIN,

12, SCHWABE STREET.

RHODES, MANCHESTER.

Northern Wireless Buyers get your requirements from The Grand Electric Wireless Supplies Depot, Ocean Road, South Shields. The Wireless Supplies Depot, 2, Market Place, Morpeth. Large stocks for amateurs making own sets. Burndept 3-valve, Burndept Ultra IV, Tingey 5-valve sets, on view. Free demonstrations. Pay us a visit or send your enquiries.

The Proprietor of the Patent No. 24231, of 1914, for improved receiving system for continuous electric waves, is desirous of entering into arrangements by way of licence and otherwise on reasonable terms for the purpose of exploiting the same and ensuring its full development and practical working in this country. All communications should be addressed in the first instance to—HASELTINE, LAKE & CO., Chartered Patent Agents, 28, Southampton Buildings, Chancery Lane, London, W.C.2.

AGENTS

10,000 IMMEDIATE DELIVERY

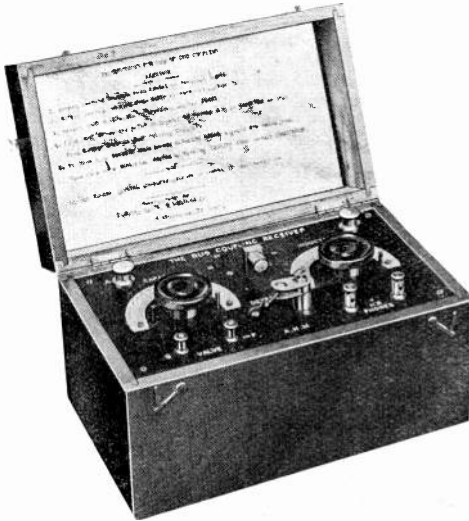

RADIOPHONE No. 2
(Registered Design)

Why Use Outside Aerials ?

There is always danger of aerial coming in contact with live wire when strung over or near power or lighting wires. Then, too, it is necessary to guard against mishap from lightning and some buildings prohibit overhead aerials, because of insurance restrictions. The Super-Antenna unit overcomes all such difficulties.

Safe—Simple—Efficient.

The Super-Antenna is shock proof, will not blow fuses, or damage any receiving set. Has an auxiliary condenser of '0005 mfd. which assures best radio results. Best for receiving wired wireless which, in the near future, will be in use in practically all cities.

Mechanically Perfect.

The Super-Antenna unit tends to reduce static effects because it is scientifically correct both electrically and mechanically. Through a filtering circuit which may be varied by eight separate connections (see below) the power current is cut off from receiving unit and the high frequency radio currents are permitted to pass through to receiving unit.

**Endorsed By All Leading
Electrical Institutions**

WIRELESS EXPLOITATION CORPORATION

BECK HOUSE,

91, Shaftesbury Avenue, London, W.1.

Telephones : GERRARD 1185
 " 1186

Telegrams : "OSOFILMY," WESTCENT, LONDON.
Cables : "OSOFILMY," LONDON.

The "Radiophone No. 2 Crystal Receiver" Set

The Radiophone No. 2 Crystal Receiver Set comprises an Air Dielectric Variable Condenser, '00025 mfd. Variometer type of Inductance wound with double silk covered wire, on Ebonite former. Blocking Condenser '003 mfd. and terminals for Aerial, Earth and Telephones, together with two extra terminals for attaching a valve amplifier if desired.

The detector is composed of brass cup containing a selected and tested specimen of "Radiocite." The upper contact works in a stiff ball socket through which a short brass stem with an ebonite handle and a fine contact wire is attached. These parts are mounted on solid ebonite panel the whole enclosed in a highly polished mahogany carrying case.

Price as above specification **£4 10**
With a set of Dictograph Phones **£6 0**

Super-Antenna Saves Cost of Outside Aerial and Installation

Think of the considerable savings effected by eliminating outside aerial and expense of installing same. Yet broadcasting can be received with the greatest accuracy by simply attaching Super-Antenna plug to any electric light socket. Stations 1,200 miles distant can readily be copied, other units being equal.

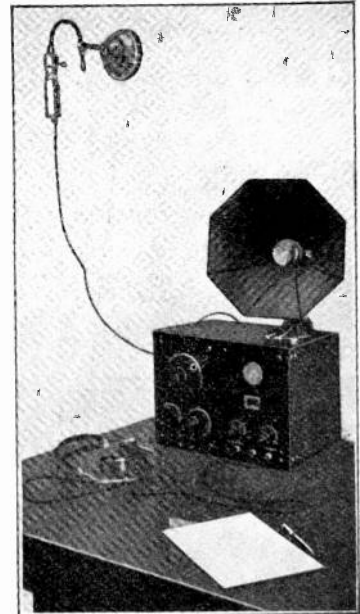

Price 35/-

GENUINE & ORIGINAL

HELLESEN DRY BATTERIES ALL TYPES

KNOWN THE WORLD OVER AS
THE BEST

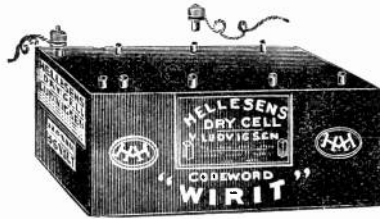

CODewORD: "WIRIT" Size 6 1/8 x 2 1/2 x 3. CODewORD: "WIRIT" 36 volts.

SPECIAL TRADE & WHOLESALE TERMS.

CODewORD	VOLTS	DETAILS	PRICE
"WIRON"	15	Sc ew terminals	4/-
"WIRTO"	15	Strip "	4/-
"WIRIT"	36	2 wander plugs	8 8
"WIRIN"	60	" " "	14/-

ALL LISTS FREE ON APPLICATION.

A. H. HUNT, LTD.
H.A.H. Works, Tunstall Rd., Croydon, Surrey.

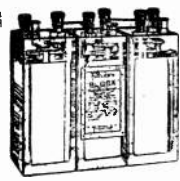

INSIST ON HAVING A
FULLER 'BLOCK' TYPE ACCUMULATOR

FOR YOUR WIRELESS SET!

The only Accumulator on the market that will hold its charge from 12 to 18 months when not in use.

4-volt 40 amp. hours. £1 12 6, plus 1/3 carriage
6-volt 40 " " £2 8 9. " 1/6 "

Note:—These prices are 33 1/3% below those of the actual makers.

8,000 Sold. 20,000 still in stock.

Descriptive and Instructive Pamphlet on request from—

The CITY ACCUMULATOR Co. (Dept. 88)
79, MARK LANE, E.C.3 (Tel. No. Avenue 91)

ALSO SUPPLIED BY—
Selfridge & Co., Ltd., Wireless Section; A. W. Gamage, Ltd., Wireless Dept.; Barnsley British Co-operative Society, Radio Section; Richford & Co., 153, Fleet Street, E.C.3. The South Wales Wireless Installation Co., Ltd., 18, West Bute Street, Cardiff.

AGENTS WANTED IN ALL PARTS.

PETO P-UNITS

Copied but Never Equalled

PETO THE MAN OF PARTS
still offers his original productions.

UNIT No. 3.

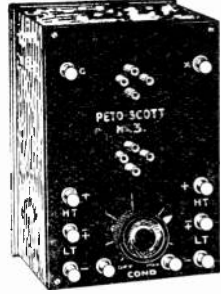

H.F. AMPLIFYING UNIT.

Set of Parts 13/6
Cabinet to fit 3/6

UNIT No. 4.

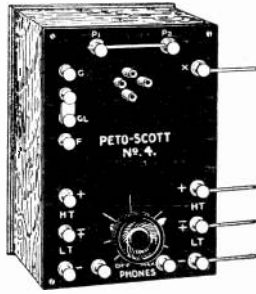

DETECTING UNIT.

Set of Parts 17/6
Cabinet ... 3/6

UNIT No. 5.



L.F. AMPLIFYING UNIT.

Set of Parts 33/6
Cabinet ... 3/6

For Prices of finished Instruments—see Catalogue.

No connections to puzzle over, just push as many units as you can afford, against each other, slip the little rods through and turn a screw, and there you are.

Get our illustrated catalogue post free 6d., with list of transmitting stations and wavelengths.

PETO SCOTT, The Condenser King
64, HIGH HOLBORN, LONDON, W.C. 1.
Also at 17, Frome Road, Wood Green.

A £20,000 DEAL IN WHICH EVERY WIRELESS AMATEUR MAY PARTICIPATE

"BROWN" "A" TYPE RADIO HEADPHONES

Guaranteed new and unused. NOT re-conditioned.

120 ohms.
42/6

Maker's Price 58/-



8,000 ohms
49/6

Maker's Price 66/-

SULLIVAN 8,000 ohms, ... **36/6**

Why pay the full price and wait weeks for delivery when we can supply from stock at less than trade price? Terms cash with order. Postage 1/- extra. Approval for 7 days. Trade enquiries for quantities solicited.

FULLER "BLOCK" TYPE ACCUMULATORS 4 volts, 4 amp., **32/6**
the only practical battery for wireless.

THE CITY ACCUMULATOR CO.
79, MARK LANE, E.C.3.

Phone: Avenue 9r. Telegrams: 'Tyche, Fen, London.'

WE SPECIALISE
IN
EBONITE
EQUIPMENT
FOR
WIRELESS SETS

SHEETS : TUBES : PANELS
KNOBS, CONDENSER COVERS
WHOLESALE ONLY
FROM STOCK

HIGHTENSITE LTD.
Normandy St., Custom House, E. 16

'Phone: EAST 3153.

WE WANT YOUR ADDRESS

Therefore we offer all Wireless Enthusiasts the 14 bargains as under

- | | |
|---|---|
| Aerial Wire, phosphor bronze, stranded, per 100 ft. ... 5/6 | Fixed Condensers, all values, Mica and Copper ... 1/6 |
| Cheaper quality, 3/20s ... 3/6 | Phones, 4,000 Ohms Double ... 37/6 |
| Flash Lamp Refills 7d. | 1" Square Brass Rod, per ft. ... 6d. |
| 16 Volt H.T. Units 3/9 | Contact Studs, 1" head, 1d |
| Grid Leaks, all values 2/3 | Ebonite, finest quality, per lb. ... 3/11 |
| Polished Ebonite Valve Sockets ... 1/4 | Filament Resistances, 3/8 Condenser Plates, per doz. ... 11d. |
| Valve Legs, set of 4, with Nuts and Washers 9d. | |
| Phones, 8,000 Ohms, Double ... 32/6 | |

The first 100 orders received will be despatched with 1 set of Ivorine Tablets, absolutely free of cost.

THE "BRUNSWICK" CRYSTAL SET, SPECIALLY DESIGNED TO REACH LONG DISTANCE STATIONS, ALSO "BROADCASTING" STATIONS ... 29/6

4' x 10" Inductance. Enamelled Wire. Two efficient Sliders. Copper, Mica and Ebonite Condenser. New type Universal Detector. Polished woodwork. Mounted on polished baseboard. All brass parts lacquered. Ivorine tablets—"aerial", "earth" and "phones." Set of parts ready to assemble, 22/6. Carriage extra.

The SCIENTIFIC WIRELESS CO.
188, BRUNSWICK STREET
OXFORD ROAD
MANCHESTER Cent. 6839
Phone

OUR MONEY BACK GUARANTEE goes with every Condenser we send out.

For the convenience of those Amateurs who prefer to make up their own Variable Condensers we are offering complete sets of parts, ready to assemble, no drilling or fitting required, at hitherto unheard of prices, in the following Capacities:

- | | | | | | |
|-------|------|--------|-------|-------|-------|
| .0015 | .001 | .00075 | .0005 | .0003 | .0002 |
| 21/- | 17/6 | 15/- | 10/- | 8/- | 7/- |
- For Assembled add 2/6 to price of each model except .0015 and .001 which are 4/6 extra.

The above are for Panel mounting and, at the price, are absolutely the best Condenser value on the market. With Engraved Ivorine Scale, 1/3 extra. Mounted in Mahogany polished Cases, 4 1/4 x 4 1/4 x 3 1/4, with ebonite top and knob, scale and pointer, .0003, 12/6; .0005, 16/-; Vernier Condensers, unmounted, 3 plates, 4/-; 5 plates, 4/9.

Buy from the makers and save middlemen's profits. Post Paid on £1 Orders

W. J. FALLON & Co., The Condenser People,
230a, HERMITAGE ROAD, LONDON, N.4.

ACCUMULATORS

Absolutely Guaranteed Best Quality

CELLULOID CASES

4 volt	40 amp.	18/6	4 volt	80 amp.	28/2
4 "	60 "	21/6	4 "	100 "	30/-
6 "	40 "	26 3	6 "	80 "	37/8
6 "	60 "	31.9	6 "	100 "	41/6

PACKING FREE.

SPECIAL PRICES TO TRADE
for quantities on application.

SPECIAL OFFER

6 volt 40 ACTUAL AMP. SET three glass cells sealed tops in well-made TEAK crate, a handsome set @ 49/6.

4 volt 24 amp., celluloid cases, 11/9, postage 1/-
2 " 16 " ebonite cases, 3/9 each, post free

AERIAL WIRE, 5/- per 100 ft. Coil.

ALL SIZES of ACCUMULATORS QUOTED FOR
Dynamos, Motors, Electrical Accessories.

Write for Lists.

F. Yates & Son, Ltd. Wholesale Electricians
144, Church Street, Kensington, London, W.8
(One minute from Notting Hill Gate Station.) Phone-Park 4276

"CASTAPHONE"

(REG. TRADE MARK)

**CRYSTAL W/T
RECEIVING SET**

PRICE

65/-

British Valves :—"R." 26/6; "R.M.R.," 15/-.

S. or E Aerial Wire, 7/22, 100 ft., 6/6 ; 150 ft., 9/-

H.T. Batteries :—36 volt, 8/- ; 60, 14/- ; 75, 16/-

Ball and Socket Detector, 4/9 ; "Egg" Insulators, 5d.

"HERTZITE"

MOUNTED IN PATENT DETECTOR

5/6

POST FREE

RUSSELL AND SHAW,
38, Great James St., Bedford Row, W.C.1

LESLIE McMICHAEL LTD.

PROVIDENCE PLACE, WEST END LANE, KILBURN, N.W.6

Bus Services 1, 8, 16, 28, 31 all pass West End Lane

Telephone: HAMPSTEAD 1261 Nearest Tube Station: KILBURN PARK (BAKERLOO)

FOR EVERY WIRELESS REQUISITE

Illustrated Catalogues 6d. Post Free.

SECOND EDITION.

"THE CONSTRUCTION OF WIRELESS RECEIVING APPARATUS"

By PAUL D. TYERS. 1/6 NET.

From all Wireless Dealers or by return Post Free from

RADIO PRESS LIMITED,

Publishers of Authoritative Wireless Books,

34/35 Norfolk Street, LONDON, W.C.2

The huge sales of this book are due to the fact that it contains the information that the amateur wants. It is essentially a book for the EXPERIMENTER. It explains how the various parts of a valve or crystal set can be made without the use of a lathe or expensive tools. It tells you how to make such things as grid leaks, filament resistances, etc. etc.

The first edition only LASTED about ONE WEEK.

TENTH THOUSAND.

I HAVE IN STOCK

**5000 BROWN'S
PAIRS** (120 ohms) "A" PHONES

NEW AND UNISSUED

POST FREE 40/- PER PAIR

CASH WITH ORDER

WILKINSON, Lonsdale Rd., Kilburn,
TRADE SUPPLIED (Same address since 1900) N.W.6

WE PUBLISH PRIZE WINNERS, Issue 29th July, 1922

Question: "Why was Sol annoyed" (Solenoid).

One of our Single Valve Panels has been sent to: Mr. C. C. Junson,

The White Cottage, Carlton Road, Weymouth,

for the following:

"Because he (a Jew) was placed next to the (H)Ammeter."

Aerial Wire, 7/22's, Enamelled Hard Drawn Copper, 6/- per 100'

Aerial Pulleys, 2 3/4" 1/-, 5" with tackle hook and bucket, 2/6.

Aerial Insulators, Shell Type, 2 1/4" x 2 1/4", 1/6 each.

Aerial Insulators, Reel Type, 2" diam. white, 4/1 each.

Batteries. For H.F. Make your own. Flash Lamp Batteries, 5/- doz.

Buzzers for Morse practice, new improved line, best quality, 4/6.

Condenser Discs, Ebonite, 3 3/4" diam., 1/- each

Condenser Dials, engraved, fine finish, 2 1/2" diam., 1/9 each.

Condensers. Fixed. Exceptional quality. Made with copper foil. From 0001 to 001. 2/6 each.

Condenser Vanes. Not rubbish. Best strong aluminium. Fixed 3 1/2", Moving 2 1/2". 1/- doz.

Condenser Spacing Washers. Remember they must be accurate. Small 4d. doz. large 6d. doz.

Condenser Screwed Rod. Brass 12" lengths, 2 B.A. or 4 B.A. 6d. each, 2 B.A. and 4 B.A. nuts 7d. doz., 2 B.A. and 4 B.A. washers 2d. doz.

Contact Studs. Studs, not rubbish, 1/6 doz. Copper Foil Sheets. 9" x 3 1/2", 4d. each.

Core Wire. Soft iron, 2/4 per lb.

Ebonite. Best quality. Any size, rod or sheet, 5/- per lb.

Filament Resistances. For Panel mounting with knob pointer and good contact. A speciality. 4/- each.

HEAD RECEIVERS. Light, sensitive, of good design and superior finish. Tested and guaranteed perfect. Complete with cords. 140 ohm 30/- each., 4,000 ohm 32/- each., 8,000 ohm 33/- each. Postage 9d. each. Illustrated pamphlet, 3d. each.

Inductance Tubes. 12" long. Specially impregnated, 2 1/2" 6d., 3" 7d., 3 1/2" 8d., 4" 10d., 4 1/2" 1/-, 5" 1/2, 6" 1/6 each, Postage 9d. each.

Inductance Slider Rod. 1/2" square in 13" lengths. Not jagged but smooth. 6d. each.

Insulating Tubing, 6d. per yard.

Ivory Scales. 0 to 180°. Engraved (Not printed), 1/2 each.

Ivoryine Tablets. Set of six. 9d.

Knobs. Ebonite. 1 1/2" diameter. Superior finish. Knurled, 7d. each.

LOUD SPEAKERS. Exceptionally efficient. 70 ohm, 2,000 ohm, 4,000 ohm £2 10s. each.

Mica. Pure Ruby. Pieces. 3" x 3" x .002" thick, 6d. each.

Paraffin Wax. 1/- per lb.

Resistance Wires. "Elsi" brand 22's (1 ohm per yard), 24's (1.7 ohms per yard) and 28's enamelled (4 ohms per yard). 2d. per yard.

Switch Arms. Exceptionally strong and well made, 2/6 each.

Terminals. A very neat wireless terminal. Polished complete with nut and washer. 2/6 doz.

Tin Foil. Free from lead. Sheets, 26" x 13", 4d. each.

Valve Sockets. With nut and washer. Fine finish, set of four, 9d.

Valve Holders. Best quality ebonite, with nuts, 1/4 each.

Wood's Metal, 8d. per packet.

CRYSTALS. Carborundum, Copper, Pyrites, Galena, Bornite, Iron Pyrites Silicon, Manganese, 8d. per packet.

SUPERIOR QUALITY WIRE. British made. All wire wound free. Post extra.

S.W.G.	S.C.C.		D.C.C.		Silk		Enld.
	Single	Dble.	Single	Dble.	Single	Dble.	
12	1/10	1/11	4/-	5/4	1/8		
14	1/11	2/-	4/-	5/4	1/9		
16	2/-	2/1	4/2	5/6	1/10		
18	2/1	2/2	4/4	5/6	1/11		
20	2/2	2/3	4/8	6/2	2/6		
22	2/6	2/11	5/-	6/8	2/8		
24	3/-	3/6	5/6	7/4	2/8		
26	3/7	4/1	6/8	8/2	3/2		
28	4/4	4/7	7/2	9/-	3/6		
30	5/-	5/6	8/-	10/-	3/10		
32	6/-	7/3	9/2	13/-	4/2		
34	7/-	8/3	11/6	14/-	4/4		
36	8/8	10/2	14/-	15/6	4/8		
38	11/3	13/2	16/-	19/-	5/3		
40	15/-	18/-	18/6	22/6	6/6		
42	17/3	21/-	31/6	34/-	9/-		

At per lb.

Carriage extra. Please remit ample postage, balance returned. Orders over £2 carriage paid. Money back if not satisfied.

J. L. CARTWRIGHT & CO., Manufacturing Electrical and Radio Engineers

*Phone—Cent. 4209.

Dept. W. 130/132, LONDON ROAD, MANCHESTER.

*Grams—Pladuram, Manchester.

Special Terms to the Trade.

Works: BERRY STREET

No Catalogues yet.



HIGH TENSION DRY BATTERIES

for WIRELESS SETS

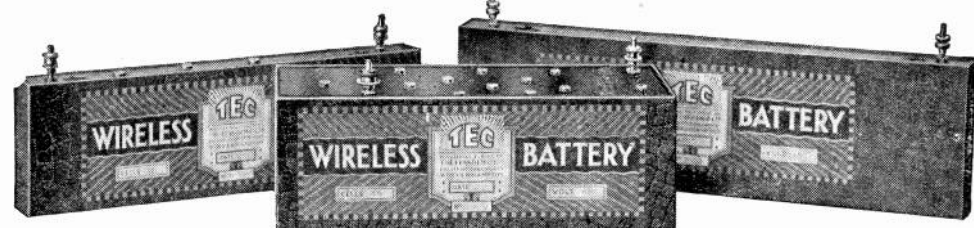

NORMAL SIZE, No. W 70 V, 15 Volts
Price 5/-

W 71 V, 50 Volts
Price 15/-

GIANT SIZE, No. W 75, 15 Volts
Price 6/6

SUPPLIED IN TWO SIZES FOR 15, 50 or 60 VOLTS.

and with Tappings in 3 Volt Steps.

ALL BATTERIES FITTED WITH PLUG SOCKETS AND MOVABLE TERMINALS.

Complete Illustrated Price List on Application.

THE EFANDEM CO., LTD., FALLINGS PARK WORKS,

DRY BATTERY MANUFACTURERS—WOLVERHAMPTON

For they are jolly good- -FELLOWS



Fellows Head Telephones,
4,000 ohms.

two earpieces in light die cast
non-ringing metal.

Price 30/- per pair.

Deliveries. Immediate against cash
with order.

Manufacture. The same high
grade workmanship as the Fellows
Magneto.

Send your order to-day. (Cheques,
P.O., P.O.O. or M.O. to be crossed
London Joint City & Midland
Bank, Ltd.)

Trade terms for quantities on request.

FELLOWS MAGNETO Co. Ltd.

LONDON, N.W.10.

Telephone:
Willesden 1560-1.

Telegrams:
Quixmag, Phone, London.

*For all Radio Apparatus and Com-
ponents.*



To ensure the
earliest attention
send this page
with your order.

And so say all of us

North Wales Wireless College & Amateur Supplies

COLWYN BAY. Phone 407.

Most Complete Stock of all Wireless Instruments and Accessories.
PROMPT DELIVERIES.

LIST BY RETURN. **14d. STAMP.**

Students prepared under ideal conditions as Wireless and Cable Operators
POSTAL AND RESIDENTIAL TUITION.
SPECIAL POSTAL COURSE FOR AMATEURS.
PROSPECTUS POST FREE.

WIRELESS



**RECEIVERS
REWOUND**

4000 Ohms
AND UPWARDS

PER **12/-** SET

G TURNOCK 41 HIGH ST ASTON BHAM

FOR YOUR AERIAL



10/6

100 ft. 7/22 COPPER WIRE, 4 REEL INSULATORS, 20 yd. SKEIN ROPE CORD, 1 MAST PULLEY, LEAD-IN-TUBE. COMPLETE

Post free British Isles.

Henry J. Brewster & Co.
11, Queen Victoria St., London, E.C.4



**TUBE, SHEET,
WIRE, STRIP,
ROD & CASTINGS**

IN
**PHOSPHOR BRONZE,
COPPER, BRASS, &c., &c.**

**CHARLES CLIFFORD & SON, LTD.,
BIRMINGHAM.**



SKINDERVIKEN BUTTON.
A Supersensitive Microphone.
Known all over the world and patented in every civilized country. Over 60,000 sold. **ENGLISH** Manufacture.
Make up your own Loud Speaker.
Transmit your GRAMOPHONE music to any room in your house.

The only practical Microphone for use in Detectophone Sets.

Price 5/- each

Special Low Resistance Receivers (for use with Skinderviken Buttons) 10/- each
Special Gramophone Attachments 1/-

Write for 16 page **BOOKLET** fully illustrated and containing much useful information for all interested in Electrical Sound Transmission. 6d. Post free.

Sole Proprietors:
MIKRO LTD., 274/6, Pentonville Rd., London, N.1
(Opp. King's Cross (Met.) Rly Station).

F. WIGGINS & SONS

Telephone :
MICA Avenue 2248

Largest Stock
in the World.

**FOR CONDENSERS
AND ALL PURPOSES.**

102, 103 & 104, Minories, London, E.1

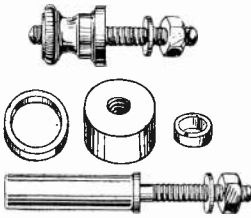

**MANUFACTURERS
and RETAILERS**

promptly supplied with
**Terminals, Screws,
Valve Legs, Spacers,
Nuts, Washers, &c.**

Prices Right. Quality Right

APPLY FOR TRADE TERMS

The ORMOND ENGINEERING Co.
199, PENTONVILLE ROAD, LONDON, N.1
Phone: HOLBORN 1812.

PHONES (Pair complete. Guaranteed) 30/- CRYSTAL SET 37/6

Special Wireless Telephones, 4,000 ohms, **30/-** post free. Receiving Set on Mahogany base, single slide Tuning Inductance, Fixed Condenser, Crystal Detector, Terminals, **40/-** post free. Valveholders in Ebonite, first quality only, 1/-.

I. K. STEVENS & Co. Wireless Section, 32a, Chester St., Grosvenor Place, S.W.1
Trade Inquiries Invited. Phone—Victoria 5837

IMPORTANT— —NOTICE

A. C. COSSOR, Limited, hereby give notice that the order of Mr. Justice Russell of the 1st March, 1922, continually advertised by the Marconi Co., was an order **ARRIVED AT BY CONSENT.**

Being engaged at the time in the production of an improved and different type of valve, A. C. COSSOR, Limited, did not consider the patents in question of sufficient importance to warrant the expense of litigation.

A. C. COSSOR, Limited, respectfully leave the public and the Trade to judge whether the constant repetition of the notification of the judgement referred to is necessary or expedient in the circumstances.

A. C. COSSOR, LIMITED
Aberdeen Works, Aberdeen Lane,
Highbury Grove, N.5

WIRELESS

Take advantage of our 14 years' experience of Wireless. Build your own receivers. We can supply all parts, and show you how to do it.

JAMES FRASER & CO.
(In collaboration with E.T.C. Address as below)

SCHOOL INSTRUCTION

Day, Evening and Postal courses in Wireless, Valves, etc. P.M.G. (Exam.), and amateur classes. Also Cable and Telegraphy. Prospectus from

'Phone : North 1036. Principal :
ELECTRICAL TRAINING COLLEGE,
Radio House, Manor G'dns, Holloway, N.7

THE LONDON RADIO CO.

Manufacturers of Wireless Requisites

Valve Holders, all types - 9d. each
Rheostats - - - - 2/9 ,,
Switch Knobs, screwed - 2½d. ,,
Condensers, Variable, from 5/- to 21/-

Ebonite Panels cut to any size

Buy from the actual manufacturers.

1, Lonsdale Rd., Kilburn, London, N.W.6

Cash with order.

Postage and packing extra.



VERNIER ADJUSTMENT FOR SLIDERS

Complete with 13 in. bar.
Bar and Slider - 4/6

TELEPHONE TRANSFORMERS

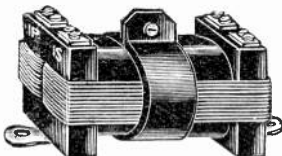

Unmounted (as illustration),
Suitable for 120 w Phones.

Unmounted - - - - 15/-
In Box with Terminals - - 18/6

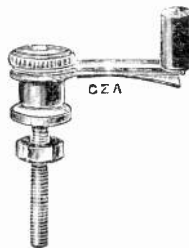

Neat "ON" and "OFF" Switches

As illustrated - - - 2/3

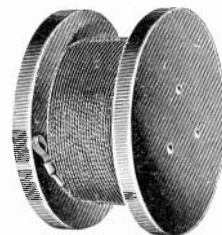

AERIAL WIRE

7/22 Enamelled Stranded.
100 ft. - - - - 6/-
150 ft. - - - - 9/-

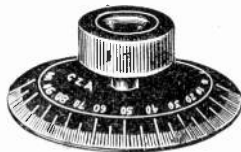

CONDENSER SCALES

Engraved 0-180°
With Knob and Bush - - - 3/9

SINGLE LAYER COILS

4½ in. diam. 9 in. long.
Wound with 24 Enamel.

Price - 6/6

G. Z. AUCKLAND & SON, 395, St. John Street, E.C.1
'Phone - - - 3173 CLERKENWELL.



Ward & Goldstone
 PENDLETON MANCHESTER LTD

We have the Goods to meet and satisfy the Boom!

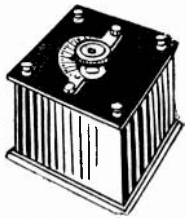

—TRADE ONLY—
Send for List A/23
 containing full particulars and illustrations of our wide range of complete CRYSTAL and VALVE RECEIVING SETS, and full range of Electro Supplies for Wireless INDISPENSABLE TO THE TRADE.

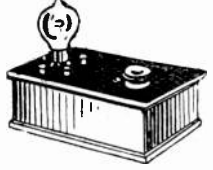
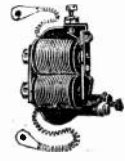

---CQ Std bi
for ERICSSON PHONES

WHEN you instal your wireless set—crystal or valve —you'll get maximum results if you fit Ericsson Phones—clarity, sensitivity, strength of signals and absence of "click." Specially suited to telephony. Ericsson Phones embody the accumulated experience of telephone manufacture for a generation. Easy to the head, light and comfortable. The magnets never lose their strength and "shorts" are non-existent.

Write for Particulars
 The BRITISH L. M. ERICSSON MANUFACTURING Co., Ltd.
 Head Office:
 60, Lincoln's Inn Fields, E.C.2

Ericsson
Telephones

They F.A.L.L. into Position:

PARTS **"K.B."** FOR
CONDENSERS.

Points to Note.

Moulded Top and Bottom Ebonite Plates.
All Vanes Guaranteed FLAT.
All Parts clear of Burrs, etc.
No Protecting Supports on Top.

RESULT.

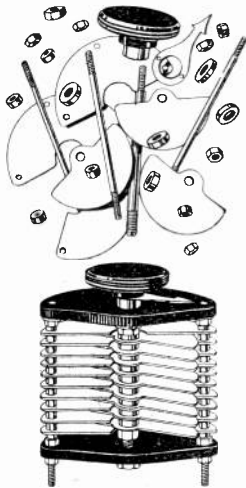

PRICES:

For Panel Mounting.		In Pol. Mahogany Cabinet.	
Capacity.	Set of Parts.	Assembled.	
'0015	27/-	30/-	38/6
'001	21/-	24/-	31/6
'00075	17/-	20/-	26/-
'0005	14/-	17/-	22/6
'0003	11/-	14/-	18/-
'0002	8/-	11/-	16/-
'0001	7/-	10/-	14/6
'00005	3/6	5/-	9/-

ENGRAVED EBONITE DIAL 3/3 extra

Large Stocks now in hand. Complete Sets, Units and

ALL AMATEUR REQUIREMENTS.

IMMEDIATE DELIVERY.

CATALOGUE—Post free 4d.
(Carriage Extra on Orders under £2)

Trade Enquiries Invited.

The "K.B." Radio Equipment Company,

Head Offices & Showrooms: **109 High Road, Kilburn, N.W.6**

Bus Services— 3 minutes Kilburn Park Station
(Bakerloo Rly.).
8, 16, 28 & 51 Pass Door.

TELEPHONY RECEIVERS

TWO-VALVE RESISTANCE AMPLIFIER.—Will receive all wavelengths from 180 metres to 30,000 metres. Perfect for telephony. Mounted in French polished mahogany cabinet with ebonite top. Perfectly simple, and can be operated by anyone. Finest workmanship and finish.

Every instrument tested and guaranteed to give perfect results.

PRICE — 2-valve £5, 3-valve £6.

One-valve panel. A very superior instrument. Price 28/-.
Illustrated Catalogue, 3d., post free.

LEWIS POLLARD,

MANUFACTURER OF WIRELESS INSTRUMENTS,

209, Cunliffe Road, BLACKPOOL.

WITH GOOD APPARATUS YOU
CAN GET GOOD RESULTS

THE "W.P."

Morse Practice Key

Well Made. First-class Finish. Thoroughly Reliable

Price **7/6** Post Free

THE WIRELESS PRESS, LTD.

12-13 HENRIETTA STREET, LONDON, W.C. 2

SOMETHING NEW

COLOURED HIGH FREQUENCY TRANSFORMERS

Interchangeable type to fit standard valve holders.

These transformers are manufactured from a new insulating material, with equal insulation properties to ebonite, and are supplied in various colours to quickly distinguish the wavelengths. The various coloured transformers will improve the appearance of your receiver and relieve the dull monotony of an ebonite panel. Supplied in white, green, red, amber, and blue.

Unwound formers fitted with split pins,
4/- to 5/6 EACH, postage extra.

The trade supplied.

LEWIS POLLARD,

Manufacturer of Wireless Instruments,

209, CUNLIFFE ROAD, BLACKPOOL.

**Questions and Answers
COUPON**

To accompany Questions
sent in during the week
commencing Aug. 19th, 1922.

VOL. X, NO. 21.

See Conditions on Page 670.

WIRELESS

Large or Small Contact Studs	..	doz.	1	0
Valve Legs, complete with nut and washer	..	each	3	3
Hart Accumulators, 4-volt, 24 amp. hour	..	each	14	9
Postage and Packing extra	..	each	1	3

STILL THE CHEAPEST FIRM FOR WIRES.

S.W.G.	S.C.C.	D.C.C.	Single Silk	F. bl. Silk	Emd.
12	1/10	1/11	4/-	5/4	1/8
14	1/11	2/-	4/-	5/4	1/9
16	2/-	2/1	4/2	5/6	1/10
18	2/1	2/2	4/4	5/6	1/11
20	2/2	2/3	4/8	6/2	2/6
22	2/6	2/11	5/-	6/8	2/8
24	3/-	3/6	5/8	7/4	2/8
26	3/7	4/1	6/8	8/2	3/2
28	4/4	4/7	7/2	10/-	3/6
30	5/-	5/6	8/-	10/-	3/10
32	6/-	7/3	9/2	13/-	4/2
34	7/-	8/3	11/6	14/-	4/4
36	8/8	10/2	14/-	15/6	4/8
38	11/3	13/2	16/-	19/-	5/3
40	15/-	18/-	18/6	22/6	6/6
42	17/3	21/-	31/6	34/-	9/-

At per lb.

All orders of 1 lb. or over wound on reels free. For less than 1 lb. reel 3d. extra.

Further Lists on application. Trade Supplied. Postages extra.

J. B. Bower & Co., Ltd.

Wireless Manufacturers,

15, Kingston Road, WIMBLEDON, S.W.19

'Phone : Wimbledon 1030. Works : Merton

Sterling Wireless Receivers

Price 31/- pair



Specification.

Double Head Telephone Receiver. Specially designed for Wireless Telephony. Excellent articulation. Single Pole piece central operation diaphragm. Case of aluminium with swivel and trunnion movement. Headbands of steel cosletized to prevent corrosion and are adjustable. Each set complete with 6 ft. best quality flexible cord, weight 10 oz.

2000w.

First quality at moderate prices

Immediate Delivery. Also 4000w. 32/-.

Price 31/-, Postage 1/- LIBERAL TRADE DISCOUNT.

RADIO SERVICE CO., LTD.

62, OXFORD STREET, W.1.

Telephone : Museum 2136.

Works : Church St., Stoke Newington, N.16.

The Construction of Amateur Valve Stations

By ALAN L. M. DOUGLAS

78 pages. 55 Diagrams and Illustrations.

PRICE **1/6** NETT.

(Postage 2d.)

The aim of the author in compiling this volume has been to place within the reach of the amateur who is interested in Wireless Telegraphy and Telephony a Handbook which will enable him to obtain data that he has otherwise difficulty in acquiring, in order that he may construct for himself apparatus which he desires to make, but does not quite know how to design correctly.

The Wireless Press, Limited

12-13, Henrietta Street, Strand, London, W.C.2

BINDING CASES

(INCLUDING INDEX)

VOL. 9

The Wireless World

Price **3/6** nett.

(Post free 4/-)

INDEX (SOLD SEPARATELY)

Price **8d.** Post free.

THE WIRELESS PRESS LTD.

12-13, Henrietta St., Strand, W.C.2

Just Received!

AMERICA'S LATEST PUBLICATIONS FOR THE WIRELESS EXPERIMENTER.

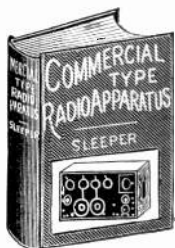

HOW TO MAKE COMMERCIAL TYPE RADIO APPARATUS

By M. B. SLEEPER.

Price **4/-** net (post free 4/3).

The experimenter will be able to get a world of ideas for the design and construction of his wireless apparatus from the very clear descriptions and ninety-eight illustrated figures.

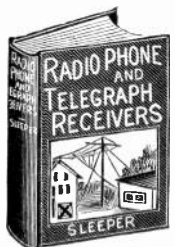

CONSTRUCTION OF RADIO PHONE AND TELEGRAPH RECEIVERS FOR BEGINNERS

By M. B. SLEEPER.

Price **4/-** net (post free 4/3).

Each piece of apparatus described was first made, tested and found efficient before the final design was accepted. Working drawings prepared especially for the novice and the man who wants to receive the wireless broadcast.



RADIO EXPERIMENTER'S HANDBOOK

By M. B. SLEEPER.

Price **5/-** net (post free 5/3).

A book which tells in a very concise way the "Why" of radio and answers many of the "Practical Questions of the Beginner," and even the more advanced student of Wireless.

To follow shortly

THE ABC OF VACUUM TUBES USED IN RADIO RECEPTION

By E. H. LEWIS.

Price **6/-** (post free 6/5).

Written particularly for those who know nothing about wireless, but who desire an understanding of the elementary principles of operation of vacuum tubes, and various circuits in which they are used for reception of wireless telegraph signals, music and speech by wireless telephone.

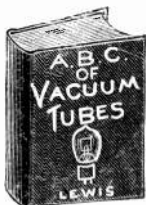

THE WIRELESS PRESS, LTD., Dept. W. W.
12-13, HENRIETTA STREET, STRAND, LONDON, W.C.2

DON'T WORK IN THE DARK.

If you have a Wireless Set and know but little of the principles of its working, you are missing a great amount of the interest and pleasure which the man obtains who has this knowledge.

*It is nice to get good results
but where is the satisfaction
if you know not how they are
obtained?*

The Elementary Principles of Wireless Telegraphy

By R. D. BANGAY,

tells in the simplest possible manner, the theory and practice of wireless.

The Author makes the subject intelligible to persons who do not possess much technical knowledge, and at the same time it is brief and accurate.

The book is so arranged as to be useful as a reference book for students and amateurs.

It is published in two parts

PRICE **4/-** EACH
(post free 4/5)

or combined in one volume

PRICE **7/6** NETT
(post free 8/3).

The Wireless Press, Limited

Dept. W.W.

12-13 Henrietta St., Strand, London, W.2.

The A B C OF WIRELESS

BY

PERCY W. HARRIS

EDITOR OF "CONQUEST"

(*The British Magazine of Popular Science.*)

Price **6^{D.}** net. Post free **8^{D.}**

THE BOOK *for the* 'MAN IN THE STREET'

This wonderful little book has been specially prepared for those who are desirous of getting a good knowledge of Wireless without delving into text books.

No technical expressions
to puzzle over.
No hard thinking to be done.
No mathematical formulæ
to be elucidated.

What is Wireless? How does it Work?

**The A.B.C. Will Tell You
Wireless is the Topic of the Day**

The Up-to-date man needs to be conversant with it.

An evening spent in reading this book will put you in a position to appreciate to the full the wonders of the latest and greatest of sciences.

The Wireless Press, Ltd.

12-13, Henrietta St., Strand, London, W.C.2

ALL - BRITISH WIRELESS EXHIBITION & CONVENTION

will be held at the
HORTICULTURAL HALL
WESTMINSTER : LONDON : S.W.1
SEPT. 30TH TO OCT. 7TH
(SATURDAY) (SATURDAY)



This will be the most representative
Wireless Exhibition ever held in
Great Britain.



THE CONVENTION will be
held under the auspices of the
WIRELESS SOCIETY OF
LONDON and all affiliated
societies.



Communications should be addressed to

THE ORGANISERS

BERTRAM DAY & CO., LTD.

WIRELESS PUBLICITY SPECIALISTS

9 and 10, Charing Cross, S.W.1

Gerrard 8063/4

11 August, 1922.

TO THE ORGANISERS OF THE RADIO AND WIRELESS EXHIBITION & CONVENTION

We desire to express our deep regret that the advertisement inserted by us in the "WIRELESS WORLD AND RADIO REVIEW" contained a very serious reflection on the Exhibition to be held at the Central Hall, Westminster, on the 2nd September, by the Radio and Wireless Exhibition and Convention. We failed to realise its full significance at the time, but we realise now the injury which it was calculated to occasion to the Radio and Wireless Exhibition.

We undertake not to repeat it and we also undertake to publish this apology in the next issue of the "WIRELESS WORLD AND RADIO REVIEW" in as prominent a manner as our advertisement, and to pay the costs.

BERTRAM DAY & CO., LTD.,

BERTRAM DAY,

Managing Director.

The OHMER INSULATION TESTING SET (COX'S PATENT)

This is the lightest, cheapest and best instrument of its kind on the market. It consists of an Ohmeter and Generator mounted in one case. The Ohmeter is of the Electrostatic type, giving extreme lightness. Absolutely unaffected by external fields. It reads directly in Megohms and is independent of the voltage or speed of the generator.

NALDER BROS. & THOMPSON, LTD.,
97a, DALSTON LANE, LONDON, E.8.



WARNING.

MARCONI'S WIRELESS TELEGRAPH CO., LTD.,
v.
A. C. COSSOR, LTD.

Marconi's Wireless Telegraph Company, Limited, GIVE NOTICE that an ORDER was made in the High Court of Justice, Chancery Division, by Mr. Justice Russell on the 1st March, 1922, restraining Messrs. A. C. Cossor, Ltd., from infringing the Marconi Company's Letters Patent Nos. 28413 of 1913 and 126658, except so far as Messrs. A. C. Cossor, Ltd. manufacture for H.M. Government.

Messrs. A. C. Cossor, Ltd., were further ORDERED upon oath to DESTROY all articles and apparatus (other than those constructed to the order of H.M. Government) made or used by them in INFRINGEMENT of these patents, and TO PAY THE MARCONI COMPANY DAMAGES AND COSTS.

The M-O Valve Company, Limited, of Osram Works, Brook Green, Hammersmith, London, W.6, is the only firm in this country licensed to manufacture thermionic valves under the patents belonging to the Marconi Company.

Any valve similar to those generally known as the "French type" constitutes an infringement of the above patents whether manufactured in this country or imported from abroad. Marconi House, Strand, London, W.C. 2.

Hoyle's Book Saves Time

The tables and equations are compiled in book form and reference to the detailed index speedily puts one in possession of the information desired.

NO OTHER COMPLETE BOOK EXISTS FOR THE USE OF RADIO WORKERS.

Send at once for a copy of

STANDARD TABLES & EQUATIONS
IN
RADIO TELEGRAPHY

By
BERTRAM HOYLE, M.Sc. Tech., A.M.I.E.E.

Price **9/-** nett. Post free **9/9**

THE WIRELESS PRESS, LTD.
Dept. W.W. 8/4
12-13 Henrietta St., London, W.C.2

Registered "NIPHAN" Trade Mark.

WATER-TIGHT PLUGS and CABLE COUPLINGS
TO MEET HOME OFFICE REQUIREMENTS



COUPLING CONNECTING CABLES

Phones:
2600 Gerrard, 12061 Central.

Telegrams:
Niphan, London.
Patented in England and Abroad.



SIX WAY TEE CONNECTORS

As used by H.M. War Office, Electric Supply Companies, Railway Companies, Marconi's Wireless Telegraph Company
SIMMONDS BROS., LTD.
4, 6 & 8, NEWTON STREET, HOLBORN, W.C.

1. Perfect insulation of grid connection ensures silent operation.

2. All connections shown in diagram ready made for you and brought out to terminals.

3. To add an amplifying stage, connect to terminals and insert valve.

4. Tapped holes in two sides and base make fitting easy.

The most important detail improvement yet made in Wireless Receiving Sets.

THE ELWELL AMPLIFYING UNIT

Comprising valve socket and ironclad interval transformer, mechanically and electrically combined in one unit.

*Exclusive design covered by patents.
British made and guaranteed throughout.*

This patented amplifying unit, when provided with a valve and connected as marked on the terminals, is all that is necessary to give one stage of amplification to your existing set. No soldering is necessary. The unit is easily attached to panel or shelf, or will stand alone.

The self-contained permanent connections are a big practical advantage, while the perfect insulation of the grid connection will appeal to all amateurs troubled with "noise."

To secure early delivery order at once.

Price **39/6** only, for complete amplifying unit, less valve.

Enquiries for all wireless components invited.

C. F. ELWELL, LTD., CRAVEN HOUSE, KINGSWAY, LONDON, W.C.2.

WIRELESS WORLD

AND

RADIO REVIEW

VOL. X. No. 22.

26th AUGUST, 1922.

Registered at the G.P.O. as a Weekly Newspaper.

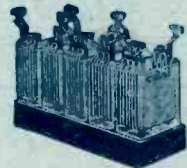
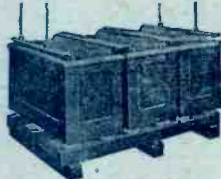

ALWAYS USE

HART ACCUMULATORS

SUITABLE FOR ALL CLASSES OF ELECTRICAL WORK



WE SPECIALISE IN

HART

HIGH TENSION BATTERIES

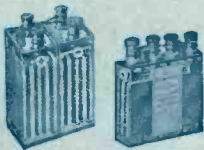

HART ACCUMULATOR CO., LTD.,

STRATFORD

BRANCH OFFICES AT:

BELFAST: 41, Chichester Street.

BIRMINGHAM: 174, Corporation Street.

BRISTOL: 37, Victoria Street.

VISIT OUR STAND NO. 17
ALL-BRITISH WIRELESS EXHIBITION
HORTICULTURAL HALL, Sep. 30th to Oct. 7th

LONDON, E.15

GLASGOW: 107, Wellington Street.

LONDON: 36, Victoria St., S.W.1

MANCHESTER: 4, Victoria Bridge.

YORK: 6, Bridge Street.

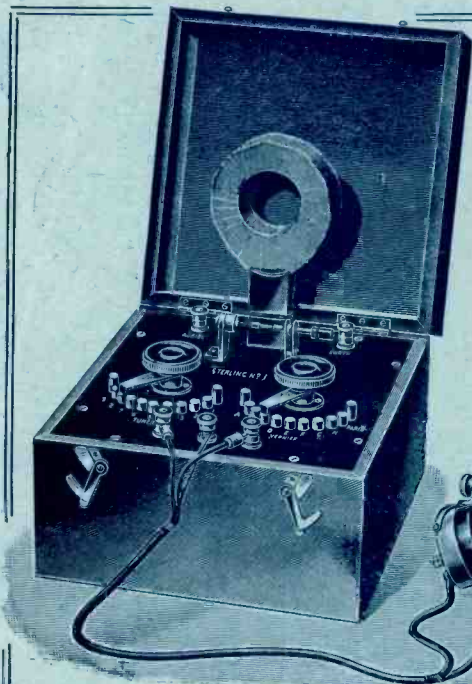

STERLING No. 1 CRYSTAL W/T RECEIVING SET

Specially designed for use in connection with the Wireless Telephony Broadcasting Scheme, and is suitable for a range of about 25 miles.

PRICE £7-12-6

Visit our Stand No. 34, All-British Wireless Exhibition, Horticultural Hall, September 30th to October 7th.

STERLING TELEPHONE & ELECTRIC CO., LTD.

210-212, Tottenham Court Road,
LONDON : : : W.1

Telephone No. : 4144 Museum (7 lines)
Telegrams : "Cucumis, Wesdo, London."

Works : DAGENHAM, ESSEX.

BRANCHES:

NEWCASTLE-ON-TYNE : 9, Clavering Place.
CARDIFF : 8, Park Place.

IMMEDIATE DELIVERY

"Wireless for all"

Before you decide on the construction of your set. It will pay you to have particulars of—

Condensite Celoron

For PANELS and OTHER PARTS.

This material is waterproof, immune to atmospheric and climatic conditions, will not warp, has high surface and volume resistivity, high dielectric strength, low specific gravity.

LET US QUOTE YOU

SEND PARTICULARS OF YOUR EXACT REQUIREMENTS TO
THE MANUFACTURERS

DIAMOND FIBRE CO. LTD.
DIAMOND-FIBRE WORKS HIGH ROAD SOUTH TOTTENHAM, N.15.



CHADWELL HEATH, ESSEX.

Wholesale Manufacturers of Wireless Apparatus. Trade Enquiries Invited.

The New
BURNDEPT Precision
 Variable
Condenser

The design of this instrument is such that it can be produced in large quantities at a reasonable price, whilst retaining a high standard of technical excellence.

SPECIFICATION. Vanes of hard thick aluminium. Bearings metal to metal. Contact to moving plates by phosphor bronze soldered strip. Adjustable operating tension. Spacing between plates sufficient for pressure up to 1,000 volts. Built upon Bakelite. Suitable for mounting on any panel from 1/2" to 1/4" thick, by drilling 3/8" clearing hole for spindle and 3/8" holes for fixing screws. Each instrument supplied complete with a high-class engraved and polished Ebonite dial and substantial knob assembled, and the necessary fixing screws. The maximum capacity is .0008 and the minimum capacity negligible.

We recommend this size condenser as being the most suitable for both A.T.I. and secondary tuning. It is the same condenser which is built up into all our new **BURNDEPT** tuners.

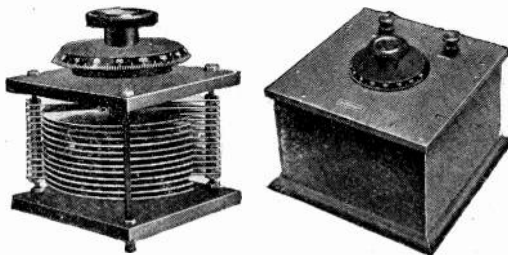

No. 141

No. 142

PRICES.

- No. 141. For Panel mounting. £2
- No. 144. A smaller size condenser capacity .000275 for high frequency amplification, Vernier tuning, reactance tuning, etc. No. 144 for panel mounting only. The specification of this condenser is precisely the same as No. 141. £1 12
- No 142. Mounted complete on Ebonite Panel and in polished walnut case £2 15

THE TRADE ARE INVITED TO ASK FOR QUOTATIONS FOR QUANTITIES

Visit our Stand No. 12A. All British Wireless Exhibition, Horticultural Hall, September 30th to October 7th.

LONDON SHOWROOMS:
 15, BEDFORD ST., STRAND, W.C.2

BURNDEPT Ltd.

Aerial Works and Eastnor Works
 BLACKHEATH VILLAGE, S.E.3

All **BURNDEPT** Apparatus is duly licensed under Marconi Patents for amateur use in Great Britain.

SHEET, ROD AND TUBE stocked in qualities suitable for all Wireless work.
KNOBS (Moulded), various patterns stocked
CONDENSER DIAL AND KNOB.
 3' and 4' dia.—0°—100°

Watch this Advert.
 for new mouldings.

EBONITE
 (HARD RUBBER)

Enquiries Solicited.

WHOLESALE ONLY.

AMERICAN HARD RUBBER CO.

(BRITAIN) LIMITED

13a, FORE STREET, LONDON, E.C. 2
 Teleg. "Eboniseth, Ave., London." Phone: Central 12754

Our Motto! Satisfaction

Filament Resistances, Smooth Action	4/-
Sound construction, easy to mount.	
Grid Leaks (Tubular enclosed), 2 Meg.	2/-
Crystals (Selected), Zincite, Bornite, Silicon, Galena, Carborundum, C. Pyrites, etc.	6d.
Crystal Cups, with side fixing screw	6d.
Brass Square Rod, 12" x 1/2" x 1/4"	6d.
Inductance Formers, 12" x 3"	6d.
Inductance Formers, 12" x 4"	9d.
Inductance Formers, 12" x 5"	1/-
Sliders with Plungers	6d.
Fusible Alloy for Fixing Crystals	6d.
Aerial Wire Stranded, 7/25	per 100 ft. 3/6
Aerial Insulators, Egg, Porcelain	6d.
Aerial Insulators, Reel Type	4d.
Aerial Pulleys, Aluminium, with cord	1/6
Condenser Vanes, Aluminium (accurate)	per doz. 1/10
Condenser Spacers, Large (true to .001")	per doz. 5d.
Condenser Spacers, Small (true to .001")	per doz. 3d.
Condensers, Tops and Bottoms (Bushed)	each 1/-
Condenser Ivorine Scales, 0-180 deg.	9d.
Switch Arms, Laminated with Bush, etc.	2/3
Brass Studs, 1/2" high x 1/4" dia.	per doz. 1/-
Brass Studs, 1/2" high x 3/8" dia.	per doz. 1/3
Brass Studs, 1/2" high x 1/2" dia.	per doz. 1/6
Hellesden 36v. H.T. Batteries, with plug.	each 8 6
Telefunken and A.E.G. Valves Tested	10 6
Headphones, Double, excellent for speech and Music, 2,000 ohms, 30/-, 4,000 ohms, 32/6.	
Panels, Tuners, etc.	Postage extra.

The ESSEX WIRELESS Co.

(Office and Showrooms)

499, Grove Green Road, Leytonstone, E11
 Telephone: WANSTED 749. (1 minute from station G.E.R.)

The Name "BURNDEPT" GUARANTEES Cent. Per Cent. QUALITY & EFFICIENCY.

LIVERPOOL:
10, SOUTH JOHN STREET.
□
BIRMINGHAM:
133 NEW STREET.

BURNDEPT

WIRELESS APPARATUS

MANCHESTER:
61, BRIDGE STREET, DEANSGATE.
□
LEEDS:
48, GT. GEORGE STREET.

LONDON OFFICE & SHOWROOMS
15 Bedford Street. Strand. W.C.2.

Burndept I. Receiver

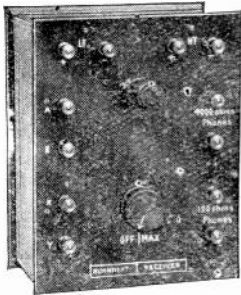

Size 9½" × 7½" × 4½"

ONE VALVE
DETECTOR SET.

PRICE:
(With 'Phone Transformer)
£5 0 0

WE HAVE A COMPLETE STOCK OF ALL WIRELESS ACCESSORIES
BURNDEPT (Patent) Coils—
COIL HOLDERS—TUNING PANELS—CONDENSERS
AMPLIFIERS—ACCUMULATORS—HIGH-TENSION BATTERIES—HEADPHONES
VALVES—MASTS—SPREADERS—AERIAL WIRE—INSULATORS—SWITCHES.
Etc., Etc.

ILLUSTRATED CATALOGUE.
(W.)
post free 6d. to all who apply and mention "The Wireless World". This gives full details of our one, two, three and four-valve RECEIVING SETS complete and ready for use. Also details of all accessories.
PRICES from **£21**

Burndept II. Receiver

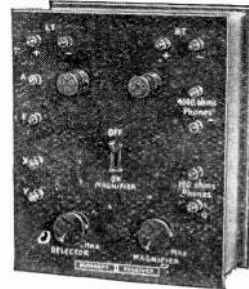

Size 11½" × 9½" × 4½"

OPTIONAL SINGLE
NOTE MAGNIFIER.

PRICE:
(With 'Phone Transformer)
£12 10 0

The Trade are invited to ask for Quotations for Quantities.

LONDON SHOWROOMS: 15, Bedford Street, Strand, W.C.2
Visit our Stand No. 12a. All British Wireless Exhibition, Horticultural Hall, Sept. 30th to Oct. 7th

BURNDEPT

Ltd. AERIAL & WORKS BLACKHEATH
EASTNOR WORKS VILLAGE S.E.3

All "BURNDEPT" Apparatus is duly licensed under Marconi Patents for amateur use in Great Britain.

The Baynton High Tension Unit Regd. No. 11896/22



Containing
45 Cells



ADVANTAGES:

- (A) Each Battery can be separately Tested.
- (B) Exhausted cells replaced at the cost of a few pence.
- (C) No soldering required, exhausted Batteries replaced by unloosening 2 screws.
- (D) Four Tapping, or more if required.
- (E) A neat Polished Box, with Ebonite Top and Brass Terminals.

PRICES:
60 volts 27/6
75 volts 32/6

SEND FOR ONE TO-DAY
The Best Value on the Market

ALL BURNDEPT AP-
PARATUS IN STOCK

Sole Manufacturers—C. S. BAYNTON & SON, 153, New Street, BIRMINGHAM.

DUBILIER

A New Condenser for Wireless Receivers

THE DUBILIER TYPE 600 MICA CONDENSER

The illustrations show two types of this new condenser for wireless receiving circuits. The condensers have the same perfect mica insulation, the same high efficiency and the same permanence of capacity as the larger Dubilier Mica Condensers used in wireless transmitters. Distortion when receiving telephony is often due to bad design of the components of the receiver—therefore use efficient Dubilier Condensers in your receiver to obtain the best out of your set.

PRICES:

Capacity between 0'0001 and 0'001 mfd - 2/6 each
 " " 0'001 " 0'005 " - 3/- "
 (inclusive)
 Condensers complete with Grid Leaks - 7/6 "

TRADE TERMS ON APPLICATION.

Both types of condenser (with or without clips for a grid leak) are fitted with screw terminals as well as tags for making soldered connections.

With Clips for Grid Leak.

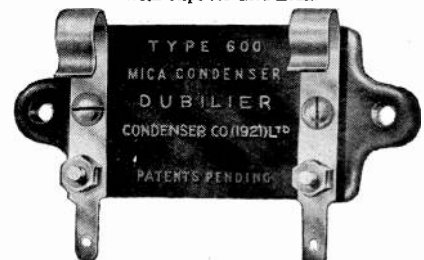

Without Clips for Grid Leak

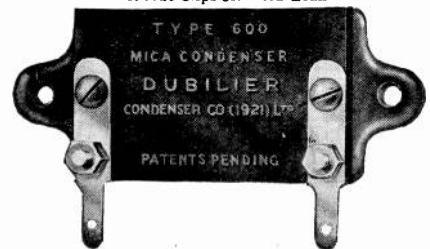

THE WAY TO DUBILIERS.

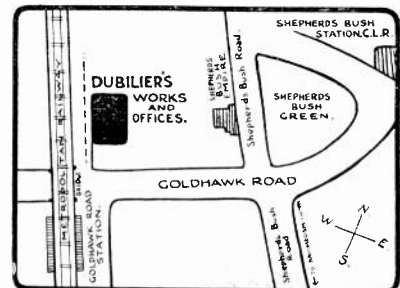

Visit our Stand No. 36. All British Wireless Exhibition, Horticultural Hall, September 30th to October 7th.

THE DUBILIER CONDENSER CO. (1921), LTD.,
DUCON WORKS, Goldhawk Road, Shepherd's Bush, London, W.12

Telephone—Hammersmith 1084.

Telegrams—Hivolteon, Phone, London.

Code—Marconi International.

ELECTRICAL AND Mechanical Engineers

Contractors to the Admiralty, War Office & Air Force

Manufacturers of . . .
MARCONI'S WIRELESS DISC DISCHARGERS.
ROTARY CONVERTERS. DYNAMOS.
ELECTRIC MOTORS. TRANSFORMERS.
BOOSTERS. BOX HIGH VACUUM PUMPS.

COMPLETE ELECTRIC LIGHT INSTALLATIONS

For Country Houses and Yachts.
Lighting Sets for Motor Cars and
Aeroplanes. Estimates Free.

AN EFFICIENT STAFF FOR REPAIRS

*Inventors' ideas carefully and skilfully
carried out from the preparation
of detailed drawings to the completion
of the finished article :: :: ::*

W. MACKIE & CO

ESTABLISHED 1882

THE PALACE ENGINEERING WORKS
129, 131, 133, Lambeth Road, London, S.E.1

TELEPHONE 182 HOP

IF YOU REQUIRE A LIGHT MAST OR AERIAL SPREADER

WRITE TO
M^cGRUER HOLLOW
SPAR CO. LTD.
COMMERCIAL ROAD,
LAMBETH, LONDON.

S.E.1

'Phone
HOP
718

Wires :
"OLLOSPARSH
WATLOO, LONDON."



TRADE MARK

The WHITECROSS
COMPANY, LIMITED
:: WARRINGTON ::

Manufacturers of All Descriptions of
**WIRE ROPES
AND WIRES**

EXPE **RI** ENCE

HIGH-FREQUENCY AMPLIFICATION

100 to 20,000 METRES

IMPROVED ADJUSTABLE REACTANCE COIL SELF-TUNED. SPECIALLY DESIGNED TO GIVE THE HIGHEST EFFICIENCY ON THE SHORT WAVELENGTHS USED IN BROADCASTING.

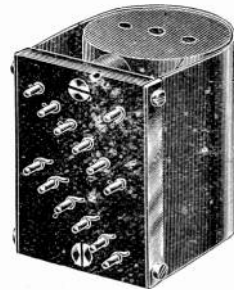

Visit our Stand No. 37. All British Wireless Exhibition, Horticultural Hall, September 30th to October 7th. This is the high frequency unit that every wireless experimenter has been waiting for. The fact that it bears our name is a guarantee that it will do all that is asked of it.

ADVANTAGE OF HIGH FREQUENCY AMPLIFICATION. All serious wireless experimenters will appreciate the great advantages of high frequency amplification before rectifying. It makes signals far below audible strength easily readable and permits additional audio frequency amplification (after rectifying) without rendering the receiving set unstable.

THE TAPPED ANODE REACTANCE COIL. This coil, originally developed by Mr. W. A. Appleton, our research director, and specially designed for short wavelengths, has now been still further improved by a finer sub-division of the tappings to obtain the best efficiency for broadcasting.

NEW AND IMPROVED DESIGN. The coil is sectionally wound and cylindrical in form as this design allows greater mechanical strength in the winding at the tapping points than does the earlier disc type.

100 TO 200,000 METRE RANGE. Twelve tapping points are provided covering a range of wavelengths from 100 to 20,000 metres.

CONSTANT REACTANCE VALUE.

The tappings have been selected to keep the reactance value approximately constant for all wavelengths.

NO TUNING CONDENSER NEEDED.

No tuning condenser is necessary as the capacity of the winding renders the coil self-tuned.

HIGHEST EFFICIENCY.

This type of coil gives a higher efficiency on short wavelengths than any other method of intervalve coupling.

DELIVERY—Immediately from stock.

PRICE—Tapped Reactance Coil as specified,
complete with wiring diagram 25/-
Twelve point switch for use with same 18/-
Audio-frequency Intervalve Transformers each 25/-
Telephone Transformers each 20/-

Radio Instruments Limited

Managing Director: J. Joseph, M.I.E.E., late Manager to Mr. H. Sullivan. Chief Designer: W. A. Appleton, M.E.E., M.I.R.E., late Admiralty Technical Research Officer.

ONLY ADDRESS. Works, Offices & Showrooms

12a, Hyde Street,
NEW OXFORD ST., W.C.1

We have the largest wireless works in Central London.

We are wireless engineers of established reputation.

Our name on wireless apparatus is a guarantee of satisfaction.

WIRELESS EQUIPMENT LTD.

Tel.:
GERRARD
6785.

RADIO ENGINEERS AND MANUFACTURERS

:: APPARATUS AND SPARES ::

Telegrams:
WIREQUIP
WESTCENT
LONDON

WRITE FOR OUR ILLUSTRATED LISTS OF SETS AND COMPONENT PARTS, 3d. POST FREE

Head Office: 90, CHARING CROSS ROAD, LONDON, W.C.2

Visit our Stand No. 14. All British Wireless Exhibition, Horticultural Hall, September 30th to October 7th

THE WIRELESS WORLD AND RADIO REVIEW

THE OFFICIAL ORGAN OF THE WIRELESS SOCIETY OF LONDON
A MAGAZINE DEVOTED TO WIRELESS TELEGRAPHY AND TELEPHONY

CONTENTS

A Broadcast Receiver. By A. J. Bull	- - - - -	677
Valve Manufacture (<i>continued</i>)	- - - - -	683
The Trans-Continental Wireless Station of Sainte Assise	- - - - -	689
A Suggestion for the Experimenter. By G. P. Kendall, B.Sc.	- - - - -	693

Contents continued on next page.

SIEMENS PRIMARY CELLS & BATTERIES DRY AND FLUID

for the

High-Tension Circuit of Wireless Apparatus
using Thermionic Valves.

*Descriptive Pamphlet (Supplement 1 to Catalogue No. 600) will be
sent on application to the Manufacturers:*

SIEMENS BROTHERS & CO. LTD.
WOOLWICH, LONDON, S.E.18

Telegrams: "SIEMENS WOOLWICH."

Telephone: CITY 6400

Visit our Stand No. 48. All British Wireless Exhibition, Horticultural Hall, Sept. 30th to Oct. 7th

NOW IS THE TIME to acquire a sound theoretical and practical knowledge of **THREE ELECTRODE VALVES**, (as applied to C.W. Radio-telegraphy and Radio-telephony), by means of my **POSTAL INSTRUCTION COURSE.**

Perfectly Simple
May I Send you Particulars?

2 Lt. E. REDPATH,
19, Niger St., BARROW-IN-FURNESS

CONTENTS *(Continued)*

Wireless Without an Aerial: A New Line of Experiment for Amateurs. By Percy W. Harris	694
Notes	696
Correspondence	698
Book Reviews	698
Calendar of Current Events	699
Wireless Club Reports	700
Questions and Answers	703
Share Market Report	710

THE WIRELESS WORLD AND RADIO REVIEW is published weekly on Saturdays.

All correspondence relating to contributions should be addressed to THE EDITOR, THE WIRELESS WORLD AND RADIO REVIEW, 12-13, Henrietta Street, London, W.C.2.

No responsibility can be taken for MSS. or photographs sent without stamps to defray cost of return postage.

Editorial and Publishing Offices 12-13, Henrietta Street, Strand, London, W.C.2.

Telegraphic Address: "Radionic, Rand, London." Telephone No.: Gerrard 2807.

Advertisement Managers, Bertram Day & Co., Ltd., 9 and 10, Charing Cross, S.W.1.
Telephone No.: Gerrard 8063 and 8064.

SUBSCRIPTION RATES.—

28s. per annum, post free. Single Copies 6d., or post free 7d.

Registered at the G.P.O. for transmission by Magazine Post to Canada and Newfoundland.

HOLLOW STEEL MASTS FOR AERIALS

These masts are light, strong, easily erected, and will last a lifetime. All lengths over 15ft. are made in sections and each mast is supplied complete with baseplate, finial, rope cleat, pulley sheave, guy clips, three steel guy ropes and strainers, painted one coat ready for immediate erection. Being made of steel, no lightning conductors are required

PROMPT DELIVERY.

PRICES F.O.R. FOR CASH WITH ORDER, EACH

10ft. ...	32/6	15ft. ...	42/6
25ft. ...	57/6	30ft. ...	84/-
		20ft. ...	45/-
		40ft. ...	126/-

Other Lengths supplied at equally Low Prices.

Trade Inquiries Invited

THE WIRELESS STEEL MAST & ACCESSORY COMPANY
Lombard Street West, West Bromwich

Telephone No. 447

VALVES

DELIVERY FROM STOCK.

RECEIVING.

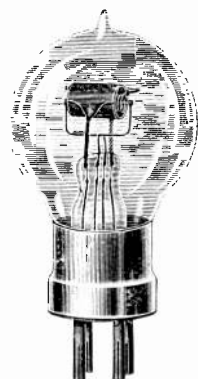

Type.	Filament Voltage.	Anode Voltage.	PRICE.
R	4	60	£1 6 6
R4B	4	50	1 10 0
V24	5.2	36	1 4 0
Q	5.2	50	1 4 0
		(150 as amplifier)	
QX	5.2	50	1 4 0

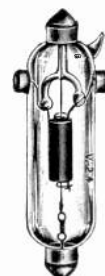

SPECIAL LOW TEMPERATURE VALVES.

Type.	Filament Voltage.	Filament Current.	Anode Voltage.	PRICE.
L.T.1	1.8	.4	36-50	£2 10 0
L.T.3	1.8	.11	„	„

TRANSMITTING.

Type	Filament Voltage.	Anode Voltage.	PRICE.
A.T.25	5.5	UP TO 1,000	£1 10 0
A.T.40X	7	„ 1,000	2 15 0

Visit our Stand No. 32. All British Wireless Exhibition, Horticultural Hall, September 30th to October 7th

THE
MARCONI SCIENTIFIC INSTRUMENT CO., LTD.

40 DEAN STREET, SOHO, W.1

TELEGRAMS: THEMASINCO, WESTOENT
 TELEPHONE: GERRARD 774

WATES

Specialities.

The SPHINK High Tension Battery



16 Volts. A battery especially designed with the object of giving a constant voltage for a maximum period.
PRICE 3/6 each. Carriage Paid.

Visit our Stand No. 15. All British Wireless Exhibition, Horticultural Hall, September 30th to October 7th.

We have Magnavox Loud Speakers in stock. Immediate delivery if ordered now.

The Ideal Valve Accumulator

6 Volts 50 Amp. In wooden case with leather strap handle.

6 Volts 50 Amp. **PRICE 35/-**
 Carriage 3/-

4 Volts 50 Amps. **PRICE 24/-**
 Carriage 7/-

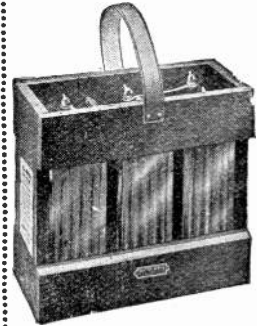

Send for Illustrated Catalogue of complete Wireless Sets and Component Parts. Post Free—Threepence.



WATES BROS.
WIRELESS ENGINEERS
 13-14, CT QUEEN ST., KINGSWAY, LONDON, W.C.2.
 Phone: GERRARD 576. Telegrams: ZYWATESENG, WESTCENT



Wireless Telegraphy & Telephony.

Special offer of Aerial Fittings.

- 150 ft. 7/22 Best H.C. Copper Aerial Wire.
- 2 Ash Spreaders, 6 ft. x 7/8 in. diameter.
- 4 Brass Spreaders Bands with two eyes.
- 4 White Porcelain Reel Insulators 2 in. diam.
- 2 Galvanised Pulley Blocks with Hooks.
- 1 Lead-in Insulator 9 in. long with Soldering Shoe and Terminal.
- 100 ft. Stout Manilla Rope.

Complete Outfit.

30/-

CARRIAGE PAID IN GREAT BRITAIN.

RADIO SUPPLIES

(Dept. 1).

236, HIGH HOLBORN, W.C.1

EBONITE AND VULCANITE

TUBES—RODS—SHEETS

LARGE STOCKS

BRITANNIA RUBBER AND KAMPTULICON CO., LTD.
 7, NEWGATE ST., LONDON, E.C.1

Telephone : 2168 Central

Telegrams : Britannia, London

THE WIRELESS WORLD AND RADIO REVIEW

THE OFFICIAL ORGAN OF THE WIRELESS SOCIETY OF LONDON

VOL. X. No. 22.

AUGUST 26TH, 1922.

WEEKLY

A Broadcast Receiver

By A. J. BULL.

I SUPPOSE that during the last few weeks quite a number of people associated with the technical side of wireless telephony have been rung up by telephone and a conversation similar to the following has taken place:

"Hullo Brown! Good morning! I hope that your cold is better." "Good morning! Yes, thank you" (and mutters to himself, "Now how on earth did he know that I had had a cold? I haven't seen him for a year.) Well! What can I do for you?"

"I want your advice about the construction of a valve receiver which will enable me to pick up all the broadcast stations, and also the Dutch concert on a very poor aerial.

"As I already possess a few odd parts from ex-service apparatus, I would like to build the set myself, and make use, if possible, of those parts. I want really a first-class instrument, but cash being limited, I should like to build the set up gradually, and to commence receiving signals from the moment I purchase the first valve. At the same time I would like the finished instrument to be complete in itself, excepting of course for the H.T. and L.T. batteries."

"Righto, Jones. I will see what I can do for you."

* * *

It is the intention of the writer of this article to give details and working particulars of a three-valve amplifier, which can be built up by anyone from odd component parts that are at present available at dealers of second-hand and new apparatus; and at the same time to produce a finished instrument of high efficiency which will enable experimenters to receive from various broadcasting stations that may be erected in the British Isles, and also from some of those on the Continent.

In the design of the instrument provision is made for reaction, but since it is understood that reaction for broadcasting receivers is likely to be prohibited by the Postmaster-General for wavelength ranges up to about 500 metres, it should be borne in mind that provision is made for the reaction terminals of the instrument to be bridged across by a brass strap for reception on these wavelengths.

Although the finished design is that of a three-valve instrument, there is no need to complete the instrument before experiments in the reception of signals can be commenced.

Provided that the dimensions of the box and consequently that of the ebonite panel is adhered to, one valve and its circuit (Fig. 2a) can be built in the panel as shown in Fig. 2b. This single valve circuit, with the addition of an aerial, etc., of course, will enable the owner to become acquainted with the doings of the nearest broadcast station.

With the introduction of the second valve and its wiring, additional experiments are of course rendered possible, and finally, with the inclusion of the remaining valve, simultaneous H.F. amplification, detection, and note magnification become available.

To those who wish to commence operations immediately with a single valve, and desire to possess a three-valve instrument complete in itself ultimately, and not made up of a number of units which have to be wired together to function as a single instrument, this design should prove of special interest.

The finished instrument, as shown in the photograph (Fig. 1), will also be found useful to the keen experimenter who desires to instantly compare methods of reception, or to demonstrate the advantage of employing

a particular method when receiving from a certain station.

For instance:—

Supposing the experimenter's station is situated about 100 miles from the Marconi telephony station (2 MT) at Writtle; by operating the switches provided on the instrument whilst this station is transmitting, radio frequency and audio frequency amplification can be compared, the advantage of reaction, and the disadvantage of carrying reaction too far demonstrated, etc., also strength of signals can be noted with one, two, or three valves in circuit.

The following table indicates the position of the switches for valves in use:—

When reaction is required the strap short circuiting the reaction terminals is opened.

The circuits employed (Fig. 3) are well known and therefore need no explanation. The condenser used (0.0005 mfd.) in the H.F. circuit, is perhaps rather larger than that usually employed for the purpose, but inductances for the most important waves to the experimenter, possibly the broadcast waves, can be suitably constructed, or purchased, which will permit of the condenser functioning somewhere near its minimum value. The advantage of the larger condenser over that more commonly employed, viz., 0.0001 mfd.) will be found when it is desired to receive wavelengths above 2,500 metres, as the wave

H.F. Valve	Detecting Valve.	L.F. Valve.	Position of Dewar Swith.	Two-way Switch turned to
	Detecting Valve		Up	Right
H.F. Valve	Detecting Valve	L.F. Valve	Neutral	Right
H.F. Valve	Detecting Valve		Up	Left
H.F. Valve	Detecting Valve	L.F. Valve	Neutral	Left

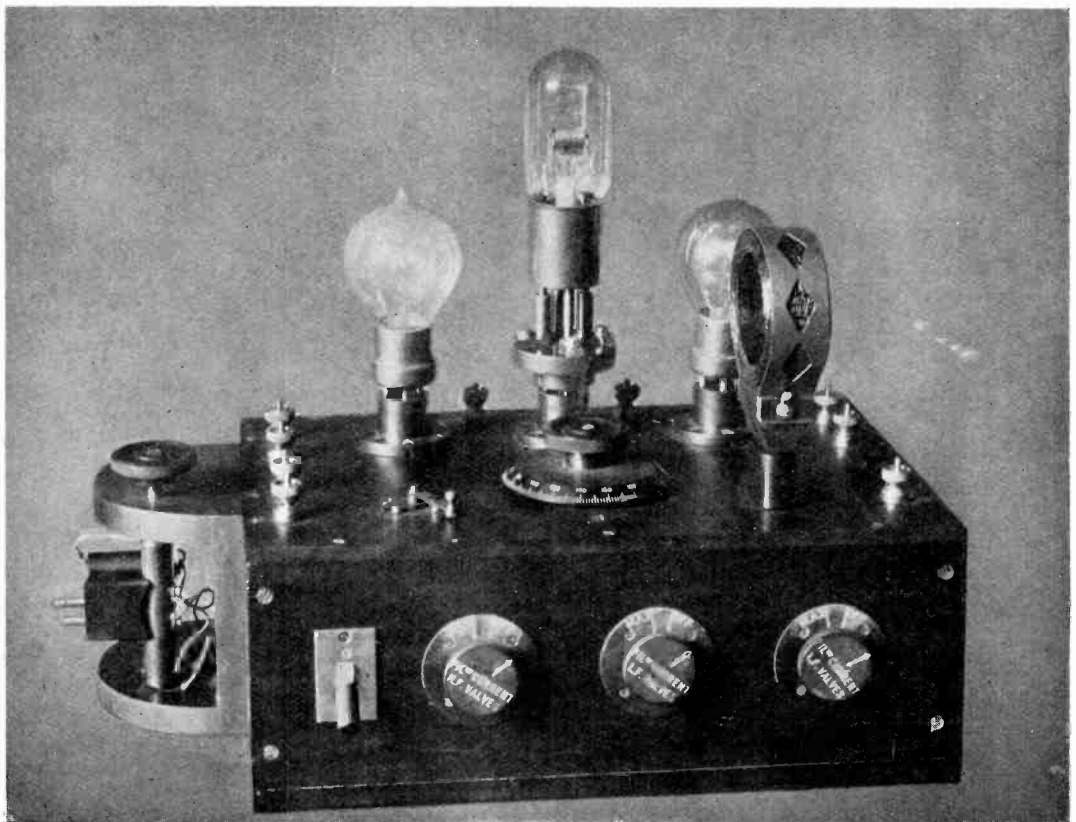

Fig. 1. The complete instrument.

range of each coil is considerably increased. For example, Igranic coil No. 600, of 19,700 microhenries inductance, tunes, with a 0.0001 mfd. condenser, from 2,500 to 4,200 metres approximately.

By a simple calculation, viz., $\lambda = 1885 \sqrt{LC}$ where L is in microhenries and C in microfarads, it will be seen that the range of this coil is increased with a 0.0005 mfd. condenser, to 5,830 metres approximately, and the loss in efficiency due to reactance of the condenser with these lower frequencies is scarcely noticeable to the experimenter.

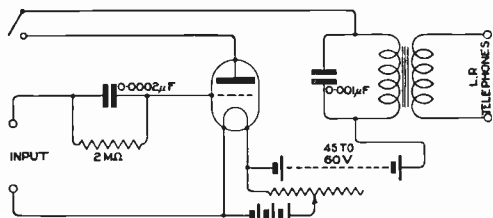

Fig. 2a. Simplified connections of single valve circuit with switch to short circuit reaction leads.

ORIGIN OF SEVERAL OF THE PARTS EMPLOYED IN THE INSTRUMENT.

As has already been stated, it is intended that this instrument shall be made up of component parts which are available at dealers, or which amateurs may already possess, and so a brief description of some of the parts from which the set shown in the photograph was constructed by the writer will now be given.

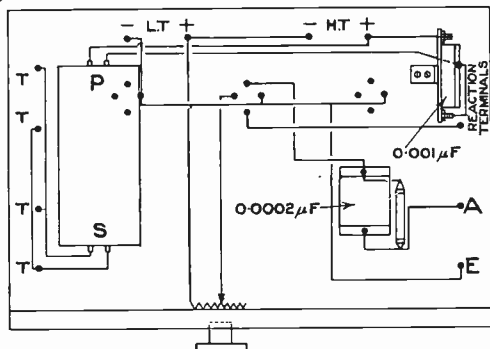

Fig. 2b. Single valve wiring diagram.

The filament resistances and valve holders were originally designed for a R.A.F. d.f. amplifier, and purchased very cheaply. The H.F. condenser and twelve terminals are from the well-known Mark III receiver. The 0.001 mfd. fixed condenser across the intervalve

transformer once did duty in a heterodyne wavemeter.

The switch which can be seen on the front of the instrument is an ordinary land-line telephone listening key, sometimes described by dealers as a "Dewar" switch.

The reader should now have the impression that no particular make of parts is essential. Some makes are, of course, preferable to others, owing to their better design and mechanical construction.

When purchasing component parts it is advisable to have the full size design (given on the next page) and dimensions of the panel (Fig. 4) at hand, so that the dimensions of various parts may be checked. Sufficient space, however, has been allowed for any moderate variation in size of the parts that are likely to be offered to the experimenter.

After the various parts have been got together, the wooden box should first be constructed. This is made of $\frac{7}{16}$ in. material and measures outside $12\frac{1}{8} \times 7\frac{7}{8} \times 4\frac{7}{16}$ ins. in height, the front being screwed on by means of four suitable 1-in. brass screws. The ebonite top to the box should next be prepared.

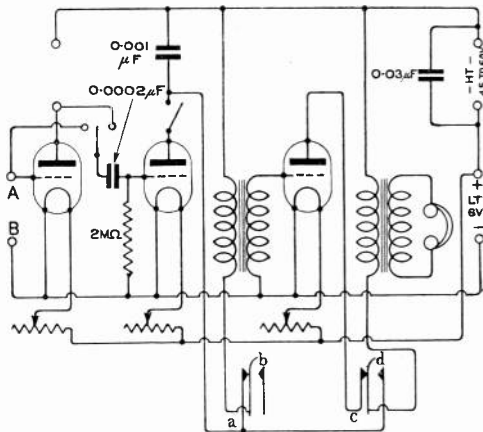
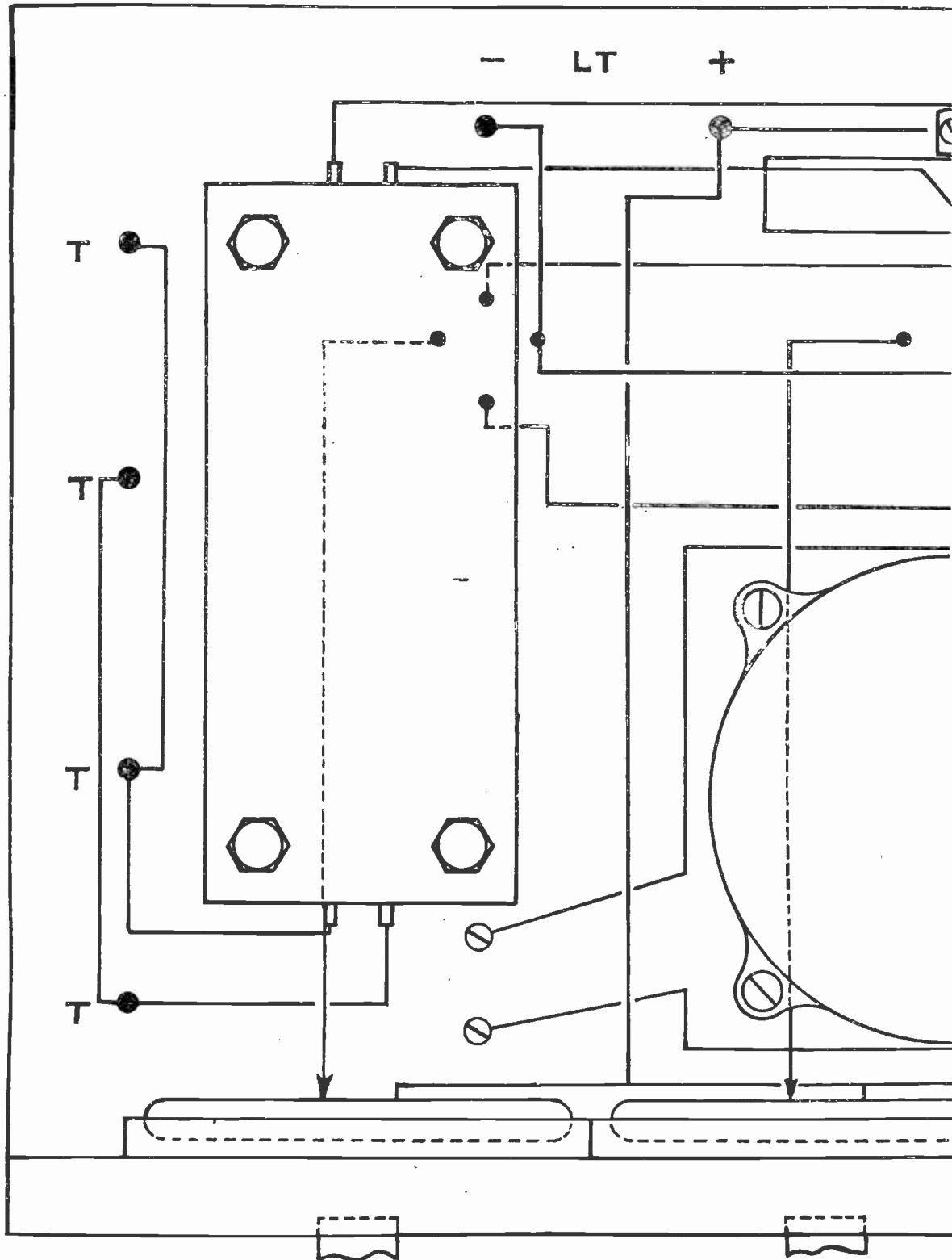
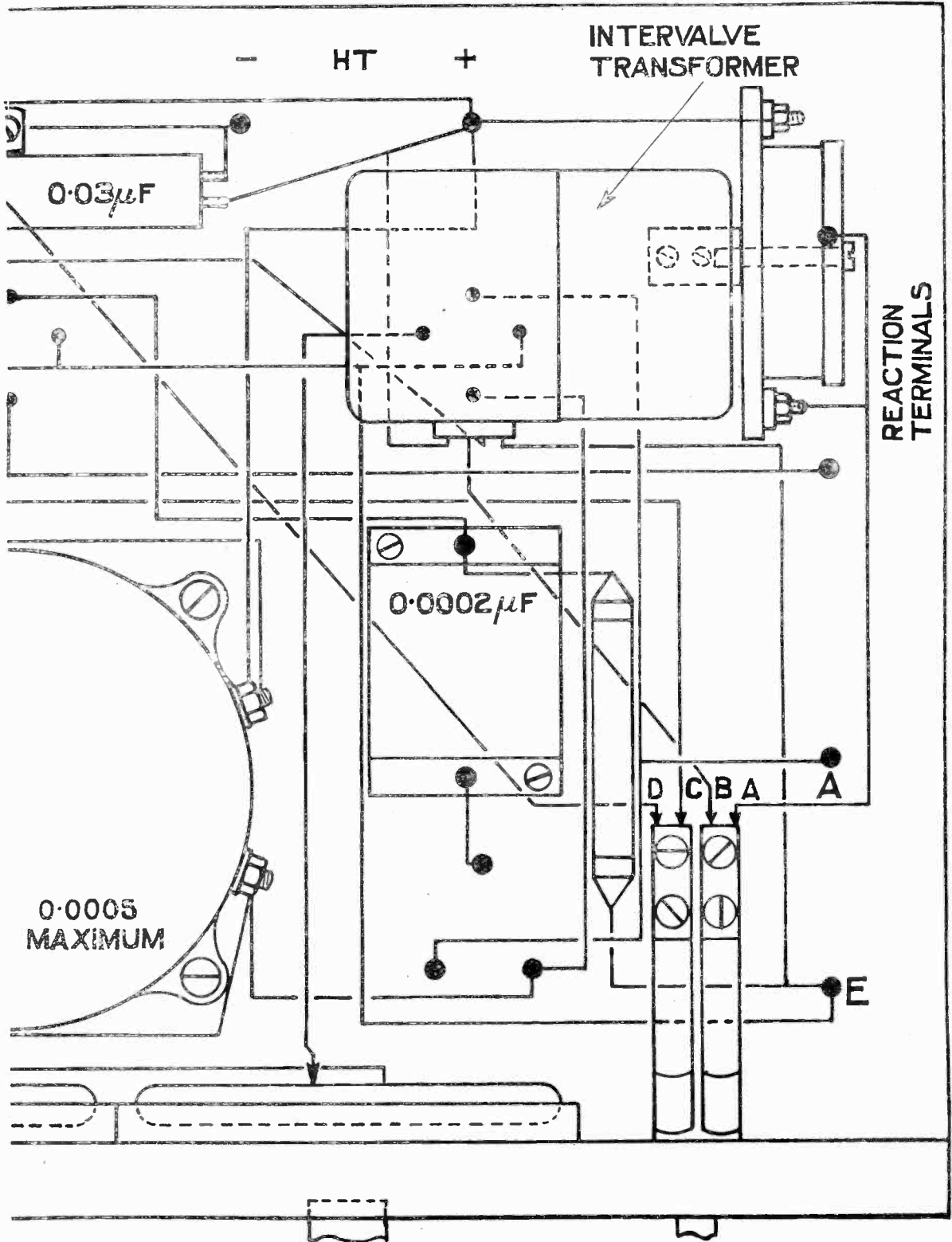

Fig. 3. Simplified circuit diagram.

This should be unpolished, $\frac{1}{4}$ in. in thickness, and secured in position by ten 1-in. brass screws. Consideration must now be given to full scale design and any alterations made to the design which may be considered necessary, owing perhaps to difference in size of one or two of the component parts purchased, to the dimensions shown in the diagram. It may be anticipated that the transformers will vary in size, and also that the diameter of the holes in the front of the box through which the three





filament spindles pass, may vary in diameter, but these slight alterations should not present any difficulty. The ebonite panel can now be unscrewed from the box and the position of all holes marked ready for drilling on the underside of the ebonite.

should be taken that there is no stretching or shrinking of the paper. After the necessary drilling has been done, the panel can be laid aside for a moment. The front of the box should now be unscrewed and the hole cut to receive the Dewar switch, and the three

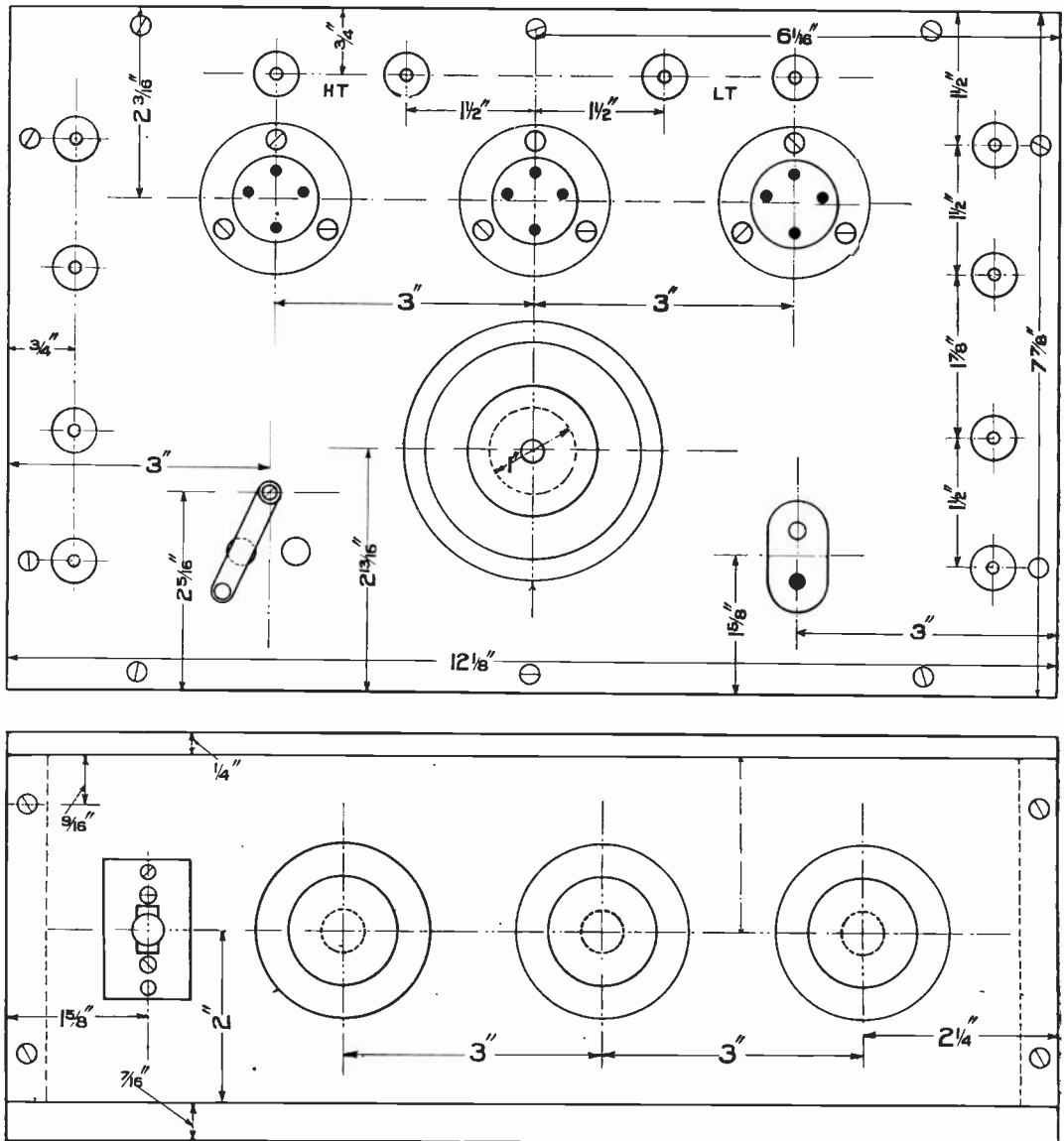

Fig. 4. Dimensions of the panels (top and front).

The design on pp. 680-681 is drawn full size. If a copy of this diagram is carefully gummed to the underside of the ebonite panel, the position of all holes to be drilled, and also the disposition of wiring, etc., is clearly defined, but great care

holes drilled for the reception of the filament spindles. The next step is to screw the complete filament resistances and Dewar switch in their respective positions, and fasten the ebonite panel to the front of the box only by

three 1-in. wood screws. By means of nine 4 BA screws, $\frac{1}{2}$ in. long, the three valve sockets are secured in position. For the drilling of the holes a $\frac{7}{64}$ -in. drill is recommended, and if a 4 BA tapered tap is not available, each screw may be made to cut its own thread in the ebonite. This method gives quite satisfactory results. It is advisable at this stage in the construction of the amplifier to wire the filament circuits. This should preferably be done with tinned bare copper wire of about No. 20 gauge, as there are a number of soldered connections to be made. A good method to follow with the wiring is to bend each wire to the shape required and then pass the

insulation over the wire. This insulation is commercially known as sleeving, and costs about 4d. per yard. It is in the form of a tube and fits closely over the wire.

Here a word of caution is earnestly given. Do not rush the wiring. It does not pay. Any extra time spent in wiring and in the disposition of the various parts is time well spent. Space the wires as far apart as is consistently possible, so as to reduce to a minimum the capacity between one wire in one circuit and another wire in another circuit. If this is not done inter-oscillation between the circuits may result.

(To be continued.)

Valve Manufacture

A BRIEF DESCRIPTION OF THE SIMPLER PROCESSES ADOPTED IN THE MANUFACTURE OF M.O. VALVES

(Continued from p. 647, Aug. 19th, 1922.)

THE dimensions of the electrodes are of considerable importance, both with regard to characteristic and rating, and in the case of transmitting valves of definite watt rating, the energy that can be handled is approximately calculated on the basis of the ratio of the rated watts to the anode area.

The disposition of the anode with regard to the container, the leads and the pinch, requires considerable attention in valve design, and also the length of anode with regard to length of filament must be carefully considered, in order that even heating may result over the whole anode during bombardment. The grid dimensions and spacing are calculated to maintain definite characteristics in specified operating conditions, and in the case of transmitting valves the spacing may be varied throughout the length of the grid, according to the extent to which it enters the field of electronic action. The filament diameter and length are calculated on the basis of the emission required at a temperature which allows of a reasonably long life, allowance being made for the cooling at the ends and a certain decrease in diameter which occurs during bombardment.

The sealing-in of the mounted electrodes is effected by the use of a special machine, and great attention is required with regard to the annealing of the glass. In the case of small

receiving valves, the point of sealing is annealed by placing the sealed end of the bulb in a gas-heated asbestos cup, which is allowed to cool down by slow stages, but the seaming end of the tube is next melted into the body of the bulb by attaching it to the exhaust system on the pumping tables.

After the bulbs have been fitted with the interior electrodes, they are given a preliminary exhaust and sealed off. Those which prove to be free from leaks are later sealed on to the glass tubing which forms part of the exhaust system on the pumping tables, and a control cock is so turned for a sufficient length of time to obtain the first degree of vacuum. The cock is then turned to another position, when the table exhaust system is arranged in three stages, *i.e.*, mercury diffusion pump, rotary oil-box pump, and motor-driven reciprocating pump. The latter is backing the box pump to a pressure of 1 mm. The box pump is in turn backing the diffusion pump to a pressure of 0.001 millimetres, and the diffusion pump is capable of reducing the pressure in the valve to something below 0.000001 mm.

The pressure is indicated by the McLeod gauge. A liquid air trap is placed between the high vacuum side of the diffusion pump and the valves undergoing exhaustion, to prevent the possibility of mercury vapour

getting back into this part of the system. Electrical or pressure tests are applied to determine the exact condition of the valve during exhaustion. The current in the valve

grid potential, the extent of which is a clear indication of the pressure in the valve and of any evolution of gas from the heated electrodes. This test is not carried out

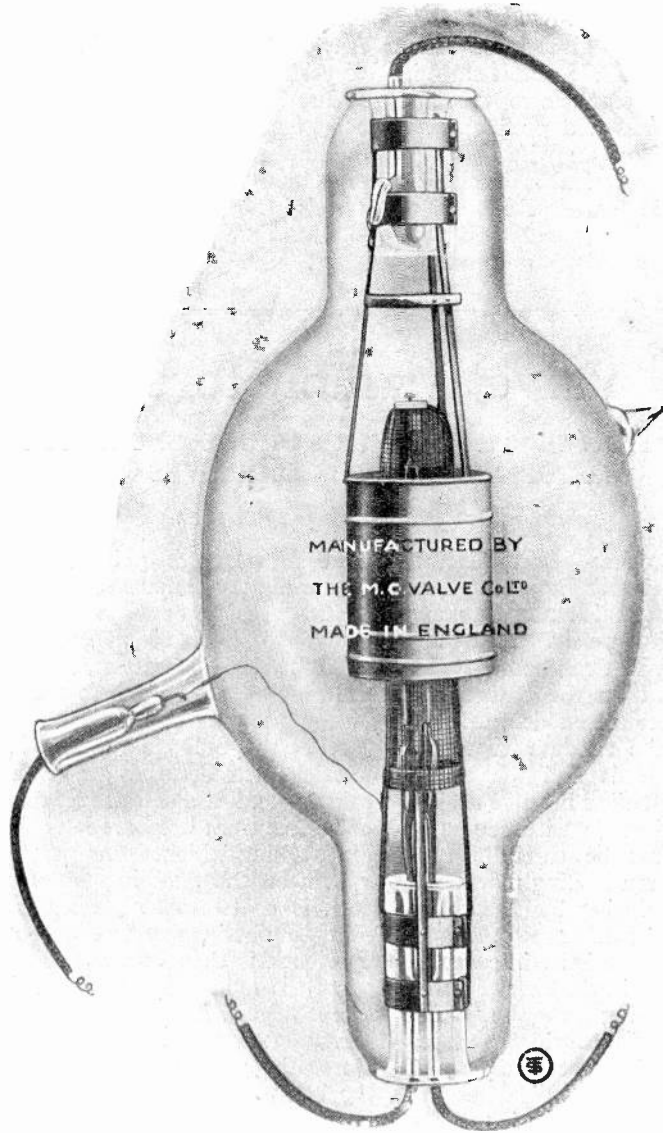

Transmitter type M.T.6. Designed to operate with anode potential of 10,000 volts and dissipating 400 watts.

anode circuit is adjusted so that the energy dissipated would be the amount that would be desired to test the valve. This current is kept constant by increase and decrease of

while the valves are still connected to the pumps, because in this case the gas would be cleared by their action as it was evolved. The test is applied by dissipating a definite wattage

in a specified time, and then comparing the gauge readings at the beginning and end of the test, which will, of course, show the amount by which the pressure has increased

then turned off and the oven allowed to cool down to a definite temperature, when it is removed and the valves again connected up to the several terminals on the inside of the

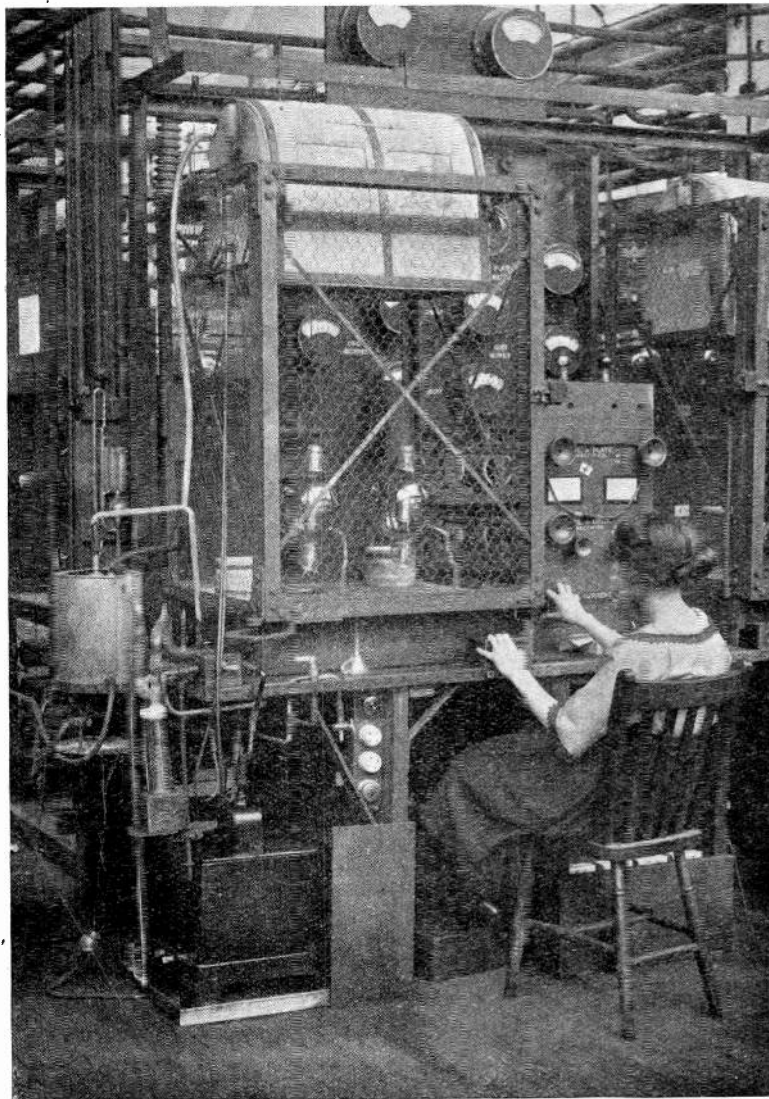

Large Transmitting Valves being exhausted. The pumps are on the left and the remote control switch on the right.

during that time owing to the evolution of gas. When the required degree of vacuum has been obtained, an oven is brought down over the valves and left there until a suitable temperature is reached. The gas heater is

cage, thus connecting anode, grid and filament to their respective circuits, after which the cage is placed in position, and then bombardment can be commenced. This is done slowly and with great care, the operator

watching for the appearance of the blue glow indicating ionisation. In the early stages of bombardment, the blue glow will appear before there is any visible sign of the anode

preliminary bombardment. The process is then repeated, commencing again with the first valve, until it is found that the glow is accompanied by visible heating of the anode.

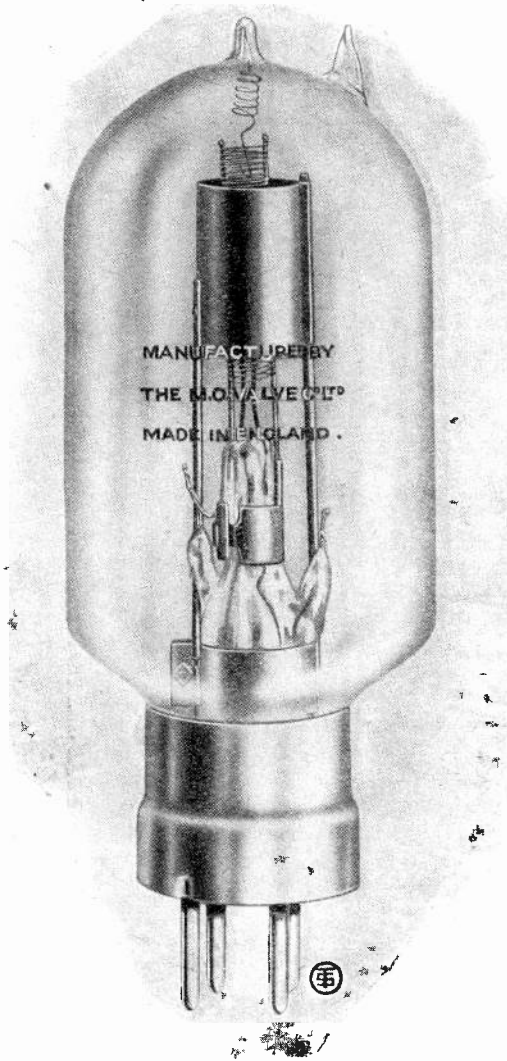

Type T30. A low power Transmitting Valve dissipating 30 watts.

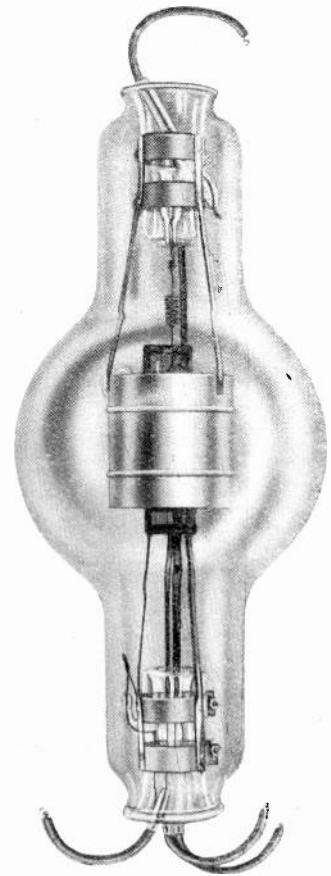

Type T250. Requires an Anode Voltage of 2,000, and dissipates $\frac{1}{4}$ -kW. Overall length 280 mm.

heating. As soon as the glow appears, the filament current is reduced to zero, and the next valve proceeded with in a similar manner, and so on until the entire batch which the operator is manipulating has received this

Experience alone on the part of the operator can show how long it is safe or wise to allow the filament current to be maintained while there is blue in the valve. Two things may occur: either a rapid increase in ionisation, resulting

in a flash over between anode and filament which would destroy the valve, or a serious wasting of the filament due to bombardment of positive ions. Even an experienced operator may produce valves which, though being good as far as vacuum is concerned, may have their filaments wasted to such a degree as to cause them to be rejected on subsequent tests, on account of the required filament voltage being too high. Further, it is clear that if this did not happen to be the case, such wastage would result in a short life for the valve in service.

Before completing the bombarding process and sealing off, the valves may again be heated in the oven to further ensure the absorption of all the available gas from the glass.

The operation of sealing off after bombardment is one that requires skill and care. It will be realised that in the baking process the glass cannot be brought up to its softening-point on account of the low pressure inside the bulb, and consequently there is a comparatively large amount of gas in the glass, which is not released during the process, so that when the blowpipe is applied to the sealing tube to seal off, gas will be liberated, and if a careless operator heats a larger surface than is absolutely necessary, or prolongs the operation for too long a time, the pumps will not be able to clear the liberated gas quickly enough, and so it will be sealed inside the valve, so that it will not pass the subsequent tests.

The electrical equipment used in valve manufacture is one provided with a large range of voltages in both alternating and continuous current, ranging from 10 to 20,000 volts, for the purpose of supplying anode, grid and filament potentials, and for operating the usual indicators, lamps and automatic switch gear.

The careful testing of valves is of the utmost importance. Tests are made to determine the emission for a given filament-current, filament-plate-current, filament-grid-current, and plate-current for given fluctuations of grid potential. The valve is also carefully scrutinised as to the concentric arrangement of the electrodes. As mentioned earlier, only those valves are passed which come within certain specified standards, which allow of only a small deviation from the prescribed characteristic. This assures that all valves of a particular type can be relied upon to have certain properties and be interchangeable with one another—a very important property

to valve users. It is this extreme care in testing that assures one that a particular valve can be relied upon to function correctly in a particular circuit, and for the purpose for which it is required, and the M.O. Valve Company, fully appreciating the importance of the standardising of the various types of valves, have laid down an extensive and elaborately equipped Test Room. Every valve during manufacture bears a registered number, and records are kept showing the results given on test.

The next and last stage in manufacture is the fitting of the cap with, in the case of the "R" valve, a four-pin socket. The capping and the soldering-off of the valve leads is executed with the same care that is shown in the other stages of manufacture, and in this case with the object of maintaining insulation during soldering and the correct spacing of the leads in the socket. The valves are then marked with type number and manufacturing details, and are ready for the market.

Particulars are given below of the more familiar types of valves manufactured by the M.O. Valve Company, Ltd. The purposes for which the various valves are suited is too wide a subject to enter into here, but a few brief notes on the action of the more important receiving valves may be helpful.

The "R" type is the well-known French form of valve, and is extensively employed for general reception purposes. It gives good results as a detector, L.F. amplifier, or oscillator, and is one of the best all-round valves for use where it is not desired to employ a special type for a specific purpose.

The "R.4B" is intended for use as a detector or for low frequency amplifying. It has a long life, and its filament voltage is well within the capacity of a 4-volt accumulator.

The "R.4C" is very similar to the "R.4B" and operates on the same filament and anode voltages, but has a slightly more open grid and lower impedance. It gives silent amplification, and has a long life.

The tubular "Q" valve is for use chiefly as a rectifier, though it can be used as an amplifying valve and for all general receiving work.

The "QX" is an efficient rectifier, and is also employed as an amplifier after several stages of H.F. amplification. It is also suitable as an oscillator.

The "V.24" is intended chiefly for use as an amplifying valve, both at high and low frequency, and also as a low-power oscillator.

The "F.E.1" is a four-electrode valve.

Particular reference should be made to a new type of valve which has been developed by the M.O. Valve Co., in conjunction with the Research Laboratories of the General Electric Co., the great advantages of which will be apparent to every valve user. In the case of an ordinary "R" valve the filament

such highly efficient valves on the market. The credit of tackling the problem of the thermionic valve in the proper way and manufacturing in quantity belongs to them by right undisputed, particularly during the War. This work—one of those aspects of war work almost unknown to the public—had a very direct bearing upon the result of the



A Test Bench where Valves are examined and data recorded.

is run from a four-volt accumulator, and takes a current of about 0.7 amperes. The new valve has a special filament, not of the coated type, which requires something less than 2 volts on the filament, while the current is in some cases as low as 0.06 amperes. Valves of this type, it is understood, are almost ready to be put on the market in large quantities, the first production in all probability being valves running at 1.8 or 2 volts with a filament current of say 0.06 to 0.1 amperes. It will be apparent that these valves can be run from small dry cells.

A description of valve manufacture would not be complete without making mention of the enormous amount of research work which has been conducted by the M.O. Valve Company, so that they are now able to place

struggle, as valves could only be manufactured in a factory where there were already highly skilled workers accustomed to the intricacies of incandescent lamps, and it is very doubtful whether we should have been able to hold our own in the under-sea warfare, and to carry on the war in the air with anything like success, without the resources of this company being at our disposal.

We are indebted to the General Electric Company, Ltd., and Marconi's Wireless Telegraph Company, Ltd., for assistance in the preparation of this article and the loan of the illustrations of the various valves.

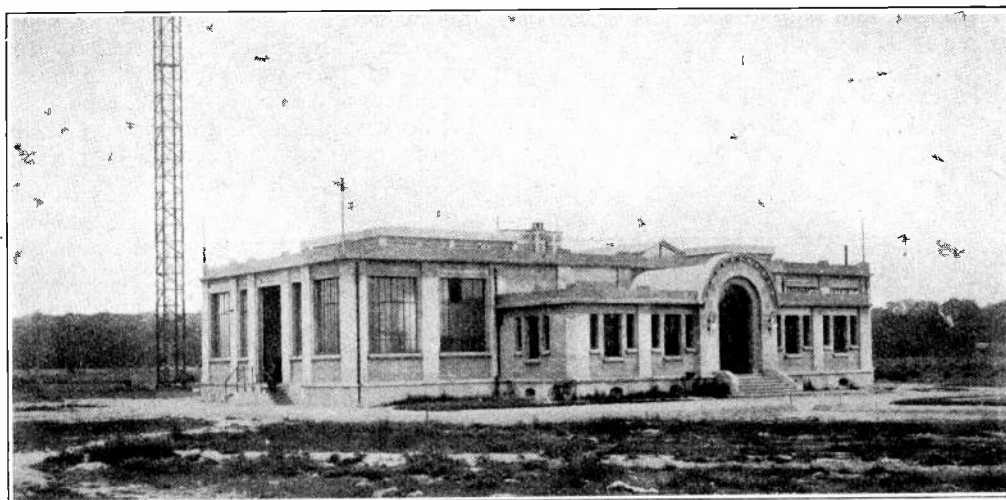

Fig. 1. The station building of the Continental transmitter.

The Trans-Continental Wireless Station of Sainte Assise

THE foundation stone of the wireless station of Sainte Assise, known as Paris Radio Central, was laid on January 9th, 1921, and the first message was transmitted from this station on the morning of July 4th, 1922, at 11 o'clock G.M.T.

The station called up Marion, U.S.A., on a wavelength of 14,300 metres. Communication was immediately established, and hand operation was then replaced by high speed automatic transmission.

During the afternoon, Senatore Marconi, from his yacht *Elettra*, in the neighbourhood of New York, reported excellent signals. A further telegram of congratulations after more detailed observations, was sent by Senatore Marconi on the following day.

Since that date, observations from all parts of the world signify to the very high efficiency of the station. Sainte Assise was formally opened on August 17th, 1922.

Previously, the wireless station of Croix d'Hins, near Bordeaux, which was opened at the end of 1920, has claimed the honour of being the most powerful wireless station of the world. The power of the new Sainte Assise station, however, now eclipses that

of Bordeaux, the Paris station being about twice as powerful.

The Compagnie Générale de T.S.F., who have constructed and who now operate the station, have carried out the work on a grand scale. The site of the station is on the plateau of Sainte Assise, about twenty-five miles from Paris (Fig. 2). The area covered by the station is bounded on the north by the road from Seine Port to Sainte Leu, on the south and west by the Seine, and on the east by the railway from Melun to Brunoy. The site is approximately level, and the soil is sufficiently moist at all times to ensure an efficient earthing system. Many conditions were laid down by the French Ministry of Posts and Telegraphs when the erection of the station was sanctioned, and it was some time before this site was selected which would comply with them all.

There are two main buildings which serve to house the station, and these are occupied as follows:—

- (1) Two valve transmitters of 5 kW. each, for short distance communications, the aerials being supported on a tower about 330 ft. high.

(2) A "Continental" station (Fig. 1), consisting of four high frequency alternators with an aerial input of 25 kW., for European services.

The aerial, which is of the "double cone" type, consists of four independent networks, and is supported by a single tower 830 ft. in height.

may also be used independently for duplex transmissions.

(3) An "International" station, consisting of two 500 kW. high frequency alternators and two of 250 kW. each.

In this case the aerial consists of a double network suspended horizontally by sixteen towers, each 830 ft. high.

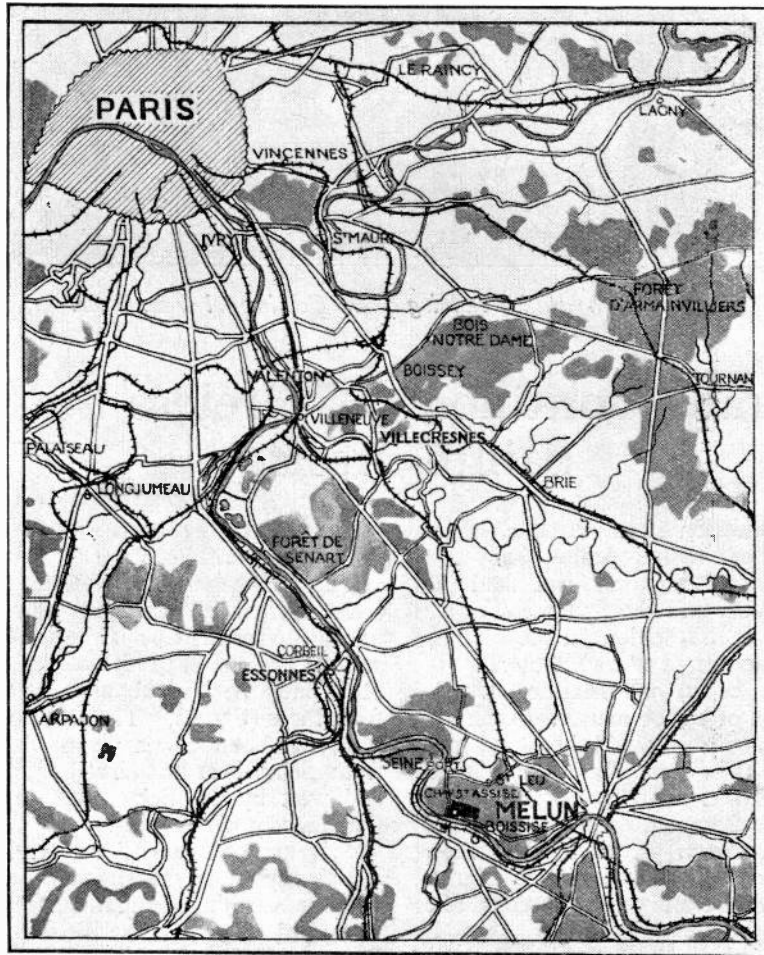

Fig. 2. Map showing the location of the Transmitting Stations at Sainte Assise, and the sites of the Receiving Centres.

The earth system consists of 240 square yards of copper plates and ten miles of buried copper wires.

The four alternators (Fig. 4) can be run independently, or they can be used in combination to increase the output. They

Two sources of power supply are available, one a power distribution network, and the other an emergency installation of three Diesel engines each of 1,800 H.P. The station can transmit either with one machine of 250 kW., or with two such machines coupled, or similarly

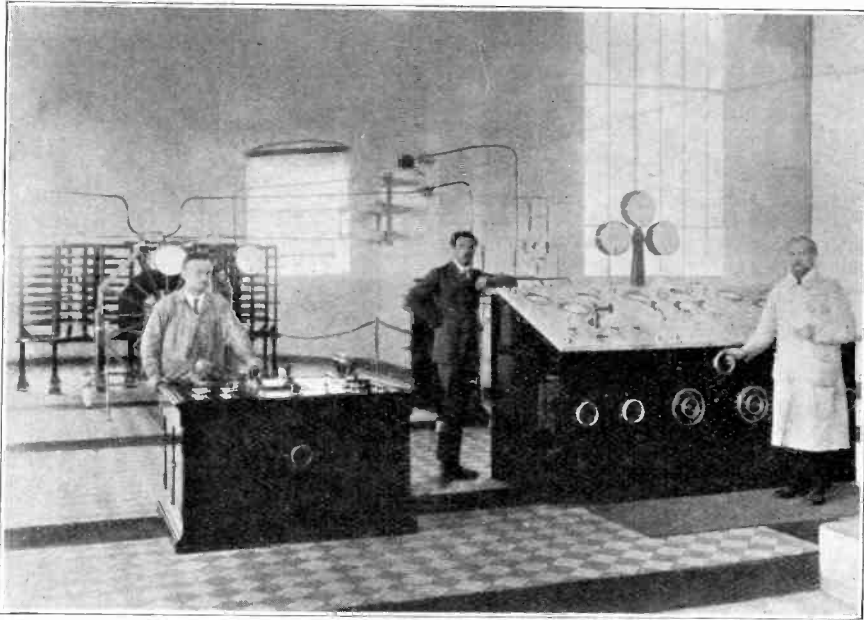

Fig. 3 Room from which the transmitter is controlled.

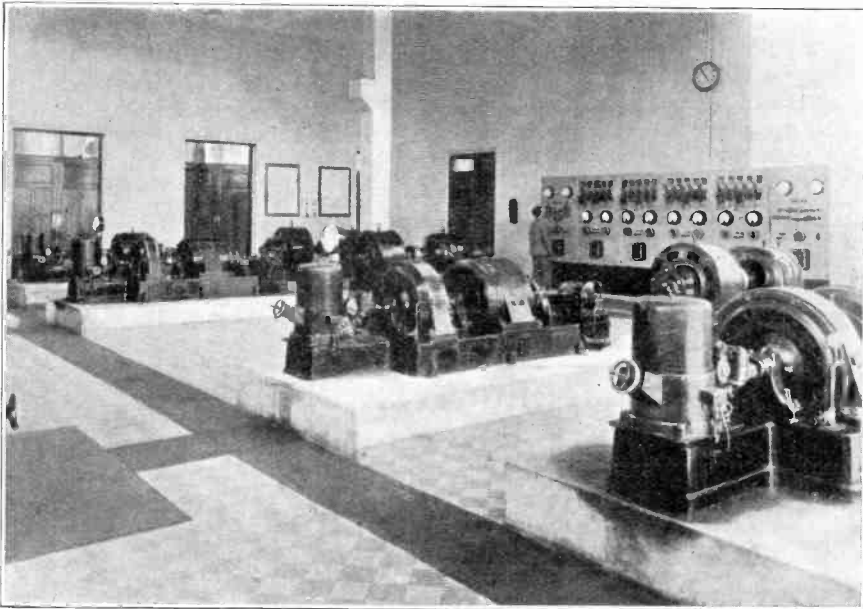

Fig. 4. High Frequency Alternators.

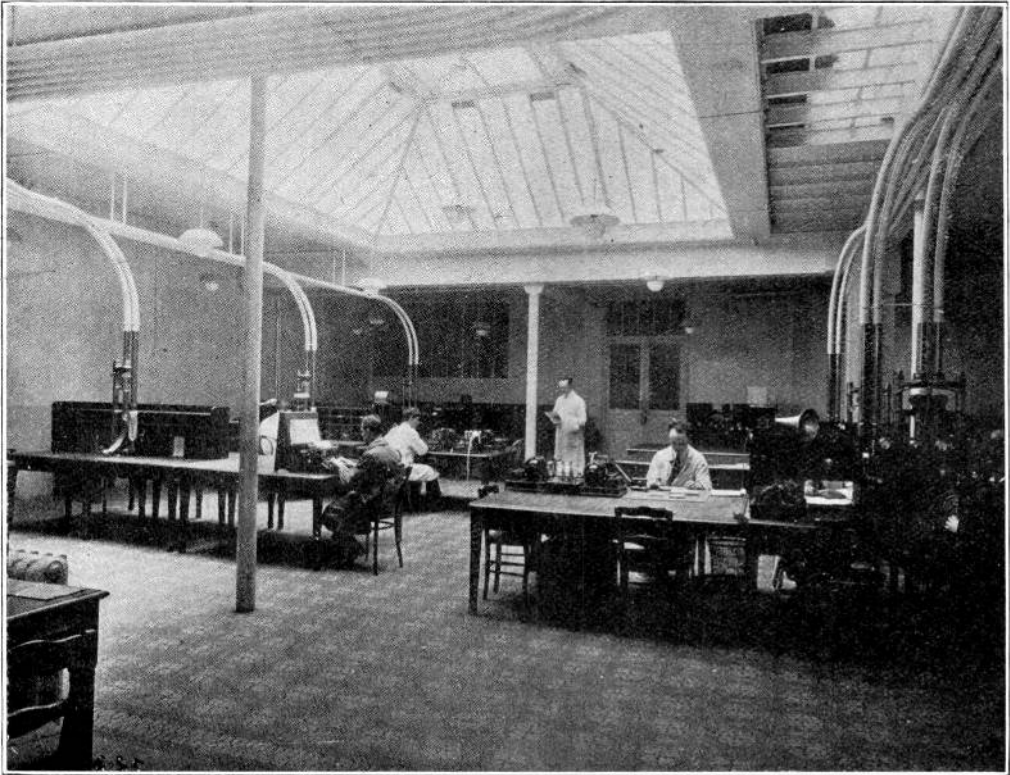

Fig. 5. A view of the operating tables in Paris.

with one or two machines of 500 kW., or it may conduct two simultaneous transmissions.

The stations are all designed to handle traffic at a speed of at least 100 words a minute, so that with all six working transmitters at the same time, 36,000 words an hour may be transmitted.

Both the transmitting and receiving stations are controlled from the Bureau Central Radioélectrique, Rue Montmartre, Paris, in the centre of the business quarter. In addition this office is connected with the two principal Paris telegraph offices of the Bourse and Rue

de Grevelle, by means of high speed Baudot and Hughes telegraphic apparatus. The recording apparatus for reception is all located on the same operating tables (Fig. 5), and the arrangements are very similar to those at Radio House, London.

The receiving stations are distinct from the transmitting centre, and these are located at Villecresnes, 22 kilometres S.S.E. of Paris, at Essonnes, 30 kilometres south of Paris, and Valenton, 18 kilometres S.S.E. of Paris. The location of these places may be seen from reference to Fig. 2.

DO NOT FORGET THESE DATES !
SEPTEMBER 30th TO OCTOBER 7th, 1922
The Wireless Exhibition and Convention
AT THE HORTICULTURAL HALL
WESTMINSTER, S.W.

A Suggestion for the Experimenter

By G. P. KENDALL, B.Sc.

DURING the war a telegraph instrument was evolved which had among other characteristics that of extraordinary sensitiveness to minute direct currents. It is the purpose of this contribution to suggest that the investigation of the properties of similar circuits would be a promising line for the experimenter who is interested in the problem of C.W. reception without valves, or at any rate, without local oscillations. The sensitiveness of the instrument referred to was achieved entirely by means of a com-

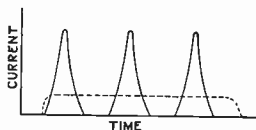

Fig. 1,

bination of filter and interrupter circuits, and not by the use of any type of relay or amplifier. As an instance of its efficiency this should suffice:—A certain signal officer was in the habit of demonstrating its powers by an experiment in which the sending battery consisted of an orange into which were struck an army knife and fork, while the “line” was a chain of twenty men holding hands. It can be imagined that the current obtained from such a combination of feeble cell and high resistance line would be very small, yet on being applied to the terminals of the set it produced good strong signals in the receiver, which was a rather insensitve pattern of only

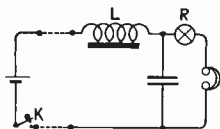
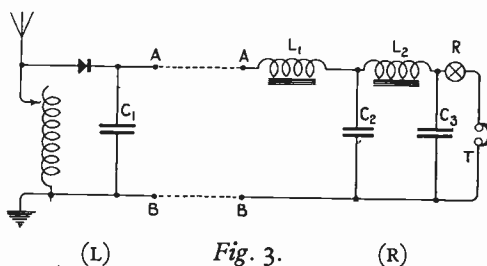

Fig. 2.

20 ohms resistance. It was said, though the writer never had the opportunity to put the statement to a rigid test, that signals could be received through a line resistance of a megohm with only a single dry cell at the sending end.

The principle upon which the instrument worked was the conversion of the very small continuous current into an intermittent current consisting of brief pulses of much greater volume, separated by comparatively long intervals during which the line current was being stored up in condensers. The pulses, of course, followed each other at a suitable note frequency. The relation of line current to receiver current will be more clearly seen from Fig. 1, where the two are represented by a dotted line and a full line respectively.

How it was done will be understood from the simplified circuit of Fig. 2, in which is an iron core choke L , a 1 mfd. condenser, and an interrupter R running at, say, 500 cycles per second. The mode of operation is as follows:—Suppose the key K to be closed at a moment when the interrupter is “making.” The line current will pass through the choke, the interrupter and the receivers. The next moment the interrupter contacts open and the current can no longer flow through the



telephones, but is forced by the choke to go on flowing somewhere, and therefore charges the condenser. The line current is thus more or less maintained until the interrupter contacts close again, when the flow through the telephones is resumed, greatly augmented by the discharge of the condenser. Repetition of the cycle then occurs, and continues so long as K is depressed, producing a note in the telephones.

The suggested use of this type of circuit is the detection of the minute d.c. which appears at the terminals AB of Fig. 3(L) when receiving C.W. A circuit which would probably give good results when connected to the respective terminals of Fig. 3(L) is given in Fig. 3(R.) The success of circuits of this type depends largely

upon suitable values for chokes and condensers, and it is here that a little experimenting is required. The following data is given as starting points :—

$C_1 = 0.005$ mfd.

$T = 120$ ohm Brown telephones (probably better than H.R.).

C_2 and $C_3 = \frac{1}{4}$ to 1 mfd. (try $\frac{1}{4}$ mfd. first, then larger values).

L_1 and $L_2 =$ Say, $\frac{1}{2} \times 3$ in. core and 1 oz. of No. 42 D.S.C. wire.

R = Interrupter, preferably one of the army double contact buzzers, which can be obtained quite cheaply from one of the

various ex-government telegraph sets now on the market. These buzzers (known as the D Mark III Type) can be easily arranged to buzz on one contact only, leaving the other free for use as an interrupter. Of course, a motor-driven one can be used if available.

The crystal detector employed should be a Perikon, or, failing that, some other combination which does not need a potentiometer.

The above values are likely to require a good deal of modification, but as they stand will probably give considerably better results than the pre-war "tikker" circuit.

Wireless Without an Aerial

A NEW LINE OF EXPERIMENT FOR AMATEURS

By PERCY W. HARRIS.

THE aerial problem, which presents certain difficulties even to those who have their own ground on which to experiment, is particularly troublesome to the flat dweller. Possessors of multi-valve sets can of course utilise a frame or loop, and a certain amount of success is obtainable with wires slung across the room. But neither of these expedients gives results comparable with those given by an outside aerial.

American wireless literature has recently contained announcements of experiments by Major-General Squier and others whereby an outside aerial is dispensed with entirely, the electric light mains being utilised instead. The idea is certainly attractive, and already several firms are advertising attachments under fancy names for connecting ordinary wireless apparatus to the mains. Particularly with alternating current supply, it might be imagined that this connection would occasion a terrible howl in the 'phones, but such is not the case.

The current American wireless journals in particular contain several such advertisements. We have, for example, the "Super-Antenna" (price \$2.80). "It is fool-proof and shock-proof and can be used effectually in place of overhead antenna. No power is used when operating with a Super-Antenna." "It

operates on any electrical circuit from 32 to 120 volts D.C. or A.C." Similarly we have the "Marble Antenna," which "completely replaces all ordinary wire aerials and outside wiring. . . . A beautiful ornament suitable for office or library," and so forth. Price 3 dollars.

The writer has no direct knowledge of the construction of these wonderful new instruments, but he can make a shrewd guess. In any case, he has succeeded in duplicating the results with the simplest possible apparatus, and the results of his experiments are hereby offered to other amateurs.

The first clue was obtained from the latest advertisement of aerial replacing devices. When one of the leading condenser companies added such a device to their list, it certainly seemed likely that a condenser formed part of the equipment. Having two or three excellent Navy-type 0.001 variable condensers, the writer wired them, two of them as in the accompanying diagram, connecting one to each wire of the mains, by means of an ordinary plug attachment, the other sides of the condensers being attached to a common wire taken to the aerial terminal of the set. The receiving apparatus was that described in recent issues (a four-valve set for short wavelengths), and the tuned anode circuit was set for 600 metres,

as there is always "something doing" on this wave.

Without daring to put the phones on, the writer switched on the valves, expecting a terrible howl. There was neither howl nor signal. Various adjustments of the aerial tuning condenser in parallel were tried with no result. The condenser was then placed in series, and almost immediately North Foreland came in loud and clear on three valves. Tuning with the series condenser was extremely sharp, and a vernier would have been useful. Other channel stations, such as FFH (Havre) were also heard with the phones on the table.

For the initial experiments the two condensers on the mains were both carefully set at maximum. Any alteration of the values was found to alter the tuning very considerably. When retuning was effected, the signals were practically the same strength with the condensers reduced to nearly minimum, and wide differences in the two values were tried without altering the general effect, other than the tuning.

As a guide to other experimenters, it may be said that to get ships signals it is necessary to use a condenser *in series* with a coil which, attached to an ordinary external aerial, would need a small condenser *in parallel*. A No. 50 plug-in coil needs 0.0005 approx. in series for tuning, and two 0.001 mfd. condensers on the mains to give North Foreland at about half its capacity.

Experiments were then tried on shorter waves, and Major Parker (2 ON) may be interested to hear that his tests with 2 KT and Luton on Monday evening, August 14th, were very useful. "The Lost Chord," "Vesti la Giubba," and other selections, as well as the familiar "Hullo, Hullo, Hullo!" were audible all over the house on four valves and the loud speaker, while three valves and the loud speaker were good enough for the occupants of the room. The coil and condenser already found satisfactory for 600 metres, were used, and tuning was effected alternately on the mains and the set, to see what difference was found. Again the tuning was found very critical, although wide differences in the mains condensers, when compensated in tuning, were found equally satisfactory. As an example, excellent results on 2 ON were obtained with the following adjustments:—

- Mains condenser 1 .. 0.0001 mfd.
- Mains condenser 2 .. 0.0005 mfd.

Series tuning condenser 0.00021 mfd.

Burndept shortwave coil No. 4.

Atmospherics were about the same strength as with the outside aerial, and switching off the light (or what would have been the light if there had been a lamp in the socket) reduced the strength of the signal to about a tenth of its previous value.

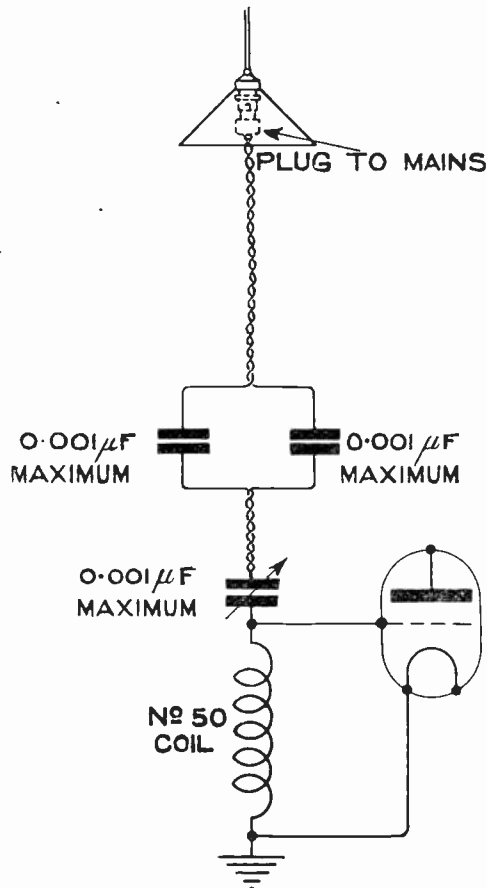

Diagram, showing Circuit.

A few experiments have been made on long waves, and Stavanger and Nauen successfully received, but on the night these experiments took place static was extremely bad on outside aerial and the mains equally. The first impression is that the efficiency is not so great on long waves. On short waves such as 600 metres and the concert band, this method seems much superior to any indoor aerial so far tried. There seems no noise whatever from the mains themselves.

Notes

Imperial Patent Rights.

A conference was held at the Patent Office, London, to consider the practicability of instituting a system of granting patents which would be valid throughout the British Empire. The Chairman was the Comptroller-General of Patents, Designs and Trade Marks, Mr. W. Temple Franks, and representatives from all over the Empire, except Newfoundland, were present.

A report of the conference (obtainable from H.M.S.O., 1s. 1d., post free) has just been issued, in which it states that an agreement was reached, without calling witnesses, that a British Empire Patent, otherwise a patent which would be operative throughout the Empire, would be desirable provided it in no way affected the autonomy of the Dominions and India, or the rights and facilities which an inventor at present enjoys in these countries. With this object they decided on a scheme for the establishment of a central office for the reception and examination of applications for, and the grant of, patents. Until it should be possible to introduce the full scheme a provisional scheme was adopted. The conference was of opinion that whether or not the schemes suggested were found to be practicable, it was of the highest importance that both the procedure and practice in respect of the grant of patents should be uniform throughout the Empire.

Demonstration at Broadstairs.

A demonstration and concert were conducted in the Piermont Hall, Broadstairs, a few days ago. The apparatus used was constructed by Mr. P. F. Cotton, and the Brown loud speaker was lent by the makers.

The function, which was organised by the *Broadstairs and St. Peters' Echo*, was the outcome of experiments which have been proceeding for some time. Perhaps one of the most persistent amateurs in that district is Mr. A. H. Pound, who since 1909 has carried out research until, with the co-operation of Mr. Cotton and the influence and practical aid of the local newspaper mentioned above, a public demonstration was attempted and met with complete success.

The precaution was taken of warning the audience that owing to the close proximity of the North Foreland station, interruption might take place. As the North Foreland Station is only 2,000 yards from the Piermont Hall, there was some interruption, but not so much as to disappoint the audience.

Esperanto and International Wireless Transmissions.

Perhaps in the near future we shall hear more of Esperanto in connection with wireless transmissions. Dr. Pierre Corret, Editor, *La T.S.F. Moderne*, who is an enthusiastic supporter of this language, proposes to make transmissions from his station in Paris in Esperanto. An interest is also being taken in the subject by the American Radio Relay League, probably in view of the possibility of international amateur transmissions of the future.

Agents for the Homcharger.

We are now able to state that the agents

in this country for the apparatus to enable electric batteries to be charged from A.C. circuits, known as the Homcharger, are Messrs. Ashworth and Smith, Bridgewater House, 60, Whitworth Street, Manchester.

South London Club's Exhibition.

Under the auspices of the South London Wireless and Scientific Club an exhibition is being held at St. John's Institute, Larcom St., Walworth, S.E.17. The Exhibition opened on Thursday at 2 o'clock and closes on August 26th at 10 p.m. One of the special features of this exhibition is a wireless controlled airship in operation by the inventor Capt. de Villiers. Other attractions are a wireless controlled torpedo boat, broadcast receptions, numerous trade and amateur exhibits, and frame aerial transmission and reception. St. John's Institute is two minutes walk from Southwark Town Hall and the same distance from the Elephant and Castle. Admission to the exhibition costs One Shilling. Refreshments are obtainable on the premises.

Radio in Northern Canada.

Broadcasting, both in the United States and Canada, has made life in the Porcupine Goldfields very different. Concerts, market reports, educational lectures, etc., are now received.

Vacuum tube sets are used, and one amateur especially has had exceptional reception from American amateurs over long distances, using very small power tubes.

The largest gold mine, the Hollinger, is equipped with an expensive tube set, and another large mine is installing one also.

A mining student of Queen's University, Kingston, Ontario, says that wireless telephony is greatly appreciated in these parts and all out-of-the-way places, but that disappointment was expressed when advertising began to creep in.

Secretary of the Norwegian "R.A.K."

Mr. Kaye Eystein Weedon points out that he is not, himself, the Honorary Secretary of the N.R.A.K. (Norwegian Wireless Amateur Club) as stated in our note on "Conditions in Norway," in July 22nd issue.

PCGG on August 17th.

Broadcasting of the *Daily Mail* concert from the Hague was suspended on August 17th on account of the funeral of Viscount Northcliffe taking place on that day.

Senatore Marconi's tribute to Lord Northcliffe.

At the annual general meeting of Marconi's Wireless Telegraph Company, Limited, Senatore Marconi said: "It is with very deep regret that we learn of the death of Lord Northcliffe. No man in this country has done more for journalism and the dissemination of news. We feel we have lost a valued and respected friend, for Lord Northcliffe always followed and took the keenest interest in the development of wireless telegraphy and wireless telephony."

British Wireless Relay League (B.W.R.L.).

Mr. Y. W. P. Evans, Hon. Secretary of the Manchester Wireless Society, has obtained permission from the Postmaster-General to form a British Wireless Relay League, which a great many amateurs possessing transmitting licences have been looking forward to. Mr. Evans will be pleased to hear from those interested with a view to forming such a League as early as possible. With a good organisation, and assuming that the forthcoming transmitting tests between the Manchester Wireless Society and the American Amateurs are a success, there is a possibility of the scheme providing a means of opening up a vast field for the experimenter. Letters should be addressed to Mr. Y. W. P. Evans, 2, Parkside Road,

Princess Road, Manchester. Suitable agenda will be drawn up and distributed to those in favour of the League. Suggestions will be welcomed, and any assistance will be appreciated.

Teletype in American Aeroplanes.

An announcement is made by the United States Navy Department that an apparatus has been perfected for the use of airmen in communication with the ground. Signals corresponding to letters struck on a keyboard are automatically sent out by the wireless set and are received on a special type of instrument corresponding to a typewriter.

German Demand.

German inhabitants of Swakopmund, South-West Africa, have demanded the re-establishment of a wireless station.

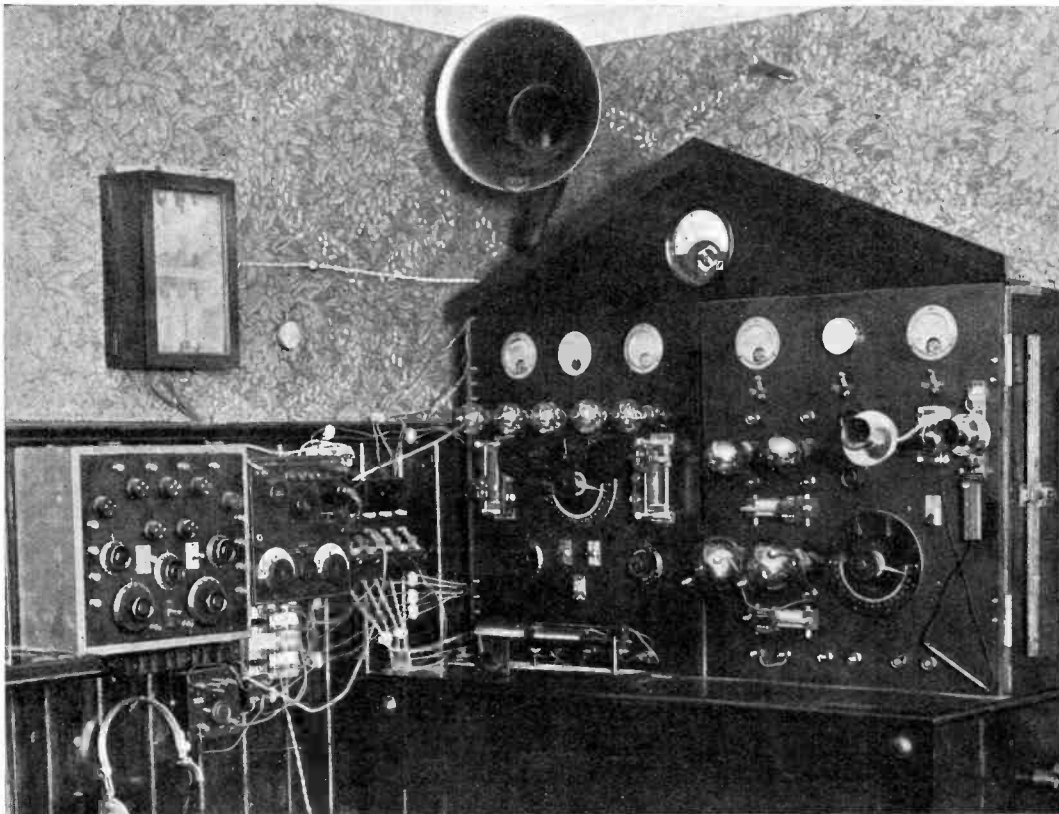
2 FG. THE TRANSMITTER AND RECEIVER OF Mr. L. H. McMICHAEL.

The main panels represent to the left-hand side a five-valve receiving set, 2 high frequency, 1 detector and 2 low frequency, with the necessary meters and arrangements for using either coils behind the panel or external tuning coils. The loud speaker speaks for itself.

The right-hand side of the main board contains the transmitting set and the lower pair of valves are for rectifying 3,000 A.C. current, the upper pair of valves for transmitting, one a power valve and one a control.

Two microphones are available, as will be seen, for use with the change-over switch.

The whole set is mounted in an ex-Marconi ship's oak cabinet. The lower portion can just be seen, and it has two doors which open, and inside are housed the transformers, chokes, condensers, accumulator charging rectifier and the accumulators. To the left on the wall, under the distributing board, is a five-valve set, and to the right of that the T.F. three-valve set. A most efficient instrument. Change-over switch for transmitting and receiving is to the right of this again.

Correspondence

To the Editor of THE WIRELESS WORLD
AND RADIO REVIEW.

SIR,—Since the last letter I wrote, an acknowledgement of which I received to-day, in answer to Mr. Stephenson, I have often been able to pick up the harmonics from EAB on 430 m. that he refers to. On comparison with the fundamental I find this much stronger than the harmonic, but not to the degree that one might expect after comparing the strength of harmonics from GBL.

With reference to this last station, the signals from GBL are readable on the 19th harmonic, just below 450 m., using two valves, one rectifier and one L.F. note magnifier.

I enclose a photograph of my station, which is entirely home-made, with the exception of valves, batteries, phones and instruments and such details as studs and terminals. In your paper I have noticed, in reply to correspondents, that you have been giving advice about engraving and filling ebonite.

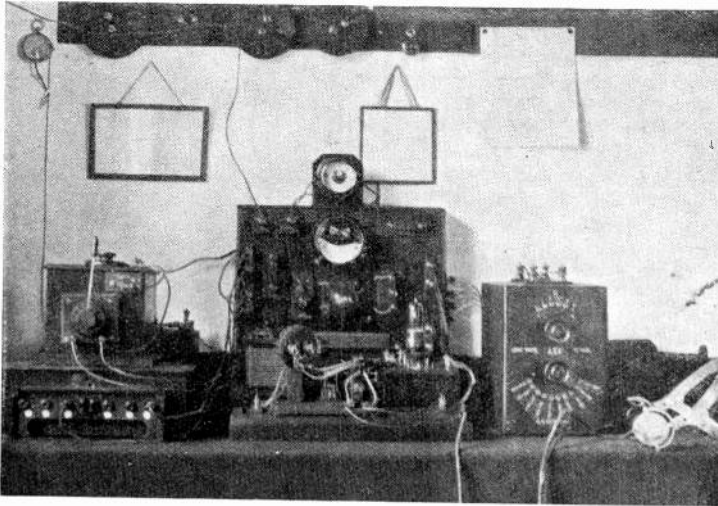

In my set this was done by engraving by means of the usual hand-tool, and filling in by means of white water colour. This makes a very good finish, and the paint is not liable to fall out. Oil paint, of course, is better, and both methods are cheaper than filling with special wax.

Since the photograph was taken a condenser (0.0005 mfd.) has been fitted across the reaction. Behind the tuner in front is a change-over switch, changing from the tuner in front to the one on the right. This large tuner may be used for wavelengths of from about 5,000 to 30,000 m., and is tapped below 5,000 m., but not used on these ranges.

Tuning on short waves is done with basket coils, sometimes using those with spaced windings, or "Lokap" coils. I find the basket coils best for this work, however.

The best telephony received here is FL, which comes in fairly strong and clear, the weather

report being very easily followed. Croydon is not bad, but PGGG and 2 MT are of practically no use up here until H.F. amplification is added.

On long waves the longest range yet is NPM time signals, about 9,500 miles. Might I take this as good for such a combination of valves as I employ—1 rectifier and 1 L.F. note magnifier?

A. C. DRUMMOND.

Book Review

THE SIGNAL SERVICE IN THE EUROPEAN WAR OF 1914 TO 1918 (FRANCE). By R. E. Priestley, M.C., B.A. (late Major, R.E.). Published by the Secretary, the Institution of Royal Engineers, and by the Signals Association. (Chatham: W. & J. Mackay & Co., Ltd.)

The aim in the preparation of this book has been to present a full yet concise history of the British Signal Service in France during the great war.

The work covers the evolution of signal policy, organisation and practice from the date that British troops first landed in France up to the cessation of hostilities.

The preparation of such a volume could only be the result of a vast amount of work on the part of the compiler, coupled with a keen observation exercised over a long period of practical experience of the lessons of the war as affecting the signal service.

It is obvious that one difficulty which must have been experienced was to sort out from an immense amount of available data, that which was suitable to be utilised in the preparation of such a history.

All those who were associated with the Signal Service during the war cannot fail to appreciate to the full the opportunity which this book affords of going over again the account of the activities of the Signal Service in all aspects of the campaign, this time being able to appreciate the reason for every fresh move in organisation or practice as it became necessary with the changing aspects of the Army's activities.

No attempt has been made in this volume to deal with the work of individual signal units, and the author rightly suggests that such a course would have been undesirable.

The book contains several illustrations of interest, whilst at the end a number of charts are given illustrating the distribution of signal units and organisation for communications at different stages of the war.

A New Publication.

Under the title of "Journal of Scientific Instruments," there has just appeared a preliminary number of a monthly publication produced by the Institute of Physics with the co-operation of the National Physical Laboratory.

The publication will deal with the principles, construction and use of scientific instruments of all kinds.

The new journal is introduced in a foreword to the first number by Professor Sir J. J. Thomson, President of the Institute of Physics. Referring to the purpose of the new journal, he states that it has long been recognised by many workers that a journal dealing with methods of measurement and the theory, construction and use of instruments would have a great value as an aid to research in all branches of science and industry. There is at present no publication in the English language which covers this ground. Descriptions of instruments and methods of measurement are given in journals devoted to particular branches of science; but in such publications results are of primary importance, and little space can be afforded to descriptions and detailed drawings of instruments. It frequently happens that instrumental methods are valuable for researches of quite a different character from that for which they were developed, and workers who may be interested in apparatus as distinct from results obtained may never see the publication in question, even if they know of its existence.

It is proposed that a journal on the lines suggested shall be produced by the Institute of Physics, which will ensure that the management shall be absolutely independent. It will be managed by a Finance Committee appointed by the Institute, on which the Department of Scientific and Industrial Research and the National Physical Laboratory, assisted by a Scientific Advisory Committee appointed by the Institute of Physics.

The expenses of the Journal will necessarily be considerable, as a high standard must be established and maintained, and it is doubtful whether receipts will cover expenditure, at any rate to begin with. Neither the Institute of Physics nor the Department of Scientific and Industrial Research has funds available to meet a deficit. Steps are being taken to raise a guarantee fund for the purpose.

Before it can be finally decided to publish the journal, it will be necessary to have some indication as to its probable circulation, and prospective readers are asked to notify their intention to subscribe. It is proposed that the journal be issued monthly, and be similar in style to the preliminary number. The price will be 2s. 6d. (postage 2d. extra), or 30s. a year, post free.

It is estimated that with a circulation of about 1,000 there will be a deficit of some £2,000 per annum, while a circulation of about 3,000 will render the journal self-supporting.

Book Received

CONSTRUCTION OF NEW TYPE TRANS-ATLANTIC RECEIVING SETS. By M. B. Sleeper. (New York: The Norman W. Henley Publishing Company. Pp. 113. 7½" × 5".)

Calendar of Current Events

Saturday, August 26th.

SOUTH LONDON WIRELESS AND SCIENTIFIC CLUB.
Last day of Exhibition, opened on August 24th, at St. John's Institute, Larcom Street, Waltham, S.E. 17.

Tuesday, August 29th.

Transmission of Telephony at 8 p.m. on 400 metres, by 2 MT Writtle, near Chelmsford.

Wednesday, August 30th.

SOUTH SHIELDS Y.M.C.A. WIRELESS SOCIETY.
7.30 p.m.—Fowler Street, General Meeting.

Thursday, August 31th.

RADIO EXPERIMENTAL ASSOCIATION, NOTTINGHAM AND DISTRICT.

7.30 p.m.—At Room 74, Mechanics Institute, Nottingham. Meeting.

WEST LONDON WIRELESS AND EXPERIMENTAL ASSOCIATION.

At Belmont Road Schools, Chiswick, W. First meeting after vacation.

Saturday, September 2nd.

CROYDON WIRELESS AND PHYSICAL SOCIETY.
Meeting.

Monday, September 4th.

ILKLEY AND DISTRICT WIRELESS SOCIETY.
8 p.m.—At Regent Café, Cowpasture Road, Ilkley, Morse practice.

Tuesday, September 5th.

Transmission of Telephony at 8 p.m. on 400 metres by 2 MT Writtle, near Chelmsford.

Friday, September 8th.

LEEDS AND DISTRICT AMATEUR WIRELESS SOCIETY.

8 p.m.—Lecture on "Automatic Telephony," by Mr. H. Mortimer.

BELVEDERE AND DISTRICT RADIO AND SCIENTIFIC SOCIETY.

8 p.m.—Erith Technical Institute. General Meeting and enrolment of members.

The Broadcasting Company

The following statement has been issued by the Committee of Manufacturers who are at present engaged in creating the Broadcasting Company:—

"The Committee have observed that a number of unauthoritative statements have been made with regard to broadcasting, and desire it to be known that until the British Broadcasting Company is registered, and the Board of that Company has been appointed, no authoritative statement, in so far as the Broadcasting Company is concerned, can be made with regard to the future of broadcasting.

The Memorandum and Articles of Association of the Company are in course of preparation, and as soon as these are approved, the Company will be registered, and the Board appointed. Thereafter a full statement will be issued."

(Signed) GEO. PELLIS,
Secretary (pro tem.)

The British Broadcasting Company.
August 17th, 1922.
Marconi House, W.C.2.

Wireless Club Reports

NOTE.—Under this heading the Editor will be pleased to give publication to reports of the meetings of Wireless Clubs and Societies. Such reports should be submitted without covering letter in the exact form in which they are to appear and as concise as possible, the Editor reserving the right to edit and curtail the reports if necessary. The Editor will be pleased to consider for publication papers read before Societies. An Asterisk denotes affiliation with the Wireless Society of London.

The Wallasey Wireless and Experimental Society.*

Hon. Secretary, Mr. C. D. M. Hamilton, 24, Vaughan Road, New Brighton, Wallasey.

On July 27th the first General Meeting of the Society was held. The Hon. Auditor read the balance sheet, which showed the Society to be in a most satisfactory financial condition.

It was arranged to print the syllabus for the coming winter session, and also to publish a report on the Society's work in the form of an annual magazine.

The meeting night, until further notice, will be every alternate Thursday, the next meeting being on August 24th.

Members will be advised by post when field meetings are arranged. Friends of the members wishing to attend the meetings will be advised of the dates on notifying the Hon. Secretary.

The rules of the Society do not permit of visitors attending more than two evenings or field meetings during any one session.

All communications should be addressed to the Hon. Secretary.

Blackpool and Fylde and Lytham St. Annes Wireless Society.*

Hon. Secretary, Mr. C. Sheffield Doeg, "The Poplars," 6, Seventh Avenue, South Shore, Blackpool.

This Society is now well established. Membership is still going up steadily, and an Assistant Hon. Secretary was appointed a short time ago to help to cope with the business side of the Society's affairs.

In June last a branch was opened in the South-West Area of the Fylde District for the benefit of members who otherwise would have to cover upwards of ten miles to reach the Blackpool headquarters.

Although Blackpool is comparatively of humble proportions, the Society finds support from a district quite as extensive as either Manchester or Liverpool.

This departure when made was very much overdue; 25 members were automatically transferred from the Blackpool headquarters, and this number has since been doubled by new members joining. Both a transmitting and receiving licence has been applied for.

A transmitting licence for the Blackpool headquarters is daily expected, and when it arrives a broadcasting service is to be inaugurated for the benefit of its members and others, and also for an interchange of messages with the Lytham St. Annes Station.

On July 13th, Mr. B. D. Taylor, the Hon. Librarian,

submitted for inspection a home-made loud speaker, an adaptation of a motor car petrol-filler.

On July 20th, Mr. Taylor demonstrated the capabilities of a home-made but very well-constructed and compact one-valve set.

On August 3rd Messrs. J. V. Potter and D. B. Taylor, after considerable trouble and patience, evolved an ingenious three-valve amplifier which should equal if not excel the well-known four-valve variety, as the clarity and intensity of the signals heard by means of this instrument amply justify the claims made on its behalf.

The Executive Committee, whilst fully realising that mere numerical strength is not everything, encourage the bashful but enthusiastic amateurs, knowing that the making of sets is half the battle, and fosters the initiative of members.

One of the many problems which the Society is tackling is the evolving of a circuit, the use of which will prevent badly manipulated amateur stations causing interference, which at the present time is causing so much trouble and annoyance.

Leamington, Warwick and District Radio Society.

Hon. Secretary, Mr. F. A. Sleath, 31, Archery Road, Leamington Spa.

The first General Meeting of the above Society was held at the headquarters, on Thursday, August 3rd. In the absence of the President, Captain Smith-Clarke, M.I.A.E., M.S.A.E., the Vice-President, Mr. G. H. Champ, carried out the duties of Chairman, and opened the meeting with a brief résumé of the Society's position and future arrangements. For the time being, lectures will be devoted to constructional items and buzzer practice.

Mr. Marriott was then called upon to give a short address, and he compared the crystal and valve receivers, dwelling on the limitations of the former. Mr. Marriott next described the five-valve receiver kindly lent for the occasion by Messrs. Champ and Kay. The set was then switched on and almost immediately station 2 KO (Mr. C. Baynton, Moseley) was heard transmitting a gramophone selection.

An attempt was next made to receive the *Daily Mail* concert, but it was only possible to hear a tremendous carrier wave, and when this was tuned out, the speech was barely audible in the phones. More selections were received from 2 KO, and with the aid of two loud speakers, the music was heard in the furthest corners of the room.

The meeting terminated at 9.30 p.m. with a hearty vote of thanks to the Committee for their arrangements, to Messrs. Champ and Kay for the loan of apparatus, and to Mr. Marriott for his address.

Manchester Demonstrators.

A group of the demonstrators at the first of a series of popular lectures the Manchester Wireless Society are giving, in order to give the public a better understanding of the instruments used, especially in broadcasting. In the centre of the back row is Mr. Y. W. P. Evans, the Hon. Secretary and one of the pioneers of wireless, who gave a most interesting and instructive lecture, assisted by Messrs. Lamb, Gregory, Barraclough, E. G. Davies and Hall, who are also shown in the group.

The headquarters are definitely fixed at the Y.M.C.A., Claypath, Durham, where a receiving station will be very shortly installed.

Affiliation with the Wireless Society of London will probably be completed very shortly.

A question box is to be fixed in the clubroom for the benefit of members who prefer not to speak at the meetings. A full list of officers is being prepared. Membership cards are now ready.

After the announcements, a lively discussion took place, during which it was decided to have

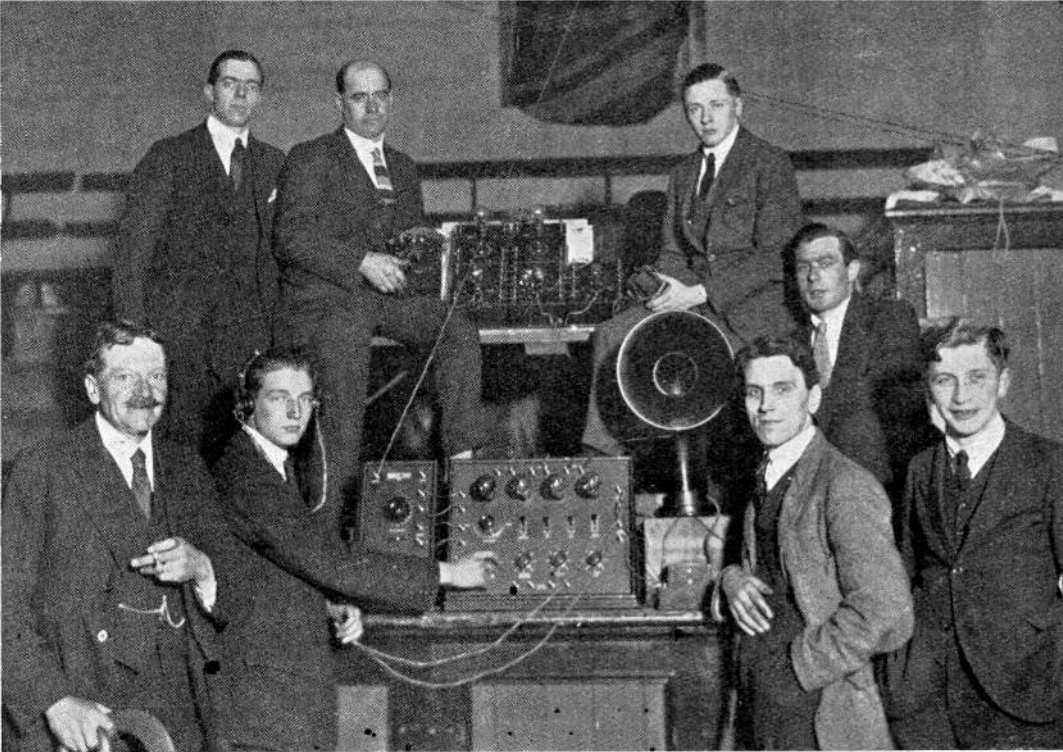

The Durham City and District Wireless Club.

Hon. Secretary, Mr. Geo. Barnard, 3, Sowerby Street, Sacriston, Durham.

The third meeting of the above club was held in the "Rose and Crown" on Friday, August 4th. Considering the fact that a large number of the members were on holiday, the attendance was quite large. Several new members were enrolled.

The meeting was a great success. The chair was once again taken by Mr. F. Sargent, F.R.A.S., of the Observatory, Durham, in his usual characteristic fashion. After the minutes were read and passed, a lecture given by Mr. G. Barnard on "The Electro-magnetic Theory and its Application to Wireless Telegraphy," proved very interesting to the members. He commenced at the very beginning so that no one would be left behind. At the termination of the lecture a hearty round of applause was given, after which the Hon. Secretary made some important announcements, among which were the following:—

a half hour's Morse buzzer practice at each meeting. Mr. Kelly (Hon. Treasurer) presented the club with a very fine loud sounding buzzer of the open type. His kind action was greeted with hearty applause. Mr. Nurthen, who is on the Committee, has undertaken to take charge of the buzzer class, he having had considerable transmitting experience. The Chairman made some very interesting remarks. He was glad the lecturer had mentioned Dr. Gilbert as one of the founders of electro-magnetism, and pointed out the wonderful achievements of Britishers in the science of wireless.

A further meeting took place in the Y.M.C.A., Claypath, on Friday, August 18th, at 7 p.m., when a lecture was given by Mr. G. Barnard on "The Production of High Frequency Oscillations."

The Hon. Secretary invites all who are interested to attend the next meeting, or send names and addresses of any person, either sex, desirous of becoming members, so that he may submit them as candidates for election to the club.

The Liverpool Wireless Society.

Hon. Secretary, Mr. C. L. Lyons, 76, Oldhall Street, Liverpool.

A very successful and interesting meeting of the above Society was held at The Royal Institution, Colquitt Street, Liverpool, on Thursday last, the 10th instant.

The early proceedings were devoted to the answering of the question box which had been passed round, and Mr. Hyde explained away the difficulties of the questioners in his usual inimitable manner, illustrating his answers by very clear blackboard diagrams.

An advisory committee was then elected, consisting of Messrs. S. Lowey (whose four-valve station was described in the August 12th issue of *The Wireless World and Radio Review*), C. J. Williams, W. A. Robinson, Hyde, Forshaw, Henderson, Balmer and Coulton.

A vote of thanks was passed in favour of Mr. J. M. Wilkie, in recognition of his very able work on behalf of the Society when occupying the position of Hon. Secretary, which position he has unfortunately found it necessary to resign, and a new Secretary (see above) was elected. All members and interested readers are requested to note carefully the name and address of the new Secretary.

The evening was concluded by Mr. A. W. Robinson bringing into operation a "Burndept" three-valve receiving set (one H.F., one rectifier, one L.F.) very kindly lent to the Society for the evening by Messrs. Burndept's Manchester agent, Mr. Barraclough. Very successful results were received of both telegraphy and telephony, which were perfectly audible to all present, and which, in view of the fact that the instruments were operated in conjunction with an indoor aerial of but moderate dimensions, reflected great credit upon both the operator and the manufacturers of the set.

Another meeting was held at the Royal Institution, Colquitt Street, Liverpool, 7.30 p.m., Thursday, August 24th. All amateurs in the district not already members of the Society are cordially invited to join, and are assured of a continuance of entertaining and instructive meetings.

Ilkley and District Wireless Society.

Hon. Secretary, Mr. E. Stanley Dobson, "Lorne House," Richmond Place, Ilkley.

The third meeting of the above Society was held at the Regent Café, Cowpasture Road, Ilkley, on August 10th.

In the absence of the President, Mr. F. Law occupied the chair. It was decided to arrange a programme of lectures and demonstrations for the coming winter session, and all members are asked to co-operate in this and also in procuring permanent headquarters, which are the most important requirement of the Society.

In order to enable those members who wish to listen in to the Hague concerts, it has been necessary to transfer the monthly meetings to the second Monday in each month, and the Morse practice classes, which are now in full swing, will be held on the intermediate Mondays.

The membership is still steadily increasing and new members are welcomed at any of the meetings.

Ladies who are interested in this subject are particularly invited to join. Particulars of membership may be had on application to the Secretary, who will also be pleased to receive offers from any gentlemen willing to give a lecture or demonstration, or to read a paper before the Society on any branch of the subject, either technical or practical.

Fulham and Chelsea Amateur Radio and Social Society.

Hon. Secretary, Mr. R. S. V. Wood, 48, Hamble Street, Fulham, S.W.6.

An informal meeting took place on Tuesday, August 1st, at 8.30 p.m., at the Stanley Ward Conservative Club, 428, King's Road, Chelsea. Mr. Oliver, the Chairman, explained the reasons of the meeting. Discussion was then invited as to the advisability of forming a local wireless society, and finally the following proposition was proposed by Mr. Scutt and seconded by Mr. Paterson: "That this meeting take the necessary steps to form an Amateur Wireless Society in Fulham and Chelsea." This was carried unanimously. On the proposition of Mr. Cox and seconded by Mr. Wood, Mr. Oliver was voted to the chair, and agreed to act for the time being. Mr. Glockler was voted to the vice-chair. Mr. Wood was elected Secretary, all the propositions being carried unanimously. A committee of management was then formed of the following gentlemen: Messrs. Scutt, Flood, Fildis, Martin, Paterson and Roberts, this committee being elected unanimously. A discussion took place on a suggested title, and that above was agreed upon.

It was then agreed that the next general meeting be called after the committee had sat to consider the necessary rules and details. A vote of thanks was proposed by Messrs. Gray and Gauntlet to the Stanley Ward Conservative Club for lending their room. Messrs. Martin and Roberts proposed a vote of thanks to the chairman, both of which were duly carried, the meeting being closed with expressions of appreciation on the forming of a local wireless society.

Ladies included, there was an attendance of 70.

West Hartlepool Y.M.C.A. Radio and Experimental Society.

Hon. Secretary, Mr. S. Tillotson, 34, Tristram Avenue, West Hartlepool.

A Society has been formed with the above title, and though but a fortnight old the membership is 36. A grant from the Board of Management has enabled the Committee to purchase components with which to build a three-valve set, the erecting to be done by the members under the direction of the technical advisers, Messrs. C. Kenyon and Wm. Garrett. In the meantime these gentlemen have kindly loaned their own apparatus for the use of the club, and a successful lecture and demonstration was held on July 21st. Classes are held every Tuesday at 7.30 p.m., and instruction is given in the elements of electricity and Morse reading.

The club has erected an aerial, etc., which is open to members for individual use at any time. Application for membership is to be made to the General Secretary or the Hon. Secretary of the Society. The age limit is 15 years.

Questions and Answers

NOTE.—This section of the magazine is placed at the disposal of all readers who wish to receive advice and information on matters pertaining to both the technical and non-technical sides of wireless work. Readers should comply with the following rules:—(1) Each question should be numbered and written on a separate sheet on one side of the paper, and addressed "Questions and Answers," Editor, THE WIRELESS WORLD AND RADIO REVIEW, 12/13, Henrietta Street, London, W.C.2. Queries should be clear and concise. (2) Before sending in their questions readers are advised to search recent numbers to see whether the same queries have not been dealt with before. (3) Each communication sent in to be accompanied by the "Questions and Answers" coupon to be found in the advertisement columns of the issue current at the time of forwarding the questions. (4) The name and address of the querist, which is for reference and not for publication, to appear at the top of every sheet or sheets, and unless typewritten, this should be in block capitals. Queries will be answered under the initials and town of the correspondent, or, if so desired, under a "nom de plume." (5) In view of the fact that a large proportion of the circuits and apparatus described in these answers are covered by patents, readers are advised, before making use of them, to satisfy themselves that they would not be infringing patents. (6) Where a reply through the post is required every question sent in must be accompanied by a postal order for the amount of 1s., or 3s. 6d. for a maximum of four questions. (7) Four questions is the maximum which may be sent in at one time.

"H.A." (S.E.10) has a two-valve receiving set comprising one detector oscillator valve and one low frequency magnifier, with which he successfully receives 2LO, 2MT and 2FQ, and is desirous of either amending his circuit or adding additional amplifiers in order that he may be able to receive PCGG.

Your circuit is quite in order, excepting that it is not necessary to connect a variable condenser across the primary of the intervalve transformer, and this condenser can be made good use of by connecting it across the ends of the reaction coil marked "S" in your circuit diagram. A small fixed condenser should be connected across the I.P and O.P., having a value between 0.001 and 0.002 mfd., and may consist of 15 plates interleaved with mica 0.002" in thickness, and having an overlap of 1" by 3/8". Seven will project at one end of the condenser and eight at the other. The tuning range of the coils would seem to be sufficient when connected to your two-wire aerial to tune to 1,070 metres, the wavelength of PCGG. The addition of a high frequency amplifying valve and another note magnifier would assure you of good reception from this station, particularly as we now understand that its power has been increased. A suitable circuit is given in Fig. 1. The rectifier valve should

be of the "Q" type, or one specially recommended to function as an efficient detector.

"M.B." (Plumstead) has a four-valve receiver, including one H.F. amplifier, which gives quite good results with a transformer designed to amplify on wavelengths between 600 and 1,200, but is unable to get good amplification between 300 and 800 metres.

One probable cause of the trouble is, as you suggest, that as the set tunes up to a wavelength of 2,000 metres it does not function efficiently on such a low wavelength as 3,000 metres. Two special aerial coils should be made for tuning at this wavelength. You do not give dimensions of the short wave intervalve H.F. transformer you use, but we would suggest that you construct one having 180 turns for primary and secondary, wound on a 1" ebonite former, and separated from one another by a single layer of empire cloth. The windings should be in the same direction, and the finishing ends taken to grid and plate. This should be bridged with a low capacity variable condenser. For short wave work you may find it helpful to bridge the reaction coil with a low value variable condenser, and also the aerial tuning condenser must be connected in series with the aerial inductance for efficient short wave reception.

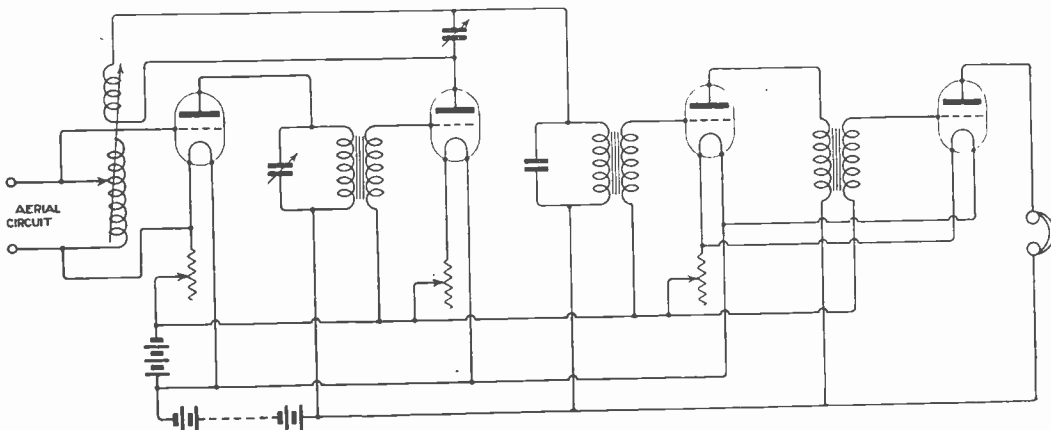

Fig. 1.

"C.H.C.G." (Otford) encloses a sketch of a three-valve amplifier and asks (1) For a method of using one, two or three valves at will. (2) Which is better, to tune the anode winding or the grid winding of the above arrangement with variable condensers. (3) If three or four lengths of 1" gaspipe would make a satisfactory earth. (4) If permission is required to use more than one valve.

(1) The second method is quite O.K. The first method is also O.K. if arrangements are made to break the grid coil of the particular valve to which S is plugged at any time. (2) There is little difference, but the anode is somewhat preferable. (3) O.K. if the pipes go well down into damp earth. (4) If the addition of further valves is not covered by your original application, you should obtain sanction from the P.M.G.

"EUREKA" (Durham) asks (1) If a circuit sketched is suitable for general purposes. (2) If circuit in No. 1 can be altered as in sketch No. 2. (3) If material enclosed is suitable for panels, etc., instead of ebonite.

(1) All right, except that the condenser shown across the reaction coil would be better across the telephone transformer. (2) Yes, with similar comment to the above. (3) Yes, unless it is to be used under very damp conditions, when the surface leakage will probably be more serious.

"IGNORAMUS" (Probus) asks (1) If the P.M.G. limits the length of aerial for amateurs. (2) If so, what is the length. (3) Will the efficiency of an aerial of given length be altered by another method of suspension. (4) The advantages of a basket coil over a solenoid.

(1) and (2) Yes. The length from the lead-in insulator to the far end, measured along the wire, must not exceed 100'. As many wires may be used as desired. (3) A single line is best. Divided up into shorter lengths is undesirable. (4) It is somewhat more portable; also losses in the coils are somewhat smaller owing to the shape of the coil, but this increased efficiency is not great enough to be of much importance.

"J.D." (S.E.18) asks (1) If a crystal receiver and valve magnifier give louder signals than a single valve with reactance. (2) Why his set will not work without a grid leak and condenser. (3) Wiring data for A.T.I.

(1) Yes, as reactance is also used in this crystal and valve set. (2) The set worked quite well as originally given. Possibly you have got the wrong value for H.T. or unsuitable potential on the grid. Try reversing the reaction coil. (3) The set will be unsatisfactory without a variable condenser in the closed circuit. For the A.T.I. use 100 turns with a slider, and for the closed circuit $4" \times 2\frac{1}{2}"$ of No. 26.

"CONWAY" (London) asks re the American short wave tuner in June 3rd issue (1) If he will be infringing patents by making up some of these sets for friends. (2) Whether the condensers need be fixed or variable.

(1) Seeing that his circuit uses magnetic reaction you will be infringing patents if you sell sets of this type. We cannot undertake to give complete advice relating to patents. (2) Neither of the condensers need be variable, but somewhat better results would be obtained if the grid condenser was variable.

"N.P." (Whitstable) asks re the pocket set on page 747, March 4th issue (1) If it is a mistake to have the A.T.I. of No. 36 and the reactance of No. 26. (2) If the telephones are shown in the right position in the diagram. (3) If the positive terminal on the telephone goes to the positive of H.T. battery, and whether a long or short dash is used for the positive of batteries in diagrams. (4) A suitable capacity for the aerial condenser.

(1) For general purposes, yes; but for a "stunt" receiver of this type the windings given may be necessary to get the required wave range, even at the cost of loss of efficiency. (2) Yes, but they may alternately be on the other side of the H.T. battery. (3) In the circuit shown, to the positive of H.T. A long thin stroke represents the positive of a cell. (4) 0.0005 mfd. maximum, minimum as small as possible.

"K.R." (Bradford).—There does not appear to be much to choose between the two aeriels suggested. The aerial between the houses is probably slightly the better. The amplifier suggested would be of no use in conjunction with your set, but you might add any one of the various L.F. amplifiers on the market or described in back issues. There will probably be very little telephony within range of a two-valve set in Bradford until the broadcast service is inaugurated.

"J.H." (Southsea).—It is useless to try and bring your wavelength up much by just adding a loading coil to the aerial, although you might get up to 1,100 metres in this way with your present coils. To get ranges above this we should recommend using a set of slab coils, connected up as in your diagram, but cylindrical coils should not be used inside each other as shown. (2) 0.0005 mfd. is sufficient up to 3,000 metres. (3) Up to 1,100 metres your windings might be as follows—A.T.I. $5" \times 4"$ of No. 24, closed circuit and reaction coil as you suggest.

"G.C.C." (Gateshead) asks for advice on a two-valve set which behaves in an unsatisfactory way.

We can see no real cause for behaviour in this way. A condenser across the telephones would improve the set, also we should omit the permanent connections between the switch arm and P.5. We think it likely that the transformer winding has a break, or disconnection in it. Try out all connections thoroughly. As a rule it is inadvisable to use windings given for pocket sets in general purpose sets, as such windings have generally to be made quite inefficient in order to get the necessary portability.

"O.T." (Bridlington) sends sketches and asks (1) If he can improve his aerial. (2) Why his set starts oscillating when he gets tuned-in for Croydon, etc. (3) If we can give a wiring diagram for his set.

(1) Yes. Raise the aerial further above the roof. (2) This is apparently due to too much reaction. If by tuning-in you include the adjustment of the reaction coil, behaviour is quite normal as signals improve with additional reaction until the set begins to oscillate. (3) We cannot say how your apparatus is connected internally, and therefore cannot give wiring diagram, and as the set gives spark stations and telephony, except for the howling trouble, there is probably very little the matter with the connections as you at present have them.

CROGROSS WOUND COILS

**PROMPT DELIVERY
HIGH EFFICIENCY
LOW PRICES**

These coils have been so designed that the overlap of range when shunted with a .0005 condenser is sufficient to enable some other number to be used for reaction purposes.

There is no need therefore to purchase a double set.

When used in the aerial circuit the wave lengths obtainable from each coil will be lengthened by an amount which will depend upon the properties of the aerial in use, this in many instances approximating about 120 metres.

The self-capacity of these coils is extremely low, and the wire

used is large enough to enable them to operate with success in sets not employing autodyne reception.

Used in crystal sets they replace the old style cumbersome cylindrical inductances.

These coils can be supplied either mounted or unmounted. All coils are nicely taped and mounted coils are fixed to standard British gauge ebonite push fittings.

Each of these coils is tested in an oscillatory circuit before despatch.

Sizes.	Ranges when used with '001 variable condenser in parallel. In closed circuit.	Ranges when used with '0005 variable condenser in parallel. In closed circuit.	PRICES.		Sizes.		
			(Subject to Trade Discount.) Postage extra				
			Unmounted. Each.	Mounted. Each.			
No.	Metres.	Metres.	s.	d.	No.		
1	175 — 400	175 — 300	1	6	4	0	1
2	250 — 550	250 — 400	2	0	4	6	2
3	325 — 750	325 — 550	2	3	4	9	3
4	450 — 1200	450 — 950	3	0	5	9	4
5	550 — 1500	550 — 1100	3	6	6	3	5
6	850 — 2000	850 — 1650	3	9	6	6	6
7	1350 — 3000	1350 — 2250	4	6	7	3	7
8	1500 — 4000	1500 — 3000	5	0	8	0	8
8a	2000 — 6500	2000 — 4800	5	3	8	3	8a
9	3000 — 9500	3000 — 6750	5	6	8	6	9

If taken in complete set of 10 coils as above £3 0 0 per set mounted, or £1 15 0 per set unmounted.

Note.—A new coil holder is now available which is strong and simple, and has been specially designed by us to secure the best results with modern narrow low-capacity coils.

Manufactured by

CROGON & CO., LTD., 230, UPPER THAMES STREET, LONDON, E.C.4

Telegrams:—CROGON, CENT. LONDON.
Telephone:—CITY 4470.

Also Manufacturers of Enamelled Aerial Conductors, prices on application.
Manufacturers of Electrical Apparatus to the Trade for over 35 years.

MAGNAVOX

THE WORLD'S FINEST

LOUD SPEAKER

RADIO
brings it
MAGNAVOX
tells it.

*Broadcasting faithfully reproduced
with marvellous clarity and volume*

Sterling Telephone & Electric Co., Ltd.

TELEPHONE HOUSE,

210/212, Tottenham Court Road, London, W.1
Telephone No.: 4144 Museum (7 lines). Telegrams: "Cucumis, Wesde, London."

Works: DAGENHAM, ESSEX.

BRANCHES: NEWCASTLE-ON-TYNE: 9, Clavering Place.
CARDIFF: 8, Park Place.

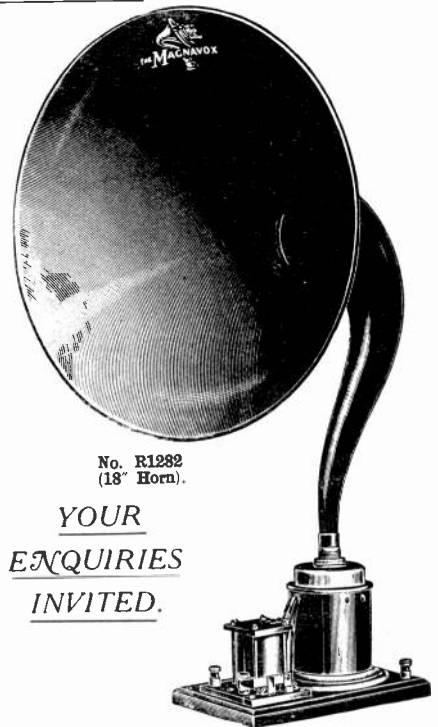

No. R1282
(18" Horn).

YOUR
ENQUIRIES
INVITED.

For they are jolly good- -FELLOWS



Fellows Head Telephones,
4,000 ohms.

two earpieces in light die cast
non-ringing metal.

Price 30/- per pair.

Deliveries. Immediate against cash
with order.

Manufacture. The same high
grade workmanship as the Fellows
Magneto.

Send your order to-day. (Cheques,
P.O., P.O.O. or M.O. to be crossed
London Joint City & Midland
Bank, Ltd.)

Trade terms for quantities on request.

FELLOWS MAGNETO Co. Ltd.

LONDON, N.W.10.

Telephone:
Willesden 1560-1.

Telegrams:
Quixmag, Phone, London.

*For all Radio Apparatus and Com-
ponents.*

Visit our Stand No. 10. All British Wireless Exhibi-
tion, Horticultural Hall, Sept. 30th to Oct. 7th.



To ensure the
earliest attention
send this page
with your order.

And so say all of us

"R.R." (Paris) asks for a design of an efficient receiver suitable for reception on wavelengths from 180 to 30,000.

The use of resistance capacity coupling for short wavelengths is not efficient, although small variations of the condensers on which it is desired to receive will improve the results. Your process of calculating the value of this condenser as being directly proportional to the wavelength which it is desired to receive is quite incorrect. The chief consideration is the high impedance of this condenser on short wavelengths. We would recommend you to adopt three to five valves, according to the degree of amplification desired. The circuit shown (Figs. 2 & 3) embodies two H.F. valves, one detector, and two L.F., and can be thoroughly recommended for general use, but if you so desire you can omit one H.F. and one L.F. valve. The type of H.F. transformer you mention can be thoroughly recommended, and it might be mentioned that the efficiency of many H.F. transformers is rather doubtful, owing to the system of winding adopted. We do not see why you should not construct such transformers yourself, winding them on 1" ebonite rod, with single layer primary and secondary, insulated from one another with a single layer of empire cloth, the finishing ends being taken to grid and plate, and both windings being in the same direction. Wind with No. 40 S.S.C., and for wavelengths up to 300 metres use 180 turns for each winding; for 600 metres, 600 turns; for 1,000 metres, 1,300 turns; for 1,500 metres use 800 turns, and this time on a 2" ebonite rod. Beyond this wavelength resistance capacity coupling with fixed condensers is

quite satisfactory. "V24" or French "R" valves may be used for amplifying, whilst a "Q" should be used for detecting. The H.F. detector and L.F. valves must be controlled with separate filament resistances, and it is an advantage to provide potentiometers for controlling the grid potential of the H.F. and rectifier valves. Separate tappings might also be arranged for the various valves to

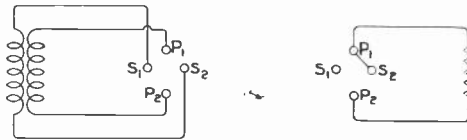

Fig. 3.

give them just the correct anode voltage required. If you adopt four-pin sockets for interchanging the H.F. transformers, the resistance capacity unit may also be built up to plug in for use on wavelengths above those provided by the transformers. The construction of the set described embodies no special difficulties, but we shall be pleased to advise you further should you have trouble during its construction.

"F.A.W." (Brixton).—(1) The inductance of the coil is about 7,000 mhys., which should tune to 2,500 metres—or more with a parallel condenser. (2) To get best value for reaction for different conditions of wavelength and aerial resistance. (3) This can be done and might give some results, but initial L.F. amplification would be better.

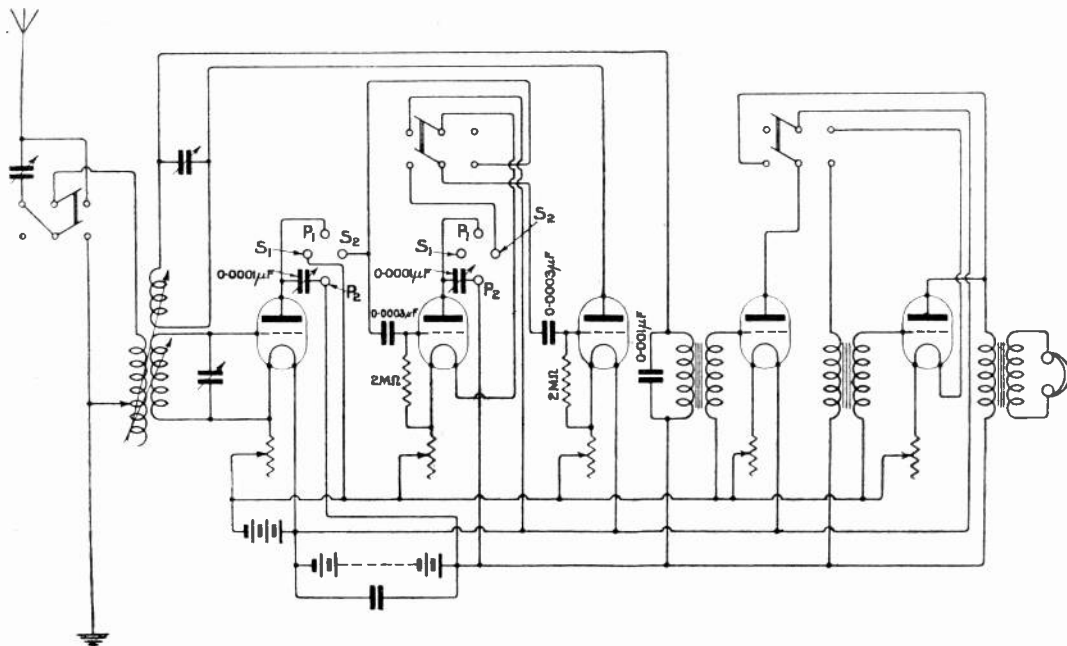

Fig. 2.

"C.N.G." (Pelton) asks how it is that he can only receive 600 metre signals on his single valve set.

Your circuit diagram would indicate that your set is in order. We would suggest that you arrange a variable condenser across the ends of the reaction coil. Are you receiving continuous wave signals, and does your set oscillate? If not, the reason why you only receive 600 metre signals is that your set will only pick up damped wave signals, the majority of which are transmitted on this wavelength. Your aerial, although inside the roof, is of good length, and should give quite satisfactory results. We hardly recommend the addition of one H.F. valve as a first step in obtaining increased signal strength. A low frequency amplifier would give much greater magnification.

"W.C.B.-G." (Bradford) asks for a diagram of a five-valve receiver, together with details as to size of inductances, number of turns, etc.

See Fig. 4. Sizes of inductances and condensers according to wavelengths required.

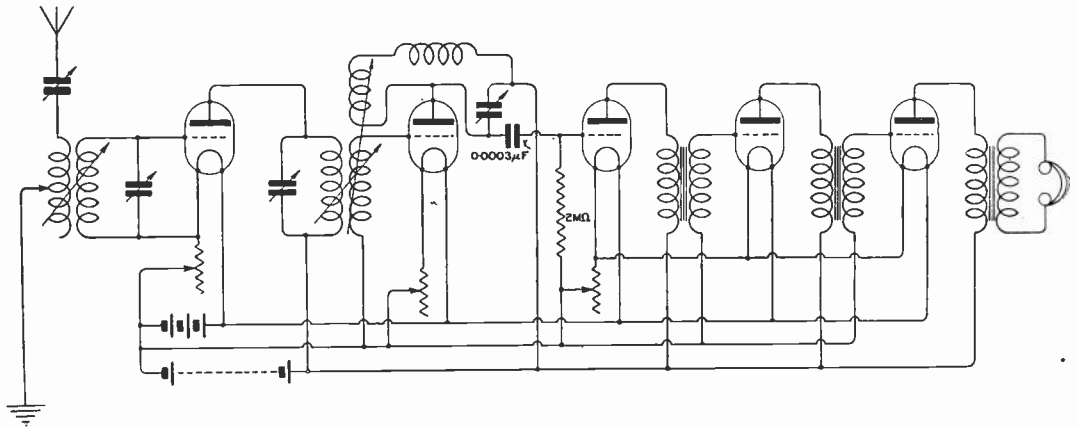

Fig. 4.

"R.M." (Coventry) is constructing a two-valve receiving set. He has a number of components, and asks for advice on the selection and details of other parts required.

Construct your own loose coupler or aerial and reaction circuits. The windings depend upon the wavelengths on which you require to receive, and for a start construct an aerial on your inductances having 4" of winding of No. 26 D.C.C. on a 5" former, and the reaction coil sliding inside this consisting of 2" of winding of No. 30 D.C.C. on a 4" former, arranging tappings at increasing intervals on both aerial and reaction coils. For short wave telephony reception construct two coils as shown on page 328, June 10th issue. The variable condenser should be of the air dielectric type, and have a maximum value between 0.0005 and 0.0015 mfd. The grid leak should have a resistance of about 2 megohms. "R.4B" valve would be found to give very satisfactory results. The panel for mounting the two valves might measure about 7" x 4½". You would obtain a good deal of useful information by reading the articles published in alternate issues on "Experimental Station Design," and in particular the one on the construction of a single valve panel, appearing

on p. 454 of the July 8th issue. This article really answers all your questions.

"A.B.T." (Wolverhampton) asks for details and diagram for the construction of a telephone transformer for use with his crystal set. His telephones have a resistance of 100 ohms.

We do not recommend you to construct a step-down transformer for use with your crystal receiver. You would be well advised to rewind your telephones to a higher resistance. This would probably be less expensive, and without doubt more efficient, and very little instruction on the method of doing it is needed. Use No. 49 S.S.C. for the purpose. If you are desirous of making a transformer, however, turn to page 343 of the June 17th issue. You will find there dimensional drawings of core and end plates of the transformer. Wind the primary with No. 47 S.S.C. up to a diameter of 7/8", over which wind a secondary of four layers of No. 32 S.S.C. Insulate carefully between primary and secondary.

"F.B." (Bayswater) submits two circuit diagrams, one showing the principle on which his

apparatus is to be connected, and the other an actual drawing of an inside view of his instrument after it is wired, and asks if the latter is correct.

We have carefully looked through the diagrams, in particular that of the actual wiring, and as far as we can tell this is quite in order. In this you have arranged for a reaction coil in series with the primary of the H.F. transformer, whilst this is not shown in the diagrammatic sketch, in which no provision is made for reaction. The set seems to be suitably wired and should function correctly.

"R.V.T." (Westminster) asks (1) Whether a single valve frame aerial set will give PCGG. (2) How tuning to various wavelengths is accomplished on the set. (3) For dimensions of a loose coupler, if necessary. (4) If the circuit shown in the issue of June 10th will work with a frame aerial.

(1) Not PCGG, but it should give London broadcasting and local amateurs. (2) By adjusting the condenser in shunt across the frame. Not necessarily for the frame aerial set but in conjunction with an outside aerial it will give much better results. Suitable dimensions have been repeatedly quoted. (4) We are unable to judge

30/-

with immediate delivery from stock
MULLARD TELEPHONE HEAD SETS

specially made for the reception of wireless broadcasting, are thoroughly well-made and fit securely and comfortably to the head.

British Manufacture.

The two high resistance ear pieces (4,000 ohms total) are flexibly attached to the fully adjustable, double head bands. The set is nicely finished in nickel plate and supplied complete with standard flexible cords.

A large stock is available at once but is being rapidly booked up. Send the coupon to secure immediate delivery to-day.

These telephones are made by the makers of the famous ORA valve and Mullard valve accessories.

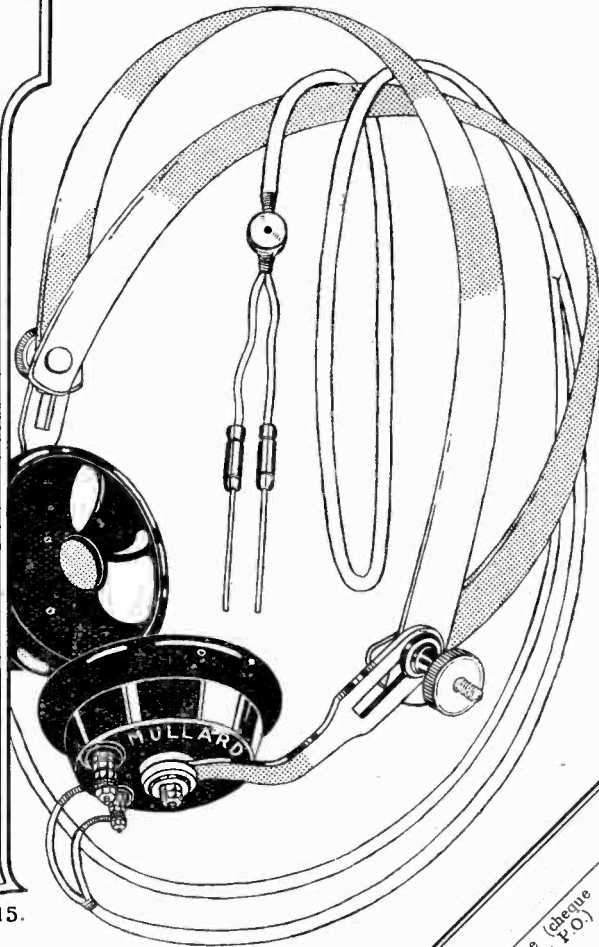

E.P.S.

15.

Mullard Radio Valve Co. Ltd.

Claybrook Road, Hammersmith, W.6.

Contractors to H.M. Admiralty,
 War Office Royal Air Force & Post Office.

Telephone: Codes: Telegrams:
 Hammersmith 312 ABC(5Ed) Radio Valve Hammer Lond.



Name and Address
 To the
MULLARD RADIO VALVE Co. Ltd.
 35, Claybrook Rd.,
 LONDON, W.6

Please send me post free:
 Quantity.

Description and Price.
 Telephone Head Sets - - - - - 30/- per set
 ORA Valves - - - - - 15/- each
 Grid A Resistances - - - - - 5/-
 Grid A or B Resistances - - - - - 2/6
 Combined res. and condenser - - - - - 2/6
 Valve bases with terminals - - - - - 1/3
 Valve sockets - - - - - 1/3
 Terminal clips - - - - - 1/3
 Name of usual wireless dealer.

I enclose (cheque
 Money Order, P.O.)
 to cover the
 cost.

SEND THIS TO-DAY.

Visit our Stand No. 41. All British Wireless Exhibition, Horticultural Hall, September 30th to October 7th

THE "BROWN" MICROPHONE AMPLIFIER

This Amplifier magnifies signals, or music, without distortion, and is of considerable interest to amateurs and scientific investigators. The Magnification is much greater than that obtained from two valves, and the current consumption is about 50 milliamps. In construction, this instrument is simple, and it is much more robust than other sensitive relays of this class. This instrument satisfies the urgent demand for a reliable, inexpensive amplifier, which the most inexperienced amateur can use, and which the most experienced requires. It is much cheaper, ultimately, than a multi-valve amplifier, and the operator is relieved from many of the varied causes of breakdown. It includes a transformer suitable for low resistance telephones or loud speakers. The price of the "Brown" Microphone Amplifier is £8 for low resistance (120 ohms) input and £6 2s. 6d. for high resistance (2,000 ohms) input.

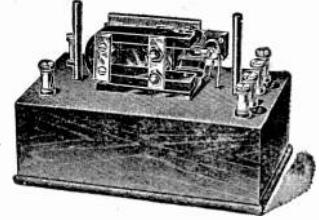

THE "BROWN" LOUD SPEAKER

With an Amplifier signals or telephony may be so magnified as to cause discomfort to wearers of headphones, yet not be loud enough to be audible at any appreciable distance from the head. Every wireless experimenter sometimes wishes to let his friends hear, which would involve the use of several pairs of telephones simultaneously with consequent loss of signal strength, as well as considerable expense. The "Brown" Loud Speaker was designed to meet this need efficiently and economically, and is used in all up-to-date receiving stations. The sound is intensified by means of a horn.

The "Brown" Loud Speaker (120 ohms), Standard Pattern with Upright Funnel up to £5 10 0
Wound to special high resistance up to £5 15 0

THE "BROWN" SUPER-SENSITIVE TELEPHONES FOR WIRELESS, ETC.

These Telephones are unquestionably the clearest and most sensitive made, and, consequently, increase the distance over which the wireless can be heard.

IN UNIVERSAL USE. As supplied to British, Allied and Foreign Governments.

The "Brown" "A" Type Radio Headphones—		£	s.	d.
Low resistance	per pair	2	18	0
High resistance	per pair	3	6	0
The "Brown" "D" Type Headphones (Improved flat diaphragm type)—		£	s.	d.
Low resistance	per pair	2	8	0
High resistance	per pair	2	12	0

The above telephone prices include Cords. CATALOGUE POST FREE ON APPLICATION.

Sole Manufacturers: **S. G. BROWN, LTD.**

SHOWROOMS where the above Instruments may be inspected **19, MORTIMER STREET, W.1**

Works: **Victoria Road, North Acton, London, W.3.**

Telegrams: "Siddbrownix, London."

Telephone: Chiswick, 1469.

Sole Agent for the Argentine: Horacio D. Guerrero, Las Heras, 2480, Buenos Aires.

Brown's Wireless Apparatus can be purchased from all Wireless Suppliers.
EARLY DELIVERY of Telephones and Loud Speakers can now be given.

Visit our Stand No. 43. All British Wireless Exhibition, Horticultural Hall, September 30th to October 7th

THE CREED HIGH-SPEED PRINTING TELEGRAPHS

The CREED SYSTEM is the only automatic printing telegraphs successfully applied to Wireless Working. It is now in regular operation on the wireless routes between London, Paris, Cologne, and Berlin. Several foreign Navies are also installing Creed apparatus as part of their standard equipment.

The new Creed apparatus is very simple in design and requires no compressed air.

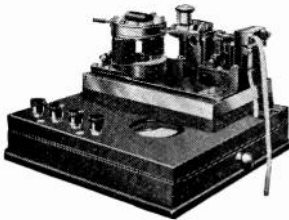

THE CREED RECEIVER
(1921 Design)

ALL WIRELESS ENGINEERS AND OPERATORS should make themselves acquainted with the "CREED"

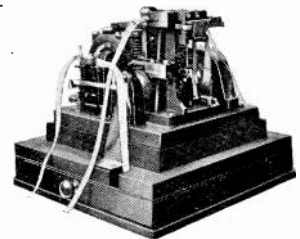

THE CREED PRINTER
(1921 Design)

Send for our Text-Book - Price 1/2 post free

CREED & CO., LTD., Telegraph Engineers, **Croydon, Surrey**

Telegrams: "Crede, Croydon."

Telephone: Croydon 2120.

which of the circuits in the article quoted you are referring to.

"T.F.T." (N.W.1.) submits a circuit comprising one detector oscillator valve followed by two note magnifiers, and asks for criticism of circuit, particularly as to its suitability for the reception of telephony.

Your circuit is incorrect. When using a common high tension battery for several valves, you must put all interval transformers on the plate side of the battery. As connected at present, all the plates are fed through the first interval transformer, which may give rise to howling. Also do not bridge both H.T. battery and transformer primary with one condenser, but bridge both with separate condensers. You should connect the aerial tuning condenser in series with the aerial tuning inductance, and this will give you more inductance in circuit to tune to a given wavelength, and consequently a bigger potential will be stepped off for operating the detector valve. The reaction coil should be bridged with a tuning condenser having air dielectric and a maximum value of 0.0005 mfd.

"C.B." (Ipswich) is desirous of adding a single valve amplifying set to that shown in Fig. 1, and asks whether H.F. or L.F. would be recommended, and for a diagram showing how the amplifier should be connected.

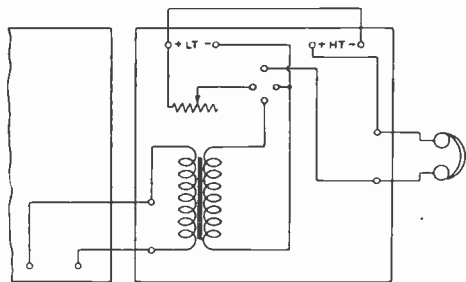

Fig. 5.

With only one additional magnifier, we recommend that it should be of the low frequency type, and the method of connecting is shown in Fig. 5.

"BENCLAY" (Port Madock) asks (1) For the wavelength of a certain loose coupler. (2) For information in regard to a certain transmitting set.

(1) This coupler will be suitable for tuning to about 2,000 metres. (2) We regret we have no information about this set.

"F.A." (Tottenham) asks (1) If a certain crystal set is correctly wired. (2) If telephones marked "40 w" are suitable, and what the figures stand for. (3) If he should be able to get signals. (4) If any rearrangement should give him signals.

(1) We cannot say from the type of sketch you send. For instance, your potentiometer appears to have five terminals, but there is nothing to show us the relation each of these terminals bears to the internal wiring. (2) The telephones are unsuitable for use except with a telephone transformer. The figures give the resistance of the windings, which in this case are low. (3) No signals are likely without change as in 2, but we cannot say whether results will then be obtained. (4) Arrangement as in Fig. 1, page 404, June 24th issue, would give satisfactory results.

"D.J." (Tankerton) has submitted a circuit to the Post Office for approval, consisting of one valve arranged to give high frequency amplification, followed by a detector valve, the plate circuit of which is coupled back to the aerial circuit, which has been rejected, and asks for a suitable circuit, making use of two valves, and arranged to give high frequency amplification.

See the diagram, Fig. 6.

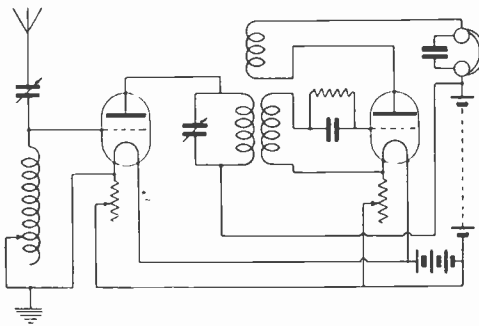

Fig. 6.

"F.M." (N.4) is constructing a long range single valve receiver on the lines described in the issue of February 5th, 1921, and has submitted the circuit shown on page 781 to the Post Office for approval, in making application for a receiving permit. He has been informed that the circuit, which is the usual single valve reaction arrangement, cannot be approved, and asks for a suitable circuit diagram.

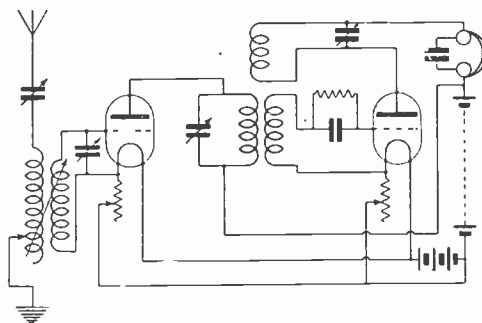

Fig. 7.

There would seem to be some doubt at the moment as to the type of circuit that one is permitted to adopt. The circuit you refer to is very extensively used and is the one usually recommended to beginners, though, of course, it is liable to give rise to serious interference as the number of users increases, and we appreciate the action of the Post Office in now forbidding its use. Re-radiation can be considerably reduced by using a two-valve circuit as shown in Fig. 7, in which the plate circuit of the second valve is coupled back to the interval high frequency transformer, and we have no doubt that the Post Office will be prepared to give you permission to use such a circuit.

"B.W.H." (Widnes) 1) *Submits a circuit of a five-valve high frequency amplifier, giving values of all components, and asks for criticism.* (2) *Submits a circuit of a five-valve amplifier consisting of two H.F. transformer coupled valves and three note magnifiers, and asks for criticism.* (3) *How to add three stage H.F. amplification to the Armstrong super-regenerative circuit.* (4) *Values of the components in building up the set.*

(1) You do not say the wavelength on which it is intended to obtain H.F. amplification, and presumably you have tested the use of 150 turns as being suitable for your purpose; but we are of opinion that 150 turns is only suitable up to wavelengths of 400 metres. Your circuit in principle is quite good for switching from transformer coupling to resistance capacity coupling. You could simplify it, however, by leaving the grid condensers marked C2 in circuit all the time without detrimental results, provided suitable valves are used. In amplifiers of this sort, it is essential that all H.F. valves are similar in characteristic and specially designed for the purpose. We would suggest the use of "V24" valves for H.F. amplification, a "Q" as detector, and a "QX" as note magnifier. A condenser of 0.001 mfd. should be bridged across the primary of the transformer T2. Resistances R1 and R2 must be very carefully constructed, and must be of uniform and constant value. The L.T. and H.T. voltage will depend upon the type of valve used. The direction of winding of the transformers is important. If both primary and secondary are in the same direction, the leads which pass from one end are taken to grid and plate. You do not provide for reaction, and this can easily be done if so desired by winding a small coil 1" in diameter with No. 38 S.S.C. wire, and connecting it in the grid circuit of the last oscillator valve and placing it near the end of the first or second H.F. transformer. (2) This circuit is quite in order, but why not provide break jacks at 3B, in order to disconnect the low frequency valves, and so obviate the necessity for turning off the filaments? H.F. amplification can easily be added to the super-regenerative circuit by replacing the telephones and the condensers at the primary of an oscillation transformer and working from common H.T. battery on similar lines to the method which you show in your circuit diagrams. (3) We do not think, however, that the circuit is particularly suited to H.F. amplification, as the action of the separate oscillator is to produce considerable damping at rapid intervals. (4) By the use of the coils in the aerial circuit, the closed circuit and reaction coil are such as will tune in the wavelength required, and as are used in a loose coupled reaction tuner. The coils, however, which are connected in the grid and plate circuits of the oscillator valve are of a value that will produce oscillations just above audible frequency. We regret we cannot advise you more fully upon the operation of this circuit until more information comes to hand.

"C.D." (W.1) *submits a circuit diagram of a five-valve receiving set, also a drawing of a proposed design of the instrument, and asks for criticism.*

The principle of the circuit is quite good, and the method of switching in the various amplifiers should be satisfactory. We would suggest that the high frequency transformers be arranged on some inter-

changeable plug-in scheme. The primary circuit of these transformers should be tuned with small variable condensers, which have a maximum value of about 0.0001 or 0.0002 mfd. As switches are being provided for various apparatus, it would be a good idea to arrange one for connecting the aerial tuning condenser either in series or parallel with the aerial tuning inductance. The reaction coil should be bridged with a tuning condenser having a maximum value of 0.0005 mfd., and all variable condensers should have air dielectric. Slightly better results would be obtained were an independent aerial circuit adopted, to which a secondary is coupled, and carried on to the terminals marked B and G. You do not show the construction of the coils, but we would recommend you to adopt single layer coils for short wave, and multi-layer coils for long wave, and connected in circuit by means of plugs. Your telephones are marked low resistance, whilst by the action of the switches you intend to connect them across the secondary of the intervalve transformers. These transformers are of the step-up type, and have very high resistance secondary windings, quite unsuitable for operating low resistance telephones. An easy arrangement, instead of using switches, is to use break jacks, and terminate the telephones on a plug. The insertion of the plug in the various jacks connects or disconnects valves as required, or alternatively the plate lead of the rectifier valve may be brought to the arm of a three-stud switch. The contacts of the three-stud switch are taps on to the primaries of the L.F. transformers. It is not necessary to bridge the last two transformers with fixed condensers. With regard to the actual design of the apparatus, this appears to be rather neat but somewhat complicated, and it does not permit of the fitting of all components to an ebonite panel which can be withdrawn complete from the woodwork. It is not an advantage, as a rule, to incorporate the accumulator inside the set, as its acid and acid fumes are liable to be detrimental to the insulation. By sloping the panel as shown, you considerably reduce the amount of accommodation inside the box, though we presume this has been considered and ample space provided. Special valves should be used for the various purposes, and the detector valve should be one giving good rectification. Potentiometer control might be arranged for the two H.F. valves, and also for the detector valve.

"NOVO" (Ipswich) *asks* (1) *If there is any advantage in spacing the turns of wire for an inductance.* (2) *What capacity of variable condenser is required for a certain coil.* (3) *How many fixed and moving vanes and what size.* (4) *If a potentiometer and battery is an advantage with a "Hertzite" crystal.*

(1) It may make a few per cent. difference in efficiency, but is not important. (2) It depends more on the circuit than on the coil it is to be used with. If the aerial circuit 0.001 mfd. in series with the coil; if for the closed circuit 0.0005 mfd. in parallel. (3) 4" diameter plates, 1 mm. apart for the 0.001 mfd., 15 fixed and 14 moving; for the 0.0005 mfd. half this quantity. (4) We have no experience of this crystal.

"H.M.W." (Kirton Lindsey) *possesses one single valve detector panel, one transformer marked earth to valves, two intervalve transformers, one*



MARCONI
GIVES
UNRIVALLED
WIRELESS
SERVICE

The MARCONI INTERNATIONAL
MARINE COMMUNICATION CO. LTD.
MARCONI HOUSE, STRAND, LONDON.

“BRITWIRE” CONDENSERS.

OWING to the demand for a good condenser, which at the same time is cheap, we are now manufacturing a Balanced Condenser for panel mounting, replacing the imported condensers hitherto sold. The plates are die-cast into the supporting columns, and are counterbalanced so that they will remain in any position when mounted on an upright panel. At present only two capacities are being manufactured, viz.: '0005 and '001, but other capacity condensers will be made in due course. Orders booked and executed in strict rotation.

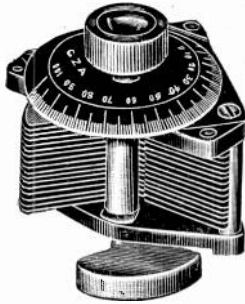

PRICE

WITH EBONITE REVOLVING SCALE:				
'0005	17/6
'001	25/-

*Liberal Discounts to the Trade.
Send for Illustrated List, post free 3d.*

POST ORDERS TO—

BRITISH WIRELESS SUPPLY COMPANY
6 BLENHEIM TERRACE, LEEDS. Telephone : 26926 **LTD.**

And at
11 Church St., West Hartlepool. Tel. 373. 18 Eldon Sq., Newcastle-on-Tyne. Tel. City 360.
33 High Street, Southampton. Telephone 403

Visit our Stand No. 42. All British Wireless Exhibition, Horticultural Hall, Sept. 30th to Oct. 7th

“Exide” BATTERIES FOR WIRELESS

WE specialize in the manufacture of batteries for filament current supply to Valves and high-tension batteries for application of Anode Potential. We can supply these batteries in glass, ebonite or celluloid containers to any desired voltage.

Exide batteries can be relied upon for wireless work and retain their charge over very long periods.

Prices and Particulars on Application.

THE Chloride ELECTRICAL STORAGE COMPANY LIMITED.

Head Office : London Showrooms :
Clifton Junction, 219/220 Shaftesbury Av.
Nr. Manchester. W.C.2

Visit our Stand No. 30. All British Wireless Exhibition
Horticultural Hall, September 30th to October 7th.

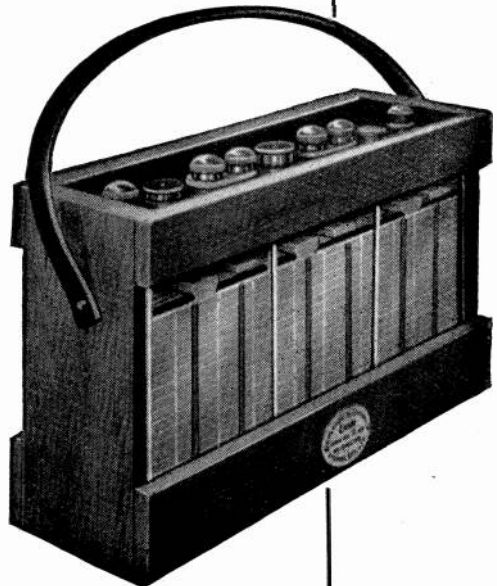

6 Volt 80 Amp. Hour Exide Battery.

telephone transformer, one grid leak and condenser, 4 Osram valves with holders and filament resistance, one pair of 2,000 ohm telephone receivers, two variable condensers of 0.001 and 0.0005 mfd., and also 1lb.

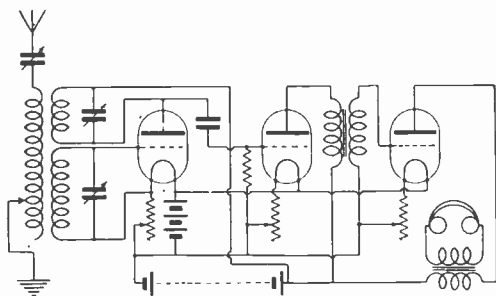

Fig. 8.

of No. 36 D.C.C. wire, and asks for a suitable circuit for reception of Hague concerts on a single wire aerial 85' in length.

For circuit see diagram Fig. 8.

“W. D.” (Blackheath) asks (1) The wavelength range of his set, which consists of tuned aerial circuit with coupled secondary and reaction coils. (2) Number of plates for variable condenser of 0.001 mfd., and if there is a formula for working out the number of plates for various capacities. (3) Area of tinfoil for making fixed condenser 0.001 mfd. (2) Dimensions for constructing transformer for use with crystal set for short wavelengths.

It is impossible to advise you on the wavelength range of your set without knowing the dimensions of your aerial. However, the ratios of windings of the various coils would appear to be satisfactory and it is quite easy to determine the wavelength range by identifying the stations which are tuned in. You should arrange to connect the aerial tuning condenser either in series or parallel with the aerial inductance, and if this is done, the wavelength range would probably be from 200 to 850 metres when connected to a two-wire aerial of the maximum dimensions specified by the P.M.G. (2) If the moving plates have a diameter of 2½" and are No. 20 S.W.G. in thickness, and the spacing washers 3/32", you will require approximately 25 movable and 26 fixed plates to give a capacity of 0.001 mfd. Other capacities are directly proportional. (3) Three plates, being two in one direction and one in the other, ruby mica dielectric 0.002" in thickness and with an overlap of 3.5 sq. cm. (4) We presume you mean an oscillation transformer, and we cannot give precise dimensions without knowing the size of aerial on which you propose to connect it. However, 1½" of winding with No. 24 D.C.C. and a 3½" former will tune the two-wire aerial from 180 to 600 metres with series condenser of 0.001 mfd. The closed circuit which would slide inside should consist of 1¾" of winding of No. 28 S.S.C. on a 2¾" former, and be bridged with a tuning condenser of 0.0005 mfd.

“T.R.K.” (Pontypool) is constructing the American short wave receiver described on page 281 of the June 3rd issue, and wishes to know how to extend the wavelength range up to 1,050 metres, at the same time permitting efficient reception on short wavelengths.

The apparatus is designed especially for short wave reception and the variometers in grid and plate circuits cannot be constructed to give a wavelength range from 100 to 1,000 metres, and for reception on the longer wavelengths we recommend you to adopt a different circuit. Alternatively you might bridge the plate circuit variometer with a variable condenser having a maximum capacity of 0.0004 mfd., and also arrange by means of a switch that will avoid dead end effect, to treble the number of turns connected in the secondary of the oscillation transformer. This secondary, together with its variometer, might then be bridged by a variable condenser. You will probably find, when connected to your aerial, that the aerial tuning circuit will tune to over 1,000 metres when the aerial inductance is connected in parallel with an aerial tuning condenser. If it does not give the required range, a few more turns might be connected in series externally. When tuning the grid and plate circuits to the longer wavelengths, you may find that insufficient reaction is provided for the reception of continuous wave, and should this be so, an additional variometer will have to be constructed for the purpose of coupling together grid and plate circuits. I think you would find it much easier to construct an independent receiver.

“R.B.K.M.” (Cirencester) asks re the American short wave receiver of the June 3rd issue (1) Whether the condensers need be variable. (2) What their capacity should be.

(1) These condensers may be fixed if desired, although the variability of the grid condenser might be a slight advantage. (2) Capacities may be, grid condenser 0.0003 mfd., telephone condenser 0.001 mfd.

“W.J.L.” (Sheffield) asks (1) (a) Maximum and minimum wavelength of a set described; (b) Size of reaction coil. (2) Sketch of dead-end switch. (3) If the terminals of a valve panel are correct in sketch enclosed. (4) Wavelength of a duolateral coil with a 0.001 condenser.

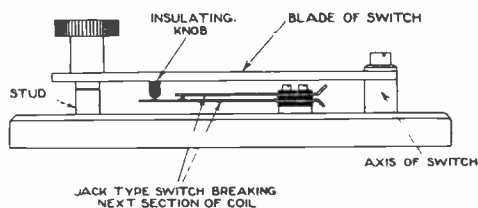

Fig. 9.

(1) Maximum wavelength about 2,000 metres. (b) As large a coil, wound with No. 36 single layer as will swing inside the A.T.I. (2) See Fig. 9. (3) The suggested arrangement will do fairly well, but why have A and E so far away from the A.T.I.? (4) If you use only 30 turns as suggested the wavelength will be very small, perhaps 50 metres. If you use 30 layers the wavelength will be of the order of 10,000 metres.

“H.W.E.” (Halesworth) asks which is the very best receiving set he can purchase, irrespective of price, for use on a single wire aerial of 100' long by 60' high. He intends to use a loud speaker, and

the apparatus is to cover the complete wavelength range.

It is regretted that we cannot advise you on the merits of the wireless apparatus at present on the market. If you make a point of arranging for the demonstration of the apparatus you propose to purchase, it is quite easy to judge its merits. We would suggest that you adopt a tuning arrangement comprising aerial coil, closed circuit coil, and reaction coil, with variable tuning condensers, one of 0.0015 and two of 0.0005. Inductances of the plug-in type can be obtained to cover the full wavelength range. The rest of the apparatus might be purchased in the form of units, which will permit of making alterations as they may be required from time to time. You might adopt two high frequency amplifying valves with interchangeable transformers for wavelengths up to 2,500 metres, after which resistance-capacity amplification might be adopted. These two amplifiers should be followed by an efficient detecting valve, the grid of which may be provided with potentiometer control. After the detector, three note-magnifying valves might be connected. Great care should be taken in selecting thoroughly efficient intervalve transformers. You should be careful in the selection of a loud speaker, with a view to obtaining one which gives a minimum of speech distortion.

"J.E." (Blackburn) is constructing the apparatus shown on page 318 of the June 10th issue for the charging of accumulators from A.C. mains, and asks for details of step-down transformer for use on a 230-volt supply.

It is presumed that the periodicity of the supply is 50, in which case you can make a closed core transformer in which the core, consisting of a number of flat plates, should have a cross sectional area of at least three square inches. The secondary should be wound on first, and consist of three layers of No. 18 D.C.C., whilst the primary should consist of 16 layers of No. 22 D.C.C., the length of winding in each case to be 5". It is advisable to connect in series with this transformer a variable choke coil consisting of about eight layers of No. 20, on a bundle of iron wires 1" in diameter, by 5" long, and tapped out at each layer. We do not recommend the apparatus for giving long runs when passing a current exceeding 2 amperes.

"H.G.L." (Gravesend) wishes to make use of a 3-coil holder, and submits two proposed circuits, and asks (1) If they are correct, and whether he may dispense with the tuning condensers across the reaction coil. (2) What make of valve would be advised for use in the circuit, and the best type of crystal. (3) Values of condensers required for tuning inductances, and (4) Whether his apparatus is suitable for the reception of telephony.

(1) Your circuit No. 2 is quite correct, though you will find tuning rather difficult after the use of the reaction tuning condenser, and particularly will you find it difficult to tune in telephony on short wavelengths. (2) "R4B," perikon (copper pyrites and zincite) or synthetic galena. (3) For short wave tuning, aerial tuning condenser should be connected in series with aerial tuning inductances, and have a maximum value of 0.001 mfd. For finer tuning, and for still further reducing the wavelength, a fixed condenser having a value of 0.001 mfd. might also be connected in series with the variable con-

denser and the inductances. The condensers for tuning the closed circuit and the reaction circuit should have a maximum value between 0.0004 and 0.0005. All condensers should be of the air dielectric type. At Gravesend you should certainly be able to receive most of the experimental London telephony, but the addition of one note-magnifying valve is to be recommended, as it would render the telephony much more comprehensible.

"W.A.C." (Herne Hill) submits a circuit consisting of oscillator valve with tuned grid and plate circuits, with crystal potentiometer and transformer connected across the ends of the reaction inductance, and with the secondary of the transformer connected to a note magnifying valve, and asks if it is correct, as he is unable to obtain results.

The circuit would appear to be correct, excepting perhaps that one lead from the secondary of the transformer should be taken to the L.T. minus instead of the L.T. plus, but this may be an error in the preparation of your diagram. Without more particulars it is impossible to suggest the cause of trouble. The small condenser which you show between grid and plate for the purpose of producing electrostatic reaction is hardly necessary when inductive reaction is provided. You should attempt to obtain results with a single valve receiver only, omitting crystal and note magnifier. Try connecting your telephones and telephone transformer in the lead between H.T. plus and reaction circuit. When this functions correctly, you might add the crystal and then the note magnifier.

"W.W.M." (Grimsby) asks (1) If circuit sketched is suitable for both "Q" and "V24" valves. (2) If a grid leak and condenser is necessary, and if so where it should be put. (3) What value H.T. would be necessary.

(1) The circuit is quite O.K. except that the grid circuit of the second valve should go to the negative of the L.T. instead of the positive. "V.24" and "Q" may be used together off about 40 volts, if the "Q" is used for rectifying. Used in this way the circuit is best without a grid condenser and leak to the rectifying valve. (2) It might be put in the grid circuit of the "V.24," but is not at all necessary. (3) For a resistance capacity coupling, increase the voltage to about 70.

SHARE MARKET REPORT

Prices as we go to press, August 18th, are:—

Marconi Ordinary	£2 8 0
„ Preference	2 6 10½
„ Inter. Marine	1 10 7½
„ Canadian	10 6
Radio Corporation of America:—	
Ordinary	1 0 9
Preference	14 4½

From "The Wireless World," April 22/22.

A loose contact almost anywhere, but generally in the plate circuit. Test by striking the instrument table. If this results in a particularly heavy peal, look for loose wires, tighten terminals, see that switch contacts are clean, and so on. This test, by the way, is quite a useful one, and can be applied so as to locate loose contacts in various parts of the set. It is so popular with some experimenters that I am told that not merely do they wear their tables into holes, but that this is the true source of the emphatic style of some wireless lecturers!

WITH the use of "REFTY" Terminals loose contacts are entirely a thing of the past. Yet, the act of attachment or disconnection takes but a second, and the wire is gripped with a perfect electrical contact. The terminals are made of best hard brass, the springs are enamelled, and the tops are ebonite.

TYPE No. 1



Single Sample,
1/1½ post free.
12/6 doz.
post free.

Takes up to
No. 11 S.W.G.

State whether Plate
or Lacquer finish

British Prov. Pat.
15594/22.
Foreign Patents Pending.

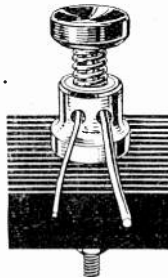

TYPE No. 4

The particular advantage of this Terminal is that wires of greatly differing gauge can be used at the same time.

Single Sample, 1/4½ post free,
or 15/6 per doz., post free.
State whether Plated Lacquer finish.

TRADE ENQUIRIES INVITED.

R. EFTY,
91, Osborne Rd., Romford, Essex

JUST PUBLISHED

NEW PRICE LIST AND
WIRELESS GUIDE FOR

AMATEURS

Sent on receipt of 3d. (stamps).

MANCHESTER ELECTRIC WAREHOUSE
1 & 5, LEVER STREET—MANCHESTER

WIRELESS HEADPHONES

4000 OHMS TOTAL RESISTANCE

DELIVERY FROM STOCK.

Double Headband, each receiver
detachable instantaneously.

Guaranteed highly efficient; complete with
flexible cord and ready for use.

PER **36/-** SET

Postage 1/- extra.

LOWTH & SMITH, LTD.,
3, HANGING DITCH, MANCHESTER

SPEARS and COMPANY
FOR

TERMINALS

SCREWS, NUTS, WASHERS, PLUGS and SOCKETS, CONTACT
STUDS, BUSHES, VALVE LEGS, CONDENSER VANES and
TURNED and PRESSED PARTS OF EVERY DESCRIPTION.

Actual Manufacturers to TRADE ONLY

WE REGRET WE CANNOT SUPPLY SMALL LOTS TO AMATEURS

CAPSTAN REPETITION WORKS,
PARK ROAD, HOCKLEY, BIRMINGHAM

Telephone: 3265 Central. Telegrams: "Firettes," Birmingham

LESLIE McMICHAEL LTD.

PROVIDENCE PLACE, WEST END LANE, KILBURN, N.W.6

Bus Services 1, 8, 16, 28, 31 all pass West End Lane

Telephone: HAMPSTEAD 1261 Nearest Tube Station: KILBURN PARK (BAKERLOO)

AN EXTREMELY EFFICIENT TWO VALVE SET

WE are very pleased to offer all readers of the "WIRELESS WORLD" an opportunity of purchasing **TWO NEW VALVE SETS** (ex-Government) suitable for all wavelengths.

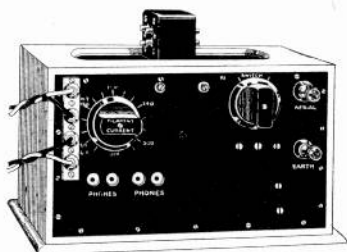

These sets are in polished mahogany cases, have one Detector and one Low Frequency Valve (see illustration).

PRICE **£6 5 0**

The same set but with Variable Condenser included

PRICE **£7 5 0**

When ordering please state whether high or low resistance phones will be used.

COIL HOLDER. Suitable for attachment to this instrument **15/-**
Do. Superior pattern mounted on solid mahogany base **20/-**

TUNING COILS. We recommend Duolateral Coils as quoted. These cover a range of 200-1,500 metres. High ranges at proportional prices. See Catalogue.

SIZE	25	35	50	75	100	150
PRICES	5/6	5/9	6/6	6/9	7/-	7/3

H.T. BATTERY. For use with above Two Valve Set **15/-**
ACCUMULATOR. 4 volt. 80 amp. do **30/-**

TELEPHONES.. From **25/-** per pair. **VALVES** from **12/-** each.

AERIAL WIRE. 100 feet **7/6.** 150 feet **10/-**, this is 7/22 stranded and Enamelled. **INSULATORS, 1/-** each.

BROWN'S PHONES. We particularly call your attention to our further half-page in this issue.

Illustrated Catalogue 16 pages, 100 illustrations, post free 6d.

Visit our Stand No. **38.** All British Wireless Exhibition, Horticultural Hall, Sept. 30th to Oct. 7th

HIGH GRADE EBONITE

SHEETS RODS TUBES MOULDINGS

"Bakelite," "Wittonite" & Fireproof Mouldings

Suitable for Electrical, Wireless and Mechanical Requirements.

ENQUIRIES INVITED

THE GENERAL ELECTRIC CO., LTD.,

Insulation Dept., MAGNET HOUSE, KINGSWAY, LONDON, W.C.2

Insulation Works: WITTON and COVENTRY.



REGD TRADE MARK



REGD TRADE MARK

“SEMAPHORE”

High Tension Dry Batteries for Wireless Receiving Sets



TERMINALS. — The 15 volt Batteries are supplied (unless otherwise ordered) with 2 Brass Connecting Strips as illustrated. All the other sizes have 2 Insulated Plugs. Brass Sockets are fixed to every other Cell so that Tappings can be taken at each 3 volts.

Other sizes can be supplied and quotations given on receipt of enquiries.

In order to prove that “SEMAPHORES” are THE BEST and induce a trial, we have reduced our price for 15-volt to 3/3 each.

Volts	Number of Cells	Price Each Carriage paid
15	11	3/3
30	22	8/6
36	24	9/3
50	36	13/6
60	44	16/6
90	66	24/6
100	72	26/6

Trade supplied promptly. Terms on application.

SEMAPHORE, Ltd., DRY BATTERY SPECIALISTS
28, John Street, Bedford Row, London, W.C.1.

Telephones : MUSEUM, 5422 and 5423.
Telegrams : ARWELIDITE. HOLB. LONDON.

“CHASE RADIO PRODUCTS”

ONLY THE BEST SUPPLIED

Tuner Unit	£4 0 0
Detector	£4 0 0
Radio F. Unit	£4 0 0
Audio F. Unit	£4 10 0
Filament Rheostat	6 0
Lead in Tubes, 9"	2 0
" " " 12"	2 6
" " " 18"	3 0
Var. Condenser with Knob and specially engraved scale	£1 10 0
Telephone Transformers	15 0
Audio F. Transformers	£1 7 6

WE ARE THE ACTUAL MANUFACTURERS

The Chase Motor Co. Ltd.

Office and Works :
Sandyford Square
Newcastle-on-Tyne

Showrooms :
Barras Bridge
Newcastle-on-Tyne

TRADE SUPPLIED BEST DISCOUNTS



---CQ Std bi for ERICSSON PHONES

WHEN you instal your wireless set—crystal or valve —you'll get maximum results if you fit Ericsson Phones—clarity, sensitivity, strength of signals and absence of “click.” Specially suited to telephony. Ericsson Phones embody the accumulated experience of telephone manufacture for a generation. Easy to the head, light and comfortable. The magnets never lose their strength and “shorts” are non-existent.

Write for Particulars

The BRITISH L. M. ERICSSON MANUFACTURING Co., Ltd.

Head Office :
60, Lincoln's Inn Fields, E.C.2

Ericsson
Telephones

RADIO INSULATION

AS SPECIFIED AND USED BY THE BRITISH ADMIRALTY

BRITISH MADE

PAXOLIN

BRITISH MADE

TUBES DISCS PLATES, &c.

MANUFACTURED IN ALL FORMS, SIZES AND THICKNESSES

BY

THE MICANITE & INSULATORS CO. LTD.

EMPIRE WORKS

WALTHAMSTOW

LONDON, E.17

TELEGRAMS:—"MYTILITE, PHONE, LONDON."

TELEPHONES:—WALTHAMSTOW 738, 739

HIGH QUALITY :: CONDENSERS ::



'001 mf. 24

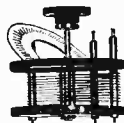

'0005 mf. 18



'0003 mf. 14

Complete with scales, post free.



Made of Ebonite and brass throughout with excellent gun metal finish.

Fixed Unit 4/2

Moving Unit 5/8

Prices post free.

UNIT
COIL
HOLDERS



Shows method of fixing.

ASHLEY RADIO

69, Renshaw Street, LIVERPOOL

Telephone:
4628 Bank.

Telegrams:
"Rotary, Liverpool."

ACCUMULATORS

Absolutely Guaranteed Best Quality

CELLULOID CASES

4 volt	40 amp.	18/6	4 volt	80 amp.	28/2
4 "	60 "	21/6	4 "	100 "	30/-
6 "	40 "	26/3	6 "	80 "	37/3
6 "	60 "	31/9	6 "	100 "	41/6

PACKING FREE.

SPECIAL PRICES TO TRADE
for quantities on application.

SPECIAL OFFER

6 volt 40 ACTUAL AMP. SET three glass cells sealed tops in well-made TEAK crate, a handsome set @ 49/6.

4 volt 24 amp., celluloid cases, 11/9, postage 1/-
2 " 16 " ebonite cases, 3/9 each, post free

AERIAL WIRE, 5/- per 100 ft. Coil.

ALL SIZES of ACCUMULATORS QUOTED FOR
Dynamamos, Motors, Electrical Accessories.

Write for Lists.

F. Yates & Son, Ltd. Wholesale Electricians

144, Church Street, Kensington, London, W.8

(One minute from Notting Hill Gate Station.) Phone-Park 4276

Ever-Ready

British Made

DRY CELLS BATTERIES

were the first in the field, and their fine qualities make them peculiarly suited for wireless installations.

THE 'UNIT' DRY CELL

"Build up your batteries as you build up your Marconi sets."

Unlimited flexibility in size, voltage and intermediate tappings. Each cell is fitted with brass screw terminal and looped wire, and they are efficiently insulated to prevent current leak.

No. UW1 **7/6** dozen
 EMF. 1½ volts Weight 3½ ozs.
 Dimensions 2¾ ins. × 1 5/16 ins. Diam.

Art catalogue of standard sizes and list of accumulators for valve filament supply sent on request.

HIGH TENSION BATTERIES

Any size or voltage with any tappings or sockets at 3 or 6 volt intervals for use with wander plugs can be supplied to order.

With 13 Sockets

No. W. 19, 36 volts, 24 cells, **8/6** each.
 Size 6½ × 2½ × 3½. Weight 2 lbs. 8 ozs.
 Wander plugs for use with above, 1/- per pair.

With 2 Spring Contacts. As illustrated.

No. W. 11, 15 volts, 11 cells, **3/6** each. Size 9½ × 7 × 2½
 Weight 1 lb. 2 ozs.

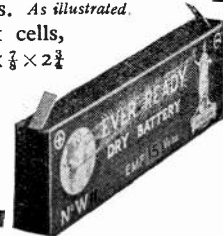

Dept. D.L.
 The EVER-READY Works, Hercules Pl., Holloway, LONDON, N.7
 Visit our Stand No. 11. All British Wireless Exhibition,
 Horticultural Hall, September 30th to October 7th.



VERNIER ADJUSTMENT FOR SLIDERS

Complete with 13 in. bar.
 Bar and Slider - **4/6**

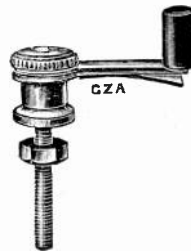

Neat "ON" and "OFF" Switches
 As illustrated **2/3**

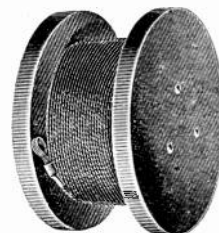

AERIAL WIRE
 7/22 Enamelled Stranded.
 100 ft. **6/-**
 150 ft. **9/-**

TELEPHONE TRANSFORMERS

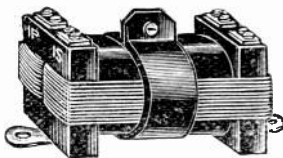

Unmounted (as illustration),
 Suitable for 120 w Phones.
 Unmounted **15/-**
 In Box with Terminals **18/6**

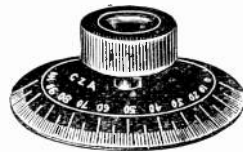

CONDENSER SCALES
 Engraved 0-180°
 With Knob and Bush **3/9**

SINGLE LAYER COILS

4½ in. diam. 9 in. long.
 Wound with 24 Enamel.

Price - **6/6**

G. Z. AUCKLAND & SON, 395, St. John Street, E.C.1
 'Phone 3173 CLERKENWELL.
 Visit our Stand No. 46. All British Wireless Exhibition, Horticultural Hall, Sept. 30th to Oct 7th.

THE WIRELESS WORLD EXCHANGE AND MART

TARIFF. Advertisements are accepted for this Section at the rate of twopence per word, with a minimum charge of two shillings. The advertiser's name and address will be charged for, and single letters and single figures will be counted as words. Compound words will be counted as two words.

FOR SALE.

Inductance Coils.—Tune to 3,500 metres. Polished mahogany ends and base. Best quality wire. 22s. post free. Stamp for illustrated pamphlet.—DAVIS BROTHERS, Thornton Dale, Yorks.

Marconi Scientific Instrument Co.'s Units, 1, 2 (Coils A1, B, D), 3, 4, 6 for Sale. Just received from factory. Good reason for disposal. Best offer gets them.—CARR, South View, Forest Hall, Northumberland.

Few Only.—Genuine Marconi "Q" valves (tested), new condition, in boxes, bargains, 7s. 6d. each. Wanted Brown's High Resistance Telephones, Valve Panels, modern parts.—SERVICE SALES, 8, Great Southsea, Southsea, Hants.

Seven Valve Amplifier.—Mark III Type Tuner, 160-4,000 metres. Three valves resistance amplifier, new. Bargains. Offers considered. Further particulars from SYDNEY WRIGHT, Albert Mills, Bingley, Yorks.

Two-Valve Telephony Receiver, for £11 10s. Can be seen working by appointment.—FRANKLIN, 36, Elmwood Road, Chiswick.

Ivoryine Tablets for Terminals, set of seven, 1s. Ivoryine scales, 8d. Why Pay More?—INDELIBLE PROCESS CO., 220, Albert Road, Peckham, London, Liberal terms to Agents.

Small Parts Supplied from Stock.—Condenser plates, crystal detectors, terminals, spacers, washers, nuts, contact studs and stops, valve legs. List free.—FRASER, Sentinel House, Southampton Row, London.

Read's 2-Valve Panel, WR/160, cost Five Guineas, as new. £3. Portable 2-Valve receiver in case, coupled Hesketh tapped reactance unit all wavelengths, £4. Mk. III 2-way switches, 2s. 6d. **All New**—two-slide cylindrical inductance £1, filament resistance 3s. 6d., L.B.C. 4/40 arcumulator 15s., Sullivan's 120-phones 12s. 6d. Back numbers *Wireless World*—Particulars, JAMBLIN, 82, York Road, Bury St. Edmunds.

Condenser Vanes, Aluminium, 20 G., fixed or movable, 7d. dozen, 6s. gross. Spacer washers, large 4½d. dozen, 4s. gross. Small 2½d. dozen, 2s. gross. Postage extra.—R. DOUGHTY & SON, Cooke Street, Wolverhampton.

Inductance Coil, 12 x 4, mounted on mahogany base, £1.—20, Sheffield Road, Grays.

Telephones Rewound any Resistance. Intervalve Transformers suitable for panel mounting, 15s. 6d. Condenser plates, per doz., 1s. 3d. Condenser moving plate stems, 5d. each. Grid leak and condenser, 3s. 6d. 9" x 6" Panel cases, 4s. 6d. Single valve panels, 25s. and 35s. We can supply all your wants. Trade enquiries.—HARRIS, 84, Ronald Park Avenue, Westcliffe-on-Sea, Essex.

Valve Receiver with Crystal Rectification, with Valve and Telephones, 300-24,000 metres, £15 15s. Seen working any evening.—"H," 24, Airedale Road, South Ealing, W.

Brass Castings.—Every description, small or large quantities. 14 years' experience. Quotations on request. NO WAITING.—GELDART & PARKER, Engineers and Brass Founders, 141B, Bartholomew Street, Newbury, Berks.

The Motor House Wireless Station Supply Depot. Telephone: Malvern 180. Malvern Link, Worcestershire. Everything for Wireless. Valves, Batteries, Telephones, Condensers, Aerial Fittings, Insulators, Filament Resistances, Grid Leaks, one, two, three and four-Valve Receivers. All instruments highest efficiency.

Two 24 H.P. Motor Generators, one 40' Mast Direction Finders, Drafting Instruments, etc. ex Admiralty surplus. Half prices.—THE LONDON ELECTRIC FIRM, Croydon.

Wireless Instrument Cases, Walnut or Mahogany, finest finish, 12" by 7½" by 4" (outside), 8s. 6d. Second quality, 7s. 6d. Any size proportionately, prompt delivery. Trade inquiries invited.—HITCHCOCK, Colchester.

Agate Cylinders, etc., for loud speaking apparatus from James R. Gregory & Co., Mineralogists, 139, Fulham Road, S.W.3.

EBONITE
RELIABLE GRADES ONLY
(See last week's Advt.)
SHEET, ROD, TUBE,
PANELS, MOULDINGS
Enquiries attended to promptly.
RADIO EBONITE SUPPLIES,
4 Little College St., London, E.C.4
Central 4711. (Nr. Cannon St. Station)

TRADE **Grecco** MARK

Small
Neat



High
Insulation

Egg Insulators, Green Porcelain	6d.
Reel Insulators, Best Quality	4d.
Aerial Wire, Stranded, 7/25	per 100' 3/6
Aerial Wire, Stranded, 7/22	per 100' 3/6
Ebonite Lead-in Insulators, with Terminals (no soldering)	2/-
Filament Resistance Panel Mounting, Smooth Action	4/-
Knobs, fluted with 2 B.A. Brass Nut in centre (Best Finish)	4d.
Valve Holders, with screwed legs and nuts, ebonite	1/-
Hellesen, 36v. H.T. Batteries with Wander Plug and Tappings	8/6
Inductance Sliders with plunger and Perikon Detectors, mounted on Ebonite complete	4/-
Enam. Wire, 23 Gauge	per ½ lb. 1/-
Intervalve Transformers	21/-
Telephone Transformers	20/-
Siemens Halske, and R.E.G. Valves, Rectifying and Amplifying	10/6
Adapters for "A" Valve Holders	3/-
Call and Inspect.	Postage Extra.

Grafton Electric Company
Showrooms—54, GRAFTON STREET,
TOTTENHAM COURT ROAD,
LONDON, W.1. Telephone—Museum 241.

ELECTRADIX WIRES

Gauge.	Highest Conductivity		at Lowest Prices.	
	D.C.C.	S.S.C.	D.S.C.	D.S.C.
16	1 7	—	—	3 6
18	1 9½	—	—	3 9
20	1 11	4 0	—	4 6
22	2 5	4 6	—	5 0
24	3 0	5 0	—	5 9
26	3 6	5 6	—	6 6
28	4 2	5 9	—	6 10
30	5 2	6 6	—	8 1½
32	6 6½	8 2	—	9 0
34	7 9	9 6	—	10 7
36	9 2	11 3	—	12 3½
38	11 10	13 6	—	17 3
40	16 2½	17 0	—	23 5

Prices at per lb. Postage Extra. Earth Clips, 6d. each. 7/22 Aerial Wire, 7/- per 100 ft. **EVERYTHING FOR WIRELESS IN STOCK.**
LESLIE DIXON & CO.,
9, Colonial Avenue, Minorities, E. 1
(near Aldgate Station. Telephone Avenue 4166.)

RADIOPHONE TUNERS,
200-1,400ms. 38/-
Valve Panels for above . . . 21/-
·0005 Variable Condensers . . 18/6
Above 3 make an Ideal Receiver.
Broadcast Concert Coils pair 2/-
Grid Leaks and Condensers 3/6
Fixed Condensers 2/6
5-Plate Condensers 6/6
2-Valve H.F. Amplifier Panels 32/-

Get our New Bargain Lists.

AMATEUR SUPPLIES,
184, COTEFORD STREET,
TOOTING, LONDON, S.W.

We can quote you very keen prices for
**SWITCH STUDS, VALVE LEGS,
TERMINALS AND OTHER BRASS
WIRELESS COMPONENTS.**
Special Terms for large Quantities.
Let us have your enquiries.
Nicholls & Wallis, Braintree, Essex.

**BROWN "A" TYPE
Radio Headphones.**

Guaranteed New and Unused.

8,000 ohm	Sullivan	120 ohm
48/6	35/6	41/6

Delivery from Stock at present.
TERMS:
Cash with order. Postage 1/- extra.
GOLLINGS & AYRES,
21 THE BROADWAY,
BEDFORD.

THE WIRELESS WORLD EXCHANGE AND MART

KEYSTONE WIRELESS SUPPLIES

WHOLESALE ONLY.

Ebonite, cabinet work, engraving, expert designers in amplifiers. Slab inductances, basket coils, etc. Switch arms, contacts, Terminals, Scales.

Low Prices Offices: High Finish.
33, Trinity Road, Tooting, S.W.

CONNOLLY, BROTHERS

WIRELESS APPARATUS MANUFACTURERS,
LOSTOCK RD., URMSTON, MANCHESTER.
Spare & Complete Components at Trade Prices.
 Examples: 50' x 6' Double Wire Aerial, 40' Lead in, ready for fixing, 17/8. 7/22 Stranded Wire, 1d. per foot. 2" Reel Insulators, 41d. each. 4" x 12" Wound Inductance Coil, 4/9. 28's Enamelled Wire, 1lb., 2/-, 1lb., 3/6.
CARRIAGE PAID ON ORDERS OVER £2.

PURCHASE YOUR WIRELESS REQUIREMENTS THROUGH

The Viper Re-Covering Co., Ltd.
 7/8, POULTRY, E.C.2.
 (1 minute from Bank) Tele.: City 1897

Marcomphonos, Sterling and R.F.H. Sets, etc., can be supplied. Place your orders NOW.

Instrument Wires

FROM STOCK

S.W.G.	S.C.C.	D.C.C.	S.S.C.	D.S.C.	En.
47	—	—	110/-	120/-	41/-
46	—	—	97/-	107/-	26/-
45	—	—	64/-	80/-	20/-
44	—	—	50/-	66/-	16/-
43	—	—	40/-	52/-	13/-
42	—	—	31/-	33/-	9/-
41	—	—	30/-	32/-	8/-
40	14	17/-	18/-	22/-	6/6
39	12/6	15/-	17/-	21/3	6/-
38	11	14	16/-	19/-	5/3
37	10	12/-	14/6	17/3	4/11
36	8/6	10/-	13/9	15/-	4/8
35	7/9	9/3	12/9	14/-	4/6
34	6/10	8/-	11/3	13/9	4/4
33	6/2	7/6	10/6	13/-	4/3
32	5/10	7/2	9/1	12/10	4/2
31	5	6/10	8/9	11/6	4/-
30	5	5/4	7/9	9/10	3/10
29	4/9	5/-	7/6	9/8	3/8
28	4/3	4/6	7/2	9/-	3/6
27	4/2	4/5	7/-	8/6	3/5

Prices per lb. Bobbins free.

Orders of £2 or over, Carriage Paid, G.B.

Terms—Cash with Order.

FINE WIRE SUPPLIES,

(A. E. DAVIS)

**41, Arlingford Road,
 Brixton, S.W.2**

THOMPSON'S SURPLUS DEPOT

have for SALE a Knockout
 Prices the following goods:—

12 only Portable Field Telephone Sets, complete Magneto ringing, unused, in teak cases, 15/- each. Below.

Direct Coupled 3½ K.W. lighting sets, comprising 8 H.P. Douglas water cooled engine, 110 volts 32 amp. G.E.C. dynamo with radiator, etc., self-contained, price, complete with switchboard and shunt regulator, guaranteed perfect, £45 each. Below.

Condensers, Variable, all high class material, same quality, double elsewhere. 0.00075, 15/- each; 0.0005, 12/- each; 0.001, 20/- each. Post 1/- Below.

200 Pairs High Resistance 'Phones, 4,000 ohms. High Class French instruments as sold elsewhere at 45/- we are selling in three grades, price 30/-, 34/-, and 35/-, all new and guaranteed perfect, cash returned if not satisfied. Post 1/- Below.

100 Single Valve Panels. For receiving speeches, concerts, Paris, Dutch concerts, etc., minus Valve and 'Phones. Offer cannot be repeated, price 27/- each. Post 1/-, all new. Below.

Wireless 1" Sterling Spark Coils, Ebonite Panels, all guaranteed tested perfect, cost £4 each, our price 10/6 each. Post 1/6. Below.

4 only Wireless Generators 40 volts 5 amps., 25/- each. Below.

100 Thompson Bennett Single H.T. Magnetos, new, less contact breakers, 17/- each. Post 1/6. Below.

100 Dixie Single Magnetos, complete and perfect, 17/6 each. Post 1/6. Below.

50 Bosch Starter H.T. Magnetos, perfect 18/- each. Post 1/6. Below.

A.V.I.A. singles Magneto-, in new condition, 25/- Post 1/6. Below.

4 Cyl., 6 Cyl. and 8 Cyl. Magnetos, incomplete, 10/- each. Below.

Potentiometers for crystal receiving sets, High Class, 8/6 each. Post 9d. Below.

Condenser Vanes, High Class, Polished, 1/6 dozen, in gross quantities, 12/- per gross. Below.

9 Stud Tuning Switches, best instrument finish on ebonite, 6/- each. Post 6d. Same quality 10/- elsewhere. Below.

Complete Crystal Receiving Sets. Guaranteed sets for receiving telephony, etc., from 25/- up to £2 10s. 'Phones extra. Below.

4 H.P. Gardner Petrol Engines, Magneto ignition solix carburettors, as new, £12 each.

2 only, 440 Volt, 1 H.P. Direct current motor, £5 each. Below.

All above material is the best to be obtained. For other numerous instruments and fittings send for lists, price 2d. Lowest discounts to trade. We have everything in the wireless line.

T. W. THOMPSON & CO.,
 Government Surplus Depot,

39, London Street, Greenwich, S.E.10.

Our Speciality:

WIRELESS

Electrical Supply Stores

5, Albert Terrace, King Cross,
 Halifax, Eng.

Our Motto:

PROMPT SERVICE

LISTS - - TWO STAMPS

ELECTRADIX RADIOS



Hundreds of Head Sets in Stock. All with cords. Sterling Brown Phones, Marconi Standard 2,000 ohms, 51/- pair; 4,000 ohms, 52/- pair; Brown's A 120 ohm L.R. head 'phones, 40/- pair, Sullivan's L.R. ditto, with 6 ft. cord, plug and jack, 22/- High Res. Head Sets, 1,500 ohms, 26/-; 4,000 ohms, 30/- complete. Second-hand 80-ohm head - sets

guaranteed, 15/- Single L.R. Receivers, 4/6. Cords for double 'phone new, 2/6 and 3/9. Used. 1.6. 4-Way Plugs, 2/-.

Microphone Transmitters, breast plate, 12/6; Hand, 2/6. Insets, 9d.

Aerials.—Wire and every accessory in stock. Condensers.—Fixed and variable in all sizes. Relays, G.P.O., 21/-; Weston M.C., £2 10s. Morse Inkers, 45/- Sounder sets for making rectifiers, 12/6 each.

Panel Switch Flush Fitting, D.P., 3/6. Plugs and Jacks, 1/6 pair. 60 volt Battery, 4½v. units, in polished mahogany case, six sockets, two plugs, 17/6. Finest set ever offered.

Receivers, all new. Marconi Trench, 50D.C. Cost £40. Complete, £5 10s.

Amplifier Receiver, Mark II, 2-valve, with variable condenser, £7 10s. Single valve panel, 35/6. 3-valve Amplifier, Mark IV, £8. H.T. Motor Generators to 1,000 volts, £15. 1 kW 220 to 25 volts, £20.

EVERYTHING FOR WIRELESS.
 Call at our Electrical Showrooms and inspect.
LESLIE DIXON & CO.
 Near Aldgate Station, Met. Ry. First Turning
 on left in Minorities.

Your Case Work

Let us quote you for your wireless casework. We are specialists in this class of work and feel sure our workmanship and prices will interest you.
 Phone: L.W. 2720.

CARRINGTON & NEWBERY LTD.,
 18/20, Normans Buildings, Old Street, E.C.

HEATH & Co., Ltd.

Instrument Works, New Eltham, S.E.9 are prepared to undertake in their fully equipped works—Wireless Apparatus and Parts for the trade. Quotations given to Blue Prints. Immediate attention.
 Phone—Lee Green 307. Wire—Polaris, London.

Strawboard Inductance Tubes

2" to 6" dia., for Crystal Sets, etc. Attractive Prices—Quick Delivery
 Enquiries attended to promptly.

A. EATON LEE & CO.,
 4, Little College Street, LONDON, E.C.4
 Central 4711. (Nr. Cannon St. Station.)

THE WIRELESS WORLD EXCHANGE AND MART

THE UNIQUE N.M.C. (Wireless Patents)
Two-valve Receiving Unit, combining
Filament Resistance, Aerial, Tuning In-
ductance, Aerial Tuning Condenser, Grid
Tuning Inductance and Oscillating Condenser,
complete in polished case, 12" x 6" x 6",
\$6 6s. less Valves.
The Set to obtain maximum efficiency.
N.M.C. 4,000 W., Double Head Gear, 35/-
Inductance Tubes.
All Experimenters' Supplies in Stock.
N. M. CO., 145, Northcote Road,
Trade Supplied. London, S.W.11.

Northern Wireless Buyers get
your requirements from The Grand
Electric Wireless Supplies Depot, Ocean
Road, South Shields. The Wireless Sup-
plies Depot, 2, Market Place, Morpeth.
Large stocks for amateurs making own
sets. Burndept 3-valve, Burndept Ultra
IV, Tingey 5-valve sets, on view. Free
demonstrations. Pay us a visit or send
your enquiries.

TO THE TRADE

Most of the big Manufacturers of Receiving
Sets, are using OUR Skeleton Condensers for
Panel Mounting. Verb Sap. Write for terms.

The W. J. Fallon
Condenser Manufacturing Company
230a, Hermitage Road, London, N.4

Aluminium

Condenser Vanes

We are open to quote low prices for the
above to the trade. Wholesale only.

G. BROWN & Co. Berkley Street
STAMPERS & PIERCERS Birmingham

FOR SALE

Tubular Steel Masts with finial, rope cleat,
guy clips and baseplate. Painted, light and
durable.

12', 25/- (2 Sections), 40/-

40' (3 Sections), 80/-

100' 7/22 copper wire, 6 insulators, halyard,
pulley and lead in tube, 10/6. Carriage
forward.

Trade Supplied.

Works, 5, Kramer Mews, Earl's Court.

L. S. COMPTON, 17, Fernshaw Road, S.W.10.

HEADPHONES.

New and Unused. Not reconditioned. Cash
refunded if not perfectly satisfied.

Brown's A-Type, 120 ohms, Usual price,
£2 18s. Our Price, 35/-.

Brown's A-Type, 3,000 ohms, £3 6s. Our
price 39/9.

Sullivan's 3,000 ohms. Usual price £2 5s.
Our Price, 29/9.

Post and packing, 1/- extra.

Write or call for our Wireless Price List.

THE MASCO PATENTS MANUF'NG COY.,

79 Rosebery Crescent, NEWCASTLE-ON-TYNE

FOR SALE—continued

B.A. Screws, Nuts and Washers, assorted gross
2s., lists 2d.—J. H. BENNETT, Station Road,
Willesden Junction.

Wireless Masts.—Improved Girder Type. Light
and strong, 30 to 50 ft. at 1s. ft. 50 to 100 ft.
at 1s. 6d. ft. Cash with order, carriage for-
ward.—F. ARMSTRONG, Weybridge.

Several Wireless one-valve Experimental Receiving
Sets, perfect, complete, cheap.—RADIO
COMPONENTS, 7, Jamaica Row, Birmingham.

TRADE ENQUIRIES.

To Manufacturers.—Wanted. All kinds of
wireless fittings and accessories. Instruct agents
to call.—LAWRENCE BROS., 102, City Road,
Cardiff.

South Wales Electrical Firm, 15 years standing,
want agencies for all kinds wireless.—Apply
Box K2, BERTRAM DAY'S ADVERTISING OFFICES,
9/10, Charing Cross, S.W.1.

Designs of Receiving Sets, Motors, etc., supplied.
Sound advice given. Enquiries invited—O. S.
PUCKLE, Buckhurst Hill, Essex.

"Danwill Wireless Supplies." Cheapest on
market. List on application.—47, Old Dover
Road, Blackheath, S.E.3.

New Firm of Factors require Manufacturers,
Lists, Samples, and keenest prices all Wireless
Supplies.—GRIFFIN, 80, Newington Causeway,
S.E.1.

Quotations Wanted for all Wireless Components
and materials. Trade only.—RIDGWAY RADIO,
Wimbledon.

Advertisers Request Quotations from manu-
facturers for all parts used in construction of
wireless instruments, also condenser scales, knobs
reostats, switches, etc.—TEXALO MANUFACTURING
Co., South Shore, Blackpool.

Wireless.—Our stocks are complete, and we can
give prompt deliveries. Send stamp for lists.—
ELECTRICAL SUPPLY STORES, 5, Albert Terrace,
King Cross, Halifax.

MISCELLANEOUS.

East Ham, Wanstead, Ilford, Manor Park and
Forest Gate. Amateurs should not fail to come
to the **RADIORENDZVOUS**, 709, Manor Park
Broadway (over Liptons). Club open till 10 p.m.
nightly.

BOOKS.

Technical Books.—Second-hand and New
Books on every conceivable subject. Catalogue
free. State wants. Books sent on approval.
Books bought.—FOYLE, 121, 125, Charing Cross
Road, London.

Radio Magazines, all the latest, "Radio
World," 10d.; "Popular Radio," 10d.;
"Radio Broadcast," 1s. 6d.; "Radio News,"
1s. 6d.; "Science and Invention," 1s. 6d.;
"Scientific American," 2s. 6d. Post Free.
INTERNATIONAL NEWS COMPANY, LTD., 15, Bream's
Buildings, London, E.C.4.

EBONITE "A" TYPE 4 PRONG VALVE HOLDERS

1/6 each, post free.

WILKINSON,
LONSDALE RD., KILBURN, N.W.6
TRADE SUPPLIED. Established 1906

Contracts Wanted!

The
Wellington Engineering Works,
ALDERSHOT.

INVITE ENQUIRIES FROM FACTORS,
MERCHANTS, SHIPPERS AND AGENTS
FOR THE MANUFACTURE OF WIRELESS
APPARATUS.

1, 2, 3 or 4 VALVE RECEIVING SETS.
VALVE PANELS ON THE UNIT SYSTEM,
L.F. AND H.F. INTERVALVE TRANS-
FORMERS, VARIABLE CONDENSERS, AND
FILAMENT RESISTANCES.
COMPLETE CRYSTAL RECEIVING SETS.
SUPERIOR FINISH. PROMPT DELIVERY.
KEEN QUOTATIONS.

CONDENSERS

VANES, WASHERS

SCREWED RODS. SCALES

CONTACT STUDS

INDUCTANCE TUBES

ROD AND SLIDERS

CRYSTAL CUPS & CRYSTALS

EBONITE. TERMINALS

WIRES, &c. &c.

Send for keenest prices to

GROVE R. & A. WORKS
Short Rd., Leytonstone London E11

STAR DELTA WIRELESS SUPPLY COMPANY

INSTRUMENTS TESTED FREE.

The House For All Wireless Accessories
Have You Called? If Not, Why Not?

838a, Oxford Road, MANCHESTER.

The Proprietor of the Patent No. 24231, of 1914,
for improved receiving system for continuous
electric waves, is desirous of entering into arrange-
ments by way of licence and otherwise on reason-
able terms for the purpose of exploiting the same
and ensuring its full development and practical
working in this country. All communications
should be addressed in the first instance to—
HASLELINE, LAKE & Co., Chartered Patent
Agents, 23, Southampton Buildings, Chancery
Lane, London, W.C.2.

RESULTS

Whether as a source of practical information
for the Amateur or as a valuable medium for
every Advertiser, the best results are
invariably obtained "Wireless World"
through the

For full particulars and advertising rates apply to
BERTRAM DAY & CO., LTD.
Complete Advertising Service,
9 and 10 CHARING CROSS, S.W.1

**DISTORTIONLESS AUDIO FREQUENCY
INTERVALVE TRANSFORMER
16/9 post free.**

Wound with 20,000 turns of wire with the layers spaced and insulated.

The wire used is of heavy gauge thus eliminating the risk of burning out. The core is of special design and built up from best quality Stalloy iron laminae.

Insulation resistance between primary and secondary windings and between both windings and core is guaranteed to be not less than 100 megohms.

This transformer is free from distortion giving perfect reproduction of speech and music.

Each one is fully guaranteed. Delivery immediately from stock.

Also H.F. plug in transformers from 3/6 each.

A. WOOD, Manufacturer of Wireless Apparatus,
44, BRACEBRIDGE STREET, NUNEATON.

**THE
PARAGON RUBBER MANUFACTURING CO.
SCULCOATES, HULL.**

E B O N I T E	W I R E L E S S
Sheet, Rod & Tube	K N O B S
E L E C T R I C A L	V A L V E S
M O U L D I N G S	S L I D E R S, E t c.

Wholesale only.

London Office : **PERCY W. C. TRICK,**
20, LITTLE PORTLAND STREET, W.1
Telephone : MUSEUM 2043.

**"DIOPLION"
INTERVALVE TRANSFORMERS**

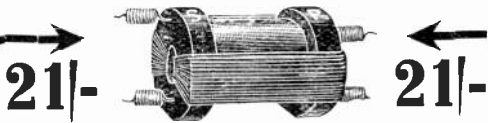

Are the result of 18 months careful research, and will be found equal to any. They are sold on the "money back" principle, and we are confident that once you have made a test, your future supplies will all be "DIOPLION" types.

IMMEDIATE DELIVERY can be given to EARLY APPLICANTS and the trade should take advantage without delay.

Visit our Stand No. 21. All British Wireless Exhibition, Horticultural Hall, September 30th to October 7th.

MITCHELL'S ELECTRICAL & WIRELESS Ltd.

McDermott Road, Peckham, S.E. 15
(Retail Store, 188, Rye Lane, S.E. 15)

**CHAS. BAKER
AND CO.'S STORES, LTD
LARGEST OUTFITTERS IN LONDON**



High-class Tailoring

AT MODERATE PRICES

INDIAN COLONIAL &
FOREIGN OUTFITS

Regulation Uniforms

Head Depot 271-274 HIGH HOLBORN
City Branch 41, 43 LUDGATE HILL
37-140 Tottenham Court Rd., 256 Edgware Rd., &c.



HEADGEAR RECEIVERS

Designed and manufactured by
leading Telephone Manufacturers
Backed by many years' experience.

Highest efficiency, concentrated
magnetic field, instantaneously
adjusted to the ears, comfortable
in wear, either receiver detachable
from headband, protected term-
inals, light weight, twin series cord.

**A.T.M. LOUD
SPEAKING
RECEIVERS**
Three types of
amplifying horn.

**A.T.M. Crystal
Detector Sets**
Highest Grade.
Maximum Efficiency.
Moderate Cost.

Ask your dealer for
A.T.M.

Broadcasting Apparatus

Visit our Stand No. 52. All British Wireless Exhibition.
Horticultural Hall, September 30th to October 7th

Automatic Telephone Manufacturing
Co., Ltd.

Head Office & Works : London Office :
Milton Rd., Edge Lane, 60 Lincoln's Inn Fields
Liverpool. W.C.2.

IMPORTANT NOTICE

A. C. COSSOR, Limited, hereby give notice that the order of Mr. Justice Russell of the 1st March, 1922, continually advertised by the Marconi Co., was an order **ARRIVED AT BY CONSENT.**

Being engaged at the time in the production of an improved and different type of valve, A. C. COSSOR, Limited, did not consider the patents in question of sufficient importance to warrant the expense of litigation.

A. C. COSSOR, Limited, respectfully leave the public and the Trade to judge whether the constant repetition of the notification of the judgment referred to is necessary or expedient in the circumstances.

Visit our Stand No. 29. All British Wireless Exhibition.
Horticultural Hall September 30th to October 7th.

A. C. COSSOR, LIMITED
Aberdeen Works, Aberdeen Lane,
Highbury Grove, N.5

WARNING.

MARCONI'S WIRELESS TELEGRAPH CO., LTD.,
v.
A. C. COSSOR, LTD.

Marconi's Wireless Telegraph Company, Limited, **GIVE NOTICE** that an **ORDER** was made in the High Court of Justice, Chancery Division, by Mr. Justice Russell on the 1st March, 1922, restraining Messrs. A. C. Cossor, Ltd., from infringing the Marconi Company's Letters Patent Nos. 28413 of 1913 and 126658, except so far as Messrs. A. C. Cossor, Ltd. manufacture for H.M. Government.

Messrs. A. C. Cossor, Ltd., were further **ORDERED** upon oath to **DESTROY** all articles and apparatus (other than those constructed to the order of H.M. Government) made or used by them in **INFRINGEMENT** of these patents, and **TO PAY THE MARCONI COMPANY DAMAGES AND COSTS.**

The M-O Valve Company, Limited, of Osram Works, Brook Green, Hammersmith, London, W.6, is the only firm in this country licensed to manufacture thermionic valves under the patents belonging to the Marconi Company.

Any valve similar to those generally known as the "French type" constitutes an infringement of the above patents whether manufactured in this country or imported from abroad. Marconi House, Strand, London, W.C. 2.

WE PUBLISH WINNERS. AUGUST 5th ISSUE

Question: At what station does the train of Oscillations stop?
 Sent by:—S. W. Bastowe, 18, Moyser Road, Streatham, S.W.16, who has been presented with a parcel of goods chosen by himself.

Best Answer: Crystal (Palace).

Head Receivers and Loud Speakers

SENSITIVE.



LIGHT.

OUR AIM

Maximum efficiency with low production costs enabling us to sell both receivers and loud speakers at most attractive prices.

All are tested before leaving works and any not meeting the test are rejected.

PHONES

140 ohm.	30/-	} Complete with cord
4000 "	32/-	
8000 "	33/-	

LOUD SPEAKERS

70 ohm	} £2 10 0 complete with cord
2000 "	
4000 "	

Delivery 1st week in September.

Extracts from our price list.
 4d. (post free).

- Condenser Vanes. 1/- doz. Postage 2d. doz.
- Valve Holders. Best moulded ebonite. Complete with nuts. 1/4 each. Postage 3d. each.
- 1 1/2" Diam. Knobs. 7d. each. Postage 3d. each.
- Aerial Pulleys. 1/- each Postage 3d. each.

EFFICIENT.



OF SUBSTANTIAL CONSTRUCTION.

LIBERAL DISCOUNTS TO THE TRADE.

J. L. CARTWRIGHT & CO., Manufacturing Electrical and Radio Engineers,
 DEPT. W.

Phone—Cent. 4209

130/132, LONDON ROAD, MANCHESTER.

Grams—Padiuram, Manchester.

Works: BERRY STREET, LONDON ROAD.

LESLIE McMICHAEL LTD.

PROVIDENCE PLACE, WEST END LANE, KILBURN, N.W.6

Bus Services 1, 8, 16, 28, 51 All pass West End Lane

Telephone: HAMPSTEAD 1261 Nearest Tube Station: KILBURN PARK (BAKERLOO)

BROWNS' PHONES

New, Unused, Ex-Government All-Aluminium Diaphragms

Reconditioned and Guaranteed by Mfs., S. G. BROWN, Ltd.

HIGH RESISTANCE LOW RESISTANCE
55/- Per Pair 50/-
 (Prices include Cords)

We also have a LARGE stock of unused ex-Government BROWNS' PHONES, which have *not* been reconditioned by Mfs. S. G. BROWNS.' These we purchased direct from the Government.

120 ohms 4000 ohms
37/6 43/6
 PER PAIR
 (Prices include Cords)

VISIT OUR STAND—No. 38
 ALL-BRITISH WIRELESS EXHIBITION
 HORTICULTURAL HALL
 September 30th —to— October 7th

A SPLENDID TWO-VALVE SET . . . **£6 5 0**
 See our further advert. in this issue.

Send for our ILLUSTRATED CATALOGUE.

16 Pages, 100 Illustrations.

Post free. Sixpence.

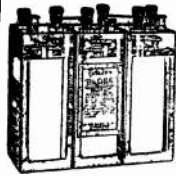

Important Announcement to the Trade

LIVE AGENTS WANTED IMMEDIATELY IN ALL PARTS OF THE COUNTRY TO STOCK

FULLER BLOCK ACCUMULATORS FOR WIRELESS PURPOSES.

There is an unprecedented opportunity for the retailer to build up a wide connection amongst wireless enthusiasts by supplying a really efficient Accumulator, one that is fool-proof, an important factor when the same is to be used by the Amateur.

Don't run the risk of making a dissatisfied customer by supplying a plate-type battery, which will not hold its charge when not in use. The E.M.F. of the "Block" cell will not fall below 2 volts even if left unattended for a period of 12 to 18 months.

We are about to establish reliable

ACCUMULATOR CHARGING STATIONS throughout the country in readiness for the rush of business which is sure to follow as soon as the broadcasting scheme is launched.

If interested, please write to "AGENCY"

THE CITY ACCUMULATOR CO. (Dept. 88)
79, MARK LANE, E.C.3

Phone: Avenue 91 (3 Lines) Telegrams: Tyche, Fen, London

WIRELESS

Large or Small Contact Studs doz. 1 0
Valve Legs, complete with nut and washer .. each 3
Hart Accumulators, 4-volt, 24 amp. hour .. each 14 9
Postage and Packing extra each 1 3

STILL THE CHEAPEST FIRM FOR WIRES.

S.W.G.	S.C.C.	D.C.C.	Single Silk	Dbl. Silk	Emd.
12	1/10	1/11	4/-	5/4	1/8
14	1/11	2/-	4/-	5/4	1/9
16	2/-	2/1	4/2	5/6	1/10
18	2/1	2/2	4/4	5/6	1/11
20	2/2	2/3	4/8	6/8	2/6
22	2/6	2/11	5/-	6/8	2/8
24	3/-	3/6	5/6	7/4	2/8
26	3/7	4/1	6/8	8/2	3/2
28	4/4	4/7	7/2	9/-	3/6
30	5/-	5/6	8/-	10/-	3/10
32	6/-	7/3	9/2	13/-	4/2
34	7/-	8/3	11/6	14/-	4/4
36	8/8	10/2	14/-	15/6	4/8
38	11/3	13/2	16/-	19/-	5/3
40	15/-	18/-	18/6	22/6	6/6
42	17/3	21/-	31/6	34/-	9/-

At per lb.
All orders of 1 lb. or over wound on reels free. For less than 1 lb. reel 3d. extra.

Further Lists on application. Trade Supplied. Postages extra.

Visit our Stand No. 19. All British Wireless Exhibition, Horticultural Hall, September 30th to October 7th.

J. B. Bower & Co., Ltd.

Wireless Manufacturers,

15, Kingston Road, WIMBLEDON, S.W.19

Phone: Wimbledon 1080. Works: Merton.

The Universal Tuner

The Universal Concert Tuner is the smallest, cheapest and most efficient tuner on the market for the reception of the Dutch Concert and Marconi Broadcasting.

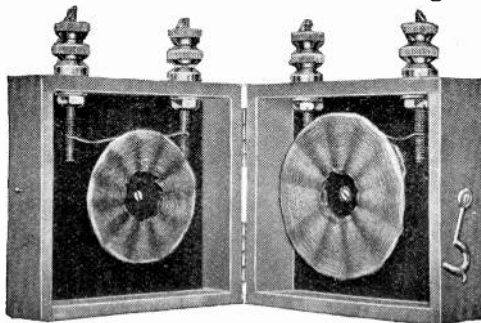

In light polished wood case, fitted highly lacquered brass terminals and fastening catch, with 2 coils as illustrated. Size 4" x 3 1/2" x 1 1/2"

Complete with full instructions.

Secure one of these Tuners today. You will be perfectly delighted.

PRICE

7s. 6d.

POST FREE

J. LIPOWSKY Electrical and Wireless Engineer
614, OLD FORD ROAD, BOW, LONDON, E.3
Telephone: East 3345

A \$20,000 DEAL IN WHICH EVERY WIRELESS AMATEUR MAY PARTICIPATE

"BROWN" "A" TYPE RADIO HEADPHONES

Guaranteed new and unused. NOT re-conditioned.

120 ohms.
42/6

Maker's Price 58/-



8,000 ohms
49/6

Maker's Price 66/-

SULLIVAN 8,000 ohms, ... **36/6**

Why pay the full price and wait weeks for delivery when we can supply from stock at less than trade price? Terms cash with order. Postage 1/- extra. Approval for 7 days

Trade enquiries for quantities solicited.

FULLER "BLOCK" TYPE ACCUMULATORS 4 volts, 4 amp., **32/6**
the only practical battery for wireless.

THE CITY ACCUMULATOR CO.
79, MARK LANE, E.C.3.

Phone: Avenue 91. Telegrams: 'Tyche, Fen, London.'

WE SPECIALISE
IN
EBONITE
EQUIPMENT
FOR
WIRELESS SETS

SHEETS : TUBES : PANELS
KNOBS, CONDENSER COVERS
WHOLESALE ONLY
FROM STOCK

HIGHTENSITE LTD.
Normandy St., Custom House, E. 16

Phone: EAST 3153.

OUR MONEY BACK GUARANTEE goes with every Condenser we send out.

For the convenience of those Amateurs who prefer to make up their own Variable Condensers we are offering complete sets of parts, ready to assemble, no drilling or fitting required, at hitherto unheard of prices, in the following Capacities:

'0015	'0001	'00075	'0005	'0003	'0002
21/-	17/6	15/-	10/-	8/-	7/-

For Assembled add 2/6 to price of each model except '0015 and '001 which are 4/6 extra.

The above are for Panel mounting and, at the price, are absolutely the best Condenser value on the market. With Engraved Ivorine Scale, 1/3 extra. Mounted in Mahogany polished Cases, 4 1/4 x 4 1/4 x 3 1/4", with ebonite top and knob, scale and pointer, '0003, 12/6; '0005, 16/-; Vernier Condensers, unmounted, 3 plates, 4/-; 5 plates, 4/9.

Buy from the makers and save middlemen's profits. Post Paid on £1 Orders
W. J. FALLON & Co., The Condenser People,
230a, HERMITAGE ROAD, LONDON, N.4.

GENTS' MAKE FITMENTS

SEND FOR OUR
SUNDRIES
PAMPHLET

MAKE USE
OF OUR
STOCKS

ASK US
TO QUOTE
FOR YOUR

WHOLESALE REQUIREMENTS

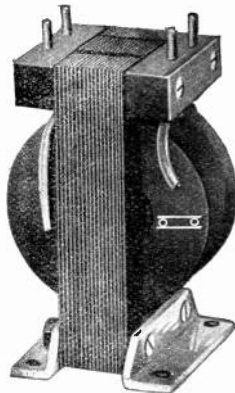

GENT & CO. LTD. FARADAY W.O.R.K.'S **LEICESTER**
LONDON: 25, Victoria Street, S.W.1
NEWCASTLE-ON-TYNE: Tangent House, 52, Blakett Street

THE opportunity you cannot afford to miss in
WIRELESS ACCESSORIES

- Accumulators, Best Make. — 4v. 20a, 18/6: 4v 40a, 22/8:
- 6v 20a, 27/6: 6v 40a, 35/-
- Aerial Wire 7/22 per 100 ft. 5/6
- Batteries, 15 V.H.T. Best Make each 3/3
- Condenser Grid, mtd. Ebonite each 2/6
- Condenser Vanes, Alum. per pair 3d.
- Condenser Washers, Large per doz. 8d.
- Condenser Washers, Small per doz. 4d.
- Contact Studs, with nut and washer per doz. 1/6
- Crystals, Best per piece 6d.
- Coils mounted with ebonite push fittings.—175-400, 4/- each:
- 250-550, 4/6 each: 325-750 4/9 each: 450-1200, 5/9 each:
- 550-1500, 6/6 each: 850-2000, 7/- each: 1350-3000, 7/6 each:
- 1500-4000, 8/- each: 2000-6500, 8/6 each: 3000-9500, 9/- each
- Ebonite Knobs each 6d.
- Headphones, complete, 4,000 ohms. 30/-
- Headphones, complete, 8,000 ohms. 35/-
- Valve Sockets, nut and washer, set of 4 10d.
- Valve Holders, ebonite each 2/-
- Filament Switch, ebonite each 3/9
- Switch Arms, laminated each 1/6
- Terminals, nut and washer. per doz. 2/-
- Ebonite, best 1/2 in. per lb. 4/6

CASH WITH ORDER GOODS BY RETURN.
CARRIAGE PAID £2 and over

Angell's Wireless Supply Stores
95, Highbury New Park, London, N.5

Crystor

COWL INSULATORS

100% PROTECTION
AGAINST SURFACE LEAKAGE



AERIAL INSULATOR
Length $3\frac{1}{2}$ " Diam. $1\frac{1}{4}$ "
Per Set of Four 10/-
Price 2/6

The Crystor Cowl Insulators are absolutely essential to every wireless aerial, and by providing complete protection against surface leakage due to rain, hail, snow, or fog, will immediately increase efficiency OF YOUR SET.

Send for full particulars without delay.

Horizontal or Wall
LEAD-IN
Price 10/6 Post Free

Vertical Roof
LEAD-IN
Price 10/- Post Free

THE Crystophone

THE SIMPLEST AND MOST
EFFICIENT RECEIVER

The Crystophone type 20 T.T. as illustrated, has a wavelength of 180 to 3500 metres. No extra coils required. Desired range can be obtained by merely operating "fine," "coarse," or "long range" controls.

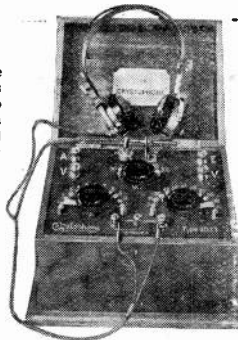

Price Complete:
£5 10 0

Complete Sets, including Aerials,
Receivers and Phones, from **£7 12 6**

Send for full particulars AT ONCE

WIRELESS SUPPLIES CO.

64, Mortimer Street, London, W.1

Phone: Museum 2672. Grams: Adragonax, Wesdo, London.

Visit our Stand No. 1. All British Wireless Exhibition,
Horticultural Hall, September 30th to October 7th.

WIRELESS

CRYSTAL RECEIVING SET.

Specification.—Solenoid type inductance with tappings, .0005 variable condenser, perikon detector or galena, the whole being assembled on 1" ebonite, and mounted in a highly polished cabinet. This receiver is ideal for the reception of telephony Wavelength, 180/1,800 metres approx. Price, complete with phones (4,000) **£5 12 6**

CRYSTAL RECEIVING SET.

Specification.—Double slide tuning inductance, galena detector with dustproof case, blocking condenser, the whole being assembled on a highly polished mahogany base, being an ideal receiver for the reception of telephony. Price, complete with phones (4,000) **£4 10 0**

Filament Switches, under panel type, ebonite	3/9
Aerial Insulators	3d.
Valve Legs with two nuts	per set of 4 10/6
Ex-Govt. 2-valve Receiver (less valves etc.)	£7 5 0
Variable Condensers (21 plate)	17/-
H.T. Units, 15v.	3/3 & 3/9
H.T. Battery Boxes, complete with switch and fuses, etc.	6/6
Condenser Spindles with knob	1/-
Grid Condensers	2/6
Valve Holders	1/-
Fuller Inert Cells, 1½v.	each 9d.
Ali Condenser Plates	per doz. 1/6
Crystals	per piece 8d.
Zincite	per piece 9d.
Valve Pins with nut	per doz. 1/9
Single-valve and 2-valve panels	
Accumulators for Valves	from 16/6
Dutch Concert Coils	per pair 4/6
Inductances wound on formers	4/9
Aerial Wire, 7/22	per 100 ft. 5/9
Microphones with replaceable insets	2/6
H.T. Leads (red and black)	each 4d.
Phones, new (4,000 m.), double	30/-
Ebonite Knobs	each 6d.
Switch Arms, laminated with bush	2/-

Carriage Free on £1 and over.

C. S. SWAN, 191 Bishopsgate,
(NEXT TO BRANDON'S).
and 65 Windsor Road, Leyton, E.10 E.C.2

Coil-Holder. Wireless

The Fraser Patent Coil-holder (Concentric variation). Adaptable for two or three coils. Very compact, and suitable for independent or panel mounting. Price 10/-. Extra coil blocks, 2/9.

SLAB COIL ADAPTER.—Invaluable for use with slab, or basket coils. Standard plug pitch. Fits any coil-holder. 2/6 each.

Condensers (assembled), 0-001, 21/-, parts 18/-.
Condensers (assembled), 0-0005, 13/6, parts 11/-.
Condensers (assembled), 0-0002, 9/-, parts 7/-.
Condenser Spindles, 9d., 10d. 1/2, 1/4.
Condenser Spacers, Large, 9d.; Small, 3d. doz.
Intervalve L.F. Transformers, 16/6.
Ebonite, 3½" × 2¼" × 3/16ths, trimmed suitable for condenser tops, 7d.

Detector Panel, parts, 18/9. With Dulled Ebonite Top.

High Frequency Panel, parts, 23/6. ditto

Low Frequency Panel, parts, 23/6. ditto

Switch Arms, 2/3.

Contact Studs, per doz. 1/6.

Ebonite Knobs, 8d.

Valve Legs, 2 nuts, washer, 3d.

Condenser Vanes, per pair, 2d.

Marconi Phones, H.R., 15 -.

Terminals, each, 3d.

Ebonite Panels, Trimmed, 9" × 4½" × 3/16ths, 2/-.

All other parts at standard prices. Orders of £1, carriage paid.

Revised Price List A. Gratis.

JAMES FRASER & CO.

(In collaboration with Electrical Training College, address below.)

SCHOOL INSTRUCTION.

Day, Evening and Postal Courses in Wireless, Valves, etc., P.M.G. (Exam.) and Amateur Classes. Also Cable and Telegraphy.

Phone, North 1036.

Prospectus Free.

PRINCIPAL:

ELECTRICAL TRAINING COLLEGE,
Radio House, Manor Gardens, Holloway, N.7

PHONES (Pair complete. **30/-** Guaranteed) **CRYSTAL SET 37/6**

Special Wireless Telephones, 4,000 ohms, **30/-** post free. Receiving Set on Mahogany base, single slide Tuning Inductance, Fixed Condenser, Crystal Detector, Terminals, **40/-** post free. Valveholders in Ebonite, first quality only, 1/-. Paris is received quite easily on this set.

I. K. STEVENS & Co. Wireless Section, 32a, Chester St., Grosvenor Place, S.W.1
Trade Inquiries Invited. Phone—Victoria 5837

THE WIRELESS AGE

THE AMERICAN MONTHLY JOURNAL OF WIRELESS TELEGRAPHY AND TELEPHONY

A "Go-a-head" Magazine for Operators and Amateurs.

Sole European Agents: THE WIRELESS PRESS LTD., 12-13 Henrietta St., Strand, London, W.C.2

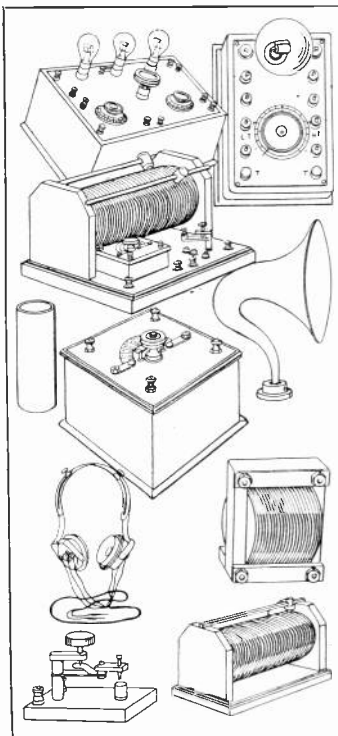

WIRELESS SUPPLIES

ACCESSORIES AND PARTS for Making

Single, Two, Three and Four Valve RECEIVING SETS, CRYSTAL SETS, VALVE PANELS, TUNING PANELS.

Transformers, Inductances, Potentiometers, Condensers, Filament Rheostats, Variable Condensers, Grid Leaks and Condensers, Telephones, Amplifiers and Loud Speakers, Honeycomb Coils and Holders, Basket and Slab Inductances, Crystal Detectors, Cups and Crystals, Valves and Valve Sockets, Aerial Wires and Insulators, H.T. and L.T. Batteries, Instrument Wires, Etc., Etc.

TRADE ONLY
Catalogue A/23 on request

Ward & Goldstone
PENDLETON. MANCHESTER

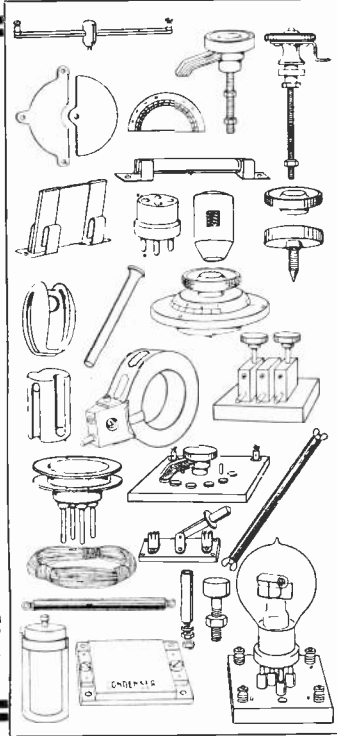

WITH GOOD APPARATUS YOU CAN GET GOOD RESULTS

THE "W.P."

Morse Practice Key

Well Made. First-class Finish. Thoroughly Reliable

Price **7/6** Post Free

THE WIRELESS PRESS, LTD.
12-13 HENRIETTA STREET, LONDON, W.C.2

Questions and Answers COUPON

To accompany Questions sent in during the week commencing Aug. 26th, 1922.

VOL. X, NO. 22.

See Conditions on Page 703.



A NEW THERMIONIC TRIODE!



THE
"E E C"
"XTRAUDION"

PRICE
15/-

ACTUAL

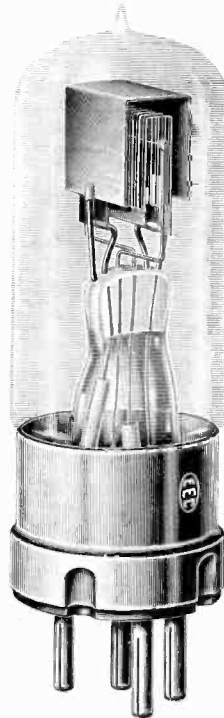

THE
"E E C"
"XTRAUDION"

PRICE
15/-

SIZE

FILAMENT CURRENT—0.5 amperes at 4 volts.

ANODE CURRENT—Anode grid potential 50 volts, + 12 volts, 2.4 milliamperes,
0 volts 0.5 milliamperes, - 12 volts 0 milliamperes.

VACUUM TEST—Anode 150 volts, Grid - 2 volts grid current less than 1 milli-ampere.

THE "E E C" "EXTRAUDION"

Rectifies, Oscillates and Amplifies. Equals any other Triode as a Rectifier or Oscillator, and surpasses all as an Amplifier. Has exceptional mechanical Strength and Rigidity of Electrodes. Is silent working. Has a specially Coloured Glass Container to screen the light rays.

Visit our Stand No. 51. All British Wireless Exhibition, Horticultural Hall, Sept. 30th to Oct. 7th



TRADE ENQUIRIES SOLICITED FROM THE PATENTEES—
ECONOMIC ELECTRIC, LIMITED,
10, FITZROY SQUARE, LONDON, W.1

OR FROM THE SOLE AGENT—

Mr. H. S. TYLER, 23b, Balham Hill, London, S.W.12



WIRELESS TRAINING COLLEGE LTD.

ST. MARY ST., CARDIFF, & NEPTUNE CHAMBERS, VICTORIA ST., BRISTOL.

The above Colleges are amongst the most successful in Great Britain for quickly qualifying Students for the Wireless Service. We have, since the outbreak of War, passed over 1,000 Students to Wireless Appointments. Two Systems are taught, the Marconi and Siemens Quench Spark System. We make a speciality in training ex-service men who have some knowledge of Wireless. ¶ Ex-service men can have a free test to ascertain the time it would take to qualify them if they will call at the College.

For Terms apply to—

LIEUT.-COMDR. J. R. SCHOFIELD, M.B.E., R.N.V.R. (C), Principal.

P.S. Every student who qualified at our Colleges was placed in a permanent situation.

TELEPHONY RECEIVERS

TWO-VALVE RESISTANCE AMPLIFIER.—Will receive all wavelengths from 180 metres to 30,000 metres. Perfect for telephony. Mounted in French polished mahogany cabinet with ebonite top. Perfectly simple, and can be operated by anyone. Finest workmanship and finish.

Every instrument tested and guaranteed to give perfect results.

PRICE — 2-valve £5, 3-valve £6.

One-valve panel. A very superior instrument. Price 28/-. Illustrated Catalogue, 3d., post free

LEWIS POLLARD,

MANUFACTURER OF WIRELESS INSTRUMENTS,

209, Cunliffe Road, BLACKPOOL.

DON'T PAY FOR YOUR SETS

AT TOP PRICES. BUY FROM THE MAKERS & SAVE MONEY

FIXED CONDENSER, 1/6. GRID LEAK, 2/8. TERMINALS, POLISHED AND LACQUERED, 2/6 doz. INDUCTANCE FORMERS, 10½" × 3½". READY FOR WINDING, 10d.

EBONITE SWITCH KNOBS, POLISHED & KNURLED, 4d. VALVE HOLDERS, EBONITE BASE, LACQUERED LEGS, 2/-.

LAMINATED SWITCH ARMS, WITH BUSH & NUTS, 2/9. CRYSTAL DETECTOR, 5/-. CRYSTAL RECEIVER, £2.

L.F. INTERVALVE TRANSFORMER (SILENT), 19/6. INDUCTANCE SWITCHES, 5 STUD, 7/8; 10 STUD, 9/- 19 STUD, 12/6.

AGATE CYLINDER FOR JONSEN-RABECK LOUD SPEAKER, 22/6.

EVLINS Mail Order Office—
126, FOREST ROAD,
DALSTON, LONDON, E.8
Price List Post Free on application. TRADE SUPPLIED.

M.E.C. 62, Crownhill Rd.,
Harlesden,
LONDON, N.W.
Phone: 3370 Willesden

WIRELESS
SPECIALISTS

TRANSFORMERS

FROM
Stock
POST FREE.

L.F. INTERVALVE 21/-
120W TELEPHONE 21/-

SOMETHING NEW

COLOURED HIGH FREQUENCY TRANSFORMERS

Interchangeable type to fit standard valve holders.

These transformers are manufactured from a new insulating material, with equal insulation properties to ebonite, and are supplied in various colours to quickly distinguish the wavelengths. The various coloured transformers will improve the appearance of your receiver and relieve the dull monotony of an ebonite panel. Supplied in white, green, red, amber, and blue.

Unwound formers fitted with split pins,
4/- to 5/6 EACH, postage extra.

The trade supplied.

LEWIS POLLARD,

Manufacturer of Wireless Instruments,

209, CUNLIFFE ROAD, BLACKPOOL.

Three Valve Receiving Panel

First-class Workmanship

Price (minus valves) £5 5 0

HENRY J. BREWSTER & CO.,
11, QUEEN VICTORIA STREET, E.C.4

I HAVE IN STOCK
5000 BROWN'S
PAIRS (120 ohms) "A" PHONES
NEW AND UNISSUED

POST FREE **40/-** PER PAIR
CASH WITH ORDER

WILKINSON, Lonsdale Rd., Kilburn,
TRADE SUPPLIED (Same address since 1900) N.W.6

P. ORMISTON & SONS

(P. H. ORMISTON) :: ESTABLISHED 1793
79 Clerkenwell Rd., London, E.C.1
"Ormiston, London." :: :: 13259 Central.

Silk and Cotton Covered H.C. Copper Wire, Resistance Wires, Fuse Wire, Binding Wires, Charcoal Iron Core Wire, Asbestos Covered Wire, Braided and Twisted Wires, Bare Copper Strand and Flexibles of any Construction, Wire Ropes, and Cords (fine sizes) in Galvanized Steel, Phosphor Bronze, &c.

THE TINGEY UNIT SYSTEM

HAS PROVED ITS EFFICIENCY

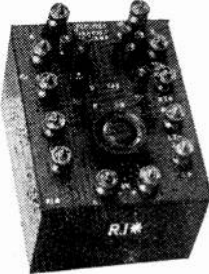

Write for
**ILLUSTRATED
CATALOGUE**
(3d. post free)

which contains an article on
Wireless Made Easy and a
**Complete List of all Wire-
less Goods in Stock**

Visit our Stand No. 25. All
British Wireless Exhibition,
Horticultural Hall, September
30th to October 7th.

W. R. H. TINGEY, 92, Queen Street,
Hammersmith, London, W.6.

WIRELESS



G. TURNOCK, 41 High St. Aston, Bham.

SENSATIONAL REDUCTIONS.

Valve Holders, 2 nuts on each leg. 1/- Post 3d.
Condenser Plates. Fixed or moving. 1/- per doz. Post 3d.
Washers for fixed plates 3d. per doz. For moving 5d. per doz.
Post 2d.
Threaded Rod for Spindles, etc. 5d. per foot. Nuts for same
3d. per doz.
3" Semi-Circular Scales 0-180 degrees. 8d. each. Post 2d.
1 1/2" Ebonite Knobs with threaded centre, 6d. post 2d. Pointers 2d.
Stop-pins 1/- doz. Bush and Lock Nut 5d. Extension Handle 4d.
Valve Legs or Sockets 1/10 per doz. Post 3d. (complete with
screw or nuts.)
Mark III Terminals with nuts 2/3 per doz. Post 4d.
Vernier Condensers, 3-plate 6/-; 5-plate, 7/- Post 9d.
7-Strand Silicon Bronze Aerial Wire, per 100 ft. 4/-; per 150 ft.
5/9. Post 9d.
Filament Resistances for panel mounting 3/9. Post 3d.
These are only a few of the numerous items contained in our
Catalogue which will be sent free with order.

SCIENTIFIC SUPPLY STORES, 8, Newington Causeway,
'Phone—Hop 4177. LONDON, S.E.1

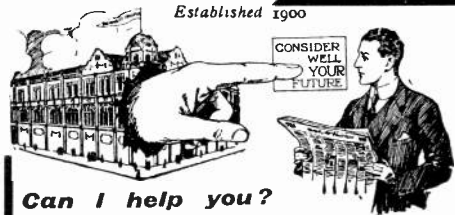

Can I help you?

I WILL GIVE YOU £50

if I fail to produce over 7,000 testimonials from others I have
helped to a successful
career.

Yours to success,

J. W. Bennett

Every man is the Architect of his own Fortune!

**ARE YOU QUALIFIED?
FOR THE JOB YOU SEEK?**

**WE TEACH
BY POST**

ADVICE FREE.
Most moderate charges
payable monthly.

**LEARN A TRADE
OR
PROFESSION.**

Write for one of our **FREE BOOKLETS** on any of the
following subjects:

Architectural Drawing
Building Construction
Clerk of Works' Duties
Aviation
Boiler Engineering
Boiler Making
Chemistry
Civil Engineering
Concrete and Steel
Draughtsmanship
Electricity
Engineering
Foundry Work
Internal Comb. Engines
Marine Engineering
Mathematics

Matriculation
Metallurgy
Mining
Mine Surveying
Motor Engineering
Naval Architecture
Pattern Making
Salesmanship
Sanitation
Shipbuilding
Structural Engineering
Surveying and Levelling
Telegraphy & Telephony
Wireless Telegraphy
Special Course for
Apprentices

What proof do you carry? Your word to an employer is not
proof that you are efficient, but a College Qualifying Diploma or
Certificate, signed by the Professional Staff, is a proof of efficiency, and a
valuable asset in seeking a remunerative position.
We specialise in all exams connected with technical subjects. If you are preparing for any exam, ask our advice. All
particulars **FREE OF CHARGE.** Parents should seek our advice for
their sons. If you are interested in any of the subjects mentioned above,
write, naming the subject, and we will send you our **FREE BOOKLET**

Please
state
your age.
Courses
specially
combined
to meet all
requirements.



North Wales Wireless College & Amateur Supplies

COLWYN BAY.

'Phone 407.

Most Complete Stock of all Wireless
Instruments and Accessories.
PROMPT DELIVERIES.

LIST BY RETURN. 1/4d. STAMP.

Students prepared under ideal conditions as
Wireless and Cable Operators
POSTAL AND RESIDENTIAL TUITION.
SPECIAL POSTAL COURSE FOR AMATEURS.
PROSPECTUS POST FREE.

10/- Carriage Paid	BRASS ROD	10/- Carriage Paid
Each Parcel contains:		
2 feet $\frac{1}{4}$ inch square		2 feet $\frac{1}{4}$ inch round
2 " $\frac{1}{2}$ " round		2 " $\frac{3}{16}$ " "
2 " $\frac{7}{16}$ " "		2 " $\frac{5}{32}$ " "
2 " $\frac{1}{2}$ " "		2 " $\frac{1}{4}$ " "
2 " $\frac{5}{16}$ " "		2 " $\frac{1}{16}$ " "
20 S.W.G. Alum. Condenser Vanes. 1/- doz. Fixed or movable.		
Spacers. Small 3d. per dozen. Large 6d. per dozen.		
(Above are guaranteed to "oor" either way.)		
Valve Legs with Nuts and Washers. 2d. each.		
Copper Foil for Condensers. .002 thick. 6d. foot. 6 inches wide.		
Hexagon Brass Nuts. 4.BA. 4d. dozen. 2.BA. 6d. dozen.		
Screwed Brass Rod. 4.BA. 4d. foot. 2.BA. 6d. foot.		
Trade Enquiries Invited. (Actual Manufacturer).		
SYDNEY S. BIRD, 34, Queen Annes Grove, Bush Hill Park, Enfield, London, N.		
Telephone: ENFIELD 672		



SKINDERVIKEN BUTTON.
A Supersensitive Microphone.
Known all over the world and patented in every civilized country. Over 60,000 sold. ENGLISH Manufacture.
Make up your own Loud Speaker.
Transmit your GRAMOPHONE music to any room in your house.

The only practical Microphone for use in Detectophone Sets.

Price 5/- each

Special Low Resistance Receivers (for use with Skinderviken Buttons) 10/- each
Special Gramophone Attachments 1/- "

Write for 16 page BOOKLET fully illustrated and containing much useful information for all interested in Electrical Sound Transmission. 6d. Post free.

Sole Proprietors:

MIKRO LTD., 274/6, Pentonville Rd., London, N.1
Opp. King's Cross (Met.) Rly Station.

OOJAH
HIGH FREQUENCY TRANSFORMERS.

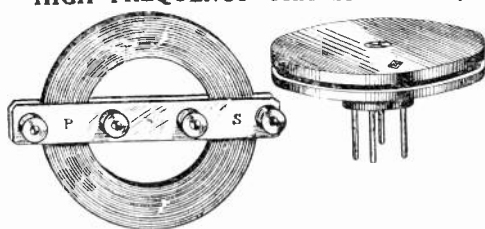

FIG. 1. FIG. 2.

Patent pending Rd. No. 685488.

These H.F. Transformers have been designed to meet the growing demand of the Wireless Experimenter for a cheap and efficient H.F. Transformer.

They were used Successfully in the recent Transatlantic Tests. All Transformers are wound with D.S.C. paraffin-waxed copper wire (affording the highest degree of insulation) of a gauge far thicker than transformers now upon the market; the H.F. resistance being extremely low.

No. 3 is recommended for the reception of the Dutch Concert and general telephony.

	Min. W/L.	Max. W/L.	Un-mounted	Fig. 1.	Fig. 2
No. 1	300	800	1/8	3/9	4/6
No. 2	600	1,400	1/8	4/-	4/6
No. 3	900	1,900	2/8	5/-	5/8
No. 4	1,800	4,000	3/-	5/6	6/-
No. 5	3,000	5,000	4/-	6/6	7/-

Postage extra.

GREENSLADE & BROWN
LANSDOWNE ROAD, CLAPHAM, S.W. 9.

Telephones: Brixton 639.
Brixton 3251.

WAR ON CHINA!

INSULATORS.

Better INSULATION of your AERIAL means LOUDER MUSIC from your RECEIVER.

We are offering at a remarkably low price 20,000 MK. II EBONITE double-hook INSULATORS (as illustration) and we can recommend these for RECEPTION or TRANSMISSION as the best of their kind extant.

They are unbreakable in wear, will last a lifetime, and have been tested to 5,000 Volts.

AS USED BY BROADCASTING STATIONS AND MANY HIGH POWER TRANSMITTING STATIONS.

Size: Length overall, 6 $\frac{1}{2}$ ". Diameter, 1 $\frac{1}{8}$ ".



PRICE: 2/- each. Set of Four 7/6

Special Trade Terms. Post free.

Read what Lieutenant G. S. GOODE, the famous Wireless Expert, says of these insulators.

Messrs. W. Ward & Son, LONDON, W. HINCKLEY.

DEAR SIRS,
I have used the type Mk. II ebonite insulators, precisely as those submitted to me by you, on Transmitting and Receiving Aerials in many different countries under all climatic conditions. Through the intense cold of the Arctic Regions and the heavy rains of the South, I have proved these insulators to be superior to any other kind I have handled. I can strongly recommend everyone using aerials, whether for Transmission or Reception to fix these insulators in preference to any yet available at such a moderate price.

C. S. Goode,
Lieutenant (Tech.) M.W.S.Ldn.

Fit these in place of your present insulators and note the INCREASED EFFICIENCY.

TRANSMITTERS MARCONI MAKE.

Good range using only 6-volt Acc.

SPARK B.MK. II.

λ 100-180 Metres on Aerial.

NEW AND PERFECT

Size 9 $\frac{1}{2}$ " x 6 $\frac{3}{4}$ " x 6 $\frac{1}{4}$ "

Complete with Tools and Spares.

Number limited

3 GUINEAS

Carriage Free.

To W. WARD & SON, Dept. "R" Wireless Engineers, Barclays Chambers, Hinckley.

Please send me post free

Quantity

I enclose P.O., M.O., cheque crossed & Co.

Name & Address

Name of usual Wireless Dealer

Address

————— We are exhibiting at the first —————

ALL - BRITISH WIRELESS EXHIBITION AND CONVENTION

HORTICULTURAL HALL
Vincent Square, Westminster
SEPT. 30th to OCT. 7th
(Saturday) (Saturday)
10 a.m. to 10 p.m. daily

1922

ADMISSION

1/3

INCLUDING TAX

SPECIAL TRADE DAY

OCT. 2nd : 1/3 (including tax)

SPECIAL PUBLIC DAY

OCT. 3rd : 5/- (including tax)

Public admitted on both days after 6 p.m.

*The only Exhibition whose Convention will be held under
the auspices of the Wireless Society of London.*

Auckland, G. Z., & Son.
Automatic Telephone Manfg. Co., Ltd.

Bertram Day & Co., Ltd.
Bower, J. B., & Co., Ltd.
British Thomson-Houston Co., Ltd.
British Wireless Supply Co.
Brown, S. G., Ltd.
Burndept, Ltd.

Chloride Electrical Storage Co., Ltd.
Cossor, A. C., Ltd.
Coomes & Co.

Dubilier Condenser Co. (1921), Ltd.

Elwell, C. F., Ltd.
Econ. Manfg. Co., Ltd.
Economic Electric, Ltd.
Ever Ready Co. (Great Britain), Ltd.
Fellowes Magneto Co., Ltd.

Gamblen & Partners, L. A.
Gambrell Bros., Ltd.
Gamage, A. W., Ltd.
General Radio Co.
Graham, A., & Co.

Harwell, Ltd.
Hart Accumulator Co., Ltd.
Hambling Clapp & Co.
H. P. R. Wireless, Ltd.

Igranic Electric Co., Ltd.
Isted, T. H., Esq.

"K. B." Radio Equipment Co.

Marconi Wireless Telegraph Co., Ltd.
Marconi Scientific Instrument Co., Ltd.
McMichael, L., Ltd.
Metropolitan-Vickers Electrical Co., Ltd.
Mitchell's Electrical & Wireless Ltd.
Mullard Radio Valve Co., Ltd.

Osram G. E. C. Lamp Works.

Pettigrew & Merriman, Ltd.
Peto Scott Co.

Radio Communication Co., Ltd.
Radio Instruments, Ltd.
Radio Service, Ltd.
Radio Press, Ltd.
Rogers, Foster & Howell, Ltd.

Siemens Bros. & Co., Ltd.
Sullivan, H. W., Esq.
Sterling Telephone & Electric Co., Ltd.

Tingey, W. R. H., Esq.
Telephone Manfg. Co., Ltd.

Wates Bros.
Western Electric Co., Ltd.
Wireless Supplies Co.
Wireless Equipment, Ltd.
Wireless Press, Ltd.

Zenith Manfg. Co., Ltd.

ORGANISERS :

BERTRAM DAY & CO., LTD.

WIRELESS PUBLICITY SPECIALISTS

9 and 10, Charing Cross, London, S.W.1

Gerrard 8063/4

IF YOU WANT A
GOOD
BOOK ON RADIOTELEPHONY
GET
TELEPHONY
WITHOUT WIRES

BY
PHILIP R. COURSEY, B.Sc. (ENG.), A.M.I.E.E.

Price **15/-** Nett
(Postage 9d.)

It contains a complete collection of information on the various schemes, proposed and tried, relative to the electrical transmission of the sound of voices through space without wires.

An excellent list of references to papers and articles, forms a complete bibliography of the whole subject.

THE WIRELESS PRESS, LTD.
Dept. W.W. 8/4
12-13, Henrietta St., London, W.C.2

H.F. TRANSFORMERS.
TO FIT VALVE SOCKETS.

No. 0	Range	150 Metres	-	5/6
No. 1	"	300 "	-	6/-
No. 2	"	600 "	-	6/3
No. 3	"	1200 "	-	6/9
No. 4	"	1800 "	-	7/6
No. 5	"	2500 "	-	8/3
No. 6	"	6000 "	-	9/9
No. 7	"	8000 "	-	12/-
No. 8	"	24000 "	-	14/3

There is good latitude on these Coils for higher and lower ranges

H.T. BATTERIES (Fully Guaranteed)

15	Volt strip connection	3/6	post 6d.
15	" 3-terminal type	3/6	" 6d.
15	" Wander plug 3-volt Variation	4/-	" 6d.
36	" " "	7/6	" 1/-
60	" " "	14/6	" 1-
108	" " "	22/6	" 1/3

Fully Illustrated List containing over 100 illustrations, post free 4d.

H. D. BUTLER & CO., LTD.

Office: Bank Buildings, 222, Great Dover Street, BOROUGH, S.E.1 (Opposite Boro Tube Station)
Works: Canonbury, London, N.7
Telephone Hop 3029. Telegrams: Ingenuity. Phone, London.

PETO P-UNITS

Copied but Never Equalled

PETO THE MAN OF PARTS still offers his original productions.

UNIT No. 3.

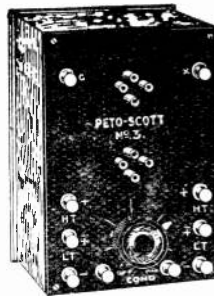

H.F.
AMPLIFYING
UNIT.

Set of Parts 13/6
Cabinet to fit 3/6

UNIT No. 4.

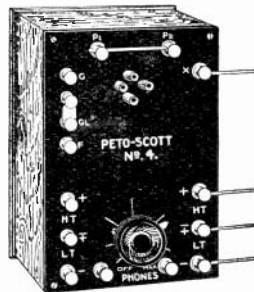

DETECTING
UNIT.

Set of Parts 17/6
Cabinet ... 3/6

UNIT No. 5.



L.F.
AMPLIFYING
UNIT.

Set of Parts 33/6
Cabinet ... 3/6

For Prices of finished Instruments—see Catalogue.

No connections to puzzle over, just push as many units as you can afford, against each other, slip the little rods through and turn a screw, and there you are.

Get our illustrated catalogue post free 6d., with list of transmitting stations and wavelengths.

Visit our Stand No. 15. All British Wireless Exhibition, Horticultural Hall, September 30th to October 7th.

PETO SCOTT, The Condenser King
64, HIGH HOLBORN, LONDON, W.C. 1.
Also at 17, Frome Road, Wood Green.

WIRELESS EXHIBITION

under the auspices of

The South London Wireless and Scientific Club

will be held

On 24th, 25th and 26th August

At ST. JOHN'S INSTITUTE

LARCOM STREET, WALWORTH, S.E. 17

2 minutes' Southwark Town Hall

5 minutes' Elephant & Castle

Open from 2 o'clock to 10.30 Thursday & Friday.

12 o'clock to 10 Saturday.

SPECIAL ATTRACTIONS

**Wireless Controlled Airship in operation
by the inventor,**

CAPT. DE. VILLIERS.

Wireless Controlled Torpedo Boat.

Broadcast Receptions, Numerous Trade and Amateur Exhibits.

Frame Aerial Transmission and Reception.

"Come and Hear Your Own Voice by Radio."

Magnavox and Other Loud Speakers.

Light Refreshment at "Light" Prices.

Sec. : W. G. ANSELL,
69, Larcom Street, S.E.17

Admission 1/-
including tax.

The London Telegraph Training College, Ltd.

Telephone
WESTERN 2696.

Morse House, Earl's Court, S.W.

ESTABLISHED
25 YEARS.

OFFICIALLY RECOGNISED BY THE WAR OFFICE AND POST OFFICE AUTHORITIES

CABLE AND WIRELESS TELEGRAPHY.

PARENTS desirous of placing their sons in either of the above Services and of affording them the best training facilities should apply for particulars of Courses and the methods of instruction which place this Institution in the first rank. **Cable Telegraphy** offers at the present time excellent prospects to youths from 15 years of age and upwards, and **the College has exclusive facilities** for obtaining posts for qualified students in the leading Cable Companies at **commencing salaries** of £150 to £300 per annum, with yearly increments of £12 to £25, and ultimate possibilities of obtaining positions as Supervisors, Assistant Superintendents, Managers, etc.

In the **Wireless Telegraph Service** the commencing remuneration at the present time is approximately £150 per annum, and Operators, when qualified by obtaining the Postmaster-General's Certificate of Proficiency, are nominated by the College for appointments.

No Correspondence Classes or Branches.

DAY AND EVENING CLASSES.

Prospectus containing all information will be forwarded on application to

THE SECRETARY (Dept. H.), 262, Earl's Court Road, Earl's Court, London, S.W.5

Sole Proprietors of the "Scott" Training Disc, which contains useful formulæ and other information for Wireless Telegraph Operators and is invaluable to Army Signalling Officers for range finding, etc.

Price, complete with instructions for use, 1/- Postage 2d.

The YEAR BOOK of WIRELESS Telegraphy and Telephony 1922

1476 Pages.

Price 15/- Nett.

Demy, 8vo.

Postage 1/-.

Abroad 1/4.

CONTENTS

Record of the Development of Wireless Telegraphy—National and International Wireless Laws and Regulations—Directory of the World's Land and Ship Wireless Stations—International Allocation of Call Letters—Alphabetical List of Call Letters—Meteorological Section—International Time and Weather Signals—National Résumés of Progress in Wireless Telegraphy—Particulars of Wireless Telegraph Patents, 1921—Aviation Section—Tabular List of Aviation Stations—Useful Data Section—Wireless Terminology—Conventional Signs used in Wireless Diagrams—Companies Engaged in the Commercial Development of Wireless Telegraphy—Biographical Section—Literature on Wireless Telegraphy and Telephony—Directory of the World's Wireless Societies—Directory of Wireless Colleges and Schools—List of Licensed Amateur Transmitting Stations—Code Section—Special Articles on "The Earthing Resistance of Antennæ," by Dr. Miessner—"The Recording of Wireless Signals," by Dr. Abraham—"The Birth and History of Long Distance Wireless Telegraphy"—"The Rectification Effect in its Reaction to the Composition and Structure of Crystals."

A valuable feature of the present issue is the specially drawn map, which gives, for the first time, a simple means of finding the distance and true direction of Wireless Stations in all parts of the World, from London as the centre.

THE WIRELESS PRESS, LIMITED,

DEPT. W.W., 12-13 HENRIETTA
ST., STRAND, LONDON, W.C.2

BROADCASTING

Sullivan Patent Telephone Receivers for Radio Telephony and Telegraphy

Of High and Uniform sensitivity and DISTORTION-LESS being thus specially adapted for receiving speeches, news and concerts from BROADCASTING and other stations.

WINDINGS highly insulated, durable and reliable in all climates and under all conditions of service. This was strikingly evidenced during the Great War when a vessel carrying "SULLIVAN" phones shipped to the order of an Allied Government was sunk through misadventure, but at a later date was successfully raised and the cargo salvaged. The Telephones themselves were found to have sustained much damage through the action of sea water, but the coils proved to be perfect electrically and mechanically notwithstanding their long immersion, and all were again brought into requisition.

IMPORTANT NOTICE

These Telephone Receivers must not be confused with the old and comparatively insensitive "SULLIVAN" phones, sold by the Disposals Board and still being retailed by certain dealers, nor with those new but comparatively insensitive Radio Telephone Receivers of Continental and other origin bearing a misleading resemblance to my own pattern.

White Metal Headbands supplied if desired.

Visit our Stand No. 49. All-British Wireless Exhibition, Horticultural Hall, September 30th to October 7th

DEMONSTRATION AND SHOWROOMS:

Liverpool House, Middlesex Street,
London, E.1

(Two minutes' walk from Liverpool Street and Broad
Street Stations).

Without public advertisement of any kind, over one quarter of a million sets of "SULLIVAN" phones have been made and sold for "Wireless" alone.

Trade Terms on Application.

<p><i>Works.</i> "LIVERPOOL HOUSE" MIDDLESEX ST., LONDON, E.1 Phone: Avenue 4871</p>	<p>H.W. SULLIVAN</p> <p>TELEGRAMS: "DEADBEAT, STOCK, LONDON."</p>	<p><i>Offices.</i> WINCHESTER HOUSE LONDON, E.C.2., ENGLAND Phone: London Wall 3518</p>
--	--	---

