

ELECTRONICS WORLD

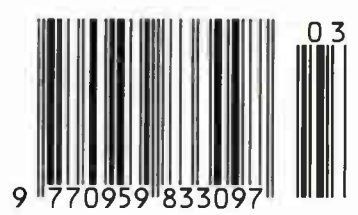

MARCH 2003 £3.25

EMC - A fatally flawed discipline?

Audio power amp frequency compensation



Modern impedance measurement techniques IV

Fourier synthesis

Circuit ideas:
Vision matrix
'return-to-n' circuit
Speaker crossover
network

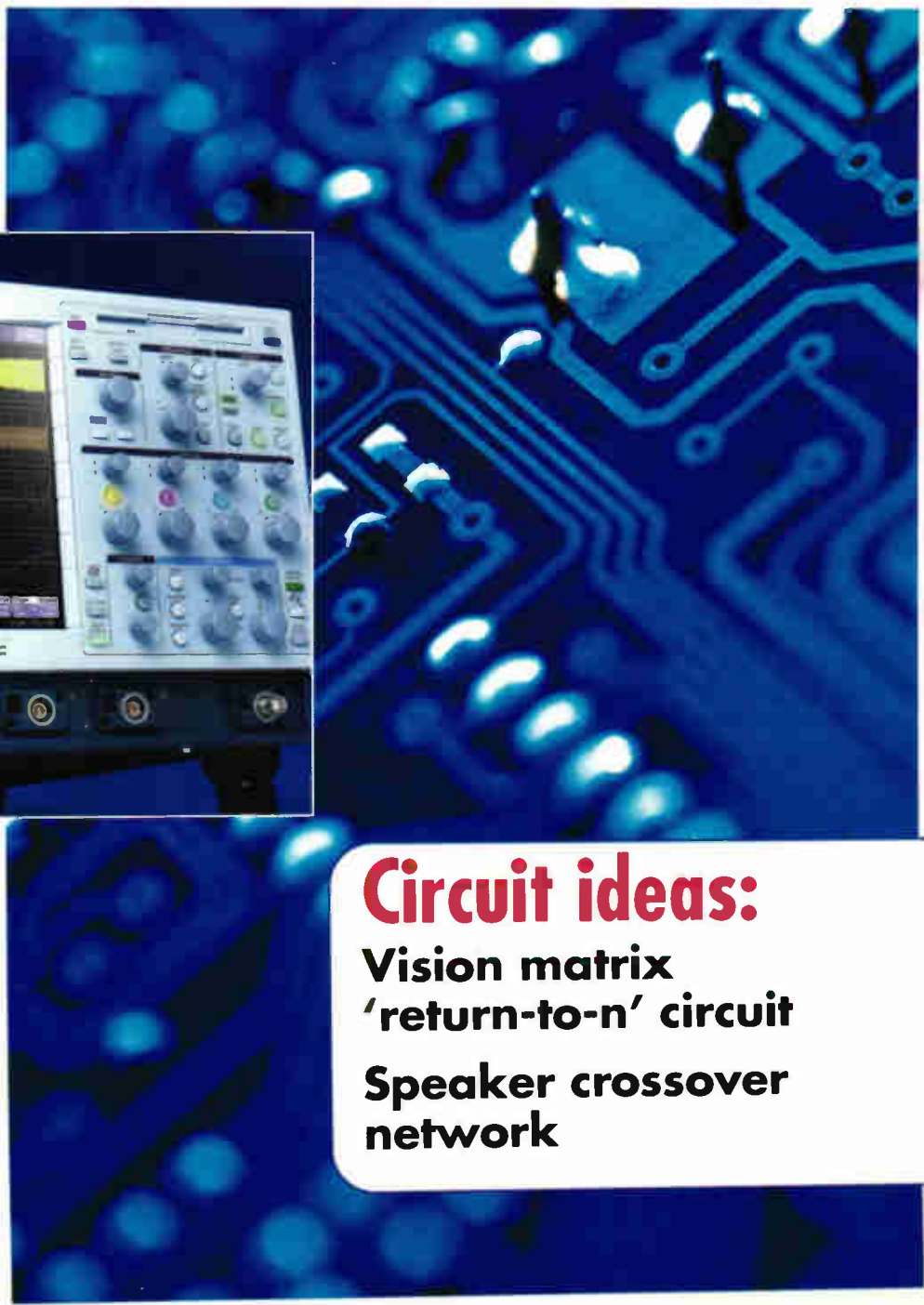

Telnet

Quality second-user test & measurement equipment

**WE ARE MOVING TO NEW PREMISES
(AS FROM 21ST JANUARY 2003)
TO THE FOLLOWING ADDRESS:-**

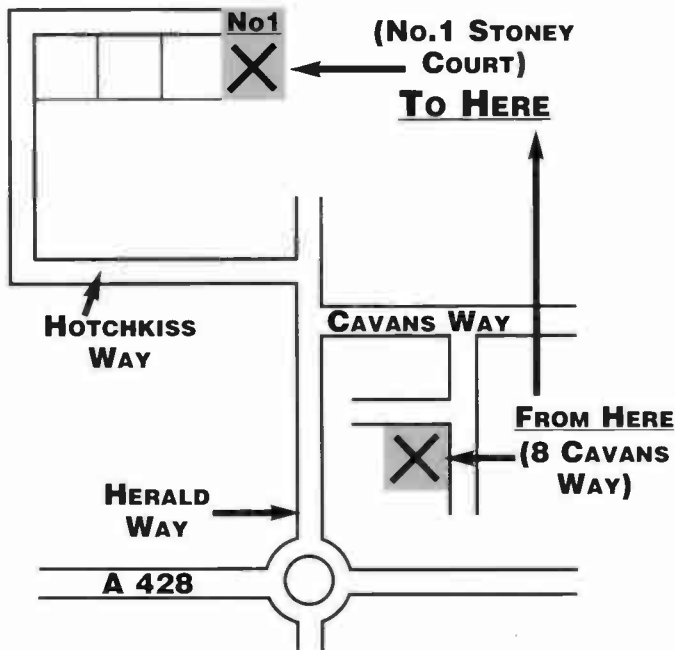

**1 STONEY COURT,
HOTCHKISS WAY,
BINLEY INDUSTRIAL ESTATE,
COVENTRY
CV3 2RL, ENGLAND.**

**THE TELEPHONE/FAX NUMBERS
WILL REMAIN THE SAME.**

Hewlett Packard 3314A Function Generator 20MHz	£1250
Hewlett Packard 3324A synth. function/sweep gen. (21MHz)	£2250
Hewlett Packard 3325B Synthesised Function Generator	£3250
Hewlett Packard 3326A Two-Channel Synthesiser	£3000
H.P. 4191A R/F Imp. Analyser (1GHz)	£4995
H.P. 4192A L.F. Imp. Analyser (13MHz)	£4000
Hewlett Packard 4193A Vector Impedance Meter (4-110MHz)	£3000
Hewlett Packard 4278A 1kHz/1MHz Capacitance Meter	£3750
H.P. 53310A Mod. Domain Analyser (opt 1/31)	£6750
Hewlett Packard 8349B (2 - 20 GHz) Microwave Amplifier	£2500
Hewlett Packard 8904A Multifunction Synthesiser (opt 2+4)	£1950
H.P. ESG-D3000A 3GHz Signal Gen	£6995
Marconi 6310 - Prog'ble Sweep gen. (2 to 20GHz) - new	£2500
Marconi 2032 10KHz-5.4GHz Sig. Gen.	£6995
Marconi 6311 Prog'ble sig. gen. (10MHz to 20GHz)	£2995
Marconi 6313 Prog'ble sig. gen. (10MHz to 26.5GHz)	£3750
R&S SMG (0.1-1GHz) Sig. Generator (opts B1+2)	£2750
Fluke 5700A Multifunction Calibrator	£12500
Fluke 5800A Oscilloscope Calibrator	£9995
H.P. 3458A DMM (8.5 digits)	£3750
Tek 371A Programmable Curve Tracer	£15000

MISCELLANEOUS

Ballantine 1620A 100Amp Transconductance Amplifier	£1750
EIP 545 Microwave Frequency Counter (18GHz)	£1000
EIP 548A and B 26.5GHz Frequency Counter	from £1500
EIP 575 Source Locking Freq. Counter (18GHz)	£1200
EIP 585 Pulse Freq. Counter (18GHz)	£1200
Fluke 6060A and B Signal Gen. 10kHz - 1050MHz	£1250
Genrad 1657/1658/1693 LCR meters	from £500
Gigatronics 8541C Power Meter + 80350A Peak Power Sensor	£1495
Gigatronics 8542C Dual Power Meter + 2 sensors 80401A	£1995
Hewlett Packard 339A Distortion measuring set	£750
Hewlett Packard 436A power meter and sensor (various)	from £750
Hewlett Packard 438A power meter - dual channel	£2000
Hewlett Packard 3335A - synthesiser (200Hz-81MHz)	£1995
Hewlett Packard 3457A multimeter 6 1/2 digit	£850
Hewlett Packard 3784A - Digital Transmission Analyser	£3750
Hewlett Packard 37900D - Signalling test set	£2950

Hewlett Packard 34401A Multimeter	£450
Hewlett Packard 4274A LCR Meter	£2000
Hewlett Packard 4276A LCZ Meter (100MHz-20KHz)	£1400
Hewlett Packard 5342A Microwave Freq. Counter (18GHz)	£850
Hewlett Packard 5350B 20KHz Microwave Freq. Counter	£2000
Hewlett Packard 5385A - 1 GHz Frequency counter	£495
Hewlett Packard 6033A - Autoranging System PSU (20v-30a)	£750
Hewlett Packard 6060A and B Electronic Load 300W	from £750
Hewlett Packard 6622A - Dual OIP system p.s.u	£1250
Hewlett Packard 6624A - Quad Output Power Supply	£2000
Hewlett Packard 6632A - System Power Supply (20v-5A)	£695
Hewlett Packard 8350B - Sweep Generator Mainframe	£1500
Hewlett Packard 8642A - high performance R/F synthesiser (0.1-1050MHz)	£2500
Hewlett Packard 8656A - Synthesised signal generator	£750
Hewlett Packard 8656B - Synthesised signal generator	£995
Hewlett Packard 8657A - Synth. signal gen. (0.1-1040MHz)	£1500
Hewlett Packard 8657B - 100MHz Sig Gen - 2060 MHz	£3950
Hewlett Packard 8657D - XX DQPSK Sig Gen	£3950
Hewlett Packard 8901B - Modulation Analyser	£2250
Hewlett Packard 8903A - B and E - Distortion Analyser	from £1000
Hewlett Packard 11729B/C Carrier Noise Test Set	from £2500
Hewlett Packard 53131A Universal Frequency counter (3GHz)	£850
Hewlett Packard 85024A High Frequency Probe	£1000
Keithley 228A Prog'ble Voltage/Current Source IEEE.	£2000
Keithley 237 High Voltage - Source Measure Unit	£4500
Keithley 238 High Current - Source Measure Unit	£4500
Keithley 486/487 Picoammeter (+volt.source)	£1350/£1850
Keithley 8006 Component Test Fixture	£1750
Marconi 2840A 2 Mbit/s Transmission Analyser	£1100
Marconi 6950/6960/6960A/6970A Power Meters & Sensors	from £400
Philips 5515 - TN - Colour TV pattern generator	£1400
Philips PM 5193 - 50 MHz Function generator	£1350
Philips PM 6654C System Timer Counter	£750
Sig. Gen. (100KHz-140MHz) AM/FM/CW	as new £650
Rohde & Schwarz FAM (opts 2,6 and 8) Modulation Analyser	£3750
Rohde & Schwarz NRV/NRVD Power meters with sensors	from £1000
Schlumberger 1250 Frequency Response Analyser	£2250
Tektronix 1720 Vectorscope	£1150
Tektronix 1735 Waveform Monitor	£1150
Tektronix AM503 - AM503A - AM503B Current Amp's with M/F and probe	from £800
Wavetek 178 Function generator (50MHz)	£750
Wayne Kerr 3245 - Precision Inductance Analyser	£1850
Bias unit 3220 and 3225L Cal.Coil available if required.	(P.O.A)
Wayne Kerr 3260A + 3265A Precision Magnetics Analyser with Bias Unit	£5500
Wayne Kerr 6245 - Precision Component Analyser	£2250
W&G PCM-4 PCM Channel measuring set	£3750

All equipment is used - with 30 days guarantee and 90 days in some cases
Add carriage and VAT to all goods.
Telnet, 8 Cavans Way, Binley Industrial Estate,
Coventry CV3 2SF.

Tel: 02476 650 702
Fax: 02476 650 773
Web: www.telnet.uk.com
Email: sales@telnet.uk.com

CONTENTS

MARCH 2003

VOLUME 109

NUMBER 1803

3 COMMENT

Mr.Catt returns

5 News

- Magnets look fractal
- Xerox develops air-stable conductive polymer
- Data transfer broken



- Bluetooth hits the highways
- Lords call for centre of excellence
- Oxford PCBs are finer



- Carbon makes contact
- Government to simplify patent law
- Research yields 6nm Mosfets
- Bipolar process from Swindon
- Hotrod heat pipe from Sandia

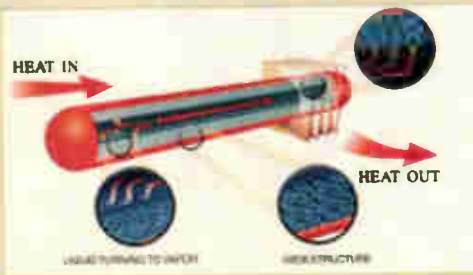

10 Audio power amplifier frequency compensation

John Ellis discusses the pros and cons of the Miller capacitor

19 Letters

- Education system to blame?
- Shrinking Horizons
- Capacitor Sounds
- No Conspiracy
- Identity Crisis
- Air Traffic Control
- Mobile phones and radiation

25 New products

The month's top new products.

34 Circuit ideas

- Cheaper crossover filter
- Vision Matrix 'return-to-n' circuit
- Keyboard saving I/O line

40 FM frequency synthesizer

Michael Slifkin and **Shai Ben-Naeh** take us through a practical circuit

44 EMC - A fatally flawed discipline?

Ivor Catt takes a pot shot at the EMC community

48 Fourier Synthesis

Leslie Green defeats the Gibbs phenomenon

52 Modern impedance techniques

Alan Bate concludes his plot to kill off the old-fashioned bridge.

60 Web directions

Useful web addresses for electronics engineers.

Next issue, dated April on sale March 6th



THE IEC 320 CONNECTION



CALL OUR SALES HOTLINE
020 8905 7273

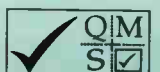

24 HOUR DELIVERY SERVICE

ISO 9002 REGISTERED FIRM

GB 1907

OLSON ELECTRONICS LIMITED
OLSON HOUSE, 490 HONEYPOT LANE, STANMORE, MIDDX HA7 1JX
TEL: 020 8905 7273 FAX: 020 8952 1232

e-mail: sales@olson.co.uk web site: http://www.olson.co.uk

EDITOR**Phil Reed****p.reed@highburybiz.com****CONSULTANT****Ian Hickman****CONTRIBUTING EDITOR****Martin Eccles****EDITORIAL ADMINISTRATION****Jackie Lowe****020 8722 6054****EDITORIAL E-MAILS****j.lowe@highburybiz.com****GROUP SALES****Reuben Gurunlian****020 8722 6028****ADVERTISEMENT****E-MAILS****r.gurunlian@highburybiz.com****EDITORIAL FAX****020 8722 6098****CLASSIFIED FAX****020 8722 6096****PUBLISHING DIRECTOR****Tony Greville****MANAGING DIRECTOR****Roy Greenslade****ISSN 0959-8332****SUBSCRIPTION QUERIES****Tel (0) 1353 654431****Fax (0) 1353 654400****Disclaimer**

We work hard to ensure that the information presented in *Electronics World* is accurate. However, *Electronics World's* publisher - Highbury Business Communications - will not take responsibility for any injury or loss of earnings that may result from applying information presented in the magazine. It is your responsibility to familiarise yourself with the laws relating to dealing with your customers and suppliers, and with safety practices relating to working with electrical/electronic circuitry - particularly as regards electric shock, fire hazards and explosions.

Mr. Catt returns

I've had quite a bit of correspondence in the last few months enquiring as to the whereabouts of Ivor Catt. Well, I am pleased to report that he is safe and well and living north of London. He still has some very clever ideas and is as anti-establishment as ever. This month, I offer readers his take on the EMC community and I am sure that his article will ensure a swelling mailbag, judging by some of his remarks. As always, your comments on this and any other issues raised in *EW* are always welcome and as regular readers know, your comments both good and bad will get published if they are deemed worthy. And for your information, there are very few letters that get binned or severely edited, as I think it important that your comments are given the space they deserve.

This month's issue (I think) is fairly balanced with items that I know are close to your hearts. For the audio buffs, John Ellis

discusses the Miller capacitor and offers some design solutions, whilst the RF officiantos, we have a practical FM frequency synthesizer. For those who like serious equations, Fourier synthesis is discussed in great detail by Leslie Green and Alan Bate concludes his thoughts on impedance measuring.

Despite some heavyweight analysis that reckons we'll all be bouncing back in 2003, the short term still looks pretty bleak from where we are. They reckon the recovery will be fuelled by wireless handsets, wireless LANs and an increase in consumer electronics spending. I think that we still have a way to go in the downwards direction before we turn the corner. And kicking the guts out of a pretty defenceless middle eastern country, although good for the military electronics industries, will not do most of the rest of us much good. Thank you Mr. Bush.

Phil Reed

Electronics World is published monthly. Orders, payments and general correspondence to **Jackie Lowe, Highbury Business Communications, Anne Boleyn House, 9-13 Ewell Road, Cheam, Surrey, SM3 8BZ.**

Newstrade: Distributed by COMAG, Tavistock Road, West Drayton, Middlesex, UB7 7QE Tel 01895 444055.

Subscriptions: Wyvern Subscription

Services, Link House, 8 Bartholomew's Walk, Ely Cambridge, CB7 4ZD.

Telephone 01353 654431. Please notify change of address.

Subscription rates

1 year UK £38.95 O/S £64.50
US\$100.62 Euro 102.55

Overseas advertising agents: France and Belgium: Pierre Mussard, 18-20 Place de la Madeleine, Paris 75008. United States of America: Roy Barnes, Reed Business

Publishing Ltd, 475 Park Avenue South, 2nd Fl New York, NY 10016 Tel; (212) 679 8888 Fax; (212) 679 9455

USA mailing agents: Mercury Airfreight International Ltd Inc, 10(b) Englehard Ave, Avenel NJ 07001. Periodicals Postage Paid at Rahway NJ Postmaster. Send address changes to above.

Printed by Polestar (Colchester) Ltd, **Filmsetting by** G&E 2000

A1 Parkway, Southgate Way, Orton Southgate, Peterborough, PE2 6YN



HIGHBURY
Business Communications

A SUBSIDIARY OF HIGHBURY HOUSE COMMUNICATIONS PLC



Quasar Electronics Limited
PO Box 6935
Bishops' Stortford, CM23 4WP
Tel: 0870 246 1826
Fax: 0870 460 1045
E-mail: sales@quasarelectronics.com

Add £2.00 P&P to all UK orders. 1st class recorded - £4.
Next day (Insured £250) - £7. Europe - £5. Rest of World - £10.
We accept all major credit/debit cards. Make cheques/PO's payable to Quasar Electronics. Prices include 17.5% VAT.
MAIL ORDER ONLY.
Free catalogue with order or send 2 x 1st class stamps (refundable) for details of over 200 kits and publications.



QUASAR 0871 CREDIT CARD SALES 717 7168
electronics

Controllers & Loggers

The I/O Module and the Call Logger include plastic cases and don't need to be attached to a computer during operation. Complete documentation available from our web site.

Rolling Code 4-Channel UHF Remote

State-of-the-Art. High security. 4 channels. Momentary or latching relay output. Range up to 40m. Up to 15 Tx's can be learnt by one Rx (kit includes one Tx but more available separately). 4 indicator LED's. Rx: PCB 77x85mm, 12VDC/6mA (standby)
Kit Order Code: 3180KT - £41.95
Assembled Order Code: AS3180 - £49.95



Computer Temperature Data Logger

4-channel temperature logger for PC serial port. Deg. C or F. Allows continuous logging of 4 separate sensors located 200m+ from board. Wide range of free software applications for storing/using data. PCB just 38x38mm. Powered by PC. Includes one DS1820 sensor and four detachable header cables.
Kit Order Code: 3145KT - £23.95
Assembled Order Code: AS3164 - £29.95
Additional DS1820 Sensors - £3.95 each



Telephone Call Logger

Stores over 2,800 x 10 digit DTMF numbers. Records all buttons pressed during a call. The time and date also recorded. No need for any connection to a PC during operation but logged data can be downloaded into a PC via a serial port and saved to disk. Includes a plastic case 130x100x30mm. 9-12VDC.
Kit Order Code: 3164KT - £54.95
Assembled Order Code: AS3164 - £59.95



Serial Isolated I/O Module

PC controlled 8-Relay Board. 115/250V relay outputs and 4 isolated digital inputs. Useful in a variety of control and sensing applications. Uses PC serial port for programming (using simple text batch files). Once programmed unit can operate without PC. Includes plastic case 130x100x30mm. Power: 12VDC/500mA.
Kit Order Code: 3108KT - £54.95
Assembled Order Code: AS3108 - £64.95



Infrared RC Relay Board

12-channel relay board. Each relay individually controlled with included infrared remote control unit. Toggle or momentary. Over 15m range. PCB: 112 x 122mm. Power: 12VDC/500mA
Kit Order Code: 3142KT - £44.95
Assembled Order Code: AS3142 - £64.95



PIC & ATMEL Programmers

We have a wide range of low cost PIC and ATMEL Programmers. Complete range and documentation available from our web site.

Programmer Accessories:
40-pin Wide ZIF socket (ZIF40W) £15.00
Power supply (PSU201) £5.95
Parallel Cable (CSLEAD108) £4.95

Enhanced "PICALL" ISP PIC Programmer

Will program virtually ALL 8 to 40 pin PICs plus certain ATMEL AVR, SCENIX SX and EEPROM 24C devices. Also supports In System Programming (ISP) for PIC and ATMEL AVRs. Free software. Blank chip auto detect for super fast bulk programming. Requires a 40-pin wide ZIF socket (not inc.)
Kit Order Code: 3144KT - £59.95
Assembled Order Code: AS3144 - £64.95



ATMEL 89xxx Programmer

Uses PC serial port. No special programming software required. 4 LED's display the status. ZIF sockets not included. 16VDC.
Kit Order Code: 3123KT - £29.95
Assembled Order Code: AS3123 - £39.95



P16Pro PIC Programmer

Super low cost programmer for 8/18/28/40 pin DIP serial PICs including 16F84 & 12C508. Software needs to be registered @ £20.95. 17-30VDC or 13-20VAC
Kit Order Code: 3096KT - £10.95
Assembled Order Code: AS3096 - £15.95



ATMEL AVR Programmer

Programmer for 20 and 40 pin DIP (AT90Sxxx) "AVR" micro controllers. Uses PC serial port. No special software required. ZIF sockets not incl. 16VDC.
Kit Order Code: 3122KT - £24.95
Assembled Order Code: AS3122 - £29.95

Timers & Counters

These modules use a microcontroller and crystal for accurate and low-cost. 4 digit 14mm LED display used on all but 3141.

Presetable Down Counter

Starting count can be set. The 4-digit counter has four modes to control how the output behaves when it reaches zero. Max count rate of 30/sec or 30,000/sec. PCB: 51x64mm. 9-12VDC.
Kit Order Code: 3154KT - £13.95
Assembled Order Code: AS3154 - £22.95

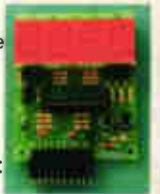

4-Digit Timing Module

The firmware included with this motherboard kit is a programmable down timer of 10,000 sec. Timing accuracy: 0.04%. PCB: 51x64mm. 9-12VDC Current: 50mA. 5 other firmware chips can be used with this motherboard. Each has a different timing mode and can be purchased as a pack.
Kit Order Code: 3148KT - £9.95
Assembled Order Code: AS3148 - £18.95
5 Piece Firmware Pack: F3148 - £14.95



Multi Mode Universal Timer

Seven different timing modes in one! Modes and delay ranges are set by DIP switches. Timing delays range between 255sec (1sec steps) and 42.5h (10min steps) Mains rated relay output. PCB: 48x96mm. 12VDC
Kit Order Code: 3141KT - £14.95
Assembled Order Code: AS3141 - £21.95



4-Digit Up/Down Counter

Count range is from 0000, 1, 2... to 9999. It can also count down. Maximum count rate of about 30 counts per second. Two counters can be connected together to make an 8-digit counter. PCB: 51x64mm. 9-15VDC.
Kit Order Code: 3129KT - £13.95
Assembled Order Code: AS3141 - £22.95



Most items are available in kit form (KT suffix) or assembled and ready for use (AS prefix).



www.quasarelectronics.com

Secure Online Ordering Facilities • Full Product Listing, Descriptions & Photos • Kit Documentation & Software Downloads

Data transfer record broken by 6Pbyte tape store

The San Diego Supercomputer Center (SDSC) at the University of California has beaten the world record for data transfer from a tape store, claims the centre.

Its huge, updated tape storage system can now transfer data at 828Mbyte/s.

"Nobody in academia has such a fast data archive system," said Phil Andrews, program director at SDSC.

Data sets in scientific disciplines from anatomy and astronomy, to climatology and particle physics have grown over the past decade, from megabytes to gigabytes, to terabytes, said the centre. SDSC holds the 10Tbyte Digital Sky astronomy project and some data sets now exceed one petabyte.

The tape store, which can hold 6Pbyte, is housed in five silos where robots pick 200Gbyte tapes from racks and insert them into one of 24 30Mbyte/s StorageTek tape drives. This rate is roughly doubled by data compression.

From the silos, data is fed through a new data routing system to San Diego's 1.7Tflops IBM Blue Horizon supercomputer. "The combined effect the new technology has been a



reduction - from days to hours - in the transfer of multi-terabyte data sets from the tape store," said the centre.

Between tape store and computer is a disc-based storage area network from Sun which allows multiple computers to share data and is due to be updated from 50 to 500Tbyte by the end of this year.

TeraGrid

The US National Science Foundation is putting \$88m into 'TeraGrid' which, when it comes on stream this year, will be the largest, fastest, distributed infrastructure for open scientific research, claims the San Diego Supercomputer Center.

When completed it will include more than 20Tflops of distributed computing power, nearly one petabyte of disk storage and San Diego's 6Pbyte of tape capacity.

San Diego, together with the University of Illinois, California Institute of Technology, Argonne National Laboratory, and the Pittsburgh Supercomputing Center, will be connected through a 40Gbit/s network.

Magnets look fractal

Theorists at the Ohio State University suggest magnetic fields can take the form of fractals, if a magnet is made of plastic molecules that are stacked in parallel chains.

Professor Arthur Epstein was modelling magnets for future electronic structures that are so small the magnets no longer behave like three-dimensional objects.

"The materials currently used in magnetic devices - for example, hard discs or credit cards - behave like three-dimensional magnets," explained Epstein. "However, the decreasing size of these devices may one day require them to be considered one- or two-dimensional in nature. As the spatial dimensions decrease, the magnetic dimensions of the materials may take on fractal values."

The model was of a compound of

manganese tetraphenylporphyrin and tetracyanoethylene, which can form polymer chains that are one-dimensional.

It showed that, as the material was magnetized by an external magnetic field and cooled, it began to behave as a special kind of glass.

At -267°C the magnetic field existed in 0.8 dimensions. Cooled further, it passed through one dimension and finally settled at 1.6 dimensions at -269°C.

"Many magnetic fields sprouted out from the material like branches of a cactus. Tiny secondary magnetic fields then sprang out from the branches," said the university. Interlocking fractal growth gave the magnetic field a unique kind of order, said Epstein who has named the material 'fractal cluster glass'.

Electronics in Shannon still growing

Based in the Shannon Free Zone, Beta LAYOUT recently welcomed their 10,000th customer to the Shannon Facility.

On placing the 10,000 order, the customer became the grand prize winner. Based in Germany, Mr. Matthias Mayer is involved with a company who specialise in electronic measuring devices. Managing Director of Beta LAYOUT, Elizabeth Nolan, had this to say "Mr Meyer represents our profile customer. He is working in a small, but highly technical research and development company. We are delighted to offer this to such a valued customer."

Xerox develops air-stable conductive polymer

Canadian researchers have made a conductive organic polymer that is stable in air and can be printed into circuits on flexible plastic substrates using inkjet techniques. By combining many of the properties necessary for large-area electronics in

an organic material that can be processed under ambient conditions, low-cost devices could be possible.

"Transistors can be made 150µm across, suitable for displays of almost 1,200dpi," said Beng Ong, the leader of the group at Xerox Research Center Canada in Ontario. Ong presented the work in a paper entitled 'High-performing semiconductor polymer designs for field-effect transistors' at the autumn meeting of the Materials Research Society in Boston in December.

Ong's material is a second-generation smectic liquid crystal, built via self-assembly. Chemically, it is a member of the polythiophenes, a group of unsaturated, sulphur-containing compounds that have been the subject of research into organic electronics for a number of years.

Ong's version has a field effect transistor mobility of up to 0.12cm²/Vs, up to an order of magnitude greater than other polymers measured in the same device architecture. It has a switching speed similar to that of the amorphous silicon already used in displays, and its ratio of electric conductivity in the on and off states is high - currently between 10⁶ and 10⁷.

It also has good bias stress.

Ong said the material's development involved identifying the structural features in existing polymer materials responsible for limitations such as air-sensitivity, then designing a synthesis.

Xerox's polymeric electronics research is being carried out at XRCC and the company's Palo Alto Research Center, with help from Motorola Labs and Dow Chemical. Xerox is aiming to develop materials suitable for large-area electronic devices that could be printed onto flexible substrates, perhaps using cheap, high volume roll-to-roll processing. It is also developing processes to print complete active matrix arrays.

In the UK the field of polymer electronics is being led by Professor Richard Friend's firms Cambridge Display Technology and Plastic Logic. CDT recently acquired Oxford-based Opsys, which has developed promising light-emitting dendrimer chemistry.

Dendrimers are middle-weight molecules with chemically adjustable properties that combine the solution-processability of polymers with the design flexibility of small molecules.

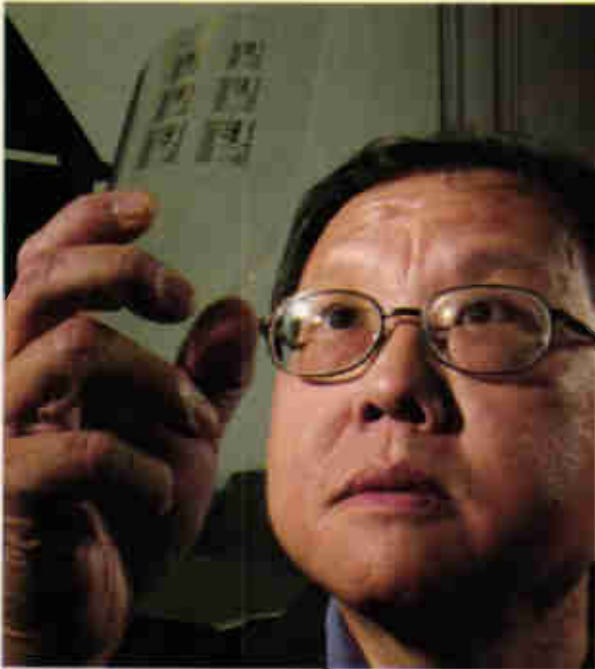

Bluetooth hits the highway

Motorcycle helmet company Momo and Motorola have teamed up to design a Bluetooth-enabled helmet to allow bike riders to use personal audio and mobiles without removing their headgear. It is currently just a concept and may be available in the shops subject to demand, said Motorola.



A complete reference design for 10/100BaseT Ethernet has been fitted into a board measuring just 35 x 29 x 7.4mm. Developed by Rabbit Semiconductor, the board combines an 8-bit processor with flash, SRAM, decoder, PWM outputs and five serial ports, and is the first of the company's cores to include analogue. The RCM3400's processor runs at 29.4MHz. The clock has a spectrum spreading feature that the firm said will reduce electromagnetic interference.

The board is designed to mount on a user's existing motherboard. It is priced at \$39 in 1,000 unit quantities, while a development kit costs \$399.

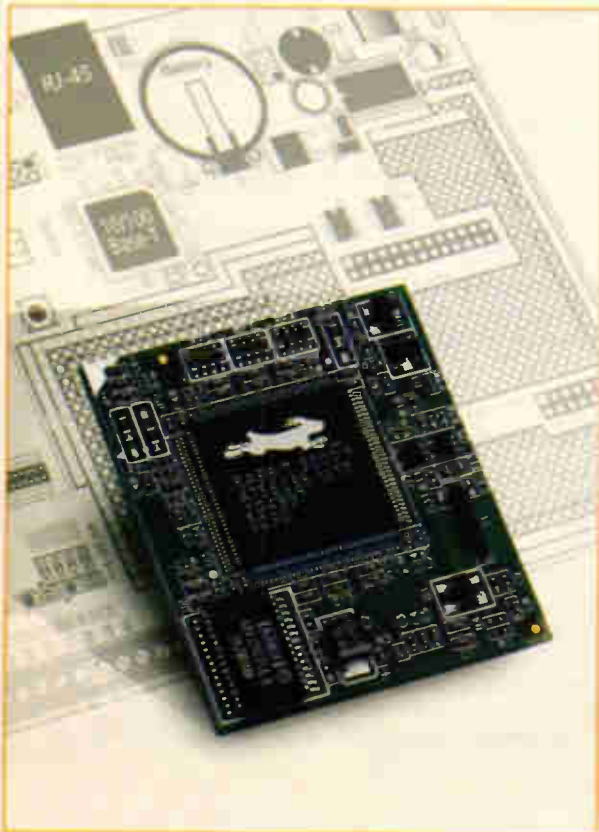

Lords call for centre of excellence

A House of Lords report on the UK's electronics industry has concluded the country needs a national centre of excellence to maintain our world standing.

Britain's leadership in microprocessor architectures and system-on-chip design can only be maintained through such a centre, the Chips for Everything report argues.

"The research we are developing could be of vast advantage," said Lord Wade of Chorlton, chairman of the House of Lords Science and Technology Committee. "There is an opportunity for the UK to take a more important role in the future."

However, the country's R&D should focus less on chip manufacturing technology, such as CMOS, but more on innovative design.

Lord Wade argued chip manufacturing is too expensive and risky, especially considering a fab plant can cost upwards of £1bn.

"Current research funding is the

wrong way around," he said. Lots of funding goes into CMOS, but that doesn't bring back revenue into the UK, as we have almost no CMOS manufacturing.

"In embedded design we are already leading the field. We need to fund research and help commercialise the technology," he pointed out.

Backing research into intellectual property, algorithm development and architecture development would give a better return for the Government's money, along with alternatives to CMOS, such as III-V semiconductors.

"We also need to make non-London research more accessible to venture capitalists, especially at the early stage."

A national centre would bring technology developers into contact with the venture capital firms and

legal people needed in company development.

"There are clear opportunities here - a lot of excellent work is being carried out," said Lord Wade.

During the nine month writing of the Lords' report, the sub-committee visited places as far afield as Silicon Valley.

Lord Wade was impressed with overseas centres such as IMEC in Belgium, which started with government money, but now receives a good slice of funding from industrial investment.

He also applauded the practice of keeping R&D in the UK, while setting up headquarters in the US, where the major markets and money are centred.

The report calls for the DTI to respond to the recommendations made and to provide regular feedback.

Oxford PCBs are finer

PCBs with tracks down to 25µm wide can be mass-produced, claims a researcher at the University of Oxford.

According to university's photofabrication head Cyril Band, current manufacturing techniques cannot attain the required precision as etching rates change with track spacing leading to variable undercutting. Widely-spaced tracks etch faster than closely spaced tracks by amounts irrelevant to conventional narrow (150µm) tracks, but crucial to tracks required for next-generation PCBs and flexible circuits. Band's methods involves designing PCBs with uniform inter-conductor gaps, leaving redundant copper to fill open areas on the PCB (see photograph).

Isis Innovation, the technology exploitation arm of the university, is looking for companies interested in exploiting Band's work. jennifer.johnson@isis.ox.ac.uk

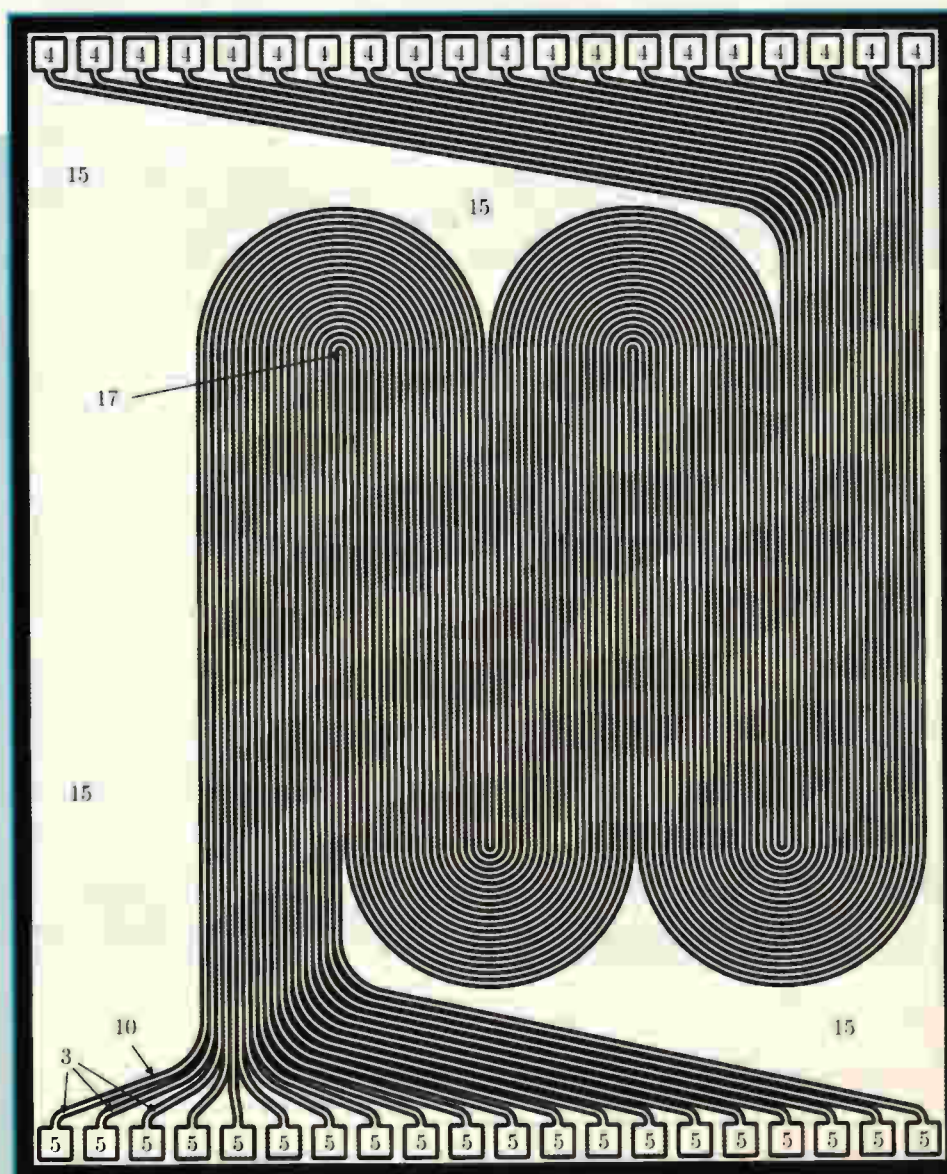

Carbon makes contact

Xerox has patented carbon-based contacts for high-reliability use in difficult environments.

CarbonConX, as the technology is called, is based on bundled carbon fibres which give the contact zone thousands, claims Xerox, of actual contact points.

The company also said carbon is non-filming, further increasing reliability.

Contacts are made by low-pressure pultrusion - pulling a bundle of fibres through a shaping die with

thermoplastic or thermosetting polymer. The polymer cures in the die and holds the fibres in shape.

"Carbon fibres are less susceptible to corrosion than metal contacts.

Their non-reactive nature makes them ideal for use in harsh environments, including saltwater, nuclear power, space, or medical X-ray environments," said Xerox, "Additionally, pultruded carbon fibre contacts can act as structural members, due to the high strength material characteristics of the

polymer and carbon bundle."

One disadvantage is high contact resistance, although metal coating the fibres before pultrusion can reduce this.

Uncoated fibres are recommended for use with voltages of 100V or less and current levels on the order of 100mA/mm². Practical contact resistances of a few hundred milliohms to a few hundred ohms are determined by contact geometry, fibre characteristics and normal force.



LeCroy has introduced 1 and 3GHz digital storage oscilloscopes in its WavePro family. All four channels in the scopes can sample at 10Gsample/s with up to 24 million points of data stored per channel. Channels can be doubled up for increased sample rate and memory depth. The colour touchscreens are 10.4inches in size. The firm is aiming the equipment at communications system design.

Government to simplify patent law

Consultation has begun over the Government's plans to revamp the UK's patent laws, which have remained relatively unchanged since the 1977 Patents Act. The major effect of the proposals is that a single application, once successful, will result in a patent that is legally valid in 24 countries.

"Changes to the law are essential if the UK is to deliver on its commitment to implement the recent changes to the European Patent Convention (EPC) with which UK law is aligned," said Melanie Johnson, the Minister for Competition, Consumers and Market.

The minister said she welcomed comments from industry: "We are seeking input on the impact of these proposals from all who have an interest in the patent system, especially from UK businesses including SMEs," she said.

Other changes could lead to the UK patent office taking over some of the preliminary work when a patent is challenged, work now done by the courts. This could reduce costs and encourage companies to maintain their intellectual property.

The new legislation will be introduced to Parliament as soon as time permits, the Government said.

Last year some 5,000 patents were applied for in the UK under the existing EPC rules, making this country the third largest user of the system.

For further information go to www.patent.gov.uk



Mitsubishi has signed a deal with New York-based Magink Display Technologies to create the world's first large-scale, full-colour digital ink displays for the outdoor advertising industry, the companies claim.

Magink is providing its digital ink technology and Mitsubishi, its large-scale video know-how display. Magink was established in 2000 after a two-year incubation within UK-based SixEye Media Technologies.

Research yields 6nm Mosfets

IBM's research division has demonstrated transistors with gate lengths down to 6 nanometres.

The key to such a small device was using a silicon-on-insulator (SOI) substrate where the silicon below the Mosfet's channel was itself just 6nm thick. This helps reduce the so-called short channel effects which wreck the performance of these extremely small devices.

To fabricate the devices, the IBM team used bonded SOI wafers with a starting silicon thickness of 70nm. These were thinned to between 4 and 8nm to create fully depleted SOI prior to making the Mosfets.

To improve short channel effects and raise threshold voltage, the team also used halo implants which increase channel doping near the source and drain.

In the 6nm p-channel Fet, drain-source current varied between 10^8 A/ μ m and 10^4 A/ μ m as V_{gs} varied from 0.5 to -1.5V.

Another significant step taken by the IBM Research team was the making of ring oscillators with 26nm gate Mosfets. CMOS inverters had delays of 10ps, while three-input NORs and three-input NANDs had delays of 23 and 14ps respectively.

What is fully depleted SOI?

Two basic forms of SOI exist - fully or partially depleted. In fully depleted SOI the silicon layer on top of the insulator is thin - normally down to 40nm in today's processes. Thus the depletion region underneath a transistor's channel extends down to the insulating oxide layer.

Partially depleted SOI, being used by some microprocessor makers, has a layer of neutral silicon between the transistor and buried oxide layer. This suits high frequency operation.

No neutral layer means fully depleted has lower leakage currents at reduced threshold voltages, so it is better for low voltage and low power.

Hotrod heat pipe from Sandia

New Mexico-based Sandia National Laboratories has taken a fresh look at heat pipes to cut thermal build-up in compact equipment.

The basic technology has been used to pull heat from confined spaces for several decades. Unfortunately, existing isotropic types fail if attempts are made to extract heat from more than one place.

"An isotropic method doesn't work because it only cools the first heat source; you need anisotropic capability to cool all sources of heat directionally," said Sandia researcher Mike Rightley.

To cool several places, Sandia persuades condensed liquid to return to multiple hot spots. "We use laws of fluid mechanics to derive the optimum wick path to each heat source," said Rightley.

The wick in Sandia's heat pipe is a pattern of 60 μ m high curving, porous

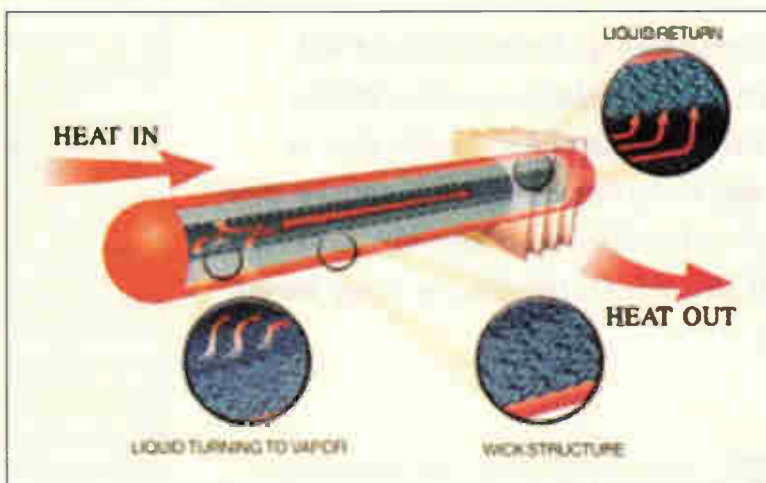

copper lines made with photolithographic techniques.

These lines can also direct the cooling liquid, in this case methanol, around fixing holes and other unavoidable obstacles.

Conventional conductive heat sinks are reaching their limits with the latest generation of microprocessors for PCs.

Surface power density in the hottest devices is around 50W/cm² which is likely to hit 100W/cm² in the near future.

Inadequate cooling is also preventing multiple high-power die being stacked inside a single package to save space.

"Space, military, and consumer applications, are all bumping up against a thermal barrier," said Rightley.

The Sandia technology is being licensed to a start-up company "that has a very interested large customer in the laptop market," said Rightley. "No internal re-design of laptops is needed.

The new design exactly duplicates in external form the heat transfer mechanism already in place in laptops. Industry won't even see the difference."

Heat pipes: the principle

Heat pipes are sealed tubes with a low boiling-point liquid inside and an internal wick running from end to end.

One end of the pipe is placed in close thermal contact with a hot spot, the other is buried in a heatsink.

The working fluid boils at the hot end and its vapour travels down the tube to the cool end where it condenses, shifting heat out of the system.

Once it is a liquid again, it is wicked back to the hot end for re-use.

Bipolar process from Swindon

Zarlink Semiconductor in Swindon has developed a high voltage, high-speed analogue chip process that it is offering to foundry customers.

The HJV process is aimed at products with fast data rates and high voltage outputs, said the firm, such as drivers for lasers and modems.

"Customers want a commercial process that uses low-cost, proven silicon technology to build high-voltage, high-speed analogue devices," said Steve Phelps, silicon bipolar foundry director at Zarlink. "Our HJV technology offers significant cost and performance advantages over more exotic chip processes, and a more comprehensive suite of design components."

The process allows for both pnp and npn transistors with transition frequencies (unity gain) of 12GHz at 5V. Collector-emitter breakdown voltages are above 12V for both types of transistor, the firm claimed.

Audio power amplifier frequency compensation:

Is PLL an Alternative to the Miller Capacitor?

A lot of audio amplifiers, from around 40 years ago right up to today, use the Miller capacitor. An inherent problem with this is that it delays the output voltage response and thus the negative feedback to the input stage. John N. Ellis, B.Sc., Ph.D. thinks he may have an alternative.

The transistor audio amplifier can be generalised as having an input stage, which may be a single transistor or differential pair, a voltage amplifying stage (VAS), a driver pair and an output pair as shown in

Fig. 1. As there are more than two time constants encompassed by the feedback loop, negative feedback can cause instability that requires frequency compensation to put right. A common method to stabilise amplifiers is to use a "Miller" capacitor C_{comp} . as this causes a monotonic roll-off at 6dB/octave. which is, as Nyquist, Bode and others have shown, stable.

Many audio amplifiers, ranging from the decidedly mediocre (typically from the 60's and 70's) to good ones from the 90's¹, use the Miller capacitor. An inherent problem with the Miller capacitor is that it delays the output voltage response and thus the negative feedback to the input stage. If the input signal is fast enough, this will cause transient distortion due to overloading in the input stage. until such time as the feedback "catches up" with it. The problem can be eliminated by using resistors in series with the input transistor emitters which are large enough to prevent overloading in the input stage. or using moderate resistors and increasing the current in the input stage to achieve the same voltage margin, such that the input

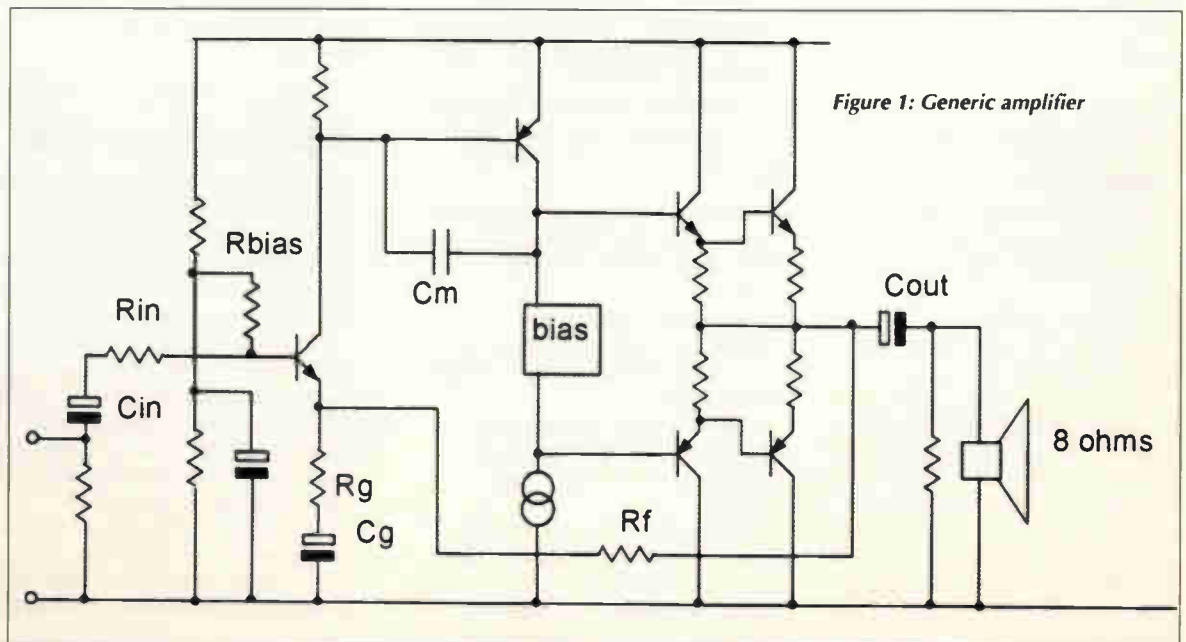

Figure 1: Generic amplifier

transistors do not cut off for any input within normal limits. This approach to "fast slew" was exploited by Stochino². I hasten to add that for ref. 1, transient distortion from slewing does not arise for normal audio-band signals usually taken to be 20kHz maximum, as it has a good margin to at least 150kHz. Nevertheless, the potential for input stage overload is not desirable, and the Miller capacitor method of compensation is not one which I would use by preference. However, the search for an alternative is not easy but phase lead compensation with input lag (PLIL) seems to be a possibility. This article reports on the investigations I have undertaken in the PLIL approach.

The use of a phase lag capacitor on the input stage of the amplifier was first suggested by Otala³ to prevent transient intermodulation distortion. Since then, there has been much debate about whether "transient intermodulation distortion" is the right term for such distortion products (intermodulation implies continuous frequency spectra) that are transient in nature. Today it is usually accepted that control of slewing is the important point.

Several authors have compensated their amplifiers by a capacitor C_{comp} connected between the collector of the VAS transistor to the feedback point FB, as shown in outline in Fig. 2, the so-called phase-lead method. The first author who caught my attention with this approach was Bailey⁴. Linsley-Hood also used this method⁵, as did Gibbs and Shaw⁶, who also included an input phase lag capacitor, and is perhaps the first example of phase-lead, input lag.

I found that when a phase-lead capacitor was used by itself, it was not reliably stable. I tested a version of Bailey's amplifier which used a small-signal PNP input transistor and NPN VAS. The original circuit used a 40361 medium-power NPN transistor in the input stage and a 40362 PNP VAS. In my circuit, using a medium power PNP input transistor (actually a 2N4036), I found that the amplifier was stable only when I increased the series input resistor to 4.7kΩ. When a small signal transistor was used, the amplifier was once more unstable.

To shed some light on the instability using phase lead compensation alone I simulated a four-stage equivalent circuit to represent the generic amplifier, Fig. 3a. The stages represented the input, VAS, driver and output transistors. Each transistor stage (treating the driver and output as singles) was modelled by a simple p-type equivalent circuit comprising an input impedance, base-emitter capacitance, collector-base capacitance and mutual conductance as shown in Fig. 3b.

To simulate Bailey's amplifier, I had to devise p-type model parameters for the 40361 and 40362, neither of which I had and are, it seems, obsolete, RCA having been taken over nearly 15 years ago now. The parameters I used were based on measured capacitance data for devices 2N2102 and 2N4036, plus estimated diffusion capacitance and gm parameters. SPICE data from some manufacturers, available on the internet, give rather better values than I suspect the original RCA transistors would have had. I also had to estimate the data for the Motorola MJ481 and MJ491 power transistors which are also past their sell-by date. The collector-base capacitance (C_{cb} or C_{ob}) is in the data sheet, but other parameters were estimated from larger transistors and adjusted for the lower current handling of the MJ481/MJ491. Table 1 gives my guesstimated data for interested readers. The rather low gm figures for the power device represents near-cut off values for a class B amplifier. Clearly there is scope for a wide range of parameters in the output stage: it is not possible to model a Class B (a large

Table 1: p-model data for the "Bailey" amplifier

transistor	hie (ohms)	Cbt (F)	Ccb (F)	gm (mA/V)
40361 (input)	880	260p	4p	.064
40362 (VAS)	100	510p	16p	0.4
40361 (driver)	210	340p	10p	0.2
MJ481 (output)	40	25n	250p	1.4
BC307B (alt. i/p)	4000	70p	1.5p	.064

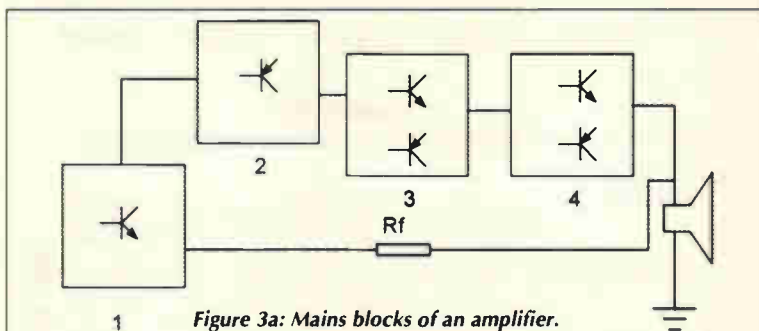
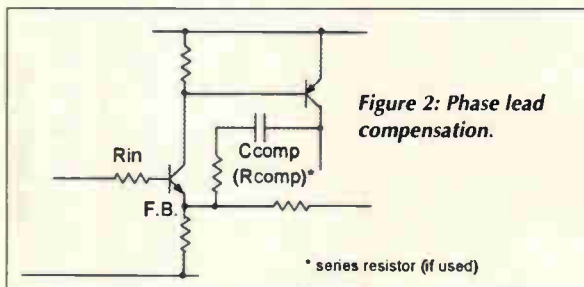

Figure 3a: Mains blocks of an amplifier.

1 - input stage; 2 - voltage amplifier; 3 - driver(s); 4 - output(s)

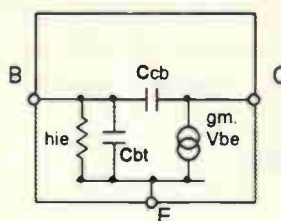

Figure 3b. π-type equivalent circuit

Fig. 3 (b)

π -type Equivalent Circuit

Cbt = total base (diffusion + depletion) capacitance
 Ccb = collector-base depletion capacitance
 hie = input impedance
 gm = mutual conductance

signal configuration) amplifier using small signals and expect it to be correct for all conditions. This could of course point to where the last vestige of amplifier design remains to be uncovered: the dynamic performance of transistors in a large-signal amplifier. In this case, I was seeking to reveal the basic properties of the compensation method.

In the above table, Cbt refers to the total base capacitance that is a sum of the depletion and diffusion parts.

Fig. 4(a) shows the rather awful-looking frequency response. Immediately one would conclude that this design is not stable. In the critical 1 to 10MHz region, the unity-

gain frequency point has not been achieved cleanly and the phase shift is undergoing some rather alarming changes. (The straight-line jump is not real: it is an artefact of the simulation returning the phase angle between the limits of $\pm p$. The top arc continues the lower phase shift in practice – but at least this acts as a 180° marker). I increased the input resistance to $10k\Omega$, and the response is shown in Fig. 4(b). This is stable, just as the unity gain point is not quite 12dB/octave and the phase at unity gain is below 180. Substituting a small-signal transistor

equivalent circuit, also listed in table 1, for Tr1, gave the response shown in Fig. 4(c) while retaining the $10k\Omega$ input resistor. This is marginally unstable. While I am happy to accept that my models are somewhat simplistic, and the parameters guesstimates, the results confirm my experimental observations. In practice, Bailey's design may well have been stable with the original components but larger input resistors may have been necessary in some cases. Evidently it required the frequency response of the input transistor to have designed-in limitations. Using a 40361 may have been judicial!

Astute readers will immediately point out that the use of a resistor-capacitor network, as Bailey described (op. cit.), should in theory never give a unity-gain response. Indeed, the concept seems flawed because the gain cannot even approach unity, until such time as the amplifier open loop runs out of steam. This is where the phase-lag (Miller) method appears superior in that it has a monotonic characteristic – the gain continues to fall throughout the whole frequency spectrum.

Linsley-Hood also appears to have found that the phase-lead capacitor was insufficient by itself when higher frequency input transistors are used because in his amplifier (op. cit), he used an additional resistor-capacitor pair generating a phase-lag across the base of the VAS transistor (e.g. Fig. 5). Evidently, this will give rise to a

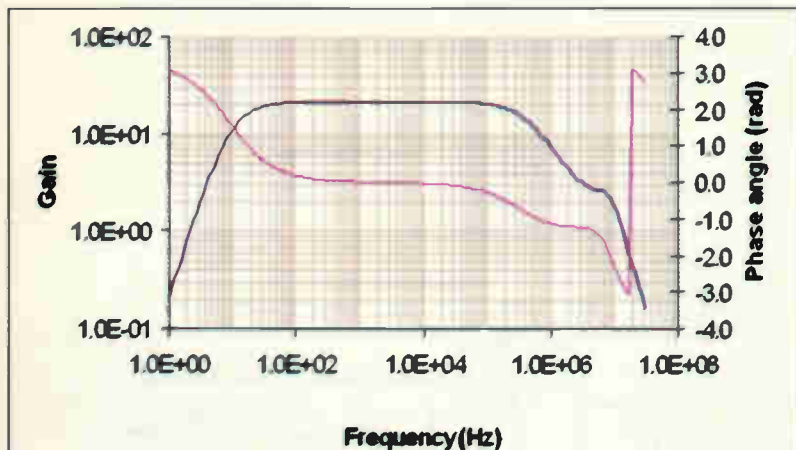

Fig 4a: "Bailey" simulated response with medium power in input stage

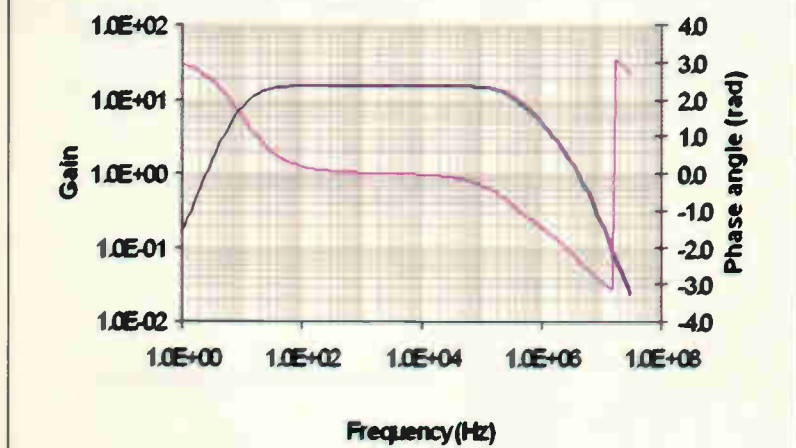

Fig 4b: With $10k\Omega$ instead of $1.5k\Omega$

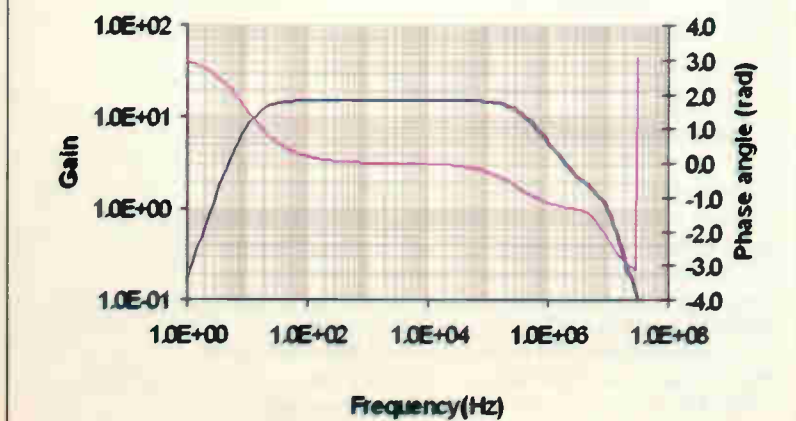
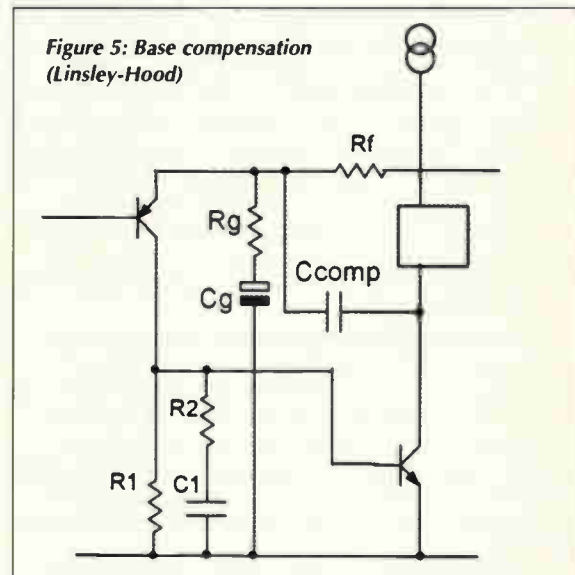

Fig 4c: With $10k\Omega$ and small signal transistor in input stage



reduction in gain which falls monotonically (until the series resistor limits it at least) and would provide the desired improvement in stability. In my view, this is as bad as using a Miller capacitor as it does nothing for the input transistor, and would also lead to transient distortion at high frequencies. Linsley-Hood, and Gibbs and Shaw (op. cit.) both avoided using the resistor, R_{comp} in Fig. 2, which Bailey had specified in series with the compensation capacitor. This at least allows the gain to be able to become closer to unity than with it. Fig. 6 shows the response for a $470pF$ compensation capacitor with no series resistor. The unity gain point hovers tantalisingly around the critical frequency point, but refuses to dip below unity until the amplifier open loop limit sets in. This is just not stable enough and in practice it may be very dependent on transistor parameters.

I simulated the PLIL approach and after several variations, I found the optimum network for the single-

ended input stage required: (i) a small resistor in series with the input phase-lag capacitor; (ii) a resistor in series with the input lead; and (iii), a small resistor in series with the emitter of the PNP input transistor as shown in Fig. 7(a). The response for a circuit with the components given is shown in Fig. 7(b). This time, the response is virtually ideal, with a monotonic decrease until well beyond the critical phase-shift point. This method of input lag with phase lead compensation is along the lines that Ojala³ recommended, but does not require extensive local feedback.

I checked the stability of this method firstly by considering the input phase-lag capacitor only in a simulation (Fig. 8). The graph shows a second-order roll-off initially, but there is a relaxation towards a single-pole slope near the unity gain point, conveniently. The circuit seems to share some similarity with a Colpitts type

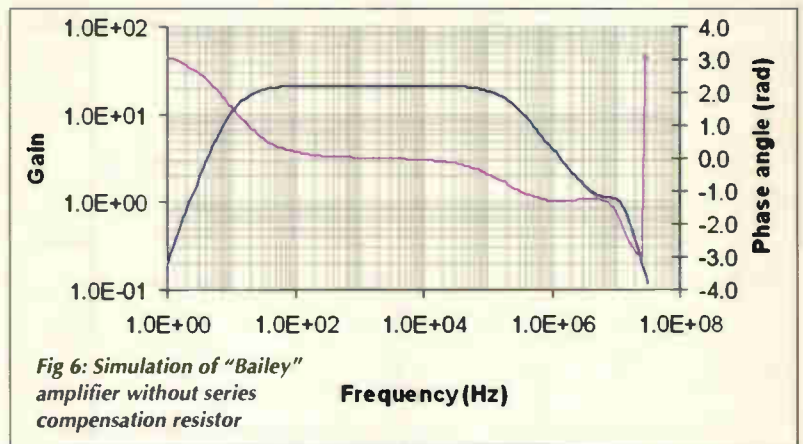

Fig 6: Simulation of "Bailey" amplifier without series compensation resistor

Figure 7a: Phase lead/input lag compensation with typical values

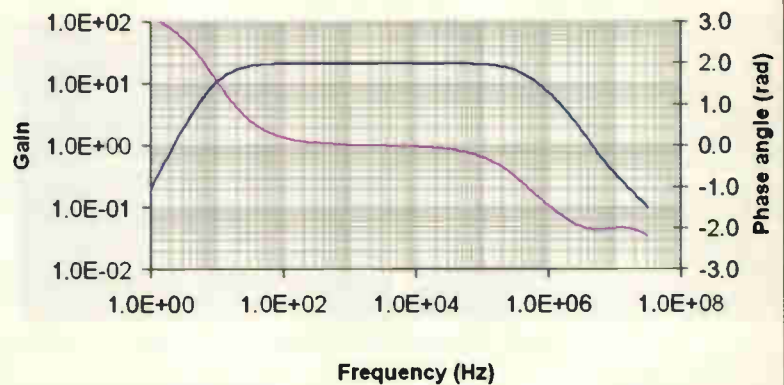
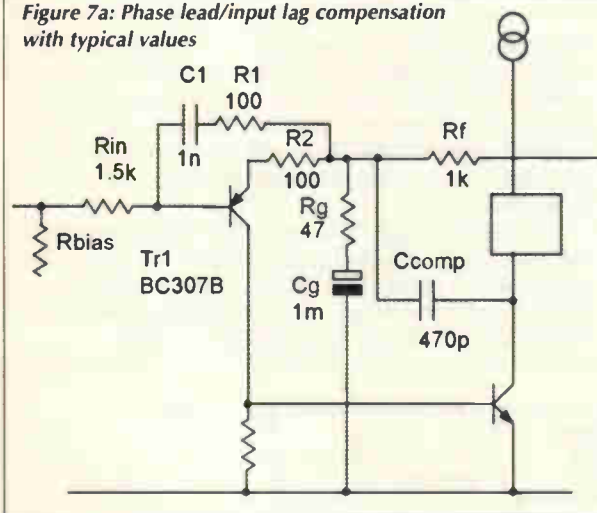

Fig 7(b): Response of "Bailey" amplifier simulation with phase lead/input lag compensation

oscillator, or a second-order filter (Figs. 9(a) and (b)). In fact, the second-order roll-off is damped by the series resistors, and is compensated by using the phase-lead network in conjunction with this phase-lag circuit. The input capacitor-resistor network, then, is capable of providing the required monotonic control of gain at high frequencies where the phase-lead capacitor rolls to unity. But the network is definitely NOT a replacement for the phase-lead capacitor, nor for the phase-lag Miller type. The method requires both phase lead and input (phase) lag together to operate correctly.

There are two advantages of the PLIL compensation method. For one, it eliminates the Miller capacitor. Instead of burdening the input stage at higher frequencies, the phase-lead capacitor provides a signal which tries to balance the feedback side of the input stage. Measurements have confirmed the simulations in a differential version of the amplifier where the base to base voltage at 20V and 20kHz output is only about 2mV compared with the 25mV or so for the Miller compensated amplifier. This has to be kinder to the transistors than forcing them into a larger signal mode than necessary. Even a degenerated input pair will experience a reduction in non-linearity from about 0.1% to 0.02%. A fast square-wave applied to the Miller-compensated amplifier shows an alarming peak of 600mV on the base-to-base differential, Fig. 10 while PLIL compensation eliminates this spike almost completely as in Fig. 11(b).

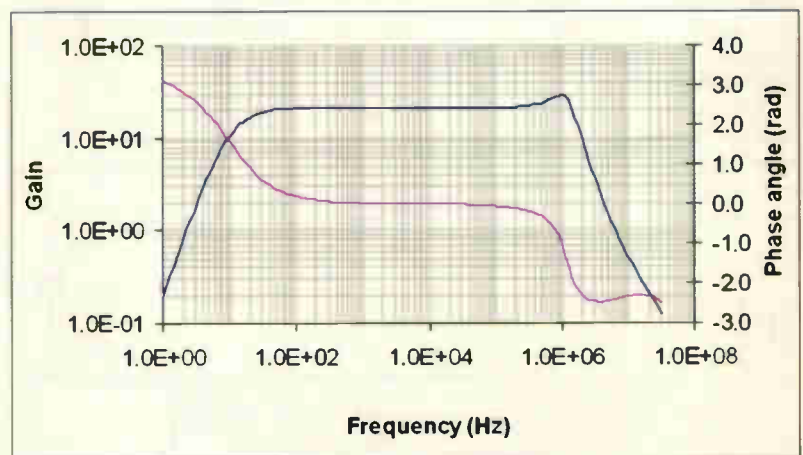

Fig 8: Simulation of input phase-lag compensation alone

The second advantage is that because the input phase-lag network has a second-order rate of climb, the loop gain is not going to be seriously impacted. This means that the distortion should be about the same as in the phase-lag compensation circuit, unlike the use of an input RC filter, Fig. 11, about which there has been some criticism⁸, and I accept is a heavy-handed approach to avoiding transient distortion.

The time-constant of the input phase-lag network should be chosen to be around the same as or a little higher than

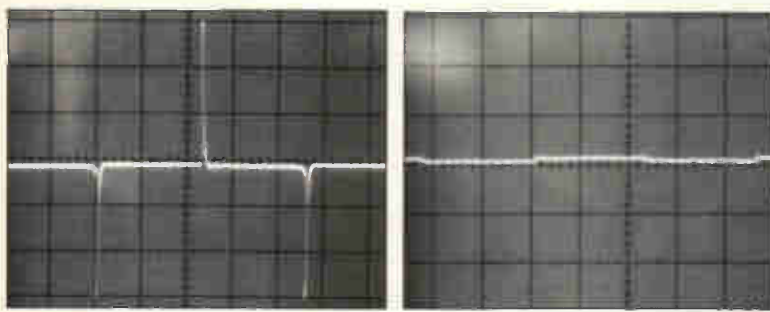
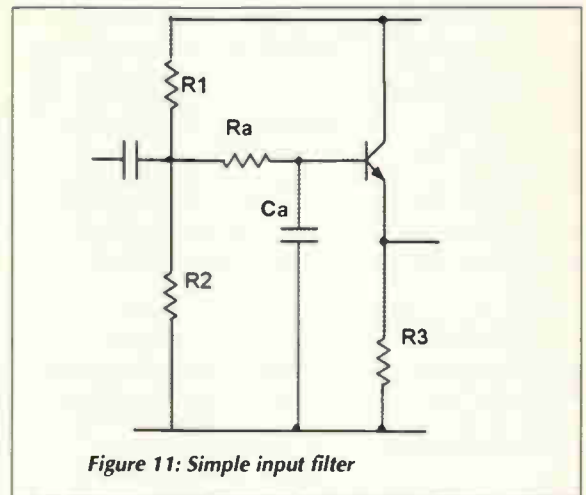
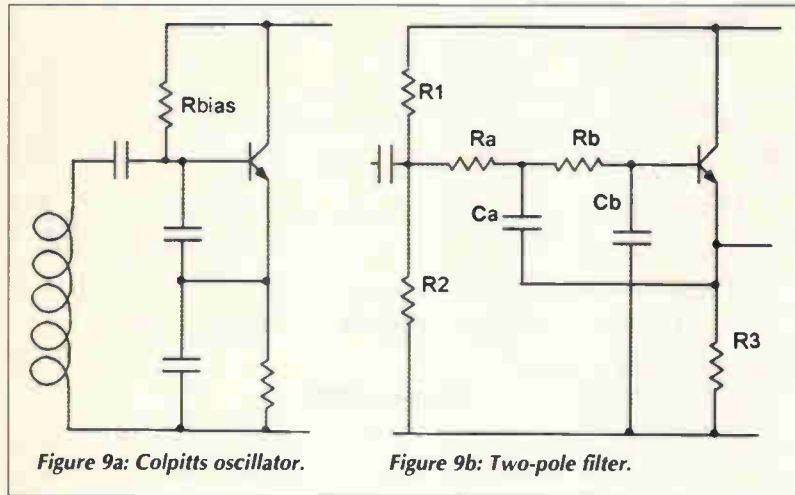

Fig 10(a): Differential signal (base to base) for Miller compensated amplifier in response to a 10kHz square wave signal
 Fig 10(b): Differential signal for a PLIL compensated amplifier for same input (vert 200mV/div, hor 20µs/div)

the amplifier closed-loop roll off as set by the phase-lead capacitor and feedback resistor. In a test amplifier shown in Fig. 12, which is based on Self's "blameless" design (op.cit), the compensation capacitor operates with the feedback resistor to give about 150kHz closed-loop cut-off. I have chosen a slightly higher overall gain of 30 rather than 20.

As a resistor is required in series with the base lead of the input stage to ensure that the additional phase-lag capacitor does not give rise to oscillation, the noise level will be higher than without. The noise voltage I measured was under 1mV, rms, or about 100dB down from

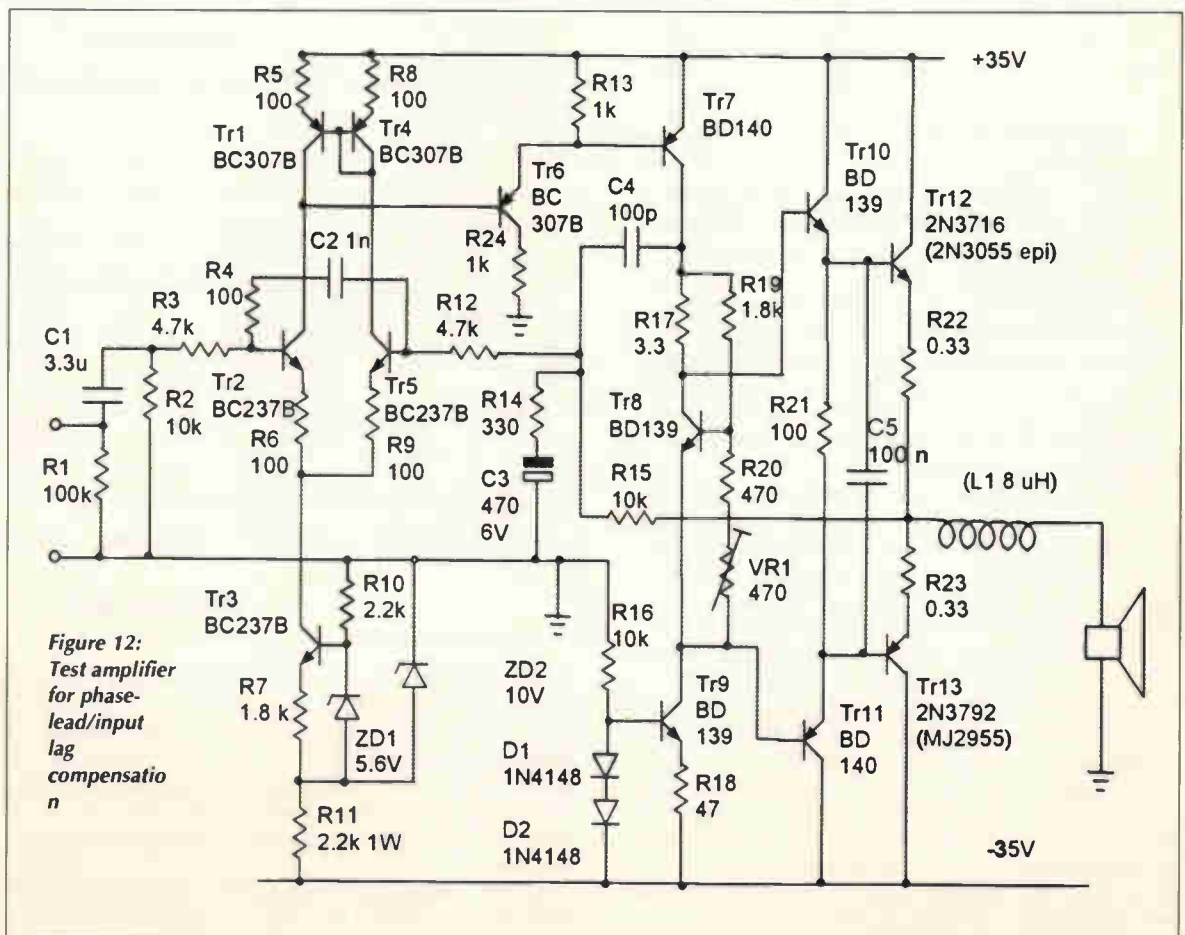

Figure 12: Test amplifier for phase-lead/input lag compensation

maximum output, and still quite acceptable.

On the question of distortion, I attempted to measure the performance but I have to say that the oscillator I used for distortion measurements was not ideal. It had more second and third harmonic distortion than the amplifier and to make any readings at all I had to subtract the reference input from the output at all frequencies, rather error-prone and troublesome.

At 1kHz and 1V RMS output, corresponding to 125mW into an 8Ω load, I could not see any additional harmonic components from the noise, setting the limit at around 0.01%, within my experimental limits. The same was true at 10kHz. At 10V RMS output, 12.5W, the distortion components were found to be largely odd harmonics, and around 1mV. Adding the fourth to ninth at 10kHz, (the odd harmonics being indicative of residual crossover distortion) the total distortion was 5mV rms giving a maximum total harmonic distortion of 0.05%. There may have been some distortion components higher than 100kHz but the analyser I used was unable to record them, and the 9th harmonic was at least smaller than the 7th. At 10V, 1kHz, the high frequency components vanished after the 6th.

Thus, it seems that, for a steady-state signal, the input-lag and phase-lead compensation method gives a distortion below 0.05% at 10kHz and 10V RMS, and considerably lower at lower frequencies, within the limitations of my experimental tests. In a short burst at 30W, before my load resistor overheated, I measured the same ratio of distortion components as at 10V. With the absence of input transient overload distortion, this approach seems to have some advantages over the Miller compensation method.

To provide a sanity check on the distortion levels, I compared the simulated open loop gains of the two methods. Fig. 13 shows the graphs. It has to be said that the phase-lead-input lag approach does suffer a little. Curve 1 is for the Miller-compensated, modelled amplifier; curve 2 is the modelled stable PLIL amplifier and curve 3 is based on real component values required in a practical amplifier. At 1kHz the gain is down about a factor of two compared with the phase-lag (Miller) circuit, with the parameters I used. If the reference amplifier is under 0.001% at 1kHz, this leaves the phase-lead/lag design at under 0.002%. Thus, it seems that while the approach may increase noise and distortion, it is by a very small margin. There is however, some additional increase at the top end, where the components required in an actual circuit were rather greater than the model prediction. Thus, it appears that the PLIL method may need some optimisation for best performance. It may be concluded that while audible distortions are controlled, high frequency distortions may be less so.

In testing this configuration for stability during clipping, the amplifier showed a very fast recovery when coming out of clipping. Initially, it oscillated alarmingly but this was found to be due to the protection circuitry, which I removed, and the emitter resistors, which I will return to. Although the recovery from clipping was then found not to cause oscillation, I nevertheless considered that the amplifier gain should be reduced, passively, during clipping. It was easy to add the standard anti-saturation diodes, following Stochino, to the upper (VAS) stage because the additional transistor in front of the BD140 lends itself to this. The current source in the lower arm required an extra three diodes (Fig. 14). The result was that the amplifier gain is killed in the pre-driver stages

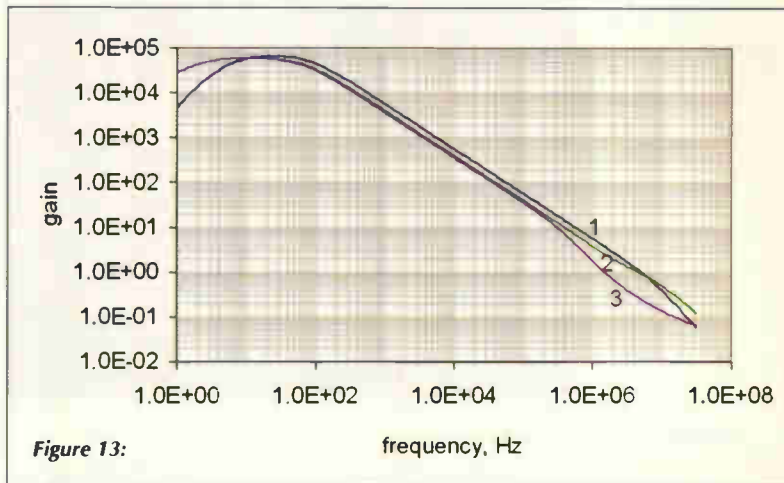

Figure 13:

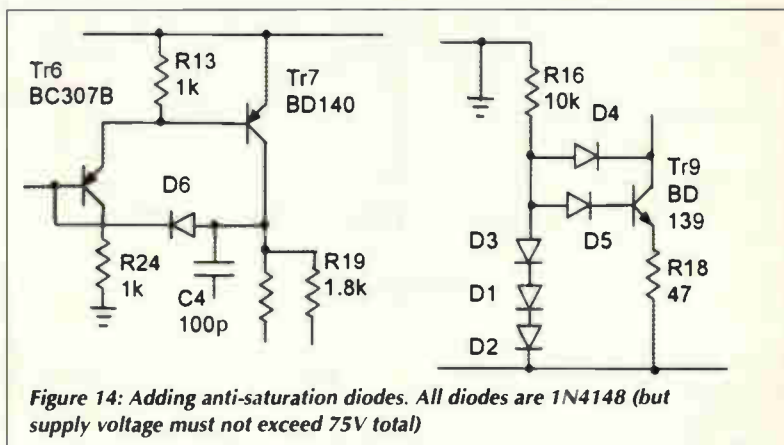
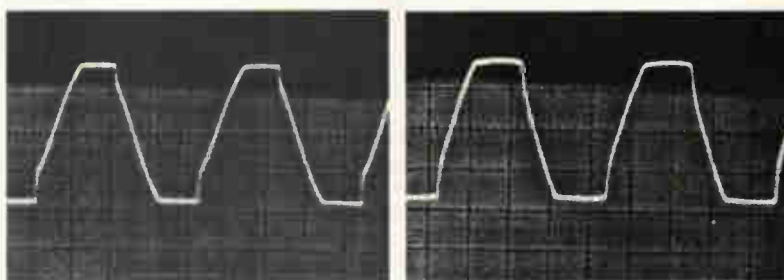

Figure 14: Adding anti-saturation diodes. All diodes are 1N4148 (but supply voltage must not exceed 75V total)



rather than in the driver and output stages, and the clipping signal is "soft". Recovery with this approach is well controlled, as shown in Fig. 15. This was measured with a reduced power supply voltage and including a pair of filter chokes to prevent mains ripple appearing on the clipped signal.

I further checked the stability by using the proverbial 2.2mF capacitor load on the output. On testing with a 10kHz square wave the amplifier showed classic ringing (Fig. 16), after I had added further power supply decoupling on the amplifier rails. For continuous operation on a capacitive load, the usual small inductor or small power resistor of 0.22Ω should be inserted in the output lead.

One final point emerged from these experiments. I found that under some circumstances the amplifiers I tested sometimes oscillated at a low level, inexplicably. There was no indication from the simulations what might have

Fig 15(a): Clipping on conventional PLIL amplifier
Fig 15(b): Clipping with anti-saturation diodes added

Fig 16: P.L.I.L amplifier response with 8Ω plus 2.2μF load at 10kHz. (vert 5V/div hor 20μS/div)

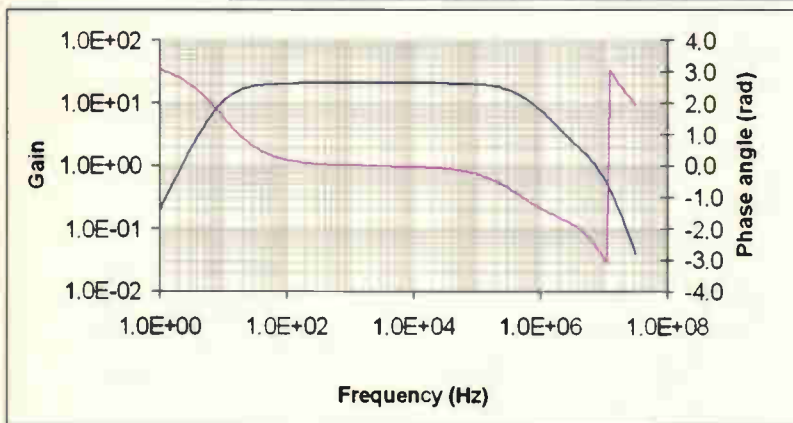
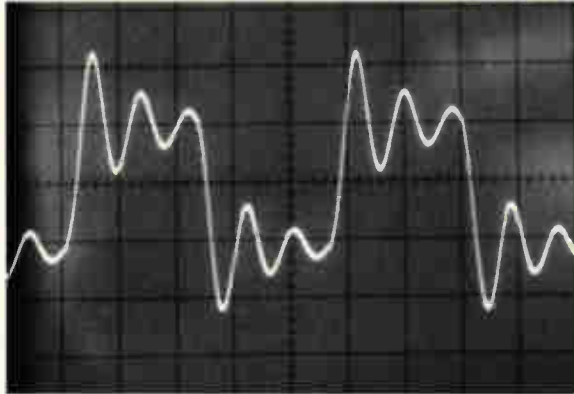

Fig. 17: Effect of 100 nH in a 0.33 ohm emitter resistor. The roll-off at the H.F. unity gain point is on an increasing slope and the phase shift is moving rapidly towards the unstable 180 degree point. The amplifier is bordering on instability. (compare with fig. 7(b)).

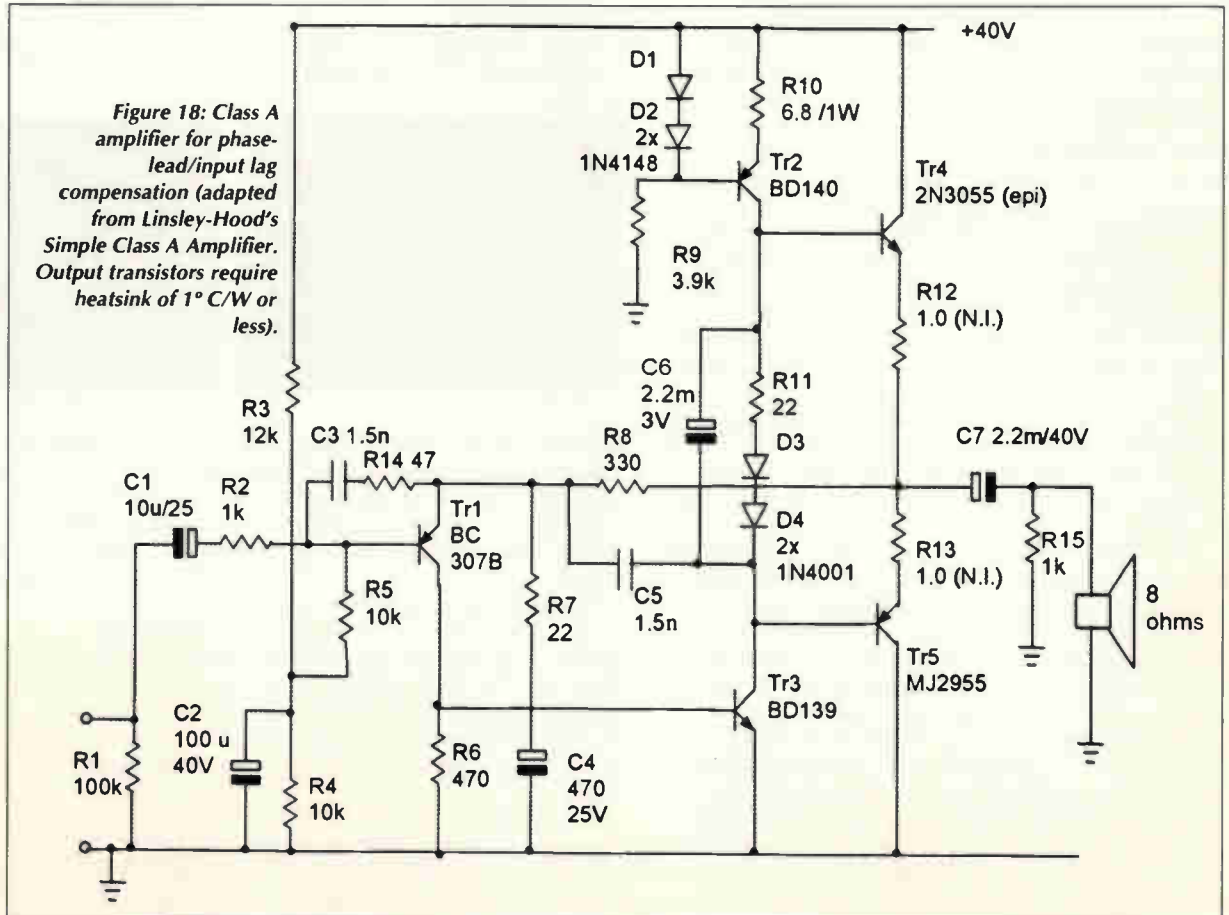
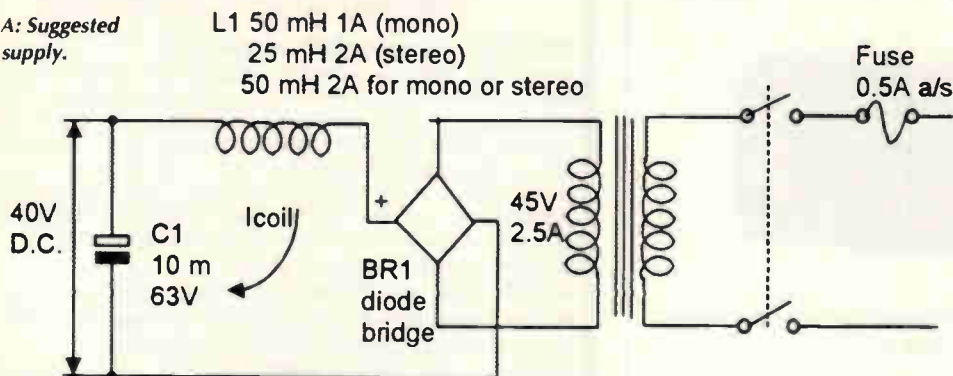

Figure 18: Class A amplifier for phase-lead/input lag compensation (adapted from Linsley-Hood's Simple Class A Amplifier. Output transistors require heatsink of 1° C/W or less).

caused this but I suspected, from the problems with the protection circuitry, the emitter resistors. Measuring two wire-wound, 0.33Ω resistor samples I found that their impedances at 1MHz were no less than 0.6Ω for the 2.5Ω sample (corresponding to 60nH) and 0.8Ω (116nH) for the 5Ω sample. Bailey quite categorically stated that the emitter resistors should be non-inductive⁹, and replacing the commercial resistors by a non-inductive helix (doubled-back) of 24 s.w.g. resistance wire eliminated the problem. I evaluated the effect of some inductance in the emitter resistor in my simulator. With just 100nH, the phase shift induced at around 5MHz, the unity gain point, is very nearly 180 degrees as indicated by the position of the step in the phase plot (Fig. 17). This confirms from simulation that inductive resistors can be a cause of spurious oscillations sometimes observed. I have yet to dare to test whether non-inductive resistors would allow the phase lead compensation capacitor to be connected to the output point rather than the collector of the VAS, though I suspect not, as three time-constants (two being significantly variable) are enclosed in such a feedback loop. Nevertheless, I would strongly reinforce Bailey's concern and state that the emitter resistors MUST be non-inductive. The simulations show that even small diameter helical windings, where the inductance is in the order of tens of nH, have too much inductance. Not only does this play havoc with the protection circuitry but also generates phase shifts right where they are least welcome. It may be possible to use a number of 1Ω metal film resistors in parallel, or series-parallel: measurements on the small, 1Ω type showed no significant change at 1MHz.

Figure A: Suggested power supply.



Choke filtered power supply - ideal for Class A as choke can be a simple air-gapped core for single current (not "saturating").
 Note: earthing on the amplifier may be more critical to avoid circulating choke current flow, not easier!

In summary, a stable amplifier performance is possible with the phase-lead/input lag method when the input phase-lag is matched to the phase lead components. This has been supported through simulation. Distortion and noise may both be very slightly degraded compared with a phase-lag (Miller) amplifier, but this seems a small price to pay for a design which minimises the differential signal, and hence improves linearity, in the input transistors, particularly at high frequencies. High frequency distortion may increase slightly, so the time constants should be as high as possible. Whether the very sharp, odd harmonic distortions present at higher power levels, which are only around 1mV, cause listener fatigue is not something I can comment on.

The capacitor between the bases of the output transistors also acts to improve high frequency switching. Though I have some reservations about such a capacitor because, at high frequencies, it will pull charge from the output transistors in the same direction, despite the A.C. output signal, potentially charging unidirectionally, and reducing the driver transistor bias dynamically. However, it too helps to minimise parasitic oscillations, and on balance improves the switching speed, so is recommended.

Distortion arising from the compensation capacitor loading the VAS stage will arise to the same degree as in a Miller compensated amplifier as it increases loading at high frequencies. But the input transistors are spared the extra drive that this would have required from them since the differential signals remain low. As with all high performance amplifiers, the decoupling on the amplifier PCB needs to be good – as Self mentioned, power supply ripple should be prevented from entering the amplifier or it may appear as distortion.

I have shown through simulation, though fairly basic, how the method of using a combined phase lead and input phase lag compensation network can offer a possible alternative to the Miller capacitor. While I cannot say that all the issues with this approach have been unravelled, the phase-lag network operates as a two-pole, low-pass filter in the audio band. This achieves the objectives of an input filter and "slow" input stage at the same time, but without significantly impacting audio frequency bandwidth.

Therefore, it is capable of providing similar performance to a Miller capacitor, but without requiring extensive local feedback (unless one counts the phase-lead network as local feedback). The method works with single and differential input stages. If a single-ended input stage requires an emitter resistor, there will be some increase in distortion due to the open loop gain reduction although this is partly offset by the extra local feedback the resistor introduces. The method can be used effectively in a 15W, modified version of Linsley-Hood's class A amplifier as shown in Fig. 18. ■

References

1. Self, D. "Distortion in Power Amplifiers" (Series of articles) Electronics World, Aug. 1993-Mar. 1994, particularly #7, Feb. 1994.
2. Stochino, G., "Non-Slewing Audio Power Amplifier", Electronics World, March 1996.
3. Ota, M., "Circuit Design Modifications for Minimising Transient Intermodulation Distortion". Jnl. A.E.S., June 1972.
4. Bailey, A.R., "A High Fidelity 30W Audio Amplifier", Wireless World, May 1968.
5. Linsley-Hood, J.L. "Simple Class A Amplifier" (Modifications, appearing in Letters, circa June 1969 to original article in April 1969).
6. Gibbs, D.S. and Shaw, I.M., "Gemini 30W Amplifier", Practical Electronics, Nov. 1970.
7. Lohstroh, J. and Ota, M., "Audio Amplifier for Ultimate Quality Requirements", IEEE Trans. AU-21, Dec. 1973
8. Ellis, J.N. and Maynard, G., Letters, Electronics World, January and April 2001
9. Bailey, A. R., "High Performance Transistor Amplifier", Wireless World, Nov. 1966.

The Balance Box

Microphone or line level amplifier for balanced or unbalanced signal lines

Professional portable units operating from an internal PP3 battery or external mains adaptor



- ★ Precision true floating transformerless balanced input and output at microphone or line level
- ★ Simple interfacing and conversion between balanced and unbalanced signal lines
- ★ Low noise and distortion
- ★ High common mode rejection
- ★ Switchable gain selection
- ★ Extensive RFI protection

The Phantom Power Box – The Headphone Amplifier Box - The OneStop DIN rail mounting radio frequency interference filter and voltage transient protector for voltage and current loop process signal lines

Conford Electronics Conford Liphook Hants GU30 7QW

Information line 01428 751469 Fax 751223

E-mail contact@confordelec.co.uk

Web: www.confordelec.co.uk/

SMALL SELECTION ONLY LISTED – EXPORT TRADE AND QUANTITY DISCOUNTS – RING US FOR YOUR REQUIREMENTS WHICH MAY BE IN STOCK

Ring for Latest Reduced Prices on this advert

EXAMPLES OF SPECIAL OFFERS

GOVERNMENT INTENSIFIER NIGHT SIGHTS tested £300 each
MARCONI TF2019A SIGNAL GENERATOR AM/FM 80kcs-1040 MCS, off the stack as come and seen untested £190 – or tested basic working £300 – or normal Johns Radio workshop test with warranty £380. All supplied with instruction book – qty available.

TEK 2445A OSCILLOSCOPE – 4 CH – 150 MCS with instruction book, off the stack as come and seen untested £250 each or tested basic working £350 – Johns Radio workshop test with warranty plus two probes and instruction book £400

TEK 2465-2465A-2465B etc available

RACAL DANA 1992 COUNTERS 1.3GHZ tested from £250

RACAL DANA 1999 COUNTERS 2.6GHZ tested from £400

H.P. 53131A COUNTERS 3.0GHZ tested from £750

BENCH + RACK POWER SUPPLIES large range qty from £10

H.P. POWER UNITS 66311B-66312A-66309D in large qty from £250

H.P. 8922 RADIO TEST SETS TYPE G-H-M-M010 with HP83220 A OR E GSM CONVERTOR from £500-£1,000 options available including Spectrum Anz. quantity in stock.

Most previous advertised items available in stock.

ITEMS BOUGHT FROM HM GOVERNMENT BEING SURPLUS. PRICE IS EX WORKS. SAE FOR ENQUIRIES. PHONE FOR APPOINTMENT OR FOR DEMONSTRATION OF ANY ITEMS. AVAILABILITY OR PRICE CHANGE, VAT AND CARRIAGE EXTRA. ITEMS MARKED TESTED HAVE 30 DAY WARRANTY. WANTED: TEST EQUIPMENT-VALVES-PLUGS AND SOCKETS-SYNCRS-TRANSMITTING AND RECEIVING EQUIPMENT ETC.

Johns Radio, Whitehall Works, 84 Whitehall Road East, Birkenshaw, Bradford BD11 2ER.
Tel: (01274) 684007. Fax: 651160

Easy-PC^{for Windows}

World Beating Value in PCB Design Software

from
£97

High performance Windows based PCB Design Capture, Simulation and Layout software at prices you'd expect from your local computer store!



NEW! Easy-PC Version 6

- Online design rule checking
- PCB footprint and schematic symbol wizards
- Import DXF from your mechanical system
- Single shot postprocessing plus much much more.....



Stop press... by customer demand, now with Tsien Boardmaker 2 design import...

Number One Systems delivers true 32 bit Windows software applications including features that a few short years ago would only have been available in software tools priced in the thousands!

Test drive Easy-PC and Easy-Spice for yourself and be prepared to be amazed at the super value...

Call for a brochure, price list and demo CD on +44 (0)1684 773662 or email sales@numberone.com

No1 Number One Systems

Number One Systems
Oak Lane, Bredon
Tewkesbury, Glos GL20 7LR
United Kingdom

or download from
www.numberone.com

LETTERS

to the editor

Letters to "Electronics World" Highbury Business Communications,
Anne Boleyn House, 9-13 Ewell Road, Cheam Road, Surrey SM3 8BZ
e-mail j.lowe@highburybiz.com using subject heading 'Letters'.

Education system to blame?

Ian Hickman's many articles amply demonstrate that having initially followed a course, which now seems outdated, is no handicap to keeping abreast of developments in ones chosen field of expertise. If there is a shortage of technically competent recruits, then I suggest we look at other changes in education in the recent past rather than being too concerned about whether courses accurately track the changing demands of industry.

Before about 1980 schools offered a more restricted range of A levels. So it was likely that an early decision about the nature of the career options to be pursued would have to be made. Anyone opting for the 'science' strand would be encouraged to study a basket of science subjects and frequently mathematics as well. One side effect was that students entering higher education had an interest in their chosen subject. They would often be expected to follow at least a year of further mathematical studies or more if their main subject had a higher mathematical content. Chemists would study a year of physics or biologists a year of chemistry.

This was perceived as too restrictive and, as post 16 education expanded, potential students were encouraged to adopt a 'pick and mix' approach to their basket of A level subjects. Such an approach may well encourage more young people to remain in post 16 education, but it may not provide any basis for entry into higher education to study a specialist subject. Choice of course on the basis of interest is replaced by choice on the basis of, 'what sort of course will I be accepted for?'

Add to this the fact that some universities have replaced a first year course of mathematical studies with 'drop in centres' for those who find

even simple mathematics 'challenging', and don't require further studies in related fields if a student already has any kind of 'pass' at A level, and it is not difficult to see that a proportion of the young people leaving universities with a degree may not actually be very competent or even interested.

A second change has been the rise in educational 'navel gazing'. By this I mean that thinking about what is taught has come to be viewed as less important than thinking about how it is taught.

Twenty five years ago the journal of the Association for Science Education, *School Science Review* (SSR), commonly had some seventy pages contributed by classroom teachers devoted to details of how to construct useful pieces of science apparatus, many of them involving electronics. In addition there were perhaps three or four longer articles of about ten pages each, dealing with the construction or use of equipment.

When I looked at the end of 2001 there were just eleven pages devoted to making or using apparatus. Nowadays SSR is filled with 'academic' articles dealing with things like concept formation or 'student' reasoning. It seems that science is no longer something that humans do, just something they talk about. Should we be surprised if those who are being taught assimilate this attitude?

It is not just in science that the 'hands on' experience of youngsters leaving school for higher education tends to be limited. Ian Hickman commented a couple of years ago on the lack of practical experience of electronics undergraduates before starting their degree course and I've heard similar comments elsewhere.

When I left school I worked for ICI for five years and have spent the last thirty seven working in secondary, tertiary and higher education, so I have had plenty of time to watch

educational fashion come and go. I keep waiting for it to swing back to day release, evening classes and part time study. It worked for me!

Les May HNC, GIBiol, MSc, PhD, G4HHS

Rochdale, Lancashire, UK.

Shrinking Horizons

Your correspondents all seem to have noticed the slimming down of the magazine until some of us have thought to hold our breath for the final 'pop' as it disappeared in a small puff of smoke. Certainly Alan Robinson likens EW to the other 'hobby' magazines and I initially felt slightly affronted, thinking that in its hey-day it was a professional and educational journal across the 'wireless' spectrum. Then I remembered that it was once the *Radio Amateurs' newsletter* or bulletin, then the high quality home constructors magazine par-excellence

A Gem

I was entertained by the December letters page, and stimulated enough to bring this little gem to your attention.

Remaindered only a year after it was published, I was fortunate at the time to pick up a book written by Ivor Catt. It was called "The Catt Concept", ISBN 0 246 10533 X and was published in UK by Rupert Hart-Davis in 1972.

Having seen some of his subsequent writings and career I realised the book was more relevant than he might have imagined when he wrote it. So I did a Google search on "Catt Concept" and Ivor is up there in the early hits.

It is almost a parable of the modern times; I now see it happening all around me, and not only in my world of technology, but in politics and new commerce as well.

I commend "The Catt Concept" to the house as a light bedtime read, should you still be able to find a copy.

See also his website for yet more gems

<http://www.ivorcatt.com/>

Richard Stevens

Ickenham Middlesex, UK

See also Ivor's tome in this issue - ED.

(in the '20's and '30's). But then again, earlier than that it started as the Marconi Journal... Oh, I give up, but what a pedigree.

Back to hobby magazines, the rate of closing down that has gone on recently does seem ominous. Also, some of the really professional papers, at least for news and advertising such as *Electronics Times* have bitten the dust so the decline is pretty universal. As to content, yes I agree that controversial topics are most important, as although downright cranky ideas and theories ('perpetual motion machines' et. al.) are dubious as a way to increase interest and circulation, devices and systems that seem to work but which have alternative explanations, do generate great interest. I am thinking of controversies like the commercial product called the cross-field antenna. Does it operate with a 'new' interaction of the (separate) electric and magnetic fields to give a

composite e-m field so that a very small antenna works as well as the large ones required by ordinary electromagnetic theory? An obvious development is the fashionable one of computing, digital devices and programming. The explosion of computing magazines of varying quality on the bookstalls shows up the present nature of this area. Whether *EW* should compete with these computer publications as regards content is a moot point. I would heartily agree that long software listings are wasteful of valuable discussion space and look stodgy even to those few who might find the programming directly useful. It's much better to have an alternative source of listings for those who need them, even for a small extra charge or postage etc. Possibly the one exception is the considerable interest that microcontrollers such as the PIC range of devices holds for a number of people, including a considerable

number of analogue engineers. These simple but versatile devices do so much that the occasional practical and tutorial type article might have a fairly universal appeal. This is especially true if the quality of the material remained up to the *EW* tradition, as some other offerings elsewhere recently have left a lot to be desired in the understanding stakes.

What a shock it was to find that the original magazine title *Wireless World* is outside the present owners control. It sounds ominously like the earlier owners might resuscitate a journal called *Wireless World*, in other words, it appears to have currency and value for something else and is therefore being carefully bottled up...? One of the more successful popular electronics (radio) journals, namely, *Practical Wireless* (although its cover title is now simply 'PW') has managed to thrive on the retention of 'wireless' in the title. The

Capacitor Sounds

Perhaps I should thank John Woodgate for reminding me of another oft quoted capacitor myth. It was included in my early drafts but deleted to reduce article sizes. I refer of course to the engineer's myth that at higher frequencies capacitor distortion disappears as voltage dropped across the capacitor reduces. This is not so. In practice capacitors distort both with applied voltage and through current. Circuits which cause capacitor voltage to reduce with frequency often also cause increased capacitor currents.

While not part of the present articles, I have recently performed constant current and constant voltage comparative measurements at 100Hz, 1kHz and 5kHz on the same test capacitors, which clearly prove this.

Many circuit applications also subject the capacitor to a near constant AC voltage regardless of frequency. For example the capacitor bypass across the output transistor bias control, C4 *EW* Feb. '94 p.139.

No doubt my view as to the signal path in an amplifier would differ from John's. Remember most amplifiers include negative feedback loops, any distortion introduced in these is then introduced into the signal path. In the above reference, the 220 μ F capacitor C2, *EW* Feb.'94 p.139 is also in the signal path.

D. Self found this component position caused distortion in his Class G amplifier, *EW* Jan.2002. The C'Dom capacitor sees significant AC and DC voltages, but being usually a small value, can use COG disc ceramic or foil with polystyrene so should contribute little.

One highly stressed and largely inadequately specified capacitor, usually 0.1 μ F, is used in the Zobel network. Being subject to large AC signals, this can introduce distortion. Many such capacitors fail OC due to excess stress at high frequency.

We should not forget the supply rail decoupling capacitors. Usually electrolytic, they are subject to significant DC bias and AC voltage at low frequency and currents at higher frequency.

Finally the input DC blocking/coupling capacitor, frequently a polar aluminium electrolytic, this no doubt was the application John

had in mind. Any distortion here is outside any feedback loop and will be amplified in later stages. While higher frequency currents will usually be small, depending on values used, significant AC voltage can appear across this capacitor at the lowest audio frequencies. Hopefully my later articles do clarify this.

As to his other points, I did not claim measuring low distortion per se was new, simply that such capacitor measurements at usable voltages using low cost equipments were. I believe my design was the first fully worked, low cost, 1ppm measuring system, complete with PCBs. I published this so that many readers could make their own measurements.

In articles 1 & 2, I included a box 'Other measuring methods' which detailed the CTLI test instrument originated by a major telecomms maker. A far better test than the one John describes. Developed in 1966, I personally used this equipment in around 1969/70 testing capacitors and resistors. This equipment claimed a dynamic range of 176dB.

Barrier layer ceramic capacitors were described in the text. To say these are rated at 6V or 12V is quite wrong. From the earliest days, usually called 'Transcap' these types were readily available at 3V, 12V, 18V, 25V, 50V and 100V. Maximum value at 100V being 0.22 μ F. The one I measured was 0.1 μ F rated at 50V as in reference 4. As to my hiding the Barrier Layer description that also is quite wrong. At the top right of each spectrum display I show brief details of each test and the test capacitor used.

Surprise surprise, even my old eyes can read the words 'Barrier Disc' in Figure 2 November, also the text quotes two references, 3 & 4. Reference 4 uses the supplier's description of the capacitor I used, 'Decoupling Ceramic Disc' while reference 3 says 'Barrier Layer Dielectrics - 1961'.

This leads me to my last point; Transcaps or Barrier Layer discs were in volume production at Gt. Yarmouth long before I joined the company in 1966. So I certainly do not claim any involvement in their development, at State College Pennsylvania.

Cyril Bateman,
Acle, Norfolk,
UK

paradox is that publications coming from the USA are full of the term 'Wireless', as though it was exclusively discovered over there. I for one would stoutly vote for the re-introduction of *Wireless World* as this magazine's title, what with all the 'Bluetooth this', 'r.f. solutions that', 'GSM the other' etc. The wireless world is burgeoning.

Finally, some correspondents denigrate what they call 'beginners' articles' and state that other magazines cover this area. If they do, where are they? I agree that poorly written, old hack theory is a textbook plod. Yet some of the historical and more controversial 'theory' and dare I say it, pedagogical stuff of the inspiring sort, used to attract a great number of students to *WW* and *EW*, who then tended to remain loyal to the magazine when they took up professional work. In 'the old days' (huh, I wonder if you thought, when is he going to mention them ...) a very lively correspondence always accrued when an in-depth discussion of, say 'Q', Fourier or other powerful mathematical techniques, or expositions of complex devices made them simple, were discussed. Of course, 'Cathode Ray', the late Mr. Scroggie, was for ever the task master of that approach. All in all, many of us hope the magazine will ride out the economic and possibly intellectual depression and grow back towards its former glory. Best wishes.

'Joules Watt'
Canterbury,
Kent, UK

No Conspiracy

I refer to the section headed "No Conspiracy" at the end of which you request an explanation of the apparent danger from use of mobile phones in petrol filling stations, but not from a more powerful transmitter in the same place.

Back in history (1960s), mobile radio apparatus fitted in vehicles used thermionic valves and power switching used electromagnetic relays. Sparking occurred when, typically, 250Vdc at 100mA was switched. The apparatus was frequently fitted in a car boot, near the fuel tank and I recall reading of a fire that was apparently caused due to use of such a radio system. I think, but am not sure, that it was a police car. It seemed most likely that ignition was due to sparks rather than radio transmissions. See note (*). I

believe that the prohibition on radio apparatus used in petrol stations followed this event.

Current radio equipment does not use sparking relays, although base stations do use higher power than hand-held phones. It may be of interest to mention some measurements I recently made near a phone base station. They were made at a busy time, with many carriers present. The maximum total power received using a suitable half-wave dipole was about 20dB less than from the local TV transmitter about 1/2 miles distant. Given that TV has been with us for decades, it is hard to see how much weaker radio transmissions from phone base stations, still less mobiles, cause significant risk.

In our litigious world, it would require a brave official to announce that it is now "safe" to use phones in filling stations where previously they were not permitted. Alternatively, on the other side of that coin, due to the measurements mentioned in the above paragraph, all terrestrial TV transmissions must now be considered dangerous and must cease.

(* NOTE:

It is true that strong radio signals can interact with certain metallic structures to create a spark. However, in this case, the low power of a modern phone is highly unlikely to cause a spark of sufficient intensity to ignite petrol vapour. In the mid-70s, I had an involvement with HSE concerning the Edinburgh medium wave 2kW commercial radio station.

In that case possible risk was not due to petrol vapour, but due to very much more inflammable hydrogen and other gasses emitted from the nearby oil processing plant at Dalgety Bay. The station was permitted after objective assessment by HSE.

I should add that I am not connected in any way with the mobile radio industry or the regulatory authorities, and expressed views are entirely personal. The first paragraph does of course depend partly upon memory of 40 years ago.

Fred Wise,
Suffolk, UK

Identity Crisis

May I impose on you to resolve a situation, which has puzzled me for some time?

I have in my possession a drive motor from a Grundig TK20 tape recorder. As a brief description, it has a 70mm rotor – containing no windings – with a 30mm pulley attached. There are three leads, two of which are in a common sleeve, any pair giving a reading of 1100 Ohms.

Is the third lead utilised for starting in any way and could you explain the necessary operational connections (if possible without the use of relays)? Is this an induction motor?

Thanking you in anticipation,
C. Holwill
Portsmouth,
Hants, UK

From memory, these big motors (almost certainly the capstan drive) used a capacitor start system. Any reader care to elaborate? – ED.

More Catt, please

Loved the spectrum pricing article. It was something I had suspected, but I didn't realise how unfair it had been until that article. It was clear and well structured.

Would like to see more stuff like Ivor Catt (is he still about?), he had interesting ideas and the maths articles relating to electronics as Joules Watt used to write.

What about a series on quantum mechanics and electrons? Also valves are fun - what about an article describing triodes, tetrodes and pentodes and what all the plates do, advantages/disadvantages etc. I'd like to see a description (mathematical and descriptive) of how co-ax works too, loss-less in theory.....

I guess 'difficult' maths or physics stuff does no harm, if people can't follow it they turn the page, and look at some adverts or something. But true engineers will treat it the same way a guardian reader treats his crossword. Something to exercise the mind! Feed our minds, as that's why we became engineers in the first place...

I'd like a build your own Theremin article too - I'll build it. I built the hot audio power amp too (March 1995 article).

Robin Clarke,
UK

Again, do look out for the return of Mr. Catt elsewhere in this issue. I'd also like to hear from anybody up to Robin's challenge.-ED

Self on Audio

Douglas Self

The cream of 20 years of Electronics World articles (focusing on recent material)

A unique collection of design insights and projects - essential for all audio designers, amateur and professional alike.

Scientific electronics based on empirical data

Douglas Self has been writing for Electronics World and Wireless World over the past 20 years, offering cutting-edge insights into scientific methods of electronics design.

This book is a collection of the essential Electronics World articles, covering twenty years of amplifier technology but with a very strong bias towards more recent material. The articles include self-build projects as well as design ideas and guidance for the professional audio designer. The result is a unique collection of design insights and projects - essential for all audio designers, whether amateur or professional.

Contents: Introduction; PRE-AMPLIFIERS: An advanced preamplifier MRPI; High-performance preamp MRP4; Precision preamp MRP10; Moving-coil head amp; Preamp '96 I; Preamp '96 II; "Overload Matters" (RIAA overload); Balanced line inputs and outputs, part 1; Balanced line inputs and outputs, part 2; POWER AMPLIFIERS: FETs less linear than BJTs; Distortion in power amplifiers 1-8; Distortion residuals; Trimodal part 1, 2; Load-invariant power amp INVAR.DOC; Common-emitter amps; Two-stage amplifiers; SPEAKERS: Excess speaker currents; Class distinction (amp classification); Relay control; Power partition diagrams; Audio power analysis.

**ELECTRONICS
WORLD**



**Self
on
Audio**
DOUGLAS SELF

Douglas Self has dedicated himself to demystifying amplifier design and establishing empirical design techniques based on electronic design principles and experimental data. His rigorous and thoroughly practical approach has established him as a leading authority on amplifier design.

Readership: Audio electronics enthusiasts;
Professional amplifier designers;
Power amp users
Paperback
Pages: 416pp

UK Price: £27.50 Europe £28.50 ROW £30.00

Return to Jackie Lowe, Highbury Business Communications
Anne Boleyn House, 9-13 Ewell Road, Cheam,
Surrey, SM3 8BZ

Please supply the following title:

SELF ON AUDIO

Total _____

Name _____

Address _____

Postcode _____

Telephone _____

Method of payment (*please circle*)

Mastercard/Visa/Cheque/PO

**Cheques should be made payable to
Electronics World**

Credit card no _____

Card expiry date _____

Signed _____

Air Traffic Control

Regarding the Air Traffic Control article by Nigel Cook, *EW* January 03, p12

Generally, I think air traffic control will be controlled by vested interests in each European country. This will block a technical fix.

However, the disaster on the German/Swiss border proved that national systems have to be replaced by a Europe-wide system. At this moment, the national vested interests will be in disarray, and so there is a better chance than at any other time to infiltrate a system (The Kernel Machine) whose merits are based on performance rather than on the kickbacks to the various parties involved.

Ivor Catt
St. Albans,
UK

Too much audio

I have been a regular subscriber to *E&W* for many years dating from 1979. I read your editorial in the October 2002 and appreciate your dichotomy in having to cater for the predilections of a diverse readership. Your points with regards to the 'audiophile' view of no computing based articles is manifestly borne out by some remarkable letters in the same issue. However, the content and bias of the issue in question was worse than disappointing.

I purchase *E&W* purely to help with my professional work. An obsession with all things audio is of little use or interest to me. Many of the recent articles have offered practical introductions to subjects that are applicable to many of the companies for which I work as an electronic design consultant. For example, Dr. Eddy Insam's pieces have served to point the interested reader in the right direction on where to get started with Ethernet networking technology. Personally, I would like to see many more of these applied technology articles.

Please could you ensure that future issues are better balanced.

Huw Jones,
UK

Audio distortion

Cyril Bateman seems slightly to have missed the point of my article on distortion testing of loudspeaker cables using audio hardware and software. It seems I was not sufficiently clear in explaining my

aims and intentions: I apologise.

First, the choice of speaker cable as a subject for the test was only intended to be illustrative of some of the techniques one can employ with such software (incidentally, the new version of Cool Edit Pro, admittedly more expensive at \$250, has a fully zoomable spectrum display and the option of exporting the spectrum, which makes it potentially nearly as powerful as the very nice Spectra software Cyril uses and avoids some of the tedious signal-manipulation tricks I described in earlier articles).

More importantly, however, I should explain my rationale in choosing the test set-up. The entire reproduction chain (CD player and amplifiers) was exactly as I use it for subjective reviewing of speaker cables, in which situation I believe I can hear differences between cables. Typically, the distortion of the system is dominated by the power amplifier, but what I was looking for was any evidence that changing cable changed the spectrum - in which case by far the most likely explanation is that the amplifier's performance was subtly modulated by the cable's parameters, rather than that the cable itself is producing distortion. In using a CD as the signal source (with a 'perfect' dithered 16-bit digitally generated test signal of four sinusoids) and a CD recorder (16-bit, of course) as the analogue-to-digital converter. I was imposing restrictions no greater than those of the recordings with which I believe I can hear differences between cables. The test is thus fair and legitimate. Of course, real audio is typically considerably more complicated than a mere four sinusoids, but one must draw the line somewhere.

Cyril's high resolution distortion

tests are impressive and may even show up effects due to cables, but having myself conducted spot-frequency THD tests that failed to show any cable-induced distortion down to about -110dB I wished to investigate other lines of attack that might perhaps show up something at a higher (more plausibly audible!) level.

In conclusion, Cyril's excellent work on capacitors is clearly much more rigorous than my own: I merely wished to present some food for thought and a few possibilities for further development on the good old engineering principle of 'what if....?'

Richard Black
London, UK

Mobile phones and radiation, etc.

A few years ago (40+), I was asked to look at the electromagnetic spectrum for any adverse effects it could have on humans. I was given; 'start at Rugby (16kHz) up to the latest radars' (2GHz), and 0.3mM to 15µM, the then laser frequencies.

What I vaguely remember is that my findings concluded there were many frequency spots and ranges, threshold power levels and continuous power levels that appeared to have some human effect. These ranged from local burning, headaches, mood changes, etc.

In Australia someone used chickens to determine any effects by mobile phones; what a load of rubbish! Non ionising radiation can be very subtle; so I would say, "Be careful". Remember, I can get drunk on, whisky and soda, vodka and soda, ... therefore soda makes you drunk - if this makes sense to you.....

John Ingram,
South Australia. ■

No bottle?

Having read Dr S.T. Hughes letter published in the December edition of *Electronics World*, please note the comments below:

The magazine has indeed very considerably reduced in page count and the range of articles. In the past there were frequent imaginative and useful designs as well as many informative of items on practical methods.

An increase in the price would be a sensible move if it meant restoring the former breadth and excellence. I fear the magazine has become a victim of the kind of corporate asset stripping

and ruthless disposal that characterises so much business in the United Kingdom these days.

It is hoped that you and your colleagues will overcome the current difficulties with the publication.

L.P.

I normally throw away any communication that comes in anonymously - I have published this one only because I know that it will generate debate. I would say however, that I am extremely surprised when anyone who feels strongly enough to write in to me at EW does not then have the courage to identify themselves.



£11.99

**Available from
Electronics World**

All tracks on this CD were recorded on DAT from cylinders produced in the early 1900s. Considering the age of the cylinders, and the recording techniques available at the time, these tracks are of remarkable quality, having been carefully replayed using modern electronic technology by historian Joe Pengelly.

21 tracks – 72 minutes of recordings made between 1900 and 1929. These electronically derived reproductions are no worse than – and in many cases better than – reproductions of early 78rev/min recordings – some are stunning...

Use this coupon to order your copy of Pandora's drums

Please send me CD(s) at £11.99 each including VAT

Cheque

Credit card details tick as appropriate

Name

Address

Phone number

Total amount £.....

Make cheques payable to TELEVISION

Or, please debit my credit card.

Card type (Master/Visa)

Card No

Expiry date

Please mail this coupon to *Electronics World*, together with payment.

Address orders and all correspondence relating to this order to Pandora's drums, *Electronics World*, Highbury Business Communications, Anne Boleyn House, 9-13 Ewell Road, Cheam, Surrey, SM3 8BZ

Pandora's drums

Unique and atmospheric music recorded in the early 1900s – the days *before 78s*.

Track

- 1 Washington Post March, Band, 1909
- 2 Good Old Summertime, The American Quartet 1904
- 3 Marriage Bells, Bells & xylophone duet, Burckhardt & Daab with orchestra, 1913
- 4 The Volunteer Organist, Peter Dawson, 1913
- 5 Dialogue For Three, Flute, Oboe and Clarinet, 1913
- 6 The Toymaker's Dream, Foxtrot, vocal, B.A. Rolfe and his orchestra, 1929
- 7 As I Sat Upon My Dear Old Mother's Knee, Will Oakland, 1913
- 8 Light As A Feather, Bells solo, Charles Daab with orchestra, 1912
- 9 On Her Pic-Pic-Piccolo, Billy Williams, 1913
- 10 Polka Des English's, Artist unknown, 1900
- 11 Somebody's Coming To My House, Walter Van Brunt, 1913
- 12 Bonny Scotland Medley, Xylophone solo, Charles Daab with orchestra, 1914
- 13 Doin' the Raccoon, Billy Murray, 1929
- 14 Luce Mia! Francesco Daddi, 1913
- 15 The Olio Minstrel, 2nd part, 1913
- 16 Peg O' My Heart, Walter Van Brunt, 1913
- 17 Auf Dem Mississippi, Johann Strauss orchestra, 1913
- 18 I'm Looking For A Sweetheart And I Think You'll Do, Ada Jones & Billy Murray, 1913
- 19 Intermezzo, Violin solo, Stroud Haxton, 1910
- 20 A Juanita, Abrego and Picazo, 1913
- 21 All Alone, Ada Jones, 1911

NEW PRODUCTS

Please quote *Electronics World* when seeking further information

UPS that rides those brownouts

Advance Galattek is offering a range of digital line interactive sine-wave uninterruptible power systems (UPS), designed to fit on a standard 19in. rackmount cabinet tray. The LineUPS-R series comprises models from 500VA to 2000VA, and features a built-in automatic voltage stabiliser that allows it to ride through sags, surges and brownouts without the need to resort to battery power. This means that loads connected to LineUPS-R are protected from potentially damaging variations in the power supply, such as spikes and electrical noise, and also allows the batteries to remain in a fully charged state in anticipation of potential mains power interruptions.

Advance Galattek
www.aelgroup.co.uk
Tel: +44(0) 800 269394

Mosfet driver can take big transients

Linear Technology is offering the LT1910 high side N-channel Mosfet driver with an operating supply range of 8V to 48V and protection against supply transient from -15V to 60V. The LT1910 can be used as a solid-state circuit breaker or load switch to protect resistive, capacitive and inductive loads



from short circuit and over-current conditions. It is designed for harsh operating environments such as industrial, avionics and automotive applications where poor supply regulation and/or transients may be present. Applications include stepper motor control, DC motor control, robotics, heavy

machinery and electronic circuit breakers. The device incorporates a charge pump to fully enhance an external n-channel Mosfet without requiring any external components. It features short-circuit and over-current protection as well as a diagnostic output signal to alert the rest of the system in the event of a fault condition. When over-current is detected, the LT1910 turns off the Mosfet then automatically turns it back on after a set time period eliminating the need for external control circuitry. The over-current value and timer are adjustable by the user. The device repeats this cycle until the fault is removed or the driver is turned off. It is offered in an 8-pin SO package.

Linear Technology
www.linear-tech.com
Tel: +44(0) 1276 677676

70mm fans with alarms and tach output

NMB Technologies has introduced two 70mm fans, the 2806KL and 2810KL, which offer optional tach output, and locked rotor alarm signals. Sizes of the 2806KL and 2810KL are 70 by 15mm, and 70 by 25mm respectively. The 2806KL fan delivers up to 64.6m³/hr and the 2810KL fan delivers up to 52.7m³/hr in a free air environment. The failure rate is specified at less than 60 parts per million based on actual field test data. Both the fans meet all UL/CSA, VDE and CE requirements.

NMB Technology
www.nmbtc.com
Tel: +44(0) 01 818 341 3355

Aluminium enclosures

Hammond Electronics has introduced an extra size in its 1590 series of die-cast aluminium enclosures. Available in standard, flanged, flanged lid and waterproof versions, the G size enclosure measures 100 x 50 x 25mm. All versions have a shallow draft angle for easy PCB mounting and use countersunk screws into drilled and tapped



holes to allow repeated openings and closures. Lapped joint construction ensures continuity between lid and base. The units are available in natural or powder coated painted finish. The flanged version has factory fitted flanges assembled to the base, so the enclosure can be screwed down to a surface while the lid remains accessible for removal. In the flanged lid

version, the lid extends beyond the body to let the enclosure be mounted to a surface.

Waterproof versions have an extruded silicone rubber gasket around the lap joint in the lid to give IP65 sealing. Electrical continuity between the lid and base is maintained.

Hammond Electronics
www.hammondmfg.com
Tel: +44(0) 1256 812812

Chassis meets space needs for avionics

SBS Technologies has introduced a standard 1/2 ATR short Arinc-404 chassis designed to meet the space limitations of the Arinc-404A envelope used in most avionics applications. The RCOM5-ATR-6V lightweight aluminium chassis is cooled by convection or via a base cold plate, which improves thermal performance and allows a

IGBTs help wash clothes

International Rectifier has introduced 600V non punch-through IGBTs for motor drive applications such as clothes washers and air conditioners, as well as light industrial motor drives. Dubbed Co-Packs, the devices consist of a 600V IGBT and one of its Hexfred fast recovery diodes rated at 5, 7, 12 or 20A. The single package devices are configured for half-bridge or inverter topology and have a 10µs short-circuit capability. They improve ruggedness during start-up and abnormal current and voltage spikes, said the supplier. A low current tail at turn-off reduces switching energy losses compared with previous devices, allowing modulated frequencies up to 20kHz. Higher modulated frequencies allow better torque control at lower speeds and reduced audible noise. Thinner wafers reduce electrical and thermal resistance, providing lower switching losses without any increase in conduction losses. Turn-off does not require a negative bias, eliminating the need for an auxiliary power supply, and simplifying the use of gate driver ICs.

International Rectifier
www.irf.com
Tel: +44(0) 208 645 8003



NEWPRODUCTS

Please quote *Electronics World* when seeking further information

maximum temperature range of -40 to $+71^{\circ}\text{C}$. The chassis houses a five-slot 6U VME64X backplane accommodating up to five toploaded conduction cooled 6U VME boards, including power supply and a 300W 28VDC plug in power supply that is MIL740D and MIL461C compliant. The chassis removable surfaces are provided with environmental and EMI gaskets, which protect internal electronic assemblies from airborne contaminants. The chassis is sealed creating a dry air environment with all boards, including the power supply, secured with wedge locks to increase resistance against shock and vibration.

SBS Technologies
Tel: +1 760 438 6900
www.sbs.com

VME graphics board

Peritek has introduced its first entry-level PCI mezzanine card (PMC) graphics board for use in VMEbus and CompactPCI embedded systems. The Tropos PMC is the first graphics controller to use Silicon Motion's SM731 graphics accelerator. The card is designed

for 2D, 3D, OpenGL and DirectX-compatible displays. It supports Linux, VxWorks and Windows operating systems. Silicon Motion's 128-bit SM731 graphics accelerator supports screen resolutions up to 1,600 x 1,200. The SM731 can be configured with 16 or 32Mbyte of high speed display SDRAM to provide local storage for image and off-screen data such as texture maps. Z-buffer and backing store.

Peritek
Tel: +1 510 531 6500
www.peritek.com

Simmer modules aid YAG laser pumping

Hitek Power has introduced a 10W simmer module for use with the flashlamps used to



pump YAG lasers and in other intense pulsed-light systems. Powered from a 24V DC supply, making it suitable for medical applications, SM10 will provide up to 100mA of simmer current at 100V. The unit incorporates a trigger pulse output to drive an external trigger transformer. Custom versions are available, either as standalone supplies or integrated into a dedicated flash lamp unit. Versions with 25 or 50W outputs will be added to the range before the end of the year.

Hitek Power
Tel: +44(0) 1243 841888
www.hitek.com

Audio IC simplifies receiver design

An audio IC from Rohm simplifies radio receiver design by integrating European RDS and American RBDS decoding functionality in one chip. Rohm's BU1924 RDS/RBDS is a CMOS-based decoder IC with a two-stage anti-aliasing low pass filter, 57kHz eight-stage band-pass filter and digital PLL for DSB demodulation. A quality indication output for demodulated data is provided. The BU1924 is aimed at



RDS/RBDS-compatible FM receivers including home stereo systems, car radios and FM pagers. By offering RDS and RBDS functionality, the device is suited to radio products for operation in Europe and the USA. Designed to operate with a normal 5V supply voltage, it has a maximum power dissipation of 350mW at 25°C . Available in either SOP16 surface mount packaging or as a DIP16, operating temperature is -40 to $+85^{\circ}\text{C}$.

Rohm
Tel: +44(0) 1908 282666
www.rohm.co.uk

Wireless system design tool models physical links

Mathworks has announced the availability of a communications Blockset, which extends its Simulink system-level design environment by providing more than 150 blocks to model the physical and link layer of communications systems. According to the company, algorithms and wireless system models enable communications systems engineers to develop more accurate system-level simulations and specifications for wireless, broadband, broadcasting, and satellite systems and semiconductors. The communications Blockset 2.5 can be used with other of the firm's products, including the DSP Blockset 2.5, Signal Processing Toolbox and Communications Toolboxes. Real-time Workshop, and Stateflow, to perform simulations of communications devices and links. The latest version contains an RF impairments library, which

Power management over 48V backplanes

Xicor's latest power management devices integrate power sequencing and hot swap functions with an SMBus interface to enable power supply control in multi-card -48V backplane applications. The devices' hot swap features allow for insertion and extraction of line cards,

network interface cards and other peripherals whilst -48V of power is present on the backplane. Power supply sequencing allows for systematic on/off control of DC-to-DC converters on the line cards or other devices. Through the use of the SMBus, interfaces allow for power

distribution designs by reporting voltage, current and manufacturing identifications to a control card that can manage power distribution, timing and voltage supplies. The -30V to 110V hot swap controllers are able to sequence and control up to five independent DC-to-DC converters, offering flexible module sequencing in parallel or relay modes. Four independent built-in delay circuits are provided for DC/DC sequencing. With on-chip 2k EEPROM for storage of customer programmed features, the X80000 and X80001 devices have selectable overvoltage and undervoltage detection and protection. Production samples are available for the X80000 and X80001 in 32-lead QFN packaging.

Xicor
Tel: +44(0) 1908 282666
www.xicor.com

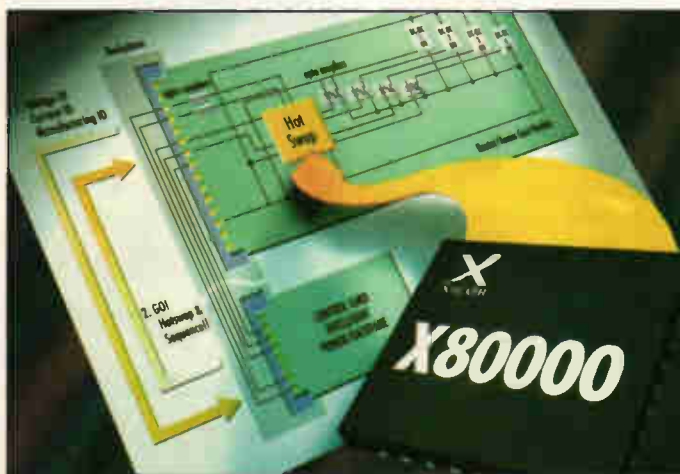

NEW VERSION B² Spice Pro v4.2

Watch your designs come alive

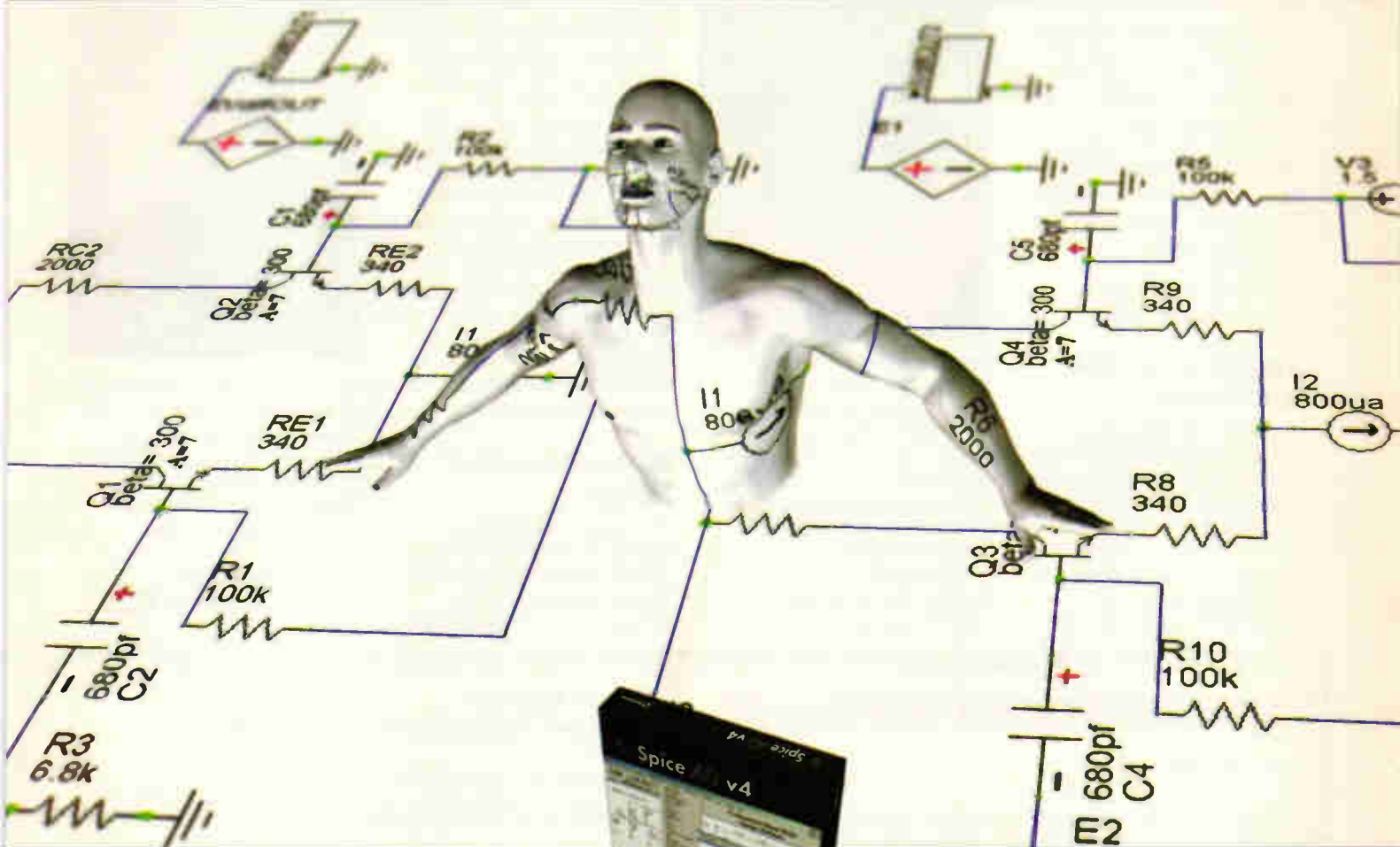

Setting new standards in price & performance for SPICE

See what's really going on with powerful new Dynamic Schematics.

Make changes to designs during simulation and watch the effects in real time.

More simulation options than ever before.

A massive parts database as standard.

Free telephone and on-line technical support.

Outstanding value at £239 ex VAT.

'We are so confident that B2 Spice Pro will impress you that we offer an unconditional 30-day evaluation of the full boxed version, complete with printed user manual. If you don't like it, then simply return it.'

Call **01603 872331**

order on-line www.spice-software.com

30 day free evaluation available on all versions

Just some of what's new

A whole range of new features not found in packages costing under £1000.

- Advanced animated schematics.
- Realtime 'live' simulation adjustments.
- 16 simulation options from Monte Carlo to RF.
- Improved PCB export and bill of materials.
- Detailed schematics with DIN and ANSI symbols.
- RF simulations and network analysis.
- Schematic borders and titles for professional output.
- Smith and polar plots.
- A massive 25,000 parts database as standard.
- Powerful new graphing and plotting - display & switch between multiple graphs easily.
- New "workspace" window to manage your projects.
- New "parts chooser" window to easily pick and place.
- Combined digital and analogue graphs.
- Even faster simulations.
- Unlimited undo / redo.
- Many new simulation models.
- Create new parts.
- Create and edit symbols.
- Create new PCB layout parts.
- New fully featured schematic editor.

Professional version **£239 ex VAT**

Standard version **£139 ex VAT**

Upgrade from earlier versions **£119 ex VAT**

Postage & packing £5.00.

Education discounts and site licences available.



Research House, Norwich Road, Eastgate
Norwich. NR10 4HA. Fax: 01603 879010
Email info@looking.co.uk



NEWPRODUCTS

Please quote *Electronics World* when seeking further information

allows users to model the impact of nonlinearity, phase noise and other RF effects on baseband communications design. New application examples of complete end-to-end communication links, including WCDMA, Hiperlan/2, IEEE 802.11, and Bluetooth, provide a starting point for the simulation of wireless systems.

Mathworks

Tel: +44(0) 1223 423200

www.mathworks.co.uk



Eight channel UART has PCI-bus

Distributor DT Electronics is offering an eight channel UART that includes a PCI-bus interface to simplify design and save on board space. The Exar XR17C158 is an octal UART designed to meet the 32-bit PCI-bus and high bandwidth requirement in communication

systems. To speed up interrupt parsing, the global interrupt source register provides a complete interrupt status indication for all eight channels. Each UART has an 16C550 compatible set of configuration registers, transmit and receive FIFOs of 64byte, fully programmable transmit and receive FIFO level triggers, transmit and receive FIFO level

counters, automatic RTS-CTS or DTR-DSR hardware flow control with programmable hysteresis, automatic software (X_{on} and X_{off}) flow control, IrDA encoder-decoder, eight multi-purpose definable inputs and outputs, and a 16-bit general purpose timer-counter. The device provides data transfer in byte, word and double-word and features read-write burst operation. With PCI compliance, it operates from 5V, or 3.3V with 5V tolerant inputs.

DT Electronics

Tel: +44(0) 2476 437437

www.dtelectronics.com

Automotive trench Mosfet

International Rectifier has introduced an automotive-specific, trench Hexfet power Mosfet which the supplier claimed has a 15 per cent lower



device on-resistance per unit area than alternative technology. The Mosfet technology offers an avalanche capability comparable to planar technology and up to twice that of currently available trench products, said the supplier.

International Rectifier

Tel: +44(0) 208 645 8002

www.irf.com

Build and Upgrade Your Own PC

Second Edition

- Save £100s by making your current PC last longer
- You can have a PC with a spec that matches your needs
- Discover the practical techniques of upgrading a PC and avoid the pitfalls

Ian Sinclair's Build Your Own books have established themselves as authoritative and highly practical guides for home PC users and advanced hobbyists alike. All aspects of building and upgrading a PC are covered; making this the book the computer retailers don't want you to read! By getting to grips with the world of PC hardware you can avoid the built-in obsolescence that seems to be part and parcel of the fast moving world of PCs, and escape the need to buy a new PC every year. You can also have a PC that keeps pace with the ever-increasing demands that new software applications place on your system.

The new edition of this book is based round building and upgrading to the latest systems such as Pentium III and dual-processor Celeron motherboards running Windows 95/98 or Windows 2000. As well as guiding you round the inside of your CPU Ian Sinclair also covers monitors, printers, high capacity disk and tape systems, DVD drives, parallel port accessories....

CONTENTS: Preface; Preliminaries, fundamentals and buying guide; Case, motherboard and keyboard; About disk drives; Monitors, standards and graphics cards; Ports; Setting up; Upgrading; Multimedia and other connections; Windows; Printers and modems; Getting more; Index

How to pay

(Build and Upgrade Your Own PC) paperback

- I enclose a cheque/bank draft for £ _____
(payable to ELECTRONICS WORLD)

Please charge my credit/charge card

- Mastercard American Express Visa Diners Club

Credit Card No: _____

Expiry Date: _____

Signature of Cardholder _____

Cardholder's statement address: (please use capitals)

Name _____

Address _____

Post Code _____ Tel: _____

Post your completed order form to:-
Jackie Lowe, Highbury Business Communications,
Anne Boleyn House, 9-13 Ewell Road, Cheam,
Surrey, SM3 8BZ

UK Price: £22.50 Europe £24.00 ROW £26.00
Price includes delivery

PROTEUS

The Complete Electronics Design System

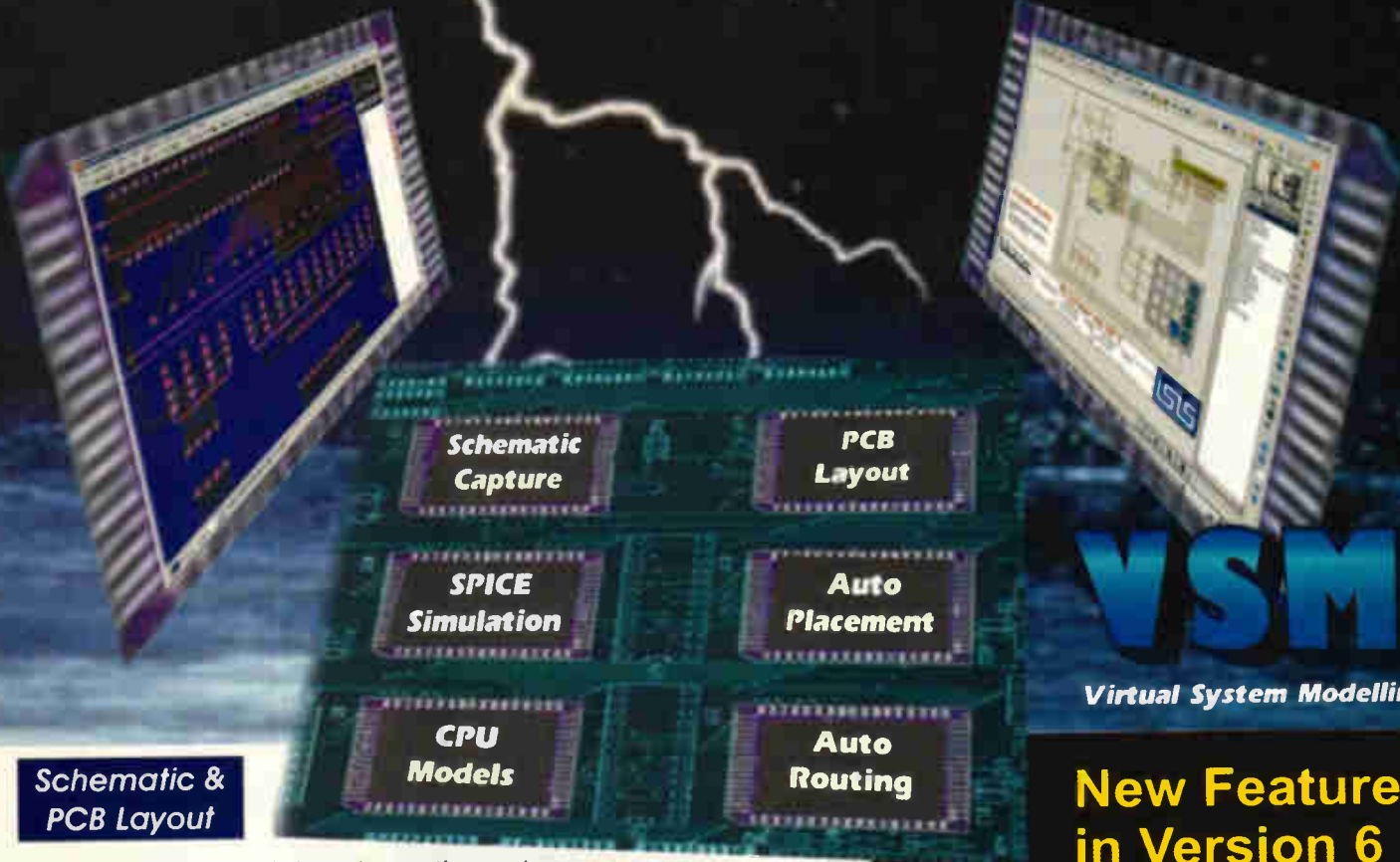

Schematic & PCB Layout

- Powerful & flexible schematic capture.
- Auto-component placement and rip-up/retry PCB routing.
- Polygonal gridless ground planes.
- Libraries of over 8000 schematic and 1000 PCB parts.
- Bill of materials, DRC reports and much more.

Mixed Mode SPICE Circuit Simulation

- Berkeley SPICE3F5 simulator with custom extensions for true mixed mode and interactive simulation.
- 6 virtual instruments and 14 graph based analysis types.
- 6000 models including TTL, CMOS and PLD digital parts.
- Fully compatible with manufacturers' SPICE models.

Proteus VSM - Co-simulation and debugging for popular Micro-controllers

- Supports PIC, AVR, 8051, HC11 and ARM micro-controllers.
- Co-simulate target firmware with your hardware design.
- Includes interactive peripheral models for LED and LCD displays, switches, keypads, virtual terminal and much, much more.
- Provides source level debugging for popular compilers and assemblers from Crownhill, IAR, Keil, and others.

VSM

Virtual System Modelling

New Features in Version 6

- Drag and drop toolbars.
- Visual PCB packaging tool.
- Improved route editing.
- Point and click DRC report.
- Multiple design rules (per net).
- Multiple undo/redo.

Call Now for Upgrade Pricing

Works with
PIC Basic Plus
from Crownhill
Associates

labcenter

Electronics
53-55 Main Street, Grassington. BD23 5AA

Tel: 01756 753440
Fax: 01756 752857

Contact us for
Free Demo CD

www.labcenter.co.uk
info@labcenter.co.uk

NEWPRODUCTS

Please quote *Electronics World* when seeking further information

PICmicro draws 0.1µA in standby

Microchip Technology's latest family of PICmicro flash microcontrollers features six power-managed modes with power consumption down to 0.1µA in standby mode and an operating voltage range from 2 to 5.5V. According to the supplier, the target power consumption will be 110µA at 1MHz, 2V and 330µA at 1MHz, 5V. The PIC18FXX20 microcontrollers are pin- and code-compatible with the firm's current 18-, 28- and 40-pin portfolio. The power

management features include a flexible clock system with six software controlled power-managed modes which allow designers to execute code from a real-time clock base as well as control the speed of their code execution, thus allowing better control of the overall system power consumption. Additional features include a new low-current watchdog timer, a two-speed start-up from a reset or sleep mode and a new fail-safe clock monitor that is used to detect an external clock failure. The devices offer up to 8kbyte of flash program memory, up to 512byte of RAM memory,

256byte of EEPROM memory and an internal multi-frequency oscillator up to 8MHz. Additional features include a 10-bit analogue-to-digital converter with up to 13 channels, and an enhanced capture/compare/PWM module with one, two or four outputs.

Microchip Technology
Tel: +44(0) 118 921 5869
www.microchip.com



that vendors comply with lead-free requirements. Environment-conscience initiatives in Europe and the US are gaining momentum as well, said the company.

Europe's Wastes from Electric and Electronic Equipment (WEEE) directive mandates the replacement of lead in electrical and electronic equipment by January 1, 2006, a deadline recently delayed by six months. While the US has no pending legislation to ban lead, the Computer Hazardous Waste Infrastructure program (CHIP), which promotes the recycling of electronic products, is currently under consideration.

Actel
Tel: +44(0) 1256 305600
www.actel.com

Controller connects to IP networks

Dallas Semiconductor has introduced the DS80C400, a networked microcontroller chip that integrates a high-speed 8051 core, a 10/100Mb Ethernet MAC, and silicon software TCP IPv4/v6 stack. It can be connected directly to IP networks. Operating at up to 75MHz, the DS80C400 provides ample speed to perform local control while also servicing network requests. In addition to the Ethernet MAC, the DS80C400 includes three synchronous/asynchronous serial ports that operate up to 18.75Mbit/s, a CAN2.0B controller, up to eight ports (64 I/O pins) and a 1-Wire master. Applications that require network connectivity such as MP3 audio players, web cameras, environmental controls, and industrial equipment can use the DS80C400's network interface for data collection,

DC-DC Converters have drive & switch transistors

The XC9211/9212 series of synchronous-rectification type DC/DC converters from Torex Semiconductor incorporate a 0.6W P-channel drive transistor and N-channel switching transistor.

According to the supplier, the intention of this is to allow for the use of ceramic capacitors. The devices are designed to be used in power supplies with an output current of 400mA, which can be configured using only a coil and two capacitors connected externally. Minimum operating voltage is 1.8V. Output voltage is internally programmable in a range from 0.9V to 4.0V in increments of 0.1V. Oscillation frequency is selectable from 300kHz, 600kHz and 900kHz.

The devices can be manually switched between the PWM control mode with synchronous rectification and the automatic PWM/PFM switching control mode with non synchronous rectification, allowing fast response, low ripple and high efficiency over the full range of load (from light load to high output current conditions). The soft start and current control functions are internally optimised. During standby, all circuits are shut down to reduce current consumption to as low as 0.5mA or less. Package options are 250mW (SOT-25) and 100mW (USP-6B).

Torex Semiconductor
Tel: +44(0) 1530 510190
www.torex.co.uk

Royalty-free RTOs for x86/Pentiums

Green Hills Software has its royalty-free Integrity 4.0 real-time operating system (RTOS) for the Intel x86/Pentium architecture. Featuring a memory-protected, micro-kernel architecture that guards against



viruses, hackers and errant code, the RTOS provides resource availability for CPU and memory access in real-time applications. The RTOS includes a USB stack and NFS client.
Green Hills Software
Tel: +44(0) 1844 267950
www.ghs.com

Lead-free FPGAs

Actel is to offer environmentally-friendly lead-free packaging options for its ProASIC 500K, ProASIC Plus, eX and SX-A field-programmable gate array (FPGA) families by the end of 2002. There are also plans for lead-free packaging for its remaining antifuse- and flash-based FPGA product families by the end of 2003. The company defines an environmentally-friendly package as one free of lead, halogenated compounds and antimony oxides. According to the supplier, the majority of Japanese-based companies insist

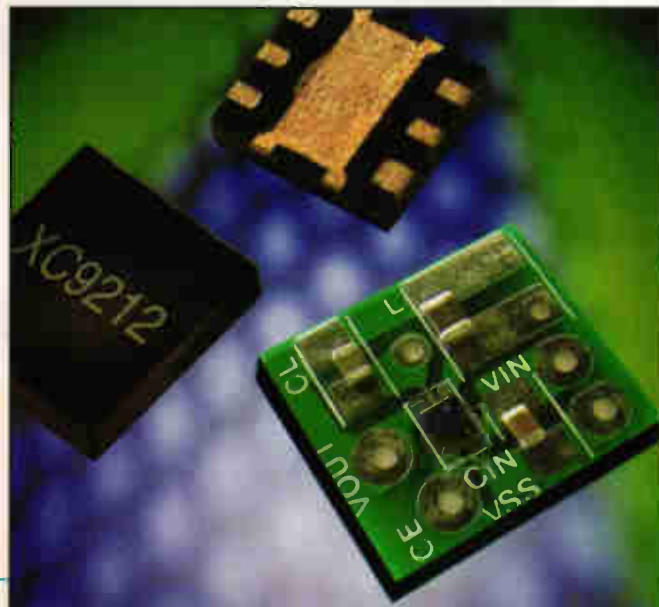

Visit our website
www.distel.co.uk

THE ORIGINAL SURPLUS WONDERLAND!

THIS MONTH'S SELECTION FROM OUR VAST EVER CHANGING STOCKS

Surplus always
wanted for cash!

GIANT 10" 7 SEGMENT DISPLAYS

A bulk purchase enables us to bring to you these GIANT 7 segment digital displays at a now affordable price! The 10" character size gives exceptional readability at long distances and enables a host of applications including score boards, digital clocks, counters, event timers etc. As the units are a simple electromechanical device and operate from 12 V DC, simple switching via switches, relays, PIC or PC may be used to control single or multiple digits. Units feature integral 'Zero Power' memory which greatly simplifies design. For an excellent DIY practical article, see the May issue of 'Everyday & Practical Electronics' magazine. Ideal School / College construction project. Supplied in good RFE condition, complete with data sheet.



Less than 30% of makers price! Only **£29.95(B)** or **4 x £99.00(D)**
Order RW44 Order PH26

THE AMAZING TELEBOX



TV SOUND &
VIDEO TUNER
CABLE COMPATIBLE*

Converts your colour monitor into a QUALITY COLOUR TV!!

The TELEBOX is an attractive fully cased mains powered unit, containing all electronics ready to plug into a host of video monitors or AV equipment which are fitted with a composite video or SCART input. The composite video output will also plug directly into most video recorders, allowing reception of TV channels not normally receivable on most television receivers (TELEBOX MB). Push button controls on the front panel allow reception of fully tuneable off air UHF colour television channels. TELEBOX MB covers virtually all television frequencies VHF and UHF including the HYPERBAND as used by most cable TV operators. Ideal for desktop computer video systems & PIP (picture in picture) setups. For complete compatibility - even for monitors without sound - an integral 4 watt audio amplifier and low level Hi Fi audio output are provided as standard. Brand new - fully guaranteed.

TELEBOX ST for composite video input type monitors **£36.95**
TELEBOX STL as ST but fitted with integral speaker **£39.50**
TELEBOX MB Multiband VHF/UHF/Cable/Hyperband tuner **£99.95**
For overseas PAL versions state 5.5 or 6 MHz sound specification.
*For cable / hyperband signal reception Telebox MB should be connected to a cable type service. Shipping on all Telebox's, code (B)

NEW State of the art PAL (UK spec) UHF TV tuner module with composite 1V pp video & NICAM hi fi stereo sound outputs. Micro electronics all on one small PCB only 73 x 160 x 52 mm enable full tuning control via a simple 3 wire link to an IBM pc type computer. Supplied complete with simple working program and documentation. Requires +12V & +5V DC to operate. **BRAND NEW - Order as MY00. Only £39.95 code (B)**
See www.distel.co.uk/data_my00.htm for picture & full details

HARD DISK DRIVES 2fi" - 14"

2fi" TOSHIBA MK1002MAV 1.1Gb laptop (12.5 mm H) New **£59.95**
2fi" TOSHIBA MK4313MAT 4.3Gb laptop (8.2 mm H) New **£105.00**
2fi" TOSHIBA MK6409MAV 6.1Gb laptop (12.7 mm H) New **£98.00**
2fi" TOSHIBA MK1814GAV 18 Gb laptop (12 mm H) New **£149.95**
2fi" to 3fi" conversion kit for Pc's, complete with connectors **£15.95**
3fi" COMPAQ 313706-B21 (IBM) 9 gb ULT/SCSI3 New **£199.00**
3fi" FUJI FK-309-26 20mb MFH I/F RFE **£59.95**
3fi" CONNER CP3024 20 mb IDE I/F (or equiv.) RFE **£59.95**
3fi" CONNER CP3044 40 mb IDE I/F (or equiv.) RFE **£69.00**
3fi" QUANTUM 40S Prodrive 42mb SCSI I/F, New RFE **£49.00**
5" MINISCRIBE 3425 20mb MFH I/F (or equiv.) RFE **£49.95**
5" SEAGATE ST-238R 30 mb RLL I/F RFE **£69.95**
5" CDC 94205-51 40mb HH MFH I/F RFE tested **£69.95**
5" HP 97548 850 Mb SCSI RFE tested **£99.00**
5" HP C3010 2 Gbyte SCSI differential RFE tested **£195.00**
8" NEC D2246 85 Mb SMD interface. New **£99.00**
8" FUJITSU M2322K 160Mb SMD I/F RFE tested **£195.00**
8" FUJITSU M2392K 2 Gb SMD I/F RFE tested **£345.00**
Many other floppy & H drives, IDE, SCSI, ESDI etc from stock, see website for full stock list. Shipping on all drives is code (C)

IC's - TRANSISTORS - DIODES

OBSOLETE - SHORT SUPPLY - BULK
10,000,000 items EX STOCK
For MAJOR SAVINGS
CALL or see web site www.distel.co.uk

COMPUTER MONITOR SPECIALS

Legacy products
High spec genuine multisync.
CGA, EGA, VGA, SVGA

Mitsubishi FA3415ETKL 14" SVGA Multisync colour monitor with fine 0.28 dot pitch tube and resolution of 1024 x 768. A variety of inputs allows connection to a host of computers including IBM PC's in CGA, EGA, VGA & SVGA modes. BBC, COMMODORE (including Amiga 1200), ARCHIMEDES and APPLE. Many features: Etched faceplate, text switching and LOW RADIATION MPR specification. Fully guaranteed, in EXCELLENT little used condition. Tilt & Swivel Base **£4.75**

VGA cable for IBM PC included. **Only £129 (E)** Order as CG73

External cables for other types of computers available - CALL

Generic LOW COST SVGA Monitors

We choose the make, which includes Compaq, Mitsubishi, IBM, etc. Supplied ready to run with all cables, Standard RTB 90 day guarantee.

14" order TD84	15" order TG21	17" order TJ66
-------------------	-------------------	-------------------

Supplied in good used condition. Shipping code (D)

VIDEO MONITORS

PHILIPS HCS35 (same style as CM8833) attractively styled 14" colour monitor with both RGB and standard composite 15.625 KHz video inputs via SCART socket and separate phono jacks. Integral audio power amp and speaker for all audio visual uses. Will connect direct to Amiga and Atari BBC computers. Ideal for all video monitoring / security applications with direct connection to most colour cameras. High quality with many features such as front concealed flap controls, VCR correction button etc. Good used condition - fully tested - guaranteed
Dimensions: W14" x H12" x 15" D. **Only £99.00 (D)**

PHILIPS HCS31 Ultra compact 9" colour video monitor with standard composite 15.625 KHz video input via SCART socket. Ideal for all monitoring / security applications. High quality, ex-equipment fully tested & guaranteed (possible minor screen burns). In attractive square black plastic case measuring W10" x H10" x 13" D. 240 V AC mains powered. **Only £79.00 (D)**

INDUSTRIAL COMPUTERS

Tiny shoebox sized industrial 40 Mhz 386 PC system measuring only (mm) 266 x X 88 h X 272 d. Ideal for dedicated control applications running DOS, Linux or even Windows! Steel case contains 85 to 265 V AC 50 / 60 Hz 70 Watt PSU, a 3 slot ISA passive backplane and a Rocky 318 (PC104) standard, single board computer with 8 MByte NON VOLATILE solid state 'Disk On Chip' RAMDISK. System comprises: Rocky 318 (PC104) SBC ISA card with 40MHz ALI 386SX CPU, 72 pin SIMM slot with 16 MByte SIMM, AMI BIOS, battery backed up real time clock, 2 x 9 pin D 16550 floppy ports, EPP/ECP printer port, mini DIN keyboard connector, serial port, IDE port for hard drives up to 528 MByte capacity, watchdog timer and PC/104 bus socket. The 8 MByte solid state 'disk on chip' has its own BIOS, and can be disked, formatted & booted. Supplied BRAND NEW fully tested and guaranteed. For full data see featured item on website. Order as OG36
100's of applications inc:
firewall routers robotics etc **Only £99.00 (D)**

19" RACK CABINETS

Save £££'s
Europe's Largest Stocks of
quality rack cabinets,
enclosures and accessories.
Over 1000 Racks from stock

This month's special
**33 / 42 / 47 U - High Quality
All steel Rack Cabinets**

BIG £ SAVER

Made by Eurocraft Enclosures Ltd to the highest possible spec, rack features all steel construction with removable side, front and back doors. Front and back doors are hinged for easy access and all lockable with five secure 5 lever barrel locks. The front door is constructed of double walled steel with a 'designer style' smoked acrylic front panel to enable status indicators to be seen through the panel, yet remain unobtrusive. Internally the rack features fully slotted reinforced vertical fixing members to take the heaviest of 19" rack equipment. The two movable vertical fixing struts (extras available) are pre punched for standard 'cage nuts'. A mains distribution panel internally mounted to the bottom rear, provides 8 x IEC 3 pin Euro sockets and 1 x 13 amp 3 pin switched utility socket. Overall ventilation is provided by fully louvered back door and double skinned top section with top and side louvres. The top panel may be removed for fitting of integral fans to the sub plate etc. Other features include: fitted castors and floor levelers, prepunched utility panel at lower rear for cable / connector access etc. Supplied in excellent, slightly used condition with keys. Colour Royal blue, some grey available - CALL - Can be supplied in many other configurations.



33U Order as BC44 External dimensions mm=1625H x 635D x 603 W. (64" H x 25" D x 23 1/2" W) Only £245	42U Order as DT20 External dimensions mm=2019H x 635D x 603 W. (79.5" H x 25" D x 23 1/2" W) Only £345	47U Order as RV36 External dimensions mm=2235H x 635D x 603 W. (88" H x 25" D x 23 1/2" W) Only £410
--	--	--

Call for shipping quotation

COLOUR CCD CAMERAS

Undoubtedly a miracle of modern technology & our special buying power! A quality product featuring a fully cased COLOUR CCD camera at a give away price! Unit features full autolight sensing for use in low light & high light applications. A 10 mm fixed focus wide angle lens gives excellent focus and resolution from close up to long range. The composite video output will connect to any composite monitor or TV (via SCART socket) and most video recorders. Unit runs from 12V DC so ideal for security & portable applications where mains power not available. Overall dimensions 66 mm wide x 117 deep x 43 high. Supplied BRAND NEW & fully guaranteed with user data, 100's of applications including Security, Home Video, Web TV, Web Cams etc, etc.

Order as LK33 **ONLY £79.00 or 2 for £149.00 (B)**

SOFTWARE SPECIALS

NT4 WorkStation, complete with service pack 3 and licence - OEM packaged. **ONLY £89.00 (B)**
ENCARTA 95 - CDROM, Not the latest - but at this price! **£7.95**
DOS 5.0 on 3fi" disks with concise books c/w QBasic. **£14.95**
Windows for Workgroups 3.11 + Dos 6.22 on 3.5" disks **£55.00**
Windows 95 CDROM Only - No Licence - **£19.95**
Wordperfect 6 for DOS supplied on 3fi" disks with manual **£24.95**
shipping charges for software is code B

SOLID STATE LASERS

Visible red, 670nm laser diode assembly. Unit runs from 5 V DC at approx 50 mA. Originally made for continuous use in industrial barcode scanners, the laser is mounted in a removable solid aluminium block, which functions as a heatsink and rigid optical mount. Dims of block are 50 x 50 x 15 mm. Integral features include over temperature shutdown, current control, laser OK output, and gated TTL ON / OFF. Many uses for experimental optics, comms & lightshows etc. Supplied complete with data sheet.

Order as TD91 **ONLY £24.95 (A)**

DC POWER SUPPLIES

Virtually every type of power supply you can imagine. Over 10,000 Power Supplies
Ex Stock - Call or see our web site.

RELAYS - 200,000 FROM STOCK

Save £££'s by choosing your next relay from our Massive Stocks covering types such as Military, Octal, Cradle, Hermetically Sealed, Continental, Contactors, Time Delay, Reed, Mercury Wetted, Solid State, Printed Circuit Mounting etc. CALL or see our web site www.distel.co.uk for more information. Many obsolete types from stock. Save £££'s

TEST EQUIPMENT & SPECIAL INTEREST ITEMS

MITSUBISHI FA3445ETKL 14" Ind. spec SVGA monitors **£245**
FARNELL 0-60V DC @ 50 Amps, bench Power Supplies **£995**
FARNELL AP3080 0-30V DC @ 80 Amps, bench Supply **£1850**
KINGSHILL CZ4031 0-50V @ DC 200 Amps - NEW **£3950**
1KW to 400 KW - 400 Hz 3 phase power sources - ex stock **EPOA**
IBM 8230 Type 1, Token ring base unit driver **£760**
Wayne Kerr RA200 Audio frequency response analyser **£2500**
INFODEC 1U, 24 port, RJ45 network patchpanels. #TH93 **£49**
3COM 16670 12 Port Ethernet hub - RJ45 connectors #LD97 **£69**
3COM 16671 24 Port Ethernet hub - RJ45 connectors **£89**
3COM 16700 8 Port Ethernet hub - RJ45 connectors NEW **£39**
IBM 53F5501 Token Ring ICS 20 port lobe modules **EPOA**
IBM MAU Token ring distribution panel 8228-23-5050N **£45**
AIM 501 Low distortion Oscillator 9Hz to 330KHz, IEEE I/O **£550**
ALLGON 8360.11805-1880 MHz hybrid power combiners **£250**
Trend DSA 274 Data Analyser with G703(2M) 64 i/o **EPOA**
Marconi 6310 Programmable to 2 to 22 GHz sweep generator **£4500**
Marconi 2022C 10KHz-1GHz RF signal generator **£1550**
HP1650B Logic Analyser **£3750**
HP3781A Pattern generator & HP3782A Error Detector **EPOA**
HP6621A Dual Programmable GPIB PSU 0-7 V 160 watts **£1800**
HP6264 Rack mount variable 0-20V @ 20A metered PSU **£475**
HP54121A DC to 22 GHz four channel test set **EPOA**
HP18130A opt 020 300 MHz pulse generator, GPIB etc **£7900**
HP A1, A0 8 pin HPGL high speed drum plotters - from **£550**
HP DRAFTMASTER 1 8 pin high speed plotter **£750**
EG+G Brookdeal 950335 Precision lock in amp **£1800**
Keithley 590 CV capacitor / voltage analyser **EPOA**
Racal ICR40 dual 40 channel voice recorder system **£3750**
Fiskers 45KVA 3 ph On Line UPS - New batteries **£4500**
Emerson AP130 2.5KVA industrial spec UPS **£1499**
Mann Tally MT645 High speed line printer **£2200**
Intel SBC 486/133SE Multibus 486 system, 8Mb Ram **£945**

Unless marked NEW, items in this section are pre owned.

HP6030A 0-200V DC @ 17 Amps bench power supply **£1950**
Intel SBC 486/125C08 Enhanced Multibus (MSA) New **£1150**
Nikon HFX-11 (Ephiphot) exposure control unit **£1450**
PHILIPS PMS518 pro. TV signal generator **£1250**
Motorola VME Bus Boards & Components List. SAE / CALL **EPOA**
Trior 0-18 vdc linear, metered 30 amp bench PSU. New **£550**
Fujitsu M3041R 600 LPM high speed bench printer **£1950**
Fujitsu M3041D 600 LPM printer with network interface **£1250**
Siemens K4400 64Kb to 140Mb demux analyser **£2950**
Perkin Elmer 299B Infrared spectrophotometer **£500**
Perkin Elmer 597 Infrared spectrophotometer **£3500**
VPE Electronics 1035 TELETEXT Decoding Margin Meter **£3250**
LightBand 60 output high spec 2u rack mount Video VDA's **£495**
Sonic SD 150H 18 channel digital Hybrid chart recorder **£1995**
B&K 2633 Microphone pre amp **£300**
Taylor Hobson Tallysurf amplifier / recorder **£750**
ADC S5200 Carbon dioxide gas detector / monitor **£1450**
BBC AM20/3 PPM Meter (Ernest Turner) + drive electronics **£75**
ANRITSU 9654A Optical DC-2.5Gb waveform monitor **£5650**
ANRITSU ML93A optical power meter **£990**
ANRITSU Fibre optic characteristic test set **EPOA**
R&S FTDZ Loud sound unit **£650**
R&S SBUF-E1 Vision monitor **£775**
WILTRON 6630B 12.4 / 20GHz RF sweep generator **£5750**
TEK 2445 150 MHz 4 trace oscilloscope **£1250**
TEK 2465 300 MHz 300 MHz oscilloscope rack mount **£1955**
TEK TDS380 400MHz digital realtime + disk drive, FFT etc **£2900**
TEK TDS524A 500MHz digital realtime + colour display etc **£5100**
HP3585A Opt 907 20Hz to 40 MHz spectrum analyser **£3950**
PHILIPS PW1730110 60KV XRAY generator & accessories **EPOA**
VARIACS - Large range from stock - call or see our website
CLAUDE LYONS 12A 240V single phase auto. volt. regs **£325**
CLAUDE LYONS 100A 240/415V 3 phase auto. volt. regs **£2900**

display
-ELECTRONICS-



ALL MAIL TO
Dept W, 29 / 35 Osborne Rd
Thornton Heath
Surrey CR7 8PD, UK
Open Mon - Fri 9.00 - 5:30

18 Million Items On Line Now!
Secure Ordering, Pictures, Information
www.distel.co.uk
email = admin@distel.co.uk

ALL ENQUIRIES
0208 653 3333
FAX 0208 653 8888

All prices for UK Mainland. UK customers add 17.5% VAT to TOTAL order amount. Minimum order £10. Bona Fide account orders accepted from Government, Schools, Universities and Local Authorities - minimum account order £100. Cheques over £100 are subject to 7 working days clearance. Carriage charges (A)=£3.50, (B)=£6.50, (C)=£10, (D)=£15.00, (E)=£18.00, (F)=CALL. Allow approx 3 days for shipping - faster CALL. All goods supplied to our Standard Conditions of Sale which can be viewed at our website and unless stated guaranteed for 90 days. All guarantees on a return to base basis. All rights reserved to change prices / specifications without prior notice. Orders subject to stock. Discounts for volume. Top CASH prices paid for surplus goods. All trademarks, tradenames etc acknowledged. © Display Electronics 2002. E & O E.

NEWPRODUCTS

Please quote *Electronics World* when seeking further information

remote monitoring and control as well as remote application updates. Applications can be executed from local memory or downloaded from the internet for quick application updates.

Dallas Semiconductor
Tel: +44(0) 121 782 2959
www.maxim-ic.com

Single chip RF transceiver

Philips is offering a single-chip RF transceiver for 2G and 2.5G mobile phones that supports up to quad-band, GSM/GPRS and full EDGE transmit/receive operations. The UAA3537 RF transceiver is designed to support dual-band and GSM to full EDGE handsets. It uses a near-zero intermediate frequency architecture for the receive channel, and a direct up-conversion architecture for the transmit channel. The intention has also been to eliminate the need for surface acoustic wave filters from the design, keeping external component count to an absolute minimum. Four integrated programmable LNAs (low noise amplifiers) in the receive channel enable designers to configure the phone for quad-band operation at 850MHz, 900MHz, 1,800MHz and 1,900MHz or for dual-band or

16-Slot backplanes for PICMG 3.1/2/3

APW Electronic Solutions has a prototype batch of 16-slot backplanes meeting the requirements of the latest AdvancedTCA (Telecommunications Computer Architecture) specification. ATCA 3.0 is the generic platform specification, defining the mechanics, board dimensions, power distribution and platform management requirements. It is fabric agnostic. The three fabrics for which specifications are in development are PICMG 3.1, 1Gbit/s Ethernet, 3.2, defining how Infiniband systems are built within the architecture and 3.3, defining a Starfabric implementation over the backplane providing TDM, cell, control and packet



connectivity over the same fabric. In order to keep the thickness down and achieve the required electrical characteristics, they are manufactured from low dielectric ($\epsilon_r = 3.5$) laminates and pre-preg instead of FR4; the backplanes are of 34 layer construction, 18 signal layers and 16 power/ground layers.

The initial prototypes are 5U high, 23in. wide and 6.9mm thick; production versions could be up to 8U high to include the Zone 3 rear I/O access area. A total of 3,200W can be distributed through the backplane.

APW
Tel: +44(0) 1489 774500
www.apw.com

triple-band combinations of these frequencies. The UAA3537's low-noise, wide dynamic range, N-ZIF receiver has a gain control range of over 68dB, providing voice and data reception over a wide range of signal conditions. Its direct up-conversion transmitter achieves a noise performance of -163dBc/Hz at 20MHz offset,

which is designed to eliminate the need for a SAW filter between the transceiver chip and the handset's RF power amplifier. The device operates over a voltage range of 2.4V to 3.0V, and is housed in a 6 x 6mm HVQFN package.

Philips
Tel: +31 40 272 2091
www.semiconductors.philips.com

Controller with 0.4µA LCD driver

EM Microelectronics has two microcontrollers with a built-in 4MUX LCD driver consuming 0.4µA and operating at 1.2V. These ROM mask microcontrollers are designed for controlling functions in battery-operated devices and lower cost applications, including toys, household appliances, sports timing devices, security devices and medical devices. These circuits include internal voltage regulators, so they have constant low-power consumption even in noisy environments. The devices consume 1.6µA in active mode and 0.4µA in the standby mode (LCD off) and 0.2µA in sleep mode. They also include a melody generator that can be used for basic sound generation. The EM6625 drives 20 segments, three or four times multiplexed, while the EM6626 drives 32 segments, three or four times multiplexed. These microcontrollers have LCD frequencies of 32, 42.7 or 64Hz, allowing them to avoid interferences with harmonics in RF and communication applications.

EM Microelectronics
Tel: +44(0)41 32 755 5111
www.emmicroelectronics.com

Small relay switches 1.5GHz signals

Omron has introduced its smallest relay capable of switching 1.5GHz signals in mobile, wireless LAN,

broadcasting and set-top box applications. With external dimensions of 20 x 9 x 8.6mm, the G6Z relay is 25 per cent smaller than the firm's current design and there are various device formats to suit applications in cable TV, broadcast studio, and set-top box applications, W-CDMA mobile basestations, ATE equipment, and wireless PABX/LAN installations alike, operating at between 1GHz and 2.6GHz. Insertion loss is only 0.2dB at 900MHz, rising to 0.5dB at 2.6GHz whilst VSWR is 1.2 and 1.5 respectively at these frequencies. Isolation is 65dB or 30dB, again at the same frequencies, whilst the relay can transmit up to 10W. It is available in both 50Ω and

75Ω variants, with E-type and Y-type PCB terminal layouts. Contact configuration can be specified in both normal and a, b reversed forms. The G6Z is available as either single-stable or 1.2 coil latching - with a very high sensitivity of only 360mW in the 2 coil latching types. The supplier has rated the relay for a mechanical life of one million operations, and an electrical life of at least 300,000 operations, under the specified operating conditions. The G6Z relay is available in both through hole and surface mounting form, and is manufactured using a lead-free process.

Omron
Tel: +44(0) 870 750 5661
www.omroncomponents.co.uk



BOOKS TO BUY



PASSIVE COMPONENTS FOR CIRCUIT DESIGN

Passive Components for Circuit Design is a unique introduction to this key area of analog electronics designed for technician engineers and anyone involved in circuit design. The coverage encompasses all component types capable of power amplification: resistors, capacitors, transformers, solenoids, motors and transducers. The behaviour of the components is explored along with the different types available and the principles of circuit design. Tolerances, stability, variation with temperature, reliability and manufacturing standards are all covered. Reading this book will improve your skills in component selection and analog circuit design. These are essential skills not only for the analog designer, but for all circuit designers, professional or amateur.

Contents: Preface; Fundamentals; Fixed resistors; Variable resistors, potentiometers and diodes; Capacitors; Inductors and inductive components; Inductive devices; Transducing components; SMT; Hardware; Index

Readership: Technician engineers, circuit designers, advanced hobbyists
 Pages: 304pp
Price: UK £23.00
Europe £24.00
ROW £27.00

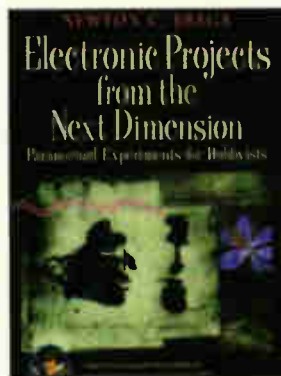

ELECTRONIC PROJECTS FROM THE NEXT DIMENSION

For years paranormal scientists have explored the detection and documentation of spirits, auras, ESP, hypnosis, and many more phenomena through electronics. Electronic Projects from the Next Dimension provides useful information on building practical circuits and projects, and applying the knowledge to unique experiments in the paranormal field. The author writes about dozens of inexpensive projects to help electronics hobbyists search for and document their own answers about instrumental transcommunication (ITC), the electronic voice phenomenon (EVP), and paranormal experiments involving ESP, auras, and Kirlian photography.

Although paranormal studies are considered esoteric, Electronic Projects from the Next Dimension teaches the technical skills needed to make devices that can be used in many different kinds of experiments. Each section indicates how the circuit can be used in paranormal experiments with suggestions about procedures and how to analyze the results.

Contents: White noise generators for use in instrumental transcommunication (ITC) and electronic voice phenomenon (EVP) experiments; Practical circuits for image experimentation, such as a



BASIC AC CIRCUITS

This is the step-by-step approach for beginners. This self-paced individualized learning tool covers concepts, terms, and the mathematics required to understand AC circuit problems. It has been designed to improve analysis techniques for prediction and control development.

Readership: Beginners meeting AC circuits for the first time: students; technicians

Pages: 921pp
Price: UK £34.00
Europe £36.00
ROW £38.00

wireless sparkling image generator, horizontal bar generator, brontophic sound, magnetic field generator, high-voltage generators (Kirlian Machine's I & II); Paranormal skills experiments with temperature change, polygraph, electro-shock, random number generation, UFO detection, and ghost-finding.

Readership: Hobbyists, Electronics Enthusiasts
 Pages: 256pp
Price: UK £28.00
Europe £30.00
ROW £37.00

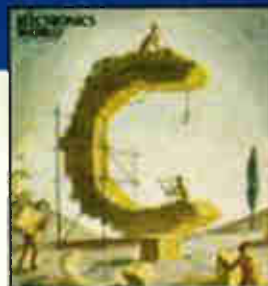

Interfacing with C

INTERFACING WITH C

A practical and painless way of becoming an expert C programme New edition also covers C++ and the Windows environment Get up to speed with the essential maths needed for C without having to buy a university maths text!

Price: UK £20.00
Europe £22.00
ROW £24.00

Post your completed order form to:-

Jackie Lowe,
Highbury Business Communications,
Anne Boleyn House, 9-13 Ewell Road,
Cheam, Surrey, SM3 8BZ

How to order

Book Title _____

I enclose a cheque/bank draft for £ _____
 (payable to *ELECTRONICS WORLD*)

Please charge my credit/charge card

Mastercard American Express Visa Diners Club

Credit Card No: _____

Expiry Date: _____

Signature of Cardholder _____

Cardholder's statement address: (please use capitals)

Name _____

Address _____

Post Code _____

Tel: _____

CIRCUIT IDEAS

Fact: most circuit ideas sent to *Electronics World* get published

The best circuit ideas are ones that save time or money, or stimulate the thought process. This includes the odd solution looking for a problem – provided it has a degree of ingenuity.

Your submissions are judged mainly on their originality and usefulness. Interesting modifications to existing circuits are strong contenders too – provided that you clearly acknowledge the circuit you have modified. Never send us anything that you believe has been published before though.

Don't forget to say why you think your idea is worthy.

Clear hand-written notes on paper are a minimum requirement: disks with separate drawing and text files in a popular form are best – but please label the disk clearly. Where software or files are available from us, please email Jackie Lowe with the circuit idea name as the subject.

Send your ideas to: Jackie Lowe, Highbury Business Communications, Anne Boleyn House, 9-13 Ewell Road, Cheam, Surrey SM3 8BZ
email j.lowe@highburybiz.com

Cheaper crossover filter

I designed the filter shown for use with an electronic keyboard. The crossover design was a second-order active circuit based upon the principles of Linkwitz-Riley^{1,2}.

Crossover frequency is 3.5kHz. The tweeter was expensive and so the capacitor C_1 was needed to protect it

in case of a fault in the tweeter amplifier. This needs to be a high quality part (polypropylene) so that sound quality is not affected.

To ensure, however, that C_1 does not contribute significant amplitude roll-off and phase shift – which would add to – those of the crossover

high-pass filter) a very large value is required. I calculated that a minimum value of $30\mu\text{F}$ was needed, which is expensive.

A better design, shown in the lower of the two diagrams, uses the capacitor C_1 to form one of the poles of the crossover high-pass filter response. The new value for C_1 is now $5.6\mu\text{F}$ so the component is much cheaper.

The other pole of the high-pass filter response was formed by a single capacitor (C_2) and R_1 on the input side of the tweeter amplifier.

The low-pass filter driving the bass unit remained as a conventional active filter using an op-amp. The capacitors in the low-pass filter and C_2 also need to be high quality types: polystyrene parts were used in the prototype.

The calculated phase and amplitude response of the crossover is unchanged. The overall component count was reduced and so construction was easier, with no loss of performance.

Peter Goodson
Bracknell
Berkshire

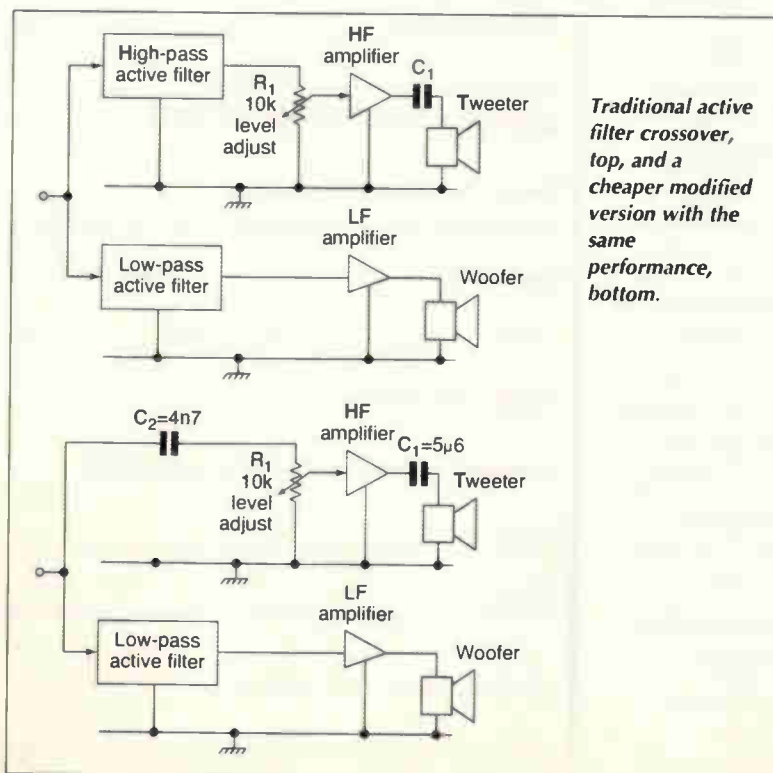

Traditional active filter crossover, top, and a cheaper modified version with the same performance, bottom.

References

1. www.linkwitzlab.com
2. www.rane.com/note107



Station Road, Cullercoats, Tyne & Wear, NE30 4PQ

Prices Exclude Vat @17.5%
UK Carriage £1.50 (less than 1kg)
£3.50 greater than 1kg
Cheques / Postal orders payable to
ESR Electronic Components.
PLEASE ADD CARRIAGE & VAT TO ALL ORDERS

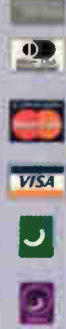

See Next / Last Months Ad for
ELECTRONIC COMPONENTS

DIL Sockets

Stamped Pin	
6 Pin DIL 0.3"	£0.07
8 Pin DIL 0.3"	£0.06
14 Pin DIL 0.3"	£0.11
16 Pin DIL 0.3"	£0.12
18 Pin DIL 0.3"	£0.12
20 Pin DIL 0.3"	£0.12
24 Pin DIL 0.6"	£0.13
40 Pin DIL 0.6"	£0.19
Turned Pin	
8 Pin DIL 0.3"	£0.11
14 Pin DIL 0.3"	£0.20
16 Pin DIL 0.3"	£0.23
18 Pin DIL 0.3"	£0.25
20 Pin DIL 0.3"	£0.28
24 Pin DIL 0.6"	£0.35
28 Pin DIL 0.6"	£0.39
40 Pin DIL 0.6"	£0.64
ZIF Sockets	
Universal ZIF DIL Sockets	
24 Way 0.3-0.6"	£5.85
28 Way 0.3-0.6"	£6.60
32 Way 0.3-0.6"	£7.50
40 Way 0.3-0.6"	£8.93
Transistor Sockets	
T018-4 Base Socket	£0.24
T05 Base Socket	£0.24
IDC Cable Sockets	
10 Way Socket	£0.23
14 Way Socket	£0.35
16 Way Socket	£0.37
20 Way Socket	£0.37
26 Way Socket	£0.38
34 Way Socket	£0.39
40 Way Socket	£0.55
50 Way Socket	£0.80
IDC Cable Plugs	
10 Way Plug	£0.52
14 Way Plug	£0.58
16 Way Plug	£0.62
20 Way Plug	£0.66
26 Way Plug	£0.70
34 Way Plug	£0.80
40 Way Plug	£0.92
50 Way Plug	£1.14
PCB Box Headers	
10 Way Straight	£0.22
14 Way Straight	£0.33
16 Way Straight	£0.32
20 Way Straight	£0.41
26 Way Straight	£0.55
34 Way Straight	£0.68
40 Way Straight	£0.68
50 Way Straight	£1.03
10 Way 90°	£0.32
14 Way 90°	£0.39
16 Way 90°	£0.42
20 Way 90°	£0.63
26 Way 90°	£0.81
34 Way 90°	£1.17
40 Way 90°	£1.17
50 Way 90°	£1.14
PCB Latch Headers	
10 Way Straight	£0.39
14 Way Straight	£0.45
16 Way Straight	£0.51
20 Way Straight	£0.55
26 Way Straight	£0.73
34 Way Straight	£0.88
40 Way Straight	£0.92
50 Way Straight	£1.27
10 Way 90°	£0.46
14 Way 90°	£0.48
16 Way 90°	£0.54
20 Way 90°	£0.59
26 Way 90°	£0.81
34 Way 90°	£1.03
40 Way 90°	£1.23
50 Way 90°	£1.41
DIL Headers	
14 Way DIL	£0.51
16 Way DIL	£0.53
24 Way DIL	£0.90
40 Way DIL	£1.37

Transition Headers

10 Way Transition	£0.42
14 Way Transition	£0.42
16 Way Transition	£0.48
20 Way Transition	£0.48
26 Way Transition	£0.52
34 Way Transition	£0.56
40 Way Transition	£0.63
50 Way Transition	£0.84
Large Range of Connectors in stock - New Connectors Catalogue now available see our web site for details.	

D Type Connectors

9 Way Male Plug	£0.20
9 Way Female Socket	£0.20
15 Way Male Plug	£0.27
15 Way Female Socket	£0.29
15 Way H.D. Plug	£0.42
15 Way H.D. Socket	£0.45
23 Way Male Plug	£0.60
23 Way Female Socket	£0.66
25 Way Male Plug	£0.30
25 Way Female Skt	£0.35

Solder Bucket

9 Way Male Plug	£0.20
9 Way Female Socket	£0.20
15 Way Male Plug	£0.27
15 Way Female Socket	£0.29
15 Way H.D. Plug	£0.42
15 Way H.D. Socket	£0.45
23 Way Male Plug	£0.60
23 Way Female Socket	£0.66
25 Way Male Plug	£0.30
25 Way Female Skt	£0.35

IDC Ribbon Mounting

9 Way Male Plug	£1.08
9 Way Female Socket	£0.93
15 Way Male Plug	£1.30
15 Way Female Socket	£1.32
25 Way Male Plug	£1.10
25 Way Female Socket	£1.13
IDC Crimp Tool	£11.80

Right Angled PCB

9 Way Male Plug	£0.33
9 Way Female Socket	£0.33
15 Way Male Plug	£0.39
15 Way Female Socket	£0.39
15 Way H.D. Socket	£0.58
25 Way Male Plug	£0.48
25 Way Female Socket	£0.50

Plastic D Covers

9 Way Cover - Grey	£0.27
9 Way Cover - Black	£0.30
15 Way Cover - Grey	£0.30
15 Way Cover - Black	£0.40
23 Way Cover - Grey	£0.38
23 Way Cover - Black	£0.34
25 Way Cover - Grey	£0.37
9 to 9 Cover / Case	£0.80
25 to 25 Cover / Case	£0.84
9 to 25 Cover / Case	£0.80

Audio Connectors

2.5mm Jack Plug	£0.25
2.5mm Line Socket	£0.24
2.5mm Chassis Socket	£0.12
3.5mm Mono Plug	£0.24
3.5mm Mono Line Skt	£0.24
3.5mm Mono Chassis	£0.14
3.5mm Stereo Plug	£0.35
3.5mm Stereo Chassis	£0.32
1/4" Mono Plug	£0.30
1/4" Mono Line Socket	£0.36
1/4" Mono Chassis Skt	£0.46
1/4" Stereo Plug	£0.36
1/4" Stereo Line Socket	£0.36
1/4" Stereo Chassis Skt	£0.38
Mini Trax Speaker Plug	£2.83

Phono Series

Red Line Plug	£0.20
Black Line Plug	£0.20
Yellow Line Plug	£0.20
White Line Plug	£0.20
Red Line Socket	£0.20
Black Line Socket	£0.20
Yellow Line Socket	£0.20
White Line Socket	£0.20
Red Chassis Socket	£0.20
Black Chassis Socket	£0.20
Gold Plated Plug Red	£0.68
Gold Plated Plug Black	£0.68

XLR Series - metal

3 Pin Line Plug	£0.96
3 Pin Line Socket	£0.96
3 Pin Chassis Plug	£1.23
3 Pin Chassis Socket	£1.22
Neutrik Line Plug	£2.10
Neutrik Line Socket	£2.10
Neutrik Chassis Plug	£2.24
Neutrik Chassis Socket	£2.40

RF Connectors

BNC Plug 50° Solder	£0.99
BNC Plug 50° Crimp	£0.68
BNC Plug 75° Solder	£1.08
BNC Plug 75° Crimp	£0.69
BNC Chassis Socket	£0.76
F Plug - Twist	£0.20
F Plug - Crimp	£0.20
TNC Plug 50° Solder	£1.08
TNC Plug 50° Crimp	£1.04
TNC Plug 75° Solder	£1.17
TNC Plug 75° Crimp	£0.96
UHF Plug 5mm Cable	£0.63
UHF Plug 11mm Cable	£0.72
UHF Chassis Skt - Sqr	£0.54
UHF Chassis Skt - Rnd	£0.75
Extensive range of RF connectors in stock, inc.F.M.E, SMA, Mini UHF & N Type.	

Terminals

Colours Red, Black, Green, Blue, White or Yellow	
2mm Cold Plugs	£0.23
2mm Chassis Sockets	£0.28
4mm Plugs - Solder	£0.34
4mm Plugs - Screw	£0.38
4mm Stackable Plugs	£0.40
4mm Shrouded Plugs	£0.74
4mm Chassis Sockets	£0.21
4mm Binding Posts	£0.48
33mm Crocodile Clips	£0.10

Power Connectors

DC Plug 0.7ID 2.35OD	£0.47
DC Plug 1.3ID 3.4OD	£0.17
DC Plug 1.7ID 4.0OD	£0.44
DC Plug 1.7ID 4.75OD	£0.50
DC Plug 2.1ID 5.0OD	£0.24
DC Plug 2.5ID 5.0OD	£0.24
DC Plug 3.1ID 6.3OD	£0.53
DC Line Socket 2.1mm	£0.66
DC Line Socket 2.5mm	£0.68
DC Chassis Skt 2.1mm	£0.44
DC Chassis Skt 2.5mm	£0.44

IEC Mains 6A 250Vac

3 Pin IEC Line Socket	£1.08
3 Pin IEC Line Plug	£1.89
3 Pin Chassis Socket	£0.55
3 Pin Chassis Plug	£0.56

8 Way Bulgin

8 Pin Line Plug P551	£3.58
8 Pin Chassis Skt P552	£1.28

Toggle Switches

Sub-Miniature	
3A 125V 1A 250V	
5mm Ø Mounting Hole	
SPST 5 x 10mm	£0.47
SPDT 5 x 10mm	£0.53
SPDT C/Off 5 x 10mm	£1.01
DPDT 9.2 x 10mm	£0.63
Miniature	
6A 125V 3A 250V	
6.2mm Ø Mounting Hole	
SPST 8 x 13mm	£0.58
SPDT 8 x 13mm	£0.55
SPDT c/off 8 x 13mm	£0.65
SPDT c/o Biased 2 way	£1.18
SPDT c/o Biased 1 way	£1.15
DPDT 12 x 13mm	£0.65
DPDT c/off 12 x 13mm	£0.88
DPDT c/o Biased 2W	£1.20
DPDT c/o Biased 1W	£1.28

Standard

10A 250V Push on terminals	
12mm Ø Mounting Hole	
SPST 18 x 30mm	£1.05
SPDT 18 x 30mm	£1.18
SPDT c/off 18 x 30mm	£1.18
DPDT 21 x 30mm	£1.78
DPDT c/off 21 x 30mm	£1.78

Slide Switches

Miniature	
300mm 125V	
7 x 15mm Mounting Hole	
DPDT 7 x 23mm	£0.17
Standard	
1A 125V	
5.5 x 12mm Mounting Hole	
DPDT 12 x 35mm	£0.27
DPDT c/o 12 x 35mm	£0.25

Rotary Switches

150mA 250V Make before Break 22mm Ø	
9.8mm Ø Mounting Hole	
1 Pole 12 Way	£0.84
2 Pole 6 Way	£0.84
3 Pole 4 Way	£0.84
4 Pole 3 Way	£0.84

Push Switches

Miniature Round	
250mA 125V 28 x 10mm	
7mm Ø Mounting Hole	
Non Latching Push to Make	
Black, Red, Yellow, Green, Blue or White	£0.23
Non Latching Push to Break	
Black PTB	£0.24

Standard Square

1A 250V	
39 x 15MM	
12mm Ø Mounting Hole	
Non Latching Push to Make	
Black, Red, Blue or White	£0.60
Latching - push on push off	
Black, Red, Blue or White	£0.65

Rocker Switches

Miniature	
13 x 19mm Mounting Hole	
SPST 4A 250V	£0.57
SPST 16A Red Neon	£1.45
SPST 3A Red LED	£1.92
DPST 6A 250V	£0.75
DPST 4A 250V	£0.81
DPST 4A Red Neon	£1.10
DPST 3A Amber Neon	£1.40
DPST 3A Green Neon	£1.32
Standard	
10(SP, 22)DP x 30mm Mounting Hole	
SPST 10A 250V	£0.60
SPST 16A 250V	£0.70
SPST 16A Red Neon	£0.75
DPST 10A 250V	£0.90
DPST 15A Red Neon	£1.18
DPST Amber Neon	£1.25
DPST Green Neon	£1.25
DPST 10A 250V	£0.90

Relays

PCB Mounting	
1A 24Vdc DPDT 5V	£1.38
1A 24Vdc DPDT 12V	£1.35
3A 110V SPDT 6V	£0.58
3A 110V SPDT 12V	£0.60
5A 110V SPDT 6V	£0.72
5A 110V DPDT 6V	£0.93
5A 240V DPDT 12V	£0.93
5A 240V DPDT 6V	£1.76
5A 240V DPDT 12V	£1.50
10A 240V SPDT 6V	£1.20
10A 240V SPDT 12V	£1.44
10A 240V SPDT 24V	£1.44

Computer Accessories

Adaptors	
9M Gender Changer	£1.73
9F Gender Changer	£1.73
25F Gender Changer	£2.20
9 Male - 25 Female	£1.73
9 Female - 25 Male	£1.73
9M - 6 Mini Din Female	£2.48
9F - 6 Mini Din Male	£2.23
5M Din - 6F Mini Din	£1.73
5F Din - 6M Mini Din	£1.73

Testers / Patch Boxes

Mini Tester 7 LEDs	£4.72
Check Tester 18 LEDs	£6.32
Enhanced+ Switches	£15.18
25D Patch Box M-F	£2.64
Anti-Static Wrist Strap	£4.76
RS232 Surge Protector	£5.43
5A Surge Protector	£5.20
13A Surge Protector	£10.00
4 Gang Surge Block	£10.50

Leads & Cables

1.5m Printer Lead	£2.55
-------------------	-------



20% discount for EW readers

Temperature controlled soldering stations



Vann Draper Electronics Ltd
The test & measurement specialists
www.vanndraper.co.uk
Grundig, Kenwood, Hitachi, Fluke, Avo, Advance

Use this coupon for your order

Please supply me:

-SL20 soldering stations(s) at £55 inc vat & del
-SL30 soldering stations(s) at £65 inc vat & del
-Extra 0.8mm bit(s) at £1.88 inc vat & del
-1.6mm bit(s) at £1.88 inc vat & del
-3.2mm bit(s) at £1.88 inc vat & del

Name:

Address:

Tel No:

Total £

Cheques payable to Vann Draper Electronics Ltd or debit my visa, mastercard or switch card:

Card type:

Card No:

Expiry date: Switch Iss No:

Signature:

Overseas readers can still obtain this discount but carriage charges vary according to country. Please telephone, fax, email or write to Vann Draper.

Vann Draper is offering over 20% discount for a period to readers of **Electronics World** magazine on their temperature controlled soldering stations.

The SL20 bar graph display soldering station normally sells at £69.33 and is available to readers of TV at only **£55** fully inclusive of vat & delivery.

The SL30 digital display version is normally priced at £81.08 but for readers of TV the price is just **£65** fully inclusive.

Both soldering stations feature 24V 48W elements for rapid heating and have full electronic temperature control between 150C and 420C (SL20), 160C and 480C (SL30).

The SL20 and SL30 are supplied ready to use complete with a 48W iron, 0.8mm long life bit, mains lead, operating instructions and a 12 month guarantee.

To order, simply post the coupon to: **Vann Draper Electronics Ltd at Stenson House, Stenson, Derby DE73 1HL.** Alternatively - Tel 01283 704706, Fax 01283 704707 or Email sales@vanndraper.co.uk

RANGER 2XL

The Professional Integrated Schematic PCB Layout Package

Free Download available from www.seetrax.com

from just **£45**



RANGER 2XL	500	1000	2000	Full
Schematic & PCB Layout	✓	✓	✓	✓
Artwork Checking	✓	✓	✓	✓
Ripup/Retry Auto-router	✓	✓	✓	✓
Copper Fill/Pour	✓	✓	✓	✓
Power Planes	✓	✓	✓	✓
Max Signal Layers	2	2	4	32
Max Parts	100	250	500	1400
Max Component Pins	500	1000	2000	16000
Price	£45	£90	£145	£190

Tel: 01730 260062 Email: sales@seetrax.com



Want to win it? Simply send us the answer to the question, "across how many carriers is the signal spread in each ensemble?" on a postcard together with your name and address and your entry will go into the hat. Address the postcard to Electronics World, Highbury Business Communications, 9-13 Ewell Road, Cheam, Surrey SM3 8BZ. Please read the competition rules first though.

This competition is sponsored by **Modular Technology Ltd.**, the makers of the DAB PCI card. More information can be found on the product in Roger Thomas' review on page 12 of this issue and also Modular's web site at www.modulartech.com.

Win DAB digital radio

Competition rules

No purchase is necessary. Strictly one entry per household. Competition closing date 12th April 2003. No entries will be accepted after that date. The draw will take place within the next working week following the 12th April and the winner will be announced as soon as possible thereafter. The prize is not negotiable. No correspondence will be entered into regarding this competition. No employee of Highbury Business Communications or Modular Technology Ltd. may enter the competition.

What is DAB

Until now, analogue radio signals such as FM or MW have been subject to numerous kinds of interference on their way from the transmitter to your radio. These problems were caused by mountains, high-rise buildings and weather conditions. DAB, however, uses these effects as reflectors creating multipath reception conditions to optimise receiver sensitivity. Since DAB always selects the strongest regional transmitter automatically, you'll always be at the focal point of incoming radio signals. The DAB system was developed by the Eureka 147 Project.

How do I get it?

DAB is broadcast on terrestrial networks, and you are able to receive it using solely a tiny non-directional stub antenna. You receive CD-like quality radio programmes even in the car without any annoying interference and signal distortion.

Aside from distortion-free reception and CD Quality sound, DAB offers further advantages as it has been designed for the multimedia age. DAB can carry not only audio, but also text, pictures, data and even videos - all on your radio!

You are able to listen to your favourite music programme and sing along with your idols, since the lyrics can be shown on your radio display, or you can contemplate the handsome face of the latest movie star, while a report is given on his current box-office hit.

Can I get it?

Over 285 million people around the world can now receive more than 585 different DAB services. Commercial DAB receivers have now been on the market since summer 1998. Furthermore, as well as all European countries, other non-European countries including Canada, Singapore, Taiwan and Australia have launched operational or pilot services. Countries like China and India have begun experimental services and Mexico and Paraguay among other countries have expressed their advanced interest in DAB.

DAB is available in the following countries: Australia, Austria, Belgium, Brunei, Canada, China, Croatia, Czech Republic, Denmark, Estonia, Finland, France, Germany, Hong Kong, Hungary, India, Ireland, Israel, Italy, Japan, Lithuania, Malaysia, Mexico, Namibia, Netherlands, Norway, Poland, Portugal, Singapore, Slovakia, Slovenia, South Africa, South Korea, Spain, Sweden, Switzerland, Taiwan, Turkey, United Kingdom, USA.

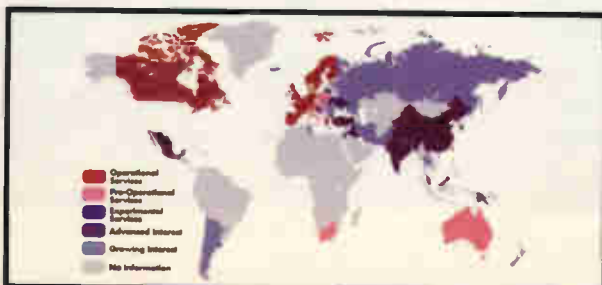

Modular Technology DAB PCI card features

The Modular Technology DAB digital radio card fits into a PCI slot in a PC's mother board and the supplied driver works with Windows-98, Me, 2000 & XP.

The user interface provides full programme information on screen, displays text associated with programmes, allows recording at the click of a mouse, and gives users the ability to schedule recordings ahead of time from programme lists. Recordings can be stored as MPEG-2 files, or in MP3 format for high quality sound downloads to MP3 players.

Features include:

- Automatic service and programme seeking
- High quality distortion free reception
- Text displayed with programmes
- Recording at the click of a mouse

Apart from just listening to the radio, here are some other things you can do with the Modular Technology DAB PCI card...

- Look at the schedule for every station for the week ahead and select any programmes to be recorded (broadcaster's EPG permitting).
- E-mail a programme presenter at the click of a mouse.
- Download recorded programmes to most portable MP3 players for 'listening on the move'.
- Easily link to the web site of the station you're listening to.
- Show all radio stations broadcasting a particular genre e.g. Sport, News etc.
- Playback high quality recordings made on the PC.
- Set your PC's clock from the accurate signal broadcast as part of the DAB transmission.
- DAB is received through an antenna, it needs no connection to the internet.
- DAB is FREE just like AM/FM radio - there are no subscriptions or sign-ups

DAB content (music speech etc) is usually augmented by the broadcaster to include text information. This allows a receiver for example to display the current track and artists' name, or the presenter's e-mail address etc.

Minimum PC specification

Pentium-200MMX, 64Mb RAM, Spare PCI slot, antenna connection

Modular Technology Ltd designs manufactures and distributes Communications, Audio, Video and entertainment products, most of them for use with Personal Computers; selling through major retailers and OEMs in the UK and North America. Products are sold under the Modular Technology brand or in OEM livery as required. The company has extensive experience of selling Television and Radio products for PCs and their new DAB digital radio card gives users a glimpse of what they can expect from radio receivers in the future.

**WATCH SLIDES ON TV
MAKE VIDEOS OF
YOUR SLIDES
DIGITISE YOUR
SLIDES**

(using a video capture card)



"Liesgang diatv" automatic slide viewer with built in high quality colour TV camera. It has a composite video output to a phono plug (SCART & BNC adaptors are available). They are in very good condition with few signs of use. For further details see www.diatv.co.uk

£91.91 + vat = £108.00
Board cameras all with 512x582 pixels 8.5mm 1/3 inch sensor and composite video out. All need to be housed in your own enclosure and have fragile exposed surface mount parts. They all require a power supply of between 10 and 12v DC 150mA.

47MIIR size 60x36x27mm with 6 Infra red LEDs (gives the same illumination as a small torch but is not visible to the human eye).....£37.00 + vat = £43.48

30MP size 32x32x14mm spy camera with a fixed focus pin hole lens for hiding behind a very small hole.....£35.00 + vat = £41.13

40MC size 39x38x27mm camera for 'C' mount lens these give a much sharper image than with the smaller lenses.....£32.00 + vat = £37.60

Economy C mount lenses all fixed focus & fixed iris

VSL1220F 12mm F1.6 12x15 degrees viewing angle.....£15.97 + vat = £18.76

VSL4022F 4mm F1.22 63x47 degrees viewing angle.....£17.65 + vat = £20.74

VSL6022F 6mm F1.22 42x32 degrees viewing angle.....£19.05 + vat = £22.38

VSL8020F 8mm F1.22 32x24 degrees viewing angle.....£19.90 + vat = £23.38

Better quality C Mount lenses

VSL1614F 16mm F1.6 30x24 degrees viewing angle.....£26.43 + vat = £31.06

VWL813M 8mm F1.3 with Iris 56x42 degrees viewing angle.....£77.45 + vat = £91.00

1206 surface mount resistors E12 values 10 ohm to 1M ohm 100 of 1 value £1.00 + vat 1000 of 1 value £5.00 + vat

866 battery pack originally intended to be used with an orbite! mobile telephone it contains 10 1.6Ah sub C batteries (42x22dia the size usually used in cordless screwdrivers etc.) the pack is new and unused and can be broken open quite easily.....£7.46 + vat = £8.77



Please add 1.66 + vat = £1.95 postage & packing per order

JPG ELECTRONICS

Shaws Row, Old Road, Chesterfield, S40 2RB

Tel 01246 211202 Fax 01246 550959 Mastercard/Visa/Switch

Callers welcome 9:30 a.m. to 5:30 p.m. Monday to Saturday

Introductory E.W. Reader Offer



DS2200C

Dual Channel USB
12-bit Digital Sampling
Oscilloscope including
EasyScope software -
£99.00

(excluding tax and shipping)
for full offer details and order
form visit

www.easysync.co.uk/ew.htm

The DS2200C sets a new price / performance standard in portable PC based Instrumentation - see the specifications below. We are pleased to offer EW readers a special introductory price of £99 (normally £120) excluding tax and shipping where applicable. A pair of quality 60MHz x1/x10 oscilloscope probes is available for the DS2200C at only £25 extra. For further technical details of the hardware and software visit www.usb-instruments.com. To order, please download our special-offer order form at www.easysync.co.uk/ew.htm.

DS2200C Brief Hardware Specification

- ADC Resolution per channel = 12 bits
- AC / DC coupling on each channel
- Uses standard x1 / x10 oscilloscope probes
- Plugs into USB port of PC or Notebook
- Max Sampling Rate (each channel) = 200k samples / sec
- Dual BNC input connectors (1M ohm input impedance)
- 1KHz calibration reference signal output
- Powered from USB (requires no external PSU)

EasyScope Software Spec

- Attractive easy to use visual display
- Single, Dual and X-Y display modes
- FFT (Fast Fourier Transform) display
- Time-Base from 50uS/div to 1sec/div
- OSD markers for voltage measurement
- OSD markers for time/frequency measurement
- Save screens to Windows BMP files
- Screen printout facility
- Input from 0 1v/div to 5 0v/div (x1)
- AC / DC coupling support
- Support for x1 / x10 scope probes

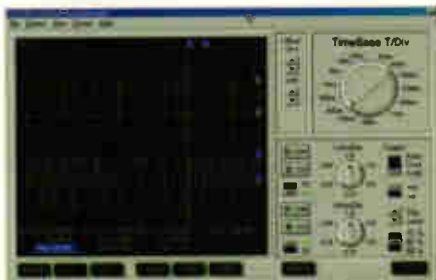

EasySync Ltd.

87 St Andrew's Drive, Glasgow G41 4DH, United Kingdom
TEL: +44 (0) 141 423 2225 FAX: +44 (0) 141 424 4547
Web: <http://www.easysync.co.uk>
E-Mail: sales@easysync.co.uk

March 2003 ELECTRONICS WORLD

**A QUANTUM LEAP IN
EMBEDDED CONTROLLERS**

Quick FIRE

SUPERCONTROLLERS

Our range provides:-

- **The fastest 68000 based Core up to 66 Mhz.**
- **Extensive I/O:-** Serial, IrDA, SPI, I²C, Analogue, Timers/Counters, RTC, etc.
- **Large Memory Capacity:-** Flash, SRAM, DRAM.
- **Supports:-** Mono & Colour LCD's, Touch Panels & Keypads, Very Low Power.

ALSO LOW COST

DEVELOPMENT

- **Target easily & quickly.**
- **Full ANSI 'C' compiler, assembler & linker all Windows32 based.**
- **Source Level Debug.**
- **Full Driver Support with Libraries.**
- **Real Time Multitasking OS with a free run time licence.**
- **Free Unlimited email support.**

www.cms.uk.com

see our web site for full details

CAMBRIDGE MICROPROCESSOR SYSTEMS LTD



Unit 17-18 Zone 'D' Chelmsford Rd. Ind. Est.
Great Dunmow, Essex CM6 1XG

Telephone: **01371 875644**

email: sales@cms.uk.com

A Frequency Synthesizer for the VHF FM Band

The origin of this project was the desire to build a VHF FM direct conversion receiver as a follow up to the direct conversion receiver we built for the AM medium wave band (Slifkin and Dori, *Synchrodyne and Homodyne Receiver, Electronics World, November 1998*). Michael Slifkin and Shai Ben-Naeh take us through the practicalities.

The first stage was the construction of a keyboard controlled frequency synthesizer covering the range 88 to 108MHz with a channel spacing of 100kHz. This synthesizer should in no way be confused with the VHF DSP receiver we described more recently (Slifkin, Mayan and

Globinsky, VHF receiver in DSP *Electronics World, October 1999*) which relies on completely different principles. We have yet to complete the whole project but feel that the synthesizer is a worthy project in its own right.

Originally, frequency synthesizers were derived from a low frequency

crystal oscillator by using multipliers. These were resonant circuits tuned to a low harmonic of the input frequency. Radio amateurs found these particularly useful as the amateur radio frequencies in the past were 3.5, 7, 14, 21, and 28MHz. So, from that one crystal oscillator, they could access all the higher amateur radio bands. However, with the appearance of IC phase lock loops, these have more or less fallen into disuse. We have discussed the phase lock loop (pll) several times in our earlier articles. However for new readers we will give again a brief description. Figure 1 shows a block diagram of the pll.

The reference signal is phase compared with the signal coming from the voltage-controlled oscillator. If there is any difference between the two signals, then the phase detector has an output proportional to the difference, this is sent to the VCO in such a manner as to bring the two frequencies together. After a brief interval, the two signals will be locked in frequency, albeit 90° out of phase with each other. The same device can be used as a simple frequency synthesizer as shown in Figure 2.

By putting an N divider, i.e. a digital device between the VCO and

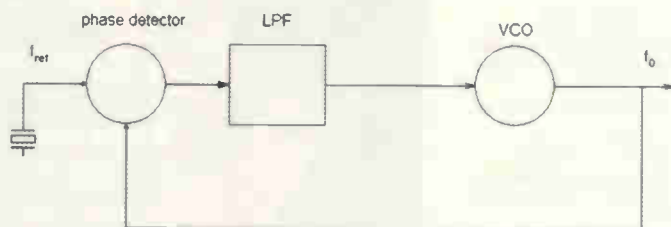

Figure 1: Phase lock loop (pll)

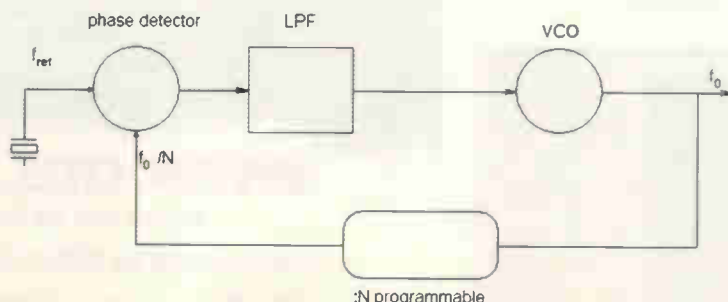

Figure 2: Simple frequency synthesizer

the phase detector, a frequency N times that of the reference signal is produced. We can get even more versatility by putting a divider after the reference signal and before the phase detector. In general this is not done as we can start from a very low reference signal. The advantages of these pll techniques are severalfold. The use of digital dividers is far simpler and far more accurate than using tuned multiplier circuits which are difficult to tune and to keep at the exact frequency. Furthermore, we can use programmable dividers operating from a microprocessor and hence use a keyboard to input the frequencies and a display to see what has been inputted

Nowadays a technique called "dual modulus prescaling" or sometimes "pulse swallowing", which allows one to use regular TTL components in spite of the high frequencies generated, is regularly employed.

First steps

Before presenting the circuit diagrams we will explain the dual modulus technique. The first step in implementing this system is the use of a high frequency prescaler. This can operate at a very high frequency and is used to divide down to a lower frequency suitable for CMOS and TTL components. The block diagram is shown in **Figure 3**. M is the programmable counter and A is the Modulus Control Counter. P is the Dual Modulus Prescaler. The prescaler can divide by n or $n+1$ under program control. The counter A gives the number of times we need to use the $n+1$ divider, whilst counter M gives the total number of divisions. This is made clearer in **Table 1**.

The total divide factor N is given by $N = (P \times M) + A$. Different values of n for the prescaler are available in the range 5/6 to 128/129 from different manufacturers

With the proviso that $2 \leq P$, $2 \leq M$, and $0 \leq A \leq P$, $A \leq M$ and P can be n or $n+1$. If one plays around with the numbers one finds that not all divisors are possible with a fixed value of n but having the ability to use $n+1$ in addition enables more frequencies to be accessed. This is illustrated in **Table 1** where we show some of the values in the counters and the final frequencies.

The 88.0MHz frequency is obtained by simply multiplying the 100kHz reference by 20 forty-four times.

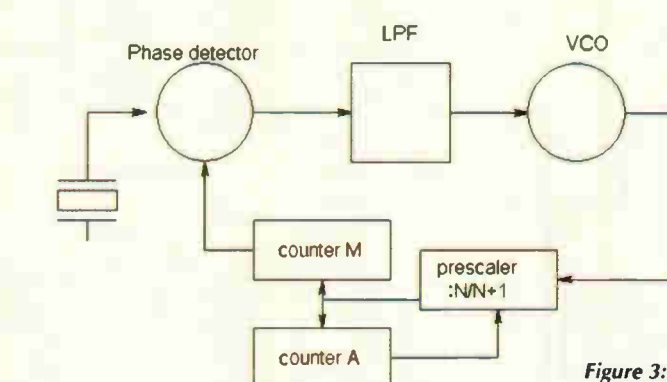

Figure 3: Dual Modulus Synthesizer

Similarly $100\text{kHz} \times 45 \times 20$ gives the 90MHz frequency. With a fixed n in the prescaler we can only get multiples of 200kHz from our 100kHz frequency. We obtain the 88.9MHz frequency by multiplying the 100kHz reference signal by 20, 35 times and by 21, nine times.

$20 \times 35 + 21 \times 9 = 889$ giving a frequency of 88.9MHz.

Similarly the 90.6MHz frequency is obtained by multiplying $(39 \times 20) + (6 \times 21) = 906$

The counter A gives the number of times we need to use the $n+1$ divider, whilst counter M gives the total number of divisions.

Commercial prescalers can be single, dual and even triple. Some also allow us to use $2n$ and $2n+1$ as the dividers.

Among the reasons given in the application sheet by Elanix for using this system are:

- A higher reference frequency can be used for the loop.
- Filtering of the VCO control voltage is easier.
- The lockup time is faster.
- There is less noise at the output.

The reference frequency sidebands are further away from the main output frequency. The use of the prescaler, which can operate at very high frequencies, enables us to bring down the frequencies to the range in which the counters can operate.

Synthesizer implementation

Most of the ICs used could be replaced by a much smaller number of more complex devices but we like to build up such systems from fairly simple TTL and other simple ICs to more fully understand how they operate. The complete circuit diagram is shown in **Figure 4**.

Table 1. Prescaler divides by 20/21

Counter M	Counter A	N	Freq. (MHz)
44	0	880	88.0
44	9	889	88.9
45	0	900	90.0
45	6	906	90.6

U1, 3 and 5 make up the crystal oscillator that is our standard. We actually used a 1MHz crystal and divided down by 10 to give the 100kHz standard frequency. We could say that the use of a crystal followed by a divider is to increase the versatility of the system, which of course it does. However the most compelling reason is that 1MHz crystals are very easily obtained.

The 80C31 microprocessor is an 8-bit device that has been around for quite a while and is an industry standard. It has on board 4 Kbyte ROM/EPROM and 8 x 128 bit RAM. The microprocessor has its own 12MHz crystal clock, separate from the frequency source of the synthesizer.

We had to assemble our own pll, as the commercially available single chips are not suitable for our purposes. U18 to U20 are the counter section of the pll, with U17 and 18 being the M program counter and U19 and 20 being the A modulus control. The phase detector is component U9. U15, U13 and U4 are the keyboard section. U8 is the dual modulus prescaler giving a divide of 10/11 or 20/21. U15 is the MM54922 16-key encoder that provides all the necessary logic to encode the keyboard. U7 is the VCO. The two Varicaps (variable capacitor diodes) control the frequency. The DC error voltage coming from the phase detector controls the capacitance of these diodes and hence the frequency

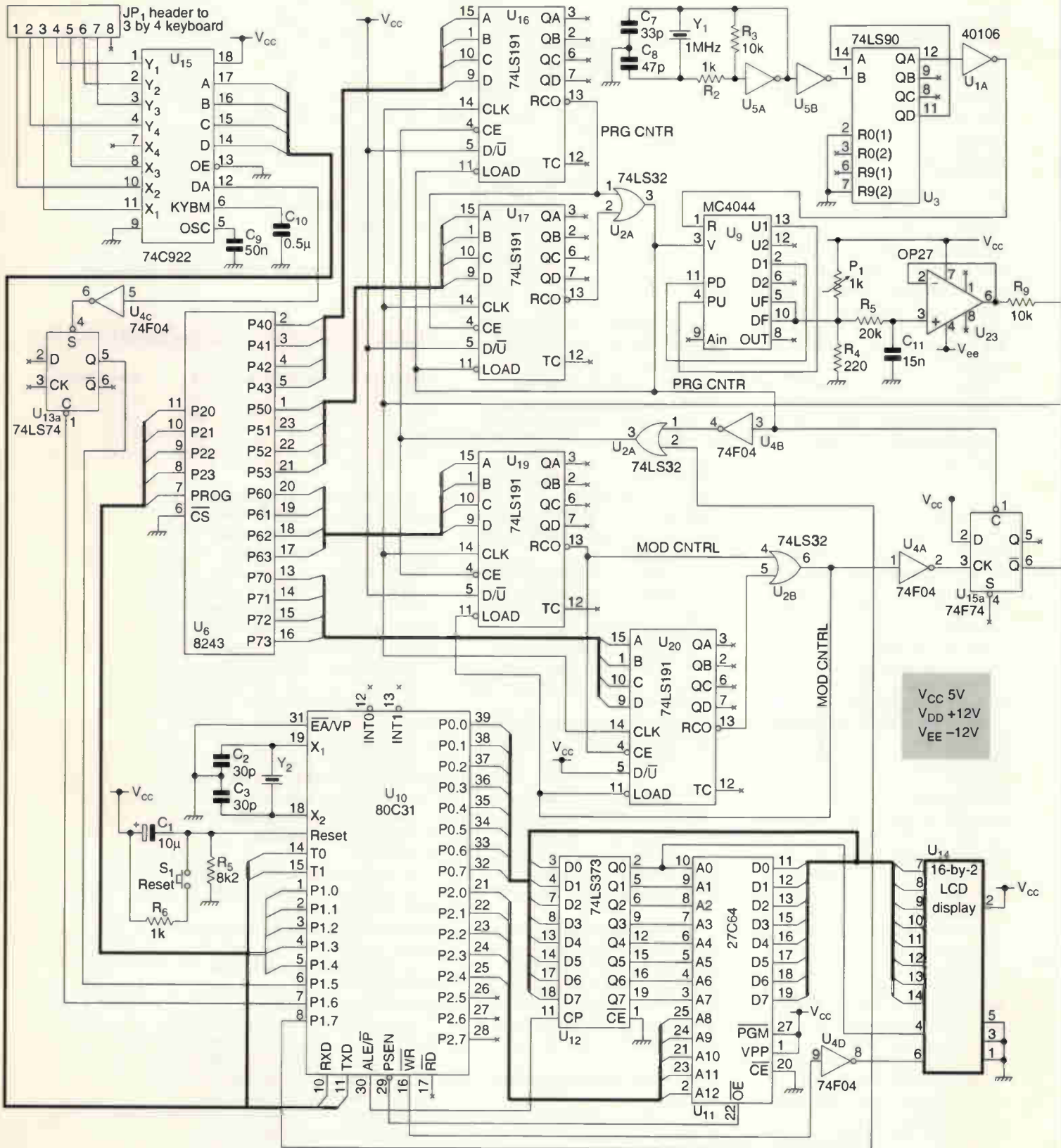

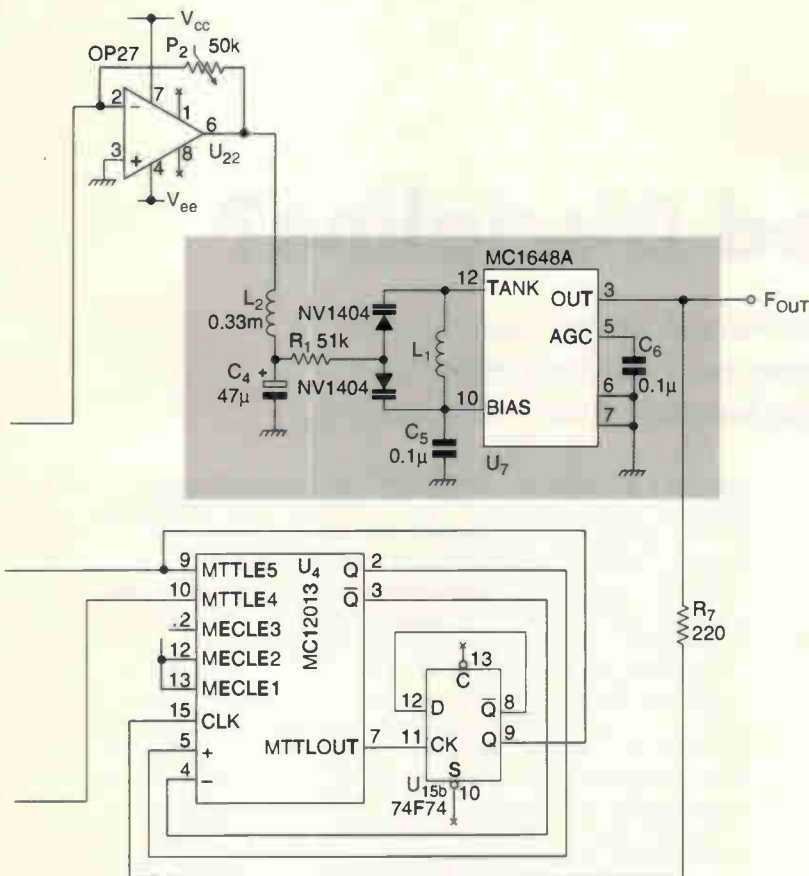

of the VCO. U10 to U14 are the display section. The display U14 is the generic 16 x 2 dot matrix. Any 16 x 2 display using the Hitachi HD44780 driver or equivalent can be used.

We use the 80C31 microprocessor to control the display. Whilst this isn't strictly necessary, it is easier to implement than using TTL and the microprocessor is already available on the board. We enhance the use of the microprocessor with U5, the input/output expander 8243, that provides a cheap and useful interface between the microprocessor and the rest of the circuit. U11 is a 64 Kbyte EPROM into which the program is stored. The most important part is the program. Without it we merely have a number of dumb ICs connected together.

The source code is written in ASEM 51 8031 Assembler language and can be obtained from Electronics World. This is annotated and should be clearly understandable. The object code is given here. The program controls the LCD display, which shows the following messages at appropriate times.

- Frequency Synthesizer Press # to Start
- Frequency Range 88-108MHz.
- Enter Frequency in Four Digits
- ERROR in data entry. try again
- Now generating
- Job terminated
- or -Press * to stop

The microprocessor program also changes data to the correct binary codes. It checks validity of inputted numbers and outputs the numbers to the counters. The hardware can be used for a much wider range of frequencies simply by changing the program. This is the major advantage of digital equipment that once the hardware is built its function can be made very versatile by changing the programming. One can also convert this synthesizer to a much higher accuracy by dividing down the primary frequency to 10kHz or even 1kHz.

For those wishing to use such a device for an superheterodyne FM receiver one would need to offset the frequencies by the usual 10.7MHz (or some other unusual IF), which is very easily done in software. ■

List of Integrated Circuits

U1	40106
U2	74LS32
U3	74LS90
U4	74F04
U5	4049
U6	8243
U7	MC1648A
U8	MC12013
U9	MC4044
U10	80C31
U11	77C64
U12	74LS373
U13	74LS74
U14	DisplayMO16L*
U15	MM74C922
U16	74F74
U17,18,19,20	74LS191
U21	74LS32
U22,23	OP27

*Please note that any 16 x 2 display using the Hitachi HD44780 driver or equivalent can be used.

EMC

A Fatally Flawed Discipline?

His attendance at an IEE Open Discussion Forum on the teaching of electromagnetics in undergraduate courses on 12th December last year encouraged him to confront the EMC incubus. Ivor Catt explains.

I have been very concerned about the EMC community since 1964, when I first ran into it in Los Angeles whilst designing a power supply for a torpedo-proof line printer for the US Navy in Data Products Corporation.

I became extremely concerned when in Europe it became a criminal offence to fail to take a piece of equipment through their ridiculous EMC tests. Of all the subcultures in electronic engineering, EMC is the worst.

There is a strong rumour that during the Falklands War, the British warship HMS Sheffield had to switch off its radar looking for incoming missiles in order to resume radio communication. This is why it did not see incoming Exocet missiles, and you know the rest. How was it that after decades of pouring money into the EMC community, this could happen? Do the EMC community agree that they should shoulder the blame? Of course not. This is because that community has gone into limbo, sucking in money but evading the real problems, like watching for missiles while you talk to HQ.

While visiting the EMC magicians in the Ford Motor Company, I found that it was illegal to have a car radio that inadvertently affected an overtaking car's electronically controlled brakes. However, the EMC community is totally indifferent if, whilst switching on your car's starter motor, you cause a passing motorist's brakes to lock suddenly.

My experience in England started with NWS3, a British copy of US test specs. It is fatally flawed at the fundamental theoretical level. These flaws remained during further decades because of the lack of grasp of the fundamentals of electromagnetism by the whole EMC community.

Los Angeles

I first came across the EMC community as a design engineer for the Data Products Corporation based in Los Angeles, in 1964¹. My family, our furniture and I were shipped to Los Angeles by the Ampex Corporation and I was fired seven months later and hired on the following Monday by the Ampex spinoff company Data Products Corporation down the road for 50% more salary.

At Data Products, I was put to design a power supply for a torpedo-proof line printer for use on board ship in the US Navy². (As luck would have it, the evening lecturer at the 12th December meeting shipped over by the IEE from the USA came from the US Navy EMC community.) We had to meet EMC requirements, so we hired an EMC magician for six months from the company whose name I remember as Geniston. He came and sat in our offices. Immediately I went to him and asked him about the EMC criteria he relied on. He would not give me any technical information. He said that I should just carry on designing and building the prototype as before. After it was completed he would add a few grilles and things.

We did as he suggested, and on completion we sent it for EMC

testing to a test company - Geniston. We were correct to choose Geniston, because this ensured that it would pass. I was mystified by all of this until I heard rumours that Navy Admirals had large holdings of stock in Geniston. Then it all made sense.

The EMC regulations prescribed that electric power drawn by the line printer must not vary at a greater rate than 3Hz. This meant that if the line printer suddenly had to print a whole row of 200 'A's:

AAAAAAAAAAAAAAAAAAAAAAAAAAAA

(requiring 720 amps) the amount of power demanded down the mains cable from somewhere else on the ship must not increase in a detectable way, at a greater rate than that indicated by the figure of 3Hz. This was because in principle the EMC test magicians would put a current probe around one of the wires, live or neutral, bringing in power. The idea was obviously that there might be a Russian spy with a current probe on the US Navy ship, and he might be able to detect whether the line printer was printing information. We all know that increased communication would indicate that the US was about to attack his brother on a nearby Russian ship. The machine sounded like a machine gun, but obviously all Russian spies were deaf, or at least all those who served in the US Navy, so the audio pandemonium was not a matter of concern for our freedom-loving democracy.

My solution to the "problem" was to take in constant power and build a shunt regulating power supply instead of the normal series regulating power supply. That is, whenever the line printer was not printing at maximum rate, I would divert all the unused power into an electric fire. This design was much admired for its novelty, and the prototype worked fine. It was appreciated most on cold mornings.

Our line printer was the most advanced and sophisticated. Each of the 120 hammers had a row of one inch square coils attached to them through which a 6 amp current would be delivered for 2msec. Thus, printing a row of 'A's meant a 6 amp sudden pulse (perhaps with a rise time of one microsecond) flowing in each of the 120 coils for 2 milliseconds. The number of turns in each coil is now unknown (although my notes do indicate 3mH), but my records tell me the rest. The DC resistance of the coil was 10 ohms, which indicates that the number of turns was large, as it would be. When EMC testing, Geniston would bring up the most sensitive antenna to two feet from the end of this gigantic electromagnet, to try to detect electromagnetic (but to ignore sonic) activity. Their resident magician would then propose blocking metal grilles and the like to blind the antenna, but on no account would he get inside our line printer and discuss our circuits and layout, with a view to causing mutual cancellation of magnetic fields. It appears that this madness continues to this day, and EMC magicians continue to stay outside each of the possibly incompatible boxes, brewing up their million pound Faraday cage test rooms and billions of nonsensical mathematical equations.

An example of some Faraday cage nonsense is when (more recently) I was an electronic engineer at GEC Chaucer House,

Portsmouth, but not at the time an EMC magician. The bright young thing designated Portsmouth Tigerfish Torpedo EMC guru talked about buying a screen room (Faraday Cage). He said it should be 100dB. It was interesting that the naïve, long term defence electronics designer sitting behind me argued with him that surely 60dB would suffice. I told him that this was ridiculous. The bright young thing's future career path required that he buy the £100,000 100dB cage. What the job needed had nothing to do with it.

Back at the line printer, the 720 amps into the hammer actuators was delivered by a gigantic resident 60v electrolytic in the line printer. At that time, electrolytics exploded at -60 degrees F. Naval

requirements were that on board items must survive down to -65 degrees F. Obviously, the US navy operated in very cold waters. It was frustrating to know that the USAF only required that their equipment survive down to -50 degrees F. This problem (how to print the message that the sea was frozen solid) was not solved by the time I was fired.

More costs

EMC was not the only ruse to increase costs in the defence of freedom and democracy. The printer had to survive 200g. This test involved strapping the equipment to a 4,000 pound anvil, and then

The fatal flaws

How do I get to Killarney? – I wouldn't start from here.

EMC will never escape from its origins – the stamping ground of ex RAF radio operators and the like. Later recruits are probably engineers who failed to cut the mustard as designers, or who were in any case in the surreal world of "defence" electronics. When a GEC or RCA product or similar failed to work properly, management would call in RFI "experts", who would do tests and write awesome reports (later on copied out from the Don White manual). Like Don White, they drew on the theory and practice in AM and then FM radio developed during the first half of the 20th century when the number of transmitters increased and they began to interfere with each other. To understand the EMC magicians of 50 years later, it is useful to see them as dinosaurs stuck in the age of radio and radio interference, decades before the arrival of digital systems.

In the IEE discussion on the teaching of electromagnetics on 12th December 2002, all the thirty attendees sounded technically naïve when they began to talk about personal computers. However, they demonstrate fatal flaws in their attitude, which would remain a problem even if digital systems did not exist.

The EMC specifications discuss conducted interference and radiated interference. Thus, the whole EMC community is committed to the idea that interference is of two types; conducted interference which travels down one wire and radiated interference which travels down no wires. This immediately confronts Kirchhoff's Laws, which insist that conducted interference travels down two wires; the signal wire and the return wire. This brings us to the second, strange weakness in the whole EMC game. They assume that two interfering units will both be electrically connected to "ground", which in their test rigs is a large plate of copper. As I moved further into high speed logic, my approach was to electrically float units in order to reduce mutual interference. Put crudely, when the length of the module is less than the wavelength of concern, grounding helps, but if it is longer, grounding hinders. (This was echoed when

the discussion on the 12th dwelt on new problems arising at above 1GHz – wavelength one foot.) Thus, the very process of coming within the EMC specifications bans a potent way of minimising electromagnetic interference! In my case, I went so far as to design a revolutionary mains filter which, although safe and within British safety regulations for being DC earthed, floated at high frequency. The simple stratagem was to insert a choke in the earth line which had a DC resistance of less than half an ohm, and similar impedance at 50Hz. The mains filter was an open circuit between earth and the unit at anything much above 50Hz⁴. The filter came to market at about that time. The ideas built into that filter are crucial for limiting interference, but cannot be communicated to the EMC community or their testing standards, since both exist within a cloud of bizarre mathematics and prejudice, and would probably not understand my idea. They limit themselves to a low frequency worldview where tying something to ground reduces interference and radiation. The worst comes by attaching two already interconnected units to ground, which increases the pickup of interference, even at lower frequencies, by creating a square loop antenna.

Another fundamental flaw is the assumption that if the emission from one unit is less than the susceptibility of another unit at every frequency, taken one at a time, then there will remain immunity when a number of frequencies are emitted from one and received by the other at the same time. This assumption is implicit in the fact that EMC wallahs sweep through frequencies

one at a time. This is true if a radio transmitter and a receiver tuned to another frequency are involved. However, if the susceptible unit contains digital electronics, it is not true. Here we see confirmation of the EMC community's ignorance of digital electronics, which means their ignorance of more than 95% of all of today's electronic equipment.

Another fundamental flaw in the EMC wallah's thinking and therefore testing standards is their resort to averages. In the lectures last December, I heard that their aim was to estimate the peak emission of unwanted interference on the basis of measured emission. The implicit assumption was that any system, including digital, needed minimal average interference. They just do not know that if a digital system loses just one bit, the result should be assumed to be catastrophic. They cannot get away from their world, where a bit of interference of a voice over the radio is O.K. so long as it does not happen too often. The truth is that peak emission should be calculated, not measured with test equipment. Similarly, the susceptibility to interference should be calculated, not measured. This is the fundamental flaw in the approach of the whole EMC community, to test instead of doing what they have to do in order to be relevant. To be relevant, they must get involved in the design process; or else leave the whole problem to the existing design engineers. When a customer buys some equipment, he or his advisers should consult the design details, not the test results from an EMC test.

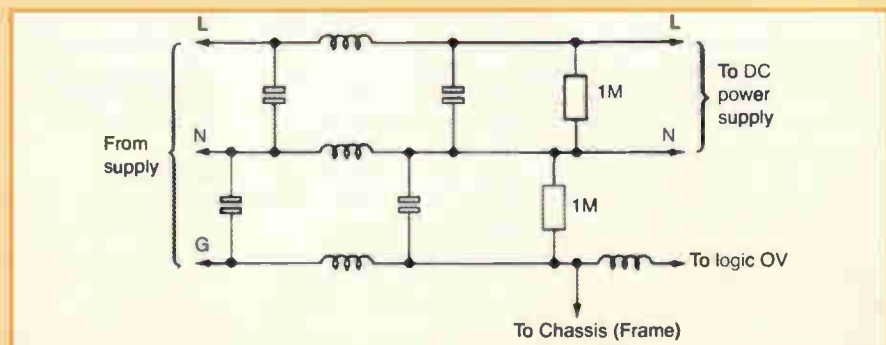

hitting the anvil with a 3,000 pound hammer which had been raised through one foot and then left to swing at the anvil like a pendulum. Presumably nervous designers would pray for a fly, or better still a wasp, to intervene. Interestingly, all the seamen aboard would have had their legs broken, but the printer would continue to print a message ("Torpedo attack" for example). The demonstration film, where I saw a nice piece of electronic equipment turn into an array of projectiles, was taken seriously by the freedom-loving Americans watching with me. They objected to my laughter, although I was only fired much later.

We have to realise that had the resident Geniston EMC magician ventured inside our equipment, or even entered into technical discussions with me, he would probably have been betrayed as part of "rent-a-crowd", similarly to the way Weinstock would rent a crowd of milkmen and the like for a weapons project to keep his roster of "electronic engineers" up to the two thirds contractual minimum. This minimum roster saved the government funded project from cancellation. In any case, at 100% of cost plus 14%, the more milkmen he hired as engineers, the more would be the GEC profits. Professor "stinking fish" Brown played his part in this when he betrayed the IEE, who were trying to establish a way to distinguish between an EE and a milkman. In both cases, the Official Secrets Act or the like would provide ample cover. Even at this late stage, this article is probably undermining the UK's defences, which are based on bluff and scam³, the EMC community fits well into such a scene.

The EMC requirements meant that the little three foot long line printer turned into something looking very much like a tank, as can be seen in the Data Products equipment brochures of the time. Since the antenna used by EMC magicians to detect emitted noise was brought up to a standard distance from the edge of the device under test, one obvious recourse was to make the device bigger and so push the EMC detecting antenna away from the workings inside.

Stingray

Whenever a major scandal hit GEC, Weinstock would rename it Marconi, or vice versa. MPs were too dim to realise that all the weapons scandals involved the single company. In this article, GEC stands for GEC or Marconi.

The Stingray project was special. GEC operated a number of "defence" weapon "design" scams, and Stingray was by far the most surreal³.

Davidson, Walton and Catt had made major breakthroughs in electromagnetic theory. We needed to find out how much of our breakthroughs were known in all the electromagnetism subcultures. Two of us were employed at GEC Borehamwood (Herts, UK) at the time, so Malcolm Davidson went upstairs to the microwave design department. He came back down to report that they were only plumbers. They knew nothing, and merely played with equations and connected together tubes to pipe around only one mode.

Later, the question arose as to whether the EMC community already knew any of our advances. So I stopped teaching remedial English and got a job as the top EMC magician on the Stingray torpedo project in Stanmore, Middlesex. As a magician myself, I would be able to find out what they knew. (For instance, I would be better placed to force them to tell me what their jargon meant.) I had to avoid the EMC experts in GEC Portsmouth, GEC Rochester, etc., until I had rumbled what some of their main buzz-words (e.g. lisen) meant and found out what books they relied on. After a few days I found out that their bible was the £400 Don White manual. However, no other EMC experts would lend me their copy, or let me see it. After about ten days, however, I met a man who sold EMC devices imported from Los Angeles to our weapons industry. He volunteered to lend me the EMC bible, which was one of his products, for two or three weeks. When I asked him why, he said that he had mixed loyalty. On the one hand he was happy to take a 10p capacitor manufactured in Los Angeles, renamed an EMC capacitor, sold to him for £2 for him to mark up to £5 and then sell to GEC. On the other hand, he was also a taxpayer, and was appalled by the drain on the taxpayer. (At the time, "defence" took 6% of GDP.

It took me a day or two to find out that Don White and his EMC

cardinals were technically ignorant. I wrote a document blowing the gaff on Don White, which I withheld. At that stage, I knew that the EMC community knew no electromagnetic theory, much as we had found for the plumbers called "microwave engineers". However, by now I preferred to sit in GEC at £11 per hour rather than sit at home for £0 per hour. I was justified, because the same British government was funding research into my inventions at Middlesex Polytechnic, Brunel University and RSRE Malvern. I was on the research management committees. Everyone else on these committees was so jealous of the fact that my inventions, not theirs, were being funded, that they were determined that anyone else on these projects would be salaried, but not me, the inventor. This was thus a double double-cross. I would sit at my GEC Stingray desk working on the Catt Spiral projects, which paperwork looked more or less the same as Stingray paperwork. I would be paid to do nothing on Stingray, and be paid nothing to work for the same government on Catt Spiral projects. An interesting moral dilemma occurred when I skipped out of "work" on Stingray to attend (unpaid) a management conference on one of my government-funded projects at Brunel or Middlesex. Should I claim pay for those hours away from my desk at Stanmore?

To keep my £11 per hour going, I had to keep away from other EMC magicians on Stingray. However, after two or three weeks the Portsmouth EMC magician could no longer be held off by my excuses. So two days before his proposed visit, I sent him my report rubbishing his Don White bible. Realising the danger to himself, he cancelled, and I never saw him. In the "defence" industry, reality threatens everyone.

By then I knew that EMC magicians were ex-RAF airborne radio operators or the like, good sound troopers who knew little electromagnetic theory. The £400 Don White manual gave them project plans which they could copy into their own reports for the MoD. They could also copy technical sections into their reports. All this copying was the reason why nobody except EMC magicians must ever see the Don White bible.

While Principal Lecturer in West Herts College, I found out that it was an offence to have no functioning earth leakage detector in the fuse box for power entering a room occupied by students. However, the indispensable mains filters on each machine in my room full of computers put too much electric current into the earth line. I set out to find out who generated the regulation. After some months, I homed in on an engineer hiding in the back of the IEE. I told him that that was fine; students' lives had to be protected. All it meant was that throughout England, computer training would have to be done without using computers. I would make sure that everyone knew his involvement in making it illegal to use computers when teaching computers, and so saving students' lives. He then replied that the standard was only advisory. Given minimal support, I could do the same with these ridiculous EMC standards, which at present have criminal sanctions against those who breach them. Under pressure, no technocrat will accept accountability for their enforcement.

In the past, EMC, spawned in "defence", would only boost the parasitic activity called "defence", and help to waste a fraction of the GDP. However, the recent move, where it becomes a criminal offence for commercial industry to avoid their ridiculous, expensive standards and tests, makes them a more serious threat to us all. I need assistance to wrinkle out the technocrats responsible for the present standards, and to require them to defend the test standards, and to be accountable for them. Such people probably do not exist. If they do, we must begin to destroy the credibility of such individuals and in the end make these ridiculous standards unviable in a criminal court, because a jury will refuse to convict. ■

References:

- 1 See my book "The Catt Concept" pub. Hart-Davis 1972 for insight into my time in the US.
- 2 I discuss it in my book "Computer Worship" pub. Pitman 1973
- 3 See <http://www.electromagnetism.demon.co.uk/gamoe.htm> for more information.
- 4 This is discussed in my out of print book "Digital Hardware Design", pub. Macmillan 1979, p83.



Electronics World reader offer:
x1, x10 switchable
oscilloscope probes,
only £21.74 a pair,
fully inclusive*

*Additional pairs as part of the same order, only £19.24 each pair.

Please supply the following:

Probes

Total _____

Name _____

Address _____

Postcode _____ Telephone _____

Method of payment (please circle)

Cheques should be made payable to ELECTRONICS WORLD

Access/Mastercard/Visa/Cheque/PO

Credit card no. _____

Card expiry date

Signed

Please allow up to 28 days for delivery

Seen on sale for £20 each, these high-quality oscilloscope probe sets comprise:

- two x1, x10 switchable probe bodies
- two insulating tips
- two IC tips and two sprung hooks
- trimming tools

There's also two BNC adaptors for using the cables as 1.5m-long BNC-to-BNC links. Each probe has its own storage wallet.

To order your pair of probes, send the coupon together with £21.74 UK/Europe to **Probe Offer, Jackie Lowe, Highbury Business Communications, Anne Boleyn House, 9-13 Ewell Road, Cheam, Surrey, SM3 8BZ**

Readers outside Europe, please add £2.50 to your order.

Specifications

Switch position 1

Bandwidth	DC to 10MHz
Input resistance	1MΩ – i.e. oscilloscope i/p
Input capacitance	40pF+oscilloscope capacitance
Working voltage	600V DC or pk-pk AC

Switch position 2

Bandwidth	DC to 150MHz
Rise time	2.4ns
Input resistance	10MΩ ±1% if oscilloscope i/p is 1MΩ
Input capacitance	12pF if oscilloscope i/p is 20pF
Compensation range	10-60pF
Working voltage	600V DC or pk-pk AC

Switch position 'Ref'

Probe tip grounded via 9MΩ, scope i/p grounded

Fourier Synthesis: defeating the Gibbs Phenomenon

Every first year electronics student knows that you can construct a square wave from the sum of an infinite series of sine and cosine waves. Text books have reproduced these Fourier coefficients for the square wave for at least 180 years. Leslie Green reaches for his calculator.

Students are told that the partial sum of the infinite series becomes a better approximation as the number of terms is increased. It is only more advanced text books that dare mention the dreaded *Gibbs phenomenon*, and even then it is often brushed aside very rapidly.



Fig 1. The Fourier partial sum up to the 11th harmonic.

Fig 2. The Fourier partial sum up to the 111th harmonic.



Any squarewave formed from Fourier coefficients has about 9% overshoot. In this article a new method is presented to simply reduce this overshoot by a factor of x30 with minimal computational expenditure.

The Fourier Series

The Fourier series for a square wave can be written as:

$$v(t) = 0.5 + \frac{2}{\pi} \sum_{n=1,3,5,\dots}^{\infty} \frac{\sin[n\omega t]}{n}$$

The reconstructed waveform is a square wave of unit amplitude, which starts from zero. It is noted that only odd harmonics are used to create the waveform and that the Fourier coefficient, F_n , of the n th harmonic is simply $1/n$ times the amplitude of the fundamental.

Although Fourier is credited with the concept, because of his 1822 book on the analytical theory of heat, it was actually Euler who first produced a harmonic series for a square wave some 50 years earlier.

The Gibbs Phenomenon

Mathematicians knew right from its inception that the reconstructed wave never converges to any discontinuity in the waveform. This was particularly highlighted by Lagrange around 1800¹, Wilbraham in 1848 and Gibbs in 1899.

Evidently when Professor J. Willard Gibbs made the observation, the world was more ready for it. Since then, the name Gibbs has been associated with all aspects of this phenomenon².

With modern computer software it is a trivial matter to reconstruct a square wave from any particular partial sum of the Fourier series.

In Figure 1, the partial sum up to the 11th harmonic has been used. For such a small number of harmonics, the 9% overshoot and overshoot could easily be attributed to insufficient terms used in the reconstruction.

In Figure 2, up to the 111th harmonic has been used. Notice that the time scale has been zoomed-in by a factor of x10 as well. The rise time is seen to decrease inversely

with the number of harmonics used.

You can keep increasing the number of harmonics and zooming in on the timescale, but the situation will never get any better. The series does not converge to a good square edge.

The limiting values of the preshoot and overshoot are around 8.9%, which is hardly a good starting point for a synthesised square wave. What we have here is a waveform with preshoot, overshoot and ringing; this can hardly be cited as a standard of excellence for a time domain system.

Discontinuity and Truncation

Digital signal processing is now a mature subject and it is well known that a discontinuity in the time domain becomes a source of a large number of components in the frequency domain. More specifically, in the FFT, it is well known that it is vitally necessary to 'window' a series of time-related data points before doing the FFT, in order to minimise spectral leakage.

In **Figure 3** a single sinusoidal frequency has been sampled digitally. The result of doing an FFT on this is shown as the blue waveform. This is the reference waveform when no window function is used. If the data series is processed using a raised cosine window function before doing an FFT, the resulting FFT shown in red shows considerably less spread; this is the von Hann† window.

What we wanted was a single spectral line at the input frequency, and nothing else. All of the remaining signal is spectral leakage due to the discontinuity at the ends of the waveform. The discontinuity is due to the input series to the FFT not containing an integer number of cycles of the input waveform.

This FFT example has highlighted the point that a discontinuity in a time domain waveform translates to excess terms in the frequency domain. It would therefore seem sensible to consider windowing the Fourier series of a reconstructed wave that has temporal (time related) discontinuities.

The situation is this; we have an infinite series of terms of which we are only going to use some finite number. We are effectively truncating the infinite series with a rectangular window function. If, however, we reduced the series to zero more gradually, it is to be hoped that a smoother reconstructed waveform would be produced. This is a somewhat practical matter, because any time we encounter an infinite Fourier series, we are always going to end up using a finite partial series.

Windowing the Fourier Series

Windowing a Fourier series is similar to windowing a time-related data series, with two major exceptions:

- The time-related data series has to be reduced to zero at both ends of the series.
- The FFT which results from a windowed time series is usually expressed in decibels. Therefore the visible dynamic range is vastly greater than that seen on a time domain waveform.

Given that the von Hann (raised cosine) window is so successful on the FFT, it makes sense to try a cosine window on the Fourier series. And indeed such a filter does have a good reduction effect on the ringing, but at the expense of the risetime. In fact a whole range of these filters have been

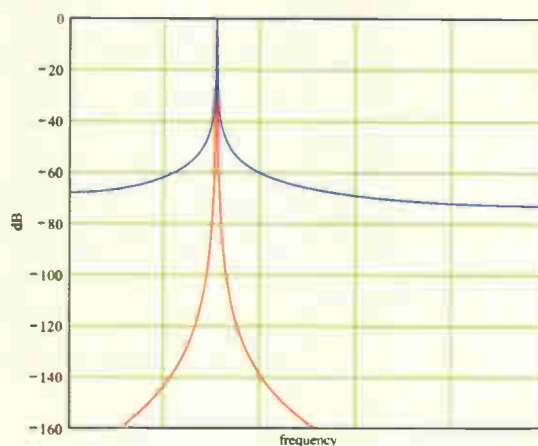

Fig 3. The FFT of a pure sinusoidal signal using a rectangular window (blue) and a von Hann window (red). Spectral leakage means that you do not get the single line that you might have expected.



Fig 4. FFT wrap-around due to aliasing.

tried, going back to Fejér in 1900; each has its own benefits and computational costs³.

Indeed the paper just cited apparently gives a resolution to the Gibbs problem in terms of Gegenbauer functions. (This may mean something to the more mathematically inclined reader, but personally I couldn't understand most of the mathematical sections. Nevertheless there is still a lot of useful non-mathematical introductory and background material in the paper.)

A Simpler Solution

What we expect is that we should be able to modify the Fourier magnitude coefficients to produce a better square wave. The phase should not need to be adjusted because of the rotational symmetry of the waveform about the $t=0$ point. In order to produce these new coefficients it is convenient to think about the frequency spectrum of a square wave.

When such a signal is viewed using an FFT, the slope of the envelope is from left to right until it 'hits' the right edge of the display. The spectral lines then get aliased back into the displayed range, with the slope of the envelope going in the opposite direction.

Figure 4 illustrates the situation. The red bars are reducing from left to right. The green bars are reducing from right to left; they also have a reversed phase. Note that the colour has been added only to highlight the envelopes. The data points would all be from the same FFT series.

In fact this construction forms an infinite series of slowly decaying aliases, with the phase reversing each time the harmonics reach the ends of the FFT.

Now if the square wave is synthesised, and the aliased harmonics are made to coincide with the non-aliased harmonics, then those reducing from right to left need to be subtracted, whilst those reducing from left to right need to be

† This has been erroneously called a "Hanning window" for many decades, no doubt due to confusion with the Hamming window.

Table 1: The coefficients of the harmonics as they alias back into the frequency range. Notice how adjacent terms in the end columns cancel each other out.

Basic	$\frac{1}{1}$	$\frac{1}{3}$	$\frac{1}{5}$...	$\frac{1}{n}$...	$\frac{1}{H-2}$	$\frac{1}{H}$	$\frac{1}{H+2}$
Negative alias	$\frac{-1}{2H+3}$	$\frac{-1}{2H+1}$	$\frac{-1}{2H-1}$...	$\frac{-1}{2H+4-n}$...	$\frac{-1}{H+6}$	$\frac{-1}{H+4}$	$\frac{-1}{H+2}$
Positive alias	$\frac{1}{2H+3}$	$\frac{1}{2H+5}$	$\frac{1}{2H+7}$...	$\frac{1}{2H+2+n}$...	$\frac{1}{3H}$	$\frac{1}{3H+2}$	$\frac{1}{3H+4}$
Negative alias	$\frac{-1}{4H+5}$	$\frac{-1}{4H+3}$	$\frac{-1}{4H+1}$...	$\frac{-1}{4H+6-n}$...	$\frac{-1}{3H+8}$	$\frac{-1}{3H+6}$	$\frac{-1}{3H+4}$
Positive alias	$\frac{1}{4H+5}$	$\frac{1}{4H+7}$	$\frac{1}{4H+9}$...	$\frac{1}{4H+4+n}$...	$\frac{1}{5H+2}$	$\frac{1}{5H+4}$	$\frac{1}{5H+6}$

added. This is best evaluated by means of a table, as shown in Table 1.

Undoubtedly this table will at first seem daunting. It is actually very simple, however. Start from the top left and it is a simple progression of odd numbers underneath. Proceed to harmonic H and then 'bounce' back with a negative amplitude, due to the 180° phase shift. Notice that the last column on the right has been arranged so that the terms in adjacent row-pairs are equal but opposite. We want this last position to be zero, because we are only working up to harmonic number H; this last column represents H+2. We now head right to left on the second row, sticking to the odd numbers again. To get the first

column value, we notice that for a row that starts with 1 and ends in H the difference is H-1. This enables the table to be built up slowly, but simply.

The following section of maths may look a bit complicated in terms of its quantity, but actually it is just a lot of simple manipulations; no complicated stuff at all. Adding the middle column of generalised terms from the table gives the new value. The modified coefficient for the nth harmonic of the Fourier expansion is:

$$G_n = \frac{1}{n} - \left[\frac{1}{2H+4-n} - \frac{1}{2H+2+n} \right] - \left[\frac{1}{4H+6-n} - \frac{1}{4H+4+n} \right]$$

Notice that the rows have been paired to give a simplification of the series. The new coefficients are always smaller than the originals, except for at N=1. This infinite series is easily expressed in sigma notation as:

$$G_n = \frac{1}{n} - \sum \left(\frac{1}{2k[H+1]+2-n} - \frac{1}{2k[H+1]+n} \right)$$

This looks pretty large and untidy and I am afraid it gets worse before it gets better!

Expand using a common denominator.

$$G_n = \frac{1}{n} - \sum \frac{(2k[H+1]+n) - (2k[H+1]+2-n)}{(2k[H+1]+2-n)(2k[H+1]+n)}$$

Simplify the top:

$$G_n = \frac{1}{n} - \sum \frac{2n-2}{(2k[H+1]+2-n)(2k[H+1]+n)}$$

Multiply out the bottom:

$$G_n = \frac{1}{n} - 2 \sum \frac{n-1}{4k^2(H+1)^2 + 4k(H+1) + 2n - n^2}$$

Take the constants out of the summation:

$$G_n = \frac{1}{n} - \frac{n-1}{2(H+1)^2} \sum \frac{1}{k^2 + \frac{k}{H+1} + \frac{2n-n^2}{4(H+1)^2}}$$

This Mathcad worksheet shows the workings with nothing hidden. Notice that there is no ringing due to the Gibbs phenomenon in this case, because the sampling rate is too low; the ringing is aliased. Also notice that the time axis has been shifted by half a point in order to eliminate the dot in the middle of the edge.

Comparing The Overshoot Against the Fourier Coefficients

H := 51 t := -2, -1, .6 $\omega := \frac{2\pi}{H}$ n := 1, 3, ., H odd values only

$K := \frac{\pi^2}{11.2(H-1.06)^2}$ $G_n := \frac{1}{n} - K(n-1)$ $F_n := \frac{1}{n}$ $K = 3.533 \cdot 10^{-4}$

$v(t) := 0.5 + \frac{2}{\pi} \sum_n G_n \sin(n\omega \cdot (t-0.5))$ $f(t) := 0.5 + \frac{2}{\pi} \sum_n F_n \sin(n\omega \cdot (t-0.5))$

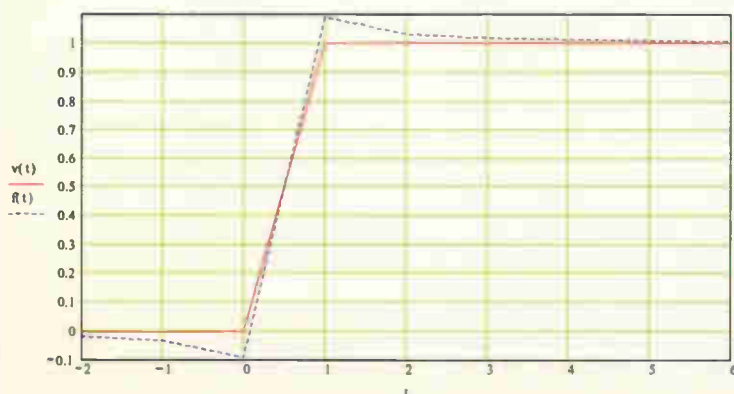

The whole point was to eliminate the infinite series of Fourier components; the result so far is another infinite series! However, the sigma term has a very small variation with n, so that to a reasonable approximation we can say that:

$$\sum_{k=1}^{\infty} \frac{1}{k^2 + \frac{k}{H+1} + \frac{2n-n^2}{4(H+1)^2}} \approx \sum_{k=1}^{\infty} \frac{1}{k^2} = \frac{\pi^2}{6}$$

This last identity being given in formula books⁴ for the Riemann zeta function. This is the justification for writing an approximation to the enhanced coefficients as:

$$G_n \approx \frac{1}{n} - \frac{\pi^2}{12} \times \frac{n-1}{(H+1)^2}$$

However, since it is an approximation, one should suspect that slightly better 'internal' coefficients could be found. Thus a better approximation is:

$$G_n = \frac{1}{n} - \frac{\pi^2}{11.2} \times \frac{n-1}{(H-1.06)^2}$$

This gives 0.3% overshoot, as compared to 8.9% for the original Fourier coefficients. In fact this 'approximation' is better than the original formula for G_n , due to a slight dependence on H in the original.

The calculation of this new coefficient is very inexpensive in computer time. Obviously the

$$\frac{\pi^2}{11.2 \times (H-1.06)^2}$$

part is calculated once before the main loop. The coefficients are then calculated from the simple equation:

$$G_n = \frac{1}{n} - K(n-1)$$

References:

1. Steven W. Smith, 'Chapter 8'. in The Scientist and Engineer's Guide to Digital Signal Processing, 2nd edn (www.DSPguide.com: California Technical Publications, 1999).
2. Edwin Hewitt & Robert E. Hewitt, 'The Gibbs-Wilbraham Phenomenon: An Episode in Fourier Analysis', Archive for History of Exact Sciences, 21 (1979), pp 129-160.
3. David Gottlieb & Chi-Wang Shu, 'On the Gibbs Phenomenon and its Resolution', Society for Industrial and Applied Mathematics, SIAM REV. 39. no. 4 (Dec 1997), pp 644-669.
4. 'Mathematical Equations', in Reference Data for Engineers: Radio, Electronics, Computer & Communications, 8th edn (SAMS, 1993), p 47-8.

SPECIAL OFFERS



TEKTRONIX 2445A 4 Ch 150MHz Delay, Cursors etc. Supplied with 2 Tektronix probes **ONLY £425**

TEKTRONIX 2232 Digital Storage Scope. Dual Trace 100 MHz 100ms with probes. £525
H.P. 54501A Digitizing Oscilloscope 100MHz, 4Ch £425
H.P. 3312A Function Gen 0.1Hz-13MHz AM/FM Sweep/Trv/Gate/Burst etc. £300
FARNELL Dual PSU XA35-2T 0-35V 0-2A Twice QMD LCD Display £180
CIRRUS CRL254 Sound Level Meter with Calibrator, 80-120dB, LED. £150
EDDYSTONE 1002 Receiver 150kHz-30MHz + Broadcast FM £125
FARNELL AMM255 Automatic Mod Meter 1.5MHz 2GHz Unused £300
FARNELL DS31 Low Frequency Syn Sig Gen 0.001Hz to 99.99MHz. Low Distortion TTL/Square/Pulse Outputs etc. £95
FLUKE 8060A Handheld True RMS DMM 4 1/2 digit As new £150. Used £95
BECKMAN HD110 Handheld 3 1/2 digit DMM, 28 ranges with battery, leads and carrying case £40

H.P. 3310A Function Gen 0.005Hz-5MHz Sine/Sq/Trv Ramp/Pulse £125
FARNELL FLM4 Sine/Sq Oscillator 10Hz-1MHz low distortion, TTL Output, Amplitude Meter £125
H.P. 545A Logic Probe with 546A Logic Pulsar and 547A Current Tracer £90
FLUKE 77 Multimeter 3 1/2 digit Handheld £60
FLUKE 77 SERIES II £70
HEME 1000 LCD Clamp Meter 0-1000A. In Carrying Case £60

Racal 9008 Automatic Modulation Meter AM/FM 1.5MHz - 2GHz **ONLY £95**

Dalton 1061 High Quality 5 1/2 Digit Bench Multimeter True RMS/4 wire Res/Current Converter/IEE **£150**

Dalton 1061A High Quality 6 1/2 digit Bench Multimeter True RMS/4 wire/Current Converter **£225**

Racal Receiver RA1772 50KHz - 30MHz LED Display. Basically Working. **£250**

MARCONI 2019A



AM/FM synthesised signal generator 80kHz - 1040MHz **NOW ONLY £400**

MARCONI 893C AF Power Meter, Sinad Measurement. Unused £100 Used £60
MARCONI 893B - No Sinad £30
MARCONI 2610 True RMS Voltmeter Autorangin 5Hz-25MHz £195
GOULD J3B Sine/Sq Osc. 10Hz-100kHz. Low distortion £75-£125
AVD 8 Mk6 In Ever Ready Case, with leads etc £80
Others Avos from £50
GODDWIN GVT427 Dual Ch AC Millivoltmeter 10mV in 12 Ranges Freq 10Hz-1MHz £100-£125
SOLARTRON 7150 DMM 6 1/2 digit True RMS - IEEE £95-£150
SOLARTRON 7150 PLUS £200

HIGH QUALITY RACAL COUNTERS

9904 Universal Timer Counter, 50MHz £50
9916 Counter, 10Hz-520MHz £75
9916 Counter, 10Hz-560MHz, 9-digit £50
WAYNE KERR B424 Component Bridge £125
RACAL/AIM 9343M, LCR Databridge, Digital £200
Automeasurements of R.C.L. O.D.

HUNTRON TRACKER Model 1000 £125
MARCONI TF2015 AM/FM sig gen, 10-520MHz £175
FLUKE 8050A 4.5 Digit, 2A True RMS £75
FLUKE 8012A 3.5 Digit, 2A £40

SOLARTRON 7045 Bench Multimeter 4.5 Digit Bright LED with Leads **ONLY £30**

Portable Appliance Tester Megger Pat 2 **ONLY £180**

H.P. 60128 OC PSU 0-60V 0-50A 1000W £1000
FARNELL AP60/50 1KW Autoranging £1000
FARNELL H60-50 0-60V 0-50A £750
FARNELL H60/25 0-60V; 0-25A £400
Power Supply HPS3010 0-30V; 0-10A £140
FARNELL L30-2 0-30V; 0-2A £80
FARNELL L30-1 0-30V; 0-1A £60

Many other Power Supplies available. Isolating Transformer 240V In/Out 500VA £40

FARNELL DTV 12-14 OSCILLOSCOPE
 DUAL TRACE 12 MHz TV. COUPLING **ONLY £75**

FARNELL LFI 12-14 Sine/Sq OSCILLATOR
 10 MHz - 1 MHz **ONLY £75**

OSCILLOSCOPES

TEKTRONIX TDS350 Dual Trace 200MHz 16S unused £1500
TEKTRONIX TDS320 Dual Trace 100MHz 500M/S £1200
TEKTRONIX TDS310 Dual Trace 50MHz 200M/S £950
LECRDY 9400A Dual Trace 175MHz SG/S £750
HITACHI VC6523 Dual Trace 20MHz 20M/S etc unused £500
PHILIPS PM3092 2+2Ch 200MHz Delay £800 As New £950
PHILIPS PM3082 2+2Ch 100MHz Delay etc £700 As New £800

TEKTRONIX T4S465 Dual Trace 100MHz Delay etc £750
TEKTRONIX 2465B 4Ch 400MHz Delay Cursors etc £1500
TEKTRONIX 465 4Ch 300MHz Delay Cursors etc £900
TEKTRONIX 468 Dig Storage Dual Trace 100MHz Delay £450
TEKTRONIX 466 Analogue Storage Dual Trace 100MHz £250
TEKTRONIX T4S465 Dual Trace 100MHz Delay Sweep £550
TEKTRONIX 475 Dual Trace 200MHz Delay Sweep £350
TEKTRONIX 465B Dual Trace 100MHz Delay Sweep £325
TEKTRONIX 2215 Dual Trace 60MHz Delay Sweep £200-£250
GOULD DS1100 Dual Trace 30MHz Delay £125
HAMEG HM303.6 Dual Trace 35MHz Component Tester. As new £240
HAMEG HM303 Dual Trace 30MHz Component Tester £200

MANY OTHER OSCILLOSCOPES AVAILABLE

MARCONI 2022E Synthesised AM/FM Sig Gen £525 - £750 10kHz - 1.01GHz LCD Display etc
H.P. 8657A Syn 100kHz - 1040MHz Sig Gen £2000
H.P. 8656B Syn 100kHz - 890MHz Sig Gen £1350
H.P. 8656A Syn 100kHz - 990 MHz Sig Gen £995
R&S APN62 Syn 1Hz - 260kHz Sig Gen £425
Balanced/Unbalanced Output LCD Display
PHILIPS PM5528 Sig Gen 100kHz - 180MHz with 200MHz Freq Counter IEEE

RACAL 9081 Syn AM/FM Sig Gen 5kHz - 1024MHz £250
H.P. 3325A Syn Function Gen 21MHz £600
MARCONI 6500 Amplitude Analyser £1500
H.P. 4192A Impedance Analyser £5000
H.P. 4275A LCR Meter 10kHz - 10MHz £2750
H.P. 8903A Distortion Analyser £1000
WAYNE KERR Inductance Analyser 3245 £2000
H.P. 8112A Pulse Generator 50MHz £1250
MARCONI 2440 Freq Counter 20GHz £1000
H.P. 8350B Freq Counter 20GHz £2000
H.P. 5342A 10Hz - 18GHz Freq Counter £800
H.P. 1650B Logic Analyser 80 Channel £1000
MARCONI 2305 Mod Meter 500KHz - 2GHz £750

RADIO COMMUNICATIONS TEST SETS

MARCONI 2955/2955A from £1500
Rohde & Schwarz GWT 0.1 - 1000MHz £2000
Schlumberger 4040 £900

JUST IN

H.P. 6063B DC Electronic Load 3-240V/0-10A 250W P.O.A

H.P. 66312A PSU 0 - 20V/0-2A £400
H.P. 66311B PSU 0 - 15V/0-3A £400
H.P. 663090 PSU Dual 0 - 15V 0-3A/0-12V 0-1.5A £750
H.P. 6632B PSU 0 - 20V/0-5A £500
H.P. 6623A PSU Triple Output ranging from £850
0-7V 0-5A to 0-20V 0-4A

H.P. Agilent 34401A DMM 6 1/2 digit £400/£450
H.P. 3478A DMM 5 1/2 digit £275
FLUKE 45 DMM Dual Display £400
KEITHLEY 2010 DMM 7 1/2 digit £950
KEITHLEY 617 Programmable Electrometer £1250
H.P. 4338B Milliohmeter £1500
RACAL Counter type 1999 2.6 GHz £500
H.P. Counter type 53131A 3GHz £850
H.P./Agilent 33120A Function Gen/ARB £900/£1000
10micromHz - 15MHz

SONY/TEKTRONIX AFG320 Arbitrary Function Gen £1250
H.P. 8904A Syn Function Gen DC - 600kHz £1000/£1250
BLACK STAR JUPITER 2010 Function Gen 0.2Hz - 2MHz with Frequency Counter £140
H.P. 8116A Pulse Generator 1mH-50MHz £1950
H.P. 8657B Syn Signal Gen 0.1-2080MHz £2500
CO-AXIAL SWITCH 1.5GHz £40
IEEE CABLES £10

SPECTRUM ANALYSERS

H.P. 8561B 50Hz - 6.5GHz £5080
H.P. 8560A 50Hz - 2.9GHz Synthesised £5000
H.P. 8594E 9kHz - 2.9GHz £4500
H.P. 8591E 1MHz - 1.8GHz 75 ohm £2750
H.P. 853A with 8559A 100kHz - 21GHz £1750
H.P. 8588B with Main Frame 100kHz - 1500MHz £750
H.P. 3585A 20Hz - 40MHz £2500
H.P. 3580A 5Hz - 50kHz £600
ADVANTEST R4131B 10kHz - 3.5GHz £2750
EATON/Alitech 757 0.001 - 22GHz £750
MARCONI 2382 100Hz - 400MHz High Res £2000
MARCONI 2370 30Hz - 110MHz from £500
H.P. 182 with 8557 10kHz - 350MHz £500
H.P. 141T Systems

8553 1kHz - 110MHz £500
8554 500kHz - 1250MHz £750
8555 10MHz - 18GHz £1000
H.P. 8443 Tracking Gen/Counter 110MHz £250
H.P. 8444 Opt 059 £650
B & K 2033R Signal Analyser £750
H.P. 8754A Network Analyser 4MHz - 1300MHz £1250
H.P. 3577A Network Analyser 5Hz - 200MHz £3000
H.P. 53310A Modulation Domain Analyser Opt 001/003 £5000
ONO SOKKI Portable FFT Analyser £1500
H.P. 8720C Microwave Network Analyser 50MHz-20GHz £12500

Modern impedance measurement techniques IV

In his fourth in-depth article covering modern methods of measuring impedance, Alan Bate* describes a hypothetical LCR Instrument based on DSP techniques.

Rounding off this final article on modern LCR instruments – which are still loosely called bridges – I look at the merits of a DSP based instrument by investigating some of the points that would need to be evaluated in the initial design phase of such an instrument.

Consider a modern DSP-based bridge such as QuadTech's 7000 series LCR measuring instrument. Its basic accuracy is 0.05% from 10Hz to 10kHz and it has seven-digit measurement resolution. It operates over a frequency range of 10Hz to 500kHz with an accuracy of 20ppm+0.02Hz using direct digital synthesis – a subject that merits another article in itself.

For non-critical applications, it can take 40 measurements a second at 0.5% accuracy. At normal speed it takes three measurements a second at 0.25% accuracy. For improved resolution, the meter can be set to take one measurement a second at full accuracy.

Now, considering the following system blocks and their associated error sources to achieve 0.05% or 500ppm total error, a possible error budget might be:

- Harmonic distortion and noise from stimulus, 100ppm.
- Three decade, range attenuator, initial ratio tolerances and temp drift, at least 100ppm +2ppm.
- Standard resistor, initial tolerance and temperature drift, 50ppm +2ppm.
- System clock frequency, initial tolerance and temperature drift, 20ppm.
- Range amplifier distortion and thermal noise, 100ppm.
- A-to-D converter accuracy, integral and differential non-linearity, quantisation and thermal noise. Effective resolution of at least 18 bits (4ppm) over the range 10% to 100% of full scale.
- Rounding errors in the dsp processing, 20ppm.
- Rounding errors from impedance calculations and display formatting, 50ppm.

Then for an even distribution of errors, each function needs to have less than 0.05%/8, or around 60ppm, total error contribution.

In practice, some functions will use more or less of the error budget. Only two, as opposed to six, AC measurements are now required. This is because the real

and imaginary components of the E_u and E_s measurement and reference signals, explained in the first article in this series, are directly extracted from the FFT analysis.

Now, the in-phase and quadrature measurements are being made from a large number of samples to derive their FFTs. Typical sample size would be 1024, known as a 1024-point FFT.

In addition to the impedance calculations, which required around 22 bits of resolution with the all-analogue method to avoid rounding errors, there's a considerable increase of numerical processing – multiplications and additions – for the two FFT calculations.

Assume that each E_u and E_s measurement would consist of 2048 time samples for full accuracy. An A-to-D converter with an effective resolution more than 22 bits would seem to be desirable. This points to using the latest dual sigma-delta converters, which are 24 bit, 192kHz sampling devices. They would have to run at the lowest possible conversion rate for minimum dynamic distortion as discussed in my third article last month.

These high performance dual A-to-D converters now enable E_u and E_s to be read simultaneously, saving measurement time and settling delays by avoiding range switching. However, the range function would need to be duplicated for the E_u and E_s signals. This would throw away the great advantage of normalising out variations in gain and phase of the whole ranging circuitry by the ratio measurement as well as adding to the instrument cost.

Matching between the separate E_u and E_s signal paths would need to be made using software corrections for each range setting increasing test time and costs. For this reason, DSP would only be considered for an up-market bridge like the QuadTech 7000 series.

Required FFT window

With the old analogue method, the phase-shift detector and A-to-D combination provided narrow band detection. Remember that the A-to-D integration time was synchronised to a whole number of the drive signal periods so that the A-to-D converter integrated the PSD ripple. This also defined the PSD bandwidth which is approximately the root reciprocal of the A/D integrate period.

By increasing the integration period, the PSD noise bandwidth could be closed, reducing the noise power as the square root of integration period. For a 2:1 improvement in noise, we needed to reduce the phase-shift detect and A-to-D conversion rate by 4:1.

The same can be done in DSP by increasing the period of the FFT window length. Remember that for an efficient FFT, it is necessary to stick to a sample length that is a binary number to aid the processor calculations.

Taking our hypothetical instrument maximum frequency

*Alan Bates BEng (Hons) MIEE

for full accuracy of 10kHz and our original analogue noise bandwidth of 50Hz, an FFT frequency resolution, or spectral line spacing (also known as bin spacing) of 25Hz would be needed. However, the FFT would respond to 50Hz and 100Hz but miss 60 and 120Hz. These are important frequencies for measuring electrolytic capacitors. A 10Hz bin spacing is therefore needed, which would cover odd and even multiples of 10 and give a theoretical noise bandwidth of 20Hz.

Now, FFT bin spacing is:

$$\frac{1}{N} \times \Delta f_{\text{sample}} = \frac{f_{\text{sample}}}{N}$$

where N is the number of samples. It is possible to have an increasingly narrow band system by increasing the size of the FFT data block or window length. In other words, the longer that the signal is viewed, the more detail that can be resolved in the frequency plane.

In order for 10kHz to be at a spectral line in the FFT output and maintain a 10Hz bin spacing, and ignoring for the moment the zero frequency or DC bin, 10kHz would need to be at spectral line;

$$\frac{\text{spectral line frequency}}{\text{bin spacing}} = \frac{10000}{10} = 1000$$

The next binary number is 1024, which would be at half the sample frequency. This would require an FFT of 2048 points as the useful FFT output is from zero to the half sample frequency. Hence the minimum sample rate to meet the Nyquist criteria would be an A-to-D conversion rate of 2048 multiplied by 10Hz spacing plus 10Hz for the DC component, which is 20.49kHz. This would bring each E_u and E_s sample FFT window to 100ms.

Assuming the dual converter and dual channel ranging discussed above, total measurement time becomes the sum of:

- the 100ms window
- data transfer from each A-to-D buffer to memory
- processing of the two 2048-point FFTs
- impedance calculations
- display rounding and formatting

The low-cost 100MHz Pentium processor mentioned in the previous article needed an estimated 170ms execution time for a 2048-point FFT. Assuming the impedance calculations and display algorithms processing are very short in comparison then this could give an acceptable reading rate of around;

$$\frac{1}{100\text{ms} + (170\text{ms} \times 2)}$$

or 1 to 2 readings a second at full accuracy.

On the faster settings, it would be necessary to trade a shortening of the FFT window length with a wider noise bandwidth. On the fastest setting of 40 measurements a second this could be approximately half the total measurement time, say 10ms sample time and 100Hz bin spacing using a 256-point FFT, sampling at 25.6kHz and a theoretical noise bandwidth of 2x bin spacing, or 200Hz.

The above line of thought is of course only approximate. Hardware development would be needed to arrive at an optimised design.

Lowering noise

It is also possible to increase resolution by averaging the impedance results. But increasing the FFT sample length, and hence closing the detection noise bandwidth would be a more desirable means of increasing the signal to noise. This is because of the increase in selectivity, which is very desirable at the supply frequencies 50/60Hz and harmonics

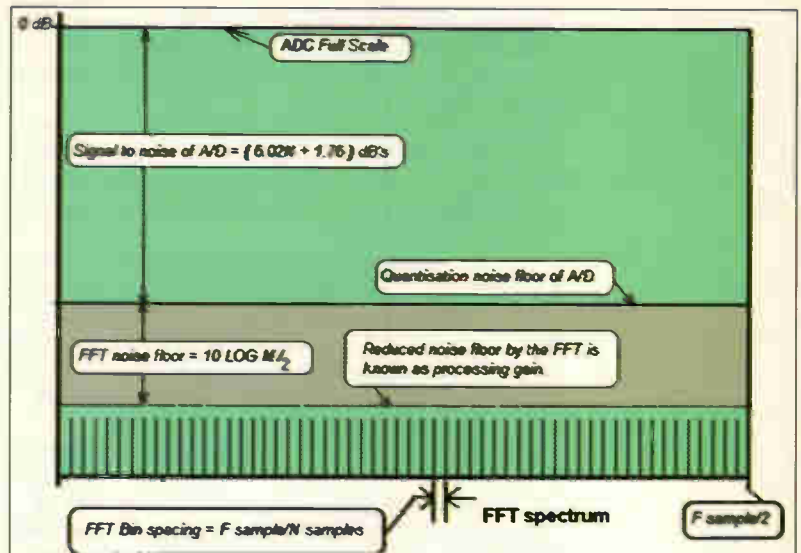

Fig. 1. The FFT noise floor is not the SNR of the A-to-D converter. This is because the FFT acts like a spectrum analyser, of bandwidth f_s/M , where M is the number of sample points in the FFT, rather than $f_s/2$. The theoretical FFT noise floor is therefore $10\log_{10}(M/2)$ dB below the quantisation noise floor due to the so-called processing gain of the FFT.

thereof.

In fact, the FFT noise floor can be reduced well below that of the A-to-D conversion hardware noise floor by simply increasing the number of samples. In other words, the FFT noise floor is not the noise floor of the A-to-D converter. This is akin to the instrument noise floor reducing on a spectrum analyser as the resolution bandwidth setting is reduced to a bandwidth of f_{sample}/M , where M is the number of points in the FFT. It can be shown that the theoretical FFT noise floor is;

$$10 \log \frac{M}{2} \text{dB}$$

below the A-to-D quantisation noise floor. In DSP talk, this is known as the processing gain of the FFT, Fig. 1. This would be desirable to help overcome noise limitations in even the latest available A-to-D converters.

My survey of recent 24bit/192kHz audio A-to-D converters in last month's article shows typical real noise floors of around 105dB – a short fall of 144–105, or 42dB. To make up this by processing gain would require an unacceptable 32 768 point FFT! This indicates that the latest 24 bit technology is still a little short on raw, unweighted noise performance. Our 2048 point FFT would give a 30dB noise reduction.

The A-to-D converter needs to have a noise floor of around -114dB. So what's available on the sigma-delta IC market? Until recently, most sigma-delta converters were designed for low-frequency, low-level applications such as strain gauge transducer amplifiers and medical instrumentation. The digital filtering is therefore designed for the low audio range for maximum signal-to-noise performance.

Sigma-delta A-to-D converters for audio applications do not necessarily have good unweighted noise performance. This is because the noise in digital audio includes psycho-acoustically noise shaped filtering. This masks the true A-to-D converter noise with frequency and in turn requires less stringent noise performance than the converter's resolution implies.

Table 1 in last month's article is a list of the latest 24 bit sigma-delta A-to-D converters – all developed for digital audio applications. Very recently, Analog Devices has launched a 24-bit sigma-delta A-to-D converter – the

AD7732. It is designed for instrumentation and can handle multiplexing up to 12.3kHz, which is well above our requirement of around 80Hz using a single A-to-D converter. Even multiplexing at 300Hz, the 7732 achieves 21 bits of effective resolution.

The overall A-to-D converter frequency response needs to be flat to within, say, less than 5% or 0.4dB at 10kHz to avoid too much signal loss. This is not a problem with the recent A/Ds developed for audio. They have pass-band flatness of 0.005dB.

At integer multiples of the modulator sample frequency the digital filter spectrum will repeat – i.e. it is periodic in nature – with zero attenuation around each sample rate harmonic (see Fig. 8 in last month's article). If noise exists in these pass bands, analogue filtering is needed at the A-to-D converter's input to remove it, otherwise it will alias and pass unfiltered to the converter output.

Ironically, after all the digital processing, an analogue filter is needed at the A-to-D converter input to band limit the measurement signal to keep it within the modulator Nyquist bandwidth. However, due to the wide separation between the over sample frequency and the wanted pass band of the A-to-D converter modulator, this can be a simple passive filter.

Theoretically, the filter needs to roll off to less than one LSB at the modulator half-sample rate f_n , Fig. 2. The number of octaves between the two frequencies is the logarithm of the frequency ratio, divided by the logarithm of 2 – the ratio of one octave.

For example, with an over-sample rate of 256x, the Nyquist frequency will be half this at 128x the A-to-D conversion rate, f_c . The required filter pass/stop-band spacing is $\log 128/\log 2$, or 7 octaves away.

There are seven octaves within which sufficient stop-band rejection can be achieved to reduce the alias noise below the 24 bit A-to-D converter resolution i.e. 144.5dB of rejection. This means a filter slope of 144/7 or 20.6dB/octave.

Since filter slopes come in 6dB/octave integer increments, we require a fourth-order filter – i.e. 24dB/octave. Expressed as a formula, filter order N is;

$$\frac{A_{sb} \times \log 2}{6 \left(\log \frac{f_a}{f_c} \right)}$$

Here, A_{sb} is the required stop-band rejection in decibels.

In practice, the filtering can be simpler as the stimulus harmonics and thermal noise above the modulator Nyquist rate would already be at a low level. For this reason, less

stringent cases like digital audio use a simple RC filter.

A simple RC filter however, rolls off at only 6dB/octave or 20dB/decade. This gives 42dB of attenuation at the Nyquist frequency, which may be minimal.

For a well engineered instrumentation solution a passive LC filter, with 12dB/octave or 40dB/decade roll-off would be more suitable, giving 84dB of attenuation at the Nyquist frequency. Choosing an LC passive filter would also give the lowest thermal noise in the pass band. Unlike active filters and RC filters, real reactances do not contribute thermal noise.

Summary of the DSP approach

Precision LCR measuring instruments based on DSP techniques have become practicable with the improvements in high-resolution A-to-D converters and cheaper, more powerful general purpose and dedicated digital signal processors.

Greatly increased processor workload would probably require the additional cost of a 32bit DSP chip to maintain acceptable measurement speeds.

Also, state of the art A/D performance would be needed in terms of conversion rate and resolution, having ideally a genuine full scale effective resolution of at least 18 to 24 bits at 25kHz.

With a practicable level of FFT processing gain, the A-to-D converter's genuine, unweighted noise floor could be -114dB. The latest ICs fall a little short of this, possibly due to manufacturers trying to get as much as possible onto one chip.

Separating the analogue and digital functions of the A-to-D converter into a chip set and running at the lower conversion rate required in an instrument like the one under discussion here should result in performance improvements. The frequency sensitive differential and integral non linearities would be smaller. In turn, noise performance would be improved (see the 'S/(D+N)' column in Table 1 of last month's article for A-to-D converter noise performance figures).

Using DSP, the improvement over the conventional analogue approach in overall accuracy appears to be marginal. Quadtech's 7000 series DSP bridges achieve no better basic accuracy than was obtainable in the eighties with the analogue PSD/AD method discussed in the first and second article.

The main improvement appears to be improved linearity and lower noise. With DSP, the multiplication required is done in software, rather than via analogue hardware, which required an ultra-linear PSD circuit using the method

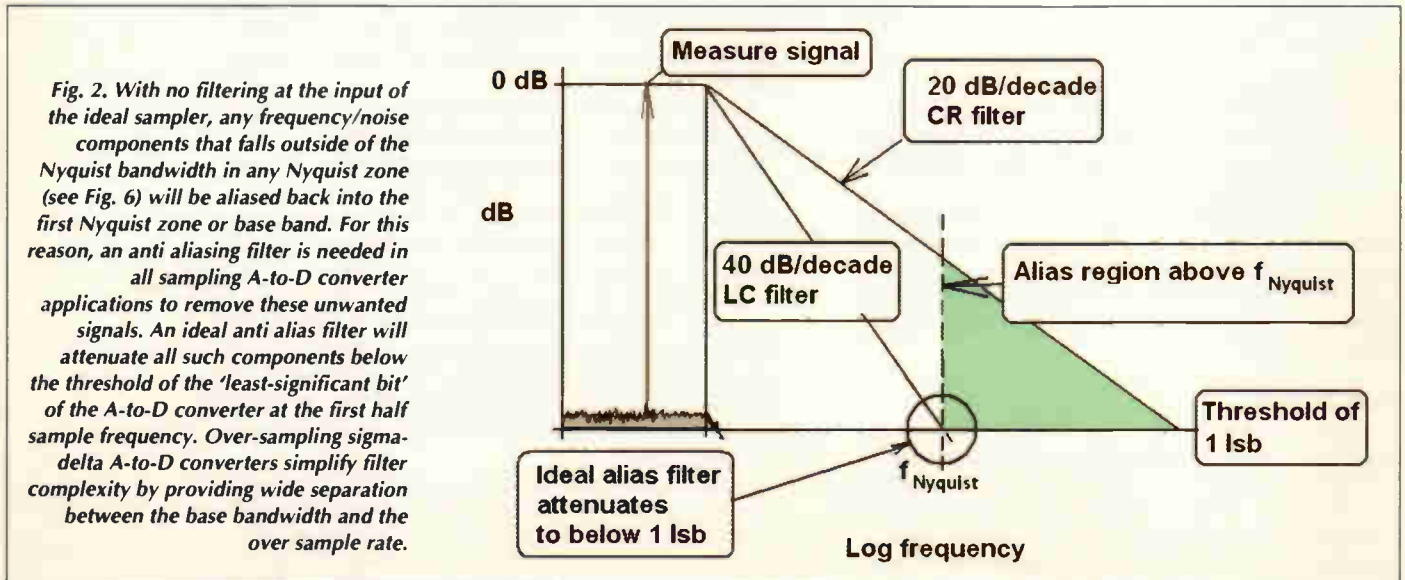

discussed in the previous articles.

With DSP, there's also possibility of deriving the fundamental and low-order harmonic impedances in one measurement. Total rejection of noise components such as supply noise is made possible by ignoring unwanted bin data in the FFT output.

DSP opens up the possibility for achieving very narrow band detection – below 1Hz and hence very low noise, beyond what is practicable with analogue methods. However, with the ever-increasing performance/cost ratio of DSP hardware, digital signal processing, as in other areas of electronics must become the standard method for the future.

The way ahead

Impedance analysers are an exception in the instrumentation field. Most signal-processing requirements conveniently fall into high-speed, low-resolution or low-speed, high-resolution categories, where as impedance measurement demands the highest possible resolution over the widest possible frequency range.

LCR instrument technology is based on assuming that the unknown impedance is linear and can be modelled as two lumped components with all the losses expressed in one term. This is valid when the component dimensions and test fixture wiring electrical lengths are small compared to the wavelength of the measurement frequency, i.e. the circuit can be viewed as lumped parameters.

As the wavelength of the measurement frequency is approached, the unknown impedance with the test fixture becomes more of a transmission line. As we increase in frequency the range of impedance, measurement converges to around 50Ω . From around 1GHz, the network analyser becomes the only viable means of measurement.

However, the network analyser can only be used for impedance measurement near to its designed characteristic impedance, which is universally 50Ω in modern RF work. Balun transformers are used to scale from 50Ω , giving a very limited extension in impedance range.

With either the DSP or analogue PSD approach, the major problem is still guarding at the measurement interface. This is particularly so for the 'I' terminal as shunt capacitance here gives a scalar error. There's more on this in the article from the December issue. My opinion is that the bridge measurement interface is the system block that really needs reviewing!

Think surface mount

With the industry increasingly moving away from leaded to surface mount devices, or SMD, components and – thanks to the mobile phone industry – of ever decreasing size, the need for accurate measurement of chip components at measurement frequencies of up to 1GHz has grown. At present, only the PN 4294A, 40Hz to 110MHz impedance analyser and RF pod extensions even begin to address this industry trend. These are produced by Agilent, which was formerly Hewlett Packard.

As virtually all volume electronics built today uses SMD technology, the modern bridge needs to be designed primarily for this type of component. Axial-leaded components are disappearing. Radial-leaded alternatives are largely now for low frequency power applications and are easily handled by the older generation of bridges.

Apart from the physical practicalities, measurement leads really need to be eliminated for the following reasons. Firstly they make it difficult to maintain good guarding at the 'I' terminal, where the cable impedance defeats the guard amplifier performance. The phase mismatch down the four measurement cables becomes

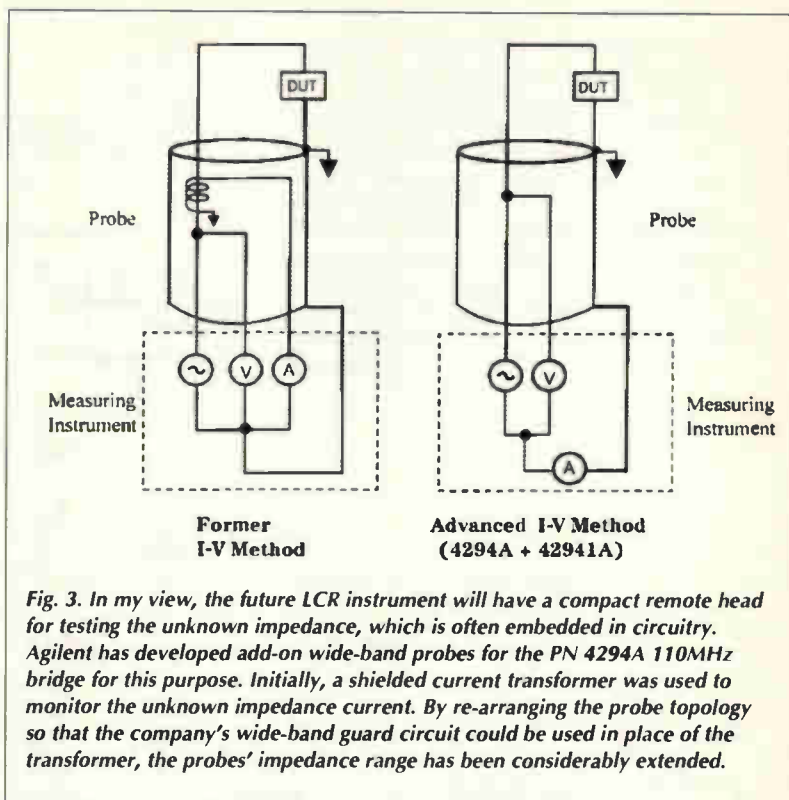

Fig. 3. In my view, the future LCR instrument will have a compact remote head for testing the unknown impedance, which is often embedded in circuitry. Agilent has developed add-on wide-band probes for the PN 4294A 110MHz bridge for this purpose. Initially, a shielded current transformer was used to monitor the unknown impedance current. By re-arranging the probe topology so that the company's wide-band guard circuit could be used in place of the transformer, the probes' impedance range has been considerably extended.

very noticeable with frequency.

Even at 1MHz, where only 1ns delay mismatch between the 'sense' leads corresponds to a dissipation factor error of 0.001 – twice the whole dissipation factor of a typical LCR instrument.

At higher frequencies, standing waves in the drive and sense leads would make a wide band guard amplifier unstable. For this reason, the HP 4194A impedance analyser was limited to 15MHz using 1m cables. Instrument manufacturers with cable-terminated bridges have developed calibration software and portable transfer standards to partly offset this problem along with the failing guard amplifier performance.

Agilent has extended the HP 4294A's performance by software correcting for the electrical lengths of the measurement cables. This is done after a calibration measurement is made with all four 50Ω measure cables terminated with their characteristic impedance at the bridge inputs.

After the cable corrections, the 50Ω termination resistors are switched out to allow normal operation. Agilent do not publish any in depth details but this interesting improvement helps in extending the instrument capability from 15 to 110MHz, way out in front of any other bridge manufacturer!

If the measurement cables are to be eliminated, this means measuring the unknown SMD component in a remote measure pod/fixture. This fixture holds the unknown impedance and shunt capacitances at the measurement terminals can be made minimal and well defined – or even eliminated – through guarding.

The unknown current and voltage sensing would be located right at the fixture measurement interface, complete with range amplifiers and A/Ds in a suitably screened housing. This would allow a fibre optic – or even a wireless – link for the digitised E_v and E_s signals to the main instrument for further processing and display. This avoids the common-mode noise, mutual coupling and HF characteristics of conventional coaxial measurement leads.

Fig. 4. My suggestion for a dedicated test fixture for the common component of today – the surface-mount service. Guarding of the current-sense resistor from the small amount of shunt capacitance is provided by the wide-band buffer and inner coaxial shield around the current sense circuit. Coaxial casing provides screening and a better-defined RF environment for Z_u , which is held by the cup jaws. The cup terminal on the generator side would be adjustable, using an insulated shaft to allow for different sized components. Access to Z_u would require a hinged lid or sleeved outer casing arrangement.

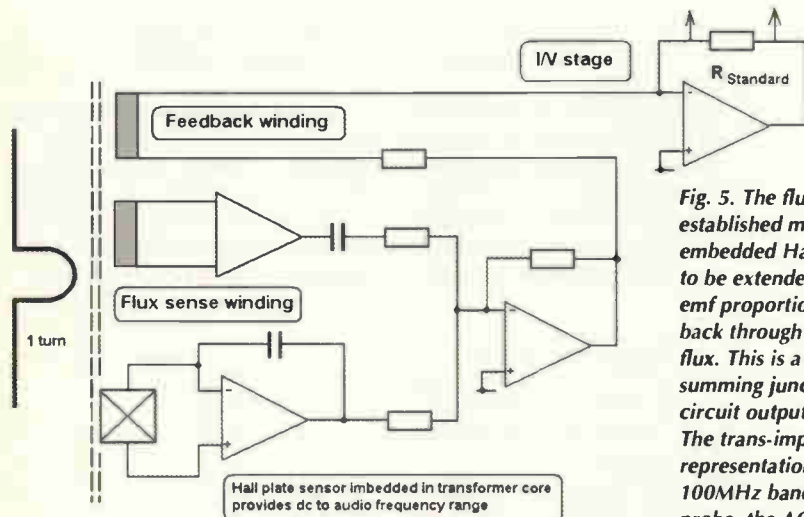
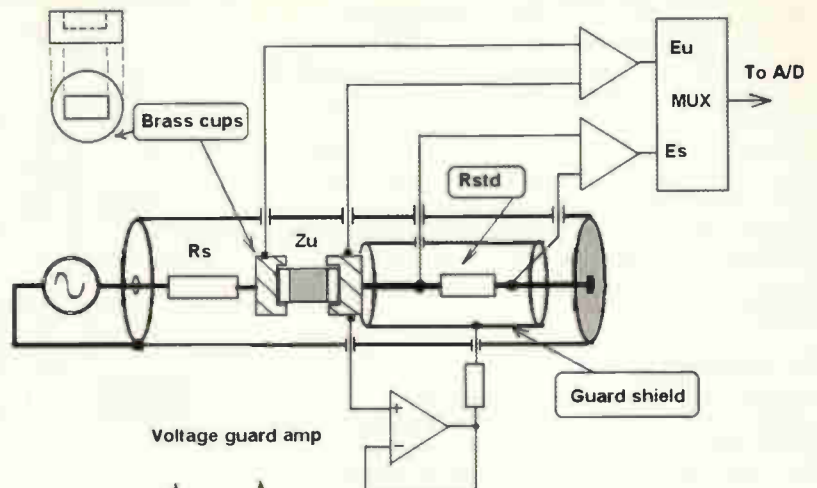

Fig. 5. The flux balancing current transformer technique is an established method of achieving a linear current transformer. The embedded Hall plate sensor enables the low-frequency response to be extended to DC. The unloaded sense winding generates an emf proportional to flux (as $e=N\delta\Phi/\delta t$) which is amplified and fed back through the feedback winding, opposing the initial primary flux. This is a control loop where the core flux is the error-summing junction. At balance, the core has zero flux and the circuit outputs a current equal to the primary current/turns ratio. The trans-impedance stage converts the current signal to a voltage representation, E_s . Tektronix has taken this technique from DC to 100MHz bandwidth with its enhanced clip on scope current probe, the A6312.

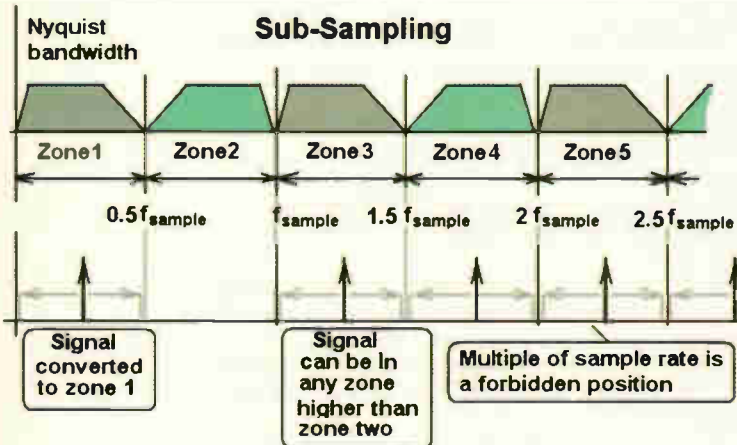

Fig. 6. With sub-sampling, aliasing is used to advantage. If the sample rate exceeds twice the Nyquist bandwidth – a zone width – the sampled signal can be down-converted into zone 1 (the base bandwidth) from any higher frequency zone, i.e. from zone 3 upwards. Even multiple zones are mirror images, but this is not a problem for the FFT process as the spectral bins in the FFT output are simply reversed in order. Two equations can be used to choose the measurement frequency to be sampled, f_m given the sample frequency f_s and the required Nyquist f_n and bandwidth Δf ; $f_s > 2f_n$. To locate the highest measurement frequency range within any Nyquist zone; $f_s = N(f_n \pm \Delta f)$ where N is even 2, 4, 6, 8... and $-\Delta f$ gives a mirrored alias.

The shunt loading scalar error is largely avoided by measuring the current right at the unknown with a very low inductive shunt resistance of, say, 100Ω at low frequencies and/or a wide-band ferrite cored current transformer for frequencies above say 10kHz. The transformer would have inherently good guarding by using a single turn or bar primary.

The snag is that at least 20dB of signal is thrown away at the front end of the system which limits our high impedance range. Agilent made such a probe as an extension to their PN 4294A, impedance analyser. The company has also recently enhanced this probe concept. More discussion on this below, Fig. 3.

Why not voltage guard?

Instead of current guarding using the virtual earth amplifier approach, which works very well at low frequencies, the well-defined test fixture 'I' terminal circuit could be voltage guarded using a very wide band buffer amp. This could consist of a FET follower to sense the 'I' terminal and a current feedback op-amp to provide wide gain bandwidth.

The whole 'I' terminal circuit, including the shunt, would need to be screened and the screen driven by the guard buffer amp. The voltage guard amp drives the screen at the same potential as the 'I' terminal.

Without any voltage difference between the 'I' terminal and screen, no capacitive current can flow from the terminal to the screen. Instead, the buffer amp drives the defined screen to ground, which provides shunt capacitance.

In practice, a compromise would have to be made between the capacitive load drive capability of the buffer and guard effectiveness by using a small load isolating resistor at the buffer output. The aim of the probe fixture would be to provide a minimal and well-defined shunt capacitance.

Figure 4 shows my own coaxial SMD device fixture idea with internal guard shield around the current-sense resistor. The outer coaxial tube provides electrostatic and electromagnetic shielding of the unknown impedance. This tube would need to have a sleeved lid to access the unknown impedance.

The cup-shaped brass terminals with rectangular

impressions help to locate the SMD component. The 'I' terminal would be fixed while the 'E' terminal is adjusted on an insulated threaded shaft.

Another possibility for the low frequency range could be to tune, or resonate, the 'I' terminal screen-to-ground shunt capacitance with a programmable active inductor. Active filter circuits working at 10MHz are now feasible with modern wide-band op-amps, so it is safe to assume that a good simulated inductor performance to 1MHz is attainable. This would be a good point to limit the low frequency performance of the bar primary current transformer, which would take over to provide a good current guard.

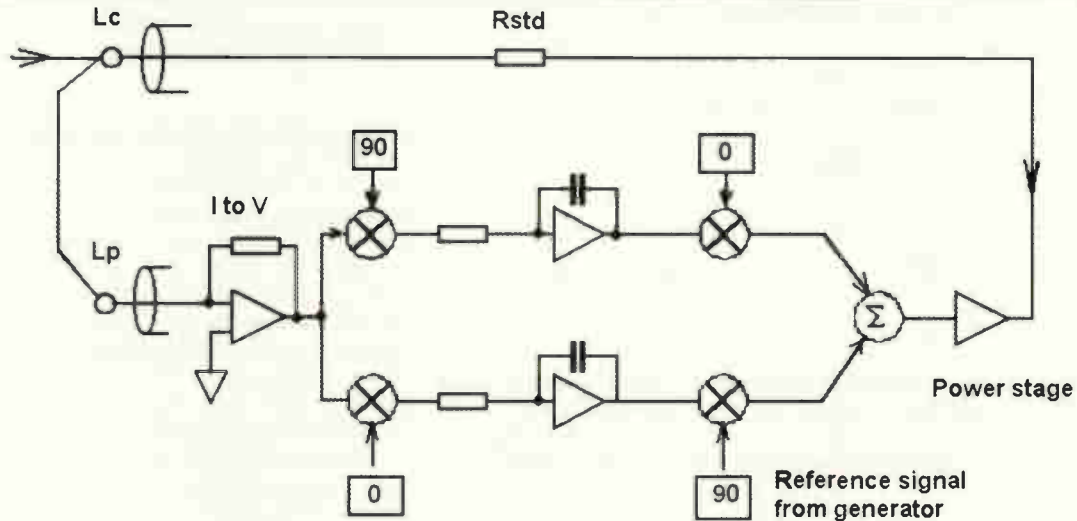
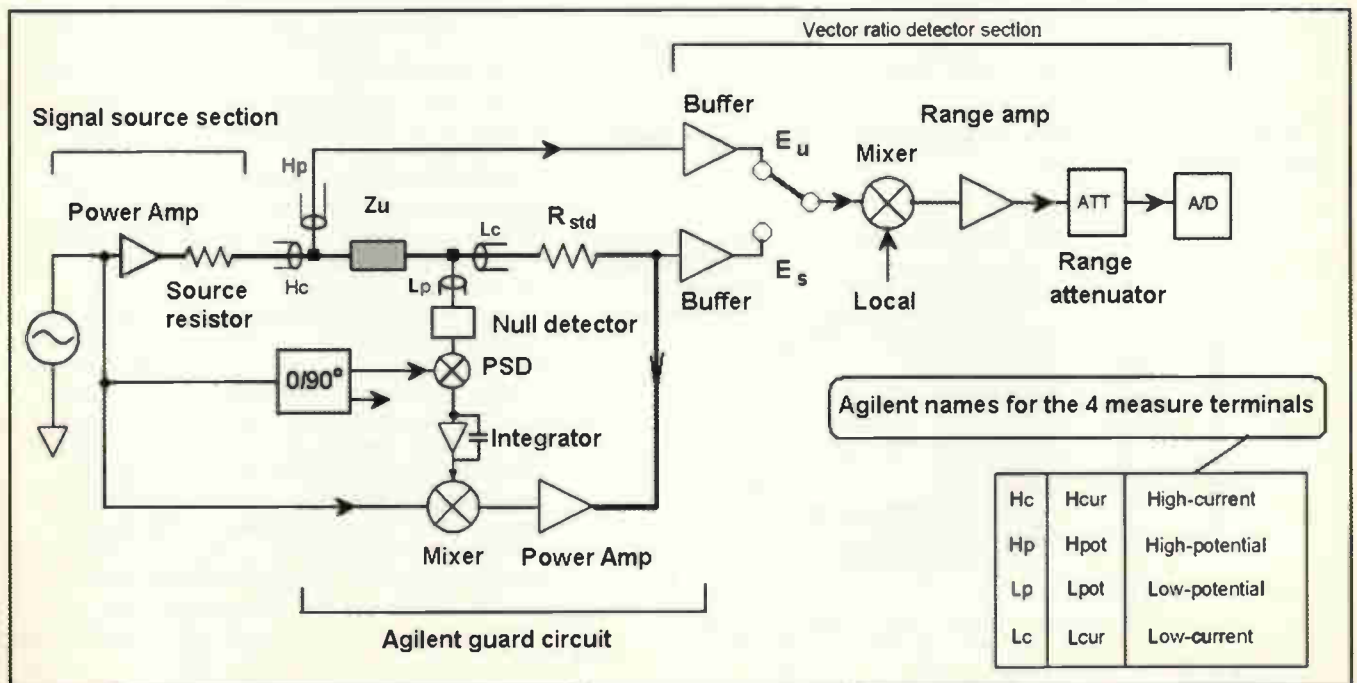

Fig. 7. In diagram a), Agilent's current-guard circuit down-converts the measurement signal at the virtual earth L_c to near zero frequency and extracts the phase and quadrature components via the PSDs. The very low-frequency signal is now noise filtered and amplified by the DC integrators to provide high loop gain before up-converting to the measurement frequency. Vector components are recombined via the phase and quadrature modulators and fed back via the wide-band buffer and standard resistor. The loop sinks signal current from L_c until a virtual earth of zero voltage is maintained. This complex approach to guarding achieves a very high gain bandwidth. Agilent has now extended this technique from 13MHz to 110MHz in the company's PN 4294A bridge. In 7b), the guard circuit of 7a) is shown in more simplified form within the measurement interface. This 110MHz instrument has the widest available bandwidth of any general-purpose LCR meter. The power of ratio measurements is maintained in the detector and ranging by multiplexing the E_u/E_s measurement signals as discussed in earlier articles. Frequency down-conversion is applied, enabling low-bandwidth ranging and A-to-D circuits to be used.



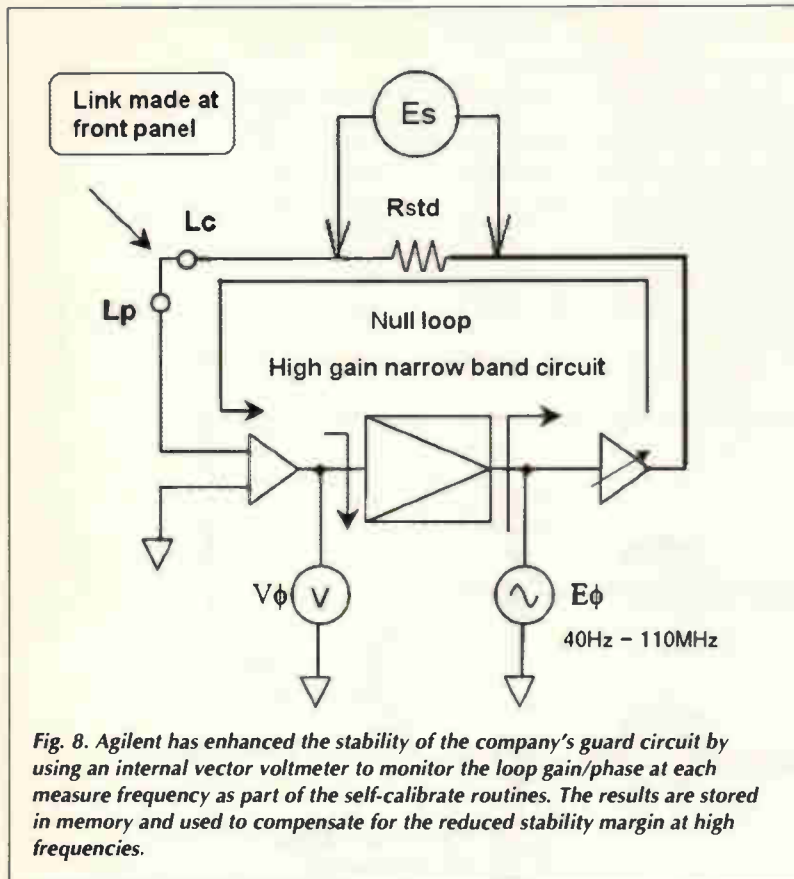

Fig. 8. Agilent has enhanced the stability of the company's guard circuit by using an internal vector voltmeter to monitor the loop gain/phase at each measure frequency as part of the self-calibrate routines. The results are stored in memory and used to compensate for the reduced stability margin at high frequencies.

An engineering rule of thumb is good transformer design can be made to work over three orders of bandwidth so with some overlap in performance we might expect the transformer to work from 0.5MHz to 500MHz.

It is possible to extend the current-transformer's low-frequency range by using a flux-balancing feedback system incorporating a Hall plate sensor. This sensor is embedded in the transformer's ferrite to sense the core flux from low audio frequencies down to DC.

Such a system achieves the highest possible linearity with a transformer since the core flux is always nulled to virtually zero by the control loop. The low-frequency Hall

plate signal is combined with the high-frequency transformer signal and fed through the feedback winding to cancel the initial primary flux.

Loop gain variations from each channel are suppressed by the overall feedback, giving a flat frequency response. The output signal is a current, precisely scaled by the transformer turns-ratio, which is converted into the E_s signal by the transimpedance stage, Fig. 5.

This last technique has been used for many years in the Tektronix A6302 DC to 50MHz clip-on current scope probe (Every self-respecting power-supply design team should have one).

Performance of the transformer should allow 100MHz operation as the clip-on capability with the associated residual air gaps/leakage inductance would not exist. Tektronix now offers a 100MHz probe, showing it can be done anyway.

Mixing with the A-to-D converter

Above 10kHz, frequency down conversion and A-to-D conversion of the two measurement signals could be combined using a sub sampling A-to-D conversion approach – also known as under-sampling or harmonic sampling. This has become a popular communication technique to sample IF signals directly. It eliminates the need for an IF demodulator as the technique is directly equivalent to analogue demodulation.

This process is better understood by studying the frequency plane again, Fig. 6. We normally think in terms of only working in the first Nyquist zone, i.e. from zero to $f_s/2$ to avoid aliasing. For signals that do not extend down to DC however, the minimum sample frequency is a function of the bandwidth of the signal as well as its position in the frequency spectrum.

Under-sampling complies with an extended version of the sampling theorem. This theorem states that a sampled input can be reconstructed from the sampled data if the input frequency components lie entirely between adjacent whole multiples of one half the sample rate. In other words, the Nyquist criteria, states a signal must be sampled at twice its bandwidth in order to preserve all the signal information.

There is no constraint on the absolute location of the band of sampled signals within the frequency spectrum relative to the sampling frequency. The only constraint is that the band of sampled signals is restricted to a single Nyquist zone, i.e., the signals must not overlap any multiple of the Nyquist frequency, $f_s/2$.

Referring to Fig. 6, you will see the first image – zone 2 – will contain all the same information as zone 1 but shifted and mirrored in frequency. The order of the frequency components within the spectrum are reversed. This is easily corrected in the FFT processing by re-ordering the output bins.

The sampled signal frequency can lie in any unique Nyquist zone, and the first Nyquist zone image or base-band will remain an accurate representation. An exception to this is the frequency reversal that occurs when the signals are located in even Nyquist zones (the zones above the half sample rate are called under-sampled bands).

Quadtech states that sub sampling is used for the company's new 7000 series 500kHz and 2MHz DSP bridges which have a 80/100kHz sampling A-to-D converter. Sub-sampling requires rock-stable timing and accurate synchronisation with the stimulus signal during the measurement process. As the stimulus and A-to-D conversion clocks are all derived from a common system quartz crystal clock this is not a problem.

With sub-sampling the A-to-D converter still makes the same number of samples of the signal, but it does so over a

Fig. 9. Impedance maps for 10% contours for the two methods used by Agilent in the company's add on probes.

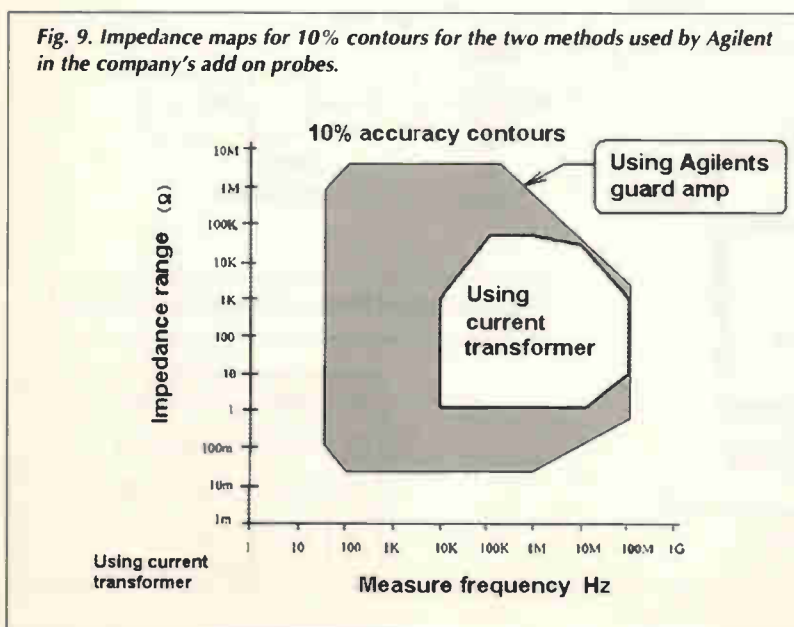

multiple of whole stimulus cycles. For example, imagine that four samples are needed from a test sinusoid signal of 1MHz (1 μ s period) and the A-to-D can only sample at 100kHz (10 μ s period). The first sample is taken at the start of the first cycle (0) then the second is not taken until ten cycles are passed. This makes the A-to-D conversion period 10 \times 1 μ s.

At this point, the wave would be sampled at 90° and the third sample 10 cycles later at 180°. The final sample is taken at 270° before starting again at 0°. Thirty cycles of the stimulus signal is therefore required to fetch all the data.

With sub-sampling, the A-to-D converter must still have good linearity at the sampled frequency. Therefore a high-performance sample-and-hold circuit prior to the A-to-D circuit would be essential to extend its HF performance while operating in the sub-sample mode.

Ultimately phase noise caused by timing jitter in the system clock and the sample and hold circuits limits performance. From published data for sample-and-hold circuits, over 80dB of spurious-free dynamic range would be feasible up to 10MHz. This is only 0.01% error contribution where the all up accuracy at the higher instrument frequencies may only be 1 to 5%.

The pathfinders

Agilent, and before it HP, has been leading the way in bridge technology for many years. The company's very effective high-frequency guard circuit together with the signal source is referred to as an 'auto-balancing bridge.' In my opinion, this term is confusing. It was originally developed in the early eighties for the HP4192 13MHz Bridge. The company's approach to guarding the 'I' terminal was touched on in the first article but deserves reviewing here, Figs 7a & 7b.

The signal at the virtual earth is compared to ground by the trans-impedance or I-V error amplifier. The error signal is now down-converted in frequency to very near DC or zero frequency using the first pair of mixers. This is sometimes referred to as zero IF conversion.

By using two phase-sensitive detectors, or PSDs, the in-phase and quadrature components are resolved. There's more on this in the first and second articles in this set. The PSDs operate as synchronous demodulators and are referenced to the stimulus.

The error signal phase and quadrature components are amplified and noise filtered using analogue integrators. The amplified error signal is now re-constructed back to the stimulus frequency using the second pair of PSDs, or mixers, to up-convert the signal.

Still in orthogonal form, the signal is summed and fed back through the reference standard via the wide-band buffer amplifier. This super-heterodyne, zero-IF approach neatly overcomes the gain-bandwidth limitation of a conventional guard amplifier by down-converting each frequency to DC, where it is easy to add loop gain. This is complex but it overcomes a major problem.

Agilent has developed this technique further with its PN4294A precision impedance analyser by adding an internal vector voltmeter to monitor the gain/phase characteristics within the loop for each measurement frequency. Fig. 8. The results are stored in memory and used to compensate for variations in loop-phase margin. This is possibly done by adding appropriate phase lead to the local oscillators. In-depth details are not published.

It would be nice if Agilent had continued with the HP Journal! The company is not as open as the original founding company.

As mentioned above, Agilent has also been going down the pod route with add on impedance probes for the 4194A and 42941A. These probes are for impedance measurement of in circuit SMD components at RF.

The company has been able to design out the current transformer with its inherent signal loss. Instead, it has adapted the complex guard circuit described earlier to be the probe current monitor. This has meant galvanically isolating the stimulus and guard circuits from the instrument ground, Fig. 3b.

Not surprisingly, this technique has considerably extended the low-frequency performance over the passive transformer type probe. However, this is far from a dedicated remote pod approach as there is a lot of wire and signal processing before the current signal is digitised. Figure 9 shows Agilent's published comparison of the extended impedance plane for – wait for it – 10% accuracy contours. Figure 10 summarises the present state of play of general-purpose impedance-measurement coverage from the market leader.

Yes the time for a re-think in LCR instrument technology is overdue! ■

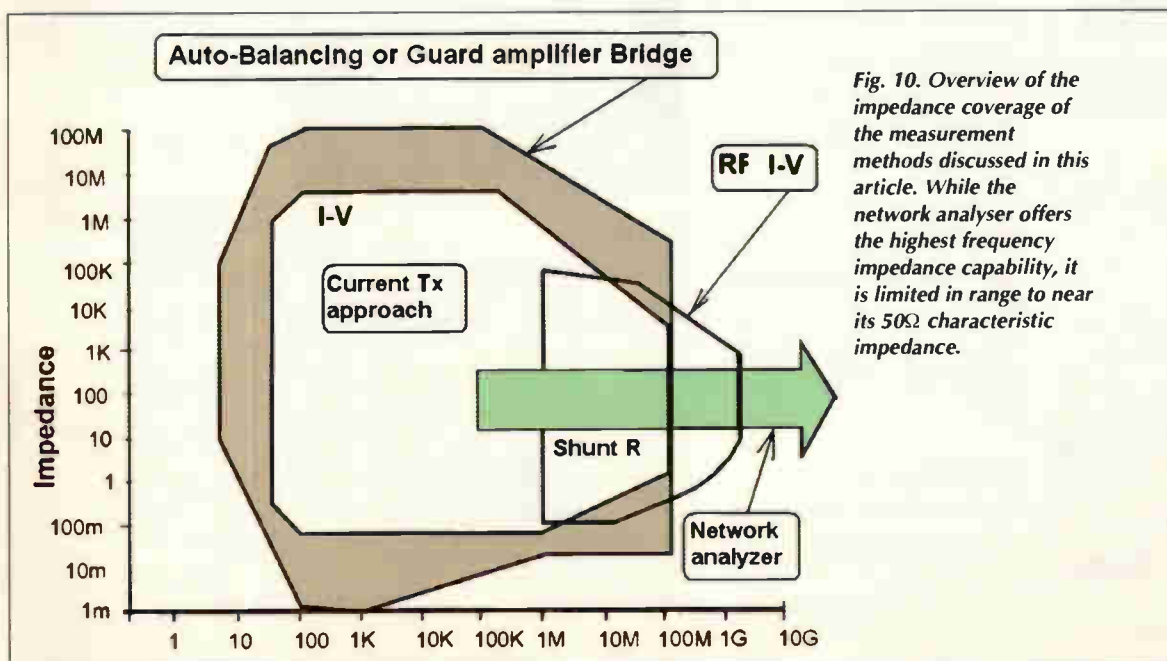

Fig. 10. Overview of the impedance coverage of the measurement methods discussed in this article. While the network analyser offers the highest frequency impedance capability, it is limited in range to near its 50 Ω characteristic impedance.



WEB ADDRESSES



Put your web address in front of 18,000 electronic fanatics. Electronics World acknowledge your company's needs to promote your web site, which is why we are dedicating 2 pages in every issue to WEB ADDRESSES.

Linage only will cost £150 + vat for a full year.

Linage with colour screen shot will cost £350 + vat for a full year, this will include the above plus 3cm shot of your web site which we can produce if required.

To take up this offer or for more information telephone

Reuben Gurnlian

Tel 0208 722 6028

E-mail

r.gurnlian@highburybiz.com

in our extensive database covering Akai, Alba, Bush, Ferguson, Goldstar, Hitachi, LG, Marantz, Matsui, Nokia, Saisho, Sanyo, Sony, Sharp, Thomson, Panasonic, Philips, Samsung, Tascam, Teac, Toshiba, Yamaha and many more. In addition huge ranges of Lasers, Loptis, Remote controls and Semiconductors may be accessed.

CHYGWYN

<http://www.chygwyn.com>

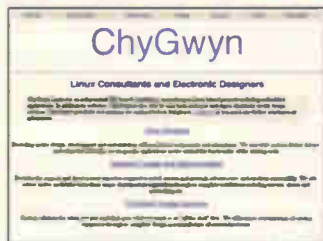

ChyGwyn Limited offers electronic design and embedded software development for remote monitoring, embedded appliances, set-top boxes and similar devices. We are experts in customisation of Linux and write device drivers for custom hardware.

CONFORD ELECTRONICS

<http://www.confordelec.co.uk/index.shtml>



Lightweight portable battery/mains audio units offering the highest technical performance. Microphone, Phantom Power and Headphone Amplifiers. Balanced/unbalanced signal lines with extensive RFI protection.

CRICKLEWOOD ELECTRONICS

<http://www.cricklewoodelectronic.co.uk>

Cricklewood Electronics stock one of the widest ranges of components, especially semiconductors including ICs, transistors, capacitors, all at competitive prices.

DB TECHNOLOGY

<http://www.dbtechnology.co.uk/>

EMC Testing and Consultancy. Anechoic chamber and open area test site.

- Compliance Tests
- Rapid, accurate pre-compliance tests.
- Fixes included. FCC Listed.



● Flexible, hourly booking available.

DESIGNER SYSTEMS CO.

<http://www.designersystems.co.uk>

Electronic product design company with



over a decade of experience promoting it's own product range and designing and manufacturing innovative products for client companies/individuals.

EAGLE PCB DESIGN SOFTWARE

<http://www.puresoft.co.uk>

● Professional PCB design made easy!

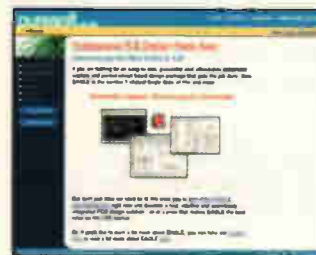

● Fully functional freeware download.
● Schematics, Layout & Autorouting.
● Free tech support

EasySync

<http://www.easysync.co.uk>



EasySync supplies a wide range of USB-RS232 and USB-RS422/485 converters. It also specialises in USB test and measurement devices.



FELLER UK

<http://www.feller-at.com>

Feller (UK) Ltd. manufacture Fully approved cordsets (Moulded mains plugs and connectors) and Power Supply Cables for all industrial Countries to National and International Standards

FUTURE TECHNOLOGY DEVICES INTL. LTD.

<http://www.ftdichip.com>



FTDI designs and sells USB-UART and USB-FIFO interface i.c.'s. Complete with PC drivers these devices simplify the task of designing or upgrading USB peripherals

GREENWELD

<http://www.greenweld.co.uk>



Audio ● Batteries & Chargers ● Books ● Communications ● Computer ● Cable ● Capacitors ● Car Equipment ● Craft Goods ● Disco Equipment ● Enclosures ● Electrical ● Fuses ● Graphic supplies ● Hardware ● Instrumentation ● Kits ● Lighting ● Mechanical ● Optical ● Photographic ● Power supplies ● Transformers ● Resistors ● Semiconductors ● Software ● Soldering Irons ● Surplus goods ● Switches ● Relays ● Telephone Accessories ● Tools ● Plus much more.

Whether your interest is in electronics, model engineering, audio, computer, robots or home and

ANASOFT LTD

<http://www.anasoft.co.uk>

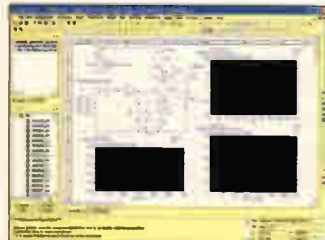

SuperSpice, the affordable, mixed-mode windows circuit simulator. Wrote by an analogue design engineer for those Teletubbies who like keeping things simple.

CHARLES HYDE & SON Ltd

<http://www.charleshhyde.co.uk>

Search for both original and copy spare parts



To reserve your web site space phone **Reuben Gurunlian**
 Tel: 020 8722 6028
 Fax: 020 8722 6096



leisure products (to name just a few) we have a wide range of new and surplus stock available.

J W HARDY COMMUNICATIONS

<http://www.jwhardy.co.uk>



R.F. Network Specialist. Shop online - for R.F. network components. We supply a full range of TV, radio reception equipment to receive analogue/digital signals from both terrestrial and satellite sources. We provide a free planning service for your R.F. networks, MATV and SMATV etc

LOW POWER RADIO SOLUTIONS

<http://www.lprs.co.uk>

LPRS produces radio modules with embedded "easy-Radio" software protocols for short range radio applications. We also represent Circuit Design narrow band modules in the UK.

MAPLIN ELECTRONICS

<http://www.maplin.co.uk>

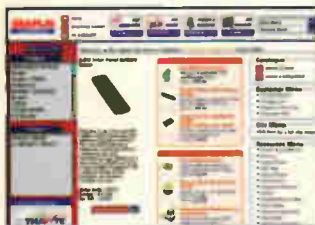

A fully secure and interactive internet ordering system from Maplin Electronics, the specialist electronic retail and mail order company to business and retail consumers alike. 15,000 products available on line.

MATRIX MULTIMEDIA LTD

www.matrixmultimedia.co.uk



Matrix Multimedia publishes a number of highly interactive CD ROMs for learning electronics including: Complete electronics course, Analogue filter design, and PICmicro(R) microcontroller programming (C and assembly).

NORCALL Ltd

<http://www.norcall.co.uk>

e-mail Norcall@aol.com

Suppliers programmers and repairers of new and refurbished two-way radio equipment. Retuning and recrystallizing service available. All types of batteries chargers and aerials supplied.

PHAEDRUS LTD

www.phaedrusltd.co.uk

Manufacturer and supplier of low cost general purpose and serial I/O digital modules and accessories. PC based software for data logging and control applications.

QUASAR ELECTRONICS

www.quasarelectronics.com



Over 250 electronic kits, projects and ready built units for hobby, educational & industrial applications. TEL: 01279 467799, FAX: 07092 203496 or EMAIL: ewsales@quasarelectronics.com

RADIO-TECH LIMITED

<http://www.radio-tech.co.uk>

Radio modules, modems, telemetry, audio transmitters, pagers, antenna, remote controls and much more. All UK designed and manufactured.

RADIOMETRIX

<http://www.radiometrix.co.uk>

Radiometrix specialises in the design and manufacture of VHF & UHF, RF data modules. We offer a broad range of PCB



mounted miniature transmit, receive and transceiver modules for OEM use. They comply with European harmonised standards EN300 220-3 and EN301 489-3 and are CE certified by an independent Notified Body.

RALFE ELECTRONICS

professional test & measurement



www.ralfe-electronics.co.uk

SOFTCOPY

<http://www.softcopy.co.uk>

As a PC data base or hard copy, SoftCopy can supply a complete index of Electronics World articles over the past ten years. Photo copies of articles from back issues are also available.

TELNET

<http://www.telnet.uk.com>



Top quality second-user Test and Measurement Equipment
 eMail sales@telnet.uk.com

TELEVES

<http://www.televes.com>

Tel: 44(0) 1633 875821
 email hbotas@televes.com

Televes website was launched as an easier way to keep in contact with our World-wide Network of Subsidiaries and Clients. This site is constantly updated with useful information/news plus you can download info on our range: TV Aerials & accessories, Domestic and Distribution amplifiers, Systems Equipment for DTT and Analogue TV, Meters and much more.

TEST EQUIPMENT SOLUTIONS

<http://www.TestEquipmentHQ.com>
 Test Equipment for rental or second user sale at the industry's lowest prices. All



types of equipment from all leading manufacturers including general purpose, communications and industrial test. Items fully refurbished with 1 year warranty. Rental rebate given on purchases.

TELONIC

<http://www.telonic.com>



Telonic specialists in laboratory AC & DC Power Supplies, Electronic AC & DC Loads, Electrical Safety Testing and complete test systems. Plus RF Filters, Attenuators, Diesel Engine Smoke Measurement, Quartz Crystal Microbalances.
 Tel +44 (0) 118 9786911

TECHNICAL AND SCIENTIFIC SUPPLIES

<http://www.technicalscientific.com>

Suppliers of pre-1985 equipment and components.

- Test/Measurement equipment
- Valves and semiconductors
- Transducers and pressure gauges
- Scientific books and catalogues
- Manuals and data sheets

THOSE ENGINEERS LTD

<http://www.spiceage.com>



Working evaluations of SpiceAge mixed-mode simulator, Spicecycle PCB design tools and Superfilter demo (synthesises passive, active, digital filters). Tech support, sales links and price list.

TOTAL ROBOTS

<http://www.totalrobots.co.uk>

Robot Kits and Control Technology

products, including OOPic the first Object-Oriented Programmable Integrated Circuit. Secure on-line ordering and fast delivery.

ULTRA-CREA OY

<http://www.ultra-crea.fi>



Our business idea is to provide our customers complete service, i.e. design from the customer specification to the delivery of finished and tested products.

Our offerings are as follows:

- RF transmission line filters from 100MHz to 3GHz
- Special antennas to frequencies as above
- Transmitter and Receiver modules
- RF-subunits such as amplifiers, oscillators, directional couplers etc.

VULTRAX PCB DESIGN SOFTWARE

<http://www.vultrax.co.uk>



Vultrax electronic schematic and pcb design system for Windows 95/98, ME, NT, 2000, XP and Linux. Limited capacity FREE version downloads available, all upgradeable to various customised level.

WILMSLOW AUDIO

<http://www.wilmslow-audio.co.uk>

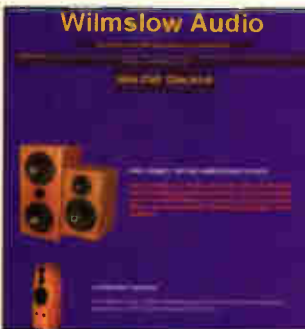

Uk's largest supplier of high quality loudspeaker kits and drive units. Comprehensive range of components and accessories, including damping products, connectors and grilles materials. Demonstration facilities available.

Ten year index: new update



Photo copies of Electronics World articles from back issues are available at a flat rate of £3.50 per article, £1 per circuit idea, excluding postage.

Hard copy Electronics World index
Indexes on paper for volumes 100, 101, and 102 are available at £2 each, excluding postage.

www.softcopy.co.uk

Hard copies and floppy-disk databases both available

Whether as a PC data base or as hard copy, SoftCopy can supply a complete index of *Electronics World* articles going back over the past nine years.

The computerised index of *Electronics World* magazine covers the nine years from 1988 to 1996, volumes 94 to 102 inclusive and is available now. It contains almost 2000 references to articles, circuit ideas and applications - including a synopsis for each.

The *EW* index data base is easy to use and very fast. It runs on any IBM or compatible PC with 512K ram and a hard disk.

The disk-based index price is still only £20 inclusive. Please specify whether you need 5.25in, 3.5in DD or 3.5in HD format.

Existing users can obtain an upgrade for £15 by quoting their serial number with their order.

Ordering details

The *EW* index data base price of £20 includes UK postage and VAT. Add an extra £1 for overseas EC orders or £5 for non-EC overseas orders. Postal charges on hard copy indexes and on photocopies are 50p UK, £1 for the rest of the EC or £2 worldwide.

For enquires about photocopies etc please send an sae to SoftCopy Ltd.

**Send your orders to SoftCopy Ltd,
1 Vineries Close, Cheltenham GL53 0NU.**

Cheques payable to SoftCopy Ltd, please allow 28 days for delivery.

TELFORD ELECTRONICS

Old Officers Mess, Hoo Farm, Humbers Lane, Horton,
Telford, Shropshire TF6 6DJ, UK
Tel: (0044) 01952 605451 / 670178
Fax: (0044) 01952 677978
E-mail: telfordelectronics@btinternet.com /
marc.007@btinternet.com / annie.007@btinternet.com
Web: <http://www.telford-electronics.com>

**SHOP NOW OPEN TO THE
PUBLIC EVERY SATURDAY
FROM 9AM – 2PM**

**Second User –
Electronic Test and Measuring
Instruments – DC to 100 GHz**

**FANTASTIC
BARGAINS
TO BE HAD**

*Please visit our regularly updated web
site for all your equipment needs.*

**We have a clearance/graveyard site
with goods from as little as £15.00!!!**

FRUSTRATED!

Looking for ICs TRANSISTORS?

A phone call to us could get a result. We offer an extensive range and with a World-wide database at our fingertips, we are able to source even more. We specialise in devices with the following prefix (to name but a few).



2N 2SA 2SB 2SC 2SD 2P 2SJ 2SK 3N 3SK 4N 6N 17 40 AD
ADC AN AM AY BA BC BD BDT BDV BDW BDX BF
BFR BFS BFT BFW BFX BFY BLY BLX BS BR BRX BRY BS
BSS BSV BSW BSX BT BTA BTB BRW BU BUK BUT BUY
BUW BUX BUY BUZ CA CD DX CXA DAC DG DM DS
DTA DTC GL GM HA HCF HD HEF ICL ICM IRF J KA
KIA L LA LB LC LD LF LM M M5M MA MAB MAX MB
MC MDA J MJE MJF MM MN MPS MP5A MP5H MP5U
MRF NJM NE OM OP PA PAL PIC PN RC S SAA SAB
SAD SAJ SAS SDA SG SI SL SN SO STA STK STR STRD
STRM STRS SV1 T TA TAA TAG TBA TC TCA TDA TDB
TEA TIC TIP TIPL TEA TL TLC TMP TMS TPU U UA
UAA UC UDN ULN UM UPA UPC UPD VN X XR Z ZN
ZTX + many others

We can also offer equivalents (at customers' risk).

**We also stock a full range of Electronic components.
FREE CD Rom stock list on request**

Mail, phone, Fax, Credit Card orders & callers welcome.



Cricklewood Electronics Ltd

40-42 Cricklewood Broadway, London NW2 3ET
Tel: 020 8452 0161 Fax: 020 8208 1441
www.cricklewoodelectronics.co.uk
E-mail: sales@cricklewoodelectronics.com

ADVERTISERS INDEX

CMS	39
Conford Electronics	18
Cricklewood Electronics	63
Display Electronics	31
EasySync	39
ESR Electronics	35
Johns Radio	18
JPG Electronics	39
Labcenter	29
Olson Electronics	2
Peak Electronic Design	IBC
Quasar Electronics	4
RD Research	27
Seetrax Advanced systems	37
Stewart Of Reading	51
Telford Electronics	63
Telnet	IFC
Tie Pie Engineering	OBC
Vann Draper Electronics	37
Warwick Wireless	63
Westdev	18

RADIO MODEMS WIRELESS CCTV RADIO MODULES



No Licence

**Range up
to 20Km**

**Data Rates
up to
50Kbps**

www.radiotelemetry.co.uk

Warwick Wireless Ltd
The Manor, Aston Flamville, LE10 3AQ
Tel: +44 (0) 1455 233616
Fax: +44 (0) 1455 233179

As an advertiser you can be certain that your sales message is going to be read by decision-making electronics professionals with the power to purchase your products.

The pre-paid rate for semi-display setting is £17 per single column centimetre (maximum 4cm). Box number £22 extra. All prices plus 17 1/2% VAT. All cheques, postal orders etc to be made payable to Highbury Business Communications Ltd. Advertisements together with remittance should be sent to Electronics World Classified, Highbury Business Communications Ltd, Anne Boleyn House, 9-13 Ewell Road, Cheam, Surrey SM3 8DZ.
Tel: 020 8722 6028. Fax: 020 8770 2016.

Service Link

ARTICLES WANTED

BEST CASH PRICES PAID

For all valves
KT88 PX4 and
other audio types

Wide range of
valves and CRT
stocked

Tel:
01403 784961

Billington Export Ltd.
Fax: 01403 783519
Email: sales@bel-tubes.co.uk
Sussex RH14 9EZ
Visitors by appointment

TOP PRICES PAID

For all your valves,
tubes, semi conductors
and ICs.

Langrex Supplies Limited

1 Mayo Road, Croydon, Surrey CR0 2QP
TEL: 020 8684 1166 FAX: 020 8684 3056

FOR SALE

PRINTED CIRCUIT BOARDS

DESIGNED & MANUFACTURED  agar
Circuits
• Prototype or production quantities
• Fast turnaround available
• PCBs designed from circuit diagrams
• Almost all computer files accepted
• PCB assembly - mechanical assembly
• Full product design-manufacture-test-repair
Unit 5, East Belfast Enterprise Park
308 Alberbridge Rd, Belfast BT5 4GX
TEL 028 9073 8897 FAX 028 9073 1802
info@agarcircuits.com

RF DESIGN SERVICES

All aspects of RF
hardware development
considered from
concept to production.

WATERBEACH ELECTRONICS

www.rlaver.dial.pipex.com
TEL: 01223 862550
FAX: 01223 440853

HP 1660A Logic Analyser

136 Channels @ 250mhz
or 68 Channels @ 500mhz
All probes and manuals included

£1,500 + VAT

Contact:

steve@csys.demon.co.uk

SERVICES

PCBs Conv/PTH/Multi-Layer/Flexible • UK & Far East production
• CAD Layout • Electronic Design • Assembly (prototype & production)
• SMD m/c assy @ 18,500 cps/hr

Deliveries from
24 Hrs

Prototype
PTH PCBs
from just
£40.00



Tel: 01635 40347

Newbury Electronics Ltd
Faraday Road Newbury Berks RG14 2AD
Fax: 01635 36143
e-mail: circuits@newbury.tcom.co.uk
http://www.newburyelectronics.co.uk

Visit

www.pcbtrain.com

The low cost source for prototype PCBs
from 1 to 6 layers

SERVICES

POWER SUPPLY DESIGN

Switched Mode PSU
Power Factor Correction
designed to your specification

Tel/Fax: 01243 842520

e-mail: eugen_kus@cix.co.uk

Lomond Electronic Services

WANTED

VALVES AND VALVE BASES

Valve associated components including
high voltage capacitors, electrolytics etc.
Must be over 250v working.
OLD 1 watt and 1/2 watt resistors
(Carbon). Obsolete semiconductors.

CBS

157 Dickson Road, Blackpool FY1 2EU
Tel: 01253 751858 Fax: 01253 302979

For a **FREE**
consultation on
how best to
market your
products/
services to a
professional
audience
contact **REUBEN**
on
020 8722 6028

SERVICES

From Concept To Production

Electronic design and manufacturing services for the new millennium:

- Embedded monitoring & control
- PSTN telephones and test equipment
- Datacom interfacing, line driving etc.
- Switch Mode & linear PSU and battery management
- Gas detection systems
- Printed Circuit Board design
- Technical documentation, schematic layout & language translation
- Wireless telemetry systems
- Audio & Video processing
- GSM telemetry via SMS or data (TCP/IP)
- DVD player control systems
- GPS positioning systems
- Specialist cable looms
- Small, medium & large scale manufacturing

Email: sales@designersystems.co.uk
Tel/Fax: +44 (0) 1872 223306

for more information see our web site @
<http://www.designersystems.co.uk>



Designer Systems
Design & manufacturing in the UK

WANTED

WANTED Surplus or Obsolete Electronic Components

Turn your excess stock into instant cash!

SEND OR FAX YOUR LIST IN STRICTEST CONFIDENCE

Will collect anywhere in the UK



Mushroom
COMPONENTS

6a St. Marys St, Bedford, Bedfordshire, MK42 0AS

Tel: 01234 363611 Fax: 01234 326611

E-mail: sales@mushroomcomponents.com

Internet: www.mushroomcomponents.com

Service Link

THERE IS INTERESTING NEWS



THE FIRST USB 2.0
100 MS/S, 12-16 bit
MEASURING INSTRUMENT
IN THE WORLD.

PC CONTROLLED MEASURING INSTRUMENT
COMPLETE PACKAGE STARTING AT £ 331

OSCILLOSCOPE

FFT ANALYSER

VOLTMETER

RECORDER

The Handyscope 3 is a powerful and versatile two channel measuring instrument with an integrated function generator.

- USB 2.0 connection (USB 1.1 compatible)
- sample speed up to 100 MHz per channel
- 8 to 16 bit resolution (6 μ Volt resolution)
- 50 MHz bandwidth
- input sensitivity from 200 mVolt up to 80 Volt
- large memory up to 131060 samples per channel
- four integrated measuring devices
- spectrum analyser with a dynamic range of 95 dB
- fast transient recorder up to 10 kHz
- several trigger features
- auto start/stop triggering
- auto disk function up to 1000 files
- auto setup for amplitude axis and time base
- auto trigger level and hysteresis setting
- cursor measurements with 21 read-outs
- very extensive function generator (AWG) 0-2 MHz , 0-12 Volt

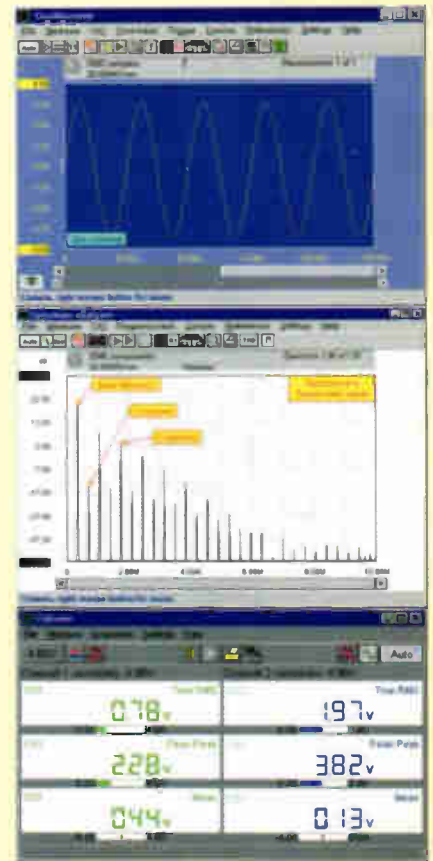

HANDYSCOPE HS3



for more information, demo software, software, source code and DLL's visit our internet page: <http://www.tiepie.nl>



TiePie engineering (NL)
Kadenwegestraat 37
3840 KL, BIEEK
The Netherlands
Tel: +31 315 455 416
Fax: +31 315 419 819

TiePie engineering (UK)
28, Stephenson Road, St. Ives
Cambridgeshire, PE17 3WJ, UK
Tel: 01480-460028
Fax: 01480-460340

WWW.TIEPIE.NL

New Product

Atlas LCR Passive Component Analyser (Model LCR40)

"No other LCR is as easy as this!"

Just clip on the test leads and press test. The Atlas LCR will automatically identify the type of component, apply the appropriate test level and frequency, display the component's value and more!

Probes are detachable too, so you can use the optional SMT tweezers for your tiny unmarked passives - **fantastic**.

- Inductance range: 1µH to 10H
- Capacitance range: 1pF to 10,000µF
- Resistance range: 1Ω to 2MΩ
- Basic accuracy: 1%
- Test signals: 1V, 3mA max

£79

fully inclusive UK price



Lots of accessories available soon!

atlas

semiconductor analyser

Check and identify your semi's

£60

fully inclusive UK price



NEW MEASURES TRANSISTOR LEAKAGE!

enclosure colours may vary

- Automatic component identification
- Pinout identification
- Transistor gain measurement
- MOSFET gate threshold measurement
- PN junction characteristics measurement
- Shorted Junction identification
- Transistor leakage measurement
- Just connect the part anyway round and press the button!
- Auto power on/off

Supports:

- Bipolar transistors,
- Darlington transistors,
- Diode protected transistors,
- Resistor shunted transistors,
- Enhancement mode MOSFETs,
- Depletion mode MOSFETs,
- Junction FETs,
- Low power triacs and thyristors,
- Diodes and diode networks,
- LEDs (+bicolours)

- NPN bipolar Darlington
- Diode protection between C-E
- Resistor shunt between B-E
- Current gain Hfe=126
- Enhancement mode N-Ch MOSFET
- Gate Threshold V_{gs}=3.4V
- RED COL Emit
- BLUE COL Emit
- 2-volt V_{ce}=0.77V
- h_{fe}=126
- β_{dc}=126

Visit www.peakelec.co.uk to download the data sheets, user guides and copies of independent reviews. You can pay using a cheque, postal order, credit or debit card and even pay securely online. Please contact us for your volume requirements.

Also available from: (prices vary)



PEAK
electronic design ltd

Atlas House, Kiln Lane
Harpur Ind. Est., Buxton
Derbyshire, SK17 9JL, UK

www.peakelec.co.uk
sales@peakelec.co.uk

Tel. 01298 70012 Fax. 01298 70046

