

# The Wireless 6<sup>d</sup> Constructor

Vol. XVI.

MAY, 1933.

No. 79.

*John Scott-Taggart Describes*

**THE  
PUSH-PUSH  
FIVE**



**A Q.P.P.  
"S-T." SET**



# A Good set needs Good Components

## for the "PUSH-PUSH FIVE"

John Scott Taggart  
again chooses

### ORMOND N°6 FRICTION CONTROL CONDENSERS

Each successive receiver from this famous designer brings yet another striking testimony to the dependability of Ormond components. First came the S.T.300; then the S.T.400; and now Mr. Scott-Taggart's first Q.P.P. set, the "Push-Push Five"—and in all of them, chosen for their superlative accuracy and precision, are Ormond Condensers.

A friction device is incorporated at the rear end of condenser, giving a superb slow-motion movement with ratio of 50 to 1. Direct drive is obtained by means of Bakelite dial, engraved 0 to 180 degrees. Slow motion is controlled by the upper small knob. Fast enough for easy searching, it is yet slow enough for finest tuning.

This condenser is strongly recommended for general use, and particularly on short-wave sets, superheterodynes, etc.

Complete with 2½-inch dial and slow-motion knob.

Cat. No.	Capacity	Price
R/491A	·00013	<b>7/6</b> each.
" R/491	·00025	
" R/492	·00035	
" R/493	·0005	

The ORMOND ENGINEERING Co. Ltd.  
Ormond House, Rosebery Avenue, London, E.C.1.

Telephone: CLERKENWELL 5334-5-6 & 9344-5-5  
Telegrams: "ORMONDENGI ISLING."

#### ORMOND COMPONENTS ALSO RECOMMENDED INCLUDE:

- Q.P.P. TRANSFORMER (Nickel iron). Cat. No. R/531C.T. Price 7/6.
- AERIAL COUPLER with slow-motion movement. Cat. No. R/149. Price 3/-.
- DIFFERENTIAL CONDENSER, slow motion. Cap. ·0003-mfd. Cat. No. R/190. Price 3/-.
- " ·0001-mfd. " R/195. " 3/-.
- 2-POINT SWITCH. Cat. No. R/323. Price 1/3.
- FIXED CONDENSER. Cap. ·0003-mfd. Cat. No. R/439. Price 7d.
- " ·006-mfd. " R/443. " 1/6.
- " ·005-mfd. " R/447. " 1/5.
- RADIOGRAM SWITCH. 3-Pole double throw. Cat. No. R/333. Price 4/-.
- MOVING-COIL LOUDSPEAKER, with Q.P.P. Transformer. Cat. No. R/494C.T. Price 26/-.
- PRESET CONDENSER. Cap. ·0003-mfd. Cat. No. R/193. Price 2/-.



**ROBUST... RIGID... AND ACCURATE!..**

# CONTENTS

	PAGE		PAGE
The Editor's Chat .....	3	As We Find Them .....	31
The "Push-Push Five" .....	4	Questions I am Asked .....	33
B.E.C. News .....	15	On the Grid .....	34
Your Output .....	17	The Month on Short Waves .....	34
From My Armchair .....	19	In Lighter Vein .....	35
"Push-Push" Parts .....	21	Remember These Next Time! .....	37
A Practical Man's Corner .....	25	Those Running Commentators .....	40
A Revolution in Condensers? .....	27	What is "Sideband Splash"? .....	42
My Set Won't Work .....	29	With Pick-Up and Speaker .....	46
Round the Dials .....	30	Can Television Be Real? .....	48
Points for Purchasers .....	30	Our News Bulletin .....	50

*As some of the arrangements and specialties described in this Journal may be the subject of Letters Patent the amateur and trader would be well advised to obtain permission of the patentees to use the patents before doing so.*

Published by The Amalgamated Press, Ltd.  
The Fleetway House, Farringdon Street,  
London, E.C.4.

## Here's more Power to your Set

THE extraordinary "life" and power of sets constructed with Lewcos Components is attributable to the precision and high quality materials with which these world-famous Units are made.

*Before building or reconstructing your set write for a series of descriptive leaflets (Ref. C.W.) which are of vital importance to every constructor.*

Follow the experts and insist on "LEWCOS."

*A pair of Lewcos "S.T.400" Coils and a type M.C. H.F. Choke are specified for the "Push-Push" Five*



# Lewcos

REGD

RADIO COMPONENTS

**LEWCOS RADIO PRODUCTS FOR BETTER RECEPTION**

THE LONDON ELECTRIC WIRE COMPANY AND SMITHS LIMITED, CHURCH ROAD, LEYTON, LONDON, E.10



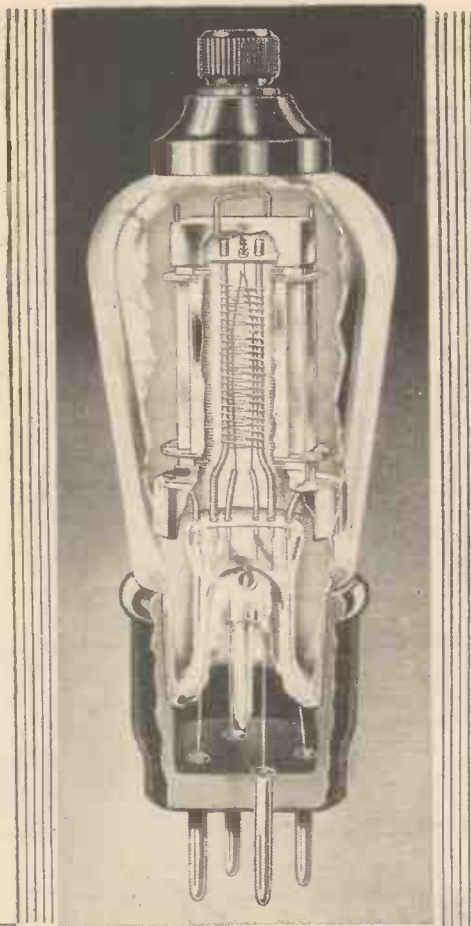

Send for a free copy of the 40-page Cossor Valve and Wireless Book which contains a wealth of interesting and useful information including Radio Definitions—Useful Circuits—List of Stations, etc., etc. Please use the-Coupon.

UNIFORMITY—  
EFFICIENCY—  
LONG LIFE—

## BETTER RADIO RECEPTION



KINGS OF THE AIR

Far too many people put up with indifferent wireless when they could easily improve it out of all recognition. Will your set bring in the stations it used to? Is its tone as good as it was? And what about its volume? Or, if you are building a new Receiver, are you sure it will give the results you expect?

Restore the youth of your Receiver—get maximum performance from your new Set—fit the correct types of Cossor Valves (your dealer will tell you which you need)—they'll give you a pleasant surprise.

# COSSOR VALVES

To A. C. COSSOR LTD.,  
Melody Dept.,  
Highbury Grove,  
London, N.5.

Name \_\_\_\_\_

Please send me free of charge, a copy of the 40-page Cossor Valve and Wireless Book B.17.

Address \_\_\_\_\_

W. C. 5/33

### 2-VOLT TYPES

Type	Filament Amps.	Anode Volts	Imped.	Amp. Factor	Mutual Conductance m.a.v.	Price
*215 S.G.	*15	120-150	300,000	330	1-10	16/6
*220 S.G.	*2	120-150	200,000	320	1-60	16/6
*220 V.S.G.	*2	120-150	110,000	—	1-6	16/6
210 R.C.	*1	75-150	50,000	40	0-8	7/-
*210 H.L.	*1	75-150	22,000	24	1-10	7/-
*210 H.F.	*1	75-150	15,800	24	1-5	7/-
*210 DET.	*1	75-150	13,000	15	1-15	7/-
210 L.F.	*1	75-150	10,000	14	1-4	7/-
215 P.	*15	75-150	4,000	9	2-25	8/9
220 P.	*2	75-150	4,000	9	2-25	8/9
220 P.-A.	*2	100-150	4,000	16	4-00	8/9
230 X.P.	*3	100-150	1,500	4.5	3-00	12/-
230 P.T.	*3	100-150	—	—	2-0	17/6
220 H.P.T.	*2	100-150	—	—	2-5	17/6
220 P.T.	*2	100-150	—	—	2-5	17/6
210 D.G.	*1	75-100	27,000	5.1	0-19	20/-
240 B.	*4	120-150	—	—	—	14/-

\* These Valves available with or without Metallised Bulbs.

A. C. Cossor Ltd., Highbury Grove, London, N.5. Depots at Birmingham, Bristol, Glasgow, Leeds, Liverpool, Manchester, Newcastle, Sheffield, Belfast, Cardiff and Dublin.

# The WIRELESS CONSTRUCTOR

## The EDITOR'S CHAT

### The "Push-Push Five"—"Quality, Power and Parsimony."—The Completion of the Regional Scheme

THE outstanding feature of this issue of THE WIRELESS CONSTRUCTOR is the "Push-Push Five," designed by our distinguished contributor, Mr. John Scott-Taggart. Readers will note that the receiver is similar to the "S.T.400," except that Quiescent Push-Pull Amplification is employed in the output stage.

The output valves are of the pentode type, and Mr. Scott-Taggart has allowed for radiogram switching. The set is of the self-contained console type, the quiescent push-pull output stage, batteries and moving-coil loud-speaker being located in the upper half of the cabinet, just above the main portion of the receiver.

As Mr. Scott-Taggart states in his article, "Q.P.P. could rightly stand for Quality, Power and Parsimony, because this system of amplification will give good reproduction at great volume with a minimum of H.T. current."

This description decidedly fits the "Push-Push Five," and it is certain that readers who want a first-class quality set for gramophone and radio, self-contained, with a maximum of undistorted output, cannot do better than build this new "S.T." receiver.

#### Too Many Good Things

A number of readers have written to us lately pointing out that within the last few weeks the home constructor has been "deluged"—to quote one correspondent from Maidstone—with an assortment of new types of receivers: Quiescent Push-Pull, Cold Valves, Class B Amplification, etc., etc. "When," asks our correspondent, "is it going to stop? Why this sudden outpouring of new designs? Why don't editors of wireless papers control this output?"

Well, we can sympathise with

readers who, perhaps, have been justifiably a little dazed, what with Q.P.P. and Class B Amplification and Cold Valves. But the fact is that wireless papers owe this duty to their readers: details of latest developments in circuit design and latest inventions cannot be held up, for the simple reason that readers would then be justified in accusing the wireless papers of being behind the times!

And when radio manufacturers

#### IN "THE SOUTHERN CROSS"



Mr. J. Stannage, the wireless operator of Kingsford Smith's record-breaking plane, "The Southern Cross," testing the short-wave transmitter prior to a "hop" to Tasmania.

release new types of, for example, valves, it is naturally to be expected that readers will want to know all about them, and what sort of circuits can be used in conjunction with them. After all, the reader has the final decision. He might have just completed building a very fine set before, say, Q.P.P. suddenly sprang into prominence, and he might feel aggra-

vated because he didn't wait a little longer until Q.P.P., or Class B Amplification, or Cold Valves, jumped into the limelight.

#### "Up to Date"

But, supposing a reader had heard about one or more of these new developments, and was waiting for publication of details before building a new set, then that reader would be justified in grumbling at the slowness of wireless papers in giving the full news if editors decided to "hold up" details until the time for release was more appropriate.

It is, admittedly, unfortunate in many respects that so many new developments have occurred so late in the season this year; but, anyway, readers can feel assured of this: That THE WIRELESS CONSTRUCTOR is up to date in giving the latest details of new developments; and no reader can say that this journal doesn't keep him completely *au fait* with "what's doing" in the world of radio.

#### The Fifth Regional

The last of the B.B.C.'s five high-power twin-wave Regional transmitters is nearing completion at Washford Cross, and readers may expect tests from the Western Regional and National transmitters to be started very shortly now.

This new transmitter will thus put the final seal on the Regional scheme, which, of course, was conceived by P. P. Eckersley when he was Chief Engineer of the B.B.C.

With the completion of this fifth and final station we do well to remember its originator, and to seize the opportunity of paying tribute to the man who, more than any other in the country, has made the technical side of British broadcasting what it is to-day.

# The push-push

THE letters Q.P.P. may in a thousand years be discovered by excavators graven on curious pieces of electrical apparatus and printed on odd pieces of paper. They may become almost as common as the Roman letters S.P.Q.R.

For the benefit of archæologists of A.D. 2933 into whose hands this magazine may fall, let me explain that the letters Q.P.P. mean Quiescent Push-Pull. On the other hand, they may stand for Quasi Push-Pull, quasi meaning similar-to-but-somewhat-of-an-imitation-of-and-yet-rather-different-from.

In fact, Q.P.P. could rightly stand for Quality, Power and Parsimony, because this system of amplification will give good reproduction at great

volume with a minimum of H.T. current.

All this sounds too good to be true, but it is true. The scheme is a great stride towards the economical working of battery sets, and also provides the means of delivering the volume ordinarily obtainable only from mains-driven sets where H.T. current is not a consideration.

Apart from the pentode, the history of the L.F. side of reception has been singularly uneventful. It has been like a quiescent volcano that has now erupted and given us Q.P.P.

## What's in a Name?

The idea of a sleeping volcano does rather convey what Q.P.P. is. The word quiescent (pronounced kwy-essent, and not kwee-essent) suggests a state of lying-low ready to burst forth. On the whole, however, there is a suggestion of quietness which does not match the terrific output one can easily obtain with quite small H.T. batteries.

Hence the desire to call my present set the "Push-Push Five." Actually, in the old push-pull circuit, one valve is producing the current in the output transformer, while

the other valve (whose anode current is being altered in the opposite direction) helps simultaneously; this effect is obtained by suitably winding the output transformer so that, although the current changes are different, they have the same effect on the secondary of the transformer which is connected to the loudspeaker.

## A Cycling Analogy

In the case of Q.P.P. each of the two valves has a high negative potential on the grid. In fact, the anode current of each is almost cut off.

When modulated signals are received, the valve whose grid is made "positive" feeds the transformer, while the other valve is lying virtually idle. As L.F. signals are alternating current, the second valve's turn comes when its grid is affected by the next half-cycle. The valves thus work in turn, each giving a "push" of anode current.

The scheme greatly resembles the "push-push" of the rider of a push-bike. While one pedal is going up the other is going down. You only help yourself along with one leg at a time. The right pedal is only doing good between the vertical top position and while it is pressed down to the bottom position.

## Alternate Passengers

The cyclist's left foot on the rising pedal is purely a passenger, but as soon as it reaches the top position it becomes useful, and the cyclist's right leg is now the passenger.

The pushes which follow each other all tend to make the cycle go forward, and the process is very similar in a Q.P.P. amplifier.

If the cyclist's feet were tied to the pedals and he pulled up with the foot



THE  
AUTHOR



# FIVE

BY  
JOHN  
SCOTT-TAGGART  
A.M.I.E.E., F.INST.P.

FOR GRAMOPHONE  
AND RADIO

Very Low H.T. Consumption

\* \* \*

SELF-  
CONTAINED

\* \* \*

EASY TO  
BUILD

\* \* \*

MAXIMUM  
UNDISTORTED  
OUTPUT  
APPROX. 1,300  
MILLIWATTS

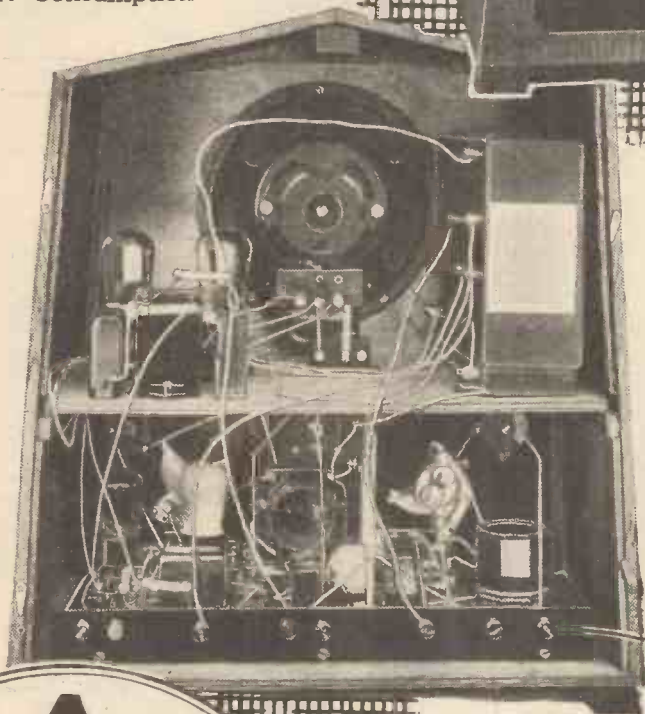
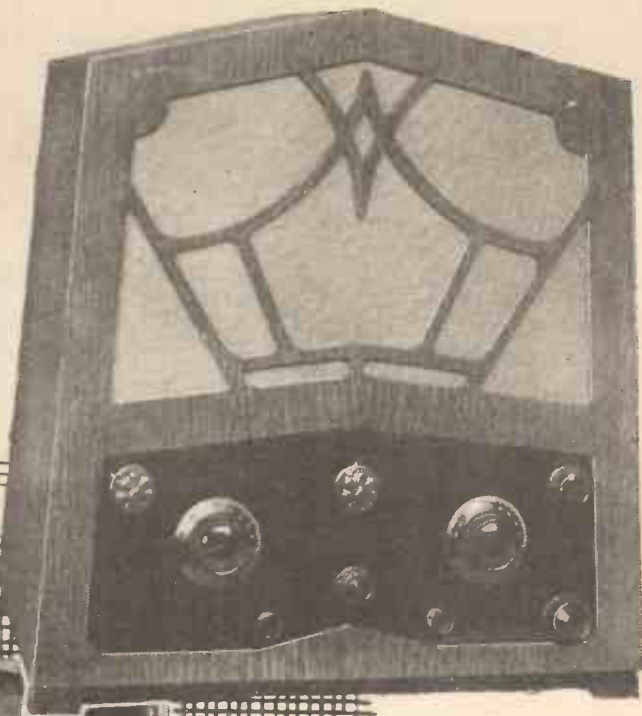

of the H.T. current is governed by the grid voltage swings—i.e. the "loudness."

#### In the Intervals

On any ordinary amplification circuit one has not only to use adequately large valves, but one has to have a steady anode current large enough to be varied by the loudest passages of music. One might easily have to have 16 or 20 milliamps. flowing through the output valve.

And this current would be flowing even though most of the music might

AMAZING  
VOLUME  
SUPER SELECTIVITY  
TONAL PURITY

A  
Q.P.P.  
"S.T."  
SET

which normally does nothing on the upstroke, then we should have a state of affairs similar to ordinary push-pull.

The merit of Q.P.P., or push-push amplification, is that when no sound is being received (the "carrier" produces no L.F.) both valves pass very little H.T. current. And even when "signals" are received, the amount

only vary the anode current between, say, 12 and 20 milliamps.

During intervals in the programmes, between words or notes, during weak passages, when volume is "turned down" by the volume control—in all these cases Q.P.P. wins every time over the straight system as regards economy. In general, over a period of an hour or two's listening you will save half your H.T. current. The experimenter and searcher will save

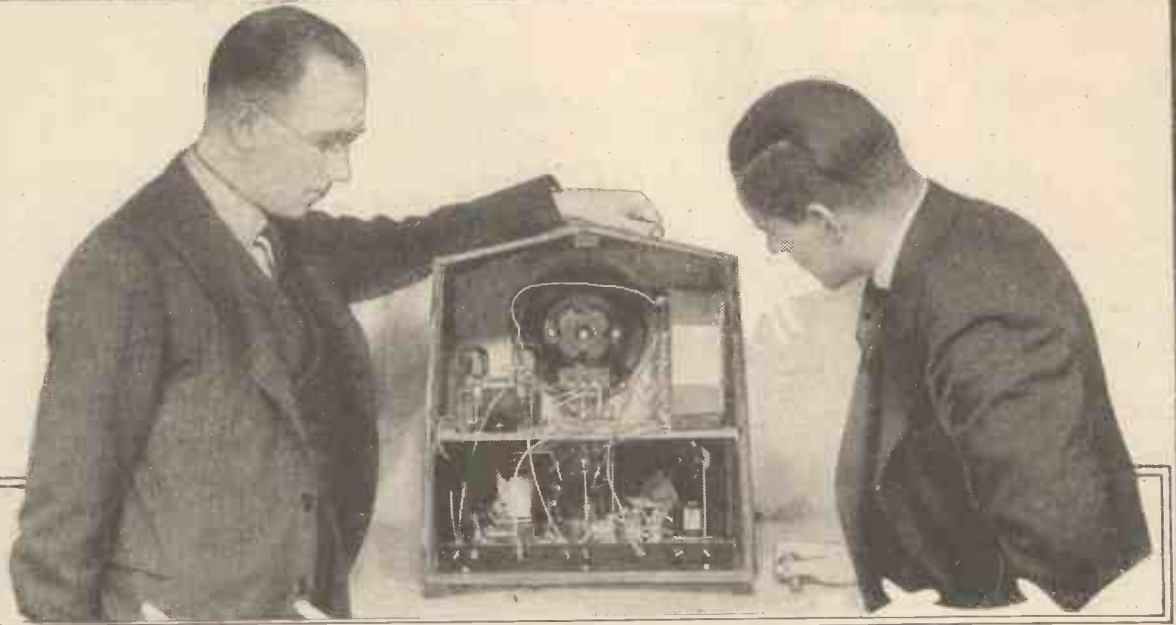

*The set proper is based on the world-famed "S.T.400" circuit. It is built on the usual baseboard style, with upright panel, and it slides into the bottom half of the cabinet. The necessary connecting leads to loudspeaker, H.T. battery, etc., are easily joined up when the two sections are placed in position. Below is a close-up which shows how the receiver section ends at the L.F. valve. The push-push output valves are located close to the loudspeaker, with which they form a compact assembly on the top shelf.*

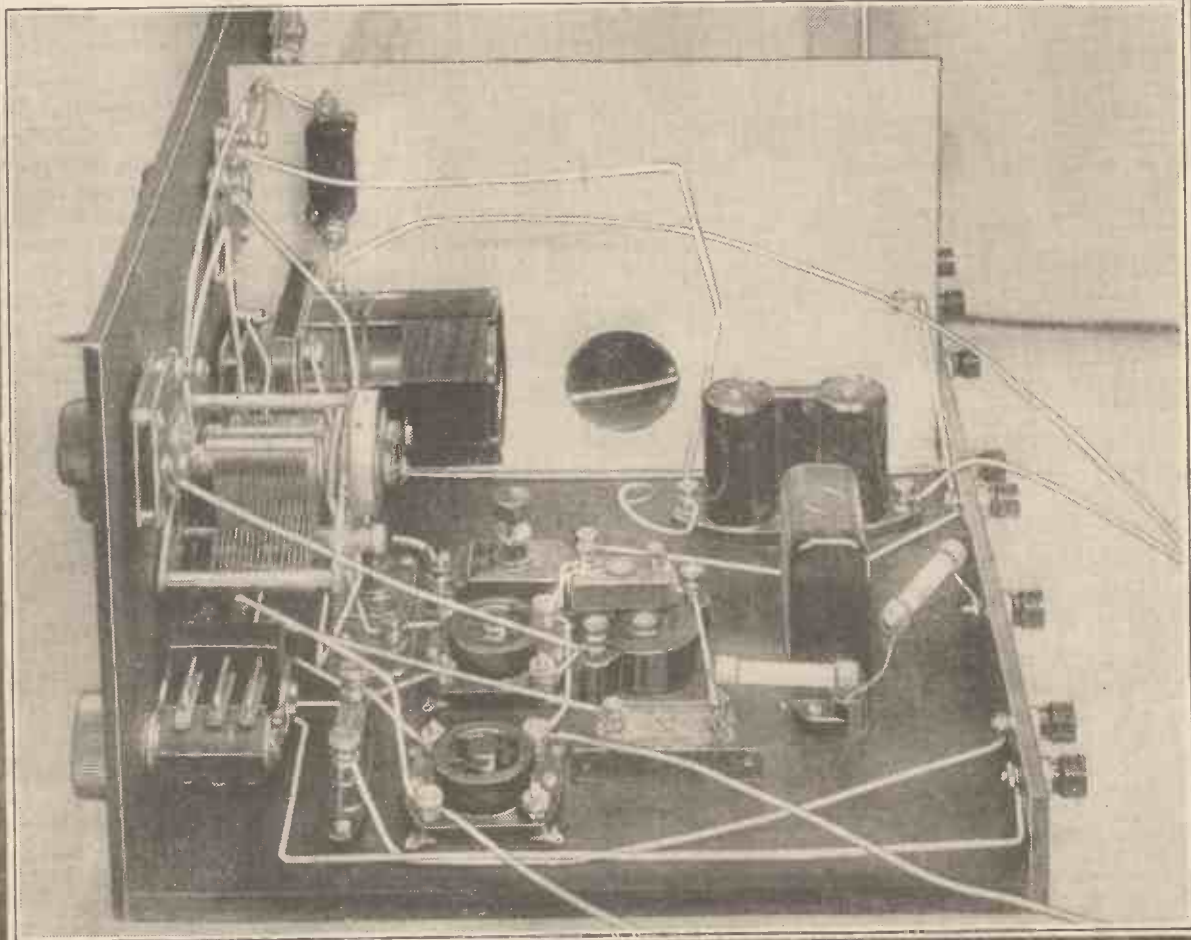



## LOUDSPEAKER AND LAYOUT

### CONSTRUCTIONAL POINTS

This view of the layout of the "upper deck" shows the Q.P.P. input transformer in the foreground with the pair of valve holders for the output pentodes. The 150,000-ohm resistance between these valve holders and the Q.P.P. transformer is connected in the output stage's grid-bias lead to prevent any possibility of parasitic oscillation. Ample space is available on the "upper deck" for the accommodation of all the batteries. The grid-bias is underneath the H.T. battery, while an L.T. accumulator of any reasonable dimensions may be stood immediately to the rear of the loudspeaker. The set thus becomes as fully self-contained as the average mains receiver, to which the "Push-Push Five," incidentally, is not inferior in performance.

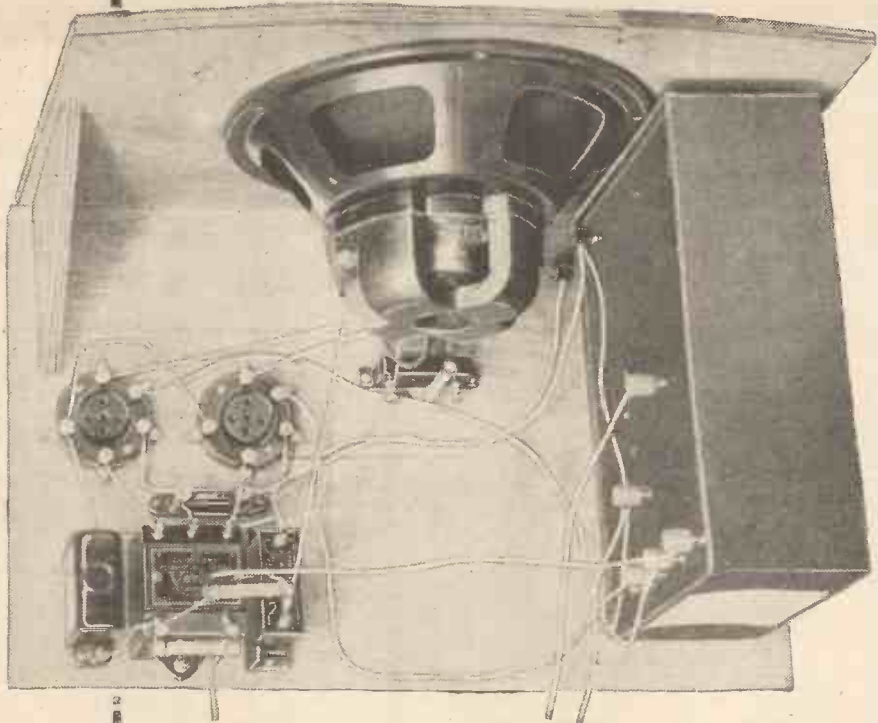

Below we have a close-up of the input end of the set, showing the aerial tuning circuit. The S.G. valve holder is standing near the by-pass condenser that is connected between the screening grid and earth. On the panel (top right) is the variable condenser for regulating the degree of aerial coupling.

### THE VALVES FOR THE "PUSH-PUSH FIVE"

- S.G.** Cossor S.G.220.  
Osram S.22.  
Mazda S.215B.  
Mullard P.M.12A.  
Marconi S.22.  
(Above S.G. valves are preferably metallised.)
- DETECTOR.** Cossor 210Det.  
Mullard P.M.1.H.L.  
Mazda H.L.2.  
Osram H.L.210.  
Marconi H.L.210.  
(Above detectors are preferably metallised.)
- FIRST L.F.** Mullard P.M.2D.X.  
Mazda L.2.  
Cossor 210L.F.  
Marconi L.210.  
Osram L.210.
- OUTPUT.** (Two) Mazda Pen.220A.  
Cossor 220P.T.

N.B.—No special significance attaches to the order of makes of valves. The set will accommodate itself to many other types of these makes. For example, the later types of S.G. valves are specified above, but many tests were carried out very successfully on the valves used in the "S.T.300."

The detector and both L.F. stages should be correctly biased. Make certain your valves are in healthy condition.

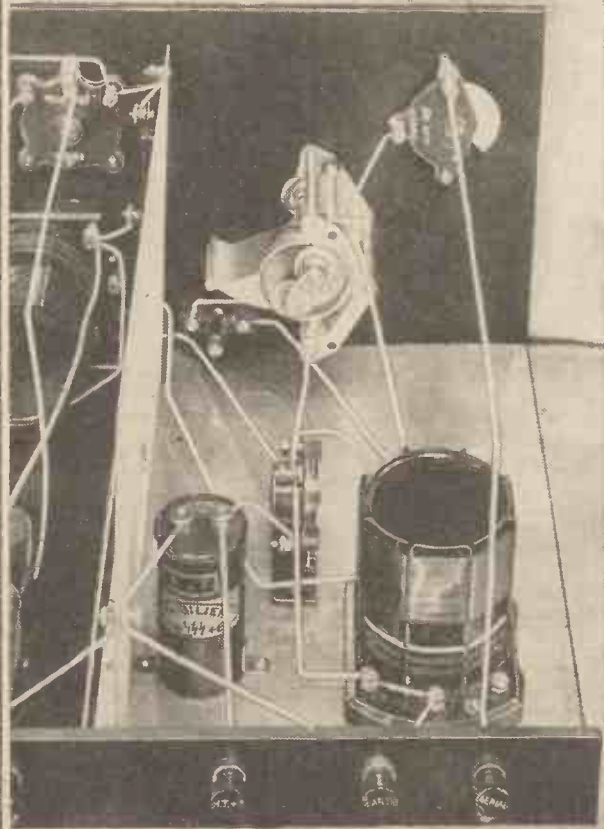

# Quiescent Power, Like a Sleeping Volcano!

even more, as he will only be using H.T. when receiving a signal.

Alternatively, you can get far more punch, but with the H.T. consumption of an ordinary output valve.

In practice you will probably operate at greater volume and also save on your H.T. bill.

The present receiver which I have designed for Q.P.P. working is the

know, an H.F. stage, a detector and two L.F. stages.

## Volume to Spare

A very large volume of sound is thus obtainable even from signals which in the aerial circuit are weak.

The maximum undistorted output from the "Push-Push Five" is about 1,300 milliwatts.

The reason why I have founded

The only changes are to provide a radiogram switch and the Q.P.P. valves and components. Nearly all of an "S.T.400" receiver is used unaltered.

A radiogram switch seemed called for because I felt that people like records played at full volume, and that those who would build this set complete would like provision for gramophone work. It is, of course, impossible to design innumerable sets

## YOUR SHOPPING LIST FOR THE "PUSH-PUSH FIVE"

- |   |   |  |
|---|---|--|
| <p>1 Q.P.P. Transformer. Varley D.P.36, or R.I. "Q." Ferranti A.F.11c. Multitone PU./1:8, Sound Sales S.S./Q.P.P.,</p> <p>1 Q.P.P. Output Choke (unless part of speaker, as in speaker used). R.I. D.Y.35, or Varley Transchoke, Ferranti, Multitone.</p> <p>1 Aerial Coupler (00004-mfd. variable with very low minimum). Ready Radio "Micalog," or Peto-Scott, J.B. Midget, Wavemaster (not metal-end plates).</p> <p>1 Pair of "S.T.400" Coils. Colvern, or Lewcos, Wearite, Goltone, Sovereign, Ready Radio, Telsen.</p> <p>2 0005-mfd. Variable Condensers. Ormond R.493, or J.B., Polar No. 2; Lotus (last make requires reaction condenser of different type or present type slewing round).</p> <p>1 0003-mfd. Differential. Polar, or Graham Farish, Magnum, Telsen, Lotus (00035 mfd.), J.B., Bulgin.</p> <p>1 00035-mfd. Differential. Lotus (00035-mfd.) M.D.35 (not their 00034-mfd. model), or 0003-mfd. of following: Graham Farish, Polar, Magnum, Telsen, J.B., Bulgin. There is no technical merit in 00035 mfd. over 0003 mfd.</p> <p>1 0001-mfd. Differential. Ready Radio, or Telsen, Polar, Graham Farish, Magnum, Bulgin, J.B., Utility, Lissen, Wavemaster.</p> <p>2 4-pin Valve Holders. Benjamin Vibroldor, or Lotus V.H.K., Graham Farish, Telsen, W.B., Bulgin, Tunewell; Ferranti, Ready Radio.</p> <p>1 S.G. Valve Holder (horizontal). W.B. Universal valve holder, or Lissen, Wearite, Telsen, Parex.</p> <p>2 5-pin Valve Holders. Benjamin, or W.B., Wearite, Telsen.</p> <p>1 H.T. Battery, Q.P.P., 130 volts. Drydex, etc.</p> <p>1 G.B. Battery, 16½ volts (or more). Ever Ready, Siemens, Drydex, Lissen, Pertrix.</p> <p>1 L.T. Battery. Exide, G.E.C., Ediswan, Pertrix, Lissen, Oldham, Block.</p> | <p>2 2-pt. Switches. Bulgin S.22, or Tunewell, Telsen, Lissen, Ready Radio, Wearite, Sovereign, W.B., Igranic, Ormond, Lotus.</p> <p>1 S.G. Choke. Telsen Binocular, or R.I. Dual Astatic, Lewcos, Ready Radio, Watmel, Magnum, Wearite H.P.O., Bulgin S.5 type, Sovereign Super, Slektun.</p> <p>1 Reaction Choke. Lewcos M.C., or R.I. Quad Astatic, Telsen, Lissen, Graham Farish, Wearite, British General, Ready Radio, Tunewell, Watmel.</p> <p>1 0003-mfd. Fixed Condenser. Goltone, or T.C.C., Dubilier, Telsen, Graham Farish, Lissen, Bulgin, Ferranti.</p> <p>1 006-mfd. Fixed Condenser. Graham Farish, or T.C.C., Lissen, Graham Farish, Telsen, Dubilier 670, Bulgin.</p> <p>1 006-mfd. Fixed Condenser. Dubilier 670, or T.C.C., Lissen, Telsen, Bulgin.</p> <p>1 005-mfd. Fixed Condenser. Lissen, or T.C.C., Dubilier, Telsen, Bulgin.</p> <p>2 2-mfd. Condensers. Igranic, or T.C.C., Telsen, Formo, Ferranti, Dubilier, Lissen, Helsby, Hydra.</p> <p>1 2-mfd. Condenser. Telsen, or Igranic, Dubilier, T.C.C., Ferranti, Lissen, Helsby, Hydra.</p> <p>1 1-mfd. Condenser. Dubilier 9200, or Telsen, T.C.C., Igranic, Ferranti, Lissen, Formo, Helsby, Hydra, Sovereign.</p> <p>1 Grid Resistance. 1 megohm, complete with holder. Ferranti Synthetic type S with holder, or Graham Farish "Ohmite," Dubilier, Loewe, Bulgin Ceramic, Ready Radio Thermium.</p> <p>1 Resistance. 150,000-ohms with holder. Ferranti Synthetic type S with holder, or Graham Farish "Ohmite," Dubilier, Bulgin Ceramic, Ready Radio, Thermium.</p> <p>1 1,500-ohm Spaghetti. Igranic, or Graham Farish, Lewcos, Varley, Magnum, Telsen, Sovereign, Bulgin. (Spaghetthis of this value are not catalogued by all alternative makers.)</p> | <p>3 50,000-ohm. Dubilier metallised 1-watt, or Erie.</p> <p>2 20,000-ohm. Dubilier metallised 1-watt, or Erie.</p> <p>1 Radiogram Switch, 3-pole, double throw. Wearite I. 23.</p> <p>2 Preset Condensers, 0003-mfd. maximum. Telsen, or Goltone. (These makes are chosen for their low minimum capacities.)</p> <p>1 Loudspeaker, ready fitted with Q.P.P. transformer. Celestion C.T.1715, or Rola F6.P.M. Q.P.P. 220A., Amplion Q.P.P., M.C.22., B.T.H., R.K. Minor Q.P.P.</p> <p>8 Terminals. H.T.+1, H.T.+2, L.T.—L.T.+, Gramo, Gramo, Aerial, Earth. Clix, Belling-Lee, Bulgin, Eelex, Igranic, etc.</p> <p>1 "S.T.400" Screen, 10 in. × 7 in., and Foil. Magnum, or Peto-Scott, Direct Radio, Wearite, Parex, etc.</p> <p>1 Panel. 16 in. × 7 in. × 3/8 in. Goltone, or Permeol, Becol, Peto-Scott, Direct Radio, Magnum, Parex, etc.</p> <p>1 Baseboard. 16 in. × 10 in. × 3/8 in. Peto-Scott, or Direct Radio, Camco, Magnum, etc. (Cabinets are usually ready fitted with baseboards.)</p> <p>1 Terminal Strip. 16 in. × 1½ in. × 3/8 in. Goltone, or Peto-Scott, Becol, Permeol, Magnum, Direct Radio, Parex, etc.</p> <p>Wander Plugs. G.B. plus, G.B.—1, G.B.—2, G.B.—3. I advise types which can fit into each other in case of G.B.—1, G.B.—2 and G.B.—3, although not illustrated. Clix, or Belling-Lee, etc. H.T. wander plugs. H.T.—, H.T.+1, H.T.+2, H.T.+3, H.T.+4, H.T.+5. Belling-Lee, or Clix, Bulgin, Eelex, etc.</p> <p>2 Spade Terminals. L.T.+, L.T.— (if desired). Belling-Lee.</p> <p>1 S.G. Anode Connector (if desired). Belling-Lee.</p> <p>Cabinet. Peto-Scott.</p> <p>Wire. Superflex No. 18, Glazite No. 18, Quickwire, or stiffish bell wire.</p> |
|---|---|--|

"S.T.400" adapted for the purpose. The "S.T.400" is, in fact, an ideal set for the purpose.

Large grid swings (up to about 14 volts) are required with Pen.220A valves to give the maximum output (and a terrific output it is!). Such grid swings are obtainable with the "S.T.400," which has, as readers

the "Push-Push Five" on the "S.T.400" circuit is simply because I am unable at present to offer any better circuit. The reason I have not altered the general set constructional design is that I want those who have built the "400" to be able to convert at minimum expense and with the least possible trouble.

with and without various features, and I must do my best to gauge the public taste.

Here I ought to emphasise the importance of constructors familiarising themselves with theoretical circuits so that I could give circuit diagrams for those, for example, who wanted special switching or wished





# "Q.P.P. Wins Every Time . . ."

to omit, say, the radiogram switch. The practical embodiment of a circuit, however, always involves a little risk, and many a good design has been spoilt by an amateur tampering with the layout, components, etc.

Although the "S.T. Push-Push Five" is called a "five" for honesty's sake, it would be technically justifiable to call it a "four." The whole question of how to count valves is now in the melting pot. The Westinghouse mains rectifier and the

Westector may rob a set of two valves without loss of efficiency.

It has ceased, therefore, to be any use to judge a set by its number of valves. The Q.P.P. system added, say, to a det. and 2 L.F. set means an extra valve, but the H.T.

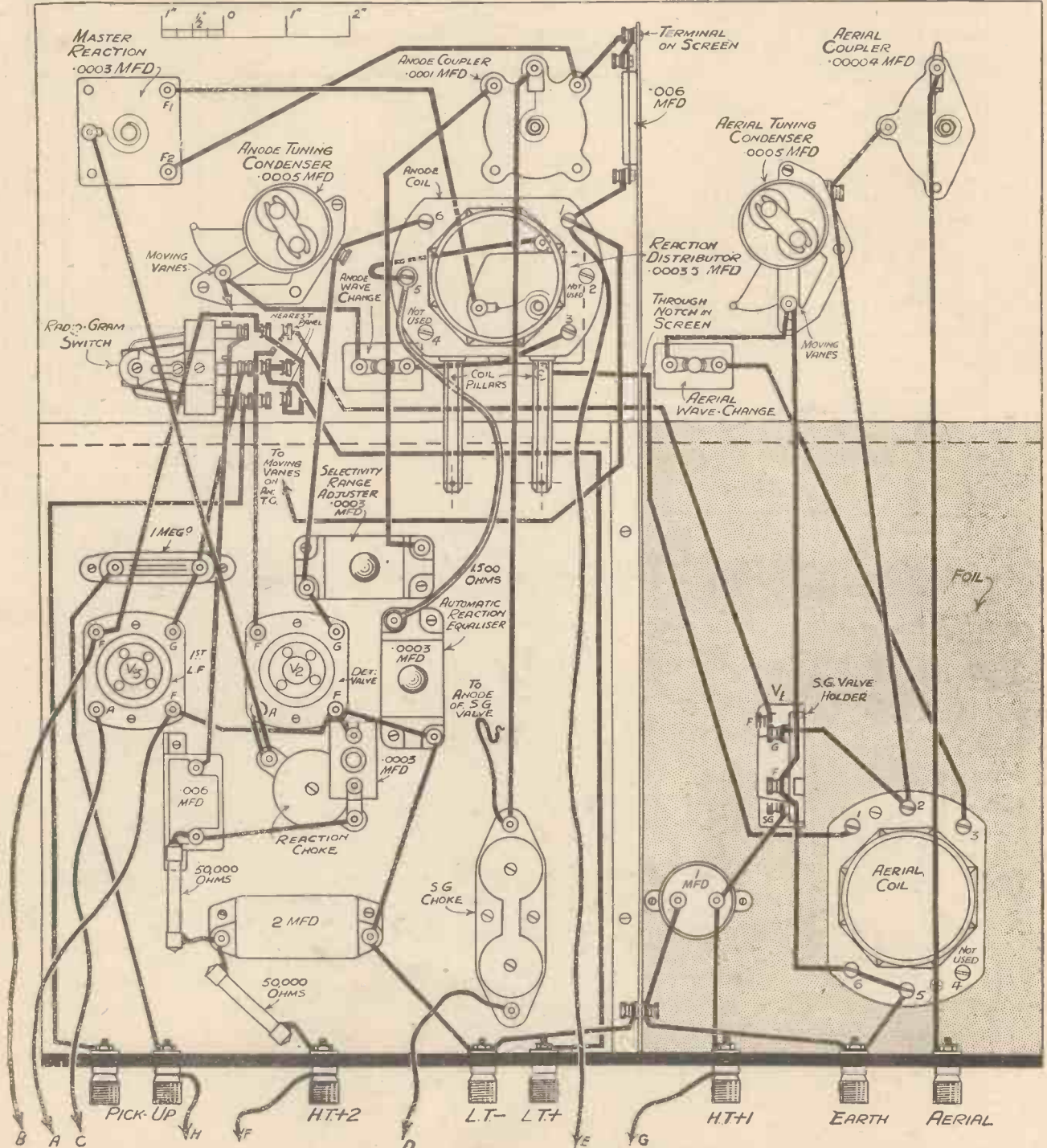

The receiver proper is very similar in general arrangement to the "S.T. 400," and in addition to the upright screen, it employs a foil-covered baseboard for the aerial input section. For the explanation of the lettered leads at the foot of the diagram, see the next page.



THE "PUSH-PUSH FIVE"

continued

consumption is reduced for a given volume. The whole set, although very powerful indeed, would not be as sensitive as if the extra valve were used for H.F. amplification.

Pays for Itself

It has, therefore, become essential for even the general public to acquire some smattering of radio lore so that they can appreciate the nature of the

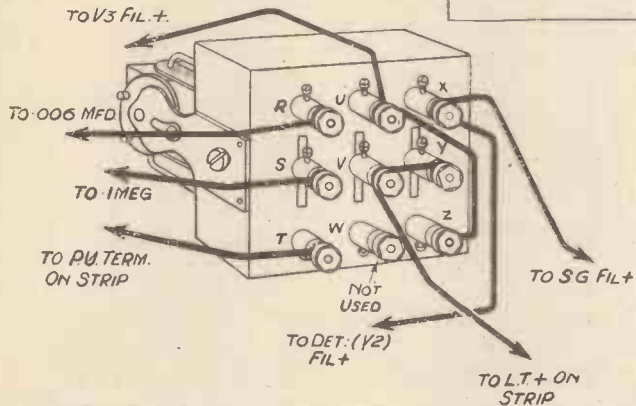
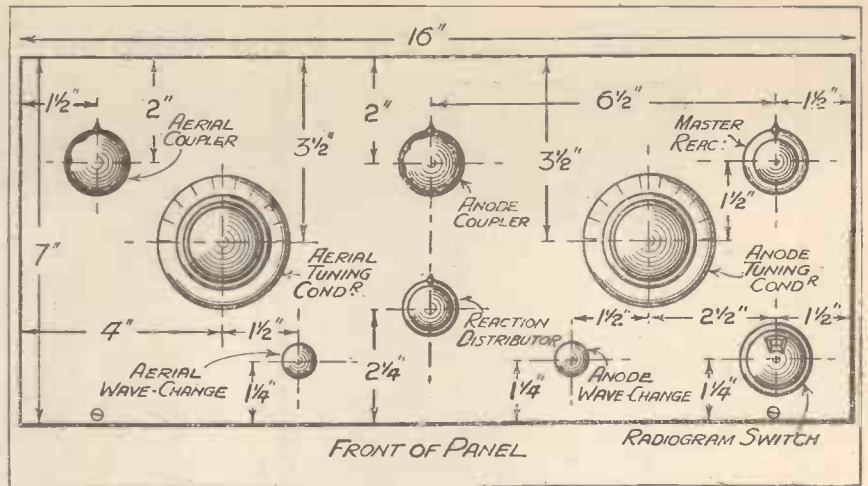

The radiogram switch is on the extreme right of the panel, and the sketch to the left shows how its back-of-panel connections are arranged.

receiver they are offered. The constructor must be the first to jettison his prejudices against valves. The introduction of Q.P.P. will be met with these prejudices, and it is my bounden duty to stifle gently the cries of those who resent a valve irrespective of its function!

I must say that I myself have resented the extra valve used in ordinary push-pull circuits and felt the cost could usually be better expended in other ways. The extra

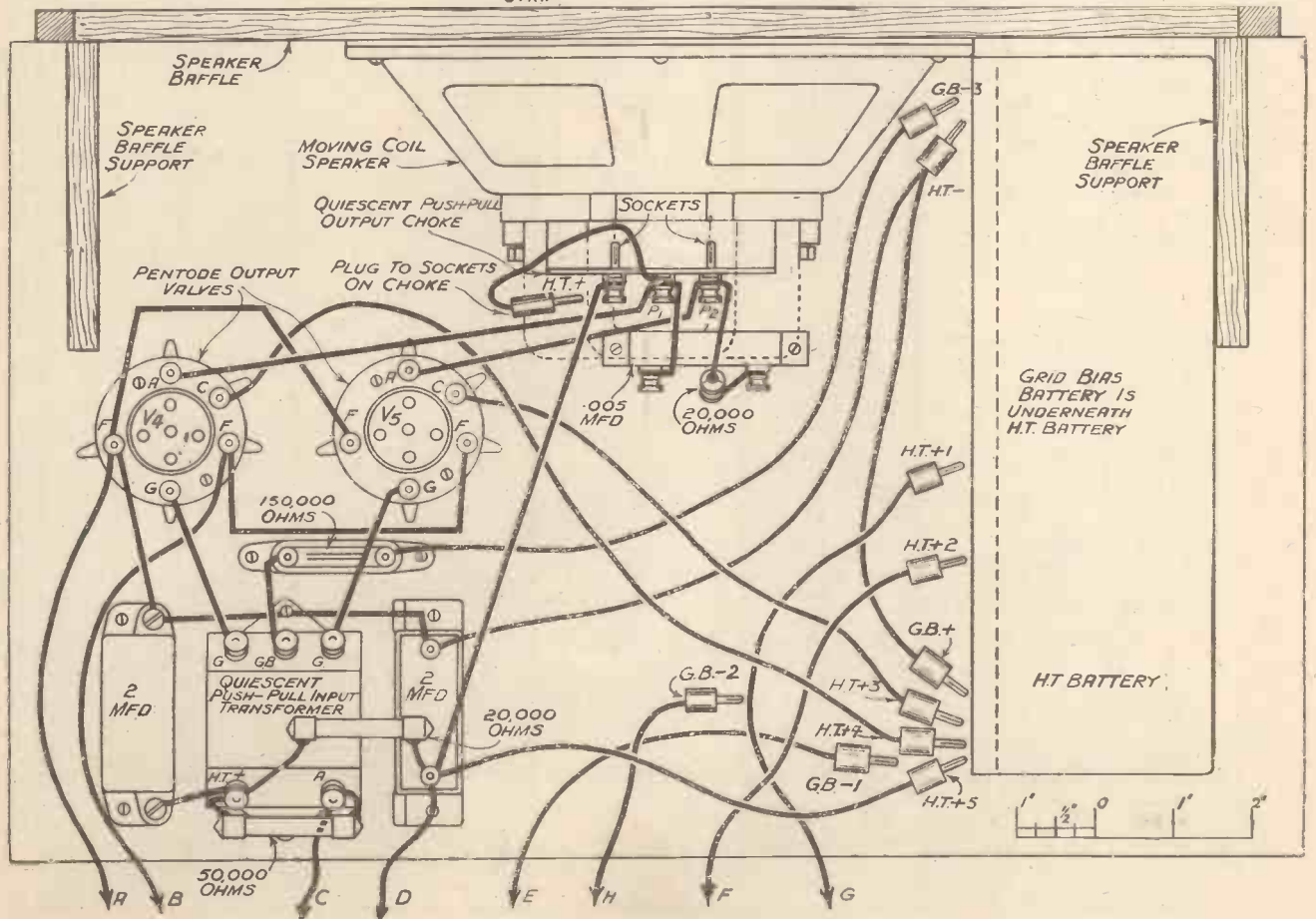

The letters A, B, C, D, etc., immediately above, correspond with those on the preceding page, and indicate how the leads from this, the upper section, run to the set itself on the shelf below.

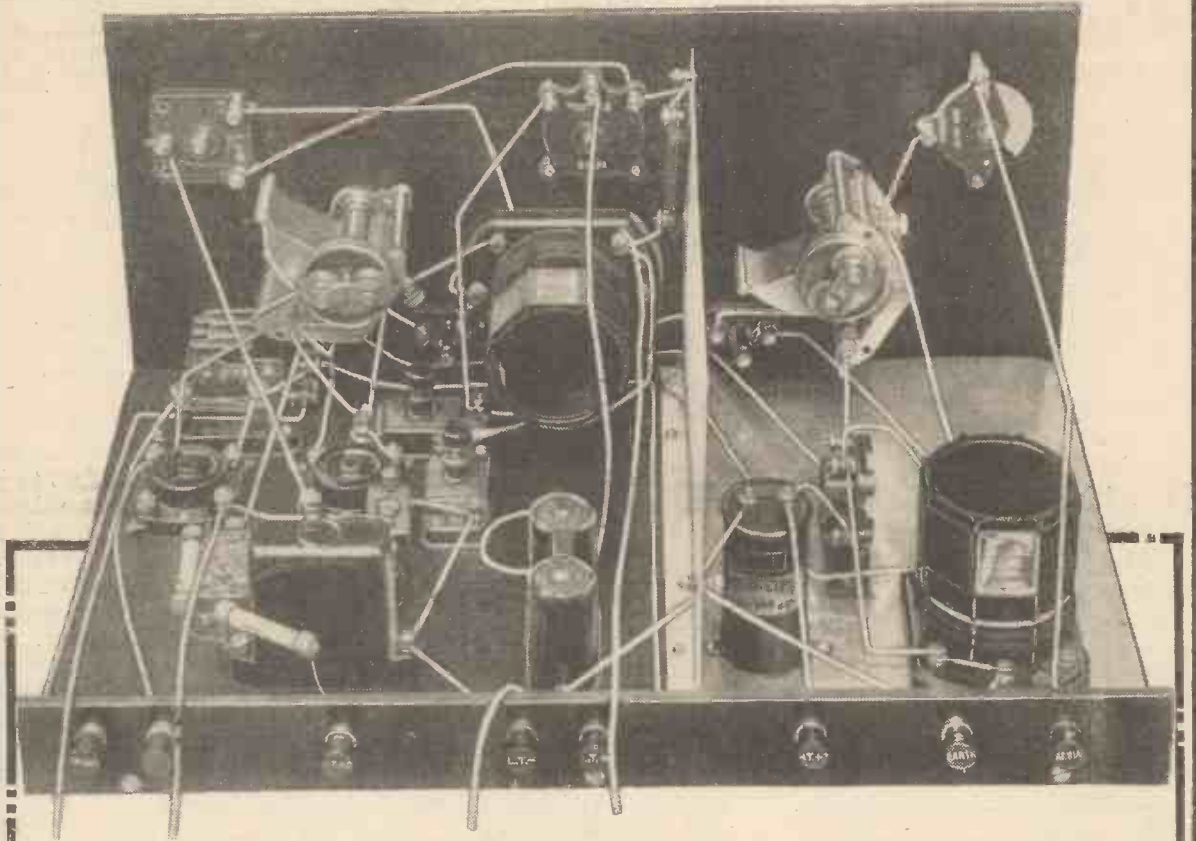

Every admirer of the "S.T.400" will notice that the "Push-Push Five" closely resembles this outstanding design so far as the main receiver portion is concerned. The principal difference is in the L.F. end, the quiescent output stage being located on a separate shelf, which also carries the batteries.

\* \* \*

The operation of the "Push-Push Five" is identical with that of the "S.T.400," full details for which appeared in the December, 1932, issue of this journal.

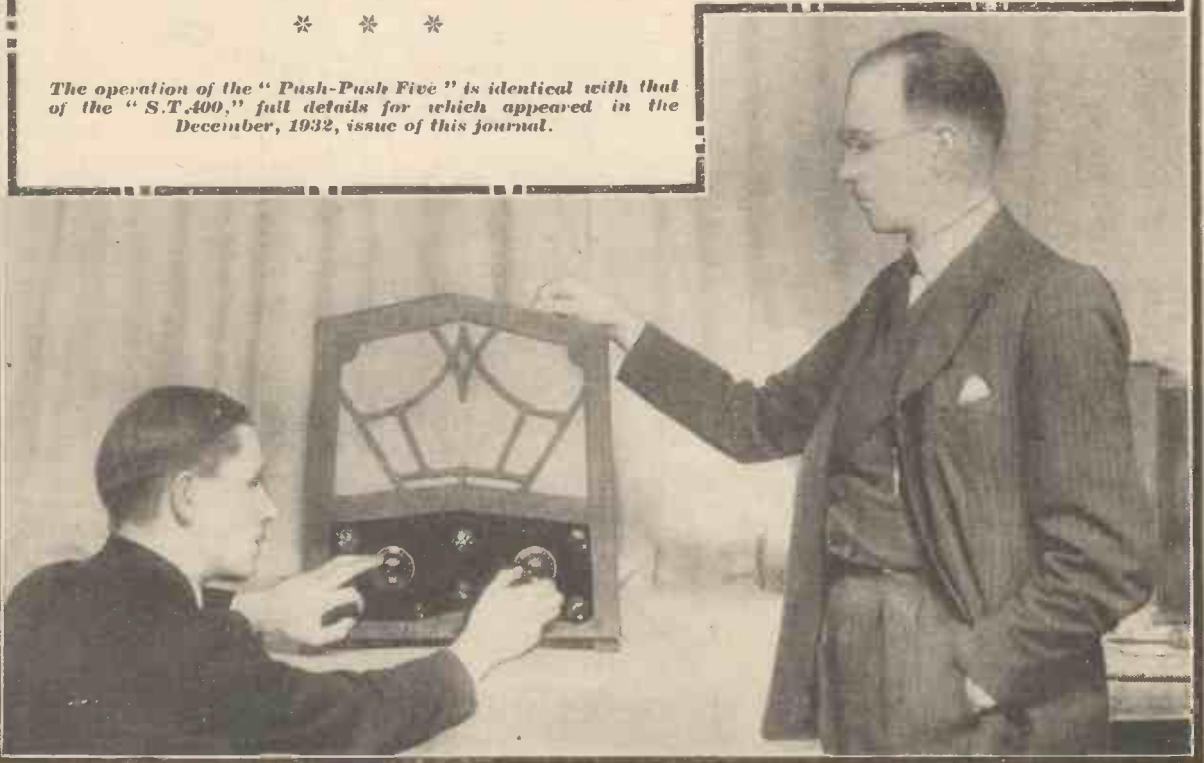



## Two Milliamps. for Each Quiescent Pentode

valve required for Q.P.P., however, will rapidly pay for itself, while enabling great volume to be obtained when desired.

### Circuit Details

Of course, you require a special intervalve L.F. push-pull transformer, and either a speaker with Q.P.P. transformer fitted or else a Q.P.P. output "choke" for the set. The

enables the best to be obtained from moving-coil speakers.

Let us examine the "Push-Push Five" "theoretical" diagram. The high-frequency portion is the same as the "S.T.400" described in the December WIRELESS CONSTRUCTOR and in subsequent issues. Readers who are interested in the new set should emphatically read all about the "S.T.400."

of these has been explained in recent issues.

The operation of the "Push-Push Five" is identical with that of the "S.T.400." A radiogram switch is provided, and when its knob is turned to the left radio is received, while in the middle position all the valve filaments are switched off.

### Safety Measures

When the radiogram knob is over to the right, the set is ready for playing records, the pick-up being permanently connected to the P.U. terminals on the terminal strip; during gramophone working the first two valves are switched off to save filament juice, H.T., and wear-and-tear. It will be noted that the pick-up E.M.F.'s are applied to the grid of the 1st L.F. valve ( $V_3$ ) of the receiver.

Volume control on records is obtained by means of an external potentiometer on the gramophone.

The push-pull equipment presents remarkably little for comment. A 50,000-ohm resistance is connected across the primary of the Q.P.P. intervalve transformer to provide a shorting path for any excessive voltages which might be set up across the primary by unintentional breaking of the  $V_3$  anode circuit. In fact, one must avoid, with pentodes, the likely risk of very high voltages being set up across their anodes and filaments.

These voltages are destructive of the valves and it should be a rule to switch off the filament (by putting radiogram switch to "off" or by disconnecting accumulator) before making any adjustment of grid bias or H.T. voltages.

### Using Existing Speakers

A resistance of 20,000 ohms and a condenser of .005-mfd. are connected as a load-limiting device across the output transformer and "choke."

The so-called choke or transchoke is really an auto-transformer, and I have tried the commercial types with success.

You can therefore use your existing speaker. (See Sketch.)

The grid-bias battery should give  $16\frac{1}{2}$  volts or a little more, and the grids of the pentodes will be usually at about -15 volts. A resistance of 150,000 ohms is connected in the common grid circuit. This is to prevent parasitic oscillations of very high

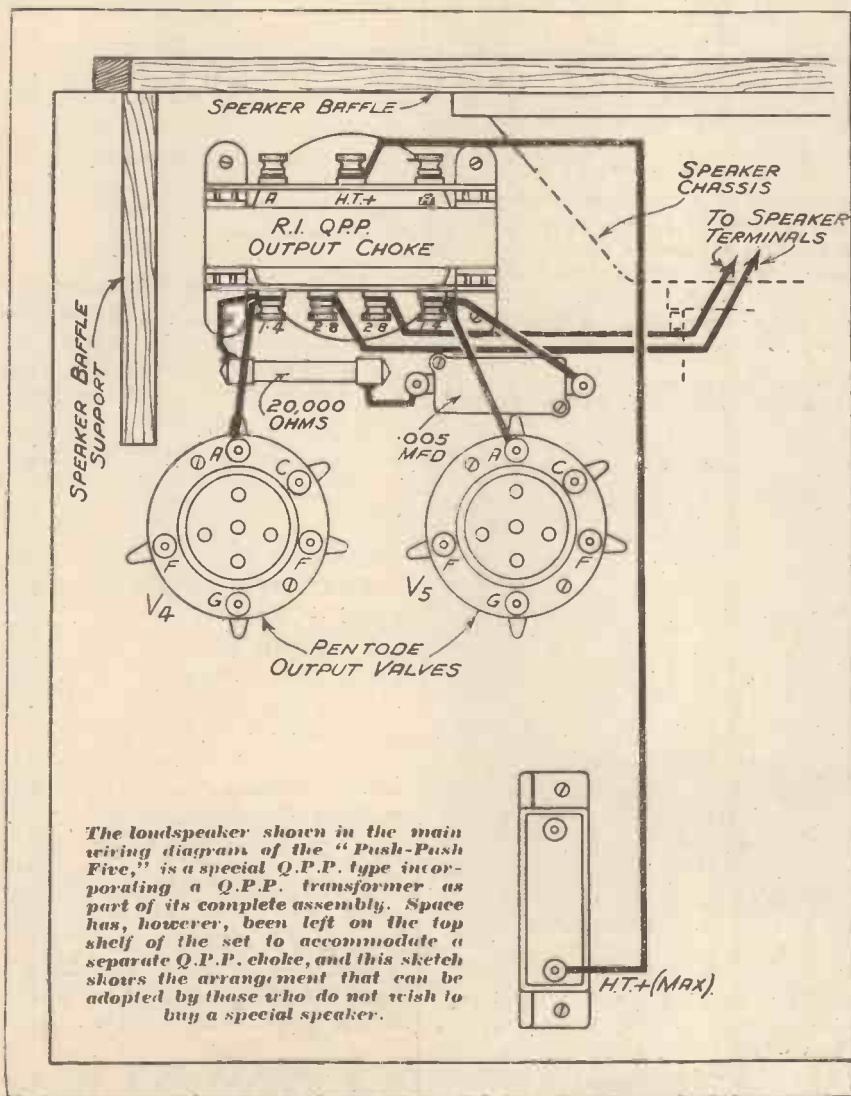

extra cost is a nuisance, and if H.T. economy were the only benefit of Q.P.P. many would take the shorter view and pay more for H.T.

But a demonstration of the "S.T. Push-Push Five" going at full tilt would make mouths water for the great volume which can only be obtained really practically by the Q.P.P. system. Moreover, Q.P.P.

The circuit consists of variable aerial coupling, my differential anode coupling system and anode bend detection. In addition, multiple reaction is employed in accordance with my basic patent, now nearly ten years old, and very recent detailed applications. A master reaction control and a reaction distributor are employed, and the use

## The "Push-Push Five"—continued

radio frequencies or high audio frequencies (or both) from being set up; separate resistances in each grid lead were found unsatisfactory as preventives.

### Housing the Batteries

The construction of the set offers no difficulty whatever. It is planned on the double-decker system employed in the A.C. "S.T.400." I have specified a different shape of cabinet to enable an H.T. battery to rest

side of the screen will be necessary and the L.F. transformer replaced by a Q.P.P. transformer.

The grid-bias battery is laid on its side on the shelf, and the high-tension battery is laid also on its side on top of the grid-bias battery. The actual H.T. and G.B. arrangements are a matter for the constructor who may prefer to have the batteries outside the cabinet, which is roomy enough, however, to house them, and also a large accumulator.

120 to 130 volts: auxiliary grid of  $V_4$  (H.T.+4).

120 to 130 volts: auxiliary grid of  $V_5$  (H.T.+3).

72 (variable) volts: the screen of the S.G. valve (H.T.+1).

130 volts (variable): anode of detector (H.T.+2).

The negative of the H.T. battery is connected to the positive of the  $16\frac{1}{2}$ -volt (or larger) G.B. battery. There is G.B.—1, the grid bias ( $1\frac{1}{2}$  volts usually) of the detector valve ( $V_2$ ); G.B.—2, the bias (—3 volts normally) for the 1st L.F. valve ( $V_3$ ); and G.B.—3, the —15 volts or thereabouts for the two pentodes. Take great care that there is no faulty connection in the grid-bias leads themselves or in the way they fit into the battery.

### Matching the Pentodes

The operation of the set requires no explanation, as the controls are the same as in the "S.T.400," but the voltages for the two pentodes (Pen.220A's) call for comment.

It is unnecessary that the valves should be matched, but the voltages applied to them should be correct. The maximum H.T. (130 volts or thereabouts) is always applied to the anodes. The usual grid bias will be about —15 volts.

What you should aim at is a quiescent steady anode current *when no signals are being received* of 2 milliamps. for each pentode.

This value may be measured by including a milliammeter in the anode circuit of one of the pentodes. It will usually be necessary to pull out of its socket the other pentode. Adjust the auxiliary grid voltage until about 2 milliamps. is passed. Then take the pentode out and proceed to find by trial the correct auxiliary grid H.T. voltage for the second pentode, which is now replaced in its holder.

### Meter Not Essential

The pentodes, once the correct voltages have been found, should be marked to show which valve holder each belongs to.

Although a milliammeter is desirable, it is not essential, and excellent results can still be obtained by a process of "wangling" the tappings, keeping the grid bias as large as possible consistent with good quality.

(Please turn to page 54.)



### CABINET ATTRACTIONS

*In addition to its handsome appearance, the cabinet has the advantage of enabling the set to be mounted separately from the Q.P.P. output equipment which, with the H.T. battery and accumulator, is accommodated on an upper shelf.*

(together with an accumulator) on the combined shelf and baffle. This combination slips right out of the cabinet, and the Q.P.P. output equipment and the pentodes are mounted on it.

### Adjusting Voltages

The set proper is built on the usual baseboard and panel and simply slides into the bottom half of the cabinet, to which, if desired, it could be screwed. If the "S.T.400" is used here, a few alterations in the position of components on the L.F.

The H.T. battery will require to have tappings every 3 volts for the last 20 to 30 volts to enable one to vary the voltages on the auxiliary grids of the pentodes. Special H.T. batteries for Q.P.P. are made by various dry-battery manufacturers, but if you wish to use an ordinary battery you can try using a large-sized grid-bias battery to give the accurate adjustment required.

The H.T. tappings are as follow :  
Maximum (130 volts): anodes of pentodes and anode of  $V_3$  (H.T.+5).





# B.B.C. NEWS

Topical notes regarding British Broadcasting Personalities and Programmes.

By Our  
Special Correspondent

## Sir John Reith Sits Back

**A**FTER more than ten years of application to the complex detail of broadcasting, Sir John Reith has at last been persuaded by his Board of Governors to hand over more responsibility, and I understand this will be made possible by adding to the senior staff. Although I doubt whether the experiment will last long, it is worth trying, and its success would be to the advantage of the service generally.

The chief defect of the B.B.C. organisation has been associated with one of its main merits. The dominating personality of Sir John Reith has been imposed on the B.B.C. to its lasting good; but there is no other personality sufficiently in evidence—at least, on the programme side. The submergence of others has gone too far.

## Those "National" Frequencies

The "May Meetings" of the International Union of Broadcasters will be of unusual importance in that they will not only fix a new broadcasting wavelength plan, but also determine the future of the Union, if any.

I myself do not share the pessimistic view which even some of the B.B.C. delegates admit, because I think that self-interest in the last resort will induce the various broadcasters to keep the Union going. But, of course, the B.B.C. will not have an easy time justifying the retention of the "national" wavelengths in regions, such as London's 261 metres channel.

The weakness about these is that they are not used enough. The full-blooded contrast policy formerly promised has been largely modified. Therefore it is clear that the best

Britain can hope for from these new wavelength meetings is the preservation of the *status quo*.

And afterwards there will have to be a reshuffle in this country to try and cope with such chronic problems as the Highlands, Wales, Newcastle, and Northern Ireland.

## The B.B.C. Moves to the Right

For years past the B.B.C. has been suspect in high Tory circles of "left-wing tendencies." Every time there was an interesting political discussion in which Socialism or mild Communism had a go, there would be a scream from masses of colonels in Bournemouth

it must not exclude either left or right views; it must keep the ring fairly between all sincerely held views. But, anyway, watch the B.B.C. move to the right and get steadily safer.

## Television Difficulties

The Post Office and the B.B.C. engineers do not see eye to eye about television. The latter want to start experimenting with several foreign systems in addition to the Baird process; but the former feel that the Baird process should be given a further exclusive run—at least, until another system can be definitely demonstrated to be superior.

## RADIO IN 1840!

*This historic apparatus was used in a broadcast from the American station WJZ when Joseph Henry's pioneer experiment on the transmission of electro-magnetic waves was re-enacted for the benefit of listeners.*



or Cheltenham, not to mention the stauncher newspapers.

Well, the new Governors have determined to eradicate even the appearance of "revolutionary" views. Viscount Bridgeman has leaped into the breach, and I can vouch for the "safety" of broadcast opinions in the next two or three years.

I wish I could be as confident about their interest, for, as Mr. John Buchan so shrewdly observed in the Commons debate on broadcasting, if the service is to be a real live force in the nation,

Anyway, whatever happens about this argument, it is universally agreed among experts that the days of the 30-line picture are numbered. If television is to become a service it will have to be with pictures of from 130 to 180 lines fineness. And it is significant that nearly all the television research labs. are working in this direction with ultra-short waves.

The Baird people, of course, have an enormous advantage in their German connection. The allied company there is far and away ahead of any other in the world, and has

## B.B.C. News—continued

wisely refrained from claiming broadcasting time until sufficiently advanced to be sure of success.

### The Sunday Gaps

The silent period between 6 and 8 on Sundays is shortly to be filled by a re-timing of the afternoon programmes. This will help the Press in their campaign against the sponsored programmes from the Continent on Sunday evenings.

It should, moreover, be welcome to millions of listeners for whom Sunday is obviously the best time of the week. I hope the extension will be in terms of the lighter musical fare which can be put over consistently with the B.B.C. Sunday policy.

this public that wants and ultimately will insist on having appropriate entertainment alternatives to the broadcast religious services on Sundays.

### Selling Radio Jointly

The Radio Manufacturers' Association is disappointed at the refusal of the B.B.C. to subscribe £25,000 towards a fund for joint publicity, to sell radio sets, programmes and licences.

It is a pity that co-operation of this kind does not seem possible.

The reasonable way to go about it would be by a three-cornered agreement between the B.B.C., the Post Office, and the R.M.A. The Post

casts, has set up a special department to deal with them, Mr. Bowker-Andrews being in charge, advised by Mr. Christopher Stone. Every now and then there is a suggestion that certain gramophone companies, perhaps inadvertently, get more than their share of other references; but there is no foundation for such charges.

And now with its own gramophone library and staff specially detailed, the B.B.C. will be in a stronger position to disprove the allegations.

### A. J. Alan

A. J. Alan, the inimitable B.B.C. raconteur, is a man of versatility. In his right name he holds a very hush-hush job in an office securely hidden away.

He is an experienced wireless amateur transmitter, both in Morse and by broadcast. His life has been filled with rare excitements and hair-breadth escapes, compared with which the most adventurous of his tales are tame. He is an authority on good eating and on rare wines.

And now he has risked broadcasting to the Empire, appearing himself for all zones. And he has made good with a bang. He was heard clearly in Yukon, Tasmania, Ceylon, Malaya, New Zealand, South Africa, Kenya and India.

### Studio Insulation

Defective sound insulation of studios at Broadcasting House has been causing the engineers some anxiety. The sound of dance band music has broken in on the philosophic calm of serious talkers, to their horror and amazement.

So important structural alterations are in progress to cure the defects, and the professors can rest assured that before long their ears will not be profaned.

### A Roof Garden at B.H.?

Many members of the B.B.C. staff would like a roof garden on the top of Broadcasting House, and the proposal is under review. It is felt that those who have to work in the tower, where both light and air are artificial, should be provided with the opportunity of getting an occasional breath of fresh air.

Also a roof garden would add to the interest and amenities of the place.

### THREE PROGRAMMES ON ONE AERIAL



These three transmitters can work simultaneously from one aerial, without mutual interference. The system has been perfected by the Intelligence Section of the U.S. Army.

As to entertainment alternatives to the religious services, this has not yet been grappled with, but the problem is obviously one which cannot be dodged permanently. As long as the B.B.C. felt itself dependent on the goodwill of the clergy and ministers, there was an expediency argument against providing entertainment alternatives to religious broadcasts. But this dependence, if it ever existed, certainly does not now.

The B.B.C. depends on the goodwill of its vast listening public, and it is

Office has a definite financial interest in selling more licences; the B.B.C. obviously wants both to sell its programmes and to encourage people to take out licences, while the trade, of course, wants to sell new receiving apparatus and components.

Perhaps the Post Office and the B.B.C. will reconsider the matter in the light of self-interest.

### Gramophone Broadcasts

The B.B.C., recognising the growing importance of gramophone broad-



# YOUR OUTPUT

By VICTOR KING

*How has all the excitement about the recent important developments in radio technique affected the home constructor? In this thoughtful article our popular contributor discusses this and other aspects of getting the best possible results at the lowest possible cost.*



THE last month or two has seen an extraordinary number of radio developments introduced to the public. First there was Q.P.P., and that had hardly got into its stride when "Class B" valves sprang into prominence.

This was followed by urgent murmurings and rumours about extraordinary things like double-tetrode triodes and high-frequency pentodes.

In the meantime, "cold valves" and compensating transformers consolidated their positions.

### Feeling Bewildered

Yes, there certainly has been no lack of novelty in radio, and those who wrote and spoke of "finality" have been made to appear very poor prophets.

Now, how has all this excitement affected the home constructor? I fancy he must feel rather bewildered. And I am still wondering how many have attempted to take immediate advantages of all these improvements, and, on the other hand, how many just plug along with their old, old sets and let the march of progress pass them unheeded.

It is great fun trying every new thing as it comes out, although it is rather an expensive hobby. Again, it is instructional, fascinating and satisfying to one's vanity always to be right up to date.

### In the Long Run

Nevertheless, it is doubtful whether topicality of this nature enables the constructor to get the best out of radio. In my opinion, it is the man who always lags a little behind, exploring to the full the possibilities of each new line of thought before proceeding on to the next, who achieves most in the long run.

That may sound very reactionary to some of my readers, and so I will "amplify" in order to justify that statement.

There is nothing so forceful as a

practical example, and I am able to quote an excellent one from personal experience.

I have a friend who is always right up to date. He is almost a fanatic in that respect. No sooner has a new thing been announced than he will make every effort to get it into his set.

He will also soak himself in all the literature concerning it so that he can talk glibly at great length about it.

If the development is such that he must build an entirely new set in order to take advantage of it, he will at once proceed to tear his existing super-de-luxe "five" ("six" or "seven," or whatever it happens to be at the moment) to pieces so as to

### FOR BEST RESULTS



*As Victor King remarks, the constructor who "makes haste slowly" by hotting-up his set, even though it is a simple one, usually scores over the man who rapidly changes from circuit to circuit.*

use as many of the bits as possible in the new outfit. Of course, when Q.P.P. came along he was on it "like a bird." He must assuredly have been the very first constructor in his town to have "push-pushed."

I had to go round to his house to hear the marvellous contraption. He would have dragged me round by force, if necessary.

"There," he said proudly; "what do you think of that? Fifteen hundred milliwatts of output and only about fifteen milliamperes of H.T.! One milliamperes per hundred milliwatts in a set using five valves! Marvellous! A darn miracle! Don't you agree?"

I listened critically for a few

minutes and then ventured a few non-committal observations. Finally, I took him to my house and asked him to listen to one of my sets.

He did so, and although he failed to condescend further than admitting my volume and quality equalled his, he definitely did endorse equality when pressed.

### Suspecting a Trap!

"Now what power output do you think I have with that little household outfit?" I inquired.

Subsequent to much concentration and considerable unease (he obviously suspected a trap!), he said:

"Oh, about a watt and a half, I suppose."

Actually, the output was less than half a watt, a mere four hundred and sixty milliwatts or so.

Having learnt this, my up-to-date friend was amazed. "But you must have spent a lot of time hotting it up," he remarked.

That is just the point. I always spend a lot of time "hotting-up" a set. It is worth it. It is a case of "making haste slowly," and places you well ahead of those who leap from novelty to novelty and never stay at one point long enough to make the best of it.

### Available Power

Where did I score so heavily, comparatively speaking, over my friend in regard to the two sets in question, the one using Q.P.P. and such modern devices, and the other a quite straight set employing "last year's" technique?

I'll tell you, but first I must make it plain that this is no indictment against Q.P.P. I have also a set using Q.P.P., and just lately have installed one with "Class B" in it, but at the time of writing both are still subject to final "hotting-up."

In brief, I was making much more of my available power. The speaker was a "senior" type of moving coil,

*(Please turn to next page.)*

\*\*\*\*\*  
 \* THE WHYS AND \*  
 \* WHEREFORES OF \*  
 \* TRIMMING \*  
 \*\*\*\*\*

MANY constructors fight shy of employing ganged condensers because of an ill-founded apprehension that "trimming" presents difficulties.

If, however, it is borne in mind why a ganged condenser has to be "trimmed," the process becomes merely one of putting something right which is known to be wrong.

Any receiver which employs a normal ganged condenser must also possess one other essential feature. All the coils which the sections of the ganged condenser tune *must be electrically identical*—that is to say, any one coil must have exactly the same inductance as all its fellows.

**Theory and Practice**

By a *normal* ganged condenser is meant one in which each section has exactly the same capacity at any setting of the dial as all the other sections.

As everyone knows, a tuned circuit consists essentially of an inductance (coil) and a capacity (condenser). If the inductance does not vary, the circuit may be "tuned" to a variety of wavelengths by altering the capacity of the condenser.

It follows, then, that if all the coils in a set are identical and all the sections of a ganged condenser remain equal wherever the dial is set, that condenser can tune the coils simultaneously to a range of wavelengths.

So much for theory—now for practice.

If an attempt is made to employ similar coils in a receiver which utilises a normal ganged condenser, it is found that a very insensitive arrangement is the consequence. Due, as investigation soon shows, to all the coils *not* being tuned to the same wavelength.

**Equivalent Results**

The reason for this is that incorporating the coils in a receiver has caused each of them to have a small fixed capacity inadvertently connected across it which is not the same in the case of each. So the result is equivalent to the sections of the ganged condenser having been made dissimilar.

Obviously, if the accidental capacities across the coils could be made equal, then each coil would be tuned by an identical capacity.

**"Accidental" Capacity**

This is the purpose of trimming. Each section of the ganged condenser is equipped with a little preset condenser.

The aerial coil will have a relatively large "accidental" capacity across it. Secondaries of band-pass tuners and coils coupling one S.G. valve to another should have exceedingly small "accidental" capacities across them. The coil preceding the detector will have an "accidental" capacity on the large side, but not generally as large as has the aerial coil.

The trimming presets *add* capacity, so, to create equality, you start by slackening off completely the one across the section of the "gang" which tunes the aerial coil. This coil then only has its "accidental" capacity.

Tightening up the presets on the other sections will then cause those coils to have capacity added and the addition should be enough to make the total in each case equal to the aerial coil's "accidental."

By listening to a weak station this is quite easily done if it is remembered that a relatively small addition is required in the case of the coil in front of the detector. All other coils will require larger and almost equal "trims."

**YOUR OUTPUT**

—continued from page 17

with an electro-magnetic field, and it was very, very carefully matched through a first-class six-tapping input transformer.

H.T. values and grid bias had been arrived at after careful experiment, in addition to close observance of the valves' "rules of use."

There was an extremely careful selection of parts (and valves) in, particularly, the L.F. stages of the set.

In short, everything that could be done to make the most of the available energy had been done.

The result was that the outfit gave results out of all proportion to its size and cost as judged by what the majority of constructors achieve.

It might be said that I have skill that all do not possess, and therefore

ought to get more out of a given circuit than the majority.

May be so, but I fancy everyone, without exception, could "hot-up" their sets and obtain more for their money if a few general rules were widely adopted.

It isn't just "hot air" to suggest that a good "senior" type loudspeaker may be worth "almost another valve." It is plain fact.

Instead of spending cash on buying new set devices to tack on to the same undersized, little permanent-magnet speaker, it can easily be a better proposition to go for a bigger and better speaker first.

And this "loudspeaker matching" that is so much talked about is worth while, believe me. Building up the qualities of an existing set can often give you a greater return than the installation of a new set.

Now, you pundits, tell me I am reactionary!

**FOR THE CONNOISSEUR CONSTRUCTOR**

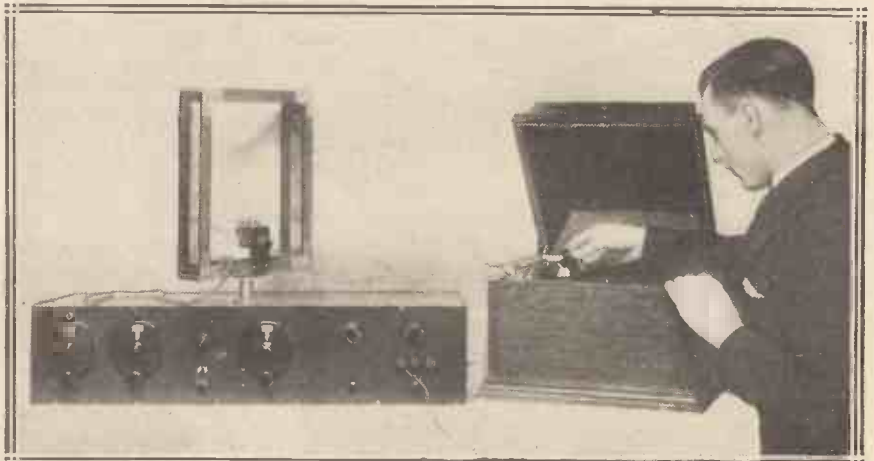

This is one of the really elaborate types of sets to which Victor King refers, it being capable of giving great volume and many programmes with a small frame aerial, although designed several years ago.





# From My Armchair

by "S.T."

WELL, it's come at last. Of course, I knew it would. In the words of the old song, "It was bound to happen in the end."

The only doubt I had in my mind was where it would come from. Such places as Pontypridd, East Grinstead, Cheam, were far too obvious. I toyed with the idea that it might arrive from Bubwith, Wormshill, Gidding, Tackley, Tickhill, Crank, Congleton—or even Fangfoss, Pocklington, Pathead or Penicuik.

All these residential quarters may be ferreted out on my zone maps by any industrious bloodhound desirous of discovering whether I have concocted some of these names.

## The Letter

Actually the letter came from Papplewick:

*Dear Sir,—I have read all the glowing guff from various places from one end of England to the other, but I haven't seen any letter from Papplewick. You yourself didn't come here on your tour, and no wonder. You're clever, I'll grant you that—far too clever to come to Papplewick. You knew it was a blind spot, and kept as far away as possible! Do your stuff down here, and I'll build your set. Or let's have some letters from Papplewick and I'll think about it.*

*Yours faithfully,*

J. R.

*P.S.—Don't think because we live in Papplewick we can't smell a rat.*

*We've smelt plenty.*

Too bad! I'm glad now I didn't go.

\* \* \*

I have received an extremely intelligent and interesting letter from "A Spinster," who adds after her signature ("Not so dithery"). I hope Miss Gwendoline Logan-Bell, of Brighton Road, Worthing, will forgive any apparent hint of patronage in my remarks, but I must confess to some surprise at the very obvious theoretical knowledge and practical skill revealed by her letter.

I always had the idea that wireless

smiled about it, although it was a pretty wan smile in many cases.

May I plead with my readers to remember the helpmeet sometimes, and arrange "leave-the-thing-alone" evenings?

It's always worse for the listener. Often when I have gone up as a passenger in an aeroplane I have been air-sick, but when I have the joystick in my hand and my feet on the rudder-bar it takes a lot of tossing to make me turn green.

The same applies to wireless. Going from station to station, a scrap of this and a scrap of that, with a few squawks thrown in, are all part of a wireless man's paradise. To the woman he promised to cherish it can be sheer agony.

## Do You Know Her?

I should like to hear of a keen wireless wife who owns a husband who hates the darned thing. Do any readers know of such a case?

Of course, I don't think we men ought to encourage muscling in on our territory. How many of us have blushed becomingly at the words, "How does it work? Of course, I'd never understand it. You must be awfully clever being able to . . . , etc., etc."

I was sixteen when I first heard these words. She was an adorable creature. Fair hair and green eyes. I was proud of my transmitting station (pre-war, of course). She had her back to me, and must have been fingering the polished aluminium

*Brilliant and provocative, as usual, Mr. John Scott-Taggart deals this month with a wide variety of unusual and interesting topics ranging from Papplewick to snakes.*

construction was exclusively a male prerogative. But women are practical creatures (far more so than romantic man, whatever they may say in "Home Chat"), and there is no reason why they should not become wireless fiends.

## A Wan Smile

I have met many wireless widows, and it has given me a new faith in the patience and tolerance of women. Eight out of ten hated their husband tuning-in, oscillating, squawking, never content with one programme. Two seemed to enjoy it. But all

## "Like a Chinese Sea-Shanty"

spark-gap. I pressed the tapping-key so that she could see the spark. Instead, she felt it. She is now married to a man who sells cotton.

\* \* \*

Miss Logan-Bell, working at odd moments, took three days to assemble and work the "S.T.400." "The first evening stations rolled in one after the other to the point of embarrassment, and have still continued to do so, even on 'bad' nights. . . . Finally, let me thank you for a set which, at a reasonable outlay, enables me to enjoy international broadcast reception at a volume and quality which cannot be beaten by any four-valver I have heard, nor by many multi-valve superhets."

### Unusual Appreciation

And now here's a letter from Miss Doris Williams, of Lamont Road, King's Road, Chelsea. I am not sure whether it is sarcastic or not. She says:

*If your "S.T.400" is for distance, the farther away it is from my young man the better. I have to hear "S.T.400" from the time he meets me each evening until he goes home. The "S.T.400" in my boy's opinion is the greatest piece of construction he has come in contact with; he has converted his "S.T.300" and now has the "S.T.400." I myself know nothing about wireless, but I feel that I must congratulate you on a wonderful piece of work.*

This is the most unusual appreciation yet received, and the most flattering. We may yet have children, fearing neglect, crying to their fathers: "Don't go building the 'S.T.400,' daddy." But I am brought quickly to earth by the following from Woolwich:

*Ho why Ho why did I alter my "S.T.300" to the "S.T.400," for it is nothing like what you make it out to be, for I am making no excuses for bad aeriels, and when the couplers are both shut up I.E. in the middle you cannot get the set to oscillate but when one's inside the other you can. I should like to say this in the "S.T.'s" favour—it will work all right on 6 milliamps. But Ho why Ho did I ever change?*

Yours faithfully,

*P.S.—I am not connected with any wireless firm.*

I am not surprised.

This letter, which opens and ends like a Chinese sea-shanty, means well,

but it is very difficult to advise in such cases.

### Of the Old School

When 217,000 have read my "S.T.400" article, I naturally get some queer letters. Obviously, it is only the specially interesting or odd letters that receive special notice in these columns.

I have received, by the way, a delightful ten-page letter from a keen constructor. It is written, I

### BRIGHTON GIVES THE LEAD



Successful experiments were recently carried out by the Brighton Police Force to determine the practicability of radio communication between headquarters and the mobile units. Here we see one of the mobile police officers actually receiving a message.

imagine, by a rather frail gentleman of the old school. "I deplore the tone of some of the letters you receive. Frankly, gentlemen do not write such letters, even if they disagree; and you deserve well of all readers. . . . It must be the arm-chair influence again!—so friendly—it has caused me to write so intimately to a stranger; how old-fashioned people would have censured such freedom of address!"

The calm, yet nervous, writing of this invalid old gentleman, who still feels a passionate love of music and an interest in the technical side of wireless dating from 1906, when he rang bells in the house by means of a spark-coil and coherer, makes me feel that I do sometimes manage to establish some sympathetic contact with readers.

### A Personal Friend

He apologises for his writing. "I tire quickly when I write much." The writing is firmer when he begins the day, and in two or three places it straggles to a shaky ending. The letter was so obviously an effort to write, and yet, "Reading your friendly conversational articles month by month makes you seem like a personal friend; and, forgetting that I am unknown to you, I feel I want to reply, as it were, from my armchair."

\* \* \*

How would you reply to a letter like this:

*I can't get eight never mind ninety-eight stations on this "S.T.400" of yours. Where do you set your aerial preset? It makes no odds to the whistle which condenser is trimmed. I've tightened up the neotrodyne condenser across the loud-speaker until the head comes off and I can't get no more stations.*

*A pal of mine says the binocular coil ought to be on the other side of the screen but it only makes a loud rushing noise so I put it back. My grandmother says it's the best set she's ever seen. No matter where you set anything you just get North Regional.*

*What troubles me is that when I touch the potentiometer across the transformer it goes pop, pop, pop. All my pals do the same.*

What queer sort of friends. From the symptoms described, I have come to the conclusion that you are attempting to father me with some other designer's technical offspring. It sounds like a set faultily built from a 1925 design from some other journal. Try the "S.T.400."

\* \* \*

News from the broadcasting centres: This is a new feature which I am introducing in these notes. Interesting things often happen—especially abroad—at places famous

(Please turn to page 55)



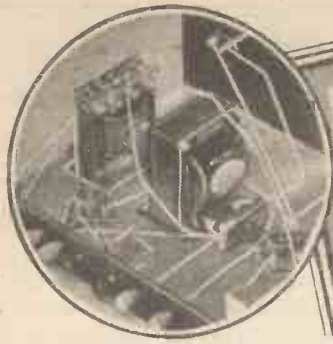

# PUSH-PUSH PARTS



The new developments in low-frequency amplification—Q.P.P. and “Class B”—call for special components and circuits. Here you will find invaluable data covering the various makes and types of push-push components at present on the market.

THE popularity of push-push amplification—or “Quiescent” and “Class B” circuits—has steadily grown during the few months it has been in use in this country, until it has become the main topic of conversation in radio circles.

### Difficult to Keep Pace

So rapid has been the spread of this type of amplifier among home constructors, in fact, that it is difficult to keep pace mentally with the movements of the component manufacturers making special Q.P.P. and “Class B” parts.

As you will be aware, special input transformers are essential for the proper working of both Q.P.P. and “Class B” amplification; the former needs a high ratio step-up component and the latter a low ratio step-down type. In addition, they both need suitable output chokes or transformers to couple the valves (in “Class B” there are two valves in one envelope) to the loudspeaker.

### Using a Choke

Sometimes the output transformer can be fed direct into the speaker’s “speech windings,” and sometimes in order to match up properly it has to be fed into a second transformer on the loudspeaker chassis.

In such a case as this latter it is possible to use an output choke or auto-transformer instead of a full-blooded two-winding transformer; but we shall say more about that later.

Incidentally, the use of these two related forms of amplification

necessitates various resistances and capacities in the circuit, as you will see by studying the “Push-Push Five,”

### A FAMOUS MAKE



A first-class quiescent input transformer, the A.F.11c, which has an inductance of over 40 henries at 2 milliamps.

described in this issue by Mr. Scott-Taggart; and in the case of “Class B” a special valve holder is also required.

But these can be looked on as incidentals—important without doubt, but not bearing any features that require special elucidation.

What do need further explanation are the “umpteen” transformers and chokes that have made their appearance during the last few weeks, and whose number is still increasing.

### Salient Facts

I am not going to bore you with a spate of technical data, or lists of figures, but I do want to point out one or two salient facts that have to be considered when choosing parts for a push-push circuit.

It is essential to the successful operation both of quiescent push-pull and of “Class B” amplification that the proper components be used. The input transformers must be suitable, while the output circuit must be such that it will enable proper matching between the valves and the speaker to be carried out.

### From the Speaker End

I am going to work backwards here, and consider the amplifier from the speaker end first. There are two possibilities—either you, who are supposed to be considering the building of a set or amplifier using one of these systems, have a loudspeaker which you want to use with it, or you are going to purchase one.

If the former is the state of affairs, you must use a choke or transformer between your set and the loudspeaker (whether or not this latter has a transformer already on it, unless it happens to be a special Q.P.P. speaker).

If the latter case holds, then you can either buy an ordinary speaker and use an intermediate

### COMPONENTS FROM THE VARLEY RANGE

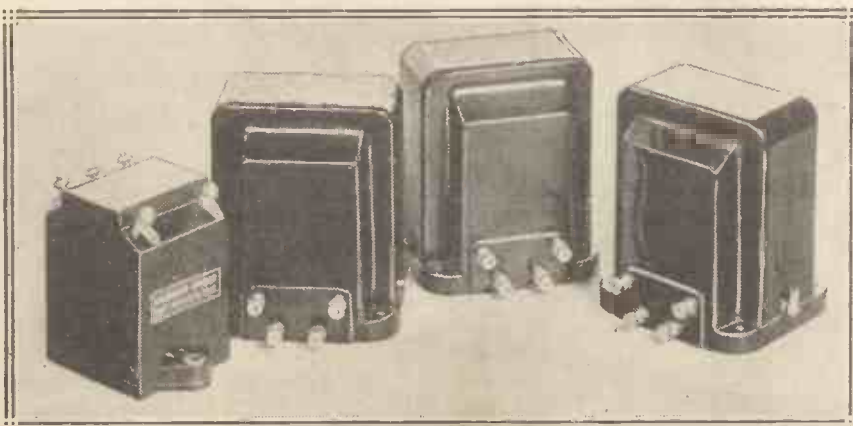

Four components from the Varley factory. On the left a Q.P.P. input transformer and to the right three of the special output models.





## Push-Push Parts—continued

Ferranti, the prices being 15s. for the O.P.M.12c, and 26s. 6d. for the O.P.M.13c and the O.P.M.11c. The first-mentioned is suitable for either high or low resistance speakers *without* "built-in" transformers, and gives ratios of 1.7 and 40 to one.

### Manufacturers' Choices

The O.P.M.13c is for speakers with "built-in" transformers and has ratios of 1.7, 2.7 and 4.5 to 1, while the O.P.M.11c is for low-resistance speakers which have no "built-in" transformer. The ratios are 35, 56, and 100 to one.

The other manufacturers who have gone in for "push-push" parts have pinned their faith to auto-transformers or tapped-output chokes. These include Varley, Sound Sales, Radio Instruments, and Multitone.

Multitone (Puchoke) 1:1, 1.5:1, and 3:1. Thus all three makes are suitable for either high-resistance speakers, or low-resistance types (moving coils) with transformers on board.

I believe other makes are on their way, but the above completes the list of those available at the moment. The same transformers and chokes are



"Class B," though the choice of component is quite easy. Let us deal with Q.P.P. first.

Here, again, inductance of the primary is important, and the higher the inductance at the current likely to be passed through the winding the better the probable results—always provided that the high ratio between P. and S. has not resulted in a high-capacity secondary. This we need not fear in a reputable make. Ratios vary between 1:8 and 1:10. I favour the highest ratio for radio purposes, as it enables the output valve grids to be fully loaded before the ratio input to the detector becomes excessive.



The popular-priced Ferranti input transformer, type A.F.12c, has a 1:9 ratio. To the right is an output model for low-resistance speakers with incorporated transformers—the Ferranti O.P.M.13c.



Here are the two R.I. Q.P.P. parts. On the left is the type "Q" input transformer, and on the right the D.Y.35 four-ratio output choke.

The first-mentioned has three chokes giving ratios of 3 and 42:1; 3 and 50:1; and 3 and 75:1, known as the D.P.37, 38 and 39 respectively. The prices are 18s. 6d. for the former and 16s. 6d. for the latter two.

The ratios provide one for "built-in" transformer speakers in each case and the other for the "free" low-resistance speaker, the Varley choke being connected direct to the speech winding.

### Others on the Way

R.I., Sound Sales and Multitone have one universal choke in each case. The prices are 12s. 6d., 10s. and 9s. 6d. respectively, and they provide the following ratios: R.I. (D.Y.35) 1:1, 1.4:1, 2:1, and 2.8:1. Sound Sales (O.P.Q.) 1:1, 2:1, and 3:1.

used for "Class B" amplification, the impedance load required being about 6,000–8,000 ohms for "B" valves.

When we consider the input transformer we have to separate Q.P.P. and

### Inductance—and Price

I am assuming that no intermediate L.F. stage is used. Should this be included, however, there is no need for the highest ratio.

The same manufacturers (again with others on the way) provide the required input transformers. Ferranti have two, Radio Instruments one,



Multitone's include a tone-control input transformer in their "push-push" range, three of the four "quiescent" components manufactured by this firm being shown above.

## Push-Push Parts—continued

Varley one, Multitone two (one for tone control "Puco" and the other—P.U.1:8—a "straight" one), and Sound Sales have one.

Here are the inductances of each, with the price and ratio to help you to choose. Ferranti: A.F.11c, ratio 1:10, 50 henries at 0 milliamp. dropping to 25 at 10 milliamps. In most cases, where between one and two are flowing, the inductance will be above 40 henries; price 34s. A.F.12c, ratio 1:9, 30/15 henries—0 to 6 milliamps., and price 15s.

### Special Valve Holder

The Radio Instruments' transformer is the "Q." type, ratio 1:8, inductance 30-16 henries—0-2 milliamps., price 16s. 6d. The Varley model is the D.P.36. It has a ratio of 1:9, inductance of 27 henries at 2 milliamps., and costs 17s. 6d.

Multitone figures are as follow: Tone control model "Puco" has a ratio of 1:8, inductance of 30 henries at 2 milliamps., and costs 17s. 6d. The "straight" type is the P.U.1:8 which has the same ratio and inductance figures, but costs 15s. Then there is the D.4, ratio 1:9, inductance 40 henries at 2 milliamps., price 17s. 6d.

Finally, the Sound Sales' product. This is the S.S./P.P.9. It has a ratio of 1:9, and the inductance is 30 henries at 2 milliamps. The price is 15s.

So much for the Q.P.P. parts; now for those input transformers—or "drive" transformers—used for "Class B" amplification. Incidentally, a special 7-socket (only 6 are used with the present "B" valve) valve holder is required for this system.

### Performances Differ

The "drive" transformer has to have either a low ratio of step-down variety, or a ratio of 1:1 as generally chosen for the Cossor valve, at present the only one available, though different designs may be required for other makes.

There are several makes of this transformer of which I have had experience so far, but others are well on their way, I know. Those makes are the Benjamin, Multitone, Lissen, Varley, Lotus, Ferranti, Sound Sales, and Radio Instruments. Similar ratios are employed, though the performances differ somewhat.

The prices rise from 9s. 6d. to 17s. 6d. or more, and the primary inductances of the early models submitted read as high as 30 henries in some cases.

### FOR THE OUTPUT CIRCUIT



The Ferranti output transformer O.P.M.11c, a high-grade "push-push" component.

In "Class B" drive transformers it is of paramount importance that the secondary resistance be low, 100 ohms per section being a usual figure. Quite considerable A.C. grid current flows when the "B" valve is all out, a matter of some 10 milliamps. being present when the output wattage is at the maximum.

Primary inductance is as important as it is in Q.P.P. transformers, but it must be remembered that in the case of the "Class B" type, the primary current will be higher than is the rule for quiescent push-pull. So it may easily be understood that the design

of a good transformer which is to carry a not inconsiderable primary D.C. current, and at the same time a large secondary A.C. current, is by no means an easy matter.

At the time of writing the system of amplification is still somewhat in the embryo stage so far as it concerns this country (though it has been known in America for some time), so it is early to give any definite data either of the transformers or of the special "B" valves that are used.

I might mention, however, that I have just received a special Lissen drive valve for use with their Class B transformer, whilst Mullard and Osram have already given details of their "B" valves. The other leading valve makers will no doubt be ready shortly.

### No Matching

Perhaps a few words should be said about the valves. In Q.P.P. two triodes or pentode valves of matched characteristics have to be used, and they are biased to their bottom bend points.

"Class B" requires a special double valve, costing 14s. and needing no anode current matching (a most important and valuable feature) and no grid bias. It gives, incidentally, a maximum "undistorted output" wattage in excess of that available by the Q.P.P. pentodes, with an output stage quiescent anode consumption of a little less.

It is, therefore, possessed of greater advantages than Q.P.P. except that it requires an intermediate "drive" valve between the detector and the output valve, with, of course, its additional anode current.

### LISSEN'S LATEST MODEL



Messrs. Lissen have also entered the field of "quiescent" components with a "Hypernik" input transformer having good inductance figures, while a tapped output choke is also available.





# A PRACTICAL MAN'S CORNER

By R. W. HALLOWS, M.A.

**A**BOUT three years ago I described in these notes a very useful type of screwdriver provided with a device for gripping firmly the screw to be driven in. It was a foreign-made article and the demand for it proved to be so large that it rapidly became unobtainable. I have since been looking for something else of the same kind, and recently I found at Woolworth's the one illustrated in Fig. 1. Ingenious and effective though the little tool is, its price is only sixpence and it is very well worth the money.

### How It Works

About two inches behind the point of the blade, the shaft of the screwdriver is threaded. On this thread travels a knurled nut to which are fixed four spring leaves or "grippers." A sliding collar can be moved up and down over these. With the collar slid back towards the knurled nut the grippers open as seen at A in Fig. 1.

Slipping the collar down in the direction of the point of the blade closes them like the jaws of a chuck, as shown at B. One of the advan-

### FOR AWKWARD POSITIONS

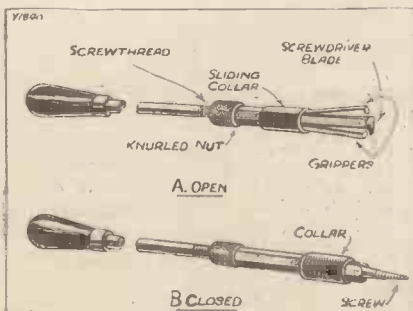

Fig. 1. A screwdriver of this kind should find a place in every radio workshop. The screw head is inserted between the "grippers," and the collar is then moved so that the screw is held tightly in place. It is an ideal tool for fixing screws in otherwise inaccessible positions.

tages of the design is that the grippers can be made to fit any size screw in a moment.

Open them, place the point of the blade in the nick of the screw and then turn the knurled nut until the grippers are in the required position.

Into these pages, month by month, our contributor packs a wealth of practical information and advice on constructional work. The regular reader of this "Corner" cannot help picking up a more or less complete training in radio workshop practice, while every month there are wrinkles to read, gadgets to make, and hints to help you.

Sliding the sleeve forward now causes the screw to be held in a vice-like grip.

Every constructor knows how difficult it is sometimes to start a wood-screw in some awkward corner, when it is desired to fix a component to a crowded baseboard or to do some other rather fiddling wireless job.

### Facilitates Constructional Work

Curiously enough, the designers of not a few modern components seem to take fiendish delight in placing the lugs for fixing screws in difficult positions! With the screw-gripping screwdriver any little job of this kind is done in a trice. The position may be so awkward that you cannot even get at it with the bradawl to make a hole for the screw.

Provided that the baseboard is of soft wood this does not matter if the screw is firmly held by the grippers, and once it has been passed through the hole in the lug a little force will persuade it to make its own way into the wood. As soon as it has been given a fair start the screw should be released by moving the sliding collar

upwards. It can then be driven home without any difficulty at all.

### Screwdriver and Spanner

A particularly handy kind of box spanner is that illustrated in Fig. 2. The business end of this is of the usual hexagonal shape to fit over the nut, but the other end is flattened so as to leave an opening into which the point of a screwdriver's blade is a comfortable push fit.

These spanners are easily made from pieces of stout brass tubing  $\frac{3}{4}$  to 1 in. in length, according to the size of the nut for which the spanner is intended. The business end is shaped as previously described by hammering round a nut. The other end is drawn in by flattening it out with the hammer.

### Some Uses

This box spanner is not intended for heavy work, though it is quite strong enough to enable small nuts to be well tightened up.

Its usefulness will be readily appreciated. It enables you to get at nuts which are too deep down in the set to

### SOLVES MANY DIFFICULTIES

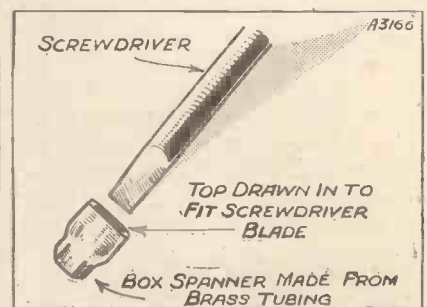

Fig. 2. Here is a handy box spanner that can easily be made from an odd piece of brass tubing. The hexagonal end is shaped by hammering the tubing round a nut.

## A Practical Man's Corner—continued

be reached with the ordinary shortish box spanner or the pliers.

Fit it on to the end of a long screw-driver, and you have a spanner that will reach the most deeply-seated nut likely to be encountered, either in the

### COMBINES "RADIO" AND "GRAM"

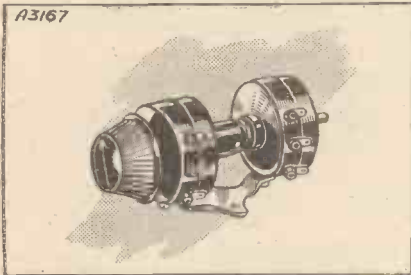

Fig. 3. Having two volume controls ganged together in this fashion saves an extra knob on the panel, and is worth knowing when modifying an existing set.

construction of wireless apparatus or in dismantling old sets.

### Volume Control Suggestion

When you are making up a new wireless set it is always as well to bear in mind that it will very likely be used, with the help of a pick-up, for the reproduction of gramophone records. In most up-to-date sets provided with volume controls the high-frequency amplification is regulated by means of a potentiometer, which adjusts the screening-grid voltage of ordinary S.G. valves or the grid-biasing voltage of multi-mus.

But with the pick-up in use the high-frequency valves are naturally not in action and the ordinary volume control is, therefore, ineffective. It is rather a nuisance to have an additional volume control outside the set, and nobody wants to add an extra knob to the array upon his panels.

### Dual Purpose Component

By far the most satisfactory method when you are building a new set, or converting an existing one for use with a pick-up, is to use a two-gang potentiometer operated by a single knob as seen in Fig. 3. One of these potentiometers (P1 in the skeleton circuit diagram) is used for controlling

the magnification of the H.F. valve. In the diagram it is placed across a grid-biasing battery, G.B.1, and is shown regulating the grid voltage of a variable- $\mu$  valve,  $V_1$ .

The second part of the gang is wired across the pick-up terminals, the sliding connection going to the "gram" terminal of the radiogram switch.

Consideration of the simplified circuit diagram will show that only one half of the ganged potentiometer is in action at a time. With the switch in the "radio" position only P1 is in use, P2 being thrown automatically out of operation. It is well to have

### USES A "GANGED" POTENTIOMETER

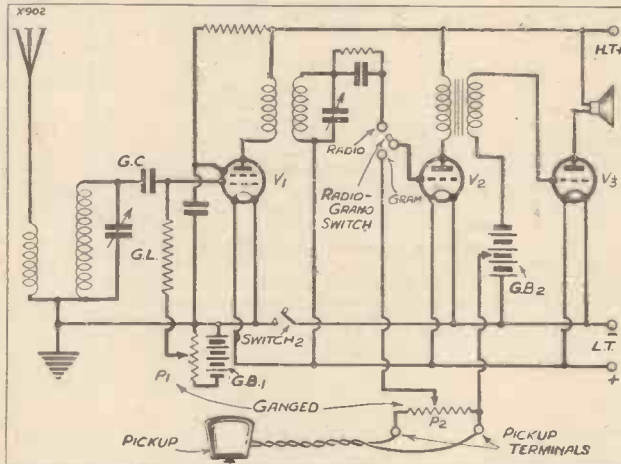

In this circuit the two potentiometers, P1 and P2, controlling the variable- $\mu$  valve and pick-up respectively, are operated by one knob.

a switch (switch No. 2 in the diagram) for cutting off the filament supply of the H.F. valve when the pick-up is being used. This switch may be ganged with the radiogram switch.

When the latter is turned to the gramophone position, P1 has no effect on the volume, but P2, the second half of the ganged potentiometer, controls it to a nicety. Thus only one knob need appear on the panel for the control of the volume during either wireless or gramophone reproduction.

Switch No. 2, by the way, has two good deeds to recommend it. First of all it saves current and prolongs valve life by cutting out  $V_1$  when this valve is not required; secondly, it completely eliminates the faint background of wireless that is sometimes heard if the high-frequency valve is not given a holiday whilst the pick-up is in use.

### Scissors for Nuts

Probably you have been driven almost to distraction at times over the problem of starting a nut, either hexagonal or of the milled terminal variety, in some spot that cannot be reached by any ordinary means. You may just be able to place it on the end of the male-threaded shank with your fingers, but as sure as fate it falls off and generally hides itself most effectively beneath or behind anything that it can find the moment you try to give it that little half-turn which should start it on its way.

A great many constructors have probably worked out their own pet methods of overcoming this irritating trouble.

### Easily Carried Out

Fig. 4 shows a tip which I have found useful on innumerable occasions. Grip the nut with a pair of scissors by placing the end of the finer-pointed blade just inside the hole whilst the point of the thicker blade rests on the exterior of the nut. You can hold it quite firmly in this way, and you will find it easy to make it start. Once it has taken a grip of the male thread a box spanner will do the rest.

### A USEFUL HINT

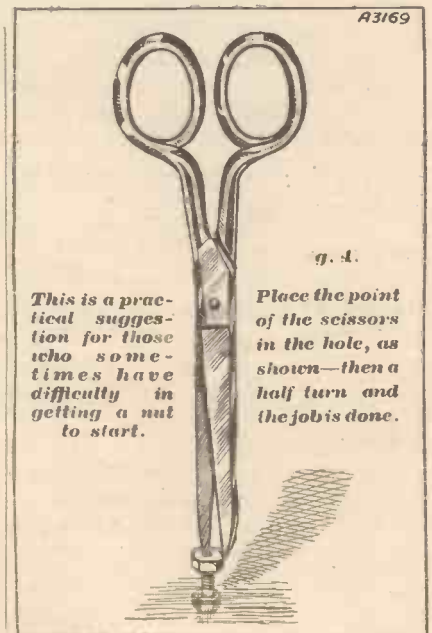

This is a practical suggestion for those who sometimes have difficulty in getting a nut to start.

Place the point of the scissors in the hole, as shown—then a half turn and the job is done.



# A REVOLUTION IN CONDENSERS?

As is well known, the selectivity and sensitivity of a receiver are reduced by the losses in the oscillatory circuits which are produced by the tuning coils and by the variable condensers.

To meet the demand of higher selectivity, large air coils and large air condensers had to be used until recently. Thanks to the development by Hans Vogt of the Ferrocart coils with magnetic core, an important step forward was made in regard to the coils.

## New Dielectric Material

So far as condensers are concerned, however, there appeared nothing fundamentally new since the beginning of radio technique. The rotary condenser is exclusively used—i.e. the precision air condenser for highly selective sets, having no losses, but being expensive and large, or the hard paper condenser for cheaper sets, producing losses and thus reducing the selectivity.

Now, Hans Vogt, continuing his researches to improve the components of radio receivers with a view to selectivity and compactness, has developed also a new condenser principle, based on a new dielectric material.

## Avoiding Losses

As is well known, the losses in a condenser are dielectric losses depending on the dielectric properties of the insulating material between the two

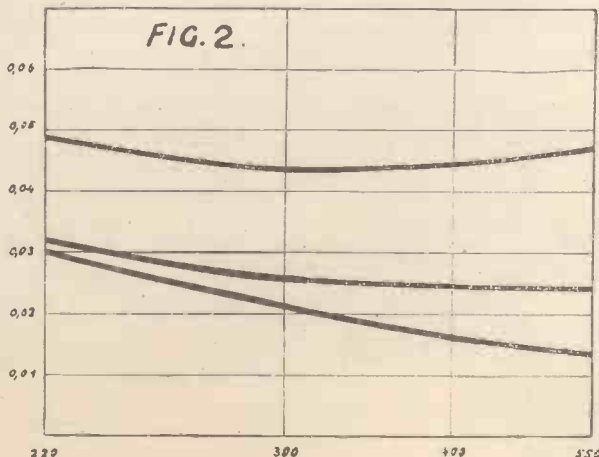

First details of a new dielectric material and a new condenser principle—designed by Hans Vogt, the inventor of Ferrocart Coils.  
By **ALFRED SCHNEIDER**, Engineer.

condenser plates. The dielectric is quasi electrostatically reversely magnetised in the rhythm of the high frequency, and thus dielectric reversing losses are produced in all solid dielectric materials, while air does not produce any dielectric losses.

It now has been found out that by electrolytically oxidizing aluminium after the so-called "Eloxal" process, a very hard and thin layer of oxide can be produced on the aluminium,

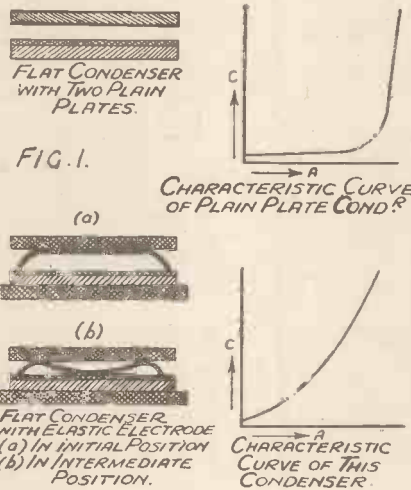

Fig. 1 contrasts the ordinary type of condenser (top) with the new "elastic electrode" type. Note the respective curves.

In Fig. 2 the damping values of a precision air condenser (a), a Vogt condenser (b) and a paper condenser (c) are contrasted. Though smaller and cheaper to make, the Vogt condenser is nearly as good as the air condenser.

which has very good dielectric properties—that is, low losses.

## Obtaining Square Law

This new dielectric has been combined with a new principle of varying the capacity of a condenser, which is illustrated by Fig. 1. The condenser consists in principle of a circular aluminium plate being covered with a layer of above-explained "Eloxal" dielectric and an elastic bronze plate, two opposite edges of which are bent down, gliding on the "Eloxal."

When screwing down the upper press plate, the large medium part of the elastic electrode first approaches the fixed electrode with an accelerated speed by a sort of angle lever effect while the other parts are following slowly, when the press plate is fully screwed down. Thus, the square law progression of capacity which is required to have an equally divided wavelength graduation is effected in a very simple way.

## Compensating Characteristics

If, on the other hand, the condenser were varied by simply approaching two flat plates to each other, one of which was covered with a thin dielectric layer, the progression of capacity would be quite different: first slow (as long as the greater portion of the dielectric consists of air), but suddenly becoming very rapid (as soon as the solid dielectric is preponderating). This characteristic is shown by

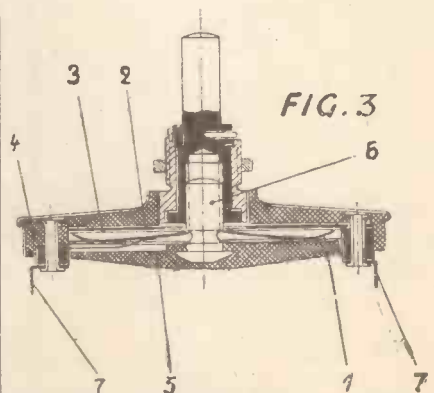

The construction of a Vogt flat condenser as used for rejector circuits. The numbered parts are explained in the article.

## A Revolution in Condensers?—continued

the upper part of Fig. 1. It is, of course, practically unsuitable.

The Vogt flat condenser is almost equivalent to an air condenser as regards its losses. Moreover, by the ingenious arrangement, the no-loss dielectric—i.e. air—is preponderating with the shorter waves (when the condenser has its minimum capacity and maximum plate distance), while with increasing wavelength the losses are somewhat increased due to the growing influence of the "Eloxal" dielectric, which is, of course, worse than air.

Accordingly, the losses of the condenser are higher with longer waves;



Fig. 4.

while, as is well known, the losses of a tuning coil forming an oscillatory circuit together with the condenser are higher with shorter waves. Thus, a certain compensation of the resulting losses of the circuit is effected, as can be seen from Fig. 2, showing the comparative losses of a circuit fitted with a hard paper condenser, a flat condenser, or a precision air condenser respectively, all being combined with the same tuning coil.

### Simple Construction

The losses of the Vogt flat condenser are shown to be almost equivalent to those of the air condenser, while those of the hard paper condenser are considerably higher.

A condenser of this principle is of very simple construction. Fig. 3 shows one arrangement, as it is now widely used for rejector circuits and selection circuits in Germany. It consists of the following parts:

- (1) Elastic bronze electrode.
- (2) Rigid counter electrode of aluminium.
- (3) Dielectric layer of "Eloxal" aluminium oxide.
- (4) Casing of insulating material.
- (5) The movable cover.
- (6) Adjusting screw.
- (7) Terminals.

By turning the screw No. 6 the movable cover 5 is more or less pressed down, thus more or less compressing the elastic electrode 1 to the counter electrode 2.

### Variety of Uses

The Vogt flat condenser is suitable for band-pass filters, rejector circuits, selection circuits, one stage and two-stage sets; moreover, as reaction and aerial condenser, it combines the advantages of low price, compactness and low losses. In its present stage it cannot be applied yet to multi-stage sets with one knob control, because ganging is difficult in mass production.

It is expected, however, to be accomplished further so as to replace

### COMPLETE!

To the left is a highly selective rejector circuit, consisting of a Vogt flat condenser and Ferrocart coil.

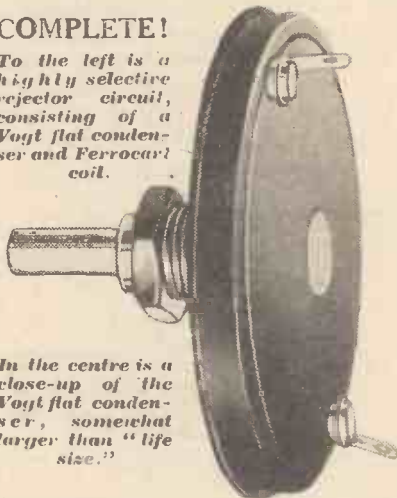

In the centre is a close-up of the Vogt flat condenser, somewhat larger than "life size."

the air condenser even for this purpose. Fig. 4 shows a rejector circuit of high selectivity, consisting of a Ferrocart coil and a Vogt flat condenser. Fig. 5 is a selection circuit with Ferrocart coil and Vogt flat condenser, compared with a high quality selection circuit with air-coil and air-condenser.

### Compact and Efficient

The small Vogt circuit is equal to the large air circuit! This comparison will clearly demonstrate the progress now realised.

It is remarkable that, as a result of pains-taking research, our standard radio components, so far believed to have achieved finality, are gradually being superseded by others of constructionally different principle, affording both a reduction of the space and an improvement of the electric properties of the receiver. Should this development go on, our

future sets are likely to require not more than half of their present space, while being more selective and sensitive.

\*\*\*\*\*  
**HOW TO TEST YOUR WIRING**  
 \*\*\*\*\*  
*Bad reception is often due to bad wiring, so keep an eye on your set's connections.*  
 \*\*\*\*\*

**C**RACKLING, hissing, howling, no reaction, weak results—in fact any obscure faults that crop up in sets, can be due to bad wiring. Not wrong connections, but sheer electrical inefficiency—high resistance or intermittent contact.

But short of completely rewiring a set, how is one to know whether the wiring is at fault?

Soldered joints are most likely to give trouble. So take your pliers and give each joint a good jerk by pulling on the wires.

Sound soldering will stand this. But a "dry joint"—the imp of radio—will probably break away. Incidentally those joints heaped up with solder are the ones most likely to prove dry.

Dry joints are often indicated by switching on a near-by electric light. If this is accompanied by a mysterious revival of faded signals, there's a dry joint in the H.F. wiring.



Fig. 5.—The smaller component is a Vogt condenser and Ferrocart coil unit, equal in selectivity to the high-class large air-spaced unit beside it, which consists of the ordinary type air-coil and air-condenser.

Wires held by terminal screws should be checked for looseness. It is not a bad idea to go over every terminal with the pliers.

If the set is battery driven, wagging each lead in turn with the L.T. switch "on" may quickly show you the offender. Just listen for clicks or bangs from the speaker as you move the leads in turn.

A. S. C.





**"MY SET WON'T WORK!"**  
**SET CALL FOR HELP!**  
 Answered by  
**HERBERT K. SIMPSON**

It is time someone told the truth. It may be unpalatable to some readers. The "mere white truth in simple nakedness" often is. Curiously enough, I have never seen a full-blooded article on constructors written by a designer. They write about sets, circuits, developments, etc., but never lash out—as they must feel like doing sometimes—at those who spoil their designs.

**Readers Who Fail**

Readers who fail to get good results with a press set fall into two classes: (a) the self-doubting, component-doubting and unaggressive, and (b) the abusively self-sufficient.

Obviously if one has spent time and money on building a new set and it is a failure, one is annoyed. Since it is not much fun just being in a vague state of annoyance, one seeks a scape-goat—some object on which to vent one's spleen.

Let us treat the matter scientifically. The objects on which we can expend our irritation are:

- (a) The designer.
- (b) Ourselves.
- (c) The components, valves, speaker, etc.

The order in which we blame (a) (b) and (c) is an index of our character and intelligence. *But we must blame someone or something.* That is the sensible thing to do.

**Amongst Friends**

As regards (a), the designer is the easier person to attack. Unfortunately, if the designer has a big reputation for both honesty and skill, our arrows not only do him no harm, but do us no good.

A certain number of unsuccessful readers do, however, let off steam in the form of angry letters. Probably a considerable number go round amongst their friends and say, "The Blank receiver's a washout!" What, of course, they should say is: "My Blank receiver is a washout," which is quite a different matter.

But as we are all more or less conceited, we are not likely to imply that we ourselves have made a mess of

things. It is so much easier to blame some Johnny in London.

Obviously, wireless designers are not equally proficient or successful any more than are doctors, writers, lawyers, mechanics.

The first thing to do, then, is to choose your designer. It is no earthly good building a set unless you have complete faith in the MAN who is asking you to build it. It is far more important to choose your designer than to choose the design.

It seems absurd to urge you to follow the instructions of the designer, but years of experience of readers' troubles convinced me that half the sets constructed are virtually designed by the builders themselves.

*"I have never seen a full-blooded article on constructors written by a designer. They write about sets, circuits, developments, etc., but never lash out—as they must feel like doing sometimes—at those who spoil their designs." Thus writes Herbert K. Simpson in this unusual and provocative article. We invite our readers to contribute their views to this interesting controversy.*

It stands to reason that if a set is built to duplicate the author's, it will do all the author's does. All you need bother about, then, is your distance from a B.B.C. station, the part of the country you live in, and your aerial.

Many faults disclose that there is something seriously wrong. If, for example, you can only get six stations; or if the reaction is not enough to make the set oscillate; or if the set oscillates and nothing will stop it; or if there is distortion or motor-boating or a constant whistle, then clearly your set is hopelessly wrong. Yet many a reader will stupidly blame the design—and merely advertise his own ignorance.

The constructor, of course, is frequently not to blame at all for the fault itself. He may, of course, have altered the layout, used other than recommended components and taken other risks; but, on the other hand, he may have a dud coil, a faulty

spaghetti, a stuck-down preset or ineffective valve.

He is much more sinned against than sinning, and every designer is on his side.

**Appreciative Letters**

Sometimes, however, the set is wrongly wired, grid-bias values are incorrect, plugs are not fitted properly into sockets, valves are not firmly inserted into valve holders.

Even the connecting wires are not properly bared or terminals not tightened. Such faults may still enable a set to work after a fashion, but results will be poor.

The constructor is wholly to blame; and, finally, there is always the question of operating the set.

The great mass of appreciative letters which this journal receives is, of course, the seal on the reputation of its sets.

It has made it impossible for the loose-thinking, abusive, conceited type of reader to "get away with it." The more he tells his neighbours about designs being a washout the more he condemns himself.

Believe me, the public soon enough finds out a designer they can trust. And the majority of those unfortunate enough to get poor results busy themselves with tracing the trouble and reading very carefully all the designer writes or has written about the set.

**When Things Go Wrong**

If I have drawn attention to a type of constructor who, even if every similar set in his road gave excellent results, would still shake his head mutteringly, this does not imply any lack of sympathy for those genuinely troubled and perplexed.

It is sometimes impossible to advise without actually seeing a faulty set, but I propose in future issues to give practical hints on component testing and fault-finding. Meanwhile, I respectfully recommend a diffident and receptive frame of mind when things go wrong.

I have had to force myself into that frame of mind too often not to know its merits.



Practical notes on what stations to look for and how the various foreign programmes are coming over.

THE big item of interest to most British listeners this month is the coming of the West Regional station, on 309.9 metres. Situated at Watchet, Somersetshire, and intended to provide for Cardiff-Bristol-Swansea and the West generally, this latest B.B.C. station seems likely to prove popular all over the country.

There has been such consistently good reception from the other British Regionals that the coming of another clear programme-alternative, on the lower part of the tuning dial, is sure of a warm welcome. And as the B.B.C. is pushing ahead with prepara-

tions for its new long-waver, as well, there seems to be a commendable stir and activity in this country to off-set the many new transmitter-developments abroad.

The West Regional's "young brother," the West National transmission, will appear on the same wavelength as London National if the present arrangements are carried through (261.6 metres). But as in the Northern and Scottish Regions, the main Regional station will be allowed to settle down to full programme production before the accompanying West National is "faded-in"

for public service on the lower wavelength.

Before leaving the topic of B.B.C. activities, mention must be made of the fact that the new 5 X X, which is to be erected at Wychbold, near Droitwich, promises to be worthy of the hopes so fervently entertained by listeners in regard to Britain's long-wave station. It is going to be a first-class affair, of unimpeachable quality, and with a power of 100 kilowatts as compared with the present 30 kw. of Daventry 5 X X. But it will be many months before we hear anything of Wychbold.

So far as foreign reception on the long waves is concerned, the past few weeks have been somewhat disappointing. Heterodyne whistles, combined with a tendency for strength to fall occasionally—very marked on some nights—have suddenly made the perfect reception of a few months back seem very remote. But experience has shown that long waves never disappoint for long, so probably this waveband will again be in excellent fettle by the time these words appear in print.

**Metal Rectification for the A.C. "S.T.400"**

THE immediate popularity of their A.C. mains unit which the Westinghouse Brake and Saxby Signal Co., Ltd., designed specially for use with the battery-operated "S.T.400," led the firm to believe that many enthusiasts who intended building the A.C. version of the same set would welcome similar facilities for metal rectification. So a blueprint and clear wiring instructions were prepared, and can now be obtained for 6d. by any reader on application to the firm at 82, York Road, King's Cross, London, N.1.

Some hundreds of applications were received in the first week of production, so it would be well not to delay your application if you intend to take advantage of this offer.

**Good Business**

Students of Spanish, of German, of French, and of up-to-date business methods will all be interested in the latest Graham Farish activities.

Having compiled an exceptionally attractive catalogue of their products, the firm has now issued editions in Spanish, in German, and in French.

\*\*\*\*\*  
\* **POINTS FOR** \*  
\* **PURCHASERS** \*  
\* *Interesting details from manufac-* \*  
\* *turers about recent trade activities* \*  
\*\*\*\*\*

Full information about "resistencias," their "Ohmios" and "milliamperios" is afforded to the Spanish señors who wish to incorporate "Ohmites" in their sets. And similarly the Frenchman who is looking for really first-class "condensateurs" will find all about them in the Graham Farish Radio "Edition Française." For each catalogue covers the whole Graham Farish range in a different language!

This is real enterprise, and we congratulate Graham Farish, Ltd., both on the idea and on the tasteful execution of the work. There should be plenty of foreign stamps finding their way to Masons Hill, Bromley, Kent, when the Continent gets wise to these tasteful productions and the applications start to pour in.

**For H.T. and G.B.**

The news that Edison-Swan Electric Co., Ltd., have recently reduced the

price of the various Ediswan grid-bias and high-tension batteries has created a demand for full particulars of this famous range.

On application to the firm at 123, Queen Victoria Street, London, E.C.4, any reader of THE WIRELESS CONSTRUCTOR can obtain the new Ediswan List A.B.856, giving all the essential particulars—voltage, exact size, etc., etc., and the various discharge rates recommended for the different types of H.T. batteries.

**New Moving-Coil Blue Spots**

The release of some new moving-coil loudspeakers from Blue Spot House, 94/96, Rosoman Street, E.C.1, is an event! The advertisements of these new models will repay the closest study, and among the high lights we must mention the 29PM., which retails at 32s. 6d., and the 22PM., which is a cabinet (oak) model at 45s. utilising the above chassis.

All the Blue Spot moving-coil loudspeakers incorporate output transformers which are provided with tappings for matching with power, pentode, or push-pull output. The Q.P.P. enthusiast should order his specially—it costs only 2s. 6d. extra, and is identified by the letters Q.P.P. quoted after the usual model number.



**AS WE  
FIND  
THEM**



**NEW  
APPARATUS  
TESTED**

**R. & A. Reproducers**

**R**EPRODUCERS AND AMPLIFIERS, LTD., of Frederick Street, Wolverhampton, are a firm who specialise in loudspeakers, and

**WELL-DESIGNED  
INSTRUMENTS**

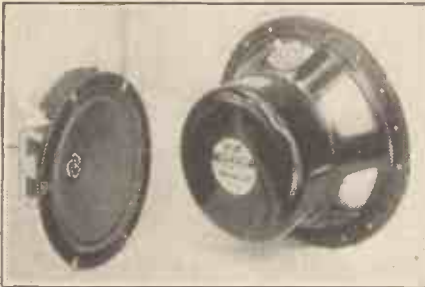

Two of the moving-coil speakers in the R. & A. range. On the left is the "Challenger" and next to it the "Victor." Both are permanent-magnet models.

included in their range are some particularly fine models.

Two that we have had the opportunity of testing are the "Challenger" and the "Victor."

Both of these speakers are of the permanent-magnet moving-coil type. The "Challenger" is a very moderately priced instrument (it retails at 35s.) incorporating a three-ratio input transformer which provides the necessary matching for power, super-power and pentode valves.

Its sensitivity is above the average for its price class, and the response remarkably even. There is an absence of peaks and resonances, and the bass notes are "clean" and free from boominess.

Like all moving-coils the "Challenger" requires proper treatment if the best results are to be achieved, and it should be used in conjunction with a baffle at least 2 ft. square, or mounted in a cabinet of generous dimensions and substantial thickness.

The "Victor" is a larger model

*Under this heading we publish reviews of apparatus submitted by radio manufacturers and traders for examination and test in "The Wireless Constructor" laboratories.*

and includes several special features. For example, the magnet system is enclosed and the transformer is built into the chassis.

This transformer is a Ferranti, made to R. and A. specification, and having six ratios so that the speaker can be matched up to practically any output valve. The cone dia-

**CHOKES FOR THE  
CONSTRUCTOR**



*These Bulgin chokes are capable of maintaining high inductance values at normal working currents. Each of the types is provided with insulated terminals.*

phragm is protected by a grill which serves to prevent accidental damage—a good point this. So far as sensitivity and tone balance are concerned both are excellent, and the speaker is undoubtedly a high-grade production. Those who are contemplating the purchase of a new loudspeaker would be well advised to hear these R. and A. models demonstrated.

**New Bulgin Lines**

Messrs. A. F. Bulgin & Co. have recently added to their extensive component range a number of L.F. chokes suitable for baseboard or chassis mounting.

There are four of these chokes. The L.F.14 has an inductance of 20 henries at 50 milliamps., and the L.F.15, 32 henries at 30 milliamps. These two chokes are priced at 10s. 6d. each.

Also there are the L.F.16, rated at 20 henries at 20 milliamps., and the L.F.20, 32 henries at 15 milliamps. Air gaps have been introduced into the cores to keep the inductance reasonably constant under varying loads.

A point that should be noted in connection with the chokes is the fact that the inductance figures are given for currents with which they are likely to be called upon to deal under normal working conditions.

Another feature of the chokes is their compactness. Moreover they are neatly shielded and have insulated terminals. Two uses which immediately suggest themselves are smoothing and output filter circuits. Their inductance-current ratings render them suitable for either type of circuit.

**COMPLETE TUNING  
ASSEMBLY**

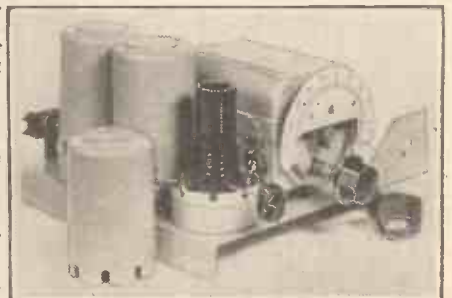

*The Colvern tuning unit which comprises bandpass coils, "gang" condenser, wavechange and gramophone switching made up as a self-contained unit.*

## As We Find Them—continued

### A Band-Pass Chassis

Colvern coils are well known for their very high efficiency—the reward of sound design and first-class workmanship.

Messrs. Colvern have now produced a complete tuning assembly consisting of the necessary band-pass and H.F. coils together with a triple-gang condenser. All are mounted upon

### FOR D.C. MAINS



The new Ward & Goldstone type W.H.F. heavy duty choke designed for use in D.C. mains circuits. Having a D.C. resistance of only .75 ohm, the winding is still capable of carrying up to .6 ampere.

a chassis, giving thorough shielding and enabling perfect matching to be achieved.

The unit is really a magnificent job, and embodies, in addition to the coils and condenser, a gramophone switch and the necessary coupling components. It will appeal particularly to those constructors who wish to give their sets the appearance of a factory product and to achieve the maximum simplicity in construction. Apart from the unquestioned efficiency of the assembly, its attractive grey finish is most pleasing to the eye. The price is £3, and the makers Messrs. Colvern, Ltd., Romford, Essex.

### Heavy Duty H.F. Choke

When D.C. mains are used for supplying the anode and "heater" currents of mains-operated receivers, it is not unusual for a certain amount of hum and other noises to occur.

Much of the trouble is due to H.F. currents in the mains leads, and one remedy is to insert a choke or chokes in series with the supply. H.F.

chokes of this type have to be constructed with well-insulated wire of substantial gauge because the whole of the current taken by the set passes through the windings.

It is therefore interesting to learn that Messrs. Ward and Goldstone, of Pendleton, Manchester, have placed on the market a special choke for this purpose. Selling at 3s. 6d., the type W.H.F. choke has an inductance of 270 microhenries, a D.C. resistance of .75 ohm, and is designed to carry up to .6 ampere without an appreciable temperature rise. Readers will appreciate that chokes intended for use in series with the mains are entirely different to the fine wire variety employed for reaction or parallel-feed circuits, which would be quite unsuitable for this class of work.

The most satisfactory method of using D.C. mains H.F. chokes is to place one in each mains lead, joining two large condensers in series across the set side of the chokes. The common centre point on the condensers is then earthed.

### Lissen Coil Unit

Readers will be interested to hear of Messrs. Lissen's latest addition to their coil range.

This is an unshielded dual-range unit retailing at 5s. 6d., and is intended mainly for use in receivers of simple type, such as those incorporating up to three valves.

On the top of the coil unit there is a variable condenser having a maximum capacity of .0002 mfd. which forms an adjustable selectivity control.

The tuning and reaction windings are set rigidly in sections on the grooved ribs of a bakelite former, and six terminals are provided on the coil base to which the various windings are connected.

Wavechanging is carried out with a simple on-off switch, and the aerial circuit wave ranges (selectivity control at maximum) are approximately 210-560 metres and 1,100-2,100 metres.

It is a thoroughly well-made and effective little unit, and should achieve considerable popularity with those constructors who pin their faith in the detector and L.F. type of receiver.

The makers are Messrs. Lissen, Ltd., Worple Road, Isleworth, Middlesex.

### A Useful Saw

We have received from Messrs. A. Barson & Co., Ltd., 53, Truro Road, London, N.22, a particularly good compass saw. A feature of the saw is the ease with which cutting can be carried out in places where the ordinary hacksaw frame would be in the way.

In shape the saw resembles the keyhole type, but the blades are interchangeable, various grades being available for different kinds of work.

We found this saw to be highly effective whether used for cutting metal, ebonite or wood, and it is undoubtedly an acquisition in any radio workshop. It will successfully carry out all the jobs that the constructor is ever likely to be faced with.

### Soldering Simplified

Messrs. Andrew R. Findlay, of Glasgow, have sent us a sample of S.M.E., a combination of flux and solder in paste form.

S.M.E. is particularly easy to use and "runs" readily upon the application of a clean hot iron and clear flame.

Our tests showed that, with it, soldered connections could be made effectively and with the minimum of time and material.

S.M.E. should be a boon to constructors who prefer soldered joints and will solve many difficulties.

### IN CASE OF STORMS

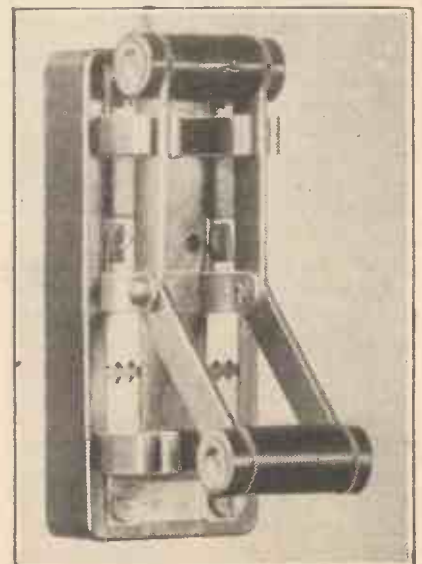

The W.B. double-throw switch incorporates a lightning "arrester gap" and forms an effective protective device against lightning discharges. This component was reviewed in these columns in the March issue.





# QUESTIONS

## I Am Asked

by JOHN SCOTT-TAGGART

**Q. 20.** Your remarks about the possible use of a grid condenser and leak in the "S.T.400" suggest that this system and "anode bend" are of equal merit in the set. Is this so?

**A.** No. The anode bend was found to be the better. Theoretically and practically this system gives greater selectivity, and the remaining points (sensitivity and quality) were also tested the length and breadth of the country, to the complete satisfaction of demonstrators. I merely suggested that those who get bad quality should try the grid-condenser system in order to convince themselves that the fault lies not in our "S.T.400s," dear Brutus, but in ourselves (or our speakers). "Anode bend" has been under a cloud ever since "power-grid detection" became popular, and obviously anyone who does not get perfect results with his "S.T.400" will want to blame it on to "anode bend."

The absurd part of the whole matter, of course, is that "power-grid detection" has become a catch-phrase like "band-pass tuning," "loss of top," and so on: phrases which too often echo about inside the brains of those who do not understand them fully.

Thus, an ordinary leaky-grid condenser rectifier working under the average constructor's conditions is entirely different from power-grid detection operated with low values, high anode volts and large H.F. input. But the circuit looks the same, and the laurels of the more ambitious scheme (which, however, is less sensitive and which introduces heavy damping on to the tuned

circuit) are apt to be bestowed with mistaken generosity on its older and more modest brother.

Such mis-shapen ideas are disseminated as a result of a queer technical snobbishness that is half-nourished on technical truths which are found too complex to be properly digested. As a result, half-truths are mumbled from mouth to mouth like a medicine-man's spell. Hence the origin of the technical parrot cries of radio.

**Q. 21.** I notice a definite hum on some broadcast stations during supposedly silent intervals. What is this?

There is no problem in the whole of radio that our eminent contributor has not been called upon to solve, as Consulting Technician to the great wireless interests of this country and of America. His unique practical experience is here placed at the disposal of every reader of "The Wireless Constructor."

**A.** The hum is presumably due to slight irregularities in the H.T. used at the transmitting station. Brussels offends in this way.

If the hum occurs on all silent carrier waves and disappears when you are not tuned to a carrier, the fault lies in your receiving conditions. The fault is modulation hum caused by A.C. voltages (deriving from the mains) being applied to the H.F. valve and so "modulating" the carrier.

**Q. 22.** Will a valve amplify infinitely small signals?

**A.** No. The limit of amplification depends upon valve noises which, when many stages of amplification are employed, can become quite a roar. The valve noises can be caused by irregularities in the filament, bad vacuum, etc. But even when these are all right, the ultimate amplification is limited by what is called the "shot effect."

The anode current is made up of electrons, and it is impossible to have

a smooth flow of anything made up of electrons. The irregularity of the "shot effect" produces a hiss which corresponds to a signal input of one-millionth of a volt. This, therefore, represents the theoretical limit of amplification. The smallest current measured by a valve is 1/1,000,000,000,000,000 ampere, which is equivalent to about six electrons per second.

**Q. 23.** Is a shielded lead-in any good to stop "static"?

**A.** If by "static" you mean atmospherics, the answer is No.

The listener must put up with them and be glad he does not live in a storm-ravaged jungle.

If you mean "man-made static," you may, if the lead-in passes near A.C. mains, etc., cut down the interference. You will lose signal strength and will require a higher and better aerial. The scheme is often useful for wireless shops in towns.

The ordinary listener will derive no benefit from the scheme in most cases.

If your aerial runs parallel to power lines, it is worth trying to rearrange it at right angles instead. As regards miscellaneous "man-made static" picked up by the aerial, I have found that loose-coupled input circuits to the S.G. valve grid circuits are desirable.

Private houses do not suffer, except very rarely, from pick-up, but in such case a separate aerial coil is recommended—i.e. a transformer input is employed.

If you use a shielded lead-in, by the way, you may—by arranging a better aerial—bring the latter nearer the source of interference.



Tightening Milled Terminals  
—Testing Presets—Voltage  
Regulation—Perverse Radio.

I EXPECT you have cursed, just as I have, about the awkwardness of tightening milled terminals on components. Pliers persist in slipping off them. And even if one has a slotted screwdriver, many of the terminals have no screwdriver "cuts."

**What's Wanted**

An implement in the form of a small hollow cone at the end of a long slender rod, and provided with a screwdriver-like handle, would be very welcome. Serrations inside the cone would ensure a good grip on the milled terminals, and each "conedriver" would fit a number of different size terminals.

But, unfortunately, special tools for radio constructors are all too few.

Here's a testing tip for the smaller capacity preset condensers. Sometimes some of them will stick at maximum, so that unscrewing the

knob produces no variation of capacity. If you suspect this fault, a simple test will decide the matter.

Connect the preset condenser across the tuning condenser of a receiver—one side of preset to moving vanes and the other to fixed vanes. Screw the knob down to its maximum position, and then tune in a station.

Now unscrew the knob on the preset condenser. If the station fades away the component is O.K.

But if only a tiny reduction of volume occurs, or none at all, the condenser is proved faulty, and should be discarded.

**Behaviour of Transformers**

"What is voltage regulation of a transformer?"

This question gets more and more common as mains receivers increase in popularity.

Put briefly, "voltage regulation" is the property of a transformer which enables the voltage of the secondary winding to remain substantially constant when supplying different values of current. The better the transformer the bigger the range of outputs over which voltage remains steady.

**A Case in Point**

Take the case of a transformer with a 4-volt, 5-amp. output for supplying heater current to A.C. valves. A four-valve set requiring 4 amps. would be quite safe. And if regulation was good, 3 amps. for a three-valve set could be drawn off satisfactorily.

But in the latter case many would prefer to be on the safe side, and would load the secondary with a resistance to consume the unwanted 2 amps. and prevent the voltage rising. The value of this resistance would be 2 ohms.

Recently I connected up a receiver that was so begrimed, everything looked the same colour—a sinister grey,

Well, nothing happened. Results were very good, and were not a bit improved after giving the set a thorough clean.

But don't let this make you careless. If no harm resulted from dust in ninety-nine cases out of a hundred, you can bet your life yours would be the hundredth case.

A. S. C.

WHAT is to me the most outstanding item of the past month on short waves is the fact that after years of "flatness" my ears are once more beginning to assume their normal shape!

Yes, I have almost completely forsaken headphones under a wave of enthusiasm for a new short-wave superhet that I have been testing out.

**Loudspeaker or Phones?**

Until comparatively recently, I must confess that I have not had very much time for "supers" on short waves, chiefly on account of the parasitical disadvantages associated with this method of reception.

But now, as a result of my past month of short-wave listening, I am not at all sure that I shall not be tempted to renounce headphones for good. As soon as I have had an opportunity over a period of confirming what I now believe to be the case—that is, that I am not missing anything, then it will be good-bye to phones for good!

\*\*\*\*\*  
\* **THE MONTH ON** \*  
\* **SHORT WAVES** \*  
\* *All the interesting news about this* \*  
\* *fascinating waveband.* \*  
\*\*\*\*\*

At present I am confident that I cannot have missed very much, for during the period under review I have heard all my "usuals" and several others besides, which would seem to be proof enough.

Some of the American "punch merchants," particularly, have been coming over remarkably well; so well, in fact, that I have been unable to resist the temptation to "sit and listen." Surely conditions, which admittedly have been good, cannot have been entirely responsible for such un-amateurish conduct? No—I'm very much afraid it's that "super."

By the way, talking of the States, I wonder if any of you have noticed how well some of the amateurs have been coming over on 'phone? Those

that I heard—quite a number of them—seemed all to be passing on urgent messages to relatives concerning families affected by the recent disastrous earthquake disturbances in and around Los Angeles. Some of the signals came over so well that I am wondering whether increased powers were being employed to meet the emergency.

**An Entertaining Broadcast**

One of the best signals, and certainly the most entertaining programme, that I have heard since last my notes appeared was one of the Sunday evening broadcasts from Rabat, Morocco. Quality and volume were both up to such a high standard that the programme was definitely at what I call "programme value," and in consequence I listened to the whole broadcast.

There are many ways of whiling away a couple of hours on Sunday evening. Take my tip and look out for him. It is certainly an excellent broadcast.

G. T. K.



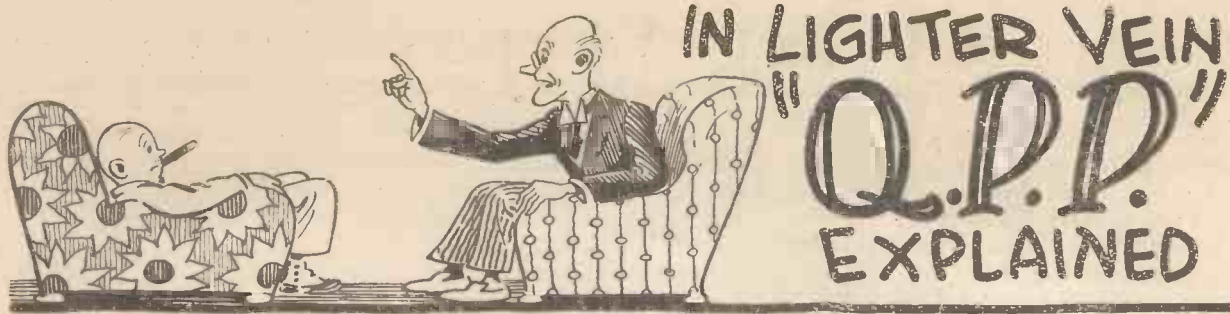

"WHAT," inquired the Professor, "is your opinion of Q.P.P.?"  
 Q.P.P., I mused. Let me see. R.S.V.P., R.I.P., S.P.Q.R.—  
 Somehow it did not seem to strike a responsive chord in that fine brain of mine. However, we Wayfarers are never at a loss, and I pass on to the reader free gratis and for nothing a little tip which I have found of inestimable value in the course of a long and, though I say it myself, successful career.

**Staving Off Disaster**

Provided that the other fellow knows the answer to the question that he is asking, you can always stave off disaster by making him furnish it himself if only you go the right way about it. Remember that he is as a rule burning not to hear your opinion, but to impart information himself.

"Don't you rather hate these strings of initials and things?" I said. "I always wonder myself why people can't give things their full name?"

"Oh, well, Quiescent Push-Pull, if you prefer it," smiled the Professor.

There you are, you see.

**DIFFICULT TO HIDE**



"Even hare pockets don't conceal them."

And here's another tip. Directly a fellow starts asking questions on a subject which is not one of your best, carry the war into the enemy's camp by asking some yourself.

"Before we can criticise," I remarked, "the best thing is to know exactly what are the claims made for it. Now suppose that you just enumerate these."

"Why," said the Professor, "it enables battery sets to produce twice the power without any more high-tension current."

"That," I murmured, "shows at

Wayfarer endeavours to obtain information concerning Q.P.P. from Professor Goop, who doesn't find the explanation a very easy task. As a result, Mrs. Goop is twice called in to render first-aid and the Goop larder suffers in consequence. So take Wayfarer's tip and don't ask your pal "how it works."

once how it got its name. In electricity and wireless names usually go by opposites. A 'condenser' is so called because it doesn't condense; and a 'microphone' because micro stands for a millionth, and it is obviously the millionth of a phone; and 'earth' because it is usually a gaspipe; and the books show that current flows from positive to negative because it really flows from negative to positive. Hence, when a circuit makes more noise they call it quiescent. Jolly good!

**Something to be Desired**

"Don't let's waste time over mere words," snapped the Professor. "There are, of course, two entirely different kinds of quiescent push-pull, or Q.P.P., as I shall call it, despite your objection. With ordinary Q.P.P. a very high negative bias is employed. The second kind calls for no grid bias at all on the output valve, and is named Class B."

"Class B seems familiar somehow," said I. "Quite reminds me of the old days when we built six-valvers with general purpose valves throughout and didn't know what grid bias was. We got volume enough to rattle up our old horn loudspeakers, but though I should hate to be hypercritical, the quality always seemed to me to leave something to be desired."

**When He's Not Looking**

"This is quite different. Just think for a moment. What happens if you don't bias your output valve, or rather, I should say, you give it zero grid bias?"

"That's an easy one. The valve becomes second-hand in about two

ticks and you have all the bother of sticking it into Goshburton-Crump's set, and taking his in exchange when he isn't looking. Then the high-tension battery gets such a kick in the neck that it also requires replacement. And believe me or not, high-tension batteries are difficult things to swap without the owner's knowledge; heavy things to carry about, and even hare pockets don't conceal them. No, I am all against zero grid bias on the last valve."

**THE OLD DAYS**

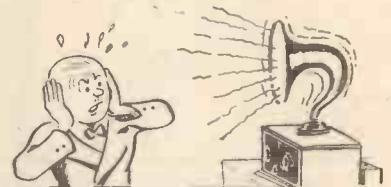

"We got enough volume to rattle up our old horn loudspeakers."

"But this," said the Professor, "is quite different. You see, there are special valves made for the purpose. You see, at zero grid volts they pass hardly any current at all."

**Out for a Walk**

"I know all about that. I made one myself the other day. It was lent to me by Poddleby whilst we were out for a walk. I don't mean that we were walking together. He had gone out into the country and my walk took me to his house. After certain extremely interesting experiments, which might have gone a lot better if I hadn't discovered that the grid-bias wander plug had come out of its socket, that valve was doing just what you've said. I believe Poddleby is still having an interesting correspondence with the makers."

"No, no," sighed the Professor. "These valves are definitely designed to pass hardly any current under the conditions that I have outlined. I am not referring to perfectly good valves of other types wrecked by your mishandling."

"By my WHAT?"

"Mishandling was the operative word."

# In Lighter Vein—continued

I can stand a lot. I remain calm if my personal beauty, my dress, my habits are criticised by those who have no artistic sense, for these things simply do not matter. But suggest by innuendo that my knowledge of wireless is minus a little something that some others have got and, like a true Briton, I am up in arms in a moment to defend my rights.

### No Steak

When Mrs. Goop had applied a mutton chop—there wasn't a steak in the house—to the Professor's black eye, we continued our discussion.

"You mentioned," I reminded him, "that special valves were being produced."

### DEFENDING HIS RIGHTS!



When Mrs. Goop had applied a mutton chop . . . to the Professor's black eye."

"Yes," said the Professor, "and the whole point about these is that when a transmission is coming in a flow of grid current takes place."

"But I thought that grid current in the output stage meant distortion? You've said so yourself heaps of times."

"Well, it doesn't, so long as you use a special transformer."

"What kind of transformer?"

"The quiescent push-pull Class B input transformer."

"I simply love those nice concise names. But how can grid current flow without causing distortion?"

"That," said the Professor, "is a question into which we need hardly enter here. It involves a somewhat complicated mathematical explanation which would probably take you out of your depth."

"That's what all the johnnies who have written on Class B have said. Don't bother about taking me out of my depth. Just get on with it."

The Professor's remaining eye took on a slightly glazed appearance whilst a hot and bothered look swept over the portions of his countenance left visible by the chop and its retaining bandage.

"I've mislaid my slide rule," he bleated.

I produced one from my pocket and handed it to him.

"This is no use without log. and trig. tables."

### Half an Explanation

These also I was able to supply. The Professor then pleaded writer's cramp, but I offered to take down at dictation. He pleaded that he could not give a full explanation with only one eye at work, so I begged him to give me half an explanation in default of anything better. He said that he wasn't feeling well. I told him that he would be feeling far worse in a minute if he didn't begin to deliver the goods.

"Well, it's like this," he said at last. "You know the ordinary low-frequency transformer?"

"Intimately," I replied, picking up one from his bench and passing it from hand to hand to demonstrate the suppleness of my wrists.

"You know, of course, that current flows through its primary but not through its secondary in the ordinary way?"

"How about parallel-feed?"

"I wasn't talking about parallel-feed. Please do try to stick to the point."

"The same to you with knobs on. I don't believe you know the faintest thing about this Class B business."

Like myself, the Professor is touched on the raw when his knowledge of wireless is brought into question. Even with a single eye functioning he was remarkably quick on the draw, and I could not duck in time to avoid the I.T.B. that he picked up and flung with unerring aim.

### From the Larder

For the second time that evening Mrs. Goop was summoned to render first-aid, and I departed homewards wearing the remaining chop from the larder.

On my way I kept on thinking what a bad term quiescent was. My only consolation was that with both their mutton chops employed upon errands of mercy the Professor and Mrs. Goop must have had a somewhat thin time gastronomically that evening.

### WITH UNERRING AIM

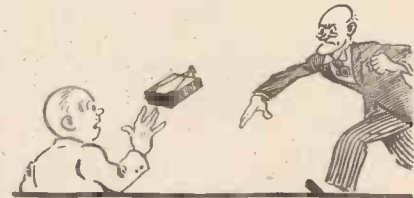

he was remarkably quick on the draw, and I could not duck in time to avoid the I.T.B. . . ."

Q.P.P., like Bass, is great stuff, but take my tip and don't ask even your best pal how it works.

HE'D been a fool to leave England; he saw that now, just when things were beginning to hum. But there were better things awaiting him abroad, he felt sure.

Not so his father.

"You leave things as they are," he had said. "You won't do better than you're doing now, wherever you go."

But he was young, ever eager to experiment, and he could not stand interference at any price.

The changing over had not been as easy as he had first imagined; he had tried his hand first at one thing, then

\*\*\*\*\*  
\* RETURN OF THE \*  
\* PRODIGAL \*  
\* If only he had listened to those at \*  
\* home! But the wanderlust came \*  
\* upon him, and . . . \*  
\*\*\*\*\*

at another. Many a time success seemed within his grasp, yet at a turn it eluded him. Merely a matter of adjustment, he told himself.

But the sounds that met his ears were strange, and somehow he could not get used to them. All these

foreign lingos sounded alike to him; what chance had he of cutting out the foreigner?

Yes, he'd been a fool right enough, and he'd got nowhere by trying to better his station. And now there was nothing for it but to go back before it was too late. He was sure of the reception his set would give him; it would be good to hear some familiar voice again.

So he tuned into London Regional, and listened to Henry Hall.

E. M.





# REMEMBER THESE—NEXT TIME!

**HULL.**—"I have had the 'S.T.400' working since before Christmas and I am amazed at the selectivity and tone. All my friends will not believe it is only a 4-valver, and one says it is much better than his superhet. The other morning I received WCAU, WGY, KDKA and six other American stations at good loudspeaker strength—in fact, so loud that the household was awakened! Up to date I have identified 63 stations (12 long wave and 51 medium wave), all at good loudspeaker strength. I have already converted several of my friends' receivers to this wonder set."—C. Taylor, Segrave Grove, Derringham Bank, Hull.

**LEYTON (E.10).**—"A few lines to let you know how the 'S.T.400' went. I finished on Saturday last and switched on at about 40 degrees. I soon switched off quickly to get my breath back. Trieste came in at terrific volume in broad daylight and about a dozen others.

"I must say I am more than satisfied with the 'S.T.400'—in fact, I am very proud to own such a set. The tone is swell: range and the ability to cut out other stations are simply fine. Should there be anyone in any trouble with the 'S.T.400' in this district I should be only too pleased to help him out."—John T. Coombes, 89, Beaumont Road, Leyton, E.10.

**BIRMINGHAM.**—"It is now three months since I built the 'S.T.400' and I would like to offer my sincere thanks and congratulations to swell the many hundreds more letters you have received on such a magnificent circuit. For sheer delight and simplicity in handling, the 'S.T.400' is marvellous. I get selectivity as I have never had it before on any previous set I have built. The volume I get is enormous. As to quality, well, you would have to hear my 'S.T.400' to believe it.

"I am sure I get reproduction as nearly perfect as it is possible to get it on any receiver, no matter how much one paid for it. I run off an Ekco A.C.25. eliminator and Blue Spot 99PM moving-coil speaker. Again thanking you for such a wonderful set."—C. H. Ockford, Rawling's Road, Bearwood, Birmingham.

**MUCH HADHAM.**—"Since carrying out the alteration of putting a 400-ohm resistance across aerial and earth I have been able to log between 80 and 90 stations."—Rev. D. Burke, Morris Cottage, Much Hadham, Herts.

"[The use of a resistance is only suggested when the local's strength cannot be adequately reduced by the coils.—ED.]

**PEMBROKE.**—"I am glad to be able to tell you that I have had all that Mr. S.T. claims out of the set. It is really a revelation in radio and the 'S.T.400' is an education. I had never built a set before and I am glad that I selected this one as my first attempt. It took me a time to handle it properly, but now, in an evening, I can get all the stations I require and the reception is perfect. It gives me a thrill to handle the set. The 'S.T.400' is a great investment."—R. Child, Monkton, Pembroke.

**SOUTHBOROUGH.**—"We thought you might like to know how pleased we are with the 'S.T.400' sets we have made. They are all that you claim, and perhaps a bit more. We are surprised at the number of stations received in daylight. If anyone in this district would like to hear our sets, we should be very glad to oblige. Wishing you every success and thanking you for two splendid sets."—Skinner and Burtonshaw, 76, London Road, Southborough.

**GLASGOW.**—"I have built five 'S.T.300's' and am building my second 'S.T.400'. In between times I have tried out other designs but always have gone back to yours."—J. Shaw, Gallowgate, Glasgow.

**ENFIELD.**—"I have built your 'S.T.400' and I want to write and thank you for giving the constructor just the very set he wants. I must honestly say it is the only satisfactory set I have ever had. I paid £8 last year for the

—1932 model, but it was a 'flop' and is now in the junk box.

"Well, I see that you tried the 'S.T.400' within 6 miles of Brookmans Park and that you say it was a 'flop.' You mustn't say that because I live that distance and I can get 25 to 30 stations any night in the week, and I couldn't wish for anything better.

"The tone and volume are as good as on the locals. Selectivity is just wonderful. I have had several friends round and when I tune in the foreigners they simply gasp with surprise. I want to say to everybody: 'Build the 'S.T.400'!"—C. H. Ernest, John Street, Bush Hill Park, Enfield.

[Mr. Scott-Taggart informs us that his own test was in Enfield and this reader's letter is a proof of the critical attitude "S.T." adopts in judging the performance of his own sets.—ED.]

**WELWYN.**—"I was very much interested by the enclosed Q. and A. in which you say that at 6 miles the 'S.T.400' was comparatively a 'flop.' I myself live in a very bad swamp area about 6 miles from Brookmans Park. What a good thing you did not write those words

**DONCASTER.**—"All controls respond exactly as you say, and I can tell you I would not exchange it for any other set I have heard. The tone and volume could not be better. I get nearly every station you show on the enlarged dials in the CONSTRUCTOR and exactly in the same positions—and am quite satisfied!"—H. Stevens, West End Lane, New Rossington, Nr. Doncaster.

**EAST GRINSTEAD.**—"I would like to add my name to your collection if I may—a draughtsman in stained glass (I wonder if that's a new one?). To be serious, I really would like to thank you for the 'S.T.400.' My first set. Know nothing about wireless. Built the set without a hitch anywhere. Results extraordinary. What my set would do in expert hands goodness only knows; with my ham-fisted tuning I can get every worthwhile station in Europe. I have had several American stations, WCAU (Philadelphia) coming in night after night—eight nights in succession at its best."—P. Refoy, Moat Road, East Grinstead, Sussex.

**BRAMHALL.**—"I have never written to the designer of any set I have built, principally through fear of scorching the paper! I have not built anything but battery sets, but their name is legion, and I had about concluded that 'all men are liars.'

"I have been running a — Four ever since he published it. Soon after publication the Continental stations began to put up their power and the set which suited me admirably when first built became insufficiently selective. I wound the — coils, bought a — tuner and a set of — band-pass coils. I have an accumulation of parts sufficient to build at least three sets, and had come to the conclusion that selectivity, volume and quality could not be obtained in one and the same set.

"Well, I then built the 'S.T.400.' In my unskilful hands it has tuned in literally dozens of stations I had never heard before, and I have no difficulty in getting them in at such volume as to be of real entertainment value. The set is a real winner. I have got a better set than I ever hoped to own. Don't, for the love of heaven, design a new circuit because I am bound to build it, having found a designer whose sets do what he says they will."—J. Riley Wood, Redcot, Hall Moss Lane, Bramhall (Cheshire).

**FOREST GATE (R.7).**—"I first followed your lead with the 'S.T.100.' My latest was another designer's 2 H.F., 2 L.F. five-valve set (neutralised), which I scrapped for your 'S.T.400.' I may say here that I am not sorry I did so, as I can easily get round about 60 stations without undue scorching."—E. A. Dowett, Tyney Road, Forest Gate, London, E.7.

**TOOTING (S.W.17).**—"I had a really good well-known make of S.G. Four till the 'S.T.400' came along. Now it sounds like a 2-valve local set compared to the 'S.T.400.' Stations, power, clarity and ease of control all go to make this a king of constructor sets, a veritable master of the ether. Stations are too numerous to mention by name, the power is like having the whole ether packed behind the panel; as for clarity, the human voice is indistinguishable from the real thing."—R. Collius, Becklands Road, Furzedown, Tooting, S.W.17.

**MONMOUTHSHIRE.**—"I am afraid I am rather a belated writer concerning your admirable set—the 'S.T.400.' I built your 'S.T.300' and was greatly satisfied, but as soon as funds permitted I converted it into your present famous set, having it working about a fortnight before Christmas. The set is in radiogram form. Apart from this slight modification, the set is exactly to your specifications, and I must congratulate you on designing a set that honestly does combine the necessary characteristics for pleasurable listening under modern chaotic conditions.

"The sensitivity, selectivity and last but not least the tonal quality are head and shoulders above all rivals, and my only complaint is that the 'S.T.400' has made me too critical when

Here are more enthusiastic letters testifying to the success of Mr. John Scott-Taggart as a designer. No other designer has had the seal of public approval so emphatically placed on his work. Such letter extracts as these will be worth remembering when "S.T.'s" next big set is offered to you.

a few months ago when I was anxiously looking round for a set that would give me some Continental stations when Brookmans Park was transmitting!

"I examined the claims of many proprietary and kit sets and finally decided upon the 'S.T.400,' much to my subsequent satisfaction, for it really is a wonderful set. I enclose a list of over 60 stations received, not once but many times and carefully authenticated.

"Of course, I cannot get all these stations when B.P. is transmitting, but I can get nearly half of them without the slightest interference. I wonder what the 'S.T.1,000' will give us!"—Frank Holme, The Shack, Marley Hill, Nr. Welwyn.

[This is another letter testifying to the modesty of Mr. Scott-Taggart's claims.—ED.]

**WALLASEY.**—"In view of the number of stations available the quality is astonishing. I am not easily kidded into trying any new circuit that makes an appearance. You have certainly gained your laurels with the 'S.T.400.' My results after a first run are 54 stations, 47 on medium waves and 7 on long. Please accept the thanks of one at last satisfied."—J. F. Wilson, Geneva Road, Wallasey, Cheshire.

**CANNOCK.**—"Having built the 'S.T.400' battery version for a friend I think I need say no more than that I am now purposing scrapping my own 2 H.F. all-mains receiver and replacing it with the A.C. 'S.T.400.'"—B. W. Lunt, Wolverhampton Road, Cannock, Staffs.

**NORTHALLERTON.**—"I wish to say how pleased I am with the 'S.T.400,' selectivity and tone being very good indeed; Q.P.P. would further improve an already excellent set."—C. Archer, Hartington Terrace, Northallerton, Yorks.

**EASTBOURNE.**—"May I congratulate you on the 'S.T.400' design and on the 'staff work' which produced your Rapid Construction Guide. I was very pleased with my previous 4-valve set, but the 'S.T.400' has proved itself to be streets ahead of this in entertainment value. The tone and volume (especially the former) are a revelation to me."—From a local doctor who prefers his name withheld.



## More Enthusiastic Reports From Readers

listening to other sets!"—Harold E. Hunter, Coronation Road, Cwmbran, Mon.

**PALESTINE.**—"I suppose it will interest you to hear about my results on the 'S.T.400' while here in Jaffa. After an evening test I logged 43 stations (on both wavebands), all European, and most of them at full loudspeaker strength."

—Hans Vouluir, SS. "Viola," at Jaffa, Palestine.  
**SEAHAM HARBOUR.**—"Having been amongst the earlier builders of your 'S.T.400,' may we compliment you on your latest design which, since we assembled it, has given us every satisfaction. We are contemplating building the 'S.T.400' all-electric console as a standard for inquiring customers."—Princess Charging Service Depot, 129, Princess Road, Seaham Harbour, Co. Durham.

**IRELAND.**—"I can endorse your claims for the A.C. 'S.T.400,' since I have logged something like 100 Europeans and 20 Yanks."—John R. Oliver, Drummussle, Holywood, Co. Down.

**OXFORD.**—"Since writing you I have traced the trouble to a defective anode coil and reaction distributor. These faults have now been rectified and the set is working perfectly. The quality is wonderful, and I have yet to hear anything to equal it. Please convey to Mr. Scott-Taggart my congratulations on a wonderful circuit. Selectivity, sensitivity, volume, quality are all there in plenty."—T. W. Hathaway, Ramsay Road, Headington, Oxford.

**LEYTONSTONE.**—"I have just completed the 'S.T.400' radiogram, and I cannot help congratulating you on having designed a most remarkable set. I have never before heard so many foreign stations at such volume. Other people who have heard it agree with me that it is a set to be proud of owning. I am 14 years of age and still at school. As I have built your set with such success, I am sure that any adult could do the same."—Frederick A. Window, Cann Hall Road, Leytonstone, London, E.11.

**HALIFAX.**—"I constructed the 'S.T.400' from a Pilot Author Kit in December, and have now given same a good testing. I am situated barely two miles from the North Regional Twin Transmitter at Moorside Edge; and in the valley, a few hundred feet below, I also have overhead electric wires running parallel to my aerial at a distance of about 15 yards. I admit I felt a little diffident about building the set, bearing in mind the above conditions, but 'S.T.' said it was a good set and that was good enough for me. Had I waited till the March issue I might have been put off altogether. The answer to Question 6 suggests unsatisfactory results at 6 miles. Your claims are far too modest with regard to this receiver. I can receive 38 stations (16 on the long waves, when working, and 22 on the medium waves) with the locals both working. The strength of everything received is comparable to the locals. My advice to constructors is: Build the 'S.T.400' irrespective of where you may live. Thanking you for this superlative circuit."—J. A. Lumb, Hollin Heys, Holywell Green, Halifax.

[EDITOR'S NOTE.—This is even more striking than the other letters which complain of Mr. Scott-Taggart's tendency to underestimate the performance of his set.]

**EDINBURGH.**—"Please allow me to congratulate you on your deserved success with regard to your latest set the 'S.T.400.' It is a wonderfully efficient and flexible set and a real joy to handle. For selectivity, power and purity of tone it really beats anything I have ever heard. I am not an old hand at the game, but in the last three years I have built numerous sets of all sorts and sizes in an effort to get something really good that wouldn't have to be pulled down in a few weeks' time. The 'S.T.400' has solved that problem for me in a very convincing fashion and I thank you heartily for making that possible. The 'S.T.400' is in a street by itself and exactly what I have been waiting so long for."—A. M. McKelvie, Orwell Place, Dalry, Edinburgh.

**CIRENCESTER.**—"I have just completed building your 'S.T.400' receiver. I am only 17 years old, but I found the construction of the set remarkably simple. The results are exceptionally fine in all respects, and with a Blue Spot 100U speaker the quality is better than I have heard from any receiver before. The controls of the set are very easy to use and an amazing number of foreigners are always obtainable at ample L.S. strength, and with absolutely no 'cutting-in' from any other station. I am deeply grateful to you for providing me with details of this unique set."—John M. Simmons, 11, Ashcroft Villas, Cirencester, Glos.

**OLNEY.**—"I have to say I am at last satisfied that in the 'S.T.400' I have got a set I am not afraid to show off to the most expert visitor. It is amazing how it cuts out interference and brings in the station one wants without a lot of mush in the background."—W. A. White, Midland Road, Olney, Bucks.

**BIRMINGHAM.**—"Radio Paris comes in top-

hole; not a hair of 5XX with it, and bags of selectivity to spare. This is a splendid set—a really good four-valver."—Herbert Clark, Aerodrome, Castle Bromwich, Birmingham.

**HASLEMERE.**—"I think the 'S.T.300' and 'S.T.400' are wonderful sets. I have made up both and consider them perfect."—A. J. Smith, King's Road, Haslemere, Surrey.

**CORNWALL.**—"I have built the 'S.T.400' and the results from your latest masterpiece are beyond my powers of adequately describing. So far as selectivity is concerned, it has many mains sets beaten hollow."—W. H. Curtis, Gerrano, Portscatho, Cornwall.

**DEPTFORD.**—"I am writing to offer my congratulations. Your 'S.T.400' is certainly 'the goods.' I have been fortunate enough to get America several nights running, and the amount of foreigners it will get is amazing."—H. White, Hyde Street, High Street, Deptford, S.E.8.

**CHORLTON-CUM-HARDY.**—"Compared with my old set the 'S.T.400' is an 100 per cent improvement. The tone is also much better on the 400" I get many stations I have read about but never heard before. Thanking you for a very fine

W. J. Blatchford, Durnford Street, Stonehouse, Plymouth.

**CARDIFF.**—"May I join in with the other constructors who have written to thank you for the 'S.T.400.' Maybe I am the first female to do so! I built the set just after Christmas, and have had great results right from the first night. I get a good number of stations during the day, and dozens at night. I have only built one set before. I would not part with my 'S.T.400' for anything. Please accept my thanks for a real good set."—L. G. Llandaff, Cardiff.

**CORNWALL.**—"I was interested to see a letter in your Armchair Notes condemning the 'S.T.400' as being useless in Cornwall! I have built three 'S.T.400's' with most excellent results, and I live at the extreme end of Cornwall. With my 'S.T.400' I get no interference whatever. If that disgruntled gentleman (Mr. Blake) would care to come a few miles and see me, he can hear six 'S.T.400's' and would probably change his mind about the efficiency of the 'S.T.400'!"

"Thanking you for giving us home constructors such a wonderful set."—J. T. Hall, Skewjack, Porthurno, Cornwall.

### THE "S.T.400" IN EGYPT

6, Champagnat,  
Palais de Koubeeh,  
Cairo, Egypt.

Dear Sir,

I feel I must write and congratulate you on your latest circuit—the "S.T.400."

I have just converted my "S.T.300" to the "S.T.400," and I am simply amazed at the result. I and my friends thought the "300" was "it," but we are now agreed that the "400" is streets ahead of any set on the market at its price—and of many sets at double the price!

The "S.T.400" will bring in the medium-wave National programme at 7.30 p.m. here (5.30 G.M.T.) at full strength on my speaker (Elu Spot 66R), and it is on some evenings too strong for comfort.

I can also use a Kelsey short-wave adaptor with your set and the results are everything that can be desired, especially from the new Daventry short-waver on 49 metres.

The long waves are also very well received on the "S.T.400."

I have not counted up all the stations received, but I am certain the set will bring in everything with any strength at all. You can understand why I, and all who have heard my "S.T.400," say it is a WINNER, and if you intend to design one that can beat it I think you will have your work cut out. If you do, I, for one, shall certainly build your new set, for it is sure to be something very good indeed.

Thanking you for the circuit you have given me and, incidentally, all the pleasure I and my family receive from it.

I am, Yours faithfully,  
L. H. PYKE.

set."—H. H. Duck, Barlow Moor Road, Chorlton-cum-Hardy.

**S.S. "THE PRESIDENT."**—"Gives splendid results. Give Mr. S.T. my thanks for the 'S.T.400'—a really magnificent circuit."—W. H. Brown, Engineer, S.S. "The President," c/o J. Hay & Son, Glasgow.

**BATH.**—"Having built your 'S.T.400,' here is my experience: I built this wonderful set about a fortnight ago. I took my time and made a thorough job of it, as I thought. When I switched on, the only station I could get was the National. I did not tear my hair or start to write nasty letters, but went over the set systematically.

"Then I discovered the trouble: I had used Telsen S.G. valve holder instead of W.B., and took it for granted the terminals were identical. I soon made the alteration, and—ye gods!—what a set!

"The volume is tremendous, the selectivity and tone a marvel. I am using a large Ormond unit in a 16-inch cone. The powers that be should take Nelson off his column and put a statue of 'S.T.' there instead! Thank you for the finest set yet designed."—I. G. D., Odd Down, Bath.

**PLYMOUTH.**—"It is with great pleasure that I pen these few lines of appreciation for a great set. I have been operating the 'S.T.400' for about two months: I have nothing but praise for such an outstanding set for tonal qualities, sensitivity and selectivity.

"My only regret is that you have robbed me of one of my pet hobbies, that is, making up 'my last set'; this one will positively be the last one until I see it in print that you have evolved a better one. I have made up about a dozen from a modest two-valver to a five-valve set, but this one beats the lot. Again thanking you for a fine set."

**LONDON. (E.9.)**—"May I congratulate you on your sets, the 'S.T.300' and 'S.T.400.' I have been constructing sets for the last five years, but I don't think I shall need to build any more as the 'S.T.400' is a real smasher.

"I would like to tell many constructors who have not built the 'S.T.400' how good it is on the long waves. I can receive one dozen any night of the week on the long waves."—C. Portway, High Street, Hounslow, E.9.

**BRISTOL.**—"It may interest you to know I have been a reader of your valuable journal ever since it came out, and I have built some of the circuits in it and had very good results; but I do not hesitate to say that the 'S.T.400' is by far the best yet. I wish to thank Mr. J. Scott-Taggart for the marvellous circuit."—T. O. Williams, Davis Street, Avonmouth, Bristol.

**NOTTINGHAM.**—"I built as a present for my brother an 'S.T.400' which is an absolute success. Thanking you for a wonderful set."—W. Westerman, Oremore Street, Nottingham.

**LOWESTOFT.**—"Power and performance of both sets ('S.T.300' and 'S.T.400') have been great, an honour to you."—E. F., Old Nelson Street, Lowestoft.

**MANSFIELD.**—"I have converted 'S.T.300' into 'S.T.400' and it is simply great. I can get practically anything. Hoping for more articles but no better sets."—G. H. Smedley, Intake Avenue, Mansfield, Notts.

**LOWESTOFT.**—"It is rather late in the day for me to add my quota to the letters praising the 'S.T.400.' I have had the set working since January, and it beats anything I have previously tried. Some talk about getting the last ounce out of a set, but there seems to be several last ounces (Please turn to page 56)



# LORD KELVIN

It was in a badly lit, disused wine cellar that Kelvin first began his scientific research. Converted into a laboratory, it was here that he made many of his important discoveries, and delivered many of his famous lectures. Whilst still a young man, he enjoyed a reputation that was the envy of many a veteran



scientist, a reputation that was earned, not by reason of his intellectual gifts alone, but because of his amazing capacity for tireless research.

The same might also be said of the Dubilier Condenser Company. Their present prominent position is due not to resting on laurels won many years ago, but to consistent and untiring research through 21 years of successful trading. A research, the result of which is seen in the high standard of dependability for which Dubilier Condensers and Resistances are to-day famous the world over.

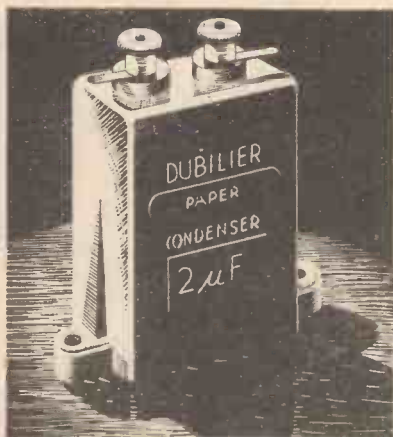

DUBILIER CONDENSER CO.  
(1925) LTD.,  
DUCON WORKS, VICTORIA RD.,  
NORTH ACTON, W.3

# DUBILIER

## CONDENSERS

You have all heard the keen men who describe what is happening at Outside Broadcasts—Captain Wakelam, Mr. R. C. Lyle, Mr. George Allison, Colonel Brand and the rest. Here are some intimate "inside" stories of



Of those

# RUNNING COMMENTATORS

WHAT is the most difficult job in broadcasting?

Impossible to answer, you say. Perhaps the engineers, whose control of the vast broadcasting machine is almost superhuman, have the most difficult task of all. Or perhaps that genius who supervises the control panel, and fades in and fades out to the fraction of a second. Or the mighty Sir John Reith. Or even that unknown hero, the commissioner, who ushers temperamental artistes into the waiting-room. Who can properly say?

On one point, however, you will probably agree. One of the most

By a  
**SPECIAL CORRESPONDENT**

difficult jobs in broadcasting is that of conducting a running commentary.

That little band of commentators, who time and time again have delighted us with their descriptions of great sporting events, are, in their own way, as great as any artistes the B.B.C. has given us.

### Most Versatile of All

Commentators are born—not made. As proof of this, I might quote the case of the world-famous boxing referee who was employed by the

B.B.C. to give a description of a popular prize-fight.

What that referee did not know about boxing was not worth knowing—but he lacked the gift of commentary. After the fight had progressed for a round or so, all that listeners heard were such remarks as: "Go on, go on—hit him!" or "Look out—mind that upper-cut!"

The most versatile of all commentators is Captain Wakelam. His strong line is Rugby football; but in the summer months he keeps in touch with listeners through his tennis, and occasional cricket, broadcasts. It was Captain Wakelam who conducted one of the first running commentaries ever broadcast—on the England and Wales match on January 15th, 1927.

### Answer to a Prayer

Nerves have no meaning for Captain Wakelam. He knows Rugby from A to Z, and all the prominent players connected with it—for it is less than seven years since he retired from the Harlequin team.

Sometimes, before the match starts, it is difficult to keep the monologue "going" without repetition. Once when Captain Wakelam had said all there was to be said, and still the teams had not appeared on the field, imagination almost failed him. And then an autogiro appeared, flying above the stands—like an answer to a prayer!

Listeners were told all about it—and a few minutes later the match started. Captain Wakelam was saved. Incidentally he was offered a flight in an autogiro during the following week as a result of his broadcast.

One more Wakelam story which is

(Please turn to page 54)

## THE FIRST CRICKET MATCH BROADCAST



The Rev. Gillingham describing a match between Essex and a New Zealand team. Few people at the time could have foreseen the recent Test Match broadcasts from right across the world.



One pair  
is all you need



COLVERN

S.T. 400

COILS



for the

**“PUSH-PUSH” FIVE**

per pair **9/10**

Send for Radio List No. 10

**COLVERN LIMITED**

MAWNEYS ROAD

ROMFORD, ESSEX.

*London Wholesale Depot: 150, King's Cross Road, W.C.1.*



Although a receiver may be sufficiently selective to separate two broadcasting stations working in adjacent channels, interference in the form of unintelligible "spitting" noises may still occur. In this article our contributor lucidly explains the reasons for this irritating trouble.

**T**SIPP—zipp—psitt—tsipp . . . Any user of a highly selective wireless receiving set knows those hateful interfering sounds only too well.

The tuning may be so knife-edged that there is no difficulty about separating the London Regional station from Stuttgart, or Sottens from the Midland Regional, or Breslau from the Poste Parisien without there being any background of intelligible interference from the unwanted station of the pair. But every now and then those hateful spitting noises force themselves through strongly enough to ruin the transmission from the entertainment point of view.

### Serious Problem

This kind of unintelligible interference is known as sideband splash, and with the large increase in the number of high-powered stations that has taken place, and is still taking place, it has become one of the most serious problems in broadcasting.

With the exception of atmospherics, most other kinds of interference are amenable to treatment. We can, for instance, get rid of heterodyne whistles between stations working with the 9-kilocycle separation of the Prague scheme by using filters with a suitable cut-off.

### Stopper Circuits

The interference produced by electrical machinery, by flashing signs, and so on can usually be prevented by fitting stopper circuits to the offending apparatus; by increasing selectivity we can ensure that there is no intelligible interference between one station and another so long as they observe the 9-kilocycle separation; even the effects of atmospheric and spark signals can be to a great extent reduced by the use of a

frame aerial or by deliberately introducing a certain amount of damping into the circuit of an aerial of the suspended type.

But so far as we know at present nothing that can be done to the receiving set is of any avail against sideband splash. Increasing selectivity is useless, for the more selective the set the worse, as a rule, does this kind of interference become.

### A Concrete Instance

The reader may have noticed that sideband splash occurs only in certain circumstances. The first condition is that one at least of a pair of stations using adjacent channels must be very strongly received.

If station A comes in much more strongly than station B, then side-

band splash will not, as a rule, be heard when station A is tuned in, but it will occur at intervals when an attempt is made to receive station B. To give a concrete instance, within fifty miles or so of Brookmans Park there is no sideband splash from Stuttgart when the London Regional is tuned in; but if you listen to Stuttgart there is splash from the London Regional.

If there are two high-powered stations using adjacent channels, both of which are received equally strongly, each will probably splash into the other. As an example, the Poste Parisien interferes in this way with Breslau, whilst Breslau returns the compliment.

And there is another condition which leads to some particularly

### SOTTENS—SWITZERLAND'S BIG BROADCASTER



Here we see the transmitting panels at Radio-Suisse Romande (Sottens), the well-known Swiss broadcasting station which works on a wavelength of 403 metres. Using a power of 25 kw., Sottens is separated by only 9 kilocycles from the Midland Regional's wavelength.



# THE MAIN SUPPLY FOR YOUR PUSH-PUSH FIVE

YOUR A  
IS

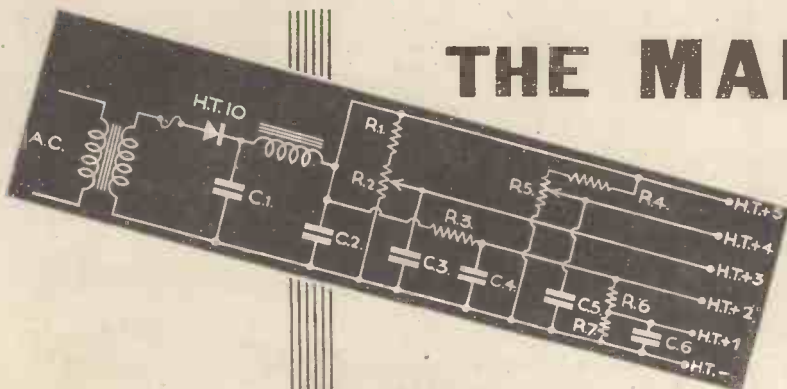

Many builders of Mr. Scott-Taggart's latest Receiver will, no doubt, wish to run it from the A.C. Mains; and Westinghouse have accordingly designed a Special Eliminator for use with this new Q.P.P. Receiver.



THE WESTINGHOUSE BRAKE & SAXBY SIGNAL CO. LTD., 92, York Road, King's Cross, London, N.1.

GET YOUR BLUE PRINT AND PARTICULARS NOW.

Enclose 6d. in stamps.

Name.....

Address.....

.....

W.C.5.

In a Q.P.P. receiver, where the anode current is naturally varying, a reliable and constant high-tension supply, with close voltage regulation is necessary, and this special eliminator, equipped with an H.T.10 WESTINGHOUSE METAL RECTIFIER, definitely meets all these requirements. Full details, circuit and blue print —together with a copy of our 44-page booklet on A.C. Mains working, "The All Metal Way, 1933" —will be sent on receipt of the attached coupon and 6d. in stamps.

would probably not be within the range of most ears.

### Other Heterodynes

But there are other heterodynes as well. The sidebands of the London Regional beat with Stuttgart's carrier. When, for instance, London is sending out C4—that is, the C four octaves above the middle, the top note of a full-compass piano—the corresponding frequency is 4,096. We have therefore on the one side of the carrier a sideband with a frequency of 847,096 ( $843,000 + 4,096$ ), and on the other a sideband of 838,904 ( $843,000 - 4,096$ ) cycles. The latter will produce a beat of 6,904 with Stuttgart's 832,000-cycle carrier.

Even if a wireless set has a good response up to 7,000 cycles, this will hardly give rise to an audible note, since during musical transmissions the attenuation of high frequencies is so great that none but feeble sidebands is produced.

### Extraordinary Interference

We can see then why it is that musical transmissions do not, as a rule, cause sideband splash; the high-pitched notes are not strong enough to be responsible for noticeable heterodyne beats.

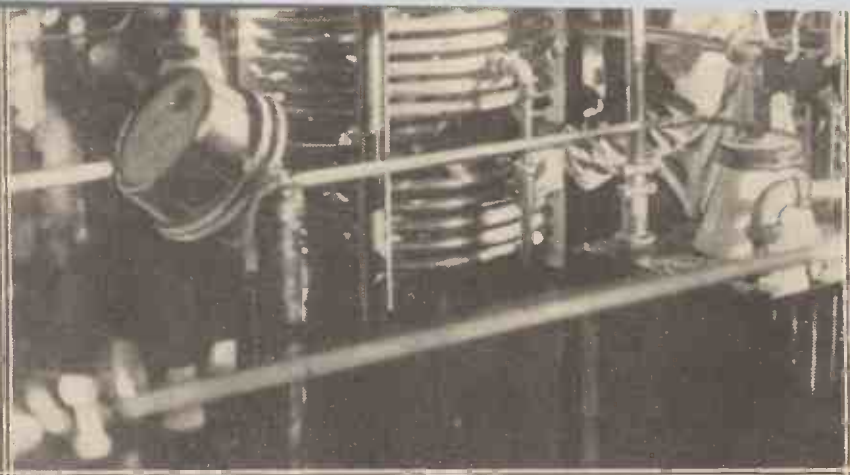

*Those listeners who have difficulty in getting Breslau or Poste Parisien without "sideband splash" will be interested in this photograph of Breslau's aerial tuning equipment. This new German station works with a power of 60 kw. and is located on 325 metres.*

Tune in Rabat and wait until there occurs an interval in his programme whilst Dublin is still sending out music. The sounds that are then heard remind one of the story of the rustic who saw a giraffe for the first time and declared emphatically "there ain't nō sich thing."

Actually music is heard inside out. Dublin sends out a 1,000-cycle note. This beats with the carrier of Rabat, 3,900 cycles away, and a 2,900-cycle

heterodyning of the wanted carrier wave by unwanted sidebands.

### A Question of Modulation

Why is it that when stations observe the 9-kilocycle separation that is regarded as the minimum for reasonably good results, or the 11-kilocycle separation that obtains between the London Regional and Stuttgart, sideband splash should

*(Please turn to page 52)*



# CONVERT YOUR EXISTING S.T.300 or S.T.400 with QUIESCENT COMPONENTS

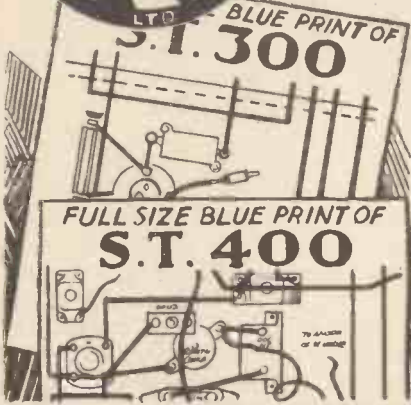

THE **Q** FULL-SIZE BLUE PRINTS SHOW YOU HOW to do so easily, efficiently and at minimum expense

Full-size Blue Prints of the "S.T.300" and "S.T.400" and many others of the most popular circuits of recent years have been issued by R.I. at 2d. each post free. The R.I. "Quiescent" Brochure gives full details of the Blue Prints available, and contains instructions and diagrams relative to the conversion of existing sets, and construction of new sets on "Quiescent" lines. Post the coupon below.

**COUPON for R.I. QUIESCENT BROCHURE and Particulars of Full-Size Blue Prints.**  
Post in unsealed 1/2d. stamped envelope.

Name.....  
Address.....

Radio Instruments Ltd., Croydon, Surrey.

Specified for the "PUSH-PUSH 5"



R.I. Q.P.P. OUTPUT CHOKE  
List No. 35. This choke acts as a highly efficient auto transformer coupling. It is more efficient in use than any ordinary push-pull output transformer. **12/6**



R.I. Q.P.P. TRANSFORMER  
List No. D.Y. 34. Primary inductance 30 henries without D.C., 20 henries with 1 m.a., 16 henries with 2 m.a. Royalty 1/6 extra. **15/-**

## FREE This big book shows how to Save Pounds on Radio running costs



PRICES IN GT. BRITAIN

90 volt	£3.3.0
120 volt	£4.2.3
150 volt	£5.1.6

Complete with Electrolyte  
Any models on Easy Hire Purchase terms

—that unique battery of everlasting nickel-cadmium cells which recharge themselves automatically from the L.T. accumulator, merely by turning a switch, and which cannot be harmed by overcharging or neglect. This interesting book shows you how hundreds of Milnes users have ended H.T. troubles for ever. No more replacement costs for them—no more

carrying to charge—no annoying background of mains hum. Their H.T. supply is always in tip-top condition, always fully charged, up to full voltage and dead silent. The Milnes Unit will save its cost within a year and will last a lifetime. Five year old units are working better than ever, to-day.

Send for this FREE BOOK to-day. It is something you should not miss. MILNES RADIO CO. (Dept. W.4) VICTORIA WORKS, CHURCH ST., BINGLEY.

It gives a full and detailed description of the wonderful

## MILNES H.T. SUPPLY UNIT

### AMAZING OFFER! ROLA P.M. M.C. SPEAKER ONLY 2/6 DOWN

The large majority of British radio manufacturers and designers of the finest "home constructor" sets, including the "S.T." Push-Push Five, use and specify British ROLA Speakers. We offer Model F6-P.M. on extremely easy terms. This Permanent Magnet Moving-coil Speaker employs a high-grade cobalt steel magnet of special design, and incorporates a universal tapped transformer for either pentode or power valves. The brilliance of tone and unrivalled fidelity of reproduction it gives will amaze and delight you. Send only 2/6 for Seven Days' Trial. If satisfied, pay further 2/6 at once, then 10 monthly payments of 5/- (cash in 7 days, 49/6). Diameter, 7 1/2 in. All other Rola Speakers on similar easy terms. Leaflet post free.

The British-made WATES UNIVERSAL METER is the only popular-priced instrument testing resistances as well as batteries, valves, circuit, and all components; 4 readings on one dial. SEND ONLY 1/6 for 7 days' trial. If satisfied, complete purchase by 5 monthly payments of 2/6 (cash 12/6).

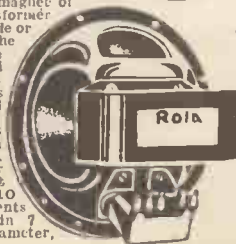

E. J. HERAUD, Ltd., Dept. C.2, NUMBER ONE, EDMONTON, LONDON, N.18  
Branches 78/82 Fove St., Edmonton; 77, West Green Rd., Tottenham; 34, St. James St., Walthamstow; and 139, Hertford Rd., Enfield Wash.



### THIS IS REMARKABLE CABINET VALUE

For all-round value, appearance and performance coupled with low price, the Camco "Popular" Cabinet is ideal. Supplied complete with baffle-board, baseboard shelf and automatic stay, it costs only 75/-. Finished in Shaded Walnut. This Cabinet is suitable for taking the Garrard Automatic Record Changer without alteration. See it at our showrooms open 9.15 to 5.45 (Sat. 12.30), and send coupon for FREE Camco Cabinet Catalogue which describes the complete range.

Camco Manufacturing Co., Ltd.  
Showrooms: 24, Hatton Garden, London, E.C.1.  
Phone: Holborn 8202.  
Works: South Croydon.



Post in 1/2d. envelope  
Name.....  
Address.....  
TOW.N.....

# WITH PICK-UP AND SPEAKER

Conducted by

A.  
JOHNSON-  
RANDALL

**R**ADIOGRAM enthusiasts often want to run two loudspeakers from their outfit at the same time. But it is not always the simple matter of two or three altered connections that is so frequently supposed.

Even if the difficulties of providing aerial and earth connections are overcome, the complete radiogram is not easily moved when one desires to listen in another room. As a complete radiogram incorporates the loudspeaker, the question immediately crops up of connecting another one externally.

Or maybe the new idea of dual speakers leads the record enthusiast to experiment with two speakers—one for high notes and one for the bass.

But a warning must be interposed here. The results from the two instruments may be far different from a commercial dual speaker which has a special input transformer.

## Worth Trying

Many difficulties lie behind certain success with two loudspeakers working together. Let us consider the usual procedure of the constructor.

He takes his two loudspeakers and blithely connects them up in series, or in parallel; perhaps he tries both ways. Possibly they work all right; he is lucky. Things have panned out satisfactorily in his case.

The matching of speaker impedances to valve impedance may be "all to pot," but that does not matter if the results suit the user's tastes. It's always worth trying.

What generally happens is that one speaker is louder than the other. This is sometimes overcome by a variable resistance. The latter is put in series with the louder instrument when the two speakers are in parallel,

and in parallel with it if series connection is employed.

Trouble from varying volume is usually worse when a moving-coil instrument is used in conjunction with an ordinary armature type. Satisfactory results are most likely when two loudspeakers of exactly similar type are used, connected either in series or parallel.

As a matter of fact, in exceptional circumstances, such connection of two

speakers in parallel their impedance is halved, or doubled when they are joined in series. Even if two similar moving-coil speakers are connected across the secondary of an output transformer intended for one, the matching is upset by the additional load on the secondary.

This scheme is sometimes adopted on commercial sets which provide sockets for an external speaker. But they are mostly portables in which the "best possible reproduction" is not a feature. Whatever the scheme used, the tendency to upset matching remains.

The only certain way of using two speakers together and retaining proper matching is to have a special output transformer, or transformers, for each particular case. Unfortunately, this usually proves a very expensive job.

Nevertheless, the foregoing shows that there is always a chance the results will satisfy you. Your attitude should be one of "try it and see."

## Using an Alternative

So far, we have assumed the two speakers are to work simultaneously. If the external speaker is required only as an alternative to the one in the radiogram, the subject is greatly simplified.

In this case, widely different types can be used. They are connected in series (or their transformer primaries are), and a single-pole change-over switch is used. The centre contact of this is joined to the common side of the two speakers. The other sides of the two speakers go each to one outside switch contact.

According to the position of the switch, so one or the other speaker comes into play.

## "WHAT'S THE TIME?"



*This is the ingenious device which answers telephone calls in Paris and automatically speaks the hour and minutes to the subscriber who inquires.*

similar speakers might provide better matching for the output valve than one by itself, in the case of a home-constructed outfit. But this would not apply with a commercial radiogram or design in which one special loudspeaker is specified.

You see, by connecting two similar



# FOR THE "PUSH-PUSH FIVE"

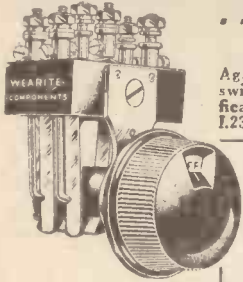

... another WEARITE SPECIFICATION

Again the unrivalled experience of Wearite in switch design has prompted another solus specification. Mr. John Scott-Taggart uses a Wearite I.23 for the "Push-Push Five." Follow his lead.

## The WEARITE ROTARY SWITCH

Made in 1-6 way D.T. Use the I.23 for your "Push-Push Five." Price

**4/-**

use these Wearite Parts too ...

- 1 pair "S.T.400" coils Price 9/10 per pair
- 1 S.G. Choke H.F.O. " 6/6
- 1 Reaction Choke H.F.P. " 3/6
- 1 "S.T.400" Screen 1/9, and Foil 6d.
- 2 2-pt. Switches (G.S.P.) Price 1/- each



THE H.F.O. CHOKE

## WEARITE COMPONENTS

WRIGHT & WEAIRE, LTD., 740, HIGH ROAD, TOTTENHAM, N.17.  
Telephone: Tottenham 3847/8/9.

♥ 2681

# RE-WIRE YOUR SET WITH THE NEW SUPERFLEX CONNECTING WIRE

Foreign.

AND IMPROVE YOUR RECEPTION

Flexible Cellulose Varnish Insulation. No Cotton Covering. No frayed edges after wiring. Tested to 5,000 volts. Stocked by all recognised Dealers. Beware of Imitations.

18 S.W.G.  
10 ft. and  
Gross yd.  
Coils.

ELECTRO INSULATORS LTD., MEADOW WKS., SHEFFIELD 3

## MAGNUM SUPERHET SHORT-WAVE ADAPTOR MODEL T.S.H.

An entirely new design which utilizes the amplification of every valve in the set. Including two Coils and Battery cord. 45/- or complete with valve, H.T. and L.T. batteries . . . . . 63/-  
Send for particulars of this and list of latest short-wave stations. Free on request.

8.T.400 MAGNASCREEN specified for the PUSH.  
PUSH V. . . . . - 1/9  
Foil . . . . . - 9d.

BURNE-JONES & CO., LTD.

"MAGNUM" HOUSE,  
296 BOROUGH HIGH STREET, LONDON, S.E.1

Telephone: HOP 6257 & 6258.



Scottish Agent: Mr. Ross Wallace, 54, Gordon Street, Glasgow, C.1.

# ESSENTIAL FOR battery operated Q.P.P.



the new day

## DOUBLE CAPACITY ACCUMULATOR

- Revolution! A new accumulator no bigger than the standard 40 a.h. type, yet each charge lasts you twice as long (its capacity is 80 a.h.s.)! Isn't such a performance essential for Q.P.P.?
- The secret? Elimination of the weight-and-space-wasting accumulator "plates" idea. John Fuller, friend of Faraday and battery pioneer, dreamt of it, though perfection has taken two generations more.
- The new accumulator is almost unbreakable and has an amazingly longer life. Beautiful Bakelite case. Thousands in use. Get the BLOCK booklet to-day.

80 AMP. 2. HRS. V. 11/6

# BLOCK Plate-less Accumulators

BLOCK BATTERIES LTD., ABBEY RD., BARKING. TEL. GRA 3346

## CAN TELEVISION BE REAL?

A number of readers have written in as a result of Mr. Scott-Taggart's provocative article in the March issue. Below we publish a highly interesting letter apropos this article, together with Mr. Scott-Taggart's comments.

Dear Sir,—Apropos your interesting article on the above, I should like to mention a point often omitted in discussions on this subject. You say, "What time would you allow between an actual happening and the 'viewing' of it?" Assuming that we hear the sound reproduction in the ordinary radio way, I would suggest there is, or should be, a direct relation between the "seeing" and the "hearing" of the event.

When in actuality we see a friend move his lips in speech, if he is, say, 3 feet away, we hear him a matter of .033 second after; similarly, if he then moves to 50 ft. the time lag will be .5 second approximately. Realism.

### Not Convincing

If we were to televise the procedure, what would happen? At the 3 ft. distance everything would be right, but at 50 ft., although we should probably see him correctly, his proximity to the microphone (invariably near) would give a misrepresentation of the situation (unless he had raised his voice well and truly!), and the effect would not be rectified if the viewer at the receiving end were the appropriate 50 ft. away from the vision and sound apparatus, since, for one thing, the image would not be of life-size; for another, even if it were, the viewer would be virtually 100 ft. away visually and only 50 ft. aurally, and the result would not be convincing.

### Relative Properties

If the transmitting apparatus is at a distance from the subject, the microphone will actually receive the lower frequencies in a less degree than the higher, depending upon the distance; in other words, the fundamentals will be received less than the harmonics, and these proportions must be maintained at the receiving end if realism is to be preserved; (assuming, of course, a perfect amplifier). It is this relative proportion of high and low frequencies, and its combination with the visual conception of distance, that determines the

realistic effect (or otherwise) produced. However good the image or however level the audio-frequency response, for absolute realism the two perspectives cannot be divorced. If in television we get these proportions somewhere near right, I do not think it matters whether the process takes a whole second or a minute fraction, provided we get it sufficiently in advance of the sound to be realistic; and we already know how long the sound takes.

At the present moment we receive the image at the speed of light, and

### CATHODE-RAY TELEVISION



The use of the cathode-ray is one of the latest methods of attacking the television problem, the picture appearing at the round end of a cathode-ray tube. Such tubes are similar to the one shown in the above photograph.

although mechanically produced, or guided, it is not mechanically or even purely electrically propelled; it is still travelling at light speed. After all, we accept ordinary radio reproduction as being truthful, with all its dismembering and reassembling processes. Of course we do; it is simultaneous; in fact, we frequently hear it more quickly than do those at the far end of the transmitting studio.

So, personally, in answer to your original question, I think there is not much choice left for us, since one of the two factors is fixed.

In conclusion, I know several enthusiasts eagerly awaiting the first WIRELESS CONSTRUCTOR Television set!

Yours faithfully,

SIDNEY B. JOSEPH.

"Woodburn,"

Southbourne Overcliffe Drive,  
Bournemouth.

February 20th, 1933.

Mr. Scott-Taggart comments on this letter:

The correspondent introduces what is another possibility, namely, lack of realism due to faulty synchronism between, say, the movement of lips and the sounds emerging from them. I do not see how, in practice, such lack of truth would arise in television, but the point reminds me of a curious example of reality which would not seem real:

### All Reality Gone

Suppose a man is talking to you at a distance of 10 ft. The sound reaches you a fraction of a second after his lips have moved. Remove the man three hundred yards away and make him shout. You will hear the shout one second after his lips (as seen through a telescope) have ceased moving. Theoretically, we could move the man still farther away and the time taken for the sound to reach you would lag so far behind the sight of what he was doing that all sense of reality would be gone. By the time his shout "Hey!" reached you his back might be turned!

All this, however, has nothing directly to do with my article, which concerns the reality or otherwise of a delayed television. I maintain that if a talkie is first made and then transmitted, it is as real as direct television. I hate to come to such a conclusion, and would like to be proved wrong.

### A Good Point

Mr. Joseph makes a good point in saying that we are given no choice. He suggests that since real speech comes over instantaneously, we cannot delay the picture. I disagree, however with his conclusions. Surely, we can "tin" the sound on a piece of celluloid just as easily as the picture? We then tele-transmit this talkie one second, one minute or one hour after it has all occurred.

It will seem perfectly real to the person with a television receiver.

I also disagree with Mr. Joseph's suggestion that we receive the image

(Please turn to page 56).



# PERTRIX

NON SAL-AMMONIAC

H.T. BATTERIES

FOR

## Q.P.P. RECEIVERS

A COMPLETE RANGE FOR QUIESCENT  
PUSH-PULL CIRCUITS :

120 volts Pertrix Battery, Cat. No. 320, price 16/3.  
Tapped at every 1½ volts from 110 to 120 volts. A 15-volt  
G.B. section is included in the same carton. Dimensions:  
10 1/8" L. x 5 1/8" W. x 3" deep.

130 volts Pertrix Battery, Cat. No. 321, price 17/9.  
Tapped at every 1½ volts from 120 to 130 volts. An 18-volt  
G.B. section is included in the same carton. Dimensions:  
11 1/8" L. x 5 1/8" W. x 3" deep.

150 volts Pertrix Battery, Cat. No. 322, price 21/9.  
Tapped at every 1½ volts from 135 to 150 volts. A 24-volt  
G.B. section is included in the same carton. Dimensions:  
14 1/8" L. x 5 1/8" W. x 3" deep.

159 volts Pertrix Battery, Cat. No. 323, price 20/9.  
Tapped at every 3 volts from 120 to 159 volts. A 9-volt  
G.B. section is included in the same carton. Dimensions:  
7" L. x 6 1/8" W. x 5 1/8" deep. This battery is specially suitable  
for Pye "G.B." Receivers.

FOR BEST Q.P.P. RESULTS FIT PERTRIX.

**BRITANNIA BATTERIES LTD.**

233, Shaftesbury Avenue, London, W.C.2.  
Telephone: Temple Bar 7971 (5 lines).  
Works: Redditch (Worcs.).

Are you interested in

MOTOR CARS  
AEROPLANES  
INVENTIONS  
HOBBIES ?

—Then you will most certainly revel in  
*Modern Boy!* For this is the paper for the  
youth of to-day, brimful of the things that  
interest you most, fascinating facts, ab-  
sorbing articles and thrilling fiction—in-  
cluding adventure stories that will hold  
you spellbound and grip you every time.  
A clean, healthy paper that you'll read and  
enjoy from cover to cover. If you don't  
have it regularly, give yourself a treat and  
buy a copy to-day—it's the best two-  
pennyworth of all!

# MODERN BOY

The Paper For the Boy of To-day.

2d.

Every Saturday

# ROLA

*the World's Finest Reproducers*

To Obtain the Maximum Results from Your  
**S.T. PUSH-PUSH FIVE**

Pay a Little Extra and Get the Best.  
USE

**ROLA MODEL F6-PM-Q.P.P.-220A**  
(Price - - 52/-)

● **CLASS B AMPLIFICATION**

The following Rola Speakers are now ready for the new Class B Valves:

MULLARD 240 B VALVE

ROLA F5-PM-14-Class B - 32/6 or ROLA F6-PM-01-Class B - 49/6

MULLARD PM2B VALVE

ROLA F5-PM-12-Class B - 32/6 or ROLA F6-PM-08-Class B - 49/6

Write to-day for the Rola folder.

THE BRITISH ROLA CO., LTD.  
Brondesbury Works, 179, High Road, Kilburn,  
Telephoné: MAIDA VALE 5017-8-9 N.W.6

● **EXTENSION  
SPEAKERS**

There is a correct  
Rola Extension  
Speaker for prac-  
tically all British  
radio receivers.  
Write for list.

**ROLA  
SPEAKERS**

for better  
Radio Reception

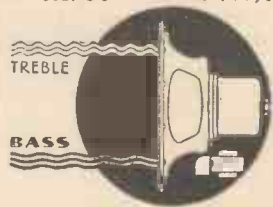

This is just  
the Set



for which the  
**AMPLION M.C.22**  
**Q.P.P. Speaker**  
was designed

Q.P.P. sets will give "all-mains" reproduction if care is taken in the choice of components. The correct speaker in this particular set is most important; the Amplion fills every requirement and should be fitted. The greater sensitivity of the Amplion is very apparent when bringing in distant stations, there is no necessity to overload to obtain audible strength, and when receiving more adjacent stations no boom is present.

Any dealer can supply.

PRICE **39/6**

**AMPLION**

AMPLION (1932) LTD., 82/84, Rosoman Street, London, E.C.1.



## OUR NEWS BULLETIN

### Is It Justified?

And how much of the money subscribed by listeners for a British broadcasting service was spent by the B.B.C. for example, on television? There are only approximately 3,000 to 5,000 people in this country with television apparatus, but the B.B.C. must be spending quite a lot of money on its television transmissions. Is it justified?

Think about it

### Where the Money Goes

Here are a few more figures. The income for the year totalled £1,628,738—of which £1,306,453 was received from licences and £322,284 from publications.

The balance on the year's working, with £1,217 brought forward from the previous year, amounts to £253,776. The expenditure on programmes, including payment of artistes, orchestras, news, royalties, performing rights, etc., etc., salaries and expenses, amounted to £663,424. Salaries, administration expenses, etc., accounted for £77,173, and Governors' fees, £5,642.

### The Perfect Programme

The B.B.C. are stated to be looking for the perfect humorous programme and the means of transmitting it, for in their Annual Report dealing with revue and vaudeville the Governors state that last year "many new experiments were made in methods of presentation, and the search for original material continued."

"The problem of conveying humour purely by aural methods within the limitations of microphone and programme policy has not yet been solved. The success of humour depends more than is generally realised upon visual impressions and on an audience."

### Your Bright Idea

That is certainly one of the big problems in radio entertainment—to work out a technique of humour depending entirely on aural presentation. If readers have any ideas on

(Please turn to page 51)

### Our Indispensable B.B.C.

THE B.B.C. Report for 1932 (published by the Stationery Office, price 4d.) is a heartening document, for it shows how remarkably steady has been the progress of broadcasting in this country. And, despite all the unkind things said about the B.B.C., it is pretty evident that the service given by the B.B.C., whatever its faults, is becoming to be regarded more and more as indispensable.

### Steady Progress

To start with, the number of licences issued—which in December, 1931, was 4,330,735—increased during the year to 5,262,953. These figures include licences issued free to the blind, which increased from 28,981 to 34,854.

### Programme Expenditure

Net revenue increased during the year by £203,388; while the net increase in licence revenue, as reduced by the Corporation's grant to the Exchequer, was £127,421, and the net revenue for publications increased by £84,450. The increase in the expenditure on programmes was small, owing to economies.

### Empire and Regional Costs

Expenditure on Regional and Empire transmitters accounted for £62,670; while £111,997 was spent on additions to plant, etc. The Corporation has offered to forgo a further £250,000 to the Treasury in 1933-34, and so in 1932 the proportion of the licence fees available for the B.B.C.'s use, after taking into account Income Tax provision shown in the revenue account, was approximately 4s. 7d.

### Less than Half

Readers are asked to think about this. Out of every 10s. you pay for a licence fee, the B.B.C. only gets 4s. 7d. these days.

Think about it.



**OUR NEWS BULLETIN**

—continued from page 50

this subject, they are advised to shoot them in to the B.B.C. Who knows? You might have a bright idea which will get you a very nice job in the Entertainment Department.

**A Reshuffle**

A lot of reshuffling is going on at Broadcasting House these days, and the Control Board is likely to be reorganised pretty completely.

Rumours are rumours, but, on the other hand, there's never smoke without fire, and we hear that in particular drastic changes are likely in the Programme Department. More of this anon.

**German Growth**

Licence figures from Germany are interesting, for the latest figures show that listeners increased by 52,651 during February, while the total on March 1st was 4,480,251. Of these, 551,693 are licences issued free to unemployed people; an innovation in Germany which has not yet taken root over here.

Incidentally, this unemployment figure shows an increase of 17,446 during the preceding month. The actual increase in paying listeners, therefore, is only 35,025.

**French Improvements**

It is reported that France will shortly be on the air with eight new broadcasting stations, two of which—Toulouse and Rennes—will have a power of 120 kilowatts, as against a power of 50 kilowatts for the most powerful British station.

The other stations are at Lyons, Lunoges, Bordeaux, Nice, Marseilles and Lille; and all except Lyons—which is a 90-kilowatt station—will have a power of 60 kilowatts. So France will shortly be second only to Russia in the amount of power used for wireless transmission. Germany comes next, and then Great Britain.

**Radio in the House of Commons**

It was suggested in the House the other day by a Member of Parliament that a wireless set should be installed in one of the committee rooms of the House of Commons, in order that members might have an opportunity of hearing broadcast Inter-Imperial or International statements of policy from time to time.

The reply was that the suggestion was fully considered three years ago, when it was strongly opposed by practically all sections of the House, and as conditions have not altered since, it is pretty apparent that the M.P.'s will be denied an opportunity of tuning-in at the House.

Which is a pity—because if M.P.'s in their spare time (if any) could hear Mabel Constanduros or John Tilley it might brighten their lives a little and inspire them with the idea of brightening the lives of those who voted for them to be Members of Parliament.

**The Past Year**

A new high record in the year's trading was set up by the radio industry in 1932, according to figures published to-day (March 28th) by a leading radio trade journal.

The gross turnover for the year, at retail values, is given in the third Statistical Survey carried out by "The Wireless and Gramophone Trader" as £36,627,425. Of this total £4,000,000 represented imported goods. 1,436,849 factory-made receivers of all classes were sold during the year, equalling a cash value of £19,323,198.

**5 New FERRANTI Transformers for QUIESCENT PUSH-PULL**

- 1 Type AF11c. Ratio 1/10. Inductance 50/25 hys. 0/10 m/A. Good amplification curve, giving approximately double the amplification at 50 cycles hitherto obtainable. Price **34/-**
- 2 Type AF12c. Ratio 1/9. Inductance 30/15 hys. 0/6 m/A. A lower priced transformer which yet has a good performance and a higher step-up than others in this price class. Price **15/-**
- 3 Type OPM11c. P.P. Output Transformer. Ratio 35, 56 and 100/1. Specially suitable for use with AF11c. will carry a current, if necessary, up to a maximum of 100 m/A in Q.P.P. (200 m/A in ordinary P.P.). For operating low resistance M.C. Speakers. Primary Res. approx. 230 ohms. Price **26/6**
- 4 Type OPM12c. Ratio: 1-7 and 40/1. To correspond in quality with the AF12c. Carries D.C. Primary Current up to 75 m/A in Q.P.P. (150 m/A in ordinary P.P.). For use with high resistance Speakers or low resistance M.C. types with or without built-in Transformers. Primary Res. approx. 210 ohms. Price **15/-**
- 5 Type OPM13c. Ratios 1-7, 2.7 and 4-5/1. Also specially suitable for use with the AF11c. but for operating high resistance Speakers of any kind, including M.C. Speakers with built-in Transformers. Max. D.C. Primary Current 100 m/A in Q.P.P. (200 m/A in ordinary P.P.) Primary Res. approx. 230 ohms. Price **26/6**

**ALL PRICES INCLUDE PUSH-PULL ROYALTY**

NOTE.—Either of these Quiescent Push-Pull A.F. Transformers may be used with any of the three Output Transformers mentioned above. Both the AF11c and AF12c types may be used in ordinary Push-Pull circuits, or as straight A.F. Transformers.

This system enables much greater power to be obtained from Battery Operated receivers and amplifiers for a given expenditure of High Tension Current than has hitherto been possible. In fact, by its use, Power Output and Volume comparable to that given by the average Mains set are obtainable, even when employing the small H.T. Batteries in common use.

Ferranti Ltd. have produced these five transformers to enable the experimenter to obtain the best possible results from the Quiescent Push-Pull system.

It will be noted that the inductances and ratios of these new Ferranti Transformers are unusually high.



**FERRANTI TRANSFORMERS**

FERRANTI Ltd., Hollinwood, Lancs. London: Bush House, Aldwych, W.C.2

**NEW "BLUE SPOT" P.M.—M.C. SPEAKERS**



**ONLY 2/6 DOWN FOR 7 DAYS' TRIAL**  
Balance on Easy Terms.

"BLUE SPOT" MODEL 45P.M., unquestionably a speaker in a class of its own. Send only 2/6 for 7 days' trial; if satisfied, pay further 5/- at once, then six monthly payments of 7/6. (Cash in 7 days, 45/-).  
Mahogany Cabinet Model, 62P.M., incorporating the above chassis, 2/6 deposit, 5/- after 7 days, then nine monthly payments of 7/6. (Cash in 7 days, 67/6).



"BLUE SPOT" MODEL 29P.M., a brilliant moving-coil speaker at a very moderate price. Send only 2/6 for 7 days' trial, if satisfied, pay further 5/- at once, then six monthly payments of 5/-. (Cash in 7 days, 32/6).  
Oak Cabinet Model, 22P.M., incorporating the above chassis, 2/6 deposit, 5/- after 7 days, then six monthly payments of 7/6. (Cash in 7 days, 45/-).

For further details of these speakers see the "Blue Spot" advertisement on Cover iii. We can supply any "Blue Spot" product on easy monthly term. Write us.  
**E. J. HERAUD, Ltd., Dept. C.3,**  
**NUMBER ONE, EDMONTON, LONDON, N.18.**  
This is our Full Postal Address. Est. 34 years.

**AN OVERWHELMING SUCCESS**  
**S.T.300 & 400 OWNERS**  
all over Great Britain and Abroad are NOW getting  
**SIMPLIFIED DE LUXE TUNING**  
by fitting  
**F.W.G. COUPLER REGISTERS**  
Patent applied for  
Mechanically accurate and automatic in action, giving a definite dial reading for every station; the certainty of control imparted to your set will increase its capabilities beyond belief. Couplers cannot be unintentionally moved and their correct use is assured.  
**NO MORE STATIONS MISSED**  
through temporary fading or interval  
**GET YOURS NOW**  
"A BRAIN WAVE," says one purchaser.  
**Fitted in Five Minutes—NO DRILLING**  
Per Set of three **1/9** with full fitting and operating instructions post free  
**F.W.G. PRODUCTS**  
86, Woodfield Ave., Penn, Wolverhampton

Write for Illustrated Catalogue of  
**RADIO-GRAMOPHONE CABINETS**  
of exclusive modern design, made by craftsmen, in highly figured Oak, Walnut, or Mahogany, post free.  
Remarkable Values Cabinets made to order a speciality. Maker, under licence of the  
**HOWE BOX BAFFLE.** Recommended by the B.E.C. Full details on request.  
**GILBERT** Cabinet Maker  
**SWINDON.** Estimates Free. Est. 1866

**AN AUTOMATIC LIGHTNING SWITCH**  
Some suggestions for the experimenter.

Is an earthing switch better than a lightning arrester? Certainly a debatable point, and one not so easily decided!

One thing we do know about lightning is its aversion for going round corners. That's why the earthing switch should be outside the window—unfortunately, the most inconvenient place for it.

But the constructor who is handy at "rigging up" things can control the switch from his set. Here is an idea for a gadget which automatically earths the aerial when the receiver is switched off.

**Adapting a Bell**

You must work out the details for yourself. An electric bell pulled to pieces will provide most of the materials.

An armature is connected to the aerial, and one end is bent at right angles. This part is cut into sharp serrations which touch an earthed "contact."

The idea is to place the bell magnets so that when energised they move the armature and break the earthing of the aerial. At the same time, a contact on the armature must come up against another contact joined to the set's aerial terminal. (These contacts should be those normally used for making and breaking the current through the bell.)

**The Re-Winding**

The bobbins on the magnets are rewound with many turns of fine enamelled or single silk-covered wire. The resistance of the two windings together should be about 20 ohms. The actual gauge will depend on the room available on the bobbins, and a little experimenting will be necessary. Use as big a gauge as possible consistent with obtaining the desired resistance. The ends are joined to the filament terminals of one of the valve holders.

When the set is switched on, current flows through the windings and causes the armature to connect the aerial to the set. Either a weak spring or the force of gravity may be employed to return the armature when the set is switched off.

A. S. C.

**WHAT IS "SIDE BAND SPLASH"?**

—continued from page 44

occur when the unwanted station is sending out speech? It is mainly a question of modulation.

During a musical transmission the control-room operator knows that very big variations are going to take place in the volume of sound produced in the studio or the concert hall. There is an enormous difference between *pianissimo* with only the violins in action and *fortissimo* with a full orchestra working its hardest. To avoid blasting he therefore keeps down the general sound level, which means that the average depth of the modulation is not very great.

**No Blasting**

But during a speech transmission circumstances are entirely different. The announcer or the topical talker is not, as a rule, addicted to *pianissimo* or *fortissimo* passages. The possibility of blasting is ruled out, and it is the general practice in control-rooms to put up the sound level considerably, which means that the average depth of modulation is much greater than it is during musical transmissions.

Now there are in speech certain very strong combinations of consonants such as ST, SP, TS, PR and TR, which give rise to remarkably high frequencies. Most of these sounds are produced by miniature explosions in the mouth of the speaker.

Repeat out loud words such as "strictest," "specialisation," "psychology" or "spirited." You will soon see that in making some of these sounds the tongue is driven violently away from the teeth; for others the lips are forced away from one another by the passage of air from the lungs; for others, again, quite an appreciable effort is required to drive air between the almost closed teeth or between the tongue and the teeth.

**You Cannot Filter**

The frequencies corresponding to such sounds range between 6,000 and 7,000 cycles. There is little attenuation, and these strong sounds produce correspondingly strong sidebands.

Now suppose that you are listening to Stuttgart whilst the London Regional is transmitting speech. A strong 7,000-cycle sound made in the London studio will cause a 4,000-cycle beat and you will hear one of those unpleasant "zippys."

(Continued on page 53)



# OF COURSE!

Mr. Scott-Taggart chose a Celestion Speaker for his latest receiver The "Push-Push Five"



It was only to be expected, when Mr. Scott-Taggart designed a Q.P.P. set, he naturally chose a Celestion Speaker. His choice was based on previous experience because he knows that the tonal quality and sensitivity of a receiver depends upon the Speaker. Experts realise the superiority of Celestion Speakers. A Celestion Speaker was specified for the first Q.P.P. Receiver ever designed in this country. Since that date, Celestion have introduced a complete range of Speakers specially designed for Q.P.P. amplification. When you build this new Scott-Taggart circuit, make certain of getting the finest results with the Q.P.P. 19a.

The Speaker illustrated above is the Q.P.P. 19a, for use with Mazda Pen/220A and equivalent valves in Quiescent Push-Pull. Price 50/-, including special transformer.

CELESTION LTD., LONDON RD., KINGSTON-ON-THAMES.

London Showrooms: 106, Victoria St., S.W.1.

# CELESTION

The Very Soul of Music

THE FOREMOST NAME IN SOUND REPRODUCTION

## WHAT IS "SIDEBAND SPLASH"?

—continued from page 52

You cannot filter them out, for to do so you would have to make the cut-off of the set something like 3,500, which would rob music of most of its brilliance.

A tour over the medium waveband with a highly-selective receiving set will show that some stations are much worse offenders than others in the matter of producing sideband splash. These are the stations which habitually raise their general sound level during speech transmissions to something too high for the comfort of their wavelength neighbours.

### Increased Service Range.

There is only one way of curing the evil of sideband splash. This is for the authorities in all countries to agree that deep modulation shall not be used during speech transmissions. The only thing to be said in favour of deep modulation is that it does increase to some extent the service range of a station.

## NEXT MONTH

The June issue of

"The WIRELESS CONSTRUCTOR" will contain full particulars of A WESTECTOR SUPERHETERODYNE RECEIVER with "CLASS B" AMPLIFICATION

On Sale May 13th.

Everyone who has tried for American stations knows that there are some nights when the carriers of certain stations can be heard, though they cannot be resolved into intelligible speech or music. They probably could be so resolved if deep modulation were employed.

### Due to Overloading

But there is nowadays no particular point in extending the service area of stations, which is already large enough. And, further, deep modulation means that within the service area it is extraordinarily difficult to receive transmissions without that horrible form of distortion due to overloading.

Sideband splash is definitely a menace to the progress of broadcasting, for it means that the highly-selective receiving set labours under a tremendous handicap. Is it not then for the authorities of European countries to come together and to arrive at an agreement which will give fair play to all?

FOR EVERY SET—there's a

## PILOT AUTHOR KIT

CASH—C.O.D.—or H.P.

## PUSH-PUSH FIVE

(Described this month.)

### KIT "A"

Author's Kit of specified parts, including READY-DRILLED PANEL, but less valves, cabinet and speaker. Cash or C.O.D. Carriage Paid.

£5-14-6

SEND ONLY

10/6

Balance in 11 monthly payments of 10/6

### KIT "B"

As Kit "A" but with valves.

SEND ONLY 16/6

Balance in 11 monthly payments of 16/6

Cash or C.O.D. Carriage Paid

£9-0-0

### KIT "C"

Complete with valves, cabinet and combined shelf and baffle, but LESS speaker.

SEND ONLY 18/7

Balance in 11 monthly payments of 18/7

Cash or C.O.D. Carriage Paid

£10-3-0

1 Celestion C.T.1715 Q.P.P. loud-speaker, fitted with Q.P.P. transformer (Cash or C.O.D.) 2 10 0

or 12 monthly payments of 4/7. NOTE. The R.I. D.Y.35 Choke has not been included in the Kit Cash Prices. If required, add 12/6 to each Cash Price or 1/3 to each monthly payment.

## KIT-BITS

Selected C.O.D. Items for "Push-Push Five." You pay the postman. We pay post charges over. 10/-

- 1 Varley Q.P.P. transformer, type D.P.36 2 s. d
- 2 Ormond .0005-mfd. var. condensers, 17 6
- 5 Valves, as specified 15 0
- 1 Peto-Scott cabinet, as specified 3 5 6
- 1 Peto-Scott combined shelf and baffle-board for above 19 6
- 1 R.I. O.P.P. choke, D.Y.35 3 6

## EXCLUSIVELY SPECIFIED

### PETO-SCOTT OAK CONSOLETTA CABINET

Specially designed at the request of Mr. John Scott-Taggart for his "Push-Push Five." In handsome Figured Oak and Silk Covered Fret CASH or vignettted C.O.D. ready to take 19/6 set panel. Combined Speaker Baffle and Shelf 3/6 extra.



## S.T.400 BATTERY MODEL

KIT "A" DELIVERED CARRIAGE PAID ON FIRST PAYMENT OF

8/9

Author's Kit of specified parts, including FREE BLUE-PRINT, ready drilled panel and foil-covered baseboard, but less valves and cabinet.

Balance in 11 monthly payments of 8/9 OR CASH or C.O.D. £4-15-0 Carriage Paid.

### KIT "B"

As Kit "A" but with valves less cabinet. 12 monthly 12/3 payments of 12/3 Cash or C.O.D. £6.14.3 Carriage Paid.

### KIT "C"

As Kit "A" but with valves and cabinet. 12 monthly 14/- payments of 14/- Cash or C.O.D. £7.11.3 Carriage Paid.

## PETO-SCOTT CO. LTD.

77, CITY ROAD, LONDON, E.C.1. Telephone: Clerkenwell 9406/7. West End Showrooms: 62, High Holborn, London, W.C.1

**RADIO  
MAINS  
POWER**



No matter what your problem in mains working, Heyberd—the mains specialists—can help you. Mains Units or Mains Unit Kits for all receivers. Mains Transformers and Chokes, the choice of every designer and amateur constructor. The Transformer illustrated below is Model W:31 for use with Westinghouse HT.8 Metal Rectifier. Rectified Outputs: 200v. or 250v. at 60 ma. L.T. 2+2v. 1 amp. and 2+2v. 5 amps. All models guaranteed twelve months.



Send NOW for special Handbook

Tear out this ad. and send, with 3d. stamps and your name and address, for 36-paged illustrated Handbook "Mains Power for your Radio." Packed with hints and diagrams.

F. C. HEAYBERD & CO.  
10, Finsbury St., London, E.C.2



**24 PAGES**

full of simple, pictorial diagrams which anyone can follow, showing easy alterations to make your wireless set right up to date at minimum cost. Illustrates numerous "gadgets" of use to every set owner and constructor.

Write Dept. C.,

A. F. BULGIN & Co. Ltd.,  
Abbey Road, Barking, Essex.

SEND NOW FOR THIS NEW RADIO GUIDE FREE ON APPLICATION

**RADIO SUPPLIES**

Send your list of Radio needs for our quotation—Kits, Parts, Sets, etc. Everything in Radio stocked; prompt delivery—7 days approval. Catalogue free. Raylex and standard Wet H.T. replacements stocked.  
C. TAYLOR, 57, Studley Rd., Stockwell, London.

THE PICTURE PAPER WITH THE MOST NEWS  
**SUNDAY GRAPHIC**  
and Sunday News

PLEASE be sure to mention "Wireless Constructor" when communicating with Advertisers. THANKS!

**THOSE RUNNING COMMENTATORS**

—continued from page 40

too good to be missed. During a match at Swansea between Wales and France, the captain was asked to broadcast an occasional sentence on the state of the match in French—for the benefit of listeners over the Channel. His own French being a little shaky, he persuaded the French Consul to write down the sentences, which he then read into the microphone.

**A Jumble of Horses**

And on the following Monday, he heard, through an unofficial channel of the B.B.C., that though his French accent was excellent, his *grammatical construction was very weak indeed!*

Mr. R. C. Lyle, who undertakes the annual Derby broadcast, has the most difficult of all commentary jobs. He is an old cavalry officer—and a most amazing man. As all racegoers know, the Derby is usually a jumble of horses from start to finish, and it seems only possible to distinguish a particular horse by the colours which his jockey wears. Yet the Derby commentator himself is—*colour blind!*

How is it done? Mr. Lyle says that he has schooled himself to distinguish shades. In addition, he knows the physical characteristics of practically every racing jockey, and the *patterns* of the owners' shirts. In this way he can pick out any horse in the race. It sounds almost like a miracle.

**Enormous Concentration**

Mr. Lyle who, in addition to the Derby, has broadcast on the St. Leger and the Grand National, speaks of the enormous concentration required for his particular type of work. A single broadcast exhausts him as much as a day of severe manual labour.

Mr. George Allison, beloved of Soccer enthusiasts, is, perhaps, the best-known commentator of all. His fluency of speech is astounding. The present writer, in timing Mr. Allison's description of a Cup Final, discovered that he spoke nearly eleven hundred words in five minutes! And the game lasts an hour and a half—to say nothing of incidental descriptions of the crowd, a summing-up of the match, and so on.

How does Mr. Allison distinguish the many players he has to describe? In the first place, he knows many of them personally, for his life is bound up in the game.

Failing personal acquaintance, he has a happy knack of picking on any peculiarity of appearance—whether a player's sleeves are rolled up, the length of his shorts, and so on—and remembering it.

**All Was Forgiven**

Colonel Brand, who shares with Captain Wakelam the tennis broadcasts from Wimbledon, was once taken into custody for going into the commentator's box! A policeman, who took him for an audacious pilferer, led him sternly by the arm to Major Larcombe, who has charge of the Wimbledon tournament. Explanations followed, of course, and all was forgiven.

**THE "PUSH-PUSH FIVE"**

—continued from page 14

A potentiometer for grid bias was not found to be essential; the desirable steady current of 2 milliamps. being obtainable by a suitable choice of G.B. and auxiliary grid voltages.

The construction of the set calls for no special warnings, except that the anode tuning condenser should be fitted after the radiogram switch is in position and the latter's wiring completed.

**Definitely Economical**

The total current taken by the set is about 8 milliamps. The pentodes take 4 milliamps., the detector and first L.F. are definitely economical, and only the S.G. valve is at all greedy.

The screen voltage can often be reduced where economy is a consideration, and a 0.9-volt Siemens' cell could also be connected next to the grid in the grid circuit of the S.G. valve for a similar purpose.

During operation, the total consumption of the set varies greatly, and if you always use the set at full power you are not going to save much in the way of H.T. Remember that you can obtain much greater volume with the same H.T. consumption, or a 50 per cent saving of H.T. if you are satisfied with reasonable signal strength.

The Q.P.P. components, speaker, pentodes, etc., of this set can, of course, be used as the output end of any future set you may build, and there is no reason why, if you prefer not to adhere to the consolette arrangement, you should not arrange the components of the "shelf" on a separate baseboard.



FROM MY ARMCHAIR

—continued from page 20

(to us) because of their broadcasting stations. Such events are then not only interesting, but almost exciting. For example, if you heard that a hen had laid an egg weighing a pound and a half at Mühlacker, that would be real news.

A Double Interest

I remember reading about a brick-layer who had swallowed, apparently in an idle moment, five forks, a lump of coal, two knives, and a bag of nails. These facts—and the articles in question—came out when the man was operated upon. He had complained of indigestion after swallowing a thimble.

This would have been quite intriguing even if it had occurred at Scarborough, but it acquired a double interest when I read that it all happened at Ljubljana.

Will readers please forward me newspaper cuttings describing unusual events at broadcasting centres. This grand new feature, unfortunately, starts off very badly as I have only one news item to offer, but I may as well pass it on to you :

Zagreb.—A local farmer, noting that one of his cows did not give its usual quota of milk, decided to keep watch. He discovered that a cat milked the cow three times a day in the cow-shed at regular times.

\* \* \*

While in California, I remember reading about some snakes which were found dead in large numbers. It was discovered that they were all of approximately the same size. Others which differed by about ten per cent did not die, but appeared to have lost all their vitality.

Tuned Snakes

Local naturalists and zoologists were greatly perplexed. It remained for the chief engineer of a local radio station working on short waves to explain the trouble. Apparently the snakes, in coiling themselves, had become inductances and were tuned-in to the destructive H.F. signals.

This, of course, all happened in America. (There was some talk of exterminating the whole brood by changing the wavelength, but probably by now the snakes have learnt to "keep straight" or to coil themselves non-inductively.)

J. S.-T.



in the  
**PUSH-PUSH  
FIVE**

- 1 J.B. POPULAR. 0005, with 3-in. dial, 8/6. Slow motion (35/1). Extra heavy gauge brass vanes. Rigid nickel-plated frame. High-grade ebonite insulation.
- 2 J.B. MIDGET. 00004, 4/-. Small dimensions. Low minimum capacity. Ebonite insulation. Rigid one-piece frame.
- 3 J.B. DIFFERENTIAL. 0003, 4/6. 0001, 4/-. Insulated centre spindle. Bakelite dielectric between vanes.

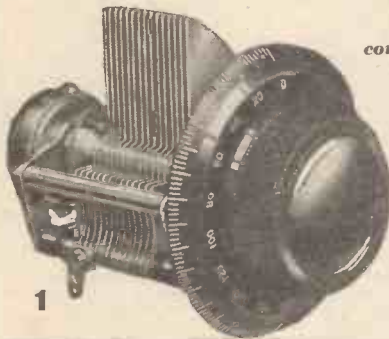
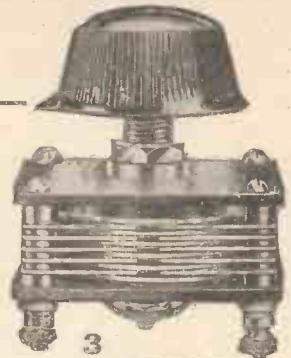

Write for complete catalogue.

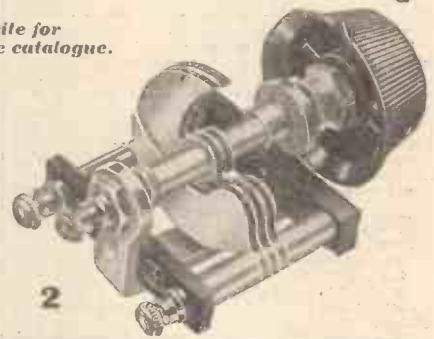

Adv. of Jackson Bros. (London), Ltd., 72, St. Thomas' St., London, S.E.1.

T.ephone: Hop 1837.

Famous Maker's Offer! £5 Radio-Gram CABINET for 65/-  
**7 DAYS' FREE TRIAL**  
 (OR 10/- MONTHLY.)  
 Polished Oak! and Piano built! The acoustic Tone brings a fine thrill. Makers to (Radio Press, B.B.C., 3,000 clientele). Other Models 35/- to £15. Photographs and List FREE.  
**PICKETTS** Piano-Tone Cabinets.  
 (G.W.) Albion Road, Bexleyheath

**FOR "S.T.400" PICKETTS CABINETS**  
 As Recommended by John Scott-Taggart.

**WHOLESALE DEPOT**  
**ALL PUSH-PUSH FIVE FERROCART** — "S.T.400" requirements in stock. Cash or G.O.D. service to bona fide traders only. When ordering enclose Trade Card. (Catalogue on request).  
**LEONARD HEYS: FARADAY HOUSE**  
 HENRY STREET, BLACKPOOL.  
 ELEVEN YEARS EXPERIENCE IN THE WIRELESS TRADE

**EASY TERMS PROMPT DELIVERY.**  
**Any Amplion, Blue Spot, Baker, Celestion, Epoch, R. & A., Rola, Sonochorde, or W.B. Moving Coil Speaker supplied.**  
 Send 5/- only.  
 and pay the balance by monthly instalments. No references. Entirely private and confidential.  
**KITS, PARTS, SETS, ELECTRIC CLOCKS ON EASY TERMS.**  
 Write for Catalogue and details to:  
**TURNADGE & PARTNERS, LTD.**  
 110-111, Fleet Street, London, E.C.4.  
 Telephone: Central 1903.

PLEASE be sure to mention "Wireless Constructor" when communicating with advertisers. Thanks!

**ELECTRIC REPRODUCTION FROM YOUR PORTABLE**  
 Gramophone without loss of portability. Alternative positions shown by dotted lines

**THE BELLING-LEE "CLIP-ON" UNIT PICK-UP**, clips on and off in an instant, with self-contained volume control, price 35/-  
 Write for Booklet.

**BELLING-LEE FOR EVERY RADIO CONNECTION**  
 Cambridge Arterial Road, Enfield, Midd.

**TAYLEX WET H.T. BATTERIES.**  
 Give long service, improved volume and tone; very economical.  
 Replacements for Taylex or Standard batteries at low prices; details post free; also Bargain List. Radio Kits and parts at lowest prices.  
**C. TAYLOR, 57, Studley Rd., Stockwell, London.**

WE invite readers to support our Advertisers —care being taken to accept only announcements of reputable firms!

**REMEMBER THESE—  
NEXT TIME!**

—continued from page 38

to be had out of this set! And the purity amazes me, even when it is on the verge of oscillation. Here I can get everything from Cork to Budapest and Leningrad to Hulzen.

"Cork comes in clear of Fécamp while working. Many of my customers have built this set with success. A man who heard it to-day was impressed by it although he has a superhet. Thanking you for a very fine set."—Wm. W. Pickard, 155, London Road North, Lowestoft.

**TRURO.**—"I regret to see the report of a failure by a Cornish owner of an 'S.T.400,' viz., Mr. Blake, of Helston. I built your set from a Pilot Author Kit in November last, and have not had any trouble, and get wonderful results and tremendous volume, using a Blue Spot 99PM and all new and specified valves. I am sure Mr. Blake has gone astray, and used either a faulty part or some component not mentioned in your list.

"I am confident that you will receive numerous reports by satisfied owners from Cornwall, and personally I am more than pleased with my reception and would not hesitate to recommend the set to anyone."—H. Anstis, 59, Kenwyn Street, Truro, Cornwall.

**HULL.**—"I have just completed constructing your A.C. 'S.T.400' all-mains receiver for a friend, and am very much impressed by the results, as also are several friends who have heard it. If you would design a D.C. model I feel sure it would add to the already unique reputation which your sets enjoy. Thanking you for the splendid sets you have already given to the public."—B. J. Smart, De Grot Street, Newland Avenue, Hull.

**KATFIELD.**—"Referring to your March number of THE WIRELESS CONSTRUCTOR, page 358, Question 6, I feel rather indignant at your answer. I, for one, was waiting for the 'S.T.400,' and built it the first week and am very pleased with the results I get even in this swamped area. I did not build your 'S.T.300,' but I did your 'S.T.300 Adaptor,' and obtained such amazing results that I decided on the 'S.T.400.' I cannot understand your calling the 'S.T.400' rather a flop at 6 miles from Brookmans Park."—E. Smith, St. Alban's Road, Hatfield, Herts.

**BARRY (Glamorgan).**—"Many thanks for a fine quality set. You certainly have delivered the goods. I shall certainly do my best to popularise the set locally. My aerial is only 40-50 feet long, and the results are astounding. Best wishes and congratulations."—H. J. Davies, Oban Street, Cadoxton, Barry, Glamorgan.

**GLASGOW.**—"I have much pleasure in writing to congratulate you on having designed the best and most efficient set I have had the pleasure of handling. The results are amazing. I have received over 74 stations, 60 medium wave, and 14 long wave."—Frederick Taylor, Castle Square, Dalmeir West, Nr. Glasgow.

**YARROW-ON-TYNE.**—"I have converted my 'S.T.300,' and am highly pleased with the result, and the envy of all who hear it that do not possess an 'S.T.400.' It is child's play to construct as I had no difficulty in doing so, although I am handicapped by the loss of four fingers of the right hand."—R. R., Albert Road, Yarrow-on-Tyne.

**PRAGUE (Czechoslovakia).**—"I have the pleasure of communicating to you that the type 'S.T.400' is the best set I have ever heard. I have arranged same for the operation on the A.C. mains,

and am quite enthusiastic over the results obtained. I should be much obliged to you if you would kindly allow me to publish a description and scheme of same in our technical paper, to be able to inform the public here of the excellent qualities of your set."—K. Parizek, Prague XII-500, Czechoslovakia.

**FULHAM (London, S.W.6).**—"First and foremost may I congratulate you on two fine sets. I have experience of four 'S.T.400's' and all their owners are delighted."—P. A. T., Lysia Street, Fulham, S.W.6.

**HORSHAM.**—"At first the 'S.T.400' was poor. Now it is perfect."—H. Heaseman, Roffey, Horsham, Sussex.

**MANCHESTER.**—"Further to my recent letter re 'S.T.400,' I am pleased to inform you that I have located and cured the fault; it was a faulty 0003-mfd. grid condenser, and a faulty 006-mfd. coupling condenser. The set is now really wonderful."—Geo. E. Ainsworth, Guide Lane, Audenshaw, Manchester.

**TAVISTOCK (Devon).**—"I used to be one of your 'S.N.U.'s,' but I can truthfully say all that is now altered. By Sunday I had the 'S.T.400' going. Jove!—what a surprise!—stations all round the dials. Let me add my name to your already large list of delighted constructors."—D. M. G., Whitechurch, Tavistock, Devon.

**BROMLEY (Kent).**—"I have constructed your 'S.T.400,' and up to date have received 85 stations on the loudspeaker. I have had many sets, but have never received so many stations on a four-valve set."—R. E., Plalstow Lane, Bromley, Kent.

**EXMOUTH.**—"May I add my congratulations on the 'S.T.400' to the multitudes Mr. Scott-Taggart has received? As regards selectivity it is marvellous, and the very thing I have been trying in vain to get."—Lt.-Col. P. H. Campbell, Craighish, Exmouth.

**COLCHESTER.**—"My advice to anyone is: Build it and be proud of it. Thanking you again for a real top-topper."—S. E. Pugh, Nayland, Colchester.

**HORNCHURCH (Essex).**—"If it be possible in these hard-headed times for one man to awaken a feeling very akin to hero-worship in the breast of another, then you have accomplished the seemingly impossible! Which leads me to shower profuse thanks on you for your epoch-making 100-per-cent-A1 set—the 'S.T.400.'"

"The 'S.T.400' is a marvellous set. I broke up a home-built S.G.4 in order to build the 'S.T.400.' There is no comparison: The 'S.T.' gives punch, clarity, tone, bass, treble—in fact, the whole gamut reproduced with faultless perfection. Many thanks for a wonderful set."—W. V. Cridland, Ardleigh Green Road, Hornchurch, Essex.

**NOTTINGHAM.**—"Having read readers' letters in February's CONSTRUCTOR, I feel I must write also of the wonderful results of the 'S.T.400,' and not forgetting it as a radiogram. The results are all you claim for it. The quality is grand, and the way the '400' brings in stations is really marvellous.

"Power is enormous. The quality of tone on the gram is all one may wish for. I am writing to demonstrate to anyone who is interested. Thanking you for a fine radiogram."—S. Trott, 3, Sherbrooke Terrace, Carrington, Nottingham.

**DUBLIN.**—"Many congratulations on your wonderful set, 'S.T.400.' I have never built a set before, as a matter of fact. I don't know the first thing about wireless. Moreover, I started on your set and completed it in three nights. As you say: "Pull-out the 'plug' and the stations roll in." It gives wonderful volume and selectivity."—B. Halpin, Killester, Dublin.

**CAN TELEVISION BE REAL?**

—continued from page 48

in television reception at the speed of light—i.e. nearly instantaneously (186,000 miles per second to be accurate). We certainly receive the individual bits of a picture nearly instantaneously, but the whole picture takes about one-twelfth of a second to complete. Since there is a delay of this amount, there is no reason why the delay should not be increased within wide limits. The speech comes over nearly instantaneously, but delayed speech would sound just the same and no one would be any the wiser.

**Several Years After**

Some of the sponsored programmes from abroad are "put over" several months or several years after the artistes have done their turn, and plenty of us are spoofed when the announcer says: "The station dance orchestra will now play you *I'm Fit and Forty*."

Probably all of us would be taken in if acute ears did not hear the needle-scratch before the record begins. And even new-comers to radio are discovering that the reason why the band starts playing before the announcer has finished speaking is that the initial needle-scratch must be drowned so that the illusion of reality can be maintained.

These pathetic subterfuges will not always be necessary. Some day we shall never know whether our programme is red-hot from the studio or weeks old. And the amusing thing is that it will not matter, and we shall not mind.

J. S.-T.

**INDEX TO ADVERTISERS**

	PAGE
Amplion (1932), Ltd.	50
Belling & Lee, Ltd.	55
Block Batteries, Ltd.	47
British Blue Spot Co., Ltd.	Cover iii
Britannia Batteries, Ltd.	49
British Rola Co., Ltd.	49
Bulgin, A. F. & Co., Ltd.	54
Burne-Jones & Co., Ltd.	47
Carrington Manfg. Co., Ltd.	45
Colvern, Ltd.	41
Cossor, A. C., Ltd.	2
Celestion, Ltd.	53

	PAGE
Dubilier Condenser Co., Ltd.	39
Electro Insulators, Ltd.	47
F.W.G. Products	52
Ferranti, Ltd.	51
Gilbert, J. C. (Cabinets)	52
Heyberd, F. C. & Co.	54
Heraud, E. J., Ltd.	45 and 52
Heys, Leonard	55
High Vacuum Valve Co., Ltd.	43
Jackson Bros. (London), Ltd.	55
London Electric Wire Co. & Smiths, Ltd.	1
Milnes Radio Co.	45
"Modern Boy"	49

	PAGE
Ormond Engineering Co., Ltd.	Cover ii
Peto-Scott Co., Ltd.	53
Pickett Bros. (Cabinets)	55
Radio Instruments, Ltd.	45
Taylor, C.	54 and 55
Turnadge & Partners	55
Varley Products	Cover iv
Westinghouse Brake & Saxby Signal Co., Ltd.	43
Wright & Weaire, Ltd.	47

All communications concerning advertising in "Wireless Constructor" must be made to John H. Lile, Ltd., 4, Ludgate Circus, London, E.C.4. Telephone: City 7261.



# NEW BLUE SPOT MOVING COIL SPEAKERS

The new Blue Spot Moving Coil Speakers have been produced after the most exacting and painstaking research, for it is realised that the public are more than ever very critical of the standard of reproduction which they expect from their Loudspeaker. These new Blue Spot models represent the very latest achievement in Speaker technique, both from the point of view of design and reproduction. The known and dependable quality of all Blue Spot products has never been better exemplified than in these new Moving Coil models.

Write for Catalogue No. W.C. 27 S.



## 99 PM

Blue Spot 99 P.M. represents the highest achievement in moving coil loudspeaker technique to-day. Its reproduction is sheer delight. Its response throughout the whole musical range of frequencies is extraordinarily even, true bass, true middle, true top. An exclusively designed magnet, ensures powerful and permanent energy. Moulded side-plates exclude dust and magnetic particles from entering the air gap. De Luxe Transformer is fitted with plugs and sockets. New process Cone and Speech Coil prevent trouble from moisture, warping or fouling in the gap. To own a Blue Spot 99 P.M. is to have at your disposal the most perfect rendering of broadcast programmes the world has known. Luxurious cabinet model in beautiful walnut 32 P.M. 87/6



## 45 PM

N.B. Standard Models 99 P.M. and 45 P.M. are suitable for Class B Output. 29 P.M. on request.



## 29 PM

This is another splendid Blue Spot achievement. The performance of the new 29 P.M. will enhance the already enviable Blue Spot reputation. The price will enable those whose means have not previously allowed them to consider the possibility of owning a Moving Coil Loudspeaker, to secure the added enjoyment of Radio which it brings. The performance and reliability of this Model are really astonishing. Complete with Matching Transformer and other special features, price Attractive Cabinet model in Oak 22 P.M. 45/- BRITISH MADE

## 32 1/6

This Blue Spot Moving Coil Speaker will be hailed with delight, for two reasons. It embodies the latest engineering and technical refinements, while its reproduction sets a new standard, a new ideal. Having an even response throughout, no excessive bass and no shrill top, 45 P.M. will meet the most exacting requirements. Dust proof plates have been fitted to the special magnet, specially designed Cone and Speech coil. The Matching Transformer which is included is complete with plugs and sockets for easy and trouble-free valve matching.

Exceptionally attractive cabinet models made in mahogany or walnut with the new Blue Spot grille 62 P.M. 67/6

## 45 1/2

### SPECIAL FEATURES OF ALL MODELS

Scientifically designed and well made Output Transformers with each Chassis ● Plugs and sockets in lieu of solder tags for easy valve matching ● Suitable for Power, Super-Power, Pentode and Q.P.P. (Triode) Output, Special Q.P.P. Pentode models 2/6d. each extra ● New process Cones and Speech Coils—no trouble from moisture, warping or fouling in the gap ● Cadmium plated pole pieces, copper plated chassis with felt surrounds ● Every model stands firmly on its own base ● Cabinet models have special acoustic features, the Chassis being mounted to an independent baffle specially fitted to cabinet ● Unrivalled finish, construction, performance.



## THE BRITISH BLUE SPOT COMPANY LTD

BLUE SPOT HOUSE · 94/96 ROSOMAN STREET · ROSEBERY AVENUE · LONDON · E C 1  
 Telephone: Clerkenwell 3570  
 Telegrams: "Bluspot, Isting, London."  
 Distributors for Northern England, Scotland and Wales: H. C. RAWSON (Sheffield and London).  
 Ltd., 100 London Road, Sheffield; 22 St. Mary's Parsonage, Manchester; 177 Westgate Road,  
 Newcastle-upon-Tyne; 37, 38, 39 Clyde Place, Glasgow.



**Varley**  
(Proprietors: Oliver Pell Control Ltd)

**S.T.'s  
choice  
for the  
PUSH  
PUSH  
FIVE**

"S.T." makes the Varley Input Transformer DP36 his first choice. He also recommends a Varley Output Transchoke unless a special Q.P.P. Choke is already incorporated in your speaker. *Can you do better than follow "S.T.'s" advice?*

Converting your existing set to Q.P.P. is very simple, if you use Varley Components. Post coupon below for free illustrated brochure.

## FREE COUPON

To Messrs. VARLEY, 103, Kingsway, W.C.2.

Please send me, post free, your new brochure on Q.P.P. (with diagrams for converting existing sets) "THE BATTERY SET COMES INTO ITS OWN."

Name.....

Address.....

W.C.1.

● **DP36. QUIESCENT PUSH-PULL INPUT TRANSFORMER**  
 Ratio..... 9/1  
 Primary D.C. Resistance..... 825 ohms.  
 Total Sec. D.C. Resistance..... 9300 ohms.  
 Prim. Inductance..... 30 henries with no D.C.  
 ..... 27 " " 2 M.A.  
 ..... 22 " " 4 M.A.  
 PRICE, including Royalty..... **17/6**

● **DP37. QUIESCENT PUSH-PULL OUTPUT TRANSCHOKE**  
 Ratios..... 3/1 and 42/1  
 Primary D.C. Resistance..... 460 ohms.  
 Sec. D.C. Resistance (3/1)..... 130 ohms.  
 Sec. D.C. Resistance (42/1)..... '8 ohms.  
 Primary Inductance..... each half  
 13 henries with D.C. current of 26 M.A.  
 PRICE, including Royalty..... **18/6**

● **DP38. QUIESCENT PUSH-PULL OUTPUT TRANSCHOKE**  
 Ratios..... 3/1 and 50/1  
 Primary D.C. Resistance..... 400 ohms.  
 Sec. D.C. Resistance (3/1)..... 130 ohms.  
 Sec. D.C. Resistance (50/1)..... '9 ohms.  
 Primary Inductance..... each half  
 8 henries with D.C. current of 26 M.A.  
 PRICE, including Royalty..... **16/6**

● **DP39. QUIESCENT PUSH-PULL OUTPUT TRANSCHOKE**  
 Ratios..... 3/1 and 75/1  
 Primary D.C. Resistance..... 400 ohms.  
 Sec. D.C. Resistance (3/1)..... 130 ohms.  
 Sec. D.C. Resistance (75/1)..... '64 ohms.  
 Primary Inductance..... each half  
 8 henries with D.C. current of 26 M.A.  
 PRICE, including Royalty..... **16/6**