

# The Wireless 6<sup>d</sup> Constructor

Vol. XIV.

JUNE, 1932.

No. 68.

CONCISE CONSTRUCTIONAL  
DETAILS OF

The "S.T.  
300"

*Inside*

ALSO  
THE "S.T. 300"  
ADAPTOR

FOR  
ANY  
SET!



**JOHN SCOTT-TAGGART**  
contributes both the above  
features as well as "HOW  
MAINS UNITS WORK" and  
"FROM MY ARMCHAIR."



# SPECIFIED

in the

# S.T.300

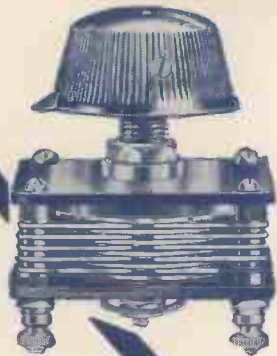

**J.B. DIFFERENTIAL**

**J.B. DIFFERENTIAL.**

·00015, 4/- . ·0001, 4/-.  
Insulated centre spindle. Baked  
dielectric between vanes.  
Also made in capacities of:—  
·0002, ·00025, ·0003.

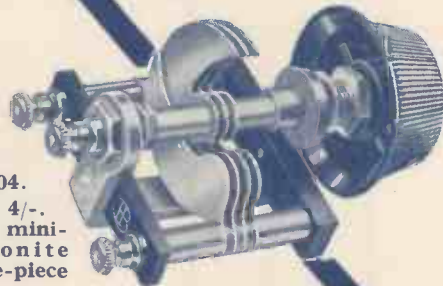

**J.B. MIDGET**

**J.B. MIDGET, ·00004.**  
Complete as illustrated, 4/-.  
Small dimensions. Low mini-  
mum capacity. Ebonite  
insulation. Rigid one-piece  
frame.  
Also made in capacities of:—  
·00025, ·0002, ·00015, ·0001  
and ·000025.

**J.B.  
POPULAR**



**J.B. POPULAR.**  
Slow-motion type (35/1).  
Capacity, ·0005. Complete with  
3" dial, 8/6. Extra heavy-gauge  
brass vanes. Rigid nickel-plated  
frame. High-grade ebonite  
insulation.  
Also made in capacities of:—  
·0003, ·00025, ·00015.

**Prompt Deliveries**

## PRECISION INSTRUMENTS

Advertisement of Jackson Bros., 72, St. Thomas' Street, London, S.E.1.

Telephone : Hop 1837





# CONTENTS

	Page		Page
The Editor's Chat	61	A Practical Man's Corner	81
The Month on Short Waves	62	How Mains Units Work	83
"On the Grid"	62	Trimming Troubles	86
The "S.T.300" Adaptor for Your Set	63	The Passing of the Triode	87
Queer Querles	68	In Lighter Vein	89
Detection Made Readable	69	That Interval Signal	92
B.B.C. News	71	Meter Multipliers	94
As We Find Them	73	The "S.T.300"	98
Tuning Down the Wave-Bands	75	Pick-up Hints and Tips	104
With Pick-up and Speaker	77	From Our Readers	107
Round the Dials	78	Trade Jottings	107
Points for Purchasers	78	Where to See the "S.T.300"	108
From My Armchair	79	Our News Bulletin	111
		Shall I Design a Portable?	112

As some of the arrangements and specialities described in this Journal may be the subject of Letters Patent the amateur and trader would be well advised to obtain permission of the patentee to use the patents before doing so.

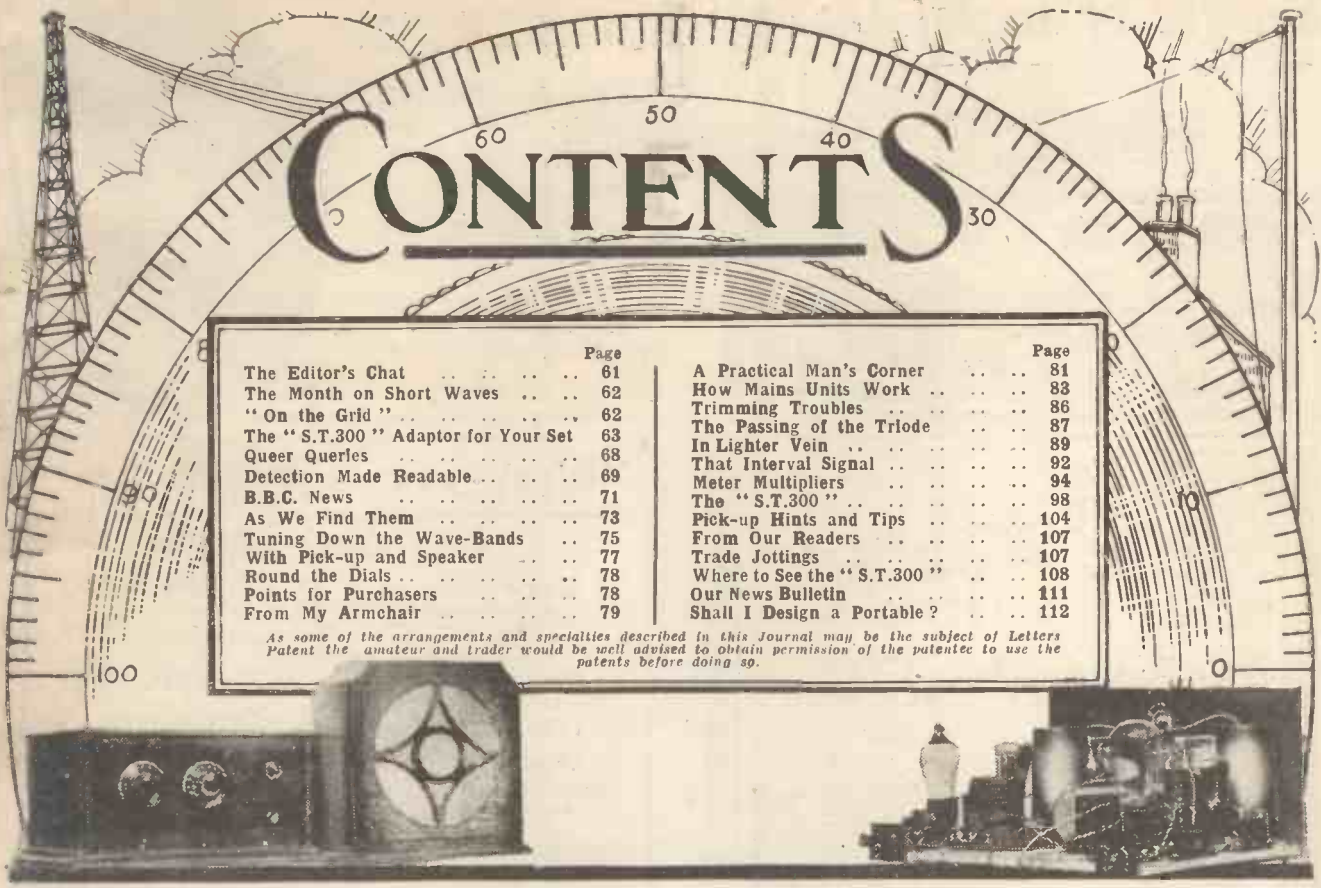

## SPECIFIED

by  
John Scott-Taggart  
in this  
issue

THE FAMOUS  
VARLEY  
"NICLET"  
TRANSFORMER

One of the Great New "Square Peak"  
series of Varley Components.

List No. D.P.21. Price 7'6.

WRITE FOR VARLEY'S NEW BOOK (FREE)

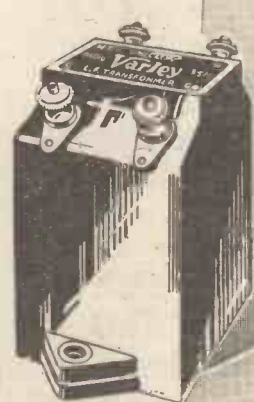

# Varley

Advt. of Oliver Pell Control Ltd., 103, Kingsway, W.C.

## Beware of Imitations!

The R. & A. "CHALLENGER" PERMANENT-MAGNET MOVING-COIL REPRODUCER has set a standard in performance, materials and workmanship that cannot be excelled at the price. *Insist on R. & A.*

Write for Descriptive Leaflet and ask your dealer to demonstrate.

REPRODUCERS & AMPLIFIERS LTD.,  
Frederick Street, WOLVERHAMPTON.



# 35/-

INCLUDING 3-ratio Ferranti TRANSFORMER (to R. & A. specification).

# The R & A "CHALLENGER"

TESTED and APPROVED by JOHN SCOTT-TAGGART for his S.T.300 and S.T.300 Adaptor

## WAVEMASTER

AERIAL COUPLING CONDENSER  
Cat. No. 80. -0004, 4/-  
DIFFERENTIAL REACTION CONDENSER  
Cat. No. 60. -001, 2/9

Write for Illustrated Catalogue.

WEBB CONDENSER CO. LTD., 42 HATTON GARDEN, E.C.1

## WIRELESS CONSTRUCTOR

### Advertisement Rates

Single Insertion - - -	£60 0 0
per page and pro rata to eighth page.	
6 CONSECUTIVE Insertions	55 0 0
per page and pro rata to eighth page.	
12 CONSECUTIVE Insertions	50 0 0
per page and pro rata to eighth page.	
ONE INCH single col. (2 1/4" wide)	2 5 0
Minimum Space, half-an-inch	1 2 6

IMPORTANT. Copy and Blocks must be in hand by 25th of each month for issue placed on sale 15th day of the following month.

ALL communications respecting advertising must be made to:

JOHN H. LILE, Ltd., 4, Ludgate Circus, London, E.C.4  
Phone: CITY 7261.

# The COVER

*to look for . . .*

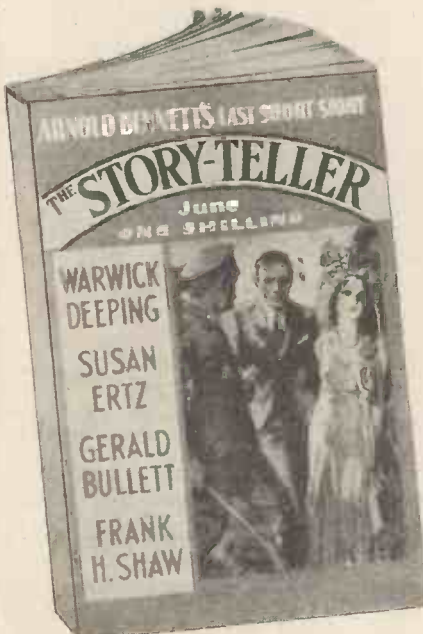

The STORY-TELLER Cover, of course! Look for it at your newsagent's or on the bookstall. Buy it and make sure of many hours of pleasant reading. The JUNE Issue contains Short Stories by famous writers, including WARWICK DEEPING, SUSAN ERTZ and GERALD BULLETT.

There is also the last story written by the late ARNOLD BENNETT, entitled "Early Morning."

JUNE Issue  
Now on Sale

1/- **STORY-TELLER**



# S.T.300

**72/6**  
**KIT 'A'**

... built with a  
**PILOT**  
**AUTHOR KIT**  
.. the most amazing set  
published since 1919

**IMMEDIATE DELIVERY—CASH, C.O.D., H.P.**  
**BATTERY VERSION**

**PRICES OF COMPLETE KITS IN SEALED CARTONS**

**KIT "A"** Author's Kit, less valves and cabinet  
CASH or C.O.D. **72/6**  
EASYWAY  
12 monthly payments of 68  
Valves as specified, £1:12:3. Cabinet, 15/-

**KIT "B"** Author's Kit, with valves but less cabinet  
CASH or C.O.D. **£5:4:9**  
EASYWAY  
12 monthly payments of 9/7

**KIT "C"** Author's Kit, complete with valves & cabinet  
CASH or C.O.D. **£5:19:9**  
EASYWAY  
12 monthly payments of 10/11

**KIT-BITS**

Selected C.O.D. or CASH items. You pay the Postman. We pay all Post charges on orders over 10/-

1 pair Colvern "S.T.300" Coils - 12/-  
2 Ormond Slow-Motion Condensers 13/-  
3 Valves as specified - £1 12 3  
Cabinet as specified - - 15/-

**A.C. "S.T.300"**  
**KIT "A"** Author's Kit, less valves and cabinet.  
CASH or C.O.D. **£5-7-0**  
or 12 monthly payments of 9/10  
Specified Valves £2:7:8. Specified Cabinet 15/-

This is the Kit of Parts actually used and specified by John Scott-Taggart

1 Panel, 16" x 7" x 3/16" ready drilled	4 6
1 Telsen .0001 differential condenser, with black knob	2 0
2 Telsen 1-mfd. Mansbridge condensers	4 6
1 Telsen binocular H.F. choke	3 0
2 ReadRad 5-point switches	2 6
1 ReadRad .00015 diff. condenser	2 6
1 Peto-Scott standard screen, 10" x 6", with notches filed	2 0
1 Peto-Scott terminal strip, 16" x 1 1/4" x 3/16", ready drilled	1 3
1 Peto-Scott baseboard, 16" x 10"	1 3
1 Peto-Scott copper sheet, 10" x 7", about .006" thick	1 0
2 Ormond .0005 mfd. S.M. condensers	13 0
1 Pair Colvern "S.T.300" coils, with supporting pillars, special "S.T.300" windings and terminal connections	12 0
1 Dubilier .0001 mfd. type 670 condenser	1 0
1 Graham Farish "Megite" 1-meg. grid leak	1 6
1 Lewcos H.F. reaction choke, Ref. M.C.	2 6
1 Lewcos Spaghettil resistance, 20,000 ohms	1 6
1 Varley "Nictel" L.F. transformer, 3:5:1, type D.P.21	7 6
2 Lotus valve holders, type T.H.K.	1 0
1 W.B. valve holder (S.G. horizontal)	1 0
10 Bulgin terminals, marked	2 6
1 J.B. midget condenser, .00004 mfd.	4 0

Use this detailed Price List when ordering parts for the "S.T.300." Any items sent separately. If value over 10/-, sent Carriage Paid or C.O.D.—all Post charges paid.

**FINISHED INSTRUMENT**

**£7 : 7 : 6** Complete with valves and cabinet. Factory wired—Aerial tested  
CASH or C.O.D. —Royalties Paid.  
or 12 monthly payments of 13/6

**KIT-BITS** Selected C.O.D. lines. You pay the postman, we pay post charges on orders over 10/-

2 Lotus .0005 mfd. slow-motion tuning condensers	£ s. d. 13 0
Peto-Scott .00004 mfd. air-dielectric variable condenser	3 6
Pair Telsen "S.T.300" coils	11 6
Wearite output choke, H.T.5	12 6
Set of specified valves	2 7 6
Specified cabinet	15 0

**S.T.300**  
**ADAPTOR**  
described this Month

**PILOT AUTHOR KIT**

**KIT "A"** Author's Kit less S.G. Valve and Cabinet.

CASH or C.O.D. only. **37/6**

This is the actual Kit of Parts as used by Mr. John Scott-Taggart

1 Peto-Scott panel 9 1/2 in. x 7 in.	s. d. 3 0
1 Wearite S.T.300 aerial coil	6 3
1 Ormond .0005 mfd. slow-motion tuning condenser	6 6
1 J.B. Midget aerial coupler .00004 mfd. max.	4 0
1 Telsen .0001 mfd. differential condenser	2 6
1 Ready Radio H.F. choke for S.G. valve	5 0
1 Dubilier type 9200 1-mfd. fixed condenser	2 9
1 W.B. universal horizontal valve holder	1 0
1 Lotus universal switch	1 6
6 Bulgin indicating terminals	1 6
1 Peto-Scott Screen 6 in. x 8 1/2 in.	1 6
1 Terminal strip 9 1/2 in. x 1 1/2 in.	1 0
1 Baseboard to fit panel, 8 1/2 in. deep	1 0
	<b>£1 17 6</b>

**KIT 'B'** Author's Kit with valve but less cabinet **£2:13:6**  
or 6 monthly payments of 7/4. 16/6  
1 Mullard P.M. S.G.12 Valve

**FINISHED INSTRUMENT**  
Factory built and wired to specification. Broadcast Tested.  
Including valve and oak cabinet **£3:10:0**  
or 12 monthly payments of 6/5.

**PILOT ECONOMY MODEL**  
**FINISHED INSTRUMENT**  
Special Offer to Readers of "Wireless Constructor."  
This PILOT ECONOMY Version of S.T.300 Adaptor—Factory built with specially selected and guaranteed components. Fully tested under actual working conditions. Complete in Oak cabinet.

Assembled from components by well-known manufacturers including Ormond Slow-Motion Tuning Condenser, S.T.300 Aerial Coil, PETO-SCOTT Midget Aerial Coupler (recommended by Mr. John Scott-Taggart), PETO-SCOTT Differential Condenser, PETO-SCOTT S.G. Choke, and T.C.C. 1 mfd. Condenser.

**45/-**  
CASH or C.O.D. (Excluding S.G. valve.)

**ALWAYS FIRST—ESTABLISHED 1919**

Messrs. PETO-SCOTT CO. LTD. 77, City Road, London, E.C.1.  
Please send me C.O.D./CASH/H.P.

# PETO-SCOTT

CO. LTD.  
77, CITY ROAD, LONDON, E.C.1. Telephone: Clerkenwell 9406-7-8. 62, HIGH HOLBORN, LONDON, W.C.2. Telephone: Chancery 8266

for which I enclose £ s. d. CASH/H.P. Deposit.

NAME.....

ADDRESS.....

W.O.6/32.

# OUTPUT MUST NEVER LEAVE QUALITY BEHIND—That's why there's a P.M.2A. and a P.M.202

They're both designed with a purpose, the P.M.2A. for small inputs, the P.M.202 for large inputs. What is your set? Is it a two-valve, or a portable? Then the P.M.2A. is the output valve you need. Do you want a valve capable of handling large signal voltages? Then there is the P.M.202.

**P.M.2A. OPERATING DATA**

Filament Voltage - - 2.0 v.  
 Filament Current - - 0.2 a.  
 Max. Anode Voltage - - 150 v.  
 Grid Bias :  
 At Anode Volts 100 - 3.0 v.  
 At Anode Volts 150 - 6.0 v.

**P.M.202 OPERATING DATA**

Filament Voltage - - 2.0 v.  
 Filament Current - - 0.2 a.  
 Max. Anode Voltage - - 150 v.  
 Grid Bias :  
 At Anode Volts 100 - 7.5 v.  
 At Anode Volts 150 - 12.0 to 15.0 v.

MADE IN ENGLAND

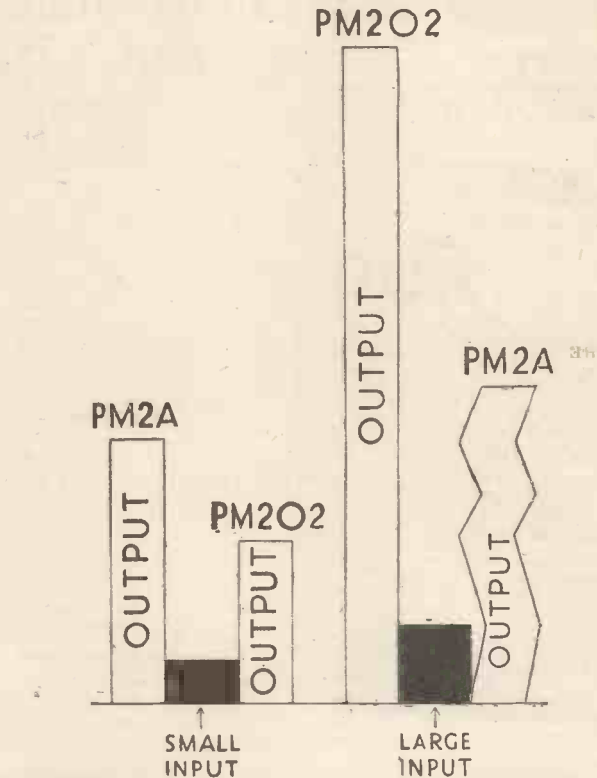

The diagram compares the performance of the P.M.2A. and P.M.202. For small inputs the P.M.2A., because of its higher amplification factor, gives a slightly bigger output than the P.M.202.

With large inputs the low-impedance P.M.202 gives a large output, but the P.M.2A., which is not designed to handle big signal voltages, will be overloaded and reproduction will be distorted.

Remember, for small inputs, the P.M.2A. ... .. 8/9  
 for large inputs, the P.M.202 ... .. 12/-

# Mullard

**THE - MASTER - VALVE**



# The WIRELESS CONSTRUCTOR

Published by the Amalgamated Press, Ltd., Fleetway House, Farringdon Street, London, E.C.4.

## THE EDITORS' CHAT



This month the Editor tells how the enormous demand for details of the "S.T.300" has been met, and of Mr. Scott-Taggart's latest design—the "S.T.300" Adapter, which instantly converts any ordinary receiver to the "S.T.300" circuit!

**I**N response to the urgent request of some thousands of our readers, we are reprinting in this issue concise constructional details of Mr. Scott-Taggart's famous "S.T.300" receiver. It appears that, despite the usual large printing order for the February issue of THE WIRELESS CONSTRUCTOR, which first contained details of the "S.T.300," and despite a reprint of that issue, thousands of readers were still unable to secure copies of THE WIRELESS CONSTRUCTOR owing to the enormous demand!

### "S.T.'s" Articles

Readers of THE WIRELESS CONSTRUCTOR who have already built the "S.T.300" will note that the reprint of the article dealing with the set has been done in such a way as not to interfere with the normal editorial issue of THE WIRELESS CONSTRUCTOR. And those who intend building the "S.T.300" from the details published in this issue may rest assured that, although the original article has been compressed, every essential detail necessary for successfully building the set will be found in the article.

Also, in this issue Mr. Scott-Taggart describes the first constructional details of the "S.T.300" Adapter. This is a simple, inexpensive unit which can be connected to any ordinary receiver and which instantly changes it into the "S.T.300" circuit.

Further articles from the pen of Mr. Scott-Taggart include: "How Mains Units Work," and another contribution in his famous "From My Armchair" series.

This last, of course, is a regular feature, but it has proved so universally popular that we have decided to enlarge it in future issues. Consequently, with more editorial space

at his disposal, Mr. Scott-Taggart will provide a greater variety of subject matter for criticism and comment.

### A B.B.C. Investment

It was rumoured some months ago that the new B.B.C. headquarters at Portland Place would prove inadequate in size for more than immediate needs, so no doubt many readers were not surprised to notice the other day in the newspapers that adjoining property to Broadcasting House in Portland Place had been purchased in anticipation of "development beyond the capacity of Broadcasting House."

Whether further additions to Broadcasting House will be started in the near future remains to be seen, but an official of the B.B.C. stated recently that the B.B.C. had no intention

of building "within the next few months." It is a business proposition, he explained, and until the property is required the purchase money is regarded as an investment which will provide a normal business return.

Of course, the trouble is that, although there is plenty of accommodation for studios, etc., at Broadcasting House, the office accommodation is not as good as it should be, and, further, there is very little spare space for expansion.

### Good Business

It was reported in the press the other day that a member of the Radio Manufacturers' Association had stated that the wireless industry has now reached a turnover approaching £30,000,000 a year, and has taken second place only to the motor-car industry in enterprise and rapidity of development.

This is good news and augurs well for the success of the Wireless Exhibition, which will be held at Olympia this year, although there is still some doubt as to the wisdom of holding the Exhibition in the month of August. We are inclined to think that perhaps the Radio Manufacturers' Association would have been wiser to have held the Exhibition as usual in September.

August may or may not be a warm month. If it is warm, then there is bound to be a rush of people out of London who want to take their holidays during the fine weather; while, if it is wet and dreary, it is equally certain that there will not be a great influx of visitors from the provinces.

There are many indications that the wireless industry will continue to enjoy great prosperity, and the trade expects wireless licences to reach the five-million mark by September.

### RADIO AT THE CAPE



Here you see the principal South African radio station. It is situated at Slung Kop, about 50 miles from Cape Town, and was recently fitted with new aerial towers.

# THE MONTH ON SHORT-WAVES

All the latest news about this interesting band.

IN turning over the pages of my log for the purpose of chronicling the happenings of the past month on short waves, there is one thing that seems to stick out above all others, and that is that conditions appear to have been much more constant than they were during the earlier months of the year.

### Conditions More Constant

Oh, no! I did not say that they were good! Nor do I intend to imply that you could pick upon a particular station, and having heard him once, could repeat the performance night after night. What a dream—but what a hope!

What I am really getting at is that, generally speaking, although conditions have not been anything to write home about, those complete wipe-out periods have been much

less frequent than they were earlier on.

For instance, almost without exception during the past month I haven't

### THIS MONTH'S "H.M." STATION

Note for Newcomers.—Every month in these columns details are given of a short-wave transmission which readers are invited to receive and, if successful, to report in detail to THE WIRELESS CONSTRUCTOR. Those sending in the best reports receive "honourable mention" in these columns, and are thereafter styled WIRELESS CONSTRUCTOR "H.M.'s."

Location: Sydney, Australia.  
Call-sign: VK2ME.  
Wave-length: 31.28 metres.  
Time of Transmission: Sunday 7-9 a.m. and 3.30-5.30 p.m. B.S.T.

had the slightest difficulty in raising one or two Yanks every night, and their strengths, too, have been very good. Talking of Yanks, by the way, what has happened to W3XAL?

This time last month he was playing havoc with the baby next door, but at the time of writing he is anything but good, even on 'phones.

### The Best Yankee

As far as my own experiences are concerned, undoubtedly the star turn in the Western Hemisphere programme was W8XK, on his 25.25-metre wave. But for the fact that he is a comparatively newcomer to the high-power class, I feel almost like raising him to the rank of "punch-merchant," but I think we had better wait and see what happens!

Our old friend VQ7LO, at Nairobi, is another one of the fairly consistent entries in my log during the last month. I have had him on several occasions, but it would appear from my results that his modulation is rather poor, because although on almost every occasion when I logged him his carrier-wave was very strong, intelligibility was decidedly bad.

For those of you who want to try him, VQ7LO is usually on the air between 6.30 and 8.30 p.m. B.S.T., with an extra hour's grace on Saturdays and Sundays. The wavelength is 49.5 metres.

Has anybody heard the remarkably good transmission that comes over from the new 42.7-metre station at Rome? I think the loudspeaker quality is excellent.

G. T. K.

My recent remarks on the fitting of screws in awkward places created a surprising amount of interest. I still get letters on the subject, which seems to indicate that many constructors have come up against the difficulty.

Mr. H. Grundy, of Essex, writes to say that for years he has found a piece of slotted brass answer every purpose for holding a screw in an awkward position. The end which holds the screw is, of course, bent practically at right angles to the remainder of the brass strip.

### That Earth Connection

If you are one of those particular people who like the so-called "earth" connection to be a real low-resistance path, and if you work from the mains, here is a tip worth trying.

As you no doubt know, practically all mains have one side joined to earth; and, let me assure you, it is joined pretty well, too. So why not connect your earth terminal to it?

You can do this whether your mains are A.C. or D.C. so long as you put a high-voltage-test 2-mfd. fixed con-

\*\*\*\*\*  
\* "ON THE GRID" \*  
\* Mains Earths—An Interesting \*  
\* Fault—Pick-up Needles. \*  
\*\*\*\*\*

denser in series with the lead. But remember that connection must be made to the mains side of the H.T. unit—not the set side.

If you connect it to the latter, the chokes, which are bound to have some H.F. impedance, will prevent your earth from being an earth connection at all. Try both mains leads—unless you happen to know which one is taken to terra firma.

I recently had the interesting job of tracking down a somewhat unusual fault.

### A Peculiar Fault

The set was perfectly O.K. on long waves; it was perfectly O.K. on medium waves—except occasionally, when it stubbornly refused to stop oscillating, and its tantrums could not be pacified "nohow." I won't the

you all that was done and said before the trouble was tracked down to the wave-change switch.

The dual-range coil was one with a tapped reaction winding, part of which was shorted out for medium waves. Occasionally the switch did not "act" properly so far as the reaction contact was concerned, although the grid-coil contact was quite O.K. The complete reaction winding was too much for the medium waves; hence the oscillation.

### Concerning Pick-Up Needles

A colleague mentioned a point the other day which I felt ought to be passed on.

It concerns some of the softer types of semi-permanent gramophone needles. These should not be tipped into a steel or iron cup like ordinary needles, as the hard metal is likely to ruin their points, and these in turn will ruin the records, which in their turn will ruin quality of reproduction. The boxes in which they are sold are specially lined.

A. S. G.



# THE S.T. 300 ADAPTOR FOR YOUR SET



Designed and Described by JOHN SCOTT-TAGGART

*The advantages of progressive selectivity and vastly increased power provided by the world-famous "S.T.300" can now be applied to any existing set by means of an inexpensive and very easy-to-build unit.*

"It's all very well"—a reader writes—"for you designers to expect us to scrap our old sets, but in many cases, such as mine, it would be much cheaper for us if you could tell us how to convert or modify our existing sets."

This reader says he has at present in use a detector and 2 L.F. type of receiver, and there are certainly a vast number of such sets in use to-day. Numerous other readers have asked whether they can convert to the "S.T.300" with minimum trouble.

The reply to all these questions appears in this article in the form of an "S.T.300" Adaptor. This consists of an H.F. unit complete with screened-grid valve, which is simply tacked on in front of your existing receiver.

### Converting Old Receivers

By means of this easily made and inexpensive adaptor any receiver can be "S.T.300"-ised, and this is done without in any way interfering with

your existing set, but with the certainty of getting vastly improved selectivity and range.

The "S.T.300" itself may be operated with this unit, thus giving another stage of S.G. H.F. amplification. But, of course, this unit will appeal primarily to those who have 2-valve sets using a detector and notemag., or 3-valve receivers of the popular det. and 2 L.F. type.

My own opinion of receivers of this class is not very high, although from

## THE PARTS YOU WANT FOR S.T.'s LATEST TRIUMPH

- 1 Panel, 9½ in. × 7 in. × 1/16 in. (Permcot, Becol, Peto-Scott, Ready Radio, Wearite).
- 1 Baseboard 9½ in. × 8½ in. deep.
- 1 "S.T.300" aerial coil (Wearite, Colvern, Telsen, Tunewell, Sovereign, Goltone, Lewcos Cordo).
- 1 .0005-mfd. slow-motion tuning condenser (Ormond, Lotus, Polar No. 2, Telsen).
- 1 .00004-mfd. max. aerial coupler (J.B. Midget, Peto-Scott, Ready Radio, Polar No.4, Wavemaster).
- 1 .0001-mfd. differential condenser (Telsen, Ready Radio, J.B., Polar, Cyldon, Lotus, Wavemaster, Igranice).
- 1 H.F. choke for S.G. valve (Ready Radio Binocular,

- Lewcos type 11, Telsen Binocular, R.I. Dual-Astatic, Sovereign Senior.
- 1 1-mfd. fixed condenser (Dubilier type 9200,

- T.C.C., Telsen, Lissen, Formo, Hydra, Helsby, Sovereign, Igranice).

- 1 Horizontal-mounting valve holder (W.B. Universal).
- 1 Universal switch (Lotus).
- 6 Indicating terminals (Bulgin, Belling & Lee, Ealex, Igranice, Clix).
- 1 Screen, see text (Magnum, Ready Radio, Peto-Scott, Wearite).
- 1 Terminal strip. 9½ × 1½ in.
- 1 Baseboard to fit panel, 8½ in. deep.
- 1 Sheet copper foil 6½ in. × 8½ in. Glazite, Lacoline, Quickwyre, flex screws, etc.
- VALVE. 1 S.G. valve (Mullard P.M.12, Mazda, Cossor, Marconi, Osram, Tungstam, Eta, Six-Sixty, Lissen).

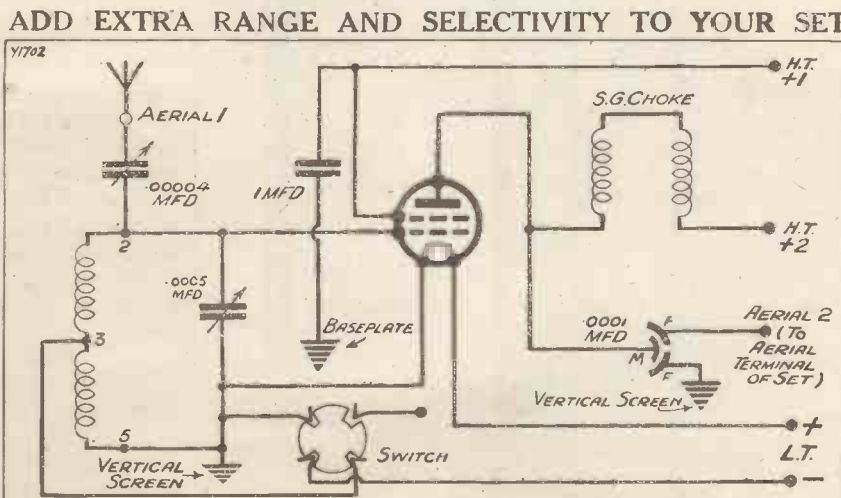

Your present set supplies the body, and then you have a complete "S.T.300" set!

## The "S.T.300" Adaptor for Your Set—continued

a cost point of view they are good value—or have been in the past. The tide of interference is, however, rising and has submerged many of these sets already. Many others are barely keeping their heads above water.

The tragedy, in my opinion, is that many of the listeners of this country are either ignorant of the interference they will experience with the average det. and 2 L.F. set, or are being forced by economic considerations to buy or build a type of set which constructors in 1924 would not consider for a moment.

### What Can Be Done?

Whatever the reason may be, whether economic or otherwise, there has in the last two years been a retrograde tendency in popular designs for home-constructors. The better sets which have exhibited features of modern design have not, for one reason or another, caught the public's fancy.

What can be done for the great mass of non-technical listeners who are operating ineffective, unselective receivers? Much as I might like personally to say "Scrap your set and start again," I realise that some have not the heart, others not the experience, and a large proportion not the money, to carry out such drastic advice.

Nevertheless, the advantages of progressive selectivity, of full control of the "balance of power" between signal strength and selectivity, and the ability to make use of a full-size aerial, are capable of being applied by means of the "S.T.300" Adaptor to the most old-fashioned of sets. In

with good reason) believe to be the ideal one.

But if his family is for most purposes satisfied with his det. and 2 L.F., he can always at any time switch off his adaptor and connect the aerial to his main set. The same L.T. and H.T. batteries (or "mains unit") are used

### YOUR EXISTING BATTERIES ARE USED

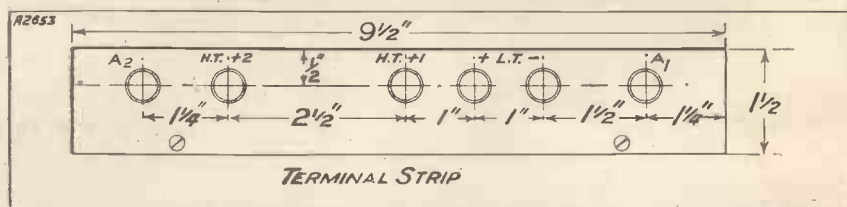

Leads are taken from the unit's terminals to the batteries already in use.

brief, you can get "S.T.300" effects by putting this unit in front of an existing set.

### An Easy Solution

To the listener who plaintively says: "My set's almost hopeless these days," you can now suggest: "Try an 'S.T.300' Adaptor in front." If you want to be generous you can give him one! If the set he is using is a det. and 2 L.F., his complete outfit becomes a 4-valve receiver—a combination which many listeners (and

when the adaptor is in circuit, and the extra current taken is not much. I think most people will want to leave the adaptor permanently in use.

And now let us see what the unit consists of. It is really the head, neck and shoulders of the original "S.T.300," and not only do these parts fit on to any sort of body, legs and tail, but the final animal may thoroughly be relied upon; it may even make the original "S.T.300" draw in its horns a little!

### THE "NO-COMPROMISE" CONTROLS

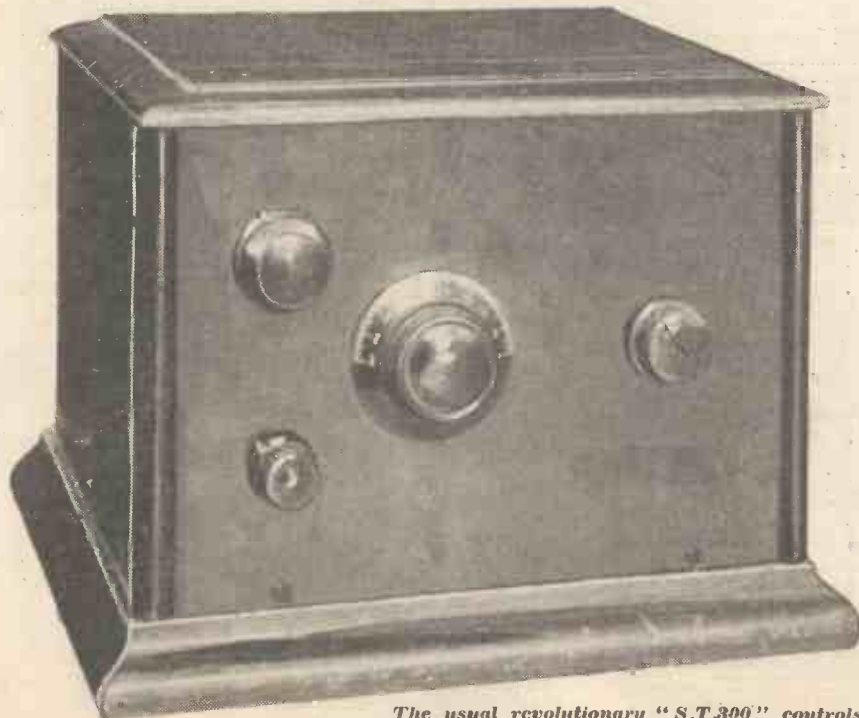

The usual revolutionary "S.T.300" controls figure in this compact and extremely effective adaptor.

### Not Quite the Same

The "S.T.300" Adaptor is not, however, the H.F. stage of the "S.T.300" in its entirety. There is only one dual-range coil and only one tuning condenser. What in the "S.T.300" set are the grid coil and grid tuning condenser are completely missing in my adaptor, and no prize is awarded for explaining their absence! But the S.G. high-frequency choke is there all right, as also is the "differential anode coupler," which forms a vital feature of the "S.T.300" circuit.

The output terminal "Aerial 2" of the adaptor is connected direct to the usual aerial terminal of whatever set is in use. This results in the input circuit of the receiver becoming the output circuit of the adaptor. The "join"—from a circuit point of view—between the "S.T.300" "head and shoulders" and the "body" of the old set will vary, but I know of no case where effective results will not be obtained. My instincts are against patching up other people's sets, but this bit of patchwork will, I am convinced, put thousands in velvet who are now in sackcloth.



## The "S.T.300" Adaptor for Your Set—continued

The aerial coupler—a .00004-mfd. condenser with air-dielectric and very low-minimum capacity (I have per-

turn brings us back to the long waves again (top-left). There are four positions possible for the switch, but only

three are to be noted. (The medium-wave position is when the "big hole" in the disc of the switch is at the top.)

It is very important to remember the proper position of the switch, because two things can easily happen: you may have the adaptor on long waves and the main set on short waves, or vice versa. And, secondly, you may switch off the main set and forget to switch off the adaptor. But which of us, I wonder, has never left a set switched on?

### HOW TO MAKE YOUR OWN SCREEN

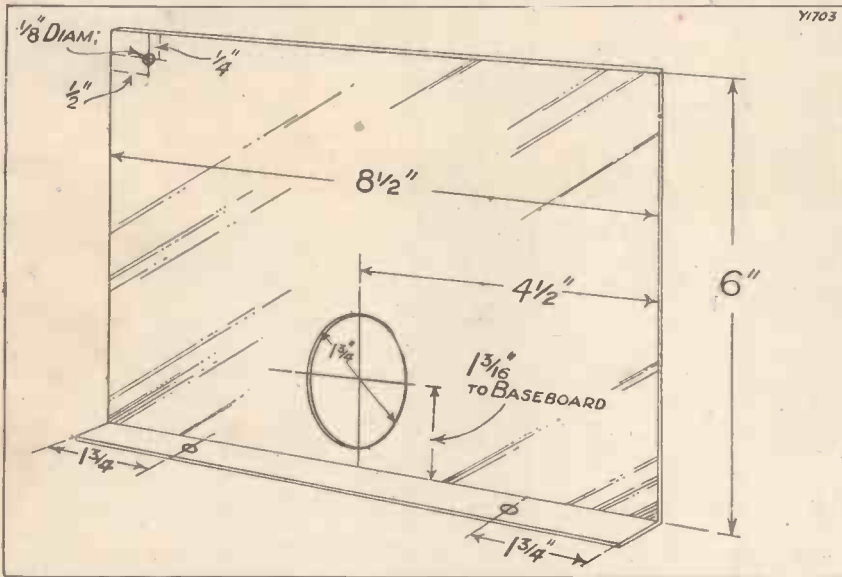

You will be able to purchase the screen all ready cut and drilled to size, but here are all the necessary dimensions for those who want to make their own screens.

sonally tested and approved Peto-Scott, Ready Radio, Wavemaster and J.B. Midget types)—is embodied in the unit, and controls aerial circuit selectivity and signal strength. The differential anode coupler (a .0001-mfd. differential condenser) controls anode circuit selectivity and signal strength.

The use of these controls is explained in the original "S.T.300" article (reprinted in this issue). In brief, they operate and may be adjusted independently, but each will give more selectivity when its knob is turned over to the left and more signal strength when turned to the right.

### Ingenious Switch

A special feature of the adaptor is the use of a Lotus switch of interesting design. It is used here as a combined wave-change and on-off switch for the adaptor. The knob is turned clockwise and is so fitted that in the top-left position the adaptor is working on the long-wave hand (remember it by "left for long").

The top-right position is for medium waves; the next position when the switch "clicks in," i.e. bottom-right, is ignored and passed over; the next position, bottom-left, is "off," i.e. the filament current of the S.G. valve is switched off. The next clockwise

### Built In An Evening

The wiring and general construction of the unit is clear from the illustrations, but I have drawn up the following simple guide which enables the whole unit to be built in an evening. All the parts, except the switch and screens, may, incidentally, be used to build a self-contained "S.T.300," exactly to approved specification, if the constructor decides to do so later.

The L.T. terminals are connected to the L.T.+ and L.T.— terminals

### ONLY ONE "S.T.300" COIL IS NEEDED



The coil in the set with which the adaptor is employed operates in place of the second "S.T.300" coil, for Mr. Scott-Taggart always aims at reducing costs.

V236

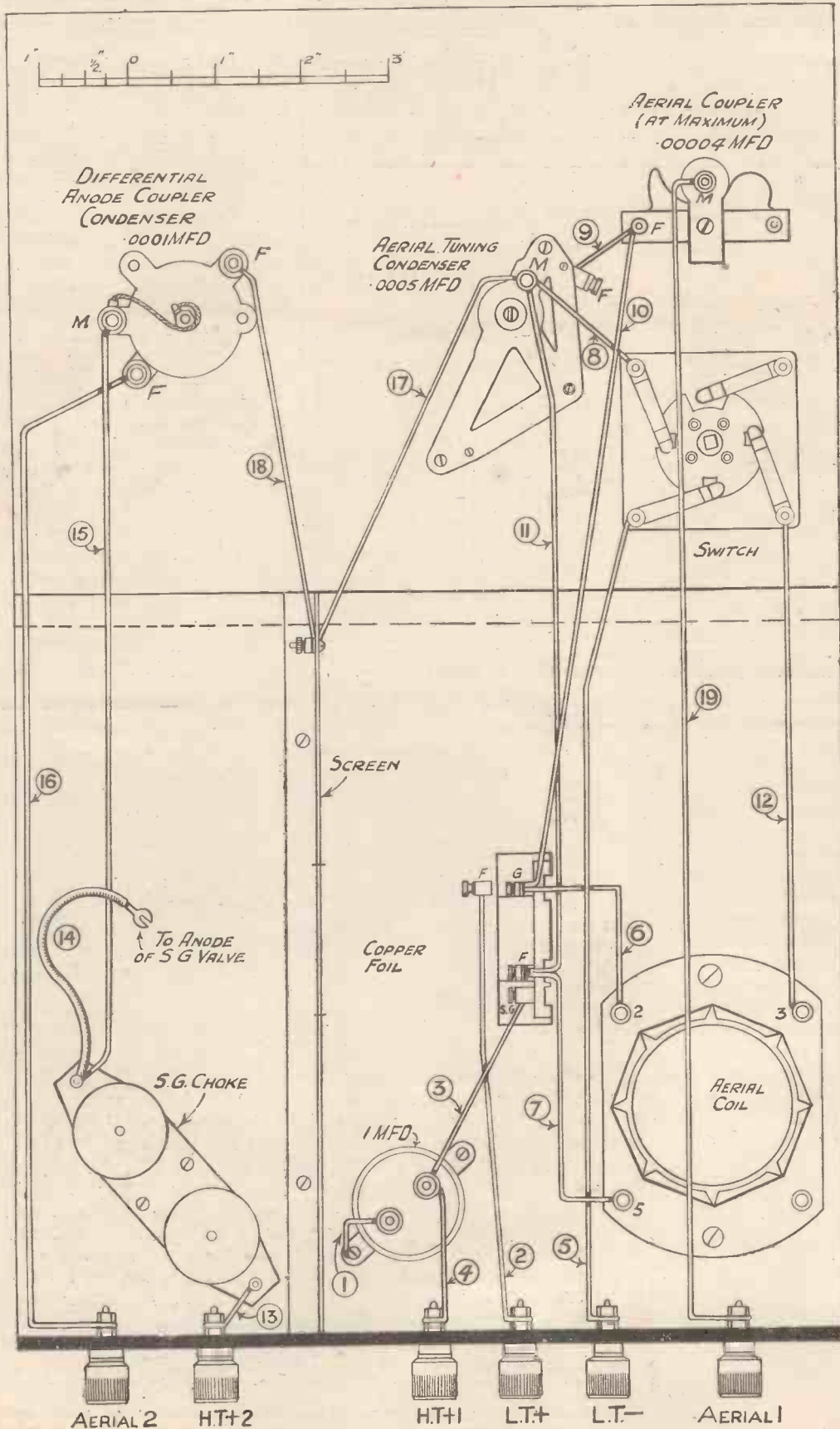

The "S.T. 300" Adaptor for Your Set —continued

of the main set. The H.T. +1 terminal is given about 75 volts, while H.T.2 is given the full voltage of the H.T. battery.

Rapid Construction Guide

This guide tells you every step to take to build the "S.T. 300" Adaptor in the minimum of time, and will ensure success to the absolute novice.

- (a) Mark out and drill panel (or buy same).
- (b) Mark out and drill terminal strip (or buy same).
- (c) Fix terminal loosely in corner hole of vertical screen. (In my case I removed for this purpose the unused terminal C on the W.B. universal valve holder, discarding the bent metal socket.)
- (d) Lay copper sheet on baseboard and screw down screened-grid valve holder, the screws going through into baseboard. (As its size



# The "S.T.300" Adaptor for Your Set—continued

## VASTLY IMPROVED SELECTIVITY

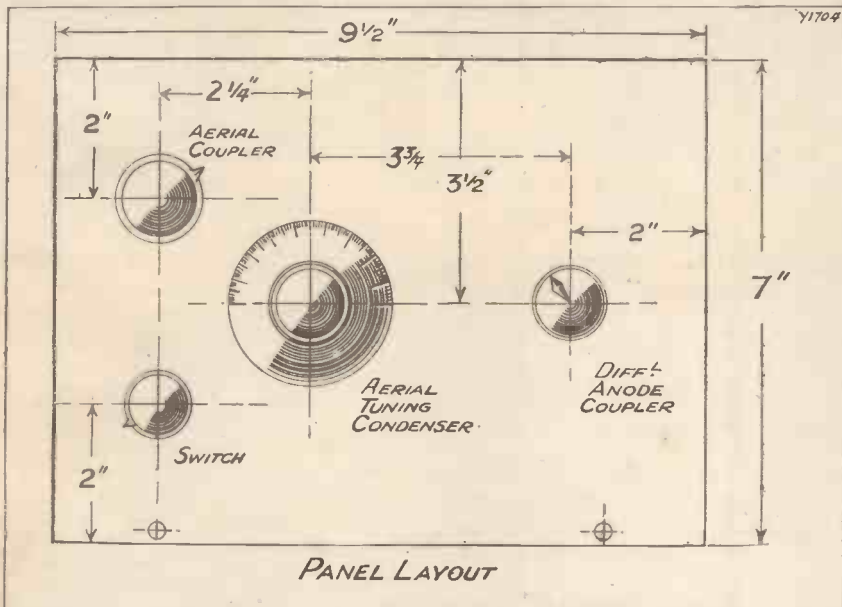

The unit enables you to cope with any other conditions, and, as with the "S.T.300," has been designed with an eye to the future, for it embodies the S.T. principle of "progressive selectivity."

should be done with stiffish insulated wire, such as bell-wire or one of the advertised varieties. To save the reader time I have numbered the wires in the most convenient order for connecting. Wire (1) has already been explained.

### Now For the Wiring

2. L.T. + terminal to lower filament terminal F of valve holder (W.B. type considered).
3. Screening-grid terminal (marked A) on valve holder to 1-mfd. condenser.
4. 1-mfd. condenser to H.T. +1 terminal.
5. L.T. - terminal to Lotus switch.
6. Terminal 2 of "S.T.300" aerial coil to control grid terminal (marked G) of valve holder.
7. Terminal 5 of coil to upper filament terminal F of valve holder.
8. Lotus switch to moving plates of tuning condenser.

(Please turn to page 104.)

indicates, the copper sheet covers the whole of the baseboard up to where the vertical screen will come, leaving a narrow strip of baseboard 3 in. wide uncovered.)

- (e) Clean copper sheet (with emery paper) where it will later be held down by ledge of vertical screen. Clean patch of copper sheet where earthing wire (1) will come into contact with it. Also clean underside of ledge of vertical screen.
- (f) Prepare holes through copper sheet and into baseboard for fixing vertical screen. (Vertical screen is not screwed down at this stage.)

### Fixing the Components

- (g) Screw down the 1-mfd. condenser on copper sheet, wire (1) having previously been bared and cleaned and then tucked under the condenser. Wire (1) is thus pressed into contact with a cleaned patch of copper sheet.
- (h) Fix "S.T.300" aerial coil and S.G. choke in position.
- (i) Screw terminal strip to edge of baseboard with two screws and fit terminals loosely.
- (j) Mount components on panel. Screw panel to baseboard with two screws.
- (k) Carry out the first part of the wiring (2) to (16). The wiring with the exception of the flex (14)

## GREAT INCREASE IN POWER

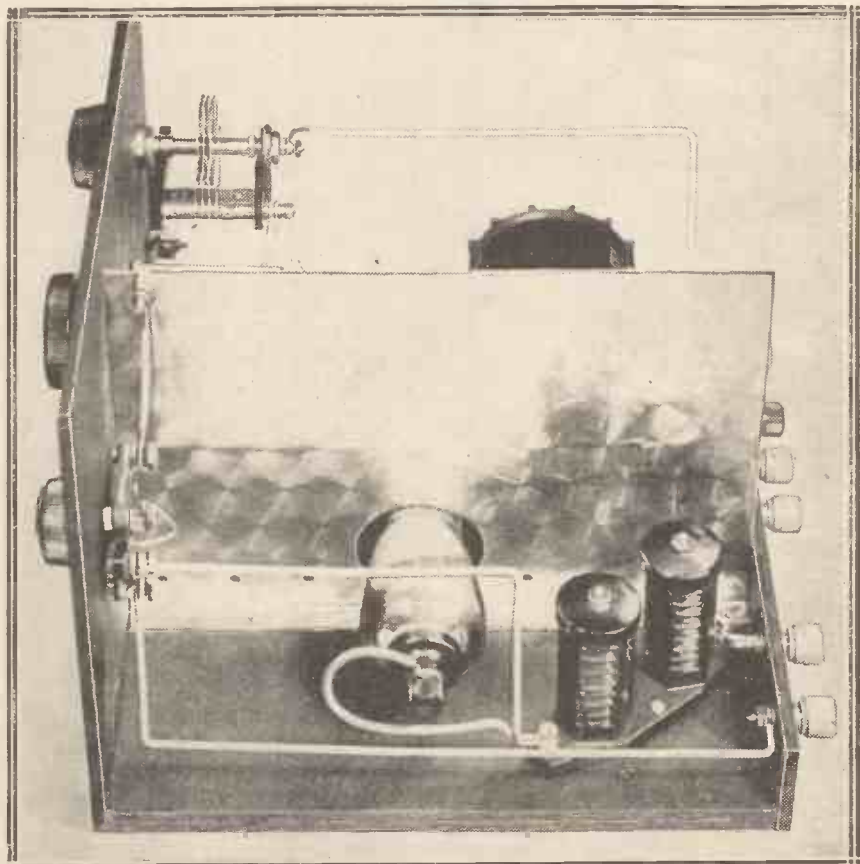

The "S.T.300" Adaptor definitely amplifies to a very considerable extent, as well as adding selectivity. This makes it possible to tune in many more stations, at vastly greater volume.

**A Timely Reminder**

THANKS are due this month to a number of readers who have forwarded accounts of queer faults and failings they have been encountering recently. Some of these adventures in set-construction have been very funny to read about.

One Staffordshire reader, for instance, tells how he was called in by his neighbour who had made a three-valver and couldn't get a sound from it. The poor chap had sat up very late on the Saturday night to finish it, and tried all Sunday afternoon and evening to tune in something. And not a word could he hear. Only the family's sarcastic remarks.

The set was a "detector and two L.F.," one resistance-capacity coupled and the other using a transformer. Everything looked all right, and when my correspondent asked, naturally enough, "Have you checked the wiring?" the frayed nerves of the

**USING A PENTODE**

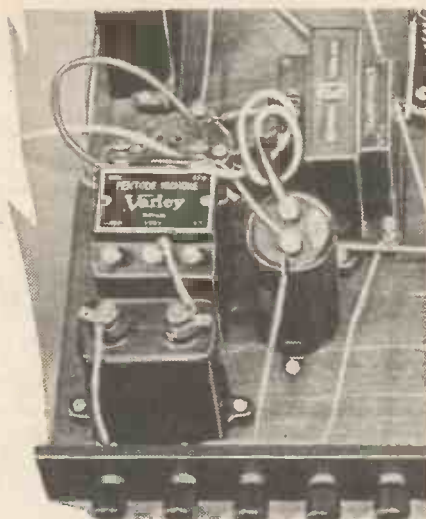

*When using a pentode always switch off before making adjustments to the connections. It is often not realised that the valve may be seriously damaged if its loudspeaker wiring is interfered with while the set is on.*

neighbour gave way, and he shouted "Checked it? I've checked it umpty-nine-million times, and every wire is right."

It was then getting on for 9 p.m., when the Sunday evening concert was coming on, so a final look-over was given to the set, and fortunately somebody happened to touch the H.T. +1 terminal while his finger was resting on a resistance. And immediately a voice from the loud speaker remarked: "There is always hope—"

Immensely cheered by this observation, it took them only about ten minutes to find that the resistance

# QUEER QUERIES



*Some details about unusual radio faults and some suggestions that may help you to better radio reception.*

By P. R. BIRD.

that had been accidentally touched was a dud, and the set was perfectly O.K. when this was replaced temporarily by a grid leak.

**"Eyelid Capacity"**

Another letter was from a London reader who, having hurt his leg in an accident which kept him in bed for weeks, decided to make a short-waver. And it certainly made him forget his leg for a while.

"The hand-capacity was so bad," he said, "that it wasn't hand-capacity at all. It was eyelid capacity, and I simply couldn't look at the set without it howled like a hyena."

So he waited a bit until he felt strong enough to deal with it, and then he checked it over and found he had omitted to connect one terminal on a small fixed condenser to earth. This was soon put right, and then another trial run was carried out, during which the set behaved like a gentleman, except for just a spot of hand-capacity.

Finally, even this was cured, by an accident; for happening to connect it up quickly after the doctor had been one day, the earth connection was overlooked. And it proved to be one of those cases that are better without any earth at all.

**Pentode Problems**

If you are using a pentode it is worth remembering that these valves, with their comparatively high amplification and closely packed electrodes, are very sensitive to any trace of H.F. which may be fed to them in addition to the L.F. they are supposed to handle.

A Manchester reader—J. V. G., of

Whalley Range—tells of a queer experience which appears to be due to this peculiarity of pentodes. He was recently getting a nasty thin whistling effect, which looked like spoiling everything, when he happened to reach out to adjust the volume control.

"When my hand was about three inches away from the volume control," he says, "the whistle disappeared completely. As soon as I withdrew my hand the whistle recommenced.

"I took a piece of tinned copper wire, secured one end to the nearest earthed terminal, and bent the wire round the top of the V.C., without connecting it in any way. The set then behaved perfectly.

"It seems impossible for the wire to be screening the volume control," he continues, "and the capacity, if any, between the two must run into thousandths of micro-microfarads."

Nevertheless, it apparently was a capacity feed-back effect, for it was

.....  
**HOW IS YOUR SET BEHAVING NOW ?**  
 .....  
 If you are troubled by a radio problem, remember that "The Wireless Constructor" Technical Queries Department is fully equipped to help you.  
 Full details of the service, including scale of charges, can be obtained on application to the Technical Queries Department, "The Wireless Constructor," Fleetway House, Farringdon St., London, E.C.4.  
**SEND A POSTCARD**, on receipt of which the necessary application form will be sent by return.  
**LONDON READERS, PLEASE NOTE.** Applications should not be made by telephone, or in person at Fleetway House or Tallis House.  
 .....

soon proved that J. V. G.'s troubles were not over. And at the end of his letter he had to write sadly :

"P.S.—I have just been demonstrating the above fact to a friend, and I find that upon removing the wire nothing will induce the wretched set to produce anything like a whistle." And, finally :

"P.P.S.—I have just moved one of the grid-bias leads, and there she goes again."

Yes, it would certainly seem like a case of H.F. going astray, and in such circumstances an H.F. choke (or extra resistance) in the screen circuit, and a by-pass condenser, will generally work wonders if the point where the feed-back is taking place cannot be located.



# DETECTION MADE READABLE

BY  
HERBERT  
K.  
SIMPSON.



A READER, writing to me about a point which had cropped up in a previous chat, mentioned that he would find it much easier to understand his radio set if he could see what was going on in the various wires!

The idea may sound all right, but even if the currents were visible we should find that they varied so rapidly that just a blur would result. As a matter of fact, we have a more practical form of help, and this consists of a series of pictures, as it were, of what is happening in the various parts of the set.

### Slow-Motion Pictures

Suppose you had to give a decision on a doubtful point in a boxing match, would you rather have seen the incident in the twinkling of an eye or be given a strip of cinematograph film on which you could study each movement? I know that I should vote for the film every time.

In much the same way it is most convenient to have a pictorial record

### ONE COMPLETE CYCLE

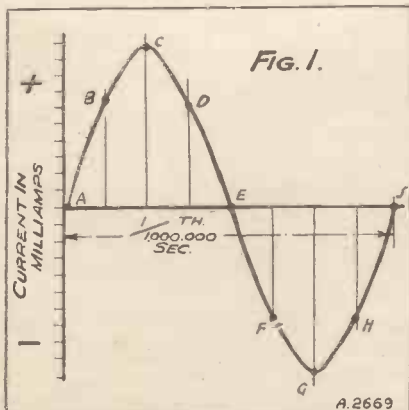

This pictorial record or "graph" of electrical current shows you what the current is doing at each instant.

Continuing his fascinating and popular series of articles for the man who wants to know how and why his set works, our contributor this month deals with the interesting process of detecting.

of electrical happenings that we can study at leisure.

First of all, let us see how electrical currents are represented on these pictorial records, or "graphs" as they are called.

A simple example is shown in Fig. 1, which represents the activities of an alternating current during one cycle. The length of the graph from left to right represents the time taken for the cycle, which would be only one millionth of a second if the current had a frequency of 1,000 kilocycles (1,000,000 cycles per second).

You can think of this curved line as being made up of a string of points marked on the graph to show what the current is doing at each instant. The position of each point represents the current in the following simple way.

The straight line running across the graph from left to right is called the base line, and if the current is flowing along the wire in one direction we mark the point above the base line. If the current is flowing in the opposite direction the point is marked below the line.

### Easily Followed

The strength of the current is represented by the distance of the point from the base line. We have a scale to the left of the graph on which we can measure the distance of any point from the base line; not in inches, but in so many amps. or milliamps. of current.

It will clear up any little difficulties in understanding this method of showing currents if we ourselves put in a few points on the curve.

Let us start at the beginning of the cycle—that is, on the left-hand side of the graph—and at this instant we find that there is no current flowing in either direction, so we put point A on the base line.

One eight-millionth of a second later the current is flowing along the wire, and we represent its direction by putting point B above the base line. The strength of the current is given by the distance of the point B above the base line.

### Varying Strength

Another eight-millionth of a second later one-quarter of the cycle has been reached, and we find the current

### EXPLAINING "MODULATION"

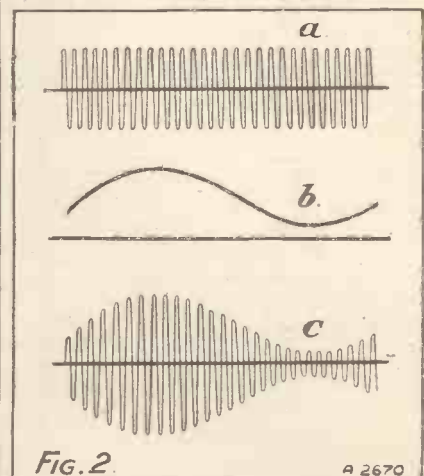

(a) depicts the H.F. energy supplied by the transmitter to the aerial and (b) the current from the microphone when it is responding to a sound. And (c) is the H.F. current when its strength is varied by (b.)

## Detection Made Readable—continued

is still flowing in the same direction, but that it is now stronger. We therefore put point C at the height which represents the new strength of the current.

The current is still flowing in the same direction one-eighth of a cycle later, but it has now decreased in strength, and so is represented by the lower point D.

Half-way through the cycle the current has fallen to nothing, so point E goes on the base line.

The second half-cycle is a repetition of the first, with the important exception that the flow of current is in the opposite direction along the wire, and so all the points on the curve will now come below the base line.

### Reversed Flow

Thus for points F, G, and H the current is flowing in the new direction, the point G showing where the current strength is a maximum. At the end of the cycle the current has fallen to zero again, and is ready to repeat, a million times per second, the cycle that we have carefully followed.

We are now ready to look at Fig. 2, which shows three of the currents at a broadcasting station.

Curve (a) shows the current that is supplied to the transmitting aerial during a short interval in the programme. This is a simple alternating current of high frequency which is necessary to radiate wireless waves. It is, in fact, like the current in Fig. 1, but here we have several cycles, and the length of the graph from left to right represents a longer time.

Curve (b) shows the current from the microphone when it is responding to some sound, and it should be noted

that the variations in this current are irregular and much slower than those of the transmitting aerial current.

It is our object to get a reproduction of this microphone current in our sets, so that by passing it through our loudspeaker or headphones we can obtain the sounds that the microphone "hears."

### Modulating the "H.F."

It is arranged that the microphone current shall vary the strength of the high-frequency (H.F.) aerial current, which is now represented by curve (c). This is a "modulated" current, i.e. the H.F. currents have been increased and decreased in strength by the microphone currents.

We will now have a look at the receiving end, and assume that our set is tuned in to the station we have just been talking about.

One of the simplest ways of receiving wireless signals is by means of the good old crystal set, a form of which is shown in Fig. 3. To the left of the dotted line we have the tuning circuit, and when we are listening in this tuning circuit has electrical pressures across it which vary in the same way as the aerial currents of the station we are listening to.

Electrical pressure can be compared to the water pressure which makes the water flow along pipes, but it is measured in volts instead of pounds per square inch. The electrical pressures, or electro-motive forces (E.M.F.'s), as they are called, try to send current through the wires which cross the dotted line.

### How It is Done

Curve (d), in Fig. 4, shows the current that the E.M.F.'s would like to produce, and you will notice that it is exactly the same in form as the aerial current at the transmitting station. Although the two graphs may look similar, it must be realised that half an inch above or below the base line represents a very much smaller current on curve (d) than it did on curve (c).

As we said before, our object is to obtain a reproduction of the microphone currents, and to do this we put a crystal detector in circuit.

A crystal detector can take many different forms, but each one has the property that it allows current to pass through it in one direction, but

resists its flow in the other direction.

As a result of the crystal detector's weakness for one-way traffic, the current which does flow through it is shown by curve (e), which is like curve (d) with the lower half wiped out.

Since this current is flowing in one direction only, the electrons forming the tiny current impulses pile themselves up on the fixed condenser and

### BACK TO THE MUSIC!

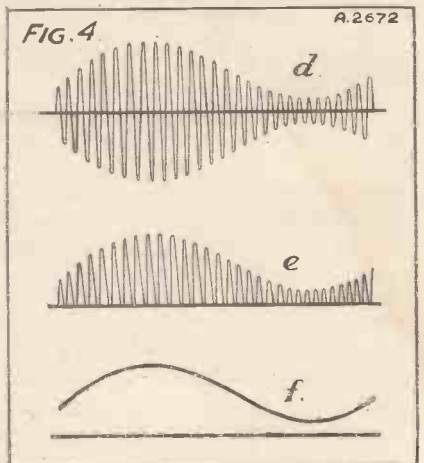

The current produced in the crystal set's tuning circuit can be shown as at (d), and (e) illustrates how the crystal detector wipes out the one half of it. And at (f) we are back again to the same shape as in Curve (c).

then leak away through the headphones. The current through the headphones is shown by curve (f). We have now obtained our object, because curve (f) is the same shape as curve (b) of Fig. 2, and the current which passes through the headphones will now make them reproduce the sound "heard" by the microphone.

### Separating the Currents

The process of separating the type of current shown by curve (f) from a high-frequency current is known as detection, and in many respects it can be compared with the pumping up of a bicycle tyre. If curve (d) represented the flow of air between our pump and the tyre it would mean that as much air came out of the tyre after each stroke of the pump as we had just pumped in. The obvious result would be that the tyre would never be pumped up.

However, the tyre is fitted with an air valve, which behaves towards the flow of air in much the same way as

(Please turn to page 106.)

### SIMPLE RECEPTION

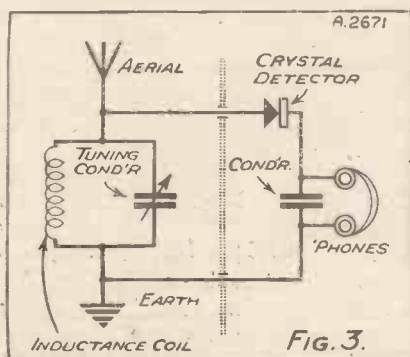

The theoretical diagram of a crystal set. On the left of the dotted line is the tuning circuit.





# B.B.C. NEWS

*Topical notes regarding British Broadcasting Stations and Programmes.*

By Our  
Special Correspondent.

## The B.B.C. Under Fire

IT has given me no small amusement, and greater satisfaction as perhaps the most stringent critic of the B.B.C., to study the outcome of the violent controversy which has been raging in the Press of North America as the result of evidence given by a B.B.C. official before a Parliamentary Committee at Ottawa.

It appears that there had been almost complete ignorance of the work and policy of the B.B.C. When the authoritative evidence was given publicly, it was met with a gasp of astonishment which for the time being nonplussed opposition. But, a few weeks later, some of the old canards were revived, curiously enough in Canadian newspapers.

It is significant that they were promptly challenged in American newspapers, which seemed profoundly impressed by the comparisons invited by the evidence at Ottawa. And there emerged several superlative personal tributes to Sir John Reith, whose successful tour of the United States last summer is still very much in the memory of those editorial commentators who count.

## Overdoing the Intervals

While agreeing that it is important to observe the essentials of artistic unity and to avoid at the same time the tyranny of artificial continuity, I would offer a word of warning to our programme builders. My feelings are that there is a certain amount of slackness about the intervals.

This may have originated with the lapse of the piano solos, so admirably done in the old days by Cecil Dixon and Victor Hely-Hutchinson. These were washed out chiefly because of the necessity on so many occasions to cut into a musical phrase.

There then followed a period of unduly rigid continuity, a kind of panic to prevent any silence. The reaction against this produced the interval signal in its various forms, stigmatised sometimes as the "womph," or "coffin-nailing."

This in due course was modified and then apparently withdrawn, at least experimentally. Thus we are now in the position of having frequently undue periods of silence between consecutive programmes. It seems to me that what is needed is a fresh intervention of common sense to establish the right balance in what is a very important subject.

I would be the last to advocate anything so insensate as the American

system of intolerable continuity; but I would suggest that the interval, whether silence or filled by characteristic signal, should be regarded as an essential part of the artistic unit—that is, the programme which is being built before and after.

## Studio Audiences

As one of those who perhaps erred in inducing the B.B.C. to allow as many listeners as possible to be present at studio performances of vaudeville and light entertainment, I would like to recant.

It seems to me that the development of the vaudeville work of broadcasting is now being hindered by the presence of audiences. I am told

## COMPILING THE WEATHER REPORTS

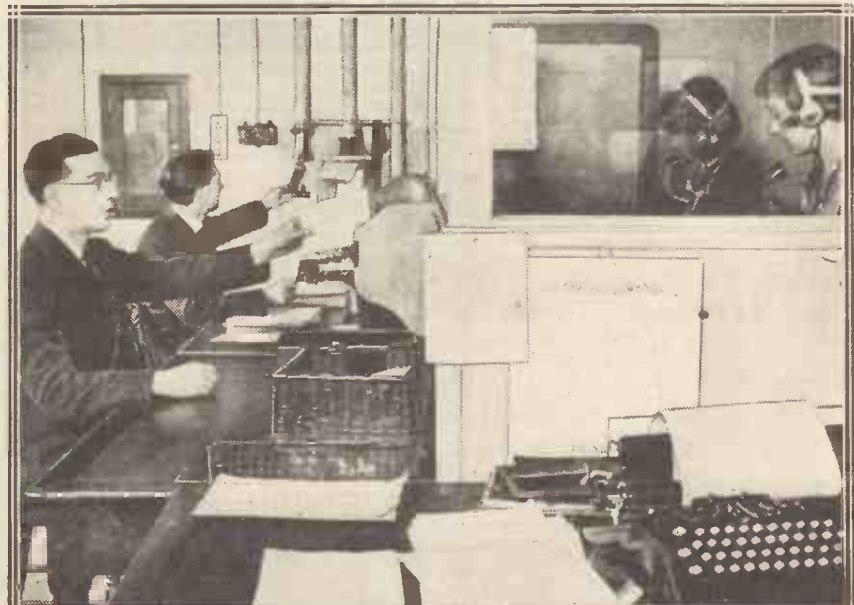

*The B.B.C. weather reports are compiled at the Air Ministry, where a special "weather" staff collects information from all parts of the British Isles, Europe, and even from ships at sea. This photograph shows clerks at the Air Ministry, building up reports from the data received from all the outlying stations.*

## B.B.C. News—continued

that there are many thousands on the waiting list for this favour.

It is not surprising, therefore, that those who have waited on an average for two years to be present in a studio should be uncritical in their applause. This being the case, two things go wrong. First of all, a wrong idea is given of the degree of acceptability of the programme as a broadcast, and, secondly, the listener is deprived of an undue proportion of the performance

Perhaps it is right that there should be no permanent solution. On the other hand, I think it is dangerous that the dice seemed to be weighted so much in favour of the advocates of centralisation—that is, of those who would demolish practically the whole of the constructive programme organisation outside London.

Fortunately, however, Sir John Reith holds an effective watching brief for Provincial interests, and

### Supplementing Broadcasting House

I find an unnecessary degree of apprehension within the B.B.C. at the prospect that Broadcasting House will be inadequate both in size and equipment. This apprehension seems to me unjustified, and for this reason—that, in view of the exceptional factor of obsolescence in connection with the whole technique, the proportion of expenditure on replacement is inevitably high.

It follows also that if the B.B.C. is doing the research and experimentation which it should do, there must be a resiliency both in the size and nature of the accommodation made available. Therefore, I hope that the B.B.C. will face squarely and without delay the pressing need of premises auxiliary to Broadcasting House.

Were there any timidity in exercising this undoubted right, there would be a difficult public reaction when the deficiencies entailed were realised.

### Announcers and the Move

None will welcome the complete closing down of the studios at Savoy Hill more than the announcing staff, whose lives are one continual rush and tear between Langham Place and the Strand. Conditions are now slightly better than they were during the first few weeks of April, when the news and talks were broadcast from Broadcasting House and other parts of the programmes from Savoy Hill or the No. 10 studio at Big Tree Wharf.

For a time it was quite common for an announcer to have to visit all three places in one evening; not once only, but two or three times. Journeys were made in official cars, if any happened to be available, otherwise the poor announcers found themselves rushing about in taximeter cabs, coming out of warm buildings into the rain and sleet and biting winds.

### The Importance of Being Pleasant

Mr. John Kettelwell's remarkable success as the head of the Children's Hour emphasises once again the importance of being pleasant in all matters of broadcasting. I commend all serious talkers and programme administrators to listen to Mr. Kettelwell and adapt his inimitable good nature to their own requirements.

### CITY OF PHILADELPHIA HONOURS MARCONI

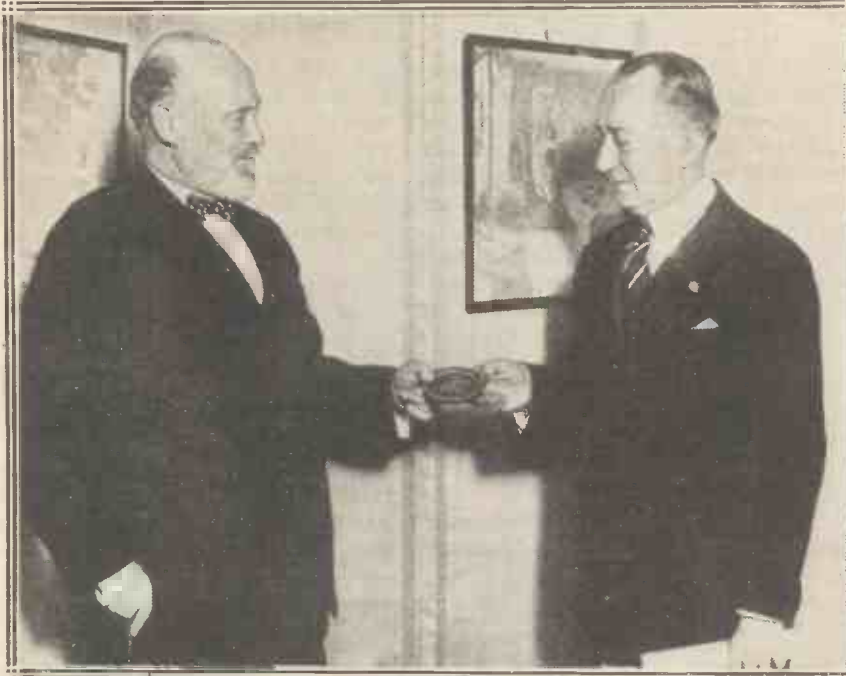

The City of Philadelphia, U.S.A., recently honoured Marchese Marconi by presenting him with the "John Scott" prize for meritorious work in radio. Here you see Mr. Ganet, the U.S. Ambassador at Rome, presenting the distinguished inventor with a gold medal, which goes with the prize.

by the intervention of singularly monotonous and, to him, irrational acclamation.

It seems to me that the time has arrived when vaudeville and light entertainment generally must be handled primarily from the point of view of the listener; in other words, technique should catch up with demand, and studio audiences should be the exception rather than the rule.

### Regional Autonomy

There are signs of another struggle within the B.B.C. on the perennial problem of Regional autonomy. No doubt this difficulty is inherent in a system of unified control such as we have in this country.

apparently no Regional Director as yet has had occasion to complain against the Director-General for failing to intervene in a case of injustice.

This is not entirely or even chiefly a matter of internal politics of the B.B.C. If the many millions of listeners who enjoy their characteristic Regional programmes were suddenly to be deprived of them, there would be, of course, a violent outburst in the areas affected, as well as in Parliament. It is the duty of the B.B.C. to prevent any such situation arising, and the best way for the B.B.C. to handle it is judiciously to give a little more control freedom to its very able corps of Regional Directors.



# AS WE FIND THEM

## NEW APPARATUS TESTED



Under this heading we publish reviews of apparatus submitted by radio manufacturers and traders for examination and test in "The Wireless Constructor" laboratories.

### Watmel Potentiometer

VARIABLE high-resistances which remain silent in operation over a long period are by no means easy to manufacture.

In order to obtain the necessary high value it is usual to construct the resistance element of composition, and

### ROBUST AND SMOOTH



The Watmel potentiometer has a composition resistance element to which connection is made by a special arrangement of wire contacts.

it is here where the success or non-success of the component rests.

Messrs. Watmel Wireless Co., Ltd., carried out intensive researches into this problem and as a result are marketing potentiometers in values from 50,000 ohms upwards.

The composition-resistance strip in the Watmel potentiometer is surrounded by wire contacts and it is to this wire that the moving arm makes connection.

There is in consequence no wear on the resistance element. A feature of the potentiometer is the method of

clamping the wire contacts to the resistance strip.

The moving-arm connection is self-cleaning and particular care has been taken to ensure a satisfactory contact with the element.

The specimen submitted had a nominal resistance rating of 500,000 ohms, and when used as a volume control we found the potentiometer to be silent in working and progressively smooth throughout its movement.

It is a robust and nicely finished component and the price is 4s. 6d.

### Wates Test Meter

A universal test meter is an extremely useful article for the constructor to possess. Unfortunately, a precision instrument is expensive; in fact, far beyond the means of the average listener.

The Standard Battery Company, Shaftesbury Avenue, London, W.C.2, have, however, brought out a meter which they are marketing at the extremely moderate figure of 12s. 6d.

The instrument has a triple scale giving readings of 0-30 m.a., 0-150 volts, and 0-6 volts.

There is also a scale marked in resistance values for approximate tests of resistances.

In view of the price it would obviously be unfair to compare the meter with a precision instrument costing five or six pounds, but for simple tests in the home it is a useful accessory.

Its usefulness is enhanced by the fact that in addition to the usual voltage or current tests, the meter can also be employed for continuity

tests when fault-finding, and for this purpose there is a small dry battery contained in the case.

With the aid of the two flexible leads provided, any components under suspicion can rapidly be given the "once-over" for continuity.

### Resin-Cored Solder

Messrs. W. H. Agar have sent us samples of resin-cored solder which the firm is placing on the market in sixpenny tins, for the benefit of constructors and experimenters.

Resin is an excellent non-corrosive flux, and for this reason is specially suitable for electrical work. It is employed in very large quantities in telephone engineering.

### A USEFUL INSTRUMENT

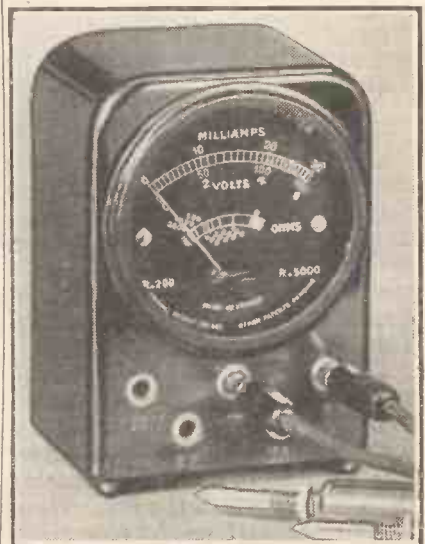

The Wates universal meter can be employed to measure volts and milliamps., it also has a battery in it for continuity tests.

## As We Find Them—continued

The resin-cored solder will appeal to those who require a good, lasting mechanical and electrical joint.

### Signal Lamps

Messrs. A. F. Bulgin & Co., Ltd., Abbey Road, Barking, have sent us two signal lamps. The lamps are



COMPACT AND EFFECTIVE

*Two very neat signal lamps marketed by Messrs. A. F. Bulgin. Special low-consumption bulbs are obtainable to fit both types.*

connected across the L.T. supply on the set side of the L.T. switch, and indicate to the listener whether the receiver is switched "on" or "off."

A red light shows that the set is switched on, hence there is no possibility of the L.T. switch being left in the "on" position by accident.

The D.9 signal lamp is a flush-mounting component, and the bulb is completely enclosed in the case, and retails at 2s. 6d.

The alternative type, known as the D.16, has a smaller lens, the frontal diameter being only 1/2 in.

It is also possible to arrange the bulb at the back of the panel so that it also illuminates a drum dial, thus performing two functions.

This lamp is known as the D.16.

### Special Bulbs Available

Low-consumption bulbs are available for both types of signal lamps, the current consumption being about 60 milliamps. This, of course, enables the load on the L.T. battery to be kept down. For mains-operated designs other bulbs are available. The price of the D.16 lamp is 2s. 3d.

The same firm have also produced a flexible connecting wire known as "Soldawyre." The wire comprises a six-strand tinned-copper conductor with a strand of solder wire running the whole length of the coil. When soldering connections the only appliances required are a soldering iron and a supply of flux.

"Soldawyre" is fitted with a slip-

back insulating covering, and is obtainable in either black or red colourings. It retails at 6d. per 8-ft. coil.

This connecting wire should greatly simplify the constructor's task and can be recommended to those who prefer good soldered joints.

to the high standard achieved by the general-purpose type. The price of these heavy-duty resistances in values from 1,000-100,000 ohms is 2s. 3d., and the makers are Messrs. Graham Farish, Ltd., Mason's Hill, Bromley, Kent.

### B.A.T. Switches

Messrs. Claude Lyons, Ltd., 40 Buckingham Gate, London, S.W.1, recently sent us a very neat and effective miniature double-pole switch known as the B.A.T.-arrow. (Cat. No. 2728.)

These switches are available either with or without indicator plates and retail at 3s. 9d. and 3s. 6d. each respectively.

Messrs. Claude Lyons state that although the rating is marked on these switches as 250 volts 1 ampere, the internals have been improved so that they are now able to handle up to 750 watts.

### Clix "Master" Plugs

Messrs. Lectro Linx, Ltd., 254, Vauxhall Bridge Road, London, S.W.1, have recently sent us samples of the Clix "Master" plug. These wander plugs are specially suited for H.T. battery and mains unit tapping sockets and are constructed with widely variable and non-collapsible prongs.

A feature of the plugs is the extreme ease with which the connecting lead can be attached and the excellent positive contact between the plug prongs and battery or eliminator socket.

These plugs may be obtained either with a long or short shank and retail in red and black colourings at 1 1/4d.

Messrs. Lectro Linx also manufacture a very efficient valve holder, which in the 5-pin type costs 9d.

### "Ohmite" Resistances

Graham Farish "Ohmite" resistances are too well known to require any introduction. We have used them for a variety of purposes over a long period, and have always found them to give silent and trouble-free service.

The makers have lately produced a series designed for heavy duty, and having a power rating twice that of a general-purpose "Ohmite" of similar resistance value.

For instance, a 50,000-ohm heavy-duty "Ohmite" will handle up to 2 watts, as compared with 1 watt in the general-purpose type.

We tested the samples submitted and found them to be accurately marked as regards their resistance values.

They were dead silent in operation and behaved in a manner which indicated that they were fully up

### EFFICIENT HEAVY-DUTY RESISTANCES

*This is a group of the special heavy-duty "Ohmite" resistances manufactured by Messrs. Graham Farish. They are similar in appearance to the well-known general-purpose "Ohmites," only larger.*





# TUNING DOWN the WAVE-BANDS

by VICTOR KING

The designer of the "I.E." Three, the most successful of any Press set of 1931, here gives his candid views regarding short-wave reception. Even if you don't agree with everything he says, we feel sure you will admire his courage and enjoy reading his article.



IT is very obvious that there is a growing interest in short-wave reception, but whether or not this is a passing phase remains to be seen. Anyway, I personally am of the opinion that the interest is definitely sectionalised, and bears the same relation to ordinary broadcasting as does motor racing, including all road endurance tests, to the normal use of private automobiles.

But that does not diminish its value; on the contrary, it tends to raise it from the level of a dull, uninteresting commodity to the heights of pioneering.

The usual criticism against the short waves is that they cannot offer "service," and that there is no entertainment value in programmes received on the higher frequencies.

But if they were of this so-called "service value" there would be no interest (and no *entertainment*) in them for all those thousands of enthusiasts who so keenly follow Mr. Kelsey's short-wave notes in the CONSTRUCTOR month by month.

## Romance v. Reliability

You see, there is no romance or excitement in *reliability*, and the outstanding fact remains that there are no alternatives to the short waves.

It is very important that this should be remembered. If the medium or long broadcasting waves offered the same potentialities and possibilities as the short waves, there would be no need for anyone to ask: "Are the short waves worth while?" for quite obviously they would not be worth while.

But by no other means than the short waves is it possible for an ordinary citizen with a shallow pocket to listen to speech and music emanating from the farthest corners of the earth. But do the *majority* of listeners want to do that?

There was a time when a great deal was heard about the B.B.C. linking itself with foreign broadcasters for special international concerts, etc.

Indeed, I fancy an intricate web of cables was serviced for broadcasting on the continent, and joined to special cross-channel lines, and arrangements of a friendly nature made with the N.B.C. of America for programme exchanges.

## International Broadcasts

For a short time after that sporadic international broadcasts (generally of a very dull and uninteresting nature!) were given, but during the past year they have declined greatly in number—almost to vanishing point, in fact.

I am saying nothing about the policies guiding such ventures, or the

## HE STARTED IT!



The present popularity of short-wave reception is largely due to Mr. King himself, for his "I.E." Three, which was the most successful Press set of 1931, was the first no-coil-changing, short-, medium- and long-waver of a popular nature ever evolved. Above you see a visitor examining a model of this "Wireless Constructor" receiver at last year's Radio Show.

technical reasons which may have combated their wide success, but the fact remains that had the B.B.C. gone international, and roped in programmes from all over the globe for relaying to its listeners, well, the world-wide fame of the "Kelsey" Short-wave Adaptor would never have been achieved!

And, paradoxically, I consider that the more popular short-wave reception as a pure sport becomes, the quicker will it fade away.

It is the fascination of exploration that gives it its present *cache*! If the short-wave stations were all on as easy tap as the powerful long and medium broadcasters of Europe, there would be no reason for the existence of a "fan" clique, for its quondam supporters would then merely be as other men!

As things are, it demands some slight skill, patience, and good staying powers to cope with the somewhat temperamental short-wave stations, and a world-wide "log" is an achievement the enthusiast can be proud of.

## Would We?

He will know that all those Joneses and Smiths who twiddle the knobs of ordinary broadcast receivers with varying success are unable to eavesdrop on the far corners of the world as he can.

But now let us suppose anyone could do this with any old set. Would the four million British broadcasting licence-holders turn nightly from the B.B.C. programmes for intervals of Japanese, Australian or American radio fare?

I don't think so. I believe only a very few would ever go much farther than the present extreme range of simple two-band receivers.

True, at first there might be a considerable amount of listening in to

## Tuning Down the Wave-Bands—continued

distant continents "to see what it sounds like." That would be the novelty appeal of the idea of being able to span such mighty distances.

But different people use different languages, and unless you are a very expert linguist indeed you cannot command more than the merest smattering of a tiny proportion of the multitudinous languages which are employed in this Bedlamic world of ours.

### "Don't You Believe It!"

One is hard enough pressed, linguistically, in only European listening. And you cannot get much out of broadcasting if you cannot understand the words which are broadcast.

But what about the music? That is international? Don't you believe it. There are very hard-and-fast boundaries in music. I've stood in the Ezbekieh Gardens in Cairo (which is only 3,000 miles away), listening to an Egyptian band playing, and wondered how grown men could demean themselves by producing such childish catawaulings! (Such was my arrogant insularism.)

No, I don't think the British public as a whole would find lasting entertainment in the reedy wails of Egyptian, Indian, Chinese, Japanese or other Eastern music.

As for Australia, New Zealand, and other British dominions overseas, well, when you do tune in programmes from such places you get the same kind of broadcasting fare as is served out by the B.B.C. and the "continentals," only, I fear, not generally quite so good in quality.

### What About America?

Working outwards from this country it is a different matter. London is able to provide musical entertainment as good as, if not better than, anything in the world, not only because it is one of the largest and richest cities, but also because it has the whole of Europe to draw on for its talent.

I know that many of you will be saying to yourselves: "All this is true, but what about America? Surely that country is able to supply an almost inexhaustible number of alternative programmes for British listeners who can command the short waves?"

Possibly; but first of all we must consider the clock, and that "goes"

for the rest of the globe as well. Unless America (and other countries) were to run special transmissions for overseas listeners (as we are going to do for our Empire), their broadcasting would not be of great value to us from the "service" point of view, even if problems of reception did not exist.

You see, we in this country are going to bed before the evening programmes in America are due to commence (and we are having breakfast and thinking about going to work just as they are getting down to their evening radio in the Antipodes).

My next point is rather unnecessary in view of this, but I might as well place it on record. It is that the average British listener is left quite "cold" by the average American programme, with its "hot" jazz music and "wise crack" comedians.

## A GIANT BATTERY FACTORY FROM THE AIR

*An aerial view of the Exide works at Clifton Junction, near Manchester.*

*It is here that the Chloride Electrical Storage Co., Ltd., operates the largest battery-making plant in the British Empire.*

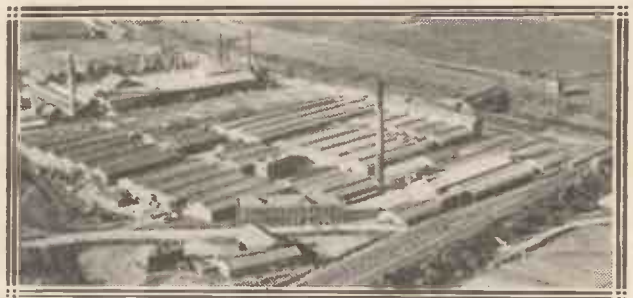

For this reason American music-hall entertainers who visit this country badly "flop" unless they adapt their repertoires to the circumstances. Of course, some wonderful "straight" musical sessions are given by the bigger New York and Chicago stations, but I venture to suggest that there is a sufficiently wide choice of such material to be obtained from the two hundred-odd European transmitters.

I know all this sounds like a laboured argument against international radio in general, and short waves in particular; but it isn't meant to be. My article is an attempt to place short waves in their right perspective.

### Space Shatterers

I believe they are vitally important, but not as mere space shatterers. That their capabilities in this direction result in thousands of enthusiasts "fanning" them is, I believe, a fortunate incidental.

I fancy that the real value of the short waves is as yet but faintly visualised. There will surely come a day when they will be harnessed and cease to be waywardly fitful channels of romance and adventure.

And it will be the "fan" who will have brought this about by continually focussing attention on this branch of radio and by exploring its practical possibilities.

### A New Spectrum

A whole new spectrum of wavelengths will be thrown open for "service" use, and the way will be wide open for television.

And I will entertain no "buts." It is seldom that I don a prophet's mantle, though on this occasion I will do so in order to answer a final question that I am sure many are burning to ask. It is: "You have

discounted the value of at least the direct reception of very distant foreign programmes; if you don't see the short waves being used for this, what broadcasting use can they have, seeing that they are technically imperfect for covering short distances?"

To this I would say that it *might* be possible in the future to render short waves of service for covering "home" territories. Is it fantastic to suggest that if they will persist in "skipping" that re-radiating stations should be erected in various countries? They would work in this manner. A short-wave programme given from London, for Londoners would be broadcast, received by a relay station at some suitable distant point (say Lisbon), and be re-radiated for reception in London.

Of course, the programme would also be available for direct reception by anyone in the world. Could international broadcasting be developed further than that?



# WITH PICK-UP AND SPEAKER



by  
A.  
JOHNSON-  
RANDALL

The H.M.V. nine-valve radio-gramophone.

RECENTLY I had the opportunity of testing what may justly be termed the "Rolls-Royce" of radio-gram receivers.

This was the H.M.V. Model 531 nine-valve super-heterodyne, incorporating the standard H.M.V. automatic record-changing mechanism.

### Fascinating to Handle

There is something particularly fascinating in handling a receiver possessing such a wealth of controlled power.

The feeling is that of having the whole world of broadcasting at one's feet—a feeling akin to that of an Aladdin holding a magic lamp.

The Model 531 is a most impressive receiver, fit to take its place amongst the most luxurious surroundings.

The circuit, as I mentioned above, comprises nine valves, and the equipment is, of course, of the all-mains type. The radio side consists of a six-valve super-heterodyne unit having a pre-detector screened-grid H.F. stage to amplify the signals before they are applied to the first detector, or "mixer" valve. There is a separate oscillator, two screened-grid intermediate stages, and a second detector. The output from this valve is fed to a separate L.F. amplifying unit.

### Band-Pass Tuning

The receiver is designed to work in conjunction with a small aerial of either the outdoor or indoor type, or, alternatively, the mains may be employed.

Band-pass filters are used throughout for the tuning circuit. You might at first think that such a multitude of tuned circuits would entail a certain amount of complication, but you

would be entirely wrong. There is only *one* tuning control, and the actual operation of tuning-in stations is simplicity itself.

This single tuning knob operates on a horizontal, illuminated scale, reading directly in wave-length, and all that you have to do is to look up the wave-length of the station you wish to listen to, and rotate the pointer on the scale to this figure.

### A SUPER SET



The H.M.V. Model 531 radio-gram employs a super-heterodyne circuit and a push-pull low-frequency amplifier. The self-changing mechanism automatically handles eight records at one setting.

A "local-distance" switch is provided so that it is possible to listen to the local station in comfort.

### Amazingly Sensitive

From the technical standpoint the receiver is a masterpiece of design, and its sensitivity and selectivity are amazing. It goes without saying that the reproduction is of the highest standard, and the H.M.V. engineers have not made any sacrifices in this direction; in fact, they have taken every precaution to ensure that the tone quality should not be impaired by the exceptional sensitivity and selectivity of the equipment.

This brings us to the L.F. side, which comprises two P.X.4 valves in push-pull.

The output stage is capable of handling approximately  $4\frac{1}{2}$  watts (undistorted), so it will be seen that the volume obtainable is fully adequate for all normal purposes.

There is a combined radio and gramophone volume control, and also a control knob which changes the radio side from medium to long waves, and from radio to gramophone.

### Automatic Record-Changer

The gramophone pick-up and turntable embodies the standard H.M.V. self-changing mechanism, playing eight records at one setting, and I still feel just as enthusiastic about this ingenious mechanism as I did when I first dealt with it on this page some months ago.

The final output is passed on to a moving-coil loud speaker, and a pair of sockets are provided for additional loud speakers external to the set.

The power consumption of the Model 531 is about 100 watts, i.e. one-tenth of a unit per hour.



*Practical notes on what stations to look for and how to get the foreigners that are coming over well.*

AFTER whiling away a pleasant half-hour recently listening to Florence—the station of that name, not the lady!—I combed the dial carefully around the 280-metre mark in search of the newest Italian of all. This is Bari, who should be transmitting regularly by this time.

Bari is fairly sure to be well received in this country, as it will be a 20-kilowatt, twice as powerful as Trieste and with nearly three times the “punch” behind Turin. The city of Bari is situated on the Adriatic, and is favourably placed for transmission northwards, so we may find that we have now yet another good Italian to tune in.

By the way, have you tried for Trieste in daylight? If you can get him at full strength after dark he is worth searching for in the afternoons, when a good set will often find him in vigorous form. If Bari beats Trieste it will be some station!

**New Irish Transmitter**

In addition to the new Luxembourg station, which should soon be creating a stir in our aerials, quite a number of powerful transmitters are due on the air before very long. There is the big Irishman, for instance, who will take the Dublin wave-length, and will be located at Moydrum, near Athlone. Vienna and Budapest are both planning to use

more power; Kalundborg has a similar ambition, and there are numerous other aspirants, especially in Spain.

While all the other countries have been increasing power, Spain seems to have been doing the “Brer Rabbit” trick. Old Brer Rabbit, you will remember, always “lay low, and say nuffin.” But now the time for silence is over, and Spain announces a very pretty programme of improvements, including a “jump” in Madrid’s power up to a total of 100 kw.!

Listeners in the London area will already be familiar with Barcelona, on 349 metres, just below the Regional. It has been coming through in fine style during the past few weeks, on a power that is not officially proclaimed, but that is probably round about the 10-kilowatt mark. But Barcelona is not content with this.

The present scheme of Spanish reorganisation embraces a 20-kilowatt for Barcelona, with Seville and Valencia each represented by a 10-kilowatt station. And, in addition, there will be quite a network of more or less powerful relays dotted about the peninsula. P. R. B.

**Some Good News**

IT is always a pleasure to record price reductions, and especially so in these troublous days when another income tax ramp is imminent, and there’s the holiday money to be thought of. So the following news from British Blue Spot Co., Ltd., is passed on gladly.

Their Upright Grand receiver, which used to be twenty-seven guineas, is now reduced to twenty-two guineas; and the Table Grand, formerly twenty-five guineas, will in future be sold for twenty guineas.

That’s not all. The Blue Spot W.S.400—the one with the inductor type loud speaker—now comes out three guineas cheaper, at £17 17s. instead of £21, and the W.400 is reduced from £18 to £15 15s.

So if you are thinking of a 4-valve S.G. set (with additional rectifying valve) capable of getting thirty or forty foreigners, your luck is in.

**Why Not?**

Those compact, reliable and sturdy metal rectifiers have proved so good for H.T. and for L.T. that somebody aptly asked: “Why not use them for measuring instruments on alternating current?”

\*\*\*\*\*  
**POINTS FOR PURCHASERS**  
 \*\*\*\*\*  
*Interesting details from manufacturers about recent trade activities.*  
 \*\*\*\*\*

There are many experimenters who have D.C. moving-coil instruments, and who would be only too happy to be able to construct units to convert their voltmeter—or whatever it is—for work on either A.C. or D.C.

And now the Westinghouse Brake and Saxby Signal Co. announce they have produced just the thing! Special types of Westinghouse rectifiers have been developed and used with great success in milliammeters, voltmeters, and even in microammeters!

Readers of THE WIRELESS CONSTRUCTOR who would like to know about this may obtain descriptive pamphlet No. 11B. on application to the above firm at 82, York Road, King’s Cross, London, N.1.

**A Useful Range**

The complete range of Marconi-phone instruments is shown in two attractive folders recently issued by the company from the Head Office

at Radio House, 210-212, Tottenham Court Road, London, W.1.

Loud speakers, pick-ups, portables, the Radio-Autogram and the Super-Heterogram—all are listed with brief specifications, and details of simple, convenient purchase terms.

Readers of THE WIRELESS CONSTRUCTOR are invited to apply for these folders either to their dealer or direct to the above address.

**Valve Price Reductions**

The Electrical Trading Association have issued two very attractive folders showing the new prices of the Eta valves. As there are full characteristics and particulars, no doubt many WIRELESS CONSTRUCTOR readers will like to have a copy.

Apply to the above firm at Aldwych House, Aldwych, London, W.C.2.

**Factory Extensions**

“Ekco’s,” who recently made a spectacular recovery from a big fire at their works, have now given the pessimists another shock. Undeterred by talk of economic depression, they have just installed three 1,000-ton hydraulic high-speed presses—the biggest in the country—for making bakelite mouldings of a size and finish hitherto unobtainable in Britain.





**R**ADIO-GRAMOPHONES are considered luxuries by many people, but it is surprising how cheaply you can rig up a gramophone motor and pick-up. Of course, if you have a gramophone already you will only need a pick-up and volume control.

I think the future tendency will be for people to build or buy a wireless set before they get a gramophone, and then to "build" a gramophone arrangement. A reader has asked me what I would advise for use with the "S.T.300" set. Well, a very simple and fairly reasonably priced arrangement which I have seen used successfully for experimental purposes is as follows:

#### Low-Cost Record Reproduction

A wooden box, such as your grocer would readily supply (my friend used a soap-box stood on end!), has fixed to it a Garrard spring gramophone motor, the motor being under the horizontal top of the box, the turntable (supplied with it, of course) being above, i.e. outside. A hole had been made for the main spindle, three holes for the fixing screws and one for the speed regulator.

This pick-up was a B.T.-H. Minor, and a Wearite 50,000-ohm potentiometer was mounted on the horizontal top of the box (the wood being the "panel"). This potentiometer, which acted as a volume control, had its ends connected across the pick-up. One of these ends and the sliding contact were wired up to the Lotus plug used.

The cost of the motor is £1, that of

*Mr. John Scott-Taggart has something to say about radio-grams this month, after which he discusses points arising out of his letters from readers.*

the potentiometer 4s., and the pick-up, complete with tone-arm, 27s. 6d. For an outlay of £2 11s. 6d. he had a very satisfactory arrangement indeed. The soap-box was a trifle homely, but at very small cost one could improve on this.

He was using an "S.T.300" A.C. model, and the gramophone reproduction was superb on the permanent-magnet moving-coil speaker he had in use (a W.B. P.M.1).

Many other combinations of apparatus will give equally good results, but I mention an example to give some idea of the simplicity of "adding a gramophone." My radio friend told me that the whole job only took him an hour and a half to fix up.

#### Volume and Quality

The gramophone output of the A.C. version of the "S.T.300" is, of course, very great—quite enough to make the hardiest listener feel overpowered. I am using, at present, my "S.T.300" A.C. for "home" purposes. It entertains friends now and again to hear real noise—if it's good noise. Personally, sheer strength rather bores me, and probably does you. The set, however, gives excellent quality, which makes the great noise more tolerable.

From the earliest days of broadcasting, in tens of thousands of homes,

some member of the family circle has cried: "Oh, turn it down!" And the reason has not always been to avoid waking the baby or annoying the neighbours. (Neighbour-annoying, as you may remember, used to be a popular sport in 1923; I've annoyed a whole road in my time!) No, the reason why loudness is so often disliked is because quality frequently deteriorates due to overloading. It is surprising what a full blast you can stand up to when the quality is really excellent.

#### A Grouse

What I can never understand properly is why everyone likes a good old noise for a gramophone, but hushes the wireless set. Do you know why? It can't be a question of quality in all cases, because with the "S.T.300" A.C. version (which gives equally good reproduction on radio or gramophone) I find I always deliberately reproduce the records more loudly. Perhaps potted music is less of a staple diet! When we put on a record we steel ourselves for stronger music and enjoy the orgy. Radio entertainment is more arm-chair, and most of us, I think, like it more subdued.

I wonder, though, if people increase volume for Christopher Stone's efforts? I always want to "turn up" the set on dance music, in spite of the fact that I can't dance!

Now, about my "grouse," that although thousands of readers wanted to hear demonstrations (heavens, those demonstrations! I am only just recovering!) only six responded

## From My Armchair—continued

to my humble and pathetic request for a brief shelter during tests of new sets.

Well, since I vented my little complaint I have had a generous response. Most of the letters or cards said that their senders would have offered before only they expected I would get thousands of offers. Apparently everyone thought everyone else would write, so only six did!

### What Does He Mean?

Many of the letters are very interesting, and I could live for a year rent free. "A good dinner, and a first-rate cigar any time you like." "Spend a week-end with us." "Come any

Three of the letters state: "P.S.—My wife doesn't mind your coming"—or words to that effect. But although only three mention the fact, I am certain all the others obtained permission from headquarters! The man I *don't* like is the one who says: "I shall be glad to get you by yourself." Thanks, P.W.L., of Chorlton-cum-Hardy, but whenever I have to slip past Chorlton-cum-Hardy, I shall remain by myself!

Two or three letter-writers apparently did not understand my request. It was not to have a drink and a pow-wow, nor to put their "S.T.300" set right, nor to be got by myself. It was to test out future sets for THE WIRE-

criticising my development experiments and offering their suggestions.

There has been a tendency to regard readers as a negligible element in these matters, designers feeling that they know better than the reader what he ought to get. This, in my opinion, is a fallacy. My demonstrations—and, therefore, my close contacts with every type of reader—have taught me that *any* group of half-a-dozen readers is in closer contact with radio realities than I am myself. And their combined practical experience, I don't mind confessing, was in all cases well worth drawing upon.

### A Queer Case

And now a word to Chorlton-cum-Hardy. He has built the "S.T.300" and can only get one station. I nearly wept on reading his letter. Not with sympathy. Not a bit of it. But with sheer annoyance and vexation at the fact that he either hasn't made the set properly or has been let down by a valve or component. I'll be generous and say it's a component. But Chorlton-cum-Hardy isn't generous. He says I'm a liar, that those who wrote about my demonstrations are d— liars, and that actual constructors who have written in must be—well, you know what comes next.

### Those Modified Designs

This problem of the dissatisfied constructor is always with us. And to me it is a tragic problem. It is a serious matter if a man has spent three or four pounds on a set and he is dissatisfied. He might just as well have applied a match to the pound notes. It's no use telling him that thousands are getting good results. That doesn't help him—although it ought to make him realise that there's something wrong with *his* set and not with the design.

Mind you, the fault often is the constructor's. He *will* modify the author's design. He does so at his own peril. A very good example in the case of the "S.T.300" was the wave-change switch. Other types were used and the set tended to oscillate on the long waves (a trouble, by the way, which may be lessened by earthing the spindle of the unsuitable switch; this is a reader's excellent suggestion). Other readers

(Please turn to page 106.)

## THE "S.T.300" BRINGS ALL EUROPE TO YOUR FIRESIDE

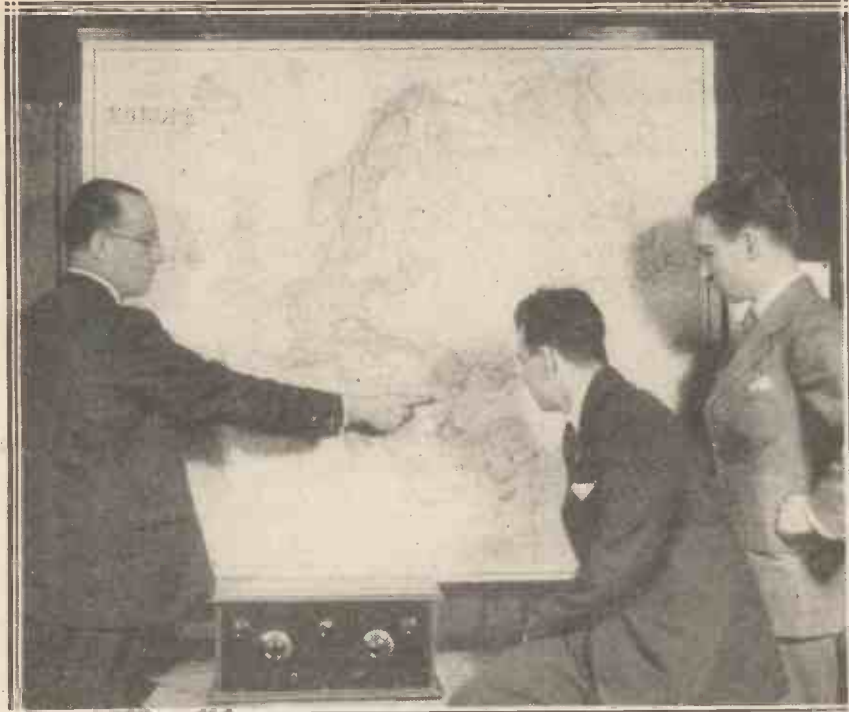

Mr. John Scott-Taggart has given numerous demonstrations of his remarkable receiver, and is no more afraid of personally upholding the claims of his "S.T.300" than of attacking "compromise" methods of set design. He is seen above pointing out some of the stations you should get with your "S.T.300."

evening you like. I shall send the wife out." (What does he mean?) Another letter says: "I am a licensed victualler. I hope this doesn't make any difference." (It might make all the difference!) Someone else writes: "We can offer you a nice bedroom with a charming outlook—the masts of Slaithwaite!" Then there's the Yorkshireman who writes: "We're only homely folk, but you look pretty homely yourself!"

LESS CONSTRUCTOR. To have a number of "test-stations" is of extreme value in preliminary trials—and I hope the result of my work behind the scenes will show in the design of the next big "S.T." set, which I am beginning to think about.

### Where You Come In

It will mean that readers themselves will have had a chance of





# A PRACTICAL MAN'S CORNER

By R. W. HALLOWS, M.A.

*Into these pages, month by month, our contributor packs a wealth of practical information and advice on constructional work. The regular reader of this "Corner" cannot help picking up a more or less complete training in radio workshop practice, while every month there are wrinkles to read, gadgets to make, or hints to help you.*

## Terminal Strips

I HAVE often wondered why so many constructors do not undertake themselves the very simple job of drilling terminal strips. The reason is, I think, probably that two hands are required to operate the hand drill, and that another seems to be needed to hold the work down.

### HOLDING IT FIRM

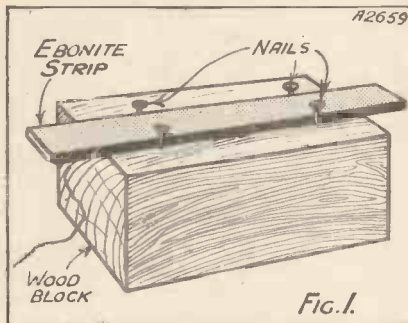

*This useful little gadget is for holding terminal strips steady when drilling the terminal holes.*

Unless it is held it whizzes round, sometimes with disastrous results, just when the point of the drill is coming through on the underside. The device illustrated in Fig. 1 makes the drilling of terminal strips an absolutely simple business. All that you need is a block of wood into which are driven two pairs of nails.

The nails in each pair are spaced so that the strip fits just comfortably in between them. The strip itself can be slid along between the nails when it is required to drill holes near its ends.

The same tip about using nails is equally useful for drilling all kinds of small pieces of ebonite, and it may be used, too, for light metal work.

Five-ply with an outer veneer of oak, mahogany, walnut, teak or some other ornamental wood is in some ways admirable for making the panels of wireless sets, the tables of radio-grams, and so on. There is, however, one snag about it which fellow constructors may have discovered for themselves.

### Just Too Short!

The average component intended for panel mounting, such as the volume control, the variable condenser and the switch, is designed for use with a panel not thicker than  $\frac{1}{4}$  in.—and the thickness of five-ply is  $\frac{3}{8}$  in.

When, therefore, having drilled the hole, you insert into it the mounting bush of the component, you are horrified to find that there appears to be no way of making the securing nut reach it.

Sometimes the tip of the bush protrudes a tantalising sixty-fourth of an inch, which is just insufficient to allow the threads of the nut to obtain a grip; more often, though, it is found

### FIVE-PLY PANELS

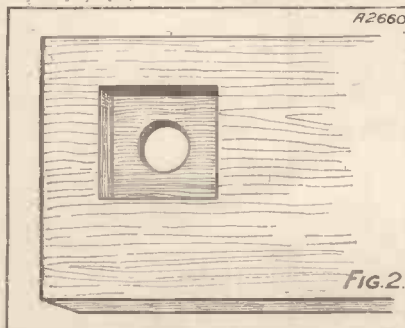

*It sometimes happens that when five-ply panels are employed they prove too thick for fitting some of the components. This difficulty can easily be overcome by a little careful "countersinking," as shown above.*

nestling cooly just beneath the surface.

There is a very simple means of overcoming this difficulty, which is illustrated in Fig. 2. In many components there is a second nut at the bottom of the spindle bush.

If we can make a recess for this at the back of the panel, or at the underside of the radio-gram table, all may yet be well. Don't try to make the recess with a countersink.

Simply mark out a square surrounding the hole, and then use a sharp  $\frac{1}{4}$ -in. chisel. With this make a cut along each side of the square. You will then have no difficulty in removing the lowest layer of plywood.

Should this be insufficient to allow

### EXTENDING SPAGHETTIS

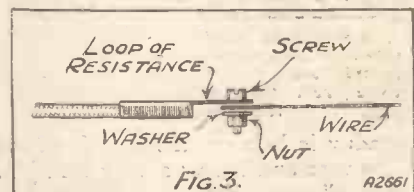

*A good method of lengthening spaghetti resistances when they are just too short to reach their destination is to attach an extension wire with the aid of a small bolt or nut.*

the tip of the bush to protrude far enough, another layer can be removed in the same way. When there is no lower nut on the bush the recess must be made on the outside of the panel or on the upper side of the table.

Make it only just big enough to take the securing nut comfortably. It will then not show at all, for it can be hidden by the knob or the dial of the component.

### The Nut and Bolt Method

Sometimes a spaghetti resistance is of exactly the right length to reach

## A Practical Man's Corner—continued

between the two terminals to which it is desired to connect its ends. Very often, though, the resistance proves to be too short to be used in this way.

There are two possible alternatives, each of which is quite good. The first is to lengthen out the resistance by attaching a wire to it, as shown in Fig. 3. Make a loop in the end of the wire and fix it to that at the end of the resistance by means of a screw, a washer, and a nut.

### Attaching to Wire

The second consists in attaching one end of the resistance to a terminal and the other to a convenient wire carrying current at the required potential. Fig. 4 shows how this is done.

Thread the wire through the loop of the spaghetti, and bare its insulation for about an inch. Now take a piece of fine tinned-copper wire and bind the loop tightly to the bared part of the lead.

Soldering now becomes the easiest thing in the world, since solder flows

### A SOLDERED JOINT

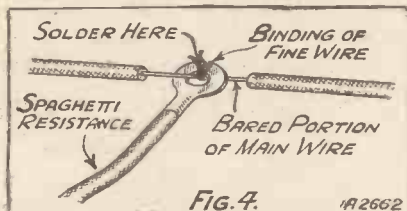

If a spaghetti resistance is joined to another wire by soldering, it is a good plan to wrap the joint with fine binding wire first. This ensures a strong electrical connection.

readily in between the strands of the fine wire and makes a very firm job. "But," says the reader, "where can you obtain fine tinned-copper wire? I don't stock such a thing in my workshop, and, if I did, I should hardly ever use it."

One moment. Cut off about 3 in. from a piece of flex. Remove the various insulations and you will find a number of strands of the required fine tinned wire twisted together. Simply untwist them, select one—and there you are!

### Gramophone Motors

Heaps of people use radio-grams whose turntables are driven by clockwork motors. There are only two things that are at all likely to go wrong with a good clockwork motor. One

of these is a breakage of the main spring; the other, a breakage of one of the little springs that go to make up the governor.

The main springs are bought from any wireless shop, and if you find it a bother to insert one yourself you can get the job done for you for a nominal charge. The governor, though, can be rather annoying should a breakdown occur.

Fig. 5 illustrates a commonly-used type of governor, and will serve to explain how it operates. The worm engages with the teeth of one of the large gear wheels. When the motor is working the governor is thus caused to revolve. Between the disc and the fixed end are three weights suspended on thin, flat springs.

As soon as the governor starts to spin, centrifugal force forces the weights to fly outwards.

### The Speed Regulator

The sliding disc moves away from the worm, and when the speed for which the motor is adjusted is reached the disc makes contact with the speed regulator. The speed of the motor is thus kept constant.

When one of the springs breaks you go lightheartedly to the nearest gramophone shop and seek to purchase a replacement. Unless yours happens to be a motor of widely-used make, or unless your local gramophone shop carries a more than usually extensive stock, the odds are that you will be offered springs that are too long, or too short, or too wide, or too narrow, or too hard, or too floppy.

By perseverance, though, you will probably be able to obtain eventually springs of the right length and width, and then comes the task of fitting them. Let me say at once that you should always replace all three; if

### BRACING THEM UP

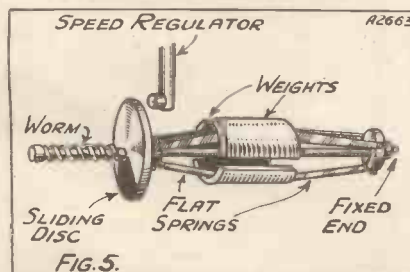

Some very useful tips on repairing governors in clockwork radio-gram motors are included in the accompanying article.

you do not the governor weights are almost certain to run unevenly.

Do not, however, remove more than one at a time or you will find the task a really difficult one. So long as you always have two springs in place you will have no great amount of trouble about fitting the third.

### Floppy Springs

It very often happens that the springs turn out to be too weak. What happens then is that you cannot get the motor to run fast enough to play records properly. A moment's thought will show why this takes place.

Owing to the weakness of the springs the weights fly out a long way when the speed is quite slow, pulling the sliding disc up against the end of

### MENDING GOVERNORS

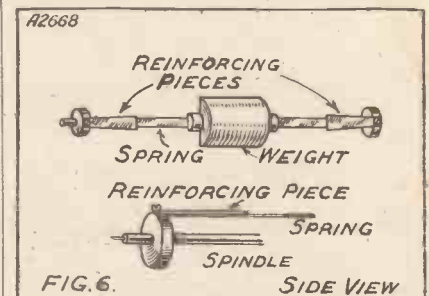

If the springs on a governor are a bit "floppy" they can often be strengthened by reinforcing them with short pieces of old spring.

the brake. The only thing to do is to strengthen the springs, and this can be done in the way shown in Fig. 6.

Break up some of your old springs, or some new ones if necessary (they are quite cheap), and use the pieces as shown in the drawing. They form little girders, preventing the springs from bending too readily and keeping the weights of the governor from flying out at too low a speed.

### A Good Repair

I used this tip recently for repairing the governor of an old motor which required rather stiff springs. The motor itself was a very good one, but parts for it could no longer be obtained.

I was able to find standard springs that were of the right length, but when they were first used the highest speed obtainable from the turntable was just under sixty revolutions a minute, as against the seventy-eight to eighty which are required for most records.



# HOW MAINS UNITS WORK

BY JOHN SCOTT-TAGGART

"Of course, I work off the mains," is a phrase I hear almost every day of my life. Usually it amuses me, because so often the speaker thereby intends to convey that he belongs to the elect.

No doubt people who installed gas in their houses in the last century would tell their lamp-burning friends: "We're on the main," in much the

## VALVE RECTIFICATION

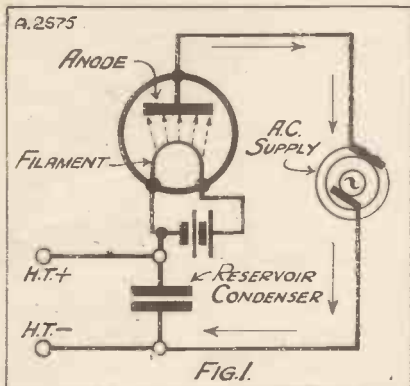

This is the basic circuit of a half-wave valve rectifier, the operation of which Mr. Scott-Taggart explains in this article.

same tones. Nowadays it is nothing to brag about that one has electricity laid on. Thirteen million nine hundred and ninety-nine thousand nine hundred and ninety-nine other people also get exorbitant bills every quarter for the same commodity. But to work a home-made wireless set completely "off the mains" is still something to boast about in a mild way.

## "This Is All Changing"

At one time the man who made his own set complete with mains transformer, rectifier, smoother circuits, fuses, etc., was regarded not only as a hot-dog amongst wireless experimenters, but a fellow who was willing almost to risk his life in pursuit of science. But this is all changing, and would change still more rapidly if the

*In the article below, which deals with a very important branch of radio, Mr. Scott-Taggart makes clear the principles and methods of utilising the electric light mains. We feel sure you will find it extremely interesting reading.*

outrageous prices of mains unit equipment were reduced.

The "eliminator" has, of course, paved the way for the 100 per cent mains receiver, and now the indirectly-heated A.C. valve has made it a simple matter to produce a trouble-free set.

I hope to give considerable attention in the future to the use of A.C. as well as battery valves, and to use all the influence I possess to bring prices within the range of the average man's pocket. The present policy of manufacturers is to sell components for mains sets to manufacturers at competitive prices, and to home-constructors at absurdly high ones.

## Growth of "Eliminators"

When I have persuaded manufacturers that there is a vast market waiting for them amongst the home constructors we may get things moving. Because I intend to put my shoulder to this particular wheel, I have chosen "mains units" and "eliminators" as the topic of an elementary article this month.

The "eliminator" was a rather gradually introduced innovation, but one man at least—starting in a very small way at Southend—has reaped the harvest resulting from his enterprise and early faith. Other firms also have successfully found a market for mains-operated devices which can be used instead of H.T. batteries on almost any set.

The growth of radio and the abandonment of crystal sets has increased

the demand of both H.T. batteries and "H.T. battery eliminators," and of the latter we have a variety of types. The word "eliminator" still sticks, but a better one is "mains unit." After all, we don't call a taxi an "eliminator" because it "eliminated" the horse-cab!

## Same Principle Used

The chief use of a mains unit for battery valves is to provide H.T. from the electric light mains, but on many such units there is provision for charging the accumulator for the set. There is also provision for grid bias sometimes. And there are also terminals in some units for supplying raw A.C. at 4 volts for A.C. valves! Circumstances dictate the require-

## UNIDIRECTIONAL PULSES

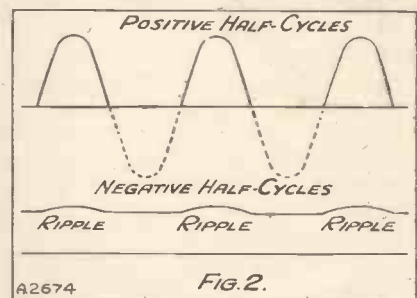

With half-wave rectification the positive half-cycles only are made use of, as indicated by the full lines in the upper diagram. The resulting unidirectional pulses are used to charge up a reservoir condenser, the discharge current from which is considerably less "lumpy."

ments—the type of set, number and kind of valves, and so on.

The variety of A.C. mains units is due to these changing factors, but in all there is the same principle at work, viz., rectification. This process of rectification consists in changing the alternating current into a steady direct current, and it can be done quite cheaply, quietly and without moving parts either by the use of valves or by metal rectifiers.

## How Mains Units Work—continued

Tubes containing mercury vapour were used at a very early date for rectifying A.C., and the vacuum valve, consisting of filament and anode, was suggested for the same purpose before Fleming, in 1904, applied such a valve to wireless reception. It is an interesting but little-known fact that Fleming did not invent the valve rectifier.

### Thirty Years Old

His patent was invalid throughout its life because he claimed too much; but that does not lessen the merit of his application of the valve to wireless reception. In fact, Fleming might well be given credit for being the first

### A SIMPLE "SMOOTHER"

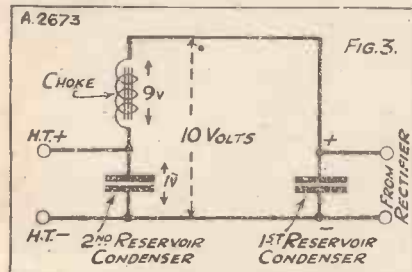

The final ripple can readily be removed from the H.T. supply by introducing a "smoother" circuit incorporating an iron-cored choke, such as that illustrated above.

person to understand that wireless oscillations can be detected by "rectification." The principle is so obvious nowadays that it is difficult to appreciate Fleming's work to the full.

In approaching, then, the subject of valve rectification of A.C. we must realise that the technique is nearly

thirty years old—years older than the crystal detector! And yet these two rectifiers—the two-electrode valve and the two-contact crystal device (in its very much modified form)—are providing us to-day with the means of using the ordinary electric lighting supply.

The operation of the valve rectifier can be seen by studying Fig. 1, which is a circuit comprising a two-electrode valve, a source of A.C. (e.g. the mains), and a "reservoir" condenser of, say, 2 mfd. Two output terminals, H.T. + and H.T. —, deliver the desired D.C. current. What happens is this: The A.C. supply makes the anode of the valve positive and negative alternately. When the anode is made positive it attracts electrons from the filament, and these flow round the circuit in the direction of the arrows and charge up negatively the bottom side of the reservoir condenser. The top side of this condenser becomes relatively positive, and if we use the circuit as an H.T. supply for a wireless set the electrons on the bottom side flow through this external circuit to the top side.

### Storing Up D.C.

The reservoir condenser is being continually fed with unidirectional squirts of electrons—one squirt of this "D.C." for every positive half-cycle of the A.C. (see Fig. 2). The negative half-cycles don't do any good at all, because electrons, being negative particles of electricity, are not attracted to the anode during the moments when it is made negative.

If there were no reservoir condenser our output D.C. would consist of these spurts and would be valueless for wireless reception; you would hear a horrible roar in your loud-speaker. But by using the condenser you store up a steady supply of D.C. which is being continually replenished. The purpose of the condenser is like that of a water reservoir. It

### FULL-WAVE RECTIFICATION

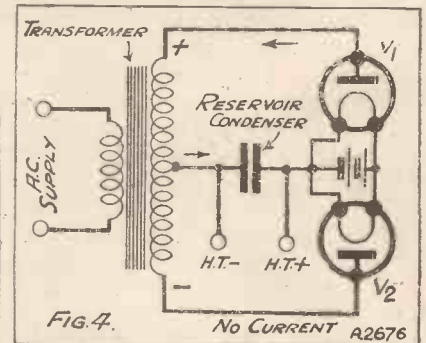

By employing two valves with a centre-tapped transformer, as shown above, the current output from the unit can be doubled. And as both half-cycles are used, the output requires less smoothing than with half-wave rectification.

would never do if we could only get water from our taps when it rained. So we store the water in great reservoirs and get a steady supply from them, however irregular the rain supply may be.

But the spurts, even with a large reservoir condenser, do still produce an irregular supply which is noticeable in a wireless receiver as excessive "mains hum." The D.C. is reasonably steady, but it has "humps" or "ripples" in it, as shown in the second line of Fig. 2.

### The Real Inventor

To cut out "hum" which is "periodic" (i.e. it occurs regularly and is similar to A.C.) we need a "smoother circuit." Smoother circuits were introduced by Ferranti (the founder of the firm of that name) about fifty years ago, and they have been re-invented at intervals ever since. Royalties on these re-inventions have flowed in as smoothly as the D.C. has flowed out, but I cannot write on the subject of mains units without drawing my readers' attention to the scientist who first introduced the ripple-eliminator.

The simplest "smoother" consists of an iron-core choke and a condenser

### THE CIRCUIT OF A COMPLETE MAINS UNIT

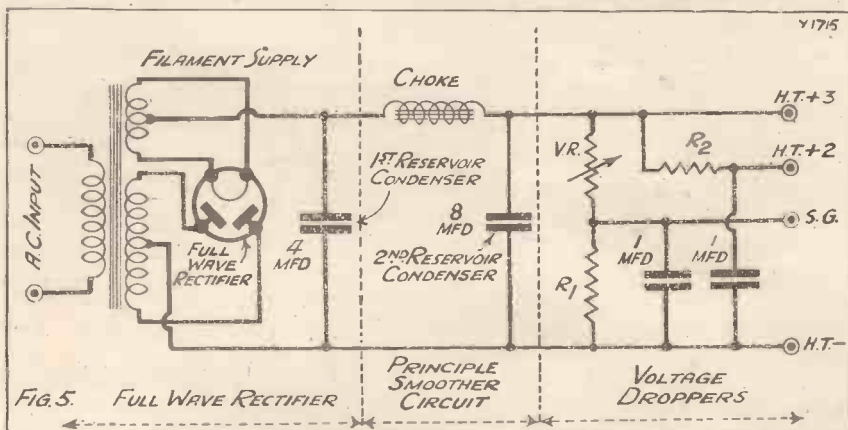

This is the theoretical circuit diagram of a typical valve mains unit of the full-wave type. Instead of employing two separate valves, a special "full-wave" valve is used having two anodes. The variable resistance is used to enable different voltages to be obtained from one of the tappings.



## How Mains Units Work—continued

arranged across the D.C. supply from the rectifier's reservoir condenser. This is shown in Fig. 3. The choke is connected between the old H.T. + terminal of the original reservoir condenser and a new H.T. + terminal, while a second reservoir condenser is connected across the H.T. output terminals. The rectified D.C. flows through the choke and charges up the second reservoir condenser. The choke is of low resistance to the D.C., and makes no difference to it. But while the choke and second reservoir condenser are perfectly friendly to the steady D.C., they are hostile to the ripple. The ripple, which is a sort of A.C. super-imposed on the D.C., passes through the choke and

there is only a 1-volt ripple where formerly there was a 10-volt ripple. We have, as it were, tapped off a potentiometer consisting of a choke and condenser in series; and this tapping-off does not materially affect the full pure D.C. output voltage.

### Double Smoothing

Sometimes two chokes are used, one in each lead to the second reservoir condenser, and frequently, if still further smoothing is desired, another choke and condenser arrangement is added to the left of the Fig. 3 circuit. Efficient smoothing is very important, because if a ripple is communicated to the earlier valves it will be amplified, and may produce

involves a phase reversal, and a simple, complete scheme is shown in Fig. 4.

The A.C. is supplied from the mains through a step-up transformer having a secondary whose middle point is connected through a reservoir condenser to the filaments of two valves,  $V_1$  and  $V_2$ . The "top" end of the transformer secondary is joined to the anode of  $V_1$ , and the "bottom" end to the anode of  $V_2$ .

### Using Both Halves

When the A.C. supply is switched on, we will suppose that the top end is positive and the bottom end negative. The top end will therefore be positive with respect to the middle point, and therefore to the filament of  $V_1$ . There will be a surge of electrons through the top valve, and these will charge up the left side of the reservoir condenser, making it negative.

Meanwhile, what has been happening to the other valve? Nothing, because its anode has been negative. But when the input A.C. changes direction there is a different story to tell. The top of the transformer is now negative, and the top valve this time does nothing. The bottom one, however, has a positive potential applied to its anode, and a flow of electrons takes place. These flow into the reservoir condenser in the same direction as the previous batch which came from the top valve. Thus each half-cycle of A.C. does a job of work in charging up the condenser, and thereby supplying a D.C. output.

### The Complete Unit

The two valves work in turns, and this, incidentally, gives a smoother output, the "spurts" occurring twice as frequently. The simple arrangement we have just considered is normally modified in four ways: (a) The two valves are replaced by an equivalent, one having a single filament but two anodes; (b) the filament is heated by A.C. from a separate winding on the transformer; (c) a "smoother" circuit is added; and (d) means are provided for supplying different H.T. voltages suitable for different valves in a set.

Fig. 5 shows a complete "full-wave" rectifier unit for working, say, an "S.T.300." I have drawn

(Please turn to page 106.)

## RELAYING ELECTION RESULTS TO THE U.S.A.



When Germany had her Presidential General Elections the results were relayed to the United States. The photograph shows the apparatus employed in the Berlin office of the "New York Times."

also through the second condenser. The D.C. cannot "leak" through this condenser, but the ripple can and does, since a condenser allows the "passage" of A.C.

### A Potentiometer Effect

Now, suppose the ripple is as much as 10 volts. This voltage is distributed across the choke and the second condenser. By using suitable values for these we can arrange that the drop across the choke is 9 volts and that across the condenser is 1 volt. This means that across the new H.T. + and H.T. - terminals

a loud hum in the speaker. This hum may even originate in an H.F. amplifying valve through the ripple modulating the carrier of an incoming signal. These modulated signals are then rectified and amplified by the rest of the set.

The simple valve rectifier so far considered is known as a half-wave rectifier, because it only uses the positive half-cycles of the A.C. The negative half-cycles, however, may easily be made to supply their quota of D.C. by applying them to a second valve in such a direction that they make the anode positive. This



An article of great practical value that will enable the home constructor to balance up his ganged circuits with considerable accuracy.

By C. P. ALLINSON.

MANY of the present-day receivers are gang controlled, two or more tuned circuits being actuated by one knob only. Now when you can afford to buy special wave-change coils which are specially matched up by the manufacturer there is not much difficulty in keeping them correctly balanced on both wave-bands by the use of the usual trimming condensers.

OBTAINING A BALANCE

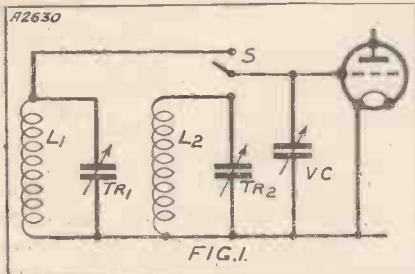

Two separate coils are used here, one for long and the other for medium waves. A small trimming condenser is connected across each so that really accurate ganging can be obtained.

In the case of home-made coils it is often extremely difficult, if not impossible, to get good ganging both on the short and the long waves. It does not matter very often if the circuits are a little bit out on the long waves, because the tuning is not so critical, but from the point of view of selectivity and performance it is just as essential that your circuits be correctly ganged on the long as on the medium waves.

Long and Short Waves

In band-pass filters it is important that the ganging be very exact at all points, or else the true band-pass action is lost, and selectivity is lost. The problem can be solved fairly simply, provided that the coils are not too badly out, by switching your trimmer condensers

as well as the coils. Fig. 1 shows what I mean. The long- and short-wave coils are shown at  $L_1$  and  $L_2$ , the tuning condenser being VC.

$TR_1$  and  $TR_2$  indicate two trimmer condensers, which you will note are connected across their respective coils, and not across the tuning condenser. By having this arrangement in each tuned circuit they can be trimmed accurately on each wave-band.

Two Good Methods

In cases where the wave-change circuit shown in Fig. 2a is used, the foregoing scheme must, of course, be modified, and two suitable arrangements are shown in Fig. 2b and 2c. The only change is that a two-way switch is used for S instead of a one-way switch in one case. This enables the long-wave trimmer  $TR_2$  to be brought into circuit on the long waves.  $TR_1$  trims the medium-wave coil only and has no appreciable effect on the long waves.

The actual procedure of trimming seems to give rise to quite a lot of discussion and all kinds of different schemes are recommended. In cases where gang condensers are used, where the relative settings of the

THE BASIC CIRCUIT

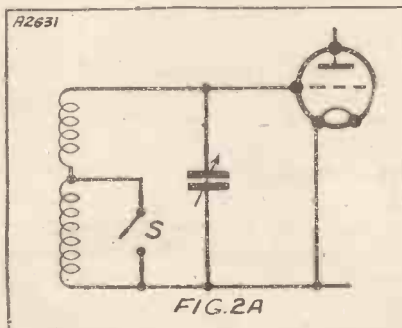

In the above diagram is shown the usual dual-wave switching scheme, and the two following sketches indicate how the double trimmer arrangement can be applied to this arrangement.

moving or fixed vanes are absolutely fixed, trim the set somewhere near the top of the scale, see how it matches up at the bottom, re-adjust and, if necessary, re-trim once more at the top.

How to Adjust

If, however, you can shift each set of moving vanes independently on the spindle so as to allow for variations in your coils, try the following.

First of all screw all trimmers right out, and then tune to a station right at the top of the scale. Start with Northern Regional and shift the various sets of moving vanes about on the operating spindle till the station

SIMPLE SWITCHING

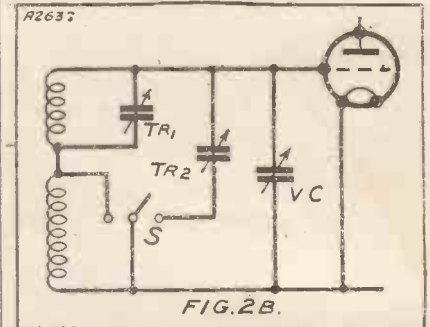

With the arrangement shown here a special double-throw switch is required, but the scheme works in much the same way as the others.

is tuned in as loudly as possible. Next work on a weaker station—Budapest or Vienna, for example—and see if you can get greater accuracy.

Now go down to the bottom of the scale, preferably choosing a weak

SEPARATE TRIMMERS

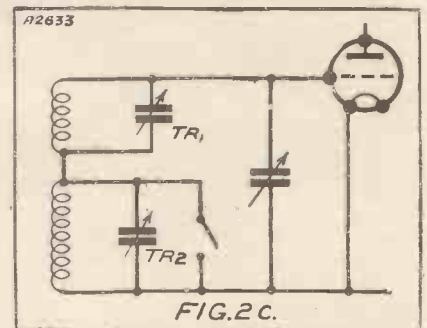

This is perhaps the simplest way of carrying out the scheme, for it does not necessitate any change to the actual wiring of the receiver. The two trimmers are just connected across their respective coils.

transmission, and match up the tuned circuits solely by the use of the trimmers. Now go right up to Budapest or Vienna again, and see if the moving vanes need re-setting—do not touch the trimmers. If they do you will need to re-trim once again at the bottom of the scale.





# The PASSING OF THE TRIODE

By J. English.

*A fascinating contribution dealing with the rapid advances made with multi-grid valves.*

THE remarkable development of Dr. Fleming's thermionic valve, from the earliest three-electrode "R" type to the present-day A.C. pentode, is perhaps the greatest technical achievement of radio science. The trend of this development is constantly towards the improvement and specialisation of valve types.

Consequently an ever-growing flood of new valves pours from the foremost manufacturers, until the amateur is bewildered by their variety. Even keen technicians have difficulty in finding time to keep abreast with this

## A SIMPLE CIRCUIT

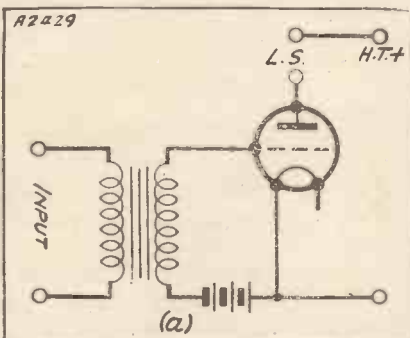

A striking illustration of the development of the output stage is given in the two diagrams shown on this page.

amazing development and multiplication of valve types.

In this country, progress in valve design centres round valve stages of the highest efficiency. This is in striking contrast to the situation in other countries, the United States for example, where receiving valves compare very poorly with our own, both in efficiency and diversity of types.

## American "Tubes"

Consequently American receivers invariably employ more valve stages; receiver design has there developed along multi-valve lines, chiefly be-

cause of this mediocre valve performance. Curiously enough, this restricted development of receiving valves in America appears to be intentional and not due to lack of the necessary technique.

Anyone who has attempted to keep pace with recent releases of new valves cannot have failed to notice the increase in the number of S.G.'s and pentodes. These new multi-grid valves are remarkable in design, with characteristics unheard of even two years ago. At the last Exhibition were to be seen pentodes with a power output of 8 watts and S.G.'s with an amplification factor of 3,000!

## Gaining Ground

A careful review of all the phases of recent progress in valve design cannot fail to emphasise this gradual intrusion of the multi-grid valve. This naturally leads to speculations on the ultimate fate of the triode, the original valve type, and whether it will not be superseded by the more specialised multi-grid types.

It certainly seems that the technical development of the three-electrode structure is approaching exhaustion, except perhaps at present in the case of output valves.

It is necessary only to reflect upon the recent progress in H.F. amplification to appreciate the complete dominance of the S.G. valve in this sphere. Not a single modern design is to be found using a triode valve. Here the tetrode has achieved a complete victory over the triode; although from the first we knew its task would not be a difficult one.

And now we find specialisation in the design of the S.G. itself; new issues including high, medium and low A.C. resistance valves, each being specially suitable for particular circuit

arrangements. The latest development of this screened tetrode is the variable-mu S.G.

This ingeniously designed valve should still further advance the design of the H.F. stage, as it promises to remove the remaining snags, such as cross-modulation and H.F. distortion.

## A New "S.G."

This new valve also places at our disposal ideal methods of automatic and manual volume control without the disadvantages of the methods of volume control which we now use.

Again, the recent introduction of a screened pentode, the Cossor M.S. Pen. A., which can be considered as a power type S.G., is a further striking example of the progress of the multi-grid valve. This new H.F. pentode, which can accept a larger H.F. input

## PENTODE PROGRESS

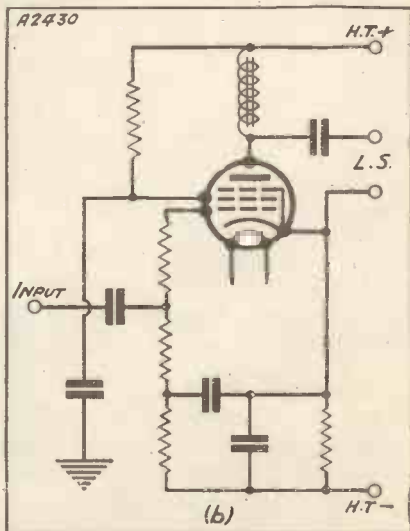

Nowadays it is seldom required that more than one L.F. stage be used. This diagram shows the latest form of pentode output arrangement for use with A.C. mains

## The Passing of the Triode—continued

than the S.G., finds its place in the second stage of an H.F. amplifier. It also promises to be extremely valuable as a power grid detector, in which position, with its negligible input damping, it scores over the triode.

The tremendous stage gain now obtainable from H.F. and detector stages is responsible for the present tendency to reduce L.F. amplification to the minimum of the output stage alone. This development has several technical advantages: the possibility of L.F. distortion and instability is very considerably reduced, less decoupling is required, while the design of intervalve couplings is simplified.

### Plenty of Pentodes

In the output stage itself we find again a growing predominance of multi-grid valves, both battery and A.C. pentodes. And not one type of pentode, but a whole family of them with an amazing variety of characteristics. These new pentodes are far and away more efficient than the best of super-power triodes.

Excepting, perhaps, the smaller battery receivers, there can be little doubt that the new pentode will soon reign supreme as the output

valve, especially in commercial A.C. receivers. In addition, the pentode is no longer the difficult child to handle that it used to be.

that it lends itself to tone control better than the ordinary output valve.

Having discussed the effect on modern receiver design of the increas-

### NOT A SINGLE TRIODE TO BE SEEN!

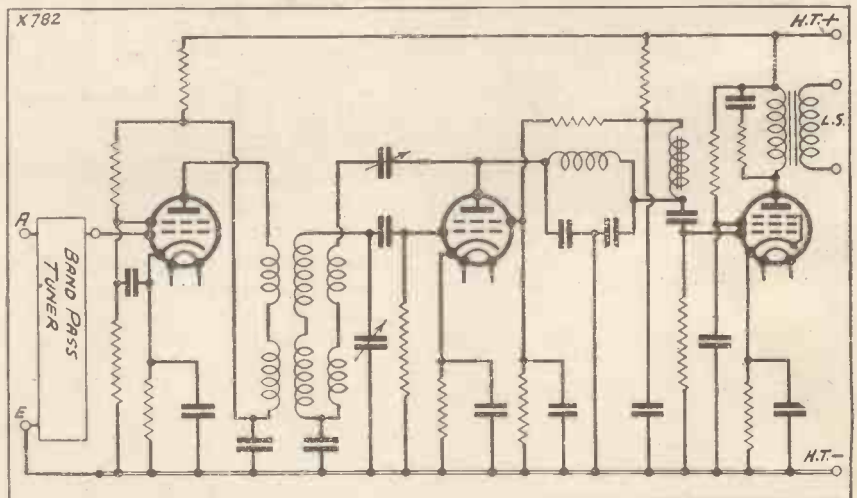

The circuit shown above does not employ a single triode! This type of valve is slowly but surely making way for the many ambitious multi-grid valves now appearing on the market.

The technique of the pentode output stage is now sufficiently advanced for exceptional volume and quality to be obtained without difficulty. One interesting feature of the pentode is

ing use of multi-grid valves in H.F. and L.F. stages, we are now left with that fascinating bundle of compromises—the detector stage.

Up to the present the triode has easily held its own here, the regenerative detector being one of the most sensitive devices known to radio science.

Thanks to the rapid advance in the design of high-efficiency H.F. stages, however, we no longer require a super-sensitive detector, which necessarily easily overloads, but one capable of accepting a large H.F. input and of providing a considerable undistorted L.F. output.

### Multi-Grid Detectors

This is where the multi-grid valve is beginning to prove a formidable rival to the triode. Witness the excellent performance of the new S.G. high-mag. detector and the pentode power-grid detector. Under proper conditions these two are a considerable improvement on the triode detectors.

A further advantage of both S.G. and pentode detectors is that their very small input impedance produces negligible damping of the preceding tuning circuit.

This makes for better selectivity and more accurate ganging of condensers.

### A BANK OF BERLIN'S BIGGEST "BOTTLES"!

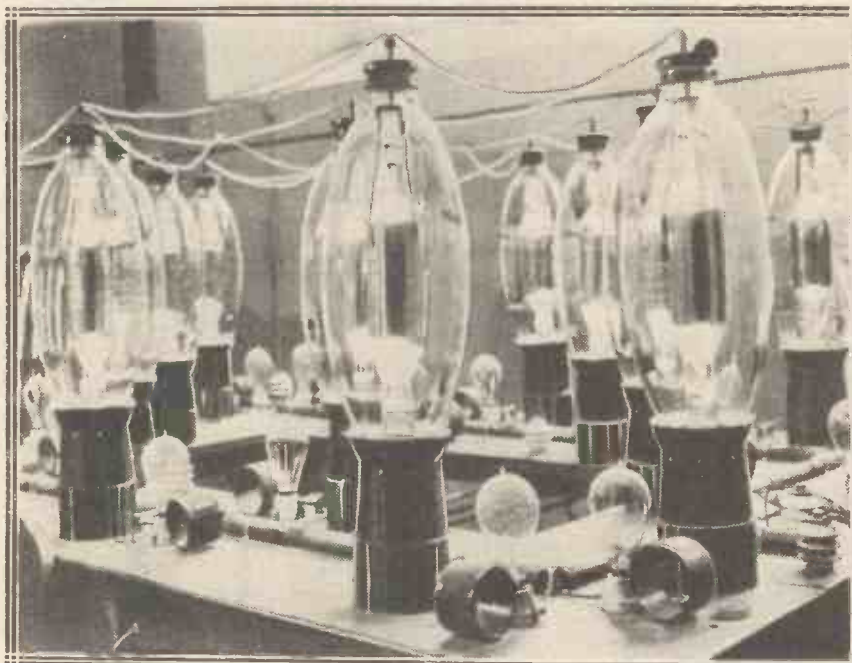

The apparatus at the Königsweusterhausen station near Berlin is constantly changing. This station is used for carrying out tests of new apparatus under proper working conditions, and many very interesting experiments are conducted under its roof. This photograph illustrates a bank of huge transmitting valves undergoing a test.



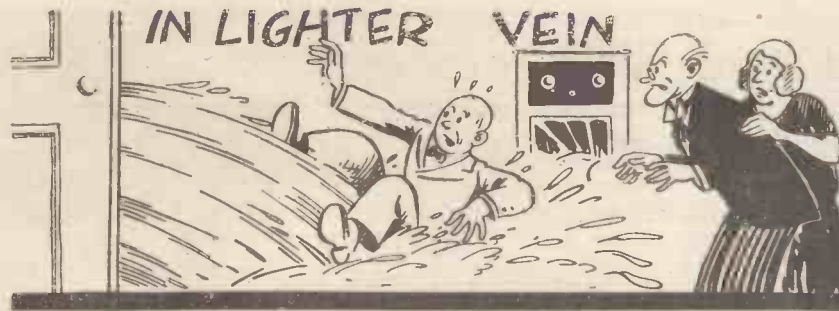

# The GOOP WATER-DRIVEN RADIO-GRAM

By WIRELESS-WAYFARER

THOUGH we have given to the world," remarked the Professor genially, "particulars of untold numbers of our great inventions, we have never, so far as I remember, supplied details for the construction of a gradioram. Now, have you ever—"

"A what?" I interrupted.

"A gradioram—tut, tut, that is to say, a gramiorad."

"Look here," I said, "you're getting a little tied up, aren't you? Calm yourself and start again. What I think you are trying to say is a ragriomad—no, that doesn't sound quite right—"

### A Little Mixed!

"Silly—ass!" shouted the Professor. "What you mean is a ragriomad."

"No, I don't, I mean a magriodad, or rather I should say a madriograd."

"Idiot," screamed the Professor. "The word is dramiorag, of course—that is to say, ramiodrag."

"This," I sighed, "is getting a little difficult. Let us start all over again. What we both mean, I take it, is a combined wireless receiving set and a phanagrome, or rather grophamone."

### INTERRUPTED RESEARCH!



"You mean a sireless wet and a gramophone," cried the Professor in triumph.

"One more try and we will get it. You had one part right and I had the other. Now then, Wireless set and—"

"—gramophone," bellowed the Professor exultantly.

"Splendid. Now for the combination word. Radio—"

"—gram," chortled the Professor. "That's the word—radio-gram. Has

it ever occurred to you what a wonderful field there is for an invention in this department? Hitherto, for instance, it is chiefly the needs of the man with A.C. mains that have been catered for. But what of the poor battery user?"

"What indeed?" I asked sympathetically. "Should not he, too, be entitled to the pleasures of the gragio—er—what you said?"

The great Professor applies his mighty mind to the problem of driving a turntable. In his characteristic manner he quickly discovers a solution, though when he put the idea into practice a slight mishap occurs—as usual!

"Clearly he should, and it is up to us now to give him what he wants. Now, the best way of solving the problem is to get down to essentials. Do you know how the gramophone works?"

"Why, of course," I replied. "You just wind up the starting handle thing. I'm rather good at that—at least I was until Poddleby's instrument backfired when I was doing it the other day and I am now suffering from a rather severe attack of gramophone-winder's elbow. Poddleby complains that I broke the spring, but I maintain that his infernal spring nearly broke my arm."

### Scientifically Explained

"Never mind about springs and things; do you understand how sounds are reproduced from a record?"

"Perfectly—the needle waggles in the grooves and makes the diaphragm waggle and that makes the sound waves waggle."

"Not expressed in very scientific language," commented the Professor, "but I think that you have the idea. And now about the pick-up. Do you understand the operation of this device?"

"Very nearly," I replied. "In fact, if Goshburton-Crump hadn't turned up five minutes too soon last night I

should have been able to answer 'yes' without hesitation. You see, I borrowed a pick-up from him when he wasn't looking, and I was just going to investigate its inside with a sardine opener, when he turned up at my place and snatched the thing away from me. Some people seem to put every possible difficulty in the way of scientific investigation."

"Too true," sighed the Professor. "Do you remember the scene that Mrs. Goop made that afternoon when she found the lawn sprinkler at work in the drawing-room? We were, if you recollect, trying to discover the effects of a damp atmosphere upon dry batteries. Most unreasonable she was."

### Radio Reminiscences

"Yes, and then there was the time when she was quite annoyed about our cutting condenser vanes from her aluminium saucepans. And do you recall her goings on when she found that we had buried a brass bedstead in order to obtain a really good earth connection?"

The Professor raised expressive hands.

### A BATTERY TEST



"But to return to the pick-up," he said. "This little device is perfectly simple, being exactly like the balanced-armature movement, only just the opposite."

"Nothing could be clearer than that."

"What I mean is that whereas the loudspeaker receives electrical impulses and turns them into vibrations, the pick-up receives vibrations and turns them into electrical impulses."

## In Lighter Vein—continued

"Loud cheers for the pick-up," I cried heartily.

"These impulses are passed to the grid of the erstwhile detector valve, now acting as a low-frequency amplifier. Thence they are delivered to the output stage, where they undergo further distortion—that is to say—amplification. It follows that anyone who has a wireless set and a pick-up has practically all that he needs to make a radio-gram. All that he requires is some means of rotating the record by turning a table."

### "Turning the Table"

"By Jove," I said, "Primpleson and Tootle are pretty useful at that. You should just have been at the seance they held the other night. Couldn't we make use of them?"

"I'm afraid not," smiled the Professor, "though the idea is well worth thinking over. We will assume, though, that the user of the battery-operated radio-gram that we are about to design will require some mechanical means of rotating his table. Clock-work motors are available, but these are distinctly expensive. An excellent

### REVOLUTIONARY!

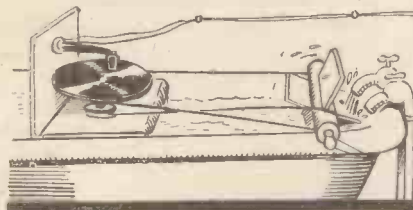

The Goop Water-driven Radio-gram Turntable.

motor can, of course, be made from the internals of almost any large clock, but bearing in mind the domestic experiences that we have just so poignantly recalled, I hesitate to recommend anything of the kind to the constructor. Have you any ideas?"

"Couldn't he put his bicycle on a stand and work the turntable from the back wheel by means of a belt? This would combine pleasure with healthy exercise. Given a three-speed gear, he should be able to obtain just the right rate of rotation for any record."

"That's a possibility, but think of the labour involved. I was just thinking myself that we might design our radio-gram to be built into the back portion of a baby car. We could then obtain the motive power for the

turntable from a small pulley wheel attached to the propeller shaft. There would, of course, be plenty of room for such a car in the average drawing-room. And possibly the scheme would kill two birds with one stone, since it would also solve the garage problem which many people find so pressing."

"Magnificent!" I exclaimed. "Just think how convenient it would be. A constant supply of hot water from the radiator and ventilation from the fan. The only drawback that I can see, though, is that there might be certain mechanical noises just audible during the soft passages."

### A Water-Wheel Affair

The Professor remained for a while plunged in thought. Presently he leapt to his feet. "Got it!" he roared. Without further parley he conducted me to his workshop, and there he gave me a brief sketch of the scheme. We set about making the things at once. The Goop Water-driven Radio-gram Turntable is illustrated in the accompanying masterly drawing.

Close to the cold-water tap of the bath is mounted a miniature water-wheel, connected by means of a cross-belt to a pulley attached to a vertical spindle. Fixed to this spindle is the turntable carrying the record. The bracket supporting the spindle of the turntable is screwed to the seat of a chair which stands in the bath. The pick-up itself is attached, again by screws, to the back of the chair, and from the instrument leads are taken to the drawing-room, or any other room in the house in which reproduction of records is required.

### The Hunt for Components

The waterwheel was soon made from certain components found in the kitchen. The rolling pin formed the axle, whilst paddles were made from strips cut from the pastryboard. The pulleys were obtained from the ends of the blind rollers in the best bedroom.

We had some difficulty over discovering a chair of suitable size and height. After searching for some time we found the very thing right under our noses in the drawing-room. It was a finicky sort of gilt thing. The tapestry coverings of the seat and the back were in the way, but we quickly removed these.

The next thing was to try out the apparatus. We had a certain amount of trouble at first, for as first mounted the water-motor played records backwards. With certain modern music this does not greatly matter, since the sounds are much the same either way.

### "Sloppy" Reproduction!

We did not find, though, that it was completely satisfactory with more classical stuff such as Beethoven's Fifth Symphony. Certain adjustments put this small defect right, and we found that by means of the tap it was possible to regulate the speed to a nicety. Those who try out the device may find that there is a certain tendency for water to be splashed upon the record, which may make the music sound a little sloppy.

Having taken our pick-up leads down to the drawing-room and connected them up to the Professor's wireless set, we at once obtained marvellous reproduction.

We were just playing the nineteenth record when Mrs. Goop came in. The Professor insisted upon giving her a demonstration. Handel's Water Music was the appropriate record

### IT CAME THROUGH WELL!



"I noticed her eye focussed on the floor."

that I chose for the purpose. It came through beautifully. Mrs. Goop seemed to be enjoying it all right, but presently I noticed her eye focussed on the floor close to the door.

Following the direction of her glance, I looked to see what she was gazing at so intently. A small trickle of water was appearing under the door. As I watched, it grew larger and larger. With a bound I skipped across the room and flung open the door, only to be swept off my feet by the deluge that was coming down the stairs.

On the whole, I think I would recommend the Goop Water-Driven Radio-gram to bachelors only, and I think that possibly it is most suitable for houses in which the bathroom is on the ground floor.



# S.T.300 ADAPTOR

## DISTANT STATIONS AT STUPENDOUS STRENGTH!

### KIT "A"

Complete kit of components less valves and cabinet. **£1-18-6**  
**OR BY EASY PAYMENTS** 7/- down and 5 monthly payments of 7/-

### KIT "B"

Complete kit of components with valves less cabinet. **£2-15-0**  
**OR BY EASY PAYMENTS** 10/- down and 7 monthly payments of 7/6

### KIT "C"

Complete kit of components with valves and cabinet. **£3-10-0**  
**OR BY EASY PAYMENTS** 10/- down and 7 monthly payments of 7/6

### S.T.300

(Battery Model)

#### KIT "A"

less valves and cabinet. **£3-18-6**  
**OR BY EASY PAYMENTS** 7/3 down and 11 monthly payments of 7/3

#### KIT "B"

with valves less cabinet. **£5-10-9**  
**OR BY EASY PAYMENTS** 10/3 down and 11 monthly payments of 10/3

#### KIT "C"

with valves and cabinet. **£6-9-3**  
**OR BY EASY PAYMENTS** 12/- down and 11 monthly payments of 12/-

**OFFICIAL BLUE PRINT FREE WITH EVERY KIT**

Showrooms: 159, Borough High Street, London Bridge, S.E.3.  
 Phone: Hop 3000.

### Readirad

**Binocular H.F. Choke SPECIFIED for the "S.T.300" Adaptor**



Absolutely efficient over all wave-lengths. Its extremely high impedance makes it specially suitable for use in screen-grid circuits. Its superiority is proved by the fact that it is specified by Mr. Scott-Taggart for the "S.T.300" Adaptor. Sturdily made, and beautifully finished.

**Price 7'6**

# READY RADIO

### List of parts for the

### S.T.300 Adaptor

	s.	d.
1 Polished Oak Cabinet	15	0
1 Ebonite Panel, 9 1/2" X 7", drilled to specification	3	0
1 Lewcos S.T.300 Aerial Coil	5	0
1 Formo .0005-mfd. S.M. Tuning Condenser	6	0
1 Wavemaster .00004-mfd. Aerial Coupling Condenser	4	0
1 Readirad .0001-mfd. Differential Condenser	2	6
1 Readirad Binocular S.G. H.F. Choke	7	6
1 T.C.C. 1-mfd. Condenser Type 50	2	10
1 W.B. Universal Valve Holder	1	0
1 Lotus Universal Switch	1	6
6 Belling-Lee Terminals, Type "R"	1	6
1 Screen, as specified	2	0
1 Ebonite Terminal Strip, 9 1/2" X 1 1/2"	9	6
1 Mullard Valve, P.M.12	16	6
Connecting Wire, Screws, Flex, etc.	11	
	<b>£3</b>	<b>10 0</b>

Any component can be purchased separately.

#### To INLAND CUSTOMERS

—Your goods are despatched Post Free or Carriage Paid.

#### To OVERSEAS CUSTOMERS

—Everything Radio can be supplied against cash. In case of doubt regarding the value of your order, a deposit of one-third of the approximate value will be accepted and the balance collected by our Agent upon the delivery of the goods. All goods are very carefully packed for export and insured. All charges forward.

Head Offices: EASTNOR HOUSE, BLACKHEATH, S.E.3. Phone: Lee Green 5678. Grams: Readirad, Blackvil.

### CASH or COD ORDER FORM

To: READY RADIO, LTD., Eastnor House, Blackheath, S.E.3.

Please dispatch to me at once the following goods.....

for which (a) I enclose (b) I will pay on delivery (Cross out line) £.....

Name.....

Address.....

W.C. 6/32.

To: READY RADIO, LTD., Eastnor House, Blackheath, S.E.3.

Please dispatch to me the following goods.....

for which I enclose first deposit of £.....

Name.....

Address.....

W.C. 6/32.

### EASY PAYMENT ORDER FORM

"WIRELESS CONSTRUCTOR" OFFICIAL EXHIBITORS SELL READY RADIO KITS



# THAT INTERVAL SIGNAL

**T**OCK, tock, tock—  
I don't think that there is any doubt that one of the most disputed programme items now is the interval signal. It is a cut above the old highbrow and lowbrow discussion. The noise, so accurately described by Capt. Eckersley as a "death-watch beetle," affects high-brows and lowbrows alike.

### Does It Worry You?

It comes in all programmes, high-brow and lowbrow, and it is one of those things which you either tolerate or which causes you to go into hysterics. Feeling that the B.B.C. would not inflict this kind of noise without due reason, I investigated—and found the task none too easy.

Perhaps it is because the B.B.C. knows that there is a certain amount of discussion about the advisability of the interval signal chosen that it is not over-eager to disclose its identity.

I chased the "death-watch beetle" all over the building. I thought it might be a gramophone record which they faded in at appropriate intervals; but no, the beetle was not to be found among the records. Listeners have suggested that it is the beating of the announcer's heart which causes the ticking; but a chat with Mr. Hibberd, the chief announcer, discounted any such possibility!

### The Whole Story

Then, by a lucky stroke, I went down to the control-room and there hunted the beetle to its lair. One of the control-room engineers—in fact, one of the men whose soulless job it is to listen to the programmes and switch on the interval signal when it is due—told me the whole story.

*Have you ever wondered where the B.B.C. interval signal—what Captain Eckersley very aptly calls the "Death-Watch Beetle"—originates? If so, you will no doubt be interested in the full explanation given below.*

By a  
**Special Correspondent.**

The noise is caused by an electric clock in a felt-lined box. The engineer and I clambered up on to the roof of the small battery-room which leads out of the London control-room. These are the batteries for the line switching, and for the amplifiers and tone correctors on the studio lines.

Standing on the rafters above the batteries is a large wooden box with rope handles; the sort of box in which amplifiers are carried at O.B. events. Two sets of wires trailed out of the box into the dusty, plastery muddle above the roof.

### A Box of Ticks!

We prised open the lid and found the "beetle"—a Reisz microphone and an electric clock, as shown below. The electric clock is of the same type used throughout the building, and has a ratchet movement which ticks at one-second intervals. It is of a rather special type. The average electric clock has its hands dragged round by a ratchet at half-minute,

### THE HOME OF THE DISMAL "DOOMPS"!



*Here you meet the mystery "beetle" at home, and as you see it is only a microphone standing above an electric clock! The slow, monotonous doomp, doomp, doomp that you hear is the large second-hand slowly striding its way round the dial.*



## That Interval Signal—continued

one-minute or two-minute intervals, but the Synchronome system has a one-second escapement device.

The master-clock is downstairs in the control-room and the current impulses from this go to the dozens of clocks all over the building to the special clocks in the studio; in fact, one reason for having this type of clock with a one-second tick is that the big studio clocks have a large second-hand, which gives the announcer his cue, and is a great help in judging programme times.

### "Slave Dials"

The clocks all over the building which are controlled by the master-clock in the control-room are known as slave dials. The death-watch beetle is just one of these slave dials put in a felt-lined box. It has a large second-hand, in addition to the two main hands, and it is the noise of the actuating mechanism of this which listeners hear.

It will probably come as a disappointment to many listeners, after having conjured up strange imaginings

### KING CAROL OPENS BUCHAREST'S NEW STUDIO



*King Carol of Rumania recently inaugurated the big new studio at the Bucharest station. Here you see him before the microphone on this memorable occasion!*

about the interval signal, to know that it is only the works of a clock. The job is not quite so simple for the B.B.C. though. Nor was it very easy to think of a good way of working the interval signal.

Most of the interval signals, such as bell chimes and cuckoo noises, used at foreign stations are from gramophone records, and the B.B.C. did not favour this method because it meant putting on a special record in anticipation of each interval.

It was while thinking out this problem in the control-room that one of the control-room engineers was swayed by the monotonous ticking of the master electric clock.

"That's just the thing we need," he said, and set about picking up the clock-ticking noise by a microphone.

Now an ordinary Reisz microphone is put face downwards on top of the wooden clock case. It stands on a layer of cloth and is never switched on to its full sensitivity, so that it picks up about as much actual vibration from the clock as it does of sound impulses as the second-hand ticks round.

The clock mechanism is never switched off. The microphone is connected through to a special fader control at the desk downstairs, and so the knob of this has only to be turned in order to super-impose the ticking on a programme.

### The B.B.C. Likes It!

I asked the control-room man if there is any possibility of the interval signal being altered, and was told that at present there is no mechanical gadget or gramophone record in preparation to take its place.

The death-watch beetle is to remain with us, apparently!

### ULTRA-SHORT-WAVE RADIO IN THE U.S.A.

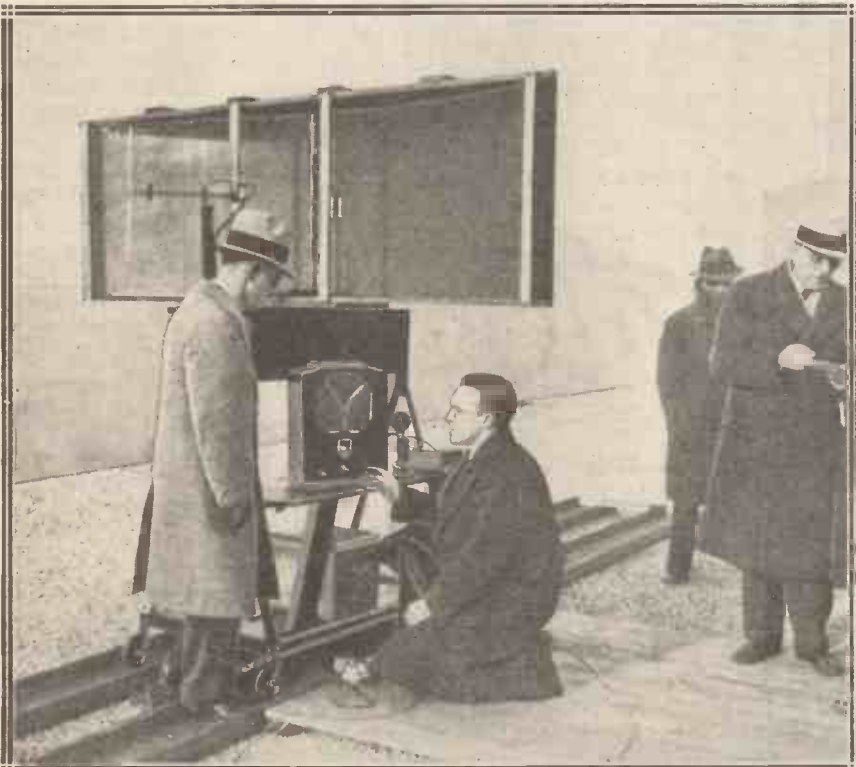

*Engineers of the Westinghouse Company experimenting with a new ultra-short-wave directional receiver at Pittsburgh, U.S.A. It works in conjunction with a special beam transmitter, the wave-length used being less than one metre. It is claimed that these extremely short waves are not reflected by the Heaviside Layer, but that they pass right through it and out into space.*

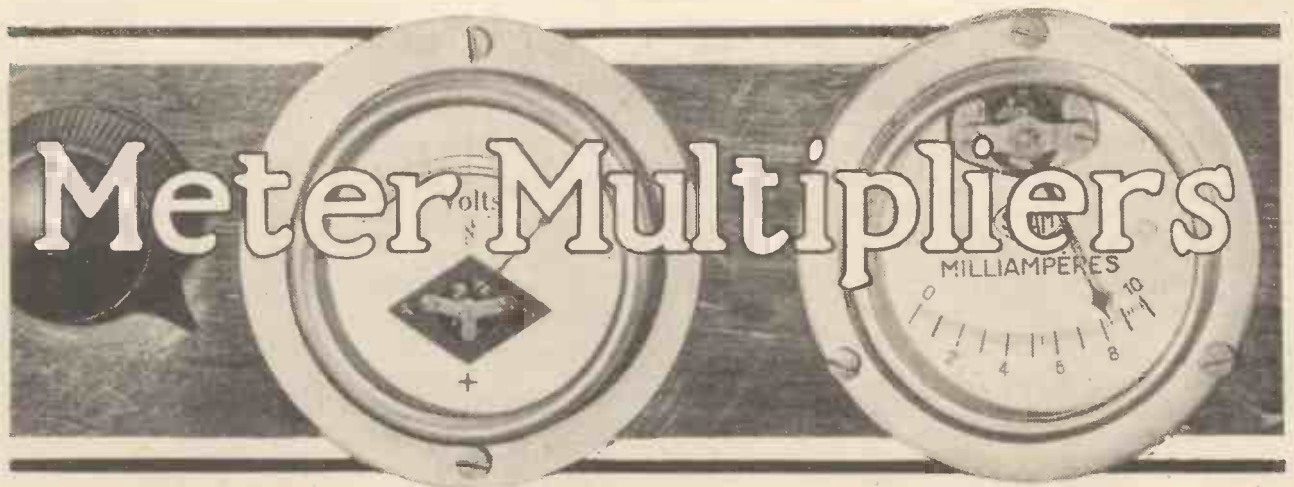

High-grade multi-range meters are expensive, but doubtless many readers already possess a low-reading milliammeter, or a voltmeter which lends itself to easy conversion, as explained in this article by "Krypton."

WITH modern receiving equipment, especially that designed for mains operation, current and voltage meters are becoming more and more important as guides to better reception in general.

The uses of even a single-range milliammeter are legion, to mention only the more important would take up far too much space here. Generally a milliammeter is more useful than a voltmeter, but to be of the fullest use to the experimenter it should have one or two extra ranges available.

**MAKING THE SHUNT**

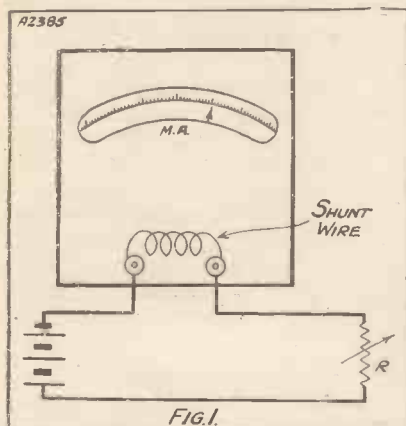

A piece of resistance wire can be used for the experimental shunt, and its length varied until the correct reading is obtained.

An accurate multi-range meter is, unfortunately, an expensive article, although worth every penny of its cost to the man who knows how to make the fullest use of it. On the other hand, it is quite possible for the amateur with a little patience and skill to make up all the multipliers he requires to convert a single low-range milliammeter or voltmeter into a very useful and valuable multi-

range instrument. With just a little care these additional ranges can be made quite accurately enough for all practical work.

**Extending the Range**

Suppose, for example, that it is required to extend the range of a 0-5 milliammeter up to 25 m.a., which is a useful range for measuring up on output stages. This means multiplying the existing scale by five, which is done by connecting in parallel with the meter terminals a shunt resistance of such a value that only one-fifth of the current being measured passes through the meter.

Now it is not necessary to make complicated calculations of the value of this shunt resistance, or multiplier, as it is called. The following practical method is far simpler. First connect a battery and a variable resistance in series across the meter terminals as in Fig. 1.

With a 2-volt accumulator a suitable value for the variable R is 0 to 5,000, or, with a 30-volt battery, 0-50,000 ohms. I use the latter type with an old H.T. battery, the exact voltage of which is relatively unimportant.

The resistance R is first adjusted so that the meter reads 5 m.a. as accurately as possible. Then measure off about 15 to 20 inches of No. 36 Eureka resistance wire, and connect this trial shunt to the meter terminals.

**Final Adjustment**

If the meter reading is now less than 1 m.a., the wire is too short, and a slightly longer length must be cut off. Then carefully reduce the length until the meter reads just a little over 1 m.a.

Remove the shunt and adjust R to give a current of 2.5 m.a. Replacing

the shunt wire, the reading should drop to a fraction over .5 m.a. A further very slight adjustment of length may be required here to get this reading.

The next step is to make up this shunt resistance in a permanent form, which means a compact and rigid assembly with heavy end connectors to screw under the meter terminals. One method is to cut a piece of ebonite 1/4 in. wide, slightly longer than the distance between the meter terminals, as a former on which to wind the resistance wire.

**The Connector Lugs**

At each end is securely fastened a short length of No. 18 tinned wire to form connector lugs, as shown in Fig. 2(a). One end of the wire is soldered to one of these lugs, the rest wound tightly round the former with turns spaced, leaving the other end

**ITS FINAL FORM**

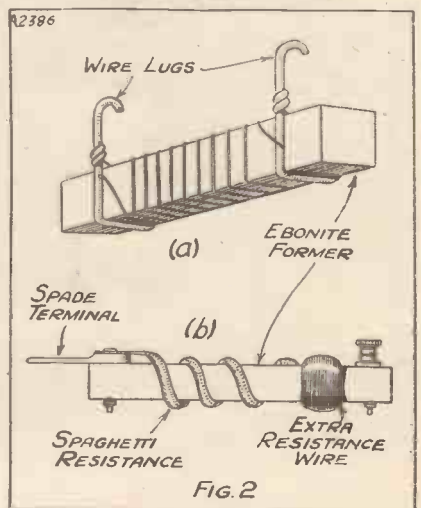

(a) When the right amount of wire has been found it can be mounted up in permanent form, as here illustrated; (b) a multiplier for a voltmeter which can be mounted in a similar manner.



# COLVERN COILS

## FOR THE SET WHICH SOLVES THE SELECTIVITY PROBLEM

**S.T.300.** Designed by Mr. John Scott-Taggart in the interest of home constructors, has enabled a very large number to enjoy distant programmes usually available only to owners of expensive receivers.

**S.T.300.** Has proved highly efficient in all parts of the country.

**S.T.300.** Is introduced by an expert in the design of receivers that can be successfully constructed at home.

**COLVERN COILS** were selected by the designer and all supplies are exact to Mr. John Scott-Taggart's original specification.

**COLVERN COILS**  
**specified for the S.T.300—12/- pair**  
also chosen for the A.C. Model.

The Colvern S.T.300 Aerial Coil is also specified  
for the S.T.300 Adaptor.

COLVERN LIMITED, MAWNEYS ROAD, ROMFORD, ESSEX

## Meter Multipliers—continued

temporarily twisted round the other lug, but not soldered.

Now replace the shunt on the meter after adjusting R to give a reading of exactly 5 m.a. Then wind on or unwind the unsoldered end of the wire from the lug until the meter reads exactly 1 m.a.

### The Completed Shunt

Before soldering this connection check up on the 2.5 to .5 m.a. adjustment as before. This final adjustment is very essential, as otherwise the length of shunt wire might be reduced by soldering to one lug a fraction of an inch too much.

When completed the former can be given a thin coat of shellac or wax to protect the resistance wire, after which a small paper label can be attached marked "25 m.a. shunt." Then to measure any current between 5 and 25 m.a., all that is necessary in future is to attach the multiplier to the meter and multiply the reading by five, each m.a. division on the scale now corresponding to 5 m.a.

In the same way other multipliers can be made quite easily for higher milliamp ranges, such as 0-50, 0-100, etc., calibrating each one with the next smaller multiplier in position. It is as well to remember that the accuracy of the larger multipliers depends on that of those below, but for general work a relatively larger percentage error can be tolerated in the high-range shunts. With careful construction, however, this should be less than 5 per cent.

It must be emphasised at this point that it pays to commence with a reliable and accurate low-range meter of the moving-coil type. Obviously it is only wasting time and effort to construct multipliers for a cheap meter, especially so if it is a voltmeter.

### Measuring Amperes

From the higher milliamp. ranges we pass to multipliers for measuring amps., which, however, are so seldom required nowadays that only brief details will be given here. Amp. multipliers have to be adjusted with the milliammeter connected up with an ammeter of the desired range. An accumulator and low-resistance rheostat supply the amps., using the same procedure as for m.a. shunts.

A suitable preliminary shunt is 5 in. of No. 20 bare copper, filing down the wire to get the final adjustment of resistance. Remember that accidentally disconnecting the shunt with the battery in circuit may burn out the meter.

Making multipliers for a voltmeter is also quite a simple matter if the right method be adopted. In this case the resistance of the multiplier runs into thousands of ohms. This may suggest serious practical difficulties, such as many hundreds of turns of fine wire and tedious resistance adjustments. The following method, however, cuts out all such snags.

### Series Resistances

In the case of the voltmeter the multiplier is a high resistance in series with one of the leads to the meter. If the latter has a range of 0-100 volts

### FOR VOLTMETERS

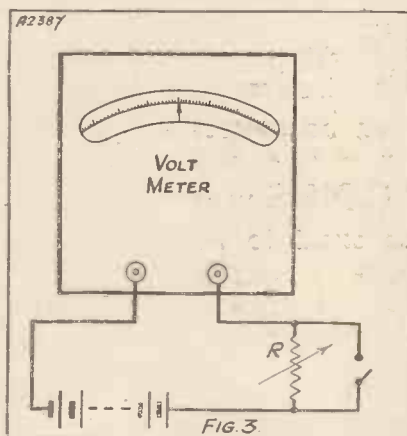

In the case of a voltmeter the range can be increased by connecting a high resistance in series with it. This diagram shows the experimental connections.

and it is required to double this range, a rough idea of the series resistance required is obtained as follows:

A variable resistance (0-50,000 ohms) is connected in series with an H.T. battery and the meter as in Fig. 3. First read the battery voltage with R shorted. Suppose this to be 56 volts. Then unshort R and adjust so that a reading of 28 volts is obtained.

The required resistance is now that of R itself. Incidentally, a variable high-resistance used in this way makes a very good temporary multiplier if it is desired to extend the range of the voltmeter at short notice.

The first step in making the voltage multiplier is thus to ascertain the re-

quired series resistance to give the desired extension. Any range above the original can be obtained, as increasing R to drop the meter reading to one-fifth multiplies the range five times, and so on.

### Spaghettis Useful

The next step is to measure the actual series resistance, replacing the voltmeter by a low-range milliammeter and noting the current passed at, say, 50 volts. Dividing this voltage by the current in milliamps. and multiplying the result by 1,000 gives a close approximation to the resistance of the multiplier.

A suitable and cheap form of high resistance for the permanent multiplier is a Spaghetti wire-wound resistance, adding a small coil of No. 36 Eureka to make up the right value.

A practical example will make this clearer. I found that to double the range of a 0-150 voltmeter would require a series resistance of 40,350 ohms. This was made up of a 40,000-ohm Spaghetti and an additional resistance of 10 yards of No. 40 Eureka.

The combined resistance is substituted for R in Fig. 3, and the wire section carefully adjusted until the required half-meter reading was obtained. The Spaghetti and extra wire resistance were then made up in permanent form as shown in Fig. 2(b).

If the required resistance cannot be closely approached by any value of Spaghetti resistance on the market, two or more odd values can be used in series. Alternatively the manufacturers would probably make up a Spaghetti to the nearest 1,000 ohms or so for a small extra charge.

### A Quick Check

When working out resistances it is as well to remember that Spaghettis are usually only correct to within one or two per cent of marked values, and due allowance must be made for this. In any case, it takes but a few seconds to substitute the Spaghetti for R of Fig. 3, and see how near it approaches the required resistance.

This method of making voltage multipliers can also be used for increasing the range of low-reading meters, making multipliers in steps of two or five times, according to the various ranges required, in the manner just described.



# Exide

The world's most  
trusted L.T.  
battery



"C" TYPE L.T. BATTERY  
FOR WIRELESS

PRICES PER 2-VOLT CELL: CZ 2 - 20 amp. hours 9/-  
CZ 4 - 40 amp. hours 13/- CZ 6 - 60 amp. hours 17/-  
Other sizes up to 120 amp. hours. These prices do not apply  
in the Irish Free State

N95

From Exide Service Stations or any reputable dealer.  
Exide Service Stations give service on every make of battery.  
Exide Batteries, Exide Works, Clifton Junction, near Manchester.  
Branches: London, Manchester, Birmingham, Bristol, Glasgow, Dublin, Belfast

# Proof!

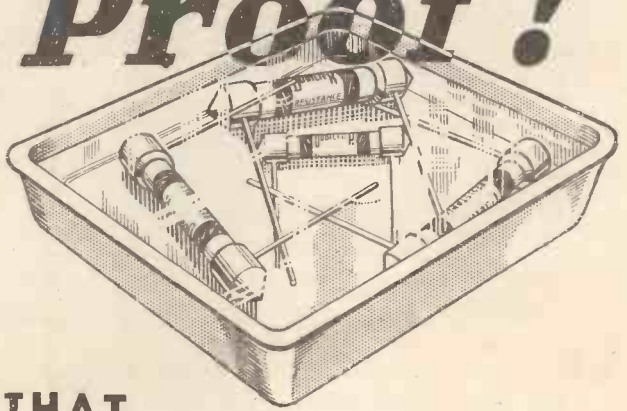

THAT  
**MOISTURE  
CANNOT HARM  
THEM!**

Don't run risks of ruining the performance of your Receiver by using ordinary resistances which will set up crackling noises at the faintest suggestion of the presence of moisture . . . use Dubilier Metallized Resistances which cannot be harmed by moisture. Look at the test carried out above . . . that's proof! The Resistances functioned perfectly after having been completely immersed.

Dubilier Metallized Resistances are manufactured under a patent process and are worthy of that great reputation for reliability which goes with all products bearing the name Dubilier.

Whatever your Resistance requirements—ask for Dubilier.

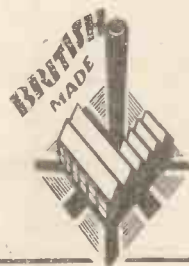

1 watt 1/-, 2 watt 2/-, 3 watt 3/-

# DUBILIER

Metallized  
**RESISTANCES**

DUBILIER CONDENSER CO. (1925) LTD.  
Ducon Works, Victoria Road, North Acton, W.3

H

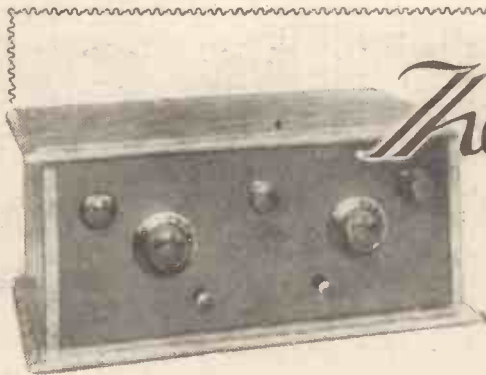

# The "S.T. 300"

## STEP-BY-STEP CONSTRUCTIONAL DETAILS

- (a) Mark out and drill panel (or buy same).
- (b) Mark out and drill terminal strip (or buy same).
- (c) Prepare holes in baseboard for anode-coil supporting pillars.
- (d) Prepare notches in vertical screen (unless bought ready-prepared). Position and size of notches need only be approximate.
- (e) Fix terminal in vertical screen. (In my set I removed, for this purpose, the unused terminal C on the W.B. universal valve-holder, discarding the bent metal socket.)
- (f) Lay copper sheet on baseboard and screw down screened-grid valve-holder, the screws going through into the baseboard.

*The February issue of "The Wireless Constructor," in which the constructional details of the "S.T. 300" first appeared, was quickly sold out. A large reprint was absorbed almost as rapidly as it left the machines. Further reprints are impossible, and as tens of thousands of constructors are still requesting details of S.T.'s wonderful set we have decided to present concise details in the form of a compact supplement. Tell all your friends about it, for this may be the last chance of securing the complete "S.T. 300" specification. It is almost unnecessary to add that the "S.T. 300" has proved to be by far the most successful kit set of any that has been introduced to the public within recent years.*

(As its size indicates, the copper sheet covers the whole

of the baseboard up to where the vertical screen will come; the "L.F." side of the baseboard is not covered.)

- (g) Clean copper sheet (with emery paper) where it will later be held down by ledge of vertical screen. Clean patches of copper sheet where connection with wires (1) and (8) will be made.
- (h) Screw down 1-mfd. Mansbridge-type condenser on copper sheet, wire (1) having been previously bared and cleaned, and then tucked under the condenser. Wire (1) is thus pressed in contact with a cleaned patch of copper sheet.
- (j) Prepare holes through copper sheet and into baseboard for

## THE COMPONENTS AND ACCESSORIES NEEDED

- 1 Ebonite or paxolin panel, 16 in. × 7 in. ×  $\frac{3}{8}$  in. (Peto-Scott, or Permcol, Ready Radio, Goltone, Lissen, Wearite).
- 1 Strip of ebonite for terminal strip, 16 in. ×  $1\frac{1}{2}$  in. (Peto-Scott, etc.).
- 1 Cabinet for above panel size, with baseboard 10 in. deep (Ready Radio, or Peto-Scott, Camco, Gilbert, Lock, Smiths, Pickett).
- 2 .0005-mfd. variable condensers, slow-motion type, or with vernier dials (Ormond No. 6 slow-motion, or Polar No. 2, Lotus, Telsen, J.B. type D.).
- 1 Midget-type condenser, maximum capacity .00004 mfd. (J.B., Polar No. 4, Peto-Scott, Ready Radio, Wavemaster).
- 1 .00015-mfd. differential reaction condenser (Ready Radio, or Telsen, Polar, J.B., Igranic, Dubilier, Cyldon, Formo).
- 1 .0001-mfd. differential condenser (Telsen, or Ready Radio, Polar, J.B., Cyldon).
- 2 Special "S.T. 300" coils (Colvern, Wearite, Telsen, Lewcos, Tunewell, Goltone, Sovereign, Cordo).
- 1 Horizontal-type valve holder (W.B.).
- 2 Four-pin valve holders (Lotus type VHK, or Graham Farish, Telsen, Bulgin, Wearite, W.B., Parex, Clix, Formo).
- 1 S.G. H.F. choke (Telsen Binocular, or Lewcos, Sovereign Senior, Wearite, R.I., Ready Radio, Varley).

- 1 Reaction-type H.F. choke (Lewcos, or Peto-Scott, Telsen, Ready Radio, Varley, Parex, Lotus, Lissen, Wearite, R.I., Magnum, Waimel, Sovereign, Atlas, Graham Farish, Tunewell).
- 2 Three-point switches, push-pull type (Ready Radio, Lissen, Tunewell).
- 1 L.F. transformer (Varley Niclet, or Ferranti type A.F.S, R.I. Hypermite, Igranic Midget).
- 1 .0001-mfd. fixed condenser (Dubilier type 670, or Telsen, T.C.C., Lissen, Ferranti, Igranic, Formo, Graham Farish, Goltone, Sovereign).
- 1 1-megohm grid leak with terminals or tags (Graham Farish Ohmite, or Dubilier, Igranic, Loewe, Ferranti with holder, Mullard).
- 2 1-mfd. condensers (Telsen, or T.C.C., Dubilier, Helsby, Hydra, Sovereign, Formo, Lissen, Igranic).
- 1 20,000-ohm Spaghetti resistance (Lewcos, or Bulgin, Sovereign, Varley, Telsen, Magnum, Igranic, Graham Farish, Peto-Scott, Goltone, Ready Radio, Lissen).
- 10 Indicating terminals (Bulgin, or Belling & Lee, Igranic, Clix, Ealex).
- 1 "S.T. 300" screen, 10 in. × 6 in. (Peto-Scott, or Parex, Magnum, Wearite, Ready Radio).
- Copper foil, 10 in. × 7 in. (Peto-Scott, Ready Radio, Paroussi).

Glazite, or Lacoline, Jiffilix, Quickwyre, for wiring up.

2 Battery plugs for grid-bias leads (Ealex, Clix, Belling & Lee).  
Screws, flex, etc.

**VALVES.** Mullard: 1st valve, P.M.12; 2nd valve, P.M.2D.X.; 3rd valve, P.M.2A.

Marconi: 1st valve, S.22; 2nd valve, L.2/B.; 3rd valve, L.P.2.  
Mazda: 1st valve, S.G.215; 2nd valve, L.210; 3rd valve, P.220.  
Osram: 1st valve, S.22; 2nd valve, L.210; 3rd valve, L.P.2.  
Cosmor: 1st valve, S.G.220; 2nd valve: 210 Det.; 3rd valve, 220P.A.

**BATTERIES** (1 120-volt H.T., and 1 9-volt G.B.). Drydex, Pertrix, Ever Ready, Lissen, Magnet, Columbia, Ediswan.

**ACCUMULATOR** (voltage to suit valves). Ealex, Ediswan, Lissen, Pertrix, G.E.C.

**LOUDSPEAKER.** Blue Spot, W.B., Celestion, R. & A., Epoch, H.M.V., Graham Farish, B.T.-H., Marconiphone, Undy.

**MAINS UNIT** (output not less than 20 milliamps. at 120 volts). Atlas, Regentone, Ekco, Tannoy, Formo, R.I., Heayberd, Lotus, Tunewell.



10/6

The MIDGET L.F. TRANSFORMER



2 Components that turn "amateur" wireless into "professional perfection!"

Constructors! Profit by the experience of experts!

First—the MIDGET L.F. Transformer, the famous "miniature masterpiece" in which ultra-efficiency has been packed into convenient size. Reproduction reaches a brilliance never before possible at the price. Ratio 3 : 1 advised for valves of 10,000—20,000 ohms. Ratio 5 : 1 for valves from 5,000 to 10,000 ohms. Second—the Igranitic Spaghetti Resistance—wire wound and protected by insulated sleeving. Made in 13 sizes. Igranitic quality—at your price!

The IGRANIC SPAGETTI Wire Wound RESISTANCE

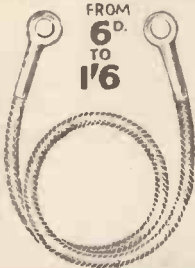

Write for descriptive leaflet No. J.1179.



IGRANIC ELECTRIC CO., LTD. 149, Queen Victoria Street, London.

"If it's IGRANIC—it's BEST for your set!"



FOR YOUR "S.T. 300"—and for the ADAPTOR too!

If you have not already built your "S.T.300," be sure that your coils are by Wearite—the only coils that are subjected to a special H.F. test—get the results that PER PAIR the designer intended—use "WEARITE." 12/6

The Wearite "S.T.300" aerial coil is specified for the "S.T.300" Adaptor—when you construct your "detector and 2 L.F."—insist on the "coil by the specialist"—WEARITE. PRICE 6/3

A GOODEARTH IS ESSENTIAL USE THIS WEARITE TUBE!



No Screwdriver. No Spanner. Price 3/6.

Write for special Leaflets to: "Technical Dept.,"

WEARITE COMPONENTS

WRIGHT & WEAIRE LTD., 740, High Road, Tottenham, N.17. Telephone: TOTTENHAM 3847/8/9.

SHORT WAVES

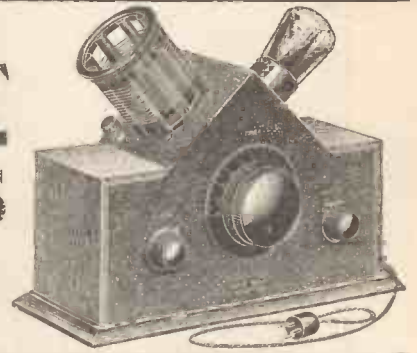

ON A.C. MAINS OR BATTERY SETS . . .

This Short-Wave Adaptor can be used with any type of receiver (except D.C.), whether A.C. Mains, Battery Operated or Super-Het., irrespective of the circuit or the number of valves. Attached in a few seconds, your set becomes a highly efficient Short-Wave Receiver. Complete with 40/80 metres Coil, Cord and Plug 39/6

Extra Coil if required, 18/40 metres, 3/-.

Send now for full particulars, with free trial offer and a list of Short-Wave Stations right up-to-date—Free on request. Particulars of the latest "Stenode" and other Magnum Products—Free on request.

SAND BLAST SCREEN

For the "S.T.300" 2/-  
For the "S.T.300" Adaptor . . . 1/6

BURNE-JONES

& CO. LTD., "MAGNUM" HOUSE, 296, BOROUGHS HIGH STREET, LONDON, S.E.1. Telephone: Hop 6257 and 6258.

Scottish Agent: Mr. Ross Wallace, 54, Gordon Street, Glasgow, C.1.

fixing vertical screen. (Vertical screen is not screwed down at this stage.)

- (k) Fix aerial coil, screened-grid choke, the other 1-mfd. Mansbridge type condenser, L.F. transformer, reaction choke, detector valve-holder, output valve holder, grid condenser (.0001 mfd.).
- (l) Screw terminal strip to edge of baseboard with three screws and fit terminals loosely.
- (m) Wire baseboard components with stiffish insulated wire (bell-wire will do, or one of the advertised varieties). To save the reader time I have numbered the wires in their most convenient order for connecting. Use the following list to find the wires quickly on the diagram and, if in doubt as to their shape, consult the perspective drawings. You need not read the wording after the number of the wire if you can find the wire without. But tick off the numbers on this list as you complete each connection.

1. One terminal of 1-mfd. condenser to copper sheet. (A bare wire is simply tucked under condenser, as explained already.)
2. Other side of condenser to screening-grid terminal (marked

THE BASIS FOR S.T.'s FAMOUS SET

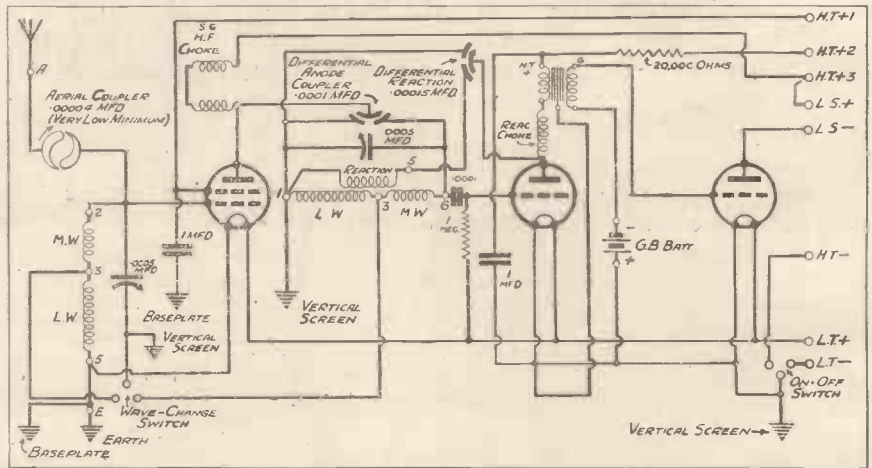

The layout of the parts in the above circuit follows the actual set very closely. Coils are at right angles, and the "aerial coupler" is shown as it is, viz., a condenser of VERY low minimum capacity and of the logarithmic type. The H.F. end of the set is actually screened in two planes to secure stability and maximum amplification, the earthing points being shown above.

3. H.T.+1 terminal to the 1-mfd. condenser.
4. Upper filament terminal F of S.G. valve holder to No. 5 terminal of aerial coil.
5. L.T.+ terminal to lower filament terminal F of S.G. valve holder. (When the vertical screen is later in position this wire passes through the corner nick.)
6. Aerial coil terminal No. 2 to control grid (marked G) of S.G. valve-holder.
7. Aerial coil terminal No. 5 to earth terminal.

8. Earth terminal to earthing screw in copper sheet. (This earthing screw is simply a brass screw going through the copper sheet into the baseboard; this earthing of the copper sheet is essential.)
9. Detector valve filament positive to output valve filament positive (the positive terminals in both cases are those nearest the edge of the baseboard).
10. Detector valve filament negative to output valve filament negative.
11. Output valve filament negative

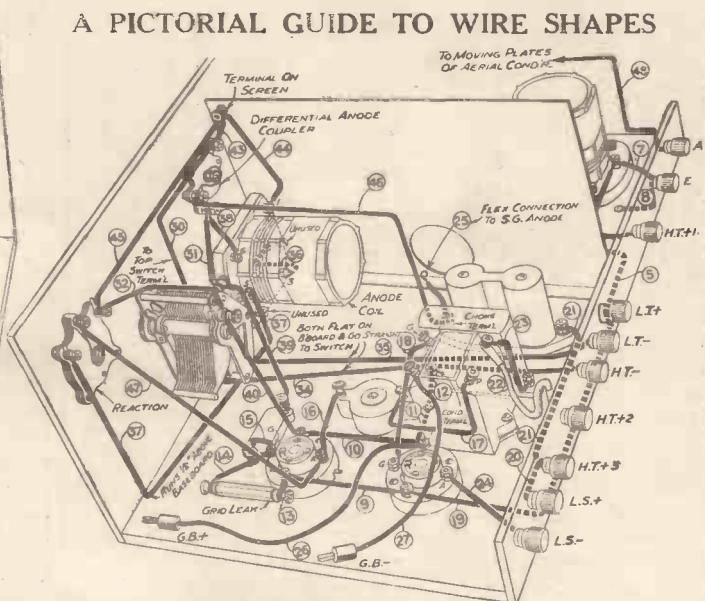
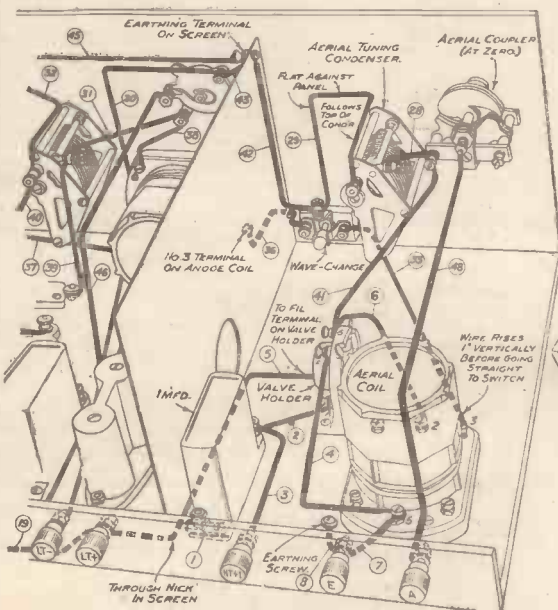

On the left is the aerial side of the "S.T.300," showing every wire; and, on the right, the other side of the screen is similarly treated. The wires are numbered in the most convenient order of wiring.



- |  |  |  |
|--|--|--|
| <p>to eyelet on L.F. transformer.<br/>(This earths the core.)</p> <p>12. Eyelet on L.F. transformer to one side of neighbouring 1-mfd. Mansbridge type condenser.</p> <p>13. Detector valve filament positive to one side of 1-megohm grid leak.</p> | <p>14. Other side of grid leak to detector valve grid terminal (marked G).</p> <p>15. Detector valve grid terminal G to grid condenser.</p> <p>16. Detector valve anode terminal A to reaction choke.</p> <p>17. Other side of reaction choke to</p> | <p>L.F. transformer terminal P.</p> <p>18. Output valve grid terminal G to grid terminal G on L.F. transformer.</p> <p>19. Output valve filament positive to L.T.+ terminal.</p> <p>20. L.S.+ terminal to H.T.+3 terminal.</p> |
|--|--|--|

HOW TO WIRE UP—BY NUMBERS!

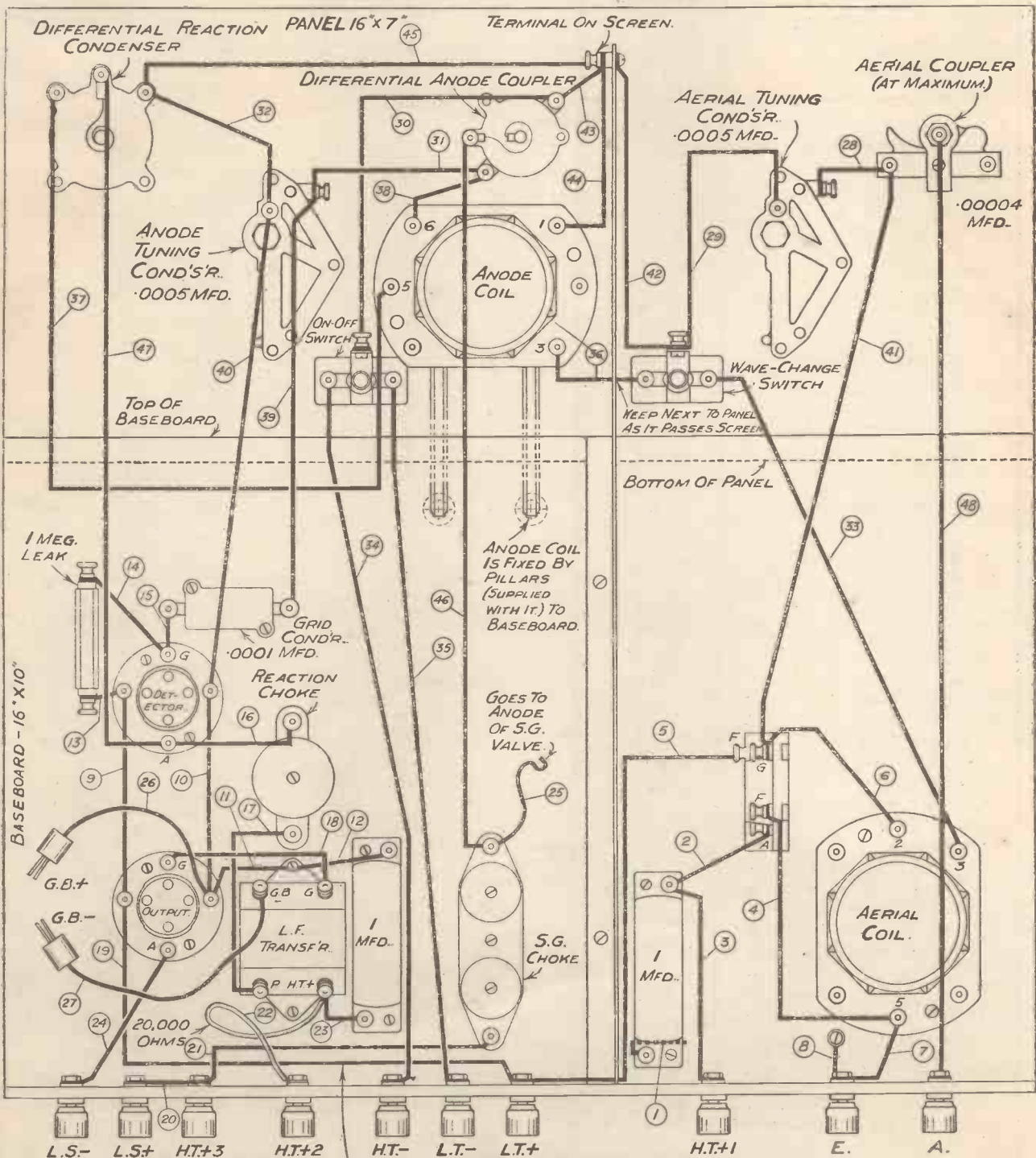

THIS WIRE IS TUCKED IN CORNER OF TERMINAL STRIP AND BASEBOARD.

Every wire has been thought out with an eye to efficiency and simplicity of construction. "Steam-pipe" wiring on the one hand and "cat's-cradle" wiring on the other have been discarded. Wherever possible every wire goes straight to its destination.

SYMMETRICAL HOLE POSITIONS MAKE DRILLING EASY

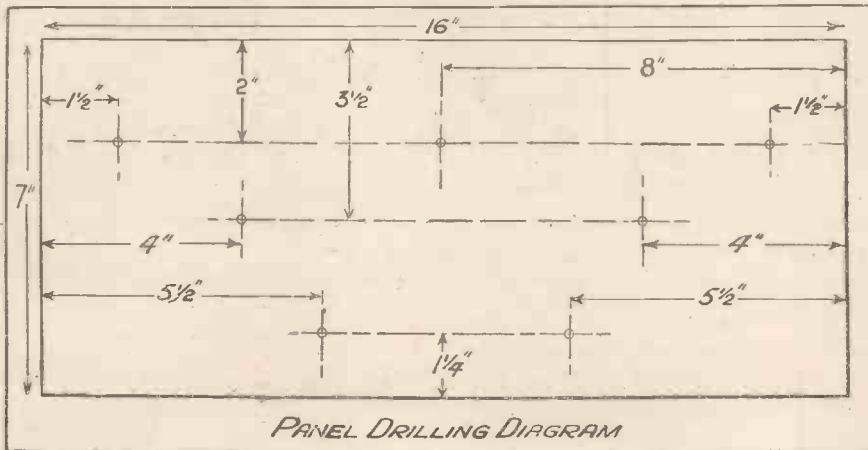

- 21. H.T.+3 terminal to S.G. choke.
- 22. This is a 20,000-ohm spaghetti wire joining H.T.+2 terminal to H.T.+ terminal on L.F. transformer.
- 23. L.F. transformer terminal marked H.T.+ to 1-mfd. condenser.
- 24. L.S.— terminal to output valve anode terminal (marked A).
- 25. Piece of insulated wire (preferably flex) connected to S.G. choke. The loose end goes to the anode terminal on the screened-grid valve when set is finished.
- 26. Grid-bias positive flex to output valve negative.
- 27. Grid-bias negative flex to G.B.— terminal on L.F. transformer.

THIS CONCLUDES THE BASEBOARD WIRING.

The next step is to fit components to panel. Then do this panel wiring:

- 28. Aerial coupler (.00004 mfd.) (fixed plates terminal) to aerial tuning condenser (fixed plates terminal).
- 29. Aerial tuning condenser (moving plates terminal) to top terminal of wave-change switch.
- 30. One set of fixed plates of anode coupler (.0001-mfd. differential) to top terminal of on-off switch.
- 31. Other set of fixed plates to fixed plates of anode tuning condenser.
- 32. One set of fixed plates of reaction condenser (.00015-mfd. differential) to moving plates of anode tuning condenser.

NOW SCREW PANEL TO BASEBOARD. (THREE SCREWS.)

- 33. Aerial coil terminal No. 3 to wave-change switch.
- 34. H.T.— terminal to on-off switch terminal.
- 35. L.T.— terminal to on-off switch.

NOW FIX ANODE COIL IN POSITION.

First attach pillars to coil former. Then place coil in position and fix it to baseboard by tightening up the screws from underneath.

36. Anode coil terminal No. 3 to wave-change switch (keeping wire close to panel where specially provided nick in screen will come).

- 37. Anode coil terminal No. 5 to reaction condenser (one set of fixed plates).
- 38. Anode coil terminal No. 6 to anode coupler (one set of fixed plates).
- 39. Grid condenser to anode tuning condenser (fixed plates).
- 40. Anode tuning condenser (moving plates) to detector valve negative.
- 41. Control grid terminal G. of S.G. valve-holder to aerial coupler (fixed plates).

NOW FIX VERTICAL SCREEN.

- The middle fixing screw of terminal strip may be slacked off if necessary while fixing screen.
- 42. Top terminal of wave-change switch to vertical screen.
  - 43. Anode coupler (one set of fixed plates) to vertical screen.
  - 44. Anode coil terminal No. 1 to terminal on screen.
  - 45. Reaction condenser (one set fixed plates) to vertical screen.
  - 46. S.G. choke to anode coupler (moving plates).
  - 47. Detector valve anode terminal A to reaction condenser (moving plates).
  - 48. Aerial terminal to aerial coupler (moving plates).

YOUR SET IS NOW COMPLETE.  
J. S.-T.

COMPLEX IN THEORY, BUT SIMPLE TO BUILD

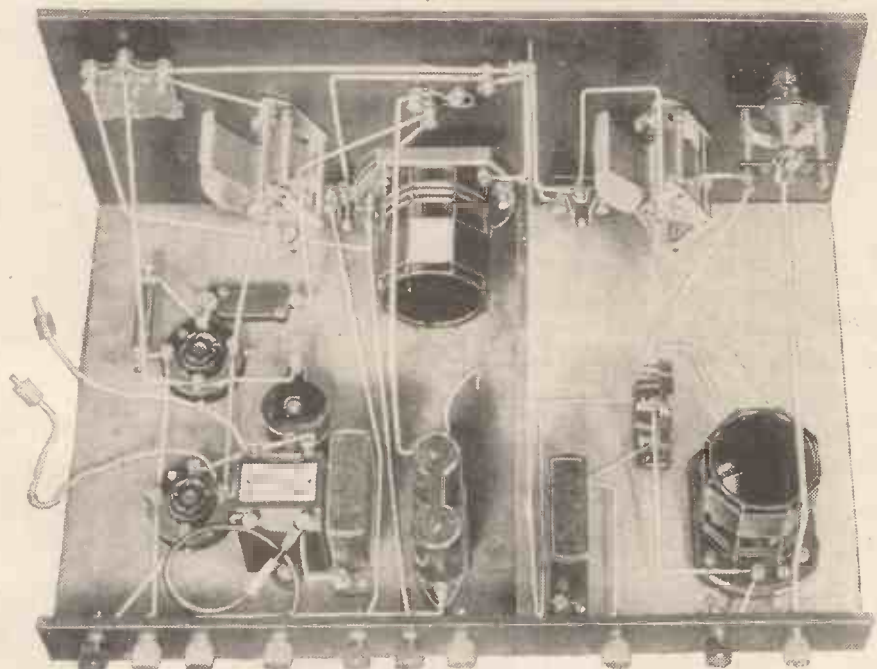

The "S.T.300" is much easier to make than the average three-valver, but it is a clean breakaway from the policy of designing a set to suit average conditions. It is adjustable to get the maximum out of every locality, every aerial and every station.



**SPECIALLY  
DESIGNED  
for the S.T.300  
and SPECIFIED in this issue  
by John Scott-Taggart**

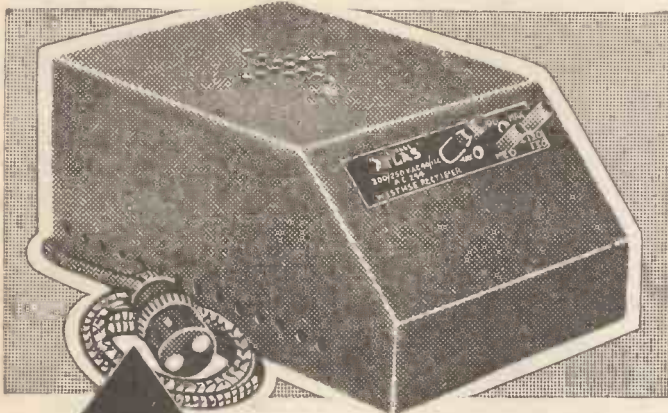

**10/-  
DOWN  
AND BALANCE  
IN EASY  
MONTHLY  
PAYMENTS**

A.C. 244/S.T. H.T. Unit for A.C. Mains. A.K. 260/S.T. H.T. Unit & Trickle Charger.

**59/6 90/-**

**2 NEW UNITS**

"ATLAS" are first again in specially designing two wonderful new models to meet the exact needs of the S.T.300. Constructors of this fine set can get even better performance at a fraction of the cost of H.T. Batteries, by feeding the S.T.300 with the new "Atlas" A.C.244/S.T. or A.K.260/S.T. Each has three H.T. Tappings: one 60/80 v. with max. and min. positions, one 50/90 v. with max., mid. and min. positions, and one 120/150 v. Output 20 mA at 120 v. Model A.K.260/S.T. also includes a Trickle Charger for 2-, 4- and 6-volt L.T. Accumulators. For A.C. Mains: 100/125 v. and 200/250 v., 40/120 cycles. Westinghouse Rectifiers, guaranteed for 12 months. Ask your dealer and insist on "Atlas," winners of the Olympia Ballots, 1930 and 1931.

**"CLARKE'S  
ATLAS"  
MAINS UNITS**

H. CLARKE & CO. (M/cr) Ltd., Old Trafford, Manchester  
Phones: Trafford Park 1744-5-6. Southern Offices: Bush House, W.C.2. Phone: Temple Bar 7130. Glasgow Office: 24, Oswald Street, Glasgow. Phone: Central 5119.



**POST THIS COUPON NOW**

H. CLARKE & CO. (M/CR), LTD., Eastnor Street, Old Trafford, Manchester.

Please send me FREE copy of "Power from the Mains," telling me how to convert my battery set to Mains Operation, and full details of the A.C.244/S.T. and A.K.260/S.T.

Name.....  
(IN CAPITALS)

Address.....

WC/6.....

**POLAR**  
TESTED for the  
**"S.T.300"**  
and the S.T.300  
**"ADAPTOR"**  
by  
**John Scott-Taggart**

**POLAR  
"No. 4"**

This condenser was specially made for use in the "S.T.300." Bonded rotor vanes prevent capacity variations and ensure permanent accuracy. Ball-bearing action gives smooth, precise control. Built for long and reliable service.

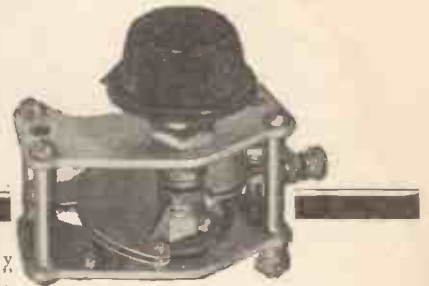

·00004 - - 3/9

**POLAR  
"No. 2"**

No other condenser gives such velvety-smooth and precise tuning as this, with its combination of Fast- and Slow-motion control. The totally enclosed and protected ball races give silent action. Bonded rotor vanes. Robustly constructed. Lasting service. Permanent accuracy.

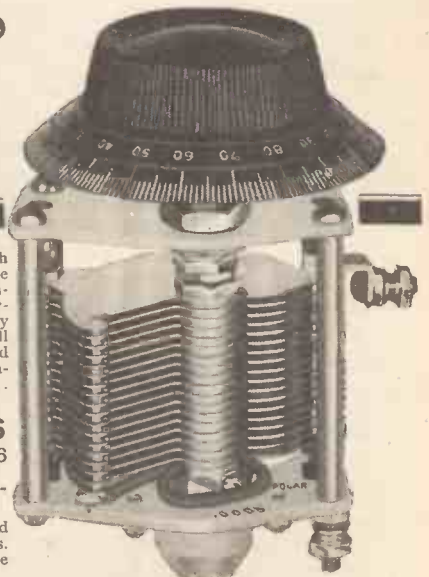

·0005 - - 6/6  
·00035, ·0003 - 6/6

**Polar Differential Condenser.**

Solid di-electric. Constructed of highest-quality materials. Smooth action. Very accurate control.

·0001 - - - 3/-

Polar Catalogue "C," Free.

Obtainable from all dealers. If your dealer has sold out, he can supply you within 24 hours.

Trade Note: We hold ample supplies for Immediate Delivery.

**WINGROVE & ROGERS LTD.,**  
188-9 Strand, W.C.2. Polar Works, Old Swan, Liverpool.



# PICK-UP HINTS AND TIPS

*Some interesting notes on various practical aspects of radio-gram reproduction.*

By A. BOSWELL

*Motor Interference—Bass Correction—Pentode Output.*

IT is not often these days that electric gramophone motors cause interference in the speaker through induced currents getting into the pick-up leads.

If, however, this trouble should occur it is advisable to try the effect of earthing the motor chassis, provided this is not already done.

Should this procedure not be beneficial, an iron plate can be interposed between the under-side of the turntable and the top-side of the motor.

## The Ideal Scheme

Of course, the ideal scheme is to completely enclose the motor in an iron box, and there is then no likelihood of interference occurring.

By the way, when purchasing a motor it is necessary to make sure that the type chosen is designed for gramophone work. Any old motor won't do!

One of the essential factors is a constant speed under varying loads. If the motor is not properly governed you will find that the turntable slows down on a heavy recording, and the results will then be hopeless.

I am sometimes asked what benefits are derived by arranging for the pick-up to give a "lift-up" or increase in the amplification of the bass frequencies. It is a well-known fact that many of the good commercial pick-ups are designed to over-emphasise the low notes, the object of this being to compensate for the attenuation of the bass notes necessary in recording.

## Boosting the Bass

Although the low notes are present on the record they are very weakly represented below about 150 cycles, but if the pick-up is designed so that it counteracts this the net results will be equal to those given by a record capable of providing a perfectly even

response over the whole frequency range.

And it is only the final results that matter. The ear doesn't worry about the record by itself, neither does it care whether the pick-up over- or under-emphasises certain notes.

All that concerns the listener is whether the resulting reproduction sounds pleasing and natural.

## HEARD THESE ?

### RECORDS WORTH HEARING.

Orchestral. Petite Suite de Concert. London Symphony Orchestra ..	H.M.V.
Clock Symphony. Philharmonic Symphony Orchestra of New York.	H.M.V.
Organ. Prelude and Fugue on B-A-C-H. G. D. Cunningham ..	Columbia
Dance. All of Me. Manhattan Merry-makers ..	Broadcast
Jealousy. Stein's Tango Orchestra ..	Broadcast
Gettin' Sentimental. B.B.C. Dance Orchestra ..	Columbia
Try to Forget. Savoy Hotel Orpheans ..	Columbia
She Didn't Say Yes. Ambrose and his Orchestra ..	H.M.V.
Violin. Legende. Mischa Elman ..	H.M.V.
Vocal. Gracie Fields Medley. Gracie Fields ..	H.M.V.

Have you noticed how some sets with pentode output stages accentuate needle scratch? This is because the high notes are being amplified much more than the middle and lower frequencies. This may be caused by the impedance of the output circuit not being matched up to the valve impedance, possibly by the use of an output transformer of unsuitable ratio, or a filter choke of low inductance.

The correct matching of the output load is an essential factor if the

reproduction is to be comparable with that obtainable when an ordinary power valve is employed.

If a filter output is incorporated in the receiver it is advisable to use a centre-tapped output choke of the type specially designed for pentodes.

In addition, a resistance and fixed condenser in series should be joined across the choke or transformer primary.

## Cutting the High Notes

The high-note cut-off may be adjusted by varying the value of the condenser. A common value is .01 mfd. It is a good scheme to make the resistance variable from, say, 10,000-50,000 ohms. In this way a satisfactory control of tone will be obtained.

Pentodes give enormous amplification, but the signal input on the grid must be carefully adjusted if "blasting" is to be avoided.

## THE "S.T.300" ADAPTOR FOR YOUR SET

*—continued from page 67*

9. Tuning condenser (fixed plates terminal) to .00004-mfd. aerial coupler (fixed plates terminal).
10. Aerial coupler fixed plates to control grid terminal G of valve holder.
11. Tuning condenser (moving plates) to upper filament terminal F of valve holder.
12. Aerial coil terminal 3 to Lotus switch.
13. H.T.+2 terminal to choke coil.
14. Piece of insulated wire (preferably flex) is connected to choke coil. The free end will go to the anode terminal of screened-grid valve when the finished unit is ready for use.
15. Choke coil to anode coupler (moving plates terminal). Anode coupler is a .0001-mfd. differential condenser.
16. Anode coupler (one set fixed plates) to aerial 2 terminal.  
At this stage fix vertical screen in position and complete wiring as follows:
17. Tuning condenser (moving plates terminal) to vertical screen.
18. Anode coupler (other set fixed plates) to vertical screen.
19. Aerial 1 terminal to aerial coupler (moving plates).

YOUR UNIT IS NOW COMPLETE.



**FOR YOUR A.C. ELIMINATOR**

**HT8**

**250 VOLTS  
60 MILLIAMPS**

**21/-**

THE fact that the large majority of manufacturers of A.C. mains eliminators fit the Westinghouse Metal Rectifier is a definite proof of its superiority and reliability. Follow their lead . . . and see that it is incorporated in the eliminator YOU buy or build.

A 3d. stamp will bring you "The All-Metal Way," which contains full details and prices of our constructors' range, and tells you how to build A.C. eliminators incorporating THE



*Please mark your envelope "Dept. W.C."*

**THE WESTINGHOUSE BRAKE & SAXBY SIGNAL CO., LTD.**  
82, YORK ROAD, KING'S CROSS, LONDON, N.1.

**Grand Stories of  
Gripping Adventure**

CHUMS is a ripping paper for the manly boy, packed with gripping tales of adventure on the high seas, of bandits, and great mystery—it is just the very paper every boy will enjoy. Each week it contains three splendid serials and short complete stories by the most popular writers of boys' fiction, and grand articles on stamp collecting and motor-cycling, besides numerous illustrations by the leading artists.

**CHUMS**

*Every Saturday, 2d.*

**John Scott-Taggart  
SPECIFIES LOTUS**

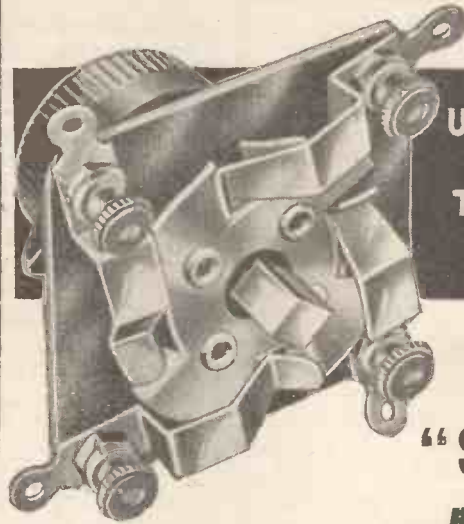

**UNIVERSAL  
SWITCH  
TYPE US/3  
1/6**

for his

**"S.T.300"  
ADAPTOR**

BY specifying the LOTUS UNIVERSAL SWITCH, John Scott-Taggart has once again recognised the superiority of guaranteed components. For designers of this calibre nothing can be too good, and only the best is good enough. That is why all the leading set designers select and specify LOTUS COMPONENTS for the most important positions in their sets.

Be sure to insist on LOTUS COMPONENTS and send the coupon for your free copy of the LOTUS Component Catalogue.

**FOR THE "S.T.300"**

Fit the following LOTUS COMPONENTS and ensure good results:—

0005 Slow Motion Condenser . . . . .	6/6
Four-Pin Valveholders (Type VHK) . . . . .	6d.
Radio-Frequency Choke, No. 1 . . . . .	2/6
L.F. Transformer, AT/13 . . . . .	5/6
00015 Miniature Type Differential Condensers . . . . .	3/-



**GUARANTEED COMPONENTS**

LOTUS RADIO, LTD., MILL LANE, LIVERPOOL

**POST THIS COUPON NOW!**

Please send FREE Copy of the Lotus Component Catalogue.

Name .....

Address .....

WC/6.

---

**FROM MY ARMCHAIR**

---

—continued from page 80

---

used a .00015-mfd. differential anode coupler, not realising it will upset things.

Frequently, however, components are faulty. Manufacturers who carelessly send out faulty stuff should be hanged from the yard-arms of their own aerial masts. I'd gladly provide a blue-print for a suitable yard-arm and pull the rope when the time came. They do not realise the inconceivable amount of vexation and exasperation they cause. Being polite afterwards is no use.

### "Coils are Kittle Cattle"

I speak with feeling on this matter, partly because I've been let down myself more than once, and partly because I have a hunch that Chorlton-cum-Hardy has a "dis." in a coil.

Coils are kittle cattle, and when tens of thousands are made by machinery some are always faulty and may get past the test-bench. Some girl is thinking of Clark Gable instead of watching the needle of an instrument.

On one "S.T.300" I handled I got the following fault: Tuning on the anode circuit was all right, but I could only get reaction to work for the first half of the condenser. My solution: H.T. down (tried higher tap—no good; measured voltage—O.K.). Reaction reversed perhaps (you can get queer reaction effects even with reaction reversed sometimes) or probably a "dis." in reaction coil.

### A Problem for You

Since no direct current flows in the reaction coil in the "S.T.300," a "dis." in the reaction coil seemed most likely—or a short of some of the turns. On test the coil was found O.K. Since the circuit tuned all right, I presumed the anode coil was O.K. However, I measured its resistance and it was absolutely right. Now it's your turn to find the fault! Oh, yes, the accumulator was O.K.—and the reaction choke and the detector valve and everything else.

It was because everything else was so all right that I examined very closely the soldered joints to the terminals of the coil. I found the anode coil had a "dry" joint (i.e. the wire stuck in the solder, but there was not a perfect join; the solder had not "run"). The result was that there was a resistance in the tuned-anode circuit. At the bottom

end of the tuning condenser the effect could be wiped out by using more reaction, but, higher up, the reaction completely packed up.

If you ask: "But why was the coil resistance O.K.?" my reply is that when the voltage of the ohm-meter was put suddenly across the coil, the well-known phenomenon of "healing" took place, i.e. the minute resisting film of oxide between wire and solder broke down temporarily and a good contact was obtained.

If you ever suspect a coil, look for dry "joints," but don't pull the wire, or you may have an awkward job putting things right. I only hope you never have an intermittent "dis." inside the coil winding itself. This may likewise "heal" when you test it. Many a good wireless man has had his temper spoiled for life through such a fault.

---

### HOW MAINS UNITS WORK

---

—continued from page 85

---

two vertical dotted lines to show the three stages, viz., rectification, smoothing, and voltage dropping. Note that a potentiometer arrangement is used for supplying the H.T. for the screen-grid; when V.R. (usually a compression type of variable resistance) is reduced the S.G. voltage is increased. An ordinary potentiometer with slider could, of course, be used.

### Extra Condensers

The H.T.2 voltage (suitable for the detector valve) is obtained by a series method, the resistance  $R_2$  being in series with the full voltage given by unit. This resistance thereby "drops" the voltage, and  $R_2$  could be variable if desired. Note, however, that a condenser is connected between H.T.2 and H.T. —. This condenser assists in smoothing and "decouples" the detector valve. (The importance of decoupling was explained last month.) A similar condenser is used for the same purpose across S.G. and H.T. —.

The Fig. 5 scheme will serve for battery valves. If indirectly-heated A.C. valves are used it is customary to supply an extra transformer to supply 4 volts raw A.C. for the "heaters," or to have an extra 4-volt winding on the main input transformer.

In a future article I propose to deal with metal rectifiers, but this simple explanation should give the novice a general idea of how mains units work.

---

### DETECTION MADE READABLE

---

—continued from page 70

---

the crystal detector does towards the flow of electricity.

When the valve is working, the flow of air can be represented by curve (e), which shows that air goes into the tyre, but that none comes back to the pump, and so the air collects in the tyre and swells it out.

The tyre can be compared to the condenser across the headphones, and the air that would escape through a leak in the tyre is rather like the current which goes through the headphones.

### A Parallel Case

If you look again at curve (d), still letting it represent the flow of air, you will see that it shows that we are giving bigger strokes with the pump at some times than at others. Now, we can easily imagine the effect this would have on the leaky tyre. When we gave big strokes with the pump we know that the tyre would fill up and more air would escape from the leak.

Just read those last few words again, and then think of the electrical case. The microphone currents vary the strength of the high-frequency current, and stronger high-frequency current can be compared to the effect of giving longer strokes with the pump, and weaker currents to the effect of giving short strokes.

### Varying Strength

Since the condenser has its counterpart in the tyre, it is not difficult to see that the current which leaks from it through the headphones will vary in much the same way as the air leaking from the tyre; that is, there will be more leakage when the high-frequency current is stronger. And so it is in this way that the current through our headphones is made to depend on the microphone current.

Next time we will talk about the thermionic valve, which is at once the most important and interesting piece of apparatus in radio.

READ AND ENJOY

"MODERN WIRELESS"

A Real Value - for - Money  
Magazine containing many  
Special Features.

On Sale First of the Month,  
Price One Shilling.



# FROM OUR READERS

*A hint for constructing cones and an account of the "I.E." Three's performance in Wales.*

## Making Cones

Sir,—The instructions in the January WIRELESS CONSTRUCTOR reminded me that I have never seen a practical method of cutting loud-speaker cones—or, rather, a practical method of marking one out—and the following method, used by tinsmiths, may be of some interest to others who, like myself, like to do all the lot, or at least as much as possible, where it is a question of making things.

The beauty of this way is that it does not require any calculations for the purpose of arriving at the correct diameter of the cone circle as projected or the angle of the portion to be cut out. On the accompanying sketch A—B is half the diameter of the required cone. A—C is the height and is drawn at right angles to A—B, and the line extended rather longer than required.

Join C to B. With the compasses at A, and A—B for radius, draw the quarter circle B—D. Join B to D. Divide D—B equally at E and draw a line from A through E to F. This preliminary drawing should be done, of course, on some scrap paper.

Take the paper that is to be used for the cone, and with C—B as the radius draw a circle, and from any point on the circle, say G, step off six times A to B. This will bring us

to H, and now we come to the point of the story. This is where we come to the part that does away with the calculating. Set the dividers to the distance E—F on the preliminary sketch and add it to the point H on the circle on the cone paper.

## CUTTING THE KRAFT

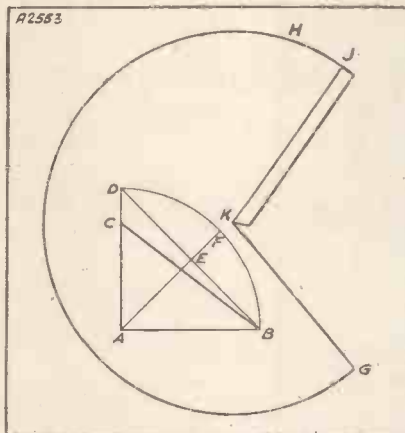

*This sketch illustrates the method described by Mr. Summerfeld.*

This brings us to J. Join J to the centre of the circle (K), also G to the centre (K), add sufficient to K—J to make a joint, and cut away the unwanted part of the desired cone. I have personally cut hundreds of templates for cones with this method and

have never had any trouble with them.

Yours faithfully,

H. SUMMERFIELD.

Moseley, Birmingham.

[EDITORIAL NOTE.—We have tried making two or three cones by this method, and while it was very easy and the "height" came out about right, the diameter generally seemed a trifle on the large side.]

## More "I.E." Praise

Sir,—Being a monthly reader of the one and only "monthly" that is well worth a "tanner," I am writing to let you know how the "I.E." Three works in North Wales.

If I could possibly think of "all the good things rolled up in one"—well, that would just about make the "I.E." Three.

"Congrats." to Mr. King and all connected in presenting the "I.E." to the public.

I made the set last Christmas and, believe me, it made my cabinet into the best "Christmas box" I ever had.

I have logged well over forty stations, including Bound Brook, Moscow, Chicago, Long Island, Rabat, Zeesen and Schenectady, on the ultra-short. I am using Mullard P.M.2D.X., L.F. and 252, also a Blue Spot super-power loud speaker, and I am enjoying full loud-speaker results on long, medium and ultra-short on all the forty-odd stations aforesaid.

Here's hoping the CONSTRUCTOR will live for ever.

Yours faithfully,

DELIGHTED WELSH READER.

Penmaenmawr.

## Just the Thing!

HAVE you ever had the pleasant experience of wanting some particular piece of apparatus for a certain set, wondering where you can get it, and then finding just the very thing for your purpose, at the right price?

Recently the writer was looking for two potentiometers, with widely different resistances and current-carrying capacities, when a new Igranice list came to hand. (In case you are in the same boat, note the number of the list—6560.)

Described on this was a whole range of wire-wound potentiometers, suitable for all sorts of things, for the resistances included a 1,000-ohm model and one of 50,000 ohms, with various other useful values in between. All at 5s. 6d. each.

## TRADE JOTTINGS

*Some notes of interest to the radio purchaser.*

Fifty-five milliamps is the very respectable—indeed load carried by one model, and even the 50,000-ohm model thinks nothing of standing up to a steady eight milliamps!

When it is remembered that at one time—and not so long ago, either—the purchaser had to take a variable resistance on trust, with no safety-load figure from the maker, and no guarantee that the resistance wouldn't burn out or play up as soon as it was put in service, the real advance made in modern component construction is revealed.

The list named is obtainable from Igranice's London office, 149, Queen Victoria Street, E.C.

## Shorts for Shoppers

Loewe Radio Co., Ltd., have completed arrangements enabling dealers to sell their Loewe apparatus, etc., on deferred terms.

Particulars can be obtained on application to Fountayne Road, Tottenham, London, N.15.

"Eelx" are now turning out so many different lines that quite a big list is needed to enumerate them all. These devices are of special interest to constructors, and any reader of this journal may apply for the list to J. J. Eastick & Sons, Eelx House, 118, Bunhill Row, E.C. P.R.B.

# Now EVERYONE can afford SUPER RADIO!

## The NEW Range of TUNEWELL COMPONENTS is Ready!

8 FREE CIRCUITS

The NEW TUNEWELL Components set a standard of quality hitherto approached only by the highest priced products. Unless huge sales result, TUNEWELL prices must advance, but already the demand has made us confident of the success of our effort to bring Super Radio within everybody's reach.

The NEW TUNEWELL Components cover a wide range; Coils, Chokes, Transformers, Resistances, Volume Controls, Mains Components and Eliminators, etc., etc. Whatever the Set, there are TUNEWELL Components to improve performance. Insist on them always.

Should you have any difficulty in obtaining, please write us giving the name and address of your nearest dealer.

In any case send the coupon for the NEW TUNEWELL "Guide to Super Radio," an interesting folder which you will keep for reference. Eight Circuits FREE, including Band Pass All Mains Three and Kit Eliminator.

TUNEWELL RADIO LIMITED,  
54, Station Rd., New Southgate, London, N.11

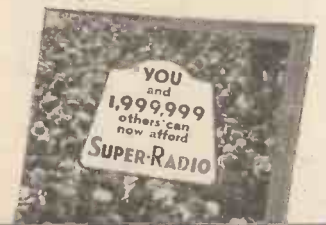

# TUNEWELL

Post this NOW!

Post in unsealed envelope—halfpenny stamp.

To TUNEWELL RADIO LTD.,  
54, Station Rd., New Southgate, London, N.11  
Send New "Guide to Super Radio" to:

Name .....

Address .....

My nearest Dealer is .....

C.I.

# WHERE TO SEE "S.T.300's" AND "COSMICS"

A further list of official exhibitors.

- ABERDEEN.**  
The Aberdeen Radio Co., Ltd., 9, Hadden Street.  
J. P. Christie, 20, Victoria Road.  
Miller Bros., 249-251, George Street.  
P. F. Paton, 34, Portland Street.  
Smith Sim, 38, Bridge Street.
- ABERDARE.**  
J. D. Williams, 65, Cardiff Street.
- ACCRINGTON.**  
Frank Edmonds, 17, Abbey Street.  
H. A. Sharples, 261, Blackburn Road.
- ARBROATH.**  
W. McKay, 243, High Street.
- ASHFORD.**  
A. Edenden, 150, Bridge Street, WYE.
- ASHTON-IN-MAKERFIELD.**  
G. F. Smith, 57, Gerard Street.
- AYLESBURY.**  
C. R. Stegall, 52, Cambridge Street.  
E. D. Hasberry, Radio Shop, Temple Street.
- BACUP.**  
J. Crawshaw, 149, Market Street.
- BANBRIDGE, CO. DOWN.**  
T. & A. Wallace, 52, Bridge Street.
- BARTON-ON-HUMBER.**  
Park Bros., 11, King Street.
- BATH.**  
C. W. Maxim, 33, Broad Street.
- BATLEY.**  
W. E. Wood, Sandyfields Wireless Stores,  
Bradford Road.
- BEDEFORD.**  
Norman Mickle, 37, Bromham Road.
- BEESTON, NOTTS.**  
C. Hall & Sons, 68, High Road.
- BELFAST.**  
The Wireless & Electrical Co., 32, Dublin Road.  
Belfast Radio & Electric Co., Ltd., 17-19, Queen  
Street.  
John Young, 217, Upper Meadow Street.
- BIDEFORD, N. DEVON.**  
F. H. Darch & Son, 13, Chingswell Street.
- BIRKENHEAD.**  
A. Allchin, 370, Borough Road.  
Radion Co., 237, Old Chester Road.
- BIRMINGHAM.**  
G. F. Collins, 511, Slade Road, ERDINGTON.  
J. Elvins, 112, Stoney Lane, SPARKBROOK.  
Hopkins Bros., 216, Hawthorne Road, KING-  
STADING.  
Lees Radio Stores, 209, Lichfield Road, ASTON.  
Malcolm & Stewart, 491, Alum Rock Road,  
ALUM ROCK.  
E. Matty, 69, Lichfield Road, ASTON.
- BISHOP AUCKLAND.**  
A. M. Hunter, Evenwood House, Evenwood.
- BLACKBURN.**  
H. H. Flintoff, 47 and 53, Copy Nook.  
Snapes, Ltd., 55, Penny Street.
- BLACKPOOL.**  
Tom Jones, 1A, Leopold Grove.  
A. Morfitt, 306, Lytham Road.  
The Radio Stores, 10, Cedar Street.  
J. Taylor (Messrs. R. H. O. Hills, Ltd.).
- BOLTON.**  
J. S. McLeod & Co., 34, Gt. Moor Street.  
J. Westhead, 38, Arlington Street, G.T. LEVER.
- BOSTON.**  
Allens Radio Service, 6, Emery Lane.
- BOURNE.**  
E. Pearce, 32, North Street.
- BOURNEMOUTH.**  
Gardiner's Radio, West Southbourne.
- BRADFORD.**  
A. Adams, 105, High Street, WIBSEY.  
A. Adams, 50, Oak Lane, MANNINGHAM.  
A. Ridgway & Co., 23, Hall Ings.  
J. Scurrah & Sons, 6-12, Rooley Lane, BANK-  
FOOT.  
H. Atkinson, Barkerend Music Stores, 211a,  
Barkerend Road.  
V. Wilson, 33, Bowling Old Lane.
- BRISTOL.**  
H. E. Hamilton, 39-40, Bridge Street, and 45-51,  
Church Road, REDFIELD.  
Polchar's Wireless, Ltd., 20, Bridge Street.

- BROMLEY.**  
Chapman & Son, 418, Downham Way.
- BROMSGROVE.**  
C. Wynna, 19, Worcester Street.
- BURNLEY.**  
T. Duerdon, Westgate.  
Northern Radio Exchange Co., 150, Trafalgar  
Street.  
G. Pye & Son, 134, Padiham Road.
- BURSLEM.**  
Bancroft Bros., 207, Newcastle Street.
- BURY.**  
Bennett & Co., 36, Union Street.  
Manchester District Wireless Co., 21, Agur Street.
- CAMBRIDGE.**  
A. W. Matthews, 41, Mill Road.
- CAMPBELTOWN.**  
A. P. Macgrory, 16-18, Main Street.
- CANTERBURY.**  
W. A. Goodhew, 22, Sun Street.
- CARDIFF.**  
J. F. Paull, 43, Caroline Street.  
Splott Radio & Gramophone Co., 9, Splott Road.
- CHATHAM.**  
Chatham Radio, 220, High Street.
- COLWYN BAY.**  
J. Hacking, "Wireless," 7, Erw-wen Road.
- CONNAH'S QUAY.**  
George M. Coppack, 80, High Street.
- COWDENBEATH.**  
H. S. Stott, 144, High Street.
- COWES.**  
F. E. Dominey, 20, Shooters Hill.
- CRAWLEY.**  
W. H. Hogger, 4, Post Office Road.
- CRIEFF.**  
Frank Thomson, 7, 9, 11, East High Street.
- CROMER.**  
J. B. Postle, 9, Mount Street.
- CWM, MONMOUTHSHIRE.**  
Douglas C. Osborne, Modern Music Depot.
- DAGENHAM.**  
Acme Wireless, 8, Goresbrook Road.
- DARTFORD.**  
J. C. Freeman & Co., 1, Spital Street.
- DEAL.**  
E. D. Newing, 138, High Street.
- DERBY.**  
Hulme & Son, 8-9, Sadler Gate.  
J. & C. Wireless, 54, Green Lane.  
E. Peabody, Three Gables, High Street,  
STAVELEY.
- DERHAM.**  
Utting & Buckingham, Ltd.
- DEVIZES.**  
James Bros. (Wiltshire), Ltd.
- DEVONPORT.**  
Barford Accessories, 66, Tavistock Road.
- DEWSBURY.**  
C. Phillips, 33, Wellington Road.
- DOVER.**  
Albert V. Nutley, 30, London Road.
- DUNBLANE, PERTSHIRE.**  
A. Gonnella, 33, High Street.
- DUNDEE.**  
Swainston's Radio Stores, 66, King Street.
- DURHAM.**  
C. N. Grundy, 27, Station Road, STANLEY.
- DURSLEY, GLOS.**  
G. E. Smith, "Elmsleigh," ULEY.
- EAST COWES.**  
H. W. Millard, The Corner Radio and Gram.  
Stores, 25, Clarence Road, I.O.W.
- EASTLEIGH.**  
Nalder C. Cox, 16, High Street.
- EDINBURGH.**  
Wm. Borthwick & Co., Ltd., 26, 28, 30, 32, 36, 42,  
44, Cockburn Street.  
Clydesdale Supply Co., 66, South Bridge.

(Continued on page 109.)



**WHERE TO SEE "S.T.300's" AND "COSMICS"**

—continued from page 108

- ELLESMERE PORT.**  
G. Salter, 56, Station Road.
- ELY, CAMBS.**  
E. Baines Cope, 36, Back Hill.
- ENFIELD.**  
Service Electrical & Radio Co., 28, Windmill Hill.
- ENNISKILLEN, ULSTER.**  
W. H. Creighton, 14, Church Street.
- EXETER.**  
G. L. Fildew, Radio House, 177, Sidwell Street.
- EXFORD, TAUNTON.**  
P. E. Heywood-Bawden, Motor Works.
- FIFE.**  
W. T. Ross, 16, Millgate, CUPAR.
- FROME.**  
Alce. G. Applegate, 47, Trinity Street.
- GAINSBOROUGH.**  
Shiple & Co., Ltd., Market Place.
- GILLINGHAM.**  
Maningtons, Ltd., 426, Canterbury Street.
- GLASGOW.**  
Wm. Blackadder, 288, Argyle Street. C.2.  
Cohen, S. W., 7-15, King Street.  
City Wireless and Cycle Stores, 666, Govan Road.  
Clydesdale Supply Co., 63, Benfield Street.  
Clydesdale Supply Co., 160, Sauchiehall Street.  
Gordon & Smith, 669, Cathcart Road, S.2.  
Gramophone Radio Service, 219, Main Street.
- CAMBUSLANG.**  
Youngs (Glasgow), Ltd., 40, Stockwell Street.
- GLOUCESTER.**  
Cycle and Wireless Services, 120, Barton Street.
- GODALMING.**  
Jordan's Garage, Ltd., 11-13, Ockford Road.
- GORLESTON-ON-SEA.**  
Gorleston Cycle Depot.  
C. A. Williams, 174, High Street.
- GOSPORT.**  
Hardway Radio, 26, Grove Road South.
- GRAYS.**  
The Harbon Radio Stores, Southend Road.
- GRIMSBY.**  
Abbey Motors, Radio House, Freeman Street.  
C. H. Turner & Co., 3, Corporation Road.  
W. Westoby, Hutton Road, Fish Docks.
- HALIFAX.**  
C. Aunber, 3, Woolshops, Old Market.
- HANLEY.**  
M. Pearson, 76, Lower Mayer Street.
- HEMEL HEMPSTEAD.**  
F. Wilkins & Sons, 54-56, High Street.
- HEREFORD.**  
S. C. Jones, Clehonger Garage.
- HOLT.**  
Sheldrake & Son, Lion Corner.  
A. V. Ship.
- HUDDERSFIELD.**  
L. Biltcliffe, 8, Church Street. HONLEY.  
P. Dyson & Co., 18, Cross Church Street.  
Radio Equipment Co., Market Avenue.  
Taylors (Hudd.), Ltd., 6, Shambles Lane.
- ILKESTON.**  
M. Kitchen, 23, Market Street.
- INVERURIE, ABERDEENSHIRE.**  
The Square Engineering Works, 39A-40, Market Street.
- KEIGHLEY.**  
W. S. Nicholls & Son, 187, South Street.
- KIDDERMINSTER.**  
T. F. Hancock, 117, Mill Street.
- KIMBERLEY, NOTTINGHAM.**  
J. Goulder, 10, Norman Street.

(Continued on page 110.)



**No cutting of flex..No stripping of thread**

Grips every battery socket and stays put even in portables under vibration—the resilient hard-drawn spring wire prongs (not soft brass) ensure exceptional self-adjustment and strength of contact. Side entry, with patent loading device —no tools required. 12 permanent indications.

The whole flex gripped—copper, rubber and braiding. No sharp cutting edge; no loose, straggling ends.

No jagged saw-cuts or cross holes to strip the thread inside the cap.

**2D**

Write for Free List.

**BELLING-LEE**  
FOR EVERY RADIO CONNECTION

Advertisement of Belling & Lee, Limited, Queensway Works, Ponders End, Middlesex.

Famous Makers Offer!

**£5 Radio-Gram CABINET for 65/-**  
7 DAYS' FREE TRIAL (or 10/- monthly.)  
Polished Oak! and Piano built! the acoustic Tone brings a fine thrill. Makers to (Radio Press, B.B.C., 2,000 clients).  
Other Models 35/- to £15. Photographs and List FREE.

**PICKETTS** Piano-Tone Cabinets.  
(C.W.) Albion Rd., Bexleyheath.



**Model RAILWAYS—  
Model AEROPLANES—  
Stamp Collecting.**

Hobbies, Sport, Adventure—all the things the boy of to-day is keen about, are dealt with week by week in **The MODERN BOY**. Every issue is brimful of thrilling stories, articles, and fascinating facts. Read it regularly and you'll enjoy every word of it.

**The MODERN BOY**  
EVERY MONDAY 2d.

Wherever you live—save 50% Radio Expense

**you must join the Radialaddin Club**

Write for particulars, Dept. W.C., 47, Berners Street, London, W.1.

THE PICTURE PAPER WITH THE MOST NEWS

**SUNDAY GRAPHIC**  
and Sunday News



**FREE!**  
THE 24-PAGE CAMCO CATALOGUE

Details of Camco's fine range of Radio Cabinets—need—YOUR need—Write immediately for a copy.

**CARRINGTON MFG. CO. LTD.**  
Showrooms: 24, Batton Garden, London, E.C.1.  
Phone: 110Lbarn 8202. Works: 8, Traillon.

THE CAMCO WINDSOR

**There's no substitute for cyldon**

- |  |   |   |  |
|--|---|---|--|
| <p><b>CYLDON EXTENSER</b><br/>Type EX5. Fitted with a perfectly timed, adjustable wave-change switch and noiseless brush wipe contacts. 4' Bakelite, 360° Dial 1/6 extra.</p> <p><b>12/6</b></p> | <p><b>CYLDON SLOW MOTION EXTENSER</b><br/>Type EX5V. Fitted with wedge drive, disc type, Slow-motion Control. Hair-line sight, 5 to 1 reduction. Perfectly timed Extenser wavechange switch.</p> <p><b>16/6</b></p> | <p><b>CYLDON SLOW MOTION DIAL</b><br/>New wedge friction drive, 8:1 ratio, non-slip, rotation in same direction as condenser, illuminated scale, hair-line sight Sector vision.</p> <p><b>7/6</b></p> | <p>SYDNEY S. BIRD &amp; SONS LTD.<br/>CYLDON WORKS,<br/>SARNESFIELD ROAD, ENFIELD<br/>S.F.B.</p> |
|--|---|---|--|



**"Of great interest to the Mains Man"**

The Heayberd List of Mains Equipment will immediately be sent you, on receipt of your name, address and 3d. stamps. One of the well-known Mains Units described therein is the "M.W.1" Model—illustrated above. Supplied complete in neat crystalline steel case with Bakelite panel, Westinghouse Rectification and length of flex—all ready to switch on. Special earth terminal for L.T. supply affixed to the panel.  
**H.T. OUTPUT:** 200 volts @ 40-50 ma. L.T., 4 v. 5 amps. Raw A.C. supply. **H.T. TAPPINGS** 60-80 volts Var. S.G., 180 and 200 v. fixed.

**Price . . . . . 127/6**



**10, FINSBURY ST., LONDON, E.C.2**  
*(One minute from Moorgate Underground Station.)*

**OAK CABINETS for S.T.300, 12/6**

Complete with Baseboard. Cash with Order or C.O.D. CARRIAGE PAID TO YOUR DOOR!!!

COMPARE OUR PRICES OF OAK CABINETS, As Illustration. SATISFACTION GUARANTEED



All highly polished with hinged lids. Panel size. Deep. 21" x 7" x 10 1/2" 15/16 19" x 7" x 10 1/2" 13/16 16" x 7" x 10 1/2" 12/16 14" x 7" x 10 1/2" 10/16 14" x 7" x 7 1/2" 8/9 (Teisen Thresh.) Let us quote you for your size. These prices do not apply to Irish Free State. Any size made to order. PEDESTAL and CONSOLE TYPE CABINETS. PRICES and SIZES ON APPLICATION.

**THE WOODWORKERS SPECIALS, HORSE-MARKET, NORTHAMPTON.**

**SCREENS & COPPER FOIL FOR THE NEW "S.T.300" RECEIVER**

Aluminium Screen, Silver-frosted finish, 10" x 6", with S.G. Hole and Notched, as specified. 1/3. Copper Foil, 10" x 7", 9d. Special Offer. Screen and Foil. 2/6 post free.

"Rex" Patents Co., "Rex" Works, Park Rd., Kingston-on-Thames

**The ACME of CRAFTSMANSHIP High-Grade RADIO-GRAMOPHONE CABINET**

of exclusive modern design, hand made and polished, on Queen Anne legs.  
 Figured Oak £4 12 6  
 Figured Walnut or Mahogany . . . . . £5 10 0  
 Carriage paid.  
 Illus. Catalogue Free. Cabinets made to order a speciality.



**GILBERT Cabinet Maker, SWINDON**  
 Estimates Free. Estd. 1866

Make **The DAILY SKETCH** YOUR Picture Paper

**WHERE TO SEE "S.T.300's" AND "COSMICS"**

—continued from page 109

- KIRKHAM.**  
 P. Croisdale, 19, Poulton Street.
- KIVETON PARK.**  
 H. P. Snowden, Snowden's Wireless Stores, Station Road.
- LEEDS.**  
 City Wireless Supplies, 49, New Briggate.  
 M. Feldman, 58, Meanwood Road.  
 O. Fox, 84, Commercial Street, ROTHWELL.  
 G. Lumley, 75, Town Street, FARSLEY.  
 A. G. Radio Stores, 39, Meadow Road.
- LEIGHTON BUZZARD.**  
 Frank Griffin, 40, Hockliffe Street.  
 Griffin Bros., 11, High Street, and 63, North Street.
- LEWES.**  
 Leory & Richardson, Ltd., 170, High Street.
- LEITCHWORTH.**  
 P. C. Millard, 195, Glebe Road.
- LIVERPOOL.**  
 The Beaver Radio Co., 60-62, Whitechapel.  
 The J. D. Wireless Co., 195, Breck Road.  
 L. A. Wireless, 304, Stanley Road, BOOTLE.  
 Stanley's Radio, Ltd., 178-180, London Road.  
 G. Street & Son, 16, Wavertree Road.  
 H. J. Coxon, 240, County Road.  
 "Hobbies," 35, Manchester Street.  
 Morris & Co., 230, Smithdown Road.  
 Tom Simm, 275, West Derby Road.  
 City Wireless, 80, Whitechapel.
- LLANGFENI.**  
 T. Hughes Davies, High Street.
- LONDON.**  
 Andy's Radio, 285, Edgware Road, W.  
 H. Amos, 244, Earlsfield Road, Wandsworth, S.W.18.  
 Beresford Bros., 6, Beresford Square, WOOLWICH, S.E.  
 Bearman Bros., Dalston Junction, N.  
 J. H. Boldy, 819, Fulham Road, S.W.6.  
 J. H. Brookman, 8, Parley Road, SOUTH NORWOOD, S.E.25.  
 Cadisch & Son, 56-8, Eagle Street, W.C.  
 S. & J. Crompton, Ltd., 129, High Road, CHISWICK, W.4.  
 A. Clarke, 22-4, Market Hall, FULHAM.  
 Direct Supply Stores, 62, Lower Marsh, WATERLOO, S.E.  
 District Supplies, 11, Brushfield Street, E.  
 District Gramophone, 315, Old Kent Road, S.E.  
 Elkay Wireless, 225, Bishopsgate, E.C.  
 Elephant Electrical Co., Radio & Electrical Engineers, 29, New Kent Road, ELEPHANT & CASTLE, S.E.1.  
 "Electrico," 97, George Street, CROYDON.  
 A. Fudge & Sons, Bendall Street, Lisson Grove, N.W.1.  
 S. Grey & Co., 745, Barking Road, E.  
 Gas Light & Radio, 464, Holloway Road, N.5.  
 J. A. Gardiner & Co., 58, Church Lane, S.E.7.  
 J. Glickman, 479, Cambridge Road, BETHNAL GREEN, E.2.  
 Griffin, 187, Broadway, Uxbridge Road, SOUTHALL.  
 Hewitt & Co., 21, South Street, GREENWICH.  
 Hogben, 272, High Road, TOTTENHAM.  
 Harro Products, 46, Hoe Street, WALTHAMSTOW, E.  
 Hurley & Baker, 172a, Roman Road, BOW.  
 Harper's Radio, 430, High Street, LEWISHAM, S.E.13.  
 W. Kerr & Co., 107, West Green Road, TOTTENHAM.  
 Keen Wireless, 1, Dane Road, EALING.  
 Lighting Supplies, 305, Green Street, UPTON PARK.  
 M. Landau, 66, High Street, CAMDEN TOWN.  
 Metropolitan Lighting Co., 25, Atlantic Road, S.W.9.  
 Northcote Motor Co., 135, Northcote Road, CLAPHAM JUNCTION, S.W.11.  
 A. Orstin, 154, Green Street, BETHNAL GREEN, E.2.  
 A. Polter, 231, Green Street, BETHNAL GREEN, E.2.  
 G. H. Pearce, 129, Sydenham Road, S.E.26.  
 Pearl & Pearl, 190, Bishopsgate, E.C.  
 Plaistow Radio Service, 178, Plaistow Road, E.15.  
 Pearl & Moore, 168, Strand, W.C.  
 Peckham Radio, 152a, Rye Lane, PECKHAM.  
 Polchar's Wireless, Ltd., 175, High Road, BALHAM, S.W.  
 Polchar's Wireless, Ltd., 5, Manifold's Market, Rushey Green, CATFORD, S.E.  
 Potchars (1919), 96-98, High Street, DEPTFORD, S.E.  
 Popular Wireless, 101, Falcon Road, S.E.11.  
 Rayette, 123, King Street, HAMMERSMITH.  
 Radio Supply Stores, 574, Old Kent Road, S.E.1.  
 Reliance Radio Service, 29, South Street, ISLEWORTH.  
 Sacks, D., 130, Kentish Town Road, N.W.  
 Service Radio, 210, High Street, SHOREDITCH.

- M. Stone, 66, High Road, BALHAM.  
 Super Radio, 31, Surrey Street, CROYDON.  
 Sovereign Products, Ltd., 52-54, Rosebery Avenue, E.C.1.  
 The Peto-Scott Company, Ltd., 62, High Holborn, W.C.1.  
 The Peto-Scott Company, Ltd., 77, City Road, E.C.1.  
 Tower Radio, 5, High Street, SHOREDITCH.  
 Willesden Radio, 267, High Road, WILLESDEN GREEN, N.W.  
 Western Lighting Co., 77, Mitcham Road, TOOTING.  
 A. W. Waldron, 60, High Street, HOUNSLOW.  
 Wholesale Components, 8-8a, Cross Street, ISLINGTON.  
 Williams Lighting, 2, High Street, TOOTING.
- LONDONDERRY.**  
 Carlisle Radio Store, 48, Carlisle Road.
- LOWESTOFT.**  
 F. J. Hughes, Junction Passage.  
 Gladwells Radio, Sussex Street.
- LUDLOW.**  
 A. W. Packer & Son, 147, Corve Street.
- LYTHAM.**  
 F. Calvert, County Garage.
- MACCLESFIELD.**  
 H. Lucking, 50, Sunderland Street.
- MAIDSTONE.**  
 J. W. See & Sons, 12, Earl Street.
- MANCHESTER.**  
 Park Wireless Depot, 37, Raby Street, MOSS SIDE.  
 S. Howarth, Ivy Nook, LOWER CRUMPSALL Hunter, 7, Cumberland Street.  
 E. Butler, 178, Princess Road, MOSS SIDE.  
 Newton Radio Co., 398, Oldham Road, NEWTON HEATH.  
 Vernon, C. N., Ltd., 11, Halliwell Street.
- MARGATE.**  
 Walker & Son, 1/2, Marine Terrace.
- MELTON MOWBRAY.**  
 Sharman & Ladbury, Ltd., Sherrard Street.
- METHIL.**  
 Methil Radio Stores, 21, East High Street.
- MONTROSE, ANGUS.**  
 Valentine & Son, Radio Corner, Murray Street.  
 M. Wilson, 138, High Street.
- MORTIMER, BERKS.**  
 F. J. Hillary, Electrical and Radio Engineer.
- MOTHERWELL.**  
 Glasgow Cycle & Wireless Depot, 113-115, Brandon Street.
- NEWCASTLE-ON-TYNE.**  
 Accumulator Construction Co., Powdenc-House, Pudding Chare.
- NORTHAMPTON.**  
 V. O. Curtis, 86, Wellingboro' Road.
- NORTHWICH.**  
 R. Manning, Engineer, Acton Bridge.
- NOTTINGHAM.**  
 H. B. Hastings, 210, Waterway Street, Meadows.  
 The Wright Wireless Service, 41, Wilford Road.  
 World Radio Supply Stores, 78, Radford Boulevard.
- NUNEATON.**  
 Collins Radio Depot, 9-11, Riversley Road.
- OLDHAM.**  
 H. Gilbert, 139, Yorkshire Street.  
 Premier Wireless Stores, 26, Manchester Street.
- OLNEY.**  
 Minney Bros., 98, High Street.
- OSSETT.**  
 A. Wainwright, Wakefield Road, FLUSHDYKE.
- OXFORD.**  
 The Oxford Radio Supplies, 29, Queen Street.  
 G. R. Cooper, 40-44, St. Ebbe's.
- PAISLEY.**  
 Clydesdale Supply Co., 9, Moss Street.
- PELTON, Co. DURHAM.**  
 H. Sayer, Front Street.
- PENRITH.**  
 W. Pears, Great Dockray.
- PERTH.**  
 A. Harrower, 150, South Street.
- PETERBOROUGH.**  
 R. J. Croft, Main Street, FARCET.
- PEWSEY.**  
 T. E. Bailey, The Bazaar.
- PLYMOUTH.**  
 E. W. Tandy, 5, Belle Vue, North Road.
- PONTYPRIDD.**  
 D. G. Ball, 72, Taff Street.
- PORTRICAWL.**  
 Waldron Electrical Manufg. Co., 126, John Street.
- PORTSMOUTH.**  
 W. Keast, 290-302, Commercial Road.  
 Southern Wireless Service, 151, London Road, NORTH END.  
 L. F. Wells, 4, Fourth Street, St. Mary's Road.  
 Wild Bros., Arundel Street.



# OUR NEWS BULLETIN



## Testing Announcers

A CORRESPONDENT in the "Daily Telegraph" recently asked whether it was not time the B.B.C. announcers ceased to make use of the inaccurate phrase "almost immediately." If, he pointed out, the next item on the programme is to be broadcast "immediately," that word is applicable; otherwise "in a few moments," or some similar phrase, would surely be better.

## Don't Hesitate!

This particular correspondent of the "Daily Telegraph" would probably be interested in the examination which potential announcers have to undergo in America before they can be accepted as suitable for the job. One of the tests is to make the candidate sit at a small desk in front of a microphone and read out at sight a complicated announcement containing queer names, musical phrases, etc. If the announcer stumbles once, or if by any chance his intonation is hesitant, he loses his chance of getting the job.

I saw a recent test paper a few days ago, and it certainly was one which might make any announcer in the world want to pause and think before he risked pronouncing certain words.

## Pronunciation Posers

Here are some of them. Perhaps readers would like to see whether they are quite certain how to pronounce, for example:

Dvorak, Goethe, Poco a poco, Brailowsky, Chapei, Nowowiejski, Badinage, Tito Schipa, Piulento.

## A Curious Mistake

The B.B.C. has discovered that the platform in the new Concert Hall of Broadcasting House is too short for the full Symphony Orchestra. By some miscalculation the stage had already been erected before it was discovered that, with the orchestra at full concert strength, it would be

necessary to place a number of the instrumentalists on the floor of the auditorium. The trouble has now been rectified, but it was certainly curious that when the stage was built the calculation had not been made to ascertain how much space the full orchestra would require.

## The New Hall

The new concert hall, by the way, is oblong in shape, and the floor of the auditorium is considerably raked. Comfortable tip-up chairs are already in position for the use of the audience, and at the back of the hall is a big gallery. On the whole the design is modern, but with a pleasant blend of elegance and simplicity.

## VICTOR KING

has a new design for set builders which he will describe fully in "The Wireless Constructor"

## NEXT MONTH

Also in the July issue more exclusive articles by

## JOHN SCOTT-TAGGART

Order Now  
6d.

On Sale  
June 15th.

## Where Will It End?

Listeners have already had some experience of the new Poste Parisien station, which has put up its power to such a degree that it is now quite as strong—or seems to be quite as strong—as Radio-Paris in certain parts of the country.

Several European stations are now busy preparing to increase power. For instance, Leningrad will shortly be operating on just about London's wave-length, on a power of at least 250, and probably 275 kilowatts.

Vienna may shortly have a new 100-kw. transmitter; while increases in power will also be made in the German stations at Munich, Leipzig, Berlin, Hamburg, Breslau and Frankfurt. In a short while Dublin will be superseded by a new 100-kw. station to be built at Athlone, while building is almost completed on the new super-power transmitter at Luxembourg.

(Continued on page 112.)

# ONE THING DEPENDS ON ANOTHER

When H.T. leads get adrift the safety of the valve filaments depends entirely on the inclusion of an efficient fuse in circuit. Competa fuses, the first and foremost low-consumption bulbs, are specially designed to prevent damage to valve filaments.

60, 100, 150, 200, or 300 M/A. Price 6d. each.

Send for the new "Competa" Fuse Folder.

**A. F. BULGIN & CO., Ltd.**

ABBEY ROAD, BARKING, ESSEX.

Telephones: Grange Wood 3266/7

London Showrooms: 9, 10, 11, Cursthorpe St., E.C.4.  
Telephones: Holborn 2072.



# SPECIFIED

in the

**S.T.  
300**

**ADAPTOR**

The World-famous

"W.B."



**UNIVERSAL VALVE HOLDER**

(Patent No. 320450.)

4- or 5-pin. For vertical or horizontal mounting, with the well-known continuous spring contacts 1/-

Made by the makers of the enormously successful

**PERMANENT MAGNET**

Moving Coil Speaker,

P.M.4 - - - 42/-

(Complete with transformer.)

Write for  
FREE  
BOOKLET  
and LISTS.

**WHITELEY  
ELECTRICAL  
RADIO CO., LTD.**

Radio Works,  
Nottingham Road,  
Mansfield, Notts.

Irish Free State Distributors:

**KELLY & SHIEL, LTD.**  
47 Fleet Street, Dublin.



OUR NEWS BULLETIN

—continued from page 111

All-the-Time Radio

Mr. C. A. Siepman, B.B.C. Director of Talks, during a recent speech made a complaint about listeners who leave their sets switched on, not for the purpose of listening, but just to provide a background of sound. To have an infernal loudspeaker dribbling along continuously, he said, throughout the whole of the evening while people in the room play, or talk, or read, completely disregarding it, is both disgusting and annoying.

The Great Difficulty

Mr. Siepman also went on to admit that one of the problems the B.B.C. have to face is that of the caprice of the individual listener who could switch off at a moment's notice. "Our great difficulty," he said, "is that we cannot see how people are taking things. The first lesson we have-learned is that we can turn our backs for ever on the whole academic world in its academic sense. The only means of getting through to the audience which listens to you of its own volition is to reach it in terms of its own immediate human experience."

Not a very simple way of expressing what he means, but nevertheless there is the germ of a very great truth in Mr. Siepman's remark. Let us hope the B.B.C. Director of Talks will bear it in mind when he prepares future

talks for the benefit of educating listeners.

Have You Heard Falkirk?

It is reported that experimental transmissions made at the new Scottish Regional station near Falkirk have proved satisfactory, and that with luck the station will be open for public tests towards the end of May. Hundreds of listeners have been picking up the engineers' tests on the

The "S.T.300" Blueprint

As we go to press we learn that a limited number of copies of "The Wireless Constructor," February issue—containing the original description of the "S.T.300," with full-size Blueprint—can be obtained from:

THE AMALGAMATED PRESS, Ltd.,  
Back Number Dept.,  
Bear Alley, Farringdon Street, E.C.4.

Price 8½d. per copy. Post Free.

East Coast, and Dundee listeners especially have expressed satisfaction at what they have heard.

A Mile of Corridors!

Here are a few facts about Broadcasting House. The length of the corridors is one mile; there are about 800 doors, 7,500 panes of glass, 180 rooms and 1,250 stairs. Nevertheless accommodation is cramped, and, as stated in our editorial, the B.B.C. has acquired certain properties for the purpose of enlarging the building.

\*\*\*\*\*  
\* "SHALL I DESIGN A \*  
\* PORTABLE? " \*  
\* Victor King comments on the let- \*  
\* ters he has received from readers \*  
\* on the questions contained in an \*  
\* article of the above title which \*  
\* appeared last month. \*  
\*\*\*\*\*

I MUST first of all extend my sincerest thanks to the hundreds of readers who have written to me. I wish I could answer them all individually, but that, I fear, is impossible.

It has been a magnificently useful postbag, and many of my correspondents wandered right away from the subject of portable sets—but I willingly and interestedly followed them!

More letters like that, please—tons of them—for I could read them all day and every day, both for the enjoyment and the education of it.

However, to revert to the subject of portables. I am afraid my post fails to give me any really definite answer—except that the requirements of those readers who do want portables (and there aren't VERY many who admit a personal longing) are so many and varied that even the most optimistic "compromises" would fail to provide a "mean" solution!

Still, I'll leave the matter open for the time being—say another three or four weeks—for letters and postcards are even now, at the time of writing, rolling in by the score. And many, many thanks once again.

V. K.

"OHMITE" RESISTANCE

ALL values from 300 ohms to 5 megohms 1/6 Holder 6d.

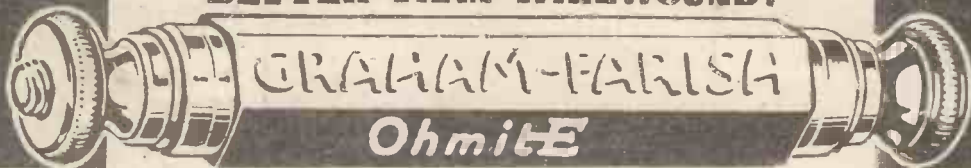

"BETTER THAN WIREWOUND!"

Made by GRAHAM FARISH Bromley Kent.

INDEX TO ADVERTISERS

	Page
Belling & Lee, Ltd.	109
Bird, Sydney S., & Sons, Ltd.	109
British Blue Spot Co., Ltd.	Cover iv
Bulgin, A. F., & Co., Ltd.	111
Burne-Jones & Co., Ltd.	99
Carrington Manufacturing Co., Ltd.	109
Colvern, Ltd.	95
Clarke, H., & Co. (M/cr.), Ltd.	103
"Chums"	105
Dubilier Condenser Co. (1925), Ltd.	97
Exide Batteries	97
Gilbert, J. C. (Cabinets)	110

	Page
Graham Farish, Ltd.	112
Hayberd, F. C., & Co.	110
Igranic Electric Co., Ltd.	99
Jackson Bros.	Cover ii
Lotus Radio, Ltd.	105
Mullard Wireless Service Co., Ltd.	60
"Modern Boy"	109
Ormond Engineering Co., Ltd.	Cover iii
Peto-Scott Co., Ltd.	59
Pricketts Cabinets	109
Ready Radio, Ltd.	91
Reproducers and Amplifiers, Ltd.	58
"Rex" Patents Co.	110

	Page
Radialaddin Club	109
"Story-Teller"	58
Tunewell Radio	108
Varley Products	57
Westinghouse Brake & Saxby Signal Co., Ltd.	105
Wingrove & Rogers, Ltd.	103
Woodworkers' Supplies	110
Wright & Weaire, Ltd.	99
Whiteley Electrical Radio Co., Ltd.	111
Webb Condenser Co., Ltd.	58

All communications concerning advertising in "Wireless Constructor" must be made to John H. Lile, Ltd., 4, Ludgate Circus, London, E.C.4. Telephone: City 7261. FOR ADVT. RATES SEE PAGE 58.



**Follow  
the Experts  
Judgement**

*The*  
**S.T. 300  
ADAPTOR**  
*uses*

*The* **ORMOND N°6** *Slow-Motion* **CONDENSER**



**Y**OU may be sure that the man who designs a circuit will be satisfied with nothing less than the best components. In the "S.T.300" Adaptor, as in many another "extra special" circuit, the man who knows specifies Ormond. They have no equal in efficiency or reliability.

This Ormond condenser is designed to follow the Log Law and is constructed of brass, being very robust. The vanes are perfectly rigid, being firmly secured to slotted spindles. Di-electric losses are reduced to a minimum by the special mounting of the fixed vanes support. The moving vanes are connected to the frame, thus eliminating stray capacity effects.

A slow-motion device, ratio approximately 9 to 1, is incorporated in the condenser and is controlled by the upper small knob, direct drive being obtained on the dial, which is engraved 0 to 180 degrees.

Easy to mount, "one-hole" fixing. Terminals and soldering tags for connections. Complete with 2½ in. dial and slow-motion control knob.

Cat. No.	Capacity.	Price.
R/484	- .0025	- 6/6
R/485	- .00035	- 6/6
R/486	- .0005	- 6/6



**THE  
ORMOND ENGINEERING  
CO., LTD.**

**ORMOND HOUSE,  
ROSEBERY AVENUE,  
LONDON, E.C.1**

Telephone : Clerkenwell 5334-5-6  
and 9344-5-6.

Telegrams : Ormondengi, Isling.



# BELIEVE IT

# OR NOT

**I**T is no exaggeration to say that Blue Spot 100U is the most outstanding achievement in loudspeaker design offered to the public. Its superiority will remain unchallenged for many a day to come.

Ask your dealer to let you hear this wonderful inductor type speaker and compare it with Moving-Coil Speakers. You will find that it is every bit as sensitive, that it reproduces bass notes to perfection and *yet gives full value to the remainder of the musical scale.*

100U gives to voices their real personality and to music the fresh crispness and distinctive individuality of the original.

Unlike Moving-Coil Speakers 100U reproduces perfectly even from very small inputs and is free from distortion. Hear this amazing speaker to-day. Send for illustrated Catalogue No. W.C.17U.

**100D**, an attractively designed Cabinet Speaker in fine quality oak, 63/-.

**100U 39%**

COMPLETE MOUNTED TO CHASSIS

**BRITISH MADE**

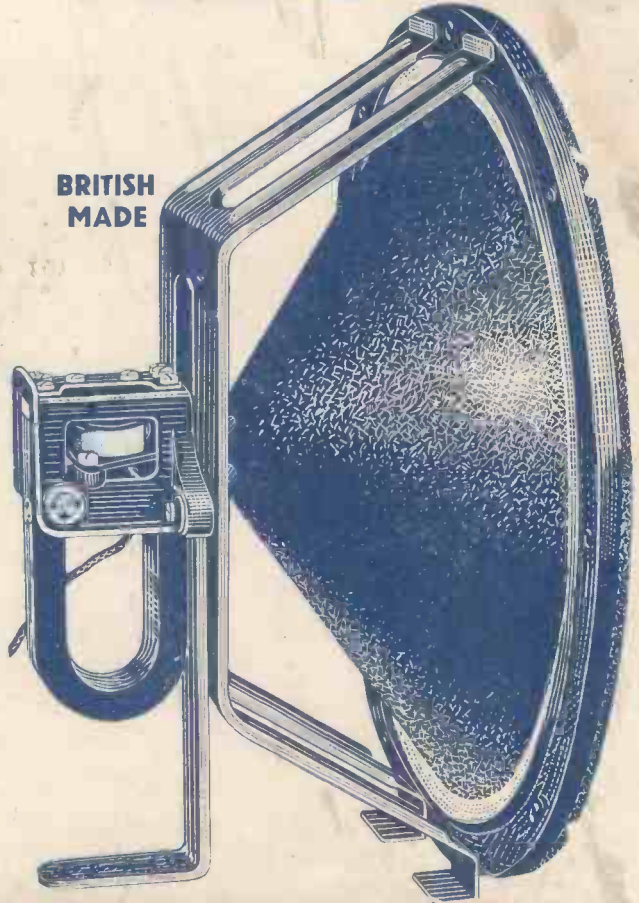

## REDUCED PRICES OF BLUE SPOT RECEIVERS

W.400 . . . . . now reduced to 15 gns.

W.S.400 . . . . . now reduced to 17 gns.

Table Grand . . . . . now reduced to 20 gns.

Upright Grand now reduced to 22 gns.

For A.C. mains, 100-240 volts. Complete with 5 valves and royalties paid.

**HIRE PURCHASE TERMS ARE NOW AVAILABLE FOR ALL BLUE SPOT PRODUCTS.**



## THE BRITISH BLUE SPOT COMPANY LTD

BLUE SPOT HOUSE · 94/96 ROSOMAN STREET · ROSEBERRY AVENUE · LONDON · E C1

Telephone: Clerkenwell 3570.

Grams: "Bluospot, Isling, London."

Distributors for Northern England, Scotland and North Wales:—H. C. RAWSON (Sheffield and London), LTD., 100 London Road, Sheffield; 22 St. Mary's Parsonage, Manchester; 183 George Street, Glasgow.